

COYNE



COYNE TELEVISION CYCLOPEDIA

*A Practical Reference
Book on Television
Receivers and Reception*



General Editors
BENNETT W. COOKE
SILAS C. NARLAND
RAYMOND A. SNYDER



Published by
EDUCATIONAL BOOK PUBLISHING DIVISION
COYNE ELECTRICAL AND TELEVISION-RADIO SCHOOL
CHICAGO, ILLINOIS

Copyright 1951 by
COYNE ELECTRICAL SCHOOL
500 South Paulina Street
Chicago 12, Illinois

thereof may not be reproduced in any form
All rights reserved. This book or any parts
without written permission of the publishers.

Printed in the United States of America

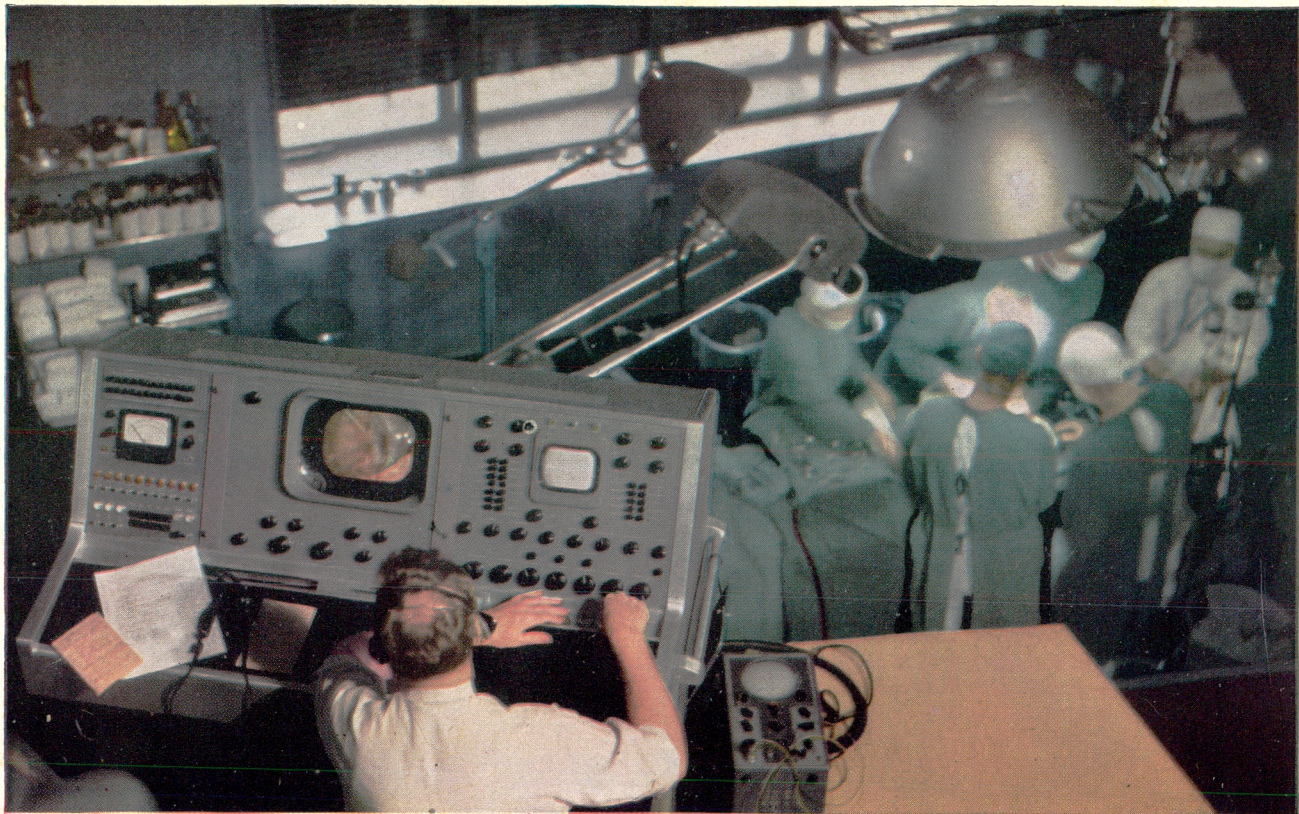

COLOR TELEVISION IN ACTION: Remarkable photo shows one of the recent color television broadcasts of surgical operations at St. Lukes hospital in Chicago. Television camera five feet above patient brought every move of surgeon on 12 x 14 inch color screen. Images were magnified twice life size. Microphone inside surgical jacket enabled surgeon to explain every step in operations. Television receiver in foreground shows picture being received in true colors. These broadcasts done by CBS were viewed by over 4000 surgeons of the American College of Surgeons and were sponsored by Smith, Kline & French Labs. They showed dramatically that color television may become one of the greatest aids to medical education. A complete section on methods of color television (printed in 4 colors) is included in this book.



COLOR TELEVISION IN ACTION: Remarkable photo shows one of the recent color television broadcasts of surgical operations at St. Lukes hospital in Chicago. Television camera five feet above patient brought every move of surgeon on 12 x 14 inch color screen. Images were magnified twice life size. Microphone inside surgical jacket enabled surgeon to explain every step in operations. Television receiver in foreground shows picture being received in true colors. These broadcasts done by CBS were viewed by over 4000 surgeons of the American College of Surgeons and were sponsored by Smith, Kline & French Labs. They showed dramatically that color television may become one of the greatest aids to medical education. A complete section on methods of color television (printed in 4 colors) is included in this book.

**COYNE
TELEVISION
CYCLOPEDIA**

PREFACE

The COYNE TELEVISION CYCLOPEDIA is an entirely new book. It was planned especially as a guide and quick reference volume to provide instant, reliable information on Television receivers and reception.

THE SCOPE OF THIS BOOK: According to Webster's dictionary a Cyclopeda is: "a work giving a complete summary of some branch of knowledge." Any good Cyclopeda to be of maximum usefulness must be all of the following:

1. CONCISE
2. AUTHORITATIVE
3. COMPLETE
4. EASY TO UNDERSTAND
5. SUBJECTS EASY TO LOCATE
6. ILLUSTRATED

The New COYNE TELEVISION CYCLOPEDIA meets all of these qualifications.

CONCISE: It is CONCISE because it expresses much technical material in brief, compact and "to the point" form. While every effort was made to present the material in a time saving way every subject was completely covered. The author and editors kept one thought foremost in mind—"make it complete but make it brief."

AUTHORITATIVE: Here is why this Cyclopeda is AUTHORITATIVE. Most of the information was selected from material contributed by over 70 companies engaged directly or indirectly in television set manufacture. The material was in the nature of special service and installation data which had previously been laboratory tested. This great quantity of tested data was then "screened" by Harold P. Manly (author of the original CYCLOPEDIA OF RADIO). This material for the CYCLOPEDIA OF TELEVISION was re-written to retain the best and most useful data. Mr. Manly's material was then carefully edited by members of the Coyne School staff. This procedure makes for the most accurate explanations possible.

COMPLETE: Any book with the above background and world of material could not help but be COMPLETE. The thought foremost in the minds of those who wrote and edited this book was—"make it completely cover each subject so there can be no doubt in the mind of the reader."

EASY TO UNDERSTAND: Throughout the book a "how-to-do-it" approach was used. Each article was written to meet the needs of the beginner but at the same time offer much that is NEW and VALUABLE to those with field experience in Radio or Television. An example of the procedure used can be seen in the material on TELEVISION SERVICING. In this section we included dozens of illustrated picture patterns (just as they were taken off the picture tube in operation). With these practical illustrations is complete information on the faults indicated and the remedy for correction of troubles. This is a MODERN, PRACTICAL approach to the servicing of Television receivers.

SUBJECTS EASY TO LOCATE: This book is written in the style of a dictionary. Subjects are arranged alphabetically making it amazingly simple for the reader to locate any subject he wishes. Hundreds of cross-references are used to assist toward easier and more complete understanding of every subject.

PREFACE

ILLUSTRATED: The illustrations in the COYNE TELEVISION CYCLOPEDIA are many in number. They have all been planned with the same care as the text. Each photo or drawing has been prepared for this particular type of book and each vividly demonstrates some important point in the text. Some of the best 4 color process photos describing the workings of several systems of Color TV are included. These much more clearly show the process of color separation in the various systems than straight black and white photos. For the added benefit of the reader a complete DIRECTORY OF ILLUSTRATIONS is included in this book.

Regardless of how many other Television books anyone may have this CYCLOPEDIA OF TELEVISION is a much needed book. Right now, great strides are being made in the industry. Television is destined to become one of the greatest forces in education and entertainment in the world. Special programs already conducted in surgical colleges (and pictured in this book) have vividly demonstrated the added advantage of this medium in teaching surgery. Where, only a few in a gallery could see an actual surgical operation in the past now hundreds can be as "close as the surgeon instructor" through the medium of Television.

There will be many uses for Television in industry, the armed services, and schools of all types. Television today is still in its infancy but there is no doubt in anyone's mind of potential progress destined for this great new industry. This new medium can very easily become more important than the Press, Radio and Films for conveying information on National and World events.

The magnitude of the service industry is just beginning to be realized. With the tremendous growth of television the need for well trained technicians becomes more imminent. There is little doubt that the industry will experience a serious shortage of trained men for some time to come.

The Television industry will employ millions of men and women in the future. Anyone who is in the field or hopes to become associated with it should have and use a book of this type. A Cyclopedic is ESSENTIAL to a man already employed in Television—it is even more essential to men entering a new field like Television.

It is my belief that the COYNE TELEVISION CYCLOPEDIA provides a reliable reference source of information on Television. It can be a very important factor in the progress of anyone who enters the field of Television.

The Educational Book Publishing Division of the Coyne Electrical and Television-Radio School wishes to express its thanks to each of the contributing companies, editors, illustrators and others for their splendid cooperation and enthusiastic interest in every stage of the development of this book. The names are formally acknowledged on a following page.



BENNETT W. COOKE, *President*
COYNE ELECTRICAL & TELEVISION-RADIO SCHOOL
CHICAGO 12, ILLINOIS

CONTRIBUTORS — EDITORS AND ILLUSTRATORS

General Editors

BENNETT W. COOKE
SILAS C. NARLAND
RAYMOND A. SNYDER

Author

HAROLD P. MANLY

Technical author for over 30 years. Has written many books and courses on electricity, radio, television and electronics including the original CYCLOPEDIA OF RADIO.

Staff of Editorial Examiners

DEWEY B. MILLER	JOHN P. HANAN
GUSTAV STEEGE	LYLE BURRICHTER
KARL J. SMITH	WILLIAM BEST
STANLEY GRUZINSKI	A. HADDOCK
E. BARRENTINE	R. LAMB
S. GILLINGHAM	A. ROSENWINKEL .

Artists and Engravers

CHARLES W. WACHTEL CLEMENT J. MAWICKE
PONTIAC ENGRAVING CO.
GEOGRAPHICAL PUBLISHING COMPANY
THE ADCRAFTERS CORPORATION

CONTRIBUTORS — TECHNICAL COPY

Television Companies and Allied Concerns

The publishers gratefully acknowledge thanks to the following companies for their interest and valuable contributions of technical material used in this CYCLOPEDIA OF TELEVISION.

Admiral Radio and Television Corp.	National Company
Philco Radio & Television Corp.	Pilot Radio Co.
General Electric Co.	Wilcox Gay Co.
Westinghouse Elect. & Mfg. Co.	Sonora Radio & Television Co.
Sentinel Television Corp.	Sparks Withington Co.
Radio Electronics News	TeleKing Television Corp.
Allen B. Dumont Co.	TeleTone Radio Corp.
RCA Mfg. Co.	Templetone Radio Mfg. Co.
Smith, Klein & French Labs.	Transvision Corp.
Crosley Radio & Television Corp.	Webster Chicago Corp.
Color Television Inc.	Wurlitzer Co.
Columbia Broadcasting System	Audar Inc.
Motorola Radio & Television Corp.	Standard Radio & Television Co.
Sylvania Electric Products Co.	Simpson Mfg. Co.
Stewart Warner Radio & Television Corp.	Remington Radio Corp.
Traveler Radio & Television Corp.	Scott Radio Laboratories Inc.
Hickok Inst. Co.	Sightmaster Corp.
Feiler Engineering Co.	Howard Sams Co.
Belmont Radio & Television Co.	Packard Bell Co.
Emerson Radio & Television	Olympic Radio & Television Co.
Zenith Radio & Television	Orthon Co.
Hoffman Radio Corp.	Duval Radio & Television Co.
Stromberg Carlson Co.	Delco Radio Co.
Meissner Mfg. Co.	Airadio Inc.
Bendix Radio Division	Andrea Radio Corp.
Farnsworth Television & Radio Co.	Arcturus Radio & Television Co.
Warwick Mfg. Co.	Bell Radio Co.
DeWald Radio Mfg. Co.	Amplitone Corp.
Emerson Radio Co.	Ansley Radio & Television Co.
Fada Radio & Electric Co.	Air King Products Co.
Federal Telephone & Radio Co.	Industrial Television Corp.
Garod Radio Corp.	Majestic Radio & Television Corp.
Howard Radio Co.	National Union Radio Corp.
Magnavox Corp.	Freed Radio Corp.
Meck Industries	Espey Mfg. Co.
	Midwest Radio & Television Corp.
	Televox Inc.
	Wells Gardner & Co.

DIRECTORY OF ILLUSTRATIONS

This Directory of Illustrations is included as an aid toward locating complete data on various television subjects. The Directory is presented alphabetically and lists a portion of the illustrations appearing in this Cyclopaedia. The caption of the illustration is given along with the number of the page on which it appears. There are over 200 additional helpful photos and diagrams to be found in this book. For further convenience in quickly locating television data a detailed INDEX of all subjects can be found at the back of the book.

	Page		Page
ALIGNMENT			
Parts or circuits of a television receiver in which there are adjustments for alignment.....	1	Parts of the video amplifier coupling which affect low-frequency response	49
Correction curves for two combinations of signal generator and voltmeter.....	4	Series compensating inductance extends the range to higher frequencies.....	52
Appearance of a gain curve or frequency response on the oscilloscope when using the intergal sweep	5	Picture signals are positive when the detector output is from the diode plate.....	54
With synchronized sweep voltage for the horizontal input of the oscilloscope the two traces are made to appear as one.....	6	Polarities required in signal inputs to the cathode and to the control grid of the picture tube....	56
Connections for coupling signal generators to tubes	11	AMPLIFIERS, VIDEO INTERMEDIATE-FREQUENCY	
Applying marker signals to the mixer tube with the sweep generator connected to the antenna terminals	15	Connections in a three-stage video intermediate-frequency amplifier system.....	58
AMPLIFIERS, BROAD BAND		Parallel resonant traps in interstage couplings of video i-f amplifiers.....	61
Typical frequency responses of broad band amplifiers	16	Where carrier frequencies and intermediate frequencies appear on the frequency response from the video detector.....	62
Parts which affect response at lowest and highest frequencies in video detector and video amplifier couplings	17	How the frequency response of the video amplifier is shaped to equalize total amplification at all applied frequencies.....	64
AMPLIFIERS, RADIO-FREQUENCY		Tube or circuit capacitances which affect high-frequency response of the video i-f amplifier..	70
Input coupling whose impedance is changed for different channels	20	Effect on separation of resonance peaks when coupling is increased.....	78
Connections used for grounded grid r-f amplifiers	21	Transformers having magnetic, resistive, and inductive couplings.....	79
AMPLIFIERS, SWEEP		Transformers with which capacitors are the coupling elements	81
Electrical relations of sweep amplifiers to other parts of a television receiver.....	22	Adjustable capacitors used for varying the coupling and the band width at the output of video i-f amplifiers.....	82
Connections for a phase inverter in an electrostatic sweep amplifier.....	24	Grounding of control grids through capacitors or resistors to prevent oscillation during alignment	86
Capacitance voltage divider feeding the grid of a phase inverter.....	26	Frequency responses when the sound system operates at the sound intermediate frequency....	88
Feedback connection for improving linearity of an electrostatic sweep amplifier.....	28	How various traps affect frequency responses in the video i-f amplifier.....	90
Electrostatic deflection requiring no amplifier tube	30	Connections of signal generator and output for video i-f alignment.....	92
Circuit for production and use of a sawtooth voltage combined with a square pulse.....	32	Typical peaking frequencies for four couplers in stagger tuned video i-f amplifiers.....	94
Typical vertical sweep circuit for magnetic deflection	34	Typical peaking frequencies used with five couplers in stagger tuned video i-f amplifiers.....	94
Typical horizontal sweep circuit for magnetic deflection	36	Overcoupled transformers and single-peaked coupling coils in the same video i-f amplifier.....	101
Sweep amplifier grid-cathode circuit with resistance type drive control.....	38	Instrument connections for observing the frequency response of a single stage or single coupler	104
Feedback connection for adding a negative pulse to the sawtooth voltage for the amplifier grid	39	Observing individual stage response by shorting out the couplers in all other stages.....	105
Modifications found in some of the circuits on the plate side of the horizontal sweep amplifier for magnetic deflection.....	40	ANTENNAS	
AMPLIFIERS, VIDEO		Connection of a dipole antenna through a transmission line to the receiver.....	110
Vertical sync pulses and blanking intervals of the composite signal in the video amplifier....	43	A half-wave dipole which may be called a conical antenna or a conical V-antenna.....	117
Horizontal sync pulses and blanking as shown by the oscilloscope.....	43	A half-wave dipole antenna with a reflector element back of it.....	120
A two-stage video amplifier incorporating features in general use.....	47	A folded half-wave dipole with a reflector element back of it and a director element in front	122

DIRECTORY OF ILLUSTRATIONS—Continued

	Page	Page
Folded dipoles and reflector elements for the high band and the low band mounted for separate orientation in the two bands.....	125	
Connections for a meter which is carried to the antenna location during orientation.....	132	
BIASING		
Varying the bias changes the operating point on the grid-voltage plate-current curve.....	136	
The principle of fixed bias.....	140	
Fixed bias with decoupling capacitors and resistors.....	141	
BRIGHTNESS AND BRIGHTNESS CONTROLS		
Relations between control grid voltage of a picture tube and average brightness of pictures or patterns.....	146	
Brightness control used when signal input is to the picture tube control grid.....	147	
Brightness control when signal input is to the picture tube cathode.....	147	
Brightness control too high or contrast control too low.....	148	
Brightness and contrast correct for a weak signal.....	148	
CAPACITANCE AND CAPACITORS		
Meanings of color code dots in various positions on mica capacitors.....	156	
Color code markings for fixed ceramic and some other cylindrical or tubular capacitors.....	157	
CENTERING AND CENTERING CONTROLS		
The pattern or picture may be off center in one or more directions.....	161	
Circuit connections for electrostatic centering control.....	162	
Electrical centering controls used with a magnetic deflection system.....	164	
Tilting the focusing coil with reference to the axis of the picture tube neck will shift the center of a pattern or picture.....	165	
CLIPPERS OR LIMITERS		
A diode used as a leveler or clipper for sync pulses.....	168	
CONTRAST AND CONTRAST CONTROLS		
Relations between screen brightness and amplitude of the signal voltage applied to a picture tube.....	177	
Contrast control by means of adjustable negative voltage obtained through voltage dividers on the B-power supply.....	179	
Contrast controls consisting of adjustable cathode bias on video amplifier tubes.....	180	
A contrast control on the cathode resistor of a cathode follower tube.....	181	
DAMPERS AND DAMPING		
Simple circuits for magnetic deflection.....	192	
How oscillation may start and continue in a deflection coil circuit having no special means for damping.....	193	
Connection of a damper tube in the coil circuit for magnetic deflection.....	194	
A horizontal linearity control connected between damper cathode and transformer primary.....	196	
Circuit connections for a triode damper tube.....	197	
DECOUPLING		
Feedback coupling through impedance of a common power supply.....	199	
Separate decoupling for plate, screen, and grid circuits.....	200	
DEFLECTION, ELECTROSTATIC		
The picture tube beam is deflected by opposite charges on metallic plates inside of electrostatic picture tubes.....	203	
Waveforms of deflection voltages applied to opposite plates of one pair.....	204	
DEFLECTION, MAGNETIC		
Positions of the yoke and deflecting coils on the neck of a picture tube.....	208	
DEGENERATION		
One method of obtaining voltage feedback.....	212	
DETECTOR, PHASE		
Connections in one type of phase detector circuit.....	213	
DETECTOR, RATIO		
Typical circuit for a ratio detector used in f-m sound systems.....	215	
DIVIDERS, VOLTAGE		
A resistance voltage divider and a capacitance voltage divider.....	229	
DRIVE CONTROLS		
Resistor type drive control and its action.....	232	
Capacitor type drive control and its action.....	233	
FILTERS, DIFFERENTIATING AND INTEGRATING		
Action of the horizontal or differentiating filter.....	236	
FOCUSING AND FOCUSING CONTROLS		
Principle of electrostatic focusing.....	241	
Principle of magnetic focusing.....	242	
GAIN CONTROL, AUTOMATIC		
Circuits for a simple type of automatic gain control.....	252	
Agc delay voltage varies by adjustment of contrast control in the cathode circuit of a video amplifier.....	254	
An amplifier for increasing the automatic biasing voltage and inverting its polarity.....	257	
Two ways in which diodes may be used as noise limiters.....	260	
Keyed agc system in which positive keying pulses for control grids are taken from the sync section of the receiver.....	264	
GAIN, STAGE		
Connections for measuring voltage gain with signal generator and electronic voltmeter.....	268	
GENERATORS, AUDIO-FREQUENCY		
A Wein bridge frequency-selective circuit as used in audio-frequency generators.....	270	
GENERATORS, CRYSTAL CONTROLLED		
A simple crystal-controlled oscillator.....	271	
An untuned crystal-controlled r-f oscillator.....	271	
GENERATORS, MARKER		
Connections of marker generator, sweep generator, and oscilloscope to amplifier or receiver.....	274	
GENERATORS, SQUARE WAVE		
Faults indicated by output traces with square wave input. A, lock of high frequencies. B, extreme high-frequency loss. C, moderate low-frequency loss. D, serious low-frequency loss. E, no low-frequency gain.....	282	
Faults indicated by traces from square waves. A, phase distortion with current leading. B, phase distortion with current lagging. C, effects of frequency compensation. D, oscillation in amplifier.....	283	
GENERATORS, SWEEP		
Connections for a sweep generator and features of the oscilloscope trace.....	285	
Electromechanical or electrodynamic method of frequency sweeping.....	287	
The same curve of frequency response may appear in different positions on the oscilloscope screen.....	290	
Response traces produced by using the internal horizontal sweep of the oscilloscope.....	292	
A phase shifting circuit for synchronized sweep voltage.....	294	
Oscillators for producing sweep frequencies which are centered at various values.....	296	

DIRECTORY OF ILLUSTRATIONS—Continued

	Page		Page
HOLD CONTROLS			
Sweep oscillator free running frequency is changed to sync frequency by the triggering pulses.....	303		
Hold control connected to a blocking oscillator.....	304		
Hold control applied to a multivibrator.....	304		
Misadjustment or faults in the vertical hold control allow the pattern to move upward or downward on the picture tube screen.....	305		
IMPEDANCES			
Impedance triangles and their meanings.....	307		
INTERCARRIER SOUND			
Signal paths in a receiver employing inter-carrier sound	317		
Typical frequency responses for receivers having intercarrier sound systems.....	319		
INTERFERENCE			
Effects of spark interference as seen at the picture tube	323		
Traps in r-f grid circuits and antenna couplings for 300-ohm balanced transmission line.....	334		
Parallel and series resonant traps shown connected to inputs from coaxial transmission line	335		
Transmission line stubs used as interference traps	336		
LIMITERS, F-M SOUND			
A limiter with its biasing resistor and capacitor in the grid return connection.....	341		
How limiting is caused by plate current cutoff and by positive grid voltage.....	343		
LINES, TRANSMISSION			
Connections of matching sections at the antenna end and at the receiver end of the transmission line	360		
LINEARITY AND LINEARITY CONTROLS			
How curvatures of the sawtooth slope affect linearity of a pattern.....	365		
Horizontal linearity controls in the plate and cathode circuits of a damper tube.....	367		
MEASUREMENTS, HIGH-FREQUENCY			
Determining resonance from maximum voltage developed in a tuned circuit.....	372		
MEASUREMENTS, HIGH-VOLTAGE			
Determining resonance from impedance of a tuned circuit.....	374		
METERS, ELECTRONIC VOLT			
Protecting the voltmeter against high direct potential	380		
METERS, FREQUENCY			
Essential parts of a heterodyne frequency meter or heterodyne detector.....	383		
METERS, GRID DIP			
Coupling of grid dip meter to transmission line sections or stubs.....	387		
METERS, RECTIFIER			
Connections of crystal diodes to d-c microammeters for measurements at high frequencies.....	388		
MIXERS			
How signal and oscillator frequencies combine with amplitude variations which furnish a beat frequency when rectified.....	391		
MODULATION, AMPLITUDE			
The principle of amplitude modulation.....	393		
MODULATION, FREQUENCY			
The principle of frequency modulation.....	395		
MODULATION, PHASE			
Phase changes for phase modulation.....	396		
OSCILLATORS, FEEDBACK			
The three principal ways in which feedback occurs in oscillators.....	408		
OSCILLATORS, NEGATIVE RESISTANCE			
Circuit connections for a dynatron oscillator.....	417		
OSCILLATORS, RELAXATION			
Connections for a multivibrator oscillator.....	420		
OSCILLATORS, TELEVISION, R-F			
Push-pull r-f oscillator with parallel resonant tuned circuit	425		
Push-pull r-f oscillator with a started quarter-wave resonant line as the tuned circuit.....	426		
How shifting of r-f oscillator frequency alters both the intermediate frequencies.....	427		
OSCILLATOR, TELEVISION SWEEP			
How a sweep oscillator controls charge and discharge of the capacitor.....	432		
How sweep oscillator frequency is controlled by sync pulses	433		
Blocking oscillator connections.....	434		
Changes of plate current and grid voltage in a blocking oscillator	435		
Discharge tube used with a blocking oscillator.....	437		
A cathode-coupled multivibrator sweep oscillator	438		
A capacitor-coupled multivibrator sweep oscillator	440		
OSCILLATOR, TELEVISION SWEEP, CONTROL OF SWEEP AFC SYSTEM USING DISCRIMINATOR AND REACTANCE TUBE WITH A HARTLEY OSCILLATOR			
Phase detector and reactance tube for automatic frequency control	446		
Phase detector for direct frequency control of a multivibrator oscillator.....	448		
A diode used as the control tube in an afc system for a blocking oscillator.....	451		
Combined pulses from oscillator output, and sine waves at sync pulse frequency, as they appear at the afc diode.....	452		
PADS, MATCHING			
Matching pads used between signal generators and receiver antenna terminals.....	468		
PATTERNS, TEST			
Features of a test pattern which are of assistance when making adjustments.....	470		
POWER SUPPLY, HIGH-VOLTAGE			
High-voltage power supply of the flyback or pulse-operated type	472		
PREAMPLIFIERS			
Preamplifier circuit employing a single r-f stage with band switching.....	480		
PROBE, DETECTOR			
Detector probes with crystal diode in series between input and output.....	482		
Detector probes may both load and detune a measured circuit	485		
PROBE, FILTER			
Filter probe for connection to an oscilloscope.....	486		
PROPAGATION, WAVE			
Factors which affect television and f-m radio reception distance	488		
Wave reflection which may cause ghost images.....	489		
RESTORATION, D-C			
Modulated i-f signals and their d-c components for light toned and dark toned pictures.....	494		
Signals for light and dark pictures reproduced with the same grid bias in the picture tube.....	496		
D-c restoration by means of grid-leak bias for a video amplifier tube.....	498		
D-c restoration by means of a diode when signal input is to the picture tube grid.....	501		
Diode method of d-c restoration when signal input is to the picture tube cathode.....	502		
Black level potential or amplitude with reference to sync pulse tips is altered by change of signal strength	505		
Effect on picture reproduction of equalizing the sync tip voltages for strong and weak signals.....	506		

DIRECTORY OF ILLUSTRATIONS—Continued

	Page	Page
D-c restoration from cathode voltage of a tube in the sync section of the receiver.....	509	
SCANNING		
Travel of the electron beam over the screen in the picture tube.....	514	
SEPARATION, SYNC		
Sync separator connected to output of a video amplifier	518	
SHIELDING		
A triode used for d-c restoration and sync separation	521	
SIGNAL, TELEVISION		
The television signal during the two vertical blanking periods of one frame.....	527	
SIZE CONTROLS		
Connections for size controls which permit magnified pictures	534	
Magnifier connections for a linearity control and for a width control.....	535	
SOUND, TELEVISION		
Scheme of connections for a dual-channel sound system	537	
Sound takeoff connections for dual-channel sound systems	538	
Audio-frequency voltage pulses produced by frequency deviations	542	
Typical circuit of a discriminator type of sound demodulator	544	
SWITCH, ELECTRONIC		
How two simultaneous oscilloscope traces are formed by the electronic switch.....	552	
Electronic switch connected for observing input and output voltages of an amplifier.....	554	
SYNC SECTION		
Connections of tubes in sync sections of receivers	560	
TELEVISION — COLOR		
<i>Illustrated in 4 Colors</i>		
The three color bands may be picked up by three separate cameras or by a single camera with rotating three-color filter disc.....	563	
CBS color camera for use with CBS color television system	567	
Table model standard black-and-white television set with a scanning adapter which will enable it to get CBS color television signals in black-and-white, in addition to getting standard black-and-white signals in black-and-white.....	568	
The RCA color television camera with cover removed to show the system of dichroic mirrors and silvered reflectors which separate the color bands	570	
RCA direct view color reproduction system using three kinescopes and two dichroic mirrors.....	572	
Three-color reproduction by means of three electron beams acting on a screen having phosphors which emit the three color bands.....	575	
How the three color bands are combined on the projection screen	578	
TELEVISION RECEIVERS		
The principal sections of a television receiver.....	581	
Principal parts of the radio-frequency section of a television receiver.....	583	
The video section with its accessories and controls	584	
TRACERS, SIGNAL		
Connections for testing with a signal tracer.....	589	
TRANSMISSION, NEGATIVE		
Negative transmission of the left and positive transmission at the right.....	594	
TRANSMISSION, VESTIGIAL SIDEBAND		
Distribution of transmitted frequencies within a six megacycle channel.....	596	
How receiver attenuation compensates for double transmission of some signal modulation frequencies	597	
TRAPS, INTERFERENCE		
Interference traps of absorption types.....	600	
Interference traps of impedance types.....	601	
Video i-f frequency response as modified by three types of traps.....	605	
Frequency responses at various points in the i-f amplifier having traps for accompanying and adjacent sound	607	
TRAPS, ION		
Ion trap of the type requiring a double magnet	611	
Paths of ions and electrons in the double magnet ion trap	613	
Operating principle of the bent-gun ion trap employing a single magnet.....	615	
TROUBLE, LOCATION OF		
Sections of receiver to be considered during location of troubles.....	617	
TROUBLE SHOOTING, BY PATTERN ANALYSIS		
Bars, Horizontal, Wide.....	625	
Bars, Horizontal, Narrow, "Sound Bars".....	626	
Bars, Slanting	627	
Bars, Vertical	628	
Brightness Excessive or Varying.....	629	
Centering Incorrect	630	
Contrast Excessive	631	
Contrast Insufficient	632	
Definition Poor, Detail Lacking.....	633	
Focus Poor	634	
Folded Pattern, Horizontally.....	635	
Folded Pattern, Vertically.....	636	
Ghosts	637	
Herringbone Effect	638	
Linearity Poor, Horizontal.....	639	
Linearity Poor, Vertical.....	640	
Line Only, No Raster or Pattern.....	641	
Lines Narrow, All-over Pattern.....	642	
Lines, White, Curved and Slanting.....	644	
Movement, Horizontal	645	
Movement, Vertical	646	
Movement, Vertical and Horizontal.....	647	
Raster Only, No Pattern or Picture.....	648	
Shadows	649	
Size Incorrect	650	
Size Incorrect	651	
Snow	652	
Split Pattern, Left and Right.....	653	
Split Pattern, Top and Bottom.....	654	
Tear Out	655	
Tilting in Mask	656	
Trailers or Smeers.....	657	
Wavy Edges on Pattern.....	658	
TUBES, PICTURE		
Location of the electron gun in a picture tube.....	664	
Factors which affect distance of deflection in a magnetic picture tube.....	669	
Picture areas and mask proportions.....	675	
TUBE, PICTURE, ELECTROSTATIC		
Base pin positions and element connections of the 7JP4 electrostatic picture tube.....	684	
TUNERS		
Circuits such as ordinarily employed in a tuner.....	688	
A turret tuner.....	691	
Tuner having movable cores in the inductors.....	692	
Tuner employing a push-pull oscillator with a twin triode tube.....	698	
Tuner employing shorted quarter-wave resonant lines in all the tube circuits.....	699	
Rf-mixer and oscillator circuits with individually adjustable inductors for each channel.....	701	

CYCLOPEDIA OF TELEVISION

ALIGNMENT. — Alignment of a television receiver means the process of adjusting certain of its tuned circuits for suitable amplification or gain, or to specified band-pass characteristics throughout bands of carrier frequencies in the various channels, and at intermediate frequencies for which the receiver is designed. Alignment adjustments are found in the tuner section, in intermediate-frequency amplifiers for video and sound, and in the inputs to video detectors and sound detectors.

The shaded blocks of Fig. 1-1 indicate tuned circuits which may be aligned. Tubes are represented by circles. The transformer (coupling) between antenna and r-f amplifier may or

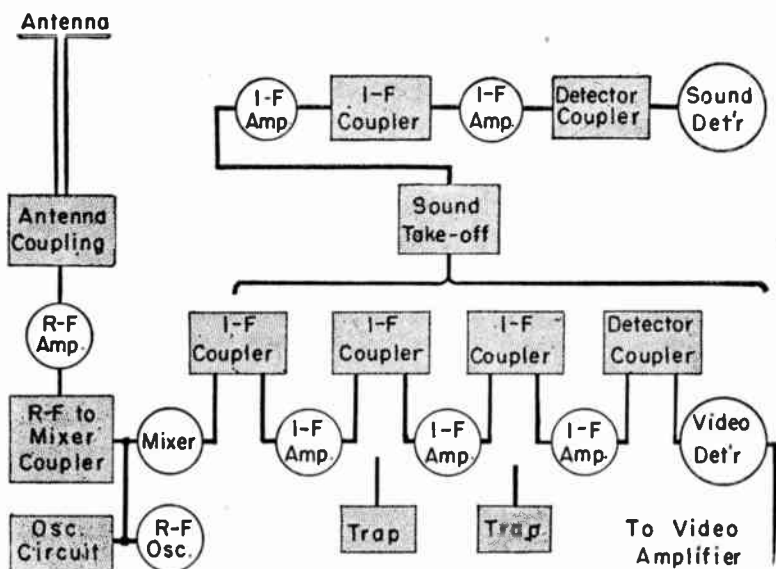

Fig. 1-1.—Parts or circuits of a television receiver in which there are adjustments for alignment.

may not be adjustable. The transformer between the r-f amplifier tube and the mixer tube usually is adjustable. The tuned circuit for the r-f oscillator nearly always is designed for alignment. Intermediate-frequency transformers between mixer,

i-f amplifiers, and video detector always are adjustable. Adjustably tuned interference traps are coupled to the video i-f amplifier stages of some receivers, and sometimes at the antenna transformer and preceding the sound takeoff. The sound takeoff may or may not be adjustably tuned. If there is more than one sound i-f amplifier each interstage transformer is adjustable, as is also the input transformer for the sound detector or demodulator.

The order in which circuits or sections of the receiver are aligned depends on several factors. If trouble is indicated as being in some one section, because of observed symptoms or as the result of tests, and if the trouble appears due to misalignment, that is the section to be first aligned. If the entire receiver is to be realigned, or the adjustments checked, this work usually begins at the transformer preceding the video detector. Adjustments then are continued back to the transformer following the mixer. Traps in this portion of the receiver are aligned along with the transformers. Next would come the sound section, commencing at the transformer preceding the detector and following back to the sound takeoff. Final steps would include alignment of the r-f oscillator, the r-f to mixer transformer, and the antenna transformer.

Instruments for Alignment. — For aligning any section of the receiver it is necessary to have a signal source and an output indicator. The source is a generator which provides signal voltages at frequencies which may be varied throughout the band in which the section operates. For tuner alignment it is necessary that the generator provide carrier frequencies, for alignment of i-f amplifiers it is necessary to provide intermediate frequencies, and so on. The generator is coupled to the input of the section or circuit to be aligned.

To the output of the aligned section must be connected some instrument which will indicate response or relative voltage gain at all frequencies within the operating band. This output indicator may be an oscilloscope, an electronic voltmeter, or in some cases a high-resistance d-c voltmeter.

By using a signal generator for the source and an elec-

tronic voltmeter as the output indicator, as in Fig. 1-2, it is possible to take output voltage readings at a number of frequencies. These output voltages may be plotted against frequency on graph paper, as at the right, and a smooth curve drawn through them. Provided certain requirements are satisfactorily met, this curve represents the frequency response of the section or circuit being tested.

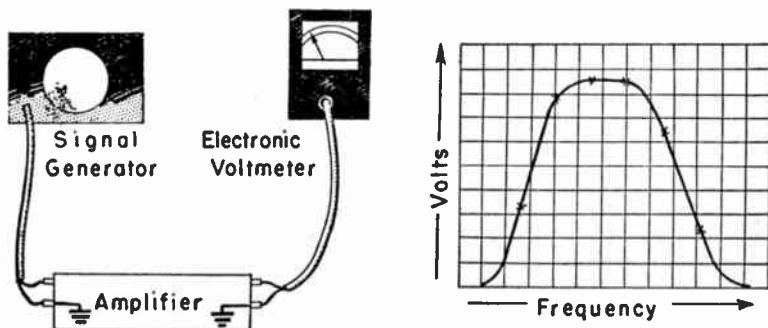

Fig. 1-2.—Frequency response may be measured by using a signal generator and electronic voltmeter.

The curve is a true frequency response only when the generator output is flat or of constant voltage throughout the range of frequencies, and when the indications of the voltmeter are unaffected by changes of frequency. Whether these requirements are reasonably satisfied may be checked by first connecting the output cable of the generator directly to the input of the voltmeter. Some generators are not capable of producing one volt of output. Note voltages obtained in Fig. 1-3. With the generator output adjusted to give a readable indication on the meter, the frequency is varied throughout the range to be used and the voltmeter readings are noted for various frequencies.

Fig. 1-3 shows variations of meter readings with frequency as found with two particular signal generators and electronic voltmeters for the range of intermediate frequencies between 20 and 27 mc. Obviously, an uncorrected response curve run with either of these combinations of instruments would not

show the true frequency response of an amplifier unless corrections were applied.

If the signal generator is equipped with a dependable calibrated attenuator the generator output may be adjusted to a uniform level at all frequencies. The voltmeter then must respond uniformly at all frequencies to be checked. Otherwise the non-uniform response voltages, such as those of Fig. 1-3, may be corrected to compensate for the variations. The ap-

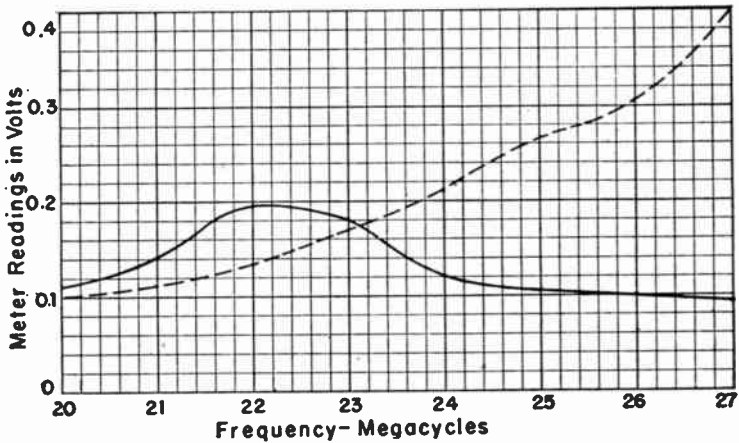

Fig. 1-3.—Correction curves for two combinations of signal generator and voltmeter.

proximate correction factor for each frequency may be determined from a curve plotted with the generator and meter connected directly together. The measured voltage at each frequency is divided by the voltage shown on the correction curve for that frequency. The corrected voltages then may be plotted on graph paper and a curve drawn through them.

Frequency response may be determined with an oscilloscope as the output indicator in a fraction of the time needed when using a voltmeter. When observing the output on an oscilloscope the input signal is provided by a sweep generator. A sweep generator furnishes a voltage whose frequency continually shifts back and forth throughout the range to be observed, usually at a rate of 60 times per second. The extent of frequency shift or sweep usually is adjustable from a fraction of a

megacycle to ten or more megacycles, depending on the design of the instrument.

If, for example, it is desired to observe the frequency response of an i-f amplifier between the limits of 21 and 29 mc, the sweep generator would be adjusted for a center frequency about midway between these limits, or to 25 mc, and the sweep width for about 10 mc to surely cover the extremes of response. Then, as shown at the top of Fig. 1-4, the frequency furnished by the generator would shift back and forth between 20 and 30 mc, increasing from 20 to 30 mc during $1/120$ second, and decreasing from 30 to 20 mc in the following $1/120$ second, assuming the sweep period to be $1/60$ second.

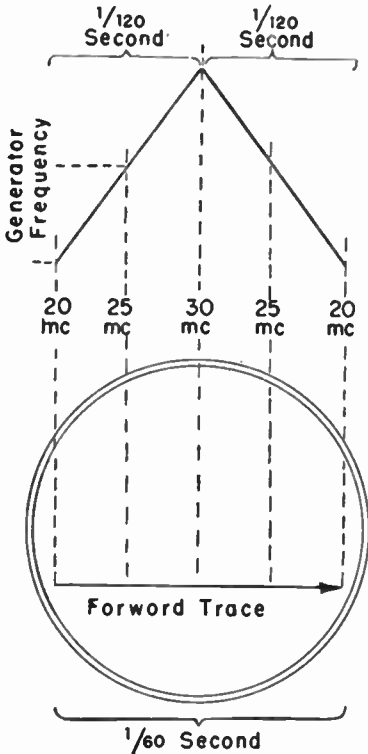

Fig. 1-4.—Generator frequency sweeps up and back again during each trace when using the internal sweep of the oscilloscope.

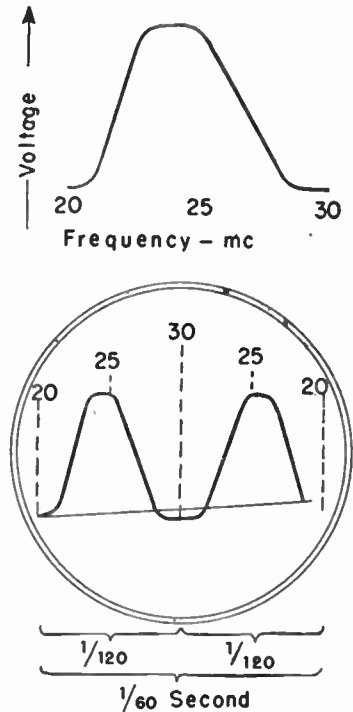

Fig. 1-5.—Appearance of a gain curve or frequency response on the oscilloscope when using the internal sweep.

The rate of horizontal sweep of the oscilloscope beam must match the rate of frequency sweep in the generator. This may be accomplished by using the internal sweep control of the oscilloscope or else by feeding to the horizontal input of the scope an external sweep voltage which is synchronized with the sweep timing of the generator.

If the generator sweep rate is 60 times per second, and the internal sweep of the oscilloscope is adjusted to 60 cycles per second, the generator frequency will increase and then decrease during each forward trace of the scope beam. This is illustrated at the bottom of Fig. 1-4.

We shall assume now that the generator output is coupled to the input of some amplifier, and that the amplifier output is connected to the vertical input of the oscilloscope. Relative voltage gain at swept frequencies might be as shown at the top of Fig. 1-5. This output voltage from the amplifier will cause two curves to be formed during each forward trace of the oscilloscope beam, as at the bottom of Fig. 1-5.

If a synchronized horizontal sweep voltage is supplied to the oscilloscope, instead of its own internal sweep voltage, and if the sweep rate still is assumed to be 60 times per second, the beam will travel from left to right during $1/120$ second, and back from right to left during the following $1/120$ second. A gain curve will be traced during each travel

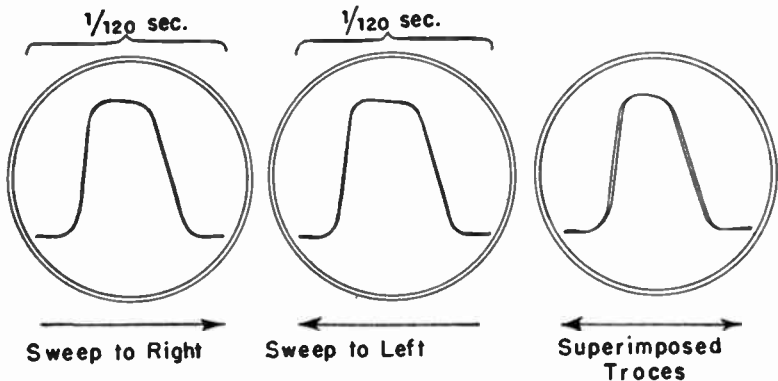

Fig. 1-6.—With synchronized sweep voltage for the horizontal input of the oscilloscope the two traces are made to appear as one.

of the beam. The forward and return curves will lie one over the other and will appear as a single curve such as illustrated by Fig. 1-6. Any change of frequency response brought about by alignment adjustment or otherwise will cause instant and corresponding change in the shape of the traced curve. The subject of synchronized sweep is treated more fully in the article on sweep generators.

Frequency calibration of a sweep generator seldom is precise enough to allow identifying an exact frequency by measuring horizontally across the response. Such identification requires an additional marker generator. The usual type of marker generator furnishes one or more steady frequencies at a time, like an ordinary frequency generator but of great accuracy. The marker frequency is adjustable, and may be set to any value within the range being observed.

When both the sweep generator and marker generator are coupled to the input of the amplifier their frequencies will beat together. At the instant in which the frequency from the sweep generator passes through a steady frequency of the marker generator the beat frequency goes through

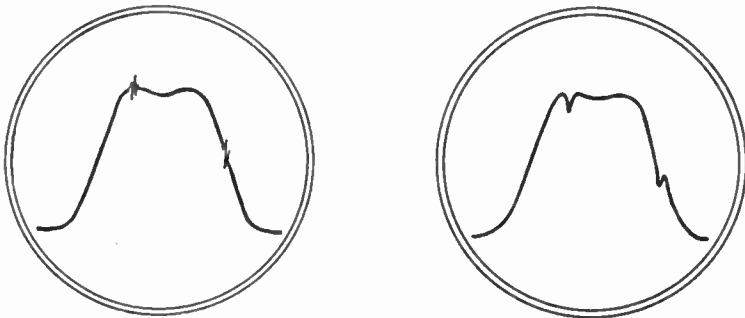

Fig. 1-7.—Frequency identification on traced responses by marker pips (left) and marker dips (right).

zero, and there is a variation of gain. This variation is visible on the oscilloscope trace in the form of a marker pip as illustrated at two points on the trace at the left in Fig. 1-7.

Some marker generators are designed to absorb power at the frequency to which they are tuned. Absorption of power from the output of the sweep generator at this frequency reduces the gain where the two frequencies coincide on the trace. The result, shown at the right in Fig. 1-7, is a gap or dip in the trace at the point corresponding to the marker frequency.

Frequency at any point on a response curve may be identified by tuning the marker generator to produce a pip or a dip at that point. If a certain relative height or other characteristic is desired at some certain frequency on a response, the marker generator is tuned to that frequency and adjustments are made for the desired results where the marker appears. The functions of sweep generator and marker generator often are combined in a single instrument.

Setups for Alignment. — Nearly always it is necessary that the metal case of every test instrument, and the chassis of the receiver or amplifier worked upon, be securely connected to a common ground. This common ground is preferably a metal top on the work bench and a metal top on the instrument shelf, with these two well bonded together.

Instruments are provided with one or more ground posts or terminals in addition to their grounding connections made through shielded cables. These ground posts or terminals are to be connected to the metal shelf covering through flexible copper straps. It is possible that the chassis of the receiver or amplifier may be well grounded by its contact with the metal bench top, but it is better to make one or more connections with flexible copper grounding straps secured by screws or clamps.

The effectiveness of grounding may be checked by connecting all instruments to the receiver or amplifier, turning them on, and letting them warm up. Adjustments should be made to produce a reading on the voltmeter and a trace on the oscilloscope. Then the hand is touched to each instrument and to the receiver or amplifier chassis while observing the meter and scope. If there is any change in the meter reading

or in the form of the trace, the grounding is insufficient and additional connections should be made.

To duplicate the results of alignment as specified in manufacturers' instructions the a-c line should supply 117 volts. If actual line voltage is less than 115 volts or more than 120 volts a voltage adjusting transformer should be used between line and receiver.

When working with a receiver having series filaments or heaters, with one side of their circuit connected directly to the line and chassis, it is advisable to use an isolating transformer between power line and receiver. If a voltage adjusting transformer has its primary insulated from the secondary it will act also as an isolating transformer. This should be checked with an ohmmeter or circuit tester, since some voltage adjusting transformers are of the auto-transformer type.

If no isolating transformer is used, the line plug should be inserted in the receptacle in a manner to ground the chassis and thus avoid danger of shock from the hot side of the line. To check the plug position first connect between the chassis and a cold water pipe ground an a-c voltmeter capable of reading line voltage. Then insert the cord plug in the line receptacle. If the meter reads line voltage or nearly so the chassis is hot and the plug should be reversed. When the meter reads zero the chassis is connected to the grounded side of the power line. Some sets are made with the chassis "hot" regardless of the way the plug is inserted and therefore the test equipment must be connected to $-B$, and the chassis insulated from ground.

When aligning the front end or tuner, and also when aligning the video i-f amplifier, the automatic gain control should be overridden with a fixed bias as explained in the article on *Gain Control, Automatic*. When aligning the sound section its automatic volume control should be overridden in a similar manner. Otherwise these automatic controls may flatten the response curve unless the generator output is kept very low. Such flattening prevents showing true variations of gain with changes of frequency.

Alignment sometimes is carried out with the picture tube removed from the chassis, if the set is not of the type in which tube filaments are in series such as AC-DC sets. When a magnetic deflection type of picture tube is removed, the lead for its high-voltage anode must be well insulated and supported where it cannot make contact with chassis metal. Removal of an electrostatic deflection picture tube may so lessen the load on the high-potential voltage divider as to increase plate and screen voltages of amplifier tubes connected to this divider. In such a case the picture tube should remain connected.

All shielding should, if possible, remain in place during alignment. If tuning adjustments are altered while shielding is removed, the frequency response will change when the shielding is replaced. If many receivers of the same type are handled it may be advisable to make up dummy shields with cutouts for passage of tools. Most shielding has openings through which alignment tools may be inserted, and if not, no harm will be done by making the necessary small holes.

Connections to Tubes. — Connections from signal generators to tubes are best made to the tube base pins from instrument leads kept on top of the chassis, rather than to tube socket lugs from the bottom of the chassis. This is because signal radiation from exposed connections on the ends of generator leads then cannot reach the wiring in other circuits.

One of the simplest ways of injecting a signal into a glass-envelope tube is to slip a metal ring over the outside of the envelope and move this ring down to a position around the internal elements. A ring bent from a thin piece of aluminum is shown at the left in Fig. 1-8. With the generator lead clipped to the metal ring there is capacitive coupling through the glass envelope to the tube elements. This method may require a rather strong signal voltage from the generator in case the aligned circuits are far out of adjustment to begin with. Instead of the ring it is possible to use a close fitting tube shield with the generator lead connected to the shield. This shield must not touch chassis metal.

Another simple connection is made with a short length of insulated wire as at the right in Fig. 1-8. One end of the wire is bared just far enough to allow making a single tight turn around a tube pin, which usually is the pin for the control grid. This turn should be formed and forced onto the base pin while the tube is removed from its socket. The other end of of

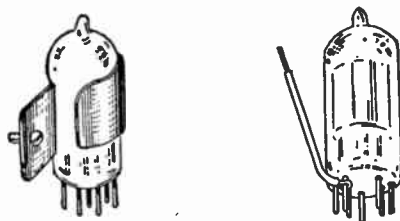

Fig. 1-8.—Connections for coupling signal generators to tubes.

the short wire is bared to take the connection from a generator. Unless too much insulation is removed, the bare wire will not touch chassis metal when the tube is replaced. Solid wire, such as hookup wire, should be used in order that the tight turn will hold in place.

Some television chassis are built with cutouts or openings in the side to enable the serviceman to reach a socket lug or other component parts. In such cases the recommended procedure is to bare one end of wire, make a small hook on the end and pass it through the opening to reach the socket lug or other component part.

Test adapters are available for all types of tubes. Each adapter has socket openings mounted above base pins, with outwardly extending lugs connected to each pin. With a tube inserted in the adapter, and the adapter placed in the tube socket, it becomes possible to make test connections to any elements. Test adapters are not recommended when working at television frequencies since the removal after alignment will detune the circuit and possibly cause mis-alignment. Some receivers have special test jacks or terminals which allow making alignment connections to correct points for both signal input and output.

If a generator connection is made to the control grid of a tube it is necessary that a capacitor be in series with the lead in order that d-c grid bias may be maintained. Some generators have a capacitor built in. Otherwise an external capacitor must be on the generator lead. At the high frequencies used in television, a capacitance of 10 to 20 mmf should be ample to pass the required signal, although it is best to adhere to the manufacturer's recommended values. The series capacitor is not needed when introducing a signal through a metal ring or a shield placed over the tube.

After all test connections have been made and the grounding checked, the receiver or amplifier and all the test instruments should be turned on and allowed to warm up for 20 to 30 minutes before commencing alignment. This is required in order that all resistors, inductors, and capacitors may reach their normal working temperatures and values before being adjusted for frequency response.

For alignment of i-f amplifiers there is no objection to using a screw driver or wrench having a metal tip in an insulating handle, but for alignment of r-f and oscillator circuits the tool should be wholly of insulating material.

Every change of a tuning adjustment in any one circuit will affect not only that circuit but also others which are connected or coupled to it, or whose inductors or capacitors are close to those of the first circuit. As a consequence, the adjustments of all associated circuits should be gone over after any alignment has been altered.

Tuning Wand. — A tuning wand is a means for determining the probable effect of altering alignment adjustments before the adjustments actually are changed. The wand, illustrated by Fig. 1-9, usually consists of six to eight inches of insulating rod or tubing having on one end a small cylinder of non-



Fig. 1-9.—A tuning wand.

magnetic metal, such as copper, brass, or aluminum, and on the other end a small cylinder of iron, such as the powdered iron slugs used in some transformers. The metal ends should be covered with insulation, possibly cellophane tape, so they won't cause short circuits when touched to bare wires.

When the iron end of the wand is brought into the field of a coil it increases the inductance, and the effect is the same as though the alignment adjustment were altered in a way to increase inductance. When the non-magnetic end of the wand is brought into the field of a coil it reduces the effective inductance, and the effect is the same as though the alignment adjustment were changed to reduce inductance.

Frequency of resonance is decreased by adding inductance, and increased by reducing inductance. Resonant frequency is also decreased by adding capacitance, and increased by lessening capacitance in a tuned circuit. Capacitance acts like inductance in its effect on resonance. Consequently, using the iron end of the wand shows what will happen with an increase of inductance, an increase of capacitance, or both. Using the non-magnetic end shows what will happen when reducing inductance, reducing capacitance, or both.

While observing a response curve on the oscilloscope the ends of the wand may be brought near each coil or transformer to identify the portions of the response curve which will undergo maximum change when that coil or transformer is adjusted.

The wand may be used to determine what adjustment is needed to make a circuit resonant at any given frequency. With that frequency being applied to the circuit the ends of the wand are brought to the coil or inductor. If response or gain is increased by the iron end, the adjustment should be changed to increase either inductance or capacitance. If gain increases with the non-magnetic end of the wand, the circuit needs less inductance or capacitance to make it resonant. If gain decreases with both ends brought near the inductor, the circuit already is resonant at the applied frequency.

Overall Check of Alignment. — After a tuner and video i-f amplifier have been separately aligned, or after either one has

been aligned, they should be operated together while observing the overall response from antenna to video detector output.

With the regular antenna or transmission line disconnected from the receiver, connect the high sides of the sweep and marker generators to either antenna terminal. Connect the low sides of the generators to ground, as shown, or to a second antenna terminal if the receiver is designed for balanced input. Connect the vertical input of the oscilloscope to the high side of the video detector load resistor and the low side to ground. The horizontal input of the scope would be connected to the sweep output of the generator if synchronized sweep is employed.

Override the automatic gain control with a fixed bias. Set the contrast control to a usual operating position, say about one-third down from maximum. If there is a fine tuning or trimmer adjustment for the r-f oscillator set this control to its midposition. Turn on the instruments and the receiver, and allow about 20 minutes for warming up.

Then set the channel selector of the receiver to any channel, preferably one on which reception is known to be possible. Advance the vertical gain control of the oscilloscope and the output control or attenuator of the sweep generator. Adjust the sweep width for about 10 mc and tune the frequency adjustment of the sweep generator to bring a response curve onto

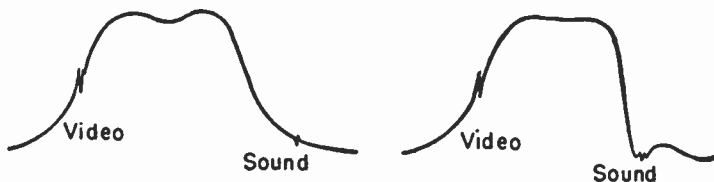

Fig. 1-10.—Overall response curves with markers for video and sound carrier frequencies.

the screen of the oscilloscope. Keeping the vertical gain of the scope well advanced, reduce the output of the sweep generator to the lowest value which produces a trace of readable height.

It is next in order to set the receiver channel selector to the highest channel and tune the sweep generator to bring a response curve onto the scope. Then tune the marker generator

to the video carrier frequency for the channel being checked, and next to the sound carrier frequency of the same channel. As shown by Fig. 1-10, the video marker should appear about half way down on one slope of the curve, and the sound marker far down or in a dip produced by a sound trap on the other slope.

If the marker generator does not provide carrier frequencies, but tunes only through intermediate frequencies, the setup may be modified as shown by Fig. 1-11. The sweep generator is connected to the antenna transformer and the oscilloscope to the video detector load resistor as previously explained. The

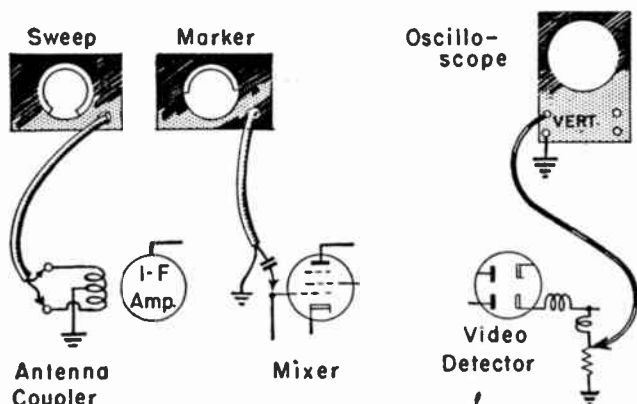

Fig. 1-11.—Applying marker signals to the mixer tube with the sweep generator connected to the antenna terminals.

marker generator is coupled to the mixer tube. All other preparations and steps for checking are the same as with the marker connected to the antenna terminals, except that the marker generator now is tuned first to the video intermediate frequency and then to the sound intermediate frequency of the receiver rather than to carrier frequencies.

This second method will show where the intermediate frequencies are located on the overall response curve. The markers will move with the curve as sweep frequency is changed. There will be nothing to identify either video or sound carrier frequencies on the response, since they are not being introduced by any of the test instruments.

AMPLIFIERS, BROAD BAND. — Broad band amplifiers are those which provide gain throughout a range of frequencies extending over three to six or more megacycles. This classification includes the television r-f amplifier, the video i-f amplifier, and the video amplifier. Typical frequency responses are shown by Fig. 2-1. R-f amplifiers must cover somewhat more than a six-megacycle band, or somewhat more than the frequency width of one channel. Video i-f amplifiers must cover a total range of about six megacycles. Video amplifiers must operate at frequencies all the way from less than 60 cycles to something between three and five megacycles.

Operating frequencies are highest in r-f amplifiers, lower in video i-f amplifiers, and lowest in video amplifiers. Thus the difficulties due to high frequency are greatest in r-f am-

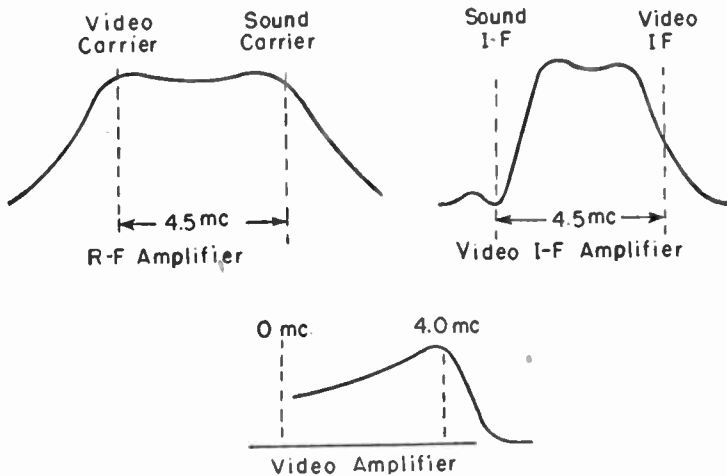

Fig. 2-1.—Typical frequency responses of broad band amplifiers.

plifiers and least in video amplifiers. In neither the r f amplifier nor the video i-f amplifier are there any problems due to low frequency amplification, both work with minimum frequencies in excess of 20 megacycles. In the video amplifier, however, it is necessary to have fairly uniform gain from very low frequencies all the way through to three or four mega-

cycles. This calls for compensation at both low and high frequencies. Design and performance of the several types of broad band amplifiers are discussed in articles relating to each type.

Effective band width of high-frequency amplifiers tends to increase with frequency. The band is widened also by increasing the ratio of tuning inductance to tuning capacitance, and by lessening high-frequency resistance or losses. The response is widened by less resistance because this increases the Q-factor, raises the entire response curve, and causes greater separation between the low and high frequency limits at which gain commences to fall off appreciably.

Operating frequencies in r-f amplifiers and video i-f amplifiers are high enough to call for careful design and construction. A principal requirement is reduction of stray and distributed capacitances. This is accomplished by using very short leads in circuits for control grids and plates, and by keeping all parts of these circuits well separated from chassis metal. Low-loss insulation and supports, including that in tube sockets, have low dielectric constants and introduce minimum capacitance. Parts of small physical size are preferable to large ones, for capacitance to ground increases with size. Capacitance is reduced by keeping plate and grid leads away from other parts.

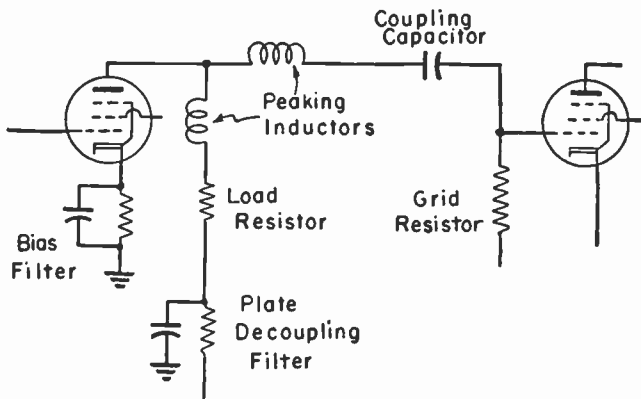

Fig. 2-2.—Parts which affect response at lowest and highest frequencies in video detector and video amplifier couplings.

R-f and video i-f amplifiers are tuned types, designed to resonate in their frequency bands. Video amplifiers are untuned. They are resistance-capacitance coupled types with special means for maintaining fair degrees of gain at lowest and highest frequencies in spite of both the reactive opposition and the bypassing effects of stray capacitances and tube capacitances. Low frequency response may be improved by correct choice of the cathode bias filter, the coupling capacitor, the plate decoupling filter, and the grid resistor shown in Fig. 2-2. High-frequency response is improved by suitable choice of peaking inductors and plate load resistor.

Capacitance for tuning at carrier frequencies and at video intermediate frequencies sometimes is in the form of adjustable capacitors. More often the tuning capacitance consists of the sum of internal capacitances of the tubes, distributed capacitance of tuning inductors, and stray capacitance of wiring and parts. Then the frequency of response is changed by varying the tuning inductance. The total of all the fixed capacitances usually is on the order of 10 to 15 mf, which is more than ample for high-frequency tuning with adjustable inductance.

AMPLIFIERS, DIRECT-COUPLED. — A direct-coupled amplifier is one in which the plate of one tube is conductively connected, without intervening capacitor or inductor, to the control grid of the following tube. The principle is shown by Fig. 3-1, where the elements of both tubes are connected to various points along a voltage divider between $B+$ and $B-$. Any suitable voltages might be used, those shown on the diagram being merely illustrative.

The grid of tube *A* is connected through a grid resistor to $B-$, which may be considered as at zero voltage. The cathode of this tube is connected to a point 10 volts positive on the divider, giving the grid a 10-volt negative bias. The plate of tube *A* and the grid of tube *B* are connected together and to a point which is 160 volts positive on the divider. Plate-to-cathode voltage on tube *A* thus becomes 150 volts. The cath-

ode of tube *B* is connected to 180 volts on the divider, and since the grid of this tube is connected to 160 volts, there is a 20-volt negative grid bias. The plate of tube *B* is connected to 380 volts at B+, making the plate-to-cathode voltage 200 volts.

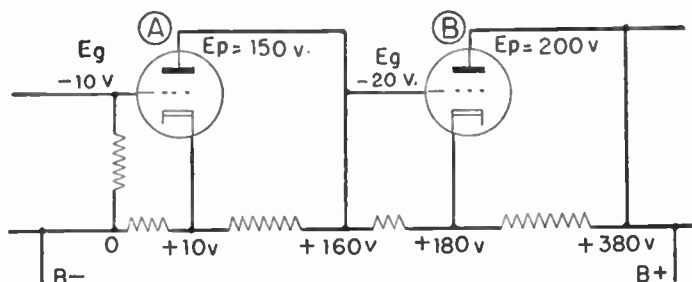

Fig. 3-1.—Elementary principle of the direct-coupled amplifier.

A direct coupled amplifier will follow very low frequencies. The low limit is determined by reactances of capacitances in the tubes and the B-supply. High frequency amplification is limited by effects of tube and stray capacitances, just as with any high-frequency amplifier. Direct coupling sometimes is used from the plate of the final video amplifier to the control grid of the picture tube.

AMPLIFIERS, RADIO-FREQUENCY. — The r-f amplifier is part of the tuner or front end of the television receiver, where are found also the r-f oscillator and the mixer. Signals from the antenna, at carrier frequencies, are applied to the input of the r-f tube, and from the output of this tube are taken to the control grid of the mixer. R-f amplifier tubes most often are sharp cutoff pentodes or else twin triodes, both of the miniature type.

Fig. 4-1 shows one of the simplest couplings used between antenna and r-f amplifier. The center-tapped coil *La* is assumed to provide a reasonably good match of its own impedance to that of the antenna and transmission line at all frequencies to be received. With such a simple coupling there

is little voltage gain from antenna input to r-f amplifier output.

The output circuit of the r-f amplifier always is tuned to frequencies in each channel to be received. This provides selectivity against signals in other channels, reduces the pos-

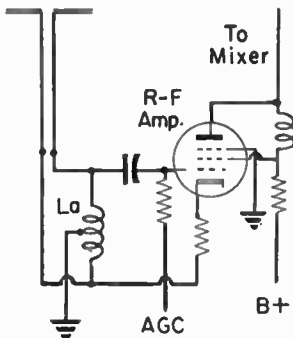

Fig. 4-1.—Untuned coupling between antenna and r-f amplifier.

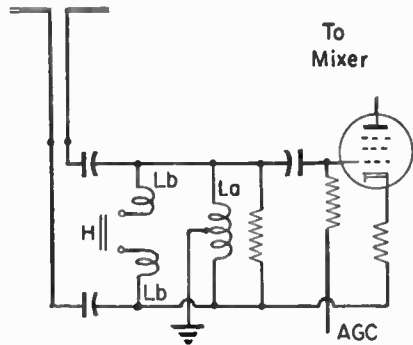

Fig. 4-2.—Input coupling whose impedance is changed for different channels.

sibility of image interference, and prevents radiation from the r-f oscillator through the antenna. It is for these reasons that the r-f amplifier is useful, even when it contributes negligible gain.

The more nearly the input impedance of the receiver is matched to the impedance of antenna and transmission line for each channel frequency the greater will be the gain. When a single antenna element is used for more than one channel there is change of antenna impedance with every change of frequency from channel to channel. In the receiver input coupling there is also a change of impedance with every change of frequency, as is true with any circuit containing inductance and capacitance.

Variation of input impedance between low band and high band channels is lessened in some receivers by altering inductance or capacitance of the input circuit. In Fig. 4-2 the inductance is lowered for high-band reception by closing switch H to place inductors L_b in series with each other and

in parallel with inductor L_a . In the article on tuners are shown more elaborate methods for tuning antenna coupling circuits for each channel, and methods for tuning the coupling between r-f amplifier and mixer tubes.

In ordinary triode amplifier circuits operated at very-high and ultra-high frequencies there is strong tendency to oscillate because of feedback through plate-grid capacitance, from the high r-f potential on the plate to the high side of the grid circuit. Oscillation may be prevented by using circuits such

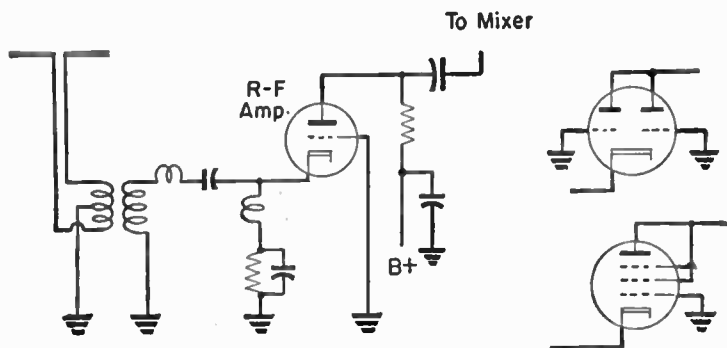

Fig. 4-3.—Connections used for grounded grid r-f amplifiers.

as that of Fig. 4-3. Here the grid is grounded. The antenna input signal is applied between the cathode and the grounded grid, which places the cathode at high r-f potential on the input side. The output signal is taken from between plate and grounded grid, with the plate at high r-f potential on the output side. The grounded grid acts as a shield between cathode and plate, or between the high sides of output and input circuits, and reduces feedback capacitance to a very low value.

In television tuners a twin triode may be connected as at the upper right of Fig. 4-3 to operate as a grounded grid amplifier. A pentode may be connected as a triode, shown at the lower right, and operated as a grounded grid amplifier. There are also single triode tubes designed especially for grounded grid operation.

AMPLIFIERS, SWEEP. — The sweep amplifiers of a television receiver have for their input signals the sawtooth voltages coming from the sweep oscillators. The output consists of amplified sawtooth voltages for deflection of the beam in an electrostatic picture tube, or else consists of sawtooth currents for a magnetic deflection picture tube. The electrical relation of the sweep amplifiers to other sections of a receiver is shown by Fig. 5-1.

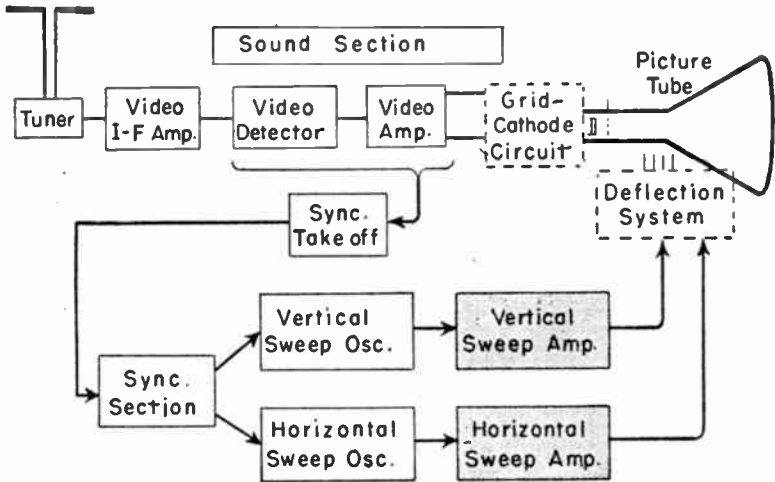

Fig. 5-1.—Electrical relations of sweep amplifiers to other parts of a television receiver.

Classified according to purpose there are four kinds of sweep amplifiers.

- a. Vertical amplifiers for electrostatic picture tubes.
- b. Horizontal amplifiers for electrostatic picture tubes.
- c. Vertical amplifiers for magnetic picture tubes.
- d. Horizontal amplifiers for magnetic picture tubes.

The operating frequency of vertical amplifiers is the field frequency of 60 cycles per second, and of horizontal amplifiers is the line frequency of 15,750 cycles per second. This great difference between frequencies calls for differences in design, with horizontal amplifiers having to meet more stringent requirements than vertical amplifiers.

Electrostatic amplifiers are required only to provide gain, without change of waveform, for a sawtooth voltage. Amplifiers for magnetic deflection systems must change the sawtooth voltage to a modified form which will produce a sawtooth current. Requirements for magnetic amplifiers are more difficult to meet than are those for electrostatic amplifiers.

Amplifiers for Electrostatic Deflection. — In order to deflect the electron beam in an electrostatic picture tube it is necessary to apply to the four deflection plates of the tube the four sawtooth voltages represented in Fig. 5-2. To the two horizontal deflection plates are applied voltages which make one plate become more and more positive, while the opposite plate becomes more and more negative. This deflects the beam

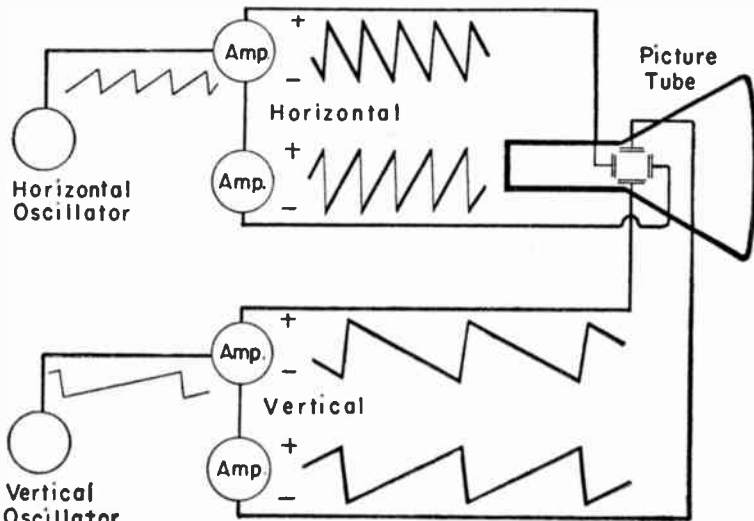

Fig. 5-2.—Sawtooth voltages for horizontal and vertical electrostatic deflection.

toward the plate which becomes increasingly positive. Then the two voltages reverse in direction of polarity changes to cause retrace of the beam. To the two vertical deflection plates are applied two sawtooth voltages which reverse their polarities in similar manner, but at the much slower rate required for vertical deflection.

It is quite common practice to use one sweep amplifier tube for each of the four deflection voltages. Two sweep amplifiers then operate from the horizontal sweep oscillator, and the other two operate from the vertical sweep oscillator. The two horizontal deflection voltages must be of opposite phase, as shown by Fig. 5-2, and the two vertical deflection voltages likewise must be of opposite phase. To accomplish this change of phase, one amplifier of each pair is operated as a phase inverter, just as one tube in any push-pull resistance coupled amplifier is operated as a phase inverter.

One method of coupling the two sweep amplifiers is illustrated by Fig. 5-3. The two amplifiers are shown by separated symbols to make the diagram easier to follow, although they ordinarily would be the two sections of a twin triode. The sawtooth voltage is formed initially by charge and discharge of sawtooth capacitor C_s as controlled by action of the sweep oscillator or a discharge tube. Amplitude of the sawtooth voltage is regulated by the size control resistor. The sawtooth voltage is applied through coupling capacitor C_c to the grid of amplifier A .

The plate of amplifier A is coupled to one of the deflection plates of the picture tube through capacitor C_t , thus applying to that plate the full output voltage of this amplifier. The opposite deflection plate of the pair is coupled to the plate

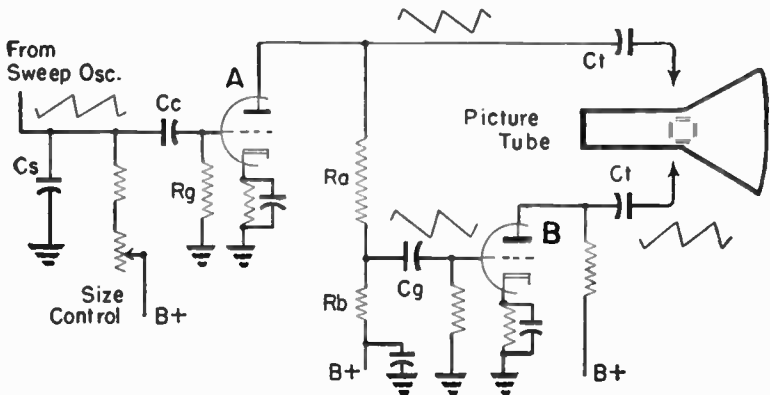

Fig. 5-3.—Connections for a phase inverter in an electrostatic sweep amplifier.

of amplifier *B* through another capacitor *Ct*. The output voltage of this amplifier must be of the same amplitude as that from amplifier *A* in order that the beam may be deflected equal distances both sides of center. To have equal output amplitude at the plate, the signal voltage at the grid of amplifier *B* must be of the same amplitude as at the grid of amplifier *A*. This voltage for the grid of amplifier *B* is secured from a resistance type voltage divider consisting of resistors *Ra* and *Rb* in the plate circuit of amplifier *A*.

Across the entire voltage divider, from the top of *Ra* to the bottom of *Rb* appears the output voltage of amplifier *A*, which is greater than the grid signal voltage on this same amplifier because of gain in the tube. By taking the connection for the grid of amplifier *B* from a point far enough down on the divider, this grid voltage is made the same in amplitude as the grid voltage for amplifier *A*, and then the plate outputs of the two amplifiers will be of equal amplitudes.

As an example, the effective gain in amplifier *A* might be 20 times. Then the signal voltage for the grid of amplifier *B* should be 1/20 of the voltage appearing across the entire voltage divider. This would require resistance in *Rb* equal to 1/20 of the sum of the resistances in *Ra* and *Rb*. The resistance of *Ra* might be 95,000 ohms and that of *Rb* 5,000 ohms. The sum of *Ra* and *Rb* will, of course, depend on the plate supply voltage, the plate current, and the voltage required at the plate of amplifier *A*. In any case, the values of resistance and of gain in amplifier *A* must satisfy this equation.

$$Rb = \frac{Ra + Rb}{\text{effective gain}}$$

Effective gain always is considerably less than the amplification factor of the tube, but depends on so many factors that computation is not practicable. Correct division of resistances in the voltage divider would be arrived at by using a potentiometer in series with enough resistance to allow desired plate current and voltage, adjusting the slider of the potentiometer to obtain equal plate outputs from the two amplifiers, and measuring the resistances as adjusted.

Inversion of sawtooth voltage polarity occurs as shown on Fig. 5-3. Polarity or phase in the plate circuit of amplifier *A* is opposite to that at the grid of this amplifier. Polarity at the grid of amplifier *B* is the same as at the plate of amplifier *A*. Polarity at the plate of amplifier *B* is opposite to that on its own grid, and so is opposite to the polarity at the plate of amplifier *A*. It must be kept in mind that there is inversion of signal voltage polarity between the control grid and the plate of any tube having these two elements.

In Fig. 5-4 the sawtooth voltage for the grid of amplifier *B* is reduced in amplitude by means of a capacitance voltage divider instead of the resistance divider of the preceding diagram. The capacitance divider consists of capacitors *Ca* and *Cb* connected in series with each other between the plate of amplifier *A* and ground. Instead of considering resistances we now consider capacitive reactances. If we still assume the effective gain in amplifier *A* to be 20 times, then the reactance of capacitor *Cb* should be 1/20 of the sum of the reactances of *Ca* plus *Cb*. The reactance at *Cb* always will be relatively small and that at *Ca* relatively large. Small capacitive reactance calls for relatively great capacitance, and large reactance calls for small capacitance. Consequently, the capacitance of *Cb* always will be much greater than that of *Ca*.

The divider capacitances in a vertical amplifier system (operating at 60 cycles) might be 0.0015 mf at *Ca* and 0.02

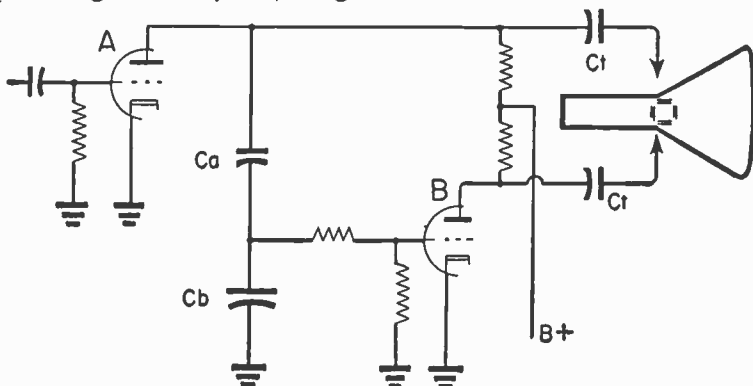

Fig. 5-4.—Capacitance voltage divider feeding the grid of a phase inverter.

mf at C_b . The respective capacitive reactances at 60 cycles would be about 1,770,000 ohms and 133,000 ohms. Then the reactance at C_b would be about 7 per cent of the total reactance, and about 7 per cent of the signal voltage from amplifier A would be applied to the grid of amplifier B .

To have the same reactances in a horizontal amplifier system (operating at 15,750 cycles) would require capacitance of about 5.7 mmf at C_a and about 76.2 mmf at C_b . This small capacitance at C_b would be in parallel with the grid-cathode capacitance of amplifier B and stray capacitances in the grid circuit, which might add 10 to 20 mmf capacitance to whatever is used at C_b . Also, the entire voltage divider is paralleled by plate-cathode capacitance of amplifier A and various stray capacitances. Correct divider capacitances would be determined by using adjustable capacitors to obtain equal amplitudes from the plates of the two amplifiers, then measuring the actual required capacitance and installing suitable fixed capacitors.

Unless the sawtooth voltages from the two sweep amplifiers actually are of very nearly equal amplitudes the pattern or picture will be enlarged on one side and contracted on the other side. There will be lack of linearity. In some receivers either one or the other of the resistors or capacitors in the voltage divider is of an adjustable type. This adjustment becomes a control for horizontal linearity.

Note that with the resistance divider of Fig. 5-3 there has to be a blocking and coupling capacitor C_g to keep B+ volt-

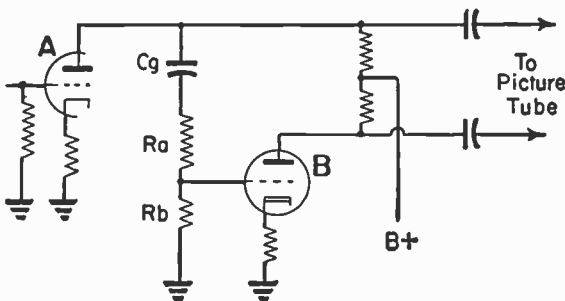

Fig. 5-5.—Resistance voltage divider fed through a blocking capacitor.

age from the grid of amplifier *B*. This d-c blocking function is served in Fig. 5-4 by capacitor *C_a* which is part of the voltage divider. Where a separate blocking capacitor has to be used, its capacitance is great enough and its reactance small enough as not to appreciably affect the voltage divider action.

In Fig. 5-5 the d-c blocking capacitor *C_g* is between the plate of amplifier *A* and the top of the resistance type voltage divider. The capacitive reactance of *C_g* adds to the resistance of *R_a* for the portion of the divider above the grid connection. The capacitance of a blocking capacitor in this position usually is large, and its reactance small in comparison with the resistance of *R_a*.

To maintain or improve the linearity of either vertical or horizontal deflection a feedback voltage may be employed as shown by Fig. 5-6. A connection is made through a resistor *R*, and sometimes through both this resistor and a series capacitor *C*, from the plate of amplifier *B* to some point preced-

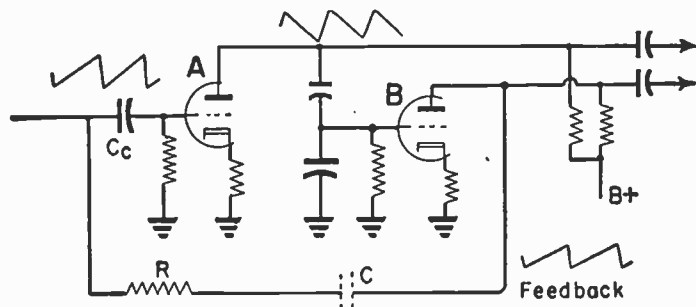

Fig. 5-6.—Feedback connection for improving linearity of an electrostatic sweep amplifier.

ing the coupling capacitor *C_c* for the grid of amplifier *A*. From phase or polarity relations shown on the diagram it may be seen that the feedback voltage is in phase with the sawtooth voltage applied to the grid of amplifier *A*.

Resistance in series with the feedback line usually is something between 2 and 10 or more megohms, but may be less when there is also a series capacitor. The resistance, or part of it, may be adjustable. This adjustment becomes a control for linearity.

Fig. 5-7 shows a method of using a single sweep amplifier tube for furnishing deflection voltages to both plates of a pair in an electrostatic deflection picture tube. In the amplifier plate circuit is an auto-transformer whose outer ends are connected through blocking and coupling capacitors to the plates

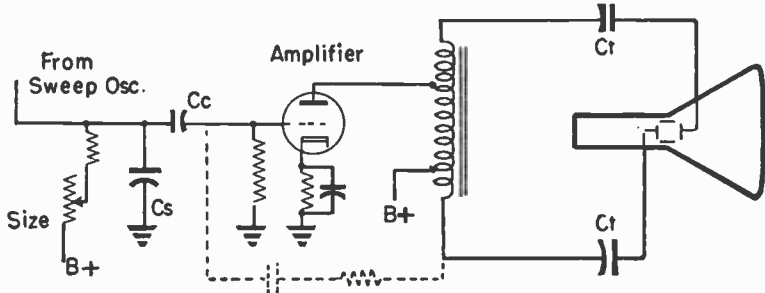

Fig. 5-7.—A single sweep amplifier feeding both plates of a pair for electrostatic deflection.

in the picture tube. As with any transformer, the instantaneous voltages at opposite ends of the winding are of opposite polarity or phase. Consequently, the sawtooth voltages supplied to the picture tube plates are opposite in their changes and produce the effects illustrated by Fig. 5-2.

Capacitor C_s charges through the size control resistors and discharges through the sweep oscillator to produce the sawtooth voltage for the amplifier grid. The series resistor and capacitor shown in the broken-line connection from the transformer back to the amplifier grid are for correction of linearity, which otherwise might be distorted with this amplifier circuit.

Fig. 5-8 shows how sawtooth voltages in opposite phase from the plate and cathode of a sweep oscillator may be applied to deflection plates of a picture tube without the use of any amplifiers. The blocking oscillator here illustrated is a conventional type with the oscillation transformer coupling the plate of the tube back to the grid. Grid bias is provided by R_g and the hold control resistor acting as grid resistance, with capacitor C_g acting as grid capacitor.

While the oscillator is blocked or non-conductive, sawtooth capacitor C_s charges through its ground connection to $B-$, and through the top winding of the double choke and the size control resistor to $B+$. When a sync pulse causes the

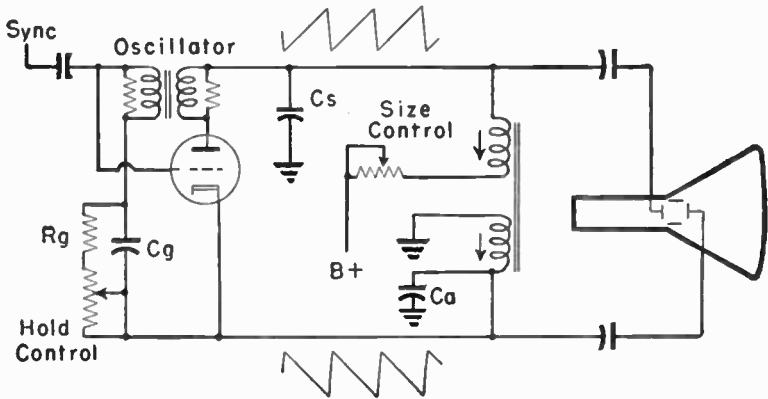

Fig. 5-8.—Electrostatic deflection requiring no amplifier tubes.

oscillator to become conductive, with its grid momentarily positive, there is sudden discharge of capacitor C_s through the tube. Electron flow for this discharge passes from cathode to plate inside the tube. Flow to the cathode comes through the lower winding of the double choke, by way of its ground connection to $B-$. Flow from the plate discharges C_s and momentarily causes a large current in the upper winding of the double choke.

The impedance of any choke windings increases with rate of change of electron flow. Discharge of the sawtooth capacitor tends to cause a sudden increase of flow in the windings, but the resulting counter-emf prevents any appreciable flow. Thus the choke windings permit the relatively slow charge of C_s through them, but offer such high impedance to sudden discharge that the discharge is forced to take place through the tube.

Magnetic Deflection Sweep Amplifiers.—The deflection voltage developed by a sweep oscillator controlling charge and discharge of a capacitor is of sawtooth waveform. In the de-

flection coils for the picture tube designed for magnetic deflection there must be a current of sawtooth waveform. When the original sawtooth voltage is applied to the control grid of a sweep amplifier there will be a sawtooth voltage developed across the load in the plate circuit, but only with amplifier tubes of high plate resistance will the plate current be of saw-

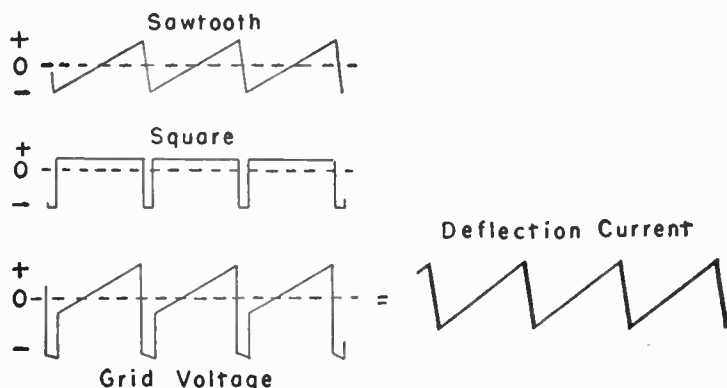

Fig. 5-9.—Characteristics of a grid voltage which produces a sawtooth plate current.

tooth waveform. Sweep amplifier tubes for vertical magnetic deflection systems ordinarily are power triodes, power pentodes, or beam power tetrodes, with the latter two types connected as triodes. All these tubes then have relatively low plate resistance and will not develop a sawtooth plate current when a sawtooth voltage wave is applied to their grids.

The reason for the difficulty is that the inductive reactance of the transformer windings and deflection coils in the amplifier plate circuit is large in comparison with the plate resistance of the tube. Were the plate load purely inductive, with only inductive reactance and no resistance, a sawtooth current would be produced in that load only by application of a square wave of voltage. Actually the plate circuit load is partly inductive and partly resistive, and to produce in it a sawtooth wave of current requires a voltage which is a combination of sawtooth and square waves. The general form of such a voltage is shown by Fig. 5-9. This is the form of voltage wave which

must be applied to the grid of the vertical sweep amplifier which has low plate resistance.

The combination sawtooth wave with a negative pulse or negative square wave may be produced by connecting a resistor R_s of Fig. 5-10 in series with the sawtooth capacitor C_s . When the oscillator or discharge tube becomes conductive for the retrace period the sawtooth capacitor has to discharge

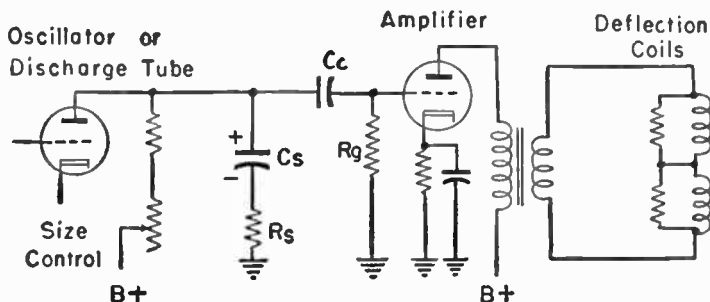

Fig. 5-10.—Circuit for production and use of a sawtooth voltage combined with a square pulse.

through the series resistor. The rate of discharge is slowed down by the resistor. The rate depends on the time constant of the sawtooth capacitor and its series resistor. The greater the capacitance and the greater the resistance, the slower is the discharge. By suitable choice of capacitance and resistance, or of their time constant, some of the original charge still will remain on the sawtooth capacitor when the oscillator or discharge tube again becomes non-conductive.

Charge and discharge of the sawtooth capacitor, and the resulting voltage for the amplifier grid, now are as shown by Fig. 5-11. Referring to the left-hand graph, the capacitor is charging and its voltage is rising until the instant represented by point a . At this instant the oscillator or discharge tube becomes conductive, and there is instant drop of voltage from a to b because the plate-cathode resistance of the tube becomes nearly zero when the grid is made positive. The capacitor discharges through the tube, and continues to discharge during the period from b to c . At the instant represented by c the

tube becomes non-conductive, its grid goes negative beyond the value for plate current cutoff.

Because the rate of capacitor discharge has been retarded by resistor R_s , there is still some charge remaining at instant c . Then the voltage rises to a value proportional to this remaining charge. The rise of voltage is from c to d . Then, with

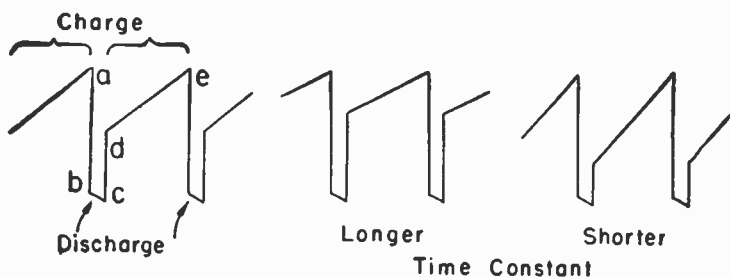

Fig. 5-11.—How the negative pulse is added to the sawtooth voltage.

the tube remaining non-conductive, there is the usual charging and rise of voltage along the line from d to e . Everything at e is the same as at a , and the performance repeats over and over.

If the resistance of R_s or the capacitance of C_s is increased, the time constant is lengthened, there is slower discharge, and a greater retained charge and voltage. Then the voltage wave changes as shown by the center graph of Fig. 5-11. If resistance or capacitance is lessened the time constant is shortened, there is more rapid discharge to a lower voltage, and the voltage wave becomes as shown at the right.

Such changes of voltage waveform at the amplifier grid cause changes in the waveform of current in the deflection coils and alter the distribution of picture elements between top and bottom of the screen. This means a change in vertical linearity. In some receivers the resistor R_s or part of it is made adjustable. This adjustment is a control for vertical linearity. Sometimes it is called a peaking control because it varies the amplitude of the negative peak added to the sawtooth voltage.

The vertical sweep circuit for magnetic deflection as shown by Fig. 5-12 is used in many receivers. In series with the sawtooth capacitor C_s is the discharge limiting resistor R_s whose function has been explained. But instead of the lower end of this resistor going to ground it connects to the high side of the cathode biasing resistors for the amplifier tube. Direct current for both charge and discharge of the sawtooth capacitor now flows through the biasing resistors in series with resistor R_s .

The adjustable cathode bias resistor forms a control for vertical linearity. Its principal effect is on the portion of the picture above the center, stretching or contracting this top portion as the adjustment is varied one way and the other.

Capacitance of the sawtooth capacitor C_s is usually 0.05 or 0.1 mf. Resistance in R_s is usually somewhere around 7,500 ohms, and in the cathode bias resistors is usually about 5,000 ohms or somewhat less, with most of this bias resistance in the adjustable unit. The full range of adjustment will vary the

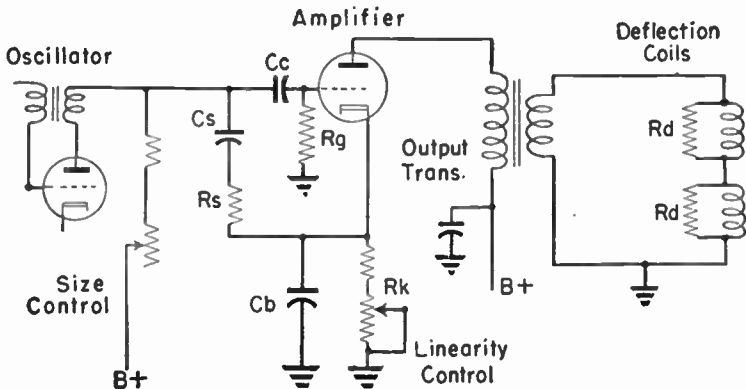

Fig. 5-12.—Typical vertical sweep circuit for magnetic deflection.

time constant of capacitance and resistance by about 25 per cent either way from its average value. At the same time, this adjustment varies the grid bias of the amplifier to make the tube operate along different portions of its grid-voltage plate-current characteristic. This latter effect changes the slope or

curvature of a curve showing plate current plotted against grid voltage, and consequently affects linearity. Capacitance of the bypass capacitor C_b always is large, common values ranging from 20 to more than 100 mf.

Oscilloscope traces taken from anywhere along the line from oscillator plate to amplifier grid will have the general form shown at the left in Fig. 5-13. The height and steepness of the sloped portion of the trace will be varied by adjustment of the vertical size control or height control. Traces taken

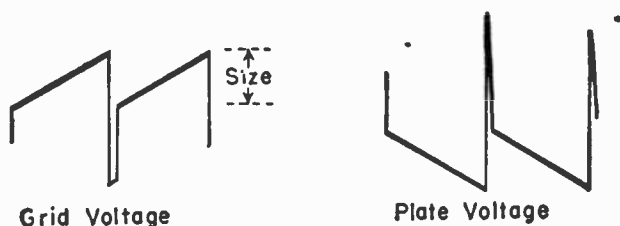

Fig. 5-13.—Oscilloscope traces from input and output sides of the vertical sweep amplifier tube.

from the amplifier plate will be of the same general form, but inverted as shown at the right. Adjustment of the vertical linearity control will make the sloped portion a practically straight line, as shown, or will make this portion curve either upward or downward.

Horizontal Magnetic Deflection Amplifiers. — In horizontal sweep systems for magnetic deflection are quite commonly found, in addition to the output amplifier circuits, some or all the features shown toward the right of the diagram in Fig. 5-14. Each is explained under its own heading in this book, but they will be mentioned here in relation to the amplifier circuit.

The high-voltage power supply shown at the top of the diagram, which is of the flyback type, furnishes 8,000 to 10,000 volts for the high potential anode of the picture tube. High voltage applied to the plate of the diode rectifier is taken from the top of the primary winding on the output transformer. The tapped primary winding raises a pulse potential of about 5,000 volts to the higher voltage for the rectifier.

The damper tube suppresses oscillation which otherwise might continue in the deflection coil circuit after each pulse of retrace current. Such oscillation would continue at a frequency determined by inductance and capacitance in this circuit except for the fact that during the first cycle the damper is made conductive and places such a load on the circuit as to prevent additional cycles. Damping is not needed in circuits for vertical deflection, chiefly because of the lower operating frequency, although resistors usually are connected across the vertical coils to further reduce any tendency toward oscillation.

The width control of Fig. 5-14 is an adjustable inductor connected in parallel with a few turns of the secondary winding on the output transformer. This control alters the effective

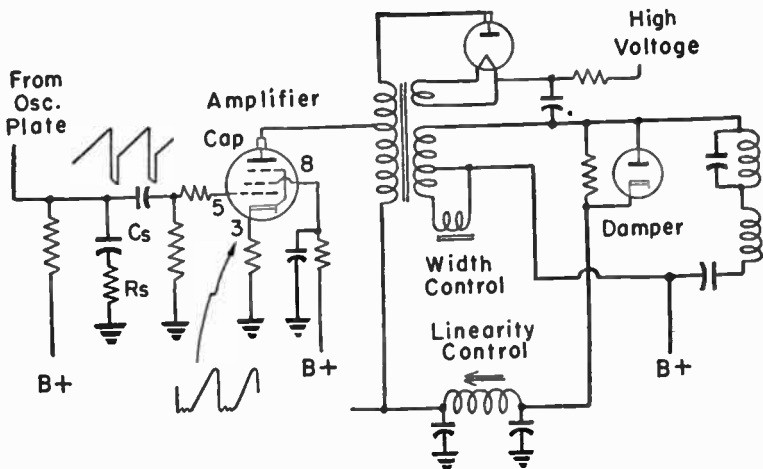

Fig. 5-14.—Typical horizontal sweep circuit for magnetic deflection.

inductance of the secondary winding, changes the strength of induced emf and deflection current, and thereby increases or decreases the extent of horizontal deflection and width of the picture. The width control here illustrated may be the only one provided for varying the horizontal size of the picture, or it may be used in addition to an adjustable resistor which varies the rate and amount of charge on the sawtooth capacitor.

The linearity control shown connected in series with the damper tube is another adjustable inductor. This inductor carries plate current for the amplifier tube. The current path may be assumed to start at B- or ground, go through the amplifier cathode to its plate, thence through the lower portion of the output transformer primary winding, the linearity control inductor, the cathode-to-plate path in the damper tube, the secondary winding of the output transformer, and to the B+ connection shown at the right. This linearity control is, in effect, a low-pass filter whose adjustment makes some change of phase in the amplifier plate voltage to alter the portion of its characteristic on which this tube operates.

All of the parts which have been mentioned are in the amplifier plate circuit or are coupled to that circuit. On the grid side of the sweep amplifier of Fig. 5-14 we find in series with sawtooth capacitor C_s a resistor R_s whose action adds a negative square pulse to the sawtooth wave going to the control grid of the amplifier. This action is the same as explained in connection with vertical amplifiers for magnetic deflection.

Oscilloscope traces taken between control grid and ground, and between cathode and ground, will be about as shown on the diagram. Without special voltage divider equipment it is not safe to try taking traces from the plate, because of the surge potentials which reach 4,000 to 5,000 volts.

Fig. 5-15 shows control grid and cathode connections for another general type of horizontal sweep amplifier circuit. Here the sawtooth capacitor C_s is connected to ground through a series fixed resistor R_s , an adjustable resistor marked *Drive Control*, and the cathode bias resistor R_k . Although the adjustable resistor usually is called a drive control, it may be called a linearity control or a peaking control. Actually it regulates the strength of the negative pulse added to the sawtooth voltage wave, by changing the time constant of the capacitor-resistor combination.

The fixed resistance at R_s may be anything between 2,000 and 10,000 ohms. Total resistance of the drive control usually is between 20,000 and 30,000 ohms. Cathode bias resistance

may be something between 50 and 150 ohms. The capacitance of the bypass, C_k , often is between 20 and 30 microfarads, although in some receivers it may be as small as 0.1 mf. The plate circuit of the amplifier, and associated parts, usually are

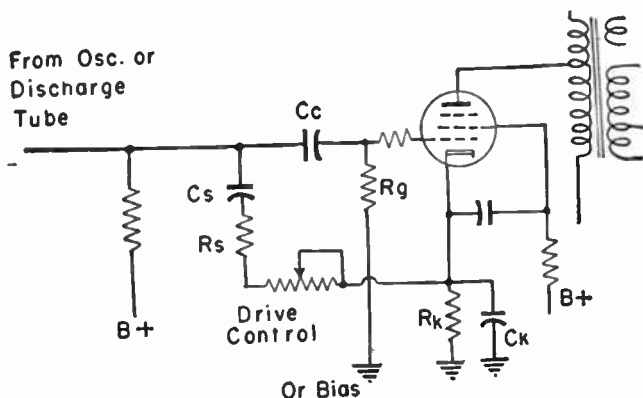

Fig. 5-15.—Sweep amplifier grid-cathode circuit with resistance type drive control.

about the same as shown by Fig. 5-14. Oscilloscope traces taken at the amplifier control grid and cathode are similar to those shown on Fig. 5-14.

In the amplifier grid-cathode circuit of Fig. 5-16 there is no means of adding a negative square pulse to the sawtooth voltage applied to the control grid. Sawtooth capacitor C_s is connected directly between the oscillator plate line and ground, being charged through the left-hand connection to B+ and discharged through the oscillator.

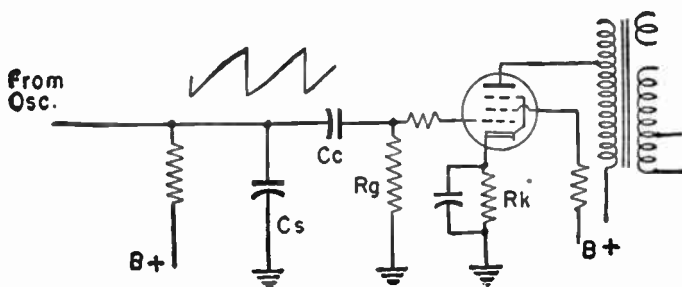

Fig. 5-16.—Sweep amplifier operated without a negative pulse on the sawtooth grid voltage.

It will be recalled that the reason for adding a negative peak to the sawtooth voltage wave is to overcome the excess of inductive reactance compared with resistance in the plate and deflection coil circuits. There is especial need for negative peaking with the low plate resistance of power triodes and other tubes connected as triodes. But beam power tubes have plate resistances in the neighborhood of 25,000 ohms, which is several times that of power triodes. By employing a beam power tube for the horizontal sweep amplifier and using the least practicable inductance in the horizontal deflection coils, the ratio of resistance to inductive reactance is considerably increased. With the tube working into a load which is more resistive than reactive, a plain sawtooth voltage applied to the control grid will produce a sawtooth current in the deflection coil circuit. This is the principle utilized for the amplifier circuit of Fig. 5-16.

In a number of receivers a negative peak is added to the sawtooth voltage for the amplifier grid by a feedback connection such as shown in Fig. 5-17. This feedback is taken through a high resistance or small capacitance from the line between output transformer secondary and deflection coils, on the side which connects to the plate of the damper tube. On this line

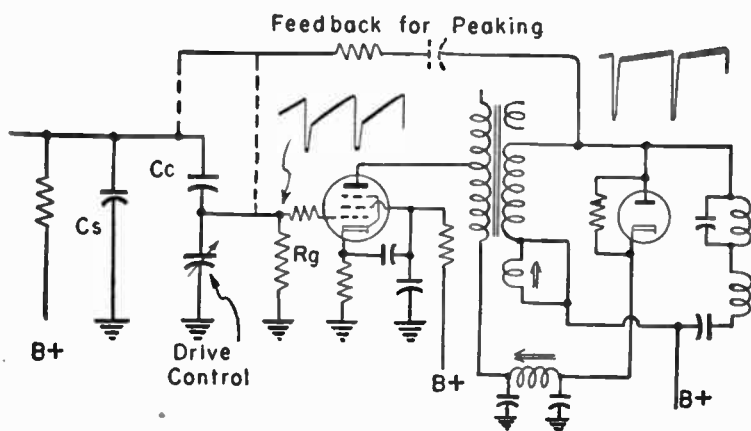

Fig. 5-17.—Feedback connection for adding a negative pulse to the sawtooth voltage for the amplifier grid.

the voltage consists of a series of sharp negative peaks. A trace taken with the oscilloscope will show peaks of the approximate form illustrated at the upper right in the figure. When a small part of the voltage from these pulses is added to the sawtooth wave developed by capacitor C_s the result is a negative peaked sawtooth of the general form illustrated above the amplifier tube. The feedback sometimes is brought to a point ahead of coupling capacitor C_c and again to a point following this capacitor.

Fig. 5-17 illustrates also a drive control consisting of an adjustable capacitor. This control capacitor and coupling capacitor C_c are in series with each other, and in parallel with sawtooth capacitor C_s . Thus the coupling capacitor and drive control capacitor form a capacitive voltage divider with voltage for the amplifier grid taken from between the capacitors. The fraction of total sawtooth voltage applied to the grid is equal to the ratio of capacitive reactance in the drive control to the sum of the reactances in the two divider capacitors. Adjusting the drive control for less capacitance increases its reactance, and increases the amplitude of voltage applied to the amplifier grid.

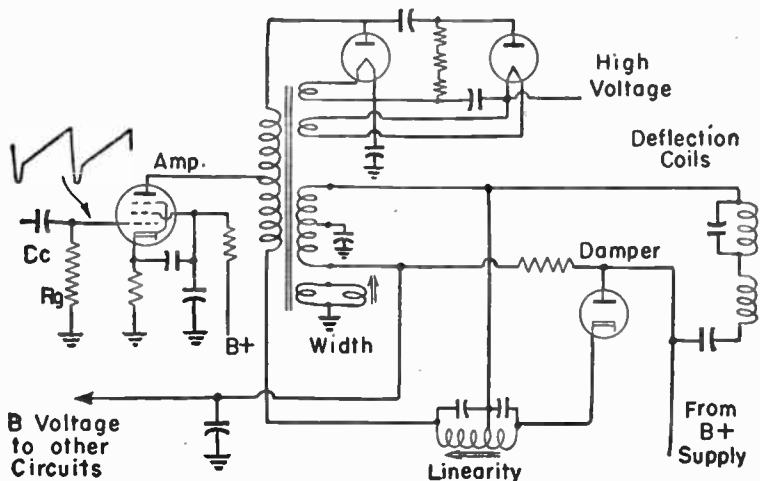

Fig. 5-18.—Modifications found in some of the circuits on the plate side of the horizontal sweep amplifier for magnetic deflection.

There are, of course, horizontal magnetic deflection amplifiers of types other than those for which diagrams have been shown. One of these other types is illustrated by Fig. 5-18. The control grid-cathode circuit of the amplifier tube is similar to types which have been described. In the plate circuit there is an output transformer with tapped primary, acting as a step-up auto-transformer for the high-voltage rectifier system. This high-voltage system for the high potential anode of the picture tube here employs the voltage doubling principle found also in other power supplies.

The width control consists of an adjustable inductor connected to one of the windings on the transformer, acting to vary the effective inductance and the extent of horizontal deflection of the picture tube beam. The horizontal linearity control is an adjustable inductor in the plate supply line to the sweep amplifier. The damper tube prevents continued oscillation in the deflection coil circuit.

There are many variations in circuit details and in connections of parts in the various sweep amplifier systems, but basic operating principles and methods of control are much the same in all of them.

AMPLIFIERS, SYNC. — In the sync section of the receiver, between the sync signal takeoff point and the sweep oscillators, are tubes operated as separators, clippers, limiters, and amplifiers. The chief purposes of these tubes, considered as a group, are (1) removal of picture signals from the composite signal to leave only sync pulses, (2) make all the sync pulses of uniform amplitude, and (3) bring the sync pulses to the sweep oscillators in correct polarity for triggering the oscillators. In carrying out these operations the sync pulses may be reduced below the needed amplitude. The sync amplifier tubes act to increase the pulse amplitude as may be required.

In addition to increasing the pulse amplitude, each sync amplifier inverts the polarity of the signal applied to its grid. Thus the amplifiers affect or determine the polarity of pulses reaching the sweep oscillators.

The sync amplifier tubes may be either triodes or pentodes.

They are operated with plate and screen voltages, and with control grid biases, which are normal for the particular type of tube when used as an amplifier. Other tubes in the sync section ordinarily are operated with very low plate and screen voltages, or with highly negative grid biases, to cause plate current cutoff, plate current saturation, or both, under some conditions.

Sync amplifiers may have coupling capacitor-resistor combinations acting in such manner as to decrease amplification of high frequencies, which would be picture signals, and to emphasize the low frequencies, which would be the sync pulses. The grid leak or grid rectification method may be used for all or part of the sync amplifier bias. This biasing often is designed in such a way that grid voltage becomes less negative on weak signals and more negative on strong ones. Thus the amplifier circuit tends to equalize incoming signals of varying strength, and to assist the action of sync limiter tubes.

AMPLIFIERS, VIDEO. — The video amplifier of a receiver consists of one or more tubes and interstage couplings between the video detector and the grid-cathode input circuit of the picture tube. The video amplifier receives composite television signals from the video detector output and delivers these signals, amplified, to the picture tube. Picture tube grid bias is such as to cut off the sync pulses while leaving the picture signals. The takeoff for pulses which go to the sync section of the receiver often is at some point along the video amplifier.

The composite signal in the video amplifier may be observed by connecting an oscilloscope to any control grid or plate between the detector output and the picture tube input. The vertical input of the scope might be connected first to the detector plate or cathode, whichever serves as output. Following connections might be to the control grid of the first video amplifier, then to the plate of this tube, then to the control grid of the second video amplifier and so on until the connection finally is made to either the control grid or the cathode of the picture tube, according to which of these elements acts as the input for this tube.

With the internal sweep of the scope synchronized for 60 cycles, 30 cycles, or other submultiple of 60, the vertical sync pulses and vertical blanking intervals will appear about as shown by Fig. 7-1. To observe a pulse and blanking interval on such a large scale as in the figure it is necessary to increase the horizontal gain of the scope while operating its horizontal centering control to bring a single blanking interval onto the screen.

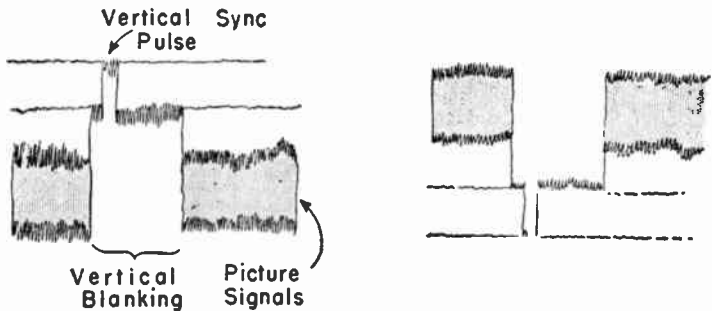

Fig. 7-1.—Vertical sync pulses and blanking intervals of the composite signal in the video amplifier.

The trace may be upright as at the left or inverted as at the right. If it is upright at the control grid of an amplifier the trace will be inverted at the plate of the same tube, and if the trace is inverted at the control grid it will be upright at the plate.

If the internal sweep of the oscilloscope is synchronized for 7,875 cycles per second, which is just half the line frequency

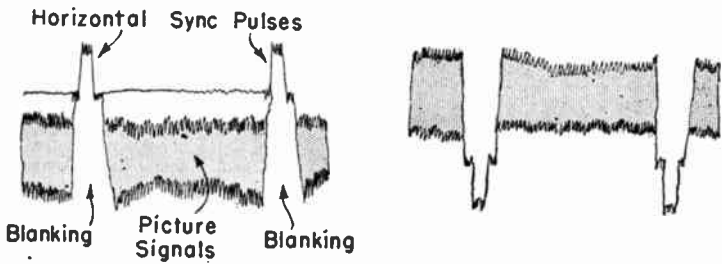

Fig. 7-2.—Horizontal sync pulses and blanking as shown by the oscilloscope.

of 15,750 cycles, it will be possible to observe the horizontal sync pulses and blanking intervals in about the form illustrated by Fig. 7-2. Again the signal may appear upright as at the left or inverted as at the right, depending on the point in the amplifier system to which the oscilloscope is connected. Because of the higher frequency it is more difficult to obtain clear traces of horizontal pulses than of vertical pulses. By connecting the oscilloscope successively to the inputs and outputs of the video amplifier tubes between the detector and picture tube it is possible to follow the composite signal all the way through this portion of the receiver. The effect of various controls is easily observed by watching for changes in the signal trace.

Frequency response.— Video amplifiers are resistance-capacitance coupled, with features which compensate in greater or less degree for the natural tendency of such amplifiers to drop off in gain at both very low and very high frequencies. If the gain of the amplifier decreases materially at low frequencies, any changes of picture tone or shading which occur only at relatively long intervals will not be well reproduced, instead of distinct changes there will be a tendency to merge all the shadings into a single tone or single degree of illumination. It is entirely possible for a certain shade to last throughout an entire frame of the picture, or for even more than a whole frame. This makes it necessary that the video amplifier have fairly good response at frequencies as low as 30 cycles per second.

The gain should extend with fair uniformity all the way to a high frequency limit which depends on how good the definition or picture detail is to be, and on the diameter of the picture tube or the size of the raster. With tubes of ten or twelve inch diameter it is assumed that there should be good definition of picture elements or details whose horizontal dimension is equal to the vertical distance between adjacent lines or traces. Since there are about 490 lines per frame it should be possible to resolve details whose width is as little as $1/490$ of the height of the picture. To attain such resolution

there must be good response of the video amplifier through frequencies up to a high limit of four or more megacycles.

With picture tubes of less than 10-inch diameter, horizontal definition equal to that assumed for a ten-inch tube may be had with a high limit in megacycles approximately equal to the ratio of diameters. That is, with a seven-inch tube the high frequency limit need be only about $7/10$ of four megacycles, or possibly something around a three-megacycle high limit. With tubes larger than the ten or twelve inch sizes there is no object in having good video response much higher than four megacycles, for there is no need of having horizontal resolution which is better than the vertical resolution. The vertical resolution can be no better than the vertical distance between adjacent lines or traces.

The video amplifier must have good high-frequency response in order to have sharply defined pictures. The low-frequency response must be good in order to reproduce slow changes in light and shade, to avoid trailers at the right-hand edges of large black objects or large white ones, and to prevent distortion of sync pulses. It is necessary also to avoid excessive differences between phase shifts at the two limits of frequency. Phase shift means a delay in the passage of signals through the amplifier. It is related to changes of voltage gain, also to time constants in the circuits. If some frequencies are delayed more than others the picture will become distorted. On top of all the other requirements it is desirable to have the highest practicable gain.

Video Amplifier Tubes. — The voltage amplitude of the picture signal as applied at the grid-cathode input of the picture tube must reach peak values which will produce white tones. That is, the picture tube input signal for white tones must overcome enough of the negative bias to cause maximum required intensity of the electron beam. This peak signal voltage depends on the type of picture tube and on the anode voltages applied to that tube, but in general the peak will be something between 40 and 80 volts.

The detector output voltage will depend on the maximum peak-to-peak video i-f input to the detector, which varies greatly in different receivers and with the strength of signal from the antenna. Maximum signal output voltage from the video detector usually will be at least 2 volts, but seldom more than 4 volts. To bring this 2- to 4-volt detector output up to the 40- to 80-volt input for the picture tube calls for an overall gain of 10 to 40 times. To provide this gain there may be one, two, or sometimes three video amplifier stages.

When there is only a single video amplifier it most often is one of the high-frequency broad-band pentodes designed especially for television service. When there is more than one stage the output amplifier most often is a power pentode or a beam power tube, and the preceding video amplifiers are voltage amplifying pentodes of types suited to high-frequency operation. In some receivers the video output amplifier is a triode.

The two features which are essential in video amplifier tubes are high transconductance or high mutual conductance, and small internal capacitances. The effectiveness of a video amplifier is very nearly proportional to the ratio of transconductance to its input and output capacitances, or, at least, this is the case at the high-frequency end of the band.

Elements of the Amplifier. — Fig. 7-3 shows fairly typical circuit connections for a two stage video amplifier. The inductors L_p in series with the plate load resistors R_o , and inductors L_s in series with coupling capacitors C_c are used only in wide-band high-frequency amplifiers such as video amplifiers. The functions of these inductors will be discussed a little later. All other elements in the circuit diagram might be found in any resistance-capacitance coupled amplifier designed to have reasonable gain at low audio frequencies.

Some of the features to be noted are as follows. There is a decoupling capacitor C_s connected from the screen to ground or B-. This capacitor bypasses variations of signal voltage which appear on the screen, and prevents interstage coupling which might otherwise occur because of the impedance of the

voltage dropping resistor in the screen line. There is a decoupling capacitor C_d to ground from a point below load resistor R_o in the plate circuit. This capacitor keeps signal voltage variations in the plate circuit from causing interstage coupling or feedback due to impedance of the plate voltage dropping resistor R_d . Capacitor C_d and resistor R_d may have

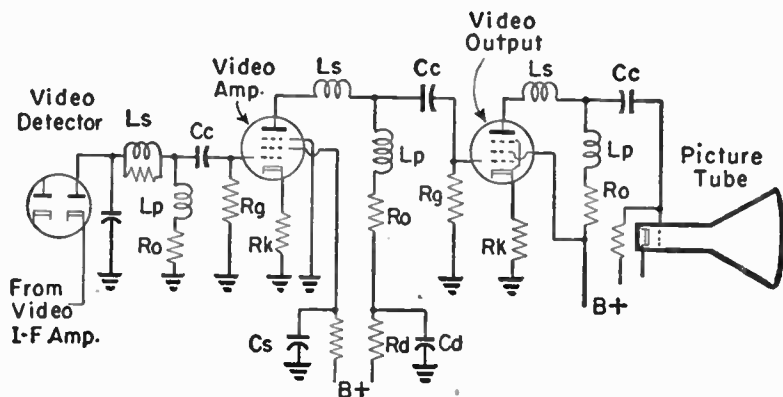

Fig. 7-3.—A two-stage video amplifier incorporating features in general use.

such values as will help to maintain good gain at the very low frequencies to be amplified, as will be explained later.

The suppressor of the first amplifier is connected directly to ground rather than to the cathode of this tube. The suppressor of the output amplifier is internally connected to the cathode of that tube, as is usual practice in power pentodes and some other types.

Cathode bias resistors R_k are shown as having no bypass capacitors in Fig. 7-3. With no bypassing there is degeneration, which lessens the gain of the stage or the effective transconductance of the tube, but makes for a more uniform gain throughout a wider range of frequencies. If a bypass capacitor is used on the cathode there will be a rather pronounced drop in gain at and near the frequency for which the capacitive reactance of the capacitor becomes equal to the resistance of R_k . To keep this frequency low enough to be out of the amplified range requires very large capacitance in the bypass. A small bypass

capacitance on the cathode will allow some degeneration at low frequencies, where the capacitive reactance becomes large, but at high frequencies this reactance becomes so small as to allow practically full gain.

Low Frequency Compensation. — Fig. 7-4 shows the parts of the interstage coupling which chiefly affect how low the frequency may be while still obtaining necessary gain. For any given transconductance in the tube, gain is directly proportional to impedance of the load in the plate circuit. With high resistance at R_g , and capacitance at C_c great enough to offer only small reactance, the plate load is approximately the resistance of R_o and R_g in parallel. It will be shown that, to have uniform gain over a wide band of frequencies, the resistance at R_o has to be small, only a few thousand ohms at most. Then the parallel resistance of R_o and R_g depends almost wholly on the resistance of R_o , the plate load resistor.

Whatever signal voltage is developed across load resistor R_o is applied through the reactance of coupling capacitor C_c to grid resistor R_g , and the signal voltage across the grid resistor is applied to the control grid of the second tube. The signal voltage divides between C_c and R_g proportionately to their impedances, or practically in proportion to the capacitive reactance of C_c and the resistance of R_g . The reactance of the coupling capacitor is inversely proportional to frequency. For example, the reactance of an 0.05 mf capacitor at 60 cycles is about 53,000 ohms, at 30 cycles it is about 106,000 ohms, at 20 cycles it is about 160,000 ohms, and so on.

If the resistance of R_g were 500,000 ohms the percentages of signal voltage appearing across this resistor when using the 0.05 mf coupling capacitor would be approximately 90.4 per cent at 60 cycles, 82.5 per cent at 30 cycles, and 75.9 per cent at 20 cycles. If the resistance of R_g were greater, the percentages of signal voltage across it and at the grid of the second tube would be greater.

In view of all this it is desirable to use the highest resistance at R_g that is permissible for the type of tube and the kind of grid biasing employed. The actual resistance usually is some-

thing between 0.5 and 1.0 megohm. At the same time the capacitance of the coupling capacitor should be as great as permissible, and its reactance low. Maximum capacitance usually is limited by the physical size of the capacitor, for the greater its size the larger is the capacitance to ground and the greater the bypassing effect at high frequencies. Capacitance of 0.1 mf is the usual high limit, although greater capacitances are used in some receivers.

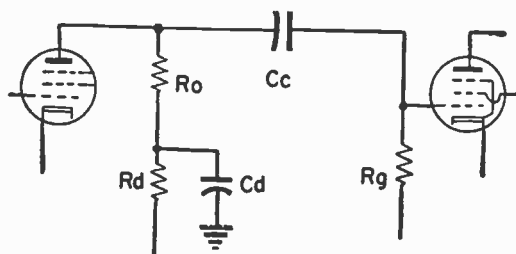

Fig. 7-4.—Parts of the video amplifier coupling which affect low-frequency response.

At frequencies for which the reactance of bypass capacitor C_d is small compared to the resistance of dropping resistor R_d , most of the a-c signal voltage in the plate circuit returns to the cathode of the first amplifier by way of the bypass. Then plate load impedance in the path of the signal includes load resistance in R_o and reactance in C_d . The reactance of capacitor C_d rises as signal frequency drops, and there is some increase of load impedance to retard the loss of gain at the lower frequencies. For this effect to be of much importance the capacitance of C_d would have to be smaller than ordinarily needed for decoupling, and the voltage dropping resistance would have to be greater than usually found in practice.

High Frequency Compensation. — Fig. 7-5 shows those portions of the interstage coupling which have greatest effect on how high the frequency may be at which the gain remains satisfactory. First to be noted are the capacitances C_o and C_i , which do not appear in usual circuit diagrams. At C_o is represented the output capacitance of the first amplifier tube, and at C_i is represented the input capacitance of the following tube.

Although these internal capacitances are of only a few micro-microfarads, their reactances drop to such low values at the higher frequencies as to have important effects on gain. It may be noted also that the coupling capacitor is not shown. This is because the reactance of this rather large capacitance becomes so very small at the high frequencies as to have no effect on circuit behavior or on gain.

The output capacitance of video amplifier tubes in general use ranges from 2 to 9 or 10 mmf. Input capacitances of these tubes range from about 5 to 12 or 13 mmf. There are also the capacitances of sockets and wiring, which usually are, at the

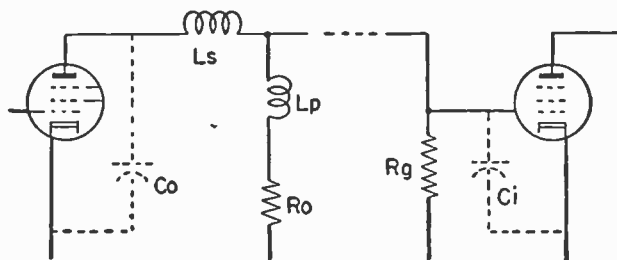

Fig. 7-5.—Elements which chiefly affect the high-frequency response of the video amplifier.

very least, from 3 to 5 mmf at each end of the circuit. All these capacitances are effectively in parallel with the load impedance, and are called shunting capacitances. A low value for total shunting capacitance on the plate side of the circuit might be 10 mmf, and the total on the grid side might be about 13 mmf. The total capacitance in parallel with the plate load then would be about 23 mmf if design and construction were first class in every respect.

The capacitive reactance of 23 mmf at a frequency of 4 mc is about 1,730 ohms, at 3 mc is about 2,310 ohms, and even at 2 mc still is only about 3,460 ohms. The impedance of elements in parallel always must be less than the impedance of any one of them alone. Therefore, the plate load impedance can be no greater than the capacitive reactances mentioned at the respective frequencies so long as the two shunting capacitances remain in parallel with each other.

The two shunting capacitances can be partially isolated from each other by inserting the series compensating inductor L_s anywhere in the line from plate to coupling capacitor. The inductance of L_s often is somewhere around 100 to 150 microhenrys. The inductive reactance of L_s increases with rise of frequency, while the reactances of the shunting capacitances become less. The inductive reactance of 100 microhenrys at 2 mc is 1,255 ohms, at 3 mc it is 1,885 ohms, and at 4 mc this reactance rises to 2,510 ohms. The reactance of 150 microhenrys would be just 50 per cent greater at each frequency.

With the shunting capacitances thus separated by L_s their total effective reactance is raised, and the plate load impedance is raised accordingly, for improvement of gain at the higher frequencies. The highest frequency at which the gain remains fairly good is that for which the capacitive reactance of the total effective shunting capacitance becomes equal to the impedance of the plate load. High frequency cutoff is extended by first doing everything economically possible to decrease the shunting capacitances. This is done by choosing tubes with small internal capacitances, using sockets whose insulation has a low dielectric constant, using short wires of small diameter in the plate and grid circuits, keeping these wires away from each other and from chassis metal, and by careful assembly in general.

Then the impedance of the plate load must be decreased until the high frequency cutoff reaches the required value. Dropping the plate load impedance decreases the stage gain while extending the frequency cutoff. Gain is approximately proportional to the product of tube transconductance and ohms of impedance in the plate load. Whereas the stage gain of an uncompensated resistance-coupled amplifier would drop at high frequencies about as shown by the full line curve of Fig. 7-6, adding series compensation will extend the gain as shown by the broken line curve.

It will be found that the inductance of the series compensating coil L_s and total input capacitance at the second tube

are resonant at about the cutoff frequency. For example, with total input capacitance of 12 mmf and cutoff around 4.2 mc the inductance at L_s would be 120 microhenrys.

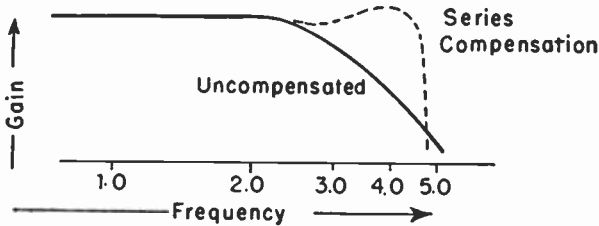

Fig. 7-6. -Series compensating inductance extends the range to higher frequencies.

As mentioned before, it is necessary to use a rather small resistance for load resistor R_o in order to extend the video range into high frequencies. Where this range is to be extended to approximately 4 mc the resistance at R_o commonly is between 2,000 and 6,000 ohms. Where the video frequency is to extend only to about 3 mc, for the smaller picture tubes, this resistance may be about 8,000 ohms. Values mentioned represent common practice, but there may be wide variations.

In series with this load resistance is the shunt compensating inductor L_p of Figs. 7-3 and 7-5. The inductive reactance of L_p increases with rise of frequency, and this action tends to maintain the effective plate load impedance at higher values in spite of the reduction in reactance of the shunting capacitances as frequency rises. The result is an extension of frequency at which there is satisfactory gain.

The inductance of this shunt compensating coil is resonant with the total effective shunting capacitance in the tube circuit at a frequency near the high cutoff value. Because this resonating capacitance is more than in the grid side of the circuit, the inductance of the shunt compensating coil is smaller than that of the series compensating coil.

Taking for an example a plate load resistor R_o of 4,000 ohms and shunt coil L_p of 50 microhenrys, the rise of total impedance with frequency would be only as shown at the left in Fig. 7-7. But as the inductance of L_p and the shunting

capacitance approach resonance there is the effect on gain as shown at the right. By suitable choice of values, the gain curve may be extended in almost a straight line well beyond where it would drop with uncompensated coupling, or the curve may

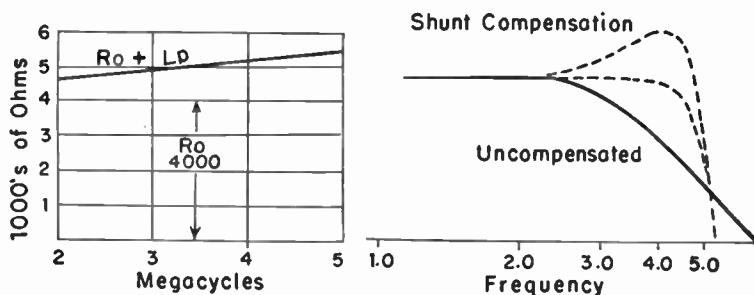

Fig. 7-7.—Effects of using a shunt compensating inductance.

be made to rise through a peak before the gain commences to drop rather sharply. The peak will be at a frequency somewhat lower than that at which the coil and the shunting capacitance would be resonant.

The load resistance which is part of the resonant circuit reduces the Q-factor and broadens whatever peaking may occur. To further reduce the peaking while still extending the frequency response a resistor sometimes is connected across the ends of shunt compensating coil Lp . In a few cases there will be connected across the ends of the shunt compensating coil a capacitor whose capacitance is about one-third the shunting capacitance. The effect is to further extend the high frequency limit, but there may be decided peaking near the high end.

Either series or shunt compensation used alone will extend the frequency range of the video amplifier and allow a more uniform gain through the high-frequency region. The greatest band width and most uniform gain may be had by using both series and shunt compensation in the same coupling. Using both kinds of compensation makes the phase shift or time delay for certain frequencies less than with shunt compensation alone, but this shift is somewhat greater than with only series compensation.

It should be mentioned that the value of grid resistor R_g has little effect on high-frequency gain. This resistor is paralleled by the input capacitance of the second tube, whose reactance becomes so low at high frequencies that no permissible value of grid resistance would appreciably affect the total load impedance.

Video amplifier frequency response is not easy to measure with instruments such as usually are available. It would be necessary to apply at the input of the amplifier, or output of the video detector, signal voltages of constant or accurately measured amplitude at frequencies all the way from below 30 cycles per second to about 5 megacycles per second. Output could be measured with an electronic voltmeter responding to alternating voltages, but the indications of usual voltmeters would vary so greatly in this range of frequencies as to require use of correction factors known to be correct for each frequency.

Number of Video Amplifier Stages. — There are definite relations between the number of stages or tubes in the video amplifier, the element from which detector output is taken, and the element of the picture tube at which there is signal input.

In Fig. 7-8 the modulated signal from the output of the video i-f amplifier is applied to the cathode element of the diode type video detector, and detector output is from the diode plate. For the detector to be conductive its cathode must

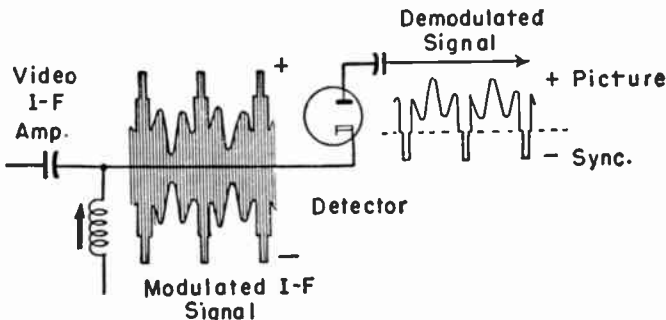

Fig. 7-8.—Picture signals are positive when the detector output is from the diode plate.

be negative with reference to its plate. With the connections shown here the cathode becomes negative only on the negative swings of the modulated signal. Consequently, only the negative side of the incoming signal envelope causes current in the detector output and this output reproduces the negative envelope. In the d-c output of the detector the picture portion of the signal is most positive and the sync pulses least positive, and when this output passes through any coupling capacitor to become an alternating voltage the picture signals are on the positive side and the sync pulses on the negative side of the wave.

In Fig. 7-9 we have the same modulated i-f signal as before, but now this signal is applied to the plate of the diode detector. For conduction to occur in the detector its plate must be made positive. The plate is made positive by the positive swings of the incoming signal, and the d-c output of the detector consists

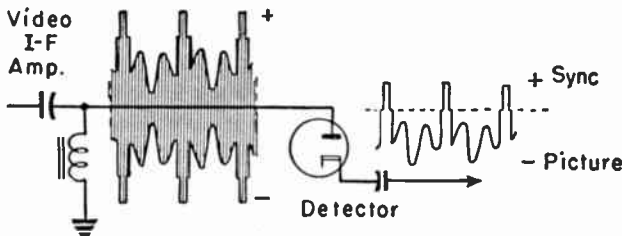

Fig. 7-9.—Sync pulses are positive in the output from the cathode of a diode detector.

of the positive envelope of the i-f signal. Now the negative side of the modulated signal has been cut off by the detector, just as the positive side is cut off in Fig. 7-8. When the detector output passes through a capacitor and becomes alternating, the sync pulses are positive and the picture signals are negative.

The left-hand diagram of Fig. 7-10 shows the signal output from the video amplifier applied to the cathode of the picture tube. In order that picture variations in the signal which are to produce bright areas may cause increase of beam current and brighter traces on the picture tube screen the control grid of this tube must become more positive or less

negative with reference to the cathode. This is the same as saying that the cathode must become less positive or more negative, with reference to the grid, to have brighter traces. Then, for increasing the beam current, it is necessary that the picture signal make the cathode of the picture tube more negative. In order for this to happen, the picture side of the applied signal must be negative, and the sync pulses positive, just as shown on the left-hand diagram. For input to the picture tube cathode, the sync pulses must be positive and the picture signal negative.

At the right in Fig. 7-10 the signal from the video amplifier is applied to the control grid of the picture tube. In order that increases of picture signal amplitude may increase the beam current and brightness on the screen these increases must make the control grid more positive or less negative with reference to the cathode. For this to happen, the picture side of the applied signal must be positive, and the sync pulses negative, as shown on the right-hand diagram. For input to the picture tube grid, the picture signals must be positive and the sync pulses negative.

The detector connection shown in either Fig. 7-8 or in Fig. 7-9 may be used in a receiver where signal input is to either the control grid or the cathode of the picture tube. If the detector output is of such polarity that it must be inverted before reaching the picture tube input, a single video amplifier

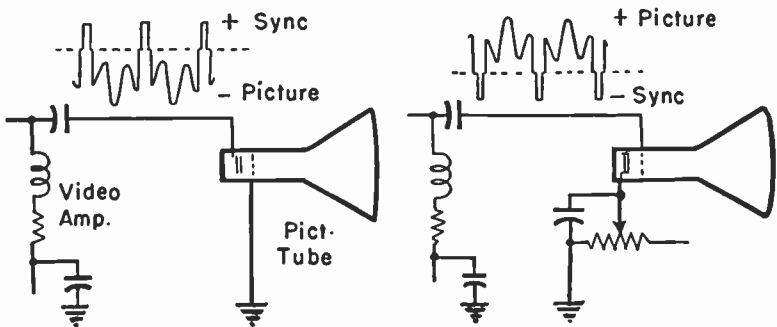

Fig. 7-10.—Polarities required in signal inputs to the cathode and to the control grid of the picture tube.

stage and tube will perform this inversion. Any odd number of video amplifiers would do the same thing, because any signal voltage applied to the control grid of a tube having a grid and a plate is inverted in the plate circuit of that tube.

If the detector output polarity is the same as the polarity required at the picture tube input this much of the problem could be handled by using no video amplifier, only a direct connection from detector to picture tube. But the detector output requires amplification. One video amplifier stage will invert the signal, and a second amplifier will bring the polarity back to its original form. Consequently, to have no inversion between detector and picture tube it is necessary to have at least two video amplifier stages. Any even number of video amplifiers would accomplish the same thing so far as maintaining signal polarity is concerned.

If output from one of the tubes in the video amplifier is from the cathode rather than from the plate of that tube there is no inversion by that one tube. Then any tube used as a cathode follower in the video amplifier system may be ignored when considering signal inversion or lack of inversion.

Video Amplifier Troubles. — The following are some of the more unusual faults which may be found in the video amplifier. If there is excessive peaking at some frequency it usually will show up as dark bands or smudges running horizontally across the vertical resolution wedges in a test pattern. The cause is likely to be too much inductance in a shunt compensation inductor or some construction or wiring fault which adds excessive stray capacitance, thus bringing a resonance peak down into the frequencies which should be uniformly amplified. Too much bypass capacitance across a cathode bias resistor may reduce degeneration too far and may allow enough regeneration to cause peaking. Any of these faults which might cause excessive or incorrectly placed peaking will affect the sync pulses when the sync takeoff is at some point in the video amplifier beyond where the trouble exists. The result may be white trailers or white bands on the right-hand edges of large black masses in the pictures, or sometimes

there may be fairly long white horizontal lines on the picture or pattern. Distortion of the sync pulse waveforms by the video amplifier may also make vertical lines appear crooked or skewed when they should be straight.

AMPLIFIERS, VIDEO INTERMEDIATE-FREQUENCY. — The video i-f amplifier of the television receiver extends from the output of the mixer tube in the tuner section to the input side of the video detector. Fig. 8-1 shows fairly typical circuit connections for one of the simpler types of video i-f amplifiers. To the control grid of the first amplifier tube come carrier and oscillator frequencies, also their sum and difference frequencies from the mixer. Tuned circuits select the difference frequencies and reject the others, just as in the i-f amplifier of a superheterodyne sound receiver. Whereas there may be only a single i-f amplifier stage in a sound receiver, the relatively low gains possible at high frequencies make it necessary to use two, three, or four such stages for television.

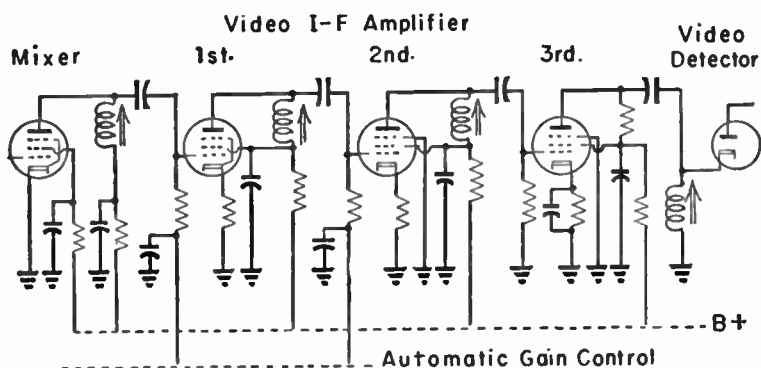

Fig. 8-1.—Connections in a three-stage video intermediate-frequency amplifier system.

Video i-f amplifier tubes are pentodes having high transconductance, usually of the miniature type. Tuning in Fig. 8-1 is by means of a single adjustable inductor in each interstage coupling. Tuning capacitance is furnished by the internal output and input capacitances of the tubes, by distributed capacitance of the inductors, and by stray capacitance

in sockets, wiring, and other parts. Each stage is tuned to resonance at some certain frequency which is close to or in between the video intermediate and sound intermediate frequencies. The tuning shown here is "staggered" at different frequencies so that the overall response of the whole amplifier is satisfactory for the band of frequencies to be handled.

In other receivers the necessary wide frequency response may be provided by transformers with two closely coupled windings, somewhat similar to i-f transformers for sound receivers. In still others, some of the couplings are with transformers giving a double-peaked response, and other couplings in the same amplifier are single tuned inductors or may be loosely coupled transformers providing a single peak in their response. In any of these designs the i-f amplifier must handle a frequency band three to four megacycles wide when it carries only picture and sync signals, or a band even wider in stages carrying the entire composite signal, including sound.

Some types of video i-f tubes have their suppressors internally connected to the cathodes. Suppressors provided with external connections or pins usually are connected directly to ground, as in Fig. 8-1, but sometimes are connected through an external resistor to the cathode. Automatic gain control commonly is provided for all except the last video i-f amplifier. Grid bias usually is by means of the agc system and a cathode bias resistor for each tube. Grid resistors seldom have resistance greater than 10,000 ohms. Coupling capacitors between plates and following control grids ordinarily have capacitances somewhere between 50 and 300 minf.

In many video i-f amplifiers there are numerous features not shown by Fig. 8-1. These include traps for various interference frequencies and for the accompanying sound frequency, also sound takeoff connections or couplings when the receiver does not operate with intercarrier sound. In such receivers the sound takeoff may be anywhere between the mixer output coupling and the tuned circuits for the last video i-f amplifier. All stages between the mixer and the sound takeoff must carry signals for video, sync, and sound. Stages

following the sound takeoff carry only video and sync signals intentionally, with sound signals removed by means of traps.

In Fig. 8-1 the plate circuit load for the last i-f amplifier consists of a resistor between the plate and the B+ line. At the left in Fig. 8-2 this resistor is replaced by an untuned choke, L , in the plate circuit, with tuning still on the detector side of the coupling. In the right-hand diagram the tuned inductor is in the plate circuit of the last i-f amplifier, with

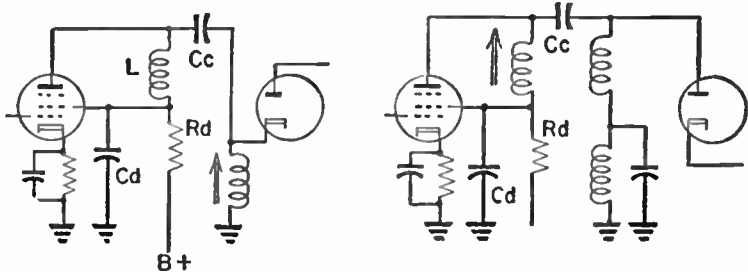

Fig. 8-2.—Tuning inductor locations in video i-f amplifiers.

an untuned choke on the detector side of the coupling capacitor. Not only in the coupling preceding the video detector, but in the coupling between any of the amplifier tubes, the tuned inductor may be on either the plate side or the grid side, either ahead of or following the coupling capacitor.

Note that the screen always is bypassed directly to ground through the capacitor marked Cd in Fig. 8-2. There is a single voltage dropping resistor, Rd , for both the screen and the plate. The bypass across this resistor carries to ground and the cathode return the high-frequency currents for both elements. If there is insufficient bypassing for the screen, high-frequency signal potentials from this element reduce signal voltage variations at the plate and drop the gain of the stage.

Parallel resonant types of traps often are found in the connection between the plate of one tube and the control grid of the following tube, in the line containing the coupling capacitor. Two such traps are illustrated by Fig. 8-3. The traps are tuned to the frequency which is to be reduced or

eliminated; they then offer high impedance at this frequency. The traps are in addition to the usual inductors or transformers which are tuned to resonance at the frequency to be amplified.

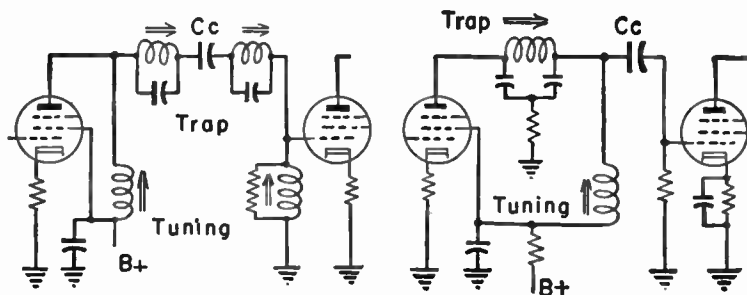

Fig. 8-3.—Parallel resonant traps in interstage couplings of video i-f amplifiers.

Video and Sound Intermediate Frequencies. — In the carrier frequencies for any television channel the sound carrier always is at a frequency 4.5 mc higher than the video carrier. For example, in channel 4 the video carrier is at 67.25 mc and the sound carrier is at 71.75, in channel 8 the video carrier is at 181.25 mc and the sound carrier at 185.75 mc, and so on.

The frequency to which the r-f oscillator of the receiver is tuned for any channel is higher than the carrier frequencies in that channel. When the oscillator frequency and the video carrier frequency beat together in the mixer, the difference frequency becomes the video intermediate frequency which is amplified in the video i-f system. When the oscillator frequency and the sound carrier beat together the difference frequency becomes the sound intermediate frequency.

We may assume that a receiver tuned for channel 4, as an example, operates with an r-f oscillator frequency of 93.85 mc. The results are as follows:

	Video	Sound
<i>Oscillator frequency</i>	93.85	93.85
<i>Carrier frequencies</i>	67.25	71.75
<i>Difference (intermediate frequencies)</i>	<u>26.6</u>	<u>22.1</u>

Although the difference between the video and sound intermediate frequencies is 4.5 mc, the same as between the two carrier frequencies, the video intermediate frequency is higher than the sound intermediate frequency, while the video carrier frequency is lower than the sound carrier frequency. The same things are true in every channel; the video intermediate always is higher than the sound intermediate, and their difference always is precisely 4.5 mc.

If an oscilloscope is connected to the output of the video detector, across the detector load resistor, the frequency response represented by the trace will be shaped principally by the characteristics of the video i-f amplifier, and will be of the same general shape whether the input is from a sweep generator connected to the antenna terminals or from a generator connected or coupled to the mixer tube. With signal input to the antenna, and markers injected for video and

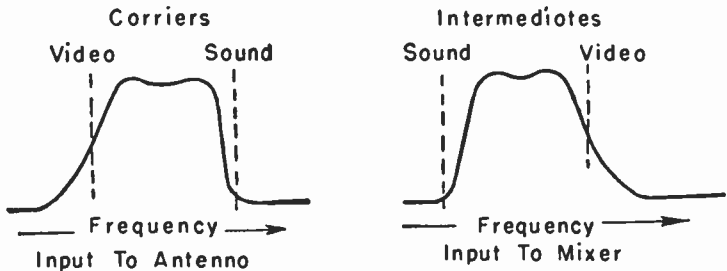

Fig. 8-4.—Where carrier frequencies and intermediate frequencies appear on the frequency response from the video detector.

sound carrier frequencies, these frequencies will lie on the response curve at about the positions shown at the left in Fig. 8-4. When signal input is to the mixer tube, with markers injected for the video and sound intermediate frequencies, these frequencies will appear on the response curve in the positions shown at the right.

The curves of Fig. 8-4 are based on the assumptions that sweep frequencies from the generator increase from left to right, and that increase of gain causes the curve to extend farther from the bottom toward the top, or that zero gain is

at the bottom and maximum gain at the top. If sweep frequencies decrease rather than increase from left to right, or if zero gain is at the top and maximum at the bottom, either of the curves may be shown with left and right sides reversed or may be shown upside down.

Fig. 8-5 shows examples of what may happen to the curve represented in its normal position at the right in Fig. 8-4. If sweep frequencies increase from right to left, with maximum gain at the top, the curve will be as at *A* in Fig. 8-5.

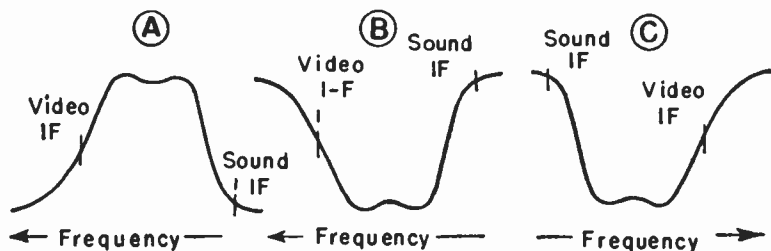

Fig. 8-5.—Inversions and reversals of frequency response curves.

With frequency the same, but maximum gain at the bottom the effect will be as at *B*. With frequency back to its first arrangement, increasing from left to right, but with maximum gain remaining at the bottom, the effect will be as at *C*. The curve, and the information it carries, are the same in every case. The differences are due solely to the characteristics of the sweep generator, the characteristics of the oscilloscope amplifiers, and the manner in which test connections are made.

Video intermediate frequencies in most common use range all the way from 25.75 mc up to 26.75 mc. The corresponding sound intermediate frequencies range from 21.25 mc up to 22.25 mc, with the sound intermediate frequency for any one receiver always just 4.5 mc lower than the video intermediate frequency for the same receiver. In many of the more recent designs the video intermediate frequencies are in the neighborhood of 35 to 38 mc, and the sound intermediates for the same receivers would range from 31 to 33 mc, with the exact difference between these two always 4.5 mc.

Receiver Attenuation. — With vestigial sideband transmission of television signals all frequencies from 0.75 mc below the video carrier to 0.75 mc above this carrier are transmitted in both the lower and upper sidebands. The strength of all these frequencies thus is doubled in the transmitted signal. Frequencies still lower than 0.75 mc below the video carrier are cut off. All frequencies still higher than 0.75 mc above the video carrier then are transmitted in only the upper sideband, and have only half the strength of those which are transmitted in both sidebands. The unequal strengths of various frequencies in the transmitted signal must be evened out or equalized in the receiver. The doubly transmitted frequencies are attenuated by the video i-f amplifier to make their strength equal to that of those singly transmitted. This process is known as receiver attenuation.

At the top of Fig. 8-6 is a curve representing relative strengths or amplitudes at various frequencies of the signal brought to the video i-f amplifier. This curve would corre-

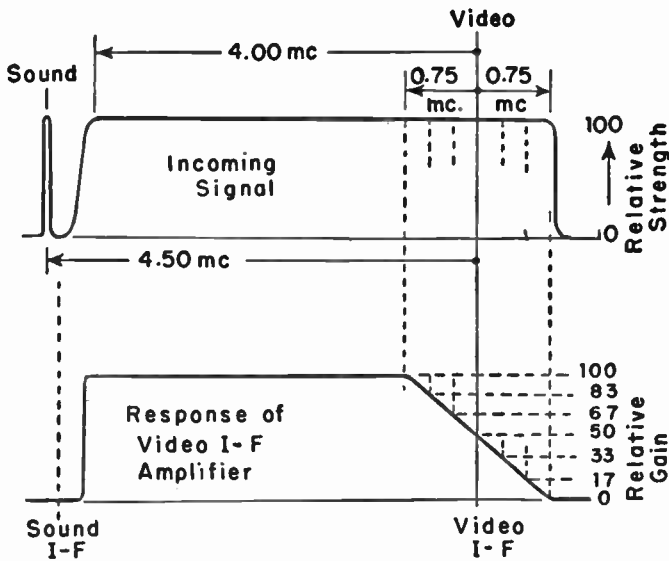

Fig. 8-6.—How the frequency response of the video i-f amplifier is shaped to equalize total amplification at all applied frequencies.

spond to the strength of the carrier signal at modulation frequencies measured both ways from the video carrier frequency as a reference point. After passing through the mixer, the video carrier frequency becomes the video intermediate frequency, so signal strengths shown by the upper curve are those measured above and below the video intermediate frequency at the input to the video i-f amplifier.

Modulation frequencies from zero up to 0.75 mc appear both above and below the video intermediate frequency. For example, with a video intermediate frequency of 26.25 mc these double-strength or doubly received modulation frequencies will be in the ranges from 25.50 mc (0.75 mc below the intermediate) up to 27.00 mc (0.75 mc above the intermediate). All greater modulation frequencies up to the limit of 4.00 mc appear on only one side of the video intermediate frequency.

In the video i-f amplifier there would be equal amplification or gain for all modulation frequencies were the amplifier response to be of the ideal form shown by the lower curve of Fig. 8-6. At the video i-f end of the response the gain is not uniform, it drops steadily from 100 at a frequency 0.75 mc below the intermediate down to zero at a frequency 0.75 mc above the intermediate, and has a value of 50, or 50 per cent of maximum, at the video intermediate frequency.

A modulation frequency of 0.25 mc will be applied to the video i-f amplifier on both sides of the intermediate frequency. On one side the gain will be 67 and on the other side the gain will be 33. The sum of the gains or the total gain at this modulation frequency then is 100 or 100 per cent. Another modulation frequency of 0.50 mc will be subjected in the video i-f amplifier to gains of 83 and 17, so that this frequency too is subjected to a total gain of 100. Every other modulation frequency between zero and 0.75 mc is similarly subjected to a total gain of 100. All greater modulation frequencies, from 0.75 through to 4.00 mc, act on the video i-f response in a region where its gain is 100. Thus all modulation frequencies receive the same total gain.

It would be theoretically possible to construct a video i-f amplifier system having a frequency response with the sharp changes illustrated at the bottom of Fig. 8-6, but it would be commercially impracticable and it is not necessary. A video i-f response of the general shape shown by Fig. 8-7 will give

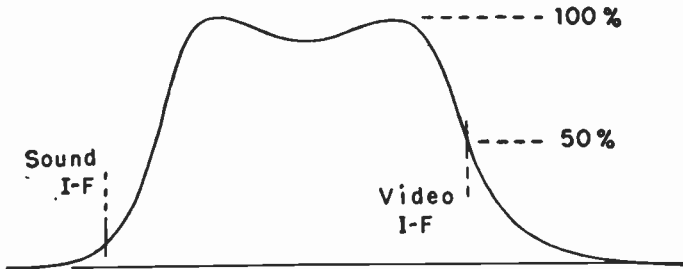

Fig. 8-7.—Typical frequency response of a video i-f amplifier system.

entirely acceptable results provided the video intermediate frequency is at or near the point of 50 per cent gain on the high-frequency side of the curve, and the sound intermediate frequency is far down on the low-frequency side.

Positions of Intermediates on Amplifier Response.—The shape of the frequency response curve for a video i-f amplifier is determined by adjustment of the tuned inductors or transformers in the interstage couplings. Altering any one adjustment will change the shape of the whole response curve to some extent, and usually will affect some one portion of the curve more than other portions. That is, the entire curve or some parts of it may be raised or lowered, or either side or both sides may be moved toward higher or lower frequencies. Adjustment ranges are limited, of course, but still it is possible to make great variations of response and always it is possible to produce a response of a shape satisfactory for required amplification.

We shall assume that the video i-f couplings have been adjusted or aligned to produce the frequency response shown at the top of Fig. 8-8. This response is well suited for video and sound intermediate frequencies used in an earlier example; 26.6 mc for video and 22.1 mc for sound.

Actual intermediate frequencies for video and sound depend on the frequency at which the r-f oscillator operates for any channel. This is because the intermediates are beat frequencies resulting from mixing of oscillator and carrier frequencies, and the carrier frequencies are fixed in any one

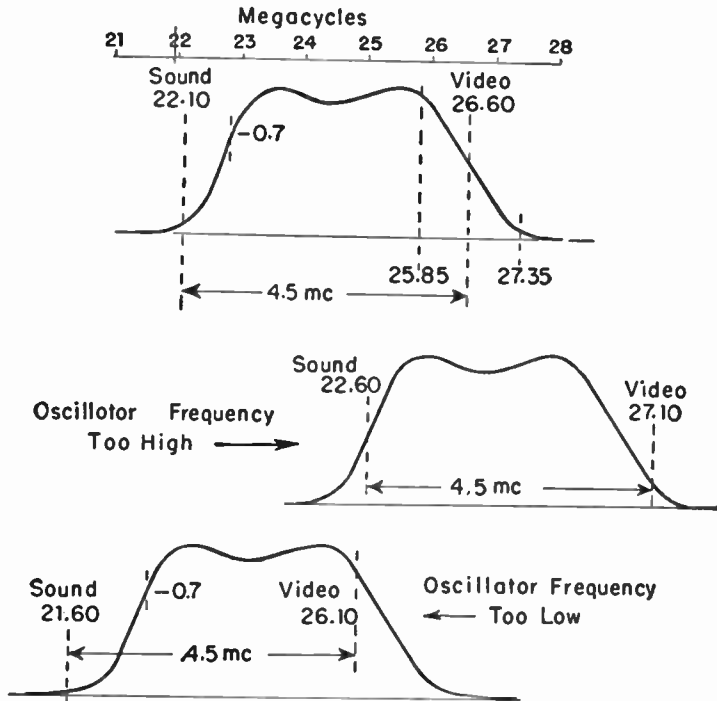

Fig. 8-8.—How video and sound intermediate frequencies are shifted on the i-f amplifier response curve by changes of r-f oscillator frequency.

channel. In the earlier example it was shown that an r-f oscillator frequency of 93.85 mc for channel 4 produces a video intermediate of 26.60 mc and a sound intermediate of 22.10 mc.

The next graph of Fig. 8-8 shows what happens when the r-f oscillator frequency is higher than it should be. For purposes of illustration the oscillator frequency is assumed to be 0.50 mc high, which makes it 94.35 mc instead of the

original 93.85 mc. Still using the carrier frequencies of channel 4, the intermediates now work out as follows.

<i>Oscillator frequency</i>	94.35	94.35
<i>Carrier frequencies</i>	<i>video</i> 67.25	<i>sound</i> 71.75
<i>Intermediate frequencies</i>	<i>video</i> $\overline{27.10}$	<i>sound</i> $\overline{22.60}$

It is apparent that the low frequencies of modulation, just above and below the video intermediate frequency, now are receiving far too little amplification—they are too far down on the gain curve. The resulting picture will be of generally dull appearance, and there are likely to be trailers or bands on the right-hand edges of any large or wide black objects. Sync pulses are of low frequency, and the lack of gain at low frequencies may make it difficult to maintain horizontal synchronization, and especially difficult to maintain vertical synchronization of the picture.

While the video intermediate has been moved too far down on the gain curve, the sound intermediate has been moved up by the excessively high oscillator frequency. Sound signals will be much too strong, and they are likely to cause horizontal bars or dark bands across the picture. These are called sound bars. If the sound section of the receiver is designed to operate from the intermediate frequency resulting from beating of carrier and oscillator frequencies, the actual sound intermediate will now have been moved far from the narrow frequency band in which the sound i-f amplifier has gain, and there will be no reproduction of sound from the loud speaker. If the receiver is designed to operate with intercarrier sound the result of the strong sound signal usually will be a loud buzz from the loud speaker, a buzz which cannot be removed by adjustment of the sound detector or demodulator circuit.

Next we shall assume that the r-f oscillator frequency has been made 0.50 mc lower than its original value, or brought down to 93.35 mc. The resulting intermediates are arrived at as follows:

<i>Oscillator frequency</i>	93.35	93.35
<i>Carrier frequencies</i>	<i>video</i> 67.25	<i>sound</i> 71.75
<i>Intermediate frequencies</i>	<i>video</i> $\overline{26.10}$	<i>sound</i> $\overline{21.60}$

These intermediate frequencies will appear on the video i-f amplifier gain curve as in the bottom graph of Fig. 8-8. Now the video intermediate is higher than originally, and the sound intermediate is much farther down. Note that the frequency response of the video i-f amplifier is not altered by these variations of oscillator frequency. The response of the amplifier is fixed by adjustments of its interstage couplings, and these are not being changed. Note also that the difference between video and sound intermediate frequencies always remains 4.5 mc. This is fixed by the difference between video and sound carrier frequencies, and never changes.

With the oscillator frequency too low the low modulation frequencies on either side of the video intermediate are receiving more than usual amplification. This may do no particular harm, in fact it may be desirable when signal strength from the antenna is very weak. There may, however, be trouble due to lack of gain at the high video frequencies or high modulation frequencies. In the top graph of Fig. 8-8 the band width from the video intermediate frequency to a point 0.7 down from maximum gain is about 3.75 mc. On the bottom graph this band width is reduced at about 3.25 mc. Frequencies farthest from the video intermediate, which are the highest modulation frequencies, are not so well amplified. This may cause poor definition or fuzzy appearance in the pictures.

With the oscillator frequency low the sound intermediate frequency is so far down on the gain curve as to be out of the band which is passed by a sound i-f amplifier designed to operate at the difference between carrier and oscillator frequencies. Then there will be no reproduction of sound. With an inter-carrier sound system the reproduction may be weak, but usually can be brought up to hearing level with the sound volume control.

Were it impossible to change the oscillator frequency to produce intermediates suited to the frequency-gain response of the video i-f amplifier, the amplifier might be realigned to make its gain curve suit the actual intermediate frequencies. With a sound system having an i-f amplifier and demodulator

designed to operate at the original sound intermediate frequency it would be necessary also to realign the sound i-f system and demodulator input for the new intermediate frequency. This might be impossible due to limited adjustment range. With intercarrier sound the sound modulation always is carried with the beat frequency of 4.5 mc which is the difference between video and sound carriers. This intercarrier beat, with its sound modulation, is not affected by changes of video and sound intermediates used in the video i-f amplifier.

Band Width and Gain. — In the interstage coupling represented by Fig. 8-9, and in every other type of coupling, it is necessary to consider the effects of capacitances of tubes sockets, and of wiring. Output capacitance on the plate side of the first tube is represented as C_o , and input capacitance on the grid side of the second tube is represented as C_i . Output capacitances of tubes in general use as video i-f amplifiers may be as low as 2 mmf, and input capacitances are as low as 5 or 6 mmf. Capacitances of sockets and wiring might be

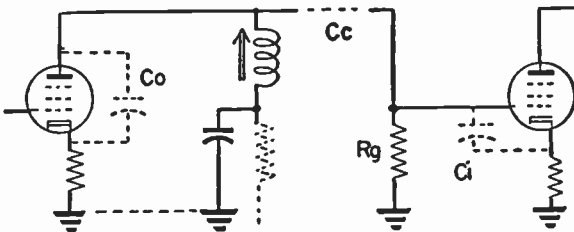

Fig. 8-9.—Tube or circuit capacitances which affect high-frequency response of the video i-f amplifier.

kept down to between 3 and 5 mmf with exceptionally good construction, but usually will be quite a bit more.

These tube and circuit capacitances add to the distributed capacitance of the tuning inductors or transformers and act with the inductance to tune the coupling to resonance. Adjustment for a desired resonant frequency nearly always is by means of movable powdered iron cores or slugs in the coils, although very small capacitors sometimes are connected across the coils.

While tube and circuit capacitances may be useful for tuning, they may also act as low reactance shunts across the tuned circuits. For example, if we consider the output capacitance C_o of Fig. 8-8 to be a tuning capacitance used with the inductor, the input capacitance C_i is in parallel with grid resistor R_g and forms part of the load impedance in the plate circuit. The reactance of coupling capacitors which would be at point C_c is much less than 100 ohms at video intermediate frequencies for capacitances in common use, and so may be neglected. The reactance of the input or output capacitances at video intermediate frequencies usually will be on the order of 500 to 1,000 ohms. The resulting small impedance of the effective plate load makes it impossible to obtain more than a small fraction of the gain which might be expected in view of high transconductance in the tubes. Transconductances of video i-f pentodes usually are somewhere between 5,000 and 10,000 micromhos.

Gain is improved by doing everything possible to lessen stray capacitances. This raises the load impedance, also allows using more inductance and a higher Q-factor in the tuned circuits. Wiring in plate and control grid circuits must be of shortest possible length, and kept separated from chassis metal and from other wiring.

To obtain a frequency response sufficiently wide to cover the i-f band there may be a fixed resistor connected across the ends of one or more of the tuning coils or windings. These broadening resistances usually are of some value between 3,000 and 20,000 ohms. Although these units are called broadening resistors, their effect is not so much to increase the range of frequencies at which there is gain but rather to flatten the gain curve to prevent resonant peaks which might cause feedback and undesirable regeneration or even oscillation in the video i-f amplifier. Grid resistors commonly have values between 3,000 and 10,000 ohms. These resistors are in parallel with the tuned circuits and act in the same manner as do broadening resistors connected directly across the coils.

Uniformity of gain throughout the frequency band often is increased by using cathode bias resistors with no bypass capacitor. An unbypassed cathode resistor allows degeneration, or an effective negative feedback from plate circuit to grid circuit of the tube. An unbypassed cathode resistor helps also to lessen variations of input capacitance which might occur on strong signals, especially with the first or second i-f amplifiers.

The output of the last video i-f stage feeds into the diode video detector. A diode acts as a low impedance load. Consequently, in the coupling from the last i-f tube to the detector it is not necessary to use any other means for broadening the response, and usually the cathode resistor of the last i-f amplifier is bypassed to prevent degeneration and allow all possible gain.

There are several basic types of interstage couplings which are used alone or in combination to produce the broad band frequency response required from the video i-f amplifier system. The three are shown by Fig. 8-10. At the left is a single tuned inductor or coil, shown earlier in Figs. 8-1 and 8-3. Such a coupling provides a response which peaks at a single

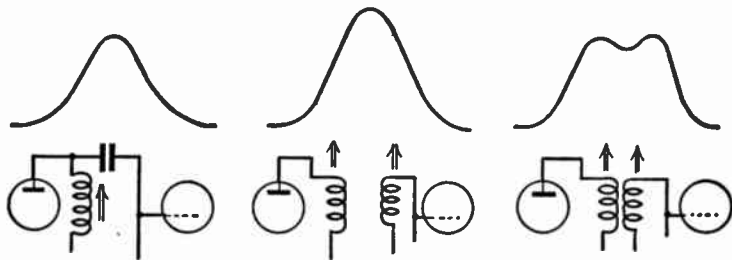

Fig. 8-10.—Basic types of interstage couplings and their frequency responses.

frequency, with gain decreasing both above and below this tuned frequency. At the center is a two-winding transformer with the windings very loosely coupled. With such coupling the transformer provides a single peaked frequency response of the same general form as the single tuned coil.

At the right is a transformer with closely coupled windings. As the coupling is increased in a transformer the single-peaked response will become broader and will develop two separate peaks. One peak is at a frequency lower than the frequency to which both windings are tuned, and the other peak is at a higher frequency. The closer the coupling, the greater becomes the separation between peaks and the less the gain at either peak. At the same time the valley between the peaks becomes deeper and deeper.

None of the couplings illustrated will produce in a single amplifying stage a frequency response broad enough for the video i-f system as a whole. In a great many receivers there are three, four, or five couplings of the type shown at the left in Fig. 8-10. The separate couplings are peaked at two or more different frequencies, with the result that their overall gain or frequency response is satisfactory. This is called stagger tuning.

Other receivers have loosely coupled transformers in each stage, with the transformers peaked at different frequencies to produce the required broadness of overall response. Still other designs utilize two or more closely coupled transformers whose combined response is wider than shown at the right in Fig. 8-10. Some receivers have one stage with a closely coupled transformer, and in other stages have single-peaked couplers to fill in the valley between transformer peaks and sometimes to extend the overall frequency response in both directions as may be required.

Stagger Tuning. — Fig. 8-11 shows responses or gains at frequencies between 20 and 30 megacycles of four interstage couplers, each consisting of a single tuned inductor. These responses represent oscilloscope traces taken from a fairly typical receiver having three i-f amplifier tubes between the mixer and video detector. The coil between mixer and first i-f amplifier was tuned to peak at 25.6 mc, the one between first and second i-f amplifiers was tuned to peak at 23.4, the coil between second and third i-f amplifiers was tuned like

the first one, to 25.6 mc, and the coil between the third i-f amplifier and detector was tuned like the second one, to 23.4 mc.

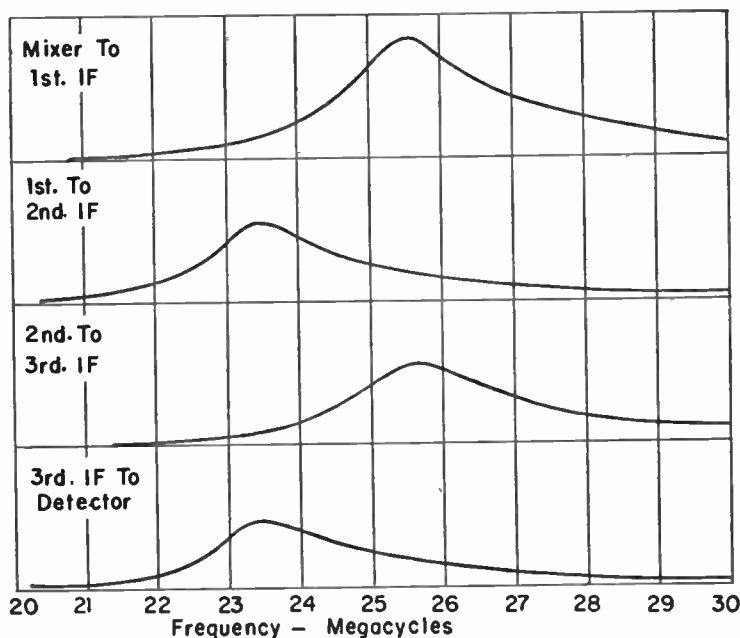

Fig. 8-11.—Individual frequency responses of four couplers used in a stagger tuned video i-f amplifier.

The output of each stage is the input for the following stage. The signal from the mixer appears like the top curve. It is amplified according to the gain characteristics of the second curve. That result is amplified according to the third curve, and so on.

The overall result of the successive amplifications is shown by Fig. 8-12. This is the frequency response as measured at the detector output with the input of a sweep generator coupled to the grid of the mixer. There are two peaks in this overall response, as would be expected from the fact that the individual coils are tuned to two frequencies. In the overall response one of the peaks is at a frequency somewhat higher than the 23.4-mc peaks of two coupling coils, and the other

peak is lower than the 25.6-mc peaks of the other two coupling coils. This overall response is suitable for use with a video intermediate frequency of 25.7 mc and a sound intermediate frequency of 21.2 mc.

It must be kept in mind that gains at any given frequency in successive stages do not merely add together, they multiply. If the gain were 2 in one stage and 3 in a following stage, the

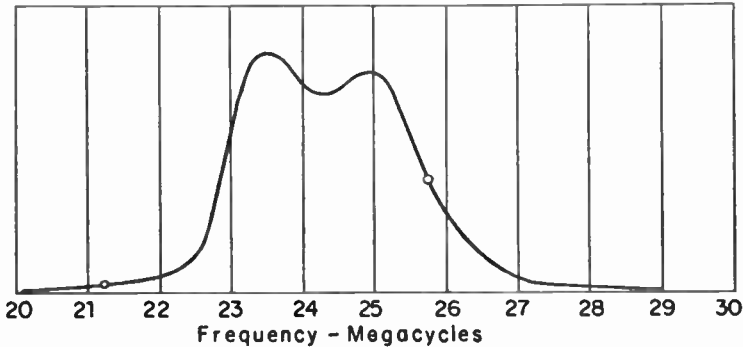

Fig. 8-12.—Overall frequency response of the four stagger tuned couplers.

combined gain would be 6 in the two stages. The shape of the overall response is influenced largely by the peak frequencies in the various stages, but it is influenced also by the shapes of the separate responses and whether they are very broad or relatively narrow. The separate responses shown by Fig. 8-11 are all very broad. This is due to the small plate load impedances and the shunting effects of circuit capacitances. Should gain at any frequency in any one of the *i-f* stages drop all the way to zero, that frequency could not appear in the overall response. It could not again be picked up in any following stage because this frequency would have been multiplied by zero as one of the factors.

The frequencies at which the separate stages are peaked depends, of course, on the intermediate frequencies with which the amplifier system is to operate. In view of the wide variety of intermediate frequencies used for different makes and models of receivers it is to be expected that staggered

stages will be tuned to a great variety of peak frequencies. But even though these peak frequencies are considered only in relation to how much they differ from video or sound intermediate frequencies in the same receiver, there still are wide differences between the peak frequencies chosen by designers to produce a suitable overall response.

There are quite a number of receivers in which all four couplers are peaked to only two frequencies, as illustrated by Fig. 8-11. But there are also numerous designs in which no two couplers are peaked at the same frequencies, and where the peak frequencies are distributed all through the frequency band from sound to video frequencies. It is a fairly general rule that at least one of the couplers, and often two, will be peaked at some frequency no more than 0.50 mc below the video intermediate frequency. Remaining couplers most often are peaked somewhere between 2.00 and 4.00 mc below the video intermediate.

When there are four video i-f stages, with five interstage tuned couplers, it is general practice to tune each of the couplers to a different peak frequency. This, however, is far from being a universal rule, for quite often two of the couplers will be tuned to the same frequency. Nearly always at least one, and usually two of the couplers, are peaked at some frequency no more than 0.80 mc below the video intermediate frequency, and in some receivers there will be a coupler peaked at a frequency somewhat above the video intermediate. It is a fairly general rule that two of the remaining couplers are peaked at some frequency between 3 and 4 mc below the video intermediate. This leaves one coupler to be peaked in the remainder of the band, between 1 and 3 mc below the video intermediate and where this peak will bring up or entirely eliminate any valley which otherwise might remain along the middle portion of the overall response.

There is no set order in which high-frequency and relatively low-frequency peaks follow one another. That is, the first coupler may be peaked at one of the higher frequencies or one of those farther below the video intermediate. Then,

as a nearly universal rule, the following couplers are peaked alternately higher and lower, or lower and higher. When two adjacent stages or couplers are not peaked at the same or nearly the same frequency there is reduced danger of feedback due to a tuned-grid tuned-plate effect. Such a feedback may cause regeneration and excessive peaking at some frequency in the overall response, or it may cause oscillation which ruins the picture.

Since gains at various frequencies in the overall response are the products of individual stage gains at each given frequency, the order in which peak frequencies follow one another is subject to much variation. As an example, the cou-

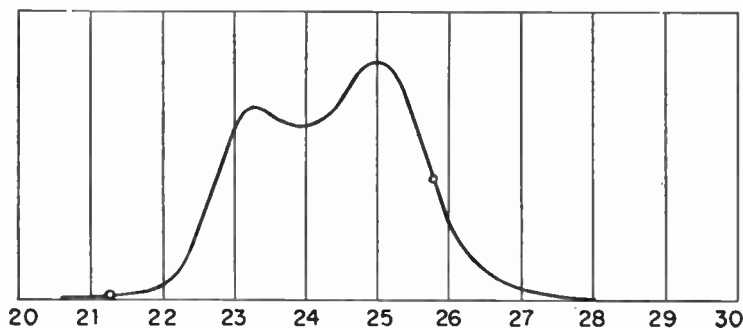

Fig. 8-13.—Effect of reversing the order of high and low peak frequencies in the video i-f amplifier.

plers whose individual responses are shown by Fig. 8-11 were peaked successively at 25.6, 23.4, 25.6, and 23.4 mc, with the overall result shown by Fig. 8-12. If the order of high and low frequency peaking is reversed, to make it 23.4, 25.6, 23.4 and 25.6 mc, the effect on the overall response would be as in Fig. 8-13.

The principal difference due to this reversal is an interchange of the relative positions of the high-frequency and low-frequency peaks. The high-frequency peak remains in about the same position, but the lower peak is shifted slightly lower still. It would be possible to use the same video and sound intermediate frequencies, as shown by their markings on this new response.

Overcoupled Transformers. — A transformer is said to be overcoupled when the coupling factor is great enough, or the coupling close enough, to cause resonance peaks at two different frequencies, as at the right in Fig. 8-10. A transformer is undercoupled when the coupling factor is small enough, or the coupling loose enough, that there is a resonance peak at only one frequency, as at the center of the figure. The coupling at which the single peak just commences to separate into two peaks is the critical coupling.

When coupling is increased beyond the critical value by only small amounts the two peaks move away from the original tuned frequency, up and down, by about equal amounts. But with greater and greater coupling the high-frequency peak moves up more than the low-frequency peak moves down in relation to the original frequency, to which both windings are tuned.

What happens with increase of coupling is shown, in a general way, by Fig. 8-14. An undercoupled transformer is assumed to be tuned, in both windings, to a frequency of 25.0

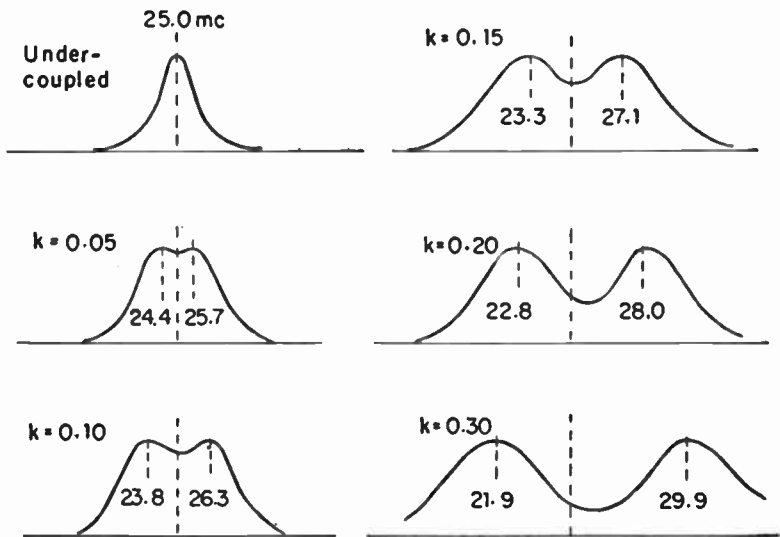

Fig. 8-14.—Effect on separation of resonance peaks when coupling is increased.

mc. The response may be of the general form shown at the upper left, the actual form depending on the Q-factor of the windings, their loading, and so on. In remaining diagrams the coupling factor is increased from 0.05 to 0.30 in successive steps. The peaks appear, and move farther and farther apart, and the valley between them becomes deeper and deeper, which soon would mean a serious loss of gain at frequencies through the middle of the band. Although all peaks are drawn to the same height, the actual peak gains would decrease with increase of the frequency spread between them, and one peak would tend to become lower than the other.

Usually we think of a transformer as a device having two insulated windings between which there is transfer of signal power or energy by means of a magnetic field passing through both windings. Such an arrangement, represented at the left in Fig. 8-15, utilizes electromagnetic coupling between the windings. There are many other devices employing two windings, one in the preceding plate circuit and the other in the following plate circuit, with signal transfer by means other than a magnetic field. In these devices, usually called transformers, there is little or no electromagnetic coupling between the two windings.

In the center diagram of Fig. 8-15 the coupling is by means of a resistance forming a portion of the plate circuit and a portion of the grid circuit. A-c signal currents between cathode

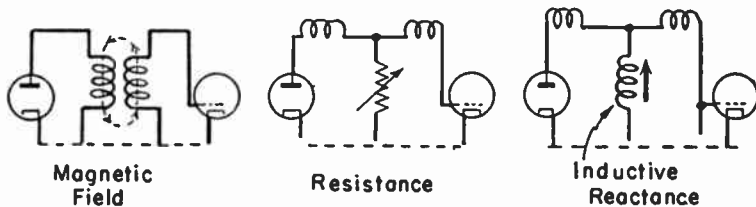

Fig. 8-15.—Transformers having magnetic, resistive, and inductive couplings.

and plate of the first tube have to pass through the coupling resistance, and a-c signal currents or voltages between cathode and grid of the second tube have to flow in or appear across the same resistance. Not shown in this diagram, and in some

of those following, is a blocking capacitor which would be inserted between plate and grid circuits to keep positive d-c potentials in the plate circuit from reaching the grid of the second tube. This diagram shows the principle of direct resistance coupling. Greater resistance increases the coupling, or makes it tighter.

The right-hand diagram of Fig. 8-15 illustrates the principle of direct inductive coupling. A coupling inductor or coil takes the place of the coupling resistance. The inductive reactance of the coupling coil is in both the plate circuit and the grid circuit. The degree of coupling is increased by increasing the inductive reactance, just as the degree of resistance coupling is increased by increasing the coupling resistance. Resistance coupling in itself is not altered by change of frequency unless the resistance element is affected by frequency. Direct inductive coupling increases with rise of frequency, because inductive reactance increases with rise of frequency.

Two-winding transformers or couplers employing capacitors are shown in principle by Fig. 8-16. In the left-hand diagram there is a capacitor common to the plate and grid circuits. This capacitor is in the same position as the inductor for direct inductive coupling or the resistor for direct resistance coupling. The greater is the capacitive reactance of the coupling capacitor the closer is the coupling. Capacitive reactance is increased by using less capacitance, so a decrease of capacitance results in closer or tighter coupling. In a practical coupler of this type there would have to be a blocking capacitor in addition to the coupling capacitor. Since capacitive reactance decreases as frequency rises, the degree of coupling in this circuit will decrease with increase of frequency.

With connections shown at the center of Fig. 8-16, capacitor C_a may have enough capacitance to make its reactance so small as to offer practically no opposition to signal transfer. Then the coupling is by means of the inductive reactances of the two coils, which are left in parallel with each other so far as a-c signal currents are concerned and which act together like the single inductive reactance coupling shown at the right in Fig.

8-15. Capacitor C_c acts merely to block d-c potential in the plate circuit away from the grid circuit.

If capacitance at C_a is reduced so low that the reactance offers decided opposition to signal currents the degree of coupling depends on this capacitor. Reducing the capacitance, and thus increasing its reactance, causes a decrease of coupling

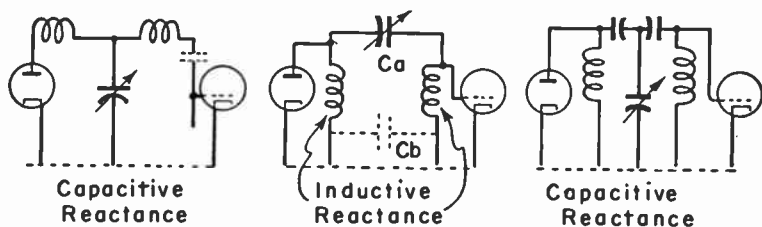

Fig. 8-16.—Transformers with which capacitors are the coupling elements.

or makes the coupling looser. Maximum coupling and maximum signal transfer still is determined by impedances of the two coils, but the coupling may be reduced below this maximum value by reduction of capacitance at C_a . When the coupling capacitor is between the plate and grid ends of the coils, as at position C_a , the arrangement may be called top coupling. If the coupling capacitor is at the low ends of the coils, as at C_b , the arrangement may be spoken of as bottom coupling.

The right-hand diagram of Fig. 8-16 shows another coupling arrangement with which maximum coupling or maximum signal transfer depends chiefly on the inductive reactances of the two coils, while adjustment below this minimum may be made by changing the capacitive reactance of the coupling capacitor. Less capacitance, which means more capacitive reactance, increases the coupling or makes it tighter. More capacitance, and less reactance, makes the coupling looser.

All the coupling methods shown in simplified forms by Figs. 8-15 and 8-16 are found in video i-f stages and many of them are used also in the r-f amplifier couplings for the tuner. The two coils in the plate and grid circuits have been represented as having no adjustments. Actually these coils would be tuned

to resonance at frequencies required to produce the i-f band pass. This tuning ordinarily would be with movable cores or slugs in the coils for varying the inductance. Tuning capacitance would be provided, as usual, by capacitances in the tubes, sockets, and wiring.

Capacitors for adjustment of coupling, as used between the last video i-f amplifier and the video detector, are shown in the circuit diagrams of Fig. 8-17. The adjustment at the left corre-

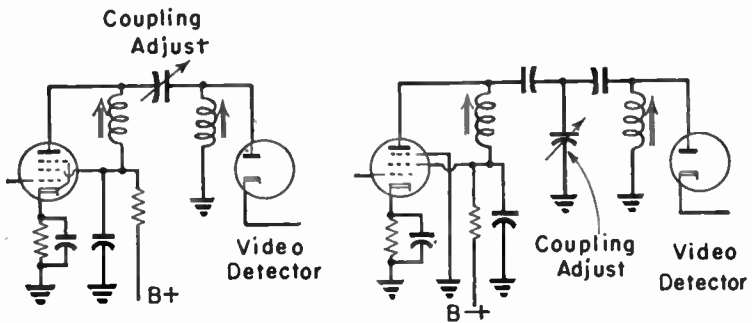

Fig. 8-17.—Adjustable capacitors used for varying the coupling and the band width at the output of video i-f amplifiers.

sponds to that shown by the center diagram of Fig. 8-16. The adjustment at the right of Fig. 8-17 corresponds to that at the right in the preceding figure. The adjustable coupling capacitors usually have maximum capacitances not much more than 10 mmf. With the circuit at the left in Fig. 8-17 the coupling is increased by increasing the coupling capacitance. With the circuit at the right the coupling is increased by decreasing the coupling capacitance.

Both adjustments of Fig. 8-17 affect the maximum amplitude of the signal passed to the video detector. Both affect also the coupling factor and consequently act to change the total band width of the video amplifier response at its output to the detector, as was explained in connection with Fig. 8-14.

Fig. 8-18 shows frequency responses of three different over-coupled transformers used in video i-f amplifiers. The frequencies are plotted with reference to the video intermediate

frequency considered as zero, and with other frequency points shown in numbers of megacycles below and above the video intermediate.

If successive stages having responses like that shown by the upper curve were connected in cascade, the height of the response would rise and the sides or skirts of the curve would draw toward the center. Such action could bring the video intermediate frequency half way down from maximum ampli-

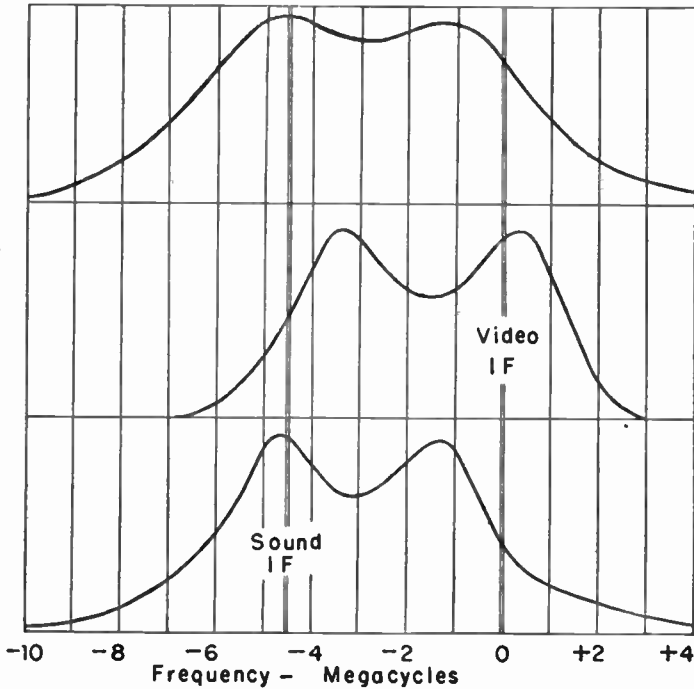

Fig. 8-18.—Typical response curves from stages having overcoupled transformers.

tude. With response of the shape illustrated, where gain is high at the sound intermediate frequency, this gain could be reduced as might be desirable by using traps tuned to the accompanying sound frequency. Traps tuned rather sharply would leave a steeply sloped gain curve on the low-frequency side of the response. This could result in excellent amplification of high modulation frequencies.

In each of the lower responses of Fig. 8-18 the separation between peaks is between 3.5 and 4.0 mc, and the skirts of both responses have rather steep slopes. Were two such stages connected in cascade, the high-frequency peak of the bottom response would bring up the valley between peaks of the response in the middle, the total response at the video intermediate frequency would move toward the 50 per cent point, and response around the sound intermediate frequency would peak slightly above this frequency and would be reduced by accompanying sound traps. Single-peaked couplers could be used in other stages to make the overall response almost anything desired.

Regeneration and Oscillation.— Sometimes there is feedback from plate circuit to grid circuit of one tube, or from one stage to a preceding stage when both are tuned to the same frequency. The result may be to twist and skew lines which should be straight in pictures, or to partially cover the picture area with short, black, horizontal streaks, or to otherwise distort the reproduction. When such troubles are due to regeneration they often may be made to appear and then disappear by varying the setting of the contrast control, and sometimes by varying the setting of the fine tuning control which acts on the r-f oscillator.

While observing the overall response of a video i-f amplifier with a sweep generator and oscilloscope, regeneration will show up as an excessively high peak, on the order of the one at the left in Fig. 8-19. If regeneration becomes so great as to cause oscillation the oscilloscope trace will take on the appear-

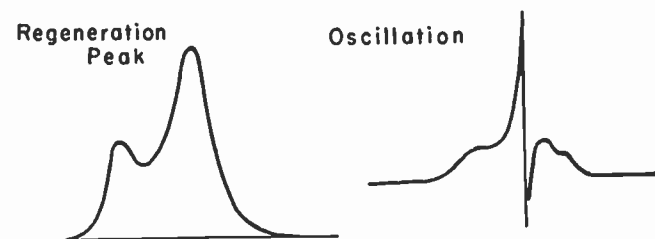

Fig. 8-19.—How regeneration and oscillation affect oscilloscope traces of response curves.

ance shown at the right. There is violent oscillation where frequencies from the sweep generator pass through the one at which the trouble occurs.

If video i-f amplifier output is being observed with a voltmeter connected to the video detector load, oscillation will make this output voltage increase to a very high value and remain there when the input signal is at a single frequency, not at swept frequencies. Reducing the input to zero will not affect the output voltage, because the oscillation is self-sustaining. If a picture or test pattern is being observed when oscillation occurs, the screen of the picture tube will become brilliantly white all over. The quickest way to stop oscillation is to turn off the power to the receiver.

Regeneration and oscillation may be the result of tuning adjacent i-f amplifier stages to the same or nearly the same frequency. These troubles may be caused also by excessively long leads in plate and grid circuits, by these leads being too close to each other, by chokes or tuning inductors being close enough or in such relative positions as to allow feedback, or

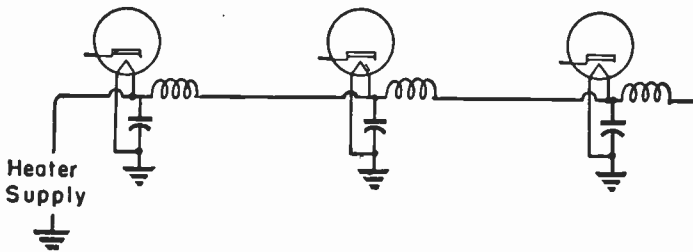

Fig. 8-20.—Decoupling capacitors and chokes in a heater circuit.

by insufficient decoupling capacitance from the bottom of the plate load to ground or from the screen to ground. These bypass capacitors must be large enough to prevent coupling through the voltage dropping resistors or through parts of the common B-power supply.

In video i-f amplifiers the tube heaters often are decoupled from one another by means of capacitors to ground, or series chokes, or both. Fig. 8-20 shows a heater circuit having one end of the heater in each tube connected to ground, which is one side of the a-c heater supply. The other side of the heater circuit is carried through insulated wire. From the end of each heater connected to this insulated line there is a bypass capacitor to ground, and between each pair of adjacent heaters there is an r-f choke. The bypasses and chokes, or either used alone, help prevent feedbacks from one stage to another and reduce tendency toward regeneration or possible oscillation.

Response curves often are badly distorted by connection of signal generator leads and oscilloscope or voltmeter leads to the receiver. The trouble is likely to be an input signal voltage which is too strong. There may be too much coupling from generator leads to tube grids. If this coupling is reduced by using a smaller capacitor in series with the lead, or by connecting a 300- or 400-ohm resistor from the grid to ground, the regeneration peaks or the oscillation often will disappear while allowing enough signal input to produce a good readable trace.

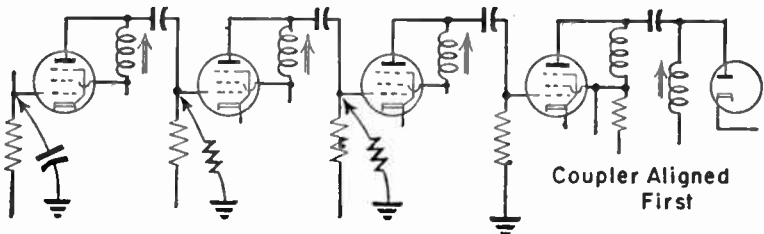

Fig. 8-21.—Grounding of control grids through capacitors or resistors to prevent oscillation during alignment.

The leads from generators and oscilloscope always should be of shielded cable. They should be no longer than necessary. The lengths exposed beyond the shielding should be as short as possible. Feedback from oscilloscope leads sometimes may be stopped by connecting a capacitor of about 0.002 mf from the vertical input lead to ground at the receiver end. It may be

possible to find certain positions of the contrast control where the trouble disappears.

If regeneration or oscillation cannot be otherwise prevented during alignment, the method of Fig. 8-21 may be used. The control grids of all tubes preceding the one for which the coupler is to be aligned are connected to ground through a capacitor or resistor. A capacitor, which should be of about 0.001 mf size, is shown on the first tube of the diagram. On the second and third tubes are shown resistors, which should be carbon types of about 300 ohms resistance. All grids are grounded through either capacitors or resistors, both being shown in the diagram only to illustrate their connections.

After aligning the coupler nearest the video detector, the grounding resistor or capacitor is removed from the next preceding tube on which it has been used, and the coupler second from the detector is aligned. The grounding elements are removed successively as alignment proceeds from stage to stage. Should regeneration or oscillation reappear after all stages are aligned, the trouble is due to some of the other causes mentioned earlier.

Alignment of Video I-F Amplifiers. — The subject of alignment as it applies to all parts of the television receiver is discussed in the article on *Alignment*, to which reference should be made. The present discussion relates specifically to alignment of video i-f amplifiers.

The shapes of the required overall response and of stage responses are affected by the type of sound system employed. With dual carrier systems the sound intermediate frequency is the beat frequency resulting from mixing of the sound carrier and r-f oscillator frequencies, and it will vary with change of oscillator frequency. The other general class of receivers employs intercarrier sound, where the center frequency for the sound system results from beating of sound and video intermediate frequencies in the video detector. Since these two frequencies always differ by 4.5 mc, the intercarrier sound frequency always is 4.5 mc, and is not affected by change of r-f oscillator frequency.

In receivers employing the sound intermediate frequency there is first the r-f response shown at the left in Fig. 8-22. This is changed by the r-f oscillator and mixer to a response of the general shape shown at the center. The sound takeoff may

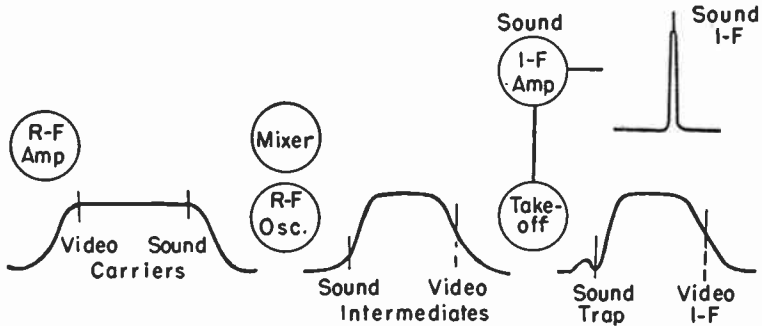

Fig. 8-22.—Frequency responses when the sound system operates at the sound intermediate frequency.

follow one or more i-f stages or may be located at the mixer output. The sound i-f signal goes from the takeoff to the sound i-f amplifier. In video i-f stages beyond the takeoff this sound i-f signal is trapped out, as shown.

The response of the sound i-f amplifier is centered at the sound intermediate frequency. This response is very narrow, seldom being more than 0.3 to 0.4 mc at points 50 per cent down on the curve. Consequently, the sound intermediate frequency, as fixed by r-f oscillator action, must be held within close limits in order to fall on this narrow response. The video intermediate frequency must, of course, be exactly 4.5 mc higher than the sound intermediate frequency. Since the sound intermediate must be exact, and the video intermediate must have an exact relation to sound, both frequencies are rigidly fixed in value. The shape of the video i-f response must be shaped to suit these intermediate frequencies. Even a small change of r-f oscillator frequency will prevent reproduction of sound, while having only a minor effect on the picture. With a correctly shaped video i-f response there will be the best picture when there is the best sound from the loud speaker.

What happens with an intercarrier sound system is shown by Fig. 8-23. There is the same r-f response as before. Both the sound and the video intermediate frequencies must pass through all video i-f stages and both must reach the video detector where they beat together to form a 4.5-mc center frequency, modulated with the sound signal. This modulated

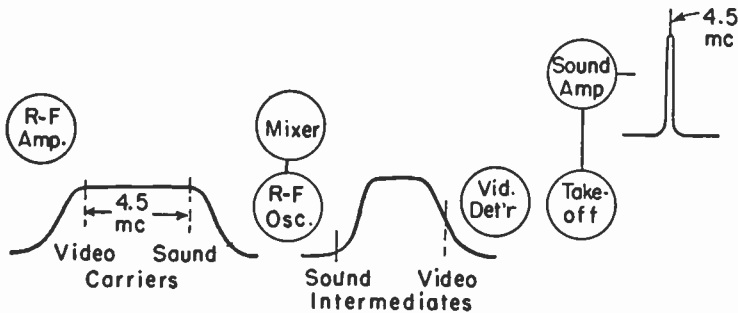

Fig. 8-23.—Frequency responses with an intercarrier sound system.

4.5-mc frequency is taken off at some point following the video detector and goes to the sound amplifier. The sound system has a very narrow response which is centered at 4.5 mc. This system always will receive a sound-modulated 4.5-mc signal unless either the sound or the video intermediate were to be completely dropped out in the video i-f amplifier.

The video i-f response for a receiver employing intercarrier sound must be so shaped that, at a frequency 4.5 mc lower than the 50 per cent point on the high-frequency slope, the response is down to something around 3 to 10 per cent with most designs. Now, provided there is sufficient range of adjustment, the frequency of the r-f oscillator may be brought to a value producing video and sound intermediate frequencies which fall on the specified points of the video i-f response. That is, shifting of the r-f oscillator frequency shifts both frequencies which result from beating with the two carrier frequencies, and these two frequencies always must remain 4.5 mc apart. At the output of the video detector there always will be a 4.5-mc modulated sound signal for any setting of the r-f oscil-

lator that does not move the sound intermediate frequency to zero on the video i-f response.

When a sweep generator is used for the signal source during alignment or test, and an oscilloscope is used as the output indicator, the presence or absence of traps in the video i-f amplifier will affect the shape of the responses. This is illustrated by Fig. 8-24, which shows successive video i-f stages.

On the coupler between first and second tubes there is no trap of any kind. A response taken at the input to the second tube would be of the general shape shown directly below, with sides or skirts sloping smoothly down to zero.

On the next interstage coupler is an accompanying sound trap, tuned to the frequency of the sound intermediate for the signal being received. As shown by the curve below this trap, the response at the accompanying sound frequency is reduced to zero or nearly so. The sound takeoff would precede this trap,

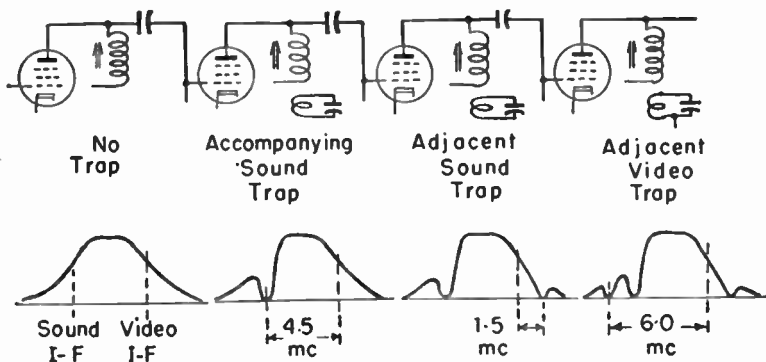

Fig. 8-24.—How various traps affect frequency responses in the video i-f amplifier.

for the sound signal will be very low or absent in following stages. The dip which appears in the response, for a correctly tuned accompanying sound trap, will be at a frequency 4.5 mc lower than the video intermediate frequency.

On the third coupler is an adjacent sound trap. The adjacent sound frequency is 6.0 mc higher than the accompanying sound, and 1.5 mc higher than the video intermediate

frequency. In the response will be a second dip at this adjacent sound frequency. The dip due to the preceding trap for accompanying sound will remain.

On the fourth coupler is a trap for the adjacent video frequency, which is 6.0 mc lower than the video intermediate frequency carrying the received signal. A third dip, corresponding to this adjacent video trap, will appear on the response which is the input for a following stage or the video detector. The other two dips still will appear.

Dips will appear in a video i-f response curve at the frequencies of any traps which are between the point of signal generator input and the point at which the output is observed. Just what dips appear on any particular response depends on the location of traps in the amplifier and the frequencies to which the traps are tuned.

It is recommended by some manufacturers that all traps be aligned before any of the interstage couplers are aligned. Others advise tuning the coupler and any trap on the same stage before proceeding to another stage or another coupler and trap. After aligning either a coupler or a trap in any one stage, the other of these two elements should be checked again for frequency response or effect. There is some change in the resonant frequency of any circuit coupled to another circuit when tuning of that other circuit is altered.

When aligning all the stages of a video i-f amplifier the test signal may be passed through one coupler or through more than one coupler between the generator and the output indicator. One method is illustrated by Fig. 8-25. The output indicator (voltmeter or oscilloscope) is connected across the load resistor in the output of the video detector. The signal generator output is coupled to the control grid of the video i-f amplifier preceding the detector, at 1, and alignment is made of the coupler between this amplifier and the detector. Then the generator input is moved back to the grid of the preceding amplifier, at 2, while aligning the coupler which precedes the one first adjusted. Next, with generator output moved ahead one more stage, 3, alignment is carried out on the next pre-

ceding coupler. Thus the work proceeds until the generator is coupled to the control grid of the mixer tube, 4, for alignment of the final coupler.

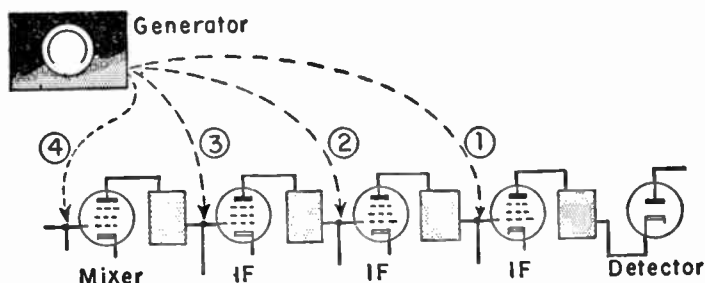

Fig. 8-25.—Connections of signal generator and output for video i-f alignment.

The method just described is commonly employed when interstage couplings are by means of overcoupled transformers, and for any type of coupling when one or more stages are thought to be far out of adjustment to begin with.

If it is probable that none of the stages are very far out of alignment, the signal generator may be coupled to the control grid of the mixer tube and kept there while aligning all couplers, with the output indicator remaining across the video detector load. This is common practice also for alignment of stagger tuned stages, where each stage is peaked at some one frequency.

The operation and use of sweep generators, single-frequency generators, marker generators, oscilloscopes, and electronic voltmeters are explained in articles devoted to these several instruments. Following are preliminaries to alignment of any video i-f amplifier.

- a. Disconnect the antenna from the receiver, remove the transmission line from the antenna terminals on the receiver.
- b. Set the channel selector for some high-frequency channel on which there is no transmission at the time of alignment.

c. Set the contrast control in its usual operating position, or about one-fourth down from maximum.

d. Override the automatic gain control voltage with a fixed bias voltage from dry cells, with battery positive to ground and negative to the agc bus. Use about 3 volts, or, if this lowers the response too much, try $1\frac{1}{2}$ volts.

e. Disable the r-f oscillator. The entire signal will be furnished by the generator, and when this signal goes to the mixer control grid the results are confusing if the local oscillator remains active. If tube heaters are in parallel the oscillator tube may be removed from its socket during alignment. With series heaters, connect the control grid of the oscillator tube or section to ground through a capacitor of about 0.001 mf. This latter method may be used also when heaters are in parallel.

f. Allow at least 20 minutes for the receiver and instruments to warm up after all of them are turned on, then proceed to make adjustments.

Alignment of Stagger Tuned I-F Stages. — The only way of knowing the frequencies to which individual stagger tuned stages are supposed to be peaked is to have the manufacturer's service instructions or some reference book giving such information for all receivers.

In receivers having three video i-f amplifier tubes, and four interstage couplers between tubes, it is fairly common practice to tune two of these couplers to one frequency, and to tune the other two couplers to a different frequency—employing only the two peak frequencies for all four couplers. Such an arrangement is represented at the top of Fig. 8-26. The values of peak frequencies shown here are with reference to the video intermediate frequency, since they refer to no particular receiver, and might be used with any video intermediate. Furthermore, these peak frequencies are merely representative of what might be called average practice. In a given receiver, the lower of these two frequencies might be lower or higher than 2.6 mc below the video intermediate, and the higher peaks would not necessarily be 0.3 mc below the video intermediate.

In other receivers having four video i-f couplers for three amplifier tubes, each coupler is tuned to a frequency different from any of the others. Such practice is represented at the bottom of Fig. 8-26. Again the peak frequencies are with reference to the video intermediate frequency, and again they show only

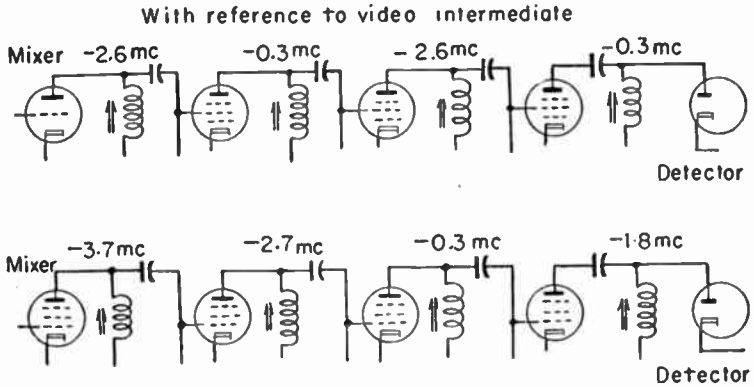

Fig. 8-26.—Typical peaking frequencies for four couplers in stagger tuned video i-f amplifiers.

average values. It is not necessary that the order of higher and lower frequencies be as shown by the diagram. Instead of the order used here, the peaks might be arranged as -3.7 mc, then -1.8 mc, then -2.7 mc, and finally -0.3 mc, or in some other order.

With four video i-f amplifier tubes, and five couplers, there is even less uniformity than with three tubes and four couplers. Sometimes two of the five couplers will be peaked at the same frequency, but more often there are five different frequencies. Fig. 8-27 shows some possible peak frequencies and orders in

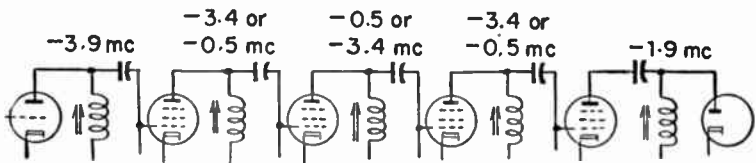

Fig. 8-27.—Typical peaking frequencies used with five couplers in stagger tuned video i-f amplifiers.

which they may follow one another. The first coupler is peaked somewhere around 3.9 mc below the video intermediate in a rather large number of receivers. Of the next three couplers, two sometimes are peaked up near the video intermediate with one peaked farther down toward the sound intermediate, or only one may be peaked up high and two of them lower down. The peak frequency for the last coupler often is around 1.9 mc below the video intermediate, or something between minus 1.4 mc and minus 2.4 mc.

Certain frequencies have been mentioned for peaking video i-f amplifiers only for use in an emergency when everything is completely out of adjustment, and when something must be tried in order to get the receiver on the road to recovery. These frequencies should not be used when there is any chance of employing those known to be correct. Some couplers have a range of frequency adjustment so limited that only those frequencies which are correct or nearly so may be tuned.

The usual method of aligning a stagger-tuned video i-f amplifier is as follows. Use a signal generator which furnishes a single steady frequency, not a sweep generator. This generator is used without modulation. Couple the generator output through a small capacitance to the mixer control grid, or connect without a capacitor to a metal ring or to an ungrounded tube shield placed around the mixer tube. When using a coupling capacitor the generator output may be applied to any point which is above ground potential in the mixer grid circuit.

Connect an electronic voltmeter across the video detector load resistor. Use the instrument as a d-c voltmeter. If the detector has a d-c bias, set the zero adjuster of the voltmeter to bring the pointer to zero or other easily identified marking on the scale when there is no signal from the generator.

Tune the generator precisely to a frequency at which one of the couplers is to be peaked, and vary the alignment adjustment of this coupler to produce maximum reading on the meter. Reduce the generator output voltage to allow using the lowest and most sensitive scale of the meter. If the pointer

tends to go off scale as alignment proceeds, bring it back by reducing the generator signal voltage, not by using a higher range of the meter.

Proceed to adjust any other couplers which are to peak at the same frequency, always aligning for maximum meter reading. Then tune the generator to another of the peak frequencies, and adjust other couplers which are to peak at this new frequency. Proceed thus until all couplers are aligned for their peaks. Always finish the alignment process by observing the overall response of the video i-f amplifier with a sweep generator feeding the mixer and an oscilloscope connected across the video detector load.

It is possible also to carry out the entire alignment by using a sweep generator and a marker generator, and by using an oscilloscope connected across the video detector load. The

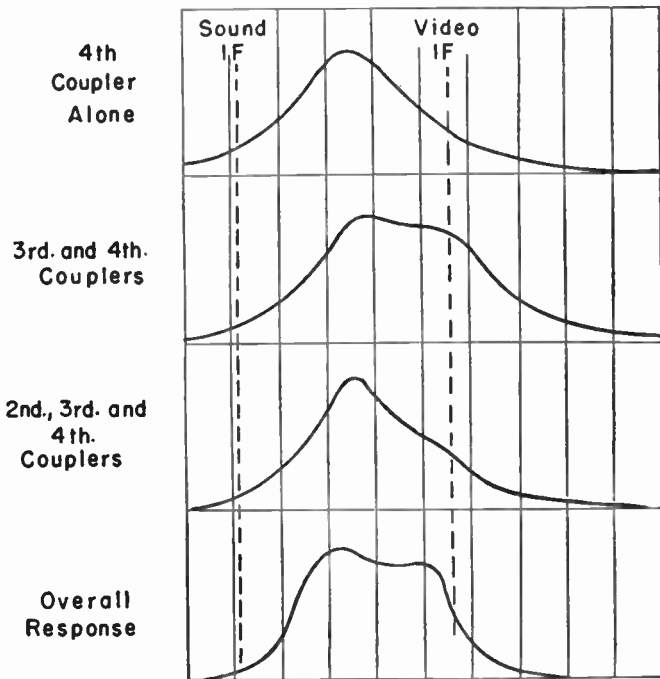

Fig. 8-28.—Frequency responses observed during alignment of a stagger tuned video i-f amplifier.

generators should be coupled first to the grid of the amplifier tube preceding the last coupler, as explained in connection with Fig. 8-25, then successively back to the grids of preceding tubes as alignment proceeds from the last coupler through to the coupler following the mixer.

To make a correct alignment by this method it is practically necessary to have available a set of response curves showing the results to be obtained in each step. The curves must, of course, apply specifically to the receiver being worked on. Fig. 8-28 shows fairly typical responses for a receiver having three i-f amplifier tubes and four couplers. At the top is the response with the generators to the grid of the last amplifier. Next is the response with the generators at the grid of the next preceding amplifier, so that the gain is affected by both the third and fourth couplers. The two lower responses show the effects of bringing in the second coupler, and of putting the signal through all four couplers for the overall response of the system.

Alignment of Overcoupled I-F Stages. — For accurate alignment of overcoupled transformers, without spending an excessive amount of time on the work, it is necessary to employ a sweep generator, a marker generator, and an oscilloscope. It is of utmost importance that the signal voltage from the sweep generator be held at the very lowest level which allows a readable trace on the scope. Otherwise the frequency response will be so distorted as to make correct alignment impossible. The signal must remain below a value with which a slight increase causes a change in the form of the trace as well as in its height or amplitude. The signal level must remain within the range where any small increase or decrease causes a proportional increase or decrease in the height of the trace, it must not be so high that further increase does not cause a proportional rise of the response curve.

If the attenuator of the generator will not drop the signal voltage low enough, try using a smaller coupling capacitor between the generator lead and the tube grid, or connect a resistor of a few hundred ohms from the grid to ground at a point beyond the coupling capacitor, not from the generator

lead to ground. A coupling ring may be moved higher up on the tube, or a tube shield used for coupling may be moved higher. Getting the ring or shield farther from tube elements reduces the coupling.

Marker signals must be kept weak enough to cause only the slightest drop of trace height when these signals are applied, and only the slightest rise when they are completely removed. Marker strength may be reduced by the same methods mentioned for the sweep signal. There may be enough coupling with the marker cable merely laid near the sweep generator cable or brought near the tube to which there is to be coupling. Another method is to couple the marker generator to the grid of some tube preceding the tube to which the sweep is coupled.

The oscilloscope usually is connected across the video detector load resistor. Sometimes the trace cannot be made high enough without using excessive signal input. To increase the height, the scope may be connected across the plate load resistor of either the first or second video amplifier tube. For still greater trace height the scope may be connected between ground and the picture tube control grid or cathode, whichever is used for signal input.

If video frequencies or high intermediate frequencies get into the lead to the oscilloscope they are likely to cause feedback to the early stages of the video i-f amplifier, which will result in distorted response. This may be prevented by connecting between the leads to the oscilloscope, at the receiver end, a capacitor of 0.002 mf or larger size, or by using a regular high-frequency filter probe on the oscilloscope vertical input.

When the trace tends to become too high for the screen as alignment proceeds, bring it down by reducing the signal voltage from the sweep generator. Always keep the vertical gain of the oscilloscope as high as possible; do not use it for reducing the height of the trace.

Overcoupled transformers usually are aligned while the oscilloscope is connected across the video detector load, and with signal generators coupled first to the video i-f amplifier

tube preceding the detector, then to amplifier tubes farther and farther from the detector until these instruments are coupled to the mixer tube.

Fig. 8-29 shows frequency responses obtained in the form of oscilloscope traces during successive steps of alignment on one type of receiver. With the generators coupled to the third i-f grid, which is the grid of the amplifier preceding the detector,

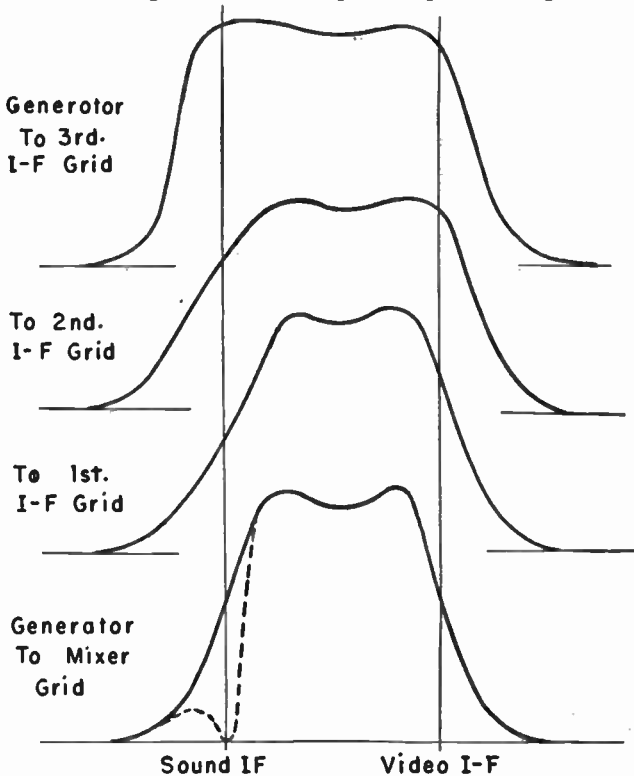

Fig. 8-29.—Frequency responses observed during alignment of overcoupled video i-f stages.

the response (at the top) is that of the single transformer between this last amplifier and the detector. With the generators moved back one stage the response, second from the top, is that of two coupling transformers working in cascade. Then, with the generators at the grid of the first i-f amplifier, comes the response for three coupling transformers working together.

Finally, with the generators coupled to the mixer tube, we have the overall video i-f response shown at the bottom of Fig. 9-29—with all four coupling transformers carrying the signal and affecting the shape of this response.

The response of a single stage is of the same general double-peaked form for any kind of overcoupled transformer. As more and more stages carry the signal from generators to oscilloscope the sides of the response curves tend to draw in, and the gain becomes much greater with each added stage. The two peaks of the overall response need not be of the same height, but at the deepest point of the valley between peaks the gain or amplitude should be no less than 70 per cent of the gain at the highest peak.

Any traps in the video amplifier will make decided change in the shape of the response from the coupling transformer with which the trap is associated, and in the shapes of responses from all stages between the traps and the video detector. As an example, a trap for accompanying sound might be coupled to the transformer between mixer and first i-f amplifier of the system to which Fig. 8-29 applies. All responses would be greatly altered from the forms shown, and in the overall response there would be an effect somewhat as shown by the broken line curve on the bottom (overall) response.

A careful analysis of the kinds of couplers used in various stages, and of the traps and trap frequencies associated with each coupler, will indicate the general form of response which should be obtained at each step in the alignment. But for best results, and least expenditure of time, the alignment always should be carried out in accordance with response curves furnished by the receiver manufacturer. Such curves show various marker frequencies in the positions they should occupy on the several responses when alignment is correct for each step in the process. For receivers having 10-inch or larger picture tubes the low frequency peak on the overall response often is about 3.5 mc lower than the video intermediate frequency. The high-frequency peak often is somewhere between 0.75 and 1.00 mc below the video intermediate frequency.

Overcoupled transformers may be used in some stages of video i-f amplifiers, with single-peaked coupling coils in other stages. As an example, Fig. 8-30 represents a video i-f amplifier in which the first and last couplings are by means of overcoupled transformers, with the second and third couplings

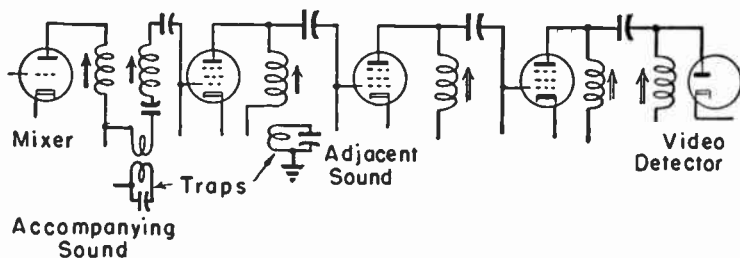

Fig. 8-30.—Overcoupled transformers and single-peaked coupling coils in the same video i-f amplifier.

by means of coils which are tuned to peak at a single frequency. On the transformer between mixer and first i-f amplifier is a trap for accompanying sound, and on the coupler in the following stage is a trap for adjacent sound.

Overall Response Check. — When a video i-f amplifier having overcoupled transformers has been aligned with the aid of an oscilloscope, the last step will have been observation of the overall response. When an amplifier having single-peaked couplers has been aligned for the several peak frequencies with the help of an electronic voltmeter it is highly advisable to make a final check on the overall response with sweep and marker generators coupled to the mixer tube, and with the oscilloscope connected across the video detector load.

The upper response curve of Fig. 8-31 shows frequencies whose positions on the trace should be checked by means of the marker generator. The video intermediate frequency on the high-frequency slope of the curve usually is required to be at 50 per cent of the height of the highest peak. This frequency should be no lower than 50 per cent, but on some receivers there is an advantage in having it somewhere between 50 and 60 per cent of the maximum gain.

At the frequency of each trap in the amplifier the gain should be zero or very nearly so. If there are any traps at all, one or more of them will be tuned to the accompanying sound frequency, which is the sound intermediate frequency. Adjacent sound traps will be tuned 1.5 mc higher than the video intermediate frequency, and adjacent video traps will be tuned 6.0 mc below the video intermediate frequency.

There should be no peak so high or so sharp as to indicate regeneration in the amplifier. The greatest dip between peaks should be no lower than 70 per cent of the highest peak. It

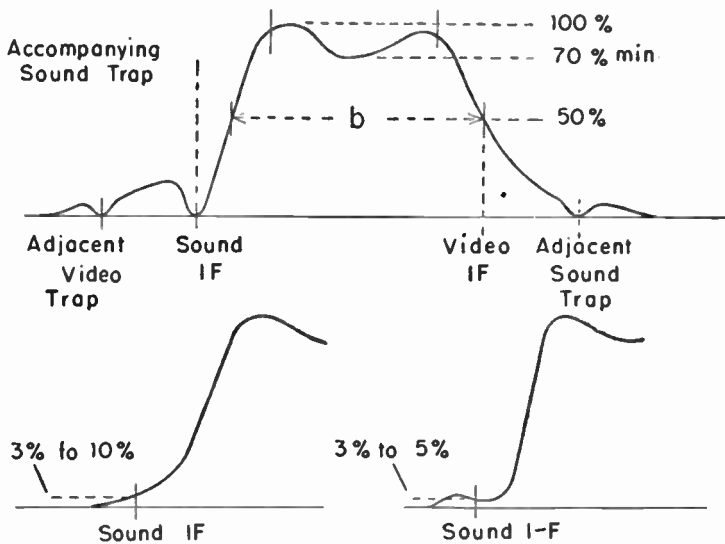

Fig. 8-31.—Frequencies at which the overall response curve should be checked for shape and height.

may be of interest to check the band width at a gain approximately 50 per cent of maximum, as indicated at *b* on the figure.

At the lower left in Fig. 8-31 is shown the low-frequency side of a response for an intercarrier sound system having no traps at all. At the sound intermediate frequency the gain should be between 3 and 10 per cent. Ordinarily the gain at this frequency must be held to 5 per cent or less in order to avoid "intercarrier buzz." If the video i-f amplifier for an

intercarrier sound system has some one stage containing a trap which forms a sound shelf or plateau, shown at the lower right, the gain at the sound intermediate frequency should be around 3 to 5 per cent of maximum.

Should the shape of the overall response require correction it is desirable to change the adjustment of only the coupler or couplers which affect the portion of the curve which requires change. If peak frequencies for the various couplers are known, it is easy to determine which should be realigned, for frequency at the portion of the curve to be changed identifies the coupler tuned nearest to that frequency. If coupler peak frequencies are not known, the ends of the tuning wand may be brought near each of the coils. The portion of the response which then rises or falls will be chiefly affected by adjustment of the coil to which the wand is being presented. Another way is to lightly touch the control grids of each of the tubes. The portion of the curve chiefly affected will be altered by adjustment of the coupler preceding the tube whose grid is then being touched.

Quite often it will be found that some one coupler will have more effect than others on the entire shape of the curve and also on the overall band width. As a rule this coupler will be either the one just ahead of the video detector or else the one which immediately follows the mixer tube.

Sometimes an overall response is checked with the sweep generator connected to the antenna terminals. Then the response is affected by the r-f amplifier and tuner coils as well as by the video i-f amplifier. When this generator connection is being used it is inadvisable to attempt adjustments on the video i-f couplers. Adjustments made under this condition often turn out to be incorrect when again checking with the sweep generator at the mixer tube, and without the r-f amplifier carrying the signal.

Individual Stage Responses. — The method usually employed for observing the frequency response of a single stage or a single coupler is illustrated by Fig. 8-32. The sweep and marker generators are coupled very loosely to the control grid of the tube preceding the coupler to be checked. If the follow-

ing tube is an amplifier, whose signal output is a high-frequency voltage, the vertical input of the oscilloscope is connected through a detector probe to the plate of this tube. If the tube following the coupler is the video detector, the oscilloscope is used without the probe and is connected across the detector load. The same general method may be used whether the

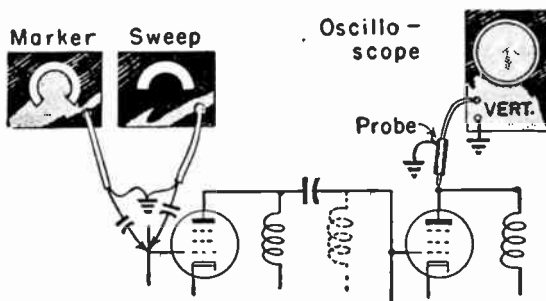

Fig. 8-32.—Instrument connections for observing the frequency response of a single stage or single coupler.

coupler being checked is a single-peaked coil or a two-winding transformer. In the case of transformer couplings it may be necessary to short to ground the control grid of the coupler ahead of the one checked, as previously explained. The response trace may be satisfactory with the oscilloscope probe connected to the screen instead of to the plate of the second amplifier.

It is useless to connect the test instruments to the plate of an amplifier preceding the coupler being checked, or to the control grid of the amplifier following this coupler. It is useless also to make response observations with either of the tubes removed from its socket, since this removes the tube capacitances and changes the tuned frequencies.

With an entirely different method the generators may be coupled to the mixer tube and the oscilloscope connected across the video detector load for observation of responses in each of the individual stages. All the interstage couplers except the one whose response is to be observed are detuned by connecting across the ends of their coil or coils a fixed carbon

resistor of about 300 ohms. After observing the response of any one stage in this manner, a resistor is connected across the coupler of this stage and a resistor is removed from the coupler in another stage. Then the response of that second

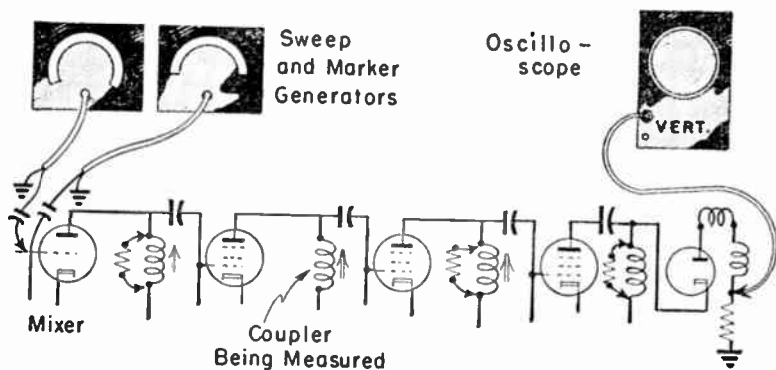

Fig. 8-33.—Observing individual stage response by shorting out the couplers in all other stages.

coupler is observed. So the work proceeds until all the couplers have been checked. The scheme of connections is illustrated by Fig. 8-33.

Instead of connecting resistors across all couplers except the one being measured, the control grids of all but one tube may be connected to ground through resistors of about 300 ohms. The results will be similar so far as the oscilloscope trace for response is concerned. The coupler remaining active is the one preceding the ungrounded grid, the coupler which is connected to and feeds to this grid.

The frequency at which any one stage is peaked may be determined with the couplers shorted with resistors or with the grids grounded through resistors on all stages except the one to be checked. The method is shown by Fig. 8-34, on which are drawn resistors from grids and detector input to ground, although the couplers might be shorted with resistors as in Fig. 8-33.

A constant frequency generator is coupled to the mixer tube. This generator may be a marker type, but it is not a

sweep generator. Across the video detector load is connected an electronic voltmeter or any high-resistance d-c voltmeter. The coupler which is not shorted or whose grid is not shorted to ground is peaked at the frequency to which the generator is tuned when meter reading is maximum. The generator is

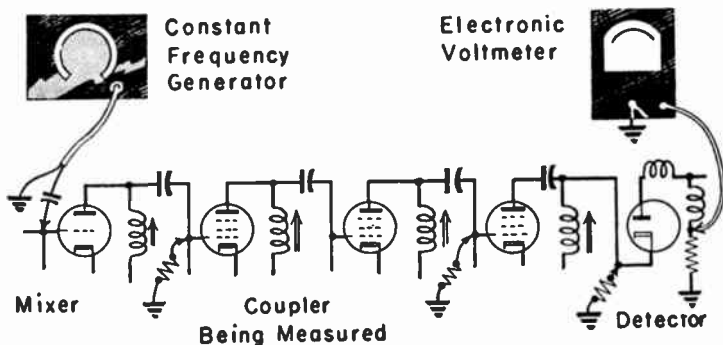

Fig. 8-34.—Determination of frequencies at which individual couplers are peaked.

tuned for maximum meter reading, and the frequency then read. An overcoupled transformer in the stage being checked will show two voltage peaks at its two peak frequencies if there is a dip or valley between peaks of the response. If there is no valley between peaks, the meter reading will remain nearly constant over a range of frequencies along the flat top of the response.

Individual couplers may be peaked at any desired frequency by using connections as described for Fig. 8-34. The generator is tuned to the desired peak frequency, then the unshorted coupler is aligned for maximum reading on the voltmeter.

If there is any doubt as to whether the meter reading is due to the coupler left unshorted or whose grid is unshorted, a finger may be touched to the grid pin or lead at the socket. The meter reading should drop nearly to zero. This finger test may be used also to make sure that an oscilloscope curve is due to the coupler being adjusted. When a grid connection is touched, the curve will flatten out if it represents response of the coupler ahead of the grid.

Coupling Adjustments. — In some video i-f amplifiers which include overcoupled transformers there are adjustments for the degree of coupling in one or more of these transformers. Usually the two windings are supposed to be tuned to the same frequency. If the coupling can be made loose enough that the response becomes a single peak (with the transformer undercoupled temporarily) each of the windings or coils may be aligned for maximum height of this peak when the correct peak frequency is being fed from a constant-frequency generator. Then the coupling may be tightened to produce the regular double-peaked response.

If the coupling cannot be adjusted for a single peak, one coil may be detuned by connecting across its ends a fixed resistor of 300 to 500 ohms while the other coil is aligned for peak response or peak meter reading at the desired frequency. Then the first coil is shorted with the resistor while the second one is aligned to the same frequency as the first.

In some cases the two windings of a transformer are tuned to two different frequencies. Then one of the coils, often the one connected to the preceding plate, is aligned to produce the required higher frequency peak, up near the video intermediate frequency. The other coil is aligned to produce the lower frequency peak, somewhere above the sound intermediate frequency. Response curves which are correct for the particular receiver should be available for an adjustment such as this.

ANTENNAS. — In localities where signals from television transmitters are strong it is possible to have excellent reception with an indoor antenna or with an antenna built into the receiver. But in outlying districts, so-called fringe areas, an outdoor antenna is a practical necessity for good reception. Investment in a good antenna system yields greater returns per dollar than anything which can be done to the receiver itself.

It is desirable that an antenna system deliver to the receiver the maximum possible signal strength and the minimum of electrical interference. These two requirements are best met with an antenna which tunes quite sharply to the frequencies

in only one selected channel, and one which is most strongly responsive to signals from the direction of a desired station while responding weakly to unwanted signals from other directions.

At the same time it is desirable that the antenna system respond well to frequencies throughout the entire television spectrum, which calls for very broad tuning, and there should be good response to signals arriving from any of many stations which may be in many different directions. Obviously, the two sets of requirements are in direct conflict with each other. Practical designs must involve compromises.

Additional information on subjects closely related to antenna operation and installation will be found in articles on *Propagation, Wave*, and on *Lines, Transmission*.

Dipole Antennas.— All television and f-m antennas are either simple half-wave dipoles or else some modification of or evolution from the half-wave dipole. The electromagnetic radiation which is the radio or television signal consists of electric or electrostatic lines of force which are horizontal, and of magnetic lines of force which are vertical, as represented in

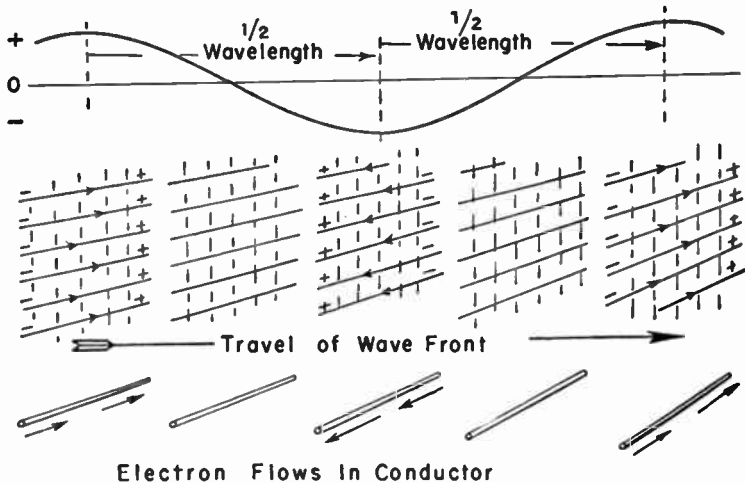

Fig. 9-1.—The electrostatic force of the radio wave causes alternating electron flows in the antenna conductors.

Fig. 9-1. As the wave sweeps through space, from left to right in the figure, the lines of force act alternately in opposite directions, and go through zero values in between.

If a conductor is held horizontally, extending in the same direction as the electric lines of force, electrons in the conductor will move in the directions of these lines, from negative to positive. When a surge of electrons comes to one end of the conductor they are reflected back in the opposite direction. Upon arriving at the opposite end of the conductor these electrons again are reflected back toward the first end. If the conductor is of such length that the electric field reverses just as the electrons are reflected from one of the ends, and reverses again as the electrons are reflected from the other end of the conductor, then the electric forces build up the maximum possible surges of electrons or the greatest possible alternating current in the conductor.

That is just what happens if the length of the conductor is equal to one-half wavelength of the signal. When maximum strength of the electric force is as represented at the left, and the electrons surge toward and reach the corresponding end of the conductor, the maximum strength of the electric force will be in the opposite polarity, as at the center, just as the electrons come to the opposite end of the conductor. The next reversal will be as at the extreme right, with electrons back at their original location. So the action continues so long as the signal waves continue to pass through the conductor.

The next step is to open the conductor at its center, as in Fig. 9-2, and connect the two ends through a transmission line to the antenna coupling coil of a receiver. So long as the transmission line runs vertically, or nearly so, it is not affected to any great extent by the horizontally polarized electrostatic lines of force in the signal. The transmission line merely carries surges of electrons from the antenna conductor, where they are induced, to and through the coupling coil. Electron

flow or current then alternates back and forth in the coupler coil at the signal frequency, and resulting induced emf's or voltages in the coupler are applied to the r-f amplifier of the receiver.

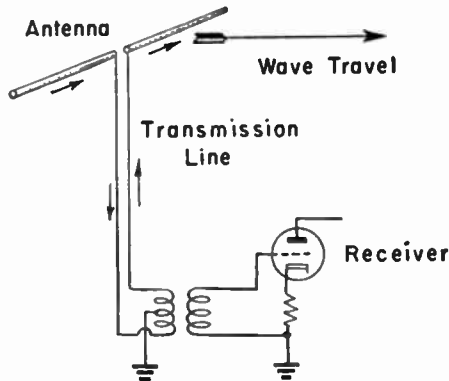

Fig. 9-2.—Connection of a dipole antenna through a transmission line to the receiver.

Length of a Dipole Antenna.— It is quite apparent that maximum rates of electron flows will occur in the antenna conductors, and in the receiver coupler, only when the overall length of the antenna conductors is equal to a half wavelength of the signal to be received. Only then will the electric forces work to give maximum assistance to the natural back and forth surges of the electrons. If the antenna is too short, the electrons will have been reflected back before the electric force reverses, and their movement will be opposed. If the antenna is too long, the wave will have reversed before the electrons come to the end of the conductor, and again the electron flow will be opposed.

When wave travel is through free space or through air, and is unaffected by surrounding materials which are either conductors or insulators (dielectrics) frequencies in megacycles may be changed to equivalent wavelengths as follows.

$$\text{Wavelength in meters} = \frac{300}{\text{megacycles}}$$

$$\text{Wavelength in feet} = \frac{984.25}{\text{megacycles}}$$

$$\text{Wavelength in inches} = \frac{11811}{\text{megacycles}}$$

When the electric field of the signal is around a conductor, and resulting electron flow is in the conductor, wavelengths would be computed according to the preceding formula were the conductor of infinitely small diameter. Diameters of actual antenna conductors are responsible for some slowing down of the electron flow. For usual diameters of antenna rods or tubing ($\frac{1}{4}$ to $\frac{1}{2}$ inch) at frequencies in the low and high bands of very-high frequency television transmission, the physical length has to be about $2\frac{1}{2}$ per cent less than given by the formulas.

There is further slowing down due to effects of conductors and dielectrics which must be used for antenna supports, and to such materials which usually are somewhere near the antenna with ordinary installations. These effects may slow down the electron travel by another 5 or 6 per cent. The result of all this is that the physical length of the antenna must be based on something like 90 to 92 per cent of wavelength in free space or in air. Then the formulas for length of a half-wave antenna become as follows:

$$\text{Antenna length, feet} = 452.75/\text{megacycles}$$

$$\text{Antenna length, inches} = 5433/\text{megacycles}$$

Lengths for half-wave antennas cut for the low-band and high-band channels in the very-high frequency range for television become as shown by the accompanying table. Other similar tables may give lengths differing from these by something like one per cent, which makes no practical difference in operation.

LENGTHS OF HALF-WAVE ANTENNAS

Channel Number	Center Freq., mc	Antenna Length		Wavelength in air, Inches
		Feet	Inches	
2	57	7.94	95.3	207.2
3	63	7.18	85.2	187.5
4	69	6.56	78.8	171.3
5	79	5.73	68.8	149.5
6	85	5.32	64.0	139.0
7	177	2.56	30.7	66.8
8	183	2.48	29.7	64.6
9	189	2.40	28.8	62.5
10	195	2.32	27.9	60.6
11	201	2.25	27.0	58.8
12	207	2.18	26.2	57.1
13	213	2.12	25.5	55.5

Antenna lengths are totals for the two halves on each side of the center gap, or rather are overall lengths from one end to the other. Maximum signal voltage is developed at the frequency for which the dipole length is cut, with diminishing response at both higher and lower frequencies. A single antenna usually is used for all the low-band channels, numbers 2 through 6, by making the length suitable for a mid-band frequency or for channel 4, which is very nearly in the middle of the low band. The response remains amply high for most reception conditions at frequencies down through channel 2 and up through channel 6. A single antenna may be used also for the entire high-band, channels 7 through 13, by making its length match channel 10, which is in the middle of this band. But a simple half-wave dipole does not have response broad enough to receive both in the low-band and high-band channels of the very-high frequency range.

Instead of cutting a simple dipole antenna for the middle of a band, it may be cut for the frequency of a channel in which there is most difficult reception, or a channel in which signals from existing stations are weaker than from stations operating on other channels in the same band. For example, were the greatest difficulty encountered on channel 8, the dipole might be cut to the length giving best reception in this channel, and

it still could be used throughout the remainder of the high band where signals are stronger.

Directional Properties of Dipoles. — Fig. 9-3 shows the directional properties of a simple half-wave dipole antenna. Relative lengths of the arrows indicate relative responses of the antenna to signals of equal strength arriving from the directions of the arrows. There is maximum response to signals traveling on a line at right angles to the length of the antenna conductors. There is minimum response to signals traveling in line with the conductors.

For best reception of signals from any given direction the antenna should be at right angles to that direction, although, as shown by the figure, the response will remain almost as good

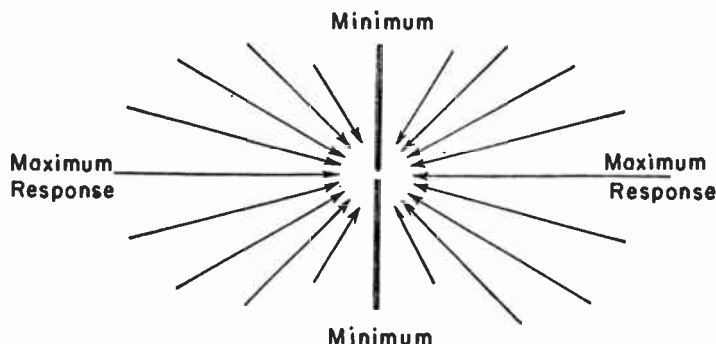

Fig. 9-3.—Directional properties of a simple half-wave dipole antenna.

when the antenna is turned as much as 15 degrees to either side. With the simple dipole now being discussed, there is maximum response to signals from two opposite directions, and minimum response in two other opposite directions.

When reception is to be in several channels or from several stations, the dipole may be placed at right angles to the direction of the weakest signal, and the lessened response to signals from other directions will be more or less counteracted by greater strength of those other signals.

Often it is possible to greatly attenuate or possibly eliminate an undesired interfering signal by placing the antenna con-

ductors in line with the direction of that signal. Response to desired signals usually will remain satisfactory. The angle for minimum response is relatively narrow. To cut out an interfering signal the antenna conductors must be almost exactly in line with that signal, whereas a desired signal may be well received with the conductors turned quite a ways either side of the maximum point.

The directional pattern of Fig. 9-3 is based on having the antenna far enough from all other conductors, and from large bodies having poor dielectric characteristics, as to be unaffected by them.

To take full advantage of the maximum and minimum response angles when receiving from stations in widely different directions, the antenna sometimes is mounted so that it may be rotated into the best position for each station. Rotation may be by hand, or, for remote control, by means of a motor or a form of Selsyn control.

The directional response of the dipole antenna remains practically unchanged as the conductor length is made less than a half-wavelength, and does not change a great deal as the length is moderately increased. Entirely different patterns result, however, when the conductors become some multiple of

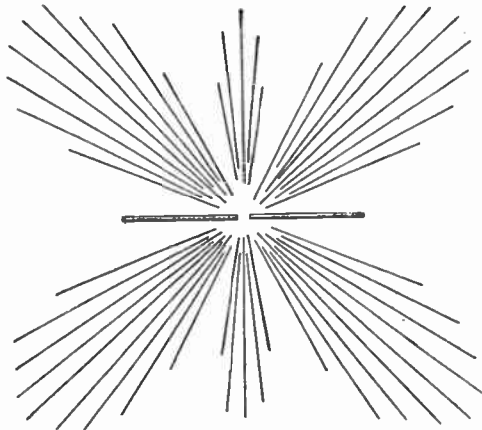

Fig. 9-4.—Directional response of a dipole cut for three-halves wavelength of the received signal.

a half-wavelength in their own overall length. At $1\frac{1}{2}$ wavelengths, usually called a three-halves wavelength, the directional response becomes about as shown by Fig. 9-4. Maximum reception now is from any of four directions, there still is good reception, but not maximum, at right angles to the conductors, and there still is minimum response for signals traveling in line with the conductors.

Broad Band Antennas. — An antenna to be used for all the low-band television channels, numbers 2 through 6, might be cut for the mid-band frequency of 71 mc. The decrease of frequency in reaching the bottom of channel 2 then would be about 24 per cent, and the increase to reach the top of channel 6 would be about 24 per cent. An antenna for all the high-band channels, numbers 7 through 13, might be cut for the mid-band frequency of 135 mc. Then the decrease in frequency to reach the bottom of channel 7, and the increase to reach the top of channel 13, would be somewhat less than 11 per cent. Even with a frequency change of as much as 25 per cent in either direction, reception will be quite satisfactory with a simple dipole in areas where signal strengths or field intensities are high.

Were it desired to have a single antenna serve for both low-band and high-band television channels, and were the antenna cut for the mid-frequency of 135 mc, the change of frequency would be 60 per cent down and another 60 per cent up in reaching the extreme frequencies. This may be done with any of a number of antennas having more elaborate design than a simple dipole, but it is difficult at best. In any case, the signal strength at the point of reception should be fairly high.

A simple dipole is inherently a rather sharply tuned circuit, of high Q-factor, at the frequency for which it is cut. To broaden the frequency response it is necessary to reduce the Q-factor and thereby sacrifice some gain. One way of broadening the frequency response of a simple dipole is to use large diameter tubing for the antenna conductors. For appreciable advantage, the diameter would have to be an inch, and preferably more, for reception in the television bands.

The half-wave folded dipole antenna of Fig. 9-5 has much broader frequency response than the simple straight dipole. The folded dipole, as usually constructed, consists of a long piece of tubing bent into the form of a flat loop with one side continuous and with the other side open at the center. The

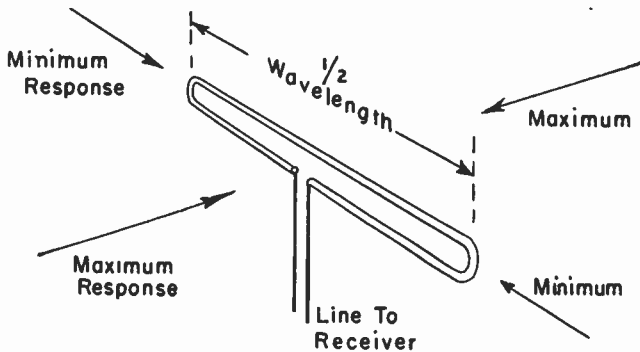

Fig. 9-5.—Half-wave folded dipole antenna and its directional properties.

transmission line to the receiver is connected to the ends of the tubing at the open gap. The loop is mounted with its plane vertical, with one side above the other. The open gap may be in either the top or bottom side. The distance between bends at the ends of the loop is made equal to a half wavelength for the frequency at which the antenna is to be resonant or at which it is to have greatest gain.

Like the simple dipole, the folded dipole has maximum response to signals traveling at right angles to the length of the antenna, and has minimum response to signals traveling in line with the conductor. The directional pattern of the folded dipole is like that shown in Fig. 9-3 when supported sufficiently far from other objects and when operated at or near the frequency for which cut.

Separation between top and bottom sides of the folded dipole usually is something between $1\frac{1}{2}$ and 3 inches, center to center of the tubing. The larger the tubing diameter the greater is the separation. Too much separation results in losing some of the broad band advantage of this type of antenna.

Fig. 9-6 shows the basic design of a number of antennas having a broader frequency response than a simple dipole. The overall length is equal to a half wavelength at the frequency for which gain is to be maximum. The angle between the top

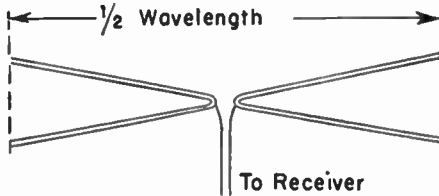

Fig. 9-6.—A double-V dipole antenna.

and bottom usually is somewhere between 15 and 30 degrees. This type may be called a double-V dipole. The upper and lower sides of each V-section lie in the same vertical plane.

An extension or modification of the V-principle is illustrated by Fig. 9-7, which may be called a conical antenna or a conical V-antenna. The upper and lower arms form on each side a V-member, with these two arms in a vertical plane. The center

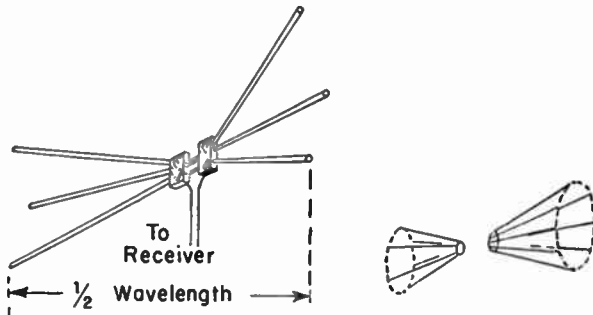

Fig. 9-7.—A half-wave dipole which may be called a conical antenna or a conical V-antenna.

arms are set a little ways back of this vertical plane. Adding more and more arms to this arrangement would result in two opposed cones, as shown by the small sketch at the right. Complete conical antennas of this style sometimes are used for ultra-high frequency reception.

V-dipoles are used also with the opposite sides of the "V" lying in a horizontal rather than a vertical plane. A fan an-

tenna, shown by Fig. 9-8, consists of a number of radial tubes arranged in two oppositely disposed groups, with all tubes lying in the same horizontal plane.

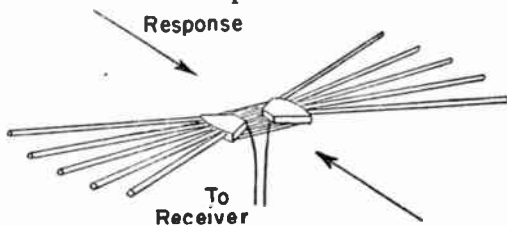

Fig. 9-8.—A half-wave fan antenna.

The H-dipole, shown at the left in Fig. 9-9, consists of two simple horizontal dipoles one above the other, separated vertically by a distance which usually is a half wavelength for the frequency to which the top and bottom sections are cut. That is, the vertical distance between top and bottom is equal to the overall width or length of the antenna from side to side. This type of antenna has a somewhat broader frequency response than a single simple dipole, but its chief advantages are increased pickup or increased gain for desired signals approaching from front or back, and a reduction of electrical interference coming from below or above the antenna. The top and bottom horizontal sections seem to act each as interference shields for the other.

If the top and bottom sections of the H-type antenna are made in the form of folded dipoles, as at the right in Fig. 9-9,

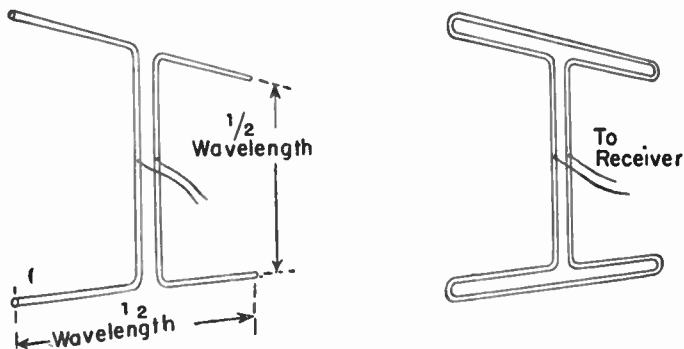

Fig. 9-9.—The H-type half-wave dipole (left) and the H-type folded half-wave dipole antenna (right).

the advantages of increased signal pickup and reduction of interference are retained, while the frequency response is made much broader. This is one of the types which often may be used for reception in both the low and high bands of the very-high frequency television spectrum.

The two sides of the H-dipole may be turned to make an angle of about 90 degrees with each other, as at the left in Fig. 9-10. This changes the directional characteristics as shown at the right. With the two sides extending in a straight line the pattern is circular on the front and back, as shown by the broken-line circles of this figure, and by the directional arrows

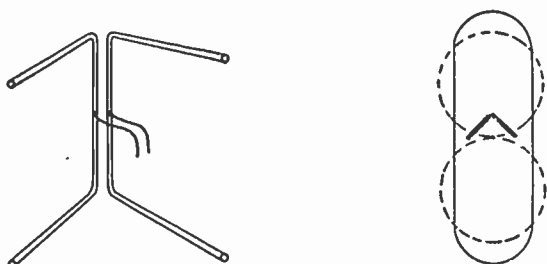

Fig. 9-10.—The H-type half-wave dipole with sides at a 90-degree angle, and the resulting directional characteristic.

for the simple dipole in Fig. 9-3. With the sides of the H-dipole turned toward each other the directional pattern becomes longer through the center of the angle, and narrower from side to side.

Reflectors and Directors. — At the left in Fig. 9-11 is a half-wave dipole antenna. The side of this antenna toward which come desired signals will be called the front, and the other side the back. Back of the antenna, at a distance of $\frac{1}{4}$ wavelength, is a straight conductor which is not electrically connected to the antenna conductors or to anything else. This second conductor is called a reflector.

In the sketch at the right is shown how a signal reaching the dipole antenna from the front not only induces electron flow in the dipole conductors, as previously explained, but also goes on to the reflector. Part of the signal energy is reflected

from this second conductor and travels back to the dipole, arriving there in such phase relation to the signal then existing at the dipole as to reinforce that signal. The result is a decided increase of electron flow in the dipole, and a stronger signal delivered to the receiver.

Signals approaching the antenna from the back arrive first at the reflector, where part of their energy is absorbed and is reflected away from the antenna or dissipated in the reflector.

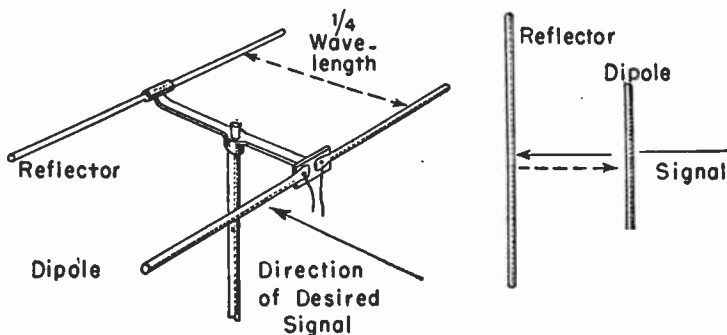

Fig. 9-11.—A half-wave dipole antenna with a reflector element back of it.

Thus there is attenuation of interfering signals coming toward the back of the antenna, and their strength at the receiver is reduced.

The reflector usually is one continuous length of tubing of the same diameter and kind as used for the dipole conductors, or, for convenience in manufacture and assembly, the reflector may be in two pieces. It is not necessary that the reflector conductor be insulated, it may be in contact with its metallic supports and thereby in metallic contact with the antenna mast.

Maximum gain in signal strength is had with the reflector $\frac{1}{4}$ wavelength or 0.25 wavelength back of the dipole. There is some drop of gain with either more or less spacing. If the spacing is made less than $\frac{1}{4}$ wavelength there is somewhat more effective attenuation of interfering signals arriving from the back, which may be of enough advantage to warrant the loss of front gain with the reduced spacing.

If the reflector is spaced $\frac{1}{4}$ wavelength back of the dipole its overall length may be the same as the overall length of the dipole. If the spacing is less than this the reflector must be longer than the dipole by something like 5 to 10 per cent, the closer the spacing the greater the length of the reflector. With spacing greater than $\frac{1}{4}$ wavelength, the reflector may be somewhat shorter than the dipole. These recommendations for reflector length are based on getting the best gain for the spacings mentioned.

Reflectors are used with all forms of antennas whose conductors lie in vertical planes or approximately so. A single straight reflector may be used for the folded dipole of Fig. 9-5, for the double-V of Fig. 9-6, and for the semi-conical antenna of Fig. 9-7. Two separate straight reflector conductors would be used with the H-type dipoles of Fig. 9-9, one directly back of the top section and the other directly back of the bottom section of these antennas.

If the reflector is of the same form as the dipole itself, rather than a straight conductor for the broad band types, the response is made somewhat broader in frequency coverage. For example, the reflector for a folded dipole might have the form of a folded dipole.

In Fig. 9-12 is shown an antenna system consisting of three elements. The element used for pickup of the signal carried to the receiver is pictured as a folded dipole, although a straight dipole or any of the modified or broad band types might be used. Back of the dipole is a reflector, whose functions already have been explained. In front of the dipole is the third element, which is being used as a director. The director acts for signal energy somewhat as a glass lens would act for light energy; the signal energy is focused toward the dipole. The increase in signal pickup, and in energy delivered to the receiver, is somewhat greater with a correctly designed director than with a correctly designed reflector.

The mechanical and electrical construction of a director element is like that of a reflector. The director ordinarily is a continuous length of tubing. It may or may not be insulated

from the supports and the antenna mast, and there are no electrical connections from the director to the dipole or to anything else.

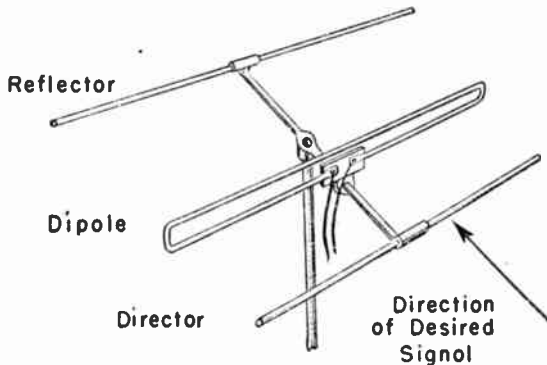

Fig. 9-12.—A folded half-wave dipole with a reflector element back of it and a director element in front.

If a director is mounted more than $1/10$ wavelength in front of the dipole element, the director must be somewhat shorter than the dipole in order to have maximum increase of gain due to director action. If the director is $1/10$ wavelength in front of the dipole, the director may be of the same length as the dipole, and if still closer together the director would have to be somewhat longer than the dipole. Because spacings almost always are $1/10$ wavelength or more, the director is shorter than the dipole by about 5 to 10 per cent. All these length recommendations are based on preserving maximum gain or maximum increase of gain from the director.

While a director increases gain at the frequency for which the antenna is cut, it also narrows the band of frequencies in which there is good gain. A director, considered by itself, tends to give the antenna a narrow-band rather than a broad-band characteristic. This is true also of a reflector, but the reflector does not peak the response anywhere near as much as does a director. The farther the director is placed in front of the dipole, and the shorter the director is made, the broader will be the frequency response but the less will be the gain.

Whether a conductor mounted parallel to the dipole element acts as a reflector or as a director depends on the spacing between this added conductor and the dipole, in terms of wavelength, and on the relative lengths of the two elements. If an antenna is cut for a mid-band frequency, reception at lower frequencies and longer wavelengths effectively moves both a reflector and a director closer to the dipole so far as fractions of a wavelength are concerned. At a frequency low enough, a reflector could change over to director operation, but if the spacing between elements is at least 0.15 wavelength for the lowest frequency in the band this will not happen in practice. There may be reversal at some frequency below the television band, and interfering signals at this lower frequency might be strengthened by an element intended for a reflector but acting as a director.

As the received frequency increases, the reflector and director are moved farther from the dipole in terms of wavelength fractions. Then the director might change into a reflector at some high frequency. If the director spacing is no more than 0.15 wavelength at the highest channel in the band, and if the director is cut no longer than the dipole, this will not happen in the very-high frequency television bands.

Reflectors and directors may be called parasitic elements. Any type of antenna element with which is mounted either a reflector, a director, or both, may be called an antenna array.

Two-band Antennas. — There are many antenna designs in which one element or set of elements is cut for the low band and another element or set of elements is cut for the high band of the very-high frequency television spectrum. One such type is illustrated by Fig. 9-13. Facing the direction from which it is desired to have signals in maximum strength is a folded dipole whose overall length from side to side is suited for reception throughout the high band, channels 7 through 13. Back of this high-band element is another folded dipole whose overall length is suited for reception in the low band, channels 2 through 6. Back of the low-band dipole is a straight reflector element whose spacing from the low-band dipole is such as to

increase the gain in this band. Spacing between the two folded dipoles is such that the longer one acts as a reflector for the shorter one, thus increasing the gain in the high-band channels.

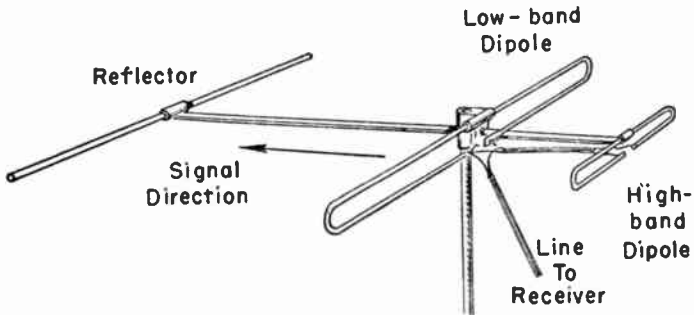

Fig. 9-13.—An "in-line" folded dipole antenna having elements for the high band and for the low band, and a single reflector element.

With the high- and low-band elements mounted in a fixed parallel relationship to each other, all signals to be received in full strength must come from the same general direction to the antenna location.

In localities where desired signals, or signals to be picked up with maximum strength, come from different directions in the high and low bands the dipoles suited to the two bands may be mounted one above the other as shown by Fig. 9-14. Either array may be rotated or orientated independently of the other, as may be found most advantageous for local conditions.

The high-band array usually is placed above the one for the low band, although this arrangement may be reversed. The figure shows the transmission line going from the high-band dipole to the receiver, with an extension or link going from the high-band dipole to the low-band dipole. This arrangement also may be reversed. Both dipoles may be provided with reflectors, as illustrated, or the reflectors may be omitted from either or both arrays—all depending on what is required for signal gain and reduction of interference from undesired signals. Not only the folded dipoles pictured in the figure may be used one above the other, but any other types of antennas may be similarly arranged.

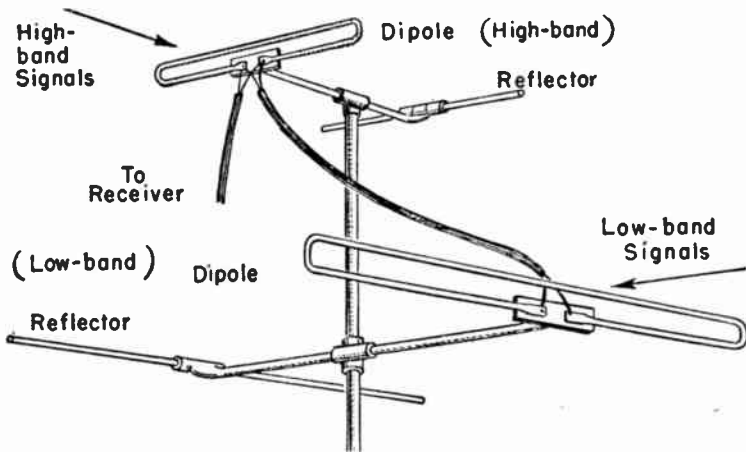

Fig. 9-14.—Folded dipoles and reflector elements for the high band and the low band mounted for separate orientation in the two bands.

In some installations there are separate transmission lines running all the way from each dipole to the receiver. In the antenna coupling of the receiver a switch operated with the band selector connects the receiver circuits to either one or the other of the dipoles according to the band in which reception is to be provided.

When high-band and low-band elements are connected to a single transmission line going to the receiver, as in Fig. 9-14, or with any generally similar arrangement, both elements must be in the same location or both must be on the same mast. If the two elements are mounted even a few feet apart, there

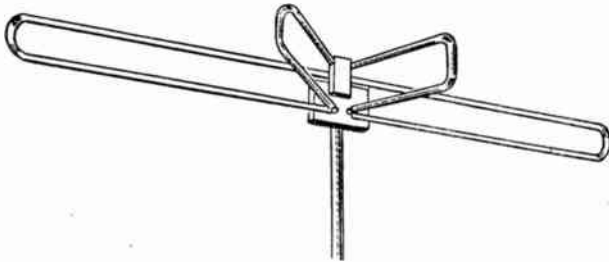

Fig. 9-15.—A folded dipole combination designed for reception in both the low band and the high band.

may be enough time difference between reception of the same signal on the two elements to cause considerable blurring of the pictures.

There are a number of combinations of V-elements with straight dipoles whose purpose is to provide satisfactory reception throughout the entire very-high frequency television bands with a single antenna or single array. As illustrated by Fig. 9-15, short loops forming a "V" may be mounted in front of a folded dipole. The V-loops provide response in the high band while the folded dipole acts for the low band.

Fig. 9-16 shows V-attachments consisting of small diameter rods mounted on a simple half-wave dipole. The V's are equally spaced from the dipole center, with the sides of the V's lying in a vertical plane with the dipole. These attachments may be

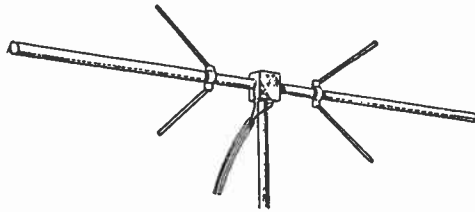

Fig. 9-16.—V-attachments on a straight dipole for reception in both bands.

mounted on any straight dipole whose length is suitable for reception in the low band, and will provide good signal pickup for frequencies in the high band. A reflector may be used in the usual position.

Stacked Antennas. — In order to provide sufficient signal strength, especially at the higher television frequencies, it may be necessary to use two or more similar arrays mounted one above the other, and suitably connected together and to the transmission line. Such an arrangement, with all the elements or arrays cut for the same frequency or the same band is called a stacked antenna or a stacked array. The H-type antennas of Fig. 9-9 really are stacked, because at top and bottom are exactly similar elements whose signal pickups add together. The antenna of Fig. 9-14 is not a stacked array, because the

upper and lower arrays do not have maximum pickup in the same band.

Part of the added gain from stacked arrays is due to the fact that they intercept a greater area of the wave front. Energy pickup is proportional to the intercepted area. This area is not merely that of the metallic tubes as projected in the direction of wave travel, but extends to a considerable distance away from the metal in all directions. The effective area becomes somewhat of a rectangle, and for antennas of short length approaches a circle. The effective signal area is approximately proportional to the square of the overall length of the pickup element. Since the average length for high-band channels is only about 0.40 of the length for low-band channels, the pickup in the high band is only about 0.16 of that in the low band for equal field strengths.

Stacking may be carried out with any style of array, with straight dipoles, folded dipoles, V-type or conical dipoles, or anything else. The two stacked elements, or any number of stacked elements or arrays, must be of the same type. Each pickup element may be used with a reflector, with a director, with both, or with neither. The separate arrays in a stacked assembly often are spoken of as bays.

Vertical spacing between bays is preferably $\frac{1}{2}$ wavelength at the frequency for which the elements are cut. Less spacing reduces the gain, but may be necessary in order to limit the overall size, especially in the low band.

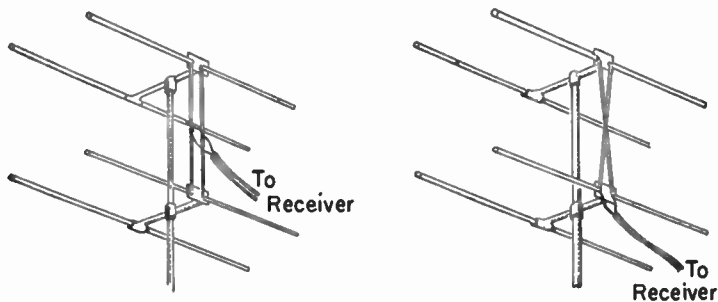

Fig. 9-17.—Whether or not the phasing link is transposed depends on the point of transmission line takeoff.

The stacked elements from which the transmission line runs to the receiver are connected together with phasing links which may be pieces of transmission line, or else may be lengths of wire or tubing in air. When only two bays are stacked, and when the transmission line takeoff point is from midway between them, as at the left in Fig. 9-17, the conductors of the phasing line join like ends of the dipole. That is, the two ends on the left of the gaps are joined together, and the two on the right are joined together. If the takeoff for the transmission line is from one or the other of the bays, as shown from the bottom bay at the right in the figure, the phasing link is transposed between upper and lower bays.

Were an additional bay to be added above or below, or in both places, to the arrangement shown at the left in Fig. 9-17, the phasing links to the outer elements would be transposed. For example, with four bays the transmission line would connect midway along the link between the two middle bays, and this link would not be transposed. The other two links, going to the top bay and to the bottom bay, would be transposed.

It is assumed that the phasing link has an electrical length of $\frac{1}{2}$ wavelength at the frequency for which the elements are cut. Because of the reduced velocity constant, a link made of transmission line will be considerably shorter in physical length than a half wavelength in air. Consequently, with a vertical spacing of $\frac{1}{2}$ wavelength between bays, a transmission line link will have an electrical length of more than $\frac{1}{2}$ wavelength. Link conductors which are separate, and in air, have velocity constants not much less than that of signal waves, and are preferable for phasing links.

Impedance of Antenna. — Dipole antennas and all the modifications may be considered as tuned circuits which are resonant at the frequency for which the electrical antenna length is equal to a half wavelength. As with all tuned circuits, the inductive reactance and capacitive reactance become equal and balance each other at the resonant frequency. This leaves the high-frequency resistance as the only remaining factor in impedance, provided the frequency is that for resonance and

there are no extraneous effects which prevent balancing of the reactances.

So far as reception is concerned, the antenna is the source of signal energy whose internal impedance depends on the type of antenna and conditions of operation. If the impedance of the antenna is matched by or is equalled by the impedance of the transmission line, half the energy picked up in the antenna will be transferred to the line. This represents maximum possible transfer of energy. If the impedance of the transmission line matches the impedance of the receiver input circuit, there will be maximum transfer of signal energy into the receiver. The subject of impedance matching is discussed in the article on *Lines, Transmission*.

The impedance at the center gap of a simple half-wave dipole (Fig. 9-2) and of other types which are essentially simple dipoles is about 73.2 ohms when the antenna is unaffected by any of the conditions to be mentioned in following paragraphs. The impedance at the center gap of a folded dipole, and of most other types which are developments of the folded dipole, is about 293 ohms, or approximately 300 ohms.

At all frequencies both higher and lower than the one for which the antenna is cut the impedance is greater than the values mentioned, because at all other frequencies there is an excess of either inductive or capacitive reactance. It follows that, if the antenna is longer than it should be for the received frequency, there is an excess of inductive reactance. And if the antenna is shorter there is an excess of capacitive reactance. An antenna used for reception in an entire band or in the whole range of very-high frequencies for television can have its working impedance matched by the transmission line and receiver at only one frequency, the one for which the antenna is cut, or the one with which the working impedance of the antenna becomes equal to the impedance of the line and receiver.

As an example, if a transmission line having an impedance of 300 ohms is used with a simple dipole antenna, there will be a match not at the frequency for which the antenna is cut, but

at some frequency enough higher or enough lower to bring the actual impedance of the antenna up to the impedance of the line. This explains why lines of 100-ohm, 150-ohm, or even 300-ohm impedance often seem to work very well with simple dipole antennas.

Antenna impedance is minimum at the center, and would become much greater were the takeoff point from either side of center. With takeoff from the center of a phasing link on stacked arrays, as at the left in Fig. 9-17, the impedance at the takeoff point is one-half that of the antenna elements, either element. With takeoff from the bottom, as at the right in that figure, or from the top, the impedance is the same as that of one of the elements.

A reflector tends to lessen the antenna impedance. The decrease is not great unless the reflector is mounted very close to the pickup element, or is of excessive length. Unless the antenna is supported at least a wavelength or farther from other conductors and from dielectrics of all kinds, the actual impedance will differ materially from theoretical values, usually being increased.

Antenna Construction. — Antenna conductors should be of weather-resistant metal, and preferably are of light weight to reduce stresses on mast and supports when subject to high winds, snow, and icing. Aluminum and aluminum alloys in tubular form best satisfy these requirements. Tubing of hard drawn copper, brass, bronze, and even of copper coated steel may be used where the weight is not objectionable. Soft-drawn copper tubing, obtainable from refrigeration supply houses, may be used for setting up experimental antennas. A dipole antenna may be made with two lengths of copper wire for the two conductors, held at the center gap with a radio antenna insulator, and similarly supported at the outer ends. The center gap of any antenna need be only great enough to allow for insulation, connection of the transmission line, and freedom from filling up with dirt.

Antenna insulation and supports must have high mechanical strength as well as good dielectric properties. These re-

quirements are satisfied by such substances as low-loss Bakelite and similar phenolic compounds, by steatite and various ceramics, by polyethylene, and under some circumstances by glazed porcelain. Experimental antennas may be set up by using wood which has been well impregnated with paraffin wax in a hot bath.

Locating and Orienting the Antenna. — If the locality is a fringe area or if signals are known to be generally weak, it is worth while to mount the antenna at the highest practicable point. In many cases an extra five or six feet makes the difference between very poor and good reception. At the selected point it must be possible, of course, to erect a mast and needed guy wires without too much trouble. Always keep the antenna as far as possible from sources of electrical interference. Such sources include automobile traffic, public garages, buildings having many electrical machines, electric signs, X-ray and other kinds of medical laboratories. Keep away from large metal objects, such as metal roofs, gutters, and vent pipes.

When a tentative position for the antenna has been selected it is necessary to make a test of actual reception before final installation. With a transmission line of approximately correct length connected to the antenna and to the receiver, the antenna is moved about and rotated as to reception direction while observing the resulting signal strength and quality. This work is done most easily and quickly with one person moving the antenna while another watches the picture tube of the receiver. There must be some means of communication. The most popular means is a pair of self-energized phones, the kind which work without batteries or other external power, connected together by a cable running from receiver to the antenna location. Many manufacturers discourage the practice of connecting phones through the transmission line, although this sometimes is done with 75-ohm lines.

If the work must be done without the assistance of a helper it is possible to connect to the receiver, somewhere between the video detector load and the picture tube input, a high-resistance voltmeter or a microammeter which is taken to the

antenna location. Meters designed for this purpose are available. Any sensitive voltmeter or current meter may be used provided there is a rectifier and filter at the receiver end of the connecting line, so that the high-frequency signals produce a direct current or voltage in the long connecting line and the meter.

A detector probe such as used with an oscilloscope or an electronic voltmeter for high-frequency measurements is entirely satisfactory for use at the receiver. The scheme of connections is illustrated by Fig. 9-18. The high side of the probe may be connected to either the video detector load, the plate of one of the video amplifier tubes, or the control grid or

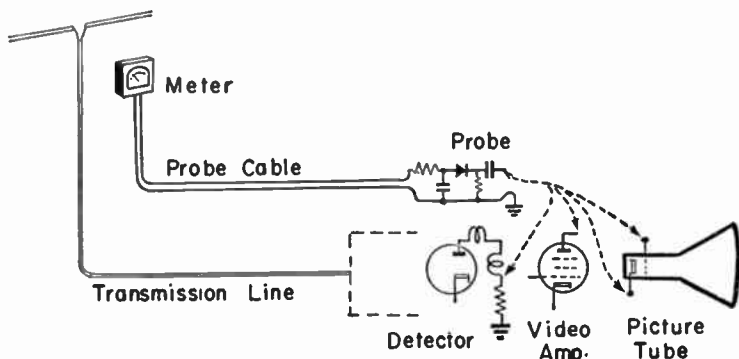

Fig. 9-18.—Connections for a meter which is carried to the antenna location during orientation.

cathode of the picture tube, whichever of these latter two elements is used for input to the picture tube in the receiver being handled. The other lead of the probe is grounded to the chassis. The cable from probe to meter may be 50 to 100 feet long, or even longer. Flexible lamp cord will do for this line, or any kind of transmission line may be used.

The receiver should be tuned to some channel, preferably one for which reception is known to be relatively weak. If a second person is watching the picture tube at the receiver the contrast control should be turned well down and all observations made on a test pattern, not a program picture. If the

meter is used, the contrast should be turned up to a usual operating position. The meter will indicate only changes in signal strength as the antenna is moved and rotated. Final inspection for picture quality must be made at the receiver with the antenna mounted in the position for greatest signal strength.

With the antenna at the position which appears to give maximum signal strength, it should be rotated one way and the other, while the conductors extend horizontally, until signal strength is at its peak. Then, if the construction allows, the antenna conductors may be inclined from the horizontal. It is possible that objects between transmitter and antenna may change the polarization of the signal away from the horizontal. If possible to make tests on more than one station, always favor the one which appears to furnish the weakest signal.

Installation of Antennas.—The actual mounting of the antenna mast and guy wires often calls for abilities such as possessed by a combination of carpenter, mason, plumber, electrician, and all around mechanic. It must be remembered that restrictions may be imposed on the height of masts, their location, or the overall size of arrays. Such restrictions may be in leases or in local ordinances. In addition, it is necessary to be familiar with rules of the National Electrical Code for antennas and transmission lines or "leadins." Elevated antennas and masts present lightning hazard. A lightning arrester of some type approved by the Underwriters' Laboratories should be used on the transmission line. With most types it is necessary only to clamp the arrester over the line, with or without removing some of the line insulation. If the arrester is grounded on a cold water pipe, keep the transmission line as nearly as possible at right angles to the pipe, never parallel for any distance at all. Often it is easier to drive a grounding rod down to permanently moist earth, solder a number 12 or larger copper wire to the top of the rod and run this wire to a location convenient for the arrester.

If the antenna mast is metal, as usually is the case, it should be connected through a heavy copper wire to a cold water pipe

or to the grounding rod. The charge accumulated on an ungrounded mast during dry summer weather, even when there is no lightning, is enough to give a shock that stings even though it is not dangerous.

If the antenna mast is 10 feet or more in height it should be supported by three or four equally spaced guy wires. A swaying antenna causes picture brightness to vary, and signal strength may drop enough to cause loss of synchronization. If guy wires have to come within one wavelength or less of the antenna conductors, one or more radio antenna insulators should be inserted in the guys somewhere within the first three or four feet from the mast.

Indoor and Temporary Antennas. — Indoor antennas often are satisfactory in areas of fairly high signal strength when used in buildings of frame, brick, stone, or stucco construction. They seldom are wholly satisfactory in steel-frame buildings, nor under metal roofs, nor where there is metal foil heat insulation. Indoor antennas in a building of any construction must be kept away from plumbing and vent pipes, from metal beams, and even from such things as curtain and drape hangers.

Any indoor antenna is handicapped by lack of sufficient elevation to receive signals unaffected by all manner of obstructions in the wave path. From this standpoint an antenna located in the attic is likely to be much more satisfactory than one near the receiver.

A simple half-wave dipole may be formed on the end of a twin-lead transmission line by slitting the line through the center of its insulation for a distance of about $\frac{1}{4}$ wavelength, then supporting the two ends in a straight line. The overall length of the spread-out portion should be somewhat shorter than the length specified for a half-wave dipole by the table in this article. Line of 75- or 100-ohm impedance may be used for this type antenna.

A folded dipole antenna for indoor use may be made from 300-ohm twin lead transmission line as shown by Fig. 9-19. A piece of the transmission line is cut to an overall length as listed in the table for half-wave antenna lengths in this article.

The wire conductors at both ends are bared for about a quarter inch and twisted or soldered together. Enough insulation is removed at the center of the conductor on one side of the line to allow cutting the conductor at this point and twisting

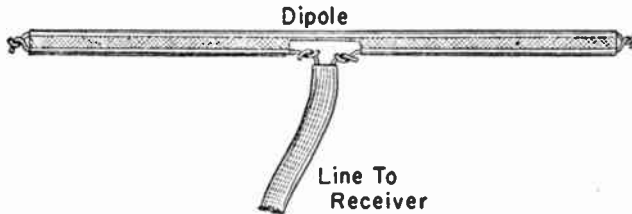

Fig. 9-19.—A folded dipole antenna made from twin-lead transmission line.

or soldering the exposed ends to the two conductors of another piece of the same kind of line, this second piece being the actual transmission line running to the receiver.

The frequency response of this folded dipole is somewhat narrower than that of a folded dipole made of tubing in the usual manner. In theory the length of the transmission line folded dipole should be somewhat longer than dimensions listed in the table, but as this kind of antenna usually is located in practice the listed dimensions provide resonance close to the centers of the channels.

B

BIASING. — Grid bias is the potential difference, measured in volts, between the control grid and the cathode of a tube. If the grid is negative with reference to the cathode there is negative bias, if the grid is positive there is positive bias, and if the grid and cathode are at the same potential there is zero bias. The more negative is the grid bias the smaller is the plate current with a given applied plate voltage. When the grid is sufficiently negative to reduce plate current to zero, the tube is biased to plate current cutoff or there is cutoff bias.

Variation or adjustment of grid bias serves two principal purposes; it determines whether or not there shall be grid current in the grid circuit of the tube, and it fixes the point of average operation on the curve showing relations between grid voltage and plate current. There will be no grid current

when the bias is appreciably more negative than zero. If the bias is very close to zero on the negative side, or is zero, or is positive, there will be grid current which becomes greater as the grid is made more positive. Grid current means that power is being taken from the source of grid signal voltage, which is undesirable in voltage amplifiers but may be allowed in some power amplifiers. To prevent flow of grid current the d-c value of negative grid bias must be equal to, and in practice must slightly exceed, the maximum peak potential of the signal applied to the grid. This peak is equal at least to 1.4 times the effective a-c value of the signal.

Fig. 10-1 illustrates effects of changing the grid bias to change the operating point on the grid-voltage plate-current curve. At the left the bias is sufficiently negative to hold the grid signal voltage on the straight portion of the curve. Plate

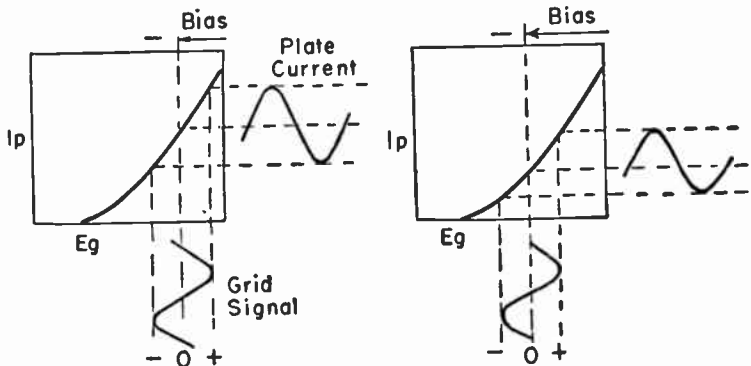

Fig. 10-1.—Varying the bias changes the operating point on the grid-voltage plate-current curve.

current changes have the same waveform as grid signal or grid voltage changes, there is no distortion of waveform. At the right the bias has been made more negative, and operation is on the lower bend of the curve. Now the plate current waveform is not like the waveform of grid signal voltage, there is greater increase than decrease of plate current with equal variations of grid voltage. Actual grid voltage for zero signal amplitude always is equal to the bias voltage. One example of such

biasing is found in some sweep amplifiers, where adjustable bias is used for linearity control.

At the left in Fig. 10-2 the grid bias is sufficiently negative to cause plate current cutoff when no signal voltage is applied to the grid. Pulses of plate current now flow only during positive swings of the grid signal. Plate current remains zero during negative swings of the signal. Were the bias slightly less negative than the cutoff value there would be some plate current during portions of the negative swings of grid signal.

If plate voltage is made very small there is limiting of maximum plate current due to saturation. That is, the low voltage is capable of drawing only a limited part of the electron emission from cathode to plate. The I_p - E_g curve then

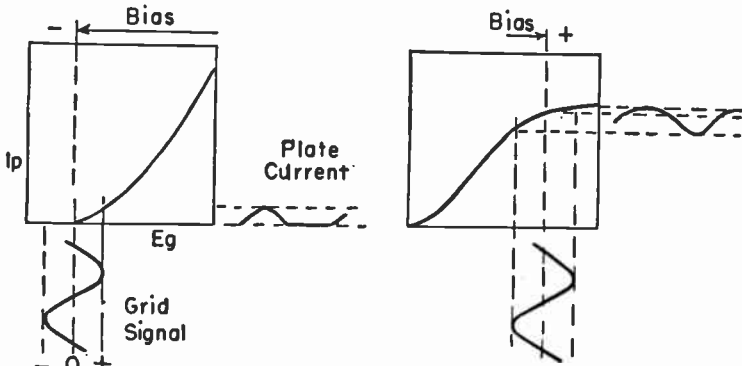

Fig. 10-2.—Biasing for plate current cutoff and for plate current saturation.

is about as shown at the right in Fig. 10-2. Even though the bias is made near zero or slightly positive, the plate current cannot be increased. Then the plate current waveform shows rather flat tops, the effect is somewhat similar to but is inverted as compared with what happens at the right in Fig. 10-1 and at left in Fig. 10-2. An example of distorted output as shown in Fig. 10-2 is found in some limiter and clipper tubes in the sync sections of television receivers.

Four different methods of biasing are found singly and in various combinations in television receivers. They are;

- a. Cathode bias, sometimes called self-bias,

b. Fixed bias secured from the B-power supply, or a partially fixed and partially variable bias sometimes called back-bias.

c. Bias by grid rectification or with grid leak and capacitor.

d. Bias furnished wholly or in part from the automatic gain control voltage.

Cathode Bias. — The principle of cathode bias is illustrated by Fig. 10-3. Between the cathode and B- or ground is a biasing resistor Rk . All d-c electron flow in the cathode must pass through this resistor. This electron flow will be the sum of the plate current, the screen current if the tube has a screen, and any grid current which may exist. The electron flow in Rk is in such direction that the grounded or B- end of this resistor is negative with reference to the cathode end. If the control grid is negative and there is no current in parts of the grid circuit such as Lg and Rg there will be no difference of potential between the grid and ground or B-. Since the grid is connected to ground or B- through the grid return, grid potential will be negative with reference to the cathode. This potential difference, which is the grid bias, is equal to the average voltage drop in Rk . Resistance for Rk is determined thus:

$$Rk, \text{ ohms} = \frac{1000 \times \text{required bias volts}}{\text{total cathode current, milliamperes}}$$

Because bias voltage depends on cathode current every variation of this current varies the bias. Every increase of plate current, screen current, or their sum increases the voltage

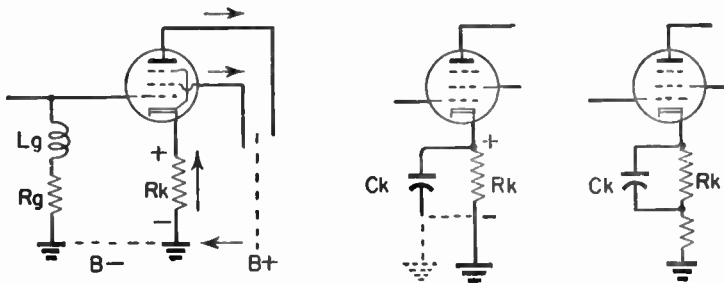

Fig. 10-3.—The principle of cathode bias.

drop in Rk and makes the bias more negative. Every decrease makes the bias less negative or more positive. Increases of plate and screen current accompany positive swings of the grid signal, and the positive swings thus make the bias more negative. Decreases of current accompany negative swings of signal, and the grid is made less negative. Consequently, the changes of bias always tend to counteract the changes of signal, and there is degeneration due to the negative feedback effect.

Cathode bias helps compensate for the differences between plate currents of original and replacement tubes, because more plate current makes the bias more negative and less plate current makes it less negative. There is small possibility of the grid ever becoming positive with this form of bias, and it is permissible to use greater values of resistance in the grid circuit than with fixed bias. Cathode bias is the kind nearly always used for power amplifiers giving high output voltages, and is used for voltage amplifiers as well.

To reduce the degenerative effect of cathode bias and allow more nearly the maximum possible gain from the tube, the biasing resistor Rk may be bypassed with a capacitor Ck as at the right in Fig. 10-3. When the chief purpose of the bypass capacitor is to lessen degeneration the capacitive reactance in ohms should be little if any more than 10 per cent of the ohms resistance in Rk , at the lowest frequency to be handled by the tube. In audio amplifiers and in cathode-biased sync and sweep amplifiers this calls for large capacitance. For example, with 300 ohms at Rk and 30 ohms reactance at Ck , the capacitance for low frequency of 60 cycles per second would have to be about 90 microfarads. For the same biasing resistance at intermediate frequencies it would be sufficient to use 250 to 300 mmf, and at carrier frequencies the capacitance would have to be only about 100 mmf. If a power supply is poorly filtered it would be necessary to bypass the 60-cycle or 120-cycle "hum" voltages even in high-frequency amplifiers. Sometimes only part of the biasing resistance is bypassed, as in the right-hand diagram.

Unless the cathode resistor is bypassed with capacitive reactance very small for the frequency considered, the cathode is not at r-f ground potential. Then it is desirable to have the least possible capacitance, stray and otherwise, between plate and cathode, also that the screen be bypassed to ground with capacitance whose reactance is low at the operating frequency.

Fixed Bias. — The principle of fixed bias is illustrated by Fig. 10-4, where the negative side of the B-power supply is shown at the left, with two amplifiers and their grid connections at the right. Between the center-tap plate connection of the power rectifier and ground are the two resistors R_a and R_b in series. All electron flow in this B-supply must pass through these resistors, in the direction shown by the arrow. The resistors form a voltage divider. The most negative point

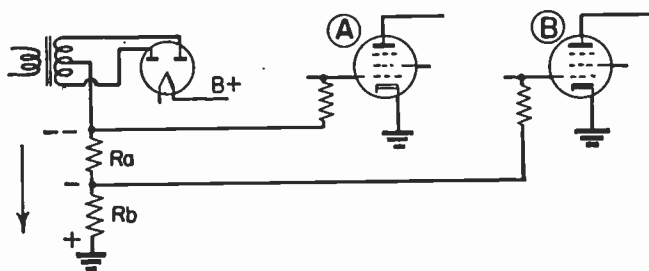

Fig. 10-4.—The principle of fixed bias.

is the top of resistor R_a , to which is connected the control grid of amplifier A . The cathode of this amplifier and the bottom of R_b are connected to the ground. Then the potential difference between grid and cathode of the tube is the same as the difference between the top of R_a and the bottom of R_b or ground. The grid bias for tube A is the total potential difference across the voltage divider. The grid of amplifier B is connected to a point between the two divider resistors, and the cathode to ground. Then the grid-cathode potential difference, or grid bias, on this tube is equal to the voltage drop across divider resistor R_b and is less than the bias for tube

A. By suitably proportioning the resistances at R_a and R_b the bias voltages may be made anything desired, and additional bias voltages may be provided by using more divider resistors.

Actual wiring for fixed bias usually will include some or all of the decoupling capacitors and resistors shown by Fig. 10-5. Across grid resistors R_g appear the r-f signal voltages for the control grids. Accordingly, these resistors are not bypassed. Near the grid resistors and tubes will be decou-

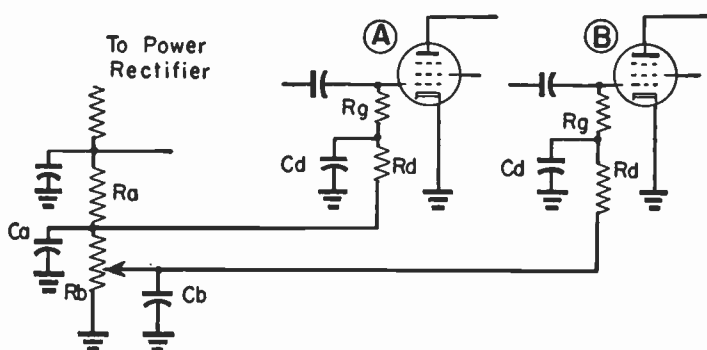

Fig. 10-5.—Fixed bias with decoupling capacitors and resistors.

pling capacitors C_d . Decoupling, or avoidance of interstage coupling and feedback, is made more certain by using decoupling resistors C_d near the tubes. To prevent interstage coupling in the d-c grid return lines, which may be rather long, additional decoupling capacitors C_a and C_b may be placed at the voltage divider, one from each return line to ground. The values of decoupling capacitances are based on the resistances and on the operating frequencies, as previously explained.

It must be noted that in Figs. 10-4 and 10-5 the current in the divider resistors includes not only bleeder current such as exists in any power-supply voltage divider, but also the cathode currents of the tubes. It is plain, from Fig. 10-4, that plate and screen circuits extend to B+, through the power rectifier, the voltage divider resistors, and ground back to

the cathodes. If most of the divider current is due to tube cathode current, variations of plate and screen currents which accompany variations of signal amplitude will vary the grid biases because they vary the divider current and voltage drops. Unless there is effective bypassing at the divider, the changes of grid bias or grid voltage due to signals in one tube may act on the grids of this tube and others too. This is a feedback. If feedback voltages to grid aid the signal voltages on the same tube there is regeneration and possible oscillation. If the feedback opposes the signal voltages there is degeneration and loss of gain.

If only a small portion of the divider current is tube cathode current, and most of it is bleeder current, changes of cathode current due to signals will have little effect on bias or grid voltage. With reasonably good bypassing there will be little danger of either regeneration or degeneration.

Fixed bias may be secured from a separate bias rectifier, one which is not part of the plate and screen power supply, and which does not carry cathode currents. Fig. 10-6 shows

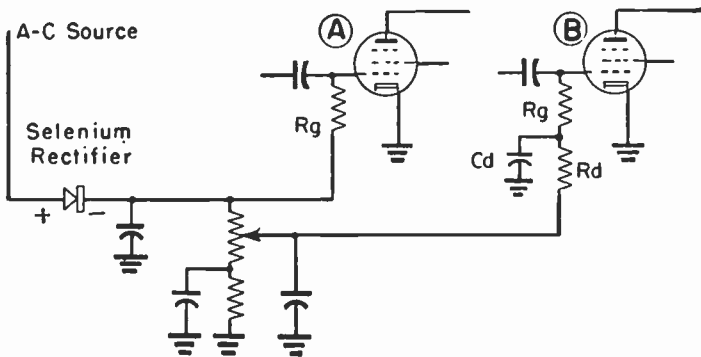

Fig. 10-6.—Fixed bias from a rectifier used only for biasing voltage.

such a system, where the rectifier is a selenium type. Any other kind of rectifier, either half-wave or full-wave, might be used provided it were capable of carrying the small current needed for biasing voltage drop. The a-c source may be anything providing a peak potential somewhat higher

than the maximum bias voltage to be provided. Heater transformers or circuits may act as this source. In Figs. 10-5 and 10-6 the biasing voltage for amplifiers *B* is adjustable, taken from the slider of a potentiometer in the divider string. With fixed bias on a tube the maximum resistance of the grid resistor usually may be only about half the maximum permitted with cathode bias.

Grid Leak Bias. — Fig. 10-7 illustrates the principle of grid leak bias, which is called also grid leak-capacitor bias or grid rectification bias. The coil at the left in the diagrams represents any source of signal voltage. Only the control grid and cathode of the tube are shown, because these are the only elements having anything to do with the biasing action. The tube might be a triode, a pentode, or a beam power tube. It might even be a diode, but then the diode plate would act like the grid of the other tubes.

In diagram *A* an alternating signal potential exists across the source and is applied through capacitor C_g between the grid and cathode of the tube. During each positive alternation of the signal voltage the grid is made positive with reference to the cathode, and there are pulses of electron flow as indicated by arrows. There can be no pulse during negative alternations of the signal, because these make the grid negative with reference to the cathode and there is no electron flow to a negative element.

As in diagram *B*, the continued pulses of electron flow add electrons to the side of the capacitor which is toward the grid. This side of the capacitor accumulates a negative charge, and because this negative side is directly connected to the grid, the grid becomes negative with reference to the cathode. The excess of electrons cannot escape from the negative side of the capacitor, for the electrons would have to flow from grid to cathode in the tube and they cannot flow from a negative to a positive element. The negative charge will build up until it equals the peak potential of the applied signal, whereupon the electron flows will cease and the grid will be highly negative.

In diagram C a grid resistor R_g has been connected between the grid and ground or between the grid and the cathode by way of ground. Some of the surplus electrons from the negative side of capacitor C_g now flow through the grid resistor as shown by long arrows. With this direction of electron flow the grid end of the resistor is negative and the

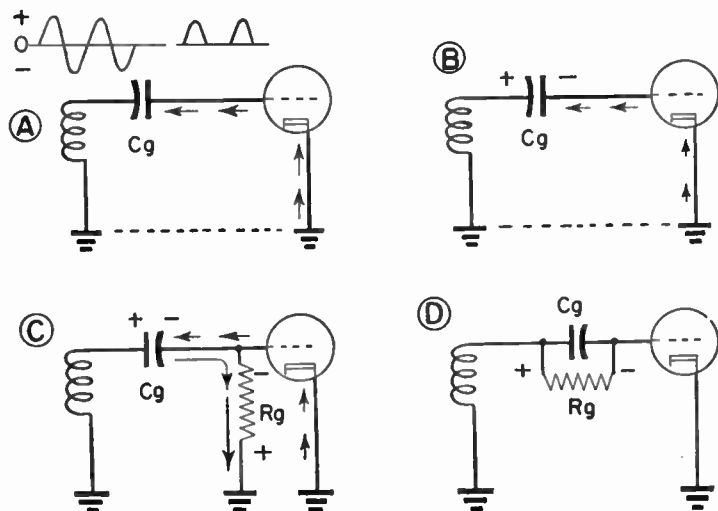

Fig. 10-7.—Principle of grid leak bias or of bias by grid rectification.

ground or cathode end is relatively positive. The potential difference between grid and cathode is the potential difference across R_g . This is a negative grid bias. Electrons, in pulses due to the signal, flow toward the capacitor while a steady electron flow away from the capacitor goes through the resistor.

The charge which remains on the capacitor varies with signal amplitude, being greater as the signal strength increases. The capacitor voltage varies likewise. The rate of electron flow through the resistor depends on capacitor voltage, or signal strength, and on the value of resistance in R_g . The greater the resistance the less will be the flow rate, the greater will be the charge held on the capacitor, and the

more negative will be the grid bias. Grid leak bias thus automatically adjusts itself to signal strength, and tends to maintain a constant output from the plate circuit of the tube when the signal varies. This feature is useful in sync amplifiers where it helps eliminate the effect of "noise" irregularities in the applied signal.

If the d-c grid return can be completed back to ground or cathode through the signal source, the biasing capacitor and leak may be in parallel with each other, as shown by diagram *D*. This simply connects the positive end of the resistor to ground or cathode through the conductors of the source.

In order that the grid leak-capacitor combination may provide bias voltage there must be a current in the resistor. This current must consist, on the average, of electron flow from the grid. This necessary grid current means that some power is taken from the signal source during positive alternations of the signal, but not during negative alternations. Thus the signal is distorted. This type of bias is not useful where the original waveform must be preserved without distortion, but it is useful where only the frequency rather than the waveform of pulses is of importance. This latter condition exists in most sync and sweep circuits. Once the bias is established by a capacitor charge which is added to and subtracted from equally, by signal pulses and leak current, the signal voltages pass through the capacitor and vary the grid voltage above and below the bias voltage.

With a grid leak-capacitor combination as the only source of bias voltage, the bias becomes zero in the absence of a signal. Then, unless there are other means of limiting plate current, this current may increase to a value harmful to the tube. Grid leak bias is used for limiters and clippers in the sync section, it may be used where detector action is wanted, it may be used with class C and other power amplifiers where grid current is permissible, and it is used with oscillators.

BRIGHTNESS AND BRIGHTNESS CONTROLS. — The brightness of a picture or pattern corresponds to the average level of

illumination on the picture tube screen. Bright portions of pictures then become lighter than this average level, while dark portions become less bright. Increases and decreases of brightness, or lights and shadows of the picture, may vary around any average level, which is the average brightness of the picture.

As may be seen from Fig. 11-1, curves showing the relation between control grid voltage and brightness on the screen of a picture tube have much the same shape as curves showing the relation between grid voltage and plate current of an amplifier tube. Just as average plate current depends on the bias-

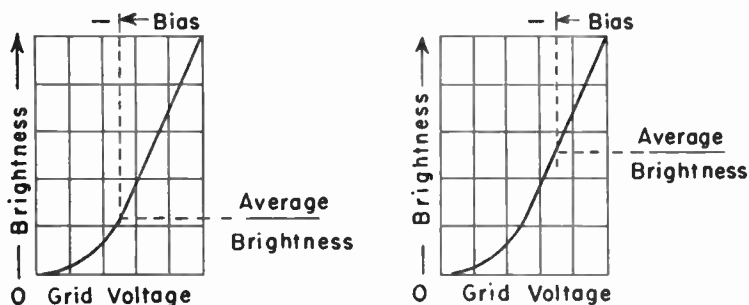

Fig. 11-1.—Relations between control grid voltage of a picture tube and average brightness of pictures or patterns.

ing of an amplifier, so average brightness of a picture or pattern depends on biasing of the picture tube with reference to the cathode. Making the picture tube grid bias less negative allows greater average brightness, which means greater beam current and also greater current in the high-voltage anode of the picture tube.

Brightness Controls.—Brightness controls, which usually are arranged for manual adjustment by the set operator, vary the control grid bias or the average potential difference between control grid and cathode of the picture tube. These controls are called also brilliancy controls, intensity controls, or background controls.

Fig. 11-2 shows connections for a typical brightness control where signal input is to the control grid of the picture tube.

Bias voltage is provided by potential drop in resistor R_a , the control potentiometer, and resistor R_b , which are in series between $B+$ and ground or $B-$. The control grid of the picture tube connects to ground or $B-$ through resistors R_c and R_d . Because of the direction of electron flow through the bright-

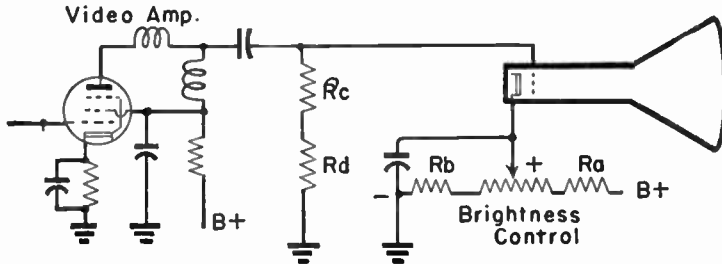

Fig. 11-2.—Brightness control used when signal input is to the picture tube control grid.

ness control resistors, the point connected to the cathode is positive in relation to the end which connects indirectly to the grid. Consequently the grid is negative with reference to the cathode, or has a negative bias whose value is varied by the control potentiometer.

Fig. 11-3 shows connections for a brightness control where signal input is to the cathode of the picture tube. Again the control potentiometer is in a resistor string between $B+$ and ground, and again the point which connects to the cathode (through resistor R_b) is positive with reference to the end which connects through ground to the control grid. Thus the

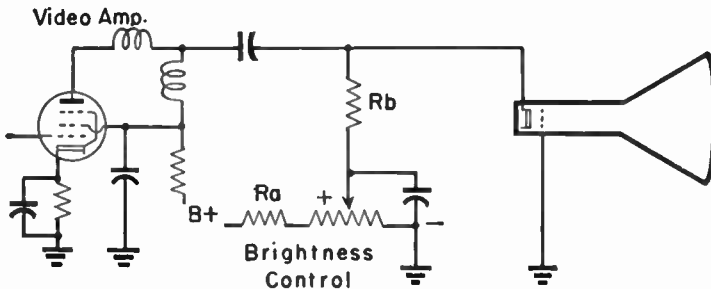

Fig. 11-3.—Brightness control when signal input is to the picture tube cathode.

grid is provided with negative bias voltage of a value which may be varied by movement of the slider on the control potentiometer.

Controls for brightness and for contrast always must be adjusted to suit each other. Too much or too little brightness for any given degree of contrast will cause poor pictures. Too much or too little contrast for any given setting of the brightness control also will cause poor pictures. It must be kept in mind that a contrast control is really a gain control, the higher the setting of the contrast control the greater is the amplification of the picture signals. A contrast control for television pictures is like a volume control for sound. It must be kept in mind too that a brightness control is a bias control, it fixes the operating point on the curve relating brightness and control grid voltage in the picture tube. Just as the bias of an amplifier tube must be suited to the amplitude or strength of the audio or radio-frequency signal, so must the bias (brightness) of a picture tube be suited to the strength (contrast) of the picture signals. The relations of these two controls are illustrated by Figs. 11-4 and 11-5.

At the left in Fig. 11-4 the brightness control is set too high for the strength (contrast) of the signal, the picture tube grid bias is not sufficiently negative. The entire signal acts high

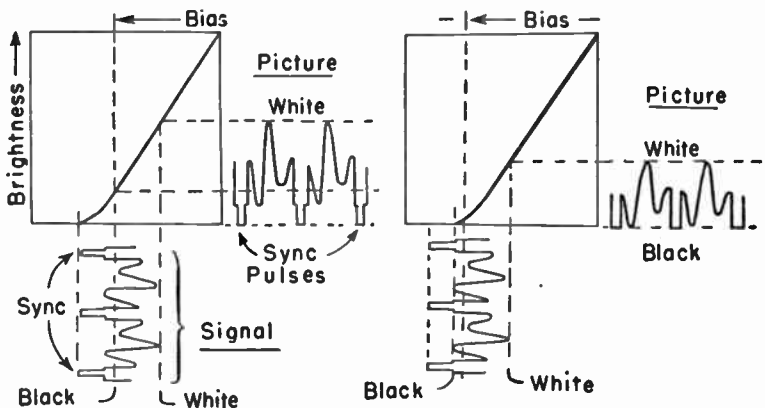

Fig. 11-4.—Left: Brightness control too high or contrast control too low. Right: Brightness and contrast correct for a weak signal.

up on the curve of brightness versus grid voltage. The intensity of the beam is varied not only by the picture elements of the signal, but also by the sync pulses. The black level of the signal is well above the cutoff point for beam current, so portions of the picture which should appear black actually are gray. The picture will appear washed out, and the blanking intervals and sync pulses will cause diagonal white lines.

These picture faults may be corrected, without changing the strength of the signal, by decreasing the brightness as shown at the right in Fig. 11-4. Decreasing the brightness makes the bias more negative. This brings the signal far enough down on the curve that the black level is at or near the point of beam cutoff. Since beam cutoff leaves the screen without illumination, the parts of the picture which should appear black actually will be black. The picture then has correct relative shading or relations of blacks, grays, and whites.

Average illumination of the picture with conditions as at the right is much lower than with them as at the left. With a signal of the strength indicated there would be no way of having a brighter picture while retaining correct shading. A signal which is weak at the input to the picture tube cannot be made to produce a very bright picture of good quality.

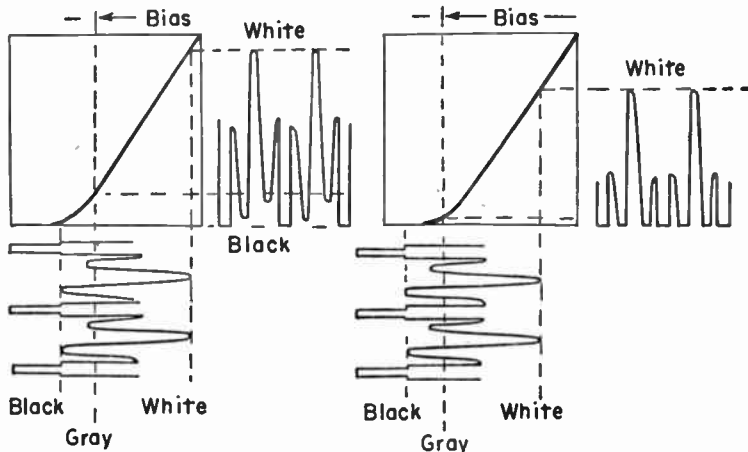

Fig. 11-5.—Left: Brightness and contrast correct for a strong signal.
Right: Brightness control too low for a strong signal.

If we wish to retain the brightness setting at the left in Fig. 11-4, and have a good picture, the signal must be strengthened as at the left in Fig. 11-5. This can be done by advancing the contrast control, provided the contrast control is not already all the way advanced. With the stronger signal the black level is at or near the point of beam cutoff. All of the sync pulses are cut off, but in the picture there is a full range of shading from black through intermediate grays, to white. The picture is bright because the average level of illumination can be maintained high because the signal is strong.

At the right in Fig. 11-5 we are using the strong input signal with the brightness adjusted too low. The signal rides far down on the curve, due to the grid bias being too negative. Now it is not only the sync pulses which are cut off, but also a considerable portion of the signal lying above the black level. Parts of the signal which should produce gray tones in the picture are brought down to the point of beam cutoff, and these parts of the signal become black. Everything which should be black in the picture will, of course, appear black because it will be below the point of beam cutoff. The result is too much black, or too much contrast in the picture. The appearance will be mostly black and white without smooth gradation of intermediate grays.

C

CAPACITANCE AND CAPACITORS. — A capacitor consists of two insulated conductors which may be charged with electrons through connections to a source of voltage and which may be discharged through any conductive circuit. Capacitance is a measure of the ability of a capacitor to receive a charge of electrons or electricity, it is the ratio of the number of coulombs of charge to the number of volts potential difference between the conductors of the capacitor. The two conductors are called the plates and the insulation between them is called the dielectric of the capacitor. A capacitor may be called an electrostatic condenser or simply a condenser. Ca-

capacitance may be called electrostatic capacity or simply capacity.

The fundamental unit of capacitance is the farad. If each capacitor plate will carry a charge of one coulomb when their potential difference is one volt the capacitance is one farad. Practical units are the microfarad, abbreviated *uf*, *mf*, or *mf**d* and equal to one one-millionth of a farad, and the micro microfarad, abbreviated *uuf*, *mmf*, or *mmf**d* and equal to one one-millionth of a microfarad. The electrostatic unit of capacitance sometimes is used. It is abbreviated *esu*. This unit is equal to 1.1126 micro-microfarads.

Rolled paper capacitors have plates of thin metal foil with two or more layers of thin paper as the dielectric. Usually there are only two plates. Adjustable trimmer capacitors may have two or more plates with air or thin sheets of mica for the dielectric, or they may be ceramic types mentioned later in this article. Capacitors used for tuning by the operator of television or radio apparatus usually have rigid metal plates and air dielectric. Alternate plates of multi-plate capacitors are conductively connected together to give the electrical effect of only two plates.

Rolled paper or rolled foil capacitors may be thought of as consisting of two long and relatively narrow plates separated by the dielectric as at the left in Fig. 12-1. All multi-plate capacitors may be represented in a general way as at the right.



Fig. 12-1.—Elementary forms of two-plate and multi-plate capacitors.

Capacitance depends on several factors. It increases with increase of active plate area, which is the area of plate surfaces in contact with the dielectric. Capacitance increases also with increase of dielectric constant of the dielectric material. The thicker the dielectric, or the greater the separation between plates, the less is the capacitance.

The approximate capacitance of a capacitor, in mmf, may be computed from the following formula when plate area is measured in square inches and dielectric thickness in inches.

$$Mmf = \frac{0.225 \times \text{dielectric constant} \times \text{area, one side of one plate} \times \text{number of plates, minus 1}}{\text{dielectric thickness}}$$

If plate area is in square centimeters and dielectric thickness in centimeters, the first term in the numerator is changed from 0.225 to 0.0885.

Actual capacitance will be affected by presence of supporting metal acting as additional plate surface, and by supporting dielectric or insulating material.

In multi-plate capacitors especially, and in two-plate types to some extent, additional capacitance results from edge effect, which is the curving of lines of force through the spaces around the edges of the plates. The approximate addition for edge effect is,

$$Mmf = \frac{\sqrt{\text{area of one side of one plate, sq. inches}}}{4}$$

In capacitors with long, narrow plates there is a considerable increase of capacitance due to elongation effect. Capacitance computed from the first preceding simple formula is multiplied by the elongation factor. The value of this factor is,

$$\text{Elongation factor} = 1 + \frac{0.015 \times \text{length}}{\text{width}}$$

The total capacitance of any number of capacitances connected together in parallel is equal to the sum of the separate capacitances. For example, with 20 mmf, 10 mmf, and 150 mmf in parallel the total capacitance is 180 mmf.

The combined capacitance of any number of equal capacitances connected together in series is the capacitance of one unit divided by the number of units. As an example, the

capacitance of three 60-mmf capacitors connected in series with one another is the quotient of 60 divided by 3, or is 20 mmf.

The combined capacitance of any two capacitances in series, regardless of whether the capacitances are equal or unequal, may be found from dividing the product by the sum. Assume capacitors of 12 mmf and 4 mmf in series. Then,

$$\frac{12 \times 4}{12 + 4} = \frac{48}{16} = 3 \text{ mmf, combined capacitance}$$

If more than two unequal capacitances are in series the combined capacitance may be found by first computing the capacitance of two of them according to the rule just explained, then considering this combined capacitance as in series with a third unit for a second similar computation, and so on. For example, assume that the capacitances of 12 mmf and 4 mmf are in series with a third unit whose capacitance is 60 mmf. The first part of the work would be to compute the combined capacitance of 12 and 4 mmf, which previously was found to be 3 mmf. The next step is to compute the capacitance of 3 mmf and 60 mmf in series, thus.

$$\frac{3 \times 60}{3 + 60} = \frac{180}{63} = 2 \frac{54}{63} = 2 \frac{6}{7} \text{ mmf}$$

The combined capacitance of any number of equal or unequal capacitances in series is equal to the reciprocal of the sum of the reciprocals of the separate units. Using the separate unit values of 12, 4, and 60 mmf, the computation would be as follows:

$$\frac{1}{12} + \frac{1}{4} + \frac{1}{60} \text{ equivalent to } \frac{5}{60} + \frac{15}{60} + \frac{1}{60} = \frac{21}{60}$$

The reciprocal of 21/60 is 60/21, which is equal to 2 6/7 mmf.

It is important to keep in mind that the total potential difference across any number of capacitors in series divides between the capacitors inversely as their capacitances. Continu-

ing with the example of 12, 4 and 60 mmf in series, any total voltage across all three would divide between them proportionately to $1/12$, $1/4$, and $1/60$. This does not mean that $1/12$ the total voltage would be across the 12 mmf unit, $1/4$ the total across the 4 mmf unit, and so on, for all the fractions would not make up 100 per cent of the overall voltage.

The fractions may be changed to equivalents having the same denominator, as to $5/60$, $15/60$, and $1/60$. Then the numerators, 5, 15, and 1, indicate the relative voltages on the capacitors. We might assume an overall potential difference of 315 volts. It would divide proportionately to 5, 15, and 1. The sum of these three numbers is 21. Dividing 315 volts by 21 gives 15 volts. Then voltages across the three capacitors are as follows:

$$\begin{array}{r}
 12 \text{ mmf unit. } 5 \times 15 \text{ volts} = 75 \text{ volts} \\
 4 \text{ mmf unit. } 15 \times 15 \text{ volts} = 225 \text{ volts} \\
 60 \text{ mmf unit. } 1 \times 15 \text{ volts} = \underline{15 \text{ volts}} \\
 \text{Total voltage} \qquad \qquad \qquad 315 \text{ volts}
 \end{array}$$

The smallest capacitance in a series string always carries the greatest voltage, and the largest capacitance always carries the least voltage. Voltage ratings must allow for this fact if small capacitors are not to be punctured.

Color Codes. — Fig. 12-2 shows arrangements of dots and their significance in color coding systems which are and have been most generally used for mica capacitors. Meanings of the colors when used in the various dot positions are given by the accompanying table.

At the upper left in Fig. 12-2 are shown dot positions for the six-dot RMA (Radio Manufacturers' Association) color code. This system allows showing on the capacitor the first three numerals of the capacitance in mmf and a multiplier which shows the number of ciphers to be added in making up the complete capacitance value. In addition there is a dot space for showing capacitance tolerance in per cent, and another one for showing the working voltage of the capacitor. To indicate a capacitance of 2,500 mmf, tolerance of 5%,

and working voltage of 300, colors would be arranged thus:

Red *Green* *Black*
Orange *Green* *Brown*

For 10 mmf capacitance, 10% tolerance, and 500 working volts, we would have,

Brown *Black* *Black*
Green *Silver* *Gold*

MICA CAPACITOR COLOR CODE

Color	Digit Numerals	Multiplier	Tolerance		Working Voltage (RMA)	Characteristic (JAN)
			(RMA)	(JAN)		
Black	0	1	20%	20%		A
Brown	1	10	1%		100	B
Red	2	100	2%	2%	200	C
Orange	3	1,000	3%		300	D
Yellow	4	10,000	4%		400	E
Green	5		5%		500	
Blue	6		6%		600	
Violet	7		7%		700	
Gray	8		8%		800	
White	9		9%		900	
Gold		0.1		5%	1,000	
Silver		0.01	10%	10%		

Characteristic	Temperature Coef. parts/million/deg. C	Capacitance Drift
A (black)	Not specified	Not specified
B (brown)	Not specified	Not specified
C (red)	-200 to +200	+ or -0.5 per cent
D (orange)	-100 to +100	+ or -0.3 per cent
E (yellow)	-20 to +100	+ or -0.1 per cent

At the upper right in Fig. 12-2 are the positions for the JAN (Joint Army-Navy) capacitor color code. This code may be called ASA (American Standards Association) or AWS (American War Standard). Capacitors marked with this code are easily identified, because the upper left-hand dot always is black. To specify capacitance value there are dots for only two digits or numerals, and a multiplier. The tolerance dot is in the same position as for the RMA code, but the lower

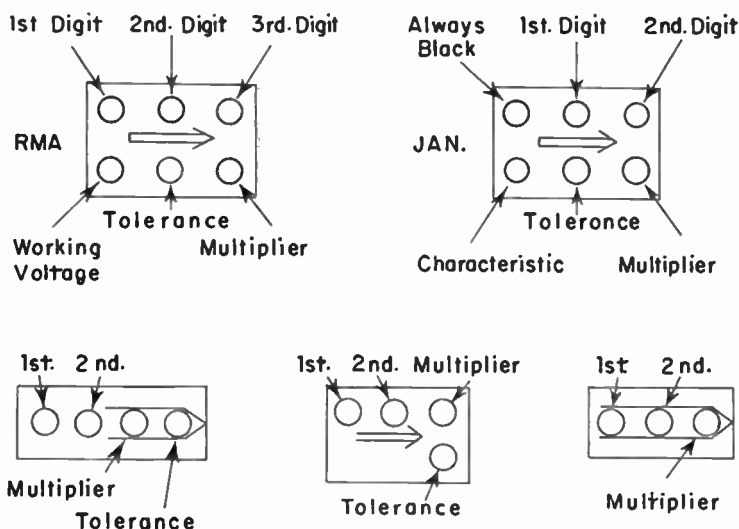

Fig. 12-2.—Meanings of color code dots in various positions on mica capacitors.

left-hand dot indicates temperature and drift characteristics as noted in the table.

For 2,500 mmf and 5% tolerance in the JAN code the color arrangement would be thus:

<i>Black</i>	<i>Red</i>	<i>Green</i>
<i>Black</i>	<i>Gold</i>	<i>Red</i>

For 10 mmf, 10% tolerance, in the JAN code the arrangement would be,

<i>Black</i>	<i>Brown</i>	<i>Black</i>
<i>Black</i>	<i>Silver</i>	<i>Black</i>

Some mica capacitors have a four-dot marking as at the lower left in Fig. 12-2. Capacitance digits, multiplier, and tolerance markings are as previously explained. With no voltage marking the working voltage of mica capacitors usually is 500. Another arrangement of a four-dot system is shown at the lower center of this figure. A three-dot marking is shown at the lower right. Here there are positions for only two capacitance digits and the multiplier. The tolerance ordinarily will be 20% and the working voltage 500 with this three-dot marking.

Tubular or cylindrical ceramic capacitors may be color coded as shown by Fig. 12-3. This coding may be found also on capacitors having paper or mica dielectric and enclosed in ceramic tubes, as well as for the types having film dielectrics. The accompanying table lists meanings of the colors.

CERAMIC CAPACITOR COLOR CODE

Color	Digit Numerical	Multiplier	Tolerance		Temp. Coef.
			If C more than 10 mmf	If C 10 mmf or more	
Black	0	1	20%	2.0 mmf	0
Brown	1	10	1%		- 30
Red	2	100	2%		- 80
Orange	3	1,000			-150
Yellow	4				-220
Green	5		5%	0.5 mmf	-330
Blue	6				-470
Violet	7				-750
Gray	8	0.01		0.25 mmf	+ 30
White	9	0.1	10%	1.0 mmf	-330 to + or -500

The temperature coefficient of capacitance is the change in parts per million, per centigrade degree of temperature change.

The position or direction in which a capacitor is to be held while reading the color coding is determined thus: For flat mica capacitors (Fig. 12-2) hold the unit so that any arrow or anything in the form of an arrow points toward the right, or so that the name of the manufacturer or any other wording is

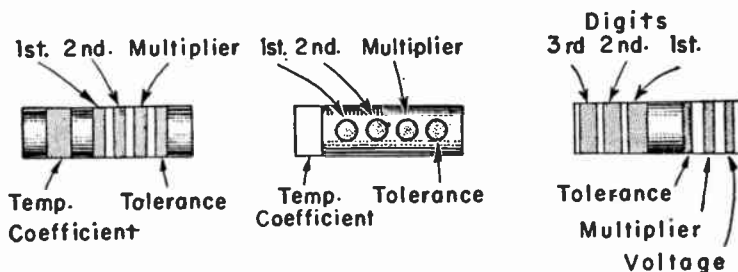

Fig. 12-3.—Color code markings for fixed ceramic and some other cylindrical or tubular capacitors.

right side up. The position of the coding bands or dots on ceramic units (Fig. 12-3) is identified by differences between widths of bands.

Temperature Compensating Capacitors. — When a temperature coefficient is specified in parts per million per degree change of centigrade temperature it is the same as saying in micro-microfarads per microfarad of capacitance per degree temperature change. It is the general tendency of tuned circuits to decrease their resonant frequency as temperature rises. This is most pronounced at very-high and ultra-high frequencies. The effect is as though there were an increase of inductance or of capacitance with rise of temperature. This tendency is opposed or compensated for by using capacitors having a negative temperature coefficient, indicated by the minus sign in the tables.

As an example, assume a capacitor having a nominal capacitance of 1000 mmf or 0.001 mf, and assume that the temperature coefficient of this capacitor -750 . Then the capacitance will decrease in the ratio of 750 parts per million, or in the ratio of 750 mmf per microfarad of capacitance. Since the capacitance has been assumed to be 0.001 or $1/1000$ microfarad, the actual decrease will be $750/1000$ or 0.75 mmf per centigrade degree of temperature rise. With a rise of 10 degrees centigrade (18 degrees Fahrenheit) the capacitance will decrease by 10 times 0.75 mmf, or by 7.5 mmf, and instead of the original 1000 mmf it will become 992.5 mmf.

When a receiver operates in such manner that tuned circuits are subjected to high temperature, it is a rather common service operation to have to change capacitors of one temperature coefficient to others having a greater negative temperature coefficient.

Mica Capacitors. — Mica capacitors have high quality sheet mica as the dielectric, with plates of metal foil or of deposited silver films, and are completely enclosed within a housing of molded phenolic or plastic compound. Such capacitors have very small d-c leakage, and they have long service life with minimum danger of puncture or breakdown if the working

voltage rating is correct in the first place. The chief disadvantage of mica capacitors is their high cost in comparison with other types, but this cost is warranted when making replacements.

Silver mica capacitors are made with mica dielectric on which a coated compound is reduced to metallic silver by heat. The molded covering is of some material having small dielectric losses at very-high and ultra-high frequencies. Such capacitors retain their capacitance value and other operating characteristics for long periods. They are especially useful in high-Q tuned circuits and wherever close tolerance is important.

Ceramic Capacitors.—The usual structure of a fixed ceramic capacitor is shown, in a general way, by Fig. 12-4. The capacitor element itself is a thin-walled tube of ceramic material, which is the dielectric, with the outside and inside surfaces of this tube coated with silver and sometimes other metals also,

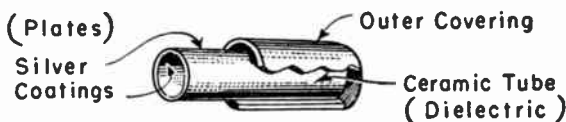

Fig. 12-4.—The principal parts of a fixed ceramic capacitor.

to form the two plates. This element is enclosed within a sealed outer covering, which may be of something such as steatite or a low-loss resin compound. The capacitor is wax impregnated under vacuum before sealing. The silver coatings are bonded to the ceramic tube by heating, and there may be over-coatings of copper or other metals.

The dielectric tube is given the desired dielectric constant by compounding the ceramic material with titanium dioxide which, by itself, has an extremely high dielectric constant. The compounding also determines the temperature coefficient of the capacitor. Ceramic capacitors originally were used almost exclusively where controlled temperature coefficients were required, but they now are used also for bypassing, coupling, and all other purposes for which moderate capacitances are needed.

Rotary ceramic capacitors are widely used as trimmers. The stationary base is of compounded ceramic material ground perfectly flat. On the under side is a silver deposit which forms one plate. The adjustable rotating member carries a semi-circular piece of metal which is held by spring pressure in close contact with the top surface of the ceramic base. There are other designs, some with the ceramic dielectric forming the rotating member. Usually the capacitance changes from minimum to maximum with a half-turn of the adjustment.

Paper Capacitors. — Capacitors with paper dielectric and metal foil plates, when used at frequencies lower than video and sound intermediate frequencies, usually are of the rolled type whose construction method is illustrated by Fig. 12-1. The cross section may be cylindrical or oval. If the sides of the long strips of foil do not protrude beyond the paper dielectric, and if terminal connections are made to the ends of the foils, there is not only capacitance but also a very considerable inductance because the foil strips are in the form of coils. The combination of capacitance and inductance makes the capacitor a complete resonant circuit at some frequency.

In a check on this feature, several 0.005-mf rolled paper capacitors were found to be resonant around 9 to 10 mc. One 0.001-mf unit was resonant at 65 mc. Where such capacitors are used for bypassing and decoupling, their high impedance at their resonant frequency makes it necessary to connect in parallel a smaller mica or ceramic capacitor which will have low reactance at this frequency provided it is to be bypassed.

Non-inductive paper capacitors are constructed with one foil protruding from one side of the paper, and with the other foil protruding from the other side. The protruding edges are pressed together to form the two terminals at which the pigtails are attached.

The pigtail or terminal connected to the outside foil of paper capacitors may be marked with appropriate wording or with a narrow colored band. This end of the capacitor should be connected to the ground side of the circuit, whereupon the outside foil acts as a shield.

CENTERING AND CENTERING CONTROLS. — The picture or pattern appearing on the screen of the picture tube may be too high and too far to the right, as shown at the left in Fig. 13-1, or too low and too far to the left, as in the right-hand illustration, or it might be off center in only one direction. Such faults are due to incorrect adjustment of centering controls. When no deflecting voltages or currents are affecting the electron beam in the picture tube the beam will not necessarily strike the exact center of the mask opening, and when there is deflection it may be greater in one direction than in the opposite direction.

Centering adjustments always are made while observing a picture or a test pattern, preferably a pattern on which the center always is easily identified. The horizontal hold control should be in its normal operating position while the picture

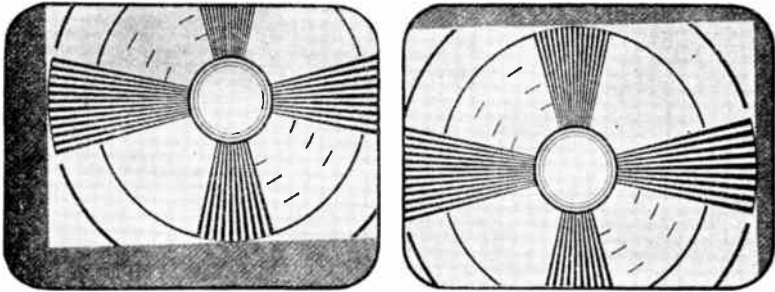

Fig. 13-1.—The pattern or picture may be off center in one or more directions.

or pattern is being centered. That is, the hold control should be set midway between its positions with which the picture goes out of horizontal synchronization either way. The reason is that this hold control usually may be turned quite a ways in either direction without losing synchronization, but while shifting the picture to the right or left.

Once correctly adjusted, the centering controls seldom require changing. Readjustment may be needed in case tubes in the sync or sweep sections are replaced, or if the picture tube is replaced, and sometimes when there are considerable changes of power line voltage. Centering controls sometimes are called framing controls.

Centering with Electrostatic Deflection.—Centering controls for picture tubes having electrostatic deflection include the essential elements shown by Fig. 13-2. Electron flow in the circuit containing the high-voltage rectifier is through two center-tapped control potentiometers, with the two potentiometers in parallel. The tap on the horizontal control is connected to one of the horizontal deflection plates in the

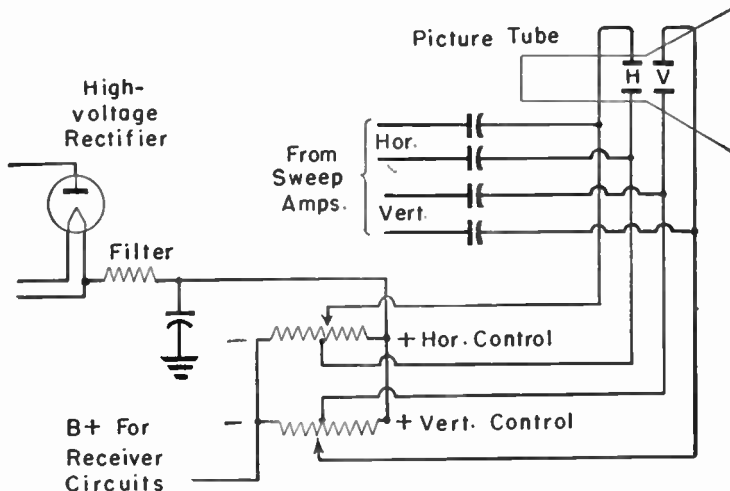

Fig. 13-2.—Circuit connections for electrostatic centering control.

picture tube, and the slider of this control is connected to the other horizontal deflection plate. The center tap and slider of the vertical control are similarly connected to the two vertical deflection plates.

Moving the control slider one way or the other will make one plate of a pair more or less positive or negative with reference to the other plate of the same pair. This will give the

electron beam in the picture tube a deflection to the right or left, or up or down, when no sweep voltages are being applied to the deflection plates from the sweep amplifiers. Then the center of the horizontal beam deflection and the center of the vertical deflection will be at points fixed by adjustment of the two centering controls. The picture or pattern will extend approximately equal distances from these centers, and may be moved up, down, or to either side.

Centering with Magnetic Deflection. — During normal operation of a picture tube designed for magnetic deflection the beam is moved up, down, and sideways by reversals of the magnetic fields from the deflection yoke or deflection coils. These magnetic fields are the result of, and are completely controlled by, currents in the deflection coils. Were a steady current passed through the deflection coils, in addition to the current causing the sweep, the beam would be deflected by magnetic fields resulting from the combination of steady and sweep currents.

Effects of a steady current are shown by Fig. 13-3. Electron flow in the left-hand diagram is in such direction around the coils as to produce magnetic polarities which deflect the electron beam to the left. Electron flow has been reversed in the right-hand diagram. This reverses the magnetic polarities and reverses the direction of beam deflection. These directions are based on the assumption that electrons in the beam are

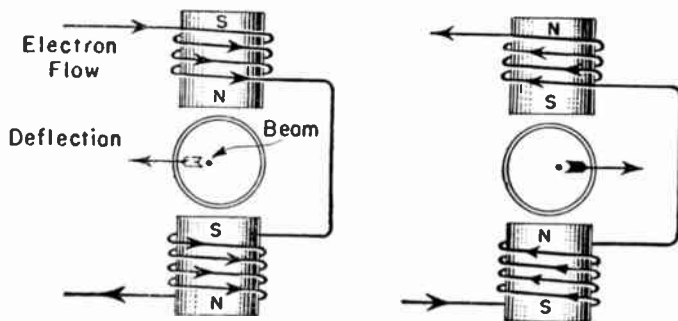

Fig. 13-3.—Effects of steady electron flow or direct currents in the yoke coils of a magnetic deflection system.

coming toward you, are coming out of the page. Variation of direction and strength of the steady electron flow will deflect the beam and hold it deflected at any distance toward the left or right. Variation of a steady current in the vertical deflection coils would deflect and hold the beam at any distance above or below center. Sweep distances will be approximately equal on both sides and above and below these centers. Thus the entire picture or pattern may be moved on the screen by varying the steady centering currents.

This principle of centering by variation of direct currents in the deflection coils is utilized with circuits such as shown by Fig. 13-4. Currents are taken from the B-power voltage

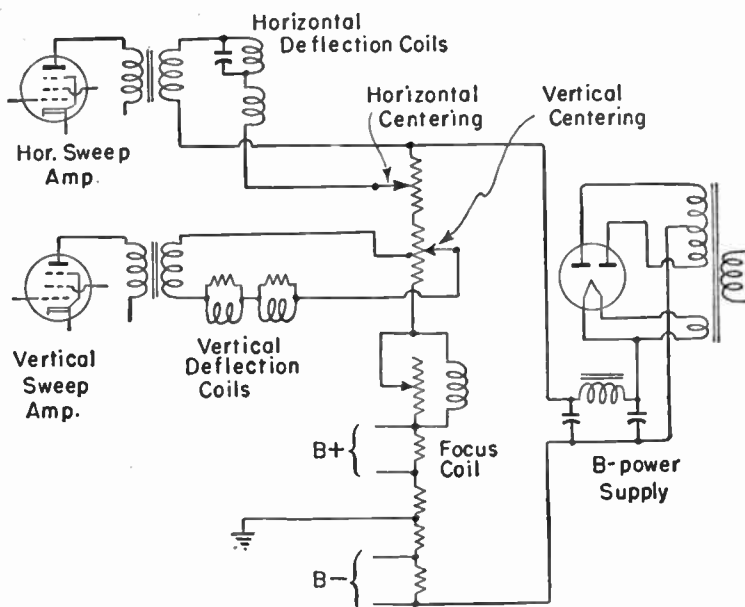

Fig. 13-4.—Electrical centering controls used with a magnetic deflection system.

divider system or other suitable source. The centering potentiometer for the horizontal deflection coils at the top of the diagram provides adjustable current, but this current flows in only one direction. It is used to counteract to a greater or

less extent another opposite current which flows in the horizontal coils during operation of the receiver. This other current tends to cause a steady deflection to one side, and the adjustable centering current or the voltage which would cause the centering current is adjusted as required to center the picture.

The centering potentiometer for the vertical deflection coils of Fig. 13-4 is a center tapped type whose adjustment allows current in either direction, and of any necessary value, through the coils. In this vertical deflection system there is no other steady direct current, as in the horizontal system up above. Therefore, it must be possible to have the centering current in either direction. This requires the center-tapped potentiometer for adjustment.

Centering with Focus Coil. — The focusing coil acts somewhat like a lens in collecting the beam electrons, which are spreading apart, and in focusing them to a small spot on the screen. Just as the position of a focused spot of light will change when the focusing lens is tilted with reference to its axis, so the beam spot is shifted on the picture tube screen when the focusing coil is tilted with reference to the axis of the picture tube.

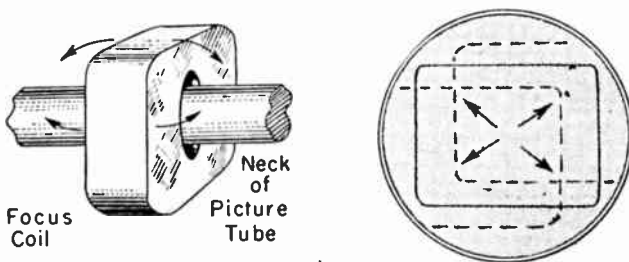

Fig. 13-5.—Tilting the focusing coil with reference to the axis of the picture tube neck will shift the center of a pattern or picture.

Focusing coils are mounted in such ways that the axis through the coil center may be shifted, as at the left in Fig. 13-5, with reference to the picture tube neck. Only a limited

degree of such shifting is possible without having the coil housing strike the tube neck, but it is enough to allow moving the picture or pattern on the screen as shown at the right. Moving the coil axis in either a vertical or horizontal plane causes diagonal shifting of the picture, so usually it is necessary to utilize both directions of coil movement for centering. In a large number of receivers this is the sole means of centering the picture.

If electrical centering controls such as those of Fig. 13-4 are employed, the initial adjustment may be of focus coil position while both electrical controls are set midway between their extreme adjustment positions. If an electrical control will not center the picture in the mask, that control should be placed at its mid-setting while the focusing coil is adjusted. Coil mounts may be of trunnion form, or may consist of three or more adjustable screws having tension springs, or of any other type which allows shifting the coil axis. The deflection yoke always should be as far toward the flare of the picture tube as possible while making any centering adjustments.

Some receivers provide centering adjustment by means of a movable magnetized ring built into the deflection yoke assembly. The ring is moved vertically to center the picture horizontally, and is moved horizontally to center the picture vertically. Rotating the ring without moving it up or down has no more effect on centering than has rotation of a focusing coil without tilting the coil.

CHANNELS, TELEVISION. — The range of frequencies in which signals from a transmitter are radiated is called a channel. Each television broadcast channel includes a range of six megacycles. In the very-high frequency band there are twelve channels, numbered 2 through 13. Channel number 1, originally assigned for television broadcast, now is used for other services. In each channel the video carrier frequency is 1.25 mc higher than the low limit of the channel, and the sound carrier frequency is 0.25 mc lower than the high limit. Channel frequencies and carrier frequencies are listed in the accompanying table.

CHANNEL FREQUENCIES, MEGACYCLES

Channel No.	Limits	Video Carrier	Sound Carrier
2	54 to 60	55.25	59.75
3	60 to 66	61.25	65.75
4	66 to 72	67.25	71.75
5	76 to 82	77.25	81.75
6	82 to 88	83.25	87.75
7	174 to 180	175.25	179.75
8	180 to 186	181.25	185.75
9	186 to 192	187.25	191.75
10	192 to 198	193.25	197.75
11	198 to 204	199.25	203.75
12	204 to 210	205.25	209.75
13	210 to 216	211.25	215.75

A band of ultra-high frequencies between 480 and 920 megacycles has been allocated for television broadcasting, but channel divisions have not been fixed or assigned in this band.

Under the original rules for assignment of channels, broadcast transmitters are not assigned to the same channel unless at least 150 miles apart, nor are transmitters assigned to adjacent channels unless separated by 75 miles or more. Note that channels numbered 4 and 5 are not adjacent, since there is a gap of four megacycles between them. Consequently, these two channels are assigned to stations in the same locality. These rules are modified to meet the public interest or necessity, and as may be required by conditions peculiar to certain geographical areas.

CLIPPERS OR LIMITERS. — In television receivers the name clipper may be applied to a tube whose purpose is to retain and sometimes to amplify the sync pulses of a signal while reducing or eliminating the picture variations of the signal. This would be one of the tubes in the sync section of the receiver. A tube performing this function may be called also a sync separator.

The name limiter may be applied to a tube whose chief purpose is to reduce all sync pulses of a signal to the same amplitude or same voltage strength, or to limit the amplitude to some certain maximum value which prevents passage of

extra strong pulses due to noise effects or to interference. Such a tube may be called also a sync clipper.

In television sound sections employing two or more intermediate-frequency stages the tube in the stage preceding the detector or demodulator may be operated as a noise limiter. The chief purpose of this limiter is to prevent passage through it of amplitude-modulated signals or impulses while delivering to the demodulator all the frequency-modulated signals for sound. The limiter may be operated with such combination of plate, screen, and grid voltages as to cause plate current cutoff, current saturation, or both effects when signal amplitude rises above a uniform level or when there are amplitude pulses which would cause noise after detection.

Diodes may be used as clippers, limiters, or levelers of sync pulses. One method is illustrated by Fig. 15-1. Sync pulses coming to the grid of the left-hand triode tube are of negative polarity, and in the output of this tube the pulses are positive due to signal inversion which always occurs in a triode amplifier. The positive pulses make the plate of the clipper diode positive and tend to make the diode conduct.

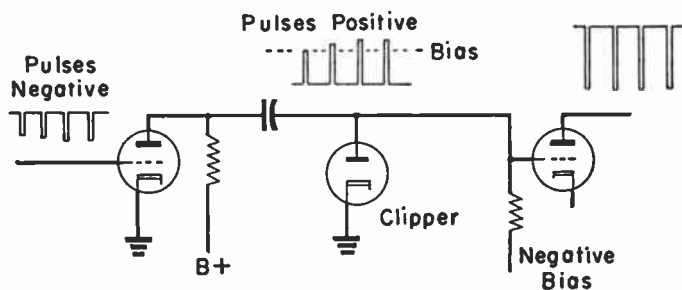

Fig. 15-1.—A diode used as a leveler or clipper for sync pulses.

But the plate of the diode is conductively connected to the negative grid bias voltage source for the right-hand triode. Only when the positive voltage of the sync pulses exceeds the negative bias voltage will the clipper diode actually conduct and reduce this positive voltage. Thus sync pulse volt-

ages applied to the grid of the right-hand diode are made fairly uniform and the output signal of this triode is likewise fairly uniform.

Another connection for a pulse clipper is shown by Fig. 15-2. Here the clipper diode plate is connected through capacitor C to the lead between the plate of the left-hand amplifier tube and the grid of the right-hand amplifier. In the circuits of video amplifiers the signal consists of both picture variations and sync pulses. It is assumed that in the signal

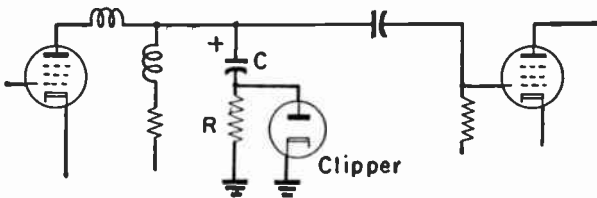

Fig. 15-2.—A clipper diode biased by a capacitor and a resistor.

applied to the diode plate the sync pulses are positive. Resulting current flowing in capacitor C and between plate and cathode of the clipper tube causes charging of the capacitor in the polarities marked. The capacitor discharges slowly through resistor R , and maintains the clipper plate negative with reference to its cathode. That is, the clipper plate is negatively biased at a potential proportional to the average or normal voltage of the sync pulses. Should interference or other external forces produce sync pulses of more than average voltage these higher voltages will overcome the negative bias and cause the clipper to conduct. The conduction loads the circuit sufficiently to level off most of the excess pulse voltage and to leave sync pulses of practically constant strength for the grid of the right-hand amplifier tube.

CONDENSERS. — Electrostatic condensers, often called simply condensers, are treated in this book under the heading of *Capacitance and Capacitors*, which see.

CONSTANTS, TIME. — There are two kinds of time constants, capacitive and inductive. A capacitive time constant is the length of time required for the charge and voltage of a capacitor to reach approximately 63 per cent of their final values when the capacitor is charged through a resistance. This same length of time, or same time constant, is required for the same capacitor to lose approximately 63 per cent of its charge and voltage when discharging through the same resistance.

An inductive time constant is the length of time required for direct or one-way current in a coil or inductor to reach 63 per cent of its final value when this current flows in resistance of the coil and its circuit.

Capacitive Time Constants. — The factors which affect the time for charging and discharging a capacitor are readily appreciated by thinking of the capacitor as similar to a toy rubber balloon and of the circuit resistance as similar to the air flow resistance of a connected rubber tube with a very small hole through it. Air pressure applied to the tube and pressure within the balloon are analogous to voltage.

With the balloon completely deflated and air pressure applied to the outer end of the tube the full force of this pressure does not immediately reach the balloon because some pressure is lost in overcoming resistance to flow through the tube. There is, however, no internal pressure in the balloon to oppose the external pressure, and the rate of flow of air into the balloon is very rapid but not infinitely great. As air flow continues, there is an increase of pressure inside the balloon. This internal pressure opposes the external pressure. The rate of air flow becomes progressively less as internal pressure increases, and flow stops when the two pressures become equal.

With a capacitor completely discharged and potential applied to the capacitor circuit there is some drop of voltage in circuit resistance and the full potential is not immediately applied to the capacitor. The discharged capacitor has no voltage between its plates to oppose the externally applied

voltage, and the rate of charge is very rapid. As charging continues, there is increase of voltage across the capacitor plates. This capacitor voltage opposes the charging voltage. The rate of charging or the current rate becomes progressively less, and the current stops when capacitor voltage becomes equal to the externally applied voltage.

The capacitive time constant is the time, in seconds, from the beginning of charge until the attainment of 63.24 per cent of the final complete charge which will be reached after charging voltage is applied for a long while. This time constant is equal to either of the following:

Time, seconds = capacitance, farads \times resistance, ohms

Time, seconds = capacitance, microfarads \times resistance, meg.

Resistance in these formulas is the total series resistance of the circuit which contains the capacitor, the source of charging voltage, and resistance of the capacitor itself.

Note that the value of applied charging voltage has no effect on the length of the time constant. With higher voltage the actual time for reaching 63 per cent of full charge will be less than with a lower voltage, but so also will the time for reaching a full charge be proportionately less. Therefore, the percentage relationship of 63 per cent charge and full charge is not altered by voltage.

Since capacitive time constant is the product of capacitance and resistance the constant is directly proportional to both. The constant is increased or decreased in direct proportional to increase or decrease of either capacitance or resistance.

Returning again to the analogy of the toy balloon and the rubber tube, we may consider what happens during loss of air from the balloon. If external pressure is removed there will be nothing to oppose loss of air except the resistance of the tubing. At first there will be a rapid loss. Reduction of the quantity of air within the balloon reduces the internal pressure, and as this pressure drops lower and lower the rate of air flow out of the balloon drops proportionately.

When the charged capacitor is allowed to discharge through resistance there is at first the full voltage of the charge acting on the resistance, and the rate of discharge or rate of current flow is high. But as the capacitor charge decreases there is less and less capacitor voltage acting on the resistance, and the rate of discharge current becomes less and less as time goes on. The length of time from the start of the discharge until the discharge is 63 per cent complete is the time constant. This time constant for discharge is the same, in seconds, as the time constant for charging.

The length of one time constant during discharge is increased by greater capacitance, by greater resistance, or both. The time constant still is directly proportional to capacitance and to resistance. At the end of one time constant during discharge there will remain in the capacitor 37 per cent of its initial charge and initial voltage, since 63 per cent of the initial charge and voltage will have been lost. Resistance through which the discharge takes place may include any path of unintentional leakage as well as the part through resistors in the circuit.

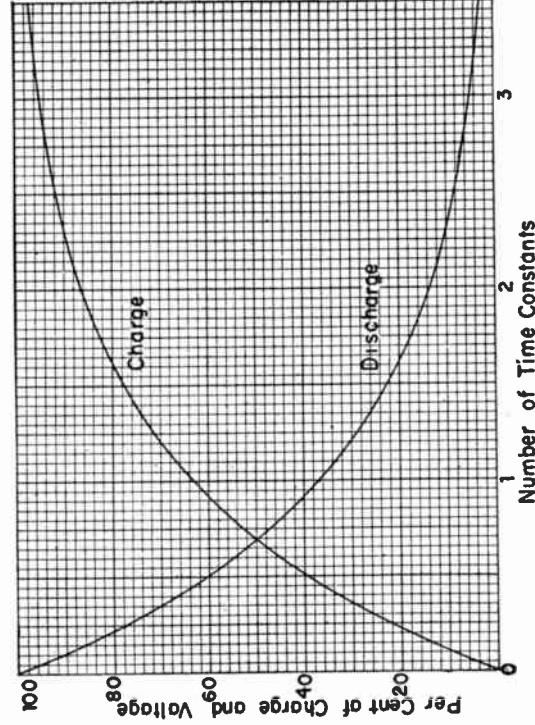

Fig. 17-1.—Rates of charge and discharge of a capacitor as related to the number of time constants.

Fig. 17-1 shows how the rate of charge and discharge of a capacitor varies with passage of time following the start of the charge into a completely discharged unit or following the start of discharge from a completely charged unit. Time is given in the number of time constants across the horizontal scale. Per cent of charge and capacitor voltage is shown by the vertical scale. The charge has come up to a value of 63 per cent at the end of one time constant. At the end of one time constant during discharge there has been a loss of 63 per cent, leaving 37 per cent of the original charge. The period of one time constant is the number of seconds or the fraction of a second found from the preceding formulas. With small capacitance and little resistance the time for one time constant may be a few millionths of a second. With large capacitance and high resistance this time may extend to many seconds.

At the end of two time constants there is about 86 per cent of full charge, or there has been about 86 per cent of discharge with 14 per cent of the original charge remaining. After an elapse of time equal to three time constants there has been about 95 per cent of charge or discharge, and the percentage increases more and more slowly through additional time constants.

Inductive Time Constants. — When voltage is applied across a circuit containing only resistance the current rises instantly to the full and final value as given by Ohm's law; $\text{amperes} = \text{volts}/\text{ohms}$. If the circuit contains inductance there is an induced counter-voltage or counter-e.m.f. which opposes the voltage applied externally. As a result the current increases rapidly at first, then more and more slowly as it approaches its final Ohm's law value. The time rate of increase of current in an inductive circuit is like the rate of voltage rise in a capacitive circuit, and is shown by the curve marked *Charge* in Fig. 17-1. The time, in seconds, for current to increase to 63 per cent of its final value in an inductive circuit is the inductive time constant of that circuit.

$$\text{Time, seconds} = \frac{\text{inductance, henrys}}{\text{resistance, ohms}}$$

The time constant and the rate of current rise are affected by circuit resistance as well as by counter-emf due to the inductance. At every instant the counter-emf is equal to the difference between the applied voltage and the voltage drop in the circuit resistance. At the instant in which the circuit is closed and external voltage is applied there is no current and, consequently, no IR voltage drop. Then current is started by the full force of applied voltage, and there is a rapid rise. But the increase of current causes increase of IR voltage drop which is subtracted from the effect of applied voltage. Then there is less rapid change of current and, since counter-emf varies with the rate of current change, there is a decrease of counter-emf. The counter-emf finally decreases to zero, and the current is determined only by applied voltage and circuit resistance.

When there is short circuiting of an inductive circuit in which current is flowing the current does not instantly drop to zero but decreases just as shown by the curve marked *Discharge* in Fig. 17-1. The emf of induction here is opposing the change of current during decrease just as the emf of induction opposes the change during increase of current.

Time Constant Effects. — If the time constant of a circuit is long in comparison with time periods between reversals of alternating voltage or current there will be time for only a partial increase of charge on a capacitor or current in an inductor. Then the higher the frequency applied to a circuit having some given time constant the lower will be the capacitor charge and voltage or the less will be the inductor current. Lower voltage or less current exists when circuits have large capacitive reactance or large inductive reactance. Such circuits have relatively short time constants.

Capacitance and resistance may be in series or in parallel with each other, or there may be series-parallel combinations. At 1 in Fig. 17-2 the resistor R and capacitor C are in series with the source of voltage and current. The time constant for charge and discharge of the capacitor will be affected by

resistance of both the resistor and the source, and by any other resistance in the circuit.

At 2 in Fig. 17-2 the capacitor C and resistor R are in parallel with each other and are connected across the source. With the switch closed the time constant for capacitor charge will depend on resistance of the source and on other circuit

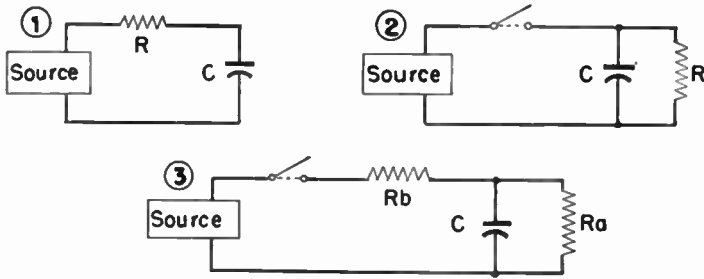

Fig. 17-2.—Circuits in which capacitor charge and discharge are affected by time constants.

resistance which is in series with C and R . With the switch opened the capacitor will discharge through resistor R , and the time constant for discharge will depend on the resistance of R . Voltage across C and R will be the same at all times.

In diagram 3 the capacitor C is in parallel with resistor R_a , and these two are in series with resistor R_b and the source. With the switch closed the time constant for capacitor charge will depend on the resistance of R_b , and with the switch open the time constant for capacitor discharge will depend on the resistance of R_a . The two time constants may differ greatly.

When a source provides alternating voltage to a capacitor which may discharge through a resistor, the capacitor is charged in intermittent pulses but discharges continually through the resistor. The longer the time constant the slower will be the rate of discharge and the higher will remain the capacitor voltage between pulses of charging current. The action is like that of a water tank having a continual leakage through a hole, with water being added in intermittent spurts.

Any given time constant may be obtained with any combinations of capacitance and resistance whose products are equal. For instance, the time constant is the same with 0.001 mf capacitance and 5 megohms resistance as with 0.0001 mf and 50 megohms, being equal to 0.005 second in both cases. A given inductive time constant may be obtained with any combinations of inductance and resistance whose ratios are equal. As an example, the inductive time constant is 0.01 second with inductance of 20 henrys and resistance of 2,000 ohms, and is the same with 0.1 henry and 10 ohms.

The time constant of a capacitive circuit is shortened by using less resistance and lengthened with more resistance when capacitance remains unchanged and is shortened by less resistance and lengthened by more resistance when capacitance remains unchanged. The time constant of an inductive circuit is shortened by using more resistance, and lengthened by less resistance.

CONTRAST AND CONTRAST CONTROLS. — Contrast refers to differences between brightness of objects which appear at the same time in a television picture. There should be enough difference to make clear distinctions between adjacent or overlapping objects. There should be enough range of brightness to extend all the way from black to white, with all intermediate grays correctly rendered. Objects which should appear black should not be merely dark gray, and those which should appear white should not be merely light gray.

Contrast controls vary the gain or voltage amplification of the signal as it passes from the antenna to the picture tube. Contrast controls are gain controls, and, electrically, serve the same purpose as volume controls in sound radio.

Relations between picture contrast and gain, or contrast control, are illustrated by Fig. 18-1. The curves are brightness characteristics of a picture tube, showing relations between screen brightness and amplitude of applied signal voltage. Below the left-hand curve is represented the voltage changes of a weak signal, one resulting from a low setting of the contrast control. Corresponding changes of brightness on the

screen are shown at the right of the curve. Picture tube grid bias is assumed to be adjusted to a value such that blacks should be produced when the black level or blanking level of the signal is at the voltage for beam cutoff, and so that pure whites should be produced when the white level of the signal reaches the voltage corresponding to the line marked *White* on the screen brightness scale.

The black level of the weak signal actually is above the beam cutoff point, and the white level of this signal is below the value which produces white on the screen. As a consequence this weak signal, of too little contrast, will produce neither blacks nor whites, but only intermediate grays. Objects which should be black will be dark gray, and those which should be white will be lighter gray.

In the right-hand diagram the picture tube grid bias is unchanged, but the contrast control has been turned up to deliver at the picture tube a strong signal. Now the black level of the signal is beyond beam cutoff. Parts of the picture between cutoff and the signal black level will appear black, whereas they should be dark gray. The white level of the signal extends far beyond the value at which the screen is made

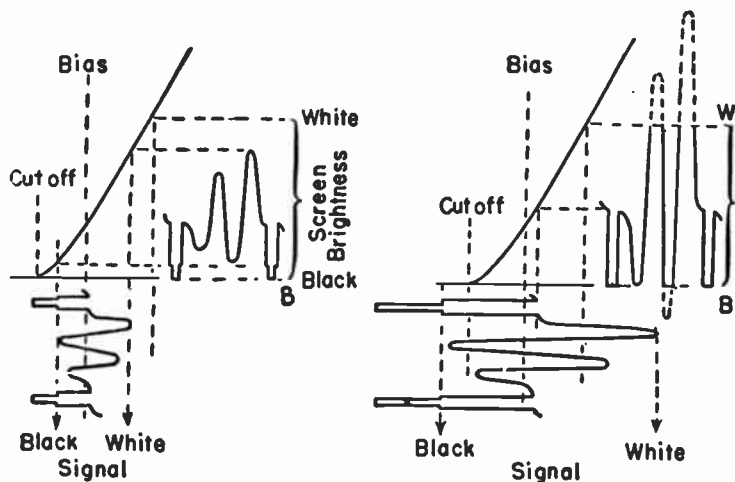

Fig. 18-1.—Relations between screen brightness and amplitude of the signal voltage applied to a picture tube.

pure white. Everything which should appear light gray now will be white on the screen, because the signal exceeds the voltage which produces white. The resulting picture will have too many objects completely black, and too many completely white. There will be too much contrast.

The conditions shown by Fig. 18-1 might be corrected by adjustment of the contrast control or by adjustment of picture tube grid bias. This bias is regulated by the brightness control of the receiver. Relations between settings of brightness and contrast controls are discussed in the article, *Brightness and Brightness Controls*.

Contrast Controls. — A simple but rather widely used type of contrast control is shown by Fig. 18-2. The video detector load resistor is in the form of a potentiometer, with the slider connected to the control grid of the following video amplifier tube. The percentage of signal voltage applied to the

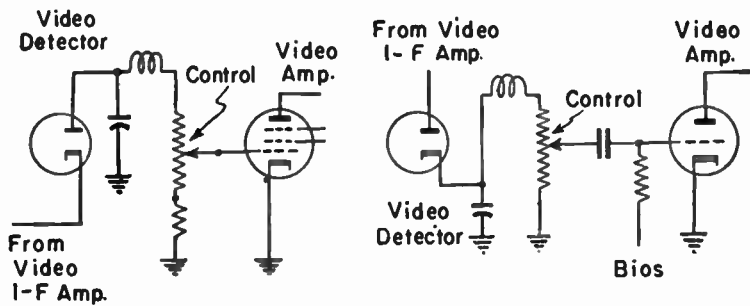

Fig. 18-2.—Contrast controls on grid input of video amplifier tubes.

amplifier grid is that portion existing between the slider and the grounded end of the potentiometer. Contrast is increased by moving the slider toward the detector connection, and is decreased by moving the slider toward the grounded connection.

In many receivers the contrast control is an adjustable grid bias for certain of the amplifier tubes which precede the video detector. This bias control usually is applied to all the video i-f amplifiers except the last one, which operates with cathode bias in most receivers. The bias control is applied also to the

r-f amplifier tube or tubes. The grid returns for controlled tubes are connected to points shown in following diagrams.

In Fig. 18-3 the negative biasing potential is obtained from a B- tap on the voltage divider system for the B-power supply. The contrast control unit is a potentiometer connected between the power supply tap and ground. Maximum negative bias voltage is applied to the r-f amplifier, and a less negative bias is applied to the video i-f amplifiers. Moving

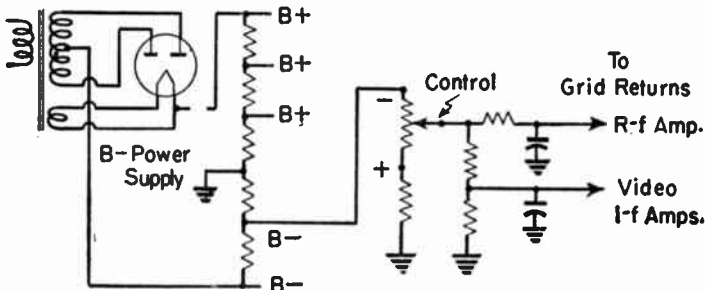

Fig. 18-3.—Contrast control by means of adjustable negative voltage obtained through voltage dividers on the B-power supply.

the control slider toward the more negative end of the resistance makes the biases more negative, to reduce the gain and the contrast. Opposite movement increases the gain and contrast. This diagram shows only one application of this general method. Many variations are in use.

Fig. 18-4 shows two methods of obtaining the negative bias-

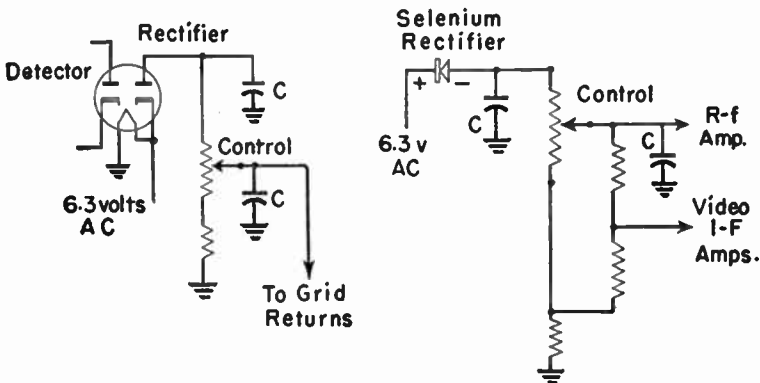

Fig. 18-4.—Adjustable negative bias voltage for contrast control obtained from the heater supply circuits of receivers.

ing potential from the 6.3-volt heater supply circuits of the receiver. In the left-hand diagram this a-c heater voltage is rectified by one section of the twin diode tube whose other section is the video detector. Rectified direct current flows in the resistance of the contrast control potentiometer and in the resistor which is between the potentiometer and ground. These resistances and capacitors C and C smooth the direct potential supplied from the control unit slider to the grid returns of whichever amplifiers are controlled for contrast variation.

In the right-hand diagram the a-c heater supply voltage is rectified by means of a selenium rectifier instead of by a tube rectifier. The direct current from the rectifier flows in the control potentiometer to produce a negative biasing potential applied to the grid returns of the r-f amplifier and some of the video i-f amplifier tubes through the voltage divider system connected between the slider and ground. Maximum negative bias is furnished for the r-f amplifier, and a less negative bias for the video i-f amplifiers. Both these bias potentials are adjusted together by movement of the control slider.

One of the most generally used contrast controls consists of an adjustable cathode bias resistor on the first or second video amplifier tube. Fig. 18-5 shows some of the connections employed for this general method of control. In any case, the adjustable resistor makes the tube cathode more or less posi-

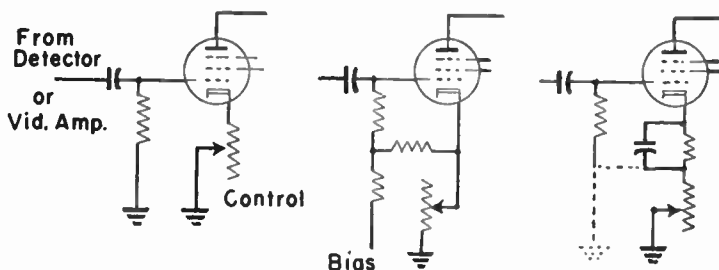

Fig. 18-5.—Contrast controls consisting of adjustable cathode bias on video amplifier tubes.

tive with reference to the control grid, thus varying the negative grid bias and the gain of this tube. Additional negative bias may be applied to the amplifier grid, as in the center diagram. Manual controls for contrast, such as shown here, ordinarily are used in connection with automatic gain control for video i-f amplifiers and a r-f amplifier. As explained in the article on *Gain Control, Automatic*, the adjustable cathode bias resistor may be connected to the agc tube from the end which here is shown unconnected.

Many other methods of gain control or contrast control may be used and are used in some receivers. Manual contrast controls most often are found somewhere in the video amplifier section of the receiver, between the video detector and the pic-

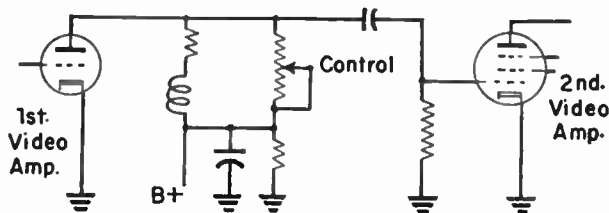

Fig. 18-6.—A contrast control in the plate circuit of a video amplifier tube.

ture tube signal input. In Fig. 18-6 the contrast control is between the first and second video amplifiers. This control consists of an adjustable resistor shunting the plate load of the first video amplifier. Reducing the control resistance and the plate load reduces the amplifier gain and lessens the contrast.

In Fig. 18-7 the manual contrast control is a potentiometer between cathode and ground of a cathode follower tube con-

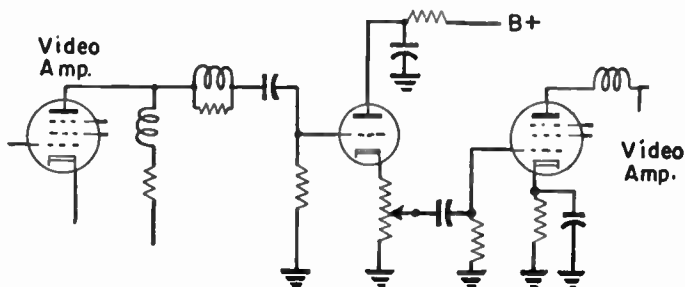

Fig. 18-7.—A contrast control on the cathode resistor of a cathode follower tube.

nected between the two video amplifiers. The signal from the first video amplifier plate is fed to the grid of the cathode follower, and appears in the control potentiometer. This potentiometer, of only 1,000 ohms resistance, provides a low impedance gain control. Moving the control slider toward the tube cathode increases the signal voltage applied to the right-hand video amplifier and increases picture contrast. There is no inversion of signal voltage between grid and cathode resistor of the follower tube.

CONTROLS, TELEVISION. — The controls or adjustments of a television receiver may be classified, first, as those operated by the user in obtaining the desired program and picture quality, and, second, as those employed only during servicing to place the receiver in operating condition or to correct certain faults. The first class may be called operating controls, the second may be called service adjustments or controls.

Operating Controls. — It is desirable, of course, to lessen the number and kind of controls which must be manipulated for satisfactory reception of a program. Controls made accessible to the operator in some receivers may be service adjustments in other receivers. In the hands of an experienced user additional operating controls allow better reception under adverse conditions, but an inexperienced or careless user is more likely to make misadjustments. The usual operating controls are as follows:

1. *Channel selector.* This is a knob, dial, or series of push buttons used to select the channel in which reception is desired. This control tunes the r-f amplifier, the r-f oscillator, and the mixer circuits to required frequencies.

2. *Fine tuning.* A fine tuning control makes slight changes of r-f oscillator frequency as may be required for best reception after the desired channel has been selected and after the receiver has had time to warm up. Not all receivers have a fine tuning control accessible to the operator.

3. *Contrast.* The contrast control varies the amplification of the signal to provide a picture containing a full range of shades from black to white, but without causing objects which

should appear either black or white actually to appear gray, and without causing those which should appear gray actually to become black or white. If contrast and brightness controls are both accessible to the operator they must be adjusted to suit each other.

4. *Brightness.* This control adjusts the bias of the picture tube control grid to bring the black level of the signal to the grid voltage for beam cutoff in the picture tube. Objects represented down near the black level of the signal then will appear black in the picture, and all sync pulses will be cut off so that they and the vertical blanking will not cause diagonal white streaks on the picture. Too much brightness makes the entire picture too light, with blacks lacking. Too little brightness makes the entire picture too dark. The brightness control sometimes is a service adjustment rather than an operating control.

5. *Vertical hold.* This control holds the picture stationary on the screen in a vertical direction, it prevents the picture from continually or intermittently shifting upward or downward. The adjustment varies the frequency of the vertical sweep oscillator to bring it into time with vertical sync pulses of the signal.

6. *Horizontal hold.* This control holds the picture stationary in a horizontal direction, preventing the picture from moving sideways either slowly or rapidly. The horizontal hold control usually will shift the picture slightly to the right or left while still keeping it from rapid or uncontrolled sidewise movement. The adjustment varies the frequency of the horizontal sweep oscillator to bring it into time or into synchronization with horizontal sync pulses of the signal.

7. *Volume.* The volume control alters the loudness of the sound program which accompanies the television picture, just as does the volume control of a receiver for sound radio. The volume control often is combined with the on-off switch. Some television receivers have controls for tone as well as for volume.

Service Adjustments. — Service adjustments usually are located on the rear of the receiver chassis, or sometimes they are concealed by movable portions of the front panel or a selector dial, and in some cases are found on the top of the chassis or even underneath.

1. *Focus.* The purpose of the focusing adjustment is to produce the smallest possible spot of light where the picture tube beam strikes the screen, thus allowing good definition or clear details in the objects pictured. Focusing with electrostatic picture tubes is adjusted by varying the voltage on one of the anodes in the tube. Focusing with magnetic picture tubes is adjusted by varying the direct current through a focusing coil or using permanent magnets.

2. *Centering.* The purpose of centering adjustments is, of course, to bring the center of the picture to the center of the mask opening which is in front of the picture tube screen. Centering, with electrostatic picture tubes, is accomplished by making one of a pair of deflection plates more positive and the other plate of the same pair more negative by means of a direct potential acting in addition to the alternating deflection voltages. Thus the picture, as a whole, is shifted in the direction of the plate which is made more positive. When this voltage change is applied to the vertical deflection plates the picture is shifted up or down, and when applied to the horizontal deflection plates the picture is shifted toward the right or left.

Electrical centering with picture tubes having magnetic deflection is accomplished by passing through the deflection coils a direct current in addition to the varying deflection currents. The polarity of the direct current determines the direction in which the picture is shifted, and the strength of this current determines the distance the picture is shifted. Centering currents are used in both the vertical and the horizontal deflection coils.

Mechanical centering with magnetic-deflection picture tubes is accomplished by tilting the axis of the focusing coil with reference to the axis of the picture tube which passes

through the lengthwise center of the neck. Both electrical and mechanical centering may be used on the same tube, or either method may be used alone.

3. *Size.* A vertical size control alters the height of the picture, and may be called a height control. A horizontal size control alters the width of the picture, and may be called a width control. Size is increased by increasing the amplitude or the maximum variation of sawtooth voltages or currents which act, respectively, in the deflection plates of electrostatic picture tubes or in the deflection coils on magnetic picture tubes.

4. *Linearity.* The word linearity refers to shapes, sizes, and positions of objects and lines in the reproduced picture as these reproductions are related to actual shapes, sizes, and positions of objects and lines in the original televised scene or its image. When the outlines of objects in the reproduced picture are altered from their original forms the picture is non-linear. The purpose of linearity adjustments is to secure and maintain true proportions. Outlines may be distorted horizontally, vertically, or in both directions. Consequently there are horizontal linearity adjustments and also vertical linearity adjustments.

In general, the picture will be linear when the picture tube beam travels horizontally and vertically as uniform speeds throughout the entire deflection distances. This requires sawtooth deflection voltages or currents having a uniform rate of increase with respect to time. Since sawtooth voltages originally produced by the sweep oscillators are ordinarily not linear, corrections are made somewhere in the sweep amplifier sections by means of various kinds of linearity adjustments.

5. *Drive, peaking, etc.* These service adjustments vary the amplitude of sawtooth voltages applied to the grids of sweep amplifiers, or vary the waveform of these voltages. Drive controls affect linearity, and affect also the size of the picture because they alter the amplitude of sweep voltages.

6. *Alignment adjustments.* Alignment adjustments vary the frequency response and band width, also the amplitude of signal voltages, in the tuner section and in the i-f amplifiers for both video and sound. These adjustments alter the inductance, the capacitance, or both in the tuned couplers or transformers between tubes in the sections mentioned.

The names used in preceding explanations are those commonly employed, but different names may be used for the same control or adjustment. Contrast controls may be called sensitivity controls. Hold controls may be called synchronizing, speed, or frequency controls. Linearity controls may be called distribution or peaking controls. A focus control may be called a detail control. The brightness control may be given names such as background, brilliancy, or intensity control. Centering controls are called also framing or position controls.

CRYSTALS, FREQUENCY CONTROL. — Crystals used for controlling or stabilizing the frequency of oscillators are thin plates of quartz cut from natural crystals of this mineral. Such plates may be called piezoelectric crystals. A quartz crystal plate will vibrate most energetically at one certain fundamental frequency, which depends on the manner in which the crystal was cut and on its thickness. When this crystal plate is in an electric field alternating at nearly the fundamental frequency of the crystal, the crystal is caused to vibrate at that frequency. The vibration produces, between opposite faces of the plate, alternating voltages at the fundamental frequency.

A vibrating or oscillating crystal is equivalent to a resonant circuit and may be used like such a circuit, usually between the grid and cathode of an oscillator tube. Connections for a simple crystal-controlled oscillator are shown by Fig. 20-1. Power for maintaining mechanical vibration of the crystal is fed back from the plate circuit of the oscillator tube. Since the crystal does not conduct direct current, a grid leak resistor is required between grid and cathode of the tube, in parallel with the crystal. A quartz crystal has a Q-factor of many thousands. It is more efficient than an ordinary resonant circuit

containing inductance and capacitance, and is less affected by the characteristics of any connected circuits.

The oscillating frequency varies inversely with thickness of any given type of crystal. A 2-megacycle crystal of the type commonly used for such a frequency is about $1/32$ inch thick. A 6.5-megacycle crystal, again of an appropriate type, may be about $1/64$ inch thick. This relation between frequency and

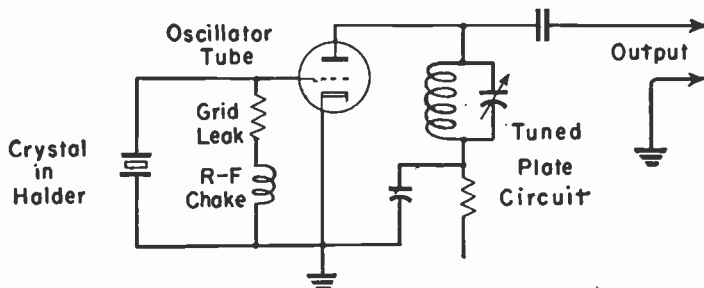

Fig. 20-1.—The circuit for a simple crystal-controlled oscillator.

thickness places practical limits on maximum fundamental frequencies, for crystals become more fragile as their thickness decreases. Fundamental frequencies seldom exceed 20 megacycles.

The maximum frequency limitation is not a serious disadvantage because, from a suitable oscillator or by the use of frequency multiplying circuits, it is possible to obtain usable harmonic frequencies of many times the fundamental. As an example, a 5-megacycle crystal will yield harmonic frequencies at every multiple of 5 megacycles all the way through to 200 megacycles, and even higher, with little difficulty.

Dual-frequency crystals will oscillate at either of two frequencies, depending on the tuning of the oscillator plate circuit. A dual-frequency crystal used in a number of signal generators will oscillate at either 0.1 or 1.0 megacycles, at 100 or 1,000 kilocycles. Harmonic frequencies are produced from both fundamental frequencies, usually as far as 20 megacycles from the 0.1 megacycle fundamental, and through 60 megacycles from the 1.0 megacycle fundamental.

The frequency accuracy of a crystal at some specified operating temperature may be expressed as a percentage, or as a maximum deviation of a certain number of kilocycles. For example, accuracy may be given as plus or minus something like 2, 5, or 30 kilocycles, with the greater deviations usually applying to crystals of relatively high frequencies. Percentage accuracies might be something like 0.002%, or 0.02%, or 0.05%, always plus or minus. These would correspond, respectively, to maximum deviations of 20, 200, and 500 cycles per megacycle of fundamental frequency.

Older types of crystals were subject to considerable frequency drift with change of operating temperature, and for maintained accuracy their temperature had to be held nearly constant by some kind of automatic heating device. Crystals of recent production undergo very small changes of frequency with moderate variation of temperature. Even in low cost units the frequency drift may be no more than 200 cycles per megacycle with the temperature varying between 14 and 140 degrees Fahrenheit. Some types of crystals have a positive temperature coefficient, their frequency increases with rise of temperature. Others have a negative coefficient, their frequency decreases with rise of temperature. The operating temperature of a crystal depends not alone on surrounding air temperature, ambient temperature, but also on the power dissipated by the crystal. Moderate oscillator plate voltage and moderate degrees of feedback help to reduce power dissipation and temperature.

Crystals are mounted in many different styles of holders. The body of the holder is of insulating material. Most often there are two extending pins which serve as mounting supports and as connections to internal metal plates which are on opposite sides of the crystal. Under the cover of the holder are insulating spacers and usually one or more pressure springs. Some of the two-pin types of crystal holders have the pins separated by $\frac{1}{4}$ inch center to center, others have separation of $\frac{1}{2}$ inch, and still others have $\frac{3}{4}$ inch spacing, center to center. There are also holders with two banana plugs instead

of the solid pins, while still others are designed for mounting in standard 5-pin or else octal tube sockets. The two-pin styles mount in crystal sockets designed for the purpose. Holders having no pins may be provided with solder lugs, or may have screws for holding solder lugs, or may have wire pigtails.

The two metal contact plates may both be in contact with the faces of the crystal, or there may be a small-air gap between the top plate and the crystal. The spacing in the gap has some effect on oscillating frequency. Crystal holders used with some types of laboratory apparatus have adjustable air gaps for varying the frequency through a small fraction of one per cent. Crystals may have the metallic contacting elements plated directly onto the quartz surface. Then additional loose metal plates provide electrical connection between the crystal coating and the terminals.

Crystal controlled oscillator tubes usually are operated with plate and screen voltages below the maximum ratings for the tube. With excessive plate voltage or excessive feedback voltage the crystal may vibrate so violently as to crack, and become useless.

Crystals and holders are originally assembled with great care. The holder never should be opened unless the crystal cannot be made to oscillate in a suitable circuit. Specks of dust or an oily film due to touching the crystal surfaces may reduce oscillation or prevent it. Crystal surfaces may be cleaned with a soft brush, warm water, and mild soap, then rinsed with clear water and dried with lintless cloth or photographic lens paper. Then handle the crystal only by its edges while replacing in the holder. Do not alter the spring pressure on metal plates, since this may have some slight effect on oscillating frequency.

CRYSTALS, RECTIFYING. — Crystal rectifiers or crystal diodes depend for their action on unequal conductivity for currents flowing in opposite directions through the contact between a crystalline body and the tip of a fine wire which touches the crystal surface. The crystalline material in most common use is germanium, employed in germanium crystal diodes. The

contact point is the end of a fine wire of non-oxidizing metal such as tungsten or platinum. Germanium crystal diodes are used regularly at frequencies up to 100 megacycles, and in some applications up to 500 megacycles. Silicon crystal diodes are available for frequencies ranging from 3,000 to more than 30,000 megacycles.

Crystal diodes are used in television for video detectors, discriminators and ratio detectors, d-c restorers, noise limiters and pulse limiters, rectifiers for high-frequency meters, and probe detectors for electronic voltmeters, oscilloscopes, and signal tracers. There are a number of special types, including matched pairs for use as discriminators or in any full-wave rectifier circuits, also single units which have been dynamically tested for use as video detectors.

The diode units are cylindrical, ranging in diameter from about $\frac{1}{8}$ to $\frac{1}{2}$ inch and in length from about $\frac{5}{8}$ to $\frac{7}{8}$ inch for different makes. Bodies are of ceramic, glass, and other insulating materials. Some types have exposed metal end caps, others are completely insulated. Circuit connections are made, and the crystal diodes may be supported, by means of wire pigtailed built into the ends of the diodes, just as such pigtailed are used on many fixed resistors and capacitors. The negative (-) end of the crystal diode corresponds to the cathode of a tube rectifier or diode detector, and the positive (+) end corresponds to the anode or plate.

Shunt capacitance of crystal diodes, by themselves, is on the order of 1 mmf. This shunt capacitance is increased somewhat by the wiring connections, but with care in mounting it need be only about 3 mmf. Different types of diodes are designed to withstand continual maximum peak inverse voltages of from 50 to 200 volts. That is, they may be used in circuits where peak a-c voltages are from 50 to 200, or where effective sine wave voltages are from 35 to 140.

Compared with tube rectifiers the crystal diodes have advantages of requiring no heater power, of easier mounting, and sometimes of simpler wiring. The general purpose crystal diodes will carry more direct current without overheating

than will commonly used miniature tube diodes. The forward resistance of these crystal diodes is considerably less than that of otherwise equivalent tube diodes. This is an advantage where the output load resistance must be small, since performance improves with a smaller ratio of rectifier internal resistance to load resistance. A disadvantage of crystal diodes in some applications is their inability to withstand as high inverse voltages as may safely be applied to tube rectifiers. Crystal diodes, except in special types, tend to be somewhat less uniform in operating characteristics than do tube diodes.

General purpose crystal diodes, such as the 1N34 and equivalent types, may be tested with an ohmmeter capable of indicating resistances all the way from hundreds of ohms up to hundreds of thousands of ohms. Back resistance must be many times greater than forward resistance. Indications will depend on the kind of ohmmeter and on the scale used, since apparent diode resistance varies with applied voltage. The most practical meter test is comparison of readings from a doubtful unit with readings from one known to be satisfactory, using the same ohmmeter scale. Substitution of a new diode for a doubtful one is even better. When making a replacement watch the diode polarity markings, and make new connections the same as the originals. Do not solder onto pigtailed closer than $\frac{1}{4}$ inch to the diode, and make the heating time brief.

D

DAMPERS AND DAMPING. — In the vertical deflecting coils for a picture tube employing magnetic deflection there is required a sawtooth current whose frequency is 60 cycles per second. In the coils for horizontal deflection the frequency must be 15,750 cycles per second. There are, however, such values of inductance and distributed capacitance in the circuit containing the deflection coils and output transformer that any sudden change of voltage or current in this circuit could cause oscillation at higher frequencies. The higher frequencies would be the resonant frequencies corresponding to circuit inductances and capacitances. Such oscillation would

prevent uniform travel of the picture tube beam. Consequently the deflection circuits must be sufficiently loaded to stop any higher-frequency oscillations. This is called damping.

In a vertical deflection circuit, as shown at the left in Fig. 22-1, sufficient damping may be obtained by connecting across each deflecting coil a resistor R of a few hundred ohms. In a horizontal deflection circuit, as shown much simplified

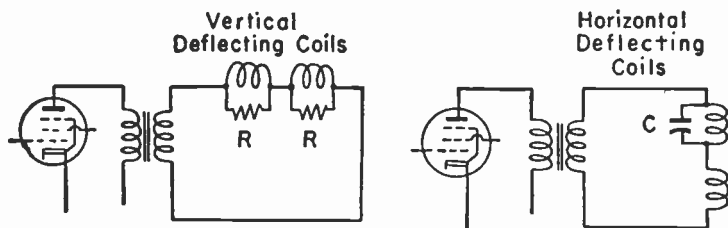

Fig. 22-1.—Simple circuits for magnetic deflection.

at the right, the tendency to oscillate is lessened by connecting across one of the coils a capacitor C of a few micro-microfarads. But because of the relatively high horizontal sweep frequency it is necessary to employ additional means for control and suppression of oscillation. These means will be described.

First it should be understood how oscillation is started and how it would continue were there no additional damping. At the top of Fig. 22-2 is shown waveform of voltage applied to the grid of the sweep amplifier tube. This is a sawtooth wave with each positive-going rise terminated by a sharp negative dip which precedes the next steady rise. The amplifier grid is negatively biased to a degree such that only about half of each sawtooth rise extends above plate current cutoff. Consequently, amplifier plate current flows only during separated peaked pulses as shown by the middle diagram. These pulses of current flow in the primary of the output transformer.

Each rise of amplifier plate current induces in the output transformer secondary and the deflecting coils a current increasing as from a to b in the bottom diagram. This is the current which causes the latter part of each horizontal trace. The rise of current produces a strong magnetic field around the

transformer and coils. When plate current is abruptly stopped by the amplifier grid going suddenly negative the magnetic field collapses. The magnetic lines contract during collapse,

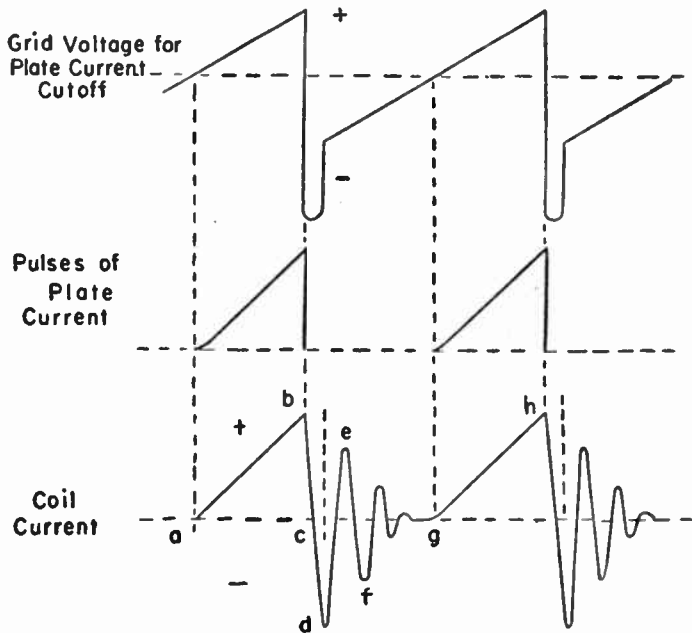

Fig. 22-2.—How oscillation may start and continue in a deflection coil circuit having no special means for damping.

whereas they expanded during growth of the field. The contraction induces in the coils and transformer secondary a current whose direction is opposite to that of the current which causes the magnetic field to expand. The opposite current is shown from *b* to *c* on the diagram: it is the start of the current which causes retrace of the picture tube beam.

Collapse of the magnetic field and decrease of current from *b* to *c* is at a rate corresponding to the resonant frequency of the coil circuit, as determined by inductance and capacitance of the coil circuit. This, of course, is the beginning of a cycle of oscillation. Since there now is little damping, the oscillatory current will continue from *c* to *d* and a new magnetic field

will be built up. Then this new field collapses and the current reverses. There are continued exchanges of energy between the magnetic fields and the circuit capacitance while the oscillatory current goes to e , then to f , and so on until it dies out because of circuit losses. Coil current would thereafter resume only with a new flow of plate current, at g .

During the period in which should be formed the first half of each horizontal trace, the beam actually would weave back and forth in following the current reversals from d to g of Fig. 22-2. Only during the second half of each horizontal trace period would the beam be deflected smoothly toward the right-hand side of the screen, by current changing from a to b

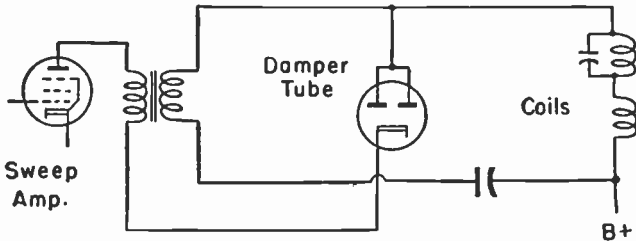

Fig. 22-3.—Connection of a damper tube in the coil circuit for magnetic deflection.

and from g to h . We need the first oscillatory reversal of current from b to d , for this is the retrace current, but to have a smooth forward trace from d to g there must be a uniform rise rather than oscillation.

To damp out continued oscillation the horizontal deflection circuit is changed as shown by Fig. 22-3. Here a diode damper tube is connected from one side of the coil circuit to the transformer primary. B-supply current flows in this path through the damper tube and the amplifier plate-cathode circuit. Because the damper tube must carry large currents at high voltage it usually is of a type such as commonly used for full-wave power rectifiers, but with its two plates connected in parallel.

Fig. 22-4 shows how oscillation is controlled by the damper tube. In the deflecting coil circuit the inductive reactance is

so much greater than the capacitive reactance that induced current lags the voltage by almost 90 degrees, and we may say that voltage leads the current by the same amount, which is almost a quarter-cycle. Consequently, by the time coil current has changed to point *b* the leading voltage has reached point

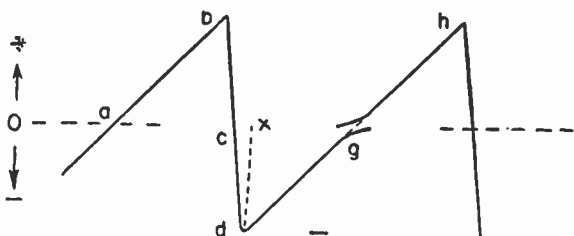

Fig. 22-4.—How oscillation is controlled and limited by the damper tube.

c and is making the damper plates negative. Then the damper tube is non-conductive. But by the time current has reached point *d* the leading voltage in this oscillating cycle has gone to point *x*, and is making the damper plates positive. Then the damper tube conducts and places a heavy current drain or heavy damping load on the coil circuit.

The loading or damping slows down the rate of magnetic field decay and the rate of oscillation. If the circuit is correctly designed and adjusted, the coil current which results from oscillation will decrease at a uniform rate from *d* to *g* and will die out on the zero line. Just as this current dies out there is the start of another current which is due to resumption of plate current in the sweep amplifier tube, as shown by the middle diagram of Fig. 22-2. This new current continues from *g* to *h* of Fig. 22-4. The two currents actually merge below and above the zero line to produce a smooth and uniform change all the way from *d* to *h*. Point *h* is the same as point *b* on the diagrams, and the whole process repeats for all following retraces and traces.

Voltage Boosting by Damper. — As shown by Fig. 22-3, the horizontal sweep amplifier receives its plate current and voltage through the damper tube. To the smooth B+ voltage from the receiver power supply are added pulses of voltage

and current produced by the quick changes of current in the deflecting coil circuit. The positive portions of these pulses are rectified by the damper tube; these are the current pulses which load the coil circuit. The voltage waveform at the damper cathode becomes as shown at the left in Fig. 22-5. In



Fig. 22-5.—Current irregularities are smoothed out by the inductor and capacitors of the linearity control.

the rising portion of this waveform are irregularities which must be removed to leave, at the lower end of the output transformer primary, a voltage waveform such as shown at the right.

Small irregularities of the voltage waveform are removed by adding a low-pass filter between the damper cathode and the transformer primary, as shown by Fig. 22-6. This filter is called a linearity control or linearity adjustment because it affects the deflection waveform through its influence on amplifier plate current. Pulses of voltage and current from the damper cathode charge capacitor C_a of the filter. This capaci-

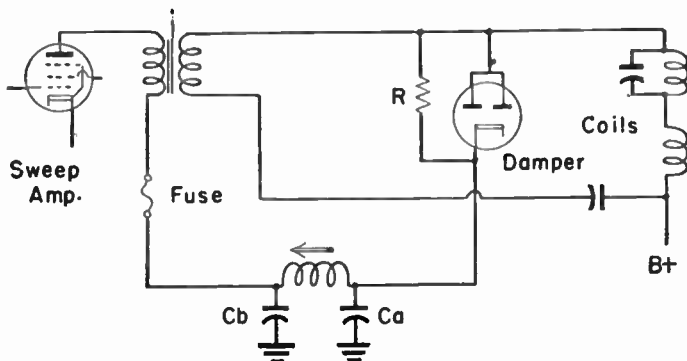

Fig. 22-6.—A horizontal linearity control connected between damper cathode and transformer primary.

tor discharges through the filter choke and the plate-cathode path of the sweep amplifier. The filter choke and capacitor Cb shift the phase of the pulses of voltage and current passing to the amplifier plate. The phasing or timing of these pulses is altered by adjustment of the core in the filter choke, so that the final result is a uniform or linear change of current in the deflecting coil circuit. Utilizing the deflection pulses or damping pulses in this manner increases the potential at the output transformer primary by 40 volts or more, in excess of the potential from the receiver B-power supply.

In the line between the filter choke and the transformer primary is a fuse, usually of $\frac{1}{4}$ -ampere rating. This fuse blows should the sweep amplifier tube become gassy and allow plate current great enough to burn out the transformer primary if continued. Resistor R , between damper plates and cathode, provides damping effect during the periods in which the damper tube is non-conductive.

Triode Damper Tube. — A twin triode tube instead of a twin diode sometimes is used as a damper. Typical connections are shown by Fig. 22-7. The two plates, the two grids, and the

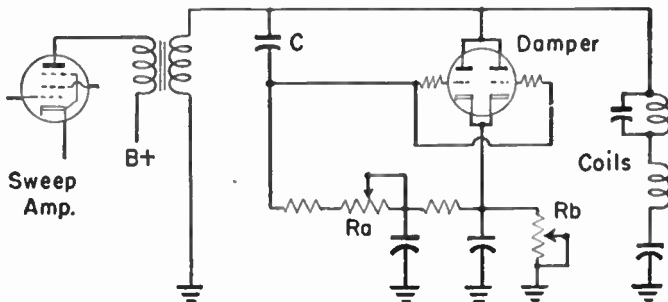

Fig. 22-7.—Circuit connections for a triode damper tube.

two cathodes are in parallel with each other, allowing the tube to act as a single heavy-duty triode. Capacitor C and resistors in the string which includes Ra and Rb form a phase shifting network. Adjustment of Ra alters the phasing or timing of voltage applied to the damper grids, and thus changes the

instant during the first oscillation cycle at which the damper becomes conductive and loads the coil circuit. Adjustment of resistor Rb varies the cathode bias of the damper and changes the portion of the sawtooth cycle during which the damper remains conductive.

Since adjustment of either Ra or Rb will affect the waveform of the sawtooth deflecting current, both these adjustments are linearity controls. The setting of Ra affects chiefly the center of the picture area. The setting of Rb affects chiefly the two sides of the picture, and also alters the width. This latter adjustment may have to be varied in connection with any other width control.

DECOUPLING. — When alternating plate currents, screen currents, or grid currents of any two or more amplifying stages flow in the same resistance those stages are resistance coupled one to another. If such currents flow in a common inductance there is inductive coupling, and if they flow in a common capacitance there is capacitive coupling, provided the circuits may operate at the same frequency. In any of these cases the alternating voltages produced across the common resistance or reactance are applied to all the stages. Intentional couplings allow signal voltages to proceed in a forward direction from one amplifying stage to the next. Unintentional couplings allow voltages to feed back in a reverse direction, from the output end back toward the input end of the amplifying system.

Back couplings which are most troublesome are due to resistance or impedance of a plate and screen power supply connected to two or more amplifying stages. In Fig. 23-1 the plates and screens of both tubes are connected to a common power supply whose impedance causes back coupling. The back coupling may be lessened to some extent by connecting bypass capacitors Cs and Cs as shown. If the capacitive reactance of these bypasses is small in comparison with the impedance of the power supply, then most of the alternating signal will flow back to the tube cathodes through the bypasses and ground and will not flow in the power supply.

Back coupling through the power supply may be further lessened by inserting decoupling resistors R_d and R_d of Fig. 23-2. These resistances, in effect, add to the resistance or impedance of the power supply and make more opposition to signal currents flowing through the power supply. This forces more of the signal currents through the bypass capacitors to the tube cathodes.

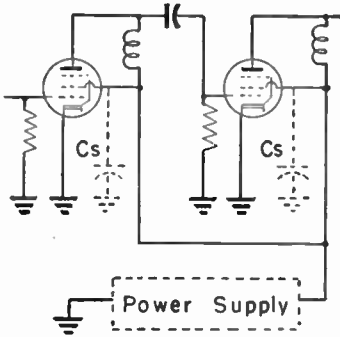

Fig. 23-1.—Feedback coupling through impedance of a common power supply.

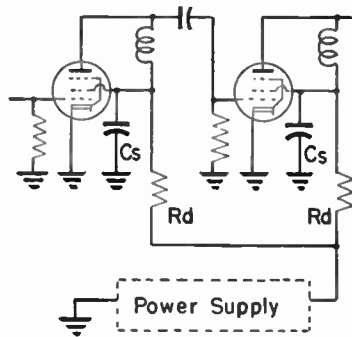

Fig. 23-2.—Partial decoupling by resistors in the plate-screen leads.

Fairly complete decoupling of one stage from all other stages is illustrated by Fig. 23-3. Plate circuit signal currents which would pass through the power supply now are opposed by decoupling resistor R_d , and are bypassed through ground to the tube cathode through decoupling capacitor C_d . Variations of signal voltage appear on the screen as well as on the plate of the amplifier. Accompanying variations of screen current are opposed in their passage to the power supply by resistors R_s and R_d , and are bypassed through decoupling capacitor C_s and ground to the tube cathode. Variations of screen current are prevented from affecting the plate circuit by the resistance of R_s and the bypassing effect of C_s .

The left-hand tube of Fig. 23-3 is shown as having a fixed bias or a bias provided by an automatic gain control system. A-c signal voltages in the grid circuit are opposed by decoupling resistor R_b in their effect on the common bias sup-

ply, and are bypassed to the tube cathode through decoupling capacitor C_b and ground. The right-hand tube is shown as having cathode bias. The bypass capacitor across a cathode bias resistor is not considered as a decoupling capacitor, its function is chiefly that of controlling degeneration and gain.

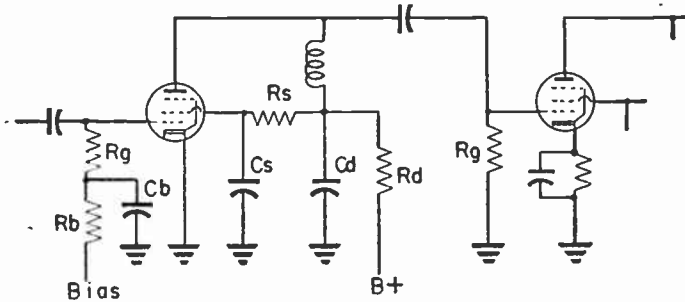

Fig. 23-3.—Separate decoupling for plate, screen, and grid circuits.

If the phase or instantaneous polarity of feedback voltage to the grid of an amplifier is opposite or nearly opposite to that of signal voltage for forward amplification the feedback is degenerative. This opposes forward signal voltage and reduces amplification. If phase or polarity of feedback is the same or nearly the same as that of forward signal voltage the feedback is regenerative. This aids the forward signal voltage and tends to increase amplification. Whether a feedback is degenerative or regenerative depends on the point from which this voltage originates in circuits following the affected grid circuit, and on whether or not there is phase shift between the origin and the amplifier grid input. Uncontrolled regenerative feedback may merely increase amplification, but usually it causes excessive peaking at some frequencies or outright oscillation. The purpose of decoupling ordinarily is to prevent uncontrolled regenerative feedbacks.

Decoupling capacitors and resistors are used in r-f amplifiers, in video i-f amplifiers, in video amplifiers, and also somewhat less completely in sound i-f amplifiers and in audio-frequency amplifiers. The subject of decoupling is closely related to that of shielding, since shielding lessens feedbacks

which are due to magnetic and electrostatic fields. Decoupling is assisted also by correct grounding, by using the shortest possible connecting leads, and by correct dressing of wires and parts.

Decoupling Capacitance and Resistance. — The effectiveness of decoupling is the ratio of the bypassed resistance to the capacitive reactance of the decoupling capacitor. If this ratio is 10 to 1, as an example, ten times as much signal voltage will be bypassed back to the cathode as goes through the power supply. Ratios between 10 to 1 and 5 to 1 are generally used. Although the bypassed resistance usually is considered as only that of the decoupling resistor, it really is the sum of this resistance plus the resistance or impedance of the power supply and associated circuits.

To retain a given effectiveness, the capacitance of a decoupling capacitor is inversely proportional to the lowest frequency at which the effectiveness is to be maintained. That is, at $1/5$ the frequency it becomes necessary to use 5 times the capacitance to maintain the original capacitive reactance. A given degree of decoupling at a frame frequency of 30 cycles would call for a million times as much capacitance as at a video intermediate frequency of 30 megacycles.

The greater the decoupling resistance can be made the smaller need be the decoupling capacitance. A high resistance allows using a proportionately high capacitive reactance while retaining a given decoupling ratio. High capacitive reactance is found in relatively small capacitances. While increase of decoupling resistance is advantageous so far as capacitance is concerned, it causes greater voltage drop, requires more power supply voltage, and wastes more power in heating.

Electrolytic capacitors are used for decoupling at maximum frequencies around 5,000 cycles. They have too much internal resistance, and usually too much inductance and inductive reactance for use at higher frequencies. Ordinary rolled-foil paper dielectric capacitors have too much inductance and inductive reactance for use at frequencies even as high as standard broadcast radio frequencies. Non-inductive paper

capacitors are used for bypassing at radio frequencies. For television carrier frequencies, video intermediate frequencies, and the higher video frequencies it is necessary to use mica and ceramic capacitors which have negligible resistance and inductance.

When circuits, such as those in video amplifiers, have to carry a wide band of frequencies the large capacitance for low-frequency decoupling may be provided with electrolytic or large-capacitance paper capacitors having in parallel a small-capacitance mica or ceramic unit. The mica or ceramic capacitor bypasses the high inductive reactance of the electrolytic or paper unit at high frequencies.

Plate and Screen Decoupling. — Too little capacitance in a plate decoupling capacitor (C_d of Fig. 23-3) may allow frequency distortion or peaking at certain frequencies even though it does not allow oscillation. If there is to be no degeneration in a stage having cathode bias, the plate decoupling capacitor should be connected directly to the tube cathode. If this capacitor is connected to ground the plate signal currents must pass from ground through the biasing resistor unless the resistor is provided with a large capacitance bypass capacitor. It should be noted that, with a plate decoupling capacitor large enough, the decoupling resistor is not a part of the load in the plate circuit. Signal currents are kept out of this resistor by the decoupling capacitor.

The screen requires effective decoupling because variations of screen voltage may have almost as much effect on electron flow as would variations of grid signal voltage. Insufficient screen decoupling allows distortion and generally erratic performance. The small screen current allows using high de-

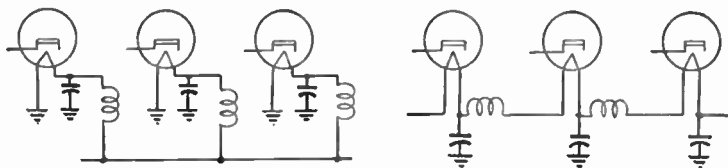

Fig. 23-4.—Decoupling chokes and capacitors for heater circuits.

coupling resistance without excessive voltage drop, and the high resistance permits fairly small capacitance for effective decoupling.

Heater Decoupling.— Back coupling may occur through leads for the cathode heaters in tubes for r-f and i-f amplifiers. Decoupling may be provided by r-f chokes and bypass capacitors to ground. A method used with heaters in parallel is shown at the left in Fig. 23-4, and a method for series heaters is shown at the right. The chokes may be made with 10 to 20 turns of enameled wire wound to a diameter of about $\frac{1}{4}$ inch, closely spaced, and with air cores. The bypass capacitors may have each a capacitance of 100 mmf or more, often as large as 0.002 mf.

DEFLECTION, ELECTROSTATIC.— Fig. 24-1 represents the electron beam from the electron gun of a picture tube passing through the space between two metallic plates charged in opposite polarities. The negative electrons in the beam are attracted toward the plate which is positive and at the same time are repelled away from the plate which is negative. Consequently, the beam is bent or deflected during its travel

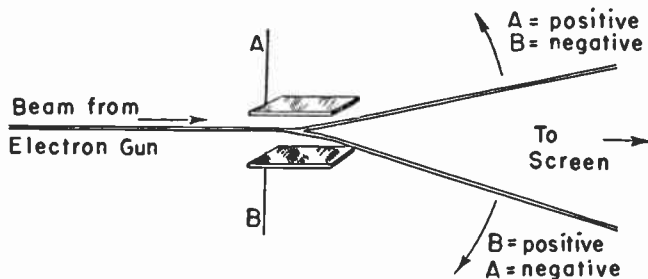

Fig. 24-1.—The picture tube beam is deflected by opposite charges on metallic plates inside of electrostatic picture tubes.

through the electrostatic field between the two plates. After the electrons of the beam leave the field they again travel in a straight line which is at an angle to the line of their original direction.

If the two deflecting plates are one above the other, as in the figure, the beam is deflected upward while plate *A* is positive and plate *B* negative. If plate polarities are reversed

the beam will be deflected downward. A pair of plates thus arranged vertically one above the other will cause vertical deflection of the beam. If plates of another pair are placed so that they are on the right and left of the beam, instead of above and below the beam, these other plates will deflect the beam horizontally.

By using two pairs of deflecting plates, one pair ahead of the other as in Fig. 24-2, it becomes possible to deflect the electron beam horizontally and vertically at the same time; horizontally to form the picture lines or traces, and vertically

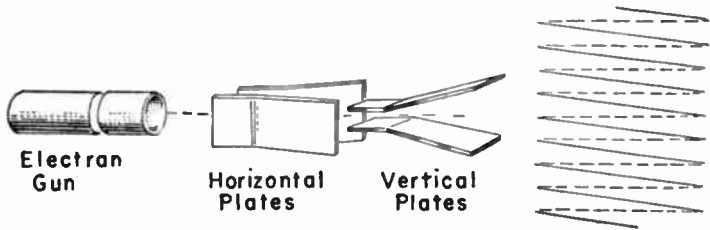

Fig. 24-2.—Relative positions of horizontal and vertical deflecting plates in an electrostatic picture tube.

to form the successive fields of the picture. The pair of plates farther from the screen and nearer the electron gun are used for horizontal deflection. These are deflecting plates or electrodes referred to as D_3 and D_4 . The pair nearer the screen, D_1 and D_2 , are used for vertical deflection.

Fig. 24-3 shows the waveforms of the two deflecting voltages

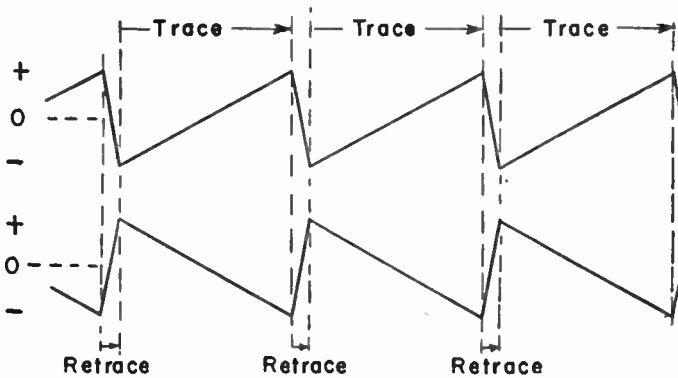

Fig. 24-3.—Waveforms of deflection voltages applied to opposite plates of one pair.

applied simultaneously to the two plates of one deflecting pair. These are sawtooth voltages changing their strengths in opposite polarities at the same instants, as supplied from the horizontal or vertical deflection amplifiers or sweep amplifiers. The deflecting voltages may be observed on an oscilloscope connected to the plate of each sweep amplifier tube.

For a tube of given construction the distance the beam is deflected across the screen, vertically or horizontally, is directly proportional to the deflecting voltage applied to the pair of plates. That is, doubling the voltage from the sweep amplifiers will double the deflection distance. This deflection distance is inversely proportional to the voltage applied to the high-voltage anode of the picture tube. Doubling the anode voltage would halve the deflection distance.

When a picture tube is first installed or when replaced, the pictures or test patterns may not be square with the mask opening. The picture or pattern may be tilted one way or the other. This is corrected by first noting the direction of displacement, then disconnecting the receiver from the power line, waiting for filter capacitors to discharge, and rotating the tube in its supports.

DEFLECTION, MAGNETIC. — The majority of television receivers have picture tubes designed for magnetic deflection of the electron beam both horizontally and vertically. These deflections are caused by magnetic fields passing at right angles through the neck of the tube at a point just back of the flare. The fields are produced by sawtooth currents flowing in deflecting coils which are built into a structure called the yoke. The yoke is mounted around the outside of the tube neck just back of the flare.

Electrons flowing in the picture tube beam act like electrons flowing in a wire conductor so far as magnetic effects are concerned. The rotor of an electric motor revolves because electrons flowing in its wires are forced to move at right angles to the flow direction by magnetic fields of the stator, and the wires and stator move with the electrons.

The direction in which the electron beam is deflected by a magnetic field is shown by Fig. 25-1. While passing through the field the beam is bent at right angles to the direction of field lines and also at right angles to its original direction. The beam is deflected out of the magnetic field. In order to have vertical deflection, as pictured at the left, the magnetic field

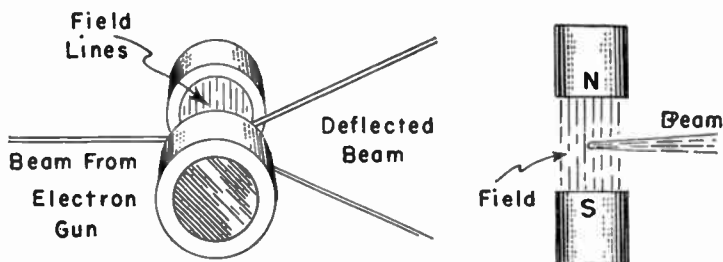

Fig. 25-1.—Deflection of an electron beam when passing through a magnetic field.

lines must run horizontally. Then the coils between which are the magnetic lines for vertical deflection must be at the sides of the tube neck, not above and below the neck. To deflect the beam horizontally the magnetic field lines must be vertical, and the coils for horizontal deflection must be above and below the neck of the picture tube.

In the right-hand sketch of Fig. 25-1 the electron beam is coming toward you, out of the paper. With north and south magnetic fields in the positions shown, the beam will be deflected toward the right. If this magnetic polarity is reversed the beam will be deflected toward the left. A magnetic field deflects electrons only when the electrons are in motion. A magnetic field does not change the speed of the electrons, only their direction.

Electrons in the beam of a magnetic-deflection tube must be pulled away from the cathode and accelerated toward the screen by electric or electrostatic fields or electrostatic attraction. This attraction is furnished by high positive potentials on elements of the electron gun and sometimes on additional anodes near the front of the tube flare. The distance the beam is deflected is directly proportional to the strength or density

of the magnetic field. Twice the field strength doubles the deflection distance. Deflection is inversely proportional to the square root of voltage applied to the high-voltage anode of the picture tube. The greater is this anode voltage the less will be the deflection for a given strength of deflecting field.

Deflecting currents must be of sawtooth waveform, just as deflecting voltages for electrostatic deflection must be of sawtooth waveform. However, a sawtooth voltage applied to a deflecting coil would not produce a sawtooth current in the coil, because the effect of inductance in the coil circuit prevents the current from following the applied voltage. If an oscilloscope is connected across a deflecting coil the voltage will be shown as an approximate square wave consisting of

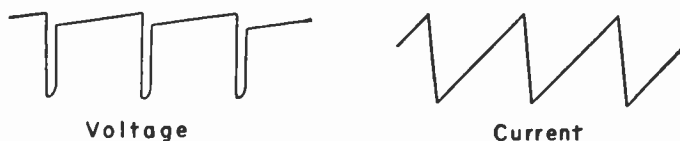

Fig. 25-2.—Waveforms of voltage and current in magnetic deflecting coils.

sharp negative dips at the instants of current reversal for retraces. Voltage will be about as shown at the left in Fig. 25-2, while current will be as at the right. To observe the current waveform a resistor of 3 or 4 ohms may be temporarily connected in series with the coil, and the oscilloscope connected across the ends of this resistor.

Deflecting coils are constructed to provide uniform distribution of field strength throughout the entire space within which deflection is to occur. Otherwise there is poor focusing, due to distortion of the spot on the screen, and there is distortion of the picture. This distortion may take the form of a picture wider or narrower at the middle than at the top and bottom, or it may be higher at the middle than at the sides. Instead of being wider or higher, the picture may be narrower or lower at the middle than at the corners. The coil inductance and resistance, or their ratio, must be adapted to the output transformer and to the characteristics of the sweep amplifier to have

satisfactory performance. The coils must be well insulated, especially in the horizontal deflection system, because the voltage induced during the retrace period is five or six times greater than the sawtooth deflecting voltage which produces deflecting current.

A typical arrangement of coils in a deflecting yoke is illustrated by Fig. 25-3. The diagrams represent a cross section cut vertically through the middle of the yoke structure, at right angles to the axis of the picture tube neck. The position

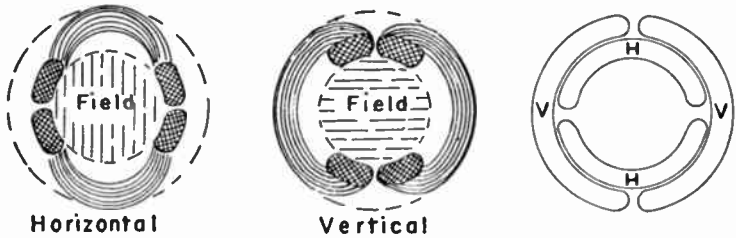

Fig. 25-3.—Arrangement of coils in a magnetic deflecting yoke.

of the horizontal deflecting coils is shown at the left. The top and bottom coils are connected together in series so that the magnetic pole on the inside of one coil is north while the pole in the inside of the other coil is south.

The center diagram shows the position of the two coils for vertical deflection. The sides of these two coils are bent down into the space within the two horizontal coils. The fields of the horizontal coils and of the vertical coils are, of course, at

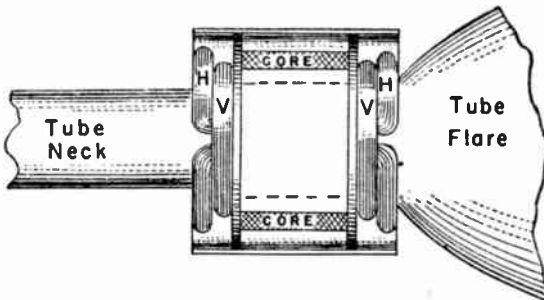

Fig. 25-4.—Positions of the yoke and deflecting coils on the neck of a picture tube.

right angles to each other. The magnetic effects of the two sets of coils are the same as though the pairs were placed as in the right-hand diagram.

Fig. 25-4 is a side view of the deflecting coils as they would appear with the fibre cover of the yoke removed and with part of the center cut away to show how the core, of finely laminated soft iron, is placed around the outside of the coils. The yoke is supported with its center axis in line with the axis through the tube neck, and is held close against the back of the flare.

If the picture or pattern is not square with the mask opening the deflecting yoke may be rotated around the tube neck to make it so. The screw or screws in the yoke housing are loosened, with the receiver turned off, while the yoke is rotated to align the picture. The yoke should remain close against the tube flare.

DEGENERATION. — Degeneration occurs when there is fed back to the input or grid circuit of an amplifier a signal voltage which opposes the signal voltage being amplified. Degeneration requires a feedback which is in opposite or nearly opposite phase to the amplified signal. Degeneration is called also negative feedback or inverse feedback. A degenerative feedback reduces the gain of the amplifier. At the same time the amplifier is less likely to oscillate, the gain becomes more uniform at all frequencies, there is less harmonic distortion, less phase distortion, and less effect of tube noise. There is also less likelihood of trouble due to power line voltage fluctuations, to changes of load resistance, or to aging of amplifier tubes.

If a feedback voltage is in phase or nearly in phase with the amplified signal voltage the result is regeneration. This increases the gain because the input or grid signal voltage is increased, but there is more distortion and the amplifier may oscillate. If there is phase shift with variations of frequency in circuits furnishing the feedback, the result may be degeneration at some frequencies and regeneration at other frequencies.

There are two general methods of providing feedback. If feedback voltage results from changes of signal current in the amplifier output or in some following stage there is said to be current feedback. If feedback results from signal voltages anywhere in the output there is voltage feedback. Current feedback tends to maintain a stable output signal current, it acts like an increase of plate resistance in the amplifier tube when there is increase of feedback. Voltage feedback tends to maintain a stable output signal voltage, it acts like a decrease of plate resistance. Both kinds of feedback may be used in the same amplifier.

Current Feedback.—The most commonly employed method of obtaining current feedback is with a biasing resistor in the cathode circuit of the amplifier tube. Such a resistor is shown at R_k in Fig. 26-1. When the input signal goes positive the grid is made more positive, or less negative when there is a negative bias. There is a corresponding increase of plate current, a greater voltage drop in the plate load, and the voltage at the amplifier plate becomes more negative. The plate current now being considered is a variation of signal current. There must be the same change of current in the entire plate circuit, which includes not only the plate load but also the cathode resistor and capacitor C_d forming the plate return for the signal current. The increase of plate current in the cathode resistor causes increased electron flow toward the cathode, and the upper end of the resistor becomes more positive while the lower end becomes more negative. This

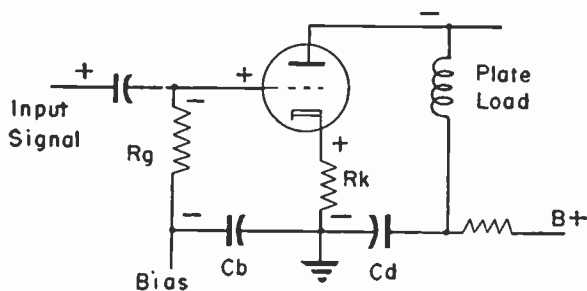

Fig. 26-1.—Current feedback obtained by means of a cathode resistor.

more negative signal voltage passes through capacitor C_b to the lower end of grid resistor R_g . Since, with negative bias, there is no current in R_g there is no change of potential in this resistor, and the increase of negative voltage is applied from the upper end of R_g to the grid. Thus a positive grid signal voltage causes a negative grid feedback voltage due to change of signal current in the cathode resistor.

The change of voltage actually applied to the tube grid is not the change of signal voltage, it is the signal voltage minus the opposing voltage developed across the cathode resistor and applied between grid and cathode. This negative feedback has the effect of flattening and straightening a curve showing the relation between grid voltage and plate current. Then harmonic distortion is reduced because such distortion results from curvature of this characteristic. Other advantages previously mentioned might similarly be traced to degenerative effects.

The greater the resistance of the cathode resistor R_k the greater will be the voltage drop or feedback voltage for a given variation of signal current, and the less will be the amplifier gain. If the cathode resistor is bypassed with a capacitor, part of the a-c signal current will act simply to charge and discharge the capacitor and less will remain across R_k to produce negative feedback. The greater the bypassing capacitance, and the less its capacitive reactance, the less will be the negative feedback. Capacitive reactance increases as frequency drops. Consequently, the bypassing will be less effective at low frequencies and there will be more degeneration at low frequencies than at higher ones.

Degeneration by means of a cathode resistor is commonly employed in video amplifiers. The degree of degeneration is determined by the resistance in series with the amplifier cathode and by the bypassing capacitance if any is used. Using a small bypass capacitance allows considerable degeneration at low video frequencies and automatically lessens degeneration and increases gain as frequency rises.

Voltage Feedback. — Fig. 26-2 shows one method of obtaining a degenerative voltage feedback. Between the plate of the right-hand amplifier and the grid input to the same tube are connected in series a capacitor C_f and a resistor R_f . Either the capacitor or the resistor often are used alone. Because change of signal voltage at the plate of an amplifier always is in opposite phase or opposite polarity to change of signal voltage at the grid of the same amplifier, the voltage fed back to the grid is degenerative. The degree of degeneration is fixed by the resistance of R_f or the capacitive reactance of C_f when only one of these elements is used. The greater the resistance or reactance the less is the degenerative voltage fed to the grid.

There is inversion of signal voltage in each stage of a cascade amplifier. Voltages are in phase, or approximately so, at the plate of a second amplifier and the grid of the first

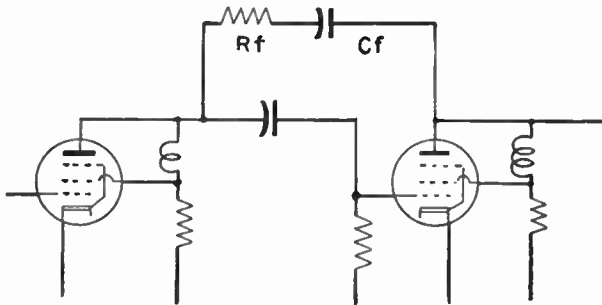

Fig. 26-2.—One method of obtaining voltage feedback.

amplifier in an adjacent pair. Were the feedback from the plate of the right-hand tube of Fig. 26-2 applied to the grid input circuit of the left hand tube the feedback voltage would be in phase with the grid voltage. The result would be regeneration instead of degeneration.

The phase or polarity of signal voltage at the cathode of an amplifier is the same as at the grid of the same tube. Therefore, a small capacitor connected between plate and cathode will apply a negative feedback to the grid.

There are numerous other methods of obtaining voltage feedback. A degenerative feedback may be had from any point after the output of an amplifier where the signal voltage is inverted or in opposite phase to the grid signal voltage of the amplifier. A regenerative feedback may be obtained from any point where the signal voltage is in phase with or of the same polarity as the grid signal voltage for the amplifier.

DETECTOR, PHASE. — A phase detector is a device which produces in its output a direct potential varying in accordance with changes of relative frequency in two voltages applied to the detector input. Fig. 27-1 shows circuit connections for a phase detector used in an automatic control for horizontal sweep frequency. The detector tube is a twin diode whose sections are marked *A* and *B*. Connected from the plate of *A* to the cathode of *B* are resistors *R_a* and *R_b*. To a point between these two resistors are applied the voltage pulses fed back from some point in the horizontal sweep output circuits. The frequency of these pulses is the same as the actual frequency of the horizontal sweep currents in the picture tube deflection coils. These sweep pulses appear without change of polarity at the upper end of resistor *R_a* and at the lower end of resistor *R_b*.

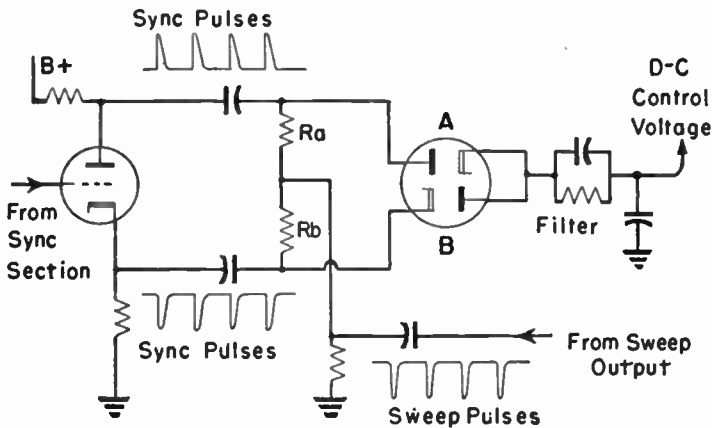

Fig. 27-1.—Connections in one type of phase detector circuit.

To the outer ends of the two resistors are applied voltage pulses coming from the sync section of the receiver. The frequency of these pulses is the same as that of the horizontal sync frequency in the received signal. The inverter tube, at the left, delivers the sync pulses in opposite polarity at the two resistors. The results of applying two voltages of the same or different frequencies to diodes connected as in Fig. 27-1 is explained at some length in the article on *Detector, Ratio*.

So long as the frequencies of sweep pulses and sync pulses are the same there is equal conduction in the two diodes, and zero potential with reference to ground at the detector output on the right. If the actual sweep pulse frequency should change with reference to the horizontal sync pulse frequency there will be unequal conduction in the diodes. Then there will appear at the output a potential which is either positive or negative with reference to ground, depending on whether sweep frequency increases or decreases. This output potential may be applied in various ways to the horizontal sweep oscillator to bring oscillator frequency and sweep frequency back into synchronization with the sync pulses. Any deviation of sweep frequency results in a change of output potential and amplitude with this phase detector, just as does deviation of signal frequency with the ratio detector for sound.

The filter of Fig. 27-1 prevents sudden changes of pulse amplitude from affecting the output potential. Such changes might result from electrical interference or other disturbances coming through the receiver to the sync section.

DETECTOR, RATIO. — A ratio detector is a device for obtaining from a frequency-modulated signal an audio voltage corresponding in frequency and amplitude to the original modulation. In a frequency-modulated signal the frequency varies or deviates above and below an average value which is the intermediate frequency of the receiver sound system. The number of times per second that the signal frequency deviates above and below the intermediate value is the same as the number of cycles per second of the audio-frequency modulation. How far each deviation goes above and below the inter-

mediate frequency corresponds to the amplitude or strength of the audio-frequency modulation.

In ratio detector circuits there are numerous modifications which do not alter the basic operating principles. These principles will be explained with reference to the circuit of Fig.

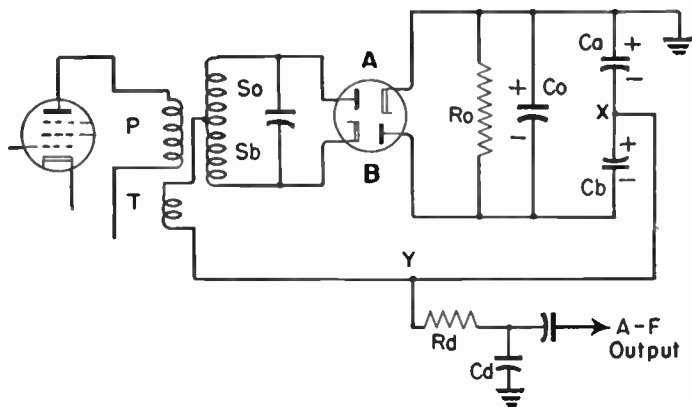

Fig. 28-1.—Typical circuit for a ratio detector used in f-m sound systems.

28-1. The detector consists of two diodes and a three-winding transformer which act together in obtaining from the f-m signal an audio voltage whose frequency is the same as the rate of deviation and whose amplitude varies as the extent of deviation.

The primary winding P of the detector transformer is in the plate circuit of the last sound i-f amplifier tube. The primary is coupled by mutual induction to a center-tapped secondary winding, Sa and Sb , whose outer ends connect to the plate of diode A and to the cathode of diode B . Primary and secondary windings have adjustable cores by means of which both windings are tuned to resonance at the sound intermediate frequency or center frequency. This is a service adjustment.

The third transformer winding T is connected from the center tap of the secondary to a point between two small capacitors, Ca and Cb , which are in series with each other between the cathode of diode A and the plate of diode B . This third winding is inductively coupled to the primary winding,

often being wound over the low end of the primary. Also connected between the cathode of diode *A* and the plate of diode *B* are the load resistor *R_o* and a large capacitor *C_o*.

In the third winding of the transformer is induced a voltage whose phase relation to the primary signal voltage is not altered by deviations of frequency. Because this fixed-phase voltage is put into the center tap of the secondary winding the same voltage appears at both ends of the secondary without change of either phase or polarity. However, the voltages which are induced in the secondary by means of its mutual inductive coupling to the primary will vary in their phase relations to the primary voltage when there is frequency deviation.

Changes of phase, and the results, are shown by Fig. 28-2. At the top are conditions when there is no frequency deviation. Voltage from the third winding of the transformer is at both ends of the secondary, being indicated by solid-line curves marked *T*. The phase is the same as in the primary. With no deviation the applied signal frequency is the resonant frequency to which the windings are tuned. Reactances balance at resonance, and only resistance remains to affect the secondary. Voltages induced in the secondary by inductive coupling to the primary are one-quarter cycle out of phase with voltage *T*. These induced voltages are shown by broken-line curves marked *A* and *B*. Their polarities are opposite at the two ends of the secondary, as occurs at the two ends of any transformer winding in which voltage is induced. The two pairs of voltages, *T-A* and *T-B*, at the top and bottom of the secondary combine as shown over at the right. These combination voltages are applied to the plate of diode *A* and to the cathode of diode *B*.

Diode *A* will conduct while its plate is positive. The brief conduction current will flow through the top half of the secondary and through winding *T*, will charge capacitor *C_a* in the polarity marked in Fig. 28-1, and go to the cathode of diode *A*. Diode *B* will conduct while its cathode is negative. This conduction current will charge capacitor *C_b* in the

polarity marked. The two diodes voltages are of equal amplitude, conduction currents will be equal, and the two small capacitors will be equally charged. Since capacitors C_a and C_b

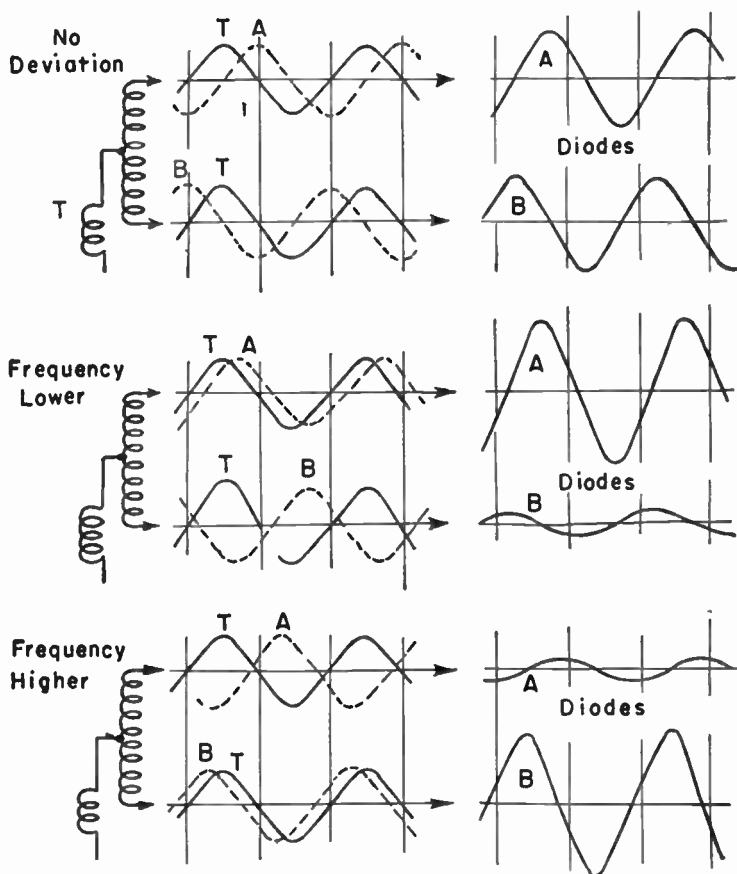

Fig. 28-2.—Changes of voltage phase in a ratio detector, and their results on diode voltage and current.

are across capacitor C_o this latter capacitor will be charged to a potential equal to the sum of the potentials across C_a and C_b . These charges gradually leak off through resistor R_o , but are continually renewed by the diode conduction currents.

The middle group of curves in Fig. 28-2 shows what happens when there is signal deviation to a lower frequency. When there is applied to a tuned circuit (the secondary wind-

ing) a frequency lower than that for which the circuit is resonant that circuit presents an excess of capacitive reactance, because capacitive reactance (in the secondary) increases while inductive reactance drops when frequency is lowered. Any capacitive reactance tends to make an induced a-c voltage lead the inducing (primary) voltage. This leading tendency has the effect of lessening the original lag of voltage A behind voltage T at the top of Fig. 28-2, and these voltages at the top of the secondary come more nearly into phase. The combination of these nearly phased voltages results in a much stronger voltage for diode A , as shown over at the right.

Since voltages at top and bottom of the secondary must remain in phase and of opposite polarity, we have at the bottom of the secondary an induced voltage B whose phase is nearly opposite to that of the fixed voltage T . Here the two voltages almost cancel and, as shown at the right, the combined voltage applied to diode B becomes very weak. Thus it appears that, when deviation is to a lower frequency, conduction in diode A will be greater than in diode B . Then capacitor Ca will receive more charge and will have greater voltage than capacitor Cb .

Conditions with deviation to a higher frequency are shown by the bottom group of curves in Fig. 28-2. Now the secondary winding offers an excess of inductive reactance, because inductive reactance increases while capacitive reactance drops when frequency goes up. Inductive reactance tends to make an induced a-c voltage lag the inducing voltage. This lagging tendency increases the original lag of voltage A behind voltage T in the top group of curves.

Now the two voltages at the top of the secondary are of nearly opposite phase, they almost cancel each other, and the combined voltage applied to diode A becomes very weak, as shown at the right. At the same time the combined voltage applied to diode B becomes much stronger. Conduction in diode B will be greater than in diode A when deviation is to a higher frequency, and capacitor Cb will receive more charge and will have a higher voltage than capacitor Ca .

It has been shown that deviation above and below the intermediate frequency causes changes of voltage on capacitors C_a and C_b . The number of deviations per second equals the audio frequency in cycles per second of the sound signal. Therefore, the changes of capacitor voltages will be at this audio frequency.

The greater the deviation or the greater the changes of frequency, the greater will be the differences between the phase of the fixed voltage T in Fig. 28-2 and the induced secondary voltages A and B . The greater the phase shift the stronger will be the combined voltages at one diode and the weaker they will be at the other diode. There will be corresponding differences in conduction currents and in charges and voltages on capacitors C_a and C_b . That is, greater deviation results in greater capacitor voltages, and since the extent of deviation represents strength of audio modulation the changes of capacitor voltages will follow the audio strength of signal modulation.

Capacitor voltages thus are found to vary at a rate corresponding to audio frequency, and to a degree corresponding to audio strength or "volume." This audio frequency voltage may be taken from across either of the capacitors C_a or C_b by suitable circuit arrangements. In Fig. 28-1 the audio frequency is taken from across capacitor C_a . The upper end of this capacitor is directly connected to ground. The lower end is connected to ground through points X and Y , and through resistor R_d and capacitor C_d . These latter two units form the de-emphasis filter required in all f-m audio amplifiers. The audio output is taken from the filter.

While a ratio detector translates frequency modulation into audio-frequency output, changes of input signal amplitude do not produce audio-frequency voltages in the output. This is due to the action of capacitor C_o and resistor R_o of Fig. 28-1. The capacitance of C_o is large, usually between 2 and 10 microfarads. The resistance of R_o is such that the discharge time constant of the combination is much longer than the period of the lowest audible frequency. Consequently, the

charge and the voltage of capacitor C_o cannot change at an audio rate.

Increases of voltage across capacitor C_a are matched by decreases of voltage across C_b , and vice versa. Although each of these separate voltages varies at audio frequency, their sum must remain practically constant because the sum always must equal the nearly constant voltage across C_o . Any change of signal amplitude (not frequency) tends to cause an increase or decrease of voltage across both small capacitors at the same time. This would change their sum voltage. But the sum voltage cannot change at an audible rate because it must remain equal to the voltage across the large capacitor C_o , and this voltage will not vary at an audible frequency.

DETECTOR, VIDEO. — The video detector recovers from the amplitude-modulated video intermediate frequency all the picture signal variations and all the sync pulses together with blanking level intervals of the television signal. This detector,

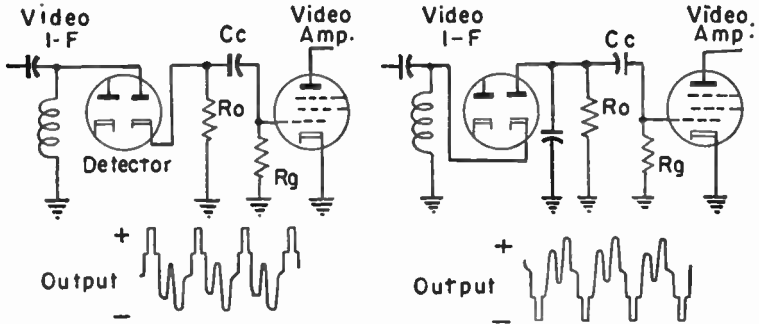

Fig. 29-1.—Video signal polarities of the outputs of diode video detectors.

as shown by Fig. 29-1, is connected between the last video i-f amplifier and the first video amplifier. In the majority of receivers the video detector is one section of a twin triode, whose other section may be used for automatic gain control, for d-c restoration, or any other purpose.

The i-f signal input may be to the plate of the detector with output from the cathode as at the left in Fig. 29-1, or the input may be to the cathode with output from the plate as at the right. With input to the detector plate, picture signals are negative and sync pulses are positive in the output. With input to detector cathode, picture signals are positive and sync pulses negative in the output.

The detector must handle the same wide range of frequencies as the video amplifier, consequently is subject to the same difficulties due to wide band coverage as are encountered in the video amplifier. The detector load resistor, R_o in Fig. 29-1, is of only 2,000 to 5,000 ohms resistance in order to lessen the effects of shunting capacitances at high frequencies. Coupling capacitor C_c is of 0.05 to 0.10 μf capacitance in order to keep its capacitive reactance reasonably small at the lowest video frequencies.

The small load resistance in the detector output and the rather small internal resistance of a diode have the effect of

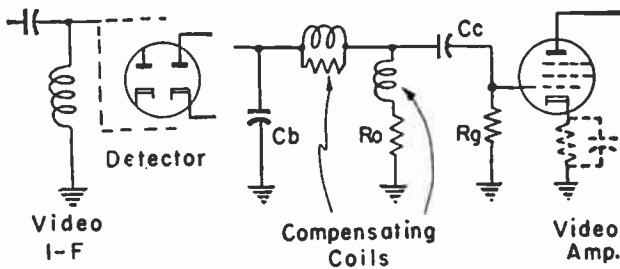

Fig. 29-2.—Features found in couplings between video detector and first video amplifier.

heavily loading the video i-f stage which precedes the detector. This broadens the frequency response while reducing the gain of that stage.

Fig. 29-2 illustrates some features which may be found in circuits between the video detector and video amplifier. The

series and shunt compensating coils are like those used in video amplifier couplings, and serve the same purpose of extending the response to higher frequencies. The small capacitor at C_b , usually 5 to 10 mmf, bypasses the high video intermediate frequencies to ground and back to the i-f coupler so that these frequencies do not go on into the video amplifier. This capacitor, in connection with the series compensating coil, form a low-pass filter which passes all frequencies up to the video limit of about 4.5 mc, while attenuating the much higher video intermediate frequencies.

Detector Output Polarity. — When video i-f input is to the detector plate, as at the left in Fig. 29-1, the positive side of the i-f carrier is rectified and in the detector output the sync pulses are positive and the picture signals are negative. Signal

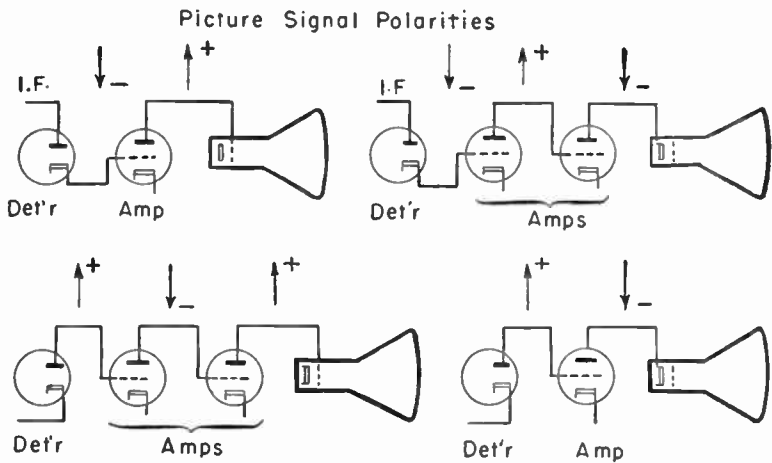

Fig. 29-3.—Picture signal polarities with i-f input to detector plate or cathode, and with picture tube input to grid or cathode.

polarity will be inverted in passing through each video amplifier between detector and picture tube. Consequently, if the signal is to reach the picture tube with the picture signals positive there must be one inversion and one video amplifier

stage, or there might be any odd number. If the signal is to reach the picture tube with picture signals negative there must be two inversions and two video amplifier stages, or any even number. The signal must reach the picture tube with picture signals positive when input is to the grid of the picture tube, and the picture signals must be negative when input is to the cathode of the picture tube. These polarity relations are shown at the top of Fig. 29-3.

At the bottom of Fig. 29-3 are shown the stage polarities when video i-f input is to the cathode of the detector. Two, or some even number of video amplifiers are needed to make the picture signals positive at the picture tube grid. One or any odd number of stages are needed to make the picture signals negative at the picture tube cathode.

The same general rules for signal polarity apply when considering the sync pulses which go through the sync section of the receiver and are used to trigger the sweep oscillators. The relations are clearly shown by Fig. 29-3 if we assume the sweep oscillator sync inputs to be the same as the picture tube inputs illustrated, and assume the amplifiers to be tubes in the sync section. Most sweep oscillators require a positive triggering pulse, although some use negative pulses. It must be kept in mind that there is polarity inversion in any tube where input is to a grid and output from a plate, but there is no inversion in cathode followers where input is to the grid and output from the cathode.

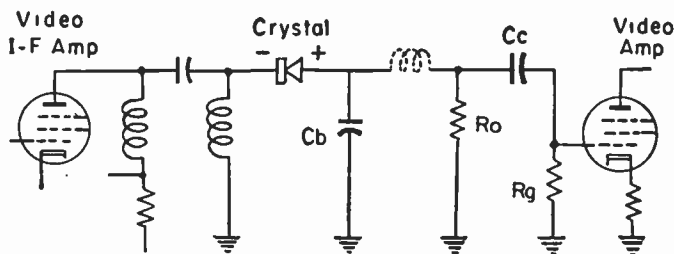

Fig. 29-4.—A crystal diode used as a video detector.

Crystal Detectors. — A number of television receivers have germanium crystal diodes for their video detectors. These diodes are described in the article on *Crystals, Rectifying*. A fairly typical crystal detector circuit is shown by Fig. 29-4. The negative end of the crystal is equivalent to the cathode of a tube diode, and the positive end is equivalent to the plate. Whether the i-f input is applied to the negative or positive end of the crystal determines the polarity of the output signal just as with tube diodes. Values of load resistance, R_o , and of coupling and bypass capacitors are like those for tube diode detectors. Series and shunt compensating coils may or may not be used, just as with tube detectors.

Care must be exercised in making service tests on crystal detectors, since strong a-c voltages from a signal generator may overload the crystal because of its low resistance to forward current. Neither end of the crystal should be connected to ground while making tests.

DIELECTRICS. — The accompanying table lists dielectric constants and power factors for materials commonly used in television capacitors and other circuit parts. The power factor is a measure of energy loss that occurs in the dielectric material. It is the fraction of the energy which would be dissipated as heat were all the current and applied voltage used to produce heating power, with this power in watts equal to EI . Were there no energy losses in a capacitor the current would lead the voltage by 90 degrees, and the power factor would be zero. When there are losses the current leads by less than 90 degrees and the power factor is more than zero.

High-frequency energy loss in a capacitor is assumed to be proportional to a loss factor which is equal to the product of dielectric constant and power factor. To provide a small loss factor both the dielectric constant and the power factor must be relatively small. This explains some of the advantage of using polystyrene, polyethylene, and some of the high grade dielectric waxes.

PROPERTIES OF DIELECTRIC MATERIALS

Kind of Material	Dielectric Constant	Power Factor
Mica	5.4 to 8.0	0.2
Paper, plain	2.0 to 2.6	
Paper, wax impregnated	3.5	
Phenolic compounds, mica filled	5.0 to 6.0	0.8 to 1.2
Phenolic compounds, low loss	5.3	0.4 to 0.7
Polyethylene	2.3 to 2.4	0.02 to 0.05
Polystyrene	2.4 to 2.8	0.02
Quartz	4.7 to 5.1	0.02 to 0.03
Steatite	4.8 to 6.5	0.4
Steatite low loss	4.4	0.2
Titanium dioxide	90 to 170	0.1
Waxes	1.9 to 3.2	0.1 to 0.3

DISCRIMINATORS. — A discriminator is a device which, when supplied with voltages of varying frequency but constant amplitude, delivers from its output a voltage of varying polarity and varying amplitude. The polarity of the output voltage depends on whether the input frequency varies above or below an average frequency or center frequency. Amplitude of the output voltage depends on the extent of frequency shift at the input, or on how far the input frequency deviates from the average or center frequency.

Discriminators are used for various purposes in radio and television. One of the earliest uses was in automatic frequency controls or automatic tuning controls for radio receivers. The most widespread use is for sound detectors in f-m radio receivers and in the sound systems of television receivers, which operate from frequency-modulated sound signals. Here the discriminator recovers audio-frequency voltages from the frequency-modulated input signals. In many television receivers a discriminator is used as part of the automatic frequency control for sweep oscillators. Oscillator frequency is compared with sync pulse frequency in the discriminator, and a correction voltage is supplied for keeping the oscillator synchronized.

Fig. 31-1 is a typical circuit diagram for a discriminator used as an f-m sound detector in a television receiver. The discriminator consists of a special type of transformer and two diodes. The two diodes, marked *A* and *B*, may be the two sections of a twin diode tube, they may be matched germanium crystal diodes, or they may be parts of a tube having other sections serving as a-m diode detector, amplifier, inverter, or some other purpose.

In the transformer are a primary winding *P* and a center-tapped secondary winding *Sa-Sb*. The two windings are coupled by mutual induction. Both windings are adjustably tuned to resonance at the sound intermediate frequency or center frequency. These are service adjustments. To the

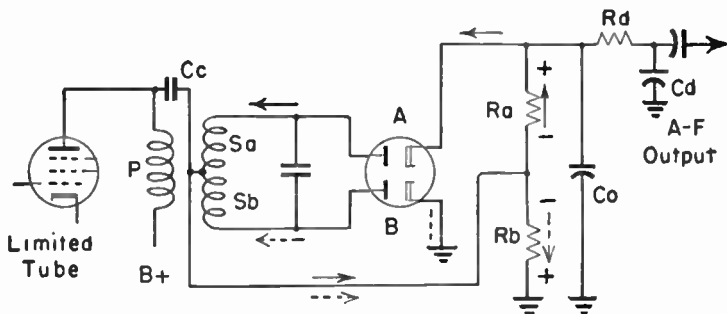

Fig. 31-1.—A typical circuit for a sound discriminator.

center tap of the secondary is applied primary voltage taken through capacitor *Cc* from the plate end of the primary winding. The outer ends of the secondary winding are connected to the plates of the two diodes. The cathode of one diode is grounded directly. The other cathode is connected to ground through two load resistors *Ra* and *Rb*. The center tap of the secondary winding is connected to a point between the load resistors. Across the load resistors is load capacitor *Co* which charges when there are unbalanced conduction currents in the two diodes and which discharges through the load resistors. Each of the resistances *Ra* and *Rb* may be of 100,000 ohms, with capacitance at *Co* of about 250 mmf. Audio output is

delivered from the top of load resistor R_a through a de-emphasis filter consisting of resistor R_d and capacitor C_d . Such a filter is required in all f-m sound systems.

A discriminator demodulates a frequency-modulated signal because, with deviation of input frequency, there is phase shift between the primary voltage and the voltage induced in the secondary winding by its inductive coupling to the primary. The phase shifting principle and its results on voltages applied to the two diodes are explained in the article on *Detector, Ratio*. In the discriminator circuit the voltage of fixed phase is that coming from the primary through capacitor C_c to the center tap of the secondary. This voltage appears without change at both top and bottom of the secondary.

Frequency deviation in one direction increases the voltage on diode A and at the same time decreases the voltage on diode B . Opposite deviation increases the voltage on diode B and decreases it on diode A . Electron flow in the circuit for diode A is indicated in Fig. 31-1 by full-line arrows, and in the circuit for diode B by broken-line arrows. Note that polarities are opposite in the two load resistors.

With deviation of frequency in one direction, the increase of voltage on diode A increases its conduction current and increases the voltage drop across resistor R_a . At the same time there is decrease of voltage on diode B , a decrease of its conduction current, and a decrease of voltage drop across resistor R_b . Then the overall voltage across both resistors, from the top of R_a to ground, becomes more positive at the top of R_a from where the audio output is taken.

When there is opposite deviation there is more voltage and more conduction current for diode B than for diode A . Consequently, there is more voltage drop across resistor R_b than across R_a . Then the overall voltage becomes more negative at the top of R_a , the audio output point.

Deviations of input frequency above and below the intermediate frequency have been shown to cause an alternating voltage at the audio output. This voltage is alternating because it goes first positive and then negative. The number of

alternations per second of this output voltage will be the same as the number of frequency deviations per second above and below the intermediate frequency. The number of deviations per second is the audio frequency of original modulation. The amplitude of the output voltage will be proportional to the extent of frequency deviation, because the greater the deviation the greater the phase shift in the transformer and the greater the difference between diode currents and voltage drops across the load resistors. This extent of frequency deviation corresponds to audio strength or "volume" of the original frequency modulation. There are many modifications of details in discriminator circuits but the basic operating principles remain as described.

While a discriminator for sound will produce output audio frequencies from input frequency modulation, it also will produce changes in the audio output whenever there is variation of input amplitude at the same time as frequency deviation. During any instant in which there is deviation of frequency there is phase shift of voltages at top and bottom of the secondary winding. Then any change of input amplitude will cause still greater difference between diode voltages, conduction currents, and voltage drops across the load resistors. This, of course, will affect the amplitude of the a-f output voltage.

Changes of amplitude in the received f-m sound signal must be removed by a limiter stage which precedes the discriminator. The limiter tube is operated with such voltages on plate, screen, and grid that alternations of signal voltage in the plate circuit cannot exceed a certain amplitude no matter how great the signal may become on the grid. So long as f-m signal voltages at the limiter input are strong enough to bring the output up to the limit of amplitude, the output must remain of constant amplitude. This frequency-modulated signal of constant amplitude is fed to the discriminator.

DIVIDERS, VOLTAGE.—A resistance voltage divider is shown at the left in Fig. 32-1. Voltage from *A* to *B* is the same as that of the source. If no current is being taken through taps *B* and *C* the voltages at these points will be proportional to the

resistances. When currents are drawn from the taps there is increased voltage drop in the resistances through which these currents flow, and tap voltages then depend on IR voltage drops rather than on resistance alone. Resistance voltage dividers have poor voltage regulation unless tap currents are very small, or voltage regulators are used between the taps and one side of the source, or a large bleeder current is allowed to flow from the source through the resistor string.

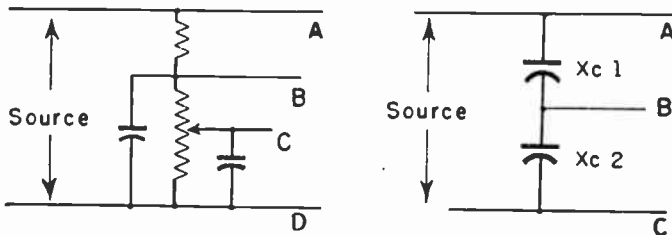

Fig. 32-1.—A resistance voltage divider (left) and a capacitance voltage divider (right).

A capacitance voltage divider is shown at the right in Fig. 32-1. Such a divider is used only with alternating voltages. Voltage at tap B depends on the relative capacitive reactances of capacitors above and below the tap. In making computations these reactances, in ohms, megohms, etc., are treated just as are resistances across the source with a resistance voltage divider. Voltage at a tap, with reference to one end of the divider, is proportional to the ratio of reactance between this tap and the end considered, to the total reactance in the entire divider.

For example, the voltage at tap B with reference to point A would be a fraction of the source voltage found by dividing reactance X_{c1} by the sum of X_{c1} plus X_{c2} . The voltage fraction with reference to point B would be found by dividing reactance X_{c2} by the sum of X_{c1} plus X_{c2} . Increasing a capacitance lessens the capacitive reactance and drops the voltage across the capacitance which is changed. Decreasing a capacitance raises the capacitive reactance and increases the voltage across that capacitance.

DRESSING, WIRES AND PARTS. — In all high-frequency circuits and in all wide-band amplifier circuits the layout of parts and the positions of connections are designed for small and constant stray capacitances and inductances. The higher the frequency or the greater the stage gain the more trouble may result from misplacement of conductors or circuit elements. All parts, including inductors, capacitors, and resistors, as well as wires and cables, should be replaced only with exact duplicates mounted in the same relative positions as the originals. When wires or cables are replaced the new ones should be of the same length, same gage size, should have the same kind of insulation as the originals, and should go in the same positions. Change of length will alter the inductance, while change of gage size or position will alter the circuit capacitances and may upset the tuning.

Grid leads and plate leads should be kept away from each other because of possible capacitive coupling and feedback. Grid leads should be kept clear of all other wiring. Plate leads often are dressed down close to chassis metal. These precautions apply also to plate and cathode leads for detector diodes. Screen leads should be dressed close to chassis metal. Grid returns and plate returns from transformers or other coupling units should be kept separated from each other until reaching the decoupling capacitors and resistors. Leads to and from r-f oscillator coils must be kept away from all other wiring and from each other. This applies to oscillators in the tuner and also in any r-f power supply. In general, all grid and plate leads should run as directly as possible between their terminals and should be kept as short as possible.

High-voltage wires and cables should be kept away from all low-voltage parts except where passing through suitable insulators or grommets. Leads to the high-voltage anode of outside-coated picture tubes should clear the coating.

Wires for the a-c power line, tube heaters, pilot lamps, and similar low-voltage a-c parts are either kept close to chassis metal or else are run well separated from all parts carrying signal voltages. These a-c leads must be kept well away from

audio detectors and amplifiers, and their plate and grid connections.

When wires remain longer than necessary between terminals, as may be the case with some transformer and choke connections, they should be kept close to chassis metal and dressed back toward the transformer or other part to which they are permanently connected.

Antenna connections or transmission line connections should be kept clear of metal parts, chassis and shielding, from their external terminals to where they enter the tuner.

Coupling capacitors should be kept clear of chassis metal and should be mounted as close as possible to the socket of the tube to whose grid the capacitors connect. Any extra length in the connections should be on the plate side of the capacitor. Changing the position of coupling capacitors may upset the alignment.

Peaking coils in wide band video amplifier and video detector circuits should be kept away from chassis metal and, so far as possible, away from other wiring. R-f chokes used for decoupling are mounted close to chassis metal unless the chokes have their own grounded shields.

It is especially desirable to keep all parts of oscillator circuits as far as possible from other parts and wiring, both in tuner circuits and sweep circuits.

Any added parts which are mounted close to other parts carrying radio or intermediate frequencies are likely to cause trouble because of altered capacitances in the original circuits.

Tuning capacitors, both fixed and adjustable, should be mounted as close as possible to the grid lugs or grid pins for the tube whose grid circuit is tuned.

The performance of high-gain audio amplifying tubes may be affected by strong magnetic fields from permanent magnets or field magnets of speakers, or from power transformers and filter chokes. New speakers or power supply parts should be mounted to avoid such possibilities.

DRIVE CONTROLS. — A drive control varies the voltage of the sawtooth wave which is taken from the output of a sweep

oscillator and applied to the grid circuit of the following sweep amplifier. It is this sawtooth voltage that drives the sweep amplifier. The sawtooth voltage is varied, in different receivers, by either of two distinctly different methods, both of which go by the name of drive control. One method utilizes an adjustable resistor, the other an adjustable capacitor. These controls are used in the horizontal sweep section of receivers having magnetic deflection picture tubes.

Resistor Drive Control. — A resistor type of drive control is shown at the left in Fig. 34-1. The control unit is an adjustable resistor in series with the sawtooth capacitor C_s . The effects of a resistor in this position are explained at some length in the article which is entitled *Amplifier, Sweep*. The resistor

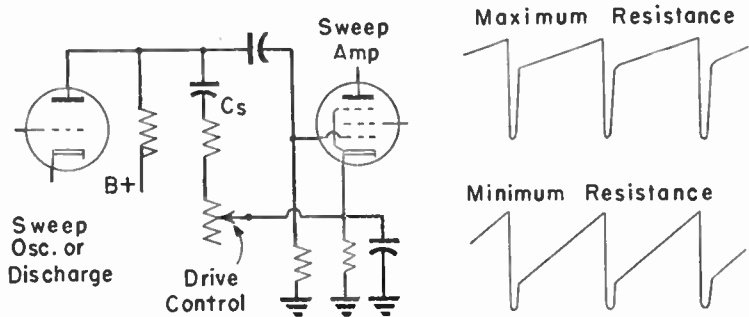

Fig. 34-1.—Resistor type drive control and its action.

causes retention of part of the charge in the sawtooth capacitor during the time in which the sweep oscillator or discharge tube is conductive. This retained charge accounts for the negative peak which precedes the sawtooth portion of the wave.

The greater the resistance in series with the sawtooth capacitor the more of the total voltage or peak-to-peak voltage of the wave appears in the negative peak, and the less remains for the sawtooth rise of voltage which follows the end of the conductive period in the oscillator or discharge tube. This is illustrated at the right in the figure. Decrease of resistance in the drive control lessens the negative peak and increases the sawtooth drive voltage applied to the sweep amplifier.

This type of drive control sometimes is called a peaking control. Again, because it affects the shape of the sawtooth wave, this adjustable resistor control may be called a linearity control.

Capacitor Drive Control.— Typical connections for a capacitor type drive control are shown at the left in Fig. 34-2. Sawtooth capacitor C_s is charged from the B-power supply and discharged through the oscillator or discharge tube in the usual manner. Across this capacitor is developed the sawtooth voltage for deflection. In parallel with capacitor C_s , and in series with each other, are coupling capacitor C_c and the adjustable drive control capacitor. The sawtooth voltage across C_s appears across this series pair, C_c and the drive capacitor, and divides between them proportionately to their capacitive reactances. Whatever portion of the voltage appears across the adjustable control capacitor is applied between grid and cathode of the sweep amplifier.

To increase the sawtooth voltage on the amplifier grid it is necessary to increase the capacitive reactance of the drive

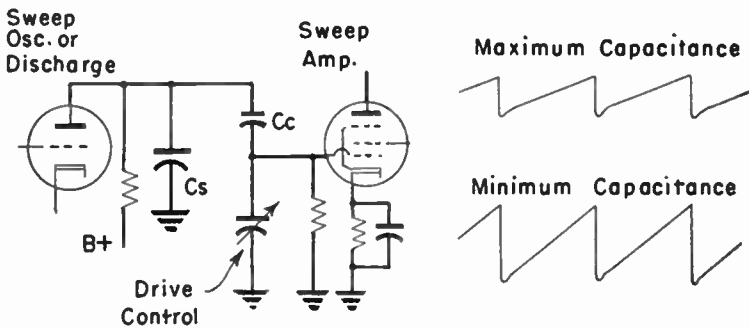

Fig. 34-2.—Capacitor type drive control and its action.

control, which requires a decrease of its capacitance. To decrease the sawtooth voltage on the amplifier grid there must be a decrease of reactance, which requires an increase of capacitance. These relations are shown at the right.

The sawtooth waves of Fig. 34-2 are shown without negative peaks because the capacitor type drive control does not pro-

duce such peaks. Negative peaks may be added, when necessary, by feedback of voltage pulses from some point on the output side of the sweep amplifier.

Adjustments. — Adjustment of the resistor and capacitor types of drive control are quite similar, since both controls alter the voltage of the sawtooth wave applied to the grid of the sweep amplifier.

If the drive control is adjusted for too little resistance or capacitance the center of a test pattern will be shifted toward the right-hand side of the screen, crowding the right-hand side and stretching the left-hand side. The width of the picture or pattern is affected by drive control adjustment because width, or extent of beam deflection, varies with voltage of the sawtooth portion of the wave. In some receivers there is no other control for width.

When either type of drive control is used in a receiver having a flyback style of high-voltage power supply, the voltage developed by this power supply and applied to the picture tube anode is affected by drive adjustment. Reducing the resistance or capacitance increases the sawtooth voltage and increases the anode voltage.

In some receivers it is possible to apply excessive anode voltage to the picture tube by wrong adjustment of the drive control, especially where this control is a capacitor type. Unless one is familiar with the effects of a capacitor drive control in the receiver being handled, it is advisable to keep a high-voltage voltmeter connected to the picture tube anode while the control is adjusted, and to avoid raising the anode voltage above the rating for the picture tube. When the drive control is so designed that anode voltage cannot be unduly increased, the control may be adjusted for maximum brightness with which there is satisfactory linearity.

Because the drive control affects both width and linearity, adjustment of any other width control or any other linearity control usually requires resetting of the drive control. One procedure is to first adjust the drive for equal distribution of the test pattern on the left and right, second to adjust any

other width control to make the pattern just fill the mask horizontally, and third to adjust any other linearity control to improve the center of the pattern and keep this point at the center of the mask opening.

With another method the drive control is initially adjusted for minimum sawtooth voltage, and any other width control is set for a picture or pattern slightly too narrow. Then any separate linearity control is adjusted for best pattern distribution right and left, and the drive control is increased just enough to make the picture or pattern fill the mask horizontally.

F

FILTERS, DIFFERENTIATING AND INTEGRATING. — Between the output of the sync section of the television receiver and the input to the sweep oscillators are filters which produce from the sync pulses the types of voltages required for triggering or synchronizing the oscillators. A differentiating filter or network produces from the horizontal sync pulses those voltages which act on the horizontal oscillator, but this filter is unaffected by vertical sync pulses. An integrating filter or network is not responsive to horizontal sync pulses, but it adds together the effects of each train of vertical pulses and produces a voltage suitable for triggering the vertical sweep oscillator.

Fig. 35-1 shows the two kinds of filters as they might be connected to the last tube in the sync section. In the plate circuit of that tube are all the sync pulses; horizontal pulses at line intervals, equalizing pulses at half-line intervals, and serrated vertical sync pulses. All the pulses go to the inputs of both filters.

The horizontal filter, often called a differentiating network, is a high-pass type consisting of a series capacitor Ch and a shunt resistor Rh . In some cases there are more than one of either or both these filter elements. The time constant of the capacitance-resistance combination usually is somewhat shorter than the time for one horizontal line, which would mean a

constant of less than 60 microseconds, and is very much shorter than the time period for a whole frame. Consequently, when the capacitor is charged by a sync pulse of any kind, there will be practically complete discharge before a following sync pulse and another charge.

The vertical filter, which may be called an integrating network, is a low pass type. There are series resistors R_v and shunt capacitors C_v . Usually there are two, three, or four pairs

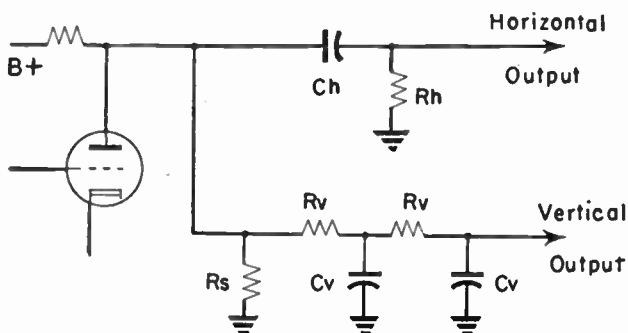

Fig. 35-1.—Differentiating and integrating filters at the output of a sync section.

of these elements. In addition there is a single shunt resistor R_s . Sync pulse voltages appear across R_s , and charge the capacitors through the resistances R_v . During intervals between pulses the capacitors discharge through resistances of R_v and R_s . The discharge time constant in this combination is such as to allow nearly complete discharge during intervals between horizontal sync pulses.

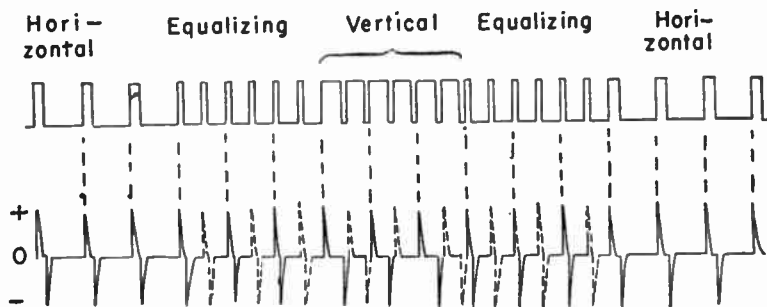

Fig. 35-2.—Action of the horizontal or differentiating filter.

The action of the sync pulses on the horizontal filter is shown by Fig. 35-2. At the top are represented all the kinds of sync pulses, with spacings between pulses proportional to time intervals. Down below are shown the voltage pips or spikes which appear at the output of the filter at corresponding instants of time. The leading edge of each pulse, of whatever kind it may be, charges the filter capacitor. Capacitor voltage goes sharply positive, followed by almost instant discharge and return to zero. The trailing edge of the same pulse then causes a negative voltage, followed by a return to zero. All these voltage pips are applied to the sweep oscillator.

Only the positive pips trigger the oscillator. Should the oscillator be of a type triggered by negative voltage the polarity would be reversed by putting the signal through an inverter tube. Note that there is a positive voltage pip at every line interval right straight through the equalizing and vertical pulses. During these pulse periods there are also voltage pips at half-line intervals, as shown by the broken-line spikes. These voltages occur while the oscillator is in a stable condition, when current and voltage in the oscillator circuit are nowhere near the values for breakdown. Consequently, the half-line voltage pips have no effect.

The action of the sync pulses on the vertical filter is shown by Fig. 35-3. The pulses, shown across the top of the figure, are exactly the same as applied to the horizontal filter in the

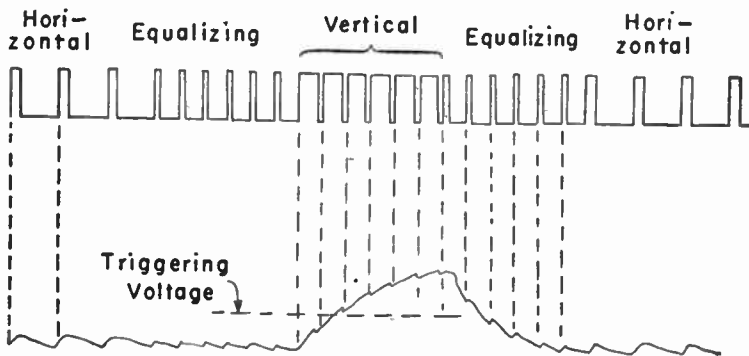

Fig. 35-3.—Action of the vertical or integrating filter.

preceding figure. During the time each pulse continues, there is charging of the filter capacitors, and during times between pulses there is discharge. The charging and discharging are shown by the jagged line or curve down below. All through the horizontal pulses and the equalizing pulses the discharge times are so much longer than the charging times that the capacitors accumulate hardly any charge and hardly any voltage.

The lengths of charge and discharge times are reversed when the serrated vertical pulses act on the filter. Then the charging times are long, and the intervening discharge times are short. During these pulses the filter capacitors accumulate an ever increasing charge and voltage. When this voltage rises to the value marked *Triggering Voltage*, it is enough to trigger the vertical sweep oscillator.

During the equalizing pulses which follow the serrated vertical sync pulse there again are short charge times and long discharge times. The filter capacitors lose their accumulated charge, and again there are only the slight rises and falls of voltage until the next vertical sync pulse.

FINE TUNING CONTROL. — A fine tuning control permits the operator of a television receiver to alter the frequency of the r-f oscillator while the receiver is in operation. The control unit usually is an adjustable capacitor, but may be an adjustment for inductance, in the tuned circuit of the oscillator. Fine tuning capacitors may have minimum capacitances of less than 1 mmf and maximums of as much as 10 mmf, but the tuning range ordinarily is something between 1 and 3 mmfd. A given change of fine tuning capacitance causes a much greater change of oscillator frequency on high-frequency channels than on low-frequency channels. The fine tuning control has more effect on tuning in the high-frequency channels.

With receivers employing intercarrier sound systems the most noticeable effect of a fine tuning control is on picture quality and brightness. In such receivers, an alteration of r-f oscillator frequency does not alter the frequency at which

the sound system operates, which always remains 4.5 mc, but does alter the point at which the video intermediate frequency falls on the frequency response curve of the video i-f amplifier and alters equally the point at which the sound intermediate frequency falls on this curve. This changes the amount of amplification applied to the picture signals, but has relatively little effect on sound reproduction unless the sound intermediate frequency is moved so high on the response curve as to introduce excessive amplitude modulation or so low as to drop the sound volume very low.

With receivers whose sound intermediate amplifiers and demodulators operate at the sound intermediate frequency corresponding to the sound carrier frequency the fine tuning control has its chief effect on sound reproduction. When the fine tuning control alters the frequency of the r-f oscillator it alters also the intermediate frequency applied to the sound section. The control must be adjusted to make this intermediate frequency match the frequency for which the sound i-f amplifiers and sound demodulator are aligned. Otherwise there will be no reproduction of sound or else excessive distortion. The video i-f amplifier must be so aligned that, when the sound intermediate frequency is correct for the sound section, the video intermediate frequency falls at the correct point on the frequency response curve.

FOCUSING AND FOCUSING CONTROLS. — Electrons from which are formed the beam in the picture tube tend naturally to spread away from one another, because they are negative charges, and like charges repel one another. To overcome this tendency and direct all the beam electrons toward a single sharply defined spot on the screen it is necessary to employ some means of focusing.

Picture tubes having electrostatic deflection nearly always employ electrostatic focusing, a process in which the electrons are turned toward the common focusing point by action of regions of constant potential in the electrostatic field between two anodes. Picture tubes designed for magnetic deflection are operated with magnetic focusing, by which the electrons

are brought to the common focusing point by action of magnetic lines of force produced around a focusing coil or focusing magnet.

Electrostatic focusing is adjusted by altering the potential of one of the anodes involved in the process, while potential of the other anode remains unchanged. Magnetic focusing is adjusted by altering the current in a focusing coil, or by moving a permanent magnet used for focusing, and thereby altering the position or the strength of the magnetic field which acts on the electron stream.

Focusing is adjusted while there is a raster on the screen, but no picture or pattern. This is accomplished by turning the receiver on and setting the channel selector for a channel in which there is no transmission at the time of adjustment. The adjustment should be such that individual fine horizontal lines are clearly visible as separated lines with the contrast control set as for normal reception. Ordinarily it is impossible to have sharp focusing (well separated lines) at all points on the raster area. The adjustment should be set to provide sharp focusing at the center and as far toward the edges as possible. Once the focusing is correctly adjusted it seldom needs further alteration.

Electrostatic Focusing. — The principle of electrostatic focusing is illustrated by Fig. 37-1. Part of the electrons emitted from the cathode are drawn by the positive charge or potential of the first accelerating anode through small openings in the control grid and in the anode. The electrons are spreading apart as they pass toward the focusing anode. The difference of potential between the accelerating and focusing anodes produces an electrostatic field between these elements. In this field are regions of equal potential which are indicated by curved broken lines in the diagram. The field force acts to make the electrons cross the equal potential lines at right angles, with the result that the electrons are made to converge just before leaving the first accelerating anode then are allowed to diverge slightly by the reversed curvature of the lines just inside the focusing anode.

The potential of the first accelerating anode is much higher than that of the focusing anode. When electrons move from a greater to a less potential they are turned toward the axis of the tube. In moving from a less to a greater potential the electrons are turned away from the axis. The high velocity of the electrons modifies both effects. The second accelerating anode is at the same potential as the first one, and greatly increases the velocity of the electrons as they move toward the screen.

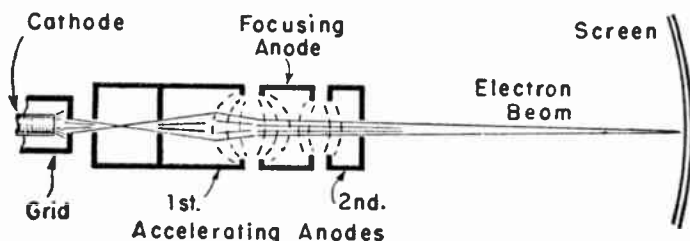

Fig. 37-1.—Principle of electrostatic focusing.

The focusing effect, and the distance from the electron gun at which the electrons meet in a small spot, depends on the ratio of potentials on the accelerating and focusing anodes. In practice, the focusing distance is made to occur at the screen surface by adjusting the voltage of the focusing anode alone. The focusing anode is connected to the slider of a potentiometer which is part of the high-voltage bleeder system. This bleeder system of resistors extends from the cathode of the high-voltage rectifier through the centering control units and the focusing control to ground or else to plate circuits of some of the low-voltage tubes. The accelerating anodes are connected to a point in this bleeder system which is more positive than the focusing potentiometer.

Magnetic Focusing. — The principle of magnetic focusing is illustrated by Fig. 37-2. Around the outside of the neck of the picture tube is the focusing coil. In some receivers a permanent magnet is used instead of the current-carrying coil. Lines of the magnetic field produced in and around this coil or

magnet are parallel with and extend in the same direction as the axis of the tube where the lines are inside the neck.

If an electron coming from the cathode and the accelerating anode happens to enter this magnetic field exactly on the axis and the field, this electron will travel straight along the axis and proceed to the screen as indicated by line *a-a* of the sketch at the bottom of the figure. If the electron is moving

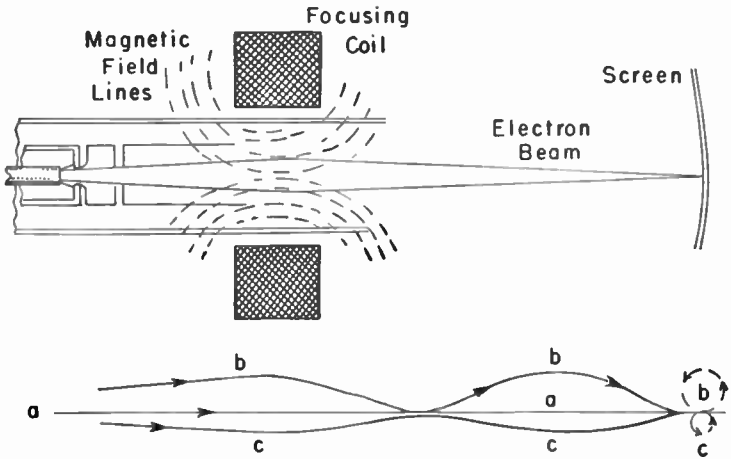

Fig. 37-2.—Principle of magnetic focusing.

outwardly from the axis when it enters the magnetic field, as most of the electrons are moving, this electron will be caused to move in a helical path as it continues on toward the screen. A helical path or a helix is the kind of curve followed by a thread on a straight screw, or around the outside of a cylinder.

The greater the divergence of the electron from the magnetic axis the larger is the diameter of the helix on which the electron is made to travel, and the less the initial divergence the smaller is the diameter. This is indicated by lines *b-b* and *c-c* of the bottom sketch. The circumferences of the helices being followed by all the electrons pass through the magnetic axis at every full turn. All the helices come in to the axis at the same points along the length of the axis. Consequently, all the beam electrons come to a sharply focused spot at each

of these points along the axis. By altering the current in the focusing coil the magnetic field strength may be made such that one of these focus points along the axis comes at the surface of the screen in the picture tube.

Various methods of altering the current in the focusing coil are shown by Fig. 37-3. At the upper left an adjustable control resistor is in series with the coil, between B+ and ground. At the upper right the adjustable control resistor is in parallel with the coil, so that more control resistance forces more cur-

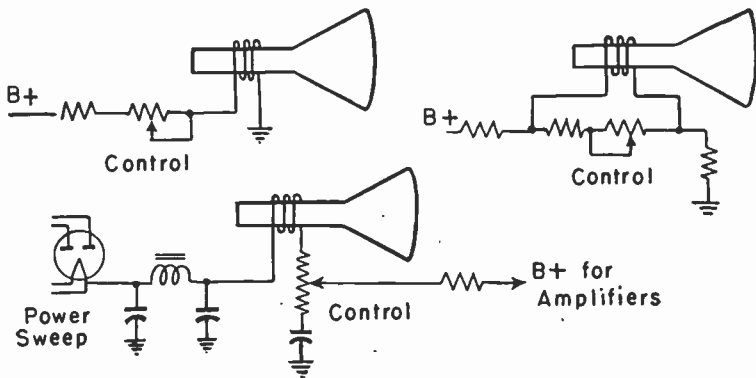

Fig. 37-3.—Control adjustments for current in magnetic focusing coils.

rent to flow in the coil. The lower diagram shows a method of using the focusing coil as a filter choke in the B+ power supply system. Adjustment of the control potentiometer causes only small variations of B+ voltage to amplifier circuits, while causing large changes of current in the coil. Coil current may be almost anything between about 75 and 150 milliamperes; the greater currents being found with the larger picture tubes and with tubes operated at high anode voltages.

The focusing coil is mounted over the front end of the electron gun in the picture tube. Between the front side of the focusing coil and the rear of the deflection yoke is a space of about $\frac{1}{4}$ to $\frac{3}{8}$ inch to lessen interaction between the magnetic fields for focusing and for deflection of the beam. Moving the focusing coil forward or back along the tube neck may bring a greater screen area into good focus. The coil position may be

changed, while keeping the control adjusted for sharp focus, until there is the best compromise between sharp focusing at the center and the edges of the picture or pattern.

The axis of the focusing coil should coincide with the axis of the tube neck. If necessary, the coil should be moved vertically or horizontally in its mounting to bring the axes into line or very nearly so. Otherwise it may be difficult to avoid shadows at one or more corners of the picture or pattern.

FREQUENCIES, BANDS OF. — The accompanying table lists the bands or ranges of frequencies usually denoted by the various names which are in general use. The names which are followed by the word *radio* in parentheses are sub-classifications in the whole range of radio frequencies. A radio frequency is any frequency at which signals may be radiated through space.

Audio frequency	20 to 20,000 cycles
F-m broadcast frequency	88 to 108 megacycles
High (radio) frequency	3 to 30 megacycles
Hyper frequency	1000 to 100,000 megacycles
Longwave	30 to 300 kilocycles
Low (radio) frequency	30 to 300 kilocycles
Medium (radio) frequency	300 to 3000 kilocycles
Microwave	more than 600 megacycles
Power frequency	25 to 60 cycles
Radio frequency	more than 10 kilocycles
Shortwave	1.5 to 30 megacycles
Standard (a-m) broadcast	540 to 1600 kilocycles
Super-high (radio) frequency	over 3000 megacycles
Ultra-high (radio) frequency	300 to 3000 megacycles
Ultra-shortwave	30 to 300 megacycles
Very-high (radio) frequency	30 to 300 megacycles
Very-low (radio) frequency	10 to 30 kilocycles
Video frequency	30 cycles to 4.5 megacycles

FREQUENCIES, BEAT. — Along the top of Fig. 39-1 are short vertical lines which may represent the instants of maximum amplitude in a wave of some certain frequency. On the middle line are vertical lines for the instants of maximum amplitude in a wave of somewhat lower frequency. If voltages at these

two frequencies are combined in a single circuit their maximum amplitudes will occur as shown along the bottom line. At certain intervals the instant of maximum amplitude in one wave will coincide with the instant of maximum amplitude in the other wave. Then the two amplitudes will add together to produce strong potentials at these instants, as indicated above the arrows.

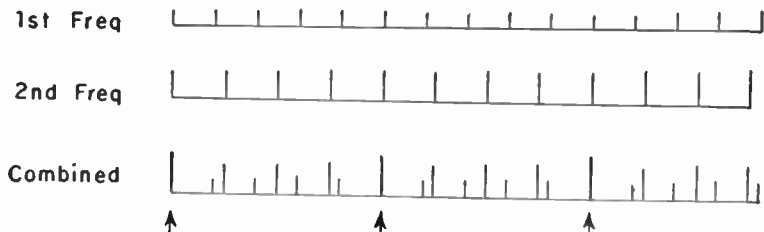

Fig. 39-1.—Constant amplitudes at different frequencies combine to form varying amplitudes and strong beats at the difference frequency.

The frequency at which these relatively strong potentials recur is equal to the difference between the two original applied frequencies. Were one frequency to be 1001 kilocycles and the other 1000 kilocycles the difference frequency would be 1 kilocycle. This difference frequency is called a beat frequency. If both frequencies are applied to a tube having the characteristics of a detector the output will contain the beat frequency, also another frequency equal to the sum of the original frequencies, and the two original frequencies.

The high potential or amplitude of the beat frequency occurs when the original waves are in phase with each other. There is a minimum amplitude when the original waves are

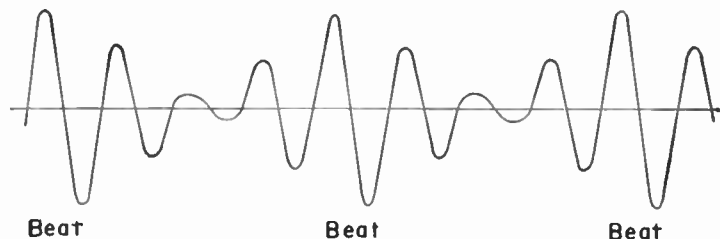

Fig. 39-2.—Output current or voltage showing beats.

in opposite phase. Changes of phase produce an output current and voltage of the general type shown by Fig. 39-2. The changes of amplitude in this combined wave are just like the changes in any wave which is amplitude modulated. To extract the beat frequency this combined wave must be applied to some kind of detector which cuts off either the top or bottom of the wave (a diode detector) or else displaces the wave toward the negative or positive side to give it a d-c component (a grid leak or a plate rectification detector). If either the original input voltages is modulated, that modulation will appear on the beat frequency in the output.

Frequencies produced by beating are employed in the intermediate amplifiers of television receivers and all superheterodyne receivers, where signal and local oscillator frequencies are applied to a mixer or converter tube. Beats are employed also for producing the 4.5 intercarrier sound signal in television receivers, where the video detector produces the intercarrier beat from the video and sound intermediate frequencies. Beat frequencies are utilized also in many types of signal generators and other testing instruments.

FREQUENCIES, STANDARD. — The most convenient and reliable source of standard frequencies which may be used for calibration of testing equipment is in transmissions from radio station WWV of the National Bureau of Standards at Washington, D. C. These frequencies are accurate to within one part in 50 million. They are broadcast continuously, day and night, with carrier frequencies of the following numbers of megacycles:

2.5, 5, 10, 15, 20, 25, 30, and 35.

The frequencies of 5, 10, 15, and 20 mc are transmitted with powers of 8 to 9 kilowatts, the 2.5 mc frequency with 700 watts, and the others with 100 watts. Carriers at 10, 15, 20, and 25 mc are modulated with audio frequencies of 440 and 4000 cycles per second. Those at 2.5, 5 and 30 mc are modulated with audio frequency of 440 cycles per second. There is a station announcement in voice at each half-hour and each hour.

FREQUENCIES, TELEVISION. — The following frequencies are used in or related to television reception.

Accompanying Sound Frequency: This is the sound intermediate frequency of the channel in which there is reception. It is a beat frequency produced by the r-f oscillator frequency and the sound carrier frequency in the received channel, and equal to the difference between those two frequencies.

Adjacent Sound Frequency: A beat frequency produced by and equal to the difference between the r-f oscillator frequency and the sound carrier frequency in a channel of lower number and immediately adjoining the one in which there is reception. This frequency is 6.0 mc higher than the sound intermediate frequency and 1.5 mc higher than the video intermediate frequency.

Adjacent Video Frequency: A beat frequency produced by and equal to the difference between the r-f oscillator frequency and the video carrier frequency in a channel of higher number and immediately adjoining the one being received. This frequency is 6.0 mc lower than the video intermediate frequency and 1.5 mc lower than the sound intermediate frequency.

Associated Sound Frequency: Same as *Accompanying Sound Frequency*, which see.

Center Frequency: An unmodulated carrier frequency or unmodulated intermediate frequency. This would be the carrier frequency before it is modulated for transmission of signals, or an intermediate frequency produced by beating of the r-f oscillator frequency with an unmodulated carrier frequency.

Channel Frequency: The carrier frequencies. In channels numbered 2 through 6, which may be called the low-band channels in the very-high frequency range, the carrier frequencies extend from 54 through 88 mc. In channels 7 through 13, the high-band channels in the very-high frequency range, the carrier frequencies extend from 175 through 216 mc. Television broadcast frequencies originally allo-

cated in the ultra-high frequency range extend from 480 through 920 mc. Television relay frequencies are still higher, as in bands such as 3500 to 4200 mc and 5850 to 8500 mc.

Field Frequency: The frequency with which successive picture fields recur; 60 cycles per second.

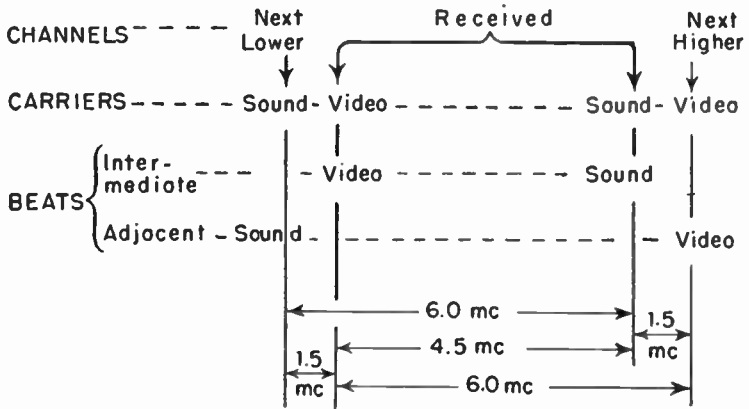

Fig. 41-1.—Relations between some of the television frequencies.

Frame Frequency: The frequency at which successive complete frames of the picture are produced; 30 cycles per second.

Intercarrier Beat Frequency: A beat frequency produced by the video and sound intermediate frequencies, and equal to the difference between those frequencies. This beat frequency always is 4.5 mc. The intercarrier beat frequency retains the modulation of sound signals and is used to feed the sound sections of receivers employing the intercarrier sound system.

Line Frequency: The frequency at which successive horizontal picture lines or traces recur. In the 525-line system the line frequency is 15,750 cycles per second; the product of 525 lines per frame and 30 frames per second.

Sound Carrier Frequency: The transmitted frequency which is frequency-modulated with signals for sound that is to accompany the visual television program. In each channel the sound carrier frequency for that channel is 4.5 mc higher than the video carrier frequency in the same channel.

Sound Intermediate Frequency: A beat frequency produced by the r-f oscillator frequency and the sound carrier frequency of the channel being received, and equal to the difference between those frequencies. The sound intermediate frequency is 4.5 mc lower than the video intermediate frequency when, as is usual, the r-f oscillator frequency is higher than the received carrier frequencies.

Video Frequency: Any frequency in the range required for reproduction of picture lights and shades. Video frequencies are employed for modulation in transmitting the picture portion of the television signal. This range extends from 30 cycles to about 4.5 megacycles, although not all receivers utilize or reproduce this entire range.

Video Carrier Frequency: The transmitted frequency which is amplitude-modulated with signals for picture lights and shadows, blanking level, and all synchronizing pulses required for reproduction of pictures. In each channel the video carrier frequency is 4.5 mc lower than the sound carrier frequency in the same channel.

Video Intermediate Frequency: A beat frequency produced by the r-f oscillator frequency and video carrier frequency of the channel being received, and equal to the difference between those two frequencies. The video intermediate frequency is 4.5 mc higher than the sound intermediate frequency in the same receiver when the r-f oscillator frequency is higher than the received carrier frequencies.

FREQUENCY-WAVELENGTH RELATIONS.—The accompanying formulas allow determination of equivalent frequencies and wavelengths.

$$\text{Wavelength, meters} = \frac{300,000}{\text{frequency, kilocycles}}$$

$$\text{Wavelength, meters} = \frac{300}{\text{frequency, megacycles}}$$

$$\text{Frequency, kilocycles} = \frac{300,000}{\text{wavelength, meters}}$$

$$\text{Frequency, megacycles} = \frac{300}{\text{wavelength, meters}}$$

G

GAIN CONTROL, AUTOMATIC. — Automatic gain control circuits in a television receiver increase the amplification in r-f and i-f amplifiers when weak signals reach the antenna, and reduce the amplification for strong signals. Inputs to video and sound detectors then remain nearly constant with changes of antenna signal strength.

Gain control systems apply a variable negative bias voltage to the control grids of one or more i-f amplifiers, also in most cases to the r-f amplifier or amplifiers, and sometimes to one of the video amplifiers as well. This bias voltage becomes more negative when the received signal becomes stronger, and less negative on weaker signals.

An effective automatic gain control lessens the need for readjustment of contrast and brightness when changing from one station to another, also maintains uniform picture quality and sound volume when there are variations of antenna signal strength during a program. Many automatic gain controls reduce picture flicker such as caused by low flying airplanes, reduce the effects of outside electrical interference classed as "noise," and prevent pictures and sound from being greatly affected by power line voltage fluctuations, swaying antennas, and other faults.

Gain control bias voltage must vary with some characteristic of the received signal which changes only with change of signal strength, and not with changes of picture tone or shading. The characteristic which meets this requirement is the amplitude or voltage of the peaks of the sync pulses. This maximum pulse amplitude is maintained constant at the transmitter, and varies at the receiving antenna only when there is some variation in signal attenuation between transmitter and receiver. The sync pulse tips represent 100 per cent signal strength, while the black or blanking level represents 75 per cent, maximum white level represents 15 per cent, and picture modulation varies between 15 and 75 per cent.

As shown by Fig. 43-1, the sync pulse tips remain at the same amplitude with dark or light pictures and all intermediate shadings. Average amplitude varies, being high for dark pictures and low for light pictures. Were this average amplitude used for regulating the gain control, as it is used in automatic volume controls for sound receivers, the picture brightness would be maintained constant instead of showing changes which actually occur in brightness of televised scenes.

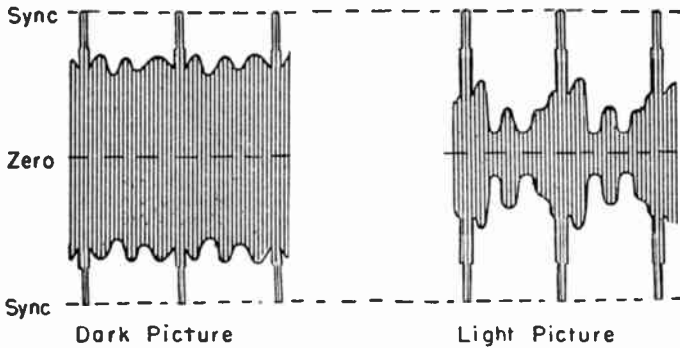

Fig. 43-1.—Sync pulse amplitude is not altered by changes of picture tone or shading.

Gain Control Circuits. — Circuits for one of the simplest automatic gain control systems are shown by Fig. 43-2. Connected to the output of the final i-f amplifier, through capacitor C_a , is the plate of the agc (automatic gain control) diode. The cathode of this diode is connected to ground. During each half-cycle of intermediate frequency in which the top of the coupling coil becomes positive with reference to the lower end and ground, the plate of the diode is made positive with reference to its cathode and ground. During this half-cycle there is electron flow in the direction of the arrows, and capacitor C_f is given a small charge in the polarity marked.

During intervening half-cycles the diode plate is made negative with reference to the cathode, and this tube becomes non-conductive. Then the charge of capacitor C_f may escape through resistors R_a and R_b and the ground path. But because the rather large capacitance of C_f and high resistance of R_a and R_b produce a long time constant for discharge, only a little of the charge escapes before more is added during the following half-cycle in which the diode again is conductive.

The charge on capacitor C_f increases until the accompanying voltage reaches and remains at practically the voltage of the peak amplitude of the sync pulses. This voltage, negative at the top of capacitor C_f , is applied as negative grid bias to the grid returns of whatever tubes are to have automatic gain control. One such tube is shown at the left in the diagram. The stronger the signal at the antenna and at the

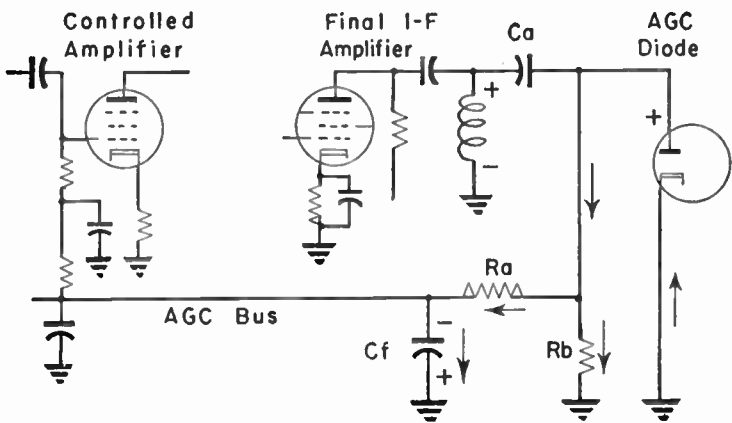

Fig. 43-2.—Circuits for a simple type of automatic gain control.

output of the i-f amplifier the greater becomes the peak amplitude of the sync pulses, and the greater the charge and voltage on capacitor C_f . The greater voltage then makes the controlled grids more negative and reduces amplification.

Weaker incoming signals reduce the amplitude of sync pulse peaks, allow reduction of charge and voltage of capacitor C_f , and make the controlled grids less negative for an increase of amplification.

The method of obtaining a gain control voltage which is proportional to peak voltage of sync pulses, as illustrated in Fig. 43-2, is utilized in some manner or other for the majority of automatic gain control systems. There is great variety in details of agc systems. Some are quite simple while others are complex. The principal variations will be examined.

Delayed Automatic Gain Control. — With the simple agc system of Fig. 43-2 the bias voltage, with no incoming signal, may be such as produces fairly high amplification. As soon as a signal is applied, or as soon as there is any increase in strength of an applied signal, there is an immediate increase of negative bias voltage and a reduction of gain. Often it is desirable that there be no such reduction of gain on very weak signals, which need all the amplification possible. Controls which do not reduce amplification until the received signal exceeds some certain strength are called delayed automatic gain controls.

A simple method of obtaining delay is illustrated by Fig. 43-3. The cathode of the agc diode is not connected to ground but to a tap on a voltage divider between $B+$ and ground.

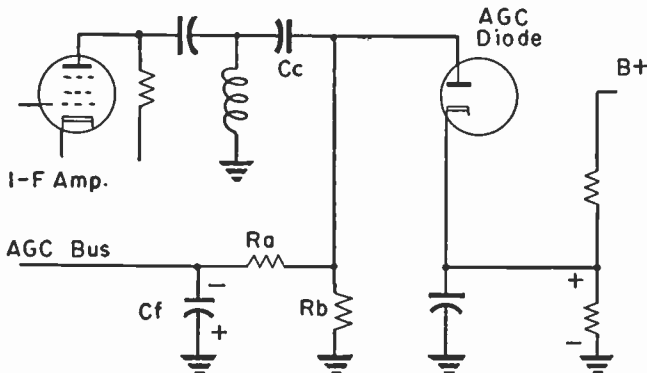

Fig. 43-3.—Delayed control resulting from a positive voltage on the cathode of the agc tube.

This tap usually is at a potential of 1 to 3 volts positive. Then, with no received signal, the cathode of the agc diode is 1 to 3 volts positive with reference to the plate, which is the same as making the plate 1 to 3 volts negative with reference to the cathode. Until i-f signal voltage applied to the agc diode exceeds the value of positive voltage on the cathode of this diode there can be no conduction in the tube. With no conduction there will be no negative biasing voltage built up across capacitor C_f , and there will be no reduction of amplification in the tubes connected to this agc system.

In some receivers the positive delay voltage is adjustable. The cathode of the agc diode is connected to the slider of a potentiometer in a voltage divider, instead of to a fixed point on the divider as in Fig. 43-3. Making the cathode less positive allows automatic reduction of gain on weaker signals, as might be required in a locality of high signal strength. Making the cathode more positive delays the agc action until stronger signals are received, as might be desirable in an area of low signal strength.

With the circuit connections of Fig. 43-4 the positive delay voltage is varied by the contrast control. This method of control is used in many receivers. The voltage divider between $B+$ and ground includes resistor R_c and the portion of the contrast control potentiometer between its lower end and the

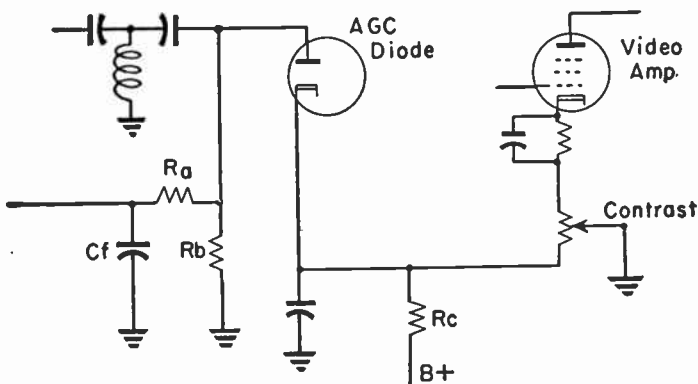

Fig. 43-4.—Agc delay voltage varies by adjustment of contrast control in the cathode circuit of a video amplifier.

grounded slider. Adjustment of the contrast control varies the grid bias and gain of the video amplifier tube in whose cathode circuit this control is located. At the same time, the adjustment varies the amount of positive delay voltage on the cathode of the agc diode.

When the contrast control is adjusted for maximum gain in the video amplifier, or for minimum bias in this tube, there is the greatest positive delay voltage. Thus, when the contrast control is set for maximum gain, the agc system is prevented from reducing the gain on weak received signals. When the contrast control is set for less gain or less contrast the agc system will act on weaker signals.

Fig. 43-5 shows another method of adjusting a positive delay voltage by means of a contrast control in the cathode circuit of a video amplifier. The variable positive delay voltage appears at the junction between resistor R_c and the lower end of the contrast control potentiometer. Instead of applying this delay voltage to the cathode of the agc diode it is fed

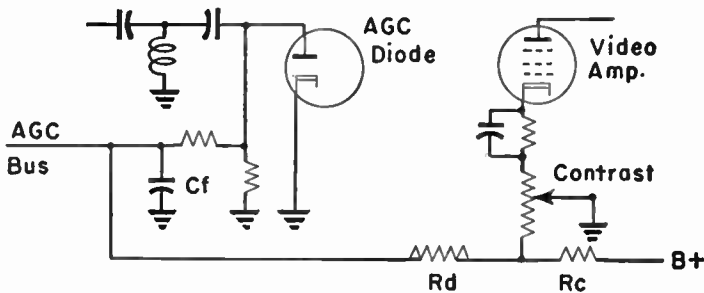

Fig. 43-5.—A positive delay voltage applied directly to the agc bus.

through about one megohm resistance at R_d to the agc bus, where the positive voltage opposes the negative voltage produced across capacitor C_f .

When the contrast control is adjusted for more contrast or more gain in the video amplifier there is increase of the positive delay voltage at the junction of R_c and the contrast control. This increased positive voltage reduces the effect of

negative biasing voltage from capacitor C_f , and tubes which are automatically controlled then operate with full gain until there is a stronger received signal.

Amplifiers in Agc Systems. — In many receivers there are agc systems which incorporate an amplifier tube in addition to the tube which furnishes a voltage proportionate to peak amplitude of the sync pulses. Some of the principles employed in circuits using an amplifier are illustrated by Fig. 43-6. As in agc circuits examined earlier, the video signal is rectified by a diode tube used for the agc takeoff. The cathode of this takeoff tube is connected to ground through a series of resistors in which is the potentiometer R_i , whose slider is connected to the grid of the amplifier tube. Increase of signal strength increases the electron flow in the diode. This flow will be upward in the resistance at R_i , tending to make the top of R_i more positive with reference to the ground end, and making the amplifier grid less negative with reference to the amplifier cathode. Thus an increase of signal strength causes an increase of amplifier plate current. Time constants in the diode cathode circuit are such that capacitor C_i remains charged to a voltage proportional to the peak amplitude of the sync pulses.

The entire amplifier system of Fig. 43-6 is connected between B- and ground. Voltage divider action in the various resistances, combined with potential drops which accompany the electron flows, may be assumed to place the elements of the amplifier tube at the voltages marked, which are with reference to ground. The grid ($-95v$) is more negative than the cathode ($-90v$), so is negatively biased. The plate ($-6v$) is much less negative than the cathode and, in effect, is 84 volts positive with reference to the cathode. All the negative potentials shown on the diagram are purely for illustration of principles. Actual receiver voltages might differ widely from these and still have the same general relations at the amplifier.

When a stronger incoming signal increases plate current in the amplifier there is increased flow in resistor R_o and the top of R_o becomes more negative with reference to ground.

The potential at the top of R_o , and at the amplifier plate, is that for the agc bus which connects to the grid returns of all tubes whose gain is automatically controlled. Thus the automatic bias voltage is made more negative by increased signal strength and amplification of the controlled tubes is reduced.

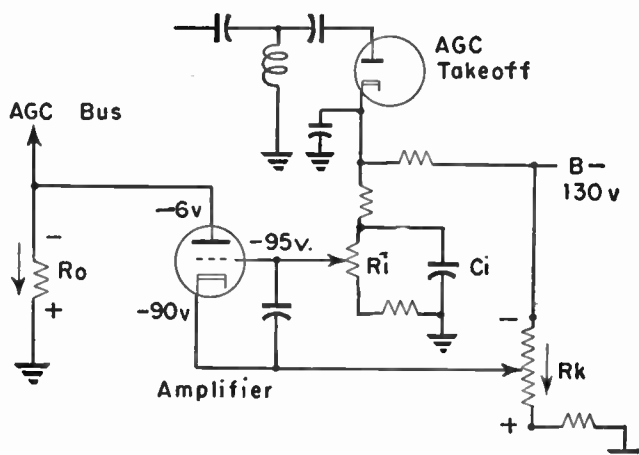

Fig. 43-6.—An amplifier for increasing the automatic biasing voltage and inverting its polarity.

Shown in Fig. 43-6 are two adjustments which affect the strength of signal necessary to cause any given automatic bias voltage at the amplifier plate. The adjustment at R_i alters the steady negative grid voltage which exists in the absence of current in the agc takeoff diode. This is a grid bias voltage for the amplifier. The adjustment at R_k alters the steady negative potential of the cathode with reference to ground. Change of cathode potential alters both the grid-cathode and the plate-cathode potential differences in the amplifier tube, alters the amplifier plate current, and the automatic bias voltage for any given signal amplitude or signal strength. Ordinarily only one or the other of these adjustments will be found in the same receiver.

Limited Control for R-f Stages.—The prime purpose of automatic gain control is to provide constant signal strength

at the video detector and thus reduce the need for readjustment of brightness and contrast controls. This purpose is satisfied by making the automatic negative bias increase uniformly with signal strength. It is found, however, that an improved signal to noise ratio may be secured by allowing the r-f amplifier or amplifiers to operate at full gain on all signals which won't cause overloading of the following i-f stages. With full automatic control on r-f amplifiers the highly negative bias may cause cross modulation, which allows strong signals to ride through with weak ones and produce an effect of poor selectivity.

In some receivers only some definite fraction of the automatic negative bias is connected to grid returns of r-f amplifiers while the full agc voltage or a greater fraction of it is connected to grid returns of i-f amplifiers. Voltage divider circuits such as those of Fig. 43-7 are used for this division. In other receivers there is a switch for cutting off the agc action

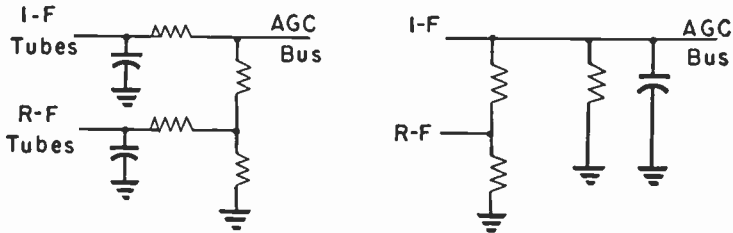

Fig. 43-7.—Methods of lessening the automatic gain control action on r-f amplifiers.

when receiving weak signals. If agc action is cut off when receiving strong signals the resulting overloading of i-f stages may cause excessive control on these stages, and a picture which appears weak or all over gray.

By using two separate diode takeoff tubes, one for i-f biasing and the other for r-f biasing, it is possible to use different delay voltages on the two tubes. Then the greater delay is applied to the r-f amplifier or amplifiers and the lesser delay to the i-f amplifiers. The same general method may be used

with two separate amplifiers, whose steady grid or cathode voltages may be adjusted for different delays, or for different signal strengths required for production of equally negative bias voltages. The same general idea is utilized by having a single takeoff diode feeding a single amplifier, with the agc voltage output of this amplifier applied to two separate diodes. One of these diodes may be cathode-biased for a delay suited to i-f amplifiers and the other diode may be cathode-biased for a delay suited to r-f amplifiers.

Time Constants and Noise. — In order that the automatic negative bias voltage may remain proportional to input signal strength the time constant of the gain control system must be longer than the period of one horizontal line. This time constant is the discharge time constant of the capacitor which has been marked C_f and the resistors marked R_a and R_b in some preceding diagrams. This time constant must be long enough to prevent any great loss of charge and bias voltage between successive horizontal sync pulses.

Should any external electrical interference be of a type causing brief voltage peaks to come through the r-f and i-f amplifiers these peaks may act on the agc system in the same manner as the sync pulses. These interference voltages, usually called noise, may establish a negative biasing voltage of their own if the interference is stronger than the sync pulses. This false agc voltage will reduce amplification for desired signals, possibly to the extent that program reception is impossible when or where the noise interference level is high.

Many expedients are employed for making the agc system more or less independent of noise interference. Referring to Figs. 43-2 and 43-3, the time constant of capacitor C_a and resistor R_b may be made relatively short. Then, even though C_a is charged by noise to a voltage higher than the sync pulse peaks, this capacitor discharges so quickly as to add but little to the biasing voltage maintained on capacitor C_f .

Fig. 43-8 illustrates the principles of two methods of using diodes as noise limiters in connection with an agc amplifier.

At *A* the cathode of the diode limiter is connected to the negative agc bus on the plate side of the amplifier. The plate of the diode limiter is connected to a negative voltage equal approximately to the maximum automatic bias which is to be allowed. That is, this limiting negative voltage would correspond to maximum peak amplitude of sync pulses. Noise peaks whose voltage exceeds that of the signal sync pulses

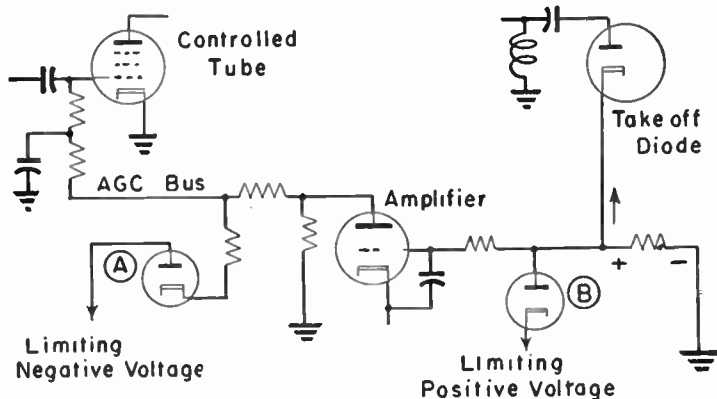

Fig. 43-8.—Two ways in which diodes may be used as noise limiters.

will make the amplifier plate and diode limiter cathode more negative. Then the cathode of the diode will be more negative than its plate, which is equivalent to making the plate positive with reference to the cathode. This will cause the diode to conduct and load the circuit sufficiently to prevent excessively negative voltage on the agc bus.

Diode *B* of Fig. 43-8 is connected to the input or grid side of the agc amplifier, with the plate of this limiter diode to the line between the takeoff diode and the amplifier. In this line the potential becomes more positive with reference to ground when there is increase of signal strength. This positive potential acts on the plate of the limiter diode. The cathode of this limiter diode is connected to a positive voltage which prevents conduction in the diode so long as voltage on the diode plate does not exceed that corresponding to peak amplitude of the sync pulses.

Noise peaks which would cause more current in the take-off diode and a more positive voltage at the amplifier grid also make the plate of the limiter diode more positive. Then this diode conducts and loads the amplifier grid circuit to keep the grid from becoming sufficiently positive to make a material increase of negative bias voltage in the plate circuit of the amplifier. Only one or the other of the diode limiters ordinarily would be used in an agc system.

Keyed or Gated Automatic Gain Control. — In keyed or gated methods of automatic gain control the control tube is conductive during only the periods of horizontal sync pulses. Unless noise peaks occur simultaneously with the sync pulses, the noise voltages can neither add to nor subtract from the automatic biasing voltage which is developed by direct or

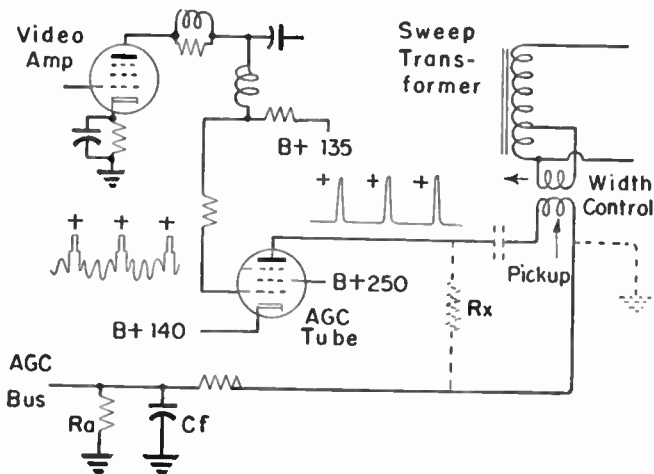

Fig. 43-9.—A keyed agc system in which keying pulses are taken from the horizontal sweep output transformer.

indirect action of the horizontal sync pulses. In between successive horizontal sync pulses the control tube is made non-conductive either by holding its plate at a voltage less positive than necessary for conduction of else by holding its grid more negative than required for plate current cutoff.

Principles employed in one method of keyed automatic gain control are illustrated by Fig. 43-9. To the grid of the agc tube is applied the entire composite video signal as taken from the output of a video amplifier. Average voltage on the agc grid is highly positive, shown here for purposes of explanation as 135 volts. The cathode is connected to a voltage slightly more positive, which makes the grid negative with reference to the cathode. Screen voltage is relatively high.

In the system illustrated the pickup coil in the plate circuit is coupled to the width control inductor on the secondary of the sweep transformer in a flyback type of high-voltage power supply. In this secondary winding there is sudden reversal of current during each horizontal retrace period. The change of magnetic field due to current reversal induces a strong voltage pulse in the coil and a brief highly positive voltage on the plate of the agc tube. This happens while the grid of the agc tube is being driven more positive by a sync pulse.

There are various ways of introducing positive voltage peaks from the sweep circuit into the plate circuit of the agc tube. With one method the conductor from the tube plate extends unbroken through the pickup coil and to the agc bus. With another method, indicated by broken lines in Fig. 43-9, the pickup coil is connected to the plate circuit through a capacitor and ground, with a conductive connection from the plate through resistor R_x to the agc bus. In any case, the average potential of the plate in the agc tube is practically ground potential except when the positive voltage peaks occur, and is so highly negative with reference to the cathode as to prevent conduction except during those voltage peaks.

While the plate of the agc tube is positive, the positive sync pulses on the grid cause conduction. The plate current charges capacitor C_f to build up a negative biasing voltage at the agc bus in the usual way. Since the tube is conductive only while sync pulses act on the grid, any voltage pulses due to noise interference occurring between sync pulses cannot affect the negative agc voltage. Strength of negative biasing

voltage is proportional to plate current of the agc tube. Plate current is proportional to strength of sync pulses on the grid, and sync pulse amplitude is proportional to strength of the received signal. Consequently, the agc bias is proportional to signal strength.

In the gated agc system of Fig. 43-10 the video signal with negative sync pulses is taken from the output of the video detector and applied to the grid of the first agc amplifier. Stronger incoming signals make the grid more negative and reduce the plate current. This plate current of the first agc amplifier flows in cathode resistor Rk , which is also in the cathode circuit of the second agc amplifier. When stronger signals

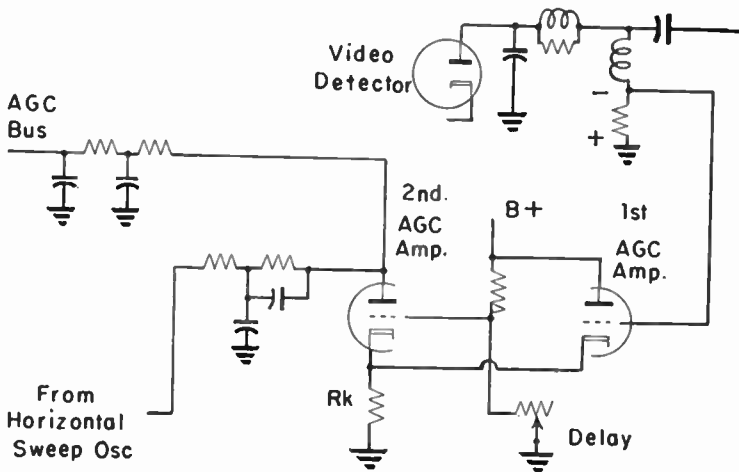

Fig. 43-10.—Gated agc system in which voltage peaks for making an amplifier conductive are taken from the horizontal oscillator circuit.

reduce plate current in resistor Rk there is less voltage drop across this resistor, which makes the grid bias of the second amplifier less negative and increases plate current in the second amplifier. Increase of plate current in the second amplifier makes its plate more negative, due to inversion of grid and plate voltages which occurs in any amplifier. Thus the automatic biasing voltage from the plate of the second amplifier becomes more negative when there is increase of signal strength.

The gated effect in the system of Fig. 43-10 results from the fact that plate current can flow in the second agc amplifier only when its plate is made positive with reference to its cathode by a sine wave voltage taken from the circuit of the horizontal sweep oscillator. This voltage is positive at the plate of the second amplifier only while a horizontal sync pulse is reaching the grid of the first amplifier. Noise voltages occurring at other times have no effect on the automatic biasing voltage.

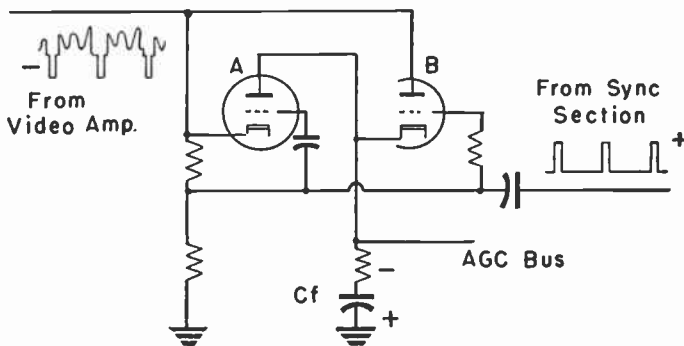

Fig. 43-11.—Keyed agc system in which positive keying pulses for control grids are taken from the sync section of the receiver.

The elementary principle of another keyed agc system is shown by Fig. 43-11. The video signal with sync pulses negative is taken from the output of a video amplifier and applied to the cathode of agc tube *A*, also to the plate of agc tube *B*. A stronger signal tends to increase conduction in tube *A*, because the cathode is made more negative, and at the same time tends to decrease or stop conduction in tube *B*, because its plate is made more negative.

To the grids of both agc tubes are applied positive sync pulses taken from a point in the sync section where picture signals have been removed and only the uniform sync pulses remain. The agc tubes can conduct only while these positive pulses from the sync section are acting on the agc grids. This happens only while negative sync pulses from the video

amplifier are acting on the cathode of tube *A* and on the plate of tube *B*. Noise voltages occurring between the sync pulses find the tubes nonconductive, and have no effect on agc voltage.

In the system of 43-11 the automatic negative bias is maintained proportional to strength of received signals by the following actions. Conduction in agc tube *A* charges capacitor *C_f* to make its upper end, connected to the agc bus, of negative polarity with reference to ground. Since conduction in tube *A* increases with a stronger signal, the stronger signal acts to increase the charge on capacitor *C_f*, which makes the automatic bias more negative and lessens amplification in the controlled amplifiers.

The plate of tube *B* is being maintained negative with reference to the tube cathode by the negative peaks of the video signal which are applied to this plate. At the same time, since the cathode of tube *B* is connected to the top of capacitor *C_f*, increase of negative biasing voltage makes this cathode more and more negative. Finally, the increase of biasing voltage makes the cathode negative with reference to the plate, and the tube becomes conductive. Then current which would cause additional charging of *C_f* flows instead through tube *B*. Biasing voltage increases no further, but is held at a value proportional to strength of the received signal.

Should strength of the received signal decrease, the plate of tube *B* becomes less negative, and through this tube there is discharge of capacitor *C_f* to reduce the biasing voltage. If there is increase of signal strength the plate of tube *B* is made more negative, stopping discharge of capacitor *C_f* until its biasing voltage builds up to a value corresponding to the stronger signal.

Gain Control During Alignment. — When frequency response is being observed during alignment of r-f and i-f amplifiers the apparent response will not conform to actual characteristics of the amplifiers if there is any automatic gain control action. For true response characteristics the grid bias of all amplifiers must remain of constant value, unaffected by

signal strength. This might be accomplished in some receivers by keeping the output voltage of the signal generator below the value which causes automatic control of amplifier bias. In receivers having delayed automatic gain control the delay voltage may be enough to permit moderately high input signal voltage without causing automatic change of bias, or it might be possible to temporarily adjust the delay voltage to a value high enough to prevent automatic control.

As a general rule it is quicker, easier, and more certain to substitute for the automatic biasing voltage a temporary fixed bias obtained from one or more dry cells. The negative terminal of the biasing battery should be connected to the agc bus, and the positive terminal connected to ground or to the positive side of the agc capacitor which has been designated as C_f in several diagrams. A battery thus connected usually will override all effect of the automatic gain control tubes and maintain a steady bias. If a gain control tube is a separate unit, not in the same envelope with the video detector or some other tube, the gain control tube may be removed from its socket while the biasing battery is connected.

If the fixed battery bias is sufficient to actually prevent all agc action there will be no change of shape in the frequency response curve when output voltage of the signal generator is increased or decreased by small amounts. Such changes of generator output should cause the response curve to become higher or lower, but not to change its shape. If there is change of curve shape the bias must be made more negative, or a gain control tube must be made inoperative.

A 3-volt bias from two dry cells in series usually is satisfactory. Adjustable bias may be had with a potentiometer of 5,000 to 10,000 ohms resistance connected across a $4\frac{1}{2}$ -volt battery. The positive side of the battery, with one end of the potentiometer attached, is connected to chassis ground, and the slider of the potentiometer is connected to the agc bus. Adjustment of the slider then will provide any negative bias between zero and full battery voltage.

GAIN, STAGE.—The gain of one stage of amplification usually refers to voltage gain unless power gain is specified. Voltage gain is the number of times a signal voltage is increased between the grid input to one amplifier tube and the grid input to the following amplifier tube, or between the first grid input and the output of the same stage into something like a speaker coupling or a picture tube.

Following are usual formulas for voltage gain of a stage.

$$\text{Gain} = \frac{Gm \times Rp \times Ro}{Rp + Ro} \quad \text{Gain} = \frac{\mu \times Ro}{Rp + Ro}$$

Gm. Mutual conductance or transconductance, micromhos.

Rp. Plate resistance of tube, megohms.

Ro. Plate load resistance, megohms.

mu. Amplification factor.

All values used in the formulas must be those actually existing with the operating conditions such as plate, screen, and grid voltages, and whatever frequency is being considered. The two formulas are equivalent because *mu*, the first term on the right in the second formula, is equal to $Gm \times Rp$ in the first formula.

Actual stage gain may be determined as illustrated in Fig. 44-1 from a load line drawn for the actual plate load resistance

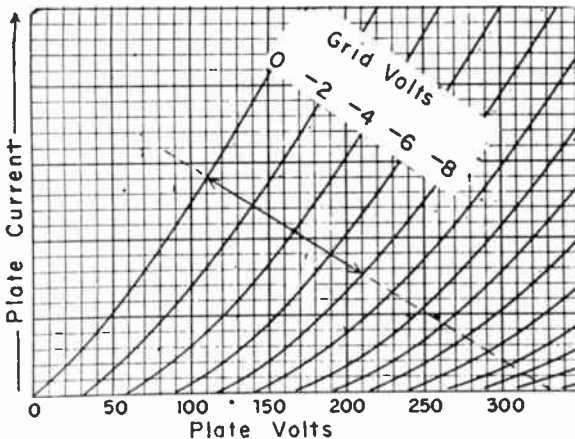

Fig. 44-1.—On the plate and plate load there is change of 100 volts for 8 volts change on the grid, indicating a gain of $12\frac{1}{2}$ times.

on a family of plate characteristics for the tube in use. Points are marked on the load line at the high and low limits of grid voltage or input signal swing above and below the point corresponding to grid bias. Plate voltages corresponding to these limits of grid voltage then are read from the graph. Change of voltage across the plate load may be assumed equal to change of plate voltage. Dividing the number of volts change in plate voltage by the number of volts change in grid voltage gives the voltage amplification of the stage.

Stage gain may be measured with a calibrated signal generator and an electronic voltmeter. The generator must have accurate calibration for its output, usually in numbers of microvolts, and should deliver minimum stray signal voltage at low settings of the attenuator. A check should be made with the generator connected directly to the electronic voltmeter while determining the relation between changes of attenuator settings and resulting meter readings, or while calibrating one of the instruments in relation to the other.

If measurements are to be made in r-f or i-f stages the automatic gain control should be overridden with a fixed bias from a battery. When working on i-f stages the r-f oscillator should be disabled in the same manner as for alignment. The remainder of the process is illustrated by Fig. 44-2.

1. Connect the electronic voltmeter across the output of the last stage in the amplifier system. If connection is to other

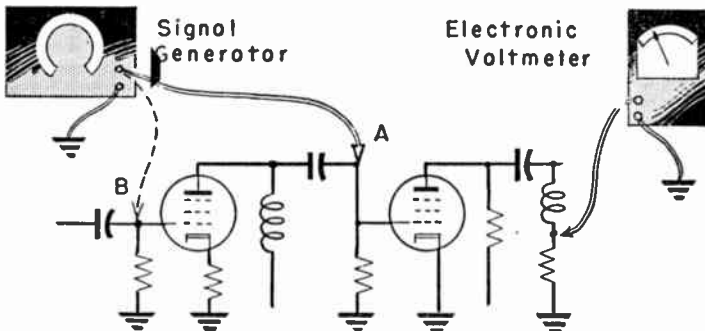

Fig. 44-2.—Connections for measuring voltage gain with signal generator and electronic voltmeter.

than the d-c output of a detector it will be necessary to use a detector probe on the voltmeter input.

2. Use the signal generator unmodulated. For measurements in r-f or i-f stages tune the generator to the amplifier frequency or to the frequency at which gain is to be measured.

3. Connect the output of the generator to the grid of the final amplifier tube, just as when making alignment adjustments. This is the connection at point *A*.

4. Adjust the generator attenuator to produce from the amplifier an output which may be read accurately on the voltmeter, such as 0.5 or 1.0 volt.

The gain, or loss, of the final stage is the quotient of dividing the amplifier output by the generator output.

5. To measure gain of the preceding amplifier stage connect the output of the signal generator to the grid of the tube in the preceding stage, as at *B*.

6. Adjust the generator attenuator to produce from the final stage of the amplifier the same output as in step 4.

7. The gain of this preceding stage is the quotient of dividing the generator output used in step 4 by the generator output used in step 7.

GENERATORS, AUDIO-FREQUENCY. — Generators which furnish variable and adjustable frequencies in the audio range usually employ the principle of beat frequencies, or of resistance-capacitance tuning, or of relaxation oscillation as found in multivibrators and blocking oscillators. For fixed audio frequencies such as used for modulation in r-f signal generators it is common practice to use some form of feedback oscillator, such as tuned grid or tuned plate with tickler feedback or else a Hartley circuit. Feedback oscillators do not lend themselves to adjustment over such wide ranges of audio frequency as do the other types mentioned.

Service types of audio-frequency generators usually provide for outputs anywhere between about 20 cycles per second and a high limit of 12,000 to 20,000 cycles per second. Beat frequency oscillators contain one r-f oscillator operating at a fixed frequency and another r-f oscillator whose frequency is ad-

justable. The outputs are fed to a mixer or converter from which is taken the difference beat frequency in the audio range. Remaining high frequencies are removed by a low pass filter. The filter often is followed by a degenerative amplifier tube.

Fig. 45-1 illustrates the principle of resistance-capacitance tuning employed in many audio-frequency generators. The operating frequency is selected or adjusted by means of a Wein bridge in which the four arms consist of $Ca-Ra$ in series,

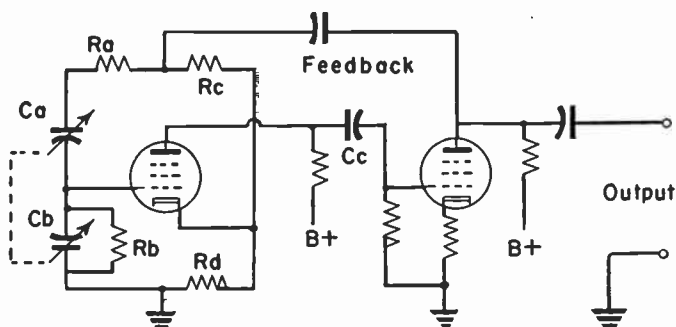

Fig. 45-1.—A Wein bridge frequency-selective circuit as used in audio-frequency generators.

of $Cb-Rb$ in parallel, of Rc , and of Rd . Adjustment of capacitors Ca and Cb will vary the frequency through a range of about 10 to 1. Additional ranges are provided by switching in different resistances at Ra and Rb .

Plate output of the left-hand tube is fed through capacitor Cc to the grid of the right-hand tube. Part of the output from the right-hand tube goes to the generator output terminals and part is a feedback. The feedback is applied to the upper input point of the bridge, between Ra and Rc , through the feedback capacitor, and is applied to the bottom input point of the bridge through ground. The output of the bridge is applied to the grid of the left-hand tube from between Ca and Cb , and is applied to the cathode of this tube from between Rc and Rd . At the frequency for which the bridge is balanced or

adjusted the feedback is regenerative, and causes oscillation. At all other frequencies the phase of the feedback is such as to make it degenerative.

GENERATORS, CRYSTAL CONTROLLED. — The characteristics of piezo-electric quartz crystals employed for maintaining the frequency of r-f oscillators are explained in the article on *Crystals, Frequency Control*. Fig. 46-1 shows the circuit

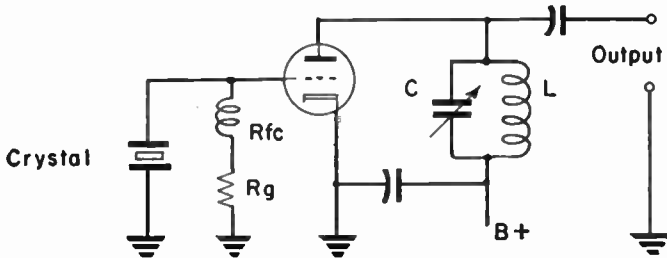

Fig. 46-1.—A simple crystal-controlled oscillator.

for a simple crystal controlled oscillator using a triode voltage amplifier tube. The radio-frequency choke R_{fc} has inductance of 1 to 3 millihenrys. The grid resistor is of 1 to 5 megohms resistance. Inductance and capacitance at L and C are of any values which will tune to the frequency of the crystal. When

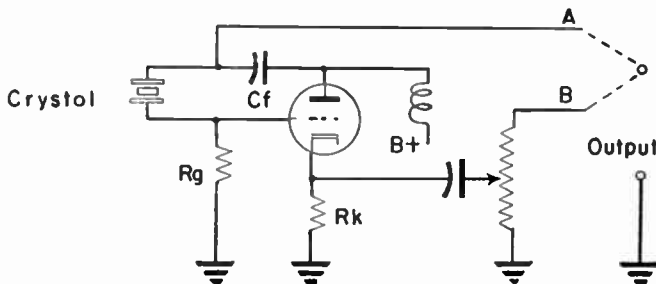

Fig. 46-2.—An untuned crystal-controlled r-f oscillator.

the plate circuit is tuned to a frequency slightly higher than that of the crystal the reactance of the plate circuit is inductive and there is feedback through the plate-grid capacitance of the tube. The feedback sustains oscillation at the crystal frequency.

Fig. 46-2 shows an untuned oscillator circuit which will,

however, sustain oscillation at the frequency of any crystal connected between plate and grid of the tube. This is one variety of the Pierce oscillator, a type used in many r-f generators where the crystal frequency is employed for markers. The feedback capacitance C_f may be about 500 mmf. The grid leak resistance R_g may be 0.1 megohm or more. The cathode resistor R_k is chosen to maintain a suitable grid bias for the tube used.

Output from the oscillator of Fig. 46-2 may be taken from the plate side of the circuit at A or from the cathode side at B . An output attenuator is shown for the cathode connection. Some generally similar attenuator would be used for plate output if employed. The oscillator tube may be a pentode instead of the triode illustrated. The only addition would be the screen supply dropping resistor and a screen bypass capacitor to ground.

GENERATORS, MARKER. — A marker generator provides means for identifying the frequency at any point along a curve of frequency response being traced on the screen of an oscilloscope with the help of a sweep generator. The marker generator is essentially an oscillator furnishing radio-frequency voltage of fixed frequency which, when introduced into the same receiver circuit with the output of the sweep generator, forms a strong beat voltage every time the frequency of the sweep generator goes through the fixed frequency for which the marker generator is adjusted.

At points on the frequency response curve where marker and sweep frequencies are equal the beat voltage produces an effect usually called a marker "pip," as illustrated at the left in Fig. 47-1. Some marker generators have provision for turning off their oscillator tube. Then, with the tuned circuits of the marker generator remaining connected to the receiver circuit in which are the sweep voltages, there is absorption of power every time the sweep frequency passes through the marker frequency. The result is a break or a "dip" in the frequency response curve, as at the right in Fig. 47-1. Either pips or dips may be used for frequency identification.

Frequency calibration of the marker generator must be highly accurate and stable. Many service operations require frequency settings to within a small fraction of one per cent of a specified value. For any frequencies which are likely to be used many times, as those for receivers most often serviced, it

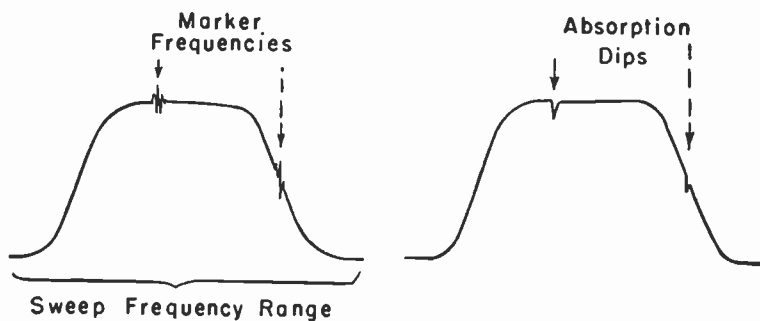

Fig. 47-1.—Marker pips resulting from oscillator action (left) and marker dips resulting from absorption (right).

is desirable to have crystal control. It is necessary also that the tuning dial drive and scale of the marker generator be such as will allow resetting to a given frequency with a high degree of accuracy after the generator has been used for some other frequency between times.

Frequency ranges of the marker generator must include all the intermediate frequencies, from 20 to 40 mc. It is necessary also to provide the 4.5 mc intercarrier beat frequency used for intercarrier sound systems. Marker frequencies are not always provided for video and sound carriers and for r-f oscillator frequencies. If carrier and oscillator frequencies are provided there will be a range from 54 through about 125 mc for the low band and from 174 through about 250 mc for the high band. Fundamental frequencies are preferable to harmonic frequencies in all ranges, although harmonics often are used for carrier and oscillator frequencies.

The marker generator nearly always is used also as a general purpose signal generator where an adjustable constant fre-

quency is needed, as for alignment of stagger tuned i-f stages and many other purposes. Such uses require that the r-f output may be modulated with audio frequency, although no modulation is needed for the marker function. It is desirable also that the output attenuator be accurately calibrated in microvolts.

The marker generator and sweep generator may be constructed as a single instrument called a television generator. In such a combination instrument the marker and sweep outputs are internally connected together so that only a single

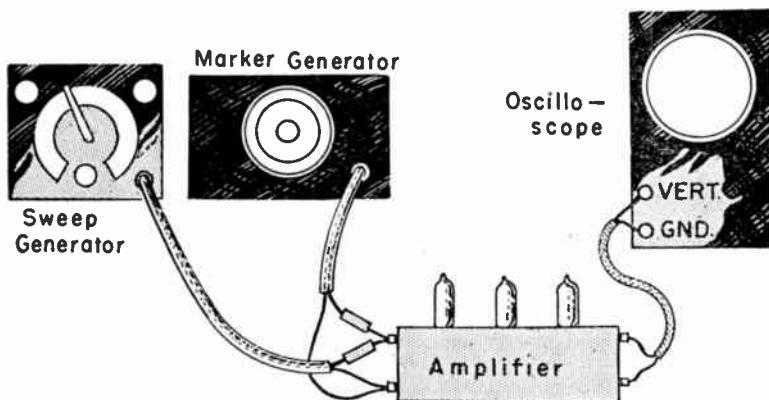

Fig. 47-2.—Connections of marker generator, sweep generator, and oscilloscope to amplifier or receiver.

external cable is used for connection to the receiver. Through this cable are applied the sweep frequency and the adjustable marker frequency, with each frequency regulated by its own controls on the generator panel.

If the marker generator is an instrument separate from the sweep generator, the sweep generator is coupled to the receiver circuits in the usual way. Usual procedure then is to connect the high side of the marker generator through a fixed capacitor of something between 2 and 20 mmf capacitance to the same point as the high side of the sweep generator. This is illus-

trated by Fig. 47-2. The low sides of both generators are connected to chassis ground or to B- of the receiver. Output cables must be shielded, with the shield grounded.

Enough coupling for marker frequencies may be secured with the cable from the marker generator laid near the cable from the sweep generator, or the marker cable may be given two or three turns around the sweep cable with the end of the marker cable left unconnected. The marker cable need not always be connected to the same point as the sweep cable; the marker may be coupled to the grid of a tube in some stage preceding that to which the sweep is coupled. In some generators there is an internal fixed capacitor in series with the output. Otherwise an external series capacitor must be used to prevent a d-c short circuit of grid bias through the generator when the sweep output is connected to the grid of an amplifier tube. If a d-c ohmmeter gives a steady resistance reading when connected to the output of the generator there is no series capacitor inside the generator, and an external capacitor should be used. The 2- to 20-mmf coupling capacitor mentioned in the preceding paragraph serves this purpose.

The marker generator employed for producing marker pips or dips is used without modulation or is used with pure r-f output. To identify the frequency at any point on a curve produced by the sweep generator, tune the marker generator to bring the pip or dip to the point in question and read the frequency from the marker dial. When it is desired to alter the response at some certain frequency, tune the marker generator to that frequency and then make changes of alignment or other adjustments as required to obtain the desired response where the marker pip or dip appears on the curve. These methods are used when working with frequency responses of r-f and i-f amplifiers, also when working with S-curves of sound discriminators or ratio detectors. Markers may be used to identify high and low limits of amplification, to identify peak frequencies, trap frequencies, and for other purposes.

Some generators provide two different marker frequencies at the same time. This is an advantage in many cases. For example, when working with the response of the television i-f amplifier section one marker may be set for the video intermediate and the other marker set for the sound intermediate frequency. When adjusting for a desired band pass the two markers may be set for the high and low limits of the band.

In order to avoid distortion of the response curve the output of the marker generator must be kept at the lowest level which gives a recognizable pip. If the marker generator is tuned through the range of sweep frequency the pip will move up on one side of the response curve, across the top, then down on the other side. The height of the pip will be maximum at the top of the curve, where there is maximum amplification, and will decrease to zero at the bottom of the curve where there is no amplification. Marker output must be adjusted according to the part of the curve being checked if the curve is not to be distorted.

It is difficult to see a marker on a steeply sloped portion of a curve. The marker may be located by widening the curve with the horizontal gain control of the scope. Weak markers may be seen more easily if the phasing control of the generator or scope is adjusted to separate the forward and return traces, or the return trace may be blanked if there is provision for blanking on the scope.

If all marker pips appear wide and fuzzy they may be sharpened by connecting across the vertical input of the scope a capacitor of something between 100 and 2,000 mmf capacitance, using the least capacitance that gives satisfactory pips. Resistance of about 10,000 to 20,000 ohms in series with the vertical input lead may help to sharpen the pips. A regular filter probe for the scope, containing a shunting capacitor and series resistance, will sharpen the pips.

Harmonic frequencies from crystal oscillators in a generator or from a separate crystal controlled generator sometimes are used to identify frequency points on r-f response curves, with the sweep generator operating at carrier frequencies and

connected to the receiver antenna terminals. Various crystal harmonics may beat with the r-f oscillator frequency and produce a variety of pips on the response curve. The spurious beats due to the r-f oscillator may be identified by shifting a fine tuning control. The oscillator beat markers will move with the curve, holding their same positions on the curve. Pips not due to oscillator beats will remain stationary on the screen of the scope or on a graph scale used in front of the screen. These pips not due to r-f oscillator beats will not move along with the response curve but will appear at different parts of the curve as the fine tuning control is adjusted.

If the r-f oscillator is not made inoperative during alignment of i-f stages the i-f response curve is likely to carry several pips, only one of which corresponds to the frequency for which the marker generator is tuned. The other pips are due to beating with the r-f oscillator voltage. These spurious pips usually are smaller than the one for the marker frequency. If the generator provides for a dip marker, and is switched from pip to dip, the dip marker will appear at the frequency to which the marker generator is tuned.

GENERATORS, PATTERN. — A pattern generator produces on the light colored raster of a picture tube a series of horizontal and vertical black lines or bars. If receiver linearity controls are correctly adjusted the lines or bars will be evenly spaced in both directions. When spacings between lines are equal horizontally and vertically the aspect ratio of the generator pattern will be four units of width and three of height. The principal use of these generators is for adjustment of linearity controls, size controls, and hold controls when there is available no test pattern such as transmitted by broadcasters. Instruments of this type are called also crosshatch generators, linearity pattern generators, and sync generators.

GENERATORS, SIGNAL. — Various types of signal generators are explained under the general heading *Generators* in separate articles on audio-frequency, crystal controlled, marker, sweep, and other varieties. The types of greatest usefulness in

television servicing and experimenting are the sweep generator and the marker generator, or a single television service generator which includes both features.

R-f signal generators such as used for servicing of sound receivers for standard broadcast are useful as marker generators for video and sound intermediate frequencies and for the intercarrier beat frequency of 4.5 mc provided the frequency calibration is as accurate as required in a television marker generator.

GENERATORS, SQUARE WAVE. — A square wave generator furnishes an alternating voltage which changes very suddenly between its maximum positive and negative values and remains at each of these values during approximately a half-cycle. Most instruments produce the square wave by generating a sine wave which is shaped or distorted into the square form.

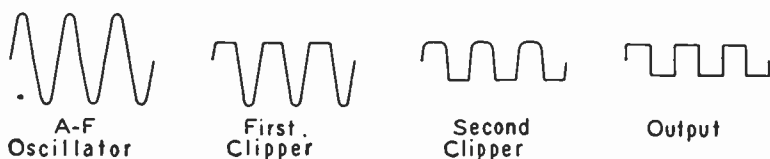

Fig. 50-1.—Steps in changing a sine wave to a square wave.

Typical steps in the formation of a square wave in successive circuits of a generator are illustrated by Fig. 50-1.

Either diodes or triodes may be used for clipping the tops and bottoms of a sine wave. Fig. 50-2 shows connections for one type of twin-diode clipper circuit. The cathode of diode *A* is positively biased from one of the adjustable potentiometers. This diode will conduct only while potential of the positive alternations of the sine wave exceeds the bias voltage. The conduction current flows in resistor *R* and is accompanied by enough voltage loss in this resistor to prevent further rise of current in the diode and, consequently, to flatten off the positive tops of the sine wave. The plate of diode *B* is negatively biased from the other potentiometer. This diode conducts only while potential of the negative peaks of the sine

wave exceeds the bias voltage. Then the conduction current through resistor R is accompanied by enough voltage drop to flatten the negative peaks of the sine wave. The greater the resistance at R the more squarely the wave will be clipped, or

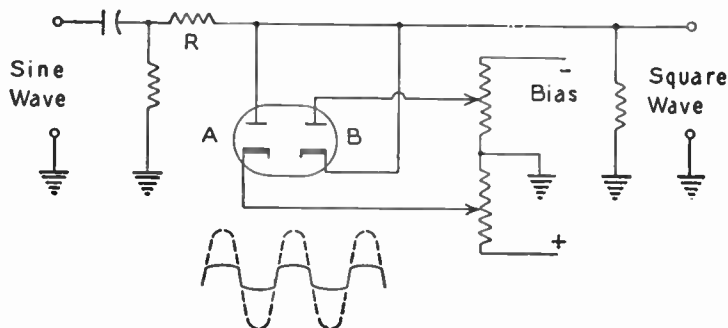

Fig. 50-2.—Square wave clipping circuit with diodes in parallel.

the flatter will be the tops of the squared wave. Squaring is improved also by using small resistance in the biasing potentiometers.

The twin-diode clipping circuit of Fig. 50-3 gives sharper squaring of the output wave and operates well at higher frequencies, but is somewhat more difficult to adjust for satisfactory performance than the circuit of Fig. 50-2. The two diodes are in series with each other and are opposed, cathode to cathode, between the sine wave input and the square wave output. Both cathodes are negatively biased to maintain conduction in both diodes until the bias voltage is overcome by input potentials during positive and negative alternations of the sine wave.

Positive alternations of the sine wave make the plate of diode A and the cathode of diode B more positive. This allows continued conduction in A , but stops it in B during the entire period in which positive sine wave potential exceeds the bias voltage. Negative alternations of the sine wave make the plate of diode A and the cathode of B more negative. This allows

conduction to continue through *B*, but cuts it off in *A* during the period in which negative sine wave potential exceeds the bias voltage.

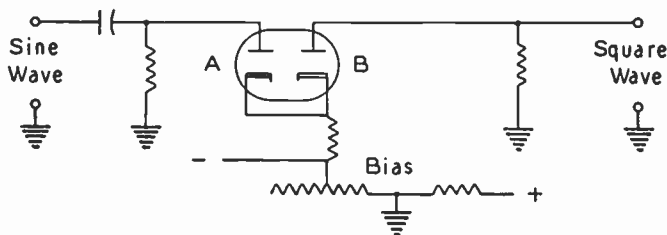

Fig. 50-3.—Square wave clipping circuit with diodes in series.

The chief difference between the two diode clipping circuits is that conduction is limited but not stopped by voltage drop in resistor *R* of Fig. 50-2, while conduction is stopped completely by interaction of sine wave and bias potentials in Fig. 50-3. Naturally, with complete stoppage of current and of output voltage the tops of the square wave will be straight across.

Triode clipping circuits utilize either of two general methods. With one method the negative peaks of the input sine wave are clipped squarely by biasing the triode grid so far negative as to cause plate current cutoff shortly after the sine wave commences to go negative. The output from the plate circuit of this first clipper is applied as grid input to a second similarly biased triode. Because of signal polarity inversion which occurs between grid and plate of any tube, the second clipper squares off the sine wave peaks which originally were on the positive side but have been made negative at the grid of the second clipper. Other triode square wave circuits employ the general method of using such resistance-capacitance constants in grid circuits as will cause plate currents and voltages to appear as sharp pulses which, by further filtering and amplification, become square waves.

Uses of Square Waves. — Square wave voltages are used as input signals for audio-frequency and wide-band amplifiers which are to be tested for frequency response and for distor-

tion. The output of the amplifier is connected to the vertical input of an oscilloscope. Using the square wave input allows rapid testing because a square wave really consists of a great number of harmonically related frequencies acting together.

The sharp corners at the leading edges of the square wave are due to frequencies 10 to 100 and more times the fundamental frequency. The flat top and flat bottom of the square wave represent no voltage change, or zero frequency, during the intervals of time occupied by these portions of the wave. Applying a square wave as a signal input is equivalent to making separate tests with a great number of sine wave frequencies. If an amplifier reproduces a square wave without serious distortion, the response of the amplifier usually will be satisfactory at all frequencies from that of the square wave fundamental up to frequencies at least ten times as high.

Any amplifier should be tested with at least two fundamental square wave frequencies. One should be the lowest frequency at which the amplifier is expected to operate satisfactorily. The other should be a frequency of about one-tenth the maximum at which the amplifier is expected to have good performance.

A preliminary check should be made with the output of the square wave generator connected directly to the vertical input of the oscilloscope. The generator should be tuned successively to each fundamental frequency which will be used later for testing the amplifier. At each of these frequencies the internal sweep of the scope should be adjusted to bring two or three cycles onto the screen. If the trace is not a true square wave the fault may be in the generator, in the scope, or in both places. Often it will be possible to secure a good square wave by trying different sweep frequency ranges on the scope, even though this changes the number of cycles traced, and by trying different settings of the vertical gain control. Often there will be improvement of the square wave within some limited range of settings for the generator output attenuator. Unless a square wave with very little distortion can be secured with this direct connection there is little use of checking the

amplifier. When a good square wave is obtained with certain settings of the controls, the amplifier tests should be carried out with the same settings.

If the output trace shown by the oscilloscope has rounded corners at the leading edges of the square wave, as shown at *A* in Fig. 50-4, the amplifier or other circuit being tested is not passing the highest frequencies in the square wave. This usually would indicate poor response at frequencies not much

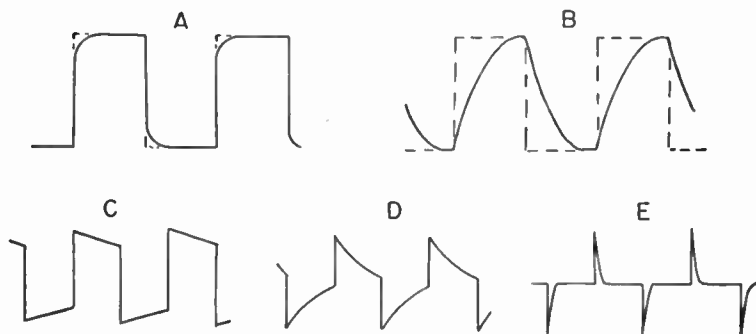

Fig. 50-4.—Faults indicated by output traces with square wave input. A, lack of high frequencies. B, extreme high-frequency loss. C, moderate low-frequency loss. D, serious low-frequency loss. E, no low-frequency gain.

higher than 10 times the square wave fundamental. The trace at *B* corresponds to an extreme case of high frequency loss or attenuation. Excessive capacitance shunted across the tested unit will cause such a trace, as will also excessive inductance in series with the signal-carrying paths.

The lower row of traces in Fig. 50-4 show the effects of poor response, lack of gain, or excessive attenuation of low frequencies or of frequencies down toward the fundamental of the square wave. A moderate degree of low-frequency distortion is indicated at *C*, a very serious loss is indicated at *D*, and at *E* the lows are wholly lacking and only the highest frequencies are being reproduced or transmitted by the circuit on test. This general class of square wave distortion indicates too much series capacitance or else too much shunted inductance somewhere between the square wave input and the output connected to the oscilloscope.

At the top of Fig. 50-5 are shown traces illustrating the effects of phase shift in the amplifier or other circuit between the square wave input and the output to the oscilloscope. At *A* the phase is leading, with current leading the voltage or voltage lagging the current, as when a circuit has excessive capacitive reactance. In an amplifier this, naturally, gives an indication somewhat similar to that from poor response at low frequencies, as at *C* and *D* of Fig. 50-4. It might result from too small coupling capacitance in a resistance-coupled amplifier used at low frequencies. At *B* is shown the opposite effect,

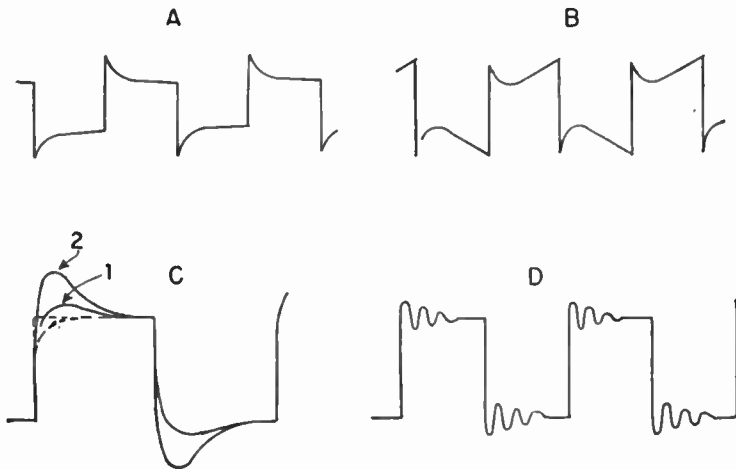

Fig. 50-5.—Faults indicated by traces from square waves. *A*, phase distortion with current leading. *B*, phase distortion with current lagging. *C*, effects of frequency compensation. *D*, oscillation in amplifier.

which results from lagging phase, with current lagging the voltage. Except for the sharp peak on the leading edges this phase shift trace bears considerable resemblance to the one indicating poor response at high frequencies as shown at *A* in Fig. 50-4.

The trace marked *C* in Fig. 50-5 shows the effects of adding inductance in the plate circuit of an amplifier to maintain or increase the gain at the high frequencies. Such inductance is supplied by peaking coils used for compensation in broad band video amplifiers. The broken line curve at the top corner

of the first leading edge would correspond to the trace at *A* in Fig. 50-4, indicating lack of high-frequency response. Adding plate circuit inductance will bring the curve up to 1, and adding still more inductance will bring it up to 2.

At *D* in Fig. 50-5 is a trace which indicates oscillation in the amplifier being tested. Following each leading edge is a train of damped oscillations. These result from circuit inductance and distributed or stray capacitance which are resonant at some frequency in the square wave. It is possible to determine the approximate frequency of oscillation by counting the number of oscillatory cycles in a half-cycle period or in some other fraction of the square wave. The square wave period is known from the generator tuned frequency. The oscillation frequency may give some indication as to the part of the amplifier circuit causing the trouble.

GENERATORS, SWEEP.—A sweep generator furnishes a signal voltage whose frequency varies continually and at a constant rate above and below some center frequency for which the generator is adjusted or tuned. The generator may be adjusted to operate above and below the center frequency of any television channel, or the center of an intermediate-frequency band of any television receiver. When correctly adjusted, the generator output frequency will continually sweep back and forth through the entire range of frequencies included in the television channel or through the entire i-f range of the receiver.

A sweep generator is used in conjunction with an oscilloscope for observing simultaneously the relative gains of an amplifier at all frequencies in the range or band being covered or swept by the generator. The method of use is illustrated by Fig. 51-1. The output of the generator is applied to the input of the amplifier whose gain is to be observed. The output of the amplifier is connected to the vertical input of the oscilloscope.

The oscilloscope beam is deflected horizontally at a rate which is exactly the same as the rate at which generator frequency is shifted through its sweep range. Consequently, the

oscilloscope beam always arrives at the same horizontal position for any given frequency during each sweep. At each horizontal position, and at the frequency corresponding to that position, vertical deflection or height of the beam and the

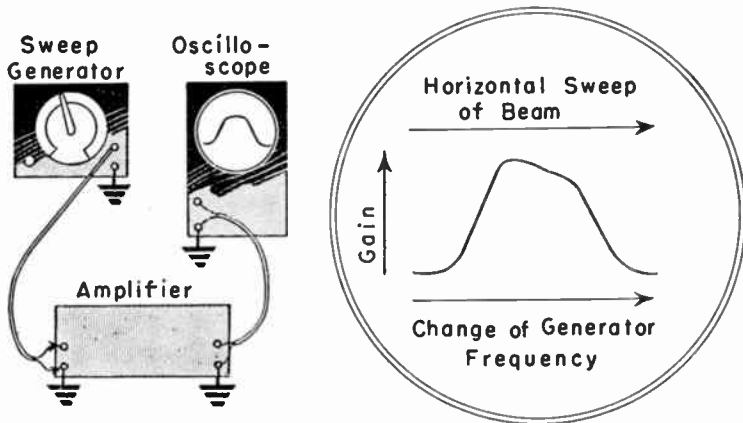

Fig. 51-1.—Connections for a sweep generator and features of the oscilloscope trace.

trace is proportional to the voltage gain of the amplifier at that particular frequency. As the beam moves horizontally across the oscilloscope screen it traces a curve of relative gains at all the frequencies within the swept range. This curve is the frequency response of the amplifier.

Sweep generators are used during alignment of antenna couplers and r-f amplifier stages in television receivers, also during alignment of video and video-sound i-f amplifiers, and in the sound section for alignment of i-f amplifiers, drivers, sound detectors, and discriminators. A television sweep generator is generally similar to f-m generators used for alignment of f-m sound receivers, except that the television type furnishes a wider range of swept frequencies and tunes in the higher carrier and intermediate frequencies of the television bands.

Methods of Frequency Sweep. — Frequency is shifted back and forth by varying the tuning capacitance or tuning inductance of an oscillator which is part of the sweep generator. One method makes use of a variable capacitor whose shaft

carrying the rotor plates is continually revolved by a small electric motor built into the sweep generator. Capacitance varies between maximum and minimum as the rotor plates are turned into and out of mesh with the stator plates of the capacitor. This rotary capacitor is connected in parallel with the main tuning capacitor or with the tuning inductance of the oscillator. Change of capacitance increases and decreases the oscillator frequency at a rate depending on the speed of the driving motor. Motor-driven capacitors were used in most of the early types of sweep generators, but less costly methods are now more generally employed.

Many sweep generators secure their frequency shift by means of a reactance tube operating quite similarly to such tubes used in some kinds of automatic frequency control for television sweep oscillators. In the sweep generator connections shown by Fig. 51-2 the plate of the reactance tube is connected to one end of the oscillator coil. High-frequency currents in the plate circuit of the reactance tube is out of phase with oscillator voltage. Connections to the reactance tube may be such that reactance plate current either lags or

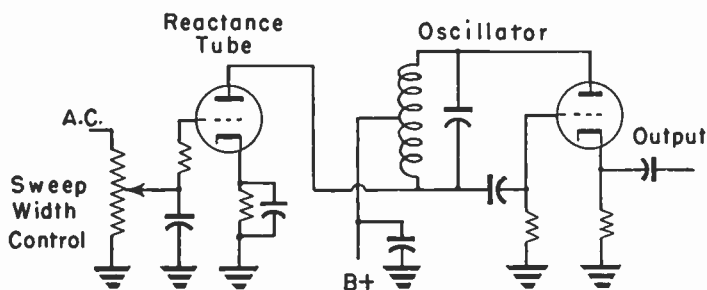

Fig. 51-2.—A reactance tube employed for frequency sweeping.

leads the oscillator voltage. With a lagging reactance current applied to the tuned circuit of the oscillator the effect is equivalent to adding inductance in the oscillator circuit. This lowers the oscillator frequency. If reactance current leads the oscillator voltage the effect is equivalent to adding capacitance in the oscillator tuned circuit, which also decreases the oscillator frequency.

How much the oscillator frequency is decreased is proportional to reactance plate current, the greater the current the greater the shift of frequency. Oscillator frequency may be thus decreased, and allowed to again increase, at a rate of any number of times per second by increasing and decreasing the reactance plate current at that desired rate of frequency sweep.

Both the extent of frequency sweep and the number of sweeps per second are controlled by suitably varying the grid voltage of the reactance tube. In Fig. 51-2 the reactance tube grid is connected through a potentiometer either to the a-c power line or else to a tube heater circuit. Grid voltage then will vary at power line frequency, usually 60 times per second, and oscillator frequency will vary or sweep at the same rate. The extent of the alternating swings of reactance grid voltage depends on adjustment of the slider on the sweep width control. This control accordingly regulates the extent of change of oscillator frequency or the width of frequency sweep.

Another method of frequency sweep, illustrated in principle by Fig. 51-3, makes use of the fact that moving a piece of metal toward and away from the inductor of a tuned circuit alters the effective inductance of that circuit, and there are

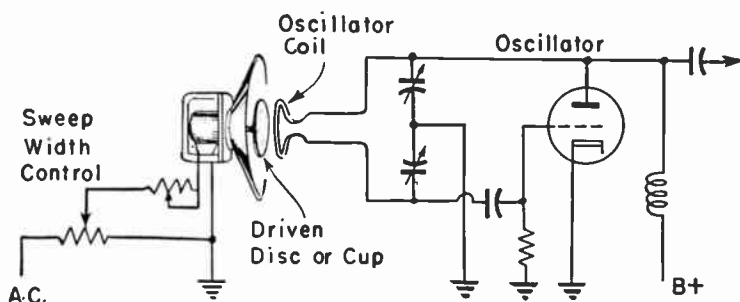

Fig. 51-3.—Electromechanical or electrodynamic method of frequency sweeping.

accompanying changes in resonant frequency of the circuit. The coil or inductor for the oscillator is supported in a fixed position. A fraction of an inch from the oscillator inductor is a metallic disc, plate, or cup which is attached to the moving

coil and cone of a small permanent-magnet speaker. The speaker is driven at power line frequency by taking current for its voice coil from an a-c heater circuit or other equivalent source.

The metal which is near the oscillator inductor is moved toward and away from the inductor at a rate corresponding to power line frequency. Consequently, the oscillator frequency is caused to increase and decrease at power line frequency, and this is the rate of frequency sweep for the generator.

The extent of frequency change is proportional to the distance through which the piece of metal is moved as it approaches and recedes from the oscillator inductor. The greater the movement of the metal the greater is the sweep. This movement, and the resulting range through which oscillator frequency is shifted, are varied by altering the current in the voice coil of the speaker. The current and the width of sweep are controlled by means of the potentiometer or rheostat connected to the voice coil.

Width of Sweep. — For television r-f and i-f alignment it should be possible to obtain maximum sweep width of at least 10 megacycles and preferably as much as 15 to 20 megacycles. This refers to the overall sweep, from minimum to maximum frequency, with part of this sweep range above the center frequency and part below. In order that a sweep generator may be used also for alignment of television sound sections and for alignment of f-m sound receivers it is desirable that the minimum sweep width be no more than two or three megacycles.

When a generator is in use, the sweep width control should be adjusted to bring onto the screen of the oscilloscope the entire gain curve or frequency response curve, plus a small extension of the zero gain or base line on both sides. The result of such adjustment is illustrated at the center of Fig. 51-4. The amplifier being tested has more or less gain over a total range of about 8 mc, as shown by the fact that the curve rises from zero and falls back to zero within this range. By making the sweep width approximately 10 mc it is possible to view the

entire curve, and to be sure of seeing all the curve by displaying a small amount of zero base line at both ends of the curve.

At the left in Fig. 51-4 is shown the result of using too much sweep width. The response curve then is cramped into a small part of the entire trace, with too much of the trace used for

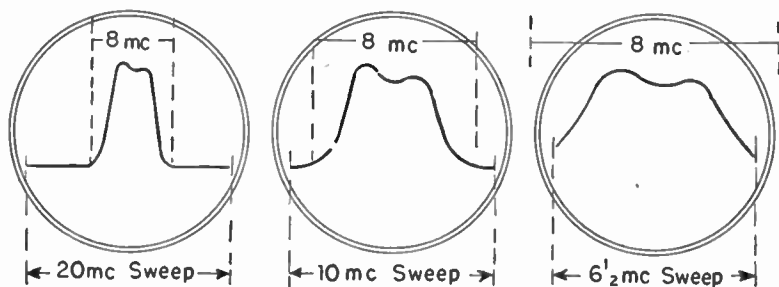

Fig. 51-4.—Effects of varying a sweep width control.

the meaningless base line or line of zero gain. The gain curve is too narrow to allow critical inspection of its shape and characteristics. At the right is shown the result of too little sweep width. Only a portion of the gain curve or frequency response can be examined. The rule is to use the least width of sweep which will display both ends of the frequency response all the way down to the zero line. Sweep width should not be altered during adjustment of any one piece of apparatus, since a change in curve width alters the appearance enough to cause some confusion.

Positioning of Response Curve. — The same frequency response or same relative gains at various frequencies may be shown by the same curve in any of four different positions on the screen of the oscilloscope. The positions are shown by Fig. 51-5. At *A* there is increase of frequency from left to right and increase of gain from the base line upward. At *B* the frequency still increases from left to right but the increase of gain is downward from the base line. At *C* there is increase of frequency from right to left, which is a reversal of the frequency direction, and the gain increases upward. At *D* the frequency increase remains from right to left, but increase of gain is downward.

If the oscilloscope beam is deflected horizontally by the internal sweep of the scope, the direction of frequency increase depends on the design of the internal sweep circuit, on the direction in which there is the relatively slow rise of sawtooth voltage which causes the useful trace, not the retrace.

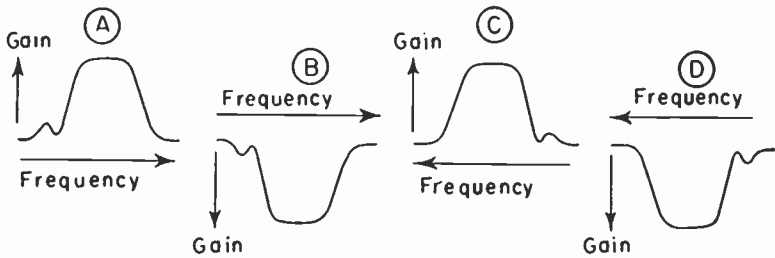

Fig. 51-5.—The same curve of frequency response may appear in different positions on the oscilloscope screen.

In practically all service oscilloscopes the trace is from left to right and there will be increase of frequency from left to right.

Usually the horizontal deflection of the oscilloscope beam is caused by a synchronized sweep voltage supplied from the sweep generator and fed to the horizontal input of the scope. Then the direction of frequency increase depends on the phase relation of this synchronized sweep voltage to the voltage which varies the frequency of the oscillator in the sweep generator. Synchronized sweep voltages from sweep generators usually are in such phase relation as to cause frequency to increase from left to right on the oscilloscope screen.

Whether there is increase of voltage gain upward or downward depends, for any given oscilloscope, on the polarity of the signal at the amplifier output or at the point connected to the vertical input of the scope. Each amplifier stage inverts the signal polarity, there are differences in numbers of stages in various receivers, and the response curve is just about as likely to show increase of gain in one direction as the other.

Any response curve may be moved bodily in a horizontal direction across the screen of the oscilloscope by changing the center frequency to which the sweep generator is tuned. At

the left in Fig. 51-6 the sweep generator is tuned to a center frequency which is too low to bring the entire response curve onto the screen. Increasing the center frequency will bring the entire curve onto the screen, as in the middle diagram.

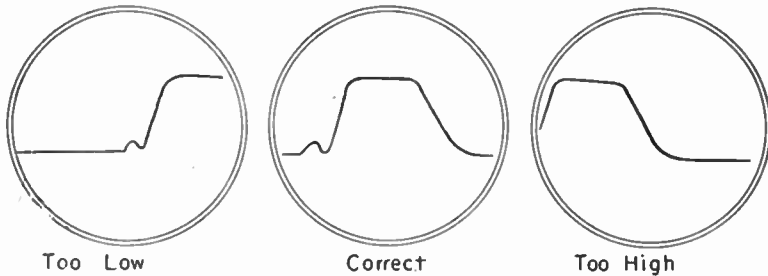

Fig. 51-6.—Effects of altering the center frequency of the sweep generator.

Further increase of center frequency will move the response curve off the screen in the opposite direction, as shown at the right.

Synchronizing the Sweep. — In order that a given point measured horizontally across the response curve may always represent the same frequency it is necessary that the horizontal sweep of the oscilloscope beam occur precisely in step with the sweep or the change of frequency of the generator. The beam may be deflected horizontally either by the internal sweep voltage of the oscilloscope or else by a synchronized sweep voltage supplied from the sweep generator. While the beam is being deflected, the frequency furnished by the sweep generator will be changing. If frequency sweep is at the rate of 60 times per second the frequency will go from minimum to maximum and back to minimum during $1/60$ second. Another way of saying the same thing is to state that frequency will go from minimum to maximum during $1/120$ second, then from maximum back to minimum in the following $1/120$ second, and will continue to change at this rate.

In order to deal with some concrete values we may assume that the generator frequency sweeps back and forth between 20 and 30 megacycles, going from 20 to 30 mc during $1/120$

second and from 30 back to 20 mc in the following 1/120 second. If the internal sweep of the oscilloscope is adjusted for a 60 cycle sweep, the beam will travel all the way across the screen in 1/60 second and the trace will show two response curves as at *A* in Fig. 51-7. One curve will show the change of gain as frequency increases from 20 mc to 30 mc, and the other curve will show the change of gain as frequency decreases

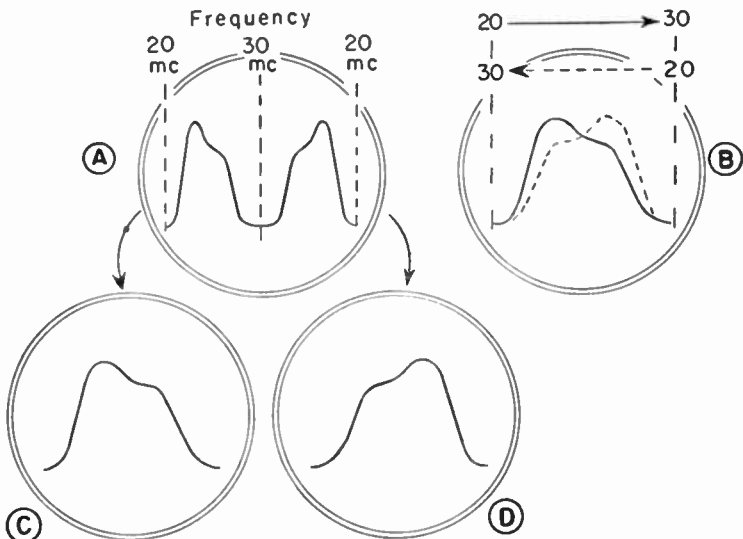

Fig. 51-7.—Response traces produced by using the internal horizontal sweep of the oscilloscope.

from 30 mc to 20 mc. The two curves will be symmetrical, and reversed left to right.

If the internal sweep of the oscilloscope is adjusted to 120 cycles per second the frequency trace will be split and the two parts will be superimposed as shown at *B*. Although this permits widening the response by using the horizontal gain control of the scope, the curves usually will be difficult to identify or to view with enough separation to make an analysis of the frequency characteristic.

A better way is to increase the horizontal gain of the oscilloscope until one of the two curves will nearly fill the screen, and

to operate the horizontal centering control of the scope to center that curve on the screen. Then it is possible to view the curve of increasing frequency as at *C* in Fig. 51-7 or to view the curve of decreasing frequency as at *D*. These separated curves would be secured with the internal sweep of the scope adjusted for 60 cycles, or for whatever may be the sweep rate of the generator.

Instead of using the internal horizontal sweep of the oscilloscope it is more common practice to sweep the beam horizontally by means of the same alternating voltage that shifts the generator frequency. The alternating voltage at power

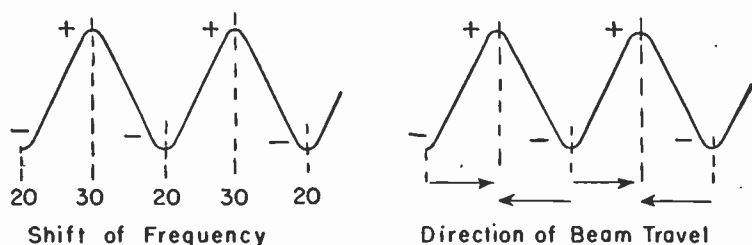

Fig. 51-8.—Relations between changes of frequency and directions of sweep of the oscilloscope beam when using synchronized sweep voltage.

line frequency used for frequency shift in the generator, as in Figs. 51-2 and 51-3, is fed also to the horizontal input of the oscilloscope. Then the oscilloscope beam is swept horizontally at a rate precisely the same as the rate of frequency shift. This principle is illustrated by Fig. 51-8. As the alternating voltage changes from negative to positive it shifts the frequency from 20 to 30 mc in the generator and at the same time deflects the oscilloscope beam to the right. While the control voltage changes from positive back to negative it shifts the generator frequency from 30 to 20 mc and deflects the beam to the left. Resulting traces on the oscilloscope screen are shown by Fig. 51-9. At *A* is the trace formed while frequency shifts from 20 to 30 mc with the beam moving from left to right. At *B* is the trace formed while frequency shifts from 30 back to 20 mc with the beam moving from right to left. Because the impression of each luminous trace remains visible while the other

one is formed, both traces appear together as in diagram C. The two traces now are formed in the same direction with respect to frequency, not in reversed directions as at B in Fig. 51-7.

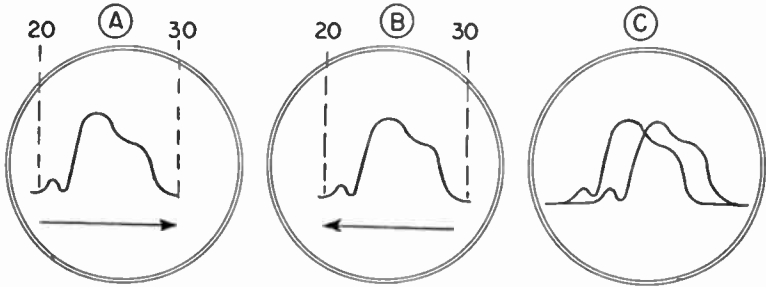

Fig. 51-9.—Traces formed by travel of the oscilloscope beam toward the left and toward the right with synchronized sweep voltage.

Because of the effects of various inductances and capacitances in the frequency shifting circuits of the generator the alternating power line voltage fed to the horizontal input of the oscilloscope will not be exactly in phase with the frequency shift. This is the reason for the displacement of the two traces at C in Fig. 51-9. It is desirable that the two traces be brought into register or superimposed to make them appear as a single trace. This requires a phase shifting circuit for the horizontal sweep voltage being fed to the horizontal input of the oscilloscope.

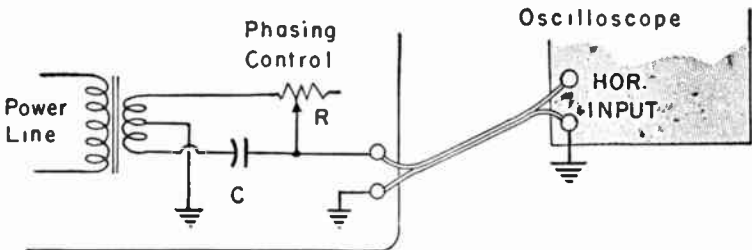

Fig. 51-10.—A phase shifting circuit for synchronized sweep voltage.

A typical method of phase shift or phase control is illustrated by Fig. 51-10. This control circuit may be in either the

sweep generator or oscilloscope, but most often is in the generator. The connection for the horizontal input of the oscilloscope is taken from between capacitor C and adjustable resistor R which are in series with each other across the ends of a center tapped transformer secondary winding. Moving the slider of the phasing control causes one trace to move toward the left while the other trace moves toward the right. There is one position of the control with which the two traces come together and appear as a single trace. The secondary winding of the control transformer usually furnishes about 6 volts from end to end. Resistance at R may be almost anything between 0.1 and 0.5 megohm. Capacitance at C may be something between 0.01 and 0.25 mfd.

Frequency Ranges. — The center frequency of the sweep generator should be adjustable throughout the video and sound intermediate frequency ranges used in television receivers. This requires continuously variable tuning from about 20 through 40 megacycles, and for the intercarrier beat frequency employed in many sound sections there must be sweep centered at 4.5 megacycles. Tuning through the carriers in the low band of the very-high frequency television channels requires continuous tuning between 54 and 88 megacycles, and the high band requires tuning from 174 to 216 megacycles.

Sweep frequency dial calibration need not be very accurate because, as explained in connection with Fig. 51-6, the tuning is varied to center the response curve regardless of what frequency may be shown on the tuning dial.

Fig. 51-11 illustrates principles commonly employed for producing sweep frequencies in the various ranges. At the left in this diagram is the sweep oscillator whose frequency is caused to continually shift back and forth through the sweep width by methods illustrated in Figs. 51-2 and 51-3, or anything equivalent in results. The center frequency of this oscillator remains fixed for all ranges or bands. Next toward the right is a variable oscillator whose frequency may be varied throughout the change required in any one range. The fre-

quency of this oscillator is adjusted by variable capacitor C whose control or dial is on the generator front panel.

Outputs of the two oscillators are fed to the mixer tube at the right where the two oscillator frequencies beat to produce difference frequencies and add to produce sum frequencies in

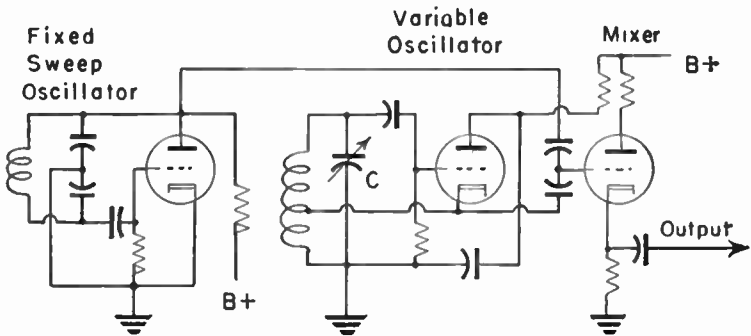

Fig. 51-11.—Oscillators for producing sweep frequencies which are centered at various values.

the mixer output. The mixer output goes to the attenuator of the generator, possibly with some amplifier or coupler tube between the mixer and the attenuator. Some sweep generators are designed to cover all required frequencies by utilizing the difference frequencies, the sum frequencies, and also harmonics of either or both these frequencies. Other instruments provide separate tuning coils for the variable oscillator in such ranges of output frequency as will avoid the use of harmonics which fall within one band while another band is being used for alignment. Still other designs use a beat frequency or difference frequency for only the intermediate-frequency ranges where relatively low sweep frequencies must be provided, and vary the tuning of the sweep oscillator to provide outputs in the carrier-frequency ranges. For this latter method the two capacitors in the tuned circuit of the sweep oscillator in Fig. 51-11 would be variable, operated by a panel control.

Output Voltage.—Maximum output voltage from the sweep generator must be enough to produce on the oscilloscope screen a response curve of useful height even when the

amplifier being tested has but small voltage gain. The fraction of a volt which will satisfy this requirement depends largely on the sensitivity of the oscilloscope, but at least 0.1 volt from the generator usually will be needed.

Output voltage should remain within a few per cent of a constant value throughout any sweep of frequency. For example, if the sweep is from 20 to 30 mc there should be practically no variation of voltage during this sweep. Any humps or valleys will be amplified when observing a response curve, and the curve will be so distorted as to be useless for alignment work. Provided the oscilloscope has high vertical sensitivity, the flatness of the generator output voltage may be checked by connecting the generator output to the vertical input of the scope and observing whether the trace is straight or wavy. To make this test it is necessary to use a detector probe on the vertical input of the scope, since the signal from the generator will be at high frequency. The trace should be observed in different frequency bands, with different settings of the attenuator, and different widths of sweep. The generator should be used for alignment work only at settings and adjustments with which the trace is a nearly straight line.

Coupling of Generator to Amplifier. — For alignment of the antenna coupling circuits and of r-f amplifier and mixer couplings in the television tuner the output of the sweep generator is connected to the antenna terminals of the receiver. To avoid distortion of the response curve it is necessary that the output impedance of the generator be matched to the input impedance of the receiver, which usually is either 300 ohms balanced to ground or else 75 ohms unbalanced. Some sweep generators provide either of these output impedances by means of jacks or switches. Others are equipped with special cables having matching pads attached. All cables must be fully shielded with the shields grounded.

For alignment of intermediate-frequency amplifiers the sweep generator most often is coupled to the grid of the mixer tube through a series capacitor of 10 to 20 mmfd capacitance or through a coupling ring or shield slipped over the mixer

tube. Signal voltage must be kept below a value which might distort the response curve. If small changes in the setting of the sweep generator attenuator cause alterations in the shape of the response, in addition to merely raising or lowering the curve, the input is too great. It is assumed that the automatic gain control is overridden by a fixed bias during alignment. Coupling from generator to amplifier may be lessened by using the generator attenuator, by using less capacitance for a series coupling capacitor, by moving a coupling ring or shield farther from the elements within the tube, and by connecting a fixed resistor of a few hundred ohms from the grid terminal of the mixer tube to chassis ground or B-minus. These and other procedures to be followed are explained more fully in the article on *Alignment*.

GENERATORS, TELEVISION. — A television generator, in the usually accepted meaning of the term, consists of a sweep generator and a marker generator built as a single instrument or built together into a single housing. The television generator may be coupled to a receiver or amplifier through a single cable which carries both the sweep and marker signals. Some form of adjustable coupling within the television generator may add the marker pips or dips to the sweep voltage. Sweep generators and marker generators are described in separate articles.

GROUNDING. — In receivers operating at frequencies no higher than those in the standard broadcast band it is assumed that all points in the chassis metal are at the same r-f potential, and that all parts directly connected to chassis metal will be at the same r-f potential even though these parts are some distance from one another. In apparatus operating at television carrier and intermediate frequencies it cannot be assumed that there is no r-f potential difference between various points on the chassis metal when high-frequency circuits are completed through this metal. The effects of capacitance, inductance, and high-frequency losses in general are equivalent to enough resistance to cause regenerative and degenerative feedbacks from plate circuits to grid circuits whose returns are through

any considerable length of chassis metal or other metallic supports. Such troubles could be lessened by using such low resistance metals as copper and aluminum alloys, but this construction is seldom economically possible in commercial products.

R-f bypass and decoupling capacitors should be mounted as close as possible to socket lugs or base pins of tubes to which these capacitors are connected. The leads from capacitors to ground should be as short as possible. When decoupling capacitors are used for the plate, screen, and grid of one tube all these capacitors should be connected to the same point on the chassis metal. This point should be the one to which the suppressor and a directly grounded cathode are connected. Then none of the element returns follow a common path through chassis metal. Ground connections for rotors of variable tuning capacitors should go to the same point at which a grid decoupling or bypass capacitor is connected.

When using paper capacitors it is essential that connections from chassis ground or from B-minus be made to the pigtail or other terminal that connects to the outside foil. This terminal is identified by words or by a printed band at its end of the capacitor.

Where center terminals of miniature tube sockets are grounded, and have various ground connections made to them, this arrangement should not be altered during servicing operations. When one heater pin of a single-ended tube is grounded to complete the a-c heater circuit, this grounded pin should be the one nearest the grid pin of that tube.

It is inadvisable to change the grounding points on a chassis, or to change the length or arrangement of wires coming to these grounds. Grounding of any part by merely bolting or screwing its frame tightly to chassis metal is not dependable in high-frequency circuits. A grounding wire or flexible metallic braid should be soldered to both the frame and the chassis metal to insure a permanent and noise-free connection. It is easy to make soldered connections directly to the metal of a steel chassis which is coated with cadmium, zinc, or copper.

Several grounding wires may be soldered to the same point on the chassis when all the wires come from nearby parts. Rather than using long grounding wires from widely separated parts it is better to make additional soldered connections to the chassis with short wires to each connection.

It must be kept in mind that chassis metal or chassis ground is not necessarily the most negative point in the B-power circuits. The most negative point is that to which is connected the plate or the plate return of the power rectifier and high-voltage winding of the power transformer. Chassis ground may be at a potential much more positive. In receivers having series heaters the chassis ordinarily is not at B-minus potential nor is it a ground so far as the B-power circuits are concerned.

H

HARMONICS. — A harmonic is a frequency which is an even or odd number of times another frequency which is called the fundamental. For example, with a fundamental frequency of 5 mc, the harmonics will be 10 mc, 15 mc, 20 mc, 25 mc and so on for still higher multiples of 5. The frequency which is twice the fundamental is the second harmonic, the one which is three times the fundamental is the third harmonic, and the fourth, fifth, and higher harmonics are respectively four, five, and higher numbers of times the fundamental. The fundamental frequency sometimes is called the first harmonic.

At the top of Fig. 54-1 are two complex waves, or two waves which are not of the same form in the first and second alternations or on positive and negative sides. Each wave is produced by combining in one circuit the fundamental and the second harmonic shown directly below. Both the fundamental and the harmonic are sine waves. Differences between the two complex waves result from different phase relations and different relative amplitudes in the fundamentals and harmonics which are combined with each other.

Any wave which recurs with the same form in succeeding cycles, and is not of sine wave form, consists of a combination

of sine waves which are harmonics of the lowest frequency in the complex wave. In highly complex waves there are large numbers of harmonics. In square waves there are, theoretically, an infinite number of harmonics with extremely high fre-

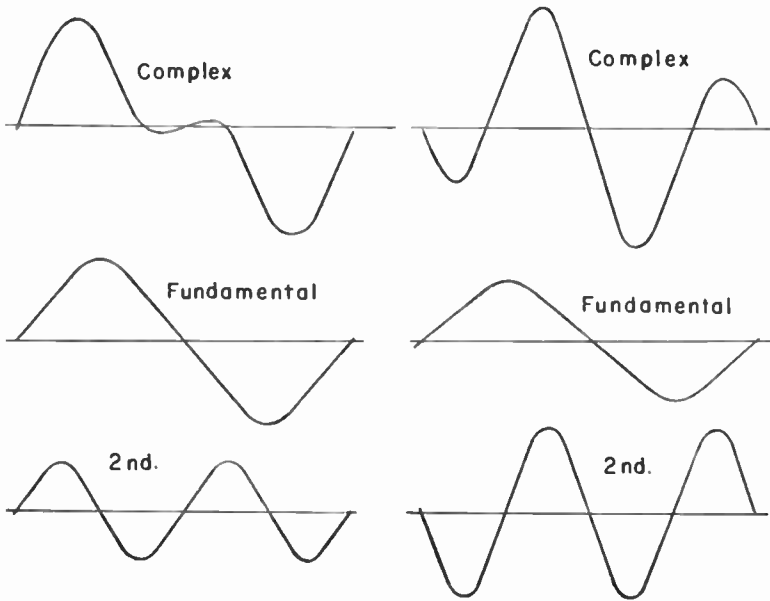

Fig. 54-1.—Complex waves formed by fundamental and harmonic frequencies.

quencies making up the straight leading edges and square corners.

Harmonic frequencies are produced by detectors and by any tube which rectifies, and by any tube with such a combination of plate voltage and grid bias that the output in the plate circuit does not follow the input to the grid, which means non-linear operation of the tube. All oscillators tend to produce harmonic frequencies. Inductive feedback types usually produce more harmonics than do those operating with capacitive feedback. All relaxation oscillators, including the multivibrators, produce many harmonic frequencies along with their

fundamentals. Crystal controlled oscillators will deliver many harmonics, the number and their strength depending on the type of circuit employed. With oscillators which produce beat frequencies there are harmonics of the beats. Harmonics are produced by frequency multipliers, which are essentially amplifiers whose plate circuits are tuned to some harmonic of the frequency applied to their grid circuits.

Harmonics are useful for calibration of testing apparatus. Following is an example of how harmonics may be used for calibrating or checking the calibration of a test oscillator or signal generator with the help of a receiver and any received signal of known frequency and accuracy. First the receiver is carefully tuned to the signal. Then the oscillator or generator is tuned to produce an audible beat note from the receiver and is adjusted for zero beat as nearly as this can be done. A lead from the generator output may be laid near the receiver antenna terminals if necessary. This procedure adjusts the generator to the frequency of the received signal. Keeping the receiver tuned to the original signal frequency, the generator now is tuned to lower and lower frequencies. There will be zero beat from the receiver each time the generator is tuned to a frequency which divides without a fractional remainder into the frequency to which the receiver is tuned. At each of these points the generator is tuned to its own fundamental, and the receiver is beating with a harmonic of that oscillator fundamental.

To check frequencies higher than that of the original received signal the generator is tuned to the received signal frequency by beating as previously described. The generator then will furnish harmonics of this signal frequency. The receiver may be tuned for zero beat with successively higher generator harmonics, thus calibrating the receiver to each of these harmonic frequencies. Finally, with the receiver tuned to any harmonic, the oscillator may be tuned to the same harmonic by listening for zero beat. The whole process is one of transferring calibration points to and from the receiver and

generator, commencing with the received signal and working with harmonics and zero beat points.

HOLD CONTROLS. — A hold control is an adjustable resistor which regulates the operating frequency of a horizontal or vertical television sweep oscillator to allow timing of oscillator action by sync pulses of the received signal. A hold control is connected to the grid of the sweep oscillator or discharge tube. The control is so adjusted that, in the absence of sync pulses, the sweep oscillator would operate a little slower or at a “free running” frequency slightly lower than the horizontal line frequency in the case of a horizontal oscillator, or the vertical field frequency in the case of a vertical oscillator. This is shown at the top of Fig. 55-1.

Just before the oscillator would become conductive in its free running state, and discharge the sawtooth capacitor for a retrace, a triggering voltage derived from a sync pulse acts on

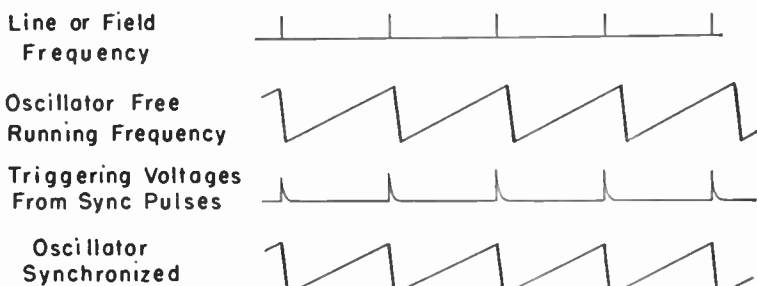

Fig. 55-1.—Sweep oscillator free running frequency is changed to sync frequency by the triggering pulses.

the grid of the oscillator or discharge tube. This causes the tube to become conductive at the instant of the triggering voltage, thus starting the sawtooth discharges and retraces in time with or in synchronization with the sync pulses and triggering voltages rather than at the slightly slower timing of the free running frequency.

The hold control is made adjustable in order that the free

running frequency of the oscillator may be brought so close to sync pulse frequency that triggering voltages surely cause starting of the retraces. The hold control allows the grid voltage of the oscillator or discharge tube to become so nearly positive just before the instant of each triggering voltage that the application of even a small triggering voltage makes the grid sufficiently positive to allow discharge of the sawtooth capacitor, thus forming the retrace. Were the free running frequency of the oscillator not kept very close to synchronization by the hold control, the triggering voltages would not be enough to overcome remaining negative potential of the oscillator grid, and the grid would not be made positive to start the retrace at the correct time.

Fig. 55-2 shows how an adjustable hold control is connected to the grid of a blocking oscillator. The control resistance determines how fast the blocking charges leak off grid capacitor C_g , and thus regulates the intervals at which the grid

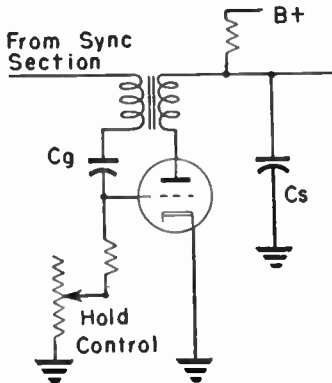

Fig. 55-2.—Hold control connected to a blocking oscillator.

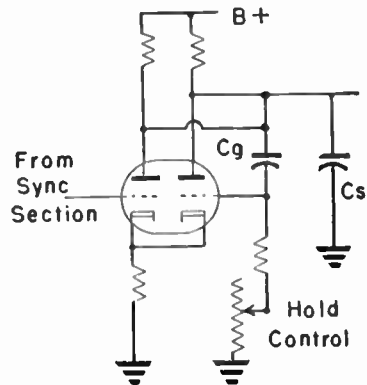

Fig. 55-3.—Hold control applied to a multivibrator.

becomes positive to allow discharge of sawtooth capacitor C_s . Fig. 55-3 shows an adjustable hold control connected to the grid of the second section or output section of a multivibrator sweep oscillator. Here too the control resistance determines

the time required for charges to leak off capacitor C_g , and determines the intervals between discharges of the sawtooth capacitor C_s . There are many modifications in details of sweep oscillator circuits and connections, but in all of them the hold control is effectively connected as illustrated or in some equivalent manner to vary the discharge rate of the grid capacitor which maintains the grid negative between the instants of sync pulses and triggering voltages.

Hold controls sometimes are called frequency controls and again may be called speed controls. In some receivers the horizontal and vertical hold controls are adjustable by the operator, and in others these controls are service adjustments

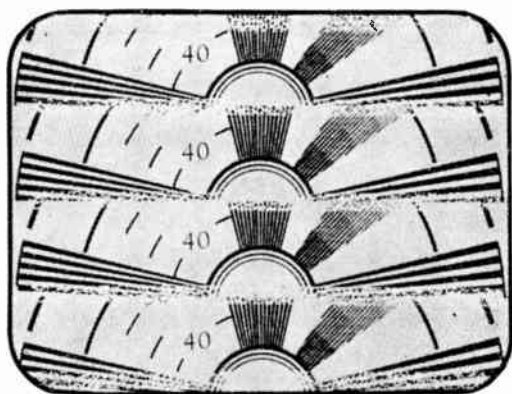

Fig. 55-4.—Misadjustment or faults in the vertical hold control allow the pattern to move upward or downward on the picture tube screen.

accessible from inside the cabinet or else upon removal of a portion of the front panel.

When a vertical hold control is incorrectly adjusted, the picture or pattern will move upward or downward on the screen of the picture tube. The greater the misadjustment the more rapid will be this movement. The picture appears to be rolling, with an effect somewhat as shown by Fig. 55-4. Incorrect adjustment of a horizontal hold control may cause com-

plete breakup of the picture or pattern to leave on the screen only a mass of horizontal streaks in rapid motion. As the hold control is slowly moved toward a correct adjustment the streaks will resolve themselves into sloping bars as at the sides of Fig. 55-5. With still closer adjustment the bars become more nearly vertical and finally the pattern drops into synchronization as at the center diagram.

Adjustment of hold controls is carried out as follows: With the receiver operating at normal contrast and brightness, and with a pattern or picture tuned in, turn the hold control adjustment as far as possible in one direction. If the pattern or picture drops out of synchronization, turn the control slowly

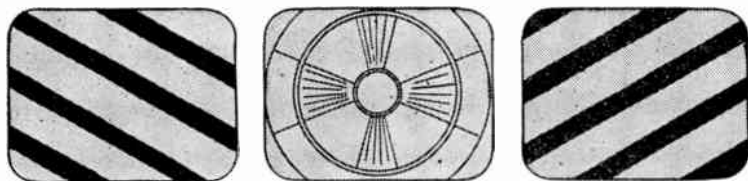

Fig. 55-5.—Effects on the pattern of adjusting a horizontal hold control either way from synchronization.

back until reaching the position at which the pattern or picture locks in. Note this position. Then turn the control as far as possible in the opposite direction and again back to the position at which the pattern or picture just locks in. Leave the control at a point midway between the two positions at which there is lock-in.

If turning the hold control all the way in one direction does not cause drop-out, leave the control in its extreme position while momentarily switching to another channel and back again, or while turning the receiver off and on again. This usually will cause drop-out of the pattern or picture. Then turn the control slowly back to the position where the pattern or picture pulls into synchronization. Note this position. Turn the control to the limit of its travel in the opposite direction,

again drop the pattern or picture out of synchronization, and slowly bring the control back to the position where there is pull-in. Leave the control midway between the two pull-in positions.

I

IMPEDANCES. — The impedance triangles of Fig. 56-1 show relations between resistance, reactance, and impedance, also the angles of lag or lead, when the resistance and reactance are in series with each other. A right angle triangle is laid out with the length of one side proportional to the number of ohms resistance and the length of the other side proportional to the number of ohms reactance, either inductive or capacitive. Then the length of the hypotenuse will be proportional

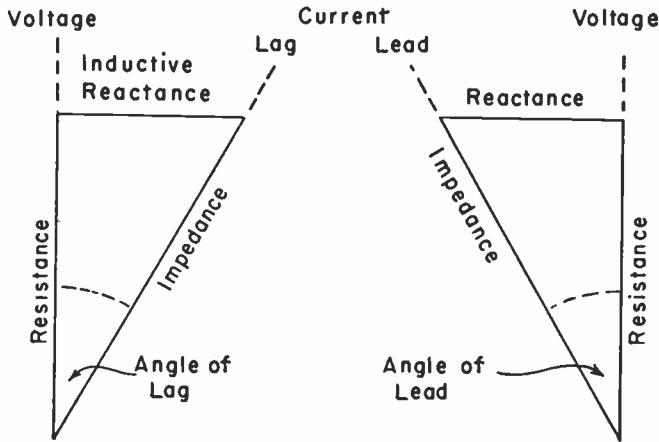

Fig. 56-1.—Impedance triangles and their meanings.

to the number of ohms impedance. The line drawn for resistance may represent the vector direction of voltage and the hypotenuse may represent the vector direction of current. The angle between these two lines is the angle of lag when the reactance is inductive and is the angle of lead when the reactance is capacitive.

With reactance and resistance in series, impedance is shown by this formula.

$$Z = \sqrt{R^2 + (X_L - X_C)^2} \text{ or } Z = \sqrt{R^2 + X^2}$$

Z Impedance, ohms

X_L Inductive reactance, ohms

X_C Capacitive reactance, ohms

X Net reactance, ohms

R Resistance, ohms

With reactance and resistance in parallel the impedance is shown by either of the following formulas, one for inductive reactance and the other for capacitive reactance. Meanings of the letter symbols are the same as before.

$$Z = \frac{R \times X_L}{\sqrt{R^2 + X_L^2}} \qquad Z = \frac{R \times X_C}{\sqrt{R^2 + X_C^2}}$$

INDUCTANCE. — The approximate self-inductance of a single-layer air-core coil may be found from this formula. The result of the computation will be fairly accurate when the ratio of winding length to winding diameter is between 0.3 and 1.0.

$$L = \frac{D \times N^2}{40 \left(\frac{B}{D} + 0.45 \right)}$$

L Inductance, microhenrys

B Winding length, inches

D Winding diameter, inches

N Number of turns

The approximate number of turns required for a single-layer air-core coil of specified inductance may be computed from the following formula. Meanings of the letter symbols are the same as before.

$$N = 6.3 \sqrt{\frac{L \left(\frac{B}{D} + 0.45 \right)}{D}} \qquad \sqrt{\frac{\quad}{D}}$$

Approximate self-inductance of a coil or circuit may be measured by a resonance method. The equipment includes a signal generator, either a high-resistance r-f voltmeter or

else a low-resistance r-f current meter, and a fixed capacitor of some non-inductive type having capacitance on the order of 0.01 to 0.02 mfd. Precision of measurement is directly proportional to the accuracy with capacitance of the capacitor is known.

The unknown inductance may be connected in parallel with the known capacitance, with the generator connected to operate the combination at parallel resonance while voltage is indicated. An r-f electronic voltmeter or a d-c type with a detector probe makes a good resonance indicator. With the alternative arrangement, the inductance, the capacitance, the r-f current meter, and the signal generator are connected in series to operate the inductance-capacitance combination at series resonance.

With either connection the signal generator is tuned for maximum meter reading. Care must be exercised to tune the generator to a fundamental frequency, not a harmonic. The fundamental will be the highest frequency at which it is possible to obtain peaking of voltage or current which indicates resonance. Unless the fundamental is used, the computed inductance will be four or more times the actual value. Inductance is computed from the following formula.

$$L = \frac{25330}{C \times f^2}$$

L Inductance, microhenrys

C Parallel or series capacitance, micro-microfarads

f Fundamental tuned frequency, megacycles

Computed inductance will be the apparent value, which is affected to a greater or less extent by distributed capacitance of the coil and other circuit parts. Distributed and stray capacitances make the apparent inductance, as computed, greater than the actual inductance. The simplest way to minimize this effect is to use the largest parallel or series capacitance which allows distinct peaking of the resonance indicating meter. Capacitances of 0.01 to 0.02 mfd are not too large provided they are non-inductive. This large tuning capacitance makes the much smaller distributed and stray

capacitances relatively unimportant in determining the resonant frequency.

INDUCTORS OR COILS. — Choice of the type of winding and support for high-frequency tuning inductors often depends largely on how much distributed capacitance can be tolerated. When a coil is in series with a source of emf, and the coil possesses distributed capacitance, the inductance and capacitance of the coil are parallel resonant at some frequency. That is, the distributed capacitance of the coil has the same effect as a capacitor connected across the ends of the coil.

There is minimum distributed capacitance in a self-supporting single-layer coil with spaced turns of solid wire. Distributed capacitance is increased by winding the turns close together and by using more than a single layer. When multi-layer coils must be used in order to have the required inductance in a limited space, small distributed capacitance is secured by using duolateral or honeycomb windings having the turns of successive layers crossing each other at an angle rather than lying parallel. Capacitance is reduced also in pie windings which consist of a number of sections, each of very short length and relatively large diameter, mounted with their axes in line and connected in series to form the entire coil.

Self-supporting coils have minimum distributed capacitance because the dielectric constant of air is less than that of any supporting material which may be used. If winding wire is too small to be self-supporting, rigidity may be had with a few narrow strips of thin insulation laid lengthwise and cemented to the coil turns. When coils are wound on solid supporting forms the distributed capacitance is reduced by using material of small dielectric constant. This also reduces energy losses because it lowers the loss factor which is proportional to dielectric constant and power factor of the material.

If coil cement is used for mounting or additional support the cement should be of some low-loss kind such as made from polystyrene.

Self-supporting or strip supported windings may be made with bare copper or tinned copper wire when the turns are

spaced. Enamel covered copper wire is in general use for both spaced and close windings. To obtain worth-while reduction of capacitance by spacing the turns the distance between adjacent turns should be not less than one-third the diameter of the wire. There is little advantage in using spacing much greater than two-thirds the wire diameter. There is little if any advantage in using Litz wire for windings to be employed at frequencies higher than about three megacycles. At very high frequencies there is more loss with Litz or other stranded wire than with solid round wire.

Self-inductances of coils in series add together like series resistances, provided the coils are so far apart or are so positioned in relation to each other that there is negligible coupling and consequently negligible mutual inductance. Otherwise the total inductance is the sum of self- and mutual-inductances. Mutual inductances adds to self-inductance when the mutuals are positive, which occurs when directions of currents in the coils are such that the magnetic fields are of the same polarity and aid each other. Mutual inductances are subtracted from the total self-inductance when the mutuals are negative, when currents are in such directions that the magnetic fields oppose each other.

If coils are connected in parallel with each other, and are so positioned or spaced as to have no coupling and no mutual inductance, their total self-inductance is equal to the product of the separate inductances divided by the sum of these inductances, just as in the case of paralleled resistors. If there is coupling, and resulting mutual inductance, the total inductance is found thus.

$$L = \frac{La \times Lb - M^2}{La + Lb - 2M}$$

Where L is total inductance, La and Lb are the two separate inductances, and M is the mutual inductance, all measured in the same unit. The formula as written applies when mutual inductance is positive. If mutual inductance is negative the last term in the denominator becomes $+2M$ instead of $-2M$.

INSTALLATION, RECEIVER. — The following should be considered when installing a television receiver in a room. The location should, if possible, be convenient to a power outlet and close enough to the point at which the transmission line enters the room that running of this line will not make an unsightly appearance nor bring the line so close to electrical machines, appliances, and switches as to allow pickup of interference. If there are ventilating openings in the sides or back of the cabinet do not place the receiver so close to a wall that these openings are shut off; leave two to three inches of clear space. See that ventilating openings in the cabinet bottom are not obstructed.

The receiver should be so placed that it may be viewed by the largest number of people in the room, allowing some viewers to be at least ten feet from the screen even though the picture tube is of only ten-inch diameter. The front of the receiver and the mask opening should be at such an angle with windows and lamps that reflections from these light sources will not make it difficult to view pictures.

When a receiver is first installed, make sure that all tubes are firmly seated in their sockets, that the face of the picture tube is against a mask cushion if such a cushion is provided, and that the front of the flare of a magnetic deflection tube is against the cushion in the neck bracket.

The chassis usually is held in its cabinet with bolts or screws through the bottom of the cabinet. These fastenings may be fitted with cushion washers. Front panel knobs usually pull straight off their shafts, although it is possible that set screws may be used and they should be looked for. Before attempting to take the chassis out of a cabinet make certain that cords or cable to the speaker are disconnected, that a cable to the picture tube socket or base is disconnected, and that the power cord is out of the wall receptacle and free from the cabinet.

INSTRUMENTS, SERVICE. — The two instruments which are essential for any kind of television servicing are a high-frequency signal generator which will furnish input voltages, and some form of indicating meter which will measure result-

ing outputs of amplifiers and other circuits. The signal generator must meet the requirements outlined for a marker generator in the article on *Generators, Marker*.

The meter for indicating output may be a moving coil voltmeter which usually will be part of a volt-ohmmeter or of a volt-ohm-milliammeter. In order to avoid such loading of television circuits as would destroy the usefulness of many indications the sensitivity of the meter should be at least 10,000 ohms per volt, and greater sensitivity is much to be preferred. For tests and measurements in circuits working at radio, intermediate, and audio frequencies an electronic voltmeter is much more useful than the moving coil type because the very high input resistance or impedance of the electronic type causes almost negligible loading of most television circuits. With either the moving coil voltmeter or the electronic voltmeter there will be needed a high-voltage probe allowing measurements to a maximum of about 15,000 volts in the anode circuits of picture tubes. With the electronic voltmeter should be provided a detector probe for measurements in circuits operating at audio and higher frequencies.

Although many service tests and adjustments may be carried out with only the signal generator and voltmeter, an oscilloscope allows much faster work and a more complete analysis of faults and of the results of adjustments. To make full use of the oscilloscope during alignment and trouble shooting in all circuits between the antenna and the video and sound detectors it is necessary to employ a sweep generator and a marker generator. These two generators may be combined in a single television generator. With the oscilloscope it is convenient to have a high-frequency detector probe which will allow observation of frequency responses directly from circuits preceding the video and sound detectors.

A variable audio-frequency generator is necessary only for checking performance in the audio amplifier and speaker of the sound section and for checking low-frequency performance of the video amplifiers. A square-wave generator allows more rapid checking of these sections than does a sine-wave

generator, and if the square-wave generator will furnish fundamentals up to 200 or 300 kilocycles it is useful for checking performance of video amplifiers throughout their usual frequency range.

It is assumed that an ohmmeter function is included in either the moving coil voltmeter or in the electronic voltmeter. In addition to this instrument for measuring resistances, it is highly desirable if not absolutely necessary to have a capacitor tester which allows direct reading of capacitances and which makes tests for shorts, opens, and leakage in capacitors. An inductance tester or bridge is convenient, but no so essential as the capacitor tester.

Many kinds of trouble may be quite quickly located by means of a signal tracer which will pick up signals at fre-

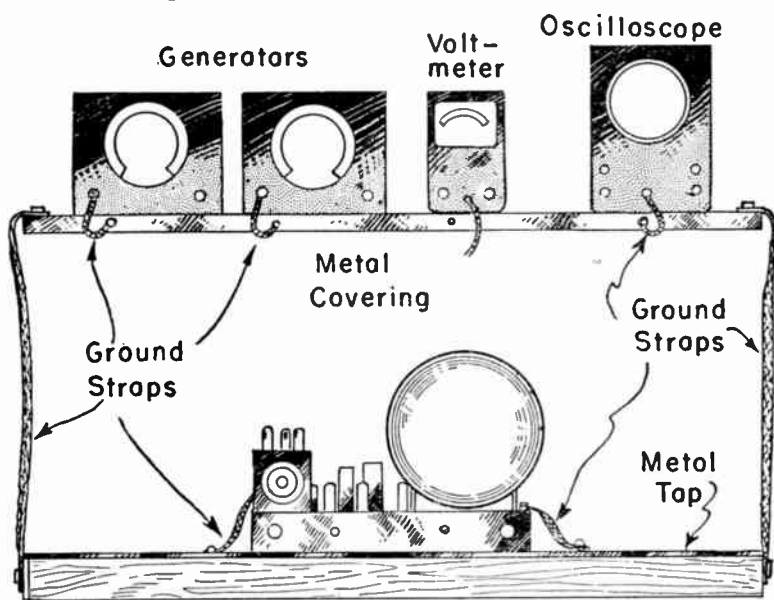

Fig. 60-1.—Service instruments and a receiver or amplifier being worked upon should be connected to a common ground.

quencies at least as high as those in television channels 2 through 6. A grid dip meter or oscillator allows measuring frequency of resonance and allows preliminary adjustment of all couplers and wave traps. Pattern generators of some types

are useful for locating troubles and making adjustments in the sync and sweep sections of the television receiver. A tube tester is convenient where a large amount of service work is being handled, although a tube which tests good with almost any type of tube tester may fail to operate in the high-frequency television circuits.

All testing instruments used during any one service operation are preferably supported on a sheet-metal covered shelf above and somewhat back of the service bench, as shown by Fig. 60-1. All instrument grounds should be made to the metal shelf cover. This cover should be bonded through large copper straps to a sheet metal covering on the test bench. The receiver being worked upon should have its chassis grounded to the bench top at one or more points. It is not necessary that the bench and shelf covers be connected to a cold water pipe or other conductor leading into moist earth. Such a ground connection makes a conductive connection to one side of the building power line. When this kind of ground connection is used, any receivers having series heaters should be fed only through an isolating transformer if shocks are to be avoided when the line cord is plugged in to make the chassis "hot."

INSULATION. — The three characteristics which chiefly determine the usefulness of a material as insulation are dielectric strength, volume resistivity, and surface leakage. Dielectric strength is measured in volts. It is the potential difference, in volts, at which the insulation punctures and an electric current in the form of a spark or arc passes through the opening. Dielectric strength usually is specified as the number of volts per mil (1/1000 inch) of thickness. This has little practical meaning unless the total thickness of the test specimen is mentioned, because dielectric strength in volts per mil decreases as the total thickness increases. As an example, in the case of polystyrene 0.005 inch thick the dielectric strength is about 3500 volts per mil and the total strength is 17,500 volts. With twenty-five times the total thickness (0.125 inch) the dielectric strength drops to about 600 volts per mil and the total strength is up to 75,000 volts.

The dielectric strength of air is somewhat less than 10,000 volts per $\frac{1}{8}$ inch between flat or gently curved surfaces, and this value holds with little change regardless of the separation. Between two sharp points the dielectric strength drops to about 1250 volts per $\frac{1}{8}$ inch. Dielectric strength of any substance varies with frequency, waveform, temperature, humidity or moisture, and length of time the voltage is applied.

Volume resistivity is the actual ohmic resistance which determines the rate of current flow through the body of insulation when a potential difference is applied on opposite sides. Volume resistivity of all commonly used insulation materials is so great as to make little practical difference in comparison with dielectric strength. Among the poorest of common insulators is red fibre, with which resistance of a cube about 0.4 inch on each side is around 5,000 megohms.

Surface leakage ordinarily results from films of moisture, oil, and dirt in general. Rough surfaces tend to collect these things and to increase the surface leakage. Some insulators absorb moisture and thus increase their leakage. Actual insulation resistance is that of volume resistance and surface resistance acting in parallel.

INTERCARRIER SOUND. — In a television receiver employing an intercarrier sound system the center frequency of the frequency-modulated signal delivered to the demodulator in the sound section always is 4.5 mc, produced by beating of the video and sound intermediate frequencies in the video detector and taken to the sound section from some point following the video detector. In receivers which do not employ the intercarrier sound system the center frequency for sound i-f amplifiers and sound demodulator is the sound intermediate frequency produced by beating of the video and sound carrier frequencies in the mixer.

The path of the sound signal in an intercarrier system is shown by Fig. 62-1. The received carriers enter the tuner as usual, and video and sound intermediate frequencies are delivered from the tuner to the i-f amplifier. The sound intermediate frequency is not separated from the video interme-

diate anywhere in the i-f amplifier, but both intermediate frequencies go to the video detector where they beat to produce the difference frequency of 4.5 mc. Regardless of the channel received, or of any other conditions, the video and sound

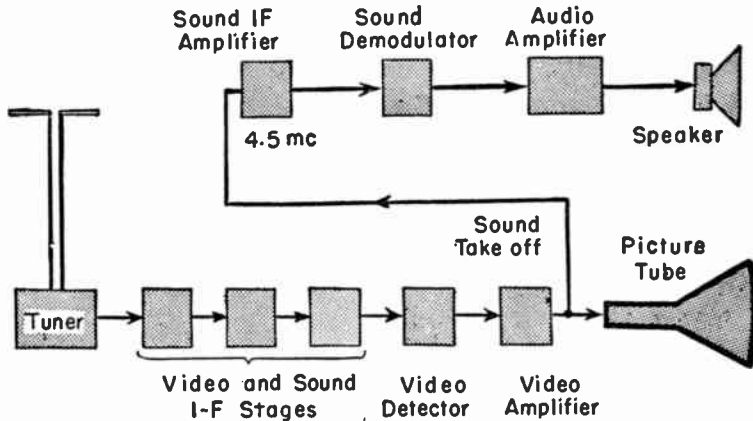

Fig. 62-1.—Signal paths in a receiver employing intercarrier sound.

carriers always are separated by 4.5 mc, the resulting intermediate frequencies always are separated by 4.5 mc, and the beat frequency from the intermediates must be 4.5 mc.

This 4.5 mc beat frequency is frequency-modulated with the sound signal, which has the standard television deviation of 25 kc. This f-m sound signal may be taken off in the output of the video detector, but usually is further amplified in one or two video amplifier stages and then taken to the sound section. It should be noted that drift or misadjustment of oscillator frequency can have no effect on the frequency difference between carriers or intermediates, nor on the center frequency fed to the sound section, which always remains 4.5 mc.

Fig. 62-2 shows connections for intercarrier sound takeoffs in which are employed double tuned transformers with their primaries in the plate or screen circuit of a video amplifier and their secondaries in the grid circuit of the sound i-f ampli-

fier or driver tube for the sound demodulator. Other takeoff couplings are shown by Fig. 62-3. The one at the left consists of an auto-transformer between the video amplifier plate and ground, with a tap connection for the sound i-f amplifier grid.

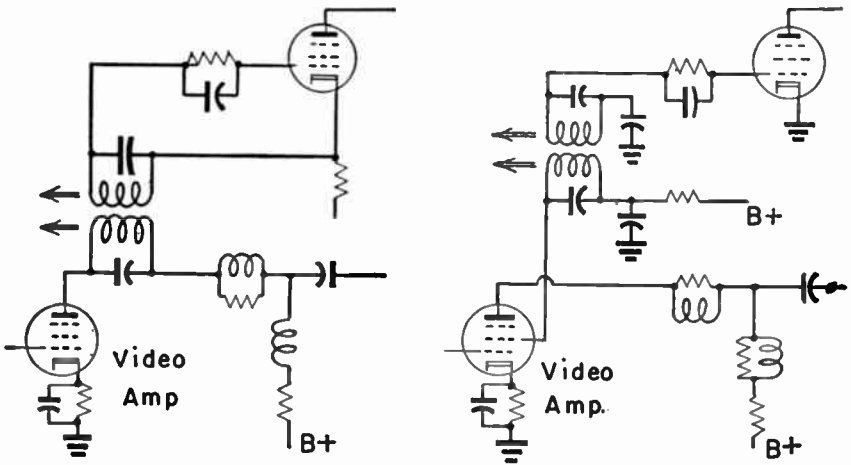

Fig. 62-2.—Intercarrier sound takeoffs consisting of double-tuned transformers.

At the right the takeoff coupling is a tuned impedance between the video amplifier plate and the sound i-f amplifier grid.

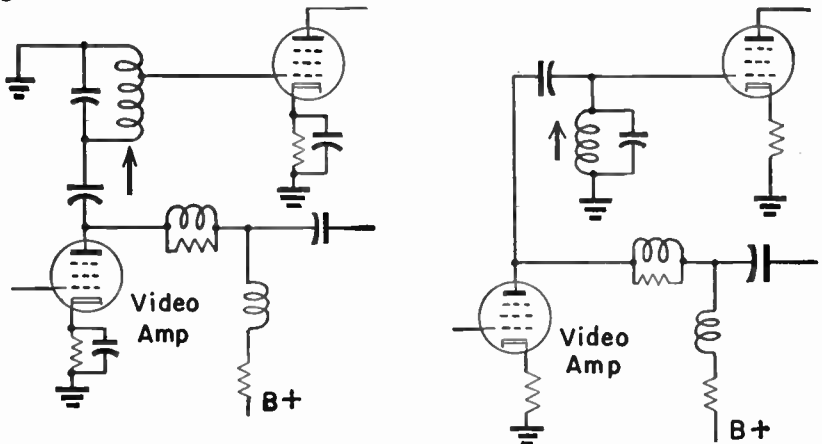

Fig. 62-3.—Intercarrier sound takeoffs through an autotransformer and a tuned impedance coupling.

All these takeoff couplings act also as traps to greatly attenuate the 4.5 mc intercarrier beat voltage which otherwise would reach the picture tube input. Following the sound takeoffs in the plate circuits of video amplifiers are the usual shunt and series compensating or peaking coils.

Frequency response of the r-f amplifier and antenna coupler of a receiver having intercarrier sound is no different from that in a receiver having any other sound system and otherwise similar. As shown at the left in Fig. 62-4 the video and sound carrier frequencies should be at or close to the peak of the response.

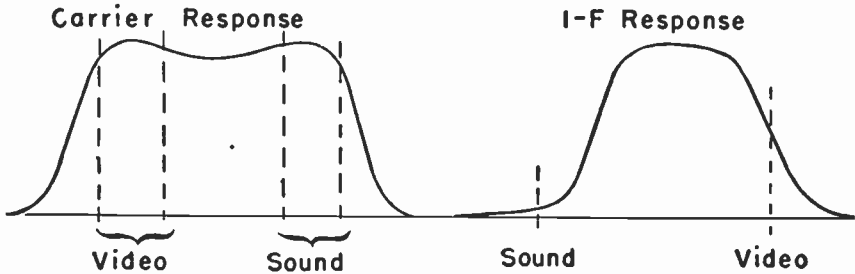

Fig. 62-4.—Typical frequency responses for receivers having intercarrier sound systems.

The intermediate-frequency amplifier of a receiver employing intercarrier sound must be aligned for a response about as shown at the right in Fig. 62-4. The video intermediate frequency should be in its usual location, about half way down on the high-frequency side of the curve. The sound intermediate frequency response or gain should be down 26 to 30 decibels or at a value of 3 to 5 per cent of the peak gain. This very low gain at the sound intermediate frequency is necessary in order that sound signals may not reach the picture tube and in order that a trouble called intercarrier buzz may be minimized.

The chief aim of the low response at the sound intermediate frequency is to keep the f-m sound signal on a relatively flat portion of the gain curve, where changes in deviation and degree of modulation, and in the center frequency itself, will not cause amplitude modulation. Were the f-m

sound signal to get onto a steeply sloped portion of the gain curve, there would be more gain with deviation toward higher frequencies than with it toward lower frequencies. Such a change of gain would constitute amplitude modulation, which would pass through the video detector along with amplitude modulation for picture and sync signals, and would place sound bars or wavy horizontal edges on the pictures.

Were the sound intermediate frequency to reach a sloped portion of the gain curve, or were the gain at this frequency to be too great even on a fairly flat part of the curve, the resulting amplitude modulation would be more than could be removed by the ratio detector which nearly always is the sound demodulator with intercarrier systems. This would

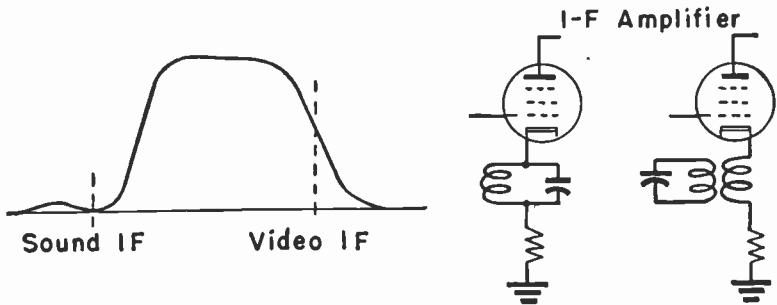

Fig. 62-5.—The shelf or plateau response sometimes used for sound intermediate frequency with intercarrier sound.

cause frequencies evident as a sharp buzzing sound. This buzz may result also from other causes, such as enough overloading of the video amplifier to bring vertical sync pulses into the audio system.

Fig. 62-5 illustrates one method of keeping the sound intermediate frequency on a low-gain and relatively flat portion of the response curve. The curve is formed with a sort of extended shelf or plateau at the point of sound intermediate frequency. This flattened extension is brought about by placing an attenuation trap on any one of the i-f amplifier tubes. Usually the trap is in a cathode circuit, as shown by diagrams at the right. The trap circuit may use a tuning

capacitor or a self-resonant coil tuning with distributed capacitance. In any case the tuning is rather broad, and, of course, is at the sound intermediate frequency.

Alignment. — With receivers which do not use intercarrier sound it is rather common practice to align the r-f oscillator so that maximum signal at the sound intermediate frequency passes through the sound i-f amplifier and demodulator, relying on the sharply peaked and narrow response of the sound i-f amplifier. This cannot be done with an intercarrier sound system, because no matter how the frequency of the r-f oscillator may be changed the result always is shifting of both video and sound intermediate frequencies in the same direction and by the same amount. The 4.5 mc center frequency or beat frequency, with more or less sound signal modulation, always remains.

A satisfactory method of oscillator alignment is as follows:

1. Check the frequency response of the i-f amplifier to see that it conforms to frequency requirements mentioned in connection with Figs. 62-4 and 62-5. This response must be reasonably correct. The check is made with a sweep generator and marker generator feeding into the mixer tube, and with the oscilloscope connected across the video detector load.

2. Adjust a fine tuning control to the center of its range and leave it there. Override the automatic gain control, set the contrast control at a normal operating position, and take other preliminary steps outlined in the article on *Alignment*.

3. Connect the sweep generator to the antenna terminals of the receiver. Couple the marker generator very loosely to the same antenna terminals. Connect the oscilloscope across the video detector load as is done for most alignment work.

4. Tune the receiver and the sweep generator for the channel to be first aligned. Tune the marker to the sound carrier frequency of this channel. Align the r-f oscillator by adjusting the trimmer for this channel to bring the sound frequency far enough down and onto a relatively flat part of the response.

5. Tune the marker generator to the video carrier of the same channel. The marker for this frequency should be approximately half way down on the high-frequency slope of the response. If the video marker is not reasonably close to this position the i-f amplifier section needs to be realigned.

For alignment of the sound takeoff in the intercarrier system (Figs. 62-2 and 62-3) a highly accurate signal at 4.5 megacycles should be applied to the high side of the video detector load. This assumes that the takeoff follows one of the video amplifiers, not the video detector. If the takeoff is from the detector output the 4.5 mc alignment signal must be coupled to the grid of the i-f amplifier which precedes the video detector. This signal should be accurate to within a small fraction of one per cent. It is best secured from a 4.5 mc crystal in the marker generator or with the marker calibrated from a crystal controlled oscillator working at this frequency. Alignment of the demodulator transformer then is carried out in the same manner as for any other sound system, the only difference being in the center frequency of 4.5 mc instead of the sound intermediate frequency of the receiver.

INTERFERENCE. — The effects of any electrical waves or fields, other than desired signals, which cause confused pictures or sound are known as interference. Kinds of interference may be broadly classified in two groups. In one class the electrical waves or fields have no definite frequency or band of frequencies, but cover very wide ranges. Such interference is caused by electrical machines and apparatus in which there are rapid changes of current, switching, sparking, and discharges. All these may be called, for convenience, spark interference. In the second class of interference are all radio transmissions, including standard broadcast, amateur, international short wave broadcast, f-m broadcast, aviation signals and communication, all governmental and commercial radio services, and television signals other than the one which it is desired to receive. All interferences in this second class are confined to definite frequencies or limited bands of frequency.

Electrical faults within the television receiver which affect picture and sound reproduction are not classed as interference. Interference from adjacent channel transmissions in the same television band, and picture interference due to accompanying sound, are considered in the article on *Traps, Interference*.

Spark Interference.—The troubles classed generally as spark interference cause steady or intermittent bright flashes, horizontal white streaks, as in Fig. 63-1, or short black lines. The trouble usually will appear on all channels. This interference will come and go if it results from passing motor vehicles, street cars, elevated trains, elevators, or other sources

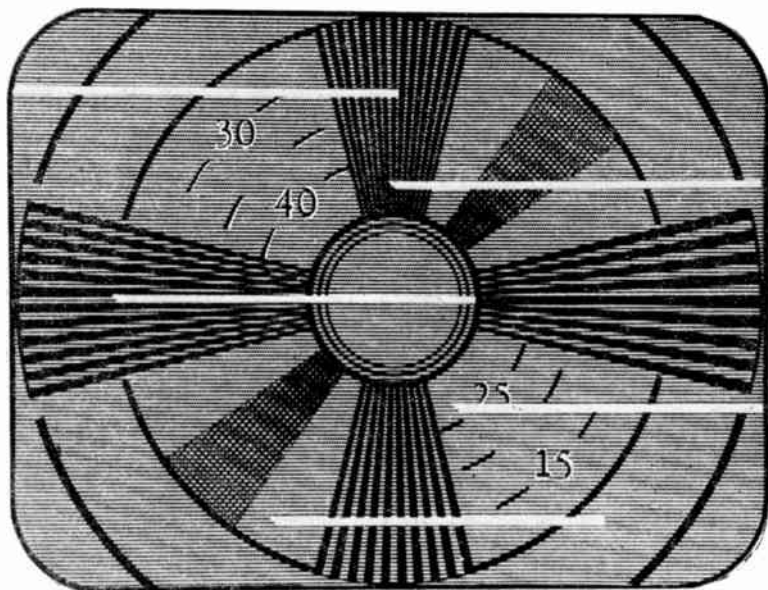

Fig. 63-1.—Effects of spark interference as seen at the picture tube.

in motion. Very strong interference may cause tearing of the picture due to momentary loss of synchronization.

Principal sources of spark interference include the following. Automobiles, airplanes, trucks, buses, and everything else which uses internal combustion engines with electric

ignition. Street cars, elevated cars, electric trains, elevators, and everything else containing direct-current motors or other motors having brushes and commutators. Flashing electric signs and any electrical display mechanism having intermittent switching. Household and store appliances operated with series a-c motors or universal motors. It should be noted that symptoms similar to those from external spark interference may result from corona or flash-over in the high-voltage power supply and wiring of the television receiver.

Remedies for spark interference are most effective if they can be applied at the electrical machine or device which is causing the trouble. Sparking contacts and brushes should be cleaned, adjusted, or replaced if necessary. Contacts may be bypassed with a quarter-mfd or larger fixed capacitor. Filters such as used for sound radio may be used in the power line connection of the offending device. Grounding of motor frames and machine frames to cold water pipes will help. If such grounding already is in use, the connections should be checked for conductivity. If nothing can be done at the source of interference, and if the electrical disturbance is being transmitted by way of the power lines, it may help to connect the television receiver to its power supply through an isolation transformer of one-to-one voltage ratio. There should be a shield between transformer windings. This shield and the transformer core, usually connected together, should be grounded to a cold water pipe.

Interference from medical apparatus such as diathermy machines and some X-ray apparatus emits high frequency radiations, but is in the general class of spark interference because these radiations extend over a very broad band of frequencies, and because remedies are generally the same as for other spark interference. Power line filtering and grounded shielding at the troublesome apparatus usually will give relief. This general class of interference, where high frequencies are radiated, causes herringbone patterns either in broad horizontal bands or all over the picture tube screen. The effect is illustrated by Fig. 63-2.

Trouble due to interference radiated through space may be lessened by using shielded transmission line. Antennas of the H-type and some other stacked arrays tend to reject signals from below and above the antenna level, hence may help in some cases of radiated interference. Any antenna may be partially shielded from interference at a lower level by con-

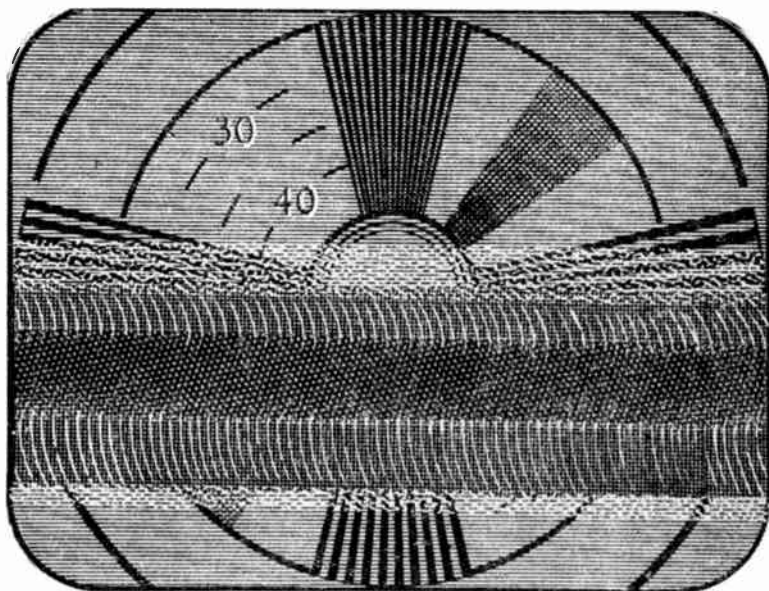

Fig. 63-2.—Effect at the picture tube of interference from diathermy machines and other medical apparatus.

ductively attaching to the metal antenna mast a dipole and reflector, or reflector and director, a few feet below the regular antenna conductors. Orienting the antenna in a direction away from the interference seldom helps, because desired signal strength on weak stations will be reduced more than the interference. Radiated interference will be reduced by an antenna with greater gain or better signal to noise ratio. This is true partly for the reason that such antennas usually are quite directional and tend to pick up more signal while excluding more interference. A tuned preamplifier at the receiver will bring up the strength of signals in and near the

desired channel more than it will increase the level of broad band interference.

Radio-frequency Interference.— Interference from f-m broadcast stations appears on the picture tube screen as narrow diagonal lines which constantly change their slope and pattern to give a weaving or rippling effect. Very strong f-m interference may produce an all-over herringbone pattern made up of fine curved lines.

Interference from transmitters using amplitude modulation in standard broadcast, short wave, amateur, or other bands may cause narrow shifting lines which appear similar to those from f-m interference. More often these transmissions produce on the picture tube screen a very fine grained all-over plain or crosshatch pattern which may change to a

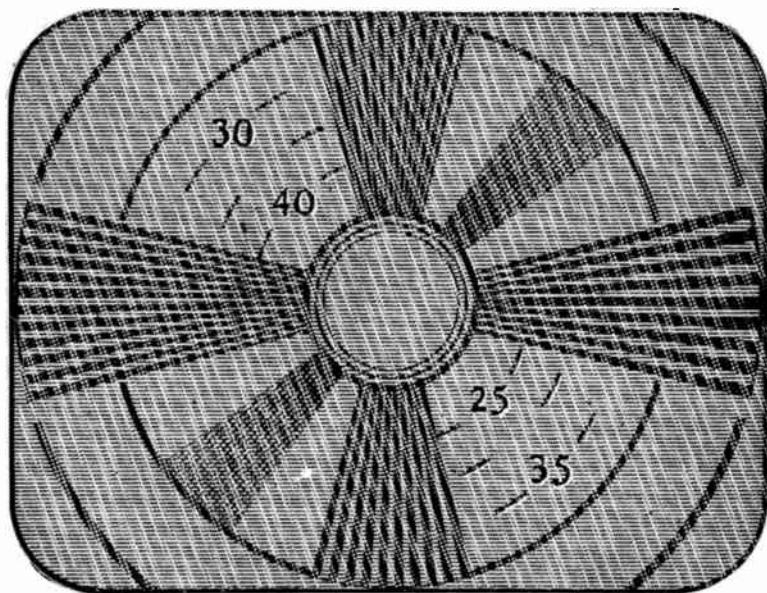

Fig. 63-3.—Radio-frequency interference causes beats which produce narrow lines on the screen pattern or picture.

fine-lined herringbone pattern with modulation of the transmission. Only when a-m interference is very strong will horizontal sound bars appear on the picture tube of the

television receiver. The usual effect is as shown by Fig. 63-3.

It is characteristic of r-f interference that the pattern will be stationary or nearly so when there is no modulation of the interfering signal. The pattern will change and weave, or may develop bars, spots, and rather strong herringbone forms when there is modulation.

Remedies for r-f interference include the following. The use of directional forms of antenna, with reflectors and possibly directors also, which are oriented for maximum desired signal and minimum interference. There is advantage in any antenna of relatively high gain or better signal to noise ratio when the interfering frequencies are not in the television bands where reception is wanted. Tuned preamplifiers are helpful when interference is not at frequencies desired. Shielded transmission line allows much improved reception in localities where there is interference extending throughout a wide range of radio frequencies.

The most direct approach to reduction of r-f interference occurring at only one frequency or in a narrow band of frequencies is use of tuned trap circuits at the antenna terminals or in the antenna coupler of the television receiver. The traps may be series or parallel resonant circuits made with coils and capacitors or they may be short sections of transmission line, all as described later in this article.

Frequency of R-f Interference. — It is possible for strong r-f interference to be picked up by parts of the i-f amplifier when the frequency of the interference is within the band pass of the i-f amplifier. Such interference does not come through the antenna and tuner, but acts directly on the i-f circuits. To occur within this range of frequencies the interference would come from government services or from police, various transportation services, commercial controls, or from one of the amateur radio bands.

If interference which affects pictures or sound is picked up by the antenna, the signals must come from the mixer at frequencies within the band pass of the i-f amplifier. The total band width of this amplifier may extend from about $1\frac{1}{4}$ mc

below the sound intermediate frequency to about $2\frac{1}{4}$ mc above the video intermediate frequency as extreme limits. In order to cover this i-f band pass, signals reaching the antenna and the r-f amplifier of the receiver must extend from about 1 mc below to 1 mc above the 6-mc limits of the channel to which the receiver is tuned when affected by the interference. This consideration fixes the limits of interfering frequencies for the channel to which the receiver is tuned. As an example, with the receiver tuned to channel 5, whose frequencies extend from 76 to 82 mc, the frequency of interference at the antenna would be between about 75 and 83 mc in order that the interference might be accepted and amplified.

There are not many signal frequencies which will fall directly in the channel limits as just mentioned. But other signal frequencies are brought within this range by second harmonics of these signals, by second harmonics of the r-f oscillator in the receiver, by signals which are at image frequencies, and by conversion action in the r-f amplifier when this amplifier is so biased as to have the properties of a detector, mixer, or converter.

To identify frequencies which may be brought within the interference range by means mentioned in the preceding paragraph we shall use letters for the several classes.

A. A frequency within the tuned channel or 1 mc either side. Here we may find radiation from the r-f oscillator of a nearby television receiver tuned to the third or fourth channel below the one in which the first receiver experiences interference. Example: Interference on channel 5. Channel frequencies are 76 to 82 mc, and assumed interference limits are 75 to 83 mc. A nearby receiver may be tuned to channel 2, where the video carrier is at 55.25 mc. If the video intermediate of that receiver is 26.4 mc its r-f oscillator frequency will be 81.65 mc, which is within the interference range of the first receiver.

B. A frequency whose second harmonic is within the tuned channel or 1 mc either side. This would be any fre-

quency whose fundamental is equal to one-half the interference range for the channel to which the receiver is tuned. When tuned to channel 5, where the interference range is 75 to 83 mc, the fundamental frequency of the interference would be between 37.5 and 41.5 mc. It would be different for other channels.

C. Any signal which is an image frequency for the channel in which there is interference. Television oscillators nearly always operate at frequencies higher than carrier frequencies. Consequently, an image frequency must be higher than the oscillator frequency, and must be equal to the sum of the oscillator frequency and the intermediate frequency of the receiver.

Example: Interference is on channel 5. This channel is being used for all examples in order to avoid confusing changes of frequencies and limits, but every channel would require computations on the basis of its own frequencies. The video carrier is at 77.25 mc. Assume the video intermediate is 26.4 mc. Then the frequency of the r-f oscillator is 103.65 mc. Interference limits for this channel are taken as 75 to 83 mc. Adding these limit frequencies to the r-f oscillator frequency gives frequency range of this interference as between 178.65 and 186.65 mc. These are within the ranges of modulated carriers in channels 7 and 8.

Correctly designed r-f amplifier stages have ample selectivity to prevent image interference, but poor design and construction or lack of a tuned r-f stage may allow such interference.

D. Any signal whose second harmonic is an image frequency for the channel in which there is interference. This would be a signal whose fundamental is within a range of frequencies equal to one-half of those in the preceding class of interference. Continuing with the example there worked out, the interference range would be one-half of 178.65 to 186.65, or would be in a range of fundamentals between 89.33 and 93.33 mc. These harmonic image frequencies of interference are not so very far above the channel frequencies

for the tuned channel, and would call for more selectivity in the r-f amplifier.

E. Any signal which may beat with the second harmonic of the receiver r-f oscillator to produce a difference frequency within the interference range for the tuned channel. In earlier examples for interference in channel 5 the frequency of the r-f oscillator was computed as 103.65 mc. The second harmonic is 207.30 mc. Frequency limits for interference signals would be arrived at by subtracting the channel limits from this second harmonic frequency. Subtracting 75 mc and 83 mc from 207.3 mc gives a range of 132.3 mc down to 124.3 mc for the interference. Some aviation radio services are in this range. It must be kept in mind that other channels and other intermediate frequencies would yield entirely different results.

F. Any signal whose frequency becomes an image frequency for the received channel when that signal beats with the second harmonic of the receiver r-f oscillator. In the example for preceding class *E* the second harmonic of the r-f oscillator was computed as 207.30 mc. In the example for preceding class *C* the image frequency range was computed as 178.65 to 186.65 mc. The interfering signal frequency range would have to be the difference between the image range and the oscillator second harmonic. The difference would be from 28.65 mc down to 20.65 mc. In this range there are amateur and other a-m transmissions.

G. This classification includes all interference which is made possible by conversion or mixing in the r-f amplifier of the receiver. When some types of automatic gain control or of manual gain or contrast control are applied to an r-f amplifier the amplifier tube may operate on the lower bend of its mutual characteristic. Then the tube does not act as a linear amplifier, with changes of plate current and voltage proportional to changes of grid voltage, but rather acts as a partial rectifier or mixer or converter.

It is quite possible for a small voltage at the frequency of the r-f oscillator to reach the grid of the r-f amplifier along

with signal frequencies from the antenna. If the amplifier is acting as a converter, there is mixing of the signal and oscillator voltages in the amplifier. If the difference frequency or beat frequency is within the band pass of the tuned coupling between r-f amplifier and regular mixer, this difference frequency will again be converted by the regular mixer and will be passed through the i-f amplifier.

In order that this action of r-f conversion may cause interference, the received signal frequency must be such that beating with the r-f oscillator frequency will produce a frequency within the interference range of the tuned channel. For channel 5 this interference range is assumed to be from 75 to 83 mc. In previous examples the r-f oscillator frequency for this channel has been computed at 103.65 mc. Then the interfering frequency must be in a range equal to the sum of the oscillator frequency and the channel range. Adding 103.65 mc to the range of 75 to 83 mc gives the range of the interfering signal as 178.65 mc to 186.65 mc. Signals within this frequency range normally would be rejected due to selectivity of a r-f amplifier stage tuned for channel 5, but conversion in the r-f amplifier produces a beat frequency which is accepted.

The class of trouble just explained may be called interchannel interference because it permits signals of transmissions in a higher channel to interfere with reception in a lower channel. The difficulty usually is interference by signals from channel 7 with reception in channel 5, and interference by signals from channel 10 with reception in channel 6.

Interchannel interference usually may be eliminated or greatly reduced by a trap circuit or circuits on the grid of the r-f amplifier or on the antenna coupling which connects to the r-f grid. This trap is tuned to the frequency of the r-f oscillator when operating for the channel in which there is interference. Thus the trap removes the oscillator frequency from the r-f grid and prevents conversion action.

Another method of preventing conversion interference is operation of the r-f amplifier with fixed bias rather than automatic or manually controlled bias. The tube then is worked on a straight or nearly straight portion of its mutual characteristic, with full gain, and so provides linear amplification without acting as a converter or mixer.

Identifying Interference Frequency.— Interference from f-m broadcasting stations sometimes is strong enough that station announcements, including call letters, will be heard from the television receiver loud speaker. When interference is evident on the television screen, changing a fine tuning control or temporarily changing the r-f oscillator alignment may bring in voice announcements which allow identifying a station and its operating frequency. A signal tracer containing a detector for amplitude modulation sometimes will make it possible to hear voice or code identifications of a-m broadcasters, short-wave stations, and amateur stations.

While interference is present, the r-f oscillator of the receiver may be removed from its socket or made inoperative by connecting the oscillator grid to its cathode or B-minus. If interference continues, it is being picked up on the i-f amplifier and interference frequency is within the band pass of this amplifier.

Interference frequency often may be determined by means of a constant frequency (marker type) signal generator having reasonably accurate calibration in the range of television carrier frequencies. The generator output is loosely coupled to the antenna terminals of the receiver. Merely laying the output cable near the antenna terminals usually gives enough coupling. While interference is evident on the picture tube screen, tuning the signal generator through the interference frequency will cause distinct changes of the interference pattern, or movement of the pattern, or a new and different pattern. If there is no transmission in the channel at the time of testing, but only the interference, audible beat notes may be produced by the generator and interference frequencies.

Generators usually produce harmonic frequencies. Con-

sequently, the interference may be at a harmonic of the frequency to which the generator is tuned. A check should be made by tuning the generator to twice the frequency at which interference effects first appear, and this doubling of generator frequency should continue until reaching the highest frequency at which the effects appear. Then the interference is at the generator fundamental frequency or tuned frequency.

This test with a signal generator identifies the frequency of interference as it reaches the television antenna. This may be a second or higher harmonic of the frequency at which the interference source is operating.

Transmission Line. — An unshielded transmission line may pick up any kind of r-f interference, and will do so where interference is strong and line layout is conducive to pickup. It is advisable to use the shortest possible length of line, to avoid horizontal and nearly horizontal runs so far as is possible, and to twist a ribbon type line about one turn per foot of length.

Shielded line is of great help where there is strong interference. This may be coaxial line with its outer conductor grounded or may be shielded two-conductor line with the grounded outer shield entirely independent from the two signal-carrying conductors. Unshielded 300-ohm line may be replaced with shielded 300-ohm two-conductor line to avoid upsetting impedance match between antenna, line, and receiver.

A balanced 300-ohm line which is open or has a high resistance joint in one side becomes unbalanced and will pick up much interference while reducing the strength of desired signal. This will happen also if there is an open in one side of the antenna coupling circuits in the receiver.

R-f Inductor-capacitor Traps. — Fig. 63-4 shows typical series-resonant traps consisting of inductor coils and capacitors connected from antenna and r-f grids to ground. The coils may be adjustably tuned with slugs or the capacitors may be of the adjustable trimmer type. In either case the construction is of high-Q design, allowing quite sharp tuning to the interference

frequency or r-f oscillator frequency which is to be bypassed to ground by the trap. When only a single r-f amplifier is used instead of a twin type, as at the right, the trap elements on the ground side of the antenna and cathode side of the tube sometimes are omitted.

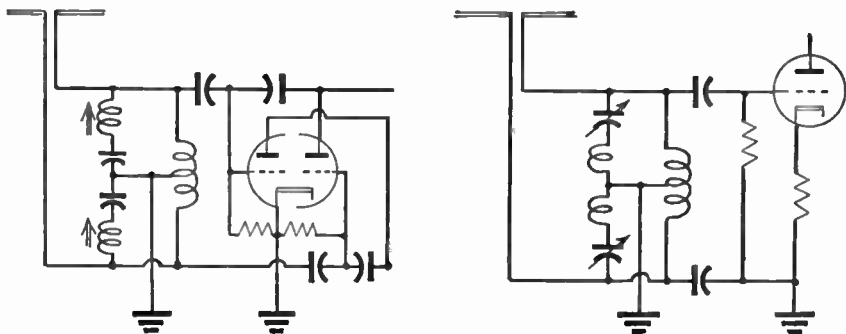

Fig. 63-4.—Traps in r-f grid circuits and antenna couplings for 300-ohm balanced transmission line.

Fig. 63-5 shows connections for traps used with unbalanced coaxial transmission lines. At the left a parallel resonant rejection trap is between the high side of the transmission line and the lead to the r-f amplifier. At the right a series resonant trap is connected from the high side of the line to ground. Either kind of trap may be tuned with adjustable inductance or capacitance. Traps of types shown in the two figures are used for reduction or elimination of every type of r-f interference which has been described.

These interference traps are adjusted by tuning the receiver to the channel in which interference is evident, or to the lowest channel of a band when interference extends throughout the entire band. If there is a fine tuning control it should be adjusted for correct oscillator frequency on the tuned channel, usually by setting this control for best sound or picture. The contrast control should be set at the highest point which does not distort the picture or pattern. The trap then is adjusted for minimum interference. When there are two tuned inductors or capacitors, as in Fig. 63-4, both should be kept approxi-

mately together in position until interference is reduced as far as possible. Then first one and then the other of the two adjustments should be changed one direction and the opposite direction to obtain any further improvement possible.

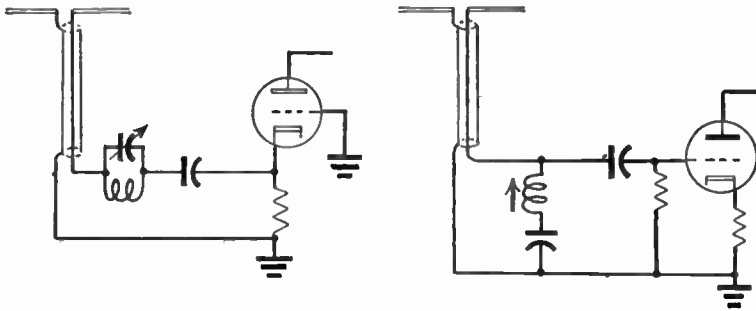

Fig. 63-5.—Parallel and series resonant traps shown connected to inputs from coaxial transmission line.

Trap adjustment may be made with a constant frequency or marker type generator coupled to the receiver antenna terminals with matched impedance, and tuned to the frequency of the interference. The generator thus simulates the interference. An electronic voltmeter or high-resistance d-c voltmeter is connected across the video detector load. Channel tuning, fine tuning, and contrast control are adjusted as in the preceding paragraph. The trap then is adjusted for minimum meter reading.

Line Stubs for Interference Traps. — Pieces of transmission line whose length is approximately a half-wavelength or quarter-wavelength corresponding to the interference frequency may be connected to the receiver antenna terminals to act as traps. Such transmission line stubs are illustrated by Fig. 63-6. A stub whose physical length is close to a half-wavelength of the interference signal, when shorted at its far end, acts like a series resonant circuit connected across the antenna terminals. A half-wave shorted stub is shown at the left. The resonance peak of the stub is quite sharp and there is correspondingly great attenuation of the interference signal. If a broader response is wanted, with some sacrifice of inter-

ference attenuation, the ends of the stub may be connected together through a fixed composition resistor of 50 ohms or less.

If the stub is cut to approximately a quarter-wavelength of the interference signal, and the ends are left open, there is

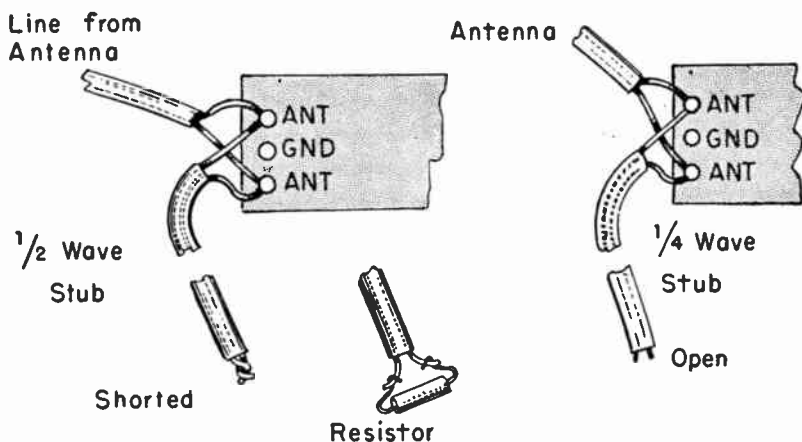

Fig. 63-6.—Transmission line stubs used as interference traps.

again the equivalent of a series resonant circuit across the antenna terminals. That is, either the half-wave shorted stub or the quarter-wave open stub is the equivalent in impedance characteristics to the series inductor and capacitor at the right in Fig. 63-5.

The interference stubs illustrated are made from 300-ohm twin-conductor transmission line, and are used where the transmission line from the antenna is of this type. If the transmission line is of the 75-ohm or 52-ohm coaxial type the stub will be made of the same kind of coaxial line with its central conductor connected to the receiver antenna terminal and the outer shielding conductor connected to the ground terminal.

Lengths of interference stubs may be computed by dividing the following factors by the interference frequency in megacycles.

Twin-line $\frac{1}{2}$ -wave stub, inches = 4900/megacycles

Twin-line $\frac{1}{4}$ -wave stub, inches = 2450/megacycles

Coaxial $\frac{1}{2}$ -wave stub, inches = 3880/megacycles

Coaxial $\frac{1}{4}$ -wave stub, inches = 1940/megacycles

The stub should be cut an inch or two longer than the computed length, then reduced after connection to the receiver until there is maximum reduction of the interference. The best length may turn out to be either more or less than the computed length. Shorting a half-wave stub with a resistor instead of a direct connection makes it necessary to cut the stub shorter in order that it may be resonant at a desired frequency. Stubs should be kept clear of chassis metal. If brought close, the stub will have to be shortened in order to be resonant at the desired frequency.

INVERTERS AND INVERSIONS. — With any tube having a grid and a plate, signal voltage at the plate is in opposite phase to signal voltage at the grid. At any one instant of time the voltage at the plate is changing in an opposite direction to change of voltage at the grid of the same tube.

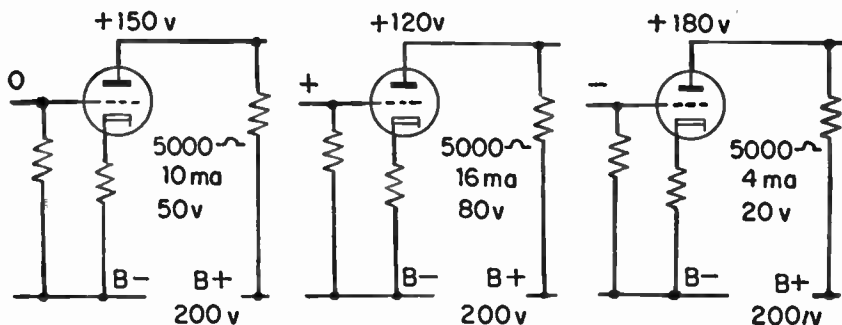

Fig. 64-1.—Inversion or phase reversal of voltages changes at grid and plate.

The reason is illustrated by Fig. 64-1, where plate load resistance is 5,000 ohms and plate supply potential is 200 volts, which is assumed to remain constant or nearly so when there are changes of plate current. At the right there is zero voltage on the grid, an assumed plate current of 10 milliamperes, and

a resulting drop of 50 volts in the plate load. This leaves 150 volts at the plate of the tube.

In the center diagram the grid voltage has been made positive, resulting in an assumed increase of plate current to 16 milliamperes, a load drop of 80 volts, and 120 volts remaining at the tube plate. Increase of grid voltage in a positive direction has made the plate voltage less positive, and output voltage from the plate and the top of the load will become less positive or negative.

In the right-hand diagram the grid voltage has been made negative. Plate current decreases to an assumed 4 milliamperes, with a consequent 20-volt drop in the load and 180 volts remaining at the tube plate. Increase of grid voltage in a negative direction has made the plate voltage more positive, and output voltage from the plate circuit will become more positive.

Signal inversion is employed in video amplifiers to make picture signals positive and sync pulses negative at the picture tube grid, or to make picture signals negative and sync pulses positive at the picture tube cathode. Inversion is used also in the sync section to provide correct or required polarity of triggering voltages for sweep oscillators. Inversion is utilized in one of a pair of deflection or sweep amplifiers for picture tubes having electrostatic deflection, and in somewhat similar fashion for one tube or one section of a tube in push-pull audio amplifiers. There is inversion also wherever signal input is to a grid and signal output from the plate of the same tube, although such inversion may not be desired and may require an additional inverter tube to bring the signal back to its original phase or polarity relation.

At the left in Fig. 64-2 the signal input is between grid and cathode, with signal output taken from across the cathode resistor. This is the arrangement usually called a cathode follower. There is no phase reversal or inversion of the signal. When the input signal makes the grid more positive or less negative there is increase of plate current. Plate current flows not only in the plate circuit as far as the B-supply, but also in

the cathode resistor. With electron flow toward the cathode, the more positive grid and increased plate current make the cathode more positive, and signal output voltage becomes more positive. An input signal making the grid more negative

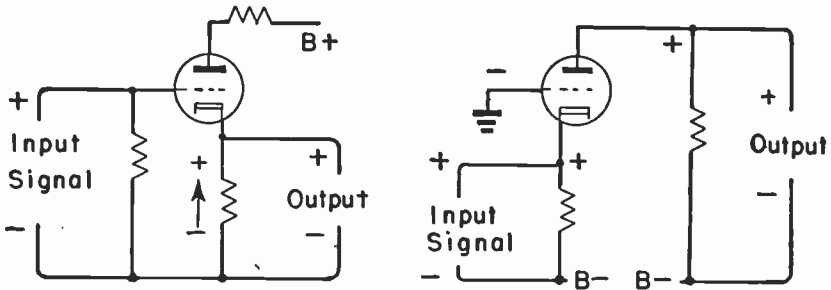

Fig. 64-2.—Tube circuits with which there is no inversion between input and output voltages.

reduces plate and cathode current, making the output voltage less positive or negative.

At the right in Fig. 64-2 the input signal is applied across the cathode resistor, as with a grounded grid amplifier. There is no phase reversal or signal inversion when the output signal voltage is taken from between plate and cathode. When the input signal makes the cathode more positive the effect is the same as making the grid more negative, and, as in Fig. 64-1, this makes the plate signal more positive. When the input signal makes the cathode less positive or effectively more negative, the result is the same as when making the grid less negative or more positive. Then the plate voltage and output voltage becomes less positive or more negative, because there is inversion between grid and plate voltages.

L

LIGHT AND VISION. — The velocity of light in empty space or a vacuum is 300 million meters per second or approximately 186,000 miles per second. Wavelength of light usually is measured in a unit called the angstrom, which is equal to one ten-billionth of a meter or about 1/250 millionth of one

inch. Another commonly used unit of wavelength is the millimicron, which is equal to 10 angstroms.

Wavelength in angstroms at the centers of the various color ranges in the visible spectrum are approximately as follows:

Violet	4150	Yellow	5800
Blue	4700	Orange	6100
Green	5200	Red	6700

Wavelengths shorter than violet and having no effect on vision are classed as ultra-violet. Those longer than red and having no effect on vision are classed as infra-red. Wavelengths of all visible frequencies reaching the eye together form white light. Absence of all visible radiation leaves the sensation of black. The average human eye is most sensitive to a wavelength of about 5560 angstroms, which is between the green and yellow bands.

LIMITERS, F-M SOUND. — A limiter consists of a tube with its grid and plate circuits so designed and operated that plate output voltage cannot increase appreciably above some certain amplitude even when input signal voltage exceeds the amplitude which first causes the plate voltage to reach its limit. A limiter stage, or sometimes two such stages, are used just ahead of a discriminator type of f-m demodulator to prevent amplitude modulation from reaching the discriminator. The limiter acts to prevent changes of amplitude, which constitute amplitude modulation, from appearing in its output even when such changes are applied to the input. This is necessary because a frequency-modulated signal originally free from amplitude modulation may acquire changes of amplitude from interference, hum voltage, video signals, and other voltages or electric and magnetic fields, and because if such amplitude modulation reaches a discriminator there will be audible distortion and noise.

Fig. 66-1 shows connections for a fairly typical limiter stage together with a discriminator. The limiter differs from an i-f amplifier in that the limiter is operated with plate and screen voltages much lower than used for amplifiers, and the limiter is biased by grid rectification or grid leak bias through action

of grid resistor R_g and grid capacitor C_g . Negative bias increases automatically when there is increase of positive amplitude of the input signal. This increase of bias opposes the effect of positive swings of input signal and thus limits the resulting plate current. When there is increase of negative amplitude of

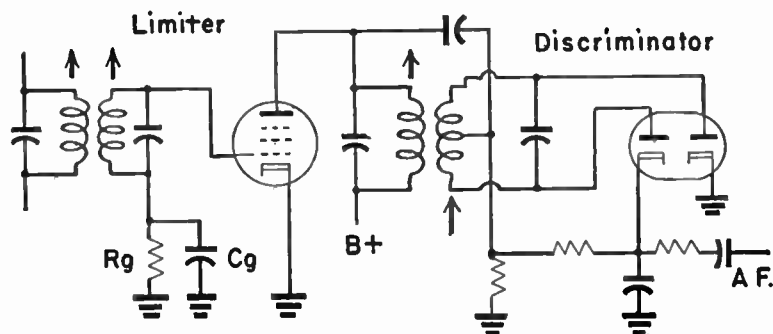

Fig. 66-1.—A limiter with its biasing resistor and capacitor in the grid return connection to ground.

the input signal the grid voltage is driven to the negative value which causes plate current cutoff. Thus the plate current is held to a low limit which is zero or cutoff, this effect being due to low plate and screen voltages. Plate current is held to a high limit which is fixed by the increasingly negative grid bias, this effect being due to the use of grid leak biasing.

Other limiter grid circuits are shown by Fig. 66-2. Here, as in Fig. 66-1, the grid return to ground and the cathode is through grid resistor R_g and grid capacitor C_g is so connected that it can discharge only through the grid resistor. With any of these circuits the limiting action affects only amplitude, not frequency. There is the same limiting of amplitude at all frequencies. Consequently, variations of frequency, or the frequency modulation which is carrying the sound signals, pass through the limiter and go to the discriminator without change.

Grid Bias Effects. — The method of biasing employed for the limiter is explained under *Grid Leak Bias* in the article on *Biasing*. Each positive alternation of input signal makes the

limiter grid momentarily positive and allows grid current to charge capacitor C_g in a polarity which is negative on the grid side. The charge leaks away slowly through resistor R_g , but enough remains to give the grid an average negative bias so long as any a-c signal is reaching the grid circuit.

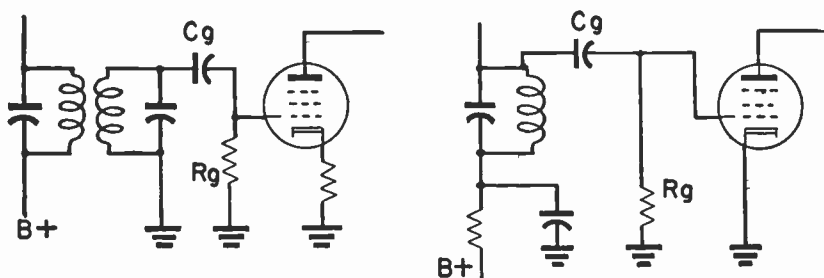

Fig. 66-2.—Limiters having biasing resistors and capacitors connected directly to the grid.

The charge on capacitor C_g , and the negative bias due to this charge, will be increased by every succeeding positive alternation of signal until the bias becomes so far negative that each positive peak merely restores the small amount of charge which leaks off through resistor R_g during one signal cycle. At this time the bias voltage is nearly equal to the signal voltage and is so far negative that negative alternations of the signal are at or close to the value which causes plate current cutoff on each cycle.

The effect of grid leak bias is illustrated at the left in Fig. 66-3 where an input signal voltage is applied to the mutual characteristic curve which shows the relation between grid voltage and plate current. The positive peaks of the input signal make the grid positive during the brief intervals at *A-A*. The result is charging of the grid capacitor and a biasing voltage which is negative to the degree indicated in the graph. Positive peaks of plate current are slightly flattened because they occur during instants in which there is increase of negative bias while the grid capacitor is charged. The flattening is shown at *B-B*.

At the right in Fig. 66-3 is shown the effect of an increase of amplitude in the input signal. The greater positive alternations of the input signal make the grid positive to a greater degree than before, as may be seen at *A-A* on this graph. There is more charging of the grid capacitor and a more negative grid bias, because there is increase of capacitor voltage due to this

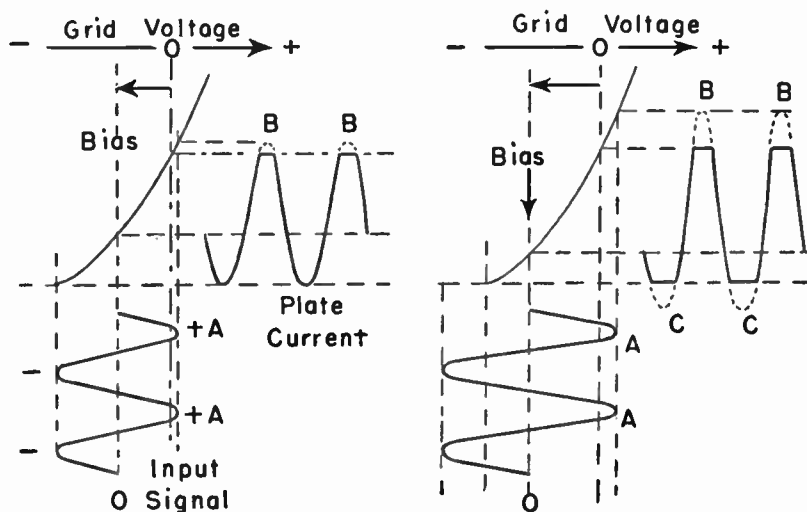

Fig. 66-3.—How limiting is caused by plate current cutoff and by positive grid voltage.

charging. This change of bias brings the operating point farther down on the mutual characteristic curve, and each negative alternation of the signal carries the grid voltage more negative than the value for plate current cutoff. This cuts off or limits the negative peaks of plate current as at *C-C*. At the same time there is additional flattening of the positive peaks of plate current as at *B-B*. The result of plate current cutoff combined with more flattening of positive peaks maintains plate current swings through a total change practically the same as in the left-hand graph, before the increase of amplitude in the input signal.

There is a small negative bias even with no signal. In a typical case this initial bias might be something like 0.3 volt. A

signal of moderate amplitude may increase the bias to about 0.5 volt, and signals of increasing amplitude will make the bias 1.5 or more volts negative.

At the left in Fig. 66-3 there is no limiting action but only development of a negative bias. At the right there is limiting action. If the input signal is of less average amplitude than represented at the left there will be no limiting, but there will be amplification. With an input of less amplitude the entire operation will be on a portion of the mutual characteristic which has moderate curvature. The plate current will not follow grid signal changes exactly, because of curvature of the characteristic, and there will be distortion — but there will be amplification rather than limiting.

In order that there may be limiting of amplitude, and a signal of constant amplitude passed on to the discriminator, the signal coming to the grid of the limiter must be of some mini-

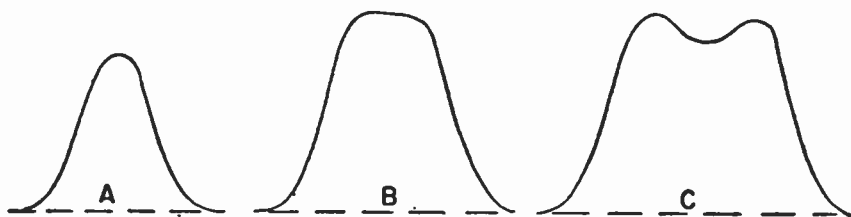

Fig. 66-4.—Frequency response of a limiter with various input voltage amplitudes.

mum strength or amplitude which will cause the limiting action illustrated at the right in Fig. 66-3. With any less signal input there will be amplification on all except strong peaks, and the discriminator will be fed a signal of varying amplitude. Then there will be continual audible noise. With signals strong enough to cause limiting the operation will be quiet other than for program voice and music.

Fig. 66-4 shows the frequency response of a particular limiter as observed on an oscilloscope while applying a frequency modulated signal at the input to the sound i-f amplifier. At *A* the input signal is too weak to cause limiting. Response is similar in shape to that of an i-f amplifier stage. Gain will be less

than with an amplifier because of low plate and screen voltages on the limiter. At *B* the input has sufficient amplitude to cause limiting. At *C* the input is so high as to cause overloading.

The time constant of grid capacitor C_g and grid resistor R_g in Figs. 66-1 and 66-2 must be long enough to maintain a negative bias for the limiter. That is, only a small portion of the capacitor charge may leak off between successive positive alternations of intermediate frequency. On the other hand, this time constant must be so short that sudden and brief noise amplitudes can cause an almost instant change of bias in order to maintain a constant output amplitude.

Time constants usually are more than 1 microsecond and less than 5 microseconds, averaging around 2.5 microseconds. With sound intermediate frequency of 22 mc, as an example, the period between successive positive pulses is about 0.045 microsecond, so there is little loss of charge between such rapidly recurring pulses. The highest audible frequency, 20,000 cycles per second, has a period of 50 microseconds, so noise pulses or other sudden and brief changes of input amplitude can change the bias much faster than any possible change of amplitude which would be audible.

Limiter tubes are pentodes of the sharp cutoff type, which allow plate current cutoff with but little increase of negative bias beyond the normal operating value. The use of low plate and screen voltages contributes to this quick cutoff with change of bias. The low voltages also prevent excessive plate and screen currents at the small grid bias existing when the input signal is of small amplitude. Plate potentials commonly are in the range between 40 and 60 volts. Screen potentials may be the same as for the plate, or may be less.

The stronger the input signal which reaches the limiter the higher may be the plate and screen voltages on the limiter and the stronger will be the signal passed on to the discriminator. Relatively weak inputs, or small average amplitudes, require lower plate and screen voltages in order to have limiting, and a weaker signal goes to the discriminator.

LINES, RESONANT. — A resonant line consists of a pair of insulated parallel conductors, usually a section of transmission line, of such length that when connected to a source of radio-frequency voltage the line will behave like a parallel or series resonant circuit, like an inductive or capacitive reactance, or like an open or short circuit.

Resonant lines sometimes are called line stubs. Ordinarily their length is a half-wavelength or less at the frequency where resonant effects are wanted. Resonant lines are not used for transmission of power, rather they are used for matching of impedances between antennas, transmission lines, and receivers, also for filters, for step-up and step-down transformers, and, in general, for circuit elements at frequencies with which coils and capacitors are inefficient because of small size.

Wave Reflections. — The characteristics of resonant lines depend on and may be explained with reference to wave reflections and resulting standing waves of voltage and current

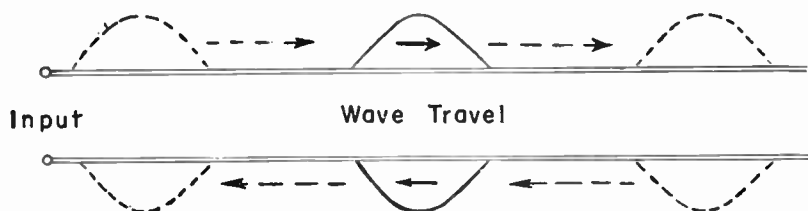

Fig. 67-1.—Electromagnetic waves and pulses of potential and current move along the line conductors.

which are formed along the lines. Reflections are caused as follows. If, in Fig. 67-1, a potential difference of particular polarity is applied across the input ends of the two conductors forming the line, an electromagnetic wave will move away from the source along one conductor and a similar wave, in opposite phase will move toward the source along the other conductor. The waves are accompanied by movements of electrons, or by currents, and by changes of potential.

Were the conductors of the line infinitely long, the waves with their currents and potentials would travel on until all

energy has been dissipated in line losses or attenuation. If the line were not infinitely long, but ended at a pure capacitance as at *A* in Fig. 67-2, the electric energy of the wave would charge the capacitance. Then the capacitance would discharge and return all the original energy to the line, since a pure capacitance absorbs no energy. This discharge would start an

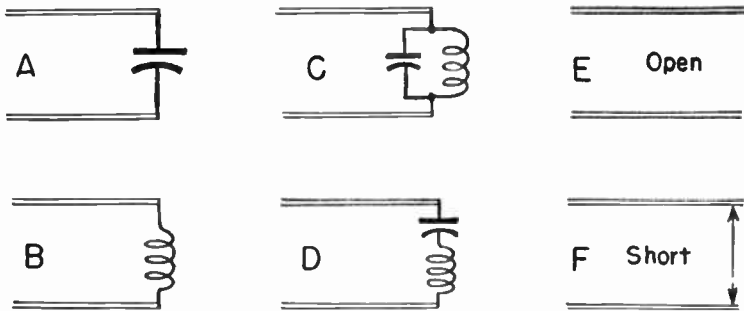

Fig. 67-2.—Line terminations which cause wave reflections.

electric wave in the opposite direction; back toward the input along the line conductors. This would be a reflected wave.

Were the line to end at a pure inductance, as at *B*, the magnetic energy of the wave would build up a magnetic field around the inductance. Then the field would collapse and return all the original energy to the line, for a pure inductance absorbs no energy. This energy would start a magnetic wave in the opposite direction, back toward the inlet. The returning wave would be a reflected wave.

There would be reflection also were the line to end at a parallel resonant circuit as at *C* in Fig. 67-2, provided the frequency from the source connected to the input were the resonant frequency of this parallel tuned circuit. Reflection would occur again were the line to end at a series resonant circuit as at *D*, provided the input frequency were the resonant frequency of this terminating circuit.

At the two terminals of an ideal parallel resonant circuit containing no resistance there would be infinitely high impedance to an applied voltage at the resonant frequency of the

tuned circuit, and there would be zero current from one circuit terminal through to the other, although there might be large circulating current within the tuned circuit. At the parallel resonant termination of the line the condition of maximum voltage and zero current is equivalent to an open circuit, with which there is maximum voltage but zero current. Consequently, there will be total wave reflection when the end of the line is open, as at *E*.

Between the two terminals of an ideal series resonant circuit there is maximum current when applied voltage is at the resonant frequency of the tuned circuit, this because a series resonant circuit containing no resistance has zero impedance at resonance. At the same time the voltage across the ideal series resonant circuit is zero, because there is no potential difference across zero impedance. Maximum current and zero voltage exist also at any short circuit. Consequently, there is total reflection from the end of the line when the end is shorted, as at *F*.

Standing Waves. — Direct waves originating at the input to the resonant line are continually traveling toward the far end of the line, while waves reflected from the end are continually traveling back to the input. The waves in opposite directions cross each other. At some points the two waves will be in phase and will add their strengths to produce a strong maximum. At other points the waves will be in opposite phase and they will cancel to leave zero strength. At intermediate points there will be such phase relations as to make the combined strength something between maximum and zero.

If the electrical length of the line is some exact multiple of a quarter-wavelength corresponding to the input frequency, the in-phase peaks and opposite-phase peaks always will occur at the same points along the line and the peaks will be of maximum strength. The waves which act together to produce the maximum and zero values are in continual motion away from and toward the input, but the points where they add and cancel stand still. These stationary points where appear the maximum and minimum voltages and currents form what are called standing waves on the line.

Standing waves of current are displaced from standing waves of voltage by one-quarter wavelength along the line. This is true because in every case where there is reflection, as illustrated by Fig. 67-2, there is maximum current accompanied by minimum voltage or else minimum current accompanied

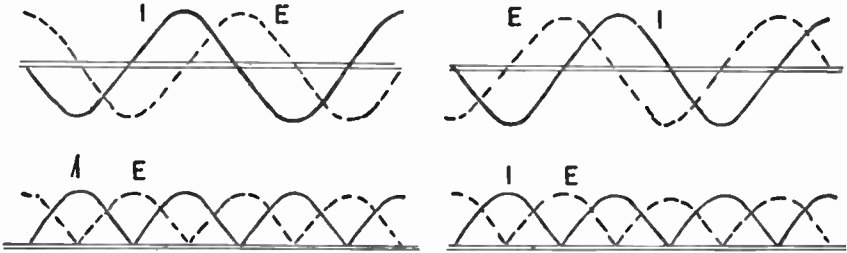

Fig. 67-3.—How standing waves may be represented in diagrams.

by maximum voltage. These phase relations of voltage and current are illustrated at the top of Fig. 67-3. Were the currents and voltages to be measured by some form of a-c meter, the readings would be the same whether the instantaneous alternating voltages and currents were positive or negative. Then the waves may be more simply and conveniently represented as at the bottom of the figure, with all the alternations above the zero line.

Open and Shorted Lines. — The relations between current and voltage in standing waves due to reflections cause certain lengths of open and shorted lines to act like particular combinations of inductance and capacitance. The relations for open lines are illustrated by Fig. 67-4. At the top are standing waves of current and voltage. At every point where there is maximum voltage and minimum current these relations are the same as at an open circuit or at the terminals of a parallel resonant circuit. Where there is minimum voltage and maximum current the relations are the same as at the terminals of a series resonant circuit.

The open ends of the lines in the figure are placed directly below a point having conditions like those of an open circuit. If the input to this line is $\frac{1}{4}$ wavelength from the open end,

this input will be at a point where voltage and current relations are like those at the terminals of a series resonant circuit. Then at the input to this $\frac{1}{4}$ -wave open line will be the same effect as though the line were a series resonant circuit, and the line may be used instead of such a circuit. If the input to the

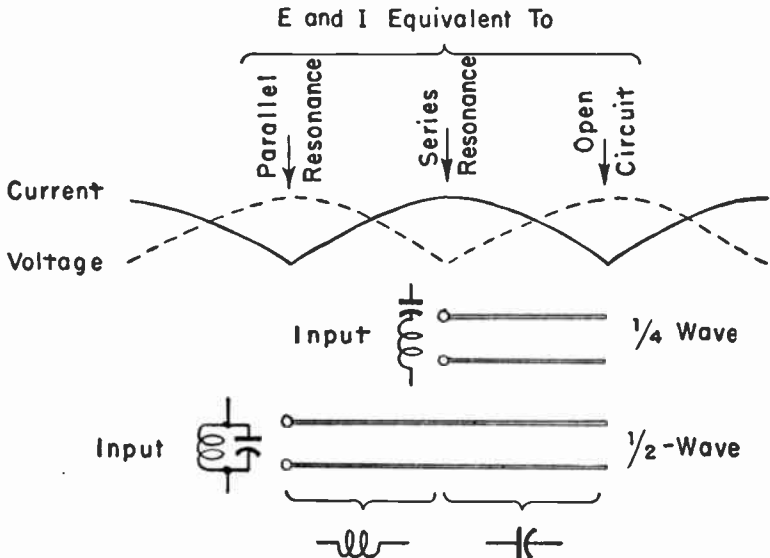

Fig. 67-4.—Relations between lengths of open lines and the kinds of circuit elements to which the lines are equivalent.

line is $\frac{1}{2}$ wavelength from its open end, the voltage and current relations at the input are like those at the terminals of a parallel resonant circuit, and this $\frac{1}{2}$ -wave open line may be used like such a circuit.

At the bottom of Fig. 67-4 it is shown that an open line whose length is less than $\frac{1}{4}$ wavelength at the applied frequency acts like a capacitance or a capacitive reactance. If the length of the open line is between $\frac{1}{4}$ and $\frac{1}{2}$ wavelength, the line acts like an inductance or an inductive reactance.

Fig. 67-5 illustrates the effect of length of shorted lines on how the lines behave toward anything connected to their input. Here the shorted ends of the lines have been placed

directly below a point where voltage and current relations are like those at a short circuit. When the input to the shorted line is $\frac{1}{4}$ wavelength from the shorted end, this line acts at the input as though it were a parallel resonant circuit or an open circuit. This $\frac{1}{4}$ -wave shorted line may be used like a parallel resonant circuit. If the input to the shorted line is $\frac{1}{2}$ wavelength from the shorted end, the line acts at the input as though it were a series resonant circuit or a short circuit. This $\frac{1}{2}$ -wave shorted line may be used like a series resonant circuit.

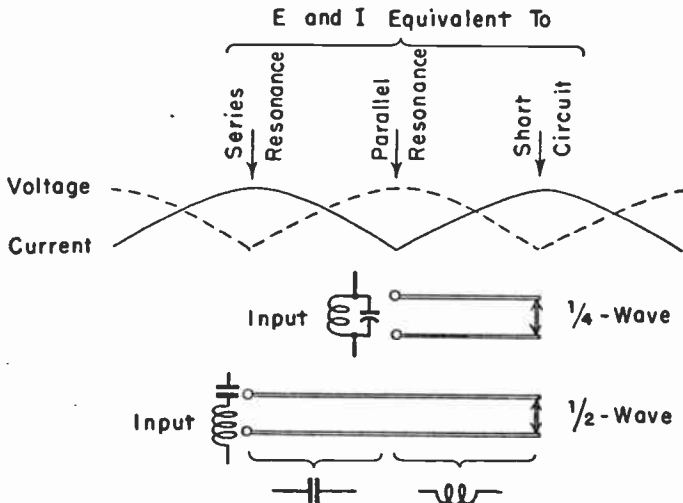

Fig. 67-5.—Relations between lengths of shorted lines and the kinds of circuit elements to which the lines are equivalent.

At the bottom of Fig. 67-5 it is shown that a shorted line less than $\frac{1}{4}$ wave in length behaves at its input like an inductance or an inductive reactance. A shorted line whose length is between $\frac{1}{4}$ and $\frac{1}{2}$ wavelength behaves at its input like a capacitance or a capacitive reactance. The behavior of shorted lines is not altered by cutting off the portion of the line which extends beyond the short.

Effects of Half-wavelengths.— Examination of Figs. 67-4 and 67-5 shows that relations of voltage and current repeat at every half-wavelength along the line. It was shown also that

the electrical effect at the input to a $\frac{1}{2}$ -wave open line is that of an open circuit, and at the input to a $\frac{1}{2}$ -wave shorted line the effect is that of a short circuit. Adding or subtracting half-wavelengths to a resonant line has no effect on the electrical behavior or characteristics of the line as seen from the input end.

Characteristics have been described for lines of four lengths; less than $\frac{1}{4}$ wave, exactly $\frac{1}{4}$ wave, something between $\frac{1}{4}$ wave and $\frac{1}{2}$ wave, and exactly $\frac{1}{2}$ wave. From any longer line it would be possible to remove exact half-wavelengths until that line was brought down to one of the lengths first mentioned. It is not necessary to remove $\frac{1}{2}$ -wave sections physically, the line may be considered as shortened by any number of half-wavelengths, and the electrical length of the remainder will indicate the properties of the whole line.

LINES, TRANSMISSION. — A transmission line consists of two conductors which connect the two halves or sections of a television or f-m antenna to the receiver circuits. In types made for reception the two conductors of a transmission line are molded or embedded in low-loss insulation, such as polyethylene. In some types of line there is additional outer covering for protection against weather and mechanical damage. High quality transmission line avoids serious reduction of signal strength due to attenuation in the line, conserves signal strength by allowing correct matching of impedances, and reduces pickup of electrical interference.

Transmission lines may be either balanced to ground as at the left in Fig. 68-1 or unbalanced as at the right. Each conductor of a balanced line is connected to the inner end of one-half the antenna and, in the receiver, to one end of a coil in the receiver antenna circuit. There is a ground connection from the center tap of the coil or of a resistance or capacitance network. The two sides of the lines and everything to which they connect are symmetrical. Radiations reaching the balanced line cause voltages and currents which act in the same direction at the same time in both conductors, either upward or downward on both sides. These forces oppose each other

in the two halves of the center tapped coil or other balanced antenna coupling in the receiver, thus canceling their effects and leaving only the signal from the antenna to act in the coupling.

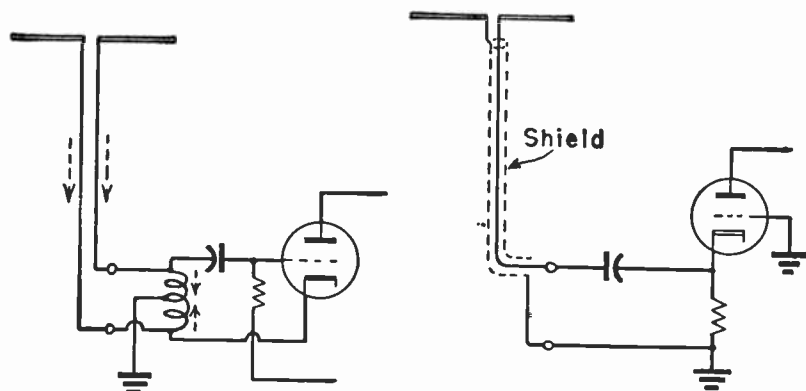

Fig. 68-1.—Connections to a balanced transmission line (left) and to an unbalanced line (right).

Cancellation of voltages picked up by a balanced line makes this type fairly immune to interference even when there is no shielding, as is the case with most balanced lines. However, where there is strong interference and electrical noise, the two signal-carrying conductors within their insulation may be enclosed by a metallic braid shield protected with other external insulation. The braid shield is connected to chassis ground and sometimes to a cold water pipe or earth ground.

A transmission line used for unbalanced connections nearly always is of coaxial construction, in which a single central conductor is embedded in insulation around which is the other conductor in the form of metallic braid. There is additional protective insulating covering outside the braid conductor. The central conductor is connected to one side of the antenna and, in the receiver, to the high side of the coupling in the r-f grid circuit. The braid of the coaxial line is connected to the other side of the antenna, to the low side of the input coupling in the receiver, and usually to ground so that

the braid acts as a shield. A coaxial line with its braid conductor grounded is not affected by external electrical fields, nor does it have any external field of its own.

Impedance of Line. — Any transmission line may be thought of as consisting of a very great number of very short sections as shown at the top of Fig. 68-2. On both sides of every section there is the inductance of the conductors in that section, with all the inductances in series with the line. Across each section is the capacitance resulting from the two conductors as plates, separated by insulation which is the dielectric. All the capacitances are in parallel with one another. A somewhat more exact representation is shown by the bottom diagram, where are included the series resistances of the line conductors and the shunt resistances across the conductors.

Any one section of the line offers a certain opposition to alternating current because of the series inductances and their inductive reactances. At the same time this section aids flow of alternating current because of the shunted capacitance and

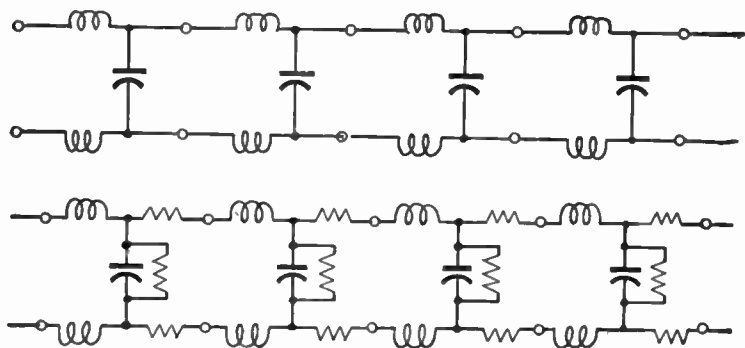

Fig. 68-2.—A transmission line consists, in effect, of many sections in which there is inductance, capacitance, and resistance.

capacitive reactance. Adding another section of line offers more opposition in the series reactance, but less in the shunt reactance, and the result is no change of impedance or in the net amount of opposition to alternating current flow. Any

number of sections may be added, and still there will be no change of impedance.

This unchanging impedance usually is called characteristic impedance. Other names are surge impedance, image impedance, and iterative impedance. This impedance depends on inductance, capacitance, and resistance in any length of line. These things depend on the size and separation of the two conductors and on the dielectric constant of the insulating material in the line. The characteristic impedance remains the same regardless of actual length of line, and it is the same regardless of frequency because inductive and capacitive reactances change oppositely with variation of frequency.

Characteristic impedance is the impedance which would exist at the input end of a line infinitely long. This impedance, in ohms, would be equal to the quotient of dividing the input alternating volts by the input alternating amperes. Line impedance could be computed from the following formula.

$$Z = \sqrt{\frac{L}{C}} \frac{1}{\sqrt{k}}$$

Where Z is the impedance in ohms, L is the inductance in henrys of any unit length of line, C is the capacitance in farads of the same length of line, and k is the dielectric constant of the insulating material in the field between conductors. Any change in unit length of line changes L and C together, and their ratio remains constant.

Capacitance increases with conductors closer together and of larger diameter. This lessens the impedance. Wide spacing and small conductors reduce the capacitance and increase the impedance. The greater the dielectric constant of the insulation the less becomes the line impedance.

With parallel conductors such as used for a balanced transmission line the formula for characteristic impedance is,

$$Z = 276 \times \log \frac{2 \times S}{D} \times \frac{1}{\sqrt{k}}$$

Where Z is the impedance in ohms, S is center-to-center separation of conductors in inches, D is the conductor outside

diameter in inches, and k is the dielectric constant of the insulation. The common logarithm is used.

When the line is of the coaxial type with concentric conductors, as commonly used for unbalanced line connections, the formula for characteristic impedance is,

$$Z = 138 \times \log \frac{D}{d} \times \frac{1}{\sqrt{k}}$$

Where Z is impedance in ohms, D is the inside diameter of the outer or shielding conductor in inches, d is the outside diameter of the inner conductor in inches, and k is the dielectric constant of the insulating material. The common logarithm is used.

Television receivers having balanced antenna inputs nearly always are designed with approximately 300 ohms input impedance at their antenna terminals. The transmission line for such receivers usually is of the type having insulated twin conductors, either unshielded or shielded, and having 300-ohm characteristic impedance. Unshielded line of this type most often is in the form of a flat ribbon about $\frac{3}{8}$ inch wide and $\frac{1}{16}$ inch thick.

Receivers with unbalanced antenna input nearly always are designed with approximately 75 ohms impedance at their antenna terminals. The transmission line should have impedance of 75 ohms. Unshielded 75-ohm twin-conductor line may be used, but the choice ordinarily is coaxial line of 75-ohm impedance which is used with the outer conductor grounded to act as a shield. There are other coaxial lines or cables having impedance of approximately 95 ohms. There are also unshielded lines having impedances of 150 ohms and of 100 ohms. Lines with impedances other than 300 ohms and 75 ohms are used chiefly for experimental work and some special applications.

Velocity Constant.—Radio-frequency waves traveling along transmission lines move more slowly than waves of the same frequency traveling in empty space. Consequently, the wavelength in a transmission line is shorter than in space. This means that a line whose length is specified as a certain number

of wavelengths or as quarter-wavelength, half-wavelength, and other fractions, will not have a physical length in inches or feet as long as the same number of wavelengths or fractions in space.

The fraction of the space speed at which a wave of given frequency travels in a transmission line is the velocity constant or velocity factor of the line. This constant or factor is also the fraction by which wavelength in space is multiplied to determine equivalent wavelength of the line. Some velocity constants for Amphenol cables and lines are as follows.

Twin-lead, 300-ohm impedance (unshielded)	0.82
Twin-lead, 150-ohm impedance (unshielded)	.77
Twin-lead, 75-ohm impedance (unshielded)	.69
Coaxial, 73 or 75-ohm impedance	.66
Coaxial, 53-ohm impedance	.66

For air-insulated twin-conductor lines supported with usual insulators the velocity constant will be something between 0.85 and 0.95 in most cases.

Actual line lengths corresponding to wavelengths and fractions are determined thus.

One wavelength, feet	=	983	×	factor/megacycles
inches	=	11800	×	factor/megacycles
1/2 wavelength, feet	=	492	×	factor/megacycles
inches	=	5900	×	factor/megacycles
1/4 wavelength, feet	=	246	×	factor/megacycles
inches	=	2950	×	factor/megacycles

Matching of Impedances. — If the impedance of a load to which a transmission line connects is not the same as the characteristic impedance of the line there will be wave reflections in the line. Signal energy which should pass into the load and be used there will be reflected back into the line. The load is the receiver, so signal energy which should go into the receiver is reflected back to the antenna and is wasted. If impedances of line and load are alike there are no reflections, regardless of the length of line, and all power or energy enters the load. When impedances are equal the line and load are said to be matched.

The transmission line is the load for the antenna, and line impedance should match antenna impedance in order to have maximum useful transfer of signal energy from antenna to line and thence to the receiver. Lack of impedance matching is the cause for weak signals at the receiver, for poor definition and apparent poor focusing, and for excessive interference or noise effects. Mismatching occurs not only where line impedance is incorrect for antenna or receiver, but wherever there are electrical changes such as high-resistance splices or couplings or material changes of spacing between line conductors.

Line Stubs for Matching. — When the impedance of a load, such as the receiver input, is an exact match for the impedance of the line the effect at the antenna end of the line is as though the receiver input were a pure resistance equal to line impedance. For instance, if receiver input impedance actually is 300 ohms, and if line characteristic impedance is 300 ohms, the antenna will effectively be connected to a pure resistance of 300 ohms. If antenna impedance is 300 ohms, as with connection at the center of a folded dipole, all signal energy picked up by the antenna will go through the line and into the receiver input without loss.

The receiver input may be considered as equivalent to a series resonant circuit in which inductance and capacitance cancel each other to leave only resistance. This resistance is the impedance of 300 ohms. If the receiver input is not effectively resonant it will have either excess capacitance or else excess inductance. In either case the impedance will increase, just as it would increase in a circuit having inductance and capacitance in series when the applied frequency is either higher or lower than that for resonance. If there is excess capacitance it may be balanced out by adding inductance to resonate with the capacitance, and excess inductance may be balanced with capacitance.

Inductance or capacitance may be added by connecting to the junction of line and receiver input a resonant line or a line stub. As shown in the article on *Lines, Resonant*, inductance

will be provided with either an open stub between $\frac{1}{4}$ and $\frac{1}{2}$ wavelength in electrical length or else a shorted stub less than $\frac{1}{4}$ wavelength in electrical length. Capacitance will be provided by an open stub less than $\frac{1}{4}$ -wave in length or by a shorted stub whose length is between $\frac{1}{4}$ and $\frac{1}{2}$ wavelength.

Ordinarily there is no apparatus available for determining the kind of mismatch, and even were measurements possible it would be quicker and more certain to try stubs of different length, with their free ends open and shorted, and to use whatever gives the most improvement. The stub is connected to the receiver antenna terminals along with the transmission line, as at the left in Fig. 68-3. It is easiest to experiment with an open stub cut initially to about half-wavelength in the channel where there is greatest evidence of faults which may be due to mismatching. While the stub is connected to the receiver and a test pattern is tuned in, pieces about one-quarter inch long may be cut from the free end of the stub until there is improvement and until reception again commences to become poor. Then a permanent stub may be cut to the length at which best results were obtained. Experiments with a shorted stub may

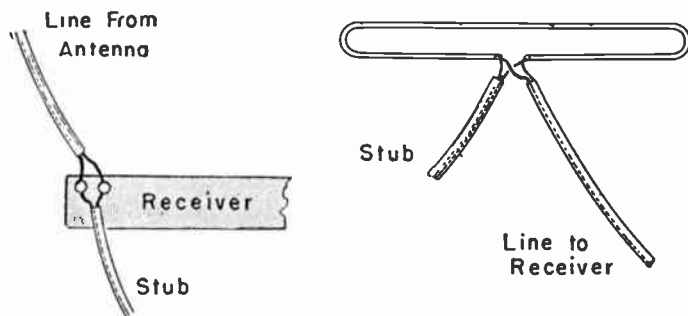

Fig. 68-3.—Matching stubs connected at the receiver and at the antenna.

be carried out by arranging pin points or needle points which can be pushed through the insulation into the conductors at various points.

Matching stubs may be used at the antenna end of the line, connected to the points at which the line conductors are soldered or screwed to the ends of the antenna rods or to the

link between upper and lower sections of a stacked array or between sections of a two-band antenna. Connection at an antenna is shown at the right in Fig. 68-3.

Line Sections for Matching.— Unlike impedances of antenna and transmission line or of transmission line and receiver may be matched with a section of line $\frac{1}{4}$ wavelength long at the frequency for which the best match is desired. The impedance of the $\frac{1}{4}$ -wavelength matching section is made equal to the square root of the product of the unlike impedances which, in the following formula, are designated as Z_a and Z_b . All impedances are in ohms.

$$\text{Matching impedance} = \sqrt{Z_a \times Z_b}$$

The most common matching problems occur with simple dipole 73-ohm antennas, folded dipole 300-ohm antennas, and receivers having inputs designed for 75 ohms or for 300 ohms.

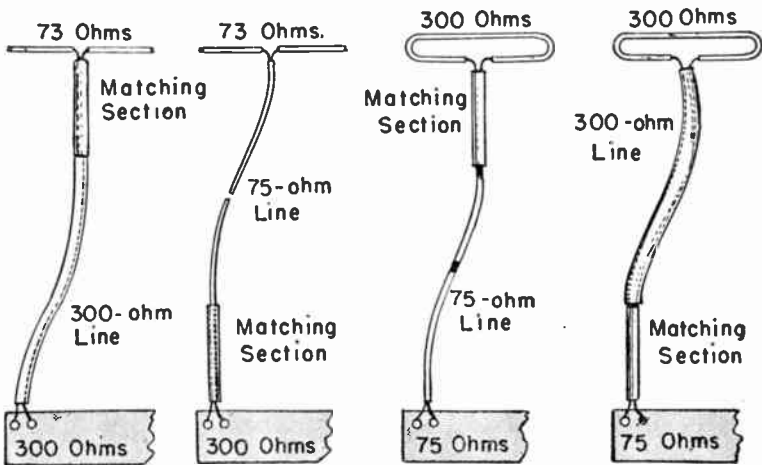

Fig. 68-4.—Connections of matching sections at the antenna end and at the receiver end of the transmission line.

The formula will show that a matching section for joining 73 or 75 ohms to 300 ohms should have impedance of approximately 150 ohms, which is the impedance of a generally available twin-conductor line. Fig. 68-4 shows several applications of such a matching section.

Installing Transmission Lines. — Loss of signal strength in the transmission line is directly proportional to line length, and for this reason the length should be as short as possible. However, the antenna should be located for best signal pickup and least interference even though such a position calls for a relatively long transmission line. Much of the loss in a long line may be compensated for by good impedance matching and by careful attention to installation methods.

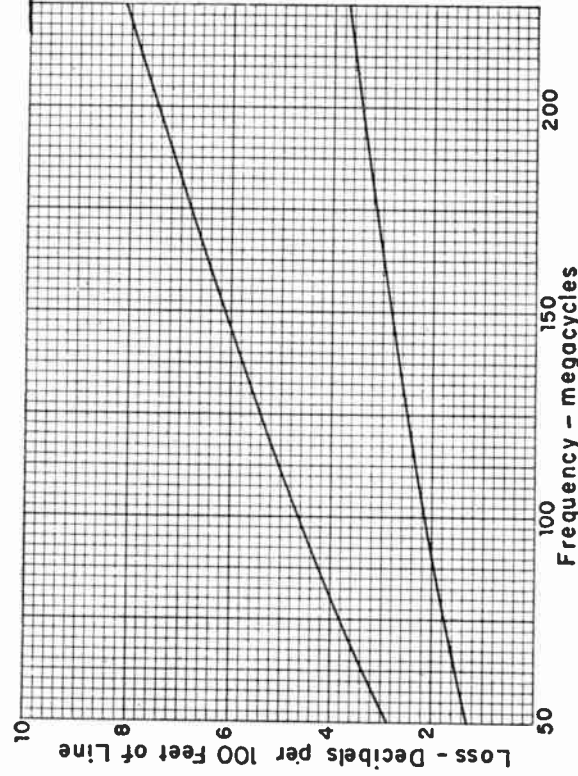

Fig. 68-5.—Average losses of signal energy in transmission lines of 75-ohm impedance (top curve) and of 300-ohm impedance (bottom curve).

Fig. 68-5 shows signal loss in decibels per 100 feet of unshielded twin-conductor transmission line. The upper curve, showing the greater loss, applies to line having characteristic impedance of 75 ohms. The lower curve applies to line of 300-ohm impedance. The loss in coaxial lines of approximately 53 and 75-ohm impedance varies widely with construction and size of the cable, but generally is within the limits of the two curves shown in Fig. 68-5.

Transmission line of any type should be fastened or supported every 6 to 8 feet in such a manner that it will not sway in the wind. Enough slack should be left in a short length at the antenna end to prevent pulling or breaking the line in case the antenna sways. Any excess length should be cut off, not folded or rolled out of the way. There should be no very sharp bends which might cause changes in conductor spacing and allow reflections. The line conductors are preferably soldered to the antenna terminals.

Coaxial and other shielded transmission line may be run almost anywhere that is convenient. It may be clamped or taped to a metal antenna mast, run inside of metal conduit or piping, in wall spaces, or in or on top of earth. Excessive heat will damage the insulation. Connections are made to coaxial line by removing the outer insulation far enough to permit exposing the inner conductor and some of the braid. The braid may be unraveled, then twisted and tinned with solder for connection to the ground terminal, or the braid may be left in place while tinned with a hot iron quickly enough to prevent damage to the insulation. Then a ground wire may be soldered to the tinned braid. The least possible length of inner conductor should be exposed beyond the shielding braid.

Unshielded transmission line should be kept from direct contact with building surfaces, even though the surfaces are nonconductors. This kind of line must be kept well separated from power lines and all electrical machinery, also from all metal. Metal includes gutters and downspouts, roof vents, conduits, water and gas piping, and the antenna mast. Unshielded line must not be run inside of conduit or metal pipe of any kind. Supports should be standoffs made entirely of insulation or with insulation held by metal. If standoffs having a metal loop around a slotted insulator are used on a line running vertically or nearly so, the loops may be squeezed down onto the insulation and line after everything is in final position.

Unshielded lines should be fastened at a point near the antenna, then carried away from the antenna mast at a slight angle. Interference pickup is lessened by twisting the line

about one full turn per foot of length. Horizontal runs should be as short as possible. One reason is that a horizontal run is subjected to the same kind of signal pickup as the horizontal antenna conductors. Another reason is that a horizontal line, unless protected by some building projection, tends to collect rain, snow, condensed moisture, and dirt. These things then are in the field space between the conductors and cause temporary or permanent changes in line impedance.

Shielded line can be spliced satisfactorily, from the transmission standpoint, only with connectors made especially for this purpose. Unshielded twin-conductor line may be spliced with soldered joints provided the conductor spacing is not altered, the least possible solder is used, and excess conductor is carefully removed. A soldered splice should be protected with wrapping of plastic tape. Most connectors made for unshielded twin-conductor cable are not weather-resistant and are not satisfactory for outdoor use. It is far better to use continuous runs rather than any kind of splice.

A line should be brought indoors through a hole sloping downward toward the outside. Unshielded line should be protected with insulating tubing large enough not to change the shape or conductor spacing of the line. Just outside the building there should be a downward drip loop in the line. Space remaining in the opening may be filled with mastic or caulking compound.

Unshielded line indoors must not be run near radiators, pipes, or other large metal objects, whether these objects are exposed or are concealed in walls and floors. A line may be run across basement joists and up through a floor near the receiver. The line should be kept out of sight so far as possible by running it behind moldings and in similar recesses, but not by placing the line underneath carpets or rugs. Twin conductor line may be fastened with a few very small tacks or brads driven through the insulation midway between the two conductors.

LINEARITY AND LINEARITY CONTROLS. — The word linearity refers to the positions of objects and lines on a reproduced test pattern or picture in relation to positions of the

same objects and lines in the original image. If all horizontal and vertical proportions are the same in the reproduction as in the original, the pattern or picture is linear. Otherwise it is non-linear. The most satisfactory check of linearity is observation of a reproduced test pattern. Non-linearity may be indicated in various ways. The intended center of the pattern or picture may be too high, too low, or too far to either side. There may be crowding in some areas and spreading in others. Lines which should be circles may be distorted.

Usually there are adjustable controls for correction of non-linearity. There may be one or more than one such control in either the horizontal or vertical sweep section, or in both sections. Some of these controls may affect chiefly the right side and others the left side, while some may affect chiefly the bottom and others the top of the pattern or picture. There

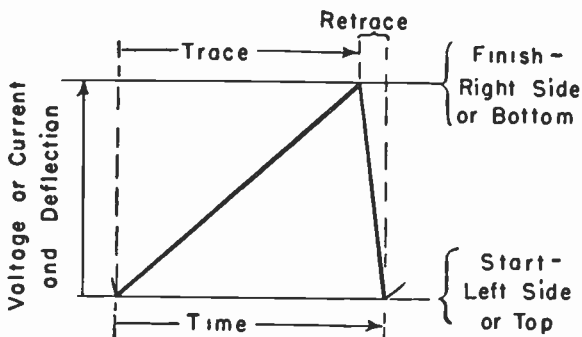

Fig. 69-1.—Relations of sawtooth wave slopes to deflections of the electron beam.

may be no controls marked specifically as linearity adjustments, the same purpose being served by drive controls or by peaking controls in some receivers. Linearity may be affected by adjustment of controls for width or height, for centering, and sometimes by adjustment of hold controls. These should be checked before changing the linearity adjustments. Always there is the possibility that the pattern from one station may be temporarily non-linear, so more than one pattern should be observed before changing adjustments.

Linearity or lack of it depends largely on the form of the sawtooth wave of voltage or current that deflects the picture tube beam. If the slope of the wave is a straight line, as in Fig. 69-1, the reproduction should be linear. During the time that sawtooth voltage or current increases, the beam is deflected from left to right or from top to bottom of the picture tube screen for a horizontal or a vertical trace. The rate of change of voltage or current should be constant in relation to time.

At the left in Fig. 69-2 the sawtooth is shown as rising too rapidly at the beginning. When half the time period for a horizontal trace or a vertical trace has elapsed, the deflection voltage or current will have gone through more than half its total increase and the beam will have been moved more than half the distance from left to right or from top to bottom of the mask area. At the left, the sawtooth rises too slowly at the beginning and too rapidly at the end. Now, by the end of half the time period for a horizontal or vertical trace, the

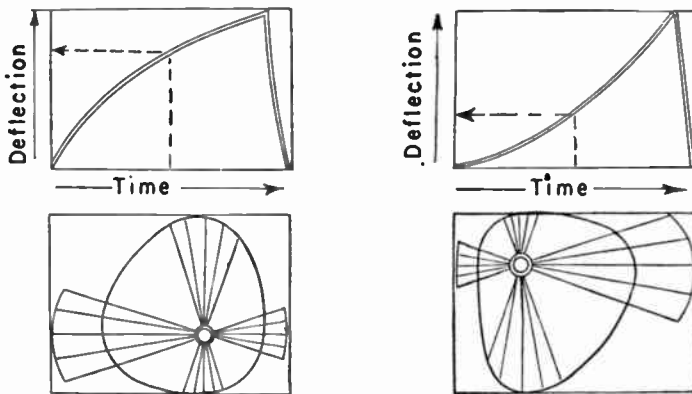

Fig. 69-2.—How curvatures of the sawtooth slope affect linearity of a pattern.

deflection voltage or current will not have gone through half its total change. The picture tube beam will not have been deflected far enough, and whatever should appear at the center of the screen actually will be too far up or too far to

the left, depending on whether the fault is in the vertical or horizontal sweep sections.

The sawtooth curve at the left in Fig. 69-2 is of nearly the same form as the charging curve for a capacitor subjected to a constant charging voltage. The sawtooth curve at the right is like the mutual characteristic for an amplifier tube having an excessively negative bias and working down near the lower bend of its characteristic. A common style of linearity control is based on balancing these opposite curvatures against each other to obtain a sawtooth curve with a straight slope. This control varies the resistance in series with the cathode of the sweep amplifier or deflection amplifier to change the grid bias and vary the points on the characteristic curve between which the tube operates.

Adjustment of amplifier bias to change the point of operation on the characteristic curve not only compensates for opposite curvature of a capacitor charge, but also for the similar opposite curvature due to inductance. A curve similar to that at the left in Fig. 69-2 would show the manner in which current increases in an inductance which is subjected to a constant voltage. Such effects on currents may occur in deflection transformers and deflection coils.

Non-linear reproduction with electrostatic deflection systems may be due to unequal outputs from the two amplifiers for horizontal deflection or the two for vertical deflection. In some receivers there is a linearity control in the voltage divider which feeds part of the plate or screen output of one amplifier to the grid of the other amplifier which operates as the inverter. Correction is made by altering the strength of sweep voltage fed to the inverter.

Fig. 69-3 shows connections for two types of linearity controls which may be used separately or in combination for horizontal magnetic deflection systems. One adjustment consists of a variable inductor in the line between the cathode of the damper tube and the primary winding of the sweep output transformer. In the article on *Dampers and Damping* is an explanation of the effect of this inductor and the capaci-

tors at its ends on voltage and current supplied to the sweep amplifier plate, also on the waveform of sawtooth current in the deflection coils. This adjustment affects the instant at which the damper tube becomes conductive, consequently affects the current waveform in the deflection coils. There is a phase shift in this linearity control which has some effect in altering the plate characteristics of the sweep amplifier tube and the curvature of the grid-voltage plate current characteristic.

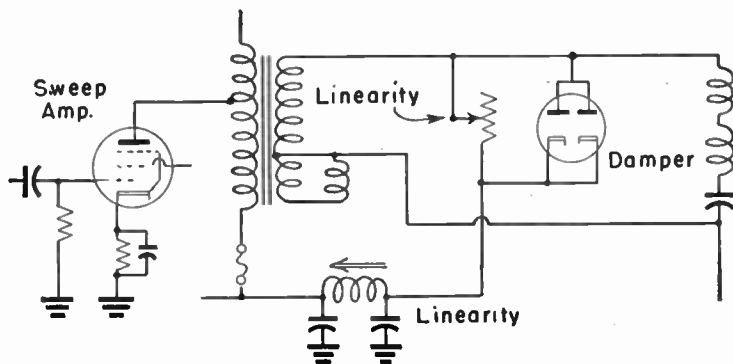

Fig. 69-3.—Horizontal linearity controls in the plate and cathode circuits of a damper tube.

Adjusting the linearity control inductor to lessen the inductance contracts the left-hand side of the pattern or picture while expanding the right-hand side and also the center to a slight extent. Increasing the control inductance has opposite effects, it expands the left-hand side of the pattern or picture, contracts the right-hand side, and slightly contracts the center.

The second linearity control shown by Fig. 69-3 is an adjustable resistor between plate and cathode of the damper tube. This resistor provides damping action during the period when the damper tube is non-conductive, also changes the rate of damper conduction or the period during which there is conduction. When the damper tube does conduct, and loads the deflection coil circuit to stop oscillation, the first cycle of oscillation decays at a rate determined by conduction through the damper. This rate must be such that the end of the decay

meets the beginning of a new current due to amplifier plate current flowing in the output transformer. Otherwise the trace or the sawtooth current will be non-linear.

Adjustment of this resistor shunted across the damper is changed only when no other linearity adjustments will produce a satisfactory pattern. When the resistor adjustment is changed it will be necessary to readjust any other linearity controls. Increasing the resistance makes the pattern wider, but all the widening effect is in the left-hand side and the center. Too little resistance will cause a white vertical edge or a bright narrow band to appear on the left-hand side of the pattern.

LOSSES, HIGH FREQUENCY. — In many types of circuits the energy losses are greater with alternating current than with direct current, and increase with frequency. The additional energy is considered a loss because it produces heat rather than doing anything useful. An equal loss of energy and production of heat might result from addition of resistance to a circuit. Consequently, the actual loss may be called high-frequency resistance or effective resistance or a-c resistance. This a-c resistance would not be the same as impedance, because impedance is the combined effect of reactance and d-c resistance in a circuit. The principal causes for high-frequency loss are mentioned in following paragraphs.

Dielectric loss or dielectric hysteresis occurs in dielectric materials subjected to an alternating electrostatic field. The electrons and the nucleus of atoms are displaced in opposite directions within the atoms. The displacements or strains reverse with alternations of the field. The result is dielectric heating.

Energy loss results from distributed capacitance in coils and circuit conductors when this capacitance resonates with coil or circuit inductance to cause oscillating currents at the resonant frequency of this capacitance and inductance, which ordinarily would not be the frequency for which the circuit is intentionally tuned. Heating and energy loss result from flow of the spurious oscillating currents in the conductor

resistance. There is no loss of energy in capacitance or inductance because all energy used for charging a capacitance and all energy used for producing a magnetic field around an inductance are returned to the circuit and source during discharge of the capacitance or collapse of the magnetic field.

Alternating current in any conductor causes self-induction or counter-emf in the conductor. This action is due to magnetic lines of force spreading outwardly from and contracting back into the conductor with alternations of current. The effect is least at the surface of the conductor, for metal at the surface is subjected only to magnetic lines from the interior, while metal inside is subjected to cutting by lines from both the center and outside. Because counter-emf is least at the surface of the conductor, the current tends to concentrate at the surface rather than flowing uniformly in all parts. The greater current density near the conductor surface causes increased heating and energy loss. This action is called *skin effect*.

Skin effect is worse in coils than in straight conductors. Loss due to this effect varies approximately with the square root of the frequency, and is serious at all frequencies in excess of about 3 megacycles. The effect is more pronounced in conductors of large diameter than in those of smaller diameter, because with larger diameter there is less surface area in proportion to the volume or the cross sectional area. Since the inner portion of a conductor is of little use at high frequencies, thin walled tubing may be used, or some highly conductive metal like silver may be plated on a core of other metal.

When alternating or varying lines of magnetic force cut through any conductive metal the cutting induces emf's and circulating currents in the metal. The currents are called *eddy currents* because they circle or eddy around the magnetic field lines. Flow of eddy currents in the resistance of the conductor wherein they are formed causes heating and energy loss. This loss increases with conductor resistance, so is greater in iron and steel than in metals such as copper and aluminum.

When magnetic cores such as used in coils and transformers are subjected to alternating magnetic fields the magnetic polarity of the atoms undergoes continual reversal. Energy is required for this magnetization first one way and then the other, and to destroy the magnetization in one polarity as the opposite polarity is established. Magnetic reversals lag behind the reversals of field lines. This lag is called magnetic hysteresis. The accompanying loss of energy is called a *hysteresis loss* or a *hysteretic loss*.

Energy loss does not always occur exclusively in the circuit wherein is the alternating current, it may occur in any nearby circuit or conductors or dielectrics. Magnetic fields around the current-carrying conductor may cause eddy currents in other conductors, or they may displace the currents in those other conductors due to an effect similar to skin effect. Energy wasted in the nearby parts must be furnished by the first current-carrying conductor and its circuit. Consequently the effect of high-frequency loss appears in this first circuit even though most of the heating appears somewhere else.

M

MAGNETIC CIRCUITS. — A magnetic circuit is a complete or closed path in which may act the magnetic force or lines of force produced by a permanent magnet or by a current-carrying winding. A magnetic circuit is like an electric circuit in several ways. Although nothing actually moves, the magnetic flux or magnetic lines of force are thought of as moving in the magnetic circuit, as current moves in the electric circuit. The permanent magnet or current-carrying winding furnishes magnetomotive force, which is analogous to electromotive force. Magnetic flux starts from one of these sources, passes through all the circuit, and returns to the source. Magnetic flux is opposed by reluctance, as electric current is opposed by resistance. Calculations for magnetic circuits cannot be so accurate as for electric circuits because flux cannot

be closely confined and because there is wide variation of reluctance with change in quantity of flux.

Except for leakage, flux is the same in all parts of a series magnetic circuit. Total reluctance is the sum of the reluctances in all the series parts. Flux is proportional to the ratio of magnetomotive force to reluctance, or to magnetomotive force divided by reluctance, just as electric current is proportional to electromotive force divided by resistance. The unit of flux is the line or the maxwell. One maxwell is equal to one line.

The unit of magnetomotive force from a current-carrying winding is the ampere-turn. Another unit is the gilbert, equal to 0.796 ampere-turn. The number of ampere-turns is equal to the product of number of winding turns and the number of amperes flowing in the winding. Magnetomotive forces add, like emf's, when there is more than one magnetic source in a circuit. There is drop of magnetomotive force in a magnetic circuit, just as there is drop of voltage or potential in an electric circuit.

Reluctance, like resistance, increases with the length of the circuit and decreases when there is greater cross sectional area. Reluctance is the same or has the same value in air, other gases, all liquids, all dielectrics and insulators, and in all metals and other solids except those classed as magnetic materials. Magnetic materials include iron, steel, alloys containing iron, and a few other special alloys which have the magnetic properties of attraction and repulsion. Nickel, cobalt, and gadolinium are weakly magnetic. In magnetic materials, especially in iron, steel, and iron alloys, the reluctance is only a small fraction of that in non-magnetic materials. If there is a gap in the iron or steel of a magnetic circuit the reluctance of the gap is so great compared with that of the iron or steel that the length of iron or steel in the circuit has practically no effect on quantity of flux.

The property of a material which determines the number of lines per square inch cross section for any given magnetomotive force per inch of length is called the permeability of

the material. The number of ampere-turns per inch is determined by dividing the total ampere-turns by the length of magnetic path in inches. This ratio is called magnetizing force. Its symbol is the capital letter **H**. The number of lines per square inch of cross section is called magnetic flux density. Its symbol is the capital letter **B**. The ratio B/H is the permeability of the material at the assumed working conditions.

MEASUREMENTS, HIGH-FREQUENCY. — Measurements of capacitance, inductance, reactance, effective resistance, and other circuit quantities existing at high frequencies are conveniently measured by resonance methods. A common type of setup is shown by Fig. 72-1. A signal generator coupled to the tested circuit through a loop or a small coil furnishes energy in the ranges of frequency where performance is of interest. A satisfactory resonance indicator is an electronic voltmeter equipped with a detector probe. With the meter connected across the tested circuit, as shown, resonance is indicated by maximum voltage. Another type of indicator may be made from a 20,000 ohms per volt meter, or any 50 to 100 microampere meter, with a crystal diode rectifier and resistance of about 5 megohms in series. See under *Meters, Rectifier*.

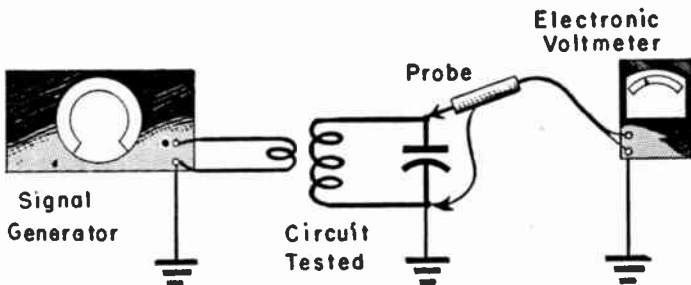

Fig. 72-1.—Determining resonance from maximum voltage developed in a tuned circuit.

The three quantities which enter into measurements are frequency, capacitance, and inductance. With any two of these known, the other may be computed. This means that an unknown inductance may be measured with a known capacitance

and generator frequency, or an unknown capacitance may be measured with a known inductance and frequency, or the resonant frequency may be determined for any combination of capacitance and inductance.

If the resonant circuit cannot be made up with inductance and capacitance in parallel, as illustrated, they may be connected in series with each other and with a fixed carbon or composition resistor of 5 to 10 ohms or more. The electronic voltmeter then is connected across the resistor. There will be maximum series current at resonance, and the voltmeter will give maximum reading.

Formulas for the various computations are as follows:

$$\text{Inductance, microhenrys} = \frac{25\ 530}{(\text{frequency, megacycles})^2 \times \text{micro-microfarads}}$$

$$\text{Capacitance, micro-microfarads} = \frac{25\ 530}{(\text{frequency, megacycles})^2 \times \text{microhenrys}}$$

$$\text{Frequency, megacycles} = \sqrt{\frac{25\ 530}{\text{micro-microfarads} \times \text{microhenrys}}}$$

In any of these formulas the frequency may be changed to kilocycles provided the capacitance is changed to microfarads in the same formula. The formulas apply alike to parallel resonance and series resonance.

Measured inductors or coils must be placed where there is a minimum of either other conductors or dielectrics in their fields. If the capacitor has a shield, ground the shield. Otherwise ground the rotor plates of an adjustable unit. If possible to use large capacitance do so, for then this known capacitance will largely overcome the effects of unknown stray and distributed capacitances. All leads and connections have appreciable capacitance and inductance, so all of them should be short and their positions and separations should not be altered during tests.

Use the weakest coupling from the signal generator which allows readable indications on the meter. Always retune to resonance after making any change whatever in any of the

parts or connections. Be sure to tune the generator either for fundamentals or harmonics in all parts of the same test, not to a fundamental one time and a harmonic the next time. If retuning the generator to some approximately integral multiple of the original frequency gives a meter reading, the origi-

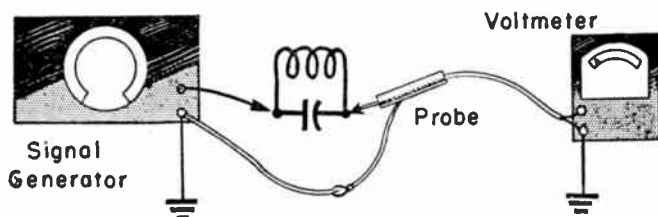

Fig. 72-2.—Determining resonance from impedance of a tuned circuit.

nal frequency is a fraction of the resonant frequency of the inductor-capacitor combination, and the tuned circuit is responding to a harmonic frequency from the generator. Always use the highest generator frequency at which there is a response from the tuned circuit and the resonance indicator.

Tests may be made without a coupling loop or coil by using the connections shown in Fig. 72-2. The high side of the signal generator is connected to one side of the resonant circuit. The opposite side of the resonant circuit is connected to the high side of the electronic voltmeter. The low sides of both generator and voltmeter are connected together and to ground, but not to the resonant circuit. With these connections the resonant circuit offers maximum impedance to current between generator and voltmeter at the resonant frequency. The generator is adjusted to the required frequency and either the capacitance or inductance of the resonant circuit is adjusted for minimum reading on the meter, or with any existing adjustment of capacitance and inductance the generator is tuned for minimum reading on the meter. The minimum reading indicates resonance.

MEASUREMENTS, HIGH VOLTAGE. — Potential differences between anodes or deflection plates and ground in popular types of television receivers range between 5,000 and 15,000

volts. Voltages so high as this may produce painful shocks and burns, and under some conditions may be dangerous to life. No part of any high-voltage circuit should be touched directly or with any tools except while the receiver is disconnected from the power line by withdrawal of the plug of the service cord from the wall receptacle. If it is necessary to work on or near a high-voltage circuit which is alive, only one hand should be used—with the other one kept in a pocket.

The greatest danger is with receivers using a high-voltage supply which rectifies at the line frequency of 60 cycles, for the relatively large filter capacitors in these systems charge with enough energy to give a serious shock. Flyback types and r-f oscillator types of high-voltage power supplies have much smaller filter capacitances and are designed with such poor voltage regulation as to drop the potential difference to a low value almost instantaneously when there is a short circuit or a low-resistance discharge path.

All parts of a power supply which are at high voltage, and above the chassis deck, are enclosed within a perforated metal shield. Removal of this shield or of any cover giving access to the power supply will separate a safety plug and jack or will open an interlock switch for disconnecting the power supply from the line. It is dangerous practice to block a switch closed or to connect a jumper across a plug and jack connection. The protected parts should be worked upon only while the interlock is open, and preferably with the line cord removed from the wall receptacle.

Filter capacitors should be discharged after the power is cut off. Both sides of filter capacitors should be discharged through a piece of insulated wire with one bared end touched first to chassis metal or B-minus and the other bared end then touched to first one and then the other terminal of the capacitor. The coating inside some picture tubes is one plate of a filter capacitance. After removal of the lead for the high-voltage anode the terminal on the picture tube should be grounded as described, and the free end of the lead should be grounded in order to discharge the filter capacitors.

Test connections to high voltage circuits should be made with spring clips or tack soldering only while power is disconnected. With connections completed, the power may be applied while taking readings or other observations. Then the power should be again disconnected while removing or changing the connections. If test connections must be made while the circuits are alive, the instrument cables should be types with high-voltage insulation and they should be fitted with high-voltage test prods which have ample insulation and barriers as protection against possible shock.

A moving coil voltmeter for high-voltage testing should have resistance of at least 10,000 ohms per volt, which will allow considerable error in indications, and preferably should be of the 20,000 ohms per volt type which draws 50 microamperes current at full scale. Total series resistance of the meter and any external multiplier should be at least 500 megohms.

Electronic voltmeters fitted with multiplier probes provide total resistance (meter plus multiplier) in the neighborhood of 1,000 megohms when multipliers are of such types as allow multiplying the indicated meter reading by 100. Then a full-scale range to 100 volts allows measuring up to 10,000 volts, a range of 300 volts allows measuring to 30,000 volts, and so on. Such a combination draws only about 10 microamperes from the measured circuit, and allows voltage readings which are very close to the actual working voltages without the meter connected.

METERS, ELECTRONIC VOLT. — An electronic voltmeter or vacuum tube voltmeter is a voltage measuring instrument whose resistance or impedance is so great that only negligible current or power is taken from the measured circuit. The high resistance or impedance of the instrument is due to the fact that potential difference to be measured is applied to the grid circuit of a negatively biased triode or pentode in the electronic voltmeter, while the rectified plate current or cathode current of the tube flows in a d-c moving coil meter calibrated to read voltage applied to the grid circuit.

Electronic voltmeters usually provide two or more ranges for voltage measurement. Full-scale reading on the lowest range most often is between 2.5 and 5 volts, with full-scale on the highest range as much as 1,000 volts or even more. The circuit of the more common types of instruments is arranged primarily for measurement of direct potential differences. Alternating potentials to be measured are applied to a rectifier whose d-c output voltage goes to the d-c measuring circuit of the instrument. Most electronic voltmeters have provision for use as an ohmmeter with a number of resistance ranges.

Electronic voltmeters have utilized a great variety of principles and many different methods of applying direct, alternating or rectified potential differences to the grid circuit of a

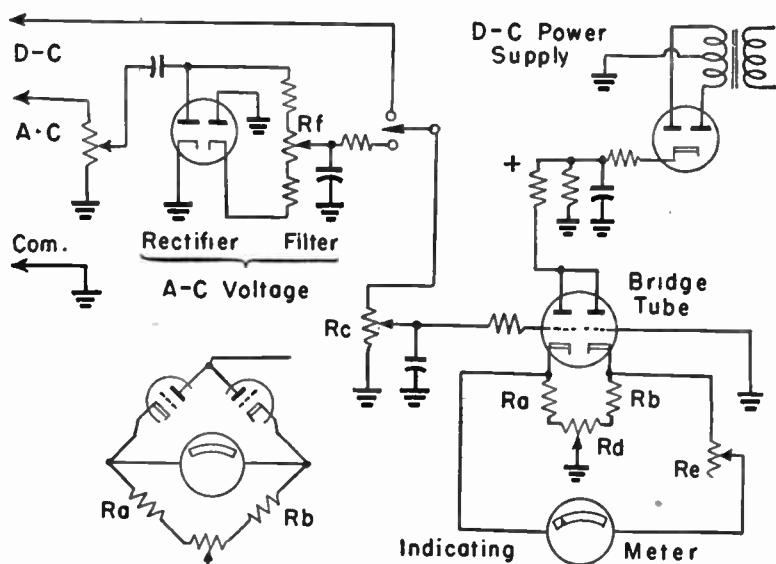

Fig. 74-1.—Typical circuits used in electronic voltmeters or vacuum tube voltmeters.

tube, and of measuring resulting changes of plate current. Fig. 74-1 illustrates features found in many present designs. The moving coil indicating meter is connected across a balanced bridge circuit whose electrical equivalent is shown at

the lower left in the diagram. Two of the bridge arms consist of resistors R_a and R_b . The other two arms are the two sections of the twin-triode bridge tube. The positive side of the d-c power supply is connected directly to the plates of the bridge tube, while the negative side connects through ground to resistors R_a and R_b .

A direct potential difference to be measured is applied between the left-hand grid of the bridge tube and ground through any conventional type of range control resistors, represented in simplified form at R_c in the diagram. The right-hand grid is grounded. With no potential difference applied to the grid-cathode circuit of the left-hand section, the zero adjustment potentiometer R_d is set for equal plate-cathode currents in the two sections of the bridge tube. Then there is no potential difference across the meter, and the meter reads zero. Resistor R_e is a calibration adjustment, of which there may be several in the complete instrument.

When potential difference to be measured is applied to the grid circuit of the left-hand section of the bridge tube, the bridge becomes unbalanced because this section then carries more or less current than the other section. Current equal to the difference of those in the two sections then flows in the indicating meter. Not shown in the diagram is a reversing switch usually installed for allowing the meter to read up scale whether d-c input to the instrument is positive or negative with reference to ground.

For measurement of alternating potentials in the range of power and audio frequencies, the a-c input to the instrument is rectified by the twin-diode rectifier at the upper left in Fig. 74-1. The d-c filtered output potential from this rectifier system is applied to the grid circuit of the bridge tube. The a-c balancing potentiometer R_f is for maintaining the pointer of the indicating meter at zero when changing from one voltage range to another. Radio-frequency voltages to be measured are rectified by a tube or a crystal diode mounted at the end of a cable long enough to bring the rectifier close to the point where measurement is desired, with the rectified voltage

brought through the cable to the bridge circuit of the electronic voltmeter. These accessories are described in the article on *Probes, Detector*.

The input resistance of an electronic voltmeter as used for d-c measurements consists of the total resistance in the voltage divider system which provides the several voltage ranges, plus a fixed resistance incorporated in the outer end of the test prod. This fixed resistance usually is something between 1 and 15 megohms, and the instrument resistance most often is on the order of 10 to 12 megohms.

Input impedance for alternating voltage measurements would vary with frequency. Instead of giving this impedance as a certain number of ohms it is specified as some certain number of megohms resistance, shunted with capacitance of some specified number of micro-microfarads. From the two values it is possible to compute approximate effective impedance for any frequency. The shunt capacitance lowers the input impedance very materially at high frequencies. The ratio between a power frequency and a frequency of 100 megacycles often is on the order of 500 to 1. A-c input resistances commonly are between 1 and 10 to 15 megohms, with shunting capacitances of 10 to 200 mmf. The input capacitance may be enough to detune any resonant circuit to which the instrument is connected. For precise measurement, the measured circuit sometimes is retuned to resonance while the meter is connected, then tuned back to the original settings after tests are completed.

Using the Electronic Voltmeter. — Although most electronic voltmeters are designed so that application of excessive voltage will not overload the indicating meter, it is well to avoid excessive voltage, just as with any other type of voltmeter. The instrument should be allowed to warm up for 5 minutes or more after it is turned on and before measurements are made. Shifting of zero during tests usually indicates too little preliminary warmup time. As a general rule, all voltages should be measured with reference to chassis ground or B-minus, with the ground terminal of the meter connected to chassis metal

or B-minus, the high side to the point whose potential is to be measured. To determine potential differences between two points when neither is ground or B-minus, make separate measurements to each point and then subtract voltages which are of the same sign or add those of opposite sign. That is, subtract when both voltages are positive or both negative, and add when one is positive and the other negative.

When measuring an alternating potential where a higher direct potential is present it is advisable to protect the meter with a series capacitor as shown at *C* in Fig. 74-2. Here the measurement is of a-f voltage in a plate circuit where the direct B+ voltage is relatively high. The series capacitor must have great enough capacitance that its reactance is reasonably low, say 5,000 to 10,000 ohms at most, and its d-c working voltage rating must be well above the maximum direct voltage in the tested circuit.

In an electronic voltmeter of usual design the basic measuring circuit operates from a direct potential whose value would be the equivalent of the peak potential of an alternating volt-

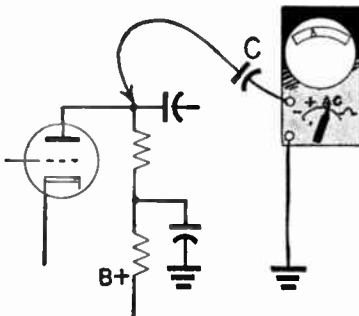

Fig. 74-2.—Protecting the voltmeter against high direct potential.

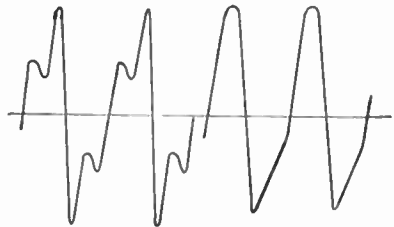

Fig. 74-3.—Waveforms which may cause errors in indications of electronic voltmeters.

age. When alternating potential actually is measured it is applied first to a rectifier, as in Fig. 74-1, whose direct voltage output goes to the measuring circuit. Although the measuring circuit is responding to peak potential, the dial of the indicating meter is calibrated and marked for effective or r-m-s

alternating voltage of sine wave form. If the measured voltage is not a sine wave, but of some other form such as that at the left in Fig. 74-3, the indicated voltage will not be the effective value of the actual wave. The wave at the left in Fig. 74-3 is symmetrical on its positive and negative alternations, and voltage indications will be the same no matter which way the meter leads are connected to the circuit in which is the measured voltage. The wave at the right is not symmetrical, and reversing the input connections will change the indicated voltage with most of the electronic voltmeters in common use.

The high input resistance and impedance of the electronic voltmeter suit this instrument for many measurements and tests which are difficult or impossible with other kinds of meters. D-c measurements may be made of grid bias voltage, of automatic volume control and automatic gain control voltages, and of r-f oscillator action. Audio-frequency measurements may be made of grid signal voltages, plate signal voltages, stage gains, and the instrument may be used as an output meter. With a detector probe it is possible to measure grid signal voltages, plate signal voltages, and stage gains in r-f, video i-f, and video amplifier sections, also to make resonance tests such as described in the section on *Measurements, High-frequency*. Other important uses include alignment of r-f oscillators, peaked couplers in i-f amplifiers, and sound discriminators or ratio detectors.

The value of a-f or r-f current in a circuit may be determined with fair accuracy from measurement of voltage drop across known resistances or reactances. The electronic voltmeter may be used to measure the voltage across any resistor which is in series with the circuit whose current is to be measured. Multiplying the indicated number of volts by 1,000 and dividing by the number of ohms resistance in the resistor then gives the number of milliamperes of current. The resistor should be a carbon or composition type, free from inductive reactance.

High-frequency current may be determined also by measuring the voltage drop across a capacitor of known capacitance

which is in series with the circuit. It is necessary to know the frequency in this circuit, and to compute the capacitive reactance in ohms. Current in milliamperes then is equal to the quotient of dividing 1,000 times the indicated voltage by the number of ohms capacitive reactance. It is assumed that the capacitor has no appreciable resistance or inductance, which is reasonable in the case of air dielectric and mica dielectric capacitors.

METERS, FREQUENCY.—The name frequency meter as used in the radio and television fields commonly refers to a device measuring radio frequencies, or sometimes for audio frequencies. The simplest frequency meters, usually called wavemeters, consist of a tunable capacitance-inductance circuit across which is connected some form of detector (such as a crystal diode) and an indicator which usually is a d-c current meter or headphones. The meter is held near the circuit whose frequency is to be measured and is tuned for maximum indication, whereupon the frequency is read from the tuning dial of the frequency meter. These instruments obtain all power for their operation from the measured circuit, hence are suitable for use only with transmitters or high-power oscillator circuits, not for receiver circuits.

Very-high and ultra-high frequencies often are measured by noting the distance between successive nodes or anti-nodes in standing waves which are excited in a length of open or short circuited air-insulated transmission line. This distance is equal to a half-wavelength. Frequency in megacycles is determined by dividing the number 5,905 by the half-wavelength distance in inches.

Heterodyne Frequency Meter:—Frequencies in low-powered circuits are conveniently measured with some form of heterodyne frequency meter. A frequency to be measured is fed to some form of detector along with an adjustable or variable frequency produced by an oscillator in the meter. The meter oscillator is tuned for zero beat from the detector, which acts as a mixer. The tuned frequency then is the same as the frequency being measured, and its value is read from the tun-

ing dial of the frequency meter. The action depends on heterodyning or beating of the known and unknown frequencies.

Fig. 75-1 shows in simplified form the essential parts of a heterodyne frequency meter. The oscillator may be of any type. Here it is an electron coupled Hartley type with tuning in the grid-plate circuit at the left and also in the isolated plate circuit at the right. Output coupling or load has little effect on frequency in the grid-plate circuit, because of electron

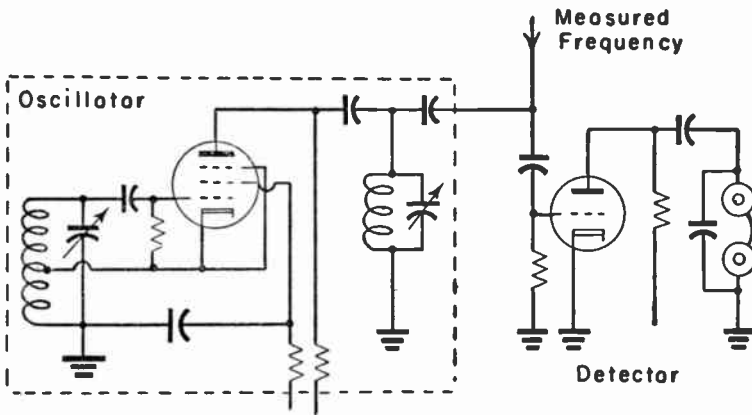

Fig. 75-1.—Essential parts of a heterodyne frequency meter or heterodyne detector.

coupling, and harmonic frequencies may be had from the plate circuit. The output of the meter oscillator and also the frequency to be measured are fed to the input of the grid-leak detector or mixer at the right-hand side of the diagram. The beat notes may be heard from headphones in the detector plate circuit.

The oscillator must have precise frequency calibration, and must be of such design and construction as to maintain its accuracy. The variable oscillator may be calibrated from a crystal controlled oscillator whose output is fed to the detector along with the output of the meter oscillator. A crystal oscillator supplying frequencies at various check points may be built into the instrument. Instead of connecting headphones into

energy in the meter oscillator circuit and a decrease of grid current. This decrease of grid current is indicated by the grid meter as a decrease or "dip." As either the meter oscillator or the measured circuit is tuned through resonance, the pointer of the meter will fall and then rise again. Approximate equality of resonant frequencies in oscillator and coupled circuit occurs at the minimum meter reading.

The pointer of the indicating meter will rise or fall to some extent as oscillator frequency is changed by rotation of the tuning dial, but this pointer movement will be steady or smooth. The resonance dip is a sharp drop and quick rise as the dial is turned through the point of resonant frequency match.

When the grid dip meter is of such size and construction as to make it possible, coupling usually is secured by bringing the oscillator coil close to some part of the measured circuit around which there is a magnetic field. Closest coupling and maximum meter indications are secured when field lines of the oscillator coil and of the measured circuit are parallel, or when the axes of the oscillator coil and a coupled coil are

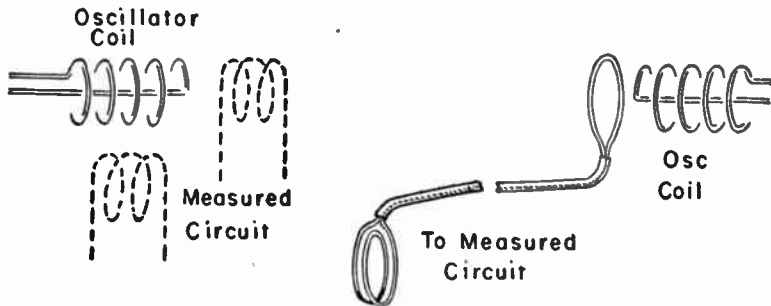

Fig. 76-2.—Methods of coupling between a grid dip meter and measured circuits.

parallel. These relations are shown at the left in Fig. 76-2. A link coupling may be used, as shown at the right. Transmission line of any kind may be used between the single turn coil at the oscillator end and a coil of two or three turns at the pickup end.

Coupling to the measured circuit should be as loose as allows readable dips on the indicating meter. Coupling which is too tight or close causes the meter pointer to snap back upward from its minimum reading. Excessively close coupling causes the meter to read too high. For example, when resonant frequency of a measured circuit actually is 20 mc the meter may indicate it as 21 or 22 mc with close coupling.

Using the Grid Dip Meter. — The measured circuit or part need not be carrying current, nor connected to any source of voltage or current when its resonant frequency is measured. This allows pretuning of transformers, couplers, takeoffs, traps, and other elements. When a pretuned unit is connected into its working circuit some final adjustment will be required because of stray capacitances and inductances, and tube capacitances, which add their effects.

If the measured circuit is operating and is carrying r-f voltages and currents, the grid dip meter is used similarly to a heterodyne frequency meter by connecting headphones into the jack of Fig. 76-1. There will be audible beat notes or whistles as the meter is tuned to the frequency of the measured circuit or as that circuit is tuned to the meter frequency, and there will be zero beat at matching of frequencies.

It is possible to measure the self-resonant frequencies of coils and chokes having distributed capacitance, or resistors, and of capacitors which are of inductive construction. The meter may be used also for locating parts which cause parasitic oscillation due to their own capacitance and inductance.

The grid dip meter may be used for measuring the resonant frequency and adjusting the lengths of half-wave dipole antennas by making a temporary wire connection across the center gap of the antenna and coupling the meter to this center connection. Similar measurements and length adjustments may be made on transmission lines and on resonant line stubs. With the meter coupled to the shorted end of a line which is open at the other end, as at *A* in Fig. 76-3, the resonant frequency corresponds to a quarter-wavelength. That is, the line is effectively a quarter-wavelength long at the frequency in-

indicated by the meter. If both ends of the line are shorted, as at *B*, the resonant frequency corresponds to a half-wavelength. For an open line, as at *C*, the meter is coupled to the center of the line. The resonant frequency corresponds to a half-wavelength.

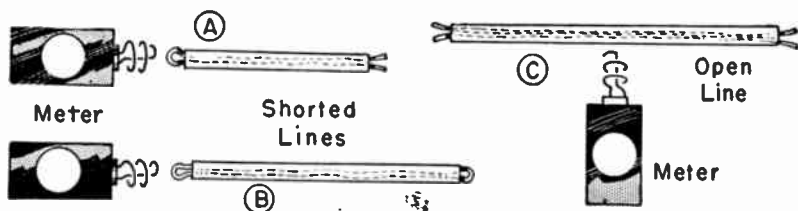

Fig. 76-3.—Coupling of grid dip meter to transmission line sections or stubs.

In making line measurements it is necessary to consider the velocity factor for the kind of line in use. The meter must be tuned to the lowest frequency at which there is a dip in order that this frequency may indicate effective wavelengths. There will be resonance and additional dips at odd multiples of the fundamental frequency, at 3 times, 5 times, and other odd multiples. These precautions apply also to measurements and adjustments of length with dipole antennas.

The grid dip meter may be used as the calibrated signal generator for measurements of capacitance and inductance as described in the article on *Measurements, High-frequency*. The meter may be used also as a signal generator for many other purposes, but since the meter oscillator coil is not shielded the signals will be radiated to everything within many feet of the instrument, and there will be no means for attenuating or otherwise regulating the output.

Amplitude modulation at audio frequencies or other frequencies may be applied to a signal from the grid dip meter by connecting the modulating voltage into the grid circuit by means of the phone jack of Fig. 76-1. For instance, the output of any type of audio generator or audio oscillator may be connected to this jack, and the audio note picked up by a receiver or any detector.

Among other uses, the grid dip meter may be used as a diode detector by cutting off plate voltage from the oscillator tube, but leaving the cathode heated. Signals picked up on the oscillator coil may be heard in the headphones. Some signal tracing may be done with the meter used thus. With no plate voltage, but with the cathode heated, the grid dip meter may be used as an absorption wavemeter by bringing the oscillator coil or coupling near an energized circuit. There will be a slight rise of the pointer on the indicating meter when the grid dip tuning is varied through the frequency of the coupled circuit.

METERS, RECTIFIER. — Voltmeters having useful readings at frequencies as high as 100 megacycles employ moving coil d-c microammeters in connection with crystal diode rectifiers. Half-wave rectifying circuits are shown at *A* and *B* of Fig. 77-1. A full-wave circuit is shown at *C*. Indicating meters are preferably of 50 to 100 micro-ampere range at full-scale. Calibra-

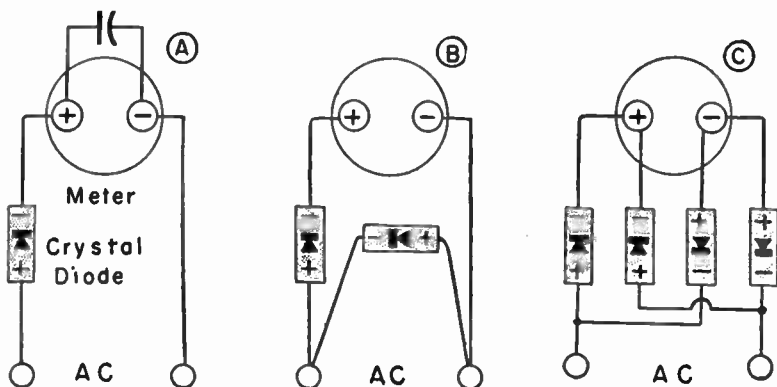

Fig. 77-1.—Connections of crystal diodes to d-c microammeters for measurements at high frequencies.

tion varies with the meter and the circuit. Scales are not linear with respect to current or voltage. Multiplier resistors for voltage measurement must be connected so that all current for all rectifiers flows in these resistors. With connections of Fig. 77-1 a multiplier resistor could be between the negative

terminal of the meter and one of the a-c terminals at *A*, but in the other diagrams the multiplier would have to be in series with one of the a-c terminals to protect all the rectifiers.

METERS, THERMOCOUPLE. — Two dissimilar metals in contact form a thermocouple which, when heated by flow of alternating current, produces a direct emf and current which may be used to actuate a moving coil meter. The meter is calibrated in terms of alternating voltage applied to the heater or of alternating current flowing in the heater. Because the thermocouple meter utilizes only the heating effect of applied alternating current these instruments may be made of high accuracy up to frequencies somewhat less than 100 mc in full-scale ranges of 1 to 5 milliamperes and up to several hundred megacycles in full scale ranges of 100 to 200 milliamperes or more. Indications are independent of waveform, always showing effective values.

Thermocouple voltmeters are quite insensitive, having resistances of 125 to 500 ohms per volt in order to permit enough current for heating. Because developed heat and indicated current or voltage are proportional to the square of applied current in the thermocouple, the scale is crowded at the low end.

METRIC CONVERSIONS. — Multiply the following metric quantities by the listed factors to determine equivalent quantities in English units.

Centimeters	×	0.3937	=	inches
Cubic centimeters	×	0.06102	=	cubic inches
Grams	×	0.03527	=	ounces
Liters	×	61.02	=	cubic inches
Liters	×	1.057	=	quarts
Meters	×	3.2808	=	feet
Meters	×	39.37	=	inches
Millimeters	×	0.03937	=	inches
Square centimeters	×	0.1550	=	square inches
Square millimeters	×	0.00155	=	square inches

To convert centigrade temperature to equivalent Fahrenheit temperature proceed thus:

$(1.8 \times \text{centigrade degrees}) + 32^\circ = \text{Fahr. degs.}$

As an example, convert -10° C. to equivalent $^\circ \text{F.}$

$(1.8 \times -10) = -18^\circ$

$-18^\circ + 32^\circ = +14^\circ \text{ F.}$

MIXERS. — A mixer is a tube, or sometimes a crystal diode, in which the frequencies of the carrier signals and the r-f oscillator combine to produce frequencies among which there is the beat frequency that becomes the intermediate frequency for the receiver. The mixer in broadcast sound receivers usually is combined with the r-f oscillator in the converter tube, but in television receivers most often is a separate tube or a separate section of a twin tube. The mixer sometimes is called the first detector, because it acts to rectify or partially rectify the frequencies applied to it.

In the article on *Frequencies, beat* it is shown that two voltages of different frequencies put into the same circuit combine in such manner as to produce peak amplitudes of resultant voltage or current when the two voltages are in phase, and to produce zero amplitude when they are of opposite phase. These peak and zero amplitudes occur when the two original voltages have equal amplitudes. Ordinarily the two input amplitudes are different and the result is not zero when the voltages are of opposite phase.

Fig. 80-1 illustrates the heterodyne action with incoming signal voltage of lower frequency and also of less amplitude than the voltage from the local r-f oscillator. These are the conditions usually obtaining in television receivers. The combined voltage is shown at the bottom of the diagram. In this combined voltage there are instants of maximum amplitude at *A*, *B*, and *C* when signal and oscillator voltages are in phase. There are instants of minimum amplitude at *D* and *E* when signal and oscillator voltages are of opposite phase. Maximum amplitudes are equal to the sum of the amplitudes of signal and oscillator voltages, while minimum amplitudes are equal to the difference. Oscillator voltage is modulated by signal voltage.

The resulting combination voltage varies in amplitude, but still is at a frequency in the carrier signal or oscillator range. This combination voltage acts on the mixer grid. The mixer is negatively biased to a degree which makes it operate as a

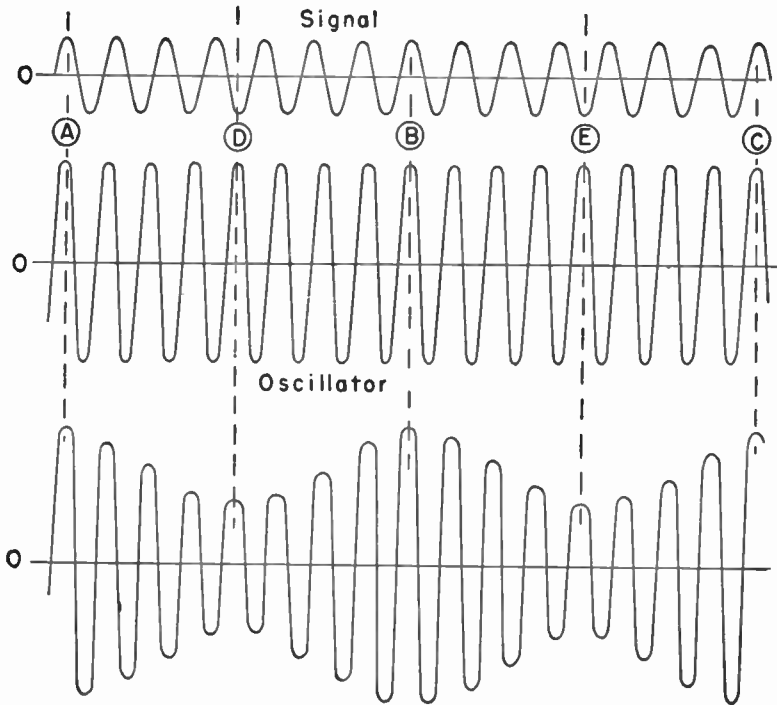

Fig. 80-1.—How signal and oscillator frequencies combine with amplitude variations which furnish a beat frequency when rectified.

detector, with the grid signal voltages working down on the lower curve of the mutual characteristic. The bias would be almost that for plate current cutoff. Oscillator voltage is held to a value such that the sum of oscillator and signal voltages, at peak amplitudes, will not exceed the bias and cause grid current to flow. Plate current flows during positive alternations of oscillator voltage, but during very little if any of the negative alternations. This is rectification or detection. The

average value of plate current then varies according to the average of alternations above (or below) the zero line at the bottom of Fig. 80-1.

One cycle of the frequency of average change in plate current would extend from *A* to *B* or from *B* to *C* in Fig. 80-1. During the time represented by the diagram there are two such cycles, and were the time to be one second the beat frequency in the mixer plate circuit would be two cycles per second. In the signal wave at the top are 14 cycles, and in the oscillator wave are 16 cycles. The difference is the beat frequency of 2 cycles. The difference frequency is selected as the intermediate frequency by tuning the i-f transformers or couplers to this frequency. In the mixer output there are also the oscillator frequency, the signal frequency, a frequency equal to their sum, and still other frequencies formed by harmonics of the oscillator frequency.

Conversion transconductance of a mixer is the ratio of i-f signal voltage in the plate circuit to carrier frequency signal voltage applied to the grid circuit. The value is specified in micromhos, which are equivalent to microamperes of i-f plate current per volt of r-f signal on the grid. Conversion transconductance of a triode or pentode used as a mixer is usually about one-third or less of the grid-plate transconductance of the same tube used as an amplifier.

Conversion gain is the voltage gain between signal voltage at the grid of the mixer tube and signal voltage delivered to the i-f amplifier, usually measured at the grid input of the first i-f amplifier. The gain is the ratio of i-f output voltage to r-f signal input voltage.

MODULATION, AMPLITUDE. — Modulation is a variation of some characteristic of a carrier wave by means of a signal which represents or is derived from sounds, pictures, or other intelligence to be transmitted. Present methods of modulation include variation of carrier amplitude, frequency, or phase. The principle of amplitude modulation is shown by Fig. 81-1. At the top of the diagram is represented the modulating signal in the form of an approximate sine wave of voltage. Any other

simple or complex signal waveform might be used. At the lower left is represented the unmodulated carrier voltage, which is of constant frequency and constant amplitude. The signal voltage is combined with the carrier voltage to increase and decrease the amplitude of the carrier without altering its frequency.

Not clearly evident from the conventional diagram of Fig. 81-1 is the fact that in the modulated carrier there are at any instant a total of three frequencies. One is the frequency of

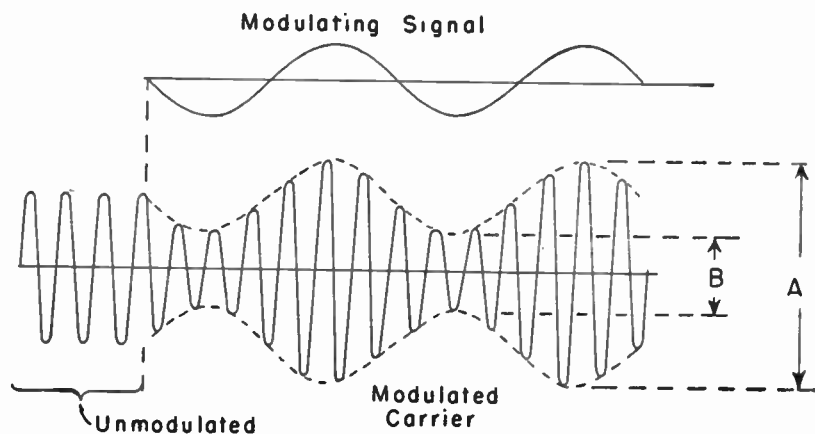

Fig. 81-1.—The principle of amplitude modulation.

the unmodulated carrier, a second is this frequency plus the instantaneous modulating frequency, and the third is the unmodulated frequency minus the instantaneous modulating frequency. Thus the transmission becomes a band of frequencies extending below and above the unmodulated carrier frequency by amounts equal to the maximum modulating frequency being used. Amplifiers must be capable of handling this entire band of frequencies.

Percentage of modulation may be determined from values of maximum and minimum voltages in the modulated carrier, these values being marked respectively *A* and *B* in the diagram.

$$\text{Percentage modulation} = 100 \times \frac{A - B}{A + B}$$

Amplitude modulation is used for transmission of picture and synchronizing signals in television, for standard broadcast and international shortwave broadcast, and for most other purposes. An amplitude-modulated carrier may be demodulated for recovery of the signal by any detector which acts as a rectifier. This class includes diode detectors of both electronic (tube) and crystal types, also grid-leak detectors and plate rectification detectors.

MODULATION, FREQUENCY. — The principle of frequency modulation of a carrier wave or carrier voltage is illustrated by Fig. 82-1. The unmodulated carrier, shown at the left, is of constant frequency and constant amplitude. The modulating signal, here shown as a sine wave voltage, may be of any waveform. This modulating signal is used to cause variations of reactance which change the frequency of the carrier in accordance with amplitude and phase or polarity of the signal. Frequency of the unmodulated carrier may be called the center frequency. At each change between maximum and minimum frequencies the modulated carrier frequency passes through this center value, at C-C-C in the diagram. The modulated carrier remains of constant amplitude so far as effects of the modulating signal are concerned, although the amplitude may be varied by effects of interference after leaving the transmitter.

The change of frequency, from the center frequency to either the maximum or minimum frequency, is called *frequency deviation* or just deviation. Deviation is not the total change as measured from maximum to minimum. Deviation is proportional to amplitude of the modulating signal. If that signal is for sound or is an audio-frequency signal, the extent of deviation is proportional to strength or volume of sound. The greater the sound volume, or the stronger the modulating signal as measured in any manner, the greater is the deviation or the greater is the change of frequency away from the center frequency.

Frequency modulation is used for television sound, for sound programs accompanying the pictures. Maximum devia-

tion for television sound is 25 kilocycles above or below the center frequency. Frequency modulation is used also for f-m broadcasting of sound in carrier channels between 88 and 108 megacycles. For this class of service the maximum deviation is 75 kilocycles. These maximum values of deviation correspond to 100 per cent modulation. There are no electrical or

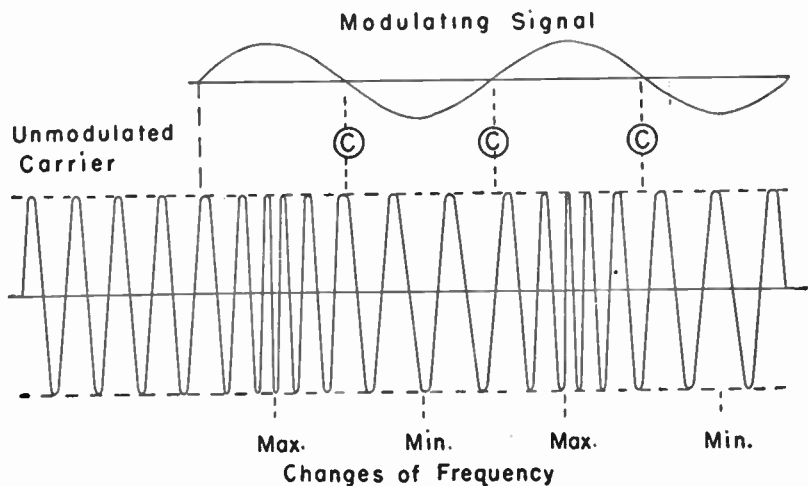

Fig. 82-1.—The principle of frequency modulation.

physical reasons why deviations might not be greater, or less. The limits mentioned have been agreed upon for the respective classes of service.

Modulation frequency is the number of times per second that the frequency goes through a complete change, as from a maximum through a minimum and back to the maximum. Each such complete change occurs during one complete cycle of the modulating frequency, as is apparent in Fig. 82-1. Consequently, the modulation frequency of the frequency-modulated signal is the same as the frequency of the modulating signal. With a sound signal the modulation frequency would correspond to frequency or pitch of the sound. The higher the sound frequency the higher will be the modulation frequency. Modulation frequency and deviation are entirely independent of each other.

Frequency-modulated signals are demodulated or detected by discriminators and ratio detectors. Limiters are used to remove amplitude modulation which may have been unintentionally added to the frequency modulation during transmission. There are articles describing *Discriminators, Detector, ratio, and Limiters, f-m sound*. The chief advantage of using frequency modulation for sound transmission and reception is its insensitivity to static and electrical interference. These, and most other forms of interference with sound transmission, tend to produce amplitude modulation rather than frequency changes.

MODULATION, PHASE. — With phase modulation of a carrier voltage or current the modulating signal is used to advance or retard the phase of the carrier with reference to the unmodulated carrier. The idea is illustrated in an elementary way by Fig. 83-1 where the unmodulated carrier in its relation to time is represented by the broken-line curve, with portions advanced and retarded in phase represented by full-line curves.

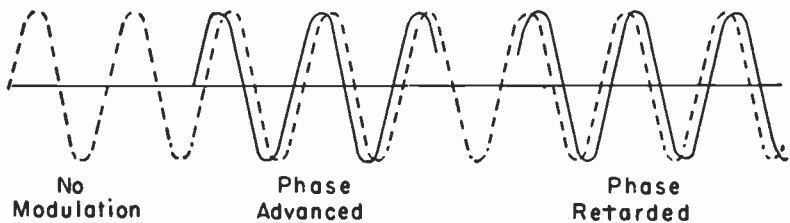

Fig. 83-1.—Phase changes for phase modulation.

The phase is shifted at the transmitter by circuits causing instantaneous lead and lag. Change of phase is proportional to amplitude of the modulating signal.

Inspection of the diagram will show that there must be an increase of frequency during the period in which phase is advanced, because the waves are compressed in time, and there must be a decrease of frequency while phase is being retarded. However, with completion of a phase change, the frequency returns to its former value. Change of phase in relation to the unmodulated carrier is measured in degrees of

the cycle, and is called phase deviation. Frequency of the modulating signal determines the number of phase changes per second. Phase modulation is at present used chiefly for experimental transmission and reception.

MULTIPLIERS, FREQUENCY. — A frequency multiplier consists of one or more amplifying stages with tuned plate circuits operated in such manner as to have distortion and strong harmonic frequencies in the plate circuit, one of these harmonics being taken as the output.

A frequency multiplier tube is biased nearly to plate current cutoff or sometimes just beyond cutoff when no signal is on the grid. The plate circuit then is tuned to the second or third harmonic of the frequency applied to the grid circuit. Such tuning of the plate circuit provides high impedance and high voltage drop (output voltage) for the tuned harmonic frequency. The fundamental and unwanted harmonics are bypassed to ground. With grid bias made somewhat more negative than for plate current cutoff the third harmonic is fairly strong, although much weaker than the second. Still higher harmonic frequencies may be obtained from the plate circuit, but they provide little power. Push-pull connections sometimes are used for frequency tripling, since the push-pull amplifier suppresses the second harmonic and provides fairly efficient operation on the third.

Frequency doublers and triplers often are used to follow a crystal controlled oscillator where the final output frequency must be higher than can be directly controlled by crystals of practicable thickness. Frequency doublers often are used in cascade; two stages then giving four times the original frequency, and three stages giving eight times the frequency.

MULTIPLIERS, VOLTAGE. — Transformerless receivers often employ voltage doubler rectifier systems which supply for plate and screen circuits a d-c voltage approximately double the effective a-c voltage from the power line. Voltage doubler circuits may employ electronic tube rectifiers, often twin tubes with two plates and two cathodes in one envelope, or they

may use pairs of selenium rectifiers. The high output voltage is obtained by allowing two or more capacitors to charge alternately during opposite half-cycles of line voltage to potential differences equal very nearly to peaks of the a-c line voltage. These capacitors then are discharged in series to the load.

A circuit commonly used for full-wave voltage doubling is shown by Fig. 85-1. Rectifiers *A* and *B* may be the two sections of a rectifier-doubler tube, or two electronic rectifiers, or two selenium rectifiers. The two capacitors which take part in the doubling action are marked *A* and *B*. These two capacitors,

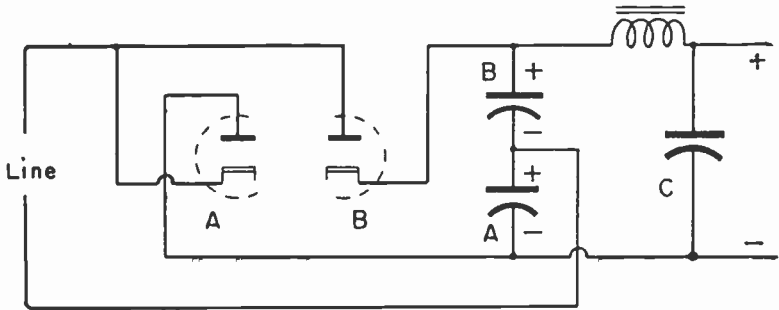

Fig. 85-1.—Connections for full-wave voltage doubler.

in combination with the choke and capacitor *C*, form a power supply filter to which the plate, screen, and biasing loads are connected at the positive and negative output terminals on the right. One side of the a-c line is connected to the cathode of rectifier *A* and to the plate or anode of rectifier *B*. The other side of the line is connected to a point between the two doubler capacitors.

When the upper end of the line is negative, electron flow through rectifier *A* charges capacitor *A* in the polarity shown, while electron flow from this capacitor goes to the lower positive side of the line. When line polarity reversed, electron flow through rectifier *B* charges capacitor *B* in the marked polarity. These two capacitors are in series with each other

across the output. Their polarities are in such relation that the voltage across the output is the sum of the capacitor voltages.

If no current were being drawn from this rectifier-filter system, the capacitors *A* and *B* would charge to the peaks of line voltage or to about 1.4 times the effective line voltage. Then the sum of the capacitor voltages would be about 2.8 times the effective line voltage. Actual output voltage becomes less when current is being supplied to external loads at the same time the capacitors are being charged from the line.

Both alternations of each a-c cycle are rectified, so ripple frequency from the filter output is twice the line frequency; for example, is 120 cycles per second on a 60-cycle line. To provide fairly high d-c output voltage and satisfactory voltage regulation, the capacitances at *A* and *B* usually are something between 16 and 32 mf, with still greater capacitance at *C*. When the circuit of Fig. 85-1 is used with high-voltage filament-cathode rectifier tubes, each of the filaments must be heated from a separately insulated secondary winding on the power transformer.

No direct or conductive ground connections may be made to either the positive or the negative output sides of the voltage multiplier system. This is because one of the line wires always is grounded in the building circuits, and this line ground extends either to the cathode of rectifier *A* and the plate or anode of rectifier *B*, or else to the connection between capacitors *A* and *B*. A ground on either side of the output would short circuit either a capacitor or a rectifier. Radio-frequency grounds are made through capacitors of small capacitance, which then are in shunt with a doubler capacitor or a rectifier.

Voltage doublers described elsewhere for use with flyback or pulse types of high-voltage supplies in television receivers are designed somewhat differently than the system just explained, this because current to those doubler systems is pulsating rather than alternating.

N

NOISE, RECEIVER. — Noise may result not only from external interference but also from many causes within the receiver itself. Many of the internal causes for noise are quite easily corrected. These include looseness, dirt, or corrosion at terminal connections, at contacts for band switches, in tuning capacitors or trimmers, and especially in adjustable potentiometers or rheostats. Where it is necessary for an adjustable resistor to carry only alternating current, and where it is also carrying direct current, noisy operation sometimes is prevented by using a series capacitor to block out the direct current.

Internal noise results also from leaky insulation or leaky capacitors, from tubes which are microphonic or which have loose elements, and from loose fastenings for shields or any other parts in which there may be electrostatic or magnetic fields. Noise results from tubes of poor quality, due to internal leakage, secondary emission, and gas effects.

An effect called thermal noise results from motions of free electrons within resistors and all conductors, even when there is no current. The random movements of electrons balance to leave no net flow or current in either direction, but there are local potential differences which cause noise when greatly amplified. The thermal noise increases with temperature and with resistance of the parts in which it originates. The effect becomes evident as a hissing sound.

Another effect, called tube noise, results from slight irregularities of the electron stream in even the best of tubes. Tube noise is lessened in tubes capable of providing large emission from the cathode in comparison with actual plate current, so that there is no emission limiting but only space charge limiting of plate current. Tube noise is lessened also by high values of transconductance in comparison with the plate current. The most severe kind of tube noise is called shot effect, which may cause popping or sputtering noises. In tubes designed especially for television all precautions

have been taken to lessen the tube noise. This is necessary because the small values of stage gain in wide band amplifiers limit the signal strength and leave tube noise more prominent.

Thermal noise and tube noise ordinarily extend throughout the entire band of frequencies which are amplified. Highly selective circuits having good amplification tend to lessen noise because they react only to the portion of noise voltage included within the range of amplified frequencies, whereas non-selective circuits would bring in a greater total noise voltage while still amplifying only the same signal. Noise voltages always are amplified by any amplifier which will amplify a desired signal. When tuning a sound receiver from one station to another, there is a great increase of noise (hiss) if there is automatic volume control allowing increased gain as signal strength drops off.

It is most important to reduce tube and circuit noise in the first stage of any amplifier. Here the desired signal is relatively weak, and may be almost completely obliterated by strong noise. If, however, the noise level in the first stage is low in relation to signal strength, equal amplification of both in following stages will not permit overemphasis of the noise.

In any receiver or amplifier there is generation of noise voltages, and these voltages will be amplified from stage to stage. The best way of obtaining the highest possible ratio of signal to noise at the output is to increase signal strength at the input. Signal input is improved by careful attention to selection and installation of the antenna and transmission line. Unless the input signal is strong enough to override the internal noise generated in the first couplings and amplifying stages it will be impossible to have good reproduction of either pictures or sound. All noise effects which would mar the reproduction of voice and music from a sound receiver will have equally bad effects on reproduction of pictures in a television receiver.



OHMMETERS. — At the left in Fig. 87-1 is shown the elementary circuit for an ohmmeter designed for connection of the measured resistance in series with the indicating meter of the instrument. The unknown resistance is connected across terminals R_x . The current source may be a battery or any rectified d-c supply. Change of source voltage is compensated for by an adjustable shunt resistance across the meter. With the R_x terminals shorted together, the meter shunt is adjusted to bring the pointer to zero. With this style of ohmmeter, zero measured resistance allows full current, and deflection of the meter pointer all the way to the right. Maximum or infinite measured resistance allows no current, and the meter pointer remains at the left.

Instead of an adjustable resistance shunt for zero setting, the indicating meter may be equipped with a magnetic shunt, or the calibrating resistance in series with meter and source

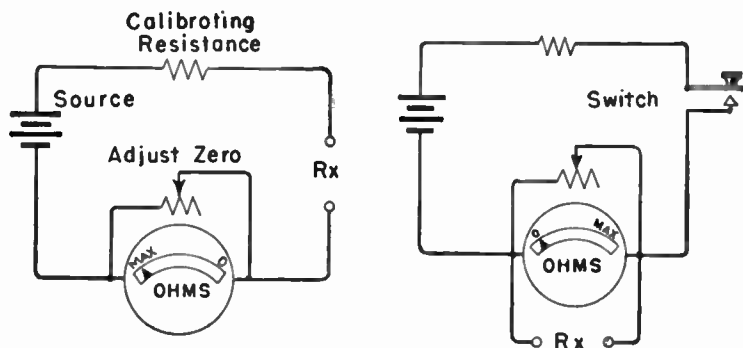

Fig. 87-1.—Series resistance and shunt resistance types of ohmmeters.

may be adjustable. The total internal resistance of the ohmmeter is the sum of the resistances of the meter as shunted, of the calibrating resistance, and of the source. Relations of internal resistance, the source voltage, and the full-scale current of the indicating meter is as follows:

$$\frac{\text{Source volts}}{\text{Full-scale milliamperes}} = \frac{\text{full-scale milliamperes} \times \text{internal resistance, ohms}}{1000}$$

$$\frac{\text{Full-scale milliamperes}}{\text{Source volts}} = \frac{1000 \times \text{source volts}}{\text{internal resistance, ohms}}$$

There is half-scale or mid-scale deflection of the meter pointer when the measured resistance connected across R_x terminals is equal to the internal resistance of the instrument.

The diagram at the right in Fig. 87-1 shows the elementary form of connections for an ohmmeter with which the measured resistance is connected across the terminals of the indicating meter, thereby acting as a shunt on the meter. Zero measured resistance leaves the meter pointer at the left, since all source current then goes through the measured resistance. With infinite measured resistance, all current flows through the indicating meter and its pointer moves to the right. The instrument circuit is closed by a switch only while measurements are being made, since otherwise there would be continual current drain on the source.

OSCILLATORS. — An oscillator, as used in radio and television receivers, consists of an electronic tube in a circuit which produces alternating currents from direct-current power. Most oscillator circuits include capacitance and inductance whose resonant frequency is the frequency of the alternating current. Energy oscillates back and forth between the capacitance and inductance as the current reverses. Some oscillator circuits include capacitance and resistance, rather than capacitance and inductance. Then the oscillating or alternating frequency is inversely proportional to the capacitive time constant.

To have sustained oscillation it is necessary to compensate for energy losses in the oscillatory circuits. In what are called feedback oscillators, losses in the grid circuit are replaced by energy fed back from the plate circuit. In this group are inductive feedback oscillators and capacitive feedback oscillators, wherein feedback is respectively through inductive coupling and through capacitance. Less common are negative resistance oscillators in which negative resistance de-

veloped between plate and cathode of a tetrode tube balances the effective resistance of the oscillatory plate circuit.

So long as circuit losses are balanced by feedback or negative resistance these losses no longer are effective in limiting the oscillating current. Limiting usually results from using plate, screen, and bias voltages with which there is plate current saturation before undesirable values are reached during the half-cycle in which the grid becomes positive. There is plate current cutoff during the negative half-cycle.

At frequencies up to a few megacycles both triodes and pentodes are used as oscillator tubes, with pentodes favored when it is desired to limit the feedback which may occur through the grid-plate capacitance of the tube. Triodes are favored for r-f oscillators operating in the carrier frequency range. The grid-plate capacitance of a triode often is part of the resonating capacitance for the oscillator circuit. With any type of tube, the same characteristics which are desirable for amplification are desirable also for oscillation.

OSCILLATORS, BEAT-FREQUENCY. — A beat-frequency oscillator consists of two separate oscillators whose frequencies beat together to produce an output frequency equal to the difference. Beat-frequency oscillators are used in testing instruments producing audio frequencies in a range usually extending from 20 to 20,000 cycles, also in types producing radio frequencies up to about 5 megacycles.

The general scheme of connections is shown by Fig. 89-1. The two oscillators at the left are represented as tuned plate types with tickler feedback, but any of various types may be used. Frequency of the upper variable oscillator is tuned by capacitor C_t in obtaining desired beat frequencies. An initial setting for the frequency of the lower fixed oscillator is made with capacitor C_a . This setting is used to bring both oscillators to the same frequency, and to zero beat, when the instrument dial shows zero output frequency.

Outputs of the two oscillators may be fed together to any type of mixer tube, but to lessen the tendency of one oscillator to pull into step with the other when approaching zero

beat, it is common practice to use a pentagrid mixer as shown in the diagram. Each of the oscillators is connected to one of the control grids of the mixer tube.

The output of the mixer contains not only the desired beat frequency or difference frequency, but also the two original frequencies, the sum frequency, and many harmonics. For a reasonably pure output from the instrument it is

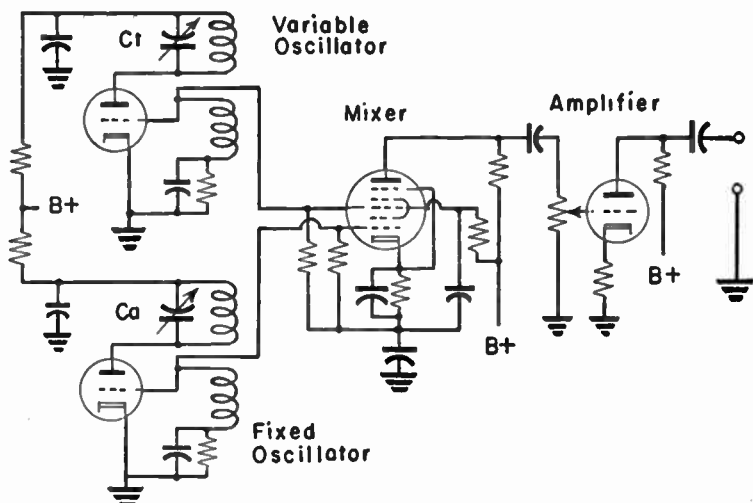

Fig. 89-1.—Circuits in one type of beat-frequency oscillator.

necessary to filter the mixer output. Usually the mixer is followed by an amplifier stage which serves as a filter and at the same time strengthens the rather weak signal from the mixer.

The variable and fixed oscillators must be well shielded from each other, and care used to eliminate common resistances, inductances, and capacitances in the two oscillator circuits. It is important that the only coupling be at the mixer. The variable oscillator may be tuned either higher or lower than the fixed oscillator to provide a desired beat frequency. The fixed oscillator sometimes is crystal controlled. Adjustment for zero beat frequency then must be provided in the circuit of the variable oscillator.

A small percentage change in frequency of the variable oscillator, or either oscillator, causes a relatively large percentage change in beat frequency and instrument output frequency. For example, with one oscillator at 100,000 cycles and the other at 105,000 cycles for an output frequency of 5,000 cycles, a change of 1,000 cycles or 1 per cent in the first oscillator frequency will change the output by 1,000 cycles, which is 20 per cent of the original output frequency. All precautions are taken to prevent greater or less temperature drift in the frequency of one oscillator than in the other one. If both oscillators drift higher or lower together there will be little or no change in output frequency.

OSCILLATOR, ELECTRON COUPLED. — An electron coupled oscillator is any radio-frequency oscillator with which the only intentional coupling between the tuned oscillating circuit and the output or load is by means of variations in the electron stream within the oscillator tube. The purpose is to prevent the capacitance and inductance of the load from reacting on the oscillator circuit to alter its tuned frequency.

Fig. 90-1 shows a Hartley oscillator arranged for electron coupling. Other types of oscillators may be used in a similar

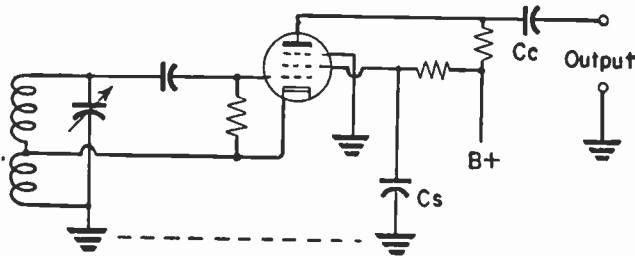

Fig. 90-1.—An electron coupled Hartley oscillator.

way. The tube is a pentode with its suppressor grounded to act as an r-f shield between the screen and the plate. The portion of the tube used as an oscillator consists of the screen, the control grid, and the cathode, with the screen acting as the oscillator plate. The screen (oscillator plate) circuit is completed through capacitor C_s , the ground connections,

the lower part of the tuned coil at the left, and to the cathode of the tube.

The plate is operated at a higher voltage than the screen. Electron flow from cathode to plate, and through the output and load, must pass through the screen. The screen-to-cathode potential is varying at the oscillating frequency and this varying screen potential modulates the plate current or output current at the oscillating frequency. The load has little effect on oscillation frequency because, in any pentode, changes of plate voltage have little effect on plate current, which is controlled almost entirely by screen voltage.

Electron coupled oscillators often are used in signal generators. The r-f output of such a generator may be modulated with audio frequency by putting the a-f voltage into the suppressor of the oscillator tube. That is, instead of connecting the suppressor to ground, as in the diagram, it is connected through some source of a-f modulating voltage and thence to ground.

OSCILLATORS, FEEDBACK. — Feedback oscillators include many types, but all are of the general class in which the tube acts as an amplifier of alternating voltages caused to appear in its grid circuit, and in which energy or power dissipated in the grid circuit is replaced by power fed back from the plate circuit of the oscillator tube. With circuit losses thus compensated for, oscillation will continue at the resonant frequency of capacitance and inductance in either the plate circuit or the grid circuit. Oscillation is begun in the first place by any change, however small, in plate current or voltage. Even the changes due to normal instantaneous variations of emission are enough to cause feedback and introduce a change of voltage into the grid circuit. Then oscillations build up to maximum value in a brief fraction of a second.

Feedback from plate circuit to grid circuit may occur in any of the three principal ways illustrated in Fig. 91-1; by means of a common magnetic field, by means of a common inductance, or through tube capacitance or other capacitance between the plate and grid circuits.

When considering any type of feedback it will be helpful to keep in mind the phase relations of grid voltage, plate current, and plate voltage. When a grid becomes more positive or less negative there is increase of plate current, but because of increased voltage drop in the plate load there is a simultaneous decrease of plate voltage at the tube. When the grid becomes less positive or more negative there is decrease of plate current, but an accompanying increase of plate voltage at the tube. Grid voltage and plate current are of like phase, but grid voltage and plate voltage are in opposite phase.

At *A* in Fig. 91-1 there is feedback by means of inductive coupling through a single magnetic field common to one coil in the plate circuit and to another coil in the grid circuit. Relative directions of currents in the two coils must be such

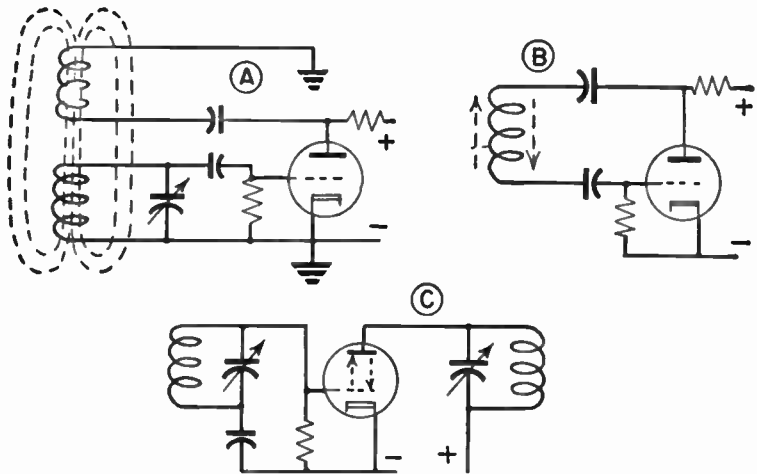

Fig. 91-1.—The three principal ways in which feedback occurs in oscillators.

that the magnetic field of the plate coil aids the field of the grid coil, or so that north and south magnetic poles of both coils point the same direction at the same time. The phase relationship of voltages and currents in grid and plate circuits determines the relative directions of the magnetic fields,

which must be in the same direction or polarity to have feedback such as will sustain oscillation.

If directions of currents in the coils happen to be such as produce opposite magnetic fields, and oppose rather than sustain oscillation, it is necessary only to turn either coil end for end, or else to interchange the circuit connections to the ends of either coil. Feedback voltage or current must be in correct phase no matter how it is accomplished.

In diagram *B* of Fig. 91-1 the same coil is in both the plate circuit and the grid circuit for oscillatory currents. The opposite phase of voltages at plate and grid insures feedback which sustains oscillation. That is, with the coil a continuous winding in the same direction throughout its length, the positive voltage polarity of the grid at one end acts to cause electron flow in the same direction as does negative voltage polarity of the plate at the other end, or vice versa.

In diagram *C* of Fig. 91-1 the feedback from plate to grid acts through the grid-plate capacitance of the oscillator tube. In order that feedback may reach the grid in such phase as to aid changes of grid voltage, the plate circuit must act as an inductive reactance rather than as a pure resistance. This is accomplished by tuning the plate circuit to a frequency slightly higher than the oscillating frequency, which is controlled by resonant frequency of the grid circuit.

With feedbacks such as have been described, every increase or decrease of plate voltage acts through the feedback to cause still further change of grid voltage in the direction that is responsible for that increase or decrease of plate voltage. This further change of grid voltage causes an even greater increase or decrease of plate voltage, and so the interaction continues until plate current reaches saturation value if it is increasing, or drops to zero at plate current cutoff if it is decreasing.

At either saturation or cutoff, the feedback can have no more increase, and the momentary loss of energy causes grid voltage to commence a reversal. This grid voltage acts immediately to start a reversal of the previous change of plate current and voltage, thus commencing a feedback in the opposite

direction or alternation. This opposite feedback continues until plate current again must cease its changing as it comes to either saturation or cutoff. Here the grid voltage is again caused to reverse, and the whole process repeats over and over.

The result of this repeated process is continual rise and fall of plate current between cutoff and saturation, and corresponding changes of voltage across the load in the plate circuit. These changes are the alternating components of plate current and voltage, having the frequency of oscillation or of resonance in the tuned circuit which controls the oscillating system.

As will appear in following circuit diagrams, oscillator tubes nearly always are operated with grid-leak bias, a method which supplies negative biasing voltage proportional to grid current.

Hartley Oscillators. — The Hartley oscillator circuit, shown in principle by Fig. 91-2 is used generally in both radio and television receivers for generation of low and intermediate radio frequencies, also in r-f signal generators for service work and in some audio-frequency generators and audio modulating circuits.

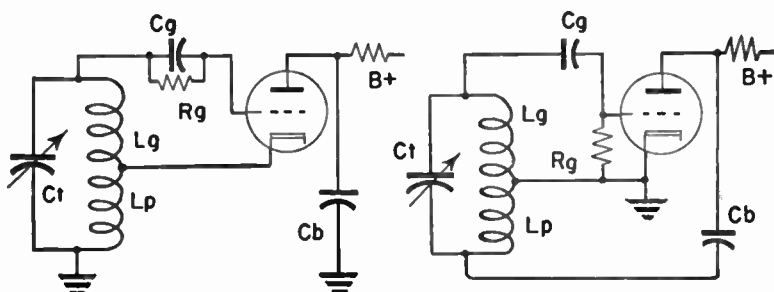

Fig. 91-2.—Hartley oscillators with grounded tuning capacitor (left) and with grounded cathode (right).

Two coils, L_g and L_p , or a single tapped coil, are tuned to resonance at the desired oscillator frequency by capacitor C_t . The two coils or two parts of a coil usually are so mounted as to have inductive coupling, although such coupling is not essential for the reason that the same oscillating currents always must flow in both parts. Feedback is from coil L_p , in the

plate circuit, to coil L_g in the grid circuit. The two coils ordinarily are about alike, or a single coil is tapped near its center. Output amplitude is increased by more inductive reactance in the plate coil.

With connections shown by the left-hand diagram of Fig. 91-2 one side of the tuning capacitor and one end of the tuned coil are grounded, an arrangement desirable for prevention of body capacitance effects if tuning is to be manually altered while the oscillator is operating. In the right-hand diagram the cathode of the oscillator tube is grounded, with both ends of the tuned circuit at potentials above ground. The oscillatory

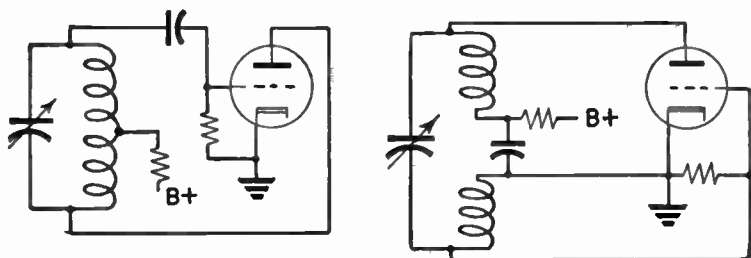

Fig. 91-3.—Modifications of the Hartley oscillator circuit.

circuit is connected to the tube plate through capacitor C_b . Capacitance at C_b , also at the grid capacitor C_g , should be great enough to have small reactance at oscillator frequencies.

Hartley oscillator circuits are found with many modifications, two of which are shown by Fig. 91-3. The essential and easily recognized feature of this circuit is connection of the oscillator cathode to a tap on a single coil or to a point between two coils which are tuned to resonance by a single capacitor or by a principal capacitor paralleled by a trimmer or a fine tuning capacitor.

Colpitts Oscillators. — The Colpitts oscillator circuit is shown by Fig. 91-4. This is a type in general use for r-f oscillators in the tuners of television receivers, also for the very-high frequency oscillators in television types of signal generators. The connection method at the left is the one almost al-

ways used. There is grounding of one side of each of the tuning capacitors C_a and C_b , also of the tube cathode. In the much older method of connection shown at the right both sides of both capacitors are above ground potential.

The single coil L_t is tuned to resonance by varying both tuning capacitors in unison, for more capacitance in both or else for less capacitance in both. Oscillating voltage in the plate circuit is across capacitor C_b . Capacitor C_a is in the grid circuit. Thus part of the energy put into the tuned circuit from the plate is fed back to the grid. Feedback is increased by increasing the ratio of capacitive reactance at C_b to capacitive reactance at C_a .

In the circuit connections at the left in Fig. 91-4, feedback is accomplished through the magnetic field of coil L_t which is common to both the plate and grid circuits. Oscillating energy

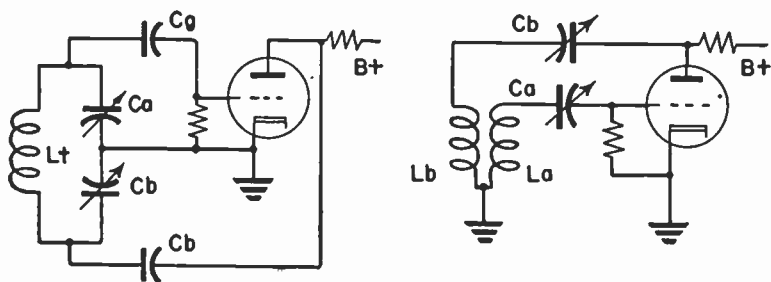

Fig. 91-4.—Colpitts oscillator circuits.

which is in this coil during one half-cycle is divided between the tuning capacitors on the opposite half-cycle. With connections at the right, feedback is by means of inductive coupling from plate coil L_b to grid coil L_a . Colpitts oscillators have less tendency than most other simple oscillators to produce harmonics of the tuned frequency.

Tickler Feedbacks. — With the oscillator circuits of Fig. 91-5, energy from the plate circuit is fed back to the tuned grid circuit by inductive coupling between the “tickler” coil L_p in the plate circuit and coil L_g in the grid circuit. Feedback is varied by changing the position or the angle of coil L_p in relation to coil L_g . The tuned-grid tickler-feedback circuit is used in

radio-frequency oscillators operating at frequencies up to 10 or 15 megacycles, and occasionally in audio-frequency oscillators. This circuit, operated with feedback just below that for oscillation, was used in most of the regenerative detectors for early radio broadcast receivers.

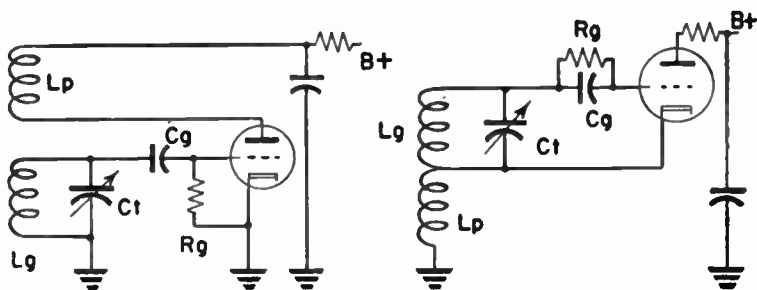

Fig. 91-5.—Tuned grid oscillators with tickler feedbacks.

In Fig. 91-6 the plate circuit rather than the grid circuit is tuned to resonance, and to the coil in this tuned plate circuit is inductively coupled a tickler coil which is connected into the grid circuit. Such tuned-plate tickler-feedback circuits are used in r-f signal generators operating at frequencies as high as 15

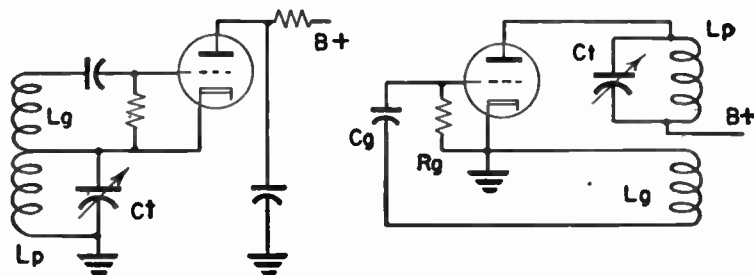

Fig. 91-6.—Tuned plate oscillators with tickler feedbacks.

to 20 megacycles and sometimes in audio-frequency generators. With the connection scheme shown at the left, one side of the tuning capacitor C_t is grounded. Although neither side of the tuning capacitor is grounded in the right-hand circuit, the one which connects to $B+$ may be grounded for radio frequencies through a bypass capacitor.

Other Feedback Oscillators. — At *C* in Fig. 91-1 are shown the essential features of what is called a tuned-grid tuned-plate oscillator. There is no inductive coupling between the tuned coils in plate and grid circuits. Feedback current flows in the capacitance between plate and grid of the oscillator tube, which is a triode because triodes have greater grid-plate capacitance than pentodes.

In Fig. 91-7 is illustrated the usual form of ultradion oscillator circuit. Feedback is through the magnetic field of tuned coil *L* which is common to both the plate circuit and the grid

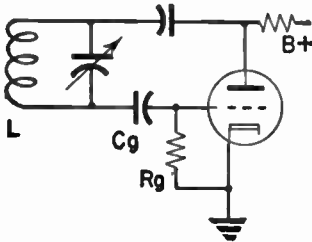

Fig. 91-7.—Ultradion oscillator circuit.

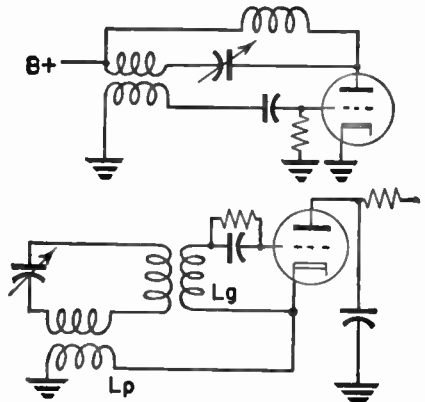

Fig. 91-8.—Two variations of the Meissner oscillator circuit.

circuit. The amount of feedback may be controlled by connecting a variable bypass capacitor from plate to cathode or plate to ground, through which part of the feedback energy is shunted.

Fig. 91-8 shows at the top an Arco-Meissner oscillator circuit in which there is a tuned plate circuit consisting of a series connected variable capacitor and coil which are paralleled by another coil. To the series plate coil is inductively coupled an untuned coil in the grid circuit to which is transferred the feedback energy.

Down below is the oscillator circuit usually associated with the name Meissner. Neither the plate circuit nor the grid cir-

cuit is tuned, but coils in both these circuits are inductively coupled to coils which are in a tuned link circuit. Feedback is from coil Lp in the plate circuit through the link to coil Lg in the grid. The Meissner oscillators are not in common use for present radio and television receivers, but sometimes are referred to.

OSCILLATORS, FREQUENCY CHANGE IN. — Frequency stability and constancy are necessary in any oscillator which is calibrated, as are the oscillators of signal generators, and is highly desirable where oscillator output is combined with other frequencies, as in superheterodyne tuners and controls for television sweep frequency. Frequency stability in test instruments is best secured by crystal control where crystal frequencies or their harmonics can be made to cover enough points in the operating band. Automatic frequency control is generally used for horizontal sweep oscillators, sometimes for vertical sweep oscillators, and occasionally for r-f oscillators in tuners.

Slow drift of oscillator frequency during possibly the first half hour of operation usually is due to temperature effects which alter the positions and dimensions of parts to change the inductance of coils and the capacitance of capacitors and tubes. Naturally, anything that lessens the production of heat will help. This will include the use of tubes requiring relatively small plate current, and of circuits and parts having least possible resistance. High-wattage resistors may allow improvement by reducing their own temperature, although this will not lessen the total production of heat. Temperature rise is lessened by good ventilation, absence of crowding, and by keeping parts free from dust and other dirt. Heat may be carried away and also distributed more uniformly by chassis metal and shielding of heavy gauge and of good thermal conductivity, as found in copper and aluminum.

When all practicable changes have been made in design and construction, the remaining temperature drift may be balanced out by connecting across the tuned oscillator circuits temperature compensating ceramic capacitors having

negative temperature coefficients. These compensating capacitors must, of course, become active parts of the circuits and replace all or part of non-compensating types of capacitance which would be connected into the same positions. As temperature rises there is decrease of the compensating capacitance with a tendency to raise the oscillator frequency to the same extent it would be lowered by heating of the various other parts.

More rapid changes of oscillator frequency may result from changes of load unless the tuned oscillating circuits are well isolated from the output. Such isolation usually is provided in test instruments by using electron coupled oscillators or by using untuned buffer amplifiers between the oscillator itself and the output to the load.

Fluctuations of plate and screen voltage will alter the frequency of oscillation by changing plate resistance and transconductance of the oscillator tube. The best preventive is use of standard voltage regulating tubes or voltage regulating transformers or both. Effects of voltage variation are minimized by using oscillator tubes of fairly high plate resistance and by working with strongly negative grid bias and the required high plate supply voltage. The use of insulation and other parts having minimum high-frequency resistance and losses helps maintain frequency stability.

Very rapid changes of oscillator frequency may be due to parts which are loose or which vibrate, or to loose electrical connections. Very slow changes which do not correct themselves usually are due to capacitors which have developed some leakage or which have changed their capacitance, or to resistors which have changed their resistance with aging. Gradual aging of tubes will alter the oscillating frequency. If no parts prove actually defective it is best not to make replacements but to make readjustments or recalibrations after the first one or two hundred hours of use. Apparatus then should operate for long periods without enough additional change to cause any difficulty.

OSCILLATORS, NEGATIVE RESISTANCE. — In negative resistance oscillators there is no feedback from the plate circuit to compensate for loss of energy in the grid circuit; rather there is utilized an effect called negative resistance to compensate for losses in a tuned circuit connected between plate and screen and cathode of the oscillator tube.

Connections for a dynatron type negative resistance oscillator are shown by Fig. 93-1. The tube is represented as a tetrode or screen grid tube, but might be a pentode connected as a tetrode or might be a triode. The essential feature for dynatron operation is that the element between plate and cathode, which may be either a screen or a control grid, shall be at a potential higher than that on the plate.

Fig. 93-2 shows variations of dynatron plate current, screen current, and total or cathode current when the screen is maintained at constant voltage while there are increases and de-

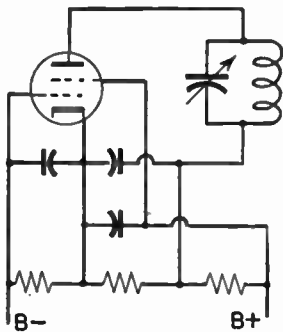

Fig. 93-1.—Circuit connections for a dynatron oscillator.

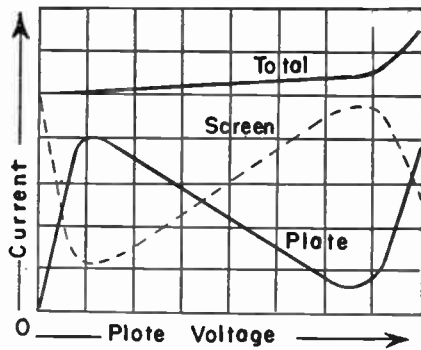

Fig. 93-2.—Currents in a dynatron oscillator tube.

creases of plate current and voltage at the oscillating frequency, as occur during operation of any oscillator. With zero plate voltage all emission goes to the screen, and screen current is total current. With increasing plate voltage, more and more electrons are drawn through the screen to strike the plate. These primary electrons cause emission of second-

ary electrons from the plate. The secondary electrons then are drawn to the more positive screen and add themselves to the screen current.

Continued rise of plate voltage increases the velocity of electrons striking the plate, which increases the rate of secondary emission. Soon there are more secondary electrons leaving the plate than primary electrons coming to the plate from the cathode. The result is decrease of electrons remaining in the plate and flowing out to the connected circuit in the form of plate current. If plate voltage rises above screen voltage there is no further dynatron action, and, as at the right in Fig. 93-2, there are rapid rises of plate current and total current, with rapid drop of screen current. The grid of the tube is maintained at such negative voltage as limits emission to a suitable rate and helps maintain a constant emission rate.

With a tube operated in the ordinary manner (plate voltage higher than screen voltage) every increase of plate current in the tube and the plate load means more voltage drop between plate and cathode. Consequently, plate current soon is limited by lack of voltage applied from the B-supply through the load. But when the tube is operated as a dynatron the increase of plate current means less voltage drop between plate and cathode, and more B-supply voltage becomes available to the tuned load circuit connected between plate and cathode. Any increase of current through the tuned circuit now is accompanied by an increase of voltage applied across it, while decrease of current is accompanied by decrease of applied voltage. Consequently, once the load current commences to either increase or decrease, there is a change of voltage across the load (plate to cathode) tending to accelerate the increase or decrease. This effect is equivalent to that obtained with any form of feedback.

Dynatron oscillators are used chiefly in test equipment, where they provide fair frequency stability and good waveform, but usually require considerable recalibration when the oscillator tube is replaced. Among other negative resistance oscillator circuits is the negative transconductance

type employing a pentode tube with the tuned oscillatory circuit connected between screen and cathode. A modulating voltage may be applied between grid and cathode of a negative resistance oscillator.

OSCILLATORS, RELAXATION. — A relaxation oscillator is a type in which control grid voltage is changed by the charging and discharging of a capacitor or inductor through a resistance rather than as a result of oscillations in capacitance and inductance. That is, the operating frequency of the relaxation oscillator depends on capacitive or inductive time constants rather than on resonant frequency in a capacitance and inductance. The output of a relaxation oscillator is not naturally a sine wave, but may be a pulsed wave, a square wave, a triangular wave, a sawtooth wave, or other forms. The output may be changed to a sine wave by suitable filtering.

The frequency of a relaxation oscillator may be quite easily synchronized with that of a periodic voltage. The oscillator is adjusted to operate naturally at a frequency slightly lower than the desired rate, and the synchronizing voltage is applied in a manner to hasten the capacitor charge or the change of grid voltage and thus start each cycle of oscillation in time with synchronizing pulses.

Multivibrator Oscillator. — One of the earliest relaxation oscillators is the multivibrator, of which a typical circuit is shown by Fig. 94-1. It should be noted that this style of multivibrator is used for testing and frequency-measuring equipment, but is not the type employed as a sweep oscillator or deflection oscillator in modern television receivers. The oscillator shown here is essentially a two-stage resistance coupled amplifier with the output of one stage fed back as input to the other stage.

Feedback is in such polarity as to reinforce the changes of grid voltage in the first stage, this being due to the fact that voltage is inverted in polarity between grid and plate of any tube. For example, when the grid of the first tube is going positive its plate is going negative. This causes the grid of the second tube to be driven negative, and the plate of that tube

goes positive. The positive-going plate voltage from the second tube is fed back and added to the positive-going grid voltage of the first tube, with which the action commenced.

The feedback voltages which act in the same way as existing grid voltages drive plate current to saturation in one tube and to cutoff in the other tube. Then the actions can continue

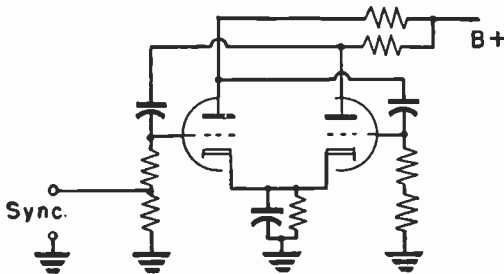

Fig. 94-1.—Connections for a multivibrator oscillator.

no further in the original directions, but reverse and again cause saturation and cutoff in the two tubes. Operating frequency depends on time constant of capacitors feeding the grids and the resistances between grids and ground. Frequency may be altered by adjustment of either capacitance or resistance, usually the latter. A synchronizing voltage may be put into either grid circuit.

Gaseous Tube Oscillator. — A relaxation oscillator shown in principle at the left in Fig. 94-2 uses a gaseous triode (thyatron) whose frequency of breakdown, along with output frequency of the system, is determined by the time constant of a capacitance-resistance combination. This type, and modifications of it, are used as sweep oscillators in many oscilloscopes.

Capacitor C is connected between plate and cathode of the gas-filled tube. The maximum voltage to which the capacitor may charge is the breakdown or ionization voltage of the tube. The capacitor charges from a d-c source through adjustable resistor R_a . The time required for capacitor voltage to rise to the breakdown value of the tube depends on the time constant of C and R_a . During the charging time there is gradual in-

crease of capacitor voltage, which also is the output voltage from terminals at the right. When the tube breaks down or ionizes, its internal resistance suddenly drops to a very low value, and the capacitor discharges through the tube from cathode to plate until voltage drops to a value at which the

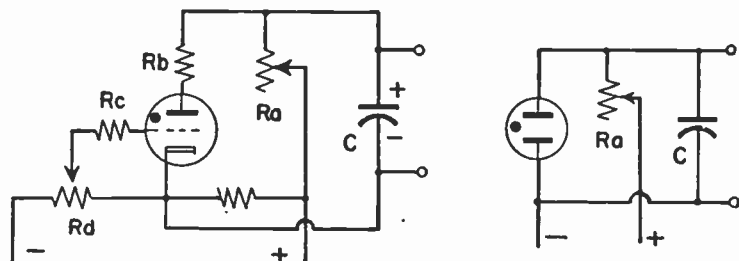

Fig. 94-2.—A gaseous tube relaxation oscillator (left) and a neon oscillator (right).

tube deionizes. Tube resistance then returns to a high value, the capacitor re-charges, and the process repeats. The output voltage is of sawtooth waveform.

Resistors R_b and R_c respectively limit the plate current after breakdown and limit the grid current. Grid voltage may be made more or less negative by adjustment of R_d . Grid voltage or bias voltage determines the plate-cathode and capacitor voltage at which the tube will break down, and so determines maximum output voltage. Frequency of oscillation is inversely proportional to the time constant of C and R_a . Various ranges of frequency may be covered by switching different values of capacitance into the circuit at C .

At the right in Fig. 94-2 is a simple "neon oscillator," which is a relaxation type. The tube is a neon lamp. D-c supply voltage is higher than breakdown voltage of the lamp. Capacitor C charges through resistor R_a . Oscillation frequency depends inversely on the time constant of R_a and C . Output voltage is of sawtooth waveform.

OSCILLATORS, TELEVISION, R-F. — A television radio-frequency oscillator produces very-high frequencies which beat with received carrier frequencies to produce intermediate fre-

quencies which are amplified in the intermediate frequency amplifier. The oscillator and carrier frequencies are combined in the mixer tube, whose output goes to the intermediate-frequency amplifier. This oscillator, which is part of the tuner, is called the r-f oscillator or the local oscillator to distinguish it from the television sweep oscillators.

In the television r-f oscillator circuit there is practically always a separate tube or separate section of a twin tube serving this one function, rather than having oscillator and mixer functions combined in a converter tube having a single electron stream, as is general practice in receivers for sound radio. Often the television r-f oscillator is one section of a twin tube whose other section is the mixer, but there are separate electron streams for the two functions. The great majority of r-f oscillator tubes are miniature triodes of high transconductance.

The output of the r-f oscillator consists of a single sharply tuned frequency for each channel. This oscillator frequency beats with the amplitude-modulated video carrier frequency to produce a video intermediate frequency having the same signal modulation and extending over the same band width in megacycles as covered by the video carrier. The same oscillator frequency beats with the frequency-modulated sound carrier in the same channel to produce a sound intermediate frequency having the same signal frequency modulation and covering the same band width as the sound carrier.

It is a general rule that the r-f oscillator frequency shall be higher than the carrier frequencies in the same channel. There are a few television receivers in which the oscillator frequency is lower than the carrier frequencies, but they are the exceptions. The difference between oscillator frequency and video carrier frequency is the video intermediate frequency of the receiver, and the difference between oscillator frequency and sound carrier frequency is the sound intermediate frequency of the receiver. The following tabulation shows these relations in a few channels for a receiver having

video intermediate frequency of 26.60 mc and sound intermediate frequency of 22.10 mc. All the listed frequencies are in megacycles.

Channel	Carriers		Intermediates		Oscillator
	Video	Sound	Video	Sound	
2	55.25	59.75	26.60	22.10	81.85
6	83.25	87.75	26.60	22.10	109.85
7	175.25	179.75	26.60	22.10	201.85
13	211.25	215.75	26.60	22.10	237.85

Oscillator Circuits. — The Colpitts circuit is used more than any other for television r-f oscillators, but it often appears in such modifications as to make identification rather difficult. The basic Colpitts circuit is shown at the left in Fig.

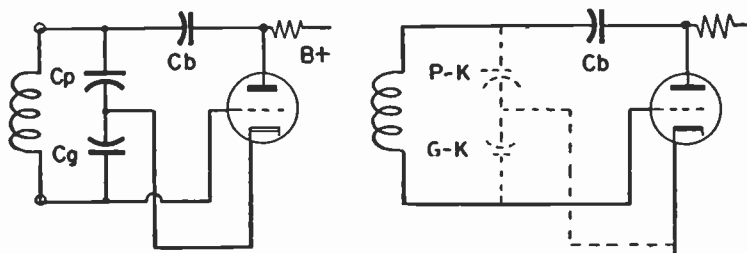

Fig. 95-1.—Colpitts oscillator with external tuning capacitances (left) and with tuning by tube interelectrode capacitances (right).

95-1. Tuning to resonance is by means of capacitor C_p in the plate circuit and capacitor C_g in the grid circuit. One side of both these capacitors connects to the cathode, either directly or through ground. The blocking capacitor at C_b keeps d-c plate current and voltage out of the grid circuit.

At the very-high frequencies existing in television r-f oscillator circuits the interelectrode capacitances of the tube are ample for tuning to resonance with only a moderate amount of inductance in the tuned circuit. Consequently, in television circuit diagrams the Colpitts oscillator may appear as shown by the full lines at the right in Fig. 95-1. Tuning of the oscillator coil is accomplished by plate-to-cathode capacitance of the tube, represented by broken lines at $P-K$, and by grid-to-cathode capacitance represented at $G-K$. These tube

capacitances take the place of capacitors C_p and C_g in the left-hand diagram.

Other Colpitts oscillator circuits are shown by Fig. 92-2. The left-hand diagram contains fine tuning capacitors C_m and C_n , of which either one might be used, but not both in the same oscillator circuit. Capacitor C_m is connected across the entire tuning coil and also is in parallel with the grid-plate interelectrode capacitance of the tube. Capacitor C_n is in parallel with the plate-cathode capacitance of the tube, which is one of the interelectrode capacitances that tune the coil to resonance. With the fine tuning capacitors removed, the oscillator circuit would be essentially the same as at the right in Fig. 95-1. With fine tuning capacitor C_m appearing in a circuit diagram the oscillator could be mistaken for an ultratun until values of capacitance, inductance, and frequency were checked to show that C_m is not the principal tuning element.

At the right in Fig. 95-2 is illustrated still another modification of the Colpitts oscillator. Capacitor C_t is for fine tuning.

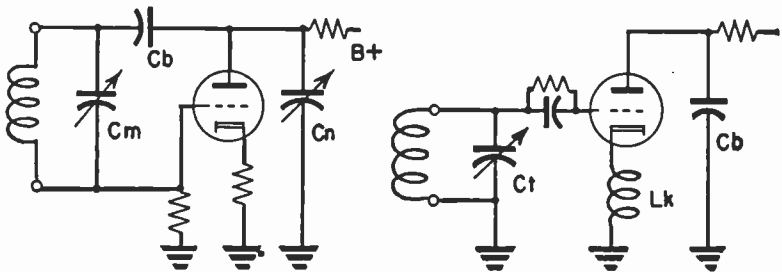

Fig. 95-2.—Circuits connections for modified Colpitts oscillators.

The r-f plate circuit with its plate-to-cathode capacitance is connected to the tuning coil circuit through capacitor C_b and ground. The interelectrode capacitances of the tube are made effective for tuning by isolating the cathode from ground by means of r-f choke L_k , so far as r-f currents are concerned, while maintaining the cathode-to-ground conductive path for direct current. There are many modifications of the funda-

mental Colpitts oscillator circuit in addition to those which have been illustrated.

Fig. 95-3 shows circuit connections for a push-pull r-f oscillator employing a twin triode tube and an oscillatory circuit consisting of capacitor C and coil L used as a parallel resonant circuit between the two plates. A different coil L , of suitable inductance for tuning, is switched into position for each channel.

This oscillator operates so far as feedback is concerned like two resistance coupled amplifiers with the output of each plate fed as the input to the opposite grid through coupling capaci-

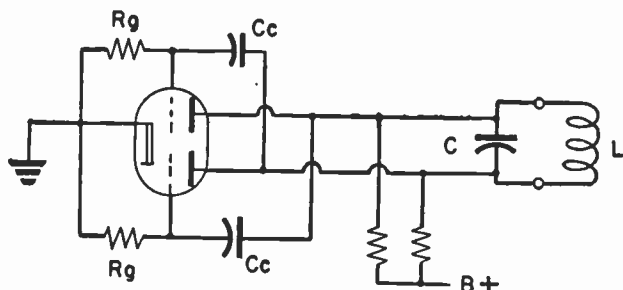

Fig. 95-3.—Push-pull r-f oscillator with parallel resonant tuned circuit.

tors C_c and C_c . The reactance of these capacitors is very small in comparison with resistance of grid resistors R_g and R_g . The oscillator output is of good frequency stability, and there is little tendency to produce harmonic frequencies.

Fig. 95-4 shows connections for a resonant line oscillator in which the tuned resonant circuit consisting of lumped capacitance and inductance elements is replaced with a quarter-wave shorted resonant line, which is the equivalent of a parallel resonant circuit so far as tuning is concerned. The left-hand end of this diagram is practically the same as the one in Fig. 95-3. Dual capacitor C_t is a variable fine tuning unit.

Opposite sides of the resonant line, shown toward the right in the diagram, consist of coils of a few turns, or small loops, or lengths of straight wire between the successive terminal

points, depending on the amount which the resonant frequency must change between tuning positions. The movable shorting bar shown between opposite line terminals is shifted one way and the other to vary the effective length of line and provide resonance in the various channels. The shorting bar

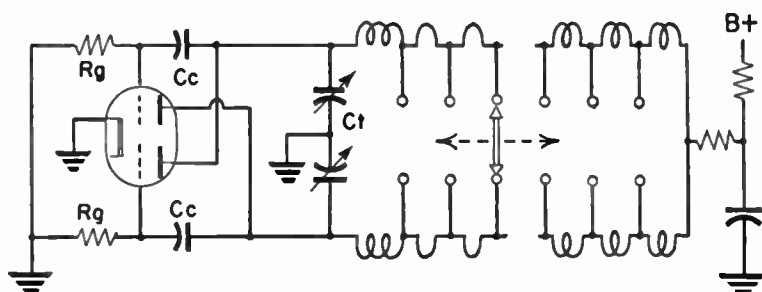

Fig. 95-4.—Resonant line oscillator with a shorted quarter-wave resonant line as the tuned circuit.

or connection usually is a conductor between movable contacts of a rotary switch, whose stationary contacts connect to or support the line inductors. The diagram would represent the circumference of the rotary switch spread out as a flat surface from left to right.

Effects of Oscillator Frequency. — Fig. 95-5 illustrates the effects of oscillator tuning or alignment in changing the intermediate frequencies which are produced in the mixer and applied to the input of the i-f amplifier. The curve, which is the same at left and right, represents the frequency response or gain versus frequency in the i-f amplifier. It is assumed that the sound intermediate frequency applied to this amplifier should come low down on the left-hand or low-frequency skirt of the response, and that the video intermediate frequency should come at the point of 50 per cent gain on the right-hand side of the response curve. The two intermediate frequencies always will be separated by 4.5 megacycles, as marked on the diagrams.

If the oscillator is mistuned or misaligned, both the sound and the video intermediate frequencies will be made too low

or too high. Their separation, however, will remain 4.5 mc because separation of sound and video carriers in any channel always is 4.5 mc, and both intermediate frequencies are produced by beating of a single oscillator frequency with the two carriers.

With the oscillator tuned or aligned for a frequency which is too low, both intermediate frequencies will be too low by the same number of megacycles or fraction of a megacycle. This is shown at the left in Fig. 95-5. If the receiver employs the intercarrier sound system the gain or response at the actual sound intermediate frequency will be so low as to allow practically no sound reproduction, while if the sound system is of the dual carrier type the center frequency fed to the sound amplifier will be nearly or completely outside the band pass of this amplifier, and there will be distorted sound or no sound at all. The video intermediate frequency will move up on the

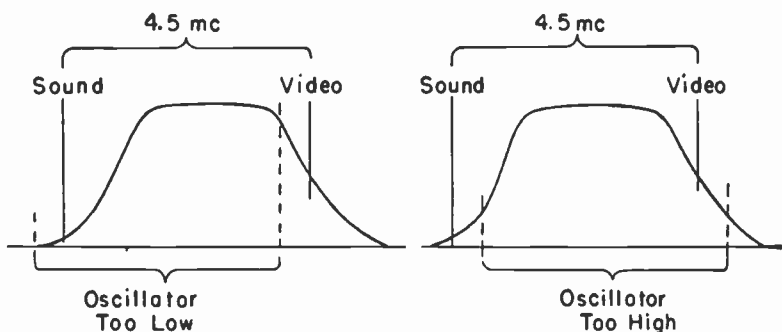

Fig. 95-5.—How shifting of r-f oscillator frequency alters both the intermediate frequencies.

response curve. There will be too much gain at low video frequencies, while the highest video frequencies will be moved down on the opposite side of the curve, to give them too little amplification. This will prevent reproduction of fine details in the pictures.

With the oscillator tuned to a frequency which is too high, the results will be as at the right in Fig. 95-5. The sound intermediate frequency now moves up on the gain curve while

the video intermediate frequency moves down. With an inter-carrier sound system the amplification for sound will be so great as to cause possible overloading of the sound amplifiers, usually also the effect called intercarrier buzz, and it is quite probable that sound bars will appear on the picture or pattern. With a dual carrier sound system the intermediate frequency passed on to the sound amplifier again will be nearly or wholly outside the band pass of this amplifier, and there will be distorted sound or none at all. The video carrier will move down on the gain curve. Low video frequencies will receive too little amplification, and there is probability of trailers and black "speckling" in pictures and patterns. Excessive reduction of low-frequency gain also may make it difficult to obtain satisfactory adjustment of the hold controls.

If oscillator frequency is not too far out of alignment, and if there is a fine tuning control accessible to the operator, this control may have enough range to make corrections in the various channels. With receivers having dual channel sound systems the fine tuning control may bring either satisfactory pictures or satisfactory sound, but not both at the same setting.

Alignment of R-f Oscillators. — General instructions for alignment in all parts of the receiver are given in the article on *Alignment*. The following precautions should be observed when aligning the r-f oscillator.

When test signals will pass through the video or sound intermediate-frequency amplifiers to be picked up by meters or oscilloscope at the detectors, these amplifiers should be in reasonably good alignment before working on the oscillator.

If a signal generator is used, the antenna should be disconnected from the receiver.

It is advisable to override any automatic gain control, even though this control does not act directly on the r-f oscillator.

A fine tuning control, if there is one, should be set at the approximate center of its adjustment range, and left there throughout the alignment process. This control sometimes is a service adjustment, as with types consisting of a cam with screw settings for each channel.

Only non-metallic alignment or adjustment tools should be used where frequencies are so high as in r-f oscillators. It is essential that the receiver and all test instruments be allowed to warm up for at least 15 minutes before any adjustments are altered.

In some tuners there is an overall adjustment for the oscillator, an adjustment that alters the tuning in all channels at once. This adjustment, if used, most often is associated with channels 2 or 13.

R-f oscillators in receivers having intercarrier sound systems may be aligned in any of several ways. One method requires use of a sweep generator, a marker generator, and an oscilloscope. The sweep and marker generators are connected or coupled to the antenna terminals of the receiver, with correct impedance matching for the sweep input. The oscilloscope is connected across the output load of the video detector. Sweep frequency and width are adjusted to produce a video i-f response curve on the oscilloscope. Then markers are applied at video and sound carrier frequencies while the r-f oscillator is aligned for correct marker positions as shown by Fig. 95-5.

Approximate alignment may be made with an electronic voltmeter connected across the video detector load and using any television signal for the input. The oscillator is aligned for a meter reading about half way between minimum and maximum shown on the meter as the tuning adjustment is changed throughout its range. Some readjustment usually is required to obtain the combination of sound fully regulated by the volume control and a picture that is clear. With correct alignment the picture will not be of maximum brightness for that would mean a low oscillator frequency and the conditions shown at the left in Fig. 95-5.

If no marker frequencies are available in the carrier ranges it is possible to feed to the mixer input a marker at the video intermediate frequency and one at the sound intermediate frequency. With an oscilloscope connected across the video detector load, these i-f markers will appear on the curve pro-

duced by a sweep generator connected to the antenna terminals and operating through the carrier frequencies for the channel in which adjustments are made. This is little more than a check on the fact that i-f markers will appear at certain positions on the i-f response curve. It will show gross misalignment, but little else.

R-f oscillators in receivers having dual carrier sound systems nearly always are aligned by putting a single-frequency signal (not a sweep frequency signal) through the sound amplifier and demodulator. The band pass of the sound i-f amplifier and demodulator hardly ever is more than a half megacycle and usually is much less. If the r-f oscillator is so aligned that a sound signal comes through this narrow band pass and is well amplified without distortion it may be assumed that the oscillator alignment is sufficiently accurate for all practical purposes. If the sound intermediate frequency is thus found to be correct, the video intermediate frequency must also be correct, and if the video i-f amplifier is properly aligned there will be good reproduction of both pictures and sound.

Some of the many methods of aligning the r-f oscillator through the sound system are as follows. The simplest method, but not the most accurate, is to tune in a signal consisting of a test pattern with accompanying audio note as sound modulation, then to adjust the oscillator alignment for maximum sound volume. An ordinary output meter may be used instead of or to supplement the speaker indications. A method of no greater accuracy, with equipment usually available, substitutes a constant frequency tone modulated signal from a generator of the marker type instead of the television signal. The r-f oscillator is aligned for maximum volume from the speaker or maximum reading of an output meter.

Satisfactory alignment may be made by using a marker generator, unmodulated, connected to the receiver antenna terminals, with an electronic voltmeter connected to the output of the sound discriminator or ratio detector. If the voltmeter is connected to a point of unbalanced demodulator output, not to the output going to the a-f amplifier, alignment

is made for maximum meter reading. Alignment is for maximum meter reading also if the meter is connected across the grid resistor of an audio limiter tube. If the voltmeter is connected to a point of balanced demodulator output, which would be just ahead of the de-emphasis filter in most cases, alignment is made for zero reading on the meter. The marker generator is tuned to the sound carrier frequency for the channel in which alignment is being carried out.

Another satisfactory method employs a sweep generator and marker generator connected to the antenna terminals of the receiver, and an oscilloscope connected to the balanced a-f output of the sound discriminator or ratio detector. The sweep frequency and width are adjusted to produce a demodulator S-curve on the oscilloscope. The marker generator is tuned accurately to the sound carrier frequency of the channel in which alignment is being carried out, and is used without modulation. The oscillator tuning is adjusted to bring the marker to the center of the S-curve.

OSCILLATOR, TELEVISION SWEEP. — The purpose of sweep oscillators in television receivers is to control charging and discharging times of a capacitor which furnishes sawtooth voltages for directly or indirectly deflecting the picture tube beam vertically or horizontally. As shown by Fig. 96-1, a sweep oscillator is essentially an electronic switch shunted across the sawtooth capacitor. When the oscillator tube is made non-conductive by highly negative grid voltage, at the left, it allows the capacitor to charge from the B-power supply through a resistor. Direction of electron flow is shown by arrows. When the oscillator tube is made conductive by positive grid voltage, at the right, the capacitor discharges through the tube.

Charging of the capacitor is at a relatively slow rate, which produces the gradual rise of sawtooth voltage for causing a horizontal active trace or a vertical downward travel of the beam in the picture tube. Charging continues while the grid of the tube is held negative. When the grid is made positive there is rapid discharge of the capacitor, producing the sharp

drop of sawtooth voltage which causes horizontal or vertical retrace in the picture tube. The discharge period lasts only while the grid of the tube is held positive. Capacitor discharge and retrace are immediately followed by another charge and active deflection of the beam.

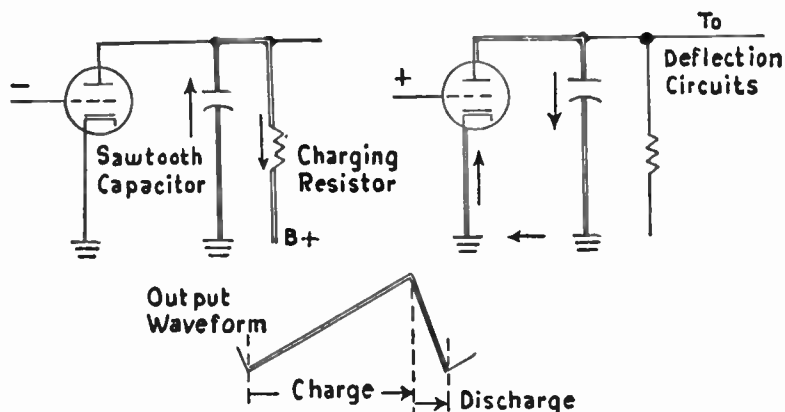

Fig. 96-1.—How a sweep oscillator controls charge and discharge of the capacitor.

The time constant of the sawtooth capacitor and charging resistor is too long to permit charging the capacitor to full voltage of the B-supply during the time in which the tube grid remains negative. The charge is thus limited in order to use only the first portion of the charging curve, which is fairly straight or linear. This helps maintain satisfactory linearity of deflection.

The frequency at which the capacitor is charged and discharged must be the same as the deflection frequency, which is 60 cycles per second for vertical deflection or is 15,750 cycles per second for horizontal deflection. In circuits having no automatic control for sweep frequency, and often in circuits which do have such control, the sweep oscillators are either of the blocking type or else are multivibrators. In both these types the operating frequency is fixed by combined effects of resistance-capacitance time constants in the oscillator grid circuits and the vertical or horizontal sync pulses coming to these circuits.

Frequency is regulated by adjustment of a grid circuit resistor which, in connection with a grid circuit capacitor, determines the time period during which the grid remains so negative as to keep the tube non-conductive. The adjustable resistor is a hold control, shown in Fig. 96-2. Frequency is adjusted to a rate just a little slower than that of the sync pulses.

Changes of grid voltage which would occur in the absence of sync pulses are shown at the center in Fig. 96-2. The principal differences between various blocking oscillator circuits and various multivibrator circuits are in the manner of producing

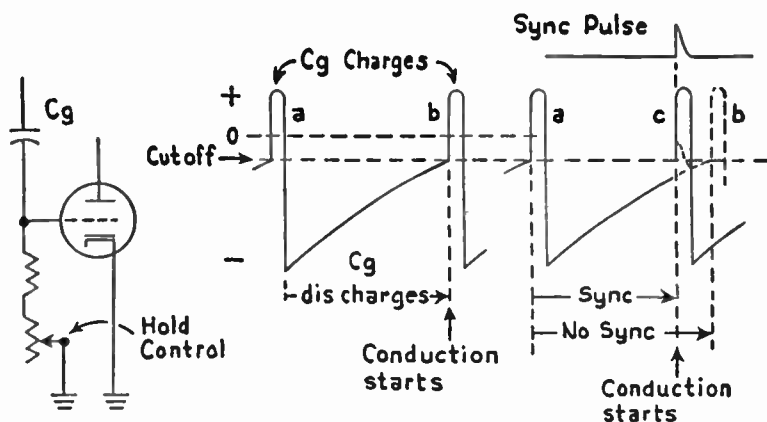

Fig. 96-2.—How sweep oscillator frequency is controlled by sync pulses.

these grid voltage changes. There is first a short interval, *a*, during which the grid is made positive and in which flow of grid current charges grid capacitor *C_g*. At the end of this interval the grid is suddenly made negative to a value well below plate current cutoff. Then the grid capacitor discharges rather slowly through the hold control resistor until grid voltage rises to the cutoff value, whereupon conduction in the tube starts a train of events which cause the grid again to become positive, at *b*, and the entire grid voltage cycle repeats over and over.

The effect of sync pulses is shown at the right. These pulses, of positive polarity, add their potential to the grid voltage just before the instant at which conduction would have started due to the action previously described. The result of adding the sync pulse potential to the grid voltage is to bring grid voltage up past the cutoff value at the instant of the pulse. This starts conduction in the tube, and there is a charging interval at *c* instead of at *b* as would have occurred with no sync pulse. The time period from *a* to *c*, marked *Sync*, corresponds to the correct deflection frequency as determined by sync pulse frequency. This time is shorter, or the frequency is somewhat higher, than *a* to *b* which is marked *No Sync*.

The sweep oscillator will continue to act even when there are no sync pulses, as when no television signal comes into the receiver circuits. Action will be at a frequency somewhat lower than signal sync frequency, as at the center in Fig. 96-2, but there will be continual deflection of the beam in the picture tube.

Blocking Oscillator. — Fig. 96-3 shows a typical circuit for a blocking oscillator. Grid capacitor C_g , the hold control resistor, and the sawtooth capacitor have been shown in

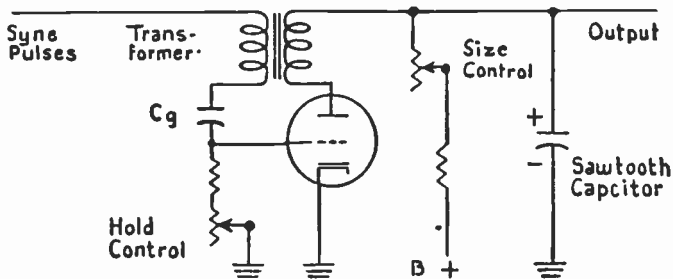

Fig. 96-3.—Blocking oscillator connections.

preceding figures. The size control resistor of Fig. 96-3 is equivalent to the charging resistor of Fig. 96-1. There is inductive feedback from plate to grid of the oscillator tube through the transformer. Transformer connections are such

that feedback is of polarity which increases the grid voltage in whichever way it is already changing. That is, the feedback is positive or is regenerative. Sync pulses are applied to the grid circuit through the grid winding of the transformer.

There are continual changes of plate current in the tube, but to explain the action we shall commence with a period during which plate current is increasing in the tube and in the plate winding of the transformer. At this time the grid voltage is becoming less negative or more positive, which accounts for increase of plate current. Regenerative feedback makes the grid still more positive. As the grid becomes positive there is flow of grid current, which charges capacitor C_g to make the side toward the grid of negative polarity. The charge voltage will reach approximately the peak value of feedback voltage. This action is like that occurring with grid-leak bias.

Feedback from the plate circuit continues because plate current continues to increase. The increase of plate current is not instantaneous because it is acting through inductance

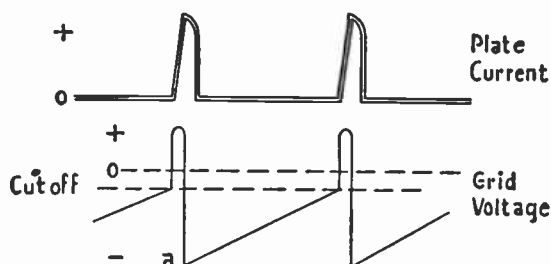

Fig. 96-4.—Changes of plate current and grid voltage in a blocking oscillator.

of the transformer plate winding wherein counter-emf slows down the rate of increase. Consequently, the grid is driven more and more positive, which causes plate current to increase to saturation at whatever value is proportional to applied plate voltage. This increase of plate current is shown at the top of Fig. 96-4, with the simultaneous changes of grid voltage shown below.

The length of time for plate current to reach saturation increases with more inductance in the transformer. It is desirable to have small inductance and small distributed capacitance to lessen this time and keep the plate current pulses narrow or of short duration, for retrace time cannot be short unless these pulses are short. When plate current reaches saturation there is no further change of current, therefore no further induction through the transformer and no further feedback. Grid voltage then commences to drop toward zero.

The negative-going grid voltage decreases the plate current. This decrease is a change which again causes feedback, but now the feedback polarity is such as to drive the grid more and more negative which, in turn, causes further decrease of plate current until this current drops to zero. Now the charge which was placed on grid capacitor C_g forces the grid voltage to a negative value far below cutoff, at a in Fig. 96-4. The capacitor discharges slowly through the hold control resistance, allowing the grid to become less and less negative until reaching cutoff voltage or until a sync pulse brings the grid voltage to or above cutoff. When this happens there is a new pulse of plate current, and the entire action repeats.

Discharge Tube. — In some receivers the charge and discharge of the sawtooth capacitor are controlled by a discharge tube which is made alternately conductive and non-conductive by a blocking oscillator. Typical connections are shown by Fig. 96-5. The oscillation and discharge functions usually are performed by the two sections of a twin triode tube.

Oscillator connections are essentially the same as in Fig. 96-3, except that the oscillator plate is connected through the transformer plate winding to $B+$ voltage for this section of the tube rather than to the sawtooth capacitor and the output. The two cathodes are connected together and to ground. The two grids are connected together. Then changes of grid voltage on the discharge section must be exactly the same, and must occur at the same times, as on the oscillator.

The plate of the discharge section connects to its own B+ voltage through the size control, also to the sawtooth capacitor and the output, just as does the plate of the oscillator in Fig. 96-3.

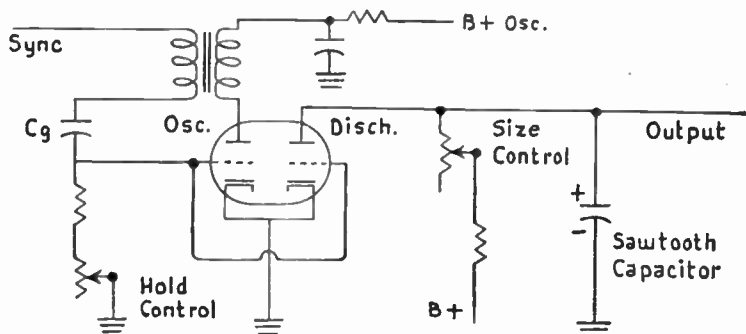

Fig. 96-5.—Discharge tube used with a blocking oscillator.

While the oscillator grid voltage is so negative as to prevent conduction, there likewise can be no conduction in the discharge section, and there is charging of the sawtooth capacitor from the B-supply. When the oscillator grid voltage becomes positive the grid of the discharge section is made positive, and the sawtooth capacitor discharges through the discharge section.

With a discharge tube in the circuit the B+ voltage applied to this tube and to the sawtooth capacitor is made higher than B+ voltage to the oscillator, thus allowing higher charge voltage on the sawtooth capacitor and a stronger sawtooth signal voltage for following deflection circuits. The relatively low B+ voltage on the oscillator allows smaller current at saturation, a quicker change of plate current, and faster action.

Multivibrator Oscillator. — Multivibrator sweep oscillators employ two triodes or two sections of a twin triode, as in Fig. 96-6, so connected that changes of plate voltage or cathode voltage from each section are applied to the grid of the other section to make the sections alternately and oppositely conductive and non-conductive. The two sections are coupled through the common cathode resistor R_k . Section B is shunted across the sawtooth capacitor to control charge and discharge

of that capacitor as this section is made alternately non-conductive and briefly conductive.

The action may be presumed to begin with electron flows as shown by arrows, and as occur when B+ voltage is applied to the circuit. One electron path is through cathode resistor R_k , the hold control resistor, capacitor C_g , and resistor R_o to

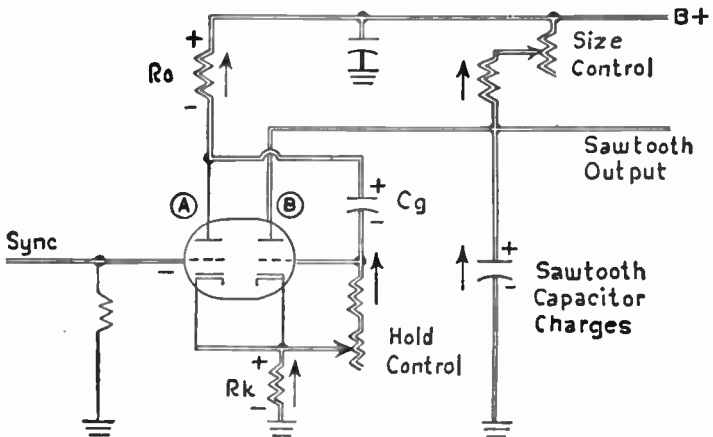

Fig. 96-6.—A cathode-coupled multivibrator sweep oscillator.

B+. Capacitor C_g is charged in the polarity marked. Capacitor voltage in relation to ground makes the grid of section B so negative with reference to its cathode that there is plate current cutoff and the section remains non-conductive.

While section B is non-conductive there is electron flow from ground (B-minus) through the sawtooth capacitor and through the size control resistors to B+. This flow charges the sawtooth capacitor in the marked polarity.

Electron flow toward the cathodes through resistor R_k means that the polarity of R_k is such as to make the grid of section A more negative. At the same time the direction of electron flow through resistor R_o indicates that the plate end of this resistor is more negative or less positive than the B+ end, an effect which reduces the plate voltage on section A . These two actions combine to cut off plate current in section A of the tube.

As capacitor C_g nears full charge there is lessening of current through resistors R_k and R_o , which makes the bias on section A less negative while increasing the plate voltage, and this section becomes conductive. Capacitor C_g discharges through section A as at the left in Fig. 96-7. This discharge through the hold control resistors is in a direction with which the grid of section B is made less negative with reference to the cathode, but still there is plate current cutoff in this section. As the discharge ceases, the grid voltage of section B becomes zero and this section is made conductive. Now there may be a discharge of the sawtooth capacitor through section B of the tube, as at the right in Fig. 96-7. Discharge current through cathode resistor R_k makes the grid of section A so negative as to maintain plate current cutoff in that section. As the end of discharge from the sawtooth capacitor we return to the starting condition of Fig. 96-6, and the events repeat as before.

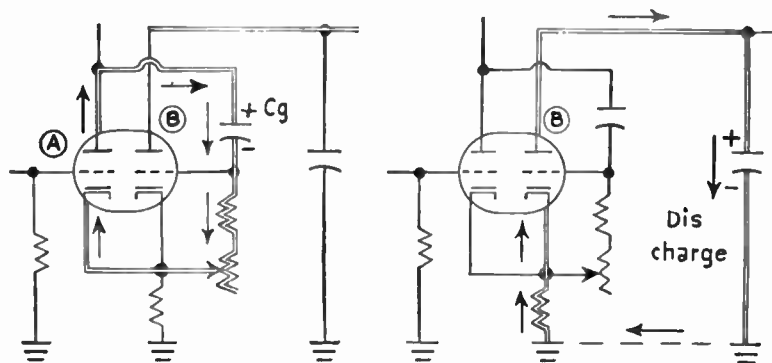

Fig. 96-7.—Actions in grid and plate circuits of the discharge section of the multivibrator.

Operating frequency of the oscillator is determined in the absence of sync pulses by the charge and discharge time of capacitor C_g , whose potential fixes the time at which section B of the tube is made conductive to allow discharge of the sawtooth capacitor. Discharge time for capacitor C_g is varied by adjustment of the hold control resistance.

Sync pulse voltages of negative polarity come to the grid of section *A* while this section is conductive, as at the left in Fig. 96-7. The pulse voltages are amplified and inverted by this section, and are applied through capacitor C_g to the grid of section *B*. The amplified pulses, now positive, make the grid of section *B* positive. Thus this section becomes conductive at the instant of each sync pulse voltage, and allows discharge of the sawtooth capacitor. The condition represented at the right in Fig. 96-7 lasts during only the very brief period of discharge for the sawtooth capacitor.

Fig. 96-8 shows the circuit of a multivibrator sweep oscillator with which coupling between the tube sections is not through a common cathode resistor but is through capacitors C_c and C_g connected between the plate of each section and the grid of the other section. Section *B* acts as an electronic switch across sawtooth capacitor C_s to control charge and discharge of this capacitor as this section is made alternately

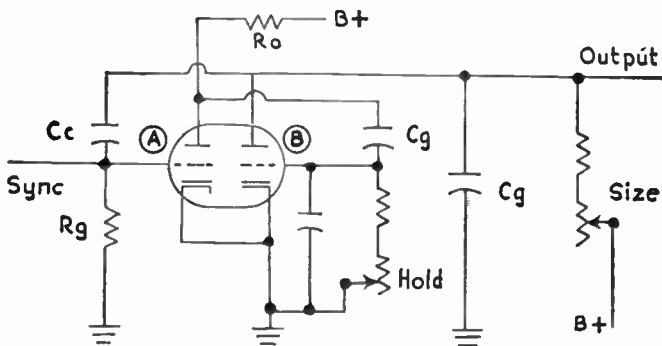

Fig. 96-8.—A capacitor-coupled multivibrator sweep oscillator.

non-conductive and conductive by charge and discharge of grid capacitor C_g . The sawtooth capacitor is charged through the size control resistance.

Increase of plate current in section *A* lessens its plate voltage because of more voltage drop in resistor R_o . The less positive plate voltage, applied through capacitor C_g to the grid of section *B*, makes that grid less positive or more nega-

tive. This change of grid voltage decreases plate current in section *B* and there is an increase of plate voltage on this section because of less drop in the size control resistance. The increased plate voltage or more positive plate voltage is applied through capacitor *C_c* to the grid of section *A*, making that grid still more positive and causing further increase of plate current and drop of plate voltage in that section until plate current reaches saturation.

Capacitor *C_g* now is charged in a polarity and to an extent making the grid of section *B* negative beyond the value for plate current cutoff. This condition continues until capacitor *C_g* discharges through the hold control resistance sufficiently to allow resumption of plate current in section *B*. Then increase of plate current in section *B* drops the plate voltage on this section, and the effect is carried through capacitor *C_c* to make the grid of section *A* become negative. Currents and voltages now are changing in polarities opposite to those first assumed. This action continues until there is plate current cutoff in section *A* while capacitor *C_c* discharges through grid resistance *R_g*. At the completion of this discharge there will be increase of plate current in section *A*, and the whole process repeats.

Sync pulses of negative polarity are applied to the grid of section *A*, are amplified, inverted, and applied to the grid of section *B* to make *B* conductive and allow discharge of the sawtooth capacitor at the instant of the pulse voltages. The small capacitor from the grid of section *B* to ground bypasses high-frequency interference voltages which otherwise might act like sync pulse voltages to trigger the tube.

OSCILLATOR, TELEVISION SWEEP, CONTROL OF.—In many television receivers there is automatic control for frequency of the sweep oscillator. Such control most often is applied to the horizontal oscillator, but may be used also on the vertical oscillator. The purpose of such afc systems (automatic frequency control systems) is to keep oscillator frequency under the sole control of sync pulses. An afc system acts to prevent momentary loss of synchronization such as might result from

interference due to sparking electrical devices or from other "noise" effects. The control also compensates for moderate drift of sweep oscillator frequency. In its correction of frequency drift the afc system acts somewhat as an automatic hold control of limited range, although it seldom replaces the regular hold control.

All afc systems utilize the same fundamental principle, as follows: Sync pulse voltages are combined with voltages taken from the oscillator tuned circuit or from some point following the oscillator output. The combined voltage waveform is utilized to produce a voltage or current which, when returned to the oscillator circuit, will correct a deviation of oscillator frequency should such deviation exist.

A voltage taken from the oscillator circuit or from any point beyond the oscillator output is, of course, varying at the actual frequency of the oscillator and may be either higher or lower than the frequency of sync pulses. An output voltage may be taken from the sawtooth capacitor, from the plate or screen circuit of the sweep amplifier, or from the secondary circuit of the sweep output transformer, which includes the deflection yoke of magnetic deflection systems.

Sync pulse voltage and oscillator voltage at their respective frequencies are combined in a control tube which may be a discriminator, a phase detector, a triode, or a diode. In some afc systems the output of the control tube is fed through a reactance tube to the grid circuit of a Hartley oscillator. In other systems the output of the control tube is fed directly or after amplification to the grid of a blocking oscillator or a multivibrator oscillator.

Control voltage or correction voltage applied to the grid of a blocking oscillator must be negative if oscillator frequency is to be made lower, or positive if oscillator frequency is to be made higher. When applied to the grid of the first section of a multivibrator the control voltage must be positive if oscillator frequency is to be made lower, or negative if the frequency is to be made higher.

Discriminator and Reactance Tube.— Fig. 97-1 shows a typical afc circuit containing a discriminator and a reactance tube for controlling frequency of a Hartley sweep oscillator. The reactance tube and oscillator might be triodes instead of the pentodes here illustrated.

The small resistance of R_k and small capacitance of C_k are effectively in parallel with the tuned circuit of the oscillator, which includes the right-hand winding of the transformer between oscillator and discriminator. Voltage at oscillator frequency is applied across resistor R_k and capacitor C_k . Because of high reactance in the small capacitance the net reactance across the resistor and capacitor is chiefly capacitive. As a result, current in C_k and R_k leads the oscillator

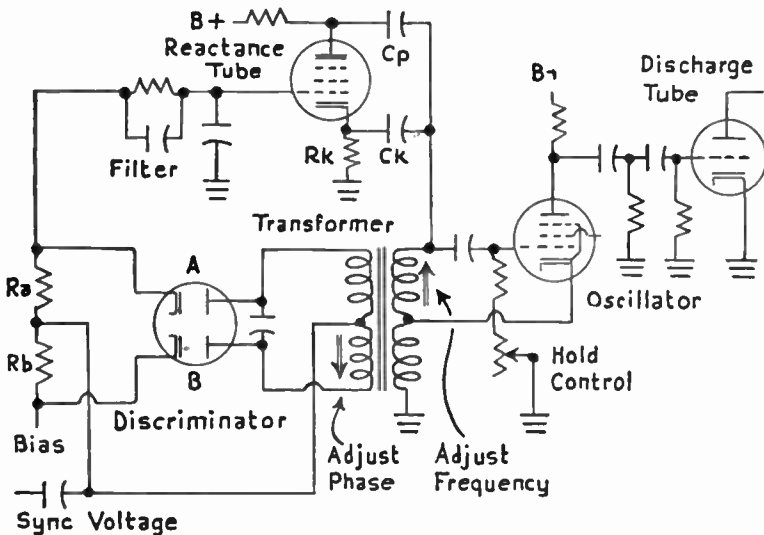

Fig. 97-1.—Sweep afc system using discriminator and reactance tube with a Hartley oscillator.

voltage by almost 90 degrees. But, as in any resistance, current and voltage in R_k are in phase. Since voltage across R_k is in phase with its current, and this current is leading the oscillator voltage by nearly 90 degrees, the voltage across R_k leads oscillator voltage similarly.

Resistor Rk is a cathode resistor for the reactance tube and is in the grid-cathode circuit. Consequently, voltage across this resistor forms an input signal for the reactance tube. This voltage is amplified by the reactance tube and fed from its plate to the tuned circuit of the oscillator through capacitor Cp . The leading amplified voltage combines with the oscillator voltage to produce in the tuned circuit of the oscillator a voltage which is leading with reference to voltage which would exist there without the reactance tube. A leading voltage would accompany more inductance in a tuned circuit, and so the effect is equivalent to adding inductance in the oscillator circuit. The oscillator frequency thus is lowered proportionately to amplitude of leading voltage coming from the reactance tube.

Voltage amplitude from the reactance tube is varied by altering the gain of that tube, this being accomplished by making the grid of the reactance tube more or less negative with reference to its cathode. Making the grid less negative increases the voltage output and lowers the oscillator frequency, while a more negative grid will increase the oscillator frequency. Grid voltage changes for the reactance tube are obtained from the discriminator.

Operation of the discriminator is generally as described in the article on *Discriminators*. However, instead of being supplied on its input side with a continually varying or deviating frequency, as in a sound discriminator, this one is supplied through the coupling transformer with a seldom changing frequency coming from the oscillator. On the output side, across resistors Ra and Rb , are produced voltages which balance unless there is a difference between oscillator frequency and sync frequency. If oscillator frequency becomes higher or lower than sync frequency there no longer are equal currents in the discriminator diodes, and output voltage becomes unbalanced across resistors Ra and Rb .

Resistors Ra and Rb are between the grid of the reactance tube and a source of negative bias voltage for this grid. Unbalanced voltage across the discriminator output resistors

is of such polarity as to counteract part of the negative bias when oscillator frequency increases above sync frequency. Then the reactance tube grid is made less negative, the gain of this tube increases, more reactive voltage goes to the oscillator circuit, and oscillator frequency is lowered. A decrease of oscillator frequency below sync pulse frequency causes opposite unbalance of voltages in resistors R_a and R_b , making the reactance tube grid more negative to decrease its gain, reduce the reactive voltage output, and allow rise of oscillator frequency.

Sync pulse voltages enter the discriminator circuit at the lower left and are applied to the center tap of the transformer winding. These voltages act equally at the plates of both discriminator diodes and, by themselves, cause no unbalance of output voltages.

The filter between discriminator and reactance tube acts to integrate or average the voltage from the discriminator, and to introduce some time delay. This prevents sudden pulses of interference voltage from getting to the reactance tube grid and upsetting synchronization.

The frequency adjustment of the discriminator transformer is a movable core reached from the top of the transformer. This adjustment tunes the oscillator circuit to an approximately correct frequency for holding the pattern or picture stationary. The phase adjustment is a movable core reached from the bottom of the transformer. This core tunes the discriminator side of the transformer to prevent appearance of a vertical black blanking bar in the picture area and to prevent a folded effect at one side of the picture or pattern. The hold control is a front panel adjustment for use by the receiver operator.

Phase Detector and Reactance Tube. — In Fig. 97-2 a reactance tube is controlled by a phase detector instead of a discriminator. The reactance tube furnishes more or less leading voltage for the tuned circuit of the oscillator as may be required to keep oscillator frequency synchronized. Action of the reactance tube is explained in preceding paragraphs.

Operating principles of the phase detector are explained in the article, *Detector, phase*.

Input to the phase detector consists of sawtooth voltage fed back from a connection on the deflection yoke, and of positive and negative sync pulse voltages from the plate and cathode of an inverter tube in the sync section of the receiver. These voltages combine as shown by Fig. 97-3. Diode

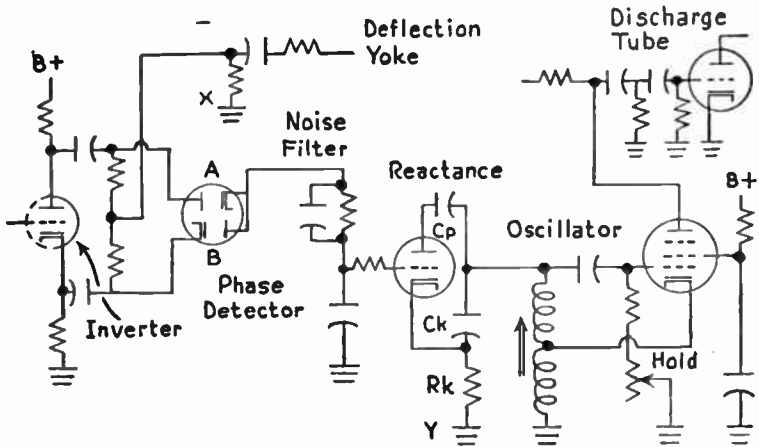

Fig. 97-2.—Phase detector and reactance tube for automatic frequency control.

A conducts when its plate is made positive by positive sync pulses, the positive alternations of the sawtooth wave, or both. Diode *B* conducts when its cathode is made negative by negative sync pulses, by the negative alternations of the sawtooth wave, or both.

At the top of Fig. 97-3 are shown the combined waveforms when oscillator frequency is correctly synchronized. If oscillator frequency increases, the sync voltages go farther down on the sawtooth for diode *A*, but produce negative peaks for diode *B*. If oscillator frequency decreases, the sync voltages cause positive peaks for diode *A*, but drop down on the sawtooth for diode *B*. The output from the phase detector is of zero voltage when oscillator frequency is synchronized, but is positive or negative when oscillator frequency varies from

sync frequency. These correction voltages are applied to the grid of the reactance tube. The phase detector of Fig. 97-2 is in the grid circuit of the reactance tube, which extends from ground connection x on the phase detector input to ground connection y on the reactance tube cathode.

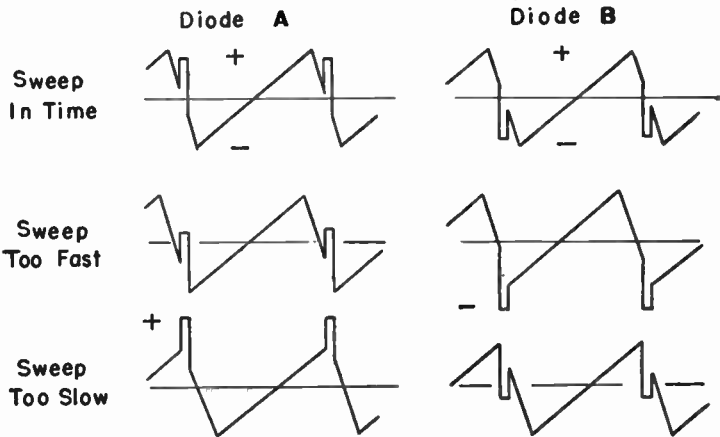

Fig. 97-3.—Combined sawtooth voltages and sync pulse voltages at the phase detector input.

Oscillator frequency is regulated by the adjustable core of the tuned coil in the oscillator grid-cathode circuit. This adjustment is set so that the hold control, a front panel adjustment, will bring the oscillator into synchronization.

Phase Detector and Multivibrator. — Fig. 97-4 shows the circuit for an afc system with which the direct output voltage of a phase detector changes the grid voltage of the first section of a multivibrator when oscillator frequency varies from sync pulse frequency. Sync pulse input to the phase detector is from plate and cathode of an inverter, as is usual practice with phase detectors. In addition, a sawtooth input voltage to the phase detector is derived from voltage at the sweep output transformer by applying transformer voltage pulses to the capacitor-resistor filter between transformer and detector.

The combination waveforms produced in the phase detector circuit are similar to those of Fig. 97-3. When oscillator

frequency, represented by the sawtooth input, is the same as sync pulse frequency the voltages across the phase detector resistors balance, and there is zero direct voltage output. Should oscillator frequency become too low, the phase detector produces a direct negative voltage which is applied through the noise filter to the grid of the first section of the multivibrator. If oscillator frequency becomes too high, a positive

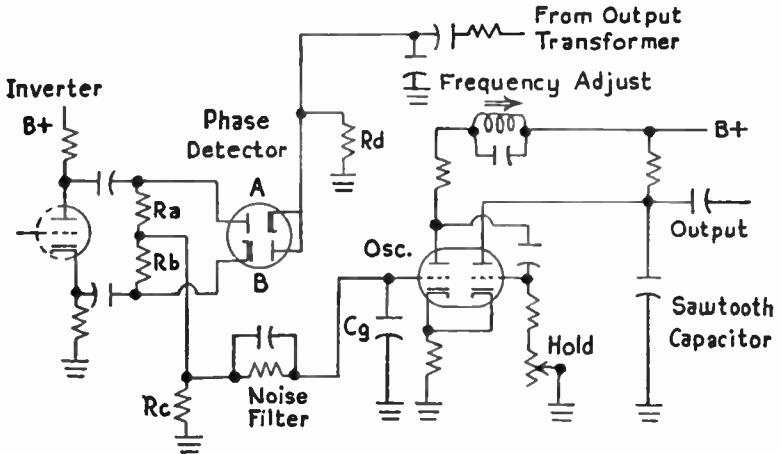

Fig. 97-4.—Phase detector for direct frequency control of a multivibrator oscillator.

output voltage from the phase detector is applied to the grid of the multivibrator. These correction voltages bring the oscillator back into synchronization with sync frequency.

During the positive alternation of the sawtooth input the cathode of diode *A* and the plate of diode *B* are positive in the phase detector. If oscillator frequency is correct, the positive sync pulse acts to make the plate of diode *A* positive. With both plate and cathode positive this diode does not conduct. At the same time, the cathode of diode *B* is negative and its plate is positive, so there is conduction through resistors *Rd*, *Rb*, *Rc*, and this diode. During the negative alternation of the sawtooth input the polarities reverse, and there is conduction through resistors *Rd*, *Ra*, *Rc*, and diode *A*.

Directions of electron flow in resistors R_c are opposite during opposite alternations of the sawtooth input. If the oscillator is in synchronization these opposite electron flows are equal, and they cancel in the time delay circuit which includes the noise filter and grid capacitor C_g on the multivibrator. If oscillator frequency becomes low there will occur a negative sync pulse on the cathode of diode B while the plate of this diode is made negative by the sawtooth voltage, this because the sawtooth wave now lags the sync pulse. There is reduction of electron flow in diode B , but much less reduction in diode A . The result is an average voltage which is negative across resistor R_c . This negative voltage goes to the multivibrator grid to increase the oscillator frequency. The entire action is reversed should oscillator frequency become too high in comparison with sync frequency.

Control Tubes and Amplifiers. — In a number of receivers a triode amplifier tube is used between either a phase detector or a discriminator and the sweep oscillator. The sweep oscillator may be either a multivibrator type or a blocking oscillator. The amplifier inverts the polarity of output voltage changes from the phase detector or discriminator before these voltage changes are applied to the grid of the oscillator. Since the different types of oscillators require opposite polarity of control voltages to produce a given change of oscillator frequency, and since polarity is inverted in the amplifier, it is necessary to supply sawtooth waves and sync pulses to the control tube in such polarities as meet the needs of the oscillator.

There are many possible ways of inverting the polarity of either the sawtooth wave or the sync pulses applied as input to the phase detector or multivibrator used as a control tube. Connections may be reversed to plates and cathodes of the control tube so that conduction intervals in the two diode sections are reversed in relation to sync input voltages. Another way is to use a transformer between the last tube in the sync section and the control tube, with the transformer taking the place of the usual inverter tube. Voltages in opposite phase

from opposite ends of the transformer secondary then are applied to the plates or cathodes of the control tube. Still another method consists of taking the sawtooth voltage from one side or the other of the sweep output transformer. If this voltage is taken from the transformer primary or the plate circuit of the output amplifier it will be of one polarity, and if taken from the secondary or deflection yoke side will be of opposite polarity.

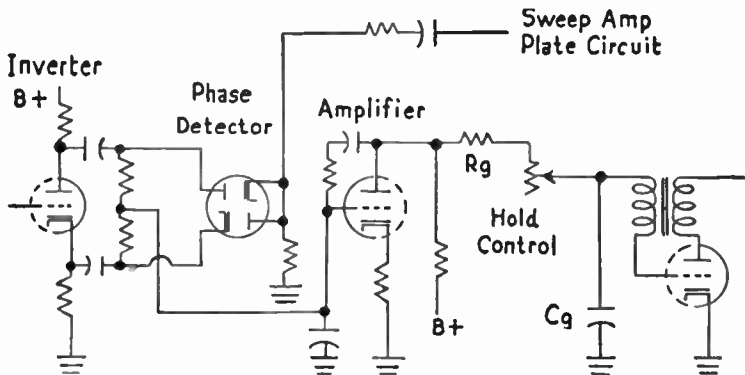

Fig. 97-5.—Sweep afc system employing an amplifier between a phase detector and a blocking oscillator.

Fig. 97-5 shows connections for a phase detector controlling a blocking oscillator through an amplifier. Sync pulse input to the phase detector comes from an inverter tube, while sawtooth voltage at oscillator frequency is fed back from the plate circuit of the sweep output amplifier.

Diode Afc Control Tube. — In the afc system of Fig. 97-6 a diode control tube is used to vary the grid voltage of a blocking oscillator as may be required to keep the oscillator frequency in time with sync pulse frequency. This control is used by Motorola in receivers having an electrostatic picture tube, for which deflection plate voltages are furnished from the plate and cathode of the oscillator through connections at the right in the diagram. The sawtooth capacitors are C_s and C_s .

This system is unusual in that there are combined in the control tube a sine wave voltage from the sync input and sharp

pulses of voltage secured from across the lower sawtooth capacitor as this capacitor discharges. Charge and discharge voltage of the sawtooth capacitor form a sawtooth wave, but this wave is differentiated by capacitor C_d and resistor R_d to furnish from between them only sharp pulses of voltage during discharge of the sawtooth capacitor. These voltage pulses are

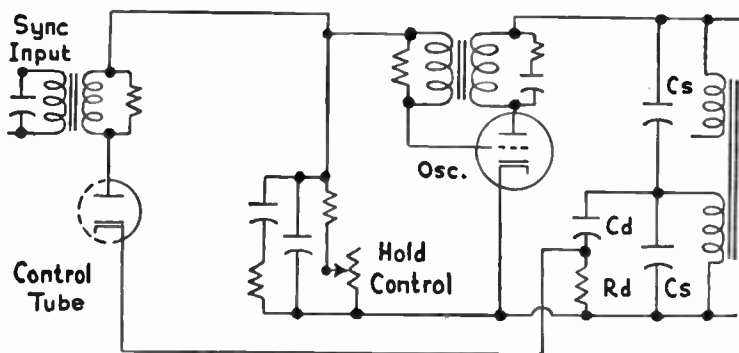

Fig. 97-6.—A diode used as the control tube in an afc system for a blocking oscillator.

applied to the cathode of the control tube. Their frequency is the same as that of the oscillator. To the plate of the control tube is applied a sine wave derived from sync pulses by means of the capacitor across the primary side of the sync input transformer. The frequency of this sine wave is that of the sync pulses.

The combination of the two voltages applied to the control tube is shown by Fig. 97-7. When synchronization is correct the oscillator pulse rides midway up on the positive alternation of the sync sine wave. If oscillator frequency becomes too low, the oscillator pulse rides higher and this side of the wave becomes more positive. If oscillator frequency becomes too high the pulse rides lower on the sync wave and voltage becomes less positive.

Voltage more positive sends more current through the hold control resistances, thus increasing voltage drop and bias on the oscillator grid to reduce oscillator frequency. With control voltage more negative there is less current and less voltage

drop in the hold control, which decreases oscillator grid bias and increases the oscillator frequency. The purpose of the capacitors and resistor across the hold control is to provide time delay which holds the sweep synchronized through a period of 20 to 50 picture lines.

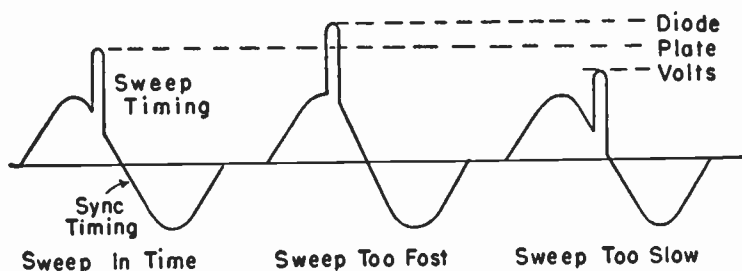

Fig. 97-7.—Combined pulses from oscillator output, and sine waves at sync pulse frequency, as they appear at the afc diode.

Triode Afc Control Tube. — Fig. 97-8 shows an afc system in which a triode control tube is used for varying the grid bias of a blocking oscillator. To the grid of the control tube is fed sync pulse voltage through capacitor C_a , also a sawtooth voltage at oscillator frequency taken from the deflection yoke through resistor R_b and capacitor C_b , and sometimes in addition through a resistor connection to sawtooth capacitor C_s .

The oscillator is negatively biased by charge of grid capacitor C_g , which leaks slowly away through grid resistors R_f and R_g . Part of the negative bias voltage at the oscillator grid is applied to the grid of the control tube through a resistance voltage divider consisting of resistors R_c , R_d and R_g . The portion of the oscillator bias voltage appearing across resistor R_g is varied by changes of control tube plate-cathode current, which flows in resistor R_g . This current is changed by variations of control tube grid voltage resulting from combination of the sync and sawtooth voltages at the grid.

The manner in which the sync and sawtooth voltages combine at the grid of the control tube is illustrated by Fig. 97-9.

Each period of conduction in the control tube charges capacitors Cc and Cd , which are in the cathode circuit, making the upper plates of these capacitors positive. The greater the total duration of conduction periods in the control tube the greater is the charge and the voltage placed on the capacitors.

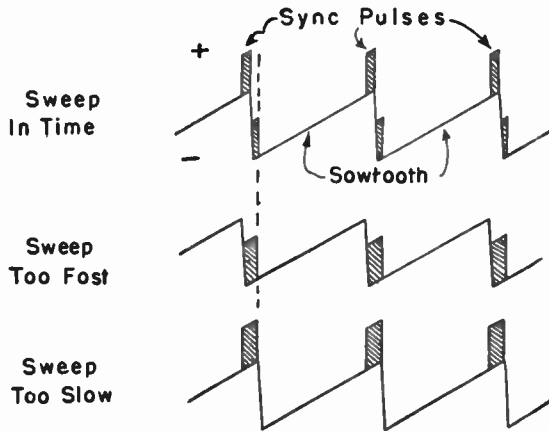

Fig. 97-9.—How the effective width of sync pulses is varied by their combination with a sawtooth voltage.

Since these capacitors are connected across resistor R_g , positive voltage of the capacitors counteracts more or less of that part of the oscillator negative grid bias which is across resistor R_g .

When oscillator frequency becomes too high there is less charging of capacitors Cc and Cd , and oscillator grid bias is allowed to become more negative. This will lower the frequency of a blocking oscillator. Should oscillator frequency become too low there will be increase of capacitor charge and voltage. Then the oscillator bias is made less negative and oscillator frequency is increased.

Feedback from plate to grid of the oscillator is through the auto-transformer shown at the right of the tube in Fig. 97-8. An adjustable core in this transformer allows varying the free running frequency of the oscillator. Output to the sweep

amplifier is from the transformer tap. An adjustable core in coil La allows resonating this coil with capacitor Ce to approximately the correct sweep frequency. This tuned circuit then causes increase of alternating plate and grid voltages at the oscillator. In some receivers there is an adjustable capacitor Cf in parallel with capacitors Cc and Cd . Adjustment of this capacitor varies the total capacitance which is charged from the control tube and alters the charge voltage and its effect on oscillator bias.

The adjustable lock-in capacitor on the grid circuit of the control tube acts as a variable bypass for allowing greater or less amplitude of combined control voltages to act on the grid of this tube. All adjustments mentioned so far are service adjustments. The one front panel adjust is the hold control which is in series with the plate of the control tube. This hold control varies the plate voltage of the control tube and thus alters the amount of charging current for capacitors Cc and Cd .

OSCILLATORS, ULTRA-HIGH FREQUENCY. — Operation of oscillators at frequencies higher than about 300 mc introduces many difficulties which are unimportant or absent at lower frequencies. Among the principal difficulties are excessive interelectrode capacitance effects in the oscillator tubes, also the inductance and capacitance of internal leads for the tube elements. Distributed and stray capacitances throughout the circuits have more effect on tuning as frequency increases, and it becomes difficult to construct circuits of high inductance-capacitance ratio or of high Q-factors. Excess capacitance tends to improve frequency stability, but the lack of inductance makes the circuits less efficient in use of applied power. Tuned circuits for ultra-high frequency operation most often are resonant lines or cavity resonators, rather than being built with coils and capacitors. Losses are reduced by having the least possible dielectric material in the electric fields.

Many miniature tubes and acorn tubes are designed for operation at frequencies up to 700 or 800 mc, and some of them will operate efficiently enough for use in receivers at frequencies as high as 1,200 mc. Some of the new tubes de-

signed for use in grounded grid circuits are satisfactory up to 3,000 mc.

Electron transit time from the cathode to other elements in a tube is the factor which limits the operating frequency in many constructions. When the distance between elements is any considerable fraction of a wavelength corresponding to operating frequency an electron may progress only part way from one element to another before the electric fields reverse. Even when electrons have time to complete their travel the variations of field strength during a cycle have an effect equivalent to reduction of resistance between cathode and negative grid, with corresponding decrease of Q-factor and increase of power taken from the grid circuit.

Transit time effects are used to advantage in certain types of ultra-high frequency oscillators. Among these types are positive-grid or Barkhausen oscillators within the tubes of which the electrons swing back and forth between cathode and plate, and through the grid. When the external tuned circuit is suited to the tube space dimensions and applied voltages the oscillating electrons transfer power to this circuit. Transit time is utilized also in some magnetron oscillators where electron paths are determined by combinations of magnetic and electric fields. Still another oscillator utilizing transit time effects is the klystron in which electrons accelerated to different velocities during different parts of a cycle will bunch together for the equivalent of current pulses at another point in the tube. Oscillators which take advantage of transit time effects commonly are used at frequencies between 1,000 and 10,000 mc.

OSCILLOSCOPES. — An oscilloscope or oscillograph is an instrument employing a cathode-ray tube on whose screen may be shown in the form of a luminous trace the waveform of an alternating voltage or of any voltage which varies with respect to time. A smooth direct current will produce no trace on oscilloscopes of usual types. The oscilloscope is used also for observation of frequency response in radio-frequency, intermediate-frequency, and audio-frequency amplifiers of

all types. Inasmuch as the functioning of television receivers depends so greatly on voltage waveforms which must be of certain shapes, and on frequency responses of the various amplifiers, the oscilloscope or oscillograph is among the most useful of instruments for television design and servicing.

Service oscilloscopes have cathode-ray tubes of the electrostatic deflection type whose operating principles are the same as those of electrostatic-deflection picture tubes in television receivers. The electron beam in the oscilloscope tube is deflected vertically by any voltage whose waveform or amplitude is to be observed. At the same time the beam is deflected back and forth horizontally by a separate deflection voltage which may be generated within the oscilloscope or else taken from any of various external sources.

Frequency of horizontal deflection is made such that during each horizontal sweep of the beam there will occur one or more complete cycles of the observed voltage which is causing vertical deflection. With horizontal and vertical frequencies thus timed or synchronized, the observed voltage wave or a trace of amplitude versus frequency will appear stationary on the oscilloscope screen. The form of the trace may be seen to change during any alterations, adjustments, or alignment operations in circuits connected to the vertical input of the instrument.

Parts of an Oscilloscope. — The principal parts of typical service oscilloscopes are shown on the simplified block diagram of Fig. 99-1. Arrows indicate directions in which control voltages are fed from part to part. At the upper right-hand corner of the diagram is represented the cathode-ray tube. Voltage which is to cause vertical deflection is fed from the vertical input terminals through a gain control and amplifier to vertical deflection plates of the tube. Voltage which is to cause horizontal deflection is fed from the horizontal input terminals, or from the horizontal sweep oscillator, or from a 6-volt line-frequency source through the sweep selector switch, a gain control, and an amplifier to the horizontal deflection plates of the cathode-ray tube.

To the plates and other electrodes of the cathode-ray tube are connected vertical and horizontal centering controls, a focus control, and an intensity control that varies the brightness of the luminous trace on the tube face. These three controls are in the circuit of the high-voltage power supply system. A low-voltage power supply furnishes voltages and currents

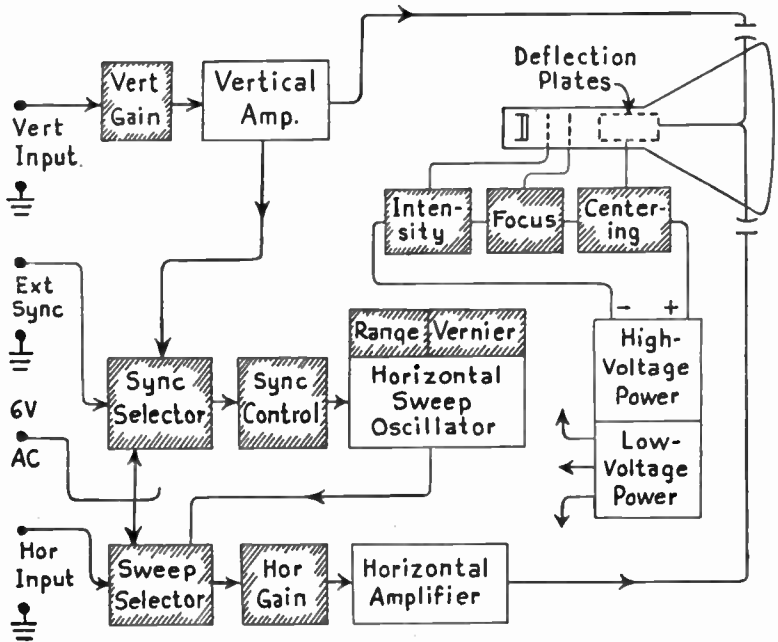

Fig. 99-1.—Principal parts used in service oscilloscopes.

for plates, screens, grid biases, and heaters in amplifier and oscillator tubes. Controls which are shaded in the diagram, and the functions of these controls, will be described in more detail in pages following.

Several of the parts in the oscilloscope are similar to certain parts of a television receiver. The centering controls are explained in the article, *Centering and Centering Controls*. The focus control is explained under *Focusing and Focusing Controls*. The horizontal sweep oscillator may use a gaseous tube

as shown in the article on *Oscillators, Relaxation*, or it may use a multivibrator oscillator described under *Oscillators, Television Sweep*.

Cathode ray-tubes of the electrostatic deflection type are used in practically all oscilloscopes because this deflection method allows satisfactory operation throughout a wide range of deflection frequencies, whereas with magnetic deflection circuits the changes of inductive reactances with frequency would limit the useful frequency range.

Screens usually are of phosphor number 1, which produces a bright green trace. Phosphor number 4, with the white trace found in television picture tubes, sometimes is used. Where a principal object is photography of traces, the phosphor may be number 5 or number 11, whose color strongly affects photographic emulsions.

When working on the high-voltage circuits of the cathode-ray tube and high-voltage power supply it is necessary to observe the same precautions as when working with high-voltage circuits of television picture tubes.

Shortcomings found in some of the lower cost oscilloscopes include lack of uniform frequency response in the vertical amplifier, insufficient gain in this amplifier, and a non-linear horizontal sweep which may be due to faults of the internal sweep oscillator but more often to poor frequency response in the horizontal amplifier. Horizontal sync signals from television receivers may be much distorted if the oscilloscope vertical amplifier does not provide nearly uniform response at frequencies up to at least 200 or 250 kilocycles. Frequency response curves taken from receiver amplifier circuits will not indicate true relative gains when using an oscilloscope with internal sweep which is non-linear. This latter difficulty is avoided when using a synchronized sweep from a signal generator or sweep generator.

Controls and Terminals. — The arrangement of controls and terminal connections on the panels of service oscilloscopes is shown in a general way by Fig. 99-2. Names used on this

figure are the same as on Fig. 99-1. Exact positions of controls, and names applied to them, will vary with the make of instrument and between models of the same make.

At the left side of the cathode-ray tube is an *Intensity* control which changes the bias on the control grid of this tube to vary the brightness of the trace formed on the screen. This corresponds to the brightness control of a television receiver. In order to prevent damaging the screen material of the cathode-ray tube, brightness or intensity always should be kept as low as produces satisfactory visibility of the trace. Keeping strong external light away from the face of the tube allows using low intensity. Many oscilloscopes have a hood extending out around the tube face or have the face recessed in the housing to provide shielding against external light.

Should there be temporarily neither vertical nor horizontal deflection of the beam in the cathode-ray tube, the intensity must be kept so low as to make the spot of light on the screen barely visible or completely extinguished. A stationary bright spot will burn the screen material. The on-off switch for the oscilloscope may be combined with the intensity control, just as it is combined with the sound volume control in receivers.

On the right-hand side of the cathode-ray tube is the *Focus* control, which performs exactly the same function as a focusing control in a television receiver—keeping the trace line of minimum width and maximum clarity. Turning this control either way from a correct setting will widen the trace. The focus control will require readjustment when the intensity control is varied.

On the left side of the panel of Fig. 99-2 is a vertical *Centering* control, sometimes called a positioning control, which will move the entire trace up or down to center it between top and bottom of the tube face or to bring the trace to any desired position. On the right is a horizontal *Centering* or position control which will move the entire trace sideways to center it between right and left sides of the tube screen or to bring the trace wherever desired.

Down below the centering controls are vertical and horizontal *Gain* controls. These controls vary the gain of vertical and horizontal amplifiers which are part of the oscilloscope.

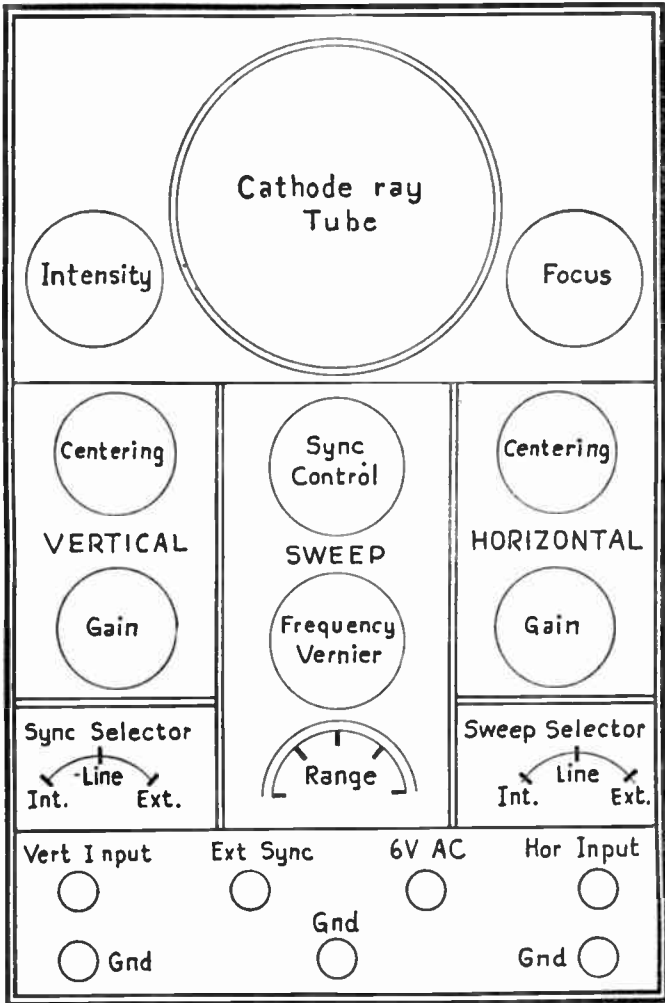

Fig. 99-2.—Controls and terminals on the panel of an oscilloscope.

Input voltage for the vertical amplifier is applied to the oscilloscope through the terminal marked *Vert Input* and a ground

terminal at the lower left-hand corner of the panel. To these terminals may be brought any voltage which is to cause vertical deflection of the beam or whose waveform is to be observed. Changing the gain of this amplifier will either extend or contract the trace in a vertical direction without altering the width.

Input to the horizontal amplifier of the oscilloscope may be from the horizontal sweep oscillator built into the instrument or from any external voltage applied between the panel terminal marked *Hor Input* and a ground terminal at the lower right-hand corner of the panel. Changing the gain of the horizontal amplifier makes the trace occupy more or less space from side to side, but does not alter the height.

When a voltage at power line frequency is to be applied to either the vertical or horizontal amplifiers this voltage may be obtained from the terminal marked *6V AC*. This terminal usually is connected inside the instrument to one of the low-voltage heater circuits. An external connection from *6V AC* to the *Vert Input* terminal allows applying power line frequency to the vertical amplifier, while a connection from *6V AC* to the *Hor Input* terminal allows applying line frequency to the horizontal amplifier.

The gain controls normally are used to provide traces of desired size from input voltages of various strengths. These controls serve the same purpose as size controls or height and width controls in television receivers. The gain controls may be used also to enlarge the trace for close examination of any one portion. This particular part of the trace then may be centered on the screen by manipulating the vertical and horizontal centering controls. Other parts of the enlarged trace then will be outside the screen area and will be invisible.

Underneath the horizontal gain control of Fig. 99-2 is a *Sweep Selector* switch that selects the source of voltage input to the horizontal sweep amplifier. When this switch is turned to the position marked *Int*, for internal, the amplifier input is connected to the output of the sweep oscillator which is within the oscilloscope. This switch position sometimes is

marked *Sweep*. With the switch set at the *Line* position the horizontal amplifier is fed voltage at power line frequency, as secured from one of the tube heater circuits inside the instrument. With the switch turned to the position marked *Ext*, for external, the input of the amplifier is connected to the terminal immediately below the switch, marked *Hor Input*. To this terminal and the ground terminal underneath may be connected any source of voltage to be used for horizontal deflection of the oscilloscope beam.

In the center of the panel of Fig. 99-2 are three controls which alter the operating frequency of the horizontal sweep oscillator built into the oscilloscope. The lowermost of these controls is a range switch for connecting sawtooth capacitors of different capacitances to the oscillator. This switch may be marked *Coarse Frequency* or with some other equivalent name. Since greater sawtooth capacitance causes increase of the time constant for charging through any given resistance, the greater capacitance decreases the oscillator frequency. Conversely, when a smaller sawtooth capacitance is switched into the oscillator circuit there is increase of oscillator frequency. The several positions of the range switch provide sweep frequency bands extending from about 15 cycles per second to about 30 kilocycles with gaseous tube oscillators, or to 70 or more kilocycles per second with vacuum tube oscillators.

Immediately above the range switch is a *Frequency Vernier* control for varying the resistance through which the sawtooth capacitor is charged. This control may be marked *Frequency*, *Fine Frequency*, or with some other equivalent name. Increasing the charging resistance lengthens the time constant for charging and lowers the oscillator frequency, while decreasing the resistance shortens the time constant and raises oscillator frequency. This control is capable of varying the horizontal sweep frequency throughout any one of the bands covered by the range switch.

The range switch and frequency vernier control may be operated to bring one or more complete cycles of vertical

input voltage onto the oscilloscope screen. If these controls are adjusted to make the horizontal sweep frequency the same as frequency of the vertical input voltage there will be one complete cycle of vertical voltage on the screen. If sweep frequency is lowered to exactly half the vertical frequency there will be two cycles, if made one-third the vertical frequency there will be three cycles, and so on.

In order that a trace to be observed on the oscilloscope screen may remain stationary it is necessary that the horizontal sweep frequency remain in time with or synchronized with frequency of the voltage whose waveform or amplitude is to be observed, and which is causing vertical deflection. If the internal sweep oscillator is being used for horizontal deflection, this oscillator must be synchronized with the vertical deflection voltage. Such synchronization may be effected by applying part of the vertical deflecting voltage to the horizontal sweep oscillator, just as sync pulses are applied to sweep oscillators in television receivers. This synchronizing voltage for the sweep oscillator is taken from some point in the vertical amplifier.

The frequency controls are used to make the free running frequency of the internal sweep oscillator just a little lower or slower than the vertical input frequency. Then a synchronizing voltage applied to the sweep oscillator will bring the oscillator frequency into time with vertical input frequency. The synchronizing voltage has the effect of locking the trace in a stationary position on the screen of the oscilloscope tube.

When the internal sweep oscillator is not being used for horizontal deflection it still is necessary to synchronize the horizontal deflection frequency with the vertical input frequency. Necessary synchronizing voltage then must be secured from some external source whose frequency is equal to or is some simple fraction (sub-multiple) of the vertical input frequency.

The source of synchronizing voltage is selected by the *Sync Selector* switch located at the left of the range switch in Fig. 99-2. With this switch turned to its *Int* (internal) position the

synchronizing voltage is taken from the vertical amplifier as mentioned before. When the sync selector switch is turned to its *Line* position the synchronizing voltage is being taken from one of the tube heater circuits within the oscilloscope, and is at power line frequency. If the switch is placed on the *Ext* (external) position it becomes possible to use for synchronizing any voltage applied between the *Ext Sync* terminal and one of the ground terminals along the bottom of the panel.

At the top center of the panel, just below the cathode-ray tube, is a *Sync Control* consisting of a potentiometer which varies the strength or amplitude of whatever voltage is being used for synchronization. This control sometimes is marked *Sync Amplitude*, *Sync Adjust*, *Sweep Sync*, or with some other equivalent name.

Synchronizing voltage must be of the least strength which allows holding the trace stationary. Otherwise the trace will be distorted and will not show true waveform or response. The sync control should first be turned nearly all the way off while the frequency vernier is used to make the trace as nearly stationary as possible. Then sync control should be increased just enough to hold the trace stationary.

Some oscilloscopes have provision for intensity modulation, which is a periodic blanking of the beam or reduction of intensity by means of some external voltage which makes the grid of the cathode-ray tube periodically more negative. A suitable modulating voltage is applied to intensity modulation terminals of the instrument, and from there passes, either with or without amplification, to the grid-cathode circuit of the tube. This voltage usually consists of short pulses at a frequency higher than that of vertical input voltage, which will break up the trace at the modulation intervals or points. The modulating voltage otherwise may be at some lower frequency which will blank certain portions of the trace.

Operating the Oscilloscope. — Any voltages applied from external sources to the vertical input of the oscilloscope must be brought from their sources through shielded cable with the shield connected to ground on the oscilloscope. Although

shielded cable may not be a necessity for other inputs it is preferable also for bringing external voltages to the horizontal input and to the external sync input terminals.

Voltage brought to the vertical input often is accompanied at its source by higher frequencies than are to be observed. A case in point is when a signal is taken from the load resistor of a video detector. The higher frequencies should be bypassed by using on the source end of the input cable a filter probe. Otherwise the traces will be indistinct or have fuzzy outlines and backgrounds.

If vertical input voltage for the oscilloscope is to be the low-frequency modulation of a radio- or video-intermediate-frequency signal taken from one of the high-frequency amplifiers, the demodulation may be accomplished by using a detector probe on the source end of the input cable. Filter probes and detector probes are described in the articles on *Probes*.

When necessary input connections have been arranged, the next step is to make preliminary settings of the various controls on the oscilloscope. When the internal horizontal sweep oscillator is to be used for horizontal deflection, place the sweep selector switch at *Int* and the sync selector switch to *Int*, thus taking a synchronizing voltage from the vertical amplifier which is carrying the vertical input voltage. There may be cases where the internal sweep is to be synchronized by some voltage other than that of the vertical input, whereupon the sync selector would be set at *Ext* and the synchronizing voltage connected to the *Ext Sync* terminal.

In most television alignment work synchronization will be by means of a synchronized sweep voltage supplied from a television signal generator or sweep generator. Then the sweep output from the generator is connected to the *Hor Input* terminal and a ground terminal. The sweep selector switch is set at *Ext*. The sweep voltage already is synchronized in the test generator, so the sync selector switch of the oscilloscope may be set at *Ext* with no connection made to the *Ext Sync* terminal.

When some other external synchronizing voltage is to be used, this voltage is connected to the *Ext Sync* terminal and a ground terminal on the oscilloscope. The sync selector switch is set at *Ext*. Setting of the sweep selector switch depends on the source to be used for horizontal sweep voltage. If this sweep voltage is to come from the internal sweep oscillator the sweep selector is set to *Int*. If an externally supplied voltage is to cause horizontal sweep the sweep selector switch is set to *Ext*, and the synchronizing voltage is connected to the *Ext Sync* terminal and a ground terminal.

When preliminary settings and connections are completed the oscilloscope is placed in operation and allowed to warm up. Final adjustments then may be made as follows:

1. Set the range switch to include the frequency of the voltage applied to the vertical input.

2. Turn the sync control to a low setting, for minimum synchronization voltage.

3. Adjust the intensity control to produce a visible trace or pattern.

4. Adjust the frequency vernier or fine frequency to produce a trace with the desired number of cycles of vertical input voltage on the screen. The range switch may have to be set for a lower frequency band to obtain the desired number of cycles. Continue adjusting the frequency vernier to make the trace stationary or until there is the slowest possible travel to the right or left.

5. Advance the sync control just enough to hold the trace stationary.

6. Adjust the focus control to make the trace line as thin as possible.

7. Use the centering controls, if necessary, to bring the trace to the desired position on the screen.

8. Adjust the gain controls to make the trace of the desired height and width.

If the oscilloscope is to be left turned on between observations, to avoid need for a reheating time, always reduce the intensity to prevent formation of a trace.

P

PADS, MATCHING. — A matching pad is an arrangement of resistors used to provide desired impedance relations between a source and a load. When a signal generator is connected to the antenna terminals of a receiver the resistance load on the generator should approximately equal the internal output impedance of the generator. At the same time the resistance

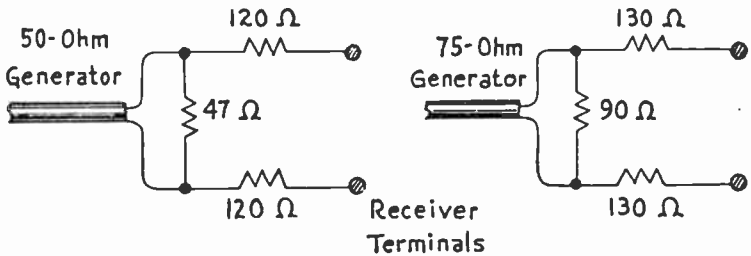

Fig. 100-1.—Matching pads used between signal generators and receiver antenna terminals.

placed across the receiver terminals should approximately equal the receiver input impedance. If this is not done there will be wave reflection losses at the junctions and standing waves at certain frequencies when generator output and receiver input impedance are not alike. Effects are similar to those with an antenna, a transmission line, and a receiver that are not matched.

Signal generators usually have output impedances of either 50 ohms or 75 ohms. The output of such generators may be directly connected to antenna terminals of a receiver designed for unbalanced transmission lines of similar impedance, such as coaxial transmission lines. But a matching pad should be used between a 50-ohm or 75-ohm generator output and the antenna terminals of a receiver designed for a 300-ohm balanced transmission line. Fig. 100-1 shows connections and resistances used in two pads arranged for this purpose. The pads usually are placed at the receiver end of the cable between generator and receiver.

PATTERNS, TEST.— A test pattern is a stationary design transmitted in the picture channel of a television station between the time when the station goes on the air and the time when regular programs are transmitted. The test pattern is accompanied by a steady audible tone transmission in the sound portion of the channel. The chief purpose of test pattern and tone transmission is to furnish types of signals which are of assistance in alignment and other adjustments on television receiver installations.

Test patterns from different stations vary in design, but many features common to most patterns are illustrated by Fig. 101-1. There are parts of a large outer circle whose edges at the left and right indicate the correct width of picture area in the mask, and there is a smaller inner circle or parts of such a circle whose top and bottom indicate the correct height of picture area. These circles are useful in adjustment of size controls for width and height, also in adjustment of centering controls. The circles provide a check on linearity and provide a guide for adjustments, since all parts of each circle should be equidistant from the center of the pattern, or the circles should be truly round.

Resolution wedges extend vertically and horizontally from the center of the pattern. These wedges consist of lines and spaces which are relatively wide and far apart at the outer ends, and narrow and close together near the center. The farther toward the center the wedge lines remain distinctly separated the better is the resolution or the greater is the detail which will be rendered in pictures. The approximately vertical lines provide a check on horizontal resolution, since the electron beam there travels alternately from dark to light shadings. The approximately horizontal lines provide a check on vertical resolution, since they extend across vertical lines of pictures. On some test patterns there are reference numbers showing resolution in number of lines at various points along the wedges. The numbers on Fig. 101-1 would each be multiplied by 10 to give corresponding numbers of lines which are separated at the respective positions.

The resolution wedges provide an additional check of linearity, since their lines and spaces should be straight at all points if there is linear reproduction. The vertical lines of the wedges for horizontal resolution will show certain kinds of peaking or excessive response at certain frequencies in ampli-

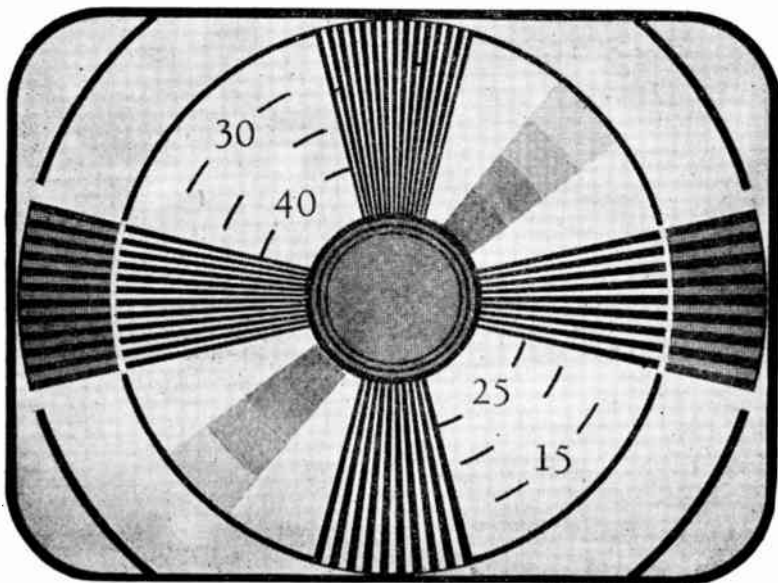

Fig. 101-1.—Features of a test pattern which are of assistance when making adjustments.

fiers. When such trouble is present there will be a dark smudge from left to right across the wedge lines.

With the pattern here illustrated there are two tone wedges whose shading varies along the length of the wedges. These wedges provide a check on contrast and brightness, for with correct adjustments the change of shading or tone will be fairly gradual. Parts of a pattern other than tone wedges often have graduated shading to allow checking contrast and brightness relations.

The lines on test patterns make evident the presence of ghosts or signal reflections. The large clear areas allow easy identification of the formations which are peculiar to and

which indicate the existence of many kinds of interference. Test pattern observation and the interpretation of various effects is the basis for a system of trouble location described in this book.

POTENTIAL, CONTACT. — Contact potential in a tube is a small negative potential, with reference to the cathode, which is produced on elements close to the cathode when the cathode is heated. This negative contact potential is the result of electrons collected by the element near the cathode when the cathode is heated to cause emission and a negative space charge within the tube. The higher the cathode temperature or the greater the emission, the greater becomes the contact potential. In tubes having heater cathodes the value usually is between 0.3 and 0.7 volt, but it may be as high as 1.4 to 1.5 volt. Contact potential is maximum on the element closest to the cathode, which is the grid of a triode, pentode or beam power tube, or is the plate of a diode.

Contact potential will cause current of a few microamperes in a resistance connected between the cathode and the nearest other element provided no other opposing potentials or voltages are present. Contact potential will affect a grid bias. It causes incorrect indications when using detector probes containing a tube unless the effect is compensated for, usually by another similar tube in the same circuit but with connections reversed between cathode and the nearest element. Contact potential is the chief cause of erratic control of plate current in a tube with a free grid or a disconnected grid. The value of negative contact potential tends to drop as a tube ages in use. Contact potential will be indicated by a voltmeter having sensitivity of 20,000 ohms per volt, or better by an electronic voltmeter, when no external voltages are applied to any of the tube elements while the cathode is heated.

POWER SUPPLY, HIGH-VOLTAGE. — The high-voltage power supply of a television receiver furnishes potentials up to 5,000 volts for plates and accelerating anodes of electrostatic deflection picture tubes, and potentials up to 12,000 or more volts for the high-voltage anode of direct-view magnetic

deflection tubes. Two principal types of high-voltage supply are in use. In one of them, called a pulse-operated or flyback type, there is rectification of high-potential pulses caused by auto-transformer action in an extension of the primary winding on the horizontal sweep output transformer. The rectified pulse voltage may be raised in a voltage multiplier before being filtered and passed to the picture tube. Flyback or pulse-operated power supplies are used with magnetic deflection picture tubes.

The other type of high-voltage power supply employs an oscillator operating at radio frequency to produce from the d-c voltages on its elements an alternating voltage which is stepped up by a transformer. This stepped-up voltage is filtered and delivered to the picture tube circuit. This type is used with electrostatic deflection picture tubes and sometimes with magnetic deflection tubes.

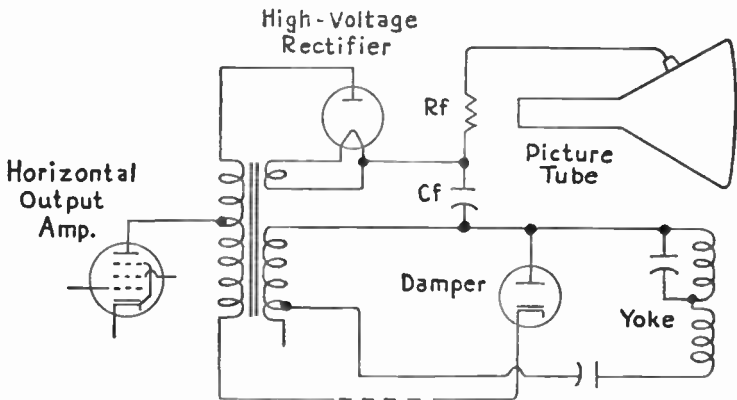

Fig. 103-1.—High-voltage power supply of the flyback or pulse-operated type.

Flyback Power Supply. — Circuit connections for a typical flyback or pulse-operated power supply are shown by Fig. 103-1. This style of power supply, shown at the top of the diagram, may be connected to any of the deflection yoke circuits in general use. One such circuit is shown in the lower part of the diagram.

At the instant of plate current cutoff in the horizontal output amplifier there is collapse of magnetic fields in the deflection yoke circuit, which includes the secondary winding of the output transformer. It is this collapse that starts retraces. The sudden change of magnetic field induces a pulse of negative potential in the secondary. Induction between secondary and primary induces a positive pulse in the primary winding. In the portion of the primary connected between the amplifier plate and damper cathode this pulse potential reaches 4,000 volts or more. The upward extension of the primary makes this winding an auto-transformer, and between top and bottom of the entire winding the pulse potential is stepped up to something on the order of 8,000 to 10,000 volts. This potential varies with operating conditions in the sweep amplifier and yoke circuits and on the strength of the negative pulse initially produced in the yoke circuit.

The high-voltage pulses are applied to the high-voltage rectifier. Rectified current charges capacitor C_f . The time constant of C_f and resistor R_f is longer than intervals between pulses, so the capacitor retains a charge and delivers fairly constant voltage to the picture tube anode through R_f . Filtering effect is increased by capacitance of conductive coatings and the glass of the envelope in some types of picture tubes.

Power supply voltage is affected to some extent by adjustment of width controls, drive controls, and peaking controls, since these adjustments alter the plate current of the output amplifier and currents in the yoke circuit. Any failure which prevents operation of the output amplifier stops the high-voltage supply to the picture tube. Damper failure stops the high-voltage supply when output amplifier plate voltage is furnished through the damper circuit.

Voltage Multipliers. — A voltage doubler circuit for a fly-back power supply is shown by Fig. 103-2. Because input to the doubler consists entirely of positive voltage pulses instead of alternating voltage the action differs from that in doublers used on line voltage in low-voltage B-supplies of receivers. In the doubler circuit are two high-voltage rectifier tubes, 1 and

2, also capacitors C_a , C_b , and C_c , and resistor R . Input is from the top of the auto-transformer type of primary winding on the output transformer. Output to the picture tube anode is through resistor R_f .

During each voltage pulse from the transformer the plate of rectifier 1 is made positive, and there is conduction through this tube to charge capacitor C_a . Capacitor C_b previously will have been charged in the marked polarity by action to be

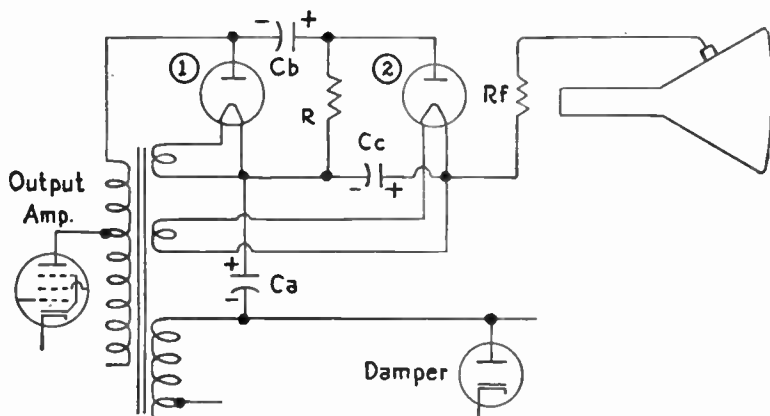

Fig. 103-2.—Voltage doubler circuit used with a flyback high-voltage supply.

explained. The potential on the side of C_b toward the plate of rectifier 2 is positive, so this rectifier conducts to charge capacitor C_c as marked. Capacitors C_a and C_c are thus charged simultaneously to approximately peak pulse voltage. These two capacitors are in series with each other and the connection through resistor R_f to the picture tube anode. Consequently there is applied to the anode a voltage approximately equal to twice the pulse voltage.

During intervals between pulses the plate of rectifier 1 is negative and there is current cutoff in this tube. Discharge from capacitor C_a flows through resistor R to charge capacitor C_b in the marked polarity. It is this charge on capacitor C_b which remains long enough to make the plate of rectifier 2

positive at the beginning of the next voltage pulse. Capacitors C_a and C_c are charged during each pulse period, and capacitor C_b is charged during intervals between pulses.

R-f Power Supply. — Connections for a typical r-f type high-voltage power supply are shown by Fig. 103-3. The oscillator tube is furnished with plate and screen voltages from the low-voltage B-power supply through a filter system which prevents escape of r-f voltages and currents from the oscillator circuit to other parts of the receiver. The entire high-voltage power supply system is enclosed within a shield to prevent r-f radiation to the remainder of the set.

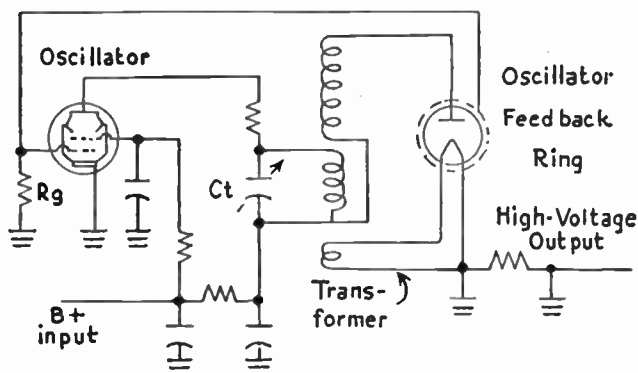

Fig. 103-3.—The r-f oscillator type of high-voltage power supply.

The oscillator tube is biased by grid resistor R_g . The tuned plate circuit of the oscillator consists of tuning capacitor C_t and the portion of the transformer winding across which this capacitor is connected. Capacitive feedback to the oscillator grid is here from a ring placed around the outside of the glass envelope of the high-voltage rectifier tube. This feedback ring usually is a coiled spring long enough to go around the envelope, with the ends of the spring joined so that it may be slipped onto the tube. Other styles of metallic clamps or rings may be used. There is capacitance between the metal ring and the tube elements, with the glass envelope and vacuum space as dielectric. In some power supplies of this general type the feedback is from a tickler coil coupled to the high end of the

transformer winding. Oscillator frequency most often is in the neighborhood of 200 kilocycles.

The oscillator tube usually is a beam power type, although it may be a triode, or a pentode connected as a triode. The oscillation transformer is an air-core type of high-Q construction. The turns ratio, secondary to primary, may be as much as 35 to 1. The transformer secondary winding is tuned by its inductance and the sum of distributed capacitance in the winding, stray capacitance in connections, and internal capacitance of the rectifier tube.

Output voltage from the rectifier will be maximum when the oscillator plate winding is tuned to the natural frequency of the secondary winding, but to provide stable oscillation the plate winding is tuned to a frequency slightly higher or lower. When capacitor C_t is adjustable it is used for varying the output voltage. The method is to connect to the output a suitable voltmeter, adjust the capacitor first for maximum voltage, and then detune it to allow normal output voltage specified for the receiver. The only other adjustment is for feedback. A feedback ring or clamp should be placed, to begin with, so that it surrounds the lower edge of the tubular shield which extends up toward the top cap inside the rectifier tube, then moved slightly if necessary to have oscillation and power output. Incorrect positioning will reduce the maximum output voltage or may prevent any output at all.

POWER SUPPLY, LOW-VOLTAGE. — Low-voltage B-power supplies for television receivers employ the same general principles as found in power supplies for sound radio receivers. In most of the larger television receivers the low-voltage supply system includes a power transformer, one or more full-wave tube rectifiers, and capacitor-choke filters which sometimes are supplemented with capacitor-resistor filters for circuits taking small currents.

Many of the smaller television receivers, and some large ones, utilize transformerless or ac-dc power supplies, often with selenium rectifiers or combinations of tube and selenium rectifiers. High voltages for plates and screens may be had from

voltage doublers and sometimes from voltage triplers. Another method makes use of two line-voltage rectifier systems in series, with the high positive voltage fed to plates and screens while the low negative voltage goes to cathodes of the same tubes.

Heaters and filaments are operated in parallel from a transformer secondary in some receivers, and in other receivers there are various series and series-parallel heater systems operated from line voltage.

Series Cathode Currents. — Amplifiers and other tubes may be connected to a B-power supply in such a manner that electron flow from B-minus of the supply goes to the cathodes of only part of the tubes. When this electron flow leaves the plates and screens of this first group of tubes it does not return directly to the positive side of the power supply but goes to the cathodes of a second group of tubes. From the plates and screens of this second group the electrons flow returns to B-plus of the power supply. This general principle of connecting tubes in series to utilize the same current for plates and screens of more than one group is subject to almost innumerable modifications of the particular tubes included in the different groups.

One application is shown by the simplified diagram of Fig. 104-1. All electron flow from B-minus of the power supply that goes through ground to the cathodes of three video i-f amplifiers passes from the plates and screens of these amplifiers to the cathodes of the audio output and driver tubes. All plate current from the audio output tube then returns to the power supply through the B+ 375-volt line. Screen current from the audio output tube, and both plate current and screen current from the audio driver tube return to the power supply through the 350-volt B+ line. Part of the electron flow which has passed from B- through the video amplifier goes from the plate and screen of this tube along with flows from the i-f amplifiers to the audio tubes. The remainder flows through a resistor to the B+ 350-volt line and the power supply.

The cathodes of one group of tubes will be at rather high positive voltage above ground. In order to maintain suitable bias voltages between grids and cathodes the grids of this group also will be highly positive. With some series circuits the B-minus lines are insulated and ground connection is made from between groups of tubes. Then cathodes of one group will be highly negative with reference to ground while their plates and screens will be at nearly ground potential.

When tubes are connected for series cathode currents the tubes in the high-voltage group provide a certain amount of voltage regulation for plates of the other tubes which are fed from the first cathodes. As an example, assume that a change of signal strength at the lower tubes of Fig. 104-1 alters the grid voltage and internal resistance of these tubes to raise their plate voltages above the 130 or 135 volts previously mentioned. There will be similar rise of voltage at the cathodes of the upper tubes, or the cathodes will become more positive. This is equivalent to making the grids of the upper tubes more negative, and their plate-screen currents or cathode currents will decrease. Then there will be less voltage drop across all the tubes in the lower group, which means decreased voltage between cathodes and plates or decreased plate voltage for these lower tubes. Since the action commenced with a rise of this plate voltage, the final effect is compensation for the change.

PREAMPLIFIERS. — A television preamplifier or booster is a radio-frequency amplifier constructed as a separate self-powered unit for connection between a television receiver and the transmission line coming from the antenna. The principal purpose of a preamplifier is to provide increased signal strength at the receiver input in localities classed as fringe areas, or when only an indoor antenna may be used, under which conditions the gain in many receivers is insufficient. There is also an increase in selectivity, as with added r-f stages in any receiver.

Signal booster units use miniature r-f pentodes for amplifiers, the most common type being the 6AK5. The amplifier

circuit most often is a tuned-grid tuned-plate type, for maximum gain, although sometimes only the grid is tuned and again only the plate is tuned. The method of tuning is about equally divided between movable coil cores, or permeability tuning, and variable capacitors. Tuning ordinarily is continuous through each television band, with switching for manually selecting either the low-band channels 2 through 6 or the high-band channels 7 through 13. A few units provide continuous tuning through both the television bands and the f-m broadcast band between them. Always there is provision for connecting the transmission line directly through the booster unit to the receiver antenna terminals, bypassing the amplifier.

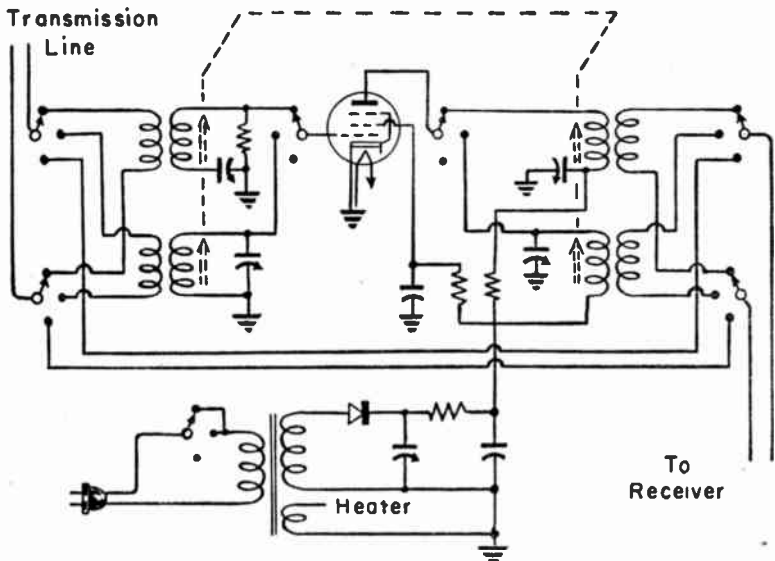

Fig. 105-1.—Preamplifier circuit employing a single r-f stage with band switching.

In boosters or preamplifiers of one general class a single tube is switched into the tuned coil circuits for whichever band of channels is to provide reception. A fairly typical circuit and switching connections are shown by Fig. 105-1. Switching for the two bands and for direct connection from

line to receiver is handled by a three-position seven-circuit ganged switch. Two switch circuits connect to the transmission line, one each to the grid and plate of the tube, two more to the output for the receiver, and one goes to the power line. With switch elements in their upper positions, as on the diagram, connections are completed for high-band reception. The next lower position makes connections for low-band reception. The bottom position connects the line input directly to the receiver output of the booster.

Tuning in Fig. 105-1 is by means of movable cores in the grid windings and plate windings of the input and output coupling transformers. Capacitor trimmers are shown on each of the four windings. In some units the tuning is with capacitors which are variable, with adjustable cores or capacitors for trimmers.

In another general class of preamplifiers there are separate tubes for each band as well as separate sets of tuning coils. The generally equivalent connections would be made upon placing a second tube between the tops of the grid and plate windings of Fig. 105-1, and omitting the switch elements there connected to the grid and plate of the single tube.

Power supplies for plates and screens of boosters nearly always have a selenium half-wave rectifier, as shown in Fig. 105-1. In this diagram is shown a power transformer which completely insulates the line from the receiver parts. The three-position switch on the primary energizes this winding for high-band and low-band positions, but turns it off on the lowermost position for a direct connection from transmission line to receiver. There are many boosters in which one side of the power line is grounded to the chassis, and few in which the entire B-minus side of the circuit is run with insulated wire and in which the chassis connection is through a small capacitor, as in many transformerless radio receivers. In any case there is required a step-down transformer for heater voltage and current.

PROBE, DETECTOR. — A detector probe consists of a detector or demodulator built into a small metallic shield which is on

the end of a flexible shielded cable. From the probe shield extends an insulated contact point which may be touched to parts of r-f, i-f, and oscillator circuits which are carrying the signal voltages to be demodulated and observed. Signal modulation or a rectified signal from the probe detector is carried through the cable to an indicator. The indicator may be only a sensitive d-c meter or headphones, but usually is an oscilloscope, an electronic voltmeter, or the a-f amplifier of a signal tracer or any other a-f amplifier feeding a loud speaker or output meter.

The detector probe and indicator permit observation or measurement of signal modulation without change of connections or excessive loading of the high-frequency circuit from which the signal is taken. The detector used in a probe most often is a germanium crystal diode or other crystal diode such as described in the article on *Crystals, Rectifying*. A diode or triode tube detector may be used, with voltages for plate and filament or heater supplied through the connecting cable.

One of the simplest detector probe circuits is shown at the left in Fig. 106-1. The insulated probe tip or contact connects through capacitor C_a and resistor R_a to a spring clip. The clip

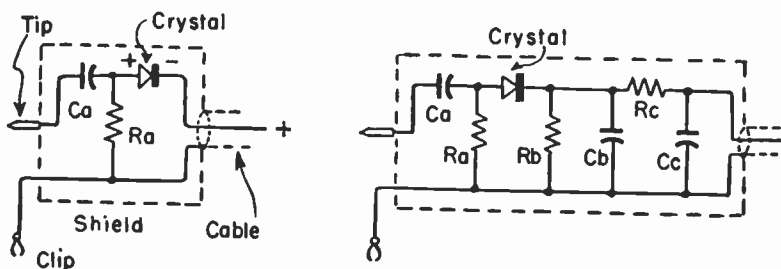

Fig. 106-1.—Detector probes with crystal diode in series between input and output.

is attached to chassis ground or B-minus or other low side point of the circuit from which a signal is to be taken, and the tip is touched to any point on the high side. The high side point might be the grid or plate of a tube. The crystal diode is connected between the junction of C_a and R_a , and the central conductor of the shielded cable. With crystal polarity

as marked on the diagram, potential to the cable conductor will be positive with reference to the shield. Reversing the crystal will reverse the output polarity, making the cable conductor negative. The crystal may be reversed to change the polarity of the trace on an oscilloscope indicator, or to make the trace "right side up."

Some or all of the additional capacitors and resistors shown by the right-hand diagram may be used in a probe. Values suitable for use when the indicator is either an oscilloscope or an electronic voltmeter are as follows:

- | | |
|------------------------------|--------------------------------|
| <i>Ca.</i> 0.001 mf | <i>Ra.</i> 3,300 ohms |
| <i>Cb.</i> 0.0001 mf | <i>Rb.</i> 3,300 ohms |
| <i>Cc.</i> 0.001 mf or less. | <i>Rc.</i> 1,000 ohms or more. |

Fig. 106-2 is a detector probe circuit often recommended for use with electronic voltmeters. Suitable values for capacitors and resistors are as follows:

- | | |
|----------------------|------------------------|
| <i>Ca.</i> 0.0005 mf | <i>Ra.</i> 1 megohm |
| <i>Cb.</i> 0.01 mf | <i>Rb.</i> 10,000 ohms |

All probe capacitors should be of the mica type. The input capacitor *Ca* is subjected to whatever d-c potential may be in

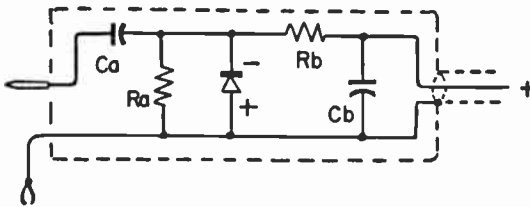

Fig. 106-2.—A detector probe with the crystal shunted across the line.

the measured circuit. This may be very high when plate circuits are measured. Consequently, the d-c working voltage of this capacitor must be enough to withstand the highest plate voltage with which the probe may be used. Capacitances listed as suitable at this position are amply large for measured frequencies as low as 100 kilocycles. For voltmeter measurement of audio frequencies down to 60 cycles this capacitance should be at least 0.25 mf. Large capacitance sometimes is placed in parallel with capacitor *Ca* for low-frequency work.

All probe resistors should be non-inductive carbon types, never wire-wound types. Increasing the resistance at R_a increases the voltage output from the probe, but will distort the waveform observed on an oscilloscope.

Filter capacitors, C_b and C_c in the diagrams, bypass radio frequencies and allow oscilloscope traces free from fuzziness. The filter capacitor shown connected directly from cable conductor to ground usually is unnecessary, its purpose being served by capacitance of the shielded cable. Filter resistor R_b in Fig. 106-1 must be used in order to have well defined oscilloscope traces. Increasing this resistance raises the detector output for use with an electronic voltmeter.

Probe Performance. — Capacitor C_a of the diagrams is charged through the detector crystal and discharges through resistor R_a . The longer is the time constant of C_a and R_a the more nearly the average capacitor charge will approach the peak value of applied signal voltage. Periods between charging pulses from the signal voltage increase as signal frequency drops, so this effect alone would cause higher charge voltage at higher frequencies. At frequencies higher than about 10 mc there are likely to be resonances of capacitances and lead inductances of the probe, which will cause peaking of probe output voltage at the resonant frequencies. These effects which tend to raise the output voltage are more or less counteracted by all the usual energy losses which occur at high frequencies.

Probe construction must be such as to minimize stray capacitances between parts, and to reduce inductances by using the shortest possible connections between parts if performance is to be satisfactory at high frequencies. Connection to B-minus or ground at the measured circuit must be with a clip connected at the probe, not through a separate conductor leading to the indicator. Such a conductor extends the high-frequency circuit all the way to the indicator.

A probe is connected across any measured high-frequency circuit as in Fig. 106-3. Across the measured circuit in the left-hand diagram is the capacitance at C_a and a parallel com-

combination of resistor R_a in one leg and the crystal and resistor R_b in the other leg. Across the measured circuit at the right is the capacitance at C_a and a parallel combination of the crystal and resistor R_a . Also across the measured circuits are all the stray capacitances of the probe, represented by a capacitor in broken lines.

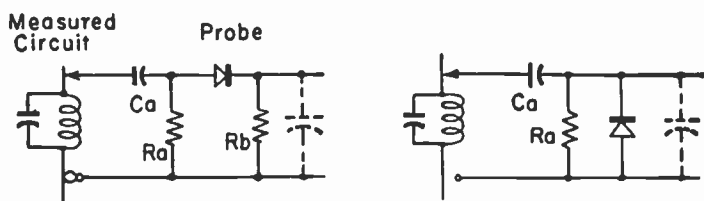

Fig. 106-3.—Detector probes may both load and detune a measured circuit.

The measured circuit is loaded by the impedance resulting from capacitances and resistances of the probe. The smaller the capacitances, including strays, and the greater the resistances, the less will be the loading and the more nearly the measured circuit will maintain normal behavior.

The measured circuit, if a tuned type, will be detuned by probe capacitances. This detuning may completely alter the performance in high-frequency amplifiers and will change the frequency or prevent oscillation in high-frequency oscillators. Often it is necessary to retune the measured circuit so that it may function with the probe connected.

Calibration of electronic voltmeters is difficult when used with a detector probe. The probe diode is a half-wave rectifier, so readings will change if connections are reversed to a measured circuit in which is an unsymmetrical waveform. Voltage readings will vary with frequency except through a rather narrow range. Harmonics are measured along with fundamental frequency voltages, and cause change of indications. Substituting a different detector or capacitor will require recalibration.

When using a probe its shield housing should be kept as far as possible from parts of measured circuits. The clip for B-minus or ground should be connected as close as possible

to the active portion of the measured circuit. If there is a choice, the operating frequency of the measured circuit should be as low as possible. It is better to work with low television channels than with high ones, and better to make measurements in i-f circuits rather than r-f circuits if the desired information can thus be obtained. Measurements are made preferably on low-impedance circuits, since then the impedance of the probe will form a smaller load and will have relatively little effect on circuit performance.

PROBE, FILTER. — A filter probe is a capacitor-resistor filter enclosed within a small metallic shield and connected through a shielded cable to the vertical input of an oscilloscope as shown by Fig. 107-1. A filter probe is used when making observations on circuits wherein there are frequencies higher

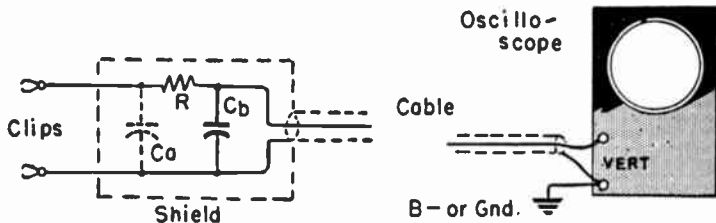

Fig. 107-1.—Filter probe for connection to an oscilloscope.

than those to be shown on the oscilloscope. Otherwise the high frequencies will cause fuzziness of the trace. Resistance at R usually is 10,000 ohms, but may be between 5,000 and 20,000 ohms.

The capacitor at C_a usually is omitted and capacitance at C_b is made 0.001 mf. If both capacitors are used, each may be 0.001 to 0.002 mf. Two capacitors provide more than twice the effective filtering action, and are useful where unwanted high-frequency voltages are strong. A filter probe is a virtual necessity when taking traces from the load of a television video detector.

PROPAGATION, WAVE. — An electromagnetic wave, as employed for television and f-m radio transmission, consists of electric force acting alternately one way and the opposite in

a horizontal direction, and of magnetic force acting alternately up and down or vertically. Such a wave is represented by Fig. 108-1. The waves travel away from the transmitter and carry their energy in a direction at right angles to both electric and magnetic forces. Velocity through space is the same as that of light, 300,000,000 meters per second or about 186,000 miles per second.

Polarization of a wave refers to the direction of its electric lines of force. Horizontal polarization is used for television and f-m radio, and is shown by Fig. 108-1. Horizontal polarization requires the use of a horizontal antenna conductor at the receiver. Horizontal polarization, compared with vertical, allows a better ratio of signal to noise, since most electrical

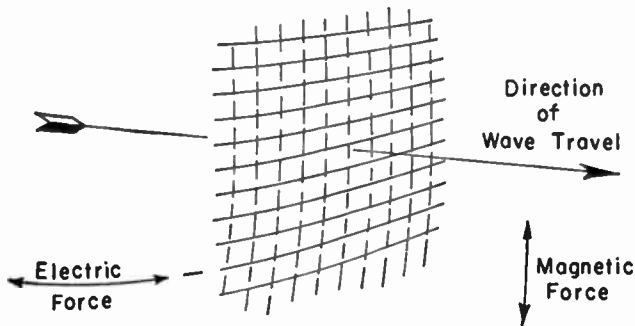

Fig. 108-1.—Forces in an electromagnetic radiation wave.

interference travels with vertical polarization. Horizontal polarization provides decided directional properties at the receiving antenna, whereas an antenna for vertical polarization is not directional. Waves horizontally polarized when leaving the transmitting antenna may become tilted slightly one way or the other, but this effect is slight in the short distances for television reception.

Electromagnetic waves at frequencies used for standard broadcast and medium short wave transmission are reflected back and forth between a layer of ionized gases high in the atmosphere, or in the ionosphere, and the moist earth and bodies of water. These successive reflections carry such waves

for long distances. Very-high and ultra-high frequency waves are not reflected from the ionosphere, and can be received in practice only so far as points which are in an unobstructed straight line or a "line of sight" from the transmitting antenna.

The maximum line of sight distance in which there is reliable reception is the sum of distances D_1 and D_2 of Fig. 108-2, these being the distances from transmitting and receiving antennas to their common horizon. Assuming uniform curvature of the earth's surface, and no high intercepting objects near the horizon, each of the distances may be computed from this formula.

$$\text{Miles} = \sqrt{2 \times \text{antenna height in feet}}$$

Any additional height which ordinarily is possible at the receiving antenna is too little to make much difference in the horizon distance. The chief purpose of added height of the

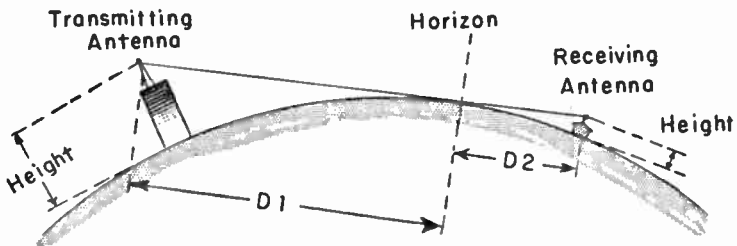

Fig. 108-2.—Factors which affect television and f-m radio reception distance.

receiving antenna is to get it above sources of interference and above nearby objects which might interrupt or reflect the radiation.

Occasionally there may be satisfactory reception at distances somewhat greater than the sum of those shown by Fig. 108-2, because of some refraction or bending of the electromagnetic waves at and near the horizon. With usual conditions and usual antenna heights there will be satisfactory reception over a range of no more than 20 to 30 miles. Unusually high transmitting antennas allow reception at great distances. With the approximately 6,000 foot elevation of transmitters on Mount

Wilson, near Los Angeles, the theoretical or computed horizon distance is nearly 110 miles, and as a rule there is good reception as far as San Diego, 116 miles away.

Reflections and Ghosts. — Radiation waves at very-high and ultra-high frequencies are reflected quite effectively from metallic objects and those consisting largely of metal and other good conductors. The strength or completeness of such reflections increases at higher frequencies or shorter wavelengths, because then the lines of force may more nearly complete their action toward one side or the other within the distance spanned by the reflecting object.

Both the direct and the reflected waves may reach a receiving antenna, as shown by Fig. 108-3. Although the reflected wave at the receiving antenna normally is weaker than the direct wave, the reflection still may act as a complete picture signal and produce on the screen of the picture tube an image of its own, in addition to the image formed by the direct wave.

The reflected wave, having traveled farther through space, will arrive at the receiving antenna slightly later than the direct wave. During the interval between arrivals of the two waves the beam in the picture tube will have traveled toward

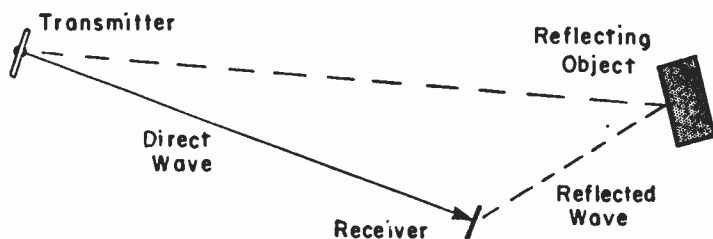

Fig. 108-3.—Wave reflection which may cause ghost images.

the right on the screen. Then the image formed by the reflected wave will appear slightly to the right of the image formed by the direct wave. The extra image due to the reflected wave usually is called a ghost. If the reflected wave has traveled 500 feet farther than the direct wave the ghost image will be displaced slightly more than $\frac{1}{8}$ inch from the regular image on the face of a 16-inch picture tube. Actual separation

may be greater with longer travel of the reflected wave, or with short extra travel the two images may be so close as to cause only a blurring effect.

Wave reflections and resulting ghost images ordinarily are more troublesome where there are large buildings, bridges, large smoke stacks, gas tanks, and such objects. Usually there is little of this trouble in districts of single homes and in suburban areas generally.

If reflected and direct waves reach the receiving antenna at a considerable angle one to the other it usually is possible to rotate or orient the antenna to strengthen the direct signal and weaken the reflected one. If the two waves arrive from nearly opposite directions, as in Fig. 108-3, a reflector back of the antenna usually helps. Strength of the reflected wave may vary greatly within short distances, and moving the antenna may so weaken reception from the reflected wave as to remedy matters. An antenna director may so sharpen the directional effect of the antenna as to make the direct wave much stronger than the reflected one.

There are cases where the reflection is stronger than the direct wave, which may encounter obstructions not in the paths of the reflection. Then the antenna may be oriented for regular reception from the reflected wave. What otherwise would be a direct wave may be completely blocked by objects between transmitting and receiving antennas. Naturally, any object which reflects a wave does not allow the wave to pass through it, unless possibly with greatly reduced strength. Thus there often are shadow effects, where the receiving antenna is the electrical shadow of some interfering object.

R

RASTER. — A raster is the illumination caused by travel of the electron beam or spot over the screen area of a picture tube when there is no modulation of the beam to produce pictures or a test pattern. The raster consists of only the horizontal luminous traces which result from horizontal and

vertical deflection. There will be a raster provided the sweep oscillators and amplifiers, and the brightness control, are operating correctly, even though no television signal is reaching the receiver there are neither picture, sync, nor sound signals present. There will be a raster likewise if a television signal is being received, but is not reaching the grid-cathode circuit of the picture tube and the sweep circuits. Synchronization of horizontal and vertical sweeps is not necessary in order to have a raster.

REACTANCES. — Capacitive reactances in ohms may be found from any of the following expressions, according to whether frequency is measured in cycles, kilocycles, or megacycles, and capacitance in microfarads (mf) or in micro-microfarads (mmf).

$$\frac{160\ 000}{\text{cycles} \times \text{mf}}$$

$$\frac{160}{\text{kilocycles} \times \text{mf}}$$

$$\frac{0.16}{\text{megacycles} \times \text{mf}}$$

$$6.28 \times \text{megacycles} \times \text{mf}$$

$$\frac{160\ 000\ 000\ 000}{\text{cycles} \times \text{mmf}}$$

$$\frac{160\ 000\ 000}{\text{kilocycles} \times \text{mmf}}$$

$$\frac{160\ 000}{\text{megacycles} \times \text{mmf}}$$

Inductive reactances in ohms may be found from one of the following expressions, in which there are various combinations of frequency measured in cycles, kilocycles, or megacycles, and of inductance measured in henrys, millihenrys, or microhenrys.

$$6.28 \times \text{cycles} \times \text{henrys}$$

$$\text{cycles} \times \frac{\text{millihenrys}}{160}$$

$$\frac{160}{\text{cycles} \times \text{microhenrys}}$$

$$\frac{\text{cycles} \times \text{microhenrys}}{160\ 000}$$

$$160\ 000$$

$$6280 \times \text{kilocycles} \times \text{henrys}$$

$$6.28 \times \text{kilocycles} \times \text{millihenrys}$$

$$\frac{\text{kilocycles} \times \text{microhenrys}}{160}$$

$$160$$

$$6\ 280\ 000 \times \text{megacycles} \times \text{henrys}$$

$$6280 \times \text{megacycles} \times \text{millihenrys}$$

$$6.28 \times \text{megacycles} \times \text{microhenrys}$$

RESISTORS, HIGH-FREQUENCY. — Wire-wound resistors, because of their inductive effects, are not suited for use in circuits operating at frequencies above about 10 megacycles. All resistors, both wire-wound and carbon or composition, have a certain amount of capacitance between their terminals. Because of this the carbon types may act as capacitive reactances to allow signal leakages when frequencies go up around 100 megacycles. A unit whose resistance measures several megohms at direct current and low frequencies may have effective resistance of only a few thousand ohms at very-high frequencies. Troublesome effects sometimes are avoided by using several units in series, with total resistance of the desired value. Then the capacitances are in series to increase the capacitive reactance. With several resistors there is, however, some danger of greatly increasing the capacitance to ground.

RESONANCE. — The accompanying formulas relate to frequencies of resonance in megacycles and kilocycles, and to combinations of inductance in microhenrys and capacitance in micro-microfarads (mmf) for such frequencies. The formulas apply to circuits which are either series resonant or parallel resonant.

$$\text{Megacycles} = \frac{160}{\sqrt{\text{mmf} \times \text{microhenrys}}}$$

$$\text{Microhenrys} = \frac{25\ 330}{\text{mc}^2 \times \text{mmf}}$$

$$\text{Mmf} = \frac{25\ 330}{\text{mc}^2 \times \text{microhenrys}}$$

$$\text{Kilocycles} = \frac{160\ 000}{\sqrt{\text{mmf} \times \text{microhenrys}}}$$

$$\text{Microhenrys} = \frac{25\ 330\ 000\ 000}{\text{kc}^2 \times \text{mmf}}$$

$$\text{Mmf} = \frac{25\ 330\ 000\ 000}{\text{kc}^2 \times \text{microhenrys}}$$

A series resonant circuit subjected to frequencies lower than the resonant frequency acts like a capacitive reactance, or a capacitance and resistance in series. At frequencies above resonance the series resonant circuit acts like an inductive reactance, or an inductance and a resistance in series. Alternating potential differences across the inductance and/or the capacitance may be many times as great as the voltage applied in series with the resonant circuit when the frequency is that of resonance. The capacitors may have to withstand potential differences much greater than the applied voltage.

A parallel resonant circuit subjected to frequencies lower than the resonant frequency acts like an inductive reactance, while at frequencies above resonance this circuit acts like a capacitive reactance. There is the same potential difference across both capacitance and inductance, and it is no greater than voltage applied in series with the resonant circuit.

RESTORATION, D-C. — D-c restoration or d-c reinsertion is a means for automatically maintaining correct values of tone or shading in a television picture when there are changes of average brightness at the scene being televised. Correct tone values can exist only when the black level of the television signal is at the grid voltage for beam cutoff in the picture tube, and when control grid bias in the picture tube is such as to maintain this condition.

The term d-c restoration means restoration of the d-c component of the video signal when this component disappears as the signal passes through any coupling capacitors between the video detector and the picture tube. The original d-c component is identified in Fig. 113-1. At *A* is represented a video i-f signal modulated with sync pulses and with picture signal variations for a light toned picture. At *B* is represented a modulated signal for a dark toned picture. So long as carrier signal strength and video i-f signal strength remain constant, the tips of the sync pulses will remain at the same amplitude with reference to the zero voltage line whether the picture is light toned or dark.

When the i-f signals are demodulated by the video detector only the positive or the negative modulation envelope will remain. If the detector is so connected as to pass only the positive envelope, the detector output will consist of a direct voltage whose variations are the sync pulses and picture signals shown at *C* and *D*. The average potential of this detector

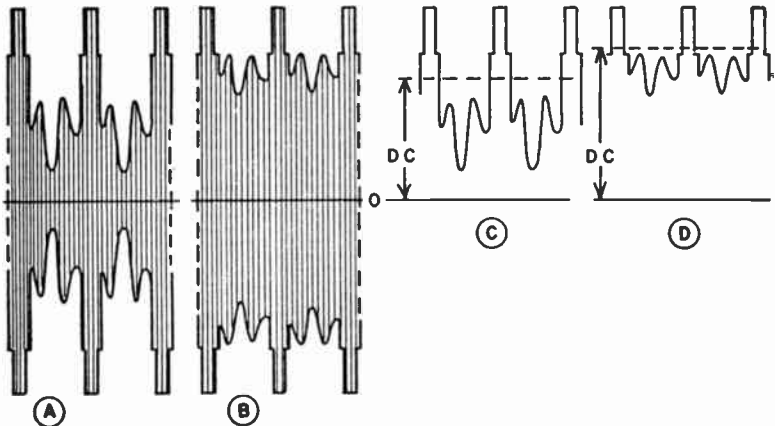

Fig. 113-1.—Modulated i-f signals and their d-c components for light toned and dark toned pictures.

output is the d-c component of the signal. For the light toned picture the d-c component is less than for the dark toned picture. In the final reproduction at the picture tube screen the amount of d-c component, or some equivalent effect, will determine whether the picture appears generally light or generally dark.

The signal voltages at *C* and *D* of Fig. 113-1 usually go through at least one coupling capacitor between the detector and a video amplifier, or between two video amplifiers, or between a video amplifier and the picture tube. Any capacitor will pass only the alternating component of the signal voltage, and on the output side of the capacitor there will be only an a-c signal voltage with no d-c component. This is shown by

Fig. 113-2. The alternating signal voltages for both light and dark toned pictures will be centered on their zero potentials, or will extend equally above and below zero.

The two alternating signal voltages which come through a capacitor are shown by Fig. 113-3 applied to the characteristic curve for control grid voltage and beam current of a picture

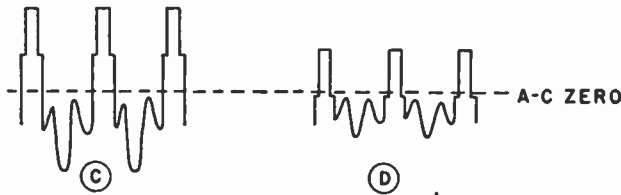

Fig. 113-2.—Picture signals and sync pulses represented as alternating potentials without d-c components.

tube. Here it is assumed that the brightness control of the receiver has been adjusted to correctly render the light toned picture, from signal *C*. The alternating signal voltage centers at the grid bias voltage, just as in an amplifier tube. The bias is such that sync pulses of the signal make the control grid more negative than for beam cutoff, and consequently these pulse voltages have no effect in the picture.

Signal *D*, for the dark toned picture, also centers on the bias voltage which is correctly adjusted for the light toned picture. In actual picture reproduction such changes of tone or average shading may come very rapidly. Nearly the entire sync pulse voltage for the dark toned signal now is above beam cutoff. The sync pulse voltages will cause white diagonal lines in the picture. The black level for this dark toned picture really should be at beam current cutoff, but it is far above cutoff. All the picture variations likewise are far above cutoff. The supposedly dark picture will be made of generally light tone.

Were picture tube grid bias made more negative, to bring the black level of the dark toned picture down to beam current cutoff, and were the light toned signal applied on this

more negative bias, there would be another fault. The darker portions of the picture would become wholly black, because they would drop below beam current cutoff. Also, the remaining portions of the picture would come down too low on the brightness scale, and the supposedly light toned picture would become dark. The result of losing the d-c component, and not

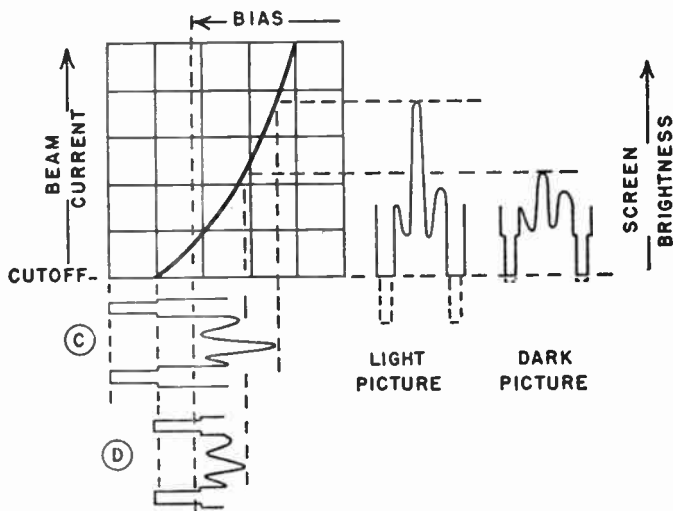

Fig. 113-3.—Signals for light and dark pictures reproduced with the same grid bias in the picture tube.

restoring it before the signal reaches the picture tube, is to make dark pictures too light and light pictures too dark. Contrast is greatly reduced.

For correct reproduction of pictures the black level of the signal voltage must be at the picture tube grid voltage which causes cutoff of the beam. Then sync pulses in the signal will make the grid still more negative, and these pulse voltages will be cut off. The black levels of the light and dark toned signals were at the same potential in the detector output, at the right in Fig. 113-1. They became of different potentials when losing their d-c components, as in Fig. 113-2. It is change of black level that causes difficulty.

In Fig. 113-4 the black levels for light and dark toned pictures are kept at equal potential by avoiding the use of coupling capacitors. The video detector is conductively connected to the control grid of the video amplifier tube. The positive tops of all sync pulses bring the control grid to the same voltage, and the black level in both signals likewise brings the

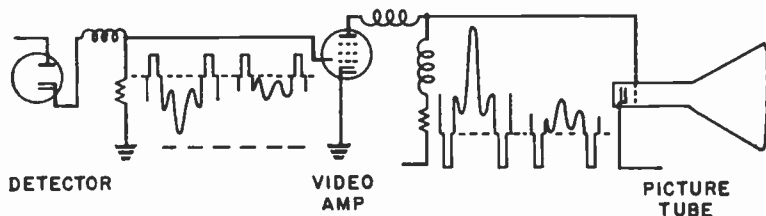

Fig. 113-4.—Direct coupling between detector and picture tube retains the d-c component of the signal.

control grid to equal voltage. The signal polarity is inverted by the amplifier. Variations of d-c plate voltage will be just like the variations of d-c detector voltage applied to the amplifier control grid, and in these plate voltage variations the two black levels will be at the same potential.

The plate of the video amplifier is conductively connected to the control grid of the picture tube. The variations of plate voltage, with their constant potential for the black levels, become the input signal voltage for the picture tube. When picture tube grid bias is adjusted to bring the black level of either signal to the point of beam current cutoff, the black level of the other signal will also be at cutoff.

Returning now to the unequal black level potentials shown in Fig. 113-3, it is apparent that both light and dark toned pictures could be correctly reproduced only by altering the control grid bias of the picture tube to compensate for every change of tone. For dark toned pictures the bias would have to be made more negative than shown. When tone again became lighter, the bias would have to be made less negative.

Picture tube grid bias can be changed by the manually operated brightness control, but not rapidly enough to com-

pensate for every change of picture tone and signal amplitude. Consequently, the bias must be changed automatically. This automatic change of bias must be brought about by the very change of signal amplitude which makes correction necessary.

Bias voltage is the difference of potential between grid and cathode of the picture tube. Bias may be altered in any way required by varying either the grid voltage or the cathode voltage, while average voltage of the other of these two elements remains fixed. Some d-c restoration systems act to alter the average grid voltage and others alter the cathode voltage. Whatever method is used to bring all black levels to the same potential it must follow the last coupling capacitor in the video detector and amplifier circuits. Black levels may be held at equal values as the signal passes from tube to tube, as in Fig. 113-4, but not when the signals go through a coupling capacitor.

Amplifier Bias for Restoration. — In Fig. 113-5 the d-c component of the signal which is present at the detector output is lost in the coupling capacitor between detector and first video amplifier grid. The resulting alternating signal voltage

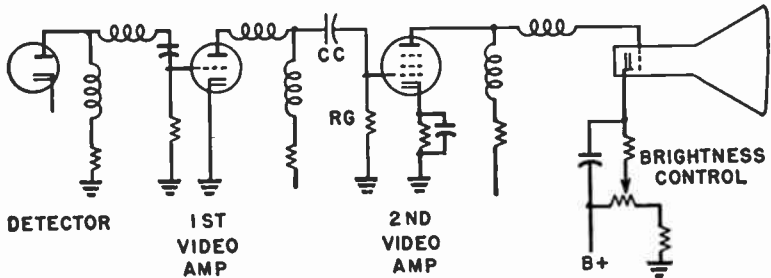

Fig. 113-5.—D-c restoration by means of grid-leak bias for a video amplifier tube.

is amplified and goes through another coupling capacitor, C_c , to the grid of the second video amplifier tube. Had the d-c component not been lost in the earlier capacitor it would disappear here.

By employing grid leak-capacitor bias for the second video amplifier the d-c component will be restored and will appear

in the plate circuit of this amplifier. The restored d-c component will not again be lost between the plate of the second amplifier and the control grid of the picture tube, because there is direct coupling between the amplifier and the picture tube.

Restoration is accomplished as illustrated in Fig. 113-6, where the alternating signal voltages for the light toned and dark toned pictures are shown applied to the mutual characteristic of an amplifier tube. With grid-leak bias the positive

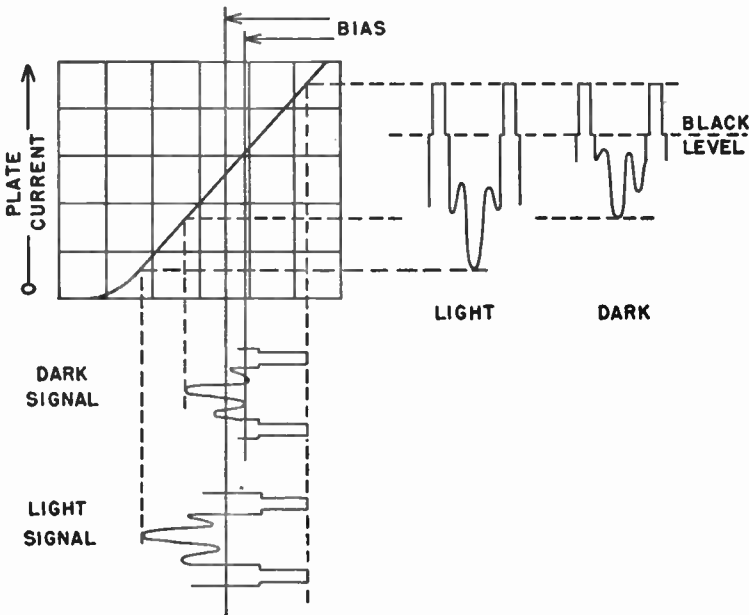

Fig. 113-6.—Action of grid-leak bias in restoring a d-c component.

alternations of the signals will add to the negative charge on the grid side of capacitor C_c . Grid bias will be made more negative because the charge leaks away only slowly through grid resistor R_g . The greater the signal amplitude the greater will be the charge added to the capacitor, and the more negative the bias will become.

The signal for the light toned picture has greater amplitude than the signal for the dark toned picture. Consequently, the light signal will make the amplifier grid bias more negative than will the dark signal, and the light signal will be applied lower than the dark signal on the characteristic curve. In the resulting amplifier plate currents, and in accompanying plate voltages, the tips of the sync pulses and also the black levels will be made equal for both kinds of pictures.

Amplifier plate signal voltages will be inverted in polarity with respect to amplifier grid signal voltages, making the sync pulses negative and the picture variations positive in the plate circuit. This inverted signal voltage will be applied to the control grid of the picture tube. When the receiver brightness control is adjusted to suit either the light or dark toned picture it will be correct for the other one, because both black levels have been brought to the same potential.

Diodes for Restoration. — When the last video amplifier tube is coupled to the picture tube through a capacitor, the d-c component of the signal must be restored in the picture tube grid-cathode circuit which follows the capacitor. The method most often used employs a diode in any of several circuit arrangements. Always the picture tube control grid is made less negative with reference to its cathode when there are light toned pictures, with their greater signal amplitude.

One of the simplest diode restoration circuits is shown by Fig. 113-7. Picture tube grid return to the cathode is through resistors R_a and R_b , ground, and the brightness control resistors. This or some equivalent grid return would be necessary even were there no restoration. Potential drop in the brightness control resistors makes the cathode of the picture tube positive with reference to ground, and since the grid is connected to ground through R_a and R_b the grid will be negative with reference to the cathode. With the grid thus negative there would be no current and no potential difference in R_a and R_b were it not for action of the diode, as will be explained.

The diode cathode is connected to the grid side of the circuit. Consequently, the cathode is made negative with reference to the plate by the negative sync pulses of the grid signal, and the diode will conduct during these negative alternations of the signal. The diode will not conduct during positive

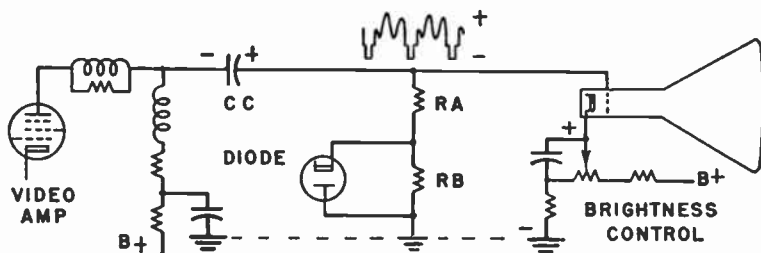

Fig. 113-7.—D-c restoration by means of a diode when signal input is to the picture tube grid.

alternations, because these make the diode cathode positive, or its plate negative. When the diode conducts during negative alternations it forms what amounts to a short circuit for resistor R_b .

Resistance at R_b is far greater than at R_a , usually 100 times or more. Then, during negative signal alternations when R_b is shorted by diode conduction, capacitor C_c charges quickly through the small resistance of R_a . Charge potential on the capacitor becomes nearly equal to the potential or amplitude of positive signal alternations, which are the sync pulses.

During positive alternations of the signal, when R_b is not shorted by the diode, capacitor C_c can discharge only slowly through the high resistance of R_b added to that of R_a . As a result, there appears on the diode side of capacitor C_c and at the top of resistor R_a a positive potential equal approximately to sync pulse amplitude. This positive potential on C_c and at the top of resistor R_a is applied to the picture tube grid. It counteracts more or less of the negative grid bias supplied from the brightness control.

Strength of this opposing voltage from the capacitor will be proportional to sync pulse amplitude and signal amplitude.

Since signal amplitude is greater for light toned pictures than for those of darker tone, picture tube grid bias is made less negative for light toned pictures. This is the action required for d-c restoration.

The restorer diode has been shown as a tube. Sometimes it is a germanium crystal diode. Restoration action is the same with one kind of diode as with the other.

The diode of Fig. 13-7 may be replaced with a triode which then is used as a combination restorer and sync takeoff tube. The grid of the triode is grounded and acts as a diode plate so far as restoration action is concerned, or the grid acts like the grounded diode plate in the diagram. The entire triode is an effective sync separator because it conducts only during the sync pulse alternations of the signal. Pulse voltage is taken from the triode plate to remaining tubes in the sync section of the receiver.

The principle of restoration just explained may be employed when signal input is to the cathode of the picture tube, as in Fig. 113-8. Here the diode plate is connected to the side

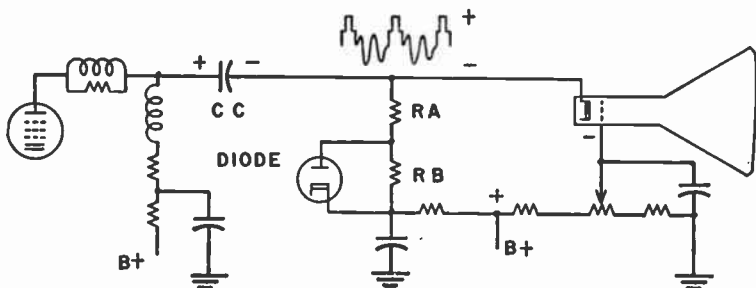

Fig. 113-8.—Diode method of d-c restoration when signal input is to the picture tube cathode.

of the circuit on which is the picture tube cathode. Sync pulses of the signal are positive in this side of the circuit, and by making the diode plate positive the pulse alternations cause conduction in the diode.

Now resistor R_b is short circuited by diode conduction during positive alternations which rapidly charge capacitor C_c .

The diode is non-conductive during negative alternations of the signal, and but little of the capacitor charge escapes during these alternations. Therefore, a negative charge is held on the side of capacitor Cc which is toward the picture tube cathode. This negative charge and its potential are proportional to signal amplitude. The greater amplitude of light toned picture signals increases the charge and the negative potential applied to the picture tube cathode.

This negative potential counteracts more or less of the positive cathode potential supplied from the B+ connection below resistor Rb . Signals for light toned pictures make the cathode more negative with reference to the grid of the picture tube, which is equivalent in effect to making the picture tube grid less negative with reference to the cathode. Thus there is the action required for restoration.

The accumulated charges on coupling capacitor Cc in Figs. 113-7 and 113-8 do not interfere with transfer of signal voltages to the grid or cathode of the picture tube. The charges which cause restoration form the average potential difference across the capacitor, this potential difference being the required d-c component for the signal. Signal variations which go to the picture tube grid or cathode are merely the instantaneous changes above and below the d-c component which exists at the capacitor.

In another diode restorer circuit, shown by Fig. 113-9, the capacitor charge which represents the d-c component is built up on a separate capacitor, Cr , instead of on the signal coupling capacitor Cc . Signal voltage for the restorer circuit is taken from across the amplifier load resistor Ro . Sync pulses are negative, just as in Fig. 113-7. This polarity is indicated by the fact that the amplifier plate is coupled to the picture tube control grid. Negative sync pulses or negative alternations of the signal act on the diode cathode to make the diode conductive. Electron flow then is as shown by broken-line arrows. This flow charges capacitor Cr in the polarity marked, then goes on through the temporarily conductive diode and resistor Rc .

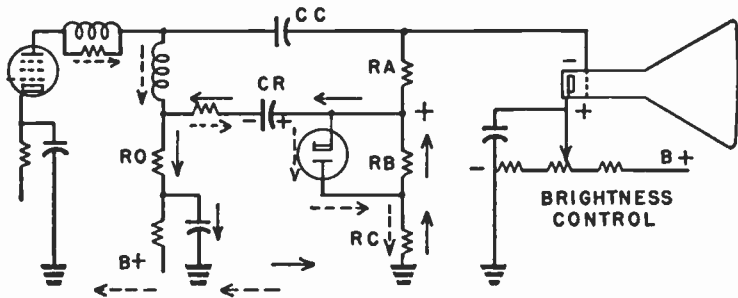

Fig. 113-9.—D-c restoration by means of a diode which allows charging of a separate capacitor for restoration potential.

During opposite alternations of signal voltage the polarity on the diode elements is reversed, and the diode is made non-conductive. Then capacitor C_r discharges slowly through the path shown by full-line arrows. Discharge is slow because it is forced by the non-conductive diode to go through the high resistance at R_b . The charge retained on capacitor C_r , and the potential at the top of R_b , become nearly equal to the peak amplitude of the signal which is intermittently charging the capacitor. This is the amplitude of the sync pulses.

Potential drop across the resistors in the brightness control makes the picture tube grid negative with reference to the cathode, because the grid is connected through resistors R_a , R_b and R_c , and through ground to the negative end of the brightness control. The positive potential developed at the top of resistor R_b by diode action counteracts more or less of the negative grid bias on the picture tube. The positive potential from resistor R_b increases with greater signal amplitude, which means a picture of lighter tone. Thus the picture tube grid is made less negative for reproduction of light toned pictures. The only purpose of resistor R_a in this system is to transfer the biasing and restoration potentials to the picture tube grid. This resistor carries no currents.

Black Level Controls. — Diode systems of d-c restoration which have been discussed derive the potentials for their d-c components from the peak amplitude of sync pulses in the video signal. So long as signal strength remains constant at

the output of the last video amplifier, and at the input to the picture tube, the black level of the signals will hold a constant relation to sync tip potential. Then, with d-c restoration voltage derived from sync tip amplitudes, the black levels will be correctly maintained during reproduction of pictures which have varying tone or shading.

But if signal strength does vary at the output of the last video amplifier there will be proportional variation between potentials at the sync tips and the black levels. This is shown by Fig. 113-10. At *A* we have the same modulated i-f signal

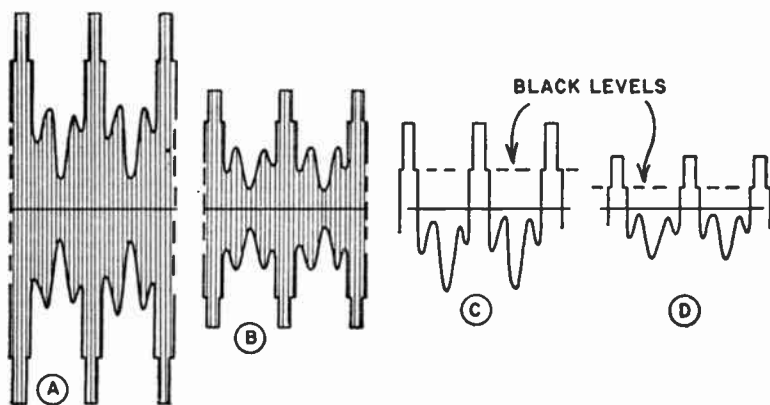

Fig. 113-10.—Black level potential or amplitudes with reference to sync pulse tips is altered by change of signal strength.

as at *A* in Fig. 113-1. At *B* in Fig. 113-10 is shown a signal of exactly the same light tone, but of less strength. At *C* is the stronger signal after being demodulated by the video detector and passed through a coupling capacitor, which removes the d-c component. At *D* is the weaker signal after demodulation and removal of its d-c component.

Sync pulse tips now are at different potentials or amplitudes for the stronger and weaker signals. Because sync pulses are higher for the strong signal than for the weaker one, the two black levels would be at different potentials even with the pulse tips brought to the same potential by d-c restoration. In Fig. 113-11 the pulse tips of the stronger and weaker sig-

nals have been brought to the same potential, and the two signals are applied to the grid-voltage beam-current characteristic of a picture tube, just as the signals for light and dark toned pictures were applied in Fig. 113-3.

Resulting beam currents and picture effects are shown at the right-hand side of the picture tube characteristic. By means of the brightness control the picture tube grid bias has been

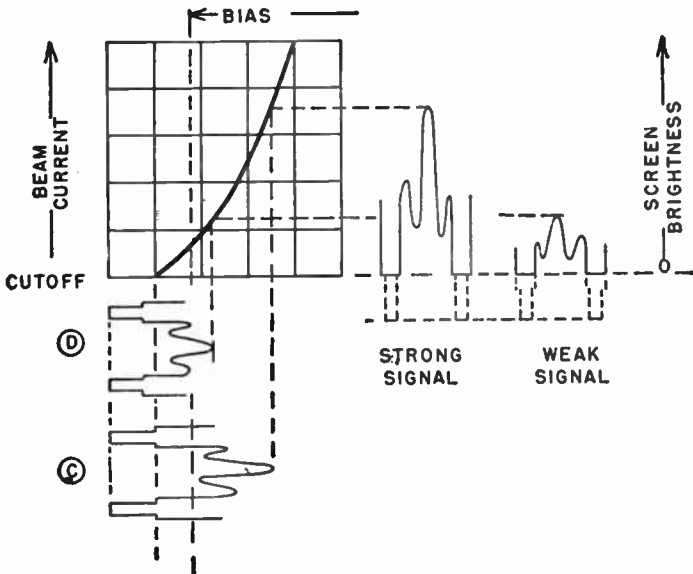

Fig. 113-11.—Effect on picture reproduction of equalizing the sync tip voltages for strong and weak signals.

made correct for the stronger signal, so that the black level of this signal is brought to beam cutoff. This adjustment brings the black level of the weaker signal beyond cutoff, and in the picture itself the average brightness is lower than it should be, while any portions of the picture which should have been dark gray will be made wholly black. Were brightness control of grid bias made correct for the weaker signal, the stronger one would produce a picture too bright and with sync pulse streaks on the screen.

The faulty reproduction illustrated by Fig. 113-11 is not too serious, because signal strength from a given transmitter seldom changes to any great extent during one program, and much of the change is compensated for by automatic gain controls. When switching from one channel to another the change of signal strength usually is enough to require readjustment of the receiver contrast (manual gain) control. If such changes are to be minimized or made unnecessary, the d-c restoration system should operate automatically from the black level potential rather than from sync tip potential. Systems which do this may be called black level controls, or by some equivalent name. There is further advantage in that adjustment of the contrast control to make any given picture more or less contrasty will not necessarily make it necessary to readjust the brightness control at the same time.

Black level controls of one general type act to remove the sync pulse voltages from the signal that charges the capacitor to the correct voltage of d-c component. The principle is illustrated in Fig. 113-12. The restorer diode and its connections may be generally similar to those shown in Figs. 113-7 or

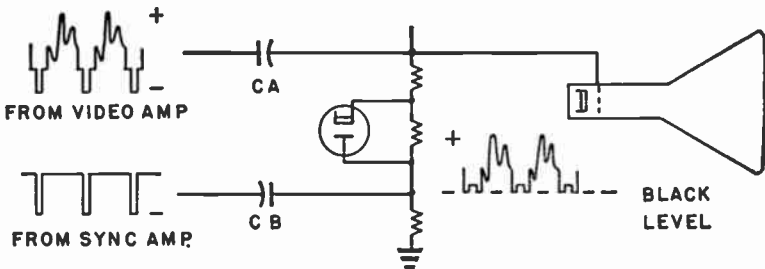

Fig. 113-12.—Black level control system in which sync pulses are removed to leave only the pedestals of the signal.

113-9. The complete signal from the video amplifier comes to the cathode of the diode through capacitor C_a . Since the sync pulse alternations of this signal are negative, the diode will be made conductive during each complete blanking interval within which a pulse occurs.

Through capacitor Cb there are applied simultaneously to the plate of the diode a succession of negative sync pulses obtained from some point in the sync section of the receiver. These negative sync pulses which act on the diode plate are stronger than pulses in the signal which is acting on the cathode. As a result, the diode plate is more negative than its cathode during each pulse period, and during these periods the diode is non-conductive.

In effect, the pulses are removed from the signal, as shown toward the right in the diagram. The negative peaks of the remaining portion of the signal are the porches or the tops of the pedestals. Potential at the tops of the pedestals is the black level of the signal. It is this signal, with sync pulses removed, which charges capacitor Ca to provide the d-c component.

Capacitor Ca , on which is produced the potential that partially counteracts negative grid bias, is charged only to a potential corresponding to the remaining black level of the signal. Thus the correction voltage which affects picture tube grid bias is based on the black level of the signal rather than on the sync pulse tips. Peak amplitude of the sync tips no longer determines the value of the d-c component, because the effect of these peaks has been removed.

Restoration from Sync Tube. — Fig. 113-13 illustrates a d-c restoration method with which the d-c component is obtained from a cathode bias resistor on a sync amplifier, separator, or limiter tube. The signal from the video amplifier is fed to the cathode of the picture tube, which requires that sync pulses be positive and picture variations negative.

A portion of the complete video signal is taken through capacitor Cr to the grid of the sync tube. This tube usually is a pentode, but it may be a triode. The sync tube is operated with cathode bias so negative and with voltages on the plate or on the screen and plate so low that the tube conducts only during the more positive portions of the sync pulses.

Increase of signal amplitude, as with a light toned picture or any generally stronger signal, increases the plate-cathode

current of the sync tube. This is accompanied by greater voltage drop across resistor Rk and greater charge voltage on capacitor Ck . Positive potential from the tops of Rk and Ck is applied directly to the picture tube grid, while the negative ends of this resistor and capacitor are connected through ground and the brightness control resistors to the cathode of the picture tube.

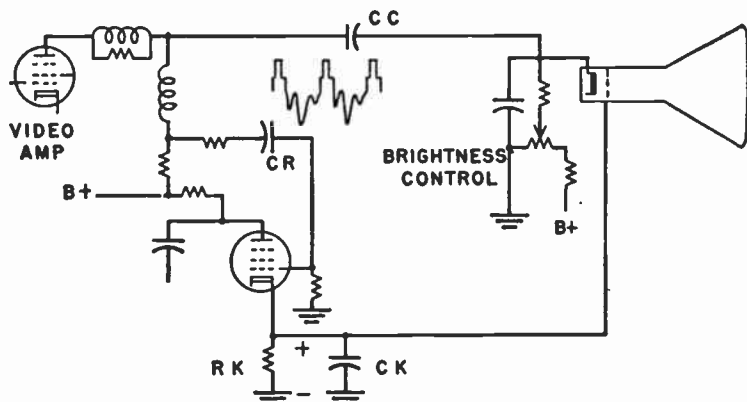

Fig. 113-13.—D-c restoration from cathode voltage of a tube in the sync section of the receiver.

Potential drop in the brightness control makes the picture tube grid negative with reference to its cathode. Voltage from across the cathode resistor and capacitor of the sync tube opposes the negative bias of the picture tube, as furnished by the brightness control. A light toned picture signal or any stronger signal increases the voltage from Rk and Ck to make the grid of the picture tube less negative with reference to its cathode. This is the action required for d-c restoration.

Time Constant for Restoration. — In any d-c restoration system the capacitor whose charge voltage fixes the value of d-c component is charged by sync pulse or pedestal top voltages which occur once for each line of the picture. There must be only negligible discharge of this capacitor between charges, or during one line period. On the other hand, the capacitor must not lose charge so slowly nor gain extra charge so slowly

that the d-c component cannot follow ordinary changes of picture brightness or of signal strength. The time required for charge voltage to change is proportional to the time constant of the capacitor and resistance in series with it.

The time constant usually is about 0.05 second, which would be the time for discharge to 36.8 per cent of the initial maximum voltage. During 0.05 second there are about 780 line periods, so discharge during one period would be entirely negligible. With this value of time constant the capacitor charge and voltage could drop to about half their initial value during one complete frame period of $1/30$ second. Such discharge, or similar increase of charge, would allow the d-c component to follow any ordinary changes of picture tone or signal strength.

S

SCANNING. — Scanning is the process of dividing the lights and shadows of the image of a televised scene into parts so small as individually to consist of only single tone values. These tone or shading values are transmitted one after another and reproduced one after another to reassemble the complete image at a receiver. Although scanning is primarily a separation of the image in the television camera tube, the word is used also to describe the building up of the reproduced image in the picture tube of a receiver.

Television is practicable because, during any one instant of time, the television camera is allowed to view, and the receiver picture tube to reproduce, only an image area so small that it can consist of only a single value of light or shade. The entire image or picture, whatever its overall size, is effectively divided into approximately 300,000 of these tiny areas.

All these areas making up a complete scene are viewed and reproduced within $1/30$ second, a time so brief that during it there can be only a little relative movement between objects in the televised scene. Movement becomes apparent in the reproduced picture due to completed images following one another at intervals of only $1/30$ second. Because of persis-

tence of vision, the human eye retains the impression of each completed image until the next one takes its place. Changes of position of objects in successive images appear as continual smooth movement. This is the principle employed also for motion pictures in theatres and the home.

Output voltage or signal voltage from the television camera tube is proportional to the intensity of light in only one small image area at a time. This is accomplished by forming the image in the camera tube on a surface which transforms light energy into electrical potential proportional to light intensity, but does so only where the surface is made light-sensitive by a stream of electrons striking it. An electron stream or electron beam in the camera tube is focused to fall on only the very small image area which has been mentioned. Consequently, signal voltage at any one instant of time is proportional to intensity of light on the small image area then being covered by the focused electron beam.

In the first step of the scanning process the electron beam in the camera tube is swept from left to right across the uppermost one of the narrow horizontal lines on the picture image as shown by Fig. 114-1. The picture in this illustration is divided into only a few of the several hundred horizontal lines of a television picture, in order to make the scanning process clearer.

Next the electron beam is dropped the width of two lines, whereupon it starts again from the left and sweeps the horizontal line which is third from the top. This continues until, within $1/60$ second, the beam has swept over every alternate horizontal line from top to bottom of the image. Then the beam is returned to the top of the image and similarly sweeps all the intervening lines which were not covered during the first downward travel. The entire image, or all its lines, are scanned in two periods of $1/60$ second each, or in a total of $1/30$ second.

Images are reproduced on the screen of a picture tube in a receiver. The screen, on the inside of the rather flat face of the picture tube, contains a phosphor compound

which becomes momentarily luminous wherever struck by a beam of electrons moving at high velocity. Such an electron beam is swept from left to right across the picture tube screen, is dropped down and again swept horizontally, and continued in such motion until this picture tube electron



Fig. 114-1.—A picture image is divided into many horizontal lines by scanning.

beam has covered the entire screen surface on which pictures are formed. This happens while the electron beam in the camera tube is sweeping over the entire light-sensitive surface on which is the image of the televised scene.

The rate of electron flow in the picture tube beam is altered by the signal voltages which originate at the camera tube, and are transmitted. While the camera tube beam is traversing a light toned area of the original image, the transmitted signal voltage increases electron flow in the picture tube beam, and a proportionately light toned area is caused to appear on the screen. While the camera tube beam is on a dark area of the image, the resulting signal causes reduction of electron flow in the picture tube beam, and a proportionately dark area appears on the screen.

Travel of the camera tube beam is controlled by pulses of voltage produced and accurately timed at the transmitter. These synchronizing pulses are added to the transmitted signal. They maintain travel of the picture tube beam in precise timing or in synchronization with travel of the camera tube beam. Therefore, light and dark areas formed on the picture tube screen appear in the same relative positions as light and dark areas of the image in the camera tube. Thus the image on the picture tube screen becomes a duplicate of the image existing at the same time in the camera tube.

The manner in which the electron beam sweeps over the screen of the picture tube is shown by Fig. 114-2. Only enough of the horizontal lines are drawn to illustrate the principles involved. The beam commences its travel in the upper left-hand corner of diagram 1, at point *A*. The beam is swept to the left along the solid line path to point *B*, and along this line there appears a trace of successive light and dark areas in accordance with variations of picture signal voltage and of variations in light in the image at the camera tube. This completes one active line or one horizontal trace.

When the beam completes the luminous trace as far as point *B* the electron flow is stopped. This stoppage of electron flow is called blanking. The electric or magnetic forces which caused the beam to sweep from *A* to *B* continue acting, and were the beam not blanked, these forces would move it along the broken-line path to point *C*. The time during which the beam would be returned to the left side of the screen is the horizontal retrace period. The retrace occurs while the beam is blanked. Horizontal traces and retrace periods continue until the beam arrives at the lower right-hand corner of the picture space, at point *D*.

When the electron beam reaches the bottom of the picture space the beam again is blanked. It remains blanked while the deflecting forces would cause travel as shown by diagram 2. Were the beam not blanked it would follow a zig-zag path from point *D* upward through the picture space until reach-

ing point *E*. This point is only half way from left to right across the picture space. The time interval during which the beam would have been moved upward to the top of the picture space is a vertical blanking period. It may be called also a vertical retrace period.

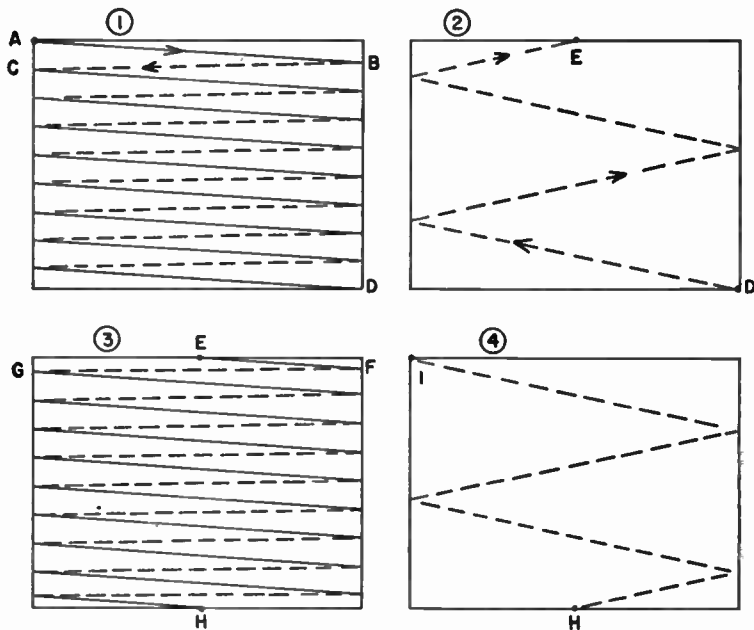

Fig. 114-2.—Travel of the electron beam over the screen in the picture tube.

The beam now is re-established or electron flow is allowed to resume at point *E* of diagram 3, which is the same as *E* on diagram 2. The beam now traces a half line from *E* to *F*. Next follows a horizontal retrace from *F* to *G*. This is followed by active traces or lines and intervening blanked retraces until the beam comes down to point *H* at the middle of a horizontal active line. Note that each active line or trace in diagram 3 is midway between traces of diagram 1.

At point *H* the beam once more is blanked, and the forces which would cause sweeping or deflection act as shown on diagram 4. During this second vertical retrace period the

beam would have arrived at point *I*. This is the same as point *A* in diagram 1, from where the entire sweeping action continues over and over again.

Fields and Frames. — One-half the total lines which form a complete picture are scanned during the action shown by diagram 1 of Fig. 114-2. This constitutes one field. The remaining half of the necessary lines are scanned during the action shown by diagram 3. This is the second field. Active lines of one field are midway between active lines of the other field. The two fields together are called one frame. A frame includes the scanning for one complete picture.

One field and the following vertical retrace are completed during $1/60$ second. The field frequency thus becomes 60 cycles per second. One frame, consisting of two fields and two vertical retraces, is completed during $1/30$ second. The frame frequency is 30 cycles per second.

During one complete frame period of $1/30$ second there would be time for 525 horizontal active traces and the accompanying 525 horizontal retraces. The time required for one horizontal line and one horizontal retrace is a line period. With 525 line periods per frame and 30 frames per second there are 15,750 line periods per second, and the line frequency is 15,750 cycles per second.

Of the 525 line periods per frame 35 will be used during the two vertical retraces. It may be seen from Fig. 114-2 that each vertical retrace period will occupy the time for some number of whole lines plus a half line. There remain for the two fields a total of 490 line periods. In one complete picture there will be 490 luminous horizontal lines. This is true regardless of the height in inches of the picture. A large picture has the same number of luminous traces as a small one, but the traces or lines are farther apart in the large picture.

The image area actually scanned at the camera tube has a width to height ratio of 4 to 3. If a reproduced picture maintains proportions like those of the original image this picture will have the same ratio of 4 to 3 for width and

height. This is called the aspect ratio. The complete picture might be 4 inches wide and 3 inches high, or 8 inches wide and 6 inches high, or of any other dimensions with which width and height are in this ratio.

The system of scanning alternate lines of the complete picture during each field or each half-frame is called interlaced scanning. There are two principal reasons for using interlaced scanning rather than line by line scanning. First, there is less danger of noticeable flickering of the pictures. Alternate lines still are so close together that the impression on the eye is that of a complete picture is each field—this because of persistence of vision. Then with interlaced scanning there is the visual effect of 60 pictures per second instead of the actual 30 completely filled-in pictures per second. Even with high levels of screen illumination there is no visible flicker at a repetition rate of 60 per second, although there might be at 30 per second.

The second advantage of interlaced scanning is reduction of line frequency, and consequently of the frequency width of the band required for transmission. If 60 completely filled-in pictures were to be formed during each second, and were there still to be 525 line periods per complete picture, the line frequency would be 60 times 525, or would be 31,500 cycles per second instead of 15,750 cycles per second as with interlaced scanning.

SENSITIVITY.—Sensitivity of a television receiver usually is specified as the number of microvolts of r-f signal at the antenna terminals which will cause a one-volt signal strength at the video detector load. The fewer the required microvolts of r-f input the better is the sensitivity of the receiver. Sensitivity is checked with an accurately calibrated attenuator of a signal generator. Measurement is made while any automatic gain control is overridden or otherwise made inoperative, and with the manual contrast control set for maximum contrast or gain.

With receivers designed and constructed for good performance in localities of low signal field strength the sensitivity

for satisfactory reception from low-band channels 2 through 6 may be between 25 and 200 microvolts, and for high-band channels 7 through 13 it may be between 100 and 400 microvolts.

SEPARATION, SYNC. — The purpose of sync separation is to provide for the sweep oscillator circuits the necessary sync pulses without any of the picture variations which accompany the pulses in the complete television signal. The complete signal from which pulses are to be obtained may be taken from any of several points. It may come from the output of the last video i-f amplifier, from the output of the video detector, or from the output of any video amplifier.

Fig. 116-1 is a circuit diagram showing signal takeoff from the output of the last video i-f stage, through a diode. The takeoff diode ordinarily would be one section of a twin diode whose other section is the video detector. The takeoff diode acts as a rectifier or detector connected to deliver a demodulated signal in which sync pulses are positive and picture variations negative. This signal is applied to the grid of a triode separator.

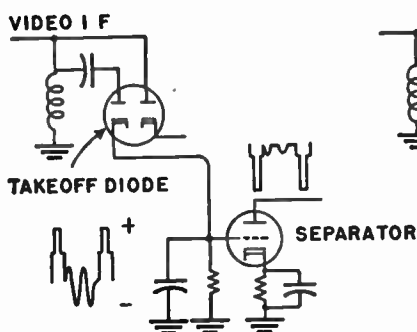

Fig. 116-1.—Sync takeoff from the final amplifier in the video i-f section.

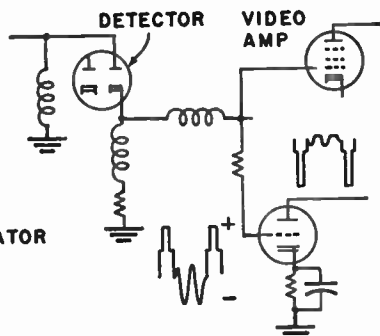

Fig. 116-2.—Sync takeoff from the output of the video detector.

The grid of the separator is biased so far negative as to partially cut off the picture variations of the applied signal. This tube passes the positive sync pulses, and may amplify them to some extent.

In Fig. 116-2 the complete television signal is taken from the output of the video detector and applied through a resistor to the grid of a separator triode. Again the separator grid is biased sufficiently negative to partially cut off the picture variations of the applied signal, while passing and possibly amplifying the sync pulses. In this circuit and also in Fig. 116-1 the separator tube might be a pentode instead of the diode shown by the diagrams.

The outputs of the separator tubes in Figs. 116-1 and 116-2 retain some of the picture variations, which were not completely removed by cutoff action. One or more additional tubes will be used to completely remove all traces of picture variations and to amplify the sync pulses. The separator output usually would go to a sync amplifier which would strengthen the signal and make the sync pulses positive. The output of this amplifier would then go to a second separator with highly negative grid bias. This tube would pass only the sync pulses.

In the circuit illustrated by Fig. 116-3 the complete television signal is taken from the output of a video amplifier. In

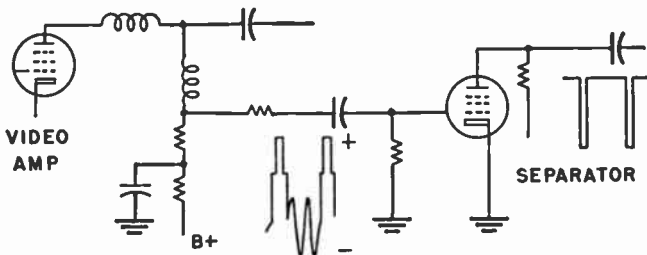

Fig. 116-3.—Sync separator connected to output of a video amplifier.

this output signal the sync pulses are positive and the picture variations negative. This might be the last video amplifier of a receiver wherein signal input is to the grid of the picture tube, or it might be the preceding video amplifier when signal input to the picture tube is to its cathode.

The signal from just above the load resistor of the video amplifier is taken through a resistor and capacitor to the grid

of the separator tube. The complete signal as taken from the output of a video amplifier has considerable overall amplitude and strong sync pulses. The grid bias of the separator may be so highly negative as to cut off all the picture variations and still have ample pulse voltage in its own output.

The process of sync pulse separation by means of a negatively biased grid is illustrated by Fig. 116-4. The bias is shown as being sufficiently negative to bring the point of plate current cutoff slightly above the black level voltage of the input signal. Bias is secured by the grid leak-capacitor method, which automatically makes the grid more negative upon increase of signal amplitude, and thus maintains the desired cutoff point even when there are decided changes of signal strength.

There may be supplementary fixed bias, with the grid resistor returned to some fixed negative potential, or there may be supplementary cathode bias. Supplementary bias which is

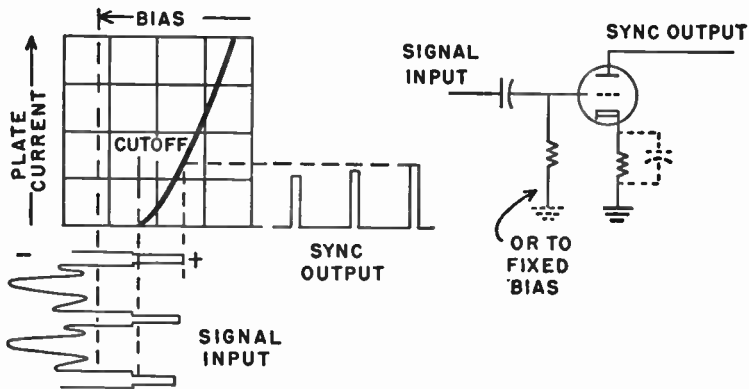

Fig. 116-4.—How sync pulses are retained and picture signals discarded by suitable biasing of a separator grid.

not wholly dependent on signal strength helps prevent formation of voltage pulses from noise interference effects accompanying the signal. Such pulses in the separator output might trigger the sweep oscillators and cause loss of synchronization.

The time constant of the grid-leak bias may be adjusted, by suitable choice of capacitance and resistance, to allow some

discharge of the capacitor between sync pulses. Then average bias voltage will be somewhat less than sync peak voltage, and cutoff may be maintained just above the black level, as in Fig. 116-4. The separator tube may be a voltage amplifying triode or one section of a twin triode, or it may be a sharp cutoff or semi-remote cutoff pentode. This tube often is operated with plate voltage or plate and screen voltages high enough to cause amplification of the sync pulses.

The function of sync separation often is combined with that of d-c restoration in a single tube. Fig. 116-5 shows a diode type restorer tube used also as a sync takeoff and partial separator. At the plate of the restorer diode the signal con-

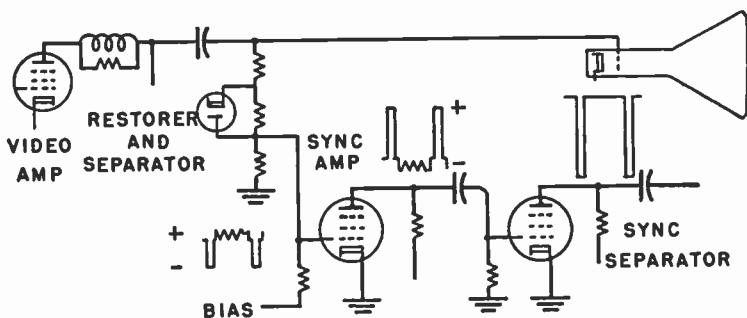

Fig. 116-5.—Sync takeoff from the plate of a d-c restoration diode.

sists of negative going sync pulses and of picture signal variations having relatively little strength. This signal from the restorer is applied to the grid of a sync amplifier. The amplifier strengthens and inverts the signal, making the sync pulses positive.

The output of the sync amplifier is applied to the grid of the sync separator tube. The grid of the separator is negatively biased to a degree which cuts off the remaining picture variations by the process illustrated in Fig. 116-4. Plate and screen voltages on the separator tube are high enough to make it also an amplifier for the sync pulses. Following tubes in the sync section may provide any necessary clipping or limiting, also inversion and amplification.

Fig. 116-6 shows how a triode used as a d-c restorer may serve also as a sync separator. Restoration action is carried out by the cathode and grounded grid of the triode acting as a diode restorer. Sync pulses at the triode grid control electron flow to the plate, where appear only the sync pulses of the signal in negative going polarity. These sync voltage pulses

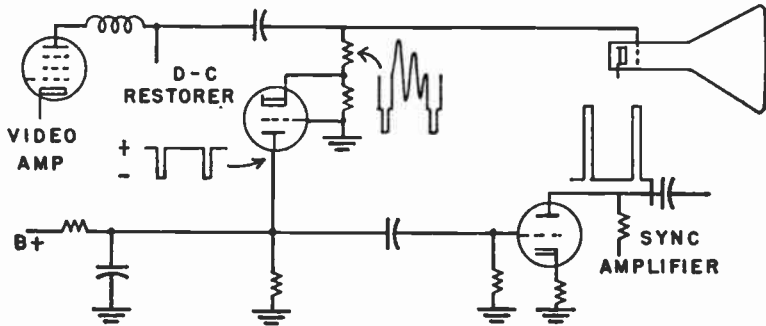

Fig. 116-6.—A triode used for d-c restoration and sync separation.

are applied to the grid of a sync amplifier, which may be a triode or a pentode. Following tubes may provide clipping, inversion, or additional amplification as required. In many receivers the output of the sync amplifier shown in the diagram goes to the sweep oscillators or to automatic sweep frequency controls through the usual vertical and horizontal filters.

SHIELDING. — Shielding consists of metal partitions or enclosures whose purpose is to protect circuits from electrostatic or magnetic fields produced by other circuits or parts. A shield is most effective when it surrounds or is near the part or circuit producing the field lines which are to be kept away from other parts. Well designed shielding is, however, effective when used at the part or circuit to be protected.

Electrostatic shielding is provided by metal even so thin as a coating or plating on a non-conductor. Field lines coming to the shield induce on the surface of the metal an electrostatic charge whose polarity is opposite to that of the body from which the field originates. This induced charge distributes

itself over the metal surface so that all electrostatic lines reaching the surface end on an opposite charge. Consequently, the field lines do not penetrate or pass through the shield.

Magnetic shielding at radio frequencies depends on induction by the magnetic field of eddy currents within the shield metal. These eddy currents produce magnetic fields of their own which oppose the field that induces the currents. The greater the conductivity of the shielding metal the stronger are the eddy currents and their fields, and the better is the shielding. Moderately thick shields of copper or aluminum are highly effective.

R-f magnetic shielding is preferably free from open spaces or joints which interfere with flow of the eddy currents, or else joints may be soldered to form a continuous conductor. Shields which are not formed by the main body of the chassis metal should be connected to this metal by soldered copper wires or straps, not only by contact pressure at screwed or bolted supports.

Magnetic shielding at audio and power frequencies depends on drawing the magnetic field lines into a shield of magnetic material and thus deflecting the lines away from or around parts to be protected. Iron and alloys of steel which have high permeability and are of considerable thickness are the most effective magnetic shields at low frequencies.

Any shield metal close enough to intercept the magnetic field of a coil will lessen the self-inductance of the coil and increase the tuned frequency in a circuit of which the coil is a part. The Q-factor of the tuned circuit is reduced by the decrease of inductance in relation to high-frequency resistance, also by increase of high-frequency resistance because of energy dissipated in the shield metal. Shielding, especially when close to current-carrying conductors, may cause a material increase of capacitance to ground or stray capacitance. This lowers the ratio of inductance to capacitance in tuned circuits, and may seriously reduce the gain or response at very-high-frequencies.

Metal tubes are shielded by their envelopes when a pin connected with the envelope is connected to ground. Some

glass-envelope tubes have internal shields connected to one of the base pins. This pin may be grounded to shield the tube. Tubes which are not self-shielded may be provided with a close fitting external shield which, when in position on the tube, is grounded by clips that hold the shield on chassis metal or other grounded metal. External shields are commonly used on r-f oscillator tubes in television receivers. When an oscillator has been aligned with a tube shield in place, removal of the shield may detune the circuit to a greater extent than can be compensated for with a fine tuning control.

Shielded wires and cables should have the shield soldered to the chassis or other grounding metal at both ends of the shield, and at any intermediate points where the wire needs support.

Television power transformers usually have a static or electrostatic shield between the primary and secondary windings. This shield consists of a band of thin copper or aluminum completely surrounding the primary but not joined together at its overlapping ends, in order that the band may not form a shorted single-turn conductor. The static shield usually is connected to the core, so that grounding the core grounds the shield. There may be an external lead coming from the shield, which allows making better connection to an external ground.

SIGNAL, TELEVISION. — The television signal consists of voltage variations which are utilized in the receiver for three purposes. First is the reproduction on the picture tube screen of lights and shadows forming the images. Second is blanking of the picture tube electron beam between picture lines, fields, and frames. Third is correct synchronization or timing of the horizontal and vertical sweep oscillators which control deflection of the beam in the picture tube. The television signal is carried between transmitter and receiver as amplitude modulation of video carrier waves whose frequencies are between 54 and 216 megacycles per second in the very-high frequency bands. Maximum frequency of signal modulation is in the neighborhood of 4 megacycles per second.

The television signal, as considered in this article, is the modulation of the video carrier wave. This signal modulation consists of voltage variations which remain after demodulation by the video detector, or consists of the output voltage of the video detector.

Sound which accompanies the television picture is transmitted as frequency modulation of an entirely separate sound carrier wave whose center frequency is $4\frac{1}{2}$ megacycles higher than that of the video carrier for the same program.

Carrier frequencies and modulations for both picture signals and accompanying sound signals on the same program are transmitted within a 6-megacycle range called a television channel. As an example, channel number 10 includes the 6-megacycle range between 192 and 198 megacycles. Within this channel the video carrier modulation utilizes frequencies from 192.50 to 197.25 megacycles, and the sound carrier modulation utilizes frequencies from 197.725 to 197.775 megacycles. Additional information is given in the article on *Transmission*.

As explained in the article on *Scanning*, a picture or pattern on the screen of the picture tube in a receiver is made up of about 490 closely spaced luminous horizontal lines. Every second line, or every alternate line, is formed during a time period of $1/60$ second, called one field. The intervening lines are formed during the following similar field period. There are 245 lines in each field. The two fields required for completing all the lines in one picture occur within a time period of $1/30$ second, called one frame. The picture actually is transmitted, received, and reproduced one line at a time.

The interval between the start of one line and the start of the next line in a field averages 63.5 microseconds. Signal voltage during one line period may be represented as at the left in Fig. 118-1. This would be the voltage applied to the control grid of the picture tube with the cathode maintained at a constant potential. Polarity is such that increase of signal voltage in the positive direction makes the grid less negative, allows increase of current in the electron beam, and produces

a brighter portion of the luminous trace or a portion more nearly white. Signal voltage less positive allows the grid to become more negative with reference to the cathode, reduces beam current, and decreases the brightness. Minimum signal voltage shown here allows grid voltage to reach the value for

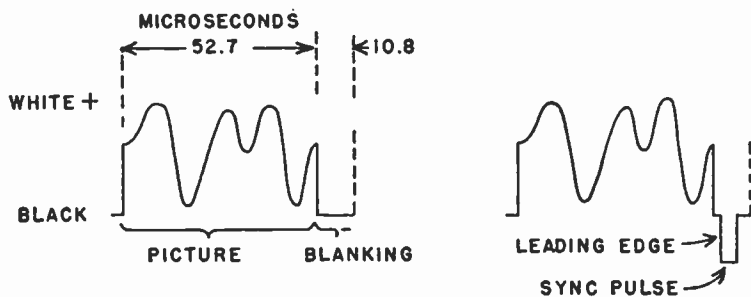

Fig. 118-1.—Television signal voltages during one line period.

cutoff of the electron beam in the picture tube. Then there is no luminous trace, or there is black in the picture.

One line of the picture or pattern is traced as the electron beam produces variations of brightness which are to exist along that particular line of the image. At the end of the line period the signal voltage goes to the value for beam cutoff, and there is blackness or blanking until time to start the next line.

Horizontal travel or sweep of the electron beam in the picture tube is caused by the horizontal sweep oscillator of the receiver. Action of the oscillator must be timed or synchronized to start each picture line at the same instant a corresponding line is started on the image in the camera tube. Oscillator action is timed in this manner by a pulse of voltage added to the signal during the blanking period between lines. This voltage pulse, shown at the right in Fig. 118-1, is called a horizontal sync pulse. The sweep oscillator is caused to commence one oscillation cycle by the sudden change of voltage at the beginning of this pulse, this being called the leading edge of the pulse. The horizontal sync pulse itself lasts for

between 5 and 6 microseconds, starting a little more than 1 microsecond after the beginning of the horizontal blanking period.

If the signal is to be applied to the cathode of the picture tube, with the control grid maintained at constant potential, the signal polarity is inverted as shown by Fig. 118-2. The signal may be obtained in either polarity from the video detector, depending on how the detector is connected to the preceding i-f amplifier. Changes of relative voltage between grid and cathode of the picture tube are the same with either polarity of the signal. There is the same reproduction of lights and shadows for a picture line, and the same blanking period at the end of a line.

The transmitted signal is of such form that sync tips of the modulation are at maximum amplitude on both sides of zero, or are at 100 per cent amplitude. Were the negative side of

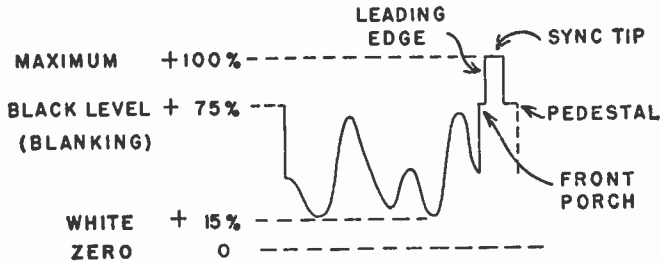

Fig. 118-2.—Voltage levels in a television signal.

the modulation recovered by the video detector, the resulting signal would appear as at the right in Fig. 118-1. Were the positive side recovered, the signal would appear as in Fig. 118-2, which is the usual way of showing the signal in diagrams.

With the tips of the sync pulses considered as 100 per cent signal voltage, blanking of the picture tube beam should occur with voltage equal to 75 per cent of maximum, plus or minus $2\frac{1}{2}$ per cent. This 75 per cent of maximum signal voltage is called the black level of the signal. Voltage from top to bottom of the sync pulse is 25 per cent of total signal

voltage. This entire range of sync pulse voltage is beyond the black level, and may be called "blacker than black."

Purest white tones of the picture correspond to 15 per cent of maximum signal voltage. Various gray tones in the picture result from signal voltages between 15 and 75 per cent of maximum. The portion of the blanking voltage occurring before the sync pulse often is referred to as the front porch of the signal. The part of the voltage waveform on which the sync pulse appears to stand may be called the pedestal. Pedestal voltage is the same as black level voltage.

During reproduction of one picture field the signal will consist of 245 picture traces and horizontal blanking periods such as shown by Figs. 118-1 and 118-2. In each horizontal blanking period will be a horizontal sync pulse. At the end of the field there will commence a vertical blanking period during which occurs the vertical retrace action, as explained in the article on *Scanning*.

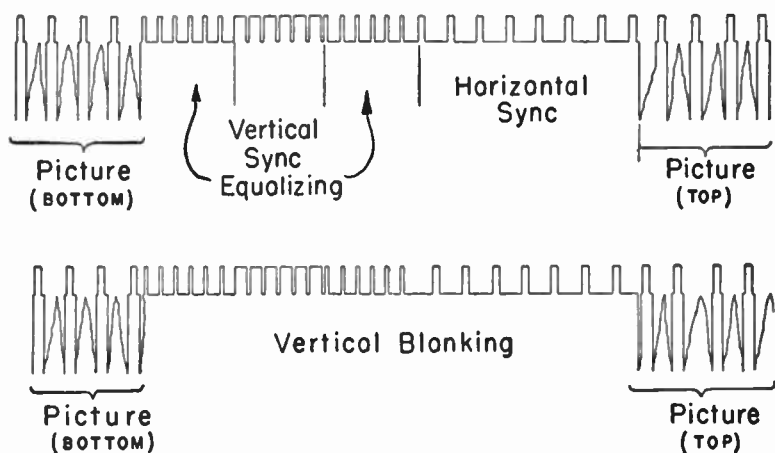

Fig. 118-3.—The television signal during the two vertical blanking periods of one frame.

Fig. 118-3 shows the signal during vertical blanking periods following each of the two fields which make up one frame. The vertical blanking period shown at the top is considered to begin with the picture tube beam at the bottom of the scanned

area, and shows at the left the last four picture signals, horizontal blanking periods, and horizontal sync pulses. Then occurs a vertical blanking period, followed at the right by the beginning of the next field, which will be at the top of the picture area. This second field ends with the horizontal lines, blanking, and pulses at the bottom of the picture area, as represented by the signal at the left on the lower part of the diagram. Then comes the second vertical blanking period, at the end of which the lines for another field are started as shown at the right in the diagram.

Note that during the entire vertical blanking period the signal voltage remains in the blacker than black region, so the electron beam remains cut off or blanked and no light appears on the screen of the picture tube. Obviously, if an increase of signal voltage as far as the black level cuts off the beam, any greater voltage in the same polarity will keep the beam cut off. Each vertical blanking period lasts for the equivalent of $19\frac{1}{2}$ line periods, which is about 1,240 microseconds.

During each vertical blanking period there occur three kinds of synchronizing pulses. First there are six equalizing pulses spaced only half as far apart in time as the horizontal sync pulses, and each lasting only half as long as a horizontal sync pulse. Then come six parts of a long vertical synchronizing pulse in which each part lasts about five times as long as a horizontal sync pulse. Each separation or serration between the parts last somewhat less than the period of a horizontal sync pulse. The entire serrated vertical sync pulse lasts about 185 microseconds. Following the serrated vertical pulse are six more equalizing pulses like the earlier ones. The remainder of the vertical blanking period contains horizontal sync pulses like those between picture lines, and spaced at one line intervals.

The sync pulses are shown by themselves in Fig. 118-4. Examination of the time spacing between leading edges of pulses of all kinds shows that there is a leading edge of one pulse or another at every line interval all through the vertical blanking period. That is, the timing between leading edges of

horizontal sync pulses occurring between lines is continued in one way or another all through the vertical blanking. Thus the horizontal sweep oscillator is kept in synchronization throughout the vertical blanking period. Otherwise the horizontal sweep oscillator might get so far out of time that sync pulses which follow the vertical blanking and equalizing pulses could not pull this oscillator back into its original synchronization.

Equalizing pulses are spaced at half-line intervals in order that alternate picture fields may begin and end on either full lines or half lines, as shown in the article on *Scanning* to be necessary for interlaced scanning. The half-line spacing also allows synchronization of both horizontal and vertical sweep oscillators to remain uniform no matter which way a field begins or ends.

In Fig. 118-4 it is easy to see that the regular horizontal pulses in the top diagram occur at times half way between those in the bottom diagram. Then picture lines in one field

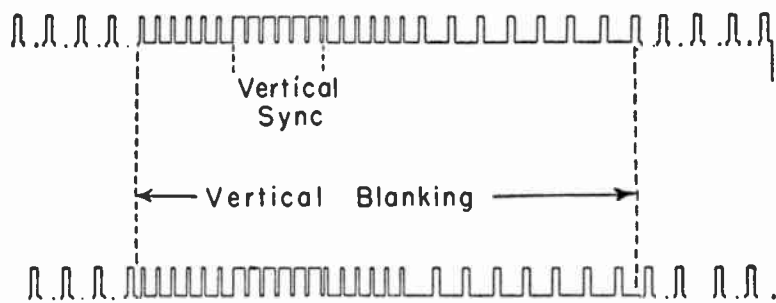

Fig. 118-4.—Sync pulses of the several kinds occurring during vertical blanking periods.

must likewise be half way between lines of the other field in a frame, as is necessary for interlaced scanning. Yet the beginning of the serrated vertical sync pulse is at the same point in both diagrams. This is necessary in order to have uniform timing of vertical retraces following both kinds of fields.

Were the regularly spaced horizontal sync pulses continued from the end of each field until the beginning of a vertical sync pulse, there would be a full-line interval preceding the vertical pulse at the top of Fig. 118-4, and only a half-line interval preceding the vertical pulse at the bottom. Then the capacitors which are to be charged by the vertical pulse would have more time for preliminary discharge with conditions at the top of the diagram than as down below. Timing of the vertical sweep oscillator would be slightly later in one case than in the other, and there would be defective interlacing. But with uniformly spaced equalizing pulses preceding both the vertical pulses, the capacitors will be equally discharged before charging commences, and timing will be uniform. These are the capacitors in the vertical integrating filter.

Half-line spacing of equalizing pulses also allows maintaining synchronization of the horizontal sweep oscillator regardless of whether a field ends with a full line or a half line. The explanation is as follows. In the upper diagram of Fig. 118-3 the final picture signal occupies a full line, while in the lower diagram it occupies only a half line. But either the first or second equalizing pulse always occurs at exactly one line period after the final horizontal sync pulse. Then timing of the horizontal sweep oscillator is picked up by an equalizing pulse after exactly one line period, whether the preceding field ends with a full line or with a half line.

The horizontal sweep oscillator is caused to commence an oscillation cycle only by an equalizing pulse occurring at full line intervals after preceding horizontal sync pulses. At the half-line points, where occur the alternate equalizing pulses, the oscillator is so far from being able to commence a cycle that it is insensitive to these alternate pulses.

The reason for breaking the total vertical sync pulse with serrations at half-line intervals is to provide leading edge voltage changes which maintain synchronization of the horizontal sweep oscillator throughout the vertical pulse periods. These leading edges after each serration in the vertical pulse act just like leading edges of equalizing pulses and horizontal sync

pulses. So far as controlling the vertical sweep oscillator is concerned, a long unbroken vertical pulse would be even better, but synchronization of the horizontal sweep oscillator might be lost.

SIZE CONTROLS. — In a television receiver there is a vertical size control or height control which alters the height of the scanned area on the picture tube screen, also a horizontal size control or width control which alters the width of the scanned area. To increase the size in either direction requires greater deflection of the picture tube electron beam in that direction. Consequently, all size controls act directly or indirectly to alter deflection voltages or fields in electrostatic deflection picture tubes, or alter deflection currents or magnetic fields for magnetic deflection tubes.

A size control used for either height or width, and found with both styles of picture tubes, is shown in elementary form by Fig. 119-1. The amount of control resistance brought into the circuit regulates the rate of electron flow for charging the

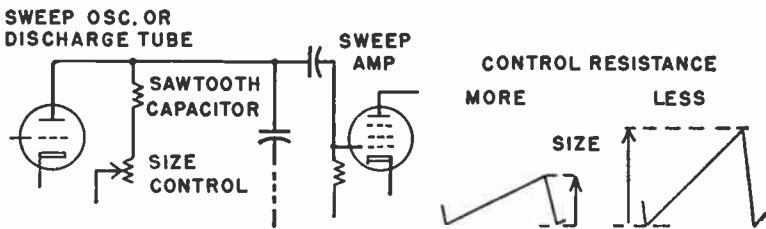

Fig. 119-1.—A size control which varies the charge and maximum voltage of the sawtooth capacitor.

sawtooth capacitor, consequently determines the voltage to which this capacitor is charged during the time in which the discharge tube or sweep oscillator remains non-conductive in the oscillation cycle. More control resistance decreases the rate of charging and the maximum charge voltage, while less resistance increases the charge rate and maximum voltage.

Changes of voltage on the sawtooth capacitor are applied to the control grid of the sweep amplifier. The greater the amplitude of grid voltage, the greater will be the deflection voltage

or current in sweep circuits connected to the amplifier output, and the greater will be the size of the picture. A smaller amplitude of grid voltage reduces the size of the picture.

In a few receivers the size control consists of an adjustable cathode-to-ground resistor on the sweep amplifier tube. Altering this resistance changes the grid bias and amplification of the sweep amplifier, and thus changes the deflection voltage or current in the output circuits. More bias resistance decreases picture size, while less resistance increases the size.

Another size control which alters the gain of the sweep amplifier tube acts by changing the screen voltage on this tube. The control unit is an adjustable resistor in series with the screen, between the screen and the B+ supply. Less resistance allows increase of screen voltage, which increases the transconductance of the tube, increases the deflection voltage or current in the output circuits, and increases the picture size. More control resistance has opposite effects. There also are size controls which vary the plate voltage on the sweep amplifier tube.

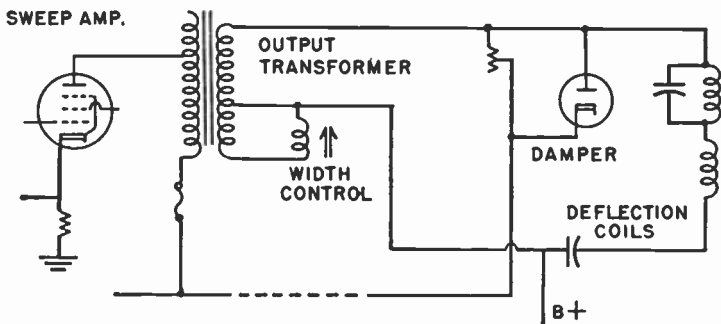

Fig. 119-2.—Width control inductor in parallel with part of the secondary on the horizontal output transformer.

Fig. 119-2 shows a method of width control used in connection with magnetic deflection picture tubes where the high-voltage supply is of the flyback or pulse operated type. The control unit is an adjustable inductor connected in parallel with part of the secondary winding on the output transformer.

Adjustment is by means of a movable core. Turning the core farther into the control unit winding increases the inductance of the unit and of the secondary winding. This increases the deflection current and makes the picture wider. Turning the core farther out of the inductor winding decreases picture width.

Still another method of width control for magnetic deflection picture tubes employs an aluminum sleeve that slides over the neck of the picture tube. One end of the sleeve goes through the focus coil and into the deflection yoke. Moving the sleeve farther into the yoke lessens the horizontal sweep and makes the picture narrower. Withdrawing the sleeve allows a wider picture. The aluminum sleeve acquires an electrostatic charge while the receiver is in operation, and should be discharged to ground before adjustment is made.

Controls for width and height should be adjusted to make the picture or pattern extend out in all directions to a small fraction of an inch beyond the edges of the mask, so that limits of the scanned area on the picture tube screen are not visible. There may be changes in size when receiving different stations, also when changing the settings of contrast and/or brightness controls. The size controls should be adjusted while the received picture or pattern is of smallest dimensions likely to result in actual reception.

Picture size is altered by adjustment of linearity controls, drive controls, and some peaking controls. When any of these other controls are changed it will be necessary to readjust the size controls at the same time.

Size Magnifiers. — Some television receivers are provided with a switch for increasing the height and width of the picture beyond the normal dimensions with which the entire picture is visible. The enlarged dimensions move the outer parts of the picture off the screen, while leaving the central portion magnified.

The magnifier switch is a ganged multi-pole single- or double-throw type. This switch may be mounted on the front panel of the receiver, or it may be constructed with a relay

mechanism whose magnet coil circuit extends through an external flexible cord to a push button which allows remote control of picture size.

With the switch in the magnifying position the height and width controls, or any circuits which provide control of height and width, are altered to allow increased size. In addition to altering the regular height and width control circuits, the switch must alter at the same time all other controls or circuits which affect picture size or which are affected by any changes that alter the size. Just which circuits are included in this classification will depend on sweep circuit design or on the make and model of receiver. They may include linearity controls, drive or peaking controls, brightness controls, hold controls, centering controls, and focusing controls in either the vertical or horizontal sweep circuits or in both.

Two methods of providing expanding operation for size controls alone are shown by Fig. 119-3. At the left either of two

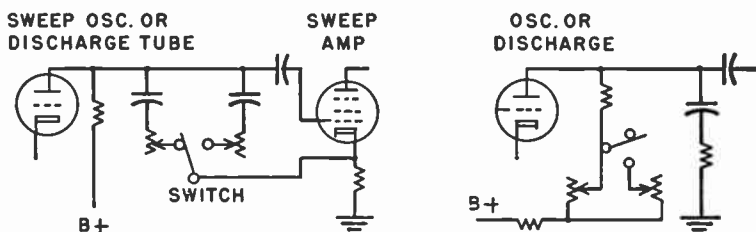

Fig. 119-3.—Connections for size controls which permit magnified pictures.

sawtooth capacitors may be charged from the B+ line while the sweep oscillator or discharge tube is non-conductive. The capacitor for normal size, shown connected through the switch, is of greater capacitance than the one for expanded size. Then the capacitor for expanded size will charge to higher voltage and the greater amplitude of the sawtooth wave will produce a larger picture.

In the right-hand diagram of Fig. 119-3 there are two adjustable resistors in series with the B+ line through which the single sawtooth capacitor is charged. Only one of these

resistors is in circuit for pictures of normal size. The second unit is connected in parallel with the first one for expanded pictures. The lessened total resistance or parallel resistance then allows more rapid charging of the sawtooth capacitor, and charging to greater voltage while the oscillator or discharge tube is non-conductive. Increased amplitude of the sawtooth wave will produce a larger picture.

At the left in Fig. 119-4 is shown a magnifier modification of a linearity control which is adjustable cathode-bias resistor on a sweep amplifier tube. When the picture is to be expanded, an additional adjustable resistor is connected in parallel with the one providing adjustment for normal pictures. The paralleled control is adjusted for satisfactory linearity of the expanded picture.

At the right in Fig. 119-4 is a picture magnifying switch section for the type of width control consisting of an adjustable inductor in parallel with part of the output transformer secondary, somewhat like that of Fig. 119-2. When the switch

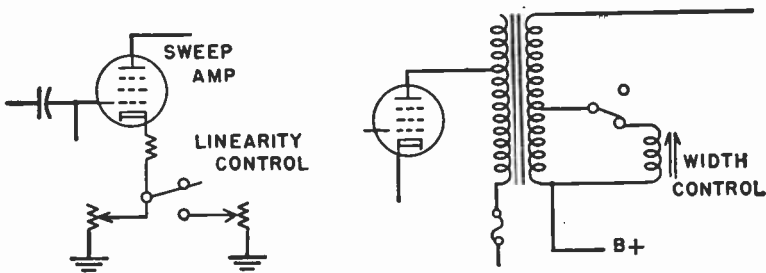

Fig. 119-4.—Magnifier connections for a linearity control and for a width control.

is opened it disconnects one end of the width control inductor from the transformer. This increases the secondary inductance and increases the horizontal deflection of the beam to produce a larger picture. Inductance is increased by disconnecting the inductor because combined inductance of paralleled inductances is less than that of either inductance alone.

There are many other methods of compensating for changes in circuit operation when the picture is magnified, but the

examples illustrated indicate the general procedure. In every case there must be separate adjustments for pictures of normal size and of expanded size.

SOUND, TELEVISION. — Voice, music, and sound effects which are to accompany the television picture are transmitted as a frequency-modulation signal on a sound carrier whose frequency is 4.5 megacycles higher than that of the video carrier in the same channel. In all television receivers the frequency-modulated sound carrier passes from the antenna and transmission line through the r-f amplifier and to the mixer. In the mixer tube the frequency modulation of the sound carrier beats with a fixed frequency introduced from the r-f oscillator. Among other frequencies in the output of the mixer there appears an intermediate frequency equal to the difference between the frequencies in the modulated sound carrier and the r-f oscillator. This sound intermediate frequency is frequency-modulated with the sound signals.

Between the output of the mixer tube and the audio frequency amplifier which feeds the speaker of the television set the sound signals may be handled by either of two general methods. One method is called the intercarrier sound system, which is described in the article, *Intercarrier Sound*. The other method may be called the dual-channel or split sound system, which will be described in this article.

There are articles in this book on *Detector*, *Ratio* and on *Discriminators*, both of which are used as sound signal demodulators. There is also an article on *Modulation, Frequency*. Principles of frequency modulation for television sound are the same as for f-m radio broadcasting and reception. There are some differences in application of principles. As an example, maximum deviation for television sound is 25 kilocycles instead of the 75-kilocycle limit in f-m broadcasting.

Intercarrier Sound. — With intercarrier sound the f-m sound signal modulation is taken all the way through the i-f amplifier section that handles also the amplitude-modulated video intermediate frequencies. Frequency difference between the i-f center frequency for sound and the video i-f carrier remains

at exactly 4.5 megacycles all the way to the video detector. This is the same difference existing between the r-f or space wave carriers. There are no traps for accompanying sound in the i-f amplifier section of a receiver employing intercarrier sound.

Since the output of the video detector is not linear, this detector acts as a mixer for the sound and video intermediate frequencies which have the 4.5 megacycle difference. In the detector output there is then a beat frequency which is the frequency-modulated sound signal with a center frequency of 4.5 megacycles. This f-m sound signal centered on 4.5 megacycles is taken from the output of the video detector, or from the output of a following video amplifier, and is carried to the i-f amplifier for sound. From this amplifier the f-m signal goes to the demodulator and thence to the audio amplifier.

Dual-channel Sound. — With dual-channel or separate channel sound systems the frequency-modulated i-f sound signal and the amplitude-modulated video i-f signal are not carried

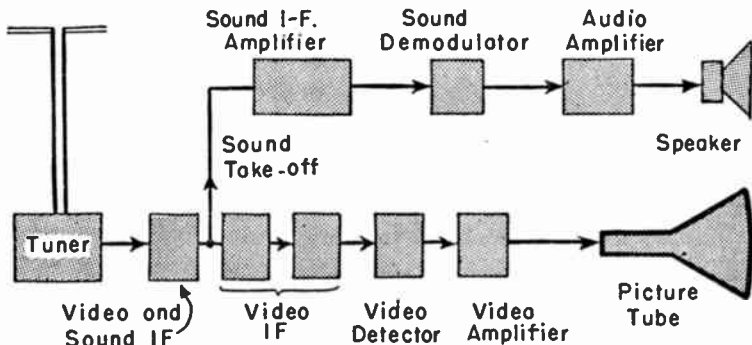

Fig. 120-1.—Scheme of connections for a dual-channel sound system.

together all the way through the i-f amplifier from mixer to video detector. Rather the sound i-f signal is separated from the video i-f signal either immediately following the mixer or at the output of one of the i-f amplifiers which precede the video detector. The principle is illustrated by Fig. 120-1. The

sound takeoff coupling is shown here at the output of the first i-f amplifier, but it might be at the output of the mixer in the tuner, or at the output of one of the following video i-f amplifiers. In a receiver employing a dual-channel sound system there may be traps for accompanying sound in one or more of the video i-f stages that follow the sound takeoff.

The intermediate frequency for sound is 4.5 megacycles lower than the video intermediate frequency for the same channel, whereas the sound carrier frequency is 4.5 megacycles higher than the video carrier frequency. This change occurs in the beating process at the mixer, because the two carrier frequencies are subtracted from the same r-f oscillator frequency.

The f-m sound signal from the takeoff coupling goes to an i-f amplifier designed to handle such a signal. Usually there are two or more sound i-f amplifier stages. If the sound demodulator is a discriminator, the last tube in the sound i-f section is operated as a limiter, as described in the article on *Limiters, F-m Sound*. Following the demodulator there is the usual audio amplifier and speaker.

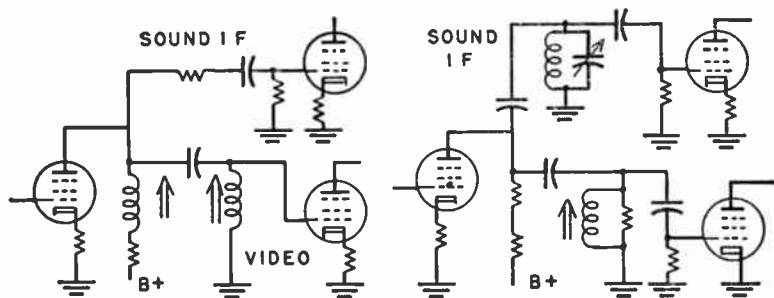

Fig. 120-2.—Sound takeoff connections for dual-channel sound systems.

Fig. 120-2 illustrates two of the several types of sound takeoffs found with dual-channel sound systems. The takeoff connection at the left is untuned and both intermediate frequencies would be carried to the first sound i-f amplifier, which is shown in the diagram. The plate circuit of this

amplifier, and following interstage couplings in the sound system, would be rather sharply tuned to the sound intermediate frequency and would amplify this frequency while rejecting the video intermediate frequency.

In the right-hand diagram there is a tuned impedance coupling in the grid circuit of the first sound i-f amplifier. Frequency response in the sound system need be no more than 300 kilocycles or 0.3 megacycle wide, and often is somewhat narrower. This provides ample coverage for the total deviation of 50 kilocycles above and below the center frequency, with allowance for some mistuning while retaining plenty of gain. Consequently, the sound takeoff couplings and the following interstage couplings in the sound system are tuned much more sharply than in the video i-f stages which handle the wide frequency range for television signals.

Fig. 120-3 shows sound takeoffs in which there are coupling transformers. In the left-hand diagram the primary of the takeoff transformer is the tuned plate coil for the mixer or the

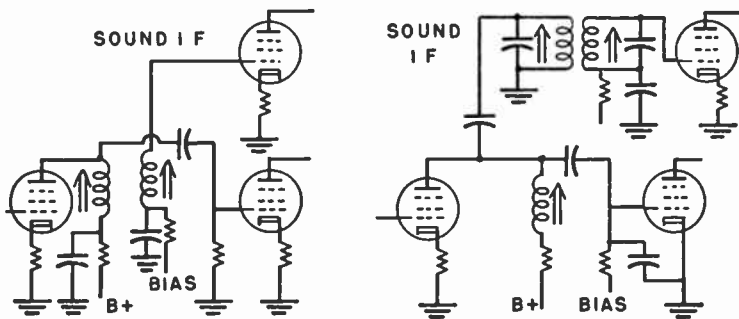

Fig. 120-3.—Sound takeoffs of the transformer type.

amplifier for both sound and video. The secondary is in the grid circuit of the first sound i-f amplifier. The plate winding is tuned for suitable response in the video intermediate frequency range, while the winding for the sound amplifier is tuned sharply to the sound intermediate frequency.

In the right-hand diagram there is a takeoff transformer whose primary winding is coupled to the plate circuit of the

mixer or first video-sound i-f amplifier, but there is a separate plate circuit coupling coil which is tuned for the video intermediate frequency range. Both the primary and the secondary of the takeoff transformer are tuned to the sound intermediate frequency.

Any tuned takeoff for the sound intermediate frequency acts also as a fairly effective trap for accompanying sound, so far as the remainder of the video i-f amplifier section is concerned. A takeoff sharply tuned to the sound intermediate frequency removes most of the energy at this frequency from the i-f amplifier circuit that is carrying both the video and the sound intermediate frequencies, leaving nearly all the video i-f energy but relatively little sound i-f energy to pass on through the remainder of the i-f amplifiers leading to the video detector.

Alignment of Sound Section. — The television sound section may be aligned in either of two general ways. One method employs an oscilloscope as output indicator, with input signals furnished by sweep and marker generators or a television generator combining both these functions. The other method employs as indicator a d-c voltmeter, either an electronic type or a moving coil type having sensitivity not less than 20,000 ohms per volt. Input signals then are furnished from an adjustable or a crystal controlled constant-frequency generator.

Either method may be used for dual-channel sound systems or for intercarrier sound systems, and either may be used where sound demodulators are of the discriminator type, ratio detector type, or other types. Instructions and precautions of a general nature are given in the article on *Alignment*.

With any method of alignment it is usual practice to connect the signal generator to the grid of the tube preceding the sound takeoff. With dual-channel sound systems this tube may be either the mixer or one of the video i-f amplifiers. With intercarrier sound systems this tube usually is the video amplifier ahead of the sound takeoff, although it would be the i-f amplifier preceding the video detector when intercarrier sound takeoff is from the output of the video detector.

If the output indicator is either an electronic voltmeter or a sensitive moving coil voltmeter the constant-frequency signal generator must be accurately tuned to the sound intermediate frequency used in a receiver having a dual-channel sound system, or to 4.5 megacycles for any intercarrier sound system. Crystal control of generator frequency or calibration against a crystal oscillator is desirable to insure accuracy. The generator is used without modulation, with pure r-f output.

If the output indicator is an oscilloscope the sweep generator is tuned for a center frequency which is approximately the sound intermediate frequency for a dual-channel sound system, or approximately 4.5 megacycles for intercarrier sound. The marker generator will be used to precisely identify this center frequency and other frequencies in the response curves.

Connections for Alignment. — General principles underlying all methods of alignment in the sound section are explained in the following paragraphs.

The output indicator, either voltmeter or oscilloscope, is connected to the load circuit of the sound demodulator. In the two sides of the demodulator load circuit are produced voltage pulses occurring at an audio frequency which is the same as the rate of frequency deviation of the sound signal during normal reception. When using the ordinary type of sweep generator this rate remains constant at 60 cycles per second.

The strength of voltage pulses on one side of the demodulator load circuit increases while pulse strength on the other side decreases when there is deviation from the center frequency. The result is a combined or net pulse voltage which is alternately stronger on one side and then on the other side of the load circuit as frequency deviates below and above the center frequency. The combined pulse voltages during deviations below the center frequency may be represented as at *A* in Fig. 120-4, and during deviations above the center frequency as at *B*.

Connections from the two sides of any demodulator load circuit are made to the following audio-frequency amplifier

in such manner that deviations below the center frequency cause negative alternations of voltage in the output to the audio amplifier. When deviations are above the center frequency the result is positive alternations in the output to the audio amplifier.

In any f-m sound signal, also in the signal from a sweep generator, are frequency deviations alternately below and above the center frequency. These deviations produce in the

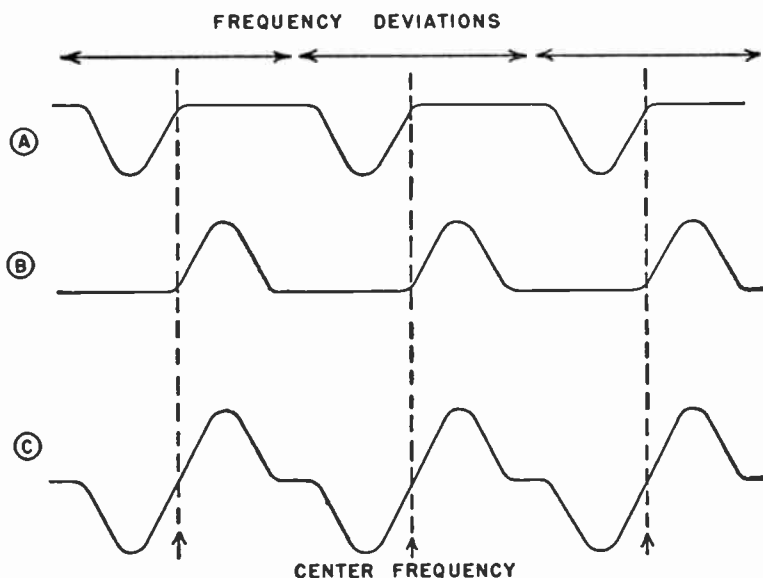

Fig. 120-4.—Audio-frequency voltage pulses produced by frequency deviations.

demodulator output to the audio amplifier a voltage wave such as shown at C in Fig. 120-4. This is a voltage alternating at audio frequency.

If we connect a d-c voltmeter across one side or the other of the demodulator load circuit the meter is subjected to voltage pulses which always are of one polarity, either positive or negative depending on the side of the demodulator load to which connection is made. Furthermore, the strength of these one-way pulses will vary with the strength of sound signal

from a transmitter or a sweep generator, and will not be affected by opposite or compensating pulses in the other side of the load circuit. It is the strength of these one-way or d-c voltage pulses that usually serves as an indication of gain or response during alignment of sound take-offs, sound i-f transformers, and the primary of the demodulator transformer. This is true whether the output indicator is a voltmeter or an oscilloscope.

With a d-c voltmeter connected to the demodulator output going to the audio amplifier the meter will be subjected to the alternating voltage at *C* in the diagram of Fig. 120-4. If the demodulator is correctly aligned the amplitudes will be equal on both sides of zero. Then the average voltage will be zero, and the meter will read zero. If the demodulator or stages preceding it are not correctly aligned the amplitudes will not be equal, and there will be a d-c component which may be either negative or positive. The d-c meter will indicate this d-c component so long as alignment is incorrect. Zero voltage on the meter is the guide for correct alignment of the secondary of the demodulator transformer.

If an oscilloscope is connected across either side of the demodulator output, and if input signal is from a sweep generator, the oscilloscope traces will show pulses like those at *A* or *B* in Fig. 120-4. The stronger the applied signal and the greater the gain the higher the traces will become.

Whenever an oscilloscope is used it is advisable to have on the receiver end of the vertical input cable a resistor whose value is between 100,000 ohms and one megohm. This resistor helps isolate the aligned circuits from capacitance of the cable and of any capacitor in the vertical gain control of the oscilloscope.

When the oscilloscope is connected to the demodulator output going to the audio amplifier, and the input signal is from a sweep generator, the trace will be as shown at *C* in Fig. 120-4. The two peaks which are on either side of a center frequency, and the portion of the trace joining the peaks, make up what is called the S-curve of the demodulator.

There are a number of alignment adjustments in any sound section whose object is to produce maximum readings of a voltmeter or maximum height of oscilloscope traces for any given strength of input signal. These adjustments include those of the takeoff coupler or transformer, of any sound i-f transformers, and of the primary in the demodulator transformer.

For these alignments in a sound section which includes a discriminator type of demodulator the meter or oscilloscope usually is connected across only one side of the demodulator output. This connection would be across resistor R_a or else

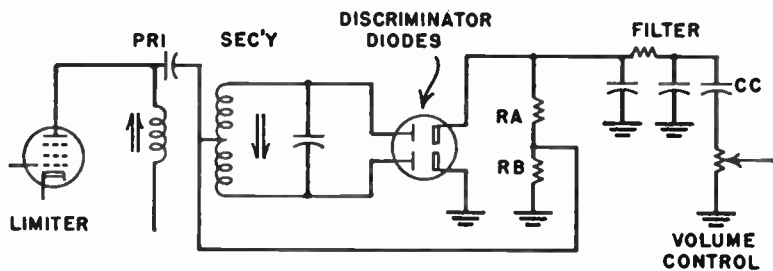

Fig. 120-5.—Typical circuit of a discriminator type of sound demodulator.

across resistor R_b of Fig. 120-5, which shows a typical discriminator circuit. Most often it is convenient to connect the meter or oscilloscope from ground or B-minus to the junction between these two resistors.

When making the adjustments mentioned in a sound section having a ratio detector for demodulator, and using a volt-

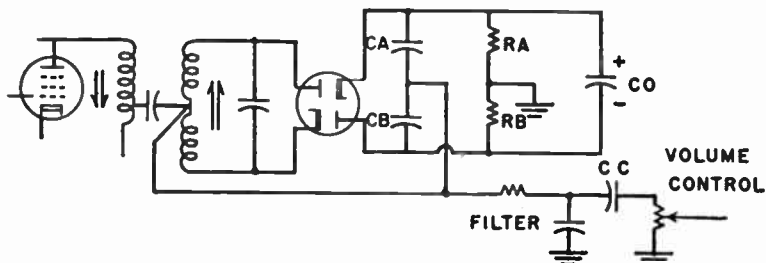

Fig. 120-6.—One type of circuit for a ratio detector type of sound demodulator.

meter for output indicator, the voltmeter is connected across the two ends of the large capacitor marked C_o in Fig. 120-6. The charge and voltage of this capacitor vary with strength of incoming signal and with gain. In some cases it may be practicable to connect the voltmeter across either of the capacitors C_a or C_b , or across either of the resistors R_a or R_b if such capacitors or resistors are in the circuit. Voltages across these elements ordinarily are so weak that this method may not be satisfactory.

Many ratio detectors employ a circuit such as that of Fig. 120-7, where a single resistor R_o is across the large capacitor C_o and the detector diodes. In this case the testing voltmeter may be connected only across capacitor C_o or resistor R_o while making the adjustments requiring maximum meter readings.

If an oscilloscope is used as output indicator for a ratio detector the vertical input may be connected across either of the divided capacitors or resistors shown in Fig. 120-6 while

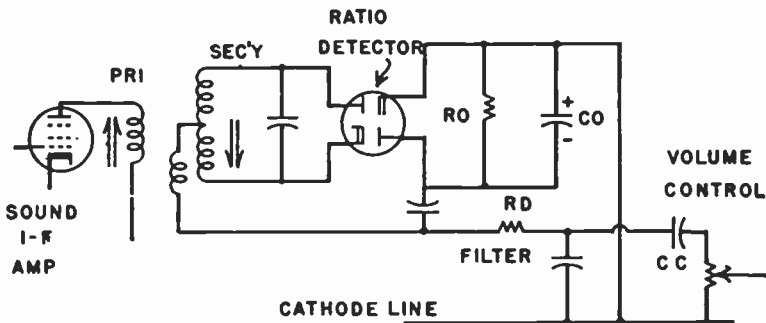

Fig. 120-7.—Ratio detector in a sound system whose cathode line supplies plate and screen voltages to other tubes.

making the adjustments requiring maximum height of trace. Traces secured with these connections often are of too little height to allow satisfactory adjustments.

When the ratio detector load circuit is arranged as in Fig. 120-7, with no divided output, the oscilloscope cannot be connected directly to the detector load for alignment of sound

takeoff, i-f transformers, and primary of the demodulator transformer. These adjustments may be made with a voltmeter connected across the large capacitor.

It is possible to align the sound takeoff, i-f transformers, and primary of the demodulator transformer with the voltmeter or oscilloscope connected to the demodulator output which goes to the audio amplifier, rather than to any of the points previously mentioned. This method is applicable with discriminator or ratio detector circuits such as shown in Figs. 120-5 and 120-6. The points for output indicator connection are from ground or B-minus to any point in the de-emphasis filter line which is on the demodulator side of coupling capacitor C_c leading to the volume control. With this connection of the output indicator it is necessary to detune the secondary of the demodulator transformer by giving its adjustment one or two turns in either direction.

While the secondary is detuned and a voltmeter connected as output indicator, all adjustments from sound takeoff to demodulator transformer primary, inclusive, are adjusted for maximum voltage. With an oscilloscope for output indicator all these adjustments are aligned for maximum height of trace. After these adjustments are completed, the meter or oscilloscope may remain connected to the same points during alignment of the demodulator transformer secondary, according to methods which will be described.

Limiter Input for Alignment Indications. — If the sound section includes a limiter tube preceding a discriminator the direct voltage developed across the limiter grid resistor may be used to indicate correct alignment of the sound takeoff and all sound i-f transformers. Voltage across this grid resistor varies proportionately to input signal strength and gain in all parts from sound takeoff through the i-f transformer just ahead of the limiter tube. Circuits are described in the article on *Limiters, F-m Sound*.

One method of using the limiter grid resistor utilizes a constant-frequency generator connected and operated as previously described, and an electronic voltmeter or highly sensi-

tive moving coil voltmeter connected across the resistor. Alignment adjustments are made for maximum reading on the meter.

Another method employs an oscilloscope connected across the limiter grid resistor, with sweep and marker generators furnishing input signals. In series with the vertical input to the oscilloscope must be the highest resistance which allows readable traces. Alignment adjustments are made for a trace of maximum height, centered at the sound intermediate frequency as identified by a marker, and reasonably symmetrical in shape on both sides of the center frequency. This method is especially useful for alignment of sound i-f transformers of the overcoupled type whose frequency response is a double-peaked curve.

When using the oscilloscope on the limiter grid resistor the two sides of the trace should be at least 70 per cent of the peak height for frequencies which are 75 to 150 kilocycles below and above the center frequency. These points on the response may be identified with markers. This response below and above the center frequency should be obtained with either single-peaked or double-peaked curves.

In case some or all the sound i-f transformers are far out of alignment, the generator may be connected first to the grid of whatever tube precedes the limiter, while adjusting the transformer between that tube and the limiter. Then the generator connection may be moved to the grid of the second preceding tube while adjusting the second preceding transformer. Thus the adjustments are carried out stage by stage until reaching the sound takeoff, which is aligned last.

Demodulator Transformer Secondary Alignment. — For alignment of the secondary in the demodulator transformer the testing meter or oscilloscope must be connected across points furnishing the voltage wave shown at *C* in Fig. 120-4. With a discriminator as shown by Fig. 120-5 this requires connection between the top of resistor *Ra* and the bottom of *Rb*. Usually the output indicator may be connected between ground or B-minus and any point along the de-emphasis fil-

ter line which is on the discriminator side of coupling capacitor C_c . The output indicator will be thus connected if preceding adjustments have been made with the secondary intentionally detuned. A voltmeter will read zero when the secondary is correctly aligned, and an oscilloscope will show a symmetrical S-curve with correct alignment.

Transformer secondary alignment for a ratio detector requires consideration of whether the detector output is practically at the potential of ground or B-minus, or is highly positive with reference to ground. Fig. 120-6 shows an output which is near ground potential, as is evident from the ground (or B-minus) connection between resistors R_a and R_b , also from the ground connections on the filter and volume control. With this general type of ratio detector circuit either the voltmeter or the oscilloscope may be connected from ground or B-minus to any point along the filter line on the detector side of coupling capacitor C_c . The meter will read zero or the oscilloscope will show a symmetrical S-curve when alignment is correct.

When using a meter to obtain zero reading upon correct alignment of the secondary it may be possible to obtain as many as three zero readings if the alignment adjustment has a very great range. The correct zero point is at the center frequency, as shown at C in Fig. 120-4. The other two zero points are at the outer ends of the complete S-curve, at frequencies in between the center frequencies of that diagram. The correct zero reading is the one occurring between two peak readings, one positive and the other negative. Adjustment for this zero point is critical. The least change of adjustment either way will produce either a positive or negative reading. At either of the two incorrect zero points the adjustment is not critical.

Fig. 120-7 applies specifically to a sound system in which the cathode line for all the audio tubes supplies plate and screen currents to other tubes in the receiver. This cathode line usually is 130 to 150 volts positive with reference to ground or B-minus. In this circuit there are no points between

which a voltmeter may be connected to indicate zero voltage when the transformer secondary is correctly aligned.

With a circuit of the general type shown by Fig. 120-7 an oscilloscope may be connected from any point on the detector side of the filter line to either the cathode line, B-minus, or ground, and will display a symmetrical S-curve when the secondary is correctly aligned.

If a ground terminal of the oscilloscope is connected to B-minus or chassis ground with a high-voltage audio system it is advisable to make this connection through a capacitor of about $\frac{1}{4}$ mf to prevent high voltage from going through a direct ground connection to the sweep or marker generator. If no oscilloscope is available the secondary may be aligned merely for good sound quality and volume and for freedom from intercarrier buzz while receiving a signal with sound from a television station. Final alignment with intercarrier sound may be for minimum buzz with the contrast control at its maximum setting.

S-curve Requirements. — Fig. 120-8 shows features which are desirable in the S-curve of a sound demodulator, as observed on an oscilloscope with signal from a sweep generator. Peak-to-peak voltage, *A*, should be maximum obtainable while

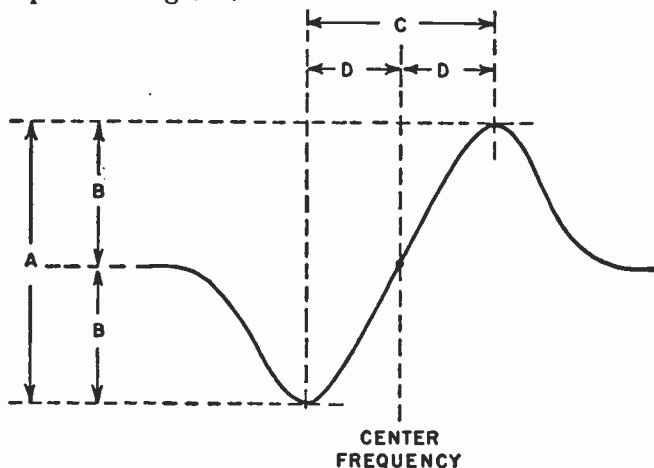

Fig. 120-8.—A demodulator S-curve showing features which are checked and adjusted during alignment.

observing other requirements. Amplitudes B and B must be equal above and below the zero point. Maximum voltage depends on correct alignment of the demodulator transformer primary and other transformers and couplers back through the sound takeoff. Equal amplitudes depend largely on adjustment of the demodulator transformer secondary.

Peak separation, C , should be not less than 300 kilocycles and not more than 500 or 600 kilocycles, this latter limit being for prevention of sound interference. The two peaks should be equally spaced from the center frequency, as at D and D . Separation and spacing of the peaks depend chiefly on adjustment of the transformer primary, but are affected also by secondary adjustment. These features are checked with markers.

The center of the curve must be at the sound intermediate frequency for a dual-channel sound system or at 4.5 megacycles for an intercarrier sound system. This point is checked with an accurate marker. It is affected by adjustment of both primary and secondary in the demodulator transformer.

The curve should be symmetrical or of similar shapes from the center out to the peaks on each side. This is chiefly a matter of primary adjustment. The sloping line between the peaks, and through the center, should be practically straight for at least 50 to 125 kilocycles on both sides of the zero or center point. The line is straightened largely by correct adjustment of the transformer primary.

Steps in Alignment. — Following is a brief summary of the steps ordinarily taken during alignment of the sound section when using an oscilloscope with sweep and marker generators.

1. Connect the oscilloscope and the sweep and marker generators as directed. Turn on all the instruments and the receiver, then allow at least a 15-minute warmup period for operating conditions to stabilize.

2. Set the sweep width for something between 1 and 3 megacycles.

3. Adjust the sweep frequency or center frequency to bring an S-curve to the center of the oscilloscope screen.

4. Readjust the sweep width to leave only small horizontal extensions on opposite sides of the S-curve, about as shown by Fig. 120-8. Readjust the sweep frequency as may be necessary to keep the S-curve in the center of the screen.

5. Adjust the oscilloscope horizontal gain so that the S-curve and horizontal lines nearly fill the screen. Adjust the vertical gain to make the curve of the general proportions shown by Fig. 120-8.

6. Adjust the transformer primary for maximum peak-to-peak height of the curve. Unless adjustments of preceding transformers and the sound takeoff are known to be correct it may be well to check them at this point for possible improvement of the S-curve.

7. Adjust the transformer secondary for equal amplitudes of peaks, for peaks equally spaced from the center, and for the straightest sloping line between peaks.

8. Work back and forth between primary and secondary adjustments to get the best balance between requirements outlined in steps 6 and 7.

9. Use frequency markers to check the frequency at the center of the curve, the separation between peaks, the frequency difference from the center to each peak, and the frequency range in which the sloping line is fairly straight.

10. To move the entire curve with reference to a marker frequency it will be necessary to adjust both the secondary and primary of the demodulator transformer. The secondary alone will shift the curve so that the marker moves up or down on the central slope, but to preserve symmetry it will be necessary to readjust the primary.

A marker strong enough to be clearly visible at the center of the S-curve may so distort the curve and alter the heights of peaks as to make adjustments difficult. When the center of the curve is at the marker frequency any change of marker strength will affect the amplitudes of both top and bottom, or both peaks, equally. As a last resort the marker may be made strong enough to be distinct, regardless of its effect on the curve. Then the sweep frequency or center frequency of the

generator may be adjusted to bring this marker exactly on the center line of the graph scale for the oscilloscope screen. Finally, the marker may be turned off and the curve adjusted to bring its center point exactly on the center line of the graph scale.

SWITCH, ELECTRONIC. — An electronic switch is an instrument that allows observing at the same time on the screen of an ordinary oscilloscope the traces for two independent voltages or signals. The switch applies each of the observed voltages to the oscilloscope during alternate very brief intervals of time. The switching rate is so rapid that traces for both voltages remain visible, due to persistence of illumination on the oscilloscope screen and persistence of vision in the eye.

The principle is illustrated at the left in Fig. 121-1. The oscilloscope beam is caused to trace first a short length of one curve, then a short length of the other curve, and so on all across the horizontal travel. By suitable adjustments it is possible to make both traces appear continuous or practically so, as at the right.

The two observed voltages are applied through separate input terminals on the switch to separate amplifiers. The amplifiers are alternately biased to cutoff, and allowed to amplify the voltages applied to their grids. The outputs or plates of the two amplifier tubes are connected together and to the output terminal of the switch. This output terminal is con-

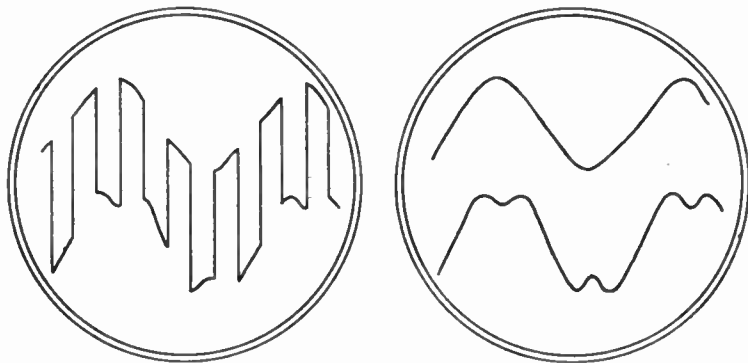

Fig. 121-1.—How two simultaneous oscilloscope traces are formed by the electronic switch.

nected to the vertical input of the oscilloscope. On each amplifier is a gain control allowing the height of its portion of the trace to be adjusted independently of the height of the trace from the other amplifier. The switching rate is adjustable, usually from 10 or 20 times per second up to 2,000 times.

The switching or cutoff biasing of the amplifiers is accomplished by a multi-vibrator oscillator. The rate of switching is altered by varying the operating frequency of the multi-vibrator. In most electronic switches the alternating positive and negative pulses from the multivibrator are applied to the grids of two blocking tubes. In the cathode resistors of these blocking tubes are produced corresponding pulses of current and voltage. These two resistors are also the cathode resistors for the two amplifier tubes. When the voltage pulses make the amplifier cathodes highly positive it is equivalent to making the amplifier grids highly negative, and during these intervals the amplifiers are cut off.

The biasing voltages have the form of square waves. The multivibrator may be designed to produce the square wave voltages when no separate blocking tubes are used, or these separate tubes may do most of the squaring of the voltage waves.

The relative vertical positions of the two traces may be varied as desired. One may be above the other, as in Fig. 121-1, or their positions may be reversed as at the left in Fig.

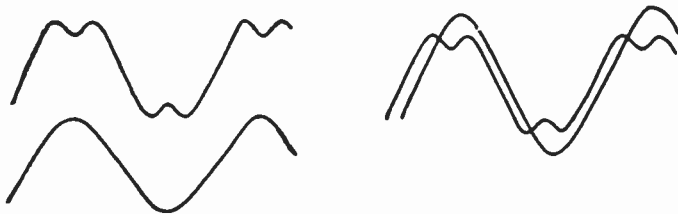

Fig. 121-2.—The two traces may be moved vertically with reference to each other.

121-2. The two traces may be superimposed for close comparison, as at the right. This is accomplished by a position control or balance control which will increase the gain of one amplifier while decreasing the gain of the other for raising one

trace above the other, or which will make the gains equal when the two traces are to have the same zero or base line, as at the right in Fig. 121-2. The gain may be altered by change of plate voltage, screen voltage, or grid bias.

Operating the Electronic Switch. — On the panel of an electronic switch are two input terminals, one for each observed voltage, also a single output terminal for the oscilloscope lead, and one or more ground terminals. Connections for observing simultaneously the input and output voltages of an amplifier are shown by Fig. 121-3. The signal source may be a generator. The place of the amplifier might be taken by any other device being tested.

All ground terminals are connected together or all are connected to a grounding metal top of a test bench. The high side of the signal source is connected to the input of the device being tested and also to either of the input terminals on the switch. The output of the device being tested is connected to the other input terminal of the switch. The output terminal

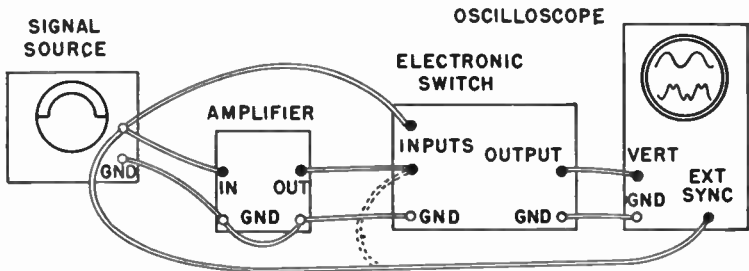

Fig. 121-3.—Electronic switch connected for observing input and output voltages of an amplifier.

of the switch is connected to the vertical input of the oscilloscope. In order to obtain reasonably continuous traces, as at the right in Fig. 121-1, it is necessary to employ the external synchronizing connection of the oscilloscope, and turn off the internal synchronization. The external sync terminal of the oscilloscope may be connected to the signal source, as shown, or to the amplifier output or to either of the input terminals of the switch.

To begin with, the two input gain controls of the switch may be set at zero while the position control or balance control is adjusted to produce two separate horizontal lines on the oscilloscope screen. Then the gain controls of the switch may be increased enough to produce two voltage wave traces. The height of either trace may be changed by its own gain control. The heights of both traces may be changed together by varying the output of the signal source. The internal sweep frequency and the sync control of the oscilloscope are adjusted in the usual manner to hold the traces steady on the screen.

The switching rate, varied by the frequency controls of the electronic switch, need have no particular relation to signal frequency or oscilloscope sweep frequency. Switching frequency should be made whatever allows the clearest and most nearly continuous traces on the oscilloscope screen. In general, it is best to employ high-speed switching when observing low-frequency signals, and to employ relatively low-speed switching for high frequency signals. This usually will allow the least flickering and greatest continuity of traces.

To avoid distorted traces it is necessary that the frequency response of the oscilloscope vertical input attenuator and vertical amplifier be practically flat up to at least ten times the switching rate. This is because voltages being applied to the vertical input are of square waveform, as shown at the left in Fig. 121-1, and such waveforms contain frequencies many times as high as the fundamental or the switch rate frequency.

If either of the gain controls on the electronic switch is set at zero the corresponding trace becomes a straight horizontal line. This line may be used as a reference level or zero level by operating the position or balance control to bring the line into any desired relationship with the remaining trace.

Uses for the Electronic Switch. — The principal uses for the electronic switch include comparison of two waveforms, checking phase relations and phase shifts, comparison of amplitudes or signal strengths, and comparison of frequency responses.

Waveforms may be compared at the input and output of any device or apparatus. It is possible also to compare the inputs to two devices or their output waveforms. Relative changes in any two such waveforms may be observed while input signals or other operating conditions are varied. As one example, the input and output waveforms of all types of filters may be compared.

One of the more important uses of the electronic switch is in checking and measuring the phase shift occurring in all types of amplifiers and amplifying stages at various frequencies. With input and output of an amplifier connected as in Fig. 121-3, and with the two traces superimposed, the direction and extent of phase shift becomes clearly apparent. Phase relations are shown because timing always remains the same in both traces. Any given instant of time is the same on a vertical line passing through both traces. The graph screen of the oscilloscope may be used to establish corresponding instants of time along both traces. Polarity inversions may be examined. Various distortions and corrections of distortion may be studied.

The electronic switch is useful for comparing waveforms and amplitudes in the outputs from the two sides of any inverter tube or cathode follower, for comparing the signals at various points in push-pull amplifier circuits, for comparing the sawtooth voltages applied to opposite plates of a pair in an electrostatic deflection picture tube, and many similar purposes.

The electronic switch allows observation of direct potentials and their changes on an oscilloscope whose input is designed for only alternating potentials. The direct potential to be observed is connected between one of the input terminals and ground on the electronic switch. The gain control for the other input terminal is set at zero, to provide a zero reference trace on the oscilloscope screen. Usually it is best to adjust the switching rate to some rather high frequency. Then the switching action breaks the direct potential into pulses occurring at the switching rate. This is the equivalent of a

square wave alternating potential, which will pass through the input attenuator and vertical amplifier of the oscilloscope to produce on the screen a second trace whose separation from the zero trace is proportional to the observed direct potential. Cathode biases, power supply bleeder voltages, and other direct voltages may be examined with this method.

Any electronic switch will serve as a square wave generator for frequencies up to about one-fourth the maximum switching rate or frequency. At higher frequencies the waveform will have considerable distortion. No connections are made to the input of the switch. Both gain controls are set at zero. The position control or balance control is used to vary the amplitude or height of the square wave. The square wave signal is taken from the output terminal and ground terminal of the switch. Frequency of the output signal is varied with the frequency controls of the switch.

SYNC SECTION. — The sync section of the television receiver extends from the video detector or a video amplifier through to the sweep oscillators. The input to the sync section consists of the composite television signal containing picture signals, vertical and horizontal and equalizing pulses, and blanking intervals. The sync section delivers to the vertical and horizontal sweep oscillators the pulses of voltage which keep oscilla-

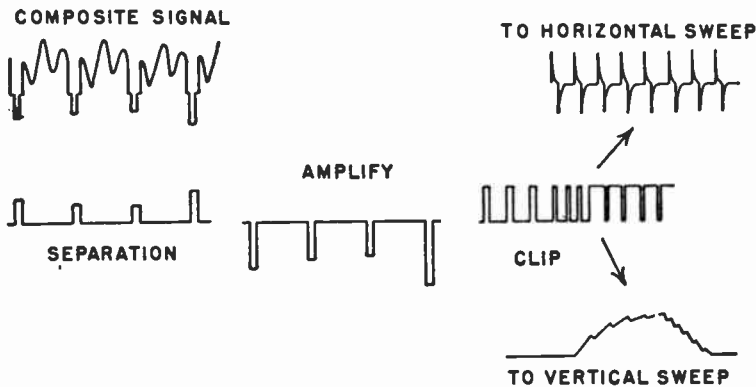

Fig. 122-1.—Principal steps in producing oscillator synchronizing voltages from the composite television signal.

tor frequencies correctly timed or synchronized with the vertical and horizontal sync pulses of the received signal.

The following operations are performed by the sync section, as illustrated by Fig. 122-1.

1. Remove all picture signals from the incoming composite signal, also remove the pedestals which are at the black level and leave only the sync pulses. This function is described in detail by the article on *Separation, Sync*.

2. Amplify the remaining pulse voltages as may be necessary to allow other functions to be carried out satisfactorily. Such amplification is covered by the article, *Amplifier, Sync*.

3. Cut down the strength of sync pulses to a uniform value, and remove so far as is practicable all abnormally strong voltage pulses due to noise types of interference. This action is explained in the article on *Clippers or Limiters*.

4. Produce from the horizontal sync pulses sharp pips of voltage which will correctly trigger or control the horizontal sweep oscillator, either directly or through some form of automatic sweep frequency control.

5. Produce from the vertical sync pulses the relatively long voltage pulses which will trigger the vertical sweep oscillator. Voltages for triggering of the vertical and horizontal sweep oscillators are produced from the sync pulses by filters described in the article on *Filters, Differentiating and Integrating*.

6. Make the polarity of the triggering voltages whatever is required by the type of sweep oscillator or automatic frequency control used in the receiver. This is done by providing a suitable number of signal or polarity inversions as explained in the article on *Inverters and Inversions*. In Fig. 122-1 inversions of polarity are indicated by the directions in which sync pulses are drawn in the composite signal and in steps of the diagram.

A blocking oscillator is triggered by positive voltage pips or pulses applied to its grid. This is true also of a blocking oscillator used with a discharge tube. Therefore, with sweep oscillators of this type the voltage pips produced by leading edges of horizontal sync pulses must be positive.

Triggering voltages applied to the first section of a multivibrator sweep oscillator must be negative. They are inverted between the first and second sections of the multivibrator, and become positive at the grid of the second section for controlling discharge of the sawtooth capacitor. If triggering voltages are applied to the cathode of the first section in a multivibrator these voltages must be positive, because they will be of this same polarity at the plate of the first section and at the grid of the second section.

When a sweep oscillator is preceded by an automatic frequency control for sweep frequency, the polarity of the synchronizing voltage pips or pulses will depend on the type of automatic frequency control as well as on the type of oscillator. In any event, the triggering voltages arriving at the grid of the oscillator itself must be as previously described.

It is not necessary that separation, amplification, and clipping or limiting be performed in the order shown by Fig. 122-1. Separation often is provided in a d-c restorer tube, with no other tube needed for this purpose in the sync section. A single tube in the sync section may partially or completely remove picture signals while at the same time amplifying sync pulses, or may both amplify and clip or limit the pulses. Any tube providing necessary inversion of polarity nearly always acts also as an amplifier, a separator, or a clipper.

Instead of combining two or more functions in a single tube there may be more than one tube for the same function. It is rather common practice to provide amplification in more than one tube of the sync section. Often there will be one clipper acting on the bottom of the pulses and a second clipper acting on the top, with inversion of polarity between the two clippers, so that what was the bottom of the pulses in the first operation becomes the top of the pulses in the second operation.

A few of the many arrangements of tubes in sync sections are shown by Fig. 122-2. In the upper left-hand diagram are shown, in order, a separator, an amplifier, and a clipper. At the upper right there is first a separator, then a clipper, fol-

lowed by two amplifiers. The top amplifier is fed from the plate of the clipper and the bottom one from the cathode of the clipper. The signal to the top amplifier will be much

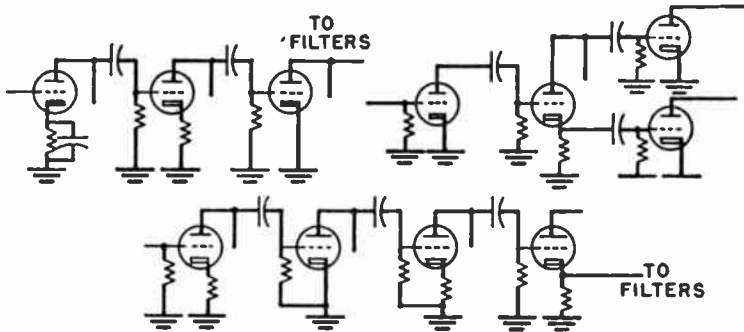

Fig. 122-2.—Connections of tubes in sync sections of receivers.

stronger than to the bottom amplifier, because there is amplification at the plate output but not at the cathode. Signals to both amplifiers would be of the same polarity. The same or a similar diagram might represent first an amplifier, then a separator, and finally two clippers. How a tube performs and what it accomplishes depend more on plate, screen, and grid voltages or biases than on circuit connections.

The lower diagram of Fig. 122-2 shows first a separator, then a clipper, then an amplifier, and at the output end a cathode follower feeding the vertical and horizontal filters. Any of the tubes in these diagrams might be pentodes instead of triodes.

At the upper left in Fig. 122-3 is first an amplifier, then a clipper, and last a combined inverter and cathode follower. From the plate and cathode of this last tube, acting as an inverter, are taken signals for an automatic frequency control system. From the cathode, with the tube acting as a cathode follower, are taken signals for the vertical sweep oscillator. The upper right-hand diagram shows a separator feeding a cathode follower for the vertical oscillator and feeding an amplifier for the horizontal oscillator. The lower diagram

shows a separator feeding a clipper, with between them a diode limiter or leveler. The clipper acts also as an inverter for its plate signal.

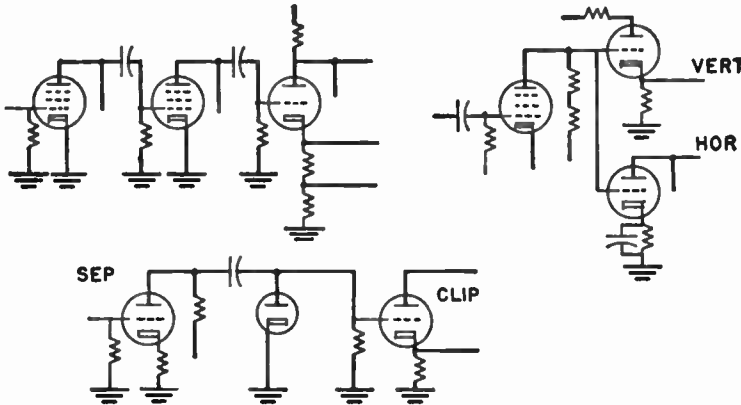

Fig. 122-3.—Connections in sync sections which provide two or more separate outputs to filters.

With input to the sync section taken at or near the video detector it becomes necessary to provide more following amplification than when a stronger signal is taken from a first or second video amplifier stage. In some receivers there are amplifiers following one or both filters. Greater amplification may be provided for horizontal synchronizing voltages than for the vertical pulses, since it is more difficult to maintain synchronization at the relatively high horizontal frequency than at the low vertical frequency.

Cathode followers may be used not only to provide low impedance couplings but also to secure or retain correct polarity of voltages going to the sweep oscillators. A cathode follower furnishes no amplification, rather there is some loss of signal strength. Therefore, an additional amplifier may be used in a branch containing a cathode follower. Also, as at the upper right in Fig. 122-2, a cathode follower might be in the line to the vertical sweep oscillator and an amplifier in the line to the horizontal oscillator.

Because a single tube may perform two or more functions, and because two or more tubes may perform similar functions, there is no standardization of names applied to tubes in the sync section. It is the intention to use names denoting the principal purpose, but the same tube may be called either a separator, an amplifier, or a clipper, and may be called by different names in different receivers.

When examining oscilloscope traces of waveforms in the sync section it usually is necessary to receive a transmitted picture or test pattern signal in order to have synchronizing pulses. For examination of vertical pulses and related actions the internal sweep of the oscilloscope should be adjusted for 30 cycles per second, which will display two vertical pulse intervals. If it is difficult to synchronize the oscilloscope for holding a vertical blanking period near the center of the screen, the sweep frequency may be changed to 20 cycles to bring three vertical pulse intervals onto the screen. Any part of the center interval then is easily examined. For examination of horizontal sync pulses and related actions the internal sweep of the oscilloscope may be adjusted to 7,875 cycles per second to display two pulse intervals, or at 5,250 cycles to display three pulse intervals.

T

TELEVISION, COLOR. — There has already been and will continue to be, a great deal of research in color television. Many ideas and plans have been developed but with the exception of four systems none have been deemed commercially practical. In this section the publishers present information on these four systems and have printed the section in four colors for easier understanding.

If we consider only the variations and combinations of color easily distinguished from one another by the average person there are approximately 150 distinctly different hues which may enter into a colored picture. To transmit each of these hues with an appropriate signal would be a practical impossibility. Fortunately for the success of television in color, every hue needed for complete portrayal of any scene may be produced by mixtures of only the three colors which we call blue, green and red.

Present practical color television systems secure the blue, green, and red signals by separating the colors of the original

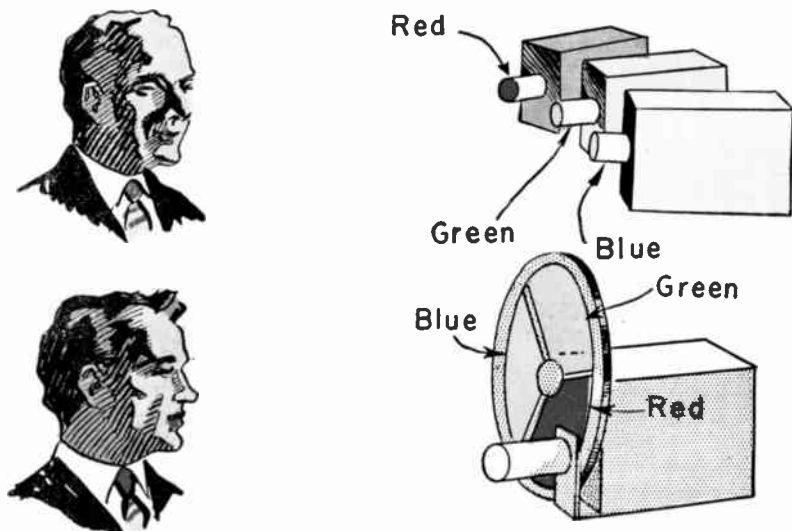

Fig. 1.—The three color bands may be picked up by three separate cameras or by a single camera with rotating three-color filter disc.

scene into three bands by means of light filters. A light filter is a sheet of colored gelatin, plastic, or glass which permits passage through it of a limited band of wavelengths or colors.

Fig. 1 shows in most elementary form two principles employed for color separation. At the top are three separate television cameras fitted with red, green, and blue filters. The mosaic in each camera is activated only by the colors or wavelengths which get through its filter.

At the bottom of Fig. 1 is a single camera fitted with a rotating disc which carries the three color-band filters in the form of sectors of a circle. The filters rotate successively into the path of light between lens and mosaic to permit formation on the mosaic of the blue, green, and red images one after another. In actual camera construction the color disc may be replaced by a small cylindrical drum around whose circumference are the filters.

With any system of color separation the camera tube is affected by colors of the scene just as it is affected by these colors for black and white reproduction. The difference is that the tube of each camera at the top of Fig. 1 is reached only by wavelengths passed by its filter and is unaffected by other wavelengths or colors. With the rotating disc or any equivalent arrangement the single camera is affected during any one

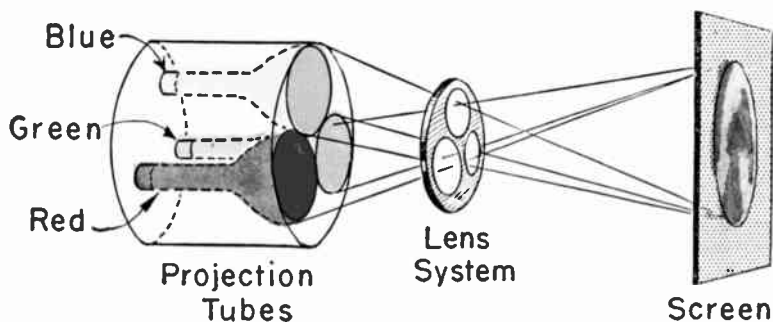

Fig. 2.—Three images for the three color bands are combined for reproduction of a full color picture. This is one of many methods used for combination.

period of time by only the wavelengths which get through the filter then in the light path.

When three color-band signals from three cameras or from a three-part camera are received, separated, and amplified they may be projected together onto a single viewing screen as illustrated in Fig. 3.

When color band signals are received successively from a single camera with rotating filters they are amplified and fed in the same succession to a single picture tube fitted with rotating filters. The rotation of the filter disc or drums at receiver and transmitter is so synchronized that filters of the same color are in their active positions at the same instants in both places. The three color bands are reproduced in such rapid sequence as to blend into a single picture containing all colors of the televised scene.

Viewing filters are not necessarily of the same types as the taking filters. The intensity of various color wavelengths as seen by the camera depends on the kind of light illuminating the scene. For example, tungsten light is strong in the red and weak in the blue end of the spectrum. Some types of fluorescent lamps have intensity distribution very much like that of daylight. The color intensities in the camera output depend also on the color sensitivity or wavelength sensitivity of the sensitive surface.

Scanning or Color Switching. — A major difference between the several possible systems of color television is the manner in which the three color bands are separately scanned at the camera end and at the receiver are applied to a single screen or viewed to form a single complete color image. One method employed by CBS (Columbia Broadcasting System) is shown in principle by Fig. 3. To simplify the explanation there is shown at the top a pattern, rather than a picture, consisting of stripes in green, red, and blue color together with one white stripe and one black stripe. Down below are shown the same lines for six successive fields, numbered 1 to 6, which are required to complete the color pattern. Fields number 1, 3 and 5 on the left are those containing the odd horizontal lines or

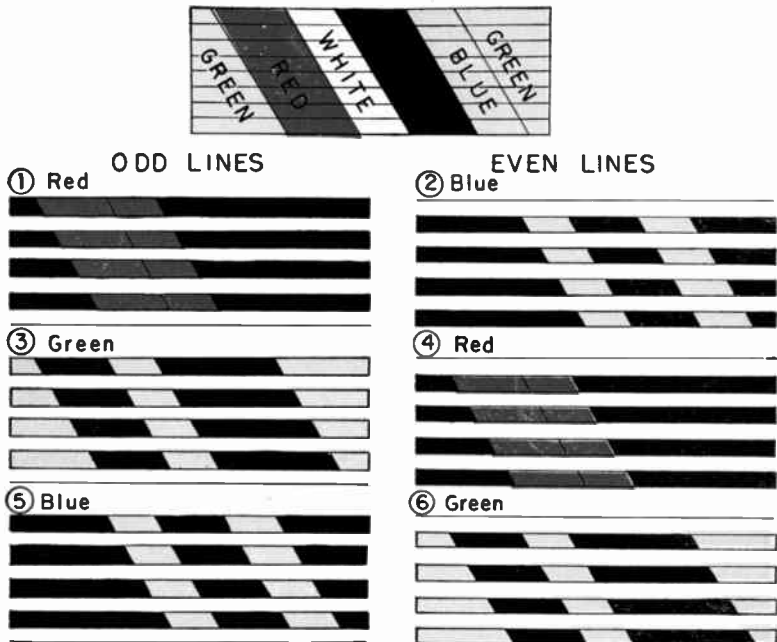

Fig. 3.—How the color bands are scanned and recombined to form all hues as well as white and black in the full color picture of a CBS system.

traces and fields number 2, 4, and 6 on the right contain the interlaced even horizontal lines or traces.

During the period of the first field the red color band is being transmitted and received, and the picture tube beam is tracing odd lines. Wherever there is red in the original pattern or scene there will be red tracing on these lines. In addition there will be red tracing wherever white appears in the original scene, because all three color bands must be present to form white. All the remaining portions of the lines in this first field will be blank or black.

In the second field will be traced the blue on the interlaced even lines. Blue tracing will appear also where the final result is to be white. The remainder of all lines will be blanked or black. The third field will be traced on the odd lines with the green color band, with green appearing also where there is to

be white in the picture. So far there has been one field for each color band, but because of interlacing only half the required lines have been traced. For the next three fields, numbers 4, 5 and 6 in this order, the three color bands are again traced but now they appear on lines which were not covered before.

Upon completion of the sixth field each of the three color bands has been traced twice, once on odd lines and once on even lines. All three color bands have been traced wherever the picture is to be white. None of the three has been traced where black is to appear in the picture. Everything in the way of color and of black and white in the original pattern or scene has been reproduced during the six fields which make up one frame. If the entire frame is completed while



Fig. 4.—CBS color camera for use with CBS color television system.

vision persists in the eyes of observers all the color bands as well as black and white will appear as occurring at the same time and will form a complete color reproduction. Each succeeding frame is made up of six fields in the manner illustrated.

There is a total of 405 horizontal lines in the complete picture, rather than 525 lines used for standard black and white television. Each line is traced three times for the complete picture, once with each of the three color bands. The six fields which make up the complete picture frame are completed in $1/24$ second, so the picture frame frequency is 24 cycles per second. Each one of the six fields then must be completed in $1/144$ second, so the field frequency is 144 cycles per second instead of 60 cycles as in black and white television. Note that there is a change of color between every two successive fields, so the color switching rate is 144 times per second.

Features of CBS Color System. — The CBS system is characterized by the use of color-band filters at the camera and



Fig. 5.—Table model standard black-and-white television set with a scanning adapter which will enable it to get CBS color television signals in black-and-white, in addition to getting standard black-and-white signals in black-and-white.

again at the receiver, with only one camera necessary for viewing a scene and only one picture tube needed at the receiver.

The filter disc or drum in the receiver is driven by a motor whose speed must be precisely synchronized with the speed of the motor doing a similar job at the camera in order that color changes may be at the same rate in both places. In addition, the filter which is active in the receiver during any one field must be of the same color as the filter then active at the camera. The synchronizing system causes the motor to run at slightly reduced speed until the correct color is in place, then locks the receiver motor into synchronization with the camera motor.

Direct view receivers for use with the CBS system of color television may have picture tubes in any of the usual diameters from three to twelve inches. For reproduction in still larger size any projection system may be used, with either a refracting or reflecting optical system. Color discs for direct view receivers are of a diameter one to two inches greater than twice the nominal face diameter of the picture tube. For example, a 10-inch tube requires a disc 22 inches in diameter.

In order to have reproduction of black and white pictures from a full color transmission on a set designed for standard black and white reception it is necessary to have a circuit arrangement allowing shift of scanning frequencies. That is, there must be means for changing from 60 to 144 fields per second and from 30 to 24 complete picture frames per second. To reproduce full color pictures with a receiver designed for standard black and white reception it is necessary to change the scanning frequencies as mentioned and to add a color disc and drive. CBS has also developed an all-electronic color TV system. The receiver is a projection type having the equivalent of a 22 inch screen. Three images are produced on the face of the tube and these are combined optically.

With a scanning method used by Color Television, Inc., there is a change of color not for each successive field, but for each line. This system employs 525 lines per picture frame, just as for black and white, and has the familiar 60 interlaced fields and 30 complete frames per second. Thus the color switching rate becomes the same as the line frequency, or 15,750 per second.

In the RCA system there are 525 lines per picture, 60 fields and 30 frames per second, and interlaced scanning just as for standard black and white television. But, so far as color switching is concerned, there may be as many changes along each horizontal line as there are vertical lines in the

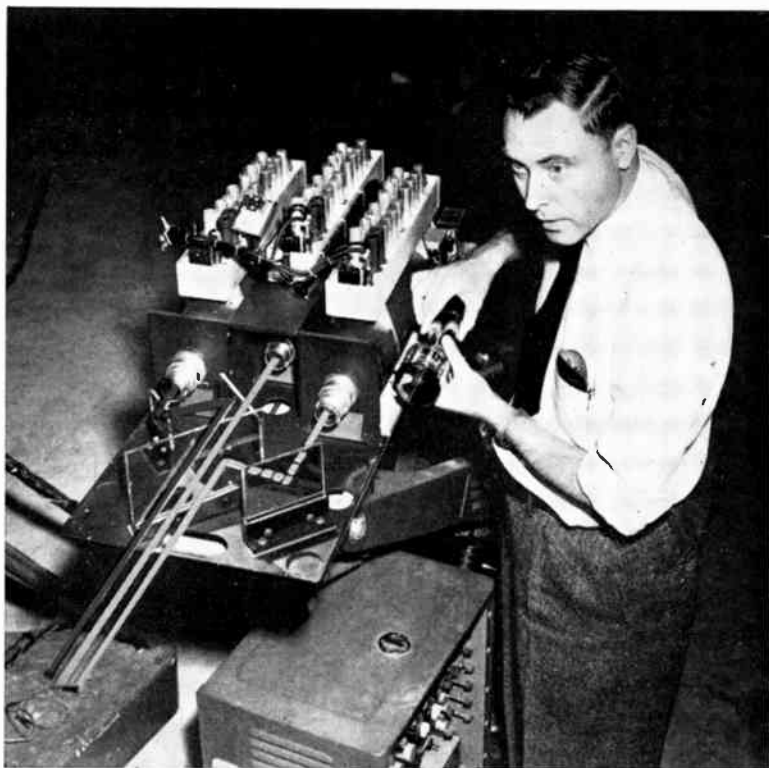

Fig. 6.—The RCA color television camera with cover removed to show the system of dichroic mirrors and silvered reflectors which separate the color bands.

picture. It is by means of this same principle that high definition is possible in black and white pictures, where, you will recall, there is a theoretical maximum of about 500 picture "elements" along each horizontal trace. One element is a shade which is different from that of an adjoining element. Were alternate elements to be black and white, there could be a maximum of about 500 changes from black to white and back to black. This would mean about 250 cycles.

For each color band in the RCA system there is a possible maximum of 3,800,000 cycles or 3.8 mc per second, this being the product of 30 (frames per second), 500 (active lines per frame), and about 250 cycles per line.

Color Cameras. — The CBS color camera, pictured in Fig. 4, contains a single lens system and a single image orthicon pickup tube, just as used for black and white pickup, and in addition there is the rotating disc or drum carrying filters for the three color bands. During the period in which a filter of any one color is in the light path a field of that color is being produced, transmitted, and used in the picture being formed at receivers.

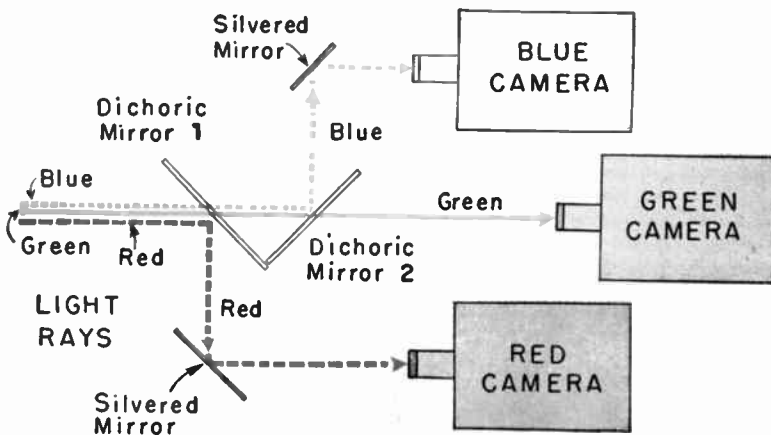

Fig. 7.—The principle of three-color separation by means of dichroic mirrors which combine transmission and reflection.

In the color disc used at the camera are twelve segments in which the filter colors blue, green, and red alternate all the way around. This disc turns at 720 revolutions per minute. This makes a total of 8,640 color changes or color fields per minute, which is 144 per second as required for the field frequency.

Fig. 6 shows the RCA color television camera with the cover removed. The principle employed for color separation is illustrated by Fig. 7. At the left are represented light rays from a scene in which are colored objects. This light, not yet separated, may have all the wavelengths or colors of the spectrum or may have all of the blue, green, and red color bands. This light strikes the first dichroic mirror, which may be thought of as a combination filter and mirror of such characteristics as stop the red band while allowing the green and blue



Fig. 8.—RCA direct view color reproduction system using three kinescopes and two dichroic mirrors.

bands to pass right on through. The mirror is optically flat, consequently acts as a most effective reflector for the light which it stops.

The red color band stopped and reflected by the first dichroic mirror is directed toward a silvered mirror which reflects this color band to the lens of the "red" camera. The blue and green color bands which pass through the first dichroic mirror come to the second dichroic mirror. This second element is of such characteristics as to stop and reflect the blue band while allowing the green band to go right on through. The green band goes straight on to the lens of the "green" camera. The blue band is reflected toward another silvered mirror which is at such an angle as to reflect this band to the lens of the "blue" camera.

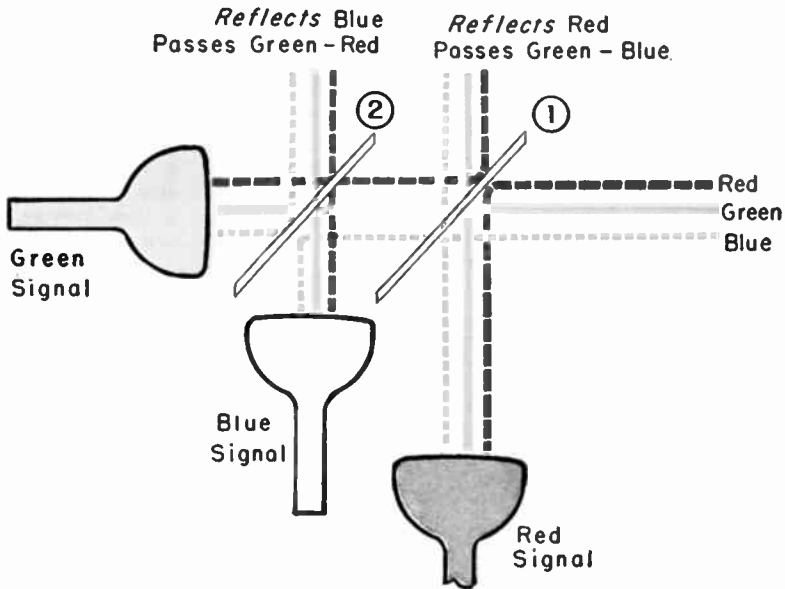

Fig. 9.—A direct view system which separates one color band from the light of each tube and combines the bands into a full color image.

With a third method the kinescopes need produce only white light traces for their respective signals, and may be used without filters at each of the tubes—the necessary filtering being performed by two dichroic mirrors. The principle is shown by Fig. 9.

Fig. 10 shows the principle of an RCA method of reproduction from three projection type kinescopes in connection with two dichroic mirrors and a reflection type optical system for directing the complete color picture onto a screen for viewing.

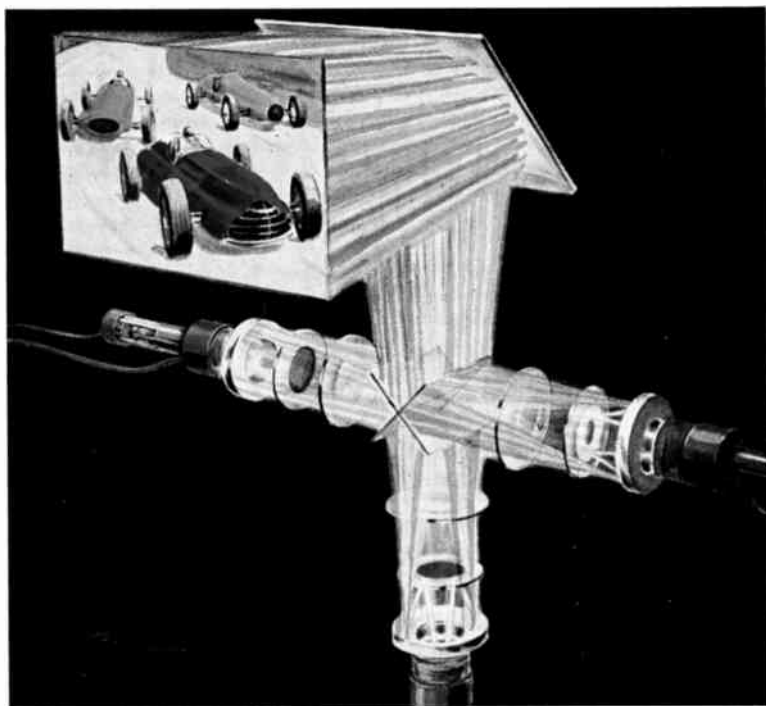

Fig. 10.—RCA full color reproduction method employing three projection kinescopes, a pair of dichroic mirrors, and a reflective optical system.

Other Color Systems. ⇐ Development of color television in England has been based on designs evolved by John L. Baird, a famous experimenter and inventor who has been closely identified with all phases of television since its beginning. One

of the principles employed for three-color television is illustrated by Fig. 11. Inside the viewing tube is a transparent screen having parallel ridges on the side toward the viewer and flat on the opposite side. There are three electron guns whose beams are modulated by the three color-band signals. The beam from one of these guns can impinge on only one side of the ridges. This side is coated with a phosphor emitting the color band which is to be reproduced by the corresponding gun. The second gun can send its beam only to the opposite side of the ridges, this side being coated with phosphor

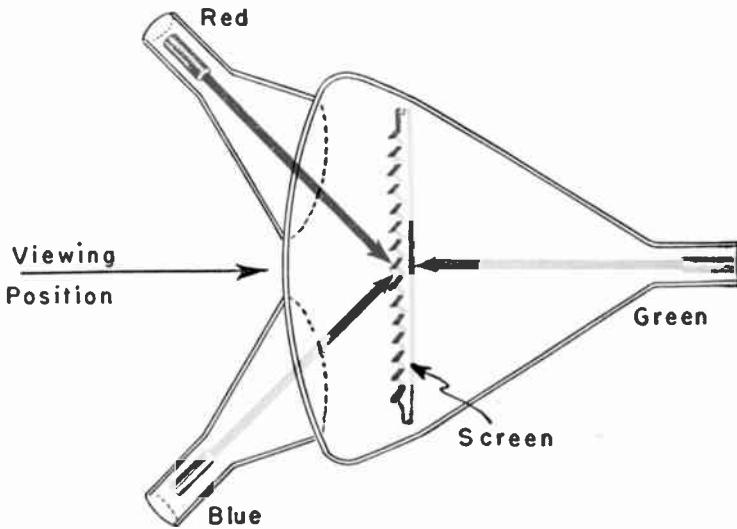

Fig. 11.—Three-color reproduction by means of three electron beams acting on a screen having phosphors which emit the three color bands.

emitting the second color band. The beam from the third gun strikes the flat surface of the screen, which carries a phosphor emitting the third color band.

The third color, produced on the back of the screen, shows through the transparent supporting material and mixes with the other two color bands produced on the sides of the ridges. The ridges actually are very narrow and closely spaced. Two

of the guns are in such positions that their beams travel different distances to opposite sides of the screen, which would tend to form a picture higher on one side than the other. This is corrected by keystoneing circuits similar to those employed with some camera tubes in which the axis of the electron gun is not perpendicular to the screen or mosaic surface.

Features of CTI Color System. — In one method developed by Color Television Incorporated each horizontal line in any one field is traced in a primary color which is different from colors in the lines above and below. In each complete field one-third of the lines trace the blue image, one-third trace the green image, and one-third trace the red image.

The composite color signal differs from the standard black and white composite signal only in the means for correctly phasing the three color bands so that the blue, the green, and the red are traced on the picture reproduction in the same relative positions as on the original televised image. This is done by introducing extra slots in some of the sync pulses. In a receiver designed for color reproduction there are circuits which respond to these phasing slots. If the same signal acts in a receiver designed for black and white reproduction the slotting has no effect, and the result is a black and white picture from the color signal.

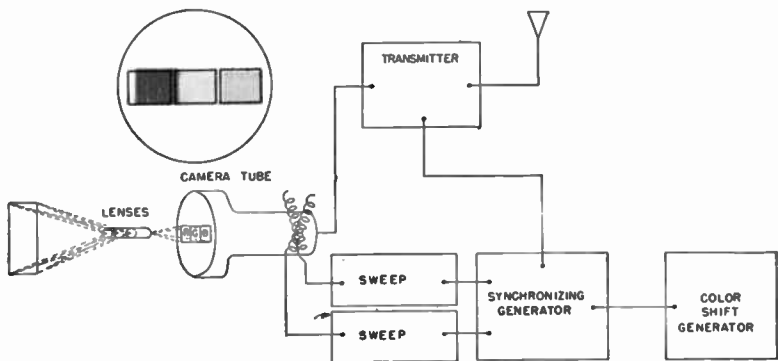

Fig. 12.—Principal parts of the CTI color transmitter.

Other than for the color synchronizing or phasing method the CTI signal has the same characteristics as a standard black and white signal. There are 525 lines per frame, with 30 frames and 30 complete pictures per second. One frame consists of two interlaced fields, each with $262\frac{1}{2}$ lines, reproduced at a frequency of 60 per second. Horizontal and vertical blanking periods are the same as for standard black and white. The overall band width is 6 mc, and the video band width is $4\frac{1}{2}$ mc.

Fig. 12 shows in simplified form the principal parts of the color transmitter. The televised scene is focused through three camera lenses and three color filters onto three side-by-side sections of the target in the camera tube. Each of the three sections is of such dimensions as to give it the standard 4-to-3 aspect ratio, and on each is focused a complete image of the scene. One image is in red, one is in green, and the other is in blue.

The electron beam of the camera tube travels across all three color images during each horizontal line. To form 525 lines in each of 30 frames per second, the beam must pass across each one of the three color images in $1/15750$ second. The time for traversing all three images then is $3/15750$ second, or $1/5250$ second. Thus the horizontal deflection frequency is 5,250 per second, which is just one-third the frequency with a single-image tube for black and white.

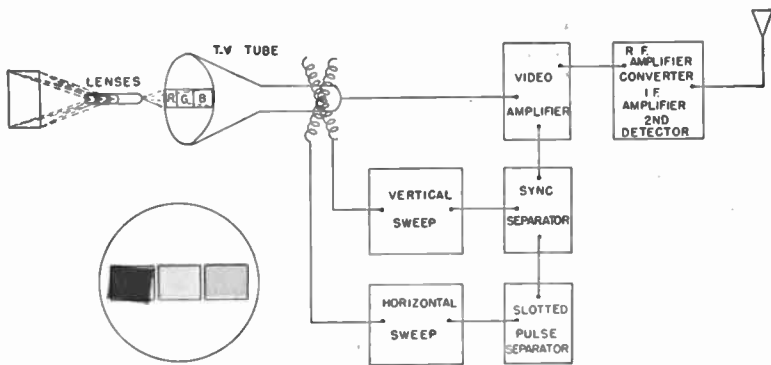

Fig. 13.—Principal parts of the CTI color receiver.

The video signals for the three color images are transmitted one after another in time. These signals reach the color receiver whose principal parts are shown in block form by Fig. 13.

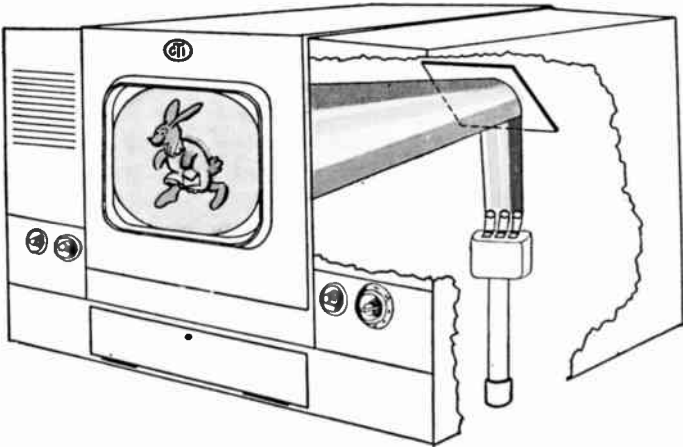

Fig. 14.—How the three color bands are combined on the projection screen.

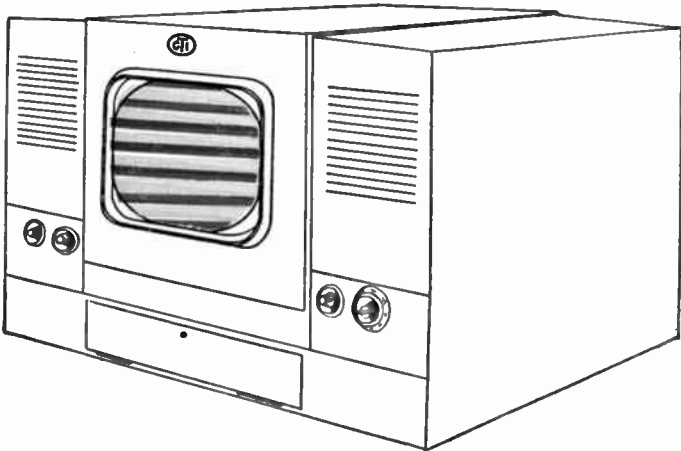

Fig. 15.—How successive lines might be traced in three colors on a direct view picture tube.

The three side-by-side sections of the picture tube screen have phosphors which produce, respectively, red light, green light, and blue light. The three color band images pass through a lens system which focuses them superimposed on a projection type viewing screen. This principle is illustrated by Fig. 14. The lenses are adjusted so that lines of different colors are traced in between those of other colors. The result is a picture in which the three color bands combine to reproduce all the hues of the original televised image. The horizontal deflection rate of the electron beam in the picture tube is the same as the rate at the camera tube, or is 5,250 traces per second.

With the CTI color system the picture tube has a three-part phosphor emitting three color bands suitable for projection of the three images through a lens system onto a viewing screen. The same color signal might be utilized with a selective color line picture tube rather than with the three-part phosphor arrangement. On such a direct view picture tube the closely spaced horizontal lines would be traced in their respective colors as shown by Fig. 15. The basic principles of transmission and reception would remain unaltered by this change from projection viewing to direct viewing. There still would be successive lines in different colors, as is characteristic of this system.

TELEVISION RECEIVERS. — The major divisions or sections of a television receiver are as shown by Fig. 124-1, where directions of signal travel are indicated by arrows.

Each television program is carried through space from transmitter to receiver by two independent radio waves at very-high frequencies in the range between 54 and 216 million cycles per second or between 54 and 216 megacycles per second. These very-high frequencies of transmission are called carrier frequencies.

One of the waves is varied or modulated by the signal corresponding to the moving pictures of television and providing also the means for controlling reproduction of pictures at the receiver. This composite picture and control signal is the video signal. The radio wave on which this composite signal is transmitted is called the video carrier.

The other wave is varied or modulated by the signal corresponding to speech, music, and other sounds which are to accompany the television picture. The radio wave on which the sound signal is transmitted is called the sound carrier.

The modulation or variation corresponding to the video signal is of the same kind employed for sound radio in the standard broadcast and short-wave bands. This is called amplitude modulation. The sound signal modulation is of the kind employed for frequency-modulation or f-m sound radio, it is a frequency-modulation signal.

The video carrier and its signal, also the sound carrier and its signal, are collected by the receiving antenna from radio wave energy being propagated through space from television stations or transmitters. The amplitude-modulated video carrier and the frequency-modulated sound carrier pass together from the antenna into the radio-frequency section of the television receiver.

In the r-f (radio-frequency) section the very-high carrier frequencies on which the signals have been transmitted are changed to lower intermediate frequencies which still carry the original signals for pictures, picture control, and sound. These intermediate frequencies are in the range between 20

and 40 million cycles (megacycles) per second. Then the video intermediate frequency carrying picture and control signals, and the sound intermediate frequency carrying sound signals, are passed on to the video section and the sound section of the receiver.

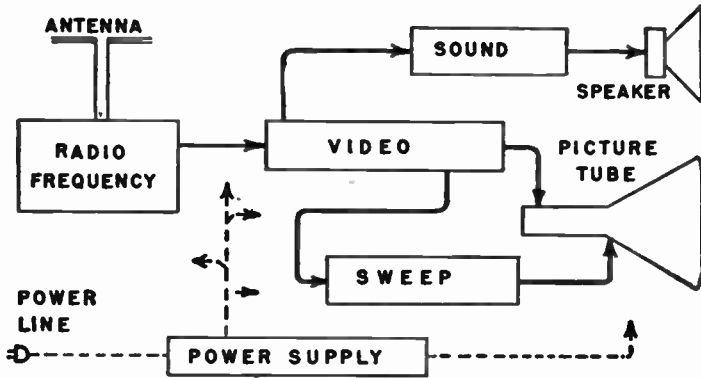

Fig. 124-1.—The principal sections of a television receiver.

In the video section the picture and control signals at video intermediate frequencies are strengthened and caused to control voltages at still lower frequencies that act in the picture tube to form lights and shadows viewed as moving pictures on the screen. These lower picture frequencies are in the range from 30 cycles per second up to about 4 megacycles per second. These are the frequencies of the picture signal itself, which have been carried as modulation on very-high and intermediate frequency waves and voltages, and which finally have been separated for use in the picture tube.

In some receivers the intermediate frequencies carrying sound signals go from the radio-frequency or r-f section directly to the sound section. More often these sound intermediate-frequency signals pass first through part or all of the video section that is handling the video intermediate-frequency signals, and then the sound signals go to the sound section.

The sound section strengthens or amplifies the signals coming to it and removes the relatively high intermediate fre-

quencies. This leaves only the signals or voltages which correspond to sounds in the television program. The sound section of the television receiver is much like that portion of an f-m sound receiver that follows the r-f section of the sound receiver.

While the video section of the television receiver is strengthening or amplifying the picture-forming signal it is also amplifying the portions of the video signal which will control reproduction of the picture. This control ensures that every light or shadow produced on the screen of the picture tube occupies the same relative position as the original corresponding light or shadow in the televised scene, so that the reproduced picture will not be scrambled.

Control of reproduction depends on correctly timing the movement or sweeping in the picture tube of the electron beam that illuminates the screen, so that this sweep will be precisely the same as that of the electron beam in the camera tube which is viewing the original scene. When the electron beams in the picture tube and camera tube are moving in the same directions over the same picture areas at the same instants of time the two beams are said to be synchronized.

Travel of the electron beam in the receiving picture tube, and also in the camera tube at the point of picture pickup, is called scanning. The sweep section of the receiver takes from the video section those control portions of the video signal which regulate travel of the electron beam in the picture tube. These portions are the synchronizing voltage pulses or the sync pulses of the signal. The sync pulses are used in the sweep section to control voltages or currents which move the electron beam in the picture tube.

The power supply section of the receiver takes energy from the electric power and lighting lines in the building, and furnishes to all other parts of the receiver whatever values of voltage and current are required for correct operation.

Radio-frequency Section. — Fig. 124-2 shows the principal parts of the r-f section of the television receiver as these parts are related to one another by signal travel through them.

Carrier-frequency signals from the antenna are applied to the grid circuit of a tube in the r-f amplifier and are strengthened in this amplifier. The carrier-frequency signals then pass to the grid of the mixer tube. The r-f oscillator tube and its circuit produce frequencies which usually are higher than the carrier frequencies, but may be lower in some receivers. These oscillator-frequencies are applied to the grid of the mixer tube

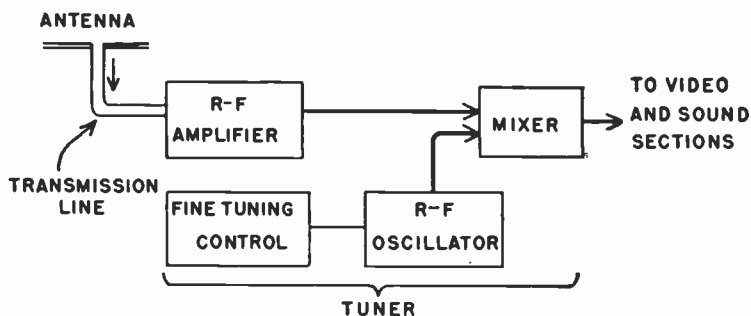

Fig. 124-2.—Principal parts of the radio-frequency section of a television receiver.

along with the carrier frequencies. The difference frequency between carrier and oscillator frequencies appears in the output of the mixer. This difference frequency is the intermediate frequency.

In the r-f section are inductances and capacitances which are tuned together for reception of programs in any of the various television channels. Selection or adjustment of inductances and capacitances for each channel is accomplished by switching or other means in the mechanism called the tuner of the receiver. With the channel selector knob or dial set for any one channel, small changes of r-f oscillator frequency may be made in some receivers by the fine tuning control. This allows improved reception in case the oscillator frequency does not at first act to produce the correct intermediate frequency by beating in the mixer tube with the carrier frequency.

Video Section. — The principal parts of the video section of the television receiver are shown in relation to signal travel by

Fig. 124-3. To this section comes the video intermediate-frequency signal from the mixer tube of the r-f section. R-f oscillator frequencies are so adjusted for each received channel by action of the tuner as to produce the same intermediate frequency from all channels or all carrier frequencies. Consequently, the video i-f (intermediate-frequency) amplifier operates in the same limited range of intermediate frequencies at all times and does not require any change of its tuning for reception in different channels.

The video i-f amplifier usually consists of three or four stages and tubes. All stages carry the video i-f signals. In receivers having intercarrier sound systems all stages of the i-f amplifier carry also the sound i-f signals. With dual channel sound systems the sound i-f signals may be carried through one or more, but not all the i-f stages, and then taken to the sound section.

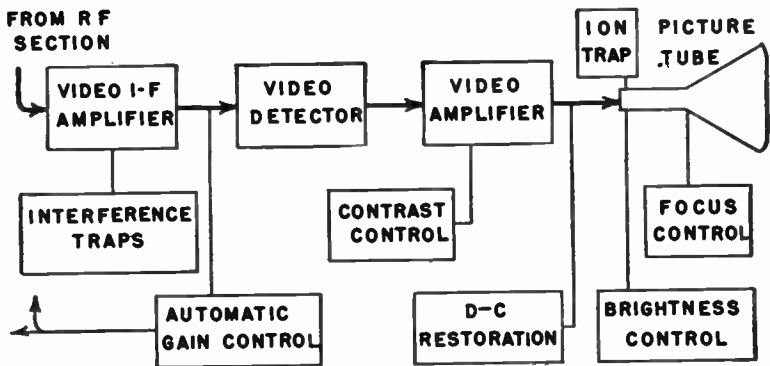

Fig. 124-3.—The video section with its accessories and controls.

Some receivers have interference traps connected or coupled into the video i-f amplifier. These traps absorb or reject signal energy at various signal frequencies which are not to pass all the way through the i-f amplifier.

The output of the i-f amplifier goes to the video detector. This detector recovers from the modulated video i-f signal the

variations which correspond to picture lights and shadows, also the synchronizing pulses. The relatively high intermediate frequencies are gotten rid of in the detector circuit, while the signal modulations are passed on to the video amplifier.

A portion of the output of the i-f amplifier may act in an automatic gain control circuit. This control regulates the amplification or gain in all or part of the i-f amplifier and possibly also in the r-f section to compensate in great measure for variations of strength in the received signal. Picture brightness and contrast thus are maintained at reasonably constant levels.

The video amplifier strengthens the composite signal coming from the video detector and applies this signal to the picture tube. The picture tube is operated with such combinations of voltages that sync pulses of the composite signal have no effect in the pictures, only the picture variations being used to control the electron beam for lights and shadows.

The contrast control varies the gain of the video amplifier to provide a picture having a full range of shades from black to white while preserving the correct relations of various gray tones. Sometimes the contrast control acts also on the video i-f amplifier, or it may be interconnected with the automatic gain control. The contrast control is adjusted during reception of programs.

With some types of signal transfer or coupling between video detector and picture tube it is necessary to employ what is called d-c restoration. This is a means for automatically maintaining correct values of tone or shading in the reproduced picture when there are changes of average brightness at the scene being televised by the camera at the point of pickup.

Inside the large end of the picture tube is a screen which is illuminated to form the reproduced pictures. The screen becomes illuminated wherever it is struck by electrons coming toward the screen in a very small beam from an internal part of the tube called the electron gun. The density of electrons in the beam is varied by the picture portion of the video signal. The greater the density the brighter becomes the illuminated spot or area on the screen.

The electron beam in the picture tube is rapidly deflected from left to right and also more gradually downward while its density is varying. Thus the lights and shadows are distributed over the screen in their correct positions. The electron beam strikes each tiny spot on the screen during only the briefest fraction of a second while being deflected, but due to persistence of illumination on the screen and persistence of vision in the human eye the impression of each illuminated spot or area remains while the entire picture is being traced by the beam.

Some types of picture tubes require a device called an ion trap. Relatively heavy ions which tend to travel to the screen along with the electrons are drawn out of the beam by this trap, thus preventing damage to the screen which would result from its continual bombardment by these heavy particles.

The brightness control acts to maintain such average density of electrons in the picture tube beam as will preserve the correct average brightness or background illumination in the picture. In some receivers the brightness control may be adjusted by the operator during reception of programs, while in other receivers this control is a service adjustment.

The focus control acts on the electron beam in the picture tube to produce the smallest possible spot of light or the narrowest possible horizontal line of light on the screen. This allows clarity of detail or good definition of lines, points, and small objects in the picture. The focus control is a service adjustment.

Sweep Section. — Electrical relations between parts of the television sweep section are illustrated by the block diagram of Fig. 124-4. The composite video signal coming from the video section goes to one or more tubes and circuits in a group which may be considered as a sub-section for handling the synchronizing voltages or pulses. The functions of these sync section tubes and circuits are as follows. Separate the synchronizing voltage pulses from the picture signals, and discard the picture signals. Amplify the synchronizing pulses to whatever extent may be necessary. Clip the pulse voltages, which means

making them of uniform strength even when there are variations of strength in the incoming composite signal. Invert the polarity or reverse the positive and negative directions of the pulse voltages as may be necessary for operation of the following sweep oscillators. The order in which these functions are performed will vary in different receivers.

The output of the synchronizing sub-section goes to two filters. The differentiating or horizontal filter selects those pulses which are to control horizontal sweeping of the electron beam in the picture tube. The integrating or vertical filter selects the pulses which are to control vertical sweeping of the beam.

Synchronizing voltages from the two filters go to the vertical and horizontal sweep oscillators. These oscillators consist of tubes and associated circuits which produce voltage waves of such forms, or waves which vary in such manner, as will cause correct sweeping rates and times of the electron beam. To fur-

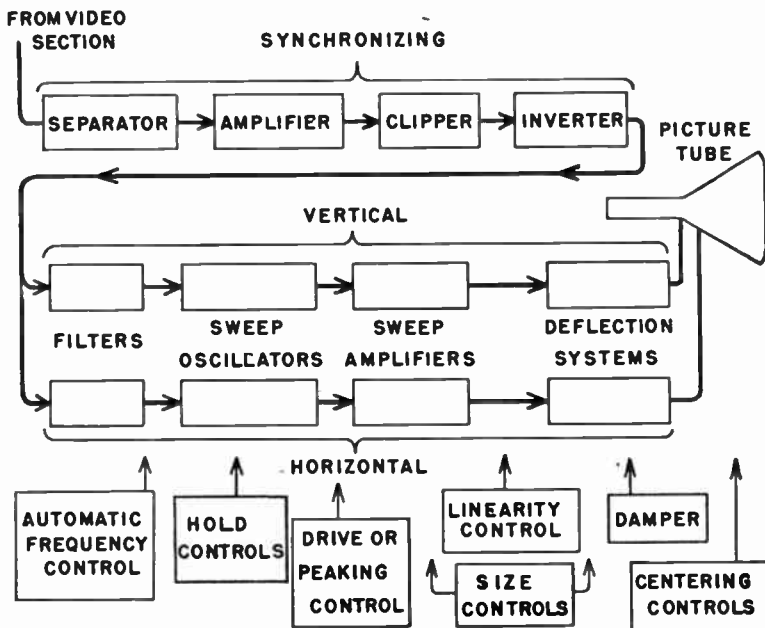

Fig. 124-4.—Principal parts in the sweep section of a typical television receiver.

ther ensure correct timing of the electron beam movements there may be an automatic frequency control for the horizontal sweep oscillator and sometimes for the vertical sweep oscillator as well. Hold controls on each sweep oscillator permit adjustment of their natural oscillating rates to values which may be easily brought under complete control of the synchronizing voltages coming from the filters or from the automatic frequency control system. The hold controls are service adjustments.

Output voltages from the sweep oscillators are applied to the vertical and horizontal sweep amplifiers. These amplifiers strengthen the voltages for application to picture tubes employing electrostatic deflection, or produce suitable currents for sweeping the beam in picture tubes employing magnetic deflection. Drive controls or peaking controls permit necessary corrections to be made in the waveforms of currents used for magnetic deflection. Linearity controls are used to prevent or correct distortion in shape, size, and relative positions of objects and lines in the reproduced picture, or to ensure that all proportions are like those in the original image or scene being televised. Size controls allow adjustment of height and width of the reproduced picture for correct proportioning and to fit within the mask that covers all but a certain central area of the picture tube screen. Controls for drive, peaking, linearity, and size are service adjustments.

Output voltages or currents from the sweep amplifiers pass to the vertical and horizontal deflection systems for the picture tube. For an electrostatic-deflection picture tube the deflection system consists of essentially flat plates between which the electron beam passes within the tube. For a magnetic deflection tube the deflection system consists of four electromagnetic coils carried by a yoke that fits around the outside of the neck or small end of the tube.

Deflection circuits for magnetic-deflection picture tubes include a damper tube which acts to prevent undesirable fluctuations or oscillations of current in the deflection coils and their connected circuit. Centering controls which are part of

the deflection system act to bring the center of the reproduced picture to the center of the mask opening in front of the picture tube screen.

Other Sections. — The sound section is completely described in the article, *Sound, Television*. The power supply section is described in articles on *Power Supply, High-voltage* and on *Power Supply, Low-voltage*. All parts which have been mentioned in the present article are explained in detail under their respective headings in this cyclopedia.

TRACERS, SIGNAL. — A signal tracer is an instrument which determines whether signals are progressing through successive stages and circuits of a receiver, and, in case of trouble, determines where the signals fail or become faulty. The principle is illustrated by Fig. 125-1. The tracer shown here consists of an audio amplifier, with speaker or headphones, operated from a detector built into an extension probe that may be applied at any point where the presence or absence of the signal is to be checked. For working in r-f, video i-f, video detector, and video amplifier circuits a tone modulated r-f generator furnishes a test signal which will give audible indication of its presence at any point where the detector probe is applied. For working in sync and sweep sections the test signal may be furnished by an audio generator, preferably one which will furnish square waves or pulses at both the vertical and horizontal sync frequencies.

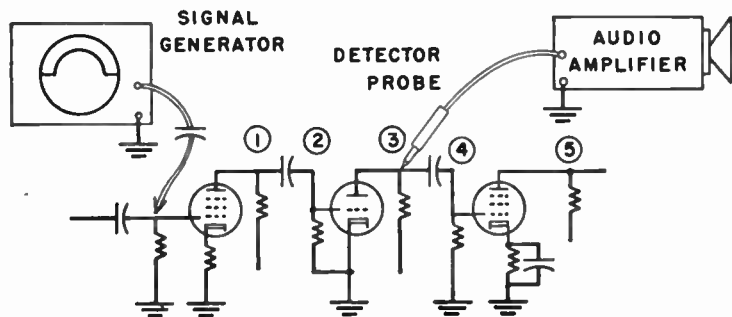

Fig. 125-1.—Connections for testing with a signal tracer.

The signal tracer determines that a fault is between the last point at which the signal is present and the first point at which it is absent when testing along the path which the signal should follow. This is helpful in locating short circuits, accidental grounds, opens, abnormally high resistance, burnouts, and similar faults in wiring and parts such as resistors, capacitors, and inductors. The tracer is especially useful for locating troubles which prevent the appearance of any picture or pattern, or any sound, and where there is no sweep.

A signal tracer of the type mentioned, with untuned pickup, will tell only whether the signal identified by tone modulation is reaching various circuits and parts of the television receiver. Since the tracer responds only to sound it will not give information related to picture quality. Such a tracer used in sync and sweep sections will tell whether pulse voltages are present or absent, but not whether these voltages are of forms required for correct synchronizing and sweeping action.

Amplifier and Probe. — The audio amplifier of the tracer should be as nearly as possible free from hum and from tube and circuit noise. This requires good filtering in the power supply, adequate decoupling, and careful layout of parts and wiring. Because tracing is carried out with a tone signal of constant audio frequency, fidelity or audio quality is not important. It is important to have high gain at the modulation frequency and at pulse frequencies.

Circuits in the receiver r-f and video line from antenna terminals to picture tube input must suffer the least possible detuning and loading by application of the detector probe. Appreciable detuning will prevent obtaining any information on performance under normal operating conditions, while loading will make the responses too weak for the tracer to indicate.

Detuning and loading effects depend almost entirely on the design and construction of the detector probe. Fig. 125-2 shows a type employing a germanium crystal diode for detector. Capacitor C_a should have a value of 1 to 3 mmf. Resistance at R_s may be about 5 megohms, and at R_b 0.1 to 0.2 megohm.

No capacitor should be connected from high side to ground in the probe, since cable capacitance will bypass very-high frequencies appearing in the detector output.

The probe must be enclosed within a non-magnetic metal shield, which is connected to the ground side of the circuit. The tip must be well insulated from the shield, preferably

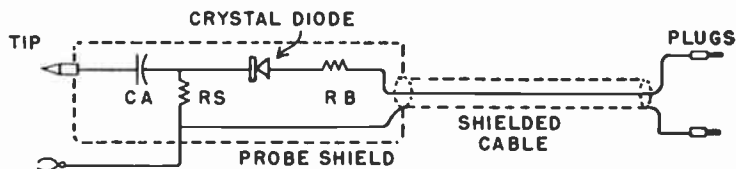

Fig. 125-2.—Detector probe suitable for use with a signal tracer.

with polystyrene or polyethylene. The spring clip for connecting the probe circuit to ground or B-minus in the receiver must be connected to the ground side of the testing circuit in the probe, not through a separate external wire to the amplifier. The cable going from probe to amplifier should be coaxial or microphone type with polyethylene insulation between the central conductor and the braided shield. Connection of the cable at the amplifier end is preferably through two tip-jacks and plugs rather than through a single telephone type jack and plug. All these structural features reduce capacitance and lessen the detuning effect of the probe.

A probe of the type described will have ample pickup at all r-f, i-f, and video frequencies. It will have weak response in audio circuits following the sound demodulator, where there are only audio frequencies. There will be good response to pulse signals because these signals, being of the square wave type, contain high-frequency harmonics.

Signal Sources. — For checking everywhere between the antenna terminals and the picture tube input, and through the sound section as far as the demodulator output, the signal generator should be an adjustable constant-frequency type, not a sweep generator. Any marker generator may be used, or any

ordinary r-f signal generator will serve provided it will furnish fundamental or strong harmonic frequencies within the normal operating ranges of circuits to be tested. The generator must provide for sound modulation, usually at 400 cycles.

If the test signal is to be put through r-f tuner circuits it must provide frequencies in the television carrier range. If the test signal is to go through only the i-f amplifier and following circuits the generator need furnish signals only as high as in the video i-f response range of the receiver. The generator need not be tuned to the sound carrier of a channel nor to the sound intermediate frequency, but anywhere within the r-f response or video i-f response range of the receiver.

An audio generator or pulse generator for checking in sync and sweep circuits will be connected to the grid of whatever tube precedes the sync takeoff or the first tube in the sync section. This generator should furnish the vertical sync frequency of 60 cycles and also the horizontal sync frequency of 15,750 cycles per second. If an audio generator is lacking, it is possible to hear the sync pulses from a television signal.

Tracing Audible Signals. — If signal input is to the receiver antenna terminals the generator impedance should be matched to the antenna input impedance. When the signal is not to pass through the r-f section, the high side of the generator should be coupled to the mixer grid through a capacitor of about 100 mmf. The tip of the detector probe is touched first to the generator cable connection at the receiver end. Tone modulation must be audible, even though faint.

The probe tip then is touched successively to grids, plates, and other points through which the signal should progress. While making the first connection beyond the first transformer or coupler following the point of signal input, tuning of the generator should be varied to obtain the loudest audible note. Ordinarily it will not again be necessary to alter the generator tuning. There is no object in making checks on the r-f oscillator, since this tube must generate its own signal or frequency during receiver operation.

The audible signal should become louder in progressing

through successive amplifying stages from the generator input to the plate of the last video amplifier and input to the picture tube grid, or to the picture tube cathode if the picture signal goes to the cathode. From the plate of one tube to the grid of the following tube there may be an apparent drop of signal strength, which is due to the probe having more detuning effect on grids than on plates.

A signal introduced at the antenna terminals or the mixer grid may be traced through the sound takeoff as far as the input side of the demodulator tube. Otherwise a tone modulated signal may be applied to the grid of the tube which precedes the sound takeoff, with the generator tuned to the sound intermediate frequency for a dual channel sound system or to 4.5 megacycles for an intercarrier sound system. The signal should be of constant frequency, not a sweep frequency.

With a modulated r-f generator connected anywhere ahead of the takeoff for the sync section the tone modulation may be heard in tubes of the sync section up to the point at which clipping is accomplished and only the sync pulses would remain. If a regular television signal is being received, and carried through to the sync section, the vertical pulses will be heard as a 60-cycle buzz. This buzz will be audible all the way through to the output of the vertical deflection amplifier or amplifiers, provided the various circuits are operating.

The horizontal sync frequency of 15,750 cycles is beyond the hearing range for most people. The horizontal pulses do, however, produce a hissing effect which always is audible and is quite easily recognized after having heard it from receivers in good operating condition. The hissing may be heard from parts which are in horizontal sync and sweep circuits. This hissing is not unlike that from tube and circuit noise, and if any appreciable noise of this kind is produced in the tracer amplifier it will be difficult to identify the horizontal pulse effect.

If no regular television signal is being received, an audio generator may be connected through a large fixed capacitor to the grid of the tube preceding the sync takeoff. Tuning the

generator to 60 cycles per second simulates the vertical sync pulses, especially so if the generator will deliver square or pulsed waves. The 60 cycle buzz may be followed through to the vertical sweep oscillator. If the vertical oscillator is operating, its frequency will beat with the audio generator frequency. The result, with the generator output at a low value, will be very slow beats at generator frequencies either side of 60 cycles. This effect will carry on through the vertical sweep amplifier. No beats can be produced if the oscillator is not operating.

The hiss due to horizontal sync pulses in a received signal may be changed to a clearly audible beat note with the audio generator connected ahead of the sync takeoff and tuned through the horizontal frequency of 15,750 cycles per second. There will be zero beat at the horizontal frequency, and sound of rising pitch as the generator is tuned either way from this frequency. At the output of the horizontal sweep oscillator and through the horizontal sweep amplifier this beating will show whether the oscillator is operating. With the oscillator inoperative there will be no beat notes.

TRANSMISSION, NEGATIVE. — Negative transmission refers to the method of television carrier modulation with which a decrease of brightness in the televised image causes an increase of transmitted power. This method, which is standard in the United States and some other countries, is illustrated at the left in Fig. 126-1. The signal modulation displayed here is explained in the article, *Signal, Television*.

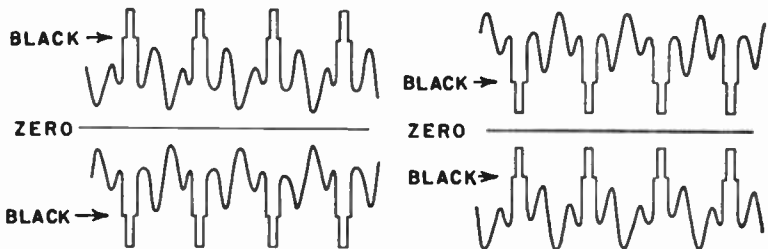

Fig. 126-1.—Negative transmission at the left and positive transmission at the right.

With negative transmission there is maximum or 100 per cent amplitude for the tips of sync pulses, approximately 75 per cent of maximum for the black level, and about 15 per cent of maximum for pure white in the pictures. With positive transmission, shown at the right, maximum amplitude corresponds to the lightest or brightest tones and minimum amplitude corresponds to the tips of sync pulses.

Negative transmission allows synchronization to be more strongly maintained, since the strongest portions of the signal are the sync pulses. Severe noise interference causes amplitude to increase beyond the black level, and thus puts dark spots rather than bright flashes in the reproduced picture. Either negative or positive transmission signals may be inverted as may be necessary for their application to picture tube grids or cathodes, and to synchronization of sweep oscillators.

TRANSMISSION, VESTIGIAL SIDEBAND. — Vestigial sideband transmission consists of transmission at full strength of all video modulation frequencies extending to a limit of 4 megacycles above the video carrier frequency, while transmitting at full strength the modulation frequencies below the video carrier to a limit of only $\frac{3}{4}$ megacycle. That is, all modulation frequencies in the upper sideband are transmitted, but the lower sideband is partially cut off. The name vestigial sideband refers to the portion or vestige of the lower sideband that remains.

This method is intermediate between double sideband transmission with which all modulation frequencies above and below the carrier are radiated, and the single sideband method in which there is radiation of modulation frequencies only above or below the carrier frequency. Vestigial sideband transmission is standard for television.

Cutting off a large part of the lower sideband still allows transmission of video signals to a high limit of 4 megacycles, also a modulated sound carrier, within a frequency channel of 6 megacycles while providing enough spare band width above and below all modulation frequencies to avoid overlapping adjacent channels.

Fig. 127-1 shows distribution of transmitted frequencies within a 6-megacycle channel. The video carrier frequency is $1\frac{1}{4}$ megacycles above the low limit for the channel. The sound carrier frequency is exactly $4\frac{1}{2}$ megacycles above the video carrier, and $\frac{1}{4}$ megacycle below the high limit for the channel. The height of the curve corresponds to the relative values of

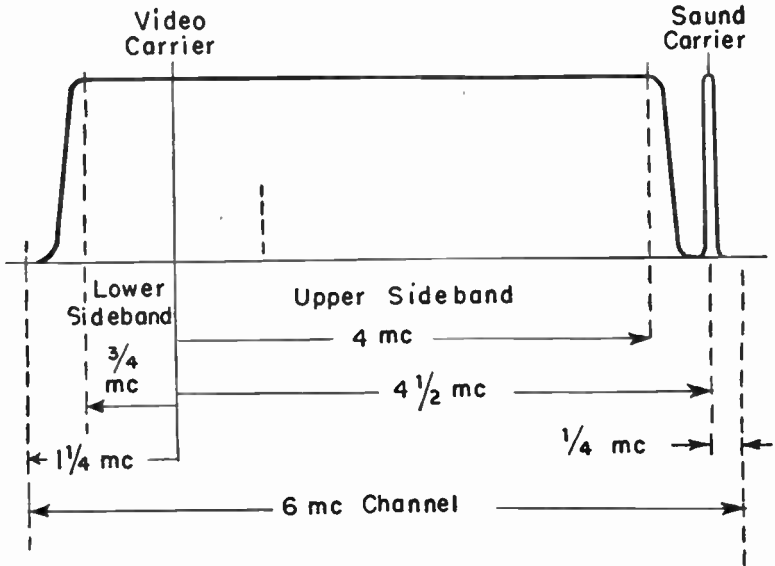

Fig. 127-1.—Distribution of transmitted frequencies within a six megacycle channel.

radiated field strength at the transmitter. Maximum field strength extends $\frac{3}{4}$ megacycle below the video carrier frequency, and to 4 megacycles above this frequency. There must be practically complete attenuation between these limits and the low side of the channel and the sound carrier with its modulation.

When any one video signal frequency is applied as modulation to a carrier it will produce two sideband frequencies of transmission. The lower sideband frequency is equal to the difference between carrier and modulation frequencies, and

the upper sideband frequency is equal to the sum of carrier and modulation frequencies.

If frequency of video signal modulation is no more than $\frac{3}{4}$ megacycle it will produce transmitted frequencies at full strength in both sidebands, as is evident from Fig. 127-1. This means that all video signal frequencies up to $\frac{3}{4}$ megacycle will be transmitted at full strength in both sidebands, while all higher video signal frequencies will be transmitted at full strength in only the upper sideband. Consequently, all video signal frequencies up to $\frac{3}{4}$ megacycle are effectively transmitted twice, and actually are transmitted in double strength. All higher video signal frequencies are transmitted in only single strength.

Were the television receiver to provide uniform amplification throughout the whole range of low and high transmitted sidebands, all video signals at frequencies up to $\frac{3}{4}$ megacycle

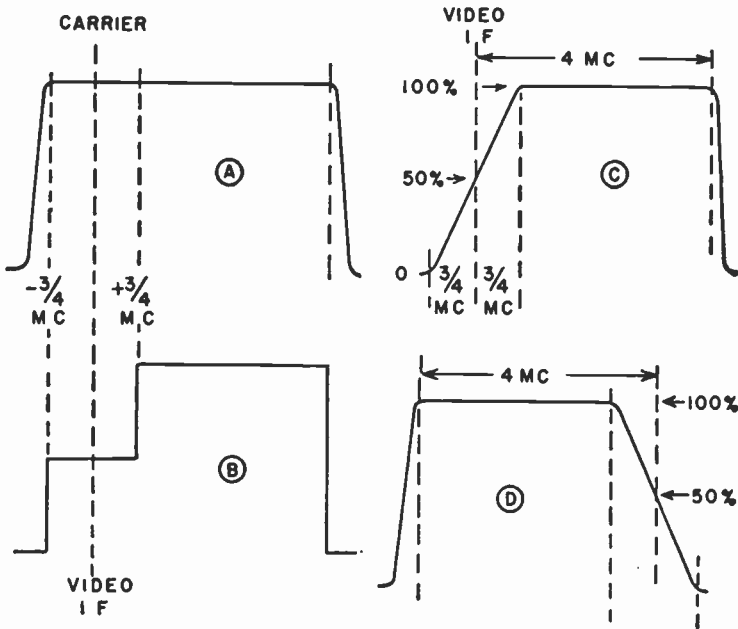

Fig. 127-2.—How receiver attenuation compensates for double transmission of some signal modulation frequencies.

which are received in double strength would be reproduced with twice the output of signals at higher video frequencies. This undesirable result is prevented by what is called receiver attenuation.

Receiver attenuation provides overall frequency response giving the effect shown by Fig. 127-2. At *A* is the curve for radiated field strength. At *B* is shown a receiver response providing 50 per cent of maximum gain for all the doubly transmitted frequencies, and 100 per cent gain for all singly transmitted frequencies. The result would be uniform output for the whole range of video signal frequencies after detection. The video intermediate frequency in circuits following the mixer corresponds to the carrier frequency in circuits preceding the mixer.

It would be difficult to construct receiver video i-f amplifiers having such sharp changes of gain at certain frequencies as shown at *B*. The same effect may be attained much more easily with a video i-f amplifier frequency response such as at *C*. Here the gain is zero at $\frac{3}{4}$ megacycle below the video intermediate frequency, increases uniformly to 50 per cent of maximum at

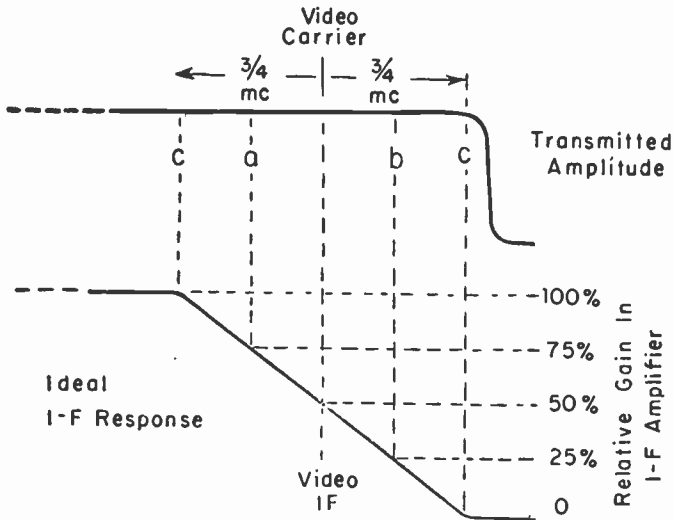

Fig. 127-3.—Relative gain percentages with an ideal form of receiver attenuation.

the video intermediate frequency, and continues uniformly to 100 per cent at a frequency $\frac{3}{4}$ megacycle higher than the video intermediate.

On this sloping portion of the receiver response any two frequencies which are equally below and above the video intermediate frequency are modulated with the same video signal. For instance, there is the same signal modulation on a frequency $\frac{1}{4}$ megacycle below the video intermediate as on another frequency $\frac{1}{4}$ megacycle above the video intermediate.

If we add together the percentage gains for any two frequencies equally below and above the video intermediate, the sum of the two gains always will be 100 per cent. This is the same as the 100 per cent gain for higher frequencies along the flat top of the curve. Therefore, with this ideal form of receiver response curve, all signal modulation frequencies will receive the same total amplification, and amplifier output will be uniform for all frequencies extending from the video intermediate frequency to 4 megacycles above this frequency.

Video carrier frequencies are lower than sound carrier frequencies as transmitted. When the video carriers and their modulation sidebands are subtracted from r-f oscillator frequencies in the mixer this relation is reversed, and the video intermediate frequency becomes lower than the sound intermediate frequency. For this reason the video i-f response curve more often is shown as at *D* in Fig. 127-2 than as at *C*.

Fig. 127-3 shows some relative gain percentages illustrating the effect of receiver attenuation. It may be seen that gains at *a* and *b* are respectively 75 and 25 per cent, making a total of 100 per cent. Also, gains at *c* and *c* are 100 per cent and zero, again making a total of 100 per cent. Curves which have been shown are ideal frequency responses for the video i-f amplifier of a receiver. Actual responses as seen on an oscilloscope approximate this ideal to a greater or less extent when alignment adjustments are correctly made.

TRAPS, INTERFERENCE. — An interference trap or wave trap is a device for preventing the appearance in an amplifier output of voltages at undesired frequencies, or at frequencies

which might cause interference with the desired signals. Interference traps described in this article are those associated with the video i-f amplifier, video detector, and video amplifier of the television receiver. Traps such as used in antenna and tuner circuits are described in the article on *Interference*.

Almost any type of circuit capable of being sharply tuned to resonance may be utilized for a wave trap. Parallel resonant trap circuits are connected in series with the signal path and tuned to offer high impedance at the unwanted frequency, and may be used to dissipate energy at unwanted frequencies by means of the large circulating currents in the resistance of the parallel resonant trap circuit. Series resonant traps may be connected from the signal circuit to ground and tuned to allow escape of unwanted frequencies while having high impedance at frequencies of the desired signals.

Fig. 128-1 shows several traps of types which absorb and dissipate the unwanted signal energy, or bypass this energy to ground. At *A* a parallel resonant absorption trap is inductively coupled to the tuning coil in the plate circuit of the left-hand tube. This trap is shown as being tuned or aligned by means of adjustable inductance, but an adjustable capacitor may be used instead. Most trap circuits are adaptable for either method of tuning. A generally similar trap is shown by broken lines

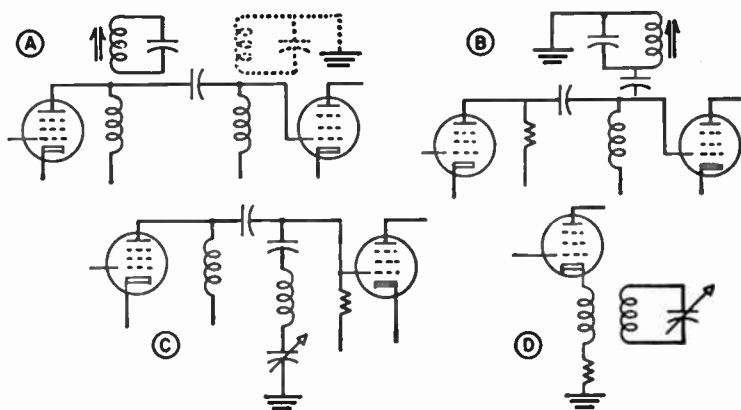

Fig. 128-1.—Interference traps of absorption types.

inductively coupled to the grid circuit of the second tube. One side of this trap circuit is grounded. Other parallel resonant traps may be similarly grounded to increase their energy dissipation.

At *B* in Fig. 128-1 a parallel resonant trap circuit is coupled through a small capacitance to the grid circuit of an amplifier tube. Diagram *C* shows a series resonant trap circuit connected through a small capacitance to an amplifier grid circuit. This trap is tuned by an adjustable capacitor. Adjustable inductance might be used instead. At *D* a parallel resonant trap circuit is inductively coupled to a coil which is in series with the cathode of an amplifier tube. Any undesired frequencies may be removed at cathode circuits, grid circuits, or plate circuits, or may be removed at two or more of these points in the same amplifying stage.

Traps offering high impedance to undesired frequencies are illustrated by Fig. 128-2. At *A* there is a parallel resonant trap circuit in series between the plate of the first tube and the grid of the second tube. A similar trap might be used on the plate side of the circuit, or there might be one of these traps on the plate side and another on the grid side. Two traps ordinarily

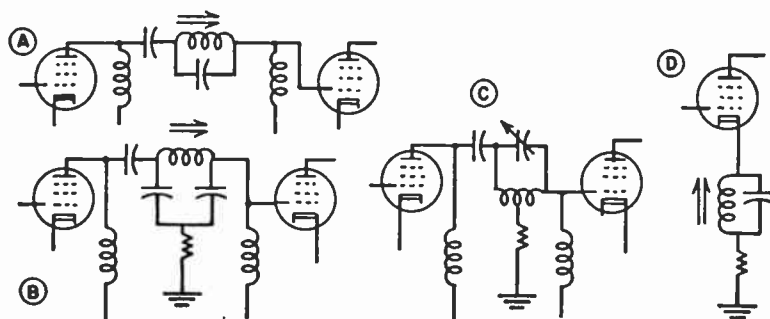

Fig. 128-2.—Interference traps of impedance types.

would be tuned to two different interference frequencies. Diagram *B* shows another series connected parallel resonant trap, this one having two capacitors in the trap circuit with a ground connection from a point between them.

Diagram *C* of Fig. 128-2 shows a series connected parallel resonant trap with a center tapped coil. From the center tap there is a connection through a resistor to ground. Any of the traps which are shown on the grid side of the interstage couplings might be on the plate side provided blocking capacitors are used to isolate the B+ lines from conductive connections with ground or B-minus. At *D* is shown a parallel resonant trap connected in series with the cathode of a tube. A trap of this general type may be in the r-f return connection of a video detector to prevent demodulation of signals for which the trap is tuned.

Trap Frequencies. — Fig. 128-3 illustrates the manner of determining the frequencies to which traps should be tuned in a receiver operating with certain video and sound intermediate frequencies. It has been assumed, for purposes of illustration, that the particular receiver here considered is to operate with a video intermediate frequency of 25.75 megacycles and with a sound intermediate frequency of 21.25 megacycles. It is assumed also that the receiver is tuned for channel 8, although trap frequencies would be the same for tuning to any channel having other channels immediately adjoining its upper and lower limits.

For reception in channel 8 the r-f oscillator of the receiver would be tuned to a frequency equal to the sum of the video intermediate frequency and the video carrier frequency for that channel, or to the sum of the sound intermediate and sound carrier, which would be the same thing. With the assumed intermediate frequencies this oscillator frequency would be 207.00 megacycles. If video or sound carriers from the adjacent channels reach the mixer these other carriers will beat with the frequency of the receiver r-f oscillator to produce beat frequencies. Along the top of Fig. 128-3 are shown these other carriers and also the carriers for the tuned channel, number 8. Each carrier frequency is subtracted from the r-f oscillator frequency to show the resulting beat frequency. All these beat frequencies would be applied to the video i-f amplifier of the receiver.

The frequency response of the video i-f amplifier might be as shown by the curve. There is the required 50 per cent of maximum gain at the video intermediate frequency of 25.75 megacycles. There is almost full gain through all frequencies extending 4 megacycles from the video intermediate, which is

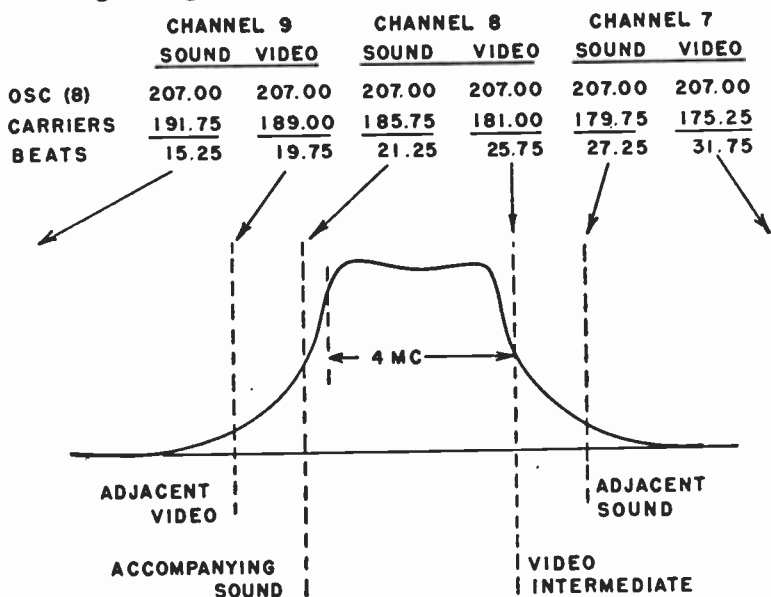

Fig. 128-3.—How the required trap frequencies may be determined in accordance with video or sound intermediate frequencies used in a receiver.

a full range for high quality picture reproduction. There is very nearly 50 per cent gain at the sound intermediate frequency which, when considering traps, is called the accompanying sound frequency or the associated sound frequency. Were such highly amplified sound signals to go through the i-f amplifier, the video detector, the video amplifier, and to the picture tube there would be severe sound interference with pictures. This would become apparent as sound bars on the screen. Consequently, the accompanying sound frequency must be trapped out before it reaches the picture tube.

With the frequency response as illustrated there is considerable gain at the adjacent channel video frequency of 19.75 megacycles. Unless this adjacent video frequency is trapped

out before reaching the picture tube it will cause beat interference patterns consisting of narrow vertical and diagonal lines which weave and sway one way and another.

There is considerable gain also at the adjacent channel sound frequency of 27.25 megacycles. This adjacent sound frequency must be trapped out in order to prevent interference patterns and possibly sound bars on the screen of the picture tube.

If the video i-f response or band pass is not so wide as shown by Fig. 128-3 some or all the traps may not be required. A relatively narrow band pass, usually not much more than 3 megacycles from the video intermediate, is found in receivers which have picture tubes smaller than the 10-inch size. In these receivers it is common practice to use none of the traps which have been mentioned; accompanying sound, adjacent sound, and adjacent video.

Traps for accompanying sound are not used in the i-f amplifiers of receivers employing the intercarrier sound system, because both the sound and the video intermediate frequencies must reach the video detector. The band pass in many of these receivers is narrow enough to exclude adjacent channel interference, so there may be omission also of traps for adjacent video and adjacent sound signals.

Trap frequencies determined as in Fig. 128-3 are correct for only the intermediate frequencies mentioned. Similar computations may be made for any other intermediate frequencies as used in particular receivers. It is not necessary to consider adjacent channel interference unless the frequency limit of the other channel is the same as that of the received channel. There is separation of 4 megacycles between channels 4 and 5. This makes it practically impossible for sound in channel 4 to affect reception in channel 5, or for video in channel 5 to affect reception in channel 4. Because there is no channel immediately below number 7 this channel would suffer no adjacent sound interference, and because there is no channel immediately above number 13 there would here be no adjacent video interference.

Were sharply tuned traps applied to the video i-f amplifier whose original response is shown by Fig. 128-3 the response as modified by the traps might appear about as in Fig. 128-4. There should be attenuation nearly to zero at each of the trap frequencies.

A trap or traps for accompanying sound always follow and never precede the point at which the sound i-f signal is taken from the mixer or i-f amplifier and carried to the sound section

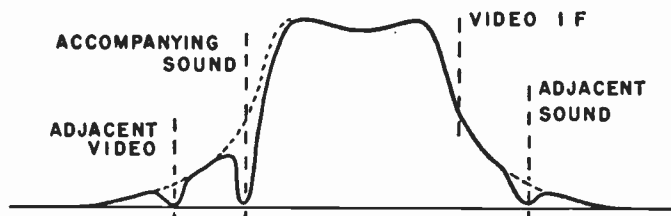

Fig. 128-4.—Video i-f frequency response as modified by three types of traps.

of the receiver. Otherwise the sound signal would not reach the point of takeoff. Other traps, when used, may be associated with any of the interstage couplers or may be on the cathodes of i-f amplifiers or video detector.

Alignment of Video I-f Traps. — Traps which are connected to or coupled to the video i-f amplifier are aligned at the same time as this amplifier, because adjustment of the traps will affect alignment of the transformers or couplers, and adjustment of the transformers or couplers will affect the trap frequencies. When working through the i-f amplifier it usually is most satisfactory to adjust the trap coupled to each transformer just before that transformer is aligned. A sound takeoff transformer should be treated like a trap, and aligned in its regular order.

Methods of alignment are the same regardless of the types of traps, the object always being to have minimum response at the trapped frequencies. Traps should be adjusted only for this minimum response at their respective frequencies, and no attempt should be made to use the traps for shaping the response curve around the video intermediate frequency. Traps

designed for certain interference frequencies usually have a total adjustment range of no more than 2 or 3 megacycles. Consequently, a trap designed for one kind of interference seldom can be used satisfactorily for any other kind.

Traps usually are aligned by means of a signal from a constant frequency generator, such as a marker type or any accurately calibrated signal generator, while attenuation is measured with an electronic voltmeter. The first steps include disconnecting the transmission line or antenna from the receiver, setting the channel selector on a channel where there is no transmission, and placing the contrast control at the maximum setting which does not cause regeneration or oscillation in the video i-f amplifier.

The signal generator is coupled to the mixer tube as for video i-f alignment, or it may be coupled to a tube preceding each trap aligned. The generator is used without modulation. The electronic voltmeter is connected to the video detector load resistor or, for greater sensitivity in adjustments, to the load resistor of a video amplifier. This latter connection will require using a detector probe on the meter.

The generator should be tuned accurately to the frequency at which each trap is to be aligned while adjusting that trap for minimum reading on the meter. If there is more than one trap for the same frequency, first adjust the one farthest from the generator. A trap closer to the generator connection may have to be temporarily detuned to pass enough signal for correct adjustment of a trap farther away in the signal path. Generator output may be increased as alignment progresses. With all traps aligned the generator should be tuned slowly through the whole range of trap frequencies while watching the meter. At each minimum voltage reading the generator frequency should be noted, and if it is not at one of the trap frequencies it will be necessary to readjust the corresponding trap.

Traps may be aligned and their effects on frequency response observed by means of a sweep generator for signal input and an oscilloscope as the indicator. Fig. 128-5 shows interstage couplings and traps of an i-f amplifier from which were ob-

served the oscilloscope responses of Fig. 128-6. Between the mixer and first i-f amplifier tube is an overcoupled transformer to which is inductively coupled a trap for accompanying sound. Between first and second i-f amplifier tubes is a single tuned coupling coil with an inductively coupled trap for adjacent sound. The next coupler is a single tuned coil and the last one is an overcoupled transformer. There are no traps on the latter two couplers.

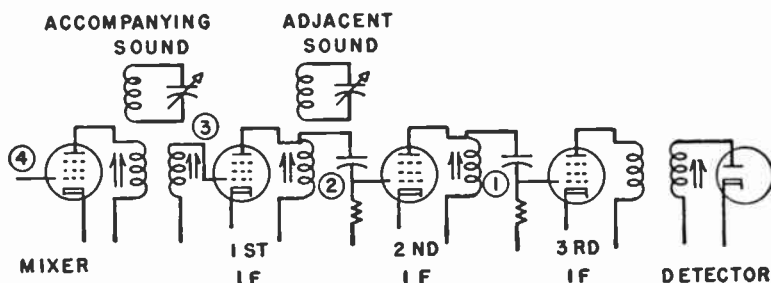

Fig. 128-5.—Traps for accompanying sound and adjacent sound coupled to a video i-f amplifier section.

The top curve of Fig. 128-6 is taken with the sweep generator coupled to the grid of the third i-f amplifier and the oscilloscope connected across the detector load resistor. The oscilloscope remains connected here for the other curves. This top curve shows a typical frequency response for an overcoupled transformer. It covers a wide range of frequencies and shows no dips due to traps.

The second curve from the top is taken with the sweep generator moved back to the grid of the second i-f amplifier. This is the frequency response of the single-coil coupler and the overcoupled transformer working together. The high peak on this response is at the frequency to which the single-coil coupler is tuned.

The third curve from the top is taken with the sweep generator at the grid of the first i-f amplifier tube. The response now shows one peak due to the single-coil coupler between first and second amplifiers, and the other peak due to the similar coupler between second and third amplifiers. There now

appears a dip in the response caused by action of the adjacent sound trap coupled to the single-coil coupler last brought into the amplification system between generator and oscilloscope.

The fourth or bottom curve is taken with the sweep genera-

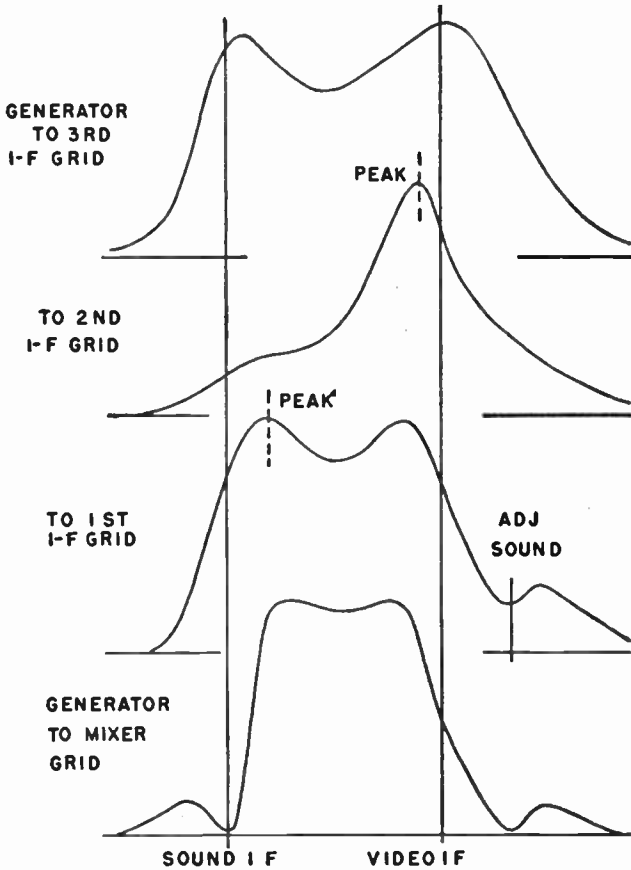

Fig. 128-6.—Frequency responses at various points in the i-f amplifier having traps for accompanying and adjacent sound.

tor coupled to the mixer grid. The effect of the first over-coupled transformer is chiefly a narrowing of the frequency response. At the sound intermediate frequency on this final curve appears a dip due to action of the accompanying sound trap which is coupled to the first transformer.

For trap alignment with the sweep generator and oscilloscope the generator should sweep the entire video i-f range and through the adjacent sound and video frequencies. A sweep of about 10 megacycles should be sufficient. The oscilloscope may be connected across the video detector load resistor for all observations, or for greater sensitivity may be connected to the load resistor of a video amplifier tube. A marker must be accurately adjusted for the frequency of each trap to be aligned. The trap is adjusted to eliminate the center of the marker pip so far as is possible while gradually increasing the output level from the marker generator.

Intercarrier Sound Traps. — The intermediate frequencies for video and for sound beat together in the video detector to produce their difference frequency, which always is 4.5 megacycles. This is called the intercarrier beat frequency. If this frequency reaches the picture tube it causes a pattern similar to that from any other high-frequency interference, closely spaced thin vertical or sloping lines which shift one way and the other.

If the sound intermediate frequency is thoroughly trapped out of the video i-f amplifier it will not reach the video detector and there will be no intercarrier beat frequency in the detector output nor in following circuits leading to the picture tube. If some of the sound intermediate frequency does reach the video detector the resulting intercarrier beat must be trapped before reaching the picture tube.

In receivers employing the intercarrier sound system the intercarrier beat frequency with its sound modulation is taken through the sound takeoff transformer or other form of coupling to the sound section of the receiver. The sound takeoff is sharply tuned, and removes practically all the 4.5-megacycle energy from circuits extending from the takeoff to the picture tube. Thus the sound takeoff acts, or should act, as an effective trap for the intercarrier beat so far as picture tube input is concerned.

In receivers having dual channel sound systems it often is necessary to place an extra trap for the intercarrier beat fre-

quency in the output circuit of the video detector or in any of the grid or plate circuits of the video amplifier. This trap nearly always is a parallel resonant type in series with a signal circuit, as shown at *A* in Fig. 128-2. High quality picture reproduction is not impaired by the trap cutoff at 4.5 megacycles, since this is well above the maximum video frequency needed for good definition.

A trap for intercarrier beat may be aligned with a 4.5-megacycle signal from an adjustable or crystal controlled constant-frequency generator and either an electronic voltmeter or an oscilloscope as response indicator. The generator is coupled to the grid of the tube preceding the trap, and is tuned accurately to 4.5 megacycles.

An electronic voltmeter with a detector probe on the input cable is applied to the plate of the tube which follows the trap or to the input of the picture tube. The generator is used without modulation. The trap should be aligned for minimum reading on the meter. This reading will not drop to zero because of other frequencies which are present in the receiver circuits, but will become minimum as the trap is adjusted.

The vertical input of an oscilloscope, fitted with a filter probe, is applied to the plate of the tube following the trap or to the picture tube input. The generator is used with tone modulation, usually at 400 cycles. The internal sweep of the oscilloscope is adjusted for the tone modulation frequency of the generator and the trap is adjusted for minimum height of the trace on the oscilloscope screen.

When using either the electronic voltmeter or the oscilloscope the output of the generator should be increased as the trap adjustment proceeds. The contrast control of the receiver may be at its maximum setting for final adjustment of the trap.

TRAPS, ION. — An ion trap consists of a specially designed electron gun acting in conjunction with the fields of one or two externally mounted magnets to separate ions from the electron beam in certain types of picture tubes which are operated with magnetic deflection.

The ions are atoms of gases which have acquired a negative charge by temporary attachment to them of one or more negative electrons. An ion has the weight or mass of an atom, nearly two thousand times that of an electron. The negative ions are accelerated toward the screen of the picture tube by the same positive potentials which accelerate the negative electrons. Because of their great mass, the ions are deflected only slightly by the magnetic fields of the deflection coils which deflect the electrons of the beam horizontally and vertically during scanning. As a result, all the ions tend to strike near the center of the picture tube screen, within an area about the size of a half dollar. Such concentrated bombardment by the heavy ions would produce on the screen a brown spot called an ion burn or ion spot.

Tubes operating with electrostatic deflection do not permit concentrated ion bombardment because the electrostatic fields which deflect the electron beam also deflect the ions to distribute them quite uniformly over the screen surface. In some magnetic deflection tubes the inside surface of the screen is protected by a metallic coating of atomic thickness which prevents ill effects from ion bombardment. Most other tubes operating with magnetic deflection require ion traps.

Separation of ions from the electron stream is made possible by two facts. First, both ions and electrons are strongly deflected by electrostatic fields or electric fields. Second, only electrons are strongly deflected by magnetic fields. Although a magnetic field acts on the negative charge of an ion just as it acts on the negative charge of an electron, the relatively great mass or weight of the ion keeps it traveling along its original course in spite of the deflection force, whereas the negligible mass of an electron does not prevent its deflection.

Double Magnet Traps. — Fig. 129-1 illustrates the construction of one style of ion trap. Looking at the side of the picture tube neck which is on the right when facing forward from the base end, there may be seen a diagonal gap between the first and second anodes of the electron gun or between the second grid and the first anode, according to which names are applied to

TRAPS, ION

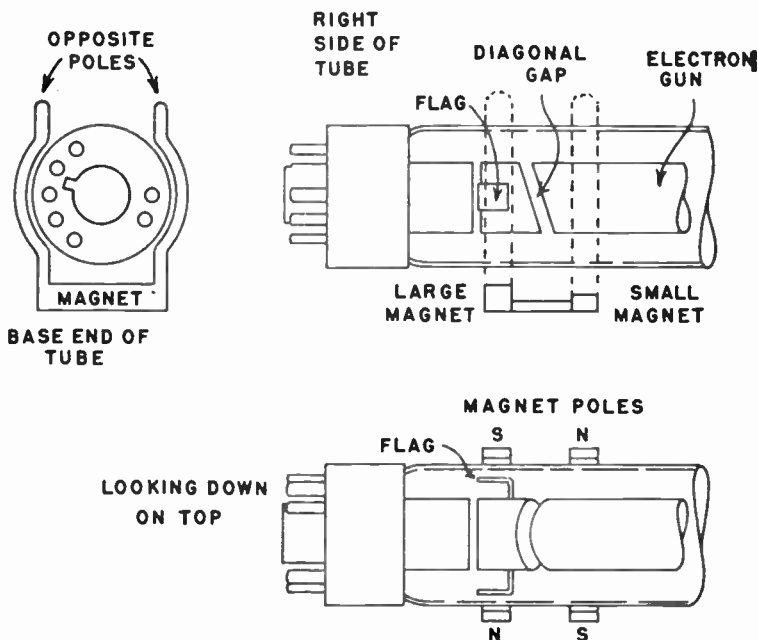

Fig. 129-1.—Ion trap of the type requiring a double magnet.

these elements. Extending through the gap is a strong electric field, due to the second element being much more highly positive than the first one. The lines in this electric field are almost at right angles to the direction of the gap, or the lines slope upward toward the front of the tube. The result is that both electrons and ions are deflected at this upward angle by the electric field.

On the outside of the tube neck are the poles of two permanent magnets. One magnet, the stronger one, is mounted a short ways back of the diagonal gap. The other magnet is ahead of the gap. The four poles of these two magnets are arranged as shown by the top view of the tube in Fig. 129-1. The magnetic field between poles of the rear magnet is in such direction as to deflect electrons downward, while the field of the front magnet is in the opposite direction, and deflects electrons upward. These two magnetic fields have hardly any effect on the ions.

The action is illustrated in a general way by Fig. 129-2 where are shown the paths followed by one ion and one electron. Direction of ion travel is practically unaffected by the field of the rear magnet, but ions are deflected upward almost into line with the electric field in the diagonal gap. The nega-

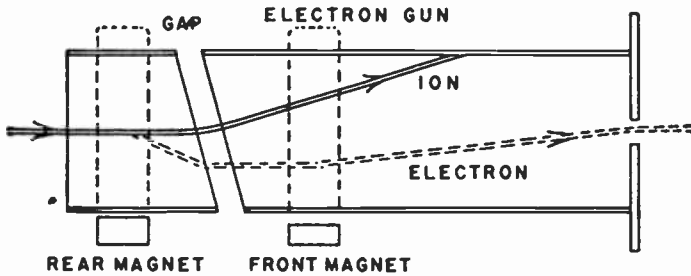

Fig. 129-2.—Paths of ions and electrons in the double magnet ion trap.

tive ions continue on their new course until striking the inside of the positively charged forward anode, where they are collected. Electrons are deflected downward as they pass through the field of the rear magnet, are straightened out by the electric field in the gap, then are deflected upward by the field of the front magnet just enough so that the electrons pass through the opening at the front end of the anode to form the electron beam.

The double magnet structure whose action has been described is attached to the neck of the picture tube as shown at the upper left in Fig. 129-3. This is a view looking down on top of the tube neck. Passing through the pole piece extensions of the two magnets are long screws fitted with knurled nuts. With these screws loosened the magnet frame will slide over the tube base and forward to its working position. Then the screws are tightened just enough to prevent slipping.

At the upper right in Fig. 129-3 is shown an arrangement consisting of two ring-shaped permanent magnets having open air gaps forming their poles. The magnets are carried by a supporting sleeve of fibre or rubber. Tension springs between the sleeve and tube neck hold the magnets wherever they are

placed, but allow sliding and rotating for adjustment. The larger and stronger ring magnet is placed toward the base of the picture tube. The smaller front ring may be rotated independently of the large one, which sometimes is desirable when making an adjustment. Normally the gaps in the two rings are in line lengthwise of the tube axis.

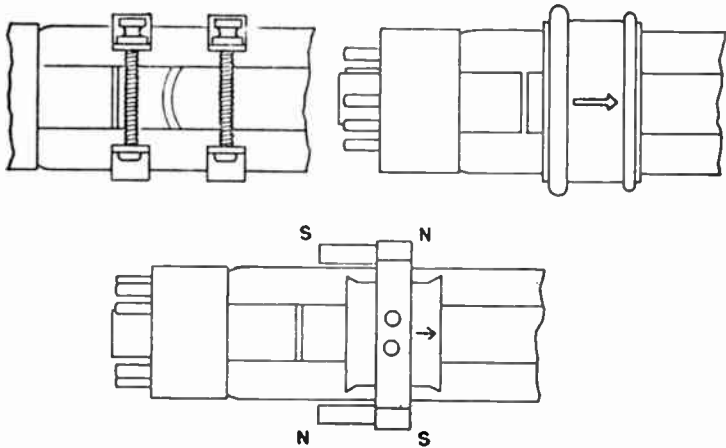

Fig. 129-3.—Methods of mounting double magnet ion traps on the necks of picture tubes.

Some ion traps are made with electromagnets instead of permanent magnets. The larger of the two magnet coils, which forms the stronger magnet, is placed toward the base of the picture tube, with the smaller coil toward the screen end. Direct current from the low voltage B-power supply flows through the two magnet coils in series, and usually in series with the focus coil.

Single Magnet Traps. — Fig. 129-4 illustrates the principle of the bent-gun ion trap which requires only a single external magnet for deflection of electrons. The cathode, the pre-accelerator anode, and the rear end of the second anode are at an angle with the axis of the electron tube neck. The remainder of the second anode is in line with the neck axis. Ions and electrons enter the rear end of the second anode while traveling

toward a point on the inside of this anode. The ions continue along this original direction until striking the anode surface, where they are collected. The field of the single external magnet deflects the electrons so that they are directed toward the opening at the front end of the second anode, where the electron beam is formed and continues through the focus coil and deflection coils to the tube screen.

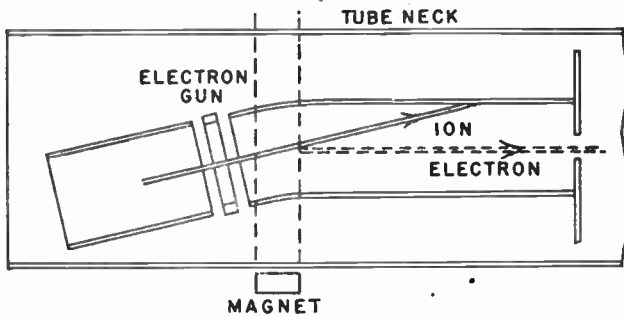

Fig. 129-4.—Operating principle of the bent-gun ion trap employing a single magnet.

Single magnets for electron guns are made in various styles. One construction is similar to that illustrated by Fig. 129-1 and at the upper left in Fig. 129-3 except for having only one magnet with its poles on opposite sides of the tube neck. Other styles have tension springs fastened to the upwardly extending magnet poles, with these springs bearing on the tube neck with enough pressure to hold the magnet structure in place.

Ion Trap Adjustment. — Double magnets for electron guns are placed on the tube neck with their larger or stronger magnet toward the tube base. With the magnets shown at the upper left in Fig. 129-3 the poles partially covered with black sleeving go toward the tube base and those having blue sleeving go toward the screen. With one style of single magnet the pole covered with blue sleeving goes on the left side of the tube neck when looking from the base toward the screen. Double magnets shown at the upper right and at the bottom of Fig. 129-3 have arrows which should point toward the front or screen end of the picture tube.

With any double magnet structure the magnet poles which are toward the tube base should be placed initially in line with the two flags which extend from opposite sides of the electron gun. These flags and the position of the rear magnet in relation to them are shown by Fig. 129-1. Adjustment is completed by moving the magnet or magnets to the position giving brightest pictures. Since magnet position affects focusing, the focus coil or magnet should be inspected to make sure that its center is in line with the tube axis or that the tilting is as required for correct centering of the picture with no shadowing in the corners.

The ion trap magnet is adjusted while viewing a picture, a test pattern, or a raster. The magnet should be moved slightly forward and back while rotating it through a small angle around the tube neck to obtain maximum brightness with no corner shadows. Such shadows sometimes are caused by wrong adjustment of the trap magnet, but usually they indicate incorrect positioning of the focus coil. The next step is to reduce the brightness control to obtain approximately viewing conditions while adjusting the focus control (not the coil position) for the most distinct horizontal trace lines. Then the trap magnet is moved as before to again obtain maximum possible brightness.

Final adjustment of the trap magnet position should be made while the brightness control is as high as it can be made while still leaving distinct horizontal trace lines. The focus adjustment should be checked after completing the trap adjustment. With double magnets of the type shown at the upper right in Fig. 129-3 and other styles allowing independent rotation of the two magnets it may be necessary to slightly rotate the front or smaller magnet to eliminate corner shadowing.

TROUBLE, LOCATION OF. — The particular point in a television receiver at which a fault exists may be located most easily by considering the receiver as made up of a number of sections, some of which probably are unaffected by the fault while others are made wholly or partially inoperative. There are various methods of determining in which of the sections a fault most probably exists. This will eliminate the need for

examining parts in which there is little likelihood of trouble and will limit the search to a relatively small portion of the entire receiver.

The several sections which may be considered during trouble location are listed below and shown by Fig. 130-1.

1. *Power supply.* This section extends from the plug inserted in the building power line receptacle through the voltage dividers of both low-voltage and high-voltage power supply systems.

2. *Sound section.* This section extends from the sound takeoff through to the speaker.

3. *Sweep section.* This section extends from the vertical and horizontal sweep oscillators through the deflection coils or plates and includes the beam deflection functions in the picture tube.

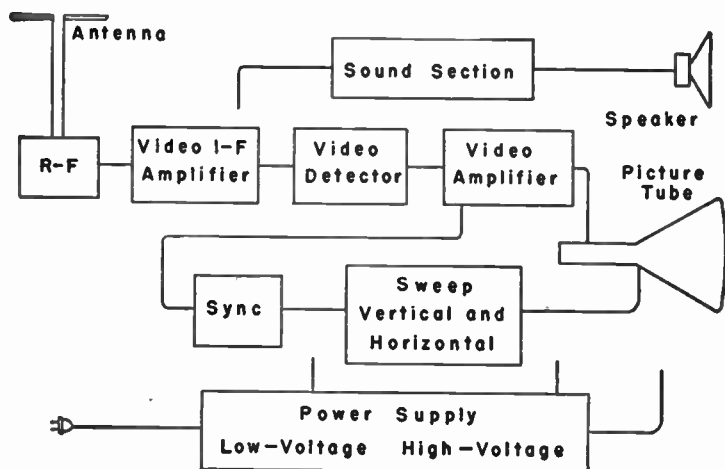

Fig. 130-1.—Sections of receiver to be considered during location of troubles.

4. *Sync section.* This section begins at the sync takeoff from the video amplifier or detector and extends to the inputs of the sweep oscillators.

5. *Video amplifier.* This portion of the receiver extends from the video detector through the grid-cathode signal input of the picture tube.

6. *Video detector.* Located between the video i-f amplifier and video amplifier.

7. *Video i-f amplifier.* This amplifier system extends from the output of the mixer or converter tube to the signal input for the video detector.

8. *R-f section.* This section includes the channel selector or tuner, the r-f amplifier, r-f oscillator, and mixer.

9. *Antenna system.* Including the outdoor, indoor, or built-in antenna, and also the transmission line.

Preliminary examination for determining in which section the trouble probably exists may be carried out by observing the screen of the picture tube, listening to the speaker, using a signal generator, and sometimes an oscilloscope or other testing instruments.

The exact procedure followed during trouble location depends largely on the kind of equipment available and on the experience and preferences of the technician. If experience has shown that the receiver being worked upon is likely to develop certain kinds of trouble, and if evidences of such trouble are present, it is that trouble that should be looked for without delay. Methods described in this article assume that no such information on probable troubles exists.

When preparing to locate trouble the receiver switch should be turned on and the channel selector set for a channel in which a station should be transmitting at the time of testing. Analysis then may be carried out in the following steps, which list parts that should be examined for each class of symptoms.

A. No picture or pattern, no raster, no sound. Glass tubes do not light nor metal tubes become warm. Examine the following parts.

1. Line plug and its contacts in the outlet receptacle.

2. Line cord or extension cord from plug to receiver.

3. On-off switch in the receiver.

4. Any interlock switch that may have been opened by removal of a cover or panel on chassis or cabinet.

B. No picture or pattern, and no sound. There is a raster, either uniform or mottled.

1. Change the selector to another channel or to several other channels where stations are known to operate. The first station may be off the air. If the trouble exists only on some channels, but not on all, the fault must be in the tuner or channel selector, in the tuned couplings of the r-f section, or in the r-f oscillator. If the same symptoms exist on all channels the fault may be in any of the following.
 2. Antenna or transmission line.
 3. R-f section, including its tubes.
 4. Video i-f amplifier stages which carry signals for both picture and sound.
 5. Video detector, if the receiver has intercarrier sound.
 6. Sync section. Since there is a raster, the vertical and horizontal sweep sections must be operating.
- C. No sound. There is a picture or pattern.
 1. Sound section. Troubles described later in this article.
 2. R-f oscillator out of alignment or fine tuning incorrectly adjusted in receivers using dual or split sound system.
- D. No distinct picture or pattern. There is a raster, either uniform or mottled. There is sound.
 1. Sync section. If neither of the hold controls have material effect on the appearance of picture, pattern, or raster it is probable that trouble exists in the sync section.
 2. Video amplifier.
 3. Video detector.
 4. Video i-f amplifier, beyond the point of sound take-off.
- E. No picture, pattern, or raster, but only a horizontal or vertical line on the picture tube screen. There is sound.
 1. Sweep section. If there is only a vertical line, trouble is in the horizontal sweep system, if only a horizontal line the trouble is in the vertical sweep.

One of the quickest ways of locating a section or part in which trouble probably exists is by observation and analysis of test patterns appearing in the picture tube screen. This method is explained in the article *Trouble Shooting, Pattern Analysis for*.

An oscilloscope instead of picture tube indications may be used for locating the section or circuit in which trouble exists. With an oscilloscope it is possible to observe the frequency response of all stages or combinations of stages between the antenna terminals and the signal input to the picture tube. This is done with the help of sweep and marker generators or a television signal generator.

With an oscilloscope it is possible to observe also the signal waveforms as well as other waveforms existing at points between the video detector and the beam deflection circuits and elements at the picture tube. Use of the oscilloscope for trouble location is discussed in the articles, *Trouble Shooting, Waveforms and Frequency Responses*, and *Waveforms*.

In the article on *Tracers*, *Signal* are described methods of using these instruments for following a signal from the point at which it enters a receiver to a point where trouble becomes evident.

After some one section has been identified as the probable location of a fault there are three commonly employed methods for tracing the trouble to a single part or circuit in that section. These methods include tube substitutions, voltage measurements, and resistance measurements.

New tubes or tubes known to be in good condition for television reception should be substituted, one at a time, for the original tubes in the section being checked. Checking by means of a tube tester may or may not indicate a defective tube. A tube which tests bad doubtless will fail to operate, but a tube may test good and yet fail to operate satisfactorily in the television circuits. Since it would be possible for more than one tube to burn out in a series heater system, an ohmmeter may be used to check heater continuity in single tubes or in groups of tubes.

Further tests require that the chassis be removed from its cabinet. If the picture tube in a series heater system is disconnected, the heater leads for this tube must be completed with a resistor of the same resistance and wattage dissipation as the heater itself.

Examine wiring, resistors, capacitors, and small inductors for evidences of overheating. Look for charring, blistering, melting of wax and other insulation, and note any burnt odor. These things indicate severe overloading, or possible short circuits or accidental grounds. When a part has failed because of overloading there is little use of replacing the part until the cause of overloading has been located and corrected.

Look for loose or dirty circuit and terminal connections while the set is turned on. At all suspected connections make checks by using light pressure, tapping, gentle pulling, or careful bending while watching for any changes in operation.

Voltage at tube socket terminals should be measured and compared with correct voltages listed in service instructions for the receiver if such instructions are available. Otherwise comparison should be made with voltages which would be suitable for each type of tube as listed in typical ratings for the tube. Voltages at plates and screens of tubes in the sync section may be much lower than any typical ratings, but there should be some voltage at these elements.

When working from service instructions it is necessary to follow testing conditions as there specified. Such conditions may include the type of voltmeter to be used, whether measurements are to be from tube sockets to ground or to B-minus, and the positions of contrast controls and other controls. Measurements usually are to be made with 117 line volts. Plus and minus voltage limits for satisfactory performance usually are given.

Resistance measurements from tube sockets to chassis ground or B-minus should be made if there is available a list or diagram showing correct resistances and resistance limits. Most faults which cause incorrect resistances will also cause incorrect voltages, and vice versa. The chief advantage of

resistance measurements is that they may be made on a completely dead receiver, where there are no voltages to measure.

It may be difficult to make measurements on individual resistors or capacitors thought to be open circuited, since, with these units connected in place, there are many paralleled paths whose effects can cause misleading readings. The suspected unit may be bridged or jumped momentarily with a good resistor or capacitor while observing results. It is important to make jumper connections with shortest possible leads to avoid introducing so much extra capacitance or inductance as will prevent normal action of the tested circuit.

Sound Section Troubles. — Causes for faulty reproduction of sound are, in general, the same as found in parts of f-m sound receivers which follow the mixer or converter tube in such receivers. In a television set these faults will be in parts which follow the sound takeoff. Articles which treat of these parts are under the following headings.

Detector, ratio.

Limiters, f-m sound.

Discriminators.

Modulation, frequency.

Intercarrier sound.

Sound, television.

A fault peculiar to receivers employing the intercarrier sound system is called intercarrier buzz. This is a distinct 60-cycle buzz, not a hum, due to amplitude modulation of the 4.5 mc sound carrier. The buzz may result from a temporary decrease of carrier signal strength from the transmitter being received, or may result when a nearly white picture suddenly follows a much darker one. The buzz may be due to any of the following faults in the receiver or its operation.

1. Contrast control too high, which may cause picture distortion as well as buzz.
2. Fine tuning incorrectly adjusted for channel being received.
3. R-f oscillator not correctly aligned for channel where buzz appears.
4. Ratio detector or discriminator incorrectly aligned.
5. Inoperative limiter tube or stage preceding a discriminator.

6. Large capacitor on output of ratio detector open or disconnected.
7. Video amplifier overloaded or supplied with plate and screen voltages which are too low.

In receivers having dual channel or split sound systems the sound may disappear or become weak and distorted while the picture remains good, a trouble usually due to shifting of r-f oscillator frequency. The fine tuning control may be wrongly adjusted or there may be incorrect alignment of the oscillator for the channel in which this trouble occurs. The trouble may result from gradual drift of oscillator frequency as the circuit parts warm up during operation. It should be possible to correct this drift by use of a fine tuning control.

TROUBLE SHOOTING, PATTERN ANALYSIS FOR. — Analysis of differences between abnormal and normal test patterns or television pictures often allows rapid determination of the kinds of trouble which may be causing the faulty reproduction. The principal features of test patterns and the relation of these features to trouble shooting are described in the article on *Patterns, Test*. In the present article are typical examples of faulty patterns, together with lists of probable causes and notes relating to tests and methods for trouble correction.

On following pages, in alphabetical order under the names ordinarily used to describe the appearance due to faulty reproduction, are lists of troubles and photographs illustrating the abnormal patterns or pictures. The photographs have been provided through the courtesy of Allen B. Du Mont Laboratories, Admiral Corporation, General Electric Company, Philco Corporation, Sentinel Radio Corp., and Radio-Electronics magazine.

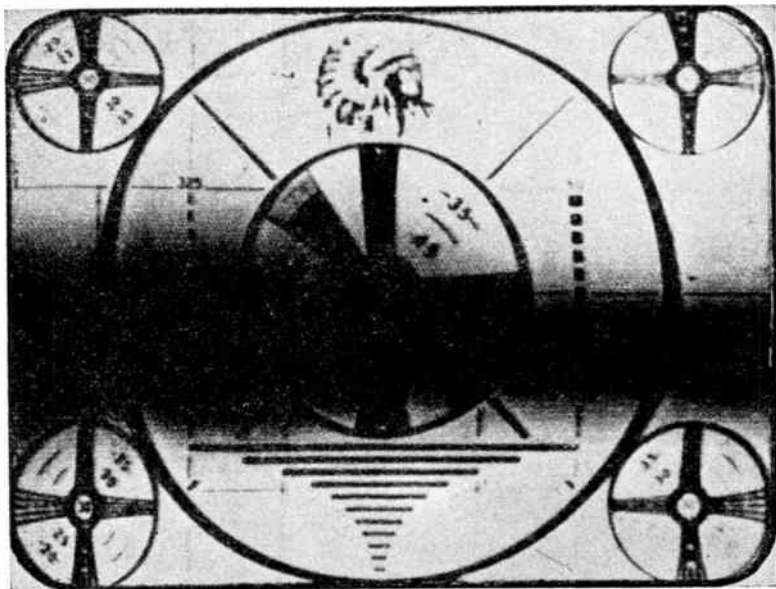

Fig. 131-1.—Bars, Horizontal, Wide.

One or more wide black or dark toned bars separated by light toned spaces of about equal size. The bars remain stationary or nearly so. The condition may be called "hum," because the bars result from faults which would cause hum in a sound receiver.

Causes for trouble.

Insufficient filtering in low-voltage B-power supply. Open filter capacitors, etc.

Open or disconnected decoupling capacitors in sound or video circuits.

Locate points at which audible hum is present by using a signal tracer, or use oscilloscope for visual tracing of hum voltages.

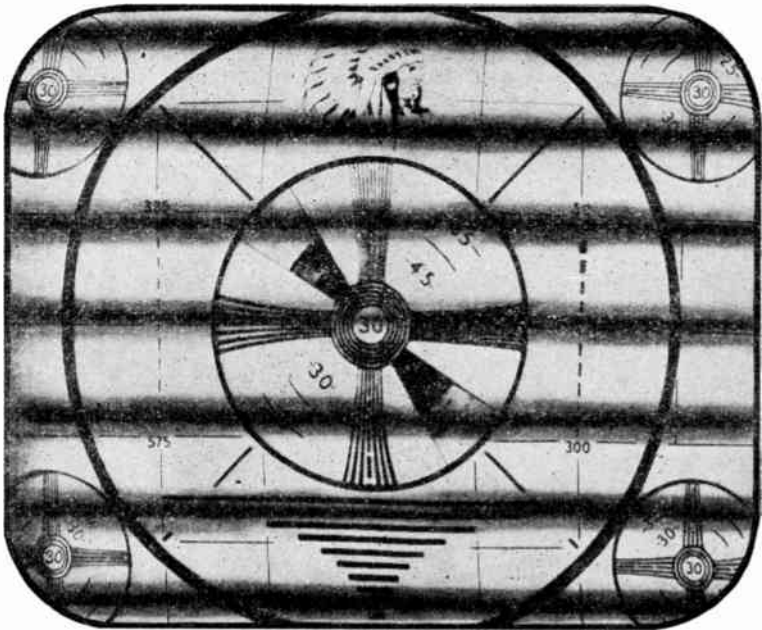

Fig. 131-2.—Bars, Horizontal, Narrow. "Sound Bars."

A number of dark toned horizontal bars which result from audio-frequency voltages getting into the video i-f amplifier, video detector, or video amplifier circuits. If the audio frequency is constant, the bars remain stationary or move up or down at a uniform rate. If the audio frequency is modulated, the bars weave and cross with the modulation. The number of cycles per second of the audio frequency causing the bars is approximately equal to 60 times the number of bars.

Causes for trouble.

Fine tuning control misadjusted.

Sound volume control set too high.

R-f oscillator incorrectly aligned. Change alignment by least amount which gets rid of the bars.

Microphonic tube in r-f section, or possibly in i-f amplifiers, sync, or sweep sections. Tap tubes lightly to identify the one causing trouble. If bars are most noticeable with the sound volume control at maximum the fault probably is in the sound amplifier. If bars are most noticeable with volume control at minimum, check the other sections mentioned.

Traps for accompanying sound or adjacent sound incorrectly aligned.

Sound takeoff coupling incorrectly aligned.

Video i-f alignment wrong.

Regeneration in video i f amplifier.

Check also for troubles listed under *Lines, Horizontal.*

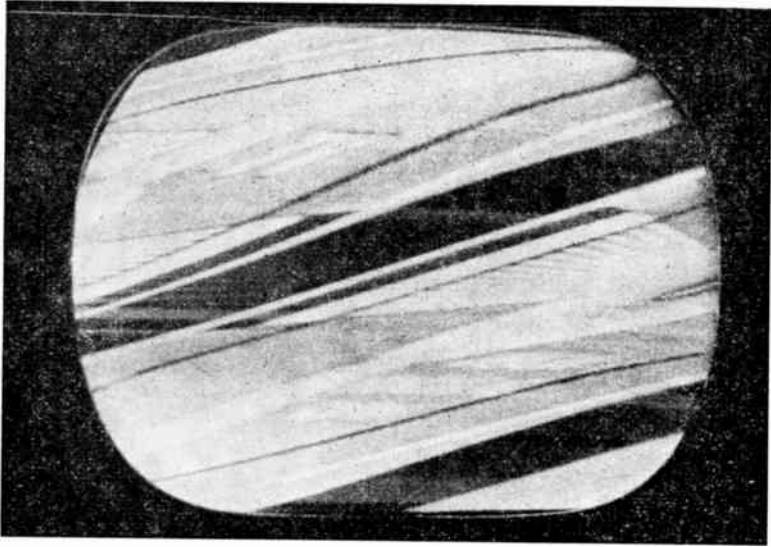

Fig. 131-3.—Bars, Sloping.

The bars change their degree of slope, their number, and their positions as the horizontal hold control is altered.

Causes for trouble.

Horizontal hold control incorrectly adjusted.

Faulty connections, resistors, or capacitors in circuits for horizontal hold control or for horizontal automatic control of sweep frequency.

See also troubles listed under *Movement, Horizontal*.

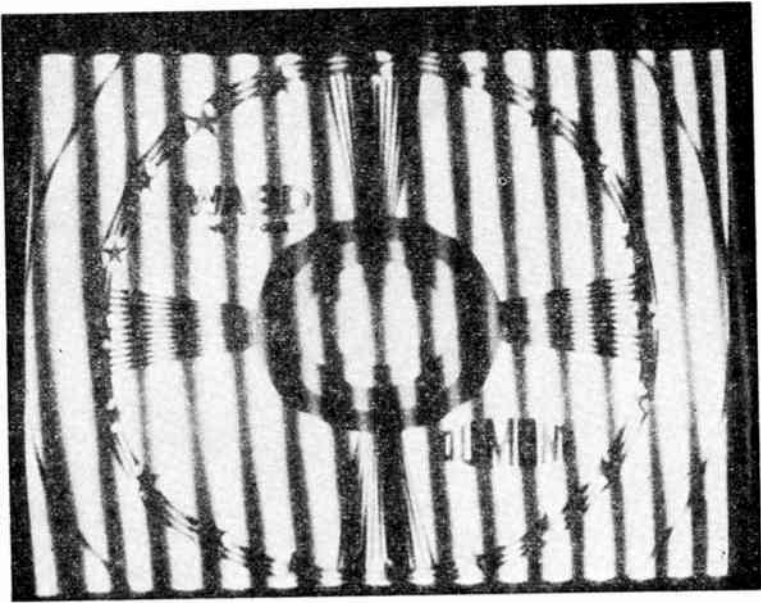

Fig. 131-4.—Bars, Vertical.

Causes for trouble.

Usually due to beat interference at frequencies lower than standard a-m broadcast carriers but higher than audio frequencies. The interference may originate inside or outside the receiver. The bars may remain stationary, may move to the right or left, or may change their slope.

The interference frequency is equal approximately to the number of dark or light bars multiplied by 15,750. Presence of the interference voltage at various points may be identified by means of an oscilloscope whose internal sweep is adjusted to maintain a steady trace pattern with the vertical input connected to various receiver circuits.

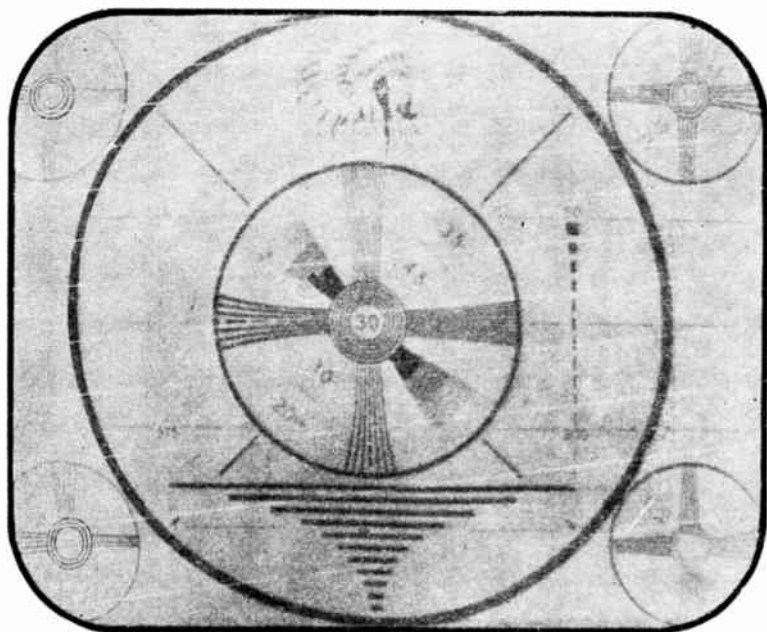

Fig. 131-5.—Brightness Excessive or Varying.

Causes for trouble.

Brightness control turned too high. Vertical retrace lines appear.

Brightness control defective or open circuited.

Open circuit in picture tube grid-cathode circuit.

Trouble in d-c restorer circuits. Brightness varies irregularly.

Oscillation in video i-f amplifier. Picture tube screen becomes brilliant white, with no pattern or picture. Receiver usually must be turned off to stop the oscillation.

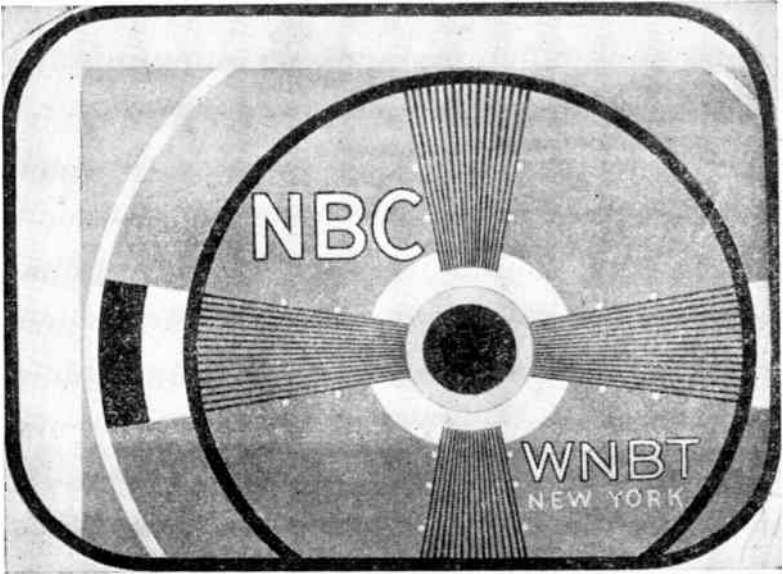

Fig. 131-6.—Centering Incorrect.

Picture or pattern may be too high or too low, incorrect vertical centering, or it may be too far to the right or left, incorrect horizontal centering, or there may be incorrect centering in both directions at once, as in the photograph.

Causes for trouble. Magnetic deflection.

Focusing control wrongly adjusted.

Ion trap magnet in wrong position on picture tube neck, or weak.

Horizontal hold control misadjusted.

Focusing coil axis direction requires adjustment. Should be in line with picture tube axis.

Focusing coil too far forward or back. Usually should be $\frac{1}{4}$ to $\frac{3}{8}$ inch from the deflection yoke.

Focusing coil short circuited.

Deflection yoke too far back on neck of picture tube, or not centered around neck.

Defective bypass capacitor on focusing control.

Causes for trouble. Electrostatic deflection.

Centering control or controls wrongly adjusted.

Horizontal hold control misadjusted.

Picture tube shield magnetized.

Leaky capacitor or capacitors between outputs of deflection amplifiers or oscillators and the picture tube deflection plates.

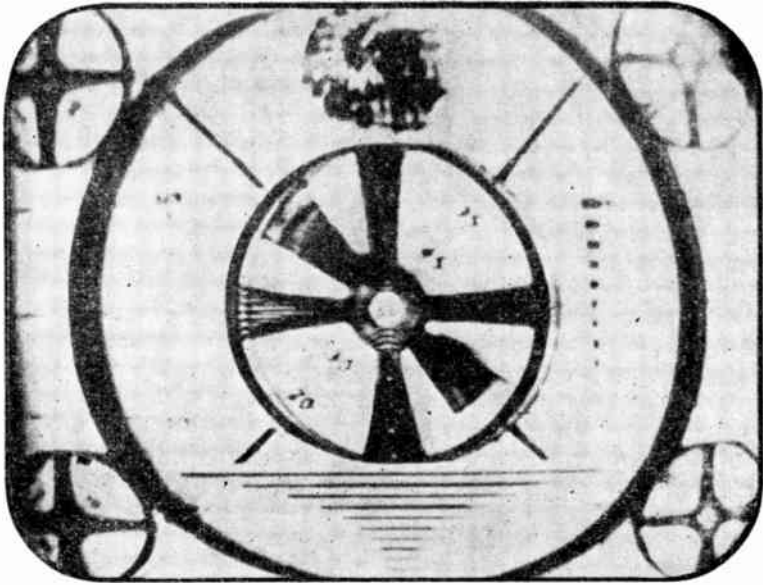

Fig. 131-7.—Contrast Excessive.

Causes for trouble.

Contrast control adjusted too high.

Faults in automatic gain control circuits or tubes.

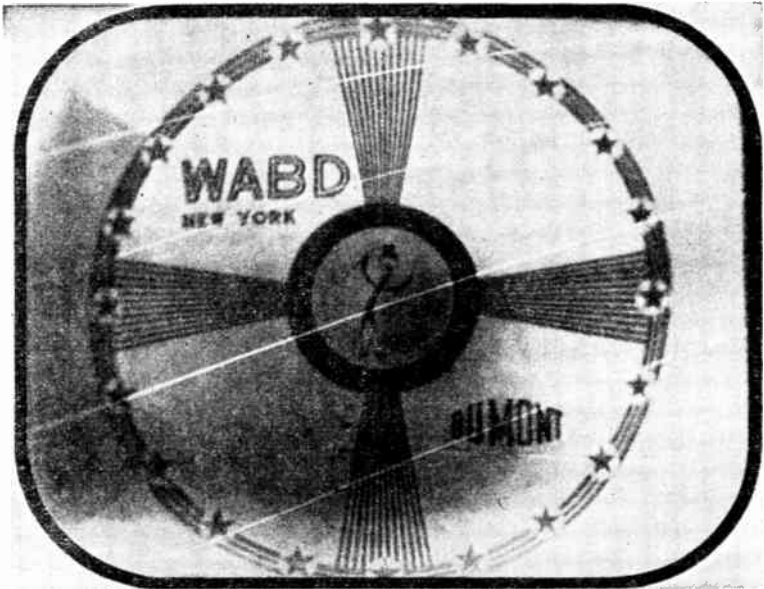

Fig. 131-8.—Contrast Insufficient.

Causes for trouble.

Contrast control adjusted too low.

Brightness control too high. Causes vertical retrace lines as in photograph.

Weak signal reaching the antenna coupling input at the tuner. Check the transmission line, the antenna, and their connections. Built-in or indoor antenna may not deliver enough signal where the receiver is located.

Video i-f amplifier wrongly aligned, or has defective tube.

R-f amplifier or antenna coupling, or both, misaligned. Defective tube in r-f amplifier position.

R-f oscillator wrongly aligned, or weak tube.

Defective tube or crystal for video detector.

Automatic gain control providing excessive negative bias.

Video amplifier tube defective.

Fault in d-c restorer circuit, or defective tube.

Picture tube defective, or so old as to have poor emission.

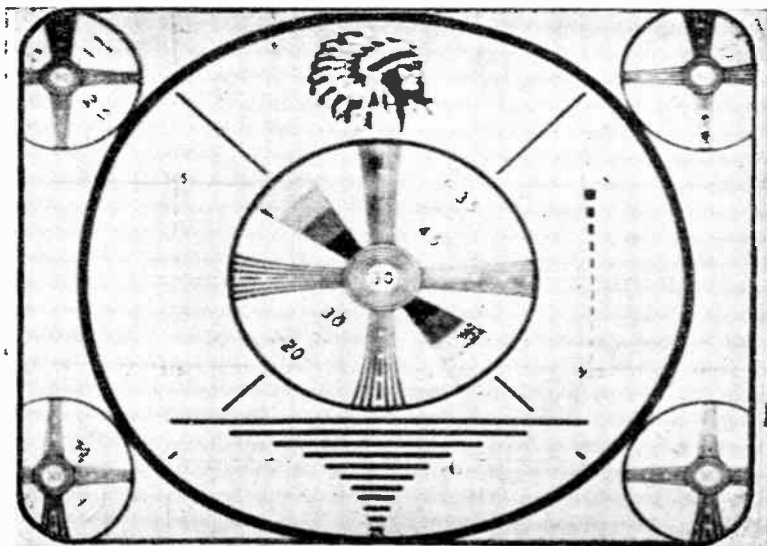

Fig. 131-9.—Definition Poor, Detail Lacking.

Poor definition which is not due to faults in focusing nearly always results from lack of response or lack of sufficient gain at the high video frequencies. Such lack of high frequency response is evident when lines and spaces of the vertically extending resolution wedges blur or run together a short distance inside the upper and lower sides of the pattern.

Causes for trouble.

Contrast control too high.

Fine tuning control misadjusted.

Weak received signal.

Ghost images. See troubles listed under *Ghosts*.

Video i-f amplifier incorrectly aligned. Not enough gain or response toward the sound intermediate frequency side of the response curve.

R-f amplifier or antenna coupling not aligned to provide sufficiently wide band pass.

Voltage too low on high-voltage anode or anodes of picture tube. Check the high-voltage power supply.

Video detector and/or video amplifier have poor response at the higher video frequencies. Coupling capacitors may be leaky or shorted. Peaking coils may be shorted. Try temporarily shorting each peaker. If this causes no change in definition, the shorted coil probably is defective.

Interlacing defective. Trouble in the sync section.

Focusing poor. See troubles listed under *Focus Poor*.



Fig. 131-10.—Focus Poor.

Focus is poor when horizontal traces or lines on the picture tube screen are not clearly separated when looking closely at the tube. Focus will vary in sharpness at different areas, even with best possible operation.

Causes for trouble.

Focusing control incorrectly adjusted.

Ghost images causing only slight displacement in the pattern. See *Ghosts*.

Focusing coil in wrong position, not centered around picture tube neck.

Ion trap magnet not in correct position, or weak.

Deflection yoke in wrong position on picture tube neck. Causes poor focusing at corners or outer edges of screen.

Voltage too low on high-voltage anode or anodes of picture tube. Check the circuits and tube or tubes in the high-voltage power supply.

Voltage and current too low or too high in focusing coil of magnetic focusing picture tube, or voltage too low or too high at focusing electrode of electrostatic picture tube. Focusing will be best with control moved to either end of its range.

Picture tube defective. Lack of emission due to age. Possibly gassy.

Weak signals may cause appearance similar to that due to poor focusing. See troubles listed under *Snow*.

Poor definition or resolution may appear like poor focusing. See troubles listed under *Definition Poor, Detail Lacking*.

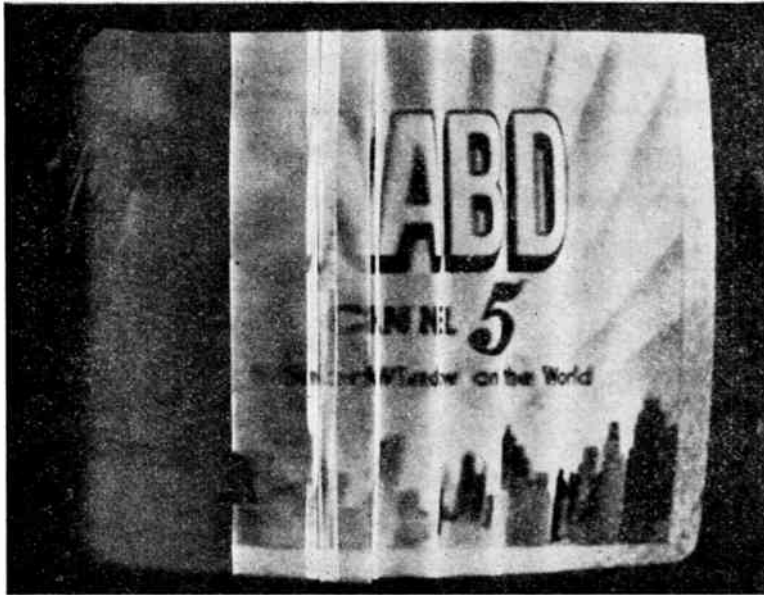

Fig. 131-11.—Folded Pattern, Horizontally.

The picture or pattern appears as though it has been pushed together from left to right.

Causes for trouble.

Incorrect adjustment of horizontal drive control.

Insufficient sawtooth voltage from horizontal sweep oscillator or amplifier.

Trouble in damper circuit of magnetic deflection system, or defective damper tube.



Fig. 131-12.—Folded Pattern, Vertically.

Causes for trouble.

Vertical hold control incorrectly adjusted.

Faults in vertical hold control circuit causing vertical deflection frequency which is too high.

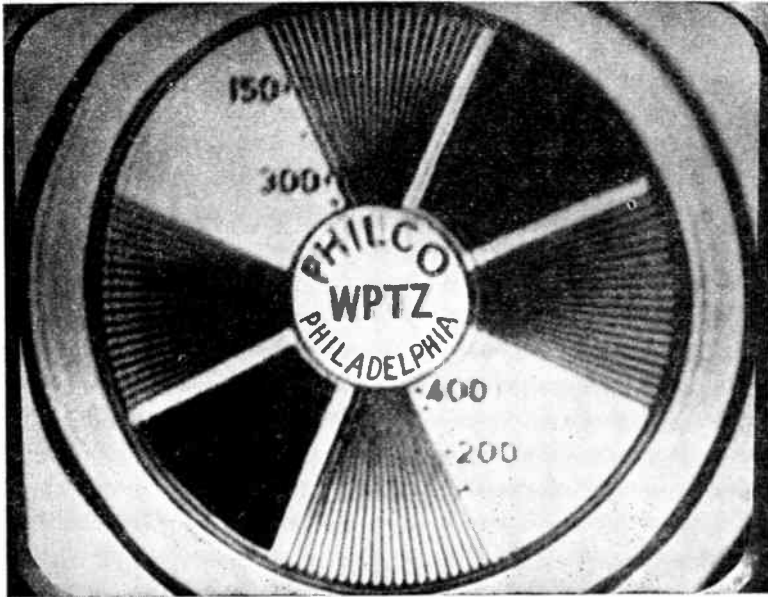

Fig. 131-13.—Ghosts.

There are multiple images in the test pattern or picture. The displaced images, of which there may be one or more, may be so close to the principal image or may be so faint as to cause only a blurring effect. In other cases the displaced images may be at a considerable fraction of inch from the principal image, and may be distinct.

Causes for trouble.

Part of the transmitted signal is being reflected from large conductive or semi-conductive objects, such as buildings, bridges, tanks, or steep hills, and the reflected portion is reaching the receiver antenna a fraction of a second later than the direct signal. Try rotating the receiving antenna to reject the reflected signal without too much loss of direct signal. Fit a reflector, and possibly also a director, on the antenna. Try the antenna in various locations.

Incorrect matching of impedances between antenna and transmission line, or between transmission line and receiver input. There are standing waves on the line. Use antenna and transmission line whose impedances match that of the receiver and of each other.

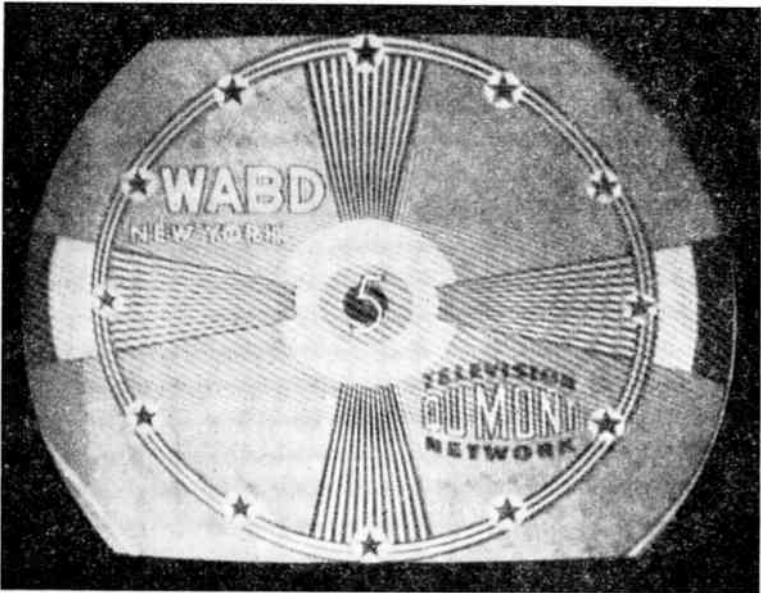

Fig. 131-14.—Herringbone Effect.

A series of fine or coarse irregular lines and curves extending horizontally near the top, center, or bottom of the picture area. The photograph shows a rather faint effect across the center of the pattern.

Causes for trouble.

Interference from medical apparatus, such as diathermy equipment, or from any similar devices being used in the neighborhood.

Signals from f-m radio stations operating in the area where the receiver is located. Other high-frequency transmitters could cause a similar effect. Turning the antenna or changing its location may be of help. An antenna trap may be tuned to the interfering frequency.

Regeneration in the video i-f amplifier.

Regeneration in the sound i-f amplifier.

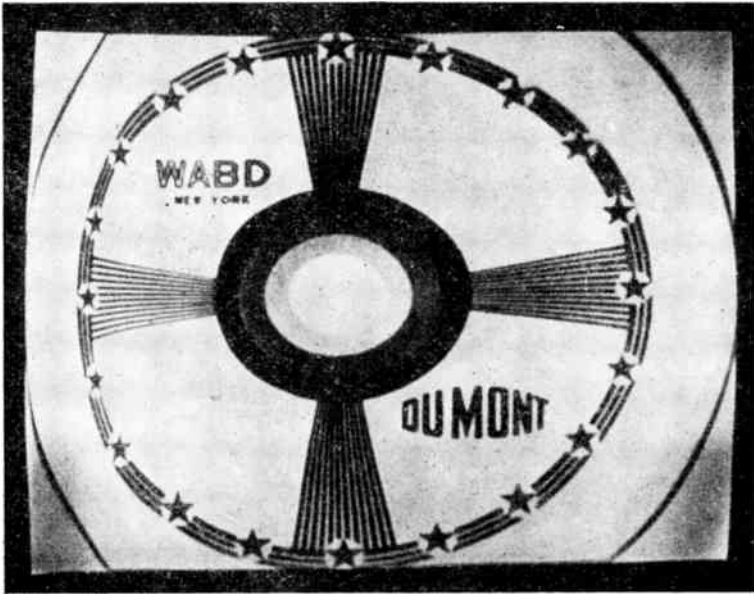

Fig. 131-15.—Linearity Poor, Horizontal.

Linearity is the name given to distortion of outlines or of proportions in television patterns and pictures. With poor horizontal linearity there may be stretching at the right and crowding at the left, as in the photograph, or there may be stretching at the left with crowding at the right. Circles become deformed.

Causes for trouble.

Horizontal linearity control or controls misadjusted.

Horizontal drive control or peaking control misadjusted.

Defective inductors, capacitors, or resistors, fixed or adjustable, in horizontal linearity control circuits.

Horizontal sweep oscillator tube defective, or supplied with incorrect voltages on its elements.

Horizontal sweep amplifier tube defective, or supplied with incorrect voltages.

Defective damper tube in magnetic deflection system.

Trouble in any circuits or parts which follow the horizontal sweep oscillator, and in which are sawtooth voltages and currents.

Horizontal sweep output transformer defective.

Shorted turns in horizontal coil or coils of the deflection yoke.

Poor filtering of low-voltage B-power supply.

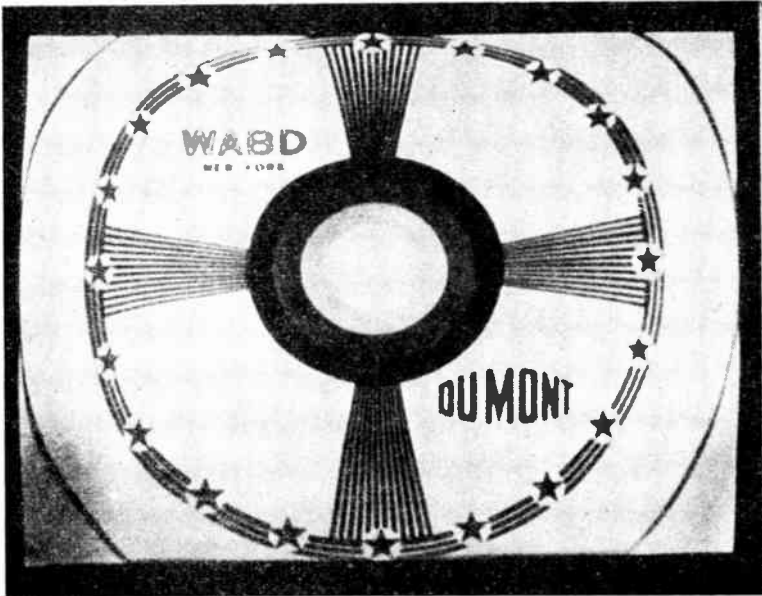

Fig. 131-16.—Linearity Poor, Vertical

With poor vertical linearity the pattern or picture is compressed or flattened from above, below, or from both directions.

Causes for trouble.

Vertical linearity control wrongly adjusted.

Defective capacitors or resistors, fixed or adjustable, in vertical linearity control circuits.

Vertical sweep oscillator tube defective, or supplied with wrong voltages.

Vertical sweep amplifier tube defective, or supplied with incorrect voltages.

Trouble in any parts which follow the vertical sweep oscillator, and which carry sawtooth voltages and currents.

Vertical sweep output transformer defective.

Shorted turns in a vertical deflection coil.

Poor filtering of low-voltage B-power supply.

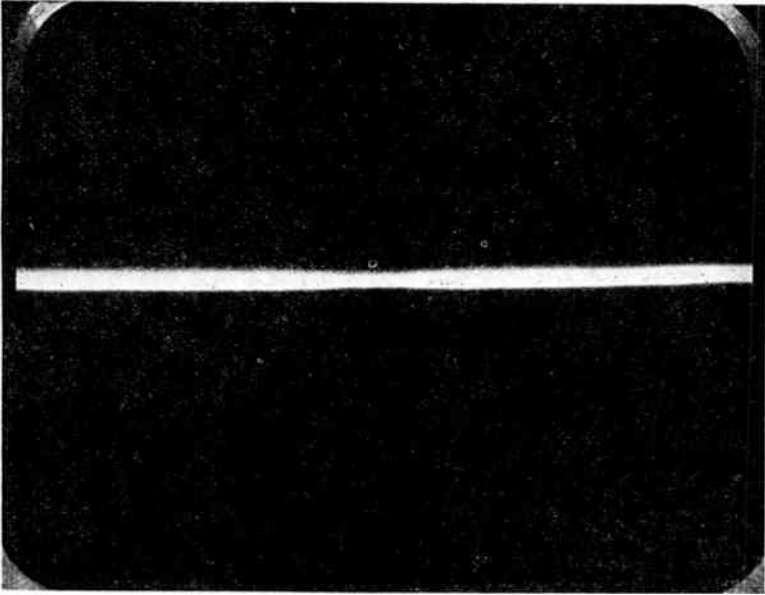

Fig. 131-17.—Line Only, No Raster or Pattern.

There may be a single trace line running horizontally, as in the photograph, or a similar single line running vertically on the screen.

Causes for trouble.

A horizontal line indicates that there is no vertical deflection, only horizontal deflection remains. A vertical line indicates that there is no horizontal deflection, only vertical deflection remains.

With no vertical deflection the trouble may be anywhere from the vertical sweep oscillator through to the deflection yoke of a magnetic picture tube or to the deflection plates of an electrostatic tube. Conversely, with no horizontal deflection the trouble may exist anywhere from the horizontal sweep oscillator through to the deflection elements at the picture tube.

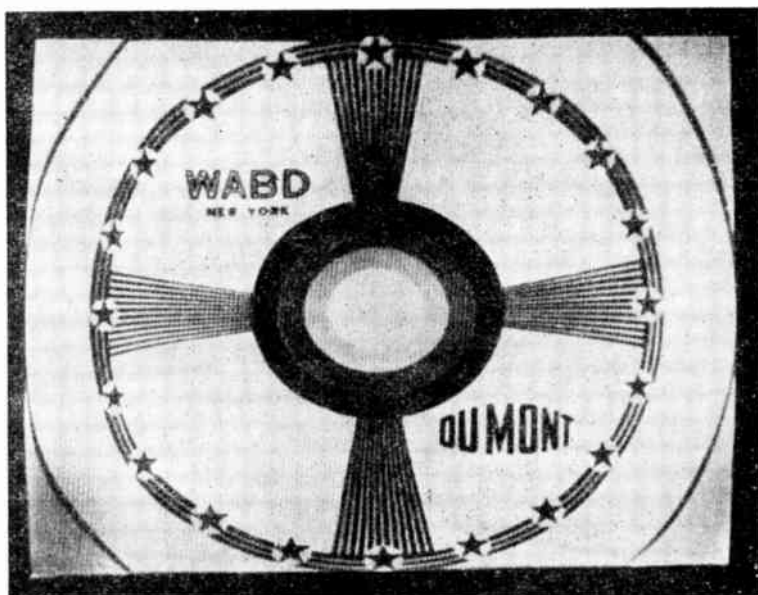

Fig. 131-18.—Lines, Narrow, Allover Pattern.

Due to beat interference from radio frequency and television frequency signals or voltages originating from outside or within the receiver. The number of cycles per second of the interfering frequency is equal approximately to the number of lines, either light or dark, but not both, multiplied by 15,750. The lines may lie vertically or diagonally on the picture tube screen. They weave or ripple and change their direction.

Causes for trouble.

Interference from f-m radio broadcasting stations operating in the area where the receiver is located. Change the direction of the receiving antenna. Tune an antenna trap to the interfering frequency. Check the transmission line for possible signal pickup.

Interference from nearby short-wave transmitters. Same remedies as for f-m interference.

Interference from television channels other than the one to which the receiver is tuned. Try adjusting the fine tuning control.

Beating frequency of 4.5 megacycles from sound section of a receiver having intercarrier sound system, or getting past the sound takeoff and reaching the picture tube grid cathode circuit through all or part of the video amplifier. Check dressing of all grid and plate leads following the takeoff.

Incorrect dressing of capacitors and resistors in grid and plate lines of the video amplifier, or dressing picture tube grid or cathode leads too close to the chassis.

Interference from r-f type high-voltage power supply in the receiver. Not shielded, shield not connected to chassis or B-minus, poor filtering at output or input, defective or shorted isolating chokes or capacitors. Incorrect dressing of r-f oscillator plate and grid leads.

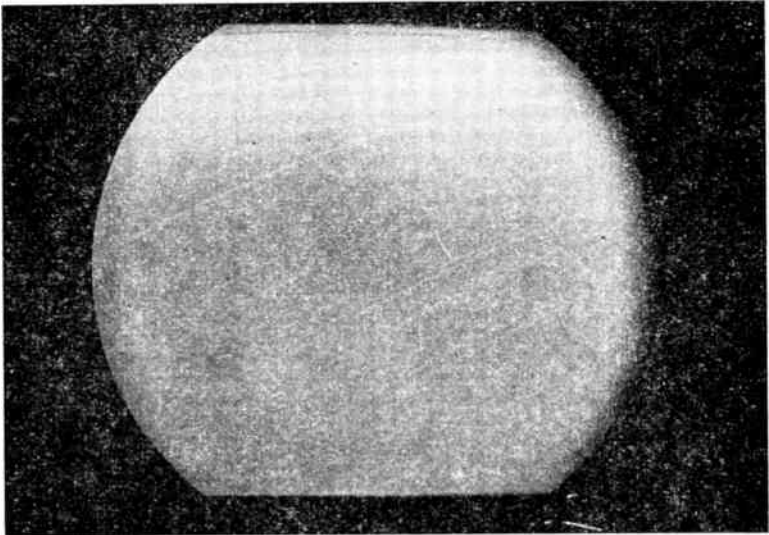

Fig. 131-19.—Lines, White, Curved and Sloping.

These are called vertical retrace lines. The photograph shows such lines on a plain raster. They appear similarly on patterns and pictures.

Causes for trouble.

Brightness control too high, contrast too low, or both together. Adjust one or both controls.

Vertical hold control slightly out of adjustment. The retrace lines will appear only while the picture or pattern moves slowly up or down. Adjust the control.

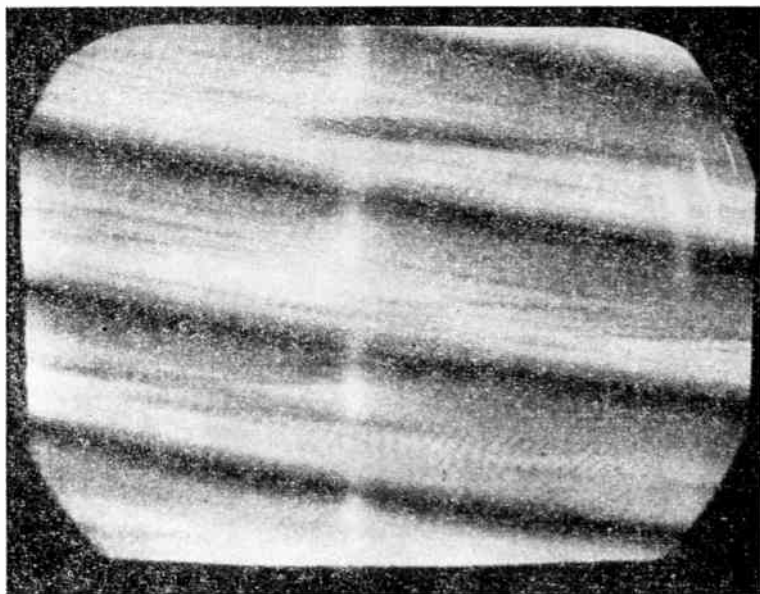

Fig. 131-20.—Movement, Horizontal.

The parts of the pattern or picture move slowly or rapidly toward the right or left, sometimes with complete scattering and breakup of all elements, and again with the appearance of strong diagonal bars at changing angles. These things are due to faulty horizontal synchronization.

Causes for trouble.

Horizontal hold control misadjusted.

Strong reflected signals prevent synchronizing action of the horizontal hold control instead of having their more usual effect of producing ghost images.

Leaky, shorted, or open capacitors or resistors in the horizontal hold control circuit that is connected to the grid of the horizontal oscillator.

Defective horizontal oscillator tube, or incorrect tube voltages.

Defective capacitors or resistors in the differentiating filter leading to the horizontal sweep oscillator from the sync section.

Trouble in the horizontal automatic frequency control for synchronizing. Check tubes, tube voltages, transformer adjustments, coupling capacitors, and all resistors.

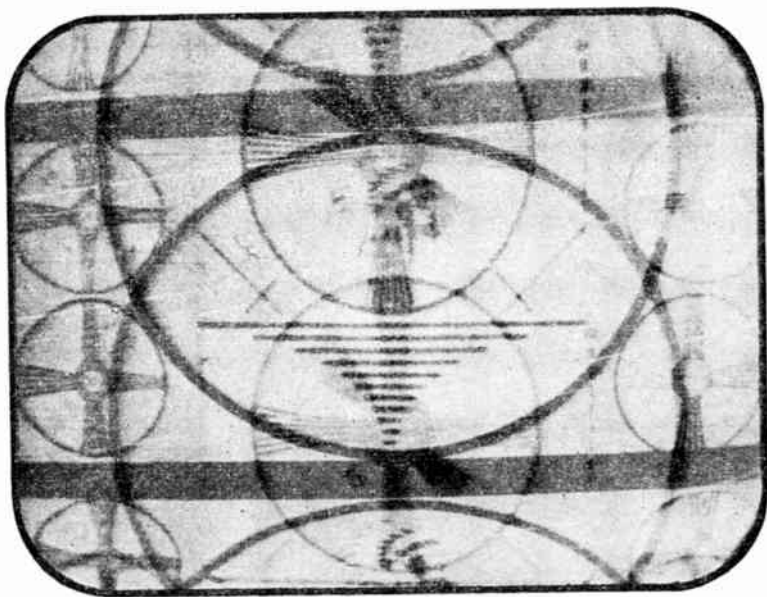

Fig. 131-21.—Movement, Vertical.

The pattern or picture moves more or less rapidly up or down on the screen of the picture tube, or appears to "roll." Vertical blanking bars appear crosswise of the screen, or, with very slow movement, there may be only one such bar at a time.

Causes for trouble.

Vertical hold control misadjusted.

Strong reflected signals may interfere with action of the vertical hold system.

Corona or arcing in high-voltage power supply may interfere with vertical hold.

Vertical sweep oscillator tube defective or supplied with incorrect voltages. Opens, leakages, or shorts of capacitors and resistors connected to the grid of the vertical sweep oscillator tube.

Leaky capacitors, or resistors open or shorted, in the integrating filter between the sync section and the vertical sweep oscillator.

Movement, Vertical and Horizontal.

Causes for trouble.

Both the horizontal and the vertical hold are out of adjustment.

Contrast control adjusted too low.

Weak signal reaching the antenna or tuner terminals of the receiver.

Strong electrical interference of the spark type.

Corona or arcing in the high-voltage power supply system of the receiver.

Strong reflected signals reaching the antenna. Such signals ordinarily cause the appearance of ghost images.

Faults in the sync section, anywhere from the takeoff through to the integrating and differentiating filters. Check tubes, tube voltages, coupling capacitors, resistors, and dressing of grid and plate leads.

Video i-f amplifier incorrectly aligned, so that the video intermediate frequency is too far down on the response curve. This reduces low-frequency response.

R-f amplifier or antenna coupling incorrectly aligned, reducing the response at low video frequencies.

D-c restorer inoperative. This trouble may cause loss of synchronization chiefly on dark toned pictures. Check the tube and all parts of its circuit.

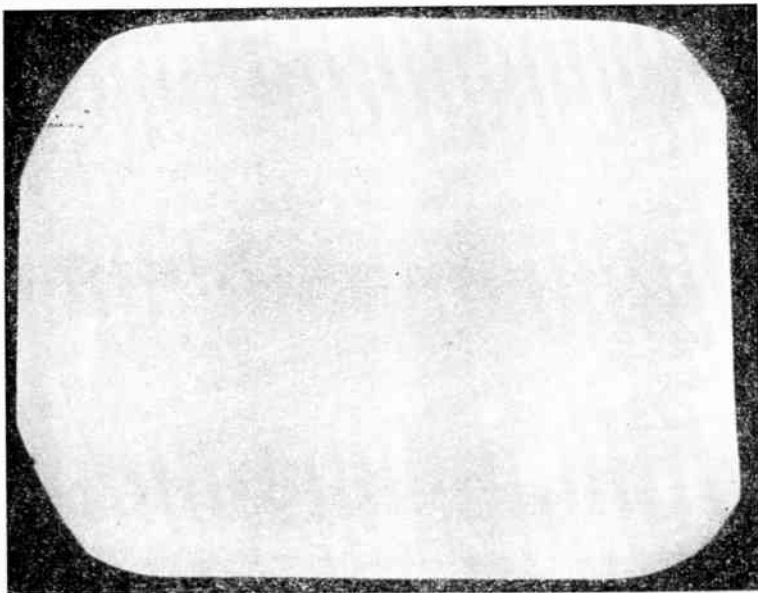

Fig. 131-22.—*Raster Only, No Pattern or Picture.*

If there is no reproduction of sound, and neither pattern nor picture, the trouble may be any of those listed. If there is reproduction of sound the trouble can be only in parts of the receiver which follow the sound takeoff.

Causes for trouble.

Antenna or transmission line open circuited, shorted, have high resistance connections, or for any reason fail to deliver a signal to the receiver.

Dirt, looseness, open connections, or other faults in the tuner.

R-f oscillator or r-f amplifier out of alignment, tube defective, wrong voltages, or other troubles preventing operation.

Video i-f amplifier far out of alignment, defective tube, no voltage on one or more tubes, open or shorted coupling capacitors, etc.

Defective video detector tube or crystal.

Contrast control open circuited or otherwise defective.

Automatic gain control system supplying excessively negative voltage.

Faults in the video amplifier. Check tubes and their voltages, coupling capacitors, resistors, wiring connections, and other causes for no amplification.

Examine all circuits through to the picture tube signal input.

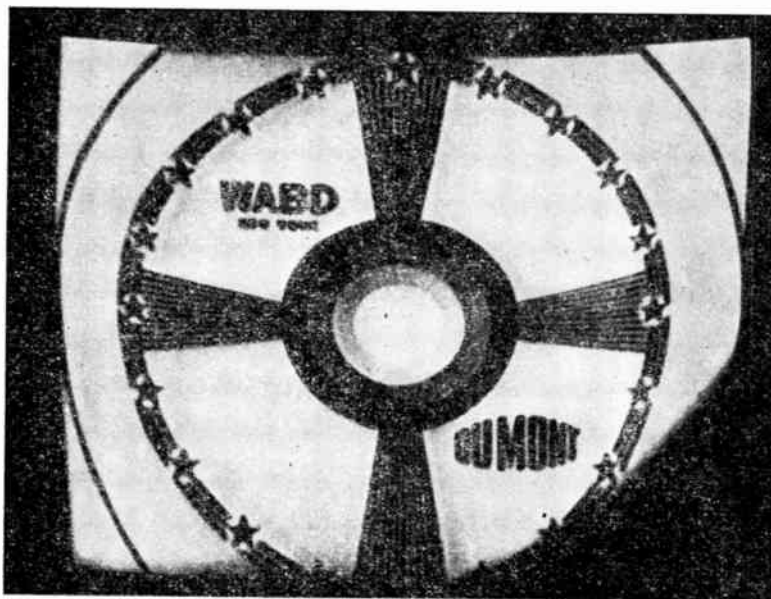

Fig. 131-23.—Shadows.

Causes for trouble.

Ion trap magnet incorrectly adjusted, in wrong position.

Focus coil or magnet not centered around neck of picture tube.

Focus coil or magnet too far back on picture tube neck, too close to base.

Deflection yoke too far back from flared portion of picture tube. It should be as close as possible to the flare.

Frame which carries the yoke and focusing coil or magnet out of position.

Picture tube may require slight rotation around its axis.

Reversing the connections to the focusing coil may help in some cases.

With an electrostatic picture tube the connections to pairs of plates used for horizontal and vertical deflection plates may have been reversed. Try changing these connections. It will then be necessary to rotate the tube through a half turn around its axis.

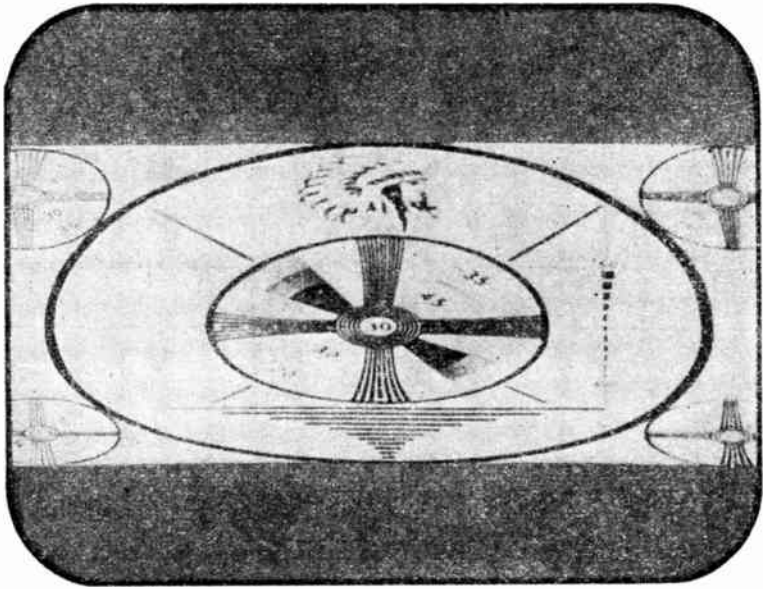

Fig. 131-24.—Size Incorrect.

The size of the picture, with reference to the mask opening or screen size, may be too small in a vertical direction as shown by Fig. 131-24 or too small in a horizontal direction as shown by Fig. 131-25. In some cases the size may be too great in both directions. In considering these faults it is assumed that both the vertical and horizontal size controls, or the height and width control, have been adjusted so far as is possible to make the size correct in both directions. Troubles listed below are to be looked for in the vertical sweep section when height is incorrect, or in the horizontal sweep section when width is incorrect, or in both these sections when size is incorrect both ways.

Causes for trouble.

Re-check adjustments of size control or controls.

Size may be affected by incorrect adjustment of linearity controls, either vertical or horizontal, and of horizontal drive or peaking controls.

(Continued on following page)

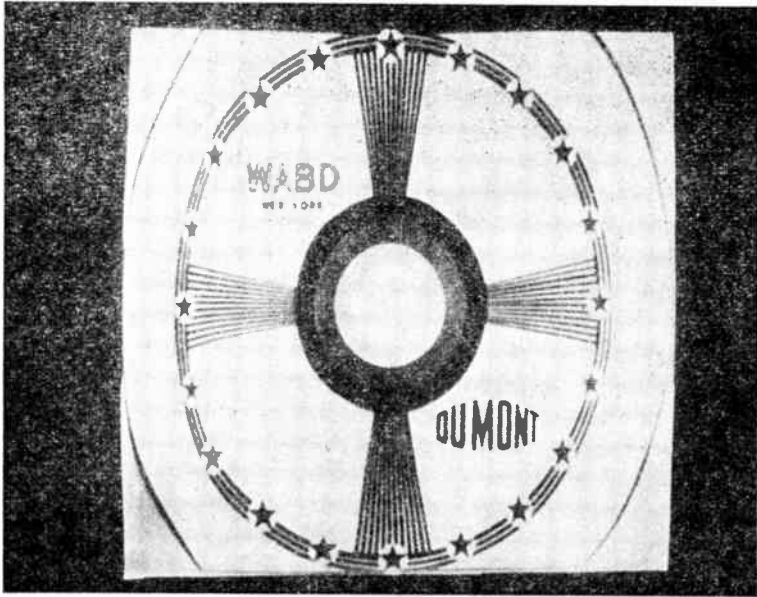

Fig. 131-25.—Size Incorrect.

Centering control adjustments may have reacted on size.

Sweep oscillator tube defective or supplied with wrong voltages.

Examine circuits which carry sawtooth voltages and currents, and check sawtooth waveforms with oscilloscope.

Trouble in circuits between sweep oscillator and amplifier. Examine coupling capacitors and voltage divider capacitors or resistors.

Defective sweep output amplifier tube, or tube supplied with wrong voltages.

Defective sweep output transformer.

Defective damper tube or incorrect damper adjustments. Only in horizontal magnetic deflection systems.

Picture tube may be gassy.

Size which remains excessive after all adjustments may indicate voltage too low on the high voltage anode or anodes of the picture tube.

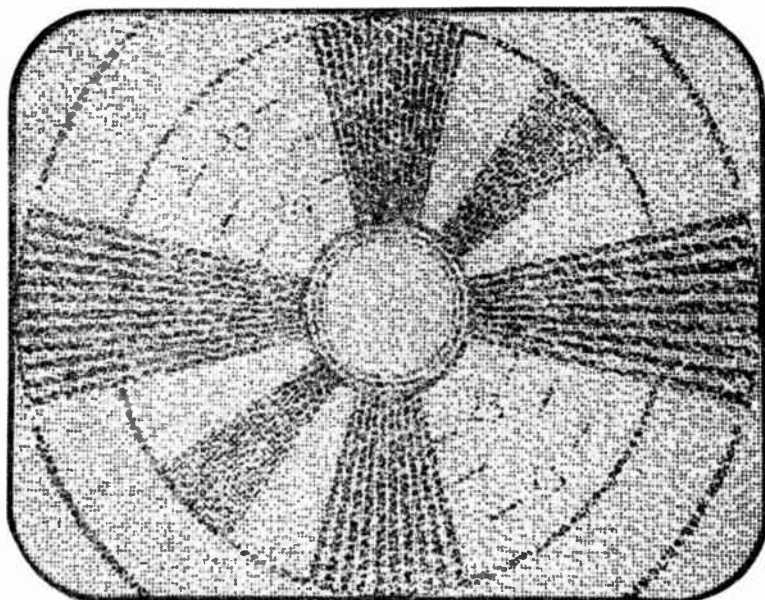

Fig. 131-26.—Snow.

The pattern or picture appears covered with small white specks or flashes. The primary cause is a weak signal at the antenna input terminals of the receiver, or there is a low ratio of signal to noise. With the contrast control turned up for maximum gain there is high amplification of noise pulses, which cause the white flashes.

Causes for trouble.

Antenna trouble. Incorrectly oriented. Poor location. Shorted, open circuited, dirty or corroded terminal connections. The receiver may be located so far from transmitters as to require an outdoor antenna instead of a built-in or indoor type, or may be too far away for good reception under any conditions.

Transmission line open circuited, shorted, dirty connections, or may be picking up excessive interference.

Antenna coupling or r-f amplifier incorrectly aligned.

Weak or noisy tubes for r-f amplifier, mixer, or r-f oscillator.

Dirty contacts or loose connections in selector switch or tuner.

Video i-f amplifier incorrectly aligned or contains weak tubes.

Weak tube or crystal in video detector.

Video amplifier has weak tubes, or there are defective parts such as coupling capacitors.

Corona or arcing in parts or wiring of the high-voltage power supply may cause interference flashes.

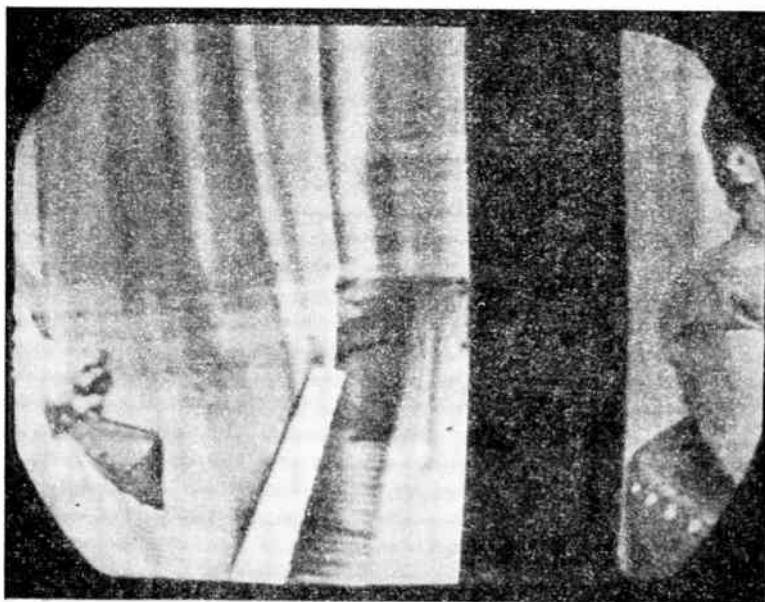

Fig. 131-27.—Split Pattern, Left and Right.

A horizontal blanking bar runs from top to bottom of the picture area, remaining stationary or moving slowly. The portion of the picture or pattern which should appear at the left is on the right side of this bar, and the portion which should be at the right is on the left side of the bar.

Causes for trouble.

Horizontal hold control wrongly adjusted.

Faults in horizontal afc system for sweep oscillator. Defective tubes, incorrect voltages. Wrong adjustments, as of phasing or lock-in controls. Coupling capacitors open or shorted.

Faults in horizontal hold control circuit, making frequency too low or of half the correct value. Check capacitors and resistors, incorrect values, opens, shorts, and leakage.

Excessive undamped oscillations in horizontal sweep oscillator circuit. Check resistors and decoupling capacitors.

Coupling capacitors for a sync inverter tube leaky or connected wrong.

Defective damper tube.

Oscillation in horizontal deflection coil. Check the bypass capacitor.



Fig. 131-28.—Split Pattern, Top and Bottom.

A vertical blanking bar runs from side to side of the picture area. The bar may be stationary or slowly moving. The top part of the picture will appear below the bar, and the bottom part will be above the bar. Sometimes there are two complete pictures, each occupying about half the total height in the mask.

Causes for trouble.

Vertical hold control wrongly adjusted.

Faults in the vertical hold control circuit, making the vertical sync frequency too low or half its correct value. Check for leaky or shorted capacitors. Check for shorted resistors. Values of capacitors or resistors may be incorrect.

If there is a vertical afc system for the sweep oscillator, check it as explained for a horizontal afc system in the preceding section.

Sync inverter coupling capacitors leaky or connected wrong.

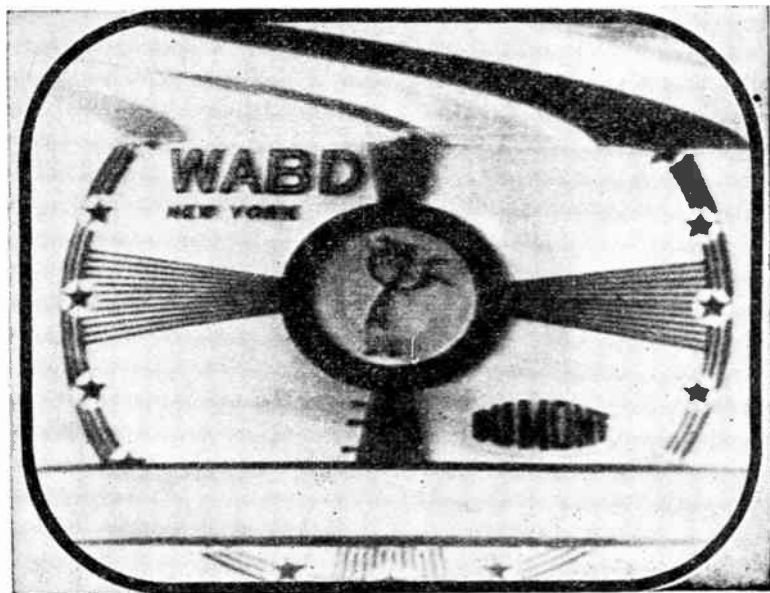

Fig. 131-29.—Tear Out.

Causes for trouble.

Horizontal hold control wrongly adjusted.

Contrast control set too high.

Excessively strong signal in channel where trouble appears.

Strong but irregular electrical interference temporarily affecting the horizontal hold control system.

Microphonic tubes anywhere in r-f, video, or sync circuits. Tear out will occur when the receiver is jarred.

Poor filtering in low-voltage B-supply.

Alignment of video i-f amplifier incorrect, bringing video i-f carrier too low down on the response curve.

Misalignment of traps for accompanying or adjacent sound, allowing audio interference to reach the picture tube input.

Poor low-frequency response in the video detector or video amplifier circuits. Check the tubes, and their plate and grid bias voltages. Look for defective units and incorrect values in coupling capacitors, decoupling capacitors, cathode bypass capacitors, decoupling resistors, and grid resistors.

Incorrect adjustments in the horizontal afc system for the sweep oscillator.

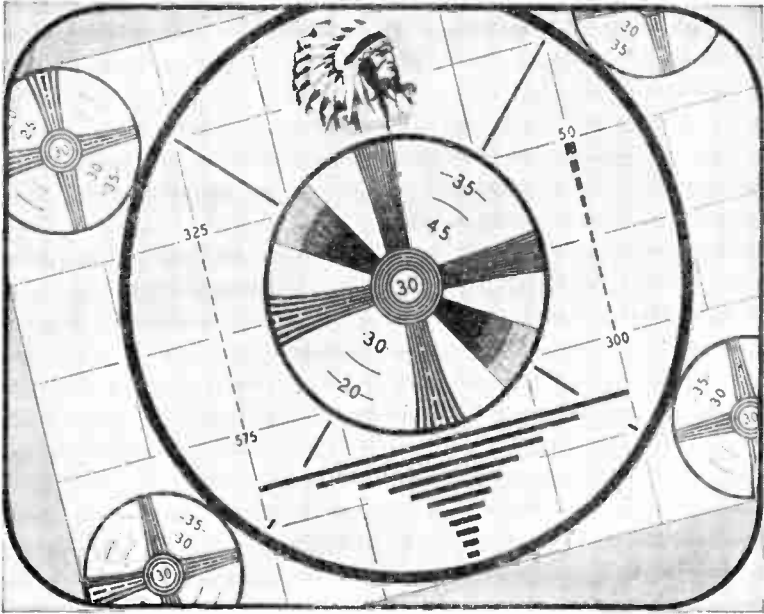

Fig. 131-30.—Tilting In Mask.

Causes for trouble.

Incorrect position of magnetic deflection yoke. Loosen the yoke fastening while rotating the yoke around the picture tube neck to straighten the pattern.

Incorrect position of electrostatic tube. Rotate the entire tube around its axis to straighten the pattern.

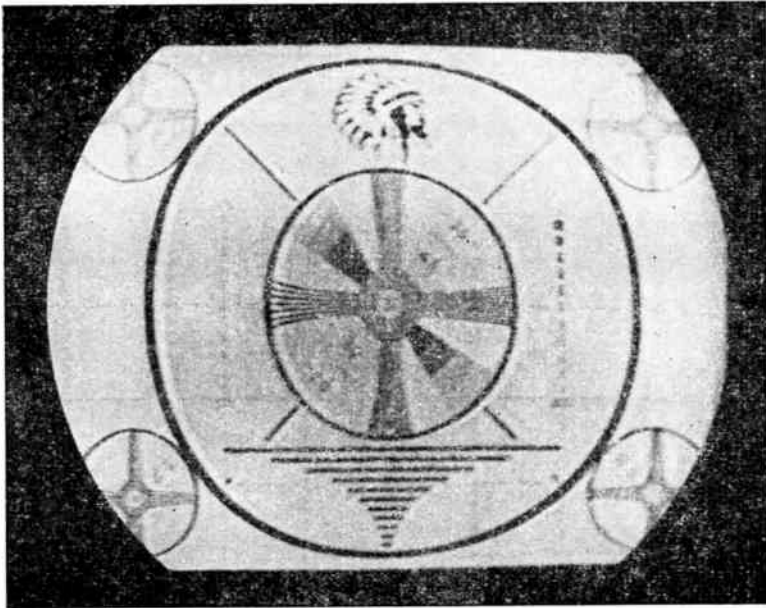

Fig. 131-31.—Trailers or Smears.

Dark objects or lines in the pattern or picture are followed on their right by light toned or white areas or lines. The trouble is due primarily to poor response or lack of gain at the low video frequencies.

Causes for trouble.

Contrast control too high, overloading the amplifiers.

Video i-f amplifier wrongly aligned, with the video i-f carrier too low on the side of the response curve.

Faults in video detector and/or video amplifier circuits. Check coupling capacitors, decoupling capacitors, and bypass capacitors for open circuits. Check plate load resistors and grid resistors for incorrect values or shorting. Amplifier grid biases may be insufficiently negative, allowing grid current to flow.

Ghost images due to signal reflections may give an appearance similar to trailing. See troubles listed under *Ghosts*.

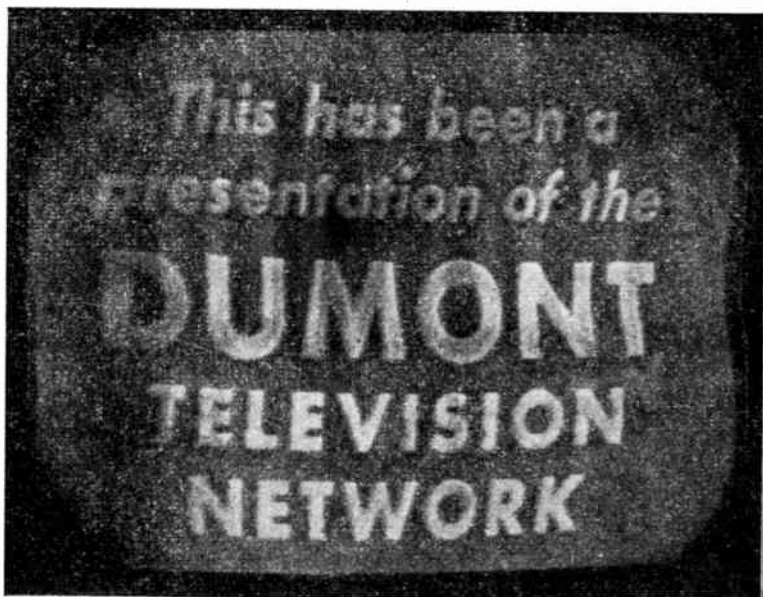

Fig. 131-32.—Wavy Edges on Pattern.

Usually the right-hand edge of the pattern or picture is waved. Dark and light bands may appear. The entire picture may appear to sway sideways.

Causes for trouble.

Contrast control adjusted too high.

Horizontal drive control wrongly adjusted.

Insufficient filtering or defective filter capacitors in low-voltage B-power supply. The ripple voltage may be getting into the focusing coil or an electromagnetic centering circuit.

Defective horizontal sweep amplifier tube. Try changing the tube.

Vertical deflection voltages or fields reacting on horizontal deflection circuits. There may be coupling between the circuits, possibly in the deflection yoke. Check bypass capacitors and resistors which are across the deflection coils.

Defective capacitor or resistor in noise filter of a horizontal afc system for the sweep oscillator.

Electrostatic picture tube in strong magnetic field at frequency of power line.

TROUBLE SHOOTING, WAVEFORMS AND FREQUENCY RESPONSES. — The oscilloscope is used for observing voltage waveforms and frequency responses throughout the television receiver during location of trouble.

A trace of frequency response on the oscilloscope screen shows relative gains at all frequencies being fed into an amplifying section or any single stage of the receiver. Traces taken from the mixer tube circuits show response of the r-f amplifier or tuner to the carrier frequencies in a channel. Traces taken at the output of the video detector or from the video amplifier show performance of the video i-f amplifier, of this amplifier and the r-f section combined, or of any single stage or combination of stages. Response traces taken from the sound discriminator or ratio detector show performance of the sound section or of parts in this section.

Observation of frequency responses requires a signal from a sweep generator, and identification of frequencies by means of a marker generator, or requires use of a combination television generator. Instructions for checking frequency response are given in the following articles.

Alignment.

Amplifiers, video intermediate-frequency.

Oscillators, television r-f.

Sound, television. Also related subjects mentioned in that article.

Tuners.

Waveform traces show signal voltages and other voltages as they actually exist at various points between the video detector and the picture tube. Signal voltage and voltages resulting from or controlled by the signal may be compared with forms known to be correct for the receiver or for the type of circuit involved. Material differences indicate trouble at or preceding the point where the faulty waveform appears. Instructions for taking waveform traces, also typical examples of such traces, are given in the article on *Waveforms*.

TUBES, HIGH-FREQUENCY. — Tubes for use at very-high and ultra-high frequencies as amplifiers, oscillators, and mixers should have small internal capacitances, small inductance in their internal leads, small dielectric losses, and, so far as is compatible with other requirements, should have high transconductance. Also, at ultra-high frequencies, the matter of transit time for electrons traveling between the elements may be of importance.

Standard types of tubes which are entirely satisfactory at the lower radio frequencies may cause losses instead of gains when used as amplifiers, or may fail to oscillate when required to do so, if these tubes are used at television frequencies. Most low-frequency tubes become unsatisfactory at frequencies above 50 to 60 megacycles. When used in amplifier circuits at higher frequencies these tubes may oscillate because their internal capacitances resonate with the inductance of even short straight connecting wires. Tube noise tends to become excessive. The high-frequency limit for satisfactory operation as oscillators usually is lower than the limit for amplification.

R-f amplifiers in circuits where signal input is to the grid usually are pentodes rather than triodes because an ordinary triode circuit tends to allow oscillation when grid and plate are tuned to the same or nearly the same frequency. Triodes may be used as grounded grid high-frequency amplifiers as explained later in this article.

High transconductance is desirable or necessary to compensate for the low effective impedances of plate circuits at the higher frequencies. This low impedance is due chiefly to input and output capacitances of the tubes and to distributed and stray capacitances of inductors and circuit connections.

Transconductance is increased in tubes having closely spaced elements and by having adjacent turns of the grid close together. These structural practices tend to increase the internal capacitances at the same time as the transconductance. A figure of merit for a tube intended for high-frequency operation sometimes is taken as the quotient of dividing the transconductance in micromhos by the total of input and

output capacitances in mmf. Such figures of merit will range between 500 and 1,000 for tubes in general use as television r-f amplifiers, video i-f amplifiers, and video amplifiers.

Triodes, as a class, have less transconductance than pentodes, but the triodes also have less total input and output capacitance. The two factors tend to balance, so that figures of merit for triodes are as high as for pentodes. The grid-plate capacitance of pentodes is, of course, far less than for triodes.

Many miniature tubes are well suited for high-frequency operation. This is due in part to absence of plastics employed in bases of other tubes and to the use of very short internal leads and small base pins. Several of the lock-in types are well suited for high-frequency operation. Lock-in tubes have only glass and metal in their construction, have small base pins and relatively short internal leads. A number of miniature and lock-in types give satisfactory performance at frequencies from 400 to 600 megacycles.

Some of the tubes especially designed for high-frequency operation have two or even three pins and internal leads for a single element. Such construction allows circuit connections which reduce the effects of lead inductance, because several inductances (leads) connected in parallel with one another have less effective inductance than any single one of the group. When external circuit connections are made to base pins which are at opposite ends of an internal lead there is division of internal tube capacitance between the connected circuits. It is the shunting effect of internal capacitances that is largely responsible for low impedances in plate and grid circuits.

When there are two pins and two internal leads for the cathode of a tube it becomes possible to maintain separation between input and output circuits right through to the cathode itself. All returns for the grid circuit should be made to one cathode pin. Plate, screen, and heater returns are made to the other pin. Then there is very little cathode lead inductance common to the output and input circuits, there is lessened coupling through common inductive reactance, and

less degeneration. This, of course, allows realizing a considerably greater gain.

Grounded Grid Amplifiers. — Fig. 133-1 shows typical circuits for grounded grid high-frequency amplifiers. The tube is a triode, usually of special design and construction for this kind of operation. The grounded grid acts as an r-f shield between plate and cathode to permit amplification without the feedback which could cause oscillation at very-high and ultra-high frequencies.

The high side of the signal input circuit is connected to the cathode of the tube, with the low side connected through ground to the grid. The output is connected from plate to

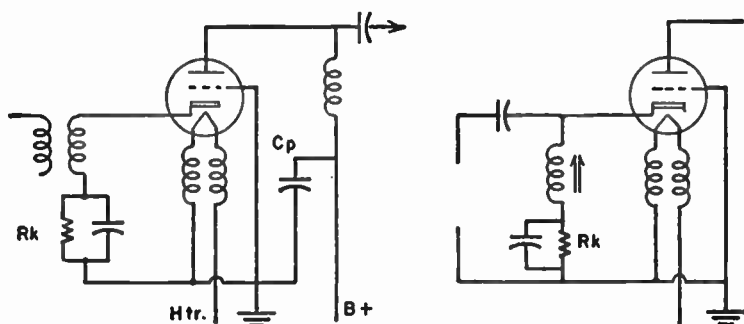

Fig. 133-1.—Circuits for grounded grid r-f amplifiers.

ground and grid through capacitor C_p . There is a certain amount of negative feedback from plate to grid, which adds to the effect of the grounded grid in preventing oscillation. Resistor R_k , which always is bypassed, provides cathode bias for the tube. R-f chokes in both heater leads maintain the r-f potential of the heater the same as that of the cathode and thus prevent adding the effect of cathode-heater capacitance to the input circuit.

Transit Time. — Transit time is the length of time required for an electron to travel from cathode to plate under the accelerating force of plate voltage. Average electron velocity in inches per microsecond is equal approximately to the prod-

uct of 11.7 and the square root of the plate voltage, assuming the electron to start from rest at the cathode. For example, with 130 plate volts the average velocity is about 133 inches per microsecond.

To illustrate the effects of transit time we may assume a cathode to plate distance of $\frac{1}{4}$ inch. Transit time then will be a little less than 0.002 microsecond. Were signal frequency to be 200 megacycles per second, each complete cycle would require a time of 0.005 microsecond. With the assumed plate voltage and cathode-plate separation an electron would travel from cathode to plate during about 135 degrees of a signal cycle.

Because of the time required for the electron to travel from cathode to plate there will be a very considerable difference between the point in a signal cycle at which the electron leaves the cathode and the point in the same cycle where the electron reaches the plate. Consequently, signal variations of plate current will not be in phase with signal variations of grid voltage. When current and voltage are out of phase there is a lowered power factor and loss or waste of energy. This reduces the output power otherwise available from the tube. There is also a reduction of effective transconductance.

Transit time is lessened by closer spacing between cathode and plate, also by use of higher plate voltage. Both these measures, however, increase the heating while reducing the ability of the elements to lose heat by conduction and radiation.

TUBES, PICTURE. — The picture tube is the television receiver tube on whose relatively flat face are formed the lights and shadows of reproduced pictures or images. Pictures or patterns composed of lights and shadows result from rapid movement of a beam or stream of electrons over the sensitized inner surface of the screen material which coats the inside of the tube face. Density of electrons in the beam is varied to produce lighter and darker areas as the beam is rapidly moved or deflected horizontally and vertically over all parts of the screen area. This action is explained in articles on *Deflection* and on *Scanning*.

Picture tubes may be broadly classified as of two general types, one of which employs magnetic deflection and the other electrostatic deflection. Tubes designed for electrostatic deflection are used only in the smaller types of television receivers. They are described in the article, *Tubes, Picture, Electrostatic*.

Magnetic deflection picture tubes may be further classified as those designed for direct viewing of the picture screen and those designed for projection viewing. Pictures formed on the screens of projection type tubes are enlarged by a system of lenses or lenses and mirrors, and are displayed on a screen or mirror which is separate from the tube itself. The present article is concerned with picture tubes designed for magnetic deflection and direct viewing.

Picture Tube Construction.— Electrons which form the beam in the picture tube are emitted, controlled in density, and accelerated in a part of the tube called the electron gun. The essential parts of the electron gun in a typical tube are shown by Fig. 134-1. An oxide coating on the forward end of the cathode sleeve is heated dull red by action of the heater

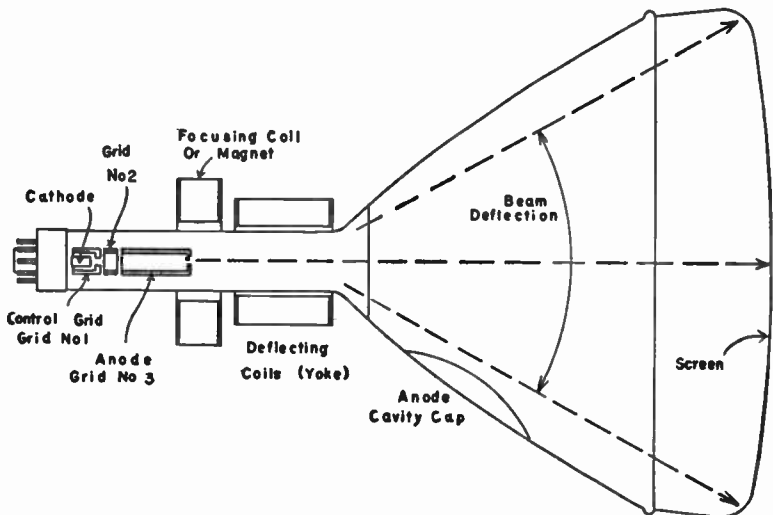

Fig. 134-1.—Location of the electron gun in a picture tube.

which is enclosed within the sleeve. Electrons emitted from the cathode are drawn into a narrow stream at the opening through the control grid or grid number 1.

The electron stream then spreads to some extent as it is drawn on through grid number 2 which is operated at a fixed potential, usually about 250 to 300 volts positive with reference to the cathode. The electrons pass next through the anode, called also the accelerating electrode or grid number 3, where they are accelerated to maximum required velocity on their way to the screen.

The inside of the flared portion of tubes of all-glass construction is covered with a conductive coating of finely divided graphite which is electrically connected to grid number 3. This internal coating is part of the anode of the tube. Sometimes the internal coating and grid number 3, considered as a single electrical element, are called the anode. The internal coating collects electrons which leave the screen as a result of secondary emission at the point where primary electrons from the gun strike the screen.

Grid number 2, due to its constant potential, insures that control of electron density of the beam by control grid voltages will be practically unaffected by different potentials applied to the anode in different receivers.

The electron stream still is spreading to some extent as it reaches the space in which is a magnetic field produced by the focusing coil or focusing magnet. This field draws the electrons together to form a narrow beam that strikes the screen of the tube on a spot of small diameter. This is the action of focusing, which is explained in the article on *Focusing and Focusing Controls*.

Approximately half the types of all-glass picture tubes which are in general use have an external conductive coating over the flared portion, in addition to the internal coating. The external conductive coating is connected to ground through a contact spring attached to the chassis, and acts as a shield against external electric fields.

The internal and external conductive coatings act as the plates of a capacitor, with the glass of the tube envelope as dielectric. The capacitance of the coatings, which may be anything between 500 and 3,000 mmf, is used as a high-voltage filter capacitor with connections shown at the left in Fig. 134-2. When the picture tube does not have an external coating a separate filter capacitor of 500 to 2,000 mmf is connected between the high-voltage lead and ground, as at the right.

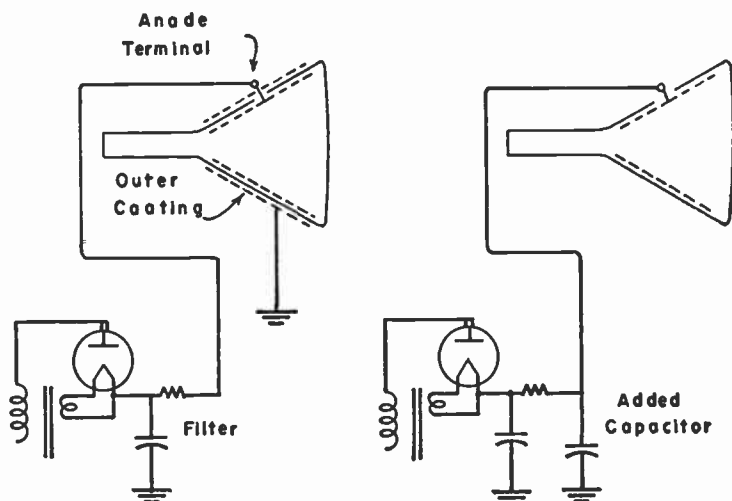

Fig. 134-2.—Using picture tube coatings as a high-voltage filter capacitor (left), and connections for an added capacitor (right).

The metallic conical portion of the envelope of metal picture tubes is an electrical part of the anode. Consequently, this cone is at a very high potential and is dangerous to touch while the receiver is turned on. The high-voltage lead for the anode of metal-cone tubes is fitted with a clip connector which attaches to the front lip of the cone. On most all-glass tubes the anode terminal is a cap recessed in a cavity on the side of the flare which ordinarily is placed at or near the top when the tube is mounted. This recess is indicated in Fig. 134-1. Other all-glass tubes have for their anode terminal a ball which is not recessed.

Tube Voltages. — All magnetic deflection picture tubes in general use are designed for 6.3 volts and 0.6 ampere in their heaters. Negative grid potential for complete cutoff of illumination on the screen of various types of picture tubes ranges from 33 to 77 volts. The higher the anode voltage and the higher the voltage on grid number 2 the more negative must be the control grid voltage to attain cutoff with any given tube.

Fig. 134-3 shows typical relations between control grid voltage and brightness of the screen. One curve is drawn for 250 volts and the other for 400 volts on grid number 2. Curves showing relations between control grid voltage and anode current would be of the same general form. This would be expected, inasmuch as illumination is roughly proportional to electron density in the beam reaching the screen.

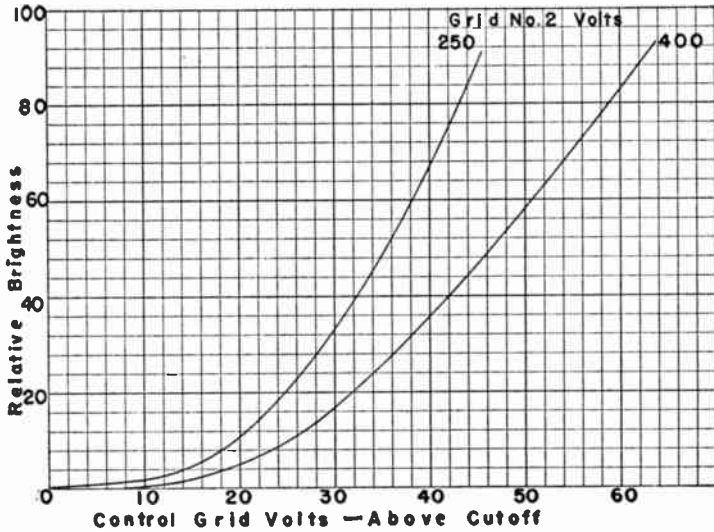

Fig. 134-3.—Relations between control grid voltage and brightness at the screen of a picture tube.

Note that voltage shown on the graph is voltage above cutoff, it is not grid-cathode voltage. As an example, were cutoff potential to be 60 volts negative, the graph voltages related to the curves would be those subtracted from 60 volts,

or would be the number of volts by which the control grid is made less negative than for cutoff in causing the degrees of brightness indicated by the curves.

All curves showing the effect of control grid voltage on brightness and on anode current are quite similar to curves showing relations between control grid voltage and plate current in triode amplifier tubes. These mutual characteristics or transfer characteristics of picture tubes may be used to illustrate relations between picture signal voltages and picture brightness just as they are used to illustrate relations between sound signal voltages and sound output of amplifiers.

Maximum permissible anode potentials for 10-inch, 12-inch, and 14-inch picture tubes are between 10,000 and 12,000 volts, with typical operating voltages ranging from 7,000 to 11,000. For 15-inch and larger tubes the maximum anode voltages are between 14,000 and 20,000 volts, depending on the type of tube, while typical operating voltages are between 9,000 and 15,000. Higher voltage on the anode tends to give better definition and greater brightness in the pictures.

Deflection of Beam. — Factors affecting the distance the electron beam is deflected either way from the center of the screen are illustrated by Fig. 134-4. Deflection distance is directly proportional to strength or flux density in the magnetic field of the deflecting coil. Flux density, in turn, is approximately proportional to deflecting current in milliamperes, but depends also on permeability of any iron core used in the coil. Permeability of an iron core varies with changes of current and of flux. Deflection distance increases with increase of deflecting current in the coil, but not proportionately when the coil has an iron core.

Deflection distance on the screen increases directly with length of the deflecting coil in line with the tube axis, or rather with length of the magnetic field when the field is uniform. The deflection is increased also, and increases directly, with increase of distance from the center of the deflecting coil to the center of the screen. This is because a longer electron beam deflected over a certain angle moves farther

at the screen end than does a shorter beam deflected over the same angle.

Deflection distance is inversely proportional to the square root of anode voltage. The greater the anode voltage the less will be the deflection distance with all other factors remaining unchanged, but decrease of deflection will be only in the ratio of the square roots of the anode voltages. Anode voltage or electron accelerating voltage tends to pull the beam along a

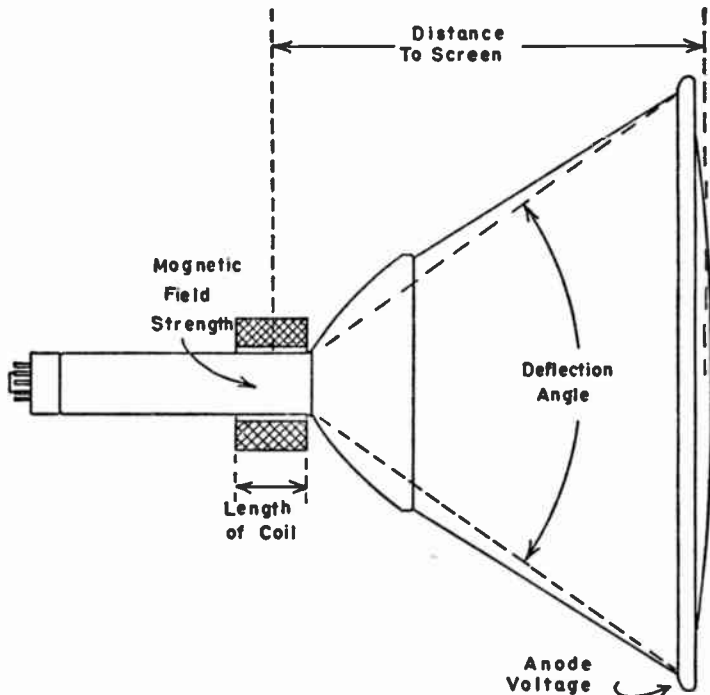

Fig. 134-4.—Factors which affect distance of deflection in a magnetic picture tube.

straight line, and opposes deflection or bending. It turns out that distance of deflection is increased by more deflecting current in the coil, by less anode voltage, or by both these changes. Deflection is decreased by less deflecting current, more anode voltage, or both.

The tube illustrated by Fig. 134-4 is designed for a maxi-

imum deflection angle of 70 degrees. The tube illustrated by Fig. 134-1 is designed for a maximum angle of 56 degrees. Various types of picture tubes at present in general use allow deflection angles all the way from 50 degrees, on most of the 10-inch tubes, up to 70 degrees on some of the tubes in 16-inch to 22-inch sizes of types having round envelopes and screens. All the rectangular tubes have maximum deflection angles of 65 to 70 degrees as measured across the diagonal line between opposite corners.

The same type deflecting yoke or deflecting coils may be used for nearly all picture tubes having deflection angles less than 66 degrees. All tubes having deflection angles of 66 degrees or more usually require a special wide angle yoke.

Tube Types and Base Connections. — Picture tubes are identified by type numbers such as 10BP4, 14CP4, 16GP4, and so on. The first number refers to the greatest diameter, at the screen end, to the nearest inch. For instance, the 10BP4 tube has an overall diameter of $10\frac{1}{2}$ inches and the 16GP4 has an overall diameter of $15\frac{7}{8}$ inches. The first number in designations for rectangular tubes indicates the approximate equivalent diameter of a round tube which would provide the same size picture. The overall diagonal size of rectangular tubes having 14 for their first number is $12\frac{3}{4}$ inches, when 16 or 17 is the first number the diagonal is $14\frac{7}{8}$ or 15 inches, and with 19 as the first number the overall diagonal is $17\text{-}21/32$ inches.

The first letter of the type designation indicates merely the order in which that particular design was registered with the Radio and Television Manufacturers Association. For example, the 16CP4 tube was registered before the 16DP4, and the 16DP4 was registered before the 16EP4.

The second letter always is *P*. It stands for the word *phosphor*, which is the fluorescent coating forming the screen of the tube. The second number in the designation is the type number of the kind of phosphor used in the tube. All television picture tubes contain phosphor number 4, so the second number always is 4.

When a letter follows the second number this final letter indicates some modification of the original design, but a modification which calls for no changes in the circuits for which the tube is adapted. As an example, the 16AP4 tube is the original design while the 16AP4-A is electrically similar but has a face plate of a type which reduces reflections.

Fig. 134-5 shows base pin positions and connections for magnetic deflection tubes. Pin positions are as seen from the bottom or the outside of the tube base. About 95 per cent of all magnetic deflection tubes have the 12-D basing arrange-

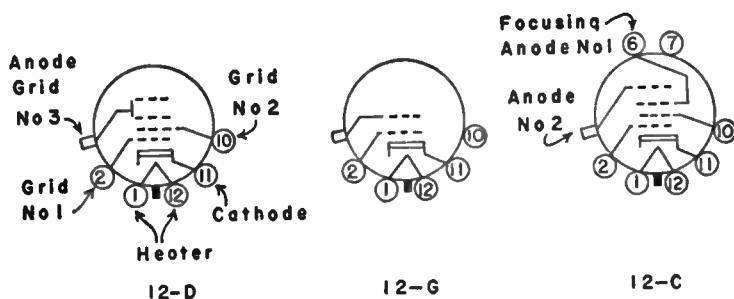

Fig. 134-5.—Base pin positions and element connections for magnetic deflection picture tubes.

ment of the left-hand diagram. The elements in all these tubes are as described earlier in these pages. The 12-G basing arrangement is used on tubes of types 10MP4, 10MP4-A, 12VP4, and 12VP4-A. The 12-C basing is used on 10DP4 tubes in which anode number 1, connected to pin 6, is used for electrostatic focusing. All the other types utilize magnetic focusing as well as magnetic deflection.

The base used on all magnetic deflection picture tubes is of the type called a small-shell duodecal 7-pin base. Pins are spaced at 30-degree intervals around the circle. This spacing would permit a maximum of 12 pins, but there are pins in only some of the positions, as shown by the diagrams in Fig. 134-5. In addition to the pins which connect to internal elements there may be one or two extra pins with no internal connections.

Sockets for the magnetic deflection tubes are specified as the duodecal type, in which there are openings and lug connections for all 12 pin positions. Picture tube sockets are supported only by being pressed onto the base pins of the tube, with circuit connections made through flexible wires leading to the socket lugs.

Screens for Picture Tubes. — In the screen which covers the inside of the exposed face of the picture tube are solid materials which become luminous when their particles are struck by the electron beam. These materials are called phosphors. Different kinds of phosphorescent substances emit light of various colors when excited by the electron beam. Mixtures of these substances will produce intermediate hues and will produce an approximation of white.

The phosphors are identified by numbers. Phosphor number 4, used in all television picture tubes, gives the effect of

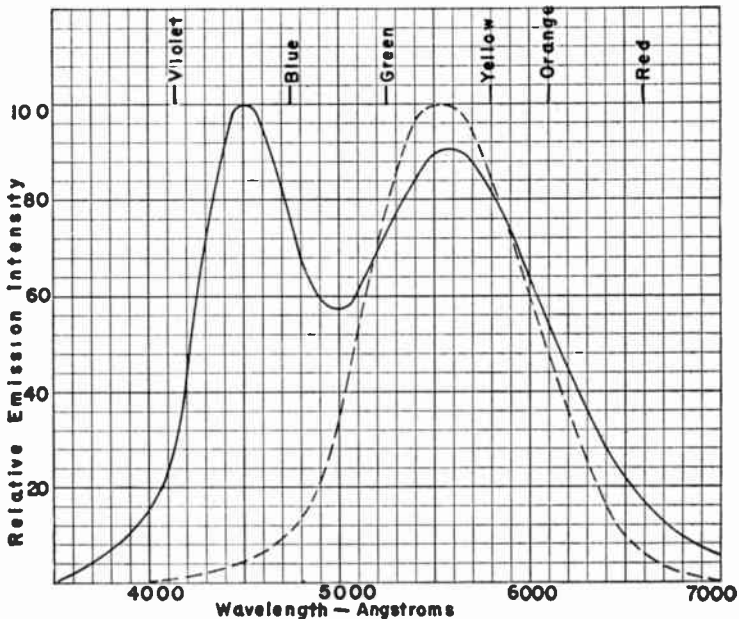

Fig. 134-6.—Luminous radiation at various wavelengths for phosphor number 4 (full-line curve) and luminous sensitivity of the average human eye (broken-line curve).

white light by delivering radiations from blue through green and yellow. The full-line curve of Fig. 134-6 shows relative intensities of emission at various color wavelengths in the visible spectrum for phosphor number 4.

Wavelengths are in Angstroms or Angstrom units. One Angstrom is a wavelength of one hundred-millionth of a centimeter or about one 250-millionth of an inch. A wavelength of 5,000 Angstroms, at the approximate center of the visible spectrum, corresponds to a frequency of 600 million megacycles per second. In the emission from phosphor number 4 there are peaks between violet and blue, and between green and yellow, with lesser intensities between blue and green, and at the violet and red ends of the curve. These emissions combine to produce the light seen on the picture tube screen.

Among other phosphors in general use, number 1 is found in the screens of most oscilloscope tubes. The color of its trace is green. Phosphors 5 and 11 produce a blue trace suitable for photography of oscilloscope traces. Numbers 7, 12, and 14 produce combinations of blue, yellow, and orange traces used for radar observation. Number 15, with a blue-green trace, is used for flying spot scanning in film reproduction.

The broken-line curve of Fig. 134-6 shows average human eye response to the various color wavelengths when radiation intensity is uniform for all wavelengths. Maximum eye sensitivity, for normal vision, is to a greenish-yellow hue of about 5,550 Angstroms in wavelength.

In the light or the luminescence appearing on the picture tube screen there are two effects. One is called fluorescence, the light from which ceases instantly when the electron beam moves on. The other is phosphorescence, which causes emission of light from the phosphor particles for an appreciable time after the beam has left a spot on the screen. Phosphorescence accounts for what is called persistence of the particular phosphor considered.

Persistence of phosphor number 4 is long enough to help prevent the appearance of flicker, but is short enough that

luminescence remaining at the end of a field period is only a few per cent of the initial value. Persistence which is too long would carry the picture of one frame over into following frames, and objects moving at high speed would be followed by streamers of light.

Reflections in Picture Tubes. — One of the chief hindrances to satisfactory viewing of television pictures consists of reflections from various picture tube surfaces of light coming from lamps and windows within the room. There is reflection from the front or outside surface of the glass in the tube face and from the back or inner surface of this glass. There is some reflection also from a light colored phosphor.

Reflections may appear as images of lamps or windows superimposed on the television pictures. Even when there are no distinct images the diffused external light reflected back along with the picture has the effect of lightening the areas which should be dark or nearly black and of reducing the contrast. Increasing the contrast control may help, but dark areas still may remain of gray tone. Reducing or shutting off the room lighting will prevent reflection, but this is inconvenient and distasteful to viewers.

Reflection effects may be reduced to some extent by placing in front of the picture tube a thin sheet of glass or transparent plastic lightly tinted with blue or green. These filter screens may increase the apparent contrast. Polaroid filter screens make a decided reduction of reflection from the picture tube and increase contrast by restoring dark areas to their correct tones, but there is considerable loss of overall brightness. This loss may be compensated for with the brightness control if a strong signal is available.

Another approach to reduction of reflection consists of coating the outside of the picture tube face with some material which does not give sharply defined or specular reflection but causes slight diffusion. Still another method consists of changing the shade of the phosphor from very light gray to a much darker gray by adding substances which serve this purpose without interfering with fluorescence. Then there is reduction

of light intensity reflected outward from the phosphor. Also, the picture light reflected back from the glass surfaces of the tube face is absorbed to a greater extent by the phosphor, and there is less scattering of light from crystals in the phosphor, with the result that definition shows some improvement.

Many of the more recently designed picture tubes have face glass or face plates consisting of a neutral density filter which often is called a gray filter face plate or which may be identified by trade names such as Filterglass and Teleglas. This kind of glass absorbs much of the light energy entering it from the room so that only a fraction of such light reaches the inner surface and the screen to be reflected back outward. There is, however, relatively little absorption of picture light passing from the screen outward. Picture areas which should be dark then are little affected by external light and there is increase of apparent contrast.

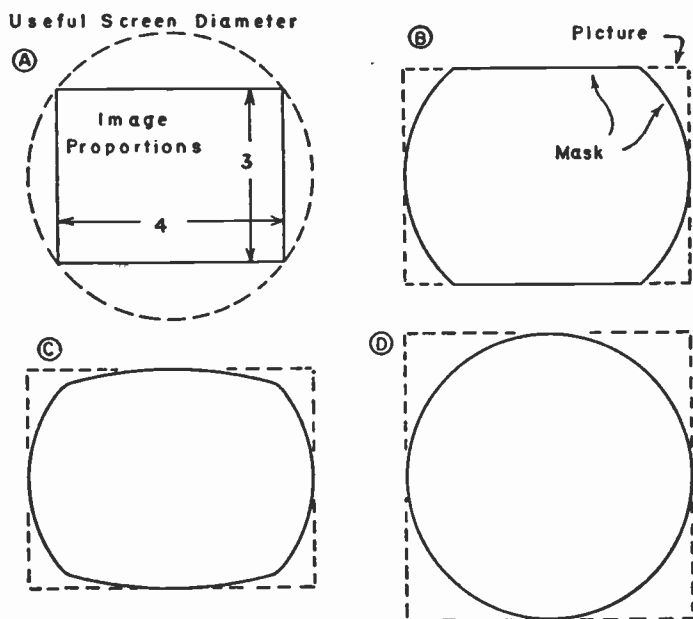

Fig. 134-7.—Picture areas and mask proportions.

In addition to reflections from the picture tube itself there may be mirror-like reflections from the front and back surfaces of the protective glass or plastic sheet which is mounted in front of the tube face. Usually it is possible to prevent such reflection by slightly changing the position of the receiver. Some sets have the protective plate tilted slightly outward at the top so that reflected images can be seen only from points near the floor of the room.

Screen and Mask Sizes. — The image as originally formed in all camera tubes is of width and height proportions shown by full lines at the upper left, diagram *A*, of Fig. 134-7. The image is a rectangle with width of 4 units and height of 3 of the same units. This gives the standard aspect ratio of $4/3$.

Were the image to be completely displayed on the screen of a round picture tube the corners of the rectangle would have to remain within the useful screen diameter. This useful screen diameter may be anything from one to one and one-half inches less than maximum outside diameter of the tube. The

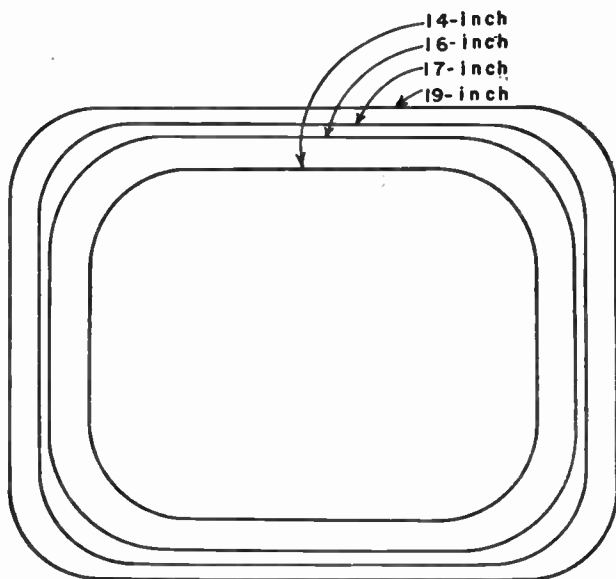

Fig. 134-8.—Relative outside dimensions of rectangular picture tubes.

outside diameter in inches is roughly equal to the first number of the type designation, being somewhat greater than the type number in most 10-, 12- and 15-inch tubes, and about equal to the type number or somewhat less in the larger sizes.

In order to provide a larger picture on any given useful screen diameter nearly all receivers of recent design employ masks which are rounded out at the sides or at both the sides and the top and bottom. One popular mask opening is shown by full lines in diagram *B* of Fig. 134-7. The picture is enlarged to the size indicated by the broken-line rectangle. Portions of the four corners of the picture thus are cut off, but since there is little of interest in the corners of most television pictures this cutting is not too objectionable.

In diagram *C* there is additional rounding of the top and bottom of the mask, and loss of the picture corners as shown by broken lines. The circular mask shown by diagram *D* requires that the height of the picture be increased, beyond the true aspect ratio until the height equals the width. Objects then appear with their height one-third greater than the actual proportion to width in the original image.

Fig. 134-8 shows the relative outside dimensions of four generally used sizes of rectangular picture tubes. The maximum overall width of these tubes is from $1\frac{1}{4}$ to 2 inches narrower than the first number of the type designation. The useful size of the screen ordinarily is given as the diagonal measurement between opposite corners. This diagonal across the useful area varies from one to $1\frac{3}{8}$ inch less than the first number in the type designation.

Handling of Picture Tubes. — All types of picture tubes must be handled with great care to avoid the possibility of breakage. On the outer surfaces of a typical 16-inch tube the total atmospheric pressure exceeds the internal vacuum pressure by more than three and one-half tons. A crack or break allows an implosion, with particles of glass driven inward and then rebounding outward with great force and possibility of serious injury unless suitable precautions have been taken.

A picture tube should not be handled by anyone not wearing shatter-proof goggles and heavy gloves. Everyone in the near vicinity should be similarly protected, or should move to a safe distance. A tube should not be held near the body. The tube should be held near the large end to support its weight, with only enough support on the neck to guide or steady the tube. Especial care should be used to place no undue stresses on the neck nor at any place where the glass is rather sharply curved.

While a tube is removed from a receiver it should be rested face down on some soft surface, with precautions against tipping over. The safest procedure is to place the tube in a regular tube carton. A picture tube must not be forced into its mountings on the receiver. Coils, magnets, sockets, and any other parts which go over the tube neck must be a free fit. A picture tube must not be struck by nor allowed to strike against any hard objects. The glass surfaces must not be scratched. It is advisable to keep all metal tools away from the tube, and to keep the tube away from metal objects so far as is possible.

Removal and Replacement of Tubes. — In the majority of receivers the picture tube is mounted on and supported by the chassis as shown in a general way by Fig. 134-9. The chassis with the tube in place may be removed from the cabinet as a unit. First it is necessary to take off control knobs whose shafts protrude through small openings in the front of the cabinet, and usually it is necessary to disconnect the leads for the speaker. Of course, any screws, bolts, or clamps holding the chassis in the cabinet must be removed or loosened. The tube may be taken off the chassis as follows.

1. Take the socket off the base of the tube, leaving the socket attached to the flexible leads that run to the chassis.
2. If there is an ion trap magnet slide it back off the base end of the tube, first loosening the clamping screws if the magnet is held in this manner.
3. Remove the high-voltage anode lead from the cap or ball on the flare of an all-glass tube or from the front rim of a

metal-cone tube. With the lead removed, and before touching its clip or cap and before touching the anode terminal of the tube, discharge the high-voltage filter capacitors by touching the clip or cap to chassis metal or a B-minus point. Then discharge any capacitance of the tube itself by touching the bared ends of a piece of insulated wire to the chassis metal or B-minus and to the cap, ball, or rim which is the anode terminal of the tube. This discharging of the tube is especially important with all-glass types which have an external conductive coating, but the same procedure should be followed for all kinds of picture tubes. It must be kept in mind that both the cone and the glass face of metal-cone picture tubes operate at anode voltage, and these parts should be treated accordingly.

4. For ease of later replacement of the socket and anode leads it is advisable to note the position of the tube with reference to its angular position around the axis. The reference point may be the anode terminal of all-glass tubes, the base key, or certain parts of the electron gun.

5. In order that the tube neck may slide forward through the yoke and focus coil or magnet it may be necessary to loosen their mountings or adjustments.

6. Loosen or remove the strap and any other fastenings that hold the large end of the picture tube on the chassis. Now the tube may be carefully moved forward out of the yoke and focus coil or magnet.

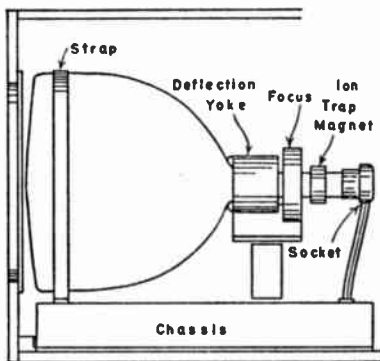

Fig. 134-9.—Picture tube mounted on chassis.

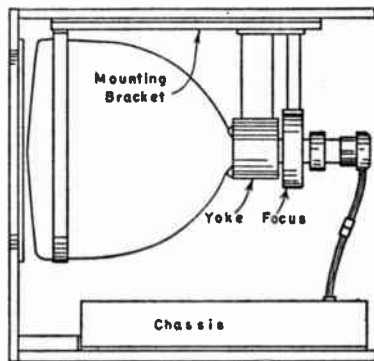

Fig. 134-10.—Picture tube mounted in top of cabinet.

Fig. 134-10 shows in a simplified manner a method of mounting the picture tube and its accessory parts in the top of the cabinet, independently of the chassis except for any necessary connecting leads. These leads must be disconnected before removal of either the tube or the chassis. Always there will be leads to the tube socket and the deflecting yoke, and leads will run also to electromagnetic focusing coils and ion trap magnets. With construction of the type illustrated a single bracket or frame ordinarily carries the picture tube, the yoke, and focusing magnet. The bracket and all these parts may be removed from the cabinet as a unit. Coils and other parts then may be removed from the tube neck, and the tube taken off the bracket as described earlier.

A bracket or separate frame mounting for the picture tube and accessory parts may be mounted on one side of the cabinet instead of from the top. In some sets the support for the picture tube mounts in the cabinet bottom alongside the chassis, and is independent of the chassis except for connecting leads.

Fig. 134-11 illustrates in a general way one method of mounting the picture tube on the front of the cabinet. The large end of the tube is carried by cushions or pads which are on the cabinet. The back of the flare or cone of the tube is supported by cushions or pads carried by the deflection yoke cover or by the yoke mounting.

When the picture tube is to be removed the first steps are to take off the socket and the ion trap magnet as earlier described. Then the focusing coil or magnet and the deflection yoke are loosened from their support or supports, their leads are disconnected if necessary, and these two parts are taken off the base end of the tube. While carefully supporting the tube with one hand, its fastenings to the front of the cabinet now are loosened or removed, whereupon the tube may be taken out from the rear of the cabinet.

Some receivers and their cabinets are designed to permit removal of the picture tube through the front of the cabinet, after opening a front panel inside of which are supports for

the large end of the tube. Such construction is illustrated in a simplified way by Fig. 134-12. To take out the tube the socket and ion trap are removed as usual, and the high-voltage anode lead is disconnected from the tube. The high-voltage filter capacitor and the tube capacitance are discharged as described earlier. Next the deflecting yoke and focus coil or magnet are loosened on their support and moved as far toward the tube base as they will go. The front panel now is opened or removed, while carefully supporting the picture tube, and the tube is taken out through the front of the cabinet as its neck slides through the yoke and focus coil or magnet.

Picture tube replacement calls for reversal of the steps carried out during removal. There are, however, a few special precautions to be observed. Make certain that the deflecting yoke and focusing coil or magnet are in such positions, or are sufficiently free, that the tube neck will pass freely through

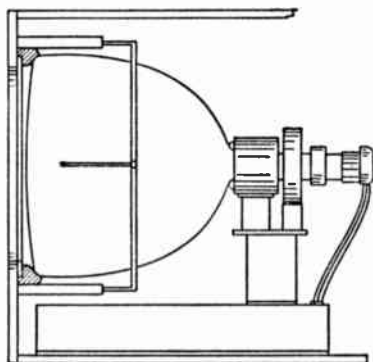

Fig. 134-11.—Picture tube mounted between cabinet front and a cushion on the yoke assembly.

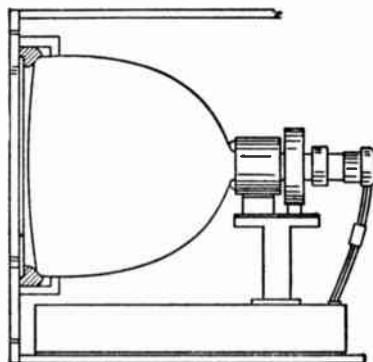

Fig. 134-12.—Picture tube removable from the front of the cabinet.

these parts. The tube neck should be centered in the openings through yoke and coil or magnet, or these parts should be adjusted to center around the neck.

The back end or small end of the tube flare or cone insulator must fit snugly against the cushion or pad carried by the deflecting yoke or its support. Either the yoke mounting or

the picture tube may be moved to accomplish this. If the tube has an outer conductive coating the grounding spring attached to chassis metal must make good contact with the coating. Since the front rim or lip of metal-cone tubes is at anode potential it must remain insulated or separated from all metal parts except the clip of the connecting lead. The face of the tube must not be forced against the sheet of safety glass or plastic which is back of the mask in the cabinet.

Picture Tube Substitutions. — Provided an original cabinet has sufficient space or a new cabinet is to be used it may be possible to change from a smaller to larger diameter round tube or to change from round to rectangular. A tube of larger diameter usually requires mechanical alterations of the supports for deflecting yoke and focus coil or magnet, and possibly for the face end of the tube. The socket of the new tube should not extend outside the cabinet unless mechanical covering or protection is added. If the original cabinet is retained it will be necessary to fit a new mask and surrounding frame or molding suitable for the larger tube.

Outside dimensions of rectangular tubes are as follows.

14-inch. 9-11/16 inches high, 12 $\frac{1}{2}$ inches wide.

16-inch. 11 $\frac{1}{2}$ inches high, 14 $\frac{3}{4}$ inches wide.

17-inch. 12 $\frac{1}{4}$ inches high, 15 $\frac{3}{8}$ inches wide.

19-inch. 13-3/32 inches high, 17 inches wide.

High-voltage for the anode and for a flyback type power supply as required by a larger tube may be insufficient. This will call for a new horizontal output transformer or sweep transformer, usually for new width and linearity controls, and for accompanying small parts as are made up in several replacement kits. When the deflection angle of the original picture tube is less than 66 degrees, and of the new one is 66 degrees or more, it usually will be necessary to install a wide-angle deflecting yoke. The deflection angle of all rectangular tubes is 65 to 70 degrees.

If the new tube requires more focusing coil current than the original, it may be possible to increase the current by alterations in the low-voltage power supply, or else there may

be substituted a new focusing coil having more turns and giving more ampere-turns with the original current.

The ion trap magnet or lack of it must be considered. If the original tube requires a trap magnet and the new tube does not, it is simply a case of discarding the old magnet. If the new tube requires a trap magnet it must be fitted with either a single or double magnet unit, whichever is needed. It is highly important that the correct style be installed. If the original tube has an electromagnet for its ion trap the magnet coil should be left connected into its circuit, but fastened somewhere on the chassis or in the cabinet where the coil will be out of the way.

If the original picture tube has an external conductive coating, and the new tube has none, it usually is necessary to add a capacitor of 500 to 2,000 mmf to the high-voltage filter, connected between the high-voltage anode lead and ground or B-minus. The voltage rating of this capacitor must be amply high for the anode voltage of the new tube. The capacitor should be mounted inside the shielded compartment which encloses other high-voltage power supply components.

If the original tube has no external conductive coating, and the new one does have such a coating, provision must be made for grounding this coating to the chassis through a contact spring which will rest on the flare of the new tube. When a metal-cone tube replaces an all-glass type the connector on the high-voltage anode cable must be changed to a style which attaches to the lip of the metal-cone tube. Also, any grounding spring which makes contact with the flare of the original all-glass tube must be removed or prevented from touching the metal cone of the new tube. Since the lip or ring around the face of metal-cone tubes, and also the face glass, operate at anode potential it is necessary to provide adequate insulation and separation for these parts of the tube.

TUBE, PICTURE, ELECTROSTATIC. — Picture tubes employing electrostatic deflection and electrostatic focusing are made, or have been made, with outside diameters of 3 to 20 inches. Principles of electrostatic deflection are explained in the

article, *Deflection, Electrostatic* and principles of focusing are explained in the article, *Focusing and Focusing Controls*.

The electrostatic tube in most general use is the type 7JP4 whose outside diameter is approximately 7 inches and on whose screen may be formed a picture about $5\frac{1}{2}$ inches wide and $4\frac{1}{4}$ inches high. The screen is made with phosphor num-

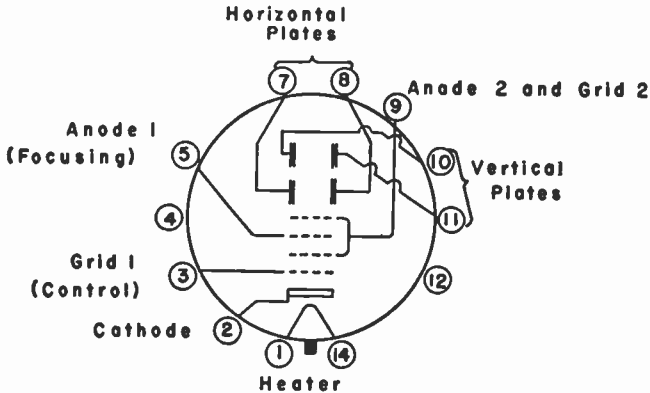

Fig. 135-1.—Base pin positions and element connections of the 7JP4 electrostatic picture tube.

ber 4, whose characteristics are described in the article on *Tubes, Picture*. Fig. 135-1 shows connections of the internal elements to the base pins when looking at the base end of the tube or at the outside of the base. The base is a medium shell diheptal 12-pin type on which there are spacings for 14 pins, with two positions left open. Suitable sockets are specified by the same name. The heater normally is operated with 6.3 a-c volts and current of 0.6 ampere.

The rate of electron emission or density of the electron stream leaving the heated cathode is controlled by potential difference between cathode and control grid or grid number 1. Electrons are drawn away from the cathode and control grid by high potential on grid number 2, and are focused to form the electron beam by electric fields between grid number 1 and the focusing electrode or anode number 1, also between this focusing electrode and the final accelerating electrode or anode number 2. The focused and accelerated beam then

passes between the horizontal deflecting plates, between the vertical deflecting plates, and to the screen. As a general rule the pair of plates farther from the screen is used for horizontal deflection and the pair nearer the screen for vertical deflection.

With typical operation of this electrostatic tube the potential on high-voltage anode 2, grid 2, and the deflecting plates usually is between 3,500 and 6,000 volts with reference to the cathode. Voltage on the focusing anode, number 1, is between 25 and 40 per cent of that on the high-voltage anode, and, of course, is adjustable in order that the electron beam may be correctly focused.

The distance the electron beam is deflected either side of the screen center in an electrostatic tube is directly proportional to potential difference between sawtooth voltages of opposite polarity applied to the deflecting plates of a pair. That is, the greater the sawtooth deflecting voltage from the sweep oscillator or amplifier the greater is the width or height of the picture. Deflection distance is inversely proportional to voltage on anode 2. Increasing this anode voltage lessens the deflection distance, while decreasing the anode voltage increases the distance when other voltages are unchanged.

The large end of an electrostatic picture tube usually is supported by a cushion in the cabinet, around the mask, or by means of some form of strap mounting on the chassis. The base of the tube may be carried by a strap or circular clamp attached to cabinet or chassis. The socket is carried by the base of the tube and has no other support, being connected to chassis circuits through flexible leads.

To straighten the picture or make it truly vertical and horizontal in the mask opening there must be provision for rotating the entire electrostatic tube, whereas with a magnetic deflection tube the straightening is accomplished by rotating the deflection yoke. Electrostatic tubes sometimes are protected from external electric fields by a conical cover or shield of non-magnetic metal, which is grounded to the chassis. Electrostatic tubes must be handled with the same precautions specified for magnetic tubes in the article, *Tubes, Picture*.

TUBES, TELEVISION. — Certain tubes have been designed especially to meet the needs of television receiver circuits. Among them are the sharp cutoff pentodes of types 6AC7, 6AS6, and 6CB6. The first of these is a metal shell tube, the other two are miniatures. For horizontal magnetic deflection amplifier use there are the special types 6BG6-G, 6AU5-GT, and 6CD6-G. All are basically beam power amplifiers. For a vertical deflection amplifier there is the 6S4 triode. The 6AS7-G is a twin triode designed for use as a damper tube in horizontal magnetic deflection circuits. The 1B3-GT is a half-wave rectifier used in nearly all high-voltage power supplies. It has peak inverse plate voltage rating of 30,000 volts.

In addition to the tubes just mentioned, many of the miniature types are so generally used for r-f amplifiers, mixers, i-f amplifiers, and video amplifiers as to rate for all practical purposes as television tubes. Requirements for tubes to be used in high-frequency circuits, and characteristics or constructions which best meet the requirements are described in the article, *Tubes, High-frequency*.

TUNERS. — The tuner of a television receiver permits the operator to change the resonant frequencies of circuits to which are applied signals from the antenna, and thus permits selection of the channel in which reception is desired. Fig. 137-1 shows relations between principal parts of the tuner.

Signals at carrier frequencies come from the antenna through the transmission line and pass to the input of the r-f amplifier through an antenna coupling. The antenna coupling may or may not be tuned for resonance at the signal frequency, or to match the impedance of the antenna at the signal frequency to be received. The r-f amplifier may consist of one stage or of two stages. This amplifier employs either sharp cutoff or twin triode tubes, or, more rarely, the remote cutoff type of pentode. R-f amplifiers are described in the article, *Amplifiers, Radio-frequency*.

Strengthened carrier-frequency signals from the r-f amplifier go through a tuned coupling to the input of the mixer tube. To the input of the mixer comes also a high-frequency

voltage from the r-f oscillator. The carrier and oscillator frequencies beat together in the mixer tube to produce in the output from this tube the signals at intermediate frequency which go to the i-f amplifier. The mixer tube may be a sharp cutoff pentode, or may be one section of a twin triode. Action of the mixer is explained in articles on *Mixers* and on *Frequencies, Beat*.

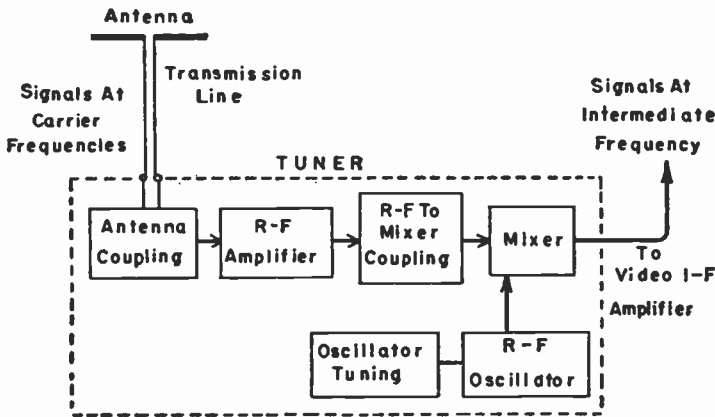

Fig. 137-1.—Principal parts of the tuner.

The r-f oscillator and its tuned grid-plate circuit produce frequencies which, in nearly all television receivers, are higher than the carrier frequencies for the channel being received. The difference frequency of the r-f oscillator and carrier frequencies for each channel becomes the intermediate frequency employed in the particular receiver. The oscillator tube may be a single triode, one section of a twin triode, or may utilize both sections of a twin triode. The oscillator and its circuits are described in articles on *Oscillators, Television R-f* and on *Fine Tuning Controls*.

Television tuners are of many different mechanical designs, and they employ any of a rather wide variety of tuning principles. In the great majority of tuners having a single r-f amplifier stage the tuned circuits are essentially as shown by

Fig. 137-2. If the antenna coupling is a tuned type there will be provision for varying either the inductance or the capacitance to suit the channel received. For rf-mixer coupling there nearly always is one tuned circuit for the plate of the r-f amplifier and another tuned circuit for the grid of the mixer tube. Either the inductance or the capacitance in these tuned circuits is varied to suit the carrier frequencies of each channel. The r-f oscillator is tuned to a frequency suited for the received channel by variation of inductance or capacitance in its tuned grid-plate circuit.

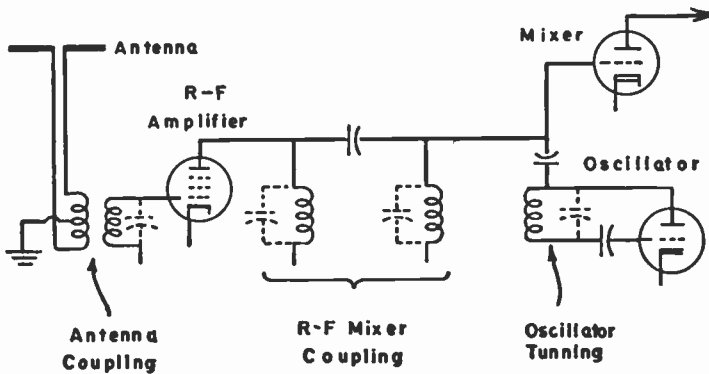

Fig. 137-2.—Circuits such as ordinarily employed in a tuner.

Principal differences between tuners are in the choice between variable inductance or variable capacitance for tuning the several circuits, and in the mechanical means employed for bringing about the variations.

If the antenna coupling is tuned and there is a single r-f stage, the tuner will have the four variably tuned circuits indicated in Fig. 137-2. If the antenna coupling is untuned there will be only three tuned circuits, two of them for rf-mixer coupling and one for oscillator tuning. Addition of a second r-f amplifier stage, with the antenna coupling untuned, still may require only three variably tuned circuits, one between first and second r-f amplifiers, one between second r-f amplifier and mixer, and one more for the oscillator. Satis-

factory selectivity then is provided by the two single-tuned circuits following each of the r-f amplifiers, just as selectivity is provided by two tuned circuits between one r-f amplifier and the mixer tube.

For each tuned circuit there may be a single extended inductor whose effective value is altered by making circuit connections to taps along its length, or by shorting unused portions of the inductor to ground or B-minus. A rotary selector switch is used for making either type of change. Otherwise there may be individual inductors or coils, suited for frequencies in each channel, which are cut into or out of the tube circuits by a rotary selector switch. This latter method is employed in the tuner of Fig. 137-3. Mounted around the

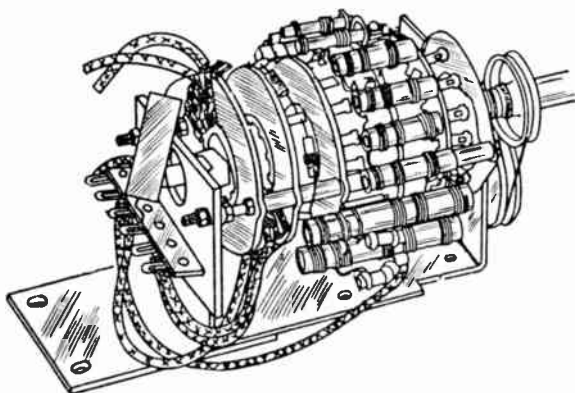

Fig. 137-3.—Tuner with individual inductors for each channel connected to tube circuits through a rotary selector switch.

outsides of the switch wafers are tubular forms on each of which are rf-mixer coupling coils and oscillator coils for one channel, with the addition at some switch positions of coils for antenna tuning.

Fig. 137-4 is a circuit diagram illustrating a method of shorting to ground various portions of the two extended tuning inductors used for coupling between the r-f amplifier and mixer tubes. Oscillator tuning here is by means of separate inductors or coils for each channel. Any one inductor is

connected to oscillator plate and grid by movement of contacts which are on the rotary switch, while other oscillator inductors are shorted across their ends by switch rotors. At the top of the diagram is shown a switch wafer whose rotor shunts two small inductors across the antenna input inductor for reception on high-band channels. This reduces the effective input inductance for these channels.

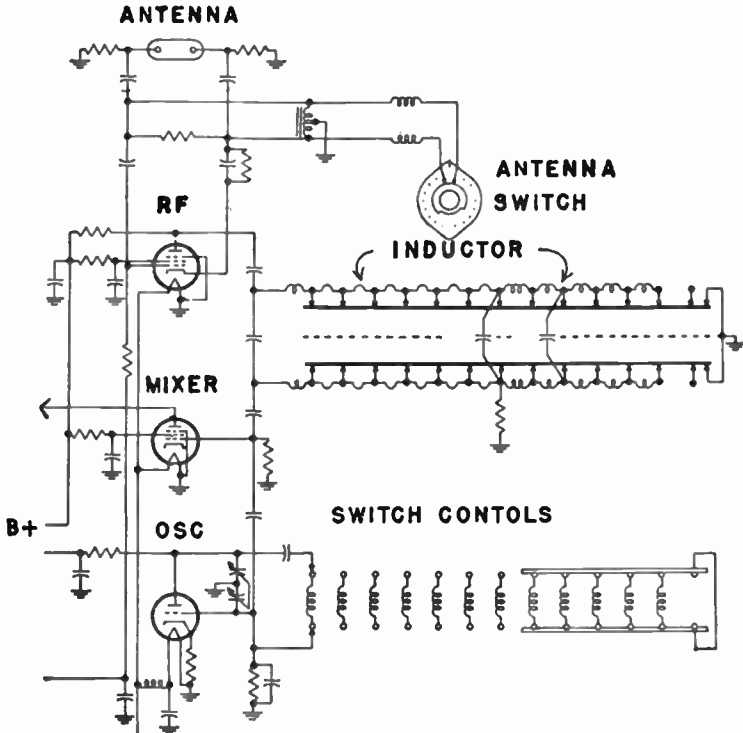

Fig. 137-4.—Shorted continuous inductors for rf-mixer coupling, and individual inductors for the oscillator.

In many receivers there is a turret type tuner of the type illustrated by Fig. 137-5 or some generally equivalent construction. The external appearance of the tuner unit is shown at the left. At the right is the rotary turret removed from the supporting frame. Equally spaced around the outside of the turret member are lengthwise insulating supports carrying on their inner surfaces all the inductors for one channel. Down

below the turret is shown one set of these inductors and supports removed from their regular fastenings. As the turret is turned into position for each channel, contact points connected to the inductors engage contact springs from which leads extend to the tube circuits.

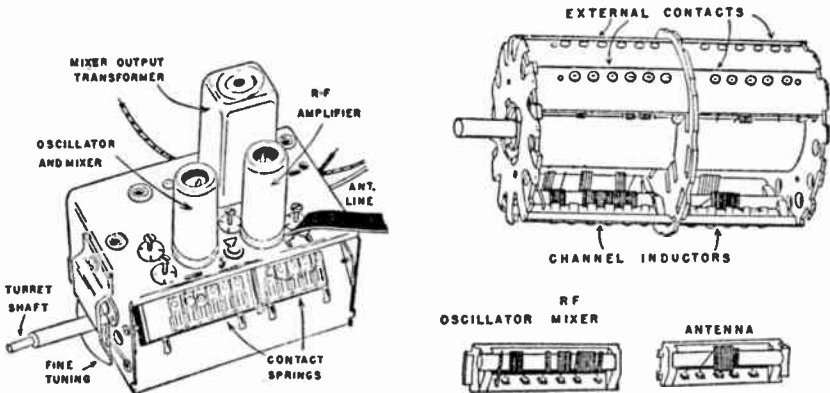

Fig. 137-5.—A turret tuner.

Another method of varying the tuning inductances to suit any channel to be received employs coils having adjustable powdered iron cores that are moved into and out of the winding forms by rotation of the tuning knob or dial. Construction of one variable inductance unit of this general type is illustrated by Fig. 137-6. There are three pairs of coils, one pair for tuning the r-f amplifier plate circuit, a second for tuning the mixer grid circuit, and a third pair for tuning the oscillator. One coil of each pair is used for low-band channels, the other for high-band channels.

Other variable inductance tuners have continuous windings or coils covering the entire television frequency range through all channels for both low and high bands, and including f-m broadcast frequencies between the two bands. There are two coils for the rf-mixer coupling, one for the oscillator, and sometimes an additional coil for the antenna input circuit. More or less inductance is brought into the various circuits by

slider contacts whose positions along the inductors are varied by rotation of the tuning dial or knob.

There are a number of tuners which, instead of varying the circuit inductances, vary tuning capacitances which are connected across fixed inductors in the several circuits. In one type of variable capacitance tuner there are three pairs of capacitors. One capacitor of each pair is used for low-band

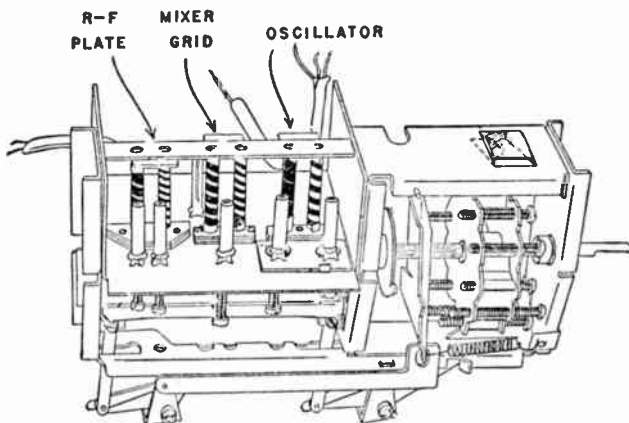

Fig. 137-6.—Tuner having movable cores in the inductors.

channels, the other for high-band channels. One of the pairs tunes the plate circuit of the r-f amplifier, another tunes the mixer grid circuit, and the third tunes the oscillator. The capacitor rotor plates are moved by rotation of the tuning dial or knob.

With another method of capacitance tuning there are fixed inductors for each of the tuned circuits. Across each inductor may be connected any one of 12 separately adjustable trimmer capacitors, one capacitor acting for each channel to be tuned. The capacitors are connected to or disconnected from the inductors by push-button switches for each channel.

Coupling Methods. — The simplest coupling between antenna and r-f amplifier when there is a balanced transmission line is shown at 1 in Fig. 137-7. Across the antenna input

terminals is a center tapped inductor whose impedance matches that of the antenna as well as is possible for the entire range of television carrier frequencies. A resistor in parallel with the inductor helps broaden the response. At 2 in the same figure are shown connections commonly used when the transmission line is a shielded coaxial type. The r-f amplifier here is a grounded grid triode.

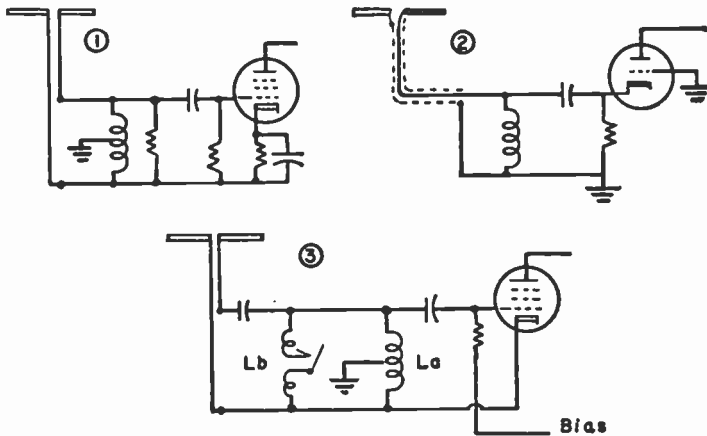

Fig. 137-7.—Untuned antenna couplings, at 1 and 2, and a coupling tuned for either the high or low band, at 3.

With the arrangement shown by diagram 3 of Fig. 137-7 the principal center-tapped inductor is used alone for reception on low-band channels. For reception in the high band the auxiliary conductors L_b are connected in parallel with L_a by closing the switch. This method permits a reasonably correct impedance match throughout the frequencies of each band. In some receivers there are separate input circuits for a low-band antenna and a high-band antenna, each antenna being connected through its own transmission line to the appropriate input circuit of the receiver.

In Fig. 137-8 diagram 1 shows connections used with individual antenna coupling transformers for each channel. The several transformers may be mounted on a turret, with their

contact points engaging stationary springs connected to the antenna and to the grid-cathode circuit of the r-f amplifier. Otherwise the transformer windings may be stationary, mounted on or near a selector switch, with connections shown by arrows made by turning the switch rotors to their various positions.

In diagram 2 of Fig. 137-8 there is a tapped inductor L_s shunted across the secondary winding of the antenna input transformer. The tap points are engaged by a switch rotor to alter the secondary inductance and thus tune the transformer for optimum performance on each channel. With the method illustrated by diagram 3 the circuit containing the secondary winding of the antenna coupling transformer contains also

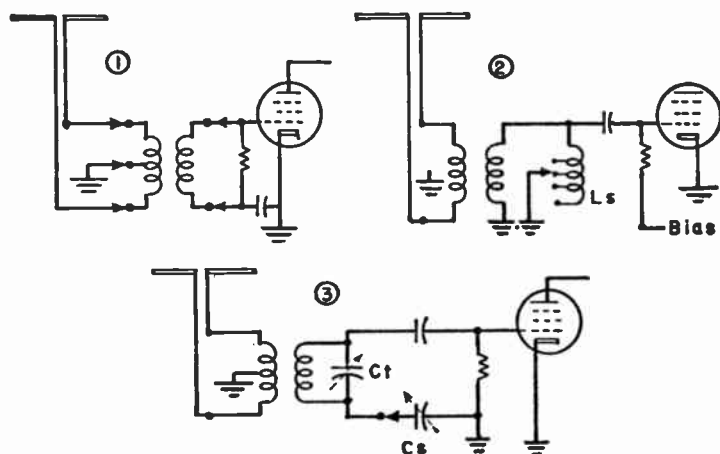

Fig. 137-8.—Antenna couplings of types which are tuned to suit each channel.

the two adjustable capacitors C_s and C_t . Capacitor C_s is one of a number of separately tuned units brought into the circuit as the selector switch is turned for various channels. Capacitor C_t is a trimmer connected permanently across the secondary for adjustment of the response on all channels.

With most input circuits designed for a 300-ohm balanced transmission line, connected across the outer ends of the input

inductor, it is possible to use a 75-ohm or 72-ohm unbalanced coaxial transmission line. The center conductor of the coaxial line is connected to either end of the center-tapped input inductor, and the shield of the transmission line is connected to the center tap and to ground. Using half the input inductor provides one-fourth the input impedance, because inductance of a coil is proportional to the square of the number of turns.

Some receivers provide for tuning only the channels which may be used in a given locality. The tuned circuits have sufficiently wide range of adjustment so that part of them may be aligned for reception in either one of the following pairs of channels: 2 or 3, 3 or 4, 5 or 6, 8 or 9, 10 or 11, 12 or 13, with channel 7 subject to alignment in all cases. Realignment is necessary in case the receiver is moved to a locality where different channels are in use.

Coupling of the r-f oscillator voltage into the grid-cathode circuit of the mixer often is through a capacitor of 1 to 3 mmf capacitance connected from the grid-plate circuit of the oscillator. This capacitance may be the same for all channels, or may be changed along with switching for channel inductances or capacitances used for tuning.

In some tuners there is inductive coupling between oscillator and mixer, secured by placing the circuits for the two tubes fairly close together or by having tuning inductors for the oscillator and the mixer grid carried by the same winding form. When oscillator and mixer are the two sections of a twin triode the coupling may be in a cathode resistor which is common to both circuits.

Tuner Circuits. — In the tuner whose connections are shown by Fig. 137-9 the effective inductances are changed by means of selector switch rotors that short circuit or ground certain portions of the inductors. These rotors are represented as straight bars, lettered from *A* through *F*. All rotors are in position for reception on channel 13.

The plate of the r-f amplifier is connected to the extended inductor at the top of the diagram. All parts of this inductor except section *L_p* are shorted together through rotor *A*, which

connects to a B+ line. Inductors L_a are shunted across the antenna input for all high-band channels. The mixer grid is connected to another extended inductor whose parts are shorted together and connected to ground through rotor C. Only section L_g is active for channel 13.

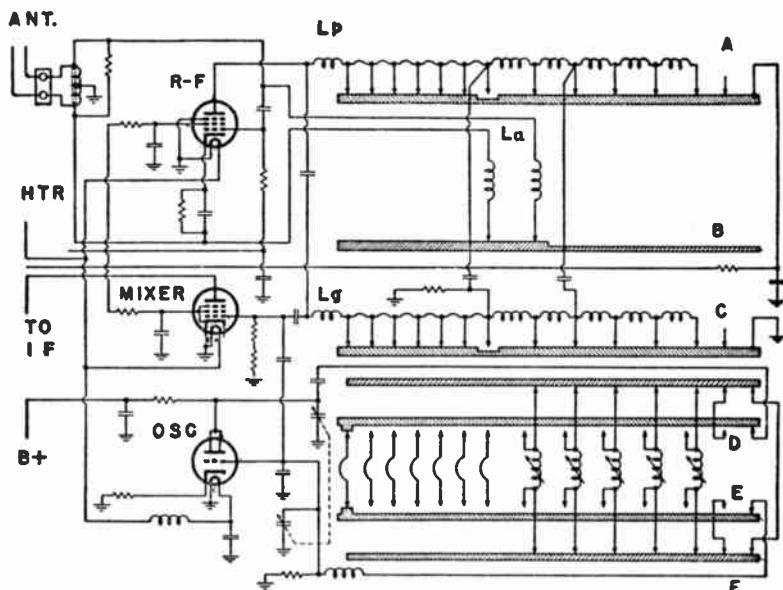

Fig. 137-9.—Shorted inductors for rf-mixer coupling and separate oscillator inductors connected through rotary selector switch.

The oscillator is tuned by means of separate inductors for each channel. These inductors are shown between rotors D and E . With the rotors in the positions shown, only the single inductor at the left-hand end of the group is active. It is connected through rotors D and E to the plate and grid of the oscillator tube. Other high-band inductors are disconnected, while all low-band inductors (toward the right) have their ends shorted together through rotors C and F .

For tuning channels of lower and lower numbers the rotors are moved to the right, as they appear on the diagram. This removes the short circuits from more and more sections of the

inductors for the r-f plate and mixer grid, and connects different inductors to the oscillator plate and grid.

In the tuner whose connections are shown by Fig. 137-10 there is tuning of the antenna-to-rf coupling circuit as well as of the r-f amplifier plate circuit, the mixer grid circuit, and the oscillator grid-plate circuit. Circuit inductances are varied by short circuiting and grounding portions of the extended inductors for antenna and for rf-mixer couplings. This is done with selector switch rotors, again shown as straight bars in the diagram, and marked *A*, *B* and *C*.

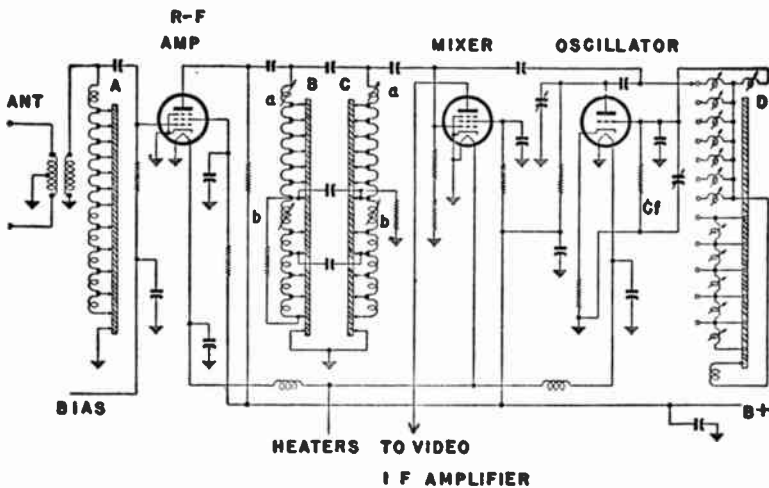

Fig. 137-10.—Addition of antenna tuning with shorting connections made through a rotary selector switch.

The oscillator is tuned by means of individual inductors or coils for each channel. One end of the high-band inductor for each channel is connected to the oscillator plate by a switch point on one of the rotors. The other ends of the seven high-band coils are connected together and to the oscillator grid. The other ends of the five low-band oscillator coils are shorted together through rotor *D* until this rotor moves away as these coils are cut into the oscillator grid-plate circuit. At *C_f* is the fine tuning capacitor for the oscillator circuit.

Connected to the antenna terminals of the tuner in Fig. 137-11 are tunable wave traps for shorting to ground such interference signals as come from f-m transmitters and other high-frequency sources. The plate of the r-f amplifier is tuned by an extended inductor of which various portions are shorted by movement of contact point *A*, which is on one of the rotors of a selector switch. The contact, and others on the selector switch, are in positions for reception on channel 3. Moving the contacts to the left in the diagram tunes to channels of increasingly higher numbers. The grid circuit of the mixer is tuned by another extended inductor of which sections are shorted out by movement of switch contact *B*.

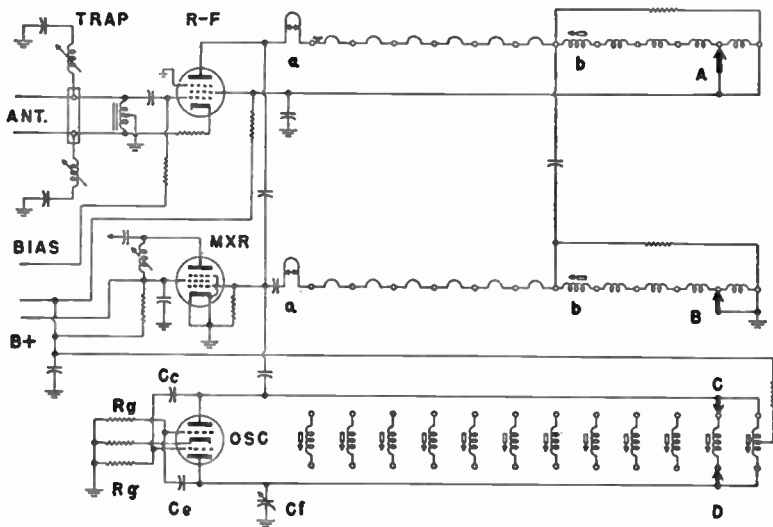

Fig. 137-11.—Tuner employing a push-pull oscillator with a twin triode tube.

This tuner of Fig. 137-11 has a twin triode oscillator with push-pull tuned plate circuit. There are separate inductors for each channel. The two ends of any one inductor are connected to the two oscillator plates by movement of switch contacts *C* and *D*. The plate of each section of the oscillator tube feeds back to the grid of the other section through

coupling capacitors C_c and C_c . The degree of feedback and the strength of oscillatory voltages is dependent on the relative reactances of the coupling capacitors and grid resistors R_g and R_g . Capacitor C_f is for fine tuning control of the oscillator.

The tuner of Fig. 137-12 operates with shorted quarter-wave resonant lines for each of the three tuned circuits. The resonant line for the r-f amplifier consists of the two extended inductors connected to the plates of the twin triode tube. For the mixer the two sides of the resonant line are connected to the grids of the second twin triode tube. The oscillator tube is another twin triode, with the two sides of its resonant line connected to the plates.

The two sides of each of the resonant lines are shorted together at points suited for tuning in each channel by movement of contact members marked *A*, *B* and *C*, which are on the rotors of a selector switch. This alters the effective lengths

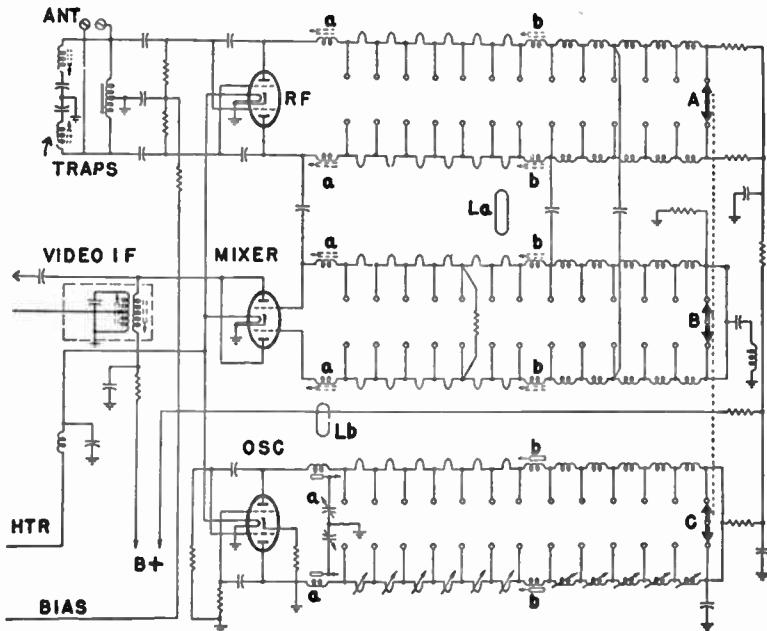

Fig. 137-12.—Tuner employing shorted quarter-wave resonant lines in all the tube circuits.

of the lines, and changes the resonant frequencies to suit each channel. A shorted quarter-wave line is equivalent in action to a parallel resonant circuit tuned to a frequency which depends on the electrical length included between the tube plates or grids and the shorting members operated by the switch. The shorting members are shown in the positions for tuning to channel 1. Moving these members to the left on the diagram shortens the electrical lengths of the lines and increases the resonant frequencies for tuning to channels of successively higher numbers.

The small link circuit marked *La*, together with capacitors shown to its left and right, provide coupling from the plate circuit of the r-f amplifier to the grid circuit of the mixer. The link shown at *Lb* couples the output of the oscillator to the input of the mixer. To the left of the mixer, on the line going to the video i-f amplifier, is a transformer from the center tap on whose secondary the signals go to the sound i-f amplifier. Connected to the antenna terminals are tunable series resonant traps for f-m signals and other high-frequency interference.

Fig. 137-13 shows connections for a tuner having separate coils for each channel in the plate circuit of the r-f amplifier, in the grid circuit of the mixer, and in the grid-plate circuit of the oscillator. For some channels and combinations of channels there are capacitors, either adjustable or fixed, which are connected into the antenna coupling circuit. The coils and capacitors are connected to the tube circuits by operation of a rotary selector switch.

The antenna coupling capacitors are connected as required by switch rotor *A*. The coupling coils between the plate of the r-f amplifier and grid of the mixer are connected by switch rotors *B* and *C*. The two ends of the oscillator tuning coils are connected to the plate and grid of the oscillator by switch rotors *D* and *E*. A fine tuning capacitor for the oscillator is shown at *Cf*.

The transmission line from the antenna attaches to a plug at the lower left-hand corner of the diagram. To this plug are

connected the primary windings of the antenna coupling transformer. There are two tuned secondaries, one of which is broadly resonant at carrier frequencies in the low-band channels, with the other one resonant over the range of carrier frequencies in the high-band channels. The r-f amplifier is a pentode. The two sections of a twin triode act as mixer and as r-f oscillator.

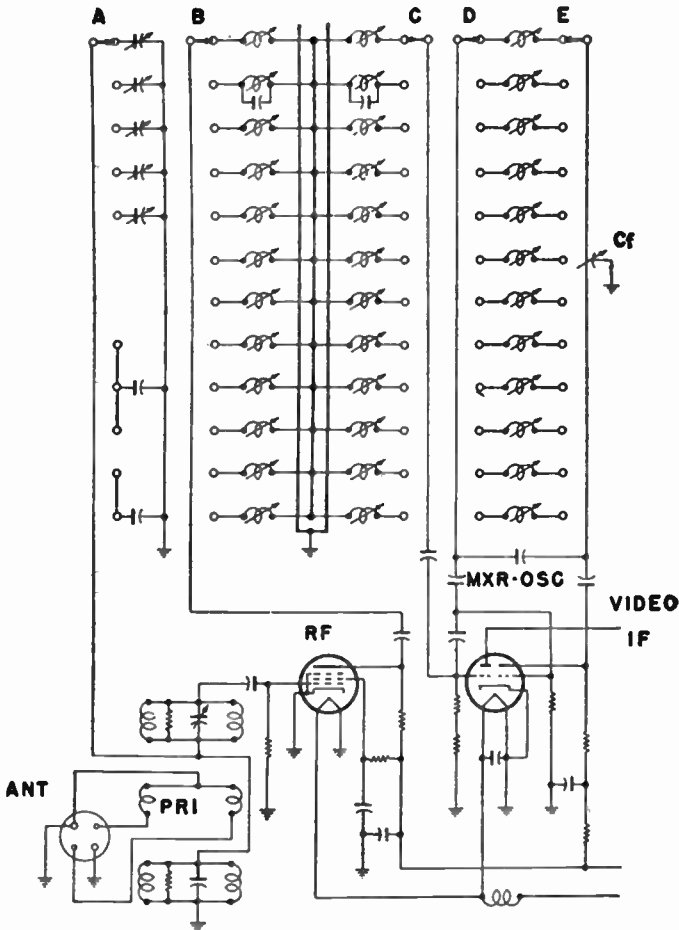

Fig. 137-13.—Rf-mixer and oscillator circuits with individually adjustable inductors for each channel.

oscillator. The oscillator here is a twin triode of which one section is used for automatic control of oscillator frequency in connection with the sound discriminator.

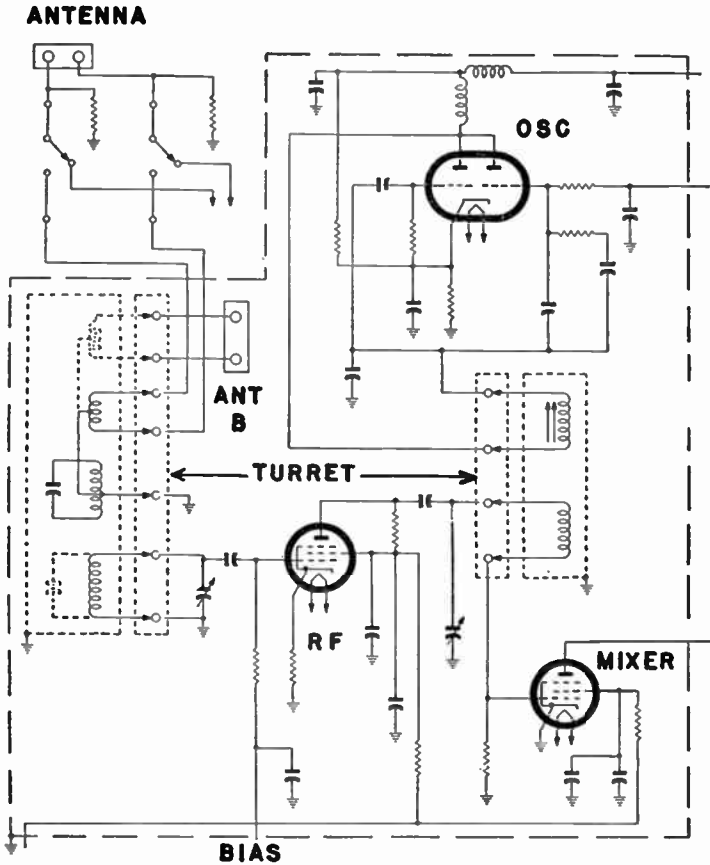

Fig. 137-15.—Circuit connections in one type of Philco turret tuner.

When a single antenna structure and single transmission line feed the tuner of Fig. 137-15 the line is connected to terminals shown at the top of the diagram. With two antennas and two transmission lines these terminals are for the low-band antenna. The separate high-band antenna and line then are connected at terminals marked *Ant B*.

Fig. 137-16 is a circuit diagram for a tuner having inductors adjustable by means of sliding contacts to cover the entire carrier frequency range from channel 2 through channel 13, including frequencies other than television lying between the two bands. The r-f amplifier is a grounded grid triode, shown connected to a coaxial transmission line. The three adjustable inductors are shown within the broken line at the center of the diagram. All inductances are changed simultaneously by the tuning knob or dial.

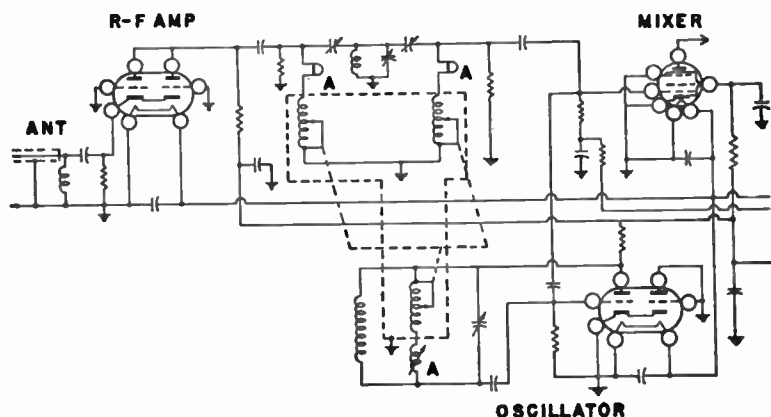

Fig. 137-16.—Circuits of the DuMont Inputuner.

The three inductors or coils are mounted along a single insulating support which is rotated for tuning. Bearing on the conductor of each coil is a fixed slider contact maintaining electrical connection between the coil conductor and a metal plate to short out more or less of the total number of turns as the coils are rotated. The unshorted portions of the coils become the effective tuning inductances. With the coil turns shorted out as far as possible, most of the remaining tuning inductance is in the end turns marked A-A-A, which are outside the tuner housing. These end turns are adjustable to fix the highest tuned frequency, for channel 13.

Frequency Adjustments. — Fig. 137-17 illustrates some of the methods of frequency adjustment employed in tuners, and shows the effects of alterations.

1. When a movable core, or slug, of powdered iron is turned farther into a coil the resonant frequency becomes lower. Turning this kind of core farther out of the coil will make the resonant frequency higher.

2. If a non-magnetic core, made of brass, copper, or aluminum, is turned farther into a coil the resonant frequency becomes higher, while turning this type of core farther out of the coil will lower the frequency.

3. With a self-supporting coil, or one whose turns can be moved along the supporting form, squeezing the turns closer together will lower the resonant frequency. Spreading the turns farther apart will make the resonant frequency higher.

4. Frequency of resonance may be changed by moving a shorted turn toward or away from the end of a tuning coil, or by moving the shorted turn along the coil. As the shorted turn is moved toward the coil or toward the center of the coil the frequency is made higher. Moving the turn away from the coil makes the frequency lower.

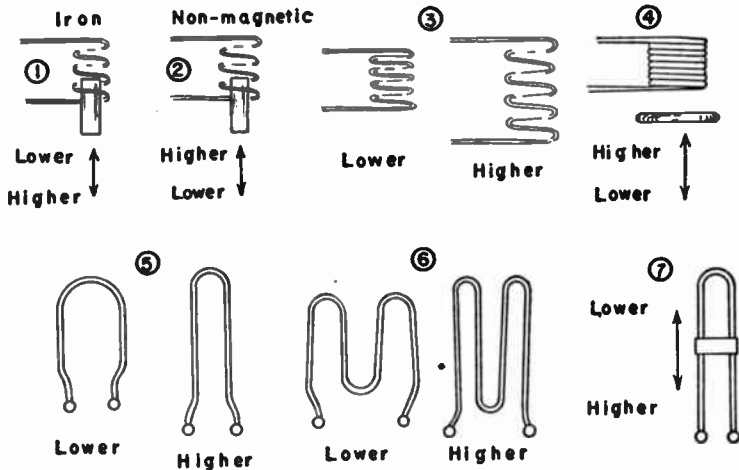

Fig. 137-17.—Methods of adjusting tuner inductances to vary the resonant frequency. Reference notes are for changes of frequency.

5. When a tuning inductor consists of a single loop of wire, moving the sides of the loop farther apart will lower the resonant frequency of the circuit, while pressing the sides closer together will make the frequency higher.

6. If the tuning inductor consists of several flat loops of wire, the frequency will be lowered by spreading the loops wider, and will be made higher by moving the loops together or making them narrower from side to side.

7. Some tuning inductors are in the form of a wire loop on which is fitted a movable slider that makes a short circuit across the loop. Moving this slider toward the closed end of the loop will lower the resonant frequency, while moving the slider toward the terminals of the loop will make the frequency higher.

Any of these adjustments which lower the resonant frequency do so by increasing the effective inductance, while those which raise the frequency are such as decrease the inductance.

Movable cores or slugs often are secured in position by a coating of wax over the end. The wax may be melted by bringing a hot soldering iron fairly close. When a new adjustment is completed the seal may be restored by warming the wax until it flows. If adjustable members are held in place with cement the fastening usually may be dissolved with lacquer thinner, methylbenzene spirits, or some solvent made especially for dissolving radio cements. Movable cores in tuner inductors should be adjusted only with alignment screw drivers or wrenches containing no metal at all. Tools used for bending or shaping wire inductors should contain no metal if adjustments are made while the circuits are in operation.

Alignment of Tuner Circuits. — What may or may not be done in the way of aligning the several circuits of a tuner depends, of course, on what adjustments have been provided in the design. Some tuners, as in Fig. 137-4, have no special provisions for service adjustments. This is true also of certain turret type tuners with which the entire inductor strip for a channel must be replaced in case of tuning trouble. In many

tuners, and in channel positions where there are no special means for alignment, it is possible to change the resonant frequencies of coils and loop inductors by methods described in connection with Fig. 137-17.

A number of tuners provide no alignment adjustments for individual channels, but do have adjustments for r-f amplifier, mixer, oscillator, and possibly for the antenna, whereby the overall performance on all channels is affected. Such a case is illustrated by Fig. 137-16, where overall adjustments are provided by inductors *A-A-A* and also in trimmer capacitors which affect the band width.

In the tuner of Fig. 137-12 each tube circuit contains adjustable inductors for alignment of all the high-band channels at one time. These six adjustments are marked *a* on the diagram. Also in each tube circuit are six adjustable inductors, marked *b*, for alignment of all low-band channels. Alignment is commenced with the tuner set for channel 7, by adjustment of inductors *a*, and is carried on with adjustment of inductors *b* while the tuner is set for channel 6. There are no individual adjustments for separate channels.

The tuner of Fig. 137-9 has individual adjustments for oscillator coils in the low-band channels, with no other adjustments for any circuit or channel. In the turret tuner of Fig. 137-15 are movable core adjustments for the oscillator coils on every channel, but other tube circuits have no alignment adjustments. The turret tuner of Fig. 137-14 provides movable core adjustments for the oscillator coils in every channel and, in addition, has overall circuit adjustments marked *C*, *Cb*, *Cd*, and *Ce* which affect performance on all channels.

In the tuners of Figs. 137-10 and 137-11 there again are individually adjustable oscillator coils for every channel. There also are alignment adjustments marked *a* which affect all the high-band channels, and other adjustments marked *b* which affect all the low-band channels. In the tuner of Fig. 137-13 there are individually adjustable coils for every channel in the r-f amplifier plate circuit, the mixer grid circuit, and the oscillator circuit.

Alignment of oscillators is described in the article, *Oscillators, Television R-f*. The remainder of the present article is concerned specifically with alignment of antenna, r-f amplifier, and mixer circuits. General instructions pertaining to all alignment processes are given in the article on *Alignment*.

Tuner alignment is carried out most satisfactorily with sweep and marker generators, or a television generator, and with an oscilloscope. The oscilloscope vertical input may be connected to any of various points, of which the most suitable will depend on design of the tuner.

One point of oscilloscope connection is to the grid circuit of the mixer tube on the end of the grid resistor farther from the tube, but on the tube side of any decoupling resistor in the grid return path. Alternatively, the connection may be made to the screen of the mixer tube at a point on the tube side of any decoupling resistor going to the B-supply. Another possible connection is to the plate circuit of the mixer tube on the tube side of the decoupling resistor, and either before or after the coupler or transformer which is between the mixer plate and the grid of the first i-f amplifier.

Alignment of the tuner has for its chief objects the attainment of sufficient band width to correctly place the video and sound carrier frequencies, the attainment of a response curve of satisfactory shape, and the greatest gain which is possible with the other requirements satisfied.

Fig. 137-18 shows some typical frequency response curves which would be considered satisfactory for nearly any receiver. It is a general rule that the video carrier marker should be at a point very little if any less than 70 per cent of the maximum response, and that the sound carrier should be at a point no less than 50 per cent of maximum response. Either or both the carrier frequencies may be outside or slightly inside the peaks. The response curve may have either a single peak or two peaks, but in any case it is desirable that the upper part of the curve be fairly flat. A dip between two peaks should reach no lower than 70 per cent of maximum response. When there are two peaks they are not necessarily of equal height. The

frequency responses of different channels need not be alike, in fact it would be almost impossible to obtain the same response on all the channels.

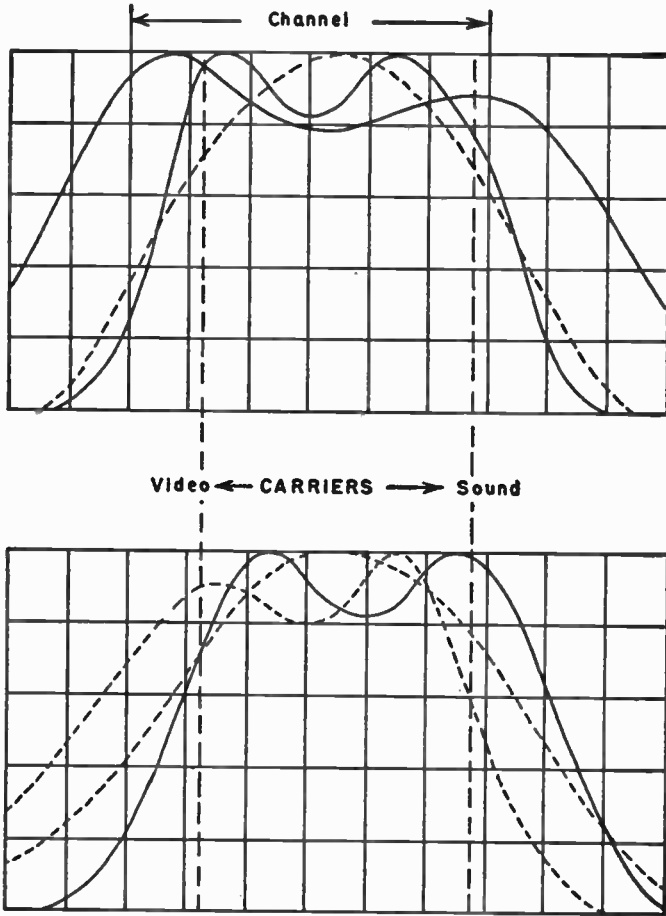

Fig. 137-18.—Typical response curves for tuners when input is to the antenna terminals and output at one of the mixer circuits.

In a general way the steps are as follows for alignment of the rf-mixer coupling and of the antenna coupling if it is adjustable.

1. Couple the sweep and marker generators, or a combined television signal generator, to either of two places:

a. To the antenna terminals of the receiver.

b. To the antenna lead terminals of the tuner after disconnecting the lead which goes from these terminals to the antenna terminals. If this is done, a final check of performance should be made with the lead in place.

The output of the sweep generator or its cable must be an impedance match for the receiver input. Matching methods are shown in the article, *Pads, Matching*.

The sweep width should be at least 10 mc to begin with. If the sweep cannot be made wide enough to show the entire response curve the generator center frequency may be changed back and forth to observe both ends of the curve.

The signal voltage from the generator should be kept low enough to avoid overloading the amplifier, which would cause peaks to appear at incorrect positions.

2. Connect the oscilloscope to the grid circuit, screen circuit, or plate circuit of the mixer tube according to earlier instructions.

3. Connect the grid of the first i-f amplifier tube to ground or B-minus through a capacitor of 500 to 1,000 mmfd or through a resistor of about 300 ohms. This will prevent video i-f traps from affecting the r-f response and will prevent regeneration in the i-f amplifier with possible feedback to the mixer circuits.

4. If wavetraps are connected to the antenna input, detune these traps.

5. To observe the actual response of the antenna coupling and r-f amplifier it may be necessary to temporarily remove the r-f oscillator tube or to connect the grid of this tube to ground or B-minus through a 1,000-mmfd capacitor. If this is done, a final check of performance should be made with the oscillator operating.

6. Tune the channel selector of the receiver and the sweep generator to the channel in which the first alignment is to be made. Ordinarily this will be one of the high-band channels.

7. If there is a fine tuning control set it at the approximate center of its range and do not again change this control during the alignment process.

8. The contrast control should be set at its usual operating position or, preferably, adjusted to place a negative bias of 1 to 1½ volts on the grid of the r-f amplifier, as measured with an electronic voltmeter.

9. Adjust the coil cores or slugs, other inductors, trimmer capacitors, and other means of alignment to produce a response curve of the general type previously described in this article. Markers from the marker generator are used for checking video and sound carrier frequency positions, band widths, and other frequency characteristics of the response curve.

10. Change the channel selector of the receiver and the center frequency of the sweep generator to each other channel which may be affected by the first adjustments and in which there are no separate adjustments. It may be necessary to slightly alter the original adjustments to obtain the best possible average of responses on all these affected channels.

11. For all channels in which there are separate adjustments make the necessary alignments with the channel selector and sweep generator set for each such channel.

12. After all alignment adjustments have been completed go back and check the frequency response on each channel. It is quite possible that some adjustments will have affected the responses obtained in earlier steps.

U

ULTRA-HIGH FREQUENCIES. — The ultra-high frequency band for television broadcasting lies between 480 and 920 megacycles. Ultra-high frequencies, by definition, include all those between 300 and 3,000 megacycles. In the ultra-high frequency television band there is allotment space for 42 channels. This will not affect the use of the low-band channels

between 54 and 88 megacycles, nor the high-band channels between 174 and 216 megacycles.

Antennas for ultra-high frequency reception should be more directional than those for lower frequencies, because at the much shorter wavelengths there is more likelihood of reflections from small objects. There is also much more shadowing effect of all conductive materials when signals are carried at ultra-high frequencies. Due to increased energy dissipations of all kinds it becomes necessary to use greater care in electrical design and mechanical layout of all parts in the r-f section or the tuner. One of the offsetting advantages of the ultra-high frequencies is reduced electrical interference of the "spark" type.

Tuned circuits consisting chiefly of resonant lines are more efficient than conventional coils and capacitors when ultra-high frequencies are being handled. Characteristics of such tuned circuits are described in the article, *Lines, Resonant*. Requirements for amplifier tubes are explained under *Tubes, High-frequency*. Some of the suitable oscillators are described briefly in the article on *Oscillators, Ultra-high Frequency*. Crystal diodes are suitable for mixers at the ultra-high frequencies, partly because the crystals are free from transit time effects, although being less sensitive than thermionic tubes.

Receivers designed for operation in the bands between 54 and 216 megacycles may be adapted for ultra-high frequency reception by the use of converters, usually of the double superheterodyne type. Ultra-high carrier frequencies are converted to lower frequencies, carrying the original signals, by the same process with which lower carrier frequencies are converted to intermediate frequencies in any television receiver or superheterodyne sound receiver. The lower converted frequencies lie in one of the channels 2 through 13, and are fed to the receiver input with the channel selector of the receiver left permanently at the frequency for which the converter is designed or adjusted.

W

WAVEFORMS. — A waveform trace on the screen of an oscilloscope exhibits the voltage variations or the “shape” of the composite television signal and of other voltages derived from or controlled by the signal.

Waveforms may be observed at the output of the video detector and at all points from there to the picture tube. The signal may be followed from the video detector through the video amplifier to the signal input at the picture tube grid or cathode. The signal may be followed also from the video detector through the sync and sweep sections to the deflection coils or the deflection plate connections for the picture tube.

For checking waveforms at all points through the video amplifier and also through the sync section as far as inputs to the sweep oscillators it is necessary to employ an input signal from a regular television transmission or one from a television pattern generator. When using a signal from a television transmission it is preferable to work with a test pattern rather than a picture in which there is movement. From the outputs of the sweep oscillators through the picture tube deflection systems it is not necessary to have an input signal, since the oscillators themselves will control sweep of the electron beam in the picture tube by providing necessary voltages.

For observation of waveforms the vertical input of the oscilloscope is connected between the point where the signal or voltage waveform is to be observed and chassis ground or B-minus. Voltage at the point of test must be no greater than the rated maximum vertical input voltage for the oscilloscope. To help isolate the tested circuit from capacitance of the oscilloscope input it is advisable to use a series resistor of about 100,000 ohms on the receiver end of the vertical input cable.

To observe waveforms related to vertical deflection the internal sweep of the oscilloscope is set for 60 cycles per second to cover a period of one field, for 30 cycles to cover two fields, or for 20 cycles to cover three fields on the same trace. To observe horizontal deflection waveforms the internal sweep of the oscilloscope is set for 15,750 cycles per second to observe one line period, for 7,875 cycles to observe two lines, or for 5,250 cycles to observe three lines on a single trace. Usual practice is to employ a trace covering two fields or two lines.

The composite television signals from different transmitters may show variations in apparent form. The shapes of all traces and the details which may be seen are affected by frequency response characteristics and such features as linearity in the oscilloscope. There may be slight differences between waveforms taken from different receivers of the same model. Waveforms taken from sync and sweep sections will conform to the operating principles employed in the receiver being tested. The height of traces taken from points between video detector and inputs to the sweep oscillators is altered by adjustment of the contrast control, while adjustment of size controls varies the height of traces taken from sweep circuits which follow the oscillators.

Examples of typical waveforms and descriptions of what they indicate are shown in articles listed below.

<i>Amplifiers, sweep</i>	<i>Restoration, d-c</i>
<i>Clippers or limiters</i>	<i>Scanning</i>
<i>Deflection, electrostatic</i>	<i>Separation, sync</i>
<i>Deflection, magnetic</i>	<i>Signal, television</i>
<i>Drive controls</i>	<i>Sync section</i>
<i>Filters</i>	

Figs. 139-1 to 139-24 are waveform traces observed at various points between video detector and picture tube of a typical receiver having a magnetic deflection picture tube and em-

ploying a triode afc control tube for the horizontal sweep oscillator. All traces in this series are reproduced by permission of the Admiral Corporation.

Traces shown by Figs. 139-1 to 139-10 inclusive are taken with the internal sweep of the oscilloscope adjusted for 30 cycles per second, to show two field periods. Consequently, all these traces show waveforms associated with complete fields, with vertical blanking intervals, vertical sync pulses, equalizing pulses, and vertical deflection voltages.

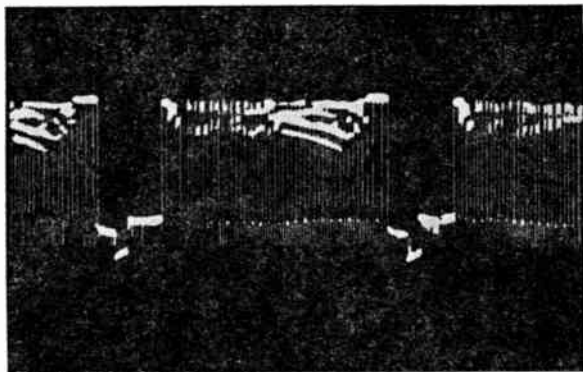

Fig. 139-1.

Fig. 139-1: Taken at the top of the video detector load resistor. This is the output of the video detector and the input to the grid circuit of the video amplifier. Here appears the entire composite television signal with picture variations, positive, at the top and with sync pulses, negative, at the bottom. Two vertical blanking intervals are plainly visible between the fields. During each blanking interval there appear in order, from left to right, the equalizing pulses which follow one field, then the vertical sync pulses at the bottom-most points along the trace, and finally the remaining equalizing and horizontal sync pulses which precede the next field.

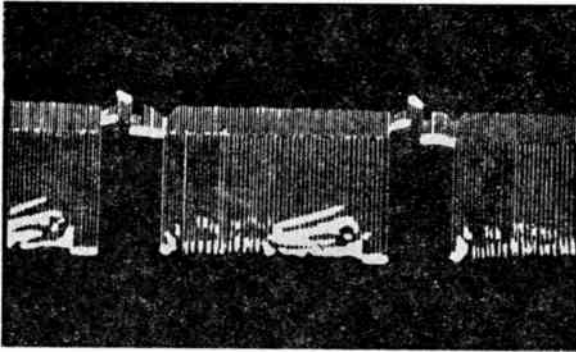

Fig. 139-2.

Fig. 139-2: Taken at the plate of the video amplifier tube. Here again is the complete composite signal, but now the polarity has been inverted to make sync pulses positive and picture variations negative. This waveform is applied to the cathode of the picture tube, which is the point of signal input to the picture tube of this particular receiver.

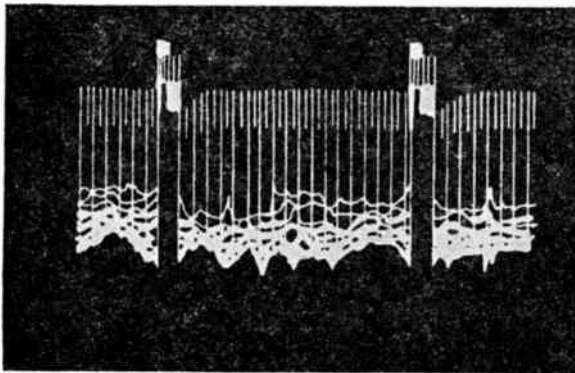

Fig. 139-3.

Fig. 139-3: Taken at the grid of the first tube in the sync section, which is a sync amplifier. The signal shown here comes from the output of the video amplifier, and accordingly is of the same polarity and has the same general characteristics as shown in Fig. 139-2.

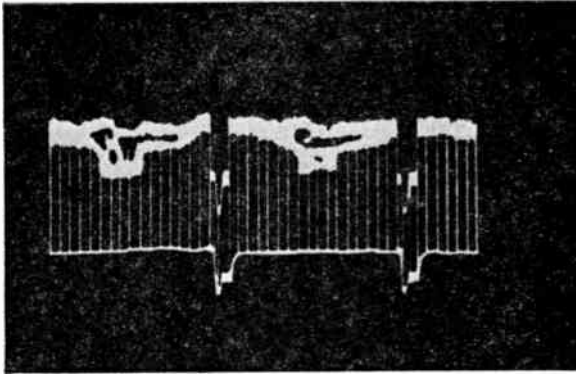

Fig. 139-4.

Fig. 139-4: Taken at the plate of the sync amplifier tube. The polarity has been inverted with respect to polarity in Fig. 139-3. The peak-to-peak voltage of this amplifier output waveform actually is about four times as great as voltage at the input to the tube.

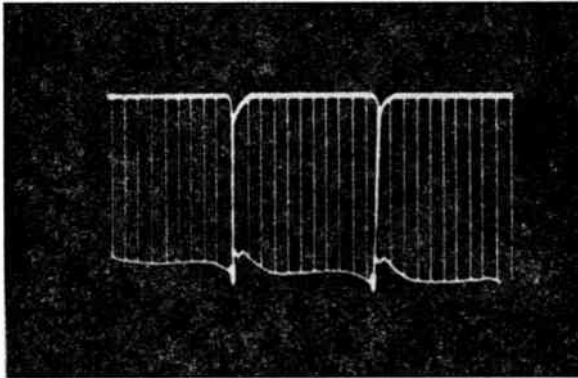

Fig. 139-5.

Fig. 139-5: Taken at the plate of the second tube in the sync section, which is operated as a separator. Picture variations have all but disappeared from the signal, while the vertical sync pulses have been retained. Polarity has not been inverted, because signal input is to the cathode rather than the grid of this separator.

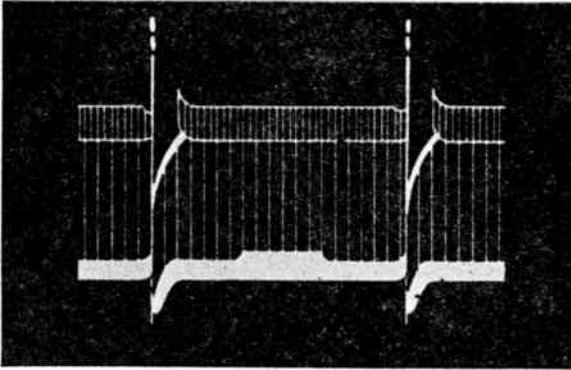

Fig. 139-6.

Fig. 139-6: Taken at the plate of the third tube in the sync section, which is operated as a clipper. Polarity has been inverted with respect to that of Fig. 139-5. Vertical sync pulse voltage peaks have become very pronounced. This is the signal which goes to the integrating filter located between the sync clipper and the input for the vertical sweep oscillator.

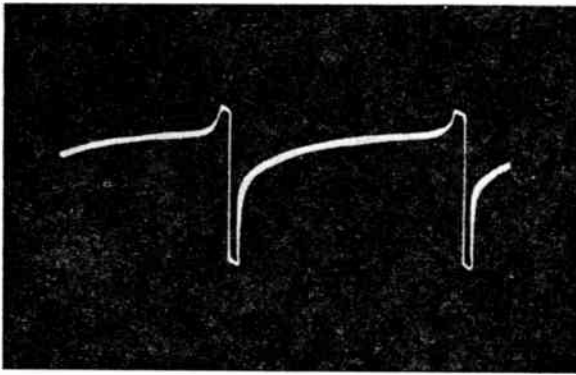

Fig. 139-7.

Fig. 139-7: Taken at the grid of the vertical sweep oscillator, which is a blocking type. Note the sudden changes of potential in the negative direction, downward on the trace, as the oscillator blocks. Then comes the quick partial recovery in the positive direction and the more gradual change preceding the positive peak that triggers this oscillator.

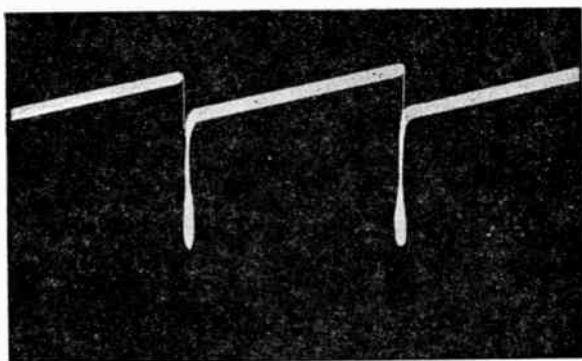

Fig. 139-8.

Fig. 139-8: Taken at the grid of the vertical sweep amplifier which follows the vertical oscillator. This is the sawtooth voltage combined with negative (downward) peaks as required for magnetic deflection.

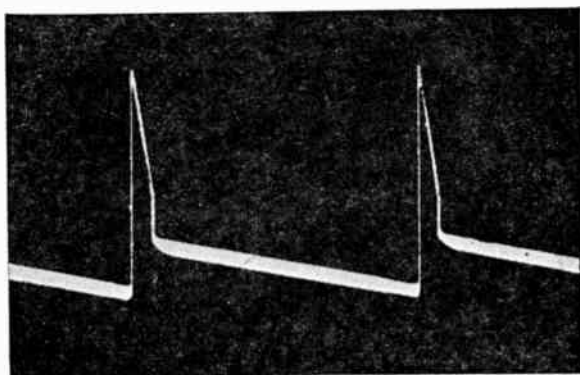

Fig. 139-9.

Fig. 139-9: Taken at the plate of the vertical sweep amplifier. Polarity has been inverted with respect to the previous trace, taken at the grid of the same tube. Peak-to-peak voltage here is about 18 times as great as at the grid.

Fig. 139-10: This final trace for the vertical deflection system is taken from the circuit which includes the secondary winding of the vertical output transformer and the two ver-

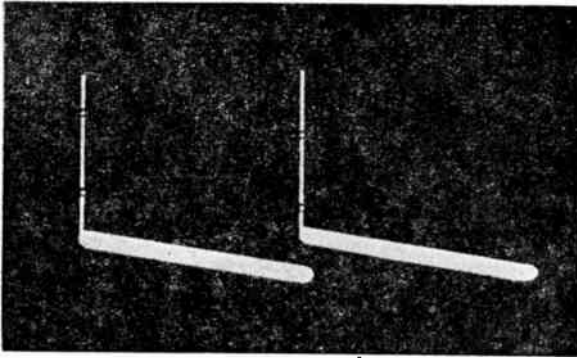

Fig. 139-10.

tical deflection coils of the yoke on the picture tube. Peak-to-peak voltage is between one-ninth and one-tenth of that at the plate of the vertical sweep amplifier, which connects to the primary of the output transformer.

Traces which are to follow in Figs. 139-11 to 139-24 are taken with the internal sweep of the oscilloscope adjusted for 7,875 cycles per second or to the frequency which produces two horizontal line periods. All these traces show waveforms associated with horizontal sync pulses and horizontal deflection voltages.

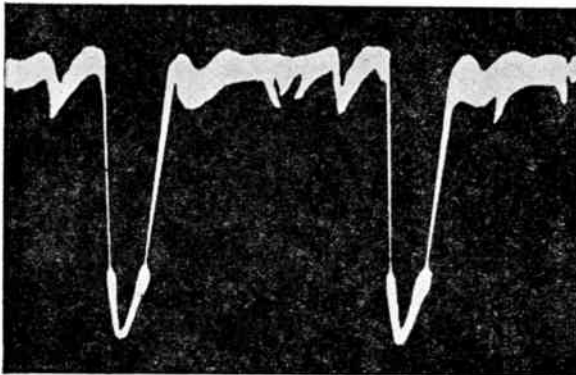

Fig. 139-11.

Fig. 139-11: From the top of the video detector load resistor. Here are two horizontal sync pulses of negative polar-

ity, also the horizontal blanking intervals, and the picture variations occurring between the blanking intervals.

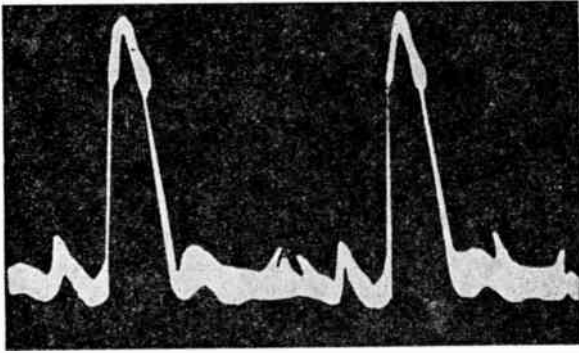

Fig. 139-12.

Fig. 139-12: From the plate of the video amplifier tube. Except for inversion of polarity this trace is similar to the one taken from the grid of this tube. Peak-to-peak voltage has been increased about nine times.

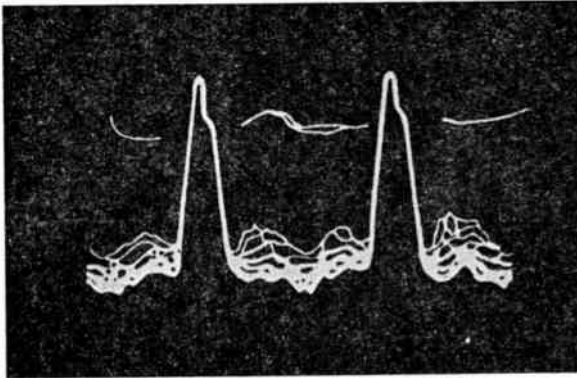

Fig. 139-13.

Fig. 139-13: From the grid of the sync amplifier, the first tube in the sync section. This signal comes from the output of the video amplifier, and is of the same polarity as in Fig. 139-12.

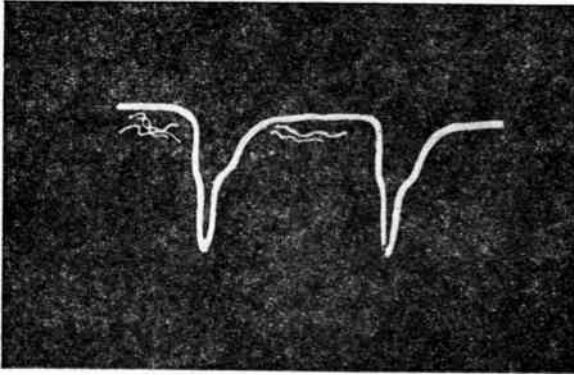

Fig. 139-14.

Fig. 139-14: From the plate of the sync amplifier. Polarity has been inverted. Voltages for picture variations have very nearly disappeared, while horizontal sync pulses have become distinct.

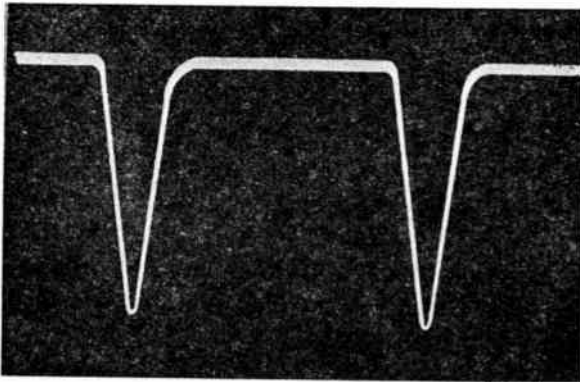

Fig. 139-15.

Fig. 139-15: From the plate of the sync separator tube. Only the horizontal sync pulses now remain. There has been no inversion of polarity, due to use of cathode input to this tube.

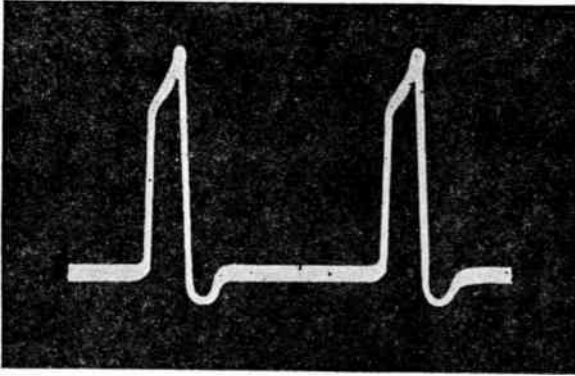

Fig. 139-16.

Fig. 139-16: From the plate of the sync clipper tube. This waveform is the input to the differentiating filter located between the clipper and the horizontal oscillator control tube of the horizontal afc system.

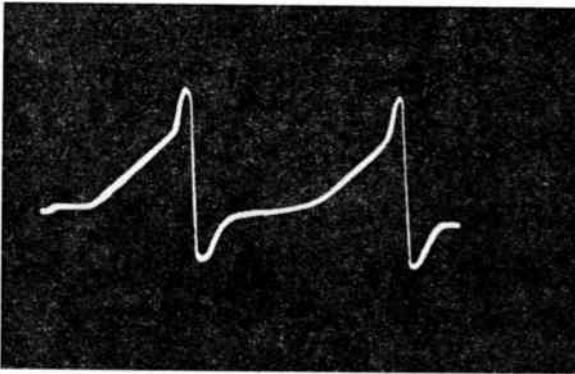

Fig. 139-17.

Fig. 139-17: From the top (ungrounded side) of the lock-in control capacitor in the grid circuit of the control tube of the horizontal afc system. This voltage results from combination of the output from the differentiating filter and a feedback voltage from the horizontal sweep output circuit, as required for this method of oscillator control. The waveform shown here is taken while a transmitted television signal is being received. The sharp or narrow positive peaks

represent synchronizing voltages which result from horizontal sync pulses in the signal.

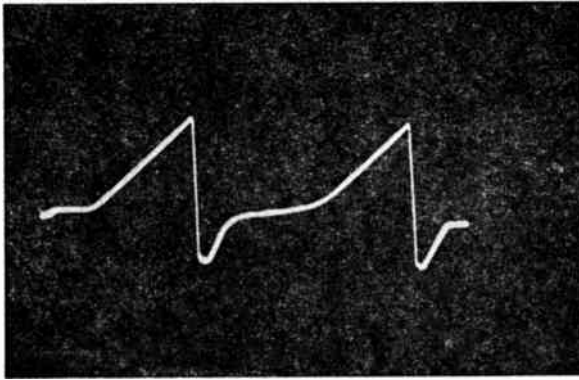

Fig. 139-18.

Fig. 139-18: This is the same as the previous trace, except that it is taken while no transmitted signal is being received. Note the absence of positive synchronizing peaks at the tops of the sawtooth portions of the wave.

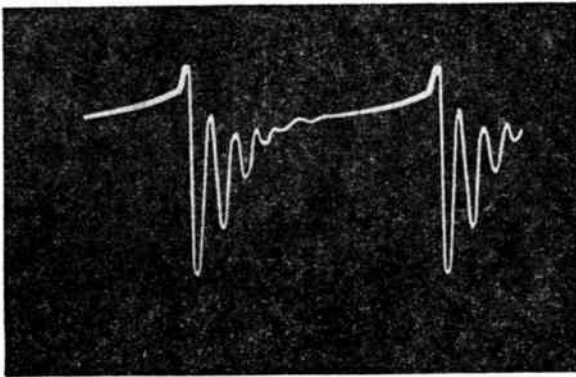

Fig. 139-19.

Fig. 139-19: From the grid of the horizontal sweep oscillator. Average grid voltage is controlled by biasing effect developed in the grid-cathode circuit of the control tube as explained in the article *Oscillator, Television Sweep, Control of* under the sub-heading *Triode Afc Control Tube*. The trace is taken while no signal is being received.

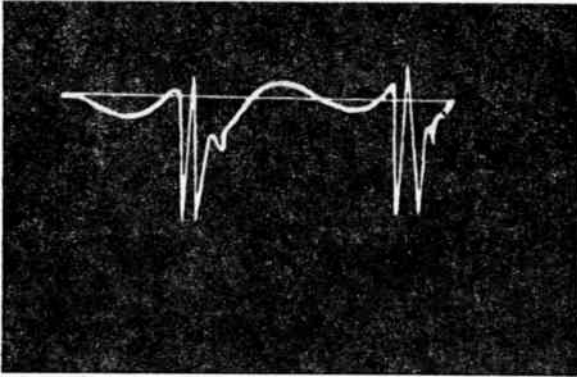

Fig. 139-20.

Fig. 139-20: From the plate of the horizontal sweep oscillator. This is the input for the transformer which is between the oscillator and the horizontal sweep amplifier tube. This trace is taken with no received signal.

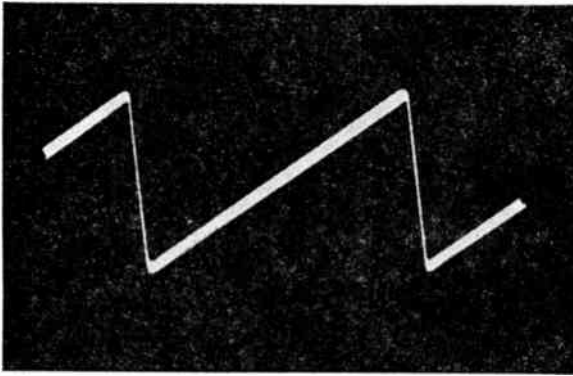

Fig. 139-21.

Fig. 139-21: This sawtooth voltage appears at the output of the transformer between oscillator and sweep amplifier. It is fed to the grid-cathode circuit of the sweep amplifier. The trace is taken with no received signal.

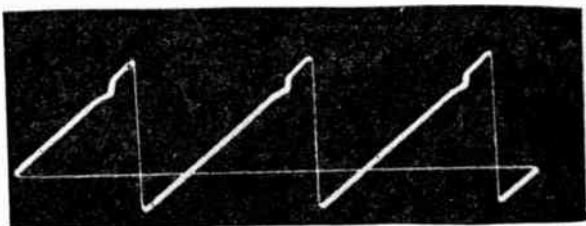

Fig. 139-22.

Fig. 139-22: From the grid of the horizontal sweep amplifier or output amplifier. No trace is taken from the plate of this tube because voltage there is too great for application to an oscilloscope without some suitable reducing means such as a high-voltage capacitive voltage divider.

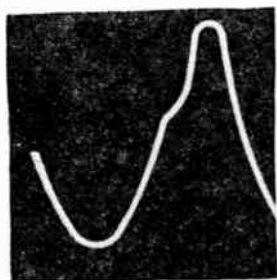

Fig. 139-23.

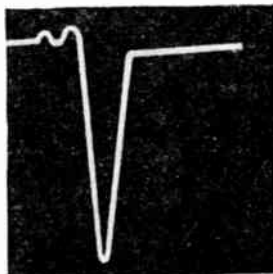

Fig. 139-24.

Fig. 139-23: From the cathode of the damper tube. This is the voltage applied to the input of the linearity control, which in this receiver is a variable inductor between the damper cathode and the primary winding of the sweep output transformer. No transmitted signal is being received.

Fig. 139-24: This is the voltage pulse appearing in the circuit containing the horizontal deflection coils of the yoke and the secondary winding of the horizontal output transformer. It is taken from the low side of the secondary winding. There is no received signal. A voltage of this form accompanies the sawtooth current in the deflection coils.

INDEX

A

- Absorption marker, 272
- Accompanying sound frequency, 247
- A-c resistance, 368-370
- Adjacent sound frequency, 247, 603
 - video frequency, 247, 603
- Adjustments, see *Controls*, also names of parts.
- A-f, see *Audio-frequency*.
- Agc systems, see *Gain control, automatic*.
- Alignment, 1-15
 - adapters for, 11
 - amplifier, r-f, 708-711
 - video i-f, 87-103
 - antenna coupling, 708-711
 - automatic gain control during, 265-266
 - check of, 13-15
 - controls for, 186
 - coupling to tubes for, 10-12
 - double-peaked transformers, 97-101
 - gain control during, 9, 265-266
 - instruments for, 2-10
 - intercarrier beat trap, 610
 - sound, 319, 321
 - oscillator, 321, 429
 - takeoff, 322
 - marker generator for, 7
 - matching pads for, 468
 - mixer circuit, 708-711
 - order of, 2, 91
 - oscillation during, 86
 - oscillator, 426-428
 - dual channel sound, 430
 - effects of, 426-428
 - intercarrier sound, 321, 429
 - intermediate frequency affected by, 426-428
 - oscilloscope use for, 4-8
 - overall check of, 13-15
 - overcoupled transformer, 97-101
 - override gain control during, 265-266
 - picture tube removal during, 10
 - regeneration during, 86
 - setups for, 8-10
 - single-peaked stages, 93-97
 - single stage method of, 103-106
 - sound system, 540-552
 - limiter used for, 546
 - takeoff, intercarrier, 322
 - stagger tuned stages, 93-97
 - transformer, overcoupled, 97-101
 - traps, intercarrier beat, 610
 - video i-f, 605-609
 - tube connections for, 10-12
 - tuner, 705-711
 - tuning wand for, 12-13
 - video i-f amplifier, 87-103
 - video i-f traps, 605-609
- Ampere-turns, 371
- Amplifiers
 - audio-frequency, square wave tests, 280-284
 - broad band, 16-18
 - deflection, see *Sweep amplifiers*.
 - direct coupled, 18
 - grounded grid, 21, 339, 662
 - high-frequency, 16-18, 662
 - radio-frequency, see *Radio-frequency amplifier*.
 - signal tracer type, 590
 - square wave tests of, 280-284
 - sweep, see *Sweep amplifiers*.
 - sync, 41-42
 - signal polarity in, 223
 - video, see *Video amplifiers*.

- Amplifiers (Cont.)
 - video intermediate-frequency, see *Video intermediate-frequency amplifier*.
- Amplitude modulation, 392-394
- Angstrom unit, definition, 339, 673
- Antennas
 - array, definition, 123
 - bays, definition, 127
 - broad band, 115-119
 - conical, 117
 - construction of, 130
 - couplings to, 20, 693-694
 - alignment of, 708-711
 - dipole, 108-115
 - directional properties of, 113-115
 - directors for, 121-123
 - fan type, 118
 - folded dipole, 116
 - guy wires for, 134
 - H-dipole, 118-119
 - height, effect of, 488
 - high-low band type, 124-126
 - impedance of, 128-130
 - indoor, 134
 - in-line type, 124
 - installation of, 133
 - interference traps on, 333-337
 - length of, 110-112
 - lightning arrester for, 133
 - location of, 131-133
 - meter for orienting, 132
 - mounting of, 133
 - orienting, 131-133
 - factors affecting, 113-115
 - reflections affecting, 490
 - reflections to, 489
 - reflectors for, 119-123
 - resonant frequency measurement, 336
 - stacked, 126-128
 - impedance of, 130
 - traps, interference, 333-337
 - two-band, 123-126
 - ultra-high frequency, 712
 - V-dipole, 117, 125-126
- ASA color code, capacitor, 155
- Aspect ratio, 516, 678
- Associated sound frequency, 247, 603
- Attenuation, receiver, 64-66, 598
- Audio, see *Sound*.
- Audio-frequency amplifier, square wave tests of, 280-284
 - generators, 269-270
- Automatic gain control, see *Gain control, automatic*.
- AWS color code, capacitor, 155

B

- Back coupling, see *Feedback*.
- Background, see *Brightness*.
- Baird color television, 574
- Balanced transmission line, 352
- Bands, frequency, 244
- Bars, blanking, trouble with, 653, 654
 - sound, trouble with, 626
- Bays, antenna, definition, 127
- Beam deflection, see *Deflection*.
- Beat frequency, 244-246
 - intercarrier, 248
 - mixer producing, 390-391
 - oscillators, 404-406
- intercarrier, traps for, 609
- interference, trouble with, 642-643
- Bench, service, 8, 314-315
- Bins
 - cathode, 138-140
 - bypass for, 139

Bias—(Cont.)
 degeneration with, 138-139
 feedback with, 210
 decoupling with, 141
 distortion due to, 136
 fixed, 140-143
 bypass for, 141
 contrast control with, 179
 degeneration with, 142
 selenium rectifier for, 142
 grid-leak, 143-145
 rectified heater current for, 179
 selenium rectifier for, 142, 179
 self, see *Bias, cathode*.
Black level, 526
 control from, 504-508
Blacker than black, 527
Blanking, 513-515
 bars, trouble with, 653, 654
Blocking oscillator, 434-437
 discharge tube with, 436
 input waveform to, 718
Boosters, television, 479-481
Boosting, voltage, damper for, 195-197
Brass slug adjustment, 705
Bridge, Weln, oscillator with, 270
Brightness, 145-150
 contrast relation to, 148-150
 controls, 146-150, 183
 grid voltage for, 667
 excessive, effects of, 148-149
 trouble with, 629
Brilliance, see *Brightness*.
Broad band amplifiers, 16-18
Broadening resistors, 71
Buzz, intercarrier, 320
 causes for, 622
Bypass, capacitors for, 201
 cathode bias, 139
 fixed bias, 141
Bypassing, see *Decoupling*.

C

Calibration, harmonics for, 302
Cameras, color, 571
Capacitance, 150-160. See also *Capacitors*.
 color codes for, 154-157
 distributed, 310
 loss from, 368
 factors in, 151, 152
 farad of, 151
 formulas for, 152
 measurement of, 372-373
 parallel, 152
 series, 152-153
 tube and circuit, 70
 voltage divider with, 228-229
Capacitive couplings, 81
 reactance, formulas for, 491
 time constants, 170-173
Capacitors, 150-160. See also *Capacitance*.
 bypass, 201
 bypassing of, 160, 202
 ceramic, 159
 color codes for, 157
 color codes for, 154-157
 decoupling, 201
 dielectrics for, 224
 inductive, 160
 mica, 158-159
 color codes for, 154-156
 non-inductive, 160
 paper, 151, 160
 parallel capacitance of, 152
 power factor of, 224
 r-f bypasses for, 160-202
 series capacitance of, 152-153
 voltage division in, 153-154
 temperature compensating, 153
 oscillator use of, 416

Carrier frequencies, 167
 sound, 248
 video, 249
Capacity, see *Capacitance*.
Cathode bias, 138-140
 bypass for, 139
 degeneration with, 138-139
 feedback with, 210
 follower, 338-339
 input, picture tube, 55-56
 -plate series circuits, 477-479
CBS color television, 565-569, 571
Center frequency, 247, 394
Centering, 161-166
 controls for, 162-166, 184
 oscilloscope, 460
 electrostatic, 162
 focus coil effect on, 165
 magnetic, 163-165
 trouble with, 630
Ceramic capacitors, 159
 color codes for, 157
Channels, frequency in, 247
 frequency distribution in, 598
 selector for, see *Tuners*.
 television, 166-167, 524
Characteristic impedance, 355
Clipper, sync, 167-169
Coatings, picture tube, 665
Coaxial line, 353
Codes, color, capacitor, 154-157
Coils
 constructions for, 310-311
 distributed capacitance of, 310, 368
 frequency adjustment of, 705
 hairpin, adjustment of, 705-706
 inductance formulas for, 308
 turns required for inductance, 308
Color television, 563-579
 Baird system of, 574
 cameras for, 564, 571
 CBS system of, 565-569, 571
 colors required for, 563
 CTI system of, 570, 576-579
 dichroic mirrors for, 572-573
 filters for, 564
 projection methods of, 565
 RCA system of, 570-571, 572-574
 rotating disc for, 565, 569
 switching methods for, 565
 three-gun method of, 575
 wavelengths of colors, 340, 672
Colpitts oscillators, 411-412, 423
Columbia Broadcasting System color television, 565-569, 571
Compensating capacitors, temperature, 158
Compensation, high-frequency, 49-54
 low-frequency, 48
 temperature, 158, 416
Component, d-c, see *Restoration, d-c*.
Composite signal, television, 523-531
 waveform of, 715, 716
Condensers, see *Capacitors*.
Conical antenna, 117
Constants, time, see *Time constants*.
 velocity, transmission line, 356
Contact potential, 471
Contrast, 176-182
 brightness relation to, 148-150
 controls, 178-182
 bias adjustment for, 179
 cathode bias for, 180
 grid input type, 178, 181
 rectified heater current, 179-180
 d-c component effect on, 496
 high, causes and remedies for, 631
 effect of, 149-150
 low, causes and remedies for, 632

D

- Controls, 182-186**
 alignment types of, 186
 automatic gain, see *Gain control, automatic*.
 background, see *Brightness*.
 black level, 504-508
 brightness, 146-150, 183
 grid voltage for, 667
 brilliancy, see *Brightness*.
 centering, 162-166, 184
 oscilloscope, 460
 trouble with, 630
 contrast, 178-182
 bias adjustment for, 179
 cathode bias for, 180
 grid input type, 178, 181
 drive, 185, 231-235
 adjustment of, 234-235
 capacitor type, 40, 233
 resistor type, 37, 232
 fine tuning, 182, 238, 239
 effect of, 428
 focus, 184, 240-244
 electrostatic, 240
 magnetic, 241-244
 oscilloscope, 460
 trouble with, 634
 framing, see *Centering*.
 gain, see *Gain control, automatic*.
 height, 531-536
 trouble with, 650
 hold, 183, 303-307
 action of, 433
 adjustment of, 306
 intensity, see *Brightness*.
 oscilloscope, 460
 linearity, see *Linearity*.
 operating types of, 182-183
 peaking, 33, 185
 service types of, 184-186
 size, see *Size controls*.
 sweep oscillator, see *Sweep oscillator, automatic frequency control*.
 volume, 183
 width, 531-536
 drive control for, 234
 trouble with, 651
- Conversion gain, 392**
 interference, 330-331
 metric measurements, 389
 transconductance, 392
- Converters, see Mixers**
 ultra-high frequency, 712
- Cores, adjustment of, 705**
 Corner cutting, causes and remedies, 649
- Couplings. See also Transformers**
 adjustable, transformer, 107
 antenna, 20, 693-694
 capacitive, 81
 frequency measurement of, 105-106
 resistance, 79
- Crosshatch (pattern) generator, 277**
- Crystals**
 diodes, 189-191
 d-c restoration with, 502
 detector probes using, 481-486
 detectors using, 189-191, 224
 meters using, 388
 testing of, 191
 frequency control, 186-189
 dual frequency, 187
 generators with, 271
 oscillators with, 187-189
 piezoelectric, 186-189
 quartz, 186-189
- CTI color television, 570, 576-579**
- Current, eddy, 369**
 feedback, 210-211
- Cutoff, picture tube, 667**
 plate current, 137
- Cutting of picture, 649**
- Dampers and damping, 191-198**
 action of, 195
 connection of, 194
 linearity control on, 367
 oscillation suppressed by, 192-194
 purpose of, 36
 triode type, 197
 vertical deflection, 192
 voltage boosting by, 195-197
 waveforms at, 196
- D-c component, 493-494**
 reinsertion, see *Restoration, d-c*.
 restoration, see *Restoration, d-c*.
- Decoupling, 198-203**
 bias resistor, 141
 capacitors for, 201
 dressing affecting, 230-231
 grounding for, 299
 heater circuit, 86, 203
 plate circuit, 202
 resistors for, 201
 screen circuit, 202
- Definition poor, causes and remedies, 633**
- Deflection**
 amplifiers, see *Sweep amplifiers*.
 angles of, 670
 beam, 668-670, 683-685
 distance of, 668-669, 685
 electrostatic, 203-205, 683, 685
 inverters for, 338
 magnetic, 205-209
 action of, 163
 centering with, 163-165
 yoke for, 205-208
 plates, positions of, 204
 yoke, 205-208
- Degeneration, 200, 209-213. See also Feed-back**
 cathode bias, 138-139
 cathode resistor for, 210
 current feedback for, 210-211
 fixed bias, 142
 voltage feedback for, 212
- Delayed automatic gain control, 253-255**
- Demodulators, see Detector, ratio and Discriminator, sound**
- Detail controls, see Focus controls**
 indistinct, causes and remedies, 633
- Detector**
 crystal, 189-191, 224. See also *Crystal diodes*.
 first, see *Mixers*.
 phase, 213-14
 sweep oscillator control with, 445-447
 probes, 481-486
 signal tracer type, 590
 use of, 485
 ratio, 214-220
 alignment of, 547-549
 circuit of, 544
 output waveform from, 542
 S-curve of, 549
 video, see *Video detector*.
- Deviation, frequency, 394-395**
- Diathermy interference, 638**
- Dielectric mirrors, color television, 572-573**
- Dielectric, 224**
 constants of, 225
 hysteresis, 368
 loss, 368
 factor, 224
 power factor, 225
 strength, 315-316
- Differentiating filters, 235-238**
- Diodes, crystal, see Crystal diodes**
- Dipole antennas, see Antennas**
- Dips, marker, 7, 272**
- Direct coupled amplifiers, 18**
- Directional properties, antenna, 118-115**

Directors, antenna, 121-123
Disc, rotating, color television, 565-569
Discharge tube, oscillator with, 436
Discriminator, 225-228
 sound, alignment of, 547-549
 circuit of, 544
 limiter for, 340-345
 output waveform of, 542
 S-curve of, 549
 sweep oscillator control, 443-445
Distance, reception, 488
Distortion, bias causing, 136
 square wave testing of, 282-284
Distributed capacitance, 310
 loss due to, 368
Distribution control, see *Linearity*.
Dividers, voltage, 228-229
Double-magnet ion traps, 611-614
 -peaked transformers, 78-84
 alignment of, 97-101
 frequency measurement of, 105-106
 -V dipole antenna, 117
Doublers, frequency, 397
 voltage, 397-399, 473-475
Dressing, wires and parts, 230-231
Drift, frequency, 158
 oscillator, 415
Drive controls, 185, 231-235
 adjustment of, 234-235
 capacitor type, 40, 233
 resistor type, 37-232
Dual-channel sound, 537-540
 i-f amplifier affected by, 87-88
Dynatron oscillator, 417

E

ECO, electron coupled oscillator, 406
Eddy currents, 369
Edge effect, capacitor, 152
Effective resistance, 368-370
Electromagnetic waves, 108-109, 486-487
Electron coupled oscillators, 406
Electron gun, 664-665
Electronic switch, 552-557
 operating, 554
 phase shift check with, 556
 square waves from, 557
 uses of, 555-557
Electronic voltmeter, 376-382
 current measurement with, 381
 detector probe for, 481-486
 gain measurement with, 268
 principles of, 376-379
 probes for, 481-486
 uses of, 379-382
Electrostatic deflection, 203-205
 centering with, 162
 linearity in, 366
 focusing, 240
 picture tubes, 683-685
 plate positions in, 204
 shielding, 521
 sweep amplifiers, 23-30
 unit of capacitance, 151
Elongation effect, capacitor, 152
Equalizing pulses, 528
Eye, luminous sensitivity of, 672

F

Faceplate, neutral density, 675
Fan antenna, 118
Farad, definition, 151
Feedback
 current, 210-211
 degenerative, 200
 dressing affecting, 230-231
 negative, cathode bias, 138-139

Feedback—(Cont.)
 oscillators, 403, 407-415
 regenerative, 200
 tickler, 412-413
 video i-f amplifier, 84-87
 voltage, 212
Fields, 515-516
 frequency of, 248, 515
 color television, 565-567, 569-570
Filter, differentiating, 235-238
 high-voltage power supply, 666
 integrating, 235-238
 light, 564
 probe, 486
 screens, picture tube, 674
Fine tuning control, 182, 238-239
 effect of, 428
First detector, see *Mixer*.
Fixed bias, 140-143
 bypass for, 141
 contrast control with, 179
 degeneration with, 142
 selenium rectifier for, 142
Fluorescence, definition, 673
Flux, magnetic, 370
Flyback power supply, 472-475
F-m, see *Frequency modulation*.
Focusing, 239-244
 coil, centering effect of, 165
 controls, 184, 240-244
 oscilloscope, 460
 electrostatic, 240
 magnetic, 241, 244
 trouble with, 634
Folded dipole antenna, 116
 picture or pattern, 635, 636
Follower, cathode, 338-339
Frames, 515-516
 frequency of, 248, 515
 color television, 567, 569-570
Framing control, see *Centering*.
Frequency
 accompanying sound, 247, 603
 adjacent sound, 247, 603
 video, 247, 603
 adjustments, tuner, 705-706
 associated sound, 247, 603
 bands of, 244
 beat, 244-246
 intercarrier, 248
 mixer producing, 390-391
 oscillators, 404-406
 carrier, 167
 sound, 248
 video, 249
 center, 247, 394
 channel, 166-167, 247
 compensation, 48-54
 controls, see *Hold controls*.
 crystals for, 186-189
 sweep oscillator, see *Sweep oscillator*,
 automatic frequency control for.
 deviation, 394-395
 drift, oscillator, 415
 temperature effect on, 158
 field, 248, 515
 frame, 248, 515
 fundamental, 300
 harmonic, 300-302
 intercarrier beat, 248, 609
 intermediate, 61-63
 sound, 249
 video, 94-95, 249
 line, 248, 515
 meters, 382-384
 grid dip meter as, 388
 heterodyne, 382
 modulation, 395. See also *Sound*.
 deviation in, 394-395
 discriminator, 225-228. See also *Discriminator*.

Frequency modulation—(Cont.)
interference from, 642-643
limiter for, 340-345
modulation frequency for, 395
ratio detector, 214-220. See also *Ratio detector*.
multipliers, 397
names of, 244
peaking, measurement of, 105-106
response, corrections for, 4
inversion of, 63
measurement of, 3-8
overall, 13-15, 101-103
overcoupled transformer, 83
r-f amplifier, 16
single stage, 103-106
square wave test for, 292-293
trouble shooting with, 659
tuner, 708-709
video amplifier, 16, 44
video i-f amplifier, 16, 64, 598-599
 markers on, 102
 overall, 101-103
 trap effect on, 608
 sound carrier, 248
 intermediate, 249
 standard, 246
 trap, 602-605
 ultra-high, 711
 video, 249
 carrier, 249
 intermediate, 61-63, 94-95, 249
 wavelength relation to, 111, 249
Front end. See *Radio-frequency and Tuners*.
Fuse, damper circuit, 197

G

Gain control, automatic, 250-266
amplifiers for, 256-257
delayed, 253-255
gated, 261-265
interference effect on, 259-261
keyed, 261-265
noise effect on, 259-261
 limiters in, 260
 override during alignment, 265-266
 r-f stage, 257-259
 time constants for, 259-261
Gain, conversion, 392
formulas for, 267
high-frequency compensation for, 49-54
load line for determining, 267
measurement of, 268
overall, check of, 13-15
single stage, 103-106
stage, 267-269
video i-f amplifier, 70-73
Gaseous tube oscillator, 420
Gated automatic gain control, 261-265
Generators. See also *Oscillators*.
audio-frequency, 269-270
crystal controlled, 271
marker, 272-277
 alignment with, 7
 coupling of, 274
 uses of, 276-277
 pattern, 277
 signal, 277
 calibrating of, 302
 gain measurement with, 268
 matching pads for, 468
 square-wave, 278-284
 electronic switch as, 557
 sweep, see *Sweep generator*.
 television, 298
Germanium crystal diodes, see *Crystal diodes*.
Ghosts, 498-490, 637
Grid bias, see *Bias*.
dip meters, 384-388

Grid dip meters—(Cont.)
frequency measurement with, 387
heterodyne frequency meter, 386
modulation of, 387
resonance measurement with, 386
input, picture tube, 56
-leak bias, 143-145
rectification bias, 143-145
Grounded grid amplifier, 21, 389, 662
Grounding, 298-300
 chassis, through power line, 9
 test instrument, 8, 314-315
Gun, electron, 664-665
Guy wires, antenna, 134

H

Hairpin coils, adjustment of, 705-706
Half-wave antennas, 108-116
 resonant lines, 246-352
Harmonics, 300-302
 calibration with, 302
Hartley oscillator, 410-411
H-dipole antenna, 118-119
Heaters, decoupling of, 86, 203
Height controls, see *Size controls*.
 trouble with, 650
Herringbone pattern, 638
Heterodyne frequency meter, 382
 grid dip meter as, 386
High-frequency
 amplifiers, 16-18
 compensation, 49-54
 losses, 368-370
 measurements, 372-374
 grid dip meter for, 387
 oscillators, 455-456
 resistance, 368-370
 resistors, 492
 tubes, 660-663
 voltmeters, 388-389
High-voltage measurements, 374
 power supply, see *Power supply, high-voltage*.
Hold controls, 183, 303-307
 action of, 433
 adjustment of, 306
 trouble with, 645, 647, 655
Horizontal
 blanking bar in picture, 654
 hold controls, 183, 303-307
 filter, 235-238
 polarization, 487
 retraces, 513
 size controls, see *Size controls*.
 sweep, amplifiers, see *Sweep amplifiers*.
 damping for, 191-198
 oscillators, see *Sweep oscillators*.
 sync, pulses, traces of, 43
 troubles, 626
 waveforms of, 720-724
Hum (picture) causes and remedies, 628
Hysteresis, dielectric, 368
 loss, 370

I

I-f, see *Intermediate-frequency*.
Image, division of in scanning, 510-516
 impedance, 355
 multiple, causes and remedies, 637
Impedance, 307
 antenna, 128-130
 characteristic, image, iterative, 355
 matching, line sections for, 360
 pads for, 468
 stubs for, 357-360
 transmission line, 357-360
 surge, 355
 transmission line, 354-356

Indoor antennas, 134
 Inductances, 308-309. See also *Coils*.
 measurement of, 309, 372-373
 parallel and series, 311
 Inductive reactance, formulas for, 491
 time constants, 173-174
 Inductors, see *Coils*.
 Inductuner, 691-692, 704
 Inputuner, circuits of, 704
 Installation, receiver, 312
 Instruments, service, 812-815. See also *names of instruments*.
 alignment types of, 2-8
 set up of, 8-10
 grounding of, 8, 314-315
 Insulation characteristics, 315-316
 Integrating filters, 235-238
 Intensity controls. See *Brightness*.
 oscilloscope, 460
 modulation, oscilloscope, 465
 Inter-carrier beat, frequency of, 248, 609
 traps for, 609
 buzz, 320, 622
 Inter-carrier sound, 316-322, 536
 alignment with, 319-321
 oscillator, 321, 429
 takeoff, 322
 i-f amplifier for, 89
 shelf on response, 102-103
 traps for, 609
 video i-f response for, 102
 Interchannel interference, 329-331
 Interference, 322-337
 antenna orientation for, 113-114
 automatic gain affected by, 259-261
 beat, causes and remedies, 642-643
 conversion, 330-331
 frequency-modulation, 642-643
 identification of, 328-333
 interchannel, 329-331
 radio-frequency, 326-332, 642-643
 frequency of, 327-332
 spark types of, 323-325
 television receiver oscillator, 328
 tests for, 332
 transmission line pickup of, 333
 traps for, see *Traps*.
 Interlacing, 514, 516, 529
 Intermediate frequency, 61-63
 amplifiers, see *Video intermediate-frequency amplifiers*.
 sound, 249
 video, 94-95, 249
 Inverse feedback, see *Degeneration*.
 Inverters, 337-339
 sweep amplifier with, 24-26
 Ion traps, 610-616
 adjustment of, 615
 double-magnet, 611-614
 single-magnet, 614
 Isolating transformer, 9
 Iterative impedance, 355

J

JAN color code, capacitors, 155

K

Keyed automatic gain control, 216-265
 Kinescope, see *Picture tube*.

L

Leakage, surface, 315-316
 Levelers, sync, 168
 Levels, black and white, 526
 Light, 339
 Lightning arrester, antenna, 133

Limiters, f-m sound, 340-345
 action of, 343-344
 alignment with, 546
 grid bias effects on, 341-344
 signal strength for, 344
 time constants for, 345
 noise, diodes for, 260
 sync, 167-169
 Line, load, gain determined from, 267
 of sight transmission, 488
 picture, 515
 color television, 568-570
 formation of, 525
 frequency of, 248, 515
 resonant, see *Resonant line*.
 stubs, 346-352
 traps from, 335-337
 transmission, see *Transmission line*.
 voltage, standard, 9
 Linearity, 363-368
 control, 185, 363-369
 amplifier bias for, 366
 damper circuits, 37, 196-198, 367
 drive control for, 232-233
 electrostatic sweep, 27, 28
 inductor for, 366
 sweep amplifier, 34
 trouble with, 639, 640
 electrostatic deflection, 366
 horizontal, trouble with, 639
 test pattern for observing, 469-470
 trouble with, 639, 640
 vertical, peaking effect on, 33
 sweep amplifier bias for, 34
 trouble with, 640
 Litz, wire, use of, 311
 Load line, gain determined from, 267
 Local oscillator, see *Oscillators*.
 Lock-in control, 453
 Loss, dielectric, 368
 factor, dielectric, 224
 high-frequency, 368-370
 Low-frequency compensation, 48
 Low-voltage power supply, 476-479

M

Magnetic
 centering, 163-165
 focus coil action on, 165
 trouble, 630
 circuits, 370-372
 deflection, 205-209
 action of, 163
 centering with, 163-165
 yoke for, 205-208
 focusing, 241-244
 hysteresis loss, 370
 picture tubes, see *Picture tubes*.
 shielding, 522
 sweep amplifiers, see *Sweep amplifiers*.
 Magnetomotive force, 370
 Magnifiers, size, 533-536
 Marker, 7, 272
 generator, 272-277
 alignment with, 7
 coupling of, 274
 uses of, 275-277
 video i-f positions for, 62, 102
 Mask, picture tube, sizes of, 674-677
 Matching, impedance, line sections for, 360
 pads for, 468
 stubs for transmission line, 357-360
 transmission line, 357-360
 Measurements, high-frequency, 372-374
 high-voltage, 374
 resonance methods for, 372
 Meissner oscillator, 414
 Merit figure, tube, 660

Metal cone picture tubes, see *Picture tubes*.

Meters

- antenna, 132
- electronic volt, see *Electronic voltmeter*.
- frequency, 382-384
 - heterodyne, 382
- grid dip, see *Grid dip meters*.
- high-frequency, 388
- ohm, 402-403
- rectifier, 388
- thermocouple, 389
- volt, see *Voltmeters*.
- wavelength, frequency equivalents, 111

Metric conversions, 389

Mica capacitors, 158-159

- color codes for, 154-156

Microphonic tubes, trouble with, 626

- Millimicron, definition, 340

Mirrors, dichroic, 572-573

Mixers, 390-392

- alignment of, 708-711
- beat frequencies in, 390-391
- functions of, 583
- oscillator coupling to, 695
- rectification in, 391

Modulation, amplitude, 392-394

- frequency, see *Frequency modulation*.
- intensity, oscilloscope, 465
- percentage of, 393
- phase, 396

Movement, picture, causes and remedies, 645-647

Multiple images, causes and remedies, 637

Multipliers, frequency, 397

- voltage, 397-399, 473-475

Multivibrator, 419, 437-441

- sweep oscillator control by, 447-449

N

Negative feedback, see *Degeneration*.

- peaking, omission of, 39
- production of, 31-33, 39-40
- resistance oscillators, 417
- transmission, 594

Neon tube oscillator, 421

Networks, differentiating and integrating, 235-238

Neutral density faceplates, 675

Noise, gain control affected by, 259-261

- limiter diodes for, 260
- ratio of, 401
- thermal and tube, 400

Non-inductive capacitors, 160

O

Ohmmeters, 402-403

Open lines, resonant, 349-351

Oscillation, deflection circuit, 192-194

- square wave test for, 284

video i-f amplifier, 84-87

Oscillators, 403-456. See also *Generators*.

- beat-frequency, 404-406
- blocking, 434-437
 - discharge tube with, 436
 - input waveform to, 718

Colpitts, 411-412, 423

crystal, 187-189

- frequency multipliers with, 397

drift in, 415

dynatron, 417

electron coupled, 406

feedback, 403, 407-415

- tickler type of, 412-413

frequency drift in, 415

gaseous tube, 420

grid dip, see *Grid dip meter*.

Hartley, 410-411

high-frequency, 455-456

Meissner, 414

multivibrator, 419, 437-441

Oscillators—(Cont.)

negative resistance, 417

neon tube, 421

Pierce, 271-272

Potter, 437-441

principles of, 403

push-pull, 425, 698

relaxation, 419-421

resonant line, 425-426

sweep, see *Sweep oscillator*.

television r-f, 421-431

alignment of, 428-431

effect of, 67, 426-428

intercarrier sound, 321

mixer coupling for, 695

tuning effect of, 426-428

temperature compensation in, 416

tickler feedback for, 412-413

time constant operation of, 419-421

tubes for, 404

tuned grid, 413

grid and plate, 414

line, 425-426

plate, 413

ultra-high frequency, 455-456

ultraudion, 414

Oscillograph, see *Oscilloscope*.

Oscilloscope, 456-467

- adjustments of, 467
- alignment use of, 4-8
- centering control, 460
- connections to, 455-466
- controls of, 459-465

detector probe for, 481-486

direct voltage observation with, 556

electronic switch with, 552-557

external synchronizing, 466-467

filter probe for, 486

focus control, 460

frequency controls of, 463

gaseous tube oscillator for, 420

intensity control of, 460

modulation of, 465

inversion of traces on, 289-290

operating, 465-467

parts of, 457-459

phase shifting for, 294-295

probes for, 481-487

reversal of traces on, 289-290

sweep generator used with, 5-7

sweep selector of, 462

synchronizing control of, 464-465

terminal connections to, 459-465

trace inversion and reversal, 289-290

waveform inspection with, 713-714

Orienting antenna, 113-115, 131-133

Overall response, 13-15

video i-f amplifier, 101-103

Overcoupled transformers, alignment, 97-

101

frequency measurement of, 105-106

video i-f, 78-84

Override gain control, 265-266

P

Pads, matching, 468

Paper capacitors, 160

Parasitic elements, definition, 123

Pattern, generators for, 277

test, 469

trouble shooting with, 624-658

Peaking controls, 185

drive control for, 232-233

frequency, square wave test of, 283

negative, linearity affected by, 33

omission of, 39

production of, 31-33, 39-40

Pedestal, signal, 527

Permeability, 371

Persistence, phosphor, 673-674

- Phase control, sweep oscillator, 445
 - detector, 213-214
 - sweep oscillator control by, 445-449
 - inverter, sweep amplifier, 24-26
 - modulation, 396
 - shift, electronic switch measurement, 556
 - square wave test of, 283
 - sweep generator, 294-295
 - Phosphorescence, definition, 673
 - Phosphors, picture tube, 672-674
 - Picture negative, detector output for, 55
 - positive, detector output for, 54
 - reproduction, scanning, 510-516
 - tilted, correction of, 205, 209
 - trouble shooting by analysis of, 624-658
 - Picture tubes, 663-685
 - action in, 585-586
 - alignment removal of, 10
 - bases of, 671, 684
 - black face, 674
 - brightness of, 667
 - cathode input to, 55-56
 - color, three-gun type, 575
 - construction of, 664-666
 - cutoff of beam in, 667
 - deflection in, 668-670, 683-685
 - electrostatic, 683-685
 - plate positions in, 204
 - external coating of, 665
 - fastenings of, 677-681, 685
 - grid input to, 56
 - handling of, 677
 - input polarity effects in, 54-57
 - magnetic, 664-683
 - mask sizes for, 675-677, 684
 - metal cone, 666
 - mountings for, 677-681, 685
 - numbering of, 670
 - phosphors for, 672-674
 - rectangular, 670, 676, 677, 682
 - reflections in, 674
 - removal and replacement of, 678-682
 - screens for, 672-674
 - sizes of, 675-677, 684
 - substitutions of, 682-683
 - type numbers for, 670
 - voltages for, 667, 684-685
 - Pierce oscillator, 271-272
 - Piezoelectric crystals, 186-189
 - Pips, marker, 7, 272
 - Plate current cutoff, 137
 - saturation, 137
 - decoupling, 202
 - Plateau, intercarrier sound, 102-103, 320
 - Polarity, signal, picture tube, 222
 - video detector, 220, 222
 - sync pulses, 223
 - Polarization, wave, 487
 - Position controls, see *Centering*.
 - Positive transmission, 595
 - Potential, contact, 471
 - Potter sweep oscillator, 437-441
 - Power factors, dielectric, 225
 - Power supply
 - high-voltage, 471-476
 - filters for, 666
 - flyback type, 472-475
 - pulse operated, 472-475
 - r-f type, 475
 - voltage multiplier for, 473-475
 - low-voltage, 476-479
 - series tubes on, 477-479, 545, 549
 - Preamplifiers, television, 479-481
 - Probes, detector, 481-486
 - signal tracer type, 590
 - use of, 485
 - filter, 486
 - Propagation, wave, 108-109, 486-490
 - Pulse operated power supply, 472-475
 - Pulses, equalizing, 528
 - sync, action of, 433-434
 - oscilloscope traces of, 43
 - polarity of, 223
 - separation of, 517-521
 - takeoff for, 517-521
 - Push-pull oscillator, 425, 698
 - sweep amplifier, 24
- Q**
- Quarter-wave resonant lines, 346-352
 - Quartz crystals, 186-189
- R**
- Radiation, wave behavior in, 108-109
 - signal, 486-490
 - Radio Corporation of America color television, 570-571, 572-574
 - Radio-frequency. See also *High-frequency*.
 - amplifiers, 19-21, 582-583
 - alignment of, 708-711
 - automatic gain control of, 257-259
 - frequency response of, 16, 708-709
 - gain control for, 257-259
 - grounded grid type, 21, 339, 662
 - requirements for, 16-18
 - interference, 326-332. See *Interference*, meaning of, 244
 - oscillators, see *Oscillators, television r-f*.
 - power supply, 475
 - section of receiver, 582-583
 - Raster, 490
 - lacking, 641
 - only (no picture), 648
 - Ratio, aspect, 676
 - Ratio detector, 214-220
 - alignment of, 547-549
 - circuit for, 544
 - output waveform, 542
 - S-curve of, 549
 - RCA color television, 570-571, 572-574
 - Reactance, formulas for, 491
 - off-resonance, 493
 - tube, action of, 443
 - sweep generator with, 286
 - sweep oscillator control, 443-449
 - Receiver attenuation, 64-66, 598
 - television, see *Television receiver*.
 - Reception distance, 488
 - Rectangular picture tubes, 676, 670, 677, 682
 - Rectifier crystals, 189-191
 - meters, 388
 - Reflections, picture tube, 674
 - signal, 637
 - wave, line, 346-348
 - signal, 489-490
 - Reflectors, antenna, 119-123
 - Regeneration, feedback for, see *Feedback*.
 - video i-f amplifier, 84-87
 - Reinsertion, d-c. see *Restoration, d-c*.
 - Relaxation oscillators, 419-421
 - Reluctance, magnetic, 370
 - Replacement parts, precautions with, 230-231
 - Resistance, coupling with, 79
 - effective, 368-370
 - high-frequency, 368-370
 - negative, oscillators with, 417
 - voltage divider, 228-229
 - Resistivity, volume, 315-316
 - Resistors, broadening, 71
 - decoupling, 201
 - high-frequency, 492
 - Resolution wedges, 469
 - Resonance, formulas for, 492
 - measurements with, 373-374
 - grid dip meter for, 386
 - Resonant circuits, off-resonance reactance of, 493

Resonant lines, 346-352
 frequency measurement of, 386
 half-wavelength, 351
 open, 349-351
 oscillator with, 425-426
 resonant frequency measurement, 386
 shorted, 349-351
 traps using, 335-337
 tuner using, 699, 707

Response, see *Frequency response*.

Restoration, d-e, 493-510
 amplifier bias for, 498-500
 black level controls for, 504-508
 diodes for, 500-504
 r-f bias for, 498-500
 sync separation with, 520
 tube for, 508-509
 time constant for, 509

Retrace lines in picture, 644

R-I, see *Radio-frequency*.

RMA color code, capacitor, 154-156

Rolled paper capacitors, 151

Rolling of pattern or picture, 646

Rotating disc color television, 565, 569

S

S-curve, sound demodulator, 543, 549

Saturation, plate current, 137

Sawtooth current, 31-33
 voltage, 23
 waveform of, 725

Scanning, 510-516
 blanking during, 513-515
 color television, 565
 interlace for, 514, 516, 529

Screen, decoupling of, 202

Filter, picture tube, 674

Picture tube, 672-674
 sizes of, 675-677, 684
 viewing, 674-675

Selectors, channel, see Tuners.

Self-bias, see *Cathode bias*.

-inductance, 308-309
 measurement of, 309
 parallel and series, 311
 -resonance, measurement of, 386

Sensitivity control, see *Contrast control*.

receiver, 516

Separate channel sound, 537-540

Separation, sound, 538-540
 sync pulse, 167-169, 517-521

Series capacitances, 152-153
 voltage division in, 153-154
 cathode-plate power supply, 477-479

Service bench, 314-315
 controls, 184-186
 instruments, 312-315

Shadows, picture, 649
 transmission, 490

Shelf, intercarrier sound, 102-103, 320

Shielding, 521-523
 transmission line, 353

Shift, phase, measurement of, 556

Shorted resonant lines, 349-351

Shot effect, 400

Sideband, vestigial, 595-599

Signal
 composite, 523-531
 waveform of, 715-716
 generators, 277
 calibration of, 302
 gain measurement with, 268
 matching pads for, 468
 inversion of, 337-339
 noise ratio, 401
 polarity, picture tube, 222
 video detector, 220, 222
 propagation of, 108-109, 486-490
 reflections, 637

Signal—(Cont.)
 television, 523-531
 levels in, 526
 waveforms of, 715, 716
 tracers, 589-594
 amplifier for, 590
 detector probe for, 481-486, 590
 signal generator used for, 591-592
 uses of, 692-594
 weak, causes and remedies, 652

Single-magnet ion traps, 614

-peaked frequency, measurement, 105-106
 tuning, 73-77
 tuning, alignment of, 93-97

Size controls, 185, 531-536
 adjustment of, 533
 amplifier bias for, 532
 drive control as, 234
 horizontal, 531-536, 651
 output transformer inductor for, 532
 remote, 534
 screen voltage for, 532
 sleeve on picture tube, 533
 vertical, 531-536

Size, magnifiers for, 533-536
 remote control for, 534
 trouble with, 650, 651

Silicon crystal diodes, 190

Skewed picture, 205, 209

Skin effect, 369

Slider, coil, adjustment of, 706

Slugs, tuning, adjustment of, 705

Smears in picture, 657

Snow, causes and remedies for, 652

Sound
 accompanying, 247
 adjacent, 247
 alignment of, 540-552
 bars in picture, 626
 carrier frequency, 167, 248
 demodulators, see *Discriminator and Ratio detector*.
 dual carrier system of, 87-88
 frequency response for, 539
 intercarrier, see *Intercarrier sound*.
 intermediate frequency for, 61-63, 249
 separate channel, 537-540
 separation of, 538-540
 shelf, intercarrier sound, 102-103
 split system of, 537-540
 takeoffs for, 538-540
 alignment of, 322
 television, 536-552
 traps, see *Traps*.
 alignment of, 605-609
 trouble, location of, 622-623

Split picture, 653, 654
 sound system, 537-540

Spark interference, 323-325

Speed controls, see *Hold controls*.

Square wave
 circuits producing, 278-280
 clipping for, 278-279
 distortion tests with, 282-284
 frequency response tests, 282-283
 generators for, 278-284
 electronic switch as, 557
 oscillation test with, 284
 peaking test with, 283
 phase shift test with, 283
 uses of, 280-284

Stacked antenna, 126-128
 impedance of, 130

Stage gain, see *Gain*.
 response, single stage, 103-106

Staggered tuning, 73-77
 alignment of, 93-97
 peak frequency measurement, 105-106

Standard frequencies, 246
 voltage, line, 9

- Standing waves, 348-349
 - Streaks, white, in picture, 657
 - Stubs, line, 346-352
 - matching impedance with, 357-360
 - traps using, 335-337
 - Substitution, picture tube, 682-683
 - trouble location by, 620
 - Surface leakage, 315-316
 - Surge impedance, 355
 - Swaying of picture, 658
 - Sweep amplifiers, 22-41
 - electrostatic, 23-30
 - inverter in, 24-26
 - linearity controls in, 27, 28
 - oscillator output for, 29-30
 - single-tube, 29
 - magnetic, 30-41
 - horizontal, 35-41
 - vertical, 30-35
 - Sweep generators, 284-298
 - alignment use of, 5-7
 - amplifier coupling to, 297
 - center frequency of, 295-296
 - center frequency adjustment, 290-291
 - coupling for, 297
 - frequency ranges of, 295-296
 - internal sweep of scope with, 292
 - phase shifting for, 294-295
 - phasing in, 291-295
 - oscilloscope use with, 5-7
 - output voltage of, 296-297
 - reactance tube for, 286
 - speaker movement for, 287
 - sweeping methods in, 285-288
 - sweep width adjustment, 288-289
 - synchronized sweep with, 291-295
 - width of sweep in, 288-289
 - Sweep inverters, 338
 - Sweep oscillators, 431-455
 - action of, 431-434
 - automatic control for
 - amplifiers in, 449
 - diode control tube in, 450-452
 - discriminator and reactance tube, 443-445
 - phase detector and amplifier, 450
 - phase detector and multivibrator, 447-449
 - phase detector and reactance tube, 445-447
 - triode control tube, 452-455
 - blocking type, 434-437
 - discharge tube for, 436
 - multivibrator, 437-441
 - Sweep, phasing of, 291-295
 - section of receiver, 586-589
 - synchronized, 6, 298, 295
 - width of, 288-289
 - Switch, electronic, see *Electronic switch*.
 - Syn or synchronizing amplifiers, 41-42
 - signal polarity in, 223
 - clippers, 167-169
 - filters for, 235-238
 - inverters, 337-339
 - levelers, 168
 - limiters, 167-169
 - polarity, detector output for, 54-55
 - pulses, action of, 433-434
 - equalizing, 528
 - oscilloscope traces of, 43
 - polarity of, 223
 - separation of, 517-521
 - takeoff for, 517-521
 - waveforms of, 720-724
 - section of receiver, 557-562, 586-587
 - tube types of, 559-560
 - separator, 167-169, 517-521
 - troubles with, 645, 647, 655
- Synchronized sweep, 6, 298-295
 - Synchronizing controls, see *Hold controls*.
- ## T
- Takeoffs, sound, 538-540
 - sync, 517-521
 - Tear out, 655
 - Television, color, 563-579. See *Color television*.
 - generators, 298
 - receivers, 580-589
 - installation of, 312
 - parts of, 617-618
 - r-f section of, 582-583
 - sections of, 617-618
 - sweep section of, 586-589
 - sync section of, 586-587
 - tuner of, 582-583
 - video section of, 583-586
 - signal, 523-531
 - levels in, 526
 - waveform of, 715-716
 - sound, see *Sound*.
 - Temperature compensation, capacitor, 158
 - oscillator, 416
 - tuning affected by, 158
 - Test bench, 8, 314-315
 - instruments, 312-315
 - patterns, 469
 - trouble shooting with, 624-658
 - Thermal noise, 400
 - Thermocouple meters, 389
 - Tickler feedback oscillator, 412-413
 - Tilted picture, 205, 209, 656
 - Time constants, 170-176
 - automatic gain control, 259-261
 - capacitive, 170-173
 - d-c restoration, 509
 - effects of, 174-176
 - inductive, 173-174
 - limiter, 345
 - oscillator operated by, 419-421
 - Time, transit, 456-462
 - Tone wedges, 470
 - Tracer, signal, 589-594
 - amplifier for, 590
 - detector probes for, 481-486, 590
 - signal generator for, 591-592
 - uses of, 592-594
 - Trailers in picture, 657
 - Transconductance, conversion, 392
 - Transformers. See also *Couplings*.
 - antenna coupling, 694
 - capacitive coupling in, 81
 - coupling adjustment in, 107
 - double-peaked, 78-84
 - alignment of, 97-101
 - frequency measurement of, 105-106
 - isolating, 9
 - overcoupled, alignment of, 97-101
 - video i-f, 78-84
 - types of, 79
 - Transit time, 456, 662
 - Transmission lines, 352-363
 - balanced, 352
 - coaxial, 353
 - connections of, 693-694
 - impedance of, 354-356
 - matching of, 357
 - installation of, 361-363
 - interference pickup by, 333
 - loss in, 361
 - matching sections for, 360
 - stubs for, 357-360
 - resonant frequency of, 386
 - shielded, 353
 - unbalanced, 353
 - velocity constant of, 356, 357
 - Transmission, negative, 594

Transmission—(Cont.)

- positive, 595
 - vestigial sideband, 595-599
- ### Traps, 333-337, 599-610
- absorption types of, 600-601
 - alignment of, 605-609
 - antenna, 333-337, 698, 699
 - circuits for, 600-602
 - frequency response affected by, 608
 - settings of, 602-605
 - impedance types of, 601
 - intercarrier beat, 609
 - alignment of, 610
 - interstage couplings types, 61
 - ion, 610-616
 - adjustment of, 615
 - double-magnet, 611-614
 - single-magnet, 614
 - line stub types, 335-337
 - parallel resonant types, 61
 - resonant line types, 335-337
 - response affected by, 90
 - sound, alignment of, 605-609
 - video i-f, 61
 - alignment of, 605-609
 - responses with, 90
- ### Triplers, frequency, 397
- ### Trouble. Causes, location, remedies.
- beat interference, 642-643
 - blanking bars in picture, 653, 654
 - blurred picture, 619
 - brightness excessive or varying, 629
 - centering incorrect, 630
 - contrast high, 631
 - low, 632
 - definition poor, 633
 - details lacking, 633
 - diathermy interference, 638
 - f-m interference, 642-643
 - focus poor, 634
 - folded picture, 635, 636
 - frequency responses for locating, 659
 - ghosts in picture, 637
 - height incorrect, 650
 - herringbone pattern, 638
 - hold control, 645-647, 655
 - horizontal hold, 645-647, 655
 - size, 651
 - hum (picture), 626
 - indistinct pictures, 619
 - interference, beat, 642-643
 - line only (no picture), 641
 - linearity, horizontal, 639
 - vertical, 640
 - methods for locating, 616-623
 - movement of picture, 645-647, 655
 - multiple images in picture, 637
 - noise, 400
 - pattern analysis for, 624-658
 - picture lacking, 618-619, 641, 648
 - raster lacking, 641
 - only (no picture), 648
 - reflections in picture, 637
 - from tube, 674
 - retrace lines in picture, 644
 - r-f interference, 642-643
 - shadows in picture, 649
 - signal reflections, 637
 - weak, 652
 - size incorrect, 650, 651
 - smears in picture, 657
 - snow in picture, 652
 - sound bars in picture, 626
 - lacking, 619
 - section troubles, 622-623
 - splitting of picture, 653, 654
 - swaying of picture, 658
 - tear out in picture, 655
 - titled picture, 656
 - trailers in picture, 657

Trouble—(Cont.)

- tubes checked for, 620, 621
 - twisted edges on picture, 658
 - picture or pattern, 656
 - vertical hold control, 646, 647
 - retrace lines in picture, 644
 - size, 650
 - video amplifier, 57
 - waveform analysis for, 659
 - wavy edges on picture, 658
 - weak signal, 652
 - width incorrect, 651
- ### Tubes
- alignment connections to, 10-12
 - merit figure for, 660
 - microphonic, 626
 - noise from, 400
 - picture, see *Picture tubes*.
 - reactance, action of, 443
 - sweep generator with, 286
 - sweep oscillator control with, 443-449
 - substitution, trouble location by, 620
 - television types, 686
 - transit time in, 662
 - ultra-high frequency, 660-663
 - video amplifier, 45
 - voltage checks of, 621
- ### Tuned grid oscillators, 413
- grid-plate oscillators, 414
 - line oscillator, 425-426
 - plate oscillator, 413
- ### Tuners, 182, 582-583, 686-711
- adjustments in, 705-706
 - alignment of, 705-711
 - circuits of, 695-704
 - coupling in, 692-695
 - frequency adjustments in, 705-706
 - response of, 703-709
 - function of, 583
 - Inductuner, 691-692, 704
 - Inputuner type, 704
 - iron core types of, 691-692
 - permeability types of, 691-692
 - push-pull oscillator in, 698
 - resonant line type, 699, 707
 - response of, 708-709
 - shorted line type, 699-707
 - shorting inductor type, 689-690, 695-697
 - tapped inductor type, 698
 - traps in, 698, 699
 - turret types of, 690-691, 702-703
 - types of, 687-692
 - variable inductance, 691-692
- ### Tuning
- fine, control for, 182, 238-239
 - effect of, 428
 - single-peaked, 73-77
 - alignment of, 93-97
 - frequency measurement of, 105-106
 - staggered, 73-77
 - alignment of, 93-97
 - frequency measurement of, 105-106
 - temperature effect on, 158
 - wand for, 12
- ### Turret tuners, 690-691, 702-703
- Twisted edge on picture, 658
 - picture or pattern, 656
- ### Two-band antennas, 123-126
- ## U
- Ultra-high frequencies, 711
 - converters for, 712
 - oscillators for, 455-456
 - tubes for, 660-663
 - Ultraudion oscillator, 414
 - Unbalanced transmission line, 353
- ## V
- Vacuum tube voltmeter, see *Electronic voltmeter*.

V-dipole antenna, 117, 125-126
Velocity constant, transmission line, 356, 357

V
Vertical
blanking, 527
bar in picture, 653
filter, 235-288
hold control, 183, 308-307
linearity, peaking effect on, 33
sweep amplifier bias for, 34
trouble with, 640
retrace, 514
lines in picture, 644
size controls, see *Size controls*.
trouble with, 650
sweep amplifiers, see *Sweep amplifiers*.
oscillator, see *Sweep oscillators*.
sync pulses, see *Sync Pulses*.
Vestigial sideband transmission, 595-599
Video, adjacent, 247

Video amplifiers, 42-58
frequency response of, 16, 44
compensation in, 48-54
requirements of, 16-18
signal polarity in, 222
stages in, effect of, 54-57
traces from, 43
troubles in, 57
tubes for, 45

Video carrier frequency, 167-249
Video detector, 220-224
crystal type, 224
polarity of, 220, 222
effects of, 54-57
video i-f amplifier coupling, 82

Video frequency, 249
intermediate frequency, 61-63, 249
formation of, 608
typical examples of, 94-95

Video intermediate-frequency amplifiers
alignment of, 87-103
band width of, 70-73
coupling in, 72
adjustments in, 107
detector coupling to, 82
frequency response of, 16, 64, 598-599
intercarrier sound, 102
marker positions on, 67, 102
trap effect on, 608
function of, 584
gain in, 70-73
oscillation in, 84-87
overall response check of, 101-103
overcoupled transformers in, 78-84
principles of, 58-107
regeneration in, 84-87
requirements for, 16-18
single-peaked tuning in, 73-77

Video intermediate-frequency amplifiers—(Cont.)
single stage response from, 103-106
staggered tuning in, 73-77
transformers in, 78-84
trap effects in, 90

Video section of receiver, 583-586
Viewing screens, 674-675
Vision, 339

Voltage, boosting of by damper, 195-197
dividers for, 228-229
doublers for, 397-399, 473-475
feedback of, 212
line, standard, 9
multipliers for, 397-399, 473-475
picture tube, 667, 684-685
sawtooth, waveform of, 725
tube, checking of, 621

Voltmeter, electronic, see *Electronic volt-meter*.
high-frequency, 388, 389
rectifier type, 388
requirements for, 313
vacuum tube, see *Electronic voltmeter*.
Volume control, 183
resistivity, 315-316
VTVM, see *Electronic voltmeter*.

W

Wand, tuning, 12-13

Wave, electromagnetic, 108-109, 486-487
propagation of, 486-490
reflections, signal, 489-490
transmission line, 346-348
standing, 348-349
traps, see *Traps*.

Waveforms, 713-727
oscilloscope connection for, 713-714
trouble shooting with, 659
typical, 715-727

Wavelength, angstrom unit for, 678
feet and inch equivalents of, 112
frequency relation to, 111, 249

Wavemeters, 382-384, 388

Wavy edges on picture, 658

Weak signal, causes and remedies for, 652

Wedges, resolution, 469
tone, 470

Wein bridge, oscillator with, 270

White level, 526

Width controls, see *Size controls*.
trouble with, 651

Wiring, dressing of, 230-231

WWV frequency transmissions, 246

Y

Yoke, deflection, 205-208