

COYNE  
RADIOMANS  
HANDBOOK

# COYNE RADIOMAN'S HANDBOOK

•  
A REFERENCE and DATA BOOK

•  
Formulas — Methods — Charts  
Rules — Diagrams, Circuits  
Laws — Specifications — Tests  
Emergency Repair Data — Definitions  
Design

*Compiled and Prepared by*

THE TECHNICAL STAFF  
COYNE ELECTRICAL SCHOOL  
CHICAGO

Copyright 1946 by  
COYNE ELECTRICAL SCHOOL  
500 So. Paulina St.  
Chicago, Illinois

---

All rights reserved. This book, or any parts thereof may not be reproduced in any form without written permission of the Publishers.

Printed in United States of America

COYNE  
RADIOMAN'S  
HANDBOOK

•

## FOREWORD

---

The value of any Radio reference handbook is determined by 4 important factors—these factors are:

1. The reputation of the publishers.
2. The book must be up-to-date and authentic.
3. It must be well written, easy to understand and complete.
4. It must be worth many times its price to the purchaser.

I feel this Radioman's Handbook meets all the above requirements for these reasons. This book was developed by the Technical Staff of the Coyne Electrical and Radio School. It is backed by over 46 years of field experience in teaching radio and allied subjects. This book was not written by just ONE man but represents the combined efforts of all members of Coyne's staff in collaboration with leading Radio, Television and Sound manufacturing companies and associations. That makes it authoritative, reliable and, above all, up to date.

There are many books that contain material on one or two of the subjects covered in this book, but up to now we do not believe there has been a convenient size radioman's handbook that covers all the material needed for quick reference on the job.

In preparing the material for this book, the thought we kept foremost in mind was to condense the information in order to include as much material as possible which the radioman needs for reference purposes in his work.

The Coyne Radioman's Handbook is easy to understand because every explanation of a law, rule, formula or definition has been put in the simplest of radio terms. You will note as you study and use the Coyne Radio-

man's Handbook, that what were once complicated radio explanations have now been put into clear understandable language.

YOU CAN USE THE RADIOMAN'S HANDBOOK  
EVERY DAY ON THE JOB

This book is worth many times its price because the information every Radioman needs is at his "finger tips." The Index and Table of Contents will refer you to formulas, rules, charts, tables and wiring methods, that have your answer all worked out for you. A successful radio man—the fellow who is on top today is the man who knows the latest methods and does all his work according to systematic procedure.

In every radio service shop or radio manufacturing plant there are men who stand out in their work. Why do they stand out? They stand out simply because they either know all the rules, formulas and laws in the radio field, or they have a source of reference to find the information required.

Although this book has been especially prepared for the experienced radioman, (the fellow who is working in radio everyday), nevertheless, the book can also be valuable to a beginner who wants to get started out right in radio.

In preparing the material in this book we have had the cooperation of leading radio, television and sound manufacturers. ALL THE DATA HAS BEEN PRE-TESTED IN THE COYNE RADIO SHOPS.

In closing, I would like to mention that the value of any book is not always determined by how often you use it, but rather how important it can be WHEN YOU NEED IT. Doctors, lawyers and other professional men, spend great sums for reference books on their work. They need these books for ready reference so they can refer to them on certain subjects and keep themselves up to date at all times. They need them also to refresh their memory on certain material which they cannot be

expected to remember in detail. It is equally important and essential for a radioman or a man preparing for advancement in radio to have a reliable reference book for the important problems that come up in his work.

When you purchase this Handbook you are not merely making a purchase—no, indeed—YOU ARE MAKING AN INVESTMENT. It can be your best investment for your present and future success.

A handwritten signature in cursive script, appearing to read "A. G. Coyne". The signature is fluid and stylized, with large loops and a long tail on the final letter.

President  
COYNE ELECTRICAL & RADIO SCHOOL

## AN ACKNOWLEDGEMENT

---

In the preparation of this book invaluable help has been freely extended by the leading manufacturers in the Radio and Electrical industries, especially by

RCA MFG. Co.

GENERAL ELECTRIC Co.

AMERICAN STANDARDS ASSN.

WESTINGHOUSE ELECTRIC MFG. Co.

SYLVANIA ELECTRIC PRODUCTS Co.

STRUTHERS DUNN, INC.

DUMONT Co.

to all of whom we extend our sincere thanks for technical data, relating to the installation, operation and maintenance of apparatus.



# CONTENTS

---

<b>Materials—Symbols—Mathematics</b> .....	1-23
Abbreviations—Wiring diagrams symbols— Tube symbols—Screws—Drills—Sheet metal Conversion tables—Square roots—Trigono- metric functions—Use of formulas.	
<b>Resistance and Insulation</b> .....	24-37
Properties of conductor and resistor materials; Wire tables; Color coding; Preferred num- bers; Resistance computations; Insulation dielectric strength; Insulating materials.	
<b>Electric Circuits</b> .....	38-49
Ohm's law chart; Series and parallel connec- tions; Sources and potentials; Rules and com- putations for series and parallel circuits; Parallel resistance chart; Parallel-series com- binations.	
<b>Power</b> .....	50-56
Power formulas for d-c circuits and for a-c circuits; Power charts for watts, ohms, volts, amperes, and milliamperes; Resistor ratings; Power transfer.	
<b>Capacitors and Capacitance</b> .....	57-70
Capacitance rules and formulas; Dielectric constants; Capacitors in series and in parallel; Series capacitance chart; Color coding of capacitors; Temperature compensation; Time constants.	
<b>Receiving Tubes</b> .....	71-142
Tube type numbers; Socket and base connec- tions; Cathode heating; Cathode types; Po- tentials for plates, screens, and control grid bias; Currents for plate and screen; Plate resistances; Transconductances and mutual conductances; Amplification factors; Load resistances; Power outputs; Tables of Charac- teristics for 446 types of tubes; Replacement tubes and changes required in circuits;	

Cathode bias; Power supply bias; Grid leak bias; Cathode returns; Load line construction and use; Tube constants.	
<b>Coils and Coil Winding</b> .....	143-160
Magnet wire tables; Single-layer coils, computation of inductance, of turns for required inductance; Tables of turns, diameters, lengths; Multi-layer coils, computations for inductance, turns, winding size; Electron flow, flux, and conductor motion.	
<b>Reactances and Energy Losses</b> .....	161-177
Sine waves; Frequency, Wavelength; Inductive reactance; Chart for inductance, frequency and reactance; Capacitive reactance; Chart for capacitance, frequency and reactance; Reactances in series and parallel; Lagging and leading currents; Impedance rules and formulas; Square root chart; Energy losses; Q-factor.	
<b>Resonance and Coupling</b> .....	178-193
Resonant circuits; Formulas for resonant frequencies and wave-lengths; Chart for L and C at resonance; Oscillation constants; Tables of constants; Coupling coefficients; Double-hump resonance; Power transfer.	
<b>Transformers</b> .....	194-208
Transformer formulas; Phase relations; Regulation; Power transformers; Design of small power transformers; Color coding for transformers; Impedance matching; Multiple and tapped windings; Winding identification; Transformers in series and in parallel.	
<b>Power Supply From A-c or D-c Lines</b> .....	209-245
Power supply principles; Capacitor input filters; Choke input filters; Current and voltage computation; Ripple; Regulation; Voltage regulator tubes; Voltage dividers and computations; Rectifier doublers; Ballast tubes; Pilot lamps; Series heaters; Substitution of tubes with series heaters; Heater resistor power ratings.	
<b>Power Supply With Batteries</b> .....	246-253
Battery-operated receivers; Ac-Dc-Battery receivers; Vibrator power supply, non-synchronous and synchronous.	

<b>Amplifiers</b> .....	254-273
Classes of amplifiers; Gain and gain computation; Power, current, and resistance conversion for tubes; Resistance-coupled amplifiers, tables of operating characteristics; Transformer coupling; Push-pull amplifiers, phase inversion.	
<b>Receivers</b> .....	274-288
Superheterodyne converters, oscillators, mixers; Intermediate frequencies; Alignment of a-m superheterodynes; Output meter connections; Alignment of F-M receivers; Volume control time constants.	
<b>Oscillators and Antennas</b> .....	289-297
Oscillator types and performance; Crystal control of frequency; Receiving antenna dimensions and patterns.	
<b>Sound Systems and Devices</b> .....	298-318
Decibel measurements for gain and loss; Loudness of sounds; Audibility; Sound velocities; Loud speakers, electromagnetic fields; Baffling; Phasing; Coupling transformers; Plug color code; Public address, power requirements, reverberation, absorption; Microphone ratings; Sound frequency ranges.	
<b>Meters and Measurements</b> .....	319-345
Moving coil meter connections; Sensitivity; Accuracy; Meter resistances; Rectifier meters; Resistance measurement; Shunts; Series resistors; Multipliers; Instrument resistors; Ac-Dc volt-milliammeter; Ohmmeter design; Insulation resistance; Capacitance measurement and test; Wattmeters; Bridge measurements.	

# COYNE RADIO HANDBOOK

## Section 1

### MATERIALS—SYMBOLS—MATHEMATICS

In the following list are abbreviations, schematic radio symbols and letter symbols generally used and recognized in radio and allied arts. The same symbol sometimes represents two or more things, and the same thing occasionally is represented by different symbols. The use of capital and small letters follows standard or accepted practice, but other usages will be found. All the Greek letter symbols are grouped together at the end of the list.

#### ABBREVIATIONS AND LETTER SYMBOLS

A	Area
	Angstrom unit (0.0000001 millimeter)
A-	Filament power supply
a	Amperes
a-c	Alternating current (adjective)
a-f	Audio frequency (adjective)
a-m	Amplitude modulation
avc	Automatic volume control
ave	Automatic volume expansion
A.W.G.	American wire gage
B	Magnetic flux density (gausses or lines per square inch)
B-	Plate power supply
b	Susceptance, mhos (reciprocal of impedance due to reactance)
b.f.o.	Beat frequency oscillator
Btu	British thermal unit (heat energy)
C	Capacitance, farads
	Centigrade temperature
C-	Grid bias potential supply
c	Cycles
c-emf	Counter electromotive force
C <sub>GK</sub>	Grid to cathode capacitance
C <sub>GP</sub>	Grid to plate capacitance
cm	Centimeter (0.3937 inch)
cm <sup>2</sup>	Square centimeters
cos	Cosine (trigonometric function)
C <sub>PK</sub>	Plate to cathode capacitance
cps	Cycles per second
c.w.	Continuous wave
d-avc	Delayed automatic volume control
db	Decibel (unit of gain or loss in power, voltage or current)
d.c.c.	Double cotton covered
d.s.c.	Double silk covered

E	Potential, potential difference, or emf; volts. (effective value)
e	Potential, potential difference, or emf; volts. (instantaneous value)
$E_B$	Plate supply potential, volts.
$E_C$	Grid bias potential, volts.
e.c.o.	Electron coupled oscillator
$E_F$	Filament potential, at filament
$E_G$	Grid potential; grid to cathode
$E_H$	Heater potential, at heater
emf	Electromotive force, volts.
$E_P$	Plate potential; plate to cathode
F	Fahrenheit temperature.
f	Frequency, cycles per second.
FM	Farads of capacitance
f-m	Frequency modulation or frequency modulated.
G	Conductance, mhos (average or effective value)
g	Conductance, mhos (instantaneous value)
	Gram (0.03527 ounce)
$G_C$ $g_C$	Conversion transconductance (as used for frequency converters)
$G_M$ $g_M$	Mutual conductance, or control grid-plate transconductance
gnd	Ground
H	Magnetizing force (as in ampere-turns per unit length of magnetic path)
h	Henrys of inductance
h-f	High-frequency (3,000 kilocycles to 30 megacycles)
I	Current, amperes (effective or average value)
i	Current, amperes (instantaneous value)
$I_B$	Plate supply current
i.c.w.	Interrupted continuous wave
$I_F$	Filament current
i-f	Intermediate frequency (of superheterodyne receivers)
$I_G$	Control grid current
$I_H$	Heater current
in <sup>2</sup>	Square inch
$I_P$	Plate current
J	Intensity of radiant energy, of magnetization, and others.
j	Joules of energy or work
K	Dielectric constant. Sometimes for other constants.
	Kelvin temperature (absolute temperature)
k	Cathode
kc	Kilocycle (1,000 cycles)
kv	Kilovolt (1,000 volts)
kva	Kilovolt-ampere (1,000 volt-amperes)

kw	Kilowatt (1,000 watts)
kwhr	Kilowatt-hour (1,000 watt-hours)
L	Self-inductance, henrys. Sometimes, with subnumbers, for mutual inductances.
l-f	Low frequency (30 to 300 kilocycles)
log	Common logarithm (The power to which 10 is raised to equal a number)
M	Mutual inductance, henrys Magnetomotive force, ampere-turns or gilberts Abbreviation for prefix meg- or mega-, meaning 1,000,000 times the unit named.
m	Meter (39.37 inches) Abbreviation for prefix milli-, meaning 1/1000 of the unit named.
ma	Milliamperere (1/1000 ampere)
Mc or mc	Megacycles (millions of cycles per second)
m.c.w.	Modulated continuous wave
mf	Microfarad (capacitance)
m-f	Medium frequency (300 to 3,000 kilocycles)
mfd	Microfarad (capacitance)
mh	Millihenry (1/1000 henry)
mm	Millimeter (0.03937 inch)
mm <sup>2</sup>	Square millimeter
mmf	Magnetomotive force, ampere-turns or gilberts
mmfd	Micro-microfarad (one millionth of one microfarad of capacitance)
mv	Millivolt (1/1000 volt)
mw	Milliwatt (1/1000 watt)
N n	Number of (as turns in a winding)
P	Average power, watts
p	Instantaneous power, watts Magnetic poles
p.d.	Potential difference, volts
p.f.	Power factor (ratio of watts of power used to volt-amperes of power in supply circuit)
Q	Quantity of electricity or charge, coulombs Q-factor; ratio of reactance to high-frequency resistance.
R	Resistance, ohms (average or effective value)
r	Resistance, ohms (instantaneous value)
r-f	Radio-frequency (adjective)
rms or	Root-mean-square. Square root of mean of squares of all instantaneous values; same as effective value.
R <sub>p</sub>	Plate resistance
S	Elastance, darafs. (reciprocal of capacitance)
s.c.c.	Single cotton covered
s.c.e.	Single cotton enamel covered

s-h-f	Super-high frequency (above 3,000 megacycles)
sin	Sine (trigonometric function)
s.s.c.	Single silk covered
s.s.e.	Single silk enamel covered
s-w	Short wave (above 1,600 kilocycles)
T	Period of time
	Absolute temperature
t	Centigrade or Fahrenheit temperature
tan	Tangent (trigonometric function)
t-r-f	Tuned radio frequency
t.u.	Transmission unit (usually the same as a decibel)
U	Radiant energy, in joules, etc.
u-h-f	Ultra-high frequency (300 to 3,000 megacycles)
V	Voltage, volts (average or effective value)
v	Voltage, volts (instantaneous value)
va	Volt-ampere (apparent alternating-current power, product of volts and amperes)
v-h-f	Very-high frequency (30 to 300 megacycles)
v-l-f	Very-low frequency (below 30 kilocycles)
v.o.m. or VOM	Volt-ohm-milliammeter
Vt vt	Vacuum tube
W w	Work or energy, in joules, watthours, etc.
w	Watts of power
whr	Watthour, energy
X x	Reactance, ohms
X <sub>0</sub>	Capacitive reactance, ohms
X <sub>L</sub>	Inductive reactance, ohms
xtal	Crystal (frequency control)
Y y	Admittance, mhos (reciprocal of impedance)
Z z	Impedance, ohms (effective opposition to flow of alternating current)

## GREEK LETTER SYMBOLS

$\alpha$ (alpha)	Temperature coefficient of resistivity
$\gamma$ (gamma)	Conductivity
$\delta$ (delta)	A change or variation. Decrement
$\epsilon$ (epsilon)	Base of Naperian logarithms. 2.71828
$\theta$ (theta)	Phase angle or phase displacement
	Time constant
	Temperature
$\kappa$ (kappa)	Dielectric constant; also other constants
$\lambda$ (lambda)	Wavelength, meters
$\mu$ (mu)	Amplification factor of tube.
	Permeability of iron or steel.
	Prefix for micro- (one millionth of units)
$\nu$ (nu)	Magnetic reluctivity

$\pi$ (pi)	3.14159 Ratio of circumference to diameter of a circle.
$\rho$ (rho)	Volume resistivity
$\tau$ (tau)	Time constant
$\Phi$ (phi)	Magnetic flux
$\Psi$ (psi)	Dielectric flux
$\Omega$ (omega)	Ohms of resistance
$\omega$ (omega)	Angular velocity. $= 2 \times \pi \times$ frequency in cycles

## TUBE SYMBOLS

The tube symbols numbered 1 to 90 are those used in schematic diagrams to represent the various basic types of radio receiving tubes. These symbols show the elements in their electrical relation to one another in each of the general types, but they do not show the relative positions of base pins, which differ between tubes of the same general class. Control grids may be connected to top caps where such caps are not indicated on the symbols, or the grid may be connected to a base pin where the general symbol shows a cap.

Any symbol shown with a filament-cathode might be re-drawn for a heater-cathode, and any shown with a heater-cathode might be rearranged for a filament-cathode. Any given amplifier symbol may represent either a power tube or a voltage amplifier. Rectifier symbols are drawn for high-vacuum tubes. A gas-filled rectifier or a mercury-vapor rectifier would be indicated by placing a small dot inside the circle that denotes the envelope in the symbol.

## Letters for Tube Elements in Symbols

<i>Ao</i> —Oscillator anode	<i>H</i> —Heater
<i>D</i> —Diode plate	<i>K</i> —Cathode
<i>F</i> —Filament	<i>P</i> —Plate
<i>G</i> —Control grid	<i>S</i> —Screen grid
<i>Go</i> —Oscillator grid	<i>Su</i> —Supressor grid
<i>Gs</i> —Signal grid	



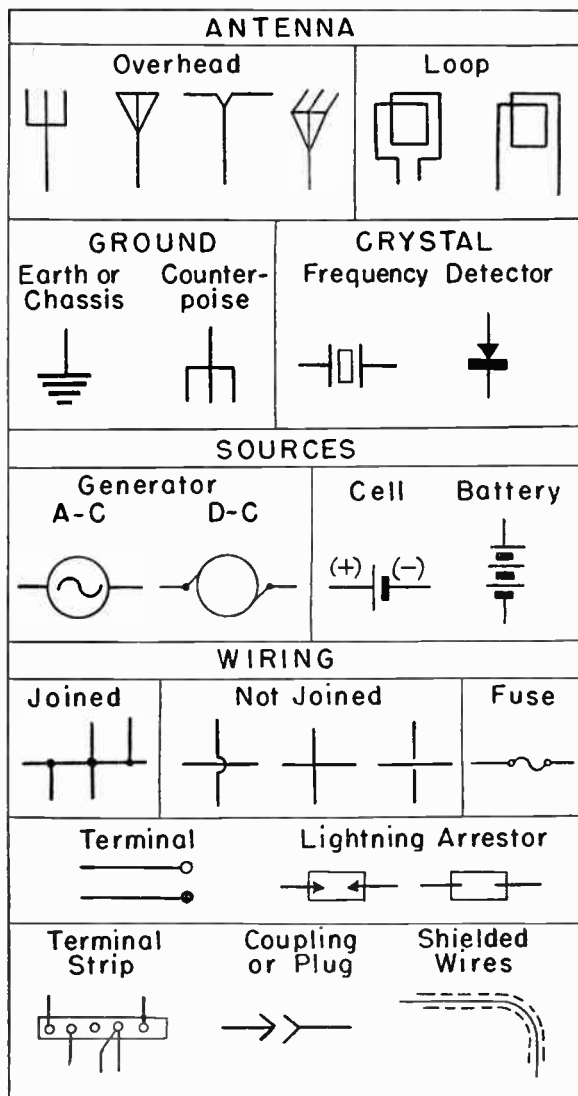

Fig. 1-1. Symbols for antennas, sources and wiring.

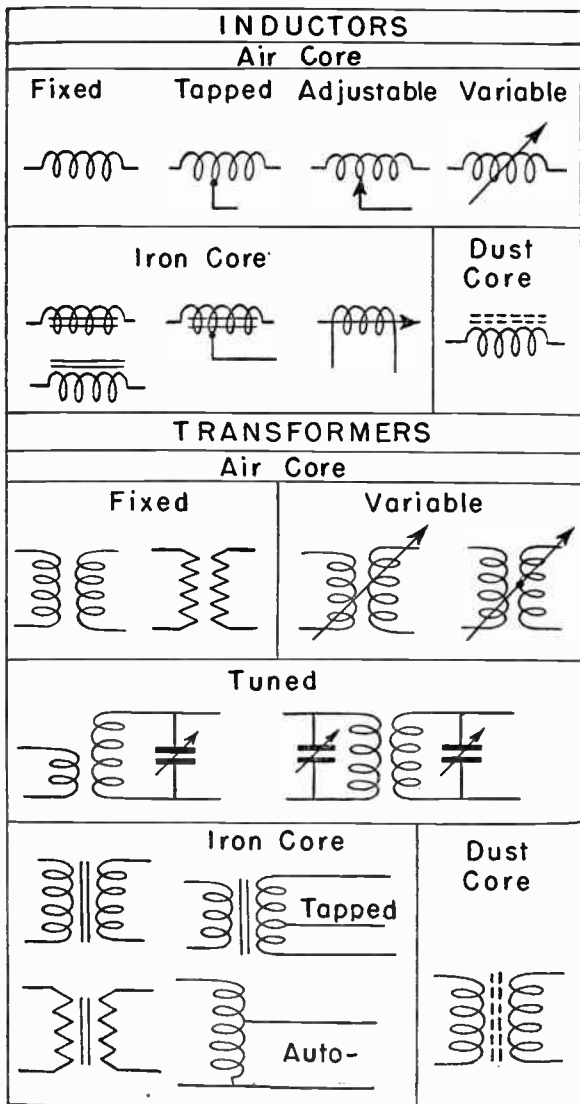

Fig. 1-2. Symbols for inductors and transformers.

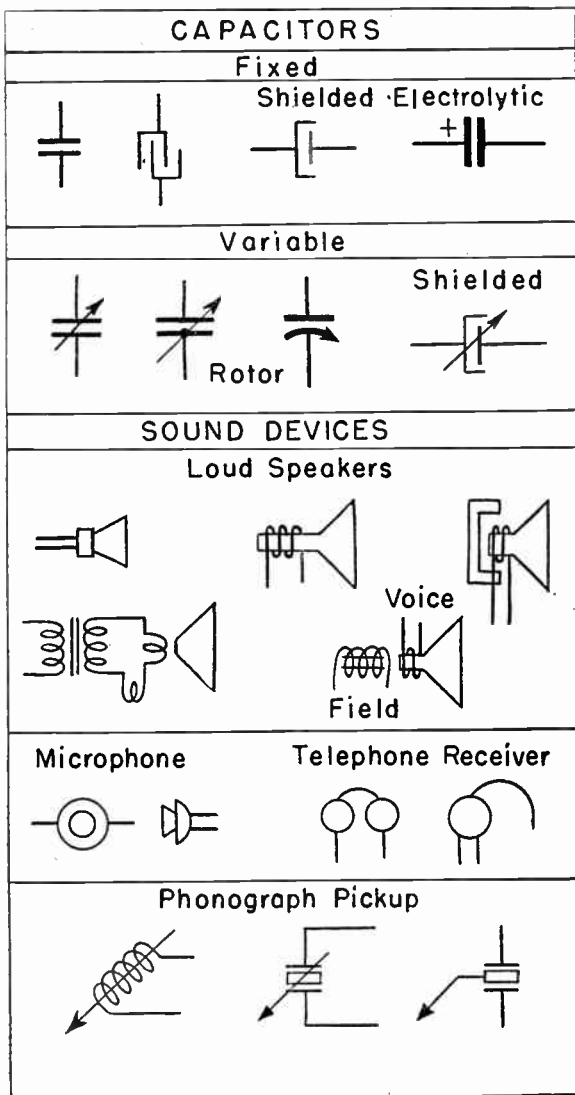

Fig. 1-3. Symbols for capacitors and sound devices.

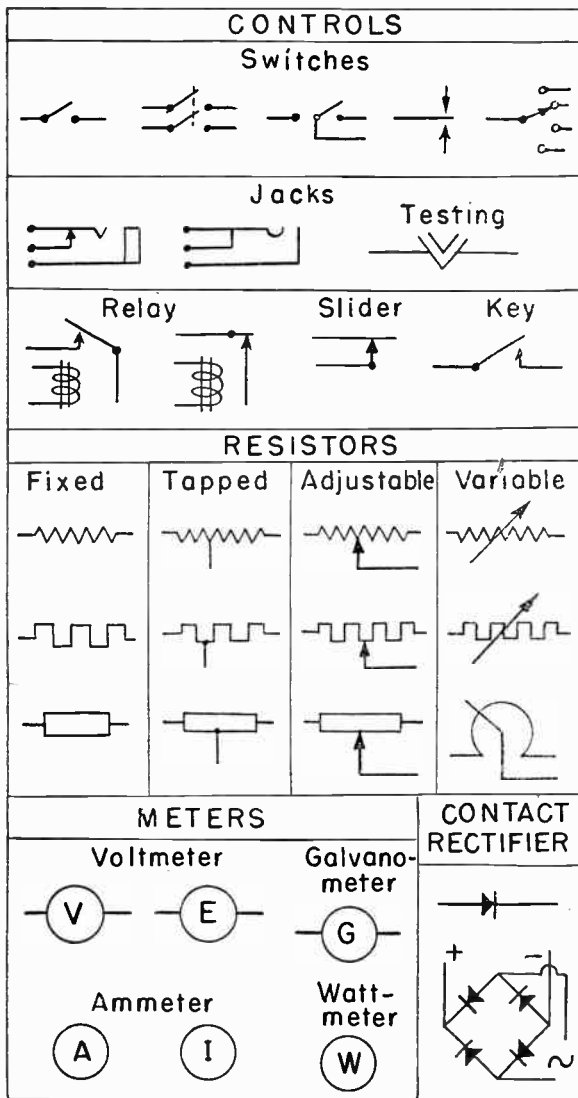

Fig. 1-4. Symbols for controls, resistors, meters, rectifiers.

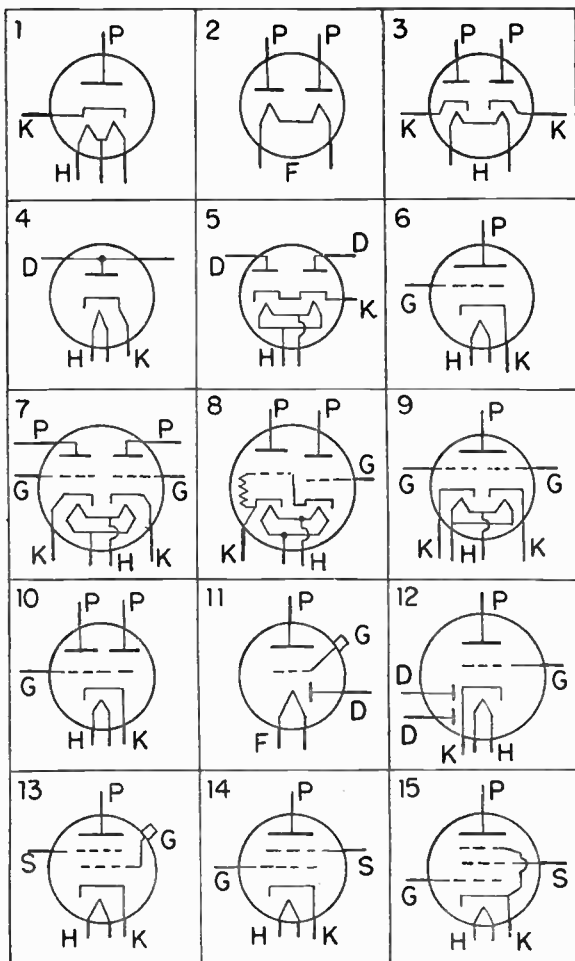

Fig. 1-5. Symbols for rectifier tubes, diode detectors, and triodes.

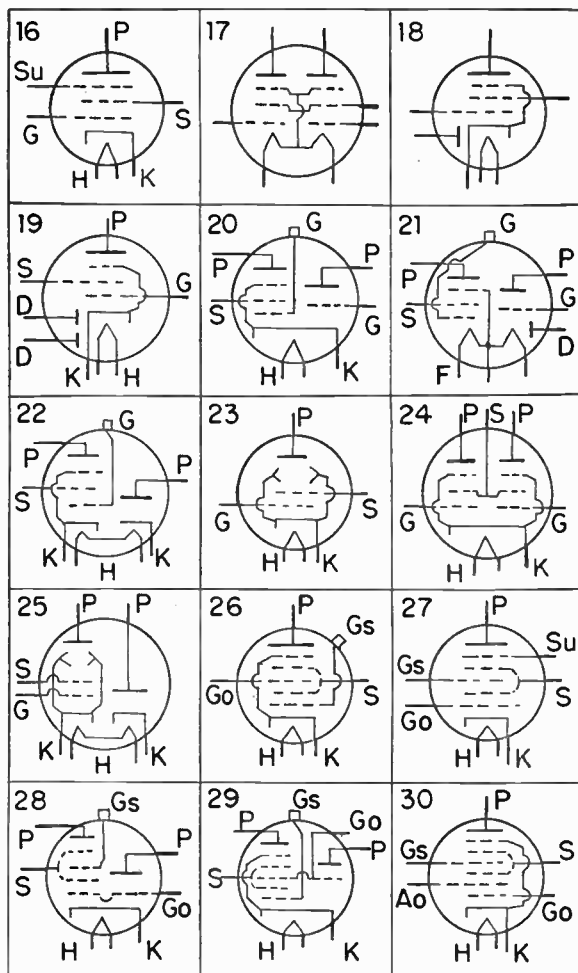

Fig. 1-6. Symbols for pentodes, beam power tubes, mixers, and converters.

## Radio

**MACHINE SCREWS****COARSE THREAD**

Size	Threads per Inch	Diameter inches	Tap Drill Sizes			Clearance Drill
			Deep	Medium	Shallow	
1	64	0.073	54	53		49
2	56	.086	51	50	49	43
3	48	.099	47	45	44	39
4	40	.112	44	43	42	33
5	40	.125	38	37	34	30
6	32	.138	36	35	33	28
8	32	.164	30	29	27	18
10	24	.190	26	25	22	11
12	24	.216	17	16		2
1/4	20	.250	8	7		1/4
5/16	18	.3125	1/4	F		5/16
3/8	16	.375	5/16	0		3/8

**FINE THREAD**

0	80	0.060	56	3/64		52
1	72	.073	54	53	1/16	49
2	64	.086	51	50	49	44
3	56	.099	46	45	44	39
4	48	.112	43	42	3/32	33
5	44	.125	38	37	7/64	30
6	40	.138	34	33	32	28
8	36	.164	30	29	28	19
10	32	.190	5/32	21	20	10
12	28	.216	15	14	13	2
1/4	28	.250	3		7/32	1/4

**WOOD SCREWS**

No.	Threads per Inch	Diameter shank	No.	Threads per Inch	Diameter shank
0	32	0.060	9	14	0.177
1	28	.073	10	13	.190
2	26	.086	11	12	.203
3	24	.099	12	11	.216
4	22	.112	14	10	.242
5	20	.125	16	9	.268
6	18	.138	18	8	.294
7	16	.151	20	8	.320
8	15	.164	24	7	.372

Symbol Number	Type of Tube	Typical Tube
1	Rectifier, half-wave .....	35Z5
2	full-wave .....	5Y3
3	doubler .....	25Z6
4	Diode detector, single.....	1A3
5	double .....	6H6
6	Triode, single .....	6J5
7	twin .....	6SC7
8	direct coupled .....	6B5
9	with two grids .....	6AE7
10	with two plates .....	6AE6
11	with one diode plate.....	1H5
12	with two diode plates.....	6SQ7
13	Tetrode voltage amplifier.....	35
14	power amplifier .....	48
15	Pentode, internal suppressor connection....	6K6
16	external suppressor connection.....	6SK7
17	twin .....	1E7
18	with one diode plate.....	6SF7
19	with two diode plates.....	7E7
20	and triode .....	6F7
21	and triode and diode plate.....	3A8
22	and rectifier .....	12A7
23	Beam power .....	6L6
24	twin .....	26A7
25	and rectifier .....	70L7
26	Mixer, pentagrid .....	6L7
27	Converter, pentagrid .....	6SA7
28	triode-hexode .....	6K8
29	triode-heptode .....	6J8
30	octode .....	7A8

## MACHINE SCREW TABLE

The table of machine screws lists diameters and threads per inch of machine screws used in radio work, also the sizes of drills for thread tapping holes and for clearance holes. For metal fastenings the sizes up to number 10 usually are of the coarse thread type, with larger sizes in the fine thread type. Phenolic and other hard insulating materials usually are tapped for coarse thread screws. The most generally used sizes are 2-56, 4-40, 6-32, 8-32, 10-32, 12-24, and ¼-20.

The three sizes of tap drills allow for deep threads or extra full threads, for medium threads, and for comparatively shallow threads such as used for fast assembly. Phenolic and other hard insulating materials usually are tap drilled for shallow threads, by using the larger drill sizes. Cast iron may be tap drilled with the smaller sizes of drills.



## DRILLS NUMBERED AND LETTERED

No.	Diam.	No.	Diam.	No.	Diam.
1	0.2280	36	0.1065	71	0.0260
2	.2210	37	.1040	72	.0250
3	.2130	38	.1015	73	.0240
4	.2090	39	.0995	74	.0225
5	.2055	40	.0980	75	.0210
6	.2040	41	.0960	76	.0200
7	.2010	42	.0935	77	.0180
8	.1990	43	.0890	78	.0160
9	.1960	44	.0860	79	.0145
10	.1935	45	.0820	80	.0135
11	.1910	46	.0810	A	0.234
12	.1890	47	.0785	B	.238
13	.1850	48	.0760	C	.242
14	.1820	49	.0730	D	.246
15	.1800	50	.0700	E	.250
16	.1770	51	.0670	F	.257
17	.1730	52	.0635	G	.261
18	.1695	53	.0595	H	.266
19	.1660	54	.0550	I	.272
20	.1610	55	.0520	J	.277
21	.1590	56	.0465	K	.281
22	.1570	57	.0430	L	.290
23	.1540	58	.0420	M	.295
24	.1520	59	.0410	N	.302
25	.1495	60	.0400	O	.316
26	.1470	61	.0390	P	.323
27	.1440	62	.0380	Q	.332
28	.1405	63	.0370	R	.339
29	.1360	64	.0360	S	.348
30	.1285	65	.0350	T	.358
31	.1200	66	.0330	U	.368
32	.1160	67	.0320	V	.377
33	.1130	68	.0310	W	.386
34	.1110	69	.0290	X	.397
35	.1100	70	.0280	Y	.404
				Z	.413

## SHEET METALS

GAGE No.	U. S. Standard		American or Brown & Sharpe			
	Thick- ness	Lbs. per Sq. Ft. (Steel)	Thick- ness	Lbs. per Sq. Ft.		
				Copper	Brass	Aluminum
1	0.281	11.25	0.289	13.40	12.80	4.10
2	.266	10.63	.258	11.90	11.40	3.65
3	.250	10.00	.229	10.60	10.15	3.25
4	.234	9.375	.204	9.46	9.05	2.90
5	.219	8.75	.182	8.41	8.05	2.56
6	.203	8.125	.162	7.49	7.17	2.28
7	.188	7.5	.144	6.67	6.39	2.03
8	.172	6.875	.129	5.94	5.68	1.81
9	.156	6.25	.1144	5.29	5.07	1.61
10	.141	5.625	.1019	4.71	4.51	1.44
11	.125	5.0	.0907	4.19	4.02	1.28
12	.109	4.375	.0808	3.74	3.58	1.14
13	.0938	3.75	.0720	3.33	3.19	1.01
114	.0781	3.125	.0641	2.96	2.84	.903
15	.0703	2.813	.0571	2.64	2.53	.804
16	.0625	2.5	.0508	2.35	2.25	.716
17	.0563	2.25	.0453	2.10	2.01	.638
18	.0500	2.0	.0403	1.86	1.78	.568
19	.0438	1.75	.0359	1.66	1.59	.506
20	.0375	1.5	.0320	1.48	1.42	.450
21	.0344	1.375	.0285	1.32	1.26	.401
22	.0312	1.25	.0253	1.17	1.12	.357
23	.0281	1.125	.0226	1.05	1.00	.318
24	.0250	1.0	.0201	.931	.890	.283
25	.0219	.875	.0179	.829	.793	.252
26	.0188	.75	.0159	.738	.706	.225
27	.0172	.688	.0142	.657	.628	.200
28	.0156	.625	.0126	.589	.560	.178
29	.0141	.563	.0113	.521	.499	.159
30	.0125	.5	.0100	.464	.444	.141
31	.0109	.438	.00893	.413	.395	.126
32	.0102	.406	.00795	.368	.352	.112
33	.00938	.375	.00708	.328	.314	.100
34	.00859	.344	.00635	.292	.279	.0895
35	.00781	.313	.00562	.260	.249	.0793
36	.00703	.281	.00500	.232	.221	.0707
37	.00664	.266	.00445	.206	.197	.0628
38	.00625	.25	.00397	.184	.176	.0560
39			.00353	.164	.156	.0498
40			.00315	.146	.139	.0444

## CONVERSION OF UNITS

Multiply or Quantity Given in These Units	By This Number	To Find the Equivalent In These Units
ampere-turns	1.257	gilberts
ampere-turns per inch	0.4650	gilberts per cm.
Btu's	778	foot-pounds
Btu's	0.2928	watt-hours
centimeters	0.3937	inches
circular mils	0.00005067	square centimeters
circular mils	0.00000785	square inches
ubic centimeters	0.06102	ubic inches
ubic inches	16.387	ubic centimeters
ubic inches	0.00433	gallons
degrees, angular	60	minutes, angular
dynes	0.000036	ounces
feet	0.3048	meters
feet per minute	0.508	centimeters per sec.
feet per second	50.48	centimeters per sec.
foot-pounds	0.001286	Btu's
foot-pounds	1.3558	joules
foot-pounds	0.0003768	watt-hours
gallons	231	ubic inches
gausses	6.452	lines per square inch
gilberts	0.7558	ampere-turns
gilberts per centimeter	2.021	ampere-turns per inch
grams	0.03527	ounces
horsepower	745.7	watts
inches	2.54	centimeters
inches	25.4	millimeters
inches	1000	mils
joules	0.7376	foot-pounds
joules	0.0002778	watt-hours
kilograms	2.2046	pounds
kilolines	1000	maxwells
kilowatts	56.92	Btu's per minute
kilowatts	737.6	foot-pounds per sec.
kilowatts	1.341	horsepower
kilowatt-hours	3415	Btu's
lines per square cm.	1	gaussia
lines per square inch	0.155	gausses
liters	61.02	ubic inches
liters	1.057	quarts
lumens per square ft.	1	foot-candles
maxwells	1	lines magnetic flux
meters	3.281	feet
meters	39.37	inches
millimeters	0.03937	inches
ounces	28.35	grams
pounds	453.6	grams
radians	57.30	degrees, angular
radius of circle	6.28318	circumference
square centimeters	0.1550	square inches
square inches	6.452	square centimeters
square mils	1.273	circular mils
watts	0.05692	Btu's per minute
watts	44.26	foot-pounds per min.
watts	0.7376	foot-pounds per sec.
watts	0.001341	horsepower
watt-hours	3.415	Btu's
watt-hours	2655	foot-pounds
webers	100,000,000	maxwells

## CENTIMETERS AND MILLIMETERS TO INCHES

cm	mm	Inches	cm	mm	Inches	cm	mm	Inches
0.1	1	0.03937	3.6	36	1.417	7.1	71	2.795
.2	2	.07874	3.7	37	1.457	7.2	72	2.835
.3	3	.1181	3.8	38	1.496	7.3	73	2.874
.4	4	.1575	3.9	39	1.535	7.4	74	2.913
.5	5	.1969	4.0	40	1.575	7.5	75	2.953
0.6	6	.2362	4.1	41	1.614	7.6	76	2.992
.7	7	.2756	4.2	42	1.654	7.7	77	3.031
.8	8	.3150	4.3	43	1.693	7.8	78	3.071
.9	9	.3543	4.4	44	1.732	7.9	79	3.110
1.0	10	.3937	4.5	45	1.772	8.0	80	3.150
1.1	11	.4331	4.6	46	1.811	8.1	81	3.189
1.2	12	.4724	4.7	47	1.850	8.2	82	3.228
1.3	13	.5118	4.8	48	1.890	8.3	83	3.268
1.4	14	.5512	4.9	49	1.929	8.4	84	3.307
1.5	15	.5906	5.0	50	1.969	8.5	85	3.346
1.6	16	.6299	5.1	51	2.008	8.6	86	3.386
1.7	17	.6693	5.2	52	2.047	8.7	87	3.425
1.8	18	.7087	5.3	53	2.087	8.8	88	3.465
1.9	19	.7480	5.4	54	2.126	8.9	89	3.504
2.0	20	.7874	5.5	55	2.165	9.0	90	3.543
2.1	21	.8268	5.6	56	2.205	9.1	91	3.583
2.2	22	.8661	5.7	57	2.244	9.2	92	3.622
2.3	23	.9055	5.8	58	2.283	9.3	93	3.661
2.4	24	.9449	5.9	59	2.323	9.4	94	3.701
2.5	25	.9843	6.0	60	2.362	9.5	95	3.740
2.6	26	1.024	6.1	61	2.402	9.6	96	3.779
2.7	27	1.063	6.2	62	2.441	9.7	97	3.819
2.8	28	1.102	6.3	63	2.480	9.8	98	3.858
2.9	29	1.142	6.4	64	2.520	9.9	99	3.898
3.0	30	1.181	6.5	65	2.559	10.0	100	3.937
3.1	31	1.220	6.6	66	2.598	20.0	200	7.874
3.2	32	1.260	6.7	67	2.638	30.0	300	11.811
3.3	33	1.299	6.8	68	2.677	40.0	400	15.748
3.4	34	1.339	6.9	69	2.717	50.0	500	19.685
3.5	35	1.378	7.0	70	2.756			

The table may be extended by moving the decimal point the same number of places in the same direction in all three quantities.

## DECIMAL EQUIVALENTS OF FRACTIONS

	$1/64$	.015625		$33/64$	.515625
	$1/32$	.03125		$17/32$	.53125
	$3/64$	.046875		$35/64$	.546875
$1/16$		.0625	$9/16$		.5625
	$5/64$	.078125		$37/64$	.578125
	$3/32$	.09375		$19/32$	.59375
	$7/64$	.109375		$39/64$	.609375
$1/8$		.125	$5/8$		.625
	$9/64$	.140625		$41/64$	.640625
	$5/32$	.15625		$21/32$	.65625
	$11/64$	.171875		$43/64$	.671875
$3/16$		.1875	$11/16$		.6875
	$13/64$	.203125		$45/64$	.703125
	$7/32$	.21875		$23/32$	.71875
	$15/64$	.234375		$47/64$	.734375
$1/4$		.25	$3/4$		.75
	$17/64$	.265625		$49/64$	.765625
	$9/32$	.28125		$25/32$	.78125
	$19/64$	.296875		$51/64$	.796875
$5/16$		.3125	$13/16$		.8125
	$21/64$	.328125		$53/64$	.828125
	$11/32$	.34375		$27/32$	.84375
	$23/64$	.359375		$55/64$	.859375
$1/8$		.375	$7/8$		.875
	$25/64$	.390625		$57/64$	.890625
	$13/32$	.40625		$29/32$	.90625
	$27/64$	.421875		$59/64$	.921875
$7/16$		.4375	$15/16$		.9375
	$29/64$	.453125		$61/64$	.953125
	$15/32$	.46875		$31/32$	.96875
	$31/64$	.484375		$63/64$	.984375
$1/2$		.5	$1$		1.0

## CENTIGRADE TO FAHRENHEIT TEMPERATURE

C	F	C	F	C	F	C	F
- 40°	- 40.0°	- 5°	+ 23.0°	20°	68.0°	45°	113.0°
- 38	- 36.4	- 4	+ 24.8	21	69.8	46	114.8
- 36	- 32.8	- 3	+ 26.6	22	71.6	47	116.6
- 34	- 29.2	- 2	+ 28.4	23	73.4	48	118.4
- 32	- 25.6	- 1	+ 30.2	24	75.2	49	120.2
- 30°	- 22.0°	0°	+ 32.0	25°	77.0°	50°	122.0°
- 28	- 18.4	+ 1	+ 33.8	26	78.8	52	125.6
- 26	- 14.8	+ 2	+ 35.6	27	80.6	54	129.2
- 24	- 11.2	+ 3	+ 37.4	28	82.4	56	132.8
- 22	- 7.6	+ 4	+ 39.2	29	84.2	58	136.4
- 20°	- 4.0°	5°	41.0	30°	86.0°	60	140.0°
- 19	- 2.2	6	42.8	31	87.8	62	143.6
- 18	- 0.4	7	44.6	32	89.6	64	147.2
- 17	+ 1.4	8	46.4	33	91.4	66	150.8
- 16	+ 3.2	9	48.2	34	93.2	68	154.4
- 15°	+ 5.0°	10°	50.0	35°	95.0°	70°	158.0°
- 14	+ 6.8	11	51.8	36	96.8	75	167.0
- 13	+ 8.6	12	53.6	37	98.6	80	176.0
- 12	+ 10.4	13	55.4	38	100.4	85	185.0
- 11	+ 12.2	14	57.2	39	102.2	90	194.0
- 10°	+ 14.0°	15°	59.0	40°	104.0°	95°	203.0°
- 9	+ 15.8	16	60.8	41	105.8	100	212.0
- 8	+ 17.6	17	62.6	42	107.6	105	221.0
- 7	+ 19.4	18	64.4	43	109.4	110	230.0
- 6	+ 21.2	19	66.2	44	111.2	115	239.0

To change centigrade to Fahrenheit equivalent:

1. Multiply the number of centigrade degrees by 9.
2. Divide the product by 5.
3. Add 32 degrees. That is, the centigrade temperature will be 32 degrees higher (more positive or less negative) than the product found in step 2 above.

To change Fahrenheit to centigrade equivalents:

1. From the number of Fahrenheit degrees subtract 32. If this gives a negative number the centigrade temperature will be below zero.
2. Multiply by 5 the number found in step 1 above.
3. Divide the product by 9.

## SQUARE ROOT TABLE

The table lists square roots, correct to four significant figures, of numbers from 1 to 9.9 by tenths and of whole numbers from 10 to 99.

The range of the table may be extended as follows: When the decimal point is moved two places in the number it must be moved one place in the square root. The point is moved the same direction in both number and root. For example; the table gives the square root of 17 as 4.123. Then the square root of 0.17 is 0.4123, and of 1700 it is 41.23.

## TRIGONOMETRIC FUNCTIONS TABLE

The table lists natural sines, cosines, tangents, and cotangents for each degree from  $0^\circ$  to  $90^\circ$ .

For values of sines between  $0^\circ$  and  $45^\circ$  read *downward* in the column headed *Sine*, and for values between  $45^\circ$  and  $90^\circ$  read *upward* in the column having the word *Sine* at the bottom. The left-hand column of angles reads downward from  $0^\circ$  to  $45^\circ$ , and the right-hand column of angles reads upward from  $45^\circ$  to  $90^\circ$ .

For cosines read downward from  $0^\circ$  to  $45^\circ$  in the column headed *Cosine*, and from  $45^\circ$  to  $90^\circ$  read upward in the column having the word *Cosine* at the bottom.

For tangents read downward in the column headed *Tangent* from  $0^\circ$  to  $45^\circ$ , and upward from  $45^\circ$  to  $90^\circ$  in the column having *Tangent* at the bottom. For cotangents read downward in the column headed *Cotan* from  $0^\circ$  to  $45^\circ$ , and upward from  $45^\circ$  to  $90^\circ$  in the column having *Cotan* at the bottom.

*Example:* For  $25^\circ$ ,  $\sin = .4226$ ,  $\cos = .9063$ ,  $\tan = .4663$ ,  $\cot = 2.1445$ . For  $65^\circ$ ,  $\sin = .9063$ ,  $\cos = .4226$ ,  $\tan = 2.1445$ ,  $\cot = .4663$

VALUES INVOLVING  $\pi$  (Pi)

$\pi = 3.14159$	$\log \pi = 0.4971$
$\frac{\pi}{2} = 1.5708$	$\log \frac{\pi}{2} = 0.1961$
$\frac{1}{\pi} = 0.31831$	$2\pi = 6.28318$
$\pi^2 = 9.8696$	$\log \pi^2 = 0.9943$
$\frac{1}{\pi^2} = 0.10132$	$\frac{1}{\sqrt{\pi}} = 0.5642$
$\sqrt{\pi} = 1.77245$	$\log \sqrt{\pi} = 0.2486$
$\pi^3 = 31.0063$	$\sqrt[3]{\pi} = 1.4646$
$4\pi = 12.5664$	$\frac{\sqrt{\pi}}{2} = 1.2533$

## SQUARE ROOTS

No.	Root	No.	Root	No.	Root	No.	Root
1.0	1.000	5.5	2.345	10	3.162	55	7.416
1.1	1.049	5.6	2.336	11	3.317	56	7.483
1.2	1.095	5.7	2.387	12	3.464	57	7.550
1.3	1.140	5.8	2.408	13	3.606	58	7.616
1.4	1.183	5.9	2.429	14	3.742	59	7.681
1.5	1.225	6.0	2.449	15	3.873	60	7.746
1.6	1.265	6.1	2.470	16	4.000	61	7.810
1.7	1.304	6.2	2.490	17	4.123	62	7.874
1.8	1.342	6.3	2.510	18	4.243	63	7.937
1.9	1.378	6.4	2.530	19	4.359	64	8.000
2.0	1.414	6.5	2.550	20	4.472	65	8.062
2.1	1.449	6.6	2.569	21	4.583	66	8.124
2.2	1.483	6.7	2.588	22	4.690	67	8.185
2.3	1.517	6.8	2.608	23	4.796	68	8.246
2.4	1.549	6.9	2.627	24	4.899	69	8.307
2.5	1.581	7.0	2.646	25	5.000	70	8.367
2.6	1.612	7.1	2.665	26	5.099	71	8.426
2.7	1.643	7.2	2.683	27	5.196	72	8.485
2.8	1.673	7.3	2.702	28	5.292	73	8.544
2.9	1.703	7.4	2.720	29	5.385	74	8.602
3.0	1.732	7.5	2.739	30	5.477	75	8.660
3.1	1.761	7.6	2.757	31	5.568	76	8.718
3.2	1.789	7.7	2.775	32	5.657	77	8.775
3.3	1.817	7.8	2.793	33	5.745	78	8.832
3.4	1.844	7.9	2.811	34	5.831	79	8.888
3.5	1.871	8.0	2.828	35	5.916	80	8.944
3.6	1.897	8.1	2.846	36	6.000	81	9.000
3.7	1.924	8.2	2.864	37	6.083	82	9.055
3.8	1.949	8.3	2.881	38	6.164	83	9.110
3.9	1.975	8.4	2.898	39	6.245	84	9.165
4.0	2.000	8.5	2.915	40	6.325	85	9.220
4.1	2.025	8.6	2.933	41	6.403	86	9.274
4.2	2.049	8.7	2.950	42	6.481	87	9.327
4.3	2.074	8.8	2.966	43	6.557	88	9.381
4.4	2.098	8.9	2.983	44	6.633	89	9.434
4.5	2.121	9.0	3.000	45	6.708	90	9.487
4.6	2.145	9.1	3.017	46	6.782	91	9.539
4.7	2.169	9.2	3.033	47	6.856	92	9.592
4.8	2.191	9.3	3.050	48	6.928	93	9.644
4.9	2.214	9.4	3.066	49	7.000	94	9.695
5.0	2.236	9.5	3.082	50	7.071	95	9.747
5.1	2.258	9.6	3.098	51	7.141	96	9.798
5.2	2.280	9.7	3.114	52	7.211	97	9.849
5.3	2.302	9.8	3.130	53	7.280	98	9.899
5.4	2.324	9.9	3.146	54	7.348	99	9.950



## TRIGONOMETRIC FUNCTIONS

Angle	Sine	Cosine	Tangent	Cotan	Angle
0°	0.0000	1.0000	0.0000		90°
1°	.0175	.9998	.0175	57.290	89°
2°	.0349	.9994	.0349	28.636	88°
3°	.0523	.9986	.0524	19.081	87°
4°	.0698	.9976	.0699	14.301	86°
5°	.0872	.9962	.0875	11.430	85°
6°	.1045	.9945	.1051	9.5144	84°
7°	.1219	.9925	.1228	8.1445	83°
8°	.1392	.9903	.1405	7.1154	82°
9°	.1564	.9877	.1584	6.3138	81°
10°	.1736	.9848	.1763	5.6713	80°
11°	.1908	.9816	.1944	5.1446	79°
12°	.2079	.9781	.2126	4.7046	78°
13°	.2250	.9744	.2309	4.3315	77°
14°	.2419	.9703	.2493	4.0108	76°
15°	.2588	.9659	.2679	3.7321	75°
16°	.2756	.9613	.2867	3.4874	74°
17°	.2924	.9565	.3057	3.2709	73°
18°	.3090	.9511	.3249	3.0777	72°
19°	.3256	.9455	.3443	2.9042	71°
20°	.3420	.9397	.3640	2.7445	70°
21°	.3584	.9336	.3839	2.6051	69°
22°	.3746	.9272	.4040	2.4751	68°
23°	.3907	.9205	.4245	2.3559	67°
24°	.4067	.9135	.4452	2.2460	66°
25°	.4226	.9063	.4663	2.1445	65°
26°	.4384	.8988	.4877	2.0503	64°
27°	.4540	.8910	.5095	1.9626	63°
28°	.4695	.8829	.5317	1.8807	62°
29°	.4848	.8746	.5543	1.8040	61°
30°	.5000	.8660	.5774	1.7321	60°
31°	.5150	.8572	.6009	1.6643	59°
32°	.5299	.8480	.6249	1.6003	58°
33°	.5446	.8387	.6494	1.5399	57°
34°	.5592	.8290	.6745	1.4826	56°
35°	.5736	.8192	.7002	1.4281	55°
36°	.5878	.8090	.7265	1.3764	54°
37°	.6018	.7986	.7536	1.3270	53°
38°	.6157	.7880	.7813	1.2799	52°
39°	.6293	.7771	.8098	1.2349	51°
40°	.6428	.7660	.8391	1.1918	50°
41°	.6561	.7547	.8693	1.1504	49°
42°	.6691	.7431	.9004	1.1106	48°
43°	.6820	.7314	.9325	1.0724	47°
44°	.6947	.7193	.9657	1.0355	46°
45°	.7071	.7071	1.0000	1.0000	45°
	Cosine	Sine	Cotan	Tangent	

## UNKNOWN VALUES FROM FORMULAS

Frequently there exists among the terms of a known formula one whose value it is desired to determine, but the formula as originally arranged gives the value of some quantity other than the one desired. In many cases the terms may be rearranged to produce a new formula in which the desired quantity is made equal to the result of mathematical operations performed on the others.

If the arrangement of terms in the known formula is like that of any of those shown here, the terms may be rearranged in any of the ways included in the same group. The letters used in the sample formulas do not represent any particular quantities or numerical values; they serve only to illustrate the various arrangements which are equivalent.

$$a = bc \qquad b = \frac{a}{c} \qquad c = \frac{a}{b}$$

$$d = \sqrt{e} \qquad e = d^2$$

$$fg = hj \quad \frac{f}{h} = \frac{j}{g} \quad f = \frac{hj}{g} \quad g = \frac{hj}{f} \quad h = \frac{fg}{j} \quad j = \frac{fg}{h}$$

$$k = \sqrt{m^2 + n^2} \quad m = \sqrt{k^2 - n^2} \quad n = \sqrt{k^2 - m^2}$$

$$p = \frac{\sqrt{s}}{r} \quad p = \frac{\sqrt{s}}{\sqrt{r^2}} \quad r = \frac{\sqrt{s}}{p} \quad r = \frac{\sqrt{s}}{\sqrt{p^2}} \quad s = p^2 r^2 \quad s = (pr)^2$$

$$t = \frac{1}{u\sqrt{vw}} \quad u = \frac{1}{t\sqrt{vw}} \quad v = \frac{1}{t^2 u^2 w} \quad w = \frac{1}{t^2 u^2 v}$$

*Example:* A formula for impedance is,  $Z = \sqrt{r^2 + x^2}$ , where  $Z$  is impedance,  $r$  is resistance, and  $x$  is reactance, all in ohms. This formula for impedance is of the same form as  $k = \sqrt{m^2 + n^2}$  in one of the groups. By changing the impedance formula into the other forms in the same group there will be produced formulas for resistance and for reactance. The rearrangements are made by substituting  $Z$  for  $k$ ,  $r$  for  $m$ , and  $x$  for  $n$ . This gives the new formulas.

$$m = \sqrt{k^2 - n^2} \qquad \text{becomes} \qquad r = \sqrt{Z^2 - x^2}$$

$$n = \sqrt{k^2 - m^2} \qquad \text{becomes} \qquad x = \sqrt{Z^2 - r^2}$$

## Section 2

### RESISTANCE AND INSULATION

**Computing Resistances.**—A convenient method for determining the resistance of a conductor of any material, length, and cross sectional area is to use in a simple formula the value of the resistivity of that material per circular mil-foot. *Resistivity* means the resistance of a section or a portion of material which is of definitely specified and limited size, while *resistance* is the opposition of the entire body of a conductor. A circular mil-foot is a cylindrical portion of material one foot long and having a diameter of 1/1000 inch. The table of *Conductor and Resistor Materials* lists circular mil-foot resistivities of materials commonly used in radio work.

The total resistance of any conductor, in ohms, is equal to the product of its length in feet by its circular mil-foot resistivity, divided by its cross sectional area in circular mils, thus,

$$\text{Ohms} = \frac{\text{length, feet} \times \text{resistivity, circ. mil-ft.}}{\text{cross sectional area in circ. mils}}$$

The cross sectional areas of wires are listed in the *Copper Wire Table*. The area in circular mils of any round conductor is equal to 1,000,000 times the square of its diameter in inches. The cross sectional area in circular mils of a conductor of any shape is equal to 1,273,000 times its cross section in square inches.

*Example:* What is the resistance in ohms of 54 feet of number 24 gage aluminum wire?

The circular mil-foot resistivity of aluminum is given by the table as 17. From the copper wire table the cross sectional area of 24 gage wire is found to be 404 circular mils. Placing these values in the formula gives,

$$\text{Ohms} = \frac{54 \text{ (feet)} \times 17}{404} = \frac{918}{404} = 2.27$$

In some tables the resistivity of materials is given in microhms (millionths of an ohm) per cubic centimeter. Conversions are as follows:

Microhms per cu. cm.  $\times 6.0153 =$  Ohms per circ. mil-ft.

Ohms per circ. mil-ft.  $\times 0.1662 =$  Microhms per cu. cm.

**Temperature Coefficient of Resistivity**—Resistance determined from values of mil-foot resistivity given in the table are those which exist when the material is at a temperature of 68° F. (20° C.). The change of resistance at higher or lower temperatures is found by using the temperature coefficient of resistivity listed in the table. *Conductor and Resistor Materials*.

The *change* of resistance in ohms is equal to the product of the original resistance in ohms, the number of degrees difference between the two temperatures, and the temperature coefficient of resistivity, thus,

$$\text{Change} = \frac{\text{original}}{\text{ohms}} \times \frac{\text{degrees}}{\text{difference}} \times \text{coefficient}$$

*Example:* What is the resistance of an aluminum conductor at 120° F. when its resistance at 68° F. is 2.27 ohms?

The difference between 120° and 68° is 52°. The temperature coefficient for aluminum is listed in the table as 0.0022. Putting these values in the formula gives,

$$\text{Change} = 2.27 \times 52 \times 0.0022 = 0.26 \text{ ohm}$$

Since the resistance of aluminum increases with rise of temperature, the change of 0.26 ohm is added to the original resistance of 2.27 ohms, giving the resistance as 2.49 ohms at 120°.

Were the temperature decreased below 68° F., any computed change of resistance would be subtracted from the original resistance to find the resistance at the lower temperature.

Resistance does not change at a constant rate with change of temperature. That is, the temperature coefficient itself varies with temperature.

It is advisable to specify the temperature when giving resistances. Resistances at normal working temperature often are called *hot resistances*, while those at room temperature are called *cold resistances*. There may be great differences between the two resistances.

In some applications it is desirable that there be very little change of resistance with variations of temperature. This result may be attained by making an entire circuit of some alloy metal having a very small temperature coefficient. When most of the conductors in a circuit must be of materials having a rather high positive coefficient, it is possible to insert one or more resistors made of material having a negative coefficient. Then the increase of resistance in the body of the circuit is counteracted by an approximately equal decrease of resistance in the units having a negative coefficient.

#### RESISTANCE WIRE TABLES

The resistances in ohms per foot of wires listed in the tables are based on resistivities of certain numbers of ohms per circular mil-foot. Consequently, the resistance values may be used for other kinds of wires having the same or nearly the same resistivities. For example, resistivities in the table for Advance wire would apply to constantan wire which has the same resistivity.

Diameters and cross sectional areas for the various American Wire Gage sizes are the same as listed in the *Copper Wire Table*.

## CONDUCTOR AND RESISTOR MATERIALS

Kind of Material or Trade Name	Ohms per Circ. Mil-ft. at 68° F.	Temperature Coefficient of Resistance per Degree F.
Advance	2974	0.00001
Aluminum	17	.0022
Brass, common	49	.001
high brass	41	
low brass	35	
Carbon	21000	- 0.00028
Chromel	540	
Constantan	294	.000005
Copper, annealed	10.4	.00218
USS	10.55	.002
hard drawn	10.65	.00212
German silver, 18%	198	.00018
Graphite	4800	
Ideal	295	.000005
Iron, pure	60	.0031
cast	540	
wrought	84	
Lead	115	.0023
Lucerno	275	.001
Magnesium, pure	277	.0022
Manganin	<b>270</b>	.00001
Nickel	52	.0027
Nickel silver, 30%	240	.0001
Nichrome II	660	.00013
III	540	.0001
IV	625	.00006
Novar	296	
Platinum	72	.0021
Silver	9.75	.0021
Steel, crucible	115	
galvanized	67	.0017
hard	162	.001
manganese	420	.0005
Tungsten	33.2	.0025
Zinc	38	.0021
	26	

## COPPER WIRE TABLE

GAGE No.	DIAM. Inches	CROSS SECTION		RESISTANCE at 68° F.	
		Circular Mils	Square Inches	Ohms per 1,000 Ft.	Feet per Ohm
0000	0.4600	211,600	.1662	0.0490	20,400
000	.4096	167,800	.1318	.0618	16,180
00	.3648	133,100	.1045	.0779	12,830
0	.3249	105,500	.08289	.0983	10,180
1	.2893	83,690	.06573	.1239	8,070
2	.2576	66,370	.05213	.1563	6,400
3	.2294	52,640	.04134	.1970	5,075
4	.2043	41,740	.03278	.2485	4,025
5	.1819	33,100	.02600	.3133	3,192
6	.1620	26,250	.02062	.3951	2,531
7	.1443	20,820	.01635	.4982	2,007
8	.1285	16,510	.01297	.6282	1,592
9	.1144	13,090	.01028	.7921	1,262
10	.1019	10,380	.008155	.9989	1,001
11	.09074	8,234	.006467	1.260	794
12	.08081	6,530	.005129	1.588	630
13	.07196	5,178	.004067	2.003	499.3
14	.06408	4,107	.003225	2.525	396.0
15	.05707	3,257	.002558	3.184	314.0
16	.05082	2,583	.002028	4.016	249.0
17	.04526	2,048	.001608	5.064	197.5
18	.04030	1,624	.001276	6.385	156.6
19	.03589	1,288	.001012	8.051	124.2
20	.03196	1,022	.000802	10.15	98.5
21	.02846	810.1	.000636	12.80	78.11
22	.02535	642.4	.000505	16.14	61.95
23	.02257	509.5	.000400	20.36	49.13
24	.02010	404.0	.000317	25.67	38.96
25	.01790	320.4	.0002517	32.37	30.90
26	.01594	254.1	.0001936	40.81	24.50
27	.01420	201.5	.0001583	51.47	19.43
28	.01264	159.8	.0001255	64.90	15.41
29	.01126	126.7	.0000995	81.83	12.22
30	.01003	100.5	.0000789	103.2	9.691
31	.008928	79.70	.0000626	130.1	7.685
32	.007950	63.21	.0000496	164.1	6.095
33	.007080	50.13	.0000394	206.9	4.833
34	.006305	39.75	.0000312	260.9	3.833
35	.005615	31.52	.0000248	329.0	3.040
36	.005000	25.00	.0000196	414.8	2.411
37	.004453	19.83	.0000156	523.1	1.912
38	.003965	15.72	.0000124	659.6	1.516
39	.003531	12.47	.0000098	831.8	1.202
40	.003145	9.88	.0000078	1049.	.953
41	.00280	7.845	.0000062	1323.	.756
42	.00250	6.250	.0000049	1659	.603
43	.00220	4.850	.0000038	2138	.467
44	.00200	4.000	.0000031	2592	.385
45	.00175	3.063	.0000024	3390	.295
46	.00150	2.250	.0000018	4610	.217

**RESISTANCE WIRE—MANGANIN**

270 ohms per circular mil-foot at 68° F.

SIZE A.W.G.	Ohms per Foot	Ohms per Pound	Feet per Pound	Lbs. per 1000 Ft.
10	0.026	0.88	34.8	28.6
12	.041	2.22	54.5	18.2
14	.066	5.62	89.5	11.5
15	.083	9.40	109.0	9.20
16	.103	14.9	139	7.20
17	.133	23.8	179	5.60
18	.168	39.6	226	4.42
19	.203	60.4	279	3.58
20	.263	96.6	353	2.83
21	.332	153	446	2.24
22	.421	247	565	1.77
23	.528	379	709	1.41
24	.668	653	893	1.12
25	.843	983	1123	.89
26	1.068	1580	1429	.70
27	1.339	2380	1786	.56
28	1.700	4020	2273	.440
29	2.114	6250	2857	.350
30	2.700	10100	3623	.276
31	3.409	16100	4566	.219
32	4.219	24700	5656	.177
33	5.357	39500	7194	.139
34	6.801	64000	9091	.110
35	8.598	102000	11490	.087
36	10.80	162000	14490	.069
37	13.36	238000	17860	.056
38	16.87	389000	22220	.045
39	22.13	675000	29410	.034
40	30.00	1240000	40000	.025

## RESISTANCE WIRE—ADVANCE

294 ohms per circular mil-foot at 68° F.

SIZE A.W.G.	Ohms per Foot	Ohms per Pound	Feet per Pound	Lbs. per 1000 Ft.
8	.017	.351	20.7	42.3
9	.022	.559	25.4	39.4
10	.028	.886	31.7	31.6
11	.035	1.410	40.3	24.8
12	.044	2.246	51.0	19.6
13	.056	3.575	63.8	15.7
14	.071	5.678	80.0	12.5
15	.090	9.030	100.0	10.0
16	.113	14.56	127	7.87
17	.145	22.83	161	6.21
18	.184	36.29	204	4.90
19	.226	57.71	256	3.90
20	.287	91.74	323	3.10
21	.362	145.9	403	2.48
22	.460	232.0	526	1.74
23	.575	369.0	667	1.50
24	.725	586.6	833	1.20
25	.919	932.9	1031	.970
26	1.162	1483	1299	.769
27	1.455	2358	1639	.610
28	1.850	3749	2083	.480
29	2.300	5964	2632	.380
30	2.940	9470	3334	.300
31	3.680	15075	4167	.240
32	4.60	23970	5263	.190
33	5.83	38110	6667	.150
34	7.40	60620	8333	.120
35	9.36	96340	10530	.095
36	11.75	153240	13160	.0760
37	14.55	243550	16670	.0600
38	18.58	388360	21280	.0470
39	24.10	616000	26320	.0380
40	32.66	1183000	35710	.0280
41	38.89	1850000	47600	.0210
42	46.40	2730000	58900	.0170
43	58.10	4150000	71500	.0140
44	72.50	6600000	91000	.0110
45	96.08	12000000	125000	.0080
46	130.67	21600000	166700	.0060



## RESISTANCE WIRE—NICHROME

660 ohms per circular mil-foot at 68° F.

SIZE A.W.G.	Ohms per Foot	Ohms per Pound	Feet per Pound	Lbs. per 1000 Ft.
8	.0408	.903	22.2	45.0
9	.0509	1.416	27.8	36.0
10	.0639	2.205	34.5	29.0
11	.0805	3.500	43.5	23.0
12	.1018	5.66	55.6	18.0
13	.1278	8.93	69.9	14.3
14	.1610	14.25	88.5	11.3
15	.2036	22.19	109	9.18
16	.2556	35.50	139	7.19
17	.3220	57.62	179	5.58
18	.4072	92.00	226	4.42
19	.5112	142.6	279	3.58
20	.6465	228.3	353	2.83
21	.8175	364.6	446	2.24
22	1.031	582.3	565	1.77
23	1.292	916.0	709	1.41
24	1.634	1455	893	1.12
25	2.060	2310	1123	.890
26	2.611	3729	1429	.700
27	3.274	5830	1786	.560
28	4.159	9438	2273	.490
29	5.168	14740	2857	.350
30	6.600	23870	3623	.276
31	8.353	37950	4566	.219
32	10.31	58190	5650	.177
33	13.10	94160	7194	.139
34	16.62	150700	9091	.110
35	21.02	240900	11490	.0871
36	26.40	381700	14490	.0690
37	32.67	583000	17860	.0560
38	41.24	916300	22220	.0450
39	54.10	1591000	29410	.0340
40	73.33	2566000	40000	.0250
41	87.30	4140000	47600	.0210
42	105.6	6230000	58900	.0169
43	130.4	9310000	71500	.0140
44	165.0	15000000	91000	.0110
45	215.7	26900000	125000	.0080
46	293.3	48700000	166700	.0060

## COLOR CODING OF RESISTORS

With small composition resistors the resistance in ohms and the accuracy or tolerance as a percentage may be indicated by colors placed on the resistor in accordance with the table, *RMA Color Code for Resistors*. The number of ohms indicated by the colors is made up of one or more numerals from 0 to 9, called "significant figures," and of additional ciphers as needed to complete the number. How many ciphers are to be added is shown by the color corresponding to the "decimal multiplier."

## RMA COLOR CODE FOR RESISTORS

Color	Significant Figures	Ciphers To Be Added	Multiplier Decimal
Black .....	0	none	1
Brown .....	1	1	10
Red .....	2	2	100
Orange .....	3	3	1,000
Yellow .....	4	4	10,000
Green .....	5	5	100,000
Blue .....	6	6	1,000,000
Violet .....	7	7	10,000,000
Gray .....	8	8	100,000,000
White .....	9	9	1,000,000,000
Tolerance, + or -			
Gold .....		5%	1/10 or 0.1
Silver .....		10%	1/100 or 0.1
No color .....		20%	

The standard tolerances are 5%, 10% and 20%, meaning that the actual resistance may be either in excess of or less than the marked value by these percentages. Gold and silver are used only for tolerance indications, except in a special system to be explained later, and if neither one appears the tolerance is 20%.

The method of using the color code for resistors having radial leads, or leads which extend from the side of the resistor, is shown by Fig. 2-1. The color of the body of the resistor indicates the first significant figure, the color of the tip or end indicates the second significant figure, and a central dot or band of color indicates the number of ciphers to be added. Tolerance may be indicated by gold or silver at the other end.

*Examples:* A red body, a green tip, and a yellow dot show that the first figure is to be 2, the second to be 5, and show that four ciphers are to be added. This makes 250,000 ohms. If there is neither gold nor silver the tolerance is 20%.

A violet body, black tip, black dot or center band, and silver end indicate 70 with no ciphers added, and a tolerance of 10%.

Fig. 2-2 shows the older method of using the color code with resistors having axial leads, or leads coming out of the ends. The body color shows the first significant figure, the second figure is shown by a color on or near one end, and tolerance is shown by gold or silver either at the opposite end or outside the numeral color that is near one end.

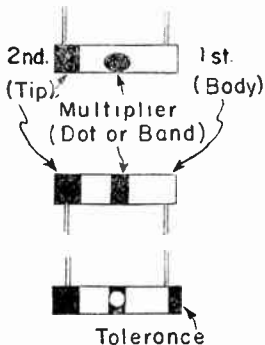

Fig. 2-1. Radial lead coding.

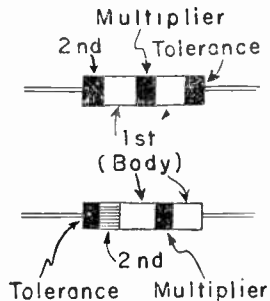

Fig. 2-2. Old axial coding.

With the systems shown by Figs. 2-1 and 2-2, absence of a dot or a band of color means that the dot or band, if present, would be of the same color as the body. Thus, a resistor with orange body and neither a tip color nor a central dot or band color would, in effect, have orange for all three positions. Its value would be 33,000 ohms; or 3 for the body, 3 for the dot or band, and 3 ciphers added.

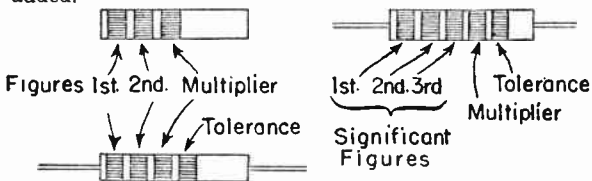

Fig. 2-3. New color coding for axial leads.

The newer system for units with axial leads or end leads is shown by Fig. 2-3. With this system the bands of colors commence at or close to one end of the resistor, they extend all the way around, there are spaces between adjacent bands, and all values are shown by color bands with no attention paid to the color of the main body of the resistor. The colors are read in order from the end at which they commence. If there are three bands the order is; first significant figure, second significant figure,

multiplier. If there are four bands the fourth one indicates tolerance, and will be either gold or silver. If there are five bands, the first three indicate three significant figures, rather than the two significant figures otherwise shown. Then the fourth band indicates the multiplier, and the fifth the tolerance.

When three significant figures are to be shown, all five bands must be employed. With five bands gold may indicate the multiplier of  $1/10$  or 0.1, and silver may indicate the multiplier or  $1/100$  or 0.01. The fourth band always is the multiplier in this five-band system, and it may show that  $1/10$  or  $1/100$  of the value is to be taken. The fifth band always is the tolerance band, and it may be either gold or silver.

**Preferred Numbers for Resistance Values.**—It is becoming common practice to employ resistors whose resistance values are confined to a limited group of numbers and other numbers formed by adding ciphers. These are the RMA Preferred Number Values. The preferred numbers between 10 and 100 are listed in the table.

RMA PREFERRED NUMBERS		
20% Tolerance	10% Tolerance	5% Tolerance
10	10	10
		11
	12	12
		13
15	15	15
		16
	18	18
		20
22	22	22
		24
	27	27
		30
33	33	33
		36
	39	39
		43
47	47	47
		51
	56	56
		62
68	68	68
		75
	82	82
		91

The table shows that the resistances of all resistors having a tolerance of plus or minus 20% should be 10, 15, 22, 33, 47, or 68 ohms, or else should be of these numbers multiplied by 10, 100, 1,000 and so on. For example, based on the number 47, there would be 20% tolerance units of 47, 470, 4,700, 47,000 470,000 and greater values of resistance; always consisting of the figures 47 with ciphers added.

With such a series of resistance values as shown in the 20% column it is possible to cover a complete range of resistance, as follows: A unit having a nominal resistance of 10 ohms may have an actual resistance of between 8 and 12 ohms. One having a nominal resistance of 15 ohms might have an actual resistance between 12 and 18 ohms. One of nominal 22 ohms would cover from 17.6 to 26.4 ohms. Thus these three values of 20% resistors cover the range from 8 to 26.4 ohms. Similar analysis of the remaining 20% numbers, 33, 47 and 68, would show coverage all the way to 81.6 ohms, and then the minimum value of a 100-ohm unit would carry on from 80 ohms.

The same principles apply with the preferred numbers for 10% tolerance and for 5% tolerance. For example; consider the preferred numbers 15, 18 and 22 in the 10% tolerance group. The actual resistance of a 15-ohm 10% unit may lie between 13.5 and 16.5 ohms. The 18-ohm unit, plus or minus 10%, covers from 16.2 to 19.8 ohms. The 22-ohm unit actually covers from 19.8 to 24.2 ohms. These three nominal values cover from 13.5 to 24.2 ohms with no gaps. There is no need for intermediate values in any of the tolerance groups, because any intermediate value would fall within the plus or minus limits of one of the preferred values.

**Table of Resistor Color Coding.**—The table of *Resistor Color Coding* shows, for all resistors of preferred number values and for most of the older standard values, the resistances in ohms corresponding to various arrangements of colors. The two columns at the left list the colors which indicate the first and second significant figures according to color positions shown by Figs. 2-1 to 2-3. The next seven columns, headed *Multiplier Color* and having colors named at the top of each column, show resistance values when the color listed at the top is in the multiplier position as shown by Figs. 2-1 to 2-3. The three right-hand columns indicate whether resistors of values listed on each line usually are found with 20% tolerance (no tolerance color), with 10% tolerance (silver), or with 5% tolerance (gold). Some resistor values come in all three tolerances, others come only in 10% or 5% tolerances, and still others come only in 5% tolerance.

To look up the value of resistance of a resistor having

a given color arrangement, find the first two colors in the first and second columns at the left. Then find the third (multiplier) color at the top of one of the middle columns. At the intersection of the line and column is shown the resistance in ohms or megohms. The meaning of a tolerance band or tip (silver or gold) is found by following along the line to the right-hand columns.

The color coding for any standard value of resistance is found by locating the number of ohms resistance in one of the columns, referring to the first and second colors on the same line at the left, and to the multiplier color at the top of the same column. Tolerances which usually are available in stock units are shown on the same line, in the right-hand columns.

Many other values are indicated on resistors by appropriate arrangements of colors in accordance with the principles explained in this section.

## RESISTOR COLOR CODING

FIRST COLOR	SECOND COLOR	MULTIPLIER COLOR						TOLERANCE COLOR			
		Black	Brown	Red	Orange	Yellow	Green (megohms)	Blue	None 20%	Silver 10%	Gold 5%
Brown	Black	10	100	1,000	10,000	100,000	1.0	10	o	x	x
Brown	Brown	11	110	1,100	11,000	110,000	1.1				x
Brown	Red	12	120	1,200	12,000	120,000	1.2			x	x
Brown	Orange	13	130	1,300	13,000	130,000	1.3				x
Brown	Green	15	150	1,500	15,000	150,000	1.5	15	o	x	x
Brown	Blue	16	160	1,600	16,000	160,000	1.6				x
Brown	Gray	18	180	1,800	18,000	180,000	1.8			x	x
Red	Black	20	200	2,000	20,000	200,000	2.0	20	o	x	x
Red	Red	22	220	2,200	22,000	220,000	2.2		o	x	x
Red	Yellow	24	240	2,400	24,000	240,000	2.4				x
Red	Green	25	250	2,500	25,000	250,000	2.5		o	x	x
Red	Violet	27	270	2,700	27,000	270,000	2.7			x	x
Orange	Black	30	300	3,000	30,000	300,000	3.0		o	x	x
Orange	Orange	33	330	3,300	33,000	330,000	3.3		o	x	x
Orange	Green		350	3,500	35,000				o	x	x
Orange	Blue	36	360	3,600	36,000	360,000	3.6				x
Orange	White	39	390	3,900	39,000	390,000	3.9			x	x
Yellow	Black	40	400	4,000	40,000	400,000	4.0		o	x	x
Yellow	Orange	43	430	4,300	43,000	430,000	4.3				x
Yellow	Green		450						o	x	x
Yellow	Violet	47	470	4,700	47,000	470,000	4.7		o	x	x
Green	Black	50	500	5,000	50,000	500,000	5.0		o	x	x
Green	Brown	51	510	5,100	51,000	510,000	5.1				x
Green	Blue	55	550	5,500	55,000	550,000	5.5			x	x
Blue	Black		600	6,000	60,000	600,000	6.0		o	x	x
Blue	Red	62	620	6,200	62,000	620,000	6.2				x
Blue	Green			65,000					o	x	x
Blue	Gray	68	680	6,800	68,000	680,000	6.8		o	x	x
Violet	Black			7,000	70,000		7.0		o	x	x
Violet	Green	75	750	7,500	75,000	750,000	7.5		o	x	x
Gray	Black		800	8,000					o	x	x
Gray	Red	82	820	8,200	82,000	820,000	8.2			x	x
White	Black			9,000					o	x	x
White	Brown	91	910	9,100	91,000	910,000	9.1				x

## INSULATION

**Dielectric Strength.**—When insulation is subjected to a large potential difference there is an exceedingly small electron flow through and across the insulation, and, at the same time, the electrons in the atoms are pulled one way or the other while remaining in the atoms. If the potential difference exceeds a number of volts called the *breakdown voltage* or the *dielectric strength* of the material, molecules are torn bodily from their places and the insulation is punctured or ruptured. Electron flow then passes through the opening and, if continued at a great enough rate, the resulting heating will burn and char the material around the opening.

Dielectric strength increases with thickness of insulation, but not directly. For example, 1/100 inch of a certain grade of mica withstands 19,600 volts, but 2/100 inch withstands only 29,600 volts, which is not twice as much, and 4/100 inch withstands 48,000 volts, which is not four times as much as with one-fourth the thickness.

Dielectric strength varies with method of manufacture. For instance, phenolic insulation which is molded has less strength than the same kind of material formed into layers, or laminated. Alternating potentials reduce the strength in comparison to its value at direct potentials, and there is a decided decrease as the frequency increases. Many materials satisfactory for power and lighting frequencies are not suited for radio frequencies.

Dielectric strength decreases with rise of temperature, it decreases if moisture penetrates the insulation, it decreases as potential differences are applied for longer and longer times, it is affected by the time intervals between applications of potential, and it varies with the shape and condition of conductors between which the insulation is placed. Unless all factors are specified, a statement that an insulator has a certain dielectric strength has little significance. Dielectric strengths and volume resistivities of a few radio insulators are listed in the table, *Insulating Materials*.

## INSULATING MATERIALS

INSULATION MATERIAL	DIELECTRIC STRENGTH 1,000's of Volts per Millimeter	VOLUME RESISTIVITY 1,000,000,000's of Ohms per Inch Cube
Air		
needle points .....	1	.....
1-inch balls .....	2-4	.....
Cloth		
oiled .....	8-30	.....
varnished .....	10-20	.....
Fibre		
hard, gray .....	7-16	8
Glass .....	30-100	200-3,000,000
Mica, white .....	50	80,000,000
amber .....	70	4,000,000
Paper		
with bec's wax .....	77	.....
with paraffin .....	50	.....
varnished .....	10-25	.....
Phenol compounds .....		8-8,000,000
molded .....	6-40	.....
laminated .....	16-56	.....
Porcelain .....	8-16	120,000
Quartz, fused .....	25	2,000,000,000
Rubber		
hard .....	.....	800,000-400,000,000
vulcanized, 30% .....	.....	120,000-2,400,000
Steatite .....	10-20	exceeds 100,000
Wood		
paraffin filled .....	4	12-16,000



## Section 3

### ELECTRIC CIRCUITS

**Ohm's Law.**—The rate of current flow, the resistance, and the emf or potential difference in any circuit or part of a circuit consisting of conductors may be found with the help of Ohm's law provided two of the three values are known. Ohm's law for direct-current circuits and for alternating-current circuits containing negligible reactance is shown by three formulas.

$$I = \frac{E}{R} \qquad R = \frac{E}{I} \qquad E = IR$$

*I*, Rate of current flow, in amperes.

*R*, Resistance, in ohms.

*E*, Potential difference or emf, in volts.

When using the preceding formulas for Ohm's law the values must be in amperes, ohms, and volts; not in other units unless the formulas are rearranged for the other units. Values in one unit may be converted to equivalent values in other units as follows:

Amperes	×	1,000	= milliamperes
Amperes	×	1,000,000	= microamperes
Milliamperes	×	0.001	= amperes
Microamperes	×	0.000001	= amperes
Ohms	×	1,000,000	= microhms
Ohms	×	0.000001	= megohms
Microhms	×	0.000001	= ohms
Megohms	×	1,000,000	= ohms
Volts	×	1,000	= millivolts
Volts	×	1,000,000	= microvolts
Millivolts	×	0.001	= volts
Microvolts	×	0.000001	= volts

The three forms of Ohm's law may be written with the various units for current, resistance, and potential difference as in the table of *Ohm's Law Formulas*.

## OHM'S LAW FORMULAS

$$\frac{\text{volts}}{\text{ohms}} = \text{amperes}$$

$$\frac{\text{volts}}{\text{megohms}} = \text{microamperes}$$

$$\frac{\text{millivolts}}{\text{ohms}} = \text{milliamperes}$$

$$\frac{\text{microvolts}}{\text{ohms}} = \text{microamperes} \quad \frac{\text{microvolts}}{\text{microhms}} = \text{amperes}$$

$$\frac{\text{volts}}{\text{amperes}} = \text{ohms}$$

$$\frac{\text{volts}}{\text{microamperes}} = \text{megohms}$$

$$\frac{\text{millivolts}}{\text{milliamperes}} = \text{ohms}$$

$$\frac{\text{microvolts}}{\text{amperes}} = \text{microhms} \quad \frac{\text{microvolts}}{\text{microamperes}} = \text{ohms}$$

$$\text{amperes} \times \text{ohms} = \text{volts}$$

$$\text{amperes} \times \text{microhms} = \text{microvolts}$$

$$\text{milliamperes} \times \text{ohms} = \text{millivolts}$$

$$\text{microamperes} \times \text{ohms} = \text{microvolts}$$

$$\text{microamperes} \times \text{megohms} = \text{volts}$$

**Ohm's Law Chart.**—When any two of the quantities, volts, ohms and amperes, are known it is possible to read the third unknown quantity from Chart No. 3-1 without having to make any computation. On the chart are three scales, one for each of the quantities. When a straight line is run through known values on two of the scales, the line will intersect the unknown value on the third scale. The straight line may be the edge of a ruler, a folded piece of paper, or anything similar that will cross the three scales.

Each scale carries two series of numbers, one series indicated by *A* and the other by *B*. When the *A*-scale is used on one value the *A*-scales must be used on the other two. Likewise, the three *B*-scales must be used together. The *A*-scale for ohms runs from 0.1 to 1,000 ohms, while the *B*-scale has values in thousands of ohms and others in megohms. The scales for amperes are in decimal fractions which allow reading the values in milliamperes quite easily. For example, .001 amperes is the same thing as 1 milliampere, and .010 ampere is equal to 10 milliamperes.

**Series and Parallel Connections.**—In Fig. 3-2 is represented a circuit consisting of a battery as the source of emf, the heated elements or filaments of four radio tubes, and a resistor whose resistance, combined with resistance of other parts of the circuit, limits the rate of flow. In the right-hand diagram the tube filaments and

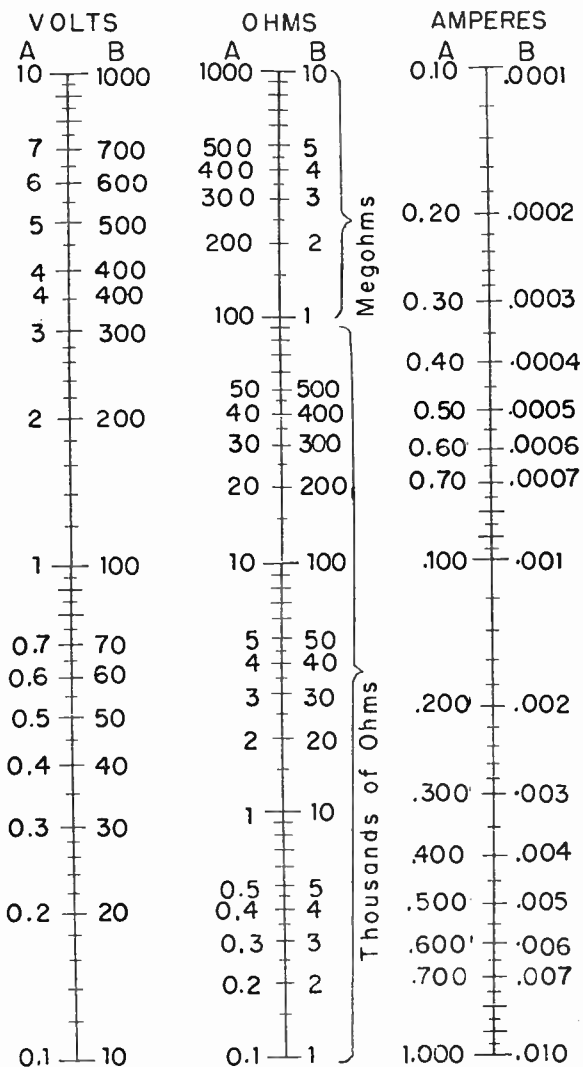

Chart 3-1. The Ohm's law chart.

resistor are shown by the radio symbol for resistance of any kind, the battery is shown by the symbol for any kind of battery, and the connecting wires are each shown by a line, which is the symbol for a wire conductor.

In this circuit all electrons which are forced by emf through the battery from one of its terminals to the other then must travel successively through all the tube filaments, the resistor, and the connecting wires before

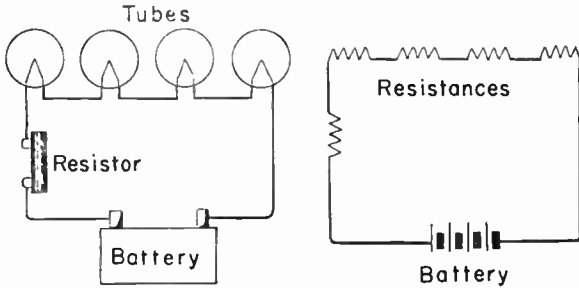

Fig. 3-2. Elements of a series circuit.

returning to the battery. Any circuit in which all of the flow must pass through every part of the circuit is called a *series circuit*, and parts so connected are said to be connected *in series* with one another.

Instead of connecting the parts of the circuit in series, the tube filaments and battery might be connected as in

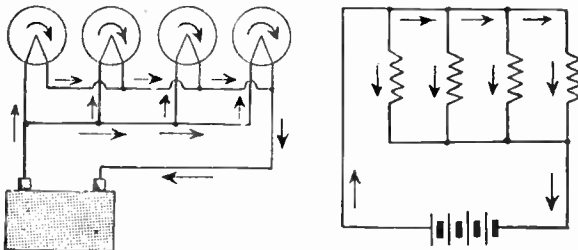

Fig. 3-3. Elements of a parallel circuit.

Fig. 3-3, so that the total electron flow leaving one terminal of the battery divides between the filaments, part passing through each filament. Then the electrons which have passed through all the filaments unite and return to the battery. The circuit is shown with symbols at the right. Any circuit in which electron flow divides so that some of it flows through one path and the re-

mainder through other parts is called a *parallel circuit*, and the parts through which the partial flows take place are said to be connected together *in parallel*.

In most radio circuits the wires and other metallic connections between the source and the principal devices are so short and of such relatively large cross section as to have resistances which are negligible in comparison with resistances of the principal units. Copper wire of number 20 gage often is used. Its resistance is only about 1/100 ohms per foot. The resistance of the connections usually may be neglected, and the resistance of the circuit considered as being made up of the resistances of its principal devices.

**Sources and Their Potentials.**—Every source is capable of developing and maintaining an emf of a certain number of volts. The emf of an ordinary dry cell is almost exactly 1.5 volts, and of a lead-acid storage battery cell is 2.1 volts. The emf of generators depends on

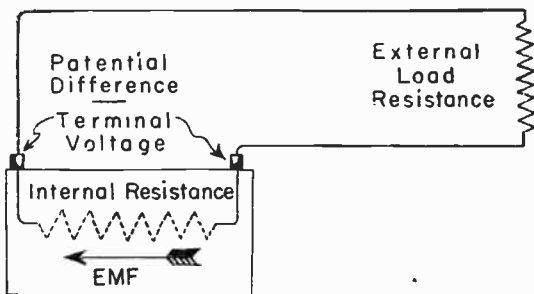

Fig. 3-4. A complete circuit, including internal resistance.

their construction and the speed at which they are driven. In thermocouples the emf depends on the materials of the couple, and in photocells it depends on the type of cell and on the strength of light reaching it.

When there is electron flow from a source through an external circuit the same rate of flow exists through the source itself. The source is made of conductive materials, and these have resistance. Consequently, inside the source there is electron flow through resistance, and part of the emf (or electron energy due to emf) is used in getting the electrons through the internal resistance of the source. The complete circuit is shown by Fig. 3-4. External parts of the circuit in which useful work may be done are called the *load*, and their total resistance is called the *load resistance*.

It is only the difference between the emf in volts and the number of volts of energy used in the internal resistance that is available at the terminals of the source

for application to the external circuit. This is called the *terminal voltage* or potential of the source. As the rate of flow increases there is more energy used inside the source, so terminal potential drops as rate of flow increases.

If the source is connected to no external circuit, or should the external circuit be incomplete or *open*, there can be no electron flow. With no electron flow there is no energy used inside the source. Then the *open circuit potential* of the source is equal to its emf. This may be called also the *no-load potential*. When the rate of flow is the full amount for which the apparatus is designed, the terminal potential is the *full-load potential*. If the source terminals are connected together externally by a conductor having negligible resistance, such as a short piece of large wire, the connection is a *short circuit*. In the negligible resistance of the short circuit there can be negligible potential difference, for  $E = IR$ . Then practically the whole resistance of the circuit is that inside the source, almost the whole potential is used in getting electron flow through this internal resistance, and the terminal potential drops almost to zero.

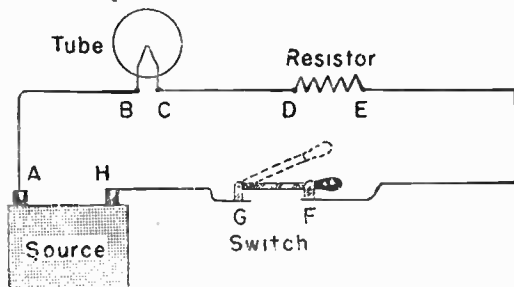

Fig. 3-5. Current path in a series circuit.

**Series Circuits.**—In Fig. 3-5 is shown a series circuit containing a source, the filament of a radio tube, a resistor, a switch, and connecting wires. The entire circuit includes everything from *A* through *B-C-D-E-F-G-H*, then through the source and back to *A*. The external circuit includes everything from *A* to *H*, but does not include the source. The external circuit may be considered as made up of various parts or groups of parts. The part from *B* to *C* includes only the tube, from *D* to *E* only the resistor, but from *A* through to *E* we have a portion including the tube, the resistor, and the connecting wires *A-B* and *C-D*.

Intelligent use of Ohm's law will show values of amperes, ohms and volts which should exist in an entire

## SERIES CIRCUITS

	Entire Circuit	External Circuit	Any One Part or Portion
Flow Rate AMPERES	$I_t = \frac{emf}{R_t}$ <p>Same I in external circuit and in source.</p>	$I_t = \frac{E_t}{R_e}$ <p>Same I as in source.</p>	$I_p = \frac{E_p}{R_p}$ <p>Same I in every part.</p>
Resistance OHMS	$R_t = \frac{emf}{I_t}$ $R_t = R_i + R_e$	$R_e = \frac{E_t}{I_t}$ <p>Equals sum of R's in all parts.</p>	$R_p = \frac{E_p}{I_p}$
Potential Differences and Emf VOLTS	$emf = I_t \times R_t$	$E_t = I_t \times R_e$ $E_t = emf - E_i$ <p>Equals sum of potential dif's in all parts.</p>	$E_p = I_p \times R_p$

## PARALLEL CIRCUITS

	Any One Path or Part	All Paths Together.
Flow Rate AMPERES	$I_p = \frac{E_p}{R_p}$ <p>There is least I in greatest R and most I in smallest R</p>	$I_t = \frac{E_t}{R_e}$ <p>Total I is more than the I in any one path</p>
Resistance OHMS	$R_p = \frac{E_p}{I_p}$ <p><math>R_p</math> is equal to the sum of all the R's which make up the path.</p>	$R_e = \frac{R_1 \times R_2}{R_1 + R_2}$ $\frac{1}{R_e} = \frac{1}{R_1} + \frac{1}{R_2} + \frac{1}{R_3}, \text{ etc.}$ <p><math>R_e</math> is less than the R of any one path.</p>
Potential Difference VOLTS	$E_p = I_p \times R_p$ <p>The same E is across each of the parallel paths</p>	$E_t = I_t \times R_e$ <p>The same E is applied to each of the paths which are in parallel.</p>

circuit, in the external circuit, or in any part or group of parts. But it is most important that flow rate, resistance, and potential difference be considered in the same part or portion. Electron flow in part of a circuit cannot be correctly computed by using the terminal potential of the source in combination with the resistance of only the part being considered. The accompanying table for *Series Circuits* shows how resistance, potential difference or emf, and rate of flow are computed for an entire series circuit, or for any part or group of parts. The table contains also several important notations with reference to series circuits.

In this table, and a following one for parallel circuits, the various values are represented by the following letter symbols:

- emf* Electromotive force (volts) of source.
- E<sub>i</sub>* Internal potential difference of source, in volts.
- E<sub>p</sub>* Potential difference across any one part or section of circuit, in volts.
- E<sub>t</sub>* Terminal potential difference of source, or total potential difference of circuit, in volts.
- I<sub>p</sub>* Flow rate through any one part or portion of circuit, in amperes.
- I<sub>t</sub>* Total flow rate through all parts or paths together, in amperes.
- R<sub>e</sub>* External circuit resistance, in ohms.
- R<sub>i</sub>* Internal resistance of source, in ohms.
- R<sub>p</sub>* Resistance of any one part or section, in ohms.
- R<sub>t</sub>* Total resistance of entire circuit.

**Parallel Circuits.**—In Fig. 3-6 are shown three paths connected in parallel between terminals *A* and *B* of a source. In the path from *C* to *D* there is a resistor; in the one from *E* to *D* there is a tube and a resistor (which are in series with each other); and in the path from *F* to *G* there is a tube.

Electron flow may leave the source at *A*, go through the path *C-D*, and back to the source along *D-G-B*. At the same time there may be electron flow from *A* to *C* to *E*, through the tube and resistor to *D*, and back through *G* to *B*. Simultaneously there may be flow from *A* to *F*, through the tube to *G*, and back to *B*. Electrons which pass through the resistor from *C* to *D* do not flow through either of the other paths, and electrons flowing through the other paths do not flow from *C* to *D*. Through the conductors between *A* and *C*, and between *G* and *B*, flow all the electrons for all the paths. Through conductors *C-E* and *D-G* flow all the electrons for two paths. But through the conductors between *E* and *F*, and from the right-hand tube to *G*,



flow only those electrons which pass through this one path.

The table for *Parallel Circuits* shows how resistances, potential differences, and electron flows are computed for each separate parallel path or part, also for all the parallel paths taken together, and gives additional important information in the notes. In addition to the symbols used in the table for *Series Circuits*, this one uses  $R_1$ ,  $R_2$ ,  $R_3$ , etc., to represent the individual resistances of separate paths which are connected in parallel.

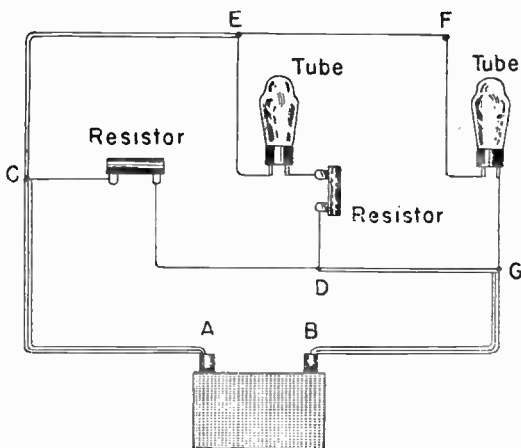

Fig. 3-6. A parallel circuit including three paths.

**Parallel Resistance Chart.**—From Chart No. 3-7 may be read the value of the combined resistance of two resistances connected in parallel when both are in the range from one to 400 ohms. The outer two scales are for the separate parallel resistances. The center scale shows the combined resistance. With a ruler or other straightedge laid across the values of the separate resistances on the outside scales, the straightedge will cross the value of combined resistance on the center scale.

This chart may be used to find the value of a resistor which, used in parallel with another resistor, will give a combined resistance of some certain desired value. For example; having on hand a 4-ohm resistor, and needing a 3-ohm unit, the chart shows that 4 ohms on an outside scale and 3 ohms on the center scale line with 12 ohms on the other outside scale.

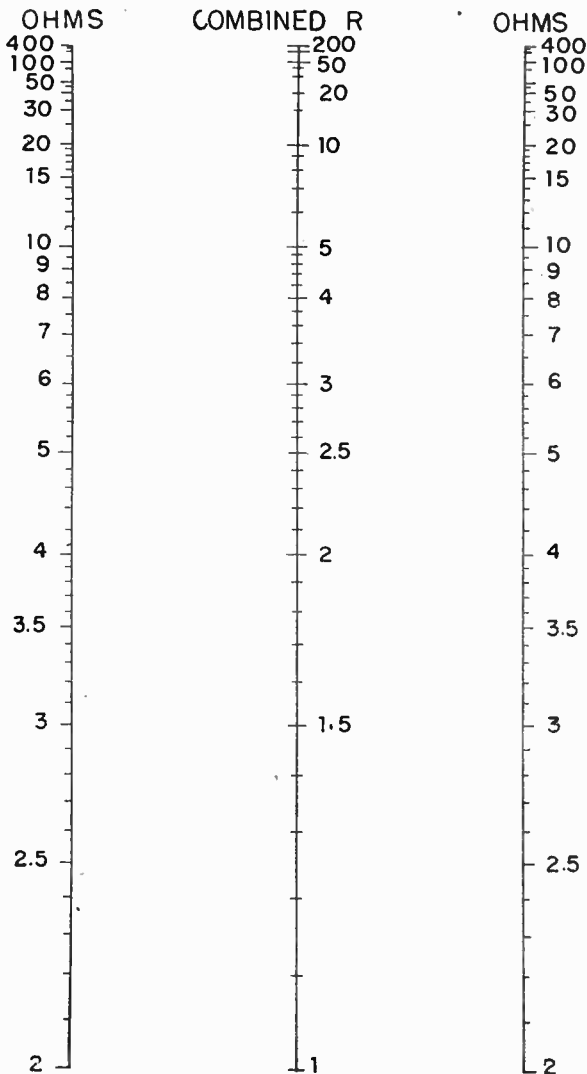

Chart 3-7. The parallel resistance chart.

From the table for parallel circuits we find that the rules for any one path or part considered by itself are exactly the same as for any one part or portion of a series circuit when we are careful to use the values of flow rate, resistance, and potential difference which apply.

The rules for parallel resistance of all paths together are important because they so often are needed in calculations. Note especially that the combined resistance of two resistances in parallel (called  $R_1$  and  $R_2$ ) may be found by dividing their product by their sum. If there are three or more parallel resistances, the combined resistance of any two may be thus computed, then this resistance may be used in connection with the resistance of a third path to find the combined resistance of all three, and so on.

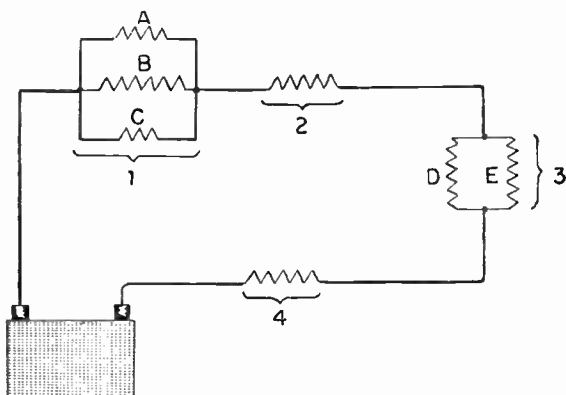

Fig. 3-8. Parallel and series elements in the same circuit.

**Parallel and Series Combinations.**—When a circuit contains some parts in parallel and others in series, as shown by Fig. 3-8, the first step is to determine the combined resistances of the groups of paralleled parts, then these single values of resistance are considered as being in series with other parts of the circuit. In the diagram shown, the combined resistance would be computed for parts  $A$ ,  $B$  and  $C$ , and this value considered as a single resistance  $1$ . Then the combined resistance would be computed for parts  $D$  and  $E$ , and this considered as a single resistance  $3$ . Then the circuit resistance would consist of the sum of resistances  $1$ ,  $2$ ,  $3$  and  $4$ .

**Sources in Series and in Parallel.**—When any number of sources are connected together in series, or are anywhere in a series circuit, their emf's add together and so

do their internal resistances. The total emf for the circuit is equal to the sum of the emf's of the sources.

With sources in series the total or maximum electron flow may be no more than the maximum permissible rate for the source of least capacity; otherwise the source of least capacity would be overheated by the excess flow. For example, with any number of dry cells in series the flow rate in amperes may be no more than for a single cell, although the total emf would be increased.

Sources connected together in parallel must have the same emf for each; otherwise the greater emf of one will force a reversed electron flow through another source. With a parallel connection the total emf, and the total potential difference applied to a connected circuit, are the same as the emf and potential difference for a single source. The total electron flow from sources in parallel may be as great as the sum of the maximum permissible rates of flow from all the sources. Since paralleled sources have their internal resistances in parallel, the combined internal resistance is less than for one source and there will be less drop of terminal potential than with a single source.

## Section 4

### POWER

Table of Power Formulas.—The power formulas show the relations between power, current, resistance or impedance, and potential differences in direct-current cir-

#### Direct-Current Circuits

$$P = EI = \frac{E^2}{R} = I^2R$$

$$I = \frac{E}{R} = \frac{P}{E} = \sqrt{\frac{P}{R}}$$

$$R = \frac{E}{I} = \frac{P}{I^2} = \frac{E^2}{P}$$

$$E = IR = \frac{P}{I} = \sqrt{PR}$$

Alternating-current circuits with negligible inductance and capacitance.

$$P = EI = \frac{E^2}{Z} = I^2Z$$

$$I = \frac{E}{Z} = \frac{P}{E} = \sqrt{\frac{P}{Z}}$$

$$Z = \frac{E}{I} = \frac{P}{I^2} = \frac{E^2}{P}$$

$$E = IZ = \frac{P}{I} = \sqrt{PZ}$$

### Alternating-current circuits with appreciable inductance, capacitance, or both.

$$P = EIk = \frac{E^2k}{Z} = I^2Zk$$

$$I = \frac{E}{Z} = \frac{P}{Ek} = \sqrt{\frac{P}{Zk}}$$

$$Z = \frac{E}{I} = \frac{P}{I^2k} = \frac{E^2k}{P}$$

$$E = IZ = \frac{P}{Ik} = \sqrt{\frac{PZ}{k}}$$

#### Meanings of letter symbols.

E, potential difference, volts.

I, current, amperes.

P, power, watts.

R, resistance, ohms

Z, impedance, ohms

k, power factor, a fraction, equal to the number of watts divided by the product of volts and amperes; also to the cosine of the angle of lag or lead of current.

uits, also in single-phase alternating-current circuits which contain negligible inductance and capacitance, and in those containing sufficient inductance, capacitance, or both to cause a lagging or leading current. In this

latter class of a-c circuits the power factor enters into most of the formulas.

The power factor, which is a fraction less than 1, is equal to the (useful) power in watts divided by the (apparent) power in volt-amperes. The power factor is equal also to the cosine of the angle by which the alternating current lags or leads the accompanying alternating potential. Cosines are listed in the table of trigonometric functions.

**Power Charts.**—For values commonly found in radio work all of the relations between watts, amperes, volts and ohms that are computed by using the formulas may be found with fair accuracy from Charts No. 4-1, 4-2 and 4-3. Each of these charts has three scales. When a straightedge is laid across known values on two scales it will intersect the third scale at the corresponding value of an unknown quantity. On each scale there are series of numbers marked *A* and *B*. If the *A*-series is used on one scale it must be used on both of the other scales, and if a *B*-series is used on one scale the *B*-series must be used on the other two scales.

Chart No. 4-1 relates volts, watts and milliamperes. On power scale *A* the values are in milliwatts (thousandths of a watt), and on scale *B* the values are in watts. Chart No. 4-2 relates ohms, watts and amperes. The single watts scale, marked *A-B*, is used both with scales *A* and scales *B* for ohms and amperes. Values on the amperes scale are shown as decimal fractions which easily may be read as milliamperes. Chart No. 4-3 relates ohms, volts and watts. The watts scale *A* is in decimal fractions which are easily read as numbers of milliwatts.

The range of Chart No. 4-3 may be extended by either multiplication or division. That is, the values on all three *A*-scales or on all three *B*-scales may be multiplied or divided by any number, provided the same multiplier or divisor is used for all three scales. For example, the *A*-scales might be divided by 100, and then would be read as from 0.01 to 1.0 ohms, as 0.001 to 0.1 volts, and as 0.00010 to 0.010 watts or as 0.1 to 10 milliwatts. The range of values covered by Charts 4-1 and 4-2 cannot be thus extended.

**Resistor Ratings.**—Resistors ordinarily are rated and specified in accordance with their resistance in ohms or megohms and with the power in watts which they may use or "dissipate" without reaching a temperature so high as to damage the resistor. If resistors which are coated with or embedded in insulating material such as enamel are used with rates of flow and potential differences which produce the full wattage rating, the resistors will reach temperatures around 450° to 500° F. above the temperature of the surrounding air when they

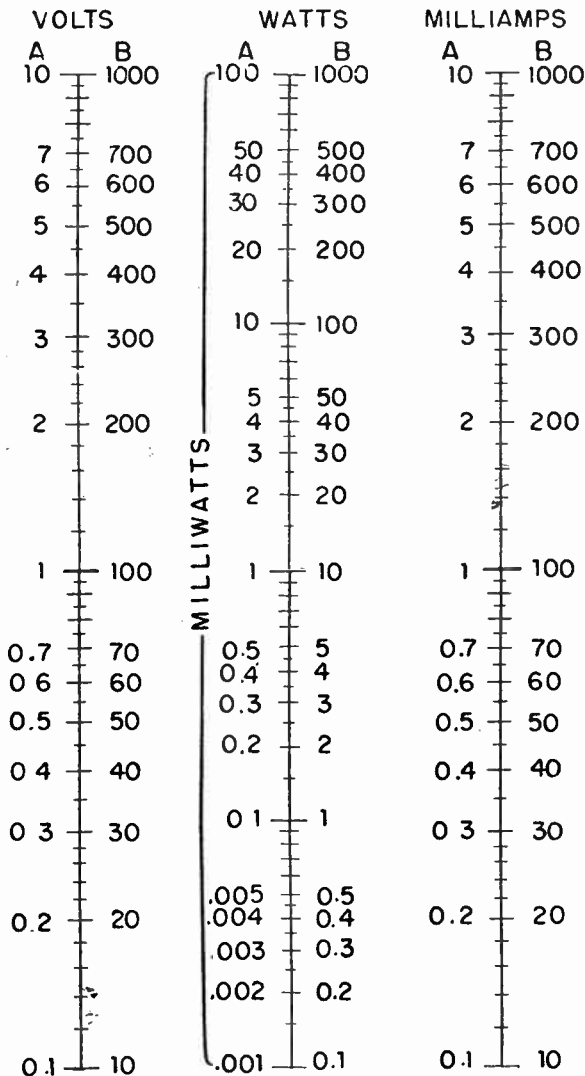

Chart 4-1. Power chart: volts, watts, and milliamperes.



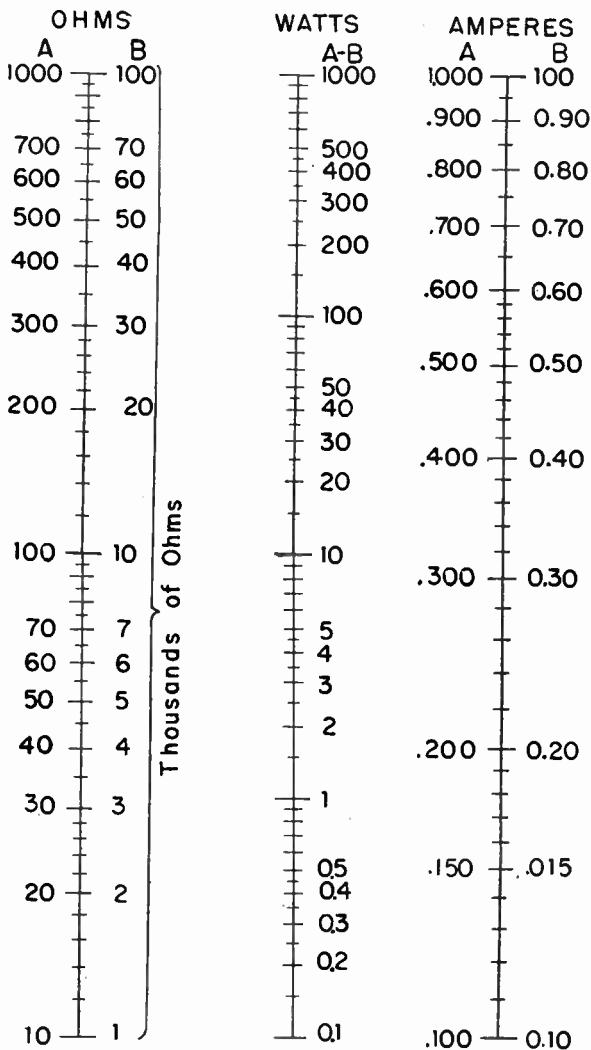

Chart 4-2. Power chart; ohms, watts, and amperes.

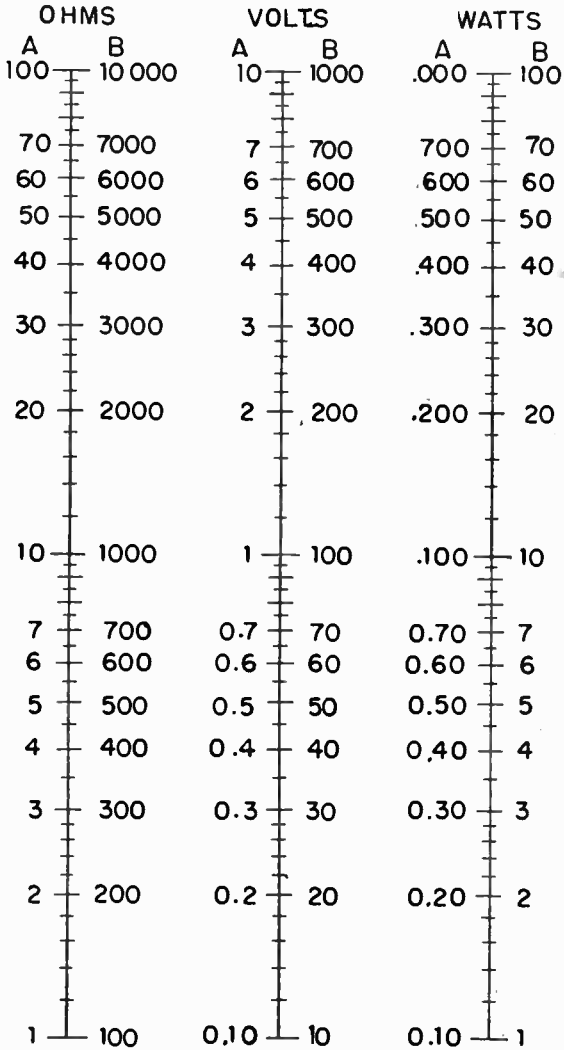

Chart 4-3. Power chart; ohms, volts, and watts.

are a foot or more from other objects. If the resistors are enclosed, or if there are other reasons for lack of free circulation of air, this limit of safe temperature will be reached with less wattage.

If the mounting is such as to restrict air circulation, or if temperature of the resistor may be high enough to damage surrounding parts when dissipating normal wattage it becomes necessary to reduce the power in watts by reducing the rate of flow, the potential difference, or both; or else a resistor of higher wattage rating must be employed. Usually a resistor is chosen with a wattage rating double the actual power in watts as computed from flow in amperes and potential in volts. Under favorable conditions the rating need be only fifty per cent more than the actual power dissipation, but often it must be three or even four times the actual dissipation. The charts or formulas may be used to determine the actual power in watts, and this computed power then increased by a suitable allowance.

The same general principles apply in selecting rheostats or potentiometers, which are units of adjustable resistance rated according to their maximum resistance and maximum permissible power dissipation in watts. Wattage ratings usually are based on having all of the resistance in circuit. When less resistance is being used in the rheostat, the circuit resistance may be decreased and the rate of flow increased. The rated wattage should be checked against the maximum flow that may occur under any possible conditions of use.

It must be kept in mind that in every device containing resistance, which means practically everything used in radio, power will be used in the device in proportion to the rate of flow through it and the potential difference between its terminals. All power used in resistance is changed to heat. The temperature of the device will rise until the rate at which the heat passes off into the surroundings becomes equal to the rate at which it is produced by the power being used.

**Power Transfer.**—When a load is connected to a source, the power used in the load, or the rate at which work is done in the load, depends on the relation between the resistance of the load and the internal resistance of the source. The power in the load is maximum when these two resistances are equal. If the load resistance is made greater, electron flow decreases to an extent which drops the power in the load. If the load resistance is made less than the source resistance, the electron flow increases, but the terminal potential decreases to an extent which causes reduction of power in the load. To obtain maximum power the resistance of the load is adjusted to a value which is equal to the internal resistance of the source.

## Section 5

### CAPACITORS AND CAPACITANCE

The basic formulas relating to capacitors are as follows; where  $C$  is capacitance in farads,  $Q$  is the charge in coulombs, and  $V$  is the potential difference in volts between plates of the capacitor.

$$C = \frac{Q}{V} \quad Q = CV \quad V = \frac{Q}{C}$$

Practical units of capacitance are the microfarad, equal to the one one-millionth of a farad, and the micromicrofarad, equal to one one-millionth of a microfarad.

A formula for the capacitance in micromicrofarads is,

$$C = \frac{0.225 \times A \times K \times (N-1)}{D}$$

$C$ , capacitance in micromicrofarads.

$A$ , area of one side of one plate, in square inches.

$K$ , dielectric constant of dielectric material.

$N$ , total number of similar plates.

$D$ , plate separation or dielectric thickness, in inches.

The dielectric constant of a material is the number of times that the capacitance is increased by using the material instead of air as the dielectric of a capacitor of otherwise similar construction.

The accompanying table of *Dielectric Constants* lists the constants for substances used as dielectrics in capacitors. The dielectric constant varies with many factors. It depends on the exact grade, kind and form of material. It varies with temperature, also with absorption of moisture by the substance. The constant is greater when the charging rate is slow than when it is rapid, it is different for direct-current charging than for alternating-current charging, and it changes with the frequency of alternating current or potentials.

*Example:* What is the capacitance of a capacitor having 9 plates, each measuring 2 inches square, separated by mica having a dielectric constant of 6 and a thickness of 0.02 inch? Note that plates 2 inches square have a surface area on one side of 4 square inches. Using these values in the formula,

$$\text{Mmfds} = \frac{0.225 \times 4 \times 6 \times (9-1)}{0.02} = 2160$$

This formula gives capacitances that are approximately correct. Some of the field may extend beyond the edges of the plates, especially in air-dielectric ca-

## DIELECTRIC CONSTANTS

Air	1.0
Alcohol, grain	.26
wood	.31
Bakelite	.4 to .8
Celluloid	.7 to 1.0
Ceramic dielectrics	.85 to .90
Cloth, varnished	3.5 to 5
Fibre, vulcanized hard	.5 to .8
Film, photo (cellulose)	.4 to .8
Gases, miscellaneous kinds	1.0 to 1.07
Glass, lead	.5 to .8
Pyrex	.4 to .5
window	.7 to .8
Glycerine	.40 to .56
Ice	.3
Mica	.4 to .8
Oil, petroleum	.2.1
transformer	.2.2 to .2.6
Paper, dry, untreated	1.5 to 3
waxed	2.5 to 4
Phenol insulators	.4 to .7.5
Plastics, casein	.6 to .7
Porcelain, unglazed	.5 to .7
Resins, synthetic	.2.5 to .4
Rubber, hard	.2 to .4
Quartz, fused	.3.5 to .4.5
Shellac	.3 to .3.7
Shellac base insulation	.4 to .7
Silk	.4.6
Steatite	.4.5 to .6.5
Sulphur	.3 to .4.2
Titanium dioxide	.90 to 1.70
Turpentine	.2.2
Water, distilled	.81
vapor, saturated	1.007
Wax, bee's	.3.2
ceresin	.2.5
paraffin	.2 to .3
Wood, dry maple	.3 to .4.5
dry oak	.3 to .6

capacitors, and this increases the capacitance. Plates which are relatively long in comparison with their width have increased capacitance due to the "elongation factor." The formula assumes the use of flat plates.

Any two conductors separated by insulation, which acts as a dielectric, have capacitance. There is capacitance between each element of a tube and every other element, because the elements are conductors and they are separated by a vacuum or a gas, either of which is a dielectric. There is capacitance between any two wires

which are fairly close together and which are insulated or separated. There is capacitance between all the wires in radio apparatus and the metallic parts of the chassis or framework.

**Capacitors in Parallel.**—When capacitors are connected together in parallel, as in Fig. 5-1, the total capacitance of the combination is equal to the sum of the capacitances of the separate units. It makes no difference how many capacitors are so connected, and it makes no difference whether their individual capacitances are alike or different; the total capacitance always is equal to the sum.

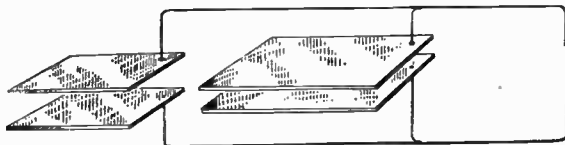

Fig. 5-1. Capacitor plates in parallel.

As shown by the capacitor formulas, the charge in coulombs,  $Q$ , is equal to the product of capacitance and voltage. When connected in parallel, all capacitors must have the same voltage. This leaves the charge proportional to the capacitance alone. Consequently, the total charge must be proportional to the total capacitance, and inasmuch as the total charge or quantity must be the sum of all the separate charges, the total capacitance must be equal to the sum of the separate capacitances.

**Capacitors in Series.**—At the left in Fig. 5-2 are three capacitors of three different capacitances connected in series to a source of potential difference. During charging of the capacitors the same quantity of electrons must return to one terminal of the source as flow out of its other terminal. This same quantity must flow onto one of the plates of the capacitor at one end, and out of the plate in the capacitor at the other end. Because the charges on both plates of a capacitor must always be equal, this same quantity flows from the left-hand capacitor into the center one, and from the center one to the one at the right. Then all three capacitors must receive equal charges, in coulombs, regardless of their capacitances. This is true of any number of any kind of capacitors connected in series.

At the right in Fig. 5-2 are three capacitors of equal capacitances. All must receive equal charges. One of the capacitor formulas,  $V = Q/C$ , shows that the voltage is equal to the charge divided by the capacitance. If all charges are alike, and all capacitances are alike, then all capacitor voltages must be alike in the right-

hand diagram of Fig. 5-2. If, for an example, the total applied potential is 120 volts and if the voltages of the three capacitors are alike and equal, then each must have a voltage of one-third 120, or 40 volts.

Knowing the capacitance and the voltage of each capacitor we may compute the charge from the formula  $Q = CV$ . The product of 6 mfd. (0.000006 farad) and 40 volts is 0.00024 coulomb of charge in each capacitor, and, as we know, this must be the charge or the quantity of electricity that has moved out of and into the source. Now assume that one of the 6-mfd. capacitors is connected by itself to the source. The product of

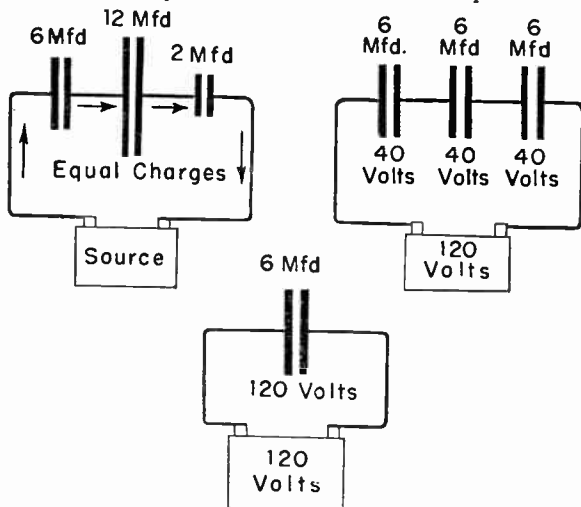

Fig. 5-2. Series capacitors, their capacitances and voltages.

6mfd. (0.000005 farad) and 120 volts is 0.00072 coulomb. This is three times the charge taken by the three capacitors in series, and the effective capacitance of the three in series is only one-third that of one of them alone.

The rules for the combined capacitance of capacitances in series are as follows:

1. The combined capacitance of any number of *equal capacitances* in series is equal to the capacitance of one divided by the number of units.
2. The combined capacitance of any *two capacitances* in series, whether they are equal or unequal, is equal to the product of the separate capacitances divided by their sum.

*Example.* What is the combined capacitance of 6 mfd. and 12 mfd. in series? The product is  $6 \times 12 = 72$ . The sum is  $6 + 12 = 18$ . And  $72 \div 18 = 4$  mfd.

This rule may be extended to handle more than two capacitances. For an example, consider the capacitances of 6 mfd., 12 mfd. and 2 mfd. The first step is to compute the combined capacitance of two of the units. In the preceding example the combined capacitance of 6 mfd. and 12 mfd. was found to be 4 mfd. The second step is to consider this combined capacitance and another of the original separate capacitances as being in series, and compute their effective value. Here we would have the combined capacitance of 4mfd. and the remaining 2-mfd. unit. The product is  $4 \times 2 = 8$ . The sum is  $4 + 2 = 6$ . And  $8 \div 6 = 1\frac{1}{3}$  mfd., which is the total effective capacitance of 6, 12 and 2 mfd. in series.

3. The combined capacitance of *any number* of capacitances in series, regardless of whether or not they are alike, may be found by adding the reciprocals of the separate capacitances, and taking the reciprocal of their sum. The reciprocal of a number is 1 divided by that number. The reciprocal of a fraction is the fraction with its terms inverted.

*Example.* What is the combined capacitance of 12, 4, 6 and 3 mfd. in series?

Reciprocals are  $\frac{1}{12} + \frac{1}{4} + \frac{1}{6} + \frac{1}{3}$  or  $\frac{1}{12} + \frac{3}{12} + \frac{2}{12} + \frac{4}{12} = \frac{10}{12}$ .

The reciprocal of  $10/12$  is  $12/10$ , and this is equal to 1.2.

So the combined capacitance is 1.2 mfd.

Chart No. 5-1 may be used for determining the combined capacitance of two capacitors in series when the values of the separate capacitors lie between 0.00015 and 0.05 mfd. This is the range of values for most of the small fixed capacitors used in radio. Scales A-A-A are used together, and scales B-B-B are used together. An A-scale must not be used in the same computation with a B-scale. With a straightedge laid at the values of the separate capacitors on the two outside scales, the straightedge will cross the center scale at the value of the combined capacitance.

This chart may be used also to determine the capacitance that must be used with another one in series to provide a desired combined capacitance for the two units.

*Example.* What should be used in series with 0.002 mfd. to provide a combined capacitance of 0.0004 mfd.? A straightedge laid across the left-hand B-scale at 0.002 mfd. and across the center B-scale at 0.0004 mfd. crosses the right-hand B-scale at 0.0005 mfd., which is the required capacitance.



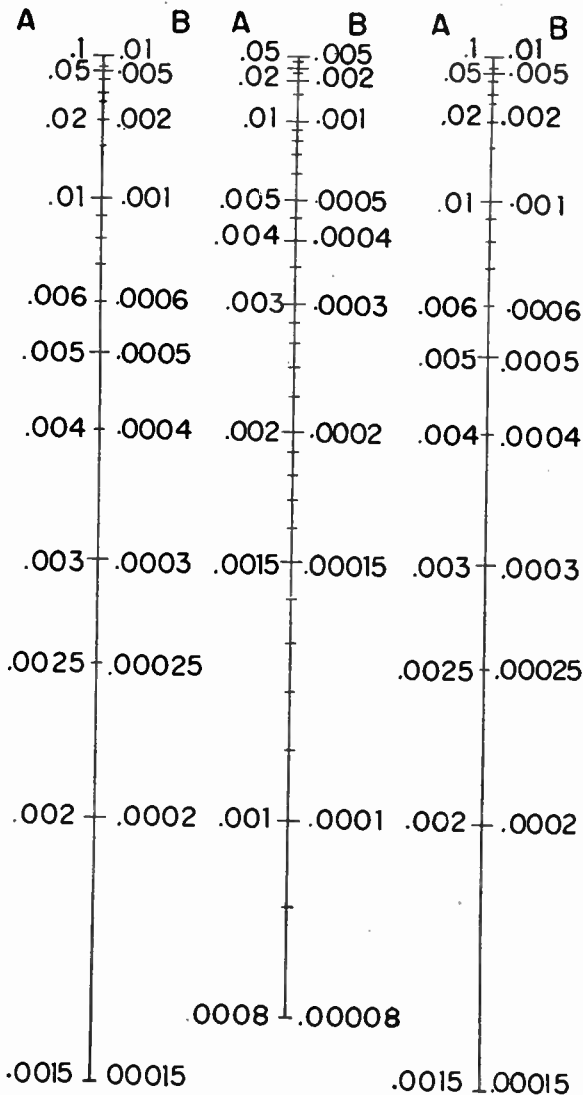

Chart 5-1. The series capacitance chart.

When capacitors are connected in series the sum of the voltages on the separate units is equal to the applied potential difference. More important, the voltages on the units are inversely proportional to their capacitances, which means that the smaller the capacitance the greater is the voltage across it. This comes about because, as shown previously, all series capacitors have equal charges, because  $V = Q/C$ , and with all the  $Q$ -values alike it is plain that the smaller is the value of  $C$  (capacitance) the larger will be the value of  $V$ .

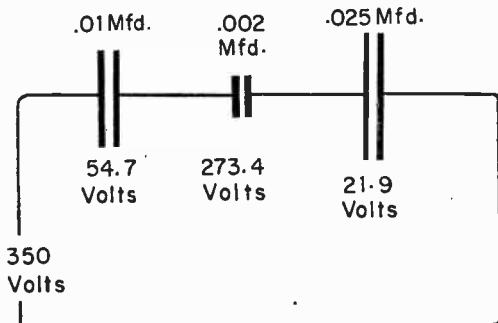

Fig. 5-3. The capacitors for which voltages are computed.

*Example.* With the three capacitors of Fig. 5-3 (.01, .002, and .025 mfd.) in series on a 350-volt source what will be the voltage across each unit?

- Capacitances are .01 .002 .025  
Reciprocals are 100 500 40  
Sum of reciprocals is  $100 + 500 + 40 = 640$
- Divide the applied potential difference by the sum of the reciprocals,  $350 \div 640 = .547$  (approximately).
- Multiply each reciprocal by the fraction found in step b.  
 $100 \times .547 = 54.7$  volts across .01 mfd.  
 $500 \times .547 = 273.4$  volts across .002 mfd.  
 $40 \times .547 = 21.9$  volts across .025 mfd.

To withstand a source potential difference which is greater than the rated voltage of available capacitors, two or more capacitors may be used in series.

*Example.* Working potential difference is 450 volts. Required capacitance is 8 mfd. Available capacitors have working voltage of 250.

Two 16-mfd. 250-volt units may be connected in series. The combined capacitance will be 8 mfd. and the combined working voltage 500, which exceeds the requirement. If the two or more series capacitors are not of equal capacitance it must be borne in mind.

that their working voltages will be inversely proportional to their capacitances.

**Color Coding of Capacitors.**—Small capacitors, flat or cylindrical, may be marked with colored dots or bands to indicate capacitance, tolerance or accuracy, and maximum working voltage. The colors, as shown by the accompanying table *RMA Color Code for Capacitors*, have values which are the same as used for resistor color coding.

Capacitance is shown in micro-microfarads unless it exceeds 10,000, in which case it is shown in microfarads. Mica capacitors are not made in voltage ratings less than 500. Small mica capacitors with three dots in a horizontal row as at *A* in Fig. 5-4, are rated in two significant figures and a multiplier as the colors are read from left to right with the capacitor viewed right side up. Which way is right side up is indicated by the maker's name, trademark, other printed matter, or by an arrow. As an example, red-green-brown would indicate 2 (for red), 5 (for green) and 1 cipher added (for brown). This makes 250 mmfds, which is the same as 0.00025 mfd.

A four-dot system, as at *B* or *C* of Fig. 5-4, may be used when capacitance is to be shown to two significant figures and when a tolerance is to be indicated.

The standard RMA six-dot system is shown at *D* of Fig. 5-4. There are two horizontal rows of dots. The top row, reading from *left to right*, indicates three significant figures for capacitance. In the bottom row, reading from *right to left*, the first dot indicates the multiplier or number of ciphers to be added after the significant figures, the second (middle) dot indicates the tolerance in per cent, and the third dot indicates the maximum working voltage. As an example: Top row (left to right) red-red-green and bottom row (right to left) red-green-gold would be read as 2, 2, 5, then 2 ciphers added, 5 per cent tolerance, and 1,000 working voltage. The capacitance would be 22500 micro-microfarads, which is the same as 0.0225 mfd.

Diagrams *E* and *F* show color positions for units having part of the coding on the front and the remainder on the back. The third position on the front of the capacitor is left blank, as an indication that the other code colors will be found on the other side. A tolerance color may or may not be shown.

Diagrams *G* and *H* show five-dot color arrangements which are not in general use, although having been employed by some manufacturers.

Diagram *I* shows the ASA (American Standards Association) American War Standard coding for fixed mica-dielectric capacitors. To indicate that this method of coding is used, the first dot at the upper left *always* is

## RMA COLOR CODE FOR CAPACITORS

Color	Significant Figures	Ciphers Added	Decimal Multiplier	Tolerance	Working Voltage	Temperature Coefficient
Black	0	none	1	20%	- -	+ or - .00003
Brown	1	1	10	1%	100	- .00003
Red	2	2	100	2%	200	- .00008
Orange	3	3	1,000	3%	300	- .00015
Yellow	4	4	10,000	4%	400	- .00022
Green	5			5%	500	- .00033
Blue	6			6%	600	- .00047
Violet	7			7%	700	- .00075
Gray	8			8%	800	
White	9			9%	900	Not specified
Gold			0.1		1,000	
Silver			0.01	10%	2,000	
No color				20%	500	

CAPACITORS AND CAPACITANCE

*black.* This dot does not indicate any figure of the coding. Significant figures, and ciphers added or decimal multipliers, are the same as in the earlier RMA table. Tolerance markings are as follows:

Black	or the letter <i>M</i>	= 20%
Silver	or the letter <i>K</i>	= 10%
Gold	or the letter <i>J</i>	= 5%
Orange	or the letter <i>H</i>	= 2½%
Red	or the letter <i>G</i>	= 2%

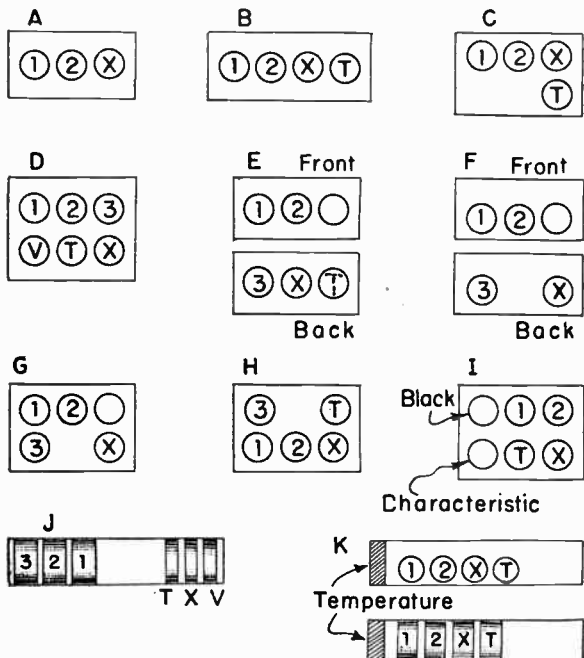

Fig. 5-4. Positions of color code markings on capacitors.

The characteristics are indicated by a letter or by a color in the lower left-hand position. The characteristics include the Q-factor (ratio of reactance to high-frequency resistance as measured at one megacycle), the temperature coefficient, and the maximum capacitance drift. The indications are as follows:

## ASA AMERICAN WAR STANDARDS CHARACTERISTICS

COLOR	LETTER	Q-factor	Temperature Coefficient	Maximum Drift
Black	A	Not specified	Not specified	Not specified
Brown	B	See note	Not specified	Not specified
Red	C	See note	- to + .0002	0.5%
Orange	D	See note	- to + .0001	0.2%
Yellow	E	See note	0 to + .0001	0.05%
Green	F	See note	0 to + .00005	0.025%
Blue	G	See note	0 to - .00005	0.025%

*Note:* The approximate minimum values of *Q* for capacitors having characteristics other than *A*, measured at one megacycle, are:

5 mmfd.	140	50 mmfd.	550	500 mmfd.	1370
10 mmfd.	230	100 mmfd.	770		
20 mmfd.	340	200 mmfd.	1030		

Temperature coefficients show variations in mmfds. per mmfd. per centigrade degree temperature change.

Diagram *J* shows code color positions for cylindrical "tubular" capacitors with paper dielectric, also those having mica or ceramic dielectric and encased in ceramic tubes. In the standard system there are two groups of bands, those of one group being much wider than those of the other. Both groups are read by starting from the center and reading toward the ends. The wide bands indicate three significant figures for capacitance value. The narrow bands indicate (in order) the multiplier, the tolerance, and the working voltage.

**Temperature Compensating Capacitors.**—Diagram *K* of Fig. 5-4 shows color code positions, which may be either dots or bands, for ceramic dielectric capacitors which are designed to have certain variations of capacitance with changes of temperature, and which are used to compensate for changes in other units of a circuit. The entire end of the capacitor which is the termination of the inside plate is covered with a color which indicates the temperature coefficient. Reading away from the colored end, the dots or bands indicate (in order) the first and second significant figures, the multiplier, and the tolerance. The accompanying table shows the color code used for these capacitors. For capacitances of more than 10 mmfd. the tolerance is specified as a per cent of the total capacitance, and for those of 10 mmfd. and less the tolerance is specified in mmfds. The temperature coefficient is in micromicrofarads per micromicrofarad of capacitance, per centigrade degree temperature change. The standard tolerance for this coefficient is + or - 15%, or else is + or - 0.00003 mmfd./mmfd./°C., whichever is the larger.

## ASA CODE FOR CERAMIC CAPACITORS

Color	Sig- nificant Fig- ures	Multi- plier	Tolerance, + or -		Temperature Coefficient
			More Than 10 Mmfd.	10 Mmfd. or Less	
Black	0	1	20%	2.0 mmfd.	+ or - .00003
Brown	1	10	1%	0.1 mmfd.	- .00003
Red	2	100	2%	0.2 mmfd.	- .00008
Orange	3	1000	2½%	0.25 mmfd.	- .00015
Yellow	4	....	....	.....	- .00022
Green	5	....	5%	0.5 mmfd.	- .00033
Blue	6	....	....	.....	- .00047
Violet	7	....	....	.....	- .00075
Gray	8	0.01	....	.....	.....
White	9	0.1	10%	1.0 mmfd.	Not specified

**Time Constants.**—If a capacitor and a resistor are connected in series to a source of emf, as at the left in Fig. 5-5, there will be an electron flow through the re-

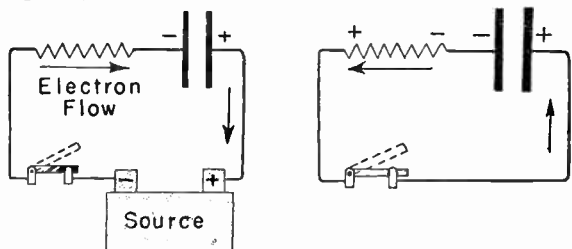

Fig. 5-5. Directions of electron flow during charge and discharge of a capacitor.

sistor, and this flow will charge the plates of the capacitor. The full potential difference of the source is not instantly applied to the capacitor, because there is a loss of potential or a drop of potential in the resistor as electron flow passes through it. Then the potential difference across the capacitor can be only the difference between the source potential and the drop of potential in the resistor. During the first instant of charging there is a relatively large electron flow, a correspondingly large potential drop in the resistor, and a small remaining potential difference across the capacitor. As the charge increases there is a rise of capacitor voltage, because  $V = Q/C$ . The capacitor voltage,  $V$ , opposes the emf of the source and the rate of electron flow commences to fall off. As  $V$  steadily increases there is a steady drop in the rate of charging and a steady falling off in the rate of electron flow. If the resistance is great enough and the capacitance great enough it may take a long time to charge the capacitor fully.

**CAPACITOR-RESISTOR TIME CONSTANTS**

TIME In Number of Time Constants	CAPACITOR POTENTIALS	
	CHARGE Fraction of Source Potential	DISCHARGE Fraction of Initial Voltage
0.00	0.000	1.000
.05	.049	.951
.10	.095	.905
.15	.139	.861
.20	.181	.819
.25	.221	.779
.30	.259	.741
.35	.295	.705
.40	.330	.670
.45	.362	.638
.50	.393	.607
.60	.451	.549
.70	.503	.497
.80	.551	.449
.90	.597	.407
1.0	.632	.368
1.1	.667	.333
1.2	.699	.301
1.3	.727	.273
1.4	.753	.247
1.5	.777	.223
1.6	.798	.202
1.8	.835	.165
2.0	.865	.135
2.2	.889	.111
2.5	.9179	.0821
3.0	.9502	.0498
3.5	.9698	.0302
4.0	.9817	.0183
5.0	.9933	.0067



If the charged capacitor in series with the resistor is short circuited, as at the right in Fig. 5-5, the electron flow through the resistor is accompanied by a drop of potential in the resistor. As appears from the relative polarities of capacitor and resistor, the potential difference across the resistor opposes the potential difference of the capacitor, and the rate of electron flow is slowed down. Again, if the resistance and capacitance are great enough, it may take a long time for the capacitor to discharge fully.

The length of time, in seconds, required for the voltage of a capacitor during charge to reach 0.632 of its final maximum value is called the *time constant* of the capacitor-resistor combination. Also, the length of time required for the short-circuited capacitor to lose 0.632 of its original voltage is the same time constant of the capacitor-resistor combination.

The time constant, in seconds, is equal to the product of the number of microfarads of capacitance and the number of megohms of resistance which are in series. This time constant is not affected by the applied potential difference nor by the voltage of the capacitor, but only by the values of capacitance and resistance. However, the final voltage and also the quantity of charge are affected by potential difference.

The accompanying table, *Capacitor-Resistor Time Constants*, lists capacitor potentials during charge and discharge at the ends of various periods of times which are given in numbers of time constants. The capacitor potentials are shown as fractions of the source potential (or final capacitor voltage) during charge, and as fractions of the initial capacitor voltage during discharge.

*Example:* A potential difference of 180 volts is applied for 0.0005 second to a capacitor of 0.0005 mfd. capacitance and a resistor of 0.5 megohm resistance in series. To what voltage will the capacitor be charged?

$$0.0005 \text{ (mfd)} \times 0.5 \text{ (meg)} = 0.00025 \text{ sec. time constant}$$

$$\frac{0.0005 \text{ time period}}{0.00025 \text{ time constant}} = 2 \text{ time constants}$$

Fraction (from table) for 2 constants = .865

$$180 \text{ (volts)} \times .865 = 115.7 \text{ volts in } 0.0005 \text{ second.}$$

*Example:* If a 0.025 mfd. capacitor is charged to 350 volts and then is discharged through a 5-megohm resistor, what will be the capacitor voltage at the end of 0.05 second of discharge?

$$0.025 \text{ (mfd)} \times 5 \text{ (meg)} = 0.125 \text{ sec. time constant}$$

$$\frac{0.05 \text{ time period}}{0.125 \text{ time constant}} = 0.40 \text{ time constant}$$

Fraction (from table) for 0.40 constant = .670

$$350 \text{ (volts)} \times .670 = 236.5 \text{ volts at } 0.05 \text{ second.}$$

## Section 6

### RECEIVING TUBES

The table of *Tube Characteristics* lists numbers, types, sockets connections, voltages, currents, and other characteristics for receiving tubes in general use. The following explanations refer to symbols and classes of information given in the various columns of the table.

#### TUBE NUMBER

Where numbers, or numbers and letters, are separated by a sloping line (/) the descriptive data applies to two or more tubes. For example, 25A6/G/GT means that three tubes, 25A6, 25A6G, and 25A6GT, are alike so far as the listed data is concerned. The number 25A7G/GT means that 25A7G and 25A7GT tubes are alike so far as listed data is concerned. The letter *G* following the number on a tube indicates that the tube has a glass envelope. The letters *GT* indicate a glass envelope of smaller size than the otherwise similar *G* type. The letters *GT/G* on a tube show that it is a *GT* size which otherwise is like a discontinued *G* type.

#### TUBE TYPE

Abbreviations in the *Tube Type* column have the following meanings. Note that the capital letters usually are the first letters in the name of the tube. For example, *P* means a pentode, *R* means a rectifier, *T* means a triode, and so on. Double letters such as *TT* mean twin tubes, in this case a twin triode in one envelope, while *PT* means a pentode and a triode in one envelope.

B	Beam power tube
BB	twin
BR	and rectifier
C5	Converter, pentagrid (5 grids)
C6	hexode-triode (6 grids)
C7	heptode- triode (7 grids)
C8	octode (8 grids)
D	Diode, single (detector type)
DD	double
II	Tuning indicator, twin type
IT	and triode
M5	Mixer, pentagrid (5 grids)
Pa	Pentode, voltage amplifying type
Pb	power amplifying type

PD	and single diode
PDD	and double diode
PPa	twin, voltage amplifying
PPb	twin, power amplifying
PR	and rectifier
PT	and triode
PTD	and triode and diode
Rd	Rectifier, doubler type
Rf	full-wave
Rh	half-wave
Sa	Tetrode (screen grid), voltage amplifying
Sb	(screen grid), power amplifying
Ta	Triode, voltage amplifying type
Tb	power amplifying type
TD	and single diode
TDD	and double diode
Tia	twin input, voltage amplifying
Tib	twin input, power amplifying
Toa	twin output, voltage amplifying
Ts	detector type
TTa	twin, voltage amplifying
TTb	twin, power amplifying
TTc	twin, direct coupled type
VR	Voltage regulator

#### TUBE SOCKET

Numbers in this column refer to numbered diagrams which follow the table and which show socket connections or tube base connections when looking at the bottom of the tube. When some of the tube base pins are of larger diameter than others on 4-, 5- and 6-pin types the larger pins are those for filament or heater connections. The locating key for octal bases always would be at the bottom of the diagrams for such tubes. Octal base diagrams with fewer than eight small circles around the outside of the diagram indicate that the missing pins are not on the tubes. Small circles with no enclosed letter indicate that the pin is present but is not connected to the tube elements. A letter enclosed in a rectangle instead of a circle indicates a cap terminal rather than a base pin. The letters enclosed in the small circles and rectangles have the following meanings.

<i>A</i>	Anode.
<i>Ao</i>	Oscillator anode. Equivalent to a plate for the oscillator section of a converter tube.
<i>CT</i>	Center tap for filament or heater.
<i>F</i>	Filament.

<i>G</i>	Control grid.
<i>Go</i>	Oscillator grid of converter tube.
<i>Gs</i>	Signal grid of converter; the grid to which is applied the high-frequency signal potential.
<i>H</i>	Heater.
<i>K</i>	Cathode.
<i>P</i>	Plate.
<i>R</i>	Ray control electrode of indicator tube.
<i>Sh</i>	Shield; internal, external, or shell.
<i>Su</i>	Suppressor grid.
<i>TA</i>	Target of indicator tube.

## CATHODE

The kind of cathode is indicated by the letter *C* for a cold cathode, by *F* for a filament-cathode, and by *H* for a heater cathode.

The *Volts* and *Amps* columns list the voltages and the currents in amperes for the filaments or heaters. The letter *p* between the voltage and current values indicates that the listed voltage and current are for a parallel connection of a center-tapped filament or heater. With a series connection the voltage would be twice that listed, and the current would be half of that listed.

## NOTES

Abbreviations used in the *Notes* are as follows:

<i>amp</i>	Amplifier section.
<i>Cl-A</i>	Class A operation.
<i>Cl-B</i>	Class B operation.
<i>in</i>	Input section of direct coupled tube.
<i>mxr</i>	Mixer section of converted tube.
<i>osc</i>	Oscillator section of converter tube.
<i>out</i>	Output section of direct coupled tube.
<i>pen</i>	Pentode section.
<i>Pl-3</i>	Plate connected to pin 3, remote cutoff type.
<i>Pl-4</i>	Plate connected to pin 4, sharp cutoff type.
<i>p-p</i>	Push-pull circuit. Output is for two tubes.
<i>ray</i>	Ray control electrode of indicator tube.
<i>rec</i>	Rectifier section.
<i>tar</i>	Target of indicator tube.
<i>tri</i>	Triode section.

## CHARACTERISTICS

The characteristics, voltages, and currents usually are those for the highest or nearly the highest plate potential ( $E_p$ ) ordinarily used for the tube. Lower potentials often are used, and higher ones may be used for some tubes. Plate potentials other than those listed ordinarily would be accompanied by different grid potentials ( $E_g$ ) and screen potentials ( $E_s$ ), and all other characteristics would be altered. Potentials, currents, and characteristics occur together. A change in any one usually would cause, or would require, changes in the others.

The characteristics for amplifier tubes are for class A or A<sub>1</sub> operation unless otherwise specified.

*E<sub>p</sub>* (plate potential). For rectifier tubes and for diode tubes the listed voltage is the maximum r-m-s or effective a-c input.

*E<sub>g</sub>* (control grid potential). The abbreviation *cath* means that control grid bias is secured with a resistor in series with the cathode. The following biasing resistances are used with listed tubes for the characteristics shown in the table.

6AC7/1852	160 ohms, min.	7V7	160 ohms
6AK5	200 ohms	7W7	160 ohms
6F4	150 ohms	14W7	160 ohms
6J4	100 ohms	1231	200 ohms
6J6	50 ohms, 2 units	1851	160 ohms, min.

The abbreviation *drv* means that the control grid bias for the listed tube and its driver tube is automatically developed by the dynamic coupled connection with a coupling resistor between ground or B— and the connection joining the driver cathode and the power tube control grid.

*E<sub>s</sub>* (screen grid potential). In volts.

*I<sub>p</sub>* (plate current). In milliamperes. For rectifier tubes and for diode tubes the listed currents are maximum values for d-c output.

*I<sub>s</sub>* (screen grid current). In milliamperes.

*R<sub>p</sub>* (plate resistance). In ohms for values up to 99,000, and in megohms and decimal fractions of megohms for values of 100,000 ohms (0.1 megohm) and greater.

*G<sub>m</sub>-G<sub>c</sub>* (conductance, in micromhos). For amplifiers the values are of mutual conductance or of control-grid-plate transconductance. For converters the values are of conversion transconductance, which is a measure of the effect of control-electrode voltage on output-electrode current in a manner similar to the mutual conductance or grid-plate transconductance as a measure of the effect of control grid potentials on plate currents of an amplifier tube.

*Mu* (amplification factor).

#### OUTPUT

*Load*. The plate circuit load resistance is listed in ohms for values up to 99,000, and in megohms or decimal fractions of megohms for values of 100,000 ohms (0.1 megohm) and greater. This is the load which, with potentials and currents shown in the table, develops the listed power output.

*Watts*. The normal output power in watts and decimal fractions of a watt is for the listed load resistance, potentials, and currents.

Number	TUBE		CATHODE			NOTES	CHARACTERISTICS							OUTPUT	
	Type	Socket	Kind	Volts	Amps		Ep	Eg	Es	Ip	Is	Rp	Gm-Gc	Mu	Load
00A	Ts	4	F	5.0	0.25	45	0		1.5		30000	666	20		
0A2	VR	182	C			150			30						
0A3	VR	181	C			75			40						
0D3	VR	181	C			150			40						
0Z4/G	Rf	186	C			300+			75						
01-A	Ta	4	F	5.0	0.25	135	- 9.0		3.0		10000	800	8		
1	See 1-V														
1A3	D	68	H	1.4	0.15	117			0.5						
1A4-P	Pa	11	F	2.0	0.06	180	- 3.0	67.5	2.3	0.8	1.0	725			
1A4-T	Pa	10	F	2.0	0.06	180	- 3.0	67.5	2.2	0.7	0.6	650			
1A5G/GT	Pb	87	F	1.4	0.05	90	- 4.5	90	4.0	0.8	0.3	850		25000	0.115
1A6	C5	33	F	2.0	0.06	mxr 180 osc 180	- 3.0	67.5	1.5 2.5	2.0	0.5	300			

Number	TUBE		CATHODE			NOTES	CHARACTERISTICS (Continued)							OUTPUT	
	Type	Socket	Kind	Volts	Amps		Ep	Eg	Es	Ip	Is	Rp	Gm-Gc	Mu	Load
1A7G/GT	C5	167	F	1.4	0.05	mxr osc	90 90	0	45	0.55 1.2	0.6	0.6	250		
1AB5	Pa	115	F	1.2	0.05		150	- 1.5	150	6.6	2.0	0.125	1350		
1B4-F	Fa	11	F	2.0	0.06		180	- 3.0	67.5	1.7	0.6	1.5	650		
1B5/25S	TDD	25	F	2.0	0.06		135	- 3.0		0.8		35000	575	20	
1B7G/GT	C5	167	F	1.4	0.10	mxr osc	90 90	0	45	1.5 1.6	1.3	0.35	350		
1B8-GT	PTD	170	F	1.4	0.10	pen tri	90 90	- 6.0 0	90	6.3 .15	1.4		1150 275	14000	0.21
1C5G/GT	Pb	87	F	1.4	0.10		90	- 7.5	90	7.5	1.6	0.115	550	8000	0.24
1C6	C5	33	F	2.0	0.12	mxr osc	180 180	- 3.0	67.5	1.5 4.0	2.0	0.7	325		
1C7-G	C5	167	F	2.0	0.12	mxr osc	180 180	- 3.0	67.5	1.5 4.0	2.0	0.7	325		
1D5-GP	Pa	97	F	2.0	0.06		180	- 3.0	67.5	2.3	0.8	1.0	750		

Number	TUBE		CATHODE		NOTES	CHARACTERISTICS (Continued)								OUTPUT		
	Type	Socket	Kind	Volts		Amps	Ep	Eg	Es	Ip	Is	Rp	Gm-Gc	Mu	Load	Watts
1D5-GT	Pa	98	F	2.0	0.06		180	- 3.0	67.5	2.2	0.7	0.6	650			
1D7-G	C5	167	F	2.0	0.06	mxr osc	180 180	- 3.0	67.5	1.5 2.5	2.0	0.5	300			
1D8-GT	PTD	170	F	1.4	0.10	pen tri	90 90	- 9.0 0	90	5.0 1.1	1.0	0.2 43500	925 575	25	12000	0.20
1E4-G	Ta	84	F	1.4	0.05		90	- 3.0		1.5		17000	825	14		
77 1E5-GP	Pa	97	F	2.0	0.06		180	- 3.0	67.5	1.7	0.6	1.5	650			
1E7-G	PPb	151	F	2.0	0.24	p-p	135	- 7.5	135	7.0	2.0				24000	0.575
1F4	Pb	15	F	2.0	0.12		135	- 4.5	135	8.0	2.4	0.2	1700		16000	0.31
1F5-G	Pb	87	F	2.0	0.12		135	- 4.5	135	8.0	2.4	0.2	1700		16000	0.31
1F6	PDD	32	F	2.0	0.06		180	- 1.5	67.5	2.2	0.7	1.0	650			
1F7-G	PDD	173	F	2.0	0.06		180	- 1.5	67.5	2.2	0.7	1.0	650			
1G4G/GT	Ta	84	F	1.4	0.05		90	- 6.0		2.3		10700	825	8.8		



TUBE Number	TUBE		CATHODE			NOTES	CHARACTERISTICS (Continued)							OUTPUT		
	Type	Socket	Kind	Volts	Amps		Ep	Eg	Es	Ip	Is	Rp	Gm-Gc	Mu	Load	Watts
1G5-G	Pb	87	F	2.0	0.12		135	-13.5	135	8.7	2.5	0.16	1550		9000	0.55
1G6G/GT	TTb	117	F	1.4	0.10		90	0		1.0		45000	675	30		
1H4-G	Ta	84	F	2.0	0.06		180	-13.5		3.1		10300	900	9.3		
1H5G/GT	TD	102	F	1.4	0.05		90	0		0.15		0.24	275	65		
1H6-G	TDD	118	F	2.0	0.06		135	-3.0		0.8		35000	575	20		
78 1J5-G	Pb	87	F	2.0	0.12		135	-16.5	135	7.0	2.0	0.105	950		0.135	0.45
1J6-G	TTb	117	F	2.0	0.24		135	-3.0		3.4					10000	1.9
1L4	Pa	71	F	1.4	0.05		90	0	90	4.5	2.0	0.35	1025			
1LA4	Pb	97	F	1.4	0.05		90	-4.5	90	4.0	0.8	0.3	850		25000	0.115
1LA6	C5	144	F	1.4	0.05	mxx oso	90 90	0	45	0.55 1.2	0.6	0.75	250			
1LB4	Pb	121	F	1.4	0.05		90	-9.0	90	5.0	1.0	0.2	925		12000	0.20
1LC5	Pa	122	F	1.4	0.05		90	0	45	1.15	0.2	1.5	775			

Number	TUBE		CATHODE		NOTES	CHARACTERISTICS (Continued)								OUTPUT	
	Type	Socket	Kind	Volts		Amps	Ep	Eg	Es	Ip	Is	Rp	Gm-Gc	Mu	Load
1LC6	C5	144	F	1.4	0.05	mxr oso	90 45	0	35	0.75 1.4	0.7	0.65	275		
1LD5	PD	137	F	1.4	0.05		90	0	45	0.6	0.1	0.75	575		
1LE3	Ta	108	F	1.4	0.05		90	0		4.5		11200	1300	14.5	
1LH4	TD	112	F	1.4	0.05		90	0		0.15		0.24	275	65	
1LN5	Pa	122	F	1.4	0.05		90	0	90	1.6	0.35	1.1	800		
1N5G/GT	Pa	97	F	1.4	0.05		90	0	90	1.2	0.3	1.5	750		
1P5-GT	Pa	97	F	1.4	0.05		90	0	90	2.3	0.7	0.8	750		
1Q5G/GT	B	88	F	1.4	0.10		90	- 4.5	90	9.5	1.3	75000	2200	8000	0.27
1R4/1294	D	109	F	1.4	0.15		117			1.0					
1R5	C5	75	F	1.4	0.05		90	0	67.5	1.6	3.2	0.6	300		
1S4	Pb	72	F	1.4	0.10		90	- 7.0	67.5	7.4	1.4	0.1	1575	8000	0.27
1S5	PD	76	F	1.4	0.05		67.5	0	67.5	1.6	0.4	0.6	625		

Number	TUBE		CATHODE			NOTES	CHARACTERISTICS (Continued)							OUTPUT		
	Type	Socket	Kind	Volts	Amps		Ep	Eg	Es	Ip	Is	Rp	Gm-Gc	Mu	Load	Watts
1T4	Pa	71	F	1.4	0.05		90	0	67.5	3.5	1.4	0.5	900			
1T5-GT	B	87	F	1.4	0.05		90	- 6.0	90	6.5	1.4		1150	14000	0.17	
1-V	Rh	3	H	6.3	0.3		325			45						
2A3	Tb	4	F	2.5	2.5		250	-45		60		800	5250	4.2	2500	3.5
2A5	Pb	27	H	2.5	1.75		250	-16.5	250	34	6.5	80000	2500		7000	3.2
2A6	TDD	31	H	2.5	0.8		250	- 2.0		0.9		91000	1100	100		
2A7 /S	C5	45	H	2.5	0.8	mxr osc	250 250	- 3.0	100	3.5 4.0	2.7	0.3	550			
2B6	TTc	48	H	2.5	2.25		250	-24		40		5150	3500	18	5000	4.0
2B7 /S	PDD	44	H	2.5	0.8		250	- 3.0	100	6.0	1.5	0.8	1000			
2C21	TTa	43	H	6.3	0.6	eaoh	250	-16.5		8.3		7600	1375	10.4		
2C22	Ta	184	H	6.3	0.3		300	-10.5		11.0		6600	3000	20		

Number	TUBE		CATHODE			NOTES	CHARACTERISTICS (Continued)								OUTPUT		
	Type	Socket	Kind	Volts	Amps		Ep	Eg	Es	Ip	Is	Rp	Gm-Gc	Mu	Load	Watts	
2E5	I	26	H	2.5	0.8	tri 250 tar 250	250	0		0.24 4.0							
2G5	I	26	H	2.5	0.8	tri 250 tar 250	250	0		0.24 4.0							
2S/4S	DD	12	H	2.5	1.5		50			40							
2W3	Rh	50	F	2.5	1.5		350			55							
19 2Z2/G84	Rh	1	F	2.5	1.5		350			50							
3A4	Pb	74	F	1.4 p	0.2		150	- 8.4	90	13.3	2.2	0.1	1900		8000	0.7	
3A5	TTa	77	F	1.4 p	0.22		90	- 2.5		3.7			8300	1800	15		
3A8-GT	PTD	171	F	1.4 p	0.10	pen 90 tri 90	90	0	90	1.5 0.2	0.5	0.8 0.2	750 325			65	
3B5-GT	B	89	F	1.4 p	0.10		67.5	-7.0	67.5	8.0	0.6	0.1	1650		5000	0.2	
3B7/1921	TTb	133	F	1.4 p	0.22		90	0		5.2			11000	1850	20	8000	1.0
3C5-GT	Pb	89	F	1.4 p	0.10		67.5	-7.0	67.5	8.0	0.6	0.1	1650		5000	0.2	



Number	TUBE		CATHODE			NOTES	CHARACTERISTICS (Continued)								OUTPUT	
	Type	Socket	Kind	Volts	Amps		Ep	Eg	Es	Ip	Is	Rp	Gm-Gc	Mu	Load	Watts
5X4-G	Rf	106	F	5.0	3.0	con 450 ohk 550				225 225						
5Y3G/GT	Rf	51	F	5.0	2.0	con 350 ohk 500				125 125						
5Y4-G	Rf	106	F	5.0	2.0	con 350 ohk 500				125 125						
5Z3	Rf	7	F	5.0	3.0	con 450 ohk 550				225 225						
5Z4	Rf	53	H	5.0	2.0	con 350 ohk 500				125 125						
6A3	Tb	4	F	6.3	1.0	250	-45		60		800	5250	4.2	2500	3.2	
6A4/LA	Pb	16	F	6.3	0.3	180	-12	180	22	3.9	45500	2200		8000	1.4	
6A5-G	Tb	113	H	6.3	1.25	250	-45		60		800	5250	4.2	2500	3.75	
6A6	TTb	37	H	6.3	0.8	C1-B 300	0		17.5					8000	10.0	

Number	TUBE		CATHODE			NOTES	CHARACTERISTICS (Continued)							OUTPUT		
	Type	Socket	Kind	Volts	Amps		Ep	Eg	Es	Ip	Is	Rp	Gm-Gc	Mu	Load	Watts
6A7 /S	C5	45	H	6.3	0.3	mxx osc 250	250	- 3	100	3.5 4.0	2.7	0.3	550			
6A8/G/GT	C5	166	H	6.3	0.3	mxx osc 250	250	- 3	100	3.5 4.0	2.7	0.3	550			
6AB6-G	TTc	93	H	6.3	0.5	in out 250	250	0 0		5.0 34.0		40000	1800	72	8000	3.5
6AB7/1853	Pa	126	H	6.3	0.45		300	-3.0	200	12.5	3.2	0.7	5000			
6AC5G/GT	Tb	62	H	6.3	0.4		250	drv		32					7000	3.7
6AC6G	TTc	93	H	6.3	1.1	in out 180	180	0 0		7.0 45.0			3000	54	4000	3.8
6AC7/1852	Pa	126	H	6.3	0.45		300	cath	150	10.0	2.5	0.1	9000			
6AD5-G	Ta	62	H	6.3	0.3		250	-2.0		0.9			1500	100		
6AD6-G	I	95	H	6.3	0.15	ray tar 150	150	75		3.0						

Number	TUBE		CATHODE			NOTES	CHARACTERISTICS (Continued)							OUTPUT		
	Type	Socket	Kind	Volts	Amps		Ep	Eg	Es	Ip	Is	Rp	Gm-Gc	Mu	Lood	Watts
6AD7-G	PT	162	H	6.3	0.85	pen	250	-16.5	250	34.0	6.5	80000	2500		7000	3.2
						tri	250	-25	4.0	19000		325	6			
6AE5G/GT	Ta	62	H	6.3	0.3		95	-15		7.0		3500	1200	4.2		
6AE6-G	Toa	85	H	6.3	0.15	P1-3	250	-1.5		6.5		25000	1000	25		
						P1-4	250	-1.5	4.5	35000	950	33				
6AE7-GT	Tia	130	H	6.3	0.5		250	-13.5		10.0		4650	3000	14		
6AF5	Ta	62	H	6.3	0.3		180	-18		7.0		4900	1500	7.4		
6AF6-G	I	95	H	6.3	0.15	ray tar	135	81		1.5						
6AG6-G	Pb	91	H	6.3	1.25		250	-6.0	250	32.0	6.0	10000			8500	3.75
6AG7	Pb	128	H	6.3	0.65		300	-10.5	300	25.0	6.5	0.1	7700			
6AH5-G	B	176	H	6.3	0.9		350	-18	250			33000	5200		4200	10.8
6AH7-GT	TTa	143	H	6.3	0.3		250	-9.0		12.0		6600	2400	16		
6AK5	Pa	78	H	6.3	0.175		180	cath	120	7.7	2.4	0.69	5100			



Number	TUBE		CATHODE			NOTES	CHARACTERISTICS (Continued)							OUTPUT			
	Type	Socket	Kind	Volts	Amps		Ep	Eg	Es	Ip	Is	Rp	Gm-Gc	Mu	Load	Watts	
6AK6	Pb	187	H	6.3	0.15		180	-9.0	180	15.0	2.5	0.2	2300		10000	1.1	
6AL5	DD	190	H	6.3	0.3		150			9.0							
6AL6	B	185	H	6.3	0.9		250	-14	250	72.0	5.0	22500	6000		2500	6.5	
6AQ6	TDD	189	H	6.3	0.15		250	-3.0		1.0		58000	1200	70			
6B4-G	Tb	84	F	6.3	1.0		250	-45		60		800	5250	4.2	2500	3.2	
6B5	Tto	29	H	6.3	0.8	in out	300 300	0		8.0 45		24000	2400	58		7000	4.0
6B6-G	TDD	101	H	6.3	0.3		250	-2.0		0.9		91000	1100	100			
6B7 /S	PDD	44	H	6.3	0.3		250	-3.0	100	6.0	1.5	0.8	1000				
6B8 /G	PDD	174	H	6.3	0.3		250	-3.0	100	6.0	1.5	0.8	1000				
6C4	Tb	69	H	6.3	0.15		250	-8.5		10.5		7700	2200	17			
6C5/G/GT	Ta	134	H	6.3	0.3		250	-8.0		8.0		10000	2000	20			
6C6	Pa	35	H	6.3	0.3		250	-3.0	100	2.0	0.5	1.0 +	1225				

Number	TUBE		CATHODE			NOTES	CHARACTERISTICS (Continued)							OUTPUT		
	Type	Socket	Kind	Volts	Amps		Ep	Eg	Es	Ip	Is	Rp	Gm-Gc	Mu	Load	Watts
6C7	TDD	41	H	6.3	0.3		250	-9.0		4.5		16000	1250	20		
6C8-G	TTa	175	H	6.3	0.3	each	250	-4.5		3.2		22500	1600	36		
6D6	Pa	35	H	6.3	0.3		250	-3.0	100	8.2	2.0	0.8	1600			
6D7	Pa	42	H	6.3	0.3		250	-3.0	100	2.0	0.5	1.0 +	1225	1500		
6D8-G	C5	166	H	6.3	0.15	mxr osc	250 250	-3.0	100	3.5 4.3	2.6	0.4	550			
6E5	I	26	H	6.3	0.3	tri tar	250 250	0		0.24 4.0						
6E6	TTb	37	H	6.3	0.6		250	-27.5		18.0		3500	1700	6	14000	1.6
6E7	Pa	42	H	6.3	0.3		250	-3.0	100	8.2	2.0	0.8	1600	1280		
6F4	Ta	196	H	6.3	0.225		180	cath		13.0		2900	5800	17		
6F5/G/GT	Ta	54	H	6.3	0.3		250	-2.0		0.9		66000	1500	100		
6F6 /G	Pb	91	H	6.3	0.7		250	-16.5	250	34.0	6.5	80000	2500		7000	3.2
						p-p	375	-26	250	34.0	5.0				10000	18.5

Number	TUBE		CATHODE			NOTES	CHARACTERISTICS (Continued)								OUTPUT	
	Type	Socket	Kind	Volts	Amps		Ep	Eg	Es	Ip	Is	Rp	Gm-Gc	Mu	Load	Watts
6F7 /S	PT	46	H	6.3	0.3	tri 100	-3.0	100	3.5	1.5	16200	525	8.5			
						pen 250	-3.0									6.5
6F8-0	TTa	175	H	6.3	0.6	each 250	-8.0		9.0		7700	2600	20			
6G5	See 6U5															
6G6G	Pb	91	H	6.3	0.15	180	-9.0	180	15.0	2.5	0.175	2300		10000	1.1	
6H4-GT	D	52	H	6.3	0.15	100			4.0							
6H5	See 6U5															
6H6/G/GT	DD	86	H	6.3	0.3	each 117			4.0							
6J4	Ta	188	H	6.3	0.4	150	cath		15.0		4500	12000	55			
6J5/G/GT	Ta	62	H	6.3	0.3	250	-8.0		9.0		7700	2600	20			
6J6	TTb	81	H	6.3	0.45	each 100	cath		8.5		7100	5300	38			
6J7/G/GT	Pa	96	H	6.3	0.3	250	-3.0	100	2.0	0.5	1.0 +	1225				

Number	TUBE		CATHODE			NOTES	CHARACTERISTICS (Continued)							OUTPUT		
	Type	Socket	Kind*	Volts	Amps		Ep	Eg	Es	Ip	Is	Rp	Gm-Gc	Mu	Load	Watts
6J8-G	C7	165	H	6.3	0.3	mxr	250	-3.0	100	1.3	3.5	2.5	290			
						oso	250			5.8						
						tri	150	-3.0		9.0						8750
6K5G/GT	Ta	63	H	6.3	0.3		250	-3.0		1.1		50000	1400	70		
6K6G/GT	Pb	91	H	6.3	0.4		250	-18.0	250	32.0	5.5	68000	2300		7600	3.4
6K7/G/GT	Pa	96	H	6.3	0.3		250	-3.0	125	10.5	2.6	0.6	1650			
6K8/G/GT	C6	164	H	6.3	0.3	mxr	250	-3.0	100	2.5	6.0	0.6	350			
						oso	100			3.8						
6L5-G	Ta	62	H	6.3	0.15		250	-9.0		8.0		9000	1900	17		
6L6 /G	B	90	H	6.3	0.9		250	-14.0	250	72.0	5.0	22500	6000		2500	6.5
						p-p	270	-17.5	270	134	11	23500		5000	17.5	
6L7 /G	M5	103	H	6.3	0.3		250	-3.0	100	2.4	7.1	1.0 +	375			
6M6-G	Pb	91	H	6.3	1.2		250	-6.0	250	36.0	4.0		9500		7000	4.4

Number	TUBE		CATHODE			NOTES	CHARACTERISTICS (Continued)							OUTPUT		
	Type	Socket	Kind	Volts	Amps		Ep	Eg	Es	Ip	Is	Rp	Gm-Gc	Mu	Load	Watts
6M7-G	Pa	96	H	6.3	0.3		250	-2.5	125	10.5	2.8	0.9	3400			
6N5	I	26	H	6.3	0.15	tri 135 tar 135		0		0.5 2.0						
6N6-G	TTc	94	H	6.3	0.8	in 300 out 300		0		9.0 42.0		24000	2400	58	7000	4.0
6N7/G/GT	TTb	131	H	6.3	0.8	C1-A 250 C1-B 300		-5.0 0		6.0 17.5		11300	3100	35	8000	10.0
6P5G/GT	Ta	62	H	6.3	0.3		250	-13.5		5.0		9500	1450	13.8		
6P7-G	PT	168	H	6.3	0.3	pen 250 tra 100		-3.0 -3.0	100	6.5 3.5	1.5	0.85 16200	1100 525	900 8.5		
6P8-G	C6	164	H	6.3	0.8	mxt 250 osc 100		-2.0	75	1.5 2.2	1.4					
6Q6-G	TD	66	H	6.3	0.15		250	-3.0		1.2			1050	65		
6Q7/G/GT	TDD	101	H	6.3	0.3		250	-3.0		1.0		58000	1200	70		
6R6-G	Pa	123	H	6.3	0.3		250	-3.0	100	7.0	1.7		1450	1160		

06

Number	TUBE		CATHODE			NOTES	CHARACTERISTICS (Continued)							OUTPUT	
	Type	Socket	Kind	Volts	Amps		Ep	Eg	Es	Ip	Is	Rp	Gm-Gc	Mu	Load
6R7/G/GT	TDD	101	H	6.3	0.3	250	-9.0		9.5		8500	1900	16		
6S6-GT	Pa	176	H	6.3	0.45	250	-2.0	100	13.0	3.0	0.35	4000			
6S7 /G	Pa	96	H	6.3	0.15	250	-3.0	100	8.5	2.0	1.0	1750			
6SA7	C5	155	H	6.3	0.3	250	-2.0	100	3.4	8.0	0.8	450			
6SA7G/GT	C5	153	H	6.3	0.3	250	-2.0	100	3.4	8.0	0.8	450			
6SC7	TTs	132	H	6.3	0.3	250	-2.0		2.0		53000	1325	70		
6SD7-GT	Pa	126	H	6.3	0.3	100	-2.0	100	6.0	1.9	1.0	3600			
6SE7-GT	Pa	126	H	6.3	0.3	250	-1.5	100	4.5	1.5	1.1	3400			
6SF5 /GT	Ta	61	H	6.3	0.3	250	-2.0		0.9		66000	1500	100		
6SF7	PD	145	H	6.3	0.3	250	-1.0	100	12.4	3.3	0.7	2050			
6SG7	Pa	125	H	6.3	0.3	250	-1.0	125	11.8	4.4	0.9	4700			
6SH7	Pa	125	H	6.3	0.3	250	-1.0	150	10.8	4.1	0.9	4900			

TUBE Number	Type	Socket	CATHODE		NOTES	CHARACTERISTICS (Continued)							OUTPUT		
			Kind	Volts		Amps	Ep	Eg	Es	Ip	Is	Rp	Gm-Gc	Mu	Load
6SJ7 /GT	Pa	126	H	6.3	0.3		250	-3.0	100	3.0	0.8	1.0 +	1650		
6SK7/G/GT	Pa	126	H	6.3	0.3		250	-3.0	100	9.2	2.6	0.8	2000		
6SL7-GT	TTa	142	H	6.3	0.3	each	250	-2.0		2.3		44000	1600	70	
6SN7-GT	TTa	142	H	6.3	0.6	each	250	-8.0		9.0		7700	2600	20	
6SQ7/G/GT	TDD	134	H	6.3	0.3		250	-2.0		0.9		91000	1100	100 -	
6SR7	TDD	134	H	6.3	0.3		250	-9.0		9.5		8500	1900	16	10000 0.3
6SS7	Pa	126	H	6.3	0.15		250	-3.0	100	9.0	2.0	1.0	1850		
6ST7	TDD	134	H	6.3	0.15		250	-9.0		9.5		8500	1900	16	10000 0.3
6T5	I	26	H	6.3	0.3	tri tar	250 250	0		0.24 4.0					
6T6-GM	Pa	178	H	6.3	0.45		250	-1.0	100	10.0	2.0	1.0	5500		
6T7-G	TDD	101	H	6.3	0.15		250	-3.0		1.2		62000	1050	65	

Number	TUBE		CATHODE			NOTES	CHARACTERISTICS (Continued)							OUTPUT		
	Type	Socket	Kind	Volts	Amps		Ep	Eg	Es	Ip	Is	Rp	Gm-Gc	Mu	Load	Watts
6U5/6G5	I	26	H	6.3	0.3	tri 250 tar 250	0			0.24 4.0						
6U6-GT	B	90	H	6.3	0.75		200	-14.0	135	55	3.0	20000	6200		3000	5.5
6U7-G	Pa	96	H	6.3	0.3		250	-3.0	100	8.2	2.0	0.8	1600			
6V6/G/GT	B	90	H	6.3	0.45		250	-12.5	250	45	4.5	52000	4100		5000	4.5
						p-p	250	-15.0	250	70	5.0				10000	10.0
6V7-G	TDD	101	H	6.3	0.3		250	-20.0		8.0		7500	1100		20000	0.35
6W5-G	Rf	58	H	6.3	0.9		350			100						
6W6-GT	B	90	H	6.3	1.25		135	-9.5	135	61	12.0	9000			2000	3.3
6W7-G	Pa	96	H	6.3	0.15		250	-3.0	100	2.0	0.5	1.5	1225			
6X5/G/GT	Rf	58	H	6.3	0.6	con 325 ohk 450				70 70						
6X6-G	I	92	H	6.3	0.3	tri 250 tar 135	0									2.0



Number	TUBE		CATHODE			NOTES	CHARACTERISTICS (Continued)							OUTPUT		
	Type	Socket	Kind	Volts	Amps		Ep	Eg	Es	Ip	Is	Rp	Gm-Gc	Mu	Load	Watts
6Y5	Rf	21	H	6.3	0.8	con	350			50						
6Y6-G	B	90	H	6.3	1.25		200	-14.0	135	61	2.2	18300	7100		2600	6.0
6Y7-G	TTb	131	H	6.3	0.6		250	0		10.5					14000	8.0
6Z3	Rh	3	H	6.3	0.3	con	350			50						
6Z4	See 84/6Z4															
6Z5	Rf	24	H	6.3	0.8	p	230			60						
6Z7G	TTb	131	H	6.3	0.3		180	0		4.2					20000	2.2
6ZY5-G	Rf	58	H	6.3	0.3	con	325			40						
						chk	450			40						
7A4	Ta	111	H	6.3	0.3		250	-8.0		9.0		7700	2600	20		
7A5	B	123	H	6.3	0.7		125	-9.0	12b	44.0	3.3	16800	6000		2700	2.2
7A6	DD	116	H	6.3	0.15		150			8.0						
7A7	Pa	124	H	6.3	0.3		250	-3.0	100	9.2	2.4	0.8	2000			

Number	TUBE		CATHODE		NOTES	CHARACTERISTICS (Continued)								OUTPUT	
	Type	Socket	Kind	Volts		Amps	Ep	Eg	Es	Ip	Is	Rp	Gm-Gc	Mu	Load
7A8	C8	157	H	6.3	0.15	mxr oso	250 250	-3.0	100	3.0 4.2	3.2	0.7	550		
7B4	Ta	111	H	6.3	0.3		250	-2.0		0.9		66000	1500	100	
7B5	Pb	127	H	6.3	0.4		250	-18.0	250	25.5	4.0	75000	2100		9000 4.5
7B6	TDD	135	H	6.3	0.3		250	-2.0		0.9		91000	1100	100	
7B7	Pa	124	H	6.3	0.15		250	-3.0	100	8.5	1.7	0.75	1750		
7B8	C5	156	H	6.3	0.3	mxr oso	250 250	-3.0	100	3.5 4.0	2.7	0.36	550		
7C4/1203A	D	109	H	6.3	0.15		117			5.0					
7C5	B	123	H	6.3	0.45		250	-12.5	250	45.0	4.5	52000	4100		5000 4.5
7C6	TDD	135	H	6.3	0.15		250	-1.0		1.3		0.1	1000	100	
7C7	Pa	124	H	6.3	0.15		250	-3.0	100	2.0	0.5	2.0	1300		
7E5/1201	Ta	114	H	6.3	0.15		180	-3.0		5.5		12000	3000	36	

56

Number	TUBE		CATHODE			NOTES	CHARACTERISTICS (Continued)						OUTPUT		
	Type	Socket	Kind	Volts	Amps		Ep	Eg	Es	Ip	Is	Rp	Gm-Gc	Mu	Load
7E6	TDD	135	H	6.3	0.3		250	-9.0		9.5		8500	1900		16
7E7	PDD	158	H	6.3	0.3		250	-3.0	100	7.5	1.6	0.7	1300		
7F7	TTa	141	H	6.3	0.3		250	-2.0		2.3		44000	1600		70
7F8	TTa	83	H	6.3	0.3		250	-2.5		10.0		10500	5000		
7G7/1232	Pa	124	H	6.3	0.45		250	-2.0	100	6.0	2.0	0.8	4500		
7H7	Pa	124	H	6.3	0.3		250	-2.5	150	9.5	3.5	0.8	3800		
7J7	C7	163	H	6.3	0.3	mxr osc	250 250	-3.0	100	1.4 5.0	2.8	1.5	290		
7L7	Pa	124	H	6.3	0.3		250	-1.5	100	4.5	1.5	1.0	3100		
7N7	TTa	141	H	6.3	0.6		250	-8.0		9.0		7700	2600		20
7Q7	C5	154	H	6.3	0.3		250	-2.0	100	3.5	8.5	1.0	550		
7R7	PDD	158	H	6.3	0.3		250	-1.0	100	5.7	2.1	1.0	3200		

Number	TUBE		CATHODE			NOTES	CHARACTERISTICS (Continued)							OUTPUT		
	Type	Socket	Kind	Volts	Amps		Ep	Eg	Es	Ip	Is	Rp	Gm-Gc	Mu	Load	Watts
7S7	C7	163	H	6.3	0.3	mxr 250 osc 250	-2.0	100	1.8 5.0	3.0	1.25	525				
7T7	Pa	124	H	6.3	0.3		250	-1.0	150	10.8	4.1	0.9	4900			
7V7	Pa	124	H	6.3	0.45		300	cath	150	10.0	3.9	0.3	5800			
7W7	Pa	129	H	6.3	0.45		300	cath	150	10.0	3.9	0.3	5800			
7Y4	Rf	110	H	6.3	0.5	con 325 chk 450				60 60						
7Z4	Rf	110	H	6.3	0.9	con 325 chk 450				100 100						
10	Tb	4	F	7.5	1.25		425	-40		18.0		5000	1600	8	10200	1.6
12	Ta	4	F	1.1	0.25		135	-10.5		3.0		15000	440	6.6		
12-A	Ta	4	F	5.0	0.25		180	-13.5		7.7		4700	1800	8.5		
12A5	Pb	38	H	6.3	p 0.6		180	-25.0	180	45.0	8.0	35000	2400		3300	3.4

Number	TUBE		CATHODE			NOTES	CHARACTERISTICS (Continued)							OUTPUT		
	Type	Socket	Kind	Volts	Amps		Ep	Eg	Es	Ip	Is	Rp	Gm-Gc	Mu	Load	Watt:
12A6	B	90	H	12.6	0.15		250	-12.5	250	30.0	3.5	70000	3000		7500	3.4
12A7	PR	47	H	12.6	0.3	pen	135	-13.5	135	9.0	2.5	0.102	975		13500	0.55
12A8G/GT	C5	166	H	12.6	0.15	mrx oso	250 250	-3.0	100	3.5 4.0	2.7	0.3	550			
12AH7	TTa	143	H	12.6	0.15		180	-6.5		7.6		8400	1900	16		
12B6	TD	66	H	12.6	0.15		250	-2.0		0.9		91000	1100	100		
12B7	See 14A7															
12B8-GT	PT	169	H	12.6	0.3	pen tri	90 90	-3.0 0	90	7.0 2.8	2.0	0.2 37000	1800 2400	90		
12C8	PDD	174	H	12.6	0.15		250	-3.0	125	10.0	2.3	0.6	1325			
12F5-GT	Ta	54	H	12.6	0.15		250	-2.0		0.9		66000	1500	100		
12H6	DD	86	H	12.6	0.15	each	117			4.0						
12J5-GT	Ta	62	H	12.6	0.15		250	-8.0		9.0		7700	2600	20		

Number	TUBE		CATHODE			NOTES	CHARACTERISTICS (Continued)						OUTPUT		
	Type	Socket	Kind	Volts	Amps		Ep	Eg	Es	ip	Is	Rp	Gm-Gc	Mu	Load
12J7-GT	Pa	96	H	12.6	0.15		250	-3.0	100	2.0	0.5	1.0 +	1225		
12K7G/GT	Pa	96	H	12.6	0.15		250	-3.0	125	10.5	2.6	0.6	1650		
12K8	C6	164	H	12.6	0.15	m <sub>ax</sub> osc	250 100	-3.0	100	2.5 3.8	6.0	0.6	350		
12XQ7	TDD	101	H	12.6	0.15		250	-3.0		1.0		58000	1200	70	
12SA7	C5	155	H	12.6	0.15		250	-2.0	100	3.4	8.0	0.8	450		
12SA7G/GT	C5	153	H	12.6	0.15		250	-2.0	100	3.4	8.0	0.8	450		
12SC7	TTa	132	H	12.6	0.15		250	-2.0		2.0		53000	1325	70	
12SF5/GT	Ta	61	H	12.6	0.15		250	-2.0		0.9		66000	1500	100	
12SF7	PD	145	H	12.6	0.15		250	-1.0	100	12.4	3.3	0.7	2050		
12SG7	Pa	125	H	12.6	0.15		250	-1.0	125	11.8	4.4	0.9	4700		
12SH7	Pa	125	H	12.6	0.15		250	-1.0	150	10.8	4.1	0.9	4900		
12SJ7/GT	Pa	126	H	12.6	0.15		250	-3.0	100	3.0	0.8	1.0 +	1650		

Number	TUBE		CATHODE			NOTES	CHARACTERISTICS (Continued)							OUTPUT	
	Type	Socket	Kind	Volts	Amps	Ep	Eg	Es	Ip	Is	Rp	Gm-Gc	Mu	Load	Watts
12SK7/G/GT	Pa	126	H	12.6	0.15	250	-3.0	100	9.2	2.6	0.8	2000			
12SL7-GT	TTa	142	H	12.6	0.15 each	250	-2.0		2.3		44000	1600	70		
12SN7-GT	TTa	142	H	12.6	0.3 each	250	-8.0		9.0		7700	2600	20		
12SQ7/G/GT	TDD	134	H	12.6	0.15	250	-2.0		0.9		91000	1100	100		
12SR7	TDD	134	H	12.6	0.15	250	-9.0		9.5		8500	1900	16	10000	0.3
100 12Z3	Rh	3	H	12.6	0.3 con	235			55						
14A4	Ta	111	H	12.6	0.15	250	-8.0		9.0		7700	2600	20		
14A5	B	123	H	12.6	0.15	250	-12.5	250	30.0	3.5	70000	3000		7500	3.4
14A7/12B7	Pa	124	H	12.6	0.15	250	-3.0	100	9.2	2.4	0.8	2000			
14AF7	TTa	141	H	12.6	0.15	250	-10.0		9.0		7600	2100	16		
14B6	TDD	135	H	12.6	0.15	250	-2.0		0.9		91000	1100	100		
14B8	C5	156	H	12.6	0.15	250	-3.0	100	3.5	2.7	0.36	550			
						osc	250		4.0						

Number	TUBE		CATHODE			NOTES	CHARACTERISTICS (Continued)							OUTPUT	
	Type	Socket	Kind	Volts	Amps		Ep	Eg	Es	Ip	Is	Rp	Gm-Gc	Mu	Load
14C5	B	123	M	12.6	0.225	250	-12.5	250	45.0	4.5	52000	4100		5000	4.5
14C7	Pa	124	H	12.6	0.15	250	-3.0	100	2.2	0.7	1.0				
14E6	TDD	135	H	12.6	0.15	250	-9.0		9.5		8500	1900	16		
14E7	PDD	158	H	12.6	0.15	250	-5.0	100	7.5	1.6	0.7	1300			
14F7	TTa	141	H	12.6	0.15	250	-2.0		2.3		44000	1600	70		
14H7	Fa	124	H	12.6	0.15	250	-2.5	150	9.5	3.5	0.8	3800			
14J7	C7	163	H	12.6	0.15	mxr osc 250	250	-3.0	100	1.4 5.0	2.8	1.5	290		
14N7	TTa	141	H	12.6	0.3	250	-8.0		9.0		7700	2600	20		
14Q7	C5	154	H	12.6	0.15	250	-2.0	100	3.5	8.5	1.0	550			
14R7	PDD	158	H	12.6	0.15	250	-1.0	100	5.7	2.1	1.0	3200			
14S7	C7	163	H	12.6	0.15	mxr osc 250	250	-2.0	100	1.8 5.0	3.0	1.25	525		



Number	TUBE		CATHODE			NOTES		CHARACTERISTICS (Continued)						OUTPUT	
	Type	Socket	Kind	Volts	Amps	Ep	Eg	Es	Ip	Is	Rp	Gm-Gc	Mu	Load	Watts
14W7	Pa	129	H	12.6	0.225	300	cath	150	10.0	3.9	0.3	5800			
14Y4	Rf	110	H	12.6	0.3	con chk 325 450			60 60						
15	Pa	18	H	2.0	0.22	135	-1.5	67.5	1.85	0.3	0.8	750			
18	Pb	27	H	12.6	0.3	250	-16.5	250	34.0	6.5	80000	2500		7000	3.2
19	TTb	23	F	2.0	0.26	135	-3.0		3.4					10000	1.9
20	Tb	4	F	3.3	0.132	135	-22.5		6.5		6300	525	3.3	6500	0.11
21A7	C6	163	H	19.0	0.3	mxr osc 250 150	-3.0 -3.0	100	1.3 3.5	2.8		275			
22	Sa	10	F	3.3	0.132	135	-1.5	67.5	3.7	1.3	0.325	500			
24A /S	Sa	17	H	2.5	0.175	250	-3.0	90	4.0	1.7	0.6	1050	630		
25A6/G/GT	Pb	91	H	25.0	0.3	160	-18.0	120	33.0	6.5	42000	2375		5000	2.2
25A7G/GT	PR	161	H	25.0	0.3	pen rec 100 117	-15.0	100	20.5 75	4.0	50000	1800		4500	0.77

TUBE Number	TUBE Type	Socket	CATHODE			NOTES	CHARACTERISTICS (Continued)							OUTPUT				
			Kind	Volts	Amps		Ep	Eg	Es	Ip	Is	Rp	Gm-Gc	Mu	Load	Watts		
25AC5G/GT	Tb	62	H	25.0	0.3		165	drvr				46.0					3500	3.3
25B5	TTc	30	H	25.0	0.3	in out	100 180	0				5.8 46.0					4000	3.8
25B6-G	Pb	91	H	25.0	0.3		200	-23.0	135	62.0	1.8	18000	5000				2500	7.1
25B8-GT	PT	169	H	25.0	0.15	pen tri	100 100	-3.0 -1.0	100	7.6 0.6	2.0	0.185 75000	2000 1500	112				
25C6-G	B	90	H	25.0	0.3		200	-14.0	135	61	2.2	18300	7100				2600	6.0
25D8-GT	PTD	172	H	25.0	0.15	pen tri	100 100	-3.0 -1.0	100	8.5 0.5	2.7	0.2 91000	1900 1100					
25L6/G/GT	B	90	H	25.0	0.3		200	-8.0	110	50.0	2.0	30000	9500				3000	4.3
25N6-G	TTc	93	H	25.0	0.3	in out	100 180	0				5.8 46.0					4000	3.8
25S	See 1B5																	
25X6-GT	Rd	86	H	25.0	0.15		117				60							

Number	TUBE		CATHODE			NOTES		CHARACTERISTICS (Continued)						OUTPUT	
	Type	Socket	Kind	Volts	Amps	Ep	Eg	Es	Ip	Is	Rp	Gm-Gc	Mu	Load	Watts
25Y4-GT	Rh	56	H	25.0	0.15	117			75						
25Y5	Rd	28	H	25.0	0.3	235			75						
25Z3	Rh	3	H	25.0	0.3	235			50						
25Z4	Rh	56	H	25.0	0.3	117			125						
25Z5	Rd	28	H	25.0	0.3	117			75						
25Z6/G/GT	Rd	86	H	25.0	0.3	117			75						
26	Ta	4	F	1.5	1.05	180	-14.5		6.2		7300	1150	8.3		
26A7-GT	BB	191	H	26.5	0.6	26.5	-4.5	26.5	20.0	2.0	2500	5500		1500	0.2
27 / S	Ta	13	H	2.5	1.75	250	-21.0		5.2		9250	975	9.0		
30	Ta	4	F	2.0	0.06	180	-13.5		3.1		10300	900	9.3		
31	Tb	4	F	2.0	0.13	180	-30.0		12.3		3600	1050	3.8	5700	0.375
32	Sa	10	F	2.0	0.06	180	-3.0	67.5	1.7	0.4	1.2	650			

Number	TUBE		CATHODE			NOTES	CHARACTERISTICS (Continued)							OUTPUT		
	Type	Socket	Kind	Volts	Amps		Ep	Eg	Es	Ip	Is	Rp	Gm-Gc	Mu	Load	Watts
32L7-GT	BR	147	H	32.5	0.3	pen reo	90 125	-7.0	90	27.0 60.0	2.0	17000	4800		2600	1.0
33	Pb	15	F	2.0	0.26		180	-18.0	180	22.0	5.0	55000	1700		6000	1.5
34	Pa	11	F	2.0	0.06		180	-3.0	67.5	2.8	1.0	1.0	620			
35 /51	Sa	17	H	2.5	1.75		250	-3.0	90	6.5	2.5	0.4	1050	420		
35A5	B	123	H	35.0	0.15		200	-8.0	110	41.0	2.0	40000	5900		4500	3.3
35L6G/GT	B	90	H	35.0	0.15		110	-7.5	110	40.0	3.0	13800	5800		2500	1.5
35S	Sa	17	H	2.5	1.75		250	-3.0	90	6.5	2.5	0.4	1050	420		
35Y4	Rh	105	H	35.0	0.15	con	125			50						
35Z3	Rh	104	H	35.0	0.15	con	235			100						
35Z4-GT	Rh	56	H	35.0	0.15	con	125			100						
35Z5G/GT	Rh	57	H	35.0	0.15	con	235			100						
35Z6G	Rd	86	H	35.0	0.3		125			110						

Number	TUBE		CATHODE			NOTES	CHARACTERISTICS (Continued)							OUTPUT	
	Type	Socket	Kind	Volts	Amps		Ep	Eg	Es	Ip	Is	Rp	Gm-Gc	Mu	Load
36	8a	17	H	6.3	0.3		250	-3.0	90	3.2	1.7	0.55	1080		
37	7a	13	H	6.3	0.3		250	-18.0		7.5		8400	1100	9.2	
38	6b	18	H	6.3	0.3		250	-25.0	250	22.0	3.8	0.1	1200		10000 2.5
39/44	6a	18	H	6.3	0.3		250	-3.0	90	5.8	1.4	0.8	1050		
40	7a	4	F	5.0	0.25		180	-3.0		0.2		0.15	200	30	
901 40Z5-GT	9b	57	H	45.0	0.15		125			100					
41	6b	27	H	6.3	0.4		250	-18.0	250	32.0	5.5	68000	2300		7600 3.4
42	6b	27	H	6.3	0.7		250	-16.5	250	34.0	6.5	80000	2500		7000 3.2
43	6b	27	H	25.0	0.3		135	-20.0	135	37.0	8.0	35000	2450		4000 2.0
45	7b	4	F	2.5	1.5		250	-50.0		34.0		1610	2175	3.5	3900 1.6
45Z3	9b	67	H	45.0	0.075		117			65					
45Z5-GT	9b	57	H	45.0	0.15	oon	235			100					



Number	TUBE		CATHODE			NOTES	CHARACTERISTICS (Continued)							OUTPUT		
	Type	Socket	Kind	Volts	Amps		Ep	Eg	Es	Ip	Is	Rp	Gm-Gc	Mu	Load	Watts
53	TTb	37	H	2.5	2.0	C1-B	300	0		17.5					8000	10.0
55 /S	TDD	31	H	2.5	1.0		250	-20.0		8.0		7500	1100	8.3	20000	0.35
56 /S	Ta	13	H	2.5	1.0		250	-13.5		5.0		9500	1450	13.8		
56AS	Ta	13	H	6.3	0.4		250	-13.5		5.0		9500	1450	13.8		
57 /S	Pa	35	H	2.5	1.0		250	-3.0	100	2.0	0.5	1.0 +	1225	1500		
57AS	Pa	35	H	6.3	0.4		250	-3.0	100	2.0	0.5	1.0 +	1225	1500		
58 /S	Pa	35	H	2.5	1.0		250	-3.0	100	8.2	2.0	0.8	1600	1280		
58AS	Pa	35	H	6.3	0.4		250	-3.0	100	8.2	2.0	0.8	1600	1280		
59	Pb	36	H	2.5	2.0		250	-18.0	250	35.0	9.0	40000	2500	100	6000	3.0
70A7-GT	PR	147	H	70.0	0.15	pen rec	110 125	-7.5	110	40.0 60	3.0		5800	80	2500	1.5
70L7-GT	BR	148	H	70.0	0.15	amp rbc	110 117	-7.5	110	40.0 70	3.0	15000	7500		2000	1.8

Number	TUBE		CATHODE			NOTES	CHARACTERISTICS (Continued)							OUTPUT		
	Type	Socket	Kind	Volts	Amps		Ep	Eg	Es	Ip	Is	Rp	Gm-Gc	Mu	Load	Watts
71-A	Tb	4	F	5.0	0.25		180	-43.0		20.0		1750	1700	3.0	4800	0.79
75 /S	TDD	31	H	6.3	0.3		250	-2.0		0.9		91000	1100	100		
75-30	VR	55	C				75			5-30						
76	Ta	13	H	6.3	0.3		250	-13.5		5.0		9500	1450	13.8		
77	Pa	35	H	6.3	0.3		250	-3.0	100	2.3	0.5	1.0 +	1250			
78	Pa	35	H	6.3	0.3		250	-3.0	100	7.0	1.7	0.8	1450			
79	TTb	34	H	6.3	0.6	C1-B	250	0		10.5					14000	8.0
80	Rf	7	F	5.0	2.0	con chk	350 500			125 125						
81	Rh	1	F	7.5	1.25	con	700			85						
82	Rf	7	F	2.5	3.0	con chk	450 550			115 115						
83	Rf	7	F	5.0	3.0	con chk	450 550			225 225						



TUBE Number	TUBE Type	Socket	CATHODE		NOTES	CHARACTERISTICS (Continued)								OUTPUT			
			Kind	Volts		Amps	Ep	Eg	Es	Ip	Is	Rp	Gm-Gc	Mu	Load	Watts	
83-V	Rf	8	H	5.0	2.0	con 375 chk 500					175 175						
84/6Z4	Rf	12	H	6.3	0.5	con 325 chk 450					60 60						
85	TDD	31	H	6.3	0.3	250	-20.0			8.0		7500	1100	8.3	20000	0.35	
85AS	TDD	31	H	6.3	0.3	250	-9.0			4.5		16000	1250	20			
89	Pb	35	H	6.3	0.4	250	-25.0	250	32.0	5.5	70000	1800	125	6750	3.4		
90-30	VR	55	C					90		10-30							
99-V	Ta	5	F	3.3	0.06	90	-4.5			2.2		14000	475	6			
99-X	Ta	4	F	3.3	0.06	90	-4.5			2.2		14000	475	6			
105-30	VR	55	C					105		5-30							
117L7/M7	BR	149	H	117	0.09	amp 105 rec 117	-5.2	105	43.0	4.0	17000	5300		4000	0.85		

110

Number	TUBE		CATHODE			NOTES	CHARACTERISTICS (Continued)							OUTPUT		
	Type	Socket	Kind	Volts	Amps		Ep	Eg	Es	Ip	Is	Rp	Gm-Gc	Mu	Load	Watts
117N7-GT	BR	150	H	117	0.09	amp rec 117	100	-6.0	100	51.0 75	5.0	16000	7000		3000	1.2
117P7-GT	BR	150	H	117	0.09	amp rec 117	105	-5.2	105	43.0 75	4.0	17000	5300		4000	0.85
117Z4-GT	Rh	56	H	117	0.04		117			90						
117Z6G/GT	Rd	86	H	117	0.075		117			60						
111 150-30	VR	55	C				150			5-30						
182B/482B	Tb	4	F	5.0	1.25		250	-35.0		20.0		2500	2000	5	4500	1.35
183/483	Tb	4	F	5.0	1.25		250	-65.0		20.0		2000	1500	3	4500	1.8
210-T	See 10															
485	Ta	13	H	3.0	1.25		180	-9.0		5.8		8900	1400	12.5		
840	Pa	9	F	2.0	0.13		180	-3.0	67.5	1.0	0.7	1.0	400	400		
864	Ta	4	F	1.1	0.25		135	-9.0		3.5		12700	645	8.2		

Number	TUBE		CATHODE			NOTES	CHARACTERISTICS (Continued)							OUTPUT		
	Type	Socket	Kind	Volts	Amps		Ep	Eg	Es	Ip	Is	Rp	Gm-Gc	Mu	Load	Watts
874	VR	2	C			90										
950	Pb	15	F	2.0	0.12	135	-16.5	135	7.0	2.0	0.125	1000	125	13500	0.575	
954	Pa	198	H	6.3	0.15	250	-3.0	100	2.0	0.7	1.0 +	1400				
955	Tb	194	H	6.3	0.15	180	-5.0		4.5		12500	2000	25	20000	0.135	
956	Pa	198	H	6.3	0.15	250	-3.0	100	6.7	2.7	0.7	1800				
957	Ta	195	F	1.25	0.05	135	-5.0		2.0		20800	650	13.5			
958 /A	Ta	195	F	1.25	0.10	135	-7.5		3.0		10000	1200	12			
959	Pa	197	F	1.25	0.05	135	-3.0	67.5	1.7	0.4	0.8	600				
991	VR	183	C			48-67										
1204	Pa	146	H	6.3	0.15	250	-2.0	100	4.0	1.3	0.8	1800				
1221	Pa	35	H	6.3	0.3	250	-3.0	100	2.0	0.5	1.0 +	1225				
1223	Pa	96	H	6.3	0.3	250	-3.0	100	2.0	0.5	1.0 +	1225				

Number	TUBE		CATHODE			NOTES	CHARACTERISTICS (Continued)						OUTPUT		
	Type	Socket	Kind	Volts	Amps		Ep	Eg	Es	Ip	Is	Rp	Gm-Gc	Mu	Load
1231	Pa	124	M	6.3	0.45	300	cath	150	10.0	2.5	0.7	5500			
1284	Pa	107	H	12.6	0.15	250	-3.0	100	9.0	2.5	0.8	2000			*
1293	Ta	64	F	1.4	0.11	90	0		4.7		10750	1300	14		
1602	Tb	4	F	7.5	1.25	425	-40		18.0		5000	1600		10200	1.6
1603	Pa	35	H	6.3	0.3	250	-3.0	180	8.3	2.1	0.9	2000			
1609	Pa	15	F	1.1	0.25	135	-1.5	67.5	2.5	0.65	0.4	725			
1611	See 6F6														
1612	M5	103	H	6.3	0.3	250	-3.0	100	2.4	7.1	1.0 +	375			
1620	Pa	96	H	6.3	0.3	250	-3.0	100	2.0	0.5	1.0 +	1225			
1621	Pb	91	M	6.3	0.7	p-p 300	-30.0	300	38.0	6.5				4000	5.0
1622	B	90	H	6.3	0.9	p-p 300	-20.0	250	86.0	4.0				4000	10.0
1629	I	92	H	12.6	0.15	tri 250 tar 250	0		0.24 4.0						

Number	TUBE		CATHODE			NOTES	CHARACTERISTICS (Continued)							OUTPUT	
	Type	Socket	Kind	Volts	Amps		Ep	Eg	Es	Ip	Is	Rp	Gm-Gc	Mu	Load
1631	B	90	H	12.6	0.45	250	-14.0	250	72.0	5.0	22500	6000		2500	6.5
						p-p 270	-17.5	270	134	11	23500	5000		17.5	
1632	B	90	H	12.6	0.6	100	-7.5	110	49.0	4.0	13000	9000		2000	2.1
1633	TTa	142	H	25.0	0.15	250	-8.0		11.5		6900	2600	18		
1634	TTa	132	H	12.6	0.15	250	-2.0		2.0		53000	1325	70		
1635	TTb	131	H	6.3	0.6	C1-B 300	0							12000	10.4
1642	TTa	43	H	6.3	0.6	250	-16.5		8.3		7600	1375	10.4		
1644	PPt	152	H	12.6	0.15	180	-9.0	180	13.0	2.8	0.16	2150		10000	1.0
1851	Pa	96	H	6.3	0.45	300	oath	150	10.0	2.5	0.1	9000			
7000	Pa	96	H	6.3	0.3	250	-3.0	100	2.0	0.5	1.0 +	1225			
7193	Ta	184	H	6.3	0.3	300	-10.5		11.0		6600	3000	20		
7700	Pa	35	H	6.3	0.3	250	-3.0	100	2.0	0.5	1.0 +	1225			
9001	Pa	82	H	6.3	0.15	250	-3.0	100	2.0	0.7	1.0 +	1400			

Number	TUBE		CATHODE			NOTES	CHARACTERISTICS (Continued)							OUTPUT	
	Type	Socket	Kind	Volts	Amps		Ep	Eg	Es	Ip	Is	Rp	Gm-Gc	Mu	Load
9002	Ta	70	H	6.3	0.15	250	-7.0		6.3		11400	2200	25		
9003	Pa	82	H	6.3	0.15	250	-3.0	100	6.7	2.7	0.7	1800			
9004	D	192	H	6.3	0.15	117			5.0						
9005	D	193	H	3.6	0.165	117			1.0						
9006	Rh	65	H	6.3	0.15	270			5.0						

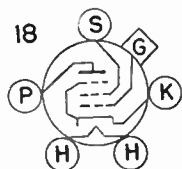
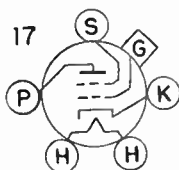
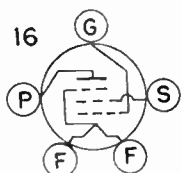
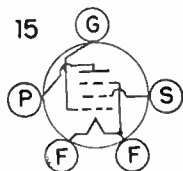
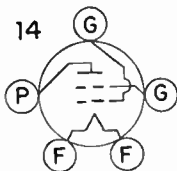
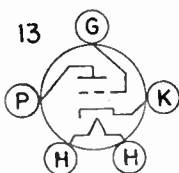
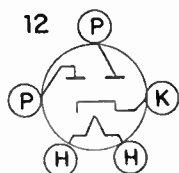
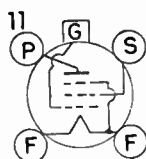
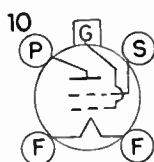
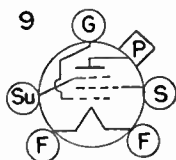
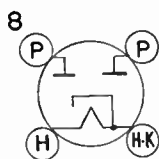
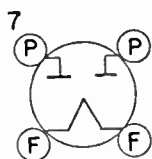
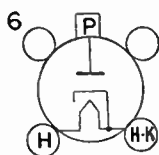
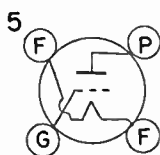
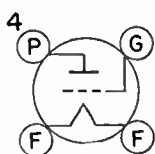
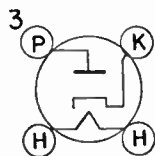
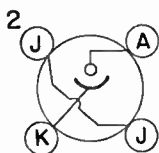
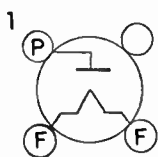

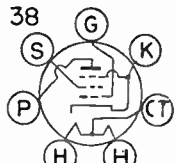
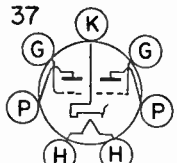
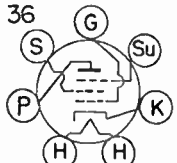
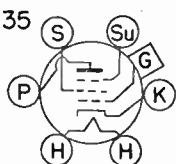
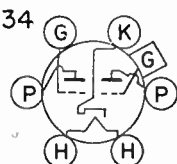
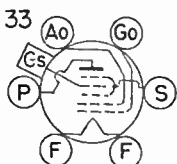
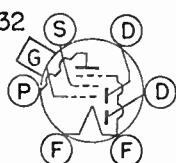
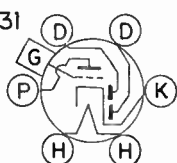
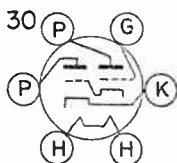
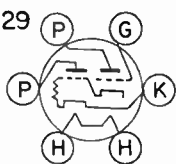
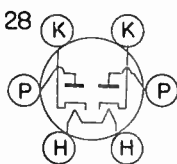
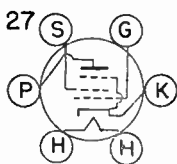
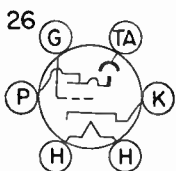
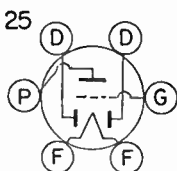
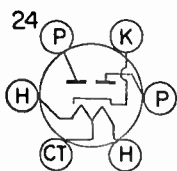
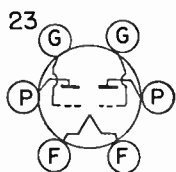
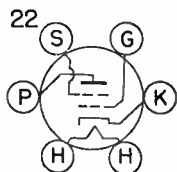
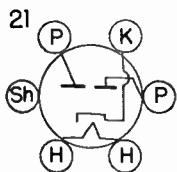



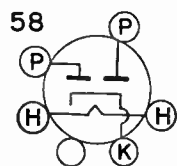
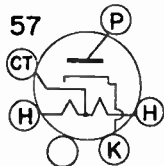
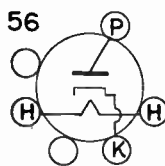
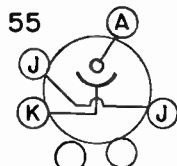
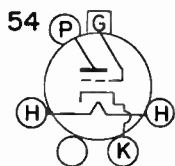
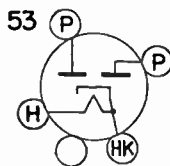
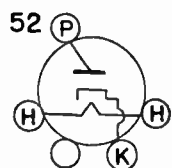
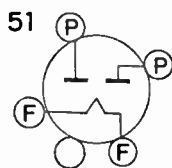
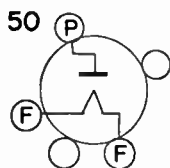
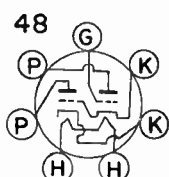
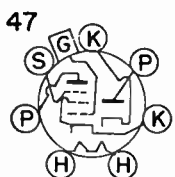
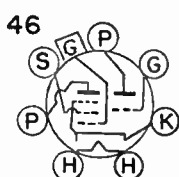
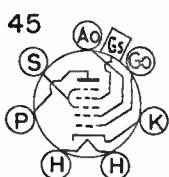
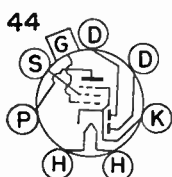
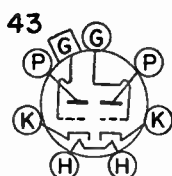
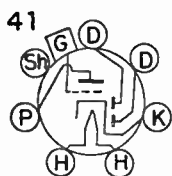

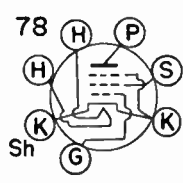
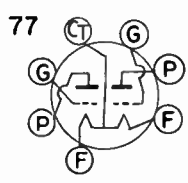
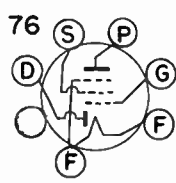
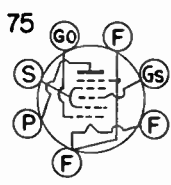
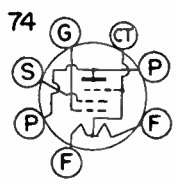
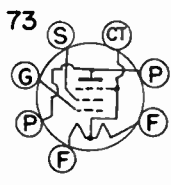
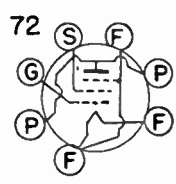
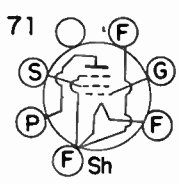
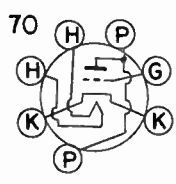
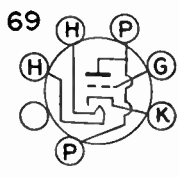
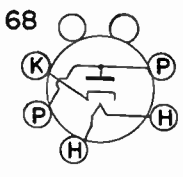
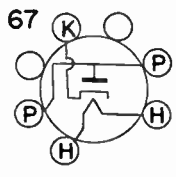
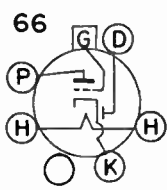
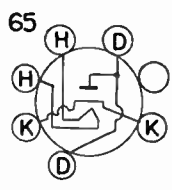
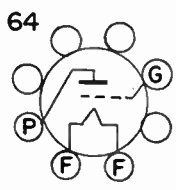
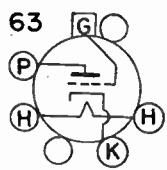
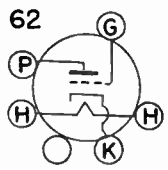
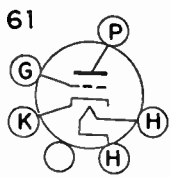

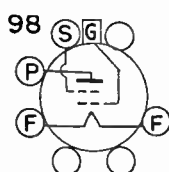
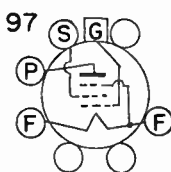
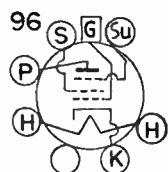
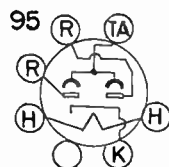
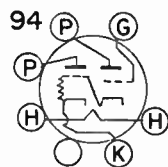
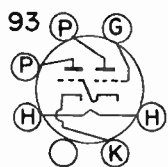
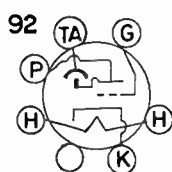
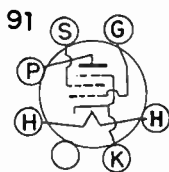
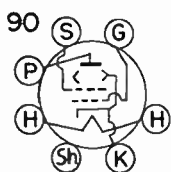
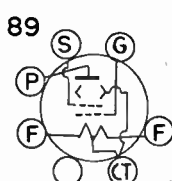
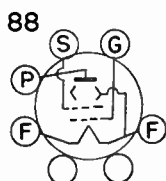
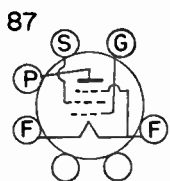
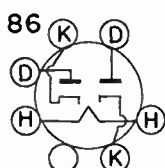
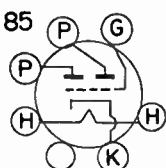
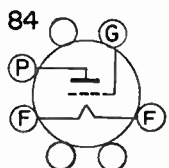
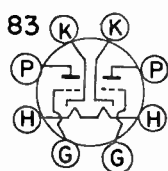
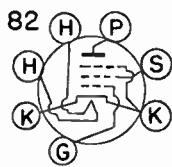
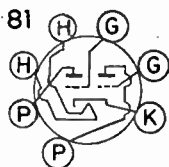

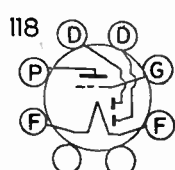
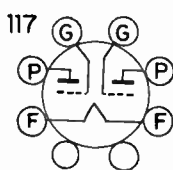
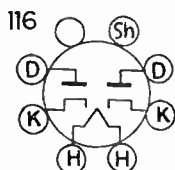
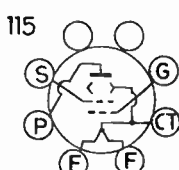
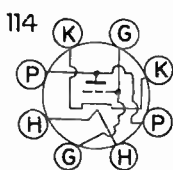
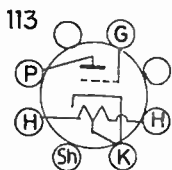
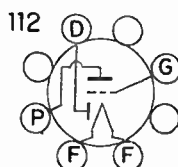
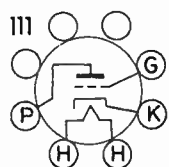
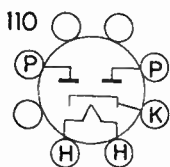
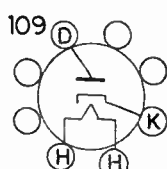
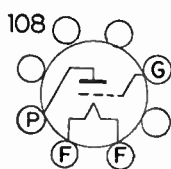
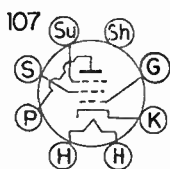
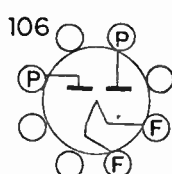
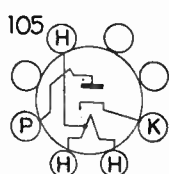
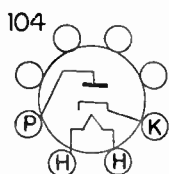
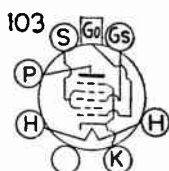
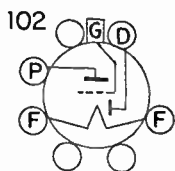
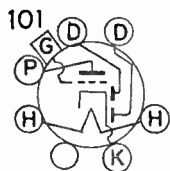

121

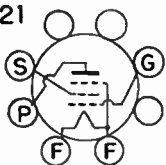

122

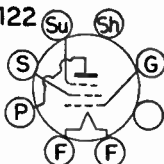

123

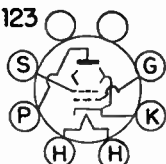

124

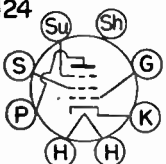

125

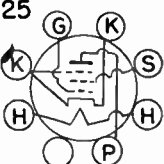

126

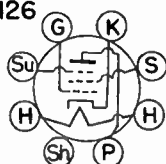

127

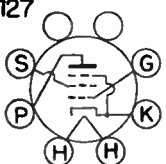

128

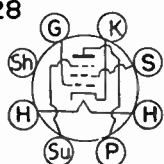

129

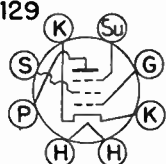

130

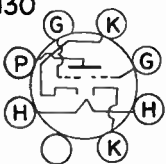

131

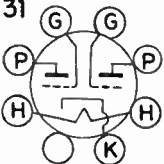

132

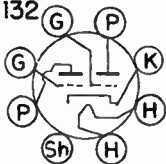

133

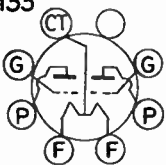

134

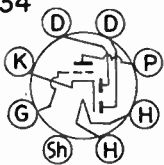

135

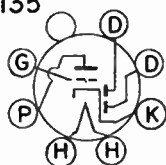

136

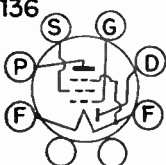

137

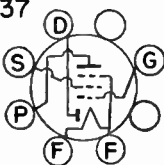

138

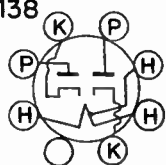

141

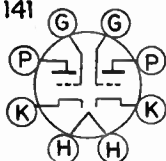

142

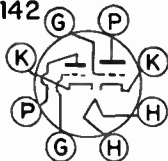

143

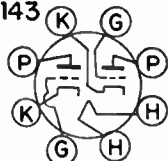

144

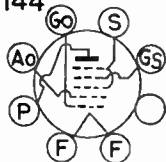

145

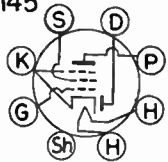

146

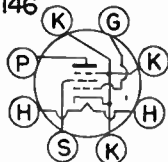

147

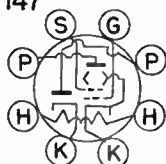

148

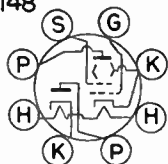

149

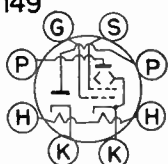

150

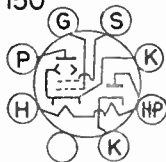

151

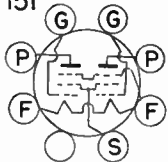

152

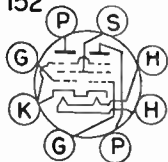

153

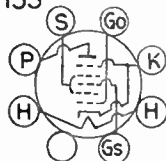

154

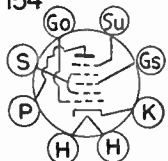

155

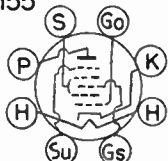

156

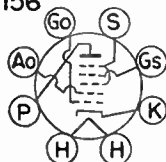

157

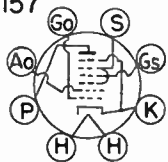

158

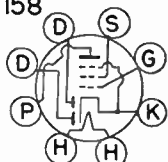

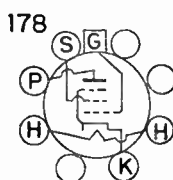
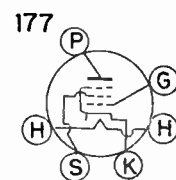
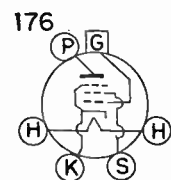
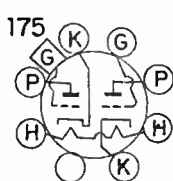
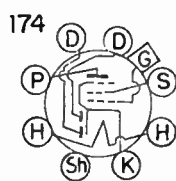
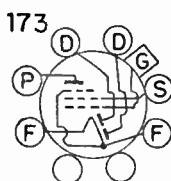
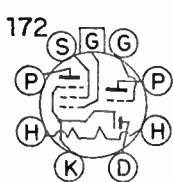
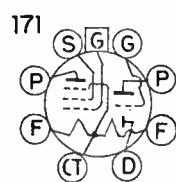
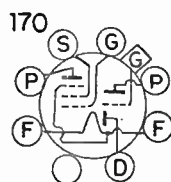
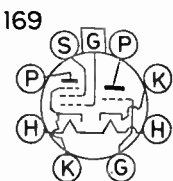
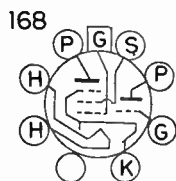
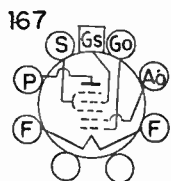
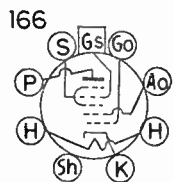
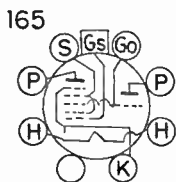
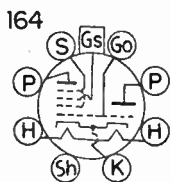
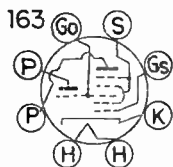
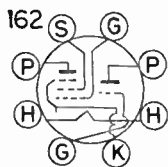
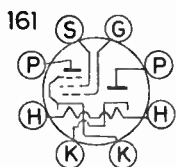

181

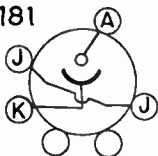

182

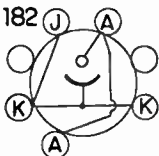

183



184

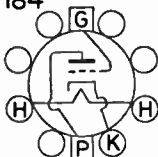

185

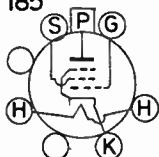

186

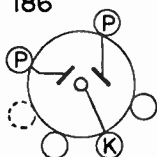

187

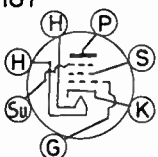

188

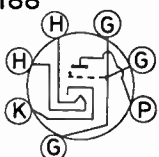

189

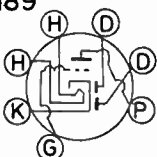

190

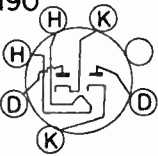

191

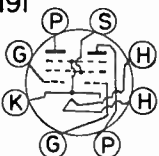

192

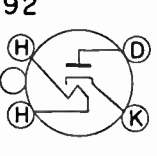

193

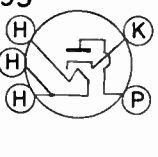

194

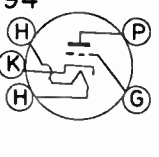

195

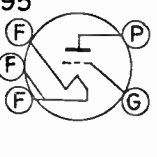

196

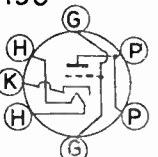

197

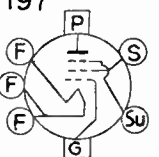

198

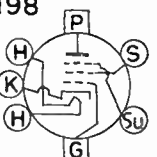



## REPLACEMENT TUBES

The table of *Replacement Tubes* lists original and replacement types which have the same or equivalent characteristics, but which require the indicated changes of sockets, socket wiring, or filament or heater voltage. The internal capacitances usually are different in the original and replacement types, which necessitates re-alignment and other readjustments.

In the column headed *Socket Type* are shown the number of pin holes for the original and replacement types, also changes between locking types (abbreviated *lok*) and octal types.

The column headed *Socket Wiring* shows wiring changes as indicated by the numbered diagrams of base or socket connections, which follow the earlier *Tube Table*. The first of the two listed numbers is that of the diagram for the original tube; the second is that of the diagram for the replacement tube.

Changes of filament or heater voltage always mean an accompanying change of current. The currents are shown in the *Tube Table*. A star (\*) in this column indicates a change of current with no change of required voltage.

## REPLACEMENT TUBES

ORIGINAL Tube	REPLACEMENT Tube	Socket Type	REQUIRED CHANGES	
			Socket Wiring	Filt or Htr Voltage
1A4P	1D5GP	5 to 8	11 to 97	
1A5GT/G	1LA4	to lok	87 to 121	
1A6	1D7G	6 to 8	33 to 167	
1B4P	1E5GP	5 to 8	11 to 97	
1B5/25S	1H6G	6 to 8	25 to 118	
1C6	1C7G	6 to 8	33 to 167	
1F4	1F5G	5 to 8	15 to 87	
1F6	1F7G	6 to 8	32 to 173	
1H5GT	1LH4	8 to lok	102 to 112	
1LA4	1A5GT/G	lok to 8	121 to 87	
1LH4	1H5GT	lok to 8	112 to 102	
2A5	6F6G	6 to 8	27 to 91	2.5 to 6.3
2A6	6SQ7G	6 to 8	31 to 134	2.5 to 6.3
2A7/S	6A8	7 to 8	45 to 166	2.5 to 6.3
2B7/S	6B8G	7 to 8	44 to 174	2.5 to 6.3
2E5	6E5			2.5 to 6.3
3LF4	3Q5GT/G	lok to 8	115 to 89	
5U4G	5X4G		51 to 106	
5X4G	5U4G		106 to 51	
5Y3GT/G	5Y4G		51 to 106	
5Y4G	5Y3GT/G		106 to 51	
5Z3	5U4G	4 to 8	7 to 51	
6A3	6B4G	4 to 8	4 to 84	
6A6	6N7GT/G	7 to 8	37 to 131	
6A7/S	6A8	7 to 8	45 to 166	
6B5	6N6G	6 to 8	29 to 94	
6B6G	6SQ7		101 to 134	
6B7/S	6B8G	7 to 8	44 to 174	
6C6	6I7	6 to 8	35 to 96	
6D6	6U7G	6 to 8	35 to 96	
6D7	6I7	7 to 8	42 to 96	
6E7	6U7G	7 to 8	42 to 96	
6F5/G/GT	6SF5		54 to 61	

## RECEIVING TUBES

127

ORIGINAL Tube	REPLACEMENT Tube	Socket Type	REQUIRED CHANGES		Filt or Htr Voltage
			Socket Wiring		
6F7	6P7G	7 to 8	46 to 168		
6F8G	6J5		175 to 62		*
6SK7	7A7	8 to lok	126 to 111		
6SN7GT	6J5		142 to 62		*
6SQ7	6B6G		134 to 101		
6ST7	6SR7				*
6V6GT/G	7C5	8 to lok	90 to 123		
7A4	6J5	lok to 8	111 to 62		
7A7	6SK7	lok to 8	111 to 126		
7B4	6SF5	lok to 8	111 to 61		
7B5	6K6GT/G	lok to 8	127 to 91		
7B6	6SQ7	lok to 8	135 to 134		
7B8	6A8	lok to 8	156 to 166		
7C5	6V6GT/G	lok to 8	123 to 90		
7E6	6R7	lok to 8	135 to 101		
7F7	6SL7GT	lok to 8	141 to 142		
7V7	7W7		124 to 129		
7W7	7V7		129 to 124		
12A8GT	6A8G				12.6 to 6.3
12C8	6B8				12.6 to 6.3
12F5GT	6F5				12.6 to 6.3
	6SF5		54 to 61		12.6 to 6.3
12H6	6H6				12.6 to 6.3
12J5GT	6J5G/GT				12.6 to 6.3
12J7GT	6J7G				12.6 to 6.3
12K7GT	6K7G				12.6 to 6.3
12K8	6K8				12.6 to 6.3
12Q7GT	6Q7G				12.6 to 6.3
12SA7/G/GT	6SA7/G/GT				12.6 to 6.3
12SC7	6SC7				12.6 to 6.3
12SF5GT	6SF5				12.6 to 6.3
12SF7	6SF7				12.6 to 6.3
12SG7	6SG7				12.6 to 6.3
12SH7	6SH7				12.6 to 6.3
12SI7GT	6SI7				12.6 to 6.3
12SK7	6SK7				12.6 to 6.3
12SL7GT	6SL7GT				12.6 to 6.3
12SQ7/G/GT	6SQ7/G/GT				12.6 to 6.3
12SR7	6SR7				12.6 to 6.3
14 types	See Note				12.6 to 6.3
18	6F6G	6 to 8	27 to 91		12.6 to 6.3
19	1J6G	6 to 8	23 to 117		
25B5	25N6G	6 to 8	30 to 93		
25C6G	6Y6G				25 to 6.3
25L6	50L6				25 to 50
25Z5	25Z6G/GT	6 to 8	28 to 86		
30	1H4G	4 to 8	4 to 84		
35A5	35L6GT/G	lok to 8	123 to 90		
35Y4	35Z5G	lok to 8	105 to 57		
35Z3	35Z4GT	lok to 8	104 to 56		
35Z5GT/G	40Z5/GT				35 to 45
40Z5GT	35Z5GT/G				45 to 35
41	6K6GT/G	6 to 8	27 to 91		
42	6F6G	6 to 8	27 to 91		
43	25A6GT/G	6 to 8	27 to 91		
45Z5GT	35Z5GT/G				45 to 35
50C6G	25C6G				50 to 25
50L6GT	25L6GT				50 to 25
50Y6GT/G	25Z6GT/G				50 to 25
53	6N7GT/G	7 to 8	37 to 131		2.5 to 6.3
55/S	6V7G	5 to 8	31 to 101		2.5 to 6.3
56	6P5GT/G	5 to 8	13 to 62		2.5 to 6.3

ORIGINAL Tube	REPLACEMENT Tube	Socket Type	REQUIRED CHANGES	
			Socket Wiring	Filt or Htr Voltage
57	6J7	6 to 8	35 to 96	2.5 to 6.3
58	6U7G	6 to 8	35 to 96	2.5 to 6.3
75	6SQ7	6 to 8	31 to 134	
76	6P5GT/G	5 to 8	13 to 62	
78	6K7	6 to 8	35 to 96	
79	6Y7G	6 to 8	34 to 131	
80	5Y3GT/G	4 to 8	7 to 51	
83-V	5V4G	4 to 8	8 to 53	
85	6V7G	6 to 8	31 to 101	
117P7GT	117L/M7-GT		150 to 149	
1221	1223	6 to 8	35 to 96	
1603	6J7	6 to 8	35 to 96	
1612	6L7			
1620	6J7			
1633	12SN7GT			25 to 12.6
1634	12SC7			
1851	6AC7/1852		96 to 126	

*Note:* Types whose numbers commence with 14 are equivalent to those commencing with 7 when remaining letters and figures are the same, and when heater voltage is changed from 12.6 to 6.3 or from 14 to 7.

#### GRID BIAS

Grid biasing potentials for radio-frequency and intermediate-frequency amplifying tubes most often are secured from the volume control circuit, which may be either automatic or manual. Biasing potentials for power amplifiers may be secured from the potential drop across a resistor in series with the cathode, called the cathode-bias or self-bias method, or may be taken from a negative point on the voltage divider system which is part of the d-c power supply for plate and screen potentials.

**Cathode-Bias.**—The biasing potential developed across a resistor in series with the cathode is equal to  $IR$ , where  $I$  is the combined plate and screen current (or total cathode current) in amperes, and  $R$  is the resistance in ohms of the biasing resistor.

An increase of plate current is accompanied by an increase of bias potential. This makes the control grid more negative, which opposes the increase of plate current. A decrease of plate current reduces the bias potential, thus making the control grid less negative, and the decrease of plate current is opposed. Because of these relations between plate current and control grid bias, the cathode-bias method tends to lessen the changes of plate current and to decrease the amplification.

Whenever potentials developed in the plate circuit react on the grid circuit to lessen the amplification, as is the case with cathode-bias, the action is called degeneration. A moderate amount of degeneration in audio-frequency amplifying circuits improves the fidelity, or prevents over-amplification of some frequencies, but

## CATHODE BIAS RESISTORS

TUBE TYPE	Kind	GRID BIAS volts	Plate Volts	Screen Volts	CATHODE Milli-amperes	BIAS RESISTOR Ohms
1L4	Pentode	0	90	90	6.5	0
1R5	Converter	0	90	45	2.75	0
1S5	Pentode	0	90	90	2	0
1T4	Pentode	0	90	45	2.45	0
3Q4	Pentode	- 4.5	90	90	11.6	400
3S4	Pentode	- 7	90	67½	8.8	800
6AC7	Pentode	- 2	300	150	12.5	160
6J5	Triode	- 8	250		9	900
6K6	Pentode	-18	250	250	37.5	500
6L6	Beam power	-14	250	250	80	175
6SA7	Converter	- 2	250	100	12.5	160
6SC7	Triode (2)	- 2	250		4 *	500
6SF7	Pentode	- 1	250	100	15.7	65
6SG7	Pentode	- 2.5	250	150	12.6	200
6SH7	Pentode	- 1	250	150	14.9	.70
6SJ7	Pentode	- 3	250	100	3.8	800
6SK7	Pentode	- 3	250	100	11.8	260
6SL7	Triode (2)	- 2	250		4.6 <sup>†</sup>	440
6SN7	Triode (2)	- 8	250		9 *	900
6SQ7	Triode	- 2	250		0.9	2200
6SR7	Triode	- 9	250		9.5	950
6V6	Beam power	-12.5	250	250	49.5	250
12SA7	Converter	- 2	250	100	12.5	160
12SG7	Pentode	- 2.5	250	150	12.6	200
12SK7	Pentode	- 3	250	100	11.8	260
12SQ7	Triode	- 2	250		0.9	2200
25L6	Beam power	- 8	200	110	52	150
35L6	Beam power	- 8	200	110	43	185
50L6	Beam power	- 8	200	110	52	150

\* Total cathode current for both sections of twin tube.

does so at the expense of some loss in amplification or gain.

The degenerative effect is lessened by bypassing the bias resistor with a capacitor. The greater the capacitance of the bypassing capacitor the smaller are the variations in resistor current and the smaller are the variations in bias potential. When degeneration is desired in audio-frequency amplifiers the bypass capacitor may be omitted. Sometimes only a portion of the biasing resistor is bypassed and the remainder is allowed to cause degeneration to some extent. Bypass capacitors always are used when r-f or i-f tubes are provided with cathode-bias.

The required resistance for a biasing resistor is found as follows:

$$\text{Ohms} = \frac{1000 \times \text{volts of grid bias}}{\text{cathode current, milliamps.}}$$

The cathode current for triodes is equal to the plate current. For pentodes and other tubes having screen grids the cathode current is equal to the sum of the plate and screen currents.

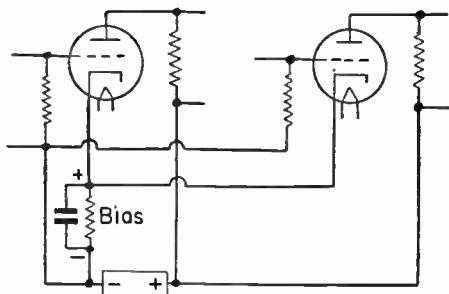

Fig. 6-1. Single biasing resistor for two tubes.

As an example, the *Tube Table* shows for a 6V6 tube a plate current of 45 milliamperes and a screen current of 4.5 milliamperes, making a total cathode current of 49.5 milliamperes. The grid bias is shown as  $-12.5$  volts. Using these values in the formula gives,

$$\text{Ohms} = \frac{1000 \times 12.5}{49.5} = 252.5$$

Since no standard fixed resistor has a value of 252.5 ohms we use a 250-ohm resistor. Resistances within 5 or 10 per cent of the computed values are satisfactory, depending on the closeness of bias potential desired.

The accompanying table, *Cathode Bias Resistors*, lists popular types of tubes together with commonly used

grid bias voltages, plate voltages and screen voltages, and gives the biasing resistances which correspond to the other values.

If two or more tubes of the same type require the same bias potential, a single biasing resistor may be used as in Fig. 6-1. The cathode current for the bias resistor is the sum of the cathode currents for all the biased tubes, or is the sum of all the plate currents and screen currents.

Tubes having filament-cathodes are provided with cathode-bias as shown by Fig. 6-2 when alternating current is used for filament heating. To a center tap *T* on the filament winding of the power transformer is connected the biasing resistor *R* and its bypass capacitor. The direction of electron flow in the plate circuit is shown by arrows. The potential drop in resistor *R* is in such direction as to make the upper end negative with reference to the lower end. The control grid, connected to the upper end of the bias resistor through the grid circuit, is provided with negative bias with reference to the filament-cathode which is connected to the lower end of the resistor through the transformer winding.

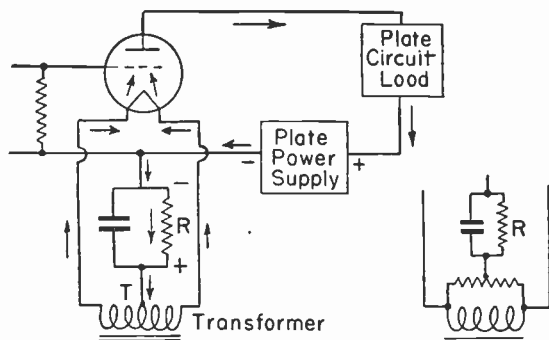

Fig. 6-2. Filament-cathode biasing with a-c heating.

If the filament supply transformer has no center tap on the winding, the bias resistor and its bypass capacitor may be connected, as shown by the small diagram of Fig. 6-2, to the center of another resistor connected between the ends of the transformer winding, or anywhere between the two sides of the filament circuit. The center-tapped resistor usually has a resistance which allows flow through it of about  $\frac{1}{4}$  ampere of current when there is no cathode current. That is, the resistance in ohms is about four times the number of volts of filament potential.

**Bias from Power Supply.**—Fig. 6-3 shows a direct-current power supply furnishing a terminal potential difference of 260 volts, to which are connected in series the resistors *A-B-C-D*. Resistances and currents in this system are of such values that there is a 100-volt drop through section *A*, a 150-volt drop through section *B*, and 5-volt drops through each of sections *C* and *D*. With reference to the negative side of the power supply the potentials at points between resistors are as shown.

The cathodes of the two tubes are connected to the 10-volt point in the power supply resistor system. The grid circuit of the left-hand tube is connected to the zero point, which makes the cathode 10 volts more positive than the grid, makes the grid 10 volts more negative

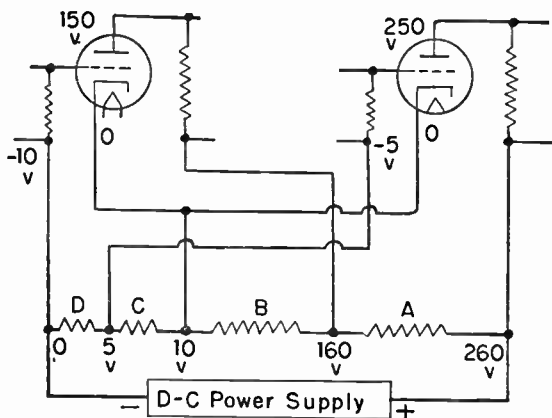

Fig. 6-3. Biasing from a d-c power supply.

than the cathode, and gives this tube a 10-volt negative bias for its grid. Incidentally, the plate is connected to 160 volts on the power system, making the plate potential 150 volts positive with reference to the cathode. The grid circuit of the right-hand tube is connected to the 5-volt point on the power supply resistor system, making the cathode 5 volts more positive than the grid, the grid 5 volts more negative than the cathode, and providing a 5-volt negative bias for the grid. The plate of this tube is connected to 260 volts on the power supply, so the plate is 250 volts more positive than the cathode.

By appropriate choices of resistance values it is possible with this method to provide any desired negative biases for the grids of any number of tubes. With a correctly designed system there is but small change in

current through the resistors which provide the biases, and the bias voltages remain almost constant during usual variations of plate currents in the tubes.

**Grid Leak-Capacitor Bias.**—A capacitor  $C$  and a grid leak or grid resistor  $R$  connected as in Fig. 6-4 between the control grid and cathode of a tube will provide a negative grid bias when alternating current or potential is introduced into the grid circuit. Grid-leak bias is used

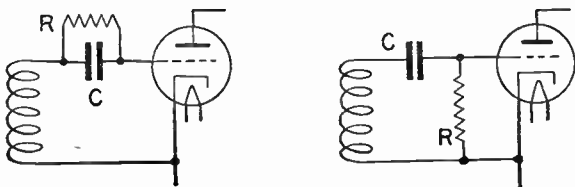

Fig. 6-4. Biasing with grid leak and capacitor.

for some types of detectors, for some types of radio-frequency power amplifiers, and for many types of oscillators, but seldom is found in present-day receivers.

The capacitor is charged by the positive pulses of grid circuit alternating potential, but cannot discharge through the tube because electron flow does not take place from a cold grid to a hot cathode. Consequently,

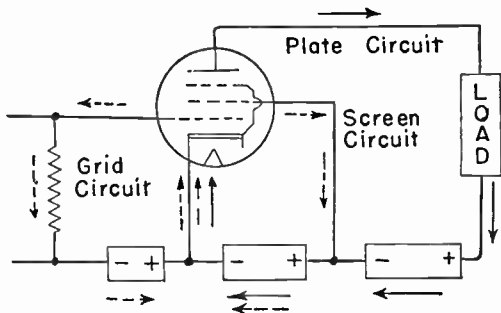

Fig. 6-5. The circuits in which returns are to the cathode.

the capacitor discharges only through the leak resistance. The rate of discharge depends on the applied a-c potential, and resulting capacitor charge potential, and on the resistance of the leak resistor. The capacitor potential remains negative on the grid side, and there is a potential drop across the resistor which maintains the grid negative so long as the a-c potential is applied to the circuit. To maintain a negative bias, the time constant (microfarads times megohms) of the capacitor-



resistor combination must be several times as long as the period (1 divided by frequency in c.p.s.) of the applied alternating potential.

**Cathode Returns.**—Circuits for the various elements in a tube are shown by Fig. 6-5. Electron flow in the plate circuit would be considered as starting from the cathode and as going through the tube space, the load, the power supply, and back to the cathode. In the screen circuit the flow would be from cathode to screen, then through part of or all of the power supply and back to the cathode. In the grid circuit any flow would be from cathode to grid, then through the input resistance, the grid bias supply, and back to the cathode. All element circuits start from the cathode and all must return to the cathode.

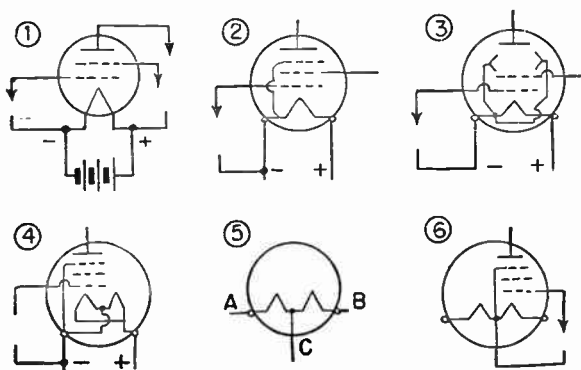

Fig. 6-6. Returns for filament-cathodes with d-c heating.

Because even small variations of grid potential are amplified in the plate circuit it is important that the grid circuit be correctly returned to the cathode in order to avoid hum and other troubles. Fig. 6-6 illustrates some points to be observed with tubes having filament-cathodes which are heated with direct current from either a battery or some other power source. As at 1 the grid return always should be made to the negative end of the filament-cathode, although plate and screen circuit returns may be made to the positive end. The average potential of the filament-cathode is equal to the potential at its center. With the grid return to the negative end, there is a negative grid bias equal to half of the potential drop through the filament-cathode, or to the drop from the center to the negative end.

When a suppressor grid is connected to one end of the filament, as at 2 in Fig. 6-6, or when beam forming

plates are so connected, as at 3, the end of the filament to which these elements are connected should be attached to the negative side of the power supply, and the grid circuit return should be made to this end.

Filament-cathodes often are arranged in two sections, as at 4, with the sections connected in parallel to the base pins. The grid circuit return should be made to whichever pin is negative. If a suppressor grid or beam plates are connected to one of the pins, that pin should be the negative one. Two sections of the filament cathode may be center-tapped as at 5, thus permitting the sections to be operated either in series or in parallel on the power supply. With the power supply connected only to *A* and *B* with *C* left open, the sections would be in series. With *A* and *B* connected together and to one side of the power supply, and with *C* connected to the other side of the power supply, the sections would

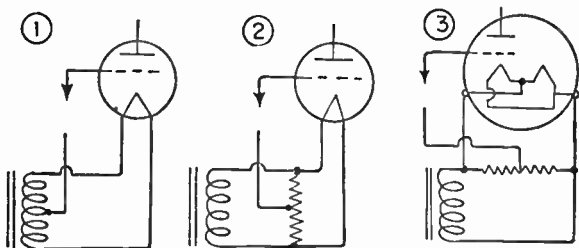

Fig. 6-7. Returns for filament-cathodes with a-c heating.

operate in parallel. The applied filament potential for parallel operation should be half that for series operation, and the parallel current would be double that with the series connection. For example, in parallel operation the filament-cathode might take 0.1 ampere at 1.4 volts, and in series take 0.05 ampere at 2.8 volts. The power, equal to  $I \times E$ , is the same in both cases. In diagram 6 the center tap of the filament-cathode is connected internally to a suppressor grid. The grid circuit return would be made to this center tap pin.

Fig. 6-7 shows filament-cathodes heated by alternating current from the winding of a transformer. While the potentials at the ends of the winding alternate, the potential at the center of the winding remains constant at the average value of the end potentials, which always is zero. The grid circuit return is made to this constant zero potential point as at 1, or may be made, as at 2, to a center-tapped resistor of 25 to 50 ohms resistance connected across the transformer winding or across the filament-cathode pins of the tube. The potential at the center of such a tapped resistor remains constant and of

zero value. With two filament-cathode sections in parallel, as at 3, the grid circuit return is made to a center-tapped resistor as shown, or else to a center-tapped transformer winding.

With tubes having heater-cathodes the grid circuit return always is made to the base pin which connects directly to the cathode in the tube. A few of the many cathode and heater connections found in cathode-heater tubes are shown by Fig. 6-8. The simplest and most

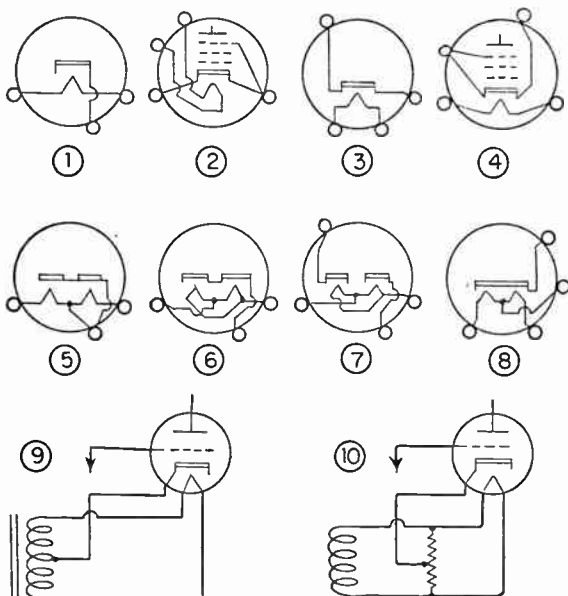

Fig. 6-8. Connections used in heater-cathode tubes.

common arrangement is at 1. At 2 the cathode is connected to two pins, and the suppressor grid to one of them. Another connection of the cathode to two pins is shown at 3, and still another at 4. At 5 the heater is in two sections, with the cathode connected to a midpoint between the sections as well as to its base pin. At 6 and 7 two sections of the heater are operated in parallel. At 8 the two sections of the heater may be operated in series, with the power supply connected to the outer ends, or in parallel with both outer ends connected to one side of the power supply and the center tap between sections connected to the other end of the power supply.

Although the cathode is well insulated, electrically, from the heater, it is possible for electron emission from the heater to flow to the cathode if there is too much potential difference between the two parts. To maintain the cathode and the average value of heater potential at the same value the cathode may be connected to a center tap on the heater winding, as at 9 in Fig. 6-8, or to a center-tapped resistor across the heater transformer or the heater pins of the tube, as at 10. In some circuits having high amplification the heater center tap and the cathode are connected to such points on the direct-current power supply system as will make the heater about 10 volts positive with respect to the cathode.

## LOAD LINES

A load line is a straight line drawn on a family of plate characteristics for a tube. The line passes through all the combinations of grid potential, plate potential, and plate current that can occur together while the tube

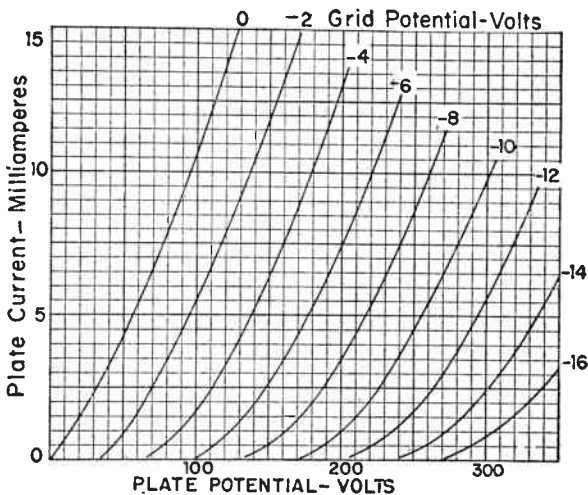

Fig. 6-9. Plate characteristics for a 6J5 tube.

is working with a plate circuit load of a certain number of ohms. Fig. 6-9 shows a family of plate characteristics for a 6J5 tube. Fig. 6-10 shows a 10,000-ohm load line for a plate supply potential of 200 volts. Load lines permit the solution of many practical problems which, without such a graphic method, would call for involved calculations. Load lines are especially useful when mak-

change of load potential, this 50 volts of plate potential means also 50 volts of load potential.

ing changes in receiver circuits and when making substitutions of tubes. They may be applied to the plate

144

## COYNE RADIO HANDBOOK

## MAGNET WIRE

GAGE No.	CURRENT CAPACITY Amperes		PLAIN ENAMEL COVERED—P.E.			
	Open Coil	Layer Winding	Diam. in.	Turns Linear Inch	Turns Square Inch	Ohms Cubic Inch
8	16.5	11.0	0.1306	7.65	58.5	0.00315
9	13.1	8.72	.1165	8.58	73.6	.00475
10	10.4	6.92	.1040	9.61	92.4	.00748
11	8.23	5.49	.0927	10.8	114	.01183
12	6.53	4.35	.0828	12.1	141	.0188
13	5.18	3.45	.0740	13.6	177	.0295
14	4.11	2.74	.0658	15.2	221	.0484
15	3.26	2.17	.0589	17.0	277	.0734
16	2.58	1.72	.0526	19.1	348	.116
17	2.05	1.36	.0469	21.5	437	.184
18	1.62	1.08	.0419	23.9	548	.291
19	1.29	.859	.0373	26.8	681	.456
20	1.022	.682	.0333	30.1	852	.720
21	.810	.540	.0297	33.7	1065	1.134
22	.642	.428	.0265	37.7	1340	1.800
23	.510	.339	.0237	42.3	1665	2.820
24	.404	.269	.0212	47.1	2100	4.49
25	.320	.214	.0190	52.9	2630	7.08
26	.254	.169	.0170	59.1	3320	11.27
27	.202	.134	.0152	66.2	4145	17.75
28	.160	.1065	.0135	74.1	5250	28.34
29	.127	.0778	.0122	83.3	6510	44.32
30	.1005	.0670	.0108	92.2	8175	70.15
31	.0797	.0531	.0096	103.4	10200	110.4
32	.0632	.0421	.0087	115	12650	172.6
33	.0501	.0334	.0077	130	16200	279.0
34	.0398	.0265	.0068	147	19950	433.2
35	.0315	.0210	.0062	162	25000	684.5
36	.0250	.0167	.0055	182	31700	1094
37	.0198	.0132	.0049	202	39600	1723
38	.0157	.0105	.0044	223	49100	2693
39	.0125	.0083	.0039	253	62600	4332
40	.0099	.0066	.0034	280	77600	6770
41	.0079	.0052	.0030	333	104000	11580
42	.0063	.0041	.0027	370	136000	17780
43	.0048	.0032	.0024	417	173000	26800
44	.0040	.0026	.0022	455	206000	42400

**MAGNET WIRE**

Single cotton enameled (S.C.E.), single cotton covered (S.C.C.), and double cotton covered (D.C.C.)

GAGE No.	S.C.E.		S.C.C.		D.C.C.	
	Turns Linear Inch	Turns Square Inch	Turns Linear Inch	Turns Square Inch	Turns Square Inch	Turns Square Inch
8	7.3	52	7.4	53	7.0	48
9	8.2	64	8.3	66	7.9	59
10	9.1	80	9.3	84	8.9	76
11	10.2	100	10.4	104	9.9	93
12	11.4	124	11.7	129	11.0	114
13	12.7	151	12.9	160	12.1	140
14	14.1	187	15.6	198	13.6	171
15	15.6	230	16.1	245	15.1	208
16	17.4	289	17.9	312	16.7	260
17	19.3	358	19.9	383	18.2	316
18	21.4	438	22.1	472	20.2	378
19	23.6	532	24.4	581	22.2	455
20	26.1	644	27.0	712	24.3	545
21	28.9	780	29.8	868	26.7	650
22	31.7	1008	33.0	1128	29.2	865
23	34.9	1220	36.2	1370	31.6	1030
24	38.1	1475	39.8	1665	34.4	1215
25	41.8	1790	43.6	2020	37.2	1420
26	45.7	2155	47.8	2445	40.1	1690
27	49.7	2590	52.0	2925	43.1	1945
28	54.0	3100	56.8	3500	46.2	2250
29	58.8	3660	61.3	4120	49.2	2560
30	63.0	4320	66.5	4900	52.5	2930
31	68.1	5120	71.9	5770	55.8	3330
32	73.2	5960	77.2	6700	59.9	3720
33	78.5	7020	82.8	7780	62.1	4140
34	84.0	8060	88.4	9010	65.3	4595
35	89.6	9200	94.3	10300	68.4	5070
36	95.2	10550	100.0	11750	71.4	5550
37	100.6	12000	105.8	13250	74.3	6045
38	106.4	13400	111.6	14900	77.1	6510
39	111.6	15150	117.2	16600	79.8	6935
40	116.6	16750	122.8	18400	82.3	7450

inch will be somewhat reduced. With random winding rather than exact layer winding the number of turns per square inch will be increased by an indefinite amount.

The tables for other insulations list turns per linear

**MAGNET WIRE**

Single silk enameled (S.S.E.), single silk covered (S.S.C.),  
and double silk covered (D.S.C.)

GAGE No.	S.S.E.		S.S.C.		D.S.C.	
	Turns Linear Inch	Turns Square Inch	Turns Linear Inch	Turns Square Inch	Turns Linear Inch	Turns Square Inch
16	18.4	326	18.9	351	18.2	327
17	20.5	408	21.2	437	20.3	405
18	22.8	505	23.6	548	22.6	503
19	25.4	622	26.3	682	25.1	619
20	28.4	769	29.4	848	27.8	761
21	31.6	946	32.7	1055	30.8	935
22	35.0	1175	36.6	1315	34.2	1150
23	39.0	1440	40.6	1620	37.7	1400
24	43.1	1775	45.2	2010	41.6	1700
25	47.8	2180	50.2	2470	45.8	2070
26	52.9	2680	55.8	3005	50.5	2510
27	58.4	3275	61.7	3680	55.5	3010
28	64.5	4030	68.4	4600	60.9	3620
29	71.4	4865	75.1	5530	67.1	4270
30	77.8	5890	83.1	6800	74.0	5100
31	85.6	7170	91.5	8260	79.2	6000
32	93.8	8560	100.5	9870	86.5	6990
33	102.7	10400	110.1	11850	93.6	8160
34	112.3	12200	120.4	14250	101.0	9480
35	122.5	14500	131.4	16800	108.5	10870
36	133.3	17300	142.8	19850	116.2	12400
37	144.1	20400	155.0	23300	124.2	14100
38	156.4	23600	166.7	27300	132.0	16000
39	166.7	27850	180.0	31700	140.0	17800
40	180.0	32000	195.0	36700	148.2	19900

inch and turns per square inch for the various gage sizes. The *Copper Wire Table* gives dimensions and resistances of the bare copper wire over which the insulations are placed to make magnet wire.

The various numbers of turns listed in the *Magnet Wire* tables are averages for different makes. Thicknesses of insulation are not always exactly uniform with different makers nor with different lots of wire from the same maker. Consequently, there will be some variations from the listed figures, but the variations seldom are great enough to seriously affect computations for coil windings.

## SINGLE-LAYER COILS

The following formula gives the self-inductance of a single-layer coil of cylindrical shape wound with round wire. Symbol letters for dimensions are shown by Fig. 7-1.

$$L = \frac{a^2 n^2 K}{10b}$$

- a* Radius from axis of winding to the center of the wire, in inches.  
*b* Length of winding, regardless of the length of the form which supports it, in inches.  
*n* Number of turns of wire.  
*L* Self-inductance, in microhenrys.  
*K* A shape factor which varies with the ratio of diameter ( $2a$ ) to winding length ( $b$ ) as shown by the accompanying table of *Shape Factors for Single-layer Coils*.

The shape factor is used because the greater the diameter in proportion to the winding length the less be-

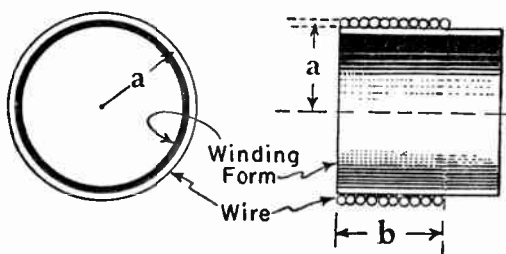

Fig. 7-1. Dimensions used in inductance formulas for single-layer coils.

comes the self-inductance. The factor for a given coil is found by first dividing the diameter (twice the radius  $a$ ) by the winding length, both in inches, then referring to the table for the factor corresponding to this ratio.

As an example, with a coil  $\frac{3}{4}$  inch in diameter and 2 inches long, divide  $\frac{3}{4}$  by 2, which gives  $\frac{3}{8}$  or 0.375. The ratio 0.375 is not listed in the table, but for .36 the factor is .863 and for .38 it is .856, so the desired factor would lie between .863 and .856. Since the actual ratio (0.375) is three-fourths of the way from 0.36 to 0.38, the factor will be three-fourths of the way from .863 to .856, or will be about .858. Ordinarily it is sufficiently accurate to estimate the shape factor by inspection of the nearest values in the table.

The winding length,  $b$ , is the total lengthwire distance covered by the turns, regardless of whether they



## SHAPE FACTORS FOR SINGLE-LAYER COILS

Diameter Length	K	Diameter Length	K	Diameter Length	K
0.10	0.959	0.50	0.818	2.0	0.526
.12	.951	.55	.803	2.1	.514
.14	.943	.60	.784	2.2	.502
.16	.935	.65	.774	2.3	.492
.18	.928	.70	.761	2.4	.482
0.20	0.920	0.75	0.748	2.5	0.472
.22	.913	.80	.735	2.6	.463
.24	.905	.85	.723	2.7	.454
.26	.898	.90	.711	2.8	.445
.28	.891	.95	.700	2.9	.437
0.30	0.884	1.00	0.688	3.0	0.429
.32	.877	1.10	.667	3.2	.414
.34	.870	1.20	.648	3.4	.401
.36	.863	1.30	.629	3.6	.388
.38	.856	1.40	.611	3.8	.376
0.40	0.850	1.50	0.595	4.0	0.365
.42	.843	1.60	.580	4.2	.355
.44	.837	1.70	.565	4.4	.346
.46	.831	1.80	.551	4.6	.336
.48	.824	1.90	.538	4.8	.328
				5.0	.320

are close together or are spaced apart. This and other formulas assume that coil current fills the winding space, and so it is the entire space occupied by the winding that is to be considered.

Although the radius,  $a$ , is supposed to be measured from the winding axis to the center of the wire, the diameter of the wires usually used is so small that only slight error is introduced by figuring with the outside diameter of the coil form and neglecting the additional distance to the center of the wire. The additional distance is equal to 1 divided by twice the number of turns per linear inch as shown by the *Magnet Wire* tables. For example, number 20 plain enamel wire winds 30.1 turns per inch, so the additional radius would be  $\frac{1}{2} \times 30.1 = 1/60.2$  or about 1/60 inch.

*Example:* What is the inductance of a coil having 80 turns in a length of 2.5 inches on a form with an outside diameter of  $1\frac{5}{8}$  (1.625) inches? See 1, Fig. 7-2.

The diameter divided by the length is  $1.625/2.5 = .65$ . For this ratio the table gives a shape factor of .774.

The radius of the coil form is one-half its diameter, or is .813 inch. The size of wire is not specified, so the form radius is taken as the winding radius,  $a$ .

Placing the known values in the formula gives,

$$L = \frac{.813^2 \times 80^2 \times .774}{10 \times 2.5} = \frac{.661 \times 6400 \times .774}{25}$$

$$= \frac{3274}{25} = 130.96 \text{ or about } 130 \text{ microhenrys.}$$

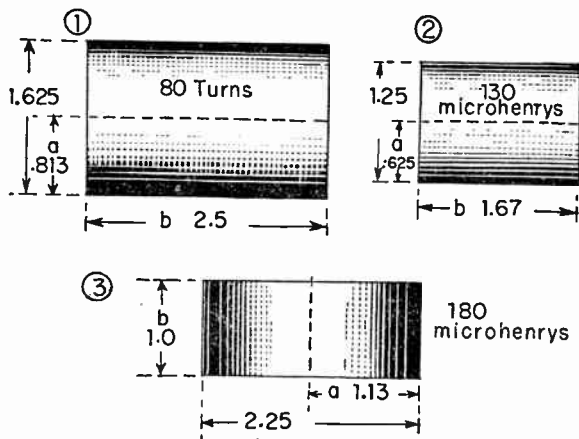

Fig. 7-2. Coils for which data are computed in the examples.

**Turns for a Required Inductance.**—Frequently it is required to design a coil of specified dimensions which will have a required self-inductance, which means determining the number of turns for the windings, also the size or gage of wire, when the diameter and length are specified. The following formula gives the number of turns. The dimensions and the letters used to denote them are shown by Fig. 7-1.

$$n = \sqrt{\frac{10bL}{a^2K}}$$

The letters in this formula have the same meaning as in the preceding one for inductance.

*Example:* How many turns are required for 130 microhenrys inductance using a winding form 1.25 inches in outside diameter and making the winding  $1\frac{2}{3}$  or 1.67 inches long? See 2, Fig. 7-2.

The ratio of winding diameter to length is  $1.25/1.67 = .75$ , and the shape factor for this ratio (from the table) is .748. With a diameter of 1.25 inches the radius.

$a_2$  is .625 inch. Placing the known values in the formula gives,

$$n = \sqrt{\frac{10 \times 1.67 \times 130}{.625^2 \times .748}} = \sqrt{\frac{2171}{.2925}} = \sqrt{7422.2} \\ = 86.15 \text{ or about } 86 \text{ turns.}$$

The next step is to select a wire size that will wind 86 turns in a total length of 1.67 inch. Dividing 86 by 1.67 or by  $1\frac{2}{3}$  shows that the winding must be about 51.6 turns per inch, if the turns are laid close together. From the tables of *Magnet Wire* it now is possible to select any kind and gage of wire that will wind 51.6 or more turns per inch. This requirement would be met by number 25 plain enamel (52.9 turns per inch), by number 30 double cotton covered (52.5 turns per inch) and by other wires.

To save making the computations called for by the turns formula, and especially the extracting of square roots, there have been prepared the tables of *Turns for Windings on Single-layer Coils*.

To use these tables it is necessary first to figure out two ratios. One is the ratio of inductance (in microhenrys) to winding diameter (in inches), and the other is the ratio of winding diameter to winding length, both in inches. The left-hand column of the tables lists *inductance/diameter* ratios. Each of the other columns applies to one *diameter/length* ratio. At the intersections of columns and lines are shown the approximate numbers of turns required.

*Example:* Consider the coil for which the required number of turns were found, with the formula, to be 86. Diagram 2, Fig. 7-2. The inductance is 130 microhenrys, the diameter is 1.25 inches, and the length is 1.67 inches. The ratio of inductance to diameter is  $130/1.25 = 104$ . The ratio of diameter to length is  $1.25/1.67 = .75$ .

There is no column in the tables for a diameter/length ratio of .75. but there are columns for 0.8 and 0.7 ratios. The required value will be midway between the numbers for the ratios of 0.8 and 0.7. There is no line for an inductance/diameter ratio of 104 in the table, but there are lines for ratios of 110 and 100, so the required number of turns will be  $\frac{4}{10}$  of the way from the number for 100 to the one for 110. The small section of the table to which reference is made appears this way:

Inductance Diameter	Diameter/Length	
	0.8	0.7
110	86	90
100	82	86

# TURN'S FOR WINDINGS ON SINGLE-LAYER COILS

Inductance Diameter	Diameter/Length					
	5.0	3.0	2.0	1.5	1.2	1.0
500	113	124	137	149	159	170
450	107	118	130	141	151	161
400	101	112	123	133	142	152
350	94	104	114	124	133	142
300	88	96	106	115	123	132
280	84	93	103	112	119	127
260	81	89	98	107	115	122
240	78	86	95	103	110	117
220	75	82	91	98	106	113
200	71	78	87	94	101	107
190	69	76	84	91	98	104
180	67	74	82	89	95	101
170	66	72	80	86	93	98
160	64	70	78	84	90	96
150	62	68	75	81	87	93
140	60	65	72	78	84	90
130	58	63	70	76	81	86
120	55	61	67	73	78	83
110	53	58	64	70	75	79
100	51	56	61	66	71	76
95	49	54	60	65	69	74
90	48.0	52.5	58.0	63.0	67.5	72.0
85	46.5	51.0	56.5	61.0	65.5	70.0
80	45.0	49.5	55.0	59.0	64.0	67.5
75	43.5	48.0	53.0	57.5	61.5	65.5
70	42.0	46.5	51.0	55.5	59.5	63.5
65	41.0	44.5	49.5	53.5	57.5	61.0
60	39.0	43.0	47.5	51.5	55.0	58.5
55	37.5	41.0	45.5	49.0	53.0	56.0
50	36.0	39.0	43.0	47.0	50.5	53.5
45	34.0	37.0	41.0	44.5	48.0	50.5
40	32.0	35.0	38.5	42.0	45.0	48.0
35	30.0	32.5	36.0	39.0	42.0	44.5
30	28.0	30.0	33.5	36.5	39.0	41.5
28	26.7	29.2	32.2	35.0	37.7	40.0
26	25.8	28.2	31.0	33.8	36.3	38.5
24	24.7	27.0	29.9	32.3	34.9	37.0
22	23.7	26.0	28.7	31.0	33.3	35.4
20	22.6	24.8	27.5	29.6	31.8	33.9
18	21.5	23.4	26.0	28.0	30.0	32.0
16	20.2	22.1	24.4	26.4	28.4	30.1
14	19.0	20.7	22.9	24.8	26.6	28.2
12	17.5	19.2	21.1	22.9	24.6	26.2
10	16.0	17.5	19.3	21.0	22.4	24.0

## TURNS FOR WINDINGS ON SINGLE-LAYER COILS

Inductance Diameter	Diameter / Length					
	0.8	0.7	0.6	0.5	0.4	0.35
500	183	193	204	221	241	256
450	174	183	194	210	229	243
400	164	173	183	198	216	229
350	153	161	171	185	201	214
300	142	149	159	171	187	198
280	137	144	153	165	180	192
260	132	139	148	159	174	185
240	127	133	142	153	167	177
220	122	128	136	146	160	170
200	116	122	129	140	153	162
190	113	118	126	136	149	158
180	110	116	123	133	145	154
170	107	113	120	129	141	150
160	103	109	116	125	137	145
150	100	106	112	121	132	141
140	97	102	108	117	128	136
130	93	98	104	113	123	131
120	90	94	100	108	118	125
110	86	90	96	103	113	120
100	82	86	92	99	108	115
95	80	84	89	96	105	112
90	78	82	87	94	102	109
85	76	80	84	91	99	106
80	73	77	82	88	96	102
75	71	75	79	85	93	99
70	68	72	77	83	90	96
65	66	69	74	80	87	92
60	63	66	71	77	83	89
55	61	64	68	73	80	85
50	58	61	65	70	76	81
45	55	58	61	66	72	77
40	52	54	58	62	68	72
35	48	51	54	58	64	67
30	45.0	47.2	50.0	54.0	59.0	62.6
28	43.2	45.5	48.3	52.1	57.0	60.2
26	41.8	44.0	46.7	50.3	55.0	58.0
24	40.0	42.0	44.8	48.3	52.7	56.0
22	38.4	40.3	42.9	46.3	50.5	53.5
20	36.7	38.5	41.0	44.0	48.0	51.0
18	34.8	36.6	38.8	41.9	45.8	48.4
16	32.8	34.5	36.7	39.4	43.0	45.7
14	30.6	32.2	34.2	37.0	40.2	42.7
12	28.3	29.9	31.6	34.2	37.3	39.4
10	25.9	27.2	28.9	31.1	34.0	36.0

## TURNS FOR WINDINGS ON SINGLE-LAYER COILS

Inductance Diameter	Diameter/Length					
	0.3	0.25	0.2	0.15	0.12	0.1
500	273	298	328	375	418	455
450	259	281	310	356	395	430
400	245	265	293	336	373	407
350	228	248	273	313	349	380
300	212	230	254	290	323	352
280	204	222	246	280	311	340
260	197	214	237	270	300	328
240	190	205	227	260	288	313
220	181	196	218	249	276	300
200	173	188	208	238	263	287
190	169	183	202	231	257	280
180	164	178	197	226	250	272
170	160	173	192	219	243	265
160	155	168	186	212	236	257
150	150	163	180	206	228	249
140	145	157	174	198	220	240
130	139	151	167	192	212	231
120	134	145	161	184	204	222
110	128	139	154	176	195	213
100	123	133	147	168	187	203
95	119	129	143	164	182	198
90	116	125	139	159	177	193
85	113	122	135	155	172	187
80	109	118	132	150	167	181
75	106	115	127	145	161	176
70	102	111	123	140	156	170
65	99	107	128	135	150	164
60	95	102	114	130	144	157
55	91	98	109	125	138	151
50	87	94	104	119	132	143
45	82	89	98	113	125	136
40	77	84	93	107	118	128
35	72	78	87	99	110	120
30	67	73	81	92	102	112
28	65	70	78	89	98	108
26	62	68	75	86	95	104
24	60	65	72	82	92	100
22	57	62	69	79	88	95
20	55	59	66	75	83	91
18	52.0	56.3	62.4	71.3	79.0	86.1
16	49.0	53.0	59.0	67.0	74.6	81.2
14	45.8	49.7	55.0	63.0	69.8	76.0
12	42.3	46.0	51.0	58.0	64.5	70.3
10	38.7	42.0	46.6	53.1	59.0	64.4

For the inductance/diameter ratio of 104 the values would be about half way between 100 and 110, and would be 84 and 88 turns. Midway between these two numbers (for the diameter/length ratio of .75) would be 86, which is the required number of turns for the winding.

*Example:* How many turns and what gage of double silk covered wire should be used for an inductance of 180 microhenrys on a form of 2.25 inches diameter with a winding length of 1 inch or less? See diagram 3, Fig. 7-2.

The ratio of inductance to diameter is  $180/2.25 = 80$ , and the ratio of diameter to length is  $2.25/1 = 2.25$ . In the table and on the line for the inductance/diameter ratio of 80 it is shown that 49.5 turns are needed with a diameter/length ratio of 3.0 and 55 turns for a diameter/length ratio of 2.0. The present diameter/length ratio of 2.25 is one-fourth of the way from 2.0 to 3.0, so the required number of turns will be about 53.6.

In the *Magnet Wire* table for double silk covered wire it is found that number 26 will wind only 50.5 turns per inch, which would make the coil slightly longer, while number 27 winds 55.5 turns per inch, making the coil slightly shorter than 1 inch if the turns are laid close together. The shorter winding will have increased inductance, and the longer one will have less inductance than the required 180 microhenrys.

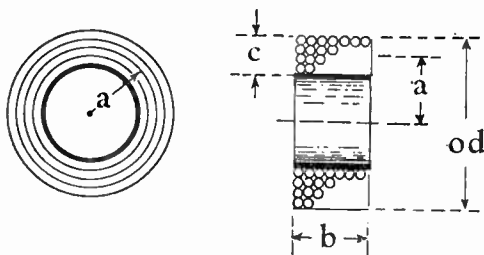

Fig. 7-3. Dimensions affecting inductance of multi-layer coils.

#### MULTI-LAYER COILS

The formulas for computing inductances or number of turns for multi-layer coils are similar to those used for single-layer coils with the exception that a different shape factor is used for the multi-layer types. When a coil is wound several layers deep, as in Fig. 7-3, the self-inductance is less than as though the same number of turns and the same radius and length were used in a single layer.

The shape factors are listed in the table, *Shape Factors for Multi-layer Coils*. To select the shape factor it

## SHAPE FACTORS FOR MULTI-LAYER COILS

Length Height	Height/Diameter					
	0.025	0.05	0.1	0.2	0.3	0.4
0.1	.0071	.0121	.0197	.0307	.0386	.0445
.2	.0140	.0235	.0383	.0592	.0737	.0845
.3	.0206	.0346	.0559	.0857	.1061	.1209
.4	.0270	.0451	.0727	.1106	.136	.154
.5	.0332	.0553	.0887	.1339	.164	.184
.6	.0392	.0651	.1040	.1559	.189	.212
.7	.0450	.0747	.119	.177	.213	.238
.8	.0508	.0839	.133	.196	.236	.262
.9	.0563	.0928	.146	.215	.257	.283
1.0	.0618	.1015	.159	.233	.276	.304
1.11	.0677	.1109	.173	.251	.297	.325
1.25	.0749	.1222	.190	.273	.321	.349
1.43	.0838	.136	.210	.299	.348	.376
1.67	.0953	.154	.236	.331	.381	.408
2.0	.1107	.177	.268	.370	.421	.447
2.5	.1322	.210	.312	.420	.470	.491
3.3	.1650	.257	.374	.486	.530	.545
5.0	.2219	.336	.467	.575	.607	.611
10.0	.3498	.495	.628	.701	.705	.691
	Height/Diameter					
	0.5	0.6	0.7	0.8	0.9	1.0
0.1	.0491	.0529	.0561	.0590	.0617	.0645
.2	.0928	.0924	.1049	.1097	.1142	.1189
.3	.1320	.1406	.1476	.1536	.1594	.1654
.4	.167	.177	.185	.192	.199	.206
.5	.199	.210	.219	.226	.233	.240
.6	.228	.239	.248	.256	.263	.271
.7	.254	.266	.275	.282	.289	.297
.8	.279	.290	.299	.306	.313	.321
.9	.301	.312	.320	.327	.334	.342
1.0	.321	.332	.340	.346	.352	.360
1.11	.342	.352	.359	.365	.371	.379
1.25	.365	.375	.381	.386	.392	.399
1.43	.392	.400	.405	.410	.415	.422
1.67	.422	.429	.433	.436	.440	.447
2.0	.458	.462	.464	.466	.469	.475
2.5	.499	.500	.500	.499	.501	.505
3.3	.548	.544	.540	.537	.536	.540
5.0	.605	.595	.586	.579	.576	.579
10.0	.672	.653	.638	.627	.621	.620



is necessary to use two ratios. One is the ratio of winding length, dimension  $b$  in Fig. 7-3, to winding height, shown as dimension  $c$  in Fig. 7-3. The other is the ratio of winding height,  $c$ , to winding diameter, which is twice the radius  $a$  shown in Fig. 7-3. The dimension  $c$  is the mean radius, or is the radius from the coil axis to the center of the radial height of the winding.

Assume that it is desired to find the shape factor for a coil (diagram 1, Fig. 7-4) having a mean radius  $a$  of 1.25 inches, a winding length  $b$  of 1.25 inches, and a winding height  $c$  of 1 inch.

The length to height ratio,  $b/c$  is  $1.25/1 = 1.25$ . The height to diameter ratio,  $c/2a$ , is  $1/2.5 = 0.4$ . In the table column for 0.4 height/diameter ratio, and on the line for 1.25 length/height ratio the shape factor is shown to be .349 for this coil.

Whether the winding is solid or is space wound in any manner makes no difference in the shape factor and the formulas. It is assumed that the winding or the total number of turns is uniformly distributed in the total space filled by the winding.

The formula for inductance is,

$$L = \frac{a^2 n^2 E}{10b}$$

- $a$  Mean radius from axis to center of the winding height, in inches.  
 $b$  Length of winding, in inches.  
 $n$  Total number of turns of wire, assumed to be equally divided between the layers.  
 $L$  Self-inductance, in microhenrys.  
 $E$  Shape factor taken from the table, *Shape Factors for Multi-layer Coils*.

*Example:* What is the inductance of a coil having a mean radius ( $a$ ) of 1.2 inches, wound 0.75 inch long ( $b$ ) with a winding height of 0.4 inch ( $c$ ) and having 180 turns? See diagram 2, Fig. 7-4.

Two ratios are determined in order to find the shape factor. The ratio of length to height or  $b/c$  is  $.75/0.4 = 1.875$ , and the ratio of height to diameter or  $c/2a$  is  $0.4/2.4 = .167$ . The nearest values in the table, and the actual ratio, are,

$\frac{\text{Length}}{\text{Height}}$	$\frac{\text{Height}}{\text{Diameter}}$	
	0.1	0.2
1.67	.236	.331
1.875		.322
2.0	.268	.370

It is necessary to interpolate between listed factors for 0.1 and 0.2 for the height/diameter ratio of 0.167, and between listed factors of 1.67 and 2.0 for the length/height ratio of 1.875. The shape factor is found to be 322 for the coil in question.

Placing the known values in the formula gives,

$$L = \frac{1.2^2 \times 180^2 \times .322}{10 \times 75} = \frac{15020}{75}$$

= 2003 microhenrys, or about 2 millihenrys.

The formula for number of turns in a multi-layer winding is,

$$n = \sqrt{\frac{10bL}{a^2E}}$$

The letters have the same meanings as in the preceding formula for inductance, and as shown by Fig. 7-2.

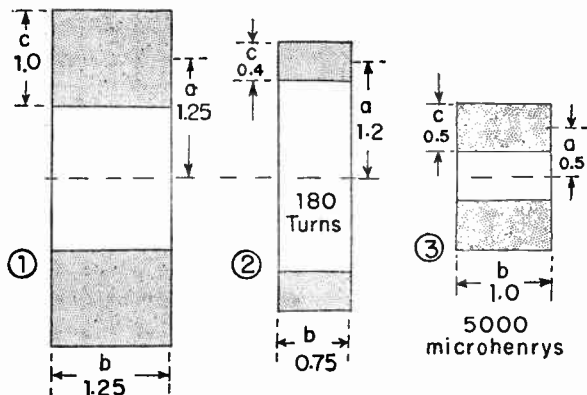

Fig. 7-4. Multi-layer coils for which data are computed.

*Example:* How many turns and what gage size of single cotton enameled wire should be used for an inductance of 5 millihenrys (5000 microhenrys) in a winding 1 inch long (b), 0.5 inch high (c), and with a mean radius of 0.5 inch (a)? See diagram 3, Fig. 7-4.

The ratio of length to height,  $b$  to  $c$ , is  $1/0.5 = 2$ , and the ratio of height to diameter,  $c/2a$ , is  $0.5/1 = 0.5$ . For these two ratios the table shows a shape factor ( $E$ ) of 458. Placing the known values in the formula gives,

$$n = \sqrt{\frac{10 \times 1 \times 5000}{0.5^2 \times 4.58}} = \sqrt{\frac{50000}{.1145}} = \sqrt{436700}$$

$$= 6608 \text{ turns}$$

In the winding space 1 inch long and 0.5 inch high the cross sectional area is 0.5 inch. In this space there are to be about 6600 turns, which means 13,200 turns per square inch. The *Magnet Wire* table for single cotton enamel wire shows that number 38 gage will wind solid with 13,400 turns per square inch, so this is the size of wire required.

**Winding Volume.**—In the *Magnet Wire* table for plain enamel covered wire there is a column for resistance in ohms per cubic inch of winding. The number of cubic inches of winding volume may be found from the dimensions shown in Fig. 7-3 as follows:

$$\text{Cu. in.} = b c (\text{od} - c) 3.1416$$

That is, the cubic inch volume is equal to the product of winding length ( $b$ ), winding height ( $c$ ), the difference between the outside diameter ( $\text{od}$ ) and the winding height ( $c$ ), and the number 3.1416.

*Example:* The dimensions for the coil of diagram 1 in Fig. 7-4 are:  $b = 1.25$ ,  $c = 1.0$ , and  $\text{od} = 3.5$ , all in inches. These values in the formula give,

$$\begin{aligned} \text{Cu. in.} &= 1.25 \times 1.0 \times (3.5 - 1.0) \times 3.1416 \\ &= 1.25 \times 2.5 \times 3.1416 = 9.817 \end{aligned}$$

Assuming that the winding is of number 30 plain enamel wire, the resistance per cubic inch is given by the table as 70.15 ohms. Then the resistance of the winding is, approximately,

$$70.15 \times 9.817 (\text{cu. in.}) = 688.6 \text{ ohms.}$$

**Directions of Electron Flow, Flux, and Conductor Motion.**—Many rules have been devised to make it easier to remember the relative directions of electron flow, of magnetic flux or field lines, and of conductor motion when there is induction. Some of the rules are shown by Fig. 7-5.

At the top it is shown that with the left hand grasping a conductor so that the thumb lies along the conductor and so that the fingers encircle it, when the thumb points in the direction of electron flow in the conductor the fingers point in the direction that magnetic lines pass around the conductor.

A somewhat similar rule, as shown at the center of Fig. 7-5, applies to electron flow around the turns of a solenoid or coil and to the direction of the magnetic flux through the interior of the coil. With the left hand grasping the coil and the thumb extended along the length of the coil, the thumb points in the direction of magnetic force, or toward the north pole of the coil, when the fingers encircle the coil in the direction of electron flow around the turns.

At the bottom of Fig. 7-5 is illustrated a rule for induced electron flow in a conductor moved through a magnetic field. The thumb, forefinger, and middle finger of the left hand are held so that each is at right angles to both the others. Then, when the forefinger points in the direction of magnetic flux lines, magnetic north to magnetic south, and when the thumb points

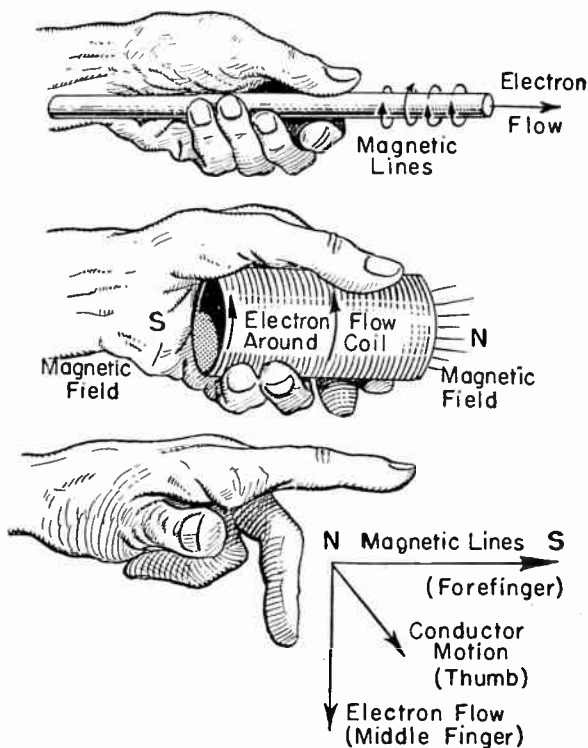

Fig. 7-5. Rules for directions of electron flow.

in the direction of conductor motion through the magnetic field, the middle finger points in the direction of induced electron flow in the conductor, which, of course, is also the direction of the induced emf.

All of these rules apply to the direction of electron flow, not to conventional current flow, and all employ

the left hand. If the right hand is used, the rules will apply with directions of conventional current flow.

The rule which involves direction of conductor movement for induction applies when the conductor moves while the magnetic field is stationary. If the conductor remains stationary while the field is moved, the direction of induced emf and electron flow may be found by using the right hand with the indications of the fingers and thumb remaining unchanged.

## Section 8

### REACTANCES AND ENERGY LOSSES

A sine wave, represented by Fig. 8-1, is the ideal wave form for alternating potential or current. The wave forms of actual alternating potentials and currents may be, and often are, quite different from a sine wave. However, in order to have a definite basis on which to work, most alternating-current calculations are made on the assumption of a sine wave.

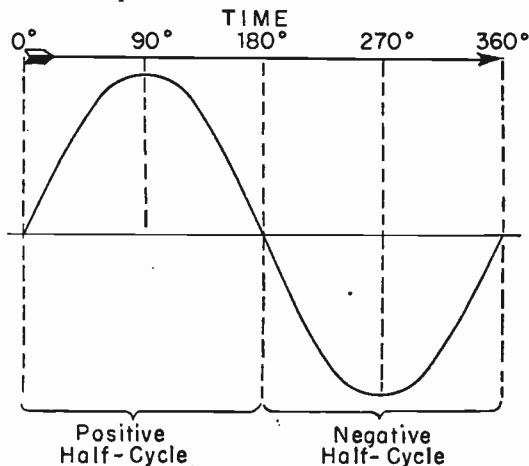

Fig. 8-1. A sine wave for alternating potential or current.

The relative values of potential or current at the various numbers of degrees from  $0^\circ$  to  $90^\circ$  in a sine wave may be read from the values of sines listed in the table of *Trigonometric Functions*. As may be seen from Fig. 8-1, the values from  $90^\circ$  to  $180^\circ$  are the same as from  $0^\circ$  to  $90^\circ$ , but are decreasing. From  $180^\circ$  to  $270^\circ$  the values are the same as from  $0^\circ$  to  $90^\circ$ , and from  $270^\circ$  to  $360^\circ$  they are the same as from  $90^\circ$  to  $180^\circ$ .

As shown by Fig. 8-2, the greatest value of current, potential or emf reached during a cycle is called the *peak*, *maximum* or *crest* value. The working ability or power producing ability of a sine wave current is called the *effective* value or the *root-mean-square* (r-m-s) value, and is equal to 0.707 times the peak value. The *average* value of current or potential in a half-cycle of a sine wave is equal to 0.636 times the peak value.

Unless definitely specified otherwise it always is the effective or r-m-s value that is referred to when talking about alternating currents or potentials. The *amplitude* of an alternating current or potential is its greatest value in either direction, or is its greatest departure from zero in either direction. The amplitude in a sine wave is equal to the peak value.

Peak or maximum  $\times 0.707 =$  effective or r-m-s

Peak or maximum  $\times 0.636 =$  average

Effective or r-m-s  $\times 1.414 =$  peak or maximum

Effective or r-m-s  $\times 0.9 =$  average

Average  $\times 1.57 =$  peak or maximum

Average  $\times 1.11 =$  effective or r-m-s

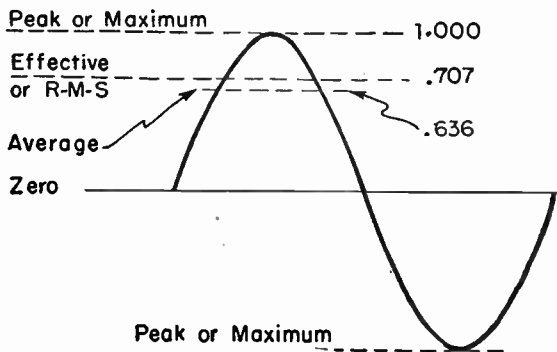

Fig. 8-2. The values of sine-wave currents and potentials.

**Frequency and Wavelength.**—Frequencies and wavelengths are measured in the following units.

Frequency: Cycles  
Kilocycles, *kc*  
Megacycles, *Mc*

Wavelength: Meters, *m*  
Centimeters, *cm*

1 cycle = 0.001 *kc* = 0.000001 *Mc*

1 kilocycle = 1,000 cycles = 0.001 *Mc*

1 megacycle = 1,000,000 cycles = 1,000 kilocycles

$kc = \frac{300000}{\text{meters}}$

$kc = \frac{30000000}{\text{cm}}$

$Mc = \frac{300}{\text{meters}}$

$Mc = \frac{30000}{\text{cm}}$

1 meter = 100 centimeters

1 centimeter = 0.01 meter

$$\begin{array}{l} \text{meters} = \frac{300000}{\text{kc}} \\ \text{cm} = \frac{30000000}{\text{kc}} \end{array} \qquad \begin{array}{l} \text{meters} = \frac{300}{\text{Mc}} \\ \text{cm} = \frac{30000}{\text{Mc}} \end{array}$$

There is no general agreement as to the names given to ranges of frequencies or wavelengths used in the various classes of radio transmission. A class of service which at one time employs a certain frequency range or ranges may later use an extended or a limited range. The table of *Transmission Frequencies* lists some of the ranges, their uses, and names.

### REACTANCES

**Inductive Reactance.**—Inductive reactance is the opposition to flow of alternating current in circuits possessing inductance, the opposition being due to the action of induction. Inductive reactance is measured in ohms. The symbol for inductive reactance is  $X_L$ . This kind of reactance increases directly with frequency and directly with inductance in the circuit. The basic formula for inductive reactance is,

$$X_L = 6.2832 f L$$

$X_L$  Inductive reactance, in ohms.

$f$  Frequency, in cycles.

$L$  Inductance, in henrys.

The inductive reactance formula may be written with other units than cycles and henrys. For example,

$$X_L, \text{ ohms} = 6.2832 \times \text{kilocycles} \times \text{millihenrys.}$$

$$X_L, \text{ ohms} = 6.2832 \times \text{megacycles} \times \text{microhenrys.}$$

$$X_L, \text{ ohms} = 0.0062832 \times \text{kilocycles} \times \text{microhenrys.}$$

$$X_L, \text{ ohms} = 6283.2 \times \text{megacycles} \times \text{millihenrys.}$$

$$X_L, \text{ ohms} = \frac{\text{kilocycles} \times \text{microhenrys}}{159155}$$

The approximate relations between frequency, inductance, and inductive reactance may be determined from Chart No. 8-1 which is used with a straightedge in the same manner as preceding charts of the same general type. The straightedge is laid on two of the scales at values of frequency, inductance, or reactance which are known. The straightedge will cross the third scale at the corresponding value of the third quantity. The inductance range of the chart is from 1 microhenry to 1,000 henrys; the frequency range is from 50 cycles to 50 megacycles; and the inductive reactance range is from 300 to 300,000 ohms. Values read from this and similar charts will not be so accurate as values determined with appropriate formulas, but for most practical problems the charts give satisfactory results.



**TRANSMISSION FREQUENCIES**

Very low frequency	v-l-f	Below 30 kc	
		Below 10000 m	
Low frequency	l-f	30 kc to 10000 m	300 kc to 1000 m
Medium frequency	m-f	300 kc to 1000 m	3000 kc to 100 m
High frequency	h-f	3000 kc to 100 m	30 Mc to 10 m
Very high frequency	v-h-f	30 Mc to 10 m	300 Mc to 1 m
Ultra-high frequency	u-h-f	300 Mc to 1 m	3000 Mc to 10 cm
Super-high frequency	s-h-f	Above 10 cm	Above 3000 Mc
Point to point radio and marine navigation*		40 kc to 7500 m	2600 kc to 115 m
Air navigation		200 kc to 1500 m	400 kc to 750 m
Radio broadcasting, amplitude modulation		540 kc to 555 m	1600 kc to 187.5 m
Amateur radio*		1750 kc to 176 m	60 Mc to 5 m
F-M radio broadcasting			
Television*		50 Mc to 6 m	282 Mc to 1.06 m
Relay, radio and television		100 Mc to 3 m	300 Mc to 1 m
General experimental work		300 Mc to 1 m	3000 Mc to 10 cm

\* These services use various bands of frequencies within the range indicated, with intermediate bands used for other services.

REACTANCE . INDUCTANCE FREQUENCY

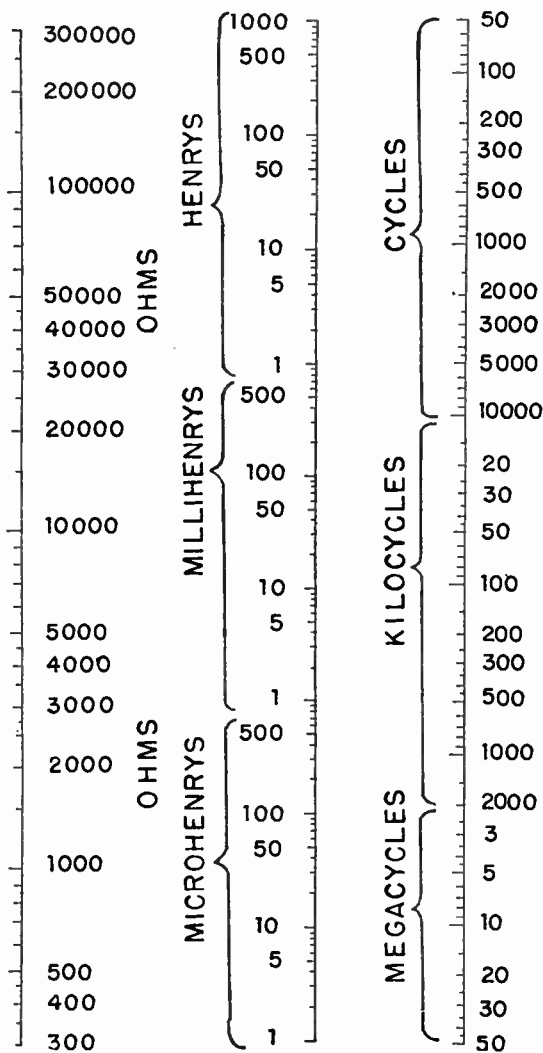

Chart 8-1. The chart for inductance and frequency

**Capacitive Reactance.**—Capacitive reactance is the opposition to flow of alternating current in a circuit containing capacitance, the opposition being due to the charging and discharging of the capacitance or of capacitors in the circuit. Capacitive reactance is measured in ohms. The symbol is  $X_c$ . Capacitive reactance varies inversely with frequency and with capacitance. The basic formula for capacitive reactance is,

$$X_c = \frac{1}{6.2832 f C}$$

$X_c$  Capacitive reactance, in ohms.

$f$  Frequency, in cycles.

$C$  Capacitance, in farads.

Capacitances never are so large as a farad, so for practical purposes the formula must be altered to show capacitances in microfarads or in micro-microfarads. Rather than dividing the number 1 by the product of 6.2832, frequency, and capacitance, it usually lessens the work to use a single equivalent number into which is divided the product of frequency and capacitance. This has been done in the following formulas.

$$X_c, \text{ ohms} = \frac{159155000}{\text{kilocycles} \times \text{micro-microfarads}}$$

$$X_c, \text{ ohms} = \frac{159155}{\text{megacycles} \times \text{micro-microfarads}}$$

$$X_c, \text{ ohms} = \frac{159155}{\text{cycles} \times \text{microfarads}}$$

$$X_c, \text{ ohms} = \frac{159.155}{\text{kilocycles} \times \text{microfarads}}$$

$$X_c, \text{ ohms} = \frac{0.159155}{\text{megacycles} \times \text{microfarads}}$$

Chart No. 8-2 allows reading either frequency, capacitance, or capacitive reactance when the other two quantities are known. Like other generally similar charts, this one is used by laying a straightedge at two known values on their scales, and reading the third corresponding value where the straightedge crosses the third scale. The ranges of frequencies and capacitances are great enough to permit using this chart for most practical problems.

Whereas all the formulas are designed to give the value of capacitive reactance when the two known quantities are frequency and capacitance, the chart permits determination of a frequency at which a given capacitance will have a particular reactance, also of the capacitance required to provide a desired reactance at some particular frequency. As an example: it is a

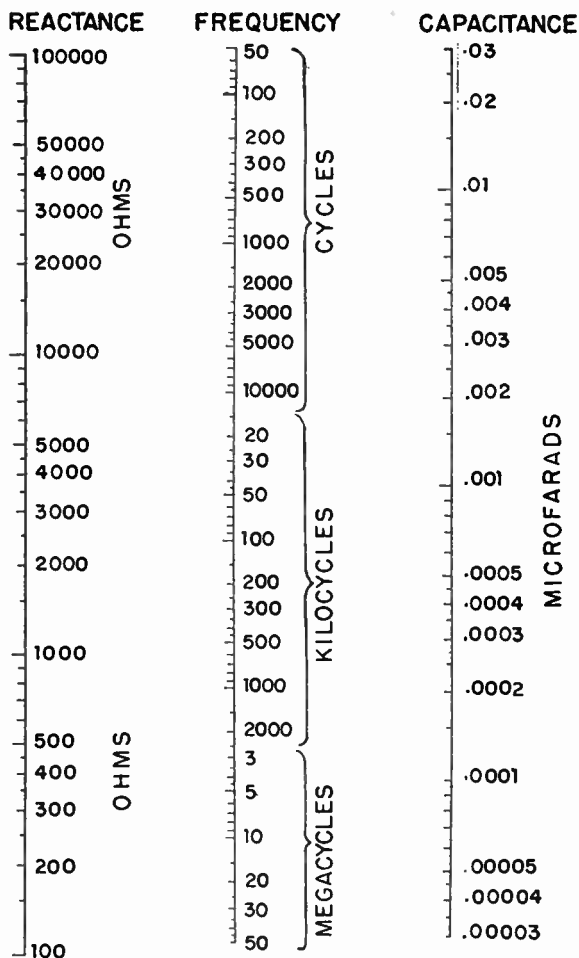

Chart 8-2. The chart for capacitance and frequency.

common statement that the bypass capacitor used across a cathode-bias resistor should have a very small reactance at the lowest frequency to be handled. In a broadcast receiver the lowest radio frequency might be 500 kilocycles, and it might be desired to have no more than 200 ohms reactance in the capacitor. Laying a straightedge across 500 kilocycles and 200 ohms of the chart shows that the required capacitance is about 0.0015 microfarad. There would be no need for computing a more exact value of capacitance for the reason that the one indicated is a standard size, and there would be no others available with only small variations from this value.

**Reactances in Series and in Parallel.**—So far as their effect on reduction or limitation of alternating current is concerned, reactances have the same effect as resistances, and, so long as their values are in ohms, reac-

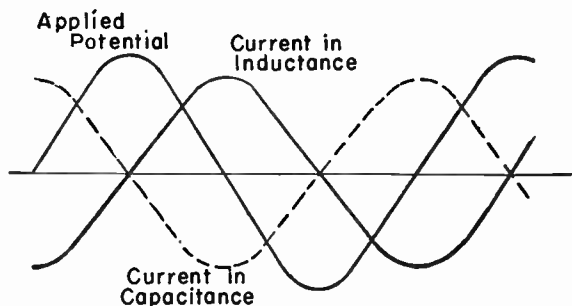

Fig. 8-3. Potentials and currents in inductance and capacitance.

tances may be treated like resistances in all calculations. All the rules for determining combined values of resistances in series apply to reactances in series, and those for resistances in parallel apply to reactances in parallel.

**Lagging and Leading Currents.**—When an alternating potential is applied to an inductance the current in the inductance lags the potential by  $90^\circ$ , as shown by Fig. 8-3. This means that the current peak in a given direction, positive or negative, occurs  $90^\circ$  later than the potential peak in the same direction. When alternating potential is applied to a capacitance the current in the capacitance leads the potential by  $90^\circ$ , as also shown in Fig. 8-3. The peak of capacitance current in a given direction occurs  $90^\circ$  earlier than the peak of potential in the same direction.

When inductance and capacitance are present in the same circuit, the current will lag the potential if the

inductive reactance is greater than the capacitive reactance, and the current will lead the potential if the capacitive reactance is greater than the inductive reactance.

To find the angle of lag (with excess inductance) or the angle of lead (with excess capacitance) the difference between the two reactances is divided by the resistance in ohms. The result of the division is the tangent of the angle of lag or lead. The angle corresponding to the tangent may be found from the list of tangents in the table of *Trigonometric Functions*.

$$\tan \text{ angle of lag} = \frac{X_L - X_C}{R}$$

$$\tan \text{ angle of lead} = \frac{X_C - X_L}{R}$$

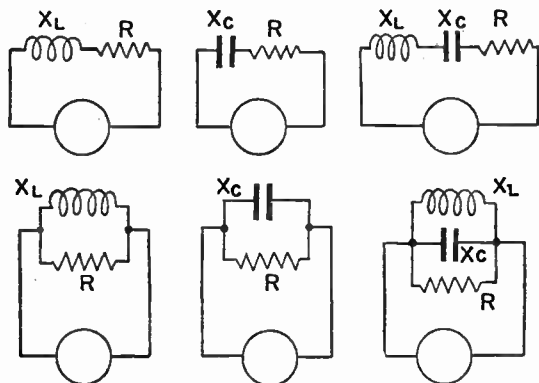

Fig. 8-4. Inductance, capacitance, and resistance combinations.

**Impedance.**—The alternating current which will flow in a circuit when an alternating potential is applied depends on the relative values of inductive reactance, capacitive reactance, and resistance, all in ohms. The opposition to current flow offered by a combination of reactance and resistance is called *impedance*. Impedance is measured in ohms. The symbol is  $Z$ .

Fig. 8-4 shows elementary circuits in which there are various combinations of inductance with its inductive reactance, capacitance with its capacitive reactance, and resistance. These circuit elements are in series for three circuits, and in parallel for the other three. The accompanying formulas allow determination of impedances in ohms for each of the combinations shown by Fig. 8-4.

Inductance and resistance in series.

$$Z = \sqrt{X_L^2 + R^2}$$

Capacitance and resistance in series,

$$Z = \sqrt{X_C^2 + R^2}$$

Inductance, capacitance, and resistance in series,

$$Z = \sqrt{(X_L - X_C)^2 + R^2}$$

Inductance and resistance in parallel,

$$Z = \frac{X_L \times R}{\sqrt{X_L^2 + R^2}}$$

Capacitance and resistance in parallel,

$$Z = \frac{X_C \times R}{\sqrt{X_C^2 + R^2}}$$

Inductance, capacitance, and resistance in parallel,

$$Z = \frac{X_L \times X_C \times R}{\sqrt{X_L^2 \times X_C^2 + R^2(X_L - X_C)^2}}$$

The term  $(X_L - X_C)$  means that the net reactance which is to be squared is taken as the difference between the inductive and capacitive reactances, regardless of which is larger and which is smaller. For example, were the inductive reactance 12 ohms and the capacitive reactance 20 ohms, the net reactance would be 8 ohms. As in all other formulas, it is a general rule that multiplications are to be made, and quantities are to be squared, before the additions are made.

All of the formulas call for squaring certain numbers of ohms of reactance or resistance, which is not difficult, and all of them call for extracting the square roots of various sums, which is not so easy without the use of a table of roots or a slide rule. However, with the help of Chart No. 8-3, square roots may be found as readily, and as accurately, as with a small slide rule.

In Chart No. 8-3 the scales for numbers and their square roots are side by side and close together. No straightedge is required, because the two sets of graduations (for numbers and corresponding square roots) are on the same vertical line and it is necessary only to read from one side to the other. In column A on the left-hand side of the vertical scale are numbers from 1 to 9, and in column A on the right-hand side of the same vertical scale are the square roots of these numbers. Column B, which is on the left-hand side of its vertical scale, contains numbers from 10 to 100, and in column B on the right-hand side of the same scale are the square roots of these numbers. Columns C

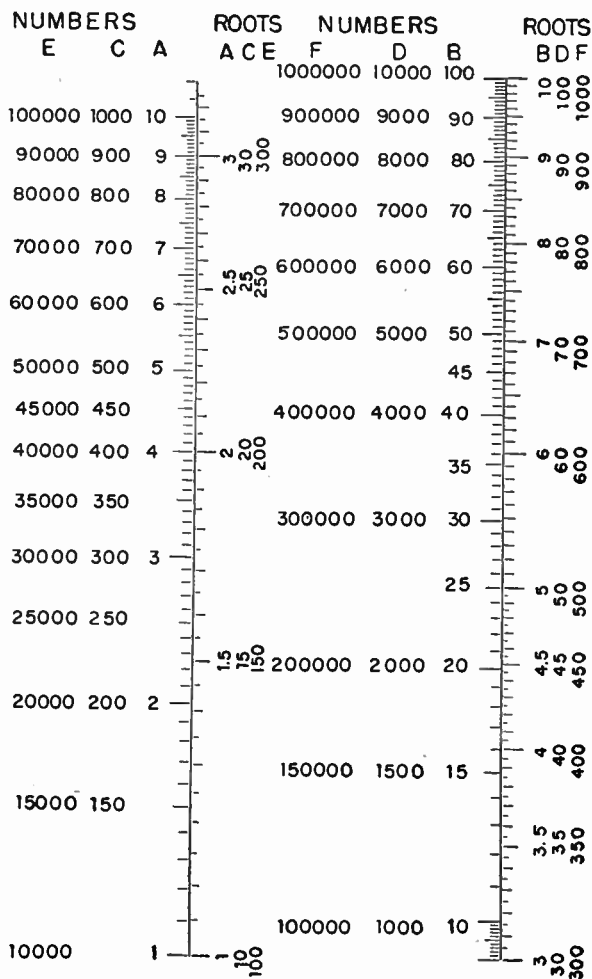

Chart 8-3. The square root chart.



similarly contain numbers running to 1,000, and their square roots. Columns *D* cover numbers from 1,000 to 10,000, and their square roots; columns *E* run from 10,000 to 100,000; and columns *F* go from 100,000 to 1,000,000—always with the numbers on the left of the scales and the square roots on the right. Thus the chart allows finding the square root of any number from 1 to 1,000,000 with an accuracy of between one per cent and 1/10 of one per cent anywhere in the range.

The chart may be extended to cover any range because, as may plainly be seen, every time two ciphers are added to the basic numerals in the columns of numbers, one cipher is added to the basic numerals in the corresponding columns of square roots. If it is desired to use the chart for decimal fractions, the rule is to move the decimal point two places in the columns of numbers and at the same time move the decimal point one place in the same direction in the columns of square roots.

Although the chart columns are marked "numbers" and "roots," it is apparent that the "numbers" columns may be considered to contain the squares of the quantities which are in the "roots" columns. Then, by picking a number which is to be squared from the columns marked "roots," the square of that number will be found in the columns marked "numbers." Thus the chart may be used for determining the squares of numbers from 1 to 1,000.

As an example in using the impedance formulas and Chart No. 8-3, assume that it is desired to know the impedance in ohms of a capacitive reactance of 200 ohms in parallel with a resistance of 500 ohms. The formula is,

$$Z = \frac{X_c \times R}{\sqrt{X_c^2 + R^2}}$$

Placing the known quantities in this formula gives,

$$Z = \frac{235 \times 470}{\sqrt{235^2 + 470^2}} = \frac{110450}{\sqrt{55000 + 220000}} =$$

$$\frac{110450}{\sqrt{275000}} = \frac{110450}{525} = 210 \text{ ohms impedance.}$$

The squares of 235 and of 470 may be read from the chart to the approximate values used in this computation. Also, the square root of 275,000 is read from the chart as approximately 525. Thus all the mathematical work except simple multiplication, division and addition is cared for by the chart of square roots and squares. There is nothing gained in accuracy by having more figures in the answer than in the original factors. That is, since there are only three figures in the original

numbers, 235 and 470, there is no object in having more figures than 210 in the final answer.

The relation of resistance to current and to potential difference in a circuit carrying steady direct current is shown by the three forms of Ohm's law,

$$R = \frac{E}{I} \quad I = \frac{E}{R} \quad E = I \times R$$

The relation of impedance to current and to potential difference in a circuit carrying a varying or an alternating current may be shown by three similar formulas in which the value of impedance in ohms,  $Z$ , is used instead of the value of resistance in ohms,  $R$ .

$$Z = \frac{E}{I} \quad I = \frac{E}{Z} \quad E = I \times Z$$

In these three latter formulas the values of current,  $I$ , and potential difference,  $E$ , are the effective or r-m-s values.

The impedance of a circuit always is greater than either the resistance or the net reactance, which latter is the difference between the inductive and capacitive reactances. If the resistance is double the reactance the impedance will be considerably more than the resistance. If the resistance is five times the reactance, the impedance will be only about 2% more than the resistance. With resistance ten times the reactance the excess of impedance is only about one-half of one per cent, and with a resistance to reactance ratio of 20 to 1, the impedance is only about one-eighth of one per cent more than the resistance. If reactance exceeds resistance in similar ratios, the impedance is in excess of the reactance by the same percentages. Thus we find that when either the reactance or the resistance is more than five to ten times the value of the other, the impedance will be nearly equal to the greater of its two factors.

#### ENERGY LOSSES

Energy is lost from a radio circuit whenever part of the circuit energy is changed into heat and whenever part of the energy is transferred into other circuits or does work in other circuits. Energy losses occur because of the following:

Resistance.

Skin effect.

Emf's induced in other circuits.

Eddy currents produced in nearby objects of metal.

Magnetic hysteresis.

Dielectric hysteresis.

Distributed capacitance.

Whenever current flows in a resistance, a part of the energy equal to  $I^2R$  watts or watt-hours is changed into

heat and cannot be recovered in any useful form unless it is the purpose of the apparatus to produce heat. No energy is lost in inductance or capacitance intentionally built into a circuit, because all energy put into these elements during part of a cycle is returned to the source during other parts of the cycle.

Skin effect is a magnetic action which forces current to travel at and near the surface of a conductor carrying high-frequency current, rather than flowing uniformly through the cross section. The excess current at the surface causes heating and energy loss. The greater the surface area of solid conductors in proportion to their total volume the less energy is lost due to skin effect.

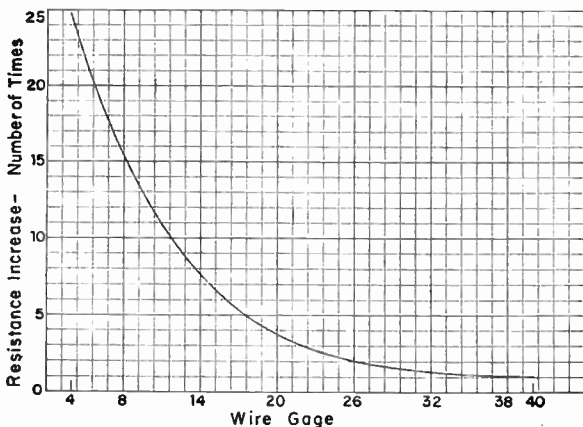

Fig. 8-5. High-frequency resistance of copper wire.

Fig. 8-5 shows, for various gage sizes of solid annealed copper wire, the number of times that the energy loss due to skin effect is increased over the d-c resistance loss when the frequency is 1,500 kilocycles.

Emf's are induced in other circuits by variations of magnetic field around the high-frequency circuit. These emf's cause currents in the other conductors, and the energy changed into heat by those currents must come from the high-frequency circuit.

Eddy currents are caused to flow in any conductors subjected to varying magnetic fields from a high-frequency circuit. The directions of the induced emf's are shown by Fig. 8-6. These emf's cause flow of eddy currents, which produce heat in the metal and thus abstract energy from the high-frequency circuit. The less is the resistance of the conductor the smaller is the

energy loss due to eddy currents. The loss is relatively small in copper and aluminum, but is large in iron or steel.

Magnetic hysteresis is a lagging of magnetization and demagnetization in iron or steel subjected to alternating magnetic fields. Because the metal does not demagnetize at the same rate with which it magnetizes, extra energy is required for the demagnetization. This energy represents a loss.

Dielectric hysteresis represents an energy loss due to the pulling back and forth of the electrons in the molecules of a dielectric material subjected to a high-frequency electric field. The work done in moving the electrons causes heating of the dielectric, and the heat energy becomes a loss.

Distributed capacitance is the capacitance which exists between all conductors which are separated by insulation acting as a dielectric. Inductance coils have

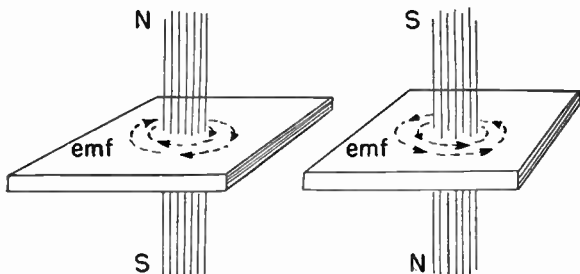

Fig. 8-6. Induced emf's which cause eddy currents.

considerable distributed capacitance; enough so that this capacitance combined with the inductance of the coil are resonant at some high frequency. Currents at this resonant frequency, also at other frequencies, represent an energy loss.

The total effect of all energy losses is the equivalent of the loss due to heat which would occur in a resistance of some certain number of ohms. Consequently, the total effect may be called *high-frequency resistance* or *effective resistance*. With the exception of the heat loss in resistance, all of the effects or energy losses which have been mentioned increase with frequency. The high-frequency resistance increases rapidly with rise of operating frequency.

**Q-factor.**—The primary purpose of the coil in a resonant circuit is to provide inductive reactance, and the primary purpose of the capacitor is to provide capacitive reactance. It is impossible to avoid having some high-frequency resistance in the coil while it is in operation,

and to have at least a small amount of high-frequency resistance in the capacitor. But the greater is the reactance of either the coil or the capacitor in comparison with their high-frequency resistance, the better is the coil or capacitor for its primary purpose. It may be said that the ratio of reactance to high-frequency resistance denotes the quality of performance obtainable from a coil or capacitor. This ratio, which may be written in fractional form as

$$\frac{X}{R} \text{ or } \frac{\text{reactance}}{\text{resistance}}$$

is called the *Q-factor* or simply the *Q* of the coil or the capacitor. Not only coils and capacitors may have *Q*-factors, but the entire circuit may have a *Q*-factor, which is equal to the circuit reactance divided by the high-frequency resistance of the circuit.

At frequencies in the broadcast band and in much of the short-wave range the causes of high-frequency resistance are associated chiefly with the coil of a tuned circuit rather than with the capacitor. Consequently, the *Q* of the entire circuit is practically the same as that of the coil. The inductive reactance of the coil increases with increasing frequency, and so does the high-frequency resistance of the coil. Also, the reactance and the high-frequency resistance increase in about the same proportion through the frequencies mentioned, and as a consequence the *Q* of the coil undergoes little change as the frequency varies. The *Q*'s of typical radio coils run from about 100 to as much as 800, meaning that their reactances at resonant frequencies are from 100 to 800 times as great as their high-frequency resistances.

A given inductance and inductive reactance of a coil may be had by winding many turns on a shorter form or one of smaller diameter, or else by winding fewer turns on a longer form or one of larger diameter. With usual types of construction, more turns will bring about a greater increase of inductive reactance than of high-frequency resistance. This is one of the principal reasons for preferring to use as many turns as are practicable for obtaining the required inductance; the effect being a lessening of the high-frequency resistance and an increase of the *Q* of the coil.

With  $Q = X/R$  the smaller the high-frequency resistance the greater will be the value of *Q*. But, the smaller the high-frequency resistance the sharper is the current peak with series resonance and the sharper is the impedance peak with parallel resonance. The sharper and narrower are these peaks, the better is the selectivity of the circuit. Then it follows that the greater values of *Q* which accompany smaller high-frequency resistance

indicate greater selectivity. Selectivity is directly proportional to  $Q$ .

The impedance, at resonance, of a parallel resonant circuit may be determined from any of several formulas that involve the values of  $Q$ , of reactance at resonance,  $X$ , of high-frequency resistance,  $R$ , and of inductance  $L$  and capacitance  $C$ .

$$Z = Q \times X$$

$$Z = Q^2 \times R$$

$$Z = \frac{X^2}{R}$$

$$Z = Q^2 \times \sqrt{\frac{L}{C}}$$

In all of these formulas the values of  $Z$ ,  $X$  and  $R$  are in ohms. In the formula involving the square root of  $L$  over  $C$ , the inductance  $L$  is in microhenrys, and the capacitance  $C$  is in microfarads, not in micro-microfarads.

In addition to the usual formula,  $Q = X/R$ , two others sometimes are useful. The three formulas for  $Q$  are,

$$Q = \frac{X}{R}$$

$$Q = \frac{Z}{X}$$

$$Q = Z \times \sqrt{\frac{C}{L}}$$

## Section 9

### RESONANCE AND COUPLING

Resonant circuits are represented in Fig. 9-1. Diagram 1 shows the ideal series resonant circuit with only inductance  $L$  and capacitance  $C$  in series with each other and with the a-c source  $E$ . Diagram 2 shows the actual series resonant circuit in which there must be more or less resistance  $R$ .

Diagrams 3 to 6 represent parallel resonant circuits. Diagram 3 represents the ideal circuit with only inductance and capacitance in parallel with each other, while the other diagrams show actual circuits having resistance in either or both branches.

In a series resonant circuit the same current flows in both the inductive and capacitive sections, but there may be differences between the potential drops across the two sections. In a parallel resonant circuit there are equal potential differences across the inductive and capacitive branches, but there may be differences between the currents flowing in the two branches.

The impedance, in ohms, of a parallel resonant circuit at resonance may be found by dividing the inductance, in microhenrys, by the product of resistance in ohms and capacitance in microfarads, thus:

$$Z, \text{ ohms} = \frac{L \text{ microhenrys}}{R \text{ ohms} \times C \text{ mfd}} \text{ (at resonance)}$$

If capacitance is in micro-microfarads the formula becomes,

$$Z, \text{ ohms} = \frac{1,000,000 \times L \text{ microhenrys}}{R \text{ ohms} \times C \text{ mmfd}}$$

The impedance at resonance is equal also to the square of the reactance divided by the resistance, all in ohms. The reactance may be either inductive or capacitive, since they are equal at resonance.

$$Z, \text{ ohms} = \frac{X^2}{R} \text{ (at resonance)}$$

In all these formulas the resistance,  $R$ , appears in the term which is below the line, which indicates that the reactance is divided by the number of ohms of circuit resistance in every case. Then the greater the resistance of the parallel resonant circuit the less will be its impedance at resonance; in fact, the impedance is inversely proportional to the resistance.

With 270 microhenrys inductance and 100 micro-microfarads capacitance in a parallel resonant circuit, the impedance at resonance works out to be 540,000 ohms when

there is resistance of 5 ohms in the parallel circuit. With 10 ohms resistance the impedance drops to 270,000 ohms, and with 20 ohms of resistance the impedance becomes 135,000 ohms. The greater the resistance in a parallel resonant circuit the less is the impedance at resonance.

The computation of the impedance of a parallel resonant circuit at frequencies other than that for resonance becomes rather involved because of the many possible

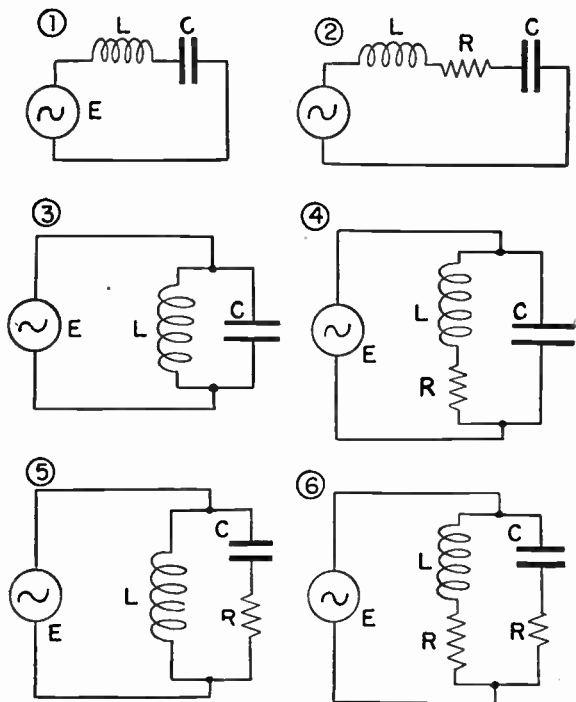

Fig. 9-1. The elements of resonant circuits.

combinations of phase relations between currents in the inductive and capacitive branches. For example, at 4 in Fig. 9-1 there is resistance in series with the inductance, but there is no resistance, or at least an entirely negligible amount in series with the capacitance. Then current in the inductive branch will be displaced in its phase relation by the series resistance, but current in the capacitive branch will not be displaced. At 5 in



Fig. 9-1 the current in the capacitive branch would be displaced from the phase position it would have were there no resistance in this branch, but the current in the inductive branch would not be so displaced. At 6 the currents in both branches would be displaced in phase or time, because there are resistances in both branches. Computation of impedance with such combinations of various possible phase relations and with the different reactances which exist in the two branches at frequencies other than resonant requires taking all these variables into account. Circuit resistance has about the same effect on impedance of a parallel resonant circuit as it has on current in a series resonant circuit.

**Frequency of Resonance.**—The frequency at which resonance occurs in a circuit containing inductance and capacitance depends only on the relative values of these two factors, and is not affected by any resistances which may be in the resonant circuit. The frequency of resonance for given inductance and capacitance is the same whether the circuit is of the series resonant type or is of the parallel resonant type. Here is the basic formula for the frequency of resonance, when frequency is in cycles per second, inductance is in henrys, and capacitance is in farads.

$$f = \frac{1}{6.2832 \times \sqrt{L \times C}}$$

The following equivalent formulas are used for capacitances in microfarads.

$$\text{Cycles} = \frac{159.155}{\sqrt{\text{mfd} \times \text{henrys}}}$$

$$\text{Cycles} = \frac{5032.5}{\sqrt{\text{mfd} \times \text{millihenrys}}}$$

If it is desired to determine the resonant frequency in kilocycles, the following formulas are used.

$$Kc = \frac{5.0325}{\sqrt{\text{mfd} \times \text{millihenrys}}}$$

$$Kc = \frac{159.155}{\sqrt{\text{mfd} \times \text{microhenrys}}}$$

$$Kc = \frac{5032.5}{\sqrt{\text{mmfd} \times \text{millihenrys}}}$$

$$Kc = \frac{159155}{\sqrt{\text{mmfd} \times \text{microhenrys}}}$$

When resonant frequencies in megacycles are to be determined, the formulas are as follows.

$$Mc = \frac{0.0050325}{\sqrt{mfd \times \text{millihenrys}}}$$

$$Mc = \frac{0.159155}{\sqrt{mfd \times \text{microhenrys}}}$$

$$Mc = \frac{5.0325}{\sqrt{mmfd \times \text{millihenrys}}}$$

$$Mc = \frac{159.155}{\sqrt{mmfd \times \text{microhenrys}}}$$

The values of the square roots which are required in all the formulas for resonant frequencies may be determined with the help of Chart No. 8-3.

When a frequency of resonance and an inductance are known, and it is desired to determine the capacitance which must be used, the following formulas are used.

$$Mfd = \frac{25330}{\text{cycles}^2 \times \text{henrys}} \quad Mfd = \frac{25330000}{\text{cycles}^2 \times \text{millihenrys}}$$

$$Mfd = \frac{25.33}{kc^2 \times \text{millihenrys}} \quad Mfd = \frac{25330}{kc^2 \times \text{microhenrys}}$$

$$Mfd = \frac{0.00002533}{Mc^2 \times \text{millihenrys}} \quad Mfd = \frac{0.02533}{Mc^2 \times \text{microhenrys}}$$

$$Mmfd = \frac{25330000}{kc^2 \times \text{millihenrys}} \quad Mmfd = \frac{25330000000}{kc^2 \times \text{microhenrys}}$$

$$Mmfd = \frac{25.33}{Mc^2 \times \text{millihenrys}} \quad Mmfd = \frac{25330}{Mc^2 \times \text{microhenrys}}$$

When a frequency of resonance and a capacitance are known, and it is desired to determine the inductance which must be used, the formulas become,

$$\text{Henrys} = \frac{25330}{\text{cycles}^2 \times mfd} \quad \text{Millihenrys} = \frac{25330000}{\text{cycles}^2 \times mfd}$$

$$\text{Millihenrys} = \frac{25.33}{kc^2 \times mfd} \quad \text{Millihenrys} = \frac{0.00002533}{Mc^2 \times mfd}$$

$$\text{Millihenrys} = \frac{25330000}{kc^2 \times mmfd} \quad \text{Millihenrys} = \frac{25.33}{Mc^2 \times mmfd}$$

$$\text{Microhenrys} = \frac{25330}{kc^2 \times mfd} \quad \text{Microhenrys} = \frac{0.02533}{Mc^2 \times mfd}$$

$$\text{Microhenrys} = \frac{25330000000}{kc^2 \times mmfd} \quad \text{Microhenrys} = \frac{25330}{Mc^2 \times mmfd}$$

In all of the preceding formulas the abbreviations or letter symbols have the usual meanings, which are,

<i>kc</i>	kilocycles	<i>mfd</i>	microfarads
<i>Mc</i>	megacycles	<i>mmfd</i>	micro-microfarads

Although the formulas give values which are quite exact for resonant frequencies and also for the necessary inductances and capacitances, values which are sufficiently close for most practical problems may be read directly from Chart No. 9-1. This chart, like many others in the Handbook, is used by laying a straight-edge across two values or quantities that are known, and reading the value of a third unknown quantity at the intersection of the straightedge with the third scale of the chart.

In Chart No. 9-1 there are three scales. At the left is the scale of inductances, graduated in henrys, millihenrys, and microhenrys. The scale is continuous, since 1 henry at the lower end of the upper series of markings is the same as 1,000 millihenrys which would form the top of the next series of markings. Also 1 millihenry, at the bottom of the millihenry markings, is the same as 1,000 microhenrys for the top of the microhenry markings. The center scale is for frequencies of resonance, in cycles, kilocycles, and megacycles. Here again the scales are continuous, since 10 on the kilocycle markings is the same as 10,000 cycles, and 3 on the megacycle markings is the same as 3,000 kilocycles. The right hand scale is for capacitances, in micro-microfarads from 10 to 1,000, and in microfarads from 0.00001 to 0.01.

This chart may be used to determine the approximate frequency of resonance for known values of inductance and capacitance; placing the straightedge across the two known values on the outer scales and reading the resonant frequency on the center scale. The chart may be used also for determining the capacitance required for resonance at a certain frequency with a given inductance, and for determining the inductance to be used with a certain capacitance when the combination is to be resonant at a particular frequency.

**Wavelength at Resonance.**—The following formulas allow determining the wavelength in meters at resonance for various combinations of inductance and capacitance.

$$\text{Meters} = 1,883,824 \sqrt{\text{henrys} \times \text{microfarads}}$$

$$\text{Meters} = 59,577 \sqrt{\text{millihenrys} \times \text{microfarads}}$$

$$\text{Meters} = 1883.8 \sqrt{\text{microhenrys} \times \text{microfarads}}$$

$$\text{Meters} = 1.8838 \sqrt{\text{microhenrys} \times \text{micro-microfarads}}$$

**Oscillation Constants.**—An oscillation constant is a number which is the product of the inductance and the

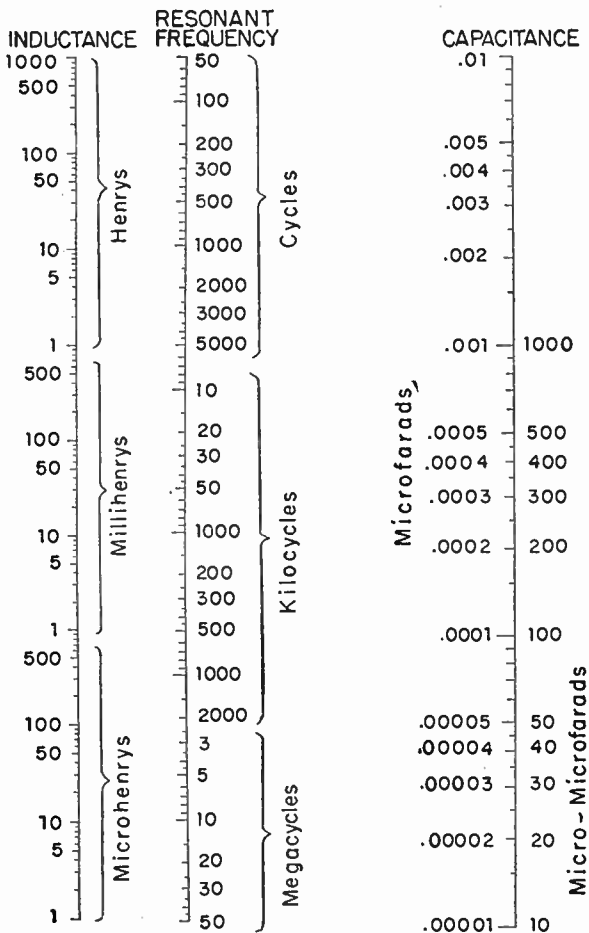

Chart 9-1. The chart of inductance and capacitance at resonance.

capacitance which are resonant at a certain frequency for which the constant applies. Because oscillation constants are products of inductance  $L$  and capacitance  $C$ , they sometimes are called *LC constants*. The accompanying table of *Oscillation Constants or LC Constants* gives constants for frequencies in megacycles and kilocycles, and in meters of wavelength, which frequently occur in radio circuits. Most of the frequencies are those of upper and lower limits of bands used for various transmissions, or of frequencies found in radio receiver circuits or used in testing such circuits.

The constants listed in the table are the products of inductance in *microhenrys* and capacitance in *micro-microfarads*, not microfarads.

To determine the inductance in microhenrys for tuning to resonance at a certain frequency, the oscillation constant for that frequency is divided by the available capacitance in micro-microfarads. To determine the capacitance in micro-microfarads, the oscillation constant for the frequency is divided by the available inductance in microhenrys.

$$\text{Microhenrys} = \frac{\text{oscillation constant}}{\text{micro-microfarads}}$$

$$\text{Micro-microfarads} = \frac{\text{oscillation constant}}{\text{microhenrys}}$$

*Example.*—It is desired to design an inductance coil for tuning in the range from 9,500 kc to 14,400 kc with a tuning capacitor having a maximum capacitance of 100 mmfds. Assume a fixed or distributed circuit capacitance of 10 mmfds. Determine the inductance required in the coil.

The frequency range of 9,500 to 14,400 kc is the same as 9.5 to 14.4 megacycles. The table gives the oscillation constants for these frequencies as 280.6 and 122.1, respectively. The total maximum capacitance, employed for the lower of the two frequencies, will be  $100 + 10 = 110$  mmfds. Dividing the constant for 9.5 Mc by the capacitance, we have,

$$\frac{280.6}{110} = 2.55 \text{ microhenrys in the coil.}$$

To check the capacitance required at the higher frequency we divide the oscillation constant for that frequency by the inductance just determined.

$$\frac{122.1}{2.55} = 47.88 \text{ micro-microfarads.}$$

Since 10 mmfds of the total capacitance is fixed, the minimum capacitance of the tuning capacitor must be  $47.88 - 10 = 37.88$  mmfds. A variable capacitor having maximum capacitance of 100 mmfds will easily reach a

## OSCILLATION CONSTANTS OR LC CONSTANTS

Fre- quency, Mega- cycles	LC Constant	Wave length, Meters	Fre- quency, Mega- cycles	LC Constant	Wave length, Meters
400	0.1583	0.75	58.5	7.400	
300	.2814	1.0	56	8.345	
294	.2930	1.2	50	10.132	6.0
282	.3187		43	13.70	
270	.3474		42.8	13.82	7.0
264	0.3633		42	14.36	
256	.3866		37.5	18.02	8.0
242	.4327		33.3	21.58	9.0
236	.4547		30	28.14	10.0
230	.4788		29.25	29.62	
224	0.5050		28.1	32.10	
216	.5428		28	32.31	
210	.5743		27	34.74	
204	.6083		25	40.52	12.0
200	.6333	1.5	21.75	53.53	
192	0.6870		21.42	55.17	14.0
186	.7320		18.73	72.21	16.0
180	.7820		17.85	79.50	
168	.8972		17.75	80.38	
162	.9648		15.35	107.5	
156	1.040		15.1	111.1	
150	1.126	2.0	15	112.6	20.0
144	1.221		14.4	122.1	
140	1.292		14.25	124.7	
132	1.454		14.15	126.5	
129	1.523		14	129.3	
119	1.788		12	175.9	25.0
116	1.881		11.9	178.8	
112	2.020		11.7	185.0	
108	2.171		9.7	269.2	
102	2.436		9.67	271.0	31.0
100	2.533	3.0	9.5	280.6	
96	2.750		7.3	475.2	
90	3.128		7.0	516.9	
84	3.590		6.2	658.8	
78	4.161		6.0	703.7	50.0
75	4.500	4.0	5.7	780.0	
72	4.881		5.57	816.0	
66	5.817		5.5	847.5	
60	7.035	5.0	4	1583	75.0

## OSCILLATION CONSTANTS OR LC CONSTANTS

Fre- quency, Kilo- cycles	LC Constant	Wave length, Meters	Fre- quency, Kilo- cycles	LC Constant	Wave length, Meters	
4000	1583	75	455	122400	750	
3900	1665		400	158300		
3500	2068	100	390	166500		
3000	2814		380	175500		
2600	3748		370	185100		
2500	4052	120	300	261400	1000	
2400	4397		278	328000		
2300	4789	200	264	363500	1200	
2060	5965		262	369000		
1800	7820		250	405200		
1750	8272		200	633300		1500
1700	8765	200	175	827300	2000	
1600	8897		170	876800		
1500	11260		150	1126000		
1400	12930	300	130	1499000	3000	
1000	25330		125	1622000		
550	83740	3000	100	2533000	6000	
515	95520		50	10130000		
475	112300		40	15830000		7500
456	121900					

minimum of 37.88 mmfds, so the combination of coil and capacitor will handle the frequency range.

*Example.*—By measurement and counting of turns on a coil it is determined to have an inductance of about 80 microhenrys. What should be the maximum and minimum capacitance of a tuning capacitor for use with this coil in covering a range from 1700 to 3500 kc?

Constant for 1700 kc is 8765, from the table.

$$8765 \div 80 \text{ (microhenrys)} = 109.6 \text{ mmfds} \\ \text{maximum capacitance.}$$

Constant for 3500 kc is 2068.

$$2068 \div 80 \text{ (microhenrys)} = 25.9 \text{ mmfds} \\ \text{minimum capacitance.}$$

If we assume a distributed or fixed capacitance of 15 mmfds in the tuned circuit the maximum and minimum capacitances of the variable capacitor must be,

$$109.6 - 15 = 94.6 \text{ mmfds maximum.}$$

$$25.9 - 15 = 10.9 \text{ mmfds minimum.}$$

A capacitor of 100 mmfds maximum capacitance should meet these requirements.

## COUPLING

**Coefficient of Coupling.**—The coefficient of coupling is a fraction which indicates the amount or degree of coupling between two coupled circuits. If the two coils having mutual induction could be of the same length, same diameter, wound with the same number of turns in the same manner, and could they occupy the same space, then the coefficient of coupling would be 1.0. In all practical cases the coefficient must be less than 1.0. In iron-core transformers the coupling coefficient may be 0.9 or more, while with air-core coils used as in Fig. 9-2 the coupling coefficient may run around 0.02 to 0.10. The usual symbol for coefficient of coupling is the letter  $k$ .

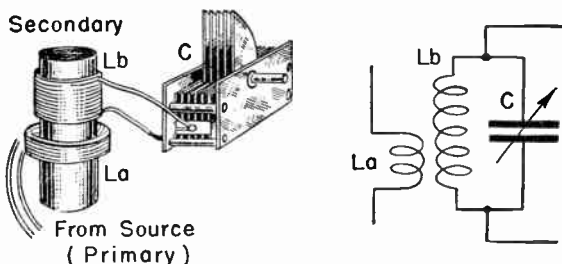

Fig. 9-2. An air-core type of tuned transformer.

If the mutual inductance,  $M$ , is known, and if the total self-inductances of each of the coupled circuits is known, the coefficient of coupling may be found from this formula,

$$k = \frac{M}{\sqrt{L_a \times L_b}}$$

$k$  The coupling coefficient, a fraction.

$M$  The mutual inductance of the two circuits.

$L_a$  The total self-inductance of one circuit; not only the self-inductance of a coupled coil, but the self-inductance due to all the coils in the circuit.

$L_b$  The total self-inductance of the other circuit.

All the inductances, mutual and self-, are to be in the same unit; in henrys, in millihenrys, or in microhenrys. The self-inductances, if measured, must be measured in each circuit while the other circuit is so far removed as to have no coupling and no mutual induction.

Coils that are connected into a circuit for the purpose of adding to the inductance of the circuit, but which take no direct part in providing coupling or allowing mutual induction, may be called *loading coils*.



If the loading coils are in series with other coils in the same circuit the inductance of the two coils together is less than that of either one alone. This reduction of circuit inductance lessens the mutual induction and lessens the coupling coefficient. If a loading coil is connected in parallel with another coil their self-inductances add.

If the coefficient of coupling is known, and if the total inductances of the two coupled circuits are known, the mutual inductance may be found from this formula,

$$M = k \times \sqrt{La \times Lb}$$

Here  $La$  and  $Lb$  are the same as in the preceding formula, and all the inductances are in the same unit.

Coupling with which there is a large transfer of energy is called *close coupling*, or may be called *tight coupling*, while coupling with which there is but small transfer of energy may be called *loose coupling*. There is no generally recognized division between close and loose coupling, although sometimes it is considered that any coupling with a coefficient of 0.5 or more is close coupling, and with a coefficient of less than 0.5 is loose coupling.

The coupling coefficient sometimes is stated as a per cent rather than as a fraction. Multiplying the fraction by 100 changes it to an equivalent per cent. For example, a coefficient of 0.5 is the same as a coefficient of 50 per cent. Percentages cannot be used in any of the usual formulas.

Resistances or reactances, or both, which are in one coupled circuit have the effect of being carried over into the other circuit to a degree that increases as the coupling coefficient is increased. For instance, resistance in one circuit adds to the effective resistance of the other circuit, and would lessen the  $Q$ -factor of the other circuit were it of a resonant type. Reactances, either inductive or capacitive, which are in one coupled circuit will affect the tuning of the other coupled resonant circuit, and the tuning will have to be readjusted as the coupling or the coupling coefficient is changed. If both the coupled circuits are tuned, the tuning of both will be upset by any change in the amount of coupling between them.

**Double Hump Resonance.**—When two tuned circuits of the type shown by Fig. 9-3 are rather loosely coupled, and each is separately tuned to the same frequency, there will be peaks of current, not at the tuned frequency but rather at two different frequencies, one of which is less than the tuned frequency and the other more. That is, the two circuits become resonant at two different frequencies. This effect is called *double hump resonance*. It is important because it occurs with the

tuned intermediate-frequency transformers that are used in superheterodyne receivers.

As an example assume, in Fig. 9-4, that the two tuned circuits have inductances of 800 microhenrys each, and that both tuning capacitors are adjusted for a capacitance of 155 mmfds in each. The resonant frequency

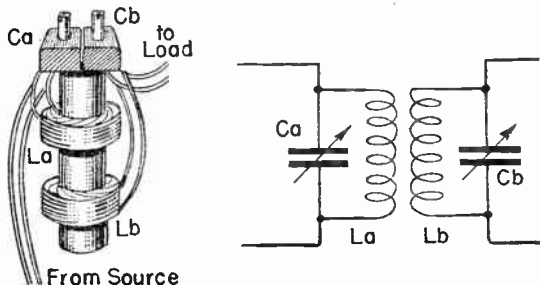

Fig. 9-3. Transformer with tuned primary and secondary.

for this combination of inductance and capacitance is 452 kilocycles. If the coupling is very loose there will be maximum current in both circuits at this resonant frequency, and the resonance curve for current will be about as shown.

Now assume that the coupling has been made closer, until the coefficient of coupling becomes 0.02 or 2 per cent. As shown at the left in Fig. 9-5 there will be two frequencies at which there are peaks of current; one

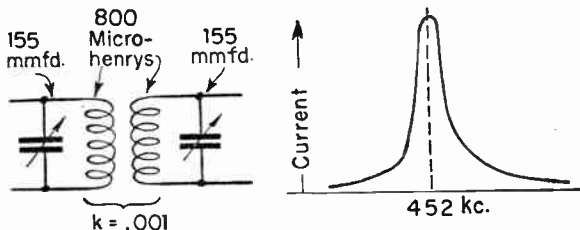

Fig. 9-4. Resonance curve for very loose coupling.

frequency at 447.5 kilocycles, which is 4.5 kilocycles below the original tuned frequency, and another at 456.6 kilocycles, which is 4.6 kilocycles above the original tuned frequency. Instead of the single narrow peak obtained with very loose coupling there now is a much broader peak, which means that the coupled circuits or the tuned transformer will have an almost uniform

response to a band of frequencies extending over about 10 kilocycles, yet the cutoff or the reduction of current at frequencies either side of this band is practically as sharp as with the original very loose coupling. Selectivity has been retained with an increase of the number of frequencies which are selected for amplification.

At the center of Fig. 9-5 the coefficient of coupling has been increased to 0.05 or to 5 per cent. Now there is a current peak at 441.0 kilocycles and another at 463.8 kilocycles. These peaks are, respectively, 11.0 kilocycles below the original tuned frequency and 11.8 kilocycles above that frequency. The band now is about 23 kilocycles wide, but there is a dip between the peaks where the current falls off. At the right in Fig. 9-5 the coefficient of coupling has been made 0.10 or 10 per cent. The current peaks now are quite distinct from each other and there is a deep dip of relatively small current in between them.

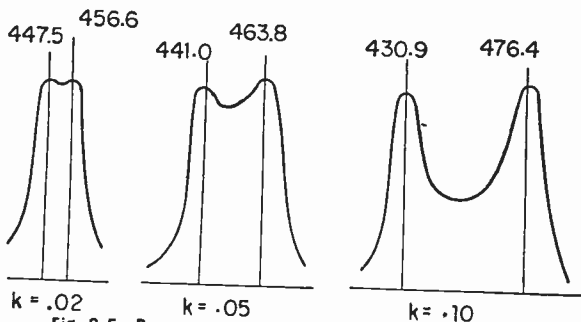

Fig. 9-5. Resonance curves for three coupling coefficients.

Denoting the original tuned frequency as  $f$ , the lower of the two resonant peaks as  $f-$ , the higher of these peaks as  $f+$ , and the coefficient of coupling as  $k$ , the frequencies of the peaks are as follows:

$$f- = \frac{f}{\sqrt{1+k}} \qquad f+ = \frac{f}{\sqrt{1-k}}$$

The frequency of the lower peak is found by dividing the original tuned frequency by the square root of 1 plus the coupling coefficient, and the frequency of the higher peak is found by dividing the original frequency by the square root of 1 minus the coupling coefficient. All of the frequencies are to be in the same unit; in cycles, kilocycles, or megacycles.

The two resonant peaks appear to be due to having two different values of inductance acting at the same

time. One of these inductances is equal to the self-inductance plus the mutual inductance, and the other is equal to the self-inductance minus the mutual inductance. In the preceding example, where the self-inductance is 800 microhenrys, the mutual inductance is about 16 microhenrys when the coupling coefficient is 0.02. Then one of the inductances which cause a resonant peak is equal to the sum of 800 and 16, or is 816 microhenrys, and the other is 800 minus 16, or is 784 microhenrys. If these two inductances, together with the capacitance of the tuning capacitors are used in any of the usual formulas for frequency, those formulas will give the frequencies of the lower and upper peaks.

If the two coupled tuned circuits such as shown in Figs. 9-3 and 9-4 are separately tuned to two frequencies which are slightly different from each other, instead of to the same frequency, there will be two current peaks. One of these peaks will be at a frequency lower than the lower tuned frequency, and the other will be at a frequency higher than the higher tuned frequency. Were the two tuned frequencies to be represented by the broken line resonance curves of Fig. 9-6, the variation of current at nearby frequencies might be about as shown by the full-line curve. A small change in the tuning of either circuit will cause a relatively large shift of the peaks of current at the two resonant frequencies.

**Power Transfer in Coupled Circuits.**—The maximum current that may be induced in the secondary of two coupled circuits is affected by the high-frequency resistance in both the primary and secondary circuits; more resistance means less secondary current, and less resistance means more secondary current, with the same applied alternating potential.

The relations between resistances and currents may be shown by formulas when using the following symbols for the various quantities:

- $E$  Applied alternating potential, volts.
- $f$  Frequency, cycles.
- $I_p$  Current in primary, amperes.
- $I_s$  Maximum possible secondary current, amperes.
- $M$  Mutual inductance, henrys.
- $R_p$  High-frequency resistance in primary circuit.
- $R_s$  High-frequency resistance in secondary circuit.

When both the primary and secondary circuits are tuned to the frequency of the applied potential the relations are,

$$(6.28 \times f)^2 \times M^2 = R_p \times R_s$$

The maximum possible secondary current is,

$$I_s = \frac{E}{2 \times \sqrt{R_p \times R_s}}$$

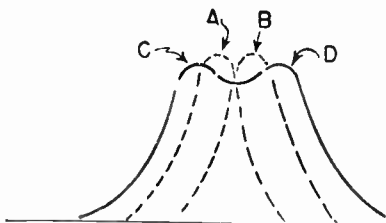

Fig. 9-6. Effect of tuning windings to different frequencies.

When the secondary current is of maximum value, as above, the mutual inductance must be,

$$M = \frac{\sqrt{R_p \times R_s}}{6.2832 \times f}$$

Under these conditions the current in the primary circuit will be,

$$I_p = \frac{E}{2 \times R_p}$$

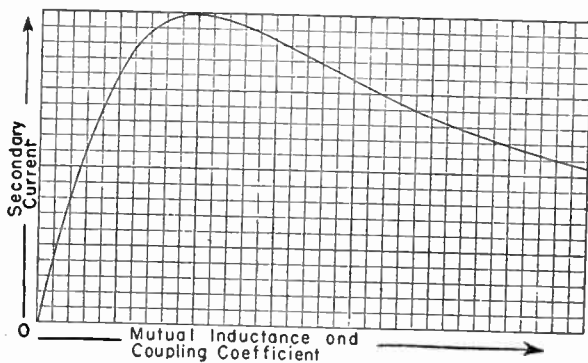

Fig. 9-7. Effect of coupling on current in secondary winding.

The secondary current varies with mutual inductance and coupling coefficient as shown, in general, by Fig. 9-7. With zero coupling or zero mutual inductance there is, of course, no induced current in the secondary circuit. As the coupling is increased there is a rapid increase of secondary current to its maximum possible value. Then, as the coupling is made still closer, which increases the mutual inductance and the coupling coefficient, the secondary current commences to fall off in value, and it continues to decrease as the coupling is

made closer and closer. The current curve falls off less and less rapidly, since no matter how close the coupling may be made, there always will be a considerable current induced in the secondary circuit. Fig. 9-7 illustrates the important fact that there is an optimum coupling with which there is the maximum possible current in the secondary, and that with a coupling which is either looser or closer there will be a smaller secondary current.

The ratio of secondary current to primary current in the double-tuned high-frequency transformer is,

$$\frac{\text{Secondary } I}{\text{Primary } I} = \frac{R_p}{\sqrt{R_p \times R_s}}$$

Thus it appears that the secondary current is increased in comparison with the primary current by lessening the resistance of the secondary circuit or by increasing the resistance of the primary circuit. This is true when the coupling is adjusted to cause maximum current in the secondary circuit.

Computation of the ratio of secondary voltage to primary voltage is more complicated. However, with both of the resonant circuits tuned to the frequency of the applied potential, and with decreasing resistances in both circuits, the ratio of secondary to primary voltage comes closer and closer to,

$$\frac{\text{Secondary } E}{\text{Primary } E} = \sqrt{\frac{\text{primary capacitance}}{\text{secondary capacitance}}}$$

If the primary and secondary circuits are closely coupled, but are not tuned to the same frequency, the ratio of secondary voltage to primary voltage comes closer and closer to the ratio of secondary turns to primary turns as the circuit resistances are made smaller and smaller. That is,

$$\frac{\text{Secondary } E}{\text{Primary } E} = \frac{\text{turns on secondary coil}}{\text{turns on primary coil}}$$

This latter relation between voltages and turns on the coils or windings is the same that exists in transformers which have iron cores. But, in view of the preceding explanations, it seldom may be correctly assumed that the voltage ratio is even approximately equal to the turns ratio in high-frequency transformers having air-core coils and tuned circuits.

## Section 10

### TRANSFORMERS

The following formulas show the approximate relations between currents, potential differences, and numbers of turns in the windings of transformers.

- $E_p$ , Primary potential difference, effective volts.
- $E_s$ , Secondary potential difference, effective volts.
- $I_p$ , Primary current, effective amperes.
- $I_s$ , Secondary current, effective amperes.
- $N_p$ , Number of turns in primary winding.
- $N_s$ , Number of turns in secondary winding.

$$E_p \times I_p = E_s \times I_s$$

$$\frac{E_s}{E_p} = \frac{N_s}{N_p} \qquad \frac{I_s}{I_p} = \frac{N_p}{N_s}$$

$$E_s = E_p \frac{N_s}{N_p} \qquad E_p = E_s \frac{N_p}{N_s}$$

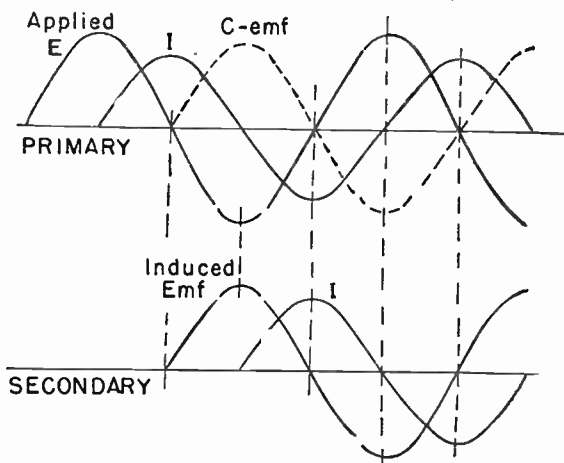

Fig. 10-1. Phase relations of transformer potentials and currents.

**Phase Relations.**—Phase relations of currents and potentials in the primary and secondary windings of a transformer are shown by Fig. 10-1. Primary current lags the applied primary voltage by approximately  $90^\circ$ . The counter-emf in the primary is in opposite phase with the applied primary voltage. The emf induced in the secondary is in phase with the counter-emf of the pri-

mary, so is in opposite phase to the applied primary voltage. The secondary current lags the induced secondary emf by approximately 90°, and is in opposite phase to the primary current.

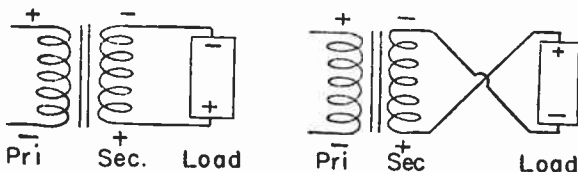

Fig. 10-2. Secondary connections determine load polarity.

The opposite instantaneous polarities in primary and secondary ordinarily have no particular significance so far as the secondary load is concerned. As shown by Fig. 10-2, it is necessary only to reverse the connections between the terminals of the secondary winding and the load in order to make either end of the load of either polarity with reference to polarity in the primary circuit or the source.

**Transformer Regulation.**—The regulation of a transformer is a measure of the difference between the secondary voltage at no load and at rated load.

$$\text{Regulation} = \frac{E_s \text{ at no load} - E_s \text{ at rated load}}{E_s \text{ at rated load}}$$

Assume that the no-load secondary voltage is 275 and that the voltage drops to 250 at rated load. Then,

$$\text{Regulation} = \frac{275 - 250}{250} = \frac{25}{250} = 0.1 \text{ or } 10\%$$

Assume that the transformer in question is to deliver 250 secondary volts at rated load when the primary voltage is 125. This is a voltage ratio of 2-to-1, secondary to primary, at rated load. But at no-load the secondary voltage is 275, and the voltage ratio, secondary to primary, is 275-to-125, which is a ratio of 2.2-to-1. In order to have a rated-load voltage ratio of 2-to-1 the turns ratio, secondary to primary must be 2.2-to-1. If, for example, there are 500 turns on the primary, the number of secondary turns will be  $2.2 \times 500 = 1100$ .

The larger the fraction or the per cent which represents regulation the poorer the regulation is said to be, and the smaller the fraction or the per cent the better is the regulation.

Regulation is improved by using a core of larger cross sectional area, also by using more turns per volt in the windings. Poor regulation sometimes is desired in certain power transformers in order that the second-



ary voltage may drop sharply with overloads, and thus protect the transformer against overheating and burn-out.

#### POWER TRANSFORMERS

The following notes apply to single-phase power transformers of rated secondary outputs up to about 3,000 volt-amperes, such as generally used in radio apparatus. Unless otherwise specified it is assumed that operation is at 60-cycle frequency. The basic transformer formula is,

$$E = \frac{4.44 f N A B}{100\ 000\ 000} \text{ or } \frac{f N A B}{22\ 500\ 000}$$

- A* Cross sectional area of portion of core on which windings are placed, in square inches.
- B* Flux density, in magnetic lines per square inch of core cross section.
- E* Terminal potential difference of winding considered, in effective volts or r-m-s volts.
- f* Operating frequency, cycles per second.
- N* Number of turns on winding considered.

The formula may be rearranged to show required core area in square inches, or required number of winding turns, or resulting flux density in lines per square inch.

$$A = \frac{22\ 500\ 000\ E}{f N B}$$

$$N = \frac{22\ 500\ 000\ E}{f A B}$$

$$B = \frac{22\ 500\ 000\ E}{f N A}$$

Small power transformers often have cores made with 3.5% to 4.0% silicon steel, of No. 29 U.S.S. sheet gage which is 0.014 inch thick, and are operated with flux densities between 60,000 and 90,000 lines per square inch. If it is assumed that the flux density is 75,000 lines and that the frequency is 60 cycles, three of the formulas are simplified as follows:

$$E = \frac{N A}{5} \qquad A = \frac{5 E}{N} \qquad N = \frac{5 E}{A}$$

With a shell type transformer having a core arranged substantially as in Fig. 10-3 the core area is the cross section, in square inches, of the center leg on which are placed the primary and secondary windings. The areas of each of the outer legs and of the top and bottom are approximately half that of the center winding leg.

Transformers usually are rated in the number of volt-amperes of secondary output, which is equal to the product of rated secondary volts and rated secondary amperes. A volt-ampere rating is independent of power

factor in the load. A rating in watts is dependent on the load power factor, and if the rating is based on assumed unity power factor, which seldom exists, the actual power-handling capacity of the transformer will be less than its rating by a percentage or fraction corresponding to the power factor. If there are two or more secondary windings, the rating for purposes of design is equal to the sum of the ratings of all the secondaries.

**Transformer Design.**—The methods of transformer design here described are useful in layout for one or a very few transformers which will have good efficiency and which will not be damaged by moderate overloads. For high efficiency combined with minimum weight and cost, as would be required for commercial production, more elaborate computations would be used.

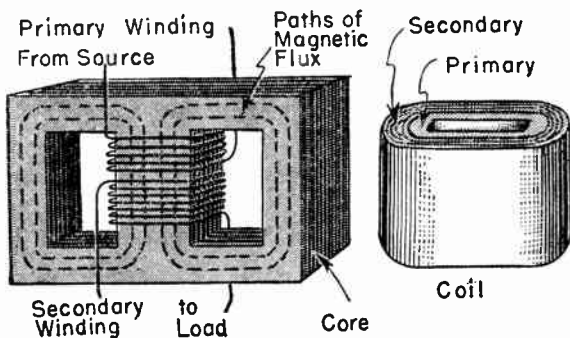

Fig. 10-3. The parts of an iron-core transformer.

The first step is to determine the required core area in accordance with the known volt-ampere rating. The following formula serves most purposes.

$$\text{Core area, sq. inches} = 0.17\sqrt{\text{volt-ampere rating}}$$

The multiplying factor given as 0.17 might be anywhere between 0.16 and 0.18. The smaller the cross sectional area the greater will be the flux density in the core.

*Example.*—What should be the core area for a transformer rated at 1200 volt-amperes?

$$\text{Area} = 0.17\sqrt{1200} = 0.17 \times 34.64 = 5.89 \text{ sq. in.}$$

Using a factor of 0.16 the area would be 5.54, and with a factor of 0.18 it would be 6.23 square inches. With square cross sections the sides of the corresponding squares would be 2.35 inches minimum and 2.50 inches maximum.

The next step is to determine the number of turns for the primary winding. The formula for number of turns,  $N$ , is used.

*Example.*—Assuming that a core of 2.5 inch sides in square shape is available, the core area  $A$  will be 6.25 square inches. It will be assumed also that the primary voltage is 117, the frequency 60 cycles, and the flux density 80,000 lines per square inch. Placing these values in the formula gives,

$$N = \frac{22\,500\,000 \times 117}{60 \times 6.25 \times 80\,000} = 87.8 \text{ turns}$$

Another method is to compute the number of turns per volt and then multiply by the number of volts.

$$\text{Turns per volt} = \frac{4.8}{\text{core cross section, sq. in.}}$$

With this method we would have,

$$\text{Turns/volt} = \frac{4.8}{6.25} = 0.768$$

$$0.768 \times 117 \text{ (volts)} = 89.8 \text{ turns}$$

The next step is to determine the number of turns for the secondary winding. The computation takes into consideration the desired voltage ratio and the regulation. For transformers of the type being considered, an approximation of the per cent of regulation may be had from the following formula:

$$\text{Regulation, per cent} = \frac{6}{\sqrt{\text{core cross section, sq. in.}}}$$

For the transformer being considered, the cross sectional area of the core is 6.25 square inches. Then the regulation is approximately,

$$\text{Regulation} = \frac{6}{\sqrt{6.25}} = \frac{6}{2.5} = 2.4\%$$

*Example.*—Assume that the secondary voltage at rated load is to be 250 and that the regulation is 2.4%. Assume also that the primary winding is to have 88 turns.

The voltage ratio, secondary to primary, is 250/117. Not considering the allowance for regulation, the number of secondary turns would be found thus:

$$\frac{250}{117} \times 88 \text{ (pri. turns)} = 188 \text{ turns}$$

This number of turns should be increased by 2.4% to allow for voltage drop due to regulation. The percentage 2.4 is the same as the fraction 0.024. Then the number of turns should be equal to the number for the voltage ratio multiplied by 1.024.

$$188 \times 1.024 = 192.5 \text{ turns}$$

The next step is to determine the wire size with the help of the tables of *Magnet Wires*.

Previously it was stated that the secondary rated output of the transformer considered is to be 1200 volt-amperes. Assuming 250 secondary volts at rated load, the secondary current is,

$$\text{Amperes} = 1200 \text{ (v-a)} \div 250 = 4.8$$

It is common practice to select a wire size having the required current capacity as based on 1500 circular mils per ampere. If there are likely to be long-continued overloads the wire should be selected for 1000 circular mils per ampere. An intermediate capacity is found by adding 1 to the gage number of the wire whose rating is based on 1500 circular mils. For example, if number 20 wire operates at 1500 circular mils, number 21 will operate at about 1270 circular mils.

For hand assembly or hand winding, wire larger than number 12 usually is double cotton covered, gage sizes between number 12 and number 26 usually are cotton enameled, and sizes smaller than number 26 may be silk enameled. Plain enamel often is used in commercial transformers for the smaller sizes, but it is difficult to wind without incurring danger of broken insulation and short circuits.

Going to the *Magnet Wire* table for current capacity it is found that for a basis of 1500 circular mils per ampere (*Open Coil* column) the required 4.8 amperes of secondary current calls for number 13 wire. Assuming the use of double cotton covered wire, the table for such wire shows that it will wind 140 turns per square inch. This information will be used in determining the window size for the core.

Current in the primary winding will be proportional to the volt-amperes of output and the transformer efficiency, or the transformer losses. That is, the primary current will be somewhat increased to care for the energy losses. Considering the volt-ampere rating of the transformer and the primary voltage, the primary current would be,

$$\text{Amperes} = 1200 \text{ (v-a)} \div 117 = 11.3$$

The total energy loss (copper plus iron losses) may be taken as double the percentage of voltage regulation, which, in the present case, would be 4.8%. Adding 4.8% to the already computed primary current gives,

$$11.3 \times 1.048 = 11.84 \text{ amperes.}$$

The *Magnet Wire* table shows that this current calls for number 9 wire. With double cotton covering this wire winds 59 turns per square inch.

To determine the required window area for the wind-

ings it is necessary to consider the numbers of primary and secondary turns, and the turns per square inch.

For the secondary winding,

$$\frac{193 \text{ turns}}{140 \text{ turns per sq. in.}} = 1.38 \text{ square inches}$$

For the primary winding,

$$\frac{88 \text{ turns}}{59 \text{ turns per sq. in.}} = 1.49 \text{ square inches}$$

Then the total window area for the windings is,

$$1.38 + 1.49 = 2.87 \text{ square inches}$$

To this must be added a safe allowance for insulation around the core, or for the cardboard or fibre bobbin on which the windings are placed, also for insulation between primary and secondary and for the insulating wrapping around the outside of the windings.

**Lower Operating Frequencies.**—For a 25-cycle transformer, as compared with a 60-cycle type of the same rated output, the core area is multiplied by about 1.67, the turns per volt by 1.3, the weight of core iron by 2.2, and the weight of copper wire by about 1.7. Losses will be somewhat greater and efficiency correspondingly lower.

For a 50-cycle transformer the core area is multiplied by about 1.13, the turns per volt by 1.06, the weight of iron by 1.2 and the weight of copper by about 1.1.

#### COLOR CODING OF TRANSFORMERS

Fig. 10-4 shows the RMA standard color coding for power transformer leads. The upper diagram shows the coding for an untapped primary and three secondaries; one for the high voltage or plate supply, a second for the rectifier filament, and a third for the amplifier filaments or heaters. Secondary center taps, if used, are colored as shown for the broken-line tap leads. A tapped primary winding is coded as shown by the lower left-hand diagram. Additional windings for amplifier filaments or heaters are coded as shown by the lower right-hand diagram.

Fig. 10-5 shows standard color coding for interstage audio-frequency transformers and for output transformers connected to the moving coil of a loud speaker. As shown by the two upper diagrams, coding is the same for interstage and output units. With center tapped windings, the coding of the third diagram from the top is used when the ends of the windings may be connected to either of the plates or to either of the grids. When necessary to distinguish the plate leads from each other or the grid leads from each other, the coding of the bottom diagram is used. Note that plate leads are blue except in the bottom diagram, that B+

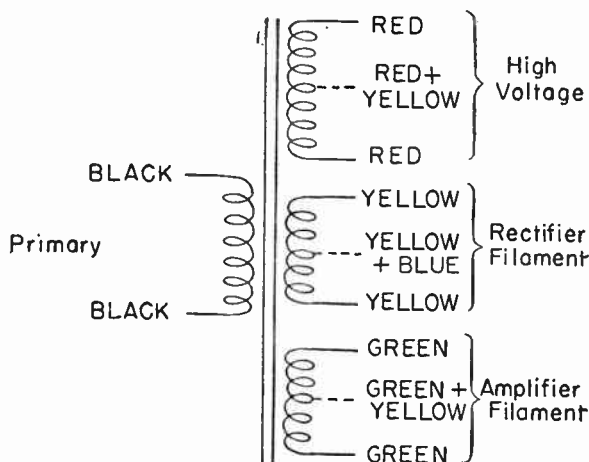

Tapped Primary

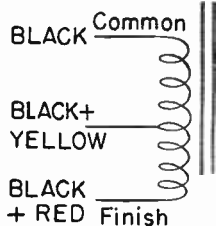

Additional Amplifier Filaments

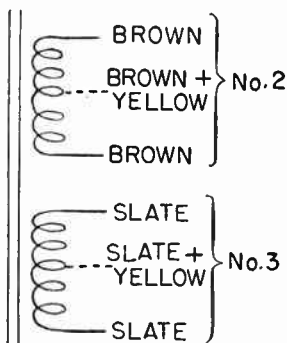

Fig. 10-4. Color coding for leads of power transformers.

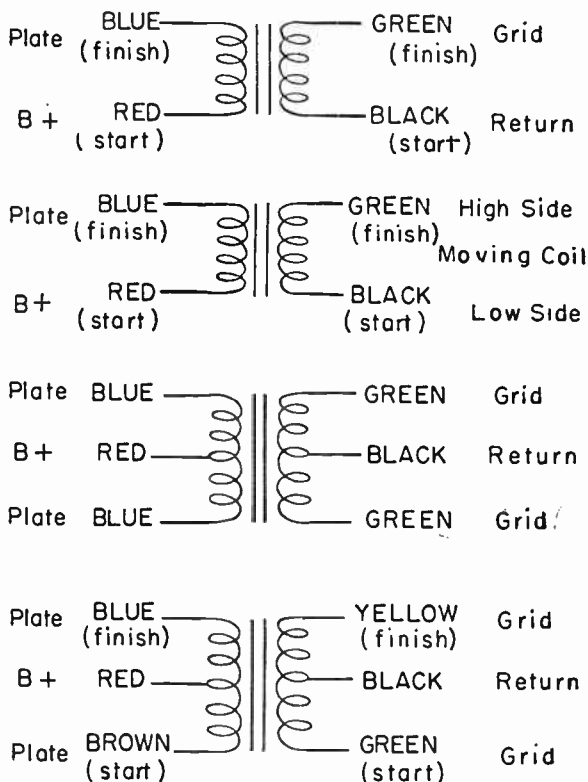

Fig. 10-5. Color coding for audio-frequency transformers.

leads always are red, that grid leads always are green except in the bottom diagram, and that grid return leads always are black.

Fig. 10-6 shows the standard color coding for loud speaker field coils and moving coils or voice coils. The lower diagrams show the coding for a tapped field winding and for two separate field windings on one core. Note that colors for the moving coil leads correspond to those on the output sides of output coupling transformers shown by Fig. 10-5.

Fig. 10-7 shows the standard color coding for intermediate-frequency transformers. The coding for the center-tapped secondary of the lower diagram is used for connections to two diodes.

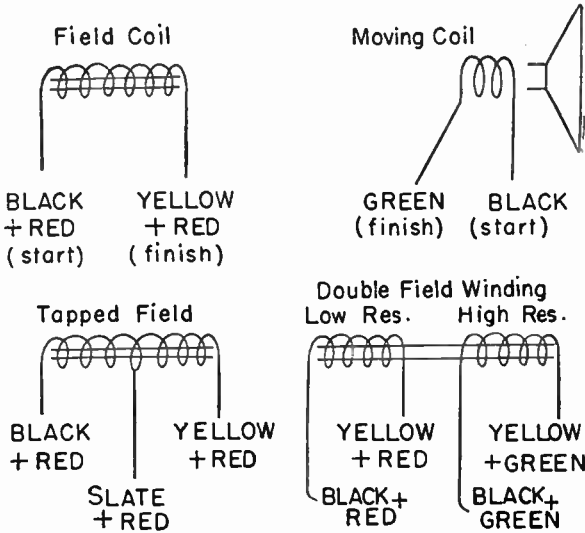

Fig. 10-6. Color coding for loud-speaker connections.

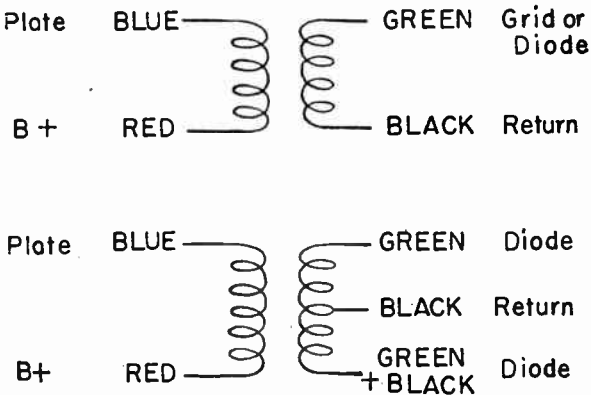

Fig. 10-7. Color coding for intermediate-frequency transformers.



## TRANSFORMER CONNECTIONS

**Impedance Matching.**—In order that a triode power tube may deliver maximum possible power output with a permissible amount of distortion, the resistance or impedance of the load in the plate circuit is made considerably greater than the plate resistance of the tube. Pentode and beam power amplifier tubes have very high plate resistances, and the impedances or resistances of loads in their plate circuits are made much smaller than the plate resistances. Plate resistances and load resistances are listed in the tables of tube characteristics.

The greater the inductance of the primary winding of the power output transformer the lower will be the audio frequency at which there is satisfactorily high output. To maintain such a satisfactory low-frequency output, the primary impedance must be increased also with the plate resistance of a triode power tube or with the optimum load resistance of a pentode or beam power amplifier.

The resistance or impedance of a loud speaker or other load on the secondary of the output transformer affects the impedance offered to the tube by the primary winding. To match the impedances so that the tube may operate as desired, the turns ratio of the output transformer, secondary to primary, is made approximately equal to the square root of the ratio of load impedance to the impedance or resistance desired in the plate circuit of the tube.

$$\frac{N_s}{N_p} = \sqrt{\frac{\text{actual impedance of load}}{\text{impedance desired in plate circuit}}}$$

*Example.*—A power tube in whose plate circuit it is desired to have a resistance (or impedance) of 6000 ohms is to feed a load having an input resistance (or impedance) of 500 ohms. What is the desirable turns ratio for the output coupling transformer?

$$\frac{N_s}{N_p} = \sqrt{\frac{500}{6000}} = \frac{22.7}{77.5}$$

This is a ratio, secondary to primary, of about 0.3 to 1.

**Multiple Windings and Tapped Windings.**—Several secondaries may be used with a single primary on the same transformer. At *A* in Fig. 10-8 is represented a 300-volt secondary and a 5-volt secondary on a transformer whose primary is designed for connection to a 120-volt supply circuit. The various secondary voltages are obtained by choosing suitable turns ratios between each of the secondaries and the single primary.

At *B* in Fig. 10-8 is shown a *tapped secondary* with a tap connection brought out at such a number of turns

along the secondary winding that the potential between the tap and the upper end of the secondary is 100 volts, and between the tap and the lower end is 5 volts. The potential between top and bottom ends of this secondary would be 105 volts.

At *C* in Fig. 10-8 is shown a tapped secondary from which may be had either of two potentials. When the load circuit is connected to the bottom common terminal and the top terminal the load potential will be 220 volts, and when connected between the common and the tap the load potential will be 200 volts. The difference in secondary voltages results from the fact that there are more turns between the common and the 220-volt terminal than between the common and the 200-volt tap. At *D* is shown a tapped primary with which it is possible to maintain the same secondary potential when the primary is connected to a 110-volt

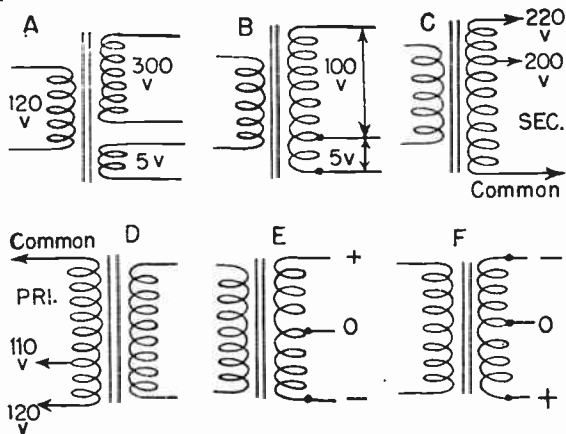

Fig. 10-8. Multiple and tapped windings of transformers.

supply through its common lead and the 110 volt tap, and when it is connected to a 120-volt supply through the common and the lower end of the primary. There are fewer primary turns between the common and the 110-volt tap than between the common and the 120-volt terminal, so there is a greater step-up ratio for secondary potential with the 110-volt primary connection than with the 120-volt primary connection. Additional primary taps might be provided to accommodate other supply potentials.

At *E* in Fig. 10-8 is shown a *center-tapped* secondary, with which the tap connection is brought out from the electrical center of the winding. During the half-cycle

in which the top of the secondary is positive and the bottom negative (diagram *E*), the center tap will be midway between the positive and negative potentials, which means that it will be at zero potential. During the opposite half-cycle, in which the polarities of the ends of the secondary reverse, as in diagram *F*, the center tap still is at a potential midway between the end potentials, so still is at zero potential. A center tap provides a point of practically unvarying potential in a circuit connected to a secondary winding. Such constant potential points or zero potential points are needed in many radio circuits.

**Identifying Transformer Windings.**—The high-voltage and low-voltage windings, or the primary and secondary windings of a transformer, together with their relative polarities, may be identified with a single dry-cell and a d-c meter reading 0 to 10 volts or having a range of this general value.

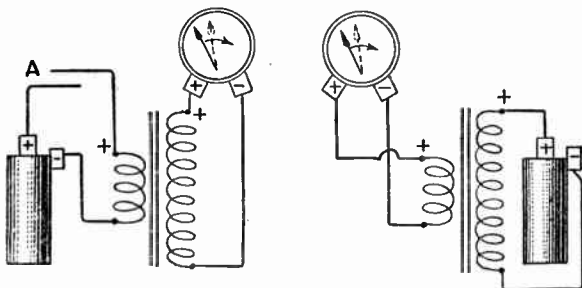

Fig. 10-9. Testing polarity of transformer windings.

When a direct potential is applied to either the primary or the secondary in a certain polarity, there will be an induced emf and an accompanying current in the other winding. The direction of the induced emf and current depends on the direction or polarity of the potential applied to the first winding. Transformer leads or terminals may be marked in such manner as to show the instantaneous relative polarities of the ends of the windings. Such markings permit correct connections of primaries, secondaries, or both, either in series or in parallel.

As shown at the left-hand side of Fig. 10-9, either winding may be connected to the terminals of the d-c meter. One end of the other winding is connected to one terminal of the dry cell, and wires (or a switch) are arranged so that a momentary connection may be made from the remaining terminal of this other winding to the other terminal of the dry cell. When the battery

connection at *A* is momentarily closed, the pointer of the meter will jump upward on its scale and then will drop back to zero, or else will jump to the left of zero and then return to zero. When the connection at *A* is opened the meter pointer will jump in a direction the opposite of its first movement, and then will return to zero. Connections to either the dry cell or the meter should be made in such a way (reversing them if necessary) that the meter pointer jumps upward on its scale when the connection at *A* is closed.

The transformer leads or terminals then connected to the positive of the dry cell and to the positive of the meter should be marked "+" or otherwise identified for future reference.

If, as at the right-hand side of Fig. 10-9, the positions of dry cell and meter are interchanged with reference to the transformer windings, it will be found that the meter behaves just as before. Thus it makes no difference to which winding of the transformer the dry cell and meter are connected when making the identifying tests.

It is evident that when current from the dry cell flows *into* either connection marked "+" there will be an induced current flowing *out* of the other similarly marked terminal. During operation on alternating potential, current will flow into one "+" terminal and out of the other one during one half-cycle, and during the opposite half cycle will flow out of the first "+" terminal and into the second one.

The distance to which the meter pointer rises on its scale gives a rough indication of which winding has the greater number of turns. With the battery connected to a winding of few turns and the meter to one of many more turns, the pointer will jump much farther than when the battery is connected to many turns and the meter to fewer turns. Ordinarily it is easy to thus distinguish primary from secondary windings, and to distinguish high-voltage or plate supply secondaries from filament or heater supply secondaries. If the dry cell is connected to one filament or heater secondary and the meter to another it is possible to determine which is the higher voltage (more turns) winding. Any winding will act as a primary, when connected to the dry cell, and any other will act as a secondary.

**Transformers in Series or Parallel.**—When the terminals of two power transformers have been identified and marked as just explained, the secondaries may be connected in series as at the left in Fig. 10-10 to deliver a high potential to the load, or in parallel as at the right to deliver more current to the load.

Transformer secondaries in series will deliver the sum

of their separate potentials, whatever those potentials may be. But the total current from both secondaries must not exceed the permissible current capacity of the one having the smaller capacity. For instance, if the capacity of one secondary is 0.5 ampere, and of the other one is something like 2.5 amperes, only 0.5 ampere may be taken from both together when in series.

If the connections of one of the series secondaries is reversed, the total output potential from the two will be

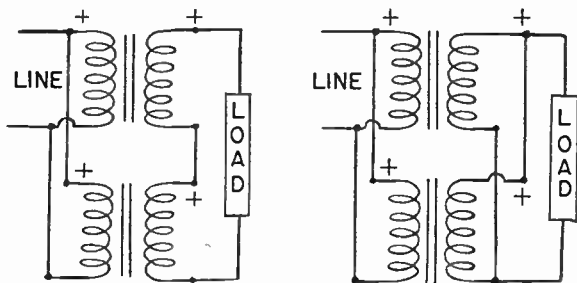

Fig. 10-10. Transformers in series and in parallel.

equal to the difference between the greater and the smaller of the separate potentials.

When secondaries are connected in parallel, both must be of the same rated voltage to avoid partial short-circuiting of one winding by the other. The two parallel secondaries should have the same voltage regulation, and preferably should have the same turns ratios and impedance ratios. For practical purposes, the parallel connection is limited to two (or more) identical transformers.

## Section 11

### POWER SUPPLY FROM A-C OR D-C LINES

Typical of power supplies furnishing plate and screen potentials up to 400 volts and d-c currents totaling up to 200 milliamperes is the arrangement shown by Fig. 11-1. Commonly used rectifier tubes include the 5U4, 5X4, 5Y3, 5Y4 and 80 types in the filament-cathode class, and the 6X5 heater-cathode type, all of which are full-wave tubes. The filter usually is of the capacitor input type having two capacitors,  $C_a$  and  $C_b$ , with the speaker field acting as the filter choke.

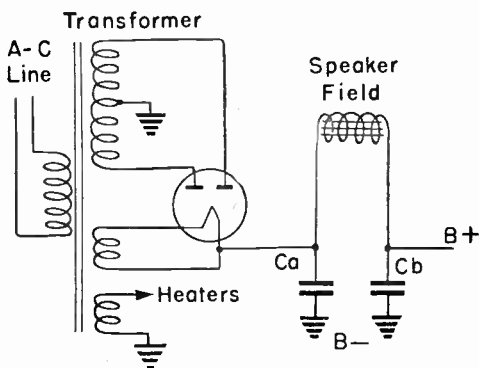

Fig. 11-1. A typical D-C power supply.

Many ac-dc receivers operating directly from power and lighting lines at 117 average a-c volts without a transformer employ the half-wave rectifier arrangement of Fig. 11-2 or some modification of it. Across the line are connected in series the rectifier heater and the resistance  $R_a$  which usually consists of the heaters of all the amplifier tubes connected in series, together with a fixed resistor when an additional voltage drop is required to make the total drop equal to line voltage. One side of the line is connected to the rectifier plate through resistor  $R_b$ , or, in some receivers, through a pilot lamp and a tapped portion of the rectifier heater in parallel between the line and the plate. The capacitor input filter includes capacitors  $C_a$  and  $C_b$  with the speaker field acting as filter choke, or else with a fixed resistor in plate of the choke. Commonly used rectifiers include the 35Z5, 35Z3, and 25Z6. The latter, being a full-wave

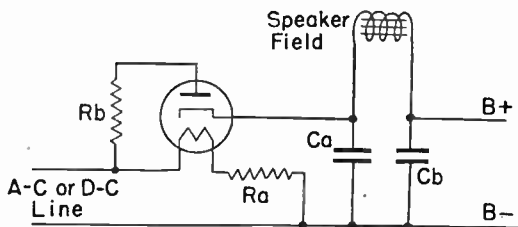

Fig. 11-2. Half-wave rectifier for AC-DC receivers.

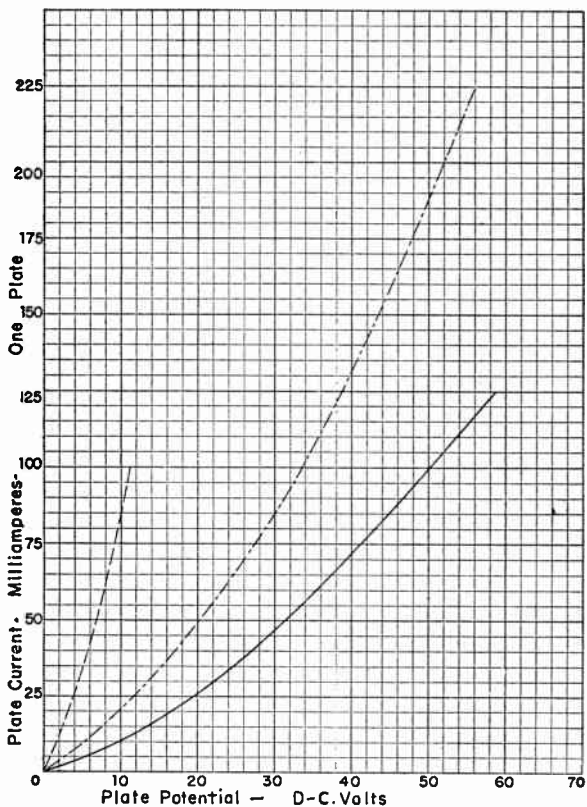

Fig. 11-3. Average plate characteristics of rectifier tubes.

type, is used with its plates connected in parallel for half-wave operation.

The average plate characteristics of several rectifiers of the high vacuum type are shown by Fig. 11-3. The right-hand broken line curve applies to types 35Z3, 35Z4, and 35Z5. The center dot-dash curve applies to types 5U4 and 5X4. The right-hand full line curve applies to types 5Y3, 5Y4, and 80. The characteristics of other types of high vacuum rectifiers lie between the left-hand and right-hand curves. At half of the maximum rated currents, the plate resistance indicated by the left-hand curve is about 100 ohms, by the center curve is about 200 ohms, and by the right-hand curve is about 400 ohms.



Fig. 11-4. Effect of various capacitances in first filter capacitor.

**Capacitor Input Filters.**—With capacitor input filters for full-wave systems such as shown by Fig. 11-1, the first capacitor  $C_a$  ordinarily has a capacitance between 8 and 30 mfd, and the second capacitor  $C_b$  may have somewhat greater capacitance. A fair average value is 20 mfd for each position. For half-wave systems such as shown by Fig. 11-2 the first capacitor  $C_a$  ordinarily has a capacitance between 20 and 40 mfd, and the second capacitor  $C_b$  may be between 20 and 50 mfd. Fair average values would be 30 mfd at  $C_a$  and 25 mfd at  $C_b$ .

Fig. 11-4 shows the effect on power supply performance of changing the capacitance of the first filter capacitor. The curves apply to rectifier types 25Z5 and 25Z6 with alternating potential of 117 r-m-s volts applied to the plate. The curves show performance with capacitances of 32, 16, 8 or 4 mfd. The vertical scale represents the resulting d-c volts across the input to the



filter, and the horizontal scale represents load current in d-c milliamperes.

When there is no current flowing through the filter to the load, the input capacitor is charged to practically the peak a-c potential which, for 117 r-m-s volts would be

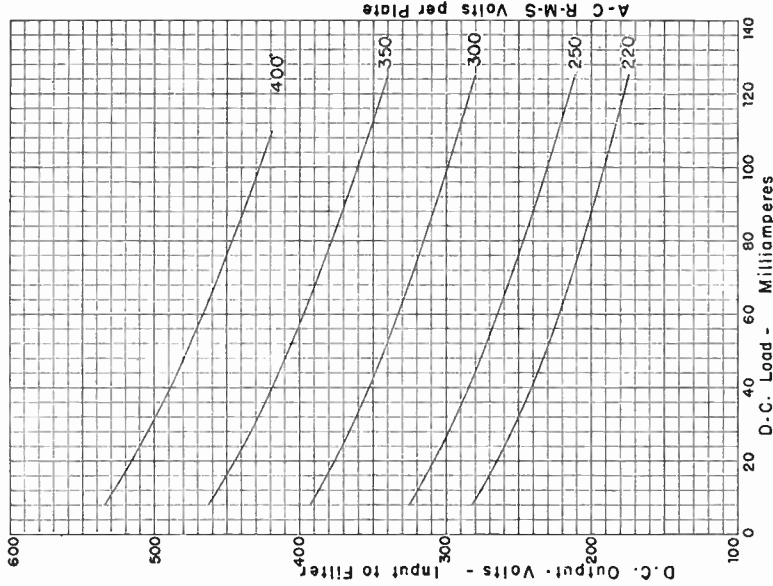

Fig. 11-5. Effect of a-c input potentials to the filter.

$1.414 \times 117 = 165.5$  volts. This maximum potential across the filter input appears as about 162 volts in the graph. As more and more load current is drawn from the filter the first capacitor is charged, between a-c potential pulses, to lower and lower voltages, which are the input voltages to the filter. The greater the capacitance of the first capacitor the less is its loss of potential between pulses and the higher remains its charge and potential.

The potential difference which is applied to the load from the output of the filter is less than the input potential shown by Fig. 11-4 because of the voltage drop in the resistance of the filter choke or the filter resistor used in place of a choke. However, the load potential is directly dependent on the input potential to the filter, and increasing the capacitance of the first filter capacitor has the effect of raising the load potential for any given load current and applied a-c potential. It is apparent from the graph that the d-c output potential may be somewhat in excess of the a-c r-m-s potential applied to the filter input, or it may be much less than the a-c input potential.

For example, assuming a 30 milliampere (0.030 ampere) load current, a speaker field (filter choke) resistance of 500 ohms, and a 32-mfd filter input capacitor: The filter input potential shown by Fig. 11-4 is 143 volts, the voltage drop in the speaker field is  $500 \times 0.030 = 15$  volts, and the potential remaining at the filter output is  $143 - 15 = 128$  volts. The field current and resistance mentioned would mean only 0.45 watt for the speaker field, which would be low for most applications. Larger load currents and greater filter choke resistances will make decided reductions in filter output potential.

Fig. 11-5 shows the effect of different a-c applied voltages on the filter input potential for various load currents. The curves apply to 5Y3, 5Y4, and 80 type tubes. The filter input capacitance for all the curves is 4 mfd. For each applied a-c voltage there might be drawn additional curves for various capacitances, each set of curves for a given a-c potential then appearing generally like those of Fig. 11-4. Such curves for a type 5T4 rectifier tube are shown by Fig. 11-6. The upper set of curves applies with 400 r-m-s a-c volts per plate, and the lower set with 300 volts per plate. Each set includes curves for input filter capacitances of 4, 8 and 16 mfd. The form and slope of the curves in both sets are the same, showing that the number of volts at the output varies in the same degree regardless of input a-c voltage when there are certain changes in input capacitance.

Resistances of loud speaker field windings range from 300 to 5,000 ohms, with values between 500 and 2,500 ohms in common use. The number of watts of power used in the field winding is equal approximately to  $I^2R$ , where  $I$  is the d-c load current in amperes and  $R$  the resistance of the winding in ohms. The power in the field may be about double the normal undistorted power output of the loud speaker. For example, assuming an undistorted power output of 5 watts the power in the field winding might be 10 watts. If the d-c load current in the field winding is, for example, 120 milliamperes

(0.12 ampere) the required field resistance is found from  $R = P/I^2$  which would be  $P = 10/0.12^2 = 694$  ohms or about 700 ohms.

Separate filter chokes, which are not a part of the loud speaker, may have resistances between 100 and 600 ohms for most applications. Inductances at rated load currents commonly range from 5 to 20 henrys. The full-line

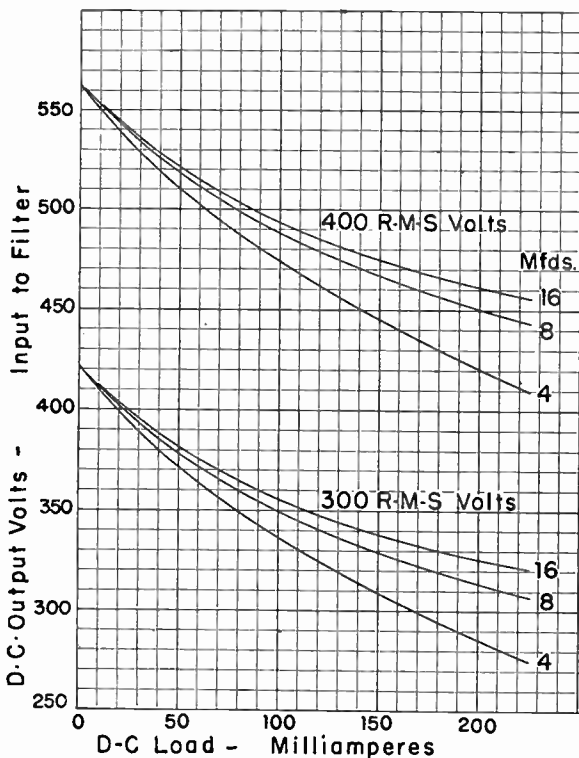

Fig. 11-6. Effect of filter input capacitance at two input potentials.

curves of Fig. 11-7 show how the inductance decreases with increase of direct current in some commercial filter chokes. With a gap in the iron core the inductance of a choke will be decreased for small currents, but will remain higher for large currents. The short-dashed line curve of Fig. 11-7 shows performance of an experimental choke with the core iron butted (no measurable gap),

and the long-dash curve shows behavior of the same core and winding with a gap of 0.018 inch in the core. Chokes ordinarily are made with cores of low permeability steel to prevent magnetic saturation and excessive drop of inductance with large currents.

The rated working voltage for the first capacitor of a capacitor input filter must be at least as high as the

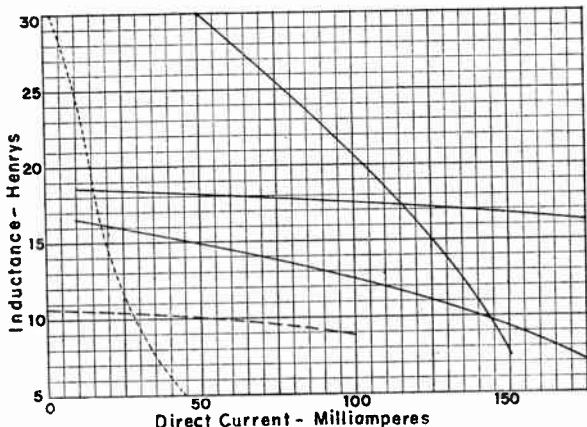

Fig. 11-7. Inductances of filter chokes vary with their current.

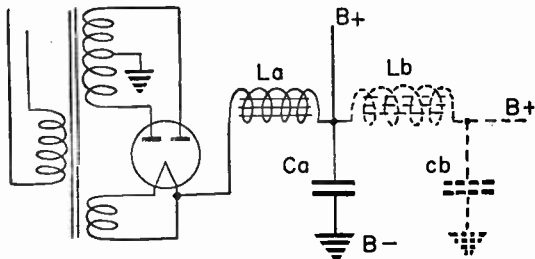

Fig. 11-8. A choke-input type of filter.

peak a-c potential, which is 1.414 times the effective or r-m-s potential as measured with an a-c meter at the filter input, or may be taken as 1.414 times the r-m-s potential from the transformer secondary, or from the line if no transformer is used. The voltage on the second capacitor normally is lower than on the first one, because of voltage drop in the filter choke or resistor, but since this voltage would be equal to that on the first capacitor with no load current, the rating of both capacitors

should be the same. Electrolytic filter capacitors are used for working voltages up to 600 or sometimes to 800, with paper capacitors for higher voltages.

**Choke Input Filters.**—With a choke input filter, shown by Fig. 11-8, the output of the rectifier tube is fed first to a choke instead of to a capacitor and a choke as in the capacitor input filter. A choke input filter system may have a single choke  $L_a$  and a single capacitor  $C_a$ , or this first section of the filter may be followed by another similar section including choke  $L_b$  and capacitor  $C_b$ .

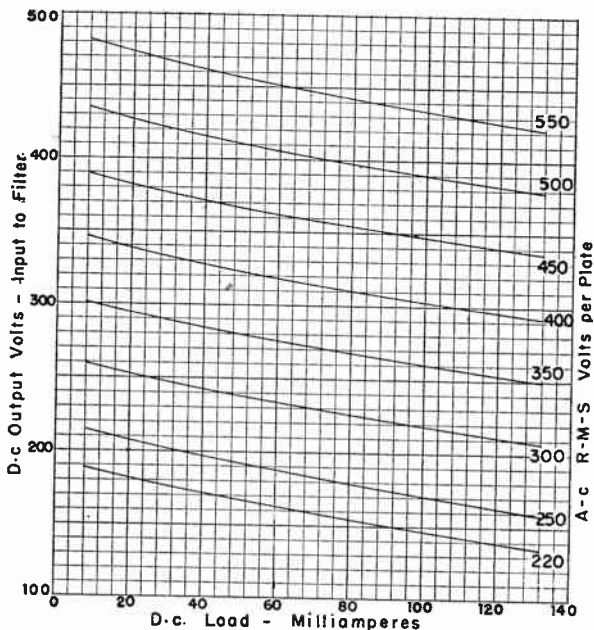

Fig. 11-9. Rectifier performance with a choke-input filter.

Fig. 11-9 shows the performance of 5Y3, 5Y4 and 80 type rectifiers with a choke input filter having a 5-henry choke. This graph may be compared with Fig. 11-5, which shows performance of the same tubes with a capacitor input filter. For the same applied a-c r-m-s potential it is seen that the rectifier output voltage, at the input to the filter, is much lower with the choke input arrangement, but that the decrease of d-c voltage with increasing d-c load current is much less for the choke input filter than for the capacitor input type.

There is a minimum permissible inductance for the first (or only) choke of a choke input filter, the value depending on the type of tube. Following are minimum inductances in henrys for the first filter choke.

MINIMUM INDUCTANCES FOR CHOKE INPUT FILTERS

Tube	Henrys	Tube	Henrys
5T4 .....	10	5Z5 .....	3
5U4 .....	3	5Z4 .....	5
5V4 .....	4	6X5 .....	8
5W4 .....	6	6ZY5G .....	13.5
5Y3 .....	5	7Y4 .....	10
5Y4 .....	5		

A rule sometimes used for selecting the choke inductance is to divide the output voltage (to the load) by the d-c load current or filter current in milliamperes. Inductances between this computed value and double the value are commonly used. For example, with 400 volts and 40 milliamperes the inductance would be  $400 \div 40 = 10$  henrys. An inductance between 10 and 20 henrys could be used. There would be little gain in voltage regulation with inductances greater than 20 henrys.

**Current and Voltage Computation.**—It is usual practice to determine the required direct current and voltage at the output of the filter, to add to the voltage the voltage drop in the filter choke or chokes ( $E = IR$ ), and thus determine the d-c output volts required from the rectifier, at the filter input, for the load current.

*Example.*—At the output of a capacitor input filter as shown by Fig. 11-1 it is desired to have a current of 68 d-c milliamperes at 300 volts. The rectifier is a 5Y3 type whose performance is shown by Fig. 11-5. The filter inductance is a speaker field coil of 850 ohms resistance. What should be the secondary voltage of the power transformer?

Drop in field winding,

$$0.068 \text{ (amp.)} \times 850 \text{ (ohms)} = 57.8 \text{ volts.}$$

Volts at input to filter,

$$300 \text{ (at output)} + 57.8 \text{ (drop)} = 357.8 \text{ volts.}$$

On the vertical line for 68 milliamperes of Fig. 11-5, 357.8 d-c output volts comes between a-c r-m-s voltages of 300 and 350, and is about two-thirds of the way from 300 to 350 volts. Then two-thirds of the difference between 300 and 350 a-c volts must be added to 300 volts.

$$\frac{2}{3} \times 50 = 33.3 \text{ volts}$$

$$300 + 33.3 \text{ volts} = 333.3 \text{ volts}$$

Then the high-voltage winding or plate winding of the power transformer must furnish 333.3 volts or about 335

volts, each side of the center tap. Since the curves of Fig. 11-5 are based on a minimum input capacitance of 5 mfd, and since the first capacitor probably would be of 8 mfd or greater capacitance, the resulting actual output voltage would be more than 300 d-c volts.

Transformer secondary current may be less or more than the d-c load current, depending on the type of filter and on whether full-wave or half-wave rectification is used. Following are the approximate relations between currents.

#### TRANSFORMER CURRENTS

Half-wave rectifier

capacitor input ..... A.C. = 1.57 × d-c output.

choke input ..... A.C. = 1.414 × d-c output.

Full-wave rectifier

capacitor input ..... A.C. = 0.785 × d-c output.

choke input ..... A.C. = 0.707 × d-c output.

In the example just considered, for 68 d-c milliamperes output from a capacitor input filter with a full-wave rectifier, we would have for the secondary current,  
 $68 \times 0.785 = 53.4$  milliamperes

**Ripple Frequency and Voltage.**—The principal frequency of the ripple or hum voltage from a half-wave rectifier is the same as the frequency of the a-c source, which ordinarily is 25, 50 or 60 cycles per second. From a full-wave rectifier the output frequency is double the power line frequency, and would be 50, 100 or 120 cycles for supply line frequencies of 25, 50 and 60 cycles respectively.

Ripple voltage increases with d-c load current, directly. This means also that the ripple voltage increases directly with d-c voltage at the filter output, and that it is inversely proportional to the effective resistance of the load on the filter output. Doubling the load halves the ripple voltage, and halving the load doubles the ripple voltage. Ripple voltage is approximately inversely proportional to the capacitances of a capacitor input filter and to the inductance of the choke. That is, doubling either capacitance or the choke inductance will halve the ripple voltage. A rough approximation of the ripple voltage from a capacitor input filter such as shown by Fig. 11-1, operating with a full-wave rectifier and 60-cycle line supply frequency, is given by the formula,

$$E_r = \frac{3.3 I}{C_a C_b L}$$

$E_r$  Ripple voltage, in volts, at 60 cycles, with full-wave rectification.

$I$  D-c load current, milliamperes.

$C_a$  Capacitance of first capacitor, microfarads.

$C_b$  Capacitance of second capacitor, microfarads.

$L$  Inductance of filter choke, henrys.

*Example.*—Assume a direct-current load of 68 milliamperes from a capacitor input filter having capacitors of 16 and 20 mfd, and a choke whose effective inductance is 15 henrys. The rectifier is a full-wave type operating on a 60-cycle supply. What is the ripple voltage at the filter output?

$$E_r = \frac{3.3 \times 68}{16 \times 20 \times 15} = 0.47 \text{ volt.}$$

For reasonably hum-free reproduction it may be assumed that the ripple voltage should not exceed one-fourth of one per cent of the d-c voltage at the filter output, and preferably should be much less. For example, with 300 d-c volts at the filter output, the ripple voltage should not exceed 0.75 volt under any conditions.

Additional reduction of ripple voltage occurs in voltage-dropping resistors which feed plates and screens of amplifying tubes when these resistors are bypassed with capacitors of ample capacitance.

**Voltage Regulation.**—Voltage regulation in the power supply system refers to the decrease of d-c output voltage that accompanies an increase of direct current to the load. This decrease of output voltage is plainly apparent in the downward slope of the curves of Figs. 11-5, 11-6 and 11-9 as the output current increases from left to right. Voltage regulation is improved, or the change of voltage is made less, by the following:

- a. Less resistance in the filter choke or chokes, or in the filter resistor.
- b. Better voltage regulation in the power transformer if one is used.
- c. Using a choke input filter instead of a capacitor input type. The difference appears in the smaller slope of the curves in Fig. 11-9 when compared with those in Fig. 11-5.
- d. Operation at higher voltages. Fig. 11-6 shows that the *change* in number of output volts for a given change of load current is practically the same at high and low operating voltages. This equal change is a smaller percentage of the higher voltage than of the low one, consequently there is better regulation at the higher voltages.
- e. Allowing a bleeder current to flow, or increasing the bleeder current. The bleeder current is a current that flows through resistance between the positive and negative sides of the filter output without going through the tube circuits. The greater the bleeder current the smaller is the percentage of the total filter current represented by any given change of current in the tube circuits, and the less is the change of voltage at the filter output.
- f. Using a mercury-vapor rectifier instead of a high-



vacuum rectifier tube. The drop of potential in a mercury-vapor tube remains at approximately 15 volts no matter what the load current, while with a high-vacuum rectifier the tube drop is many times greater, and it changes with changes of load current.

**Voltage Regulator Tubes.**—A voltage regulator tube is a gas-filled glow discharge tube in which the internal voltage drop, anode to cathode, undergoes but little variation when there are relatively large changes in current flowing through the tube. When such a tube is connected across a load in which there is varying current, the load voltage is maintained fairly steady. As the load current decreases, tending to permit higher voltage, the regulator tube draws more current from the filter system. Thus the filter output current and output voltage remain fairly constant.

### VOLTAGE REGULATOR TUBES

TYPE	VOLTAGES, D-C			CURRENT Range D-c ma.	REGULATION Per Cent approx.	BASE Diagram
	Operating, approx.	Supply, minimum	Change total			
0A2	150	185	2	5 to 30	1.3	182
0A3/VR75	75	105	3	5 to 30	4.0	181
0C3/VR105	105	133	1	5 to 30	1.0	181
0D3/VR150	150	185	2	5 to 30	1.3	181
VR 75/30	75	105	3	5 to 30	4.0	55
VR 90/30	90	150	6	10 to 30	8.3	55
VR 105/30	105	127	1	5 to 30	1.0	55
VR 150/30	150	180	2	5 to 30	1.3	55
874	90	130	7	10 to 50	3.9	2
991	60	87	8	0.4 to 2	13.3	183

The table, *Voltage Regulator Tubes*, lists operating characteristics for various types in general use. The approximate operating voltage (second column) is the voltage maintained across the load. The minimum d-c supply voltage is the lowest voltage from the filter which insures starting or breakdown of the regulator tube throughout its normal life. The change of voltage shows the number of volts by which the load voltage may vary when regulator tube current varies through the range from minimum to maximum milliamperes shown in the column headed *Current Range*. This range of current is approximately the same as the change of load current. During normal operation the regulator tube must not

be permitted to carry a current greater than the higher of the two values listed. If the tube draws much less than the lesser of the two current values ionization may cease, and the tube will stop regulating.

The regulation in per cent listed in the table represents the percentage change from the operating voltage (second column) that occurs when the tube current changes in a ratio of one to six. The numbers of base diagrams listed in the last column of the table refer to tube base connection diagram shown in the section of the Handbook dealing with *Receiving Tubes*.

Fig. 11-10 shows basic circuits for voltage regulator tubes connected across the filter output and across the load. The tube anode is connected to the positive ter-

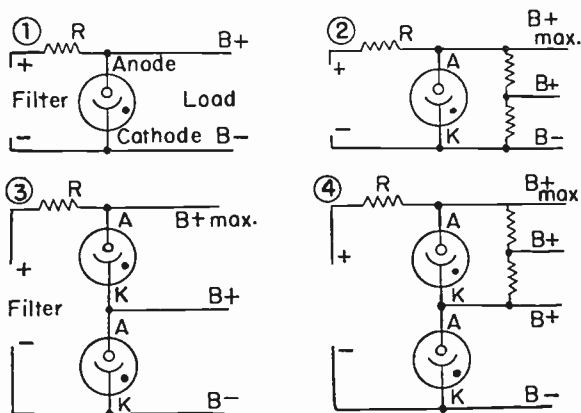

Fig. 11-10. Circuits for voltage regulator tubes.

minal of the filter and to the  $B+$  lead to the load, with the cathode connected to the negative terminal of the filter and to  $B-$  of the load. Diagram 1 shows a single tube regulating a single load voltage. Diagram 2 shows an *intermediate*  $B+$  tap on a voltage divider. Here the regulation is effective for the *maximum*  $B+$  voltage, while the *intermediate*  $B+$  will vary with load current from this tap. Diagram 3 shows two voltage regulator tubes regulating two load voltages. The load voltage between  $B-$  and  $B+$  is maintained by the lower tube, and that between  $B+$  and  $B+ \text{ max.}$  is maintained by the upper tube. The voltage between  $B-$  and  $B+$  will be the operating voltage of the lower tube, that between  $B+$  and  $B+ \text{ max.}$  will be the operating voltage of the upper tube, and that between  $B-$  and  $B+ \text{ max.}$  will be equal to the sum of the operating voltages of the two

tubes. Diagram 4 shows connections for two regulated load voltages and for an intermediate B+ tap between the two higher voltages.

A fixed resistor,  $R$  in the diagrams of Fig. 11-10 and those following, must be between the filter or other supply and the regulator tube in order to limit the tube current under normal operating conditions to the higher of the two values shown in the current range column of the tube. The required resistance at  $R$  may be determined from the formula,

$$R = \frac{1000 (E_s - E_o)}{I_m}$$

$R$  Required resistance, ohms.

$E_s$  Maximum supply potential, volts.

$E_o$  Regulated load potential, volts.

$I_m$  Maximum permissible operating tube current, milliamperes.

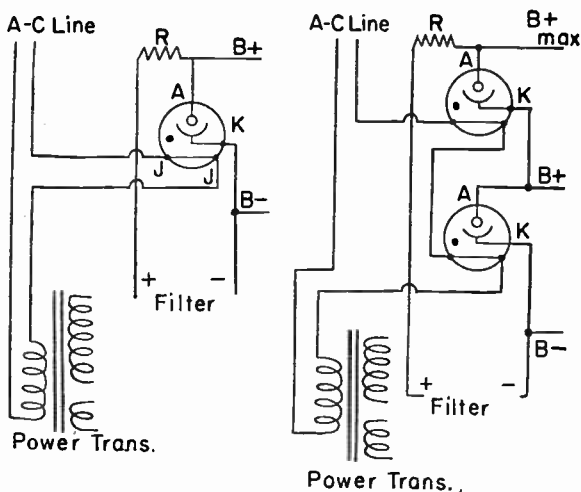

Fig. 11-11. Connections for voltage regulators with jumpers in base.

*Example.*—What protective resistance is needed for a VR-75/30 voltage regulator tube whose regulated load potential (from the table) is 75 volts and whose maximum operating current is 30 milliamperes, when the maximum supply voltage may reach 120 volts. Substituting these values in the formula gives,

$$R = \frac{1000 \times (120 - 75)}{30} = \frac{45000}{30} = 1500 \text{ ohms}$$

With such a resistor, were the load current to drop to zero and were 30 milliamperes (0.030 ampere) to flow through the resistor and the voltage regulator, the drop in the resistor would be equal to  $IR$  or  $0.030 \times 1500 = 45$  volts, and the 120 maximum volts from the supply would be dropped to  $120 - 45 = 75$  operating volts for the tube.

Fig. 11-11 shows voltage regulator tubes having a jumper in their bases, so connected that removal of the regulator tube from its socket opens the primary circuit of the power transformer. In the left-hand diagram the jumper of the single regulator tube is in series with the transformer primary. In the right-hand diagram the jumpers of the two regulators are in series with each other and with the transformer primary, so that removal of either tube disconnects the power supply.

Fig. 11-12 shows connections for voltage regulator tubes which have more than one base pin connected to the anode and cathode of the tube. The upper left-hand

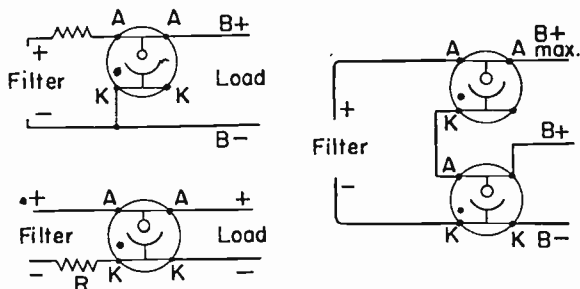

Fig. 11-12. Voltage regulators with multiple connections for base pins.

diagram shows connections for opening the B+ lead to the load when the tube is taken from its socket. The lower left-hand diagram shows connections for opening both the positive lead and negative lead to the load. The right-hand diagram shows connections for two regulator tubes regulating two load voltages, so connected that removal of either regulator opens the load circuit.

Current through regulator tubes may be much more than the operating maximum during the period before amplifying tubes heat sufficiently to draw plate and screen currents. To control larger load currents, voltage regulator tubes sometimes are connected in parallel with each other. An extra resistor of about 100 ohms resistance then must be in series with each regulator tube, as with any other paralleled gas-filled tube, to equalize the currents in the two tubes. The percentage regulation of paralleled regulators is not so good as for single tubes of similar type.

**Voltage Dividers.**—In the voltage divider of Fig. 11-13 the symbols have the following meanings:

- Ea* Supply volts.
- Eb* Intermediate output voltage.
- Ec* Lowest output voltage.
- Ib* Current from intermediate tap, milliamperes.
- Ic* Current from lowest tap, milliamperes.
- I1* Current in resistor R1, milliamperes.
- I2* Current in resistor R2, milliamperes.
- I3* Current in resistor R3, milliamperes.
- R1* Resistance of resistor R1, ohms.
- R2* Resistance of resistor R2, ohms.
- R3* Resistance of resistor R3, ohms.

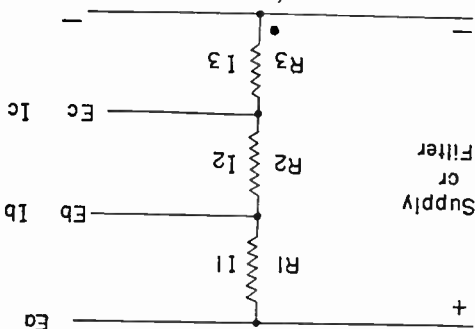

Fig. 11-13. A voltage divider.

Known to begin with are the voltages required at *Ea*, *Eb* and *Ec*, also the required currents *Ib* and *Ic*, and the desired bleeder current *I3* through resistor *R3*. The bleeder current *I3* usually is selected as about 10% or 0.1 of the total load current, although it may be either more or less. The greater the bleeder current the better is the regulation of the voltage divider system.

It is desired to determine the values of resistance for *R1*, *R2* and *R3*, also the currents in these resistors so that their power dissipation in watts may be computed. The following formulas are used.

$$I1 = Ib + Ic + I3$$

$$I2 = Ic + I3$$

$$R1 = \frac{1000 (Ea - Eb)}{Ib + Ic + I3}$$

$$R2 = \frac{1000 (Eb - Ec)}{Ic + I3}$$

$$R3 = \frac{1000 Ec}{I3}$$

*Example.*—Assume the following required values. The total load current is 74 milliamperes, so the bleeder current  $I_3$  is taken as about 10% or 7.5 milliamperes.

$E_a$ , 250 volts.  $E_b$ , 200 volts.  $E_c$ , 120 volts.

$I_b$ , 22 ma.  $I_c$ , 5 ma.

Substituting in the formulas gives,

$$I_1 = 22 + 5 + 7.5 = 34.5 \text{ ma.}$$

$$I_2 = 5 + 7.5 = 12.5 \text{ ma.}$$

$$R_1 = \frac{1000 (250 - 200)}{22 + 5 + 7.5} = \frac{50000}{34.5} = 1450 \text{ ohms.}$$

$$R_2 = \frac{1000 (200 - 120)}{5 + 7.5} = \frac{80000}{12.5} = 6400 \text{ ohms.}$$

$$R_3 = \frac{1000 \times 7.5}{7.5} = \frac{7500}{7.5} = 1000 \text{ ohms.}$$

Resistor power dissipations in watts now may be computed from the known and calculated values for current and resistance in each unit.

The same principles used in making calculations for the three resistors may be used with any number of resistors and taps. The current through any resistor is equal to the sum of the current taken from the tap next below that resistor and the current flowing through the resistor next below. The determination of currents must begin with that through the lowest or bleeder resistor,  $R_3$  in Fig. 11-13, and to this current are added those taken from the taps in proceeding toward the high voltage end of the system. The resistance required for any resistor is  $R = E/I$ , with  $R$  in ohms,  $E$  the difference between voltages required at the two ends of the resistor, and  $I$  the current in amperes which must flow through the resistor.

**Rectifier Doublers.**—A rectifier doubler system employs a twin rectifier, with separately insulated plates and cathodes, which is used to charge capacitors whose discharge potential combined with the supply potential provides for the filter system a total voltage greater than that of the supply. Tubes whose construction permits voltage doubler service include types 25X6, 25Y5, 25Z5, 25Z6, 35Z6, 50Y6, 50Z6, 50Z7, and 117Z6.

A circuit for a full-wave voltage doubler is shown by Fig. 11-14. The input capacitance for the filter consists of capacitors  $A$  and  $B$  in series with each other. Capacitor  $A$  is charged by the rectifier section marked  $A$ , and capacitor  $B$  is charged by the  $B$  section of the rectifier tube. One side of the a-c supply line connects to the cathode of section  $A$  and the plate of section  $B$ , sometimes through a protective resistor at  $R_a$ . The plate of section  $A$  connects to the negative side of the filter system, and the cathode of section  $B$  connects to the

positive side of the filter. The rectifier heater is connected across the a-c line in series with resistors  $R$ , which usually consist of the heaters of other tubes and of any additional fixed resistance needed to reduce the current to the correct value for the heaters. Rectifier doublers are easily recognized in wiring diagrams by the direct connection of one plate to the cathode on the opposite side of the tube. The same tubes which are used for voltage doublers often are used as two ordinary half-wave rectifiers, or as a single half-wave rectifier with the two plates tied together and the two cathodes tied together to place the sections in parallel.

In order to provide fairly high d-c voltage from the filter output, together with satisfactory regulation of voltage, the capacitors  $A$  and  $B$  usually are of 16 to 32 mfd. capacitance each, and capacitor  $C$  often has a capacitance of 50 mfd. The filter choke  $L$  may be the speaker field winding or may be replaced with a fixed resistor.

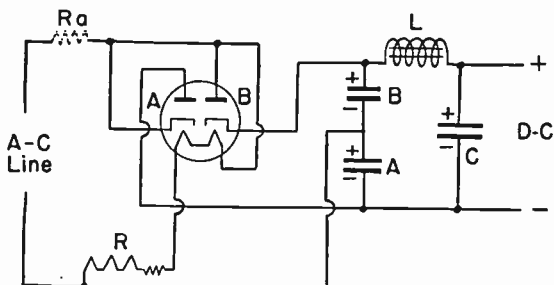

Fig. 11-14. Circuit for a full-wave voltage doubler.

The capacitors  $A$  and  $B$  are charged in the polarities shown by their respective sections of the rectifier tube. With no current being taken from the filter output, each capacitor charges to the peak potential of the a-c supply, and when direct current is being drawn from the system the capacitor charges and potentials are less than this peak value. It may be seen from Fig. 11-14 that with the capacitor polarities shown the potentials are in series across the filter input, and consequently add together to give an input voltage which is double that of either capacitor alone.

Fig. 11-15 shows connections for a half-wave voltage doubler rectifier. During the a-c half-cycle in which the lower a-c line is positive, current through rectifier section  $A$  charges capacitor  $A$  in the polarity shown. During the opposite half-cycle capacitor  $A$  discharges in series with the line potential through rectifier section  $B$  into the

filter system. Thus there is rectified current to the filter during only one half of each a-c cycle.

**Ballast Tubes or Resistors.**—A ballast tube consists of a resistance filament made of iron or iron alloy enclosed within an envelope filled usually with hydrogen gas. The resistance of iron increases at a moderate rate with rise of temperature until a dull red heat is reached, whereupon the resistance increases rapidly with further rise of temperature. Consequently, a ballast resistor tends to maintain a fairly constant current when there are changes of applied voltage. Ballast resistors are used in series with series connected heaters of the tubes in AC-DC receivers. Some types are used in series with the filaments of 2-volt filament tubes operated from a 3-volt dry battery. Still others are used in series with the primary of power transformers.

Ballast resistor tubes for series heater service are mounted either on octal bases or on 4-pin bases. Fig.

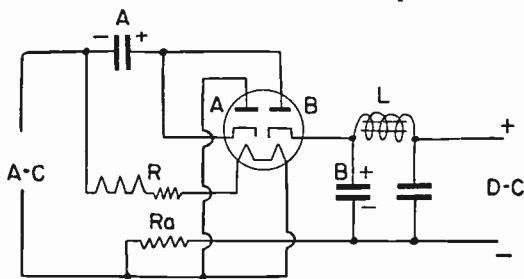

Fig. 11-15. Connections for a half-wave voltage doubler.

11-16 shows connections of resistance elements between base pins when looking at the bottom of the tube or socket. As indicated by the diagrams, many types are designed for connection of pilot lamps or dial lamps across certain of the resistance elements.

Many ballasts are lettered and numbered in accordance with a standard RMA system as follows.

A type designation always includes a number followed by a letter, and may include letters preceding the number. A single number and letter designation might be 42A.

The number indicates the potential drop in volts across the entire resistance or set of resistances within the tube when current through the connected heater circuit is 0.3 ampere and when the resistor is operating at normal temperature for this current. This is the hot resistance. The cold resistance will be lower.

The letter following the number indicates the internal connections of the tube as shown by the similarly let-



tered diagrams of Fig. 11-16. Thus, the designation  $42A$  indicates the internal connection shown by diagram  $A$  for an octal base, and indicates that the potential drop across the resistance from pin 3 to pin 7 is 42 volts when the current is 0.3 ampere.

A letter  $X$  preceding the number in the designation indicates a 4-pin base. For example, placing the letter  $X$  before the designation  $42A$ , making  $X42A$ , would indi-

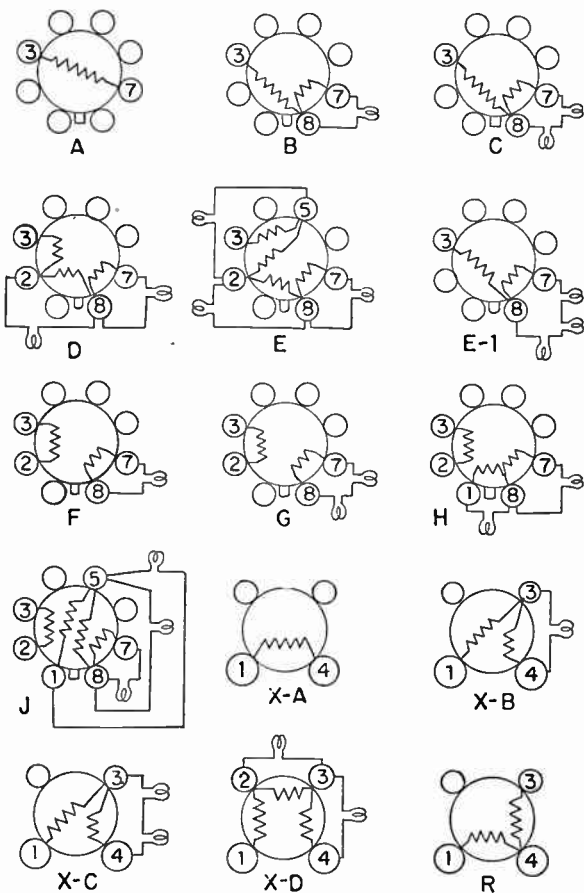

Fig. 11-16. Base connections and letter designations of ballast tubes.

cate a potential drop of 42 volts in a 4-pin tube having the internal connection shown by diagram X-A.

Letters *K*, *L* or *M* preceding the number indicate the type of pilot lamp or dial lamp connected across some of the resistance elements in the tube.

*K* No. 40 or 40A lamp. 6-8 volts, 0.15 amp.

*L* No. 44 or 46 lamp. 6-8 volts, 0.25 amp.

*M* No. 50 or 51 lamp. 6-8 volts, 0.20 amp.

As an example, the designation *K42B* indicates the use of a No. 40 or 40A lamp, a tube having the internal connections shown by diagram *B* of Fig. 11-16, and a potential drop of 42 volts across both sections of the internal resistance (pin 3 to pin 7) when the current through the externally connected circuit is 0.3 ampere.

A letter *B* preceding the lamp designation letter (*K*, *L* or *M*) indicates that there is a ballast action in the lamp section of the tube. Thus the designation *BK42B* means a tube having ballast action on the lamp section, designed for use with a No. 40 or 40A lamp,

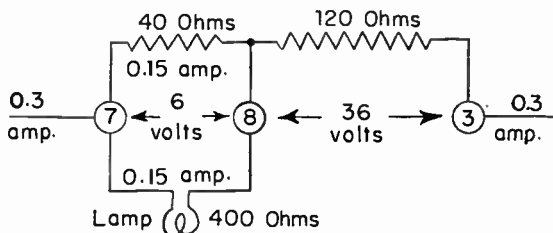

Fig. 11-17. Circuit through a ballast tube with pilot lamp connected.

having a total potential drop of 42 volts when operating normally, and having internal connections shown by diagram *B*.

In this tube having ballast action on the lamp section the cold resistance between pins 7 and 8 (diagram *B*) is 15 ohms and the hot resistance is 40 ohms. When the No. 40 or 40A lamp operates at 6.0 volts and 0.15 ampere its hot resistance is  $R = E/I = 6.0/0.15 = 40$  ohms. As shown by Fig. 11-17, the hot resistances of 40 ohms each in the lamp and resistance are in parallel, so their parallel resistance is 20 ohms and the potential drop is 6 volts. The resistance between pins 8 and 3 is 120 ohms, making a total resistance of  $20 + 120 = 140$  ohms from pin 7 to pin 3. Current between pins 7 and 3 is 0.3 ampere, half flowing through the resistance from pin 7 to pin 8 and half through the lamp. With a current of 0.3 ampere through 140 ohms the potential drop is  $E = IR = 0.3 \times 140 = 42$  volts, which is the rated potential drop of this ballast.

As shown at the top of Fig. 11-18, ballast tubes may have jumper connections of zero resistance between octal base pins 3 and 4, 3 and 5, or 6 and 7. Any of these jumpers may be indicated by the letter *J* on the right-hand end of the designation.

The three lower diagrams of Fig. 11-18 show internal connections for ballast tubes having octal, 5-pin, and 4-pin bases as used with 2-volt tubes operated from a 3-volt dry battery. With the battery voltage varying from an initial 3.4 volts to a final 2.2 volts during battery life the ballasts having an average voltage drop of 1.0

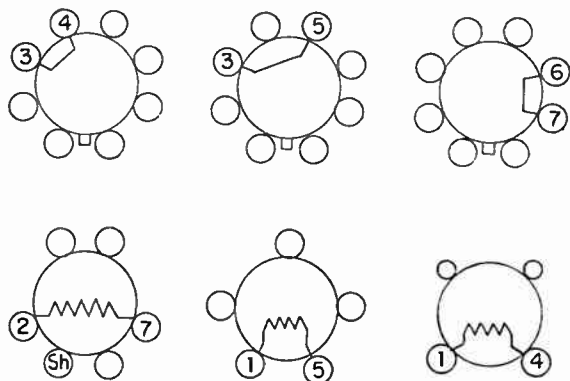

Fig. 11-18. Jumpers in ballast tubes (top) and ballasts for 2-volt tubes (bottom).

volt maintain tube filament potential between 2.2 and 1.8 volts. These ballasts are rated for total load currents as follows:

BALLASTS FOR 2-VOLT FILAMENT TUBES					
TYPE	Amperes	Base Pins	TYPE	Amperes	Base Pins
1A1/5E1	0.500	4	1K1	0.550	4
1B1	.360	4	1R1G	.540	octal
1C1	.745	4	1T1G	.560	octal
1D1	.240	4	1X1	.780	4
1E1	.480	4	1Y1	.540	4
1F1	.720	4	1Z1	.900	4
1G1	.420	4	6	.685	4
1J1	.620	4			

Ballasts with internal connections shown in the lower row of Fig. 11-18 are made also for AC-DC receivers and for receivers operating from d-c supply lines. Types and average voltage drops are as follows:

## BALLASTS FOR A-C-D-C AND D-C RECEIVERS

TYPE	Current Amperes	Volts Drop	Base Pins	TYPE	Amperes Current	Volts Drop	Pins Base
46A1	0.400	46.1	5	4	0.400	115.0	4
46B1	.300	46.1	5	5	.460	115.0	4
				7	.300	176.0	4
2	.300	9.0	4	8	.300	132.0	4
3	.300	128.0	4	9	.300	50.0	4

Tubes listed in the table, *Current Regulator Tubes*, are ballast tubes designed for maintaining a nearly constant load current with considerable variation of supply voltage, which may be either alternating or direct. These tubes, or some of them, may be connected in series with the primary winding of power transformers to maintain a nearly constant primary current and a consequent nearly constant secondary voltage to the load. The primary of the transformer must be designed to operate at an a-c voltage equal to the difference between the average line voltage and the average voltage drop in the regulator tube. For example, with a 117-volt a-c supply line and a regulator having a voltage range of 20 to 30, an average drop of 25 volts, the transformer primary is designed for  $117 - 25 = 92$  a-c volts. These tubes are used also in series with filaments or heaters of electronic tubes to maintain a nearly constant current and voltage drop with variations of filament or heater supply voltage. They may be used too for maintaining a fairly constant during discharge.

**Pilot Lamps.**—The table, *Pilot, Panel or Dial Lamps*, lists the principal characteristics of such lamps used for radio receivers, testing instruments, tuning meters, automobile panelboards, and coin operated machines. The design voltages and currents are employed in determining voltage drops and current requirements. Note that a nominal 6-8 volts rating applies to lamps with design voltages of 6.3, 6.5 and 7.5 volts. Lamps with 2.9-volt ratings are used as replacements in 2.5 volt circuits when other lamps burn out too frequently.

On the heaters of certain rectifier tubes used in AC-DC receivers are taps between which and the end of the heater may be connected a pilot lamp as shown by Fig. 11-19. These tubes include types 35Y4, 35Z5, 40Z5, 45Z5 and 50Z7.

Plate current for the rectifier flows from the upper side of the a-c line through the pilot lamp and the tapped section of the heater in parallel. A lamp shunting resistor  $R_a$  is used when the d-c output current exceeds 60 milliamperes. Resistances  $R$  in series with the rectifier heater consist of the series connected heaters of other tubes and of an additional fixed resistor if required to limit the heater current to the rated value for the tubes.

## CURRENT REGULATOR TUBES

TYPE	TUBE DROP	CURRENT CHANGE	AMPS. PER VOLT
	Volts	Amperes	Approximate
4	105 to 125	1.240 to 1.360	0.0060
6	15 to 21	0.950 to 1.010	.0100
7	3 to 10	0.500 to 0.530	.0043
25	7 to 16	1.070 to 1.160	.0100
46	8 to 18	2.700 to 3.250	.0550
47	8 to 18	2.050 to 2.350	.0300
50	5 to 8	0.225 to 0.275	.0167
710	20 to 30	0.225 to 0.275	.0050
711	7 to 11	0.473 to 0.531	.0145
712	19 to 25	0.468 to 0.532	.0107
788	9 to 18	0.225 to 0.275	.0055
876	40 to 60	1.675 to 1.725	.0025
886	40 to 60	0.225 to 0.275	.0025
896	5 to 8	0.225 to 0.275	.0167

## PILOT, PANEL OR DIAL LAMPS

TYPE No.	BASE Type	BULB Type	VOLTAGE Nominal	DESIGN		BEAD Color
				Volts	Amps.	
40	Screw	T-3 $\frac{1}{4}$	6-8	6.3	0.15	Brown
40A	Bayonet	T-3 $\frac{1}{4}$	6-8	6.3	0.15	Brown
41	Screw	T-3 $\frac{1}{4}$	2.5	2.5	0.50	White
42	Screw	T-3 $\frac{1}{4}$	3.2	3.2	0.35	Green
43	Bayonet	T-3 $\frac{1}{4}$	2.5	2.5	0.50	White
44	Bayonet	T-3 $\frac{1}{4}$	6-8	6.3	0.25	Blue
45	Bayonet	T-3 $\frac{1}{4}$	3.2	3.2	0.35	White
45	Bayonet	T-3 $\frac{1}{4}$	3.2	3.2	0.50	Green
46	Screw	T-3 $\frac{1}{4}$	6-8	6.3	0.25	Blue
47	Bayonet	T-3 $\frac{1}{4}$	6-8	6.3	0.15	Brown
48	Screw	T-3 $\frac{1}{4}$	2.0	2.0	0.06	Pink
49	Bayonet	T-3 $\frac{1}{4}$	2.0	2.0	0.06	Pink
49A	Bayonet	T-3 $\frac{1}{4}$	2.1	2.1	0.12	White
50	Screw	G-3 $\frac{1}{2}$	5-8	7.5	0.20	White
51	Bayonet	G-3 $\frac{1}{2}$	6-8	7.5	0.20	White
55	Bayonet	G-4 $\frac{1}{2}$	6-8	6.5	0.40	White
292	Screw	T-3 $\frac{1}{4}$	2.9	2.9	0.17	White
292A	Bayonet	T-3 $\frac{1}{4}$	2.9	2.9	0.17	White
1455	Screw	G-5	18	18.0	0.25	Brown
1455A	Bayonet	G-5	18	18.0	0.25	Brown

Rectifier types 35Y4, 35Z5, 40Z5 and 45Z5 are designed for use with a pilot lamp having design voltage of 6.3 and current of 0.15 ampere, types 40, 40A or 47. With the normal heater current of 0.15 ampere for these rectifiers, the pilot lamp voltage across the tapped section of the heater is 5.5. If the lamp burns out or is removed from its socket, the voltage across the tapped section of the heater becomes 15.0 maximum. In designs having no pilot lamp across part of the heater the voltage of the tapped section is 7.5. A resistance of at least 25 ohms then is connected in series with the rectifier plate.

Resistor  $R_a$  has resistance of 300 ohms for a d-c output of 70 milliamperes, 150 ohms for 80 milliamperes, and 100 ohms for 90 milliamperes. Maximum resistances for the three currents are respectively 800, 400 and 250 ohms.

The 50Z7 rectifier is similarly designed, but furnishes a maximum of 2.5 volts across the tapped section of the heater for operation of pilot lamps types 292 or 292A. This rectifier is used with its two plates in parallel and

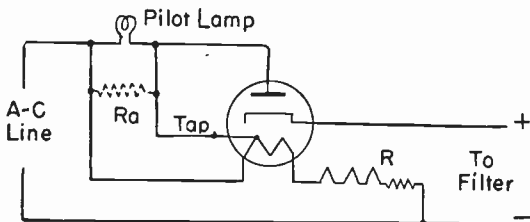

Fig. 11-19. Pilot lamp connection for rectifier of AC-DC receiver.

its two cathodes in parallel for half-wave rectifier service, and with resistors in series with each plate to insure equalizing the currents in both sections of the tube.

**Series Heaters.**—Fig. 11-20 shows a typical series heater circuit for a 5-tube AC-DC receiver. The rectifier is a 35-volt heater type used on a 117-volt a-c or d-c line supply without a transformer, usually with the pilot lamp connections of Fig. 11-19. The other tubes consist of a converter, an i-f amplifier, and a double-diode triode acting as detector, automatic volume control, and a-f amplifier, all these having 12.6-volt heaters, and finally a power tube having a 50-volt heater. Since all of the heaters are connected in a single series circuit, all must carry the same current which, with tubes most often used, is 0.15 ampere. The total of the rated heater voltages for the five tubes is 122.8 volts, and at the design center line voltage of 117, operation is at about 95% of rated heater voltages.

The order of heaters in the "string" usually is shown on wiring diagrams as indicated just below the large dia-

gram of Fig. 11-20. Invariably the rectifier is at one end of the string, and the detector a-f amplifier is at the other end. The detector a-f amplifier always is at the grounded end of the heater string, because this is the tube most sensitive to a-c hum voltage. The rectifier and power amplifier are least sensitive to a-c hum, so are placed at the ungrounded end of the string. As shown by the lower simplified heater diagrams, the i-f amplifier and converter may be connected in either order between the power tube and the detector a-f amplifier tube.

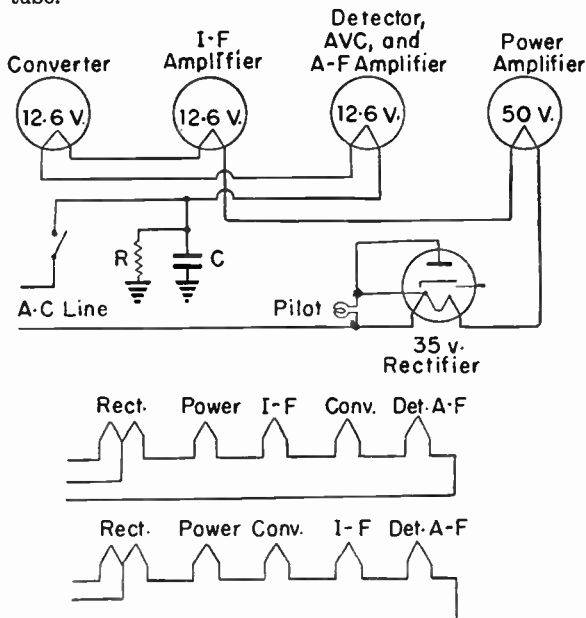

Fig. 11-20. Typical series heater circuit for AC-DC receiver.

While the heater arrangements of Fig. 11-20 are generally used, others are possible. For example, a double diode pentode may be used as a detector and i-f amplifier, being connected next to the power tube in the string, with a separate a-f amplifier at the grounded end.

A typical 6-tube AC-DC receiver uses a rectifier and a power amplifier tube, both having 35-volt heaters, with tubes having 12.6-volt heaters for r-f amplifier, converter, i-f amplifier, and a double-diode triode or pentode for detector, avc, and a-f amplifier. Commonly used

heater strings for series heaters are shown by diagrams 1, 2 and 3 of Fig. 11-21. At the ungrounded end of the string comes first the rectifier and then the power amplifier, followed in various orders by the r-f amplifier, i-f amplifier, and converter, with the detector a-f amplifier at the grounded end of the string.

In 6-tube receivers having separate oscillator and mixer, and no r-f amplifier, the heater arrangements often are as shown by diagram 4 of Fig. 11-21. The oscillator may precede the mixer tube, or the mixer may

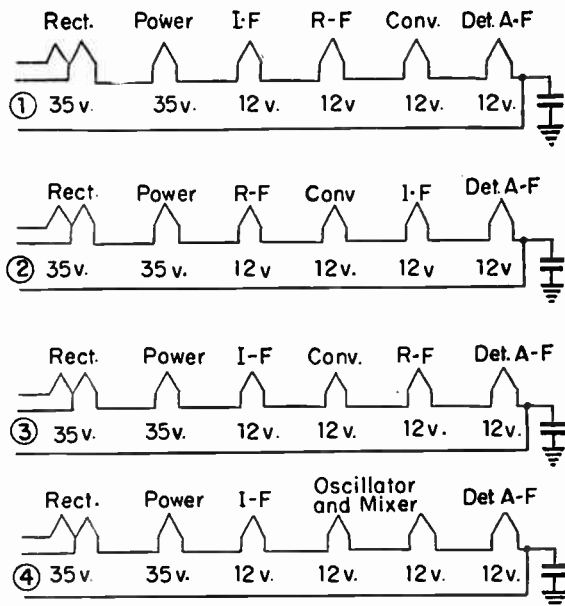

Fig. 11-21. Series heater strings used in six-tube AC-DC receivers.

precede the oscillator. Many other heater arrangements are possible, and are used, but those shown represent the more common circuits. Except in rare instances, the detector a-f amplifier always is at the grounded end of the heater string. The ground connection ordinarily is made through a capacitor of 0.02 mfd. or greater capacitance rather than through a conductive connection, thus avoiding the possibility of short circuiting the a-c supply line should the line plug be inserted the wrong way in its receptacle.



Some receivers having tube heaters in series are designed for operation only on a-c power, with the series heaters supplied with current from the secondary winding of a power transformer. Other receivers with series heaters are so designed that rectifier plate voltage is raised by a transformer which acts on alternating current supply while the heater string is across the supply line.

**Resistors for Series Heaters.**—When the total of the voltage drops through all the heaters in a series string is not as great as the a-c supply line voltage it is necessary to insert additional resistance in series with the heaters to make the total voltage drop across this resistance and all the heaters equal to the line voltage. For purposes of design the a-c line voltage is assumed to be 117. The required extra resistance is determined from the formula,

$$R_s = \frac{El - Eh}{Ih}$$

*El* Supply line voltage; usually 117.

*Eh* Sum of heater voltages of all tubes with heaters in series.

*Ih* Heater current, amperes. The heater current is the same for all the heaters connected in series.

*Rs* Resistance, ohms, to be added in series with heaters.

Resistances computed from the formula usually turn out to be of values not available in standard units. Usually it is satisfactory to use a standard resistor of the nearest value, since the small difference in total resistance across the supply line will not make much difference between actual and rated heater currents. The accompanying list, *Series Resistors in 0.15-ampere Heater Strings*, shows in columns *A* to *F* six combinations of resistances and heater voltages used with tubes having a rated heater current of 0.15 ampere.

The top three lines of the list show the rated heater current, 0.15 ampere, the added fixed resistance in ohms, and the voltage drop in the resistor were the current actually 0.15 ampere. To this voltage drop is added the sum of the rated heater voltages for the tubes. The combinations shown in the list include various numbers of heaters having rated voltages of 50.0, 35.0, 12.6 and 6.3. The sum of the voltage drops thus computed for a current of 0.15 ampere always is a little less than or a little more than 117 volts. The total resistances of the tube heaters and added resistors would be 780 for a current of 0.15 ampere with 117 line volts. Actually the total resistance always is a little more or less than 780 ohms.

Series strings of heaters rated for heater current of 0.3 ampere may have added fixed resistors to provide

## SERIES RESISTORS IN 0.15-AMPERE HEATER STRINGS

	A	B	C	D	E	F
Rated heater amperes, I	0.15	0.15	0.15	0.15	0.15	0.15
Added resistor ohms, R	80	60	47	190	233	120
Resistor volts drop, $E = IR$	12.0	9.0	7.1	28.5	35.0	18.0
Rated voltage	35.0	35.0	35.0	50.0	35.0	50.0
drops in heaters.	50.0	35.0	50.0	12.6	35.0	50.0
	6.3	12.6	12.6	12.6	12.6	
	6.3	12.6	12.6	12.6		
	6.3	12.6				
Total volts drop at 0.15 ampere	115.9	116.8	117.3	116.3	117.6	118.0
Total resist- ance, ohms	772	778	781	775	783	786

any additional required voltage drop between the line voltage and the total rated voltages of the heaters. Frequently tubes of this type are provided with additional resistance in ballast resistors or ballast tubes which are designed for a current of 0.3 ampere. Pilot lamps usually are connected across one or more sections of the ballast resistance. The voltage drop across the pilot lamp section or sections is equal approximately to the design voltage of the lamp or lamps. The voltage drop across the remainder of the ballast resistance is equal approximately to the  $IR$  drop in this section with rated heater current of 0.3 ampere. The total of rated or computed voltage drops in the series heaters and the ballast system will be somewhat more or less than 117 volts, just as with the 0.15 ampere heater strings previously explained. When checking the cold resistance of ballast sections it should be kept in mind that the hot resistance will be considerably higher, and that the hot resistance will be in parallel with the resistance of a pilot lamp connected across the section.

The power in watts dissipated by an added resistor is equal to the product of voltage drop in the resistor by current in amperes ( $P = EI$ ), or is equal to the product of the square of the current in amperes by the resistance in ohms ( $P = I^2R$ ). The rated wattage of the resistor should be double or more the computed number of watts, this to avoid overheating of parts near the resistor when installed.

**Tube Substitutions with Series Heaters.**—In some cases it is possible to replace in a series heater string a tube having a certain heater voltage and current with another tube having a different heater voltage, different current, or both. Eight cases are represented by Fig. 11-22,

$R$  which may be a separate fixed resistor, a ballast element, or resistance in a line cord. There might be fewer heaters or more heaters in actual apparatus. The tube which is assumed to be replaced is indicated by a heavy-line filament. As marked at the left of each diagram, the new tube or the tube which replaces an original tube, may have the same heater voltage, *Same E*, less heater voltage, *Less E*, or more heater voltage, *More E*, and may have the same, less, or more heater current as marked *Same I*, *Less I*, or *More I*.

Letter symbols used on the diagrams and in following formulas are as follows:

- $E$  Heater voltage when no change in voltage is made. Or, the greater of two heater voltages when a change is made in voltage.
- $e$  The smaller of the two heater voltages when a change is made in voltage.
- $Ea, Eb, Ec$  Rated voltages of heaters of other tubes in the string.
- $Er$  Voltage drop across the original series resistor  $R$ .
- $I$  Heater current when no change of current is made. Or, the greater of the two heater currents when a change is made.
- $i$  The smaller of the two heater currents when there is a change of current.
- $R$  Resistance, ohms, of original series resistor.
- $Ra$  Resistance, ohms, of added resistor shunting original resistor  $R$ .
- $Rb$  Resistance, ohms, of added resistor shunting both the original series resistor  $R$  and one or more tubes at one side of the substitute, or shunting tubes alone when there is no series resistor.
- $Rc$  Resistance, ohms, of added resistor shunting all tube heaters beyond the substitute tube.
- $Rd$  Resistance, ohms, of added resistor shunting one or more heaters, but not the original series resistor  $R$ .
- $Rn$  Resistance, ohms, of new resistor or resistance element used to replace the original series resistor  $R$ .
- $Rp$  Resistance, ohms, of resistor added in parallel or shunt with the substitute tube.
- $Rs$  Resistance, ohms, of resistor added in series with the heater of the substitute tube.

Formulas and solutions for the several cases are as follows. The table, *Resistances of Heaters*, lists resistances in ohms of the heaters operated with various rated voltages and currents. These values are convenient for checking computations.

## RESISTANCES OF HEATERS

CURRENT Amperes	Rated Heater Voltage							
	6.3	12.6	25	35	45	50	70	117
0.04								2925
.075					600			1560
.09								1300
0.15	42	84	167	233	300	333	467	760
.175	36							
.225	28	56						
0.3	21	42	83.3	117		167		
.4	15.8							
.45	14	28						
0.5	12.6							
.6	10.5	21						
.65	9.7							
0.7	9.0							
.75	8.4							
.8	7.88							
0.85	7.42							
0.9	7.0							
1.0	6.3							
1.1	5.73							
1.2	5.25							
1.25	5.04							

1. *Same voltage but less current for heater of substitute tube.* A resistor  $R_p$  is shunted across the heater to carry the additional current flowing through heaters of other tubes.

$$R_p = \frac{E}{I - i}$$

*Example.*—Replace a tube having a 12.6-volt, 0.3-ampere heater with one having a 12.6-volt, 0.15-ampere heater.

$$R_p = \frac{12.6}{0.30 - 0.15} = \frac{12.6}{0.15} = 84 \text{ ohms}$$

2. *Less voltage but same current for heater of substitute tube.* A resistor  $R_s$  is connected in series with the heater to provide the additional required voltage drop at this point.

$$R_s = \frac{E - e}{I}$$

*Example.*—Use a tube having a 6.3-volt, 0.15-ampere heater instead of one having a 12.6-volt, 0.15-ampere heater.

$$R_s = \frac{12.6 - 6.3}{0.15} = \frac{6.3}{0.15} = 42 \text{ ohms}$$

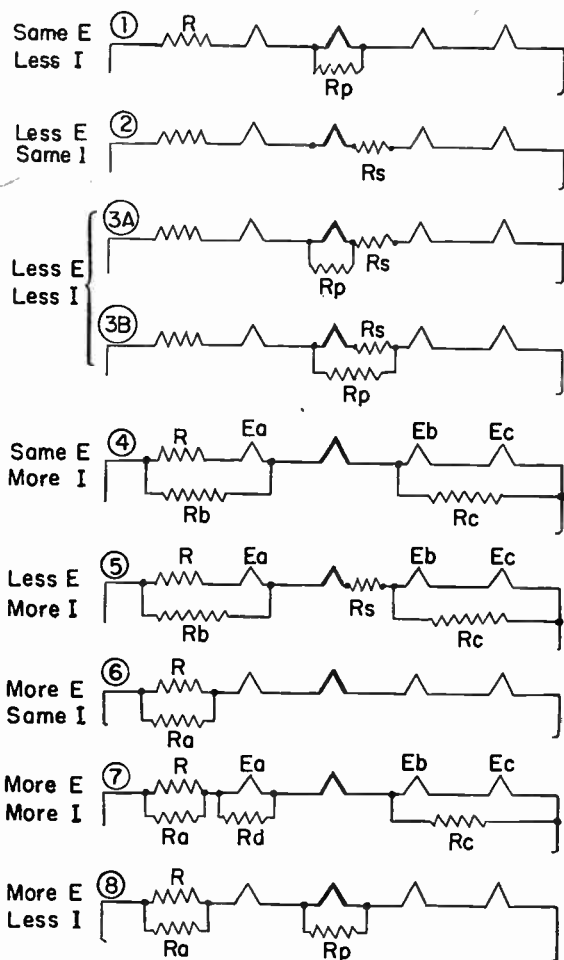

Fig. 11-22. Resistor changes which permit tube substitutions when heaters are in series.

3. *Less voltage and less current for heater of substitute tube.* Because of the smaller voltage drop in the new heater it is necessary to connect a resistor  $R_s$  in series to use the extra voltage at this point. Because of the smaller current it is necessary to use a shunting resistor  $R_p$  to carry the excess of current flowing through other heaters in the string. With resistors connected as in diagram 3A, resistors  $R_p$  and  $R_s$  are selected as follows:

$$R_p = \frac{e}{I - i} \quad R_s = \frac{E - e}{I}$$

*Example.*—Substitute a tube having a 6.3-volt, 0.175-ampere heater for one having a 12.6-volt, 0.3-ampere heater.

$$R_p = \frac{6.3}{0.300 - 0.175} = \frac{6.3}{0.125} = 50.4 \text{ ohms}$$

$$R_s = \frac{12.6 - 6.3}{0.3} = \frac{6.3}{0.3} = 21 \text{ ohms}$$

With resistors connected as in diagram 3B the resistors are selected thus:

$$R_p = \frac{E}{I - i} \quad R_s = \frac{E - e}{i}$$

*Example.*—Assume the same substitution as for diagram 3A. That is, the change is from 12.6 volts and 0.3 ampere to 6.3 volts and 0.175 ampere.

$$R_p = \frac{12.6}{0.300 - 0.175} = \frac{12.6}{0.125} = 101 \text{ ohms}$$

$$R_s = \frac{12.6 - 6.3}{0.175} = \frac{6.3}{0.175} = 36 \text{ ohms}$$

4. *Same voltage but more current for heater of substitute tube.* To carry the extra current around other tubes and a series resistor  $R$ , if used, these other elements must be shunted with resistor  $R_b$  ahead of the substitute tube and with resistor  $R_c$  for all tubes following the substitute. If the original voltage drop in  $R$  is known this drop  $E_r$  is used directly in one of the following formulas. If the original current and resistance in  $R$  are known they should be changed to equivalent voltage drop, which is equal to  $IR$ , or to amperes multiplied by ohms.

$$R_b = \frac{E_r + E_a}{I - i} \quad R_c = \frac{E_b + E_c + \text{etc.}}{I - i}$$

*Example.*—Use a tube having a 35-volt, 0.3-ampere heater instead of one having a 35-volt, 0.15-ampere heater. Assume the original voltage drop in  $R$  to be 44 volts, and to be 12.6 volts in each of the heaters  $E_a$ ,  $E_b$  and  $E_c$ .

$$R_b = \frac{44 + 12.6}{0.30 - 0.15} = \frac{56.6}{0.15} = 377 \text{ ohms}$$

$$R_c = \frac{12.6 + 12.6}{0.30 - 0.15} = \frac{25.2}{0.15} = 167 \text{ ohms}$$

5. *Less voltage and more current in heater of substitute tube.* To permit flow of the extra current around other tubes and a series resistor  $R$ , if used, it is necessary to shunt these other elements with resistors  $R_b$  and  $R_c$  just as in case 4. To reduce the heater voltage on the substitute tube it is necessary to connect in series with it a resistor  $R_s$  to provide the needed voltage drop at this position. Resistances at  $R_b$  and  $R_c$  are computed just as in case 4, while resistance  $R_s$  is computed as in case 2.

$$R_b = \frac{E_r + E_a}{I - i} \quad R_c = \frac{E_b + E_c}{I - i} \quad R_s = \frac{E - e}{I}$$

*Example.*—Substitute a tube having a 35-volt, 0.3-ampere heater for one having a 50-volt, 0.15-ampere heater. Assume that series resistor  $R$  originally carries 0.15 ampere and has a resistance of 46 ohms, that  $E_a$  is 35 volts, and  $E_b$  and  $E_c$  are 12.6 volts each. The first step is to determine the voltage drop in  $R$ .

$$E_r = 0.15 \times 46 = 6.9 \text{ volts}$$

Then the known values are used in the formulas.

$$R_b = \frac{6.9 + 35}{0.30 - 0.15} = \frac{41.9}{0.15} = 279 \text{ ohms}$$

$$R_c = \frac{12.6 + 12.6}{0.30 - 0.15} = \frac{25.2}{0.15} = 167 \text{ ohms}$$

$$R_s = \frac{50 - 35}{0.3} = \frac{15}{0.3} = 50 \text{ ohms}$$

6, 7 and 8. These are cases requiring more voltage for the heater of the substitute tube than for the original heater, which means more total voltage drop in the heaters of all the tubes. If the rated voltage drops of all the original heaters together total approximately 117 volts, no additional voltage is available and the substitution cannot be made. If there is extra resistance  $R$  in a separate resistor, a ballast, or a line cord, and if the voltage drop in this resistance is equal to or more than the extra heater voltage needed for the substitute tube, the change can be made. Sometimes it is convenient to shunt the original resistance  $R$  with an added resistance  $R_a$ , and again it may be more convenient to replace the original resistance  $R$  with a new and different resistance  $R_n$ .

6. *More voltage but same current for heater of substitute tube.* When the known values are the resistance of  $R$  and the heater current  $I$ , the resistance of a new

resistor  $R_n$  and of a shunting resistor  $R_a$  may be found as follows:

$$R_n = \frac{I R - (E - e)}{I} \quad R_a = \frac{R R_n}{R - R_n}$$

*Example.*—A tube having a 25-volt, 0.3-ampere heater is to be replaced with one having a 35-volt, 0.3-ampere heater. The resistance of the original series resistor  $R$  is 106 ohms.

$$R_n = \frac{0.3 \times 106 - (35 - 25)}{0.3} = \frac{31.8 - 10}{0.3} = 72.7 \text{ ohms}$$

To determine the value of a shunting resistor  $R_a$  with the formula given it is necessary first to determine the resistance  $R_n$ , which has been found to be 72.7 ohms. Using this value in the formula for  $R_a$  gives,

$$R_a = \frac{106 \times 72.7}{106 - 72.7} = \frac{7706}{33.3} = 231.4 \text{ ohms}$$

When the known values are the voltage drop  $E_r$  in resistor  $R$ , and the current  $I$ , the values of  $R_n$  (a replacement resistor) and  $R_a$  (a shunting resistor) may be found as follows. Again it is necessary to determine the resistance  $R_n$  before using the formula for  $R_a$ .

$$R_n = \frac{E_r - (E - e)}{I} \quad R_a = \frac{E_r R_n}{E_r - (I R_n)}$$

*Example.*—Make the same tube change as in the preceding example; from 25-volt, 0.3-ampere to 35-volt, 0.3-ampere heater. The voltage drop  $E_r$  in original resistor  $R$  is 32 volts.

$$R_n = \frac{32 - (35 - 25)}{0.3} = \frac{32 - 10}{0.3} = 73.3 \text{ ohms}$$

$$R_a = \frac{32 \times 73.3}{32 - (0.3 \times 73.3)} = \frac{2346}{32 - 22} = 234.6 \text{ ohms}$$

7. *More voltage and more current for heater of substitute tube.* The extra voltage for the substitute heater must be taken from the original voltage drop in resistor  $R$ , either by replacing  $R$  with a new resistor  $R_n$ , or else by shunting  $R$  with a resistor  $R_a$ . The values for  $R_n$  and  $R_a$  are computed with formulas similar to those used for case 6, employing either the known resistance  $R$  or the known voltage drop  $E_r$ . Note, however, that the first formula for  $R_n$  and the second one for  $R_a$  employ in one term the smaller of the two currents,  $i$ , rather than the larger current  $I$ .

$$R_n = \frac{i R - (E - e)}{I} \quad R_a = \frac{R R_n}{R - R_n}$$

$$R_n = \frac{E_r - (E - e)}{I} \quad R_a = \frac{E_r R_n}{E_r - (i R_n)}$$



*Example.*—Substitute a tube having a 12.6-volt, 0.6-ampere heater for one having a 6.3-volt, 0.3-ampere heater. The resistance of  $R$  is originally 37 ohms. With  $R$  known, the first formulas for  $R_n$  and  $R_a$  are used thus:

$$R_n = \frac{0.3 \times 37 - (12.6 - 6.3)}{0.6} = \frac{11.1 - 6.3}{0.6}$$

$$= \frac{4.8}{0.6} = 8 \text{ ohms for replacement resistor.}$$

$$R_a = \frac{37 \times 8}{37 - 8} = \frac{296}{29} = 10.2 \text{ ohms if shunt used.}$$

When the known value is the original voltage drop  $E_r$  in resistor  $R$ , the second formulas are used. Assuming that  $E_r$  is 11.1 volts the computation is,

$$R_n = \frac{11.1 - (12.6 - 6.3)}{0.6} = \frac{4.8}{0.6} = 8 \text{ ohms}$$

$$R_a = \frac{11.1 \times 8}{11.1 - (0.3 \times 8)} = \frac{88.8}{8.7} = 10.2 \text{ ohms}$$

To carry the extra current around other tubes in the string it is necessary to use shunting resistor  $R_d$  around any tube or tubes on one side of the substitute, and shunting resistor  $R_c$  around all tubes on the other side. The requirements are similar to those in cases 4 and 5.

$$R_d = \frac{E_a}{I - i} \quad R_c = \frac{E_b + E_c + \text{etc.}}{I - i}$$

*Example.*—Continuing with the substitution for which  $R_n$  and  $R_a$  have just been computed in this case, 7, assume that heater voltage  $E_a$  is 50 and that heater voltages  $E_b$  and  $E_c$  are 25 volts each. As for the preceding computations, the larger current  $I$  is 0.6 ampere and the smaller one  $i$  is 0.3 ampere.

$$R_d = \frac{50}{0.6 - 0.3} = \frac{50}{0.3} = 167 \text{ ohms}$$

$$R_c = \frac{25 + 25}{0.6 - 0.3} = \frac{50}{0.3} = 167 \text{ ohms}$$

8. *More voltage but less current for heater of substitute tube.* The additional voltage drop in the substitute heater must be deducted from the original voltage drop in resistor  $R$ , just as in cases 6 and 7. This may be accomplished by replacing  $R$  with a new resistor  $R_n$  having less resistance, or by shunting  $R$  with a resistor  $R_a$ . The excess current that must continue to flow through heaters other than the substitute is carried around the substitute heater by a shunting resistor  $R_p$ .

$$R_n = \frac{I R - (E - e)}{I} \quad R_a = \frac{R R_n}{R - R_n}$$

$$R_n = \frac{E r - (E - e)}{I} \quad R_a = \frac{E r R_n}{E r - (I R_n)}$$

$$R_p = \frac{E}{I - i}$$

In using these formulas the difference should be noted between greater and smaller voltages,  $E$  and  $e$ , and between greater and smaller currents,  $I$  and  $i$ .

**Power Ratings for Resistors.**—Having determined the resistances in ohms required for the various series resistors  $R_s$ , for resistors which are to replace original unit  $R$ , and for shunting resistors  $R_a$ ,  $R_b$ ,  $R_c$ ,  $R_d$  and  $R_p$ , it then is necessary to determine the required wattage ratings for these resistors.

$$P = I^2 R \quad P = \frac{E^2}{R}$$

- $P$  Actual power dissipation, watts.
- $I$  Current, amperes, through resistor.
- $E$  Voltage drop, volts, across resistor.
- $R$  Resistance, ohms, of resistor.

To avoid overheating, the wattage rating of resistors used should be double or more than double the actual watts dissipation as computed. If the resistors are installed close to other parts and where there is little chance for air circulation, the wattage rating may have to be three or more times the computed dissipation.

Instead of using the formulas for power dissipation, the number of watts may be determined from the power charts in an earlier section of the Handbook.

## Section 12

### POWER SUPPLY WITH BATTERIES

The standard RMA color code for battery cables is as follows. Many other color arrangements are in use.

Red	A+	Yellow	B-
Black	A-	Brown	C+
Blue	B+	Orange	C- intermediate
White	B+ intermediate	Green	C-

**Receivers with Batteries Only.**—The tubes having filaments rated at 1.4 volts commonly have the filaments in parallel with one end of each grounded, and are supplied from one or more 1.5-volt dry cells connected in parallel. During the life of such a battery the maximum voltage is assumed to be 1.6, the design center voltage 1.4, and the minimum or end voltage 1.1. Filament operation usually is without any series resistor or ballast, but the filament voltage may be dropped by a series resistor using about 0.08 volt with a battery voltage of 1.50. When  $I$  is the total current in milliamperes for all tubes, the series resistance  $R$  in ohms is,

$$R = \frac{80}{I}$$

Filaments rated at 2.0 volts require an adjustable resistor or rheostat when operated from a nominal 3.0-volt dry battery. Such filaments may be operated from one cell of a lead-acid storage battery without a series resistance. Air-cell batteries used for 2.0-volt filament tubes have an open circuit voltage of 2.8, which decreases while the battery furnishes current. To maintain a satisfactory filament voltage a series resistor is used, which, in combination with the resistance of the battery cable, provides a drop of about 0.4 volt. When  $R$  is the combined resistance of the resistor and cable, and  $I$  is the total filament current in milliamperes,

$$R = \frac{400}{I}$$

Tubes having 6.3-volt heaters connected in parallel may be operated from a 3-cell lead-acid storage battery without any series resistance. The maximum voltage of such a battery while being charged should not exceed 7.5 volts, the open circuit voltage is approximately 6.3 volts, and during normal discharge to a heater load the battery voltage should not drop below 5.7 volts, at which the tubes still will operate satisfactorily.

Receivers operated from a 32-volt farm light battery usually are of types in which the heater current is 0.3 ampere. The heaters are connected in series. The design voltage of such a battery is 32 volts. The usual minimum is 28 volts and the maximum 40 volts.

**A-C-D-C-Battery Receivers.**—Many receivers having a total of five, six, or seven tubes are designed for operation at the user's choice either from a-c line power, d-c line power, or battery power. A typical filament and

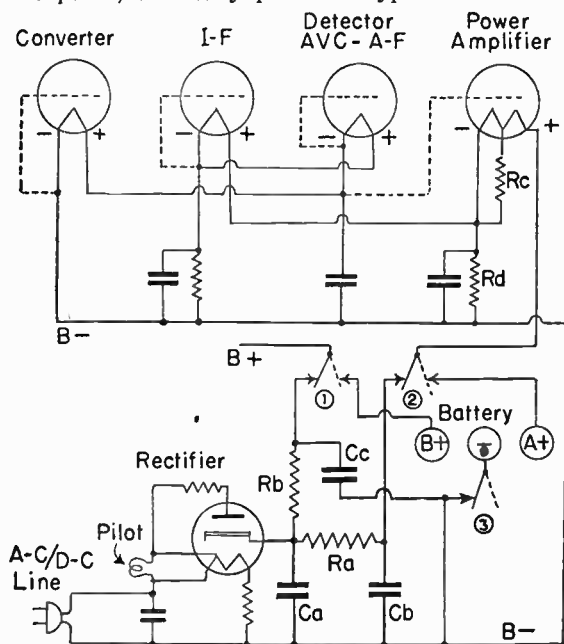

Fig. 12-1. Power supply and filament circuit for typical Ac-Dc-Battery receiver.

power circuit for such a "three-way power" set is shown by Fig. 12-1.

The rectifier tube rectifies a-c line voltage, which then is filtered by the combination of resistors  $R_a$  and  $R_b$ , and capacitors  $C_a$ ,  $C_b$  and  $C_c$  for the plate and screen power supply, and by resistor  $R_a$  with capacitors  $C_a$  and  $C_b$  for the filament supply. On d-c line supply the rectifier passes the steady d-c current, which then flows through the resistors used for a-c filtering.

Switches 1, 2 and 3 are placed in their full-line posi-

tions for either type of line power supply, and in their broken-line positions for battery power supply. The self-contained battery is indicated by its terminals marked B+, —, and A+. Switch 1 makes connections from the power supply to the B+ circuits in the receiver, switch 2 makes connections for A+, which is the positive end of the filament circuit, and switch 3 makes connections to B— and A—.

The receiver tube filaments, connected in series, usually are of the types taking 0.05 ampere at 1.4 volts. The power amplifier tube of Fig. 12-1 has two filament sections which are connected in series, each section taking 1.4 volts. Resistor *Rc*, shunted between the filament center tap and the negative end, bypasses plate and screen currents which otherwise would increase the total cathode or filament current beyond the rated maximum value for the tube. When plate and screen currents from other tubes add to the cathode current of the power tube, through their return circuits, an additional resistor *Rd* may be needed across the two sections of the power tube filament.

Grid returns, indicated by broken lines in the receiver portion of the diagram, are, of course, connected to the negative end of the filament of each tube. Tubes other than the power tube often are of types designed for operation with zero fixed bias and with increase of negative bias through an automatic volume control system. The power tube grid return may go to a point in the series filament circuit which is more negative than the negative end of the tube filament, as shown by Fig. 12-1.

In some three-way power receivers the rectifier tube is a full-wave type with its two sections connected in parallel to increase the rectified current. In other sets the rectifier may have two insulated plates and cathodes, a rectifier-doubler type, with one plate and its cathode used for the B-supply, and the other plate and cathode used for the filament supply. The power amplifier tube nearly always is at the positive end of the filament string, following the rectifier. Various orders are used for the remaining receiver tubes.

**Vibrator Power Supply.**—Wherever there is available only a low-voltage source of direct current, such as the battery of an automobile, and it is desired to have high-voltage direct current for the plate and screen circuits, the voltage may be raised by using a vibrator, a transformer, and a rectifier tube, or else by using two vibrators and a transformer, without a rectifier tube.

The principal parts of a B-supply system using a vibrator and rectifier tube are shown by Fig. 12-2. Consider that flow of current is from the grounded terminal of the battery to the grounded terminal of the vibrator, through the magnet coil inside the vibrator, through the lower half

of the transformer primary winding, the filter chokes  $L_a$  and  $L_b$ , the switch, the fuse, and back to the ungrounded terminal of the battery. The vibrator magnet attracts the flexible reed to the right, closes the right-hand pair of contacts to short circuit the coil, thus releasing the reed and allowing it to swing to the left and close the left-hand pair of contacts. The reed continues to swing back and forth, or to vibrate, and close the pairs of contacts alternately. Battery current flows alternately through the lower half and the upper half of the transformer primary, flowing in opposite directions in the two halves, and inducing in the secondary

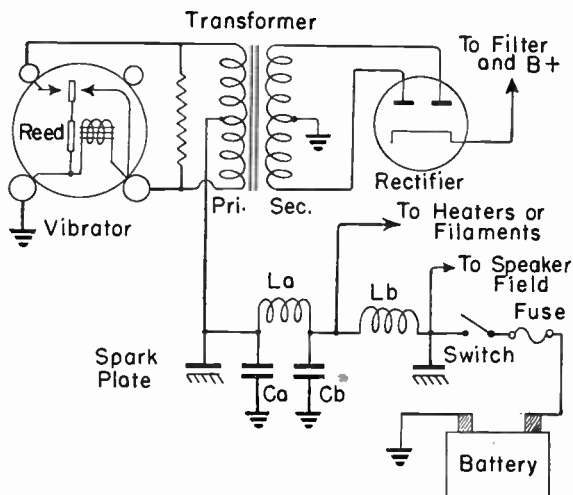

Fig. 12-2. Typical B-supply circuit with non-synchronous vibrator and rectifier tube.

winding of the transformer an alternating potential and current at a voltage which is raised by the step-up ratio of the transformer. The high-voltage alternating potential is passed through the full-wave rectifier tube to cause flow of high-voltage pulsating current from the rectifier cathode through the usual filter system to the plate and screen circuits of the receiver. The type of vibrator having only the single pair of contacts, used with a rectifier tube, is called a *non-synchronous vibrator*.

The filter system between battery and transformer is for the purpose of preventing high-frequency or radio-frequency interference from the battery-charging genera-

tor and ignition system from entering the B-supply and tube heater system. Choke  $L_b$  may consist of 40 or more turns of large gage wire on a form an inch or less in diameter. Choke  $L_a$  usually is of two or three millihenrys inductance. The filter capacitors may be of 0.1

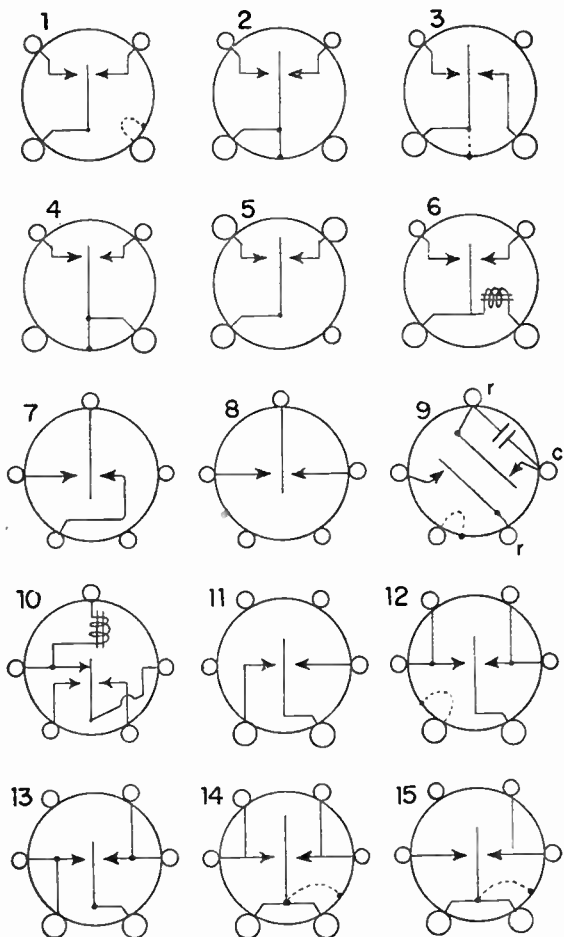

Fig. 12-3. Internal connections to base pins for non-synchronous vibrators.

to 1.0 microfarad capacitance, or of other values found suitable by experiment. All of the parts of the vibrator power supply, including the wiring leads, must be well shielded to prevent objectionable radio-frequency interference, called "hash."

Vibrators commonly are mounted on bases similar to the bases of radio tubes, with connections made through the base pins. Internal connections and pin arrangements for fifteen styles of non-synchronous vibrators are shown by Fig. 12-3. The numbers on the diagrams are arbitrary, and have no significance other than as a means of identification in this book. In most cases only the reed and contacts are indicated by the diagrams. Diagram 3 shows the same vibrator as used in Fig. 12-2.

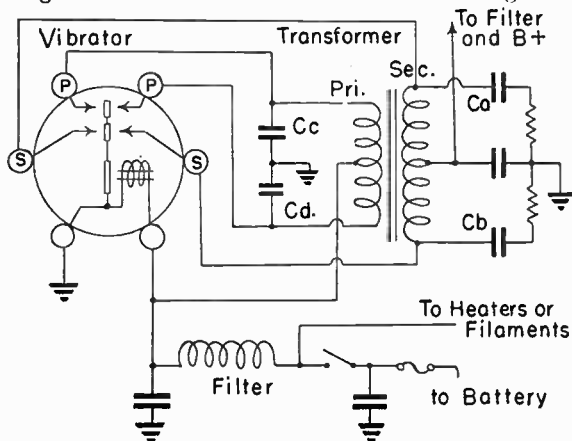

Fig. 12-4. Typical circuit for a synchronous vibrator.

Broken line connections for grounds on the vibrator housing may or may not be used. Double reeds, as in diagram 9 are mechanically tied together so that they vibrate in unison. In diagram 10 there is an additional starting contact closed on the reed with the vibrator idle.

The rectifier tube used with a non-synchronous vibrator may be of either the hot-cathode type or of the cold-cathode type. The cold cathode 0Z4 rectifier tube often is used. Non-synchronous vibrators with tube rectifiers ordinarily are used to provide higher B-voltages and currents than taken from synchronous types, although there will be some synchronous types operating at higher voltages and currents than found with some non-synchronous types. Non-synchronous systems usually



operate at voltages between 250 and 400, and currents between 50 and 200 milliamperes, while synchronous types deliver voltages between 90 and 300, and currents of from 10 to 100 milliamperes.

Fig. 12-4 shows a typical circuit for a *synchronous* type vibrator, called also a *self-rectifying* vibrator. This

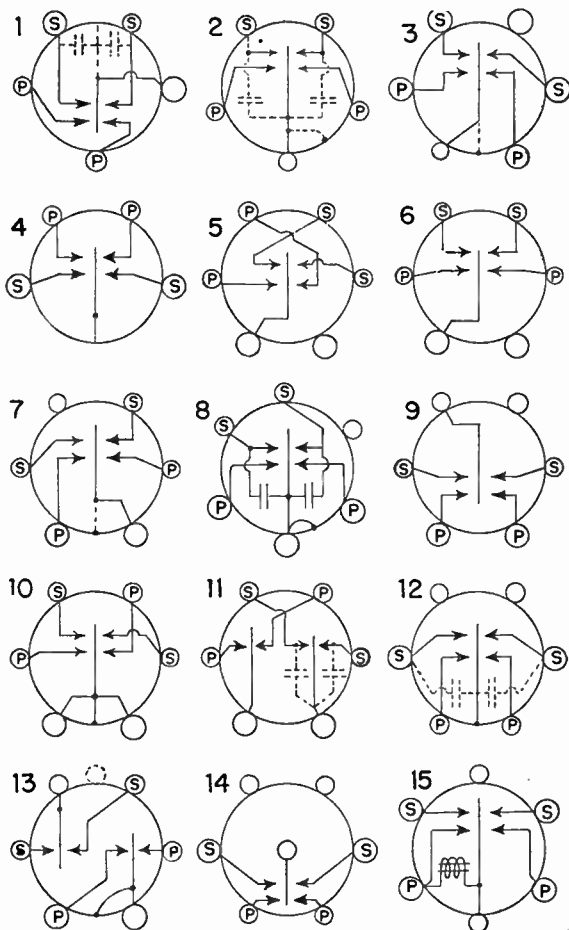

Fig. 12-5. Internal connections to base pins for synchronous vibrators.

vibrator has two sets of contacts which are alternately closed and opened by vibration of the reed. One set is used, just as in the non-synchronous vibrator, to furnish for the primary winding of the step-up transformer a reversing or alternating current. But instead of feeding the alternating potentials from the transformer secondary to a rectifying tube for production of pulsating direct current, they are fed back to the second set of contacts in the vibrator. Since the two sets of contacts are operated in time or in synchronism with each other, the pulses of high-voltage current are rectified by the vibrator so that they flow in the same direction, forming a pulsating direct current, to the filter in the B+ line.

Internal connections and base pin arrangements are shown by Fig. 12-5 for fifteen styles of synchronous vibrators. Broken lines indicate parts and connections which may or may not be found in the various types. In many of the diagrams, numbers 1 and 2 for example, capacitors are shown between the secondary contacts and the reed or the ground connection. These buffer capacitors may be in the vibrator itself, or they may be externally connected as at *Ca* and *Cb* of Fig. 12-4. These capacitors, and sometimes others similarly connected in the primary circuit as at *Cc* and *Cd* of Fig. 12-4, absorb energy as the contacts open and return it to the circuits when the contacts close, thus improving the output waveform, preventing excessive drain on the battery, and reducing sparking at the contacts. In all of the diagrams the connections for the transformer primary are marked *P* and those for the secondary are marked *S*.

## Section 13

### AMPLIFIERS

**Classes of Amplifiers.**—The manner in which amplifiers operate with respect to grid bias, grid signals, and resulting plate currents is indicated by classifications designated by letters.

**Class A Operation.**—The grid bias and the alternating grid input voltage are such that plate current flows at all times during the cycle, with variations of plate current limited to the practically straight portion of the grid-voltage plate-current characteristic so that variations of voltage in the plate circuit load have practically the same form as variations of grid voltage. Class A operation is employed for all r-f voltage amplifiers, for most a-f voltage amplifiers, for single a-f power tubes, and for some a-f push-pull power amplifiers. The distortion is lower for power triodes, and somewhat greater for power pentodes and for beam power tubes in Class A operation. Triodes have low power efficiency, pentodes and beam power tubes have high power efficiency. The power efficiency is the ratio of the a-c power output from the plate circuit to the d-c power input.

The operation may be designated as Class A<sub>1</sub> when there is no grid current at any time, and as Class A<sub>2</sub> when grid current flows for a brief period in each cycle.

**Class B Operation.**—The grid bias is nearly equal to the plate current cutoff value, so that there is only a small plate current when no signal is applied to the grid circuit, and a flow of plate current during approximately half of each cycle when an alternating signal potential is applied to the grid circuit. Class B operation is used for some push-pull a-f power amplifiers in receivers, and in transmitters is used for r-f power amplifiers working within a narrow frequency band. Class B operation permits a considerable increase of power output without overheating the tube or tubes, also a high rate of power amplification.

**Class AB Operation.**—The grid bias is made more negative than for Class A operation, thus permitting the use of higher plate and screen voltages, and affording a greater power output. Such operation is used with a-f push-pull power amplifiers. The action is similar to Class A operation on relatively weak signals, and to Class B operation on strong signals.

The operation may be designated as Class AB<sub>1</sub> when there is no grid current at any time and when the grids never become positive, and as Class AB<sub>2</sub> when the grids become positive for brief periods and thus permit flow of some grid current.

*Class C Operation.*—The grid bias is made appreciably greater than the value for plate current cutoff, so that plate current is zero while no alternating signal voltage is applied to the grid circuit, and flows for less than half of each cycle when there is a grid signal. Such operation is used in transmitters, often for r-f power amplification, but is not used in receivers.

*Voltage Gain.*—Voltage gain is the number of times that a voltage, applied to the grid circuit, is increased in the plate circuit of a tube. Gain is the ratio of voltage changes produced in the plate circuit load to voltage changes applied to the control grid circuit. Gain which is originally due to the tube may be increased or decreased by the coupling devices, so that the stage gain may be more or less than the gain of the tube.

The following formulas are used for computing voltage gain of a tube. The two formulas are equivalent, and give the same results.

$$VG = \frac{\mu \times R_o}{R_p + R_o} \qquad VG = \frac{G_m \times R_p \times R_o}{1000000 (R_p + R_o)}$$

$\mu$  Amplification factor of tube.

$R_p$  Plate resistance of tube, ohms.

$R_o$  Resistance of plate circuit load, ohms.

$G_m$  Mutual conductance of tube, micromhos.

Amplification factor, plate resistance, and mutual conductance vary with changes in operating conditions. When operation is changed in such manner as to bring about a reduction of plate current, there is (1) a decrease of amplification factor, (2) a decrease of mutual conductance, and (3) an increase of plate resistance.

Gain is increased by higher resistance in the plate circuit load, but unless the B-supply voltage is increased to maintain the original plate current through the greater load resistance, the decrease of plate current lessens the rate of gain otherwise obtained.

The voltage gain never is as great as the amplification factor of the tube. Usually the gain is around 60 to 80 per cent of the amplification factor.

*Example:* Assume that a 6J5 tube is operating with an amplification factor ( $\mu$ ) of 20, a plate resistance ( $R_p$ ) of 12000 ohms, and a load resistance ( $R_o$ ) of 50000 ohms. Using the first of the formulas for voltage gain, we have,

$$VG = \frac{20 \times 50000}{12000 + 50000} = \frac{1000000}{62000} = 16.1$$

*Voltage Gain from Load Lines.*—The voltage gain for given operating conditions may be determined with the help of load lines. Fig. 13-1 shows plate characteristics for a 6J5 tube with two load lines; the upper one for a plate circuit load of 20000 ohms, and the lower one for

a load of 50000 ohms. Voltage gains are found thus:

1. It is necessary to know the peak potential of the a-c signal applied to the control grid. If the a-c grid voltage is given in r-m-s or effective volts, that value is multiplied by 1.414 to find the peak potential.

2. The peak grid potential is subtracted from the grid bias voltage to determine the maximum potential reached by the grid during each cycle. The peak grid potential is added to the grid bias voltage to determine the minimum potential reached by the grid during each cycle.

3. From the load line for the load resistance in use are read the plate currents for the maximum and minimum potentials reached by the grid.

4. Subtract the minimum from the maximum plate current to determine the change of plate current. If the currents are in milliamperes, change them to amperes.

5. Multiply the change of plate current, in amperes, by the load resistance, in ohms, thus determining the change of potential across the plate circuit load.

6. Divide the change of potential in the load by twice the peak a-c signal potential as found in step 1 above. The result of this division is the voltage gain. The division is made with twice the peak a-c potential because this gives the total swing of grid voltage, the swing being equal to the peak a-c potential each way from the bias voltage.

*Example:* Assuming a 20000 ohm load, use the upper load line of Fig. 13-1. Assume an a-c grid signal of 2.0 r-m-s volts. Multiplying by 1.414 gives the peak signal potential as 2.83 volts. The grid bias will be assumed as 3.000 volts negative. Then, following the numbered steps of the foregoing explanation, we have,

1. Peak signal potential = 2.83 volts.
2. 3.00 (bias) - 2.83 = 0.17 max. Eg.  
3.00 (bias) + 2.83 = 5.83 min. Eg.
3. From load line,  
Ip for 0.17 Eg = 8.20 milliamps.  
Ip for 5.83 Eg = 3.50 milliamps.
4. 8.20 - 3.50 = 4.70 = 0.0047 ampere.
5. 0.0047 × 20000 (load R) = 94 volts.
6. 94 ÷ (2 × 2.83) = 16.6 voltage gain.

If the load is increased to 50000 ohms, with the same signal potential and grid bias, the steps from 3 through 6 are as follows:

3. From 50000-ohm load line; lower line of Fig. 13-1,  
Ip for 0.17 Eg = 4.00 milliamps.  
Ip for 5.83 Eg = 2.15 milliamps.
4. 4.00 - 2.15 = 1.85 = 0.00185 ampere.
5. 0.00185 × 50000 (load R) = 92.5 volts.
6. 92.5 ÷ (2 × 2.83) = 16.35 voltage gain.

It is apparent that the grid bias voltage is assumed to remain constant. If the tube is operated with self-bias, by means of a resistor in series with the cathode, there will be some degeneration as the bias becomes greater at high plate currents and less at low plate currents, and the voltage gain will be less than computed.

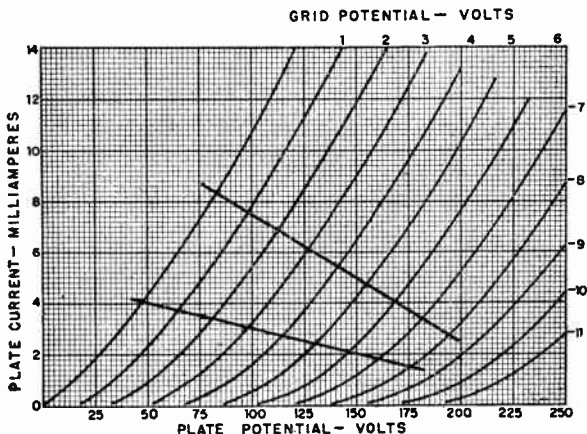

Fig. 13-1. Load lines used for computing voltage gain.

**Power Output of Triodes.**—The power output of a triode may be determined with the help of a load line drawn on its family of plate characteristics for the existing load and potentials. The change of plate current, in amperes, is multiplied by the change of plate potential or the change of load potential, which is the same thing, and the product is divided by 8 to find the power output in watts. As a formula, the computation appears thus:

$$\text{Power,} = \frac{(I_p \text{ change, amps}) \times (E_p \text{ change, volts})}{8} \text{ watts}$$

**Power, Current, and Resistance Conversion.**—The tables of tube characteristics in a preceding section of this book list plate, grid and screen voltages, also plate and screen currents, together with plate and load resistances and power outputs for the various power amplifier tubes. Only one set of conditions is listed for each tube. When it is desired to operate the tube at plate voltages not less than half nor more than twice the listed values, the operating conditions and power output for the new plate voltage may be determined with reasonable accuracy with the help of Fig. 13-2, which is a conversion

graph adapted from one published by the RCA Manufacturing Company.

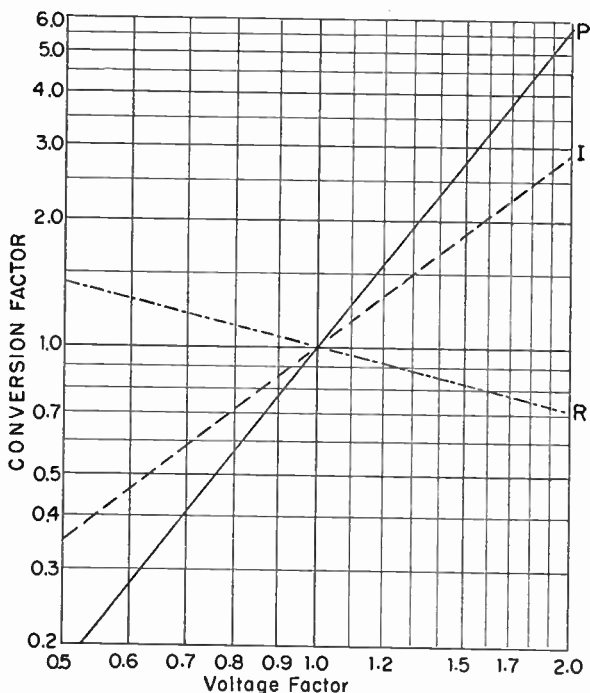

Fig. 13-2. Conversion factors for power tube operation.

*Example:* For a 6V6 beam power tube the table of tube characteristics shows the following:

Plate voltage	$E_p$	250 volts
Grid voltage	$E_g$	-12.5 volts
Screen voltage	$E_s$	250 volts
Plate current	$I_p$	45 milliamps.
Screen current	$I_s$	4.5 milliamps.
Plate resistance	$R_p$	52000 ohms
Load resistance	...	5000 ohms
Power output	...	4.5 watts

Assume that this tube is to be operated at 175 plate volts.

The ratio of the new plate voltage to the listed plate voltage is  $175/250$ , which is equal to  $7/10$  or to 0.7.

This ratio, 0.7, is the voltage factor. The listed screen and grid voltages are multiplied by this factor.

$$E_s \quad 250 \times 0.7 = 175 \text{ screen volts.}$$

$$E_g \quad -12.5 \times 0.7 = -8.75 \text{ volts grid bias.}$$

The conversion factor for plate and screen currents is found on the long-dash current line (I) of Fig. 13-2 at the intersection of this line with the vertical line for the previously determined voltage factor 0.7. At this intersection the conversion factor is read as about 0.59. Now the currents are multiplied thus:

$$I_p \quad 45.0 \times 0.59 = 26.5 \text{ milliamps.}$$

$$I_s \quad 4.5 \times 0.59 = 2.65 \text{ milliamps.}$$

The conversion factor for plate resistance and load resistance is found on the dash-dot line of Fig. 13-L at the intersection of this line with the line for the voltage conversion factor 0.7. The conversion factor on this resistance (R) line is about 1.2. Now the resistances are multiplied thus:

$$\text{Plate resistance} \quad 52000 \times 1.2 = 62400 \text{ ohms.}$$

$$\text{Load resistance} \quad 5000 \times 1.2 = 6000 \text{ ohms.}$$

The conversion factor for power output is found at the intersection of the full-line power line (P) of Fig. 13-2 at its intersection with the voltage factor line for 0.7, the factor being a little less than 0.41. The output power is multiplied thus:

$$4.5 \times 0.41 = 1.85 \text{ watts, approximately.}$$

Thus have been determined the approximate values of all the operating characteristics which will accompany the new plate voltage. The changes for any other plate voltage change within the limits of Fig. 13-2 may be similarly determined by using the voltage ratio or factor, and the appropriate conversion factors for currents, resistances, and power output.

**Resistance Coupled Amplifiers.**—Fig. 13-3 shows, at the left, the principal elements in resistance coupling for a triode, and at the right the elements in resistance coupling for a pentode. Supply voltage for plate and screen circuits is applied at *a*, from where current flows through plate resistor *b* to the plate. Output voltage from the plate circuit is applied across grid resistor *c*, which is in the grid circuit of the following tube, through coupling capacitor or blocking capacitor *d*. The amplifier tube has self-bias or cathode-bias from the potential drop in biasing resistor *e* which is bypassed with capacitor *f*. Screen current for the pentode flows from supply voltage *a* through screen resistor *g* which is bypassed with capacitor *h*.

Variations in the value of plate resistor *b* affect chiefly the amplification or gain at the higher frequencies, and have relatively little effect at the low frequency range.



Less resistance at this point makes for a more nearly uniform gain over the entire frequency range, or increases the upper limit of frequency at which amplification commences to fall off.

Variations in value of grid resistor  $c$  have decided effects on the low frequency response, and but little effect at the medium and high frequencies. It always is desirable to use the greatest resistance which is permissible at this point. The high limit depends on the type of tube, since current leakage, ionization, and other effects will permit enough current to flow in an excessively high grid resistance to alter the grid bias for the tube.

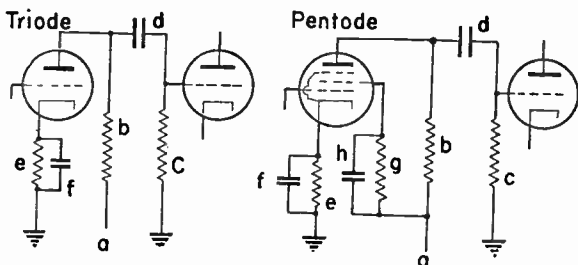

Fig. 13-3. Resistance couplings for triode (left) and pentode (right).

The capacitance of the coupling capacitor  $d$  is made great enough to provide a reactance much smaller than the resistance of the following grid resistor  $c$ . A larger capacitance, making a smaller reactance at this point, brings about a considerable improvement in low-frequency response, especially when the resistance of the grid resistor  $c$  is rather small or when this resistance is a

Tube Type	Table No.	Tube Type	Table No.
2A6	3	6N7, phase inverter	6
2B7	5	6Q7	13
6A6, phase inverter	6	6R7	14
6B6	3	6S7, as pentode	11
6B7	5	6SC7	4
6B8	5	6SF5	16
6C5	8	6SJ7, as pentode	1
6C6, as triode	8	6SQ7	3
6C6, as pentode	7	6T7	9
6C8, one triode	15	6W7, as triode	8
6F5	16	6W7, as pentode	7
6F8, one triode	2	6Z7	10
6J5	2	53, phase inverter	6
6J7, as triode	8	57, as triode	8
6J7, as pentode	7	57, as pentode	7
6L5	12	75	3

## RESISTANCE COUPLED AMPLIFIERS

SUPPLY VOLTS	COUPLING			BIAS		SCREEN		OUTPUT Peak Volts	GAIN (at listed volts) (j)	
	RESISTORS (megohms) Plate Grid		CAPA- CITOR (mfd) (d)	R Ohms	C Mfd.	R Ohms	C Mfd.			
(a)	(b)	(c)	(d)	(e)	(f)	(g)	(h)	(i)	(j)	
Table 1										
180	0.1	0.1	.019	760	9.1	0.29	0.10	49	55	5v
		0.25	.015	800	8.0	.31	.09	60	82	5v
		0.5	.007	860	7.8	.37	.09	62	91	5v
	0.25	0.25	.001	1050	6.8	.85	.06	38	109	5v
		0.5	.004	1060	6.6	.94	.06	47	151	5v
		1.0	.003	1100	6.1	.94	.07	54	161	5v
	0.5	0.5	.003	2000	4.0	1.85	.05	37	151	5v
		1.0	.002	2180	3.8	2.2	.04	44	192	5v
		2.0	.0015	2410	3.6	2.4	.035	54	208	5v
300	0.1	0.1	.019	500	11.5	.35	.10	72	67	5v
		0.25	.016	550	10.9	.37	.09	96	98	5v
		0.5	.007	590	9.9	.47	.09	101	104	5v
	0.25	0.25	.011	850	8.5	.89	.07	79	139	5v
		0.5	.004	860	7.4	1.10	.06	88	167	5v
		1.0	.003	910	6.9	1.18	.06	98	185	5v
	0.5	0.5	.004	1300	6.0	2.0	.06	64	200	5v
		1.0	.002	1410	5.8	2.2	.05	79	238	5v
		2.0	.0015	1530	5.2	2.5	.04	89	263	5v
Table 2										
180	0.05	0.05	.06	1190	3.27			24	13	5v
		0.1	.032	1490	2.86			30	13	5v
		0.25	.0115	1740	2.06			36	13	5v
	0.1	0.1	.038	2330	2.19			26	14	5v
		0.25	.012	2830	1.35			34	14	5v
		0.5	.006	3230	1.15			38	14	5v
	0.25	0.25	.013	5560	.81			28	14	5v
		0.5	.007	7000	.62			36	14	5v
		1.0	.004	8110	.50			40	14	5v
300	0.05	0.05	.06	1020	3.56			41	13	5v
		0.1	.034	1270	2.96			51	14	5v
		0.25	.012	1500	2.15			60	14	5v
	0.1	0.1	.035	1900	2.31			43	14	5v
		0.25	.0125	2440	1.42			56	14	5v
		0.5	.0065	2700	1.20			64	14	5v
	0.25	0.25	.013	4590	.87			46	14	5v
		0.5	.0075	5770	.64			57	14	5v
		1.0	.004	6950	.54			64	14	5v

## RESISTANCE COUPLED AMPLIFIERS (Continued)

SUPPLY VOLTS	COUPLING			BIAS		SCREEN		OUTPUT Peak Volts	GAIN (at listed volts)	
	RESISTORS (megohms)		CAPA- CITOR (mfd)	R Ohms	C Mfd.	R Ohms	C Mfd.			
(a)	Plate	Grid	(d)	(e)	(f)	(g)	(h)	(i)	(j)	
Table 3										
180	0.1	0.1	0.025	2600	3.3			16	29 5v	
		0.25	.015	2900	2.9			22	36 5v	
		0.5	.007	3000	2.7			23	37 5v	
	0.25	0.25	.015	4300	2.1			21	43 5v	
		0.5	.007	4800	1.8			28	50 5v	
		1.0	.004	5300	1.5			33	53 5v	
	0.5	0.5	.007	7000	1.3			25	52 5v	
		1.0	.004	8000	1.1			33	57 5v	
		2.0	.002	8800	0.9			38	58 5v	
300	0.1	0.1	.03	1900	4.0			31	31 5v	
		0.25	.015	2200	3.5			41	39 5v	
		0.5	.007	2300	3.0			45	42 5v	
	0.25	0.25	.015	3300	2.7			42	48 5v	
		0.5	.007	3900	2.0			51	53 5v	
		1.0	.004	4200	1.8			60	56 5v	
	0.5	0.5	.007	5300	1.6			47	58 5v	
		1.0	.004	6100	1.3			62	60 5v	
		2.0	.002	7000	1.2			67	63 5v	
	Table 4									
	180	0.1	0.1	0.031	960				17	25 5v
			0.25	.012	1070				24	29 5v
0.5			.0065	1220				27	33 5v	
0.25		0.25	.011	1850				21	35 5v	
		0.5	.006	2150				28	39 5v	
		1.0	.003	2400				32	41 5v	
0.5		0.5	.006	3050				24	40 5v	
		1.0	.003	3420				32	43 5v	
		2.0	.002	3890				36	45 5v	
300		0.1	0.1	.033	750				35	29 5v
			0.25	.014	930				50	34 5v
			0.5	.007	1040				54	36 5v
		0.25	0.25	.012	1400				45	39 5v
			0.5	.006	1680				55	42 5v
			1.0	.003	1840				64	45 5v
		0.5	0.5	.006	2330				50	45 5v
			1.0	.003	2980				62	48 5v
			2.0	.002	3280				72	49 5v

## RESISTANCE COUPLED AMPLIFIERS (Continued)

SUPPLY VOLTS	COUPLING RESISTORS (megohms)			BIAS		SCREEN		OUTPUT Peak Volts	GAIN (or listed volts)	
	Plate (b)	Grid (c)	CAPA- CITOR (mfd) (d)	R Ohms (e)	C Mfd (f)	R Ohms (g)	C Mfd (h)			
(a)	(b)	(c)	(d)	(e)	(f)	(g)	(h)	(i)	(j)	
Table 5										
180	0.1	0.1	0.02	1000	4.4	0.44	0.08	30	30	5v
		0.25	.015	1200	4.4	.5	.08	52	41	5v
		0.5	.008	1200	4.0	.6	.07	53	46	5v
	0.25	0.25	.01	1900	2.7	1.18	.05	39	55	5v
		0.5	.007	2100	3.2	1.2	.06	55	69	5v
		1.0	.003	2200	3.0	1.5	.05	53	83	5v
	0.5	0.5	.005	3300	2.1	2.6	.04	47	81	5v
		1.0	.003	3500	2.0	2.8	.04	55	115	5v
		2.0	.002	3500	2.2	3.0	.04	53	116	5v
300	0.1	0.1	.025	950	4.6	.5	.09	60	36	5v
		0.25	.015	1100	5.0	.55	.09	89	47	5v
		0.5	.009	900	4.8	.6	.08	86	54	5v
	0.25	0.25	.015	1500	3.2	1.2	.06	70	64	5v
		0.5	.008	1600	3.5	1.2	.06	100	79	5v
		1.0	.004	1800	4.0	1.5	.08	95	100	5v
	0.5	0.5	.006	2400	2.5	2.7	.05	80	96	5v
		1.0	.003	2500	2.3	2.9	.05	120	150	5v
		2.0	.0025	2800	2.8	3.4	.05	90	145	5v
Table 6										
180	0.1	0.1	0.03	1300				35	19	5v
		0.25	.015	1700				46	21	5v
		0.5	.007	1950				50	22	5v
	0.25	0.25	.015	2950				40	23	5v
		0.5	.007	3900				50	24	5v
		1.0	.0035	4300				57	24	5v
	0.5	0.5	.007	5250				44	24	5v
		1.0	.0035	6600				54	25	5v
		2.0	.002	7650				61	25	5v
300	0.1	0.1	.03	1150				60	20	5v
		0.25	.015	1500				83	22	5v
		0.5	.007	1750				86	23	5v
	0.25	0.25	.015	2650				75	23	5v
		0.5	.0055	3400				87	24	5v
		1.0	.003	4000				100	24	5v
	0.5	0.5	.0055	4850				76	23	5v
		1.0	.003	6100				94	24	5v
		2.0	.0015	7150				104	24	5v

## RESISTANCE COUPLED AMPLIFIERS (Continued)

SUPPLY VOLTS	COUPLING			BIAS		SCREEN		OUTPUT Peak Volts	GAIN (or listed volts)		
	RESISTORS (megohms)		CAPA- CITOR (mfd)	R	C	R	C				
	Plate	Grid		Ohms	Mfd.	Ohms	Mfd.				
(a) Table 7	(b)	(c)	(d)	(e)	(f)	(g)	(h)	(i)	(j)		
180	0.1	0.1	0.02	1000	6.5	0.44	0.05	42	51	5v	
		0.25	.01	750	6.7	.5	.05	52	69	5v	
		0.5	.006	800	6.7	.5	.05	59	83	5v	
	0.25	0.25	.008	1200	5.2	1.1	.04	41	93	5v	
		0.5	.005	1600	4.3	1.18	.04	60	118	5v	
		1.0	.0035	2000	3.8	1.4	.04	60	140	5v	
	0.5	0.5	.005	2600	3.2	2.45	.03	45	135	5v	
		1.0	.0025	3100	2.5	2.9	.025	56	165	5v	
		2.0	.0015	3500	2.8	2.7	.02	60	165	5v	
	300	0.1	0.1	.02	500	8.5	.44	.07	55	61	5v
			0.25	.01	450	8.3	.5	.07	81	82	5v
			0.5	.006	600	8.0	.53	.06	96	94	5v
		0.25	0.25	.008	1100	5.5	1.18	.04	81	104	5v
			0.5	.005	1200	5.4	1.18	.04	104	140	5v
			1.0	.005	1300	5.8	1.45	.05	110	185	5v
0.5		0.5	.005	1700	4.2	2.45	.04	75	161	5v	
		1.0	.003	2200	4.1	2.9	.04	97	350	5v	
		2.0	.0025	2300	4.0	2.95	.04	100	240	5v	
Table 8											
180		0.05	0.05	0.055	2200	2.2			34	10	5v
			0.1	.03	2700	2.1			45	11	5v
			0.25	.015	3100	1.85			54	11	5v
		0.1	0.1	.035	3900	1.7			41	12	5v
			0.25	.015	5300	1.25			54	12	5v
	0.5		.008	6200	1.2			55	13	5v	
	0.25	0.25	.015	9500	.74			44	13	5v	
		0.5	.008	12300	.55			52	13	5v	
		1.0	.004	14700	.47			59	13	5v	
	300	0.05	0.05	.075	2100	3.16			57	11	5v
			0.1	.04	2600	2.3			70	11	5v
			0.25	.015	3100	2.2			83	12	5v
		0.1	0.1	.035	3800	1.7			65	12	5v
			0.25	.015	5300	1.3			84	13	5v
			0.5	.008	6000	1.17			88	13	5v
0.25		0.25	.015	9600	.9			73	13	5v	
		0.5	.008	12300	.59			85	14	5v	
		1.0	.003	14000	.37			97	14	5v	

## RESISTANCE COUPLED AMPLIFIERS (Continued)

SUPPLY VOLTS	COUPLING			BIAS		SCREEN		OUTPUT Peak Volts	GAIN (or listed volts)	
	RESISTORS (megohms)		CAPA- CITOR	R	C	R	C			
(e)	Plate	Grid	(mfd)	Ohms	Mfd.	Ohms	Mfd.	(i)	(j)	
Table 9										
180	0.1	0.1	0.023	2420	2.55			21	24 4v	
		0.25	.0135	2830	2.25			29	28 4v	
		0.5	.008	3080	2.0			32	31 4v	
	0.25	0.25	.012	4410	1.5			27	34 4v	
		0.5	.008	5220	1.25			34	36 4v	
		1.0	.005	5920	1.11			39	38 4v	
	0.5	0.5	.007	7250	.91			31	38 4v	
		1.0	.0045	9440	.74			39	41 4v	
		2.0	.0035	10850	.6			43	41 4v	
	300	0.1	0.1	.0245	1950	2.85			44	27 4v
			0.25	.0135	2400	2.55			58	32 4v
			0.5	.008	2640	2.25			64	33 4v
		0.25	0.25	.012	3760	1.57			57	37 4v
			0.5	.0075	4580	1.35			69	40 4v
			1.0	.005	5220	1.23			80	41 4v
0.5		0.5	.008	6570	1.02			62	42 4v	
		1.0	.0055	8200	.82			77	43 4v	
		2.0	.004	9600	.7			86	44 4v	
Table 10										
180		0.1	0.1	0.028	930	3.4			18	26 5v
			0.25	.0115	1100	2.6			28	31 5v
			0.5	.007	1210	2.32			33	32 5v
		0.25	0.25	.012	1820	1.71			28	35 5v
			0.5	.007	2110	1.38			34	38 5v
	1.0		.0035	2400	1.1			41	39 5v	
	0.5	0.5	.006	3240	.9			32	39 5v	
		1.0	.0035	3890	.703			38	40 5v	
		2.0	.002	4360	.553			44	41 5v	
	300	0.1	0.1	.028	670	3.81			38	31 5v
			0.25	.012	950	2.63			52	34 5v
			0.5	.007	1050	2.34			60	36 5v
		0.25	0.25	.012	1430	1.87			50	38 5v
			0.5	.006	1680	1.46			59	40 5v
			1.0	.0035	1930	1.19			66	43 5v
0.5		0.5	.006	2540	.97			55	42 5v	
		1.0	.0035	3110	.72			70	44 5v	
		2.0	.002	3560	.56			75	45 5v	

## RESISTANCE COUPLED AMPLIFIERS (Continued)

SUPPLY VOLTS	COUPLING			BIAS		SCREEN		OUTPUT Peak Volts	GAIN		
	RESISTORS (megohms)		CAPA- CITOR (mfd)	R	C	R	C		Peak Volts	(of listed volts)	
	Plate	Grid		Ohms	Mfd	Ohms	Mfd			(i)	(j)
(a)	(b)	(c)	(d)	(e)	(f)	(g)	(h)	(i)	(j)		
Table 11											
180	0.1	0.1	0.017	530	7.2	0.58	0.073	33	47	4v	
		0.25	.01	540	6.9	.68	.07	43	66	4v	
		0.5	.0063	540	6.6	.71	.065	48	75	4v	
	0.25	0.25	.0071	850	4.6	1.6	.05	33	79	4v	
		0.5	.005	890	4.7	1.8	.044	40	104	4v	
		1.0	.0037	950	4.4	1.9	.046	44	118	4v	
	0.5	0.5	.0041	1410	3.5	3.3	.041	30	109	4v	
		1.0	.003	1520	3.0	3.6	.037	38	134	4v	
		2.0	.0024	1600	2.9	3.8	.031	42	147	4v	
	300	0.1	0.1	.0167	430	8.5	.59	.077	57	57	4v
			0.25	.01	440	8.0	.67	.071	75	78	4v
			0.5	.0066	440	8.0	.71	.071	82	89	4v
0.25		0.25	.0071	620	6.0	1.7	.058	54	98	4v	
		0.5	.005	650	5.8	1.95	.057	66	122	4v	
		1.0	.0036	700	5.2	2.1	.055	76	136	4v	
0.5		0.5	.0037	1000	4.1	3.6	.04	52	136	4v	
		1.0	.0029	1080	3.9	3.9	.041	66	162	4v	
		2.0	.0023	1120	3.8	4.1	.043	73	174	4v	
Table 12											
180		0.05	0.05	0.06	1810	2.9			32	10	4v
			0.1	.03	2240	2.2			41	11	4v
	0.25		.014	2660	1.8			46	12	4v	
	0.1	0.1	.03	3180	1.46			36	12	4v	
		0.25	.0145	4200	1.1			46	12	4v	
		0.5	.009	4790	1.0			50	12	4v	
	0.25	0.25	.014	7100	.7			38	12	4v	
		0.5	.009	9290	.54			46	12	4v	
		1.0	.0055	10950	.46			52	13	4v	
	300	0.05	0.05	.06	1740	2.91			56	11	4v
			0.1	.032	2160	2.18			68	12	4v
			0.25	.015	2600	1.82			79	12	4v
0.1		0.1	.032	3070	1.64			60	12	4v	
		0.25	.014	4140	1.1			79	13	4v	
		0.5	.0075	4700	.81			89	13	4v	
0.25		0.25	.013	6900	.57			64	13	4v	
		0.5	.0075	9100	.46			80	13	4v	
		1.0	.005	10750	.4			88	13	4v	

## RESISTANCE COUPLED AMPLIFIERS (Continued)

SUPPLY VOLTS	COUPLING			BIAS		SCREEN		OUTPUT Peak Volts	GAIN (at listed volts)	
	RESISTORS (megohms)	RESISTORS (megohms)	CAPACITOR (mfd)	R Ohms	C Mfd.	R Ohms	C Mfd.			
(a)	Plate	Grid	(d)	(e)	(f)	(g)	(h)	(i)	(j)	
Table 13										
180	0.1	0.1	0.02	1600	3.0			19	28	5v
		0.25	.01	1900	2.5			26	33	5v
		0.5	.005	2100	2.3			29	35	5v
	0.25	0.25	.01	3400	1.6			25	36	5v
		0.5	.005	4000	1.3			31	38	5v
		1.0	.003	4500	1.05			37	40	5v
	0.5	0.5	.006	6000	.86			30	39	5v
		1.0	.003	7100	.76			36	40	5v
		2.0	.002	7900	.63			41	41	5v
300	0.1	0.1	.03	1200	4.4			35	34	5v
		0.25	.015	1500	3.6			52	39	5v
		0.5	.007	1700	3.05			53	40	5v
	0.25	0.25	.015	2600	2.4			43	42	5v
		0.5	.007	3000	1.66			52	45	5v
		1.0	.004	3600	1.45			62	45	5v
	0.5	0.5	.007	4600	1.2			47	45	5v
		1.0	.004	5500	.9			60	46	5v
		2.0	.002	6200	.9			66	47	5v
Table 14										
180	0.05	0.05	0.05	1700	2.3			31	9	5v
		0.1	.03	2100	1.9			40	9	5v
		0.25	.01	2500	1.5			45	10	5v
	0.1	0.1	.03	3000	1.3			35	10	5v
		0.25	.01	4100	.9			43	10	5v
		0.5	.006	4600	.8			46	10	5v
	0.25	0.25	.01	6700	.54			33	10	5v
		0.5	.006	8800	.4			40	10	5v
		1.0	.003	10000	.33			47	11	5v
300	0.05	0.05	.055	1600	2.6			50	9	5v
		0.1	.03	2000	2.0			62	9	5v
		0.25	.015	2400	1.6			71	10	5v
	0.1	0.1	.03	2900	1.4			52	10	5v
		0.25	.015	3800	1.1			68	10	5v
		0.5	.007	4400	1.0			71	10	5v
	0.25	0.25	.015	6300	.7			54	10	5v
		0.5	.007	8400	.5			62	11	5v
		1.0	.004	10600	.44			74	11	5v



## RESISTANCE COUPLED AMPLIFIERS (Continued)

SUPPLY VOLTS	COUPLING			BIAS		SCREEN		OUTPUT Peak Volts	GAIN (at listed volts)			
	RESISTORS (megohms)	CAPACITOR (mfd)	CAPACITOR (mfd)	R Ohms	C Mfd.	R Ohms	C Mfd.					
(a)	Plate	Grid	(d)	(e)	(f)	(g)	(h)	(i)	(j)			
Table 15	180	0.1	0.1	0.028	2420	2.34			30	20	5v	
			0.25	.012	3080	1.84			40	22	5v	
			0.5	.0065	3560	1.6			45	23	5v	
		0.25	0.25	.012	5170	1.25			35	24	5v	
			0.5	.007	6560	.95			45	25	5v	
			1.0	.0035	7550	.85			50	26	5v	
		0.5	0.5	.007	9840	.66			38	25	5v	
			1.0	.004	12500	.5			44	26	5v	
			2.0	.0015	15600	.44			51	26	5v	
	300	0.1	0.1	.037	2120	3.93			55	22	5v	
				0.25	.013	2840	2.01			73	23	5v
				0.5	.007	3250	1.79			80	25	5v
			0.25	0.25	.013	4750	1.29			64	25	5v
				0.5	.0065	6100	.96			80	26	5v
				1.0	.004	7100	.77			90	27	5v
		0.5	0.5	.007	9000	.67			67	27	5v	
			1.0	.004	11500	.48			83	27	5v	
			2.0	.002	14500	.37			96	28	5v	

Table 16

Table 16	180	0.1	0.1	0.025	1800	4.4			16	37	5v	
			0.25	.015	2000	3.3			23	44	5v	
			0.5	.006	2200	2.9			25	46	5v	
		0.25	0.25	.01	3500	2.3			21	48	5v	
			0.5	.006	4100	1.8			26	53	5v	
			1.0	.004	4500	1.7			32	57	5v	
		0.5	0.5	.006	6100	1.3			24	53	5v	
			1.0	.003	6900	.9			33	63	5v	
			2.0	.0015	7700	.83			37	66	5v	
	300	0.1	0.1	.025	1300	5.0			33	42	5v	
				0.25	.01	1600	3.7			43	49	5v
				0.5	.006	1700	3.2			48	52	5v
			0.25	0.25	.01	2600	2.5			41	56	5v
				0.5	.007	3200	2.1			54	63	5v
				1.0	.004	3500	2.0			63	67	5v
		0.5	0.5	.006	4500	1.5			50	65	5v	
			1.0	.004	5400	1.2			62	70	5v	
			2.0	.002	6100	.93			70	70	5v	

half-megohm or less. High-frequency response is but little affected by the value of capacitance at  $d$  unless the grid resistor has a very low value, such as a value of less than one-fifth megohm.

The tables headed *Resistance Coupled Amplifiers* list representative values for all of the elements shown by letters in Fig. 13-3, and, in addition, list peak output voltages and voltage gains. All of the values in the tables are taken from publications of the RCA Victor Division, Radio Corporation of America. The accompanying list shows the numbers of the tables which apply to tubes of various types.

There are two sections of each table; the upper nine lines being for a supply voltage of 180, and the lower nine lines for a supply voltage of 300. Plate voltage and screen voltage are less than the supply voltage by the drop through the plate resistor (column b) and screen resistor (column g) and the small additional drop through the biasing resistor (column e). Even though the supply voltage differs by as much as 50 per cent from the value listed in the table, the values of resistors, capacitors and gain remain approximately the same, but the ratio of the new output voltage (column i) to the listed output voltage is the same as the ratio of the new supply voltage to the listed supply voltage. For example, with a supply voltage of 250, the output voltage would be 250/300 of the output voltage listed for 300 volts supply.

The coupling or blocking capacitor (column d) and the bypass capacitors for bias and screen resistors (columns f and h) have been selected to give, at a frequency of 100 cycles, an output voltage equal to 0.8 of the listed output with triodes and equal to 0.7 of the listed output with pentodes. The listed output voltages are for a frequency of 420 cycles and, in general, apply throughout the medium frequencies.

If the frequency at which the output drops to 0.8 (with triodes) or to 0.7 (with pentodes) of the listed output voltage is to be something other than 100 cycles, it is necessary to change the values of the coupling and bypass capacitors. The ratio of the new capacitance to the listed capacitance is the same as the ratio of 100 to the selected frequency. For example, if the frequency is to be 200 cycles for the drop to 0.8 or 0.7 of the listed output, the listed values of capacitance will be multiplied by 100/200 or by 1/2 to find the new values for 200 cycles.

The values of bypass capacitors for biasing resistors (column f) are based on direct current for the heaters of the tubes. With alternating current for the heaters more capacitance usually will be needed to prevent excessive hum and other disturbances.

The output peak volts (column *i*) is the a-c voltage applied across the grid resistor in the grid circuit of the following tube, which is resistor *c* in Fig. 13-3.

The value of voltage gain listed in column *j* is that obtained with an r-m-s or effective a-c voltage output as listed in this column, which usually is 5 volts.

The values of resistances and capacitances listed in the tables may vary by as much as 10 per cent, plus or minus, with only slight effect on performance. Decoupling filtering, other than that afforded by the bypass capacitors, is not required for one or two stages of amplification.

**Transformer Coupling.**—With an audio frequency coupling transformer of given primary inductance, the amplification decreases with increase of plate resistance in the tube feeding the transformer. This is especially noticeable at low frequencies and with tubes having plate resistances in excess of 10,000 ohms.

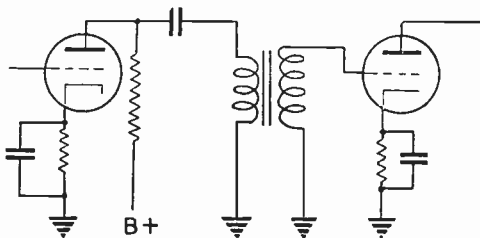

Fig. 13-4. Parallel feed for increasing effective primary inductance.

Increase of primary inductance increases the amplification from a given tube feeding the transformer. Effective primary inductance is greatest when no direct current from the plate supply flows through the primary winding, as with the parallel feed arrangement of Fig. 13-4. There is a rapid dropping off of primary inductance with increase of primary direct current, this being due to partial saturation of the core iron by the steady current.

To maintain a given low-frequency response with a given type of tube, the primary inductance is inversely proportional to the frequency. For example, to maintain the same response at 100 cycles as was obtained at 200 cycles the primary inductance must be doubled, because the frequency is halved. To maintain the same response with different tubes, the primary inductance is changed in direct proportion to the plate resistance of the tubes. For example, to maintain the same response with a tube of 20,000 ohms plate resistance as with one of 10,000 ohms plate resistance, the primary inductance is doubled for the tube of higher plate resistance.

**Push-pull Amplifiers.**—The power output of two triodes operating in push pull is equal, approximately, to one-fifth of the product of maximum plate current and plate supply voltage.

$$\text{Watts (2 tubes)} = \frac{I_p, \text{ max. amps} \times \text{plate supply volts}}{5}$$

Maximum plate current, as used in this formula, is assumed to be the current at zero grid bias and at a plate potential equal to 0.6 of the plate supply potential. For example, with triodes whose performance is shown by the plate characteristics of Fig. 13-5, operated with a plate supply potential of 140 volts,

$$140 \times 0.6 = 84 \text{ volts}$$

At 84 volts  $E_p$  and 0  $E_g$  (Fig. 13-5),  $I_p = 39$  milamps. Then, placing the values in the formula, we have,

$$\text{Watts} = \frac{0.039 \text{ amp.} \times 140 \text{ volts}}{5} = 1.09$$

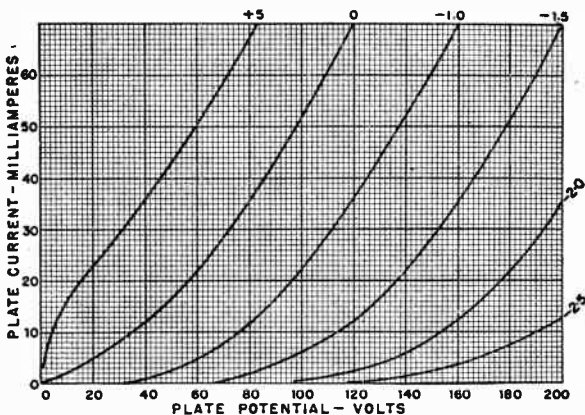

Fig. 13-5. Plate characteristics used in example of push-pull power output.

The plate load resistance, from plate to plate of the two push-pull tubes, will be approximately,

$$\text{Load, ohms} = \frac{1.6 \times \text{plate supply volts}}{I_p, \text{ max. amps.}}$$

For the example being followed, the load resistance would be,

$$\text{Ohms} = \frac{1.6 \times 140}{0.039} = 5743 \text{ ohms, plate to plate.}$$

The most negative grid bias which may be employed for Class A operation of the tubes is one-half of the bias

which will cause plate current cutoff with a plate voltage equal to about 1.4 times the plate supply voltage. With the supply voltage of 140 assumed in the example being followed, the cutoff voltage would be  $1.4 \times 140 = 196$  volts. From Fig. 13-5 it appears that cutoff at 196 volts will occur with a negative bias of about 22 volts, so the maximum negative bias will be about 11 volts. If the bias is made still more negative, plate current will drop to zero during some periods and there will be Class AB or Class B operation.

**Phase Inversion or Phase Splitting.**—In any push-pull amplifier it is necessary that the two power tubes connected in push-pull be supplied with simultaneous grid voltages that are equal in strength and that increase and

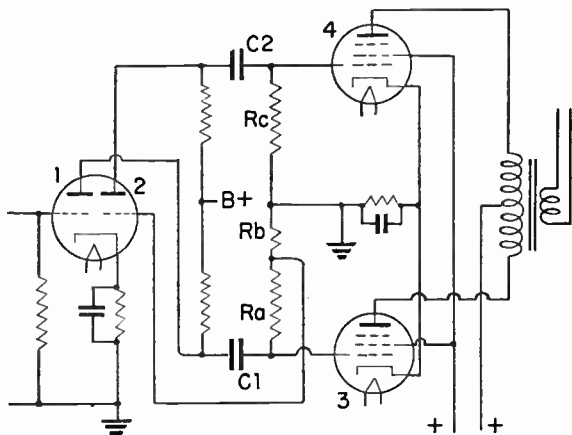

Fig. 13-6. Circuit for phase splitting or phase inversion.

decrease in opposite polarities or that are  $180^\circ$  out of phase. This is easily accomplished with transformer coupling wherein the grids of the push-pull tubes are connected to opposite ends of a center-tapped secondary winding.

With resistance coupling the grid voltages for the push-pull tubes are obtained by the use of a tube as a *phase inverter* or *phase splitter*. Fig. 13-6 shows a commonly employed circuit in which the phase inversion occurs in one section of a twin triode marked 1 and 2. Section 1 is resistance coupled to the control grid of power tube 3 through coupling capacitor  $C1$ , the plate resistor leading to  $B+$ , and the grid resistor consisting of  $Ra$  and  $Rb$ . Section 2 is resistance coupled to the

grid of power tube 4 through capacitor  $C_2$ , the plate resistor, and the grid resistor  $R_c$ .

The input signal is applied to the grid of section 1, and causes corresponding variations of potential in resistors  $R_a$  and  $R_b$ , which are in the plate circuit of section 1. The portion of the total potential variations in  $R_a$  and  $R_b$  that occurs across  $R_b$  is applied to the grid of section 2 of the twin triode. Since the grid of section 2 is excited by potentials developed in the plate circuit of section 1, the output potentials from the two sections, which form control grid voltages for the push-pull power tubes, are  $180^\circ$  out of phase.

To obtain equal control grid signal voltages for the push-pull power tubes, the voltage across resistor  $R_b$ , which is the grid voltage for section 2 of the twin triode, must equal the signal voltage applied to the grid of section 1. This is accomplished by making the resistance  $R_b$  such a fraction of the total resistance ( $R_a + R_b$ ) as represented by 1 divided by the voltage gain in the triode section. For example, if the voltage gain is 24, then resistance  $R_b$  is made  $1/24$  of the total resistance in  $R_a$  and  $R_b$ .

Ordinarily resistors  $R_a$  and  $R_c$  are made of equal resistance, and of some value that is obtainable in standard resistors. Then the resistance for  $R_b$  is determined thus.

$$R_b = \frac{R_a}{(\text{voltage gain}) - 1}$$

If  $R_a$  and  $R_c$  are, for example, 100,000 ohms each, and if the voltage gain in section 2 of the twin triode is 24, then the formula shows,

$$R_b = \frac{100000}{24 - 1} = 4350 \text{ ohms, approximately.}$$

Voltage gains for various tubes used as phase inverters may be found from the tables of *Resistance Coupled Amplifiers*.

## Section 14

### RECEIVERS

**Superheterodyne Frequency Conversion.**—Fig. 14-1 shows one of the most commonly used frequency conversion circuits, employing pentagrid converters such as the 6SA7, the 7Q7, and the 12- and 14-volt counterparts of these tubes. Grid 1 acts as the control grid for the oscillator circuit which consists of coils  $L_a$  and  $L_b$ , with  $L_a$  tuned by means of variable capacitor  $C_a$  which is

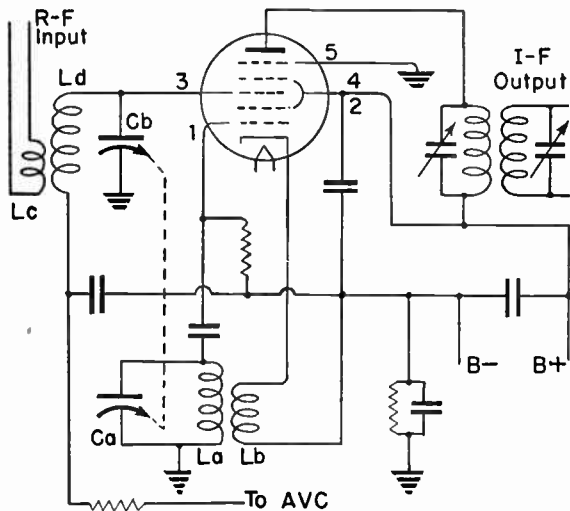

Fig. 14-1. Pentagrid converter circuit.

ganged with tuning capacitor  $C_b$  for the r-f input circuit which includes coils  $L_c$  and  $L_d$ . Grids 2 and 4 are internally connected together to form the screen grid surrounding grid 3 to which is applied the r-f signal. Grid 2 acts as the anode or plate for the oscillator system.

Various oscillator circuit arrangements are used with this general type of converter. At *A* in Fig. 14-2 is an oscillator circuit using a single tapped coil  $L_a-L_b$  with a padding capacitor  $C_p$ . Tubes of G and GT types have the suppressor, grid 5, internally connected to the cathode as at *B* in Fig. 14-2. A filament-cathode type of pentagrid converter, such as the 1R5, has the sup-

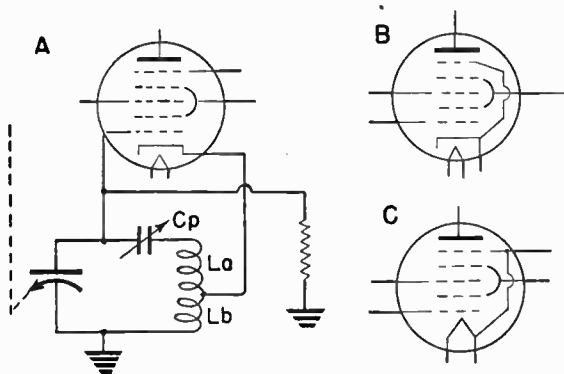

Fig. 14-2. Variations found in pentagrid converters.

pressor internally connected to the negative end of the filament, as at C in Fig. 14-2, and, in addition, has a separate base pin connection for the suppressor.

All of the pentagrid converter tubes represented in Figs. 14-1 and 14-2 have the same arrangement of the five grids between cathode and plate. Tubes of this general type have high plate resistance and high conversion conductance.

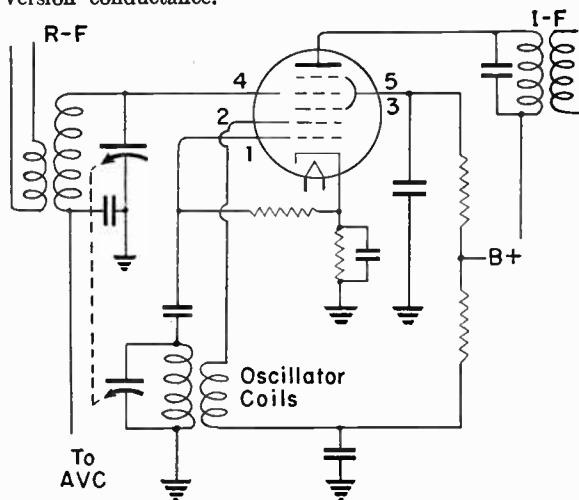

Fig. 14-3. Pentagrid converter with separate oscillator anode.



Fig. 14-3 shows a typical circuit for a different type of pentagrid converter. In this type grid 1 is the oscillator grid, grid 2 is the oscillator anode or plate, grids 3 and 5 are internally connected together to form the screen for grid 4, to which is applied the r-f signal. There is no suppressor grid between the plate and the screen grid, as there is in the tube shown by Fig. 14-1. For operation at the higher frequencies in the short wave band a small adjustable neutralizing capacitor sometimes is connected between grids 1 and 4.

The following list gives type numbers of some of the pentagrid converters having grid arrangements shown by Fig. 14-3, and gives also the base connection diagram numbers used in the section on *Receiving Tubes* in this book.

Tube Type	Socket Diagram	Tube Type	Socket Diagram
1A6	33	2A7	45
1A7	167	6A7	45
1B7	167	6A8	166
1C6	33	6D8	166
1C7	167	7B8	156
1D7	167	12A8	166
1LA6	144	14B8	156
1LC6	144		

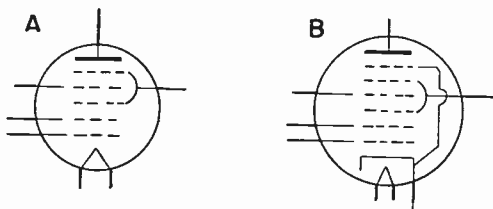

Fig. 14-4. Pentagrid converter (A) and octode converter (B).

Filament-cathode tubes in this pentagrid converter class have their elements arranged as at A in Fig. 14-4.

At B in Fig. 14-4 are shown the elements for an *octode converter*, such as the 7A8. The difference between this converter and the ones represented by Fig. 14-3 is in the extra suppressor grid internally connected to the cathode of the octode converter. The tube has only six grids between the cathode and the plate, rather than the eight that might be indicated by the word "octode."

High-frequency reception sometimes is difficult because of interaction and pulling between mixer and oscillator circuits when a single tube performs both functions. In some receivers the difficulties are lessened by using sep-

arate tubes for mixer and oscillator. Fig. 14-5 shows a pentagrid tube of the same style as used in Fig. 14-1 as a converter, here used as a separate mixer. The oscillator is a triode shown at the right-hand side of the diagram. The oscillator frequency is introduced to the mixer through its grid number 1, with the r-f signal brought in at grid 3. The oscillating circuit, consisting of the oscillator coils and the tuning and padding capacitors, is in the circuit for number 1 grid of the mixer and is also in the grid circuit of the triode oscillator. This, in effect, provides direct coupling between oscillator and mixer. Other methods of coupling may be used.

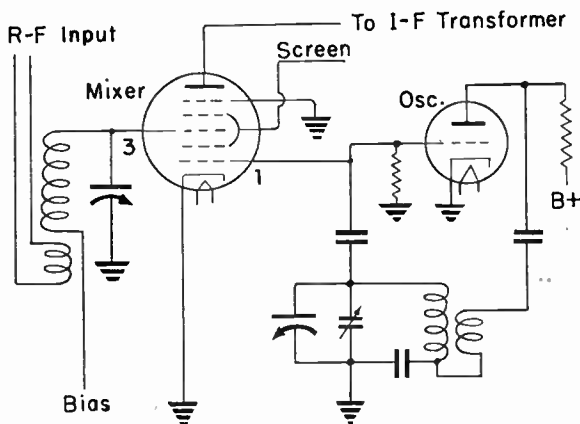

Fig. 14-5. Pentagrid tube used as mixer, with separate triode oscillator.

Fig. 14-6 shows one circuit which may be used for a *pentagrid mixer*, such as the 6L7, and a separate triode oscillator. This circuit is generally similar to the one in Fig. 14-5, but here the oscillator frequency is introduced into the mixer through mixer grid number 3 instead of through grid number 1 as in the former circuit. With the pentagrid mixer tube the r-f signal is brought in through grid number 1. The pentagrid mixer with separate oscillator often is used for high-frequency reception.

Fig. 14-7 shows a frequency conversion circuit containing a *triode-hexode converter*, such as the 6K8 or 6P8. The tube consists of two units in a single envelope; the hexode with its cathode, four grids, and plate forming one unit, and a triode, with cathode, grid and plate, forming the other unit. The hexode is the mixer and the triode is the oscillator. The circuit is similar in many

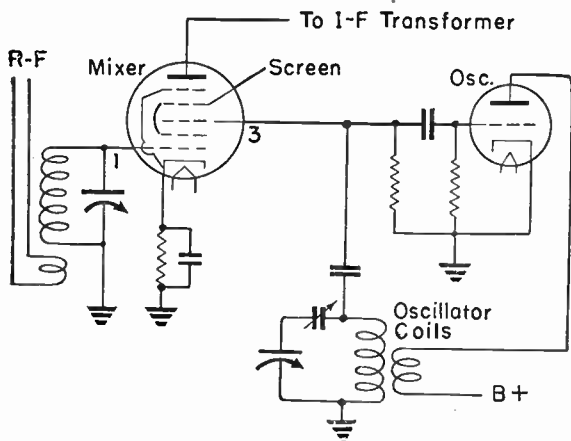

Fig. 14-6. Pentagrid mixer tube used with separate oscillator.

respects to the one of Fig. 14-5, where the oscillator grid of the mixer and the control grid of the oscillator are connected directly together, with the oscillating tuned circuit coupled to both grids, and where the r-f signal frequency is introduced into the mixer through the grid enclosed by the two sections of the screen. The triode-hexode conversion arrangement sometimes is used

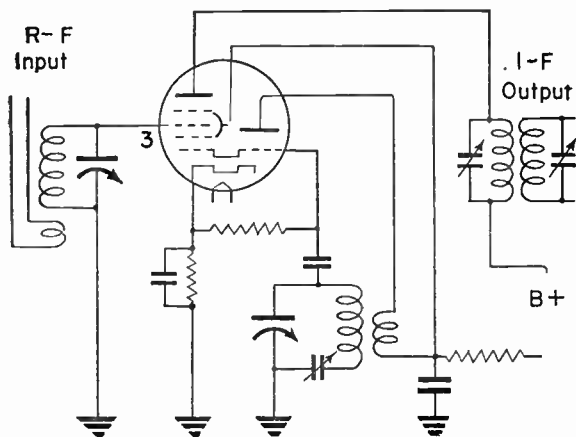

Fig. 14-7. Circuit for triode-hexode converter.

for all-wave receivers, since it gives good results at high frequencies.

Fig. 14-8 shows two types of tube called *triode-heptode converters*. Both behave similarly to the triode-hexode of Fig. 14-7, and they are used in similar conversion circuits. Diagram A represents the 6J8 tube in which the grid nearest the plate in the mixer or heptode section is a suppressor grid connected internally to the cathode. The r-f input is introduced into the heptode units through their number 1 grid, nearest the cathode, instead of through the screened number 3 grid as in Fig. 14-7. There is direct coupling between the oscillator and mixer circuits by means of the direct connection between the oscillator grids in the triode and heptode units of the tubes.

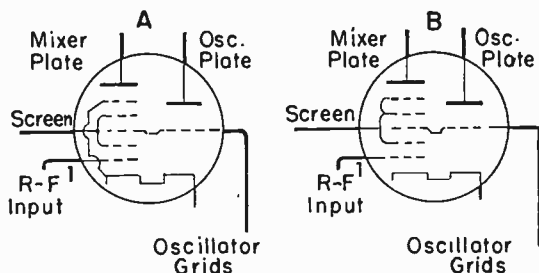

Fig. 14-8. Triode-heptode converters.

Diagram B of Fig. 14-8 represents triode heptode converters such as the 7J7, 7S7, and their 14-volt counterparts. The arrangement of elements differs from that in diagram A in that the grid number 5 of the heptode is a portion of the screen grid structure rather than being a suppressor. This change has no effect on the number or kind of external connections, which are the same for all the tubes represented in Figs. 14-7 and 14-8.

**Intermediate Frequencies.**—The following frequencies, in kilocycles, have been used and are being used as the peaks for intermediate frequencies in amplitude-modulated superheterodyne receivers for broadcast reception.

#### INTERMEDIATE FREQUENCIES

115	170	252.5	370	432	465
125	172.5	260	374	445	470
130	175	262	385	450	472.5
132	177.5	262.5		455	480
	180	264		456	485
	181.5	265		460	490

**Superheterodyne Alignment.**—The following instructions for alignment apply in a general way to any super-

heterodyne receiver, and may be used when specific instructions for a particular receiver are not available.

Most signal generators provide three different kinds of output, (1) modulated, with an r-f signal modulated with 400 cycle audio frequency, (2) unmodulated, with the r-f signal and no modulation, and (3) an a-f signal, usually of 400 cycles, with no radio frequency. Attenuation controls for r-f and a-f signals permit adjustment of the voltage available from the output terminals or jack of the generator.

Alignment most often is performed while a rectifier-type of meter (an output meter) is connected across the a-f output of the receiver, or across the leads going to the loud speaker voice coil. (Fig. 14-11.) A cathode-ray oscilloscope may be connected to the output of the detector stage that follows the i-f amplifier. When an output meter is used, the signal generator must be set to provide a modulated output. For some receivers an unmodulated r-f generator output is used, with a d-c meter of suitable range connected in the output of the detector circuit. If it is necessary to provide more voltage for the output meter in order to obtain satisfactory deflection, the meter, in series with a half-microfarad paper capacitor, may be connected between the plate of one of the output (power) tubes and the chassis.

The usual procedure is first to align the i-f amplifier, then the oscillator, and finally the r-f amplifier and mixer. For i-f alignment, the signal generator may be connected to the r-f input grid of the converter or mixer as shown by Fig. 14-9. The lead is disconnected from the r-f input grid of the converter or mixer, and reconnected in series with a  $\frac{1}{4}$ -megohm resistor, thus maintaining normal grid bias for the tube. The signal generator then is connected to the grid pin through a capacitor of 250 mmfd. capacitance. The shielding cover of the generator lead should be connected to the receiver chassis.

If the intermediate frequency for the receiver is known, set the signal generator for this frequency. Set the receiver volume control in maximum volume position. Turn the r-f and a-f attenuator controls of the generator toward higher output positions until a reading is noted on the output meter or sound is heard from the loud speaker.

Should there be no receiver output indication with the signal generator output at maximum, the receiver may have been aligned to some intermediate frequency other than the one assumed. Change the frequency setting of the generator very slowly until there is an output indication from the receiver, which will show that the receiver is aligned at the frequency then produced by the generator.

If no receiver response can be obtained with any adjustments, it is probable that the i-f amplifier is completely out of adjustment. Then commence at the control grid of the final i-f tube, the one preceding the detector, and with the signal generator connected to this grid align the stage. Proceed similarly to align other i-f stages, working back toward the r-f input for the converter or mixer.

When making alignment stage-by-stage, the output of the signal generator must be reduced as the work proceeds. Otherwise the action of any automatic volume control system will make the response seem broad, and there will be incorrect alignment. The generator output

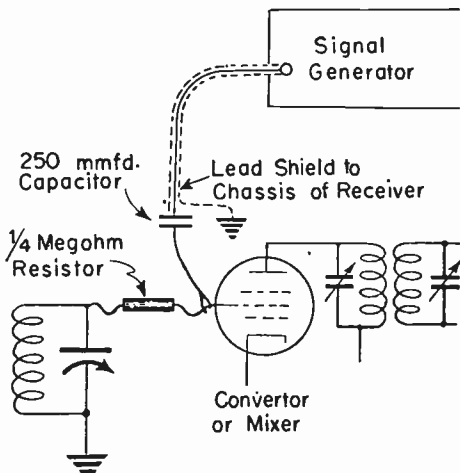

Fig. 14-9. Connection of signal generator for alignment.

should be only enough to get readable indications on the output meter. After aligning each i-f stage, leave the generator connected as in Fig. 14-9 and go over all the trimmers a second time to make certain of correct settings.

The r-f and oscillator circuits should be aligned at frequencies specified in service instructions for the receiver when such instructions are available. Otherwise, for the standard a-m broadcast band, use 1,400 kc for the higher frequency and 600 kc for the lower frequency. For each other band in which alignment is to be made, frequencies are selected slightly below the high end and slightly above the low end of the band.

When aligning the r-f circuits, some form of dummy antenna element must be used between the output lead

of the signal generator and the antenna connection of the receiver to prevent undue reaction between the output circuit of the generator and the input circuits of the receiver. Alignment instructions for particular receivers specify the values of capacitors or resistors to be connected between generator and receiver during the various steps in alignment. Lacking specific information, it may be sufficient to connect a 1/10-mfd capacitor between generator and receiver. Usually it is better to use the standard IRE dummy antenna shown by Fig. 14-10, where are indicated also the correct connections to the signal generator output and the receiver antenna and ground posts. Such a dummy antenna may be made up with fixed capacitors of the values shown, and with any 400-ohm resistor that is non-inductive. The 20-micro-

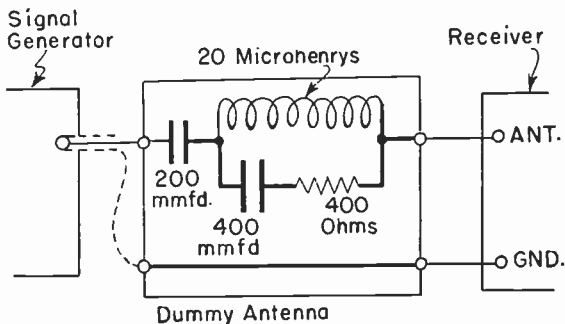

Fig. 14-10. The IRE dummy antenna and its connections.

henry inductance coil may be made up with 45 turns of number 34 double silk covered wire close wound on a cylindrical form  $\frac{1}{2}$  inch in diameter.

For alignment at the higher of the two selected frequencies in the band being checked, set both the signal generator and the receiver tuning dial to this frequency, then adjust the oscillator trimmer of the receiver until there is a response shown on the output meter. Next adjust the trimmers of the converter or mixer, and of the r-f tuned circuit, to obtain maximum response. The output of the generator will have to be reduced by adjusting its attenuator as the various circuits are aligned.

The next step is to set the signal generator for the lower of the frequencies, and turn the receiver tuning dial until the output meter shows a response. The frequency indicated by the receiver dial should agree with the frequency being furnished by the generator. If there is an oscillator padding capacitor in the receiver, adjust it while slowly rocking the main tuning capacitor of the

receiver back and forth until there is maximum response. Then recheck the oscillator trimmer at the higher frequency, and readjust it if necessary. The lower frequency adjustment should again be checked, since one of these oscillator adjustments affects the other.

If the frequency indications of the receiver tuning dial do not agree with the frequencies furnished from the generator it may indicate that incorrect parts have been used for replacements of tuning capacitors, coils, and transformers. It may mean also that the alignment process has been performed incorrectly, or possibly that the alignment in the i-f stages has been carried out at a frequency other than that for which the parts are designed.

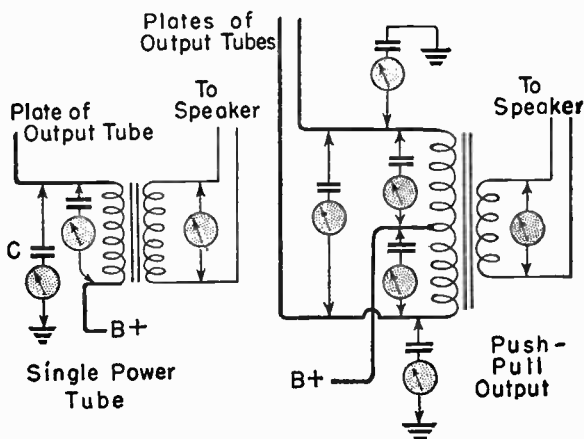

Fig. 14-11. Connections of output meter for alignment.

**Output Meter Connections.**—For alignment of an amplitude-modulation receiver the output meter may be connected between any of the points indicated by the left-hand diagram of Fig. 14-11 when there is a single output tube or power tube, and as in the right-hand diagram for push-pull output tubes. The meter must be of an a-c type, usually a rectifier meter, with a range of zero to 5 or 10 milliamperes. As shown in the diagrams, a high-voltage paper capacitor of 1/10 mfd. or greater capacitance must be in series with the meter whenever connections are made on the plate side or power supply side of the output transformer.

With a diode type detector, used for automatic volume control as in Fig. 14-12, or used without such a control, the output during processes of alignment may be indi-



cated by connecting across the load resistor  $R$  of the detector either a cathode-ray oscilloscope (vertical deflection plates) or else a high-resistance d-c voltmeter. Either indicating instrument is connected between the high end of the load resistor and ground. The voltmeter should have the highest possible resistance, preferably at least 20,000 ohms per volt, and may have a range of zero to 5 or 10 volts.

**Alignment of F-M Receivers.**—Since the amplitude-modulated output of the ordinary signal generator does not get through a frequency-modulation receiver as far as the a-f amplifier, it is necessary to use an unmodulated signal of correct frequency. The signal is fed to the converter or mixer, as in Fig. 14-9, for alignment of i-f stages, limiter stages, and the discriminator, and is fed to the antenna post of the receiver, or sometimes by

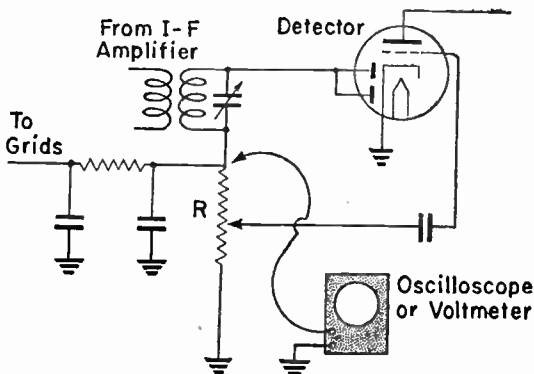

Fig. 14-12. Oscilloscope or voltmeter connection for alignment.

radiation to a built-in antenna from a wire connected to the generator output, while aligning the r-f stages.

Fig. 14-13 shows a typical two-stage limiter, and a discriminator using a double diode tube, which are the only parts of an f-m receiver which differ in principle from parts of an a-m superheterodyne receiver. The purpose of the limiters is to get rid of all or nearly all of any amplitude modulation which may have become a portion of the frequency-modulated carrier due to electrical interference of one kind or another. The discriminator produces, from the frequency-modulated potentials, other potentials which vary at the audio-frequency corresponding to the original sound frequencies introduced at the transmitter. Thus the discriminator of the f-m receiver corresponds to the detector of the a-m receiver.

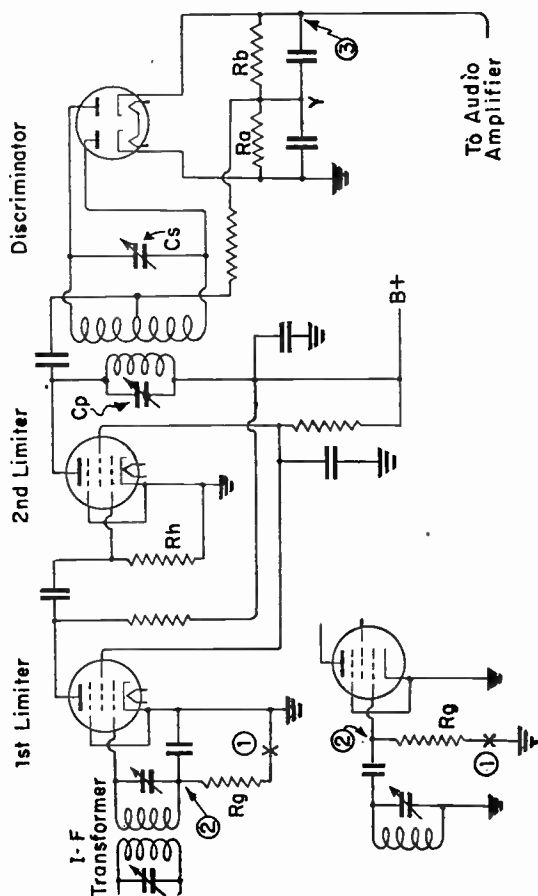

Fig. 14-13. Limiter and discriminator stages for a frequency-modulation receiver.

Instead of the grid circuit shown in the large diagram for the first limiter tube, the circuit shown by the lower left-hand sketch may be used. The chief difference is in the connection of the grid return resistor  $Rg$ . Instead of the double-diode discriminator tube with separately insulated cathodes, other equivalent circuits employ a double-diode with only one cathode, while still others may have included within the same envelope a phase-inversion triode for push-pull output tubes. However, in any of these cases, the a-f output of the discriminator is taken from resistors  $Ra$  and  $Rb$ . When feeding a single a-f amplifier, as in the diagram, the output is from one end of one resistor, the right-hand end of  $Rb$  in the diagram, and the opposite end of the resistor pair is grounded. For output to a push-pull amplifier the center point  $Y$  is grounded, and the outer ends of the resistors are connected to the grids of the push-pull tubes.

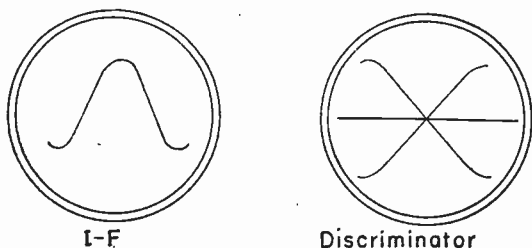

Fig. 14-14. Desired cathode-ray oscilloscope traces for alignment of f-m receiver.

For alignment of i-f and r-f trimmers there are several possible connections for different types of output meters or indicators. A d-c milliammeter or microammeter having a range of one milliamper or less may be connected between the ground end of grid return resistor  $Rg$  and ground, by opening the connection at 1 in Fig. 14-13 and inserting the meter. The prod of a vacuum-tube voltmeter, such as used in signal tracers, may be connected to the grid end of the grid return resistor, at 2 in the diagram. A high-resistance voltmeter (preferably 20,000 ohms per volt or more) may be connected between point 2 and ground, with a resistor of 0.4 to 0.5 megohm resistance in series with the meter. With any of these meters the i-f and r-f trimmers are adjusted for maximum meter deflection.

The high side of a cathode-ray oscilloscope may be connected to point 2 in the diagram, and the low side to the receiver chassis. The trimmers should be adjusted to produce a trace with a somewhat flattened top, as at the left in Fig. 14-14.

For adjustment of the primary tuning capacitor  $C_p$  and the secondary tuning capacitor  $C_s$  of the i-f transformer between the limiter and discriminator in Fig. 14-13 there are several possible ways of checking the output. In any case the output indicator is connected between the a-f output of the discriminator, point 3 in the diagram, and the chassis ground. The lead to the audio amplifier usually is shielded, and usually goes to a volume control unit or to a channel selector switch.

The indicator may be a vacuum-tube voltmeter. The indicator may be a high-resistance voltmeter in series with which is connected a resistor of about one-half megohm resistance. With either kind of meter as an indicator, first detune the secondary trimmer  $C_s$ , then

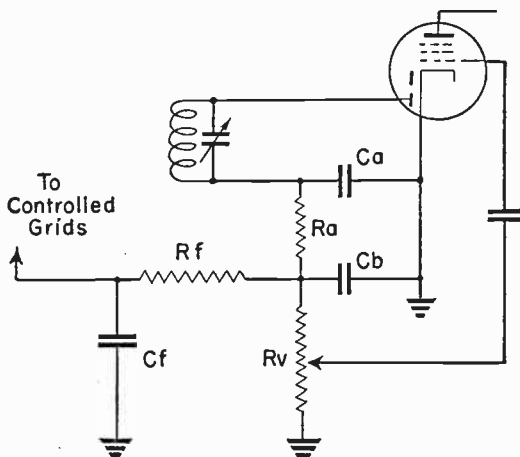

Fig. 14-15. Elements of a typical AVC circuit.

adjust the primary trimmer  $C_p$  for maximum deflection of the meter, and finally adjust the secondary trimmer  $C_s$  until this voltage drops to zero. Since the voltage reverses its polarity during this final adjustment, the meter pointer will drop to zero and continue on to below zero on the meter scale. The adjustment should be for exact zero.

The indicator may be a cathode-ray oscilloscope, with its high side in series with a half-megohm resistor connected to point 3 in the diagram of Fig. 14-3, and its low side connected to the chassis ground. The trace will appear as at the right in Fig. 14-14 when the adjustments are correctly made. Adjustment of the primary trimmer  $C_p$  affects chiefly the straightness of the traces

where they cross each other, while adjustment of the secondary trimmer moves the crossing point up or down on the screen. The adjustments should be for the straightest possible traces, and for a crossing point midway in the vertical plane.

**Volume Control Time Constants.**—In a typical circuit for automatic volume control, such as shown by Fig. 14-15, resistor  $R_a$  and capacitors  $C_a$  and  $C_b$  form a filter system for removal of r-f or other high-frequency potentials before the a-f potentials reach volume control resistor  $R_v$ . Resistor  $R_f$  and capacitor  $C_f$  form a filter to remove a-f variations from the grid bias control potential going through the volume control bus to the controlled grids. The biasing potential is the potential existing at any time across capacitor  $C_f$ . This filter capacitor is charged through the resistance of all resistors between it and the diode plate or plates of the detector tube, in this case through  $R_a$  and  $R_f$ . The capacitor discharges through all resistors between it and ground, which here are resistors  $R_f$  and  $R_v$ . If there are any other capacitors in parallel with  $C_f$ , between the avc bus and ground, the effective capacitance is increased.

The time constant, in seconds, of the avc filter system is equal to the product of the effective capacitance (usually  $C_f$  only) in microfarads, and of the total series resistance ( $R_f + R_a$  or  $R_v$ ) in megohms. For example, if the capacitance is 0.1 mfd and the resistance 1.5 megohms, the time constant is  $0.1 \times 1.5 = 0.15$  second.

Time constants for broadcast receivers usually are between 0.1 and 0.3 second. For short wave reception, where fading may be greater, the time constant usually is no more than 0.2 second. For high-fidelity broadcast receivers the constant may be as long as 0.3 to 0.5 second. Too long a time constant prevents regulation of volume when there is fairly rapid fading, and permits sudden interference pulses, as static, to stop reception for a short period. Too short a time constant allows low audio frequencies to affect volume, and reduces the low-frequency response.

Automatic volume control bias for a frequency-modulation receiver may be taken from the d-c potential drop across the grid return resistor for either of the limiter tubes, resistors  $R_g$  or  $R_h$  in Fig. 14-13.

## Section 15

### OSCILLATORS AND ANTENNAS

**Oscillators.**—Fig. 15-1 shows elementary circuits for six types of radio-frequency oscillators employing inductive feedback from plate circuit to grid circuit. The type names are,

- 1 Hartley.
- 2 Hartley; variation of same principle.
- 3 Tickler feedback.
- 4 Tickler feedback with single tapped coil.
- 5 Meissner.
- 6 Ultraudion.

The letter symbols in the diagrams have the following meanings.

- $L_g$  Coil in grid circuit.
- $L_p$  Coil in plate circuit.
- $L_c$  R-f choke coil preventing oscillating potentials and currents from passing into the d-c voltage supply system.
- $R_g$  Grid return resistor or grid leak acting in conjunction with grid capacitor  $C_g$  to provide negative grid bias for the oscillator tube.
- $C_g$  Grid capacitor which isolates the oscillator grid from high-voltage potentials and currents in the plate circuit, and which acts also in the grid biasing system.
- $C_b$  Bypass capacitor completing the plate circuit for oscillating currents while insulating the oscillating circuits from the high positive voltage of the d-c supply system.
- $C_t$  Variable tuning capacitor for adjusting the frequency of oscillation.

Feedback in the *Hartley* circuit (diagrams 1 and 2) depends on the ratio of inductances or inductive reactances in the portions of the winding which are in the plate circuit and grid circuit. The two parts of the winding may or may not have mutual inductive coupling. In the *tickler feedback* circuits (diagrams 3 and 4) there must be mutual inductive coupling between windings in the plate circuit and grid circuit, since it is through such coupling that feedback takes place.

In the *Meissner* circuit (diagram 5) energy from the plate circuit passes by mutual inductive coupling from coil  $L_p$  to the lower portion of the winding in series with the tuning capacitor, then from this winding to coil  $L_g$  in the grid circuit. There may or may not be mutual inductive coupling between coils  $L_p$  and  $L_g$ , but each

must be inductively coupled to coils in the tuned circuit containing capacitor  $C_t$ . In the ultraudion circuit (diagram 6) the same coil is in both the plate circuit

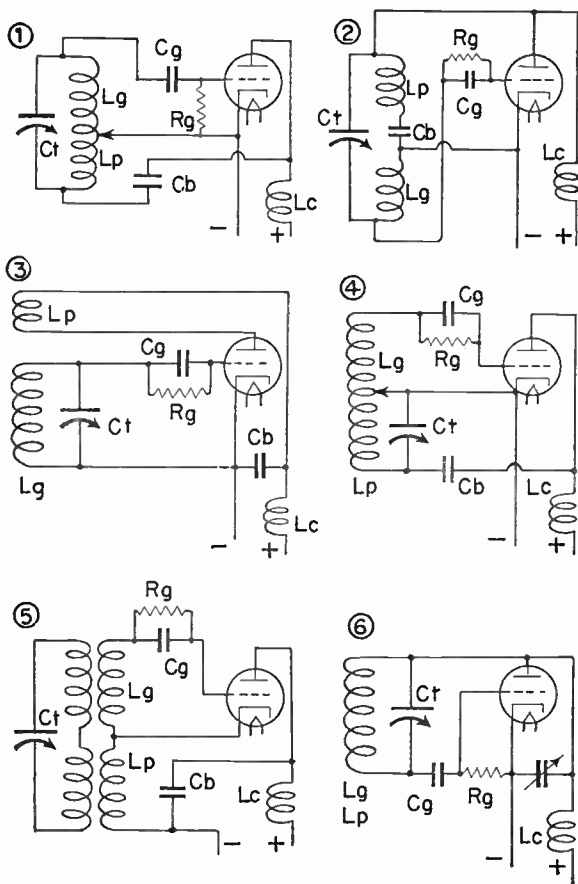

Fig. 15-1. Elementary r-f oscillator circuits, inductive feedback. 1 and 2, Hartley. 3 and 4, Ticker feedback. 5, Meissner. 6, Ultraudion.

and the grid circuit. Oscillation may be controlled within limits by adjustment of the capacitor connected between the plate and cathode of the tube.

Negative grid bias for most oscillators is provided by the rectifying action of the tube which charges grid capacitor  $C_g$  during positive pulses of the high-frequency alternating currents, the charge and resulting negative biasing potential depending on the capacitance of  $C_g$  and on the resistance of grid leak  $R_g$  through which current from the capacitor flows away to the cathode of the tube. This is the same action that produces negative grid bias for the grid-leak type of detector.

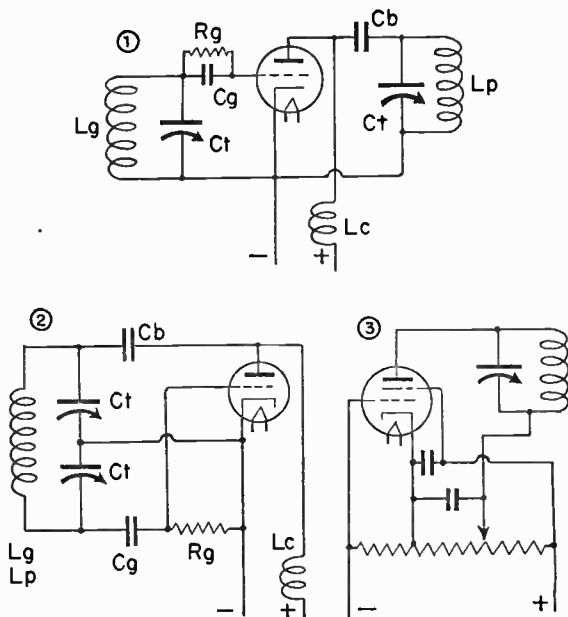

Fig. 15-2. Elementary r-f oscillator circuits. 1, Tuned-plate tuned-grid capacitive feedback. 2, Colpitts capacitive feedback. 3, Dynatron circuit.

Fig. 15-2 shows two types of capacitance feedback oscillators in diagrams 1 and 2. In the tuned-plate tuned-grid oscillator of diagram 1 the feedback is through the grid-plate capacitance of the oscillator tube. The grid circuit is tuned to the frequency at which oscillation is desired, and the plate circuit is tuned to a frequency a very little lower in order that the plate circuit may have inductive reactance necessary for correct phase relationship of the feedback potential.

The *Colpitts* oscillator of diagram 2 has a single coil



in both plate and grid circuits, tuned by means of two variable capacitors connected in series with each other and with the coil. The ratio of oscillating plate voltage to oscillating grid voltage is determined by the ratio of the two variable capacitances. The total effective capacitance of the two tuning capacitors determines the frequency of oscillation.

The basic oscillator circuits which have been described are subject to almost innumerable modifications in arrangement of the elements and of the connections between them.

Diagram 3 of Fig. 15-2 shows a circuit for a screen grid tube operated as a *dynatron* oscillator. The plate voltage is lower than the screen voltage, and the control grid is maintained at a constant negative potential with ref-

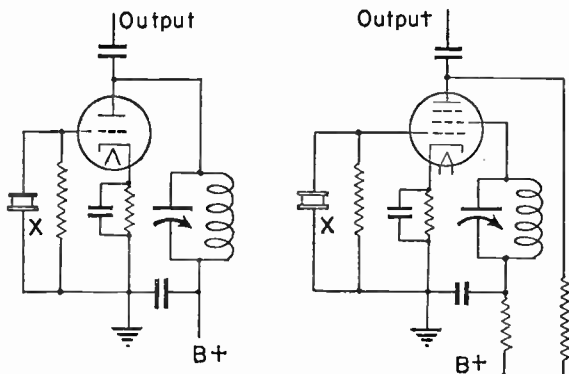

Fig. 15-3. Elementary circuits for crystal frequency control of oscillators.

erence to the cathode. As plate voltage increases during oscillation, secondary emission from the plate to the more positive screen becomes greater than the rate of electron flow into the plate. Thus the plate current actually decreases as the plate voltage increases, whereas in ordinary circuits there always is an increase of current with increase of voltage applied. This action in the dynatron oscillator is called *negative resistance*. The plate current decreases to a point at which oscillation ceases for an instant. Then the plate voltage drops, plate current again increases, and so the variation of plate current and the oscillation continues. There is no feedback of energy in the dynatron oscillator. There are other types of oscillators employing the principle of negative resistance.

**Crystal Control of Frequency.**—A piezo-electric crystal, usually made from quartz, has the property of producing electrostatic charges and potentials between opposite faces when compressed, and the property of changing its own dimensions when placed in an electrostatic field. The crystal "vibrates" most energetically at certain frequencies determined by the thickness of the piece and the manner in which it is cut. Such a crystal, connected in the grid circuit of a tube as shown by diagrams of Fig. 15-3 and in other equivalent ways, will maintain oscillation in tuned circuits connected to the tube, and will maintain a frequency near one of the frequencies at which the particular crystal vibrates most easily and energetically.

The mother crystal from which the operating pieces are cut may have the generally hexagonal shape indicated at the left in Fig. 15-4, wherein the lengthwise

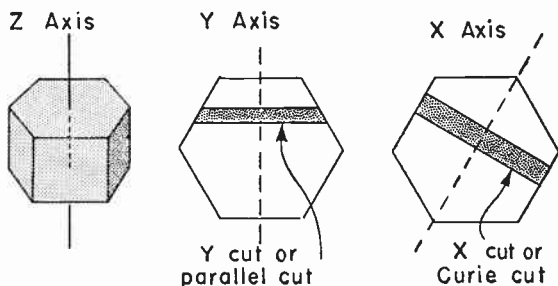

Fig. 15-4. Types of cuts for oscillating crystals.

axis or optical axis is called the *Z*-axis. If the resonant piece is cut so that its parallel faces are parallel to the sides of the original, and are perpendicular to the *Y*-axis, as in the center diagram, the crystal is said to be *Y*-cut, parallel cut, or thin cut. If, as in the right-hand diagram, the piece is cut so that its faces are perpendicular to the *X*-axis between opposite corners of the original crystal, the piece is said to be *X*-cut, Curie cut, or thick cut.

The approximate thickness of the finished oscillating crystal is,

$$Y\text{-cut. Inches} = \frac{77.0}{\text{frequency, kilocycles}}$$

$$X\text{-cut. Inches} = \frac{112.6}{\text{frequency, kilocycles}}$$

**Antennas.**—Receiving antennas have the same general properties as transmitting antennas of similar type and

of equal dimensions. This applies to the distribution of current and voltage, and to the directions to and from which transmission and reception are strongest and weakest.

At the top of Fig. 15-5 is represented a type of antenna consisting of two lines of equal length extending in opposite directions from the point at which energy is introduced. This is called an electric *dipole* or a *Hertz* antenna. At the fundamental frequency, which is the lowest frequency at which the antenna can resonate, the distribution of current and voltage is as shown by broken-line curves in the upper left-hand diagram.

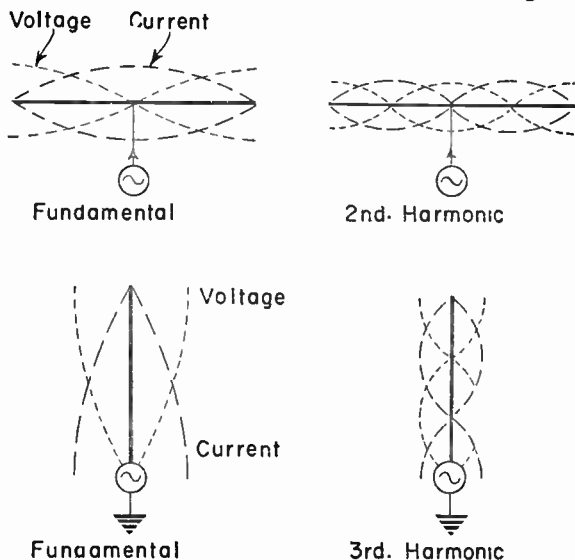

Fig. 15-5. Current and voltage in Hertz and Marconi antennas.

The corresponding radiated wavelength is twice the length of the antenna, since each of the curves represents only half of a complete cycle. If the antenna is excited at twice the fundamental frequency, or at the second harmonic frequency, current and voltage distribution is as shown at the upper right, and the radiated wavelength is equal to the length of the antenna.

If one half of the antenna is replaced by the earth or a ground connection, as in the lower diagram of Fig. 15-5, the current and voltage distribution, and the radiated wavelength with reference to length of the

remaining half of the antenna are the same as before. Such an arrangement is called a *Marconi* antenna. Then, as indicated by the diagrams, the wave length at the fundamental frequency will be four times the length of antenna, and at the third harmonic (three times the fundamental) will be  $4/3$  or  $1\frac{1}{3}$  the length of antenna.

If an antenna is too short for the wavelength being used, the antenna is resonant at a higher frequency and it acts as a capacitive reactance. This reactance may be counteracted by inserting in series with the antenna an inductance coil to furnish inductive reactance. Similarly, if the antenna is too long it resonates at a frequency which is too low and acts as an inductive reactance. This may be counteracted by connecting in series with the antenna a capacitor to provide capacitive reactance. Thus the antenna may be tuned to the wavelength being used.

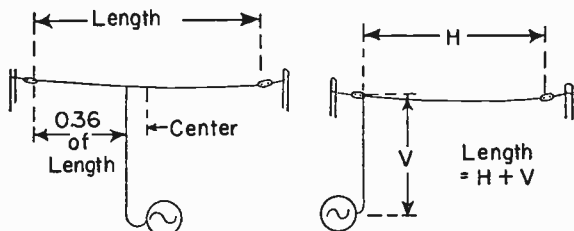

Fig. 15-6. Hertz antenna with single-wire feed (left), and long-wire antenna (right).

A Hertz antenna with single-wire feed is shown at the left in Fig. 15-6. The length of the horizontal portion should be equal to a half wavelength at the principal frequency to be handled. Wavelength in meters is equal to 300 divided by the frequency in megacycles, and, since one meter is equal to 3.281 feet, the length of a half wave is a little more than 492 feet divided by the frequency in megacycles. Because of the effect of capacitance at the ends of the antenna, this figure usually is reduced to 468 for frequencies up to 30 or 40 megacycles, and is made slightly less, or about 461 for still higher frequencies. Then the length of the horizontal wire for the half-wave antenna should be,

$$\text{Length, feet} = \frac{468}{\text{frequency, megacycles}}$$

The single-wire feed is a modification of a two-wire feed with the ground supplying the other feed line through the capacitance between antenna and ground. The single wire is not connected to the flat top at the

center of the top, but is connected at a point distant from either end by 36% or 0.36 times the length of the flat top portion.

*Example.*—What should be the length of such an antenna for operation at a frequency of 5,000 kilocycles, and where should the feed wire be connected?

The frequency of 5,000 kilocycles equals 5 megacycles.

$$\text{Length} = \frac{468}{5} = 93.6 \text{ feet, total length}$$

$$93.6 \text{ ft.} \times 0.36 = 33.7 \text{ ft. from one end.}$$

At the right in Fig. 15-6 is shown a so-called *long-wire antenna*. The length of such an antenna is equal to the sum of the lengths of the horizontal flat top and of the vertical feed wire. This total length should be equal to one or more wavelengths at the principal frequency to be handled. Since the length of a half wavelength antenna is equal to 468 divided by the frequency in megacycles, a full wavelength is taken as,

$$\text{Length} = \frac{936}{\text{frequency, megacycles}}$$

*Example.*—What should be the length of a long-wire antenna for a frequency of 5,000 kilocycles? Note that this is a frequency of 5 megacycles.

$$\text{Length} = \frac{936}{5} = 187 \text{ feet.}$$

This is the minimum length for the flat top and vertical feed wire combined. The feed wire is connected to either end of the flat top.

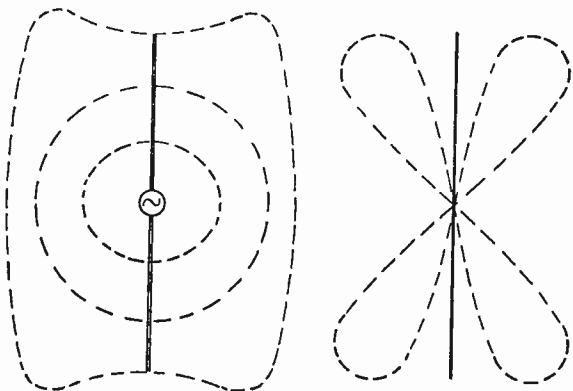

Fig. 15-7. Radiation patterns for Hertz antenna (left) and for long-wire antenna (right).

The radiation pattern or the directional characteristic of a Hertz or dipole antenna is about as indicated by the broken-line figure at the left in Fig. 15-7. Radiation is quite uniform in all directions, with some emphasis along the length of the antenna. The pattern for a long-wire antenna is of the general form shown by the right-hand diagram, with the principal radiation lengthwise and to the sides of the antenna. The greater the length of this style of antenna the closer together come the lobes at the ends of the wire and the more sharply pronounced is the directional characteristic lengthwise of the antenna, with a decrease in the directions perpendicular to the length.

## Section 16

### SOUND SYSTEMS AND DEVICES

Gains or amplifications, also losses or attenuations, of power, voltage or current between different points in devices or systems operating at audio frequencies usually are specified or compared in terms of a unit called the *decibel*. Decibels measure the ratios of powers, voltages or currents to each other. For instance; if power input to an amplifier is 2 watts and power output is 4 watts, the ratio of gain is  $4/2$  or is 2. A ratio of 2 between powers corresponds to 3 decibels, so in this case there is a gain of 3 decibels. In another case the input might be 0.25 watt and the output 0.50 watt. The ratio of gain is  $50/25$ , which is a ratio of 2. Again there is a gain of 3 decibels, because a ratio of 2 in a power system always means a change of 3 decibels regardless of the values of the powers involved when measurements are in watts or other absolute units. We might say that a power of 4 watts exceeds one of 2 watts by 3 decibels, also that a power of 0.50 watt exceeds one of 0.25 watt by 3 decibels, and that any other power which is double another one exceeds that other one by 3 decibels. The abbreviation *db* is used for decibel or decibels.

The number of decibels by which one power exceeds another is found thus.

$$\text{Decibels difference} = 10 \times \left( \text{common logarithm of } \frac{\text{larger power}}{\text{smaller power}} \right)$$

That is, the number of decibels is equal to 10 times the logarithm of the power ratio, the ratio being found by dividing one power by the other.

The common logarithm of any number is the power to which 10 must be raised to produce that number. To illustrate;  $10^2$  or 10 to the 2nd power equals 100, and so 2 is the logarithm of 100, because 2 is the power to which 10 must be raised to produce 100. Again,  $10^3$  or 10 to the 3rd power equals 1000, so the logarithm of 1000 is 3.

Assume that there is a gain of 100 times in a power amplifying system. The gain might be from 0.01 to 1.0 watt, or from 0.75 to 75 watts, or from 1 to 100 watts, or any other gain which is in the ratio of 100 times. The logarithm of 100 is 2. The preceding formula shows that the number of decibels is 10 times the logarithm. Then, multiplying the logarithm, 2, by 10 gives 20 decibels. A power gain of 100 times is a gain of 20 decibels, no matter what may be the wattage levels at which the gain occurs.

The accompanying table, *Gains and Corresponding Decibels*, lists in the first column various ratios of gain extending from 1.0 to 10 billion. The ratio of 1.0 really represents no gain, for it means that the powers are equal. The logarithm of the number 1 is zero, and since 10 times zero equals zero, the decibel change is 0.0.

The table is so arranged that whole numbers and simple fractions will be found both in the column for ratios and in the column for decibels. That is, in the gain column there will be found 1.0, 2.0, 2.5, 3.0, 4.0, and so on. These whole numbers and fractions appear also in the decibel column. The corresponding fractional numbers, of decibels for gains, and of gains for decibels, are found in the other column for each case.

One of the chief advantages of measurements in decibels, which are logarithmic, is that the response of the human ear is logarithmic. That is, if we are listening to a sound having an intensity of 1 watt, and it is increased to 2 watts, the degree of increase seems to be the same as when an original power is 10 watts is increased to 20 watts; although in the first case there is a real increase of only 1 watt, and in the second of 10 watts. Another advantage is that a change of 1 decibel is a change that is just noticeable to the average ear, this being true whether the sounds are at a very low level of intensity or at a very high level.

Another advantage is that gains in decibels may be added to find the overall gain. For instance, if one section of an apparatus gives a power gain of 6 decibels and a following section gives a gain of 13 decibels, the overall gain is  $6 + 13 = 19$  decibels. The table shows that the ratios of gain are,

$$\begin{array}{l} 6 \text{ db} = 3.98 \text{ gain ratio} \\ 13 \text{ db} = 19.95 \text{ gain ratio} \\ \hline 19 \text{ db} = 79.43 \text{ gain ratio} \end{array}$$

To determine the overall gain from the two ratios of gain in the two sections it is necessary to multiply together the two ratios, thus,

$$3.98 \times 19.95 = 79.43$$

If the ratio is that of one voltage to another, or of one current to another, the corresponding number of decibels is twice that for the same ratio of powers. This appears when comparing the columns for decibels corresponding to power ratios and to voltage or current ratios as given in the table. The reason is:

The watts of power dissipated in equal resistances or impedances are proportional to the squares of voltages or currents in the equal resistances or impedances. This is shown by the power formulas,

$$P = E^2/R \qquad P = I^2R$$



## GAINS AND CORRESPONDING DECIBELS

RATIO OF GAIN	DECIBELS Power	DECIBELS Voltage or Current	RATIO OF GAIN	DECIBELS Power	DECIBELS Voltage or Current
1.0	0.0	0.0			
1.1	0.414	0.818	6.0	7.782	15.56
1.12	0.5	1.0	6.31	8.0	16.0
1.2	0.792	1.584	6.5	8.129	16.26
1.26	1.0	2.0	7.0	8.451	16.90
1.3	1.139	2.278	7.5	8.751	17.50
1.4	1.461	2.922	7.94	9.0	18.0
1.41	1.5	3.0	8.0	9.031	18.06
			8.5	9.294	18.59
1.5	1.761	3.522	9.0	9.542	19.08
1.59	2.0	4.0	9.5	9.777	19.55
1.6	2.041	4.082	10.0	10.0	20.0
1.7	2.304	4.608			
1.79	2.5	5.0	11.0	10.41	20.83
1.8	2.553	5.106	12.0	10.79	21.58
1.9	2.788	5.576	13.0	11.14	22.28
1.99	3.0	6.0	14.0	11.46	22.92
			15.0	11.76	23.52
2.0	3.010	6.020	16.0	12.04	24.08
2.1	3.222	6.444	17.0	12.30	24.61
2.2	3.424	6.848	18.0	12.55	25.10
2.24	3.5	7.0	19.0	12.79	25.58
2.3	3.617	7.234	19.95	13.0	26.0
2.4	3.802	7.604			
			20.0	13.01	26.02
2.5	3.979	7.958	25.0	13.98	27.96
2.51	4.0	8.0	25.12	14.0	28.0
2.6	4.150	8.300	30.0	14.77	29.54
2.7	4.314	8.628	31.62	15.0	30.0
2.8	4.472	8.944	35.0	15.44	30.88
2.82	4.5	9.0	39.81	16.0	32.0
2.9	4.624	9.248			
			40.0	16.02	32.04
3.0	4.771	9.542	45.0	16.53	33.06
3.16	5.0	10.0	50.0	16.99	33.98
3.2	5.051	10.10	50.12	17.00	34.00
3.4	5.315	10.63	55.0	17.40	34.81
3.6	5.563	11.13	60.0	17.78	35.56
3.8	5.798	11.60	63.10	18.0	36.0
3.98	6.0	12.0	65.0	18.13	36.26
4.0	6.021	12.04	70.0	18.45	36.90
4.2	6.232	12.46	75.0	18.75	37.50
4.4	6.435	12.87	79.43	19.0	38.0
4.6	6.628	13.26	80.0	19.03	38.06
4.8	6.812	13.62	85.0	19.29	38.58
			90.0	19.54	39.08
5.0	6.990	13.98	95.0	19.78	39.56
5.01	7.0	14.0	100.0	20.0	40.0
5.2	7.160	14.32			
5.4	7.324	14.65			
5.6	7.482	14.96			
5.8	7.634	15.27			
6.0	7.782	15.56			

## GAINS AND CORRESPONDING DECIBELS

RATIO OF GAIN	DECIBELS Power	DECIBELS Voltage or Current	RATIO OF GAIN	DECIBELS Power	DECIBELS Voltage or Current
100	20.00	40.00	100,000	50.0	100.0
120	20.79	41.58	200,000	53.01	106.0
140	21.46	42.92	316,200	55.00	110.0
160	22.04	44.08	400,000	56.02	112.0
180	22.55	45.11	500,000	56.99	114.0
			750,000	58.75	117.5
200	23.01	46.02			
220	23.42	46.85	1,000,000	60.0	120.0
240	23.80	47.60	2,000,000	63.01	126.0
260	24.15	48.30	3,162,000	65.0	130.0
280	24.47	48.94	4,000,000	66.02	132.0
			5,000,000	66.99	134.0
300	24.77	49.57	7,500,000	68.75	137.5
316	25.0	50.0			
350	25.44	50.88	10,000,000	70.0	140.0
400	26.02	52.04	20,000,000	73.01	146.0
450	26.53	53.06	31,620,000	75.0	150.0
			40,000,000	76.02	152.0
500	26.99	53.98	50,000,000	76.99	154.0
600	27.78	55.56	75,000,000	78.75	157.5
700	28.45	56.90			
800	29.03	58.06	100,000,000	80.0	160.0
900	29.54	59.08	200,000,000	83.01	166.0
			316,200,000	85.0	170.0
1,000	30.0	60.0	400,000,000	86.02	172.0
2,000	33.01	66.02	500,000,000	86.99	174.0
3,162	35.0	70.0	750,000,000	88.75	177.5
4,000	36.02	72.04			
5,000	36.99	73.98	1,000,000,000	90.0	180.0
7,500	38.75	77.50	2,000,000,000	93.01	186.0
			3,162,000,000	95.0	190.0
10,000	40.0	80.0	4,000,000,000	96.02	192.0
20,000	43.01	86.02	5,000,000,000	96.99	194.0
31,620	45.0	90.0	7,500,000,000	98.75	197.5
40,000	46.02	92.04	10,000,000,000	100.0	200.0
50,000	46.99	93.98			
75,000	48.75	97.50			
100,000	50.00	100.00			

If we assume a voltage of 10, denoted by  $E$ , and another of 2, denoted by  $e$ , the corresponding powers are  $E^2/R$  and  $e^2R$ . If  $R$  is the same in both cases it may be cancelled, and the power ratio is  $E^2/e^2$ . With the assumed values for  $E$  and  $e$ ,

$$E^2/e^2 = 10^2/2^2 = 100/4 = 25$$

The common logarithm of 25 is 1.398. Multiplying by 10, to find the number of decibels, gives,

$$10 \times 1.398 = 13.98 \text{ decibels.}$$

This value of 13.98 decibels for a voltage ratio of 5 is double the value of 6.99 decibels shown in the table for a power ratio of 5.

The formula for decibels corresponding to voltage (E) ratios or current (I) ratios, when the resistances or impedances are equal for both voltages or both currents, is,

$$Db = 20 \times \left( \frac{\text{common of } E \text{ or } I}{\log \text{ of } e \text{ or } i} \right)$$

From the foregoing explanation it is apparent that any differences between the resistances or impedances would prevent cancelling them from the power equivalents, and the power ratio no longer would be equivalent to  $E^2/e^2$  or to  $I^2/i^2$ . Consequently, voltage or current ratios may be expressed in decibels only when both values are measured in the same resistances or impedances.

Since decibels indicate only the difference between two powers, or only the ratio of one power to another, a number of decibels taken by itself has no equivalent in watts of power unless it is also stated that the smaller or larger power is of a certain number of watts. Unless otherwise stated, the *reference level* usually is taken as 0.006 watt or 6 milliwatts of power, and this rate of power is that for zero decibels. The resistance or impedance may be taken as either 500 or 600 ohms, sometimes one and sometimes the other.

To determine an actual power in watts corresponding to a certain number of decibels above or below a reference level of 0.006 watt, this power of 0.006 watt is multiplied by the ratio of gain or of loss corresponding to the given number of decibels. For example, assuming a gain of 5 decibels, for which the power ratio is 3.16 (from the table) the final power would be,

$$3.16 \times 0.006 = 0.019 \text{ watts, approximately.}$$

**Losses and Decibels.**—In the table, *Losses and Corresponding Decibels*, are listed ratios of loss or attenuation and the corresponding numbers of decibels when the ratios are of powers or are of voltages or currents. When the output power or final power is less than the input power or initial power the ratio is a fraction less than 1, and shows a loss

$$\text{Ratio} = \frac{\text{output power, voltage, or current}}{\text{input power, voltage, or current}}$$

Suppose, for example, that the output power is 15 watts and the input power 75 watts. The ratio is 15/75 or 0.20. The table shows, for a loss ratio of 0.20, a corresponding loss of 6.990 decibels. Were there the same ratio of 0.20 between voltages or currents the loss would be 13.98 decibels.

## LOSSES AND CORRESPONDING DECIBELS

RATIO OF LOSS	DECIBELS		RATIO OF LOSS	DECIBELS	
	Power	Voltage or Current		Power	Voltage or Current
0.98	0.086	0.172	0.010	20.00	40.00
.96	.179	.358	.008	20.97	41.94
.94	.269	.538	.006	22.22	44.44
.92	.362	.724	.004	23.98	47.96
.90	.457	.914	.0032	25.0	50.0
.891	.50	1.00	.002	26.99	53.98
0.85	.704	1.408	.0010	30.0	60.0
.80	.969	1.938	.0008	30.97	61.94
.794	1.00	2.00	.0006	32.22	64.44
.75	1.248	2.496	.0004	33.98	67.96
.708	1.50	3.00	.00032	35.00	70.00
.70	1.550	3.100	.0002	36.99	73.98
0.65	1.870	3.740	.00010	40.00	80.00
.631	2.00	4.00	.00008	40.97	81.94
.60	2.219	4.438	.00006	42.22	84.44
.562	2.50	5.00	.00004	43.98	87.96
.55	2.596	5.192	.000032	45.00	90.00
.501	3.00	6.00	.00002	46.99	93.98
0.50	3.010	6.020	.000010	50.00	100.0
.48	3.187	6.394	.000008	50.97	101.9
.46	3.373	6.746	.000006	52.22	104.4
.44	3.566	7.132	.000004	53.98	108.0
.42	3.768	7.536	.0000032	55.00	110.0
.40	3.979	7.958	.000002	56.99	114.0
0.398	4.00	8.00	.0000010	60.00	120.0
.38	4.203	8.406	.0000008	60.97	121.9
.36	4.437	8.874	.0000006	62.22	124.4
.34	4.685	9.370	.0000004	63.98	128.0
.333	4.771	9.542	.00000032	65.0	130.0
.32	4.949	9.898	.0000002	66.99	134.0
.316	5.00	10.00	.00000010	70.00	140.0
0.30	5.228	10.46	.00000008	70.97	141.9
.28	5.528	11.06	.00000006	72.22	144.4
.251	6.00	12.00	.00000004	73.98	148.0
.22	6.576	13.15	.000000032	75.00	150.0
.20	6.990	13.98	.00000002	76.99	154.0
.199	7.00	14.00	.000000010	80.00	160.0
0.18	7.448	14.90	.000000008	80.97	161.9
.159	8.00	16.00	.000000006	82.22	164.4
.14	8.537	17.07	.000000004	83.98	168.0
.126	9.00	18.00	.0000000032	85.00	170.0
.10	10.00	20.00	.000000002	86.99	174.0
0.09	10.46	20.91	.0000000010	90.00	180.0
.08	10.97	21.94	.0000000008	90.97	181.9
.07	11.55	23.10	.0000000006	92.22	184.4
.06	12.22	24.44	.0000000004	93.98	188.0
.05	13.01	26.02	.00000000032	95.00	190.0
0.04	13.98	27.96	.0000000002	96.99	194.0
.0316	15.00	30.00	.0000000001	100.0	200.0
.02	16.99	33.98			
.015	18.24	36.48			
.01	20.00	40.00			

Note that the loss in decibels for a loss ratio of 0.20, which is a ratio of 1/5, is the same as the gain in decibels for a gain ratio of 5.0, which is a ratio of 5/1. The loss and the gain are reciprocals, each of the other, for the same number of decibels.

**Loudness of Sounds.**—The loudness of a sound may be expressed in several different ways; in the pressure exerted by the sound waves in air, in the power represented by the rate of energy dissipation due to the sound waves, and in decibels representing the increase above some selected minimum level. The minimum level in any case is the least which will affect an average normal human ear when the frequency is that for which the average ear is most sensitive. This minimum level is called the threshold of hearing or the threshold of audibility.

If measurements are of sound pressures, the usual unit of pressure is the *bar*, which is a pressure of one dyne per square centimeter. A dyne is a force equal to 0.00000225 pound, and a bar (dyne per sq. cm.) is equal to 0.00209 pound per square foot. The threshold often is taken as 0.0002 bar, or as 0.0002 dyne per square

### LOUDNESS OF SOUNDS

Kind of Sound	Pressure Dynes/cm <sup>2</sup>	Decibels
Threshold of feeling	3000.0	143.5
Hammer blows on steel plate, 2 ft.	100.2	114
Boiler factory	39.90	106
Riveter, 35 ft.	14.16	97
Elevated railroad train, 15-20 ft.	6.32	90
Motor truck, heavy, 15-20 ft.	1.13	75
Orchestra, full	.710	71
Traffic, busy street	.564	69
Conversation, ordinary, 3 ft.	.356	65
Street sounds, residential	.178	59
Automobile, 15-50 ft.	.0632	50
Office sounds, average	.0448	47
Residence, noisy	.0356	45
Music, soft	.0200	40
Residence, average	.0071	31
Whisper, 4 ft.	.0020	20
Leaves rustling, gentle breeze	.00063	10
Threshold of hearing	.00020	0

centimeter. If measurements are in units of power, the corresponding threshold level is 0.000000000001 milliwatt. For either of these threshold levels, which are taken as reference levels, the decibels are taken as zero and the ratios of increases in loudness are expressed as decibels above the zero reference level.

The accompanying table, *Loudness of Sounds*, lists values for various common sounds. Such tables are useful chiefly for showing comparative levels of sound intensities, since the values are the merest approximations in any case.

The threshold of audibility varies with sound frequency about as follows:

#### THRESHOLD OF AUDIBILITY

Frequency, cycles	Pressure dynes/cm <sup>2</sup>	Frequency, cycles	Pressure dynes/cm <sup>2</sup>
32	2.100	1000	0.00052
64	0.120	2000	0.00040
128	0.021	4000	0.00043
256	0.0040	8000	0.0030
512	0.0011	16000	0.18

**Sound Velocities.**—Sound velocities in feet per second, at usual room temperatures unless otherwise specified, are listed in the accompanying table.

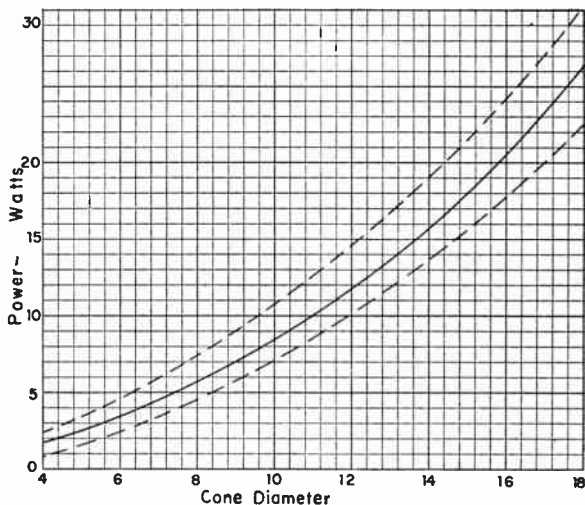

Fig. 16-1. Average relations between power and cone diameter in electro-magnetic or permanent magnet speakers.

## SOUND VELOCITIES

Material	Ft. per Sec.	Material	Ft. per Sec.
Air, 0° F.	1,050	Copper	11,700
Air, 32°	1,086	Cork	1,650
Air, 70°	1,127	Glass	16,500 to 19,500
Air, 100°	1,160	Iron, cast	12,400
Aluminum	16,800	Steel	16,500
Brick	12,000	Water, fresh	4,800

## LOUD SPEAKERS

Fig. 16-1 shows the relation between cone diameter and normal undistorted power output for typical speakers having either permanent magnet or electromagnetic fields. Average performance is shown by the full-line curve. The upper and lower limits shown by the broken line curves are affected by various factors in construction. One factor is the diameter of the voice coil used with a cone of given diameter. The greater the diameter of the voice coil the higher may be the power output. Power outputs are measured in line with the axis of the speaker, and at a point close enough to the cone so that the focusing effect is maximum.

The upper curve of Fig. 16-2 shows, in a general way, the manner in which the impedance of a voice coil varies

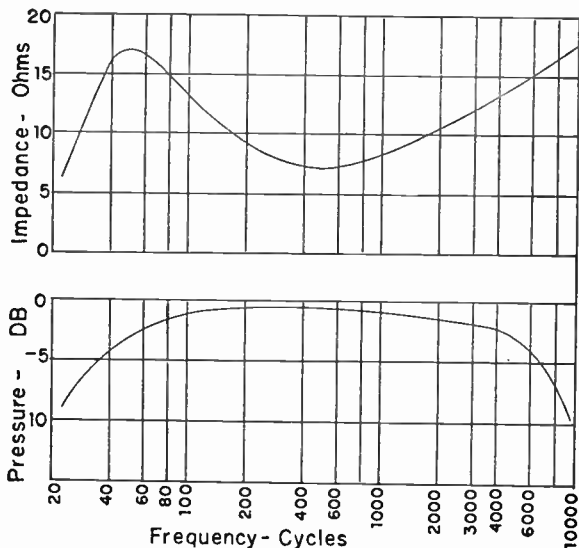

Fig. 16-2. Effect of sound frequency on voice coil impedance and on sound pressure output of typical speakers.

with frequency. Usually there is a point of low-frequency resonance, here shown at around 50 cycles, where the impedance rises to a relatively high value. The impedance falls to a minimum somewhere around 400 cycles, which is the frequency at which speaker performance often is measured. Then there is a fairly steady rise of impedance into the higher frequencies. The curve represents a voice coil having a nominal impedance of 6 to 8 ohms.

The lower curve of Fig. 16-2 shows how the output sound pressure usually varies with frequency. The speaker response or output is maximum through the middle frequencies, and is relatively low at the lowest and highest frequencies. The decreases of power at the bottom and top of the frequency range are due largely to the increases of voice coil impedance at these regions.

**Electromagnetic Field Windings.**—The resistances of field coils for electrodynamic speakers ordinarily are somewhere between 300 and 5,000 ohms. The number of watts of power put into the field winding usually is about equal to, or may be somewhat more than, the normal undistorted power output from the speaker. That is, a 5-watt speaker might use 5 to 7 watts in the field.

The tables, *Electrodynamic Speaker Field Coils*, list for various powers in watts used in field coils of various resistances in ohms, the voltage drops and the current through the field winding.

For an example in using the table, assume that 4 watts of power is used in a field winding of 1200 ohms resistance. In the last column of the first section of the table, under the heading *4 Watts*, and on the horizontal line for 1200 ohms in the coil, as read from the first column, it is shown that the potential drop will be 69.6 volts with a current of 58 milliamperes. If the field coil is in series with the plate circuits, 69.6 volts of the total potential from the rectifier will be used in the field coil when the current is 58 milliamperes. If the current is decreased in the same coil, the voltage drop and the power dissipation will decrease, while an increase of current will raise the voltage drop and power dissipation; all as shown by following along the 1200-ohm lines of the table sections.

Doubling the field coil resistance and using the same current will double the voltage drop and double the number of watts. Doubling the field resistance while maintaining the same voltage drop means halving the current and halving the power. For any given field power, the voltage drop is increased and the current decreased by more field resistance, while there is less voltage drop and more current with less resistance. So long as the power remains unchanged, the product of volts drop and milliamperes current remains unchanged.



## ELECTRODYNAMIC SPEAKER FIELD COILS

OHMS In Coil	1 Watt		2 Watts $\lambda$		3 Watts		4 Watts	
	Volts	Milli-amps	Volts	Milli-amps	Volts	Milli-amps	Volts	Milli-amps
300	17.3	58	24.5	82	30.0	100	34.5	115
400	20.0	50	28.4	71	34.8	87	40.0	100
500	22.4	45	31.7	63	38.8	78	44.7	89
600	24.6	41	34.8	58	42.6	71	49.2	82
700	26.6	38	37.8	54	46.2	66	53.2	76
800	28.0	35	40.0	50	48.8	61	56.8	71
900	30.0	33.3	42.3	47	52.2	58	60.3	67
1000	31.6	31.6	45.0	45	55.0	55	63.0	63
1200	34.7	28.9	49.2	41	60.0	50	69.6	58
1400	37.4	26.7	53.2	38	64.4	46	75.6	54
1600	40.0	25.0	56.0	35	68.8	43	80.0	50
1800	42.5	23.6	60.0	33	74.0	41	85.0	47
2000	44.8	22.4	63.2	31.6	78.0	39	90.0	45
2250	47.5	21.1	67.0	29.8	81.0	36	94.5	42
2500	50.0	20.0	70.8	28.3	87.5	35	100	40
3000	55.0	18.3	77.4	25.8	95.0	31.6	110	36.5
3500	59.1	16.9	83.6	23.9	103	29.3	118	33.8
4000	63.2	15.8	89.6	22.4	110	27.4	127	31.6
4500	67.0	14.9	95.0	21.1	116	25.8	134	29.8
5000	70.5	14.1	100	20.0	123	24.5	142	28.3
	5 Watts		6 Watts		7 Watts		8 Watts	
300	38.7	129	42.3	141	45.9	153	48.9	163
400	44.8	112	49.2	123	52.8	132	56.4	141
500	50.0	100	54.8	110	59.2	118	63.3	127
600	54.6	91	60.0	100	64.8	108	69.0	115
700	59.5	85	65.0	93	70.0	100	74.9	107
800	63.2	79	69.6	87	74.4	93	80.0	100
900	67.5	75	73.8	82	79.2	88	84.6	94
1000	71.0	71	78.0	78	84.0	84	89.0	89
1200	78.0	65	85.2	71	91.2	76	98.4	82
1400	84.0	60	92.4	66	99.4	71	106	76
1600	89.6	56	97.6	61	106	66	114	71
1800	95.4	53	104	58	112	62	121	67
2000	100	50	110	55	118	59	126	63
2250	106	47	117	52	124	55	135	60
2500	113	45	123	49	133	53	143	57
3000	123	41	135	45	144	48	156	52
3500	133	38	144	41	158	45	168	48
4000	140	35	156	39	168	42	180	45
4500	150	33.3	164	36.5	176	39	189	42
5000	158	31.6	173	34.6	185	37	200	40

## ELECTRODYNAMIC SPEAKER FIELD COILS

OHMS In Coil	10 Watts		12 Watts		15 Watts		18 Watts	
	Volts	Milli -amps	Volts	Milli -amps	Volts	Milli -amps	Volts	Milli -amps
300	54.9	183	60.0	200	67.2	224	73.5	245
400	63.2	158	72.8	182	77.6	194	84.8	212
500	70.7	141	77.5	155	86.5	173	95.0	190
600	77.4	129	84.6	141	94.8	158	104	173
700	84.0	120	91.7	131	102	146	112	160
800	89.6	112	98.4	123	110	137	120	150
900	94.5	105	104	115	116	129	127	141
1000	100	100	110	110	123	123	134	134
1200	109	91	120	100	134	112	148	123
1400	119	85	129	92	144	103	160	114
1600	127	79	139	87	155	97	170	106
1800	135	75	148	82	164	91	180	100
2000	142	71	154	77	174	87	190	95
2250	151	67	164	73	185	82	200	89
2500	158	63	173	69	195	77	213	85
3000	174	58	189	63	213	71	231	77
3500	189	54	207	59	231	66	252	72
4000	200	50	220	55	244	61	268	67
4500	212	47	234	52	261	58	284	63
5000	225	45	245	49	275	55	300	60
	21 Watts		25 Watts		30 Watts		35 Watts	
300	79.5	265	86.7	289	94.8	316	103	342
400	91.6	229	100	250	110	274	118	296
500	103	205	112	224	123	245	133	265
600	112	187	125	204	134	224	145	242
700	121	173	132	189	145	207	157	224
800	130	162	142	177	155	194	166	207
900	138	153	150	167	164	182	177	197
1000	145	145	158	158	173	173	187	187
1200	158	132	173	144	190	158	205	171
1400	172	123	186	133	204	146	211	158
1600	184	115	200	125	219	137	237	148
1800	195	108	212	118	232	129	252	140
2000	206	103	224	112	246	123	264	132
2250	218	97	236	105	259	115	281	125
2500	230	92	250	100	275	110	295	118
3000	252	84	273	91	300	100	324	108
3500	270	77	298	85	322	92	350	100
4000	288	72	326	79	348	87	376	94
4500	306	68	337	75	368	82	396	88
5000	325	65	355	71	385	77	420	84

**Baffling.**—When the cone or other radiating member of a loud speaker moves in one direction during part of a cycle, air is forced away from the front of the cone and drawn toward the back at the same instant. In whatever portion of air that moves around the edge of the cone the two air movements cancel, and no movement is caused to travel away from the speaker in the form of sound waves. The sound waves may be forced to travel relatively long paths between front and back of the cone, as in the flat baffle at the left in Fig. 16-3 or the box-type baffle at the right, whereupon most of the sound energy is radiated into the surrounding space.

The shortest distance from the front of the cone around to its back is the sum of the distances *A*, *B* and *C*, in Fig. 16-3. The greater this minimum total

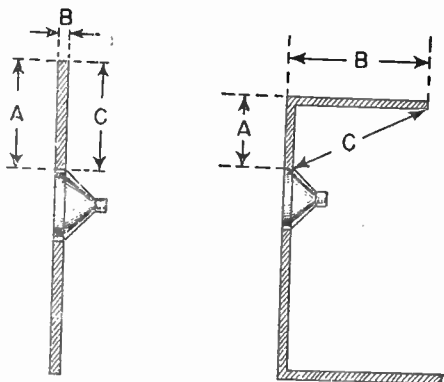

Fig. 16-3. Measurements of baffle dimensions.

distance, the lower the sound frequency that will be radiated without undue loss from cancellation between front and back pressures. The following formulas show relations between the sum of the distances *A*, *B* and *C* in the diagrams and the lowest sound frequency which is not to be partially cancelled.

$$D = \frac{282}{f} \quad f = \frac{282}{D}$$

*D*, total distance, in feet, from front to back edges of cone.

*f*, sound frequency, cycles.

**Phasing of Loud Speakers.**—When two or more speakers are operated from the a-f output of the same amplifier, with the voice coils connected either in parallel or in series across the output transformer, all the cones or

radiators must move outward together and move inward together in order that maximum energy of sound may be delivered to the surrounding space. Connecting the voice coils so that this condition is satisfied is called *phasing* the speakers.

One method of phasing is shown by Fig. 16-4. The leads to the voice coils are disconnected from the secondary of the output transformer and connected in series with a battery and a capacitor *C*. When connection *A* is touched to one battery terminal the capacitor is charged by a momentary pulse of current flowing through the voice coils, and when touched to the other battery terminal the capacitor discharges with another current pulse through the coils. A capacitor of 1-mfd. size and a battery of  $22\frac{1}{2}$  volts or less will give ample current pulses for most speakers. Smaller capacitors and more battery potential, or vice versa, will give the same results.

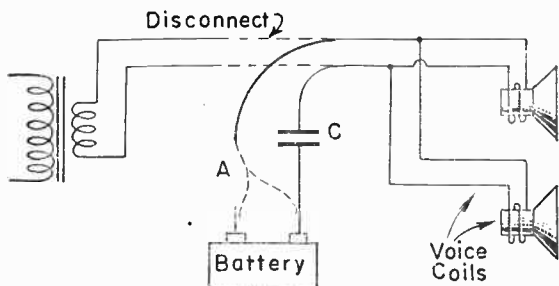

Fig. 16-4. Test connections for phasing two loud speakers.

The direction of motion of the cones may be watched as the pulses are applied, or the direction may be noted by touching the cones lightly with the finger tips. If the speakers are of the electrodynamic type the field coils must be excited during the tests. The direction of motion of a cone may be reversed by reversing the connections to its voice coil. With electrodynamic speakers the direction may be reversed by reversing the connections to either the voice coil or the field coil, but not to both coils.

**Speaker Coupling Transformers.**—In the table of tube characteristics in the section on *Receiving Tubes* in this book are listed output loads in ohms for the various power tubes. These are the loads assumed to be in the plate circuit of the power tube for the listed power output. The actual impedance of the loud speaker input, which usually is the impedance of the voice coil, is not the same as the resistance desired for the tube

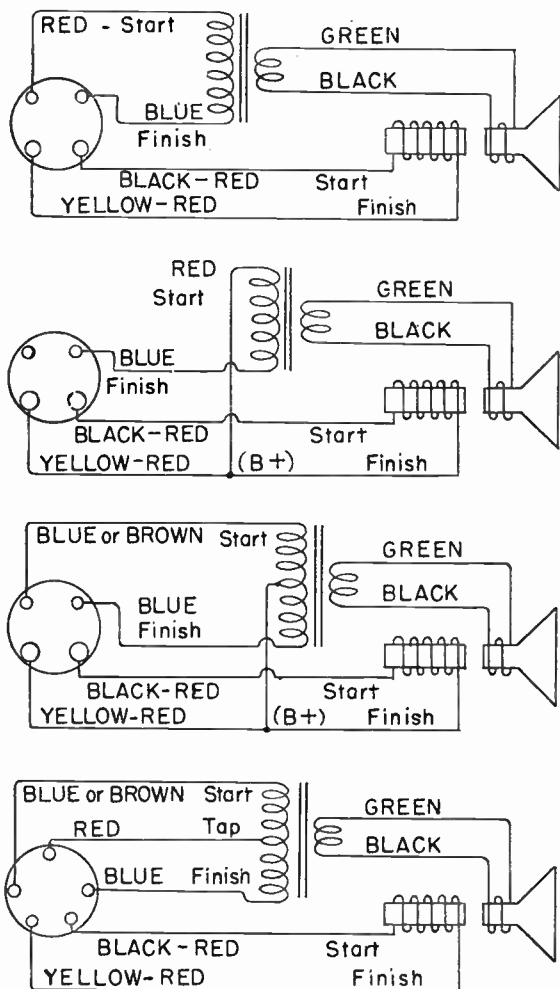

Fig. 16-5. Standard RMA color coding for speaker connection plugs.

load, and so the speaker is coupled into the plate circuit by means of a matching transformer usually called the output transformer.

The inductance of the transformer primary determines in great measure the lowest audio frequency at which there is satisfactory transfer of power. For any given tube the frequency is inversely proportional to the primary inductance. For instance, if an inductance of 7 henrys gives the desired response at 150 cycles, it will take an inductance of 14 henrys to give an equally good response at 75 cycles.

The turns ratio of the output transformer, primary to secondary, depends on the relation of the desired load resistance (as listed in the tube tables) to the actual load impedance or to the speaker input impedance. The following formula gives the approximate desirable turns ratio.

$$\text{Ratio pri. to sec.} = \sqrt{\frac{\text{desired load resistance, ohms}}{\text{actual load resistance, ohms}}}$$

*Example:* For a 6K6 power tube the load resistance is shown by the tube table as 7600 ohms. This tube is to be matched to a voice coil having an impedance of 7 ohms at a frequency of 400 cycles. What should be the transformer turns ratio?

$$\text{Ratio} = \sqrt{\frac{7600}{7}} = \sqrt{1086} = 32.96$$

The primary winding then should have 32.96 times as many turns as the secondary winding, with the primary in the plate circuit and the secondary in the voice coil circuit. Then the 7-ohm impedance of the voice coil will "appear" in the plate circuit like 7600 ohms.

**Speaker Plug Color Code.**—Standard color coding for audio-frequency transformers, including speaker coupling transformers, is shown in the section of this book dealing with *Transformers*. Fig. 16-5 shows color coding and locations for connections made from the speaker and output transformer through a plug. Connections to the plug pins are shown when looking at the bottom of the plug, or with the pins pointing toward you.

#### PUBLIC ADDRESS SYSTEMS

Fig. 16-6, showing the relations between power output in watts of the amplifiers or loud speakers, and the areas in square feet which are to be served by the sound system, represents the average of common practice in this field rather than any particular rules or formulas. The full-line curve *A* applies indoors for conditions usually encountered where public address systems are used. This includes auditoriums, dance halls, dining places, churches, and wherever people gather in fairly large

numbers. This curve applies when the loud speakers have efficient projectors or horns for a full range of frequencies. The dot-dash curve *B* applies indoors where conditions are unfavorable. Such conditions are found in factories, skating rinks, and other places where the normal noise level is high. This curve applies also when

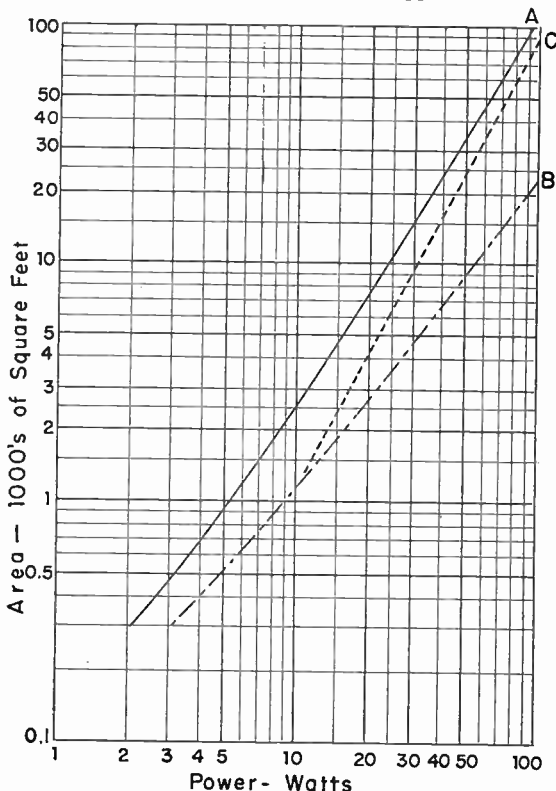

Fig. 16-6. Usual practice in selection of amplifier and loud speaker power output in accordance with the area to be served.

the loud speakers are intentionally limited in frequency range, as when they are "softened" to emphasize lower notes, or in any case where the speaker sound output is considerably less than the full power handling ability of the amplifier.

The broken-line curve *C* of Fig. 16-6 applies out of

doors. It is assumed that the loud speakers are fairly directional, so that most of the sound energy is directed into the area occupied by the people present. It is this occupied area that is to be read from the graph.

It must be kept in mind that Fig. 16-6 represents only averages. The areas which may be effectively covered are almost anything from 60% to 160% of those indicated by the curves, and the power required may be from about 60% to 150% of that indicated. Much of the possible variation is cared for by volume adjust-

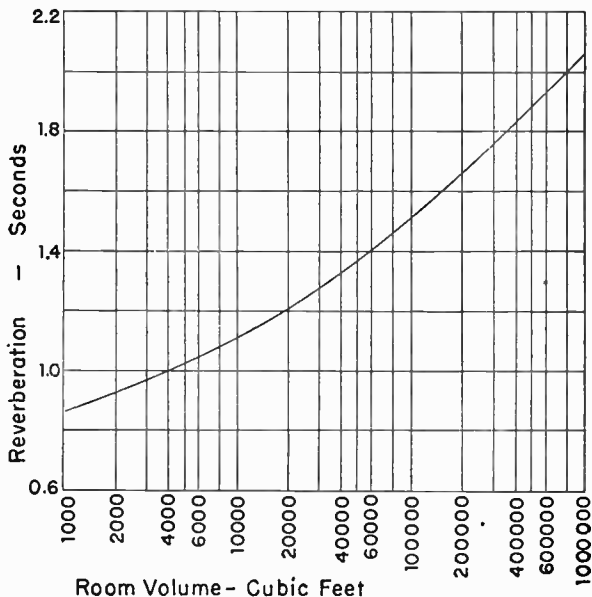

Fig. 16-7. Desirable reverberation periods for various room volumes.

ments or by power output and input adjustments in the amplifiers. Available power often may be used more effectively by employing more small speakers rather than fewer large ones, also by using types of baffles or projectors that either spread the sound or else confine and direct it, as may be required for the proportions of the space to be served. Flat baffles spread the sound, while trumpet and projector types confine and direct the sound in greater or less degree.

**Reverberation.**—Reverberation means a continuation of sound within an enclosure because of reflection of the



sound waves back and forth between walls and other surfaces forming an enclosure. A certain amount of reverberation is desirable to make speech and music sound natural, but too much allows so great interference as to make the sounds unintelligible, especially speech. The *period of reverberation* is the number of seconds required for a sound to decrease in intensity by 60 decibels after the sound source ceases to act. The period is increased by greater room volumes, and is decreased by the presence of surfaces which absorb rather than reflect the sound waves. Sabine's formula for reverberation period is,

$$\text{Reverberation, seconds} = \frac{\text{room volume, cu. feet}}{20 \times \text{absorption units}}$$

One absorption unit is the dissipation for sound energy that occurs when the sound waves reach a clear opening one foot square. Energy passing into such an opening is assumed to disappear completely.

Fig. 16-7 shows reverberation periods in seconds which are usually considered as desirable for rooms of various cubic foot volumes. For example, in a room of 60,000 cubic foot volume the period is read from the curve as 1.4 seconds.

#### SOUND ABSORPTION UNITS

at 512 Cycles

Brick, in Portland cement.....	0.025/sq. ft.
Carpets .....	0.15 to .29 sq. ft.
Celotex, regular .....	.22 sq. ft.
acoustic, Type B .....	.47 sq. ft.
acoustic, Type BB .....	.70 sq. ft.
Concrete .....	.015 sq. ft.
Cork tile .....	.03 sq. ft.
Cretonne cloth .....	.15 sq. ft.
Curtains, in heavy folds.....	.50 sq. ft.
Flaxlinum, 1/2 inch.....	.34 sq. ft.
Glass, window, single thick.....	.027 sq. ft.
Hairfelt (Johns Manville), 1/2 inch.....	.31 sq. ft.
1 inch .....	.55 sq. ft.
Linoleum .....	.030 sq. ft.
Marble .....	.010 sq. ft.
Nashkote, Type A, 3/4 inch.....	.27 sq. ft.
Opening, clear (windows, doors).....	1.00 sq. ft.
Plaster, smooth .....	.25 to .34 sq. ft.
acoustic, Sabinite .....	.21 sq. ft.
Tile, Sanacoustic, 1 inch, with rock wool filler	.74 sq. ft.
Wood, rough sheathing.....	.061 sq. ft.
varnished .....	.030 sq. ft.

Persons in audience.....	4.7	each
Chairs, completely upholstered.....	3.0	each
partly upholstered .....	1.6	each
plain plywood .....	.24	each
Church pews, upholstered.....	up to 1.6	lin. ft.
plain .....	.18	lin. ft.

The absorption units listed in the table are for a sound frequency of 512 cycles. Considering the absorption at this frequency as being 100%, the relative absorption at lower and higher frequencies varies about as follows.

128 cycles .....	22%	1000 cycles .....	132%
256 cycles .....	61%	2000 cycles .....	118%
512 cycles .....	100%	4000 cycles .....	107%

According to Sabine's formula, the required number of absorption units is,

$$\text{Absorption units} = \frac{\text{room volume, cu. feet}}{20 \times \text{reverberation period, secs.}}$$

In the room of 60,000 cu. ft. volume requiring a period of 1.4 seconds, the required number of absorption units would be,

$$\text{Absorption units} = \frac{60000}{20 \times 1.4} = 2142$$

Every enclosure has a large number of absorption units in the surfaces of its structural elements. Additional absorption, when needed, may be supplied with hanging draperies, sound absorbing coverings for walls and ceiling and floor, with upholstered furniture, and such items.

The accompanying table, *Sound Absorption Units*, lists the number of absorption units, called also *coefficients of absorption*, of various surfaces per square foot area. The values for the materials represent the fractions of sound energy absorbed. For instance, a material having an absorption of 0.25, absorbs 0.25 or  $\frac{1}{4}$  of the sound energy and reflects the remainder.

**Microphone Ratings.**—Microphone outputs or responses usually are specified as being "down" so many decibels. This rating may be based on an output of one volt into an open circuit as corresponding to the reference level of zero decibels. The rated output is based on a sound input of one volt per bar, or one volt per dyne per square centimeter. When the rating is that of voltage across an open circuit, and the microphone actually is coupled to the input of an amplifier, or even directly to the grid of an amplifying tube, the output will fall to about 6 decibels less than the open circuit rating. Listed output ratings run about as follows for generally used types of microphones.

Carbon, 1 or 2-button.....	-30 to -42 db	Avg. -38
Dynamic, moving coil.....	-50 to -60 db	Avg. -55
Velocity or ribbon.....	-64 to -68 db	Avg. -65
Crystal .....	-48 to -62 db	Avg. -52

**Sound Frequency Ranges.**—The accompanying table, *Sound Frequency Ranges*, lists the extent of fundamental sound frequencies produced by voices and musical instruments of various types. Overtones or harmonics extend the high-frequency end of the scale.

### SOUND FREQUENCY RANGES

Bass clarinet	81 to 488	cycles
Bass tuba	43 to 345	"
Bass viol	40 to 244	"
Bassoon	61 to 488	"
Cello	65 to 691	"
Clarinet	173 to 1550	"
Cornet	163 to 1035	"
Flute	259 to 2323	"
French horn	109 to 870	"
Oboe	244 to 1740	"
Organ	20 to 8276	"
Piano	27 to 3480	"
Piccolo	517 to 4138	"
Trombone	81 to 488	"
Trumpet	163 to 1035	"
Viola	129 to 1161	"
Violin	194 to 3100	"
Voice: alto	192 to 683	"
baritone	96 to 384	"
bass	85 to 320	"
soprano	256 to 1152	"
tenor	128 to 512	"

## Section 17

### METERS AND MEASUREMENTS

The basic indicating element for current or for potential difference in radio measuring instruments is the permanent-magnet moving-coil unit consisting of a coil or armature winding mounted so that it may rotate through a part of a turn in the field of a strong permanent magnet, with rotation opposed by increasing tension of a coiled spring. The application of this unit for various kinds of measurements is shown in principle by Fig. 17-1.

The permanent-magnet moving-coil unit must be actuated by direct current flowing in the moving coil to produce a magnetic field that reacts with the field of the permanent magnet to cause rotation of the coil and its supporting armature structure. The internal resistance of the meter movement is the resistance of the coil. In usual high grade instruments this resistance may be between 50 and 150 ohms when a current of 200 to 500 microamperes is required to move the coil so that the attached pointer moves all the way across the dial scale, or moves to full-scale. In movements requiring currents of 1 to 1.5 milliamperes for full-scale deflection the coil resistance may be in the neighborhood of 20 to 50 ohms. In 2 milliampere movements typical resistances are 15 to 30 ohms, and in 5-milliampere types 10 to 15 ohms.

Referring to Fig. 17-1, direct currents within the range which may flow through the moving coil are measured by connecting the coil terminals in series with the circuit wherein the current is to be measured, as in diagram *A*. Larger direct currents are measured as at *B*, where a shunt resistor is connected between the coil terminals and in series with the measured circuit. The total measured current divides between the shunt and the moving coil inversely as their resistances. Thus large currents may be measured by diverting a small but proportionate part through the meter coil, with the remainder going through the shunt.

Direct potentials or d-c voltages are measured as in diagram *C*, where a multiplier resistor is connected in series with the meter coil and the source of potential difference. The greater the resistance of the multiplier the greater must be the applied potential difference in order that enough current may go through the coil to cause a given deflection of the pointer across its scale.

Alternating currents and potentials of all frequencies up to and through the audio-frequency range are measured by means of rectifier meters as in diagrams *D* and *E*

of Fig. 17-1. The moving coil of the meter is connected to the d-c output of a bridge type full-wave rectifier, usually of the copper-oxide contact type, and the a-c

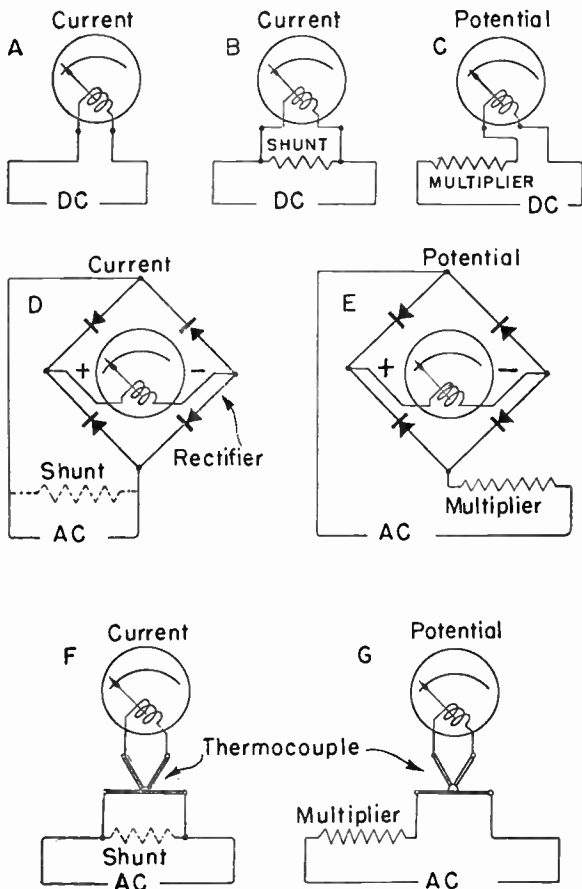

Fig. 17-1. Connections of moving coil element for d-c and a-c measurements of current and potential difference.

circuit is connected to the input of the rectifier. For current measurements a shunt may be connected as shown in diagram *D*, or may be across the moving coil terminals. For voltage measurements the multiplier re-

sistor is connected in series with the potential source, as at  $E$ , to prevent excessive current through the rectifier as well as the moving coil.

Alternating currents and potentials of all frequencies up to several megacycles may be measured with good accuracy with the thermocouple meters shown by diagrams  $F$  and  $G$  of Fig. 17-1. High-frequency thermocouples may be enclosed within an evacuated glass envelope, like that for a miniature radio tube. The thermocouple consists of two dissimilar metals, such as copper or an iron alloy and constantan, soldered or welded together at a junction point which is in contact with a heater wire carrying alternating current to be measured. Heat produced by current flow generates a potential difference at the thermocouple junction and causes direct current to flow through the thermocouple junction and the connected meter coil.

**Voltmeter Sensitivity.**—The sensitivity of voltmeters usually is expressed as the number of *ohms per volt*. This sensitivity is determined by dividing the total resistance of the meter, including that of any multiplier resistor, by the number of volts indicated at the full scale reading. For example, if the total resistance of a meter reading from 0 to 100 volts is 50,000 ohms, the sensitivity in ohms per volt is equal to 50,000 divided by 100, or to 500 ohms per volt. For this meter the current at full scale would be found by dividing the applied voltage (100) by the total resistance (50,000), giving 0.002 ampere or 2 milliamperes current for full-scale deflection. Full-scale current for any sensitivity is found thus,

$$\text{Full-scale milliamps.} = \frac{1000}{\text{ohms per volt}}$$

**Accuracy of Meters.**—Meter accuracy usually is expressed as a percentage of the full-scale reading. For example, a 100-volt meter of 2% accuracy may have an error of 2% of 100 volts, which is a possible error, plus or minus, of 2 volts. This error may exist anywhere on the scale. If this meter reads 50 volts the actual applied potential difference may be 2 volts less than 50 or 2 volts more than 50, which means an actual potential difference of between 48 and 52 volts. At a reading of 10 volts the actual potential may be 2 volts more or less than 10, or may be from 8 to 12 volts. The actual percentage error, as distinguished from the rated percentage of accuracy, becomes greater and greater as the readings decrease. Consequently, every meter should be used as nearly as convenient to its full-scale reading. Attempting to measure differences of one or two volts or milliamperes near the bottom of the scale on an instrument having a full scale reading of 20 or more units does not give dependable indications.

**Choice of Meter Resistances.**—Current-measuring meters such as microammeters, milliammeters, and ammeters, should have low resistances—the lower the better—because these instruments are connected in series with the line carrying the measured current, and the less the resistance added by the meter itself the less will be the reduction of current below the value flowing before inserting the meter. This applies especially to measurements of current in low-resistance circuits. The error introduced by the meter resistance is nearly equal to the ratio of meter resistance to circuit resistance. For instance, inserting a 20-ohm current meter in series with a 200-ohm circuit will reduce the measured current to about 0.91 or 91% of the flow without the meter.

Voltmeters should have the highest possible resistance, because they are connected across points whose

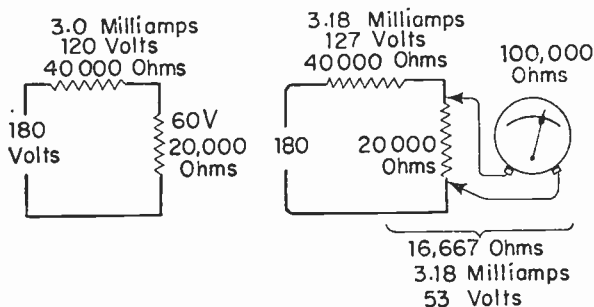

Fig. 17-2. The effect of connecting a voltmeter to a circuit.

potential difference is to be measured, and the higher the meter resistance the less is its shunting effect and the less current is diverted from the measured circuit to flow through the meter.

Fig 17-2 illustrates an example of what happens when using a voltmeter. At the left is a circuit containing a total of 60,000 ohms of series resistance. With 180 volts applied, the current is 3.0 milliamperes. The potential drop across the 20,000-ohm resistor is 60 volts. In the right-hand diagram the potential across the 20,000-ohm resistor is being measured with a voltmeter whose resistance is 100,000 ohms. The parallel resistance of the meter and the 20,000-ohm unit is 16,667 ohms. Now the total circuit resistance is  $16,667 + 40,000 = 56,667$  ohms, and so the current increases to 3.18 milliamperes. The potential drop across the 40,000-ohm resistor rises to 127 volts, and the drop across the meter and the 20,000-ohm unit in parallel is 53 volts. Thus the meter indicates 53 volts, whereas the drop without

the meter in use is 60 volts, making an error of 14 per cent even with a meter of fairly high resistance.

**Rectifier Meters.**—With the rectifier meter, whose principle is shown at *D* and *E* of Fig. 17-1, the full-wave rectifier may be built into the meter case or else may be mounted outside the meter and connected between the a-c line and the moving coil. Small rectifiers, especially designed for this service, are available in various maximum current ratings such as 5, 10, 15, 20 or 50 milliamperes as required for use with various d-c current meters.

Rectifier meters should be used, if possible, at temperatures between 65° and 95° F. At lower or higher temperatures there may be a considerable increase in the error of readings. These meters are calibrated for sine wave alternating currents and potentials, and for r-m-s values. There may be serious errors in readings for wave forms that are not approximately of sine form. The resistance of the meter and rectifier is least at

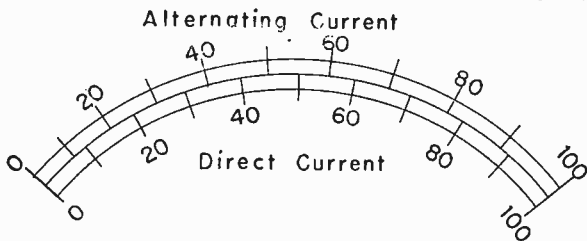

Fig. 17-3. A-c readings on rectifier meter compared with d-c readings without the rectifier.

full-scale, and increases for smaller currents through the meter. The resistance in the lower part of the scale may be about double that for full-scale. Readings decrease in proportion to actual current as the frequency increases, the rate of decrease in some popular types of rectifier meters being about one per cent for each frequency increase of 2,000 cycles. The accuracy of good quality rectifier meters is in the neighborhood of 5% of the full-scale reading when the meters are used in the desirable temperature range and on approximate sine wave currents and potentials.

When the same meter movement is used for direct-current measurements and then for alternating-current measurements with a rectifier, the readings with the rectifier will be slightly crowded at the lower end of the scale, as shown by Fig. 17-3 for a typical combination.

**Meter Resistance Measurement.**—In the selection of resistors for meter shunts and multipliers it is necessary to know the internal resistance of the meter movement



or the resistance of the moving coil. The resistance of some meters is marked on the dial or on a nameplate. Otherwise it may be measured as shown by Fig. 17-4. The meter is connected in series with a battery and a fixed resistor of such values that the reading is something less than full scale. Then an adjustable resistor is connected across the meter as shown by broken lines. The adjustable resistor is set so that the meter reading is decreased to exactly half of its first value. Then the resistance of the adjustable resistor, as set, is equal to the internal resistance of the meter. This is true because, with half of the total current flowing through the meter, an equal half must be flowing in the adjustable

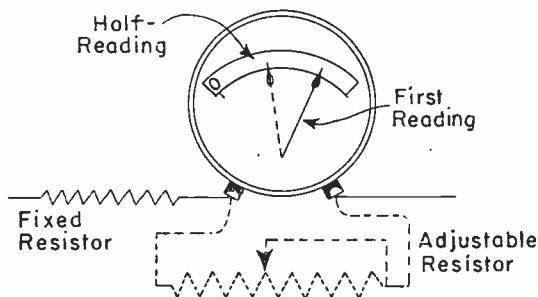

Fig. 17-4. Method of measuring the resistance of a meter.

resistor, and with equal currents in parallel resistances subjected to the same potential difference the resistances of the parts must be equal. The resistance of the adjusted resistor may be measured with a resistance bridge, an accurate ohmmeter, or other resistance measuring apparatus.

**Shunts for Current Meters.**—The resistance of a shunt resistor for increasing the full-scale range of a current meter is determined from this formula.

$$Rx = \frac{Rm}{\frac{Ib}{Ia} - 1}$$

*R<sub>x</sub>* Resistance of shunt, ohms.

*R<sub>m</sub>* Resistance of meter or of moving coil, ohms.

*I<sub>a</sub>* Original full-scale reading of meter in current units.

*I<sub>b</sub>* Desired new full-scale reading of meter in current units.

The units of current must be the same for *I<sub>a</sub>* and *I<sub>b</sub>*. That is, both must be in amperes, milliamperes, or microamperes.

*Example:* What shunt resistance should be used with a 1-milliampere meter having an internal resistance of 27 ohms when the full-scale reading is to be 20 milliamperes?

$$R_x = \frac{27}{\frac{20}{1} - 1} = \frac{27}{19} = 1.42 \text{ ohms}$$

*Example:* What shunt resistance is required for a 5-milliampere meter with internal resistance of 12 ohms if the new full-scale reading is to be 1 ampere? Note that 1 ampere is the same as 1000 milliamperes.

$$R_x = \frac{12}{\frac{1000}{5} - 1} = \frac{12}{199} = 0.06 \text{ ohm}$$

If only the approximate value of meter internal resistance is known, fair accuracy may be had by placing in series with the meter a resistor,  $R_s$  in Fig. 17-5, with a resistance 9 times the approximate meter resistance, then basing the value of the shunt resistor  $R_x$  on 10

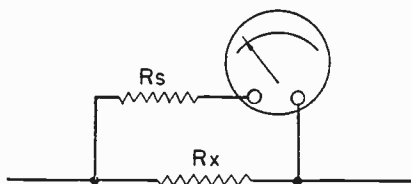

Fig. 17-5. Shunting a meter whose resistance is known only approximately.

times the approximate meter resistance. The effect of  $R_s$  is to increase the effective resistance in parallel with the shunt to 10 times the meter resistance, with at least 9/10 of this effective resistance accurately known. This lessens the percentage of possible error due to not knowing the actual resistance of the meter. Then the value of the shunt resistor  $R_x$  is found as follows.

*Example:* What shunt resistance and series resistance should be used with a 2-milliampere meter of about 20 ohms resistance to obtain a full scale reading of 50 milliamperes?

$$R_s = 9 \times 20 = 180 \text{ ohms}$$

$$R_x = \frac{10 \times R_m}{\frac{I_b}{I_a} - 1}$$

$$R_x = \frac{10 \times 20}{\frac{50}{2} - 1} = \frac{200}{24} = 8.33 \text{ ohms}$$

**Series Resistors for Voltmeters.**—When a current meter, such as a milliammeter, is to be converted for use as a voltmeter it is necessary to connect in series with the moving coil, the rectifier, or the thermocouple a resistor marked *multiplier* in diagrams *C*, *E* and *G* of Fig. 17-1. The required value of this series resistor is found from the formula,

$$R_s = \frac{E}{I} - R_m$$

*R<sub>s</sub>* Series resistor or multiplier resistor, ohms.

*R<sub>m</sub>* Resistance of meter, ohms.

*E* Desired full-scale range in volts.

*I* Original full-scale range of meter in amperes.

Note that the value of the original current range *I* is in amperes. If it is in milliamperes or microamperes, the value must be changed to the equivalent number of amperes or else the formula must be altered as follows.

$$R_s = \frac{1000 \times E}{\text{full-scale milliamps}} - R_m$$

$$R_s = \frac{1000000 \times E}{\text{full-scale microamps}} - R_m$$

*Example:* What value of series resistor should be used with a 5-milliamper meter having a resistance of 200 ohms when the meter is to have a full-scale reading of 10 volts? Using the formula based on milliamperes,

$$R_s = \frac{1000 \times 10}{5} - 200$$

$$= \frac{10000}{5} - 200 = 2000 - 200 = 1800 \text{ ohms.}$$

If the new full-scale reading in volts is equal to or greater than the meter resistance in ohms there will be little error if the meter resistance is not subtracted in the formula. Resistances of rectifier meters, including the rectifier, usually are high enough to warrant their subtraction from the value of series resistance otherwise needed.

*Example:* What series resistor should be used with a 200-microampere meter with internal resistance of 60 ohms which is to be used as a voltmeter with full-scale reading of 500 volts?

$$R_s = \frac{1000000 \times 500}{200} = 2,500,000 \text{ ohms}$$

$$= 2.5 \text{ megohms}$$

It is apparent that subtracting the meter resistance of 60 ohms from the resistance of 2.5 megohms would have negligible effect on accuracy of readings.

**Multipliers for Voltmeters.**—If an instrument already calibrated in volts is to have its voltage range increased by

adding a series multiplying resistor, the required value for this multiplier is found from the formula,

$$R_s = R_m \times \left( \frac{V_b}{V_a} - 1 \right)$$

- $R_s$  Series multiplying resistor, ohms.  
 $R_m$  Original meter resistance, ohms.  
 $V_a$  Original full-scale reading, volts.  
 $V_b$  Desired new full-scale reading, volts.

*Example:* What should be the resistance of a multiplier used with a 10-volt meter having a resistance of 10,000 ohms when the meter is to have a full-scale reading of 1000 volts?

$$\begin{aligned} R_s &= 10000 \times \left( \frac{1000}{10} - 1 \right) \\ &= 10000 \times (100 - 1) = 990000 \text{ ohms} \end{aligned}$$

Note that the meter originally has a resistance of 10,000 ohms for 10 volts, which is a sensitivity of 1000 ohms per volt. With the series resistor in place the total resistance becomes  $990000 + 10000 = 1000000$  ohms for 1000 volts, which still is a sensitivity of 1000 ohms per volt. The resistance of the meter always is equal to the product of the number of volts at full scale by the number of ohms per volt sensitivity. This gives a means for determining the total meter resistance when the known factors are sensitivity and full-scale reading.

**Wattage Ratings for Shunts and Multipliers.**—The number of watts of power dissipated as heat in shunt resistors is found from the formulas,

$$\begin{aligned} \text{Watts} &= (\text{amperes})^2 \times \text{ohms in shunt} \\ \text{Watts} &= \frac{(\text{milliamps})^2 \times \text{ohms in shunt}}{1000000} \\ \text{Watts} &= \frac{(\text{microamps})^2 \times \text{ohms in shunt}}{1\ 000\ 000\ 000\ 000} \end{aligned}$$

The current through the shunt resistor will be the difference between the full-scale reading with the shunt in use and the full-scale reading of the meter without the shunt. For example, if the full-scale reading of a 1-milliamper meter is increased to a full-scale reading of 20 milliamperes, the current through the shunt resistor will be  $20 - 1 = 19$  milliamperes. The watts dissipation in shunt resistors usually is so small that units rated at  $\frac{1}{4}$  watt or more have ample heat dissipating ability.

Multiplying resistors used in series with current meters to convert them to voltmeters carry, at full-scale readings, the full-scale current of the original meter through the resistance of the multiplier. Consequently, the preceding formulas may be used with one of the factors taken as *ohms in multiplier* instead of *ohms in shunt*.

The dissipation in multiplier resistors used in series with voltmeters to increase the voltage range is conveniently found from,

$$\text{Watts} = \frac{(E_s - E_m)^2}{R}$$

$E_s$  New full-scale voltage reading, volts.

$E_m$  Original full-scale meter reading, volts.

$R$  Multiplier resistance, ohms.

This formula is merely one of the usual power formulas,  $P = E^2/R$ , with the value of  $E$  taken as the volts drop across the resistor. The resistor drop must be the difference between the new and original voltage readings, since the meter still responds to the same voltage drop as before, and the additional voltage must be used in the resistor.

*Example:* What is the wattage dissipation in a 990,000-ohm multiplier used to permit a range of 1000 volts on a meter originally reading to 10 volts?

$$\text{Watts} = \frac{(1000 - 10)^2}{990000} = \frac{990 \times 990}{990000} = \frac{99}{100}$$

**Choice of Instrument Resistors.**—There are six properties of resistors to be considered when they are to be used as shunts or multipliers.

1. Resistance in ohms, as determined from preceding formulas.

2. Heat dissipation in watts, as determined from formulas. The wattage rating of a resistor must never be exceeded, and preferably should be well in excess of the computed requirement.

3. Accuracy. Instrument resistors usually have an accuracy of 1%, or less than 1%, plus or minus, when used with meters having an accuracy of 2%. If the meter has greater accuracy the accuracy of the resistors should be proportionate.

4. Temperature coefficient. The resistance should undergo negligible change in the range of working temperatures. Precision resistors for meter work ordinarily are wire-wound with wire having a very small temperature coefficient of resistivity.

5. Inductance. If the resistors are to be used for alternating-current work, and especially if for audio- or radio-frequency measurements, they must be practically non-inductive, which means having inductance not much more than two microhenrys.

6. Distributed capacitance. For audio- and radio-frequency work the resistors should have distributed capacitance of not much more than two mmfds.

Carbon and composition resistors have practically no self-inductance or distributed capacitance, but they may have large temperature coefficients. Wire-wound re-

sistors require special construction in avoiding inductance and capacitance.

**A-C-D-C Volt-Milliammeter.**—Fig. 17-6 shows a typical circuit for a combination instrument which will measure direct or alternating current in several ranges, also direct or alternating voltage in several ranges. The principal parts include,

1. A current meter (upper left) which usually has a full-scale range of 200 or 500 microamperes, or 1 or 1.5 milliamperes.

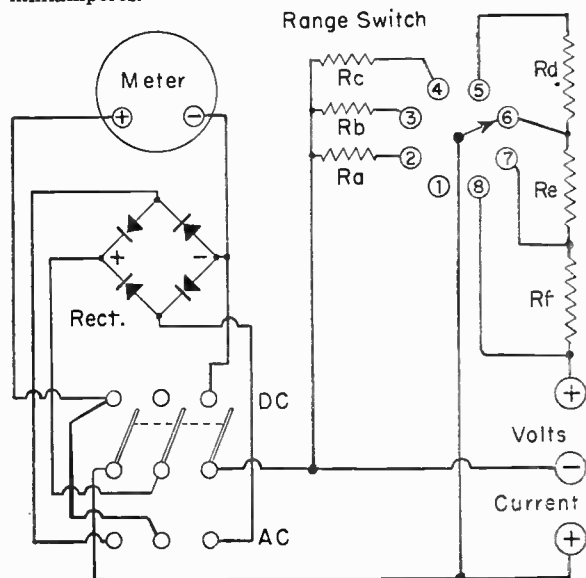

Fig. 17-6. Circuit of Ac-Dc volt-milliammeter.

2. Immediately below the meter is the full-wave bridge rectifier used for alternating currents and potentials.

3. Shown below the rectifier is a three-pole double-throw switch of any convenient or available type. With the three center terminals connected to the three upper terminals the measurements are of d-c quantities, and when connected to the three lower terminals the measurements are of a-c quantities.

4. The range switch, at the upper right, is shown as an eight-pole rotary type with which the rotor arm, connected to the center, may be turned into contact with

any one of the terminals numbered 1 to 8. On point 1 the meter is not shunted, and will read its normal current range. At 2 the meter is shunted with resistor  $R_a$ , at 3 with resistor  $R_b$ , and at 4 with  $R_c$ . The resistances for these shunt resistors are computed with formulas previously shown, in accordance with the characteristics of the meter and the current ranges to be provided.

With the range switch rotor at 5 there is placed in series with the meter the multiplying resistance which is the sum of the resistances in  $R_d$ ,  $R_e$  and  $R_f$ , thus providing the maximum multiplying resistance and highest voltage range. At 6 the multiplying resistance is the sum of  $R_e$  and  $R_f$ , at 7 it is  $R_f$  alone, and at 8 there is no multiplying resistance. With no multiplier the meter will read in millivolts or microvolts. The full-scale reading for this position will be a potential equal to the product of moving coil resistance in ohms and the full scale current of the meter movement, which, if in milliamperes will give millivolts, and if in microamperes will give microvolts. Unless such small potential readings are desired it is advisable to leave point 8 unconnected to provide an off position, or else to place an instrument fuse in the line from the common negative terminal.

5. The three terminals for external connections are shown at the lower right in the diagram. Connections for voltage measurements are made from the upper "+" terminal to the center common "-" terminal. For current measurements the connections are made from the bottom "+" terminal to the center common "-" terminal.

Resistance for multipliers  $R_d$ ,  $R_e$  and  $R_f$  are computed from formulas previously given.

*Example:* Assuming a 1-milliamperemeter movement with internal resistance of 50 ohms, and desired voltage ranges of 3, 30 and 500 volts. The required multiplying resistances will be,

For 3 volts, 2950 ohms

For 30 volts, 29950 ohms

For 500 volts, 499950 ohms

Resistor  $R_f$  of Fig. 17-6 then will be of 2950 ohms. The sum of  $R_f$  and  $R_e$  is to be 29950 ohms, so  $R_e$  will be  $29950 - 2950 = 27000$  ohms. The sum of all three resistors is to be 499950 ohms, and since there already is 29950 ohms in  $R_e$  and  $R_f$ , the resistance for  $R_d$  will be  $499950 - 29950 = 470000$  ohms.

Resistances for any other ranges may be similarly determined. Any number of voltage and current ranges may be provided with an appropriate number of terminals on the range switch. A press-button type of safety switch may be connected in series with the common negative terminal, with this switch remaining open

until connections have been checked, then pressed while taking readings. The safety switch may be shunted with a protective resistor of something like 100,000 ohms, which will allow enough current to reach the meter to give an indication of wrong connections.

**Ohmmeters.**—The principle of one type of simple ohmmeter is illustrated by Fig. 17-7. A meter is connected in series with a battery, a calibrating resistor, and the two terminals to which are connected the unknown resistance to be measured. The calibrating resistor is of such value that, with the test terminals short circuited on each other, the meter reads to full scale. When the short circuit is removed from the terminals, and an unknown resistance connected in its place, the meter reading will indicate the value of the unknown resistance when the meter scale is suitably graduated.

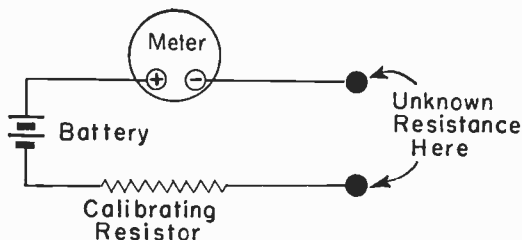

Fig. 17-7. Principle of ohmmeters in general use.

The value for the calibrating resistor is found from the formula,

$$R_c = \frac{E_b}{I_m} - R_m$$

- $R_c$  Calibrating resistor, ohms.  
 $E_b$  Voltage of battery, volts.  
 $I_m$  Full-scale range of meter, amperes.  
 $R_m$  Resistance of meter, ohms.

*Example:* With a 2-cell dry battery giving 3.0 volts, what calibrating resistance is required for a 1-milliamperemeter having an internal resistance of 50 ohms?

$$R_c = \frac{3.0}{0.001} - 50 = 2950 \text{ ohms.}$$

The total resistance in series with the battery now is the sum of  $R_c$  and  $R_m$ , which here is  $2950 + 50 = 3000$  ohms. The current, with the test terminals shorted, will be 0.001 ampere or 1 milliamperemeter. If a resistance of 3000 ohms is connected between the test terminals the total resistance in series with the battery will be  $3000 + 3000 = 6000$  ohms, which is double the former



value. Doubling the resistance will halve the current, which becomes 0.5 milliamperes and causes the meter to read to half scale. Then, in this example, a half-scale reading indicates a tested resistance of 3000 ohms. The ratio of the unknown resistance to the total resistance in the ohmmeter ( $R_c + R_m$ ) is 3000/3000 or is 1. For other ratios of unknown resistance to ohmmeter resistance the fractions of full scale reading will be as shown in the table, *Ohmmeter Scale Readings*. These fractions apply with any total ohmmeter resistances. From them it is possible to graduate any meter dial in ohms by selecting the various numbers of ohms at which marks are to be placed.

### OHMMETER SCALE READINGS

<u>Unknown</u> Ohmmeter	FRACTION of full scale	<u>Unknown</u> Ohmmeter	FRACTION of full scale	<u>Unknown</u> Ohmmeter	FRACTION of full scale
40	0.02439	4.5	0.1818	0.5	0.6667
35	.02778	4	.2000	.4	.7143
30	.03226	3.5	.2222	.3	.7692
25	.03846	3	.2500	.2	.8333
20	.04762	2.5	.2857	.1	.9091
18	0.05263	2.0	0.5333	0.09	0.9259
16	.05982	1.8	.3571	.06	.9434
14	.06667	1.6	.3846	.04	.9615
12	.07692	1.4	.4167	.02	.9804
10	.09091	1.2	.4545	.01	.9901
9	0.1000	1.0	0.5000	0.008	0.9921
8	.1111	0.9	.5263	.006	.9940
7	.1250	0.8	.5556	.004	.9960
6	.1429	0.7	.5882	.002	.9980
5	.1667	0.6	.6250	.001	.9990

*Example:* Using a 1.5-milliamperes meter of 50 ohms internal resistance with a 5-cell dry battery giving 7.5 volts the required calibrating resistor is found, from the preceding formula, to be 4950 ohms. Then the ohmmeter resistance will be 5000 ohms. At what milliamperes points on the dial scale should markings be placed for the following numbers of ohms: 100, 200, 500, 1000, 2000, 5000, 10000 and 20000?

The ratios of the measured ohms to 5000 (the ohmmeter resistance) are found by dividing the specified numbers of ohms by 5000. The scale fractions corresponding to the ratios are read from the table. The full-scale meter reading of 1.5 milliamperes is multiplied by the fractions to determine the points on the milliamperes scale at which resistances in ohms are to be marked.

Any other resistance marking points may be similarly determined.

As the battery voltage decreases with use there will be smaller and smaller currents, causing the meter to indicate higher and higher resistance values for the same measured resistance. In practical ohmmeters this tendency is counteracted by adjusting the readings of the meter itself, as with an adjustable magnetic shunt on the meter movement, or by some arrangement such as those shown by Fig. 17-8. In any case, the meter should read full-scale, or should be brought to this reading, while the test terminals are short circuited.

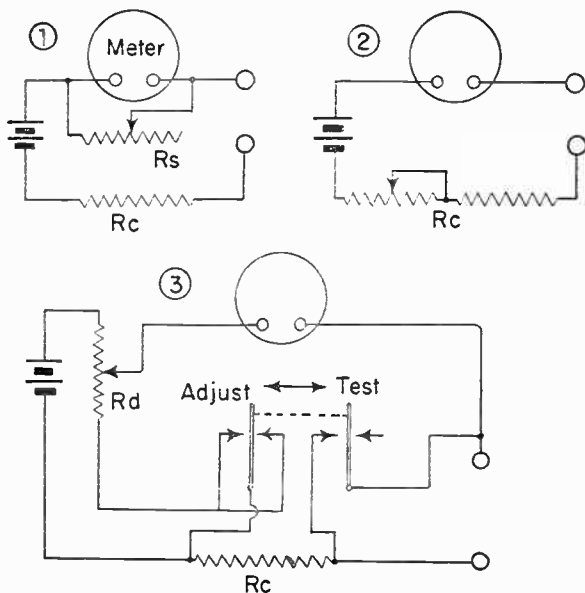

Fig. 17-8. Methods for compensating battery discharge in ohmmeters.

In diagram 1 of Fig. 17-8 an adjustable shunting resistor  $R_s$  is connected across the meter terminals to reduce the deflection with a fresh battery and increase it as the battery discharges. At 2 a portion of the calibrating resistor  $R_c$  is made adjustable so that the effective resistance may be increased with a fresh battery and decreased as the battery discharges. In diagram 3 a voltage divider resistor  $R_d$  is connected across the battery. A two-pole double-throw center-off switch is thrown to the left side while the meter is adjusted, thus

connecting the divider to the battery and shorting the test terminals. The switch is thrown to the right for testing unknown resistances, connecting the divider across the battery. The switch is open while the ohmmeter is out of use, keeping the battery disconnected and preventing its needless discharge. Part of  $R_d$  is in series with  $R_c$ , and unless  $R_c$  is much the greater, calibration is affected by the measured resistance.

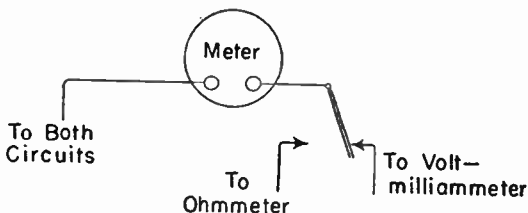

Fig. 17-9. Connection of single meter to ohmmeter and volt-milliammeter circuits.

An ohmmeter circuit may be incorporated with a volt-milliammeter circuit, using a single meter, by connecting one terminal of the meter through a double-throw switch as in Fig. 17-9 to either the ohmmeter or the volt-milliammeter circuits, with the other meter terminal permanently connected to both circuits.

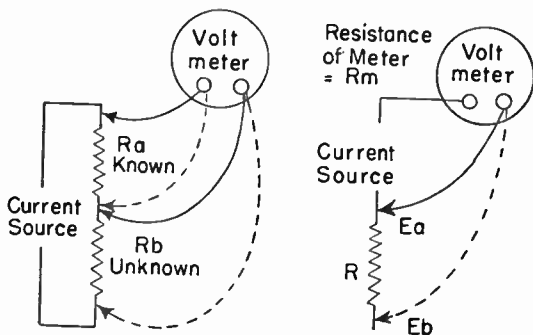

Fig. 17-10. Measuring resistance with a voltmeter.

**Resistance Measurements.**—Fig. 17-10 shows two methods of measuring unknown resistances with a voltmeter. At the left any known resistance  $R_a$  is connected in series with the unknown resistance  $R_b$  and a source of current such as a battery or a d-c supply. The voltage is measured first across the known resistance, with the full-line meter connections, and is called  $E_a$ . Then the

voltage is measured across the unknown resistance, with the broken line connections, and is called  $E_b$ . Then,

$$R_b = R_a \times \frac{E_b}{E_a}$$

*Example:* Assume that the known resistance  $R_a$  is 1000 ohms, that the reading across it ( $E_a$ ) is 22.5 volts, and that the reading across the unknown resistance  $R_b$ , which is called  $E_b$ , is 31 volts.

$$R_b = 1000 \times \frac{31}{22.5} = 1378 \text{ ohms.}$$

The resistor  $R_a$ , used for comparison, should be, as nearly as convenient, of about the same resistance that is thought to be in the unknown unit  $R_b$ . The more nearly alike the two resistances the less will be the error due to shunting effect of the meter.

At the right in Fig. 17-10 the unknown resistance  $R$  is connected to one end of a current source such as a battery. A voltage  $E_a$  is measured with the meter connected directly across the source (full-line connection) and then a second voltage  $E_b$  is measured across the source and the unknown resistor (broken-line connection). The resistance of the meter must be known; it is called  $R_m$ . Then,

$$R = R_m \times \left( \frac{E_a}{E_b} - 1 \right)$$

*Example:* Assume that the meter has a 100-volt range and a resistance of 1000 ohms per volt, making a total meter resistance  $R_m$  of 100,000 ohms. Assume too that the reading  $E_a$  is 90 volts and reading  $E_b$  is 42 volts.

$$\begin{aligned} R &= 100000 \times \left( \frac{90}{42} - 1 \right) \\ &= 100000 \times (2.143 - 1) = 114,300 \text{ ohms.} \end{aligned}$$

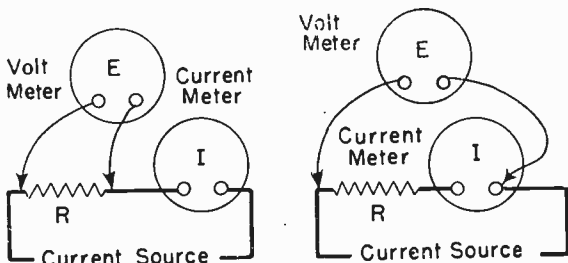

Fig. 17-11. Measuring resistance with voltmeter and current meter.

Resistance may be measured with a voltmeter and a current meter (ammeter, milliammeter, etc.) with either of the arrangements shown by Fig. 17-11. In either case,

$$R, \text{ ohms} = \frac{E, \text{ volts}}{I, \text{ amperes}}$$

$$R, \text{ ohms} = \frac{1000 \times \text{volts}}{\text{milliamperes}}$$

$$R, \text{ ohms} = \frac{1000000 \times \text{volts}}{\text{microamperes}}$$

The connection at the left is preferred for measuring small resistances. The current flowing through the voltmeter, in addition to that through the measured resistance, passes through the current meter and increases the current reading, but with low resistance at  $R$  the extra meter current will be a small part of the total current.

The connection at the right is preferred for measuring large resistances. Here the voltmeter measures and indicates the potential drop across both the current meter and the measured resistance, which increases the voltage reading. However, with high resistance at  $R$  the added resistance of the current meter, and the proportional voltage drop, are of little importance.

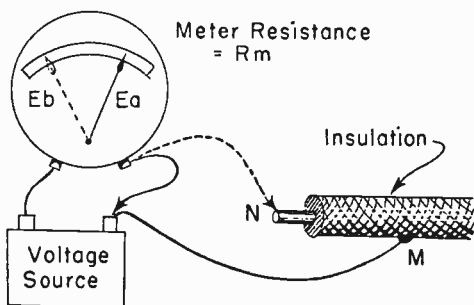

Fig. 17-12. Measuring insulation resistance with a voltmeter.

**Insulation Resistance.**—Fig. 17-12 shows a method of testing the resistance of insulation, or of any other element having high resistance, by the use of a voltmeter and a voltage source. The resistance of the meter,  $R_m$ , must be known. One terminal of the meter is connected to one side of the voltage source and left there. The other terminal of the source is connected to a point on one side of the insulation, as at  $M$  in Fig. 17-12. Then a voltage reading, called  $E_a$ , is taken directly on the source as shown by the full-line meter connection, and a second reading, called  $E_b$  is taken on the side of the insulation not connected to the source, as at point  $N$ .

in the diagram. The resistance insulation,  $R$ , is determined thus.

$$R = R_m \times \left( \frac{E_a - E_b}{E_b} \right)$$

*Example:* Assume a meter resistance of 300,000 ohms, a reading  $E_a$  of 180 volts, and a reading  $E_b$  of 22 volts. What is the insulation resistance  $R$ ?

$$\begin{aligned} R &= 300000 \times \left( \frac{180 - 22}{22} \right) \\ &= 300000 \times \frac{158}{22} = 300000 \times 7.182 \\ &= 2,154,600 \text{ ohms} = 2.15 \text{ megohms, approx.} \end{aligned}$$

Unless the meter is of great accuracy the results of this test may vary widely from the actual resistance when the measured resistance is very great. This comes about because of the low readings for  $E_b$ , with which the actual percentage error of the meter is greatest.

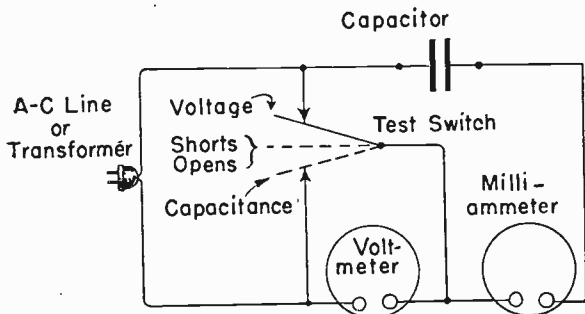

Fig. 17-13. Capacitance measurement with voltmeter and milliammeter.

**Capacitance Tests.**—The capacitance of fixed capacitors of types which may be subjected to alternating potential may be tested with an a-c voltmeter and an a-c milliammeter with the connections of Fig. 17-13. The voltmeter, shunted by a three-position test switch, is in series with the milliammeter, the capacitor to be tested, and an a-c line or the secondary of a transformer. The voltmeter must have a range great enough for the line or other applied voltage. The test switch must be normally held closed in its upper position by a spring to avoid possibility of meter burnout when attempting to measure a shorted capacitor.

With the test switch in its upper *voltage* position the applied voltage is read from the voltmeter. The switch then is moved to its intermediate *shorts-opens* position.

If the voltmeter reads zero, the capacitor is open-circuited. If the voltmeter reads line voltage the capacitor is short-circuited. If neither of these faults is indicated, the switch is moved to its lower capacitance position, which shorts out the voltmeter and leaves the capacitor and milliammeter in series across the line. The current through the capacitor now is read from the milliammeter. With a supply frequency of 60 cycles the capacitance of the capacitor is found from the formula,

$$\text{Capacitance} = 2.653 \times \frac{\text{milliamperes}}{\text{applied volts}}$$

*microfarads*

*Example:* The applied voltage or line voltage is read as 115 volts with the switch in its *voltage* position. With the switch in its *capacitance* position the current is read as 22 milliamperes.

$$\text{Capacitance} = 2.653 \times \frac{22}{115} = 0.508 \text{ mfd.}$$

If an a-c voltmeter of known internal resistance is available, or if the resistance of such a meter is measured and used in the computation, the approximate capaci-

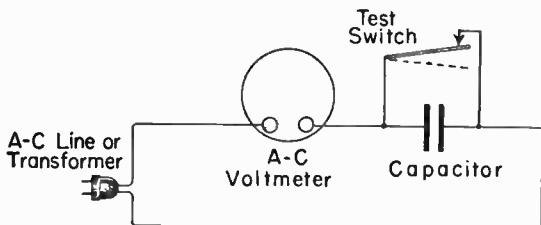

Fig. 17-14. Capacitance measurement with voltmeter.

tance of a capacitor may be measured with the connections of Fig. 17-14. The voltmeter must have a range sufficient for the line voltage of other applied voltage. The meter and capacitor are connected in series across the applied voltage, with the capacitor shorted out by a normally closed test switch. With the test switch closed, as shown by the full line, the applied voltage or line voltage is read on the meter. Then the switch is opened, as shown by the broken line, to leave the capacitor in series with the meter. The lower voltage now indicated by the meter is noted. This lower voltage will be some certain fraction of the original applied voltage.

$$\text{fraction} = \frac{\text{voltage with capacitor in series}}{\text{applied voltage}}$$

A corresponding capacitance constant is taken from the table, *Capacitance Constants for Voltmeters*, and is divided by the meter resistance in ohms. The result of

## CAPACITANCE CONSTANTS FOR VOLTMETERS

Voltage Fraction	Constant	Voltage Fraction	Constant	Voltage Fraction	Constant
0.04	1060	0.35	9920	0.70	26000
.05	1330	.36	10250	.71	26700
.06	1600	.37	10560	.72	27500
.07	1860	.38	10920	.73	28300
.08	2130	.39	11250	.74	29200
.09	2400				
		0.40	11600	0.75	30000
0.10	2670	.41	11950	.76	31000
.11	2940	.42	12300	.77	32000
.12	3210	.43	12650	.78	33000
.13	3480	.44	13000	.79	34100
.14	3750				
		0.45	13400	0.80	35400
0.15	4020	.46	13750	.81	36600
.16	4300	.47	14150	.82	38000
.17	4570	.48	14500	.83	39500
.18	4850	.49	14950	.84	41100
.19	5130				
		0.50	15300	0.85	42800
0.20	5420	.51	15750	.86	44800
.21	5710	.52	16150	.87	46900
.22	6000	.53	16550	.88	49200
.23	6270	.54	17000	.89	52000
.24	6590				
		0.55	17500	0.90	55000
0.25	6870	.56	18000	.91	58500
.26	7180	.57	18450	.92	62200
.27	7450	.58	18950	.93	67200
.28	7740	.59	19450	.94	73000
.29	8030				
		0.60	19950	0.95	80350
0.30	8350	.61	20500	.96	90450
.31	8630	.62	21000	.97	105700
.32	8960	.63	21500		
.33	9280	.64	22050		
.34	9600				
		0.65	22700		
		.66	23300		
		.67	24000		
		.68	24550		
		.69	25300		



the division is the capacitance of the capacitor in microfarads.

*Example:* Assume that an a-c voltmeter of 5000 ohms resistance reads an applied voltage or line voltage of 115, and with a capacitor in series reads 23 volts.

$$\text{Fraction} = \frac{23}{115} = 0.20$$

The constant for this fraction is found, from the table, to be 5420. This number is divided by the meter resistance.

$$\text{Capacitance} = \frac{5420}{5000} = 1.08 \text{ mfd., approx.}$$

For fractions less than about 0.15 and more than 0.85 to 0.90 the constants are so far apart that measurements of capacitance may have rather large percentage errors. The greater the meter resistance the smaller are the capacitances which may be measured with fair accuracy. This becomes evident by assuming a fraction of 0.50, meaning that the meter reading is reduced to half with the capacitor in series. Then the capacitances for various meter resistances are as follows.

500-ohm meter	30.6	mfd
1,000-ohm meter	15.3	mfd
10,000-ohm meter	1.53	mfd
100,000-ohm meter	0.153	mfd

If the meter has several a-c voltage ranges it has several corresponding resistances, and will read capacitances through several ranges. Any voltmeter scale may be graduated in capacitance values by the use of the table provided the meter resistance is known and provided that the line voltage or other applied voltage remains fairly constant. If the applied voltage is taken from the secondary of a transformer with tapped primary or secondary allowing fairly close adjustment of secondary voltage, the initial voltage may be adjusted to some value such as 100 at the beginning of each test; much as an ohmmeter is set to zero. Many toy transformers have continuously adjustable voltages within limited ranges, and may be used in connection with an a-c voltmeter to make up a capacitance meter.

This method of testing checks the condition of the capacitor, as well as its capacitance, since, if the meter reads the same voltage with and without the capacitor in series the capacitor is shorted, and if the meter reads zero with the capacitor in series the capacitor is open-circuited.

**Wattmeter Connections.**—Fig. 17-15 shows connections of a dynamometer type single-phase a-c wattmeter to the power supply line and a load. The current terminals,

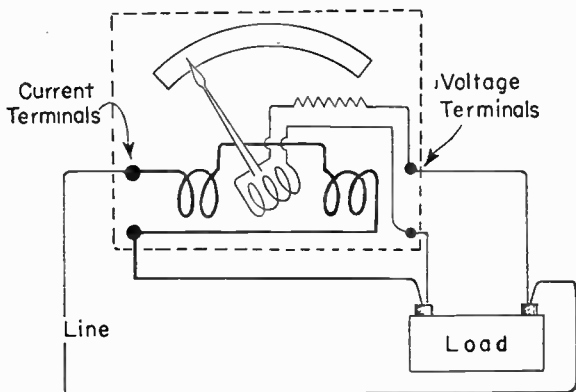

Fig. 17-15. Connections of wattmeter to line and load.

connected internally to the stationary coils, are connected externally in series with the line and the load. The voltage terminals of the instrument, connected internally through a resistor to the moving coil, are connected externally across the load so that the moving coil is affected by the potential difference across the load, while the stationary coils are affected by load

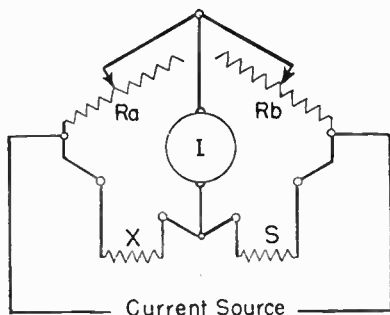

Fig. 17-16. Connections of Wheatstone bridge for resistance measurements.

current. The bottom current terminal and the bottom voltage terminal of the diagram may be connected together at the instrument, or sometimes inside the instrument case.

**Bridge Measurements.**—The elementary circuit for a Wheatstone bridge is shown by Fig. 17-16. The bridge, as shown here, is an instrument for measurement of re-

sistance by comparison with another known resistance. The bridge is supplied with direct or alternating current from a source connected to opposite terminals. Between the intermediate terminals is connected an indicator  $I$ , which may be a sensitive a-c or d-c current meter when the source is an a-c or d-c type, a headphone or headset when the source furnishes audio-frequency current, or an amplifier whose output is indicated by a meter when the source furnishes alternating current of frequencies not audible.

Resistors  $Ra$  and  $Rb$ , called the *ratio arms* of the bridge, are adjustable. Resistor  $X$  is the unknown to be measured. Resistor  $S$  is the standard, whose resistance is known. When,

$$\frac{Ra}{Rb} = \frac{X}{S}$$

there is no difference of potential across the indicator and the bridge is said to be *balanced*. With no potential difference the indicator shows zero current, hence is called a *null indicator*. Resistance measurements are made by adjusting the resistances of the ratio arms  $Ra$  and  $Rb$ , and the resistance of the standard resistor  $S$ , to obtain a zero indication. Then,

$$X = S \times \frac{Ra}{Rb}$$

That is, the unknown resistance  $X$  is equal to the product of the known resistance  $S$  and the ratio of resistance  $Ra$  to resistance  $Rb$ , all in the same unit, such as ohms.

*Example:* With  $Ra$  adjusted to 1000 ohms,  $Rb$  to 10000 ohms, and the standard resistor  $S$  adjusted to 255 ohms, what is the resistance at  $X$ ?

$$X = 255 \times \frac{1000}{10000} = 255 \times \frac{1}{10} = 25.5 \text{ ohms}$$

There are various convenient arrangements for the ratio arm resistances. Two of them are shown by Fig. 17-17. At the left  $Ra$  is a fixed resistance, say of 1000 ohms. By means of a tap switch any one of seven resistors may be cut into the position  $Rb$ . If these resistors vary by multiples of 10 from 1 ohm to one megohm the available ratios will be,

$Ra$	1000	$Rb$	1	Ratio	1000 to 1
	1000		10		100 to 1
	1000		100		10 to 1
	1000		1,000		1 to 1
	1000		10,000		0.1 to 1
	1000		100,000		0.01 to 1
	1000		1,000,000		0.001 to 1

Then resistances measured at  $X$  may have values of from 1000 times to  $1/1000$  of the standard resistance at  $S$ .

With the arrangement at the right in Fig. 17-17 the resistors are all in series. The sum of the resistances to the left of the switch arm forms resistance  $R_a$ , and the sum of all those on the right of the arm forms resistance  $R_b$ . Possible values of resistance in the several sections might be,

No. 1,	2.0 ohms	No. 5,	818.2 ohms
No. 2,	17.8 ohms	No. 6,	162.0 ohms
No. 3,	162.0 ohms	No. 7,	17.8 ohms
No. 4,	818.2 ohms	No. 8,	2.0 ohms

It will be found that the ratios, from left to right on the switch tap points, are very close to 0.001, 0.01, 0.1, 1.0, 10, 100 and 1000 to 1. With the switch as shown in the diagram, resistances 1, 2 and 3 form resistance  $R_a$ , while resistances from 4 to 8 form resistance  $R_b$ .

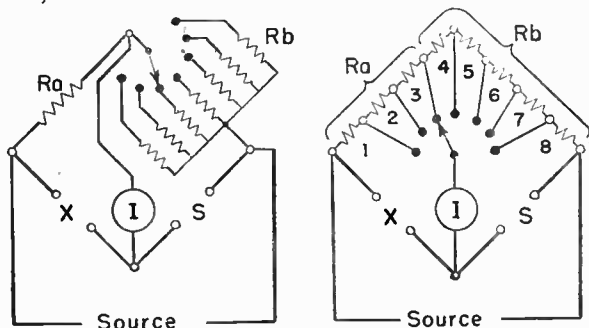

Fig. 17-17. Methods for adjusting ratio arm resistances with a tap switch.

The sum for  $R_a$  is 181.8 ohms and for  $R_b$  is 1818.2 ohms, giving a ratio of  $1/10$  with an error of about  $1/10$  of one per cent. Resistances of odd values may be made up with several units in series. For example, for 162 ohms it would be possible to use 150, 10, and 2 ohms in series.

The greater the voltage from the source, and the less the current range of the indicator, the easier it is to obtain a balance and the better is the accuracy, but the greater is the danger of burning out the indicator. When the source is a battery, a press-button switch may be used to apply potential from one or two cells while adjusting to an approximate balance, after which a greater voltage is used. It is possible also to use several current ranges on the indicator, employing one for rela-

tively large current while getting the approximate balance and then going to more sensitive ranges.

It is desirable to have the standard resistance somewhere near the measured resistance when possible, since this allows using a ratio around 1-to-1 where measurements are likely to be most accurate. With greater ratios in either direction it is more difficult to get a balance.

As shown at the left in Fig. 17-18, capacitances may be measured with a bridge having resistances for its ratio arms. The capacitor of unknown value is connected in the *X* arm, and an adjustable calibrated capacitor, or one of known value, is connected in the *S* arm. Then, calling the unknown capacitance *C<sub>x</sub>* and the known one *C<sub>s</sub>*,

$$C_x = C_s \times \frac{R_b}{R_a}$$

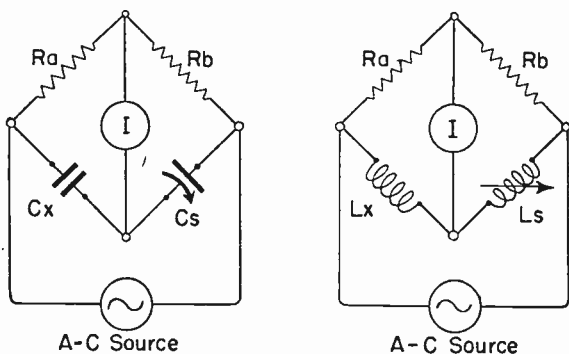

Fig. 17-18. Principle of the capacitance bridge (left) and of the inductance bridge (right.)

Note that the ratio is that of *R<sub>b</sub>* to *R<sub>a</sub>*, while, on the resistance bridge, it is of *R<sub>a</sub>* to *R<sub>b</sub>*. This is because we are comparing impedances in both cases. The impedance of the resistance is practically equal to the resistance in ohms, and the impedance of the capacitor is practically equal to the capacitive reactance in ohms. But capacitance, which we desire to measure, is inversely proportional to capacitive reactance, and so we have to use the inverse ratio *R<sub>b</sub>/R<sub>a</sub>*.

For measurement of small capacitances the standard *C<sub>s</sub>* may be a straight-line capacitance, adjustable unit which may be had with a dial uniformly graduated from 0 to 100 in any of various capacitance ranges. The source may provide a power frequency of 60 cycles, although frequencies from 400 to 1,000 cycles, as ob-

tained from buzzers and oscillators, are preferable. With an audible frequency the indicator may be a headset. Otherwise a sensitive rectifier meter is satisfactory.

Inductances may be measured, as at the right in Fig. 17-18, with a bridge having resistance ratio arms. It is necessary to have a standard inductor which is calibrated or which is of known value. Since calibrated variable inductors are not readily obtainable, inductance measurements are most conveniently made with one or more fixed inductors of known values and a bridge whose ratio resistances (or one of them at least) are continuously adjustable or are adjustable in small steps. Measurement then is made by adjusting the ratio arm or arms to obtain a balance, rather than by adjustment of the standard as has been described.

Calling the unknown inductance  $Lx$  and the standard inductance  $Ls$ , the bridge formula is,

$$Lx = Ls \times \frac{Ra}{Rb}$$

Here the ratio is of  $Ra$  to  $Rb$ , as with resistance measurements, because inductance and inductive reactance are directly proportional.

## INDEX

### A

- Abbreviations, 1-4
- AB-class amplifier, 254
- Absorption, sound, materials for, 316
  - units of, 316
- Accuracy, meter, 321
- Ac-dc- battery receivers, 247
- A-class amplifiers, 254
- Acoustic absorption materials, 316
- Acoustics, 313-318
- Address systems, public, 313-318
- Advance wire, table for, 29
- Alignment, f-m receiver, 284-288
  - charts, see *Charts*.
  - superheterodyne receiver, 279-284
- Alternating current, Ohm's law for, 173
  - power formulas for, 50, 51
  - values in sine wave, 161
- Aluminum, sheet, table for, 15
- Ammeter, see *Meter, current*.
- Ammeter-voltmeter resistance measurement, 335
- Amplification, see *Gain, voltage*.
  - factor, explanation, 141
  - tubes, table of, 75-115
- Amplifiers, 254-273
  - classes of, 254
  - push-pull, 271-273
  - resistance coupled, 259-270
  - transformer coupled, 270
  - voltage gain of, 255
- Angles, cosines of, 22
  - cotangents of, 22
  - lag or lead, determination of, 169
  - sines of, 22
  - tangents of, 22
- Antennas, 293-297
  - dipole, 294
  - dummy, 282
  - Hertz, 294
  - length required, 295
  - long-wire, 296
  - Marconi, 295
  - single-wire feed, 295
  - symbols for, 6
- Areas, units of, conversion of, 16
- ASA capacitor color coding, 64, 67
- Audibility, threshold of, 305
- Audio amplifiers, resistance coupled, 259-270

### Audio—continued

- transformer, color coding for, 200, 202
- Automatic volume control, 288
- Average value, a-c, 161

### B

- Baffles, loud speaker, 310
- Ballast tubes, 227-232
- Base connections, tube, 72, 75-125
  - ballast tube, 228, 230
  - vibrators, 250, 252
- Battery cable color code, 246
  - line power receivers, 247
  - power supplies, 246-253
  - receivers, 246
- B-class amplifiers, 254
- Bias, grid, 128-134
  - cathode resistors for, 128-131
  - grid leak-capacitor type, 133
  - oscillator tube, 291
  - power supply for, 132
  - resistance amplifier, 261-268
  - resistors for, 128-131
  - tubes, values for, 75-115
- Brass, sheet, table for, 16
- Breakdown voltages, 36
- Bridge, capacitance measurement with, 344
  - inductance measurement with, 345
  - measurements with, 341
  - resistance type, 341-343
  - Wheatstone, 341-345
- B-supply, see *Power supply*.
- Bulbs, see *Lamps*.

### C

- Cable, battery, color code, 246
- Capacitance, 57-70. See also *Capacitors*.
  - distributed, 175
  - feedback oscillator, 291
  - filter input, effect of, 212, 214
  - formulas for, 57
  - inductance oscillation constants, 182-186
  - measurement of, 337-340
    - with bridge, 344
  - resistance time constants, 68-70
  - resonance value of, 183
  - testing, 337-340
- Capacitive reactance, 166-168

- Capacitor-input filters, 211
- Capacitors, 57-70. See also *Capacitance*.
- capacitance formula for, 57
  - ceramic, color code for, 68
  - charging time of, 68-70
  - color coding of, 64
  - coupling, amplifier, 261-268
  - discharge time of, 68-70
  - measurements on, 337-340
  - parallel, 59
  - Q of, 176
  - series, 59
    - capacitance of, 60, 62
    - chart for, 62
    - voltage of, 60
  - symbols for, 8
  - temperature coefficient code for, 67
    - compensating, 67
    - testing of, 337-340
    - time constants of, 68-70
- Capacity, see *Capacitance* and *Capacitors*.
- Cathode bias, 128-131.
  - degeneration with, 130
  - currents, 129
  - filament types, connections of, 135
  - heater type, bias for, 136
  - connections for, 136
  - returns for, 134
  - tube, volts and amperes for, 75-115
  - types of in tubes, 75-115
- C-class amplifier, 255
- Center-tapped transformer winding, 205
- Centigrade-Fahrenheit conversion, 19
- Centimeters, convert to inches, 17
- Ceramic capacitors, color code for, 68
- Characteristics, plate, 137
  - tube, conversion of values
  - explanations of, 71-74
  - tables of, 75-115
- Charging time, capacitor, 68-70
- Charts
  - amperes-volts-ohms, 40
  - capacitance-frequency-reactance, 167
  - capacitance-inductance-resonance, 182-183
  - capacitive reactance, 167
  - capacitors in series, 62
  - inductance-capacitance-resonance, 182-183
  - inductance-frequency-reactance, 165
  - inductive reactance, 165
  - Ohm's law, 40
  - ohms-volts-amperes, 40
  - parallel resistance, 47
  - power, 53-55
  - reactance, capacitive, 167
  - reactance, inductive, 165
  - resistances, parallel, 47
  - resonance, 182-183
- Charts—*continued*
  - series capacitors, 62
  - square roots, 171
  - volts-ohms-amperes, 40
  - watts, 53-55
- Choke input filters, 216
- Chokes, filter, power, 213-215
  - inductance for, 217
- Circuits, coupled, 187
  - power transfer in, 191
  - parallel, computations with, 39, 44, 45
  - Q of, 176
  - resonant, 178
  - series, computations with, 39, 43, 44
- Circular mil-foot computations, 24
  - resistivity, 26
- Circumference-diameter ratio (pi), values involving, 20
- Classes of amplifiers, 254
- Clearance drills, table of, 12
- Close coupling, 188
- Code, color, see *Color code*.
- Coefficient, amplification, 141
  - amplification, tubes, 75-115
  - coupling, 187
  - temperature, resistivity, 24, 26
- Coils (inductors), 143-160
  - directions of flux in, 158
  - loading, 187
  - magnetic fields around, 158
  - multi-layer, 154-158
    - inductance of, 154-156
    - shape factors for, 155
    - turns for required inductance, 157
  - Q of, 176
  - single-layer, 147-154
    - inductance of, 147
    - shape factors for, 148
    - turns for required inductance, 149, 151-153
    - symbols for, 7
  - turns per linear inch, 143-146
  - per square inch, 143-146
  - winding, 143-160
    - volume of, 158
    - wire for, 143
- Cold resistance, 25
- Color codes
  - battery cables, 246
  - capacitors, 64
  - ceramic capacitors, 68
  - loud speakers, 202, 203, 312
  - resistors, 31-35
  - transformers, audio, 200, 202
    - i-f, 202, 203
    - power, 200-201
- Colpitts oscillator, 291
- Combination receiver, battery-line
  - receivers, 247
- Compensating capacitors, temperature, 67
- Condensers, see *Capacitors*.



- Conductance, mutual, 142  
of tubes, table, 75-115
- Conductor motion for induction, 158
- Connections, parallel, 39  
series, 39  
tube bases, 116-125
- Constants, dielectric, table, 58  
time, 68-70  
volume control, 288  
tube, 142  
relations between, 142
- Control, frequency, crystal, 293  
grid, see *Grid*.  
volume, automatic, 288
- Conversion, electrical units, 38  
factors for tube operation, 257  
frequency, superheterodyne, 274  
-wavelength, 162-163  
table, general, 16
- Converter, octode, 276  
pentagrid, 274-276  
triode-heptode, 279  
triode-hexode, 277  
tubes, symbols for, 11
- Copper, sheet, table for, 15  
wire, table for, 27
- Core area, transformer, 197
- Cosine of angles, 22
- Cotangents of angles, 22
- Cotton covered wire, double and single, 145
- Coupled circuits, 187  
power transfer in, 191
- Coupling, 187-193  
capacitors, amplifier, 261-268  
close, 188  
coefficient of, 187  
factor, 187  
loose, 188  
resistance, amplifier, 259-270  
resonance affected by, 190  
transformer, amplifier, 270
- Crest a-c value, 101
- Crystal, frequency control with, 293  
symbol for, 6
- Current capacity of wires, 144  
regulator tubes, 227-231  
relations in transformer, 194
- Currents, cathode, 129  
decibel measurements of, 298  
eddy, losses from, 174  
filter, computation of, 217  
gains, decibel, 300-301  
lagging and leading, 168  
losses, decibel, 303  
plate, tube, 75-115  
screen, tube, 75-115  
transformer, power supply, 218  
tube element, 75-115
- Cycles, see *Frequency*.
- D**
- De-ac-battery receivers, 247
- D.c.c. wire, 145
- D-c power supply, see *Power supply*.
- Decibels, addition of, 299  
gains in, table, 300-301  
losses in, table, 303  
measurements in, 298  
microphone ratings in, 317  
reference level for, 302
- Decimal equivalents of fractions, 18
- Degeneration from cathode-bias, 130
- Diagrams, see *Charts*.
- Dial lamps, 231-233
- Diameter-circumference ratio (pi) values involving, 20
- Dielectric constants, table, 58  
hysteresis, 175  
strength, 36
- Dielectrics, table of, 36
- Diode tube symbols, 10
- Dipole antenna, 294
- Discharge time, capacitor, 68-70
- Discriminator, f-m receiver, 264-285
- Dissipation, resistor power, see *Resistors*.
- Distributed capacitance, 175
- Divider, voltage, 224  
grid bias from, 132
- Double cotton covered wire, 145  
hump resonance, 188-191  
silk covered wire, 146
- Doublers, rectifier, 225
- Drills, clearance, 12  
lettered, 14  
numbered, 14  
tap, 12, 13
- D.s.c. wire, 146
- Dummy antenna, 282
- Dynatron oscillator, 292
- E**
- Echo, reverberation as, 315
- Eddy current losses, 174
- Effect, skin, 173
- Effective a-c value, 161
- Electrical quantities, conversion of, 16
- Electron flow, see *Currents*.
- Electrostatic capacity, see *Capacitance*.  
condensers, see *Capacitors*.
- Emf, induced in moving conductor, 158
- Enameled wire, plain, 144  
single cotton, 145
- Energy losses, 173-175  
units, conversion of, 16
- Equations, see under names of parts, functions, properties, etc.  
transposing for unknown values, 23
- Equivalents, decimal to inch, 18
- F**
- Factor, amplification, 141  
of tubes, 75-115

- Factor—continued**  
 conversion, for tube operation, 257  
 coupling, 187  
 power, 52  
 Q-, 175-177  
 shape, multi-layer coils, 155  
 single-layer coils, 148
- Fahrenheit-centigrade conversions, 19**
- Field, magnetic, direction around coil, 158**  
 speaker, filter choke, 213  
 winding characteristics, 307-309
- Filament-cathode connections, 135**
- Filaments, ballast tubes for, 230**  
 battery receiver, 246  
 volts and amperes for, 75-115
- Filters, capacitor input, 211**  
 choke input, 216  
 chokes for, 213-215  
 current computation for, 217  
 input capacitor effect on, 212, 214  
 potential effect on, 212  
 output from, 213  
 voltage computation for, 217
- F-m receiver, alignment of, 284-288**  
 discriminator for, 284-285  
 limiter for, 284
- Flux, magnetic, direction around coil, 158**
- Formulas, see under names of parts, functions, properties, etc.**  
 transposing for unknown values, 23
- Fractions, decimal equivalents of, 18**
- Frequency, capacitive reactance for, 167**  
 control, crystal, 293  
 conversion, superheterodyne, 274  
 inductive reactance for, 165  
 intermediate, superheterodyne, 279  
 -modulation receiver, see *F-m receiver*.  
 ranges of, 164  
 reactances for, 165, 167  
 resonant, 180-182  
 chart for, 182-183  
 ripple, 218  
 sound, ranges of, 318  
 transmission, 164  
 units of, 162  
 -wavelength conversions, 162-163
- Full-load potential, 43**
- Functions, trigonometric, table, 20-22**
- G**
- Gage numbers, wire, 27**
- Gains, decibel units for, 300-301**  
 resistance coupled amplifier, 261-268  
 voltage, 255  
 load line for computing, 255
- Generator, signal, use of, 280**
- Greek letter symbols, 4, 5**
- Grid bias, 128-134**  
 grid leak-capacitor type, 133  
 oscillator, 291  
 power supply for, 132  
 resistance amplifier, 261-268  
 tube, table, 75-115  
 leak-capacitor bias, 133  
 potentials, tube, 75-115  
 rectification bias, 133  
 returns, 134  
 voltages, tube, 75-115  
 conversion factors for, 257
- H**
- Hartley oscillator, 289**
- Hearing, threshold of, 305**
- Heat quantities, conversions for, 16**
- Heater-cathode bias, 136**  
 connections, 136
- Heaters, resistances of, 239**  
 series, connections for, 233-245  
 resistors for, 236  
 resistor ratings for, 245  
 substitution of tubes with, 237-245  
 string, 233-245
- Hertz antenna, 294**
- High-frequency, definition, 164**  
 resistance, 173
- Hot resistance, 25**
- Hysteresis, dielectric and magnetic, 175**
- I**
- Impedance, 169-173**  
 formulas for, 170  
 matching transformer, 204  
 Q in formulas for, 177  
 resonant, 178
- Inches, fractions, decimal equivalents, 18**
- Inductance-capacitance oscillation**  
 constants, 182-186
- Inductance coils, see Coils.**  
 filter choke, 217  
 measurement with bridge, 345  
 mutual, 187-188  
 resonance values of, 183
- Induction, direction of motion for, 158**
- Inductive reactance, 163**  
 chart for, 165
- Inductors, see Coils.**
- Instrument, musical, frequency range of, 318**  
 resistors, choice of, 328

Insulation, 36  
 materials, table for, 36  
 resistance, measurement of, 336  
 Intermediate-frequency align-  
 ment, 279-284  
 transformers, 189  
 color coding of, 202, 203  
 Intermediate frequencies, super-  
 heterodyne, 279  
 Inversion, phase, amplifier, 272  
 IRE dummy antenna, 282

## L

Lag, angle, determination of, 169  
 Lagging current, 168  
 Lamps, dial, panel or pilot, 231-  
 233  
 Law, Ohm's, a-c forms of, 173  
 chart for, 39, 40  
 d-c forms of, 38-40  
 L-C oscillation constants, 182-186  
 Lead, angle, determination of,  
 169  
 Leading current, 168  
 Leak, grid, biasing with, 133  
 Left-hand rules, induction, 158  
 Length units, conversions for, 16  
 Letter symbols, 1-4  
 Lettered drills, table, 14  
 Light, units, conversion of, 16  
 Limiter, f-m receiver, 284  
 Line, load, see *Load line*.  
 Load, definition, 42  
 line, 137-141  
 construction, 138  
 gain computed from, 255  
 uses of, 139  
 resistance, conversion values  
 for, 257  
 for tubes, table, 75-115  
 Loading coil, 187  
 Long-wire antenna, 296  
 Loose coupling, 188  
 Losses, decibels of, 303  
 eddy current, 174  
 energy, 173-175  
 skin effect, 173  
 Loud speaker, see *Speaker*.  
 Loudness of sounds, 304  
 Low-frequency, definition, 164

## M

Machine screw tables, 12, 13  
 Magnet wire tables, 143-146  
 Magnetic hysteresis, 175  
 units, conversion of, 16  
 Manganin wire, table for, 28  
 Marconi antenna, 295  
 Matching transformer, imped-  
 ance, 204  
 Measurements, 319-345  
 conversions of, 16  
 Medium-frequency, definition,  
 164  
 Meissner oscillator, 289  
 Metals, sheet, tables for, 15

Meters, 319-345  
 accuracy of, 321  
 current, ohmmeter from, 332  
 resistance of, 322  
 shunts for, 324  
 voltmeter from, 326  
 ohm-, 331-334  
 output, connections for, 283  
 rectifier, 323  
 connections of, 320  
 resistance, choice of, 322  
 measurement, of, 323  
 sensitivity of, 321  
 shunts, 324  
 choice of, 328  
 wattage rating of, 327  
 symbols for, 9  
 thermocouple, connections of,  
 320  
 watt-, connections of, 340  
 Metric lengths, convert to inches,  
 17  
 Microphone outputs, 317  
 symbols for, 8  
 Milliammeter, see *Meter, current*.  
 volt-, 329  
 Millimeters, convert to inches, 17  
 Mixers, superheterodyne, 277  
 symbols for, 11  
 Motion, conductor, induction, 158  
 Moving coil instruments, 319  
 Mu, tube, see *Amplification fac-  
 tor*.  
 Multi-layer coils, 154-158  
 -winding transformer, 204  
 Multiplier, voltage, rectifier, 225  
 voltmeter, 326  
 choice of, 328  
 wattage rating for, 327  
 Musical instrument frequency  
 ranges, 318  
 Mutual conductance, 142  
 of tubes, 75-115  
 inductance, 187-188

## N

Negative resistance, dynatron,  
 292  
 Nichrome wire, table for, 30  
 No-load potential, 43  
 Nomographs, see *Charts*.  
 Non-synchronous vibrator, 249-  
 250  
 Null indicator, bridge, 342  
 Numbered drills, table, 14  
 Numbers, preferred, RMA, 33  
 square roots of, chart, 171  
 table, 20, 21  
 squares of, 171  
 tube type, 71

## O

Octode converter, 276  
 Ohmmeter, 331-334  
 compensation of, 333  
 scale readings for, 332

- Ohm's law, a-c forms, 173  
 d-c forms, 38-40  
 d-c, chart for, 39, 40  
 d-c, formulas for, 39
- Ohms-per-volt sensitivity, 321
- Open circuit potential, 43
- Oscillation constants, 182-186
- Oscillators, 289-293  
 alignment, superheterodyne. 27-284  
 capacitance feedback, 291  
 Colpitts, 291  
 dynatron, 292  
 grid bias for, 291  
 Hartley, 289  
 Meissner, 289  
 signal, use of, 280  
 superheterodyne, 277  
 tickler feedback, 289
- Output meter connections, 283  
 microphone, 317
- Output power, push-pull, 271  
 triode, 257  
 tube, 75-115  
 resistance, tube, 75-115
- P**
- Panel lamps, 231-233
- Parallel capacitors, 59  
 circuits, rules and table. 44, 45  
 connections, rules for, 39  
 reactances, 168  
 resistances, chart for, 46, 47  
 -series resistances, 48  
 sources, 48  
 transformers, 207
- P.e. wire, 144
- Peaks, a-c, values for, 161  
 resonant, 189-190
- Pentagrid converter, 274-276  
 mixer, 277
- Period, reverberation, 315
- Permanent-magnet moving-coil instruments, 319
- Phase differences, current, 168  
 inversion, amplifier, 272  
 relations, transformer, 194  
 splitting, push-pull amplifier, 272
- Phasing loud speakers, 310
- Pi, values involving, 20
- Piezo-electric crystal, 293
- Pilot lamps, 231-233
- Plain enamel wire, 144
- Plate characteristics, 137  
 rectifier, 210  
 currents, conversion values for, 257  
 tube, 75-115  
 potentials, conversion values for, 257  
 tube, 75-115  
 power supply, see *Power supply*.  
 resistance, 141  
 conversion values for, 257
- Plate—continued  
 resistance—continued  
 tube, 75-115  
 returns, 134  
 voltages, conversion values for, 257  
 tube, 75-115
- Polarity, transformer, test for, 206  
 windings, 194
- Potentials, see *Voltages*.
- Power, 50-56  
 charts, watts-volts-ohms-amperes-milliamperes, 52-55  
 computations, 52-55  
 decibel measurements of, 298  
 factor, 52  
 formulas, a-c and d-c, 50-51  
 gains, decibel, 300-301  
 losses, decibel, 303  
 measurement, wattmeter for, 340  
 output, conversion factors for, 257  
 push-pull amplifier, 271  
 triode, 257  
 tubes, 75-115  
 supply, battery type, 246-253  
 bias from, 132  
 current computation, 218  
 filters, see *Filters*.  
 line type, 209-245  
 vibrator type, 248-253  
 voltage divider for, 224  
 voltage determination from load line, 140  
 voltage regulation for, 219  
 transfer, 56  
 coupled circuits, 191  
 transformer, color coding for, 200-201  
 design of, 196-200  
 units, conversion of, 16
- Preferred numbers, 33
- Primary winding, identifying, 206
- Projectors, sound, see *Speakers, loud*.
- Public address systems, 313-318
- Push-pull amplifiers, 271-273  
 phase inversion in, 272
- Q**
- Q-factor, 175-177  
 capacitor color code for, 66  
 formulas for, 177
- R**
- Radiation antenna patterns, 296  
 frequencies, 164
- Radio-frequency amplifier alignment, 279-284
- Ratio arm resistances, bridge, 342
- Reactances, 163-169  
 capacitive, 166-168  
 inductive, 163  
 chart for, 165  
 parallel, 168  
 series, 168

- Receivers, 274-288  
 battery power, 246  
 combination battery-line power, 247  
 f-m, alignment of, 284-288  
 discriminator for, 284-285  
 limiter for, 284  
 series heater types of, 233-245  
 superheterodyne, 274-284  
 alignment of, 279-284  
 Receiving tubes, 71-142. See *Tubes*.
- Rectification, grid, bias from, 133  
 Rectifier, a-c d-c type, 210  
 doublers, 225  
 full-wave, 209  
 half-wave, 210  
 meter, 323  
 connections of, 320  
 plate characteristics of, 210  
 power supply type, 209  
 transformerless, 210  
 tube symbols, 10  
 vibrator type, 251  
 Reference levels, decibel, 302  
 Regulation, transformer, 195, 198  
 voltage, power supply, 219  
 tubes for, 220-223  
 Regulator, current, tubes for 227-232  
 voltage, tubes for, 220-223  
 Replacement, tube, see *Substitution, tube*.
- Reproducers, sound, see *Speakers*.
- Resistance bridge, 341-343  
 -capacitance time constants, 68-70  
 coupled amplifiers, 259-270  
 wire, Advance, table, 29  
 Manganin, table, 28  
 Nichrome, table, 30  
 tables for, 25  
 Resistances, 24-35. See also *Resistors and Resistivity*.  
 cold, 25  
 computation of, 24  
 copper wire, 27  
 definition, 24  
 high-frequency, 173  
 hot, 25  
 insulation, measurement of, 336  
 load, definition, 42  
 tubes, 75-115  
 measurement, ammeter-voltmeter, 335  
 ohmmeter for, 331-334  
 voltmeter, 334  
 meter, choice of, 322  
 measurement of, 323  
 negative, dynatron, 292  
 output, tubes, 75-115  
 parallel, chart for, 46-47  
 plate, 141  
 tubes, 75-115  
 preferred numbers for, 33  
 ratio arm, bridge, 342  
 Resistances—*continued*  
 tube heater, 239  
 wire, copper, 27  
 Resistivity, circular mil-foot, 26  
 computations with, 24  
 definition, 24  
 temperature coefficient of, 24, 26  
 volume, table, 36  
 Resistor tubes, 227-232  
 Resistors, see also *Resistances*  
 biasing, 128-131  
 color coding for, 31-35  
 meter, choice of, 328  
 wattage ratings of, 327  
 preferred numbers for, 33  
 series heater, 236  
 tolerances, preferred number, 33  
 symbols for, 9  
 voltmeter, 326  
 Resonance, 178-186  
 chart for, 182-183  
 circuits for, 178  
 coupling effect on, 190  
 curves showing, 189-190  
 double-hump, 188-191  
 frequency of, 180-182  
 impedance at, 178  
 oscillation constants for, 185-186  
 peaks of, 189-190  
 wavelength for, 182  
 Returns, grid, plate, etc., 134  
 Reverberation, 315  
 Right-hand rules, induction, 158  
 Ripple frequency and voltage, 218  
 RMA color code, battery cable, 246  
 capacitor, 65  
 loud speakers, 202, 203, 312  
 resistors, 31-35  
 transformers, 200-203  
 preferred numbers, 33  
 Root-mean-square (r-m-s) a-c value, 161  
 Roots, square, chart for, 171  
 table of, 20, 21

## S

- S.c.c. wire, 145  
 S.c.e. wire, 145  
 Screen (grid) currents, conversion factors for, 257  
 tubes, 75-115  
 returns, 134  
 voltages, conversion factors for, 257  
 tubes, 75-115  
 Screws, machine, tables, 12, 13  
 wood, table, 12  
 Secondary winding, identifying, 206  
 Self-inductance, see *Inductance*.  
 Self-rectifying vibrator, 251-253  
 Sensitivity, voltmeter, 321  
 Series capacitors, 59  
 capacitance of, 60, 62

- Series—*continued*  
 chart for, 62  
 voltages on, 60  
 circuits, rules, tables, 43, 44  
 connections, rules for, 39  
 heaters, resistors for, 236  
 resistor ratings for, 245  
 substitution of tubes with,  
 237-245  
 -parallel resistances, 48  
 reactances, 168  
 sources, 48  
 transformers, 207  
 Shape factors, multi-layer coils,  
 155  
 single-layer coils, 148  
 Sheet metals, tables for, 15  
 Short circuit, definition, 43  
 Shunts, meter, 324  
 choice of, 328  
 wattage rating for, 327  
 Signal generator, use of, 280  
 Silk covered wires, 146  
 enameled wires, 146  
 Sine wave, 161  
 Sines of angles, 22  
 Single cotton wire, 145  
 layer coils, see *Coils*.  
 silk wires, 146  
 Skin effect, 173  
 Socket changes for tube substi-  
 tution, 126-128  
 connections, ballast tube, 228,  
 230  
 tubes, 72, 75-125  
 vibrators, 250, 252  
 Sound absorption units, 316  
 energy dissipation, 316  
 frequency ranges, 318  
 loudness of, 304  
 systems, 298-318  
 velocity of, 305  
 Sources, parallel, 48  
 potentials of, 42  
 series, 48  
 Speakers (loud), 306-313  
 baffling for, 310  
 color coding for, 202, 203, 312  
 coupling transformers, 311  
 field windings, 307-309  
 filter choke, 213  
 phasing of, 310  
 public address requirements  
 for, 314  
 symbols for, 8  
 Speeds, conversion of, 16  
 Splitting, phase-, amplifier, 272  
 Square root chart, 171  
 table, 20, 21  
 Squares of numbers, chart, 171  
 S.c.c. wire, 146  
 S.s.e. wire, 146  
 Strength, dielectric, 36  
 Strings, heater, 233-245  
 Substitutions, tube, 126-128  
 with series heaters, 237-245  
 Superheterodyne receivers, 274-  
 284  
 Superheterodyne—*continued*  
 alignment of, 279-284  
 Super-high frequency, definition,  
 164  
 Symbols, letter, 1-4, 5  
 tube, 10-11, 116-125  
 explanation of, 5  
 wiring, 6-9  
 Synchronous vibrators, 251-253
- T
- Tables, see under names of parts  
 and materials.  
 Tangents of angles, 22  
 Tap drill table, 12, 13  
 Tapped winding, transformer,  
 204  
 Temperature, centigrade to Fah-  
 renheit, 19  
 coefficient, capacitor, code for,  
 67  
 resistivity, 24-26  
 compensating capacitors, 67  
 conversion of, 19  
 Fahrenheit to centigrade, 19  
 Terminal voltage of source, 43  
 Thermocouple meter connections,  
 320  
 Thicknesses, sheet metal, 15  
 Three-way power receivers, 247  
 Threshold of audibility, 305  
 Time constants, 68-70  
 volume control, 288  
 Tolerances, resistor, preferred  
 number, 33  
 Transconductance, 142  
 of tubes, 75-115  
 Transfer, power, 56  
 coupled circuit, 191  
 Transformer-coupled amplifier,  
 270  
 Transformers, 194-208  
 color coding for, 200-203  
 core area, 197  
 current-volts-turns relations,  
 194  
 design, power type, 196-200  
 double-tuned type, 189-191  
 fifty cycle, 200  
 formula, basic, iron core, 196  
 heater, cathode connections to,  
 131  
 impedance matching, 204  
 intermediate-frequency, 189  
 multi-winding, 204  
 parallel, 207  
 phase relations in, 194  
 polarity test of, 206  
 power supply, current from, 218  
 primary turns, 198  
 regulation, voltage, 195, 198  
 secondary turns, 198  
 series, 207  
 speaker coupling, 311  
 symbols for, 7  
 tapped winding, 204  
 tuned type of, 189-193

- Transformers—continued**  
 turns-volts-current relations, 194  
 twenty-five cycle, 200  
 volts-current-turns relations, 194  
 windings, identifying, 206  
 window area, 199-200  
 wire sizes for, 199  
**Transmission frequencies, 164**  
**Trigonometric functions, tables, 20, 22**  
**Triode-heptode converter, 279**  
**Triode-hexode converter, 277**  
**Tubes, ballast, 227-232**  
 base connections of, 72, 75-125  
 characteristics, tables, 75-115  
 control grid bias for, see *Grid bias*.  
 constants, 141  
   relations between, 142  
 current regulator, 227-231  
 grid bias for, see *Grid bias*.  
 heaters, resistances of, 239  
   series connection of, 233-245  
 power output of, 257  
 receiving, 71-142  
 rectifier, see *Rectifiers*.  
 replacement, see *Tube substitution*.  
 regulator, current, 227-231  
   voltage, 220-223  
 resistance types of, 227-232  
 series heaters for, 233-245  
 socket connections for, 72, 75-125  
 substitutions, 126-128  
   series heaters with, 237-245  
 symbols, 9-11, 116-125  
 tables, 75-115  
   explanation of, 71-74  
 types, numbers of, 71  
   by number, 75-115  
   typical, 13  
   voltage regulator, 220-223  
**Tuned transformers, 189-193**  
**Turns, coil, see Coils.**  
 transformer, see *Transformers*.
- U**
- Ultra-high frequency, definition, 164**  
**Units, conversions of, 16**
- V**
- Velocities, conversions of, 16**  
 sound, 305  
**Very-high-frequency, definition, 164**  
**Very-low-frequency, definition, 164**  
**Vibrator power supply, 248-253**  
 non-synchronous, 249-250  
 self-rectifying, 251-253  
 synchronous, 251-253
- Voice frequency ranges, 318**  
**Voltage dividers, 224**  
 grid bias from, 132  
 doublers, rectifier, 225  
 gain, 255  
   decibel measurement of, 300-301  
   load line computation of, 255  
   resistance coupled amplifier, 261-263  
 losses, decibel measurement of, 303  
 multiplier, rectifier, 225  
 regulation, power supply, 219  
 regulator tubes, 220-223  
**Voltages, bias, tube, 123-134**  
 table of, 75-115  
 breakdown, 36  
 decibel measurements of, 298  
 filter, computation of, 217  
 grid, tube table of, 75-115  
 plate, tube table of, 75-115  
 relations, transformer, 194  
 ripple, 218  
 screen, tube table of, 75-115  
 terminal, source, 43  
**Voltmeter-ammeter capacitance measurement, 337-340**  
 resistance measurement, 335  
 capacitance tests with, 338  
 capacitor tester from, 338-340  
 effect on measurements, 322  
 insulation resistance measurement, 336  
 multiplier for, 326  
   choice of, 323  
   wattage rating of, 327  
 resistance, 322  
   measurement with, 334  
 resistors for, 326  
 sensitivity of, 321  
**Volt-milliammeter, ac-dc, 329**  
**Volume control, automatic, 288**  
 resistivity, table, 36
- W**
- Wattmeter, connections of, 340**  
**Wave, sine, 161**  
**Wave length, antenna, 295**  
 -frequency conversions, 162-163  
 oscillation constants for, 185-186  
 resonance, 182  
 units of, 162  
**Weights, conversion of, 16**  
 sheet metals, 15  
**Wheatstone bridge, see Bridge.**  
**Windings, coil, see Coils.**  
 field, speaker, 307-309  
**Wire, Advance, table for, 29**  
 copper, current capacity of, 144  
 table for, 27  
 double cotton covered, 145  
   silk covered, 146  
 enamel, 144

- Wire—*continued*  
magnet, current capacity of, 144  
  tables for, 143-146  
Manganin, table for, 28  
Nichrome, table for, 30  
resistance, tables of, 25-30  
single covered, 145, 146  
turns per linear inch and square  
  inch, 143-146  
Wiring symbols, 6  
Wood screws, table of, 12  
  X  
X-cut crystal, 293  
  Y  
Y-cut crystal, 293



