COYNE
MIRIAM ESTADIO
SCHOOL

REFERENCE
NEWSPAPERS
LIBRARY



COYNE

Electrical School

CHICAGO ~ ~ ILLINOIS



ESTABLISHED 1899

COPYRIGHT 1942

AUTOMOTIVE ELECTRICITY

Principles of Internal Combustion Engines
Carburetion, Ignition, Combustion, Spark Advance
Multiple Cylinder Engines, Firing Orders
Battery Ignition Systems
Parts, Connections, Operation
Ignition Timing, Dual Ignition, Special Distributors
Ignition Locks, Ignition Troubles and Repairs
High Tension Magnetos
Operation, Care and Repair
Starting Motors
Operation, Troubles and Remedies
Automobile Generators
Voltage Regulation, Charging Rate Adjustment
Cutouts, Field Protection, Troubles and Remedies
Automotive Lighting Equipment
General Trouble Shooting on Complete Wiring Systems

AUTOMOTIVE ELECTRICITY

With the tremendous number of automobiles used today for pleasure and for commercial purposes, there is a splendid field of opportunity for trained men in ignition and battery service and general automotive electrical work.

There are in the U. S. over 25,000,000 automobiles, trucks, tractors, and busses which use electricity for ignition and other very essential features of their operation.

One of the reasons for the growth of the automobile industry, which is one of the very largest of all industries in this country, lies in the improved efficiency and convenience obtained through the use of electricity for numerous things in connection with the operation of automobiles, as well as in the great improvements made in their mechanical design.

Electric ignition makes possible the high engine speeds and resulting high efficiencies of the engines used in modern motor cars. In addition to using electricity for ignition, or the igniting and exploding of the fuel at the correct time in the engine cylinders, electricity is also used: to start the engine by means of an electric motor; to provide illumination for night driving; and to operate the horn, windshield wiper, radio, stop light, tail light, dash light and electrical instrument, cigar lighter, heater, and numerous other safety and convenience devices.

In fact, the modern motor car—with its generator, starting motor, storage battery, ignition devices and wiring, lights, horn, and other equipment—can be said to have a complete small electric power plant of its own and it has quite a variety of electrical devices and circuits which must be maintained in the best of condition for efficient operation of the car.

There are throughout the country thousands of garages which require trained electrical service men to take care of the electrical equipment on their customers' cars. This ignition and battery work is in general much cleaner, lighter, and more interesting than making mechanical repairs on automobiles. The salaries paid to experts in this line are generally a great deal higher than those of ordinary mechanics.

There are also thousands of places where a good ignition and battery man can establish a shop or business of his own and just specialize in this branch of automotive repair work.

In addition to the millions of pleasure cars there are in use a vast number of huge trucks and busses for hauling produce and carrying passengers all over the country; and there are also many thousands of tractors, which are becoming more and more extensively used in farming areas.

With the recent developments in automobile radio there is another vast field of opportunity opened up for the man with general training in electricity, radio, and ignition. Several millions of automobiles are already equipped with radio receiving sets; and, millions more are still to be equipped. Installing and servicing these sets requires the service of many trained radio and ignition service men.

The aviation industry also affords tremendous opportunities in good paying and fascinating work for practically-trained ignition men. The safe operation of an aeroplane depends, of course, upon continuous operation of its engines, and the majority of these engines use electrical ignition for igniting their fuel. Therefore, it is extremely important that the magnetos, spark plugs, wiring, and all other electrical equipment on these engines be kept in perfect condition at all times. This work requires men who have a very thorough knowledge of electricity and ignition equipment and affords splendid opportunities to get into the aviation field.

Whether you ever specialize in ignition work or not you will find it very convenient and valuable to have a good general knowledge of this subject in connection with the operation of your own car, as a great deal of time and money can often be saved just by being able to quickly locate and repair some minor electrical trouble in the ignition system or wiring of your automobile.

In order to be thoroughly capable in ignition or automotive electrical service work a thorough general knowledge of practical electricity in its several branches is essential, as well as a knowledge of the operating principles of the common types of internal combustion engines. It is the purpose of this section to show you how the knowledge which you have already obtained of electricity and circuits can be applied to automotive equipment. The operation of common types of automobile engines is also briefly explained.

1. OPERATION OF INTERNAL COMBUSTION ENGINES

It is not our purpose to cover in this material all of the details of theory or design of internal combustion engines, but merely those practical points regarding their operation which will be essential to the automotive electrical service man.

In addition to being able to locate and repair troubles in the electrical wiring and electrical devices on automobiles, trucks, and tractors, the "tuning" of the ignition system is very important.

The term "internal combustion engine" is used on account of the fact that the energy which oper-

ates these engines is generated by the combustion or burning of a fuel mixture inside the engine itself.

One of the first commercially practical internal combustion engines was developed in France by J. J. Lenoir in 1860, and was known as a "two-stroke-cycle engine". Later in 1876 this engine was greatly improved by a German named Nicholas Otto who produced an engine of the "four-stroke-cycle type". The basic principles of these latter engines are the same as those on which all automotive engines operate.

As has been previously stated, power is developed within an internal combustion engine by the explosion or burning and expansion of a fuel mixture in a manner to apply pressure to the pistons, which in turn drive the crank shaft and flywheel of the engine.

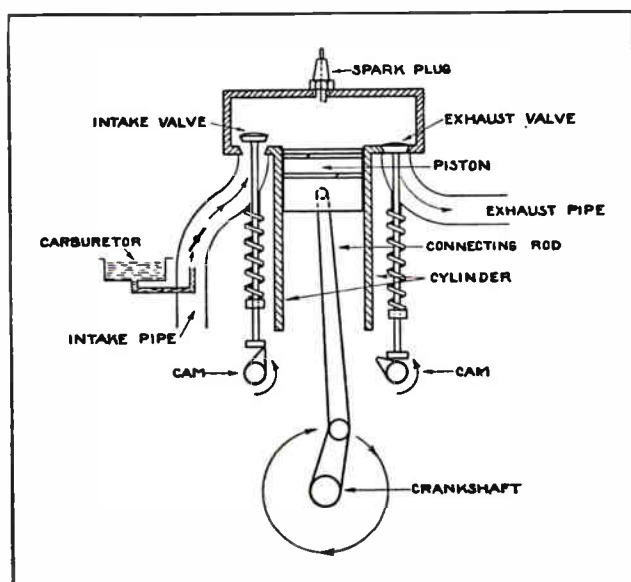

Fig. 1. This diagram illustrates the operating principle of a simple one-cylinder internal combustion engine. Study the diagram carefully while reading the explanation.

For continuous operation of these engines it is necessary to maintain a certain series of events known as a cycle. These cycles are then continuously and rapidly repeated as long as the engine operates.

In the four-stroke-cycle engine these steps of each cycle are as follows: 1. Intake of fuel charge. 2. Compression of fuel charge. 3. Ignition and combustion of fuel charge. 4. Exhaust of burned or waste gases.

To complete all of these steps for one cycle in any one cylinder of an ordinary automobile engine requires four strokes of the piston and two revolutions of the crank shaft. This is the reason they are called "four-stroke-cycle engines", or sometimes just "four cycle engines".

Fig. 1 is a simple diagram showing a sectional view of one cylinder of an automobile engine, and shows the following important parts: Cylinder, piston, connecting rod, crank shaft, valves and valve operating cams, and carburetor.

In this diagram the piston is shown at the commencement of the intake stroke; the intake valve on the left is open and the exhaust valve is closed. If the crank shaft is rotated to the right, or clockwise, the piston will be drawn downward on the intake stroke and, as it fits tightly in the cylinder walls, a suction or vacuum will be formed in the cylinder head and will draw in a mixture of gasoline and air from the carburetor and through the intake pipe.

When the crank shaft revolves far enough so that the piston is about 30 degrees beyond lower dead center the intake valve is allowed to close by the cam moving out from under its lower end. Then, with both valves closed, the piston moves up on the compression stroke. This compresses the fuel charge into the relatively small space in the cylinder head called the combustion chamber.

When the piston arrives at the upper end of its stroke, or upper dead center, a spark is forced across the points of the spark plug, igniting the gas charge. Once this mixture of gasoline vapor or gasoline and air is ignited it burns at a very rapid rate. In fact so rapidly that this combustion action is often called an "explosion".

This burning of the fuel creates a very high temperature of about 3000° F. maximum, and an expansion pressure of about 300 to 400 lbs. per square inch which is exerted on the top of the piston.

The pressure is, of course, due to the tendency of the gas to expand when heated. This pressure generated by the rapidly expanding gases, forces the piston to move downward on the power stroke, both valves remaining closed until the piston reaches a point about 40° before the lower dead center position. At this point the exhaust valve opens through the action and timing of its cam. This stroke is known as the power stroke.

With the exhaust valve remaining open, the piston again moves up to the upper dead center, forcing the burned gases out through the exhaust pipe. The exhaust valve then closes and one cycle is completed. This brings the engine back again to the position first mentioned, with the piston again ready for a downward intake stroke.

As long as the engine continues to operate this cycle is rapidly repeated, with the piston moving up and down and transmitting the force of each power stroke to the crank shaft through the connecting rod. The crank shaft converts this force into rotary movement of the flywheel attached to its end.

2. VALVES, PISTON, CAMSHAFT, CRANKSHAFT, and OTHER ENGINE PARTS

From the foregoing facts it is easy to see the importance and necessity of having the valves operate at exactly the right instant with respect to the position and direction of movement of the piston. This is accomplished by the rotation of the cam shaft,

which is connected to and driven by the crank shaft. The valves are normally held closed by the action of springs shown in the diagram in Fig. 1, and are forced open at the proper instant by the rotation of the cams or projections on the cam shaft, which press against the lower ends of the valve stems or push rods which are sometimes placed underneath the stems.

You can also see the importance of having the spark occur at exactly the right instant to ignite the fuel mixture, that is, when the piston is at the top of its compression stroke and just ready for the downward power stroke. The method by which this is accomplished will be explained in later paragraphs.

Fig. 2 shows at the upper right a pair of valves for an automobile engine, and at the bottom is shown the cam shaft which operates the valves by means of the short push rods shown directly beneath the valves on the right. These push rods are located between the cams and the lower ends of the valve stems.

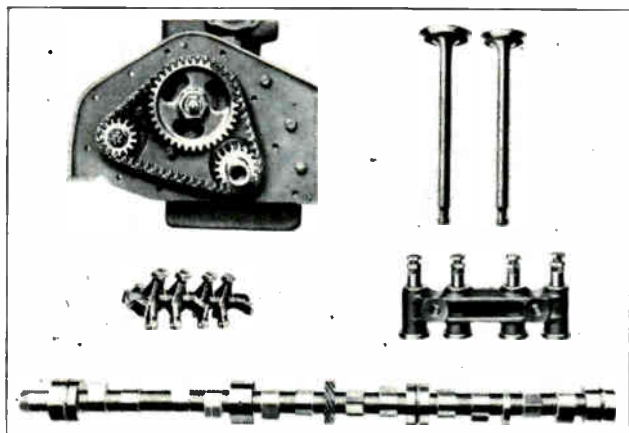

Fig. 2. This figure shows valves, push rods, rocker arms, cam shaft and cam shaft drive gears of an automobile engine. Courtesy Oldsmobile Mfg. Co.

At the upper left in this figure are shown the gears and chain by means of which the cam shaft is driven from the end of the crank shaft of the engine. On engines having overhead valves the valves are often operated by means of long push rods and overhead rocker arms. A set of these rocker arms are shown above the cam shaft on the left in Fig. 2.

Fig. 3 shows at the top a crank shaft and flywheel for a 6-cylinder engine. At the lower left in this figure is shown a piston attached to the connecting rod by means of which the piston imparts its energy to the crank shaft.

Note the piston rings which are located in grooves around the top of the piston to secure a tight fit to the cylinder walls and prevent leakage of any of the force from the expanding gases. These rings also help to maintain the proper suction and vacuum to draw in the fuel during the intake stroke.

At the lower right in Fig. 3 is shown the cylinder

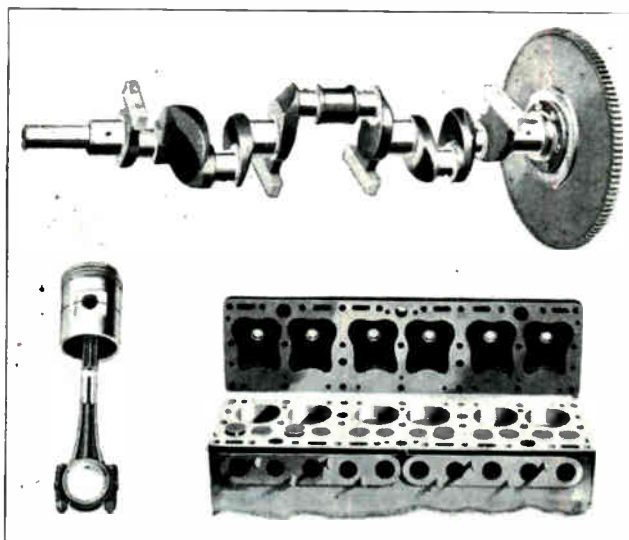

Fig. 3. At the top of this figure is shown a crank shaft and flywheel for a six-cylinder engine, and below are shown a piston and connecting rod and the cylinder block with the head lifted to show the cylinders, valves, etc. Courtesy Oldsmobile Mfg. Co.

block of a 6-cylinder engine with the cylinder head removed. In the block you can see the intake and exhaust valves for each cylinder, some of these valves are open and some closed. The intake and exhaust ports or openings which admit the gases to and from the valve chambers are shown along the side of the cylinder block. In the cylinder head can be seen the combustion chambers with their spark plug openings. When the head is in place on the cylinder block these combustion chambers each fit directly above their respective cylinders and valves.

Fig. 4 shows an excellent sectional view of the end of an automobile engine of the side valve or L-head type. In this view the piston can be seen at the top of the cylinder and the connecting rod is shown leading from the piston to the crank shaft. Just above and to the left of the lower end of the connecting rod can be seen the end of the cam shaft with one cam projecting to its left. The push rod can be seen directly above and resting upon this cam, and above the push rod are the valve and valve spring. The tubular guide through which the valve stem slides up and down is called the "valve guide".

The intake and exhaust manifolds are shown projecting from the left of the cylinder block, and the passage through which the exhaust gases leave the cylinder through the valve can be clearly seen. The spark plug is located on top of the combustion chamber, and is connected by a wire to one of the terminals of the ignition distributor mounted on top of the engine.

3. VALVE TIMING

Theoretically each stroke of an automotive engine begins and ends at either the upper dead center or lower dead center, and we might think that the valves should open and close at these positions. However, in actual practice the valves are timed to open and close at points earlier and later than the

exact upper and lower dead centers, because of the inertia of the gases.

For example, the closing of the intake valve is usually delayed to about 30 degrees after lower dead center (L.D.C.), in order to allow the engine to draw in the maximum gas charge and develop its maximum power. During the intake stroke the column of gas mixture moves through the intake manifold to the cylinder with a velocity of about 200 feet per second, and the gas due to its momentum continues to crowd into the cylinder even after the piston has passed L.D.C.

As long as this gas fuel is flowing into the cylinder the valve should remain open, in order to take in the maximum fuel charge; and this is the reason for delaying the closing of the intake valve until about 30 degrees after L.D.C.

On the power stroke the exhaust valve generally opens when the piston reaches a point about 40 degrees before L.D.C., thus allowing the exhaust gases to start their escape while there is still a little pressure in the cylinder (approximately 50 lbs. per square inch). This loses a little of the pressure from the fuel combustion, but it actually increases the total power of the engine by effecting a more thorough cleaning or scavenging of the exhaust gases from the cylinder, and also by eliminating all back pressure on the piston as it starts to move up on the exhaust stroke.

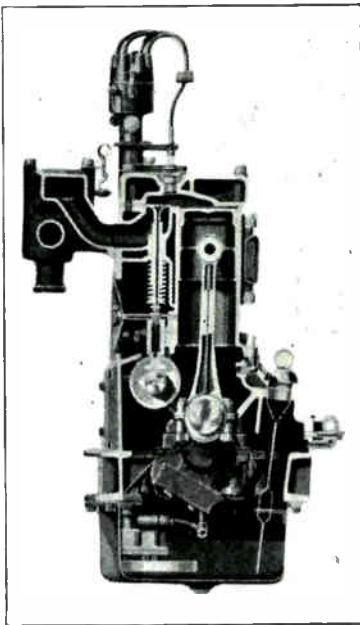

Fig. 4. This sectional end-view of an automobile engine clearly shows the arrangement and location of important parts such as piston, connecting rod, crank shaft, cam shaft, valves, etc. Courtesy Oldsmobile Mfg. Co.

When the U.D.C. is reached the exhaust valve closes, and about 10 degrees later the intake valve opens. The purpose of this slight delay in the opening of the intake valve is to create a slight vacuum in the cylinder before opening it, and also to eliminate the possibility of fuel loss through the exhaust valve which has just closed.

Fig. 5 is a diagram illustrating this valve timing or the points at which the valves open and close with regard to upper and lower dead center in each revolution of the crank shaft. In this figure the time is expressed in degrees of crank movement, allowing 360 degrees for the complete cycle, or one revolution of the crank shaft.

The diagram not only shows the positions at which the valves open and close but also shows in degrees the length of the intake, compression, power, and exhaust strokes.

The timing values given in this diagram represent popular or general practice, but it should be remembered that different engines require widely varying valve timing, according to their design, speed of rotation, compression used, fuel efficiency, etc.

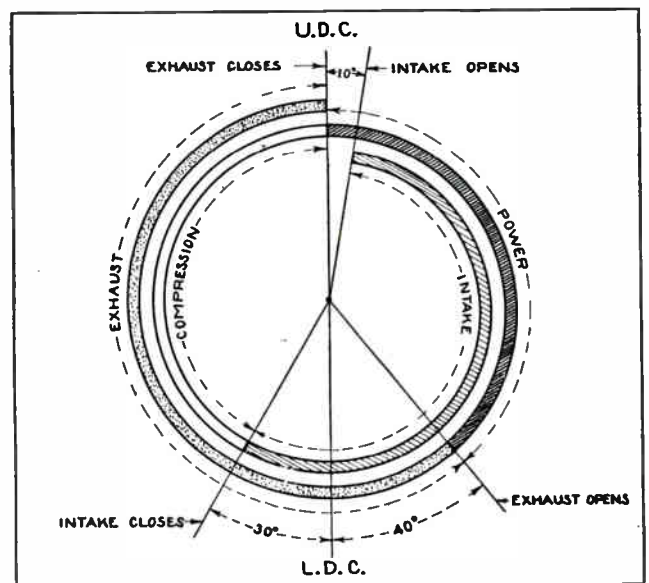

Fig. 5. Diagram illustrating valve timing or showing the points at which the valves open and close, and also showing the degrees of open and closed periods during each revolution of the crank.

4. PRINCIPLES OF CARBURETION

The purpose of the carburetor on an automobile engine is to supply the proper mixture of gasoline vapor and air for fuel to be burned in the cylinders. The carburetor also provides a means of controlling the speed and power output of the engine by admitting more or less fuel under the control of a throttle valve.

Raw gasoline will not burn in the cylinders, so the function of the carburetor is to mix a spray or jet of gasoline with a proper amount of air to provide combustible fuel.

Fig. 6 is a diagram showing a sectional view of a simple elementary type of carburetor. The gasoline enters the fuel bowl through a small tube or pipe from the gas tank, vacuum tank, or fuel pump. The float in the fuel bowl automatically keeps the gasoline at the proper level in the bowl by shutting off the flow from the pipe whenever the float rises high enough. From the fuel bowl the gasoline is drawn through either the high-speed jet or low-speed jet,

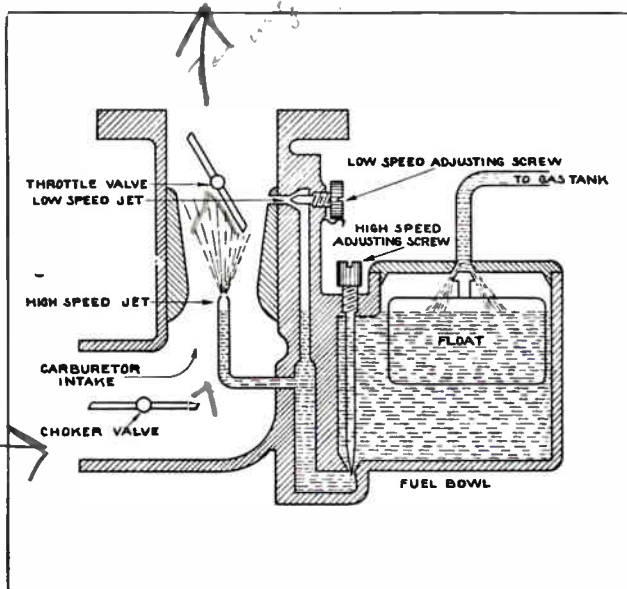

Fig. 6. Diagram showing a sectional view and the operating principles of a simple carburetor used for supplying the proper mixture of gasoline and air for fuel to the engine.

according to the speed at which the engine is operating. Note the positions of these jets in Fig. 6.

As long as the engine operates at moderate or high speeds, the rapidly repeated intake strokes of the pistons in the various cylinders maintain a practically constant suction, which draws a steady stream of air in through the carburetor barrel and intake manifold. This air, rushing upward through the narrow or restricted opening in the carburetor barrel, sucks gasoline from the high-speed jet in the form of a fine spray which mixes thoroughly with the air, and passes on into the cylinders as combustible fuel as long as the throttle valve is open.

When the throttle valve is closed it cuts off the supply of gasoline from the high-speed jet and creates a higher vacuum or suction above the valve. This raises the gasoline and draws it from the low-speed jet for idling or low speed operation of the engine.

For satisfactory engine operation the proper mixture or proportion of fuel and air must be maintained at all times. If there is too much gasoline the mixture is said to be too "rich", and this will cause irregular operation and may stop the engine entirely. An excessively rich mixture is generally indicated by heavy, black smoke coming from the exhaust pipe.

If, on the other hand, there is too little gasoline and too much air, the mixture is said to be too "lean", and the engine will misfire and lack power.

For average conditions a mixture consisting of about sixteen parts of air to one part of gasoline (by weight) gives the best results. A mixture of less than seven parts of air to one of gasoline is too rich to burn at all, while at the other extreme more than twenty parts of air to one of gasoline will cause the engine to misfire and develop very little power.

When starting up a cold engine a rich fuel mixture is required, and to obtain this a choker valve in the lower end of the carburetor barrel is partly closed in order to shut off part of the air and create a higher suction at the fuel jets and draw more gasoline. As soon as the engine is running smoothly and slightly warmed up, this choker valve should be opened to again thin the fuel mixture and prevent fouling of the spark plugs and cylinders.

From the preceding explanation of carburetor principles it is easy to see the importance of correct carburetion or carburetor adjustment for smooth and efficient operation of an internal combustion engine.

The adjustments for the high-speed and low-speed jets are made by adjustable needle valves which control the flow of gasoline to each jet. The one marked "low-speed adjustment" controls the flow of fuel issuing from the jet located in the carburetor barrel above the throttle valve, and which is generally known as the idling jet. This jet supplies the fuel up to speeds of about twenty miles per hour in high gear.

As the throttle is opened farther than this it breaks the high suction at the upper jet and will not draw the gasoline up to this level any longer. From this point on the fuel is supplied by the lower jet for the higher speeds.

Fig. 7 shows a photograph of a carburetor of a dual type, for use on 8-cylinder engines. You will note the fuel bowl on the left and the air intake opening on the right. The openings which connect with the intake manifold on the engine are shown on the top. The adjusting screws for both the high-speed and low-speed jets can be clearly seen in this view. You can also see the levers which operate the throttle and choker valves.

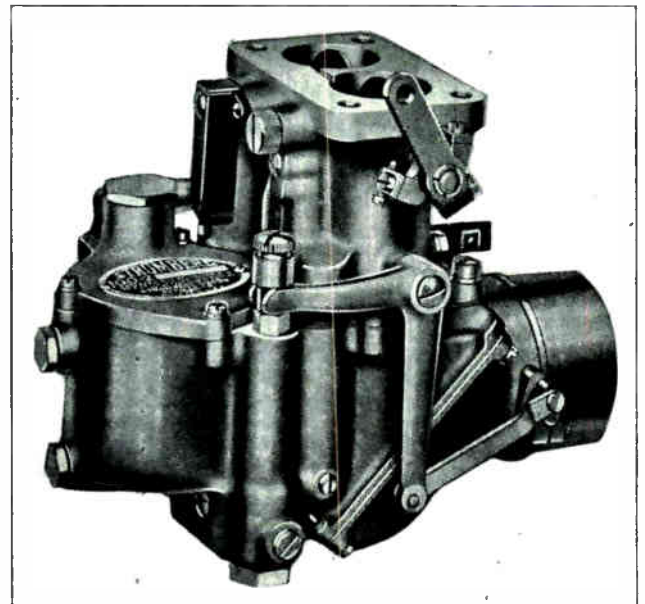

Fig. 7. Photograph view of a double or twin barrel carburetor with some of the operating levers and adjustments in plain view.

Improper carburetor adjustment will often cause faulty and irregular operation of the engine that is sometimes blamed upon the ignition or valve timing; so, when "tuning" an engine one should make sure that the carburetor is properly adjusted for smooth operation.

5. FUEL COMBUSTION and SPARK ADVANCE AND RETARD

When the fuel charge that is supplied to the cylinders by the carburetor is ignited by a spark from the plug it requires a very small fraction of a second for the flame to spread throughout the entire charge in the combustion chamber. In other words, the combustion of the gasoline vapor is not actually an instantaneous explosion, but instead requires a certain small period of time after the charge is ignited before combustion is complete.

The period of time required between ignition and the complete combustion of the fuel depends on the amount of compression, the type of fuel used, the shape of the combustion chamber, location of the spark plug, etc. On an average, this time period is about .003 of a second.

In order to obtain maximum pressure on the piston the ignition spark should be timed so that combustion will be completed just when the piston is on upper dead center. Because of the short period of time between ignition and complete combustion the spark must, therefore, occur at some point slightly ahead of the upper dead center position or just before the piston reaches this point.

This is known as **advancing the spark**, and is very important in obtaining maximum speed and power from modern automobile engines, because at the speed these engines operate the piston will travel a considerable distance in even as small a period of time as .003 of a second. Just how far the spark should be advanced depends upon the operating speed of the engine, the degree of compression used, and the grade of fuel.

As the amount of spark advance depends upon the engine speed, it is generally necessary to advance and retard the spark according to the speed

at which the car or engine is being operated. This enables one to obtain the maximum power both at low speeds, such as when climbing steep hills, and also at high speeds on good level roads.

Ordinarily the spark is so timed that during low-speed operation of the engine ignition will occur when the piston is at U.D.C. The spark is then advanced as the speed of the engine is increased. This is usually accomplished by rotating the ignition timing device or distributor, and thus causing the spark to occur a little earlier with regard to the piston stroke.

On some cars this spark adjustment is made by hand from a control on the steering wheel, while on many of the modern automobiles it is made automatically by a sort of governing arrangement which operates whenever the engine changes speed.

Excessive spark advance will cause the engine to knock while insufficient advance will result in a loss of power and overheating of the engine.

Generally the best position of spark advance for any certain speed is reached when a little more advance will cause the engine to knock. The amount of spark advance varies from 15 to 45 degrees in different types of pleasure cars, according to the design of the engine.

The method of adjusting the spark advance and retard mechanism will be covered later in connection with ignition distributors.

6. ARRANGEMENT OF VALVES

One of the most important things in gasoline engine design, and one that has a material effect on their efficiency and operating characteristics is the shape of the combustion chamber and the arrangement of the valves. The valves which admit the fuel and discharge the burned gases from the cylinder may be placed either alongside the cylinder as in "side valve" engines or they may be in the cylinder head as in "overhead valve" engines.

Fig. 8 shows the four different valve arrangements, giving both side sectional views of the cylinder and top views looking down on the cylinder and valves. At "A" both valves are located in

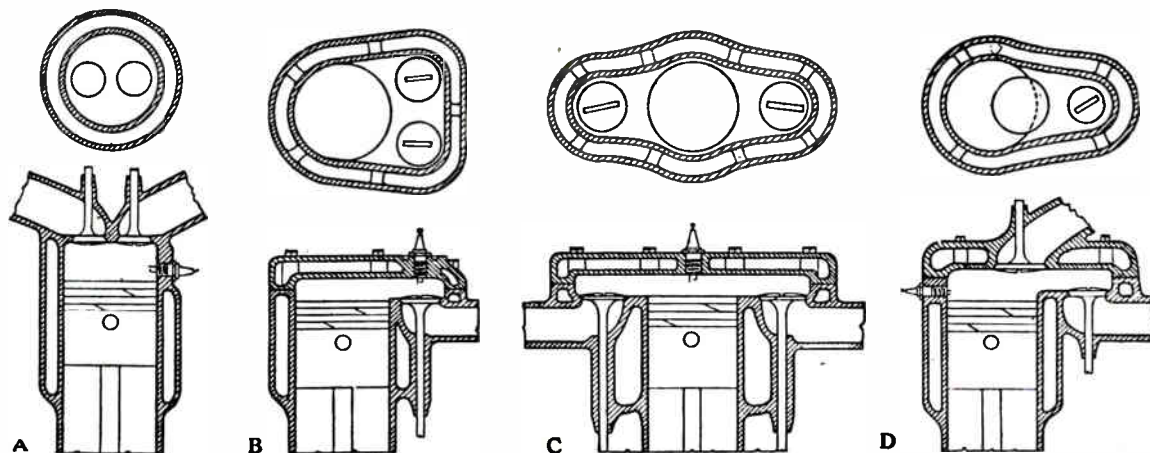

Fig. 8. The above diagrams show the location and arrangement of valves with respect to the cylinder in various types of automobile engines.

the cylinder head above the piston. An engine of this type is known as the "overhead valve" type.

"B" shows a cylinder of a side valve engine in which all of the valves are placed on one side of the engine. Engines of this type are commonly called "L-head" engines because the combustion chamber and cylinder form a sort of inverted L shape.

At "C" is shown one cylinder of a "T-head" engine in which the exhaust valves are located on one side of the engine and the intake valves on the other.

At "D" is shown the valve arrangement for what is called an "F-head" engine, which uses a combination of the first two types, the intake valves being located in the head and the exhaust valves on the side.

Fig. 9 shows an end view of an engine with overhead valves. The cam shaft shown at the left of the connecting rod operates a long push rod which in turn operates a rocker arm at the top of the engine. The right-hand end of this rocker arm opens the valve by pushing it downward into the combustion chamber.

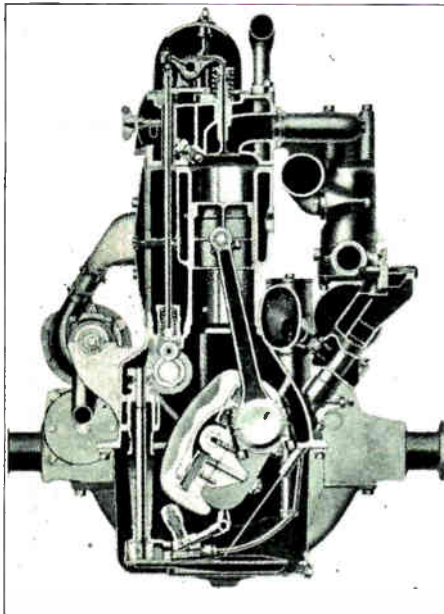

Fig. 9. End and sectional view of a Buick engine showing the overhead valve construction, the method of operating valves by means of long push rods, and overhead rocker arms.

Probably 80% of modern automotive engines are of the L-head type and most of the remainder use the overhead type. One decided advantage of both the L-head and overhead valve types of engines is that all valves are arranged in one line, and therefore only one cam shaft is required to operate all of the valves. This results in a very definite arrangement of the valves from the front to the rear of the engine.

In Fig. 10 you will note that the first and last valves are exhaust valves and the intermediate ones are arranged in alternate pairs of intakes and ex-

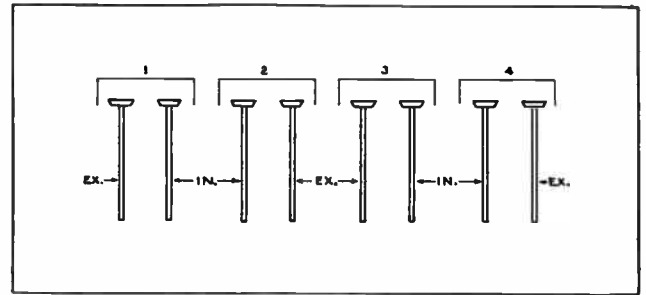

Fig. 10. This simple sketch shows the order or arrangement of exhaust and intake valves which is used on practically all automobile engines. Knowing this arrangement will be a great help in locating certain valves when timing an engine.

hausts. While this sketch shows the valves for a 4-cylinder engine the same arrangement is used regardless of the number of cylinders as long as they are all in one line. This valve arrangement provides a convenient means for setting the engine on U.D.C. when timing the ignition.

In order to obtain even torque and better balance in automobile engines the crank shafts are generally made so that the pistons move up and down in pairs, the first and last piston always moving up and down together. The two pistons of any pair, however, are always on different parts of the cycle.

For example, when the last piston is moving up on exhaust the first is coming up on compression, and when the last piston arrives at U.D.C. position the last valve on the engine will close, as it is an exhaust valve. Therefore, when the last valve on the engine closes, No. 1 piston is on upper dead center on the compression stroke and the engine is set on the timing position or ready for the spark to occur in No. 1 cylinder. This method is particularly applicable to overhead valve engines and is a very good rule to remember.

No. 1. Cylinder on an automobile engine is always the one next to the radiator or on the cranking end, the remainder of the cylinders are numbered in order from here back to the flywheel end.

7. MULTIPLE CYLINDER ENGINES

A single-cylinder, four-stroke-cycle engine receives only one power impulse for every two revolutions of the crank shaft, as four strokes are required to complete the cycle and only one of these strokes is a power stroke. In single-cylinder engines, therefore, a rather heavy impulse is required on the power stroke in order to build up sufficient momentum to keep the engine turning through the three idle strokes which follow.

Due to the severe strain imposed on the engines by this heavy power impulse such engines had to be very strongly constructed, and as a result both the stationary and moving parts were excessively heavy. In addition, they required a very heavy flywheel, capable of storing sufficient energy on the power stroke to keep the engine running at approximately constant speed through the rest of the cycle.

Such engines cannot run at high speeds without severe vibration, and this disadvantage along with the excessive weight has led to the production of multiple-cylinder engines which provide more frequent power impulses, run more smoothly, and have greater flexibility and lighter weight for a given power output.

The greater the number of cylinders the more frequently the power impulses occur and the more even is the flow of power applied to the crank shaft. For a given power output the size and weight of the moving parts of the engine become less as the number of cylinders increases, and this makes possible higher engine speeds and higher efficiencies.

On any engine with more than four cylinders there is no point in the rotation where the engine is not receiving power from the expanding gases on one or another of the power strokes.

For the above reasons six and eight-cylinder engines are the most popular for automobiles, although a number of "fours" are still being built. Twelve and sixteen-cylinder engines are also used and deliver extremely smooth power to drive the car.

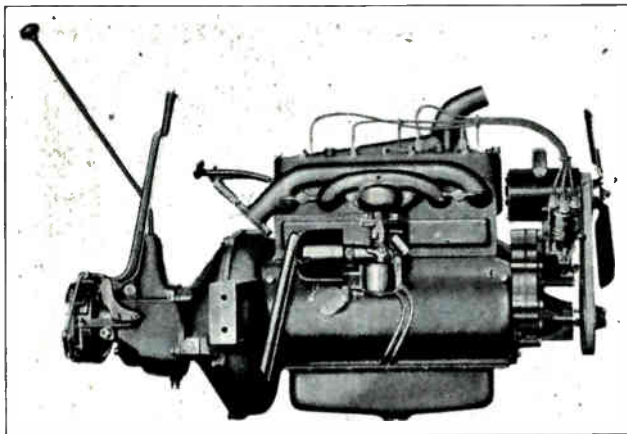

Fig. 11. Side view of a four-cylinder automobile engine used by the Chrysler Plymouth automobile. Note the position of the carburetor, intake and exhaust manifolds and spark plugs.

8. FOUR-CYLINDER ENGINES. FIRING ORDER

Fig. 11 shows a side view of a four-cylinder engine.

Any four-stroke-cycle engine fires all cylinders in two revolutions of the crank shaft, or 720° of crank rotation. Therefore, the angle between the power impulses of a four-cylinder engine of this type will be $720 \div 4$, or 180° .

The crank shaft for the four-cylinder engine is designed so that the pistons travel up and down in pairs, 1 and 4 traveling up and down together and 2 and 3 traveling together. In this manner, when 1 and 4 are at upper dead center 2 and 3 are at lower dead center, as the crank throws to which they are attached are 180° apart. See Fig. 12, which shows a sketch of the pistons and crank shaft of an ordinary four-cylinder engine.

Fig. 12-A is a sectional view of a four-cylinder engine, showing the crank shaft and other important parts.

When piston No. 1 is moved to L.D.C. on its power stroke the crank shaft has turned 180° from the point of ignition, and at this time another power stroke should commence in one of the other cylinders. At this time pistons 2 and 3 will be at U.D.C., and the one that is fired will depend on the design of the cam shaft, as the operation of the valves will cause one of these pistons to be up on compression stroke and the other on exhaust stroke. If 3 fires after 1 it must be followed by 4, and then by 2, so the firing order of the engine in this case will be 1-3-4-2.

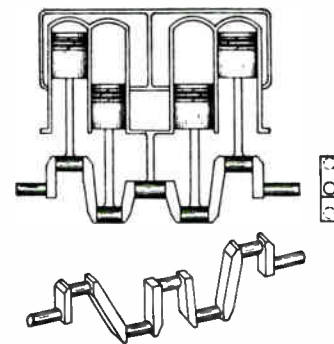

Fig. 12. Sketch showing the design of the crank shaft and arrangement of pistons in a four-cylinder engine.

If the cam shaft is arranged so that No. 2 cylinder fires after 1, then the firing order will be 1-2-4-3. These are the only two firing orders used on four-cylinder automobile engines. The last firing order mentioned is used on the four-cylinder Ford and Chevrolet engines.

It is very important to know the firing order of various engines on which one may be working, in

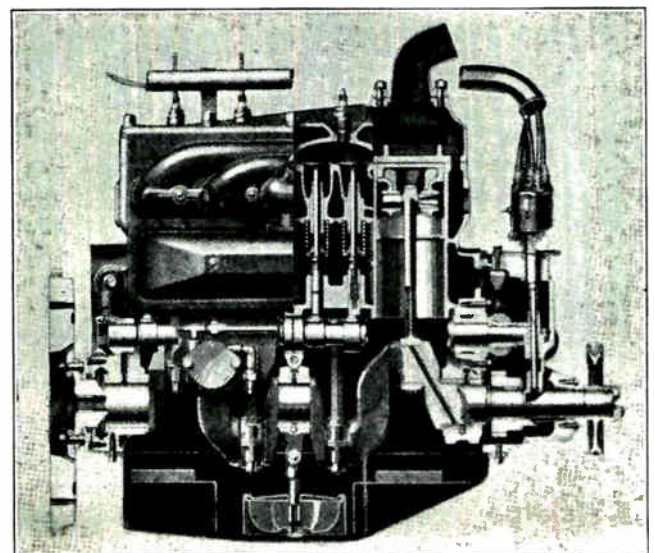

Fig. 12-A. Side sectional view of Chrysler Plymouth four-cylinder engine showing the shape of the crank shaft and arrangement of pistons, valves, etc.

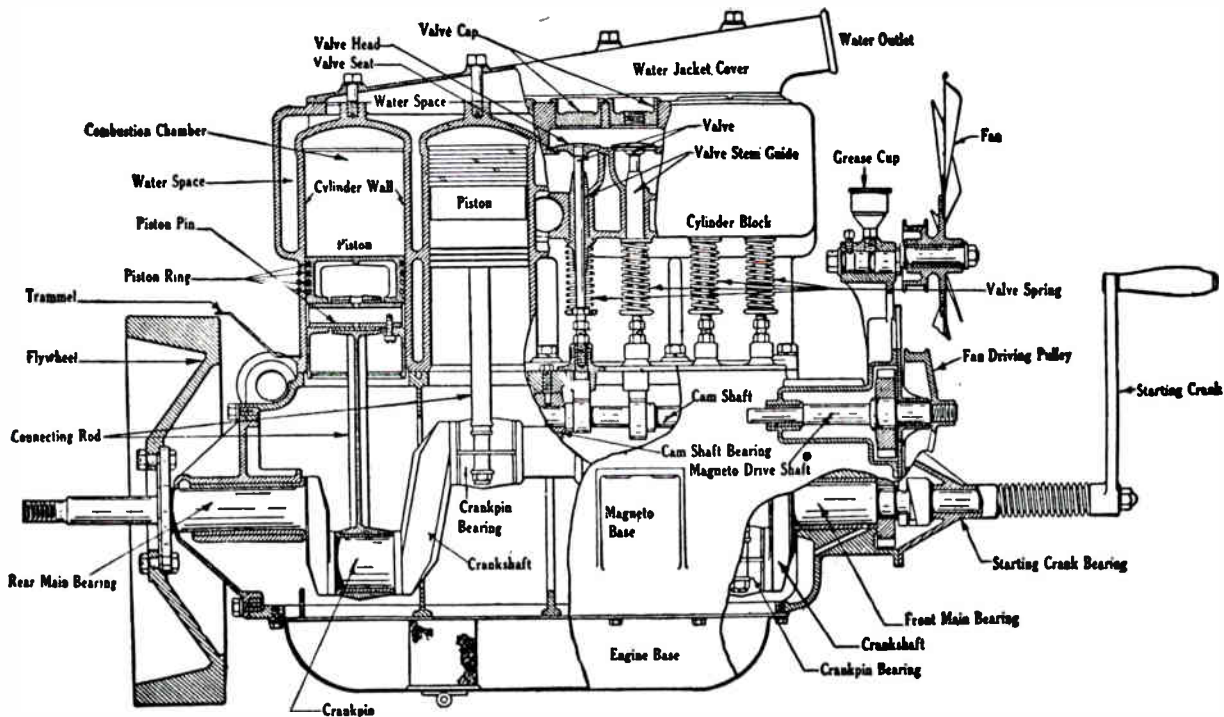

Fig. 13. This diagram shows a sectional view and a number of the important parts of a heavy-duty four-cylinder engine. Note the names by which each of these parts are called. Also note the water jacket around the cylinders for cooling them and carrying away the heat developed by combustion.

order to be able to properly connect the ignition wires from the distributor to the spark plugs,

Firing orders of various engines can be obtained from the manufacturers or dealers, and garages and ignition service stations generally carry a book which gives the firing orders for all of the common types of engines. The method for determining the firing orders by checking directly on the engine will be explained a little later.

Fig. 13 shows a sectional view of a heavy-duty four-cylinder engine and gives the names of many of the important parts. Examine this figure carefully.

9. SIX-CYLINDER ENGINES. FIRING ORDER

Six-cylinder engines are generally preferred to four-cylinder types as the power strokes overlap each other and occur more frequently, or at smaller angles in the revolutions of the crank shaft. As six-cylinder engines of the four-stroke-cycle type fire all cylinders in only two revolutions of a crank, or in 720° , their power strokes will be $720 \div 6$, or 120° apart.

The cranks are arranged at this angle so that they project out at three different points around the crank shaft. This is shown in the small sketch at the right in Fig. 14 which shows the arrangement of the crank throws and pistons in a six-cylinder engine.

By referring to the lower view of the crank shaft in this figure you will note that the cranks are also arranged in pairs, so that pistons 1 and 6 will move up and down together, 2 and 5 together, and 3 and

4 together. Remember, however, that no two pistons which travel up and down together are on the same part of the cycle at the same time, as when one is going up on its compression stroke the other piston is going up on its exhaust stroke.

By referring back to Fig. 3 an excellent view of a six-cylinder crank shaft can be seen. This view, shows quite clearly the position of the cranks with respect to each other, and also shows the main bearings of the crank shaft.

In Fig. 14 four of the pistons seem to be at about the same position, part way between the lower and upper ends of the stroke; but by noting the position of the crank throws in the lower view of the crank shaft you will find that if pistons 2 and 5 are traveling downward at this point, pistons 3 and 4 will be traveling upward.

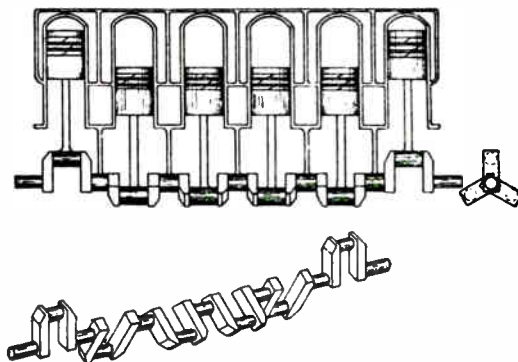

Fig. 14. Diagram showing the design of the crank shaft and the arrangement of pistons for a six-cylinder engine. Note that the cranks are arranged in pairs 120° apart around the shaft.

Because of their more frequently occurring power impulses six-cylinder engines deliver much smoother power than four-cylinder types. There are several firing orders possible with six-cylinder engines having crank shaft arrangements such as shown in Fig. 14, but the only two firing orders which are used are as follows: 1-5-3-6-2-4, or 1-4-2-6-3-5; these having been adopted as more or less standard by various engine manufacturers.

Firing in the proper order is very important in balancing the internal forces in the engine. The firing order is determined by the design of the crank shaft.

By this time you can, no doubt, readily see the great importance of the firing order in wiring the ignition system of an engine; because if the distributor wires were connected wrongly to the spark plugs the sparks would occur at the wrong time in the cylinders, and the engine would misfire, operate irregularly, and deliver very low power; or possibly not even start.

For example, if the spark occurred in a cylinder when the piston came up on exhaust stroke instead of compression stroke there would be no fuel mixture present at the time of the spark and therefore no explosion.

Fig. 15 shows a side-view of a six-cylinder engine with sections of the casing cut away to show

some of the important parts. No. 1 cylinder is completely open, showing a sectional view of the piston, wrist pin, connecting rod, etc. No. 2 cylinder is arranged to show a sectional view of the exhaust and intake valves, valve guides, valve springs, push rods, and a section of the cam shaft.

On the left end of the engine are shown the flywheel, clutch, and transmission. The distributor, high-tension ignition wires, and spark plugs are shown on top of the engine.

10. EIGHT-CYLINDER ENGINES. FIRING ORDER

The decided advantages of the engines with a greater number of cylinders, both in smooth power performance and in reduced manufacturing cost per horsepower, have resulted in a definite trend toward the construction of engines of this type, and quite a number of the latest automobiles are equipped with "straight-eight" engines. This term "straight-eight" refers to engines having eight cylinders in line. There are other very popular eight-cylinder engines which are of the V-type and which will be discussed later.

The straight-eight engine produces a remarkably smooth torque, as its power impulses occur every 90° , or $720 \div 8$. Fig 16 shows an eight-cylinder engine of this type. Practically all of the straight-eight engines use the firing order: 1-6-2-5-8-3-7-4.

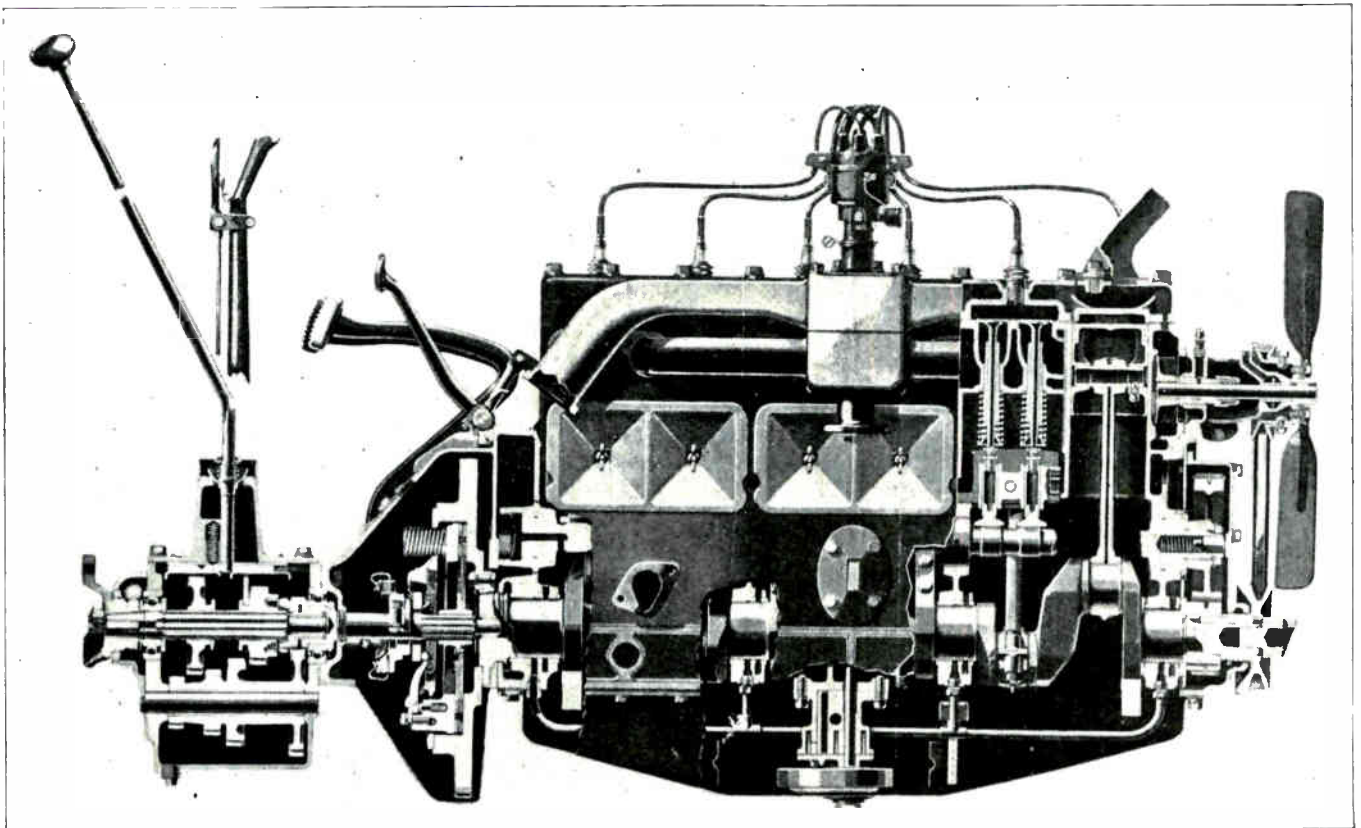

Fig. 15. An excellent side sectional view of a six-cylinder Oldsmobile engine cut away to show the crank shaft, pistons, connecting rods, valves, push rods, cam shaft, flywheel, clutch and transmission. Also note the position of the distributor and spark plugs on top of the engine. Courtesy Oldsmobile Mfg. Co.

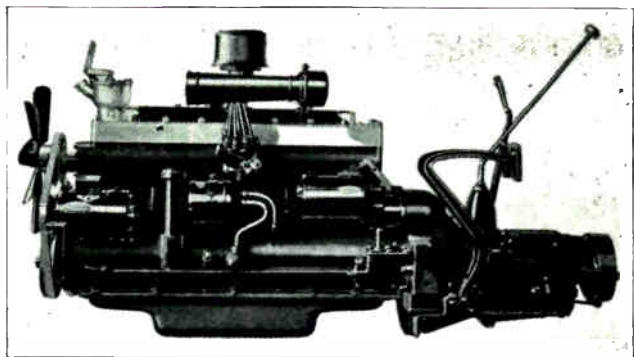

Fig. 16. Popular "line-eight" automobile engine with eight cylinders in line. Engines of this type are very extensively used on modern cars and deliver extremely smooth power.

Straight-eight engines are used by Chrysler, Oldsmobile, Packard, Buick, Studebaker, and other manufacturers of popular cars.

V-type eight-cylinder engines have their cylinders arranged in two rows or "banks" of four each, as shown in Fig. 17. Engines of this type are used in Lincoln, Cadillac-LaSalle, and Oldsmobile-Viking cars.

The firing order of a V-type engine alternates consecutively, firing first one cylinder on the right bank and then one on the left bank, and so on down the bank, following this arrangement as closely as the design of the crank shaft will permit.

In the earlier types of V-eight's crank shafts similar to those used in four-cylinder engines were employed, having two pistons one from each bank connected to each crank throw, as shown in Fig. 18.

The firing order for this type of engine is either 1R- 4L- 2R- 3L- 4R- 1L- 3R- 2L; or 1R- 4L- 3R- 2L- 4R- 1L- 2R- 3L. The letters "L" and "R" denote cylinders on the left and right banks, as viewed from the drivers seat, and always keep in mind that number one cylinder is the one nearest the radiator.

Most of the more modern V-eight's use a crank shaft with the cranks arranged 90° instead of

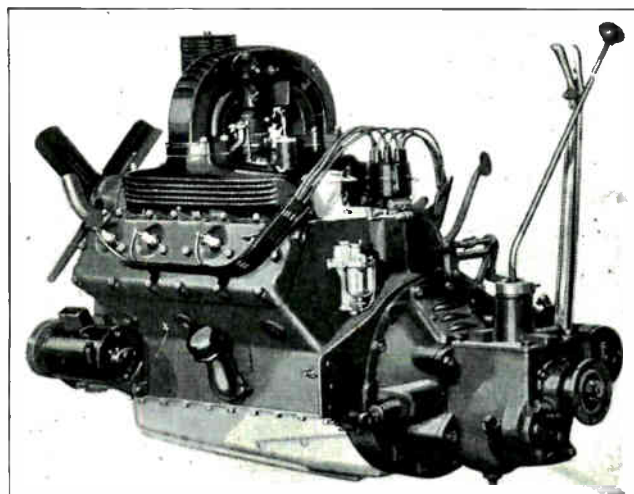

Fig. 17. V-type, eight-cylinder engine with cylinders arranged in two banks of four each. Carefully compare the construction of this engine with the "line eight" type shown in Fig. 16. Courtesy Oldsmobile Mfg. Co.

180°, and thus obtain still better balance and smoother operation. Engines of this type are used by the Cadillac-LaSalle and Ford cars.

They require a different firing order from the earlier type V-eight's. The firing order of the Cadillac-LaSalle engine is: 1 L- 4 R- 4 L- 2 L- 3 R- 3 L- 2 R- 1 R.

The firing order of the Ford is 1R-5L-4R-8L-6L-3R-7L-2R.

The firing order of the Lincoln is: 1R- 4L- 2R- 3L- 4R- 1L- 3R- 2L.

Fig. 19 shows a photo of a crank shaft such as used in these later type V engines, and Fig. 20 shows an excellent sectional end-view of a V-eight engine. In the foreground can be clearly seen the crank shaft with its counter-balancing weights and two connecting rods attached to the one crank. Note the position of each of the pistons attached to this crank and observe that one of the pistons is at the extreme outer end of its stroke, or U.D.C., while the other piston on the left is approximately midway on its downward stroke. Also note the position of the spark plugs and valves in the combustion chambers.

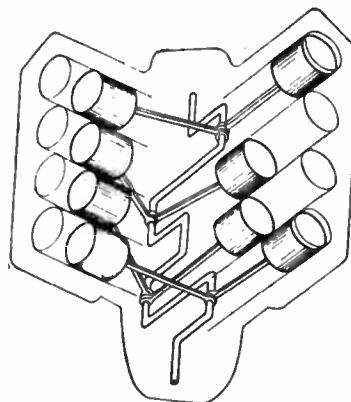

Fig. 18. Diagram showing the type of crank shaft and arrangement of pistons used with V-type, eight-cylinder engines.

The end of the cam shaft can be seen located between the cylinders. The cams of this shaft operate short rocker arms, which in turn press against the valve stems to operate the valves in the proper order. The carburetor, air filter, and intake and exhaust manifolds are shown above the engine in this view.

One of the types of multiple-cylinder engines is the Cadillac V-16, which is in reality two straight-eight's mounted at an angle of 45° to each other. This engine delivers remarkably smooth power and a tremendous amount of horsepower for its weight, and is a very good example of the weight reduction possible with an increase in the number of cylinders. The weight of this engine is only 25% greater than that of the Cadillac Eight, but its horsepower is double.

The firing order of the V-16 is: 1 L- 4 R- 5 L- 7 R- 2 L- 3 R- 6 L- 1 R- 8 L- 5 R- 4 L- 2 R- 7 L- 6 R- 3 L- 8 R.

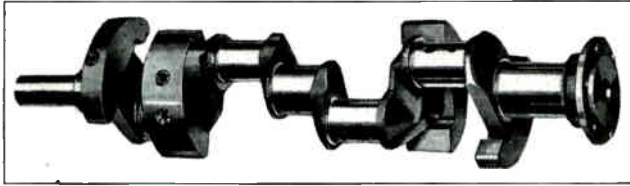

Fig. 19. Photograph of crank shaft used with V-type, eight-cylinder engines. Note that there are only four cranks, each of which have two connecting rods from pistons in opposite banks connected to them.

11. DETERMINING FIRING ORDERS BY TEST

In case the firing order of any engine is not known it may be quickly determined by any one of several methods. The simplest and most popular of these is the compression method.

We know that each piston must move up on its compression stroke just before its cylinder is fired, and the order in which these compression strokes occur in the different cylinders must be the same as the firing order. Keeping this fact in mind, the firing order may be quickly and accurately determined in the following manner.

Remove all spark plugs and seal the plug hole in cylinder No. 1 with a piece of paper or waste. Then slowly crank the engine until the paper blows out. Stop cranking at this point and seal the remaining spark plug holes, and then slowly turn the crank, noting the order in which the remaining wads are blown from the cylinders. This will indicate the firing order.

As each successive wad is blown from the cylinder a chalk mark may be put near that plug opening denoting the number of the wad blown—as 1, 2, 3, 4, etc. When all cylinders are marked the firing order can be read from cylinder 1 to the last cylinder.

Keep in mind that the firing order of an engine cannot be changed, as it is determined by the design of the crank shaft and cam shaft. These would have to be changed before the firing order could be altered.

Another method of determining the firing order—and one that is sometimes more convenient than that just given, particularly when the engine is of the overhead valve type—makes use of the fact that the valves open and close in the same order as the firing order.

When the intake valve closes on No. 1 cylinder the piston is rising on the compression stroke. Since the compression stroke takes place in each of the different cylinders in the same order as the firing order, the order in which the intake valves close must be the firing order.

To determine the firing order by this method, first locate the intake valve of each cylinder and then rotate the engine slowly until the intake valve on No. 1 cylinder closes. The next intake valve to close will be located at the cylinder that follows No. 1 in the firing order, or the one which fires second.

Continue turning the crank slowly and note the order in which the remaining intake valves close. This will show the firing order.

The same procedure could be used with the exhaust valves if desired.

12. IGNITION SYSTEMS. PRINCIPLES

As previously explained, the purpose of the ignition system on an automobile engine is to provide a means of setting fire to or igniting the fuel charge in the combustion chamber each time the piston comes to U. D. C. on the compression stroke.

A number of different methods of igniting the gas charge in internal combustion engines have been tried, but electrical ignition has proved to be the most positive and reliable for the high engine speeds required in automotive service.

Many modern automobile engines rotate at speeds of about 4000 RPM and require from 200 to 300 sparks per second, depending upon the number of cylinders. Electrical ignition is the only type capable of giving sufficient instantaneous heat to ignite fuel charges at such speeds, and has the added advantage of being easily and accurately controlled.

The important parts of a common electrical ignition system are:

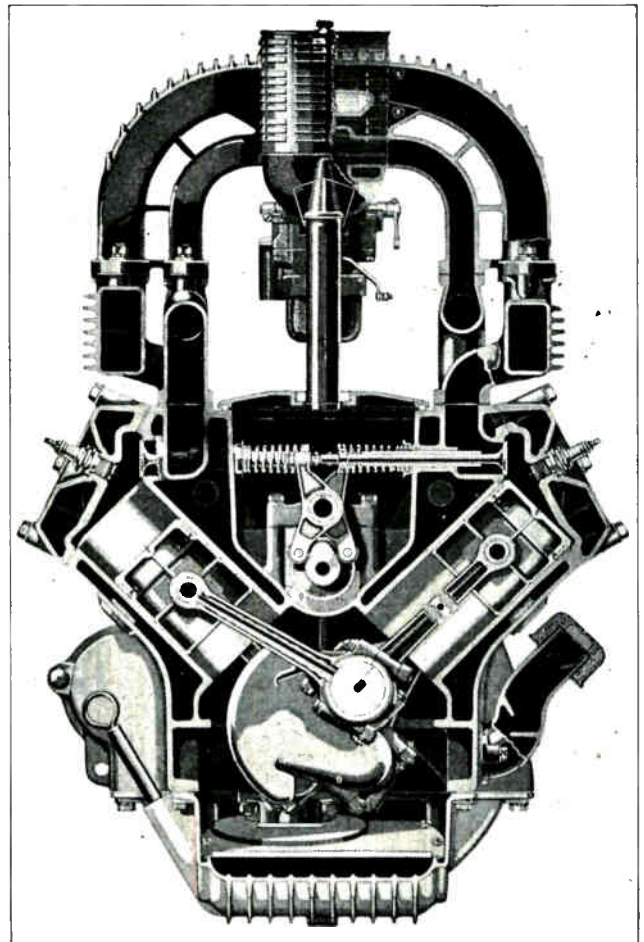

Fig. 20. An excellent end sectional view of a V-type, eight-cylinder engine. Note carefully the arrangement of the pistons, valves, cam shaft, rocker arms, spark plugs, carburetor, and intake and exhaust manifolds. Courtesy Oldsmobile Mfg. Co.

1. A battery or generator for a source of current supply.
2. A spark coil or magneto to produce high-voltage sparks at certain regular intervals.
3. Spark plugs to introduce the sparks into the combustion chamber of the engine.
4. A distributor to direct the high-voltage current to the spark plugs in the correct order.
5. A means of varying the time of the spark with relation to the piston position.

Each of these devices will be explained in the following paragraphs.

13. STORAGE BATTERIES

Storage batteries are commonly used as the source of current for ignition and other uses on modern automobiles. The majority of these batteries are the three-cell, six-volt type, but some are of the twelve-volt type.

Fig. 21 shows a common type six-volt storage battery in a rubber case, with the connector straps and terminal posts showing on top of the battery.

Storage batteries provide a convenient small portable device for supplying electricity for ignition, lights, horn, starting motor, etc. These batteries are fully charged when installed in a new car, and are then kept charged by current supplied from a low-voltage generator which is driven directly from the engine as long as it is running. This prevents the battery running down or discharging and eliminates the necessity of removing it from the car for frequent recharging.

The combination of this battery and generator provide a dependable supply of low-voltage energy as long as the generator charging rate is properly maintained and the battery is not abused or used



Fig. 21. Common three-cell, six-volt storage battery of the type extensively used to supply current to ignition and lighting systems on automobiles.

excessively when the engine is not running. Both storage batteries and generators for automobiles will be discussed more fully in later paragraphs.

14. IGNITION COILS

Electrical ignition is accomplished by forcing a spark across a small air gap in the combustion chamber. The voltage required to break down the resistance of this air gap and form a spark will depend principally upon the length of the gap and the degree of compression. With a compression pressure of about 100 lbs. per square inch and a spark gap length of about .025 inch, the voltage required to produce the spark will range from 6000 to 10,000 volts. These values of compression and spark gap length represent common practice in modern automobile engines.

We can readily see that the six-volt energy supplied by the battery will not be of high enough potential to break down the gap and form a spark, and that this voltage will need to be increased or stepped up considerably for ignition purposes. To accomplish this we use a special type of direct current transformer called an ignition coil.

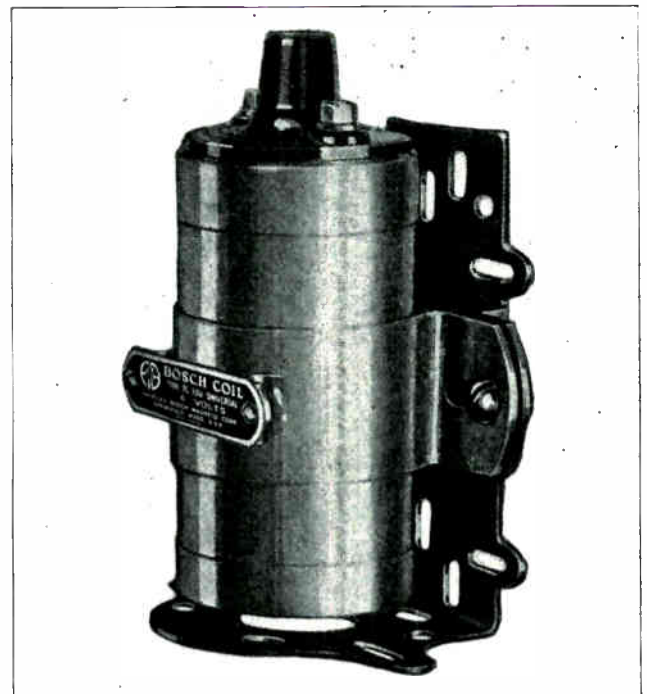

Fig. 22. High-tension ignition coil such as used for supplying high voltage impulses to the spark plugs on the ignition systems of automobiles. The heavily insulated bushing on the top of the coil is where the high voltage lead connects.

Fig. 22 shows a high-tension ignition coil such as used with many automobiles. In this figure the coil and core are shown enclosed within a waterproof case which is attached to a bracket for convenient mounting on the engine or behind the instrument panel.

An ignition coil consists essentially of a soft iron core which is laminated or built up of a bundle of soft iron wires and on which are wound two separate windings called a primary and secondary. The

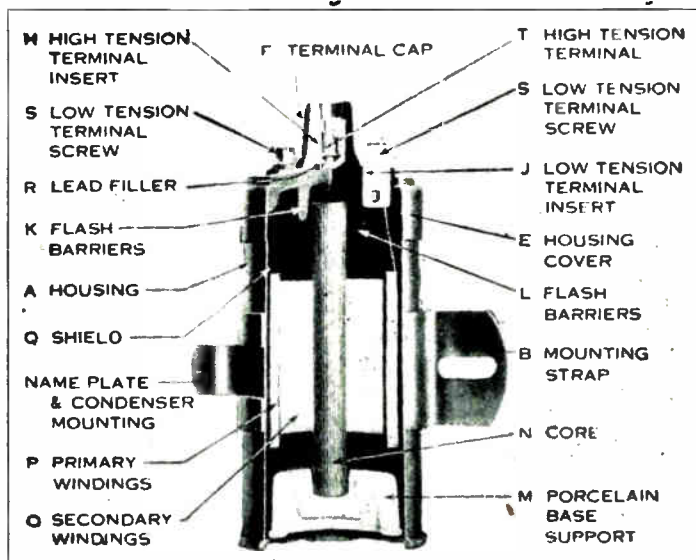

Fig. 23. Diagram showing a sectional view of an ignition coil and the location and names of each of the important parts.

primary winding generally consists of about 200 turns of No. 18 wire and is connected in series with the battery and a make and break contact or interrupter. The secondary winding generally consists of about 12,000 turns of No. 36 wire and is connected in series with the spark plug gap.

Fig. 23 is a sectional view of an ignition coil, showing the position of the core and coils within the case and also giving the names of the more important parts.

You already know that with a transformer of this type, when alternating current or pulsating current is passed through the primary winding consisting of a smaller number of turns, a much higher voltage will be induced in the secondary winding because of its greater number of turns. As the current supplied by the automobile battery or generator is D. C., it is necessary to provide some form of make and break device in the primary circuit of the ignition coil, in order to cause the variation of the current and magnetic flux necessary for the induction of the high voltage in the secondary.

Fig. 24 is a diagram showing some of the essential parts and the operating principles of a modern battery ignition system. When the switch, SW., and the contacts, A, of the interrupter are closed, current will flow from the positive terminal of the battery, through the primary winding of the ignition coil, through the interrupter contacts; then, through the grounded connections and metal frame of the car, back to the battery.

This flow of current sets up a strong magnetic field around the iron core of the ignition coil. As the engine operates, the cam (B) is caused to rotate and each of its projections bump the movable spring contact, causing the circuit to be momentarily opened at "A".

Each time the circuit is thus opened the magnetic flux around the core in the ignition coil collapses

and induces a momentary high voltage in the secondary winding. You will note that one end of this secondary coil is connected to the primary terminal and has a circuit back through the battery to ground, G. The other end of the high-tension winding goes directly to the spark plug, so that the high voltage will flash across the spark plug points in the form of a hot spark; then through the shell of the plug to the ground connection, G2, and back through the metal frame of the engine to the grounded battery terminal, and on to the start of the secondary coil. This completes the high-tension circuit for one plug.

The voltage induced in the secondary winding of the coil not only depends upon the number of turns in the secondary and the amount of flux set up by the primary, but also depends upon the speed of flux collapse around the coil and core when the breaker points open the circuit.

When the primary circuit is open the current flow does not stop instantly because of the effect of self-induction in the windings. The collapsing flux induces a rather high voltage in the turns of the primary winding, and tends to maintain a current flow in the form of an arc across contacts A for a small fraction of a second after these contacts are open.

This tends to slow up the flux collapse and thereby reduce the voltage induced in the secondary. The arc that is caused at the breaker points by this self-induction would also tend to burn and damage the surface of these points if something were not done to quickly extinguish the arc.

15. IGNITION CONDENSERS

To eliminate the arc at the breaker points and also to counteract the tendency of current to flow after the primary circuit is broken, a device known as an ignition condenser is used.

In Fig. 24 this condenser is shown at "C", and is connected directly across or in a parallel with the contact points at "A".

These condensers consist of a number of layers or small sheets of tinfoil separated by sheets of insulating material, usually paraffin paper or mica. Alternate tinfoil sheets are connected together forming

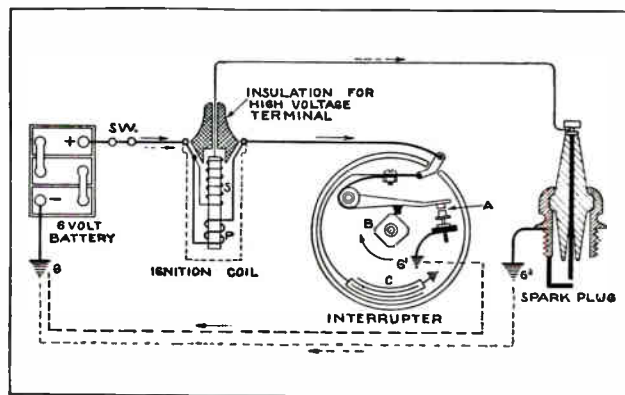

Fig. 24. This simple sketch shows both the primary and secondary circuits of a battery type ignition system. Trace the primary current through the heavy wire and ground connections, and the secondary current through the light wire, spark plug, and ground connections.

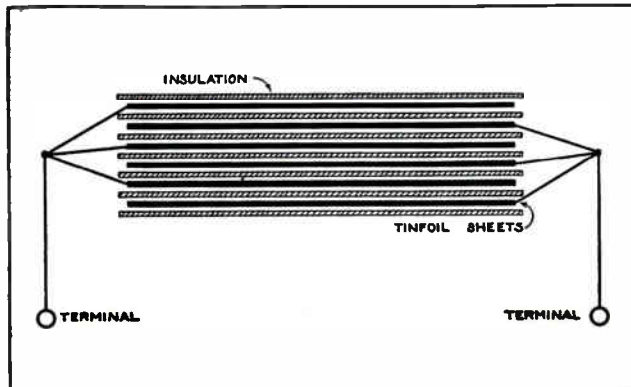

Fig. 25. Diagram showing the construction of a simple condenser with groups of conducting sheets separated by sheets of insulation. In ignition systems it is very important that this insulation be in good condition and have no shorts or grounds.

one terminal of the condenser, and the remaining sheets form the other terminal, as shown in Fig. 25.

With the condenser connected across the points as shown in Fig. 24, when the points open the primary circuit the self-induced voltage which tends to keep current flowing through the primary is absorbed by the condenser. This induced voltage, which at times reaches an instantaneous value of 200 volts, charges the condenser instead of forming an arc at the breaker points.

The charged condenser then applies a back voltage to the primary coil and circuit, thus effecting an almost immediate stoppage of current flow and greatly speeding up the demagnetization of the iron core.

This increase in the speed of flux collapse greatly increases the voltage induced in the secondary and applies to form the spark at the plug points. In fact, a coil with a good condenser of the correct capacity may often produce a spark ten times as great as a coil without any condenser. If the condenser is defective the ignition system will not operate.

In addition to this great improvement in the ignition itself, the condenser greatly increases the life of the breaker contacts and enables them to operate for long periods without attention, by almost entirely eliminating the arc when these points open the primary circuit.

16. EFFECTS OF SELF-INDUCTION

A fact that has a very important effect upon the operation of ignition coils is that it requires a small fraction of a second for the current in the primary coil to build up to full value after the breaker points are closed. This is also due to the counter-voltage of self-induction. The time required for the current to build up to maximum value depends upon the design of the coil and the self-induction of the primary circuit.

This becomes a very important factor, particularly with high-speed engines with a large number of cylinders, because, as already mentioned, it may be necessary for the breaker points to open and close several hundred times per second. If there is not

sufficient time between the closing and opening of the breaker points for the primary current to build up to full value, then when the points are opened there is less flux to collapse across the secondary turns, and there will be less induced voltage in the secondary and at the spark plug points.

An ordinary ignition coil may require approximately .012 of a second for its primary current to build up to full value after the points are closed. By changing the design of the coil and providing a magnetic circuit of lower reluctance and a primary winding with less turns, it is possible to reduce the amount of self-induction in the winding and thereby speed up the action of the coil.

Referring to Fig. 26 and carefully comparing the curves for the fast and slow ignition coils, you will note that on the coil design for fast operation the current can build up to its full value of approximately 6 amperes in a time of .006 second; while the slow coil requires approximately .012 second, or twice as much time, to build up to its maximum current.

From this we can see that the design or speed of operation of ignition coils is very important and must be considered when changing or replacing coils, particularly on high-speed engines.

A slow speed coil would require the breaker contacts to be closed for nearly .012 second in order to build up full current and obtain a good spark on each break, and with high-speed engines the period during which the breaker points remain closed may be considerably less than .006 second.

This matter of speed or time lag in the operation of ignition coils also explains why the sparks supplied by the battery ignition system become weaker as the engine approaches higher speeds; because, as the speed increases, the period of time during which the breaker contacts remain closed becomes less.

17. IGNITION COIL RESISTANCE

Decreasing the number of turns in the primary winding of an ignition coil to speed up the action of the coil has the undesirable effect of reducing the primary resistance to a point that will cause it to take an excessive current at low engine speeds when the breaker points are allowed to remain closed for

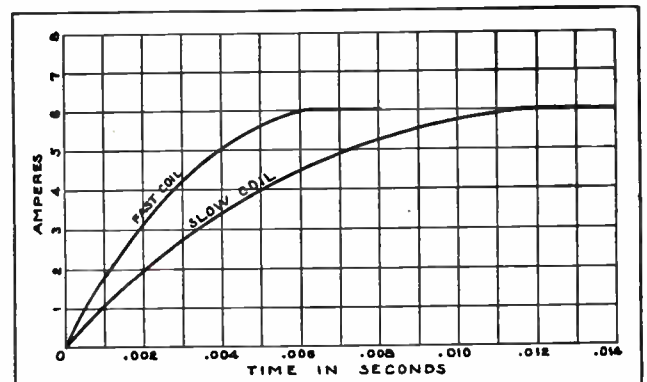

Fig. 26. The above curves show the difference in time required for different types of coils to build up their full primary current after the breaker points close.

longer periods. This tends to cause the coil to overheat.

To prevent this a current-limiting resistance is connected in series with the primary winding of the ignition coil. This resistance is made of material of such a nature that its resistance increases with its current and temperature.

When the engine is operating at high speed and the breaker points are closed only for very short periods the current flow through the primary and the resistance is less. This allows the resistance unit to remain cool and keeps its resistance low, so that it does not interfere much with the flow of current through the coil primary.

As the engine speed is reduced and the breaker points are closed for longer periods, allowing the coil to draw a heavier current, this increased current raises the temperature of the resistance unit, causing its resistance in ohms to increase and thus limiting the primary current to the proper value to prevent overheating of the winding and coil.

This small resistance unit also protects the coil from burning out in case the ignition switch is left turned on when the engine is stopped, and also during the periods of high voltage which may occur due to faults in the generator.

Excess current from either of these causes will heat up the resistance element to a point where its resistance becomes very high, thus limiting the current flow and protecting the coil.

In case the switch is left on too long or the generator fault is not removed, the resistance unit may be burned out and thus open the circuit; but this unit is much easier and cheaper to replace than a burned out coil would be.

These primary resistance units are generally wound on small porcelain or asbestos insulators and are mounted right on the ignition coil.

18. VIBRATING-TYPE IGNITION COIL

Some of the earlier types of ignition systems, a few of which are still in use on older cars, use the vibrator-type spark coil. On these coils the circuit is made and broken by a magnetically operated armature and a set of contacts attached directly to the end of the coil, instead of being broken by the breaker points in the distributor as with modern ignition systems.

Fig. 27 shows a coil of this type mounted in a wooden box equipped with spring contacts and screw terminals for completing the circuits through the ignition wires. When this coil is connected in the ignition circuit the current enters the terminal marked "connect to switch" and flows around the primary winding, through the vibrator contacts, to the terminal marked "connect to commutator".

From this point it flows through the timer or "commutator", and back to the battery. When the current flows through the coil the iron core becomes magnetized and pulls down the steel spring or armature to which the lower contact is attached,

thus breaking the primary circuit and inducing the high voltage in the secondary.

Breaking the circuit by demagnetizing the core allows the spring to move up and again close the contacts, thus repeating the operation very rapidly as long as the primary circuit is completed by the timer.

These contacts when properly adjusted vibrate with a speed of 200 breaks per second or more. To prevent the contacts from opening before the coil is fully magnetized, the upper contact is also mounted on a spring and tends to follow the lower contact down a short distance when it is attracted to the core.

This action continues until the upper spring strikes a stop on the under side of the adjusting bar; and at this point a quick, snappy break is effected.

The vibrator can be adjusted by turning the nut at the end of the adjustment bar, thus varying the distance between the spring and the iron core. Coils of this type were used extensively on Model T Fords, but are now considered obsolete.

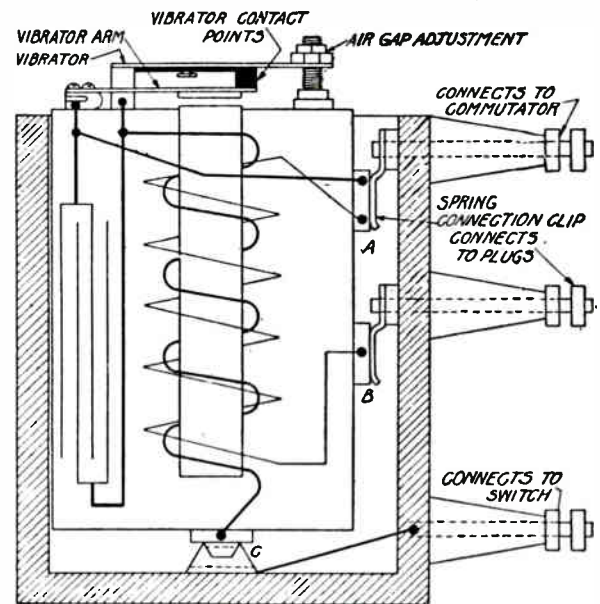

Fig. 27. Diagram of a vibrating type spark coil such as used on older model Fords and single-cylinder gasoline engines. Note the location of the condenser and trace out both primary and secondary circuits carefully.

Fig. 28 shows a wiring diagram of the ignition equipment for the model T Ford. You will note that these systems used four separate spark coils, one for each cylinder, and that the current from the battery was supplied to the primary of each spark coil at the proper time by means of the timer, or "commutator".

By tracing out this diagram you will find that current flows from the positive terminal of the battery to the switch which is used for connecting the ignition system to either the battery or the magneto. From the switch the current is supplied to a common bus or battery connection which feeds to all primary windings of the ignition coils.

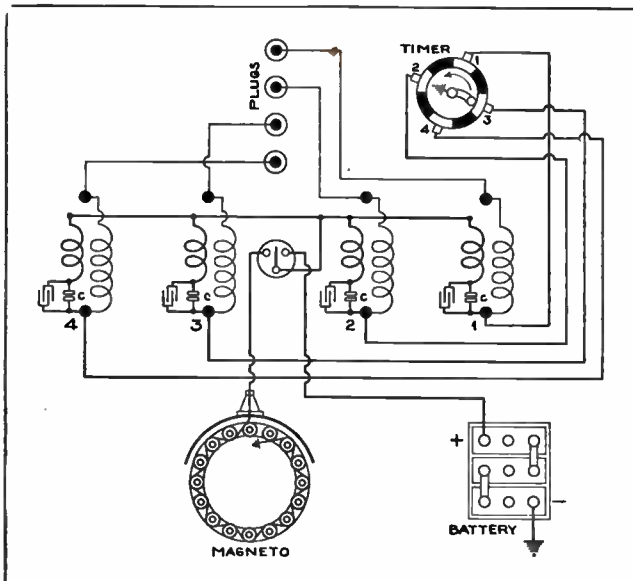

Fig. 28. Wiring diagram of the ignition systems used on the Model T or older type Fords.

Tracing the circuit of coil 3, the current would flow through the primary, then through the vibrator contacts, C, and out along the wire to terminal 3 on the timer; then through the rotor or movable arm of the timer to ground. From the ground connection it returns to the grounded negative of the battery, thus completing the circuit for this coil.

As the timer arm rotates counter-clockwise, as shown by the arrow, it closes the circuits to the primaries of the various coils in the order 1, 2, 4, 3. As each coil is excited in turn it delivers a spark from its secondary directly to the spark plug to which it is connected.

From this we find that systems of this type use four ignition coils instead of one coil as used by modern systems. The vibrating contacts on these coils also have a tendency to wear out or become burned and blackened, so that they require more or less frequent attention.

Note that the timer, which at the proper instant supplies the current to the various coils in order to create sparks at the right time in the different cylinders, is located in the primary circuit to the coils.

Modern ignition systems use a distributor in the secondary circuit and this will be explained in later paragraphs.

19. SPARK PLUGS

In order to introduce the ignition sparks inside the cylinders or combustion chambers, some highly insulated heat-resisting device is needed to carry the high voltage through the metal cylinder-head to the spark point located inside. For this purpose spark plugs are used.

Spark plugs are made in a number of different types, but in general they consist of a threaded metal shell which screws into the opening in the cylinder-head and which contains the electrodes or spark gap terminals, and a heavy porcelain or mica

insulator which has the high-voltage terminal run through its center. The outer end of this insulated high-voltage terminal is equipped with a nut or clip for attaching the high-tension ignition wire.

Fig. 29 shows several different styles of spark plugs, and Fig. 30 shows sectional views of several plugs with each of the various parts marked and named. Examine this figure very carefully until you are sure you are thoroughly familiar with the construction of these devices.

Because of the very severe conditions under which spark plugs operate they must be carefully designed both as to materials and shape, and it is also very important to use the proper plugs when replacing old ones in an engine. The porcelain insulator for the center electrode must be a good insulator capable of withstanding at least 8000 volts or more, and should maintain its insulating qualities at very high temperatures. Under certain conditions this insulator may be subjected to temperatures of over 3000° F.

If this insulator cracks or breaks down in any way the high voltage will leak from the center electrode directly to the shell of the plug and be grounded to the engine without passing across the spark gaps between the electrodes inside the cylinder. Porcelain is used almost entirely for insulation in spark plugs made by leading manufacturers.

The metal used for the electrodes themselves should have a rate of expansion approximately equal to that of the insulation, so that it will not crack the insulator with changes of temperature and will not loosen and allow leakage of the compression or expanding fuel gases. This metal should also be of such a nature that it will not be rapidly burned away

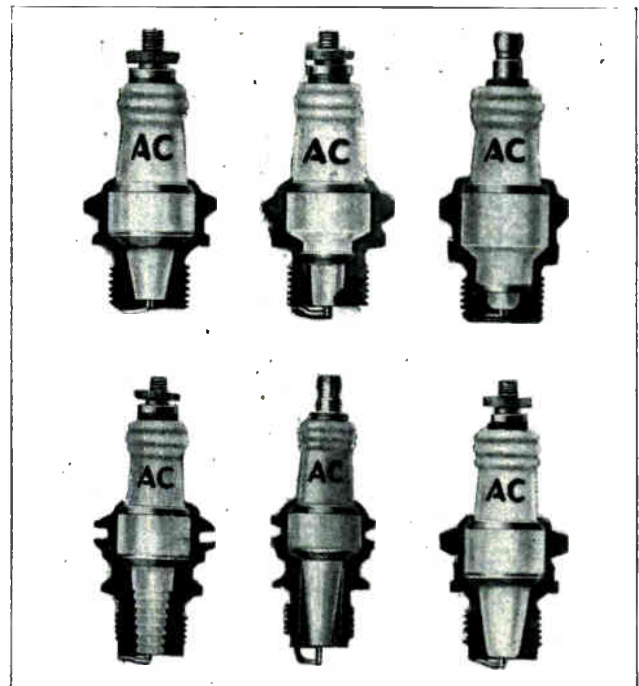

Fig. 29. Above are sectional views of several types of spark plugs showing their construction and the arrangement of the metal and porcelain parts, as well as the electrodes or points.

by repeated sparks, and it should not distort or change the length of the spark gap appreciably with various changes in temperature. The metal generally used for these electrodes is a nickle alloy.

The spark plug shells are made of steel and they are threaded on their lower ends to fit tightly into the threaded openings in the cylinder head and also to allow the plugs to be conveniently removed for cleaning, adjustment, or replacement.

If the plug points become badly fouled with carbon, it may tend to short circuit them and reduce the heat of the spark. In such cases the plugs should be removed and scraped or sand blasted clean. If the points become bent or badly burned away this may interfere with the efficiency of the spark and ignition of the fuel mixture, and such points should be adjusted or the plug replaced with a new one.

The top or outer end of the porcelain insulator should be kept free from dirt and moisture; otherwise the high-voltage energy may leak from the connection terminal down over the surface of the insulator to the metal plug shell, instead of flashing across the points inside the cylinder as it should.

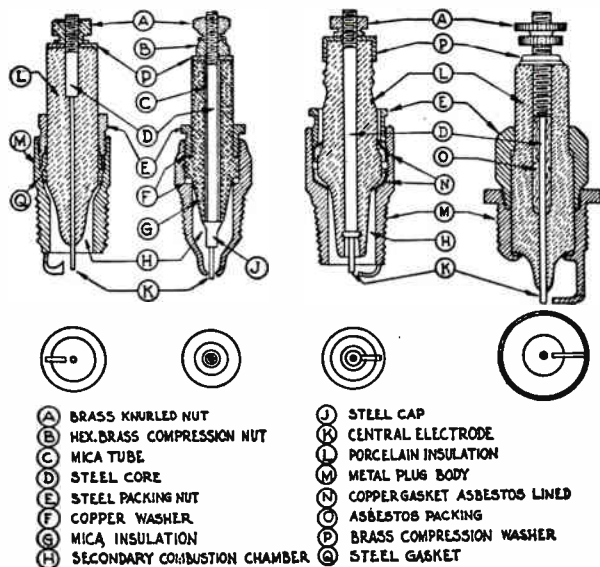

Fig. 30. This diagram also shows sectional views of several different spark plugs and gives the names of the various parts.

20. SELECTION OF PROPER TYPE PLUGS

There are two different sizes of spark plugs used in automobile engines and these are classified according to the type of threads used on the plug shell, and according to the diameter of the threaded portion of the shell.

The S.A.E. plug, so called because it has been declared standard by the Society of Automotive Engineers, has a diameter of $\frac{7}{8}$ of an inch at the threaded portion and is still used by the majority of automobile manufacturers. The other type of plug is known as the "metric" plug, because it uses metric threads and has a diameter across the threads of 18 millimeters (approximately $\frac{11}{16}$ of an inch).

Due to the definite tendency toward higher compressions and higher operating temperatures in modern engines, the metric plug is coming into favor with engine manufacturers. Its smaller diameter results in less distance between the plug points and the water-cooled metal of the engine, and this means that the heat from the plug points is dissipated more quickly, thus enabling the plug to run cooler at very high engine temperatures.

When changing spark plugs in an engine, the manufacturer's recommendations should always be followed; that is, plugs should be replaced with those of the same type as originally supplied.

Extreme operating conditions may occasionally make it necessary to change the type of plugs, but in general this should not be done. One reason for using the same type of plugs is that the thickness of metal in the cylinder head varies with different engines, so various engines require longer or shorter plug bodies below the threaded portions in order to locate the points in the best igniting position in the combustion chamber.

Spark plug bodies are made in different lengths—short, medium, and long. If a long bodied plug is used in an engine built for short plugs the lower end of the plug will extend too far into the combustion chamber, as shown at the left of Fig. 31, and it may be bumped and damaged by a moving valve or the top of the piston. This will also cause the plug points to overheat and may cause pre-ignition or early firing.

On the other hand, if a plug that is too short is used the points will be located in a pocket above the combustion chamber, as shown in the center view in Fig. 31. There is a tendency for dead gas to lie in this pocket and cause such a plug to misfire. This position of the plug points will often cause them to become badly fouled with carbon. In a few cases of extreme operating conditions short plugs may be temporarily used to avoid overheating and other troubles.

On the right in Fig. 31 is a plug of the proper length with its lower end just flush with the upper surface of the combustion chamber, and with the electrodes or spark points projecting about $\frac{3}{16}$ of an inch into the chamber.

The distance or spacing between spark plug points has a very definite effect upon the performance of the engine. Incorrect setting of these points will often cause irregular operation and sometimes complete failure of an engine.

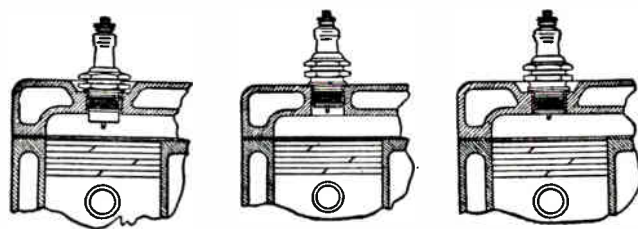

Fig. 31. The above sketches show spark plugs improperly fitted to the cylinder on the left and properly fitted in the cylinder on the right.

For normal compressions a gap of approximately .030 inch gives best results. High-compression engines will usually operate more satisfactorily with a shorter plug gap of about .025 inch for engines with compression pressure exceeding 80 lbs. per square inch.

In many cases the exact proper setting can only be determined by experiment or test, the best setting depending upon the running speed at which perfect performance is desired. For example, good low-speed operation can best be obtained with a rather wide gap setting while at very high speeds best performance is often obtained by closing up the plug gap slightly.

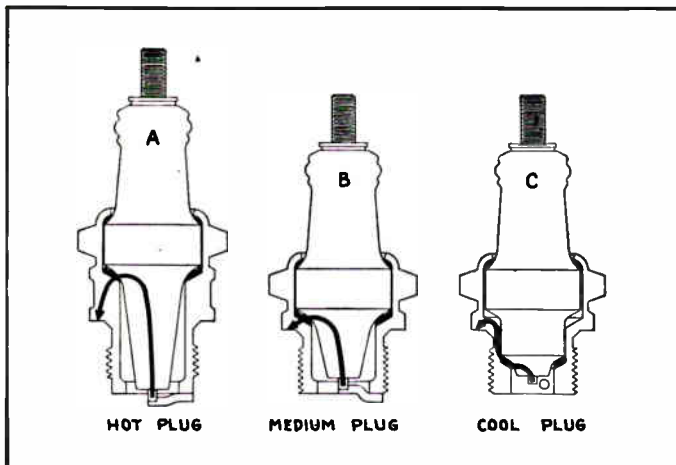

Fig. 32. Sectional views of A. C. spark plugs. Note length of heat path as shown by arrows.

21. SPARK PLUG HEAT RANGES

To give satisfactory performance spark plugs must operate within a certain temperature range. They should not run too hot or too cool. The temperature should be high enough to burn away oil or carbon as they collect on the insulator, otherwise the plug will become short-circuited, and require cleaning. On the other hand, if the operating temperatures are too high, blisters will form on the insulators, electrodes will wear away rapidly and pre-ignition may occur with its loss of power and poor engine performance.

The heat range of a plug is determined by the ability of the insulator to conduct heat away from its hot lower end, to the metal shell of the spark plug. The metal shell is cooler because of its contact with the water-cooled engine block. Just how fast this heat can be carried away depends largely on the length of the path the heat will have to follow.

For example, if the path is long as in plug A, in Fig. 32, heat dissipation will be slow, and the insulator will maintain a high temperature. This type of plug is known as a "hot plug" and is suitable for engines that tend to run cool, due to de-

sign or operating conditions. Used in such an engine, the temperature of the insulator will be high enough to burn away oil or carbon as they collect on the plug.

On the other hand, if the path of heat travel is short as in plug C, the heat will be carried away rapidly, which would prevent the insulator from becoming overly hot even when used in an engine that has a tendency to run at high temperatures. This plug would be known as a "cold plug."

Automobile and engine manufacturers, always select a plug having a heat range that is satisfactory for average driving conditions. However, a plug that is correct for average driving conditions may not be satisfactory if the car is operated at high speed over long periods, or under a constant heavy load. The heat generated under these conditions may not get away fast enough and the plug will become too hot causing pre-ignition, fast burning away of the plug electrodes and in some cases blistering of the insulator, which will eventually lead to short-circuited plugs and faulty engine operation.

If a cold type plug is used in an engine that is only driven for short distances and allowed to idle for long periods, the heat generated in the plug may be carried away so fast that the insulator may operate at too low a temperature, causing the plug to carbonize rapidly. Or if the engine has a tendency to pump oil, the cold plugs will become oil fouled.

To meet these unusual driving and engine conditions spark plug manufacturers build plugs having different heat ranges. One prominent manufacturer makes plugs with 18 different heat ranges, running from an extremely cold plug, suitable only for racing engines that operate at high temperatures, to a very hot plug suitable for engines that run cool and tend to pump oil.

All A. C. plugs have a number on the insulator. This number indicates in sixteenths of an inch, the length of the insulator that is exposed to the heat of the combustion chamber, or the length of the path that the heat has to travel in order to reach the metal shell of the plug. The lower the number, the shorter the path, and the cooler the plug. The higher the number, the longer the path, and the hotter the plug.

Manufacturers and distributors of spark plugs put out heat range charts that are useful in selecting plugs to meet unusual operating conditions. Service manuals always give the type of plug that the engine builder found to be best for average driving conditions, and this is the plug that should be used in replacing plugs that have worn out in service. But if you have a case of chronic fouling,

then a plug "hotter" than the original should be tried.

In cases of pre-ignition, blistered insulators, or electrodes burning away rapidly, you should try a cooler plug. If the plug develops "blow-by" which will be indicated by a black streak on the outside or upper part of the insulator, try a cooler plug.

In making a change from the plugs or recommended heat range, it is not a good policy to make too much of a change at once. It is best not to lower or raise the heat range more than two numbers for a trial.

22. DISTRIBUTORS

On a modern ignition system the ignition coil produces the high-voltage impulses at the right time by the operation of breaker points or an interrupter such as was shown in Fig. 24. To deliver these high-voltage impulses to the proper spark plugs or to the cylinders in their proper firing order a device called a distributor is used.

The diagram in Fig. 33 illustrates the operation of this distributor. The rotor, R, is driven by a direct connection to the engine, so that it always revolves at a definite speed with respect to the engine speed. This rotor arm is connected to the high-tension lead from the ignition coil; so that as it revolves it delivers the spark impulse to the spark plugs in the various cylinders in the order in which they are connected to the stationary contacts in the distributor cap, which is made of insulating material.

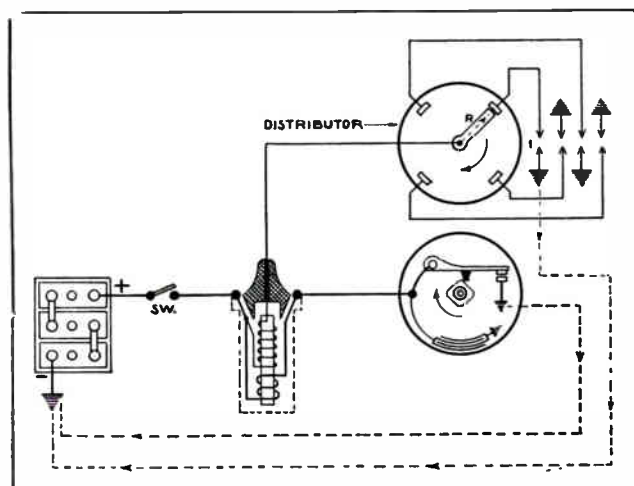

Fig. 33. Diagram of a battery ignition system showing both the primary circuit through the breaker points and the secondary circuit through the distributor arm contacts to the spark plugs.

The current flows from the distributor wires through the center electrodes of the various plugs; then across the spark gaps to the plug shells, which, of course, are grounded to the engine and allow the current to flow back through the engine and frame to the grounded terminal of the battery, and then to the return of the ignition coil secondary.

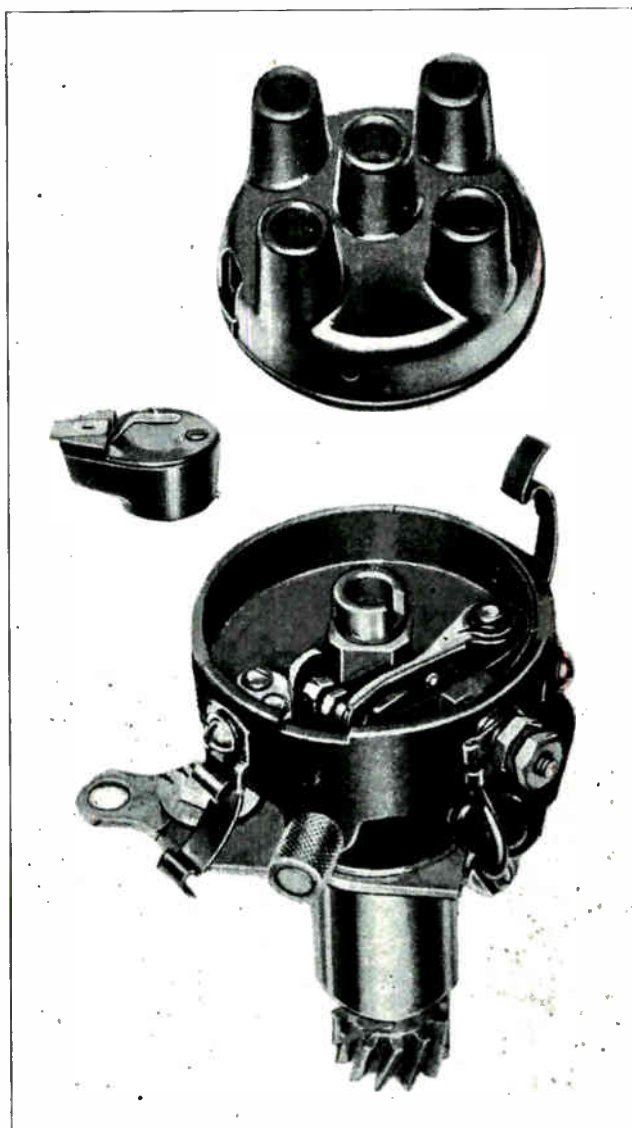

Fig. 34. This view shows a distributor with the high tension cap and rotor removed so that the primary breaker points and cam can be clearly seen in the distributor housing.

The term "distributor" is generally applied to the complete unit which contains both the interrupter points and the distributor rotor and contacts.

Fig. 34 shows a photograph of a distributor with the "cap" or "head" removed. This cap is shown at the upper right with its terminals for connecting the high-tension ignition wires. The one high-voltage wire from the ignition coil always connects to the center terminal of these caps, while the spark plug wires connect to the outer terminals in the proper order.

This distributor cap or head is made of bakelite or a compound of high insulating quality. On the inner side of the cap are located metal electrodes or stationary contacts for each terminal. The small rotor shown at the upper left fits on the top of the distributor shaft directly above the cam and rotates when the engine is running, delivering high-voltage impulses to the plugs through the stationary contacts in the distributor caps as it passes them.

In the lower part of Fig. 34 is shown the interrupter mechanism with the breaker points and cam in plain view. The small metal lever projecting to the left and fitted with a round eye is for shifting the distributor to advance or retard the spark by moving the breaker points a slight distance around the cam.

Fig. 35 is a top view of a distributor with the cap removed to show more clearly the breaker arm or contact lever, breaker contacts, cam, and condenser. The arm for shifting the breaker mechanism to advance and retard the spark is also shown in this view.

The number of sparks generated per revolution of the distributor shaft will depend upon the number of corners or projections on the cam. If the cam is four-cornered four sparks will be produced, and if the cam is six-cornered six sparks will be produced for each revolution.

As any automotive engine fires all cylinders in two revolutions of the crank shaft and the distributor is built to generate the sparks required for all cylinders in one revolution of the distributor shaft, the distributor therefore must be geared to the engine so that it rotates at one-half engine speed. This rule applies to all automotive engines.

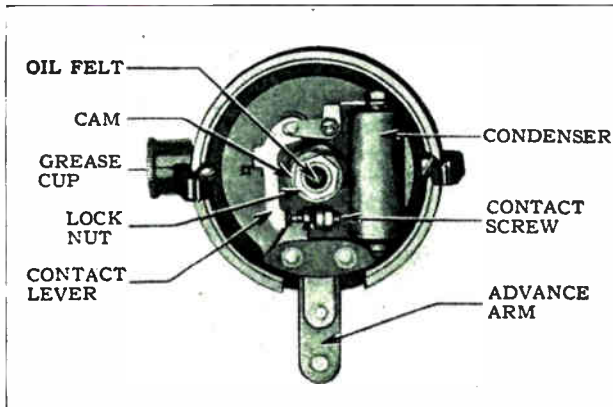

Fig. 35. Top view of the breaker mechanism and condenser of an ignition distributor. Note the names of the various parts.

23. METHODS OF ADVANCING THE SPARK

We have already mentioned the necessity for advancing the spark to obtain earlier ignition of the fuel charge and maximum power and efficiency when the engine is operating at very high speeds. There are two general methods used for advancing and retarding this spark through shifting the breaker plate or housing around the cam in the distributor.

These methods are the manual control, or hand-operated method, and the automatic control obtained by means of governor weights which advance the spark automatically with an increase of engine speed and without any attention from the drivers.

The manual method advances the spark by moving either the breaker plate or the entire distributor

housing to shift the breaker contacts a slight distance around the cam. Moving the breaker contacts in the opposite direction to cam rotation causes the contacts to open sooner and advance the spark; while moving the housing or breaker in the direction of rotation of the cam will retard the spark. This movement may be obtained by the driver moving a small lever attached to the steering wheel and connected through a rod to the lever on the side of the distributor.

Efficient engine operation requires a gradual advance of the spark as the engine speed is increased and a proportional retarding of the spark as the engine speed is reduced. It is practically impossible to meet this condition by hand operation, but the spark advance and retard can be much more accurately regulated by automatic control.

Automatic spark advance is generally accomplished by shifting the position of the cam with relation to the distributor shaft. The cam is mounted in such a manner that it can be moved around the shaft a slight distance in either direction.

The operating mechanism consists of a set of weights which are attached to and rotate with the distributor shaft. As the speed of the shaft increases with an increase in engine speed, centrifugal force causes the weights to move outward from the shaft, the amount of this movement being proportional to the speed of the engine.

The governor weights are attached to the cam so that they cause it to shift around the shaft in the direction of rotation as the weights fly outward, thus advancing the spark. When the speed is decreased the weights are drawn in by springs and

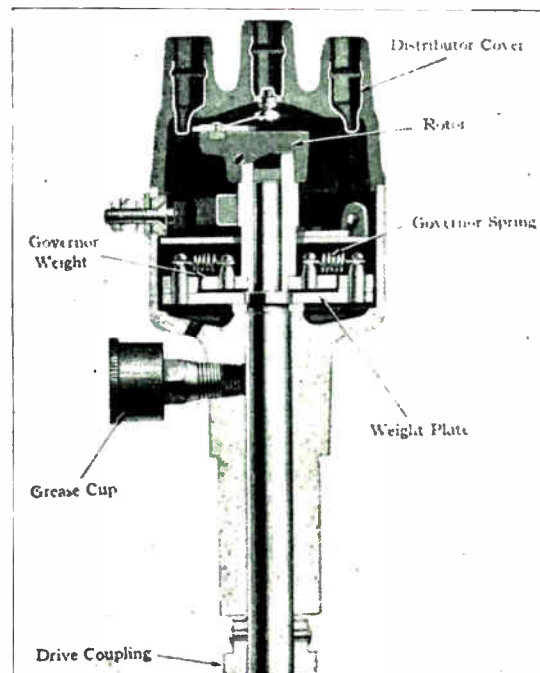

Fig. 36. Side sectional view through a distributor with automatic spark advance mechanism shown in the lower part and secondary rotor and contacts shown in the upper part.

the cam gradually moves back against the direction of rotation and retards the spark.

Fig. 36 shows a sectional view of a distributor in which the governor weights and springs can be seen in the lower part of the housing. Directly above these are located the cam and breaker points, and in the top of the distributor a rotor can be seen. The rotor has a permanent sliding contact connection with the center terminal of the distributor cap, while the metal tip of the rotor arm delivers a high-voltage impulse through a very short gap to the terminals of the spark plug wires as it passes them.

Fig. 37 shows a distributor of the automatic spark-advance type, with the cap and breaker element removed and the governor unit raised up out of the housing to show the weights and springs clearly. A loose cam is shown directly above the governor unit. When this cam is set in place on the shaft the wings on each side of its lower end fit over the pins on the governor weights; and, as these weights are thrown out or drawn in, the pins shift the position of the cam with respect to that of the shaft, thus effecting smooth and automatic adjustment of the spark with various engine speeds.

24. TIMING THE IGNITION

Timing the ignition means setting the distributor so that it supplies the spark to the correct cylinder at the right time; that is, not too late or too early.

The methods used to accomplish this vary somewhat with differences in distributor design; but the general procedure should be as follows:

1. Set the engine with No. 1 piston at U.D.C. on the compression stroke.
2. Move the spark lever to the full retard position.
3. Adjust the breaker contacts so that they are .020 inch apart when fully open.
4. Loosen the screw or nut which locks the advance lever to the housing.
5. Turn the distributor housing until the rotor arm comes in line with the contact on the cap that is connected to the spark plug in No. 1 cylinder.
6. Adjust the housing so that the breaker contacts are just beginning to open.
7. Lock the advance lever screw.

On some distributors the spark lever is riveted to the housing and cannot be moved. In such cases timing is effected by adjusting the cam on top of the shaft to a point where the rotor is lined up with segment 1 on the distributor cap as the breaker contacts are just opening. The cam is then locked in position by the locking screw or lock nut.

After the ignition has been timed, it is a good plan to carefully check the wires in the distributor cap to see that they are correctly connected. To do this the firing order of the engine and the direction of rotation of the rotor arm must be known.

The firing order is usually stamped on some part

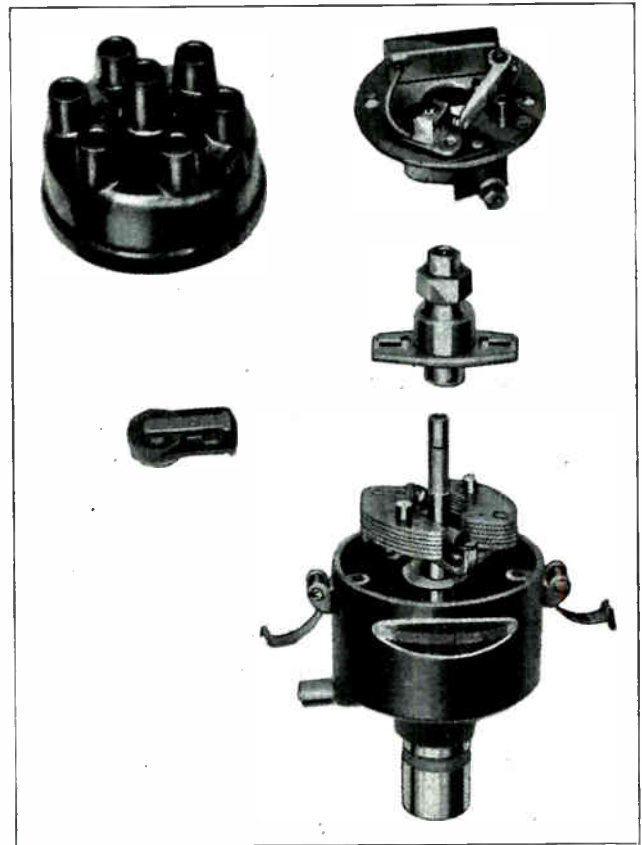

Fig. 37. Disassembled view of a distributor with automatic spark advance, showing the governor weights in the view at the lower right.

of the engine; but, if not, it can be readily determined by the methods explained in Article 11.

For example, on a six-cylinder engine with the firing order 1-5-3-6-2-4, No. 5 cylinder fires immediately after No. 1 and the wire from No. 5 spark plug should connect to the distributor cap segment that the rotor arm passes next after No. 1. The wire from No. 3 cylinder should connect to the next segment. And so on until they are all attached in the proper order. This method applies to all distributors using a single rotor arm.

25. SETTING THE ENGINE ON UPPER DEAD CENTER

One of the easiest methods of setting No. 1 piston on U.D.C. and one that can be applied to all side valve engines, is the "spark plug leakage" method. Unscrew the plug in cylinder No. 1 a few turns so that air can leak past its threads. Then pour into the recess around the plug just enough oil to seal this air leak. A couple of shots from an oil can will generally be sufficient.

Next, crank the engine slowly until bubbles are seen coming through the oil, which means that the piston is coming up on the compression stroke. Now bump the crank around just a little bit at a time and at each movement watch for the bubbles. When a point is finally reached where no bubbles arise when the crank is moved, that will be U.D.C.

The above method cannot be used on overhead valve engines as the plugs are generally screwed

into the side of the cylinder instead of the top. With engines of this type the U.D.C. for cylinder No. 1 can be found by watching the valves, and is reached just at the time the exhaust valve of the last cylinder closes or seats. This point can be determined by slipping a small piece of paper between the valve stem and rocker arm. As long as the rocker arm is holding the valve open against the tension of the spring the paper will be held firmly in place; but just as soon as the valve seats or closes, this tension will be removed from the paper and it will slip out if lightly pulled upon.

Remember that it is the exhaust valve in the last cylinder which is to be observed to determine upper dead center for No. 1 cylinder.

26. SPECIAL IGNITION SYSTEMS FOR HIGH-SPEED ENGINES

Some of the high-speed, high-compression engines used on late model automobiles require specially designed ignition systems for maximum operating efficiency. This can be better understood if we consider the fact that a six-cylinder engine using a six-cornered cam in the distributor and rotating at 3000 R.P.M. will have its breaker contacts opening 150 times per second, and these contacts remain closed only for about .004 second each time after making the primary circuit. These periods will be still shorter on a high-speed eight-cylinder engine.

In order to secure satisfactory operation at such speeds the ignition coil must be fast enough in action to build up its current during the short period of contact closure, and the breaker must do its work very accurately.

During the very short period that the contacts are closed a good contact without chatter or vibration must be made; otherwise the coil will not have time to completely magnetize and a very weak spark or complete miss will be the result.

27. DOUBLE OR "DUAL" IGNITION

To reduce the period of time required to burn the fuel charge and insure more complete combustion at high speeds, some engines are now being equipped with two ignition systems which operate together to supply two sparks to each cylinder.

These sparks occur at the same instant at different points in the combustion chamber, thus spreading the flame more quickly through the entire fuel charge.

The advantages claimed for the dual system are increased horsepower and efficiency, and also greater dependability because there are two separate ignition systems. If one should fail the engine can still be run on the other.

Fig. 38 shows a simple diagram of the coils, breaker, and high-tension leads to the distributor of such a system. From this diagram you can see that there are simply two separate sets of breaker points,

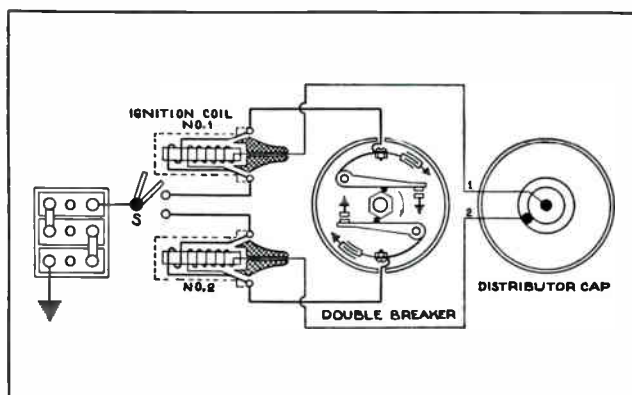

Fig. 38. This diagram shows the parts and connections of a dual ignition system used for firing two plugs in each cylinder. See the rest of this system in Fig. 39.

condensers, ignition coils, and high-tension leads to the distributor.

The only point at which these two systems are connected together is at the ignition switch, S; and, even though the two breaker arms are both operated by the same cam, they are electrically insulated or separated from each other.

Both breaker contacts are caused to open at the same time by the cam, and this causes a collapse of flux in both coils at the same time, in turn causing them to send high-voltage impulses to the two distributor terminals at the same instant. From this point the two impulses are delivered separately to the two spark plugs located in opposite sides of the combustion chamber.

Early types of double ignition systems used two separate distributor units, but these were later combined into one by changing the design of the rotor arm and distributor cap.

In Fig. 39 is shown a diagram of the connections from the distributor head to a six-cylinder engine equipped with dual ignition. The distributor cap has 14 terminals, 12 of which connect to the spark plugs, and the other 2 are connected to the high-tension terminals of the ignition coils.

The rotor arm for such a distributor really con-

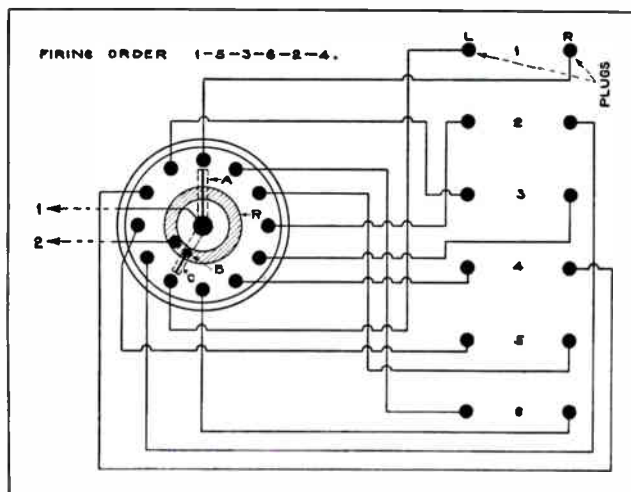

Fig. 39. Diagram showing distributor rotor arms and high voltage leads from the distributor cap to the spark plugs of a six-cylinder engine with a dual ignition.

sists of two arms electrically insulated from each other and rigidly connected together at an angle as shown in the figure. One arm conducts current from coil 1 to the spark plugs on one side of the engine. The other arm supplies current from the other coil to the plugs on the opposite side of the engine.

The high-tension lead from coil 2 connects to a conducting ring or slip ring, R, imbedded in the insulation material of the cap. From this ring the current is collected by a small carbon brush, B, that is mounted on the upper side of No. 2 rotor arm. From this point it travels along the arm to the plug segments on the cap and then to the spark plugs.

Six double sparks occur during each revolution of the distributor which means that sparks are produced every 60° of shaft travel, or $360 \div 6$. However, the angle between the segments is only 30° , or $360 \div 12$, and from this it can be seen that the rotor arm, A, for example, doesn't fire at every terminal it passes, but only at every other one. The same applies to rotor arm, C.

From the diagram you will note that when A is in position to fire any certain cylinder, C is in line with the segment which connects to the opposite plug in the same cylinder.

To obtain the best results from a double ignition system the sparks should occur at exactly the same time, and if they do not the breaker contacts should be adjusted so that they both open at the same instant.

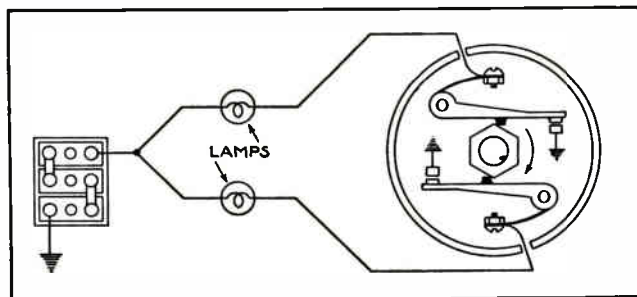

Fig. 40. This sketch shows the method of using test lamps for synchronizing breaker points of a dual ignition system.

To synchronize these breaker contacts, connect a six-volt test lamp in series with each set and then rotate the distributor shaft very slowly until one light goes out. Now adjust the other set of contacts which are still closed so that the second light goes out. If both contacts are correctly set both lights will go out at the same instant when the distributor shaft is slowly turned.

Fig. 40 shows the methods of connecting lamps for synchronizing and adjusting the breaker points of a double ignition system.

28. SPECIAL DISTRIBUTORS FOR EIGHT-CYLINDER ENGINES

On account of the high operating speeds of modern eight-cylinder engines and because of the

fact that every ignition coil requires a certain definite fraction of a second to fully magnetize its iron core, ordinary distributors have been replaced by specially designed units to meet high-speed requirements.

On earlier types of eight-cylinder distributors an eight-cornered cam and a single set of breaker contacts were used. This arrangement did not give good ignition at high speeds, as the period of contact closure was too short to allow the coil to become fully magnetized.

With eight-cylinder engines eight sparks must be produced in one complete revolution of the distributor shaft and cam, or one spark must occur for every 45° of shaft rotation, or $360 \div 8$. This means that the breaker contacts must open and close once in every 45° .

After the contacts have opened the insulated cam follower which is mounted on the movable breaker arm has to travel over the corner of the cam and down the other side before the contacts are closed again. For this reason the contacts are held open for a longer period than is necessary. This results in the contacts being closed for only 20° out of each 45° of rotation, and being open for the remaining 25° .

As the contacts need to be open for only 10° to effect a clean break of the primary current, we can see that 20° of opening is unnecessary. What is required, then, for high-speed eight-cylinder engines is a distributor which will open the contacts for 10° to allow them to remain closed for the balance of the 45° interval during which each break must occur.

This has been accomplished by using distributors equipped with a four-lobe cam and two breaker arms which are mounted at an angle of 45° to each other, as shown in the center view in Fig. 41. With this arrangement the breaker arms are raised one at a time or alternately at 45° intervals so that one set of contacts closes 10° after the other set opens.

As both sets of contacts are connected in parallel in the primary circuit, the circuit is kept closed except for the 10° intervals during which both contacts happen to be open.

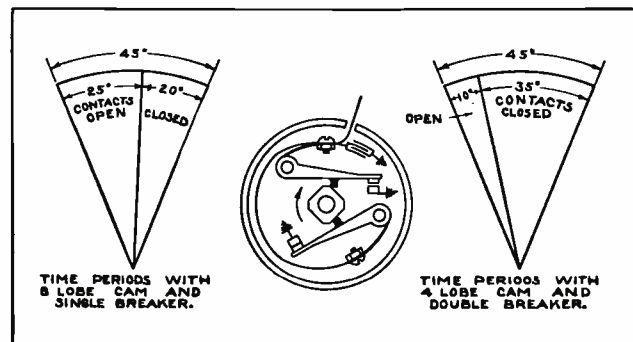

Fig. 41. Diagram showing construction of breaker mechanism for high-speed distributor and also showing periods of time which contacts remain open and closed with both single breaker and double breaker distributors.

As each set opens four times in one revolution of the distributor shaft and also opens at a point 45° from the opening of the other set, eight sparks per revolution are obtained, thus providing the proper number of sparks for an eight-cylinder engine.

Keep in mind that with this type of distributor when either set of contacts opens the other set is still open for another 10° ; so, even though the contacts are in parallel, this effects a complete opening in the circuit for a period of 10° once during each 45° .

The sketch on the left in Fig. 41 shows 45° of the rotation of the old type distributor, illustrating the 25° period during which the contacts are open and the 20° period during which they are closed.

The sketch on the right in Fig. 41 shows a 45° period of the rotation of the new type distributor. In this sketch you will note that the contacts are open for only 10° and are closed for 35° , thus giving the ignition coil much more time to build up maximum flux and resulting in much better sparks at high speed.

The top view in Fig. 42 shows one of the double-breaker-arm, high-speed distributors in use with a single ignition coil on an eight-cylinder engine, and in the lower view in this figure a distributor of the same type is shown in use with two separate ignition coils, one of which is used with each set of breaker points.

With this system the distributor contact arms are not connected in parallel, but each one is connected to its own coil and each coil only produces a spark for every other plug or cylinder. This only requires the coils to operate at the same speed as for a four-cylinder engine and therefore gives them plenty of time to build up to full magnetization in the period during which the contacts are closed.

It also allows the coils to operate at a much lower temperature.

So we can see that this arrangement accomplishes the same result as the distributor and connection in the top view.

With either of the types of distributors shown in Fig. 42 each set of breaker contacts fires only every other cylinder, or one set firing four cylinders and the other set firing the remaining four.

For example, if the firing order of an engine is 1-6-2-5-8-3-7-4 one set of breaker contacts would fire cylinders 1-2-8-7, the other set firing cylinders 6-5-3-4. Therefore, if each cylinder is to get its spark at the correct time the angle between breaker openings must be exactly 45° . Any variation from this angle would mean that four of the cylinders would fire later in the piston stroke than the other four, and this would result in loss of power and poor, uneven engine performance.

To check the setting of breakers of this type a six-volt test lamp can be connected in series with the contacts. With a system such as shown in the upper view in Fig. 42, only one test lamp is neces-

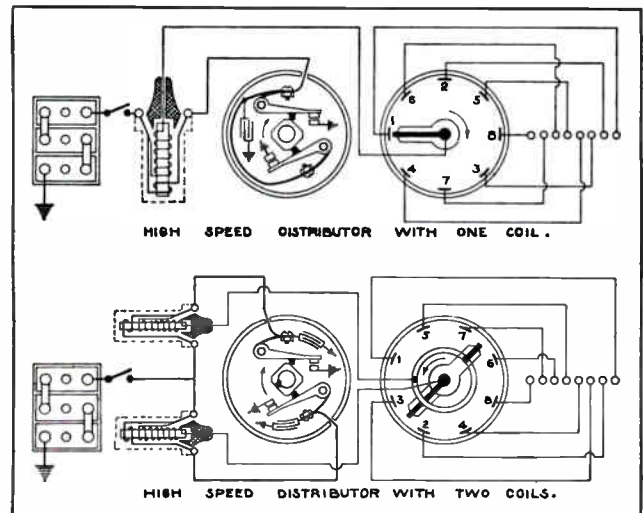

Fig. 42. The top diagram shows the connections for a high-speed distributor using one coil on an eight-cylinder engine. Below is shown the same type breaker using two coils and a slightly different arrangement of the secondary rotor arms and distributor cap contacts.

sary in the primary lead to the distributor. With the other system shown in the lower view in Fig. 42 two test lamps should be used, one connected in each of the primary leads to the separate sets of breaker contacts.

Then turn the distributor shaft very slowly by cranking the engine until the light goes out. Mark the position of the rotor arm on the edge of the distributor housing at this exact point. Then slowly turn the distributor again to the point where the light goes out once more. Mark this position of the rotor arm, and the space between the two points marked should be exactly 45° of the circle around the housing. Special gauges for accurately measuring this angle and instructions for their use can be obtained from the manufacturers of these special distributors.

In the case of the first system mentioned where one test lamp only is used the marks should be made at two points where this lamp goes out. In the case of the second system the first mark will be made where one lamp goes out and the second mark where the opposite lamp goes out.

29. IGNITION LOCKS

All automobiles are equipped with a key switch to close the primary ignition circuit when the engine is to be started and during running, and to open this circuit when the engine is to be stopped and the car to be left standing. Key switches of this type make it difficult for anyone but the owner of the car to turn on the ignition to start the engine and thereby tend to prevent automobile thefts. However, ordinary ignition switches can be quite easily wired around by anyone knowing something about electricity or ignition circuits, and for this reason such switches do not give very complete protection from theft.

Many of the later types of cars are equipped with special ignition locks and primary wiring that is a

great deal more difficult to tamper with. Cars so equipped are therefore more nearly theft proof.

Fig. 43 shows a diagram of a system of this type. By examining this sketch you will note that when the ignition switch is turned off it not only breaks the primary ignition circuit, but also grounds the wire which leads to the insulated movable arm of the breaker contacts. As the stationary breaker point is already grounded, this short circuits the breaker points, thus making it impossible for them to open the circuit and create a spark even if the ignition switch is shorted out with an extra wire.

The wire leading from the ignition lock or switch to the distributor is enclosed in heavy, steel-armored cable, to make it very difficult to cut this wire and release the locked short on the breaker points. Locks of this type are, of course, not absolutely theftproof but they make it so much more difficult for a car to be tampered with that they afford a great deal of additional protection against theft of the car.

In the case of trouble in an ignition system it may be necessary to test the switch to determine whether the fault is located in it or not. To test these lock switches use a six-volt battery and a head light bulb connected in series with a set of test points or leads.

To make the test proceed as follows: Turn the engine until the breaker contacts are fully open and then remove the coil wire from the switch terminal, T. Next place one test point on the insulated or movable breaker arm and the other on the switch terminal. With the switch turned on the lamp should light and with the switch off the lamp should not light.

Then place one test point on the insulated breaker arm and the other on the lock case. With the switch off or locked the lamp should light. With the switch turned on or unlocked the lamp should not light. If the lamp lights with the switch in the "on" position, the insulated breaker arm has become grounded due to defective insulation, the condenser is grounded, or there is a ground in the lock itself.

Disconnect the condenser and repeat the test. If the lamp does not light now the condenser is defective. If the lamp does light, disconnect the breaker arm and repeat the test again. If this puts the lamp out the breaker arm was grounded. If the lamp still remains lighted the trouble is undoubtedly in the lock, and will necessitate removing the lock to disassemble and test it.

30. TROUBLE-SHOOTING ON IGNITION SYSTEMS

In order for an automobile engine to start readily and operate satisfactorily throughout its entire speed range it must have fuel of the correct mixture, good compression, and a good spark or ignition.

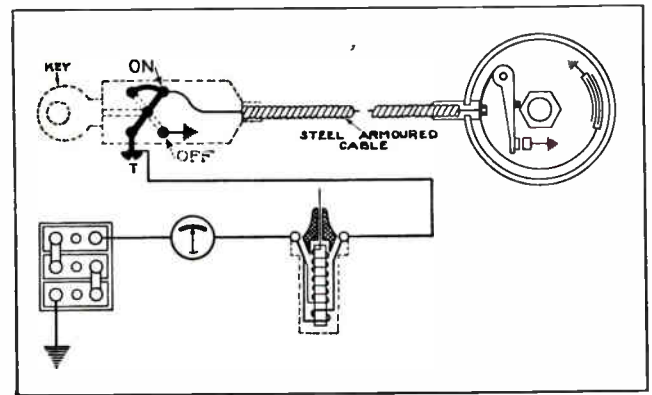

Fig. 43. The above sketch shows the primary ignition circuit through a special ignition lock switch and cable. Study the principles of this circuit carefully while reading the accompanying explanation.

Failure of any of these will result in poor performance or may prevent the engine starting at all.

When checking to locate troubles and causes of poor operation or refusal to start, the automobile trouble-shooter will generally commence with the ignition system, partly because it is one of the easiest things to check and also because trouble more frequently develops in the ignition than any other part of the engine.

Ignition systems and devices have been greatly improved in the last few years, but because of the number of small parts necessary in these systems and the delicate nature of some of these parts, there are numerous possibilities of small troubles developing which may interfere with the operation of the engine.

When we also consider the fact that the ignition devices and wiring of the systems are subjected to very extreme service conditions due to the severe vibration, dirt and dust, engine heat, and oil which the ignition devices and wiring are subjected to, we can understand better why some of these troubles occur.

We should also consider the fact that on an automobile ignition system there are used both extremely low-voltage circuits and extremely high-voltage circuits. In the six-volt circuits to the primary of the ignition coil and to the starting motor, lights, horn, etc., the slightest loose connection or resistance in the circuit will greatly interfere with the current flow.

In the high-voltage circuits from the ignition coil and distributor to the spark plugs, the slightest defect in the insulation will allow leakage or grounding of this energy.

It is estimated that approximately 75% of the ordinary engine failures encountered by the service man are due to ignition faults. However, as many engine failures are due only to an empty gasoline tank, clogged fuel line, choked or flooded carburetor, leaky vacuum tank or fuel pump, loose intake manifold or poor compression, it pays to keep these things in mind and not overlook them before going

into any elaborate overhauling or repairs to the ignition system.

It is so easy to check to see whether the gas tank is empty or not, or whether gasoline is reaching the carburetor, and also to check the engine compression by merely turning the engine slowly with the crank, that every electrical service man should watch for these troubles and know how to check them. Keeping these possible troubles in mind, as well as those that may occur in the electrical system, may also save you considerable time and money with your own car when it fails to operate properly out on the highway.

If the compression of an engine is poor because of leakage past the piston rings or through poorly fitting valves, the engine will operate irregularly because of loss of part of the fuel charge on such cylinders and loss of power or misfiring due to the low pressure of the fuel charge.

Therefore, it is necessary for smooth operation of the engine that the pistons and valves be in good condition to maintain good and uniform compression in all cylinders.

If the intake manifold or carburetor connections are loose the suction on the carburetor jet may not be sufficient to raise the proper amount of fuel, or the amount of extra air drawn in through these openings may be great enough to make the fuel mixture so "lean" that it will not fire properly.

In electrical trouble-shooting on an automobile engine two of the most important things are careful and close observation of the wiring and parts of the system, and the use of a definite systematic method of testing each part of the system.

Very often electrical troubles are caused by loose connections, broken wires, defective insulation, or faults in some of the devices which can be easily seen by carefully checking over the system. There is probably no single rule or method of trouble-shooting that will apply to all cases, because of the various types of equipment used and the varying trouble indications that may sometimes be produced by the same fault.

One very good general rule, however, is to start at the unit which appears to cause the trouble and work from that point back toward the battery.

For example, with a failure in the ignition system start at the spark plugs and check from there back from the high-tension wire to the distributor. Check the distributor for faults both in the high-tension and low-tension circuits, and then if the fault is still not located, check the wiring back to the ignition coil.

Next check from the ignition coil to the ignition switch; and so on, making sure before leaving any particular point that the system is O. K. up to that point and cannot be the cause of the trouble.

Some of the various defects which commonly occur in ignition systems and also their symptoms and remedies will be discussed in following paragraphs.

31. COMMON ELECTRICAL TROUBLES AND REMEDIES

First, let us suppose that an automobile engine will not start. One of the first things to check in this case, after making sure that there is fuel in the carburetor is the battery.

Try to operate the starting motor and if the starter turns the engine over quite lively the battery is O. K. If the engine turns over sluggishly or not at all the battery should be checked for low-voltage, low gravity of the acid, or loose connections. The tests for voltage and acid conditions will be covered more fully in the section on Storage Batteries.

Very often starter trouble and weak ignition are a result of loose connections at the battery terminals. Because of the very heavy currents required at low-voltage to operate the starting motor, the battery connections should be very securely tightened and the terminal posts and connecting clamps should be well cleaned. Otherwise the small amount of resistance placed in the circuit by dirty or loose connections will cause so great a voltage drop during the flow of the heavy starting currents that the starting motor will not develop sufficient torque to turn the engine.

Even if it does turn the engine the voltage drop during operation of the starting motor may be great enough to reduce the current flowing to the ignition coil and produce sparks too feeble to ignite the fuel mixture.

Battery connections may be good enough so that the lights and horn will operate alright when the car is standing idle, but yet not good enough to supply sufficient current to the starting motor and ignition coil to start the engine.

One of the reasons why an engine that will not start when being slowly turned over by the starter can often be started by cranking, is that when the starting motor is left out of service it allows the battery to supply more current to the ignition coil and produces a hot enough spark to ignite the gasoline mixture when the engine is cranked.

32. TROUBLE AT SPARK PLUGS

After the battery and its connections prove to be O. K., next test for a good healthy spark at the plugs. Remove one of the high-tension wires from its plug terminal and hold it about one-fourth of an inch away from the engine as at "A" in Fig. 44, to see if a good spark can be obtained when the engine is turned over.

If regular and healthy sparks can be obtained in this manner from each plug wire, the trouble is either in the plugs themselves or the ignition is out of time.

In judging the spark obtained on such tests remember that a thin, weak, threadlike, blue spark may not be sufficient to ignite the gasoline mixture in the cylinder, and also remember that a spark will jump considerably farther in open air than it will under compression inside the cylinder. In order

to dependably ignite the fuel mixture, the spark should be hot and fiery appearing, or "fat" as it is often called. It is not alone the voltage of the spark that ignites the gasoline mixture but also the amount of current and the heat developed that make a good spark.

If good hot sparks can be obtained from all of the plug wires and yet the engine will not start, remove the plugs and examine them. If they are dirty or carbonized they should be cleaned and the points should be checked to see that they are set about .025 inch apart. If any of the plugs have cracked insulators or the points are badly burned away, they should be replaced.

Also be sure to see that the outer ends of the plug porcelains are clean and free from dirt and moisture, as sometimes a layer of moisture or damp dirt will allow the spark to creep along the surface of the porcelain and short circuit to the plug shell in this manner, rather than jump across the plug points inside the cylinder. Carefully wiping the plugs with a clean cloth or a cloth dampened with kerosene will generally remedy this.

Very often a car that has become water-soaked in a heavy rainstorm or has had snow blown in through the radiator and melted on the plugs will refuse to start because of the combination of water and dirt on the surface of these insulators.

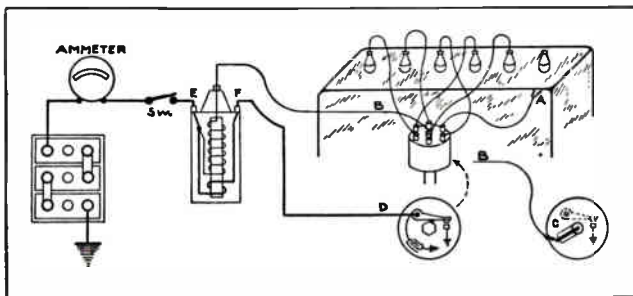

Fig. 44. Sketch illustrating methods of testing for ignition troubles. Refer to this sketch frequently while reading the paragraphs on this subject.

33. DISTRIBUTOR TROUBLES

If the plugs are in good condition and receiving good sparks and the engine still doesn't start, check the timing. Crank the engine around to bring No. 1 piston at U.D.C. on the compression stroke. Then retard the spark lever and remove the distributor cap.

The rotor arm should be in line with the contact on the cap that is connected to cylinder No. 1, and the breaker points should just be opening. If this condition is not found then retime the ignition as explained in Article 24.

If no sparks are obtained when a plug wire is held near the engine, pull the high-tension coil lead, B, Fig. 44, from the center terminal of the distributor cap and hold it close to the engine. If a hot spark jumps regularly to the engine with this test, the trouble is in the distributor cap, rotor arm, or plug wires; because you have proved that the ignition impulses are being delivered from the coil to

the distributor but are not getting from the distributor to the plugs.

In this case remove the distributor cap and hold the high-tension coil lead close to the rotor arm, as at "C" in the small illustration in Fig. 44. Make and break the circuit at the interrupter points, and if a spark jumps to the rotor it is defective and should be replaced. If the rotor is O. K. examine the distributor cap. If it is wet, dirty, or oily it should be thoroughly cleaned with gasoline and a cloth. If the cap is cracked or burned it should be replaced.

In the type of distributor caps now in general use the end of the rotor arm doesn't make actual rubbing contact with the cap terminals, but instead allows the spark to jump through a very small air gap as it passes from the rotor arm to the cap contacts. This spark in time burns away the contacts and forms upon them a scale which has a very high resistance and may weaken the spark to a point where it can no longer ignite the fuel charge.

To remedy this, remove the scale with emery cloth or sandpaper. If the contacts are badly burned away the air gap will be too great and the cap and arm should be changed.

If the high-tension section of the distributor has been carefully checked and found to be in good condition, carefully inspect the high-tension wires leading from the distributor cap to the plugs. These wires are heavily insulated with rubber and are generally protected by an additional coating of varnished braid, as they must carry the very high voltage impulses to the plugs without allowing leakage or grounding to the metal parts of the engine which they are near to and often come in contact with.

The insulation of these wires is subjected to very severe conditions, due to heat of the engine and the oil which is often thrown upon them and is very damaging to the insulating qualities of rubber. Leakage through the insulation of one of these wires would not be likely to interfere with the starting of the engine, although it would probably cause missing when the engine is operating.

However, if several of these wires should become grounded or leak badly it might prevent the engine from starting. If these wires are found to have cracked or brittle insulation, or if the rubber has become soft and mushy due to the action of oil, and particularly if sparks or leaks are detected along the surface of these wires, then they should be replaced.

34. BREAKER POINT TROUBLES AND DEFECTIVE CONDENSERS

If no spark can be obtained from the high-tension wire of the ignition coil when the engine is cranked or when the breaker points are opened, the breaker contacts should be carefully inspected to see that they make good contact when closed and that they are separated the proper distance (.020 inch) when fully open.

The surfaces of these contacts very often become burned or dirty, and a very small amount of dirt or blackening can increase their contact resistance to such an extent that the primary of the ignition coil will not receive anywhere near enough current. Small particles of grit or sand stuck to one of these points may prevent the engine starting.

Dirty breaker-contacts can be cleaned by drawing a piece of fine sandpaper through them, with a light pressure applied to hold the contact surfaces against the rough side of the paper. They can also be cleaned by use of a thin breaker point file. Contacts that are badly burned or pitted should be replaced, as the cost of new contacts is very low compared to the trouble bad contacts may cause.

To determine whether these contacts are properly making the primary circuit to the coil, snap them apart and watch for a small spark as they open. If this spark occurs it indicates that primary current is flowing through them. The trouble with the system is then likely to be in the condenser or coil.

Bad sparking and heating of the breaker contacts generally indicates an open-circuited condenser. A shorted condenser will prevent current flowing through the breaker points at all. A good way to check the condenser is to disconnect it and connect in another one that is known to be good. If the breaker points and condenser are proven to be O.K. then the trouble is probably in the ignition coil and the coil should be removed and tested.

35. TROUBLE TESTS ON IGNITION COIL AND PRIMARY WIRING

If the coil tests O.K. then carefully check the primary circuit for high resistance caused by poor contacts or loose connections. If the coil delivers no spark when the primary circuit is broken the failure may be caused by a ground between the coil and the breaker arm, or by the breaker arm being grounded, the condenser grounded, or an open circuit somewhere between the distributor and the battery.

Disconnect the primary wire, D, Fig. 44, from the distributor and touch it to the engine, and if a flash is obtained it proves that this wire is good and is carrying current from the battery to the distributor, and that the trouble is probably in the breaker arm.

Disconnect the condenser and touch the primary wire to the distributor arm while the breaker contacts are open. If this produces a flash the arm is grounded. Repeat this test on the insulated terminal of the condenser and if a flash is produced it indicates a grounded condenser. If the primary wire, D, fails to produce a flash when touched to the engine it should be disconnected from the coil terminal and replaced by another wire.

If the new wire gives a flash when touched to the engine the original wire must have been grounded or open. If no flash can be obtained with the new wire then remove the other wire from the opposite primary coil terminal, E, and touch it to the engine.

If a flash is obtained in this manner it proves that current was supplied from the battery to the primary of the coil and that the ignition trouble is probably in the coil.

This trouble is likely to be a burned out resistance element, a burned out primary coil, or a grounded coil. With the wire, D, between the coil and the distributor connected and the breaker points closed, or with a direct ground connection from coil terminal F to the engine, if no flash can be obtained on the other coil terminal it indicates an open circuit such as a burned out resistance or burned out primary.

With the connection entirely removed from terminal F, or the distributor side of the coil, if the lead touched to the other side produces a flash it indicates that the coil is grounded. If no flash can be obtained when touching to the engine the end of the wire which has been removed from terminal E and should feed current to the coil, this indicates an open circuit, probably due to a fault in the ignition switch or a poor connection at the ammeter, or possibly it is due to a break in the wire underneath the insulation.

The ammeter itself will often give some helpful indications in ignition troubles. If when the breaker contacts are known to be closed the ammeter gives no reading when the ignition switch is turned on, this indicates an open circuit in the primary ignition wiring, or dirty high-resistance breaker contacts.

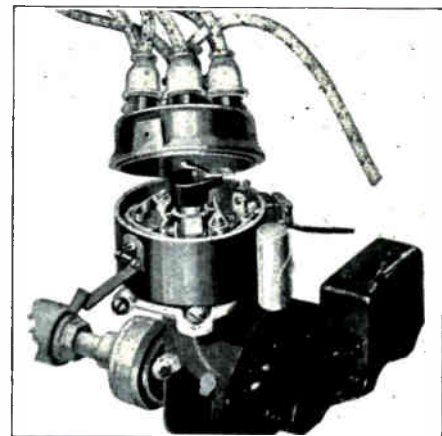

Fig. 45. Photograph of distributor with high-tension cap removed showing rotor arm in place and double breaker points beneath. Also note the high-tension wires connected to the cap and the water shields which are placed over the connections.

The open circuit may, of course, be a broken wire, loose connection, or a defective coil or coil resistance. It may also be in the ignition switch itself.

If the ammeter gives an excessive reading or throws the needle clear across the scale when the ignition switch is turned on, this indicates a ground in the primary wiring or one of the devices of this circuit.

From the foregoing explanation we can see that electrical trouble shooting on an automobile igni-

tion system is just a process of systematic elimination. By testing one part at a time in the manner suggested, it is possible to definitely and accurately corner the trouble in whichever part of the device or wiring it may be located.

For this reason it is well to thoroughly study the very simple diagram given in Fig. 44, or the diagram of any particular ignition system on which you may be working, and also to have the circuit well in mind before starting to shoot trouble. You can easily locate any trouble if you know exactly where the current ought to flow to operate the various devices and then check to find just how far it does go along this path.

After the first general inspection to see if any broken or grounded wire or loose connections can be noted, one should avoid jumping from one part of the system to the other but should rather follow the system straight through, testing one part at a time, each in order, as explained.

36. IGNITION TROUBLES THAT CAUSE ENGINE TO MISS

Various faults can occur in ignition systems which, while they do not prevent the engine starting, will cause it to fire very irregularly or miss on certain cylinders and operate with greatly reduced power.

One very common cause of an engine missing is faulty spark plugs. To check the spark plugs, short circuit the plug gap by bridging between the plug terminal and the engine with a screw driver. This grounds the plug and prevents a spark from occurring at its points. When the engine is running and a good plug is shorted in this manner the engine will slow down and run more unevenly than before.

Shorting out a bad plug, however, will have no noticeable effect on the operation of the engine. In this way a bad plug can often be quickly located and adjusted or replaced. This same test, however, might also indicate a cylinder that is not firing because of poor compression due to leaky valves or some other cause, so the test is not always an indication that the plug is bad.

When an engine with many cylinders is being tested in this manner it is sometimes difficult to tell whether a plug is firing or not, as one bad plug in an eight-cylinder engine, for example, would not produce a very noticeable indication or slowing down.

To overcome this and quickly detect the missing cylinder or cylinders, the engine can be run on one-half of its cylinders by removing the plug wires from the spark plugs in the remaining half. While operating in this manner the missing cylinder can be easily and positively located, because of the great difference that will be noticed when one of the good plugs is shorted out.

When a bad plug is found it should be cleaned and adjusted or replaced.

Missing may also be caused by defective insula-

tion on the high-voltage secondary wiring, either between the distributor and the plugs or between the secondary of the coil and the distributor. This can generally be found by carefully inspecting these wires for cracked, softened, or defective insulation, and also by feeling along their surfaces for slight leakage which will produce a shock when the spot is touched.

Sometimes by carefully watching and listening when the engine is running you can detect sparks or light, snapping noises from leakage sparks which are flashing through the insulation on the wires to the metal parts of the engine or to the tube or clamps in which the wires are supported.

When any of these wires begin to leak high-voltage energy, the best remedy is to replace all of them with new ones.

Distributor faults may also be the cause of missing and irregular engine operation. Some of the more common of these faults are breaker contacts dirty, pitted, or improperly adjusted; movable breaker arm sticking in its pivot; untrue breaker cam; distributor shaft wobbling due to worn bearings, or distributor housing loose in its socket.

If the bearings allow the distributor shaft to move off center more than .003 inch they should be replaced. If the engine runs smoothly at low speeds but misses at higher speeds it may be caused by the plug points being set too far apart, breaker contacts set to open too far, insufficient spring tension on the movable breaker arm, worn cam follower, defective condenser, etc.

All battery ignition systems produce weaker sparks at high speeds because of the shorter period of contact closure and less complete magnetization of the coil between breaks. Therefore, anything which tends to further reduce the very short period of time that the coil primary circuit is closed (such as weak breaker springs or worn and lengthened cam follower) will interfere with ignition at high speeds.

Any of the causes of missing previously mentioned might also be responsible for poor engine performance at high speeds.

If the engine lacks power and overheats, the ignition timing should be checked to see that the sparks are not occurring too late or too far retarded.

Late ignition will always decrease the power of an engine and cause it to overheat, and it should be corrected by timing the engine properly as explained in Article 24.

If the timing is right the carburetor adjustment should be checked. If changing this adjustment fails to "pep" up the engine, next check the valves and see that the clearance between the end of the valve stem and its tappet or rocker arm is correct. This clearance varies with different engines and the manufacturer's recommendation should always be followed when it is known, but if the manufacturer's figure is not known, a clearance of .006 inch for

intake valves and .008 inch for exhaust valves will generally give good results.

These settings should be made while the engine is warm and the clearance should be determined by a feeler gauge.

Another possible cause of an overheated or sluggish engine may be improper valve timing.

A good general rule to follow when checking engine trouble is to first check the ignition, then the fuel system, and then the valves, always keeping in mind that any of these can be the cause of the various troubles outlined in this section.

37. RESISTANCE TYPE GASOLINE GAUGES

This type of gauge is very popular and is standard equipment on a large number of cars. It is composed of two units, an instrument panel or indicating unit and the tank unit. These two units are connected together as shown in the diagram (Fig. 46). The current supply is obtained from the coil side of the ignition switch, or if an electro-lock type of switch is used a special terminal is provided on the switch for this purpose. Drawing the current from this point renders the gauge inactive whenever the ignition is turned off, so there will then be no drain on the battery.

The instrument panel or dash unit consists of 2 coils set at an angle of 90 degrees, with an armature and a pointer mounted where the coil axis intersects. The 2 coils are wound so as to produce the same polarity. An extended pole piece is used. Since the extended pole piece is fastened to the

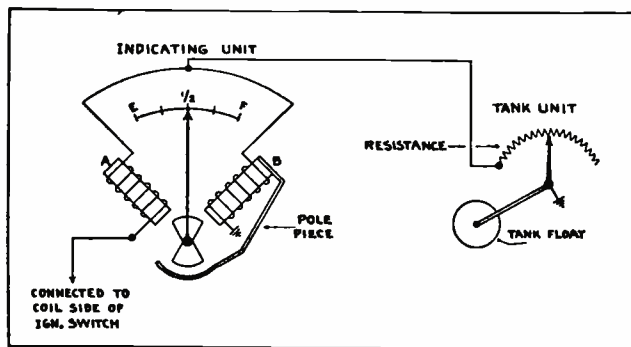

Fig. 46. Diagram of a resistance type gasoline gauge.

top of one of the coils, its polarity will be opposite to that of the lower end of the coil cores.

The tank unit is simply a rheostat, the moving contact of which is operated by a cork float resting on the surface of the gasoline in the tank.

The indicating unit is not operated by voltage changes brought about by the action of the rheostat but by a change in the relationship of the current flow in the 2 coils.

When the tank is empty the resistance is all cut out providing an easy path for the current to flow

to ground through the tank unit. This practically short circuits coil "B" so that very little current flows through it, the greater part of the current flowing through coil "A." Thus coil "A" is strengthened and coil "B" is weakened, pulling the armature and pointer to the empty position on the indicator.

Raising the level of the gasoline in the tank will increase the resistance in the tank unit circuit, reducing the current going to ground through the tank unit but increasing the amount of current going to ground through coil "B." This increases the strength of coil "B" and the armature and pointer are pulled toward the right end of the indicating scale.

If the gauge fails to operate disconnect the wire from tank unit. When this is disconnected, the indicating unit should read "Full." Grounding this lead should cause the indicating unit to read "Empty." If it performs in this manner the tank unit is defective and should be replaced.

If the gauge fails to indicate when the ignition switch is turned on the trouble may be due to a broken lead from the ignition switch to the indicating unit, or to a ground between the indicating unit and the tank unit.

If it shows "Full" under all conditions, the trouble may be due to a break in the wire between the indicating unit and the tank unit, or no contact between the stationary and moving parts of the tank unit resistance, due to wear. Wear or poor contact at this point will cause the gauge to read high.

A quick check can be made by disconnecting the lead from the tank unit and connecting this lead to an extra tank unit that is known to be in good order. Ground the extra tank unit against any clean metal part of the car chassis and operate the float manually, moving it from "Empty" to "Full" positions. If the indicating unit registers corresponding readings, the trouble is in the original tank unit.

When connecting the wires to the indicating unit care must be taken to see that they are connected to the correct terminals, otherwise the gauge will not operate. The terminals are all plainly marked so that with reasonable care no mistake can be made. The current required to operate the gauge is from about 125 M.A. when tank is full, up to 175 M.A. when empty.

38. THERMAL OR BI-METAL TYPE GAUGE

In this type the tank unit is known as the "sender" and the indicating unit on the dash is known as the "receiver." The controlling elements of both the "sender" and the "receiver" are bi-metal strips around which, heater coils are wound. See Fig. 47.

When the tank is empty the two contacts in the "sender" or tank unit are just touching. When the ignition is turned on current will flow through the circuit causing both heater coils to warm up and the bi-metal strips will bend. Since the contacts in the sender are just touching, the circuit will be immediately broken, and the heater coils will cool off causing the contacts to come back together again. With the tank empty this will require a very small amount of current, so that the bi-metal strip in the "receiver" will be bent but very little and the pointer which is linked to the end of the receiver bi-metal strip will indicate "empty."

As the gasoline level is raised pressure on the "sender" contacts is increased by means of a float operated cam. As pressure is increased it takes more current to bend the "sender" strip in order to break the circuit. This increased current will also raise the temperature of the heater coil around the "receiver" strip causing it to bend more and move the indicating pointer to the right. The two bi-metal strips must be exactly similar, so they will bend an equal amount and since they are in series they will both be heated at the same temperature. The circuit is made and broken approximately once a second. This type of gauge is also used in some cases to indicate oil level in the crank case.

Due to make and break action in the "sender" radio interference may be set up. This can be

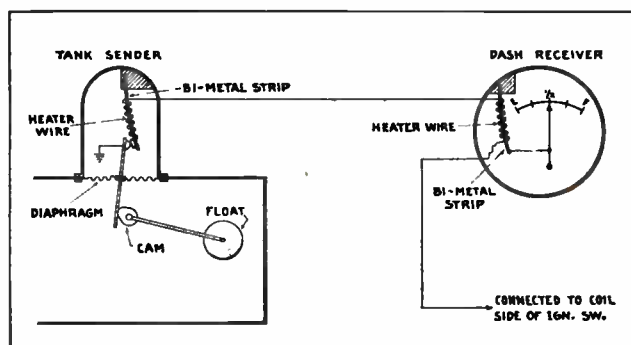

Fig. 47. The thermal or bi-metal gauge.

eliminated by connecting a condenser between the sender terminal and ground.

Over-reading is caused by a ground in the lead between the two units, or by a shorted condenser if one is used.

Other faults can be checked by substituting units that are known to be good. When an extra "sender" is substituted and the float is manually operated allow the "receiver" 10 or 15 seconds to read "Full" scale as this is a heat operated unit.

The current required to operate this type of gauge will range from $1/25$ of ampere when tank is empty to $1/5$ of ampere when full.

It is not convenient to make repairs to this type of unit in the field, so defective parts are generally replaced.

HIGH-TENSION MAGNETOS

High-tension magnetos are extensively used in the ignition systems of trucks, tractors, and aeroplane engines. Their principle of operation is almost the same as that of the high-tension ignition coil, except that magnetos generate their own low-voltage primary current instead of receiving it from a battery.

You are already well familiar with the principles of operation of D.C. and A.C. generators, so it is not necessary to go into great detail as to these principles of magnetos.

High-tension magnetos consist of the following important parts:

1. A set of permanent magnets for producing a magnetic field.
2. A rotating iron core or armature on which the coils are wound.
3. A primary winding to generate low-voltage energy, and a secondary winding to step up this voltage.
4. A set of breaker contacts to interrupt the primary circuit and cause the flux to collapse.
5. A condenser to prevent arcing at the breaker contacts and increase the secondary voltage.
6. A distributor to direct the spark impulses out to the different spark plugs.

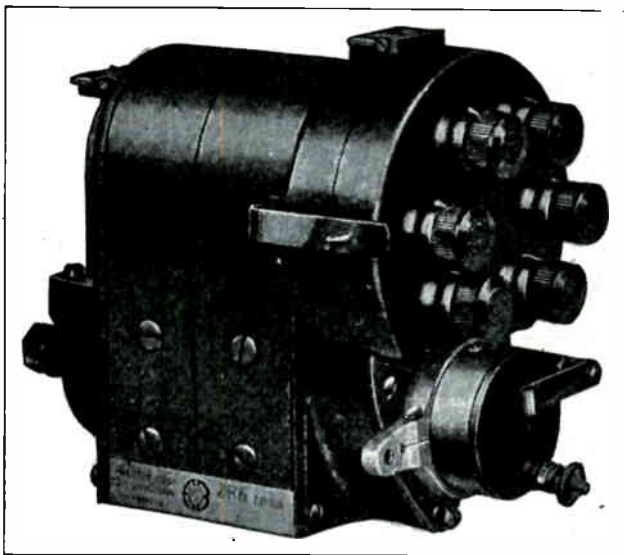

Fig. 48. Photograph of a high tension magneto used for ignition purposes on trucks, busses, tractors, etc. Courtesy Bosch Magneto Corporation.

Fig. 48 shows a common type of magneto for use with six-cylinder engines. The two large horse-shoe-shaped permanent magnets which supply the magnetic field can be seen over the body of the magneto. On the lower right-hand end is the housing which contains the breaker points, and on the upper

right end is the distributor housing with the terminals for the six spark plug leads clearly shown. On the left end of the magnet is shown a coupling by which its armature is driven by connection to the engine. The armature revolves between pole faces attached to the lower ends of the permanent magnets.

Fig. 49 shows a magneto armature removed from the housing and field frame. The heavily-insulated primary and secondary coils are shown wound on a simple spool form, or the center leg of the armature core at No. 1.

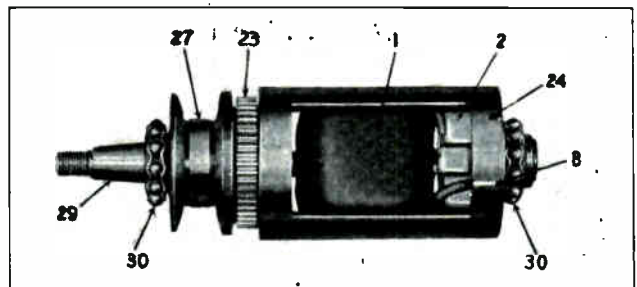

Fig. 49. Magneto armature removed from housing to show bearings, slip ring, armature core, windings, and condenser.

At 2 is shown the condenser, which is also contained in the armature. The ground on the iron armature core is shown at 24, and one of the primary leads is grounded or connected to this core at B.

No. 23 is the gear which drives the distributor mechanism, 27 is the insulated slip ring at which the high-voltage energy from the secondary is collected by means of the brush and carried to the distributor.

At 30 are the ball bearings in which the armature rotates, and at 29 is the end of the shaft by which the magneto is coupled to the engine.

39. CIRCUITS AND OPERATING PRINCIPLES

Fig. 50 shows a diagram of the primary and secondary windings of a magneto armature. You will note that the upper end of the primary connects to one side of the condenser and then through the breaker points to ground, while the lower end of the primary connects to the other side of the condenser, and directly to ground. This places the breaker points in series with the primary winding and the condenser directly across the breaker points.

The inner end of the high-voltage secondary coil is connected to the primary and thus obtains a ground connection, while the outer end of the secondary is connected to the insulated slip ring, S, and delivers the high-voltage energy from this ring

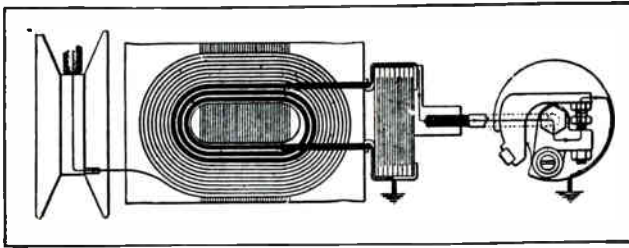

Fig. 50. Diagram of primary and secondary windings of a common magneto armature. This diagram also shows condenser and breaker points on the right and the high tension slip ring on the left. Courtesy Bosch Magneto Corporation.

to a brush and then through the distributor to the spark plugs.

Fig. 51 is a diagram showing the position of a magneto armature between the pole faces of the permanent magnets, and also shows the direction of magnetic flux travel through the armature from the north to the south pole.

With the armature core in its present position, the flux built up between the two field poles is at maximum; but as the core is turned to a point at right angles to its present position it doesn't provide nearly as good a path for the magnetic lines and thus causes a great reduction or sudden collapse of the flux, twice during each revolution.

This collapse and building up of the magnetic field as the armature is rotated causes the magneto to generate low-voltage A. C. in the primary winding. By using in this primary coil circuit a set of breaker contacts to interrupt the current flow just as the field flux is collapsing, the flux around the primary turns is also allowed to collapse, with the result that the double flux collapse induces a very high-voltage impulse in the secondary winding, which consists of a great number of turns of fine wire.

To obtain maximum voltage the primary circuit should be broken just at the point when the greatest amount of voltage and current are being induced in it.

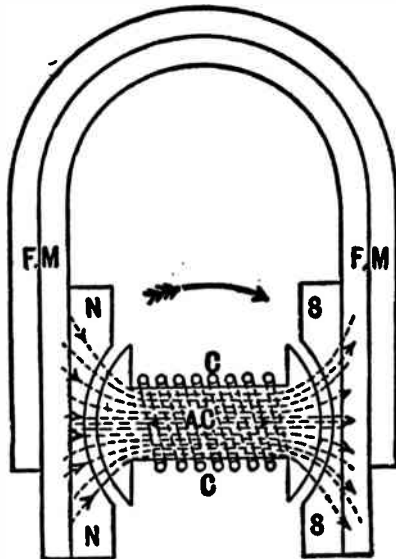

Fig. 51. This sketch shows the position of the armature between the pole pieces of a magneto and shows the path of the flux from the permanent magnetic field.

Referring to Fig. 52 we find that with the magneto armature in a position shown at "A" flux is passing from the north pole downward through the core to the south pole.

If this armature is revolving clockwise we can see that its top and bottom sides are just about ready to break away from the poles they have been passing and approach the opposite poles. As they pull away from the poles the strong magnetic field which was passing through the armature core collapses and shifts over in the opposite position shown at "B". Here the flux is still passing from the north to the south poles of the permanent magnets, but it is now passing upward, or in the reverse direction, through the armature core.

We find, therefore, that the point of maximum flux movement or change, and also the point of maximum voltage generated in the primary, will be just as the magneto armature breaks away from one set of poles and passes on to the next, or while it is moving from the position shown at "A" to that shown at "B".

The maximum voltage will be generated in the primary winding when the armature is in the position shown at "C" in Fig. 52, and this is the point at which the breaker contacts should interrupt the circuit.

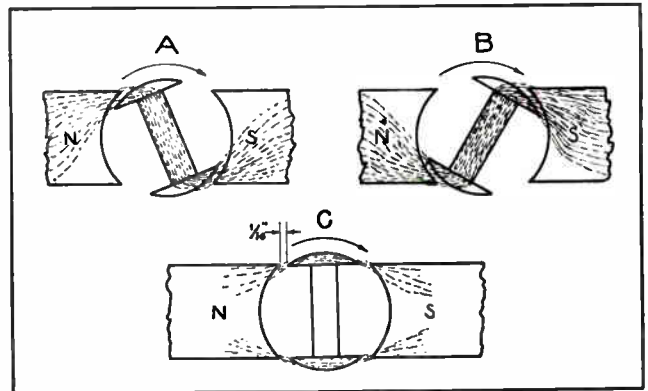

Fig. 52. The above sketches illustrate the shift and collapse of flux as a magneto armature rotates between the field poles to cause the induction of voltage in the armature coils.

Magnetos are so constructed by the manufacturer that when the breaker housing is in the full advance position the breaker contacts will open the primary circuit when the armature is in the position shown at Fig. 52-C, or when the armature tip has left the pole tip by a distance of about 1/16 of an inch.

Any variation from this setting would greatly weaken the spark, and to prevent altering the timing of the breaker contacts when the magneto is taken apart for inspection or repair, a keyway is cut in the armature shaft to receive a key on the breaker plate so that the two will always be locked together in the proper position.

Fig. 53 shows a diagram of the primary and secondary circuits of an ordinary magneto, and also shows the connections and locations of the various important parts. Trace this circuit carefully and

compare it with Figs. 48 and 50 until you thoroughly understand the general construction and wiring of a magneto.

Note how a number of the circuits are completed by grounding the connections to the armature core and metal parts of the magneto frame. The solid black parts of the sketch indicate the insulating material which separates various metal parts of the magneto and parts of the circuit.

In tracing this circuit you will find that the breaker points are in series with the primary coil and that the condenser is connected across these breaker points. One end of the secondary coil is connected directly to the primary winding to obtain a ground through this low-resistance winding, although in many magnetos it is connected directly to ground at the other end of the primary. The other end of the high-voltage secondary delivers its impulses to the distributor through the insulated collector ring, brush, and conductor rod or pencil. From the distributor the impulses are sent in the proper order by means of a timed rotor to the spark plugs.

40. MAGNETO SAFETY GAPS

Note the safety gap which is connected between the high-tension lead and ground, to protect the secondary winding from excessive voltage strain in case the spark plug gaps become open too far or the secondary lead becomes broken.

As long as the spark plugs remain in proper condition and connected to the secondary leads the magneto needs to build up only about 6000 volts to flash across the 100,000 ohms approximate resistance of the spark plug gaps under compression.

If the resistance of this secondary circuit is increased by a broken secondary wire or the spark plug gaps becoming too widely open, the secondary voltage will rise to an excessive value. This places a very high strain on the insulation of the windings and if allowed to continue will eventually puncture and break down this insulation. As the armature insulation cannot easily be repaired this generally means that the entire armature will have to be replaced.

The safety gap connected in the manner shown is really in parallel with the spark plug gaps and the entire secondary winding to ground. With this gap set at about 5/16 of an inch, 8000 volts will send a spark across it, so the voltage strain on the insulation can never rise above this value, and the possibility of puncture is greatly reduced. Under normal operating conditions the spark will jump the plug gaps, as their resistance is lower than that of the safety gap.

Fig. 53-B shows a simplified wiring diagram quite similar to the one in Fig. 53-A, except that the various parts are shown further apart to make the circuit easier to trace. In this diagram it is very easy to trace the circuit of the primary coil through

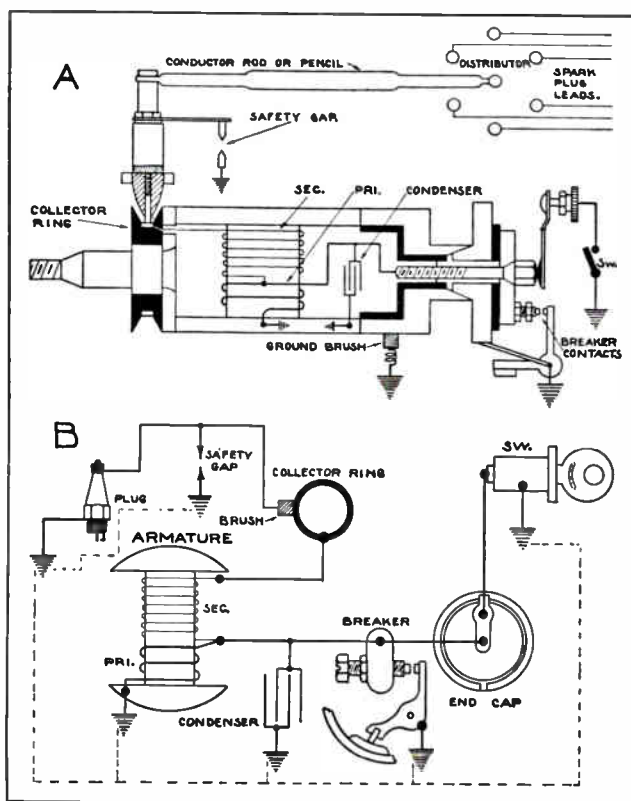

Fig. 53. The top diagram shows complete primary and secondary circuits of a magneto. B. Another diagram showing a different arrangement of the primary and secondary circuits and important parts of the magneto.

the breaker points and to note that the condenser is connected across these points.

The secondary circuit can also be easily traced through the collector ring, brush, the single spark plug shown, and back through the grounded connections, primary coil, and to the start of the secondary. The dotted lines in this circuit show the ground path created through the metal parts of the magneto by grounding one end of each of the various devices.

41. GROUND BRUSH AND IGNITION SWITCH

Magneto armatures are generally supported in ball bearings, and in order for the secondary current to complete its circuit from the frame to the armature through the grounded connections, the current would ordinarily have to flow through these bearings. This would tend to pit the balls and ball races of the bearings and also to carbonize the grease with which they are lubricated, and thus would result in very rapid wear of the bearings.

To avoid this a small carbon brush is inserted through the base of the magneto and held in contact with the rotating armature by a light spring. This brush is called a ground brush, and provides a path of lower resistance than the bearings, so that most of the current will flow through this brush circuit.

To prevent any current at all from flowing through the bearings most manufacturers insulate

them from the magneto frame with pressed paper or fibre insulation.

In both Figs. 53-A and B you will note that a grounding switch is used to shut off the magneto and ignition by short-circuiting the breaker points. When these points are short-circuited by the switch they cannot open the primary circuit any longer, and this prevents the sudden collapse of flux and the induction of high-voltage impulses in the secondary, thus stopping the spark.

This is a very effective method of shutting off the ignition to stop the engine and is much more convenient than trying to place a switch to open the primary circuit, as this circuit is all contained within the armature of the magneto itself.

The ignition switch in this case merely grounds the insulated breaker point, thus entirely shorting out the breaker contacts.

42. BREAKER MECHANISM

The breaker assembly of the armature-type magneto consists of five principal parts, as follows:

1. A circular metal breaker-plate which supports the contacts.
2. Contact points, one of which is attached to the breaker plate but insulated from it, and the

other mounted on the grounded movable breaker arm.

3. Breaker housing.

4. Steel cams attached to the inside surface of the breaker housing.

5. Fastening screw which holds the breaker plate to the armature and also makes connection between the insulated breaker contact and the ungrounded end of the primary winding.

The upper view in Fig. 54 shows a diagram of the breaker mechanism of a magneto in which both the stationary and movable contacts can be seen. As the breaker plate and contacts are rotated the fibre block on the outer end of the arm rides over the cams attached to the inside of the breaker housing, thus causing the breaker points to open. When the fibre block drops off the cams the breaker points are closed by the action of a small spring attached to the movable arm.

Contact points are generally tipped with platinum as this metal stands up very well under the continuous sparking and make and break action and doesn't burn or corrode as easily as most other metals.

Magneto contacts are generally set for a maximum opening at .015 of an inch, although certain variations of this gap may be necessary with different magnetos under various operating conditions.

It is just as important to keep these contact surfaces bright and clean and properly fitted as it is with those of interrupters on battery ignition systems. For efficient ignition, breaker contacts must make a good low-resistance closure in the primary circuit each time they touch, and must make a quick, clean break when they open.

The lower view in Fig. 54 shows the manner in which the spark of a magneto can be advanced or retarded by shifting the breaker housing and cams by means of the advance lever attached to the side of the housing.

43. DISTRIBUTOR

Magneto distributors are quite similar to those used with battery ignition systems, except that instead of using a small distributor arm, magnetos use a distributor plate which is rotated by means of a gear that is driven from a small gear on the armature shaft.

Fig. 55 shows an end view of a magneto with the distributor cap removed to show the plate and gear. As this plate revolves its metal arm makes contact in rotation with the stationary contacts which are mounted in the cover and connect to the various spark plug leads. Below the distributor gear and plate in Fig. 55 can be seen the breaker housing with the cover removed, showing the breaker points and mechanism inside.

44. SETTING THE DISTRIBUTOR GEAR

In order that the rotating contact or segment will be at the correct position when the breaker contacts open, it is very important that the distributor gear

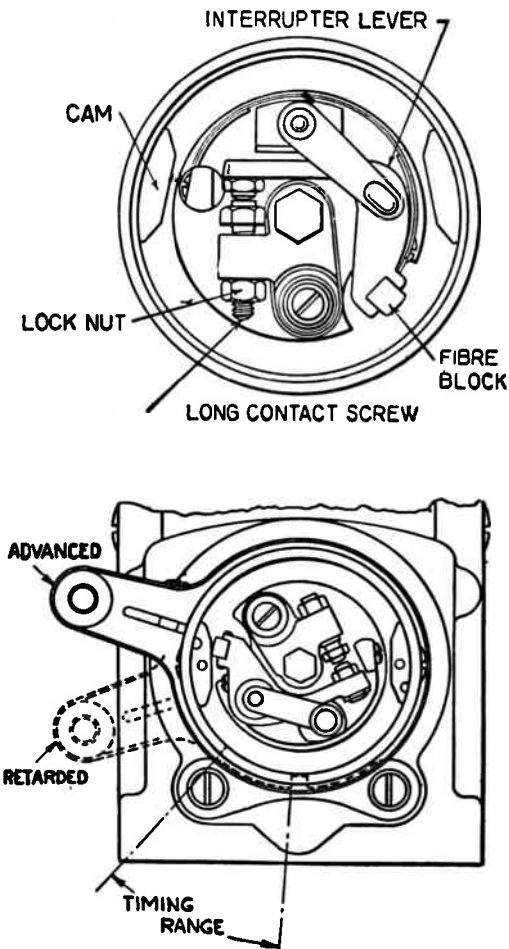

Fig. 54. The top view in this figure clearly shows the breaker mechanism of a magneto. Below is shown another view of a breaker with the points open and the cam under the breaker arm, and also showing the method of advance and retard of the spark by means of a lever on the breaker housing. Courtesy Bosch Magneto Corporation.

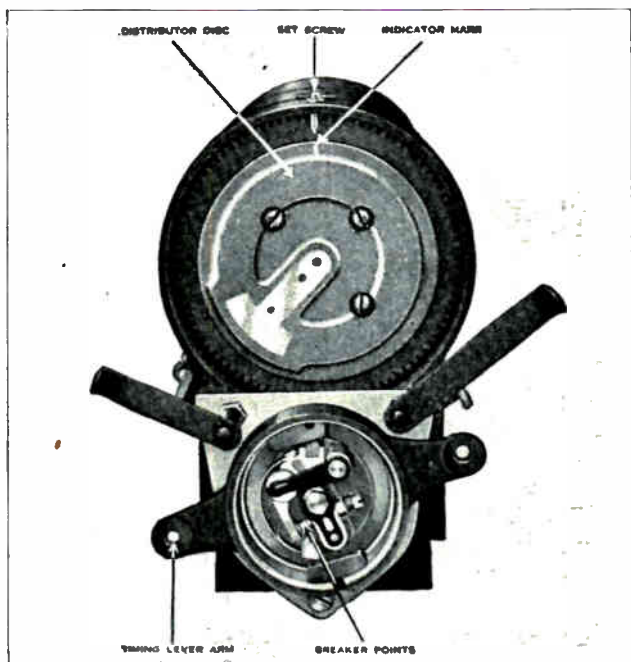

Fig. 55. Photograph of a magneto with covers removed showing the breaker mechanism below and the high voltage distributor disk and contact arm above. Courtesy Eisemann Magneto Corporation.

and its smaller driving gear on the end of the armature be properly meshed together. If these gears are not properly meshed it may result in the rotating brush or segment being at a point midway between the stationary segments when the spark occurs.

This would tend to make the spark jump the gap between the rotating and stationary contacts as well as the plug gap, and in all probability the increased resistance would result in the spark occurring at the safety gap of the magneto or at the wrong plugs of the engine.

To insure proper operation and make it easier to properly set and time the magneto in overhauling, manufacturers generally place small punch marks on the edges of the gears, one mark on the armature gear and two on the distributor gear, as shown in Fig. 56-A.

Magnetos are often arranged so that by making small changes they can be driven either clockwise or anticlockwise, according to the most convenient

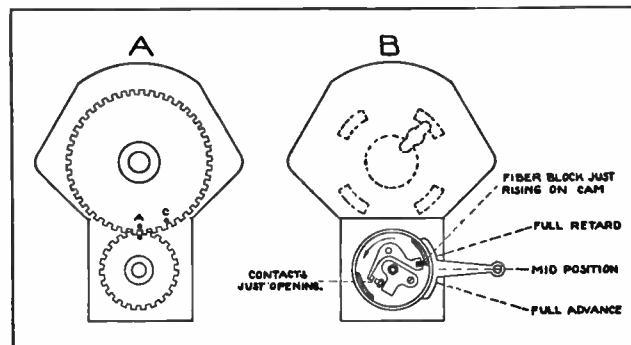

Fig. 56. A shows method of properly timing or setting the distributor gears by means of marks on their edges. B shows breaker arm, spark advance lever and breaker points all in proper position for timing the magneto.

connection to the engine. If the magneto is for clockwise rotation, the C mark on the distributor gear should line up with the mark on the armature gear when meshing the gears together. If the magneto is to be driven anticlockwise, the A mark on the distributor gear should be lined up with the mark on the armature gear. See Fig. 56-A.

The direction of magneto rotation is always designated as clockwise or anticlockwise when facing the drive end of the magneto. The direction of rotation for which the magneto is intended is generally marked by an arrow on the oil cover over the drive end bearing.

Sometimes a magneto is found which has already been overhauled several times and on which the original marks may have been obscured or scratched off, and other marks may have been made by the men who previously overhauled the magneto.

As these marks cannot be depended upon, the gears should be carefully meshed or set by the following procedure and as illustrated in Fig. 56-B. Set the breaker housing in mid position, half way between full advance and full retard. Turn the magneto armature in the normal direction of rotation until the fibre block on the breaker arm is just moving up on the cam and opening the contacts. Then rotate the distributor gear to a point where the brush is in the middle of the segment, as shown. Now, while making sure that the armature and distributor gear maintain these positions, move the gears into mesh with each other.

To check the setting move the breaker housing to the full retard position and, turning the magneto armature in the correct direction of rotation, see if the brush is still on the segment with the breaker contacts open. Make the same test with the breaker housing in the full advance position. The brush should be on the segment in both positions.

Magnetos are made with distributors for various numbers of cylinders, according to the types of engines they are to operate with. The upper view in Fig. 57 shows a complete wiring diagram of a magneto connected to the plugs of a four-cylinder engine, while the lower view in this figure shows another magneto connected to the plugs of a six-cylinder engine.

The arrangement of the distributor brushes and segments and also of the primary connections are slightly different in these two diagrams, but the circuits and principles are in general the same. In both diagrams the breaker contacts are shown in the circuits of the primary coils, and the high-voltage secondary circuit is shown leading from the collector ring through the brush to the distributor, which in turn are grounded to complete the circuit back to the magneto frame.

The ground circuit and connections in each case are shown by the dotted lines. The wires leading

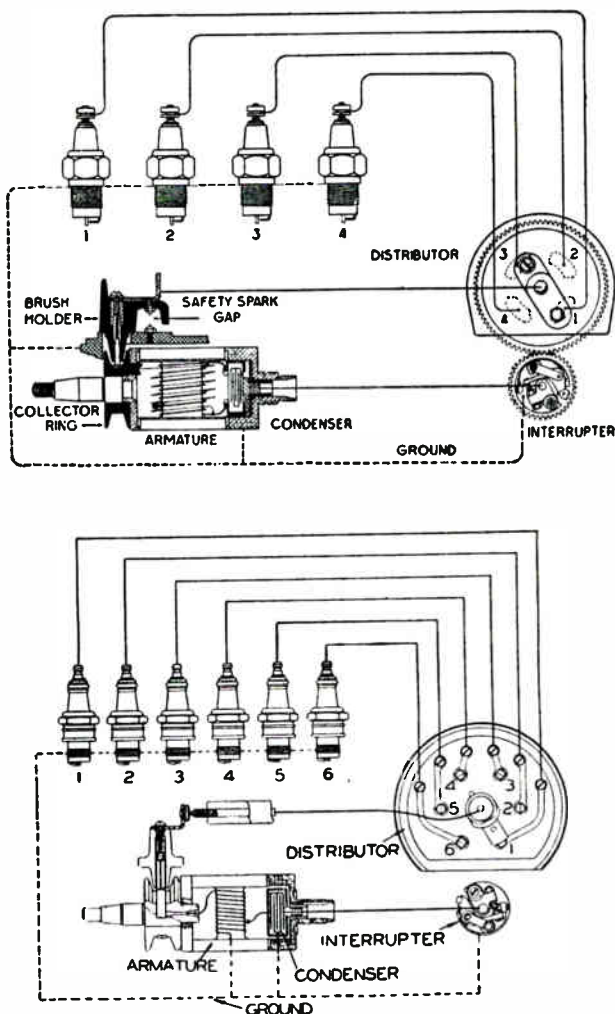

Fig. 57. The upper view shows complete primary and secondary circuits of a magneto with the high tension leads connected from the distributor to the spark plugs of a four-cylinder engine. The lower view shows the circuits of a magneto for use with six-cylinder engines. Note that the spark plugs are lined up numerically in these figures and are not in their proper order on the engine.

from the distributor terminals to the spark plugs in this figure are connected to the plugs according to their firing order, and the rows of plugs are arranged this way also and not in their actual positions on the engine.

45. TIMING A MAGNETO TO THE ENGINE

When connecting a new magneto to an engine or when reinstalling one that has been taken off for repairing or overhauling, the magneto should be carefully timed to the engine in the following manner, which you will note is very similar to the method used for battery ignition systems.

Set the engine so that No. 1 piston is at top dead center on the compression stroke. Fully retard the magneto breaker housing and turn the magneto armature in the normal direction of rotation until the distributor brush is on segment No. 1 of the distributor cap and the breaker contacts are just beginning to open.

Then connect the magneto to the engine through the drive coupling, being very careful not to allow the armature or distributor to change position while

making the connection. Some magneto manufacturers place on the distributor disk or gear a mark which when lined up with a mark or screw on the distributor housing indicates that the distributor brush or rotating segment is in position to contact with the stationary segment which connects to No. 1 cylinder. These marks can be seen by referring to Fig. 55.

Fig. 58 shows a sectional view of one type of magneto, giving the names of the various parts. Examine each part very carefully and make sure that you understand the function of all of the important parts which have been explained in the preceding paragraphs.

You will note in this figure that the ground brush is located in the revolving breaker plate and rubs against the metal collar or frame of the magneto in the back of the breaker housing. In this position the brush not only makes a good return for the grounded secondary current, but also makes a positive ground connection from the rotating breaker mechanism to the magneto frame, to make more certain the shorting or grounding action of the ignition switch when the magneto is turned off.

The path of the high-tension energy can be traced from the upper right-hand end of the secondary coil to the collector ring, collector brush, up through the metal strip imbedded in the insulation of the distributor cap to the center distributor brush, across the rotating strip on the distributor disk, and out of the upper distributor brush to the spark plug wire. Only one of the outer brushes that connect to the spark plugs is shown in this view.

Fig. 59 shows another sectional view of a different type of magneto and, while the construction is different in some respects, you will note that the general arrangement and principles are the same. Note the position of the oil holes and the ground brush shown in this figure.

46. DISASSEMBLING MAGNETOS

The exact procedure for taking apart a magneto to make repairs or for overhauling will vary somewhat with different types of magnetos and detailed instructions for these can be obtained from the manufacturer of any certain magneto.

The following general rules, however, will prove to be very helpful and any magneto can be disassembled by this method with a little care and observation on the part of the workman so as not to overlook other small details.

First remove the breaker housing and distributor cap. Then remove the breaker plate by taking out the holding screw. Next remove in order the magnets, high-tension collector plug, high-tension pencil or conductor bar, ground brush, bearing plate at the interrupter end, distributor gear, and then the armature.

It is very important to remember that the armature should be removed last, for if this rule is not

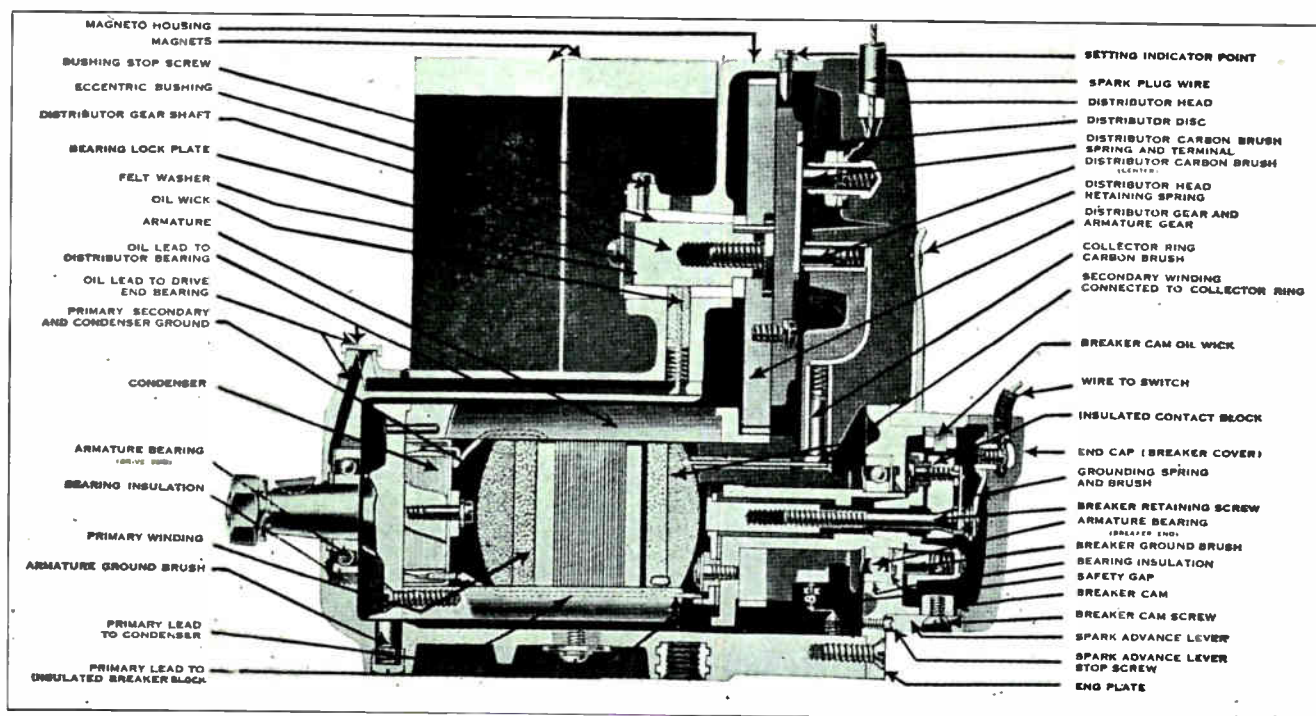

Fig. 58. This excellent sectional view of a magneto shows the arrangement and names of all the important parts. Examine each part very carefully and compare with instruction describing various magneto parts. Courtesy Eisemann Magneto Corp.

followed it may result in cracked collector ring insulation and broken ground brushes.

To reassemble the magneto follow the same procedure in the reverse order. Extreme care should be used not to batter, scratch, or damage any of the finely machined metal parts and not to crack or injure the molded insulation.

When removing field magnets their magnetic circuits should be kept closed by slipping an iron bar or keeper across the pole ends before completely removing them from the pole shoes. This bar should be left on the field magnets as long as they are off the magneto, in order to prevent weakening the poles, which will occur if the magnetic circuit is broken and left open.

Magneto magnets can be easily recharged by means of a powerful electro-magnet operated from a storage battery or other source of D.C. When fully magnetized the average magneto magnet should lift about 20 lbs.

In replacing these magnets be careful to get all like poles on one side. It doesn't matter which side the north or south poles are on as long as all north poles are kept together and south poles together. If some of the poles are reversed the magnetic flux will short directly between adjacent poles and will not pass across the armature gap between the pole pieces. This results in no field or a very weak field across the coils and practically no induction or spark.

Like poles can easily be determined by holding the magnets side by side or end to end in a position so that their poles tend to repel.

Field magnets should not be banged around or

handled roughly when they are off the magneto, as such treatment causes them to lose their charge. The armature should also be very carefully handled in order not to damage the insulation on the coils or harm the bearings.

On some magnetos when the distributor gear and shaft are put back in place the end of the shaft may catch upon an oil wick in the lower side of its bearing. This wick can be held down with the end of a screw driver or other slender metal tool inserted in the back end of the bearings while the shaft is pushed in the front end.

47. MAGNETO TROUBLES AND CARE. RECHARGING FIELD MAGNETS

Some of the common magneto troubles which may be the cause of an engine missing or starting hard, or complete failure of the ignition system, are as follows:

When the field magnets become weak it will cause very poor sparks at low engine speeds and make the engine start hard. The magnets should be removed as previously explained and recharged by holding or rubbing their poles in contact with the poles of a powerful electro-magnet.

Regular magnet chargers can be purchased for this work or a very effective charger can be made by winding about 500 turns of No. 14 magnet wire on each of two soft iron cores about two or three inches in diameter and six inches long and bolting the bottom ends of these cores securely to a soft iron plate to form a keeper for a closed magnetic circuit across their ends. See Fig. 60.

With these coils connected in series in a manner to create unlike poles at the top ends of the electro-

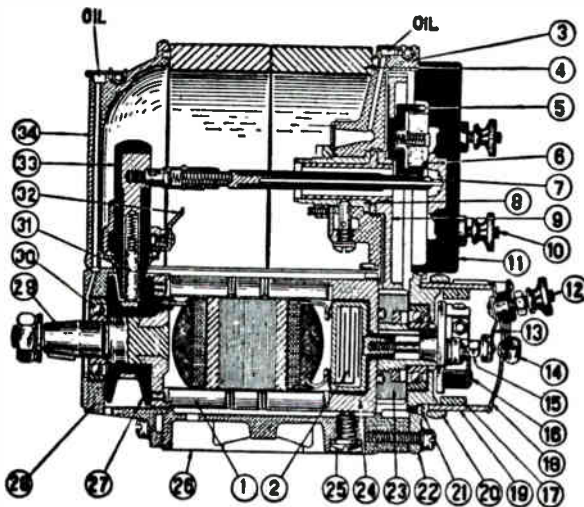

1. Armature wound core
 - NOTE: Complete armature consists of parts indicated by the following numbers: 29, 1, 2, 24 and 27.
 2. Condenser
 3. Gear housing
 4. Magnet
 5. Distributor brush holder
 6. Distributor brush
 7. Conducting bar
 8. Distributor gear bearing
 9. Distributor gear
 10. Distributor plate terminal screw
 11. Distributor plate
 12. End cap terminal nut
 13. End cap contact spring with brush
 14. End cap holding post and spring
 15. Interrupter fastening screw
 16. Interrupter complete
 17. Interrupter cam
 18. Magneto end cap
 19. Interrupter housing
 20. Timing arm
 21. Interrupter housing stop screw
 22. Rear end plate
 23. Armature gear
 24. Armature flange—condenser end
 25. Grounding brush with holding screw
 26. Base plate
 27. Collector ring
 28. Shaft end plate
 29. Driving shaft and flange
 30. Ball bearing—either end
 31. Collector brush
 32. Safety gap electrode
 33. Collector brush holder
 34. Waterproof hood
- NOTE: The numbers given above are for reference only. Do not use these reference numbers when ordering parts.

Fig. 59. Diagram showing sectional view and names of important parts of a magneto of somewhat different type than the one shown in Fig. 58. Courtesy Bosch Magneto Corporation.

magnet and then connected to a six-volt storage battery, a very powerful magnetic field will be set up across the open pole ends.

For added convenience these ends can also have small square pieces of soft iron bolted to them, in order to make a broader surface for the ends of the horseshoe magnets to contact with. If the inner edges of these pole pieces are made 1 to 1½ inches apart and the outer edges from 7 to 8 inches apart, they will accommodate almost any of the ordinary sized magneto magnets.

Care should be taken to place the horseshoe magnet on the charging magnet in the proper position to strengthen the poles it already has, rather than to reverse them and build them up in the opposite direction. The proper polarity can easily be determined by suspending the horseshoe magnet above the electro-magnet when the current is turned on.

If the horseshoe magnet is free to turn its poles will be attracted to the proper poles of the electro-magnet.

The charging magnet should be bolted to a bench in a vertical position so that the horseshoe magnet can be rubbed or rocked across the ends of the electro-magnet poles for several seconds with the current turned on.

When removing the magneto magnets from the charger always remember to place the iron keeper or bars across their ends first. A fully-charged magnet should pull about 20 lbs. on an iron bar attached to a small spring scale, as previously mentioned.

During the test and after the magnet poles are in contact with the scale bar, the temporary keeper bar should be removed in order to get maximum pull. It should, however, be placed on the magneto magnet again before removing it from the scale to replace it on the magneto, otherwise a great deal of the charge will be lost.

48. BREAKER TROUBLES

If the breaker points on a magneto are set too close or if they are dirty and not making a good contact, it will probably cause the engine to miss, particularly at low speeds. By means of a thin gauge obtainable for this purpose the breaker points should be kept set to open the proper distance. As previously stated, the maximum gap or opening between these points should be about .014 or .015 of an inch.

The contact surfaces should be kept clean and bright and should meet squarely when they are closed. If the platinum tips or surfaces of the breaker points have been burned off or filed off, the points should be replaced with new ones, because efficient operation cannot be obtained with points that are badly burned or those that have had the contact metal ground away.

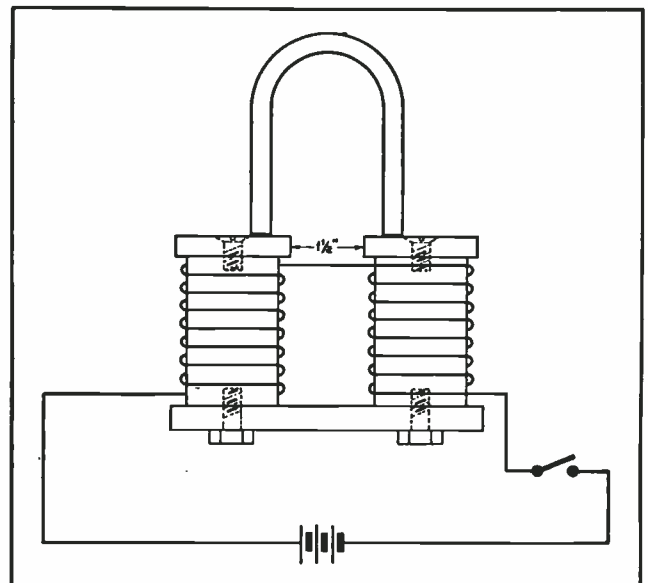

Fig. 60. This sketch shows the method of constructing a simple electro-magnet for recharging field magnets of magnetos.

If the points are only slightly burned or blackened they can be dressed off with fine sandpaper drawn between the contacts when they are pressed lightly together. They can also be dressed or re-surfaced with a fine breaker-point file. These files should be carefully used because if not they can do more harm than good.

One should never hold the file rigidly in the hand or attempt to file one contact at a time. Instead, the file should be held between the contacts by pressing them lightly together against the file surfaces. Then draw the file easily back and forth, always allowing its surfaces to align with those of the contacts which are pressed against it.

Sometimes the stationary contact becomes loose or the pivot of the movable arm becomes worn or loose, and either of these will result in faulty ignition. When found in this condition they should be tightened or replaced.

If the spring tension on the movable breaker arm becomes weak or if this arm is allowed to bind on its pivot, the engine will miss at high speed. The correct tension on the breaker arm should be approximately 16 ounces when the contacts are closed. A temporary repair or increase in spring tension may be effected by bending the spring or shortening it until a new one can be obtained.

49. CONDENSER, ARMATURE, SLIP RING, AND DISTRIBUTOR TROUBLES

An open-circuited condenser will generally cause excessive arcing and severe burning of the contacts and greatly reduce the high-tension spark. If the condenser is shorted it will also prevent the magneto operating, because it shorts out the breaker contacts and prevents the opening of the primary circuit.

The only remedy for a condenser that is actually open or grounded inside is to replace it with a new one. A ground in the armature windings due to defective insulation may result in weak ignition and missing, or in complete failure of the engine. Unless the trouble is right in one of the leads or connections of the coils, the best remedy is to replace the magneto armature with a new one.

If the insulating rings or material on each side of the collector ring become oily and dirty it will allow the high voltage to creep over the surface and to ground. In such cases the rings should be carefully washed with gasoline and well dried before being put back in service.

These rings or insulating barriers sometimes become cracked or punctured and in some cases must be replaced with new ones. To remove a damaged ring, first pull the inner bearing race off the armature shaft. Then stand the armature on end with the collector ring down and apply a little alcohol to dissolve the varnish which cements the secondary lead to the ring. Be careful not to drop any alcohol on the winding insulation, as it will ruin it.

When the varnish is soft the secondary lead can

easily be removed, after which the ring is pulled off the shaft with a special puller. If such a puller is not available expand the ring by immersing it in hot water, after which it can generally be tapped off with a hammer or sometimes pulled off by hand.

Distributor plates and caps sometimes become dirty or carbonized and should then be carefully washed out with gasoline and dried with a clean cloth. Never use sandpaper to clean blackened surfaces of the distributor plate, as this roughens the surface and makes it collect additional dirt much more rapidly.

The magneto ground brush should always make good contact with the rotating armature, and if it doesn't the armature should be cleaned and a new brush installed when necessary.

Some of the other faults which may cause defective magneto operation and for which the remedies can be clearly seen are: Wrong timing, wrong breaker plate, incorrect meshing of armature and distributor gears, cracked distributor cap, broken distributor brush, worn bearings, wrong direction of rotation of armature, etc.

Magnetos are supposed to operate in one direction only, but the direction of rotation can be reversed if necessary in many magnetos by changing the breaker plate for one made for opposite rotation and resetting the meshing of the armature and distributor gears as previously explained.

It is a good plan to check and clean the distributor and interrupter mechanisms of magnetos and readjust the breaker points after every 1000 miles of operation on trucks and busses, or after every 100 hours of operation on tractors and stationary engines.

Cleaning and adjustment are required more often than this on aeroplane engines where the ignition is extremely important.

At these intervals the magnetos should also receive one or two drops of good light machine oil in each of the oil openings. Be very careful not to oil them excessively because too much oil is very often the cause of magneto trouble due to damaged insulation or collection of excessive dirt.

50. STARTING MOTORS

One of the greatest conveniences provided by electricity on the modern automobile is the electric starter which eliminates the necessity of cranking the engine by hand as with earlier model cars. The electric starter which turns the engine over at a mere touch of the starting switch is so much quicker, safer, and more convenient that every car owner wants the starter to be in good condition at all times.

Electric starters are very rugged and simple devices, and do not often get out of order, but there are a few simple faults which do occasionally occur that interfere with their proper operation. These troubles can be easily corrected by an experienced service man.

As it requires considerable torque to turn the automobile engine over rapidly when starting, and particularly when the oil is cold and stiff, series motors are used for this work. You have already learned that series motors have an excellent starting torque characteristic. The series D.C. motors used for automobile starters are constructed and operated on the same general principles as those you have already covered in the D.C. Power Sections of this Set.

The principal difference between power motors and those used for starting automobiles is that the automobile starting motor is smaller and is designed for operation on 6 or 12 volts.

Fig. 61 shows a starting motor with the brushes and a commutator on the right end, and on the left end, the driving pinion that meshes with the flywheel gear of the engine.

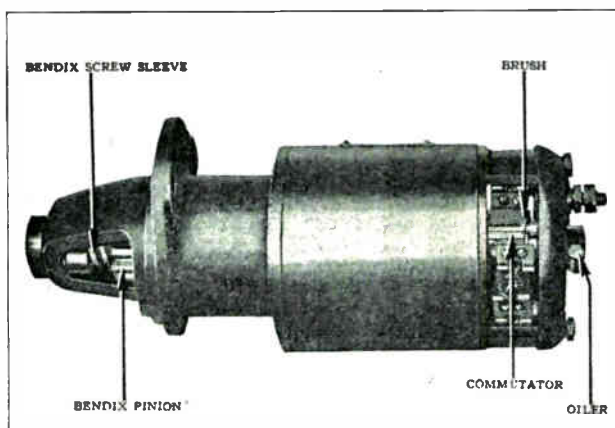

Fig. 61. Photo of common type of automobile starting motor, the commutator and brushes shown on the right and driving pinion on the left.

Fig. 62 shows the location of the starting motor mounted on the engine near the right-hand end, near the flywheel. In this view you will note that the starting motor housing is bolted securely to the flywheel housing. The shaft and driving pinion of the starting motor project through into the flywheel housing to mesh with the teeth of the flywheel gear and turn the engine over when the starting motor switch is closed. The switch in this case is mounted on top of the starting motor where it is operated by a small lever and a pedal which projects through the floorboard of the car.

Starting motors consist of the following principal parts:

1. Cylindrical field frame.
2. Armature.
3. Brushes and brush rigging.
4. End plates in which the bearings are supported.
5. Mechanism used to connect and disconnect the motor armature to the engine flywheel.

As starting motors operate on very low voltage and require heavy currents, both their armatures and fields are wound with very heavy conductors,

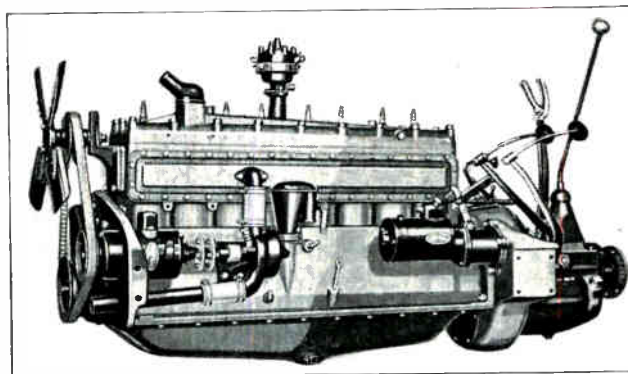

Fig. 62. Side view of an eight-cylinder Studebaker engine showing location of starting motor attached to the flywheel housing on the right.

generally in the form of copper bars or strips. This makes their construction very rugged and tends to eliminate troubles due to short circuits, grounds, and defective insulation which occur more frequently with smaller insulated wires.

The commutator and brushes of starting motors, however, are necessarily rather small and are sometimes sources of trouble on account of the very heavy currents they are required to carry.

Starting motors are made to develop from approximately one-half to one horse power, according to the size of the automobile engine they are to operate. At six volts this results in very heavy operating currents ranging from 100 to 200 amperes when the starter is turning the engine over at about 125 RPM.

During the first instant of operation, however, when the starter is just getting the engine in motion starting currents may run as high as 400 or 500 amperes for a fraction of a second.

From this we can see the necessity of having tight connections and a good low-resistance circuit from the battery to the starter, and through the brushes and windings of the starter itself.

Fig. 63 shows a simple circuit-diagram of the field and armature connections of a series starting motor of the four-pole type. You will note that the motor only has one connection terminal, which is

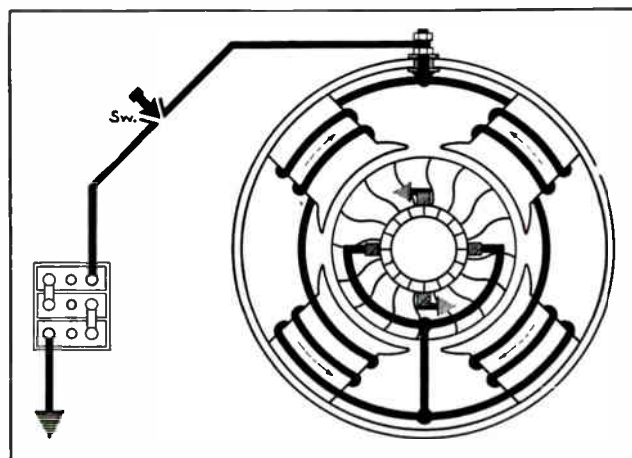

Fig. 63. Diagram showing connections of series wound automobile starting motor. Carefully trace the circuit from the battery through the switch, field coils, armature, and from the grounded brushes back to the battery.

insulated from the frame and feeds the battery current through the field coils and armature in series. Two of the brushes are grounded, thus giving the armature current its return to the other side of the battery, which is also grounded.

The upper view in Fig. 64 shows the commutator end of a starting motor with the cover and brush-holder mechanism removed. Note the arrangement of the brushes, one set of which is grounded to the metal cover, and also note the heavy armature bar conductors attached to the commutator. The large leads projecting from the field frame are those of the series field coils. The insulated connection terminal by means of which the heavy starter cable is attached to the motor can be seen on the lower left corner of the field frame.

In the lower view the opposite end of the starter is shown, and the heavy armature conductors can again be seen projecting from the frame. This view also shows the special pinion and coupling arrangement by which the starting motor is connected to the engine flywheel.

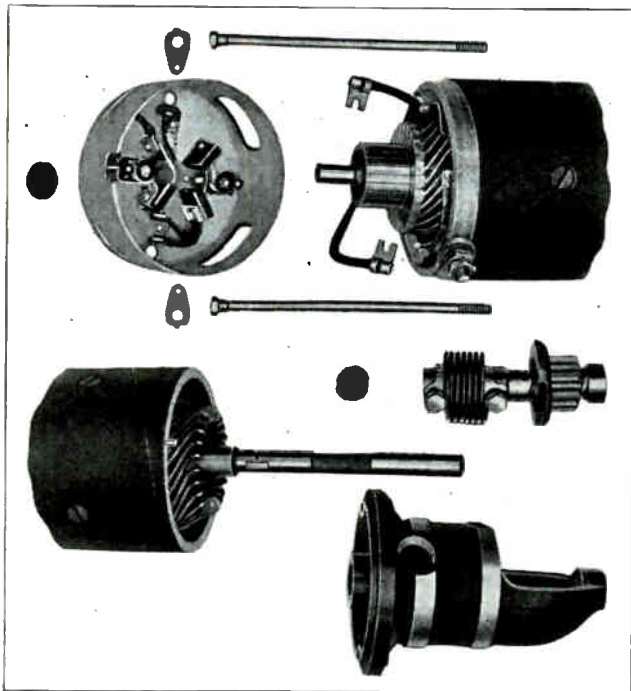

Fig. 64. Disassembled view of a starting motor showing commutator end and brushes above, and drive end with Bendix drive and pinion below.

51. BENDIX DRIVE FOR STARTERS

When the electric starter on an automobile is brought into use it must momentarily connect with the engine flywheel in order to turn the engine, but as soon as the engine is started and running under its own power, the starter must be immediately disconnected, or it would otherwise be driven at an excessive speed, because of the high gear ratio between the starter and the engine flywheel.

This gear ratio is generally about 15 to 1 and enables the starter to crank the engine at a speed of about 125 RPM. When the engine is running under its own power, however, the normal speed will

range from 500 to 3500 RPM, which you can readily see would drive the starter at a terrific rate if it were left connected to the flywheel.

To avoid this requires some form of device which will automatically and reliably connect the starting motor to the engine flywheel when it is desired to start the engine, and quickly disconnect it as soon as the engine begins to run under its own power.

One of the most popular arrangements developed for this purpose is known as the **Bendix drive**, which is shown in Fig. 65. This device connects to the end of the starter armature and consists of a coarsely threaded sleeve mounted on the end of the armature shaft, a small gear or pinion which has threads cut in its inner surface to correspond with those on the sleeve over which the pinion fits, a strong coil spring, and the necessary studs to attach the assembly to the drive head.

Fig. 66 shows a sectional view photo of a starting motor with the Bendix drive attached to its armature. Keep in mind that the drive head or left end of this Bendix drive is rigidly attached to the armature shaft and the rest of the assembly is driven through the coil spring.

When current is sent through the motor by pressing the starter switch, the armature almost immediately goes up to a speed of about 4,000 r.p.m. As the small gear has a certain amount of weight its inertia tends to prevent its accelerating with the

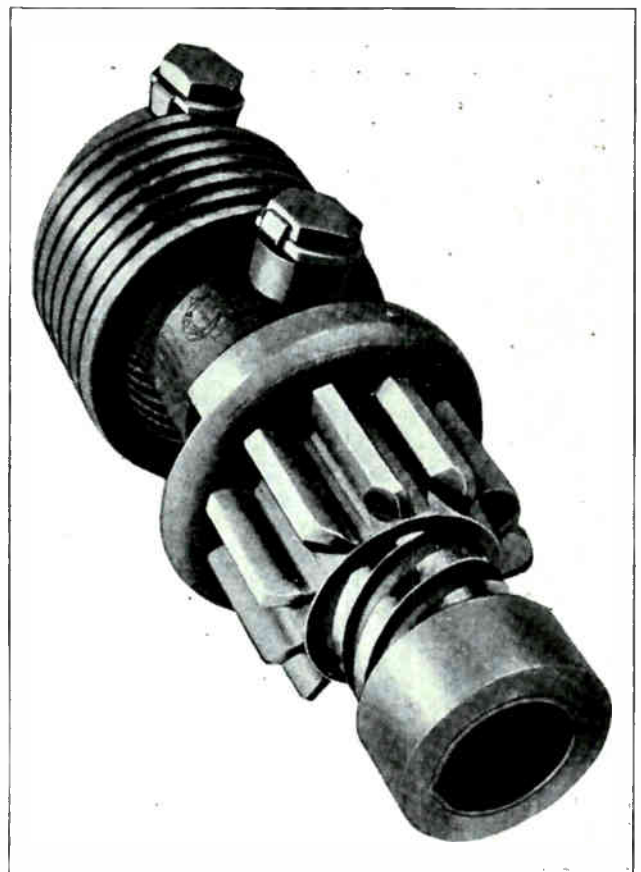

Fig. 65. Photograph view of Bendix drive mechanism showing spring, sleeve, and pinion.

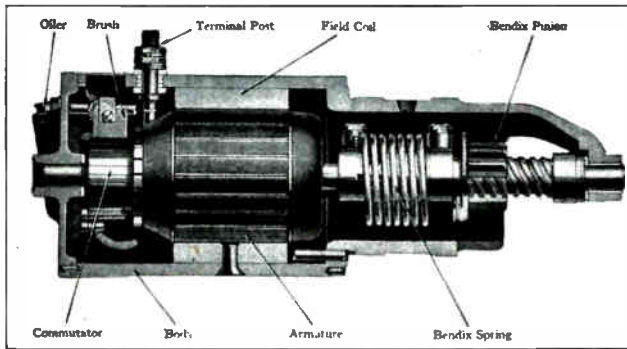

Fig. 66. Sectional view of an automobile starting motor showing commutator and brushes on the left and Bendix drive on the right. Examine this figure carefully while reading the explaining paragraphs.

motor, and as it is loose on the threaded sleeve it tends to turn slower than the sleeve, which causes the threads to force it outward to engage the teeth of the flywheel. The coil spring then absorbs the shock as the motor starts to crank the engine.

As soon as the engine starts to operate under its own power the speed of the flywheel tends to exceed that of the starter gear and causes it to revolve faster than the drive sleeve, so that the threads force the gear back toward the starting motor and out of mesh with the flywheel teeth.

To avoid the possibility of the small pinion or gear revolving and creeping along the threaded sleeve due to car vibration and thus possibly engaging the flywheel when the engine is running, the gear has attached to it a flange one side of which is much heavier than the other. This heavy side tends to hang downward and prevents the gear from revolving except when the starting motor operates it.

In addition to this weighted flange, an added precaution is provided in the form of a small stop pin which can be seen in the lower edge of the flange in Fig. 66.

When the pinion gear is thrown to the idle position this little pin is forced by a light spring into a shallow groove in the driving head, thus holding the gear in this retarded position.

Two of the great advantages of the Bendix drive are its very simple construction and the fact that it allows the starting motor to come up to full speed before connecting it to the engine, thus giving the motor a tremendous "break away" or initial starting torque to crank the engine.

52. MANUAL PINION SHIFTS

Another method that is quite sometimes used for engaging the starter pinion with the flywheel gear is known as the manual shift. With this system the pinion is attached to the starter pedal by a lever arrangement which, during the first downward movement of the starter pedal shoves the pinion into mesh with the flywheel gear.

Further movement of the pedal operates the starter switch, starting the motor and cranking the engine. Just as soon as the engine starts the foot should be removed from the pedal to allow the strong spring

which returns the pedal to normal position to also withdraw the pinion from the flywheel gear.

Starters of this type generally also have in the pinion a form of slipping clutch arrangement which will prevent the motor from rotating at excessive speeds in case the pinion should stick or jam in the meshed position when the engine starts.

Fig. 67 shows a starter with the manual-type shift mounted on the transmission of an engine and with a section of the flywheel casing cut away to show the manner in which the gears are meshed. Attached to the starter pedal is the lever which first moves the small gear into place and then presses the starter switch, which is located on top of the motor.

Fig. 70 shows a starting switch of the foot-operated type for mounting in the floorboard of the car. The connections from the battery to the starting switch, and also from the starting switch to the terminal of the starting motor, are made with heavy stranded copper cable which is equipped with soldered lugs to secure low-resistance connections to the battery, switch, and motor terminals.

It is very important to see that the lugs of this starter cable are well soldered to the conductor, and that they are securely tightened to all terminal connections. When you consider that it is necessary for the 6-volt battery to send several hundred amperes through this circuit, you can readily see that the slightest amount of looseness in these terminal connections, or even a thin layer of dirt or corrosion at such terminals, would create enough resistance to greatly interfere with efficient starter operation. Even a small fraction of an ohm would cause too much voltage drop at the starter. For example, $1/50$ of an ohm in a circuit carrying 200 amperes would cause a voltage drop of $1/50 \times 200$, or

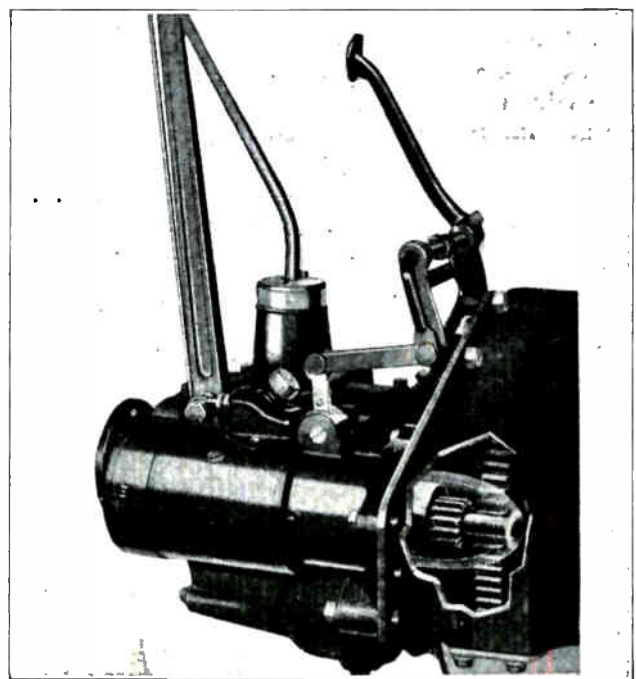

Fig. 67. This view shows method of meshing the starter pinion with the flywheel gear by means of the starter pedal which operates both the gear and starter switch.

4 volts, thus leaving only 2 volts effective pressure at the starter brushes.

For this same reason it is very important to keep the contacts of the starting switch clean and in good condition and the switch properly operating, to avoid unnecessary resistance at this point. These contacts sometimes become burned and pitted, due to making and breaking the heavy current circuit, and they then require scraping and polishing to provide a bright, new surface.

53. AUTOMATIC STARTER CONTROLS

Automatic starter controls are used to provide a positive and convenient means of operating the starter drive and closing the starting switch contacts. Control may be through a push-button on the dash, or a switch attached to the throttle, or accelerator pedal. Either method starts the engine automatically and as soon as the engine starts firing the starter circuit is broken and the gears are disengaged. In most cases the solenoid relay circuit is connected to the coil side of the ignition switch if an electro-lock type of switch is used, so that the starting system will operate only when the ignition is turned on.

Fig. 68 shows a diagram of a common type of automatic starter switch. Examine all the parts and connections carefully.

The control consists of a small relay known as the solenoid relay, and the solenoid switch. The solenoid relay is a small relay energized by means of a push-button switch, or a throttle or accelerator operated vacuum switch. The function of the solenoid relay is to energize the solenoid switch, which operates the starter drive and closes the starting motor switch contacts. This unit will be found mounted directly on top of the starting motor.

To insure positive de-energizing of the relay circuit as soon as the engine begins to fire, this circuit is usually grounded through auxiliary contacts on the generator cut-out, as shown by the dotted line

X in Fig. 68. These contacts will open when the main cut-out contacts close. The second method is to ground the solenoid relay circuit through the main brushes of the generator as shown by dotted line XX. As soon as the engine begins to fire, the rising generator voltage will oppose the flow of current through the solenoid relays and cause its contacts to open.

With ignition turned on, if the push-button is pressed, or accelerator pressed down on cars using vacuum switch control, current will then flow from the coil side of the ignition switch, through the push-button or vacuum switch to one of the solenoid relay terminals, then through auxiliary contacts on generator cut-out. (Trace this circuit in Fig. 68.) This energizes the solenoid relay and closes the contacts.

When these contacts close, current will flow from the battery through the heavy winding or pull-in coil of the solenoid switch to ground through the starting motor windings and armature. At the same time current will also flow through the hold-in coil to ground. The powerful magnetic field set-up by these two windings will draw in the plunger that operates the starter drive, causing the small gear or pinion on the drive to mesh with the ring gear on the flywheel of the engine. As the pull-in coil is in series with the starting motor the armature will be rotating slowly when the gears are brought together, thereby assisting the meshing action.

As the plunger reaches the end of its movement, it closes the main starting switch and current flows directly from the battery to the starting motor. The closing of the main switch shunts out the pull-in coil, but the hold-in coil will hold the plunger in as long as the small solenoid relay is energized.

As soon as the engine begins to fire, releasing the push-button will break the solenoid relay circuit, which in turn will open the solenoid switch contacts. With the solenoid coils no longer energized, the shift lever return spring draws back the

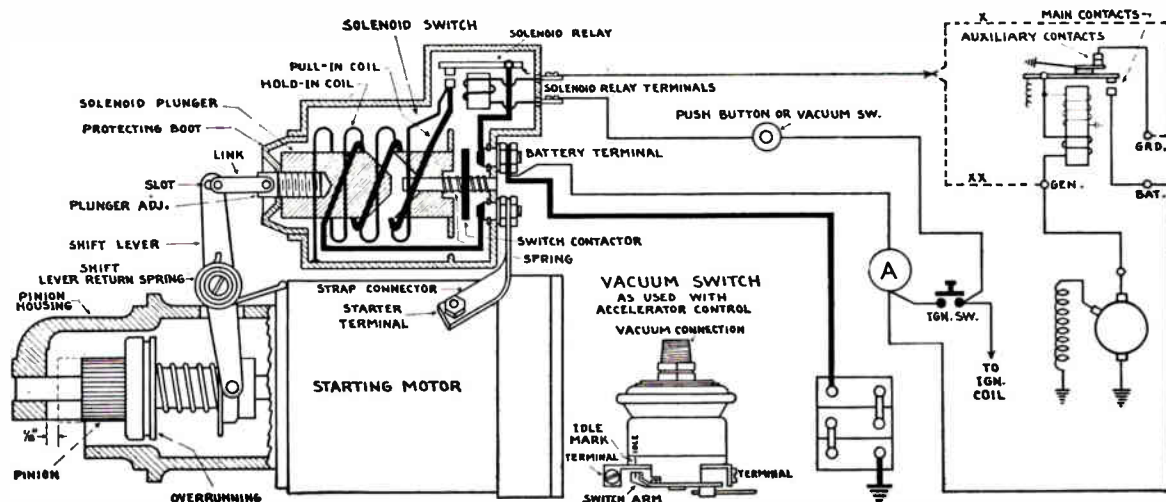

Fig. 68. Wiring diagram for a common type automatic starter switch.

plunger, which opens the main starter switch and also disengages the gears. Should the operator fail to release the push-button as soon as the engine starts, the solenoid relay circuit would be rendered inoperative either by the opening of the auxiliary contacts on the cut-out relay or by the use of the opposing generator voltage depending on which hook-up was used.

When a throttle or accelerator vacuum switch is used, as soon as the engine begins to fire the vacuum built up in the intake manifold will operate the vacuum switch and open the solenoid relay circuit. In case the vacuum switch should stick, the opening of the auxiliary contact on the cut-out, or the opposition of the rising generator voltage would render the solenoid circuit inoperative.

54. AUTOMATIC STARTER CONTROL ADJUSTMENTS

Solenoid relay contacts should close with a maximum terminal voltage of 4 volts, and should remain closed until the voltage drops to 1.6 to 2 volts. If the operation of this relay is not satisfactory, check the contact gap which should be .030" to .045" and the air gap which should be .010" to .014" with the contacts open. When the solenoid relay circuit is grounded through auxiliary contacts on the cut-out, the gap of these contacts should be .015" to .025" when the main generator contacts are closed. Total failure of this system might be due to poor contact in the push button, vacuum switch, or auxiliary contacts on the generator cut-out. If the solenoid relay circuit is grounded through generator brushes, failure could be caused by a dirty commutator.

There is only one adjustment on the solenoid switch but it is very important. The clearance between the end of the pinion gear and the housing should be $\frac{1}{8}$ of an inch when the shift plunger is at the inner end of the stroke. See Fig. 69.

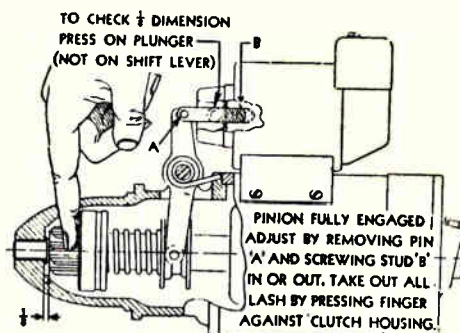

Starter pinion and solenoid plunger adjustment on Delco Equipment.

Fig. 69. This diagram shows the proper adjustment for the solenoid plunger on a Delco starter.

The only adjustment on the vacuum switch is the "off" position. When the accelerator pedal is released and the engine is not running, the line at the end of the switch arm should line up with the "idle" mark on the case of the vacuum switch as shown in the small sketch in Fig. 68. If these marks do

not line up, adjust the rod that operates the switch arm.

55. STARTER TROUBLES AND REMEDIES

Because of the very rugged electrical construction of starting motors, troubles of an electrical nature are not very often encountered within the motor itself. In most cases electrical troubles will be found to be at the commutator, brushes, brush holders, or leads. This fact should be kept well in mind by the trouble shooter or ignition service man.

When the starting motor gives trouble, it is generally in the form of low cranking torque or complete failure of the motor. It should be kept in mind that satisfactory operation of the starter depends not only on the condition of the motor itself, but also on the condition of the battery, connecting cables, and starter switch, and one should carefully check each of these items before spending the time necessary to remove the starting motor for thorough inspection or overhauling.

56. LOW VOLTAGE AT STARTING MOTOR

If the starting motor fails to crank the engine properly, a good test to determine the cause of the trouble is to switch on the lights and press the starter pedal. If the lights are extinguished when the starter switch is closed, the trouble is generally due to a loose or dirty connection in the starter circuit. Carefully check the battery terminals, cell connectors, and ground connection.

To help locate the trouble, hold the starter switch closed for about one-half a minute and this will cause the loose connection to heat up so that it can be readily located by feeling along the different parts of the circuit with the hand.

If the lights gradually dim down and go out when the starter switch is closed, this generally indicates a dead battery. The battery should be removed from the car and tested with a high rate discharge test, which will be explained later in the Battery Section.

57. MECHANICAL TROUBLES

If, when the starter switch is closed, the lights dim slightly, but do not go out, it generally indicates mechanical trouble, which may be either in the engine or the starter and is causing an overload on the starting motor. Crank the engine by hand to see if it is unusually tight, as might be the result of cold, heavy oil, tight bearings, etc.

Sometimes the starter pinion becomes jammed or locked just as it starts to mesh with the flywheel gear. The pinion can usually be released by putting the car in high gear and rocking it back and forth to disengage the pinion. If none of these troubles seem to be present, then remove the starting motor and check it for a bent armature shaft or loose bearings.

Sometimes the starter may stick because of loose bearings which allow the armature to rub the pole pieces and lock magnetically when current is applied.

If, when the starter switch is pressed, the lights do not dim at all, there is probably an open somewhere

in the starter circuit. This trouble will generally be found at the starter switch or at a loose cable connection, or sometimes at brushes stuck in the brush holders so that they do not rest upon the commutator. An extremely dirty commutator or brushes may also give this indication.

If the starting motor operates and spins at high speed without cranking the engine, it may be due to hardened or gummed oil on the Bendix sleeve which prevents the pinion from traveling into mesh with the flywheel gear. Washing off the threaded sleeve and parts with a brush and gasoline will generally cure this trouble.

Sometimes the Bendix spring or studs become broken or there may be several teeth broken out of the flywheel, thus preventing the starter pinion from meshing at a certain point. If the starter uses a manual pinion shift, check carefully for disconnections or excessive play in the pedal rods or levers.



Fig. 79. Starter switch for mounting on the floorboard and connecting in series with the lead from the battery to the starting motor.

If, when the starter is operated, a loud clashing or banging noise occurs when the pinion meshes with the flywheel, check the bolts that hold the starter to the flywheel housing to see that they are tight. If this doesn't remedy the trouble, remove the starter and examine the teeth on the flywheel gear.

The edges of the teeth on both the flywheel and pinion gears are beveled to allow them to engage with each other easily. If these teeth are badly burred, due to rotating with only the entering edges meshed, noisy starter operation will result. This condition can only be remedied by replacing the gears.

Burred teeth are generally caused by improper alignment of the pinion, which may be due to a bent armature shaft, worn starter bearings, or loose starter. Clashing may also be caused at times by the threaded Bendix sleeve sticking or "freezing" to the armature shaft, and thus preventing the slight lateral movement which is necessary for silent gear meshing.

To correct this trouble, the Bendix drive should be removed and disassembled and the armature shaft carefully polished with fine emery cloth. Any rust should also be removed from the inside of the Bendix sleeve. Then apply a little light oil and reassemble.

When the starting motor cranks the engine very slowly, the trouble may be due to short circuits or high-resistance connections in the motor, or loose connections and high resistance at the starter switch or cable. If the switch gets hot, remove it and look for burned contacts. Also inspect the switch for possible defects in the insulation. Examine the starter cable carefully for loose connections or for damaged insulation where it rubs against the car frame and may have become grounded.

The starting motor should be carefully checked for poor brush contact, weak brush-spring tension, dirty commutator or brushes, or unsoldered field or armature connections.

If the trouble is still not located, the armature, field, and brushes can be tested for grounds. A weak battery may also cause the starter to crank the engine very slowly.

58. ELECTRICAL AND MECHANICAL TROUBLES IN MOTOR

If no trouble can be located at the battery, starting switch, or cable and there appears to be electrical trouble within the starting motor, it should be taken apart and carefully examined for both mechanical and electrical defects, such as the following:

Armature rubbing on the pole shoes, worn bearings, bent shaft, broken brushes or brushes stuck in the brush holders, loose connections to the brushes or field coils, grounded cable terminal, poor brush-spring tension, loose connections between commutator bars and armature leads due to solder having been melted and thrown out of the commutator risers, high resistance in the field circuit caused by solder melting and running out of the joints between field coils, etc.

Always remember that anything that increases the resistance of the motor or its circuit will greatly decrease its torque. The mistake that is sometimes made by inexperienced or untrained automobile service men is that of replacing worn starter brushes with brushes of the wrong grade or material.

In order to be of sufficiently low resistance, the brushes for starting motors are made of carbon and powdered copper, the copper content being the greater portion of the material used in these brushes. If these brushes are replaced with ordinary carbon or carbon graphite brushes, their resistance will be altogether too high for use on such heavy currents at low voltage.

Sometimes wrong brushes of this type become red-hot when the starting motor circuit is closed, but they will not allow enough current to flow to start the engine.

You are already familiar with the methods of testing field coils or armature windings for grounds, shorts, opens, etc., as covered in the Sections on Armature Winding and Motor Repairs.

An ordinary 110-volt test lamp can be used very conveniently for checking for these faults on starting motors. The brush holders should also be checked to

see that those which are supposed to be insulated have not become grounded to the starting motor frame.

After a starting motor has been repaired and overhauled it can be thoroughly tested before it is replaced on the car by means of a regular garage test bench such as is used in most medium and large-sized garages or automotive electrical service stations.

On these benches the starting motor is securely clamped in a special vise and a spring scale and lever arrangement are attached to the shaft to measure its torque when battery voltage is applied.

59. AUTOMOTIVE GENERATORS

As stated in an earlier article in this section, the generator is a very important piece of the electrical equipment on a modern automobile. With the extensive use of electric current for lights, ignition, horn, starting motor, and various other purposes, any ordinary-sized battery would soon become discharged if there were no means for supplying it with current.

The length of the battery discharge could, of course, be prolonged by using batteries of larger sizes, but as this would add considerable weight and additional expense, it is much more practical to equip each car with a small low-voltage D. C. generator to keep the battery charged, and also to supply the current for various uses and prevent drain on the battery when the engine is running at normal speed.

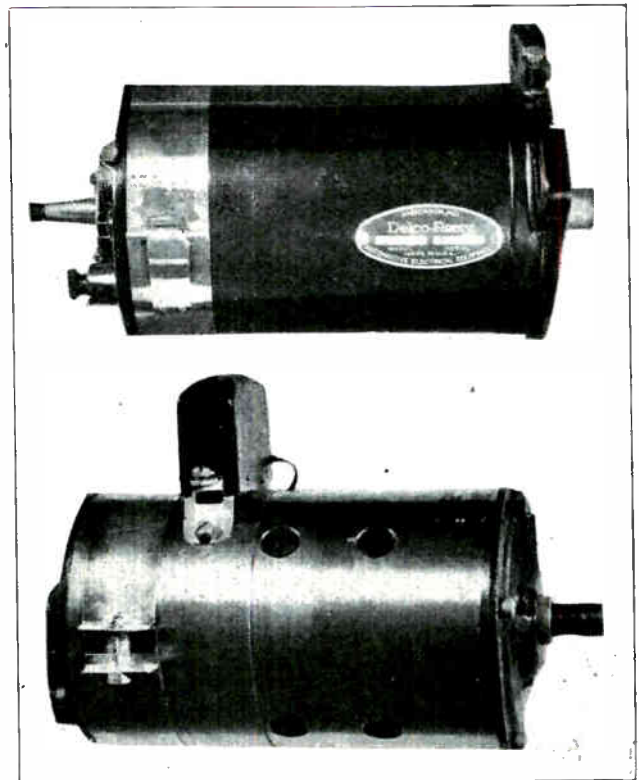

Fig. 71. Photograph views of two types of automobile generators. Note the metal band on the left end of each generator which can be removed for access to the brushes and commutator. Also note the cut-out mounted on top of the lower generator.

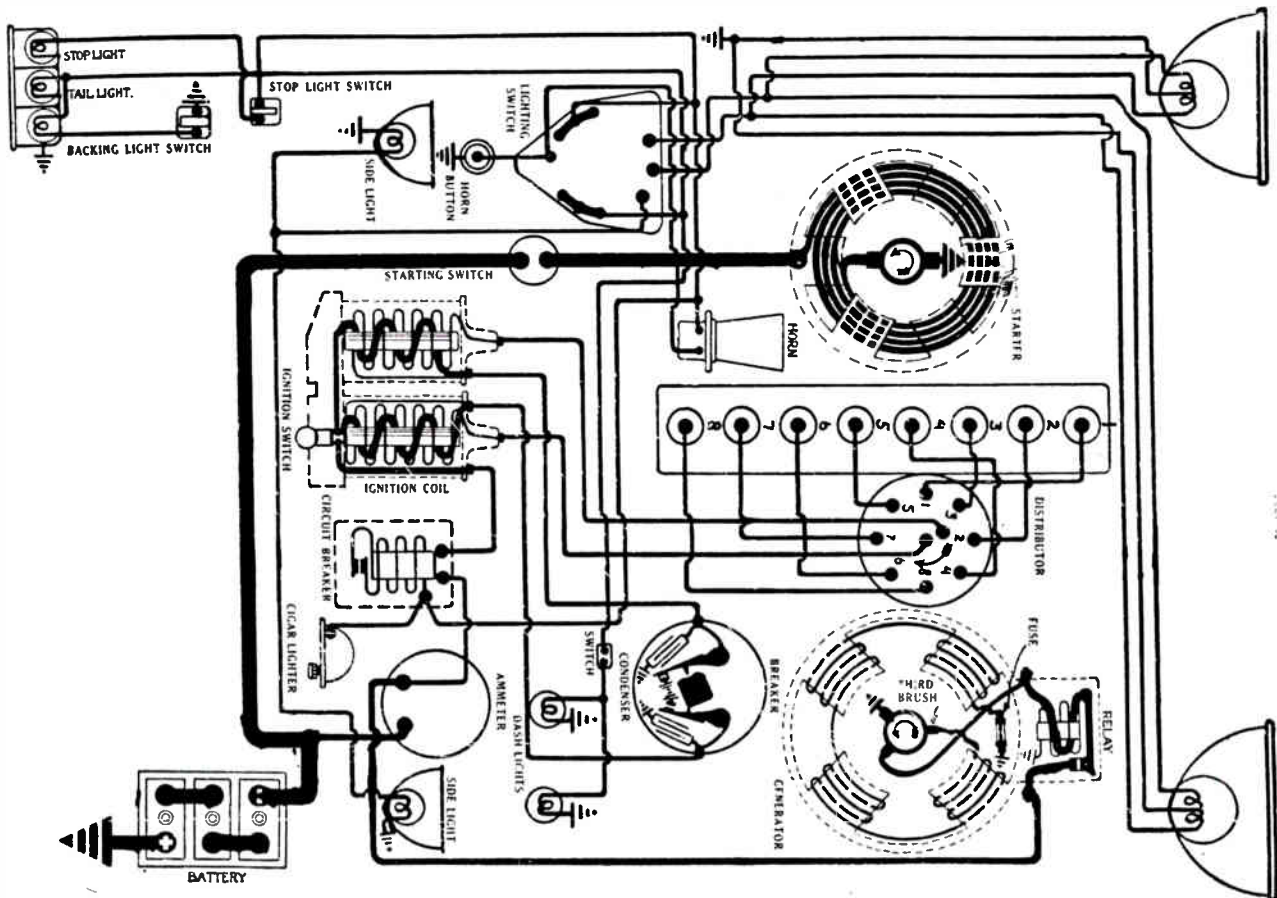

Fig. 72. Complete wiring diagram of an eight-cylinder Packard automobile. Note the two ignition coils and high speed distributor with double breaker arms used on this "line eight" engine. Also note the starting motor and generator connections, and the generator cutout relay. Courtesy National Automotive Service.

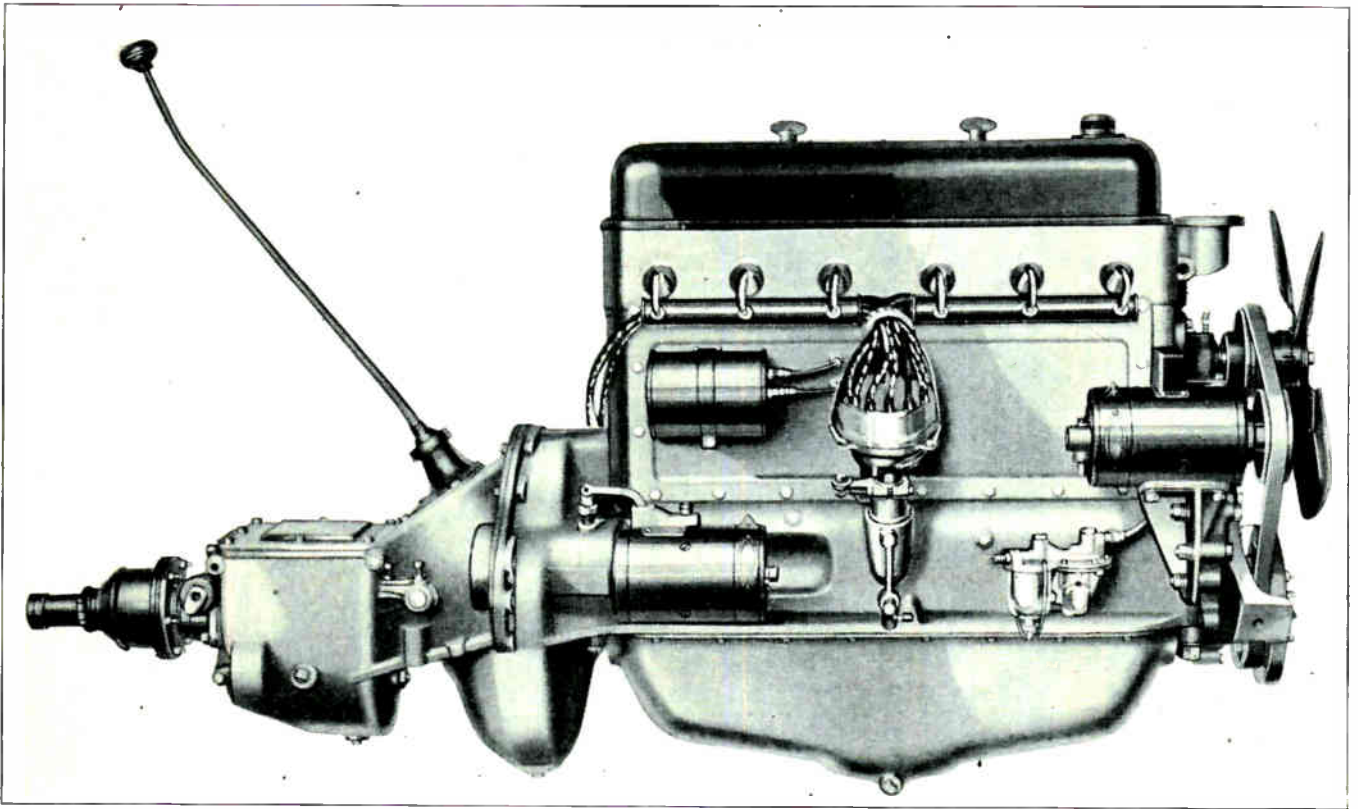

Fig. 73. Side view of a six-cylinder Nash engine showing the location of the starting motor, generator, double ignition distributor, and fuel pump. Note the generator driving belt which drives both the generator and fan.

For this purpose a small shunt-wound D. C. generator is connected to the engine by means of a chain, belt, or gear, and is driven at a speed of about one and a half times engine speed, producing from 6 to 8 volts within the normal speed range of the engine.

Fig. 71 shows two very common types of automobile generators, and Fig. 73 shows a generator attached to a bracket and mounted upon the engine at the right-hand end. In this figure you will note the "V" belt used to drive the generator and fan.

The general construction and operating principles of D. C. generators have been thoroughly covered in the previous section on D. C. power equipment, and the principles of automobile generators are very much the same. Because of the peculiar conditions under which they operate, however, there are certain special features in their design that are very important and interesting to consider.

For example, a generator must be capable of rotating at very high speeds without injury, as it may often be revolved at speeds of 6,000 r.p.m. or over. Another special feature is the very interesting voltage control, which has been developed to enable the generator to produce high enough voltage to charge the battery and supply current when the car is operating at comparatively low speeds and yet prevent the generator from developing excessive voltage and charging currents at high speeds. When we consider that it is desired to have the generator commence charging the battery at a speed of about 12 miles per hour and yet not charge excessively or develop too high voltage at speeds of

even 60 or 70 miles an hour, this voltage regulation is quite an accomplishment.

Another feature of the automobile generator is the convenient means provided for adjusting or changing the charging rate so that it can be set to suit various driving conditions.

60. THIRD BRUSH REGULATION

One of the most commonly used and popular types of automobile generators which fulfills the above requirements is known as the "third brush" type, because it uses a small third or auxiliary brush to regulate the voltage at different speeds.

This brush is connected to one end of the field winding and is placed in such a position on the commutator that it tends to decrease the field voltage and current when the generator speed increases, and so prevents the armature voltage and current from rising above the limit for which the brush is set.

The location and connection of this third brush is shown in Fig. 74.

You have already learned in an earlier section on D. C. motors and generators that when the armature windings are carrying current there is set up around them a strong magnetic field which tends to distort the flux from the field poles, and cause the pole flux to shift around the pole faces in the direction of rotation. This armature reaction results in weakening the flux at one pole tip and strengthening it at the other, as shown at Fig. 74.

In this diagram the coils A to G are under one field pole and will have generated in them a voltage propor-

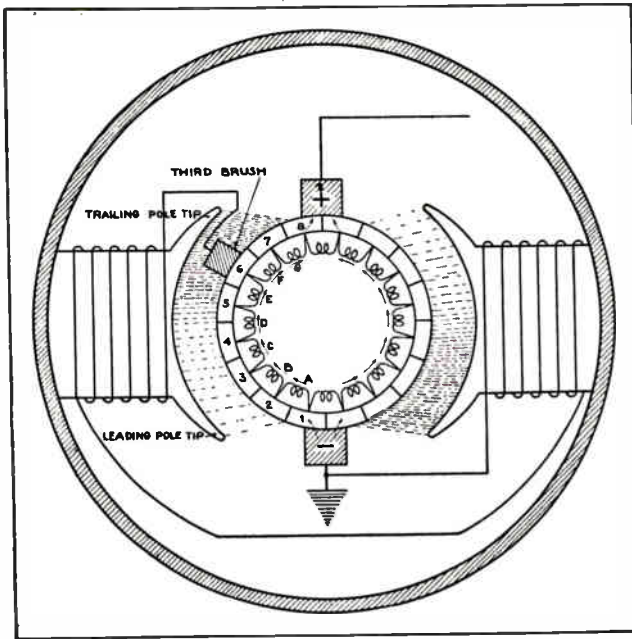

Fig. 74. Diagram showing the armature reaction, field distortion, and principles of third brush voltage regulation on an automobile generator.

tional to the speed at which they are rotated and to the strength of the magnetic field of the generator. Assuming that each coil generates 1 volt, the voltage between adjacent commutator bars will be 1 volt; and the voltage between the main brushes will be the sum of the voltages generated in the separate coils in one side of the winding, or in this case 7 volts.

Note that the two sides of the armature winding form two parallel paths from the negative to positive brush. With a pressure of 1 volt between bars, the voltage applied to the field coils which are connected between the negative brush and third brush will be 5 volts.

This voltage doesn't remain constant, but varies with the shifting of the field flux due to the change of current load in the armature conductors. For example, if the armature develops a certain voltage and delivers a current of 10 amperes at a speed of about 1,800 r.p.m., then if the speed is increased the voltage and current will tend to increase.

A slight increase in the armature current increases the field distortion, moving the more dense field flux farther toward the pole tips. This weakens the field through which coils A, B, C, D, and E are moving thus reducing the voltage applied to the field coils, cutting down the total generator field strength, and tending to prevent the voltage at the main brushes from rising in proportion to the increase of speed.

In actual practice this third brush method of voltage regulation allows the charging rate to gradually increase up to generator speeds of about 1,800 r.p.m., at which point the correct relation between armature current and field voltage is obtained. From this point the charging rate gradually falls off as the speed is increased above this limit. This is generally a desirable feature, particularly in the summer time, when the car may often be operated for long periods at high speeds, as it pro-

fects the battery from being overcharged and the generator from overheating.

As the voltage applied to the field varies immediately with any change of generator speed and armature current, resulting in a change of field distortion, this regulation is entirely automatic and maintains a fairly steady voltage even with sudden variations in the engine speed.

61. ADJUSTING CHARGING RATE

To adjust the charging rate of a generator of this type, all that is necessary is to slightly shift the position of the third brush on the commutator to include more or less bars between it and the negative brush.

You can readily see that if the third brush in Fig. 74 were shifted farther to the right it would include more armature coils in the field circuit and supply higher voltage to the field, thus causing the generator to develop higher armature voltage at the main brushes and increase the charging rate.

On the other hand, if the brush were shifted to the left to cut out part of the winding between it and the negative brush, there would be less voltage applied to the field coils, and the generator voltage and charging rate would be decreased.

The third brush holder is generally arranged with a set screw or locating nut which normally holds it securely in one position, but which can be loosened to allow the brush to be shifted, either by lightly tapping against the holder with a screwdriver or by the adjustment of an auxiliary shifting screw. This provides a convenient method of increasing the charging rate during winter months when the engine starts hard, due to cold, stiff oil and therefore requires considerably more starting current. This is also the season when the daylight hours are

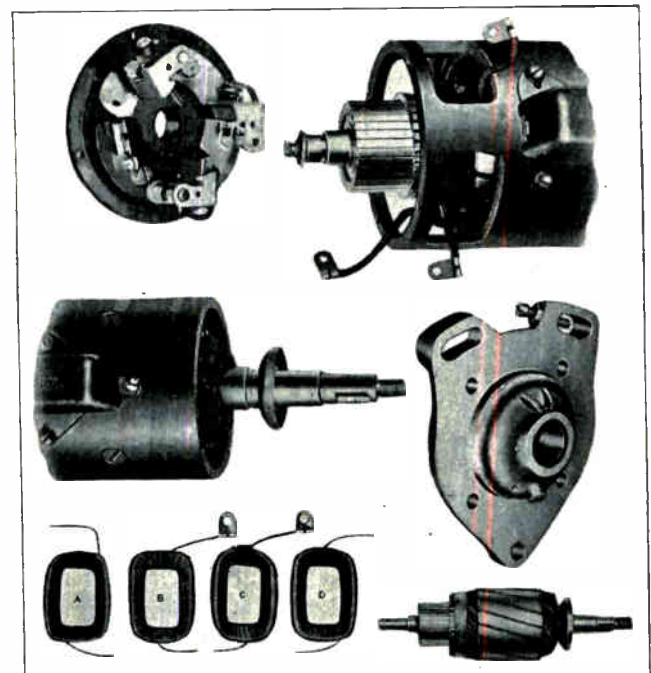

Fig. 75. Disassembled view of an automobile generator showing commutator and brushes above, drive end of generator in the center, and small views of field coils and armature below.

shorter and the headlights are used a great deal more on an average.

In the summer time, to prevent overcharging the battery, the generator charging rate should be cut down by adjusting the third brush. This is particularly true when the car is being used on long trips at high speeds, as the battery would otherwise be overcharged and overheated, and the generator would also tend to overheat due to the continuous high operating current through its armature.

It is important to know by merely looking at the generator in which direction to shift the third brush. To increase the charging rate, the brush should be shifted in the direction of rotation of the commutator, and to decrease the charging rate the brush should be shifted in the direction opposite to that of commutator rotation.

The upper view in Fig. 75 shows the commutator end of an automobile generator with the end-plate and brush rigging removed. The two large brushes placed at right angles to each other are the main brushes and the smaller brush is the third brush, or voltage regulating brush.

The center view in this figure shows the opposite end of the generator, opened up to show the end of the armature winding and the drive shaft by which the unit is coupled to the engine.

At the bottom of this figure are shown four field coils and an armature completely removed from the generator frame.

Fig. 76 shows a set of curves which indicate the variations in voltage and current at different engine speeds and for generators operating both cold and hot. Note the difference in the operating current due to the increased resistance of the generator windings after the unit has been operating for some time and is warmed up.

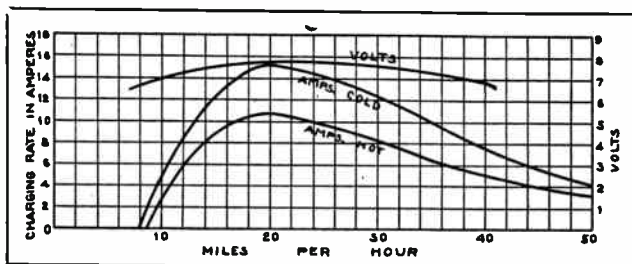

Fig. 76. These curves show the variation in generator voltage and charging current with changes of car speed and variations in generator temperature.

62. GENERATOR CUT-OUTS

In order to prevent the battery discharging back through the generator when the engine speed falls too low to allow the generator to develop a voltage equal to that of the battery, a device known as a reverse current cut-out is commonly used.

This device is simply a magnetically operated switch or relay equipped with both a series and shunt winding and a set of contacts, as shown in Fig. 77. The cut-out is generally mounted on top of the generator, as shown in Fig. 77 and also on the photographic view of the lower generator in Fig. 71.

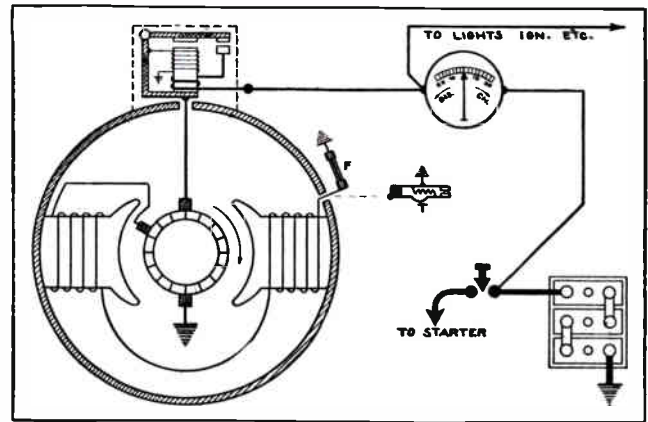

Fig. 77. This diagram shows the connection of an automobile generator and complete charging circuit, including the cut-out, ammeter, battery and field protective devices.

The shunt winding consists of a good many turns of fine wire and is connected directly across the main generator brushes, as can be noted by carefully tracing the circuit from the top brush of the generator in Fig. 77 up through the cut-out frame and shunt coil to ground, by which it returns to the lower brush of the generator. This means that the strength of the shunt coil will always be proportional to the voltage out-put of the generator.

When the generator voltage rises to about 7 volts the shunt coil becomes strong enough to magnetize the core and attract the armature, closing the contacts in the charging circuit through the ammeter to the battery. This charging current flows through the series coil consisting of a few turns of heavy wire, and this coil is wound so that the current flows in the same direction as through the shunt coil, thus adding the magnetic strength of the series coil to that of the shunt coil and holding the contacts firmly closed.

Whenever the generator speed falls below a certain value, its voltage drops below that of the battery and the battery commences to discharge back through it. This discharge current flowing through the series coil in the opposite direction sets up a magnetic field which opposes that of the shunt coil and demagnetizes the core, allowing the spring to pull the armature back and open the contacts.

A reverse current or discharge current of not over 2 amperes should be sufficient to release the cut-out contacts. These cut-outs not only prevent the battery from discharging through the generator at low speeds, but also prevent the generator from being overheated and burned out in case the engine was stopped and the battery discharged a heavy flow of current through the generator armature in an attempt to motorize the generator. The generator is connected to the engine and cannot turn it because of insufficient torque to rotate the engine.

Fig. 78 shows two types of cut-outs, one with the cover removed showing the coil and contacts.

By referring to Fig. 77 again you will note that the ammeter is connected in series with the generator and the battery so that it will register the current flowing to the battery by a movement of the needle over the side of the scale marked "Charge." This instrument

will also register the flow of current out of the battery whenever the battery is discharging through the lights and other equipment.

The ammeter should always be observed when looking for battery or generator troubles, because it gives a good indication of possible reasons for the battery being discharged or overcharged due to too low or too high charging rates, and will also indicate sticking contacts in the cut-out by showing a very heavy discharge when the engine is stopped. Note that the starter connection to the battery is made in such a manner that this very heavy current doesn't flow through the ammeter.

63. FIELD PROTECTION

Since the third-brush generator depends upon the current flowing through the armature to produce the field distortion necessary for voltage regulation, we can readily see that if the charging current were interrupted it would entirely destroy the regulating action of the generator.

In fact, if the battery becomes disconnected or the charging circuit open, the generator voltage may rise to 30 or 40 volts, because of insufficient current flowing through the armature to distort the field and keep the voltage reduced in those coils between the third brush and the grounded main brush.

With the field flux in a normal, evenly-distributed position over the pole face these coils would generate much higher voltage, excite the field much more strongly, and allow the generator to develop sufficient voltage to quickly burn out the field coils.

To prevent this, field protection is generally provided either in the form of a fuse or a thermostatic cut-out placed in series with the field windings.

In Fig. 77 the fuse is shown at "F" in the grounded field lead.

If the field current rises above the normal value of approximately 5 amperes this fuse will blow and the generator will become dead. Another method of field protection and one that is rapidly replacing the fuse for this purpose is the thermostatic cut-out, such as shown at "T" in Fig. 77.

These devices merely consist of a set of contact points, a small resistance, and a spring-like blade made of two dissimilar metals welded together so that when they become overheated they warp in a manner with which you are already familiar.

With this thermostat connected as shown by the dotted lines to the field terminal, in place of the fuse, whenever an excessive current flows through the generator its temperature increases and the strip becomes heated and bends, opening the contacts and thus inserting the small resistance in the field circuit and reducing the charging rate about 40%.

As soon as the temperature in the generator drops enough to allow the strips to cool off the contacts automatically close and bring the generator back

into normal operating condition. This device is also a precaution against the generator overheating.

For maximum life of the generator insulation the temperature inside the unit should not exceed 180° F., so the thermostat is designed to open the cut-out points at this temperature and thus reduce the charging rate by inserting resistance in the field.

When the generator cools off again the contacts close and allow the charging current to again rise to normal value. We can see, therefore, that the thermostatic cut-out not only protects the field winding from burning out due to excessive voltage, but also protects the generator against overheating due to heavy charging currents and high engine temperatures.

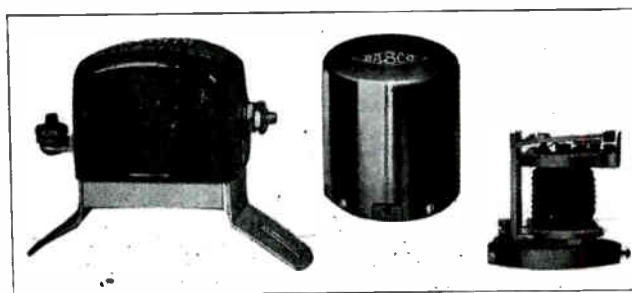

Fig. 78. This view shows two types of generator cut-outs and the one on the right has a cover removed showing the coil and contacts.

64. AUXILIARY GENERATOR CONTROLS

While the generators used on modern cars are still of the third brush type, many of them are equipped with auxiliary controls. These controls make it possible for the generator to meet unusual operating conditions, such as extra load due to auto radios or other electrical accessories, or the operation of the car at high speed, which tends to reduce the output of the generator.

Auxiliary controls are designed to either increase the output of the generator to meet an increase in load on the electrical system, or to charge the battery at a high rate until it reaches a charged condition after which the rate is reduced. The first system, known as the two-rate or step-down control keeps the battery from being robbed by an increase in load, since the output of the generator is stepped up until the battery is fully charged, and then the charging rate is stepped down. The second system, known as the vibrating regulator control, quickly brings the battery up when it drops to a certain voltage. Auxiliary control is obtained by means of resistance connected in series with the field circuit of the generator.

65. TWO-RATE STEP-DOWN CONTROLS

This type of control is generally built on the same base and housed in the same casing as the generator cut out. The control shown in Fig. 79 consists of one or two potential coils which are connected across the brushes of the generator, a moving contact, a stationary contact, a field resistance,

and in some cases, a field fuse. The contacts and the resistance are connected in parallel with each other, between the field terminal and ground, and the fuse will be in series with both the resistance and the contacts.

This type of control is designed to charge a battery at a high rate, the value of which will be determined by the third brush setting, until the battery is charged, after which the rate will be reduced one-half.

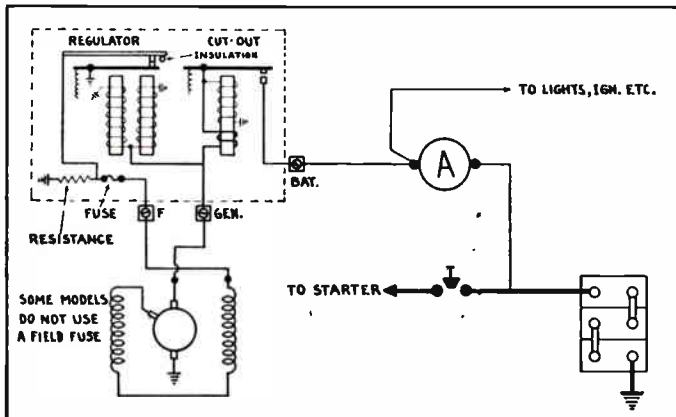

Fig. 79. Circuit and connections for a two-rate or step-down charging control.

66. OPERATING PRINCIPLE OF THE TWO-RATE CONTROL

Since the coils of this field control are connected across the brushes of the generator, the voltage applied to them will be generator voltage. As the voltage of the generator under normal conditions depends upon the state of charge of the battery, the voltage applied to the field control coils will rise or fall as battery voltage rises or falls. Under normal conditions the voltage of the generator will be $\frac{1}{2}$ to $\frac{3}{4}$ of a volt higher than that of the battery. This difference represents the voltage drop in the connections between the generator and the battery. So when battery voltage is about six volts, generator voltage will be between $6\frac{1}{2}$ and $6\frac{3}{4}$ volts. A well charged battery with charging current flowing through it, will reach 7.5 volts which would raise the generator voltage to 8 or $8\frac{1}{4}$ volts.

As long as battery and generator voltage are low the amount of current forced through the coils of the field control will not be sufficient to build a magnetic field strong enough to pull the contacts open, so the field current has a circuit directly to ground through these contacts without going through the control resistance.

As long as the contacts remain closed and keep the control resistance shunted out of the field circuit, the field current will be at maximum value and the charging rate will be high. As the battery becomes charged, its voltage will increase, causing the voltage of the generator to also increase, which

will increase the amount of current forced through the coils of the field control. When the voltage of the generator reaches 8 or 8.25 volts, the current flowing through these coils will build a field strong enough to open the contacts, breaking the field circuit at that point and causing the field current to flow through the resistance. This causes the field strength to decrease and the charging rate is automatically reduced.

When battery voltage drops to a point that brings the generator voltage down to about 7 volts, the contacts close and the battery charges at a high rate again.

67. TROUBLES AND SERVICING OF TWO-RATE CONTROLS

Since the operation of this control depends upon the voltage of the generator, anything that causes the generator voltage to rise will cause this control to operate. Bad connections in the circuit between the generator and the battery or between the battery and ground would cause the voltage of the generator to rise, regardless of the condition of the battery, and the control contacts would open and thereby reduce the charging rate. This would cause the battery to run down quickly. So it is important that all connections, over which the generator current flows, be kept clean and tight.

In some cases, the constant pull exerted by the moving contact spring upon its anchorage bracket will bend the bracket slightly, and reduce the spring tension; thus allowing the contacts to open before the correct generator voltage is reached. This would also tend to cause the battery to run down, especially during winter months.

To check and adjust these controls, 2 pieces of equipment are required: A $\frac{1}{8}$ ohm, 30 ampere rheostat is used to artificially raise and control the voltage, and an accurate voltmeter should be used to check the voltage at which the contacts open.

With the engine of the car stopped the generator lead is disconnected from the terminal marked "Bat." on the cut-out. The rheostat is then connected in series with that terminal and the generator lead that has just been disconnected. One side of the voltmeter is connected to the terminal marked "Gen." on the cut-out case. If it is difficult to make connection at this point, connect to terminal marked "Bat." instead. The other side of the voltmeter is grounded. If the "Bat." terminal is used for a voltmeter connection, it is highly important that the cutout contacts make good connection, as high resistance at this point would make it impossible to set the control correctly.

With the rheostat set so that all resistance is cut-out, the engine can be started. The throttle should be set so that the generator charges at 10 or 12 amperes. Now gradually insert resistance, which will

cause the voltage of the generator to rise. When the voltage reaches 8 or 8.25 volts, the contacts of the field control should open. When they open, a slight drop in voltage will be noticed on the voltmeter, so it won't be necessary to watch the contacts.

If the points open too early, increase the tension on the contact spring by bending the bracket. If the points open too late decrease the tension in the same manner. To set third brush for maximum charging rate on a generator equipped with a 2 rate control, ground the field terminal and set the rate at maximum recommended by manufacturer. After rate is set, be sure to remove ground on field terminal.

68. VIBRATING TYPE REGULATOR

This type of regulator is also designed to charge the battery at the maximum rate allowed by the third brush setting, as long as the battery is in a discharged condition, and then gradually reduce the rate when the battery reaches a fully charged condition. Construction and action are somewhat different from the two-rate or step-down type. See Fig. 80.

Two windings are used on the regular unit. The series or heavy winding is connected in series with the field and the regulator contacts, so that full field current can flow only when the regulator contacts are closed. The shunt or fine winding is connected at a point near the battery, usually the coil side of the ignition switch, and being connected at this point, this winding is actuated by battery voltage, rather than generator voltage.

When the regulator contacts are closed, current flows through both windings, creating a magnetic field which will attract the armature of the regula-

tor. This reduces the strength of the field coils in the generator and also the strength of the magnetic field built up by the regulator coils, so that the contacts will immediately close. This opening and closing of the contacts is an extremely rapid vibrating action, and it holds the voltage of the generator fairly constant. With this type of control, the generator will charge a discharged battery at the maximum rate for which the third brush is set, but the rate will taper off as the voltage of the battery reaches maximum because the voltage of the generator is limited by the vibrating action of the regulator.

In some cases where this type of control is used, the third brush is eliminated, full control being obtained from the regulator. However, this method is seldom used for pleasure car service, since the elimination of the third brush does away with maximum current control, which would be dangerous in case of a ground in the wiring, or a shorted battery.

69. TROUBLES AND SERVICING OF VIBRATOR REGULATORS

If the generator fails to charge, then with the engine running at a speed equivalent to 25 M.P.H. ground terminal F on the generator. If this causes the generator to start charging the trouble is in the regulator or the lead between the field terminal on the generator and the regulator. If the generator does not charge the trouble may be in the cut-out or inside of the generator itself.

If the charging rate is too high or too low, this may be caused by incorrect spring tension on regulator armature, or to a fault in the regulator, such as bad contact at regulator points, defective shunt winding, etc. With a fully charged battery installed, after the generator has operated at a speed equal to 25 M.P.H. for 15 minutes, the charging rate should be less than 10 amperes, if the charging rate should be of greater than 10 amperes, the setting is too high. With a discharged battery in the car, the charging rate should not be less than 14 amperes. If it is less than 14 amperes, temporarily ground the field terminal on generator. If this causes the rate to increase, the regulator setting is too low, or the battery is sulphated, or there may be a loose connection in the circuit over which the charging current flows.

To check the regulator operating voltage, connect a variable resistance between "Bat." terminal of the control unit and the ammeter of the car. Disconnect the lead on "IGN" terminal of control, and connect a jumper wire from this terminal to "Bat." terminal. Connect an accurate voltmeter between ground and the lead that was disconnected from the "IGN" terminal. Then start the engine and operate at approximately 25 M.P.H. and adjust the rheostat or resistance so that the charging rate will be about 8 to 10 amperes, and check the voltage. With the control at room temperature (about 70 degrees F.) voltage should be between 7.7 and 8.0

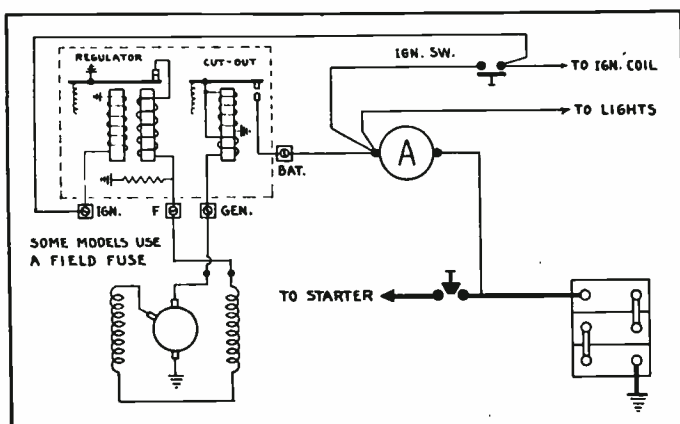

Fig. 80. Circuit diagram of a vibrating type generator control.

tor and open the contacts when the maximum voltage for which the regulator has been set is reached. When the contacts open, the field current through the series winding is interrupted, but it can still flow to ground through the resistance unit at a reduced

volts. With the regulator hot, (about 150 degrees F.) the voltage should be between 7.45 and 7.55 volts. Adjustments are made by bending the spring anchorage brackets.

70. CHEVROLET LAMP LOAD CONTROL

This is a very simple type of control designed to increase the output of the generator when the lights are turned on. The control consists of a resistance and a short-circuiting device both of which are built in as part of the lighting switch. See Fig. 81.

When the lights are turned off, the field current flows through the resistance and the battery charges at a normal rate, usually about 10 amperes. When the lights are turned on, the field resistance is short-circuited and the field current automatically increases, thereby increasing the output of the generator. This increase in output makes it possible

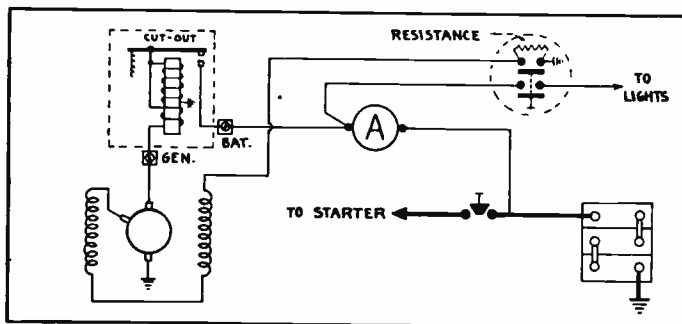

Fig. 81. Wiring diagram showing the Chevrolet lamp load control.

for the generator to supply the current for the lights without a reduction in the battery charging current.

The standard resistance used is 1 ohm. Resistors of $\frac{1}{2}$, $\frac{3}{4}$, and $1\frac{1}{2}$ ohms may be obtained to meet different operating conditions, or if head light bulbs other than standard sizes are used. To set the third brush, the field terminal of the generator should be temporarily grounded and the third brush set so that the output will be between 16 and 17 amperes. If set too high there is some danger of burning out the generator, especially during summer months.

71. GENERATOR TROUBLES AND REMEDIES

The generator circuit consists of a generator, cut-out, ammeter, and battery, and the wires which connect these units together. So whenever the battery doesn't charge properly the trouble may be in any of these devices or wires of this circuit.

Normally the generator begins charging the battery at a car speed of about 12 miles per hour and reaches its maximum output at about 25 miles per hour. If the battery doesn't charge properly or the generator performance is not satisfactory the generating system should be checked over until the trouble is found and remedied.

Some of the more common troubles encountered are as follows:

If the generator doesn't charge at any speed it may be due to faults in the generator itself or to a defective cut-out, open circuits or grounds somewhere in the charging circuit, or defective drive where the generator connects to the engine.

A good place to start tracing the trouble is at the cut-out. Remove the insulated wire from the cut-out and touch it to the car frame or engine. If a flash results there is no break or opening in the charging circuit, but if no flash is obtained the circuit should be checked for loose or broken wires.

If the circuit is O. K. start the engine and remove the cut-out cover, and see if the contacts close when the engine is accelerated. If they do not, close them by hand and if the generator then charges the battery the cut-out must be defective.

Quite often the shunt winding will be found to be burned out and in this case the cut-out should be replaced with a new one.

If with the engine running at moderate speed the generator doesn't charge after the cut-out contacts are closed by hand remove the cut-out from the circuit and connect the generator directly to the battery. If the generator now charges there must be a ground in the cut-out and this unit should be replaced or repaired.

Sometimes the cut-out contacts may be found burned or dirty so that they do not close the charging circuit to the battery. In this case they should be carefully cleaned with fine sandpaper.

A defective field protection device may also prevent the generator from charging. If a fuse is used for this protection see whether or not it is blown, and if not see that it is making good contact with the fuse clips.

If the generator is equipped with a thermostat examine this device carefully for dirty or pitted contacts or bent spring blade. If the thermostat is defective it should be adjusted or replaced.

If no trouble can be located in any of the above devices or in the wiring of the generator circuit then the fault is likely to be in the generator itself and it should be removed, and carefully tested.

If the generator charges, but at a very low rate it may be due to a loose drive belt, poor brush contact, high resistance in the field circuit because of loose or dirty connections, improper setting of the third brush, or partial short circuits in the winding. The remedies for each of these troubles can be clearly seen without further explanation.

If the generator charges at too high a rate when the car is run at high speed this may be caused by a grounded third brush; or, in case the generator has been recently repaired, the field leads may have been connected wrong. Where one end of the field is connected to the ungrounded main brush the

grounding of the third brush will cause the generator to operate as a straight shunt-wound machine and the regulating action of the third brush is eliminated.

If the generator charges when the car operates at low speeds but the charging current falls to zero at high speeds, this is usually the result of poor brush contact, which may be caused by burned or glazed commutator surface, commutator out of round, high mica, loose bearings allowing the commutator to vibrate, weak brush-spring tension, worn or dirty brushes, or brushes stuck in the holders.

If the commutator is out of round or has a very rough surface it should be turned down in a lathe and the mica should then be carefully undercut. The brushes should be sanded in, as explained in the D. C. Motor and Generator Sections, to see that their faces properly fit the commutator and are clean and free from gum or dirt.

Be careful to see that the brush springs are at the proper tension and that the brushes do not stick in the holders.

If the generator overheats badly it may be due to shorted armature coils, or to the armature laminations having been burred together by rubbing on the pole faces, or by rough handling while being repaired.

Burred laminations promote eddy currents which overheat the core and the trouble can be corrected by taking a very light cut off from the core in a lathe or by replacing the armature.

A loose connection in the charging circuit causing high field voltage will also result in the generator overheating; and wrong setting of the third brush allowing an excessive charging rate may be another cause.

If the generator voltage is too high and causes the lights to flare or burn out this is generally due to loose or dirty connections in the charging circuit. High resistance in this circuit prevents the normal flow of current through the armature of the generator and thereby prevents field distortion and the voltage regulating action of the third brush. So an open circuit or loose connection at the battery, ammeter, or anywhere in the generating circuit will cause excessive voltage and may result in a burned out field winding if it is not quickly corrected. In such cases all connections should be carefully cleaned and tightened.

When the generator brushes squeal during operation at certain speeds or at all speeds this may be remedied by cleaning the commutator and sanding off the faces of the brushes; or, in case it is caused by hard brushes, by boiling them for a few minutes in paraffin wax. If the trouble cannot be corrected in this manner replace the brushes with those recommended by the manufacturer.

When testing a generator for internal troubles first take the machine apart and carefully examine it for mechanical defects or any electrical troubles which can be noted. Then test the armature for opens, shorts, or grounds, as previously explained in the section on Armature Winding and Testing.

Next test the fields for the same troubles. Test each of the brush holders for possible grounds due to defective insulation, check the commutator to see that its surface is clean, that there is no high mica, and no short circuited bars. Check the brushes to see that they are all properly fitted, have the right spring tension, and move freely in the holders.

Replace any defective parts before reassembling the generator.

AUTOMOBILE LIGHTING EQUIPMENT

One of the most important uses of the electrical system, including the generator and battery on the modern automobile, is for the operation of the lighting equipment.

Many of the lights used on modern autos are so important in the safe operation of the cars, that state laws and city ordinances require that certain lights be regularly inspected and maintained in good operating condition. For this reason there are excellent opportunities for well trained auto electrical service men to do profitable service and repair jobs on the lighting equipment of automobiles.

A great deal of the knowledge you have obtained so far, of electric circuits, relays, controls, illumina-

tion principles and circuit tracing and trouble shooting can be applied to your study and work in this important branch of electricity. Many large garages and automotive service stations employ special service men for this work. Every auto electrical service man operating his own business or service shop should give special attention to lighting equipment servicing.

The head lights are a very important part of every modern automobile, as it is impossible to drive safely on unlighted country highways without two good headlights. The head lights also provide a great safety feature by indicating the position and approximate speed of an approaching car even on lighted streets and highways.

The headlights of a modern automobile should illuminate the road surface for several hundred feet ahead of the car, in order to enable the driver to see people or obstructions in the road in time to bring the car to a full stop from the high speeds at which modern cars are commonly operated.

In order to avoid "blinding" an approaching driver, the headlights should throw definite beams of light which can be kept down on the road surface and below the level of the eyes of other drivers.

Electric lights meet these requirements very nicely by supplying a concentrated beam of high candle power that can be quickly and easily focused and controlled. Therefore, electric lighting is now used without exception on all modern automobiles.

The headlights are generally provided with a switching arrangement which enables them to be dimmed, or their beams to be dropped lower, when meeting another car, and then brightened or raised for vision farther ahead on a dark country road.

Small parking lamps are sometimes located above the main bulbs in the head lamp reflectors or housings.

In addition to the headlights, most cars are equipped with tail light, stop light, dash light, and dome light, while some have additional small convenience lights at various places in the car.

Cowl lights are small lights located one on each side of the body of the car just in front of the wind shield. These lights can be left on when the car is parked and they serve to show the position of the car to another driver. They are much smaller and require a great deal less battery current than would be used if the headlights were left on.

A tail light is very essential to indicate the rear of the car to a driver approaching from behind and also to illuminate the license plate as required by state laws. The tail light should always be kept in good condition so that it shows a distinct red light to the rear of the car, as this affords a great amount of protection from rear end collisions both when the car is in operation and when parked. A car should never be operated or left parked without a good tail light.

The stop light is also a very important light which goes on when the brake is pressed and indicates to a following driver that the car ahead is about to slow down or stop. Stop lights also afford a great amount of protection to the rear ends of automobiles; and, for reasons of one's own safety as well as courtesy to fellow drivers, cars should never be operated without a good stop light.

The purpose of the dash light or lights is to illuminate the various instruments on the dash or instrument board of the automobile, enabling the driver to see his speedometer and the meters and instruments which indicate various conditions, such as engine temperature, fuel level, oil pressure charging rate, etc.

Dome lights illuminate the interior of the car

and are particularly convenient when getting in and out of the car at night, or whenever one desires to see within the interior of the car. Dome lights, however, should not be left on when a car is driven along a dark highway as they interfere with the view of the road ahead.

All automobile lamps are designed to operate at low voltage, generally six volts, and are connected to the battery through the ammeter and conveniently located switches.

The bulbs for the various lights are designed with filaments of various resistance and wattages according to the amount of light required. The headlights, of course, are the larger and the various other lights use smaller bulbs.

A single-wire system is now in general use for the wiring of automobile lights, and the other terminal of each light socket is grounded so that the current returns through the car frame to the grounded terminal of the battery. This arrangement greatly simplifies and reduces the cost of wiring systems, and also lessens the possibilities of trouble in the circuits.

Many people are inclined to operate their cars with one or more defective lights because they do not realize the importance of lights as a safety feature, or do not realize how easily and cheaply lights can all be kept in good condition. It is a simple matter for the experienced or trained service man to quickly locate and repair almost any trouble in the lighting system, and every attempt should be made to encourage customers to have defective lights repaired or replaced immediately and keep them in good condition at all times.

72. HEADLIGHTS

Headlights, as previously mentioned, are the most important of any lights on the automobile. Headlights are carefully designed to project the light beams on the roadway in the proper manner to give the driver a good view of its surface some distance ahead and to avoid glare in the eyes of approaching drivers.

Each headlight consists of the following important parts: Electric light bulb which supplies the light; reflector which controls and concentrates the light beam; lamp housing in which the bulb and reflector are supported; bulb adjusting devices used to focus the light; front glass or lens; and lamp standard or bracket which attaches the headlight to the car.

Fig. 82 is a diagram showing a sectional view of a headlight and in which each of the above parts can be noted.

The lamp housings are made in various styles and shapes to fit the design of the car, and the reflectors are made of silvered metal of the proper shape to gather all the light rays thrown backward and side-wise from the bulb and concentrate them forward in one beam upon the road surface.

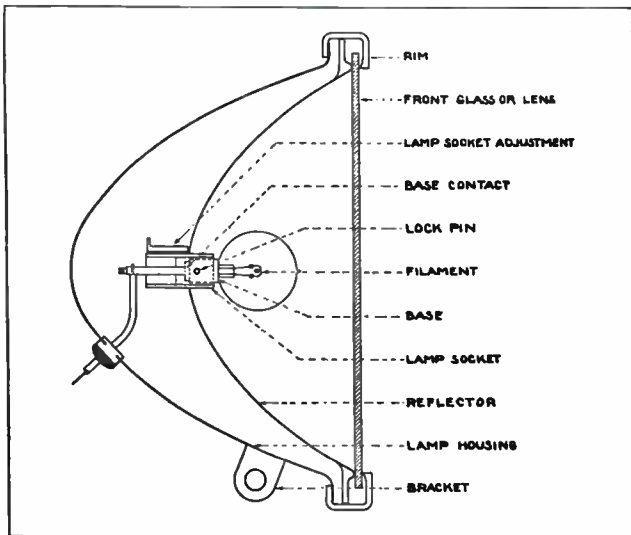

Fig. 82. Diagram showing the construction of one type of automobile headlight. Note that the lamp socket is adjustable for focusing the light rays properly with the reflector.

Headlight lenses are of various types, some having specially cut or ground glass with ribs or corrugations to aid in directing or diffusing the light as desired.

The lamp adjusting device allows the bulb to be moved either forward or backward in the socket to adjust the focus of the light beam and make it broader or narrower.

Automobile headlight bulbs are constructed quite similarly to regular incandescent light bulbs, with which you are already familiar, except that their filaments are designed for lower voltage and are therefore made of lower resistance and to take heavier currents in order to produce the desired wattage. These bulbs have a concentrated filament which produces the light from a source of a very small area, thus making it easy to focus and direct with the reflector and lens.

The bulbs are small, ranging in diameter from about an inch to an inch and a half, and are secured to a metal base or ferrule by means of which they are held into the socket and connected to the electric circuit.

Some headlight bulbs are of the single filament type but most of those used on recent makes of cars are of the double filament type, having two separate filaments located one above the other and either of which can be turned on at will by the light switch.

One filament is used for directing a bright beam a long distance down the road, while the other is used for directing a beam of less brilliancy slightly downward and at a spot on the road closer to the front of the car. This latter filament is used when meeting another driver and helps to further reduce the blinding glare in his eyes.

On single filament lamps one end of the filament is connected to the outer metal ferrule of the lamp base which is grounded to the lamp housing when the lamp is placed in the socket. The other filament

lead is insulated and connected to a small terminal in the base of the socket by which it makes contact with a spring terminal attached to the insulated light wire leading from the battery and switch to the lamps.

Double filament bulbs have one end of each filament grounded to the ferrule and the other two ends brought to separate insulated contacts in the lamp base.

On the left in Fig. 83 are shown two headlight bulbs, one of the double filament and one of the single filament type; and on the right are shown two of the smaller bulbs such as are used for dash lights, tail lights, etc.

73. DIMMING OF HEADLIGHTS

As mentioned before, it is desirable to provide some means of dimming or dropping the headlight beams when meeting another driver, and thus avoid throwing in his eyes a glaring light which would make it impossible for him to see the road or the exact location of the approaching car.

There are two methods of dimming; one by using a resistance that is cut in series with single filament bulbs, and the other and more popular method of using double filament bulbs.

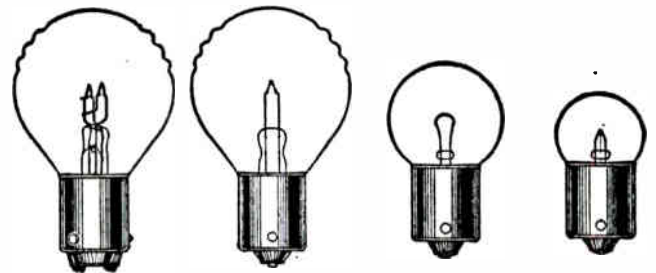

Fig. 83. Several types of double and single filament bulbs used for headlights and other lights on automobiles.

Fig. 84-A shows a diagram of the wiring for headlights using the resistance method. When the switch is at the left in the position shown, the resistance is in series with the bulb filaments and reduces their current and light output. When the switch is moved to the right the resistance is cut out, bringing the bulbs up to full brilliancy.

In Fig. 84-B is shown the wiring for the double-filament type lamps. When the switch is on the left contact the lower wattage upper filaments of the lamp are in use. These filaments being located somewhat above the center of the reflector cause the beam to be thrown downward and closer to the front of the car. When the switch is thrown to the right-hand contact the heavier wattage lower filaments are in use, and as these filaments are in the center of the reflector their light beams are thrown slightly higher and farther ahead along the road.

The smaller or dimmer filament is generally of 21 candle power, (C.P.) and the larger filament or main headlight filament of 32 C.P.

The light switch for turning headlights on and

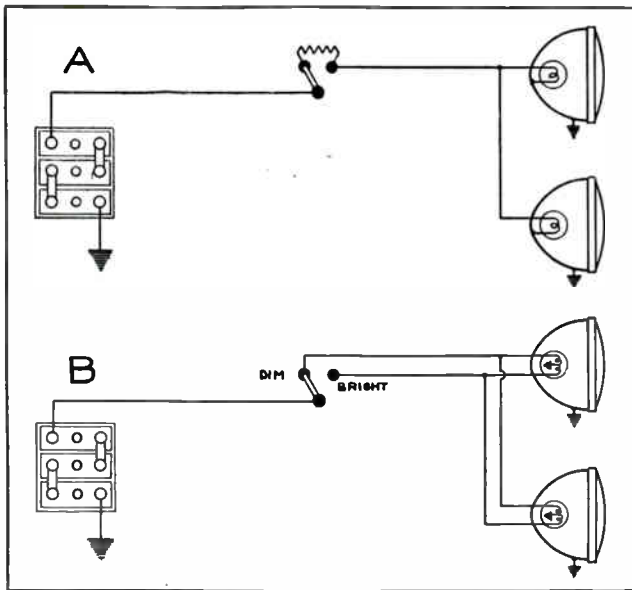

Fig. 84. A. Diagram showing resistance method of headlight dimming; B. Double filament method of dimming or "dropping" headlight beams.

off and for dimming them was formerly located on the dash of automobiles, but on modern cars the dimming switch is often located either on the steering wheel or column; or a foot switch is placed near the clutch pedal. Either of these arrangements is much more convenient than the dash switch for dimming the lights when necessary.

74. LIGHTING SWITCHES

The upper view in Fig. 85 shows several types of operating levers for lighting switches and below are shown the switch contacts mounted on the insulating base of the switch. When the switch levers are mounted on the dash the switch mechanism and contacts are generally mounted directly behind them. When the switch levers are mounted on the top of the steering column the switch mechanism is generally mounted on the lower end of the column and operated by a long rod which runs from the lever down through the column.

The switch-lever positions are generally marked according to the lights that are turned on in each position, such as cowl or side, bright or head, dim, off, on, etc. The stationary contacts on the switch bases are also usually marked, so that it is an easy matter to connect the various light wires to the switch.

One of the contacts is connected directly to the battery. When the switch is turned on the contact fingers slide around to close circuits from the battery contact to the various sets of lights, according to the position the switch is placed in.

In case the switch contacts are not marked the battery terminal can be located by testing with a piece of wire or a test lamp grounded to the frame of the car. The battery terminal is the one which will give a light or flash when touched with this grounded wire and with the switch in the off position.

Now connect one end of the test wire to the battery terminal and try out the remaining contacts with the other end, and note the results. When the end of the wire is touched to the headlight contact the headlights will light; and if the tail light contact is touched this lamp will light, etc., and in this manner the different terminals can be quickly and easily located.

If a switch has been removed for repairs and all the wires are disconnected they can be tested out and connected up as follows:

Test between the car frame and each of the wires that connect to the switch until one is found which gives a light or flash. That is the live wire from the battery and should be connected to the battery contact on the switch. Touch the remaining wires on the battery contact until the tail light wire is found by the tail light burning when a certain wire is touched. Then connect this wire to the contact marked "tail light," or to the one which will give a light when the switch is on in any position. The tail light is generally switched on when any of the other lights are on.

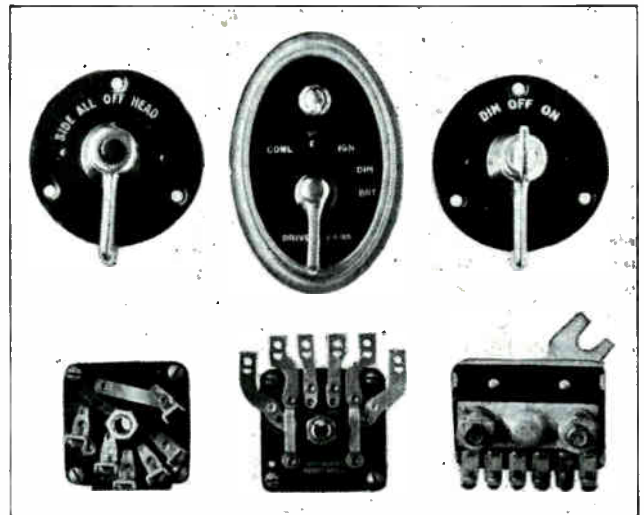

Fig. 85. At the top of this figure are shown several types of light switches and below are shown the backs of the switches with their various contacts for the different light circuits.

The wires to the other lights can be found in the same manner and connected to the properly marked switch contacts or to the contacts which will give a light when the switch lever is in the proper position for whichever light is being connected.

The stop light is generally controlled by a small switch located under the floorboards of the car and operated by a wire and spring attached to the brake pedal.

Dome lights and other convenience lights around the car are generally operated by small snap or push button switches located in convenient places.

The dash light on modern cars is generally switched on whenever the headlights or other driving lights are on. In some cases it is left off when only the parking lights are on, and in other cases

it is equipped with a special snap switch of its own so that it can be turned off when desired.

Dash lights are sometimes connected in series with the tail light, so they will go out and warn the driver any time the tail light burns out.

75. TROUBLES IN LIGHTING SYSTEMS

Although there is considerable wiring on a modern automobile one who has a good knowledge of circuit testing and a few simple test instruments should be able to check the system for such common troubles as opens, shorts, grounds, loose connections, etc.

A simple low-voltage test lamp made up with a six-volt bulb or a low reading voltmeter is often very convenient. However, in many cases a screw driver and a short piece of test wire are all that is necessary to locate troubles.

Some of the more common troubles and remedies of automobile lights are covered in the following paragraphs.

If all of the lights fail to light when the switch is turned on, check to see if the main fuse is burned out, and if it is not, see that it is making good contact with the fuse clips.

If a circuit breaker is used, check to see if the contacts are dirty or pitted, or if the plunger is sticking.

Test with a short test wire from the battery terminal on the switch to ground or to some metal part of the car, and if a flash is obtained this indicates that battery current is reaching the switch and that the trouble is very likely in the switch itself. By removing and checking the switch the loose, dirty, or bent contacts can generally be located.

If no flash results when the battery contact on the switch is grounded with the test wire, check for a broken wire between the switch and battery or for a burned out ammeter.

Failure of all lights might also be caused by all of the bulbs being burned out due to a surge of high voltage from the generator, but this is very unlikely as all the lights will not usually burn out at once and such a surge would be noticeable if they did.

If at any time during the operation of the car the lights all brighten up considerably, shut off the engine immediately and check for a loose connection in the generator charging circuit, since this is the most probable cause of an abnormal increase in generator voltage as previously explained.

76. HEADLIGHTS FAIL

If the headlights do not light up but all of the other lights do, the trouble will be in the headlight bulbs or the headlight circuit somewhere.

If the lighting system is one in which each of the light circuits is separately fused, examine the headlight fuses first. Next remove the insulated plug which leads to the lamp housing and connects to the bulb socket, and test between this plug the back of the lamp housing or car frame. If no light

or spark occurs it indicates a break between the headlight and the battery, probably in the switch but possibly in the wire.

If no light is obtained when this terminal is tested, next test between the headlight contact on the switch to ground, and if no light occurs here connect the test wire from the battery terminal on the switch to the headlight contact. If the lights then burn the trouble is proved to be in the switch.

Remove the switch and check for dirty, burned, or pitted contacts and switch fingers. Also see if the contact fingers have lost their spring tension due to overheating. The switch lever must be in the headlight position while making these tests.

If the test lamp lights when connected between the insulated headlight plug and the car frame, the trouble must be in the headlight. Remove the lens and examine the bulb or test it, and if it is burned out, replace it. If the bulb is all right, the trouble may be due to the fact that the contact on the insulated plug is not making good contact to the bulb. It may also be caused by rust forming between the reflector—in which one end of the light filament is grounded—and the lamp housing, or between the lamp housing and the car frame.

Rusty or dirty connections at these points mean an open or high-resistance circuit between the grounded terminal and the battery.

To test for an open or high-resistance connection between the reflector and the grounded terminal of the battery, place one of the test leads on the wire which carries the current to the headlights and touch the other to the reflector. If no light is obtained, check for poor contact between the lamp contacts and housing, or between the housing and car frame.

The various other lighting circuits can be tested out in the same manner as outlined for headlights. Check to see if the current is carried through the wire all the way up to the light, and then test for burned-out bulbs and poor grounds between the lamp housing or socket and car frame.

77. FLICKERING AND FLARING OF LIGHTS

Headlights and other lights are sometimes caused to flicker by loose connections in the lighting circuits, and very often this trouble is found to be at the insulated plug which connects to the lamp housings.

The small springs which connect the plug and bulb terminals together either become weak or stuck, or burned and dirty. Sometimes it is only a small amount of corrosion that is responsible for high resistance in the circuit and causes the lights to dim or flicker occasionally.

In this case the trouble may be remedied by merely working the plug back and forth in its socket to rub off the corrosion and brighten the contacts. When the trouble is due to weak contact springs, these springs may be stretched out or the trouble may be remedied by adding a small drop of solder to the bulb contacts, thereby increasing the pressure and tension on the spring contacts.

If the flickering is not due to trouble in the lamps or at the plug connections, then check over the entire circuit, cleaning and tightening any dirty or loose connections; and, if it is necessary, check the switch for loose or burned contacts.

As previously mentioned, flaring lights are generally caused by loose connections in the generator circuit or defects in the generator. In such cases all connections in the generator and charging circuit should first be carefully cleaned and tightened.

If the lights still burn excessively bright, the trouble may be a partially broken wire in the generating circuit or some defect in the generator itself. If the trouble seems to be in the generator, it should be removed and checked for broken wires, poor brush contact, sticking brushes, or grounded third brush.

78. TEST PROCEDURE

When checking the electrical system on a car for faults or troubles, always follow the plan of testing out first those parts of the circuit that are easily accessible and therefore most easily eliminated as possible sources of trouble.

For example, when lights fail, always check the fuses or circuit breaker first before checking over the switch contacts and wiring. Never disassemble the lighting unit to check for bulb and other lamp troubles without first making a test with the light switch on and the test lamp connected between ground and the plug at the lamp housing to make sure that current is reaching the lamp. If a light is thus obtained, it indicates that the trouble is in the lamp itself.

If the car lights burn dim, it is generally caused by a weak battery or connections that are loose, corroded, or dirty and of high resistance.

If only certain lights burn dimly, check that circuit carefully, cleaning and retightening any contacts or connections that appear doubtful.

If all lights are dim, the battery and its connections should be checked first of all. Poor contact due to corrosion or rust forming between the terminals of the lamp base and the spring connection to the plug are often the cause of dim lights, and in other cases they are caused by rust forming between the various parts of the lamp housing or between the lamp housing and the car frame where the light obtains its ground circuit.

Sometimes rust or a poor connection between the lamp housing and car frame can be burned out or welded into a better connection by connecting one lead of a battery to the housing and the other to the frame, thus passing a heavy current through this circuit.

If this doesn't work, the housing should be removed and the contact surface sandpapered or scraped clean, and then remounted and securely tightened.

High-resistance connections between the ammeter and battery will cause the lights to flare when the engine is speeded up.

79. SHORT CIRCUITS and CIRCUIT BREAKERS

As some of the wiring on automobiles is run along the metal parts of the frame and held in small

clips, and as the frame is used for the other conductor of the circuit, it is quite common to find short circuits resulting from chafed or damaged insulation, allowing the wires to touch the frame or metal parts of the car.

These wires are subjected to very severe service, due to road vibration, dirt and oil accumulating on them, and occasional abuse by careless mechanics working on other parts of the car. Oil tends to rot the rubber insulation, and vibration tends to chafe the insulation off the wires where they rub under the clips or against other metal parts. Sometimes the insulation becomes damaged by being jammed with a heavy tool or metal part during some mechanical repair or overhauling of the car.

To protect the wires in case of such grounds and short circuits, and also to eliminate the fire hazard as much as possible, the lighting and accessory circuits of automobile electric systems are generally protected by fuses or circuit breakers.

Fuses and circuit breakers are never connected in either the generating or ignition circuits. In some cases fuses are used in each separate circuit, while in other cases one main fuse is used to protect all the circuits. In this case the fuse is generally placed on the back of the lighting switch.

The small circuit breakers which are often used in place of fuses are very simple devices consisting of a switch operated by an electro-magnet or solenoid, as shown in Fig. 86.

When the normal load current, which is generally under 15 amperes, is flowing through the coil and contacts of the circuit breaker it doesn't create enough magnetism in the coil to lift the plunger and open the circuit; but if the current should rise to a value of 25 amperes or more, due to a short circuit in the wires, it creates sufficient magnetism to raise the plunger, causing it to strike the contacts and break the circuit.

When the contacts are thus opened and the circuit is broken, the coil is demagnetized and allows the core to drop, due to the action of gravity and of a small

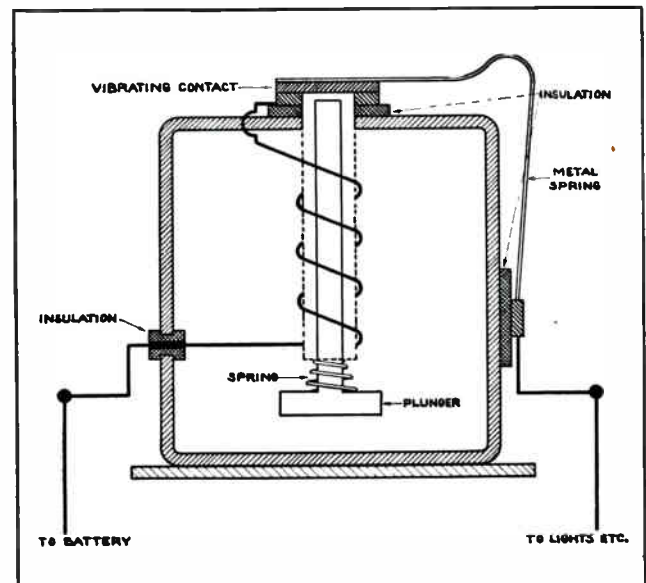

Fig. 86. Diagram of a simple magnetic circuit breaker for protecting automobile wiring circuits in case of shorts and grounds.

spring, which also tends to pull it back. This again completes the circuit, magnetizing the coil and once more raising the plunger to break the contacts.

From this we see that the breaker continues to vibrate somewhat on the order of a vibrating bell, thus limiting the current to prevent overheating of the circuits and also making considerable noise to call attention to the fault so that the defective circuit will be switched off and the trouble removed.

80. TESTING FOR SHORTS

When a short occurs in the wiring to the lighting system or horn, it may be either in the wires themselves or at the switches, lamp, socket, connectors, etc. To locate the short, first determine whether a fuse or circuit breaker is used.

If a fuse is used, connect a 21-candle power lamp across the fuse clips to serve as a trouble light. If a circuit breaker is used, just turn on the switch and let the breaker buzz. If the lamp lights or the breaker buzzes with the lighting switch in the "off" position, then look for the trouble in the stop light and accessory circuits.

Disconnect the wire from the stop light switch and if this stops the breaker buzzing or extinguishes the trouble lamp, the fault is in the stop light circuit between the switch and the lamp, and in the majority of cases it will be found in the switch itself.

As the horn is generally connected through the fuse or breaker, the same test should be made on it. Disconnect the wire from the horn to see if the breaker stops or the light goes out. If it does, the fault is in the horn; and if not, the trouble is in the wire. If the fault is in the wire leading from the horn to the button, the horn will blow continuously.

If a short circuit occurs only when the light switch is on, turn the switch lever from one position to the other to determine which part of the circuit the trouble is in.

If the circuit breaker stops buzzing or the trouble lamp burns dimly in certain positions of the switch, it indicates that these circuits are clear, and the trouble lamp burns dimly in such cases because it is in series with the other lights.

If a clear indication is obtained with the switch on all positions except the headlight position, this indicates that the trouble is in the headlight circuit, and you should next remove the plugs which connect the wires to the lamp housings and bulb socket.

If the breaker then stops or the trouble lamp goes out, the short is due to the plug contacts or wire touching the lamp housing in some way. Careful inspection will then generally show where the fault is and the trouble can be remedied by properly adjusting or reinsulating the wires or sockets according to the nature of the fault.

If the trouble lamp remains lighted or the breaker continues to buzz after the plugs have been removed from the lamps, it indicates that the trouble is in the wiring. To locate the exact point, start at the lamp and trace each circuit back, paying particular attention

to any point where the wire is secured to the frame by clips. Pulling or moving the wire will often help to locate the trouble, because, if the breaker stops buzzing or the trouble light goes out when the wire is moved to a certain point, the fault is evidently close to that position.

In certain cases where the system is wired with armored cable and the short is hard to locate, it is cheaper to rewire the circuit with new wires than to spend too much time trying to locate the fault.

Sometimes an intermittent short will occur and last just long enough to blow the fuse and then disappear. This is generally caused by a loose wire touching the car frame when the machine is in motion, and this wire may strike against the frame when the car hits a bump. Try to determine what position the switch was in when the short occurred and then carefully inspect that circuit for loose wires, defective insulation, etc.

If the trouble is noticed in all switch positions, the fault is very likely to be in the tail light circuit; while, on the other hand, if the short occurs with the lighting switch off, look for trouble in the stop light and accessory circuits.

81. LEAKY INSULATION

Sometimes a partial short or high-resistance ground will allow a slow leakage of current from the battery that is not enough to blow the fuse or operate the breaker, but will cause the battery to continually run down. Generally this trouble will be indicated by a low reading on the ammeter when all the electrical devices are turned off, but the ammeter would not indicate a fault in the starting circuit or in the wire from the battery to the ammeter.

In some cases the leak may not be great enough even to show a noticeable reading on the ammeter.

To test the system for such leaks, disconnect one of the cables from the battery terminal and connect in the circuit a low-reading voltmeter with a range of 6 to 10 volts. With all switches and electrical devices turned off, the voltmeter should not give any reading, and if it does a leak is indicated.

First disconnect the stop light wire and see if it causes the meter to read zero, and if it does the leak is in that circuit. If the trouble is not in the stop light circuit, then disconnect the wire which leads from the battery to the ammeter by removing the connection at the meter.

If the voltmeter now reads zero the trouble is in or beyond the ammeter. Next remove the wires from the other ammeter terminal and touch them one by one on the "hot" lead to the battery. When the faulty wire is touched to the battery lead the voltmeter will show a reading, and in this manner the defective circuit can be located. This circuit can then be carefully checked over for defective insulation or leaks. Very often it is easier and cheaper to entirely rewire the circuit.

Of course, one should not assume that such a leak is always the cause of a run-down battery, as it is more often due to too low a charging rate or the car is not being operated enough hours per week or month to keep the battery well charged.

Excessive operation of the starter or driving mostly at night with the lights on, or equipping a car with too many additional electrical accessories will also result in a run-down battery.

Remember that to keep a battery fully charged in the winter, so that it will properly operate both lights and starter, requires a considerably greater charging rate than during the summer months.

With normal driving the winter charging rate should be about twice as great as that for summer use.

From the foregoing explanations of lighting circuit troubles and remedies you can readily see the advantage of having a good general knowledge of electrical principles and circuits, as trouble shooting on the electrical systems of automobiles is simply a matter of definite circuit tracing and testing, the same as with any electrical power or signal devices.

With all the general training that you have had in this line and the knowledge you can obtain from this section on automotive electrical devices and circuits, it should be quite an easy matter for you to locate troubles in any part of the wiring system of a car.

82. AUTOMOBILE HORNS

Automobile horns are made in many different types and sizes, but most of them are of two general types as far as their mechanical operation is concerned. One type uses a small motor to drive a notched or toothed wheel that rubs against a pointed button mounted on a diaphragm, as shown in Fig. 87.

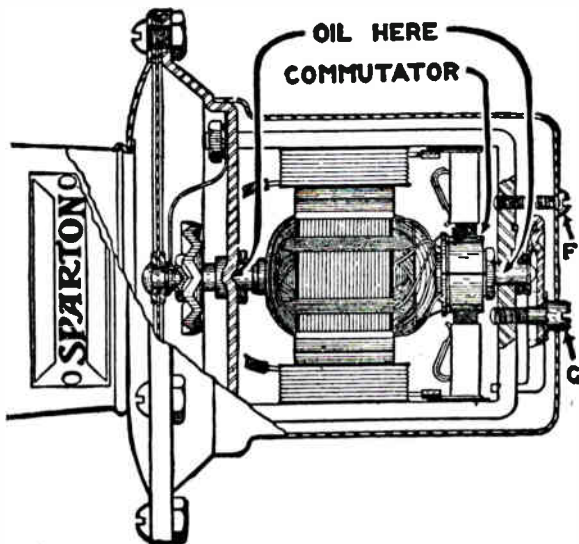

Fig. 87. This diagram shows a cut-away view of a motor-driven automobile horn. Note the notched wheel which vibrates the diaphragm by rubbing on the pointed button at its center.

When the horn button is pressed, current flows through the motor and causes the toothed wheel to rub on the button and vibrate the diaphragm rapidly. This vibration is transmitted out through the horn in the form of air waves or sound.

The other common type of horn uses a magnetic vibrator with one or two electro-magnets and an armature, and operates very much on the principle of an ordinary vibrating bell or buzzer.

The armatures of automobile horn vibrators are generally much heavier and are fitted with special springs

to obtain the loud notes required to be heard in automobile traffic. The different high and low pitched notes are obtained by designing the vibrators or motor wheels for different speeds to get different frequencies of vibration of the horn diaphragm.

The care of motor-type horns is very similar to the care of any small D. C. motor such as those with which you are already familiar. Commutator and brushes generally require the most frequent attention and the bearings should be occasionally lubricated, unless the horn is of a type using ball bearings, or has inside of it permanent lubricating cups which do not require attention for a year or more at a time.

The greater number of troubles affecting horn operation are in the wires leading to the horn or at the horn button, rather than in the horn itself, except perhaps in some of the very cheaper grades.

Care of the vibrating-type horn is similar to the care that would be given any heavy-duty vibrating bell, in that it will possibly require occasional cleaning of the make-and-break contacts or adjustment of the armature spring.

A great many horns are equipped with an adjusting screw either against the back end of the armature shaft or sometimes located down inside of the horn at the center of the diaphragm. By means of this screw the pressure of the diaphragm button against the notched wheel or vibrating armature can be adjusted to slightly change the pitch or note of the horn, or to improve the operation of the horn in case the button or wheel becomes worn away with use.

Some special types of horns are operated by air supplied by a small motor-driven air pump of the rotary type which is built right into the back of the horn. The connections of the horn and horn button to the switch or ammeter terminal are shown in some of the complete wiring diagrams of automobiles.

83. HORN RELAYS

Horn relays are used to improve the tone of horns by providing a shorter and more direct circuit from the source of current supply to the horns.

The conventional horn-circuit is rather long since the current that operates the horn or horns must be carried up through the horn button which is located at the top of the steering column. When a large horn or twin horn is used, the resistance of this

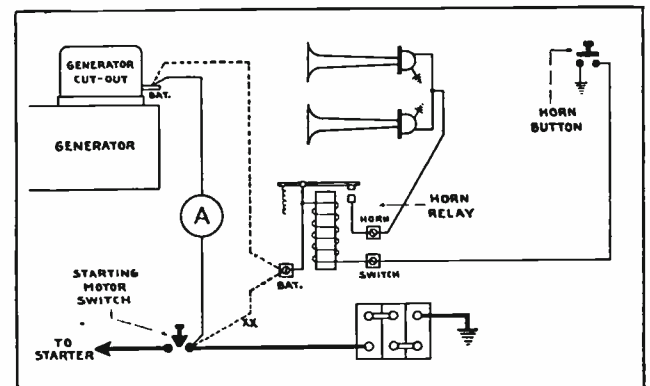

Fig. 88. Diagram of a horn relay circuit.

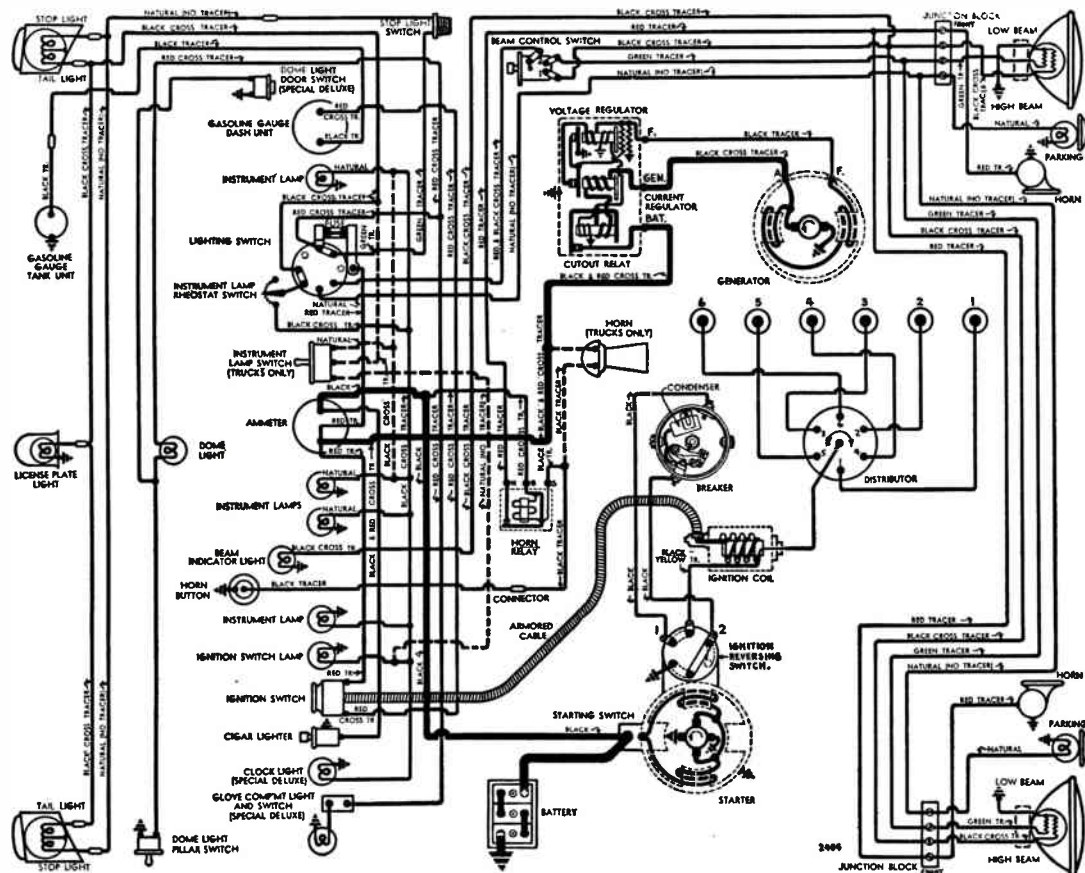

Fig. 88. Complete wiring diagram of 1941 Chevrolet. Note carefully the location and arrangement of all of the electrical devices. Trace the circuits one at a time to become thoroughly familiar with the common types of automobile wiring systems. Courtesy National Automotive Service.

long circuit to the flow of the rather heavy current required, causes considerable voltage drop, which reduces the current flow through the horns, thus effecting the tone.

By means of a relay this circuit can be considerably shortened, because the full horn current need not be taken through the horn button. (See Fig. 88.) When the horn button is pressed, current will flow from the battery or the generator through the relay coil winding, and through the horn button to ground. The current required by this relay coil circuit is only a fraction of an ampere, but it will be sufficient to close the relay contacts and complete the circuit to the horns.

Horn relays are usually located in the forward part of the engine compartment. The horn current can be taken from the battery side of the generator cut-out as shown by dotted line X, in Fig. 88. With the engine running, this hook-up supplies the horn with full generator voltage, which is always a trifle higher than battery voltage. The disadvantage of this type of connection is that when the generator is not charging, the full horn current will have to flow from the battery back through the ammeter, and if the horn current is greater than the ammeter capacity, the meter may be damaged. So it is always a good policy to check the amount of current that the horns require and see that it does not exceed to capacity of the meter before using this hook-up.

Sometimes these relays are connected to the battery side of the starting motor switch as shown by dotted line "XX." This hook-up does away with any possibility of damaging the ammeter.

To secure the best operation and tone of the horns with these relays, the wire used in the circuit that carries the full horn current must be of ample capacity. No. 12 wire is generally used but in case of heavy twin horns, No. 10 may be needed.

These relays come as standard equipment on some of the higher priced cars, but can be obtained from automotive supply stores and installed in any car. Quite often they make a remarkable difference in the tone of a horn.

84. COMPLETE WIRING SYSTEMS

Fig. 94 shows a complete wiring diagram for a V Eight Ford. Note carefully the general arrangement of the various parts and circuits, and trace out each circuit one at a time.

For example, first trace the starting circuit from the battery, through the starting switch and starting motor to ground. Then trace the generator and charging circuit from the generator through the cut-out, ammeter, and battery. Next trace the ignition circuit from the battery through the ignition switch, primary coil winding, breaker points, and back to the battery; and the secondary circuit from the high-tension lead of the coil through the distributor to the spark plugs.

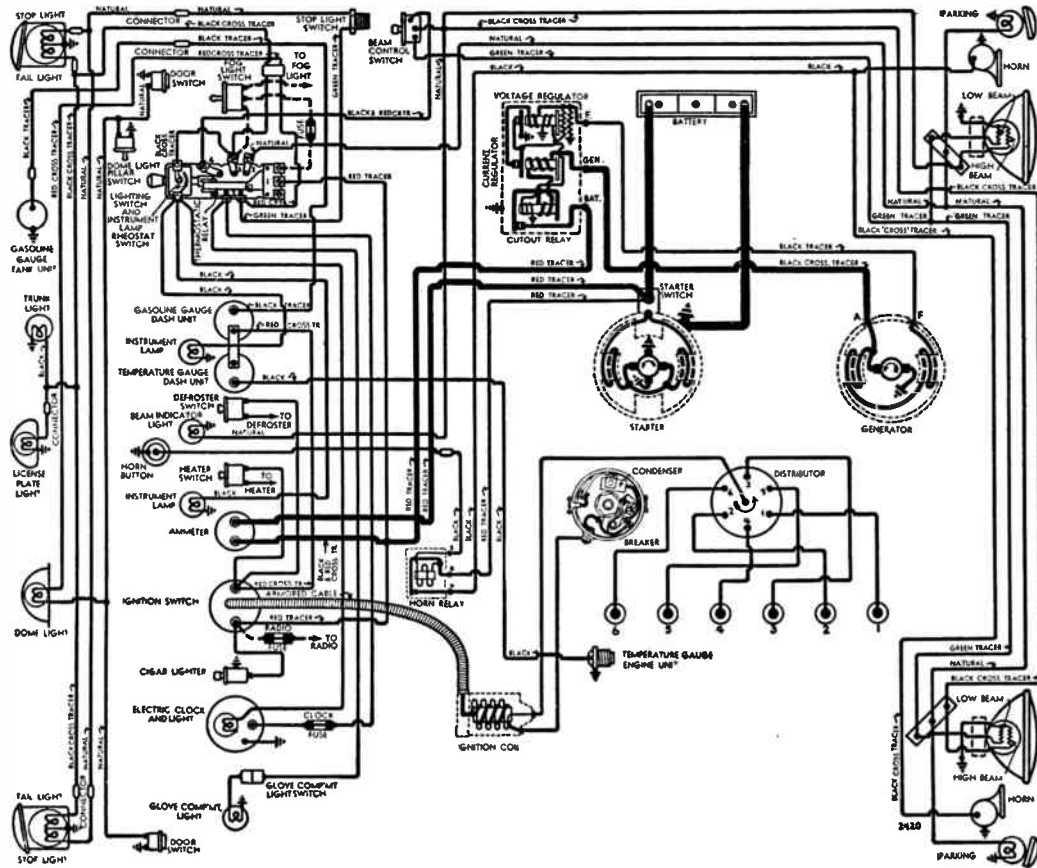

Fig. 90. Wiring diagram of 1941 Oldsmobile car. Note the current-voltage regulator used for controlling generator output, and also the lighting switch and instrument lamp rheostat. Courtesy National Automotive Serv. Co.

Finally trace out the lighting circuit from the battery through the ammeter, lighting switch, and to the various lights.

Note that the wires of different parts of the system have insulation with different colored markings, which is a great aid in tracing circuits on the car and shooting trouble in various parts of the system.

Fig. 89 shows the complete wiring diagram and all of the electrical devices for the 1941 model Chevrolet.

The electrical equipment used on these cars is made by the Delco Remy Company, who are one of the larger manufacturers of automotive electrical equipment.

Trace out this circuit very carefully and you will note that although there are some small differences in the arrangement of parts and wires, the general system is very much the same as the other diagrams.

Fig. 90 shows the complete wiring diagram of a 1941 Oldsmobile, which is also equipped with Delco Remy apparatus.

Fig. 72 shows the wiring system of an eight-cylinder Packard automobile, using two coils and the double breaker contacts.

In addition to the automotive electrical equipment made by the Delco Remy Company of Dayton, Ohio, there is also that supplied by two other leading manufacturers—The Northeast Electric Company, Rochester, N. Y., and the Autolite Corporation of Toledo,

Ohio. These concerns make most of the electric devices for automobiles; while magneto ignition systems for trucks, tractors, marine engines, etc., are supplied by the American Bosch Corporation at Springfield, Mass.; Eisemann Magneto Corporation, New York, N. Y.; Sims Magneto Company, Orange, N. J., and several others.

It is a very good plan to keep in mind that special information on various ignition devices or repair parts can always be obtained by writing directly to the manufacturers or by getting in touch with their nearest local distributor.

For those who may wish to specialize in automotive electrical service there are special service manuals or books containing wiring diagrams of practically all cars and trucks manufactured.

These diagrams are very convenient to have on hand when tracing troubles or testing circuits of certain makes of cars, but these systems are a great deal alike in many respects and are far too numerous to include all of them here.

The wiring diagram for any certain make of car can generally be obtained without charge from the automobile manufacturers, or we will be glad to supply at any time information as to where you can obtain special books on wiring diagrams for any graduates who may make a specialty of automotive electrical work.

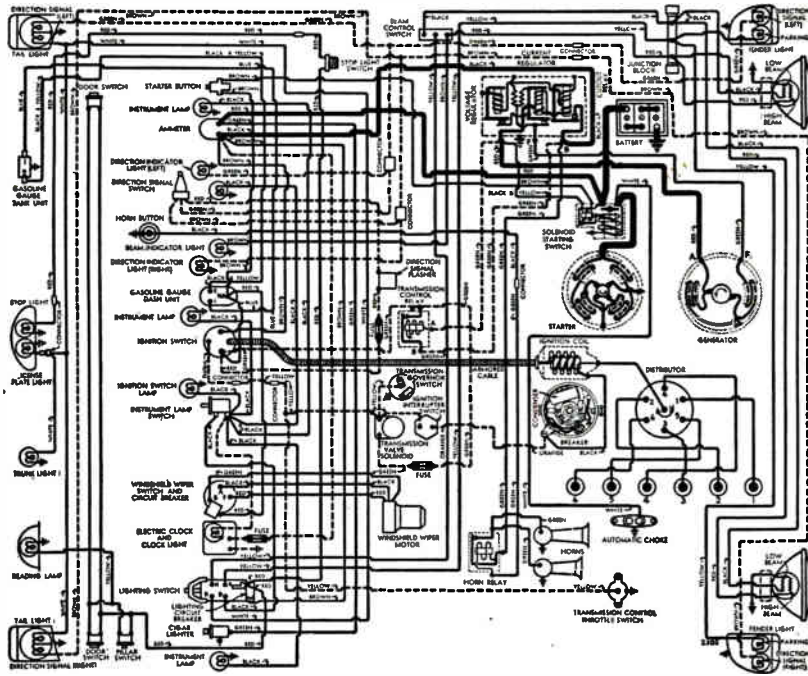

Fig. 91. Wiring diagram of a 1941, eight cylinder Chrysler auto. Traces out the primary and secondary ignition circuits, the starting motor and generator circuits and the various light circuits. Note the color code of the various wires. This is a great help in electrical trouble shooting on the car.

Whether or not you make automotive electricity your regular trade or business, remember that to be able to locate and repair electrical troubles on your own car will often come very handy and will save you considerable time and money; and it may also enable you to make extra money on the side by repairing the ignition equipment of someone else's car.

Keep in mind at all times that systematic, thoughtful

circuit tracing and testing will locate any electrical trouble that can possibly occur in any part of an automobile ignition or wiring system; and that in a great majority of cases these troubles arise from such simple things as loose connections, shorts or grounds, all of which can be easily repaired by anyone with the general knowledge of electricity that you should have from this reference set.

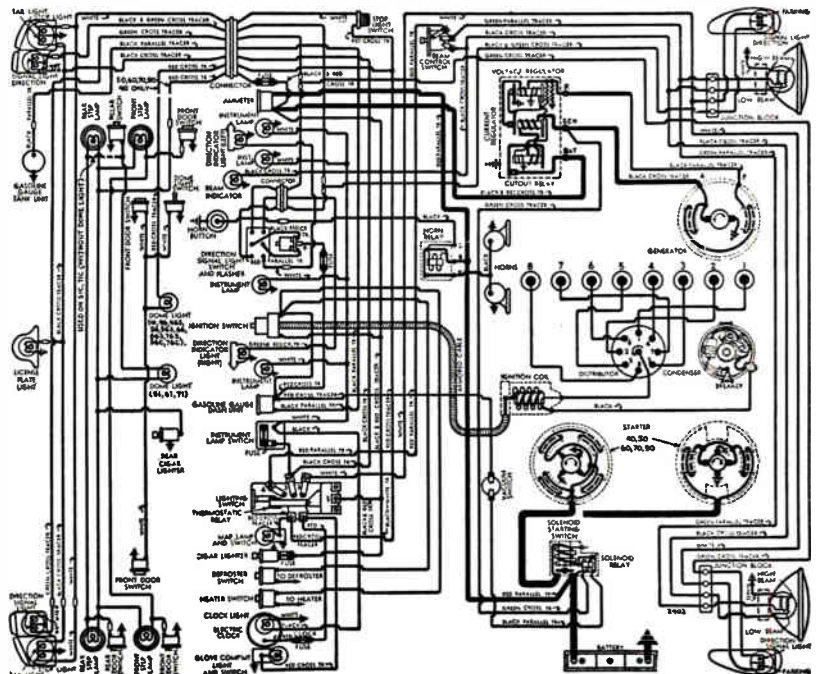

Fig. 92. Wiring diagram of a 1941 Buick car. Examine the light wiring, ignition wiring and the generator, starter and horn circuits.



ESTABLISHED 1899

COYNE

Electrical School

CHICAGO ~ ~ ILLINOIS



COPYRIGHT 1942

DIESEL ENGINES

Full Diesel and Semi-Diesel Engines

Spark Ignition Type Oil Engines

Fuel Injection Systems

Fuel Pumps, Injectors, Governors and Filters

Fuel Combustion Systems

Diesel Fuel Oils

Diesel Engine Starting Systems

Diesel Exhaust and Cooling Systems

Diesel Engine Lubrication

Mechanical Lubricators, Lubricating Oils

Diesel Engine Construction Features

Frames, Pistons, Rings, Rods, Cranks, Valves

Diesel Engine Operation and Care

Starting, Stopping, Reversing

Inspection and Maintenance

DIESEL ENGINES

The great popularity and rapid development of the Diesel engine during the past few years makes it a subject of considerable interest and value to the student of power equipment. Because of the fact that Diesel engines are often used as prime movers or power units to drive electric generators, a knowledge of their operation and care is often very helpful to electric plant operators.

This lesson and the following ones on Diesel engines will deal principally with the practical phases of operation, care and adjustment of these engines, rather than the design and overhaul, as these latter items are not so necessary to the electrical operator.

Diesel engines are internal combustion engines, very similar in many respects to ordinary gasoline engines such as used in automobiles or for stationary power units. See Figures 1 to 4. The principal difference being that the Diesel engine operates on cheap fuel oil instead of gasoline; injects this fuel oil into the combustion chamber with a high pressure fuel pump instead of a carburetor; and in the full Diesel engine the fuel is ignited by heat of compression instead of with electric ignition or sparks.

Contrary to popular belief the Diesel engine is not a recent invention. The Diesel principal was patented by Dr. Rudolph Diesel, a German inventor, in 1893. Formerly these engines were designed for stationary service and heavy duty Diesels have been in use both in this country and in Europe

for about 40 years. They have been used quite extensively in power plants, oil fields, mills, and on ships and dredges for some time. See Figures 1, 2, 3, 5 and 8.

However, the design of the high-speed, light-weight Diesel is a much more recent development, and has greatly widened the application of these engines, until today they are being successfully used in busses, trucks, tractors, farm machinery, construction equipment, small power plants, and even in automobiles and airplanes to some extent. This type of Diesel engine is also becoming extensively used in railway service, both for switching locomotives and for main line passenger and freight service. See Figures 6, 7, 12 and 13.

Modern high-speed Diesels are made in single and multiple cylinder types, in sizes ranging from 10 to 300 h.p. and more. Slow speed and medium speed units are made in single or multiple cylinder types, in sizes from 5 h.p. to 20,000 h.p. and over.

Some of the advantages of the modern Diesel engines are: that they operate on cheaper fuel of higher B.T.U. (heat) content; they use less fuel per h.p. hour due to their higher compression and resulting higher thermal efficiency; and they are more simple and rugged due to the elimination of carburetors and ignition devices. Some of their disadvantages when compared with gasoline engines are: they are heavier, noisier and more costly for a given h.p. size.

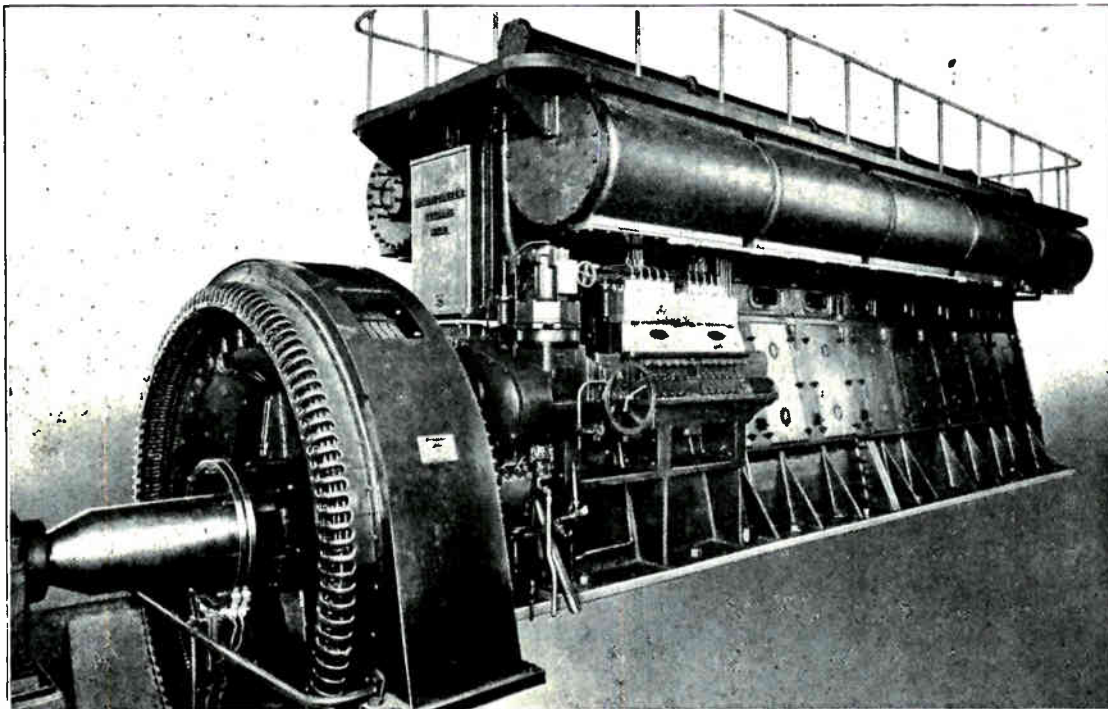

Fig. 1. Diesel-engines of the type shown above can be made in very large sizes for power plants and ships. This unit develops 14,000 h.p. Note the electric generator on the left. Many Diesel-Electric generating units of this type are used in power plants of utility companies and industrial plants. (Courtesy of the Busch Sulzer Engine Company.)

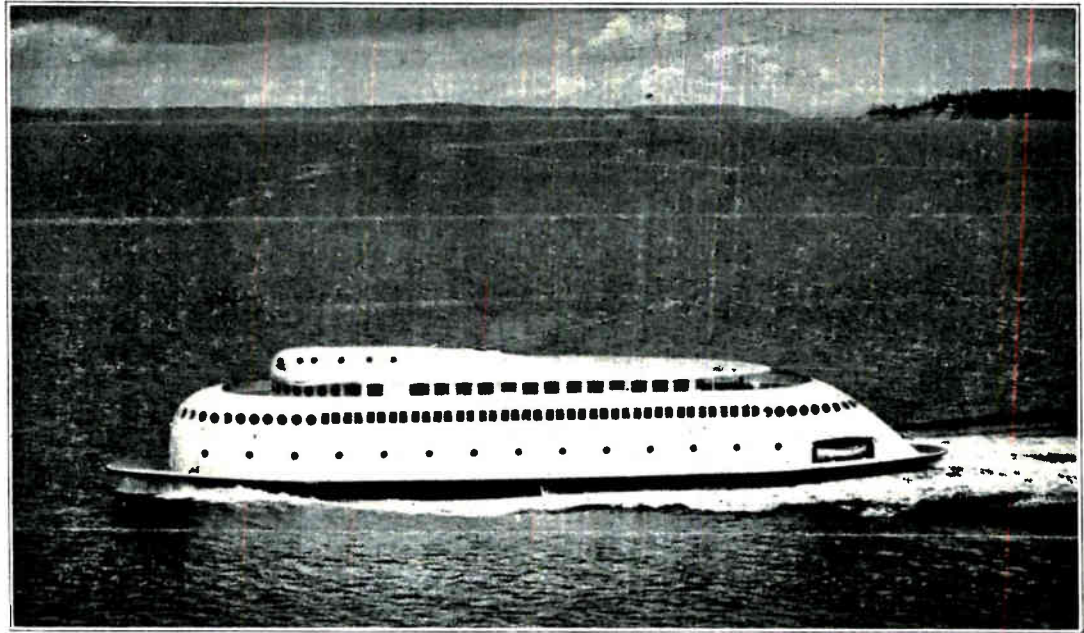

Fig. 2. Photo of a modern streamlined Diesel powered ferry boat. Diesel engines are extensively used on boats, dredges and tugs. Many of these units are also Diesel-Electric combinations, and require trained men with electrical and Diesel knowledge to operate and maintain them.

Many thousands of Diesel engines are being made each year for use in trucks, busses, tractors, etc. In time, they may even be developed to a point where they will replace many of the gasoline engines now in use in pleasure cars.

However, it is interesting to note that in a great many installations of Diesel engines in this country they are used in conjunction with electric generators, because of the much greater flexibility and wider range of smooth speed control of electric motors.

Diesel-Electric locomotives used Diesel engines, direct coupled to electric generators, which in turn supply power to electric motors on the trucks of the locomotives. This same principle of Diesel-Electric drive is used in some busses, ships, dredges, etc. Then there are the Diesel-Electric power plants in use in industrial plants, municipal generating stations, and public utility company plants. See Figures 11, 12 and 13.

1. DIESEL ENGINE CONSTRUCTION FEATURES AND OPERATING PRINCIPLES

As previously mentioned, Diesel engines are similar in many respects to gasoline engines. They both have cylinders, pistons, crank shafts, connecting rods, valves and cam shafts. See Figures 4 and 7. The principal difference lies in the fuel system, the method of introducing the fuel to the cylinder or combustion chamber, and the method of igniting the fuel.

The Diesel engine uses a high-pressure fuel pump to measure the liquid fuel charge and inject it through a nozzle in the form of a high-pressure spray into the cylinders. The gasoline engine uses

a carburetor to mix air and gasoline into vapor which is drawn into the cylinder by the vacuum on the intake stroke. Where the gasoline engine uses a spark to ignite the gasoline vapor, the Diesel engine uses the heat of highly compressed air to ignite the oil spray.

All atmosphere or air normally contains a certain amount of heat. If such air is quickly compressed to very high pressure, the concentration of the heat into the smaller space will greatly increase the temperature of the air. You have probably experienced this condition in working with a tire pump or an air compressor at some time or other.

The higher the pressure to which the air is compressed the higher its temperature will be raised. In the full Diesel engine the compression pressures range from 450 to 575 lbs. per sq. inch.

When air at normal temperatures is quickly compressed to 500 lbs. pressure, if no heat was absorbed by the cylinder walls, its temperature would rise to about 1050 degrees F. Since the metal cylinder walls and piston head quickly absorb some of this heat, the temperature at the end of the compression stroke will usually be about 850 degrees F.

If fuel oil is broken up into finely divided spray, it will ignite in air at temperatures about 680 degrees F. Therefore, if fuel oil is injected through a spray nozzle into the cylinder at the end of the compression stroke in a full Diesel engine the oil charge will immediately ignite and burn. See Figure 16. The resulting heat of about 3000 degrees F., and the expansion of the burning gases, delivers the pressure to the piston head for the power stroke. For this reason Diesel engines are sometimes called compression ignition engines.

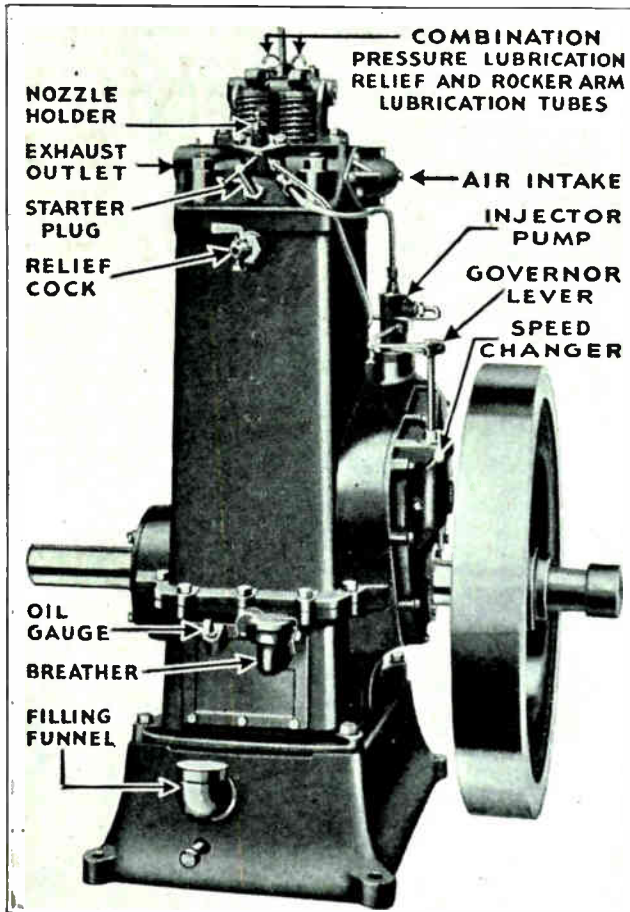

Fig. 3. This illustration shows a popular type of vertical, single-cylinder, 10 h.p. Diesel-engine for stationary use. Note the names and locations of the various parts shown on this engine. (Courtesy of the Stover Engine Company.)

2. FULL DIESEL AND SEMI-DIESEL ENGINES

Not all engines that operate on fuel oil are true Diesel engines. Fuel oil engines are divided into three general classes, called the Full-Diesel, Semi-Diesel, and Spark Ignition injection engine.

The full Diesel engine has a compression ratio of about 15 to 1, (meaning that the air in the cylinder is compressed or squeezed down to 1/15 its former volume), resulting in compression pressures of about 500 lbs. per sq. inch, as previously mentioned. This engine generally starts quite readily on fuel oil without the aid of any auxiliary heat for ignition. In some cases, however, hot glow-plugs may be used to assist in starting, especially in very cold weather.

The semi-Diesel or oil engine has a compression ratio of about 8 to 1, resulting in final compression pressures of 200 to 225 lbs. per sq. inch. This type of engine requires the application of some extra heat besides compression heat to start, and the heat must be applied until the engines warms up to operating temperature.

Blow torches are used on some types of semi-Diesel engines. The cylinder heads are so designed, that the head or a hot plug which extends into the combustion chamber, can be heated red-hot with a torch. For this reason, these engines are sometimes called "hot plug" or "hot tube" engines.

Some modern semi-Diesel oil engines are started and kept running with the aid of electric glow-plugs which are screwed into the cylinder like spark plugs. These plugs have a heating element consisting of a spiral of heavy resistance wire, which is heated red-hot or white-hot by the application of low voltage D.C. or A.C. current from a battery or transformer.

The spark ignition type of oil engine uses an injection pump and nozzle to introduce the fuel into the cylinders, and also uses a magneto and set of spark plugs to ignite the fuel, both during starting and running. The compression ratio of this type of engine is about 7 to 1, and the compression pressure about 150 lbs. per sq. inch. This lower pressure does not raise the air temperature high enough to ignite the fuel oil without the aid of ignition sparks.

Due to the lower compression, this type of engine can be cranked by hand. The Waukesha-Hesselman engine is an example of this type of spark ignition oil engine. Many of these engines are in use in trucks and busses.

3. FOUR STROKE CYCLE, FULL DIESEL ENGINE

The four stroke cycle or "four cycle" Diesel engine, like the four cycle gasoline engine, requires

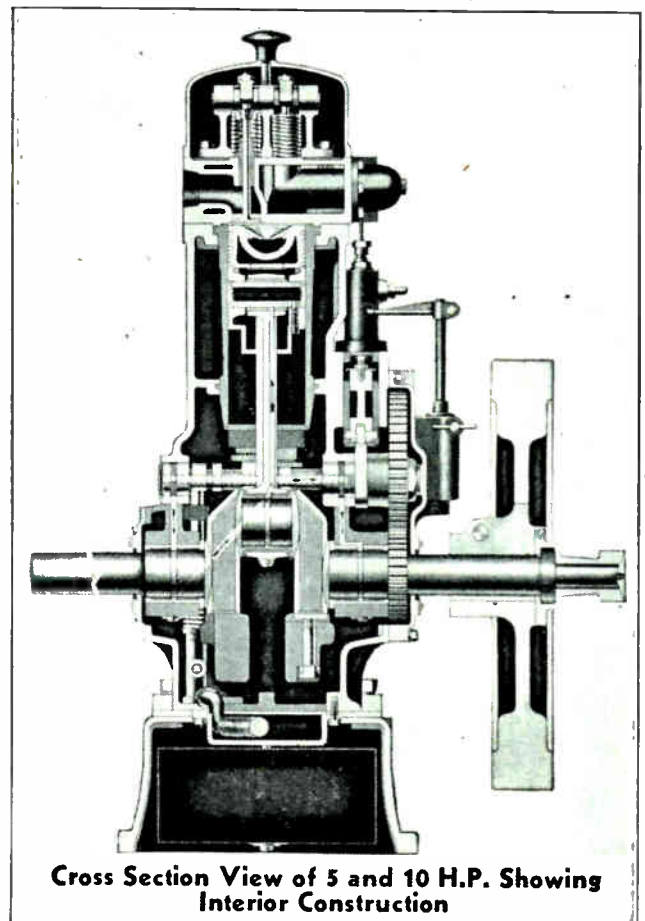

Fig. 4. A sectional view of the same engine shown in Figure 3. Note carefully the construction and arrangement of the cylinder, water jacket, piston, valves, crank-shaft, cam shaft, etc. (Courtesy of the Stover Engine Company.)

four strokes to complete each cycle that produces one power stroke. The strokes follow each other in the same order that they do in the carburetor type engine, namely—intake, compression, power and exhaust strokes.

During the intake stroke the piston moves downward, with the intake valve open, drawing air only into the cylinder. See Figure 17-A. No fuel enters the cylinder of a Diesel engine during the intake stroke. During the compression stroke the intake and exhaust valves are closed and the air in the cylinder is compressed, raising its temperature high enough in the case of the full Diesel engine to ignite the fuel oil. See Figure 17-B. At the end of this stroke, when the hot air is compressed above the piston head, the fuel pump plunger forces a measured (or metered) quantity of liquid fuel oil under high pressure into the cylinder through the injection nozzle, which breaks the oil up into a fine spray, so that it ignites immediately upon contact with the hot air. See Figure 17-C.

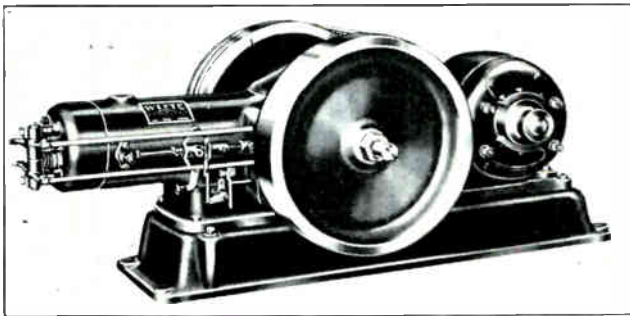

Fig. 5. Another very popular type of small Diesel-engine of the horizontal single cylinder type. Note the electric generator which is connected to one fly-wheel by "V" belts, making a very convenient small light-plant unit. (Courtesy of the Witte Engine Company.)

Some Diesel engines are equipped with pre-combustion chambers into which the fuel is injected, instead of directly into the cylinder. The turbulence of the hot air which rushes into this chamber during compression, and also the turbulence set up in the cylinder by the rush of partly burned fuel out of the combustion chamber, promotes better combustion. It also permits the use of larger openings in the injector nozzle, and these are less likely to become clogged. The engine illustrated in Figure 17 uses a pre-combustion chamber. Also see Figures 16 and 21, which show pre-combustion chambers.

During the power stroke the intake and exhaust valves are still closed and the piston is being forced downward by the pressure of the hot expanding gases produced by the burning of the fuel oil. See Figure 17-D.

A little before the piston reaches lower dead center (L.D.C.) on the power stroke, the exhaust valve opens and allows the burning gases to start

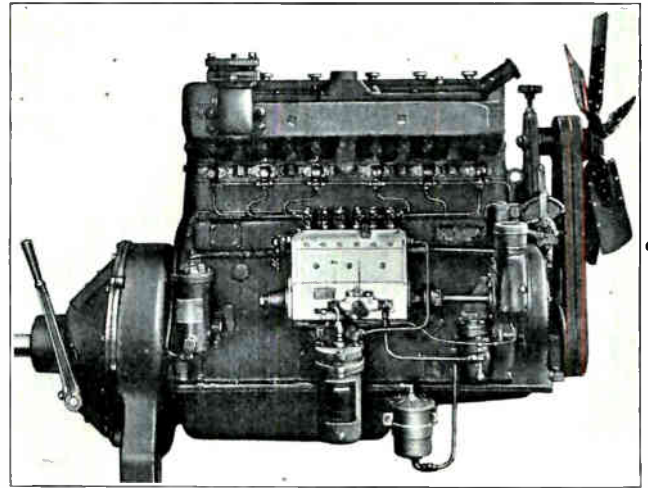

Fig. 6. This photo shows a modern six cylinder automotive type Diesel-engine. Note the similarity to the ordinary gasoline engine except for the fuel pump and the injectors which replace the ordinary carburetor and spark plugs. (Courtesy of the Buda Company.)

flowing out of the cylinder into the exhaust line.

During the exhaust stroke the piston travels upward, forcing the exhaust gases out of the cylinder, thus completing the four stroke cycle and putting the cylinder back in condition for the beginning of another intake stroke. See Figure 17-E.

Like the 4 cycle carburetor engine, the 1 cylinder, 4 cycle Diesel engine requires 2 revolutions of the crank shaft to produce one power stroke. If the engine has more than one cylinder, all cylinders will be fired in two revolutions of the crank shaft.

4. TWO STROKE CYCLE DIESEL ENGINES

Many of the larger Diesel engines used for marine and stationary power units are of the two stroke cycle type. One of the advantages of the two cycle engine is that it produces one power stroke for every two strokes of the piston, or for every revo-

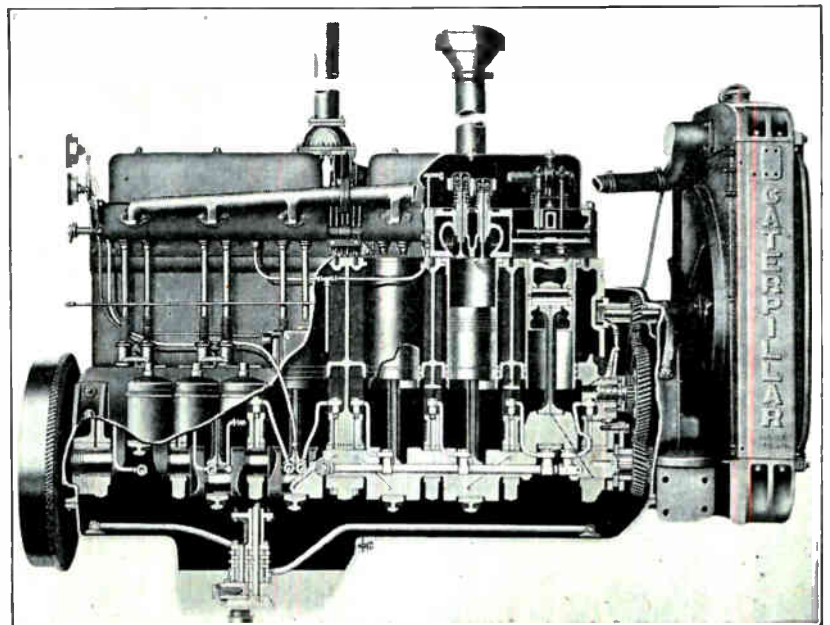

Fig. 7. This excellent sectional view of a modern six cylinder Diesel-engine clearly shows many important construction features. Note the pistons, connecting rods, crank shaft, timing gears, valves, and cylinder liners. (Courtesy Caterpillar Tractor Company.)

lution of the crankshaft, while the four cycle engine only produces one power stroke in four strokes or two revolutions of the crank shaft; thus the two stroke cycle engine will produce twice as many power strokes and somewhat greater horsepower for a given speed and weight of engine.

Another feature of the two stroke cycle engine is that it does not use the conventional intake and exhaust valves. Instead, a system of ports or openings in the cylinder walls take the place of ordinary valves. These ports are opened and closed at the proper time by the movement of the piston as it slides over them. See Figure 18. This feature eliminates the necessity of periodically grinding and repairing valves.

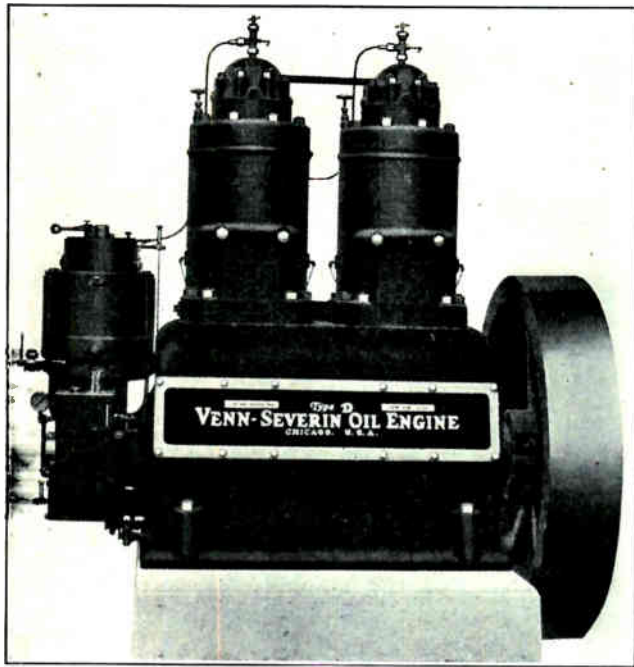

Fig. 8. Heavy duty two cylinder semi-Diesel engine for stationary power purposes. (Courtesy of the Ven-Severin Engine Company.)

Most two stroke cycle engines depend on crank case compression, or the air pumping action of the piston, to remove the exhaust gases and charge the cylinder with the air needed for combustion of the fuel oil. For this reason the crank cases of these engines must be practically air-tight. In multiple cylinder engines of this type the crank case is divided by metal partitions, into separate air-tight compartments for each cylinder. Special seals are sometimes used to prevent excessive air leakage where the crankshaft passes through these partitions.

In this manner, the up and down movement of the piston, and the slight vacuum and air pressure which it alternately produces in the crank case, can be used to draw in outside air and force it through proper ports to the cylinders. Carefully observe this action as shown by the arrows in Figure 18.

When the air is blown through the cylinder to

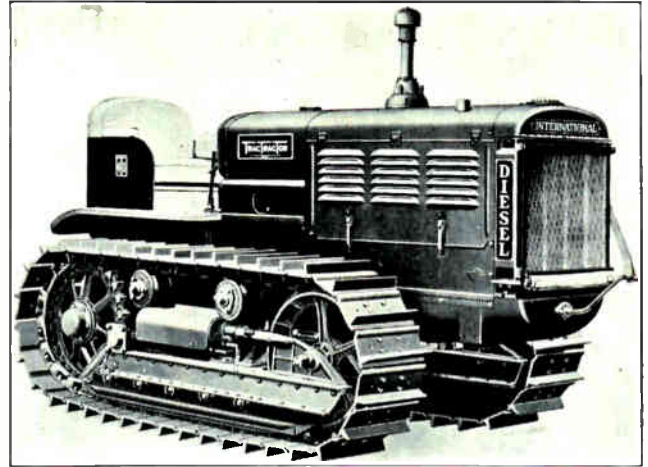

Fig. 9. Thousands of Diesel powered tractors are built each year for operating farm machinery, road building, construction and lumbering equipment. (Courtesy International Harvester Company.)

remove the exhaust gases, it is called "scavenging." The remaining clean air which is to be compressed and used for fuel combustion is called "charging" air.

5. TWO STROKE CYCLE PRINCIPLES. THREE PORT TYPE ENGINES

The three port type of engine illustrated in Figure 18 requires no mechanical valves whatever, as the scavenging and charging air is taken in through the crank case and forced through the cylinders entirely by means of the ports which are opened and closed by the pistons. During most of the upward travel of the piston on the compression stroke the ports I, S and X are closed and a partial vacuum is created in the crank case. See Figure 18-A. When the piston approaches top dead center as at B in Figure 18, the port I is uncovered, allowing air to be drawn into the crankcase with a rush. This port I starts to open when the piston reaches about 30 degrees from top dead center.

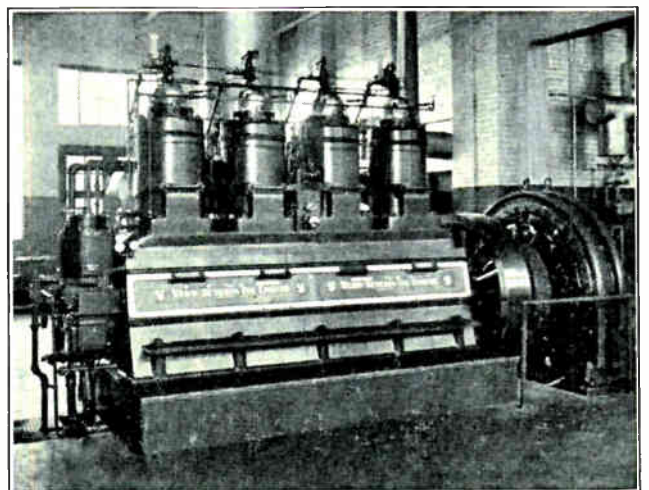

Fig. 10. Four cylinder 300 h.p. engine driving a 200 kw. D.C. generator for electric power supply in a foundry and machine shop. (Courtesy of the Ven-Severin Engine Company.)

When the piston reaches top dead center, as shown at B, the fuel oil is injected and ignites, starting the power stroke. As soon as the piston moves downward a short distance, port I is closed and both I and S remain closed during most of the power stroke. See Figure 18-C. The downward motion of the piston during this stroke compresses the air in the crank case to about 5 to 7 lbs. pressure.

About 50 to 60 degrees before the piston reaches lower dead center the exhaust port X starts to open or become uncovered as at D, Figure 18. This permits the exhaust gases to start to escape under their own pressure and allows the pressure in the cylinder to drop rapidly. About 10 degrees after the exhaust port is uncovered, the by-pass port S is

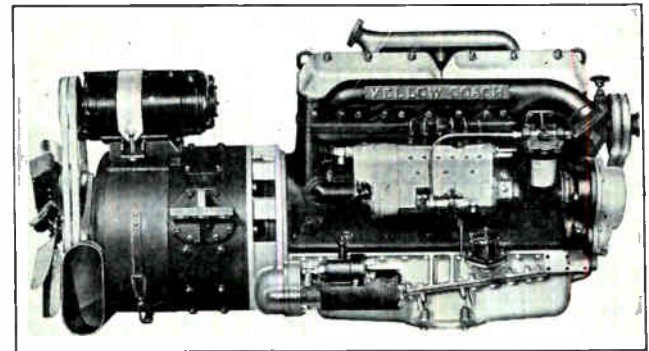
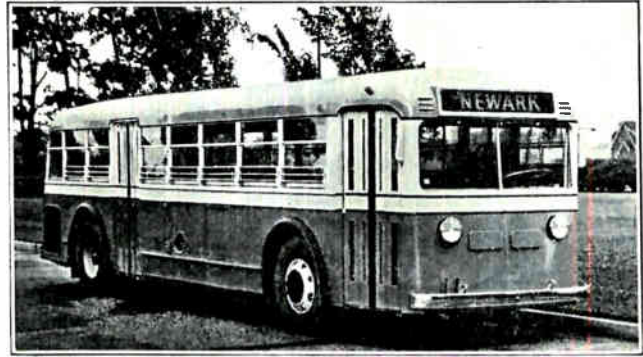

Fig. 13. The upper view in this Figure shows a modern motor bus equipped with a Diesel-Electric drive unit such as shown in the lower view. (Courtesy of the Hercules Engine Company.)

then the exhaust port X is covered, and the new supply of clean air is again compressed to ignite and burn the next fuel charge. Thus, one power stroke is produced in each revolution of the crank shaft. See the cycle chart shown in Figure 19, and note the points at which the various ports open and close, and also the length in degrees of each stroke or operation.

6. TWO PORT TYPE ENGINES

This type of engine has only two ports, the by-pass and exhaust ports, in the cylinder. The air intake is through a spring loaded valve in the side of the crank case. See Figure 20. This intake valve is not mechanically operated by any cams or connections to moving parts of the engine. Instead

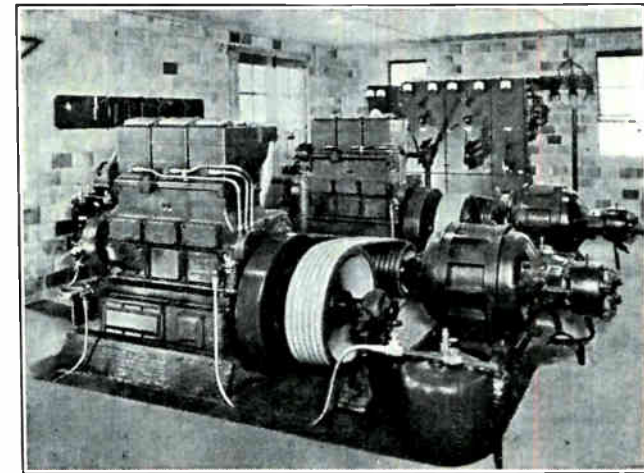

Fig. 11. Two Diesel-Electric generating units in a small town municipal power plant. Note the neat compact arrangement of this plant. (Courtesy of the Cummins Engine Company.)

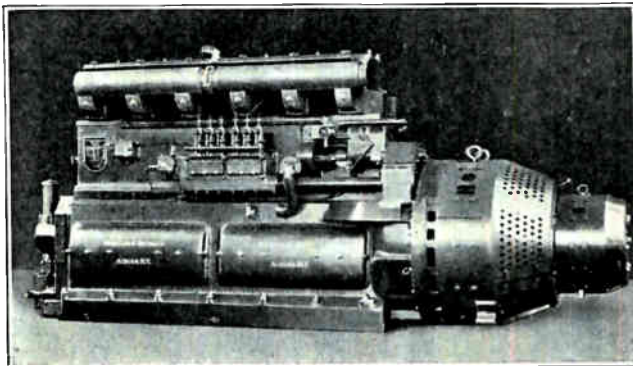

Fig. 12. This photo shows a 600 h.p. Diesel-electric unit for railway locomotive service. Note the direct coupled main generator and auxiliary generator. (Courtesy of the McIntosh & Seymour Company.)

uncovered as at E, allowing the air under pressure in the crank case to rush into the cylinder and force out the remaining exhaust gases. The shape of the piston head causes this air to be deflected upward into the cylinder as shown by the arrows in Figure 18-E, in order to more thoroughly scavenge or clean the cylinder of exhaust gases.

As the piston moves upward on the next compression stroke, the by-pass port S is covered first,

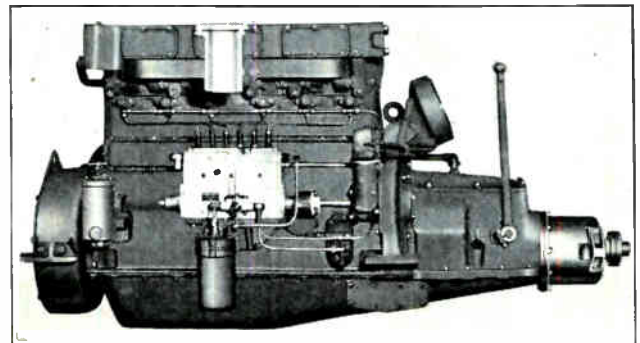

Fig. 14. Photograph of a modern marine type Diesel-engine such as used in pleasure craft and small service boats. Note the oil filter, fuel pump, and fuel lines running to the injector nozzles. (Courtesy of the Buda Engine Company.)

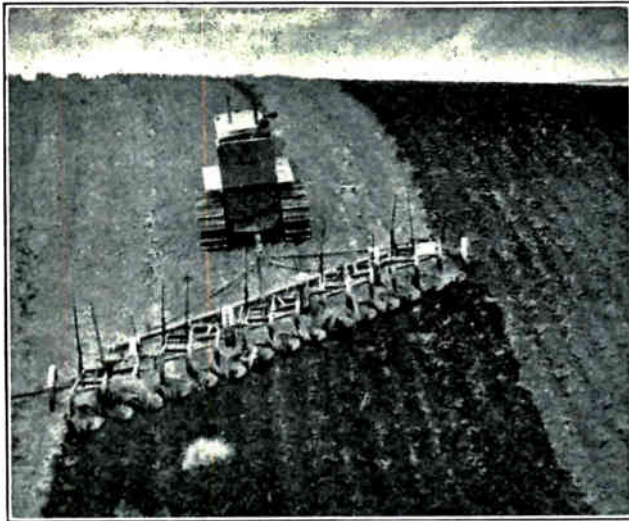

Fig. 15. This photo illustrates the enormous pulling power of a tractor equipped with a Diesel-engine. (Courtesy of the International Harvester Company.)

it is held closed by a light spring until the vacuum in the crank case allows the external atmospheric pressure to open the valve. This takes place almost as soon as the piston starts upward to compress the air in the cylinder.

This valve is open during a longer period of the stroke, than is the cylinder port type valve, and therefore permits better charging of the crank case and improves the operating efficiency of the engine due to the greater charge of air supplied to the cylinder for combustion. This system is the one most commonly used on large Diesel engines using crank case compression. With the exception of this feature the two port engine operates the same as the three port type. See the photo in Figure 21 which shows a sectional view of this type of engine. Examine it carefully and note the air travel as shown by the arrows.

7. BLOWER OR COMPRESSOR CHARGING

The efficiency of the two stroke cycle engine depends partly upon the thoroughness with which the exhaust gases are removed and the amount of fresh air with which the cylinders are supplied for combustion of the fuel charge. The amount of air drawn into the crank case is proportional to the volume of space swept by the piston as it moves upward during the compression stroke.

The amount of air actually retained in the cylinder for compression is less than the amount of air forced into it from the crank case, as some air is lost through the exhaust port which does not completely close until the piston has traveled up part way on the compression stroke. Generally only about 65 per cent of the air charge is retained in the cylinder for compression. Since a certain amount of air and oxygen is required to burn a given amount of fuel charge, this air loss reduces the efficiency of the crankcase compression type of engine.

In order to overcome this loss some of the larger Diesel engines obtain their scavenging and charging air from a low pressure, high volume blower or

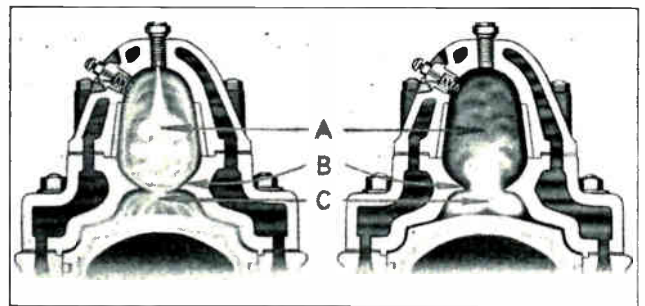

Fig. 16. On the left, the fuel charge is shown being sprayed at high pressure through the injector nozzle into the heated air of the combustion chamber. On the right the burning oil and gases are expanding into the cylinder and exerting pressure on the piston head. (Courtesy of the Ven-Severin Company.)

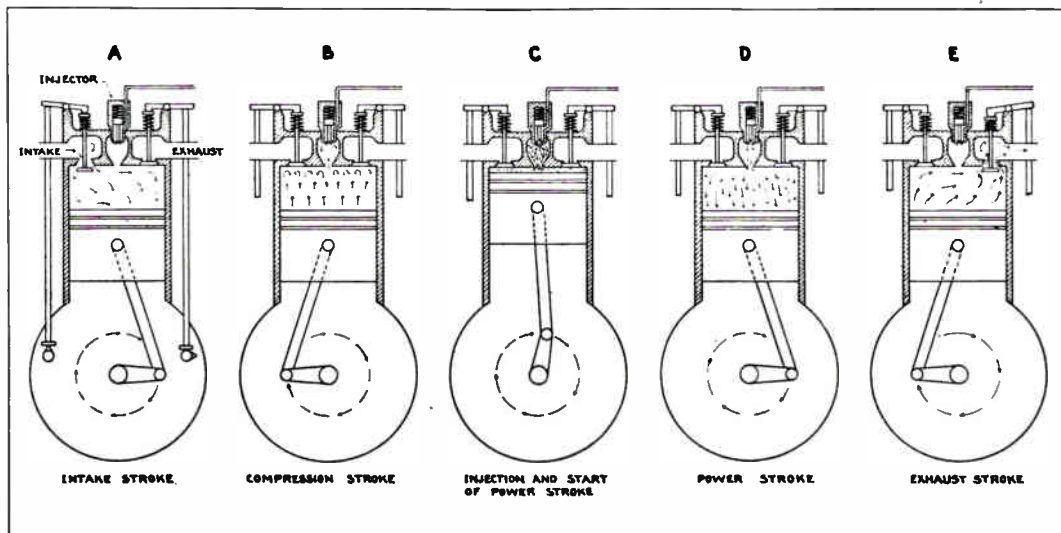

Fig. 17. The above sketches illustrate the operation of a four stroke cycle Diesel engine. Examine each of the views carefully while studying the explanation on the accompanying pages.

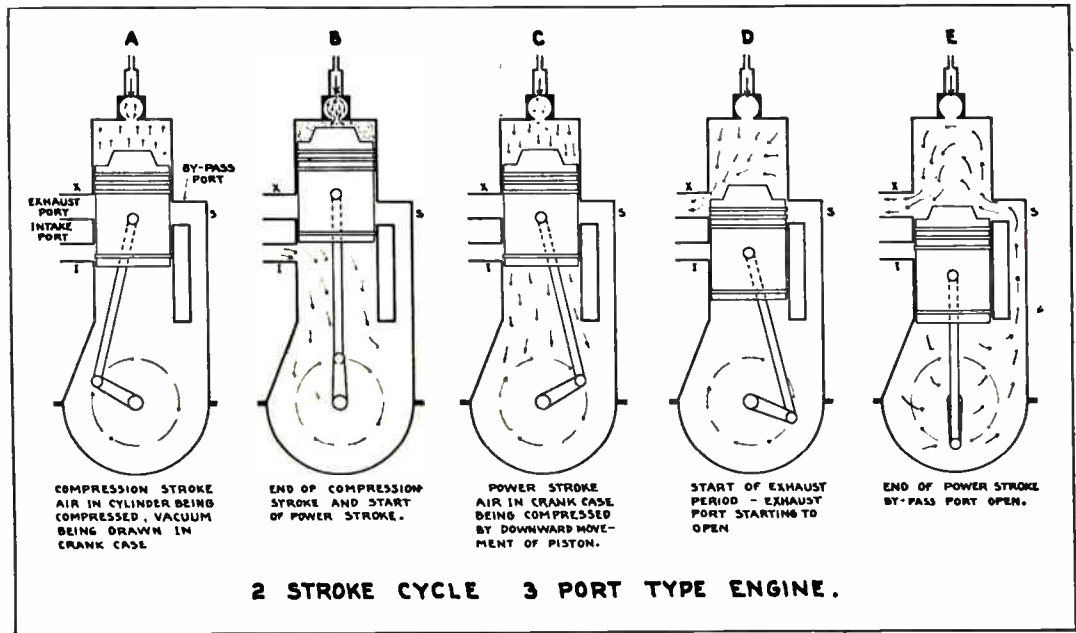

Fig. 18. The diagram on the right illustrates the operation of a two-stroke cycle Diesel engine. Note carefully the operation of the cylinder ports and the admission of air and fuel, and also the power and exhaust strokes.

compressor, instead of getting it from crank case compression. See Figure 22. Instead of the limited quantities of air at 5 to 7 lbs. pressure from the crank case, these blowers supply larger quantities of air at 10 to 25 lbs. pressure. This provides more complete removal of exhaust gases and more complete charging of the cylinders with fresh air, thereby improving the efficiency of this type of engine.

Air compressors for scavenging and charging Diesel engine cylinders are frequently built as a part of the engine and operated by the same crank shaft. See Figure 22-A. Some blowers are driven by a separate small engine or by an electric motor.

The capacity of these blowers is usually about 1.6 times the air displacement volume of the engine, and thus one blower can serve all cylinders.

8. SEMI-DIESEL OR OIL ENGINES

Semi-Diesel engines are always of the two cycle, two or three port type. These engines are very similar to the full Diesel engines except that they operate at lower compression pressures and must therefore be supplied with auxiliary heat to start the engine and keep it running until it is heated up enough to automatically ignite the fuel when it is injected into the cylinder.

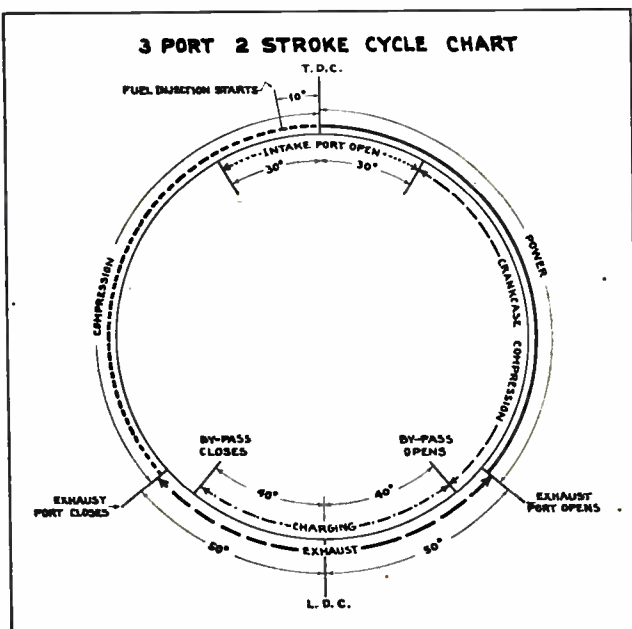

Fig. 19. The above cycle chart shows the order and length of the strokes and also the periods of port openings for a two cycle engine.

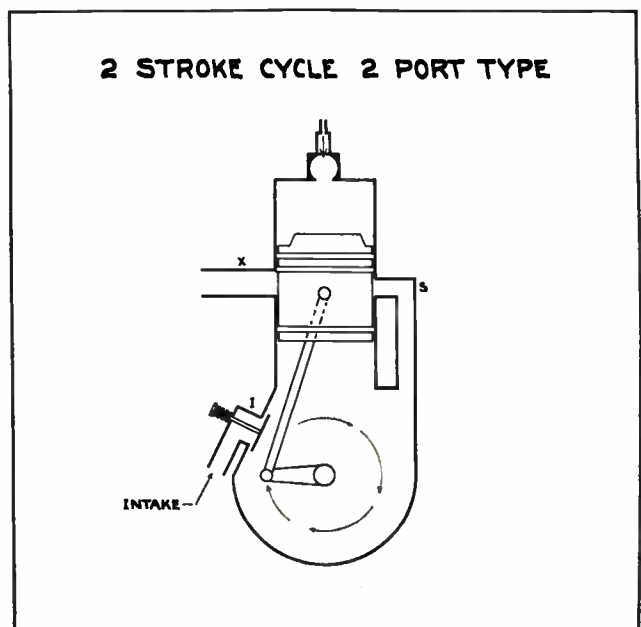

Fig. 20. This diagram illustrates construction of a two cycle, two port type engine which uses a valve "I" to admit air to the crank case during the upward stroke of the piston.

One method of accomplishing this is to build the engine with a portion of the cylinder which is not water-jacketed. This part of the cylinder can then be heated with a gasoline or kerosene blow torch until the metal reaches a dull cherry red heat. The same effect can be accomplished by use of a hot plug or tube projecting into the cylinder or combustion chamber. The injection nozzle is so placed that it will spray the fuel against this hot portion of the cylinder head, or the hot plug, to quickly vaporize and ignite the fuel. This is sometimes called "surface ignition." The torch must be kept in use until the engine has been thoroughly warmed up.

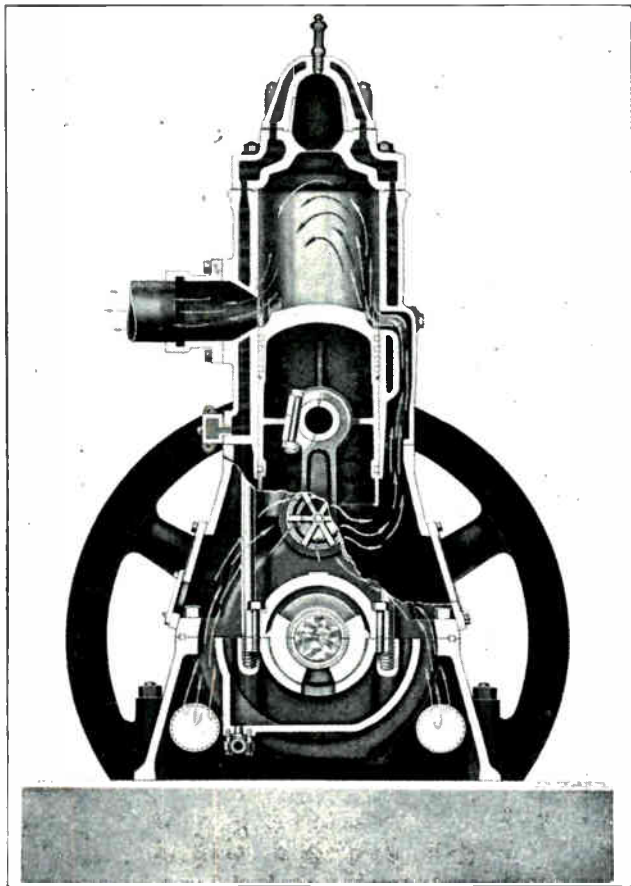

Fig. 21. Sectional view of a two stroke, two port Diesel engine clearly showing the path of the air and exhaust gases. (Courtesy of the Ven-Severin Company.)

Modern semi-Diesel engines use electric glow plugs as previously explained. These glow plugs are located, so that part of the injected fuel oil spray sweeps across the red-hot wires of the plug, thus instantly vaporizing this portion of the fuel.

Semi-Diesel engines are not as efficient as full Diesel engines and will not idle or run without load as smoothly as full Diesel engines. Semi-Diesel engines are sensitive to temperature changes, and will operate better if the cooling water outlet temperature is maintained above 180 degrees F. If the temperature is allowed to drop below this point

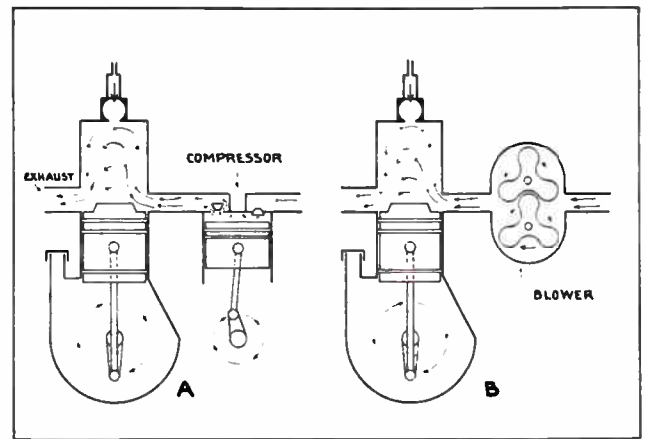

Fig. 22. The above sketches illustrate the operation of air compressors and blowers for charging and scavenging Diesel-engines.

the engine will stop unless the torches or glow plugs are again turned on.

9. SPARK IGNITION OIL INJECTION ENGINES

This type of engine is always of the four stroke cycle type, and uses valves similar to those in the regular gasoline automobile engine. They use a fuel pump and injection nozzle instead of a carburetor, and inject the fuel into the cylinder 50 to 60 degrees ahead of top dead center. Spark plugs and a magneto are used to ignite the fuel spray, as the compression of this type of engine is too low to provide sufficient heat for ignition.

To start these engines they are often primed with a small quantity of gasoline from a priming pump.

10. COMPRESSION RATIO

Since the final pressure at the end of the compression stroke in any internal combustion engine depends largely upon what is known as compression ratio, you should have a good understanding of this factor in connection with Diesel engines. Many persons have an incorrect conception of the meaning of the term "Compression ratio."

Compression ratio is not the ratio of piston displacement to the clearance left in the top of the cylinder when the piston is at top dead center. Instead it is the ratio of piston displacement plus

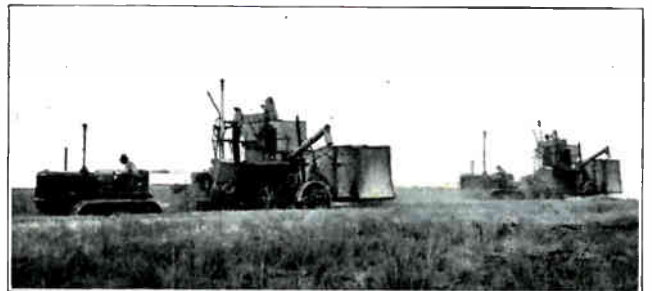

Fig. 23. Diesel-tractors are extensively used for operating harvesting combine machines. (Courtesy of the International Harvester Company.)

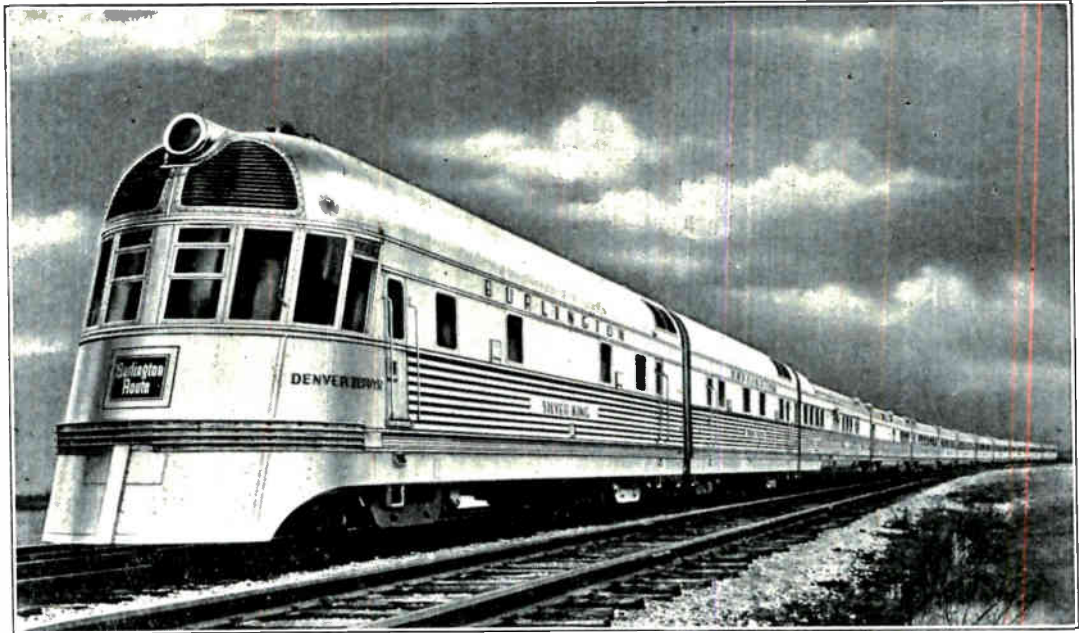

Fig. 24. Powerful Diesel-Electric generating units are becoming extensively used for operation of modern high speed trains such as shown in the photo on the right. Courtesy of the Burlington Ry.

clearance, or maximum cylinder volume, to the final clearance.

When the volume of air is reduced by being compressed, both the pressure and the temperature changes depend upon the ratio of the volume of air at the start of the compression stroke to the volume at the end of the compression stroke. At the start of the compression stroke air fills the entire cylinder including the clearance, as shown in Figure 26-A. At the end of the stroke the air has been all compressed into the clearance above the piston, as shown at B in Figure 26.

The smaller the clearance at the end of the compression stroke, the higher the final pressures will be. Since compressing air will increase its temperature, the more the air is compressed, the higher the temperature will be.

Adiabatic compression is compression without the loss of any heat to the engine parts. The actual compression in any internal combustion engine is only approximately adiabatic, because some of the heat is absorbed by the cylinder walls, pistons, cylinder head, etc. For this reason a high cranking speed is highly important in starting a Diesel engine, because high piston speeds reduce the time that the air is in contact with the engine parts, thereby reducing heat losses. As soon as the engine is started with normal piston speeds of 600 to 1200 feet per minute, compression is so rapid that very little heat is lost to the engine parts.

The final temperature at the end of the compression stroke depends not only on compression ratio and heat losses, but also on the temperature of the air before it was drawn into the cylinder. Figure 27 shows the relation between compression ratios, pressures, and temperatures, for intake air at 60 degrees F., and also at 150 degrees F.

11. FIRING ORDERS

Firing orders used by Diesel engines depend upon the number of cylinders and whether the engine is a 4 stroke or 2 stroke cycle type.

The following firing orders are used by 4 stroke cycle Diesel engines:

- 3 cylinders 1-3-2
- 4 " 1-2-4-3- or 1-3-4-2
- 5 " 1-3-5-4-2
- 6 " 1-4-2-6-3-5 or 1-5-3-6-2-4
- 8 " 1-5-2-6-8-4-7-3

Two stroke cycle firing orders are as follows:

- 3 cylinders 1-2-3
- 4 " 1-3-4-2 or 1-4-2-3
- 5 " 1-4-3-2-5
- 6 " 1-4-5-2-3-6 or 1-6-2-4-3-5
- 8 " 1-6-4-7-2-5-3-8 or 1-8-6-4-2-7-5-3
- 10 " 1-10-5-7-2-8-3-9-4-6
- 10 " 1-6-4-9-3-8-2-7-5-10



Fig. 25. This photo shows a Diesel-tractor used for dragging out logs in the lumber woods. (Courtesy of the International Harvester Company.)

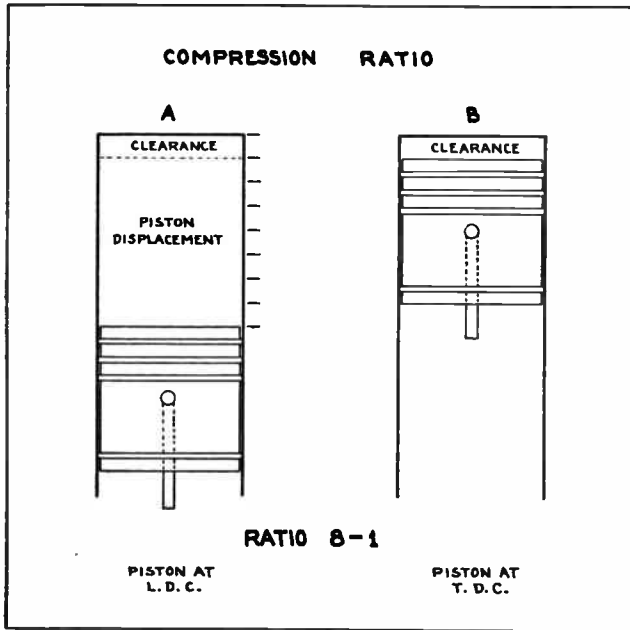

Fig. 26. This diagram illustrates what is meant by the term "compression ratio." Note how the air in the cylinder at "A" is compressed at "B" to $\frac{1}{8}$ of its original volume.

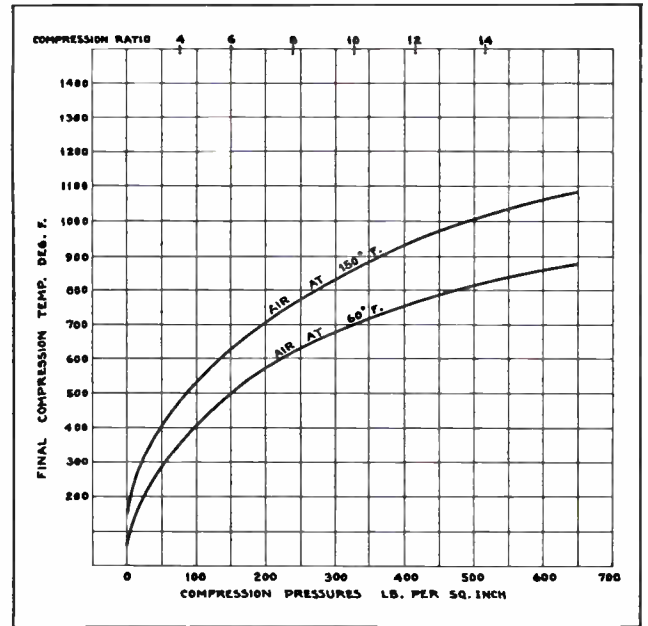

Fig. 27. The above chart shows the relation between compression ratios, air pressures, and temperatures of Diesel-engines.

FUEL INJECTION SYSTEMS

One of the principal differences between Diesel engines and the carburetor type gasoline engine, is found in the fuel system. Diesel fuel oil does not evaporate or vaporize as readily as gasoline, so its vaporization for rapid combustion is accomplished by injecting the fuel into the cylinders under high pressure and at high velocity, through properly designed spray nozzles.

This requires the use of a high pressure fuel injection pump which forces the proper amount of fuel to each cylinder at the proper time for the beginning of each power stroke. By referring to Fig. 28, we see that the Diesel engine fuel system consists of the oil supply tank, supply line, transfer pump, filter, high pressure injection pump, high pressure fuel lines and the injector nozzles.

Sometimes the fuel oil flows from the supply tank to the injection pump by gravity, while in other cases a small gear type transfer pump such as shown in Fig. 28 is used to create a more positive flow of oil to the injection pump. The purpose of the filter is to remove from the oil, any dirt which might otherwise clog the small openings in the injector nozzles, or score the cylinder walls and piston. Note carefully the path of the fuel oil as shown in both views in Fig. 28.

12. METHOD OF FUEL INJECTION

The fuel cycle and system just described is known as the solid injection system, meaning that the fuel oil is injected into the cylinders in liquid form, without any previous mixing with air. A more correct term might be liquid injection. This

system is used on practically all modern Diesel engines, and is standard for all high speed Diesels. The fuel oil is delivered to the injector nozzles under pressures ranging from 1,500 to 2,000 lbs. per square inch, and leaves the nozzle tips at velocities of about 300 feet per second. This high velocity discharge breaks the oil up into a very fine spray so that it mixes readily with the hot air inside the cylinders, and easily ignites.

The original Diesel engines used an air injection system to introduce the fuel oil into the cylinders, and this method was used for many years on large heavy duty Diesel engines. This system uses a blast of air at about 900 lbs. pressure, to force the oil into the cylinder through a mechanically operated nozzle.

The disadvantage of this system lies in the rather complicated injection equipment, the need of a high pressure air compressor, and the possibility of air leaks. Although the air injection system gives very good results with fuels having a high carbon content, it has been practically abandoned in favor of the less complicated solid injection system.

13. FUEL PUMPS

On Diesel engines using the solid injection system the fuel or injection pump is a highly important unit, and the correct operation of the engine depends very largely upon the condition and adjustment of this pump.

The fuel injection pump for a single cylinder engine consists of a small plunger which is closely fitted in a pump cylinder, and operated by a cam

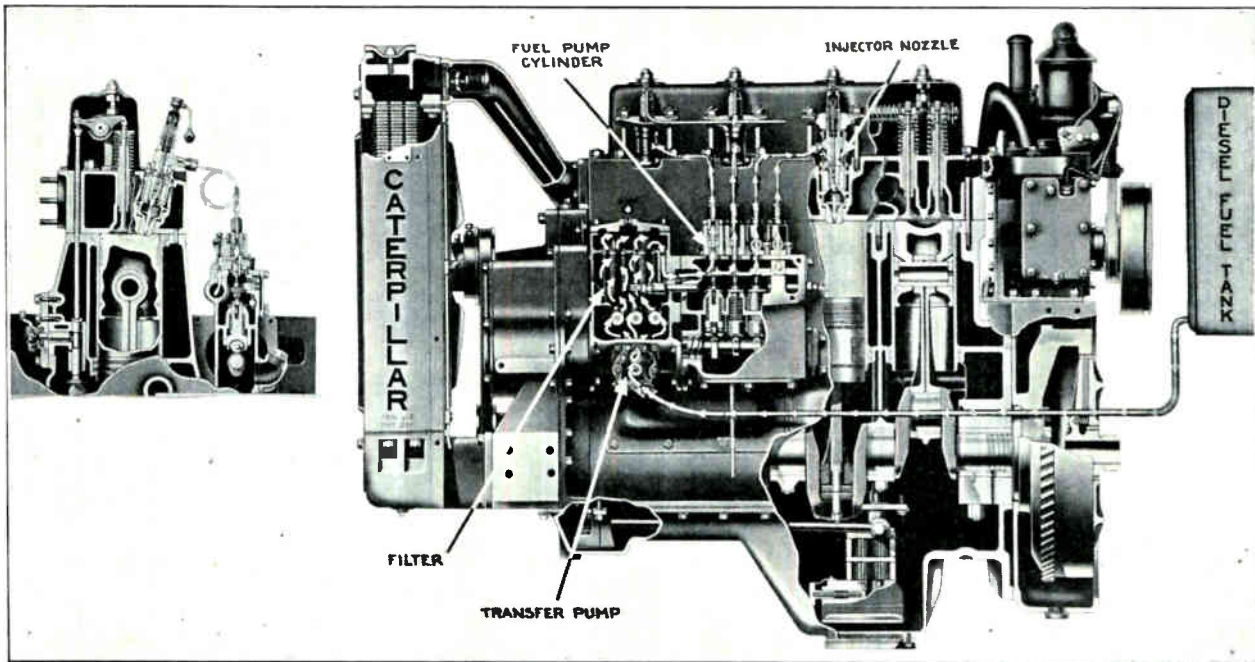

Fig. 28. This illustration shows a sectional view of a Diesel engine including the important parts of the fuel system. Note the fuel tank, fuel line, transfer pump, filter, fuel injection pump, and injector nozzles, and trace the path of the fuel oil through the system. (Courtesy Caterpillar Tractor Company.)

on a cam shaft. On multiple cylinder engines, the fuel pump unit consists of a number of separate pumps, one for each engine cylinder, all mounted or cut into one pump block. See Figures 28 to 33, and note carefully the construction of the fuel pumps shown.

Note the pump plungers and cylinders, and the cams which operate the plungers causing them to make their stroke and deliver fuel oil to the injector nozzles in each cylinder at the proper time. Also note the by-pass ports or valves which meter or regulate the amount of fuel charge delivered on each stroke, and note the check valves in the fuel lines.

Diesel fuel injection pumps must be capable of building up very high pressures, since the breaking up of the fuel is accomplished by means of high fuel velocities. While the pressure on the fuel as a rule does not exceed 2,000 lbs. modern pumps are capable of building up to 10,000 lbs. pressure. These pumps are all of the plunger type, and the parts are so accurately fitted that the plungers require no packing, the clearance being only .00003 of an inch.

Besides being capable of building up very high pressures, these pumps must measure or meter out the fuel for each power stroke in order to control the speed and power output of the engine, because under a light load the engine will require only a small quantity of fuel, but if the load is increased the amount of fuel will also have to be increased.

Fuel pumps are divided into two types, as to the method used to regulate the amount of fuel delivered. The most popular type is known as a **constant stroke pump**. This means that the length of the pump stroke will be the same regardless of the load on the engine. The second type is known as the **variable stroke pump**, the stroke being varied as the load on the engine varies.

14. CONSTANT STROKE, PORT METHOD OF REGULATION

This system is used by all Bosch injection pumps, which are very popular, for high speed Diesels. It is also used in the Timken, Caterpillar, and other pumps.

This method of regulation requires a specially designed pump plunger. Inspection of Fig. 31 shows that the plunger has a helical cut located just below its top. This helical cut we can see is connected to the plunger top by a narrow passage. Referring to illustration No. 1 in Fig. 31 we see the plunger at its lowest position. Level with the top of the plunger are the two intake ports through which

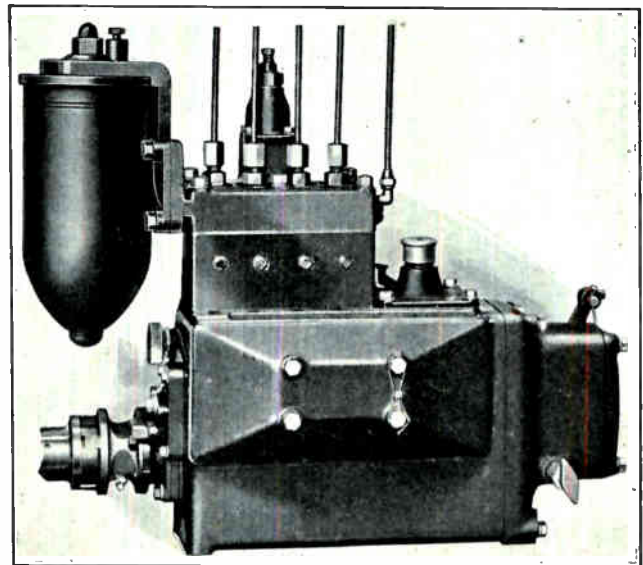
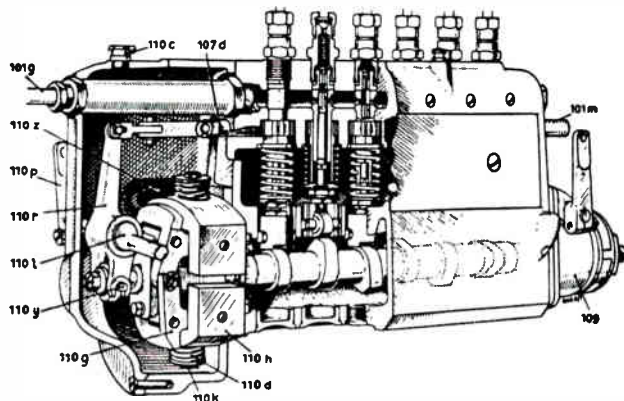

Fig. 29. Photograph of a Diesel engine fuel injection pump, governor and filter assembly for a four cylinder engine. (Courtesy International Harvester Company.)

the fuel is supplied to the injection pump. With the plunger in this position, the space above the plunger and the helical cut around it would be filled with fuel oil, the oil being brought to the injection pump either by gravity or a small transfer pump.

As the cam forces the plunger upward, the two intake ports will be covered and closed and the fuel oil above the plunger will be forced through the fuel line to the nozzle, and injection starts. Injection continues until the upward movement of the plunger causes the upper edge "B" of the helical cut to uncover one of the intake ports. This allows the remaining fuel in the pump barrel to escape and flow back to the intake side of the pump, and injection stops. From this we can see that the length of the injection period determines the amount of fuel that will be injected into the cylinder, and also that the length of the injection period depends on the length of time that the intake port is covered by the pump plunger at any given speed.



Bosch Fuel Injection Pump model PE 6 B, with governor

- | | | |
|-------------------------------|---------------------------|------------------------|
| 101 g = Fuel Inlet Connection | 110 d = Spring | 110 p = Control Lever |
| 101 m = Control Rod Stop | 110 g = Bell Crank Levers | 110 r = Floating Lever |
| 107 d = Control Rod | 110 h = Fly Weights | 110 y = Coupling Pin |
| 109 = Advance Device | 110 k = Adjusting Nut | 110 z = Access Plug |
| 110 c = Oil Cup | 110 i = Eccentric | |

Fig. 30. This sectional view of a Bosch fuel injection pump for a six cylinder engine shows the cam shaft, cam rollers, pump cylinder, plungers, springs, check valves, and governor. Also note the descriptive references in the figure. (Courtesy United American Bosch Corp.)

When the engine is heavily loaded the injection period will have to be of maximum length to provide the proper amount of fuel to carry the load, and the intake port will have to be kept covered for the maximum length of time. When the load is reduced the amount of fuel must also be reduced. This is accomplished by shortening the injection period by slightly rotating the entire pump plunger and shifting the helical cut around so that the intake port is uncovered earlier as the plunger moves upward. See illustration "4" in Fig. 31. Comparing the position of the pump plunger in illustration "4" with illustration "2," you will notice that in 4 the plunger has traveled only one-half the distance that it has in 2 when the intake port was uncovered and injection ended. To stop the engine the plunger is rotated so that the vertical passage between the plunger top and the helical groove is in line with the intake port. In this position as the

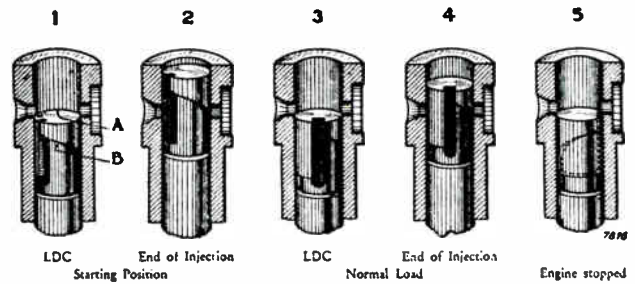

Fig. 31. The above sectional views of Bosch fuel pump cylinders and plungers show the plungers in five different positions of the stroke, and rotated at different angles to illustrate the variable discharge feature of this type of pump. (Courtesy United American Bosch Corp.)

plunger moves up the fuel oil in the pump barrel by-passes back to the intake side of the fuel system. This stops the delivery of any fuel to the injector nozzles and thereby stops the engine.

The pump plungers are rotated by means of a gear segment on each plunger. This segment engages a toothed rack which in turn is connected to a governor or throttle. See Figs. 32 and 33.

15. FUNCTION OF THE DISCHARGE VALVE

The discharge valve or check valve shown in Figs. 32 and 33 serves two purposes. It acts as a non-return valve to prevent the backward flow of fuel when the helical groove uncovers the port at the end of the injection period; and it also reduces the pressure in the fuel line between the injection pump and the injection nozzle. This is highly important, because reducing the pressure in the fuel line allows the valve in the injection nozzle to close with a quick, snappy action and prevent dribble of

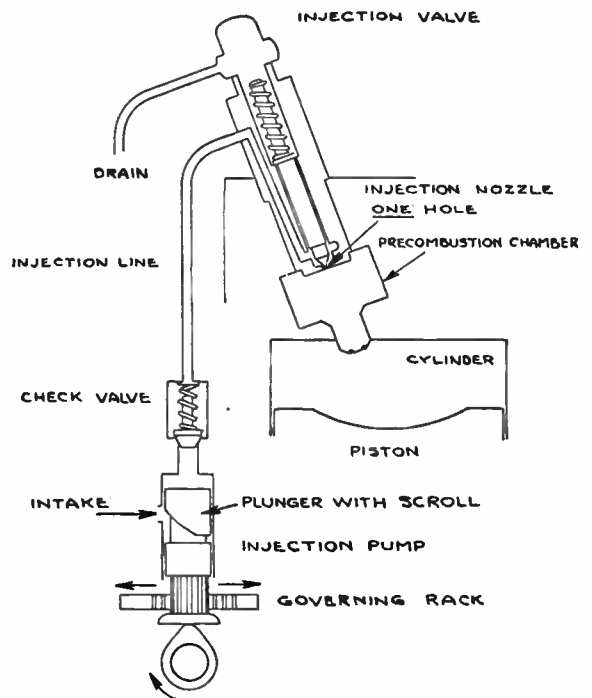

Fig. 32. This sketch shows a single cylinder Bosch constant stroke, variable discharge fuel pump, with check valve, injection nozzle, pre-combustion chamber, and drain line. Refer to this figure often while reading the accompanying explanation. (Courtesy United American Bosch Corp.)

oil into the cylinder after the fuel injection is ended.

The discharge valve is an ordinary mitre-faced valve with a guide that is divided into 2 sections. The upper part of the guide is a small piston that accurately fits the passage below the discharge valve seat. The lower part of the guide has four grooves that extend up the piston-like part of the guide. See Fig. 33.

As soon as the pump plunger moves upward and covers the intake port, fuel pressure rises and the discharge valve is pushed up until the piston-like part of the guide is above the discharge valve seat as shown in Fig. 33-A, and fuel is forced under high pressure to the injection nozzle.

When the port is uncovered at the end of the injection period, the pressure in the pump barrel drops, allowing the discharge valve to drop back on to its seat under the action of its spring. As the discharge valve with its piston-like guide drops, the space above the discharge valve is increased. This sudden increase in space reduces the pressure in the fuel line to almost atmospheric pressure and the valve in the injection nozzle can close with a snap, thus resulting in an abrupt, clean-cut termination of the injection period.

16. BY-PASS OR RELIEF VALVE METHOD OF FUEL CONTROL

Some constant stroke fuel pumps use a mechanically operated valve to control the quantity of fuel injected into the combustion chamber of the engine, as shown in Figs. 34 and 35. This valve operates in connection with the pump plunger, being opened to by-pass the fuel back to the low side of the pump at the end of the injection period.

The by-pass valve is operated by means of a short rocker-arm, one end of which moves up and down with the plunger of the pump. The other end of the rocker-arm is pivoted on an eccentric. Rotating this eccentric through part of a revolution

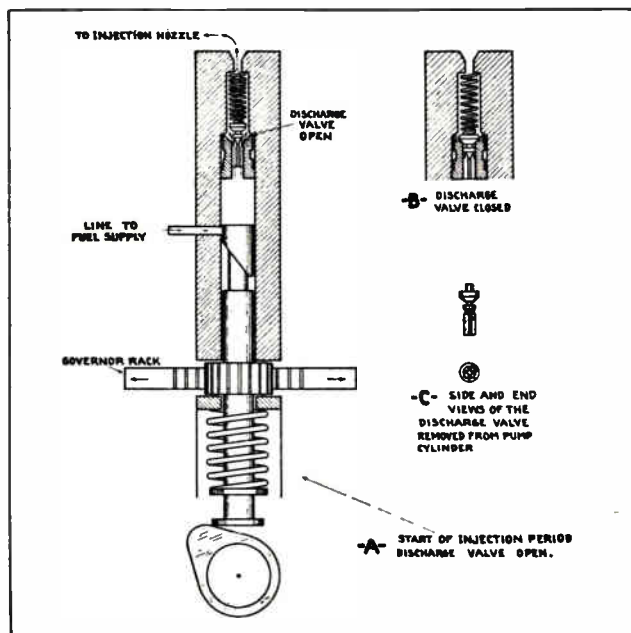

Fig. 33. Sectional view of one cylinder element of a Bosch fuel pump, showing cam, plunger, return spring, governor rack, cylinder and discharge valve.

will raise or lower the pivoted end of the rocker-arm.

The illustration in Fig. 34 shows the cam that operates the pump plunger, just about to start moving the plunger upward. At "A" you will see that there is a small clearance between the lower end of the by-pass valve stem and the rocker-arm. As the cam lifts the pump plunger, the rocker will also move up, but the by-pass valve will not be lifted off of its seat until the movement of the rocker-arm eliminates the clearance. At this point the by-pass valve is lifted off of its seat and the remaining fuel in the pump barrel is by-passed back to the low side of the pump and injection stops.

The amount of clearance between the rocker-arm and the lower end of the by-pass valve at the

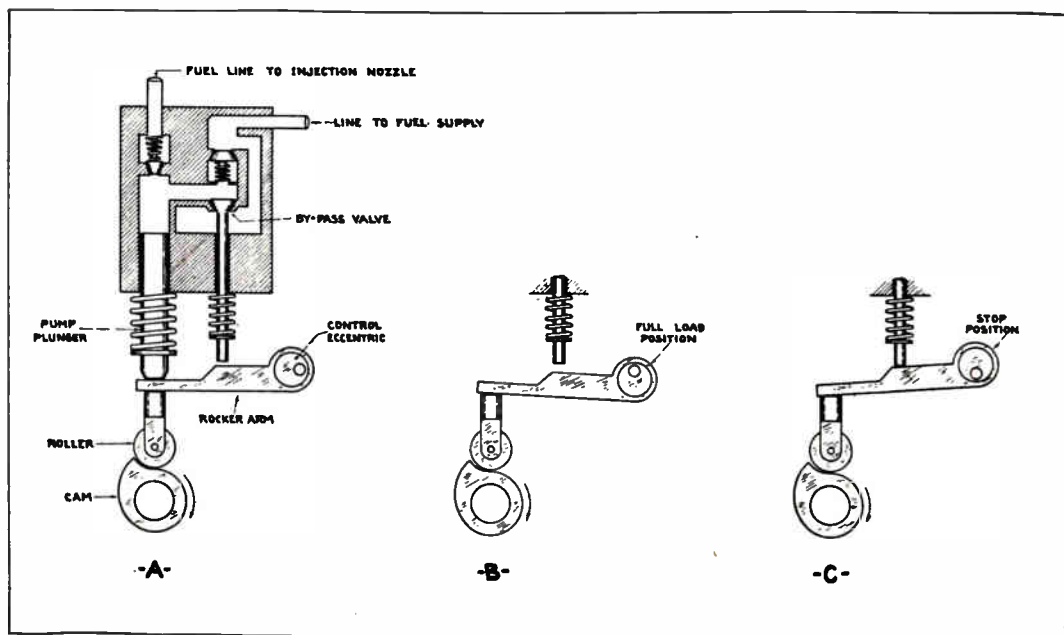

Fig. 34. The figures on the right illustrate the operation of a Diesel fuel injection pump using the by-pass valve method of fuel control. Note how the time of opening of the by-pass valve, and the amount of fuel charge is governed by the position of the control eccentric.

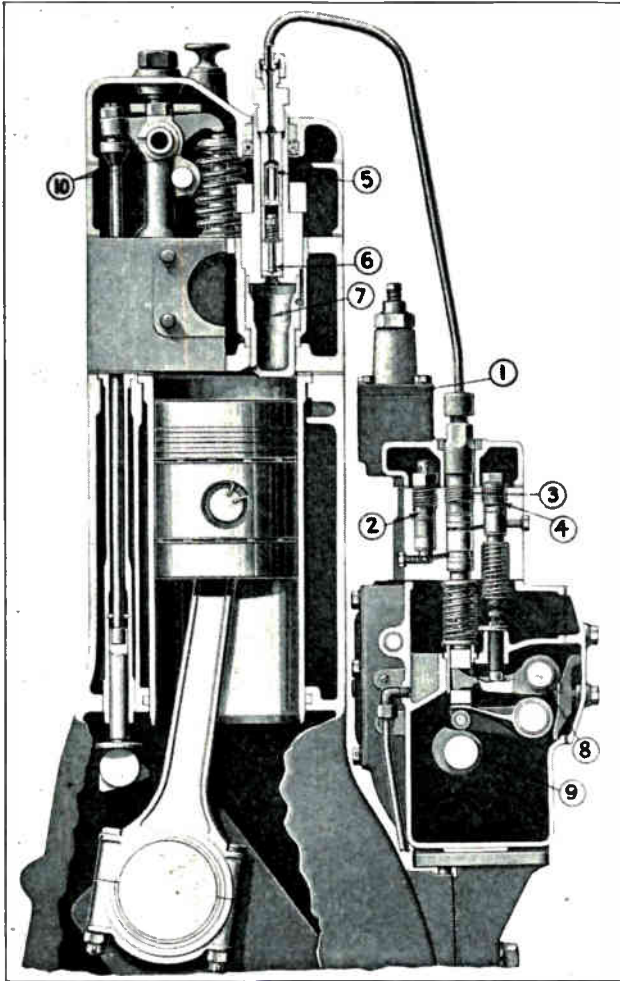

Fig. 35. This excellent sectional view of a Diesel engine cylinder, fuel pump, and injector nozzle clearly shows the construction and arrangement of these important parts of a Diesel engine, using the by-pass method of fuel control. Study this illustration in detail while reading the lesson material which refers to it. (Courtesy International Harvester Corporation.)

start of the injection stroke of the pump plunger determines the length of the injection period. For example, if the clearance was $\frac{1}{8}$ of an inch as shown at "A," Fig. 34, and the point of lift was midway between the pivoted end, and the outer end of the rocker-arm, the pump plunger would move up $\frac{1}{8}$ of an inch before the by-pass valve opened to terminate the injection period. By rotating the eccentric, a quarter turn as at "B," the pivoted end of the rocker-arm would be lowered increasing the clearance $\frac{1}{8}$ of an inch at the start of the injection stroke and the plunger would move $\frac{1}{4}$ of an inch before the by-pass valve opened, thus delivering twice as much fuel.

To stop the engine, the eccentric would be rotated to position "C" in Fig. 34 raising the pivoted end of the rocker-arm so that there would be no clearance between the by-pass valve and rocker, the by-pass valve being held slightly off of its seat. This would prevent any fuel from being injected into the combustion chamber, because as soon as the pump plunger moved upward, the fuel would by-pass back to the low side of the pump. Fig. 35 shows a sectional view of a fuel pump that uses the by-pass method of fuel control. Also note the fuel

line running from the fuel pump to the injector nozzle, which on this engine injects into a pre-combustion chamber above the cylinder.

17. VARIABLE STROKE PUMPS

The amount of fuel that is injected into the combustion chamber can also be controlled by varying the stroke of the fuel pumps; a stroke of maximum length being used when the load is heavy, and shortening the stroke as the load becomes lighter. Two very simple methods can be used to vary the pump stroke. One is known as the variable lift cam method and the other is known as the wedge method of control.

With the variable lift cam control, the cams that operate the pump plungers are cut with a taper or slope as shown in Figs. 36 and 37. The roller on the pump plunger is also beveled so that it will have more bearing surface on the sloping face of the cam.

The stroke of the pump is varied by moving the entire cam assembly back and forth. At "B" in Fig. 36, when the cam is moved to the left as far as it will go, the pump stroke will be maximum because the roller will ride the highest part of the cam and push the pump plunger up the full distance. If the cam is shifted to the right, due to the sloping face, it will not lift the roller so high and the stroke will be reduced, thereby reducing the amount of fuel delivered. If the cam is moved to the right as far as it will go, the lift will be zero, no fuel will be delivered and the engine will stop. Fig. 37 shows this method of control as applied to the fuel pump for a 2 cylinder, 2 stroke cycle oil engine. Note the governor incorporated in the pump assembly, and the simplicity of the entire unit.

18. THE WEDGE METHOD OF CONTROL

This type of control uses a sliding steel wedge to vary the stroke of the pump as shown in Fig. 38. The stroke is varied by shifting the wedge and con-

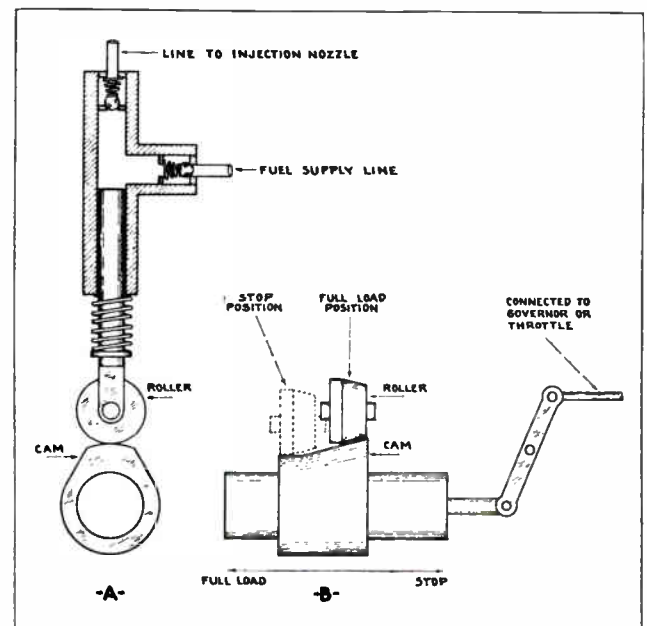

Fig. 36. The above diagrams illustrate the variable stroke type of Diesel fuel injection pump. Note how the amount of fuel charge is controlled by shifting the tapered cam.

trolling the distance that the plunger drops as the cam leaves the plunger roller. At "B," Fig. 38, the wedge has been drawn to the right as far as it will go, and as the cam rolls away from the plunger roller the plunger drops maximum distance, the clearance between the roller and the back side of the cam being zero. When the cam lifts the plunger, the stroke will be of maximum length, and the maximum quantity of fuel will be delivered.

If the wedge is moved to the left as in "A," the plunger will drop until the stop pin rests on the wedge. This will increase the clearance between the back side of the cam and the roller, and the pump stroke will be shortened. For example, if at "B" with the clearance zero, the pump stroke was $\frac{1}{4}$ of an inch, and at "A" the clearance was $\frac{1}{8}$ of an inch, the pump stroke would be only $\frac{1}{8}$ of an inch and only 50% as much fuel would be delivered.

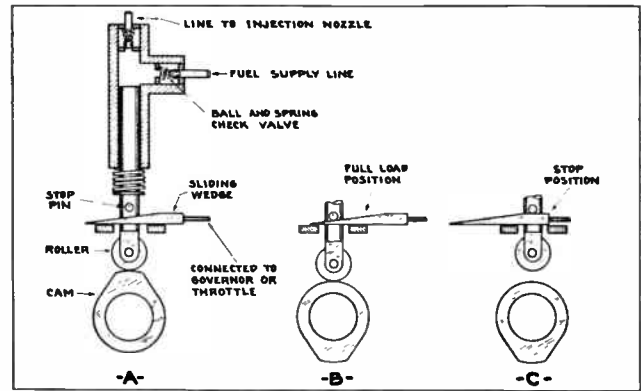

Fig. 38. The above sketches illustrate the method of operation of the wedge system of fuel control on a Diesel engine fuel pump.

closed fuel tank valve, clogged inlet pipe, dirty filter element, air lock in pump, damaged pump plunger (sticking in pump barrel), delivery valve clogged with dirt and sticking.

If the pump does not deliver fuel uniformly the probable causes are:—air lock in pump (shown by air bubbles issuing with oil when delivery valve holder is unscrewed), broken delivery valve spring, damaged delivery valve face or guide, broken plunger spring, plunger sticking due to dirt, insufficient fuel supply to pump, (due to partly clogged supply line or filter,) or because of faulty operation of transfer pump, or not enough gravity head to supply tank.

Notes on Dismantling and Re-assembling of pumps

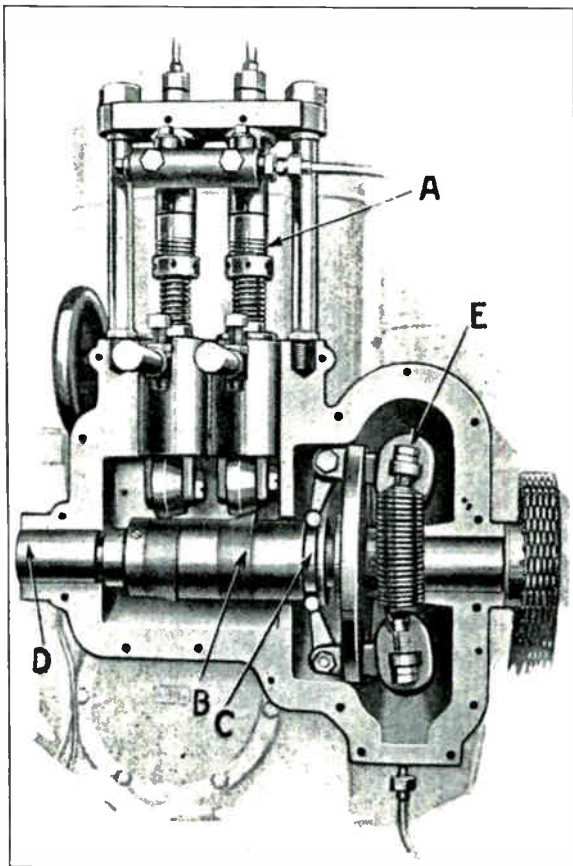

Fig. 37. Sectional view showing cams, fuel pump, cylinders and governor of a variable stroke fuel pump for a two cylinder engine. (Courtesy Anderson Engine Company.)

At "C" the wedge has been shifted to the left as far as it will go, resulting in a very wide clearance between the back side of the cam and the roller. If this clearance is equal to or greater than the maximum stroke of the pump, the cam will be unable to reach and lift the plunger, so the plunger movement will be zero and no fuel will be injected into the combustion chamber of the cylinder, thus stopping the engine.

19. FUEL PUMP TROUBLES AND CARE

If a Diesel fuel injection pump does not deliver any fuel, the probable causes are:—empty fuel tank,

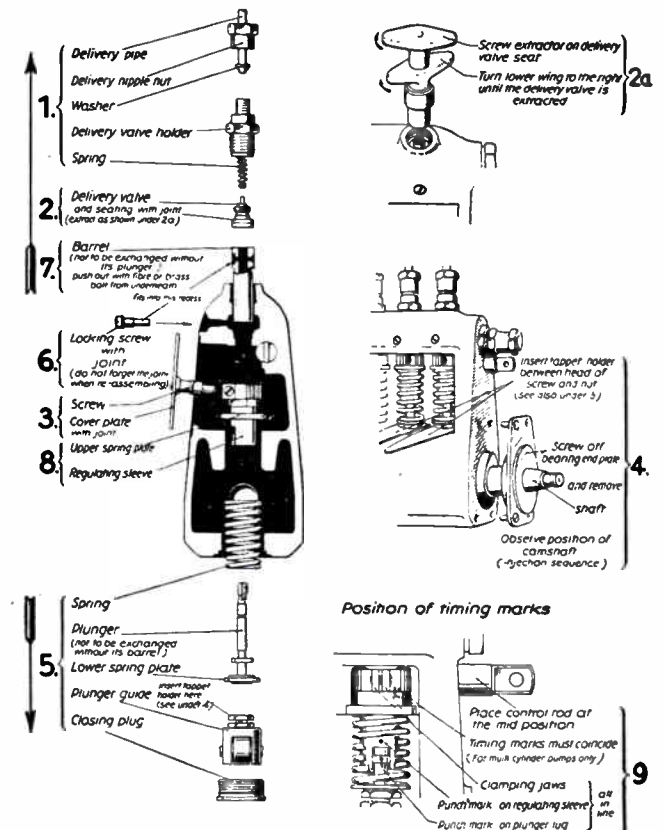

Fig. 39. This figure shows the proper steps in dis-assembling a Bosch fuel injection pump for cleaning and repairs. Carefully note the instructions printed at the various steps. (Courtesy United American Bosch Corp.)

If the pump fails to deliver enough fuel per stroke the cause may be:—a leaky delivery valve or leaky joints in pressure system. If the pump delivers too much fuel per stroke, the cause may be a loose clamp screw on toothed regulating quadrant (in case of multi-cylinder pumps). If the time of injection starting has changed, it may be due to a loose adjusting screw in the tappet, or to damaged cam surfaces due to poor lubrication. In some cases, the control rod may become jammed due to dirt or poor lubrication.

When dismantling a fuel pump, the work bench should first be covered with clean grease-proof paper (oiled or waxed paper) and all dirt removed from outside of pump by thorough washing and brushing in kerosene or gasoline.

Then proceed with extreme care in the order or steps shown in Fig. 39. Reassembling is done in the reverse order, with particular attention being given to point 8 in Fig. 39.

In case of any damage to pump plunger or barrel these should always be replaced as a pair or set, and never singly, in order to get a perfect fit. This also applies to delivery valves and their seats. These parts have been lapped and fitted together with extreme accuracy at the factory and should never be rubbed down with grinding powder or it will ruin them.

Some pump repairs are best made at the factory where proper tools and skilled specialists are available. For this reason spare fuel pumps are sometimes carried in Diesel engine plants for exchange or use while defective pumps are returned to the factory for service.

Some fuel injection pumps have removable pump elements (barrel, plunger, and discharge valve) so that on multi-cylinder pumps any one defective cylinder or element can be quickly replaced with a spare unit. See Fig. 40.

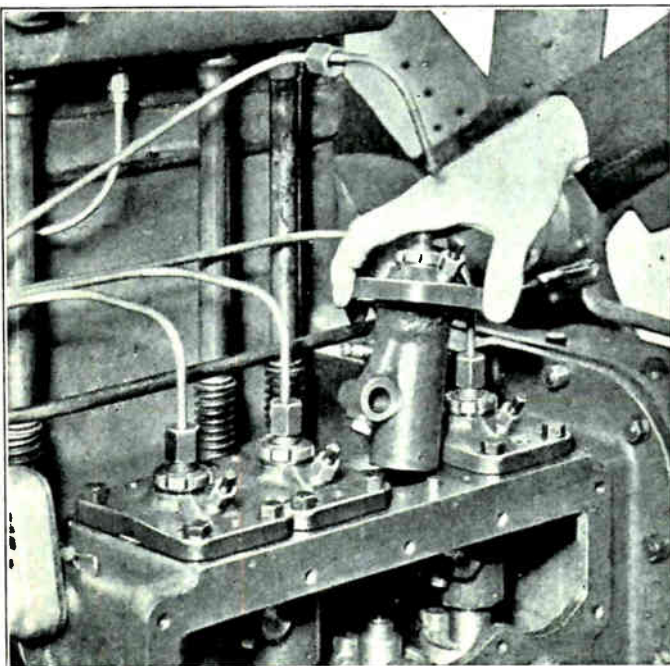

Fig. 40. This photo shows the ease with which a fuel pump element can be replaced on the Caterpillar Diesel tractor engine. (Courtesy Caterpillar Tractor Co.)

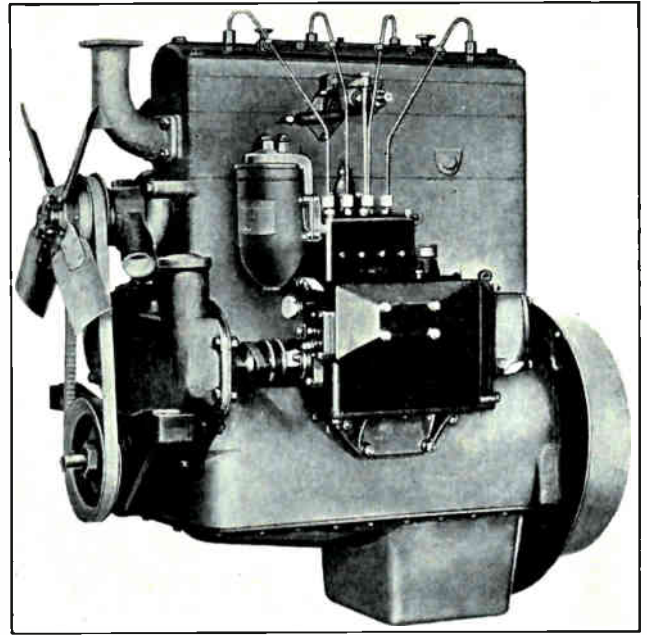

Fig. 41. Photograph of a four cylinder truck or tractor engine showing the fuel pump, governor and filter unit properly mounted on the side of the engine. Note the fuel line connections from the pump to the injection nozzles. (Courtesy International Harvester Co.)

20. FUEL NOZZLES

With solid injection fuel systems some means must be used to break the fuel oil into a very fine spray as it is introduced into the combustion chamber at the end of the compression stroke. Fuel nozzles are used for this purpose. They not only break the fuel oil up into very small particles, but also control the shape of the spray as it issues from the nozzle. This is important in order to thoroughly mix the fuel and the air together.

The breaking up of the fuel oil is accomplished by forcing the fuel through the very small opening or orifice of the nozzle under pressures running from 1,200 to 2,000 lbs. per square inch. The shape of the resulting spray is controlled by the shape or number of orifices that the nozzle has. In general, nozzles are divided into two classes: closed type, which is the most popular, and the open type used on some engines.

A closed type nozzle is one that has a spring loaded valve that seats on a conical seat just above the orifice of the nozzle as shown in Fig. 43. When the injection pump plunger begins to move up, the pressure in the fuel line and nozzle will immediately rise because both are at all times filled with fuel oil. This rising pressure will act on shoulder "X" on the nozzle valve. As soon as the pressure exerted on this shoulder is greater than the resistance of the spring that holds the valve down on its seat, the valve is lifted. This now allows the pressure to also act on the tapered or pointed part of the valve, with the result that the valve is lifted full distance immediately, and will remain open until pump delivery ceases. At the end of the delivery stroke the pressure on the fuel line between the injection pump and the nozzle drops, and the nozzle valve snaps shut.

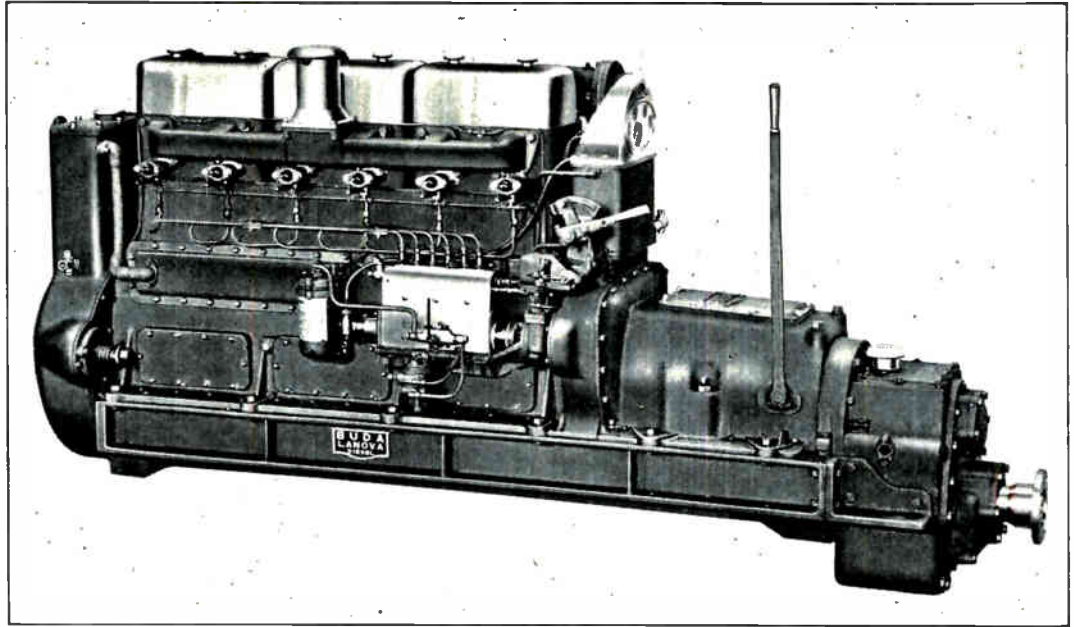

Fig. 42. This photograph shows the mounting and arrangement of the fuel injection pump, filter, fuel lines, injector nozzles, and throttle control on six cylinder marine type Diesel engine. (Courtesy Buda Manufacturing Co.)

Closed type nozzles are classified according to the type of orifice that they have. A single hole nozzle like that shown at "C," Fig. 44, produces a cone shaped spray having an angle from 4 to 15 degrees. This type is used on engines that are equipped with pre-combustion chambers. The advantage of this type is that having but one orifice it can be made rather large, which reduces the tendency to clog up. The multi-orifice nozzle has several very small holes, as shown at "D," Fig. 44. Some have as many as 6 openings. This type is used where a fan-shaped or very wide angle spray is required, which is the case where no pre-combustion chamber is used.

The pintle type nozzle has a valve that has a short extension known as a pintle that projects through the single hole in the nozzle body as shown at "A" and "B" in Fig. 44. By properly shaping this pin either a hollow cylindrical spray or a tapered spray with an angle ranging from only a few degrees up to 50 or 60 degrees, can be obtained. By using a pin that is tapered or made in 2 cylindrical steps, the orifice can be opened gradually. This would cause but a small quantity of fuel to be injected as the valve began to lift, increasing as the valve reached maximum lift, causing the pressure produced by the expanding gases in the combustion chamber to rise gradually, thereby reducing fuel knock.

21. DISASSEMBLING INJECTION NOZZLES

When the small orifice openings of an injector nozzle become clogged with carbon or dirt they can be cleaned with a special small cleaning drill or tool supplied by the pump manufacturers. Be very careful not to enlarge these orifice openings, and not to make them smaller by accidental battering or rough handling of the nozzles. Great care must be exercised if a nozzle has to be taken apart. To dismantle a Bosch nozzle in order to clean it, unscrew nozzle cap nut 151, Fig. 45. This will allow the nozzle body 150 "A," and nozzle

valve 150 "D" to be removed for inspection and cleaning. The inside of the nozzle body can be cleaned with a thin wood strip, after soaking the nozzle in kerosene. The nozzle valve can be cleaned with a soft gasoline-soaked cloth. Never use hard sharp tools or emery paper or powder for this work. When replacing valve and nozzle body, all parts must be absolutely clean, special attention being given to all ground joints in this respect. All parts should be lubricated with clean engine oil before reassembly.

If the spring is removed, it must be done without disturbing the threaded spring compression adjusting member, otherwise the spring tension will have to be readjusted. This requires special equipment. To remove the spring, remove protecting cap 159

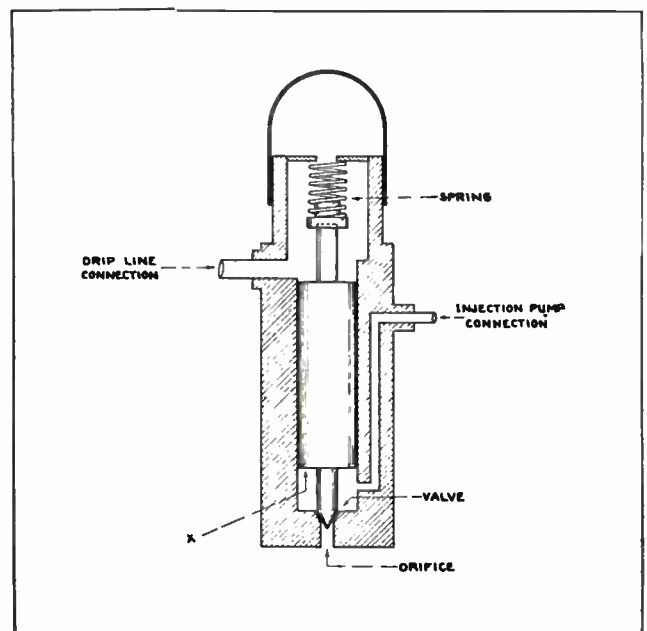

Fig. 43. Sectional view showing the construction of a closed type injector nozzle. Note the spring loaded valve which keeps the nozzle orifice closed until the oil pressure underneath the piston overcomes the spring pressure.

and unscrew spring cap nut 156. Do not unscrew compression screw 158 as this will destroy the spring setting. The feeling pin 160 is used to check the operation of the valve while the engine is running. With the finger resting on the head of the feeling pin slight knocks indicate that the nozzle is operating.

22. DRIP LINES

The valve stems of closed type nozzles are very accurately fitted to the nozzle bodies and no packing is required. When new, there is very little oil leakage past these stems in spite of the extremely high pressure at which these nozzles operate, but with wear, leakage will develop. This is taken care of by a drip or leak-off connection 162, Fig. 45. In multi-cylinder engines, the drip connections are connected to one common line and the fuel that leaks past the valve stems is returned to the fuel tank or to a special tank.

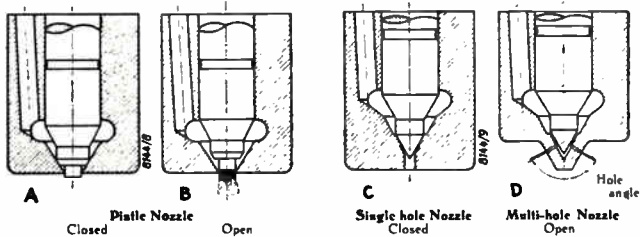

Fig. 44. The two views on the left above show closed and open positions of a pintle type nozzle valve. On the right are shown closed and open positions of single hole and multiple hole injector nozzles and valves. (Courtesy United American Bosch Co.)

23. OPEN TYPE NOZZLES

Some manufacturers prefer the open type nozzle shown in Fig. 46. Instead of a heavily spring loaded valve, this type uses a series of ball checks. Sometimes as many as 3 of these ball checks are used in an open type nozzle. These ball checks are held against their seats by light springs, and their function is to prevent an up flow of air and gases into the fuel lines during the compression and power strokes of the engine. The oil passage just above the orifice is equipped with spiral grooves. This gives the fuel oil a rotary or corkscrew

motion so that the spray leaves the nozzle in a conical form.

Since this type of nozzle does not use a heavily loaded spring valve, the fuel pressure will be determined by the size of the orifice and the rate at which the engine is turning over.

24. TIMING OF INJECTION

Since the fuel oil is automatically ignited as it is injected into the hot air in the combustion chamber, it is highly important that the injection pumps be correctly timed. Injection always starts before the piston reaches top dead center of the compression stroke. In some case only 7 degrees before top dead center, in others as much as 30 degrees, depending upon the type of engine. In most cases the flywheel of the engine is marked to make it easy to correctly set the engine in order to time the injection pumps, the mark on the fly wheel being lined up with a pointer on the fly wheel housing or frame of the engine.

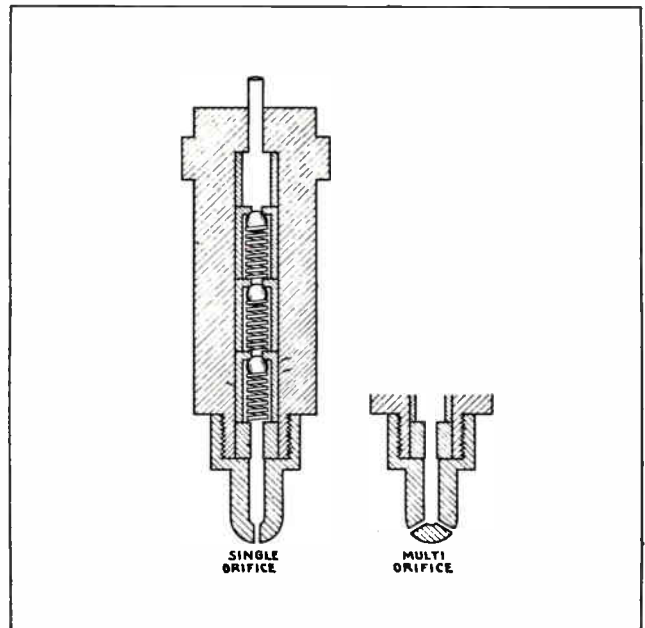

Fig. 46. Sketch showing a sectional view of single orifice and multi-orifice open type injector nozzles. Note the series of spring loaded ball check valves.

If the engine has more than 1 cylinder, the mark will be for cylinder No. 1, which is the farthest away from the fly wheel. When setting 4 stroke cycle engines care must be taken that No. 1 cylinder is on the compression stroke and not the exhaust stroke. This can be determined by watching the valves. The compression stroke starts just as the intake valve closes.

When the engine has been correctly set, the next thing to do is to set the injection pump. If a port control type of pump such as shown in Figs. 29, 30, 31, and 32 is used, injection starts as soon as the plunger covers the port as it moves upward. Some pumps of this type have a vertical mark on the drive end bearing plate, and two marks on the coupling hub. These marks are labeled "R" and "L," for right and left-hand rotation. Remove the side inspection plate from the pump and rotate the pump hub in the direction that it is normally driven by the engine until number 1 plunger is

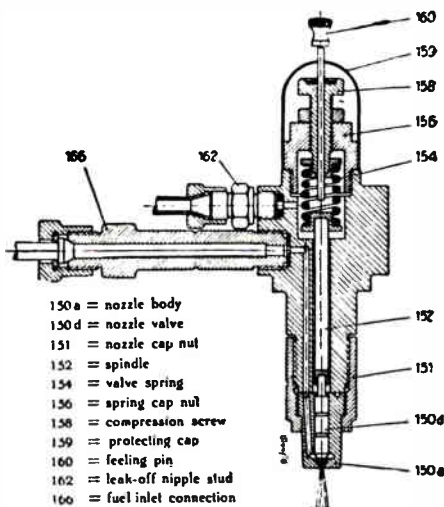
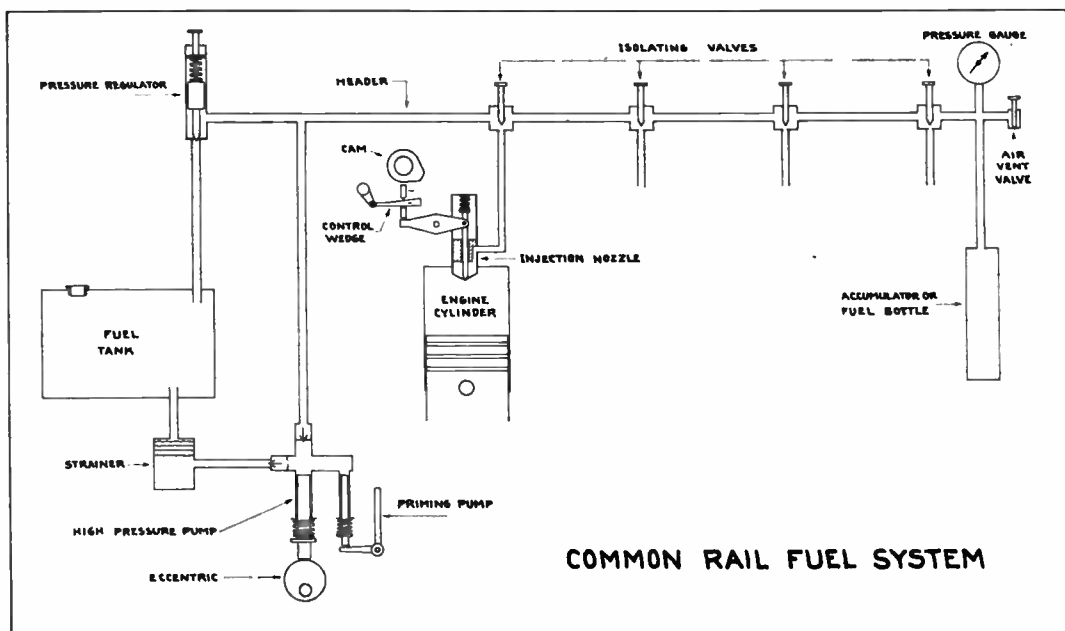

Fig. 45. Sectional view of Bosch fuel injection nozzle, nozzle holder and valve, showing pintle valve in open position. Refer to this figure and the numbered parts while studying the explanation in the lesson. (Courtesy United American Bosch Corporation.)



COMMON RAIL FUEL SYSTEM

Fig. 47. Diagram showing the essential parts of the common rail fuel system for a Diesel engine. Carefully note the arrangement and purpose of each part while studying the accompanying explanation.

just beginning to lift. If the rotation is clockwise or right hand, rotate until the "R" on the hub lines up the vertical mark on the drive end bearing plate and then insert the cap screws in coupling members.

On some engines the two halves of the pump coupling have marks that must line up. In a case of that kind, set the engine flywheel as before and rotate the pump half of the coupling until the two marks line up perfectly.

If a variable stroke or relief valve type of pump is used, injection starts as soon as the pump plunger begins to move up. So all that one has to do to time this style of pump is to first set the engine and rotate the pump drive until number 1 plunger just begins to lift and then couple the pump to the engine.

25. COMMON RAIL SYSTEM

While most builders of Diesel engines favor the pump injection systems just described, there are

some that use the common rail or constant pressure type of fuel injection system. Among manufacturers that use this system on some or all of their engines are: Winton, Cooper-Bessemer, National, and Atlas-Imperial.

In this type of fuel system the pump is not used to meter the amount of fuel injected into the cylinder or to time the injection. It is used only to maintain a constant pressure on a heavy fuel line, known as a header, to which all of the injection valves or nozzles are connected as shown in Fig. 47. This pump is always of the plunger type and may have one or two main plungers which are operated by eccentrics instead of cams. This pump keeps the header filled with fuel oil under a pressure of from 3,500 to 6,000 lbs. per square inch. A relief valve or pressure regulator connected to the header is used to keep the oil under the correct pressure. A pressure gauge on the header indicates the pressure on the fuel oil. Note the location of the pressure valve and pressure gauge in Fig. 47.

A receiver or fuel bottle is connected to the extreme end of the fuel header to absorb fluctuations in pressure due to plunger action. An air vent valve at the end of the line is used to release any air that might be trapped in the header if the fuel system should run dry.

On the common rail system, the injection nozzles or fuel valves are not opened by fuel pressure, but are mechanically operated by means of a cam. The cam is timed to lift the needle valve at the proper time just before the piston reaches top dead center. The pressure in the header forces a spray of fuel oil into the cylinder as long as the cam holds the needle valve off of its seat.

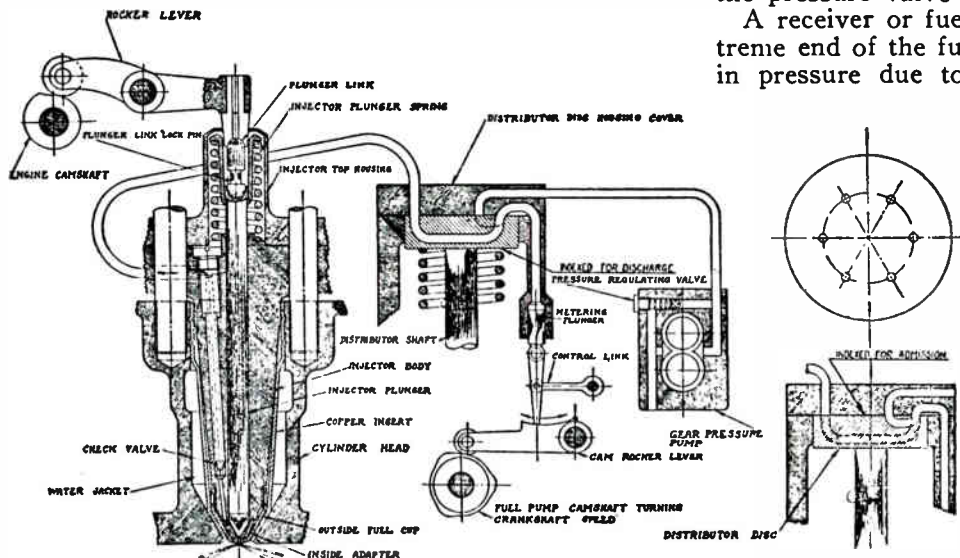

Fig. 48. Diagram showing distributor type fuel oil system of Cummins Diesel engine. Note the gear pump, distributor, metering plunger, and the injection plunger within the injector nozzle. (Courtesy Cummins Engine Co.)

A sliding steel wedge placed between the cam and the rocker arm that operates the valve, controls the lift of the needle valve, which in turn controls the power output of the engine. See Fig. 47. With the thick part of the wedge between the rocker-arm and the cam, the needle lift would be maximum and the power output of the engine would also be maximum. If the wedge was shifted so that the thin part was between cam and rocker arm, the needle would not be lifted and the engine would stop.

Isolating valves are used with this type of common rail system so that any of the fuel nozzles may be cut off from the fuel header. This might be done to make repairs, or in some cases if the engine is lightly loaded or idling, one-half of the cylinders may be cut out.

Before the engine can be started, the pressure in the header should be between 1,500 and 2,000 lbs. If for any reason the pressure is less than this, it can be quickly raised by means of a hand operated priming pump built in as part of the main high pressure pump. If air finds its way into the fuel system, it can be expelled by opening the air vent valve shown in Fig. 47, and operating the priming pump until fuel free from air bubbles flows from the air vent valve, after which the valve should be closed tightly and the fuel pressure raised to 1,500 or 2,000 lbs., and the engine is ready to be started.

26. DISTRIBUTOR TYPE FUEL SYSTEM

The distributor type fuel system used by the Cummins engine is divided into four parts: a low pressure gear pump that draws the fuel from the supply tank, a metering pump that controls the

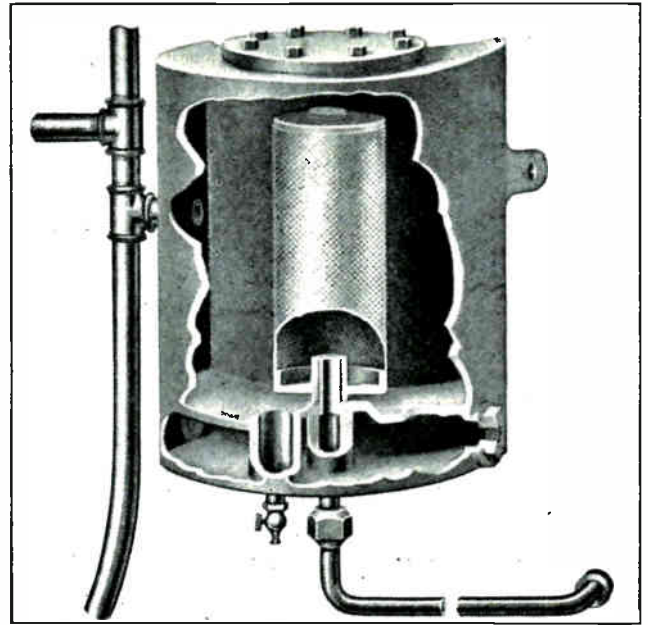

Fig. 50. Cut-away view of auxiliary fuel oil tank, showing filter screen, water sump and valve, and hot water chamber for pre-heating heavy fuel oils. (Courtesy Venn-Severin Co.)

amount of fuel delivered to the engine, a rotary distributor, and mechanically operated injection nozzles. See Fig. 48.

A feature of this system is the rotary fuel distributor, which as it rotates, first connects the metering pump to the transfer pump so that it can receive the fuel, then to the proper injection nozzle so that the metering pump can force the required fuel to the nozzle. By using a distributor only one metering pump is required.

As the piston in the engine cylinder moves downward on the intake stroke, the rotary distributor will connect the metering pump with the injection nozzle in that cylinder. This will allow the metering pump to force a measured quantity of fuel into a space between the inner and outer cups at the lower end of the injection nozzle. Since this space is always filled, the addition of this fuel will cause a like amount to be forced into the plunger chamber of the nozzle.

In order to make room for this fuel in the plunger chamber, the nozzle plunger is lifted upward as shown at "A" in Fig. 49. The lifting action of the nozzle plunger also creates a vacuum in the plunger chamber which holds the fuel in suspension during the engine piston intake stroke and prevents fuel leakage into the cylinder.

At the start of the compression stroke, the nozzle plunger will be at the top of its stroke and the correct amount of fuel will be in the plunger chamber as shown at "B" in Fig. 49. During the compression stroke, hot air will be forced through this fuel, vaporizing it into a rich gas. At the end of the compression stroke the nozzle plunger is forced down by means of a cam and the vaporized fuel is driven into the combustion chamber, as at "C" in Fig. 49, and ignites automatically.

During the exhaust stroke, the nozzle plunger is seated as at "D" in Fig. 49 and the fuel in the space between the inner and outer cups is being heated.

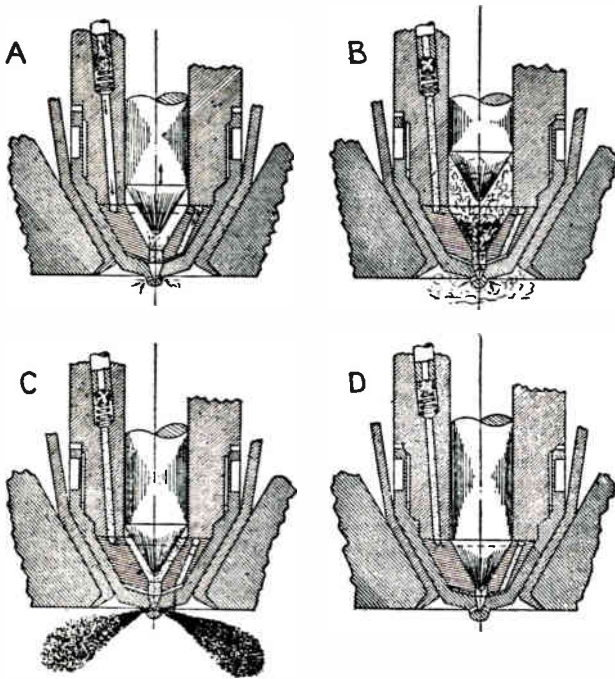

Fig. 49. Four sectional views of Cummins fuel injector nozzle. A—during the engine intake stroke, the ball check valve is open, plunger is moving up and heated fuel oil is entering plunger chamber. B—During engine compression stroke the ball check valve is closed, plunger is at the top of its stroke, correct amount of fuel oil is in the plunger chamber being mixed with hot compressed air from the engine cylinder. C—Power stroke, plunger moving down and driving gasified fuel charge into the engine cylinder. D—Exhaust stroke, plunger seated, next fuel charge being pre-heated in space between inner and outer cups in the end of the nozzle. (Courtesy Cummins Engine Co.)

The distributor passages being in the position shown in Fig. 48, the transfer pump is connected to the metering pump, so that the latter receives its fuel for the next charge.

The nozzles used are of the multi-orifice type, some having 5 holes, others 6 holes. It is highly important that all holes function. Should one hole in a nozzle become clogged, it tends to lower the power of that cylinder due to an unbalanced distribution of the fuel. To counter-act this condition, the governor causes the metering pump to deliver more fuel which will cause overloading of the engine and a very smoky exhaust. The Cummins Co. supplies special drills to clean clogged spray holes.

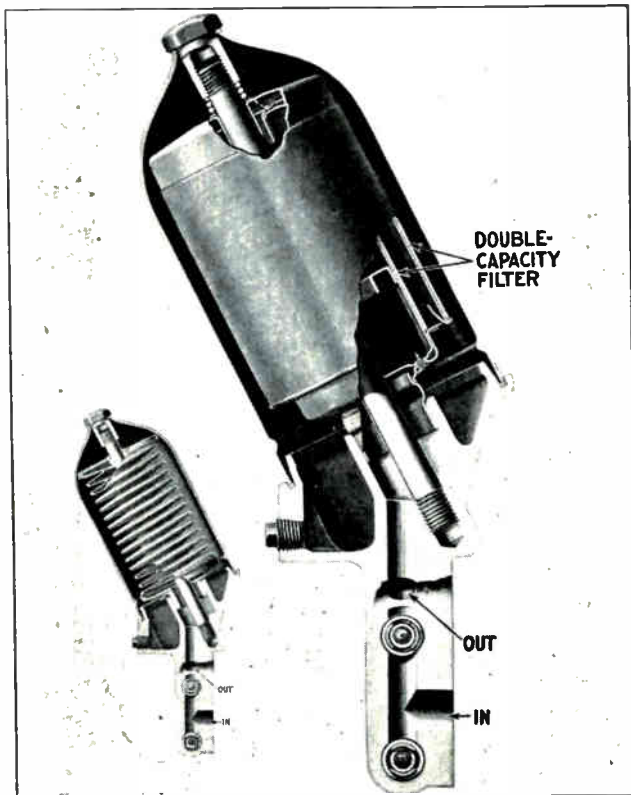

Fig. 51. The above sectional views show the construction of metal screen and cloth bag type fuel oil filters as used on International Harvester Diesel engines.

The metering pump is a low pressure variable stroke pump. The stroke of the pump is varied by means of a control link and shifting the lower part of the plunger that contacts the rocker lever in Fig. 48. If shifted to the left, the pump stroke would be long, while shifting to the right shortens the stroke.

27. AUXILIARY SUPPLY TANKS AND FILTERS

Diesel engine fuel oil for small portable engines and tractors is generally stored in drums or storage tanks, and poured into the fuel tanks on the engines when needed. For large stationary Diesel engines, the fuel oil is usually delivered by tank truck or tank car to large storage tanks holding several thousand gallons.

From the large storage tank, the oil may flow by gravity or be pumped to a smaller underground tank for safety reasons, or it may be pumped

directly to small auxiliary tanks on the engines.

Some of these auxiliary tanks are arranged so that heat from the engine exhaust or cylinder cooling water preheats the fuel oil to facilitate handling and to permit settling or precipitation of water or heavy dirt particles in the oil. A tank of this type is shown in Fig. 50. Note the hot water chamber in the bottom, and also the water trap and drain cock for removal of any water or dirt that settles from the fuel oil. Also note the strainer which removes any coarse dirt.

As previously mentioned, fuel oil filters are generally located in the fuel oil line near to the fuel injection pump, to remove dirt and grit which might clog injector nozzles, or cause excessive wear in the fuel pump and engine cylinders. Some of these filters have a very fine screen of special construction as shown in the larger view in Fig. 51. Some filters also have a cloth filter supported by special wire springs as shown in the smaller insert in Fig. 51. Some of these filter screens are arranged so that they can be cleaned by merely rotating them against a brush or scraper built right in the filter. Others may have to be removed and cleaned with gasoline and a brush. A badly clogged filter may cause enough restriction to the oil flow to interfere with proper operation of the engine.

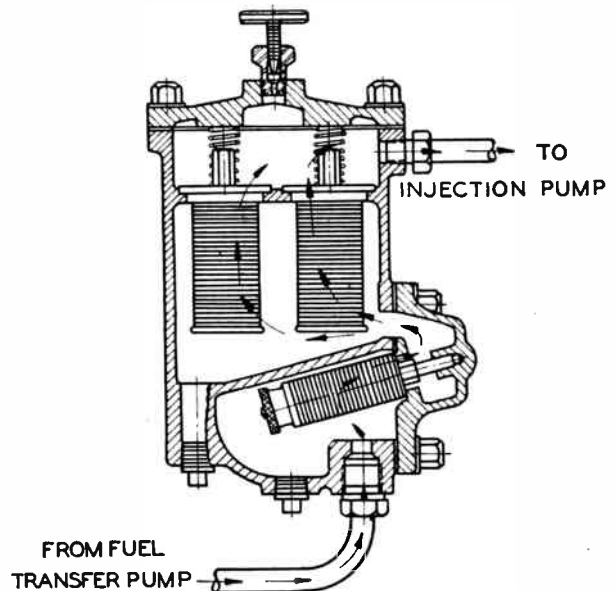

Fig. 52. Diagram showing sectional view of a fuel oil filter using metallic filter elements which can be easily removed for cleaning. Note the air-vent in the top of the filter cover. (Courtesy Caterpillar Tractor Co.)

To clean the filters shown in Fig. 51, remove the cap nut at the top of the filter case and the filter cover or housing can then be removed. Filter bags of the type shown in Fig. 51 can be unscrewed and washed with kerosene or light fuel oil. After washing the inside of the bag, it should be flushed or rinsed with clean fuel oil to be sure that no dirt particles are left on the inside when it is reassembled.

When reassembling such filters, be sure that the gasket between the two sections of the filter case is in good condition, or a leak may develop and cause loss of fuel oil or an air lock in the fuel system. After reassembling a filter, it should be

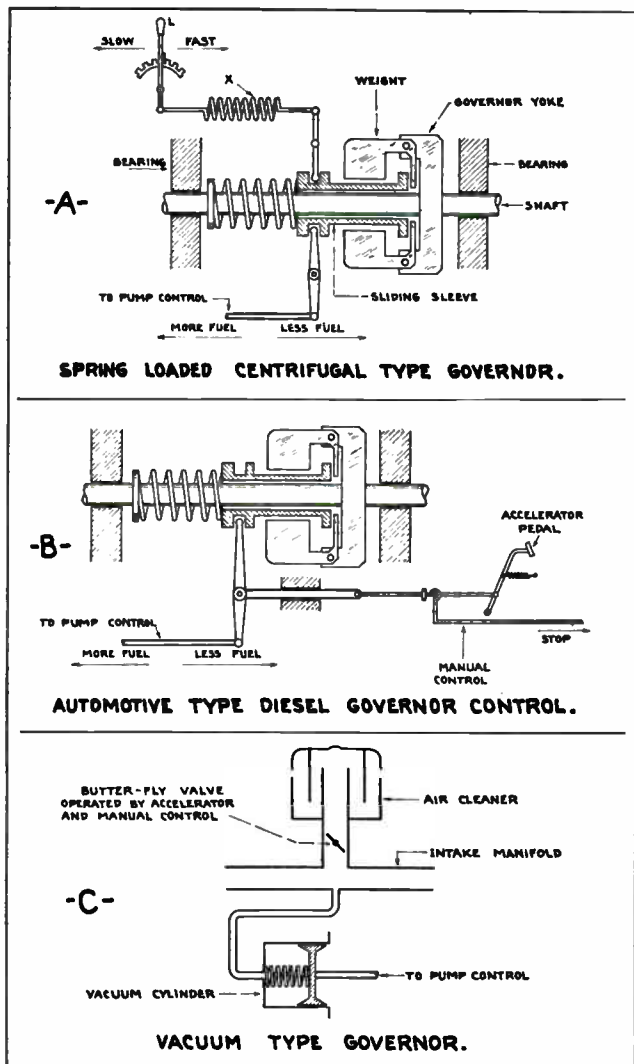

Fig. 53. The above three diagrams show the construction and operation of centrifugal type and vacuum type Diesel engine governors.

filled with fuel oil and any air allowed to escape by loosening the air vent screw or cover cap screw while oil is in the filter under pressure. Note the sump (settling cup) and drain at the bottom of the filters in Fig. 51, for removal of accumulated dirt or moisture.

Some filters use felt pads, or cloth filter elements of different shape than shown in Fig. 51. These cloth, felt or fabric elements should be cleaned periodically by washing in kerosene.

Fig. 52 shows a two stage filter using a set of coarse filter elements below and a set of finer elements above. The coarse elements are made by winding thin metal ribbon edgewise on a tubular form, and keeping the turns of ribbon spaced very slightly by crimped projections on their surface. The finer element is made by winding fine spaced crimped wires on a tubular form. These filter elements can be removed for cleaning by simply removing the side and top cover plates of the filter case. This is the type of filter shown at the left of the fuel pump in Fig. 28.

28. GOVERNORS

The injection pumps in Diesel engines govern the power output of the engine by controlling the

amount of fuel injected by the fuel pumps, into the combustion chambers, and the fuel pumps are in turn controlled by means of a governor.

The function of the governor is to maintain any desired engine speed regardless of the load on the engine. If the load is suddenly reduced the governor immediately acts on the fuel pump control reducing the amount of fuel injected, thus preventing the engine racing or materially increasing its speed. On the other hand if the load is increased, the governor will cause the pump to deliver more fuel to meet the increase in power required and prevent the engine from slowing down. Even for automotive work where engine speeds have to be varied, the manual control is never connected directly to the injection pump, but is used to change the governor setting which in turn changes the speed of the engine.

29. TYPES OF GOVERNORS

Diesel engines other than those used for automotive work generally use centrifugal type governors. Some automotive type Diesels also use centrifugal governors, while others use a vacuum type governor.

Spring loaded centrifugal governors consist chiefly of a pair of metal weights mounted on a yoke which in turn is keyed to a revolving shaft. See Fig. 53-A. The shaft is driven by the engine or in some cases by the same drive that operates the injection pump.

When the engine is running, the weight and yoke assembly being keyed to the revolving shaft, rotate with it. Centrifugal force acting on the weights causes them to be thrown outward, forcing the sliding sleeve against the governor spring. When the resistance of the spring balances the force of the weights, there will be no more outward movement of the weights and the pump control which is shifted by the sliding sleeve will be held in that position and the engine will maintain a fairly constant speed.

If the load is increased the engine tends to slow down slightly and as it does so the centrifugal force acting on the weights is reduced, and the governor

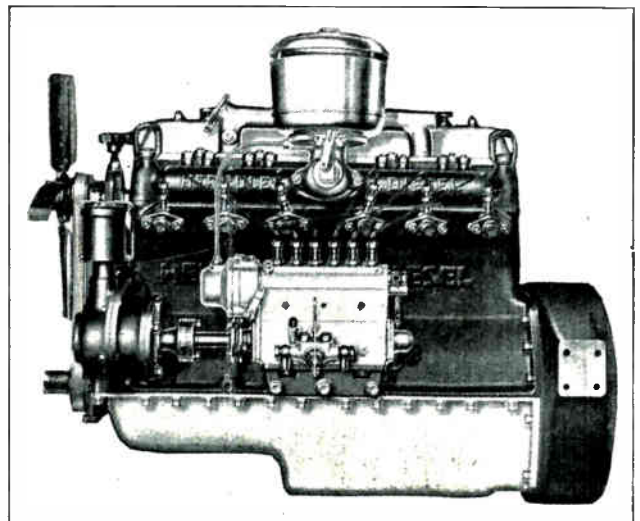

Fig. 54. Photo of Hercules automotive type Diesel engine showing vacuum type governor unit attached to left end of fuel pump, and connected by tubing to the intake manifold.

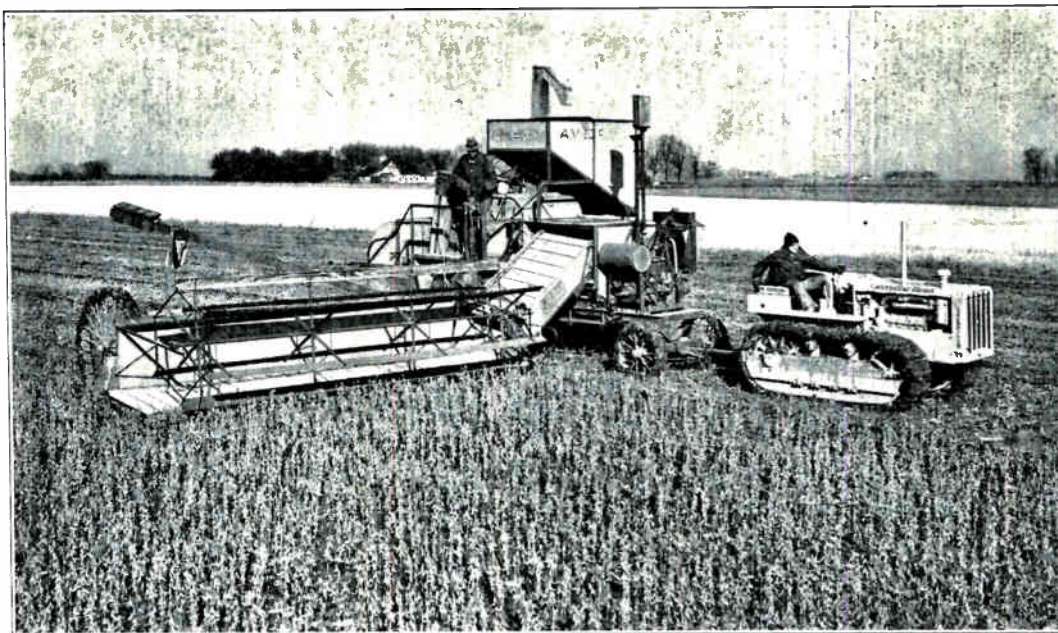

Fig. 55. This photo shows a Caterpillar Diesel tractor pulling a 16 foot combine machine harvesting soy beans. Thousands of tractors of this type are now used in farm work.

spring forces the sliding sleeve to the right. This causes the injection pump to deliver more fuel to meet the increased load and the engine increases its speed until the original speed is again reached.

On the other hand if the load is reduced, the slight increase in engine speed increases the centrifugal force applied to the weights, so that the sliding sleeve is moved to the left until again the resistance of the spring balances the centrifugal force acting on the weights. Moving of the sleeve to the left shifts the pump control so that the amount of fuel delivered will be reduced, and the speed of the engine is brought back to its original rate. As these governors are very sensitive and quick acting, the variations in speed as to load changes are very small.

To change the speed at which the governor will hold the engine, two methods may be used. In Fig. 53-A an auxiliary spring "X" is used to change the spring resistance offered to the sliding sleeve. Increasing the tension of this spring would increase the speed of the engine, while reducing the tension would reduce the speed. The tension of this spring can be controlled by the manual speed control lever "L." For automotive service, the arrangement shown in Fig. 53-B is used. In this case the governor is used to prevent racing or stopping when idling and also to limit the maximum speed of the engine.

On the road, speed variations are obtained by shifting of the pump control rod by means of the accelerator pedal or manual control independent of the governor. If it is desired to maintain a certain road speed, the manual control is set for this speed and the governor maintains the predetermined speed over wide variations of road conditions. The manual control is also used to set the idling speed and to stop the engine.

Quite often the governor is built in as part of the injection pump assembly. This makes a very compact unit.

30. VACUUM TYPE GOVERNORS

The vacuum type governor is much simpler in design than the centrifugal type, but can be used only where the engine can maintain a uniform intake manifold vacuum. For this reason it is found only on high speed multiple cylinder engines. It is used widely on the automotive type Diesel engines which have to operate over a wide range of speeds.

This governor consists mainly of a vacuum cylinder and piston as shown in Fig. 53-C. The piston is spring loaded and connected to the pump control. The vacuum cylinder is connected by means of tubing to the engine's intake manifold.

A butterfly valve, similar to the throttle is located in the intake manifold just below the air cleaner. This is in turn connected to a hand throttle or foot accelerator. When the butterfly valve is wide open the vacuum in the intake manifold will be practically zero and the spring in the vacuum cylinder will force the vacuum control piston to the right as far as it will go and the injection pump will deliver maximum fuel, and maximum power and speed will be developed.

If the throttle valve is partly closed, vacuum in the intake manifold will increase and the vacuum control piston will be drawn to the left until the resistance of the spring balances the force exerted by the vacuum, and the pump control is held in that position. Since moving the piston to the left reduces the amount of fuel delivered, the speed of the engine decreases.

This type of control will maintain a fairly constant speed for any setting of the throttle, because a reduction of engine speed caused by an increase in load will cause the vacuum in the intake manifold to drop, and the fuel delivered will be increased, whereas an increase in engine speed due to a reduction in load will cause the vacuum to increase and the amount of fuel will be decreased. This type of control is built in as part of the injection pump.

DIESEL ENGINE FUEL COMBUSTION SYSTEMS

The operating efficiency of a Diesel engine depends to a great extent upon the use of the proper fuel and the manner in which the fuel is injected into the cylinders or combustion chambers. Therefore a general knowledge of this subject is quite important to the Diesel plant operator.

Oxygen is required for the burning and combustion of any fuel. You undoubtedly know that the fire in a furnace or the wood or coal in a stove will not burn without air. The more draft or air you feed a furnace the hotter the fire burns. Theoretically, 14 lbs. of air are needed to burn each lb. of oil. Actual air requirements are nearly double this amount. The oxygen needed for burning of the fuel oil charge in a Diesel engine, is obtained from the charge of compressed air in the cylinder. Therefore, in order to secure efficient combustion and complete burning of the entire fuel charge, it is highly important to have the fine oil spray thoroughly mixed with all of the heated air charge in the cylinder.

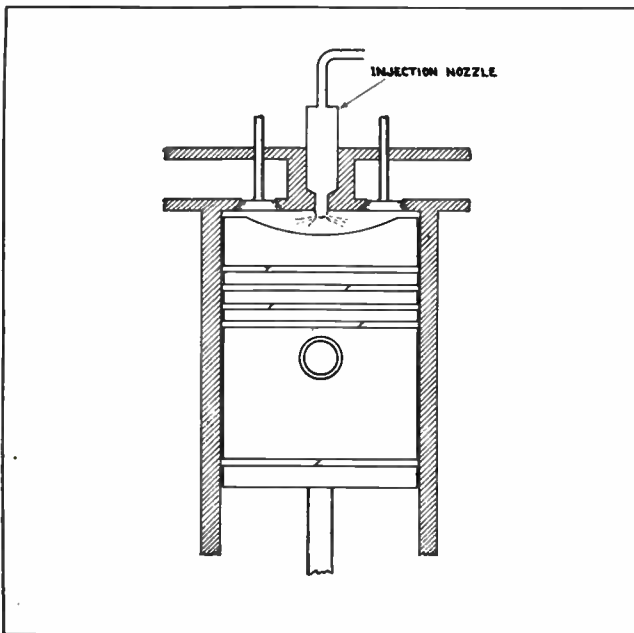

Fig. 56. The above diagram shows the shape of the piston head used in certain types of Diesel engines to concentrate the air charge in the center for thorough mixing with the fuel spray.

Solid injection Diesel engines that turn at less than 900 R.P.M. employ direct injection, the injection nozzle spraying the fuel oil directly in the clearance between the top of the piston and the under side of the cylinder head. In order to reach all parts of the clearance space with fuel oil, a multi-orifice nozzle is always used for this type of engine.

To assist the mixing of the fuel oil spray and air, many Diesel engines using direct injection have pistons with concave heads as shown in Fig. 56. This concentrates the highly compressed air in the center of the clearance space, and directly under the injection nozzle, so that the fuel spray can easily reach all parts of the clearance space.

31. CONSTANT PRESSURE AND CONSTANT VOLUME CYCLES

In slow speed Diesel engines using direct injection, the fuel is sprayed in rather slowly so that there is

no great increase above the final compression pressure, but as the piston moves downward, increasing the space above it, this pressure is maintained, until the injection period ends. Then the expanding, highly heated air and gasses from the burning fuel drive the piston the rest of the way down on the power stroke. This is known as the **constant pressure cycle**.

In high speed engines, the time interval for ignition and combustion being very short, the fuel oil must be injected slightly before the piston reaches top dead center, and the fuel combustion is actually completed before the piston begins to travel downward. Since combustion takes place and is completed in a space that does not increase in volume during the combustion process, there is a considerable rise in pressure, in some cases running as high as 800 lbs. per square inch. This is known as the **constant volume cycle**. All high speed Diesel engines operate on the constant volume cycle.

32. INDIRECT INJECTION AND PRE-COMBUSTION CHAMBERS

In some Diesel engines the fuel oil is not sprayed directly into the clearance above the piston, but into a small chamber that is connected to the cylinder by a small passage. These chambers are called

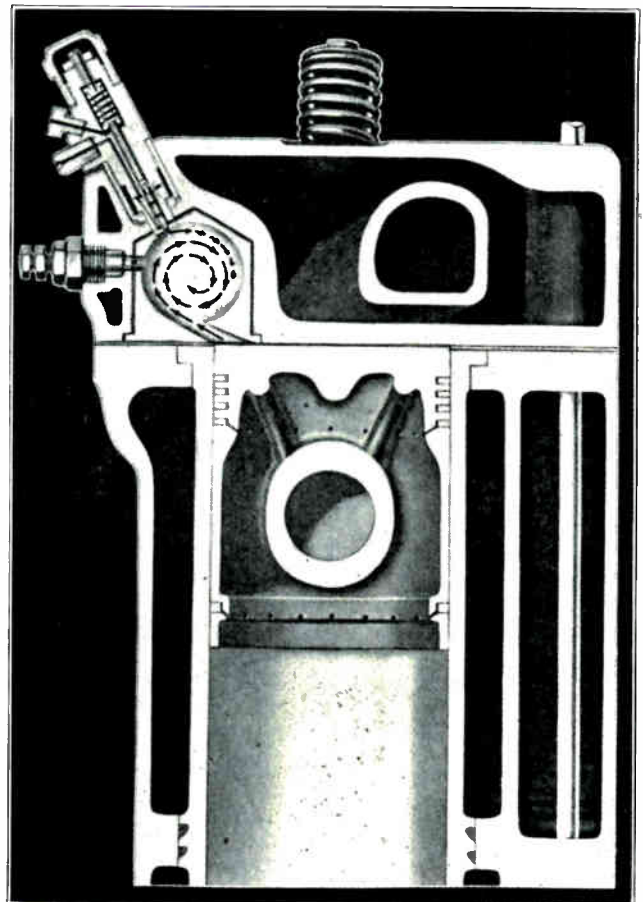

Fig. 57. Sectional view of a cylinder for a Comet Diesel engine, showing the injector nozzle and combustion chamber which produces turbulence for thorough mixing of the air and fuel oil. Note that when the piston is at top dead center, practically all of the air is compressed into the combustion chamber in this type of engine. (Courtesy Waukesha Engine Co.)

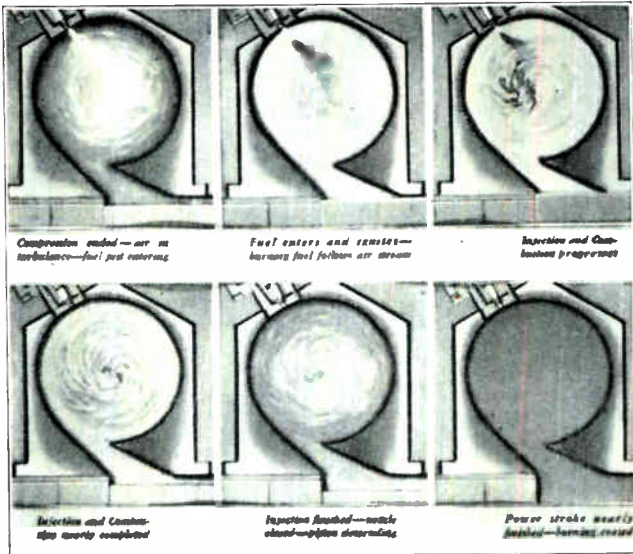

Fig. 58. The above illustrations show the fuel injection, turbulence and combustion, in a pre-combustion chamber of the Waukesha Comet Diesel engine. Examine each view carefully and note the various stages through which the fuel oil passes during ignition and combustion, all within a small fraction of a second.

combustion chambers or in some cases pre-combustion chambers. See Fig. 57, in which the pre-combustion chamber is shown at the upper left of the cylinder. Combustion chambers are designed to accomplish two things. First, to provide a thorough mixing together of the fuel oil spray and the air in a very short interval of time; and second, to make it possible to use a single orifice nozzle by concentrating the heated air into a very small space directly in line with the tip of the injection nozzle. You will recall previous mention of the fact that single orifice nozzles are easier to maintain and less likely to become clogged because the hole is much larger than those used with multi-orifice nozzles.

The combustion chamber shown in Fig. 57 is of the Ricardo type. In this case when the piston is at top dead center, practically all the air is compressed into the spherical combustion chamber. Due to the shape of the chamber and the location of the passage between it and the cylinder, the air will rotate or whirl at a high rate as it is compressed in the combustion chamber, as shown by the arrows in Fig. 57. This creates what is known as air turbulence, and is highly important because it improves combustion by thoroughly mixing the fuel and air together in a very short interval of time. As the piston starts down on the power stroke, and the air begins to discharge from the combustion chamber, it tends to rotate in the opposite direction. In a properly designed combustion chamber turbulence will be maintained during the entire combustion period.

In the combustion chamber just described, all of the fuel injected into it is burned within the chamber, and the hot expanding gasses rush into the cylinder and force the piston downward. Fig. 59 shows a pre-combustion chamber such as used on the Caterpillar Diesel engine. In this case only a portion of the fuel is burned in the pre-combustion chamber. As the injection nozzle sprays fuel into the chamber, the highly heated air will ignite a small portion of the fuel, and as injection continues,

the heat produced in the pre-combustion chamber will vaporize the remaining fuel, and the high pressure developed will force it out into the clearance above piston, where combustion will be completed.

33. AIR CELLS

Some Diesel engines are equipped with auxiliary turbulence devices designed to agitate the burning mixture after ignition has taken place, thereby improving combustion. Fig. 60 illustrates a cylinder and piston in which mechanical turbulence of the air is obtained by the use of a piston top having a raised edge, and an air cell or chamber in the center of the piston head. As the piston moves upward on the compression stroke the air is driven toward the center of the cylinder producing considerable turbulence. At the same time, air is compressed into the small air cell in the center of piston head.

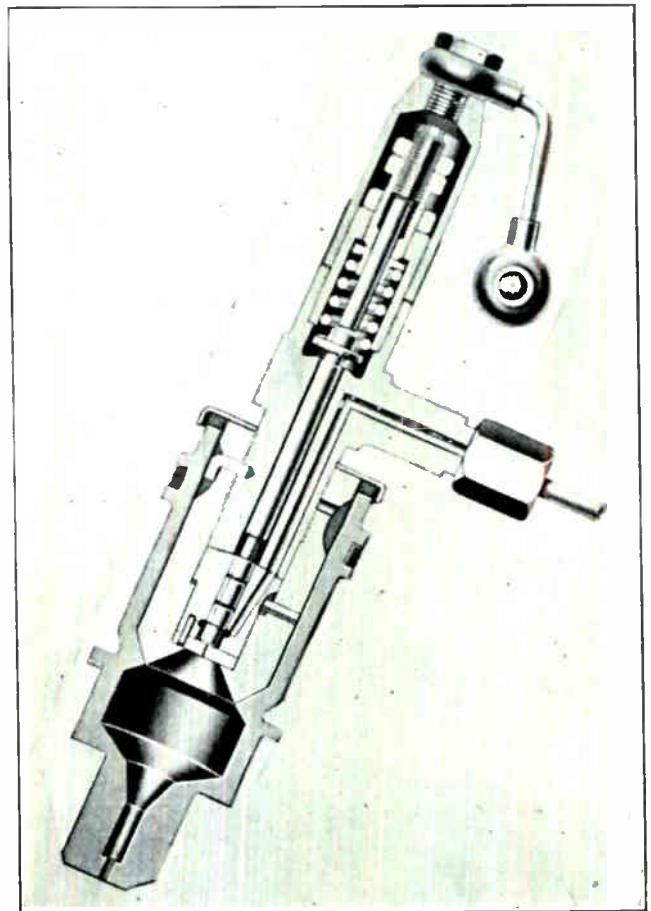

Fig. 59. Injection nozzle and pre-combustion chamber of Caterpillar Tractor Diesel Engine. Note that this pre-combustion chamber is attached right to the end of the injector nozzle and has a rather small opening which somewhat restricts or slows down the discharge of partly burned fuel to the cylinder.

At the end of the compression stroke, the pressure in the air cell and in the combustion space above the piston will be the same. At this point, the fuel is sprayed into the combustion space and ignition takes place, and the piston is forced downward on the power stroke. This increases the space above the piston and the pressure in the cylinder immediately drops, allowing the highly compressed air in the air cell to rush out and strike the tip of

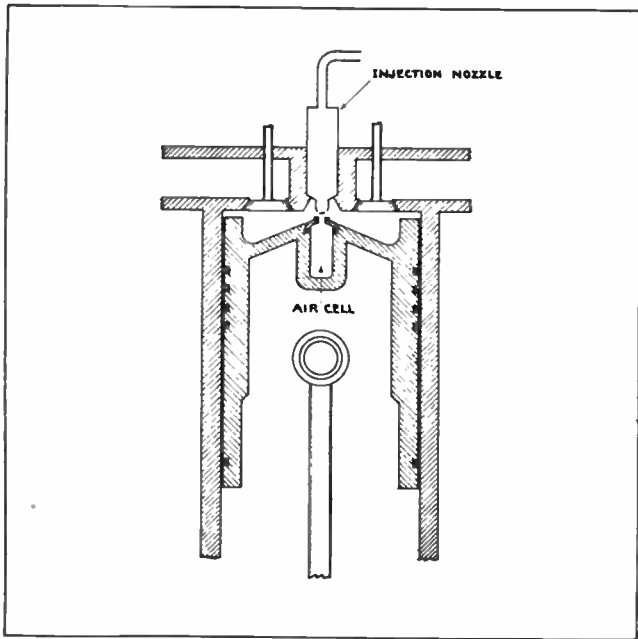

Fig. 60. Sectional view of another type Diesel engine cylinder and piston showing the specially shaped piston head and air cell used to provide turbulence and proper mixture of fuel and air for thorough combustion.

the injection nozzle, breaking up the rich fuel mixture at this point. This action also tends to blow away any soot that might be forming on the tip of the injection nozzle. This type of piston and air cell is used on the Cummins Diesel engine.

34. LANOVA COMBUSTION SYSTEM

Fig. 61 shows the method used in the Buda-Lanova engine to secure turbulence of the fuel and air mixture. In this system as the fuel leaves the tip of the injection nozzle it passes along the common center of two circular cavities under the intake and exhaust valves, and some of it enters the minor and major air chambers, shown. As the fuel ignites, the pressure in the air chambers will increase, causing a violent discharge back into the main combustion chambers. This discharge or back fire from the air chambers sets up a violent turbul-

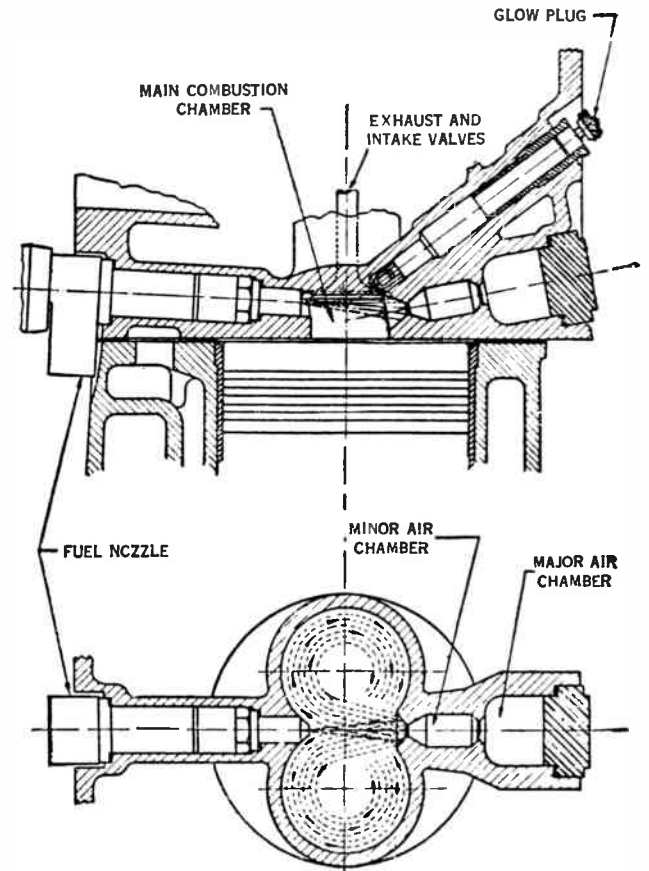

Fig. 61. This illustration shows side and top views of turbulence chamber of the Lanova combustion system used with the Buda Diesel engines. (Courtesy of Buda Engine Co.)

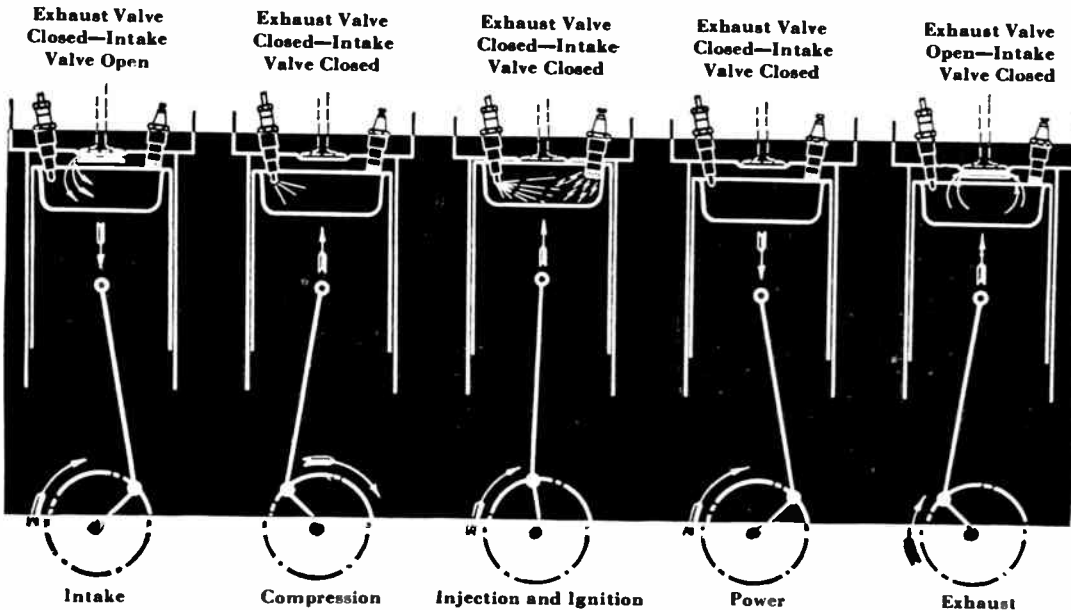

Fig. 62. The above views show the shape of the piston head, the angle of fuel injection and the combustion cycle of a Waukesha Hesselman engine. This engine is one of the lower compression types using spark plug ignition. The shape of the depression in the piston head mixes the fuel spray with the air and also directs the mixture against the spark plug. (Courtesy Waukesha Engine Co.)

35. DIESEL FUELS

While Diesel engines will operate on a wide range of inexpensive petroleum fuels, and in tropical countries sometimes on vegetable oils, the successful operation of these engines depends largely on the quality of the fuel used. Experience shows that no one type of fuel will suit all Diesel engines. Each different type of engine will perform better if supplied with some particular type of fuel.

Contrary to popular belief Diesel engines are very seldom operated on crude oil. Pumping stations on oil pipe lines usually burn crude oil in their Diesels because it eliminates the cost of transportation of other fuel oil. In a case of this kind the crude oil is put through a special cleaning process before being used as fuel for the engines.

The reason why crude oils are not favored as Diesel fuels is that in some cases the oil carries a high percentage of water in emulsion, which interferes with combustion. The crude oil from some fields contains a high percentage of wax which may clog the fuel lines between the injection pumps and the fuel nozzles, especially when subjected to high pressures. Sometimes sulphur is present in crude oils in such large quantities that it causes serious

corrosion of the engine cylinders. Thus it can be seen that crude oils are hardly suitable for general Diesel operation, and when used at all these crude oils should be given a thorough cleaning.

For medium or high speed engine operation, Diesel distillates give best results. These fuels are distilled oils and as a general rule are very clean, and therefore a desirable class of fuel. These distillates are often sold under different names such as "gas oil," "Diesel distillates," or "distillate". Some domestic furnace oils come under this classification. Some fuel oils are blends of distillates and residue from oil cracking stills. These fuels are satisfactory for slow or medium speed engines, but often give poor performance in a high speed engine, due to ignition lag.

In order to be suitable for Diesel engines, fuel oil should meet four requirements:

1. It should ignite easily: This is especially important for high speed operation. A slow igniting fuel tends to cause combustion knock, by allowing too much fuel to accumulate before ignition occurs. Fuels of paraffin base, give the smoothest combustion in Diesel engines.

2. Diesel fuel oil should be free from excessive



Fig. 63. The above photo shows a large heavy duty 200 RPM, 8 cylinder, 1600 h.p. Diesel engine. Note the operator standing near the control, governor, and fuel pump units. Also note the temperature indicating meters for each cylinder and the removable plates on the side of the engine frame to permit access to the bearings. (Courtesy Baldwin-Southwark Corp.)

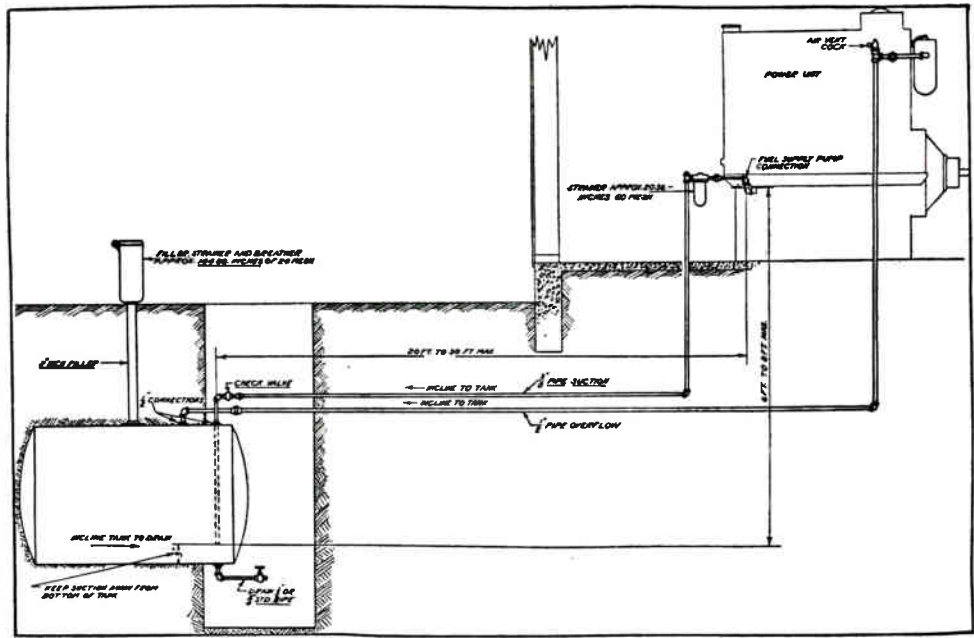

Fig. 67. This diagram illustrates a convenient arrangement of an outdoor fuel supply tank and pipe lines for the fuel supply to a small Diesel engine. (Courtesy McCormick Deering Co.)

at what temperature the oil vapors ignite, and then go out. If the oil is heated 50 to 125 degrees above the flash point the vapor will continue to burn. This is known as the burning point.

37. FUEL SPECIFICATIONS

	A	B	C
A.P.I. Gravity	16-20	24-28	30-35
Ash content (by weight).....	.04	.02	.02
Carbon residue (max.)	5%	3%	2%
Water and sediment			
(by volume)6	.2	.05

from 24 to 28. High speed engines which operate at speeds of 1000 to 2000 R.P.M. require fuels of from 30 to 35 degrees gravity. The amount of power or expansive force available from a pound of fuel oil depends upon its heat content in B. T. U. (British Thermal Units.)

Fuel oils such as used in Diesel engines usually contain from 18,000 to 19,000 B.T.U. per pound. The heavier fuels having the higher heat contents.

39. FUEL CONSUMPTION

The amount of fuel required to develop 1 Brake horsepower hour (or 1 horsepower for 1 hour) de-

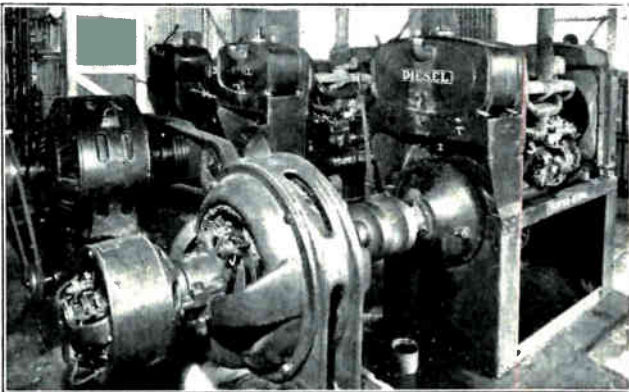

Fig. 68. This photo shows 3 McCormick Diesel engines used for driving electric generators in a small industrial Diesel-Electric power plant. Note the fuel tanks located right on the engine stands. Also note the "V" belt drives used on one generator and the direct shaft coupling on the other unit.

38. ENGINE SPEEDS AND FUEL REQUIREMENTS

The gravity of the fuel used in a Diesel engine depends largely on its rate of turn-over. Heavy duty slow speed engines having a long injection and combustion period can be operated on heavy fuels, whereas a high speed engine with its short injection and combustion period requires a light, volatile fuel.

Slow speed engines that do not run over 350 R.P.M. can be operated on fuels having an A.P.I. gravity varying from 16 degrees to 20 degrees. Medium speed engines that operate at speeds up to 1000 R.P.M., usually require a fuel having a gravity

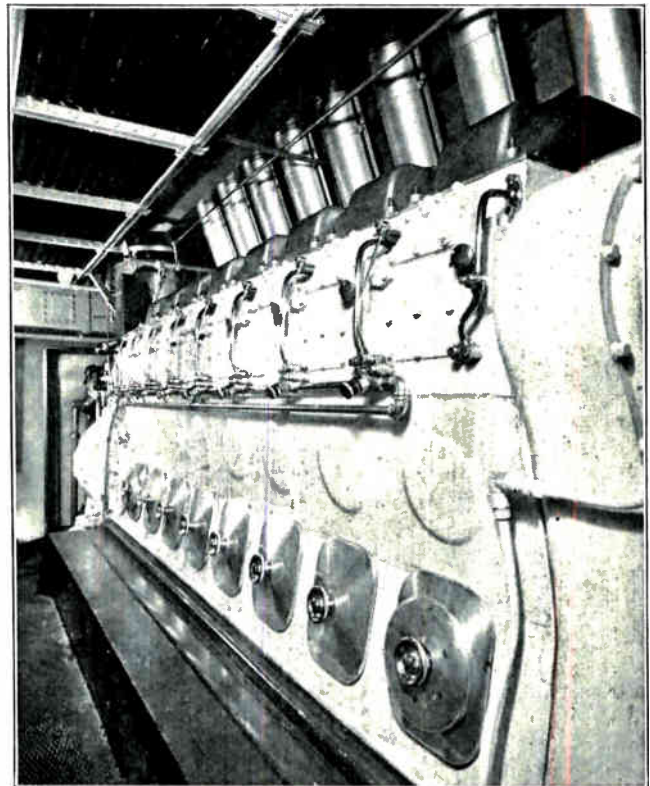

Fig. 69. The above photo shows the fuel supply and drip lines on one side of a "V" type Diesel engine used on a Diesel-Electric locomotive. (Courtesy Burlington Railway.)

depends on the size of the engine and its mechanical condition. Engines under 100 h.p. usually require about .5 of a pound of fuel per horsepower hour. Engines of 100 to 500 h.p. usually require from .4 to .45 lb. per horsepower hour. Large modern engines of 500 to 3000 h.p. may operate on as little as .35 of a lb. of fuel per horsepower hour.

The convenient fuel consumption chart shown in Fig. 65 gives the approximate fuel consumption rates in pounds per horsepower hour for engines ranging from 50 to 3,000 h.p.

With this information at hand, it is a simple matter to calculate the approximate cost of generating electric power with a Diesel-Electric unit of any given size. If we wish to calculate the cost of electricity per kilowatt hour from a Diesel-Electric unit, we generally allow about $1\frac{1}{2}$ h.p. of engine size per kilowatt, or divide the horsepower rating of the engine by 1.5 to find the kilowatt size of generator it will drive. Or to determine the required size of engine, multiply the kilowatt rating of the generator by 1.5 to determine the engine horsepower required.

Manufacturers of Diesel-Electric generating units usually quote the fuel consumption of their units in pounds per kilowatt hour. These figures can then be multiplied by the cost of fuel oil per pound to determine the fuel costs. You will note from the table of fuel gravities and weights, the Diesel fuel oil averages about 7.5 pounds per gallon.

There are, of course, other costs to be considered such as lubricating oil, engine maintenance and repairs, depreciation and interest on the cost of the unit, operator's salary, etc.

The fuel requirements of various Diesel engines can also be obtained from their manufacturers test data. Such information is important when checking the operating condition or efficiency of a Diesel engine, or when calculating the cost of Diesel or Diesel-Electric power.

Bunker "C" oil is the cheapest fuel that can be obtained for Diesel engines. It is satisfactory for slow speed air injection engines and also for some

slow speed solid injection engines. It costs much less than standard Diesel fuel but contains considerable dirt, water and carbon, and so it must be centrifuged or cleaned in a centrifugal oil separator. Even after cleaning out the foreign matter the carbon content may be high enough to increase cylinder wear and cause rings to stick. The rate of wear may be 100% higher with this fuel than with a standard Diesel fuel, so it is economical only as long as it can be obtained at prices much lower than the better grade oils.

TABLE OF FUEL GRAVITIES AND WEIGHTS

A.P.I. Gravity	Specific Gravity	Pounds Per Gallon
16	0.959	7.99
17	0.952	7.94
18	0.946	7.89
19	0.940	7.83
20	0.934	7.78
21	0.927	7.73
22	0.921	7.68
23	0.915	7.63
24	0.910	7.58
25	0.904	7.53
26	0.898	7.49
27	0.892	7.44
28	0.887	7.39
29	0.881	7.35
30	0.876	7.30
31	0.870	7.26
32	0.865	7.21
33	0.860	7.17
34	0.855	7.12
35	0.849	7.08
36	0.844	7.04

40. CENTRIFUGING

When using Bunker "C" fuel, or fuels of a similar type, centrifuging is required to remove dirt, water, carbon, etc. A centrifuge is similar to a cream separator and operates on the same principal, separating the water and heavier materials from the oil by whirling at high speed. Before heavy fuel oils

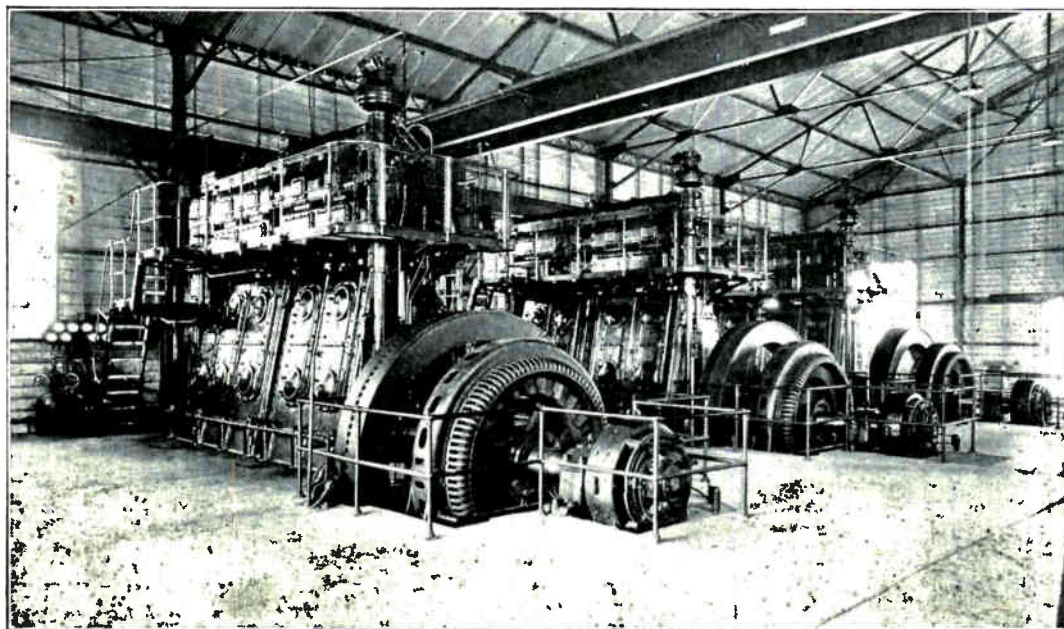

Fig. 70. Modern Diesel-Electric power plant showing three 500 kilowatt, 2300 volt, 3-phase alternators, driven by direct connection to 180 R.P.M. Diesel engines. (Courtesy Allis-Chalmers Manufacturing Co.)

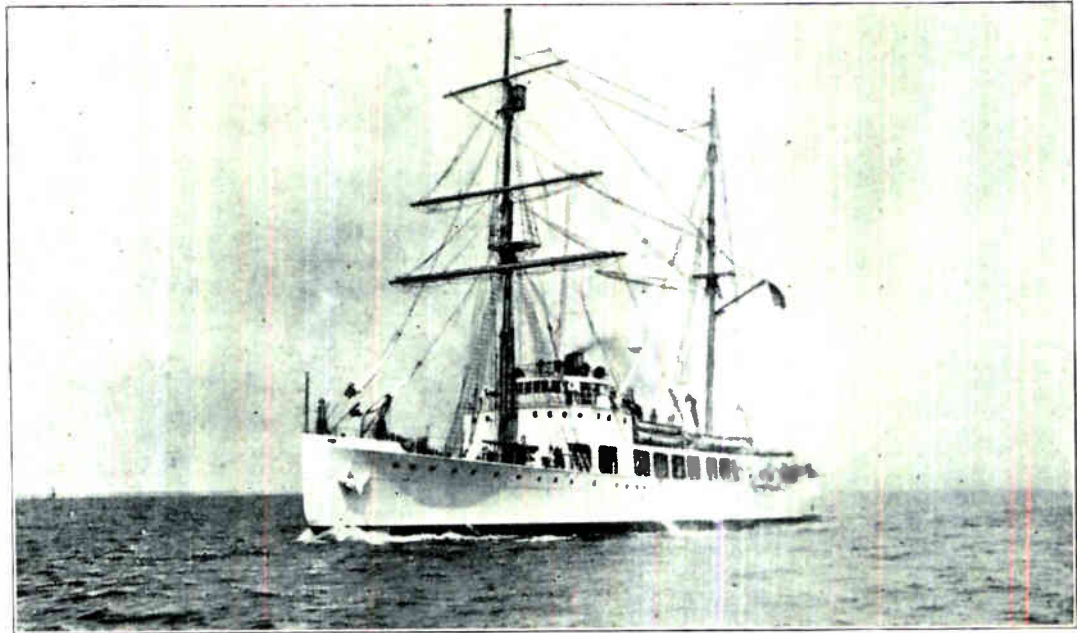

Fig. 71. Many modern ships are powered with Diesel engines or Diesel-Electric power units. The boat shown in the photo on the right is driven by Diesel engines.

can be centrifuged, they must be heated. In some large Diesel plants the hot water from the engine jackets is used to bring the fuel oil to the proper temperature before centrifuging. Electric heating elements with automatic temperature control are also used.

Fuel oil vapors are highly explosive when mixed with air. Therefore never allow open flames or sparks of any kind within 25 feet of an open fuel tank, hose or pipe line.

Empty fuel oil tanks should be blown out with air before entering them, or working near them with any heat sufficient to ignite oil vapor.

The amount of ash or non-combustible residue in fuel oil can be determined by what is known as an "open-cup" combustion test. This test is made by placing 100 grams of fuel sample in a standard type of copper cup in which the oil is burned. The oil can be lighted by placing a teaspoonful of gasoline on its surface and lighting it with a match. The cup should be protected from drafts that might extinguish the flame before the fuel is entirely consumed. After all the fuel has been burned, the residue should not weigh over 2 grams. Some of these test cups are equipped with a mark or rolled bead in the cup rim to show the proper level for filling, and also a small raised point in the bottom of the cup to indicate the amount of residue without weighing. If this point is covered with residue, it indicates too much impurity in the oil, while if the point is still exposed after the oil is burned, the amount of residue is within the limit of 2%.

When purchasing fuel oils for any Diesel engines it is best to follow the engine manufacturers recommendations. Most large oil companies also have fuel experts who are able to recommend the proper type and grade of fuel for use with any certain type of engine.

Use of wrong grade or poor quality fuels is generally not economy in the long run, due to increased clogging of fuel pump valves, injector nozzles, sticking piston rings, and increasing wear on fuel pump parts, injectors and engine pistons and cylinders.

All fuel lines, tanks and connections in a Diesel engine fuel system should be kept tight and free from leaks, and also kept clean and free from dirt, water and air locks.

Fuel strainers and filters must be kept cleaned and water should be drained from any water sumps or traps, by cocks or valves generally provided for this purpose.

FIRM HERCULES MODEL DRX SERIAL N° _____ TEST N° D-148
 N° CYL 6 BORE _____ STROKE 5 1/4 DISPLACEMENT _____ DATE 9-3-34
 FUEL FUEL OIL - COMPRESSION-IGNITION ENGINE -

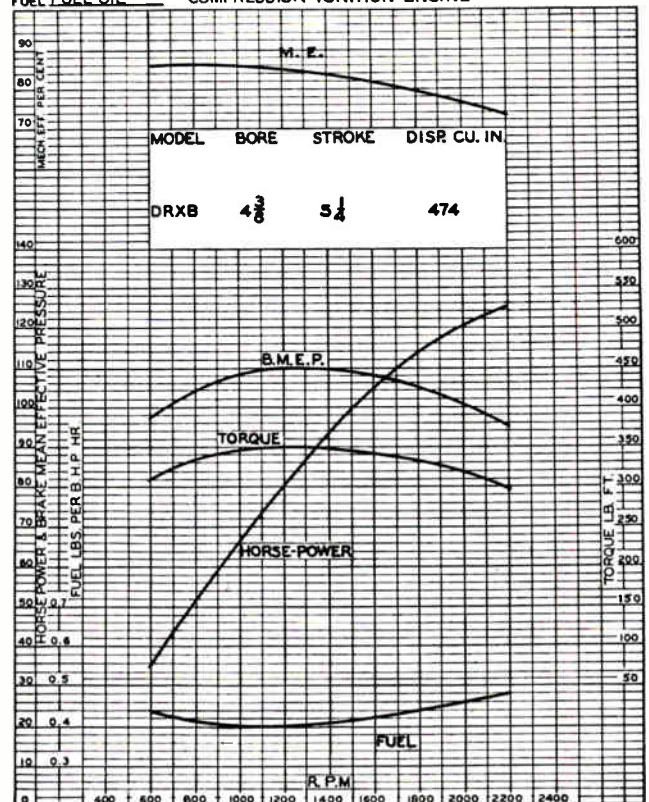

Fig. 72. Curves showing h.p., torque, efficiency, and fuel consumption, per h.p. hour, for a 6 cylinder Hercules engine. Note that the h.p. increases with the speed, and also that the fuel consumption per h.p. hour is less at speeds between 1000 and 1200 R.P.M.

DIESEL ENGINE STARTING SYSTEMS

As Diesel engines are internal combustion engines, they must be "turned over" or rotated by some other form of power in order to start them. They are similar to gasoline automobile engines in this respect. Diesel engine starting systems in general use are: 1, Hand cranking for small units; 2, Electric starter motors; 3, Auxiliary gasoline starting engines; 4, Diesels which operate on gasoline during starting only; 5, Compressed air starting.

Small stationary type Diesel engines up to 10 h.p. are started by hand cranking. Since cranking speed must be high, some means is provided to release the compression until the engine has been brought up to speed by means of a hand crank. Some engines have a compression release that prevents the exhaust valve from closing, while others have a relief valve cock which can be opened, so that the engine can be turned over rapidly.

In full Diesel or cold starting Diesel engines, as long as the exhaust valve is held open, the fuel pump is set in neutral or stop position. This prevents fuel oil from accumulating in the cylinder while the engine is being brought up to speed.

With the engine being cranked rather rapidly, the compression release lever is quickly shifted to running position, or the relief cock closed, and the engine pulled through one or more compression strokes by continued cranking, aided by the flywheel momentum. It should then start.

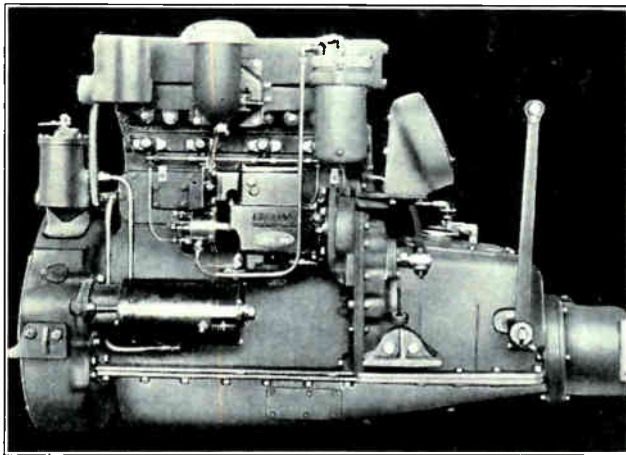

Fig. 73. Above photograph shows a Diesel engine equipped with an electric starting motor similar to those used for starting automobile engines. Diesel engines used on trucks and busses are commonly equipped with this type of electric starter. Courtesy Buda Engine Company.

41. ELECTRIC STARTING MOTORS

High speed Diesels used for trucks, tractors, busses, motor boats, or stationary service, are usually started by means of a battery and low voltage electric starting motor equipped with a Bendix drive. In trucks, tractors, or motor boats, the same battery is also used to take care of the lights. This starting system is similar to that used for general automotive service, but a 12 or 24 volt battery is used instead of the regular 6 volt automotive type. See Fig. 73, which shows a Diesel engine equipped with an electric starting motor.

With temperatures of 80 degrees F., 100 to 300 amperes are required to crank the engine, whereas low temperatures of 0 to 20 degrees F. might call for 800 to 2000 amperes, depending on the size of the engine. Batteries having as many as 25 plates per cell are used. A small generator mounted right on the engine keeps the battery charged. This method of starting is suitable for engines up to 300 h.p.

Engines of 300 to 1200 h.p., as used in railcars and Diesel-Electric trains, are started by using the large generator which the Diesel engine normally drives, as a starting motor. Current from a 32 or 56 cell (64 or 112 volt) battery is sent through the armature and a special series field in the generator, causing it to operate as a motor.

42. AUXILIARY GASOLINE ENGINE STARTERS

Where batteries are not practical, small gasoline engines are sometimes used. This applies especially to tractors and stationary Diesel engines, or Diesel engines used on portable equipment. These small gasoline engines are usually 2 or 4 cylinder, 4 stroke cycle engines, mounted on the side of the Diesel as shown in Fig. 74, or across the back of the engine above the flywheel as shown in Fig. 75.

The small engine is cranked and started by hand, and then connected to the Diesel through a clutch and Bendix drive. Note the clutch control handles between the gasoline engine and the flywheel in Fig. 74. Also note the small magneto located on the left end of the gasoline engine for ignition of the gasoline vapor in this starting engine.

To assist in starting, especially in cold weather, the exhaust heat from the small starting engine is often used to heat the intake manifold of the Diesel. Warm intake air produces a higher temperature at the end of the compression stroke and promotes quicker starting. At temperatures slightly below

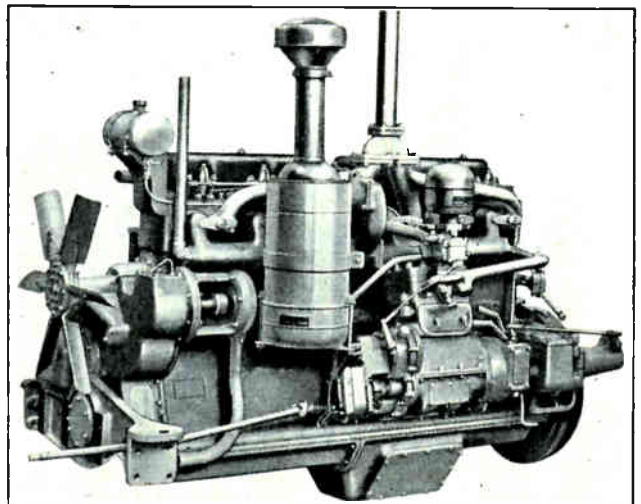

Fig. 74. This view shows a Diesel tractor with a small gasoline engine built right on the side of the Diesel for use in starting. The gasoline engine is first started by hand and then connected to the Diesel engine flywheel by means of a clutch and Bendix drive, thus rotating the Diesel engine until it starts on its own fuel. (Courtesy Caterpillar Tractor Co.)

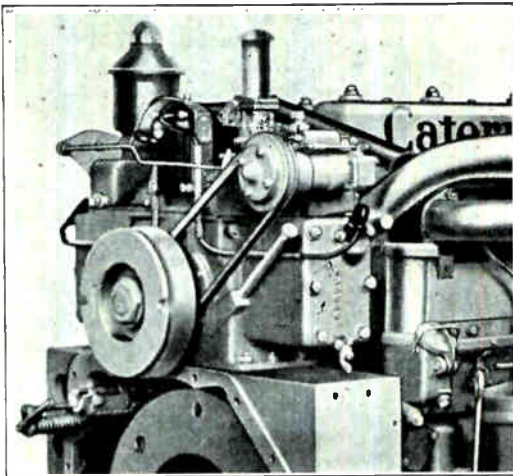

Fig. 75. This figure shows the gasoline starting engine mounted above the flywheel at the rear of the Diesel engine. (Courtesy Caterpillar Tractor Co.)

zero, the starting engine should be allowed to run for 8 to 10 minutes to warm up the Diesel air intake manifold before attempting to start the Diesel.

43. GASOLINE STARTING DIESEL ENGINES

The International Harvester Diesel is started directly as a conventional gasoline engine, by admitting gasoline instead of fuel oil to the cylinder during starting. This engine is equipped with a magneto, carburetor, spark plugs, extra clearance chamber and valve, and duplex intake manifold, which are only used during starting. See the sectional view of one cylinder of this type of engine shown in Fig. 76.

To start this engine, the operator applies crank (1) shown in Figs. 76 and 77, which through a cam mechanism opens valve (3) between the cylinder proper and the auxiliary combustion chamber (4). This added space reduces the compression pressure so that the engine can be easily cranked by hand.

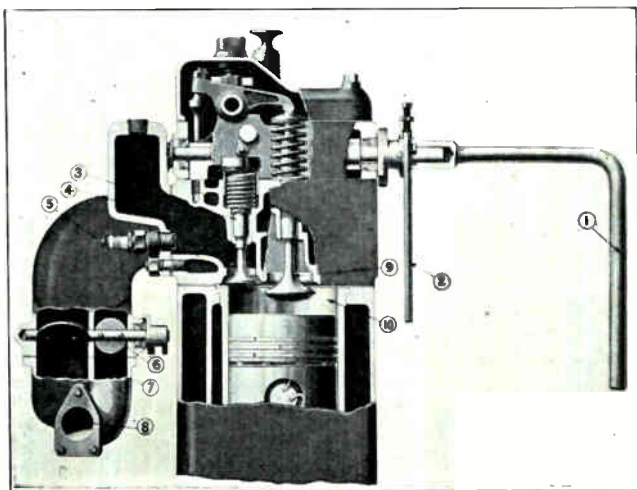

Fig. 76. This excellent sectional view of a Diesel engine cylinder shows the auxiliary combustion chamber (4), which is opened up by valve (3) to permit this type of engine to start on gasoline fuel. The starting valve is opened by the hand crank (1) shown at the right. Also note the valves in the intake manifold which change over from air to gasoline vapor for starting. Note the spark plug (5) which ignites the gasoline vapor in the auxiliary chamber during starting. (Courtesy International Harvester Co.)

A spark plug (5) is located in each auxiliary combustion chamber. When valve (3) is opened, the double butterfly valve (6) closes one side (the Diesel air intake side) of the duplex manifold, but opens the other side which is connected to a standard carburetor which supplies a mixture of gasoline and air for starting.

A high tension magneto which supplies current to the spark plugs is also engaged and the engine is ready to operate as a gasoline engine.

As soon as the engine starts and has made 700 revolutions, the rod (2) which is operated by an automatic device built into the injection pump assembly, releases the shaft that was turned manually by crank (1), and valve (3) closes, cutting out the auxiliary combustion chamber (4), raising the compression pressure to 500 lbs. At the same time the double butterfly valve cuts off the carburetor, the magneto is disengaged, and the engine runs as a full Diesel.

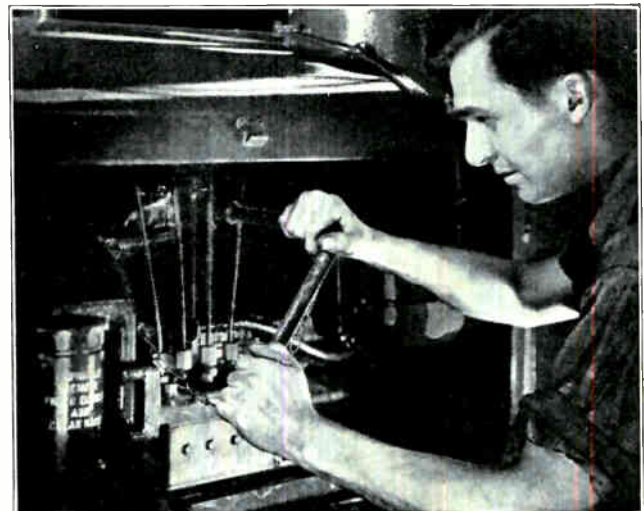

Fig. 77. This photo shows an operator attaching the hand crank to shift the valves for starting an International Harvester Diesel on gasoline fuel.

44. COMPRESSED AIR STARTING

Large Diesel engines are often started by means of compressed air. This also applies to some of the smaller ones where battery or gasoline engine starting is not desirable. Air under pressures of 200 to 300 lbs. per square inch from a pressure tank or cylinder is admitted to the engine cylinders. A rotary air distributor valve starts admitting air to the proper engine cylinder when the piston is a few degrees past top dead center, or just as the piston is starting downward on the power stroke. This high pressure air forces the piston down and starts the engine rotating. As the engine rotates the rotary air distributor valve turns and admits air to the different cylinders in the same order that the engine fires, thus causing the engine to rotate until it begins to fire.

As soon as the engine starts to operate by compression igniting the fuel oil, the main air valve is closed, shutting off the starting air. Fig. 78 shows a large Diesel engine with the air cylinders

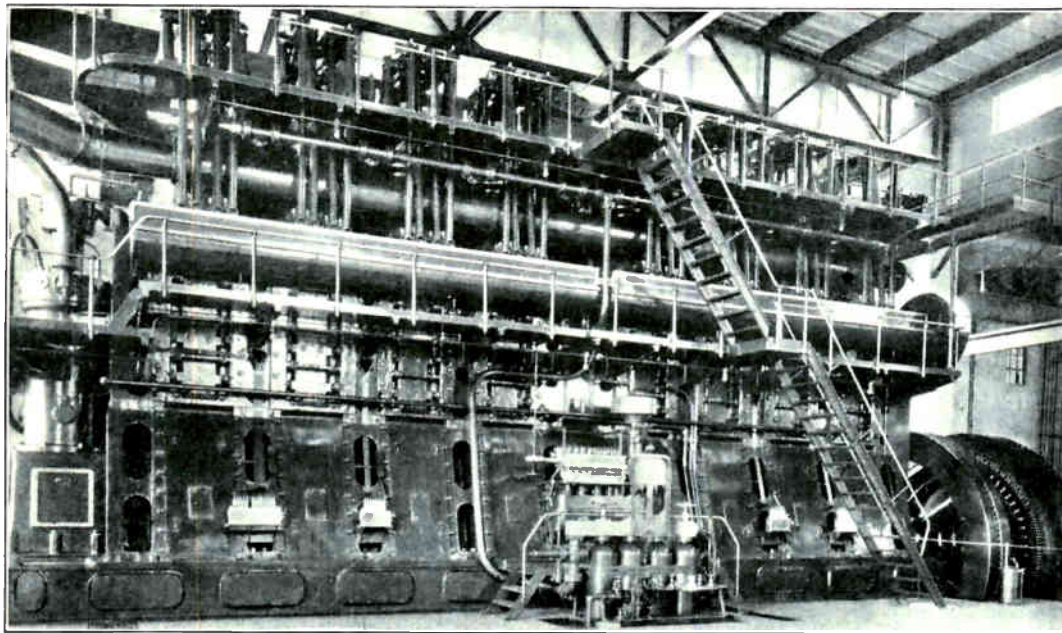

Fig. 78. Photograph of a 2865 h.p. 8 cylinder Diesel engine, with the air starting cylinders and controls shown in center foreground. This engine has a 48 inch stroke and pistons 29 inches in diameter, and operates at 120 R.P.M. Note the flywheel and electric generator at the right. (Courtesy American Locomotive Co.)

and starting controls in the foreground. Fig. 79 shows a smaller engine equipped for air starting. Note the rotary air valve mounted on the right hand end of this engine, and also the air lines leading from this distributor valve to each cylinder.

To prevent back flow of hot gases through the air starting lines to the rotary distributor valve, air starting valves are used. These are simple spring loaded bevel faced valves, as shown in Fig. 81 where the air line enters the engine cylinder. The pressure of the starting air is sufficient to overcome the resistance of the spring, so the valve opens automatically, as soon as the rotary distributor allows the air to flow to any cylinder. The instant the air stops flowing the starting air valve closes, and thus prevents back fire from the engine cylinder.

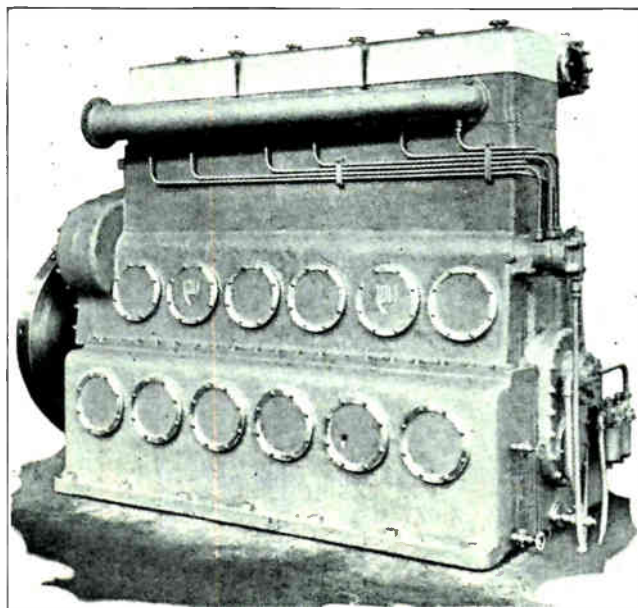

Fig. 79. On the right of the above Diesel engine can be seen the rotary air distributor valve which admits air under several hundred pounds pressure to the proper cylinders at the proper time, for starting this type of engine. (Courtesy De La Verne Engine Co.)

45. STARTING AIR SUPPLY

The air used to start Diesels is generally supplied by separately driven air compressors, and stored in tanks or cylinders under proper pressure until needed. Usually these compressors are of the two stage type such as shown in Figs. 80 and 82. A two stage compressor has two cylinders, one larger in diameter than the other. The air is first compressed by the large or low pressure cylinder, from which it passes to the small or high pressure cylinder, which compresses it to still higher pressure and forces it into the storage tank or tanks.

Since compressing air tends to increase its temperature, the air connection between the low and high pressure cylinder is always designed to remove

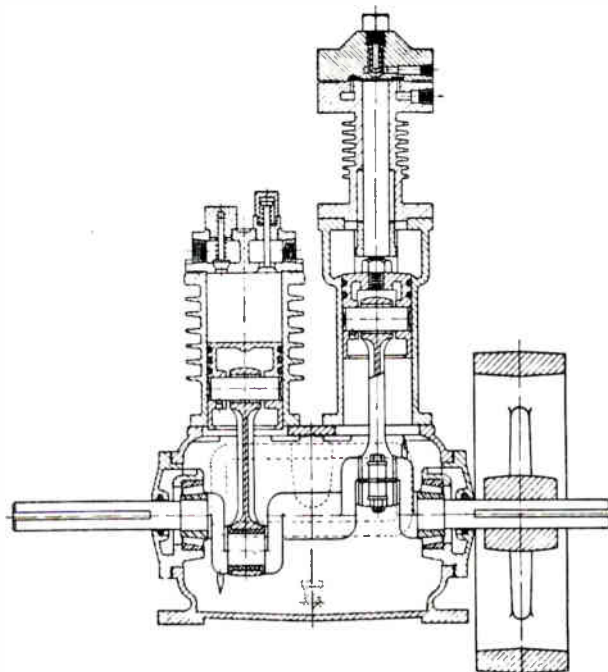

Fig. 80. Sectional view of a 2 stage air compressor used for supplying starting air for Diesel engines.

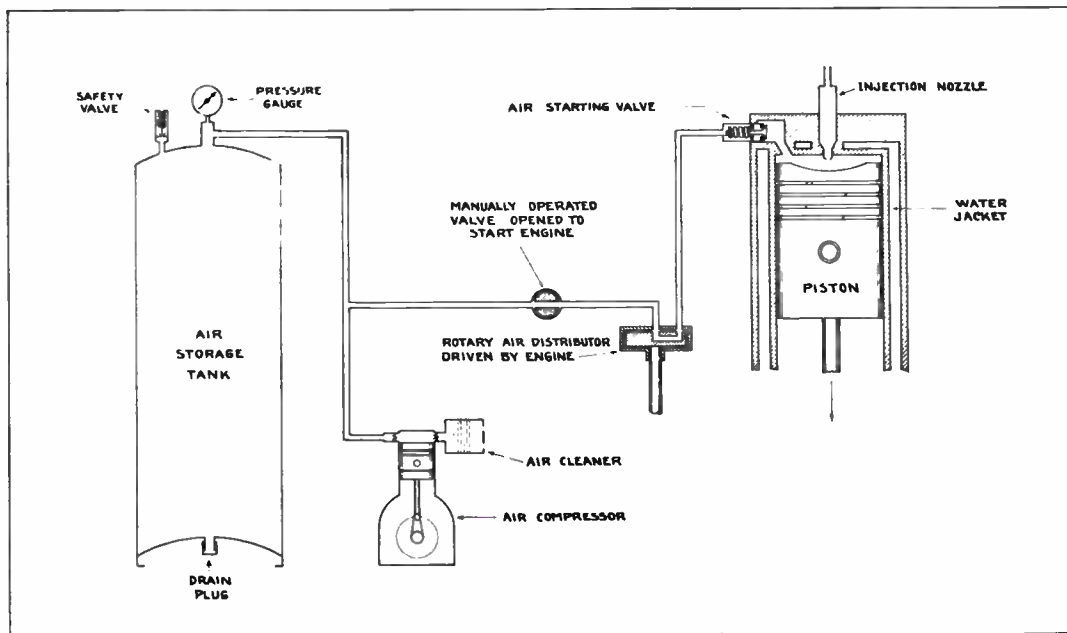

Fig. 81. This diagram shows a complete air starting system for a Diesel engine. Note the air compressor, air storage tank, manual starting valve, rotary distributor valve, and check valve or air starting valve at the engine cylinder.

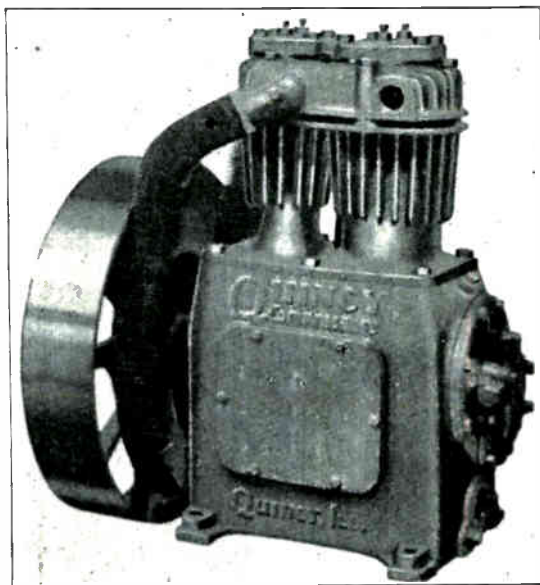

Fig. 82. Two stage air compressor equipped with a pulley for belt drive from an electric motor or Diesel engine. Note the cooling fins on the connecting tube between the low pressure and high pressure cylinders. Air which is circulated across this finned tube by the fan blades in the pulley removes some of the heat that is generated when the air is compressed. (Courtesy Quincy Compressor Co.)

some of the heat. Fig. 82 shows a 2 stage compressor with a heavily finned air connection pipe or "intercooler" between the two cylinders. Some air compressors are water cooled to keep them from overheating during long periods of operation.

As a rule, air compressors are driven with an electric motor as shown in Fig. 83. In large Diesel plants, gasoline engine driven compressors such as shown in Fig. 84, are often installed in addition to the regular motor driven units, to be used in case of electric power failure.

In some cases air compressors are direct connected to one or more of the Diesel engines in a Diesel plant, and used to store up in pressure tanks, an ample supply of starting air while the engines

are running. In plants where several Diesel engines are installed, in emergencies an idle engine can sometimes be started by connecting an air line from one cylinder of a running engine, with a check valve in the line to store up air in a tank. In this manner the compression pressure of one cylinder of the running engine can be used to compress air in a starting tank. The fuel oil must of course be shut off from this cylinder to prevent firing while it is being used as a compressor.

Air compressors are generally equipped with a hand "unloader valve" on top of the cylinder, for releasing compression while the driving motor or engine is started. This unloader valve should always be opened before starting the compressor.

46. STARTING AIDS

Several schemes are employed to assist starting Diesel engines at low temperatures. One of the most common is the use of glow plugs which are

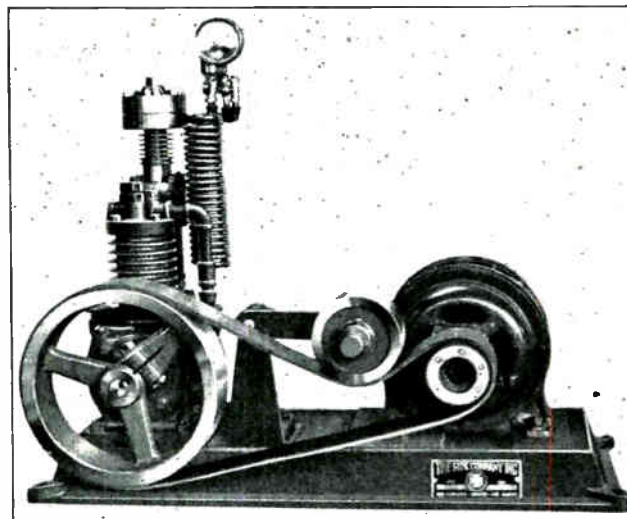

Fig. 83. Above view shows a 2 stage air compressor driven by an electric motor. Note the pressure gauge and cooling coil attached to the compressor. (Courtesy Rix Compressor Co.)

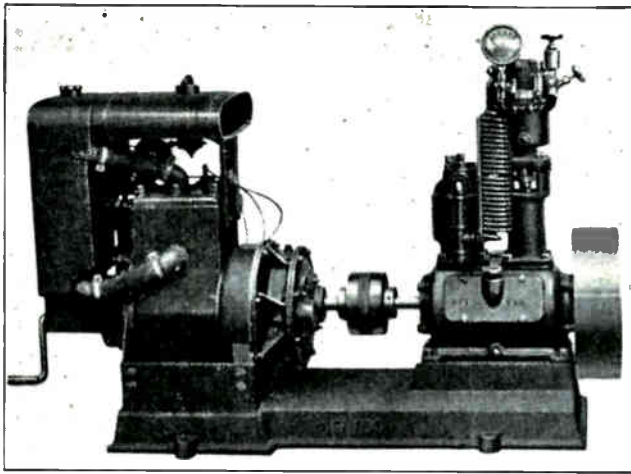

Fig. 84. Two stage air compressor driven by direct connection to a small gasoline engine. This type of unit provides a dependable supply of starting air in Diesel engine plants regardless of possible failure of the electric power supply when all Diesel engines are stopped. (Courtesy Rix Compressor Co.)

similar to spark plugs in general appearance and construction, but have a piece of heavy resistance wire in place of a spark gap. See Fig. 85-A. When electric current is sent through this resistance wire, it immediately heats up until it becomes red hot. The glow plug is so located that some of the oil spray from the injection nozzle will strike the red hot heating element and ignite readily with this heat added to that of compression.

Some glow plugs are designed to operate from a 6 volt source, while others require only 2 volts. The current drawn by each glow plug will vary from 20 to 30 amperes. As a rule current obtained from a battery is used to heat these glow plugs, but A.C. stepped down to the correct voltage, by means of a transformer can also be used. In plants where A. C. is available, this is the best method, since it does away with the need of a battery. On truck

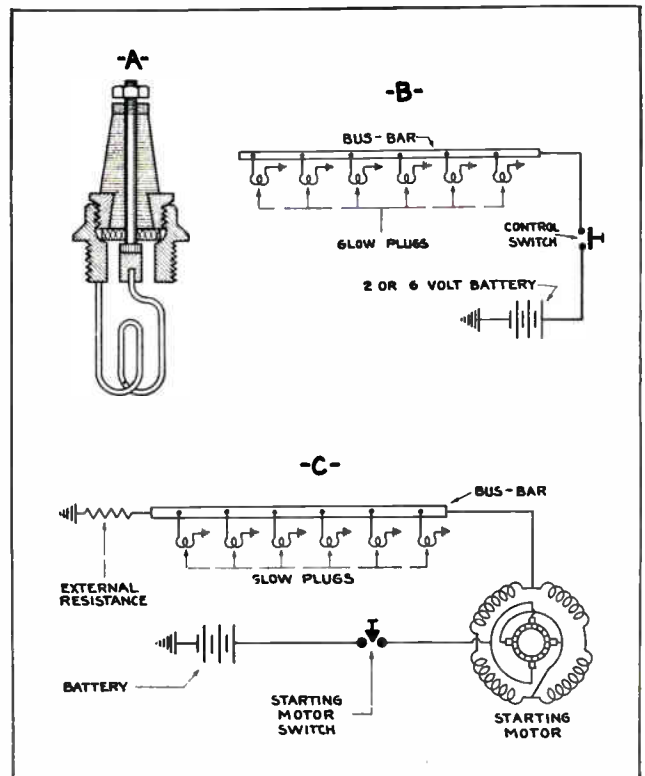

Fig. 85. At "A" is shown a glow plug using a loop of high resistance wire which is heated red hot with electric current, to aid in starting certain types of Diesel engines. At "B" is shown the connections for the glow plugs of a 6 cylinder engine. These plugs are operated from a storage battery and controlled by hand or foot switch. At "C" is shown a set of 6 glow plugs connected in series with the starting motor of a Diesel engine so that the glow plugs are automatically heated whenever the starting switch is closed.

and tractor engines, batteries must of course be used to heat the glow plugs.

Glow plugs are usually designed to operate connected in parallel. While sometimes series type glow plugs are used, they are not favored because the burning out of one plug opens the entire circuit

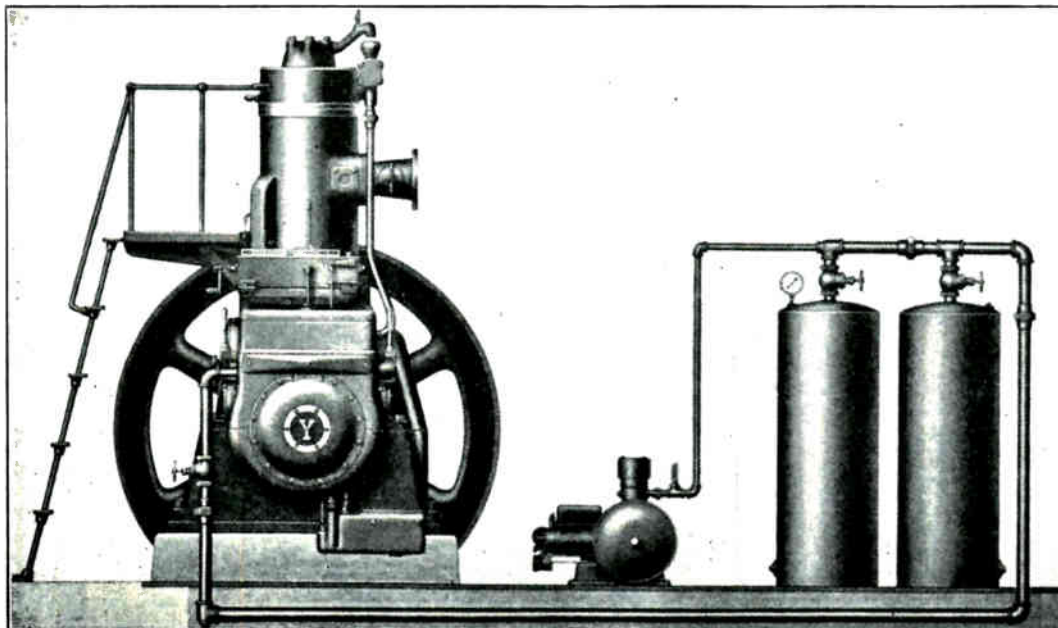

Fig. 86. Complete air starting equipment, including gasoline engine driven compressor, air storage tanks, and air line, connected to large stationary Diesel engine. (Courtesy Fairbanks Morse Co.)

and puts all the others out of commission at the same time.

As a rule glow plugs are connected directly to the source of supply and controlled by a switch as shown in Fig. 85-B. In this case the switch is turned on and the plugs allowed to heat for 15 or 30 seconds before the engine is started. If the engine is a full Diesel, the glow plug switch is opened as soon as the engine begins firing. When used on semi-Diesel or oil engines, the glow plugs are left on until the engine is hot enough to run without their assistance.

Fig. 85-C shows a system used on the Waukesha Comet Diesels. The glow plugs are connected in parallel to a bare copper bus bar, which in turn is connected between the starting motor and the grounded side of the electrical system. When the

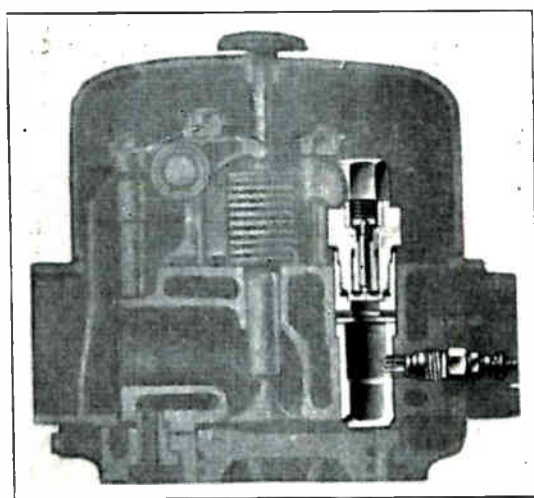

Fig. 87. The above view shows a glow plug mounted on a Diesel engine cylinder with a heater wires extending into the side of the combustion chamber directly beneath the injector nozzle.

starting switch is closed, part of the starting motor current flows through the glow plugs and through the ground connection on the engine, back to the battery. The 6 glow plugs have a total current capacity of 180 amperes, so the remainder of the starting motor current is carried to ground by means of an external resistance which is in parallel with the glow plugs between the copper bus and ground.

The plugs being of the quick heating type heat up immediately and assist in starting the engine. As soon as the engine starts and the starting motor switch is opened, the glow plugs are cut off. If the external resistance between the bus-bar, and the engine becomes disconnected, or if its connections become corroded, the engine will not start readily and the glow plugs receiving more than their normal current will burn out.

47. HOT BULB OR TUBE

Some semi-Diesels use a hot bulb or tube to ignite the fuel when the engine is cold. This tube which is hollow but closed at one end, extends into the combustion chamber with the open end on the inside as shown in Fig. 88. The flame of a kerosene or gasoline torch is directed against the closed end of the tube until it is red hot, and the engine is

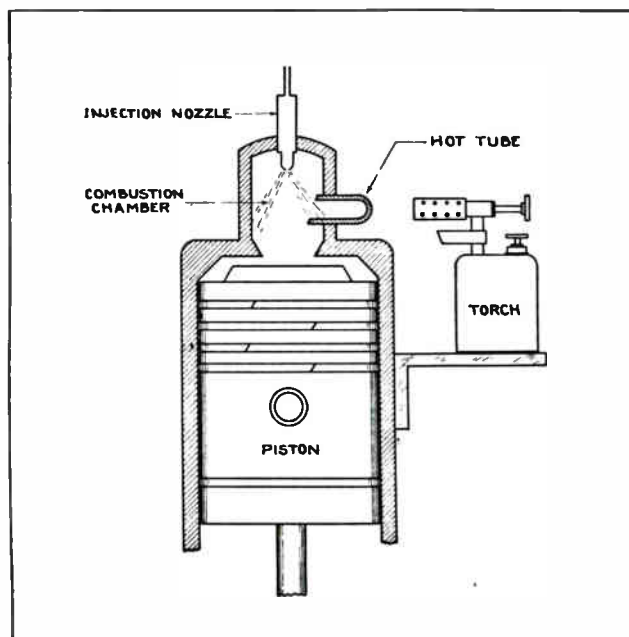

Fig. 88. Diagram showing a sectional view of a Diesel engine cylinder equipped with a hot tube and torch for aiding in the combustion of the fuel charge during starting.

then started. When the engine is turned over, part of the fuel charge from the injector nozzle strikes the inner end of the hot tube and ignites quite readily. The torch is kept on until the engine is hot enough to run without its assistance. Several types of hot tubes or hot bulbs are used with certain Diesel and semi-Diesel engines to facilitate starting in this manner, especially in very cold weather.

Some semi-Diesels or oil engines use starting wicks instead of a hot tube. A starting wick consists of a piece of cotton sash cord pressed firmly into a hollow fitting, called the starting plug. To use this device the wick is dipped into fuel oil, then lighted with a match, and held with the flame up so that it will not burn the entire length of the wick. It is allowed to burn until the tip glows red, then



Fig. 89. Modern high speed Diesel Electric Train. The operation of trains of this type is made possible through the economy and efficiency of the Diesel engine, plus the flexibility and ease of control of the electric generator and electric driving motors. (Courtesy Burlington Railway Co.)

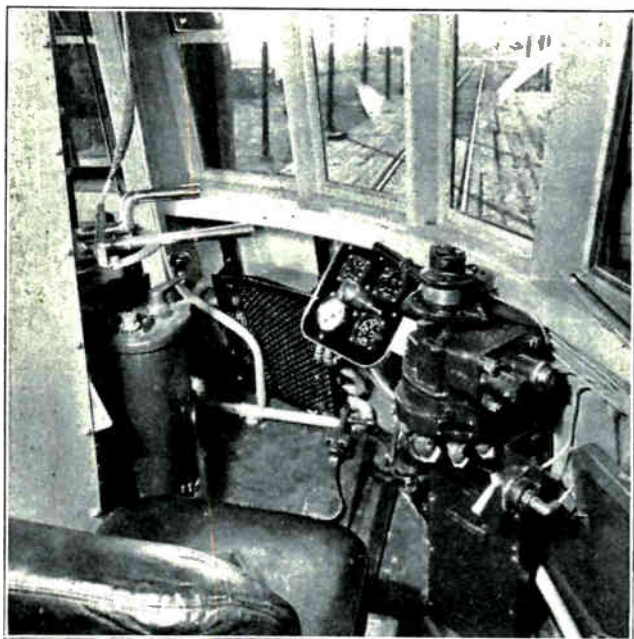

Fig. 90. Photo of the inside of the engineer's cab of a Diesel-Electric locomotive showing the engine and generator controls. (Courtesy Burlington Railway Co.)

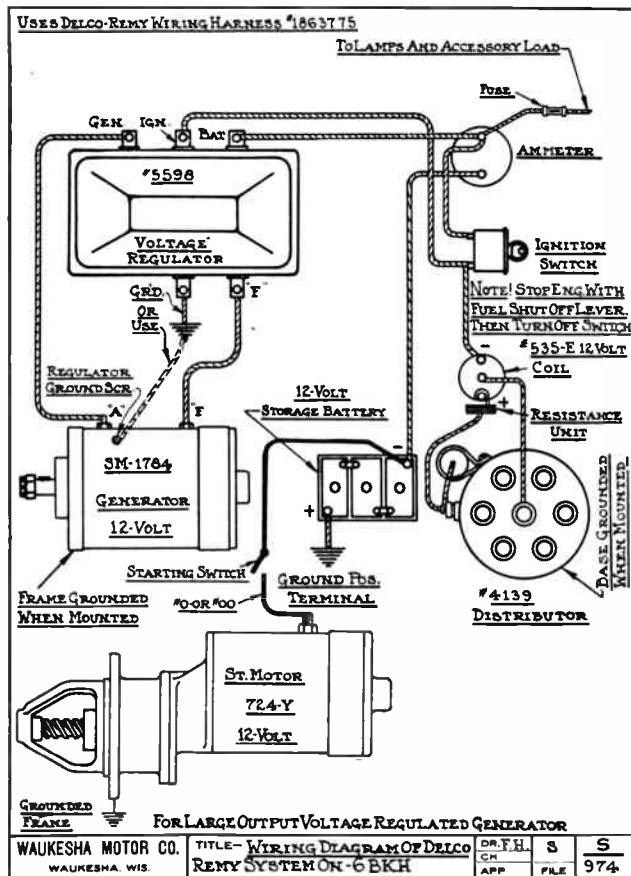

Fig. 91. Circuit diagram of the electric starting motor, battery, generator and ignition equipment of a Waukesha engine, which uses spark plug ignition. Note the instructions for stopping this type of engine. (Courtesy Waukesha Motor Co.)

the starting plug is screwed into place in the combustion chamber, and the engine is ready to start. The glowing coal on the end of the wick helps to ignite the fuel oil charges until the engine gets hot.

48. FAILURE TO START

Failure of a Diesel engine to start may be due to:

1. Lack of fuel.
2. Air in the fuel system.
3. Improper timing of injection.
4. Low compression.
5. Low cranking speed.
6. Low glow plug voltage.

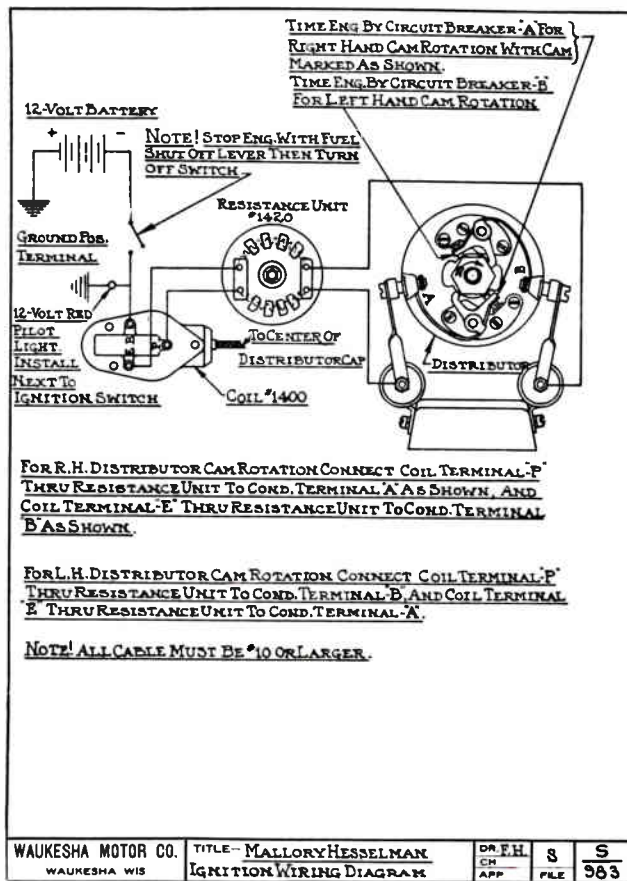

Fig. 92. Ignition wiring diagram for Waukesha Hesselman fuel oil engine. Note the printed instructions for timing and stopping this engine (Courtesy Waukesha Motor Co.)

In case the engine will not start, the fuel supply should be checked. If the fuel tank is full, be sure the tank valve is open. To check the fuel line between the tank and injection pump, loosen fuel line at injection pump. If the fuel is fed by gravity, it should flow freely when the fuel line is loosened. If a transfer pump is used, turn the engine over and then fuel should flow freely. If it does not flow freely check the filters and the fuel line for clogging obstructions.

Air in the fuel system will cause starting failure or erratic operation of the engine. For this reason, the fuel tank should never be allowed to run dry. Should the system become air bound, be sure that fuel reaches the injection pump, then open the air bleeder screws, or loosen fuel lines at the injection nozzles. Turn the engine over, or operate the injection pump plungers manually until fuel free from air bubbles, flows from the bleeder opening or loosened fuel line connection.

If the injection pump has just been installed, it may be improperly timed, very likely too late.

Low compression, especially if no starting aids are used, will often cause starting failure. Causes of low compression are leaky valves, stuck or worn piston rings and leaky gaskets. For a full Diesel engine about 350 lbs. is considered to be the minimum starting compression.

If a starting motor and battery is used the battery must be kept well charged, otherwise the starting motor will be sluggish and much of the compression heat will be lost and starting will be difficult.

Glow plugs, are very sensitive to voltage changes. A 20% drop in battery voltage will often cause the glow plugs to fail to generate sufficient heat to provide ignition. Since using the starting motor tends to lower battery voltage, it is best to check the battery while it is under load.

In case of an emergency, or failure of the regular air starter or starting motor on a Diesel engine, it is sometimes possible to start an engine that is equipped with glow plugs or a hot tube, by priming the cylinders and then rocking the flywheel back against compression. In order to start an engine in this manner the glow plugs or hot tube must be well heated first, in order to vaporize the oil charge when the cylinder is primed by operating the fuel pumps by hand with a screw driver or small pry bar. Then rocking the flywheel back quickly against compression may in some cases start the engine.

Such emergency starting may be aided by having one person operate the fuel pump plunger by hand, just at the instant the flywheel is rocked back hard against compression. This method is of course only applicable on small engines.

DIESEL ENGINE EXHAUST AND COOLING SYSTEMS

Disposal of the exhaust gases and heat produced by Diesel engines is an important problem, especially in connection with large engines where exhaust noises and fumes may be considerable, and where the heat may be utilized instead of wasted.

Small high speed Diesels used outdoors for either portable or stationary service usually release their exhaust gases to the open air, through a short open exhaust pipe or stack. If for any reason the exhaust noise is objectionable, a muffler can be used. Diesel engines in trucks are generally equipped with an exhaust pipe that discharges the exhaust gases above the cab. This keeps the smoke and odor well above road level.

For larger engine installations indoors, a more extensive exhaust layout is required. In designing an exhaust system, it is highly important that the size of the piping and fittings be large enough so that the back pressure be kept down to a minimum. Any back pressure in the exhaust system raises the cylinder pressure during the exhaust stroke, which results in poor scavenging* or cleaning of the exhaust gases. This in turn reduces the power output of the engine, and means that more fuel must be burned to deliver the same power. This is especially true of 2 stroke cycle engines because of the short exhaust period and the low pressure of the scavenging air, unless the engine happens to be

equipped with a blower or scavenging compressor as explained in one of the earlier lessons.

The back pressure in an exhaust line is the sum total of two losses. In order to cause a gas to flow through a pipe some pressure will be required. Added to that will be the pressure loss due to friction of the gases in the pipe.

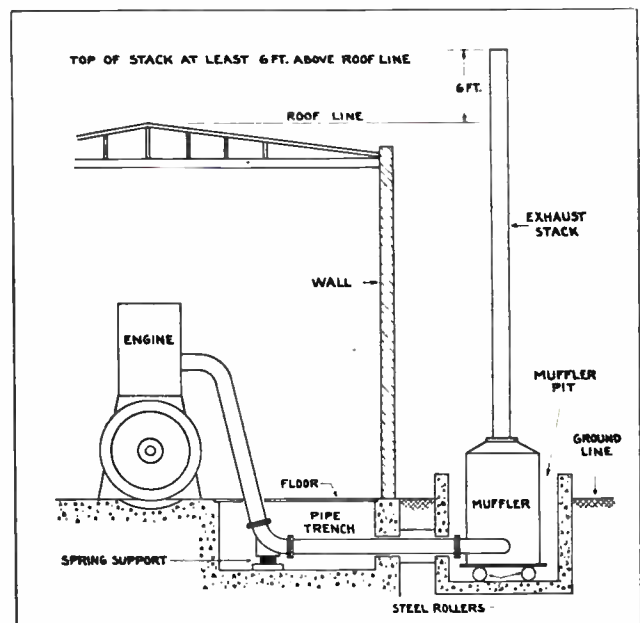

Fig. 93. Diagram showing layout of exhaust system in Diesel engine plant. Note the exhaust pipe, muffler and stack, and the provision for movement due to expansion.

*You will recall from an earlier lesson that the term scavenging as applied to Diesel engines, means cleaning the cylinder of exhaust gases.

If the pipe is too small the velocity of the gases will have to be higher and will therefore require a greater pressure difference between the engine and outer end of the exhaust system, to obtain the required velocity. An increase in gas velocity means an increase in pressure loss due to friction. For this reason a small exhaust line will offer a higher back pressure than a larger line. The piping should be of such a diameter that the back pressure measured at a point close to the engine does not exceed .5 lb.

Assuming that the mean effective pressure on the piston is 75 lbs. the loss due to exhaust back pressure would be $0.5 \div 75 = .066$ or approximately $2/3$ of one per cent. If on the other hand the back pressure was 5 lbs., the loss would be $5 \div 75 = .66$ or about 7%. This would mean an increase of 7% in fuel consumed to produce the same power. So you can readily see the importance of having proper sized exhaust lines.

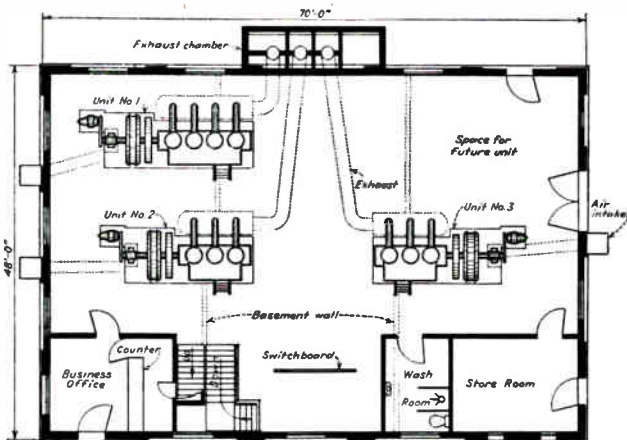

Fig. 95. This diagram shows the layout of a Diesel-Electric power plant with 3 engines driving electric generators. Note the arrangement of the exhaust and air intake pipes. (Courtesy Diesel Power Magazine.)

header under the floor, shown by the dotted lines in Figure 95, from which the exhaust is carried by a single line to the muffler chamber.

A number of silencers specially designed for Diesel engines are on the market. Three common types offered are: (a) Baffle type, (b) Absorption type, and (c) Expansion type.

In the baffle type shown in Figure 96, the sound wave is suppressed by passing around a system of baffles or barriers, thus cushioning and breaking up the gas pressure waves which create the noise. This smooths out the flow of exhaust gases to the discharge end of the muffler and greatly reduces the noise or sharp "barking" which would otherwise result.

The absorption type muffler shown in the two upper views in Figure 97, consists of an outer casing with a perforated tube running through the center, the space between the two being filled with a fire proof, absorbent material. Part of the gases pass through the perforations at one end of the inner tube, filter through the absorbent material and flow back through the perforations at the other end of the tube, thus breaking up the sound waves in the absorbent material. Since the central gas passage is free from obstructions, the back pressure offered by this type is practically zero. The lower view in Fig. 97 shows a combination baffle and absorption type muffler.

In the expansion type muffler shown in Figure 98, water is sprayed into the exhaust chamber. This cools the gases, reducing their volume by contraction, and thereby reducing the velocity of the pressure wave that is responsible for the noise. The

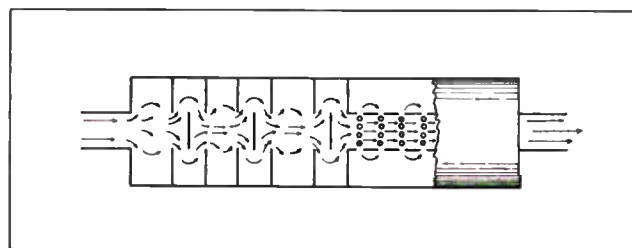

Fig. 96. This sketch shows how the exhaust gases pass through a muffler of the baffle type.

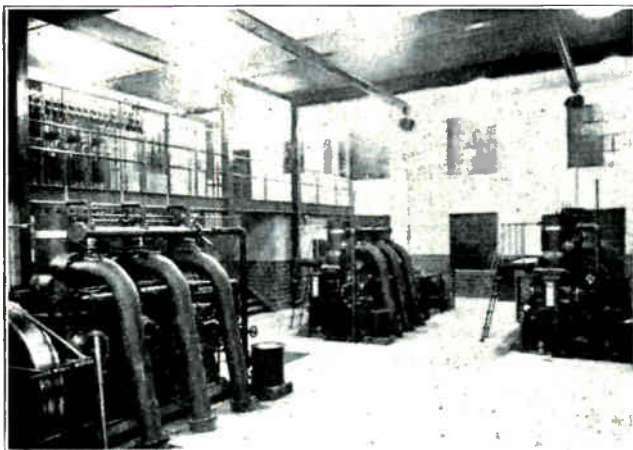

Fig. 94. Photo of Diesel plant interior showing 3 engines with exhaust lines for each cylinder taken through the floor to a common exhaust header or manifold and then discharged through the muffler and stacks as shown in Fig. 3. (Courtesy Diesel Power Magazine.)

49. EXHAUST SILENCERS

In localities where the noise of the exhaust is objectionable, mufflers or silencers are part of the exhaust system. Many large Diesel plants reduce the noise of the exhaust by running the exhaust line from the engine into a concrete pit filled with large stones. The expanding of the gas through the crevices in the rock mass, reduces its velocity and absorbs or deadens the noise. The pit has a tall stack that carries the gases well above the roof line of the surrounding buildings.

Figure 93 shows a typical exhaust system and muffler for a large Diesel engine plant. Notice that the exhaust pipes are generous in size and that wherever possible gradual bends are used. You will also notice that the system is laid out so that all parts are free to move in order to allow for expansion and contraction due to changes of temperature, as these exhaust pipes get very hot. The piping is free where it goes through the walls and the muffler is mounted on a set of rollers.

Figure 94 shows the interior of a Diesel plant, in which the exhaust from each cylinder is taken through the floor by a separate exhaust pipe. The three exhaust pipes discharge into a common

water spray also washes the exhaust gases and carries away some of the carbon, thus reducing the amount of smoke.

50. FLEXIBLE EXHAUST CONNECTIONS

To compensate for expansion and contraction of exhaust lines due to changes in temperature, sections of flexible metallic tubing such as shown in Figure 99, are often installed in the exhaust line close to the engine. Some of these flexible tubes are made of thin corrugated or ribbed metal, while others are made of tightly fitted overlapping metal rings with their edges crimped together. The use of flexible sections also prevents transmission of stresses and vibration from the engine to the exhaust line. Figure 100 shows the exhaust lines of a Diesel engine with flexible sections connected between the rigid pipes on the engine and the pipes leading to the muffler. The insert on the upper right shows a flexible section of exhaust tubing connected from the engine manifold to the roof stack.

51. DIESEL ENGINE EXHAUST TEMPERATURES

One of the chief problems that a Diesel engineer is faced with is to detect trouble before it becomes serious enough to cause a lengthy shutdown of the engine. As the Diesel is a heat engine, its power output can be measured by the heat it produces. Therefore checking the exhaust temperature is an ideal method of determining general engine operating conditions.

As an example, a 4 cylinder Diesel engine is in reality four separate units, since each cylinder has

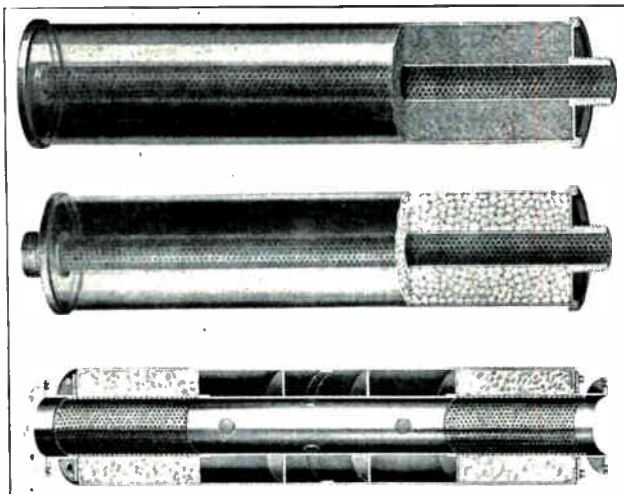

Fig. 97. Sectional views of 2 absorption type mufflers above, and a combination absorption and baffle type muffler below. Note that the center pipe is perforated to permit exhaust gases to expand into the absorbent material and then flow back into the center pipe. (Courtesy Burgess Battery Company.)

its own fuel pump, injection nozzles, pistons, valves, etc. In order to obtain satisfactory operation of the engine, the load must be distributed so that each cylinder carries its share. If, for any reason, one cylinder does not carry its share of load, the remaining cylinders may be overloaded and damage may be the result.

Since the power output is measured in terms of heat, checking the temperature of the exhaust of

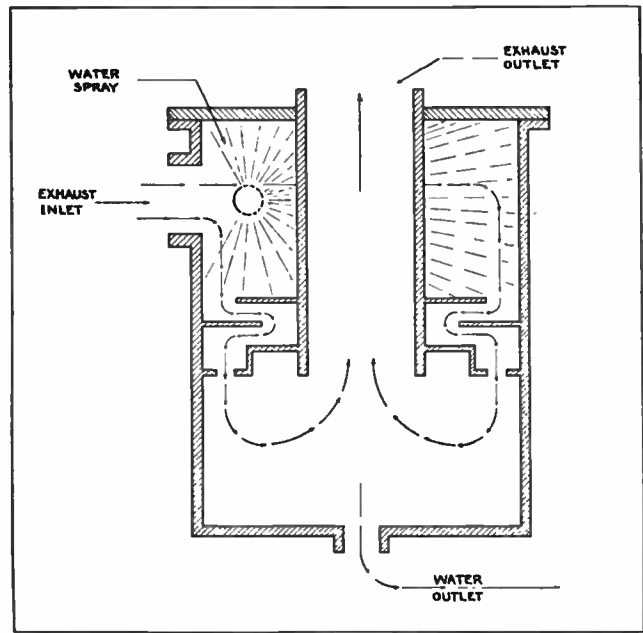

Fig. 98. Sectional diagram showing construction and operation of an expansion type muffler for Diesel engine exhaust. Note how the water spray chills and washes the exhaust gas.

each individual cylinder will indicate whether each is carrying its share of the load or not. If the temperatures are uniform, the cylinders are all carrying their share of the load. If the temperatures vary greatly, it indicates that some cylinders are loafing, and others are carrying more than their share. If allowed to continue, this unbalanced condition might result in scored cylinder walls, broken pistons, damaged bearings, or even broken crank shafts.

52. PYROMETERS

Pyrometers are used to check exhaust temperatures. As explained in an earlier lesson, pyrometers operate on the principle that if two wires made of dissimilar metals are brazed together, a potential or voltage difference will be produced at the junction of the two wires when they are heated. This potential difference varies with the temperature, so a millivoltmeter connected across the cold ends of the two wires to measure the potential difference, can be made to indicate the temperature at the joint. See Figure 101.

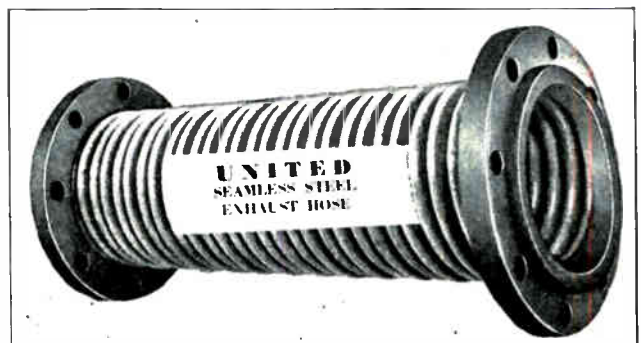

Fig. 99. Short section of flexible exhaust tubing, such as frequently connected in exhaust pipe lines to reduce vibration and to allow for expansion and contraction. (Courtesy United Steel Tubing Company.)

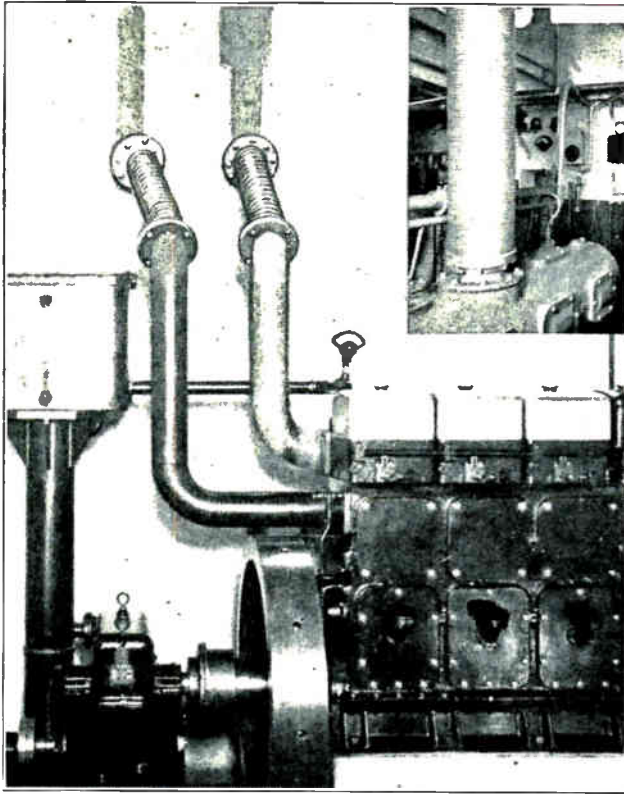

Fig. 100. Photo showing the use of flexible tubing sections installed in the two exhaust lines on the left. The small view inserted on the upper right shows a section of large flexible exhaust tubing connected from the engine exhaust manifold to the roof stack.

The part of the pyrometer consisting of the two dissimilar metals is known as a thermo-couple, and is generally made of iron and constantan metal. The two wires of the thermo-couple are protected by a steel tube as shown in Figure 102. This tube is fitted with a threaded section so that it can be screwed into the exhaust pipe of the engine. The scale of the millivoltmeter is calibrated in degrees of temperature instead of in millivolts.

Each cylinder should have its own thermo-couple screwed in the exhaust pipe as close to the cylinder as is practical, and in such a way that the stem of the thermo-couple extends to the center of the exhaust passage. On large engines, the thermo-couples are connected to the indicating unit by means of permanent wiring. A selector switch built into the indicating unit makes it possible to check the temperature of each cylinder separately by merely shifting this switch to connect the meter to the various thermo-couple elements, one at a time. See Figure 103. Figure 105 shows two types of pyrometers and selector switches for use with Diesel engines.

Portable pyrometers, such as shown in Figure 104, are sometimes used on smaller engines. In this case, the indicating unit is not connected directly to the thermo-couple, but its two pointed prods are held against the terminals of the thermo-couples as shown in the left view. Since portable pyrometers have prods made of the same metals as the thermo-couples, they can also be used to check the temperature of the cylinder head, or any clean metal surface by simply holding them in firm contact with the metal as shown on the lower right in

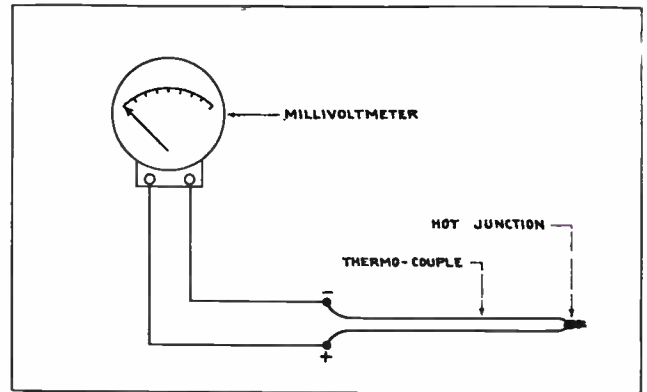
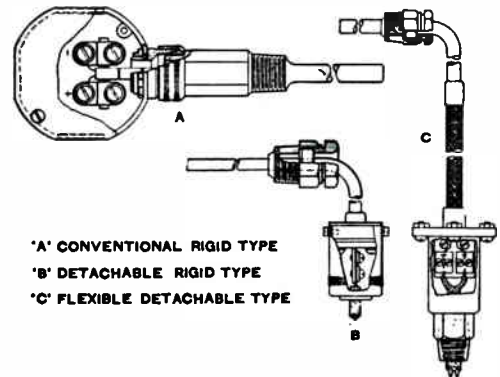

Fig. 101. Diagram showing the connections of a thermo-couple and millivolt-meter used for indicating exhaust gas temperatures on Diesel engines.

Figure 104. When used in this manner it is good practice to indent the surface of the metal with two punch marks in order to make better contact with the points of the test prods.

The temperature of the exhaust will depend to quite an extent on the load carried by the engine, and on the efficiency of the exhaust system. Four



'A' CONVENTIONAL RIGID TYPE
'B' DETACHABLE RIGID TYPE
'C' FLEXIBLE DETACHABLE TYPE

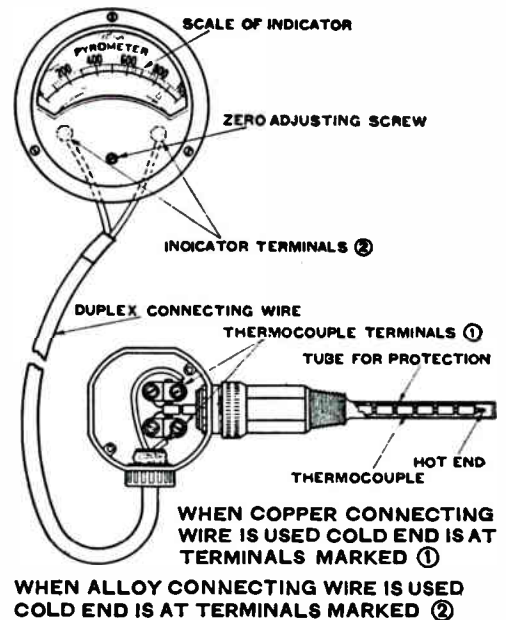
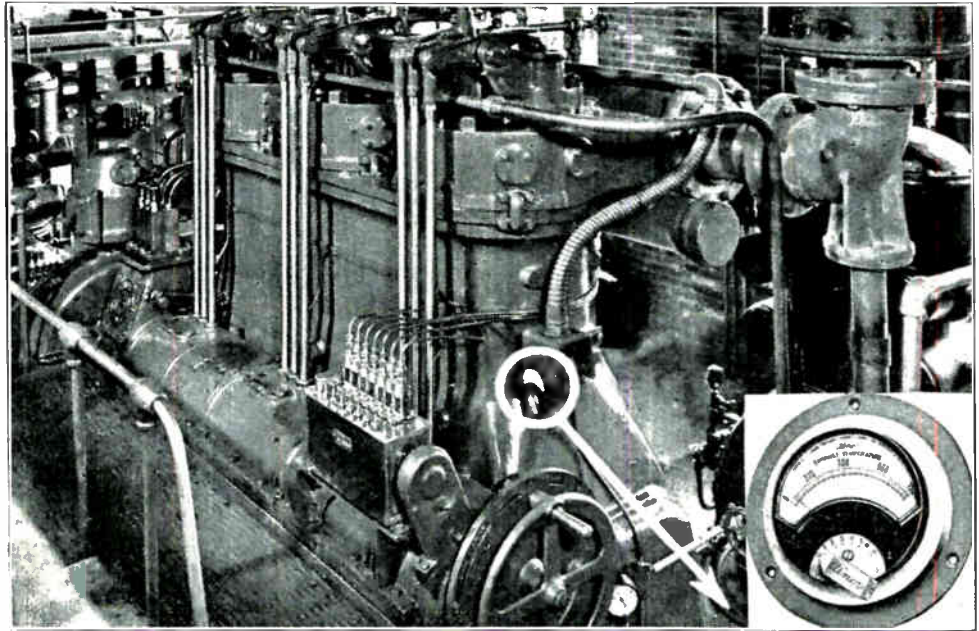

Fig. 102. The above view shows several different types of thermo-couple pyrometers for measuring Diesel exhaust gas temperatures.

Fig. 103. This photograph shows the pyrometer indicating meter located on the right end of the engine and marked by the white circle. The wiring runs from this meter through the flexible tubing shown, to the thermo-couples located in the exhaust outlet of each cylinder. The insert on the lower right shows a larger view of the meter and the selector switch which is used for taking readings of the temperatures of individual cylinders.



cycle engine exhaust gases will have a temperature range up to 1000 degrees Fahrenheit, and two stroke cycle engine exhaust gases will range up to 700 degrees Fahrenheit. The lower temperature of the two stroke cycle engine is due to the cooling effect of the scavenging air on the exhaust gases.

If the power output of the engine decreases the exhaust gas temperature drops, while if the power output increases the exhaust temperature also increases. Once the operator of the engine becomes familiar with the relation between the power and

the temperature of his engine, he should immediately notice any change from normal operation.

53. CAUSES OF OVERHEATING

A general increase of temperature of all cylinders would indicate that the engine is carrying a heavier load than usual. A gradual increase in general temperature with no increase in load might be caused by scale deposits in the water jackets, due to impure water. This scale acts as insulation between the water and the cylinder walls, causing them to run abnormally hot, and may burn away the lubricating oil film, resulting in scoring the cylinders and pistons.

With individual pump plungers supplying fuel to each cylinder, there is always the possibility of a variation in the fuel delivered to each cylinder, due to pump defects. If for any reason a plunger delivers less fuel than it should, the exhaust temperature will be lower in that cylinder, and higher than normal in the others that have to carry more than their share of the load. Leaky valves or worn piston rings would also mean a higher temperature due to inefficient performance.

If the injection pump had just been installed, high temperatures in all cylinders would indicate late injection timing, whereas if the fuel was injected too early, the temperature would be lower than usual.

In order to obtain accurate readings the stems of the thermo-couples must be kept reasonably free from carbon, as this would insulate them. How often they should be cleaned depends upon how clean the engine runs. If the exhaust is smoky they will require frequent attention. When removing thermo-couples that have wires attached, be sure that each wire is re-connected to the same terminal from which it was disconnected.

When two Diesel engines are belted to the same load, pyrometers and thermo-couples are sometimes

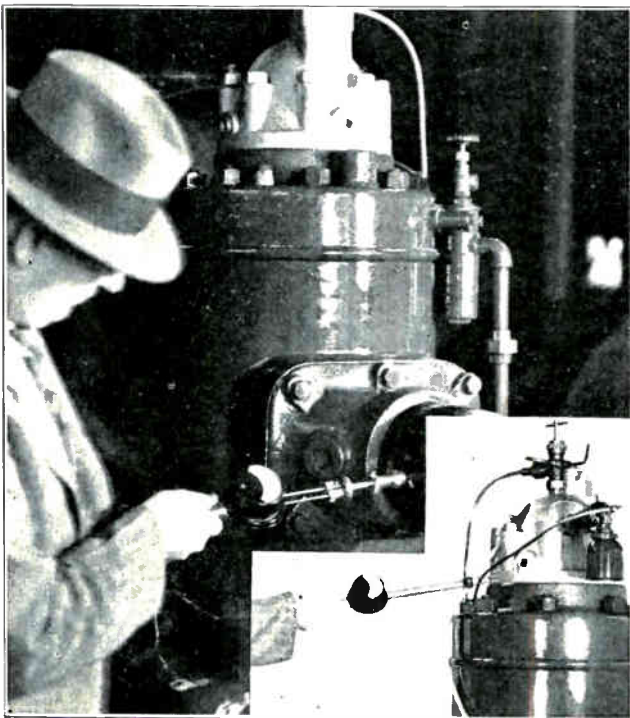

Fig. 104. The above view shows portable pyrometers being used to check exhaust gas and cylinder head temperatures of Diesel engines. (Courtesy Illinois Testing Laboratories.)

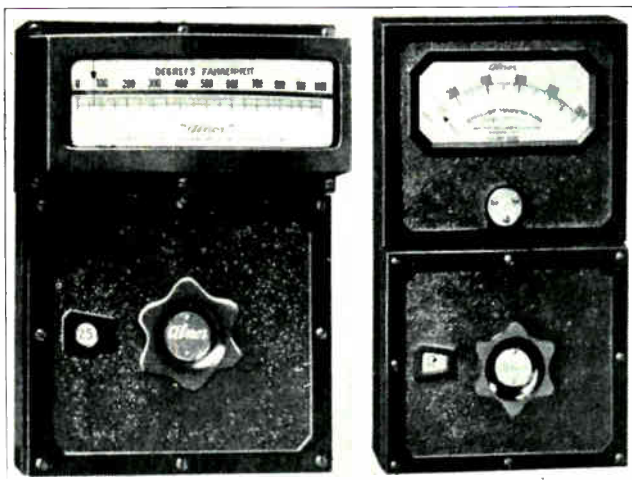

Fig. 105. Two common types of pyrometer meters and switches for panel or switchboard mounting.

used to divide the load equally between the engines. In this case each engine is equipped with an extra thermo-couple, besides the regular ones used to check the exhaust temperature of the individual cylinders. This extra thermo-couple is installed in the main exhaust line at a point where it will be swept by the exhaust gases from all of the cylinders, thereby being affected by the average temperature of the entire exhaust gases from that engine.

If the load is evenly divided, the exhaust temperatures of the two engines will be the same. If one is carrying more than its share, its exhaust temperature will be higher because it is using more fuel. The operator can quickly remedy this condition by re-adjusting the governor of the engine that is not carrying its full share, so that the injection pump delivers a little more fuel. When both engines operate with the same exhaust temperatures they are properly balanced.

Sometimes automatic governor controls operated by thermo-couples are used to properly divide the load between the engines.

54. COOLING SYSTEMS

Since the Diesel engine, like all internal combustion engines, burns its fuel within its cylinders, and generates very intense heat, some means must

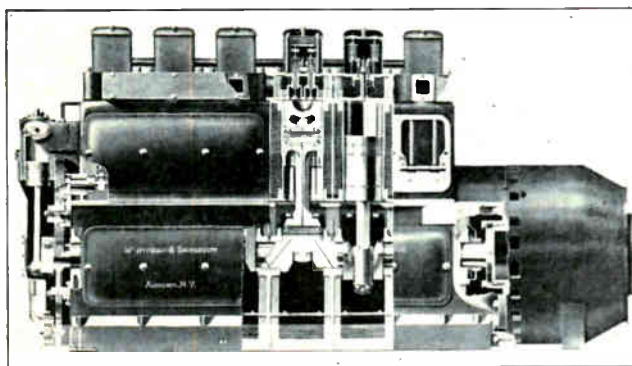

Fig. 106. The above sectional view shows how the cooling water surrounds the cylinders, cylinder heads, and valves of a Diesel engine. (Courtesy McIntosh & Seymour.)

be provided to cool the parts that are exposed to this terrific heat. If some of this heat were not carried away the valves would quickly warp and leak; the oil film on the cylinder walls would break down or burn away and the pistons would "seize" or stick, putting the engine out of commission.

With the exception of air cooled engines designed for air craft uses, Diesel engines are water-cooled. Water is circulated through passages that surround the cylinder walls and also through passages in the cylinder heads. These passages are generally referred to as water jackets, and the water that circulates through them is often referred to as the jacket water. Figures 106 and 107 show sectional views of two different types of Diesel engines with cylinders cut away showing cooling water jackets.

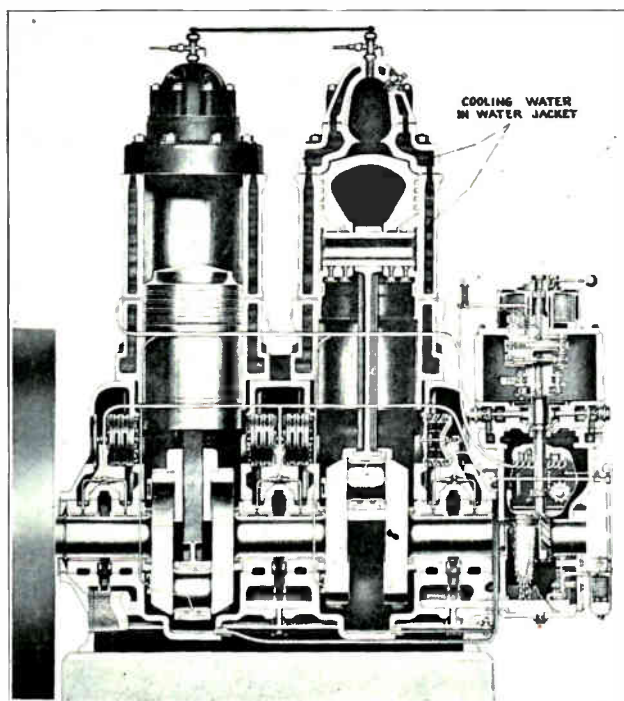

Fig. 107. This sectional view shows the cooling water in the water jacket around the cylinders, cylinder head and pre-combustion chamber of a Diesel engine. Also note the oil lines which carry lubricating oil to the bearings and piston surfaces. (Courtesy Venn-Severin Engine Company.)

There are several different types of cooling systems in use. The system that is selected depends largely on the size of the engine to be cooled, and also on the purity of the water that is available. Among the systems in use are: (1) Radiators with pump circulation of the water, (2) Thermo-syphon system, (3) Circulating non-return system, (4) Open and closed cooling systems. The last two are used for large installations.

55. RADIATOR COOLING SYSTEMS

With the development of high speed Diesels, radiators similar to those used for automotive engine cooling came into use because, in many cases, these engines are complete power units and must be independent of any outside power source for a continuous water supply. This applies especially to

trucks, tractors, Diesel locomotives, and engines used on portable equipment. Even for highspeed stationary Diesel engines radiators are sometimes used because they provide a very compact, effective and reliable cooling system. See Figure 108.

The core of these radiators consists of a large number of small round or flat tubes. These tubes are finned to increase the radiating surface. The tubes run vertically, with the top and bottom ends opening into tanks or headers.

The cooling agent is air. The water is merely used to absorb the heat from the hot parts of the

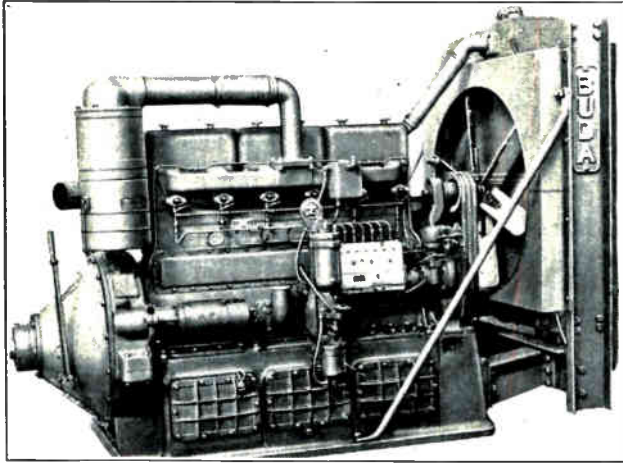

Fig. 108. Photograph of a six cylinder Diesel engine with cooling radiator and fan attached. The cooling water is circulated through the radiator and cooling jackets by means of a pump located beneath the fan. (Courtesy Buda Engine Co.)

cylinder and carry that heat to the radiator where it is absorbed from the water by the finned tubes in the radiator core. A fan behind the radiator draws air through the core and removes the heat from the tubes. So as the heat laden water enters the top of the radiator it loses some of its heat as it travels downward and is returned back to the lower part of the water jackets to absorb more heat. Cir-

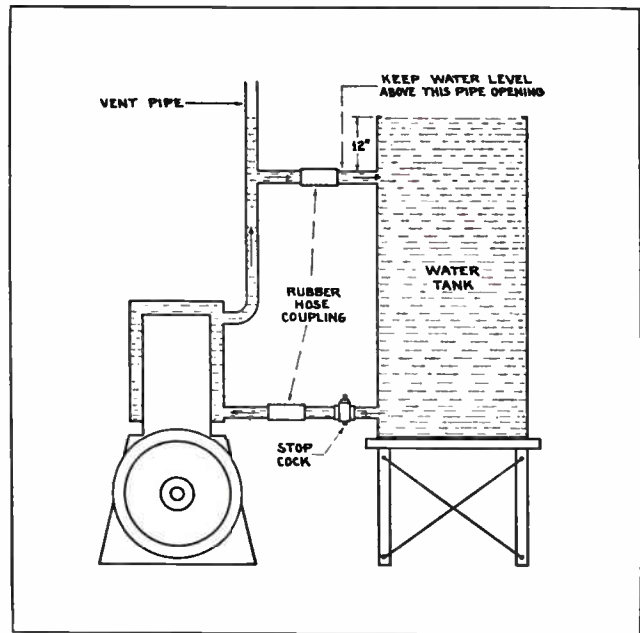

Fig. 109. Diagram showing the tank and pipe arrangement for a thermo-siphon cooling system for a stationary Diesel engine.

ulation of the water is maintained by means of a pump mounted on the engine.

Sometimes the core of a radiator is made up of a number of separate vertical sections instead of one piece. In radiators of this type, very often one or two of the sections are used to cool the lubricating oil, the remaining sections being used to cool the water. There are partitions in the upper and lower tanks between the oil and water cooling portion of the radiator so that the two systems are entirely separate, although mounted in the same frame and cooled by the same fan.

56. THERMO-SYPHON COOLING

This is the simplest engine cooling system in use, and is practical for small stationary engines up to 10 h.p. Above this h.p. rating the size of tank

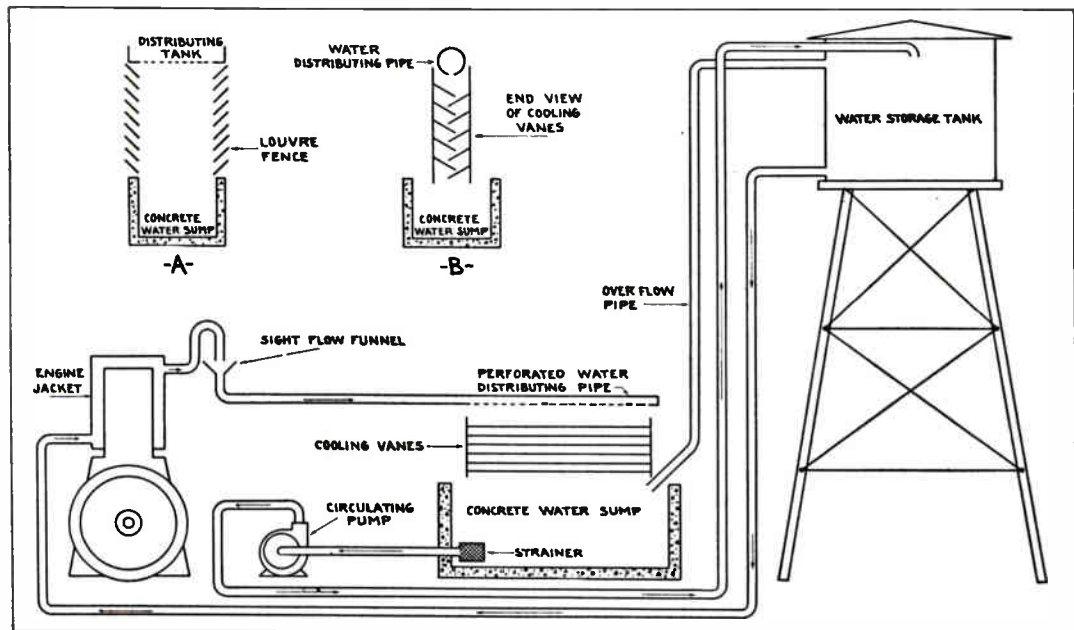

Fig. 110. Diagram of a single flow, open type cooling system for a Diesel engine plant. Trace the flow of water through the various pipes and parts of the system.

required makes the system impractical. This system consists of a tank and connections as shown in Figure 109. No pump is used, the water circulation being maintained by thermal action. As the water in the engine jacket heats it expands and becomes lighter in weight and tends to rise, as shown by the arrow, and discharges into the top of the tank. The sides of the tank being exposed to the air radiate some of the heat absorbed from the water. The air also absorbs some heat from the upper surface of the water. This lowers the temperature of the water, reducing its volume and increasing its weight, causing the cooled water to drop to the bottom of the tank. Thus, continuous circulation is maintained without the help of a pump. Since circulation depends upon thermal action, the rate of circulation will be determined by the amount of heat generated in the engine, which in turn will depend upon the load that the engine is carrying. In some ways this system is ideal because circula-

tion will not start until the engine has had a chance to warm up, and the water begins to warm up and expand.

While this system is extremely simple, there are rules that must be observed in making an installation of this type and getting the tank of the proper size. For a 5 h.p. engine, the tank should be 60 inches deep and 24 inches in diameter, which will provide a capacity of 110 gallons. For a 10 h.p. engine, a 210 gallon tank, 70 inches deep and 30 inches in diameter should be used. The tank outlet at the bottom must be level with the lower water jacket connection on the engine. If the tank outlet is set any lower than the connection on the water jacket, the water circulation will be restricted.

The tank should be set as close to the engine as is practical. For best results the lower water connection in Figure 109 should not be over 30 inches long. For both 5 and 10 h.p. engines, 1 inch pipe is used for the lower connection and 1¼ inch pipe for the top connection. The top tank connection should be about 12 inches from the top of the tank, and the vent pipe should extend about 8 inches above the top of the tank. Rubber hose couplings 12 inches long are used on both lower and top connections, to relieve vibration and misalignment strains. A stop cock should be installed in the lower connection as close to the tank as possible, so that the engine jacket can be drained when idle in freezing weather, without emptying the entire cooling tank. While the engine is in operation, the water level must be maintained above the top connection in the tank, otherwise the engine will overheat.

57. CIRCULATING NON-RETURN SYSTEM

This system is used only where large quantities of clean water may be obtained cheaply. In this system the engine is supplied with water from a continuous source, and the hot water discharge is allowed to go to waste. A manually or thermostatically operated valve is used to control the flow of water in order to maintain the operating tem-

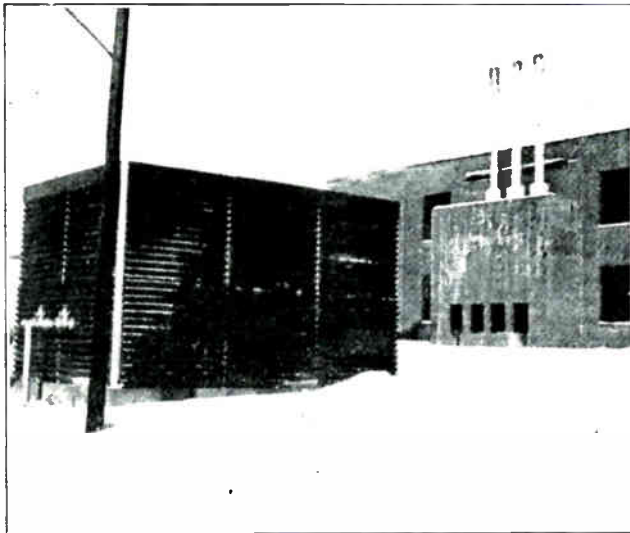

Fig. 111. Photo showing a water cooling tower and the exhaust chamber and stacks of a Diesel power plant.

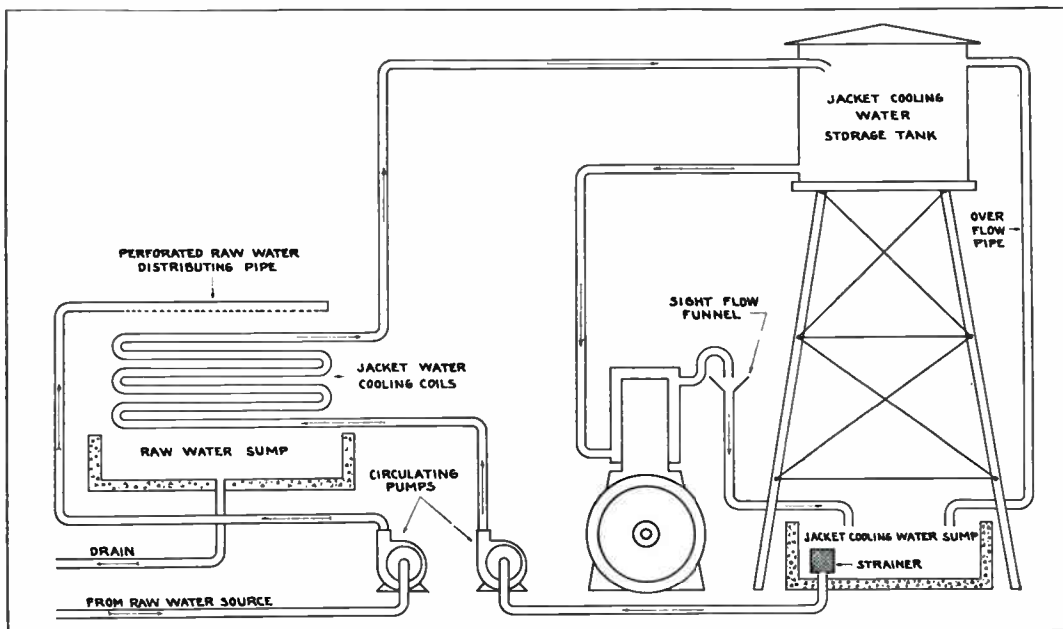

Fig. 112. Diagram showing the water tank, piping, pumps, and arrangement of a double flow, closed type cooling system for a Diesel power plant.

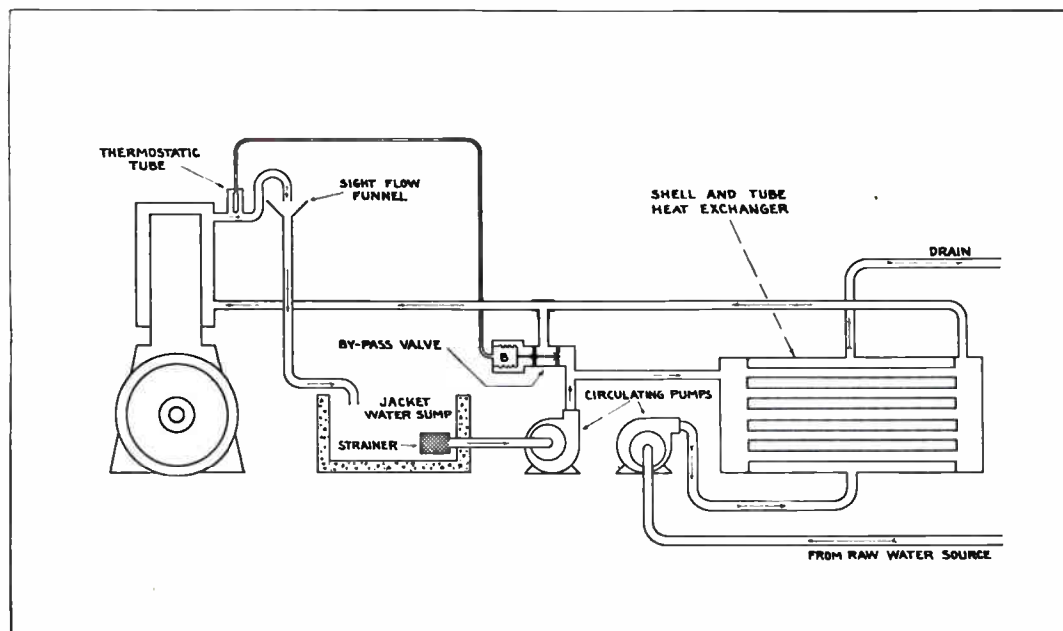

Fig. 113. This illustration shows the piping and water circulating arrangement of a closed type cooling system using a shell and tube heat exchanger and automatic temperature regulating valve.

perature of the engine at the correct value. Since this system demands a continuous supply of water and is wasteful, it is not often used except on boats, where an unlimited amount of water is always available. On boats a pump driven by the engine circulates the water. If the water supply is already under pressure, no pump is required.

58. OPEN TYPE COOLING SYSTEMS

In large Diesel plants where radiators are not practical due to their limited cooling capacity, single or double flow cooling systems are employed. Where water of reasonable purity is obtainable, the single flow or open type cooling system such as shown in Figure 110, can be used. The cooling water is fed from a storage tank to the jackets of the engine by gravity. The hot water from the engine jackets discharges into an open funnel so that the operator can check the rate of flow. From the sight-flow funnel, the water is discharged by means of a perforated distributing pipe over a series of sheet metal vanes installed outdoors. As the water trickles downward from vane to vane, it is cooled by evaporation and by the air absorbing some of the heat. The cooled water collects in a concrete sump (trough or basin) under the cooling vanes and is pumped back to the storage tank. The circulating pump is sometimes located so that it can be driven by the main Diesel engine, or in a power house it might be electric motor driven.

In some cases, instead of being discharged into a perforated distributing pipe and allowed to run down over vanes, the hot water is discharged into a large, shallow, square or rectangular tank with a perforated bottom. The water drops in small streams through the air which absorbs some of the heat. The water then collects in the concrete sump below.

The two methods just described for cooling the engine jacket water are known as atmospheric cooling systems and the equipment used is known as atmospheric cooling towers. To prevent the wind

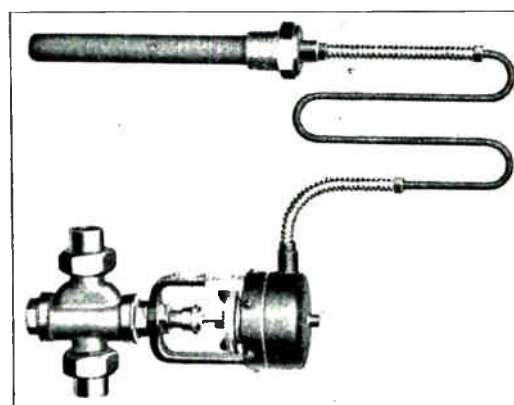

Fig. 114. Temperature control valve for regulating the flow of cooling water to a Diesel engine. The valve is operated by the expansion and contraction of the liquid in the bulb and tube shown connected to it.

from picking up and carrying away some of the water, these towers are surrounded from top to bottom by what is known as a louvre fence. See the insert at "A" in Figure 110. Also see Figure 111.

Since this method of cooling evaporates some of the water to cool the remainder, there is a continual loss that has to be replaced. The approximate loss is 1 gallon per 1000 gallons of water cooled, for each degree of heat lost. Thus, if the temperature of the water is lowered 30 degrees, 3 gallons of water will have to be replaced for every 100 gallons cooled. Since the evaporation of water leaves behind whatever minerals, salts, etc., that were contained in it, this system can be used only in localities where water is free from such material. Otherwise excessive deposits of scale will form in the jackets of the engine, causing serious overheating.

59. DOUBLE FLOW COOLING SYSTEMS

Where water contains impurities that might cause scale deposits in the engine jackets, the cooling water must be chemically treated. Since this is rather costly, the water loss must be reduced to a

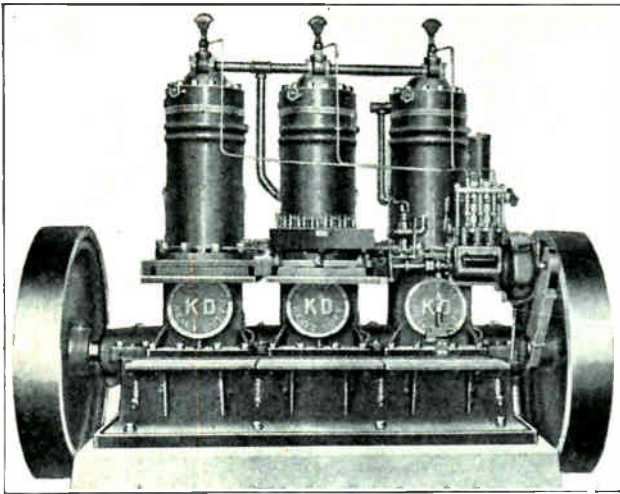

Fig. 115. Note the temperature indicating thermometers located on the top of each cylinder of this heavy duty stationary Diesel engine. (Courtesy Anderson Engine Co.)

minimum. In such cases, the single flow, or open type, cooling system is not practical. To reduce the loss of treated cooling water, a double flow or closed-cooling system is used. See Figure 112. In this case, the hot water from the engine jackets is not cooled by trickling over sheet metal vanes as in the open type system, but instead it is pumped through a series of pipe coils over which cool, untreated or raw water flows. Thus, the temperature of the treated jacket water is reduced without exposure to the air or evaporation losses.

If there is an unlimited supply of cheap raw water available it may be used only once, and then al-



Fig. 116. Three common types of thermometers used for checking the temperature of Diesel engine cooling water. (Courtesy Moto-Meter Co., Inc.)

lowed to go to waste. Otherwise it may be used over and over again by cooling it with sheet metal vanes similar to those used in an open cooling system.

A cooling coil made up of twelve 2 inch pipes, 20 ft. long will be sufficient to take care of a 100 h.p. Diesel engine.

60. SHELL AND TUBE HEAT EXCHANGERS

Double flow or closed cooling systems sometimes use a shell and tube heat exchanger such as shown in Fig. 113. These heat exchangers are so designed that the treated jacket water is continuously recirculated through the tubes, while the raw water surrounds the tubes. This type of cooling system is highly efficient because the raw water entirely surrounds each tube and readily absorbs the heat of the inner water, through the metal pipe walls.

Fig. 113 also shows a method of maintaining the temperature of the jacket water at a constant value over a wide range of engine load. A thermostatic tube filled with a volatile (easily evaporated) liquid

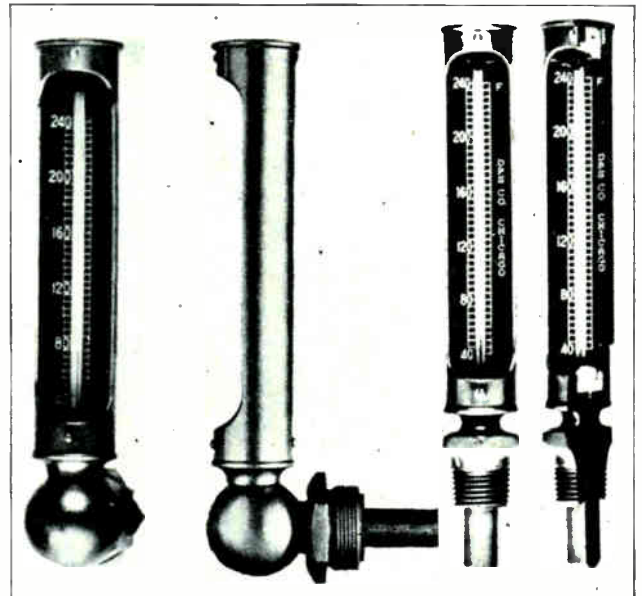

Fig. 117. Several types of mercury column thermometers used to indicate the temperature of Diesel engine cooling water. (Courtesy Diesel Specialties Corp.)

is installed so that it will be immersed in the water that discharges from the engine jackets. This thermostatic tube is connected to a metal expansion bellows "B" that operates the by-pass valve between the discharge side of the jacket water circulating pump, and the water line connected to engine jacket.

As long as the temperature of the water discharging from the engine jackets is below normal, the pressure developed by the liquid in the thermostatic tube will not be sufficient to close the by-pass valve, so that most of the jacket water will return to the engine without passing through the heat exchanger, therefore losing very little of its heat. As the temperature of the cooling water approaches normal, the liquid in the thermostatic tube expands and builds up pressure which is transferred to the metal bellows, causing it to expand and close the

by-pass valve so that the jacket water must pass through the heat exchanger.

61. QUANTITY OF COOLING WATER REQUIRED

The amount of water required to absorb the heat from the cylinder walls depends upon the size and design of the engine, and the desired difference in temperature between the water that enters the jackets and the water that leaves them. As a gen-

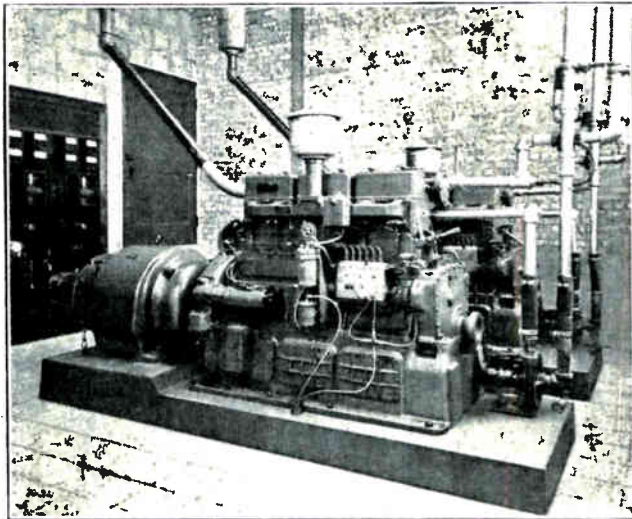

Fig. 118. Photo of Diesel-Electric power plant showing two high-speed six cylinder engines with the generators and switchboard. Note the exhaust and cooling water connections.

eral rule, the water capacity should be sufficient to handle 3000 B.T.U. per hour, per horsepower rating of the engine.

The maximum temperature of the discharge water should not exceed 165 degrees F. at any time, and 145 degrees is better, especially in very large engines. The smaller the difference between the "in and out temperature" the better. In many large installations a 10 degree difference is maintained between the water that enters and the water that discharges from the engine jackets. This narrow "in and out" temperature difference reduces temperature strains in the iron cylinder walls.

To calculate the quantity of water required to cool an engine, the following formula can be used:

$$\frac{\text{h. p.} \times 3000}{\text{"Out" temp.} - \text{"in" temp.}} = \text{Lbs. of water per hour}$$

Example: If a 300 h. p. engine is to operate with a water inlet temperature of 135 degrees and an outlet temperature of 145 degrees F., then

$$\frac{300 \times 3000}{145 - 135} = 90,000 \text{ lbs. of water per hour}$$

$90,000 \div 60 = 1500$ lbs. per minute, and as 1 gal. weighs 8.3 lbs., $1500 \div 8.3 = 180$ gal. per minute.

It is very plain to see from these figures that the wider the "in" and "out" temperature range, the less water is required.

62. COOLING WATER THERMOMETERS

Thermometers are used to check Diesel engine cooling water temperatures; one being installed on

the discharge side of each cylinder jacket, so that the water temperature of each individual cylinder can be observed. In Fig. 115, thermometers can be seen on top of each cylinder.

Three types of commonly used thermometers are shown in Fig. 116. This type of thermometer is actually a pressure gauge, calibrated to read in degrees temperature. The pressure to operate the pointer is produced by a very volatile liquid sealed in the slender tube seen at the bottom of the thermometer. The thermometer is installed so that the liquid filled tube is surrounded by the hot water at a point where it leaves the engine jackets. The heat from the water causes the liquid in the sealed tube to expand, building up pressure which in turn moves the pointer over the thermometer scale.

In some of these instruments, the sealed tube is air filled; the heat causing the air to expand. The advantage of this type is that the indicating part can be connected to the unit that is immersed in the water, by a long slender flexible tube, so that the thermometers for all the cylinders can be grouped together at some point on the engine or on a control panel which is convenient to the engine opera-

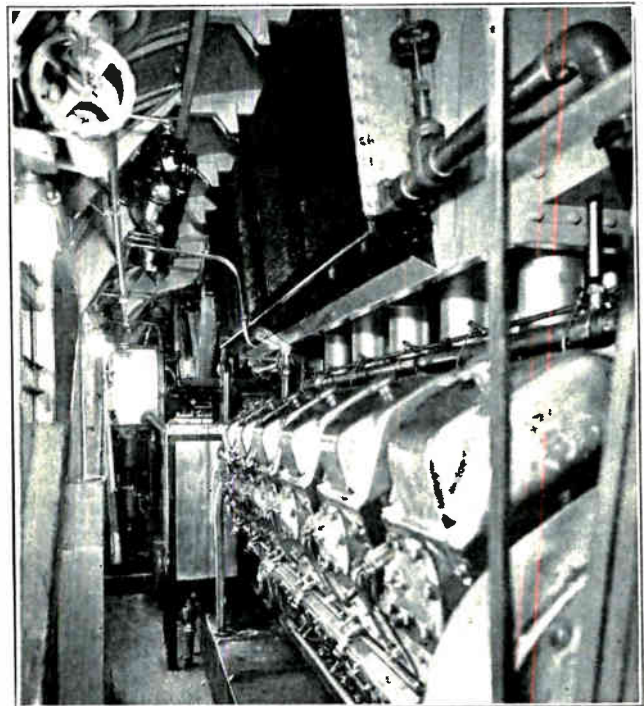

Fig. 119. Photograph showing one side of the engine compartment and engine in a modern Diesel-Electric locomotive. Note the large radiator located above the engine cylinders. Air is passed into the engine compartment through louvres at the front end and out through the radiator and a duct through the roof of the locomotive. (Courtesy of Burlington Railway.)

tor. This is especially convenient on large engines, where thermometers mounted at the point where the water leaves the jackets, would be some distance from the floor of the engine room and difficult to read.

Thermometers similar to standard thermometers having a mercury or alcohol column are also used. See Fig. 117. This type cannot be grouped like the pressure type, and is somewhat more difficult to read from a distance.

63. UTILIZATION OF DIESEL ENGINE HEAT

In some Diesel engine installations, the heat from the exhaust and also from the cooling water is used to heat all or part of the building in which the engines are located, thus obtaining double use of the fuel burned in the engines. This can be accomplished by pumping the engine cooling water through room heaters or radiators of the unit type, behind which fans are located to blow the heat off into the room.

The hot engine exhaust gases are sometimes sent

through a heat exchanger in which they are passed over a set of water pipes. The water absorbs a large part of the exhaust gas heat, and is then circulated through radiators or room heaters of the type above mentioned.

In some cases the cooling water can be circulated through one or more ordinary large wall or ceiling type radiators located in another room or part of the plant.

The use of the heat from Diesel engines in this manner, makes them even more practical and economical for use in certain types of plants where this waste heat can be well used.

DIESEL ENGINE LUBRICATION

Lubrication is one of the most important operating factors that a Diesel engine operator has to contend with. Long engine life and freedom from trouble depend largely on the proper lubrication of every moving part on the engine. Lubrication also plays an important part in assisting the piston rings in maintaining a tight seal between the piston and cylinder wall, which prevents a loss of compression and power. Therefore, it is highly important for a Diesel engine operator to have a good knowledge of Diesel engine lubricating systems and equipment, and also of the proper or most efficient lubricating oil to use.

The principal parts of a Diesel engine which require lubrication are the crank shaft, main bearings, connecting rod or crank pin bearings, pistons and cylinder walls, piston pin bearings, cam shaft bearings, cams, push rods, valve rocker arms, valve stems, timing gears, fan and water pump bearings and governor. On engines which have a scavenging air pump or starting air compressor attached, the pistons, bearings and connecting rods of these units must also be kept well lubricated.

64. TYPES OF LUBRICATING SYSTEMS

Three types of lubricating systems will be found in general service. Light weight high speed Diesel engines usually depend on a force feed circulating system similar to that used on gasoline automobile engines, and consisting of an oil pressure pump, oil filter, and oil lines or tubes which carry the oil under pressure to the important bearings and wearing surfaces. In addition to the oil tubing, lubricating oil is also carried through holes or passages bored in the crank shafts, cam shafts and connecting rods to reach these important bearings.

This system, while simple and compact in design, is not suitable for large slow speed engines. Such engines use a mechanical lubricator consisting of a number of separate plunger type pumps, to supply the oil to all moving parts, including the main crank shaft bearings. Or in some cases, a mechanical lubricator is used for the cylinders and crank pins, and an oil circulating pump for the main crank shaft bearings.

65. FORCE FEED PRESSURE SYSTEM

In light weight high speed Diesel engines, the oil supply is carried in the lower part of the crank case

as shown in Figs. 120, 121 and 122. A gear type pump also shown in Fig. 120, and driven from the cam shaft, draws oil from this supply and forces it under pressure to the main bearings.

The oil is usually carried from the pump to the main bearings by holes or passages drilled in the crank case, or cylinder block. In some engines a main oil pipe "or header" runs the entire length of the crankcase, and small tubes feed oil to each main bearing. Sometimes the cam shaft is hollow and serves as a "header," with passages drilled between the cam shaft bearings and the main bearings feeding the latter with oil.

From the main bearings, the oil is carried to the crank pin bearings by means of drilled passages in the crank shaft. The wrist pin bearings are lubricated by passages drilled the whole length of the connecting rods, the oil being fed under pressure from the crank pin bearing oil supply at the lower end of the connecting rod. Carefully note these oil passages shown in Figs. 120, 121 and 122.

The cylinder walls are lubricated by the oil that seeps out at the connecting rod bearings. Oil is also thrown up into the cylinders as the crank shaft revolves. Oil lines from the main oil header carry oil to the timing gears at the front of the engine and

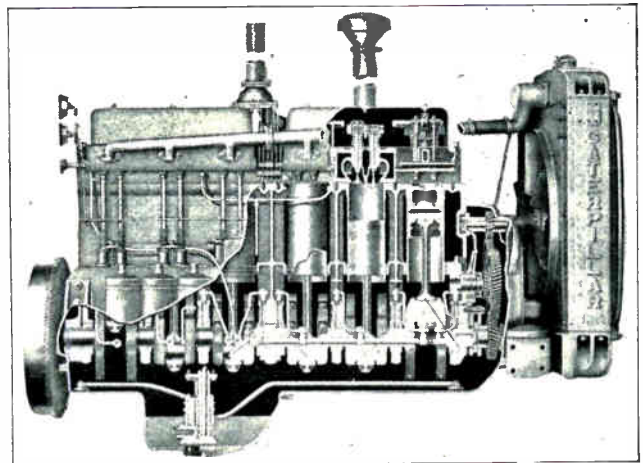

Fig. 120. The above sectional view of a Diesel tractor engine shows the lubricating oil lines and the holes drilled in the crank shaft and connecting rods for conveying oil to the various bearings. In the lower part of the crank case can be seen the gear type oil pump, which feeds oil under pressure to the oil lines and bearings. (Courtesy Caterpillar Tractor Co.)

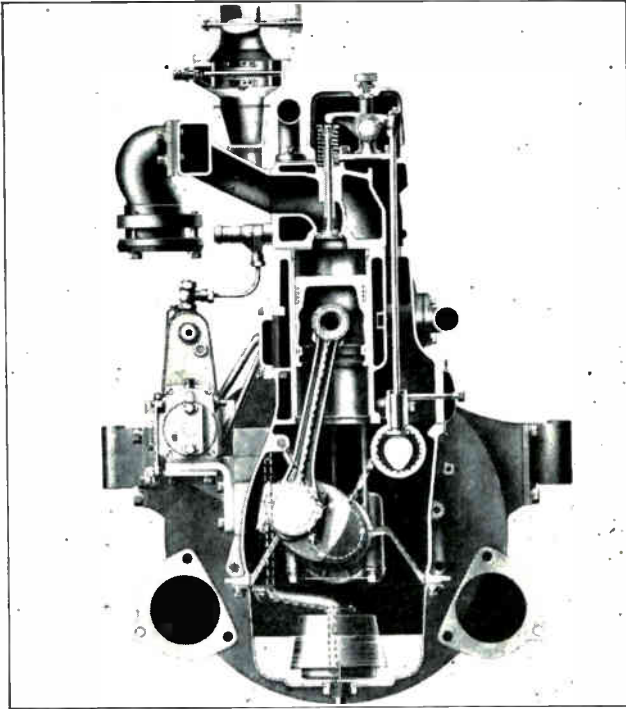

Fig. 121. This end sectional view of one cylinder of a Diesel engine shows by dotted lines the path of the lubricating oil to the main bearings, crank shaft bearings, wrist pin bearings and cam shaft bearings. (Courtesy Buda Engine Co.)

also to the overhead valve mechanism, as shown in Figs. 120 and 122.

Since the engine uses but a very small amount of the oil pumped, the surplus returns back to the crank case oil sump to be again pumped through the system. Thus all the moving parts are continually supplied with an ample amount of lubricating oil.

The oil pressure maintained on a system of this type will range from 10 to 45 lbs., depending on the make of engine. A spring loaded relief valve is used to regulate the pressure, which in some cases is adjustable and in others non-adjustable.

Oil filters are used to keep the oil clean and may be connected in the system so that all of the oil that the pump forces to the main oil header has to pass through the filters. Sometimes as many as three of these filters are used on one engine. With this system an extra oil line or "by-pass" around the filter is used so that lubrication will not be interrupted in case the filters become clogged due to neglect. In other engines, the oil is pumped directly to the header, and a tube by-passes a part of the oil through the filter, this clean oil returning to the crank case.

66. MECHANICAL LUBRICATORS

Large Diesel engines cannot depend on the oil thrown off of the crank shaft to lubricate the cylinder walls, because of the slow speed at which the crank shaft rotates and the distance from the crank shaft to the cylinder walls.

In the case of 2 stroke cycle engines, the crank case compartments must be kept relatively free from oil fog or vapor because the charging air coming through the crank case would carry this oil vapor into the combustion chambers, where it would be burned, resulting in high oil consumption and for-

mation of carbon in the combustion chambers and on the piston heads. Such engines may employ mechanical lubricators to oil all the points that require lubrication, or in some cases a mechanical lubricator is used to oil the cylinders and crank pins, and a low pressure pump and oil circulating system is used to lubricate the main crank shaft bearings.

A mechanical lubricator such as shown on the engine and also in the insert in Fig. 123 is an oil reservoir or tank equipped with a series of small plunger pumps, and individual oil lines that carry the oil to various parts of the engine. The pumps are operated by means of a rod connected to an eccentric driven by the engine.

The lubricator shown at the upper right in Fig. 123 is designed to supply oil through 12 separate lines. The amount of oil pumped through each line can be regulated by means of regulating screws, the heads of which can be seen along the top of the lubricator shown in the insert at the upper right in Fig. 123. The rate of oil flow is checked by means of visible drip feeds under the glass covers on the top of the lubricator.

At the right end will be seen the hand crank used to operate the pumps manually and force some oil to the bearings before starting the engine, in case it has not been operated for some time. At the extreme right of the lubricator mounted on the engine in Fig. 123 can be seen the rod that operates the pumps. Just below the cooling water manifold, and just above the crank case compartment covers, can be seen the small copper oil tubes that carry the oil to various parts of the engine.

67. AMOUNT OF LUBRICATING OIL REQUIRED

On some engines no provision is made to collect the excess oil, so the amount of oil that each pump delivers has to be regulated closely, because if too much is fed, the oil consumption will be high. On the other hand, too little oil would result in damage or rapid wear.

If the right grade of oil is used, very little will be needed. As a rule, 0.2 of a pint of oil every 10 hours, will lubricate 1500 to 2000 sq. ft. of cylinder wall surface covered per minute. In figuring the

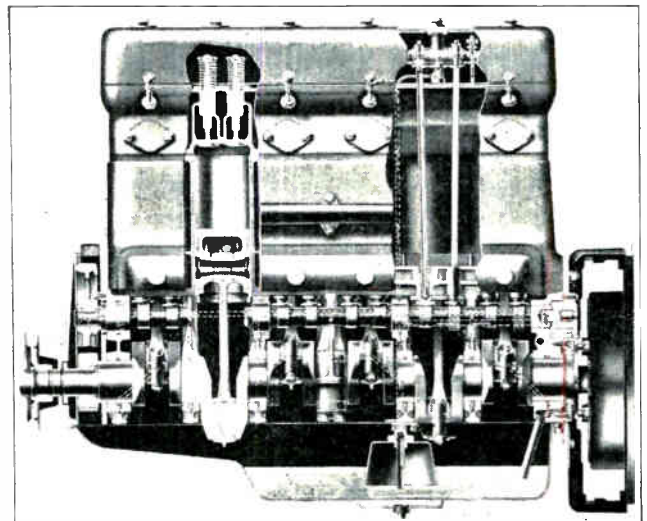

Fig. 122. This photograph also shows the oil passages to the main bearings, crank bearings, wrist pins, cam shaft, and to the overhead valve rocker mechanism of a Diesel engine.

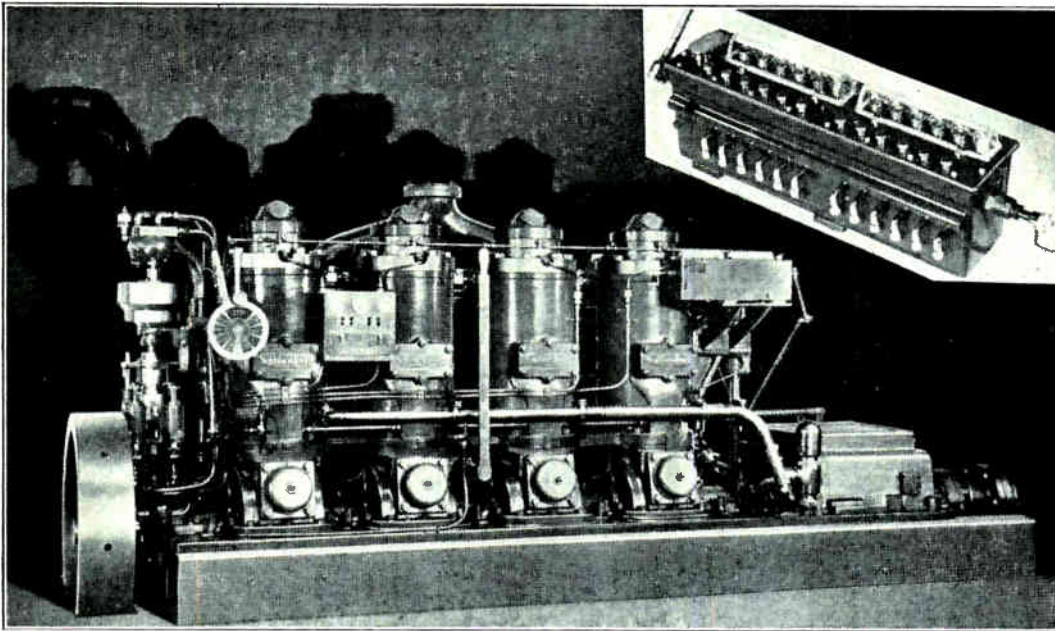

Fig. 123. This photo shows a four cylinder heavy duty Diesel engine equipped with a mechanical lubricator which is mounted on the last cylinder at the right. The insert at the upper right hand corner shows a larger view of this same type of lubricator. Note the hand crank for manual feed before starting the engine. Also note the connecting link and rod by which the lubricator is driven by connection to the engine.

surface on this basis, the stroke times the cylinder circumference, both measured in feet, should be multiplied by twice the revolutions per minute. One pint of oil will equal from 12000 to 16000 drops, depending on the thickness or viscosity of the oil.

As an example, if the stroke was 2 feet, the circumference 3.5 feet, and speed 300 R.P.M., then:—
 $2 \times 3.5 \times 600 = 4200$ sq. ft. covered per minute.
 $4200 \div 2000 = 2.1$

$2.1 \times 0.2 = .42$ pint of oil per 10 hrs. of operation
 $16000 \times .42 = 6720$ drops per 10 hrs.

$10 \times 60 = 600$ minutes in 10 hrs.

$6720 \div 600 = 11.2$, or about 12 drops per minute to each cylinder.

Sometimes the name plate on the engine, or the instructions shipped with the engine will state the correct number of drops of oil required per minute.

In some engines, the excess oil from the lubricators is collected in a sump or oil well under, or at the end of the crank case. From this sump it is forced through a filter by means of a pump and from the filter it is returned to the lubricator. Such a system is shown with the engine in Fig. 125.

Sometimes only the cylinders and crank pins on the crank shaft are lubricated by means of a mechanical lubricator. The main crank shaft bearings being supplied with oil under low pressure by a pump, or oiled by means of oil rings that pick up oil from pockets directly under the bearings as shown in Fig. 124. These pockets are kept full of oil by a pump.

In this type of system the excess oil is returned to the mechanical lubricator. To keep the mechanical lubricator from flowing over, an over-flow line is provided, which usually carries this surplus oil to lubricate some part of the engine such as the governor mechanism or the fuel pump drive.

68. PROPER GRADES OF OIL FOR DIESEL LUBRICATION

While there is practically no crank case oil dilution in a Diesel engine, due to the fact that the fuel is not mixed with the air during the entire compres-

sion stroke, Diesel engines do however subject the lubricating oil to more deterioration than other engines. The reason for this is that compression and working pressures are higher in the Diesel engine. High compression pressures mean higher temperatures, and though they exist for only a small fraction of a second at a time, they re-occur very rapidly and these high temperatures tend to carbonize the oil, resulting in stuck piston rings and partially clogged exhaust passages, which reduce the power and efficiency of the engine.

For this reason, oils that might give first class results in a gasoline engine may not be suitable for Diesel engines. High speed Diesel engines subject the oil to such severe operating conditions that there is a tendency for the oil to thicken or form excessive sludge deposits, if the oil is not of a grade suitable for this type of service.

The major oil companies, through their re-search

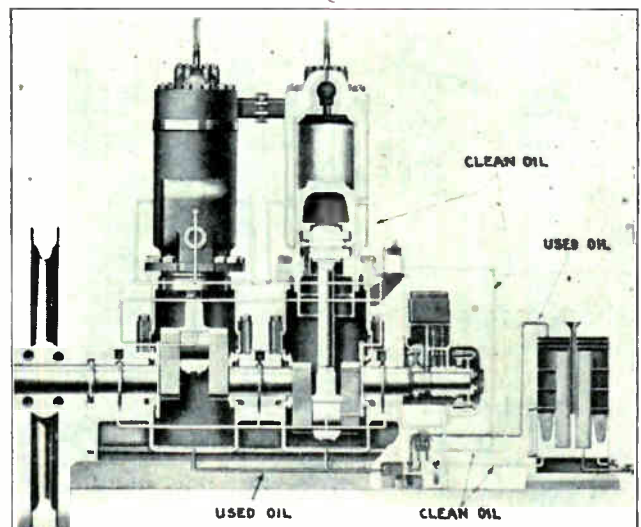

Fig. 124. Sectional view of a heavy duty two cylinder Diesel engine showing the path of the clean oil from the filter, through the oil pump to the engine bearings and also the path of the used oil from the crank case back through one section of the pump, to the filter. (Courtesy Fairbanks Morse Co.)

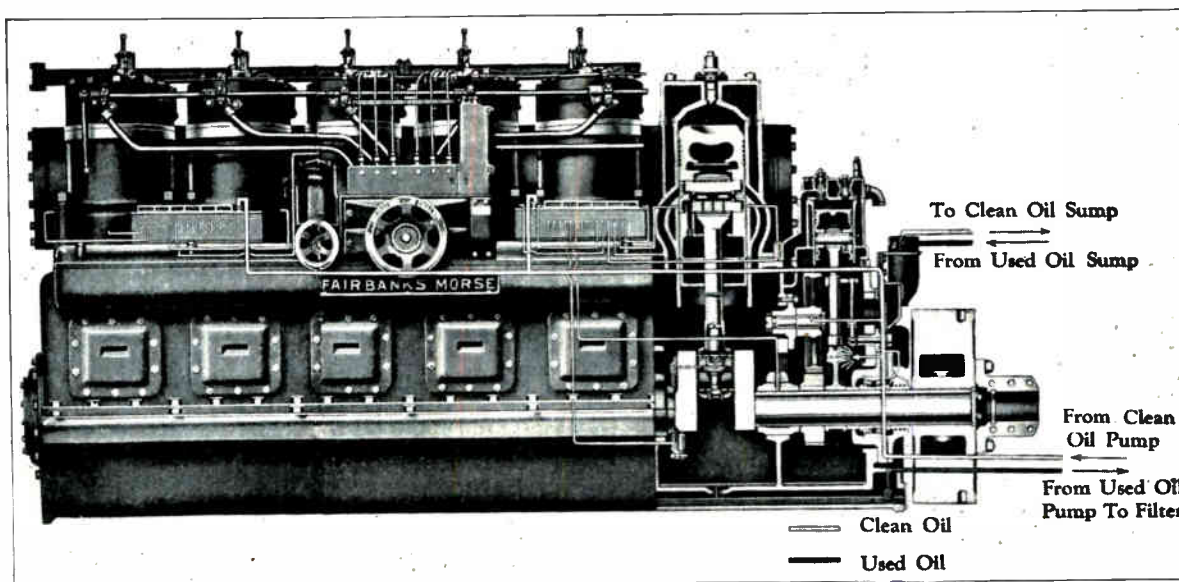

Fig. 125. This six cylinder heavy duty Diesel engine is equipped with two mechanical lubricators. Note the oil lines and the path of the oil to the cylinders and bearings. (Courtesy Fairbanks Morse Co.)

laboratories and tests made in numerous Diesel plants, have developed lubricating oils for every type of Diesel engine in common service.

69. VISCOSITY OF LUBRICATING OILS

The stickiness or "body" of an oil is known as its viscosity. The viscosity of oils is tested by allowing 60 cubic centimeters of oil to flow by gravity through an opening of a certain standard size, and noting the time that it requires. This is sometimes referred to as the "Saybolt" test. Fig. 126 shows a Saybolt viscosimeter for testing lubricating oil viscosity.

When we hear the expression "75 seconds Saybolt at 210 degrees F.," it means that it requires 75 seconds for the 60 C. C. (cubic centimeters) of oil to flow through the standard opening with the temperature of the oil at 210 degrees F.

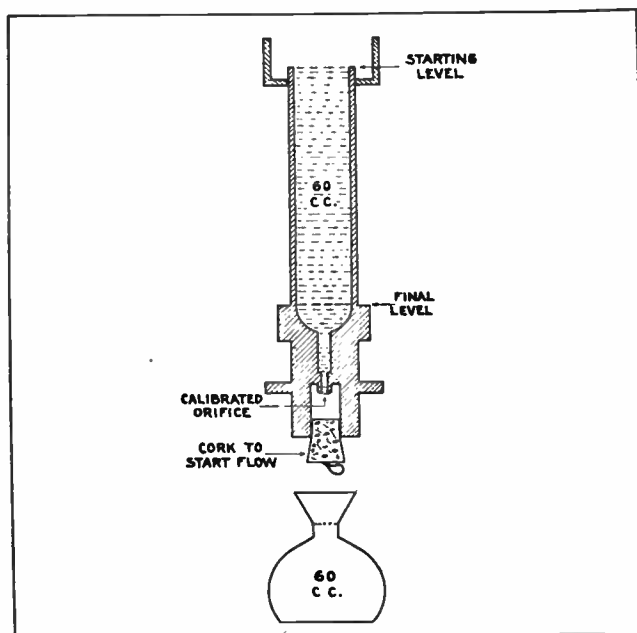

Fig. 126. This diagram shows a Saybolt viscosimeter such as used for testing the viscosity of lubricating oils.

Temperature causes a change in the viscosity of all oils, the higher the temperature the lower the viscosity becomes. For example, an oil with a viscosity of 600 seconds Saybolt at 100 degrees F. may drop to 75 seconds Saybolt at 210 degrees F. Some oils thin out more than others when heated. As a rule, oils made from a good grade of Pennsylvania paraffin base crude oil, do not thin out as much as oils made from asphalt base crudes.

For tractors, trucks, or other Diesels that have to operate outdoors, it is important that the oil be not too viscous at low temperatures, otherwise starting may be difficult. However, the oil must maintain a reasonable viscosity at high temperatures in order to maintain an oil film on the bearing surfaces under the severe operating conditions imposed on these engines.

For this type of service, the flatter the viscosity-temperature curve, or the less variation of viscosity with temperature changes, the better the oil. For engines that are located indoors in heated buildings, this is not so important since the oil is not subjected to low temperatures.

The best policy to follow is to use an oil recommended by the builder of the engine. For the smaller Diesel engines, S.A.E. No. 30 or 40 Diesel oil is usually recommended, if outdoors or room temperatures do not fall below 50 degrees F. For engines operating in temperatures below 50 degrees F., S.A.E. No. 20 Diesel oil is generally used.

70. VISCOSITY METERS FOR ENGINE MOUNTING

Some engines are equipped with visco meters such as shown in Fig. 127, so that the operators can tell when the oil is too thin for safe operation. Oil from the main header enters the supply side of the instrument and passes into an automatically controlled chamber "A," which has a spring loaded relief valve on one side and a calibrated orifice on the other. (The term "calibrated" here means an orifice or opening of a certain pre-determined size to admit a certain amount of oil.)

The oil may enter this instrument at any pressure, but the relief valve is set at a pressure low enough so that oil in chamber "A" (Fig. 127) is held at a constant pressure, unless the engine oil pressure becomes less than the setting of this relief valve. The excess oil flows past the relief valve and is returned to the crank case. The remainder of the oil flows through the calibrated orifice into a small chamber "B", to which the indicating meter or gauge is connected. A calibrated resistance tube "C" drains the oil from this chamber back to the crank case.

While the pressure in chamber "A" will remain constant, the oil pressure in chamber "B" will vary according to the ease with which the oil can flow through the resistance tube "C". This in turn will depend on whether the oil is thick or thin. Thick oil will mean a high pressure in chamber "B" with a corresponding high reading in the gauge, while thinner oil would reduce the pressure, and lower the gauge reading.

This instrument, with the exception of the gauge, is mounted directly on the crank case of the engine. The supply tube is kept as short as possible, and is insulated so that the oil which passes through the calibrated orifice and resistance tube will be kept at the same temperature as the oil which is fed to the engine bearings.

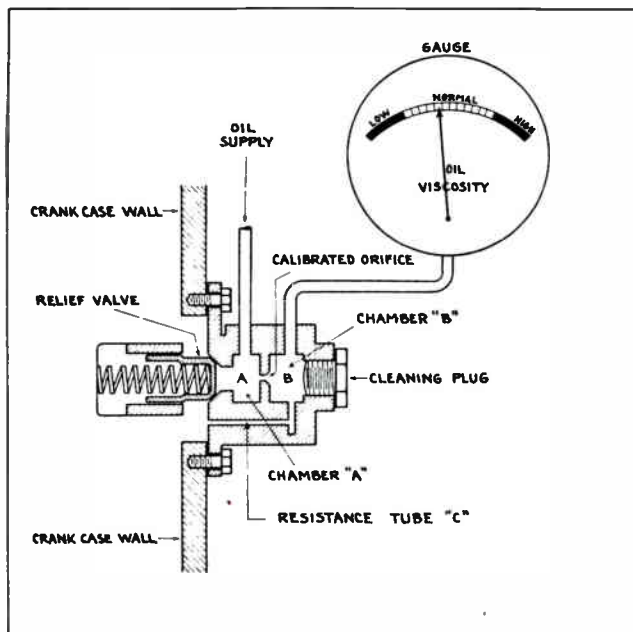

Fig. 127. This type of viscosity meter is sometimes mounted right on the side of Diesel engines to give a continuous indication of the viscosity condition of the oil during engine operation.

Readings should be checked with the engine at normal operating temperature, and at all times during engine operation the pointer should indicate in the "normal" section of the gauge. A "low" reading would indicate that the oil used is too light or badly diluted, and in either case would result in damage or rapid wear of engine parts.

A high reading would indicate that the oil is too heavy. Due to the small clearances at some bearings, oil that is too heavy sometimes cannot reach all the parts that require lubrication, with the result that wear will be excessive.

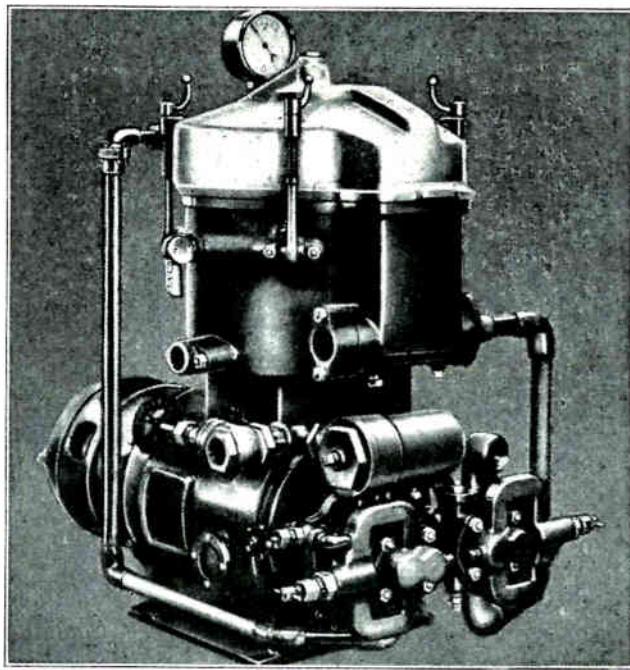

Fig. 128. Centrifugal oil purifier such as commonly used for cleaning and purifying the lubricating oil in Diesel engine plants. (Courtesy Goulds Pumps, Inc.)

71. OIL FOAMING. OIL CLEANING

Two important points to keep in mind, besides using a high grade lubricant are, to keep all oil screens clean and free from lint and dirt, and to drain the crank case of high speed Diesels every 50 to 100 hours of service. It is a good policy, in connection with such engines to flush the crank case with kerosene every other time that it is drained.

Foaming of the oil in the crank case of slow speed engines is usually due to air being drawn in by the oil pump, and churned into the oil. This might be due to an air leak on the intake side of the pump, or to the oil level being a little too low.

In high speed engines using cylinder liners, foaming is often caused by leaky rubber gaskets at the lower end of the cylinder liners, which allows water to drip into the crank case, and mix with the oil.

When oil persists in turning to a slate grey color, after a short period of service, the cylinder block should be very carefully inspected for water leaks.

In very large plants where draining and throwing away of the crank case oil would be costly, "centrifuging" or cleaning in a centrifugal oil separator is standard practice. The oil may be drained and "centrifuged," or the centrifuging equipment may be permanently connected to the engine oiling system and the oil subjected to a continuous cleaning process. Fig. 128 shows a centrifugal oil purifier such as commonly used with Diesel engines.

72. DIESEL ENGINE CONSTRUCTIONAL FEATURES

In your study of Diesel engines this far, you have of course obtained considerable general knowledge of their constructional features and principal parts. However, there are certain details of construction of important parts such as pistons, piston rings, cylinder liners, connecting rods, crank shafts, bearings, etc., with which you should be familiar in

order to better understand the care and maintenance of Diesel engines. Therefore, we would advise that you carefully study the following pages which explain these important points.

A thorough knowledge of these engine parts and their purpose or function will also make your study of the following material on operation and maintenance of Diesel engines much more interesting.

73. PISTONS

The pistons used in ordinary Diesel engines are made of cast iron or aluminum, and fall into two general types, called trunk type and crosshead type pistons. Each has its own particular field of application. The trunk type piston being used in the smaller and medium sized engines, and the crosshead type in the larger engines.

The upper left view at A in Fig. 129 shows a trunk type piston. This type is similar to the pistons used in gasoline automotive engines. During the compression and power strokes of a Diesel engine, the pressure on the piston tends to crowd it against the side of the cylinder, due to the angle of the connecting rod during part of each stroke. This is known as side thrust.

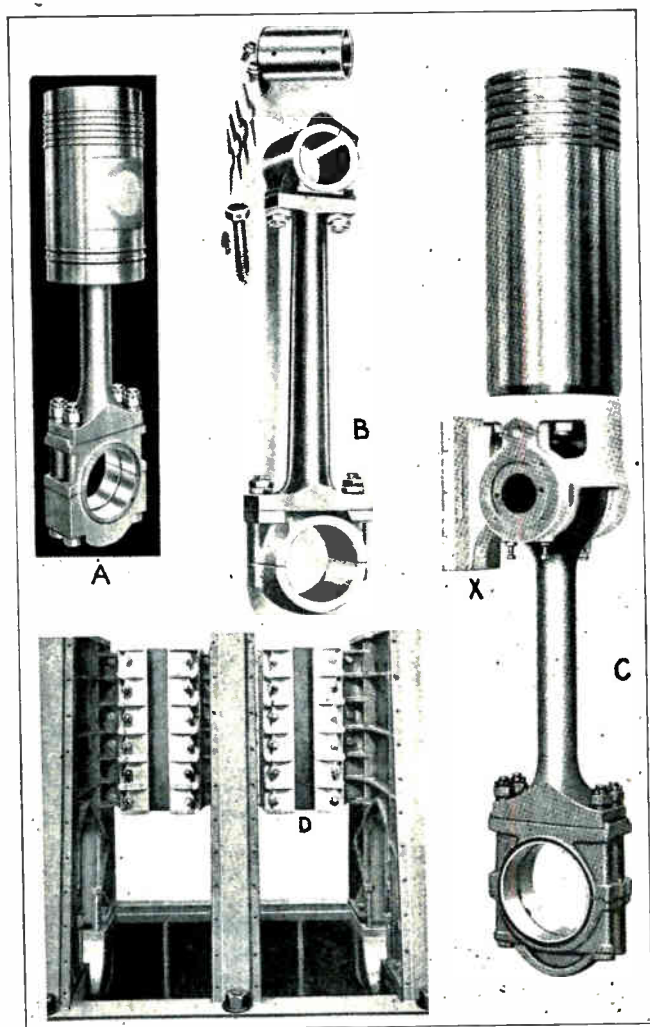

Fig. 129. A trunk type Diesel engine piston is shown at "A" and a crosshead type piston at "C". Note the crosshead pad at "X" which slides up and down in the guides shown at "D". At "B" is shown a connecting rod for a large Diesel engine. Note the provision for adjustments to compensate for wear at both the top and bottom of the bearings of this rod.

In the trunk type piston, all side thrust is taken on the skirt of the piston. This causes the piston and cylinder to wear more on these sides and become out of round. Fig. 130 shows a sectional view of an engine with the piston on the down stroke with the connecting rod at an angle and all side thrust being taken by the left side of the piston.

In Diesel engines, the piston skirts are always longer than those used in general gasoline engine practice, because of the higher working pressures and side thrust during the compression and power strokes.

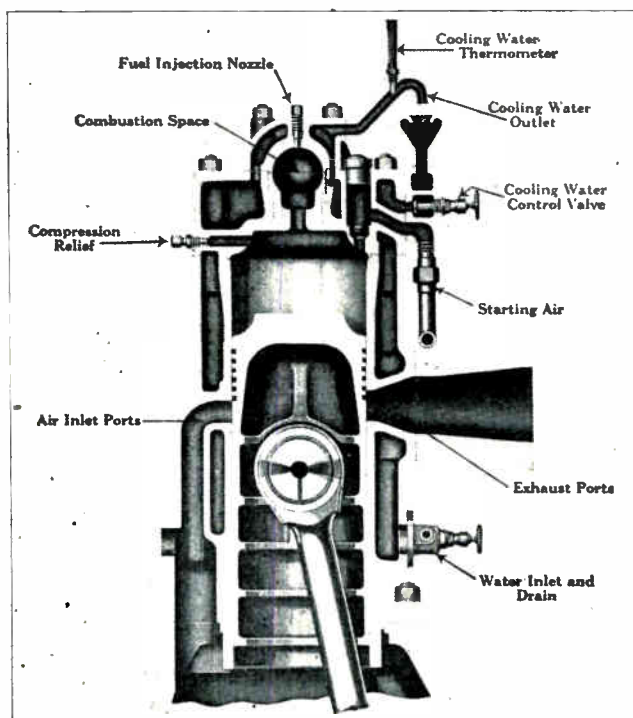

Fig. 130. Sectional view of a Diesel engine showing the piston on its down stroke and the connecting rod at an angle. Note how this would cause the piston to be forced against the left hand side of the cylinder, increasing wear at this point during the power stroke. Courtesy Fairbanks Morse Co.

For very large engines with a cylinder bore of large diameter, the trunk type piston becomes impractical, because side thrust increases as the square of the cylinder diameter, and the length of the skirt required to carry this side thrust would increase the weight of the piston beyond practical values.

To meet this condition, the crosshead type piston is used. Such a piston, with its cross head pad "X" and connecting rod, are shown on the right at "C" in Fig. 129. With this type, no wrist pin is used in the piston itself. The piston is rigidly fastened to a crosshead pad "X" which slides up and down between two vertical guide bearing surfaces, shown at "D" in the engine frame section at the lower left in Fig. 129.

The connecting rod is attached to the lower end of the piston rod by the hollow crosshead pin which is similar to the wrist pin of the trunk type piston. By this arrangement, all side thrust is taken up by the lower end of the piston rod, and the crosshead pad, and a much shorter piston skirt can be successfully used, thus reducing the weight of the piston assembly.

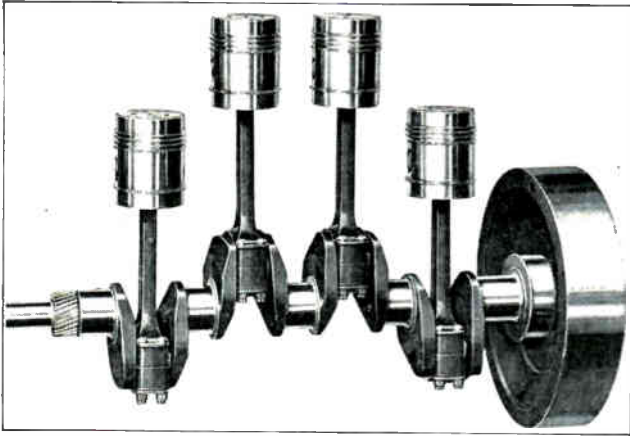

Fig. 131. Photograph showing the crank shaft, connecting rods, pistons and flywheel of a four cylinder tractor type Diesel engine. (Courtesy International Harvester Co.)

74. PISTON RINGS

Piston rings are necessary on Diesel engine pistons, the same as with gasoline automobile engines, to provide a good seal with the cylinder wall and prevent leakage or loss of power and compression. Piston rings being made thin, and being compressed when inserted in the cylinder, thereby tend to spring out against the cylinder wall and maintain a tight fit, even after some wear.

On account of the high compression and power stroke pressures, Diesel engines require more piston rings on each piston than are used with gasoline engines. Small tractor type engines may have five rings per piston, while large stationary engines may have from 8 to 10 rings on each piston. To protect the top rings from the high temperatures generated during combustion, the top rings are sometimes located some distance from the top of the piston as shown in Fig. 131.

When piston rings become worn, they allow leakage or "blow-by" of the hot gases and the charging air, thus lowering the efficiency of the engine and sometimes causing difficult starting. Worn rings should therefore be replaced with new ones.

Special double seal or split piston rings with in-

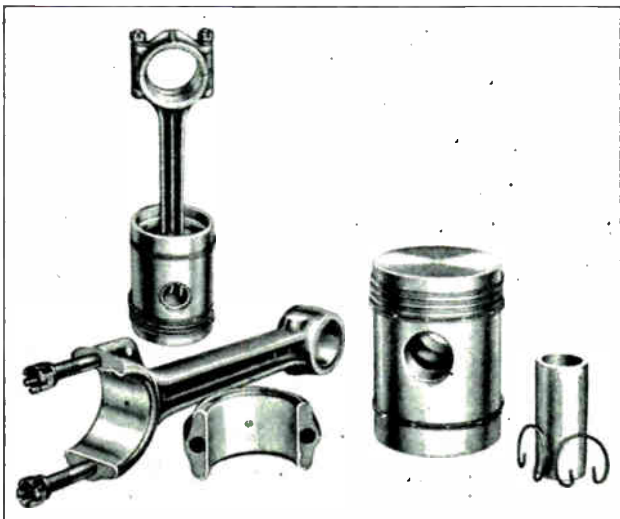

Fig. 132. Pistons, connecting rods, piston pin and retainer springs for a high speed Diesel engine.

ner expanding rings are sometimes used to replace the original rings in engines with badly worn cylinders, to reduce loss of power and improve compression. More about piston rings will be covered in a later section on maintenance.

75. CONNECTING RODS AND WRIST PINS

The connecting rods of Diesel engines serve to connect the pistons to the crank shaft as shown in Fig. 131. They also serve to transfer to the crank shaft the power that is applied to the piston during each power stroke by the force of the expanding gases of the burning fuel oil. Connecting rods are generally made of forged steel.

On the smaller engines the connecting rods are similar in design to those used in automotive service, only the lower end being adjustable to take up wear. See Figs. 131 and 132.

Larger engines are generally equipped with connecting rods that are adjustable at both the crank shaft and wrist pin ends as shown at "B" in the top center view in Fig. 129. One of the most difficult points to lubricate in a Diesel engine is the wrist

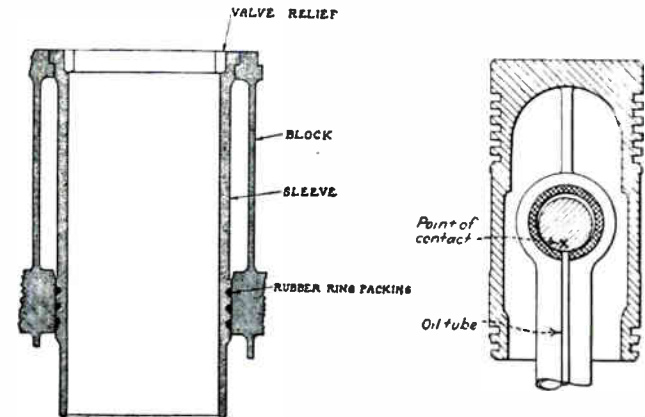

Fig. 133. On the left is shown a cylinder liner pressed into the skeleton cylinder block of a Diesel engine. Note the water space between the liner and the block. This type of liner is known as "wet type" because the water is in direct contact with the outside surface of the liner. Note the rubber packing rings to prevent leakage of cooling water into the crank case. On the right is shown a sectional view of a piston and wrist pin bearing showing how the constant pressure on the lower side of the bearing causes the greatest wear at this point and also tends to prevent proper flow of lubricating oil.

pin in the piston. This is especially true in a two stroke cycle Diesel because the pressure is always downward, as shown on the right in Fig. 133. The wrist pin is stationary in the piston and free in the connecting rod. On the power stroke, the piston is pushing down on the rod and the piston pin contacts the connecting rod bushing at "X" during the entire stroke. On the compression stroke, the connecting rod is pushing the piston upward and the point of contact is still at "X".

Even though the wrist pin is fed oil through a drilled connecting rod as shown in Fig. 133, the constant pressure at "X" prevents this point from receiving much oil. To overcome this handicap, large engines use what is known as a needle or quill type bearing at this point. See Fig. 134. This is simply a roller type bearing using rollers of very small diameter, the ratio of diameter to length being 1 to 10. If the bearing is long, several rows of these needles or quills are used as shown at "S" in the

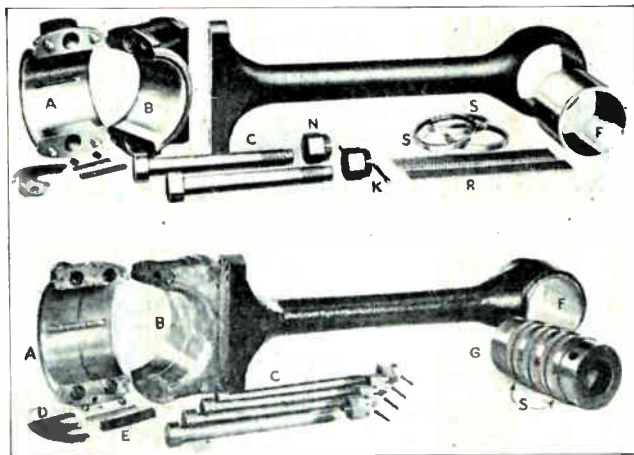

Fig. 134. The above connecting rods are equipped with quill type roller bearings at the right hand or wrist pin ends. Plain split type bearings are used on the crank ends at the left. The split feature allows convenient adjustments to take up the slack due to wear.

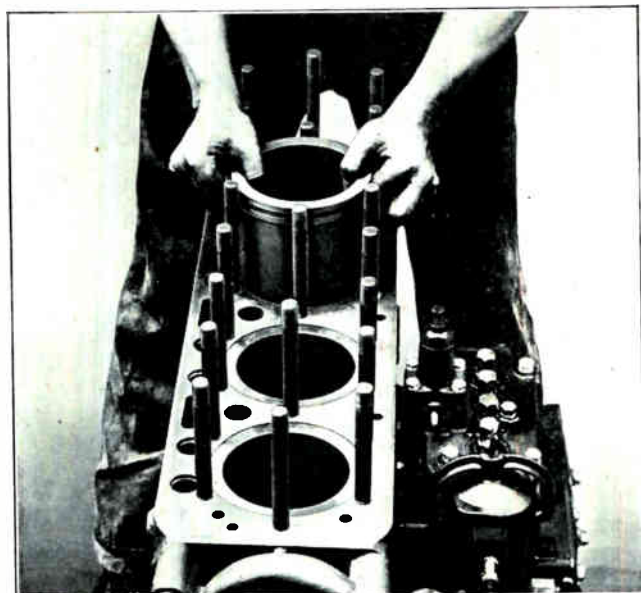

Fig. 135. Photograph showing how cylinder liners can be conveniently removed and replaced on Diesel engines of this type of construction. (Courtesy International Harvester Co.)

lower view in Fig. 134. Narrow rings are placed between the rows of needles and one is placed at each end. The narrow black bands shown around the bearing assembly "G" in Fig. 134 are retaining cords used to keep the needles in place until the whole assembly can be slipped into the connecting rod eye.

These bearings reduce lubrication troubles at this point for two reasons: First, they require very little oil, due to reduced friction of a roller type bearing; second, because of the clearance between the individual rollers, it is an easy matter to get oil to the pressure point of the bearing. This type of bearing also tends to make the engine run quieter, because it eliminates piston slap that is often caused by static friction at the wrist pin.

Connecting rod bearings of the plain babbit lined type can be seen at "A" and "B" at the left ends of the connecting rods shown in Fig. 133.

76. CYLINDER LINERS

The majority of the modern Diesel engines in service are equipped with removable cylinder liners, as shown in Fig. 135. Cylinder liners are favored for two reasons. First, they make the re-conditioning of an engine less costly, as when they become worn they can be removed and replaced with new liners. Second, they can be made of a harder, better wear resisting material than the rest of the cast iron engine block.

There are two common types of cylinder liners called dry type and wet type liners. Dry type liners are sleeves that slip into over-sized bores in the cylinder block. In order to get good contact between the liner and the bore in the block, sometimes these liners are made a trifle larger than the bore, then chilled with dry ice to shrink them so that they will slip easily into place. Then when the metal warms up the liners expand into a very tight pressure fit with the cylinder block.

Some engines use a wet type liner. In this case, the cylinder block merely serves as a water jacket and support for the liner, as shown in Fig. 136, the cooling water being in direct contact with the outside wall of the liner.

The top view in Fig. 136 shows a cylinder block for a large 2 stroke cycle engine with a liner about to be placed in position. Note the exhaust and intake ports in the liner.

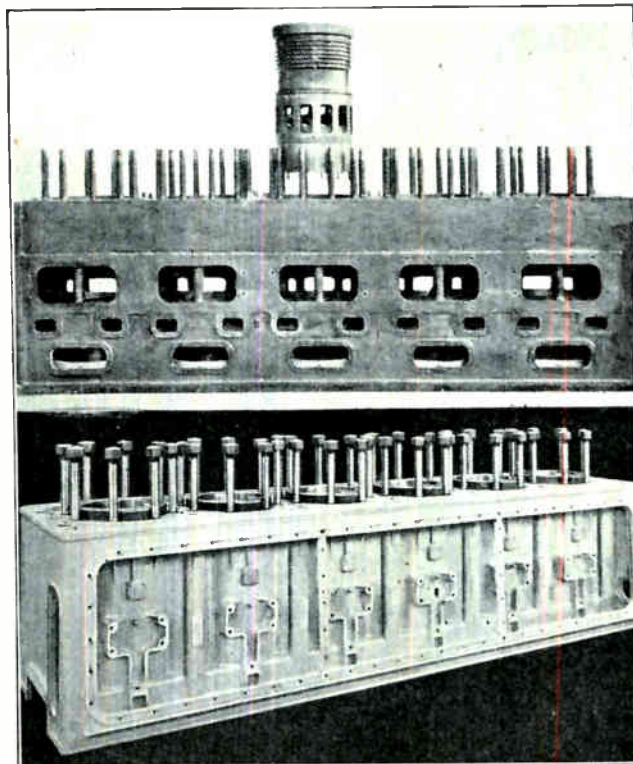

Fig. 136. In the top view is shown the upper section of a Diesel engine frame or cylinder block with one of the cylinder liners removed. In the bottom view is shown a six cylinder engine block with the liners all in place.

While small high speed Diesels usually have the cylinder block and crank case cast in one piece as in automotive practice, large Diesels have the crank cases built up in two sections. The lower part is called the bed plate and carries the crankshaft bear-

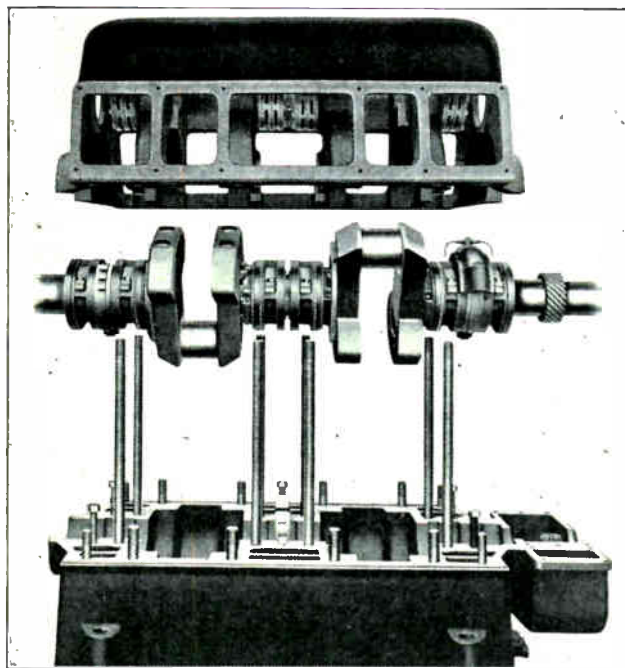

Fig. 137. This view shows the upper and lower sections of a two cylinder Diesel engine crank case with the crank shaft and bearings removed. Note the various bolts which hold these parts in place. (Courtesy Fairbanks Morse Co.)

ings as shown in Figs. 137 and 138. The upper part supports the cylinder sleeves or, in some cases, completely water jacketed individual cylinders. See Fig. 136.

77. VALVES

As mentioned in an earlier lesson, valves are used on many types of Diesel engines to admit the charging air and allow the escape of exhaust gases. These valves are made of forged steel to enable them to stand the wear and heat to which they are subjected.

To make it easy to grind the valves, large stationary type Diesels have both intake and exhaust valves installed in cages that can be removed without disturbing the cylinder head. The lower view in Fig. 139 shows a cylinder head assembly using caged valves. Removing two nuts makes it possible to remove the valve assemblies as shown in the

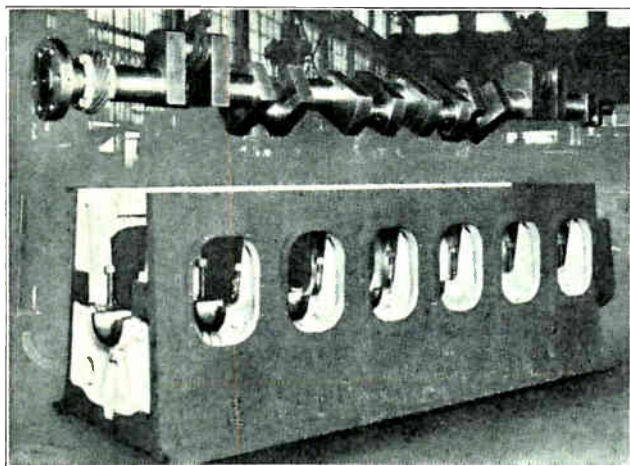

Fig. 138. Lower section of large Diesel engine with crank shaft removed. (Courtesy Busch Sulzer Co.)

upper view, for servicing. Fig. 140 shows another cylinder head with caged valves, and also shows the various parts of the valve assemblies removed.

Small Diesel engines have the valves mounted directly in the cylinder heads without cages, and the entire cylinder heads must be removed to grind the valves. See Fig. 141. The heads are usually divided so that each section covers only two cylinders.

78. CRANKSHAFTS

Due to the very high pressures used with Diesel engines, their crankshafts have to be extremely rugged and always have one main bearing on each

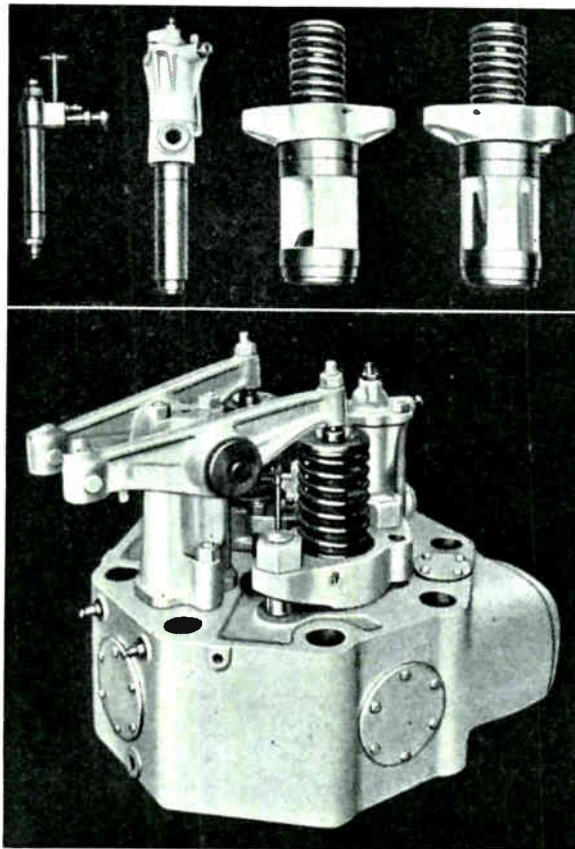

Fig. 139. In the lower view is shown a removable cylinder head which is equipped with removable valve cages and assemblies. In the upper view are shown in order from left to right, the fuel valve, starting air valve, intake and exhaust valves as they appear when removed from the cylinder head shown below.

side of every crank throw. A four cylinder engine having 5 main bearings and a 6 cylinder engine, seven main bearings, etc.

Steel tie rods extend through the cylinder block tying the cylinder heads and lower crank shaft bearing caps together as shown by both the photo and the insert "A" in Fig. 142. This system relieves the cylinder block of load strains, making possible a lighter block.

Accessibility of the wearing parts is extremely important, especially in large engines designed for stationary work, because all moving parts have to be inspected periodically. To make inspection and adjustments easy, removable covers and doors are provided, as shown in Figs. 143 and 144 and by the lower view in Fig. 145.

DIESEL ENGINE OPERATING PROCEDURE

79. GENERAL RULES FOR STARTING DIESEL ENGINES

The procedure to be followed to start a Diesel engine depends upon the type of engine and type of starting equipment used, as explained in Articles 41 to 48 covering types of starting systems and equipment.

Regardless of type of equipment however, there are two rules that apply in all cases. First, the fuel system must be free from air, otherwise the engine may not start or if it does start, it will run erratically. As a rule, fuel systems will hold their prime, but if the fuel tank has been allowed to run dry or if any part of the fuel system has been removed and replaced, all air will have to be expelled or "bled" out, of the fuel system before the engine can be started.

To free the system of air, the air bleed valves in the injection nozzles should be opened, or if no valves are provided, each fuel line should be loosened at the nozzle. If the fuel transfer pump is

equipped with a manual priming handle, operate the transfer pump manually until fuel, free from air bubbles, flows from the air bleed valves or loosened fuel lines.

When this method is followed, if the injection pump is one that uses the port method of regulation, the pump control should be set in the stop position. On other types, the pump control can be set either in stop or full load position.

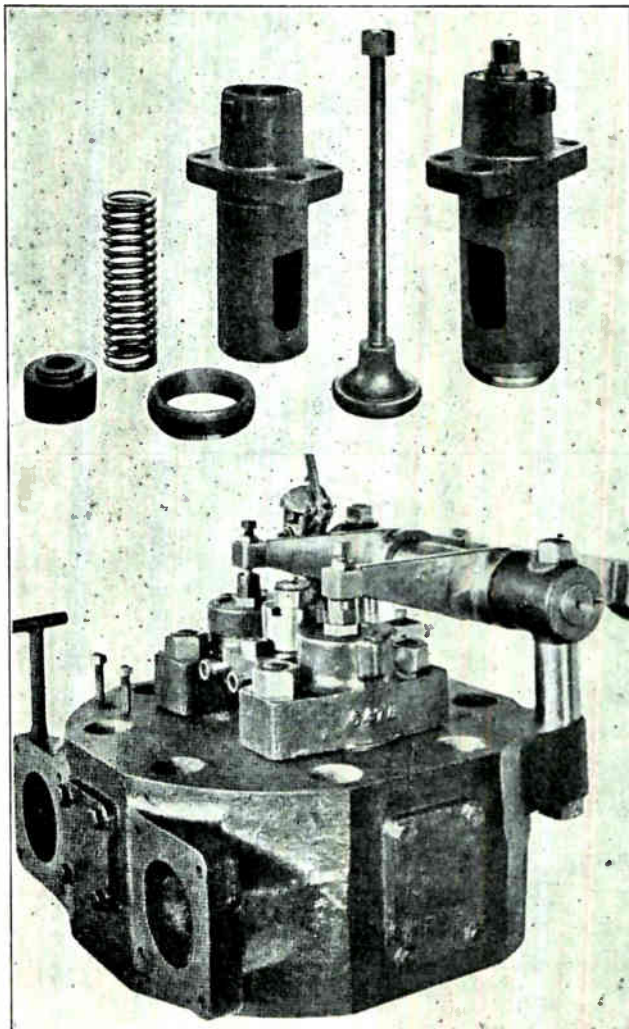

Fig. 140. Another type of Diesel engine cylinder head showing removable valve cages and assemblies and rocker arms. In the upper view one of the valves with its seat ring and spring has been completely removed from the cage. (Courtesy Bush-Sulzer Co.)

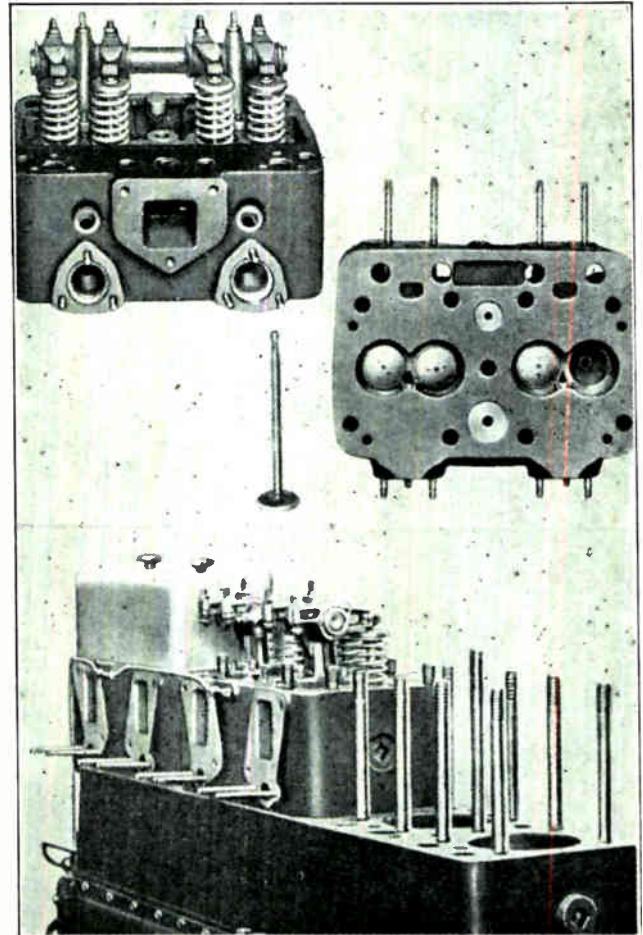

Fig. 141. In the lower view is shown a six cylinder Diesel engine from which one section of the cylinder head has been removed. Note that each cylinder head section covers two cylinders and is equipped with the intake and exhaust valves which are located right in the cylinder head.

If the transfer pump has no manual handle, set the fuel control in full load position for all types of pumps, and operate injection pump plungers by turning the engine over with the starter or by working each plunger up and down with a heavy screw driver, until fuel free from air spurts from the air bleed valves or the loosened ends of the fuel lines.

The second rule is to be sure that the engine is supplied with lubricating oil and that the cooling system is supplied with water. In starting light weight high speed Diesels that are equipped with separately heated glow plugs and compression release, proceed as follows:

1. Set the manual fuel control in starting or idling position.
2. Turn on the glow plug switch.
3. Set compression release lever in the "off" position.
4. After 15 or 20 seconds, close starting motor switch and as the engine starts to turn, throw the compression release lever back to "on" position.
5. As soon as engine begins firing open starting motor and glow plug switches.

If the glow plugs are connected to the starting motor circuit and no compression release is used, set the manual fuel control to starting or idling position and apply the starting motor.

If a gasoline engine is used for starting purposes, when the Diesel engine is cold allow the gasoline engine to run for a few minutes before attempting to start the Diesel engine. The exhaust heat which is used to heat the intake manifold of the Diesel will make starting easier.

To stop the engine, set the manual fuel control to "stop" position.

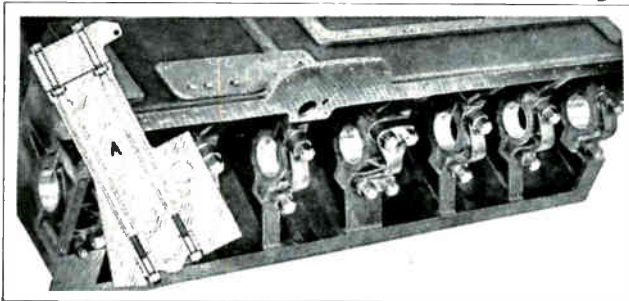

Fig. 142. Photograph showing the arrangement of the bearings in a six cylinder Diesel engine. Note the bottom ends of the through bolts which are shown full length in the insert at "A." These bolts run clear through from the crank shaft bearings to the cylinder head.

80. STARTING WITH COMPRESSED AIR

In starting large engines with compressed air see that the air pressure is between 250 and 300 lbs. All lubricators for cylinder lubrication must be full. Be sure that no tools are left lying on the engine platform and that all belted machinery, generators, etc., are clear.

If the engine is equipped with motor driven cooling pumps they should be started and the cooling water circulation checked. If the engine has less than 4 cylinders, it will have to be turned over until one of the pistons is slightly past top dead center. Marks on the fly wheel are provided to set the engine properly. The engine is turned over by inserting an iron bar into holes, drilled in the rim of the fly wheel.

With the engine properly set, the fuel control handle is put in starting position, and the air is turned on. As soon as the engine begins firing, the air is turned off, and the fuel control handle is set in full load position, which turns the control over to the governor.

If glow plugs are used, they should be turned on and allowed sufficient time to heat before any attempt is made to start the engine.

In starting semi-Diesels or oil engines which use blow torches, sufficient time must be allowed for the hot tubes to heat up before the engine is started.

81. STOPPING

To stop these engines, move the fuel pump control to stop position. If the engines use separately driven cooling pumps, they should be left running until the outlet water temperatures are not more than 5 or 10 degrees above the inlet temperatures. This prevents local overheating which tends to cause scale deposits to form in the jackets if hard water is used. If the cooling pump is driven by the engine, the engine should operate with a light load or idle for 10 minutes before stopping. This allows it to cool down enough to be safe to stop the cooling water circulation.

After the engine is stopped, it should be gone over thoroughly to see that everything is in good order. Bearings and other parts should be checked to see if any are abnormally warm.

Engines should not be allowed to stand continuously idle for more than a week in dry climates, or for more than a day or two in damp climates or sea air. Short periods of running without load, or merely turning the engine over several times with a bar will will maintain a protective oil film on the bearing surfaces. If there is any danger of freezing, all water jackets and pipes should be thoroughly drained, otherwise serious damage to the equipment may result.

82. REVERSING

For marine operation, the larger Diesel engines are built so that they can be reversed. This eliminates the need of a reverse gear and gear box, thereby reducing the weight of the power plant. The entire operation of stopping the engine and

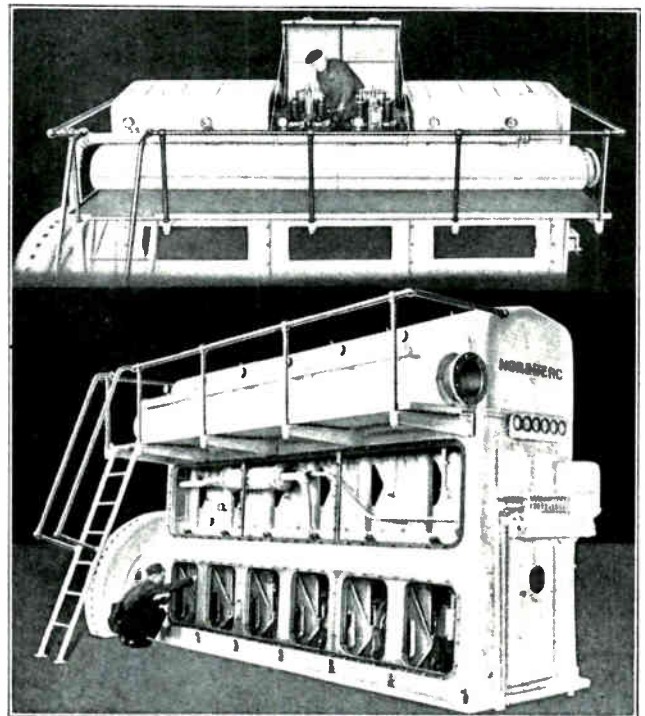

Fig. 143. Some Diesel engines are equipped with covers or housings such as shown above and which make them neater in appearance and quieter in operation. Note in the upper view how the top covers can be conveniently opened for access to the valve mechanisms and cylinder heads. Note in the lower view how the side plates can be removed for access to connecting rod and crank shaft bearings.

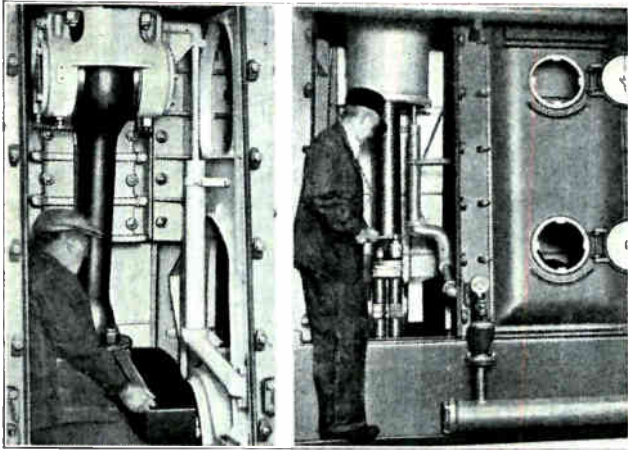

Fig. 144. These photos show how the side plates can be removed from a large heavy duty Diesel engine to permit the operator or repair man to get at the connecting rod and crank bearings to adjust them for wear. Note in the left hand view the crosshead between the top of the connecting rod and the bottom end of the piston to which it is bolted. Also note the guide bearing directly behind the crosshead and connecting rod.

reversing the direction of rotation is accomplished by means of a control wheel such as shown in Fig. 146. The complete operation of reversing some engines requires four revolutions of the hand wheel.

The first turn puts the injection pumps out of action and the engine begins to slow down to a stop. Next the angular position of the shaft that drives the injection pumps and the rotary air distributor is changed for proper timing for reverse operation. If the engine is a 4 stroke cycle type the angular position of the cam shaft is also changed. The third turn puts the injection pumps back into action and at the same time opens the main air starting valve, causing the engine to rotate in the opposite direction and start firing. At the end of the 4th turn, the main air valve is closed and the engine is in full operation. The entire operation requiring not more than 3 or 4 seconds.

Some reversing equipment is designed to reverse the engine with less than one turn of the hand wheel, the order of events being the same as described above.

83. STARTING AND STOPPING THE HESSELMAN SPARK IGNITION INJECTION ENGINE

The normal procedure to start a Hesselman type engine is as follows:

Prime the engine with 2 or 4 strokes of the gasoline primer pump. Then crank the engine by hand or with the electric starter if it is equipped with one. As soon as the engine starts to fire, watch the exhaust and continue to feed gasoline with the primer pump until engine runs smoothly.

Watch the exhaust for $\frac{1}{2}$ minute more and if smoke appears, one or more strokes of the primer pump should clear it up.

To stop this type of engine, set the pump control in stop position. After the engine has come to rest, if it is equipped with battery ignition, turn the ignition switch off.

Caution: Never stop a Hesselman engine by turning the ignition off. Always cut off the fuel supply first by setting pump control in "stop" position.

84. INSPECTION DURING OPERATION

In large Diesel plants, a running engine should be thoroughly inspected at least once every half hour, and the operator should check the lubricating oil pressures, the action of the mechanical lubricators, and the outlet water temperature from each cylinder.

Inspect the valve mechanism regularly. All parts not automatically lubricated should be oiled every two hours. Exhaust valve stems should be given a few drops of kerosene every 3 or 4 hours to keep them in good working condition. Keep the top of cylinder heads and all parts of the engine wiped off clean.

If a pyrometer is used, note the exhaust temperatures. These should be no higher than the values recommended by the manufacturer of the engine, or the value given on the name plate.

Note the appearance of the exhaust gas. Normally it should be clear. If the engine is overloaded, the exhaust may become cloudy. Black, smoky, exhaust is caused by too heavy load, leaky fuel nozzles, injection too late, plugged holes in multi-orifice nozzles, low compression, or a dirty air filter.

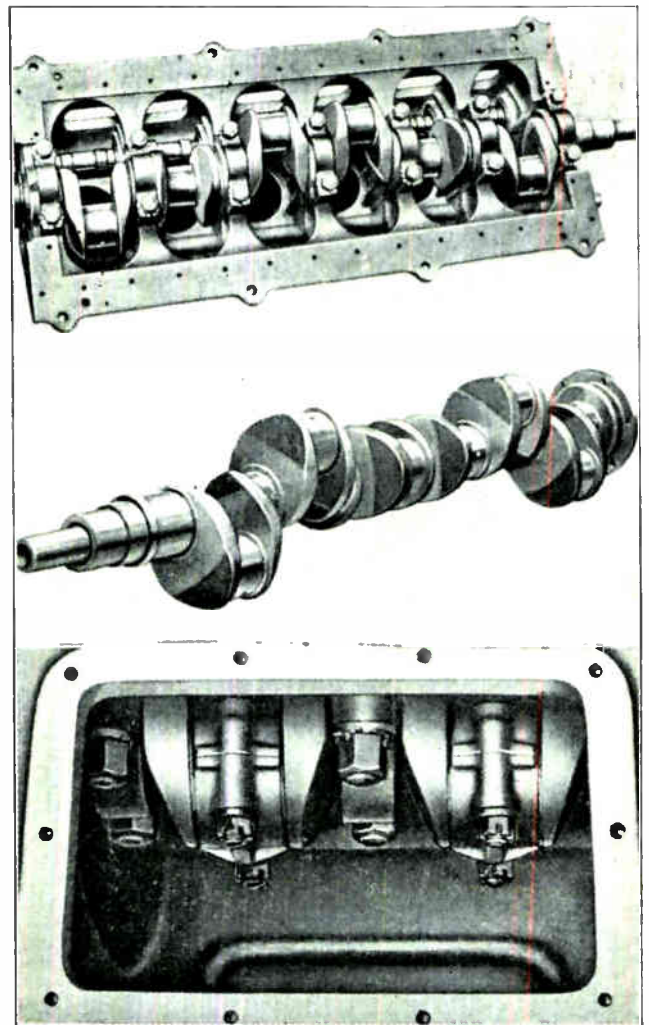

Fig. 145. At the top is shown a crank shaft mounted in the bearings and crank case while in the center view it is shown removed. Below one of the side plates is shown removed to permit accessibility to the crank shaft bearings for easy adjustment.

A bluish exhaust is sometimes caused by an excessive amount of lubricating oil. This might be caused by defective oil rings, too high oil pressures or incorrectly adjusted mechanical lubricators.

If, for any reason, the cooling water or oil should stop flowing, or any part of the engine become overheated, stop the engine immediately and allow it to cool off gradually. Under no circumstances admit cold water to a hot engine, as this may cause the pistons to seize, or it may result in cracked cylinder heads or liners.

In case of low air pressure if the compressor equipment is out of commission, two methods may be used to obtain the necessary pressure for starting. Tanks of compressed air may be obtained from concerns that sell oxygen. As the air in these tanks is under 2000 lbs. pressure, they should be connected to and equalized into the regular air starting system.

If compressed air cannot be obtained, a tank of carbon-dioxide may be obtained from dealers in soda fountain supplies and connected to the air starting system. This gas is a liquid at ordinary temperatures and 800 lbs. pressure. The application of heat by pouring hot water over the carbon-dioxide container or applying rags soaked in hot water may be necessary to bring about evaporation.

Caution: Never use oxygen for starting purposes, as it is highly explosive when mixed with oil and may result in a wrecked engine.

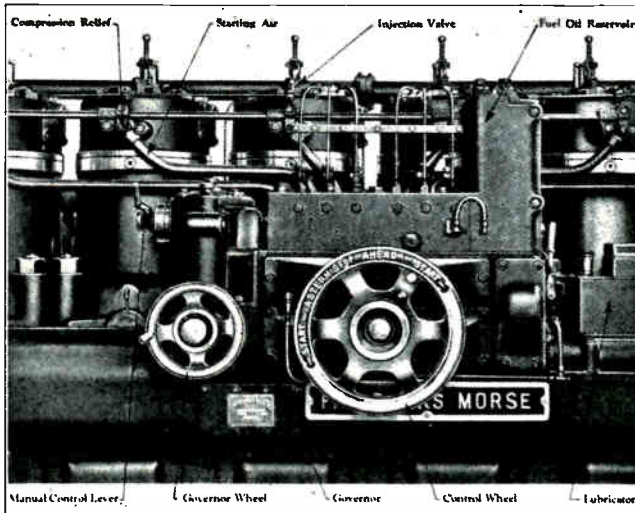

Fig. 146. This view shows the starting, stopping and reversing controls of a heavy duty Diesel engine. Note that the start, stop, and reverse positions are marked on the control wheel. Also note the governor wheel and the manual throttle or control lever. (Courtesy Fairbanks Morse Co.)

85. DIESEL ENGINE MAINTENANCE

Diesel engine maintenance can be divided under four headings: cleaning, adjusting, renewal of parts, and re-conditioning.

In the smaller plants, which as a rule are not equipped with machine tools, precision gauges and skilled machinists, the common practice is to replace any defective parts with spare parts kept on hand. In large plants that have a machine shop, worn or broken parts can be machined, re-fitted and repaired right in the plant.

86. CLEANING

No matter whether the plant is small or large, cleaning is a part of the operator's daily routine, and should be attended to regularly and thoroughly.

The engine should be wiped frequently enough to keep it free from oil, grease and dirt. Frequent cleaning has two advantages; first, it keeps the engine looking neat and also removes dirt that might work into some of the bearings or working parts, and second, the operator may, while regularly cleaning and inspecting the engine, detect a fault before it becomes serious.

A systematic cleaning routine should be applied not only to the engine, but to the electric generators and switchboards in Diesel-Electric power plants, and all other equipment used in the plant.

87. LOW COMPRESSION

Engine compression should be watched closely, and maintained within 20 lbs. of the recommended pressure. The most probable causes of low compression are leaky valves, leaky gaskets, worn or stuck piston rings, and badly worn cylinders. Low compression causes difficult starting and reduces the operating efficiency of Diesel engines.

Leaky exhaust valves are caused by burning and pitting of the valve edges and valve seat, and also by valve stems becoming stuck due to carbonized oil. A leaky valve can usually be detected by overheating of the valve or cage, and by the sound of escaping gas or air.

Valves should be ground periodically, the frequency depending upon operating conditions.

88. VALVE GRINDING

To grind valves, the cages or cylinder heads are removed, and disassembled. A light coating of grinding compound, is put on the valve face, then it is rotated back and forth on the valve seat until a bright seat $\frac{1}{8}$ of an inch wide shows all around the seating surface. After valves have been ground, the clearance between the valve stem and rocker arm, or valve lifter should be checked and set according to the manufacturers specifications.

When replacing valve cages in the cylinder head after grinding valves be sure the copper covered gaskets are in place, all surfaces clean and a good tight fit secured. Fig. 140 shows a cylinder head and valve mechanism in the lower view, and above are shown the valve cages and valves removed.

89. WORN RINGS—RING CLEARANCES

Worn rings allow leakage because the ring gap or slot and side clearance become too great. While it is impossible to give general rules that would give the correct clearance in all cases, a gap of .003" for each inch of ring diameter is considered safe. When a new ring is fitted, it should be inserted in the smallest part of the cylinder liner, and the gap measured with a feeler gauge. The smallest part of the liner is near the bottom, because at this point, wear takes place slower.

While piston rings must be free in their grooves, side clearance between the side of the ring and the ring groove must not be excessive. As a rule, the top ring is given a little more clearance than the others because it is in a hotter zone and therefore, expands more than the lower rings.

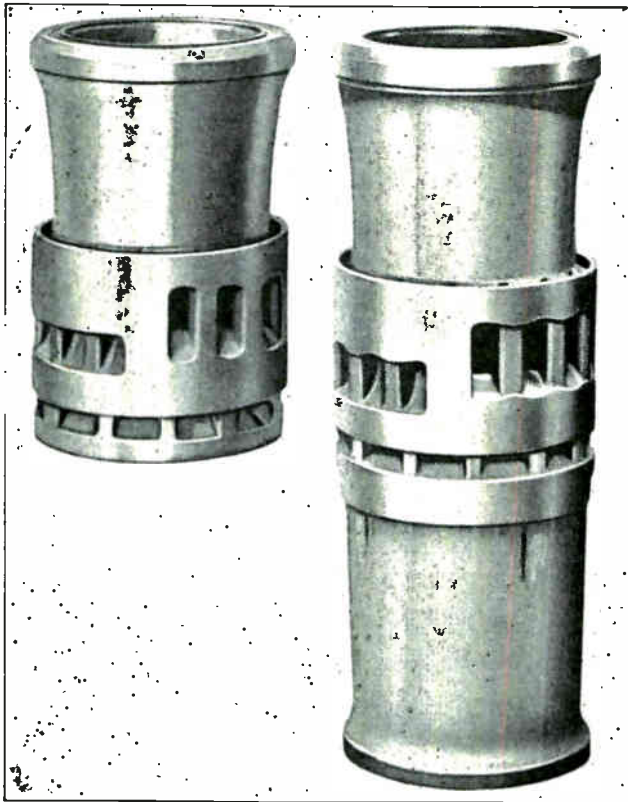

Fig. 147. Two types of removable cylinder liners for Diesel engines. The one on the right is for a trunk type piston and the one on the left for a crosshead type piston. Note how the use of the crosshead bearing reduces the necessary length of the cylinder liner. Also note the intake and exhaust parts in these liners.

MINIMUM SIDE CLEARANCES IN THOUSANDTHS OF AN INCH

Cylinder Diameters	4 Cycle Engines		2 Cycle Engines	
	Top Ring	Other Rings	Top Ring	Other Rings
Under 6 inches	.003	.002	.005	.004
6 to 12 "	.004	.003	.006	.005
Over 12 "	.006	.004	.008	.006

90. BEARING WEAR AND CLEARANCES

The connecting rod bearings should be checked periodically for excessive clearance. On large engines this can be done by removing the inspection doors on the side of the crank case and using a long bar for a pry, test for up and down play. If excessive clearance is noticed, the amount can be checked by removing the lower half of the bearing and placing two pieces of soft lead wire lengthwise across the babbit lining. The bearing is then replaced and drawn up tight. This will flatten the lead wires, and when the bearing is again removed, the lead wires are measured with a micrometer.

The normal clearance is .001 inch, per inch of crank pin diameter. As an example, if the crank pin is 5 inches in diameter, the normal clearance should be .005 inch. If the lead wires used to test the clearance measured .012 inch, then enough shims to measure .007 inch should be removed from between the bearing halves. When replacing bearing bolts, be sure that all cotter pins are in place, to prevent bolts working loose during engine operation.

Wrist pin clearance for a 4 stroke engine should not exceed .00075 in. per inch of pin diameter (.003 in. on a 4 inch pin.) Two stroke cycle engines require .001 in. clearance per inch of pin diameter, because the higher temperatures occurring in 2 stroke cycle engines bring about more expansion and distortion of bearings and parts. Soft lead wire 1/16 of an inch in diameter should be used to check the clearances, by the same method described for rod bearings.

Main bearing wear should not exceed .002 inch in 4000 hours of operation. The usual clearance should be .001 inch per inch of crank shaft diameter. The lead wire method is also used for measuring or checking this clearance. The lower view in Fig. 145 shows how a crank case cover can be removed for access to the crank shaft and connecting rod bearings.

91. PISTON AND LINER WEAR AND CLEARANCES

The two parts subjected to the most wear in a Diesel engine are the pistons and the liners. The rate of wear of these parts is determined by several factors, among which are piston speed, quantity and quality of lubrication, and grade of fuel used.

In slow speed engines, the rate of liner wear may be as little as .001 inch per 1000 hours of operation, while in a high speed engine, the wear may run as high as .001 inch per 400 hours. Inferior lubricating oil, and fuel with a high ash content will also mean short liner life. Fuel containing more than .05% ash by weight will cause rapid liner wear, and greatly increase the cost of maintenance.

As a general rule, the clearance between the skirt of the piston and the liner is .001 inch, per inch of cylinder diameter for cast iron pistons, and .0015 inch, per inch of cylinder diameter for aluminum pistons. At the upper or "fire end" of the piston, the clearance should be .005 inch, per inch of cylinder diameter for cast iron pistons, and .010" for aluminum. The reason for this piston taper or difference in clearance at the top and bottom ends is because of the greater expansion that occurs at the top due to higher temperatures at this point.

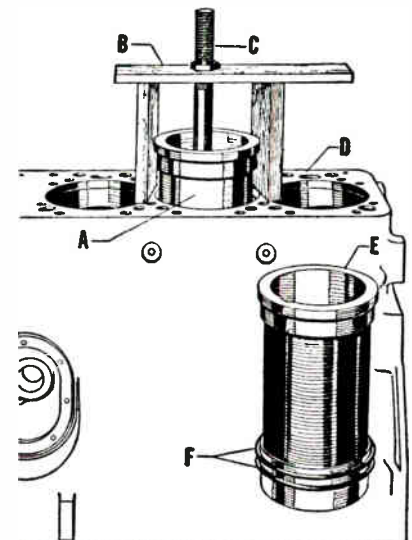

Fig. 148. This illustration shows a convenient method of removing cylinder liners from a Diesel engine. Note the printed explanation above.

Renewal of the liners should be considered when they show, .006 inch wear per inch of cylinder diameter. If the wear reaches .009 inch, per inch of cylinder diameter, engine operation will be unsatisfactory. The wear is always greatest at the top of the liner because this part is exposed to higher temperatures and pressures.

Fig. 147 shows two cylinder liners for large Diesel engines. The one on the left is for an engine using a crosshead type piston and the one on the right is for a trunk type piston. Fig. 148 shows a method used to pull cylinder sleeves from a Diesel engine.

Compression and operating efficiency of engines with badly worn cylinders, can often be improved by use of special flexible double seal piston rings, which will shape themselves to the worn contour of the cylinder walls. After cylinder walls or liners become too badly worn, the liners should be replaced, or the cylinders rebored and fitted with new pistons and rings.

Figure 149 shows on the left the condition of a piston that has been lubricated with an inferior grade of oil. Note the gummy condition of the piston, the stuck rings and indication of blow-by. On the right in Fig. 149 is shown a piston that has been lubricated with a high grade Diesel oil. Note the free condition of the rings, and the general clean condition of the piston, although it was operated for the same time period as the one on the left.

92. CLEANING CYLINDER JACKETS

Once a year the cylinder jackets and cylinder heads should be inspected for mud or scale deposits. Mud and sand can be flushed out with a hose. If there is a deposit of scale, it should be removed with some special scale remover or with a solution of one part muriatic acid to 10 parts of water. This solution should be mixed in a barrel, and circulated through one cylinder jacket, at a time with a pump.

If no pump is available, the jackets can be filled with the solution and allowed to remain for 10 hours, after which it should be flushed out thoroughly with water. All copper or brass fittings should be removed before this solution is used, or they will be damaged by the action of the acid.

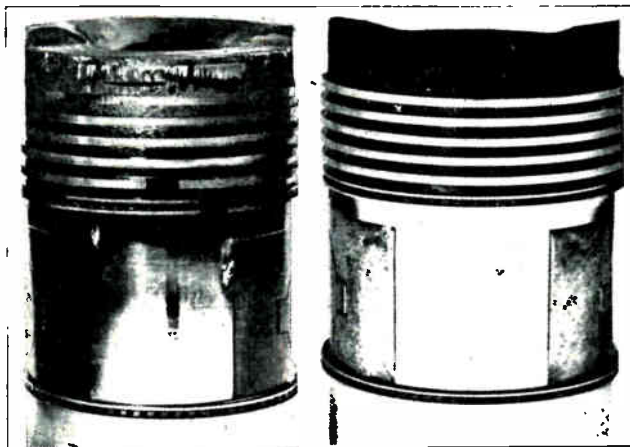

Fig. 149. This view shows two pistons which were both operated for the same period of time but with different grades of lubricating oil. The piston on the left shows signs of badly stuck rings, blow-by and wear, while the piston on the right which was operated with the better grade of oil shows all rings free and the piston and rings in very good condition.

93. TOOLS AND SPARE PARTS FOR REPAIRS

The amount of shop equipment and the stock of replacement parts that a Diesel plant should be provided with depends largely on the size of the plant, location in respect to machine shops, and maximum allowable length of time that an engine can be kept out of service.

If no machine shop is available, the Diesel plant should have one of its own to handle the general repair and overhaul work. The equipment should include a lathe, drill press, forge, vise, tool grinder, valve grinder lathe attachment, rig for pulling pistons, pipe cutting and threading tools, flaring tool for copper tubing, micrometer, mandrils for various bearings, scrapers, wrenches, dies, taps, punches, chisels, hammers, files, blow torch, etc.

Replacement parts that should be kept in stock depend upon the ease with which they can be obtained from the engine factory or a supply house in case of an emergency. In the case of an isolated plant (plant which is located far from any source of parts) the following list of parts should be kept on hand.

- Two or 3 spare injection nozzles
- 1 injection pump
- 2 exhaust valves complete with cages (4 stroke cycle engines)
- 2 exhaust valves only (4 stroke cycle engines)
- 1 spare piston
- 1 set of piston rings (for 1 cylinder)
- 1 complete connecting rod assembly
- 1 of each type of gasket used on engine
- 1 of each type of spring used on engine
- 1 set rings for air compressor
- 1 suction and 1 discharge valve for compressor
- 1 pump unit for lubricator

The service department of the engine builder can often suggest special spare parts that should be kept in stock at the Diesel plant for any particular make of engine.

94. DIESEL-ELECTRIC PLANT OPERATION

If you are an operator in a Diesel-Electric power plant, the same general operating rules as given in the sections on D.C. generators and A.C. generators and switchboards, can be applied to the care and operation of the electrical equipment.

Special attention should be given to the cleaning, lubrication, operating temperatures and ventilation, synchronizing, paralleling and load adjustment of the generators. Full instructions on these items, as well as care and repair of bearings, brushes, commutators, windings and switchboard equipment are given in the above mentioned sections. Review them thoroughly in case you wish to prepare for work as an operator in a Diesel-Electric power plant.

Combination Diesel-Electric operators have excellent opportunities for pleasant, interesting, good paying jobs in municipal, industrial, railway, oil field and ship power plants of this type. Therefore, this combination training should be very valuable to you if you are interested in this class of work.

AIRCOOLED RADIAL DIESEL ENGINES

Another recently developed type of Diesel engine is the Guiberson Radial Diesel engine shown in Figures 1 and 2. This engine is air cooled and has nine cylinders arranged radially around a central crank shaft.

This type of construction provides an unusually compact and powerful engine adaptable for use on Aircraft, Army tanks, portable earth drills, and other uses where large amounts of power are needed and where space and weight limitations or cumbersome liquid cooling systems would make other types of Diesel engines impracticable. The engine shown develops 250 h. p. at 2200 R. P. M. with cylinders having $5\frac{1}{8}$ inch bore and $5\frac{1}{2}$ inch piston stroke.

Figure 150 shows the arrangement of cylinders and the valve rocker arms and rods which are operated by a large central cam ring located in front of the central cover plate. The injector nozzles can be seen on the cylinder head between the valve arms, and with fuel pipes running to individual fuel pumps located in the accessory case and also operated by central cam ring.

Figure 151 shows the opposite side of this engine and the cooling fan which blows air around the cylinders and through the cooling fins on each cylinder.

Figure 152 shows the crank case in the process of machining, with cylinder openings and seats, and smaller openings for valve rods and fuel pump cylinders.

Figure 153 shows cylinder head and barrel assembly for one of the nine cylinders.

Figure 154 shows assembly of crank shaft and connecting rods in rear half of crank case.

Note how all nine connecting rods are attached to one central bearing hub so they can all deliver power from their pistons to the one central crank. This part of the construction is similar to that of the conventional gasoline operated radial Aircraft engines.

95. CONSTRUCTION FEATURES OF GUIBERSON RADIAL DIESEL ENGINE.

This type of engine has a crank case made of two aluminum alloy castings bolted together on the center line of the cylinders. See Figures 152 and 154. Hardened bearing liners are pressed into the front and rear portions of the crank case. Ball or roller bearings are fitted into these liners and furnish support for the crank shaft.

The crankshaft is a two piece heat-treated steel forging, drilled throughout for lightness and plugged to form oil passages. See Fig. 154.

The cylinders have heat treated aluminum alloy heads which are screwed and heat-shrunk onto forged steel barrels. See Fig. 153. Both heads and barrels have cooling fins to provide ample heat radiating surface for air cooling of the engine. Cylinder bores are honed to a mirror finish and to extremely close size limits.

Pistons are of aluminum alloy and are provided with three compression rings, one scraper ring

above the piston pin and one oil ring in the skirt.

The connecting rods are forged steel, heat treated and machined. One being a master rod for timing purposes and the eight others called link rods. Fig. 154 shows how they are attached to the main bearing hub on the crank shaft.

The valve cam ring is of forged steel with four cam lobes and is driven by gears at one eighth engine speed in the direction opposite to crankshaft rotation.

The fuel pump cam ring is also of forged steel and is bolted to valve cam ring through slots which permit adjustment of the angle of the fuel cam with relation to the valve cam. This adjustment can be made by means of an adjusting eccentric extending through the valve cam, when the nuts on fuel cam mounting bolts are loosened.

96. FUEL SYSTEM.

This engine uses the solid injection system as previously described on Page 892, Article 12, for supplying liquid fuel oil to the individual cylinders. The fuel pump units for each cylinder are of the variable stroke type, similar to those described on page 896, Article 17. Fuel injectors are of the closed spring loaded type similar to those described on Page 898, Article 20.

Figure 155 shows a diagram of the fuel supply system and paths used with this type of radial engine. A transfer pump "E" is used to draw fuel oil from tanks "B" and "B", through filter "D" and force it through check valve "F" to the circular fuel channel or pipe "G" which supplies all nine individual high pressure fuel pumps "H", only one of which is shown in this diagram.

High pressure pump "H" the plunger of which is operated at the proper time by the fuel cam forces fuel oil through injector valve and nozzle "J" into the engine cylinder at the top of compression stroke.

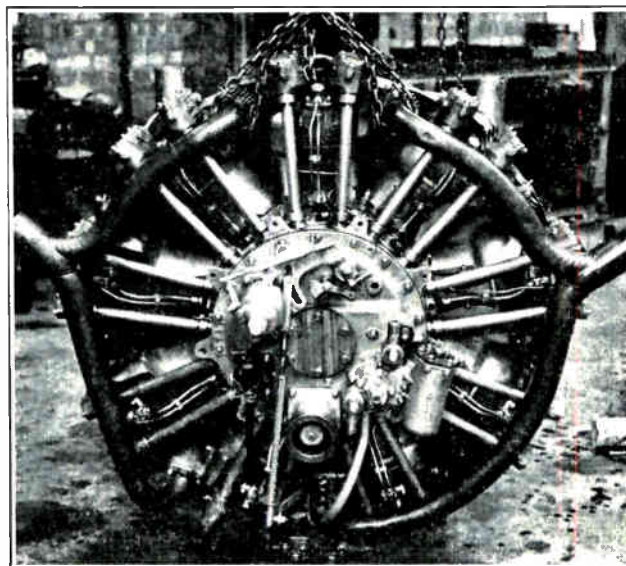

Fig. 150. Buda-Guiberson Diesel engine for tanks and aircraft. Note arrangement of cylinders, valve push rods, injectors and control auxiliaries.

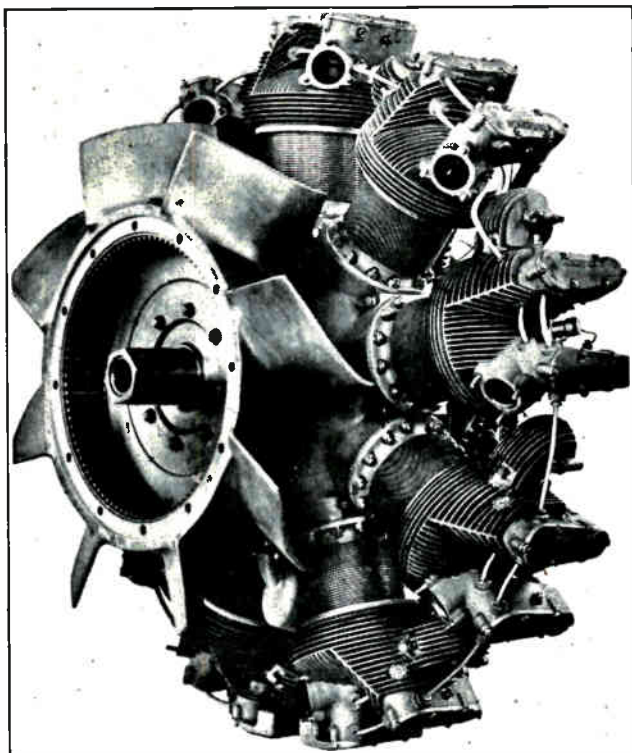

Fig. 151. Another view of Buda-Guiberson Diesel engine, Model T-1040 radial aircooled type. Note air fan for cooling cylinders.

Drip line "K" returns excess or leakage fuel from injectors through return ring "L" and return line "N" to tank "B" for re-use.

Only approved fuel oil of 28-40 A. P. I. gravity, 35-45 Saybolt viscosity, 150° F. flash point, Diesel index 50 min. and Cetane number 50 min. should be used with these engines. See further fuel oil specifications in item 6 of Article 102 in this Chapter.

97. LUBRICATION SYSTEM

The lubrication system used with this type engine is shown diagrammatically in Figure 156. Lubricating oil pressure pump "B" draws oil from tank A, forces it through filter "C" to remove any particles of dirt or carbon. The oil then passes through a cored passage and drilled oil line (not shown) to a circular groove located in the engine accessory case. From this groove, oil passes through drilled passages to the intermediate gear, idler gear and governor. It also goes through another drilled passage in the starter jaw to the center of the crankshaft, which is drilled to carry oil to the master rod bearing, knuckle pin bushings, valve cam and fuel cam.

The oil in the crank case and accessory case is thrown around by the rotating parts of the engine and lubricates the piston pins by oil splash. From the bottom of the crank case the oil is drawn from sump "M" by scavenger pump "N", forced through return line "G" to oil cooler "H" and then back to supply tank "A".

Part of the oil from pressure pump "B" is bypassed through a spring loaded pressure regulating valve "E" to the return line. Valve push rods, tap-

pets and rocker arms are lubricated by oil passing from the pressure pump through a cored passage and drilled holes in the accessory case, to a circular groove in the mounting flange of the rear half of the crank case, then through holes which connect with other holes drilled in the tappet guides.

Oil which collects in the rocker arm boxes is drained through a system of inter-cylinder drain tubes which can be seen in Figure 151, to the oil sump rocker box covers of lower cylinders 5 and 6, and is then pumped through rocker box scavenger pump "S" to the joint return line.

Only standard approved aviation engine lubricating oils should be used for this type of engine, and different brands of oil should not be mixed. If necessary to change brand or grade of lubricating oil, drain entire oil system including storage tank, sump and filter and renew filter cartridge before refilling system with new oil.

98. STARTING SYSTEM

This type of engine uses a method of starting quite different from those described in previous chapters. The Guiberson radial Diesel engine uses a starting cartridge inserted in a special breech and combustion chamber attached to the starter gear and fired by an electrical impulse from a small battery and starter contact switch. This type of starter eliminates the necessity for any auxiliary starting air tanks, electric starter motors and heavy storage batteries or auxiliary gasoline engine starters such as used with stationary Diesel engines or those used on tractors and trucks. A standard shot gun shell loaded with powder only, is used.

When preparing this engine for its first startup in service, or after the fuel system has been drained, the procedure should be as follows:

1. Fill fuel tanks with fuel oil of proper quality according to engine manufacturers specifications.
2. Fill lubricating oil tank to the full mark on bayonet gauge, with proper grade of lubricating oil.
3. Open shut off valves of both fuel tanks, and open the air vent valves located in the top of purolator filter.

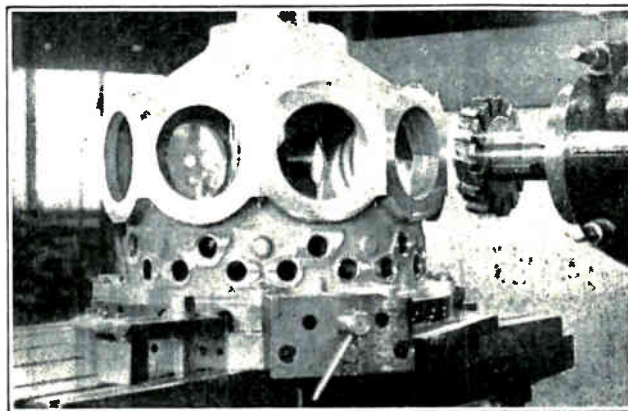

Fig. 152. Complete crankcase in process of machining. Note large openings to which cylinders will be attached and small openings for valve rods and fuel pump barrels.

4. Remove check valve spring and check valve of the fuel channel pressure regulating valve, located between No. 1 and 2 cylinders, by unscrewing the 1" nut. (Do not remove the dome shaped cover).

5. If fuel from the tank does not force the air out of the channel through the pressure regulating valve body, remove the fuel transfer pump and turn it anti-clockwise (facing pump shaft), while lines remain connected to fuel transfer pump. Allow fuel to flow until air free fuel flows through the regulating valve body. Reassemble the regulating valve and fuel channel is now filled with fuel.

6. Place idling control lever in the off or stop position, meaning that top of quadrant lever must be in farthest position to the right or toward the throttle shaft.

7. Move the throttle arm up and down from off to wide open position 10 or 12 times. Turn flywheel 90° in direction of rotation and repeat throttle movement. Repeat this set of operations until at least 2½ turns of flywheel have been made. Moving the throttle operates the injection pump plungers and fills the injection lines. Pressure build up can be felt on the upward stroke of throttle as the lines fill up with fuel. The fuel injection, which will occur when pump, line and injector are filled, is clearly discernible. This operation will be necessary each time fuel system has been drained.

8. Remove the inspection plate located in the rear of the accessory case directly above starter flange, and spray one pint of S. A. E. 30 oil over all parts in the rear case section. Replace cover.

9. Check throttle controls for proper adjusted lengths to assure shut off and wide open positions. See that all controls work freely without binding or sticking. The throttle rod idling adjusting screw and governor controls

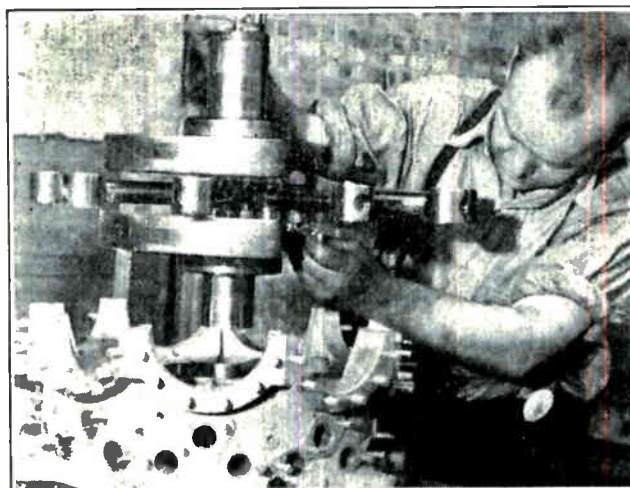

Fig. 154. Assembly of crankshaft and connecting rods in rear half of crankcase of Guiberson radial Diesel engine.

are set at the factory and should not require changing.

10. Now, to start engine, turn fan wheel with engine on decompression for two or more complete revolutions. Turn Cuno oil filter handle one complete turn. Open throttle, depress clutch pedal to reduce starting load, set idling control lever in idling position and close starter contact switch to fire starting cartridge. To secure first start of engine after installation may require 3 or 4 cartridges, depending upon the care used in filling injection system.

As soon as engine starts release throttle control to allow engine to operate at 500 to 550 R. P. M.

Watch oil pressure gauge and do not operate engine more than 30 seconds if gauge does not register 40 lbs. or more at 500 R. P. M. In case oil pressure is less than 40 lbs. stop the engine immediately and check oil level in oil tank and check all oil connections.

Disconnect suction line at the pump, prime pump and refill oil lines. Connect line to pump and repeat starting operation.

Then if oil pressure is normal, warm up the engine carefully by operating at 800 R. P. M. for 2 minutes, 1000 R. P. M. for 2 minutes, 1200 R. P. M. for 3 minutes, and then with engine in 3rd or 4th gear operate at 1300 to 1600 R. P. M. until oil temperature has reached 100° F. After that, watch the tachometer and open throttle slowly until engine speed reaches 2000 R. P. M., then on up to 2325 R. P. M. If throttle is now opened wider, engine speed should not increase further if governor is properly adjusted.

99. CARTRIDGE STARTER UNIT OPERATION AND TROUBLES.

In order to place a starter cartridge in the Breech Barrel, revolve breech opening lever 90 degrees upward, and breech housing downward about its axis to open position. Place cartridge in breech barrel,

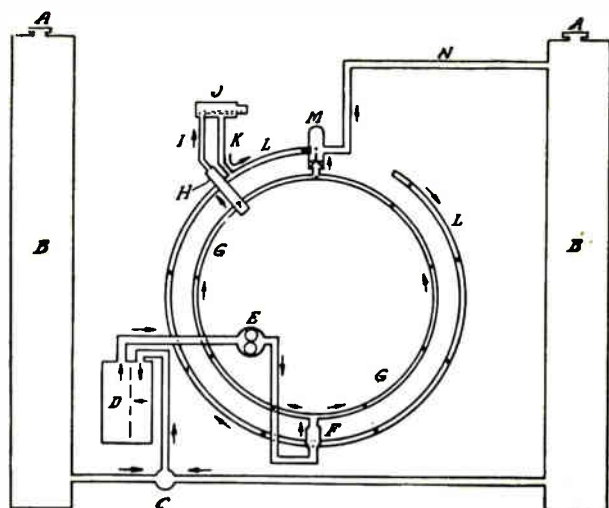

Fig. 153. Assembly operation on cylinder head and barrel of radial Diesel engine.

**KEY**

<i>A-TANK VENT</i>	<i>H-PRESSURE PUMP</i>
<i>B-FUEL TANK</i>	<i>I-PRESSURE LINE</i>
<i>C-TANK VALVE</i>	<i>J-INJECTOR VALVE</i>
<i>D-FUEL OIL FILTER</i>	<i>K-DRIP LINE</i>
<i>E-TRANSFER PUMP</i>	<i>L-FUEL RETURN RING</i>
<i>F-ONE WAY VALVE</i>	<i>M-REGULATOR VALVE</i>
<i>G-FUEL CHANNEL</i>	<i>N-RETURN LINE</i>

Fig. 155. This diagram shows the fuel supply system and units, also the paths traveled by the fuel oil in this type of radial engine.

close breech housing and move the breech opening lever downward again to stop position.

As a safety precaution the electrical firing contacts in the breech assembly are arranged so that it is impossible to complete the firing circuit by closing the switch until the breech opening lever is closed and against the stop.

After priming the fuel injection system, close the toggle switch to ignite starting cartridge.

Remove empty cartridge cases immediately after firing, by moving breech opening lever 45 degrees upward and holding it in this position until any residual pressure escapes, as indicated by hissing noise at bottom of relief valve assembly on breech barrel. Then raise breech opening lever and open the breech downward, which will partially eject the cartridge case so it can be removed by hand.

The breech should only be loaded immediately before starting the engine. Always keep breech closed at all times except when loading or unloading.

In an emergency, if the standard source of electrical energy to the breech is not available, the starting cartridge may be fired by use of one cell of a flash light battery, by placing one pole of the cell against the breech barrel and the other pole against the wire extending from the flexible shielded conduit.

In case of failure of a cartridge to fire on first attempt, at least three additional attempts should be made. If cartridge still fails to fire it should not be removed from the breech for at least five minutes.

If cartridge fails to fire after following the above procedure, remove cartridge from breech and inspect the hole in cartridge base and also inspect contact pin in breech housing for presence of any foreign matter. Also check wiring system for loose connections.

If engine fails to start after firing 3 cartridges, check the engine to see if it can be turned by hand and can function normally. Determine if proper cartridge is being used by noting identification mark on cartridge base. Examine the safety disc located in safety disc holder in fuel combustion chamber. This safety disc is provided to protect the starter and aircraft mechanism, by bursting of the disc in case of excessive pressures. A loud report with propeller barely moving indicates a burst safety disc. In this case remove safety disc holder from combustion chamber, remove the burst disc with a pointed tool, being careful not to scratch the edge of disc shearing ring, and insert new disc with asbestos side upward and visible when in disc holder. Never substitute coins or other similar articles. Use only proper specified safety disc.

After 40 hours of engine operation the inside of breech barrel should be cleaned with penetrating oil on a cotton swab on a cleaning rod. After 80 hours of operation the breech should be removed, disassembled, cleaned, lubricated and tested electrically.

100. STOPPING THE ENGINE.

AVOID SUDDEN STOPPING OF THIS TYPE OF ENGINE. Before stopping, the engine should be throttled down and operated with no load at about 1150 R. P. M. for 4 minutes. This permits uniform cooling and contraction of various parts of the engine. Then permit engine to operate at low idling speed for 2 minutes more to allow splash oil to accumulate in the oil sump so scavenger pump can return the oil to the supply tank.

If an unavoidable forced stop occurs during high speed operation, place the throttle lever on decompression and turn engine at least 2 revolutions in direction of normal rotation before again attempting to start the engine. This is to force the oil which might have collected in No. 5 and 6 cylinders out through the exhaust so there will not be a hydraulic lock between the piston and cylinder head.

101. ENGINE TROUBLES.

If the ENGINE FAILS TO START it may be caused by: 1. Improper starter operation due to a need for cleaning and servicing. 2. A blown safety disc. 3. Incomplete combustion of starter cartridge fuel. 4. Air in the fuel injection lines. 5. Low fuel level in tank. 6. Closed fuel shut off valve. 7. Leaks in the fuel lines.

LOW COMPRESSION with resulting loss of engine efficiency after 500 hours of operation is due normally to wear affecting the pistonrings, valves and valve guides. Insufficient valve clearance when the engine is cold will cause valves to remain partly

open and result in loss of compression. Valves that are pitted, warped or burned will also cause loss of compression.

IF ENGINE STOPS it may be due to no fuel in the fuel tanks, partially closed fuel tank valves, plugged fuel tank vents, clogged filters or restrictions in fuel system, or fuel supply pump not delivering fuel at required pressure.

LOW OIL PRESSURE may be caused by dirt in the screen or filters, loose connections or leaks in supply line, low oil level in supply tank, foreign matter under pressure regulating valve, or worn or scored accessory case or master rod bushing.

EXCESSIVE OIL CONSUMPTION may be caused by worn or broken piston rings, clogged oil sump screen, leaks in scavenger pump line or connections, scavenger pump failure or incorrect installation, or by leaks in oil return line. Oil should be changed at least every 25 hours of engine operation.

If the ENGINE RUNS UNEVENLY and fails to deliver full power it may be caused by improper fuel, dirt or water in fuel, leaking injection line connection, injection pumps not delivering fuel due to stuck plungers or broken plunger springs, or injectors not operating properly, due to sticking pintle valve or leaky injector valve seat, causing poor atomization of fuel.

When injectors give trouble in field service they should be REPLACED AS UNITS. All injector servicing should be done in shops which have proper equipment and skilled mechanics.

102. IMPORTANT RULES FOR OPERATION AND CARE OF GUIBERSON RADIAL DIESEL ENGINES.

1. Turn the engine two revolutions on decompression before starting, if engine has been standing idle more than 5 hours.

2. Operate engine between 1400 and 2000 R. P. M. by shifting gears to avoid continued lower speed operation. Maximum engine speed under load should not exceed 2200 R. P. M., and for long continued operation it is better to operate at speeds less than 2000 R. P. M.

3. Regulate oil temperature within recommended range or near mid-values of following temperatures, 100 to 140 deg. F. when atmospheric temperature is 40° F. or lower, 100 to 160 deg. F. when atmospheric temperature is 40° to 90° F., and 100 to 180 deg. F. when atmospheric temperature is above 90° F.

4. Allow engine to warm up gradually to permit engine parts to maintain proper temperature equilibrium. For atmospheric temperatures of 30° F. and higher operate engine at 800 R. P. M. for 2 minutes, then at 1000 R. P. M. for 2 minutes, then at 1200 R. P. M. for 2 minutes. For atmospheric temperature at below 30° F. operate engine at 800 R. P. M. for 5 minutes, then at 1000 R. P. M. for 5 minutes, then at 1200 R. P. M. for 5 minutes.

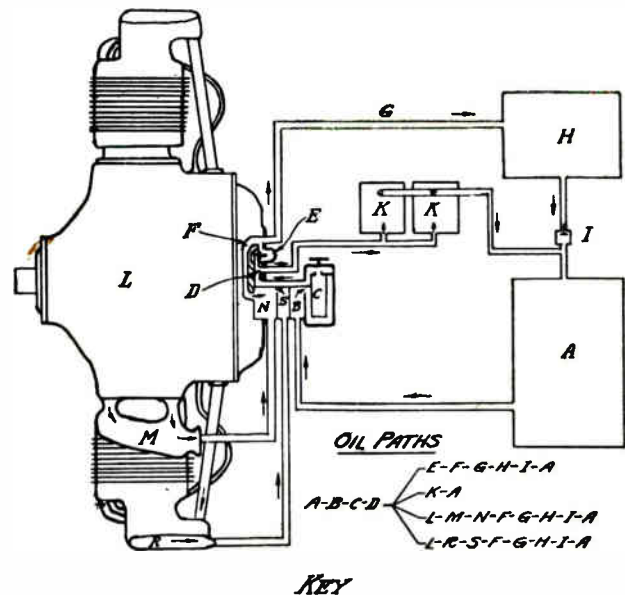

Fig. 156. The above diagram shows the lubricating oil system and units used with the Guiberson radial Diesel engine.

5. Avoid sudden stopping and cool engine down gradually, to avoid damage to parts due to too rapid or unequal cooling and contraction. After load is released allow engine to run idle at 1150 R. P. M. for 4 minutes to cool down, then at 500 R. P. M. for 2 minutes to allow scavenger pump to remove oil from crank case and sump.

6. Use only clean fuel of correct specification. Gravity A. P. I. 28-40, Viscosity, Saybolt Universal at 100° F., 35-45, Flash F. 150° F. min., Diesel Index 50 min., Cetane No. 50 min., Pour point 0° F. min., Distillation (curve furnished by mfr. with engines), Water and sediment .05% max., Ash .01% max., Carbon residue .10% max., Sulphur .75% max., I. B. P. 375° F. min., E. P. 725° F. max. Fuel should be handled carefully to keep it free from water and dirt.

7. Change lubricating oil regularly, at least every 25 hours of engine operation. Use only aviation oils with National distribution to aviation industry. DO NOT MIX BRANDS. When changing grade or brand, drain entire oil system, including tank, sump, lines and filter.

8. Keep all connections tight by frequent inspection to avoid leaks.

9. Check injection nozzles periodically. They should be set for 2500 lbs. pressure per square inch on a regular injector test unit. Spray angle should be adjusted to be parallel to top of piston.

These engines are a modern marvel of maximum power in minimum space and with minimum weight. Their fine precision machined parts accomplish these results if given the care they deserve.



COYNE

Electrical School

CHICAGO ~ ~ ILLINOIS



ESTABLISHED 1899

COPYRIGHT 1942

ELECTRIC REFRIGERATION AND AIR CONDITIONING

Section One

Refrigeration Principles
Nature of Heat and Cold, Heat Transfer
Evaporation and Pressures
Refrigeration Systems and Cycles
Refrigerator Parts and Construction
Compressors, Condensers, Evaporators,
Expansion Valves
Control Switches, Motors, Cabinets
Refrigerants and Lubricating Oils
Absorption Type Refrigerators
Installation Methods
Tubing Connections.

ELECTRIC REFRIGERATION AND AIR-CONDITIONING

During the past few years Electric Refrigeration and Air-Conditioning have rapidly grown to be one of the greatest industries in this country. The speed with which this great new industry has developed is almost unbelievable.

Up to 1925 there were only 75,000 electric refrigerators installed in the United States. In 1926, over 210,000 more units were added, and in 1927, sales jumped to 390,000 units. In 1931, over 965,000 more homes were equipped with electric refrigerators.

During the depression, this great industry continued to expand, and in 1935, the new units installed reached 1,688,600. Then, in the single year of 1936, over 2,000,000 more electric refrigerators were added, bringing the total to over 10,000,000 of these machines in use in this country. Since then the Refrigeration Industry has continued to grow and develop at an amazing pace. Note the chart in Fig. 3, which clearly shows this sensational rate of growth in the number of household refrigerators made and sold each year.

This tremendous growth of the electric refrigeration industry has created an enormous demand for trained men in the manufacturing, installing and servicing of these interesting machines.

There are still many millions of electrically wired homes that have no electric refrigerators, and the number of these units in service will undoubtedly be doubled within the next few years.

Just try to picture the number of men required to install and service all these units and you will realize the splendid opportunities that exist in this field for trained service men to work at interesting good paying jobs for refrigeration companies and shops, or to start a service shop or business of their own.

In addition to the millions of refrigerators now used in homes, there are also many thousands of large refrigeration machines in use in ice plants, meat packing and food storage plants, refrigerated railway cars, refrigerated trucks, ice cream plants, food freezing plants, meat markets, stores, restaurants, etc.

Air-conditioning is another great new field which has developed from Refrigeration, and although its real growth has only started within the last several years, it has already become a great industry employing thousands of trained men. And the work in this fascinating new field is only just well begun. Homes, offices, stores, hotels, restaurants, theatres, schools, radio studios, hospitals, and even factories and manufacturing plants are being air-conditioned, for summer cooling, winter heating, and year-round washing, filtering, and humidity control of the air we breath and live in. Fig. 6 shows a convenient type of room cooling unit, and Fig. 7 shows a central air-conditioning plant located in the basement of a building.

Air-conditioning has become a necessity in the manufacture of many articles, and to increase business in many hotels, stores, theatres, restaurants, and other commercial establishments.

The increased efficiency and improved health of employees in air-conditioned plants is making air-

conditioning essential and economical from this angle. The increased comfort and improved health provided by the clean, crisp, cool air in homes in the summer, is creating a demand for air-conditioning in thousands of homes each year. It will only be a short time before millions of average homes are equipped for comfort cooling in the summer, just as they are for comfort heating in the winter.

Air-conditioning systems use refrigeration machines to cool the air, and both electric refrigerators and air-conditioners use electric motors, electric temperature controls, electrically operated valves, fuses, switches, etc. Therefore, a combination training in Electricity, Refrigeration and Air-Conditioning should help to qualify you for a real job in this field.

So study these lessons carefully and thoroughly. A good refrigeration service man must know the fundamentals of Refrigeration. He must know how

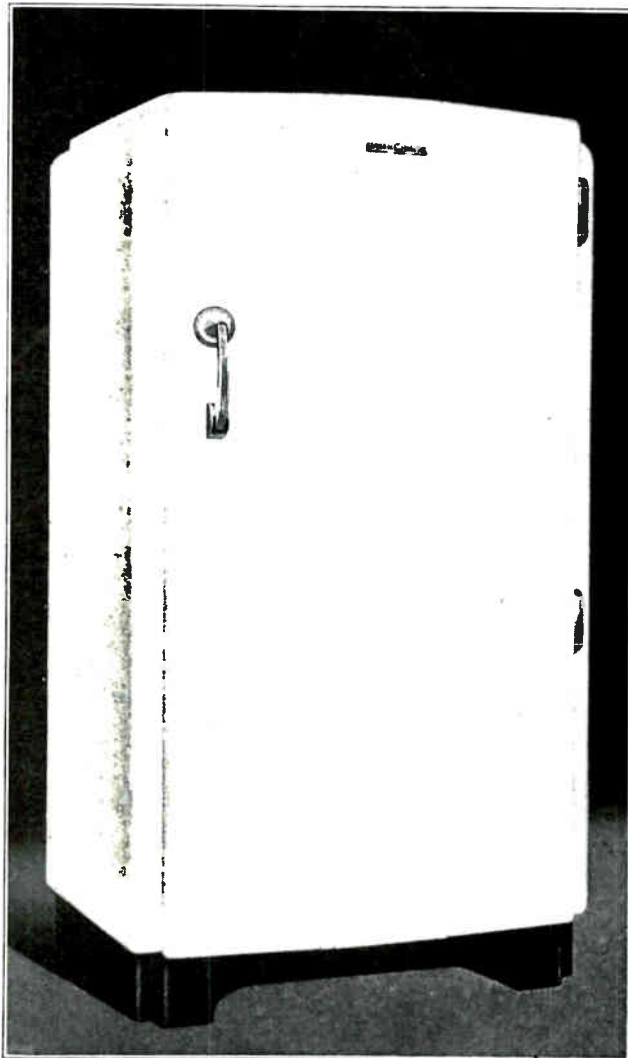

Fig. 1. Photograph of a modern electric refrigerator for domestic or home use. Note the beautiful cabinet design, which has been one of the factors in the great popularity and great number of sales of units of this type. The food storage compartment and operating mechanism are completely enclosed within the cabinet. Courtesy General Electric Company.

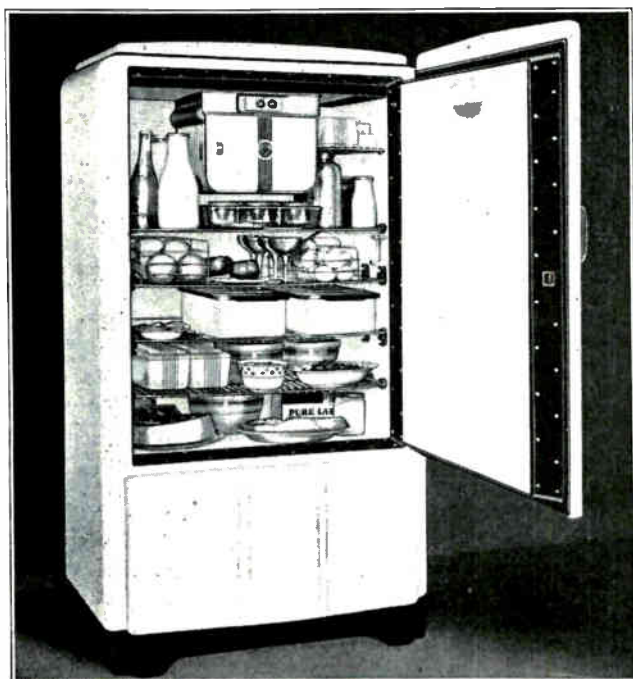

Fig. 2. Another view of a modern electric refrigerator with the door open showing the cooling unit in the top of the cabinet, and some of the various food articles which can be stored and preserved in electric refrigerators. Courtesy General Electric Company.

the equipment works and why it works, in order to know what is wrong when it does not work.

1. WHAT IS REFRIGERATION?

Refrigeration is the process of reducing the temperature of a certain body or space by removing some of the natural heat.

For hundreds of years people have been trying to cool certain objects or bodies below the temperature of the atmosphere. Early attempts were rather crude, and limited to only a few degrees of temperature reduction.

Liquids and foods were often placed in cool caves where the sun's heat could not reach them and where cool water and the process of natural evaporation kept them cooler than the surrounding air.

It was found that evaporation of perspiration or moisture from the human body reduced the surface temperature and carried away the body heat much more rapidly. Liquids were kept cool by placing them in slightly porous stone jars, through which part of the liquid continuously evaporated, thus cooling the remainder.

Snow and ice were often saved from winter seasons and used in the hot summer months to preserve food and to cool beverages. In more recent years, ice became quite commonly used in ice boxes in the average home, and commercial harvesting, storage, and sale of ice became an extensive industry.

Then, with the development of mechanical refrigeration equipment, the manufacture of ice for use in ice boxes in city homes became a substantial industry. Ice is still used in some homes, but it has the disadvantage of not maintaining an even temperature in the ice box, and of being rather messy and inconvenient due to the necessity for frequent ice replacement and the disposal of the water from the melted ice.

The development of the electric refrigerator has provided a much more convenient, efficient and economical refrigerating unit for home or commercial use. Its popularity and efficiency, as well as practical necessity, are borne out by the tremendous growth in the number of units sold in the past few years. Figs. 1 and 2 show views of one popular make of modern household refrigerator.

The principal reason for refrigeration is, of course, the preservation of food such as meats, fruits and vegetables, which will rapidly spoil and decay if kept in warm places. This spoilage is caused by the growth of bacteria which can only thrive or multiply at warm temperatures. Bacteria cannot develop at temperatures below 40 to 45 degrees F. (Fahrenheit). Fig. 2 shows a variety of food articles that can be preserved in a refrigerator in the home, and Fig. 5 shows a refrigerated cold storage room for preserving fruits.

The modern electric refrigerator can be set to maintain these proper food preserving temperatures very accurately, and will also provide much lower temperatures, even below zero F. for freezing of ice cubes, ice cream, or other desserts. These machines will provide this service at a cost of a few cents a day and with reliable operation over years of time with very little service or attention. Very often the saving on food spoilage, and the ability to buy and store larger quantities of foods will, in a period of several years, more than pay for the cost and operation of an electric refrigerator.

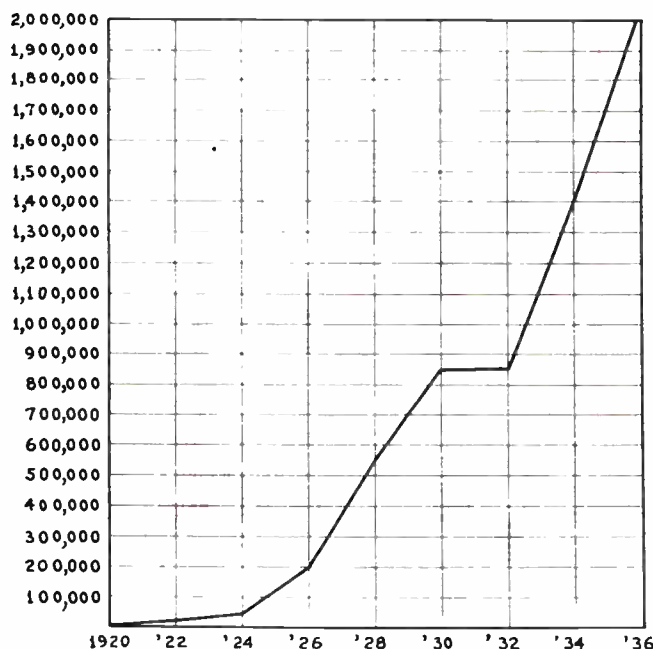

Fig. 3. The above chart graphically shows the rapid and almost continual rate of growth of the vast electric refrigeration industry. Note that in a period of only ten years, the number of yearly sales of household refrigerators increased from 200,000 per year to over 2,000,000 per year.

2. NATURE OF HEAT AND COLD

In order to obtain a proper understanding of refrigeration principles, it is necessary to first understand the nature of heat and cold.

Heat is a form of energy, or molecular activity, and is present to a certain degree in all things. The hotter any material becomes, the faster the motion of the molecules of which all substance or matter

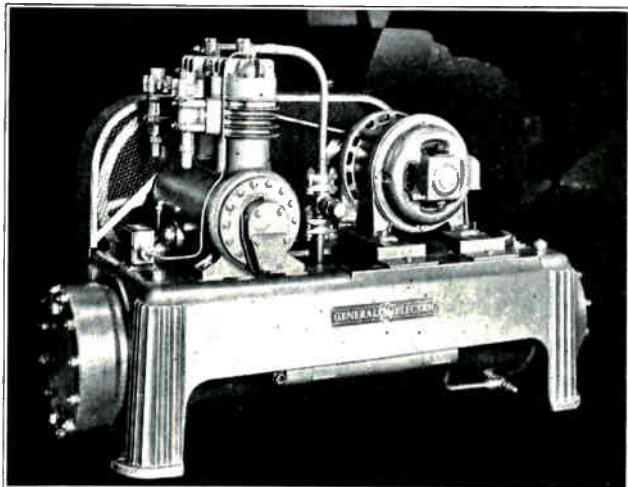

Fig. 4. Photograph of a multiple cylinder electric refrigeration machine for commercial use. Note how the electric motor drives this compressor through a "V" belt connection. Also note the condenser cylinder underneath the frame. Many trained refrigeration men are needed to install and service such equipment. Courtesy General Electric Company.

is composed. Heat is supplied to the earth by the sun's rays, and is also produced by oxidization or burning of combustible materials. All atmosphere or air contains a certain amount of heat even on the coldest winter day. All ordinary materials and bodies, whether in solid, liquid, or gaseous state, contain a certain amount of heat. If enough heat is applied, it will cause solids to melt into a liquid state, and if still more heat is applied, the liquid will boil and change into a vapor. For example, ice melts into water, and water boils and evaporates into steam. See Fig. 9.

Cold is merely the absence of heat, or rather a partial absence of heat, because, although we may extract most of the heat from a body or space, it is not possible by any known means to remove quite all of the natural heat.

We are accustomed to thinking of zero temperature as a point 32 degrees below the freezing point of water, which is the coldest temperature that can be obtained by a freezing mixture of ice and salt. However, the theoretical absolute zero is 459.6 degrees, or approximately 460 degrees below zero on the Fahrenheit scale. This is the temperature at which there would be no movement of the molecules of any matter or material if it were cooled to that low temperature.

In order to better understand and deal with heat,



Fig. 5. Interior view of a refrigerated room used for cooling and storing fruits. Note the refrigeration unit in the background. Courtesy York Ice Machine Corporation.

we must have a unit for measuring it. The standard unit of heat is the British Thermal Unit, or B.T.U. This unit refers to the quantity of heat contained in a given space or volume of any material. The standard B.T.U. is the amount of heat required to raise the temperature of one pound of water one degree F.

When the ice in Fig. 9 melts, it absorbs heat from the surrounding air and cools the air. When the water in the pan boils it absorbs heat from the burner flame.

The more a given quantity of heat energy is concentrated in one spot, the higher the temperature becomes. Temperature is measured in degrees. There are two scales of temperature measurement called the Fahrenheit and the Centigrade scales. The Fahrenheit scale is the one most commonly used on ordinary thermometers. The thermometer is a convenient device to measure the temperature by the expansion of mercury or some liquid in a thin glass tube which has a scale marking on the glass or mounted alongside it. See Fig. 10 which

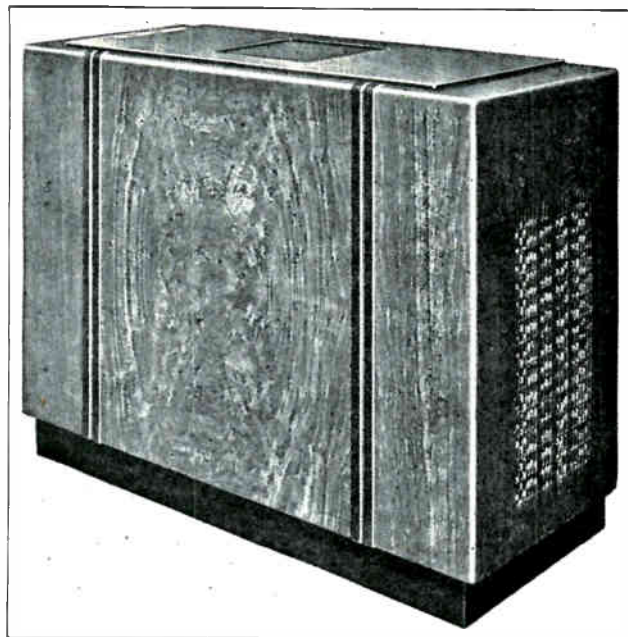

Fig. 6. This view shows a room cooling unit for air-conditioning small offices or rooms in the home. Such units provide cool, clean, crisp air for more comfortable and healthful working and sleeping conditions. The electric refrigeration unit which cools the air, and the circulating fans are enclosed within the decorative cabinet. Courtesy Westinghouse Electric & Mfg. Corporation.

shows a comparison of the Fahrenheit and Centigrade thermometers.

3. HEAT TRANSFER

Heat energy follows a natural law in that it always tends to flow from bodies of higher temperature to those of lower temperature.

Heat can be transferred from one material or space to another by three methods known as conduction, convection and radiation. Heat conduction refers to the flow of heat through the molecules of solids. An example of heat transfer by conduction is demonstrated in the flow of heat to the handle of a teaspoon when one end is immersed in a cup of hot liquid, or in the heating of the handle

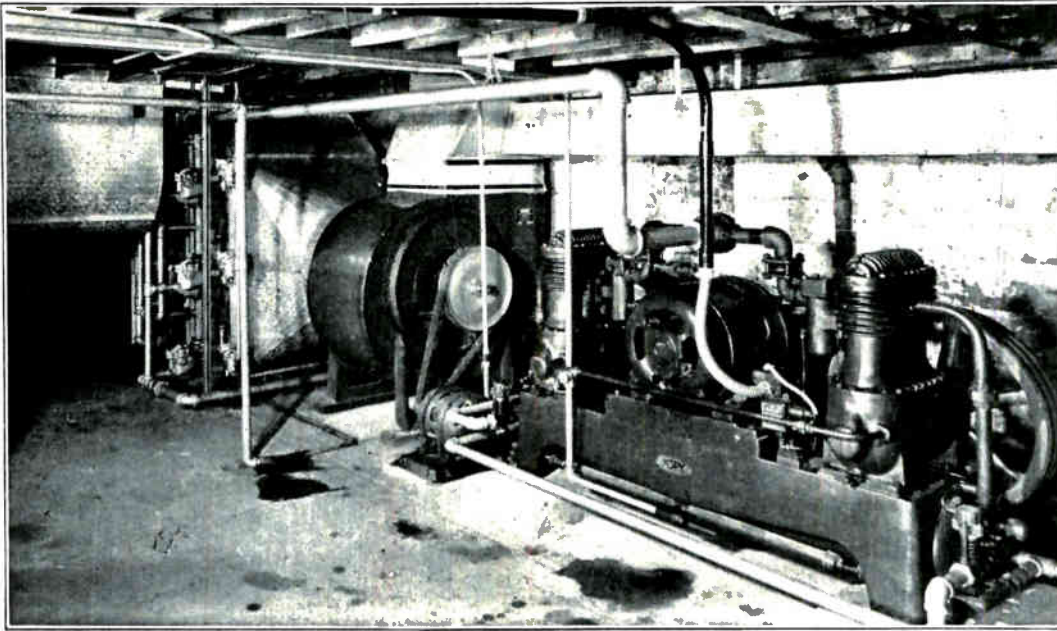

Fig. 7. Photograph of a centrally located air-conditioning plant. Note the electric motor-driven double unit compressor on the right and the air washing and circulating equipment on the left. Many plants of this type are now in use in homes, stores, restaurants, theatres, etc. Courtesy York Ice Machine Corporation.

of a frying pan where the pan is held over a fire. Most metals are good conductors of heat, copper and brass being much better conductors than iron or lead. See Fig. 11-A.

Heat transfer by convection means the carrying of heat from one place to another by the actual movement or circulation of heated air, water, or other gases or liquids and can be accomplished by the natural circulation of air or water when heated. See Fig. 11-B. Heat transfer by convection can also be accomplished by setting up air currents around a hot object by means of a fan, or by circulating currents of water or other liquids around a hot object or material. A hot air furnace for home heating is an excellent example of heat transfer by convection.

Heat radiation is demonstrated by the heat rays or waves which are thrown off through space by the sun, by a hot stove or fire place, an incandescent light bulb or other highly heated object. Such

heat rays being very similar to light rays, except of lower frequency and longer wave length. See Fig. 11-C. When heat energy is radiated through space, it may not heat the space through which it passes, but does heat up objects which the heat rays strike.

If one end of an iron bar is heated red-hot in a flame and then withdrawn, it will lose its heat by all three methods, radiation to the surrounding air, convection by surrounding air currents, and conduction to the cooler end of the bar and anything with which it may contact.

Although there is no perfect insulator of heat, some materials are such poor heat conductors that



Fig. 8. Interior view of a modern air-conditioned lunch-room. Note the air delivery ducts and openings along the ceiling. Air-conditioned eating places are much more popular and generally do a much greater business than those that are not so equipped. Courtesy York Ice Machine Corporation.

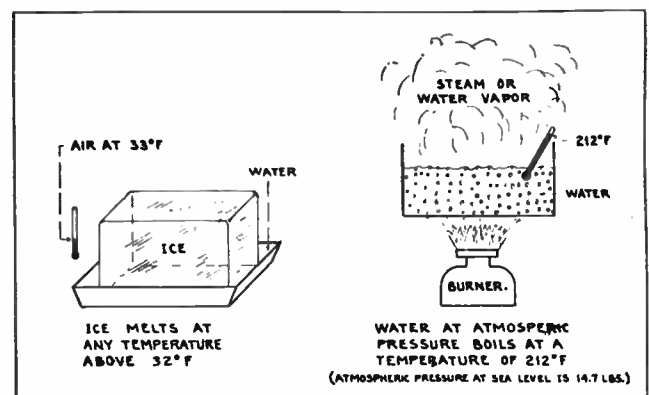

Fig. 9. The above illustration shows how the absorption of heat by ice will cause it to melt into water. Also how the further absorption of heat by the water will cause it to evaporate into steam or water vapor.

we term them heat insulation materials. Cork, sawdust, asbestos and some other fibrous and porous materials are good heat insulators. Such materials can be used to hold most of the heat in a certain space or to exclude most of the heat from a certain space. The space within the hollow walls of refrigerator cabinets is generally filled with some such heat insulating material.

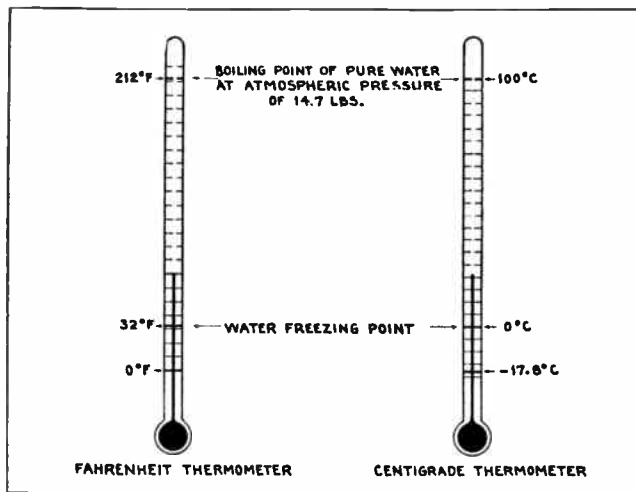

Fig. 10. Diagram showing the comparison between Fahrenheit and Centigrade thermometers. Carefully note how the zero points, freezing points and boiling points compare on these two scales.

4. SENSIBLE HEAT AND LATENT HEAT

The heat which we can feel or detect with our senses is known as sensible heat. For example, if water is heated over a flame, one can feel or detect the rise or increase in temperature by immersing your finger in the water. In other words, when the temperature of a liquid or any substance rises, sensible heat is being absorbed, or as the temperature of a substance drops, sensible heat is being given off.

The term **specific heat** refers to the relative capacity of a substance for absorbing heat. Water is taken as a standard and is given a specific heat of 1.00. As a comparison the specific heat of cast iron is .1298, ice has a specific heat of .502, copper .093, brass .09, gasoline .535, methyl alcohol .6, etc.

The specific heat rating of any substance indicates the quantity of heat that would be required to raise the temperature of a given weight of the material. For example, it only requires half as much heat to raise the temperature of a pound of ice one degree or ten degrees as would be required to raise the temperature of a pound of water the same amount.

We can determine the amount of heat needed to effect a certain change in temperature of any substance by multiplying the weight of the substance

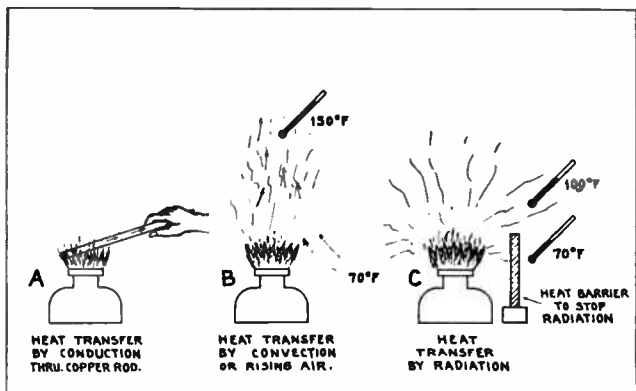

Fig. 11. The above illustration shows three different methods of heat transfer, by conduction, convection and radiation. Examine these illustrations closely while studying the accompanying explanations in the lesson material.

by its specific heat rating and by the temperature increase desired.

The term **latent heat** refers to the amount or quantity of heat that is required to change the physical state of a substance from a solid to a liquid, or from a liquid to a vapor, without changing the temperature of the substance.

For example, it requires 144 B.T.U.'s to change one pound of 32 degree ice to one pound of 32 degree water. In other words, a certain amount of heat is needed or absorbed to change any solid to a liquid even with no noticeable rise in temperature beyond that critical point at which the substance changes its state.

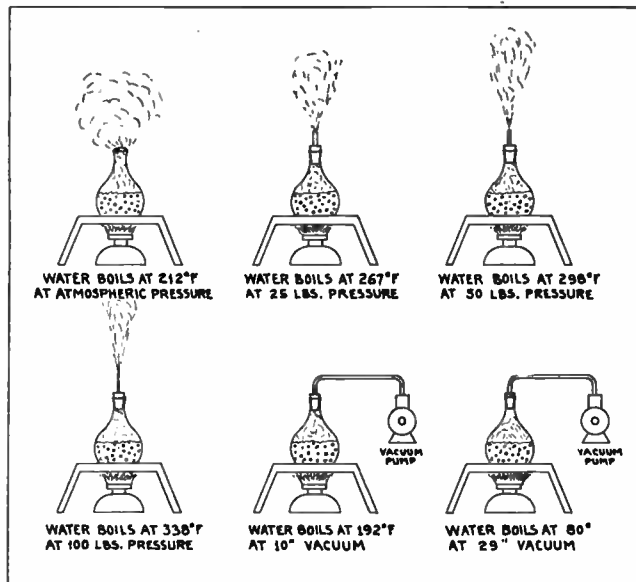

Fig. 12. The above sketches show the very important effects of pressure and vacuum on the boiling point of water. Keep this important principle well in mind.

The foregoing example illustrates the **latent heat of evaporation** refers to the amount of heat required to change a liquid to a vapor. For example, it requires 970 B.T.U.'s to change one pound of 212 degree water into steam at 212 degrees.

Therefore, we note that although one B.T.U. is required to raise the temperature of a pound of water one degree F., it actually requires nearly one thousand times as much heat to convert a pound of water into steam at no appreciably higher temperature.

This is an important point to remember, that a considerable amount of heat must be added to cause a substance to undergo a physical change from a solid to a liquid or from a liquid to a vapor. This latent heat is stored in the substance and again given off when the substance changes back to its original state by cooling.

The term **condensation** refers to the process of changing a vapor or gas back to a liquid. When this happens, the substance gives off the same amount of latent heat as it required to change it from a liquid to a vapor. If we chill steam or absorb the heat from it, it will condense back into water. When warm moist air is passed over a cold water glass or cold metal pipes, some of the moisture will condense in the form of water drops on the surface of the glass or pipe.

5. EFFECT OF PRESSURE ON EVAPORATION TEMPERATURES

You undoubtedly know that ordinary water boils or evaporates at a temperature of 212 degrees, when under atmospheric pressure. It is also commonly known that atmospheric pressure, or the weight of air at sea level, is about 15 pounds per square inch. (14.7 lbs. to be more exact.) The air pressure on top of a high mountain or up several thousand feet in an airplane is much less than 14.7 lbs.

Any pressure lower than atmospheric pressure is called a vacuum, or more correctly a partial vacuum. Vacuum is measured in inches on a mercury column in a glass tube, by the action of air pressure against gravity, causing the mercury to rise in the tube. A perfect vacuum or absence of all pressure is calculated to be 30 inches on the mercury column. Commercial pumps and equipment can produce a vacuum of over 29 inches.

If water is placed in a closed container and the pressure upon the surface of the water increased

of water. For example, sulphur-dioxide, a chemical commonly used in refrigerators, will boil at a temperature of 14 degrees F. at atmospheric pressure. This is 18 degrees below the freezing point of water. At 56 lbs. pressure, the boiling point of sulphur-dioxide is 90 degrees F. Under a 9 inch vacuum sulphur-dioxide will boil at zero F., and under a 21 inch vacuum, it will boil at -30 degrees F., or 30 degrees below zero. Ammonia, which is also used in commercial refrigerators will boil at a temperature of 27 degrees below zero F., at atmospheric pressure.

Because of the very definite effect which pressure and vacuum have on the boiling points of various liquids, it is important for you to understand the relationships between vacuum, pressure, and boiling points, and also to know how to measure vacuum and pressure.

Pressures of air, steam, water or any liquid or vapor can be conveniently measured in lbs. per square inch, by means of common pressure gauges such as shown in the upper view in Fig. 13. You have undoubtedly seen or used such gauges on air compressors, steam boilers or water pumps.

These gauges are operated by the pressure of the air, steam or liquid on a thin metal diaphragm or bellows, or on a curved metal tube, against the action of a spring or the tension of the springy metal. The movement of the diaphragm or curved tube under application of pressure is transferred by mechanical connection to a needle or pointer which in turn moves over a marked scale to indicate the pressure in lbs. per square inch.

Ordinary pressure gauges, of course, only indicate pressures above atmospheric pressure, because ordinarily atmospheric pressure affects both sides of the gauge diaphragm or tube equally. Therefore, the zero ("0") point on an ordinary pressure gauge really starts at 15 lbs. atmospheric pressure, and a gauge pressure reading of 25 lbs. would mean 25 lbs. above atmospheric pressure, or 15 plus 25 equals 40 lbs. absolute pressure. Absolute pressure equals gauge pressure plus 15.

A perfect vacuum or complete absence of all pressure (if such were possible to obtain) can also be called zero absolute pressure. It so happens that a cubic inch of mercury weighs about 1/2 lb., and therefore each inch of mercury displacement on the mercury vacuum gauge is equal to approximately 1/2 pound pressure per square inch. The scale or chart shown in Fig. 14 shows the relations between inches vacuum from 30 inches to zero, and lbs. pressure from zero absolute to 15 lbs. absolute, or atmospheric pressure.

Gauges can also be made to indicate vacuum or pressures below atmospheric pressure by arranging a diaphragm or tube for double action, to be moved one way by pressure and the other way by

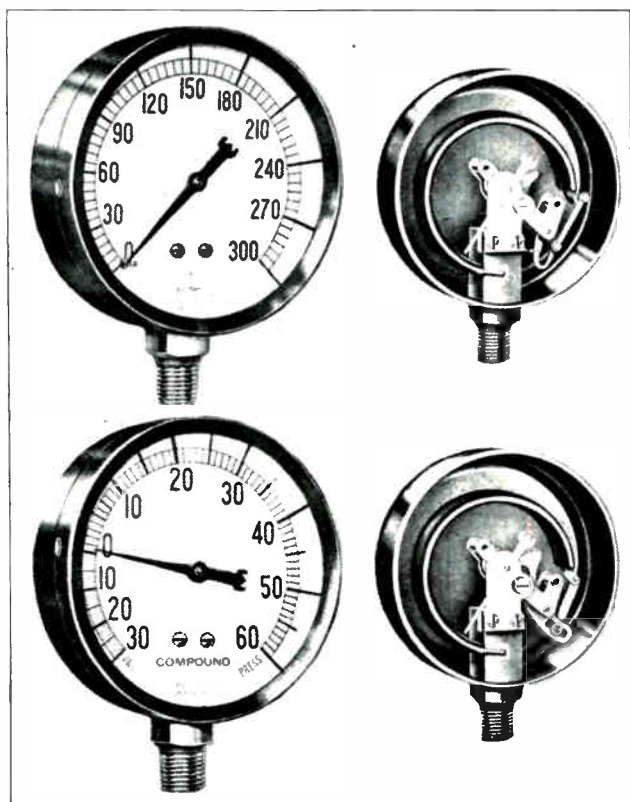

Fig. 13. In the upper view is shown a common type of pressure gauge used for measuring pressures of refrigerant gases and thereby determining operating conditions of refrigeration machines. In the lower view is shown a compound pressure and vacuum gauge such as commonly used by refrigeration service-men. Courtesy J. P. Marsh Corporation.

to 25 pounds per square inch, then the water will not boil or evaporate until a temperature of 267 degrees F. is reached. If we reduce the pressure on the water below atmospheric pressure, say to a 10 inch vacuum, it will then boil at 192 degrees F. See Fig. 12.

Keep in mind this important rule, that the higher the pressure on any liquid, the higher will be its boiling point.

There are other liquids or chemicals which boil at temperatures much lower than the boiling point

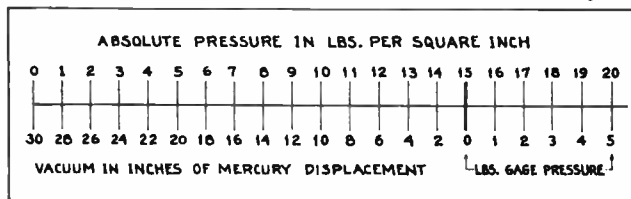

Fig. 14. This diagram shows relation between inches vacuum and pounds absolute pressure. Note that gauge pressure starts at 15 pounds absolute pressure.

suction or vacuum. See the lower view in Fig. 13. The pointer is arranged to set at zero for atmospheric pressure and moves to the right of zero to indicate lbs. pressure per square inch, and to the left of zero to indicate vacuum in inches. Such gauges are called **compound gauges** and are very convenient for use in refrigeration testing and service.

(Note: wherever the term pressure is used in these lessons it refers to gauge pressure, unless otherwise specified.)

The curve in Fig. 15 shows the effect of pressure or vacuum on the boiling point of sulphur-dioxide, which is one of the most commonly used refrigerants. Carefully examine this chart and note that the boiling point of SO₂ (sulphur dioxide) varies from 30 degrees below zero F. at 22 inch vacuum, to 110 degrees F. at 85 lbs. pressure.

6. PRINCIPLES OF REFRIGERATION

As we have previously stated, Refrigeration is simply a process of reducing the temperature of a certain substance or space by removing some of the heat from that body or space to bring its temperature below that of the surrounding air. In most refrigerators, this process is continuous or frequently repeated, in order to hold the temperature down to the desired level, even though some heat leaks into the box or room.

We have learned that heat will flow of its own accord from points of high temperature to points of lower temperature. We know that heat will es-

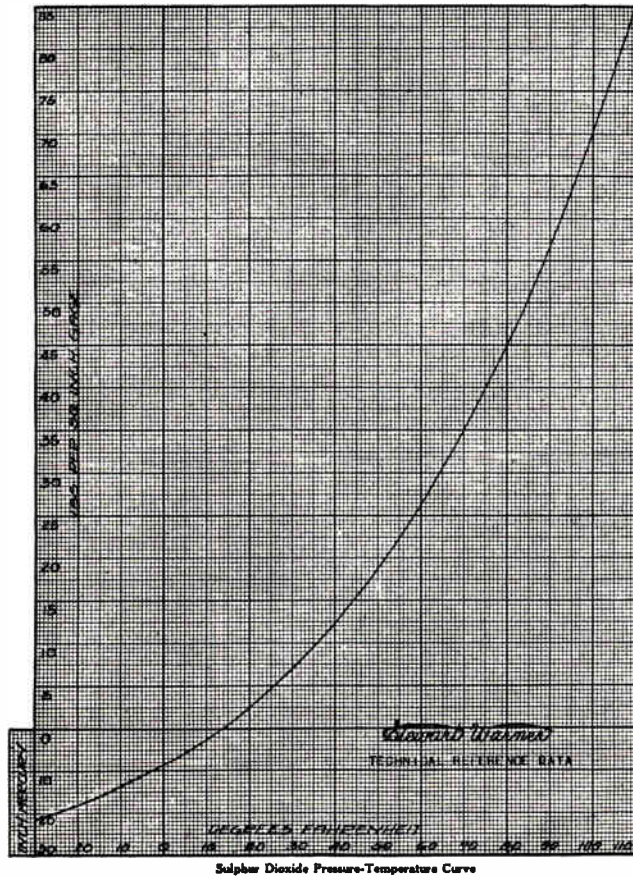

Fig. 15. Chart showing the boiling point of sulphur-dioxide (SO₂) refrigerant at various pressures and vacuums. Refer to this chart often while studying about pressures and evaporation. Courtesy Stewart-Warner Corporation.

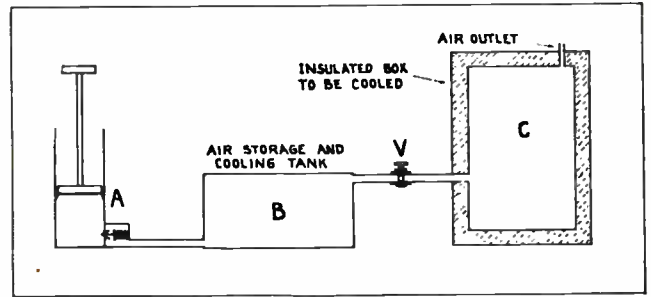

Fig. 16. Diagram illustrating a simple method of accomplishing heat transfer and refrigeration by means of compressed air.

cape from a hot object by radiation through the air, by conduction through any metal or solid parts of the hot object, and by convection due to the circulation of air around the hot space or object. See Fig. 11.

If we were to blow a stream of air from a fan across the top of an electric heater, the air stream would absorb and carry away a great deal of the heat produced by the heater. We could also remove heat from a hot object or space by circulating cool water over the object or through the space and allowing the water to absorb some of the heat and carry it away. If this same water were then passed through an ice compartment or some space which is

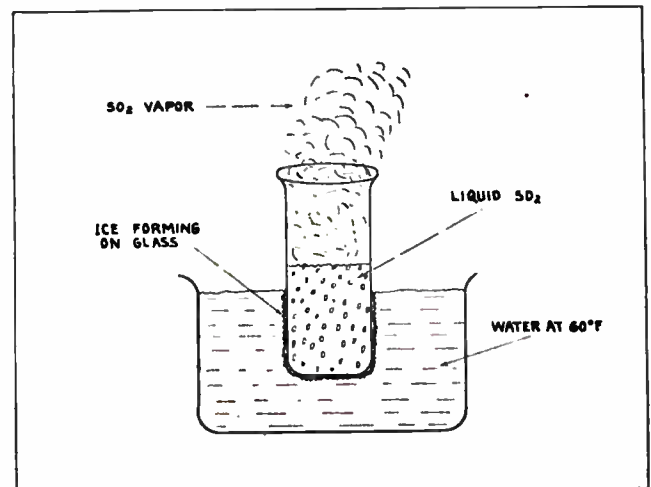

Fig. 17. The above sketch shows an elementary method of refrigeration by the rapid evaporation of liquid sulphur-dioxide due to its very low boiling point. This is a basic principle of refrigeration and should be carefully observed.

cooler than the water, it could be made to give up its absorbed heat and again be re-circulated to carry away more heat from the object or space we desire to cool.

One of the most common ways of accomplishing refrigeration by mechanical means is by compressing some gas or refrigerant to literally squeeze the heat from it.

Did you ever notice how hot an automobile tire pump, or any other air pump becomes when it is used to compress air? The reason for this is that ordinary air contains a certain amount of natural heat and if we compress a large volume of this air into a very small space, we concentrate its heat, thus raising the temperature of this smaller volume of air.

Another very interesting example of the surprising amount of temperature increase that can be pro-

duced by compressing air is the fact that in Diesel engines when the air is compressed to about 500 pounds pressure, its temperature raises to over 1000 degrees F., or hot enough to ignite fuel oil.

The reverse of this principle is also true. If highly compressed air were stored in a metal cylinder for a period of time, the heat concentrated by compression would escape by conduction through the metal walls of the cylinder to the surrounding air. Then if the air in the cylinder was suddenly released and allowed to flow out, it would carry away the little remaining heat it contained and the space within the cylinder would become icy cold.

Therefore, simple mechanical refrigeration can actually be accomplished by means of an air pump, air cooling cylinder and an insulated box such as shown in Fig. 16. The air pump at "A" can be

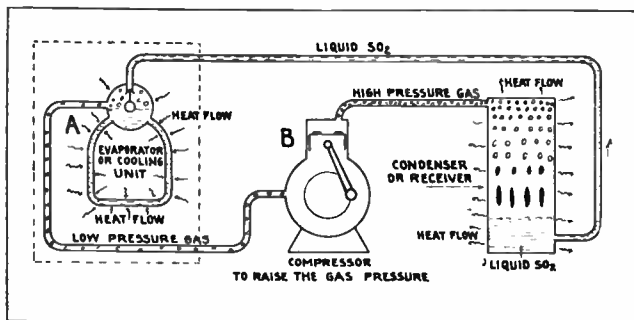

Fig. 18. Diagram of a simple refrigeration system illustrating the refrigeration cycle of a compression type refrigeration unit.

used to compress air into the cylinder "B" where it can be held by means of the check valve and hand valve until its heat of compression escapes to the surrounding atmosphere.

Then, if the hand valve "V" is opened and this air from which the heat has thus been extracted is allowed to enter the insulated cabinet "C" and expand, it would cool the space inside the cabinet. By repeating this process, the cabinet could be kept cool.

Instead of using air for refrigeration, we use some other chemical or gas which absorbs heat and releases it more readily than air, and is thus cheaper to operate with. Such materials are known as re-

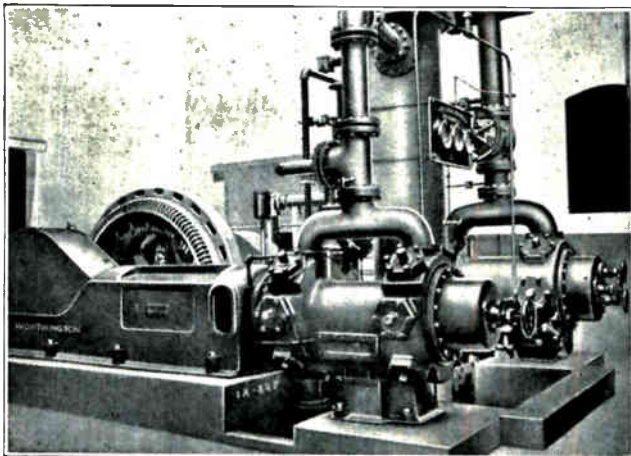

Fig. 19. Photo of a large commercial refrigeration machine. Note the two large horizontal compressors are both driven by direct connection to one large electric motor. This machine is capable of producing the same cooling or refrigerating effect as the melting of 600 tons of ice per day. Such plants provide good jobs for trained operators. Courtesy Worthington Pump & Machinery Corp.

frigerants and will be explained more fully a little later.

7. REFRIGERATION BY EVAPORATION

Another simple way to produce refrigeration is by the evaporation of a liquid into a vapor or gas. We have learned that when water evaporates or boils it absorbs heat from the air, the body or the fire which is causing its evaporation or boiling.

We have found that evaporation of perspiration cools the human body. We know that if the finger is moistened and held up in a draft of air, the side which the air strikes will become cooler. If the finger is moistened with gasoline and held in an air draft, it will be cooled more rapidly because gasoline has a boiling point of 147 degrees F. instead of 212 degrees F., and therefore evaporates much more rapidly and produces more cooling effect.

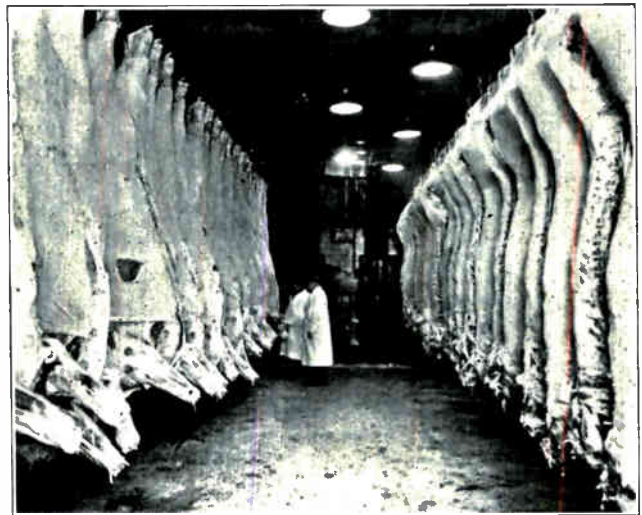

Fig. 20. Photographs of one section of a large meat chilling and storage room which is kept at very low temperature by means of mechanical refrigeration. Courtesy Carrier Corporation.

We have previously mentioned that sulphur-dioxide has a boiling point of 14 degrees F., which means that this chemical or liquid will boil violently if exposed to the heat of ordinary air at normal room temperature.

The very rapid evaporation of sulphur-dioxide causes it to rapidly absorb heat from the air and therefore cool the surrounding air. If a small quantity of sulphur-dioxide were placed in a glass tube, and this tube immersed in 60 degree water as shown in Fig. 17, the heat from the water would flow through the glass tube and be rapidly absorbed by the evaporation of the liquid SO_2 . The water immediately surrounding the glass tube would be chilled and frozen to ice and the entire quantity of water would be cooled by convection, or circulation of the water.

This is actually a very simple system of refrigeration, but it is a very expensive one because the chemical vapor escapes to the open air and is wasted. In actual mechanical refrigeration systems, this chemical vapor is kept in a closed metallic system, compressed, and condensed back into liquid form and used over and over again to cool the same space. See Fig. 18.

In this figure the evaporator at "A" absorbs heat from the air within the enclosure shown by the dotted lines. This causes the liquid SO_2 in the evaporator tank and tubes to change into a low pressure vapor or gas. The compressor at "B" draws off this gas from the evaporator and compresses it to a much higher pressure and temperature so that the gas will condense and give off its heat to the surrounding air.

The pressure set up in the condenser or receiver by the compressor, forces this liquid SO_2 back to the evaporator to be used over again whenever the float valve drops to admit more liquid. In other words, the SO_2 refrigerant absorbs heat during evaporation like a sponge absorbs water. Then

the refrigerant gives off its load of heat when compressed, similarly to squeezing the water from a sponge.

The following section covers types of refrigeration systems, various refrigerant chemicals, and detailed information on the various parts of refrigerators. However, before proceeding with this next section be sure to have a thorough understanding of these vitally important fundamental refrigeration principles which are covered in this section. If you do this it will enable you to understand the following material much more easily, and will also prepare you to service these interesting machines more efficiently.

REFRIGERATION SYSTEMS AND CYCLES

Now that you have learned the principles of Refrigeration you are ready to learn about types of refrigeration systems, important parts of refrigerators, and the compression refrigeration cycle.

Study this section carefully as a thorough knowledge of these subjects is essential to the successful refrigeration service man.

There are two common types of mechanical refrigeration systems in use. These are known as the **compression system** and the **absorption system**.

The compression system uses a motor driven compressor as shown in Figs. 21, 22, and 23. The absorption system uses heat from the burning of gas, oil, or other fuel, to set up the required pressures and circulation of the refrigerant. The compression system is the one most extensively used in popular types of household and commercial refrigerators. It is also the one which requires the most mechanical service and will therefore be explained in detail in these lessons. The absorption system will be explained more fully in a later section.

Small compression units are in use by the millions in household refrigerators while many thousands of larger compression units, called commercial refrigerating machines, are in use in meat markets, stores, restaurants, packing plants and air-conditioning installations. The principal difference between household or domestic units and commercial units is in their size and their application. The parts and principles are practically the same otherwise.

8. PARTS OF MECHANICAL REFRIGERATORS.

All compression type refrigerators have eight important parts. (1) the compressor, (2) the condenser, (3) the control valve, (4) the evaporator, (5) the electric switch, (6) the electric motor, (7) the refrigerant chemical, and (8) the cabinet.

Other auxiliary parts and devices are often added to improve the operation of refrigerators, but the above named parts are the most essential and the ones of which the refrigeration service man must have a thorough understanding.

As we learned in the preceding lesson, the com-

pressor is used to compress the low pressure gas coming from the evaporator, into a high pressure gas suitable for condensing. The compressor also serves to move or force the liquid refrigerant to flow from the condenser to the evaporator.

The **condenser** is used to radiate or give off the heat from the high pressure gas, thereby causing it to condense to a high pressure liquid. Carefully note the construction of the condenser shown directly back of the motor and fan in Fig. 23. The condenser generally discharges its condensed liquid refrigerant into a cylinder or drum called a **receiver**,

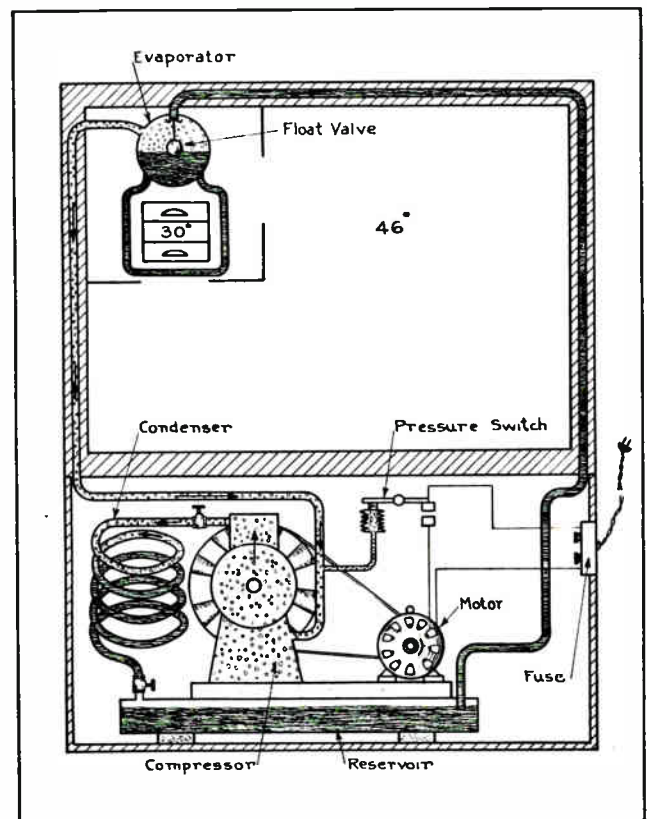

Fig. 21. This diagram shows the circulation of the refrigerating solution throughout the machine, and also illustrates the general principles of the mechanical refrigeration cycle.

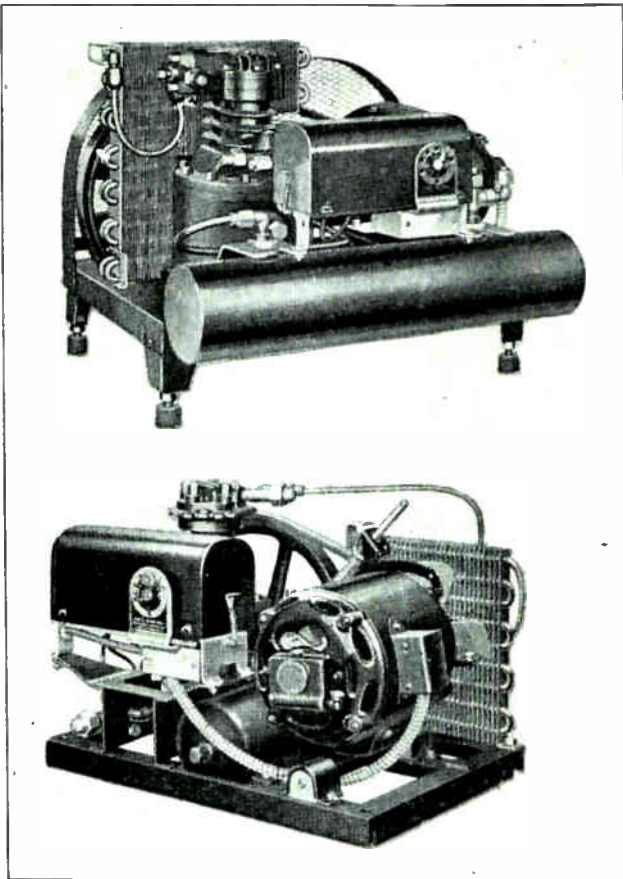

Fig. 22. Above are shown two electrical refrigerator units commonly known as condensing units. These units include the compressor, motor, condenser, receiver, and control switch.

where it is held under pressure until needed again at the evaporator. Frequently the compressor, condenser, and receiver are all mounted on one base and the whole assembly called a condensing unit.

The control valve is a sort of throttle valve used to control or limit the flow of liquid refrigerant to the evaporator as needed. This valve also serves to separate the high pressure side of the system from the low pressure side.

The high pressure side includes the condenser, receiver, and liquid line, or everything from the discharge side of the compressor to the control valve at the evaporator. The low pressure side includes the evaporator, suction line and intake side of the compressor.

The evaporator is used to contain the liquid refrigerant which absorbs and removes heat from the air in the space to be cooled, and in so doing, evaporates into a low pressure gas which is drawn off by the compressor.

The electric switch, sometimes called a pressure switch, is used to automatically start and stop the motor and compressor as often as necessary to maintain the desired temperature in the refrigerator.

The electric motor is used to drive or operate the compressor and is therefore a very important part of any electric refrigerator. These motors should be kept in good condition at all times if the unit is to function properly.

The refrigerant is used to absorb heat at the evaporator, inside the cabinet or room which is to

be cooled, and carry this heat through the compressor to the condenser where it releases or gives off the heat to the surrounding air, or to running water in case the condenser is water cooled instead of air cooled.

In the case of the household refrigerator or large cabinet type commercial units, the cabinet is also an important part. The cabinet is usually heavily insulated and equipped with a tightly sealed door to prevent as much as possible the leakage or entrance of heat to the cooled space inside.

All of the above mentioned parts, including the cabinet are shown in the diagram in Fig. 21. The upper view in Fig. 22 shows a condenser, compressor, control switch box and liquid receiver. The lower view in this figure shows the motor in the foreground. Fig. 23 shows a modern "condensing unit," as these assemblies are often called. Note the compressor, motor, condenser, control switch and liquid receiver all mounted on one base. The receiver is underneath the base.

9. REFRIGERATION CYCLE.

The term "refrigeration cycle" refers to the series of events which occur repeatedly in the operation of a mechanical refrigerator. Briefly it is as follows:

Heat is first absorbed by the liquid refrigerant at the evaporator, changing the liquid into a gas. The gas is compressed and forced into the condenser where it gives off its heat to the cooling air or water and condenses back into a liquid, ready for use once more in the evaporator.

You should have a thorough understanding of this mechanical refrigeration cycle and principle in order to properly operate, service or repair refrigerators.

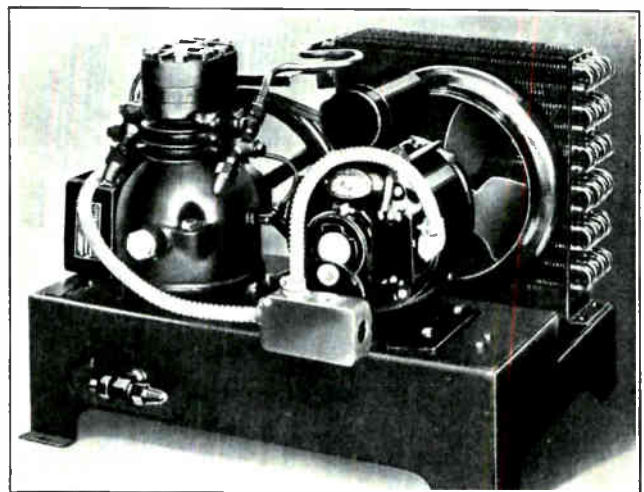

Fig. 23. This photograph shows a modern electric refrigerator condensing unit. Note the compressor and driving motor which are connected together by means of a "V" belt and pulleys. Also carefully note the construction of the condenser which is located behind the fan on the motor pulley. Courtesy General Electric Co.

Referring again to Fig. 21, let us trace out this refrigeration cycle in detail. In the evaporator tank and tubes, we have liquid SO_2 shown by the darkly shaded area. As heat is absorbed from the air in the refrigerator through the metal walls of the evaporator, the liquid refrigerant evaporates or boils, creating sulphur-dioxide gas or vapor. This gas flows under its own pressure out through the

left hand pipe toward the compressor. As long as the compressor is idle this gas cannot escape beyond it because of the compressor valves, and therefore gradually builds up a pressure as evaporation continues.

You will note that this gas pressure is also applied to the thin metal expansion bellows or syphon of the pressure switch. When the evaporation pressure builds up to about 5 lbs. pressure in machines of this type, the thin metal bellows expands enough to snap the switch closed and start the motor which drives the compressor. The running compressor then sucks in the sulphur-dioxide gas from the evaporator line and compresses it to about 55 lbs. pressure, forcing it into the coils of the condenser.

When the gas is thus compressed, its temperature is raised to about 100 degrees, which causes it to give up its heat through the copper tubing and fins of the condenser, to the outside air which is of lower temperature.

A set of fan blades on the driving wheel of the compressor or on the motor pulley, forces air through the condenser coils and assists in cooling them and carrying away the heat.

When the gas is thus chilled it condenses back into a liquid and is forced on into the reservoir or receiver where it is held under pressure until the float valve opens again, admitting it to the evaporator.

When the compressor has run long enough to reduce the gas pressure on the evaporator line and syphon bellows to about a 9" vacuum, the bellows will contract and open the pressure switch, stopping the motor and compressor.

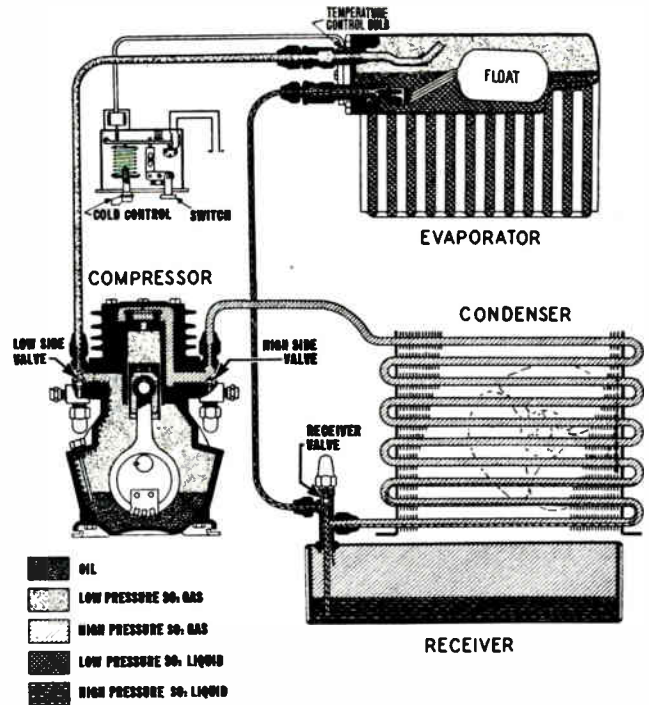

Fig. 25. The above diagram clearly illustrates the refrigeration cycle of a Stewart-Warner household refrigerator. Examine carefully each part shown and trace the flow of refrigerant throughout the system while reading the accompanying instructions in the lesson. Courtesy Stewart-Warner Corp.

If the temperature in the refrigerator is still too high, the evaporator will soon build up enough gas pressure to start the compressor again, and this cycle is repeated as often as necessary to keep the desired temperature in the cabinet.

When the liquid level in the evaporator is lowered by evaporation, the float valve shown in Fig. 21 allows more liquid SO₂ to again enter from the receiver or liquid line where it has been held under pressure. Ordinarily the liquid in the receiver will not boil, as it requires about 90 degrees F. to boil, SO₂ at 55 lbs. pressure. This same feature acts as a safety control to prevent the evaporator from building up too high pressures if the motor or compressor should fail.

When the gas builds up to 40 lbs. pressure, evaporation stops unless the room and box temperatures are above 75 degrees F. When the compressor reduces the gas pressure to 9" vacuum, the liquid SO₂ of course boils easier and faster at this low pressure. This greatly increases the rate of heat absorption at the evaporator, and speeds up the process of refrigeration. So we can now see how extremely important are the evaporator, compressor, and condenser in this type of mechanical refrigerator, and also how important it is to have an absolutely air tight system on all the parts and connecting tubing of such a unit, so no gas or liquid can escape, or no air enter the system.

10. CYCLE DIAGRAMS OF COMMON UNITS.

Although there are many makes of refrigerators on the market, the general principles of most of them are very much the same, and even the mechanical arrangement of parts is often very similar. Therefore, if you carefully study these general prin-

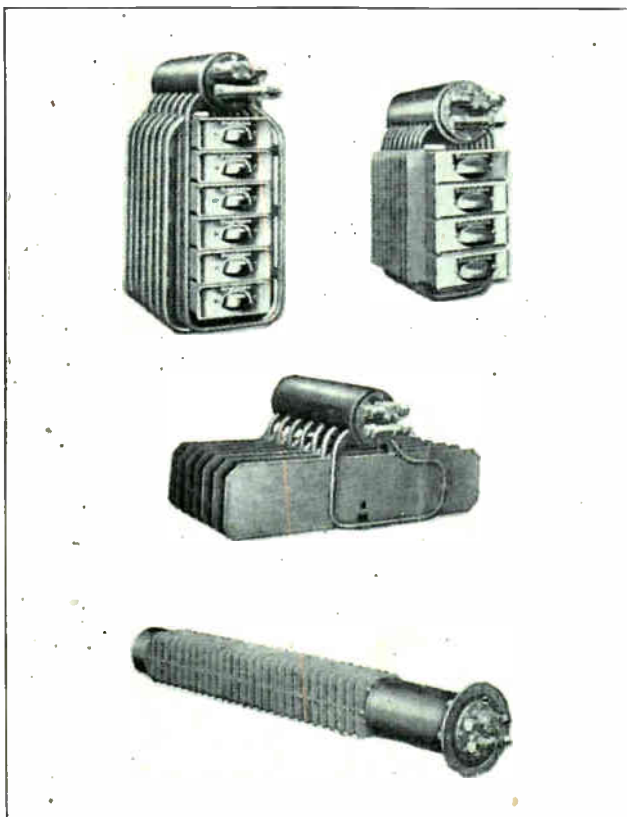

Fig. 24. Several types of evaporator units. Note the coils of tubing and the metal fins which are attached to the refrigerant drum to aid in absorbing the heat from the air in the refrigerator.

ciples and become familiar with some of the more common units you should be able to easily understand and service most any type.

In Fig. 25 is shown the cycle and parts diagram of a Stewart-Warner domestic, or household refrigerator. In this diagram you will also note the same important parts, such as evaporator, compressor, condenser, receiver, control valve, and starting switch. The motor is not shown in this case.

Examine each of these parts very carefully and trace the cycle of operation by referring to the code markings shown underneath the compressor, so you can quickly recognize high or low pressure gas, high or low pressure liquid, or oil when you see them in the system.

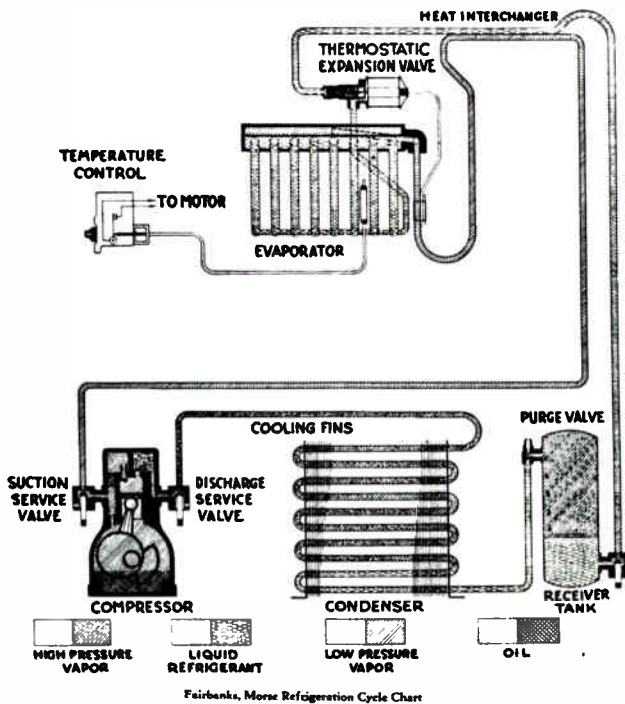

Fig. 26. Cycle diagram of a Fairbanks-Morse refrigerator. Note the different shadings used to represent the refrigerant vapor and liquid and the lubricating oil, and then carefully trace this refrigeration cycle until you thoroughly understand its operation. Also note the similarity between this unit and the one shown in Fig. 25. Courtesy Fairbanks-Morse Co.

Note that here again the heat is absorbed by the low pressure liquid in the evaporator, causing the liquid refrigerant to boil or vaporize into low pressure gas which in turn passes down the large tube on the left to the compressor.

Here the gas is compressed to increase its temperature and is then forced thru the condenser where it is chilled and condensed back into liquid and forced into the receiver. From the receiver it passes under pressure back to the evaporator, whenever the float lowers and opens the valve.

Note the oil in the compressor crank case and also forming a thin layer on top of the liquid refrigerant in the evaporator. Some of this oil is picked up by the refrigerant gas and carried back to the compressor.

Note that the control switch for the motor of this unit is operated by a temperature control bulb attached to the evaporator, instead of by a pressure switch connection to the suction line as in Fig. 21.

Also note the low side and high side valves on

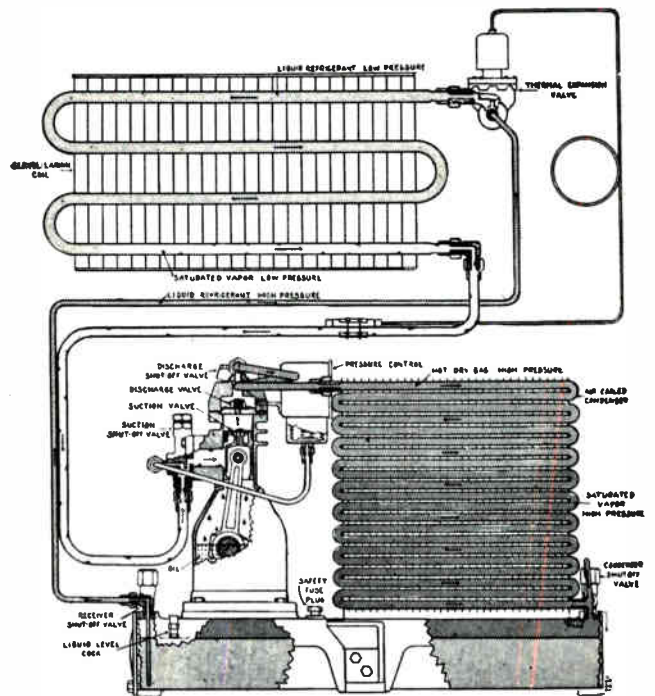

Fig. 27. Cycle diagram of a Servel refrigerator using a dry type evaporator, thermal expansion valve, air-cooled condenser, and reciprocating compressor. Courtesy Servel Corp.

each side of the compressor, by means of which the compressor can be shut off from the balance of the system and removed from the cabinet for repairs.

One of the compressor check valves is in the piston head and one is in the cylinder head.

Fig. 26 shows the cycle chart of a Fairbanks-

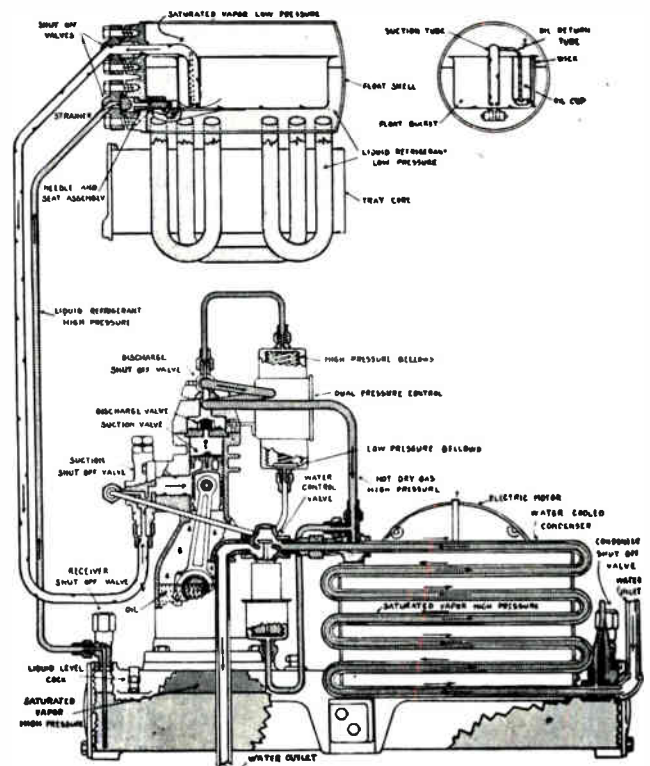

Fig. 28. Cycle diagram of a Servel unit using a flooded evaporator, low side float valve, and water-cooled condenser with a water flow control valve. Courtesy Servel Corp.

Morse domestic refrigerator. Again you will note that the same general principle and the same important parts are used, as in the machine in Fig. 25. Although in the machine shown in Fig. 26, the liquid receiver is in a slightly different position, it still receives the condensed high pressure liquid refrigerant from the condenser. This unit uses a thermostatic expansion valve instead of a float valve to control the flow of liquid to the evaporator. It also uses a thermostatic expansion bulb attached to the side of the evaporator to control the motor starting switch. Each of these devices will be fully explained a little later.

Carefully trace the flow of refrigerant throughout this system as with those previously shown, and observe the different shadings which represent gas, liquid and oil. Note that both the suction and discharge valves of the compressor in this unit are located in the cylinder head, instead of the suction valve being in the piston head as in Fig. 25.

Also note the suction service valve and discharge service valves, which although referred to by a different name, serve the same purpose as the low side and high side valves shown in Fig. 25.

Fig. 27 shows a diagram of a Servel household

type refrigerator using a dry type evaporator with a thermal expansion valve, and an air-cooled condenser. Carefully examine all parts of this diagram and note the names and descriptions marked for each part.

Fig. 28 shows a diagram of another Servel refrigerator using a wet type or "flooded evaporator" and float valve control, and a water cooled condenser of the double tube type. Carefully examine all parts of this system.

Fig. 29 shows a diagram of one of the earlier types of Kelvinator units, and clearly shows the construction of the float valve in the evaporator. This unit has the electric switch for the motor located right on the side of the evaporator and operated by the expansion of a non-freezing solution in the pressure bulb attached.

Fig. 30 shows a commercial refrigerating unit. Note the similarity of general operation and parts with those of the household units.

11. OPEN AND HERMETIC TYPE UNITS.

By far the greater majority of household refrigerators now in service use condensing units of the "open unit" type, in which the compressor, motor

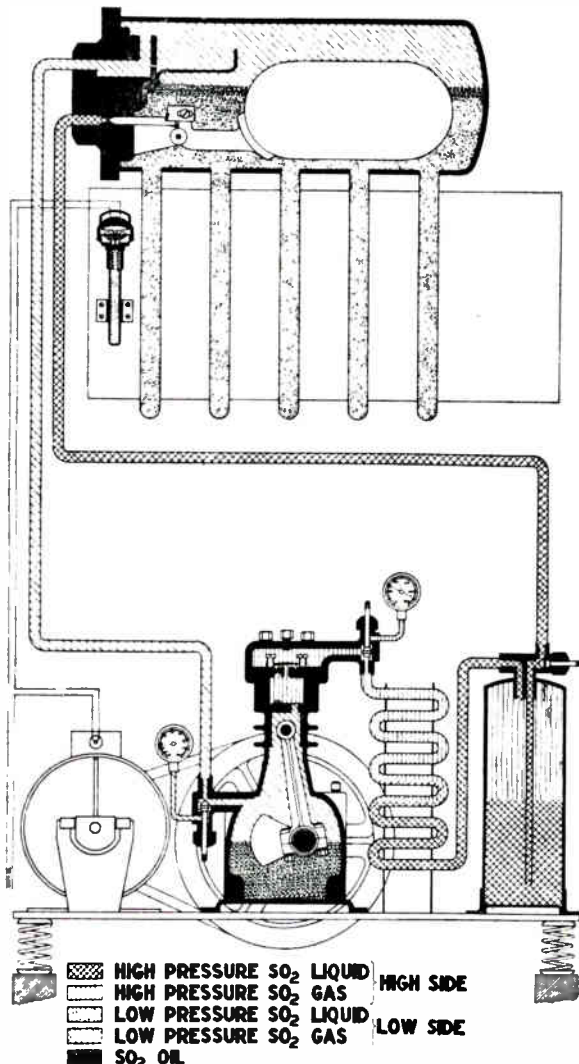
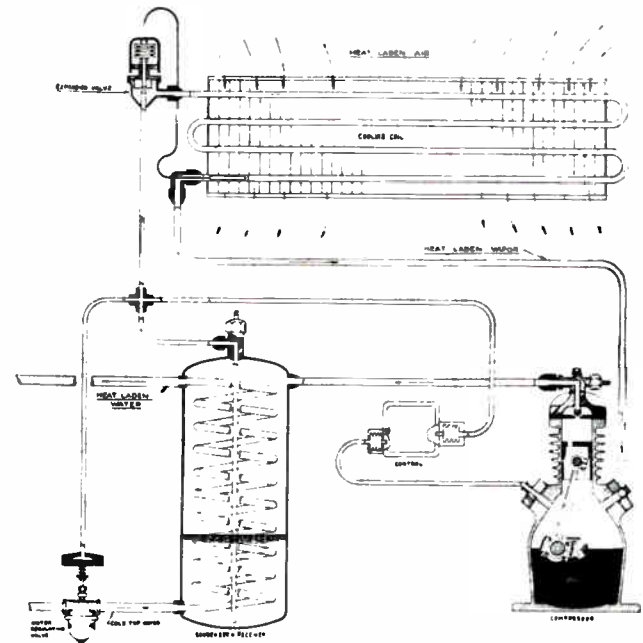

Fig. 29. Cycle diagram of a Kelvinator household refrigerator. Note the construction of the low side float valve in the evaporator and carefully check the flow of refrigerant and the operation of this unit. Courtesy Kelvinator Manufacturing Co.



Copeland Commercial Refrigeration Cycle

Fig. 30. Cycle diagram of a Copeland commercial refrigerator. Carefully check all parts of this system and note the water-cooled condenser and water regulating valve. Courtesy Copeland Manufacturing Co.

and condenser are accessible for repairs and service operations in the field. Practically all large commercial refrigeration machines are of the open type.

There are, however, several makes of "hermetic units" in which the compressor and motor are tightly or "hermetically" sealed inside a welded steel housing. Such a unit is shown in Fig. 31, with the compressor and motor sealed in the steel casing at the bottom. The evaporator is located above and a flat vertical type condenser at the rear. Also see Fig. 41 on page 20. These units cannot be repaired or overhauled in the field, but are usually returned to the factory for replacement or sent to a specially

equipped service shop for repairs when they be come defective.

The purpose of this hermetically sealed construction is to reduce the possibility of leakage of the refrigerant gas or liquid, at tubing connections, compressor shaft seals, etc.

Although hermetic units cannot be conveniently overhauled or repaired in the field, special auxiliary service valves are available for attachment to these units to permit discharging or recharging the refrigerant, or removing air from the system, etc

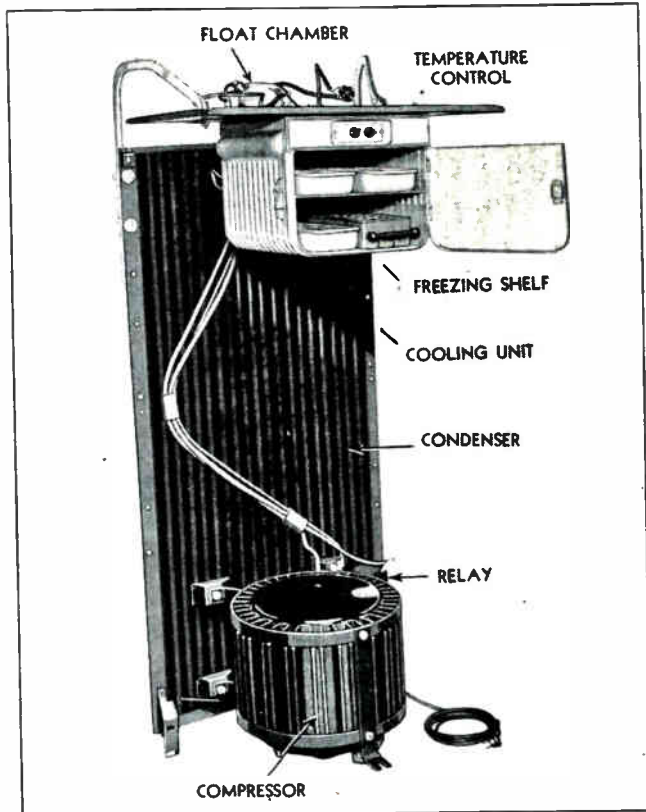

Fig. 31. This photograph above shows the important working parts of a modern General Electric household refrigerator. Note the construction of the evaporator or chilling unit above, the condenser at the rear, and the hermetically sealed compressor unit at the bottom. Courtesy General Electric Co.

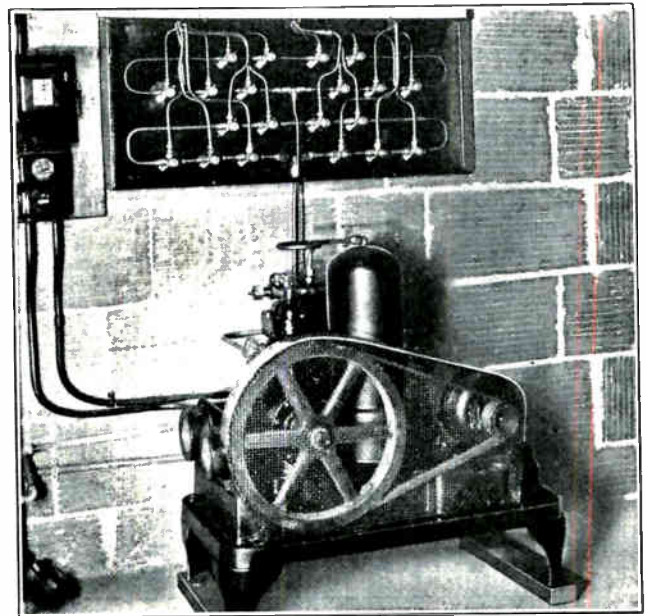

Fig. 32. This view shows the condensing unit and valve manifold panel for a multiple refrigeration system such as used in large apartment buildings. Courtesy Servel Manufacturing Co.

There are, of course, other service operations on the evaporator, control valve, electric switch, etc., which can be performed right in the field on refrigerators using hermetic compressor units.

Some compressors and motors are enclosed in a gas tight housing with a removable plate or cover to make them accessible for servicing. These are called semi-hermetic units.

12. MULTIPLE SYSTEMS.

Sometimes one large compressor and condensing unit is connected up with tubing to several evaporators located in separate cabinets or rooms, with the flow of refrigerant separately controlled to each evaporator by separate control valves. See Figs. 32 and 33. Such systems are called multiple systems,

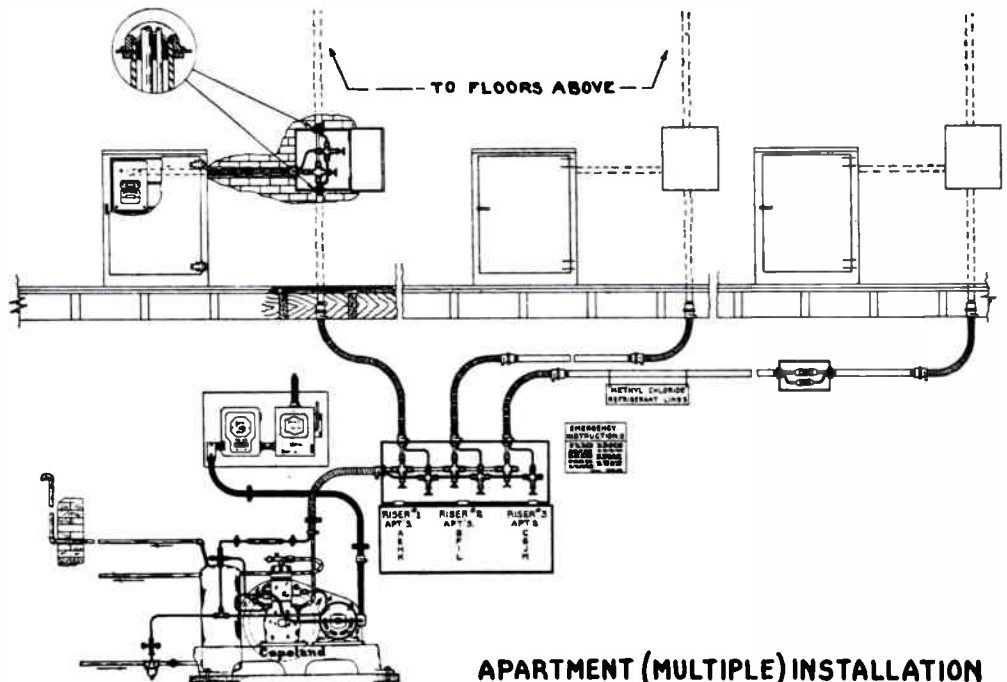

Fig. 33. On the right is shown a diagram of the general arrangement of electrical connections and refrigerant connections for a multiple refrigeration system. Courtesy Servel Manufacturing Co.

APARTMENT (MULTIPLE) INSTALLATION

and are often used in large apartment buildings and some commercial installations.

This type of installation costs less than the use of a number of separate small compressors, and permits locating the large central condensing unit in the basement or some out of the way place, thus eliminating any compressor noise in the apartments.

In some multiple installations, one main liquid line is run from the condensing unit throughout the building, and separate branch liquid lines tapped off this main to feed the various evaporators, which may be located in individual refrigerator cabinets in each apartment. The gas from each evaporator can be returned through separate suction lines to one main suction line leading back to the compressor.

However, more recent installations generally have separate liquid lines and separate suction lines run to each evaporator, and all of these lines connected to a main header or valve manifold right at the compressor as shown in Figs. 32 and 33. Then by use of valves in each line any one refrigerator can be entirely separated from the others in case of trouble.

The separate control valves used with individual evaporators in multiple systems, are generally of the low side float type. That is, float valves in the

evaporator tank, which is in the low pressure side of the system. Many such multiple installations have all evaporators set for the same temperatures.

However, there have been developed more recently two special adjustable valves for use with evaporators using low side float valves. These are known as snap action valves and two temperature valves, which when installed in the suction lines of multiple system evaporators, permit maintaining different temperatures in the various evaporators.

One of the disadvantages of such multiple refrigeration systems is that in case of trouble with the main condensing unit all refrigerators in the building are put out of service. For this reason many apartment building owners prefer complete, separate, self contained refrigerators in each apartment.

The following section describes in detail the construction and operation of each of the important refrigerator parts with which you have become acquainted in this section. Let us remind you again that it is highly important that you have a thorough understanding of the refrigeration cycles covered in these pages and the refrigerator parts which are covered more fully in the next section.

This knowledge should help you prepare for many profitable jobs in refrigeration service work.

REFRIGERATOR PARTS, CONSTRUCTION AND OPERATION

Now that you have learned the fundamental principles of refrigeration and the mechanical refrigeration cycle, and have a general understanding of the parts used in these interesting machines, let us take up in detail the construction and operation of each of these important refrigerator parts.

Study carefully the instructions in this section and then you will be ready for your following material on common refrigerator troubles and actual service methods.

13. COMPRESSORS—RECIPROCATING TYPES.

There are several different types of refrigerator compressors in common use. One of the most common and popular of these is the single acting, reciprocating compressor which is constructed very much like the ordinary air compressors which were explained in earlier lessons. These reciprocating compressors have the advantages of being very low in manufacturing cost, and easy to repair. They have the disadvantages however of being somewhat noisy in operation and slightly lower in efficiency than some of the rotary type compressors.

Fig. 23 shows a single cylinder reciprocating type compressor mounted on the condensing unit base and connected by a "V" belt to its driving motor on the right. Most of the compressors of this type used in small household refrigerators are single cylinder units, while those for large household units and for commercial units may have from two to four cylinders, to increase their capacity for handling larger volumes of gas.

Fig. 34 shows a sectional view of a two cylinder compressor with the important parts numbered and named. Examine this view very carefully to become familiar with all these parts. You will note that the principal parts of such a compressor are the crank case, cylinders, pistons, piston pins, valves, connecting rods, crank shaft or eccentric shaft, drive wheel, bearings, and shaft seal.

Due to the somewhat porous nature of the cast iron or steel used in the construction of compressor crank cases, there would normally be some tendency for refrigerant gases to slowly leak through these metal walls. To prevent this, compressor housings are often given a solder bath or galvanizing dip to fill the pores of the iron.

Early types of compressors used pistons which were ground to a very close fit with the cylinder walls and which did not use any piston rings. Many of the later types of compressors use pistons having piston rings to provide a better seal with the cylinder walls and thereby improve the compressor efficiency. Many reciprocating compressors rely on oil splashed up from the crank case to lubricate the pistons and connecting rod and bearings, although some compressors use oil pumps and pressure lubricating systems.

The suction and discharge valves in these compressors may be located in the piston head and cylinder head or in some cases they are both in the cylinder head. These valves are frequently of the reed type, merely consisting of thin flat steel reeds held lightly against the valve openings by their flat springs or their own spring tension. Thus the gas

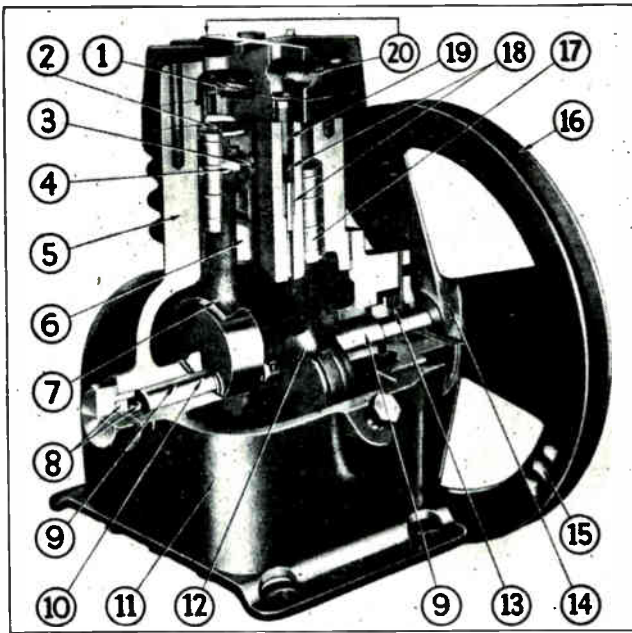

KEY TO NUMBERS ON CUT-AWAY COMPRESSOR

- | | |
|--|---|
| 1. Multi-reed discharge valve. | 10. One-piece drop-forged eccentric shaft. |
| 2. Spring-disc intake valve. | 11. Extra large crankcase. |
| 3. Spring thrust washer. | 12. Directional oil distributor. |
| 4. Lubricated wrist pin. | 13. Balanced seal. |
| 5. One-piece body. | 14. Fan blade type spokes. |
| 6. Diamond-bored, micro-honed, hand-lapped cylinder walls. | 15. Balanced flywheel. |
| 7. Diamond-bored connecting rod. | 16. V-belt drive. |
| 8. Shaft thrust ball with hardened insert and plug. | 17. Selective fit pistons. |
| 9. Diamond-bored oversize bearing. | 18. Cylinder and piston oiling system (Patent pending.) |
| | 19. Suction line screen. |
| | 20. Service valves in head cap. |

Fig. 34. Carefully study each part shown in this excellent sectional view of a reciprocating compressor such as used in domestic and small commercial refrigerators. Thoroughly familiarize yourself with the name and purpose of each part while studying the accompanying lesson material. Courtesy Copeland Refrigeration Corp.

can be forced thru the valve in one direction by the pressure built up by the piston. Then on the down-stroke of the piston, the valve reed is held tightly closed against the valve seat by the spring and by the back pressure of the gas. See Fig. 35-A.

Some compressors use disc or flat plate type valves while others use poppet type valves which will be explained later. In some cases the suction valve is merely a port or opening in the side of the cylinder wall; this port being opened and closed at the right period by the piston passing over it. See Fig. 35-B. Also note the several types of compressor valves shown in Fig. 36.

Fig. 37 shows a sectional view of a large two cylinder commercial compressor with feather type valves, roller bearings and water cooled cylinder heads. Carefully examine all of the parts of this unit.

Another type of compressor used in some refrigerators is of the double acting type, using a scotch yoke or eccentric cam instead of a crank shaft and connecting rod, to move the piston back and forth in its stroke. This type of compressor is somewhat more efficient but is also more complicated than the ordinary reciprocating compressor. See Fig. 38. Sparton and Wellsbach refrigerators use these double acting compressors.

One of the most important parts of a reciprocating compressor is the shaft seal which is designed

to prevent leakage of gas at the point where the drive shaft passes through the crank case. There are several types of shaft seals in use, one very common type being the siphon bellows type seal shown in Fig. 39 and also in the compressor in Fig. 34. In this type of seal a spring holds a smoothly ground seal ring tightly against a smooth shoulder on the shaft.

One special bellows type of shaft seal is shown in the sectional view of the compressor in Fig. 40. Note the parts of the seal which are shown removed from the compressor. These seals must be maintained in perfect condition in order to prevent gas leakage, and they are therefore one of the compressor parts which may need frequent attention from the service man.

Large commercial refrigerator compressors often use packing glands in which soft packing is wrapped around the shaft and tightly compressed against the moving shaft surface by a plate or collar over the packing gland.

14. ROTARY TYPE COMPRESSORS.

There are several types of rotary compressors used in refrigeration machines for domestic service. Some of these are called rotary vane compressors, stationary vane compressors, "rollator," and rotary gear type compressors.

Fig. 35-D shows a diagram of a rotary vane compressor having four vanes or blades set in slots in the revolving rotor. The rotor and vanes revolve in an iron casing which fits closely against the flat sides of the rotor. The vanes are held outward against the rim of the casing, either by centrifugal force or by small springs placed in the slots behind the blades.

The rotor and its shaft are located off center with the rotor casing, or in other words, they are not concentric with the casing. By examining the figure you can see that as the blades revolve past the intake and discharge ports they will trap gas in the larger area "L," between the rotor and casing, and

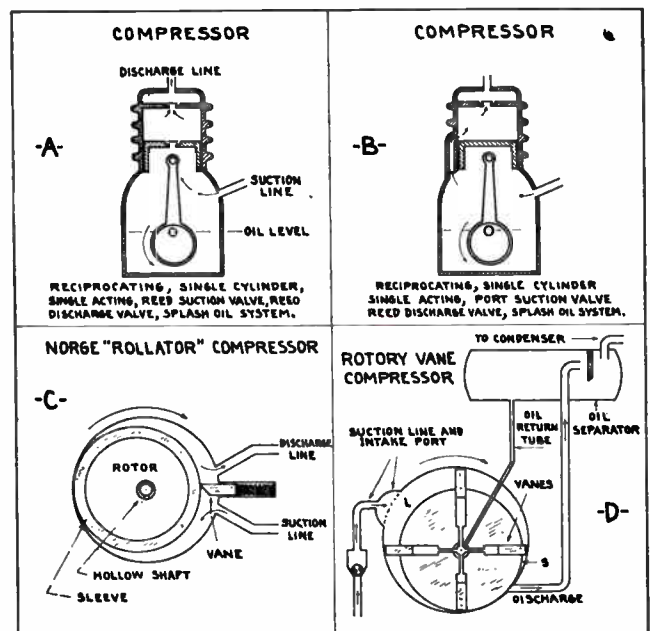

Fig. 35. The above diagrams show several types of reciprocating and rotary refrigeration compressors. Examine and check every operation carefully while reading the lesson material.

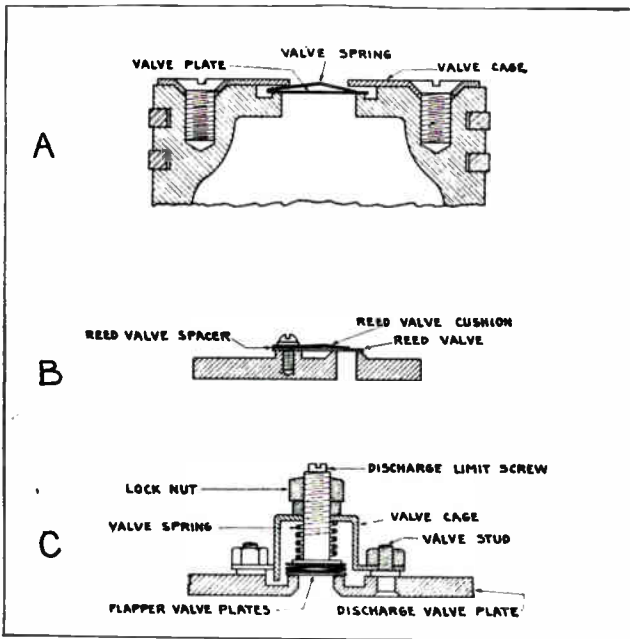

Fig. 36. These diagrams show the construction of several types of refrigerator compressor valves.

squeeze the gas down into the smaller area "S," where it is forced out through the discharge opening at increased pressure.

A check valve must be used in the suction line from these compressors to prevent back flow of the gas when the compressor is idle. All rotary compressors revolve in a clockwise direction when facing the drive end.

Several of the advantages of this type compressor are that they will handle large volumes of gas with quite high efficiency, and they are very quiet in operation. They are also made for high speed operation and can therefore be direct connected to the motor shaft, thus eliminating belt drives.

Most reciprocating compressors are equipped with a drive pulley for "V" belt or flat belt drive from the motor pulley. However, some of the smaller ones are made for direct connection to the motor shaft. See Fig. 41.

15. "ROLLATOR" AND GEAR TYPE COMPRESSORS.

Another type of rotary compressor is the stationary vane "rollator" unit used in the Norge refrigerator. See Fig. 35-C. In this compressor a round iron rotor with flat sides, and equipped with a free metal sleeve, is mounted eccentrically (off center) on the drive shaft and rotated in a casing having a single stationary vane which is held against the rolling, wobbling sleeve by a spring. The stationary vane separates the high pressure side from the low pressure side.

As the rotor revolves the sleeve rolls around the inside wall of the casing and sucks in gas from the suction line, and squeezes it out of the discharge line.

The clearance between the sides of the rotor and the casing of these compressors is .0003 inch and an oil film provides the seal to prevent gas leaking back between the rotor and casing.

Rotary gear type compressors are used in some refrigerators. See Fig. 43. Two herring bone gears,

one the driven gear and the other an idler, are enclosed in a housing. Gas enters at the suction side and is carried in the spaces between the gear teeth and the casing, around to the discharge side where it is compressed out due to the meshing of the gear teeth closing up these spaces.

Gear wear in these compressors is rather rapid due to the very close fit required between the teeth of the two gears to prevent back flow of the gas.

Refrigerator compressors are usually driven by electric motors, and are connected to them by belts, gears, or direct shaft connection. Belt driven compressors generally operate at 1/4 to 1/3 of motor speed. "V" belts are better than flat belts because they have better traction or grip on the pulleys, and are less likely to slip off the pulleys.

There should generally be about 1/2" of slack or "belt play" in either direction when moving the belt up and down midway between the pulleys.

Pulleys should be kept lined up to prevent excess belt wear and noise. The compressor pulley is generally stationary and the motor pulley is movable. Therefore proper belt alignment can be obtained by shifting the motor pulley on its shaft.

16. CONDENSERS.

Refrigerator condensers are made in both air-cooled and water cooled types. The great majority of those used on domestic units are air-cooled, while those used on large commercial refrigeration or air-conditioning machines are generally water cooled.

Water cooled condensers have a much greater heat absorbing capacity for a given size than air-cooled condensers. However, the low cost and simplicity of air-cooled condensers makes them much more popular for use in ordinary household refrigerators.

As previously explained, the primary purpose of

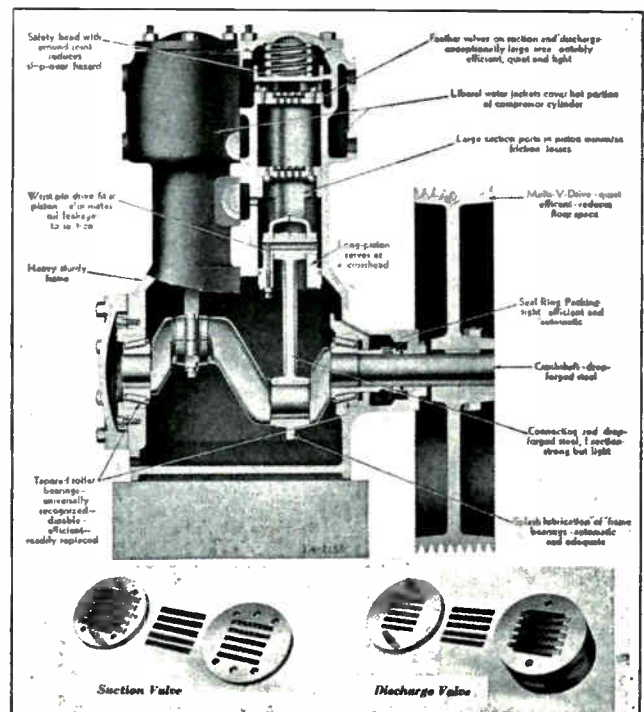

Fig. 37. This excellent sectional view clearly shows the important parts of a heavy duty commercial refrigerator compressor of the two cylinder reciprocating type. Courtesy Carbondale Mfg. Co.

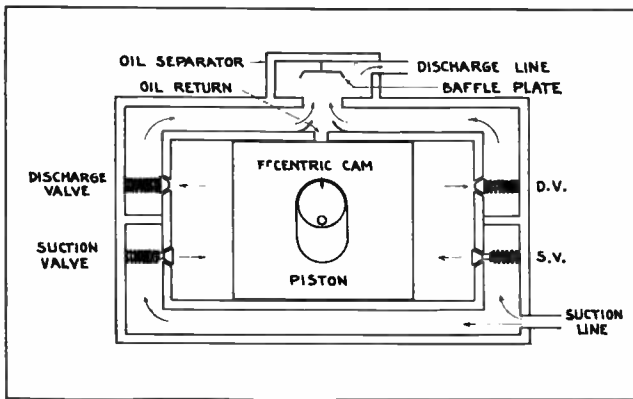

Fig. 38. Sketch showing the construction and operation of a double acting reciprocating compressor using poppet type valves.

a refrigerator condenser is to give off the heat of the high pressure refrigerant gas to the cooling air or water, and thereby chill the gas enough to condense it back to a liquid.

Most condensers are made of copper tubing, as copper is an excellent conductor of heat and therefore very efficient in transferring the heat of the gas through the tube walls to the cooling air or water.

Simple condensers can be made of loops or coils of plain copper tubing of $\frac{1}{4}$ to $\frac{1}{2}$ inch or larger diameter, as shown in Fig. 45-A. The heat transfer efficiency of a condenser can be greatly increased, however, by the use of copper fins attached to the tubing wall as shown in Fig. 45-B, to increase the metal surface area in contact with the cooling air.

In some condensers these fins are merely pressed tightly on to the tubes, while in others they are soldered on, or formed as an integral part of the copper tube itself, by a special machine with revolving dies. The better the contact or joint between the tube and fins, the more efficient will be the condenser.

Another type of condenser, known as the radiator

type, has continuous metal fins joining all the tubes, as shown in Fig. 45-C. One foot of radiator fin type tubing will do as much work as 6 to 8 ft. of plain tubing of the same diameter. A very good view of an air-cooled condenser is shown in the unit in Fig. 23. Other air-cooled condenser views can be seen in Figs. 25, 26, and 27. Such condensers are cooled by air circulated by a fan on the motor or compressor pulley, or sometimes on a separate fan motor. The air velocity is generally from 400 to 500 ft. per minute.

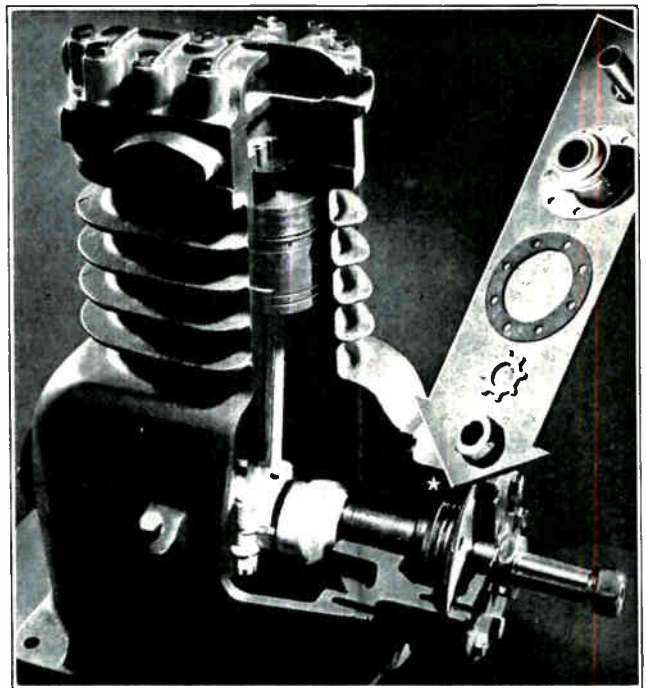

Fig. 40. Sectional view of a two cylinder reciprocating type compressor showing pistons, crank shaft and shaft seal. Courtesy Mills Novelty Co.

Water-cooled condensers are made in dome type, shell and tube type and double tube type.

A dome type condenser is shown in Fig. 45-D, and consists of a gas dome mounted directly over the compressor cylinder head to receive the hot gases discharged from the compressor. Cooling water is circulated through coils of copper tubing inside the dome, and absorbs the heat from the gas as it contacts these coils.

A shell and tube type condenser is shown in Fig. 45-E and is quite similar to the dome type except that they are usually in cylindrical form and can be mounted either vertically or horizontally.

A double tube or "counter flow" condenser is shown in Fig. 45-F, and consists of a small copper tube within a large one. The gas is circulated through the large tube in one direction and the water is passed through the smaller tube in the opposite direction. This is one of the most efficient types of condensers made.

Water-cooled condensers have an automatic water regulating valve to control the flow of water to match the load on the compressor and to maintain a temperature difference of about 20 degrees between inlet and outlet water. For example, if the inlet water temperature is 50 degrees F., the outlet water temperature should be about 70 degrees F.

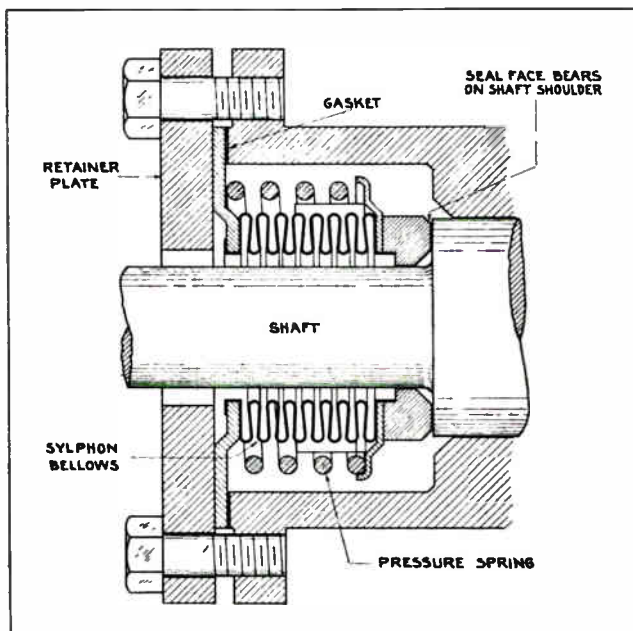

Fig. 39. Carefully examine all details of the syphon bellows type shaft seal shown in the above diagram. This type of seal is extensively used in domestic type refrigerators.

Such a valve is shown with the water-cooled condenser in Fig. 28. Another water-cooled condenser with a water regulating valve is shown with the unit in Fig. 30.

17. EVAPORATORS.

You have learned that the function of the refrigerator evaporator is to absorb the heat from the air in the cabinet and transfer this heat to the liquid refrigerant, which in turn vaporizes into a gas which carries the heat away outside the cabinet to the compressor and condenser.

Therefore evaporators are also made of copper because of its excellent heat conductivity. Evaporators generally consist of a drum or header to which a number of copper tubes are connected. Some evaporators use finned tubes similar to those used in condensers.

Evaporators are often classified as flooded type or dry type, according to the amount of liquid refrigerant they normally contain. Those having liquid drums or headers and low side float valves are flooded type units, and their tanks or drums are usually $\frac{2}{3}$ to $\frac{3}{4}$ filled with low pressure liquid refrigerant.

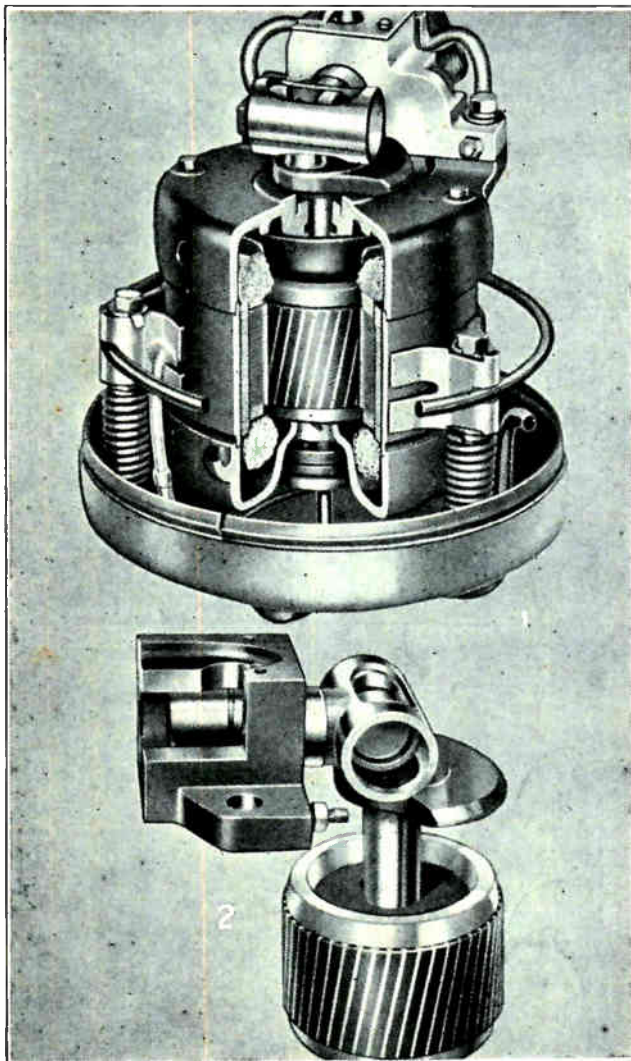

Fig. 41. The above views show the construction of the compressor and motor used in the General Electric hermetic type unit. Courtesy General Electric Co.

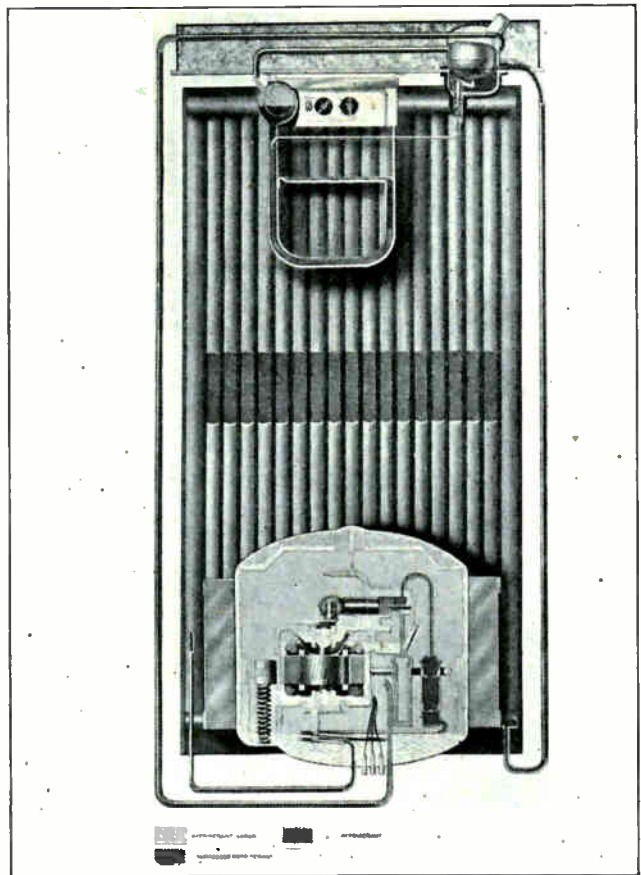

Fig. 42. This sectional view shows the important parts and also the cycle of operation of a modern General Electric refrigerating unit. Carefully observe the details of the hermetic type compressor and also of the evaporator and high side float valve. Courtesy General Electric Co.

Those using expansion valves to discharge the liquid directly into the tubing or manifold are dry type units.

Figs. 21, 25, 28 and 29 show several styles of flooded evaporators, while Figs. 27 and 30 show dry type units. Examine and compare each of these carefully. Fig. 31 shows an evaporator with the door open to the space or compartment surrounded by the tubing. This is one of the coldest spots in the refrigerator and is used for chilling and freezing desserts, and ice cream, and for making ice cubes.

At the top of Fig. 42 is shown a cut-away view of an evaporator using a high side float valve to control the flow of refrigerant. Fig. 47 shows an excellent view of a modern evaporator used in the Fairbanks-Morse refrigerator. Carefully note the construction features and the various parts which are marked in this view.

18. DIRECT AND INDIRECT TYPE EVAPORATORS.

Evaporators are also classed as direct or indirect types. The direct type of evaporator has its tubes or flues exposed directly to the air in the cabinet. The indirect type has the tubes enclosed in a metal tank. The space around the tubes in the tank is filled with a non-freezing brine solution.

The brine is sometimes referred to as a hold-over solution, and in addition to conducting the heat from the tank walls to the evaporator tubes, the heat absorbing capacity of the solution lengthens

the running periods and idle periods of the refrigerating cycle, thereby reducing the number of starting and stopping operations.

These non-freeze solutions may be made of 40% denatured alcohol and 60% water; or 40% radiator glycerine and 60% water; or 2¾ lbs. of calcium-chloride to one gal. of water. Some refrigerator manufacturers use other special patented chemical non-freeze solutions.

The brine tank should be kept completely filled within about ¼" of the top for efficient operation, and the solution should be kept at the proper strength or it may freeze and burst the tank.

One of the most efficient types of evaporators is the **direct, dry fin type**, because of its great active surface and rapid rate of heat transfer. This type of evaporator when used in large commercial units does not frost over, because, although its temperature is low enough to cool the cabinet, it is not low enough to freeze moisture on its surface. See Fig. 46.

Many other types of evaporators need to be defrosted occasionally by shutting off the refrigerator until the frost melts off the tubes. Otherwise they may become so covered with frost as to prevent proper air circulation and heat transfer.

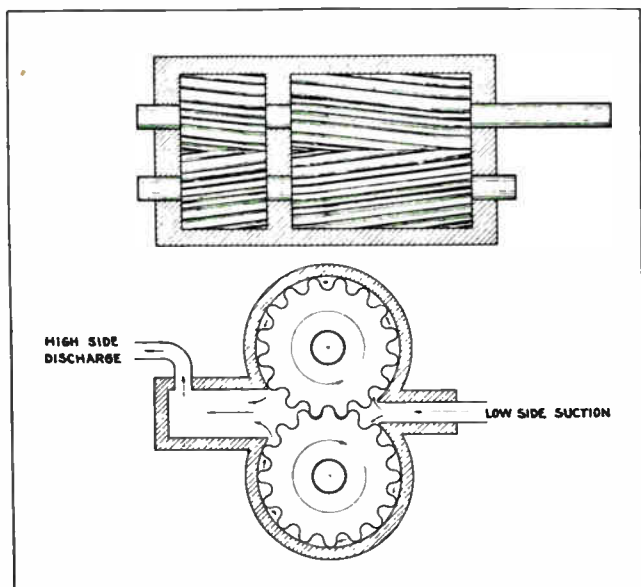

Fig. 43. Diagram showing the construction and operation of a rotary gear type compressor such as used in some refrigerators.

Fig. 46 shows a large dry type evaporator such as frequently used for cooling large commercial refrigerator boxes, meat storage boxes, walk in coolers, etc.

19. CONTROL VALVES, LOW AND HIGH SIDE FLOAT VALVES.

As previously explained, all refrigerator evaporators use some kind of control valve to limit or regulate the flow of refrigerant to the required amount to maintain the proper cabinet temperature.

Several of the more common of these valves are as follows: **Low side float valve**, **high side float valve**, **automatic expansion valve**, **thermostatic expansion valve**, and the **capillary or choke tube**.

You no doubt already have a fair understanding of the low side float valve from the views shown in Figs. 25, 28, and 29. The view in Fig. 29 is particu-

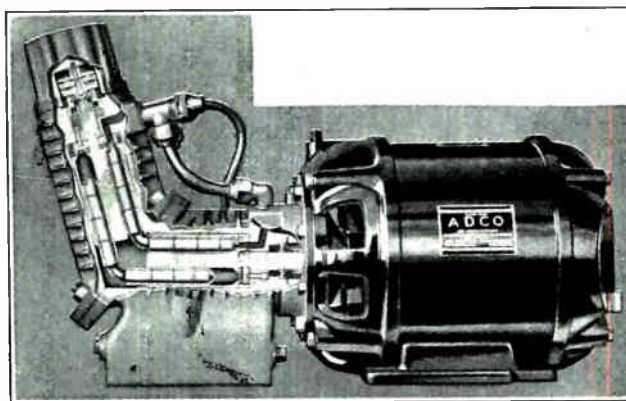

Fig. 44. Sectional view of a unique combination rotary and reciprocating compressor used in one type of refrigerator and air-conditioning unit. As the rotary blocks revolve in the angular chambers the small pistons are caused to move back and forth in the cylinders, thus obtaining compression action. Courtesy Air-Conditioning Devices Corp.

larly clear and should be referred to again while reading the following explanation.

Low side float valves are located inside the drum of the flooded type evaporator and consist of the float ball or pan, float arm, pivot, body, needle and needle seat. Its operation is as follows: When the low pressure liquid evaporates the liquid level drops, causing the float to lower and due to the action of the pivot the needle is withdrawn from the valve seat, or opening, allowing additional liquid refrigerant to enter the evaporator from the high pressure liquid line.

When the liquid level rises, the float also rises and

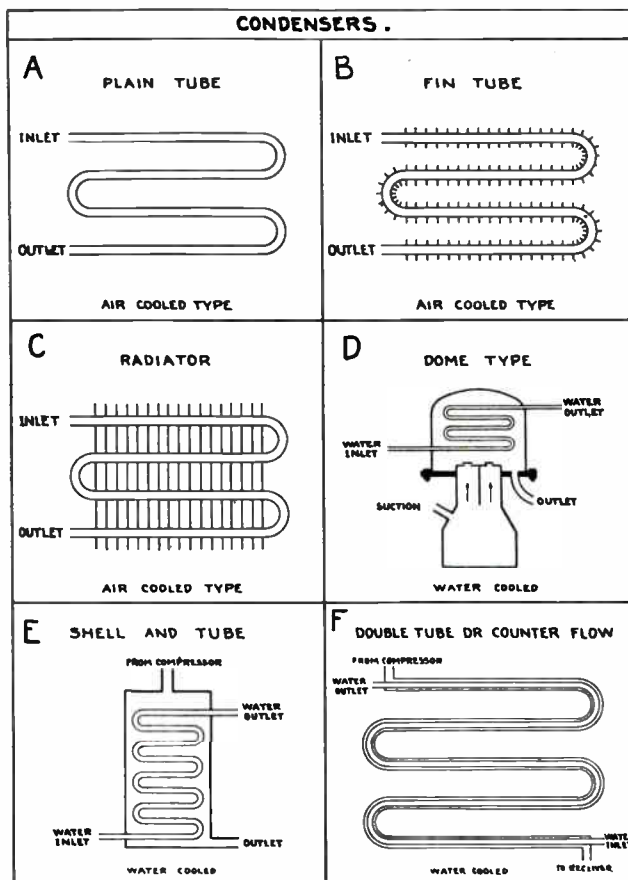

Fig. 45. The above diagrams show the construction of several different types of air-cooled and water-cooled condensers such as used in electric refrigerators.

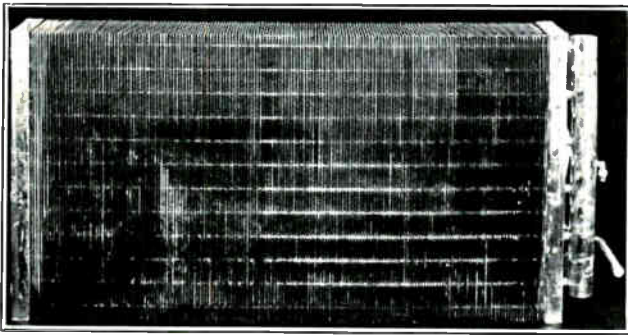

Fig. 46. Photograph of a large commercial type evaporator. Note the fins which are attached to the tubes to more rapidly absorb the heat and air. Courtesy York Ice Machine Co.

at a certain level again closes the needle valve. There are no adjustments on this type of control valve and they are calibrated or set at the factory.

Units using low side float valves require a greater quantity of refrigerant for the charge than those using high side floats or expansion valves.

High side float valves are located in the liquid receiver. See Fig. 42. As the liquid from the condenser accumulates in the receiver, the float rises, opens the needle valve and allows more liquid to enter the evaporator.

When this type of valve is used, the liquid line between the float valve and evaporator becomes part of the low pressure side of the system and the tendency of the refrigerant to evaporate and expand in this line frequently causes it to frost over. This can be prevented by insulating the liquid line from the point where it leaves the float chamber to the point where it enters the evaporator and thus preventing moisture contacting its cold surface and condensing and freezing on the tubing.

Another method recently developed for preventing frosting of the liquid line on refrigerators using high side floats, is to install a throttle or choke valve in the liquid line near the evaporator. This maintains enough back pressure in the liquid line to prevent evaporation and chilling. When ordering throttle valves for this purpose, be sure to specify the type of refrigerant used.

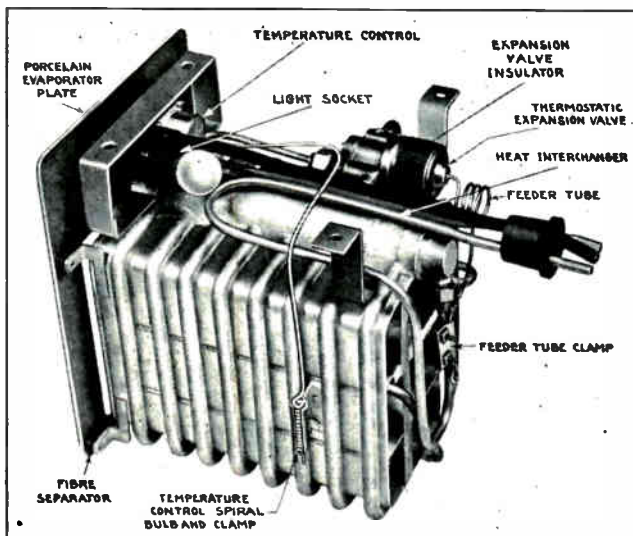

Fig. 47. Carefully examine this excellent photograph of an evaporator used in a modern household refrigerator. Note the details of construction and all the parts which are named in this view. Courtesy Fairbanks-Morse Co.

20. CAPILLARY TUBES.

On some refrigerators a capillary or choke tube is connected in the liquid line near the evaporator and used in place of a float valve to regulate the flow of refrigerant to the evaporator. These tubes are usually made of copper with a very small opening, and from 8 to 18 feet long, and wound in a spiral or coil.

The resistance to the flow of the liquid refrigerant through the long and very small opening in the tube, restricts the flow to the evaporator and maintains sufficient pressure in the receiver and condenser. These tubes are made of the right size and length at the factory and there is no adjustment on them except by changing their length.

21. AUTOMATIC EXPANSION VALVES.

One of the most popular types of control valves used with domestic refrigerators is the automatic expansion valve. See Fig. 48-A and B, and also

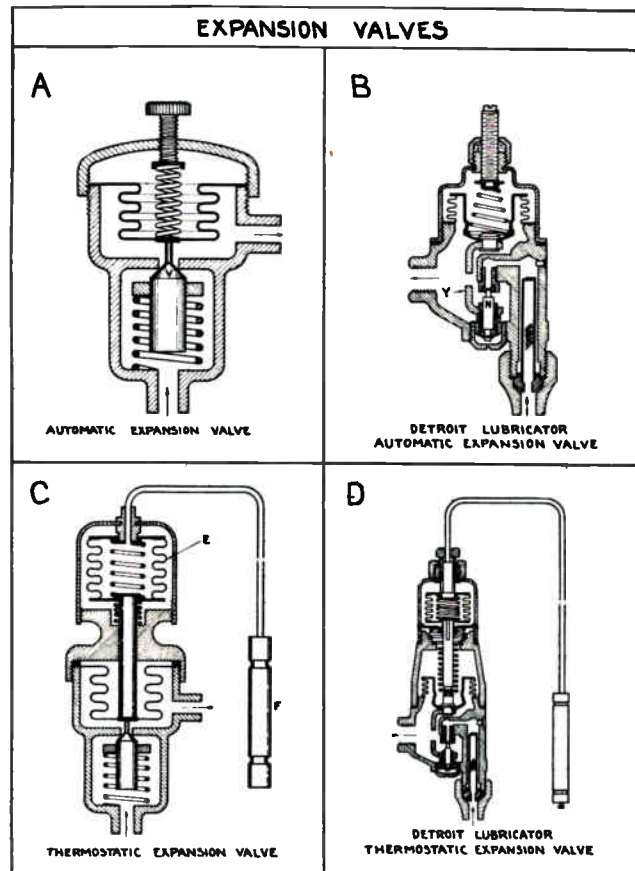

Fig. 48. The above diagrams illustrate the construction and operation of automatic expansion and thermostatic expansion control valves such as commonly used with refrigerator evaporators.

Figs. 49 and 50 which show various views of automatic expansion valves. These valves are operated by the pressure of the gas in the evaporator or low side.

Fig. 48-A shows a diagram of a very simple expansion valve, and if you will carefully observe its operating principle you will find that other types of slightly different construction, nevertheless operate on very much the same principle.

The liquid line supplies liquid under pressure to the bottom connection of this valve. If there is plenty of liquid in the evaporator, the pressure from

the evaporated gas will push upward on the sylvhon bellows and hold the valve "V" closed.

When the liquid supply in the evaporator is reduced and the gas pressure on the bellows is lowered, the top spring and atmospheric pressure combined will force the valve open and permit more liquid to flow into the evaporator, through the right hand opening. Therefore, we can see that these valves operate automatically to permit the flow of liquid refrigerant to the evaporator as needed.

The valve shown as 48-B operates on the same principle, except that the needle valve "N" is connected to the sylvhon bellows by means of the yoke "Y."

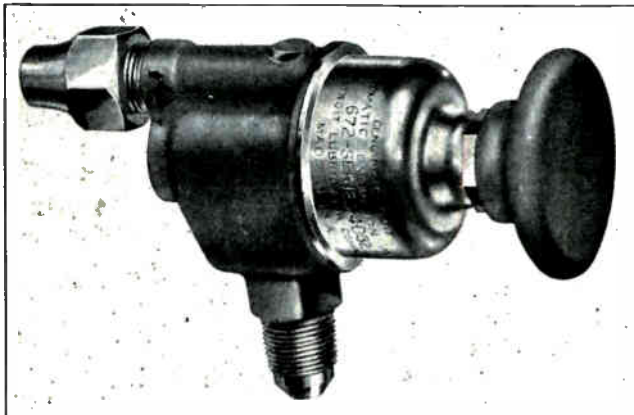

Fig. 49. Photograph of an automatic expansion valve. Note the soft rubber cap over the adjusting nut. Courtesy Detroit Lubricator Co.

Note the adjusting screws on the top of both of these expansion valves. By means of these screws, the valves can be adjusted to maintain the right amount of refrigerant in the evaporators. Turning the screws clockwise increases the amount of refrigerant, while turning them counter clockwise decreases the flow of refrigerant.

Automatic expansion valves maintain practically constant low side pressure all the time the compressor is in operation, regardless of the evaporator temperature.

Carefully examine and note the names of all parts of the expansion valve shown in Fig. 50. Note the strainer "F" in the liquid line opening. Sometimes these strainers become clogged and prevent proper flow of liquid refrigerant. They are therefore removable for cleaning.

The rubber cap over the adjusting screw is to prevent moisture entering the valve body. Grease is sometimes packed around this screw for the same purpose in case there is no protective cap.

22. THERMOSTATIC EXPANSION VALVES.

Thermostatic expansion valves are very similar in general construction and use to automatic expansion valves, except that the thermostatic valves have an extra control bellows "E" and a power bulb "F" to make these valves self-adjusting. See Figures 48-C and D.

The power bulb is filled with a volatile liquid and attached to the top bellows chamber by means of a small copper tube. The power bulb is clamped to the suction line or to the evaporator as shown in Figs. 26, 27, and Fig. 47. Carefully note the arrange-

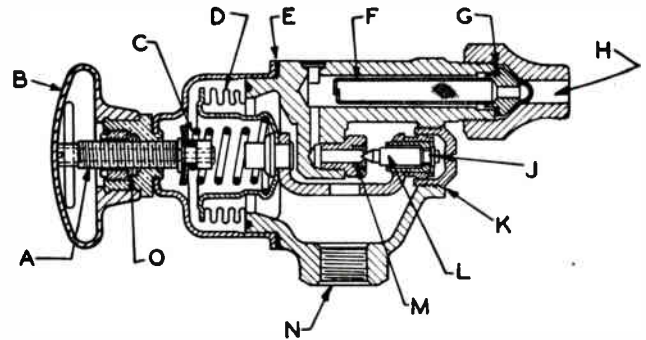

- A—Adjusting screw.
- B—Adjusting screw breather cap
- C—Adjusting spring.
- D—Bellows.
- E—Moisture tight joint.
- F—Strainer.
- O—Copper gasket.
- H—Inlet connection 1/4" copper tube.
- J—Needle Swivel.
- K—Plug hermetically sealed with solder.
- L—Stainless steel needle.
- M—Stainless steel seat.
- N—Outlet connection.
- O—Moisture tight packing.

Fig. 50. Sectional view of an automatic expansion valve. Carefully examine all working parts and note the names of each as marked. Courtesy Detroit Lubricator Co.

ment of the power bulbs and thermostatic valves in each of these figures.

When the evaporator or suction line temperature raises, the volatile liquid in the power bulb expands and applies increased pressure on the bellows and push rod, opening the valve to admit more refrigerant. As soon as the added refrigerant has chilled the evaporator and reduced its temperature and that of the suction line, the liquid in the power bulb contracts or the vapor condenses and releases the pressure on the bellows, allowing the valve to close.

This type of valve is very commonly used in commercial refrigerating units, and on direct expansion air-conditioning units, as well as on some household units. Note the adjusting nut at the top of the valve in Fig. 48-D.

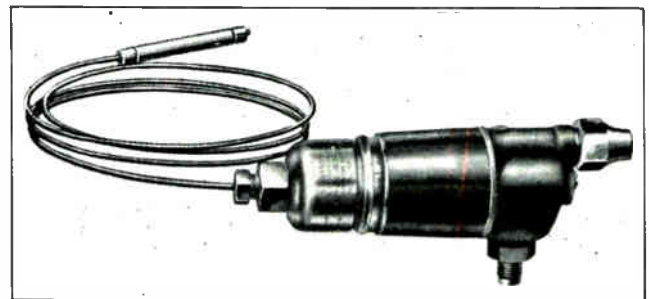

Fig. 51. Photo showing a thermostatic expansion valve with its power bulb and connecting capillary tubing. Courtesy Detroit Lubricator Co.

Fig. 51 shows a photo of a thermostatic expansion valve, and Fig. 52 shows a detailed sectional view with all the parts named. Examine these views very carefully until you are sure you understand the operation of these important refrigeration control units.

23. ELECTRIC CONTROL SWITCHES.

One of the smallest, and yet one of the most important units on an electric refrigerator is the electric control switch. This unit starts and stops the motor and compressor, and controls the running time and the temperature of the refrigerator. These switches and their operating mechanisms are often called pressure-stats or thermo-stats, according to their method of operation.

Pressure type control switches have electrical

contacts which are opened or closed by a syphon bellows which is connected by a tube to the low pressure side of the refrigerator unit, so that the switch is operated by the variations in gas pressure in the evaporator or suction line. See Figs. 21, 27, and 28, and note the arrangement of the control switches with these units. As the cabinet temperature increases the gas pressure in the evaporator and suction line also increases, causing the bellows to expand and close the switch to start the motor.

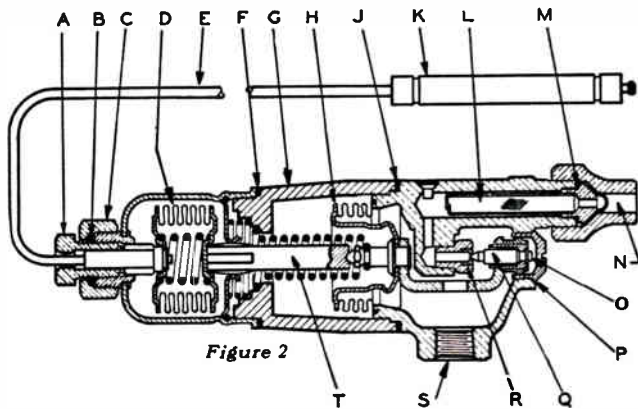

Figure 2

A Adjusting Nut	K Thermostatic Bulb
B Moisture-tight packing around adjusting screw	L Strainer Screen
C Packing Nut	M Copper Gasket
D Thermostatic Power Element	N Inlet Connection for $\frac{1}{4}$ inch copper tube
E Flexible Capillary Tube	O Needle Swivel
F Moisture-tight Joint	P Solder-sealed Plug
G Bakelite Extension	Q Delubaloy Needle
H Bellows Seal	R Delubaloy Seat
J Moisture-tight Joint	S Outlet Connection
	T Bakelite Push-rod

Fig. 52. Sectional view of a thermostatic expansion valve showing all important parts. Carefully examine this diagram while studying the accompanying explanation in the lesson. Courtesy Detroit Lubricator Co.

As the motor and compressor continue to operate the cabinet is cooled and the gas pressure in the evaporator and suction line are reduced. This allows a spring to collapse the bellows, opening the switch and stopping the motor and compressor until the low side gas pressure again rises.

Fig. 53 shows one common type of pressure switch which is used extensively on household and small commercial refrigerators. Carefully note all the parts which are marked in this view. These switches have an adjusting nut to change the temperature range at which the refrigerator will operate. See this range adjusting nut in Fig. 53.

24. COLD CONTROL SWITCHES.

Some control switches often called "cold control" units are operated by a power bulb attached to the evaporator or suction line, instead of by a direct gas line connection into the low pressure side of the system. These are called thermal control switches, because the pressure to expand or contract their

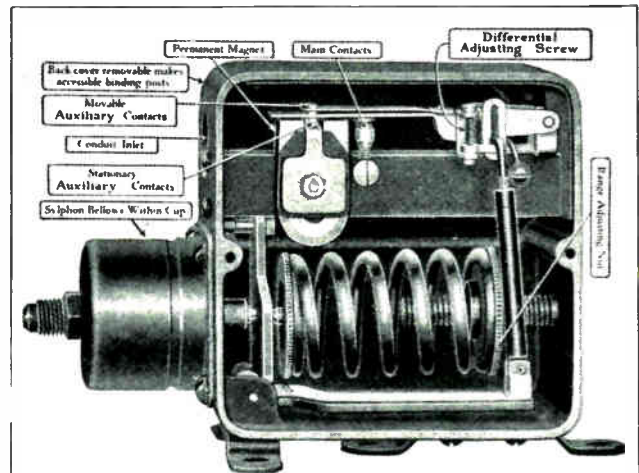

Fig. 53. This view shows the construction and parts of a pressure type electric control switch such as used to start and stop the motor in electric refrigerators and thereby maintain proper operating temperatures. Courtesy Penn Electric Switch Co.

bellows is governed by the temperature of the volatile liquid in the power bulb.

These power bulbs should be securely clamped to the evaporator or suction line with a metal clip, so that they will respond properly to temperature variations of the evaporator or suction line. Figs. 26, 29, and 47 in this section show such control switches in use.

Fig. 54 shows a very popular type of thermal control switch with its power bulb and cold control adjustment. This type of switch can be installed on any ordinary refrigerator in a few minutes, and many service men make good money equipping old style units with this new switch and cold control.

Fig. 55 shows a sectional view of this same type of control switch. Carefully examine all the parts and note the construction of the bellows, range adjustment and switch contacts.

Large commercial refrigerators may require motor starters to start their heavy duty motors. In such cases the control switch is often used to close a circuit to a magnetically operated motor starter.

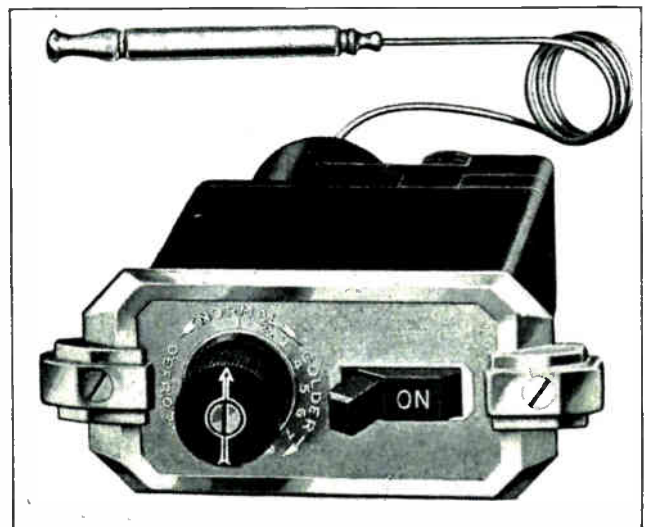
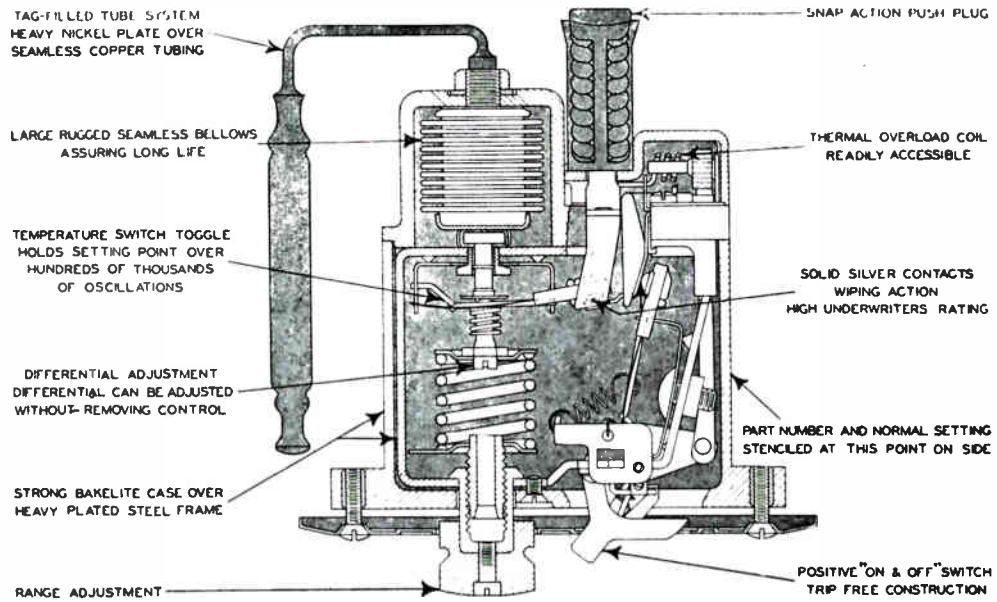

Fig. 54. Photo showing a thermal operated control switch of a type which can be conveniently attached to any household refrigerator. Note the on-and-off switch and the cold control knob. Courtesy Tagliabue Manufacturing Co.

Fig. 55. Carefully examine each part and detail of this sectional view of the same electric control switch which was shown in Fig. 54. Courtesy of Tagliabue Mfg. Co.



Cross-Section of TAG R-18 Snapon Control

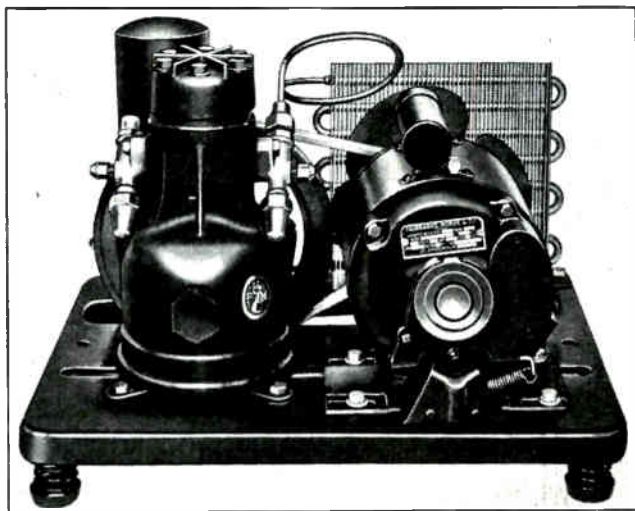

Fig. 56. Note the mounting arrangement of the capacitor type drive motor on this condensing unit. Courtesy Fairbanks-Morse Co.

25. BI-METAL THERMOSTATS.

Some refrigerator control switches use a curved strip of two dissimilar metals or a thermostat element to tilt or operate a mercury switch that is connected in the motor circuit.

You are already familiar from earlier lessons, with the manner in which two unlike strips of metal will bend or warp if riveted or welded together and then heated. By anchoring one end of a spiral strip of brass and nickel steel, and attaching the mercury switch tube to the free end, the switch will tilt and close or open a circuit whenever temperature changes cause the strip to bend. These switches are also adjustable by rotating or shifting the element housing a small amount in either direction.

26. PENCIL TYPE SWITCHES.

This type of switch is a self-contained unit having its power bulb in to the lower part of the switch. This power bulb is filled with a low freezing point solution of alcohol and water.

The whole switch unit is clamped to the side of the evaporator like the unit shown in Fig. 29. When the evaporator temperature lowers the solution freezes and expands enough to open the switch contacts and stop the motor and compressor. When the evaporator temperature rises the solution melts and contracts, allowing the switch to close and start the motor once more.

27. ELECTRIC MOTORS.

Electric motors used to drive refrigerator compressors range in size from $\frac{1}{8}$ h.p. to $\frac{1}{2}$ h.p. for household units, and from $\frac{1}{2}$ h.p. to several hundred h.p. each for commercial units.

These motors may be either D.C. or A.C. according to the available power supply. As most homes are supplied with alternating current, the great majority of domestic refrigerators use A.C. motors.

A.C. refrigerator motors for domestic units are commonly of the repulsion induction, single-phase, split-phase, or capacitor motor types. Large commercial refrigeration plants use squirrel cage or slip ring induction motors and synchronous motors. See Fig. 196 in A.C. section 5. Many of the earlier refrigerators used the commutator type repulsion motor because of its good starting torque at moderate starting currents. However, this motor has the disadvantage of commutator and brush wear and troubles, and is somewhat noisier in operation.

Single-phase split-phase induction motors with centrifugal starting switches are extensively used, especially with rotary compressors where the required starting torque is not so great.

A more recent type of capacitor motor, using a capacitor or condenser to obtain the split-phase effect and improved torque, has become increasingly popular in recent years. These units are very quiet in operation, have good starting torque, and very few wearing parts, and are therefore becoming more and more extensively used for household and small commercial refrigerators.

All of these types of motors have been explained

in earlier sections on A.C. motors, so we will not devote much time to them here. However, the electric motor is such an important part of any electric refrigerator that its care and service requirements should never be overlooked by the refrigeration service man. More on this subject will be covered in a later section. (Notice, also review A.C. section 5 for information on repulsion, split-phase, and capacitor motors.)

Fig. 56 shows a capacitor type motor with its condenser mounted on top of the motor. These condensers occasionally puncture or burn out and can be easily and quickly replaced with a new unit at very moderate cost.

Motors in household refrigerators are frequently mounted on rubber or spring mountings to reduce vibration and noise. Note the special spring and belt tightener support on the motor in Fig. 56.

28. CABINETS.

The cabinet is one of the most important parts of a refrigerator, because it not only serves as a convenient storage space for the food articles to be preserved, but it should also prevent as much as possible of heat leakage from the warm air in the room to the cold interior of the cabinet.

Therefore, the walls of refrigerator cabinets are insulated with several inches of cork, hair felt, asbestos fibres, tree bark, kapok, corrugated paper, aluminum foil, dry zero (ciba tree seed pod fibres), etc.

The doors are sealed with rubber or composition gaskets to close up all possible cracks through which warm air and heat might enter. Great reductions in the cost of electric power for operating electric refrigerators can be made by use of proper cabinet insulation. Cabinet wall insulation is often wrapped in water-proof paper or coated with asphalt paint to prevent absorption of moisture which would destroy the heat insulating value of the material.

The food storage compartment and evaporator or cooling unit are located inside the insulated space. The motor, compressor and condenser, or heat dispensing units are of course located outside of this space; usually in the bottom, although sometimes at the top of the cabinet. The section of the cabinet in which they are located is not heat insulated, but instead should have a free circulation of air to carry away the heat they liberate. Carefully observe the construction features and conveniences of the cabinet shown in Fig. 57.

Modern household refrigerator cabinets are generally made of pressed steel, and are streamlined, attractively designed, and covered with high-grade enamel in white or other colors. DeLuxe models have the inside of the cabinet lined with porcelain enamel, and some cabinets are porcelain enameled inside and out.

Domestic cabinets range in size from 4 cu. ft. capacity to 8 cu. ft. capacity. They are equipped with wire grill shelves to permit free circulation of cold air in the cabinet. Some units have convenient sliding shelves, door shelves and trays, in-

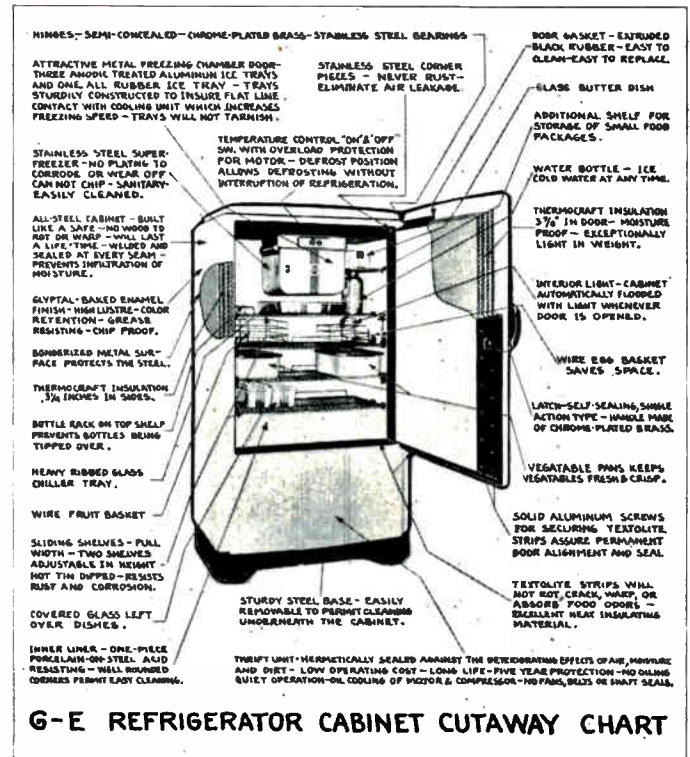

G-E REFRIGERATOR CABINET CUTAWAY CHART

Fig. 57. Photo diagram showing construction features and convenient devices of a modern household refrigerator cabinet. Courtesy General Electric Company.

terior electric light, and other special conveniences.

Small cabinets usually have a single door, while larger ones may have two or more doors. Doors that latch on the right open from right to left are called left-hand doors, while those that latch on the left and open from left to right are called right-hand doors. Door latches are made to hold doors tightly closed, and the doors should be opened only when necessary and then promptly closed again, to avoid wasteful operation and excess frosting of evaporator due to moisture condensed from the air.

Cabinets and coolers for meat markets, stores, and other commercial units are generally of wood construction. Quite frequently they consist of an outside wall of $\frac{7}{8}$ " oak, then a layer of waterproof paper, and an inner wall of $\frac{7}{8}$ " tongue and grooved ash boards which are coated with odorless varnish or shellac.

The thickness of cork insulation, or its equivalent, recommended for various cabinet temperatures are as follows:

- 20 degrees F. to —5 degrees F., 8 inches of cork.
- 5 degrees F. to 5 degrees F., 6 inches of cork.
- 5 degrees F. to 20 degrees F., 5 inches of cork.
- 20 degrees F. to 35 degrees F., 4 inches of cork.
- 35 degrees F. to 45 degrees F., 3 inches of cork.
- 45 degrees F. and up 2 inches of cork.

Now that you are familiar with the refrigeration cycle, the important parts and general construction features of compression type refrigerators, you are ready to learn about the refrigerants or chemicals used in refrigerators.

REFRIGERANTS, CHARACTERISTICS AND LEAK TESTS

It is highly important for the refrigerator service man to have a good general understanding of the nature and characteristics of the more commonly used refrigerant chemicals. This knowledge will help you to better understand the operation, behavior and troubles of different types of refrigerators using these various refrigerants, and it will also help you to properly and safely handle the refrigerant chemicals when charging, installing or servicing refrigerators.

We have already mentioned that a refrigerant is any chemical that is used for absorbing, transferring and releasing heat in the process of refrigeration. It has also been shown that air or water can be used, but that they are not nearly as efficient as certain other chemical refrigerants which absorb heat more readily by evaporation at low temperatures, and give off heat easily by condensation at lower pressures.

A good refrigerant should have as many as possible of the following properties:

1. High latent heat of evaporation, meaning high heat absorbing capacity.
2. Low boiling point at atmospheric pressure, meaning easy to evaporate, and thus absorb heat.
3. Low condensing pressure and temperature, meaning easy to condense and release its heat.
4. Non-injurious to health, lungs and eyes.
5. Non-inflammable and non-explosive.
6. Non-injurious (not corrosive) to metals.
7. Non-injurious to lubricating oils.
8. Stable in chemical composition (does not change chemical form).
9. Easy to test for leaks.
10. Low in cost.

29. COMMON REFRIGERANTS.

Among the most commonly used refrigerants are sulphur-dioxide (SO₂), methyl-chloride (CH₃CL), freon or "F12" (CCL₂F₂), ammonia (NH₃), carbon-

dioxide (CO₂), methylene-chloride or "carrene" (CH₂CL₂). Isobutane or "Freezol" C₄H₁₀, Methyl formate and "F114" are also used in some units. The letters in parenthesis after each refrigerant are the chemical symbols or formulas for these chemicals. For example SO₂ means 1 part sulphur and 2 parts oxygen; CH₃CL means 1 part carbon, 3 parts hydrogen, and 1 part chlorine, etc.

Sulphur-dioxide is one of the most commonly used refrigerants for household refrigerators. Methyl-chloride is also extensively used in household units and in small commercial units. Freon is one of the more recently developed refrigerants which has become very popular in both domestic and commercial units. Ammonia is one of the most efficient and most commonly used refrigerants in large commercial refrigerating plants, ice plants, etc., and is also used in gas operated absorption type units for home use.

The more common of these refrigerants can be purchased from refrigeration supply houses in convenient sized steel drums, for use in filling or "charging" refrigerators. SO₂ is sold in 5, 10, 25, 35, 70 and 150 lb. drums. CH₃CL is sold in 3, 6, 15, 40, 60, 90, and 130 lb. drums. Ammonia in 50, 100 and 150 lb. drums, etc. See Fig. 59.

Some of the most common refrigerators and the refrigerants they use are as follows:

Absopure.....	Methyl-chloride
Bohn.....	Sulphur-dioxide
Brunner.....	Methyl-chloride
Buckeye (1½ to 2 lbs.)....	Sulphur-dioxide
Carbondale.....	Freon or methyl-chloride
Carrier.....	Freon, sulphur-dioxide, methyl
Coldspot (1 lb. 14 oz.).....	Sulphur-dioxide
Copeland (1 to 1¼ lbs.)....	Methyl-chloride or isobutane
Crosley (2 to 2¼ lbs.).....	Sulphur-dioxide or "Thermon"

Fig. 58. This photo shows three twin-cylinder refrigeration compressors, all driven by "V" belts connected to electric motors and supplying refrigeration for a large commercial installation. Courtesy Carrier Co.

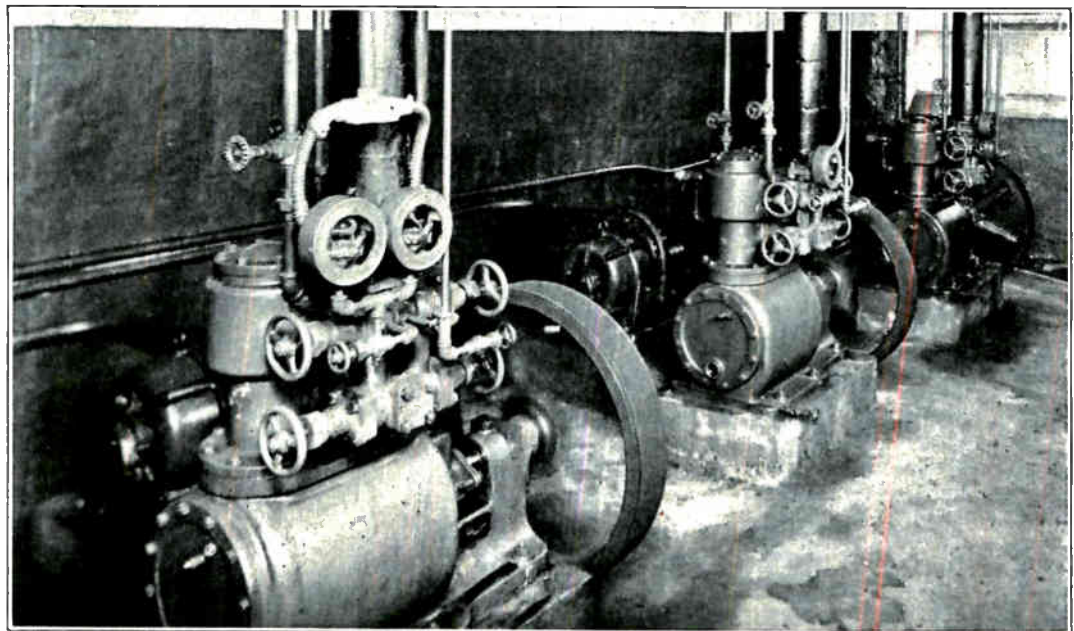

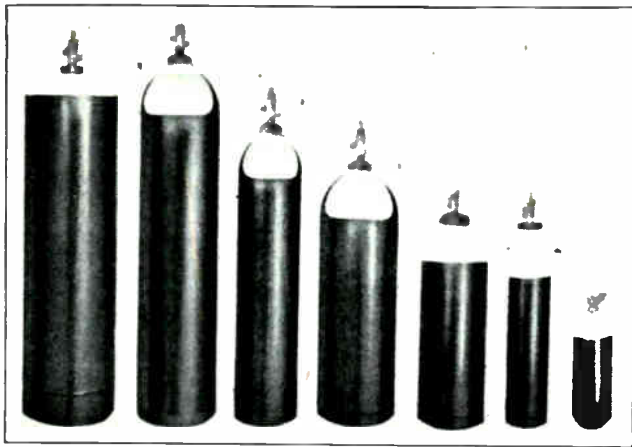

Fig. 59. Several types and sizes of metal cylinders or drums which are used for shipping and handling refrigerant chemicals.

Electric.....	Sulphur-dioxide
Electrokold (1½ lbs.).....	Sulphur-dioxide
Electrolux (gas unit).....	Ammonia
Fairbanks-Morse (1½ lbs.)	Sulphur-dioxide
Frigidaire (1 to 2½ lbs.)..	Freon, sulphur-dioxide, or F114
General Electric (1 to 2 lbs.).....	Sulphur-dioxide or methyl-formate
Gibson (2 to 3½ lbs.).....	Sulphur-dioxide
Graybar 1lg Cold (10 oz.)	Isobutane
Grunow (3 to 4 lbs.).....	Carrene
Holmes.....	Ethyl-chloride
Hot Point (1 to 3 lbs.).....	Sulphur-dioxide
Howe.....	Methyl-chloride
Ice-O-Matic (2½ to 5 lbs.)	Methyl-chloride
Icyball (Crosley).....	Ammonia
Jack Frost.....	Sulphur-dioxide
Kelvinator (2 to 3 lbs.).....	Sulphur-dioxide
Leonard.....	Freon or sulphur-dioxide
Lipman.....	Methyl-chloride, freon or ammonia
Majestic (1½ lbs.).....	Sulphur-dioxide
Mayflower (1½ to 4 lbs.)	Sulphur-dioxide
Nash.....	Methyl-chloride
Norge (5½ lbs.).....	Sulphur-dioxide
Reliance.....	Freon or methyl-chloride
Servel (1 to 1¾ lbs.).....	Methyl-chloride
Stewart-Warner (5 lbs.)..	Sulphur-dioxide
Sunbeam (1 lb. 14 oz.).....	Sulphur-dioxide
Universal.....	Sulphur-dioxide or Freon
Wayne.....	Sulphur-dioxide
Westinghouse.....	Freon or sulphur-dioxide
York.....	Freon or ammonia
Zerozone (1 to 1¼ lbs.)...	Sulphur-dioxide

The approximate amount of refrigerant charge for recent models of domestic units is given for some of the above machines merely to furnish a general idea of the amounts of refrigerant used.

Fig. 60 shows the boiling points of several common refrigerants at various pressures and vacuums, and Fig. 61 gives the pressure-temperature characteristics of common refrigerants. Carefully examine these charts as they contain valuable information which you may often wish to refer to when working with refrigerants.

30. SULPHUR-DIOXIDE.

Sulphur-dioxide is a colorless liquid and is obtained by burning sulphur and air or oxygen. It remains in liquid form when kept sealed under pressure but vaporizes very rapidly when exposed to air. SO₂ vapor has a very strong and unpleasant sulphur odor which is highly irritating to eyes, nose, throat and lungs, if inhaled in strong mixtures.

SO₂ is non-inflammable and non-explosive, and has a boiling point of 14 degrees F. at atmospheric pressure. SO₂ is a very stable chemical and does not break down under the pressures and temperatures encountered in ordinary refrigerators. It will not harm lubricating oils unless it is allowed to absorb moisture.

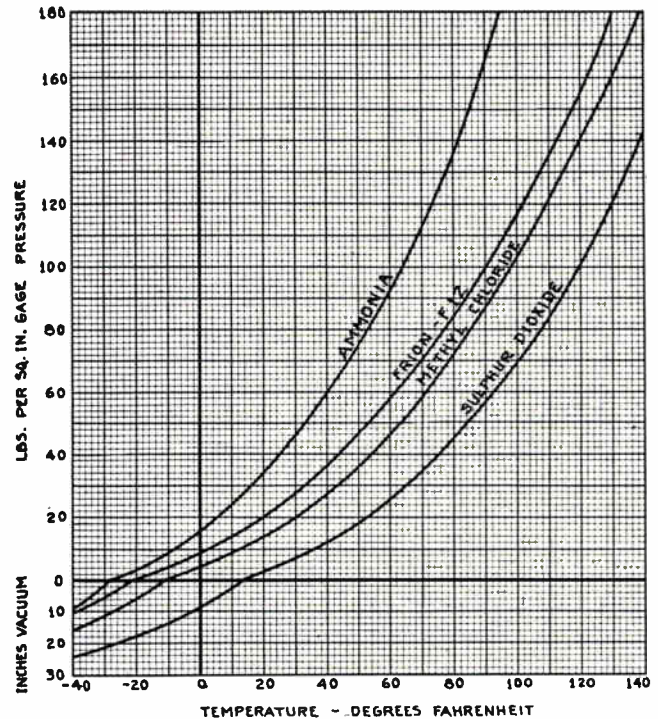

Fig. 60. The above chart shows the boiling points at various pressures and vacuums, of several of the most commonly used refrigerants. Examine this chart carefully as you may wish to use it for future reference.

Sulphur-dioxide absorbs a certain amount of lubricating oil and circulates it through the system, thus actually aiding lubrication. Any surplus oil will float on the surface of the SO₂ liquid as the oil is lighter in weight than SO₂.

Dry SO₂ having less than .003 per cent of moisture is non-corrosive to the metals commonly used in refrigerator units. If moisture, even in very small amounts, is allowed to get into SO₂ it will form sulphurous acid which will attack iron and steel, and may cause the compressor pistons, cylinders and bearings to "seize" or stick and stop the compressor. In such cases it is best to remove the entire SO₂ charge, overhaul the compressor, thoroughly dry out the entire system and replace the refrigerant with a new charge of dry SO₂.

A simple test for moisture in SO₂ is to immerse a small piece of clean bright steel in a small quantity of SO₂ which has been drawn from the refrigerator unit and placed in a dry glass covered with a dry cloth. Allow the SO₂ to evaporate and examine the surface of the steel for dark spots or

signs of corrosion, which will develop, if moisture is present.

31. TESTING FOR LEAKS, SAFETY PRECAUTIONS:

Refrigerators using sulphur-dioxide refrigerant can be tested for leaks with a small cloth or brush soaked in 26 per cent ammonia. By passing this ammonia soaked swab along near the tubing, valves and parts of the unit, a cloud of white smoke-like vapor will appear when the ammonia gets near to any SO₂ leak. Do not get aqua ammonia on copper or brass fittings as it will corrode them.

In case of a large leak or very much SO₂ vapor in the air, it will have a strong irritating odor when inhaled, and serves to warn persons to leave any room in which it may be free.

Strong SO₂ vapor is very irritating to the nose, eyes, throat and lungs, and service men should always have available a gas mask, equipped for SO₂ for any emergencies when working with machines using this refrigerant.

Goggles should be worn to protect the eyes wherever there might be any chance of SO₂ splash-

ing or squirting into them. In case of SO₂ getting into the eyes it should be immediately washed out with clean oil and a doctor should be consulted.

While SO₂ vapor will usually not be inhaled in sufficient quantities to be seriously harmful to humans, it may cause illness if too much is inhaled. It may also be fatal to birds and other pets. Therefore, any pets should be removed from a room in which SO₂ vapor is present. SO₂ is also injurious to plants.

Sulphur-dioxide should always be handled with extreme caution. It can be neutralized by discharging it through a jug of strong lye water. Ammonia vapor also neutralizes SO₂ vapor.

Low side operating pressures on machines using SO₂ generally range from 0 gauge pressure to 8" vacuum, with average refrigerant temperature of about 5 degrees F. High side pressures with SO₂ generally range from 4 lbs. below to 4 lbs. above the temperature of the cooling air.

32. METHYL-CHLORIDE.

Methyl-chloride is very extensively used in domestic refrigerators and in small commercial units. Methyl-chloride is a mixture of chlorine, hydrogen and carbon. It can be maintained in liquid form if kept under pressure or at temperatures below -11 degrees F. When exposed to air at room temperatures, it boils or evaporates rapidly. The vapor is colorless and sweet smelling.

Methyl-chloride has a boiling point of about 11 degrees below zero F. (-11 degrees F.). It is inflammable (combustible) and explosive when mixed with air in proportions of about 8 to 17 per cent methyl by volume.

However, there is little danger of explosions with methyl-chloride as the amount of methyl used in an ordinary household refrigerator, if mixed with the air in the average kitchen would not make a mixture nearly strong enough to explode. It should be kept away from flames however.

Methyl-chloride is a stable chemical and does not harm or dilute lubricating oils objectionably. It does not mix with water. Therefore any water that might get into a refrigerator using methyl-chloride can be removed by a dehydrator or filter unit containing activated alumina or calcium oxide, placed in the liquid line.

Low side operating pressures of systems using methyl-chloride generally range from 5 to 12 lbs. gauge pressure. High side operating pressures may range from 15 to 35 lbs. above the temperature of the condenser cooling air.

Methyl-chloride vapor when inhaled in considerable quantity has an intoxicating effect on humans, and excessive exposure to the vapor may cause illness. Anyone becoming ill from over exposure to methyl fumes should be placed in fresh air and encouraged to breath freely.

Goggles should be worn to protect the eyes from any direct contact with liquid methyl-chloride, as it will boil or evaporate so rapidly when in contact with warm flesh that the tissues would be frozen.

Methyl-chloride leaks can be located by covering suspected joints or parts with a film of soap suds or oil and watching for bubbles. Another method is to use a Halide torch, the flame of which will turn from pale blue to blue-green in the presence

TEMP. °F	SULPHUR DIOXIDE SO ₂	METHYL CHLORIDE CH ₂ CL	FREON F-12	METHYLENE CHLORIDE CARBENE CH ₂ CL ₂	ISOBUTANE (CH ₃) ₂ CH	AMMONIA NH ₃	CARBON DIOXIDE CO ₂
-40	23.5	15.8	11.0			8.7	
-35	22.4	13.7	8.4			5.4	
-30	21.2	11.4	5.5			1.6	
-25	19.6	9.1	2.3			1.3	
-20	17.9	6.1	0.5		14.8	3.6	204.6
-15	16.1	3.0	2.4		13.0	6.2	227.9
-10	13.9	0.2	4.5	28.08	11.0	9.0	255.3
-5	11.5	2.0	6.8	27.61	6.6	12.2	275.5
0	8.9	3.8	9.2	27.46	6.3	15.7	298.8
5	5.9	6.2	11.9	27.11	3.3	19.6	324.8
10	2.6	8.7	14.7	26.69	0.2	23.8	353.3
15	0.5	11.2	17.7	26.19	1.8	28.4	384.3
20	2.5	13.6	21.1	25.06	3.5	33.5	417.3
25	4.6	17.2	24.6	24.98	5.5	39.0	452.3
30	7.0	20.6	26.5	24.27	7.6	45.0	488.3
35	9.6	24.3	32.6	23.48	9.9	51.6	527.3
40	12.4	28.1	37.0	22.63	12.2	58.6	565.5
45	15.5	32.5	41.7	21.72	14.8	66.3	604.3
50	18.6	36.3	46.7	20.67	17.6	74.5	646.3
55	22.4	46.3	52.0	19.49	20.6	83.4	686.6
60	26.2	48.1	57.7	18.19	24.0	92.9	733.3
65	30.4	52.6	63.7	16.72	27.5	103.1	783.8
70	34.9	57.6	70.1	15.09	31.1	114.1	836.8
75	39.8	65.2	76.6	13.43	35.0	125.8	897.3
80	45.0	72.3	84.1	11.54	39.2	138.3	940.3
85	50.6	79.4	91.7	8.44	43.9	151.7	
86	51.7	80.8	93.2	6.22	44.8	154.5	
90	56.6	87.3	99.8	7.32	48.6	165.9	
95	62.9	95.4	108.1	5.02	53.7	181.1	
100	69.8	102.3	116.9	2.40	59.0	197.2	
105	77.2	110.4	126.2	0.19	64.6	214.2	
110	85.0	118.3	136.0	1.62	70.4	232.3	
115	93.3	127.8	146.5	3.12	76.7	251.5	
120	106.2	139.3	157.1	4.75	83.3	271.7	

Fig. 61. Table showing the temperature-pressure relations of common refrigerants. The figures above the black lines indicate vacuum while those below the black divider lines indicates pressure. For example, the pressure of sulphur-dioxide in a closed container at 70 degrees F. would be 34.9 pounds, methyl 57.8 pounds, Freon 70.1 pounds, etc.

of very minute quantities of methyl vapor. See Fig. 62. The end of the rubber breather tube is held near to the suspected joints or fittings when testing for leaks.

The Halide torch burns alcohol (U. S. chemical formula No. 5). Another type of torch which burns prestolite gas is also used for leak testing.

If the air in a room is all mixed with strong methyl vapor this type of torch or lamp is of little value, as the flame burns green continually and will not show where the leak exists. However, if the surrounding air is pure so that the flame normally burns blue, then when the breather tube of the torch is brought near to the leak, the flame turns green.

33. FREON.

The chemical name for Freon or F12 is dichlorodifluoromethane (CCL₂F₂) (But who cares? Call it Freon or F12.) It is made by substituting fluorine for the chlorine in carbon tetra-chloride. Freon vapor is colorless and practically odorless, and has a boiling point of about -22 degrees F. at atmospheric pressure.

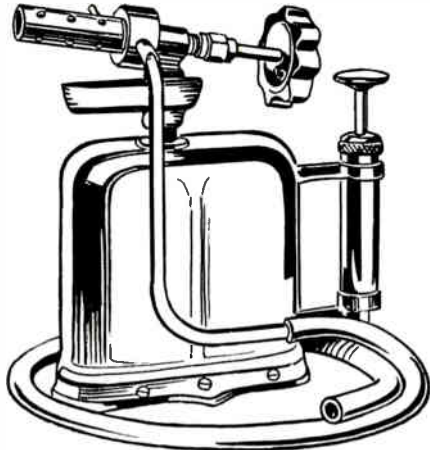

Fig. 62. This view shows a Halide torch of the type used for testing refrigerating systems for leaks. Note the rubber breather tube, the end of which is held near the suspected joints when testing for leaks.

One of the distinct advantages of Freon is that it is non-inflammable, non-irritating and non-toxic. However, it has the disadvantage of somewhat lower latent heat value than methyl or SO₂.

Freon is from 3 to 4 times as dense as methyl-chloride or sulphur-dioxide, and therefore all tubing, valves and fittings in a refrigerating system using Freon should be made larger to permit free circulation of the proper amount of refrigerant.

Freon mixes readily with lubricating oils and does not harm their lubricating properties. However, oils of higher viscosity, about 150 to 300, and entirely free of moisture should be used with Freon.

All moisture should be kept out of systems using either Freon or methyl-chloride, or it may form ice at the control valves and interfere with liquid flow to the evaporators. Water can be removed with dehydrators in the liquid lines as previously mentioned in the article on methyl-chloride.

Low side pressures with Freon units range from about 12 to 21 lbs. gauge, for average refrigerant temperature. High side pressures range from about 90 to 150 lbs.

CHEMICAL OR TRADE NAME	CHEMICAL FORMULA	BOILING POINT AT ATMOSPHERIC PRESSURE °F.	BOILING POINT AT DOMESTIC LOW SIDE PRESSURE °F.	BOILING POINT AT HIGH SIDE PRESSURE °F.	NO. OF CUBIC FEET OF REFRIGERANT PER TON OF REFRIGERATION AT 100° F. CONDENSING TEMPERATURE	LATENT HEAT OF EVAPORATION IN B.T.U. PER LB.	INFLAMMABLE NON-INFLAMMABLE	EXPLOSIVE	OFFENSIVE ODOR OR NOT	METHOD OF TESTING FOR GAS LEAK	DEHYDRATING PROCESS
SULPHUR DIOXIDE	SO ₂	14*	0*	65*	9	172	NON-INFL.	YES	AMMONIA SWAB	HEAT	
METHYL CHLORIDE	CH ₃ CL	11-	6*	85*	6	180	INFLAMMABLE	NO	HALIDE TORCH	CHEMICAL	
ETHYL CHLORIDE	C ₂ H ₅ CL	55*	20*	30*	22.7	168	"	"	"	"	
ISOBUTANE	C ₄ H ₁₀	10*	3*	60*	11.4	173	"	"	LIQUID SOAP	"	
CARRENE	CH ₂ CL ₂	105*	28*	0*	74.5	163	NON-INFL.	"	HALIDE TORCH	"	
FREON	CCl ₂ F ₂	22-	14*	105*	5.8	69	"	"	"	HEAT	
METHYL FORMATE	C ₂ H ₄ O ₂	86*	26*	1*	50	?	"	"	LIQUID SOAP	CHEMICAL	
AMMONIA	NH ₃	28-	20*	175*	3.4	565	INFLAMMABLE & EXPLOSIVE	YES	SULPHUR STICK	HEAT	

Fig. 63. The above chart gives convenient condensed information on the characteristics of common refrigerants. Carefully examine this chart and become familiar with its material so that you can use it for future reference.

Freon leaks can be detected with the Halide torch and will cause the flame to burn blue-green as with methyl leaks. Leaks can also be noticed by traces of oil at leaky joints.

Protect the eyes with goggles when handling liquid Freon. In case of liquid Freon getting into the eyes, drop sterile mineral oil in the eyes and then wash out with water. If liquid Freon gets on the skin it may freeze the tissues, and should be treated the same as frost bite.

34. AMMONIA.

As previously stated, ammonia is one of the most efficient refrigerants for commercial refrigeration machines, as it has a very high latent heat value of 565 B.T.U. per lb. Ammonia is not used so much in domestic units of the mechanical compression type because of the rather high condensing pressures and due to the fact that ammonia fumes are dangerous if inhaled in large quantities.

Ammonia is a chemical mixture of nitrogen and hydrogen, and has a boiling point of -28 degrees F. at atmospheric pressure. Its vapor is colorless, somewhat inflammable or explosive with proper mixtures of air, and very injurious to inhale. The service man should always wear a gas mask when working in ammonia fumes.

Ammonia leaks can be located with a burning sulphur taper or sulphur coated stick, and produce a white vapor when the flame contacts the ammonia fumes.

Low sides pressures on ammonia refrigerating systems range from about 20 to 29 lbs. High side pressures range from about 150 to 200 lbs.

Ammonia does not harm lubricating oils. It has a high affinity for water (readily absorbs water) so it is somewhat difficult to keep perfectly dry. Anhydrous ammonia (dry ammonia) does not harm copper or brass tubing or fittings, but aqua ammonia (ammonia mixed with water) will attack or "eat into" copper or brass.

35. CARBON-DIOXIDE.

At ordinary pressures and temperatures, carbon-dioxide (CO₂) is a colorless, odorless, non-toxic, non-inflammable, non-explosive refrigerant gas. It has a boiling point of 79 degrees below zero F., at

atmospheric pressure. Even at 300 lbs. pressure CO₂ will boil at slightly over 5 degrees F.

Therefore carbon dioxide requires very high pressures and water cooling for condensing. It is not used with air-cooled condensers or in household units.

Carbon-dioxide ice at temperatures of 109 degrees or more below zero F., is sometimes used to refrigerate or chill boxes or cars and to preserve ice cream or other frozen foods in transit. When the CO₂ ice melts it changes directly into a gas and therefore leaves no messy liquid in the package or compartment.

36. METHYL FORMATE, CARRENE, AND F114.

Methyl formate is the refrigerant used by General Electric Co. in some of their refrigerators. The liquid is colorless and the vapor has an odor similar to ether. It is anesthetic if inhaled, and, is highly inflammable. When no moisture is present in methyl formate, it does not attack metals, but if water gets with it, formic acid is produced which severely attacks metals. Its boiling point is 86 degrees F. at atmospheric pressure. Low side pressure is 26" vacuum and high side pressure is about 2" vacuum under normal conditions.

Carrene (CH₂CL₂) is used in Grunow refrigerators. This refrigerant has a boiling point of 105

degrees F. at atmospheric pressure. For this reason, the entire cycle of a machine using carrene is operated at some degree of vacuum, and the refrigerant is never compressed above atmospheric pressure. With room temperature at 80 degrees F. the low side pressure on a unit using carrene is about 27 inch vacuum, and high side pressure is 8 inch vacuum. Carrene is non-toxic and non-inflammable.

Leaks are difficult to detect with systems using methyl formate or carrene as the refrigerant is never at a pressure above atmosphere, so leaks are of air into the system rather than refrigerant out of the system.

F114, or dichloro-tetrachloride-ethane, is used by General Motors in some of their models. F114 has a boiling point of 38 degrees F. at atmospheric pressure. It is odorless and non-inflammable. The approximate low side pressure on machines using this refrigerant is 16.2 inches vacuum, and the high side pressure about 21.2 lbs. gauge.

The refrigerant charge for various types of domestic units may vary from about 1 lb. to 6 lbs., depending on the size of unit and the type of refrigerant used. As there are so many different models, and as models change from year to year we will not attempt to state the correct charge for every unit in this lesson. The service man should follow the information given in the manufacturers bulletins for this data, or from the tag on the base of the unit on all late model refrigerators. However the amount of refrigerant charge for several common models is given in article 29. Fig. 63 gives in condensed form some very valuable and convenient information on various refrigerants, for your present and future reference.

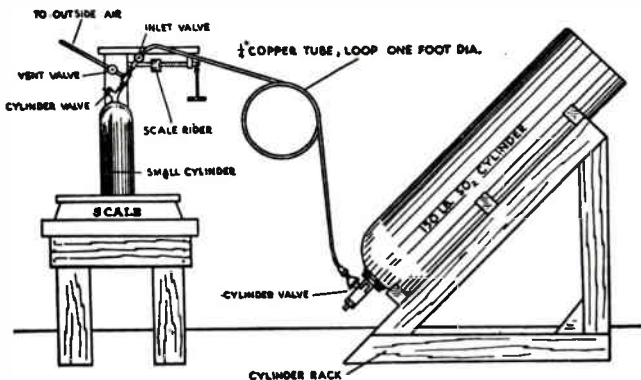

Fig. 64. The above diagram illustrates the method of transferring SO₂ refrigerant from a large shipping cylinder to a small service cylinder. Note the air-vent for purging the transfer tube of air, also the scales for weighing the amount of refrigerant placed in the small cylinder. The large cylinder is inverted so that any vapor in this cylinder will rise above the liquid and force liquid refrigerant to flow through the tube.

37. REFRIGERATOR LUBRICATING OILS.

Of course we know that the wearing parts of refrigerator compressors must have proper lubrication to permit quiet, efficient operation and to prevent excessive wear. This applies especially to the crank shaft or eccentric shaft bearings, the eccentric or connecting rod bearings, piston pins or

Fig. 65. On the right are shown the most common symbols used for representing various pieces of refrigeration equipment in construction and installation diagrams. Examine each symbol carefully and remember where to find them for future reference.

	DISCONNECT SWITCH		HAND SHUTOFF VALVE		HEAT INTERCHANGER
	THERMOSTAT (SELF CONTAINED)		THERMAL BULB		CONDENSING UNIT AIR COOLED
	THERMOSTAT (REMOTE BULB)		SCALE TRAP		CONDENSING UNIT WATER COOLED
	PRESSURESTAT		DRIER		COMPRESSOR
	HAND EXPANSION VALVE		STRAINER		A.C. MOTOR
	AUTOMATIC EXPANSION VALVE		HIGH SIDE FLOAT		D.C. MOTOR
	THERMOSTATIC EXPANSION VALVE		SAGE		ONE LINE } FUSES
	EVAPORATOR PRESSURE REGULATING VALVE. THROTTLING TYPE.		FINNED TYPE COOLING UNIT NATURAL CONVECTION		COMPLETE } FUSES
	EVAPORATOR PRESSURE REGULATING VALVE. THERMOSTATIC THROTTLING TYPE.		PIPE COIL		COOLING TOWER
	EVAPORATOR PRESSURE REGULATING VALVE. SNAP ACTION VALVE.		FORCED CONVECTION COOLING UNIT		EVAPORATIVE CONDENSER
	COMPRESSOR SUCTION-PRESSURE LIMITING VALVE. THROTTLING TYPE.		IMMERSION COOLING UNIT		SOLENOID VALVE
			ICE MAKING UNIT		PRESSURESTAT WITH HIGH PRESSURE CUT-OUT

wrist pins, pistons, cylinder walls and valves. Some compressors use only the splash system of oiling, while others use fuel pumps and pressure to force oil to important bearings, through holes in the crank shaft.

Only a good grade of highly refined mineral oil should be used in refrigerators. The oil should be entirely free of all moisture and dirt. Moisture in the oil in a machine using SO₂ causes sulphurous acid to form and "freeze up" or stick the compressor. Dirt tends to clog up needle valve openings and gets under compressor valves, causing them to leak. Poor grade oils may tend to carbonize and the carbon will clog compressor valves and control valves.

A good grade of oil in a refrigerator may last and remain good for many years if all dirt and moisture are kept out of the system. Various oil companies and refrigeration supply stores can generally furnish proper grades of oil for various refrigerators and the refrigerants they use. It is well to follow the recommendations of refrigerator manufacturers on the type of oil for their unit.

Oil of the proper viscosity should be selected, according to the type of compressor and the refrigerant used.

For reciprocating compressors using SO₂, oil of 150 to 200 viscosity should be used. For rotary SO₂ compressors, 95 to 160 viscosity oil is recommended. For reciprocating compressors using methyl-chloride, 200 to 300 viscosity oil is satisfactory. Freon machines using reciprocating compressors use 300 to 500 viscosity oil, and for rotary

compressors 300 to 325 viscosity. Rotary compressors for Carrene use oil of 300 to 325 viscosity.

With machines where extremely low temperatures are obtained the "pour test" of the oil should be checked to be sure the oil will flow at the low temperatures.

38. AMOUNT OF OIL REQUIRED FOR COMMON UNITS

The oil charge for common domestic refrigerators ranges from about 3/4 pt. to 2 qts. The correct oil charges for several common types of domestic machines are as follows:

Coldspot	3/4 pt.	Frigidaire..	7, 10 & 16 oz.
Copeland	7/8 pt.	Gibson	16 oz.
Crosley	10 to 25 oz.	General Electric..	2 qts.
Dayton	22 oz.	Grunow	36 oz.
ElectroKold	12 oz.	Hotpoint	2 qts.
Fairbanks-Morse ..	20 oz.	Ice-O-Matic	
Norge	1 3/4 pt.	1 1/2 to 2 1/2 pts.
Sparton	14 oz.	Kelvinator....	24 to 26 oz.
Stewart-Warner ..	24 oz.	Leonard.....	15 to 24 oz.
Servel	1 pt.	Universal Cooler..	1 1/2 pt.
Universal (Ro-		Westinghouse	7/8 pt.
tary)	32 oz.	Zerozone	7/8 pt.

If too much oil gets in to a flooded type evaporator, it will interfere with proper operation of the unit.

A common indication of this condition is a rumbling noise in the evaporator. It can often be corrected by filling the ice cube trays with boiling water to cause the refrigerant to boil violently and carry some of the excess oil back to the compressor with the rush of vapor.

ABSORPTION TYPE REFRIGERATORS

We have previously mentioned the absorption type of refrigeration system as one that uses heat instead of a mechanical compressor to set up the required pressures and flow of the refrigerant.

Domestic or household type absorption refrigerators generally use a small gas burner or kerosene or oil burner to generate the necessary heat and pressure. Large commercial absorption refrigeration systems in meat packing plants, ice plants or air-conditioning installations sometimes use exhaust steam from engines in the power plant to furnish the required heat.

One advantage of the absorption system is the absence of moving or wearing mechanical parts. A disadvantage however is that the system is somewhat more complicated and very difficult to service in the field in case it does get out of order. It also discharges some odor and smoke from the burning gas or oil. The Electrolux is one common make of absorption refrigerator.

The operation of this type of unit is based on the fact that pressure can be produced by heat, and also on the fact that certain gases can be absorbed by water, and then driven out of the water again by means of heat.

We know that air expands when heated, and also that water boils when heated and forms vapor or steam which expands and creates pressure if kept confined in a closed vessel or boiler. We also know

that if two different liquids having different boiling points are mixed together and then heated, the one having the lowest boiling temperature will evaporate or boil out of the other liquid first.

Water will absorb ammonia vapor and the mixture becomes aqua-ammonia. The Electrolux absorption type refrigerator uses distilled water, ammonia and hydrogen gas. These materials are sealed tightly in a welded steel system or unit having a pressure of about 200 lbs. throughout the entire system. See Fig. 66.

The ammonia acts as the refrigerant, the water serves as an absorber for the ammonia and the hydrogen gas creates a partial pressure which permits the ammonia to evaporate at low temperature.

One of the fundamental principles of this absorption type unit is based on Dalton's law for gases, which states that, "the total pressure of a mixture of gases is approximately equal to the sum of the individual pressures, which each gas or vapor would produce if it alone filled the enclosed space."

By taking advantage of this fact, in the absorption refrigerator the evaporator is filled with hydrogen gas to provide a partial pressure or low pressure in which the ammonia can readily evaporate. The total pressure in the evaporator is the same as in other parts of the system, but as part of the pressure is due to the hydrogen gas, the actual ammonia vapor pressure is lower in the evaporator

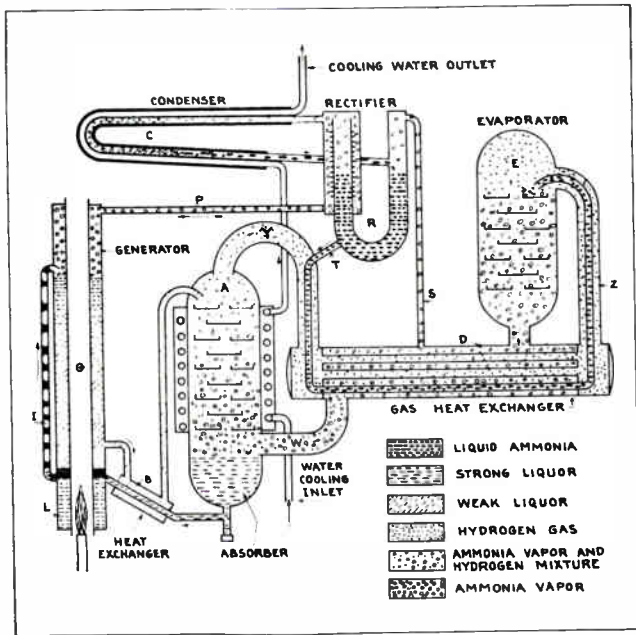

Fig. 66. This diagram clearly illustrates the operating principles of the Electrolux absorption type refrigerator. Carefully study and check each part of the cycle as explained in the accompanying instructions.

than in other parts of the system. Or we might say for the purpose of illustration that hydrogen gas molecules have an attraction for ammonia vapor molecules and thereby make it easier for the ammonia to evaporate when in the presence of hydrogen gas.

Carefully examine Fig. 66 and become familiar with the name and location of each part of this system. Note the evaporator, gas heat exchanger, absorber, cooling water coils, rectifier, condenser, generator and small heat exchanger.

39. ABSORPTION SYSTEM CYCLE.

Now let us trace out the cycle of operation shown in Fig. 66. We have liquid ammonia in the U shaped section of the rectifier, at slightly higher level than the top of the small curved tube entering the evaporator on the right. This will force some ammonia to flow out of the rectifier, down through tube "T", through the gas heat exchanger and up into the evaporator or cooling unit which is filled with hydrogen gas. Here the ammonia trickles down over a series of small trays or pans where it absorbs heat and, due to the partial pressure produced by the hydrogen gas, the ammonia readily evaporates.

The hydrogen gas in the evaporator, being lighter than ammonia vapor, tends to stay in the top of the evaporator. However, when this hydrogen gas mixes with the ammonia vapor it becomes heavier and the mixture passes down through the large opening in the bottom of the evaporator to the gas heat exchanger. Here the cool vapor mixture discharging from the evaporator cools the hydrogen gas which is returning through the tubes of the heat exchanger to the evaporator.

From the heat exchanger the mixed hydrogen and ammonia gases pass through the large tube "W" into the lower part of the absorber. In the absorber, water or weak liquor is continually trickling down over a series of baffle plates and absorbs the ammonia vapor, freeing the hydrogen gas.

The hydrogen gas being lighter, now rises and passes out of the absorber through the large curved tube "Y", back through the center tubes of the gas heat exchanger and up through the large tube "Z" into the evaporator once more.

The water and ammonia or strong liquor now in the bottom of the absorber, flow through the center tube of the small heat exchanger into the lower section of the generator. Note that this lower section of the generator is separated from the upper section.

The heat from the gas flame causes the water and ammonia to bubble and forces small charges of water and ammonia up through the percolator tube "I" to the top section of the generator where further heating drives the ammonia out of the water in vapor form.

This ammonia vapor passes off through the tube "P", to the outer section of the rectifier. Here the metal cooling fins condense out any water vapor that might have been carried with the ammonia vapor. This water flows back through tube "P" to the generator.

The rectified ammonia vapor passes on through the water-cooled condenser where it is condensed into liquid and flows out into the U shaped receiver section of the rectifier, once more ready to enter the evaporator and start the cycle over again.

Referring back to the upper section of the generator again, when the ammonia is driven off from the water, the remaining water or weak liquor flows out through the small curved tube, through the outer section "B" of the small heat exchanger and up into the absorber to pick up more ammonia vapor again.

The cooling fins in the left-hand section of the rectifier are kept cool by the evaporation of a certain amount of ammonia in the U shaped section of the evaporator. The ammonia vapor thus produced goes out of the top of the left center section, and through the condenser with the vapor from the generator.

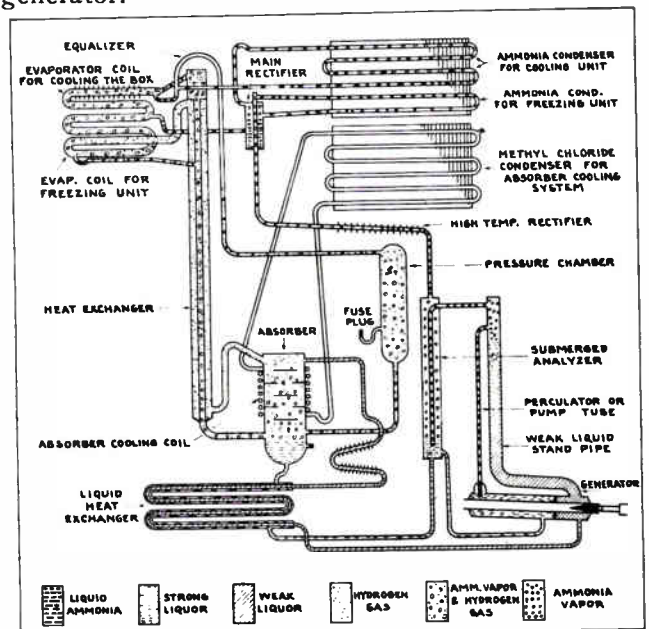

Fig. 67. Cycle diagram of an air-cooled absorption type refrigerator. Note that the absorber in this unit is cooled by methyl-chloride instead of by running water as in the preceding unit.

40. AIR-COOLED ABSORPTION UNIT.

Fig. 67 shows a diagram of an air-cooled Electroflux absorption refrigeration unit. The operating principle of this unit is the same as that of the water-cooled unit shown in Fig. 66. The parts are merely arranged in different positions and the generator tube is horizontal instead of vertical.

Instead of using running water to cool the condenser, this unit uses an air-cooled condenser which is divided into three separate sections. One section condenses ammonia for the cabinet cooling unit, and one section condenses ammonia for the freezing unit. The third section condenses methylchloride which is used instead of water for cooling the absorber.

Carefully observe the code markings for the various gases and liquids and trace out the cycle of operation for this unit.

The absorption refrigeration systems just explained are of the continuous operating type, the liquids and vapors being constantly circulated. The rate of circulation, evaporation and refrigeration is controlled by adjusting the gas burner to vary the amount of heat produced and applied at the generator.

41. INTERMITTENT ABSORPTION SYSTEM

Another type of absorption refrigeration system which is similar in principle and simpler in construction and operation is the intermittent absorption unit such as the Trukold refrigerator manufactured by Gibson Co., and sold by Montgomery-Ward; or the Superfex unit made by Perfection Stove Co.

These two units are quite similar in operation and construction. In these units the burner is operated for several hours during the generating part of the cycle, and then the burner is off during the refrigeration part of the cycle. See Fig. 68 which illustrates the operation of the Superfex unit.

A special solution is used around the evaporator coils, which freezes up during the refrigerating period and remains cold, or never completely thaws

out during the normal generating period. This produces a sort of cold holdover effect to keep the unit at nearly constant temperature throughout the off and on periods.

Referring again to Fig. 68-A you will note that while the burner is operating ammonia vapor is being driven out of the water and ammonia mixture and forced up through tube "C" to the condenser which is located in a tank of water on the top of the cabinet. Here the ammonia vapor is condensed and the liquid ammonia goes down into the evaporator.

The ammonia vapor from the generator will not pass up through tube "D" to the evaporator, because the lower end of this tube is submerged under the liquid in the generator. The vapor pressure forces the liquid to rise part way up in this tube until its gravity pressure balances the vapor pressure and forces the vapor through the condenser.

When the burner is shut off as shown in Fig. 68-B, the generator cools and its pressure drops. Then evaporation of the ammonia in the evaporator starts. The ammonia vapor leaves the evaporator through tube "D" and returns to the generator where it is again absorbed by the water. Another reason for having the lower end of tube "D" submerged in the water in the generator is to force the ammonia vapor to bubble up through the water to effect thorough mixing and more complete absorption by the water.

During evaporation the ammonia vapor in the evaporator cannot pass up tube "E" to the condenser because the lower end of this tube is also submerged and the vapor pressure forces some liquid up the tube until the gravity pressure of the liquid forces the vapor out through tube "D" to the generator.

42. INSTALLATION OF REFRIGERATORS.

Most modern household refrigerators are complete self-contained units, with all parts of the unit assembled, connected and pre-tested at the factory. Therefore, many people think that all there is to

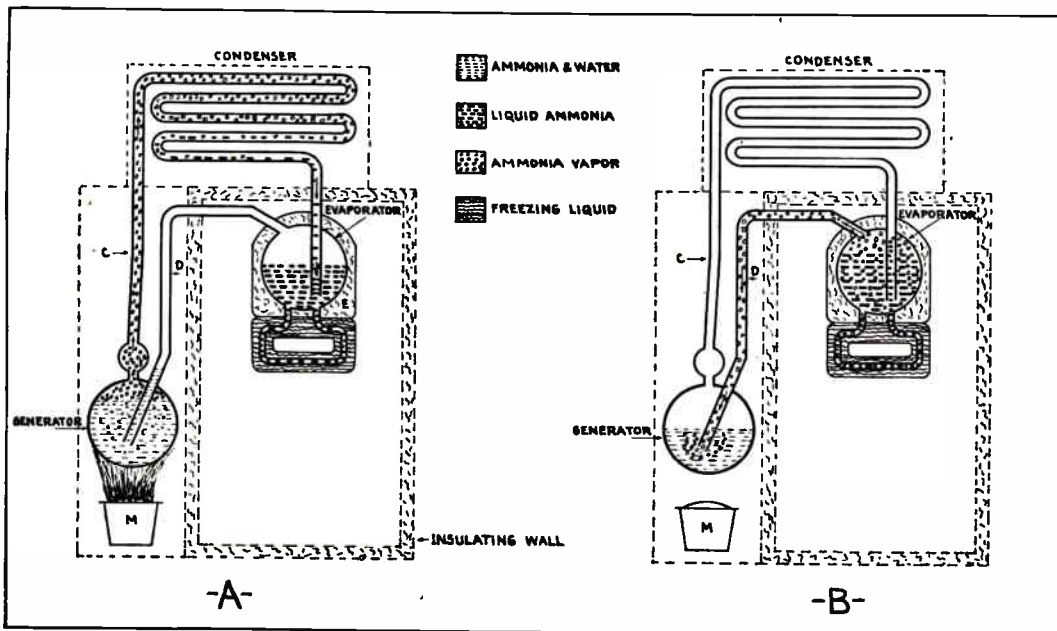

Fig. 68. The illustrations on the left shows the operating cycle and principles of an intermittent type absorption refrigerating unit in which the generator operates during part of the cycle and the evaporator operates during the remainder.

installing such a refrigerator is to set it in any convenient place in the kitchen and insert the plug on the end of the electric cord in the nearest outlet.

There is, however, considerably more involved in making a proper installation of a new refrigerator, if it is to give satisfactory operation and operate over long periods with a minimum of service requirements.

If the unit is shipped or delivered crated, it should be uncrated very carefully to avoid marring the finish of the cabinet.

Carefully unpack all loose interior parts, trays, shelves, etc., clean them and place them in their proper locations. Check the door latch to see that it operates freely and properly and holds the door snugly closed.

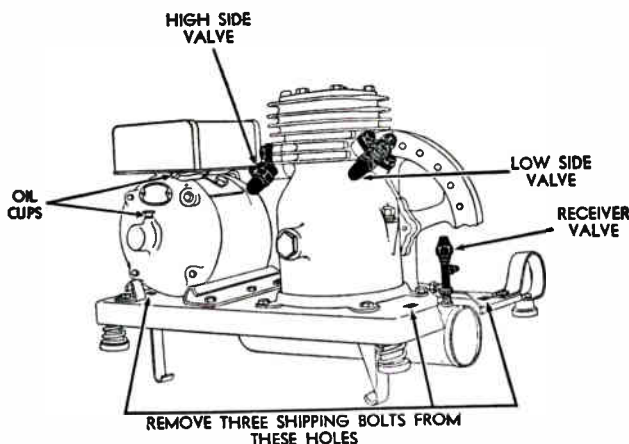

Fig. 69. Diagram showing the location of the high side valve, low side valve, and receiver valve on a Stewart-Warner condensing unit. These valves must be opened before placing the refrigerator in service. Courtesy Stewart-Warner Corp.

In selecting a location for the refrigerator, you should of course consult the owner as to his or her desires and convenience. However, it is important to place the unit on a firm, level spot on the floor, and away from any sources of heat, such as stoves, radiators, hot air registers, chimneys, gas ranges, etc., and out of direct sun rays.

In leveling the refrigerator, do not rely on guess work or haphazard methods. Instead use a spirit level, and if necessary shim up one side or the other with thin pieces of wood, linoleum or cardboard, until the machine is accurately leveled. The operation and performance of the unit will be considerably better if this extra care is taken.

Be very sure that the back of the cabinet is located several inches from the wall so that the warm air discharged from the condenser can freely circulate or escape and carry away the heat from the condenser. If this important point is overlooked the unit may operate continuously or it may fail to cool down to the proper temperature. There should also be several inches clearance at both sides of the refrigerator.

Remove anchor bolts and blocking which are used to hold the condensing unit in place during shipping. This permits the unit to rest freely upon its rubber or spring mountings, and prevents excessive vibration being transferred to the cabinet.

Before starting the unit, remove the valve caps from the low side valve, high side valve and receiver valve shown in Fig. 69. Then using a suit-

able wrench, open these valves by turning their stems all the way to the left, (counter-clockwise) until they seat firmly. Never use pliers or a pipe wrench on these valve stems or you may damage the square corners of the soft metal from which they are made.

Also before starting the unit be sure to check the motor name plate to make certain that its voltage rating is correct for the current supply available. Keep the electric cord clear of the belt, fan and pulley. Instead of connecting the refrigerator to an ordinary convenience outlet on the regular lighting circuit, it is often advisable to install a separate circuit and outlet wired direct to the service cabinet in the basement. This will prevent the refrigerator causing the house lights to dim when the motor starts.

Check the belt for proper tension and alignment. Although the motor has probably been previously oiled at the factory, it is well to make sure that the oil cups are filled with a good grade of medium machine oil. Number 20 automotive oil is satisfactory.

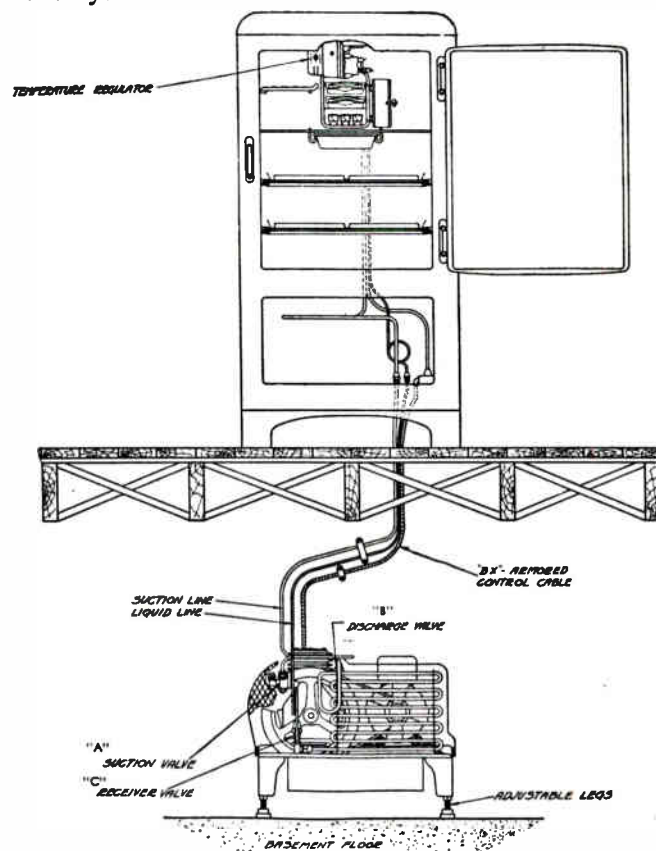

Fig. 70. Diagram showing the method of installation of a refrigerator with a condensing unit located in the basement some distance from the cabinet.

Carefully observe any starting instructions that may be on the tag or in the envelope attached to the shipping crate or to the unit. Also check over all flare nuts, tubing connections and gasket joints with a flashlight, an ammonia swab, Halide torch or soap suds, according to the type of refrigerant used, for any possible trace of leaks. Then the unit should be ready to insert the plug in the electric outlet and push the starting button or switch to start the refrigerator.

If the machine starts to "slug" oil or liquid refrigerant and vibrate excessively or operate jerkily, quickly pull the plug for a few seconds, and repeat this several times if necessary, until the machine settles down to smooth operation.

While checking the operation of the unit to make sure that it is working smoothly and quietly, and that the evaporator is chilling, clean off any grease marks on the cabinet and clear away any packing material, or waste left from the uncrating.

If you have a recording thermometer it is advisable to install it in the refrigerator for a day or so to check and have a record of the box temperatures and the on and off periods of the condensing unit.

43. REMOTE INSTALLATIONS.

In cases where the refrigerator cabinet and evaporator are to be located in the kitchen and the condensing unit located in the basement or some other room as shown in Fig. 70, then it will be necessary for the installation man to connect up the

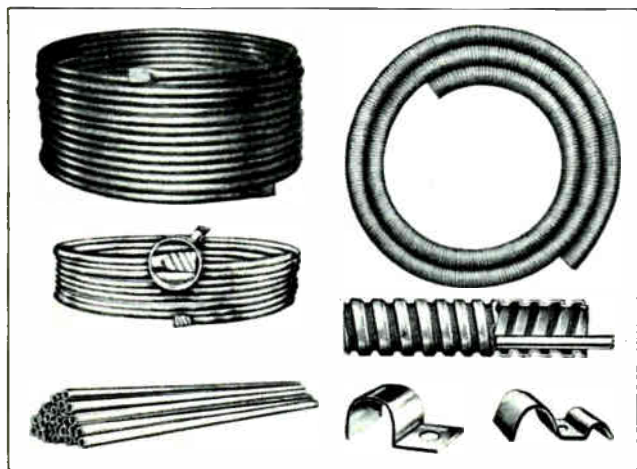

Fig. 71. In the views on the upper left are shown coils of copper tubing such as used for refrigeration installations while at the lower left is shown a number of pieces of larger hard drawn copper tubes. On the upper right is shown a piece of flexible metallic armor or sheath for protection of copper tubes and at the lower right are shown two types of clips for mounting tubing on walls or cabinets.

two units by means of copper tubing for the liquid and suction lines, and electrical wiring for the control switch.

This type of remote installation is sometimes used to eliminate from the kitchen the heat developed by the condensing unit and also the noise of operation of this unit. For the average household refrigerator $\frac{1}{4}$ inch copper tubing may be used for the liquid line and $\frac{5}{16}$ or $\frac{3}{8}$ inch tubing for suction line. The electric wires may be run in BX, Romex, conduit, or open wiring where the latter is permitted. One large hole about $1\frac{3}{8}$ inch in diameter may be bored in the floor to take both tubes and the wiring, or small individual holes can be drilled if preferred.

Measure the required length of tubing carefully and prepare the ends of the tubing by flaring them to take the proper flare fittings for secure connections to the condensing unit and evaporator.

In remote installations using SO_2 the compressor should always be located lower than the evaporator, to permit oil to return to the compressor. Avoid

any loops or oil traps in the tubing. In case a horizontal run is necessary, make the tubing slope toward the compressor to drain back the oil.

Always keep in mind whenever installing or repairing any refrigerator, the importance of making secure, leak proof connections in all tubing, so that refrigerant cannot leak out of the system, and so that air or moisture cannot enter the system. For this reason extreme care should be used in making tubing flares, tightening flare nuts, making soldered or sweated joints in tubing, etc.

In some large cities there are certain code rules or ordinances governing the safe installation of refrigeration equipment. Therefore, before installing any remote systems, multiple systems or commercial units in any large cities, be sure to become familiar with the local code or rules.

Fig. 71 shows two coils of copper tubing at the upper left and some pieces of large hard drawn copper tube at the lower left. On the upper right is shown a piece of flexible metallic armor or sheath through which refrigerator tubing lines are often run as shown in the center right hand view, to protect them from mechanical damage. At the lower right are shown two types of clips used to hold liquid and suction lines in place on walls or on cabinets.

Copper tubing used for refrigerator lines should be seamless to prevent possibility of leaks. It should also be dehydrated (all moisture removed) and the end sealed. This is usually done by the manufacturer before shipping the coils of tubing. Heavy walled tubing should be used for long runs.

In case of installations using long runs of tubing you should always "purge" or blow out all air

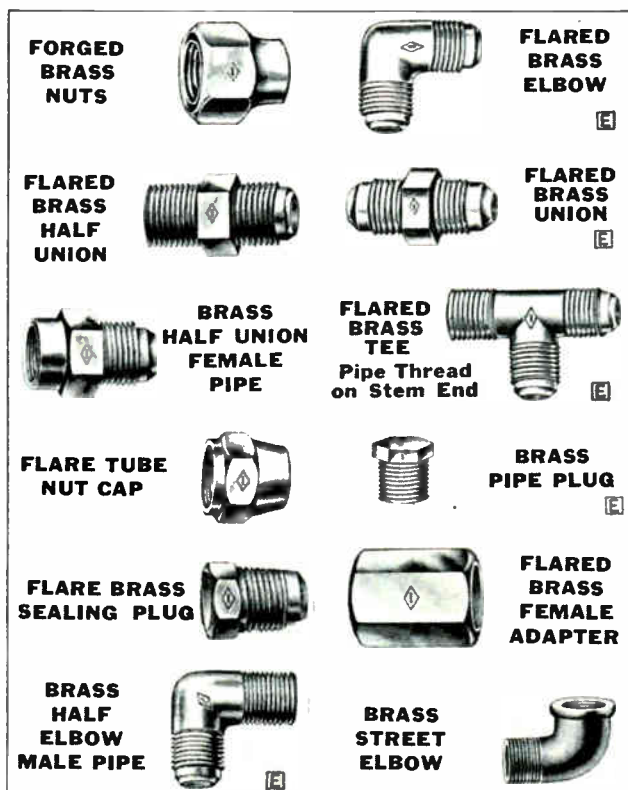

Fig. 72. Above are shown several types of common fittings used for making flare type connections to copper tubing. Carefully note the shape and the name of each of these fittings.

- B. Cause: Air in system.
 Indication: Excessive head pressure, over-heated condenser, evaporator partially or entirely defrosted.
 Remedy: Purge air from system as explained in Article 87.
- C. Cause: Stiff compressor.
 Indication: Compressor hard to turn by hand even though head pressure is normal.
 Remedy: Repair or replace compressor.
- D. Cause: Defective motor.
 Indication: Motor does not run, or runs very slow, hot and noisy.
 Remedy: Repair or replace motor.

62. MOTOR RUNS TOO HOT

- A. Cause: Motor overloaded due to stiff compressor, or to high head pressure caused by air in system or overcharge of refrigerant, worn motor bearings, or belt too tight.
 Indication: Motor too hot to touch without discomfort. Odor of burning insulation. Motor operates slow and noisy.
 Remedy: Repair or replace compressor, purge excess air or refrigerant from the system or repair motor bearings.

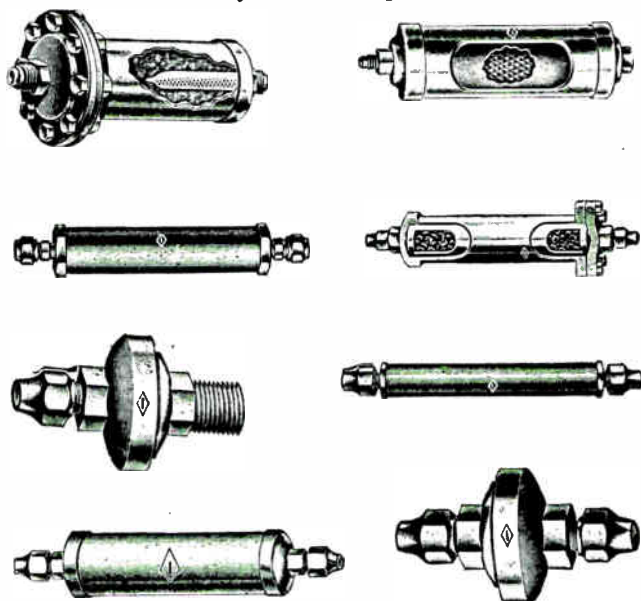

Fig. 88. The top four units in this view are dehydrators for connection in the liquid lines of refrigerators to remove moisture from the refrigerant. The lower four units are strainers for connection in the liquid lines to remove dirt or scale which might otherwise clog control valves and interfere with their proper operation. Dehydrators and strainers of this type can be purchased from refrigeration supply houses by the service man.

- B. Cause: Defective brushes or starting switch.
 Indication: Sparking at commutator or brushes, motor growls and does not come up to full speed.
 Remedy: Repair brushes or starting switch and clean commutator as outlined in the section on A. C. motors.
- C. Cause: Under-voltage at motor.
 Indication: Motor runs noisy and does not come up to full speed. Meter test

shows motor terminal voltage below 95.

- Remedy: Locate and correct cause of low voltage as explained in Article 61 under cause "A."
- D. Cause: Defective capacitor or condenser on capacitor type motors.
 Indication: Motor fails to start or runs slow and noisy.
 Remedy: Replace capacitor.
- E. Cause: Brushes set in wrong position on repulsion-induction motors.
 Indication: Sparking at brushes, motor fails to start or come up to full speed, or motor runs slow and noisy.
 Remedy: Shift brush holder mechanism to point where motor starts and runs best.

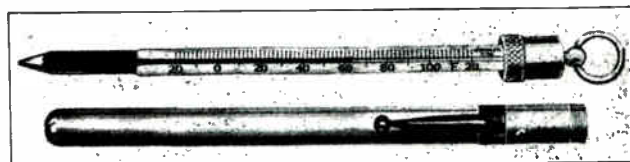

Fig. 89. The above view shows a convenient pocket type thermometer and case such as used by refrigeration servicemen in checking the temperatures of refrigerators under test.

- F. Cause: Lack of oil in motor bearings.
 Indication: Bearings dry, hot and worn.
 Remedy: Fill oil cups and replace bearings if necessary.
- G. Cause: Defects in motor winding. Grounds, shorted coils, open circuit in starting or running winding.
 Indication: Motor fails to start, or runs slow and noisy. Windings overheat in spots. Test for grounds and shorts as explained in motor lessons.
 Remedy: Rewind or replace motor.
- H. Cause: Poor air circulation through unit compartment, or thru motor because of openings being plugged with dirt.
 Indication: Evident upon inspection.
 Remedy: Clean motor and provide for free air circulation through unit compartment.

63. WATER IN CABINET OR DRIPPING ON FLOOR

- A. Cause: Defrosting tray may have overflowed due to waiting too long before defrosting the evaporator.
 Indication: Defrosting tray full of water, and question customer on time of defrosting.
 Remedy: Instruct customer to defrost unit whenever frost becomes 3/8" thick.
- B. Cause: Water or other liquids spilled in cabinet.
 Indication: Water or liquids on other foods and on bottom of cabinet.
 Remedy: Show customer the source of the water.

- C. **Cause:** Cabinet door left open too long.
Indication: Moisture condensing on inside of cabinet walls.
Remedy: Instruct customer not to leave door open any longer than necessary.
- D. **Cause:** Poor air circulation in food compartment.
Indication: Shelves covered or overcrowded.
Remedy: Uncover shelves, rearrange food articles and instruct customer on need of good air circulation.
- E. **Cause:** Leaky float valve.
Indication: Frost on suction line.
Remedy: Repair or replace float valve assembly, as explained in Articles 75 and 76.
- F. **Cause:** Defective door gasket, warped door or door hinges out of line.
Indication: Inspection will show these defects. Moisture most noticeable near edges of door. Close the door on a single piece of newspaper and if gasket and door are fitted properly the paper strip should not pull out easily.
Remedy: Replace gasket or repair door or hinges.
- B. **Cause:** Slight refrigerant leak.
Indication: Noticeable odor of refrigerant, or use ammonia, soap suds or torch test.
Remedy: Repair leak and wash the inside of cabinet thoroughly with soap and water and then with a mild solution of water and baking soda.
- C. **Cause:** Refrigerator defrosts between cycles.
Indication: Evaporator only partly covered with frost.
Remedy: Reset cold control or determine cause for warm evaporator.
- D. **Cause:** Storage of milk, butter, or cream in open containers.
Indication: Evident upon inspection.
Remedy: Instruct customer to keep milk, butter and cream in closed containers because they readily absorb odors from other foods or the refrigerator.
- E. **Cause:** Brine leak in units with indirect evaporators.
Indication: Odor of brine, and brine leaking from evaporator tank.
Remedy: Locate and repair leak or replace evaporator.

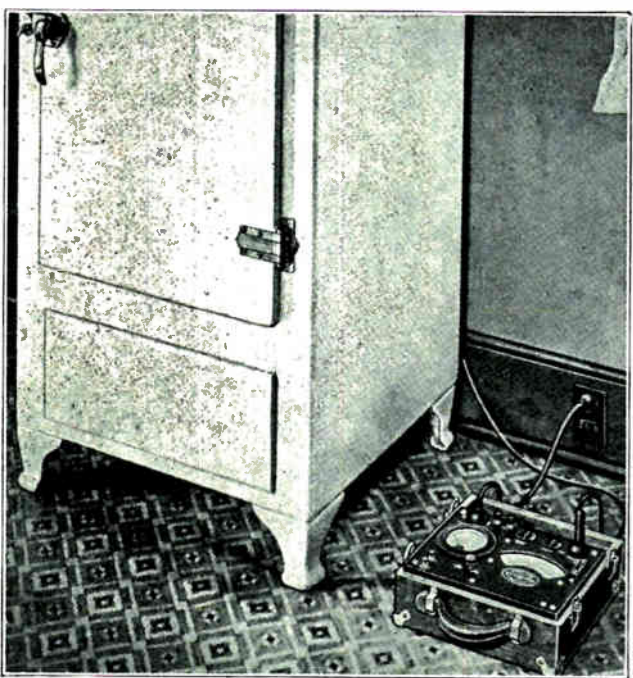

Fig. 90. This photograph shows how a convenient portable meter can be used for checking the amount of current consumed by a refrigerator, the amount of current drawn by the motor during starting, and the amount of voltage drop on the line. A meter of this type is extremely valuable to the serviceman in testing for motor or line troubles or in demonstrating the economy of operation of an electric refrigerator. Courtesy Servel Corp.

64. BAD TASTE IN ICE CUBES OR IN MILK, BUTTER AND CREAM

- A. **Cause:** Water from melted frost getting in ice trays when defrosting.
Indication: Empty the ice trays and defrost the unit. Check and see if water has run into ice trays.
Remedy: Advise customer to scald and refill ice trays after defrosting.

65. OBJECTIONABLE ODORS

- A. **Cause:** Particles of stale food left on shelves or in corners.
Indication: Evident upon careful examination of inside of cabinet.
Remedy: Wash cabinet interior with soap and water and then with soda water solution.
- B. **Cause:** Milk, meat juices or other liquids spilled in cabinet and seeped into cracks at corners or bottom of cabinet.
Indication: Usually some traces can be seen, or the nature and location of the strongest odor may be apparent to the experienced service man.
Remedy: Remove base strips if possible, clean out food, wash or flush with hot soapy water and seal crevices with hot hydrolene or other sealing compound.
- C. **Cause:** Leak of refrigerant inside of cabinet.
Indication: Noticeable odor, or test with ammonia, soap suds, or torch.
Remedy: Locate and repair the leak and wash out cabinet.
- D. **Cause:** Refrigerator shut down for long periods with water in the trays and the door closed.
Indication: Musty odor when door is opened.
Remedy: Instruct customer that whenever a refrigerator is to be shut down for more than a few days, the evaporator should be defrosted and wiped dry, trays should be emptied and dried, food compartment cleaned and dried and the door left open.

66. EVAPORATOR FROSTS TOO MUCH

Causes: Cabinet door open too long and too often, leaky door gasket or poorly fitting door, hot foods placed in cabinet, or cold control set too cold.

Indication: Question owner about door opening and hot foods; examine door and gasket, check cold control.

Remedy: Advise owner about door opening, repair door or gasket, set cold control.

You should find the preceding list of common refrigerator troubles, indications and remedies very helpful if you will refer to it often during any refrigeration service work you may do.

In the next section we will explain in detail the methods of testing and repairing important parts such as compressors, evaporators, controls, condensers, motors, etc., as well as other general service and repair methods. But before studying the following section, be sure that you have a good knowledge of the common troubles and their symptoms as explained in this section.

REFRIGERATION SERVICE PROCEDURE

As you begin your study of this important section, we wish to remind you again that the servicing and repairing of electric refrigerators offers some of the finest opportunities for profitable and interesting work in most towns and neighborhoods.

In many localities there is an actual shortage of good refrigeration service men. There are also many so-called refrigeration service men who can only do a few of the simpler service jobs, but who cannot find or fix many of the troubles that occur in refrigerating units and in their electric motors and controls.

These conditions, along with the ever increasing number of electric refrigerators in use in both city and farm homes, should spell real opportunities for you if you thoroughly learn refrigeration service methods as covered in this section.

In the preceding section there were mentioned a number of refrigerator troubles that called for repairs to the compressor, control valves, control switches, evaporators, condensers, etc. In this section we will discuss the method and procedure of making some of these more commonly needed repairs.

67. COMPRESSOR TROUBLES

First we will consider the compressor as this is one of the most important parts of any refrigerator, and having a number of moving parts which are subject to wear, the compressor should have close attention from the service man. As the compressor is virtually the heart of the refrigerating unit we can readily see that in order to secure efficient and economical operation of the refrigerator, the compressor must be in good condition.

Some of the most common troubles that occur with reciprocating compressors are as follows:

1. Discharge valve not seating properly.
2. Suction valve not seating properly.
3. Worn pistons or piston rings
4. Shaft seal faces not seating properly, or siphon bellows broken.
5. Leaky gaskets.
6. Worn bearings on crank shaft, connecting rod or wrist pin.
7. Noisy compressors.
8. Lack of oil.
9. Leaks in crankcase casting.

Fig. 91. The above photograph shows a very neat installation of two commercial refrigeration units in the basement of a meat market. The unit on the right is a two cylinder motor driven compressor while the unit on the left has two four cylinder compressors each driven by a separate motor. Note the electrical wiring and switch box installation for these units. Courtesy Carrier Corporation.

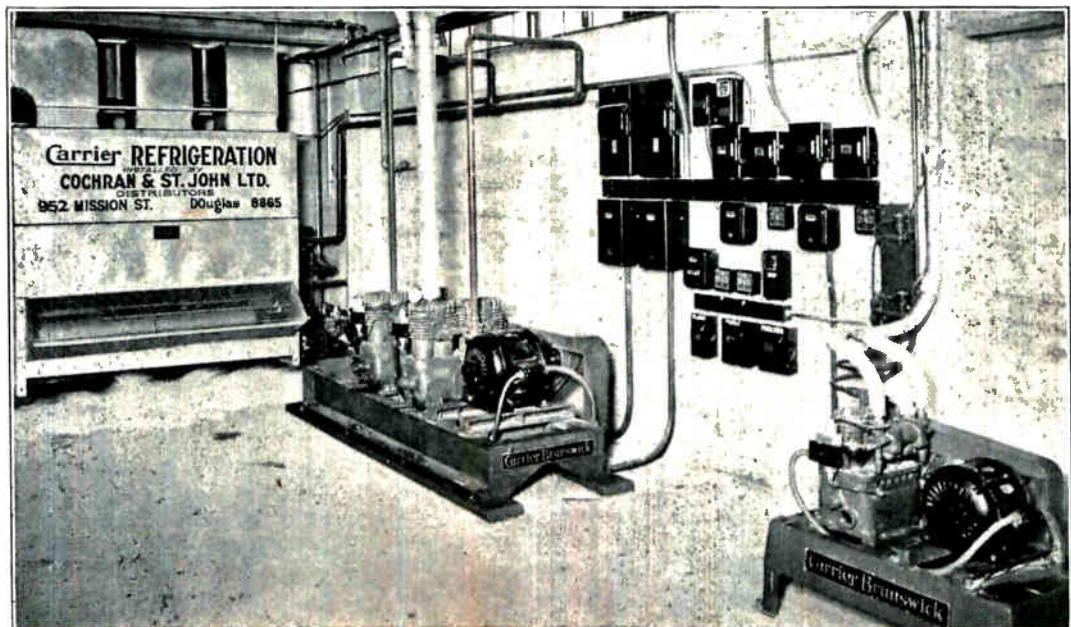

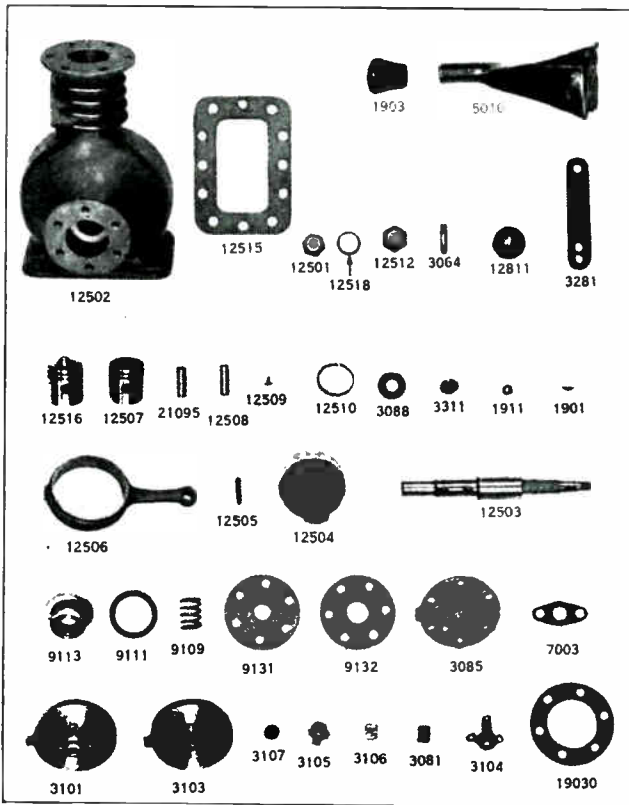

Fig. 92. Above are shown a number of replacement parts for a single cylinder refrigeration compressor. Note the compressor body, pistons, piston pins, piston ring, eccentric rod, eccentric, eccentric shaft, shaft seal, cylinder head, valve plates, gaskets, etc. Courtesy Kelvinator Corporation.

Rotary compressor troubles may be due to:

1. Worn bearings.
2. Worn rotor.
3. Worn casing.
4. Worn vanes or broken vane springs.
5. Defective or leaky check valves.
6. Lack of oil.
7. Defective shaft seal.

In many cases when certain of these compressor parts become badly worn or defective, the most practical and economical thing to do is to discard them and replace them with new parts which are obtainable from refrigeration service and supply stores. Standard replacement parts for most common makes of refrigerators are usually available in well stocked supply houses. Figs. 92 and 93 show a number of these common replacement parts for single cylinder and multiple cylinder reciprocating compressors.

In many instances, however, defects such as leaky valves, leaky shaft seals, etc., can be serviced right on the job.

68. COMPRESSOR EFFICIENCY TEST

To test the efficiency of a compressor, attach a compound gauge to the suction service valve as described in the preceding lessons. Turn the valve stem all the way to the right and start the unit. If the compressor is in good condition, the compound gauge should almost immediately show a vacuum which will rapidly increase to a 20" vacuum or more.

When the vacuum will increase no further, stop

the unit and allow it to remain idle for five or six minutes. If at the end of this period, the vacuum has not changed, it shows that the compressor valves, shaft seal and gaskets are in good condition.

If the compressor does not hold a good vacuum during this period it indicates a leaky discharge valve, leaky suction service valve or a leaky shaft seal. However, if there was no odor or no signs of any leak of refrigerant before starting the unit then the trouble is very likely to be a faulty discharge valve.

If when the compressor is started it requires a long time to pump a vacuum, it usually indicates a defective suction valve, but it may also be due to an inefficient discharge valve. In either case the compressor should be removed and both valves put in good condition, by lapping or replacing as will be described in later paragraphs.

If the compressor starts to "slug oil" while drawing the test vacuum, stop the unit for a few minutes and then start it again, repeating this several times if necessary.

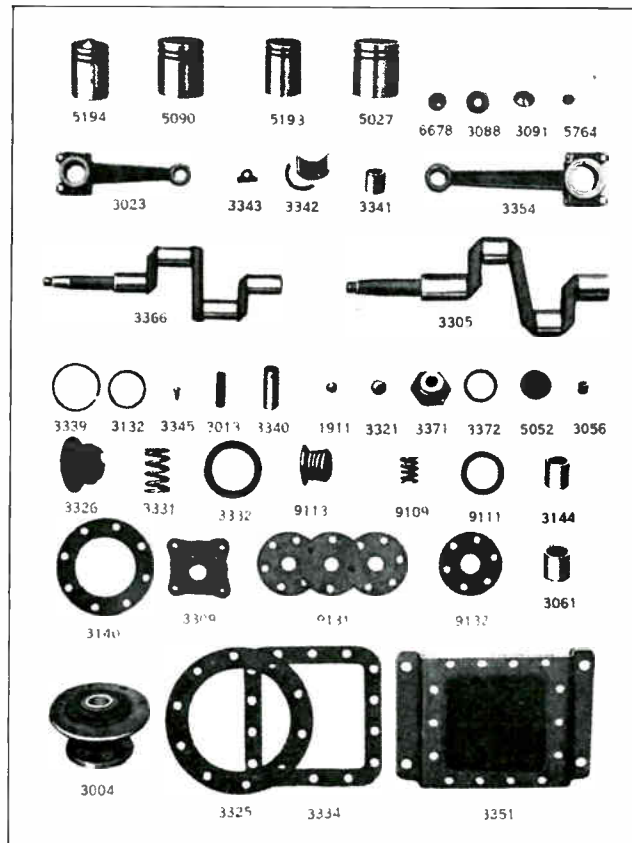

Fig. 93. This figure also shows a number of replacement parts for two cylinder compressors. Note the pistons, connecting rods, bearings, crank shafts, piston rings, piston pins, shaft seals, valve plates, gaskets, etc. Courtesy Kelvinator Corporation.

To test a compressor for a leaky shaft seal or for loose or blown gaskets, the pressure on the low side should be built up by allowing the compressor to stand while the refrigerant in the evaporator builds up gas pressure in the compressor base or crank case. Then test for refrigerant leaks at the gasketed joints or shaft seal by means of the ammonia swab, torch test or soap suds test as previously explained.

If there is a leak around the gaskets it may be due to vibration having loosened some of the compressor bolts. In this case, tighten the bolts and test for further leaks. If this does not remedy the trouble, the gaskets should be replaced with new ones.

In case it becomes necessary to remove the compressor and condensing unit from the cabinet in order to disassemble it for repairs to suction or discharge valves, seals, bearings, pistons, etc., proceed as shown in Figs. 94, 95, 96 and 97.

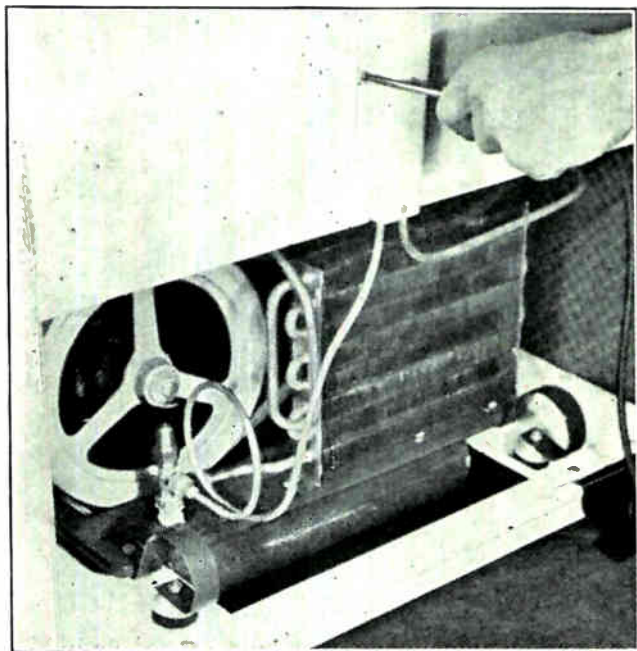

Fig. 94. When removing a condensing unit from the cabinet, be sure to loosen all tubing and wiring so they will not be broken or strained when the condensing unit is pulled out of the cabinet. Courtesy Stewart-Warner Corporation.

First make sure that tubing and wiring are loose and free to permit unit to be removed. Then carefully work the unit out onto the floor where it is conveniently accessible for servicing. A piece of linoleum, canvas or building paper should be used to protect the floor.

69. SHAFT SEAL TROUBLES

As explained in preceding articles, compressor shaft seals have highly polished surfaces on the shaft seal face or shoulder and on the bellows seal face, with a film of oil between these faces to prevent wear. If for any reason this oil film breaks down or disappears, a squeak similar to a belt squeak will be noticed, and if the compressor is allowed to continue running in this condition, the seal faces will become scored or roughened. This will allow refrigerant to escape whenever gas pressure exists in the crank case; or it will permit air to be drawn into the compressor whenever a vacuum exists in the crank case.

In the case of a leaky shaft seal, it is necessary to remove and reface the seal by lapping or polishing, or replace it by installing a new seal. Before the reconditioned seal or new seal is installed be sure that the seal face on the crank shaft shoulder has a smooth and well polished surface. If this surface is rough or grooved, it should be turned

down or polished smooth with a shaft seal facing tool. Or if this is not possible, a replacement shaft seal face should be installed. If necessary, a complete new crankshaft can be installed without very great expense.

When a compressor has been fitted with a new shaft seal, or when replacing a reconditioned seal be sure that both seal faces have a film of good compressor oil or vaseline between them, and also see that a charge of new oil is put in the compressor. After reassembling the compressor, it should be run from twenty to thirty minutes before reinstalling it in the refrigerator.

70. LAPPING OF SHAFT SEALS AND SEAL RINGS

For resurfacing or lapping bellows seal faces, a lapping block such as shown in Figs. 98 and 99 can be used. In emergencies a piece of flat plate glass can be used as a lapping block. Generally two different lapping blocks are used, one for the rough lapping with pumice stone or bon ami and the other for the finish lapping or polishing with fine emery powder, powdered sulphur and oil, or lapping rouge.

For the rough lapping, mix a small amount of fine pumice stone or bon ami with an equal amount of clean compressor oil. Spread a thin film of this paste over the surface of the lapping block. Then grasp the bellows assembly lightly between the thumb and fingers as shown in Fig. 98, let the seal surface rest flat on the block with very light pressure and grind with a rotating or figure 8 motion.

After lapping until the surface appears to be flat and true it can be tested with a surface testing block. To make this test, thoroughly wash the seal in gasoline or carbon tetra-chloride to clean all lapping paste and material from the seal, including the inside of the bellows. Then place the dry ring surface on the surface testing block and rotate several times. The face of the seal ring should then show

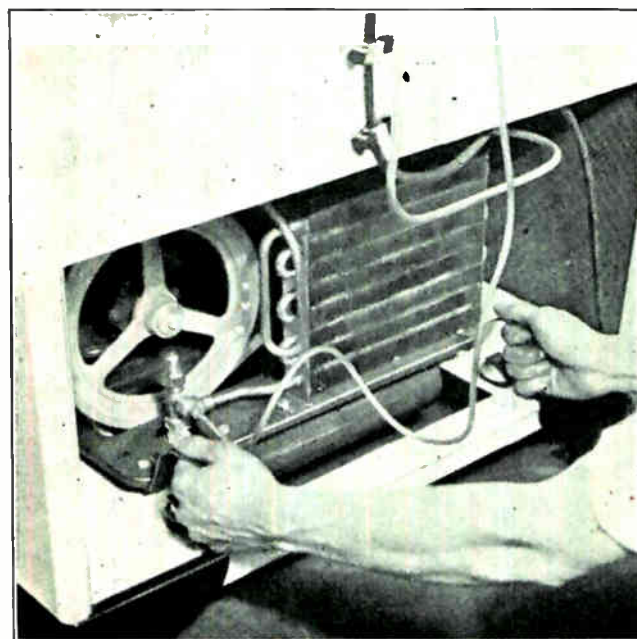

Fig. 95. Here the tubing is shown loose from the back of the cabinet and the serviceman is preparing to pull out the condensing unit. Courtesy Stewart-Warner Corporation.

a bright polished finish extending over its entire surface.

To lap the shaft seal ring, mix a very thin paste of number 303 emery and compressor oil and spread this paste thinly over the surface of the lapping block. Then rotate the seal face of the shaft seal ring on this block as shown in Fig. 99, being very careful not to allow the seal ring to tip when lapping. The seal face must be flat on the block to obtain a true surface which will not leak.

Never lap a bellows seal with emery or on the emery block, as emery particles might become imbedded in the soft bronze ring, and when the seal is reassembled and the compressor started, these particles would rapidly wear away the seal faces and cause another leak.

71. LAPPING OF DISCHARGE VALVES

To lap the seats of discharge valves use a lapping block and pumice paste as shown in Fig. 100, following a procedure similar to that described for lapping seal rings, and being careful to keep the valve seat flat on the block during the lapping process.

After lapping valve seats thoroughly, clean them with gasoline or carbon tetra-chloride and wipe dry. Reassemble the discharge valves, using new valve reeds or springs if the old ones are worn or eroded. Coat the surface of the valve seat with compressor oil when reinstalling.

On compressors using poppet valves, the valve seats can be lapped or cleaned by wrapping a $\frac{3}{4}$ " strip of Luminox sandpaper around the valve and placing this lapping device in the valve seat so that the valve holds the sandpaper firmly against the valve seat. Rotate this lapping device back and forth until the valve seat is clean and true.

If discharge valves are badly worn or damaged, it is often more practical to replace the entire valve and valve seat with a new replacement valve assem-

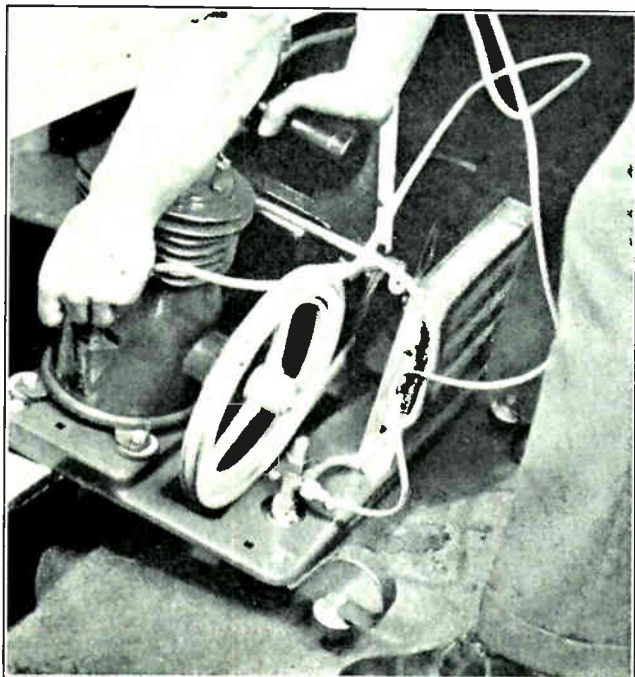

Fig. 96. By grasping solid parts on the compressor motor or condensing unit frame, the unit can be slid out of the cabinet as shown above. Courtesy Stewart-Warner Corporation.

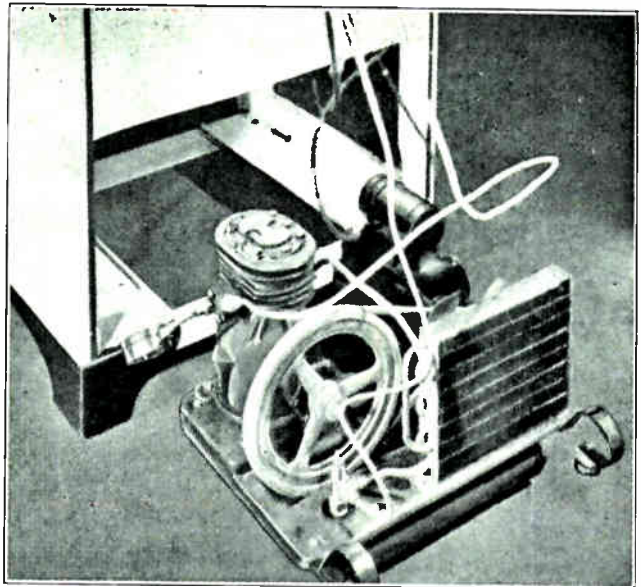

Fig. 97. Here the condensing unit is shown completely removed from the cabinet and in convenient position for adjustment and servicing. On some refrigerators, the tubing is not long enough to permit removal of the condensing unit without pumping down the system and disconnecting the tubing. Courtesy Stewart-Warner Corporation.

bly. In some cases, however, a troublesome valve leak may be caused by a mere particle of hard dirt or scale which has become lodged between the valve reed and the valve seat, and which can be easily cleaned off.

After repairing or replacing compressor valves, be sure to give them a thorough test by running the compressor and watching the compound service gauge as previously explained.

72. DEFECTIVE PISTONS OR RINGS

When compressor pistons and rings become worn too much, it allows gas to escape back between the sides of the pistons and cylinder to the crank case during the compression stroke. This greatly reduces the efficiency of the compressor, and the condition would be indicated by low high side pressure and by continuous or too frequent operation of the compressor as well as improper refrigeration of the unit.

If the pistons and rings are not too badly worn, a new set of rings may remedy the trouble. If the piston is badly worn, it may be necessary to replace it with a new piston. It may even be necessary to regrind the cylinder to bring it back to a smooth round surface and then fit the compressor with slightly oversized pistons and rings to match the new cylinder diameter.

73. COMPRESSOR BEARINGS

When compressor bearings become badly worn, if the shaft surface is not seriously worn or rough, new bearings can be installed and the trouble thus remedied. If the shaft is badly worn, it can be regrind and polished and refitted with slightly undersized bearings to match the new diameter of the shaft.

In case the crank bearings or eccentrics are badly worn, the crank shaft or eccentric shaft and eccentric rods can be replaced with new ones.

If piston pins become loose and noisy they can be replaced with new pins, also replacing the pis-

tons if necessary, because of the pin holes being worn too large.

On large compressors which use crank shafts and connecting rods with split bearings such as shown in Figs. 37 and 93, bearing play or wear can be taken up and remedied by removing shims and tightening the connecting rod bearing bolts to close up the split bearing shell. Be careful not to remove too many shims or tighten the bearings too much or they will overheat and shortly burn out or give more trouble.

74. REPAIRS TO ROTARY TYPE COMPRESSORS

Some of the troubles which the service man will most frequently encounter with rotary compressors are:—low oil charge, indicated by compressor running hot and noisy; leaky check valves, indicated by whistling noise heard by placing ear against line near valve, or by unit short cycling; leaky shaft seals, indicated by odor of refrigerant or by leak tests previously described.



Fig. 98. The above photo shows how to hold a bellows type shaft seal on the lapping block for lapping or polishing the face of the seal. Courtesy Servel Manufacturing Company.

In addition to these troubles, weak or broken vane springs, worn vanes, rotors or sleeves, and worn bearings are also troubles which the serviceman can repair. In case of a badly worn compressor, in which the rotor, casing, and bearings are all worn, the most practical remedy would be to replace the compressor, with a new unit from the factory.

In case of low oil charge, fresh oil can be added as explained in Art. 88 on adding oil.

In case of leaky check valves, the unit must be discharged as explained in Art. 81. Then the dirty or defective valve can be removed and cleaned or replaced.

In case of a leaky seal on a rotary compressor the seal should be removed and resurfaced or replaced as explained in Articles 69 and 70 on repairing seals on reciprocating compressors. If the unit has two service valves, these can both be closed thus isolating the compressor from the rest of the system. The compressor can then be removed for repairs to seals or other parts.

If the unit has only one shut off valve then it is necessary to discharge the unit by means of a special charging and purging valve such as shown in Fig. 101 which attaches to the shut off valve. When the stem of this charging-purging valve is turned to the left or toward open position, it turns the stem of the shut off also; allowing the refrigerant to discharge through the charging-purging valve, and through an attached tube to service drum or neutralizer as explained in Art. 81.

In case of broken vane springs as used with the Norge Rollator compressor, a small cap or plate at the side of the compressor can be removed for easy access to, and replacement of the vane spring. Before removing this cap or plate, be sure to balance the pressure on the compressor so that gauge shows about 1 lb. pressure in compressor, as explained in article 76.

In case of worn rotors and vanes on rotating vane type compressors, or in case of worn rotor and sleeve on the Rollator compressor, a complete new rotor unit can be obtained from the factory and replaced in the old compressor casing. To perform this operation, both service valves must be closed or the unit discharged to permit removal of the compressor.

A limited amount of wear and clearance can be compensated for by use of a heavier grade of oil.

75. FLOAT TYPE CONTROL VALVES

We have previously learned that the control valve or throttle valve is one of the vitally important parts of any refrigerator, as it controls or regulates the flow of refrigerant to the evaporator and thereby regulates the temperature maintained in the cabinet. You will also recall that control valves are of three principal types known as float type valves, thermostatic valves and pressure operated valves.

If the control valve becomes stuck or defective, the flow of refrigerant cannot be properly regulated and the unit will not refrigerate properly. If the



Fig. 99. This view shows the method of lapping a bellows seal ring. The ring should be held perfectly flat on the block while lapping with a rotating or figure 8 motion. Courtesy Servel Company.

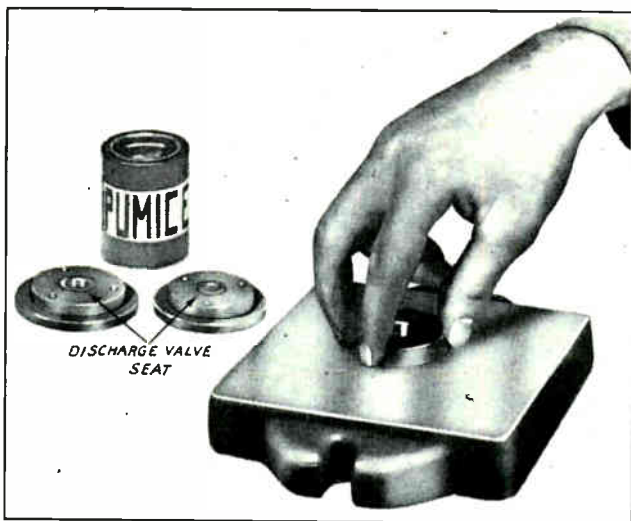

Fig. 100. Valve seats can also be lapped on a lapping block with lapping compound as shown above. Courtesy Servel Manufacturing Co.

control valve sticks in an open position, too much refrigerant will flow, the suction line will frost over, the low side pressure will become abnormally high and the compressor will probably run continuously.

If the control valve sticks in a closed position not enough refrigerant will flow, the unit will not cool properly and the low side pressure will be abnormally low.

Float valve troubles may be caused by a leaky float, stuck float arm or mechanism, by dirt or scale lodged in the needle valve opening, or by needle becoming pitted. A method of flushing dirt from this opening was explained in Article 53. If this does not eliminate the trouble, then it may be necessary to remove the float valve header and repair or replace the valve.

In many cases, a stuck float valve can be freed by jarring the valve header or evaporator with a hammer and a block of wood or a brass rod. In case this fails to free the valve, it may be necessary to remove the valve header to make repairs or replacements.

76. REMOVING FLOAT VALVE HEADER

If it becomes necessary to remove the float valve header from an evaporator, you should proceed as follows: First install the pressure and compound service gauges, then close the receiver valve or "king valve" and set the cold control at the coldest position. Next remove and empty the ice trays, fill them with hot water and replace them in the evaporator.

Leave the cabinet door open and renew the hot water in the ice trays several times until all refrigerant is removed from the evaporator. Operate the compressor until all refrigerant vapor has been pumped from the evaporator, by which time the frost should have disappeared from the evaporator and it should feel warm to the touch. When the compound gauge registers 20" of vacuum and all parts of the evaporator are warm to the touch, it may be assumed that all refrigerant has been removed from the evaporator.

Before removing the old float and header be sure to have the new or replacement header and float all

ready with new gaskets, for immediate replacement so that the float chamber will be opened the shortest possible time.

Also before removing the header, crack the receiver valve open just long enough to balance the pressure or to cause the compound gauge on the suction service valve to register one pound pressure, then close the compressor low side service valve.

On some units it is advisable to tilt the evaporator or cabinet backwards so that the front end of the evaporator is about one inch higher than the back end, in order to avoid spilling out any oil which may remain in the evaporator, when the header is removed,

Be sure to wipe the front of the evaporator absolutely dry so that no moisture will get into the unit when it is opened.

Disconnect the liquid and suction lines from the header and plug the ends of both lines with flare type seal plugs or rubber stoppers to prevent dirt or moisture from getting into these lines. It is also advisable to cap the float fittings if the job cannot be immediately completed.

Caution: Always use goggles and extreme caution when actually removing the valve header because in some cases enough refrigerant may be released from the oil in the evaporator to build up a pressure and cause refrigerant and oil to be blown into the face of the serviceman if proper caution is not observed.

First loosen, but do not remove the header bolts and then loosen the header by tapping with a hammer. After the header is loose remove the bolts and take out the float mechanism, being very careful not to bend or damage it.

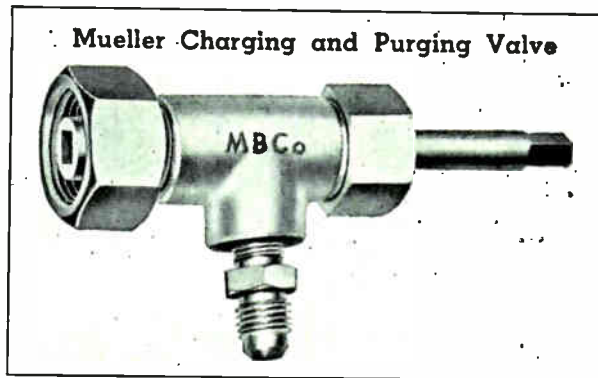

Fig. 101. Charging and purging valve such as used in connection with the regular shut-off valve for charging or purging rotary type compressors which are not equipped with regular low side and high side service valves. Courtesy Mueller Brass Company.

Next clean off the gasket face of the float chamber, being careful not to get any dirt in the float chamber. Then replace the new or repaired float and header, using a new gasket, and tighten the bolts evenly and firmly all around.

Reconnect the liquid line and suction line. Loosen the flare fitting at suction service valve and purge the air from the lines and evaporator by cracking the receiver valve open until refrigerant odor can be noted at the loose fitting.

Then tighten all connections and open the low side valve, crack receiver valve open until compound gauge shows 5 lbs. pressure. Test all connections

for any possible leaks. If no leaks show then open receiver valve and again check for leaks at this increased pressure before operating the unit.

77. REPAIRING PRESSURE TYPE THERMOSTATIC CONTROL VALVES

Pressure or thermostatic type valves may also give trouble by becoming stuck or clogged and may be freed by flushing as previously explained in Article 53, under remedy D, or by rotating the adjusting screws from fully closed to fully opened position and back to normal.

Thermostatic valves may fail to operate properly due to the power bulb becoming loose from its connection to the evaporator or suction line, in which case the remedy is to securely tighten this connection.

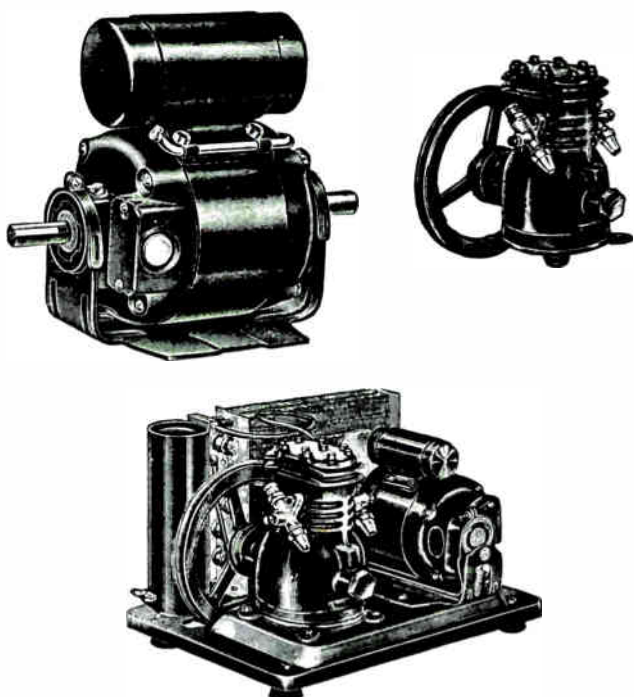

Fig. 102. Complete replacement motors, compressors, or entire condensing units such as shown above can be obtained from the refrigeration supply houses for replacing defective units.

These valves may also fail due to loss of liquid from the power bulb. On many of these pressure or thermostatic valves, the power bulb and pressure bellows can be conveniently removed and replaced with new elements without opening any connection to the evaporator or the suction or liquid lines.

In case the complete control valve needs to be removed for cleaning or repairs, the same procedure should be followed as previously explained with regard to closing the receiver valve, boiling out all refrigerant from the evaporator, pumping the low side down to 20" vacuum by running the compressor, then cracking the receiver valve open to build up one pound pressure before loosening the bolts and removing the valve header.

If pressure does not build up when receiver valve is cracked, it indicates the control valve is stuck closed and liquid line may be full of refrigerant. In this case carefully bleed the liquid line by loosening the flare fitting at the receiver valve.

Also exercise the same caution previously mentioned with regard to any refrigerant which might escape from the evaporator when it is first opened. Also follow carefully each step of the purging operation to remove all air that may have entered the evaporator or lines while they were open.

78. CONTROL SWITCH TROUBLES

As explained in the list of common refrigerator troubles and symptoms in Articles 52, 53, 55 and 56, faulty operation of a refrigerator may be caused by a defective control switch. You will recall that control switches are connected in the motor circuit and consist of a set of contacts which are operated by a pressure bellows or a thermostat strip.

One of the most common troubles occurring with control switches is dirty, burned or pitted contacts. Repeated opening and closing of these contacts to start and stop the motor hundreds of times each month will naturally cause them to burn and corrode a certain amount.

In some cases, these contacts may become burned and melted so that they stick together causing the refrigerator to run continuously even though proper temperature or excessively low temperature has been reached in the cabinet. The force exerted by the pressure bellows or thermostat element may not be sufficient to break the contacts apart.

When contacts are found to be stuck, dirty or pitted they should be carefully cleaned with fine sandpaper, emery cloth or a contact point file. Be sure to keep the contact faces flat and parallel so that they make a contact of sufficient area to be of low resistance and thus prevent overheating.

Another common trouble with control switches is a weak or broken spring. This fault can easily be remedied by replacing the defective spring with a new one at a cost of a few cents.

In case of a leaky pressure bellows or a warped or defective thermostat element, these can also be

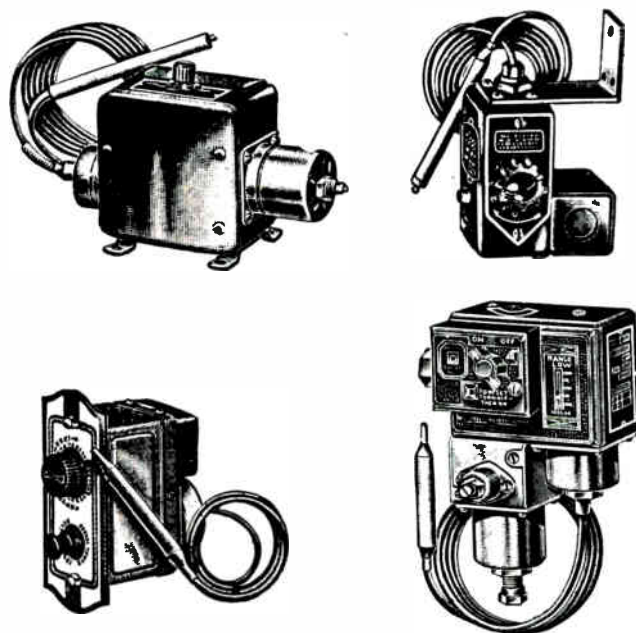

Fig. 103. Several types of cold control units which can be obtained for replacing defective controls or for installation on old refrigerators which were not originally equipped with such controls.

replaced with new ones. Sometimes control switches may fail to operate properly because the power bulb is loose from the evaporator, or has not been properly installed.

79. EVAPORATOR TROUBLES

Aside from the float valve which is located inside of some evaporators there is little else about an evaporator to give trouble. Float valve repairs have been covered in a preceding article. However, evaporators may give trouble due to leaky gaskets at the float valve header, or in some cases, the evaporator may become rusted or corroded so that slight refrigerant leaks develop somewhere in the tank or tubes.

In case the trouble is caused by a leaky gasket, the gasket should be replaced with a new one. When performing this operation, follow the same procedure in pumping down the unit and then setting up a slight gas pressure before removing the header and gasket, as explained under article 76 on removing float valves. Also follow the same procedure in purging any possible air from the evaporator after replacing the gasket and valve header.

When it becomes necessary to remove and replace an evaporator the first step is to install service gauges and pump down the unit to a 20" vacuum as explained in Article 76 for removing float valves. Also crack the receiver valve open just long enough to cause the compound gauge to register about one pound pressure, so that a slight amount of refrigerant will force its way out of the evaporator and lines, instead of permitting any air to be sucked in when the connections are opened. Also follow the same precautions regarding opening the connections or header slowly and protecting the eyes from any liquid refrigerant that might escape when the connections are first opened.

The new evaporator which is to be used for replacing the old one should be right on hand for installation as quick as the old unit is removed. After installing the new evaporator be sure to purge it and both the liquid and suction lines of any air which might have entered them when the connections were open. After installing an evaporator or any other new part in a refrigerator, be sure to check all joints and connections for leaks.

On evaporators of the indirect type using a brine solution and brine chamber, the brine level should be kept within $\frac{1}{4}$ " of the top of the brine compartment. If a bad brine leak develops, it is generally best to replace the entire evaporator. The defective evaporator may possibly be repaired later in the service shop by soldering, brazing or welding.

80. CONDENSER TROUBLES

If the condenser of a refrigerator does not function properly, and cool and condense the high pressure gas from the compressor, the refrigerator will not operate satisfactorily or produce the low temperatures desired in the cabinet and in the ice cube chamber.

One of the most common condenser troubles is caused by the condenser becoming clogged with dirt so that the cooling air cannot properly circulate through its tubes and fins. This trouble can be easily remedied by thoroughly cleaning the conden-

ser with a brush and vacuum cleaner. The condenser can also be washed with carbon tetra-chloride to remove any grease or oil accumulations. Grease or oil, if left on a condenser will cause it to collect dust and lint from the air much more rapidly.

Condensers may in some cases develop leaks due to corrosion or to mechanical abrasion by being bumped with some sharp object, or by vibration and rubbing of some metal part against the condenser.

To remove and replace a condenser it is necessary to discharge or remove the entire charge of refrigerant from the unit as described in the following article. After the new condenser has been installed, the unit should be recharged as explained in Art. 83, and the usual tests made for leaks as previously explained.

The air velocity through air-cooled condensers should be from 400 to 500 feet per minute to accomplish proper cooling and condensing of the high pressure gas. The top coil of a condenser when properly operating should be about 25° F. above room temperature.

If a condenser tube is sharply bent or dented it may restrict the flow of gas and cause high head pressure.

On water-cooled condensers the water control valve sometimes becomes clogged with sediment and restricts the flow of cooling water, preventing proper condensing. This valve should be set or regulated for a 20 degree temperature difference between inlet and outlet water.

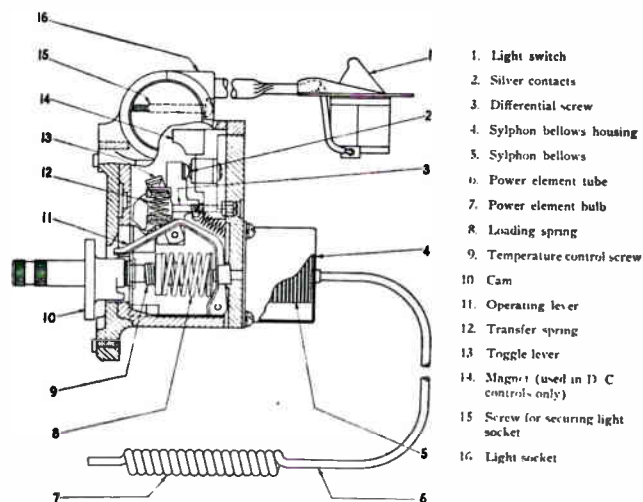

Fig. 104. Sectional view of a refrigerator control switch showing the contacts, springs, pressure bellows and power bulb. Examine each of these parts carefully while studying the instruction on control switch repairs. Courtesy Stewart-Warner Corporation.

81. DISCHARGING A REFRIGERATOR UNIT

When it becomes necessary to remove the refrigerant charge from a refrigerator unit, in order to replace a condenser or receiver, or to completely overhaul the system, or merely to renew with a fresh charge of refrigerant and oil, the following steps should be taken. First, connect several feet of tubing or a discharge hose to the discharge service valve gauge opening by means of a half union fitting. The other end of this tube is attached to an empty service drum by means of a "T" fitting, to which a pressure gauge is also attached. See Fig. 106. Then purge the air from the discharge line by leaving the fitting loose at the drum and cracking

the discharge service valve open until gas blows all air from this line. Then tighten fitting at the drum.

Next open the valve on the service drum and close the discharge service valve all the way to the right so that when the compressor is operated, the refrigerant will discharge through the gauge opening and tube into the drum.

Then operate the compressor until all parts of the unit, such as evaporator, condenser, receiver and lines are all warm, showing that all refrigerant has been removed from them. The compound gauge on the low side service valve should also show a high vacuum.

While pumping the refrigerant out of the unit and into the service drum, the pressure gauge attached to the drum should be watched to see that the pressure does not exceed 125 lbs.

The service drum should be immersed in a bucket of cold water to cool it and condense the refrigerant so as to keep the pressure down and permit all of the charge to enter the drum. Stirring the water or pouring some over the top of the drum will help to keep the drum cool.

After the refrigerant has all been pumped out of the unit and into the drum, if the entire unit is to be overhauled, the valve on the drum should be closed and the discharge line and fittings disconnected. However, if the unit was discharged for the purpose of removing just one part such as the receiver or condenser, then the pressure should be balanced by cracking the discharge service valve open or to the left, just long enough to allow refrigerant from the drum to flow back and build up about one lb. pressure in the system, as indicated by the compound gauge on the suction service valve.

82. DISCHARGING AND NEUTRALIZING WORTHLESS REFRIGERANT

In case the unit only contains a small amount of refrigerant which it is not desired to save, and especially if the refrigerant is non toxic and non-irritating, then the gas can be discharged to open air, by attaching a longer tube to the discharge service valve and extending this tube out of a door or window.

In case of discharging any appreciable quantity of SO_2 , if no service drum is available, or if the refrigerant is bad and not worth saving, it can be neutralized by discharging it slowly through an earthenware or glass jar of lye water or caustic soda. This is done by immersing the end of the discharge line well down in the lye water, and watching to see that no gas bubbles reach the surface. This means that all gas is being absorbed or neutralized by the solution. About $1\frac{1}{2}$ lb. of lye per gal. of water makes the proper neutralizing solution.

Be careful not to open valve too far or the discharge pressure may cause violent bubbling and splash lye solution on the floor. This solution is injurious to paint, varnish, clothes, hands and face.

83. RECHARGING A REFRIGERATOR

After a refrigerator has been discharged and overhauled, it can be recharged with refrigerant as follows: First, the entire system should be thoroughly dehydrated by baking all parts such as compressor, evaporator, condenser, control valve and re-

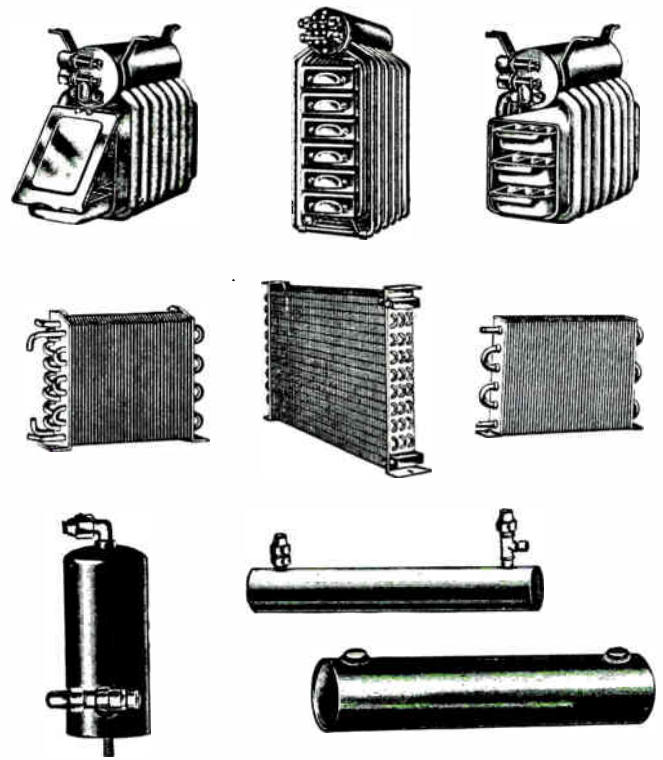

Fig. 105. Several types of evaporators, condensers and receivers which can be obtained by the serviceman from refrigeration supply stores for replacing defective units on old refrigerators.

ceiver in an oven at a temperature of about 235 degrees F. for 10 to 12 hours. If the units are connected together and have a vacuum drawn on them by an external compressor, then 5 to 6 hours is usually sufficient.

After dehydrating the parts in the oven they should be plugged with hot air still in them and removed, for assembly and connecting up in the refrigerator. After connecting up the parts close the discharge service valve all the way to the right, remove the gauge plug and run the compressor to pump all air out of the system through this opening, and draw a good vacuum of 20 to 24 inches on the system. Before drawing this vacuum, the correct oil charge should be put in the compressor. Then install pressure gauge at high side service valve and open this valve by turning the stem all the way to the left. Then crack the valve $\frac{1}{4}$ turn to the right to permit the gauge to indicate pressure.

Next open the suction service valve all the way to the left and remove the gauge to permit attaching a charging hose or tube.

Connect the charging hose or tube securely to the service drum, which contains the fresh refrigerant for the charge. Use a "T" fitting at the service drum and attach the compound gauge to one end, and the charging line to the other end. Attach the other end of the charging line to the half union on the suction service valve gauge opening but do not tighten the fitting more than "finger tight" until after purging the air from this charging line. Crack the valve on the service drum slightly open until an odor of refrigerant is noticed, showing that all air is out of the charging line and then tighten the fitting at the suction service valve.

Next turn the suction service valve all the way

to the right, start the compressor and slightly open the valve on the service drum, permitting refrigerant to be drawn into the system by the compressor. Do not open the service drum valve too far or pressure of the refrigerant in the drum may build up too high a pressure on the low side of the compressor. Watch the compound gauge and maintain a charging pressure of about 15 lbs.

84. DETERMINING AMOUNT OF CHARGE

To determine when enough refrigerant charge has entered the unit, watch the high side pressure gauge, and when it indicates about 15 lbs. over normal high side pressure, close the service drum valve all the way to the right. The amount of charge can also be determined by weighing the service drum before starting the charge and during the charging operation, by having the drum setting on a scale and noting its decrease in weight. Make sure that the charging hose is free and slack, or the charging tube if used should have a loop in it so that it bends easily and does not interfere with the scale indication.

After enough charge has apparently entered the unit, stop the compressor, close the drum shut off valve, turn the suction service valve all the way to the left and then crack it $\frac{1}{4}$ turn to the right to permit compound gauge at the drum to indicate low side pressure. Then cycle the unit, observing both low side and high side pressures to see that they are correct.

If the charge is still low, turn suction service valve all the way to the right and open drum valve to add more refrigerant.

Considerable time can be saved on this operation if a gauge manifold such as shown in Fig. 107 is used. This permits readings of high and low side pressures, charging, purging, etc., by merely adjusting the valves.

The several diagrams in Figs. 108 and 109 show the method of connecting this test manifold to the compressor service valves, and also show the proper settings of the various valves for several of the most important service operations. Examine each of the diagrams and the valve positions very closely and refer to these figures whenever necessary for later reference on the job.

85. DEHYDRATION WITHOUT AN OVEN

In case an oven is not available for dehydrating the parts of a disassembled refrigeration unit, a fair job of dehydration can be accomplished by flushing the parts with carbon tetra-chloride to wash out any sludge or dirt and the bulk of any moisture that might be inside the parts or tubing. Then if possible, blow out the lines and parts with compressed air to speed the drying of the carbon tetra-chloride.

The parts of the unit can then be assembled in the refrigerator and heated by carefully passing a torch over their surfaces while a vacuum is drawn on the system by opening the discharge service valve and running the compressor.

Be very careful not to heat any of the parts to temperatures above 250 degrees F., or some of the soldered joints might be loosened.

As a final means of removing the last traces of moisture a dehydrator such as shown in Fig. 88

should be installed in the liquid line between the receiver and control valve at the evaporator.

These dehydrators contain such drying agents or materials as calcium chloride, calcium oxide, or activated alumina. These materials have a high moisture absorbing ability and as the refrigerant is circulated through such a dehydrator the moisture is absorbed by the drying agent.

Calcium-chloride or calcium-oxide is best for quite rapidly absorbing larger amounts of moisture, while activated alumina is good for thoroughly absorbing small quantities of moisture.

Calcium-chloride or oxide dehydrators should not be left in the system more than a few days as the chemical may dissolve or break down and mix with the refrigerant. Activated alumina dehydrators can be left in the system indefinitely if desired. However, the activated alumina units can be reused in other machines by removing them and baking them out at temperatures of 215 to 250 degrees F. to drive out the moisture.

Therefore, dehydrators are not usually sold and installed permanently, but are more often rented to the customer for a week or so and then removed, refilled and used in other units.

86. REMOVING CONDENSING UNIT WITHOUT DISCHARGING SYSTEM

In some cases it may be desirable to remove an entire condensing unit consisting of the compressor, condenser, receiver and motor, and take it into the service shop for major repairs, or to replace it with a new condensing unit.

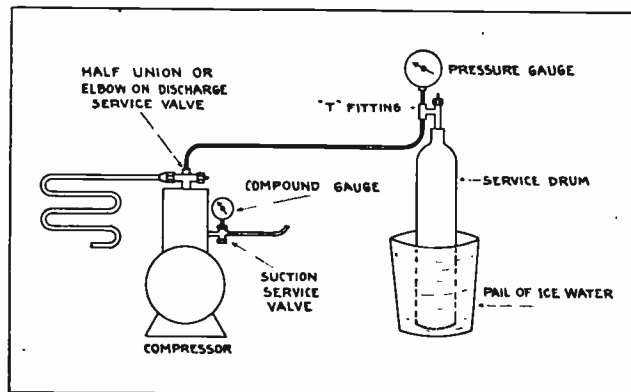

Fig. 106. The above diagram shows the method of connecting a refrigerant service drum to a compressor for discharging the refrigerant from the unit. Observe this diagram carefully while reading the explanation in article 81.

In such cases, the condensing unit can be disconnected and removed from the refrigerator, and a new one installed if desired, without discharging the refrigerant from the system.

This is done by "pumping down" the unit so that the entire charge of refrigerant is locked in the condenser and receiver.

To do this, we first stop the unit and install a compound gauge at the suction service valve. Then close the king valve or liquid line valve at the receiver and start the compressor.

Run the unit until the compound gauge shows a 20" vacuum. Fill the ice trays with hot water and warm the evaporator and lines with hot cloths or with a torch to drive out all traces of refrigerant.

Next stop the compressor, close the discharge

service valve all the way to the right and crack the receiver valve open just enough to build up 1/2 to 1 lb. pressure on the compound gauge.

The entire condensing unit can then be disconnected by loosening the flare fittings and tubing lines at the suction service valve and the receiver valve.

If these lines are immediately corked with rubber stoppers or metal plugs and kept corked while a new condensing unit is being installed, and if the time required is not over 30 minutes, the system may not need to be purged of air when reconnected.

87. PURGING AIR FROM THE SYSTEM

If the lines are not plugged, or if there is a period of several hours or more before the condensing unit is reinstalled, then any air should be purged from the system.

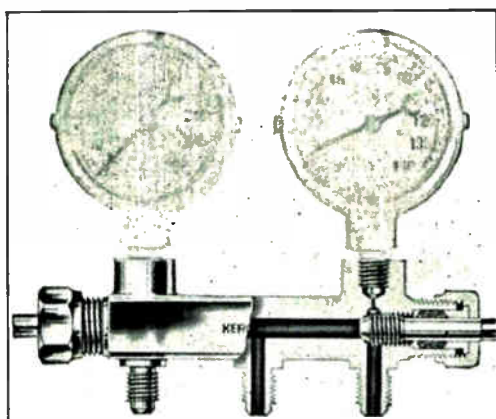

Fig. 107. Sectional view of a valve manifold with gauge attachment fittings for every convenient charging, purging, and testing of refrigerators. This type of valve manifold is a very useful and popular piece of equipment in the serviceman's tool kit.

After running the unit for a time any air in the system will usually be trapped in the condenser and receiver. To purge this air from a household unit having a discharge service valve, you need only stop the unit, remove the gauge or plug from the gauge fitting and crack this valve about 1/4 turn to the right and the air from both the receiver and condenser will discharge through the gauge opening.

If the unit is charged with SO₂, it is best to attach a tube or charging hose and purge through a lye solution as previously explained under discharging a unit, so that any SO₂ that might escape with the air will be neutralized.

When purging slowly through a proper lye solution, the air will bubble to the top as the lye solution does not absorb the air. When no more air bubbles are seen, the air is all out and only refrigerant is escaping. Then turn the discharge service valve back to the left.

Another good way to tell when the air is out of the unit is to hold one hand on the receiver tank while purging. When this tank begins to sweat or get cold, it indicates that the refrigerant inside it is starting to boil and that the air is probably all out of the unit.

On commercial machines or others that have no discharge service valve, air can be purged by crack-

ing open or loosening the flare nut fitting at the connection from the condenser to the compressor. The compressor should of course be idle when purging air.

88. ADDING OIL CHARGE

When it is necessary to replace the oil charge in a refrigerator that has been discharged and disassembled for overhaul, the correct amount of clean, dry refrigerator oil of the proper grade can be poured into the oil filler opening on the compressor by removing the oil plug. On compressors having no oil plug, the oil can be placed in the compressor before it is assembled. This should be done before the unit is evacuated and charged with refrigerant.

The correct amount of oil charge can be determined from the factory tag which is attached to the condensing unit of late model refrigerators, or from the data in Article 38 for some common types of units.

When charging or adding oil to a unit that is operating and already charged with refrigerant, a convenient procedure is to use the connection and fittings shown in Fig. 110. This device consists of

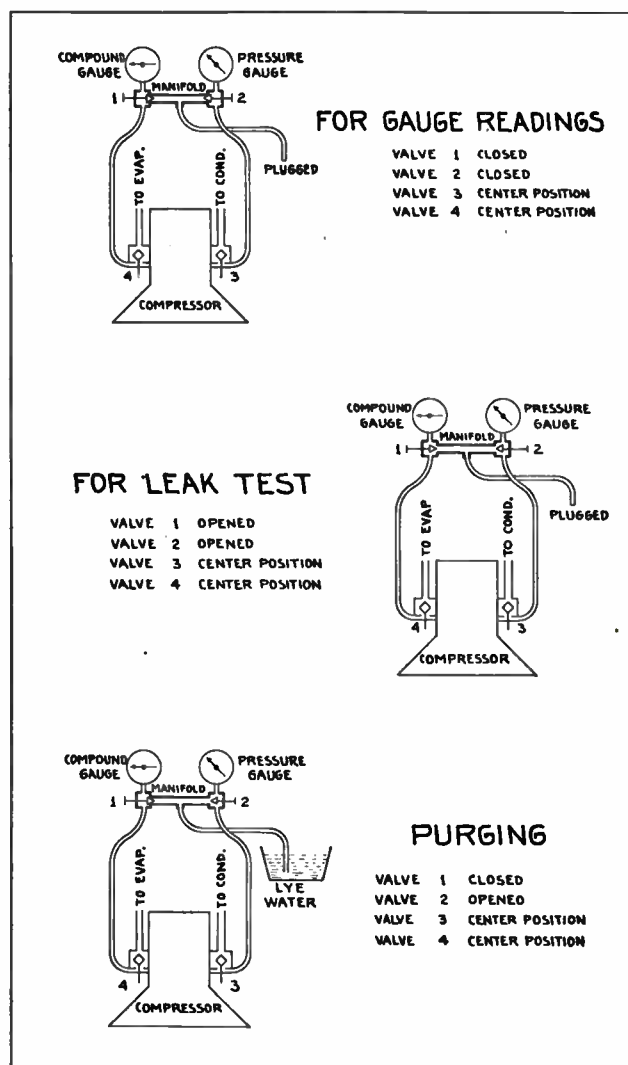

Fig. 108. The above diagrams show proper methods of connecting valve manifold and service gauges for testing and purging refrigerator systems. Carefully observe the position of all valves for each test and refer to these diagrams when making any such tests on refrigerators.

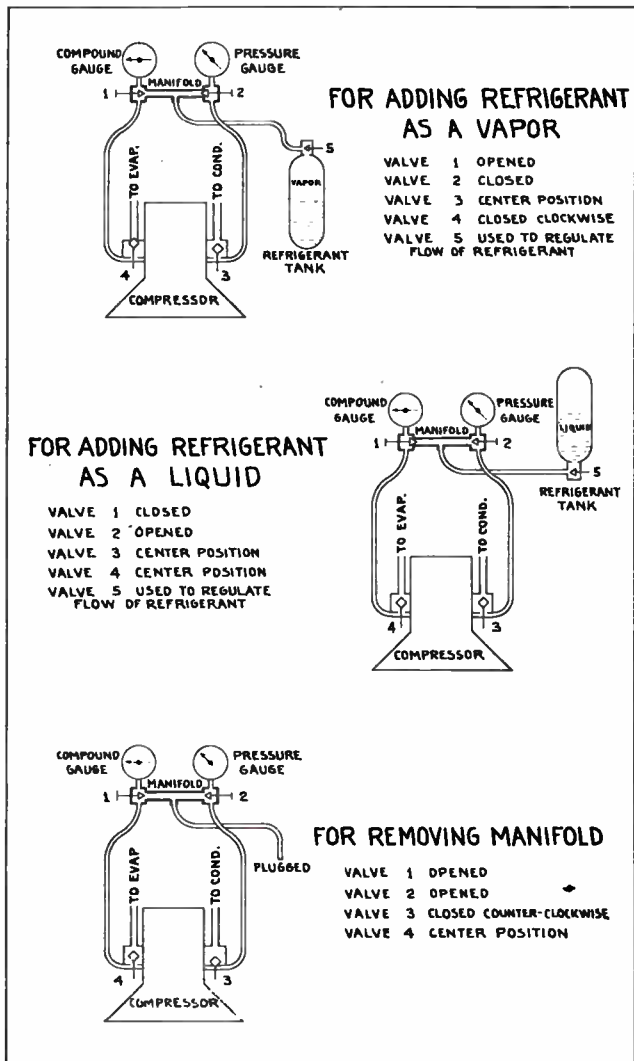

Fig. 109. These diagrams show proper connection of valve manifold, service gauges and the correct valve positions for charging refrigerating systems and for removing the valve manifold.

several short lengths of tubing equipped with a compound gauge, tee fitting and pet cock.

Turn the suction service valve all the way to the left and attach a compound gauge. Let the compressor stand idle a few minutes until gauge shows a lb. or so of pressure on the low side. This pressure is to be used to purge the oil line.

Then turn the suction service valve all the way to the left, remove the gauge and attach the tubing as shown in Fig. 110. Next immerse the other end of the tube or charging device in a bottle containing slightly more than the correct charge of oil. This tube should be down near the bottom of the oil.

Now open the pet cock and crack the suction service valve slightly open just long enough to purge all air from the charging tube. Also be sure that this tube is clean and dry.

Then close pet cock and turn the suction service valve all the way to the right. Start compressor and pull a good vacuum and then stop the compressor.

Next open the pet cock and allow the charge of oil to be drawn into the compressor by the vacuum

on the low side. Be careful to close the pet cock before the oil level in the bottle reaches the lower end of the tube, so that no air will be drawn in to the unit.

Then turn suction service valve all the way to the left and disconnect the charging tube and plug the gauge opening.

89. RECEIVER TROUBLES

Sometimes scale will collect in a liquid receiver and clog the end of the liquid line so that refrigerant cannot flow. The remedy for this trouble is to remove the receiver and clean it out or replace it with a new one.

A common symptom of this trouble is abnormally high vacuum on the low side and a cold liquid line, due to the restriction acting as an expansion valve and causing refrigeration to take place in the liquid line.

A receiver can be removed by the same procedure as explained in Article 81 on "discharging a unit."

In some cases, receivers may develop leaks at welds, tubing connections or sand holes in the metal and allow refrigerant to escape. Such leaks can be detected by the leak tests previously described. The remedy would be to remove and replace the receiver drum or repair the leaks by brazing or welding.

Normally a receiver is only partly filled with liquid refrigerant and the space remaining in the upper portion is filled with gas and acts as part of the condensing surface. If a unit is overcharged this space may become filled with liquid, thereby reducing the condensing area and causing high head pressure.

90. LIQUID LINE TROUBLES

Liquid lines on household units and small commercial units of a ton or two capacity are usually of $\frac{1}{4}$ " tubing. If smaller tubing is used it may become clogged by sediment or a gummy deposit on its inner walls.

Liquid line bends should be gradual (not less than 3" diameter for $\frac{1}{4}$ " tubing) and soldered type fittings are preferable to flare type fittings, because the latter may work loose with vibration and cause leaks of liquid refrigerant.

91. LIQUID LINE FILTERS

Filters such as shown in Fig. 88 are often installed in liquid lines of refrigerators to collect dirt and scale and prevent clogging of control valves and sticking of compressor valves.

These filter units generally contain a fine mesh screen or felt pad with a screen. They sometimes become clogged and can then be removed and cleaned by washing out with carbon tetra-chloride, or the filter pads can be replaced.

On some refrigerators small strainer screens are mounted in the body of the control valve, where the liquid line attaches. In other units strainers are built into the compressors at the suction line connection. These strainers sometimes clog and need to be cleaned. It is advisable to install liquid line filters on old refrigerators when overhauling or reconditioning them.

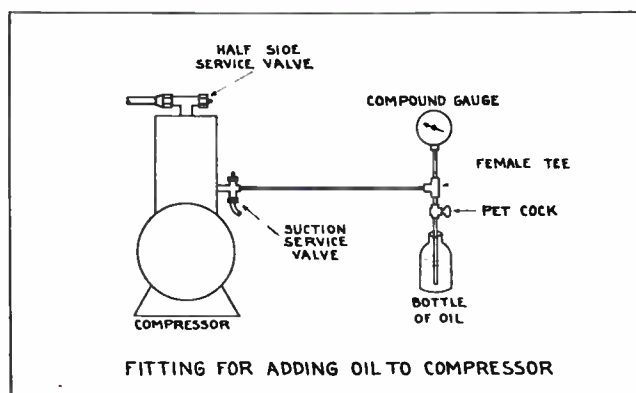

Fig. 110. A very convenient device for adding oil to refrigerator compressors can be made with short lengths of tubing, compound gauge, and pet cock as shown above.

92. SLUDGE

Old refrigerators often become clogged at control valves or liquid lines by sludge which is formed from carbonized oil and refrigerant.

This sludge can be dissolved and freed to a certain degree by introducing into the system about one tablespoonful of a special fluid known as "Xylene." Xylene is obtainable from refrigeration supply stores or from the Barrett Co., 40 Rector St., New York City, N. Y., who are the manufacturers.

93. CARE OF SERVICE VALVES

Low side and high side service valves normally have their stems covered with a brass seal cap. Their stems are also packed with graphite packing to prevent refrigerant leaks.

Whenever these valves are uncapped and used, it is advisable to check or tighten the packing nut.

When closing or opening service valves, always use a proper valve stem wrench. A very convenient type of wrench is the ratchet wrench such as shown in Fig. 20, article 98 on refrigerator service tools. You should have several valve stem wrench adapters on hand for the common sized valve stems. Never use a plier or pipe wrench on these soft brass valve stems or their corners will be ruined.

When operating service valves, be careful not to seat them too tightly or both the valve seats and stems may be damaged.

Be sure that you have a good understanding of the many important service operations explained in this section. Review any parts that are not perfectly clear to you and then refer to this section often if you are doing refrigeration service work.

Now carefully study the following important section on motor troubles, cabinets, refrigerator service tools and commercial units.

Norman Beder
41 Georgia Ave.
Brooklyn 7, N. Y.

REFRIGERATOR MOTOR AND CABINET TROUBLES MULTIPLE AND COMMERCIAL REFRIGERATING SYSTEMS

All household or domestic refrigerators of the compression type have their compressors operated by fractional horsepower electric motors, usually $\frac{1}{8}$ to $\frac{1}{4}$ h. p. size. Practically all of the small commercial refrigeration units of the compression type are also operated by electric motors ranging in size from $\frac{1}{4}$ h. p. to 10 h. p. or more. Many of the large commercial refrigerating units and ice machine compressors are also driven by electric motors.

Therefore, the electric motor is one of the most important parts of any electric refrigerator and should be given close attention and proper care by the service man. If the electric motor which drives the compressor, is defective or operating at speed below normal, the refrigerator will of course not function properly. If the electric motor fails to start when the refrigerator control switch closes its circuit, then the refrigerant will not be circulated through the system and the machine will not refrigerate.

Many refrigeration servicemen, although fairly capable on repairs to compressors, evaporators and control valves, are often very weak on their knowledge of electric motor and controller troubles and repairs, and therefore neglect a great deal of very profitable service work of this nature. When we consider the fact that there are over 10,000,000 electric refrigerators in use we can readily see the op-

portunities for profitable repair work on refrigerator motors.

94. REVIEW MOTOR LESSONS

D.C. motor and controller operation, care and repair, were covered in the D.C. Section 3 of this Reference set, and A.C. Section 5 deals with A.C. motors. Articles 164 to 185 of A.C. Section 5 should be reviewed if you are planning to service refrigerators, as this section deals with A.C. motors of single-phase, repulsion-induction and capacitor types, such as are most commonly used on domestic and small commercial refrigerators. A.C. Section 5 also covers larger A.C. motors, and Section 6 deals with A.C. motor controls. Section 8 covers maintenance and repair of A.C. motors and controls and should therefore be referred to for information on refrigerator motor troubles and repairs.

However, in addition to this information given on motors in previous sections, for your convenience a few general and special points on refrigerator motors are covered in the following paragraphs of this section.

As previously explained in Article 27 of this section, motors for domestic and small commercial refrigerators are generally of the single-phase A.C., repulsion-induction type with a commutator and brushes, as shown in Fig. 112; or of the single-phase

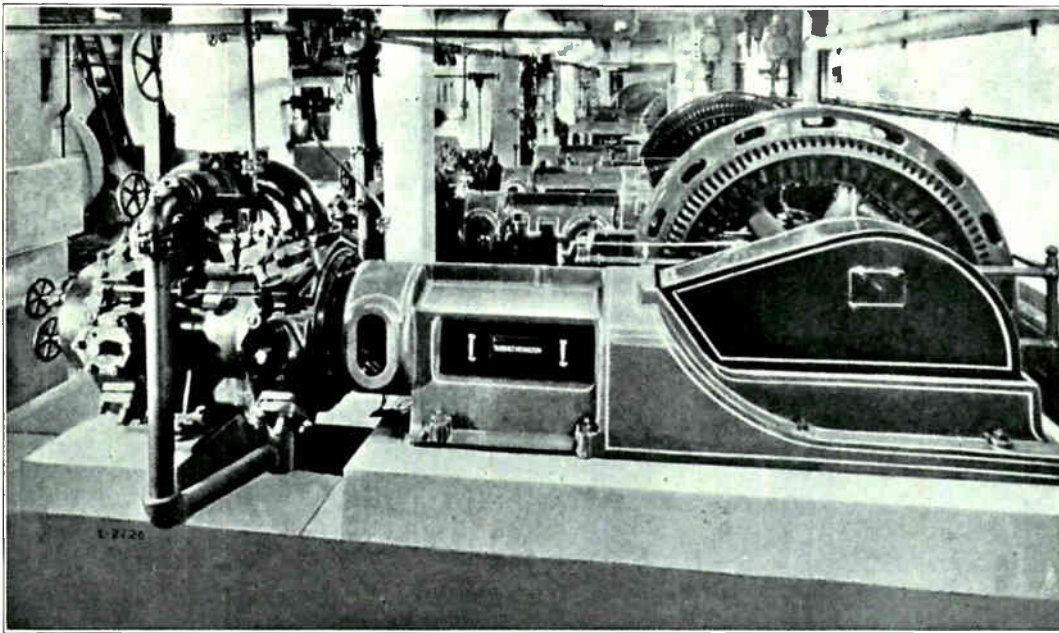

Fig. 111. Photo showing five large electric motor driven refrigeration compressors such as used in ice plants, cold storage buildings and air-conditioning systems. These five machines have a cooling capacity equal to the melting of 1600 tons of ice per 24 hour day. Courtesy Worthington Pump & Machinery Co.

A.C. capacitor type such as shown in Fig. 23 and Fig. 56. Two very popular types of capacitor motors are shown in Fig. 113 of this section.

From your previous study of the above mentioned sections you have learned the operating principles and common troubles and remedies for motors of these types, and by reviewing those lessons you can quickly brush up on any of these points which you might need.

95. COMMON MOTOR TROUBLES

The most common troubles with such motors are lack of oil, worn bearings, worn brushes, loose brush springs, brushes stuck in holders, dirty or pitted commutator, stuck or defective starting switch on split-phase A.C. motors, and winding troubles such as grounds, shorts, opens, or burned out winding. And, don't forget that failure of the motor to operate may be due to nothing more than a loose plug at the socket, a broken wire, or a blown fuse. Always check these things first and make sure that proper voltage is available at the motor terminals, before suspecting the motor.

The remedies for the other motor troubles just mentioned are obvious and were explained in earlier electrical lessons. It is generally a simple matter to clean a commutator with sandpaper or turn it down in a lathe if necessary; or to fit new brushes, replace weak brush springs, renew worn bearings, free up or repair a starting switch, etc. Fig. 112 shows the parts of a disassembled motor of the repulsion-induction or commutator type.

Refrigerator motor windings will not often burn out unless the unit is badly overloaded or develops a stuck compressor and if the fuse or circuit breaker fails to operate. Oil soaked windings sometimes develop shorts or grounds, which may in some cases be cleared by washing out the winding with gasoline or carbon-tetrachloride, and then drying and coating the winding with good insulating varnish and baking it in an oven.

If a motor winding burns out completely, a new

motor or spare used motor can be substituted and the old one rewound or exchanged.

96. CAPACITOR TYPE MOTORS

Capacitor type motors such as shown in Fig. 113 are becoming more and more popular and common on domestic refrigerators, because they have no commutators or brushes to wear out or give trouble or to cause radio interference.

The connection diagrams of three common type capacitor motors are shown in Figs. 114 and 115. Carefully note the connections of the capacitors, the starting and running windings, centrifugal switches, overload relays, thermotron overload device, cabinet light switch, cord, etc.

If the condensers or capacitors on capacitor type motors burn out or become open-circuited or shorted, the motors will not operate. In such cases, a new capacitor from the factory or refrigeration



Fig. 112. This view shows the important parts of a disassembled refrigerator motor of the repulsion-induction type. Courtesy Kelvinator Corp.

supply house is generally used to replace the defective capacitor, as it is not usually practical to try to repair these condensers.

A simple test for these capacitors is to connect a 10 or 15 watt lamp in series with the condenser and a 110 volt A.C. line. If the lamp lights dimly the condenser is probably good. If the lamp lights at full brilliancy the condenser is shorted. If the lamp does not light at all the condenser circuit is open.

Another simple test is to touch the condenser leads to an A.C. line and then remove them from the line and short circuit them. If a spark occurs when the leads are shorted, it indicates a good condenser. If no spark occurs, the condenser is open or shorted. If the condenser is badly shorted, it may blow the fuse when the leads are touched to the A.C. line.

Many service shops have a standard charge of \$0.75 for motor inspection, \$2.95 for minor repair job, \$5.35 for major repair job, and \$7.60 for complete rebuild jobs on 1/8 h. p. motors, and slightly higher on 1/4 or 1/2 h. p. motors.

Inspection service covers inspection, air cleaning, minor adjustments, oiling, testing and repainting.

insulating material on its surfaces to confine the noise of the compressor.

Refrigerator cabinet doors are also thick and heavy and filled with insulating material, and equipped with soft gaskets to prevent leakage of heat or warm air into the cabinet. See Fig. 116. There is not much to get out of order on the well-made refrigerator cabinet, except that doors sometimes lose their proper fit due to worn hinges, worn latches or worn gaskets. The remedy for these troubles would be to replace or line up the hinges, adjust or replace worn latches, and replace defective gaskets.

In some cases, doors on old refrigerators may become warped so that they do not fit closely against the door frame, and thus permit warm air to enter the cabinet. This can be remedied by placing soft balsa wood or sponge rubber shims, behind the regular door gasket at points where the edge of the door does not fit closely.

If it becomes necessary to make any holes or openings in an enameled cabinet, the porcelain enamel should first be removed very carefully with a sharp center punch or small chisel. Then the metal can be drilled with an ordinary hand drill

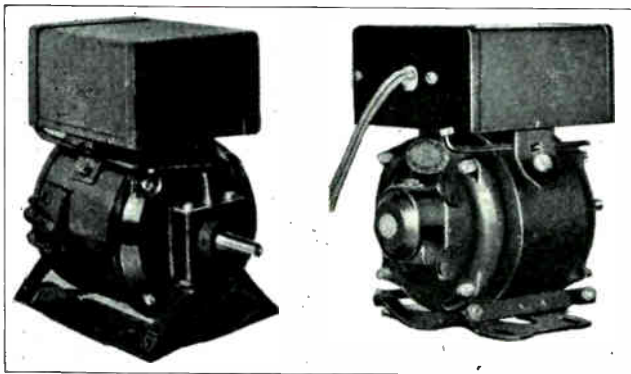

Fig. 113. Two popular types of capacitor motors such as are used by the millions on domestic refrigerators. Note the condensers on top of the motors.

Minor repairs cover inspecting, cleaning and repair or replacement of small parts such as brushes, bearings, etc., but not including a new condenser.

Major repairs cover inspection cleaning, minor parts replacement, and rewinding of the stator, but does not include a new condenser.

Complete rebuilding covers all of above mentioned items and a new condenser.

97. CABINET REPAIRS

As explained in Article 28, refrigerator cabinets for modern domestic refrigerators are generally made of pressed steel with enamelled surfaces both inside and outside. The insulated portion of the box, in which the evaporator or chilling unit and food articles are located, generally has walls several inches thick which are filled with insulating material having low heat conductivity.

The condensing unit is always located outside of the insulated food compartment so that the heat of the condenser can be blown away by the cooling air (or carried away by water in the case of water-cooled units). The condensing unit compartment may in some cases have a certain amount of sound

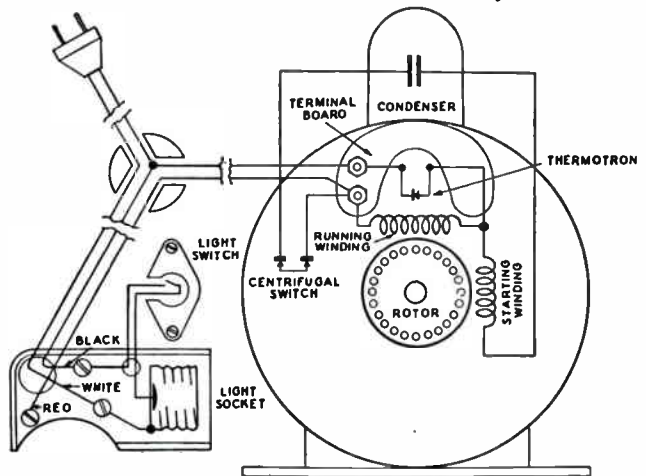

DELCO MOTOR WITH THERMOTRON

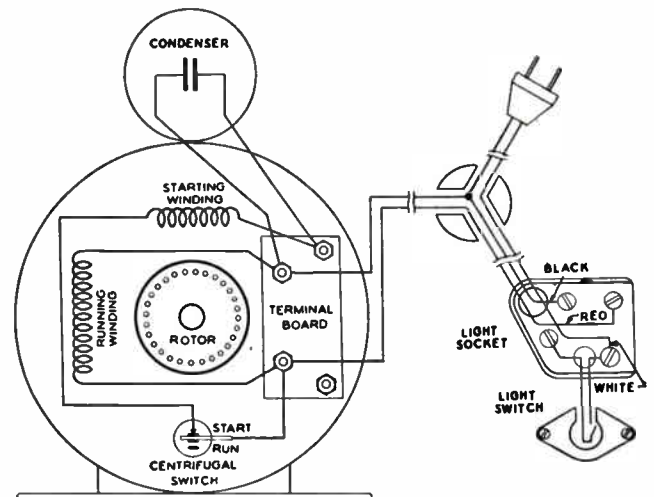

G.E. MOTOR

Fig. 114. Diagrams of circuit connections of two very common capacitor type refrigerator motors. Note carefully the connections of the starting switches, condensers, motor windings, light switch, etc.

or electric drill. Great care must be used to prevent cracking or chipping the enamel around the edges of the opening.

If the paint or enamel on the inside of the food compartment becomes damaged or discolored, it can be re-enamelled with a spray gun or brush. Always use high grade enamel for this purpose as cheap or soft finish paints will rapidly discolor and may develop a bad odor after a period of service.

In case the enamel on the outside of a cabinet becomes scratched or damaged, these spots can be repaired or patched with special Duco patching enamels or porcelain patching materials. Tuttle's Tite-On cement, or another material called Vite-Re-Pair are both good patching materials.

Patching kits sold for this purpose generally consist of a supply of filler material and several different shades of coloring material, so that with reasonable care the color of the original surface can be very well matched.

To prepare the damaged spots for patching, the edges should first be sanded smooth with very fine sandpaper, and all sanding dust removed with a clean dry cloth.

On old boxes on which the enamel has become badly marred or discolored, a complete repainting or re-enamelling job can be done with a small spray gun and will greatly improve the appearance of the

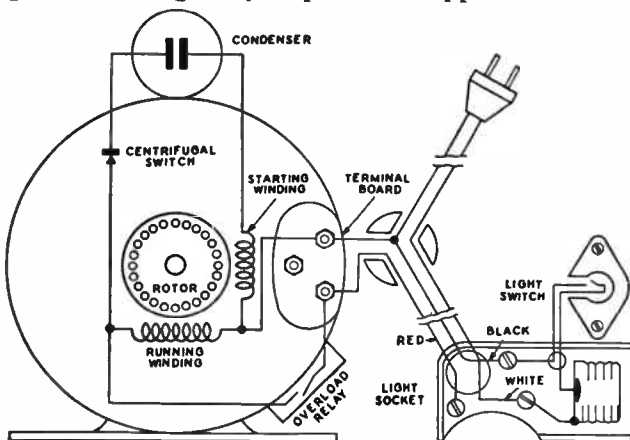

WAGNER MOTOR WITH OVERLOAD RELAY

Fig. 115. Another connection diagram of a popular capacitor type refrigerator motor.

cabinet. Such cabinet refinishing jobs often afford a very profitable part of the overhaul jobs on old refrigerators.

Fig. 117 shows a diagram of the interior of a large commercial cabinet or cooler with two evaporators suspended from the top of the cabinet. Note the manner in which the air should circulate over the evaporators and thru out the box. Also note the drain baffles which are located underneath the evaporators to carry off any moisture from condensation or defrosting of the evaporators.

Fig. 118 shows another view of such a drain baffle. Note how the sheet metal fins are constructed and overlapped to catch all water and prevent it from dripping on the food, and yet permit free circulation of the air in the box.

Fig. 119 shows a glass front display cabinet such as used for refrigerating and preserving meats and food articles in meat markets and grocery stores

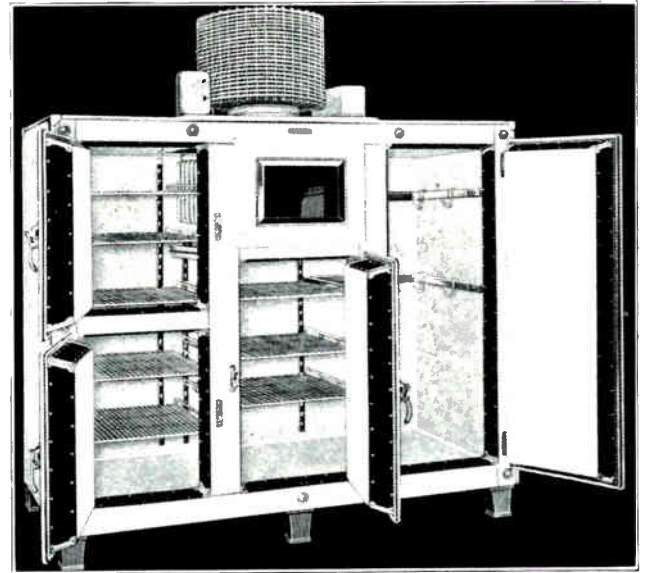

Fig. 116. View of a large refrigerator cabinet, opened up to show door construction, door liners, cabinet lining, etc. Courtesy General Electric.

Such display cases are cooled by evaporator coils located in the top or back section.

98. REFRIGERATION SERVICE TOOLS

In order to save time and efficiently perform service jobs every refrigeration service man should have a proper kit of tools. A number of refrigeration service tools are specially adapted to this type of work and without these tools the work would be very inconvenient and many common service jobs could not be done at all.

However, most of the ordinary service jobs can be performed with a few rather inexpensive tools, and then if one desires to set up a complete service shop and equip it for the more complete overhaul jobs, additional tools and equipment can be added as needed.

Some of the most essential tools are as follows:

Compound gauge (60 lbs. to 30" vacuum)

Pressure gauge (0 to 300 lbs.)

Set of flaring tools

Tube cutter

Ratchet wrench

Set of valve stem adapters

Set of socket wrenches

Set of open end wrenches

Thin model 6" adjustable wrench

Thin model 10" adjustable wrench

Pocket type thermometer

6" screwdriver

10" screwdriver

Side cutting pliers

Long nose pliers

Small pipe wrench

Hack saw

Blow torch

Soldering copper

File

Set of spring type tubing benders

Packing gland wrench

Bottle of 26% ammonia

Small can of white lead.

Additional tools and articles which are very convenient are as follows:

- Service gauge manifold
- Purging hose
- Set of 12 point box socket wrenches
- Leak detector torch
- Wheel puller
- Gas mask
- Goggles
- Hand vacuum pump for setting pressure type controls
- Several service drums
- Paint spray gun
- Recording thermometer.

It is also advisable for the service man to have on hand several sheets of $\frac{1}{32}$ " thick gasket material of both lead and asbestos types, several rolls of dehydrated copper tubing of $\frac{1}{4}$, $\frac{5}{16}$, $\frac{3}{8}$, $\frac{1}{2}$ and $\frac{5}{8}$ sizes, and an assortment of the most commonly used tubing fittings such as ells, tees, unions, flare nuts, cap nuts and plugs.

A small paint spray gun is also very handy for doing profitable cabinet refinishing jobs. Figs. 120 and 121 show a number of the more common refrigerator tools.

A very convenient and economical drying oven for dehydrating refrigerator parts can be made from an old, large-sized domestic refrigerator cabinet equipped with a gas burner or heated by an electric resistance type heating unit or several large lamp bulbs.

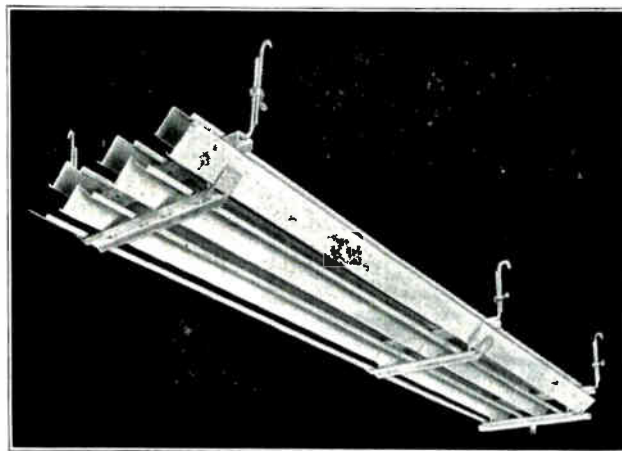

Fig. 118. Drain baffles such as used underneath large commercial refrigerator evaporators to prevent dripping of water from condensation or defrosting.

The box should be equipped with a small opening or vent to carry away moist vapor and with a thermometer to check the temperature.

An overhauled refrigerator compressor can be used for evacuating the parts to be dehydrated, while they are in the oven, by connecting them to the suction side of the compressor by means of copper tubing run through the wall of the cabinet.

A very convenient type of thermometer for use in checking cabinet temperatures on refrigerators when servicing or adjusting cold control switches,

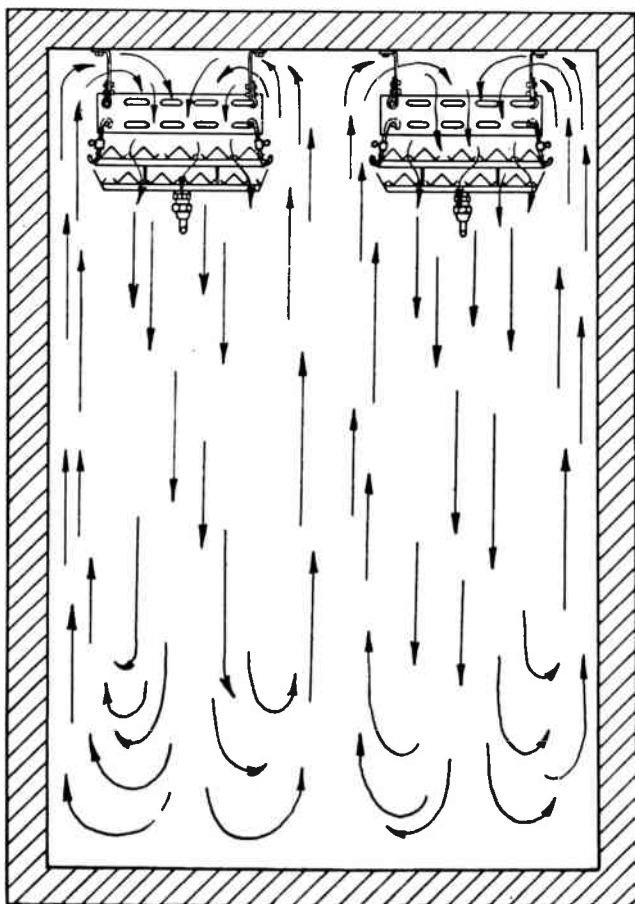

Fig. 117. This diagram shows the location of two direct dry type evaporators in the top of a commercial refrigerator cabinet, and also shows how the cool air should circulate in the cabinet.

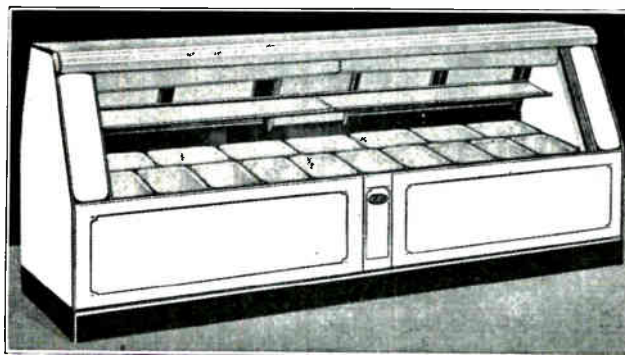

Fig. 119. Glass front refrigerated display case for meat market or grocery store use.

is shown in Fig. 122. This thermometer has a length of capillary tubing attached to the element so that the thermometer can be set on top of the cabinet and the capillary tubing extended inside the cabinet, and the door closed on this tubing.

The tubing is armored and is so small that it does not injure the tube or the door gasket when the door is closed on the tube. This makes possible frequent observation of cabinet temperatures without repeatedly opening the door.

99. SERVICING MULTIPLE INSTALLATIONS

Multiple refrigeration systems such as used in apartment buildings, stores and restaurants were described in Article 12 of the previous section, and you will recall that such systems consist of a centrally located condensing unit of proper size, connected to a number of separate evaporators which



Fig. 120. Above are shown some of the most commonly used refrigeration service tools.

may be located at various places in cabinets or coolers throughout the building.

Servicing any part of the condensing unit on the ordinary multiple system is approximately the same as servicing the condensing unit of an ordinary single refrigerator. One exception is that due to the greater amount of refrigerant which is generally contained in the evaporators and longer runs of tubing of the multiple system, if the system has no valve manifold, it is usually necessary to pump down and discharge some of this refrigerant into service drums before the condensing unit can be re-

moved. This is due to the fact that the condenser and receiver will probably not hold all of the refrigerant from the system. However, if the system has a valve manifold and shut-off valves near the condensing unit, this is not necessary.

Fig. 123 shows a diagram of a typical multiple system in which the condensing unit is connected through valve manifolds and tubing lines to four different cabinets or coolers in a restaurant.

Fig. 124 shows a diagram of another multiple system such as would be used in a six flat apartment building. Note that separate liquid and suction lines are run from each evaporator to shut off valves on a valve manifold panel located in the basement or wherever the condensing unit is placed.

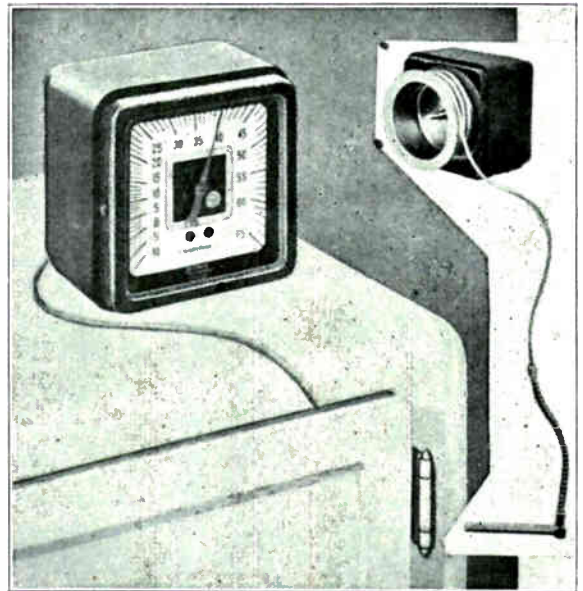

Fig. 122. A very convenient type of thermometer for checking refrigerator cabinet temperatures without repeatedly opening the door, after making adjustments.

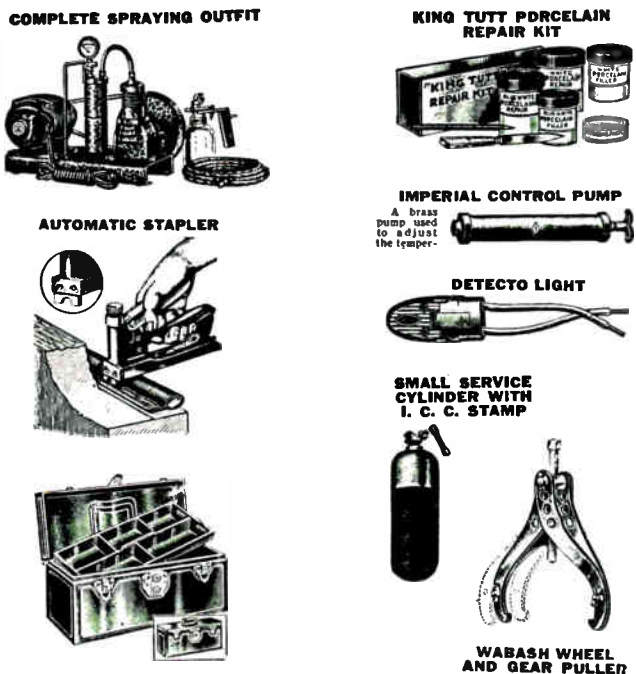

Fig. 121. These refrigeration service tools are also very convenient for the service man to have.

Fig. 125 shows another multiple system using main liquid line and suction line risers with shut-off valves located where the short liquid and suction lines from each evaporator attach to these risers. This system is not as convenient or as much approved as the one in Fig. 124.

To service an evaporator on a multiple system on either of these types, it is only necessary to close off the liquid shut-off valve to that particular evaporator and allow the condensing unit to continue to run until all refrigerant has been drawn from the evaporator. Then close the suction line shut-off valve to isolate the evaporator from the rest of the system. Due to the long liquid and suction lines this pumping down of one evaporator in a multiple system may require several hours, or over night.

However, it does not interfere with the operation of other evaporators on the system. The prompt pumping down of the defective evaporator can be speeded somewhat by filling the ice trays with hot water and applying hot cloths to the float chamber.

100. TWO-TEMPERATURE VALVES

Some multiple refrigeration systems use special control valves known as two-temperature valves,

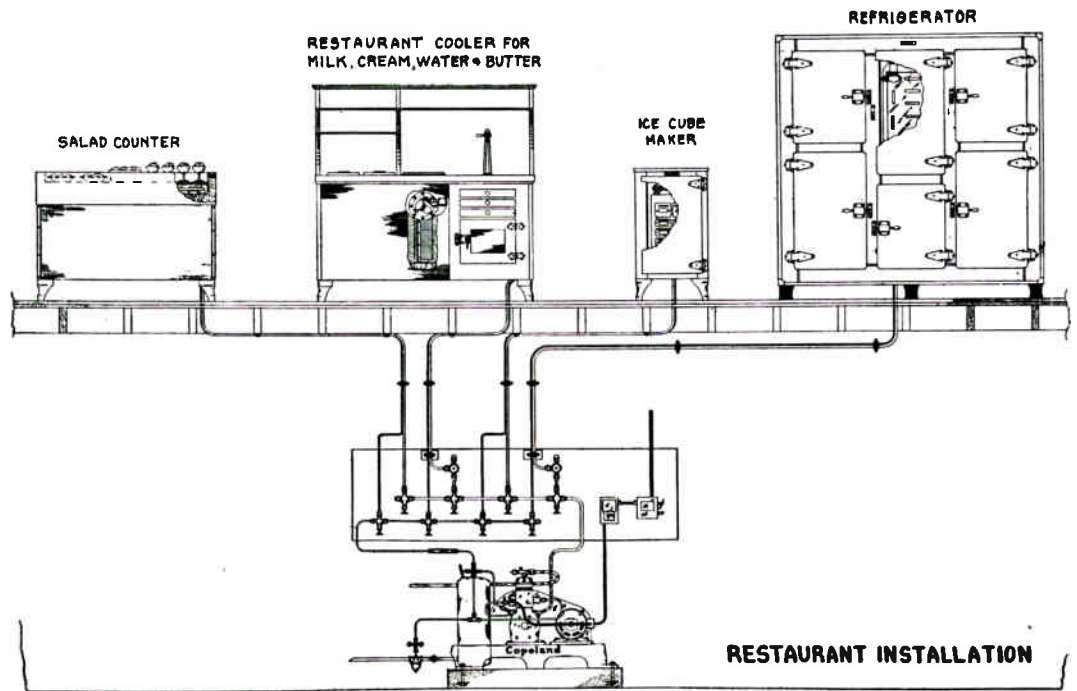

Fig. 123. Diagram showing arrangement and connections of a commercial refrigeration system in a restaurant. Note the separate liquid and suction lines running from the valve manifold panel to each cabinet.

to maintain two or more evaporators at different temperatures, although they may all be supplied with refrigerant from the same condensing unit. For example, we may desire to have one evaporator on a multiple system maintain a temperature of 20 degrees F., another evaporator 25 degrees, and another 35 degrees, etc. This can be accomplished by means of the two-temperature valves just mentioned, by using one of these valves to control each evaporator and by adjusting each valve for the desired temperature.

Two-temperature valves are of two common types, namely, the mechanical or pressure operated type and the electrical or solenoid operated type. The pressure type two-temperature valves are used in the suction lines to control the back pressure on the evaporators and thereby control the rate of evaporation and refrigeration. The solenoid valve is used in the liquid line to control the flow of refrigerant to the evaporator and thereby control the amount of refrigeration and the evaporator temperature.

Fig. 126 shows a view of a Barostat pressure type two-temperature valve, such as used in the suction lines of multiple system evaporators, as shown in Fig. 129. You will note that these valves can be used to control the individual evaporator temperatures in multiple systems using all flooded type evaporators, in systems using all dry type evaporators or in systems using a combination of flooded and dry type evaporators. All three types of systems are shown in Fig. 129.

With the pressure type two-temperature valve, when the evaporator temperature rises, its gas pressure also rises and acts through the suction line on a diaphragm in the valve, causing the valve to open and allow more rapid flow of the gas from the evaporator to the main suction line. This lowers the evaporator pressure and speeds up evaporation, thus producing more refrigeration or cooling effect.

When the evaporator cools sufficiently, its rate of evaporation is decreased, the gas pressure drops allowing the valve to partially close and build up higher back pressure again.

101. SNAP ACTION VALVES AND SOLENOID VALVES

Some two-temperature valves are of the snap action type as shown in Fig. 128. Instead of gradually opening or closing, these valves snap wide open or tightly closed when the evaporator back pressure changes sufficiently to operate the diaphragm or bellows. Such valves are less likely to stick or become clogged with small particles of scale or dirt that may get in the system.

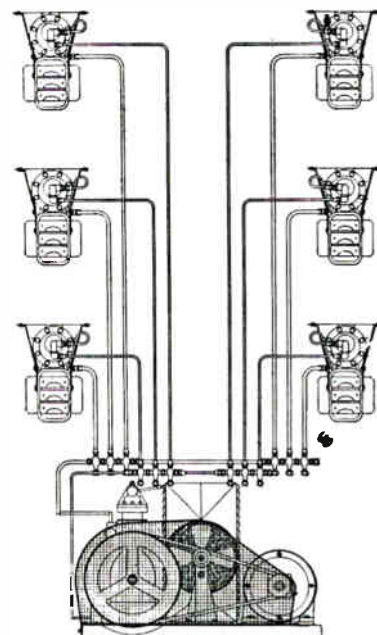

Fig. 124. Diagram of a multiple system with six evaporators and separate liquid and suction lines from each evaporator to the valve manifold at the condensing unit.

They also allow more immediate response of the evaporator and quicker chilling when the valve opens, in case of sudden loads on the refrigerator cabinet, such as when large amounts of warm foods are placed in them.

Fig. 127 shows two views of a solenoid type valve for use in the liquid line of an evaporator. Such valves are operated by a thermostat located at the evaporator, or in the cabinet or room in which the temperature is to be controlled.

When the evaporator or cabinet temperature rises, the thermostat closes an electrical circuit to the solenoid, causing it to open the liquid line valve and admit more refrigerant to the evaporator. When this added flow of refrigerant cools the evaporator sufficiently, the thermostat opens the circuit and the solenoid allows the liquid line valve to close.

102. ADJUSTING TWO-TEMPERATURE VALVES

Each of these various types of valves has an adjusting nut or screw at the valve or thermostat to adjust or set the valve for the temperature range to be maintained.

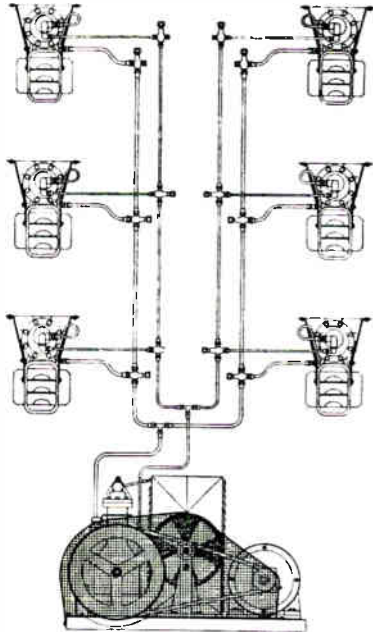

Fig. 125. This diagram shows a six evaporator multiple system with liquid and suction line risers, and shut-off valves located at each evaporator.

The Barostat pressure type valve has adjustments both on the top and bottom of the valve. The top adjustment will raise or lower equally the cut-in or cut-out pressures, about one pound for every two and one-half turns. The bottom adjustment will go the full range of pressure differential of the valves in about one revolution. Any changes in pressure differential should be made by small turns of the bottom adjustment, that is about $\frac{1}{8}$ turn at a time.

To increase the temperature turn the top screw clockwise, and to lower the temperature turn it counter clockwise.

To widen the differential or range between cut-in and cut-out pressures, turn the lower adjustment clockwise and to narrow the range, turn it counter clockwise.

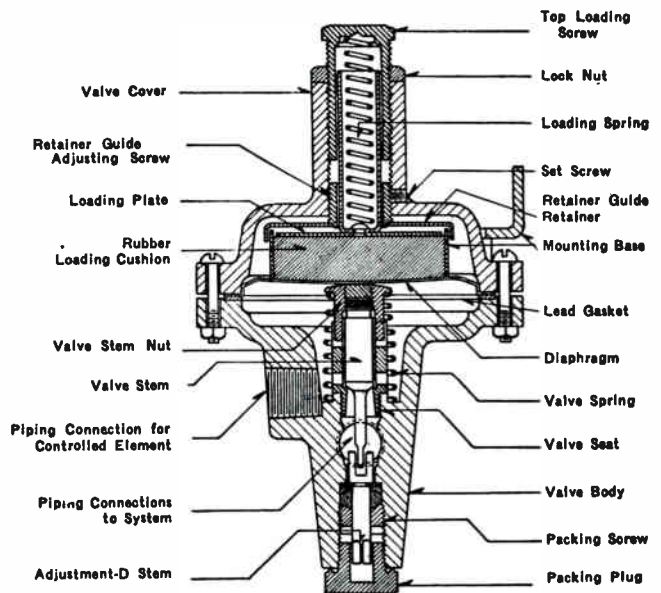

Fig. 126. Sectional view of a Barostat two-temperature valve such as used for controlling temperature on separate evaporators in a multiple system.

When adjusting two-temperature valves to set the temperatures of a number of separate evaporators on multiple systems, it is advisable to adjust the higher temperature units first, and the lower temperature units last, because otherwise the higher back pressures of the high temperature units may feed back against the suction line control valve of the low temperature units and interfere with their normal operation.

Adjusting the highest temperature units first eliminates the necessity of repeated checking or service "call backs" on the lower temperature units. This saves time for the serviceman and helps to keep a better satisfied customer.

103. GENERAL TIPS ON MULTIPLE SYSTEMS

When servicing multiple or commercial refrigerating systems, you should keep in mind that their operating principles, common troubles and general service requirements are practically the same as those of household units. The multiple or commercial systems merely use larger compressors and condensing units, longer lines of tubing, larger evaporators or a greater number of evaporators, and

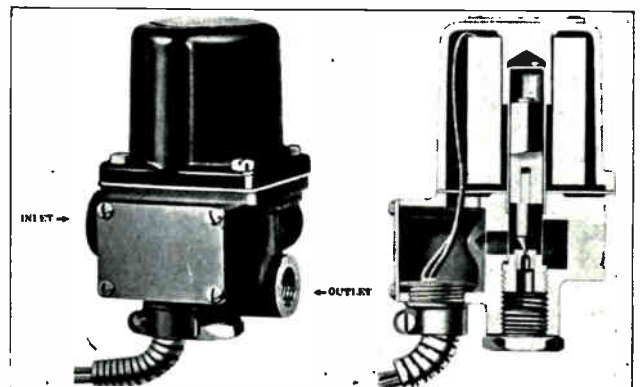

Fig. 127. Two views of a solenoid valve such as used in liquid lines to evaporators for controlling the temperature by starting and stopping the flow of liquid refrigerant.

more control valves. The servicing or adjustment of each compressor, motor, evaporator, or control is much the same as for those on smaller refrigerating units or systems.

Careful study of the multiple system diagrams shown in these lessons, and of diagrams of any multiple or commercial systems you may have to operate or service, will make the systems much easier to understand and enable you to apply your knowledge of refrigeration principles and troubles to any ordinary system.

The longer liquid and suction lines used with multiple systems should be carefully checked for leaks at all connections, couplings and fittings, and at any place where damage might possibly occur to the tubing.

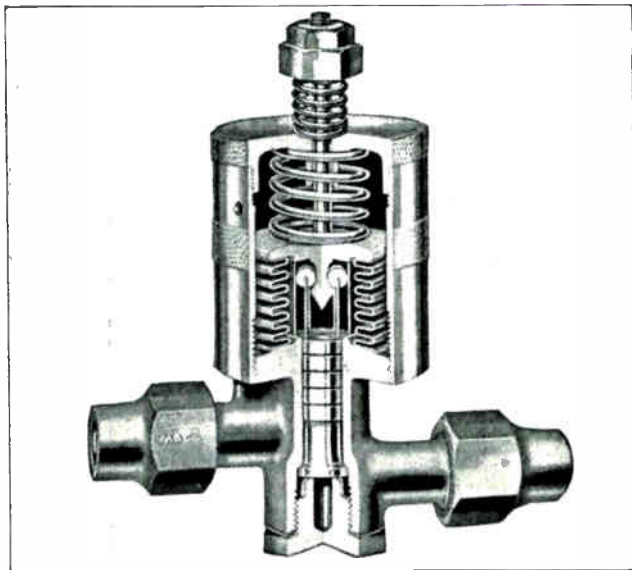

Fig. 128. Sectional view of a snap-action valve for temperature control on evaporators in multiple systems. Courtesy Mueller Brass Company.

Liquid lines for multiple systems in apartment buildings are generally of 1/4" tubing. Suction lines for systems using 1 to 3 cabinets should be of 3/8" tubing, for 4 to 7 cabinets 1/2" tubing, and for 8 or more cabinets 5/8" tubing, etc.

104. LOCAL REFRIGERATION CODES AND ORDINANCES.

Some towns and cities have a set of code rules or ordinances governing the installation and operation of multiple and commercial refrigeration installations, from the angle of safety to the public or occupants of the building in which such equipment is located.

Such rules are designed to prevent the possibility of injury to persons, which might result from the leakage or escapement of quantities of refrigerants which are of a toxic, irritating, or explosive nature.

In general, these code rules govern the amount of toxic or non-toxic refrigerants which can be used in a system in certain types of buildings, and also govern the location of direct type refrigerating units using large amounts of refrigerants, in certain rooms or sections of the buildings.

For purposes of classification under code rulings, refrigerating systems are divided or classified into groups or divisions according to the amount of refrigerant they contain. For example, systems containing 6 lbs. or less of refrigerant are in one group, 6 to 20 lbs. of refrigerant in another group, 20 to 100 lbs., 100 to 1000 lbs., and 1000 or more in other groups, etc.

Complete, self-contained household units are not subject to such rigid rules as most of these units use less than 6 lbs. of refrigerant, and a few use from 6 to 20 lbs.

On larger multiple or commercial systems containing 100 lbs. or more of refrigerant, a leak would naturally be much more dangerous. On such systems it is generally required that the condensing unit and all parts containing refrigerant be located in a machinery room having self-closing, tight-fitting doors, and either natural or mechanical ventilation. The purpose of this provision is so that any escaping refrigerant would not get into other parts of the building, but would be carried directly to the outside of the building.

In hospitals, homes for children or aged people, or other places where people would be helpless to leave the building, the rules are very strict and require that large refrigerating units be installed in machinery rooms having doors leading only to the outside of the building, and no doors opening into the rest of the building.

One rule in effect in certain large cities is that no multiple system in apartment buildings shall contain more than 50 lbs. of sulphur-dioxide or methyl-chloride, or 100 lbs. of dichlorodifluoromethane.

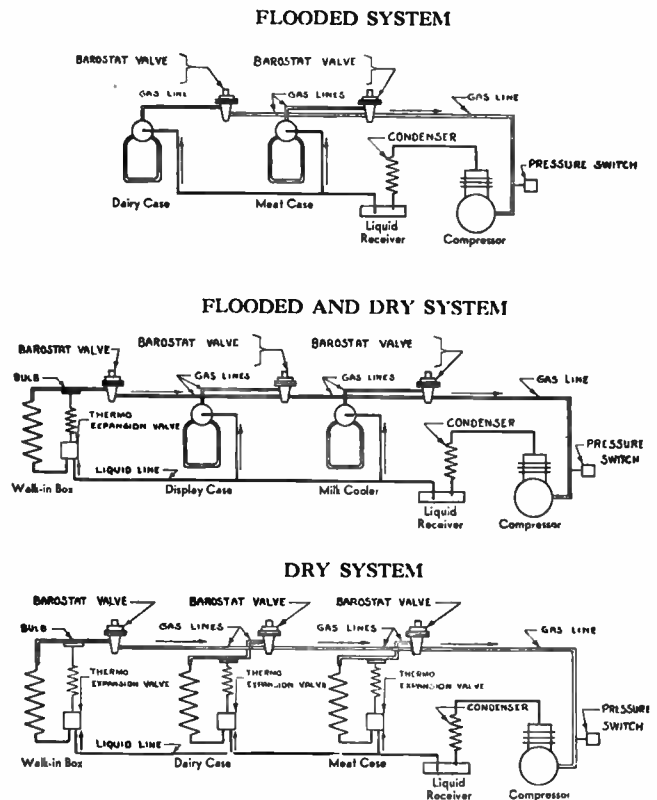

Fig. 129. The above three diagrams show connections of a flooded system, a dry system, and a combined flooded and dry system, using Barostat two-temperature valves for separately controlling the temperatures on each evaporator.

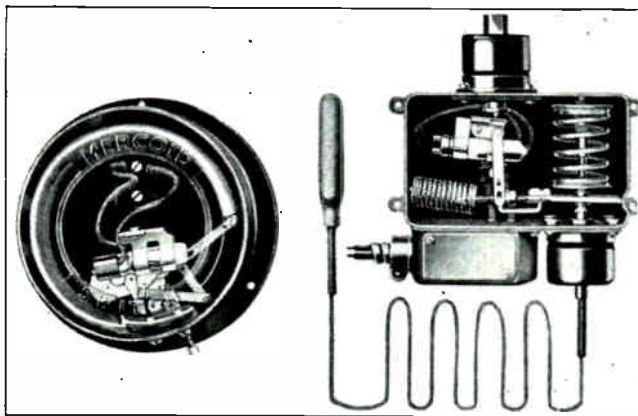

Fig. 130. Two different types of mercury switch controls. Note the mercury tubes with flexible wire leads attached. The tubes can be tilted by pressure bellows and bulb or by thermostat strips.

Another rule states that no evaporators shall be placed in sleeping rooms. Another rule is that on multiple systems in dwellings, each liquid line or suction line riser shall be equipped with a shut-off valve at or near the condensing unit.

On certain large installations it is required that the system be provided with an automatic relief or discharge valve which is set to automatically discharge the refrigerant through a line direct to the outdoors in case of excessive pressure being built up in the system. Emergency manual relief valves are also to be provided in some systems to permit the release of refrigerant to the outside of the building in case of fire, which would cause excessive refrigerant pressures to be built up in the system.

Other rules govern the thickness and strength of materials that shall be used for tubing lines, evaporators and condensers in certain installations, to make sure that they will safely withstand the normal or maximum pressures that are likely to be built up in the system.

Indirect refrigerating systems in which brine is used to carry the heat from cooling coils to the refrigerator evaporator, permit all refrigerant chemicals to be kept out of the rooms to be cooled, and confined to safe quarters or locations in basement machinery rooms.

In air-conditioning systems, the evaporators containing refrigerant can be kept out of the air ducts or path of the air, by use of brine circulated from the evaporator to cooling coils located in the air stream. On small air-conditioning systems or self-contained room coolers this is not necessary if other safety rules are complied with.

Every refrigeration service or installation man, or operator of commercial refrigeration plants, should secure a copy of the local code rules of his city and become thoroughly familiar with these rules, and then comply with them faithfully for the safety of his customers and for the good of the industry and his own reputation as a safe and responsible workman.

105. MERCURY TYPE CONTROL SWITCHES

Many control switches for modern refrigerators use a mercury type circuit breaker to open and close the electrical circuits by the action of a power bulb and bellows or a thermostat which tilts a small mer-

cury tube, into which are sealed the electrical terminals or contacts. A decided advantage of this type of switch over the ordinary open metal contact switch is that it has no exposed contacts to burn, corrode or cause fire hazard.

The tube containing the mercury may be of either glass or metal and is evacuated to prevent the formation of an arc when the circuit is broken. When the tube is tilted slightly, the pool of mercury flows from one end to the other, opening or closing the circuit between small metal electrodes which are sealed into the tube and connected to flexible wires on the outside. Two control switches of this type are shown in Fig. 130. Carefully examine their construction and parts.

The life of these mercury type switches is usually much longer than that of the open contact types and they are much more trouble free and reliable in operation.

106. RECORDING THERMOMETERS

Recording thermometers are often used for making tests on household or small commercial refrigerators, or for checking the operation of large commercial units. These thermometers consist of a box or case in which is located a temperature operated element which moves a pen over the face of a paper chart which is driven by a time clock mechanism in the case.

Fig. 131 shows two charts taken from a recording thermometer which was used to check the operation of a refrigerator before and after adjustment of the controls. The up and down points of the black line traced by the pen indicate the variations in temperature in degrees as marked on the radial lines of the

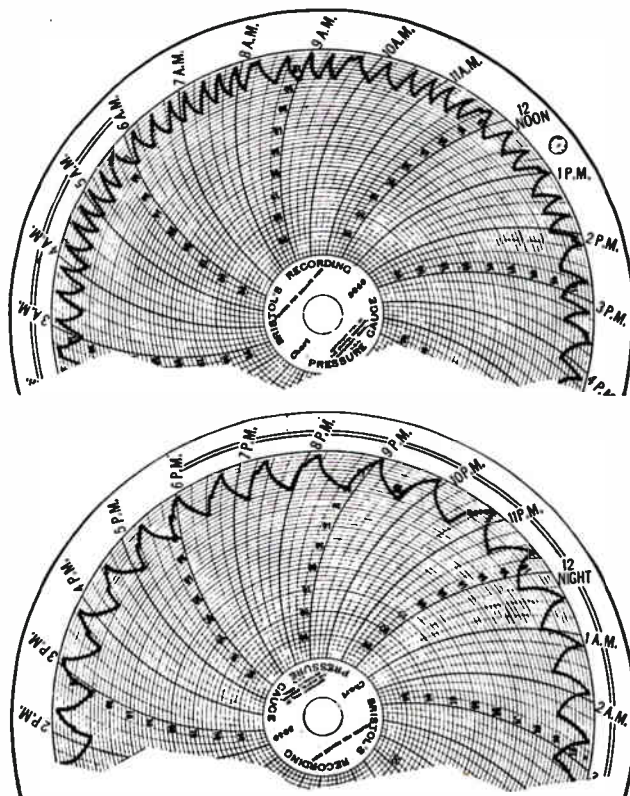

Fig. 131. Note the difference in these two recording thermometer charts taken before and after adjusting the controls on a refrigerator.

chart. This variation being caused by the starting and stopping, or cycling of the compressor due to the cutting in and out of the pressure switch control.

The distance or spacing between points on the ink line indicate the time intervals of the cycles of operation. The time is marked around the outside edge of the chart. On the top chart these cycles were very short or only of a few minutes duration. Also note that the peaks of these lines have a broader top with an extra dip at 2:35 A. M., 5:40 A. M., 8:10 A. M., 9:35 A. M., 11:40 A. M., etc. These dips indicate the only times at which the float valve opened.

Note the difference in the lower view which shows a chart taken on the following day after the controls were adjusted by raising the "cut-on" point to permit the float valve to open once during each cycle. Notice that this reduced the number of starting and stopping operations or cycles of the compressor and also produced lower average refrigeration temperature.

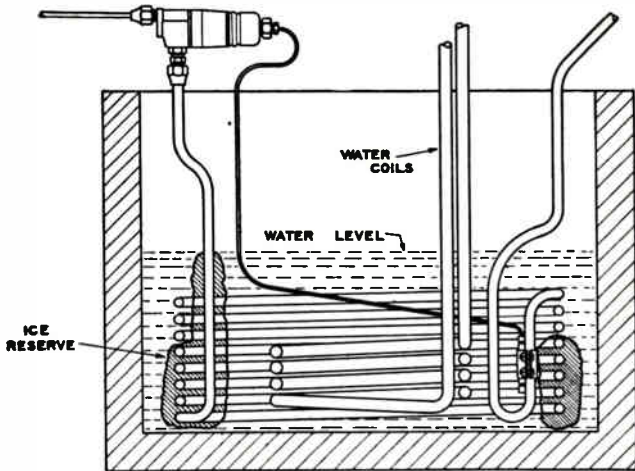

Fig. 132. Refrigerator evaporator coil used in a drinking water cooler.

107. WATER COOLER AND ICE CREAM FREEZER UNITS

Fig. 132 shows a refrigerating or cooling coil in a drinking water cooler. Note that both the refrigerating coil and the drinking water coil are submerged under water, which conducts the heat from the drinking water coil to the chilling coil. In other words, the cooling coil which contains the refrigerant is not in direct contact with the drinking water.

Note the expansion valve which is connected between the liquid line and the evaporator coil, and controlled by a power bulb which is attached to the suction line of the evaporator coil. Also note the ice which has formed around sections of the cooling coil and which acts as reserve or stored refrigeration between on and off cycles of the evaporator.

Fig. 133 shows a complete cycle diagram of a commercial type refrigerating unit such as used to chill a modern ice cream freezing machine and hardening cabinet, through their respective expansion valves.

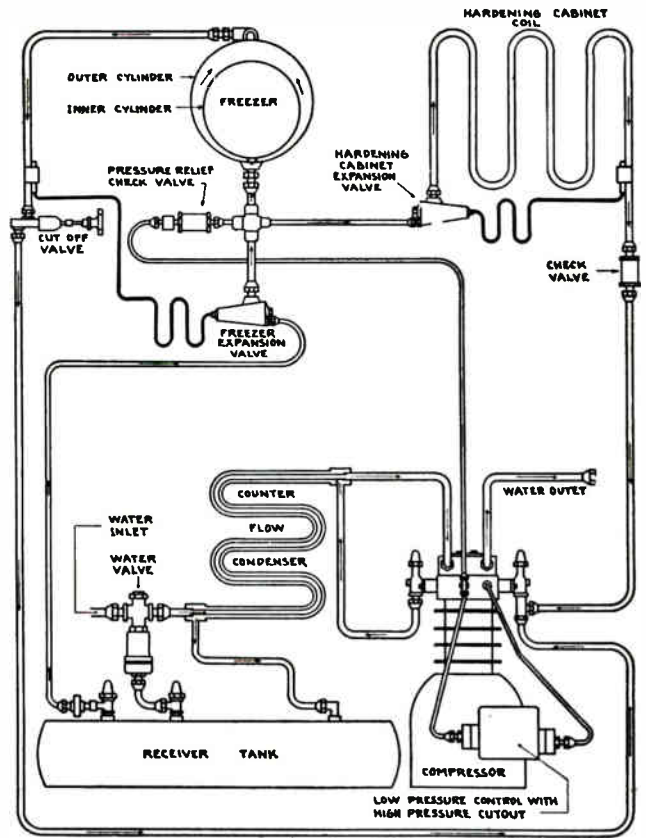

Fig. 133. Cycle diagram of a commercial refrigerating unit used in an ice-cream freezing machine and hardening cabinet. Courtesy Mills Novelty Co.

Fig. 134 shows a diagram of a large ammonia refrigerating system such as used for ice plants or cold storage buildings. Carefully examine all parts of this system and note the two expansion coils or chilling coils, one of which is located in the cold storage room and the other in a freezing tank. Also note the condenser, receiver, oil separator or oil trap, and the reserve ammonia drum.

The operation of this type of refrigerating plant is very similar to that of the household multiple or small commercial systems which you have previously studied. The compressor may be driven by an electric motor connected to it by means of a belt on the large flywheel. The compressor increases the pressure of the ammonia vapor and passes it through the oil trap and valve "M" to the condenser. The oil trap collects the excess oil which might be carried over from the compressor with the ammonia vapor. This oil which accumulates in the oil trap can be drawn off through valve "T" and returned to the compressor. This prevents excessive accumulation of oil in the liquid receiver.

During operation of this system, liquid ammonia flows through the small pipe to the expansion valves "J" and "J" at the two expansion coils where it evaporates into ammonia vapor. The vapor flows back through valves "O" and "O" and the large pipe or suction line to the compressor.

Note the pressure gauges which are attached to the suction and high side lines and also the main shut-off valves "A" and "B" located in the suction and pressure lines at the compressor.

Extreme care should be used in operating or servicing ammonia systems because ammonia vapor is very dangerous to inhale, and liquid ammonia will quickly freeze any parts of the body with which it may come in contact. Even a few breaths of strong ammonia vapor may render a person unconscious or helpless. Therefore, extreme care should be used to prevent leakage of ammonia from the system, and goggles and gas mask should always be immediately accessible when operating such units, or worn when opening up any parts of these systems which might contain ammonia refrigerant.

The piping and connections, evaporator coils and condenser coils of ammonia refrigeration systems are made of iron pipes and iron pipe fittings. No copper tubes or parts are used with ammonia, as ammonia attacks or corrodes copper very rapidly. Special ammonia gauges are also used with ammonia refrigerating plants for this reason.

When it is necessary to add refrigerant to a system such as shown in Fig. 134, the valve "R" is opened to permit liquid ammonia to flow from the tilted drum directly into the liquid line. If necessary the pressure in the drum can be raised by warming the drum with hot water.

To purge air from this system, open the valve "P" on the line between the oil trap and condenser. A purging tube can be run through a bucket of water, as water readily absorbs ammonia vapor. Spilling water on the floor of the plant or spraying it in the air will quickly absorb ammonia vapor or fumes.

Operators of large refrigeration or ice plant systems and machinery should secure copies of the manufacturers operating and service bulletins which always provide valuable information on their particular type of equipment. Fig. 37, shows a sectional view of a commercial refrigeration compressor which would be well for you to re-examine at this time.

108. CALCULATING SERVICE LOADS FOR REFRIGERATORS

In some cases the refrigeration service and installation man may be called upon to calculate the service load in B.T.U. on a certain refrigerator cabinet, and to select or specify the proper size of refrigerating unit to handle this load or cool the cabinet to the desired temperature.

The following data and the two charts on the next page will greatly simplify such problems.

The service load on a refrigerator is based on the amount of heat units or B.T.U. which leak into the cabinet or room through the walls and windows, through the door opening whenever the door is opened to insert or remove food or other articles, or when persons enter the large "walk in" types of coolers. Also the heat that is stored in warm foods, meats or other articles which are placed in the cabinet.

To calculate the load on a given cabinet, both of the following charts should be used. Chart number one gives the heat leakage in B.T.U. per 24 hrs., per sq. ft. of outside wall surface. In figuring this total surface include walls, ceiling, floor and door areas.

Glass windows should be figured separately from regular wall and ceiling surfaces, using the figures in the last two columns, as the heat leakage is much greater thru each sq. ft. of glass than it is thru insulated cabinet walls.

If wood is not used on both sides of the cabinet walls, deduct $\frac{1}{2}$ " from the cork insulation thickness given in the table. That is, use the B.T.U. figures in a column for cork $\frac{1}{2}$ " thinner than the wall actually is, to allow for the greater leakage due to the absence of the wood.

After calculating the total heat loss by leakage thru walls, by means of table number 1, then use the second table to determine the heat gain in B.T.U., due to the average number of door openings and the class of food or other items put in

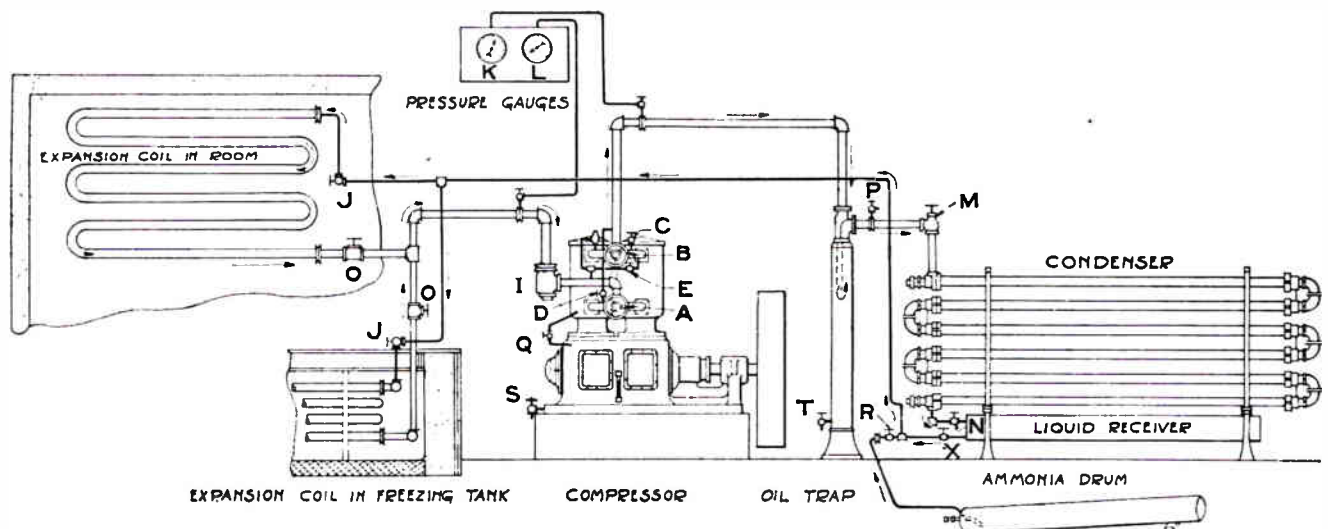

Fig. 134. This diagram shows the arrangement of a large refrigerating system such as used in packing plants and cold storage houses. These plants use ammonia as the refrigerant. Ammonia flows through the pipe shown by the small solid line, and as shown by the arrows, to the expansion valve "J." Here it is allowed to expand through the large coil and absorb heat from the room to be cooled, at the upper left. A branch is also taken to the expansion coil in the freezing tank at the lower left. This coil could absorb the heat from a brine solution, and freeze ice cakes or water in tanks immersed in this brine. The compressor then draws the expanded gas from both of these coils and compresses the gas to concentrate its heat and raise its temperature, and then forces it into the condenser coils shown at the right. In a plant of this type cool water is run over the condenser coils to chill the gas back into a liquid, and carry away the heat from it.

Number 1

Temperature difference in degrees Fahrenheit	Thickness of Insulation (Cork or Equivalent)				Glass	
	2½"	3"	3½"	4"	Double Thickness	Triple Thickness
40 degrees	84.0	72.0	64.0	60.0	440.0	280.0
50 "	105.0	90.0	80.0	75.0	550.0	350.0
60 "	126.0	108.0	96.0	90.0	660.0	420.0
70 "	147.0	126.0	112.0	105.0	770.0	490.0
80 "	168.0	144.0	128.0	120.0	880.0	560.0
90 "	189.0	162.0	144.0	135.0	990.0	630.0

Number 2

Temperature difference in degrees Fahrenheit	USE OF CABINET			
	Florist	Grocery or Normal Market	Busy Market or Fresh Killed Animals	Restaurant or Short Order
40 degrees	40.0	65.0	95.0	120.0
50 "	50.0	80.0	120.0	150.0
60 "	60.0	95.0	145.0	180.0
70 "	70.0	114.0	167.0	210.0
80 "	80.0	130.0	190.0	240.0
90 "	90.0	146.0	214.0	270.0

Fig. 135. Charts showing heat leakage per sq. ft. and heat loads per cu. ft. for various classes of refrigerators.

the cabinet, under various classes of service such as, florist shop, grocery, meat market, restaurant, etc.

These heat load values in B.T.U. per cubic foot of total inside space of the cabinet, per 24 hrs., is given in the second table.

Then add the total B.T.U. figures calculated from tables one and two, to determine total heat load.

For example, suppose we have a meat market "walk in" type cooler, 6 ft. wide, 10 ft. long and 8 ft. high outside dimensions, with a triple glass window 3 ft. x 5 ft. and 4" cork insulated walls. The temperature in this cooler is to be maintained at about 35 degrees F., or 50 degrees below the warm weather room temperature, of say 85 degrees F.

By referring to chart No. 1 we find that for a 50 degree temperature difference on a box with 4" cork insulation, the heat leakage per sq. ft. of wall surface will be 75 B.T.U. per 24 hr. day. The leakage per sq. ft. through triple glass windows at a 50 degree temperature difference is shown to be 350 B.T.U. per 24 hours.

To get the total cabinet wall area we proceed as follows:

Two side walls 10 ft. long and 8 ft. high would be $2 \times 10 \times 8 = 160$ sq. ft.

Two end walls 6 ft. wide and 8 ft. high would be $2 \times 6 \times 8 = 96$ sq. ft.

Ceiling and floor of 6 ft. wide and 10 ft. long would be $2 \times 6 \times 10 = 120$ sq. ft.

Then $160 + 96 + 120 = 376$ sq. ft. total surface. From this we will deduct 3×5 or 15 sq. ft. for the window, leaving 361 sq. ft. for walls, floor and ceiling.

Then with the leakage factor of 75 B.T.U. per sq. ft., as shown in table 1, $361 \times 75 = 27,075$ B.T.U. heat leakage through walls.

For the window, 15 sq. ft. \times 350 B.T.U. per sq. ft. leakage factor = 5,250 B.T.U. leakage.

So from our cabinet dimensions and the data in chart number 1, we find $27,075 + 5,250$ or 32,325 B.T.U. heat leakage from the 85 degree room temperature into the 35 degree cabinet interior temperature.

Now from table number 2, we find that the service load on a cabinet in a busy meat market, due to door openings and fresh meats placed in the cabinet, etc., is 120 B.T.U. per cu. ft. of gross interior cabinet space (gross interior means total space including shelves, meat, air, etc.)

For a cabinet 6 x 10 x 8 ft. outside measurement with walls, floor and ceiling of 4" cork plus about 2" boards on inner and outer walls, or 6" total wall thickness, the inside dimensions would be 5 x 9 x 7 or 315 cu. ft.

Then $315 \times 120 = 37,800$ B.T.U. service load. Adding this to the heat leakage load, we have $32,325 + 37,800 = 70,125$ B.T.U. total load or heat to be removed from the cabinet every 24 hours.

Now to determine the proper size compressor or condensing unit to do this job, we should keep the following important facts in mind.

Melting 1 lb. of Ice Absorbs 144 B.T.U.

Therefore melting 100 lbs. per 24 hours, absorbs 14,400 B.T.U. during this time. Or melting 1 ton (2,000 lbs.) of ice will absorb 288,000 B.T.U.

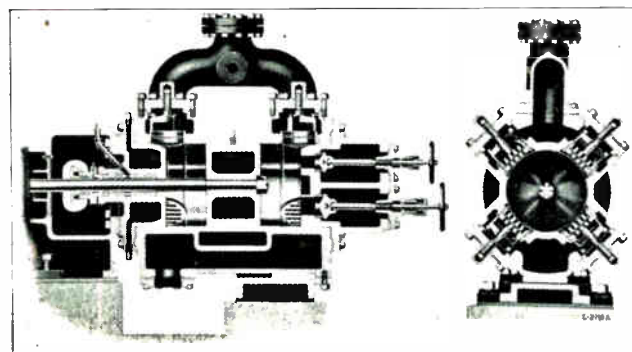

Fig. 136. Sectional view of compressor cylinder and valves for large commercial refrigeration compressors such as shown in Fig. 111.

Refrigeration compressors commonly have their capacity rating or refrigerating effect stated in lbs. or tons I.M.E. (Ice Melting Equivalent.)

Therefore, a compressor rated at 200 lbs. I.M.E. would produce the same cooling or refrigeration effect per 24 hours as the melting of 200 lbs. of ice per 24 hours. Or a unit rated as 1 ton I.M.E. would cool as much as melting 1 ton of ice per 24 hours.

The average ¼ h.p. domestic unit produces about 160 lbs. I.M.E.

The ¼ h.p. unit about 220 lbs. I.M.E.

The ½ h.p. unit about 500 lbs. I.M.E.

On domestic units the evaporator temperatures are rather low for freezing ice cubes and desserts.

On units for meat market boxes the evaporator temperature need not be so low, so the unit will handle a little more B.T.U. load, or

¼ h.p. unit about 300 lbs. I.M.E.

½ h.p. unit about 700 lbs. I.M.E.

1 h.p. unit about 2000 lbs. or 1 ton I.M.E.

Therefore, we can figure about 1 ton I.M.E. per h.p. of commercial compressor size, for continuous operation of the compressor.

If we wish to have the compressor run periodically or in "on and off cycles" and operate about 18 hours out of the 24 hour day, then in order to accomplish the same refrigerating effect the compressor and condensing unit would need to be correspondingly larger.

So for our cabinet, having a total heat load of 70,125 B.T.U. per 24 hours, the compressor would have to remove this heat load in 18 hours of actual running time. Therefore the compressor must remove $70,125 \div 18$ or 3895 B.T.U. per hour.

Then $3895 \div 144 = 648$ lbs. I.M.E. rating for the compressor. So we find that a $\frac{1}{2}$ h.p. unit would be about right for this job.

Therefore we can see that with the aid of the charts given in this lesson it is a comparatively simple matter to calculate the heat load and size of compressor required to cool a cabinet or room

of a given size, to a certain temperature below that of the surrounding air.

In determining the proper size of direct dry type, non-frosting evaporator to be used for such a cooling job, we can allow about 300 B.T.U. of heat absorbing capacity per sq. ft. of evaporator surface per 24 hours. This means total evaporator surface, including fins.

Now, if you have carefully studied this important section and the preceding one, you are ready to commence your next very interesting section on Air-Conditioning, keeping in mind that all you have learned about Refrigeration units and principles will be applied to your study of Air-Conditioning. Refrigerating units of various types are used for the very important function of cooling the air to comfortable temperatures during hot summer months. Other functions of Air-Conditioning, such as heating, washing circulating and humidifying or de-humidifying of the air in our homes and offices, factories, stores, theatres, etc., will be explained in the following section.

AIR CONDITIONING

In starting to study the subject of air conditioning, let us first thoroughly understand what air conditioning is. Many people are talking about Air Conditioning as one of our greatest new industries. An industry that is growing by leaps and bounds and providing new jobs for thousands of trained men, and more comforts and better health for people in their homes and at their work.

We hear about air conditioned theaters, restaurants, hotels, stores, offices, homes and factories, trains and ships. But few people know exactly what air conditioning is.

Correctly used, the term air conditioning means controlling the temperature, circulation, humidity, and purity of the air we breathe and live in. Or more broadly speaking, complete air conditioning means heating the air in winter, cooling it in summer, circulating the air and renewing it in both seasons, dehumidifying (removing moisture) when the air is too moist, humidifying (adding moisture) when it is too dry, and filtering or washing the air to remove dust, pollen and germs both summer and winter. Any system which only performs one or two of these functions, but not all of them is not a complete air conditioning system.

Many people have been lead to believe that air conditioning meant simply the cooling of air by refrigeration, but this is not correct. This operation should be termed **Comfort Cooling**.

When we consider the full scope and possibilities of air conditioning, we can readily see what a tremendous effect it can have on our comfort, efficiency and health in our daily lives at home and at work, if our work is indoors. It is easy to see why air conditioning has captured the interest of people all over the country, and why it has such a tremendous growth ahead of it.

For hundreds of years people in cold climates have been heating their homes, shops and offices to make them comfortable in winter. But only in recent years have we learned how to economically cool them for better comfort and health in the hot summer months.

We have also learned how to control the humidity or moisture content of the air, which greatly affects the comfort of human beings. Then too, we have learned how to remove about 98% of the dust, dirt and disease germs from the air we breathe. The prevention of the spread of many contagious diseases in this manner is one of the great blessings of air conditioning.

When we consider the fact that the average person daily breathes a total amount of air weighing 5 times as much as all the food and water they consume in a day, we can see the importance of having this air properly conditioned.

Even when it is necessary for certain persons to work in the heat of the outdoor sun or in hot buildings during the day, think of the comfort of being able to come home to a good nights rest in a cool air conditioned sleeping room. Compare this with nervously and sleeplessly tossing through half the night in a bed wet with perspiration.

Theater owners were quick to recognize the advantages and comforts of air conditioning and today there are hundreds of air conditioned motion picture theaters. There are still thousands of others to be air conditioned and most of these will install such systems soon, as few people will go to a hot stuffy theater if there is an air conditioned one near by. Tests made on a large group of theaters showed that air conditioning increased their business over 25%.

Fig. 137. Photo of the interior of a modern air-conditioned store. Note how clean and inviting the walls, ceilings and show cases can be kept with dust free, conditioned air. Thousands of stores are already air-conditioned and hundreds more are being air-conditioned each year. Courtesy of York Ice Machinery Corp.



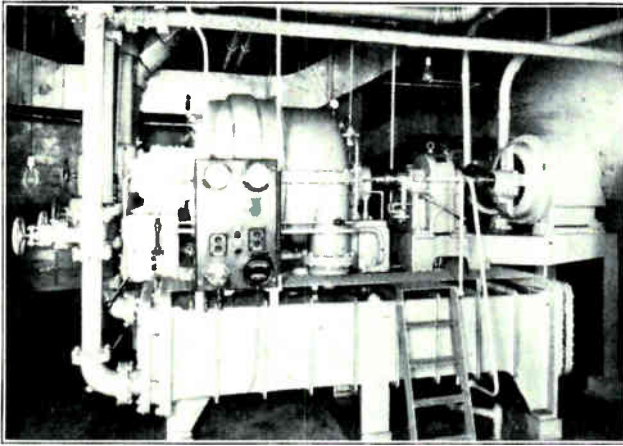

Fig. 138. Large refrigeration unit for an air-conditioning system in a department store. Note the motor driven rotary type compressor above, the water cooled condenser below, and the controls and gauges on the small panel at the front. Courtesy Carrier Corp.

Restaurants are finding it increasingly profitable to air condition. A test of a large number of restaurants showed that their business was increased about 35% by air conditioning. More patrons go to the air conditioned restaurants, and they eat more food in cool comfort than they do when hot, sweaty and uncomfortable.

Department stores, clothing shops, barber shops, beauty parlors, and dental offices, have all shown very profitable increases of business by air conditioning. Entire huge sky-scraper office buildings are now air conditioned, resulting in their earning higher rents and keeping more fully occupied with tenants.

Thousands of railway passenger coaches and Pullman cars have been air conditioned, resulting in cleaner, cooler, more comfortable traveling facilities and increased numbers of passengers.

In the very near future many of our modern passenger automobiles will undoubtedly be equipped with air conditioning.

Many factories and industrial plants are now air conditioned for reasons of better employee working efficiency and health, as well as for more economical production of better quality products.

Such processes as printing, baking, enameling, the manufacture of textiles, flour, chewing gum, candy, paints and varnishes and many other ar-

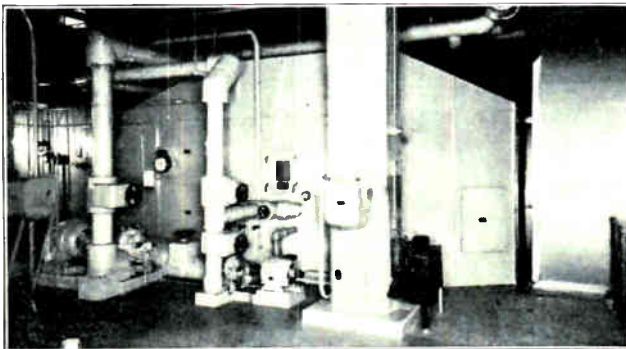

Fig. 139. Air-conditioning unit mixing chamber or "plenum chamber" for the air-conditioning system of a department store. The cooling coils, heating coils, and air washing sprays are located in the large rectangular chamber, and the blower fan is on the right. Note the electric motors, starters, control valves and recording thermometer. Courtesy Carrier Corp.

ticles can be done much more speedily and with much higher quality of product, if the air in such plants is maintained at proper temperatures and a proper degree of humidity or moisture content.

In such plants huge air conditioning systems using refrigerating units with capacities equivalent to the melting of thousands of tons of ice per day, are in common use.

In certain plants where manufacturing processes or materials create unfavorable atmospheric and working conditions, because of heat, dust, fumes, etc., air conditioning becomes a vital factor in the preservation of employees health and efficiency.

Even in this machine age the cost of man power is one of the biggest items of production costs. Therefore, if by proper air conditioning we can reduce fatigue and increase energy, reduce dullness and increase alertness, reduce irritation and increase contentment, reduce carelessness and increase interest, the investment in such air conditioning equipment will pay good dividends.

Even mines have found it profitable to air condition to permit operations at lower levels where human life and labor could not otherwise be maintained, because of the high earth temperatures encountered at such great depths below the earth's surface.

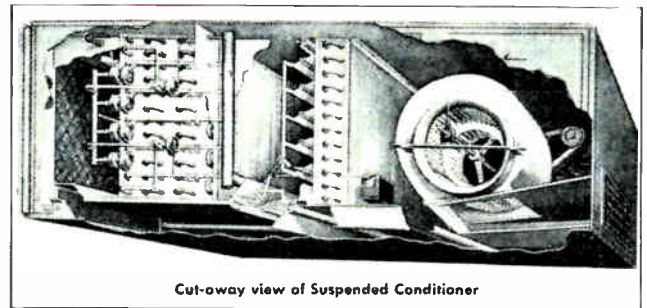

Cut-away view of Suspended Conditioner

Fig. 140. Cut-away view of a ceiling suspended type air-conditioner. Note from left to right, the filter screen, cooling coil, heating coil and blower. Courtesy Airtemp, Inc.

With costs of air conditioning equipment becoming lower each year with increasing mass production, millions of homes will be air conditioned during the next few years. Over 200,000 homes were air conditioned in 1936.

So we can readily see the enormous possibilities and opportunities which air conditioning opens up for trained men.

109. TYPES OF AIR CONDITIONING SYSTEMS AND UNITS

Air conditioning equipment is of two general types, known as central air conditioning plants and individual room coolers.

Central air conditioning plants for homes, offices, factories, theaters, etc., have the heating unit, refrigerating or cooling unit, filter unit, humidifier and circulating fan or blower located in one compact unit or group in the basement or machinery room, with ducts to carry the conditioned air to the various rooms or departments. See Figs. 138, 139, 140, 141, 142 and 143.

Individual room coolers are generally in the form of a compact cooling unit, humidifier, filter and blower, all contained in a neat cabinet to be located right in the living room, dining room, sleeping room or office which they are to cool. See Figs. 144, 145, 146 and 147.

Some of these room coolers have an air-cooled or water-cooled refrigerator condensing unit contained in the same cabinet. Others may have the refrigerating unit located in the basement, with copper tubes run up through the floor to carry the refrigerant to one or more coolers in the occupied rooms.

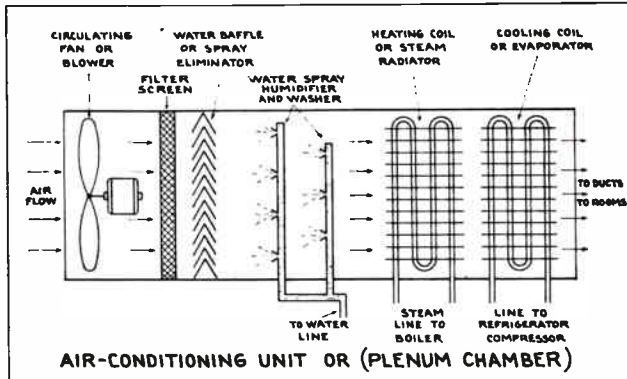

Fig. 141. Diagram showing how air can be filtered, washed, humidified or dehumidified, cooled or heated all in one chamber or unit.

Some of these self-contained units also include a heating coil for winter use, while others rely on the existing heating system to warm the rooms in winter seasons.

Air conditioning systems are also classed as direct and indirect systems. In the direct type of system the refrigerant evaporator or cooling coil is located in the air stream and is in direct contact with the air to be cooled. In the indirect type of system water is chilled by circulation around the refrigerant evaporator, and then piped through a cooling coil or to spray nozzles in the air stream.

The indirect system is safer on large installations because the evaporator containing the refrigerant chemical is not located in the air duct, and in case of a refrigerant leak none of the gas could enter the air stream. On small units such as individual room coolers however, the direct system is generally used.

110. HEATING OF AIR

As previously mentioned, heating the air in homes and other buildings is one of the functions of a complete air conditioning system. However, methods of heating are so well known that we will not attempt to cover this function or part of the system here, except in a general way.

For hundreds of years, homes in the cool climates have been heated by fires. First in open fire places, then in wood burning and coal burning stoves, and more recently by means of furnaces burning coal, oil or gas.

Fire places heat the air principally by radiation of heat from the open fire. Stoves heat the surrounding air by conduction of the heat through the iron jacket and then by radiation and conduction to the air.

Hot air furnaces heat the air by direct contact of the air with the hot iron jacket of the fire box. Such furnaces are often located in the basement and the air rises through sheet metal ducts to the rooms above, due to convection, and the tendency of the warm expanded air to rise. Or, in some cases, electric fans or blowers are used to speed up the air circulation and increase the heat transfer efficiency. Some modern hot air furnaces also have air filters and humidifiers to clean and moisten the air. See Fig. 142.

Hot water and steam heating systems use water or steam to carry the heat through pipes from the furnace or boiler to radiators in the rooms above.

Modern heating plants have the temperature automatically controlled by means of electrical thermostat switches which open or close an electrical circuit to the oil burner motors, solenoid gas valve, or in some cases motor operated coal stokers or draft controls.

In planning a heating system for a home or other types of buildings we must consider the size of the building, total area of walls and windows, amount of insulation, maximum difference between outside and inside temperatures and the amount of heat leakage in order to calculate the total heat load or size of heating unit needed.

These same factors and several others, must be considered when calculating the size of an air conditioning system required for a given building. They will be explained in detail in later paragraphs.

111. COOLING THE AIR

By far the most common method of cooling the air in air conditioning systems is by means of refrigerator units very similar to those you have just studied for refrigeration. In fact, practically all you have learned so far about refrigeration principles and equipment can be applied to air conditioning.

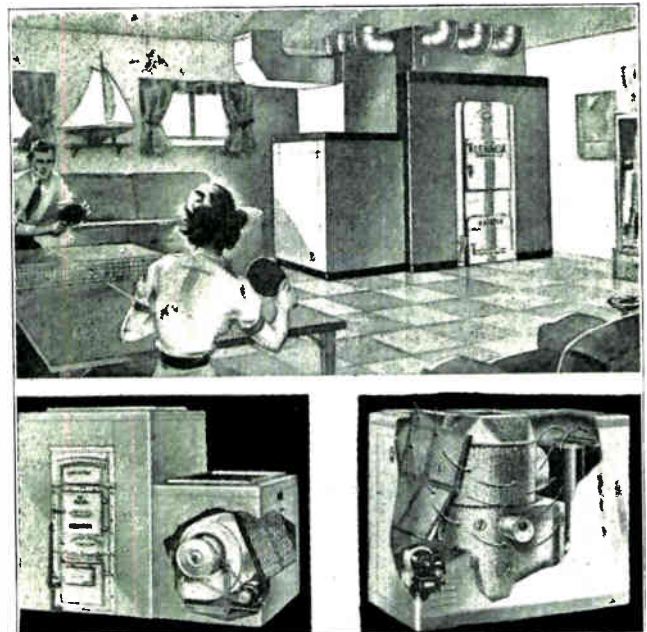

Fig. 142. Upper view shows a combined furnace and air cooling and cleaning unit, or summer and winter air conditioner installed in the basement of a home. The lower views show cut-away views of these units. Courtesy Lennox Furnace Co.

However, in some installations, ice is used to cool the air by blowing the air through a chamber filled with ice. In other cases where plenty of cool well water is available, this water is sometimes circulated through cooling coils through which the air is passed. This provides a very economical means of cooling the air.

To cool the air by refrigeration we simply locate a dry type evaporator in the air path so that the air in passing through this coil becomes cooled. Or, as previously mentioned we may cool water with the evaporator and then pass this chilled water through a finned coil located in the air stream.

Evaporators or cooling coils for air conditioning units and systems have extra large finned surfaces, to provide more contact of the cold metal with the passing air and thereby improve the heat absorbing efficiency of the coil.

Note the evaporator coils shown in Figs. 140, 145 and 146.

As previously mentioned, air is sometimes cooled and washed by passing it through a cold water spray. In such units a solid blanket of fine water spray is produced by forcing the cold water under pressure, through a set of spray nozzles.

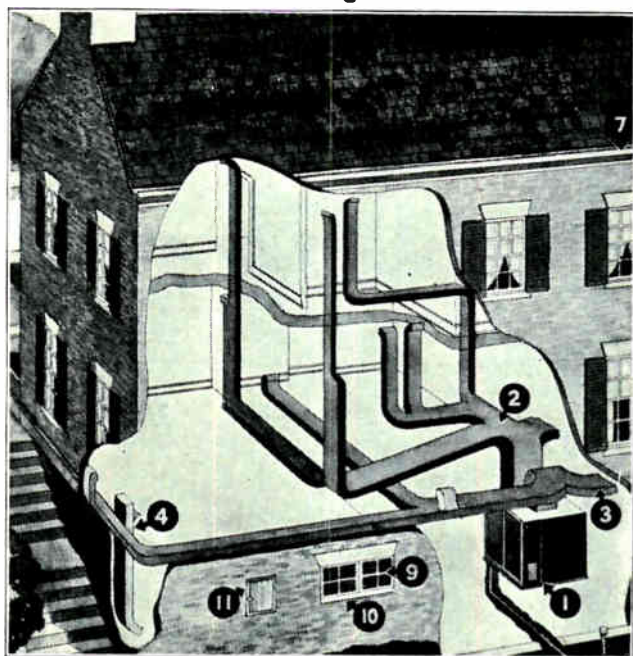

Fig. 143. Cut-away view of a two-story house and basement, showing layout of ducts used to carry conditioned air to the various rooms, and back again to the conditioning unit in the basement. Courtesy Superior Sheet Steel Co.

112. PROPER AMOUNT TO COOL THE AIR

When conditioning the air inside a building for comfort and health, we should be careful not to cool the air to a temperature too much below that of the outside air.

While it is true that cooler air is both more comfortable and more healthful than excessively hot summer air, it is not advisable or healthy for persons to go directly from extremely hot air into a place that is too cool. In other words the contrast or **temperature differential** between the outside air and that of the air conditioned space should not be

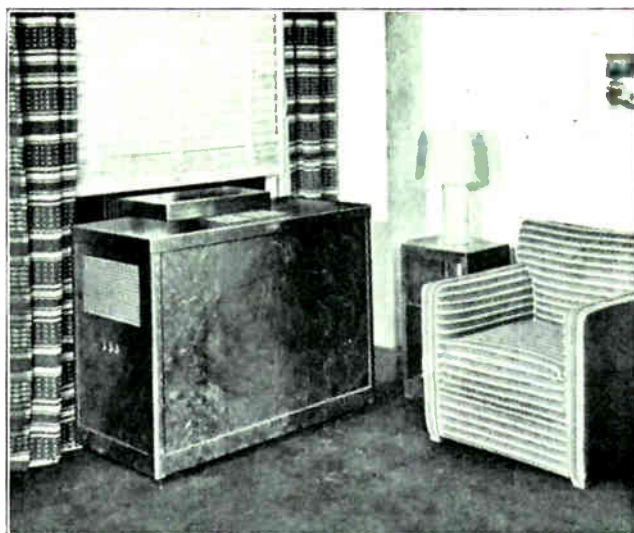

Fig. 144. Photo showing convenient portable room cooling unit located in a living room. This electrical cooling unit draws air from the window for cooling and ventilating the room, and also for cooling its own refrigerator condensing unit. Courtesy Pacific Mfg. Corp.

too great. Usually a temperature reduction of 10 to 12 degrees is sufficient to greatly increase the comfort factor, and is much more healthful than a drop of 15 to 20 degrees or more.

In some of the first air conditioning installations, theaters and restaurants in which they were installed advertised and maintained inside temperatures of 70 degrees when the outside temperatures were from 90 to 100 degrees. This is not a healthful condition because the sudden and excessive temperature drop is likely to cause persons to become chilled and to develop colds.

The normal temperature of the human body is about 98.6 degrees F. This body heat is developed by the combustion of oxygen and food materials which are taken in by breathing and eating. In other words the human body is something like a house with a stove or furnace, and has its own heating plant within it.

When the surrounding air temperature is lower than that of the body, the excess body heat is given off to the air by radiation and conduction and through the evaporation of perspiration. The rate of this heat escapement and the control of the body temperature is effected by what is known as the metabolism system of the body.

If the surrounding air is at higher temperature than 98.6 degrees F. then heat cannot flow by conduction from the body to the air, and can only be dissipated by the evaporation of perspiration.

We are then inclined to feel uncomfortably warm and this condition tends to exhaust nervous energy and reduce working efficiency.

Another effect of working in too high temperatures is that people are inclined to change their diet and eat more fruits and salads, and avoid meats, starches and sweets because these latter foods generate more body heat. However, if the air temperature is reduced to a more comfortable degree, we can then eat more of the heavier foods which produce more body energy and strength, thereby increasing our working efficiency and reducing tiredness.

A normal person when at rest gives off heat at the rate of about 400 B. T. U. per hour. When exercising moderately this rate is increased to about 600 B. T. U. per hour. When exercising vigorously or doing heavy labor, the rate rises to 800 B. T. U. per hour, or even to 1,000 B. T. U. in some cases.

This body heat given off by persons in a room or building must be taken into account when planning an air conditioning system. This will be explained in detail later.

Keep well in mind, however, that the temperature of an air conditioned space which is to be occupied by humans, should not be lower than 10 to 12 degrees below outside temperature. While a temperature of 70 degrees F. is normally a comfortable

humidity, and when the R. H. was reduced to 30%, they were comfortable at temperatures up to 85° F.

113. DEHUMIDIFYING THE AIR

The amount of moisture in the air is referred to as relative humidity, meaning the percentage of moisture as related to the total amount which the air will hold or carry when it is saturated. The saturation point of air will depend upon its temperature. The warmer the air the more moisture it will hold before becoming saturated or reaching the dew point, at which the moisture begins to fall or settle from the air.

For example air at zero degrees F., is saturated when it contains one-half grain of water per cubic foot. Air at 70 degrees F. is saturated when it contains 8 grains of water vapor per cubic foot. Air at 83 degrees F. will hold 12 grains of water vapor per cubic foot, and at 90 degrees F., 16 grains, before becoming saturated.

NOTE: 7000 grains of water equal one pound or approximately one pint of water. It is a rather surprising fact that the air in a normal sized living room or private office may easily contain a gallon or more of water on a warm day when the relative humidity is high. The air in an average size room weighs about 170 lbs.

The quantity of moisture actually contained in a given volume of air is called its absolute humidity. For example, if air at any temperature contains six grains of moisture per cubic foot, then its absolute humidity is said to be six grains per cubic foot.

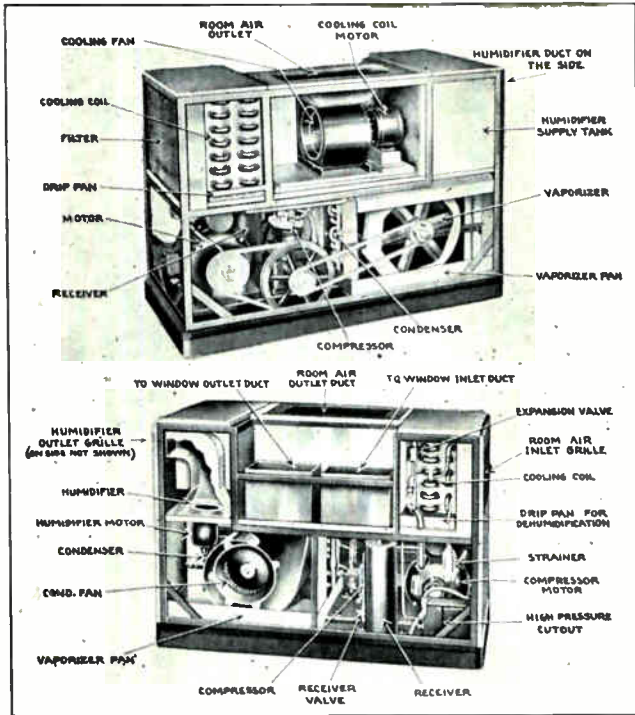

Fig. 145. Two excellent views of a room cooler unit with cover removed to show all working parts. Note the location and names of all the parts as marked on the photos. Courtesy Pacific Mfg. Corp.

and healthful temperature for building interiors during winter months, when outside summer temperatures are 95 degrees the inside temperature should not be lower than 82 degrees. This amount of temperature reduction will usually be found quite comfortable providing the humidity or moisture content of the air is reduced to the right value.

You have probably often heard the statement that "It is not so much the heat as it is the humidity," that causes discomfort on a hot summer day.

This is quite true because the humidity or moisture content of the air does affect the rate of evaporation of perspiration on the skin, and thereby affects the feeling or sensation of heat or cold.

In a series of laboratory tests made on a group of people, 98% of the group were comfortable at 73° F. and 70° relative humidity (R. H.), but when the R. H. was reduced to 30% these persons were comfortable at 79° F. Of this same group, 50% were still comfortable at 79° F. and 70° relative

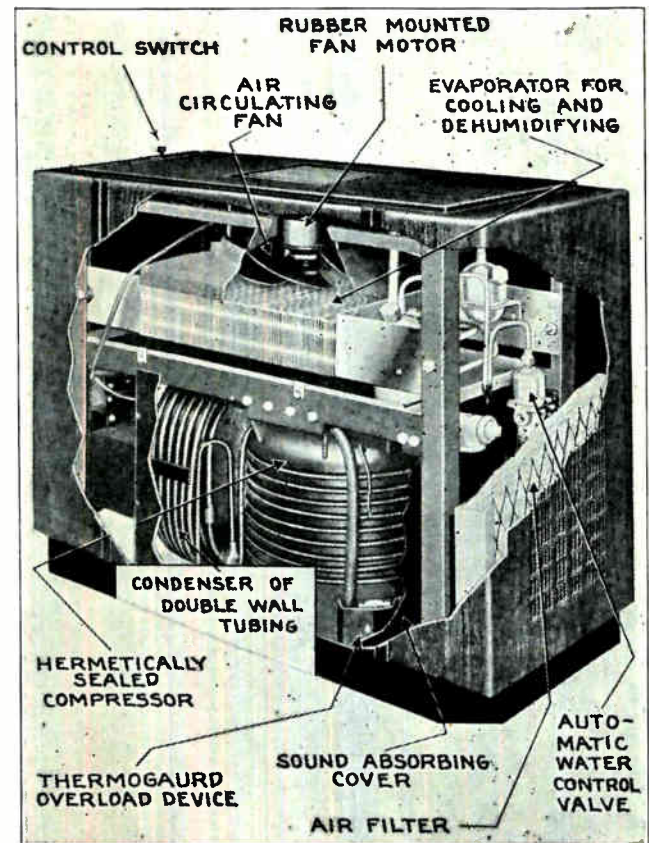

Fig. 146. Cut-away view of another type of electrical room cooler unit. Note the location and description of all the parts shown. Courtesy Westinghouse Electric Co.



Fig. 147. Individual electric room coolers also very popular in private offices, where they greatly increase comfort and working efficiency on hot summer days. Courtesy Pacific Mfg. Corp.

As previously mentioned the relative humidity of air is expressed in percentage of the total amount of moisture required to saturate the air at a given temperature. For example, if the saturation point of air at 70 degrees F. is 8 grains per cubic foot, then if 70 degree air contains 4 grains of moisture per cubic foot, its relative humidity would be 50%. Or if this air contained 6 grains of moisture per cubic foot its relative humidity would then be 75%.

The relative humidity of air on a hot summer day may often rise to 70 or 80%, and make the heat much more oppressive to persons than it would be if the air were drier.

Proper relative humidity for most comfortable and healthful conditions ranges from 35% to 65%, or a good average is about 50% relative humidity.

The humidity or moisture content of air is also very important in the processing or manufacture of certain articles in manufacturing plants. For example, textiles handle better when not too dry or too damp. Textile fibres that are too dry tend to become brittle and break and also repel each other and fray out due to static electricity. Properly



Fig. 148. Photo of the inside of a modern air-conditioned general office. Note the duct outlets along the ceiling beams. Much better efficiency and health can be maintained in such air-conditioned offices. Courtesy Jewell Tea Co.

humidified air will prevent this and also keep down objectionable dust.

The manufacture of flour in flour mills is also greatly improved by proper humidity which prevents stickiness or extreme dryness and dust. The handling of paper in printing plants is greatly facilitated by proper moisture content in the air, to prevent static on the paper.

Chewing gum can be produced in much better quality when made under proper humidity conditions. The softness or hardness of bread loaves and other baked goods can be controlled by adjusting the relative humidity of the air in bakeries.

Therefore, we can readily see how important it is to be able to control the humidity of air for reasons of comfort, health and efficiency. Many large plants have complete air conditioning systems installed because the improvement in quality of prod-

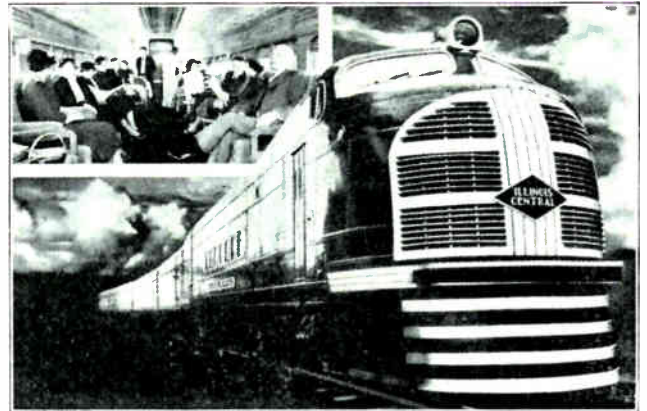

Fig. 149. Outside and inside views of a modern air-conditioned, streamlined Diesel-Electric train. The air inside is as cool, clean and refreshing as the air among the clouds outside. Courtesy Illinois Central Ry.

uct and speed of production will more than pay for the cost of installing and operating the system. In addition to this economy feature the improved comfort, health and efficiency of employees makes it of added advantage and profit to air condition many plants.

Excessive moisture can easily be removed from air by passing it through cooling coils or cold water sprays. It is quite commonly known that chilling air will cause part of its moisture to condense. Most everyone has seen this effect where moisture condenses on the surface of a water glass or pipe containing cold water. Chilling moisture laden air to the dew point will cause the water vapor to settle out of the air like dew or heavy mist.

In air conditioning machines the water which is condensed in the cooling coils drains off into a drip pan and drain pipe.

The percentage of relative humidity can be very accurately controlled, in fact controlled within one per cent or less, by means of humidistats which operate electric controls on the atomizing water sprays or jets. This in turn controls the amount of moisture that will be added to the air.

114. HUMIDIFYING AIR

During winter weather when the outside air is cold and dry, or of low relative humidity, and when

this air is further dried out by operation of heating plants in buildings, the humidity of the inside air often becomes much too low for comfort, health or efficient processing of various articles. It is a rather astonishing fact that the air in the average home during winter months is often drier than the desert air in Death Valley. The relative humidity in Death Valley, California, is about 23% while that of the air in homes often falls as low as 18 or 20%. A given amount of outdoor winter air at zero temperature and a typical relative humidity of 40%, will, when heated to 70 degrees F., have a relative humidity of only 5% to 6%.

Such dry air, or "thirsty air" as it might be called, very rapidly absorbs moisture from the tissues of the mouth, throat, nose and lungs and causes these surfaces to become parched and irritated, and highly susceptible to inroads of disease germs. Many cases of colds, flu, bronchitis and other such ills can be prevented by proper humidification of the air in buildings during winter months.

Humidification, or addition of moisture to the air can be accomplished by passing the air through fine, mist-like sprays of water, or through steam jets. In some cases, it is accomplished by passing the air over moisture soaked pads. Radiators and furnaces in homes are often equipped with evaporator pans filled with water. The warm air which is circulated over and around these pans will pick up considerable moisture in this way.

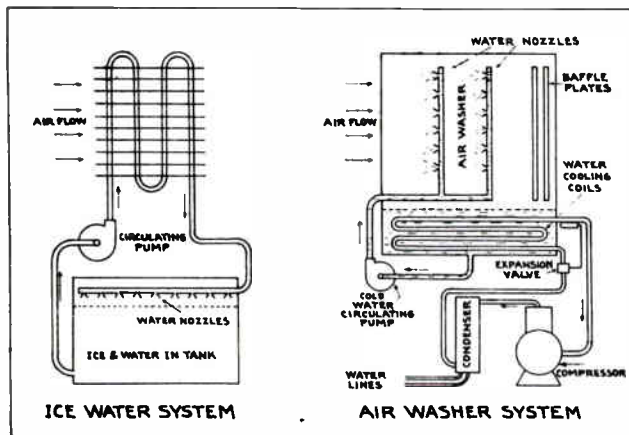

Fig. 150. The diagram on the left shows a simple method of cooling and dehumidifying air by circulating ice water through the finned cooling coil above. On the right is shown an indirect system, using a refrigerator unit to cool water, and then circulating the cold water through spray nozzles to cool and clean the air.

Air will absorb water like a sponge, and like the sponge, air can only hold so much water and then it becomes saturated. Its relative humidity is then 100%. As explained in Article 113, the warmer the air, the more moisture it will absorb before becoming saturated.

- 1 lb. of air at 20° F. will hold 20 gr. of moisture.
- 1 lb. of air at 50° F. will hold 54 gr. of moisture.
- 1 lb. of air at 75° F. will hold 131 gr. of moisture.
- 1 lb. of air at 100° F. will hold 300 gr. of moisture.

The relative humidity of air can be approximately determined by means of an instrument called a **hygrometer**, such as shown in Fig. 152. This device has a pointer which is caused to move over a scale

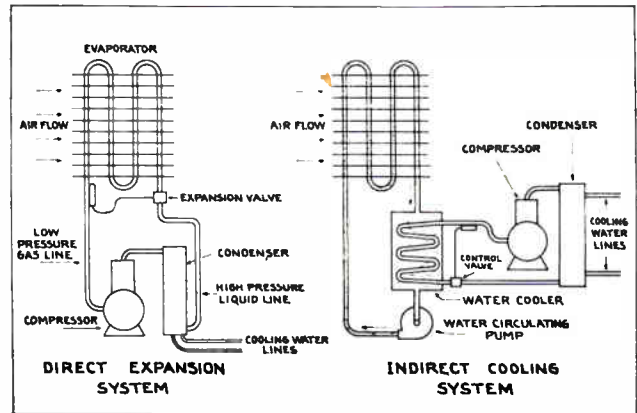

Fig. 151. On the left is shown a diagram of a direct type cooling system in which refrigerant from the compressor is fed through the air cooling coils of the evaporator. On the right is shown an indirect system using cold water to chill the air cooling coil and to carry the heat to the water cooler where it is absorbed by refrigerant from the compressor and condenser unit.

by the expansion and contraction of strands of hair or other organic fibres which are very sensitive to moisture. Hair, which is commonly used in these instruments, expands when moistened and contracts when dried.

115. PSYCHROMETERS

Another method of more accurately determining the relative humidity of air is by the use of a sling psychrometer, two types of which are shown on the left in Fig. 153. This device consists of a dry bulb and a wet bulb thermometer mounted on a frame with a handle to permit them to be rotated or swung rapidly through the air.

The dry bulb thermometer is of the ordinary alcohol or mercury type. The wet bulb thermometer is similar except that its bulb is covered with a soft absorbent cloth or wicking material, which

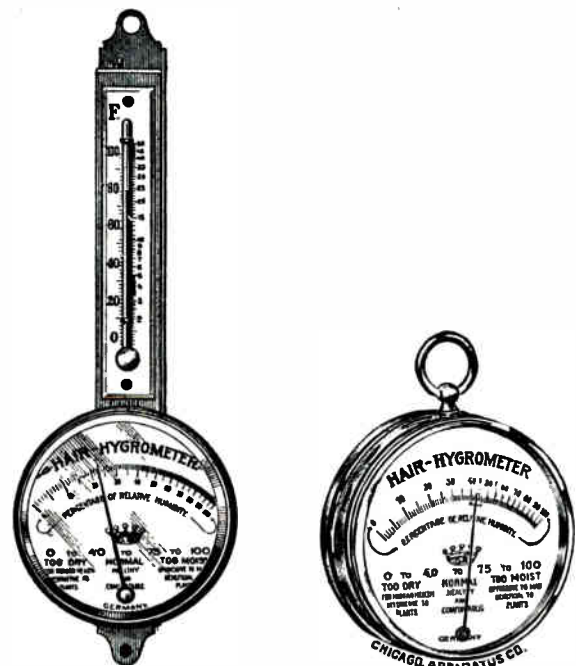

Fig. 152. Two types of hair operated hygrometers for indicating the approximately relative humidity of air. Courtesy Chicago Apparatus Co.

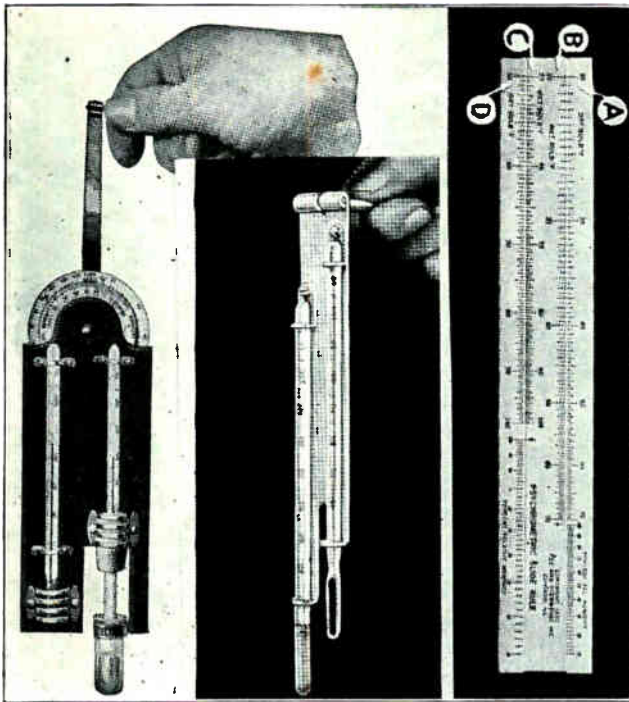

Fig. 153. Two types of sling psychrometers and a psychrometric slide rule, used for determining the relative humidity of air, for establishing comfort conditions in air-conditioned buildings.

should be moistened in clean water of approximately room temperature.

When the psychrometer is swung rapidly through the air, the moisture from the wicking will evaporate into the air and the process of evaporation will cool the bulb so that the wet bulb thermometer gives a lower reading than that of the dry bulb thermometer.

The rate of evaporation will depend on the relative humidity of the air at the time and place of the test. The lower the R. H. or the drier the air, the faster will be the evaporation and the greater the difference between the readings of the dry bulb and wet bulb thermometers.

Then, by taking these two readings at the same instant and checking them on a special psychrometric slide rule or chart, we can determine the relative humidity of the air.

The sling psychrometer shown on the left in Fig. 153 has a convenient circular slide rule attached. For the psychrometer shown in the center of this figure, we use the straight slide rule shown on the right.

For reading the instrument shown on the left we first take the dry bulb reading and set this figure on the outer scale at the 100% marking on the inner scale.

Then holding the instrument well away from the body, rotate it rapidly through the air about 50 revolutions, or until wet bulb thermometer will go no lower. Then quickly take the wet bulb reading and locate this figure on the outer scale, and read relative humidity directly opposite on the inner scale.

To use the other type of psychrometer and the straight slide rule shown in Fig. 153, twirl the thermometers and take both readings. If the wet bulb temperature is below 50 degrees F., use scales A

and B on the slide rule. Set the wet bulb reading on scale "B" opposite the dry bulb reading on scale "A." Read the R. H. at the right end of scale "A" directly above the pointer or arrow on scale "B."

If the wet bulb temperature is above 50 degrees F., use scales "C" and "D." Set wet bulb temperature on scale "C" opposite dry bulb temperature on scale "D." Read the R. H. at the right end of scale "D" below the pointer on scale "C".

Examples for checking correct use of the slide rule would be as follows: Wet bulb temperature of 48 degrees F. and dry bulb temperature of 59 degrees F. would indicate 43% R. H. Wet bulb temperature of 56 degrees F. and dry bulb temperature of 63 degrees F. would indicate 64% R. H.

The wicking on the bulb of the wet bulb thermometer should never be allowed to get dirty or greasy or it will cause inaccurate readings by slowing up the normal rate of evaporation.

116. PSYCHROMETRIC CHARTS

Another convenient method of determining relative humidity when wet and dry bulb temperatures are known, is by means of a psychrometric chart, a section of which is shown in Fig. 154. The chart we have shown in this figure is one which has been cut down for convenience, and covers dry bulb tem-

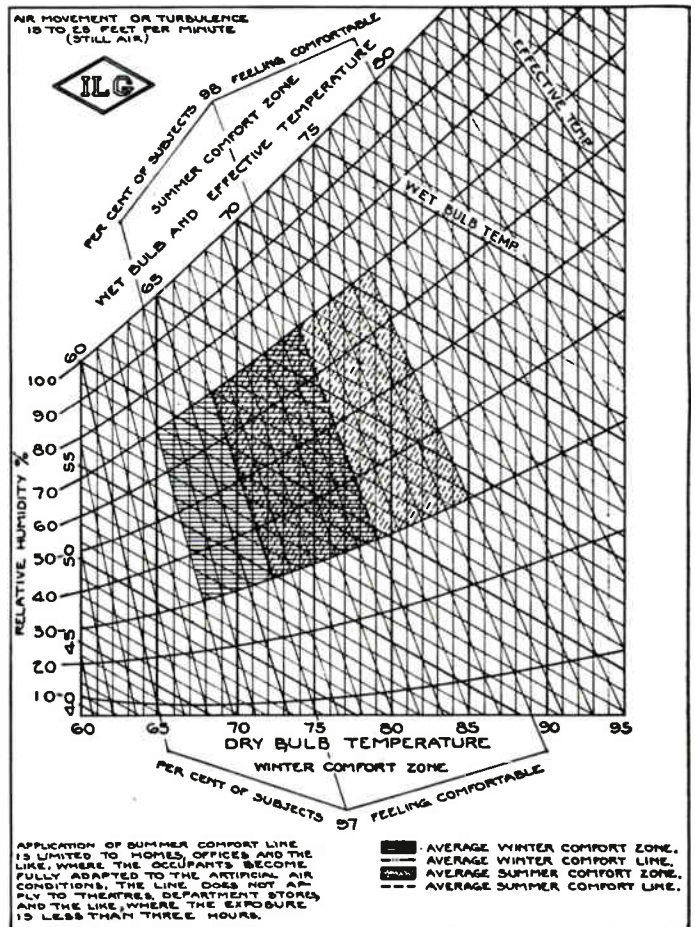

Fig. 154. Simplified psychrometric chart showing comfort zones, for determining proper temperatures and humidities for comfort and health. Study this chart carefully and become familiar with its use while reading the lessons material pertaining to it. Courtesy Iig Electric Ventilating Co.

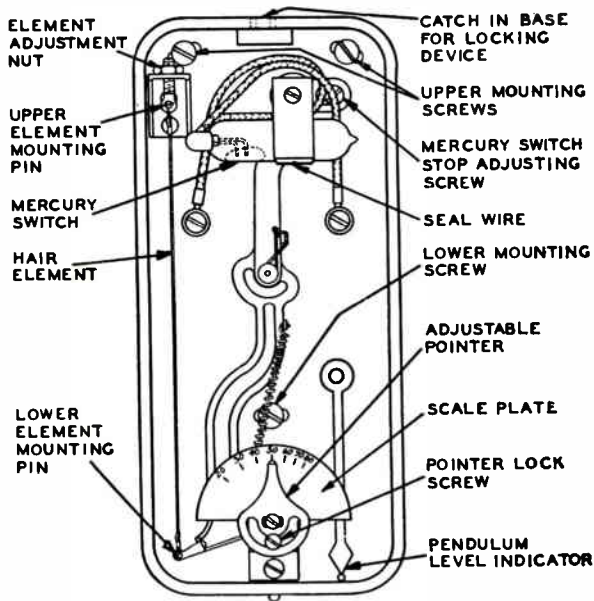

Fig. 155. Diagram of a humidistat such as used for controlling humidity in air-conditioning installations. An electric switch is operated by expansion and contraction of strands of human hair. Courtesy Minneapolis Honeywell Corp.

peratures from 60 degrees to 95 degrees F., wet bulb temperatures from 40 to 85 degrees F., and relative humidities from 10 to 100%.

This chart has also been shaded in the center portion to show average winter and summer comfort zones, or desirable relative humidities for comfort at the dry bulb temperatures commonly encountered indoors in summer and winter seasons.

Note that the most desirable average values (center area of shaded comfort zone) are at about 70 degrees to 75 degrees F. dry bulb temperature, 60 degrees to 65 degrees F. wet bulb temperature, 40 to 60% relative humidity, 67 to 72 degrees F. effective temperature.

Also note that the dry bulb, wet bulb and dew point temperatures are the same at 100% saturation, as shown by the intersection or joining of the vertical dry bulb lines and the angular wet bulb lines at the 100% relative humidity line. This line also represents saturation or dew point at the various temperatures.

With any two of these factors known, all the others can be quickly determined with the aid of such psychrometric charts.

Air conditioning equipment installation and service men should be thoroughly familiar with the use of psychrometric charts. Larger and more complete charts, covering wider temperature ranges can be obtained from principal manufacturers of air conditioning equipment.

Relative humidity can be automatically controlled by means of a Humidistat such as shown in Fig. 155, and which would be located in the air conditioned room or space. This device consists of a mercury switch operated by the expansion or contraction of strands of hair, something like the hygrometer, except that in the humidistat the expanding element operates a switch.

An adjustment is provided as shown at the bottom of the diagram in Fig. 155, to set the desired

humidity at which the switch is to operate and open or close the circuit to a solenoid operated valve in the water line to the humidifier spray unit.

117. FILTERING AND CLEANING AIR

As previously mentioned, a great deal of the dirt, dust and disease germs which are normally contained in air, especially in large cities and industrial areas, can be removed by passing the air through filter screens or pads of various types of construction.

One of the most commonly used types of air filters in air conditioning systems, is made of spun glass or glass wool which is coated with a thin film of oil. Such filters are highly efficient and will remove 98% of the dust and many of disease germs normally in the air. Fig. 156 shows 2 of these filter pads, one of which is clean and the other of which is loaded with dirt collected from the air while in service in an air conditioning unit.

Another method of removing dirt from the air is to wash it by passing it through fine water sprays or "scrubbers." Sometimes both the water spray and filter are used in the same air conditioning unit for more thorough purification of the air.

Still another method which is highly effective in removing dust particles from the air, is known as the electrical precipitation process. This system uses high voltage electricity to charge a set of metal tubes and plates which are located in the path of the air stream. See Fig. 157 which shows one type of electrostatic dust precipitator. The dust particles, in passing near these highly charged metal electrodes take on by induction a static charge of a

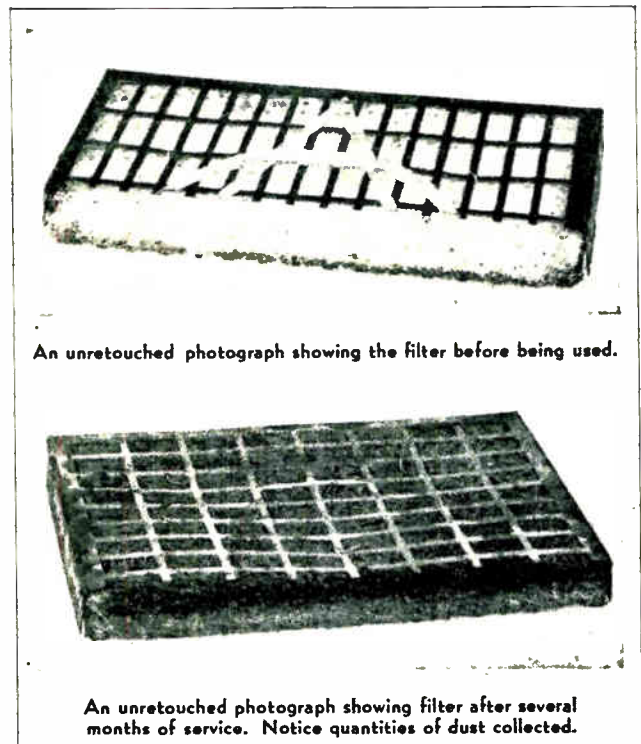

An unretouched photograph showing the filter before being used.

An unretouched photograph showing filter after several months of service. Notice quantities of dust collected.

Fig. 156. Two views of a section of an air filter, showing the amount of dirt removed from the air by such filters. This shows how air conditioning improves health by keeping such dirt out of the lungs of persons in air-conditioned buildings.

polarity opposite to that of the electrodes. This causes the charged dust particles to be attracted to the metal electrodes, where they cling until dislodged by jarring the electrodes.

During the period while one set of precipitator electrodes is being cleaned the air is usually bypassed by means of dampers through another set of electrodes. Shutting off the flow of air through the set which is being cleaned permits the dust to settle to the bottom of the chamber from which it can be removed.

Air cleaning or filtering is highly important in many industrial plants and in bakeries and food producing plants. For example, automobile painting departments can only produce a fine finish on the cars if the air is free of dust. In tobacco manufacturing plants, it is highly essential from the standpoint of the employees' health to have the highly irritating tobacco dust removed from the air. In shops or laboratories handling watches and meters and other delicate instruments the air must be kept clean. In breweries air filtering and washing removes highly infectious yeast and mould germs from the air.

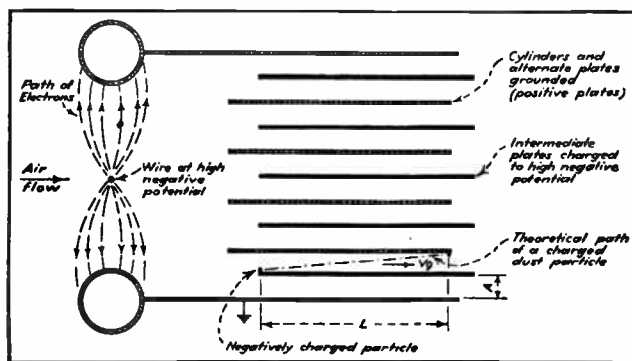

Fig. 157. Diagram illustrating the principle of operation of an electrostatic dust precipitator or collector, which will remove extremely fine dust and smoke particles from the air. Courtesy Electric World.

Filtering or cleaning air in homes, offices, stores and theaters, to remove dust, weed pollen and germs, affords great relief to hay fever sufferers and reduces diseases such as colds, flu, etc.

Cleaning the air in homes, offices and stores also helps to keep walls, drapes, rugs, furniture and clothes much cleaner, and thereby reduces laundry and cleaning bills. So we can readily see the importance of the cleaning function of air conditioning.

In addition to cleaning the air, some air conditioning systems are also equipped to absorb odors or to introduce into the air stream some material to produce pleasing odors to offset disagreeable odors.

Electric ozone generators are used with some air conditioners to ionize the air and to kill foreign odors. Ozone is a form of concentrated oxygen and is very effective in eliminating objectionable odors and purifying air.

Electric ozone generators use high voltage applied to grids or electrodes to ionize the air which passes through them. A unit of this type, consuming only a few watts of electric energy will provide sufficient ozone for a very large room.

118. CIRCULATION OF AIR, VENTILATION

One of the most important functions of any air conditioning system, and yet one of the least costly, is the circulation of the air, or proper ventilation. Proper movement and distribution of the air in a room or building is necessary to provide proper comfort and health conditions. It is also necessary to provide a certain amount of fresh air or a certain number of changes of air per hour for healthful conditions.

A minimum of 20 cubic feet of fresh air per minute should be provided for each person in any room. City health departments require this in all public buildings such as schools, theaters, restaurants, stores, etc. Some cities require 25 to 30 cubic feet per person per minute.

Human beings consume the oxygen in the air and liberate nitrogen and carbon dioxide by breathing. A fresh supply of oxygen is absolutely necessary to sustain life, health and a clear mind.

When heating or cooling the air in a building, a certain amount of the air can be recirculated, but a certain amount of fresh air must be added continually. Normally about 25% of fresh air is added in the circulation system.

Air in occupied rooms becomes stagnant and foul with odors if it is not circulated and renewed. In heated rooms if the air is not kept in motion the warm air rises to the top of the room, creating unnecessarily high temperatures in this upper level, with resulting high heat leakage loss through ceilings unless they are very heavily insulated. It is therefore more efficient to keep the air in motion.

Body odors, cooking odors, tobacco smoke, etc., can be removed from homes, offices and other buildings very economically by means of electric ventilating fans such as shown in Fig. 161. In buildings having only ordinary winter heating plants such added ventilation is a decided advantage.

During hot summer months the temperature of kitchens, bedrooms and offices can be considerably lowered by means of ventilating fans to remove the heat from cooking appliances, electric lamps, air-cooled refrigerator condensers, body heat, etc.

119. ATTIC VENTILATORS

A great deal of comfort cooling in homes can be accomplished during the summer months by use of attic ventilators or large fans placed in the attic. By proper location of such fans and proper adjustment of doors and windows downstairs, such fans can be made to blow out the hot air from the attic and draw in cool night air through the various rooms of the house. See Fig. 162.

When we consider the fact that with the hot sun beating on the roof all day, attic air temperature will often reach 120 to 130 degrees F., we can readily see the benefits of removing this heated air from the house. As much as 40% of the total heat entering an uninsulated one story house during a hot summer day comes through the roof. (Note, about three-fourths of this heat can be kept out of the rooms of the house by proper insulation of the attic floor.)

In many localities even though outside air temperatures during the day may reach 90 to 100 degrees F., in the evening after sundown the outside

Fig. 158. This photo shows a modern air-conditioned building. Modern electric air-conditioning and electric lighting permit such buildings to be constructed without windows, thus shutting out noise, dirt, heat and cold very effectively. Courtesy National Aluminate Corp.

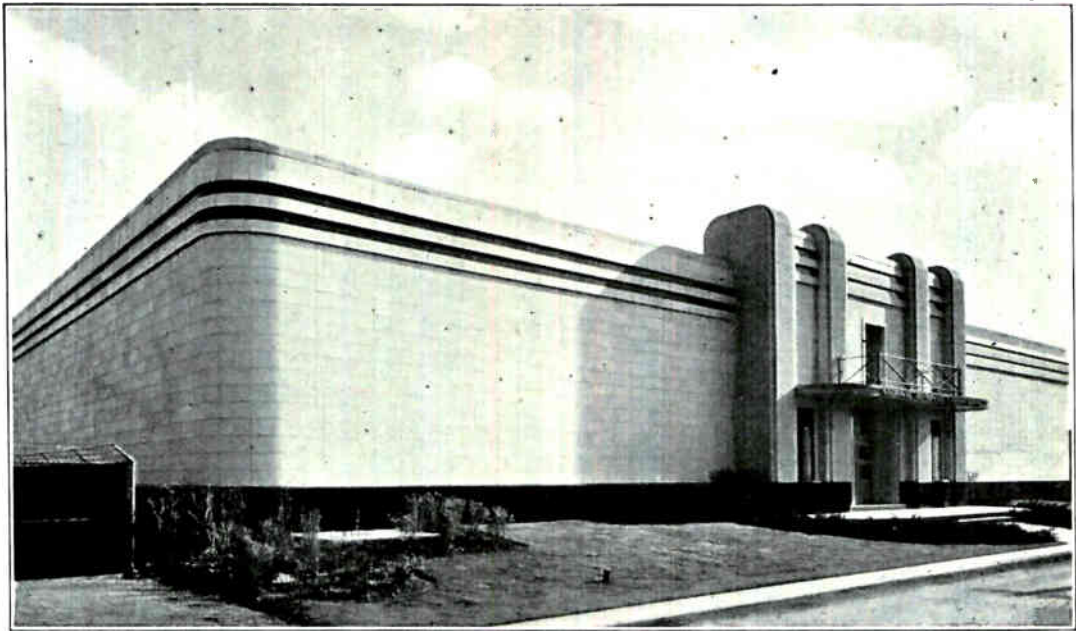

temperatures commonly drop to 70 to 80 degrees F. With a proper size attic ventilator set to automatically turn on in the early evening and turn off in the morning, and changing the entire air in the house every 10 or 15 minutes, temperature reductions of from 5 to 10 degrees or more can often be accomplished.

By closing most of the doors and windows during the day, a well insulated house may be kept considerably cooler if all walls, floors and furniture are well cooled down at night.

Attic ventilation provides a very inexpensive means of securing considerable comfort cooling during summer months. Many home owners who cannot afford complete air conditioning gladly welcome such an installation when fully acquainted with its advantages.

Another benefit of moving or circulating the air through rooms in the summer, is that when air in motion comes in contact with the human body it increases the rate of evaporation of perspiration, thereby producing a sensation of coolness. Note how the window curtains in the upper view in Fig. 163, are blown inward from the window, by cool night air drawn in by an attic fan of the type shown in the lower view.

120. BLOWERS AND DUCTS

Complete air conditioning systems of the central plant type use blowers and ducts to circulate the conditioned air to the various rooms, and to return the air from the rooms to the conditioning plant. See Figs. 139, 142, 143 and 148.

Instead of fans with propellor type blades, centrifugal blowers of the type shown in Fig. 164 are generally used with central conditioning plants. These blowers provide a better positive pressure which is required to force the air to flow through the resistance of long ducts and resistance offered by filters, cooling and heating coils, and louvres through which the air must pass.

When selecting or ordering such blowers for any given air conditioning system, the proper size and power of the blower is determined by the required amount of air in cubic feet per minute (C.F.M.), the size and length of the ducts, the area and type of cooling coil, heating coil, filters and louvres through which the air must pass. The resistance of the ducts, coils, etc., to the flow of air is measured and stated as static pressure in "inches of water column," meaning the amount which a column of water would be raised in a tube by the pressure required to force air through the resistance of the devices at a given velocity.

The table in Fig. 165 gives approximate duct sizes required to carry various amounts of air in C.F.M. at given velocities. For average resistance conditions a one h. p. motor driven blower will deliver about 2500 C.F.M. On large installations blower manufacturers will recommend the proper size and type of blower according to the requirements and construction features of the system.



Fig. 159. Interior view of spotlessly clean air-conditioned chemical laboratory, in the building shown in Fig. 158. The advantages of air-conditioning in chemical laboratories, food manufacturing plants, and fine instrument shops are very apparent. Courtesy National Aluminate Corp.

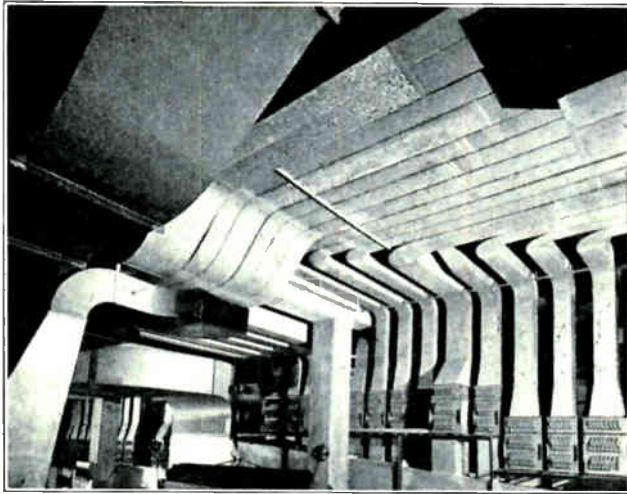

Fig. 160. View of part of the air duct system in the building shown in Figs. 158 and 159. Note the neat duct layout and the cooling coils installed in each duct in this rather unusual installation. Courtesy National Aluminate Corp.

As a general rule, air velocities through ducts are not over 800 ft. per minute, as at higher velocities the friction losses are high and the noise level is greatly increased. Velocities of 400 to 600 ft. per minute are much more common.

Blowers are often coupled to plenum chambers or ducts by means of a flexible canvass coupling to prevent transfer of blower vibration and noise to the duct system, which would carry the noise throughout the building.

121. DUCT OUTLETS

Duct outlets are generally located in the ceilings or high up on the walls of rooms, so that the air will discharge or distribute downward. Duct openings to return the used air from the room to the conditioner, are generally located in the walls near the floor.

In some cases, however, the direction of air flow may be reversed and pass from bottom to top of the room, or from side to side. It may also enter a room at the center of the ceiling and be taken out at the sides of the ceiling, or enter at one side of the ceiling and leave at the other side.

Ducts should be equipped with a sufficient number of openings to provide even distribution of the air and prevent strong drafts. The temperature variation at different points in the room should not be over 4° F.

Duct openings are provided with grilles or louvres, both to improve appearance and to improve air distribution. Fig. 166 shows two grilles for duct openings. These grilles are equipped with louvres (slanting vanes) to direct the air flow in the desired direction. They also have adjustable dampers operated by the pull chains shown.

Ducts are usually made of sheet metal, with the joints soldered or tightly bolted together to prevent leakage loss of the conditioned air. In some cases, however, the spaces between joists of walls may be used as ducts.

The inside surfaces of ducts should be smooth to reduce air friction as much as possible. Duct turns

or bends should be rounded to reduce turbulence and to permit a smooth flow of air.

122. DUCT INSULATION

If ducts are exposed to air that is much warmer or colder than the conditioned air they are carrying the outer surfaces of the ducts should be covered with insulation. Sheet cork or asbestos covering materials are commonly used for this purpose.

Such insulation prevents considerable loss of heat and also deadens noise that might otherwise travel along the ducts. Slabs or strips of cork or asbestos covering are generally cemented to the metal surfaces of the ducts with asphalt cement as shown in Fig. 167.

In some installations, the ducts are also lined with sound absorbing material to prevent any noise from the air or from vibration in the building.

Fig. 168 shows a duct layout for one floor of a simple office or hotel building. Fig. 169 shows a diagram of a complete air conditioning system of the indirect type. Note the refrigerating unit, water cooler, plenum chamber with its heaters and cooling and dehumidifying sprays, fan, ducts, etc.

Dampers are used in the ducts to regulate the distribution of air to various rooms, and at air inlets and outlets to the plenum chambers to regulate the mixing of fresh air and recirculated air. Note the dampers at "D" in Fig. 169.

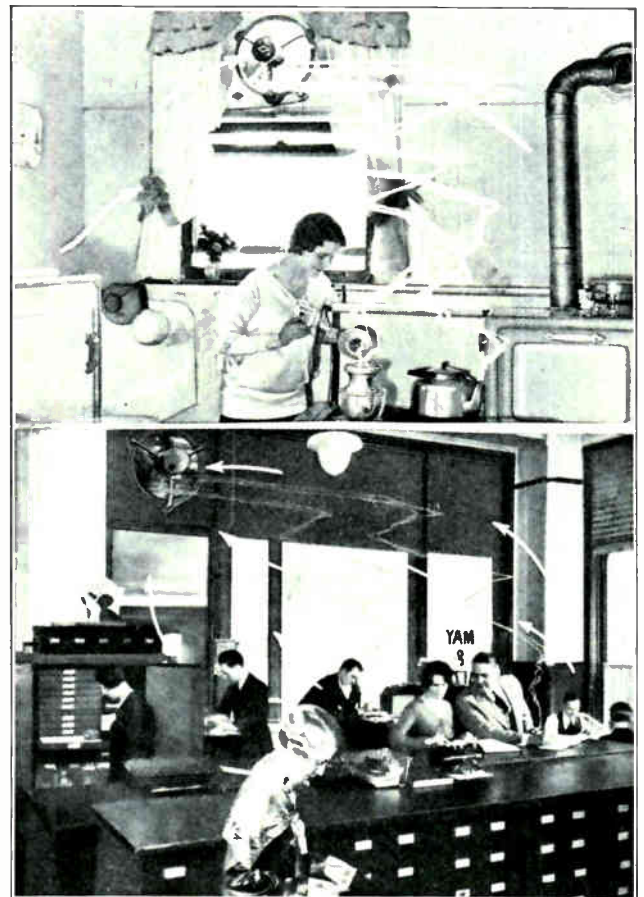
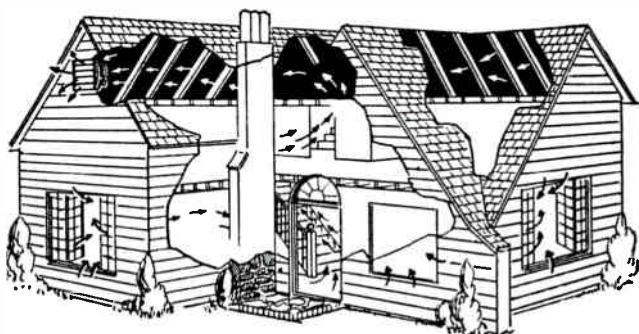

Fig. 161. Upper view shows how a ventilation fan removes odors and heat from a kitchen. Lower view shows ventilator removing smoke and heat from an office. Courtesy Ilg Electric Ventilating Company.

Brez-Air mounted in attic side wall with ventilating louvres



Brez-Air Fan mounted in box which stands on attic floor.

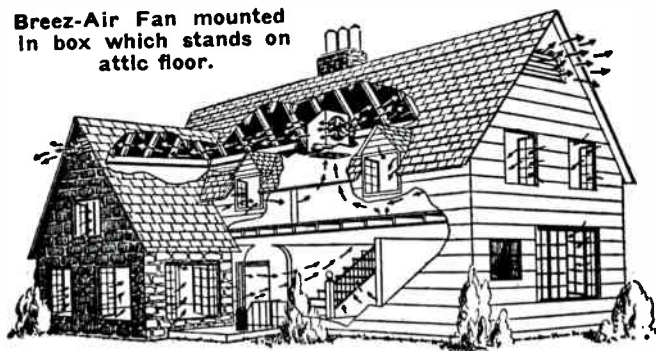

Fig. 162. These two diagrams show how attic ventilator fans can be used to remove heat from attics and draw cool night air into all the rooms of the home.

operate an individual room cooler for the average size living room or small private office, and cool the room to 10 to 12 degrees below outside temperatures if the room has average insulation and not too many windows exposed to direct sunlight.

The following table gives good average or desirable wet and dry bulb temperatures and relative humidities for summer comfort conditions with various outside temperatures.

Outside dry bulb temperature	Inside temperatures dry bulb	Inside temperatures wet bulb	Inside relative humidity per cent
85	74	64	60
85	74	59	35
90	77	67	62
90	80	63	40
95	79	68	58
95	82	65	40
100	80	69	58
100	83	65	38
105	81	70	58
105	84	66	39

123. SIZE OF AIR CONDITIONING UNITS REQUIRED

The exact size of refrigerating unit required for cooling the air for any given building can be calculated by considering the size of the building, type of building construction, class of service, temperature difference to be maintained between inside and outside air, maximum outside temperatures, and total heat load or heat gain in B.T.U. The heat comes from such sources as leakage through walls, doors and windows, infiltration of heat through open doors, and with fresh air used for ventilation, body heat of occupants, heat from electric lights, appliances, motors, cooking ranges, etc.

However, for simple reference purposes we can generally figure that under average conditions a one ton refrigeration unit, if run continuously, will cool

- 1000 cu. ft. of storage space to 32 degrees F.
 - 4000 to 6000 cu. ft. of residence space to 75 degrees F.
 - 8000 cu. ft., or 15 seats, in a theater to 75 degrees F.
 - 3000 to 5000 cu. ft. of store space to 75 degrees F.
 - 3000 to 5000 cu. ft. of dining room space to 75 degrees F.
 - 3000 to 8000 cu. ft. of candy factory space to 68 degrees F.
 - ¾ gal. of drinking water per minute to 40 degrees F. or
 - Freeze .6 ton of ice per 24 hours.
 - Freeze .75 ton of fish per 24 hours.
- We can also figure that a ½ to 1 ton unit will

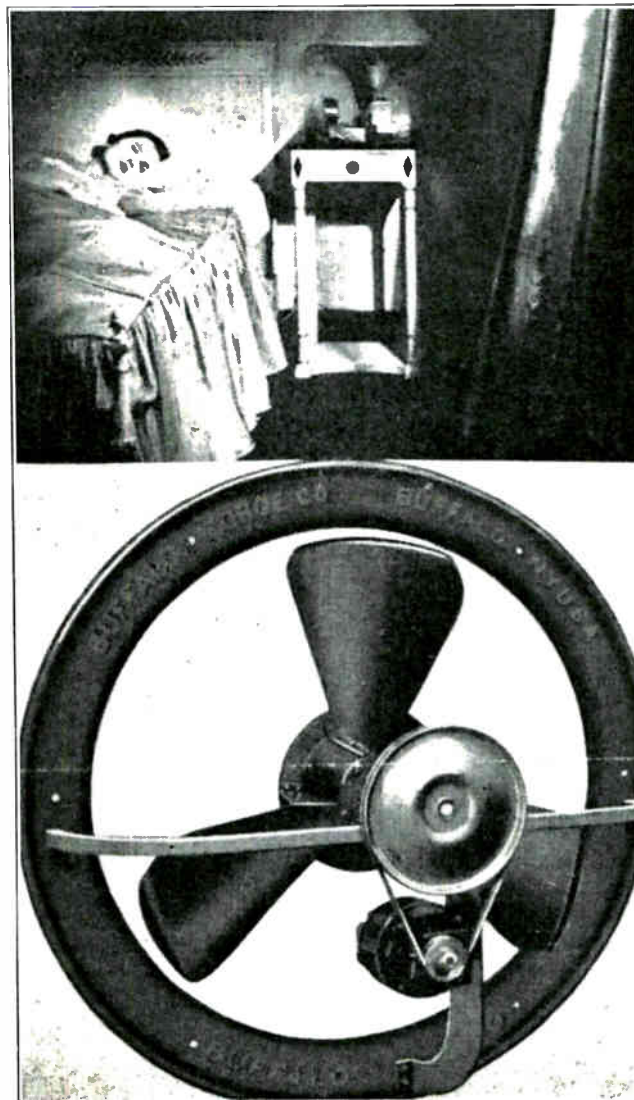

Fig. 163. Lower view shows an attic ventilator fan operated at low speed by belt drive from a small motor. Upper view shows how night breeze drawn in the bedroom window provides comfort for sleeping on summer nights. Courtesy Buffalo Forge Co.

The values given in this table are those recommended by the air conditioning manufacturers Association (A.C.M.A.)

Typical examples of heat loads or size of refrigerating units required for various classes of buildings are given in the following table and should prove helpful as an approximate guide to unit size requirements.

	Tons of refrig. per 1000 sq. ft. of floor area	Tons of refrig. per 1000 cu. ft. of bldg. vol.
Department stores....	3	.21
Office buildings	2.8	.26
Restaurants	9.5	.81
Theatres	8.8	.23
Residences	4	.30

The approximate kilowatt hours required per h.p. of compressor size, per season for such buildings are as follows:

Department stores	1100 kw. hrs. per h.p. per season
Office buildings	1000 kw. hrs. per h.p. per season
Restaurants	800 kw. hrs. per h.p. per season
Theaters	500 kw. hrs. per h.p. per season
Residences	900 kw. hrs. per h.p. per season

We can generally figure a cost of about \$400.00 per ton installed, for refrigerating units for air conditioning.

124. HEAT LOAD CALCULATION

As we have previously stated, to determine the size of refrigeration unit needed to cool a given space or building, we must take into account the heat load from several different sources. The most important of these are the heat that leaks in through walls, ceiling, floor, windows and doors; the heat that enters with the fresh air used for ventilation; the heat from electric appliances, motors, and gas burners, and the heat from the bodies of persons occupying the space to be air conditioned.

We have already learned that each person will give off about 400 B.T.U. per hours when idle, 600 B.T.U. when doing light work, and 800 or more B.T.U. when doing heavy work.

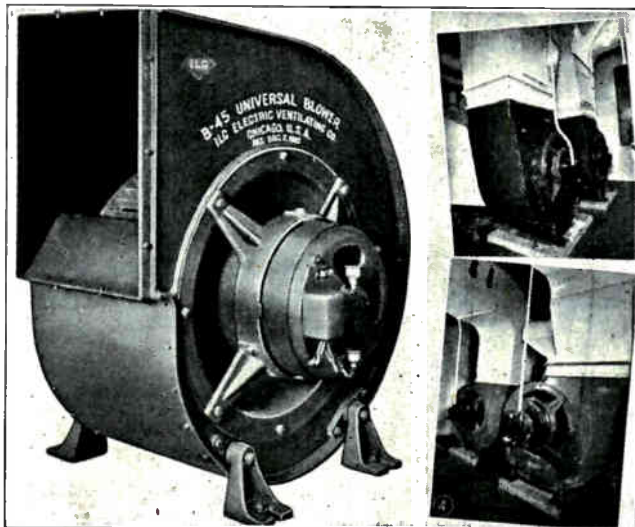

Fig. 164. Large centrifugal fans or blowers of the type shown above are used to circulate air through ducts of air-conditioning systems. Courtesy Ilg Electric Ventilating Co.

TABLE OF AIR DUCT SIZES
SIZE IN INCHES OF RECTANGULAR AIR DUCT REQUIRED FOR PASSAGE OF A GIVEN VOLUME OF AIR AT A GIVEN VELOCITY.

VELOCITY IN FEET PER MINUTE	CUBIC FEET OF AIR PER MINUTE									
	100	200	300	400	500	1,000	1,500	2,000	2,500	3,000
350	6 x 8	8 x 12	12 x 12	12 x 14	12 x 16	16 x 24	22 x 28	24 x 36	26 x 36	26 x 44
400	6 x 6	8 x 10	10 x 12	12 x 12	12 x 16	16 x 20	20 x 26	24 x 30	26 x 32	26 x 40
450	6 x 6	8 x 8	8 x 12	12 x 12	12 x 16	16 x 20	20 x 24	24 x 28	26 x 30	26 x 34
500	6 x 6	8 x 8	8 x 12	10 x 12	12 x 12	16 x 18	20 x 22	24 x 24	26 x 28	26 x 32
550	6 x 6	8 x 8	8 x 10	10 x 12	10 x 14	16 x 18	20 x 20	22 x 24	24 x 28	26 x 28
600	4 x 6	6 x 8	6 x 12	8 x 12	10 x 12	16 x 16	18 x 20	20 x 24	24 x 26	26 x 28
650	4 x 6	6 x 8	6 x 12	8 x 12	10 x 12	14 x 16	16 x 18	20 x 22	24 x 24	26 x 26
700	4 x 6	6 x 8	6 x 10	8 x 12	10 x 10	14 x 16	16 x 20	20 x 22	22 x 24	24 x 26
750	4 x 6	6 x 8	6 x 10	8 x 10	10 x 10	14 x 14	16 x 18	20 x 20	22 x 22	24 x 24
800	4 x 6	6 x 6	6 x 10	8 x 10	8 x 12	14 x 14	16 x 18	18 x 20	22 x 22	24 x 24

DUCT SIZE IN INCHES GIVEN IN COLUMNS ABOVE

Fig. 165. Convenient table for determining proper duct sizes for handling various quantities of air at different velocities.

We also know that electric lamps and appliances give off about 3.41 B.T.U. per hour per watt of electric energy consumed. On large motors it is simpler to figure 2540 B.T.U. per h. p. per hour.

Gas ranges and ovens give off about 500 B.T.U. per cu. ft. of manufactured gas burned, or about 1000 B.T.U. per cu. ft. of natural gas.

Now if we also knew the heat leakage factor per sq. ft. of various common building materials, then with a knowledge of the maximum outdoor temperatures and the desired indoor temperature, it should be a simple matter to calculate the total heat load in B.T.U. per hour from these various sources.

Therefore, the following data on heat leakage in B.T.U. per sq. ft., per degree of temperature difference, per hour, should be valuable in estimating the size of refrigeration unit required to handle the heat load or to cool a given building.

We know that the heat conductivity of different materials varies considerably, or that the heat leakage through glass is much more rapid than through wood or brick. We also know that the greater the area exposed to two different temperatures, the greater will be the total heat leakage. And, of course, the higher the temperature difference between outside and inside air the more rapid will be the heat leakage.

That is why the following heat leakage values are stated in B.T.U. per sq. ft., per degree of temperature difference, per hour; or (B.T.U./sq.'/°/hr.)

125. HEAT LEAKAGE FACTORS IN B.T.U. PER HR. FOR VARIOUS COMMON BUILDING MATERIALS

Plain glass	1.1
Double glass45
Wood siding and sheathing on 2 x 4 studs, plastered26
Wood siding and sheathing on 2 x 4 studs, plastered and 1/2-in. insulation between studs15
Wood siding and sheathing on 2 x 4 studs, plastered and space filled with insulation....	.11
Brick veneer, sheathing, studding, plastered....	.25
Brick veneer, 8-in. hollow tile, no interior finish26
Brick veneer, 8-in. hollow tile, furred and plastered20

Brick veneer, 8-in. concrete, no interior finish	.36
Brick veneer, 12-in. concrete, no interior finish	.33
Plain brick, 8-in. no interior finish	.39
Plain brick, 8-in. furred and plastered	.26
Plain brick, 12-in. furred and plastered	.22
Plain tile, 10-in., no interior finish	.25
Plain tile, 10-in., furred and plastered	.20
Plain concrete, 6-in., no interior finish	.58
Plain concrete, 12-in., furred and plastered	.41
Stucco, wood sheathing, studding, plastered	.30
Stucco, on 8-in. hollow tile, furred and plastered	.23
Stucco, on 8-in. concrete, furred and plastered	.30
Outside doors, 1 -in. thick	.69
Outside doors, 1½-in. thick	.52
Outside doors, 2 -in. thick	.46

Inside Partitions:

Single glass partition	.75
Double glass partition	.50
Single metal partition	.91
Double metal partition	.53
Studding with metal lath and plaster on one side	.55
Studding with metal lath and plaster on both sides	.33
Studding with metal lath and plaster on both sides and 2-in. space filled with insulation	.12
Hollow tile, 4-in., no plaster	.39
Hollow tile, 4-in., plastered on both sides	.33
Brick, 4-in., plastered on both sides	.37
Wood door, 1-in. thick, in partition	.43

Ceilings and Floors:

Average wood floors	.28
Average concrete floor	.33
Average well-built wood roof	.20
Average well-built concrete roof	.25
Plastered ceiling, no attic floor or insulation above	.55
Plastered ceiling, 4-in. joists and 1-in. wood floor above	.44
Plastered ceiling, 4-in. joists and 1-in. wood floor above, filled with 2-in. insulation	.14
Concrete, 4-in. no ceiling finish, no floor above	.51
Concrete, 8-in. no ceiling finish, no floor above	.41
Concrete, 4-in. plaster underneath, 1-in. wood floor above	.34
Concrete, 4-in. suspended metal lath and plaster underneath, 1-in. wood floor above	.19

Note, floors of the first story of a building can be ignored in the heat leakage calculation for cooling jobs if there is a basement underneath, as basement temperatures are generally lower than those in the rooms above.

126. SOLAR HEAT OR SUN EFFECT

In addition to the heat leakage through walls, due to the difference in temperature between inside and outside air, we also have the radiant heat of the sun to consider, wherever sun strikes any part of the building for certain hours of the day.

Average figures to allow for this heat are as follows:

- 250 B.T.U. per hr., per sq. ft. of glass sky light.
- 15 B.T.U. per hr., per sq. ft. of ordinary roof.
- 10 B.T.U. per hr., per sq. ft. of ordinary wall.
- 100 B.T.U. per hr., per sq. ft. of south windows.
- 180 B.T.U. per hr., per sq. ft. of east windows.
- 180 B.T.U. per hr., per sq. ft. of west windows.

For windows shaded by awnings, merely double the normal temperature difference or heat leakage factor in calculating the total heat leakage and sun effect.

For north windows, or windows entirely shaded by other buildings use only normal heat leakage factor.

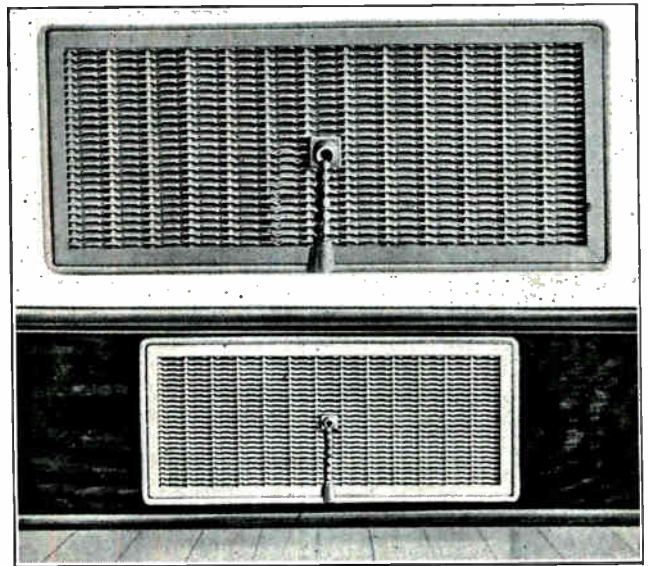

Fig. 166. This view shows grilles for mounting over air duct openings in ceilings, walls or base boards. Note damper control chain and louvres for controlling and directing the air.

127. HEAT CONTAINED IN FRESH AIR

As previously mentioned, considerable heat enters a building with the fresh air taken in for ventilation. This heat is carried by the air in two forms. There is the sensible heat contained in the warm air itself, and there is also the latent heat of vaporization stored in the moisture carried by the air.

To condense this moisture and dehumidify the air requires considerable refrigeration or cooling capacity, as the moisture gives off the same amount of heat when condensed, as was required to evaporate it from liquid to vapor, or 1050 B.T.U., per lb. as we learned in an earlier Refrigeration Lesson.

The table on page 54 gives approximate average amounts of heat that must be removed from each 1000 cu. ft. of air per hour in various localities, to dehumidify the air from its average humidity in that locality to the proper humidity for comfort.

Locality	B.T.U. Per 1000 cu. ft. air per hr.	Locality	B.T.U. Per 1000 cu. ft. air per hr.
Atlanta	636	Miami	544
Boston	506	Minneapolis	466
Chicago	400	New Orleans	544
Cleveland	518	New York.....	529
Dallas	655	Philadelphia	445
Denver	655	S. Francisco	496
Kansas City..	540	San Antonio	670
Los Angeles..	506	Tampa	593

Or we can use an average value of .63 B.T.U. per cu. ft. of air entering the building.

We should keep in mind that at least 3 complete changes of air per hour are required in buildings containing very many people. For example:

- Offices should have 3 changes per hour.
- Stores should have 4 changes per hour.
- Restaurants should have 6 changes per hour.
- Homes should have 3 changes per hour.

In addition to the heat which enters with ventilating air, we also have to contend with the heat in the air that leaks into buildings through walls and through cracks around doors and windows. Figured on average wind velocities of 15 miles per hour, this is equivalent to from 1 to 2 additional air changes per hour on average buildings.

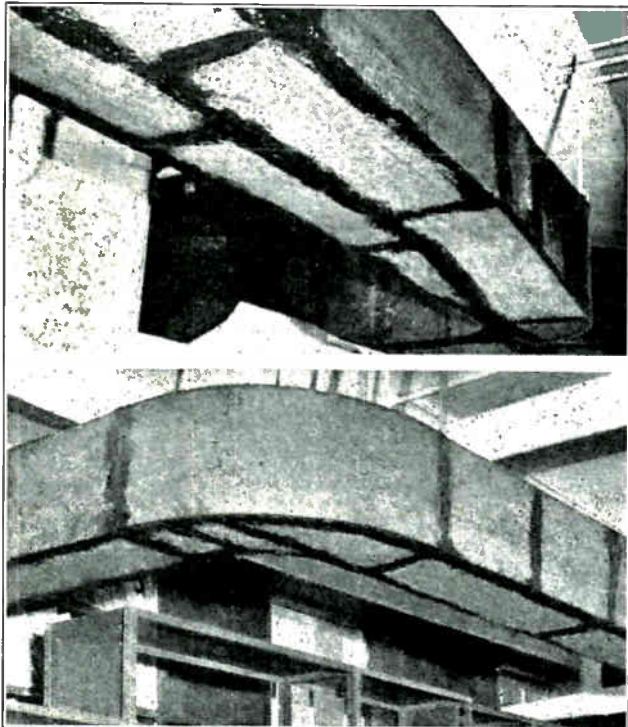

Fig. 167. Two views of air ducts, covered with slabs of cork insulation which is cemented in place and has joints sealed with asphalt cement. Courtesy Armstrong Cork Co.

128. INSULATION OF BUILDINGS

By reference to the heat leakage factors given for various types of building construction, you will note a great reduction in heat leakage per sq. ft. on walls and ceilings that are insulated.

Therefore it is highly important for best economy in air conditioning that buildings be properly insulated. Both the initial size and cost of the equip-

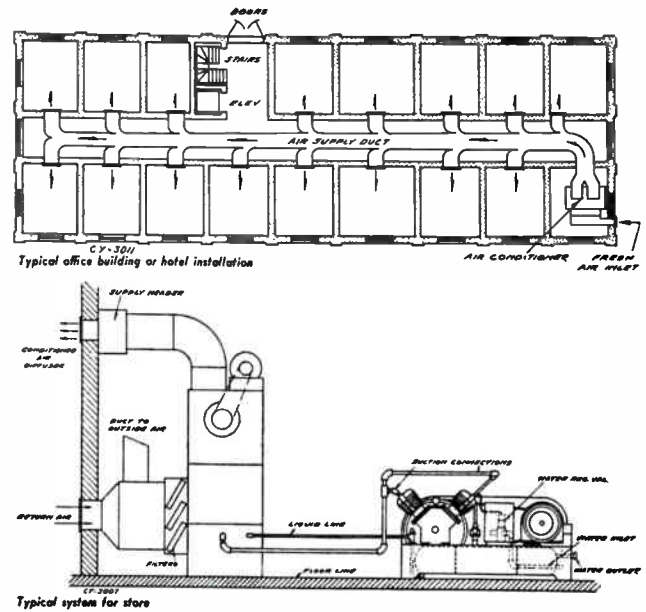

Fig. 168. Top diagram shows duct layout for distributing conditioned air to a group of small offices. Lower diagram shows the air-conditioning unit and refrigerating compressor and condenser for a store or office. Courtesy Carbondale Machine Corp.

ment, and the yearly operating cost can often be cut in half by properly insulating the building. These savings apply to both winter heating costs and summer cooling costs.

Most modern homes that are being built nowadays have insulation included in the walls and ceilings when they are built. Celotex, flax-linum, Cabot's quilt or other forms of fibrous insulation, 1/2" or more in thickness is commonly used between the brick or siding and the plaster.

In some buildings the spaces between studding of walls and joists of ceilings is filled with porous or fluffy insulation material such as rock wool or expanded mica, etc. This form of insulation can generally be applied to older homes that were not insulated when built. Such insulation can often be poured or blown into the space between studding, from the attic.

Awnings over the windows to keep off the heat of the direct sun also reduce the amount of heat entering a building in summer, and thereby reduce the cost of air conditioning.

129. HEAT LOAD PROBLEM IN STORE

Now, with the foregoing data and information, let us calculate the heat load, and the size of refrigerating unit required to cool a given building. Let us assume a simple store or shop building such as shown in Fig. 170, built of 8" brick, furred and plastered, one story or 14 ft. high and 35 ft. wide by 60 ft. long, with no windows on the sides, one 3 x 7 ft. door in the rear, one 4 x 7 ft. door and two 10' x 14' plate glass show windows with awnings in the front.

The building contains a maximum of 15 people, and uses 16 150-watt lights. There is a basement underneath so we can ignore heat leakage through the floor as there are no large motors or heat producing appliances in the basement. Only the roof and west side are exposed to sun, the other sides being shaded by adjoining buildings.

We will assume that the temperature of the air inside the building is to be kept 10 degrees F. below the outside air temperature. We can easily total our heat load in B.T.U. per hr., as follows:

To figure one side wall, we first get the area in sq. ft., or $14 \times 60 = 840$.

Then multiply this by our heat leakage factor of .26 B.T.U. per sq. ft. or $.26 \times 840 = 218.4$.

Then multiply this figure by 10 degrees temp. differential or $10 \times 218.4 = 2184$ B.T.U. per hr. heat leakage through this wall.

Or, to simplify totaling the heat from all sources, we can set down the figures in the following manner (Note: K=heat leakage factor, and TD=temperature differential):

Walls	Size	Construction	Area	K	TD	B T U Per Hour
N. wall	14 x 60	8 in. br., fur. & pl.	840 ft. x .26 x 10			2,184
S. wall	14 x 60	8 in. br., fur. & pl.	840 ft. x .26 x 10			2,184
E. wall	14 x 35	8 in. br., fur. & pl.	490 ft. minus			
	3 x 7 door or 21 sq. ft.		469 ft. x .26 x 10			1,219
Door	3 x 7	2 in. wood	21 ft. x .46 x 10			97
W. wall	14 x 35	8 in. br., fur. & pl.	490 ft. minus			
	308 ft. of windows & doors		182 ft. x .26 x 20			946
(Note: T.D. factor doubled to compensate for sun effect on this wall.)						
Glass windows and glass in door			295 ft. x 1.1 x 20			6,490
(Note: T.D. factor doubled for sun effect on glass with awnings.)						
Door frame	2 in. wood		13 ft. x .46 x 20			120
Ceiling	35 x 60	4 in. pl., 2 in. insul.	2100 ft. x .14 x 20			5,880
(T.D. factor doubled for sun effect on roof.)						
Electric lights			16 x 150 x 3.41			8,184
People, max.			15 x 400			6,000
Ventilation—3 changes per hour			14 x 35 x 60 = 29,400 cu. ft.			
			3 x 29,400 x .63			55,566
Infiltration			2 x 29,400 x .63			37,044
Total						125,914

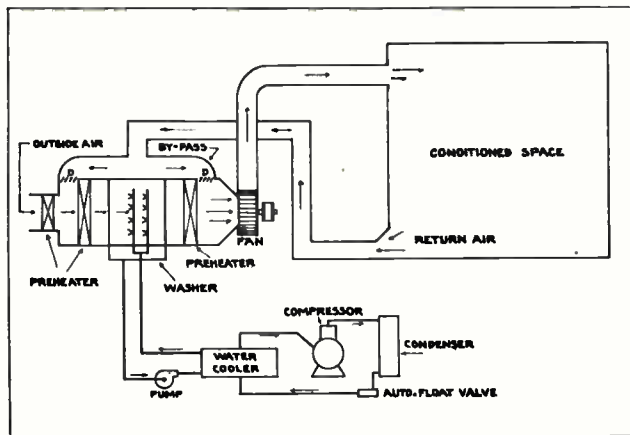

Fig. 169. Diagram of another type of air-conditioning system, showing heater coils, spray cooler and dehumidifier, by-pass dampers, blower, ducts, compressor, etc.

One ton of refrigeration supplies 12,000 B.T.U. per hr., therefore $125,914 \div 12,000 = 14.9$, or approx. 15 ton unit required to cool this building.

If the building already has a hot air heating plant, it may be possible to install the refrigerating unit, humidifier and blower in the basement near the furnace and feed the cool air through part of the same ducts used by the heating plant. Or it may be necessary to install some new ducts to handle the required volume of ventilating and cooling air, and to discharge the cool air at the proper points in the building for good air distribution and circulation.

130. UNIT TYPE COOLERS

In some cases where a hot water or steam heating system may already be installed in the building,

and where it might be difficult to install ducts, it may be desirable to use several individual cooling, circulating and dehumidifying units located at various points in the space to be cooled. See Fig. 171 which shows a direct evaporator of this type, housed in a neat casing and with a fan behind it to circulate the air.

Fig. 172 shows several units of this type installed at various points to distribute cool air in a store. Refrigerant can be fed to all of these coolers from one large compressor and condensing unit located in the basement or in a back room.

If a central plant system is to be used, a unit similar to one of those shown in Figs. 138, 139, 140, 168 and 169 may be used.

131. RESTAURANT COOLING PROBLEM

In another case, suppose we have a job of comfort cooling a one-story restaurant dining room space that is 10 ft. high, 20 ft. wide and 75 ft. long. The walls are brick veneer with sheathing, studding and plaster. Only the roof, south and east sides are exposed to sunlight, and the roof has a 6 x 10 ft. skylight. The north wall has three 3x5 windows.

Let us assume that the restaurant uses 10 200-watt lamps and 10 60-watt lamps. A 5500-watt toaster is used about 2 hrs. per day, and a gas coffee urn consuming about 20 cu. ft. of manufactured gas per hr., is used continuously. This urn has a ventilated canopy which carries away about 70% of the heat produced by the gas.

The restaurant seats about 94 persons during the busier hours and has 6 employees in the dining room space. We will not consider the kitchen range or other heat producing equipment or employees in the kitchen, as the kitchen is not to be cooled by refrigeration, but will have a separate large ventilator fan.

The east wall or front has two 6' x 6' plate glass windows and one 3' x 7' door (2" wood) with 2.5' x 4' glass. The rear partition has two 3' x 7' doors (1" wood) to kitchen.

We wish to cool the dining room space to 12 degrees below outside temperature and kitchen temperature averages about the same as outside temperature and is separated from the dining room by a partition of

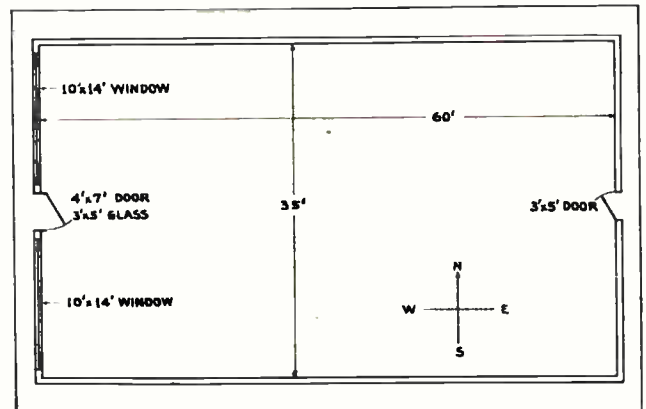

Fig. 170. Floor plan of a simple shop building to be air conditioned. See explanation of heat load calculation in accompanying lesson material.

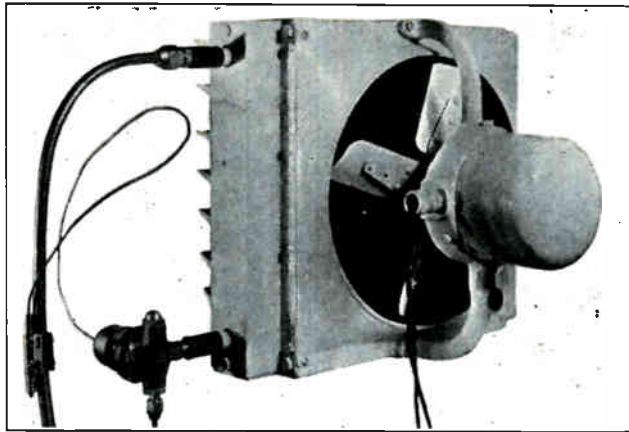

Fig. 171. Compact unit type evaporator or air cooling unit and fan. Note control valve and power bulb on the liquid and suction lines. Courtesy Iig Electric Ventilating Co.

ordinary studding with metal lath and plaster on both sides.

The heat load can be estimated as follows:

			B.T.U.s Per Hr.
Walls	Area	K TD	
S. wall	10' x 75' x .25 x 12.....		2,250
	Doubled for sun effect		2,250
N. wall	10' x 75' minus 45' for three 3' x 5' windows equals 705' x .25 x 12.....		2,115
Windows	three 3 x 5=45' x 1.1 x 12.....		594
E. wall	10' x 20' minus 72' plate glass windows and 21' door = 107' x .25 x 12.....		321
	Doubled for sun effect.....		321
Plate glass windows:			
	two 6' x 6' x 1.1 x 12.....		950
	Doubled for sun effect (with awnings)....		950
Door	(3' x 7' with 2.5' x 4' glass)		
Glass	2.5' x 4' x 1.1 x 12.....		132
	Doubled for sun effect.....		132
Door frame	11' x .46 x 12 (2" wood and double for sun).....		122
W. Partition:			
	10' x 20' minus two 3' x 7' doors or 42' equals 158' x .33 x 12.....		626
Two 1" wood doors:			
	3' x 7'=42' x .69 x 12.....		348
Roof (average wood) 20' x 75'=1500' minus 6' x 10' skylight equals 1440' x .20 x 12....			3,456
	Doubled for sun effect.....		3,456
Skylight	6 x 10 x 250 (sun effect).....		15,000
Skylight	6 x 10 x 1.1 x 12 (leakage).....		792
Ventilation	10 x 20 x 75=15,000 cu. ft. air space, 6 changes per hour:= 6 x 15,000 x .63.....		56,700
Infiltration, 2 changes per hour := 2 x 15,000 x .63.....			18,900
94 people, cus- tomers sitting	94 x 400.....		37,600
6 employees, light work	6 x 600		3,600
Lamps.....	10 x 200W x 3.41		6,820
Lamps.....	10 x 60W x 3.41		2,046
Electric toaster	5500 x 3.41 = 18,755		
Divided by 12 as toaster is only used 1/12 of day. 18,755 ÷ 12 =			1,563
Coffee urn	20 x 500		10,000
			Total 171,044

Then $171,044 \div 12,000 = 14.25$ tons of refrigeration required, or a 15 ton unit would be proper size.

By following this same procedure, it is a simple matter to calculate the heat load and size of cooling unit required for a small private office, living room, bedroom, or complete home, or most any other type of building.

In addition to the central air conditioning plants and room coolers previously described, some companies make complete individual air-conditioning units for use in commercial buildings, store rooms, etc. See Fig. 173.

Some of these units contain their own water cooled compressor and condensing unit, while others are connected by copper tubing to liquid and suction lines of central condensing units. Steam coils are also provided in many of these units for winter heating.

132. INSTALLATION AND TESTING

When connecting up evaporators and condensing units for air conditioning systems, sweated or soldered connections are preferred for all liquid and suction lines.

Copper tubing lines of ample size should be used, depending on the size of the units and the length of the lines. Otherwise resistance to the flow of liquid and gases may restrict proper operation of the unit. Manufacturers of refrigeration units or air conditioning equipment usually specify the proper size of lines, depending on the type of refrigerant used.

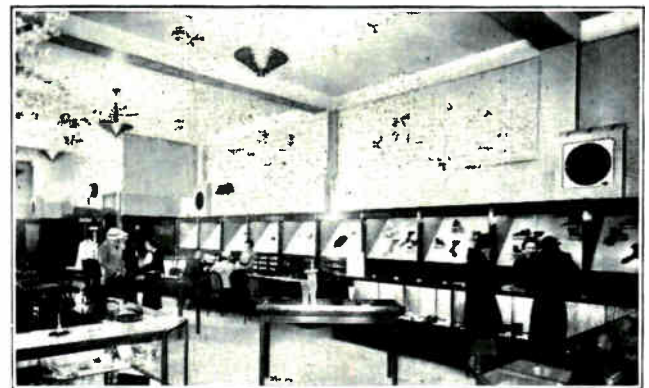

Fig. 172. Store equipped with unit type air coolers located above show cases. Courtesy Iig Electric Ventilating Co.

Liquid and suction lines should be covered with insulation to prevent sweating or dripping due to condensing of moisture, which would occur if the air were allowed to contact these cold lines.

Some small air conditioning systems use methyl-chloride, but most large systems use Freon, because of its greater safety factor. Some systems use Carrene, and as previously mentioned, others use steam jet systems and chilled water.

After installing any air conditioning system, all lines and units should be carefully tested for leaks before charging the system with refrigerant.

Carbon-dioxide gas, which can be purchased in metal drums, is very good for pressure testing air conditioning lines and systems. The CO₂ can be

fed through a pressure reducing valve, until proper pressure is built up in the system, as shown by a pressure gauge. Then inspect and clean all joints and cover with soap suds or liquid soap to test for leaks while under pressure.

After testing for leaks, if the system is leak proof, allow the CO₂ gas to discharge to the air. It is harmless. (Note: Never use compressed oxygen for testing refrigerant lines, as it is explosive.)

Next purge all remaining CO₂ and air from the lines and parts, with refrigerant gas as explained in earlier lessons.

Extreme care, good workmanship and critical inspection and testing should be exercised on all air conditioning installations. Also consult local authorities or ordinances on who is permitted to install certain types of large systems in cities, or in public buildings. Strictly follow all local safety rules and code rules.

After an installation is complete and ready to start in operation, observe the following procedure before starting the condensing unit: (1) check

compressor and motor for proper oil content and lubrication; (2) open the receiver intake valve between condenser and receiver; (3) open discharge valve on compressor head; (4) open return or compressor intake valve. After opening these last two valves, close them back part way until gauges operate smoothly when compressor is running; (5) slowly open the king valve or refrigerant supply valve at the receiver discharge line; (6) open solenoid valve by means of control switch or thermostat. If all electrical circuits are complete the pressure control should then start the motor as soon as back pressure builds up on the low side; (7) check the condenser cooling water supply, open the hand valves and see that the automatic water flow control valve operates properly to control the flow of condenser cooling water according to the load on the unit; (8) See that pressure control switch is properly connected to both high and low sides of the compressor, and that it is operating properly to shut off the unit before head pressure gets too high or back pressure too low. **This is an important safety precaution.** (9) See that solenoid valves and expansion valves at evaporators are properly working and that the expansion valves are properly adjusted for the desired evaporator temperatures of 37 to 39 degrees F.

Service requirements for refrigerating units of room coolers and air conditioning systems are similar to those previously explained for domestic and commercial refrigerators.

Now, after careful study and review of this important and valuable instruction on air conditioning, keep ever on the alert for opportunities to apply your knowledge to increase your earnings, whether working for some refrigeration and air conditioning company, or selling, installing and servicing refrigeration and air conditioning equipment in a business of your own.

This is one of the greatest fields of opportunity for well trained, "live wire" electrical and refrigeration men.

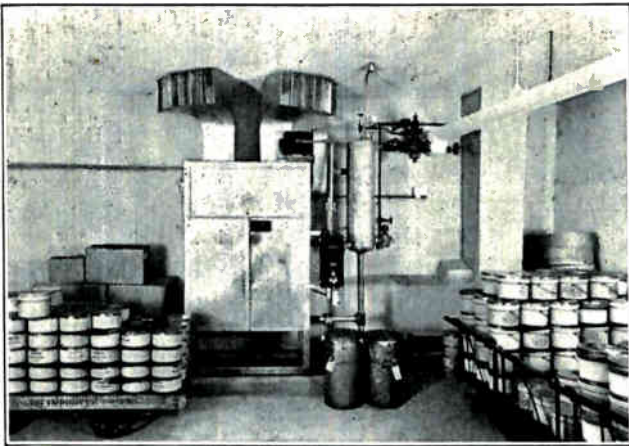

Fig. 173. Commercial unit type air conditioner for storage rooms, etc. Courtesy Carrier Corp.



ESTABLISHED 1899

COYNE*Electrical School*

CHICAGO ~ ~ ILLINOIS



COPYRIGHT 1942

RADIO

Radio Field Opportunities
Radio Principles, Wave Form Energy
Sources of Radio Energy
Oscillating Circuits
Signalling and Modulation
Types of Antennas
Radio Reception
Tuning Coils and Condensers
Crystal Detectors
Radio Symbols
Vacuum Tubes

RADIO

While Radio today has grown to such tremendous size, that it is practically an independent and separate industry by itself, it must be remembered that fundamentally and basically, **RADIO IS A BRANCH OF ELECTRICITY.**

Radio, as a study, is **NOT** a separate subject from Electricity, but rather a new or different application of already known electrical principles and circuits.

For this reason, we have always felt that getting a thorough and complete knowledge of electricity **FIRST**, is the best way to be able to thoroughly master Radio and its associated fields.

You will find that the knowledge of Electricity and Electrical Equipment that you have obtained so far in your training will be of tremendous value and help to you in your study of Radio. You will also be much better qualified for profitable work in sales and servicing by your general knowledge of electricity than you would be if you took only a special Radio training which would not include that valuable and necessary ground work of the laws, principles, and many different applications of Electricity.

As you proceed with your Radio training, you will realize, more than ever before, the great advantage of having studied Electricity **FIRST**.

We consider it to be of utmost importance to help our students increase their earning power as much as possible. This objective has been kept constantly in mind throughout your electrical training and it is also the reason for preparing this additional radio instruction material.

It is not the purpose of these sections to cover the theory of design or other highly technical problems. We are concentrating instead on the general principles of Radio transmission and reception, and the care, operation, and servicing of Radio receivers, amplifiers, public address equipment, etc.

We have tried to give you the necessary training to help you profit from the splendid opportunities in Radio work without including a lot of dry, unnecessary theory that you may never use.

1. OPPORTUNITIES IN RADIO

Although Radio is one of the newest branches of electrical work, it has grown to such a tremendous size during the past few years that it now offers a vast amount of interesting and profitable work for the man with the **RIGHT KIND OF PRACTICAL TRAINING** in **ELECTRICITY** and **RADIO**.

There are over 25,000,000 radio receivers of various types in use in homes in this country alone, and new ones are being made and sold at the rate of several million per year. The installation and servicing of these sets, as well as the repairing and remodeling of older types, creates a splendid field for practically trained Radio service men, working for dealers, or operating a business of their own as a dealer, selling radios, and doing service and repair work for their customers.

A great number of trained men are also required for inspection, test and research work in the factories where these sets are made.



Fig. 1. Main transmitter panel of WLW, Crosley Radio Co.'s large 500,000 watt broadcast transmitter. Only men with thorough training and a good knowledge of electricity and Radio are qualified to operate a station such as this.

Radio receivers are also becoming a very popular addition to the modern automobile and already there are over 5,000,000 auto Radios in use in this country, thus creating more jobs for the trained service man. Radio service work is one of the most profitable branches of work in this field, and offers more numerous opportunities in most any part of the country than do many other branches of Radio.

There are also many splendid opportunities for Radio operators in broadcasting stations, commercial Radio stations, aboard ships, on passenger aircraft, at airports, etc. These jobs provide very fascinating work and pay good salaries to properly trained men who operate, adjust, and service the transmitting equipment, and in some cases send code messages where Radio telegraphy is used.

Modern hotels and apartment buildings are very often equipped with elaborate radio service to all of the rooms, and require a vast system of wiring, outlets, controls, and amplifiers which must be installed and then maintained and serviced by properly trained men.

Public address systems with their powerful amplifiers and huge speakers are becoming very common and are extensively used in schools, auditoriums, theatres, churches, ball parks, amusement parks, sound trucks, stores, and now even in factories.

Installing, operating and servicing this equipment creates another profitable field for trained men.

Talking picture equipment in movie studios and in the thousands of theatres throughout the country also uses radio amplifiers, microphones, speakers, etc., similar to radio equipment, and any man with a good knowledge of practical electricity, radio and sound can easily understand and handle this equipment.

Then there is the field of television, which is steadily growing and developing and which will create a demand for service men with a good knowledge of Radio amplifiers and equipment, and a knowledge of the operating principles, care, and adjustment of the television apparatus. In the very near future this branch may offer some of the most fascinating and profitable work in the Radio field.

In addition to the opportunities offered in employment by various manufacturers and dealers, shipping organizations, commercial land stations, broadcasting stations, aviation interests, theatres, etc., Radio offers wonderful opportunities for building up a small business of your own, because it requires very little capital and equipment to start a radio service shop, and your general knowledge of both electricity and radio should qualify you for selling, installing, and servicing any ordinary type of radio equipment.

You may soon be operating a very profitable business of this kind, or making good money as a side line from your regular employment.

Here is another important advantage to having a thorough knowledge of ELECTRICITY along with your Radio training. For example, if you are em-

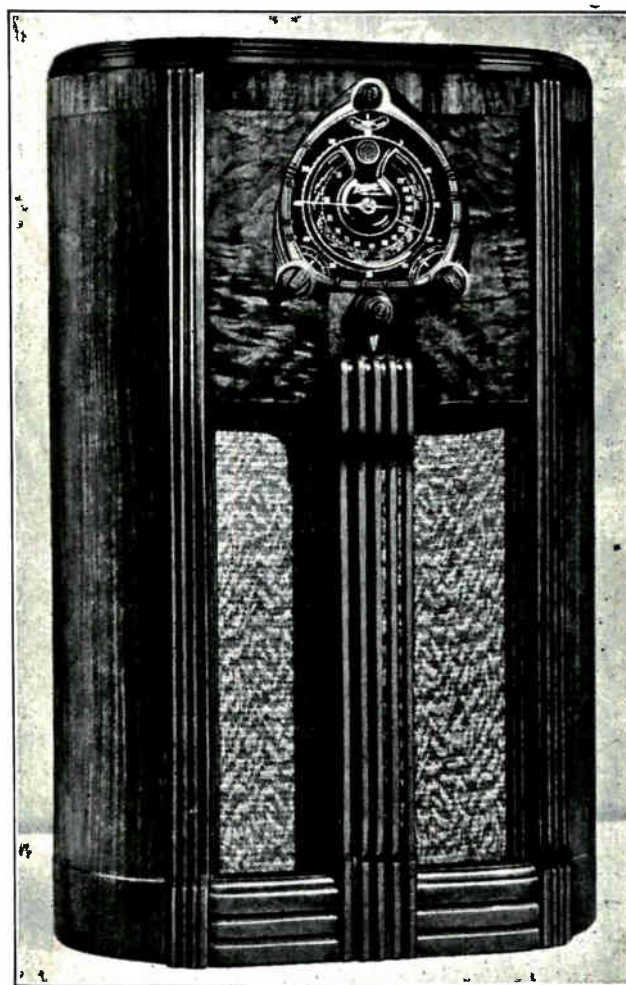

Fig. 2. Console type of radio receiver. Thousands of these sets are in use in homes throughout the country. (Photo courtesy of Zenith Radio Corp.)

ployed as a Radio service man or if you are operating a business of your own and doing Radio work, you will find that you can increase your income by being able to do Electrical work as well, such as installing convenience outlets for Radio receiving sets, etc.

Radio service men often have need for a knowledge of house wiring, installing outlets, etc. Very frequently long, unsightly extension cords running around the room, under rugs, could be eliminated by installing a convenience outlet in close proximity to the Radio receiver.

When the convenience, advantage and low cost of such an outlet is suggested to the home owner or housewife, they are often willing to have the job done, but most Radio service men are not trained to do work of this kind and either have to pass the job on to someone else to do or let it go entirely.

This is just one example of the value of increasing your knowledge in every way you possibly can, and we feel sure that when you have been qualified by a thorough training in the many branches of the great field of ELECTRICITY, you will realize more fully the importance of the slogan, "The more you learn, the more you earn."

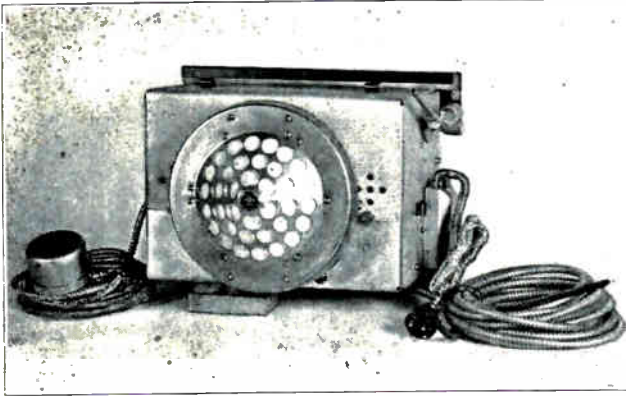

Fig. 3. Automobile radio with shielded conductors for preventing inductive interference from the car ignition system. Millions of automobiles are already equipped with radios of this or similar types. (Photo courtesy of American Bosch Magneto Corp.)

2. EARLY RADIO DEVELOPMENTS

The term Radio is a rather new one, coming from the word radiate, and applies particularly to the general radiation or broadcasting of messages and radio entertainment and education.

Before 1920 when radio broadcasting began to get its start, the term **wireless** was used almost entirely with reference to such equipment.

The first known attempts at wireless communication were made by Professor Steinheil of Munich, Germany, in about 1837. Approximately thirty years later, between 1860 and 1870, a famous mathematician in England named Maxwell proved by theoretical analysis and calculations that wireless communication was possible, but Maxwell did not put his ideas into practical operation.

The next development along this line was made by Heinrich Hertz of Germany, who within a few more years discovered and established the various laws of electric wave transmission, or transmission of energy through the atmosphere without wires. The laws established by Hertz are still used and found dependable today, so Hertz is often called the founder or inventor of wireless.

Due to his early death, Hertz was unable to complete this work and put his discoveries into actual practice, but very shortly afterward Marconi successfully accomplished the first wireless communication, thus completing the work started by Hertz and also proving that such communications were possible over great distances. For this reason Marconi is also often called the father or inventor of wireless.

In early years wireless communication messages were sent from point to point by means of codes signals, using the same general principles of transmission and reception as are used today, but with much cruder and more elementary types of equipment.

The first highly valuable use of wireless was to establish means of communication between ships and land stations, from one ship to another, and particularly for sending distress signals in case of a ship in trouble. This is still one of the very valuable and extensive uses of modern radio equipment.

The first transmission of wireless energy was accomplished by means of what was called a **Spark Transmitter**. These transmitters made use of a high-voltage spark or arc across a pair of adjustable electrodes, to set up high frequency current or oscillations in a local condenser and inductance coil circuit, and also in the antenna and ground circuit.

This high frequency energy in the antenna circuit sets up combined electro-static and electro-magnetic waves of energy which are transmitted a considerable distance through the air, of course becoming weaker and weaker as the distance from the transmitter is increased.

An ordinary telegraph key was used to interrupt or break up this energy into dots and dashes, or code signals. These signals were then picked up at a distance by another aerial and detected by means of a coherer, or device somewhat similar to the crystal detectors with which you may be familiar.

The coherer consisted of a small tube of insulating material filled with small particles or filings of iron or magnetic material, which had a tendency to draw and cling together when current impulses were passed through them, thus increasing and decreasing the resistance of a local battery and headphone circuit in which they were connected.

In this manner the very feeble signals picked up



Fig. 4. This view shows a radio receiver installed in a mail plane, for use in receiving weather reports and instructions from ground stations. (Photo courtesy of National Air Transport Co.)

by the aerial and applied to the coherer caused its resistance to vary and produce a sort of valve action, which set up current impulses from the local battery through the headphones, thus making audible signals. Fig. 7 shows a sketch of an early device of this type.

In this figure small metal plates "C" and "Cr" are used for the radiating and collecting system instead of using aerials and grounds. A simple set up of this type will actually send enough energy through a space of 5 to 50 feet to operate a bell by means of a battery and a sensitive relay. Signals can be heard in headphones a much greater distance.

With this type of wireless transmitting and receiving equipment signals could be successfully transmitted and received only a very short distance.

A little later the crystal detector came into use and, being much more sensitive to feeble electric impulses, made possible the detection of signals over distances of quite a few miles.

In the early part of this twentieth century came the invention of the vacuum tube, and its development and perfection made possible wireless telephony or voice transmission in addition to code signals. The vacuum tube also made possible broadcasting and reception of radio entertainment and education as we know it today.

It was not until about 1920 that this means of radio transmission and reception became popular for the purpose of entertainment, thus making a general demand for radio equipment in the homes throughout the country, and making much more efficient and reliable the equipment used for sending commercial messages and radio telephone conversations.

3. WAVE FORM ENERGY

As radio signals are transmitted through space by energy in wave form, it is very important in beginning the study of radio to first obtain a general knowledge of wave form energy and how it is produced and transmitted.

Almost everyone has seen waves in water, set up by wind or by dropping some object into it. These waves represent traveling energy, as can be observed from the way they will bob a small boat up and down, or even rock a large steamer. The small circular waves set up by dropping a stone in a pond,

and which radiate outward in all directions from the source, gradually dying out in the distance, are very illustrative of the nature of radio waves set up by a transmitting antenna.

Let us next consider sound waves which although invisible are very common, and which you already know something about from explanations in an earlier lesson on telephones.

You will recall that sound is also energy in the form of air waves, and is created by anything that sets up vibration of the air. See Figs. 108 and 109 in the Telephone Section B-3.

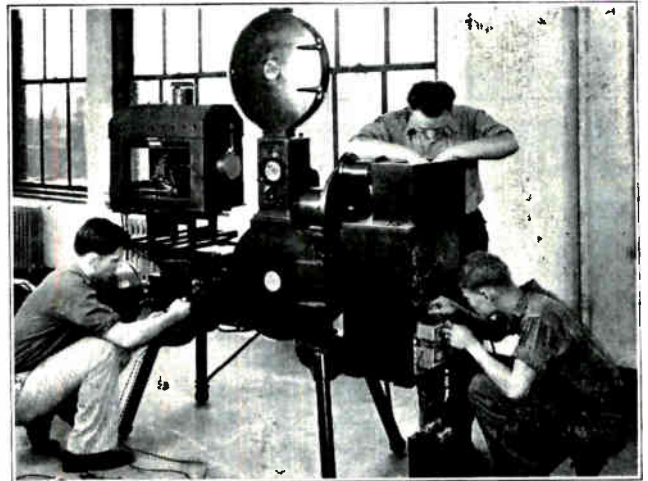

Fig. 6. Film scanning machine of a television transmitter. This machine makes possible the transmission of a talking picture which can be received in the home with radio and television receivers.

Air waves or vibrations ranging between 16 and 15,000 per second create audible sounds, or sounds which can be heard by the average human ear. So all frequencies between 16 per second and 15,000 per second are called Audio Frequencies.

A very interesting and important fact to note about sound waves is the manner in which certain objects will vibrate in tune with them if their natural rate of vibration happens to be the same as the frequency of the sound waves.

This can be readily demonstrated with a pair of tuning forks of the same pitch. Striking one fork will set up audible vibrations of the other one some distance away, by the energy radiated through the air.

This same thing is often noticed in connection with the strings of a piano or some other instrument, or even a tin pan, vibrating very noticeably when sounds of the proper pitch or frequency strike them. This principle of tuning is somewhat similar to the action of radio energy between the transmitting and receiving equipment.

Now if sound consists of air waves or vibrations, and will travel through the air, it is easy to see that air must be a conductor of sound.

Sound travels through air at a speed of about 1100 feet per second. Water will also conduct sound and various solids will carry sound more or less according to their nature.

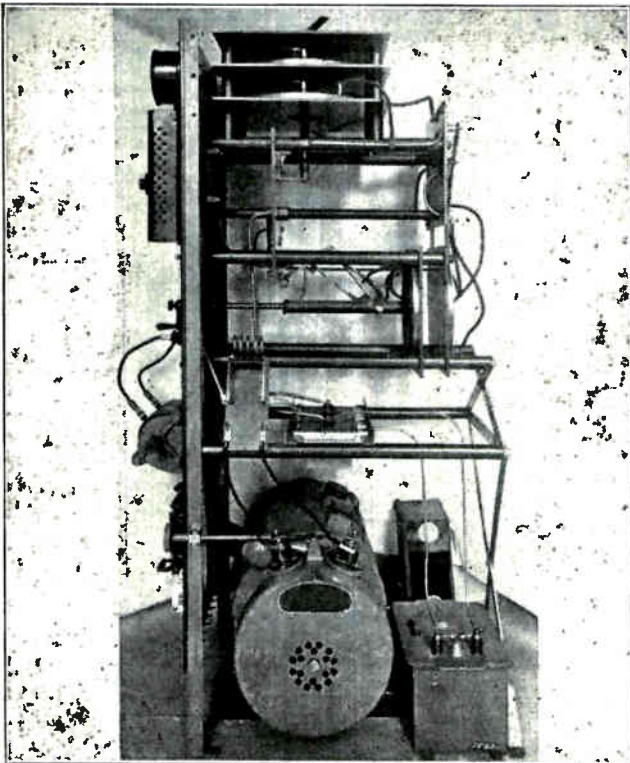

Fig. 5. Side view of a spark transmitter such as formerly used very extensively in ship radio installations. (Photo courtesy of Radio-marine Corp. of America.)

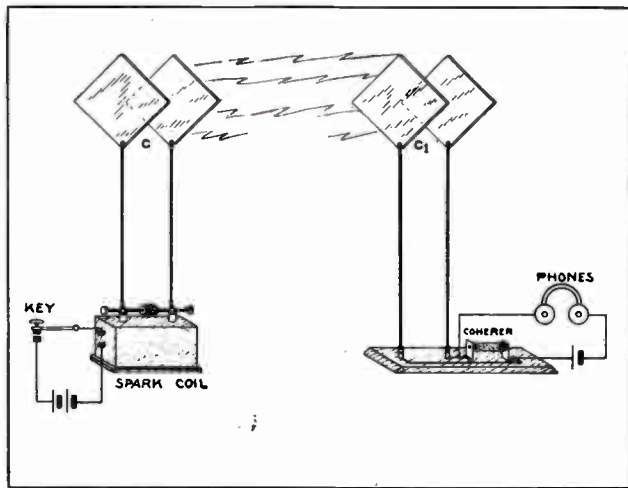

Fig. 7. Diagram of an elementary type radio transmitter. The spark coil on the left radiates from its antenna plates, energy that is received by the coherer and phones on the right.

At the rate sound travels through air we can readily see that it would be impractical for long distance communication, because of the time it would take the sound to travel any great distance.

The time required for a sound echo to return from a distant hill or building well illustrates this. You have probably also noticed the fact that thunder is often heard considerably later than the distant flash of lightning is seen, due to the fact that the sound travels so much slower than light.

4. RADIO ENERGY OR WAVES. NATURE AND SPEED

Radio energy instead of being in the form of air waves is supposed to consist of electro-magnetic and electro-static waves set up around conductors by the high frequency currents flowing in them. These radio waves are thrown off into space in all directions, and for great distances if sufficient electrical energy is used. See Fig. 8 which roughly illustrates radio waves traveling from a transmitter antenna in all directions to be picked up by various receiver antennas.

Radio waves travel through all substances and all space, even where no air is present. So we find

that air, which is the conductor of sound waves, is not the carrier of radio energy.

Radio waves are said to be set up in an invisible something which exists in all space and in all materials. Ether is the name which has been given to the medium by which Radio waves are carried.

Radio waves cannot be insulated by any known material, although they can be shielded or kept out of certain spaces by using metal shields. Large steel buildings often shield their interiors and certain spaces near them in this manner. Natural mineral deposits and hills also produce shielding effects on radio energy.

Radio waves travel at a speed many thousands of times faster than sound waves—186,000 miles per second, or 300,000,000 meters per second, which is the same as the speed of light and electricity.

At this rate a radio signal will travel about 7 times around the earth in one second, or from New York to San Francisco in a time period so short it is usually not worth considering.

5. FREQUENCY AND WAVE LENGTH

Radio waves are much higher in frequency than sound or audio frequency waves. Frequencies above 15,000 cycles per second and up to many millions of cycles per second are known as Radio Frequencies. Above this range are the various light frequencies.

The radio waves used in the ordinary broadcast band range from about 500,000 to 1,500,000 cycles per second. A special band of frequencies from 1,500,000 to 1,600,000 cycles is also used for high fidelity broadcasting.

Fig. 9 shows a comparison of the frequency of sound and radio waves, the upper curve representing a simple sound wave of 5,000 cycles per second, which is quite high frequency in the sound range; and the lower curve representing a constant radio wave of 100,000 cycles frequency, which is in the lower range of radio frequencies.

Radio waves are set up around transmitting antennas by passing through the antenna wires alternating current such as you are already familiar with, except that in Radio work much higher frequency is used.

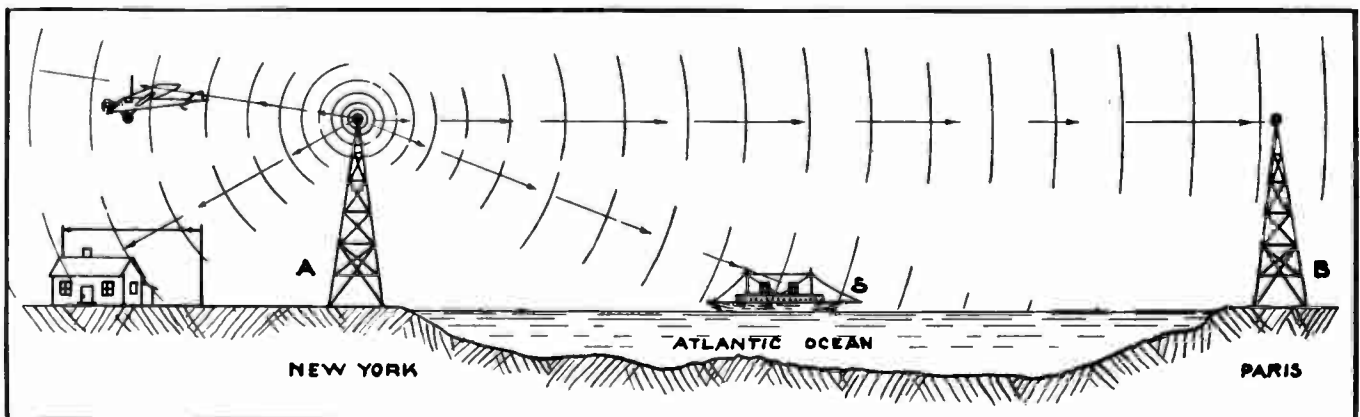

Fig. 8. Diagram illustrating the manner in which radio waves are thrown off in all directions from a transmitting antenna. These waves can be received by a number of different aerials at various distances from the transmitter as shown in the sketch.

In addition to referring to radio waves by their frequency, they are also classified according to **wave length**.

The length of each wave produced by a cycle of the radio frequency current can be accurately measured or calculated.

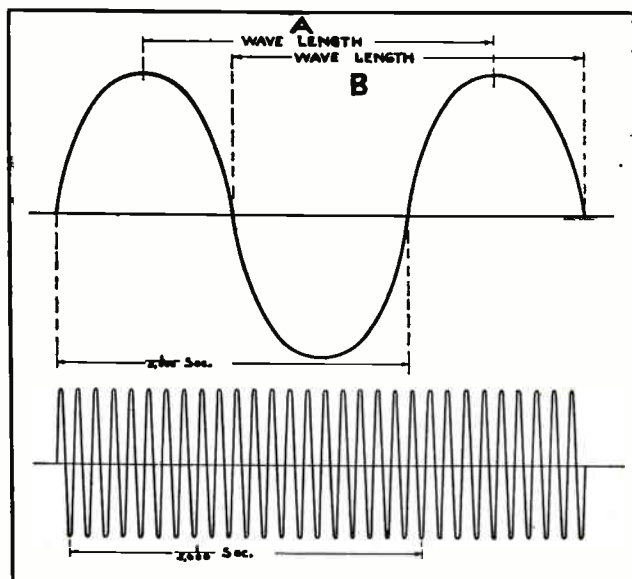

Fig. 9. The above two sets of curves roughly illustrate the difference between the frequency of sound waves and that of radio waves. The contrast between ordinary 60 cycle alternating current and the radio waves would be still greater.

Radio wave lengths are expressed in meters, and one meter is equal to 39.37 inches. The length of one wave can be measured either from the crest of one wave to the crest of the next of the same polarity as at A in Fig. 9, or from the start to the finish of a wave as at B in this same figure.

When the frequency of radio energy is known, the wave length can be easily calculated by dividing the distance in meters which the waves travel in one second, by the frequency or number of waves per second.

For each cycle of current applied to the transmitting aerial there will be one complete wave radiated from it.

Therefore

$$\text{Wave length in meters} = \frac{300,000,000}{f}$$

in which

300,000,000 = speed of wave travel in meters per second, f = frequency of current in cycles per second (C.P.S.)

For example a station transmitting at a frequency of 1,000,000 cycles will have a wave length of

$$\frac{300,000,000}{1,000,000} \text{ or } 300 \text{ meters.}$$

Checking the ordinary broadcast frequencies of 500,000 to 1,500,000 cycles (500 to 1,500 kilo-cycles) in this manner, will show that they cover a wave band of 200 to 600 meters.

This formula can also be transposed and used to find the frequency of a station when the wave length is known, as follows:

$$f = \frac{300,000,000}{\text{wave length in meters}}$$

For example if a certain station is using a wave length of 400 meters, the frequency will be

$$f = \frac{300,000,000}{400}, \text{ or } 750,000 \text{ cycles or } 750 \text{ kilo-cycles.}$$

One kilo-cycle (K.C.) being 1,000 cycles.

One mego-cycle is 1,000,000 cycles (M.C.).

6. SOURCES OF HIGH FREQUENCY ENERGY

We have mentioned that radio waves are set up at the transmitter antenna by the flow of high frequency current in the antenna circuit.

You are already familiar with the nature of alternating current from your study of earlier sections. You will recall that alternating voltage is generated by A. C. generators or alternators at the common frequency of 60 cycles per second for power and lighting purposes. Also that this alternating voltage causes current to flow back and forth through the circuits, setting up a constantly changing and reversing magnetic field around the conductors.

Keep these simple facts well in mind as you study radio and remember that the currents used in radio transmission are simply alternating currents of much higher frequency.

While low frequency current in conductors sets up changing magnetic flux around them, and this flux will induce energy in other conductors or coils even several feet away, high frequency currents seem to throw off or radiate their magnetic and static energy much more efficiently, and much farther into the atmosphere.

Radio signals sent out at this high frequency energy with very low power are often received on the opposite side of the earth.

Ordinary A. C. generators can not be used to produce radio frequency currents, because they cannot be practically designed with enough poles, or operated at high enough speeds to generate the very high frequencies required.

Radio frequency currents can be produced by means of **Special Oscillating Circuits** in spark or arc transmitters, by special design **Inductor Type Alternators**, or by **oscillating circuits using power vacuum tubes**. The last method is the one used in most modern code transmitters and in all broadcast stations.

7. SPARK TRANSMITTER PRINCIPLES

Spark transmitters have become obsolete because of their low efficiency, poor tuning characteristics, and the interference they cause, but the principles of the oscillating circuit used in these transmitters are both very interesting and valuable in getting an understanding of radio energy and circuits.

Fig. 10 shows the parts and circuits of a simple spark transmitter, and the method of producing high frequency radio energy with this equipment is as follows:

Ordinary low voltage, low frequency A. C. is supplied from a light or power circuit to the primary winding of the power transformer "A", which steps

the voltage up to 15,000 volts or more. As this secondary voltage rises up toward maximum value during each alternation it charges the high voltage condenser "C" storing electrical energy in it. Let us assume the polarity to be as shown by the arrows and positive and negative signs for the alternation we are considering.

A quenched spark gap "S.G." consisting of a number of metal plates to form several small gaps in series, is connected in series with the condenser and the inductance coil "L", to complete a closed oscillating circuit.

If this spark gap is properly adjusted, when the voltage from the transformer secondary rises about to its maximum for an alternation, the gap will break down or discharge. As soon as an arc or spark is formed at the gap its resistance is greatly reduced, allowing the condenser to discharge its energy with a rush, through the coil L and around to the negative side of the condenser.

During the condenser discharge the heavy current flowing through coil L builds up a strong magnetic field around it. When the condenser is discharged and its current dies out this flux collapses and induces a voltage in coil L that tends to keep the current flowing in the same direction, thus charging the condenser again with polarity opposite to what it was on the first charge.

As soon as the flux around coil L collapses and its induced voltage dies, and before the spark can completely die out at the gap the condenser discharges right back again in the opposite direction, and once more charges up from the magnetic energy stored in the coil during discharge.

This action continues at very high frequency, the current surging back and forth from several to a few dozen times for each primary charge the condenser is given at the peak of each low frequency alternation from the secondary of the power transformer.

Of course each succeeding oscillation is lower in voltage and power, due to the resistance losses in the closed oscillating circuit and in the spark gap, so with a certain adjustment the series of high frequency oscillations will just about die out by the time the condenser receives its next charge from the low frequency current.

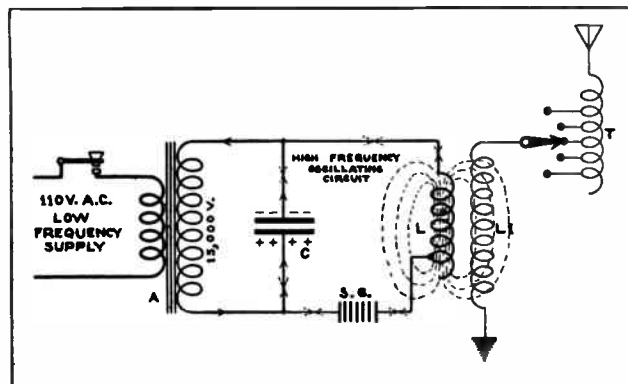

Fig. 10. Diagram of a simple spark transmitter showing the low frequency, oscillating, and antenna circuits.

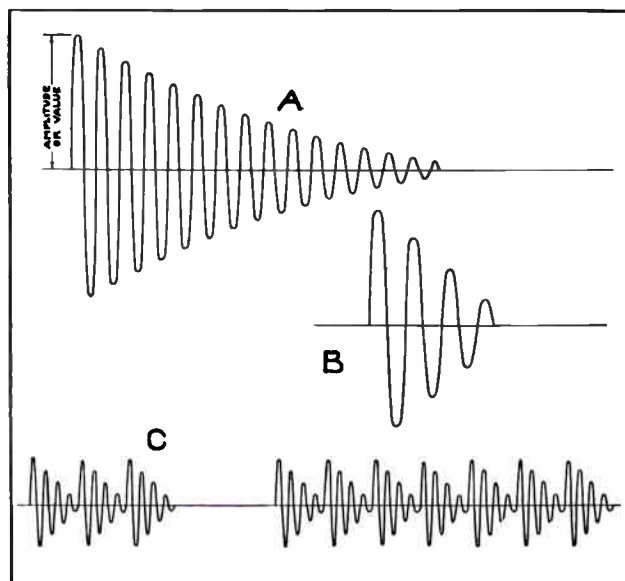

Fig. 11. Curves illustrating the nature of damped wave signals from a spark transmitter. Note how the oscillations die out at the end of each wave train.

The frequency of the oscillations set up in such a circuit depends principally on the inductance of coil L and the capacity of condenser C, and to some extent upon the resistance of the circuit. An increase of either the inductance or capacity reduces the frequency and increases the wave length.

The high frequency energy produced by such a spark transmitter is called "Damped" energy due to the "dying out" or attenuation of each series of oscillations.

Fig. 11-A shows a curve representing one train of oscillations produced in this manner. Fig. 11-B shows a curve of the oscillations set up by a circuit in which a quenched gap is used and so adjusted as to quench out or stop the spark sooner, without allowing the condenser to discharge down to such a low voltage.

If a key is used in the primary circuit of the transformer to make and break the circuit and thus cut up the current flow into dots and dashes, the oscillating circuit will produce short and long series of wave trains, as shown in Fig. 11-C.

As the flux around coil L in Fig. 10, builds up and collapses for each oscillation of current it of course cuts across the secondary L1 in the antenna circuit and induces voltage in this coil which causes current to flow in the antenna circuit and set up radio signals.

The adjustable coil T is the antenna tuning inductance for changing the wave length of the transmitter. This will be more fully explained later.

8. INDUCTOR TYPE ALTERNATORS

The form of damped wave energy produced by a spark transmitter gives a rather broad or harsh sounding note to the signals received, because of the variations in value or amplitude of the oscillations in each wave train or group.

Special high frequency alternators of the inductor type previously mentioned, produce high frequency

current of constant value as shown by the curve at "A" in Fig. 12.

Because this constant value energy is generated continuously by such an alternator when in operation, it is commonly called **continuous wave** or **C. W. energy**.

Continuous wave energy when used for radio telegraphy produces a much purer and clearer signal note than does the irregular or varying amplitude energy of a spark transmitter, and the C. W. is much sharper in its tuning.

The inductor type alternator is often called an **Alexanderson alternator** after the name of its inventor.

These machines can be made to produce alternating current with radio frequencies as high as 100,000 cycles per second. These waves are of course too high in frequency to produce an audible note or signal themselves, but if a rotary interrupter or "chopper" is used to break the high frequency circuit from 500 to 1,000 times per second, a clear musical note or signal will be produced. Fig. 12 "B" shows a curve representing the high frequency wave interrupted at audio frequency by the chopper.

If a key is then used to make and break the high frequency supply from the generator, these audio frequency groups of waves can then be sent out in the form of dots and dashes, as illustrated by the smaller curves at "C" in Fig. 12.

Another method of making the high frequency waves audible, without the use of a chopper, is to use a regenerative receiver which generates oscillations of its own, and which is tuned to heterodyne with the received waves and thus set up an audible beat note. This principle will be explained in a later section.

High frequency alternators are not used as a source of radio energy in modern radio stations on account of their high cost and difficulty of operation, but their principles are very interesting and valuable to know in connection with other radio equipment.

9. CONSTRUCTION AND OPERATING PRINCIPLES OF INDUCTION ALTERNATORS

Fig. 13 is a diagram showing the circuits and principles of one of these machines. The core "C" has two windings, one the field winding F, which is excited by D. C. and sets up a strong magnetic flux through the core and between the pole pieces P and P1; and the armature windings A and A1 in which the high frequency current is induced by increasing and decreasing the flux through the core.

A high speed rotor wheel or disk "R" carries a row of iron plugs or projections around its outer edge, and as the wheel rotates these iron plugs passing rapidly between the pole pieces cause the flux in the core to vary. When a piece of iron is between the pole pieces the magnetic reluctance of the core circuit is lower and the flux set up by coil F is much greater. When the iron piece passes out

from between the poles the air gap is much greater and the flux is materially reduced.

This rapid change in the magnetic flux causes its lines to cut across the armature coils A and A1 and induce very high frequency A. C. voltage in them.

For example in one machine of this type the rotor carries 300 teeth or projections and revolves at 20,000 R. P. M., thus producing $300 \times 20,000$ or 6,000,000 cycles per minute; or $6,000,000 \div 60 = 100,000$ cycles per second.

The same results can be produced in these machines by using a steel disk rotor with slots or holes cut in its edge, to form teeth or sections of magnetic material alternating with non-magnetic spaces or sections. This construction is better than using the plugs or projections because it has less air friction or resistance at high speeds. The openings are generally filled in with brass or other non-magnetic material to make a smooth surface and further reduce air resistance.

The larger machines of this type have regular

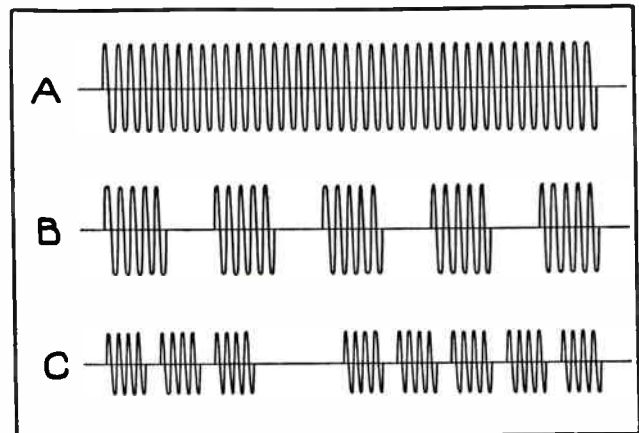

Fig. 12. Curves illustrating the nature of continuous wave (C W) and intermittent continuous wave (I C W) radio signals.

round stator frames in which both the armature and field coils are located, and as the rotor teeth pass by the coil slots the field flux is varied, thus inducing voltage in the stationary armature coils.

By making and breaking the field circuits and interrupting the excitation for a generator of this type, the high frequency output of the armature coils can be cut up into signals for radio telegraph messages. Or the C. W. output can be modulated by a telephone transmitter and voice, and this energy used for radio telephone transmission.

10. VACUUM TUBE OSCILLATORS

By far the most common method of producing pure continuous wave, high frequency energy for modern radio transmitters is by means of a vacuum tube used as an oscillator, or rather as a valve in a circuit in which it sets up oscillations.

Vacuum tube oscillator systems for radio transmitters are much more economical and efficient than the other sources of high frequency so far mentioned. They can be adjusted to produce almost any

desired frequency, and they produce a pure continuous wave that is quite ideal for either radio telephone or telegraph use, and which can be very sharply tuned, thus minimizing interference and making it possible to cover great distances with comparatively small amounts of energy.

Vacuum tube oscillators use high voltage direct current from D. C. generators, rectifiers, or batteries, and convert it into high frequency A. C.

To understand how this is accomplished one must first observe the construction and operating principle of the tube itself. As vacuum tubes are not only used for oscillators but are also the heart of most all modern radio equipment, you should study very carefully the following general explanation of the vacuum tube as an oscillator, and also the more detailed material which is given later on tubes for other uses.

Almost everyone has seen ordinary vacuum tubes such as used in radio receivers, and knows that they consist of an evacuated glass or metal bulb containing several internal parts or elements sealed inside, and provided with terminals or connecting prongs to the outside of the insulating base.

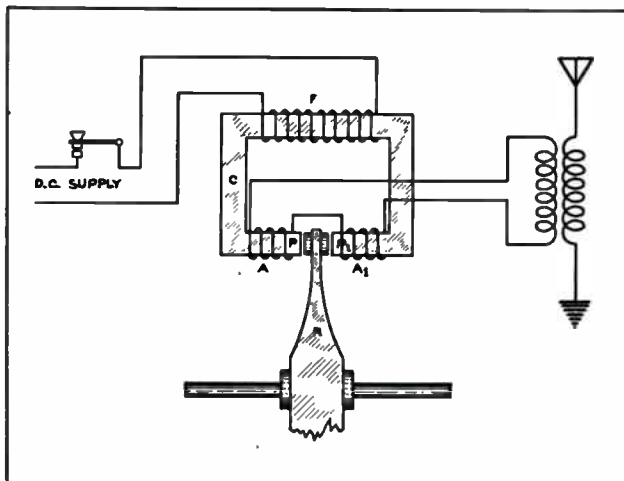

Fig. 13. Diagram illustrating the principles of a high frequency alternator for producing radio frequency energy in earlier types of transmitters.

Many of these small tubes can be used as oscillators, but for radio transmitters larger tubes are generally used, as they will handle more power. Fig. 14 shows one type of power tube used in radio transmitters.

In the simpler three element tubes the internal parts or elements are the Filament, Grid, and Plate.

Fig. 15 shows common symbols used for representing a tube in circuit diagrams. The filament or electron emitting element is shown as a loop of wire. The grid or control element which acts as a shutter to regulate the flow of electrons is shown in the center of each symbol. The plate or anode which is supplied with voltage from a D. C. source is shown at the right in one symbol and at the top in the other one. In Fig. 14 the metal plate can be seen in the center of the bulb with its terminal brought out of the metal cap or tip on the bottom of the tube. The plate is often in the form of a slightly flattened or oval cylinder and the grid and

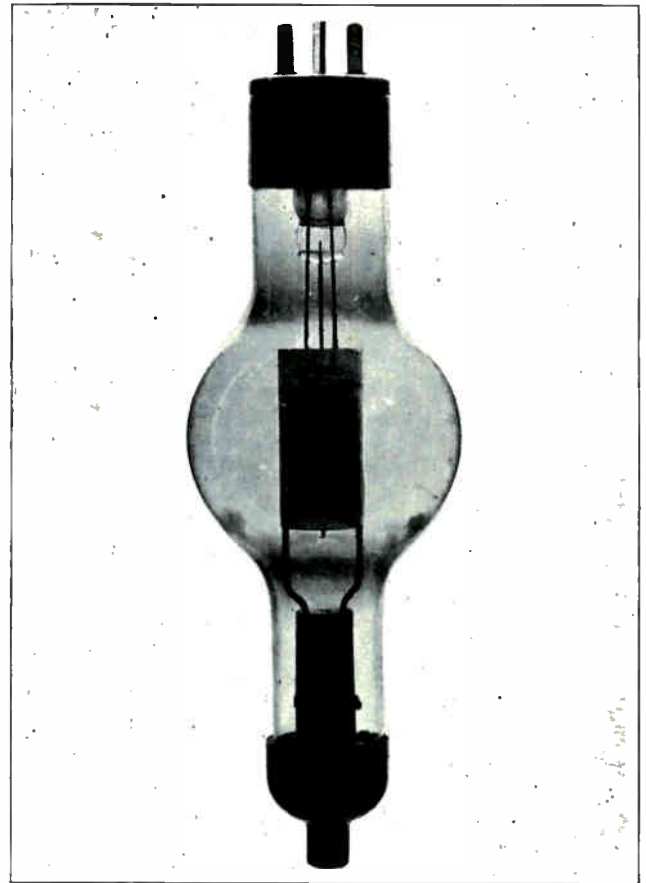

Fig. 14. Photo of a large vacuum tube such as commonly used in radio transmitters.

filament are inside it. Their leads are brought out at the top of this tube.

We do not need to go into much detail in regard to the construction or characteristics of vacuum tubes at this point, to enable us to understand their use as oscillators or producers of radio frequency energy.

11. OPERATION

Fig. 16 shows a tube connected in a simple circuit with the necessary devices for setting up high frequency oscillations. By referring frequently to this sketch it will be easy for you to understand the following explanation of the action of the tube as a valve, and its function as an oscillator.

When the filament is heated by current from the low voltage battery "A," it throws off or emits negative electrons by the millions. These little electrons are strongly attracted by the plate which is charged positively by its connection to the positive terminal of the high voltage battery "B." This stream of electrons from the filament to the plate actually constitutes a flow of current according to the electron theory. But considering the more common understanding of current flow, in a direction from the positive terminal of the battery or source, through the wires and back to the negative terminal, let us simply say that the electron-stream completes the circuit by bridging the gap between the plate and filament.

Current then flows as shown by the solid arrows, from the "B" battery through the plate coil L2, to the plate, through the electron stream from plate to filament, and then back to the negative of the "B" battery.

As long as the filament is heated and emitting electrons some plate current will flow from the "B" battery, and this current will vary directly with any change in the number of electrons passing between filament and plate, the current increasing as the electrons are increased and decreasing as they are decreased. As long as there is no change of voltage on the grid the number of electrons does not change and this plate current remains at a certain normal value.

When the filament circuit is first closed, and as the filament heats up and starts to emit electrons, the plate current starts to build up. As this current through coil L2 increases, the magnetic field set up by this coil expands and cuts across the grid coil L1, inducing a voltage in it.

If this grid coil is properly connected so that the lead attached to the grid becomes positive at this instant, this positive voltage applied to the grid causes it to attract more electrons from the filament, and thus increases the plate current to considerably more than normal. This current can only increase to a certain amount because of the limited amount of electrons which can be emitted by the filament. This is known as the saturation point of the tube.

When the plate current stops increasing the flux around coil L2 stops expanding and stops inducing voltage in the grid coil L1. This allows the grid potential to fall back to normal, so the grid attracts

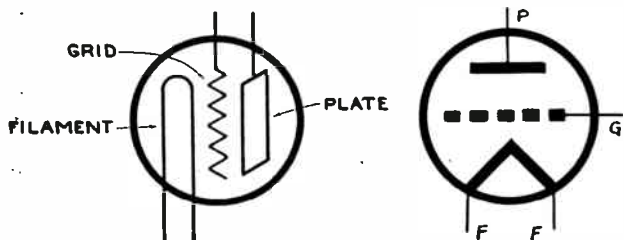

Fig. 15. Sketch of the symbols commonly used for representing a three element vacuum tube in radio diagrams.

less electrons and allows the plate current to decrease.

As soon as the plate current starts to decrease the flux around coil L2 starts to collapse and cuts across coil L1 in the opposite direction to what it did at first. This induces voltage of opposite direction and charges the grid with negative polarity. So we see that alternating current is set up in the grid circuit as shown by the small dotted crosses.

As the grid becomes negative, it repels the negative electrons from the filament and decreases the number that reach the plate, thereby reducing the plate current still further.

The plate current of course cannot fall below zero value so when it finally stops decreasing the flux around coil L2 stops collapsing, and stops inducing voltage in the grid coil to make the grid negative, and this allows the grid to return to normal or zero potential.

As the grid becomes less negatively charged, the electrons from filament to plate once more start to increase and the plate current starts to build up again as previously explained.

This reversing action or cycle keeps on repeating, and as the pulsating current in coil L2 causes its flux to expand and collapse across L1, it induces alternating current in the grid circuit as shown by the small dotted crosses. It also does the same to the antenna coil L, thus setting up high frequency alternating current in the antenna circuit, as shown by the large dotted crosses.

The frequency of these oscillations depends on the inductance and capacity of the tuned circuit, including the coils, the tube parts, and any condensers that may be used to tune the circuit. Inductance determines the length of time required for the current and flux to build up to full value in each direction through a coil. As these coils usually consist of only a few turns and have no iron cores, their inductance is low enough to allow very rapid oscillations, or frequencies, ranging up to millions of cycles per second in some cases.

A variable condenser can be connected across either the grid coil L1, or plate coil L2, and also used to vary the frequency of the oscillations as desired.

12. ARC TRANSMITTERS

Direct current arcs are also used to produce radio frequency energy in certain types of commercial transmitters.

Arc transmitters are supplied with direct current from a D. C. generator or rotary converter, and this current is used to maintain an arc between two copper electrodes. In some cases one electrode is carbon and one copper.

These electrodes are mounted inside a chamber in which an atmosphere of hydrogen is maintained by vaporizing and decomposing alcohol which is allowed to drip into the heated chamber.

In some arc transmitters a powerful electromagnet or blow out coil is located near the electrodes to keep repeatedly and rapidly "blowing out" the arc. See Fig. 17-A.

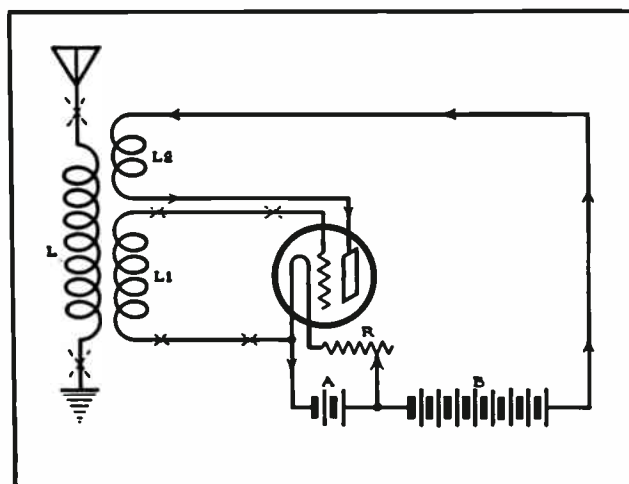

Fig. 16. Diagram of a simple vacuum tube oscillator circuit for producing radio frequency energy. Study this sketch carefully while reading the accompanying explanation.

As long as an arc of this type is operating in a circuit with inductance and capacity, it sets up continuous high frequency oscillations in the antenna circuit. This is due to an interchange of energy between the inductance and condenser varying the voltage at the arc, and the action is somewhat similar to that in spark transmitter circuits, except that with arcs the energy wave is not damped as in Fig. 11, but instead is continuous wave (C. W.) energy as shown in Fig. 12-A.

In Fig. 17 the condenser effect is obtained from the capacity between the aerial and ground as shown by the dotted lines. This effect will be more fully explained later.

The antenna tuning coil L , serves both as an inductance to store magnetic energy for interchange with the condenser and thus set up oscillations, and also to adjust the frequency and wave length of the transmitter.

The high frequency waves emitted by an arc transmitter would not be audible at the receiver unless varied at audio frequency in some manner, or heterodyned by a regenerative receiver. This principle will be explained later.

To provide an audible note a chopper is often used as shown in Fig. 17-A, to vary the frequency of the antenna current at regular audio frequency intervals. When the key is closed it allows the chopper to rapidly and repeatedly short circuit the little coil L_1 . Each time this coil is shorted, current is induced in it from the flux of coil L , and the reaction between the fields of these two coils then slightly changes the inductance of the antenna circuit and thus changes the frequency of the emitted wave.

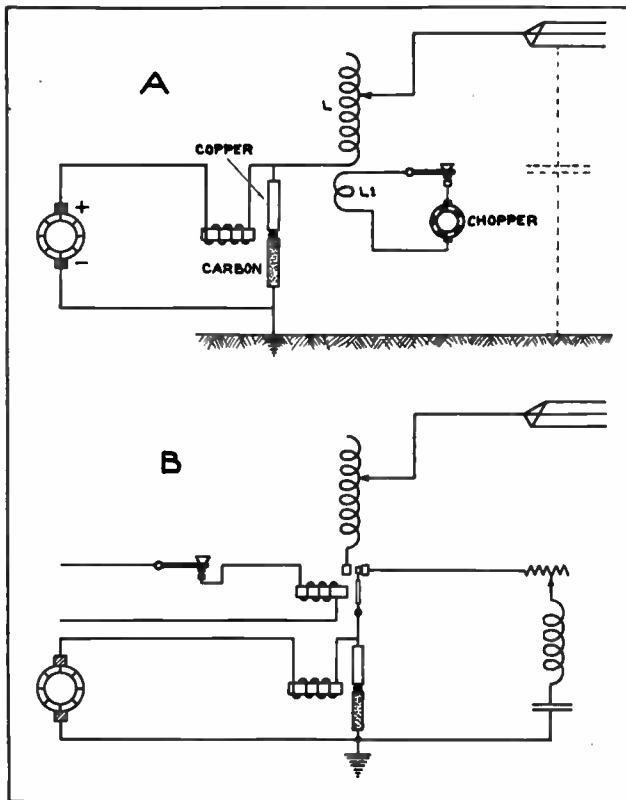

Fig. 17. Two simple sketches of arc type radio transmitters, using different methods of controlling the antenna current for code signalling.

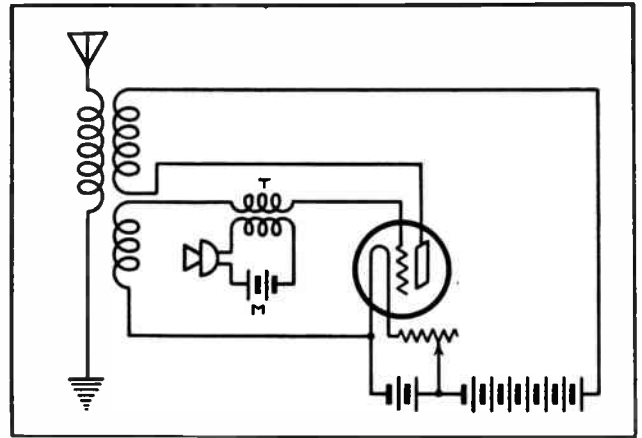

Fig. 18. Diagram showing how a telephone transmitter or microphone can be coupled to an oscillator circuit of a simple radio transmitter, to modulate the carrier wave with the audio frequency voice energy. This circuit uses what is known as grid modulation.

Another method sometimes used is to leave the antenna circuit open normally, as shown in Fig. 17-B, and only close it by means of a key or relay just during the signal intervals.

During the periods the key is not closed and the antenna circuit is open, the oscillations from the arc are maintained through a shunt circuit consisting of a variable resistance, an inductance and a condenser, which are connected in series with each other and then across the arc as shown in Fig. 17-B.

13. SIGNALLING AND MODULATION

Now that we have learned the different methods of setting up radio frequency current or oscillations in various transmitters, let us find out how the signals are impressed on these high frequency Carrier Waves, and conveyed by them in leaving the transmitter.

We have already learned that the high frequency carrier wave necessary for radio transmission is not audible to the human ear, except in the case of spark transmitters where the damped wave trains have audio frequency variations in their amplitude. We have also learned that with C. W. or continuous wave radio energy, the carrier can be made audible for code signals by means of a chopper or by the beat note from a regenerative receiver.

Then for telegraph signals it is only necessary to send this signal energy out in proper code impulses or dots and dashes to form the various letters. This is done by means of a key placed in the circuit so that it will control the power to the antenna, either directly, or by means of a relay in the case of large transmitters.

In order to send voice or music, however, it is necessary to impress the audio frequency sound waves on the radio frequency carrier waves, in such a manner that they will vary or control the volume or amplitude of the carrier wave, directly with the volume and frequency variations of the sound. This is known as Modulation of the carrier wave, by the voice or music waves.

Modulation can be effected by coupling a telephone transmitter or microphone into the radio transmitter circuit so that it controls or varies the output of the radio frequency wave by means of the voice frequency currents from the microphone.

Fig. 18 shows a simple low power radio telephone transmitter circuit with one oscillator tube, and with a microphone coupled to the grid circuit by means of a **Microphone Coupling Transformer "T."**

The operation of a telephone transmitter or microphone has been explained in Art. 91 of Section B-3. It may be well for you to briefly review Articles 88 to 93 in Section B-3 before continuing with this Section.

You will recall that the microphone controls or varies the current from a battery, in impulses that correspond exactly in value and frequency to the sound waves striking the diaphragm.

In Fig. 18 you will note that the microphone is connected in series with a microphone battery "M," and the primary of the coupling transformer. Therefore, the pulsating current set up through this primary coil when voice or music waves strike the microphone diaphragm, induces alternating current of corresponding value and frequency in the secondary coil, which is connected in series with the grid circuit of the oscillator tube. Fig. 19-A and B show curves representing the pulsating D. C. of the micro-

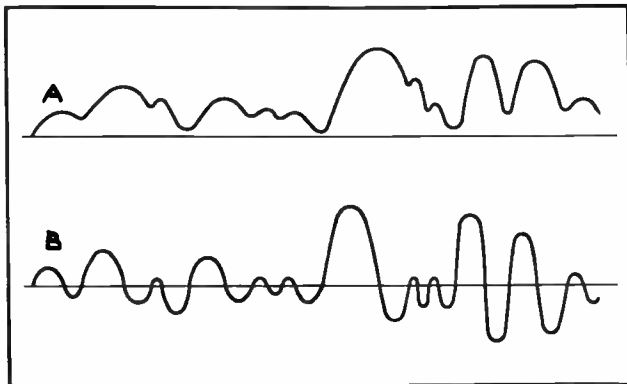

Fig. 19. The curve at A illustrates the nature of the pulsating current set up in the circuit of a microphone. At B is shown the curve for the alternating current of varying value which is induced in the secondary winding of a microphone coupling transformer.

phone circuit, and the varying value A. C. which will be induced by them in the secondary of the coupling transformer. Now you will remember that any change in the grid voltage of a vacuum tube causes a corresponding change in the plate current. So as the microphone transformer supplies alternating voltage of varying value and frequency to the grid of this tube the plate current will vary accordingly. If the tube is already oscillating and delivering a radio frequency carrier current to the antenna, these audio frequency variations impressed on the radio frequency waves will cause them to vary in value; the variation being at audio frequency and corresponding to the original sound waves at the microphone. Fig. 20 shows a modulated carrier wave on which the value or amplitude of the high frequency waves has been varied by impressing the audio frequency energy upon it.

This modulated wave is what reaches the antenna and is sent out through space to reproduce voice and music at the distant receivers.

14. THE ANTENNA CIRCUIT

Now that we know the nature of the energy used in radio transmission and how it is produced, we

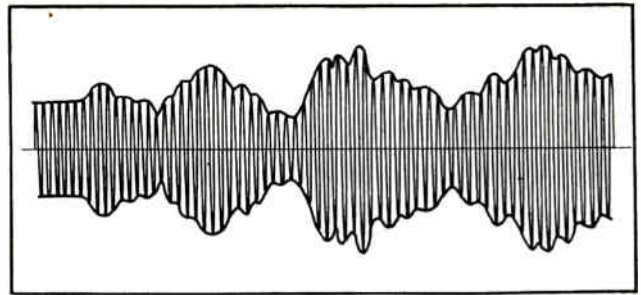

Fig. 20. Curve showing a high frequency carrier wave modulated or varied in value by the audio frequency voice waves.

will next want to know how this modulated wave or energy, is radiated or thrown out into space from the transmitter.

You probably know of course that this is done with an **Aerial or Antenna**, but you may have wondered how current can flow in the antenna as it is not a complete metallic circuit.

When high frequency alternating voltage supplied by the transmitter is applied to the antenna circuit, either by direct connection or by induction to the antenna coil, current does actually flow due to the condenser or capacity effect between the antenna and ground. This current is measurable with special high frequency ammeters of the thermocouple or hot wire or other types. In large high power transmitting stations the antenna current may be over 100 amperes.

From explanations given of condensers in earlier lessons you already know that a condenser consists of two or more conductors or conducting surfaces or plates, separated by insulation of some kind.

Transmitting aerials for medium or long wave stations often consist of one or more long wires, supported horizontally or parallel to the earth's surface. If several parallel wires are used, they are all connected together to form a network. These wires are attached to their supporting poles or towers by high voltage insulators, and are further insulated from the earth by the air between the aerial and the ground.

This construction forms a simple condenser as shown in Fig. 21. The dotted lines simply show that the aerial acts as one plate, the earth as the other, and the air as the dielectric of the condenser.

15. CURRENT FLOW IN ANTENNAS

You have already learned that when D. C. voltage is applied to a condenser it will charge the condenser with one plate or group of plates positive, and the other plate or group negative. We also know that while the condenser is being charged current flows into it, even though it does not pass through the condenser dielectric.

Then when the applied voltage is removed and the condenser shorted or merely left connected in a closed circuit, it will discharge and cause current to flow out of it in the opposite direction to that of the charging current

A condenser can be charged in either direction by simply reversing the polarity of the applied voltage.

You have also learned that if alternating voltage is applied to a condenser by connecting it in an

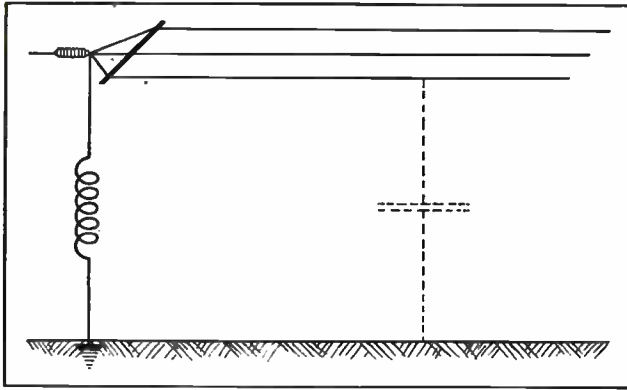

Fig. 21. Sketch showing the antenna circuit of a radio transmitter, completed by capacity to earth. A single wire is often used instead of several wires as shown above.

A. C. circuit, alternating current will flow in the condenser leads as the condenser charges and discharges with the rise and fall of the applied voltage during each alternation. See Fig. 22. The amount of charging current that will flow to a condenser depends directly upon the voltage and frequency of the A. C. energy applied, as well as upon the size or capacity of the condenser.

As radio transmitters supply extremely high frequency to the antenna circuit, and usually at several thousand volts potential, considerable current will flow, even though the actual capacity between the aerial and ground may not be very great in micro-farads.

As the high voltage, high frequency current flows in the antenna of a transmitter each cycle sets up a complete electro magnetic wave, and also a complete electrostatic wave around the antenna.

These waves travel through space, earth and other objects with the speed of light, and when they strike or cut across a receiving aerial they induce very feeble voltages in it.

Transmitting aeriels are not always horizontal, some being merely a vertical wire or mast. There is sufficient capacity between a long vertical wire and the earth, however, to allow current to flow in such antenna circuits. Fig. 23 shows an illustration of electro-static waves leaving a vertical antenna. The magnetic waves are not shown in this sketch.

It is very important that transmitting antenna circuits, including their ground connections be of low resistance, in order to avoid resistance losses as much as possible. Due to the skin effect or tendency of high frequency currents to flow close to the outer surface of a conductor, rather large conductors are often used in transmitting antennas.

16. TUNING AND RESONANCE

We have already learned that a variable inductance, or a condenser can be used to change the frequency or oscillation period of a transmitter oscillating circuit.

The same is true of the antenna circuit and as the length of this circuit, including the antenna, lead in wire, and ground lead, determines the amount of inductance and capacity of the circuit, it

should be made of the proper length for the wave length of the station.

In addition to making this circuit the proper length, variable inductance coils and variable condensers are used, either in series or parallel, to tune the antenna circuit to the frequency of the energy produced by the transmitter. Generally they are connected in series with the antenna for tuning.

When the open antenna circuit is adjusted to the same natural frequency as that of the closed oscillating circuit of the transmitter, the two are said to be in resonance with each other.

Proper tuning of the antenna circuit enables maximum current to flow and produces best results and efficiency with a transmitter.

Tuning of radio transmitters has another very great advantage, in that it makes possible the sending of signals at one certain wave length, which can be received only by receivers that are also tuned to that wave length, without interfering with other stations that are operating on different wave lengths. This makes possible the operation of many transmitting stations at the same time without confusion, and also makes possible the selection of the desired station by the receiver. More about radio circuit tuning, and tuning devices will be given later.

17. TYPES OF ANTENNAS

As already explained, a radio Antenna or aerial consists of one or more elevated wires, or conductors, connected to the radio transmitter or receiver by means of a lead-in wire, running from the near end of the antenna to the transmitting equipment. As previously mentioned, a ground lead and connection is practically always included as part of the antenna circuit.

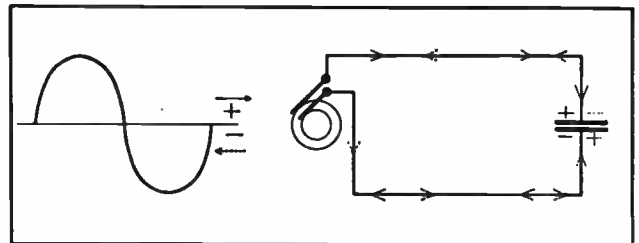

Fig. 22. On the left is shown a curve for one cycle of alternating current. On the right is shown the manner in which the alternations charge a condenser and set up current flow in its circuit.

Antennas may be made of bare copper or bronze wires, or in some cases merely a steel mast or tower is used.

Insulated wires are often used for receiving antennas, as the insulation does not stop the passage of the radio waves which cut across the wire to induce energy in them.

All antennas and lead-in wires should, however, be well insulated from their supports, from any adjacent objects, and from ground. This is particularly important with transmitting antennas which are often supplied with very high voltage, sometimes ranging as high as 10,000 to 100,000 volts in large high-powered broadcast or commercial land stations.

Glass, porcelain and composition insulators of suspension, pillar, and bushing types, are used for insulating antennas, lead-in, and guy wires. Isolantite and Mycalex are trade names for two very common radio insulators.

There are several common types of antennas in use for radio transmission. Some of these are the **Vertical Wire or Radiator**, the **Flat Top Inverted "L" type**, **"T" type**, **Cage type**, **Fan type** and **Umbrella type**. Each of these types has certain advantages for various uses. The **Vertical Antenna** is one of the simplest of all, and consists of a straight vertical wire suspended from some support or wire overhead, or it may be just a steel mast or tower. Antennas of this type are extensively used in short wave transmission.

The **Flat Top Inverted L Antenna** is one commonly used both on land and ship stations, because it is convenient to install. Fig. 24 shows an antenna of this type, supported between two tall masts, above the transmitter building.

These antennas may consist of several parallel wires attached by means of insulators to spreaders at each end. The spreaders are also often insulated again from the supporting cable used to draw the antenna up and hold it in place.

The ends of the parallel wires are all fastened together as shown and connected to the lead-in cable, which should be of the same carrying capacity or area as all of the antenna wires.

With the lead-in wire attached to the end of such an antenna, it is called an inverted L, from its shape or appearance. If the lead-in wire is attached to the center of the flat top section as shown by the dotted lines in Fig. 24, the antenna is then called a "T" type. Flat top antennas of this type are often fitted with tie ropes attached to the ends of the spreaders by means of insulators, and fastened down to the pole or tower, to help prevent the antenna from swaying in the wind. Very much swaying is objectionable as it tends to change the wave length of the antenna, as it moves nearer to or farther from the ground, thus changing its capacity.

Inverted L antennas are particularly convenient for use on ships, and are also used at broadcast stations, commercial land stations, and homes.

These antennas are somewhat directional, that is, they transmit or receive over a greater range in a direction opposite to that in which their free ends point.

In many cases just one large wire or cable is used as an inverted "L" type aerial with very good results.

The T type antenna usually has a slightly lower wave length than an L type of the same dimensions, because the T type is in effect the same as two shorter antennas connected in parallel. Therefore, the capacity remains about the same but the inductance is somewhat less than that of L type antennas.

Fig. 25 shows a **Cage type** antenna which is sometimes used for transmitting stations. These antennas consist of a number of parallel wires held in the form of a tube or cage by hoop-like spacers of micarta or other insulating material. The wires are all brought together at one end of the horizontal cage, and then often continued down in the form of a much smaller cage for the lead-in.

The top view in Fig. 26 shows a **Fan type** antenna in which a number of wires are suspended from the horizontal wire between two masts or towers. The bottom ends of all these wires are brought together to the lead-in wire or cable. Antennas of this type are quite efficient and are used in certain localities.

The lower view in Fig. 26 shows an **Umbrella type** antenna, consisting of a number of wires spread out like spokes of a wheel around one center mast. The tops of these wires are all connected together to the lead-in wire, and their top and bottom ends are insulated from the mast and earth. The lower insulators are generally located some distance up from the ground to give the antenna the proper effective height from earth. Antennas of this type are well adapted to military use and for other portable or temporary transmitters, as only one center pole is needed and it is held erect by the antenna wires themselves acting as guys.

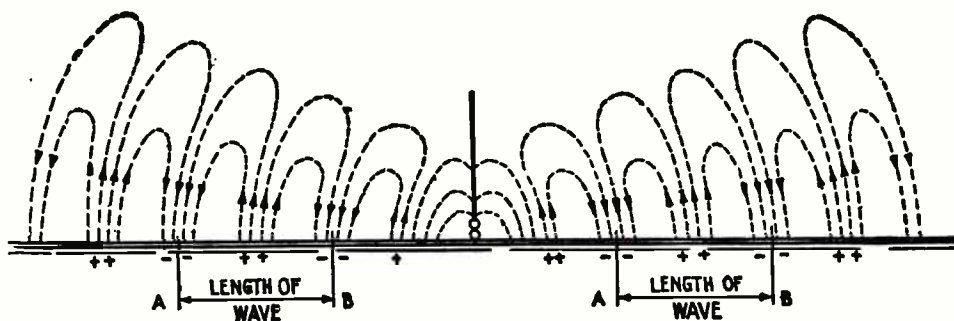

Fig. 23. This diagram shows the manner in which electro-static waves are assumed to radiate in all directions from a vertical radio transmitting aerial.

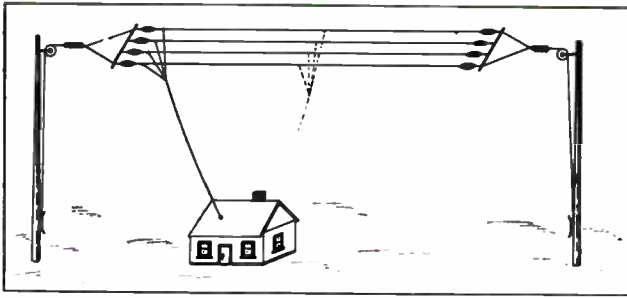

Fig. 24. The above sketch shows a flat top, L type antenna. The dotted lines show where the lead-in would be connected for a T type antenna.

18. ANTENNA HEIGHT AND LENGTH

In general the greater the height of a transmitting antenna, the greater its radiating or receiving efficiency or range, and they should always be high enough to be well above any nearby trees, buildings, hills, etc., if possible.

The length of an antenna depends upon the wave length of the energy it is to handle, and upon the conditions or location. The length should be chosen so that the antenna will have a natural or fundamental wave length bearing a definite relation to that of the transmitted energy.

When it is not possible to use an antenna of the proper length it can be "loaded" with extra inductance in the form of a coil, to increase its natural wave length; or it may have a condenser connected in it to decrease the wave length.

The natural or fundamental wave length of an antenna can be calculated by means of the following formula, if the capacity and inductance are known

$$4 \times V \times L \times C = \text{wave length in meters}$$

in which

V = velocity of radio waves in meters per second

L = Antenna inductance in Henry's

C = " capacity in Farads.

A simpler method of calculating the approximate wave length is as follows: for a 4 wire flat top L antenna with, wires spaced about $2\frac{1}{2}$ feet apart, multiply the entire length in feet, including the lead-in, by 4.5. For "T" type antennas multiply

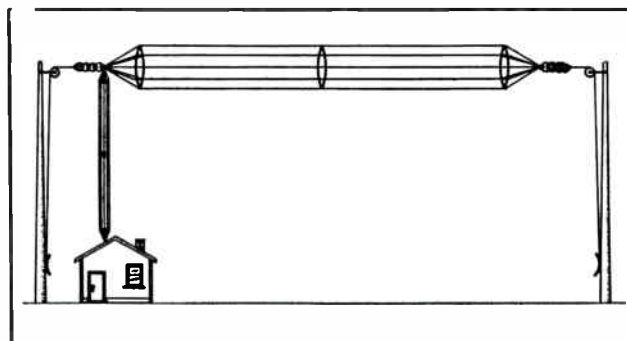

Fig. 25. This diagram shows the construction of a cage type antenna with a cage lead-in.

the length of one end of the flat top and the lead-in by 5.

The height of an antenna also influences its wave length, both by changing its capacity to earth and by changing the length of the lead-in wire.

For example a 4 wire, inverted "L" type antenna with a flat top 50 feet long usually has a natural wave length of about 95 meters at 30 ft. height, 134 meters at 60 ft. height, and 186 meters at 100 ft. height.

The same type of antenna with a flat top 100 feet long has a wave length of about 159 meters for 30 ft. height, 200 meters for 60 ft. height, and 252 meters for 100 ft. height.

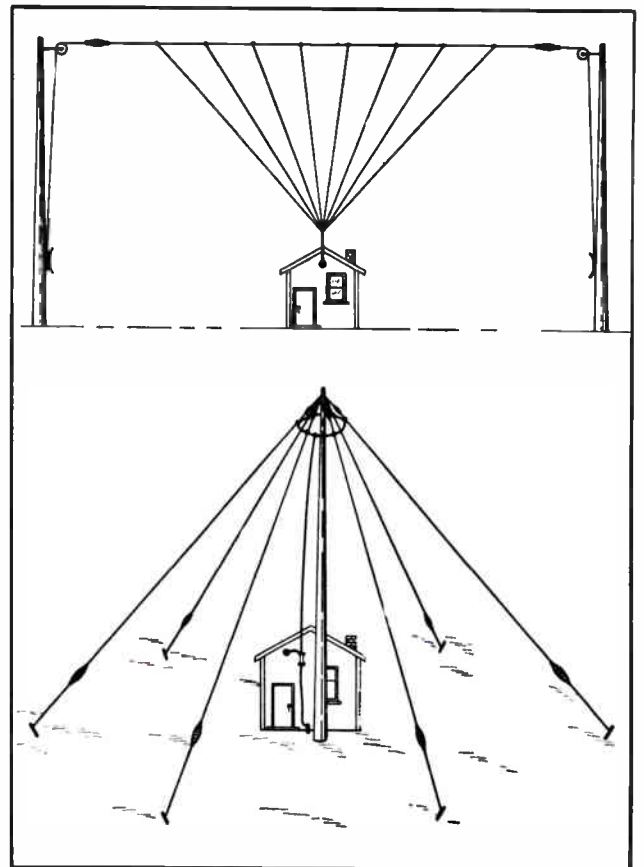

Fig. 26. The sketch at the top shows a fan type antenna and the lower sketch shows an antenna of the umbrella type.

Flat top antennas of the "T" type have somewhat lower wave length for the same dimensions, as can be seen by comparing the following figures with those just given for "L" types.

A 4 wire "T" type antenna with a flat top 50 feet long has a wave length of about 70 meters for 30 ft. height, 117 meters for 60 ft. height, and 173 meters for 100 ft. height.

This "T" type antenna with a flat top 100 feet long has a wave length of about 106 meters for 30 ft. height, 154 meters for 60 ft. height, and 211 meters for 100 ft. height.

If the flat top is lengthened to 200 ft., its wave length will then be about 178 meters at 30 ft. height,

229 meters for 60 ft. height, and 291 meters for 100 ft. height.

Transmitting antennas range from 75 to 600 feet or more in length for broadcast and ship work, up to over a mile in length for some of the very long wave commercial stations.

19. GROUNDS AND COUNTERPOISE

All connections in antenna circuits should be well made and soldered to keep the resistance as low as possible.

It is very important, particularly with transmitting aerials to have good low resistance ground connections, as the current flows through this connection to the earth side of the condenser the same as it does through the lead-in cable to the antenna side.

Good ground connections can be made by driving a long, perforated, galvanized pipe into the ground and pouring salt water into it, to soak through the holes into the soil; or by burying large copper plates or a network of copper wire. Sometimes a water piping system can be used for a ground.

Where it is difficult to obtain a good ground because of soil conditions, or for example in cases where a transmitter is located on top of a tall building, a special wire network known as a Counterpoise is often used beneath the regular antenna, and a few feet above ground or the roof. The ground lead is attached to this counterpoise which serves as the other plate of the aerial circuit condenser. Fig. 27 shows two methods of arranging counterpoise wires.

In some radio stations the same antenna is used both for transmitting and receiving, by using a change over switch to connect the lead-in wire either to the transmitter or receiver as desired. Generally, however, a separate antenna is used for receiving.

20. VERTICAL RADIATORS FOR TRANSMITTING ANTENNAS

The use of this type of radiator is becoming very common for broadcast stations today.

In general, it consists of a radiator of one or more conductors arranged in a vertical position.

The advantage of the vertical radiator lies principally in the fact that it radiates the energy closer to the earth where the receiving antennas are located.

The poorest transmitting antenna may be very efficient in the radiating of R F (Radio Frequency) energy, but very ineffective in serving the area desired, due to too much of the energy being diverted into the air, thereby wasting a great portion.

In general, the use of vertical radiators is an effective and economical means of increasing the service range of a station, over a given area.

Some of the factors which govern the coverage of a station are: power; antenna design; soil conditions, as they determine the decay of waves over the earth; interference from other stations; local noise level; frequency assignment.

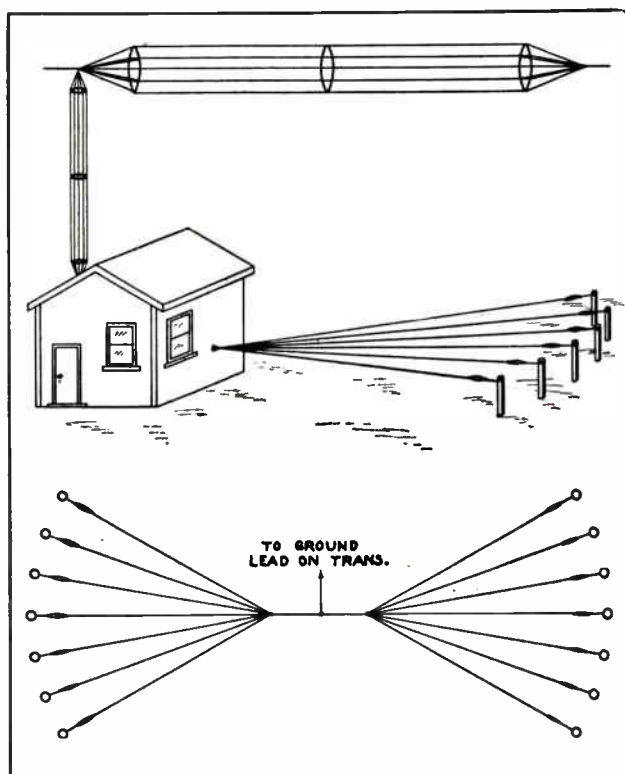

Fig. 27. The upper sketch shows the manner in which a group of wires forming a counterpoise can be used underneath an antenna to take the place of the ground connection. The lower sketch shows a counterpoise which can be used with a T type aerial.

The height of vertical radiators may be expressed in quarter wave, half wave, etc., or in terms of angular measurement 90 degrees, 180 degrees, etc. In order to avoid confusion the actual physical height is generally determined by converting operating frequency into wave length in feet, and multiplying the result by the proper decimal ratio:

$$\frac{300,000}{\text{Freq. Kcs.}} \text{ equals meters. Meters} \times 3.28 \text{ equals ft.}$$

$$\text{Feet} \times .25 \text{ equals the physical height of a quarter wave radiator.}$$

The important factors to consider are safe structural design, and maximum radiating efficiency. The requirements being uniformity of horizontal field pattern (except for directional installations), maximum local signal strength or field intensity, and maximum coverage. In general, the height, shape, and insulation will play a great part in these factors.

The radiators are made up in either guyed or self-supporting types, the self-supporting type being the most economical of the two. See Fig. 28.

In most cases they are constructed of standard structural steel, all sections being galvanized by the "hot dip" process; the zinc coating being used as a corrosion preventative, and affording a high conductivity for R F current, because galvanized structure has low resistance. In cases where such radiators have to be painted as a marker on account of hazard to aviators, the painting should be carried out at widely spaced intervals in order to preserve the conductivity of the coating.

The factors to consider in the insulators used are: wet and dry flashover voltage; continuous operating voltage; proper leakage distance along the porcelain. Voltage requirements may be as high as 100,000 volts.

Porcelain is used because of its ability to withstand extremely high mechanical loads, such insulators being designed so that they are subjected to compressive strains only, using the pushpull type.

Ground systems for this type of radiator are important and will consist of a number of radials at least a quarter wave long made of copper tubing or copper strip. The number of these radials recommended by the FCC (Federal Communications Commission) is a minimum of 70. Such radials, in conjunction with a ground screen which is a net work of wires directly beneath the radiator, constitute the ground system, the screen and radials generally being buried a few inches under the earth.

Vertical radiators may be of the tuned or untuned top type. Tuned top radiators have an added induc-

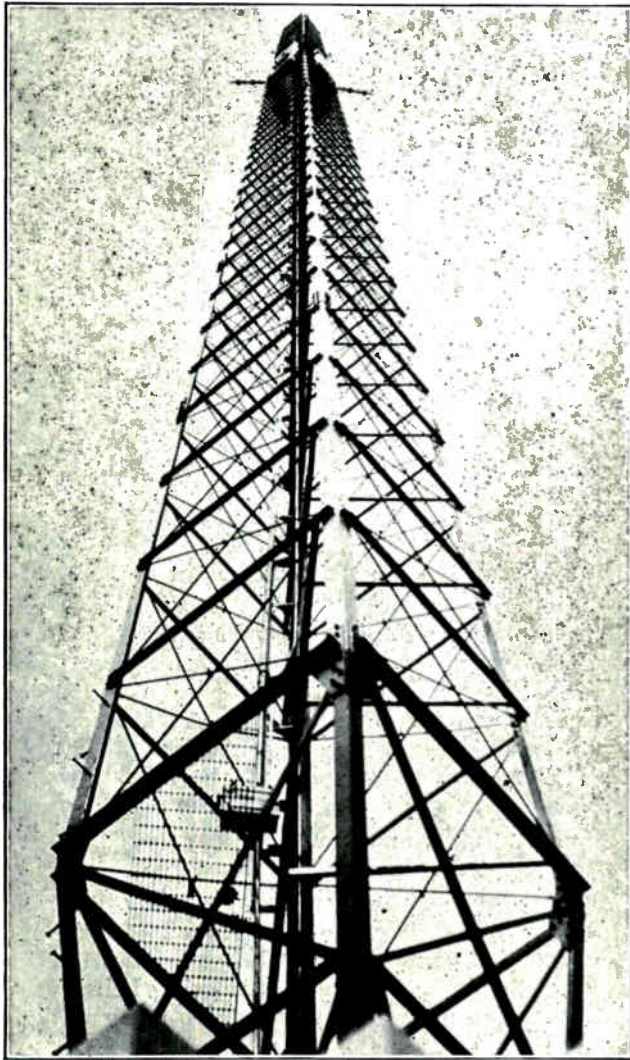

Fig. 28. Vertical Radiator for Station WWJ. (Courtesy Detroit News.)

tance in a lumped form at the top of the antenna, connected in series with the antenna proper. This is generally arranged by having a set of outriggers or cross arms at the top of the tower. In the case of the tuned type, the tower is sectionalized, and the coil for tuning the top portion which is loaded, is connected at the bottom of the first section from the top, which is insulated from the rest of the tower.

It is possible by the above methods to increase the effective height when the proper physical height cannot be obtained.

The top section of these radiators may be constructed to withstand a wind load of 35 lbs. per square foot, and the lower section 25 lbs. per square foot, comparable to an indicated wind velocity of 125 miles per hour, or actual wind velocity of 95 miles per hour.

If guy wires are used they should have a tensile strength three times as great as their maximum strain will ever be with full wind loading. These guy wires should be stretched with a tension equal to at least one-half the stresses they will be subjected to under full wind loading conditions. This is to minimize the whipping of the tower during violent gusts of wind.

The RF (Radio Frequency energy) is fed to this type of radiator generally through the medium of a co-axial cable consisting of an outer tube and an inner tube made up of an aluminum alloy. Sizes of these cables or tubes depend on the power to be handled. They are capable of handling a wide range of frequencies and adaptable to AF (Audio Frequency) or RF (Radio Frequency). In cases where they are buried they may be filled with dry nitrogen to neutralize the effects of moisture.

Lighting of these towers may be direct, indirect, or oscillating types.

21. ANTENNA WAVELENGTH CALCULATIONS

For simple Hertz types:

Length in feet equals 1.56 times the desired natural wavelength in meters.

Example:—For a 7050 KC (42.5 meter) antenna, the length in feet equals 42.5×1.56 , or 66 feet approximately.

In this section you have made a study of high frequency alternating current as used in Radio broadcasting. You have learned how this energy is used in carrying the sound waves, and how the modulated waves are transmitted into space by means of the transmitting antenna. In the next section you will learn how the signals are received by the receiving antenna, and then in the following sections how the energy picked up by the antenna is used in reproducing the sound that we hear in our Radio-receiving sets.

RECEIVING ANTENNAS

In homes and places where radio is only received and not transmitted, the receiving antennas are of much simpler construction than those described in the previous lesson.

Receiving aerials do not need to handle much current and so generally consist of just one small wire about No. 12 or 14 B & S gauge, and of the proper length for desired results.

Either solid or stranded copper or bronze wires are very good for receiving antennas.

With early forms of radio receivers such as crystal sets, where all of the energy to operate the headphones came from the antenna, or even with sets using only one or two tubes, long, high receiving aerials were needed to pick up sufficient induced voltage to give good signals. But with modern multiple tube sets and the great amount of amplification they accomplish, very little receiving aerial is needed.

It is well to remember, however, that the higher a receiving aerial is located and the more free it is kept from surrounding trees, buildings, or other tall objects, the more energy it will usually receive. Also remember that increasing the length of a receiving antenna increases the energy it will pick up; of course keeping in mind that the antenna should not be so long that its natural wave length is much greater than that of the energy to be received.

In rural communities and certain out of the way places which are a long distance from any radio station, long, high, outdoor antennas may still be used to good advantage.

22. KINDS OF RECEIVING ANTENNAS

Receiving antennas of the outdoor type usually consist of a single straight wire insulated from the

support at one end and connected to the receiver at the other end. This is called an inverted L antenna, as previously explained under transmitting antennas. A connection is sometimes made to the center of the elevated wire rather than at one end and the resulting antenna is called a T-type antenna.

Indoor Antennas consisting of a single wire may be installed in the attic, run around the moulding, or they may be of the loop type. Both of these are described under their respective headings.

They may also consist of 10 to 20 ft. of insulated No. 18 wire run along the edge of a carpet or looped behind a book case, etc.

A cage aerial or antenna consists of several parallel wires supported around the edge of the frames so that they have somewhat the appearance of a squirrel cage. This was also shown and explained in the previous lesson.

Umbrella aerials consist of a number of wires radiating from a central support and slanting downward toward the earth at the outer ends. The conductors of a fan or harp aerial radiate upward from the central point to a supporting wire across the top.

23. UNDERGROUND ANTENNAS

Because of the fact that radio waves penetrate to some depth into the earth, it is possible to use a buried wire as an antenna in place of the usual elevated wire type. An underground antenna has a better signal to static ratio (less static pick up for a given signal pick-up), is more selective than the elevated type, and also has a more pronounced directional effect. To offset these advantages, the

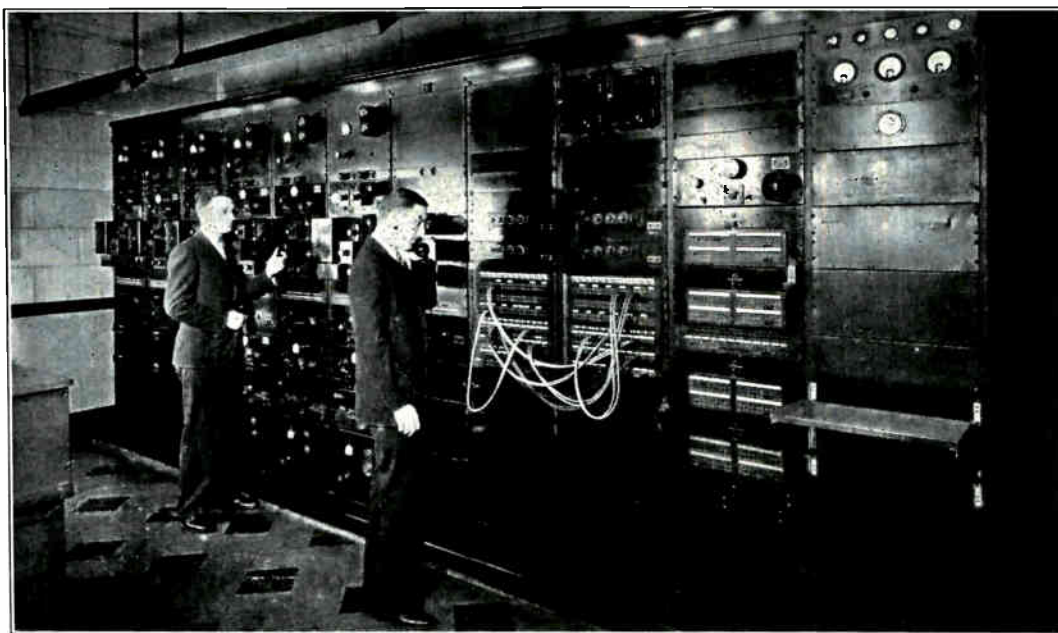

Fig. 29. Master Control Room for Crosley Radio Station WLW. (Courtesy Crosley Radio Co.)

signal strength with the under ground antenna, is only a fraction of that obtained with the usual elevated antenna and it is necessary to use at least two tubes to obtain head-phone reception.

The wire for a buried antenna should be of copper, No. 14 gauge, or larger. It must be well insulated with rubber covering. To obtain the greatest length of service from a buried antenna, the wire should have a live rubber covering about $\frac{1}{4}$ " thick. For broadcast reception, the buried portion of the antenna should be about 75 feet long and may be buried from 6 inches to 2 feet deep. The more moist the earth, the better will be the results with this method of reception.

24. SPECIAL ANTENNAS

Where a fairly long antenna is required and it is difficult or objectionable to erect an outdoor one, a long insulated wire, or a bare wire supported on insulators, can often be strung in an attic, keeping it as far as possible from any piping or electric wires.

Aerials located inside of steel frame buildings, buildings of steel reinforced masonry, or those using metal lath will generally not pick up much radio energy, as the steel work provides a definite shielding effect, and tends to ground or shunt the radio waves around the aerial.

Automobile radio receivers generally use a copper wire or screen located in the car top, or a metal plate under a running board for the antenna; and use the metal frame of the car for a ground. In this case we know the car frame is insulated from earth by the rubber tires, but its mass of metal serves as a sort of counterpoise or condenser type aerial even without any actual connection to earth.

Another popular type of auto radio antenna consists of a small metal rod or mast attached to the bumper or top of the car. In some cases the bumper itself is insulated from the frame and used as an antenna.

Airplane transmitters and receivers sometimes use a trailing wire which can be reeled in, or a short wire or metal mast attached to the wings or fuselage for the antenna, and use the metal frame of the plane for the ground connection.

25. LOOP ANTENNAS

Loop antennas consisting of several rather large turns of wire are often used with portable radio equipment and in some home type receivers.

Loop aerials have a distinct advantage of being very directional, and are therefore a great help in receiving certain stations and keeping out interference from other powerful nearby stations, by simply turning the loop so that its edge or plane is in line with the station desired. Loops receive signals much better from either direction in line with their flat plane, than they do from stations located in a direction out from either side of the loop.

Loop aerials require no ground connections, as one end of the loop generally connects to the antenna terminal, and the other end to the ground terminal of the set.

Receivers designed for operation with a loop sometimes have the loop terminals connected direct to the grid and filament terminals, thus eliminating the usual antenna coil and radio frequency transformer ahead of the first tube or stage.

The top sketch in Fig. 30 shows a loop connected in this manner to the first stage of a receiver, and

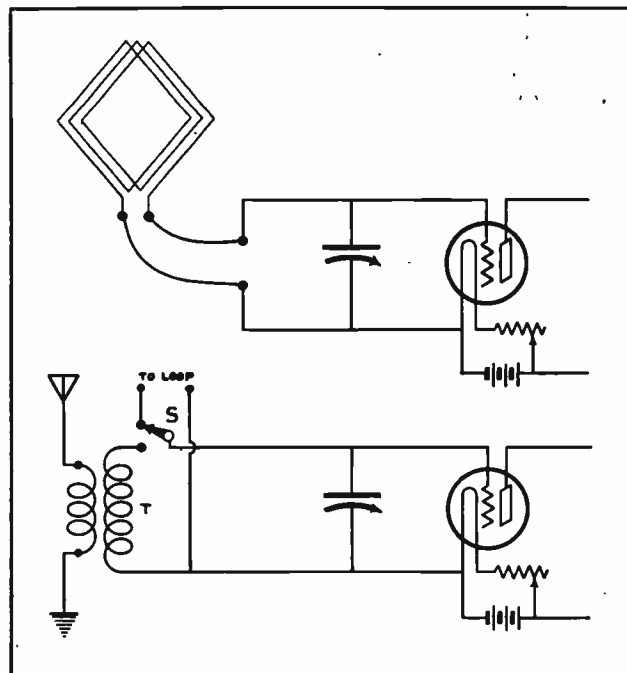

Fig. 30. The top sketch shows a loop aerial connected directly to the grid circuit of a vacuum-tube receiver. The lower sketch shows how a receiver can be adapted for use with either a loop or an aerial and ground.

the lower sketch shows how a receiver can be adapted for use either with a loop or with an antenna and ground, by means of a simple change-over switch "S".

With the switch in its present position on the upper contact the antenna coil or radio frequency transformer T is cut out, and the grid circuit is connected to the loop terminals. With the switch moved to the lower contact the loop circuit is disconnected and the antenna coupling coil is connected to the grid of the tube.

The sharply directional characteristics of the loop aerial make it a very valuable device as a direction finder or interference locator. By rotating a loop while listening to a certain station or interference, the direction of the station or source of interference can be determined quite accurately by observing the position of the loop where the signal is loudest.

By use of specially constructed rotary loops with pointers and scales, observations can be made at various places around a transmitter or source of radio interference, and its location determined almost exactly by noting where the lines of direction of the different wave tests cross or focus.

The natural wave length of loop antennas depends upon the number of turns and the length of

each turn, or size of the loop. It also depends somewhat upon the spacing of the turns. This spacing generally ranges from $\frac{1}{2}$ to 1 inch between turns, although some loops for reception of very long wave lengths may have a number of slots $\frac{1}{2}$ to 1 inch apart, with from 2 to 10 turns in each slot.

The wave length of a loop antenna can be increased by connecting a condenser across its terminals as shown in Fig. 30. By means of a variable condenser the wave length can be varied and the loop tuned to any wave length within its range.

A 4 foot loop with one turn can be used for wave lengths up to 180 meters with a .001 mfd. variable condenser in parallel, or up to 310 meters with a variable condenser of .003 mfd. capacity.

With 3 turns, a loop of this size can be used for wave lengths up to 400 to 675 meters according to which of the condensers is used, and with 6 turns its range is increased to 710 or 1200 meters according to the condenser used.

Many loops for indoor use are made about 2 ft. high, with from 6 to 20 turns, and used with a .00035 variable condenser.

26. WIRES FOR ANTENNAS

Stranded enameled copper or phosphor bronze wire is very efficient and generally preferred for antennas. Solid enamel covered wire is also good, and sometimes bare stranded wire or bare solid wire is used. Iron or steel wire should not be used for antennas, except that sometimes steel cored, copper covered wire is used for greater mechanical strength than a wire of solid copper or bronze would have. Wires for receiving antennas should be of No. 14 or No. 12 gauge, although smaller sizes are sometimes used.

Radio impulses travel mostly near the surface of a wire due to "skin effect" at high frequencies. Therefore, hollow wires are sometimes used. The great majority of the antennas are covered with corrosion after being exposed to the weather for a time. This corrosion is formed by the combination of the oxygen in the air with the copper of the wire, and unlike a covering of enamel or other

properly applied insulation, the corrosion becomes part of the wire itself; in other words, the outside of the antenna is no longer copper, but is copper oxide.

Copper is one of the best conductors for radio impulses, but copper oxide is very poor. Since radio impulses travel near the surface of the wire, if this surface is composed of the high resistance copper oxide such an antenna has lost much of its effectiveness as a conductor of signals.

27. INSTALLATION OF RECEIVING ANTENNAS

Fig. 32 shows two methods of installing receiving aerials. The wire can often be stretched between two buildings or from a tall tree to a building and thus save the trouble of erecting masts or poles.

Antennas should not be drawn up tight enough to place excessive strain on the wires or fastenings, but they should be tight enough to prevent excessive swaying in the wind, as this varies their wave length and interferes with sharp tuning. Sometimes a coil spring at one end, or a weight on a rope over a pulley, can be used to keep an antenna tight when a mast or tree to which it is attached moves with the wind.

Remember that inverted "L" type aerials such as shown in the top sketch in Fig. 32, are quite directional and receive better from a direction opposite to that in which the free end points.

It is very important to have good low resistance soldered connections in a receiving antenna, because the received energy is so extremely small that there is not much to waste or lose. When we realize that the voltage induced by a radio signal in an ordinary receiving aerial may be less than 1 micro-volt, or $\frac{1}{1,000,000}$ volt, we can readily see the necessity of having good aerial and ground connections.

Joints or splices that are not soldered allow corrosion to creep in between the wires or parts, and in time build up a very high resistance film that may reduce the signal strength to less than $\frac{1}{10}$ its former value when the splice was new.

A good ground connection often makes it possible to dispense with a very long antenna or to avoid the trouble and cost of installing one in the first place.

In houses or buildings equipped with piping, the pipes usually make a very good ground for a receiver. A cold water pipe is generally best as they are almost sure to be well grounded, and to form a complete metallic circuit to ground. Some steam or gas pipes are equipped with insulating joints at certain places, which prevent them from being a good ground. Gas pipes should not be used for grounds, because of the explosive hazard in case of heavy static discharge.

With powerful multi-tube receivers, very often a short piece of insulated wire about 10 to 30 feet long,

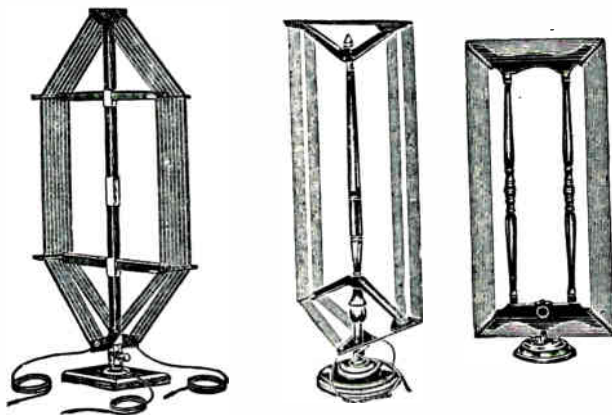

Fig. 31. Several different types of loop antennas for use with radio receivers. By rotating these loops directional reception can be accomplished.

laid under the rug or along a moulding is all the antenna required, and some sets will operate fairly well with no antenna at all.

It is well to keep in mind that longer antennas than necessary will generally pick up excessive static and interference, and that shorter antennas are more selective and make it much easier to tune out local stations if one desires.

Generally an outdoor aerial 50 to 150 feet long is suitable for receiving distant stations even with medium cost sets, and an indoor aerial much shorter is best for receiving local stations, or even distant ones if the receiver is a good well designed multi-tube set.

28. INSULATORS FOR ANTENNAS

The end of the antenna farthest from the receiver should be supported with an insulator made especially for this purpose. Good insulators are made of porcelain, glass, Pyrex, or high-grade moulded materials. Glass is excellent but well glazed porcelain is probably as good as glass as long as the glaze is not chipped or cracked.

The far end of the antenna should be fitted with one or two of the insulators as in Fig. 32 and in Fig. 34-A, and to the far end of the insulator should be attached 5 or 10 feet of strong galvanized iron wire. This is used to make the mechanical connection to whatever post or other support used.

When running antenna or lead-in wires along walls or around corners, they should be kept well away from the wall by stand-off insulators. A stand-off insulator consists of a piece of glass or porcelain that holds the antenna wire, and is itself held by a metal flange or rod that may be fastened to the wall, post or roof edge around which the antenna turns the corner. There should be at least two inches of insulation surface between the antenna wire and the nearest part of the metal support. Many stand-off insulators are made with a porcelain bushing, that is a piece of porcelain with a hole through it, which is held in an eye formed on a metal screw or bolt. These are not as good as the kind which provide a greater length of insulating surface between the antenna and the metal support.

29. HEIGHT AND LENGTH OF RECEIVING ANTENNAS

The effective height of the antenna is considered from an electrical and not the physical standpoint. The effective height is usually less than the physical height because of buildings and objects in the antenna field. On transmitting antennas, the effective height is generally considered to be 60% of the average physical height. With receiving antennas, the higher and longer the antenna the more powerful the signals brought in, but unfortunately, the louder will be all forms of interference as well.

A high antenna brings in lots of signals and also lots of static, and interference. As the antenna is lowered, the signal strength becomes less, but it does not fall off as rapidly as the static, in other

words, a low antenna has a material gain in the ratio of signal strength to the static level. By a low antenna we generally mean one that is less than 30 feet high.

Of course, this low antenna will not bring in such powerful signals, but a good receiver will amplify its weaker signals to a point which is entirely satisfactory. Many radio men feel that 30 feet is the right height for an antenna. This is not based on any exact rule, because the best height depends on particular conditions.

As a rule, it is best to have the horizontal or straight part of the antenna at least 60 to 75 feet long. This does not mean that excellent work cannot be done with 50 feet or less, but that 75 feet may be better. An antenna with the straight horizontal part more than 100 feet long, is not required by modern receivers. With many of the better sets, the result will not be as good with 150 to 200 feet of antenna as with 100 feet or less, considering selectivity, static interference, and everything else that goes to make or mar satisfactory reception.

All of this information applies to antennas used for broadcast receivers. Reception from long wave commercial stations will require a much longer antenna, and short wave reception, will call for much shorter antenna.

The best length of antenna depends on local conditions and on the type of receiver being employed. The following list gives lengths that are satisfactory generally. These lengths are the sum of the horizontal part of the antenna, the lead-in to the receiver, and the ground connection from the receiver.

For receivers having 6 or more tubes—40 to 50 feet.

For 5 tube, T. R. F. sets—60 to 75 ft.

For 4 tube sets with R. F. stage—80 to 100 ft.

For 3 tube regenerative receivers—100 to 120 ft.

For 1 tube sets, crystal sets, etc.—100 to 150 ft.

30. LEAD-INS FOR RECEIVING ANTENNAS

The lead-in includes all antenna circuit connections running from the horizontal portion of the antenna, down the side of the building and to the receiving set. If there is anything more generally neglected than the antenna itself, it is the lead-in. Too many radio enthusiasts seem to think that the chief purpose of the lead-in is to provide for final disposition of any scrap wire that may be lying around the premises.

The first rule for the lead-in is to make it short. A lead-in, like an antenna, has inductance, capacity, and resistance, but the inductance and capacity can not be used to such a good advantage as when used in the antenna itself. For example, a lead-in 100 feet high used with an antenna only 30 feet long would have three times the inductance and capacity of the antenna itself, but if the lead-in for this 30 foot antenna were reduced to 40 feet, its inductance and capacity would be only about 20% more than that of the antenna.

The lead-in is part of the antenna circuit and should be well insulated by proper use of stand-off insulators wherever they are required. Because insulated wire for the lead-in does not mean it may be dropped over the edge of a roof without any protection. There is no objection to using insulated wire for the lead-in if the wire is properly supported, but neither is there any advantage.

The lead-in wire should be kept away from, or insulated from, walls, ceilings, mouldings, etc., in the room through which it passes on its way to the receiver.

Lead-in wires should always be at least as large as the aerial wire, or with an area equal to all aerial wires in parallel where a number of wires are used. Remember that the length of lead-in wires should be added to that of the antenna proper, when calculating the effective length or natural wave length of the antenna. That is, with the exception of certain special types of transmitting aerials. Long ground leads will also affect the wave length of the antenna circuit.

Sometimes, the lead-in is connected nearer the center of the antenna rather than at one end. Then the effective length of the antenna is equal to about $\frac{1}{2}$ of its physical length, or half that of an antenna of the same length in feet but having the lead-in at one end. Where the lead-in enters the building it should be run through a porcelain or glass insulator. Such an insulator may be passed through $\frac{9}{16}$ to $\frac{3}{4}$ inch hole bored in the window frame.

The outer end of the lead-in wire should be scraped perfectly clean and a secure mechanical joint made between it and the end of the antenna wire, which has also been thoroughly cleaned of all insulation or oxide. This joint should then be thoroughly soldered. If it is impossible to solder the joint, wrap it tightly with tin foil, then cover the foil with a layer of rubber tape followed by a layer of friction tape. If rubber tape is not available, use two layers of friction tape and cover the outside with a heavy coating of shellac.

If the lead-in wire enters a wall or window through a porcelain tube insulator, drill the hole for the insulator with a slant so that the outdoor end will tilt downward, thus preventing entrance of rain into the building.

In case it is objectionable to bore holes in the window frames, it may be best to cut a notch in the top edge of the sash, pass the bushing through this opening, and push the window up against the bushing to hold it.

Various kinds of special lead-ins may be purchased. Some of these consist of flat ribbon copper incased in a covering of insulation. Such a device may be laid over the window-sill and the window closed tightly over it. The danger in this construction comes from the fact that the insulating covering may be broken through, and water from rain or snow will ground the antenna, which means weak signals, or no signals, in the receiver.

Never use a lead-in device in the ends of which wires are held by spring clips or similar devices.

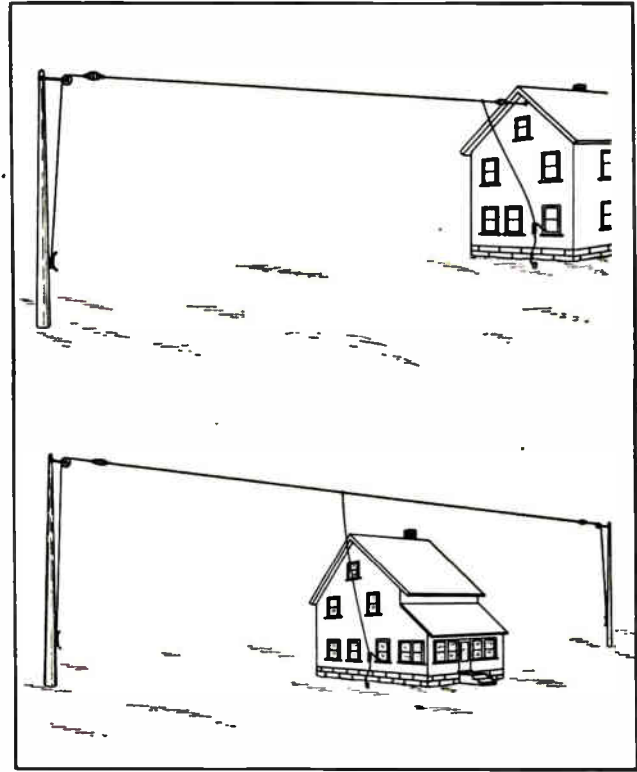

Fig. 32. The above sketches show L type and T type receiving antennas of single wire construction.

All such joints corrode with wet weather and after they corrode for a few months, the antenna might just about as well be disconnected. Every joint from the farthest end of the antenna to the binding post of the receiver must either be soldered or else solidly bolted, and well-shellacked to keep water from the joint.

After the lead-in has entered the building, it should be carried along the walls, base-boards or mouldings until it reaches the receiver. This inside part should be made of well insulated stranded copper wire. From the standpoint of appearance, a silk-covered wire is best, although any other insulated wire will be as good from the standpoint of radio reception. As a final precaution, bring the lead-in from the building entrance to the receiving set in the straightest line possible, avoiding unnecessary turns.

31. SHIELDED LEAD-IN

In many installations, as in apartment houses, hotels, etc., it is necessary to install the aerial wire a considerable distance above or away from the receiver.

The long lead-in wire, of course, serves to pick up some radio signals, but it also has electrical impulses induced in it by an electrical appliances used in the building.

Elevator motors and switching devices, relay contacts on electric refrigerators, oil burners, etc., may induce considerable disturbing voltages in it, so that reception becomes extremely noisy. In cases of this kind, the lead-in wires should be shielded.

This shielded lead-in may be a rubber insulated copper wire, surrounded by a lead covering; or by a braided copper shielding. The outside shield covering is connected to ground either at the lower end, or preferably at several intervals along its length. The wire from the radio receiver to the ground connection may also be shielded in this way if it is long.

The aerial wire portion of the antenna system will then be the only part picking up signals and electrical disturbance. Of course, shielded wire should not be used for this part, for then very little signal would be picked up.

Since the shielded lead-in adds considerable capacitance to the antenna circuit, it may throw out the tracking of the antenna tuned stage of a single dial receiver used with it, and necessitate realignment of the first tuning section of the gang condenser in the receiver. This will be fully explained in a later lesson.

We also have what is known as the impedance matched antenna kits, which are composed of impedance matched transformers, one of which is connected at the lead-in end where it connects to the horizontal portion of the antenna, the other connects to the receiver end of the lead-in. These transformers are for the purpose of taking care of the loss of energy in the lead-in due to the grounded shield. See Fig. 34B.

32. CAPACITY OF ANTENNAS

Considering the horizontal portion of an antenna, the capacity or condenser effect of the antenna increases almost directly with its length up to 100 feet but increases less rapidly for greater lengths. This might be expected since an increase of antenna length increases the area of the condenser which is formed by the antenna and ground. There is only a small change in capacity as the height of the antenna above the ground is increased above 30 feet. From a height of 30 feet up to a height of 120 feet, the decrease in capacity is only about 7%, but as the antenna is lowered under 30 feet, the capacity increases quite rapidly. This effect might also be expected because lowering the antenna brings the parts of this condenser closer together. The capacity of a vertical lead-in wire increases directly with the length of the lead-in. The capacity of a vertical lead-in must be added to that of the antenna to obtain the total capacity of the whole antenna system.

In earlier lessons we used the Farad as the unit of capacity but this unit is too large for Radio work so we use the micro-farad which has the symbol mfd., or the micro-micro-farad, with the symbol mmfd. One Farad = 1,000,000 micro Farads and one micro-farad = 1,000,000 micro-micro Farads.

In the table at the top of the next column is given the capacity in mmfds. of the horizontal portion of the antenna and also the capacity of the vertical lead-in. Preceding the hyphen is the capacity in

CAPACITY OF HORIZONTAL AND VERTICAL PORTION OF A SINGLE WIRE ANTENNA IN MICRO-MICRO-FARADS

Antenna Height in Feet	Length in Feet of Horizontal Portion of Antenna				
	30 Feet Hor.-Vert.	45 Feet Hor.-Vert.	60 Feet Hor.-Vert.	75 Feet Hor.-Vert.	100 Feet Hor.-Vert.
20	59-40	83-40	111-40	139-40	182-40
30	58-56	81-56	109-56	131-56	175-56
40	57-71	80-71	107-71	123-71	172-71
60	57-103	80-103	105-103	121-103	170-103
100	56-166	79-166	104-166	119-166	158-166

mmfds. of the horizontal portion and following the hyphen is the capacity of the vertical lead-in.

Thus for an antenna 60 feet long and 40 feet high, the capacity of the horizontal is 107 mmfds. and the vertical portion, or lead-in, is 71 mmfds. a total of 178 mmfds. for the entire antenna system. The capacity of the lead-in must be added to that of the antenna.

The effective capacity of the antenna system is somewhat greater at the higher frequencies or lower wave lengths used in broadcasting than at the other end of the scale. Taking the effective capacity at 1000 K.C. or approximately 300 meters as represented by 100%, the following changes are found in practice.

At 1500 K.C. or 200 meters, the capacity is 120% and at 600 K.C. or 500 meters, it is 90% of the value at 1000 K.C.

33. INDUCTANCE OF THE ANTENNAS

The horizontal portion of the antenna and vertical lead-in not only have capacity but also have inductance even though they are straight wires. The following table gives the value in micro-henries of the horizontal portion of the antenna and of the vertical lead-in. (a micro-henry equals one millionth part of a henry or 1,000,000 micro-henries = one henry).

INDUCTANCES OF ANTENNA SYSTEM IN MICRO-HENRIES

Antenna Height in Feet	Length in Feet of Horizontal Portion of Antenna				
	30 Feet Hor.-Vert.	45 Feet Hor.-Vert.	60 Feet Hor.-Vert.	75 Feet Hor.-Vert.	100 Feet Hor.-Vert.
20	20-10	30-10	41-10	50-10	68-10
30	20-15	30-15	41-15	51-15	69-15
40	20-21	30-21	42-21	52-21	71-21
60	20-34	30-34	42-34	53-34	72-34
100	20-61	30-61	42-51	52-61	72-61

The inductance of the antenna and lead-in are not lumped inductance as found in coils, but are distributed over the whole length of these wires. These distributed inductances are due to the changing magnetic field set up around the wires when alternating current flows in them. The total inductance of the antenna and lead-in is not as great as

the sum of their separate inductances, as would be the case with lumped inductance in series, nor is it as small as the two inductances in parallel.

Practice shows that the approximate effective inductance of antenna and lead-in may be found by adding the two together and dividing the sum by three. Thus, for an antenna system 45 feet long and 40 feet high, it is seen that the inductance of the horizontal portion is 30 micro-henries and of the vertical portion 21 micro-henries. Their sum is 51 micro-henries and the approximate effective inductance is $1/3$ of 51 or 17 micro-henries.

34. DIRECTIONAL EFFECT OF ANTENNAS

It is often found that signals will be received best from a direction opposite to that in which the antenna runs from the receiver. If the antenna points westward, best reception may be had from points to the east. Unless the antenna is at least 100 feet long it will show little directional effect, regardless of the direction it runs and will receive, just as well from one point of the compass as any other. Any apparent directional effects in such cases are due to local conditions such as interference of trees, buildings, and antenna location in general.

35. PROTECTION FROM LIGHTNING AND HIGH VOLTAGE LINES

All outdoor antennas should always be equipped with some form of approved lightning arrester, to ground any severe static charges exceeding 500 volts and prevent them passing through the set and possibly damaging it or injuring operators.

On small receiving antennas these arresters usually consist of a simple needle gap arrangement connected between the lead-in wire and ground. On large, high transmitting antennas a more rugged arrester is required to safely handle the very high voltage atmospheric charges picked up, as well as possible direct lightning strokes.

A ground switch is also often used to connect the antenna direct to earth in case of electrical storms, or whenever the antenna is not in use. Fig. 33 shows a sketch of the connections for both a ground switch at G and a lightning arrester at A.

Antennas should never be erected over or directly beneath high voltage power lines, because of the danger of accidental contact in case either should break and fall across the other. Antennas that are near to power lines should be erected at right angles to them and not parallel to them, as this will help to prevent interference hum from induction of 60 cycle energy, and may also prevent induction of sufficient voltage to be dangerous, as might be possible with parallel wires.

36. ANTENNAS FOR SHORT WAVE AND ALL-WAVE RECEIVERS

The interference commonly called static, which may be picked up by the antenna system can be di-

vided into two types. First, atmospheric static produced by spark discharges between two unlike charged particles in the atmosphere, and solar radiation; second, man-made static produced by various types of electrical equipment.

Atmospheric static exists on practically all frequencies although there is a marked decrease in the strength of this type of static on extremely short wave, particularly below 10 meters.

Man-made static is just the reverse, its strength being greater on short waves. The ignition system of an automobile radiates the maximum amount of its energy around 10 meters.

It is not possible to reduce atmospheric static without producing a corresponding decrease in the radio signal, but it is possible to erect an antenna system that will reduce the pick-up of man-made static without materially reducing the pick-up of the signal from the transmitter. This may be done by placing the horizontal portion of the antenna high above the earth so that it will be out of the strong local static field and then shield the lead-in, or construct the lead-in so that the energy it picks up is balanced out and is, therefore, not transferred into the receiver. There are various ways of doing this as shown in Fig. 34, B and C.

Another method is to use an antenna constructed in two sections and using as a lead-in wire a twisted pair of wires. This antenna is commonly known as the "Doublet". Such an antenna consists of two equal lengths of wire which may be anywhere from 20 to 50 feet each in length. The two wires are connected together with an insulator and mounted between uprights as shown by A and A in Fig. 34-D. The wires should be mounted as high as possible so as to be above man-made static. The twisted pair

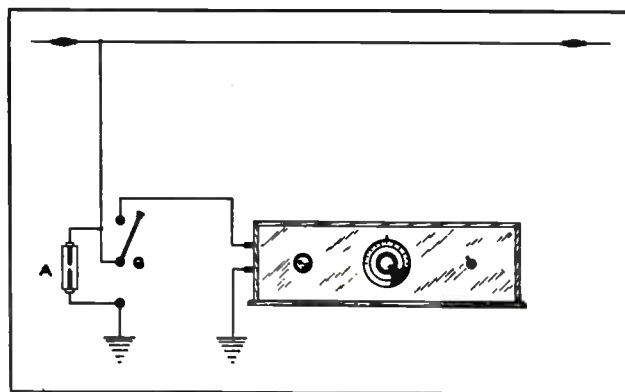

Fig. 33. This diagram shows the method of connecting a lightning arrester and a grounding switch to the lead-in of a radio receiver.

of insulated wires are attached to the antenna wires on each side of the center insulators as shown. The twisted wires are then used as the lead-in wire and since they are twisted together they accomplish the same result as transposition and effectively balance out local interference.

The twisted lead-in is usually connected to the Radio set by means of a coupler. The purpose of the

coupler is to match the impedance of the lead-in with antenna coil of the receiver.

Since the length of the antenna system will greatly determine the particular frequency to which it will best respond, it is apparent that the ordinary

antenna will not give the same efficiency on both short waves and broadcast waves. This makes it desirable to use on all wave receivers, a special type of antenna made of two sections, of different lengths so that the longest section will be effective on broadcast while the shortest section will be effective as the antenna for short waves. Such an antenna is shown in Fig. 34-D.

This antenna consists of two "Doublet" antennas connected together in parallel. The two sections A and A make up one antenna to which is connected the twisted lead-in wire. The two sections B and B make up another antenna which is also connected to the twisted lead-in. The "B" sections of the antenna being shorter than the "A" sections will be more sensitive to short wave signals, and the longer section "A" will be more sensitive to longer waves. Therefore, when these two antennas are connected in parallel to the same radio set the short antenna is effective when the radio is tuned to short waves and the long section is effective when the radio is tuned to the longer broadcast waves.

There are also a number of factory made antennas of special design which may be obtained for use in all wave receivers. The operating principle may vary somewhat on different kits, but details regarding operation and installation are usually included with the kit.

Now that you know how radio energy may be sent out into space by use of proper equipment and control apparatus, and how the energy may be picked up in the form of induced current in the receiving antenna, your next step will be to learn how the energy picked up by the receiving antenna may be used in reproducing radio programs in the home.

In the next section you will learn how the radio set may be tuned to select the desired program, and how the sound waves may be detected or separated from the high frequency waves.

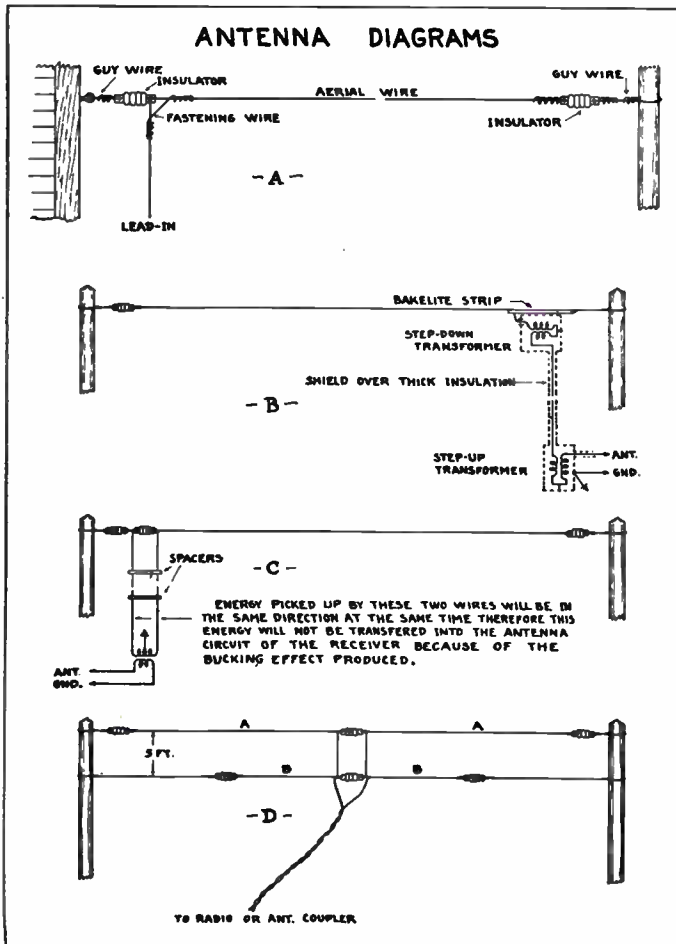

Fig. 34. The above diagram shows a single wire inverted L antenna at "A", a single wire antenna with a shielded lead-in at "B", a single wire antenna using a parallel lead-in at "C", and at "D" two "Doublet" type antennas connected in parallel.

RADIO RECEPTION

If George Washington, Benjamin Franklin, and others of their time were alive today and we were to show them a modern radio receiver in operation they would probably regard it as something supernatural or suspect us of some sort of "witchcraft." Voices and music being produced out of thin air would astound the people of even more recent times, even as recent as 25 years ago. They most certainly would be spell-bound and at a loss to understand the miracle of radio. Today, however, it is different. We accept these things and simply take them for granted, without giving much thought to the amazing accomplishments that the inventions and developments of our present era have made possible.

When we stop to give it a little serious thought, it really does seem like a miracle to be able to have voices from not only any part of our own country, but from foreign countries, ships at sea, airplanes, etc., brought right into our very homes.

If we were able to receive on our radio sets, just one program from one transmitting station it would still be wonderful. But we have gone further. By the mere turn of a dial—sometimes only a fraction of an inch—we can select programs at will, music, speeches, entertainment, etc. We can choose stations thousands of miles apart, instantly and with such little effort that even a child may bring about an accomplishment that until recent years was an impossibility—in fact would have been considered a miracle less than 25 years ago.

The tuning of radio transmitters and receivers is one of the most important factors in efficient radio operation, servicing, repair, etc. It is this interesting branch of radio that is covered in this lesson.

37. RADIO TUNING

Now that we have a general understanding from previous lessons of how radio energy is produced and transmitted through space, let us see how this energy and the signals it conveys can be picked out

of the atmosphere at will, and even to the extent of selecting just the signals we wish to receive.

You have already learned how the modulated high frequency waves of magnetic and static energy are radiated out through space by the transmitting antennas, and how receiving antennas are constructed to collect enough of this energy to operate receiving sets.

In an earlier section it was thoroughly explained how electro-magnetic waves or lines of force induce voltages in conductors when these lines cut across them, and if you will recall the principles of transformer action, you can readily understand how the waves radiated from a transmitting antenna induce feeble voltages in receiving antennas. Just think of the transmitting antenna as a sort of primary conductor which radiates its field great distances through space because of the nature of the high frequency energy it uses, and then think of the receiving antennas as secondary conductors in which secondary voltages are induced.

Because of the great distance which usually separates the receiving and transmitting antennas, the induced voltage in the receiving antenna will be extremely small or feeble. As previously mentioned this voltage is often less than one micro-volt, or $\frac{1}{1,000,000}$ of a volt.

Nevertheless this induced energy will be of exactly the same frequency as the energy at the transmitter from which the signal is coming, and it will also vary in value just exactly as the transmitted waves do when modulated by voice or audio frequency signal notes.

In this manner the energy flowing in a receiving antenna duplicates faithfully all of the conditions or characteristics of that at the transmitter, only on a much smaller scale. So now if we can make this received energy reproduce an audible sound, this sound will be a faithful reproduction of

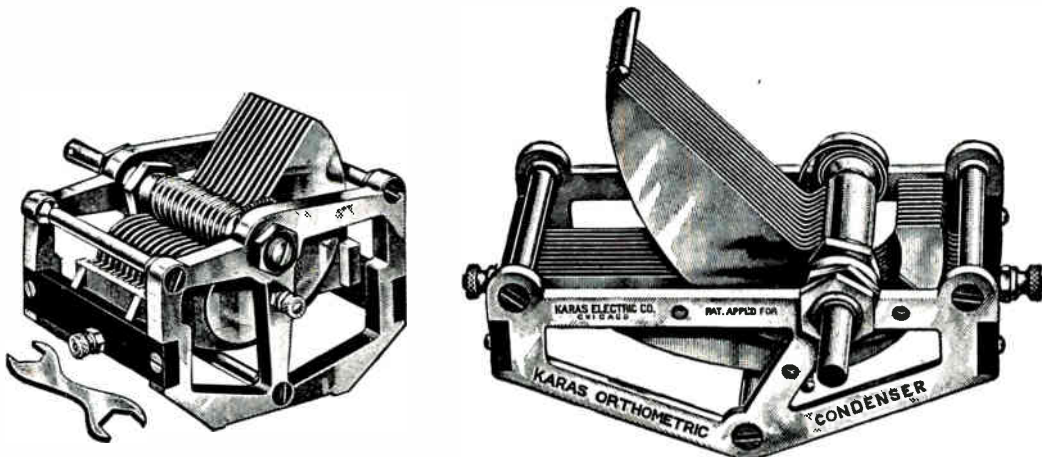

Fig. 35. Variable condensers, used for tuning the circuits of radio receivers to the desired wave length. These condensers each have one set of stationary plates, and one set of movable plates by which their capacity can be varied.

that used at the transmitter and impressed electrically on the carrier wave.

Before we consider the construction and operation of the receiver itself, however, it will be well to emphasize the fact that the very feeble amounts of energy received in radio work must be handled with extreme care, and by devices and circuits of very critical and exact design and connection, in order not to lose much of this small amount of energy, and to get the results desired from it.

While low resistance is very important, we have already learned that counter voltage of self-induction and impedance in A. C. circuits, play a much greater part than resistance does in the control of alternating currents. This is particularly true when dealing with the extremely high frequency currents used in radio work.

For example, we find that receiving antennas and receiving set circuits must be "tuned" just right by having just the right amount of inductance and capacity in order to allow any appreciable current of a certain radio frequency to flow in them.

This can perhaps be understood more easily if we recall the operation of the oscillating circuit used with a spark transmitter. In this circuit you will remember the frequency or rate of oscillation of the current was determined by the size of the

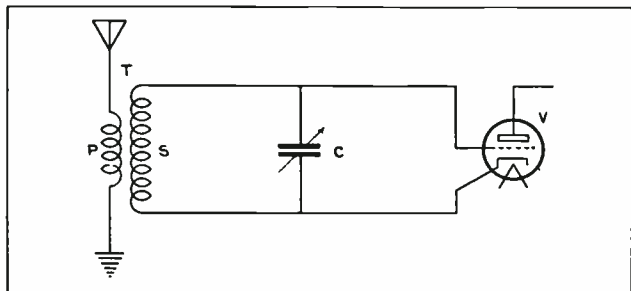

Fig. 36. A simple radio frequency tuning circuit.

condenser and the inductance coil, the length of time required to charge the condenser, and the time required for the flux around the inductance coil to build up and collapse during each alternation.

If these factors can absolutely control the frequency of the energy generated in a transmitter oscillating circuit where very high voltages are applied, it is easy to see how they will also control the building up of high frequency currents in receiving circuits where the induced voltages are so very small.

If the capacity and inductance of a receiving antenna circuit are just right they will allow the induced voltage of a certain frequency to establish current which can oscillate freely in the circuit. If the capacity and inductance or the natural frequency of the circuit are not right for a certain signal frequency, current will not build up under feeble induced voltage of that frequency.

Of course this same circuit would allow current to build up at some other frequency for which its tuning happens to be just right, if some other station is sending waves of that frequency.

Another illustration of this tuning effect is in the vibration of a tuning fork to only those sound waves of its own natural frequency; or the response of certain reeds of a vibrating reed frequency indicator to the magnetic pull of alternating current of that same frequency. We also know that in order to keep a heavy pendulum swinging freely with the smallest possible pushes or impulses, these impulses must come at just the right time, according to the natural frequency or swing of the pendulum, so that they will aid the strokes of the pendulum.

This rather particular or "choosy" nature of radio frequency energy is a very valuable characteristic, as it is only through this feature that we are able to operate a large number of radio stations on different wave lengths at the same time, and yet select any one we wish to receive by simply tuning our receiver circuit by changing its inductance or capacity.

In other words it enables us to adjust a receiver so that a station of the desired frequency will be able to induce sufficient energy in the circuit to produce audible signals. Other stations of different frequencies may be able to induce a very little energy in the circuit also, but not enough to interfere with the desired signal, if the receiver is a good one and capable of sharp tuning.

This tuning of a receiving circuit is of course accomplished by changing either the amount of inductance or capacity, generally the latter.

Increasing either the inductance or capacity of a circuit increases its natural wave length. Decreasing the inductance or capacity will decrease the natural wave length of a circuit.

The importance of tuning a radio circuit may readily be seen from the following explanation of the circuit shown in Fig. 36. Let us assume that the signal voltage picked up by the antenna causes a feeble alternating current to flow through the primary coil "P" of the radio frequency transformer "T," and that this current flow induces 1 microvolt (.000001) volt in the secondary coil "S." Let us also assume that the secondary coil has an inductance of 300 microhenries and that its circuit is tuned to resonance for a 500 kilocycle signal by a condenser "C" of .00025 mfd. capacity.

A circuit is said to be resonant when its capacitive reactance and inductive reactance are equal and thereby neutralize and cancel out each others effects in that circuit. This would leave only the D.C. or ohmic resistance of the circuit to be overcome by the applied voltage in forcing current to flow. Thus we can see that a much heavier current will flow when the circuit is tuned to resonance.

Let us assume that the ohmic resistance of the series circuit through the coil "S" and condenser "C" is 2 ohms. Then with .000001 volt induced in coil "S" the current flow would be .000001 divided by 2 equals .0000005 ampere.

The capacitive reactance of the .00025 mfd. condenser at 500 K.C. is approximately 1274 ohms. Although this reactance is neutralized by the coil

"S" in the series circuit between the coil and condenser, the condenser reactance is still effective in the circuit to the grid of the vacuum tube "V." Therefore the voltage drop across the condenser due to the flow of current through it will be .0000005 amp. x 1374 ohms equals .0006 volt. This voltage drop across the condenser will be applied to the grid of the tube.

This voltage drop of .0006 which is set up by current oscillations in the tuned or resonant circuit is 600 times greater than the .000001 volt induced in the coil "S" by the antenna signal voltage. Thus we can see the great gain in signal strength which can be obtained by tuning radio circuits.

38. VARIABLE INDUCTANCE TUNERS

A method of tuning which was quite extensively used in earlier types of receivers, and is still used in transmitters and on some styles of receivers, consists of using a variable inductance such as shown at A in Fig. 37.

This form of variable inductance uses a **tapped coil "P,"** as the antenna coil or primary of the coupling transformer of the set. By shifting the rotating switch arm, turns can be cut in or out of the coil, thus increasing or decreasing the inductance and natural wave length.

Inductance coils of the smaller sizes for radio receivers are commonly wound in a single layer on a tube or cylinder of fibre or bakelite. Those with a large number of turns are often specially wound so that the turns are criss-crossed at a slight angle, in what is called honeycomb formation. This reduces the distributed capacity effect between turns. If the turns of large coils are all wound parallel and tightly together, this capacity effect often becomes considerable at the very high frequencies carried by the coils. Some simple small coils of single layer winding have the turns spaced apart a short distance. Inductances for tuning vary from about 1 micro-henry ($\frac{1}{1,000,000}$), to 125 millihenrys (.125 henry).

At B in Fig. 37 is illustrated another method of inductance tuning using a device known as the **Vario-Coupler**, consisting of a stationary coil S and

a smaller coil M which is located inside or very near to the open end of the larger stationary coil.

When the turns of the movable coil are parallel to those of the stationary one, the induction or transfer of energy between them is maximum. When the movable coil is turned at right angles to the stationary one, the induction between them is almost zero. This rotation of the one coil not only varies the amount of energy it will absorb from the primary coil, but also changes the inductance of coil S by the reaction between its flux and that of the movable secondary coil.

Vario-couplers of this type provide a very smooth means of tuning a set because of the stepless change in inductance and coupling as the rotor coil is slowly turned.

Some such couplers also have taps on the primary coil for further changes in the inductance.

The slender arrow through the two coils indicates that they are coupled together inductively and variably. A number of different methods have been developed for varying the coupling between primary and secondary coils of this type.

Primary and secondary tuning coil units such as shown at A and B in Fig. 37 are really **Coupling Transformers** to inductively couple the antenna circuit to the rest of the receiver circuit, and are commonly called R. F. or radio frequency transformers.

One distinct advantage of being able to change the coupling between the primary and secondary coils of these transformers, is that moving them farther apart greatly increases the **selectivity** or sharpness of tuning of the set. Even though this separation of the coils loses some of the energy or volume, it makes it much easier to separate nearby stations when tuning.

When the coils are close together they are said to be **close coupled**, and this makes broader tuning. When the coils are widely separated, they are said to be **loose coupled**, and effect sharper tuning.

At C in Fig. 37 is shown still another method of varying inductance in a circuit, by using one coil which rotates within another slightly larger one, and connecting the two in series. This device is known as a **Variometer**, and is connected in series with the circuit to be tuned.

When the inner coil is in a certain parallel position inside the stationary one, its flux coincides with that of the stationary coil thus setting up a strong magnetic field around all the turns, and increasing the inductance of the unit. When the small coil is rotated 90 degrees to a position at right angles to the larger one, its flux neither aids or opposes that of the other coil very much, and the field is about normal around both, thereby reducing the inductance to a little less than it was at first. When the small coil is rotated 180 degrees to the exact opposite parallel position to what it was at first, its flux will oppose and largely neutralize that of the stationary coil, thus weakening the total field around them both and greatly reducing the inductance of the unit.

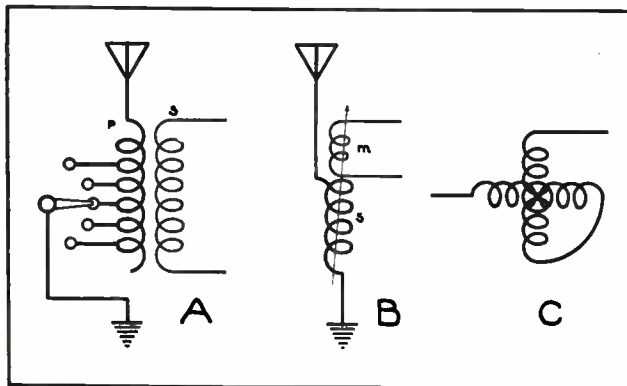

Fig. 37. The above three sketches show different methods of tuning radio circuits with variable inductances.

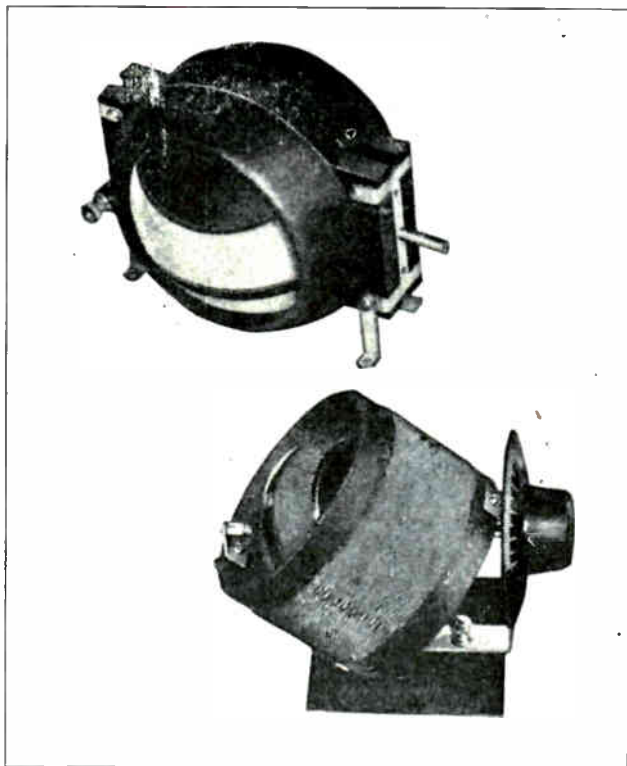

Fig. 38. Two types of variometers or variable inductances, such as formerly used very extensively in tuning radio receivers.

Variometers of this type are not used as much in modern receivers as they formerly were. Fig. 38 shows two types of variometers such as were used extensively in earlier types of radio sets.

Some radio receivers use a set of changeable inductance coils known as plug-in coils, which can be conveniently interchanged for making definite changes of considerable amounts in wave length.

39. VARIABLE CONDENSERS FOR TUNING

Another very efficient and convenient device for tuning radio circuits is the variable condenser, two of which are shown in Fig. 39.

These condensers consist of a set of stationary plates and a set of rotary or movable plates, closely spaced and separated from each other only by air.

When the rotary plates are fully meshed between the stationary ones the capacity of the condenser is at its maximum, as the greatest possible area is active. When the rotary plates are entirely removed from between the stationary ones the condenser capacity is at its minimum, as only their edges are then exposed to each other.

By rotating the movable plates of such a condenser slowly, very fine and smooth changes can be made in the tuning of the circuits in which they are connected.

The plates are generally made of aluminum or brass, with the rotary ones mounted on a shaft and both sets mounted in a metal supporting frame, for convenient attachment to the panel or frame of a radio set.

The greater the number of plates used the greater the capacity and tuning variation or range, and the

coarser the adjustment for a given amount of movement. The less the number of plates the smaller is the capacity and the finer the adjustment for a given movement.

Some variable condensers are made with only three plates, two stationary and one rotary, for very fine adjustments. These are called Vernier condensers.

Convenient tuning knobs and graduated dials are generally attached to the shaft of the rotary elements. Some of these controls have a reducing gear or mechanism to enable slower movement and finer tuning with the condenser. Fig. 40 shows an earlier type of variable condenser which has the main element and also a smaller vernier element, and is equipped with the dial and knob.

Variable condensers are rated in micro-farads, a unit with which you are already familiar from an earlier section on A. C. They are sometimes rated by their maximum capacity such as .001 mfd., and sometimes by their range of capacity, as .000045 to .0005 mfd. Variable condensers are commonly made in sizes ranging from .000025 to .001 mfd. maximum capacities, one of the most common sizes being the

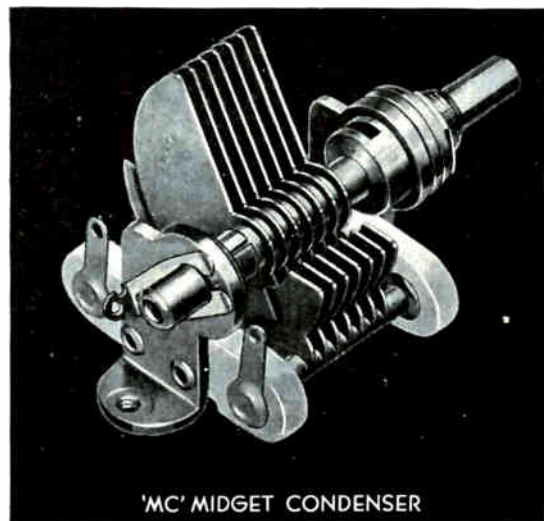

'MC' MIDGET CONDENSER

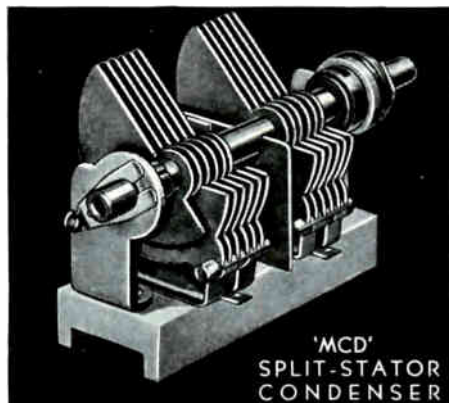

'MCD'
SPLIT-STATOR
CONDENSER

Fig. 39. The top view shows a popular midget variable condenser, and the lower view shows a split stator or gang variable condenser for tuning two different circuits. (Courtesy Hammarland Mfg. Co.)

standard .00035 mfd. condenser used in ordinary broadcast band receivers. Condensers are also made with different plate spacings for high or low voltage circuits, and are used both in radio transmitters and receivers. Fig. 41 shows three common methods of connecting variable condensers for tuning radio circuits. The first two shown at A and B are often used in transmitters but are seldom used in modern receivers. The method shown at C being most generally used in modern receivers.

With the condenser connected as at A, in series with the antenna capacity, the total capacity and the wave length of the circuit are reduced; as you will recall from your previous study of condensers that connecting them in series reduces the voltage across each and thereby reduces their effective capacity.

When the condenser is connected in parallel with the inductance as shown at B, it increases the total capacity and thereby increases the wave length of the circuit.

When the condenser is connected across the secondary of the radio frequency transformer or tuner as shown at C, it tunes the secondary directly and

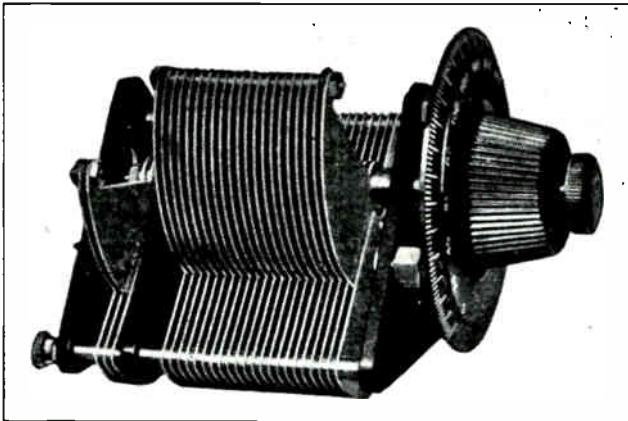

Fig. 40. Variable condenser, with vernier adjustment or small section operated by a separate knob on the tuning dial.

also tunes the primary or antenna circuit indirectly, by inductive coupling between the coils. This method provides one of the smoothest and best methods of tuning and is therefore extensively used in radio receivers.

(NOTE)—Remember that adding inductance or capacity increases the wave length of a circuit. Connecting a condenser in series with the antenna or with a coil reduces the capacity and wave length of the circuit, and connecting the condenser in parallel with a coil increases the capacity and wave length.

40. RADIO RECEIVERS AND DETECTORS

While the tuning elements are absolutely essential to a radio receiver, the detector or device which makes it possible to hear or see the signals received, is often considered to be the heart of a receiver.

We have mentioned both hearing and seeing the signals because in addition to hearing code signals, voice and music with headphones or loud speaker,

some commercial radio receivers print the code marks or symbols directly on a paper tape or ribbon as they come in. Television devices also convert the received energy directly into visual pictures or material, and transmission of still pictures or photos by radio is another process in which the energy received is converted directly into visible form.

As previously explained the transmitted radio energy or carrier wave is much too high in frequency to be audible to the human ear. Even after modulation by audio frequency currents the signal energy or current induced in the receiving aerial circuit, is alternating current of such high frequency that the diaphragms of the headphones cannot respond to it, because even their slight inertia prevents them from vibrating at such high speed.

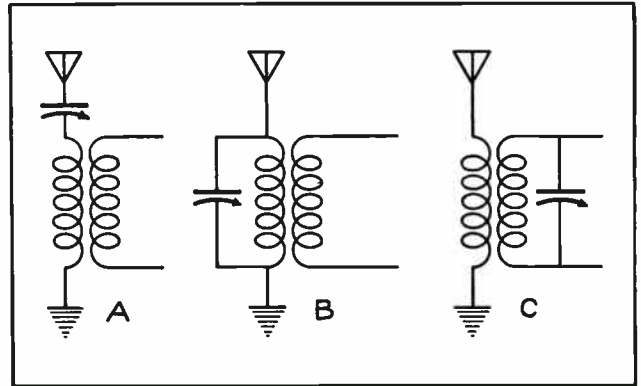

Fig. 41. Sketches showing three different methods of connecting variable condensers for tuning radio circuits.

We find, however, that if we convert this high frequency alternating current into pulsating D. C. with the same variations in value as the modulated A. C. has, then the phone diaphragms can respond, as the pull set up on them by the pulsating D. C. through their magnet coils is all in one direction, and simply varying in strength.

This is the job or function of the detector, to rectify the received high frequency current into pulsating D. C. There are two common devices used for this purpose, namely, the crystal detector and the vacuum tube. The coherer mentioned earlier in this section was one of the earliest devices used as a detector, but is entirely obsolete now.

Crystal detectors were very extensively used for a number of years and were a great improvement over coherers. Crystals have certain disadvantages such as a lack of any appreciable amplifying ability and a need for frequent adjustment, so they have been almost entirely replaced by vacuum tube detectors.

Crystals are still used along with tubes, however, in a few special types of sets, in certain experimental equipment, and are also carried as emergency equipment in certain stations, so we will very briefly cover their use and principles at this point.

41. CRYSTAL DETECTORS

As previously mentioned, the function of a radio detector is to rectify the high frequency alternating current received.

There are a number of crystals which have more or less of this property when current is passed through them. One of the most commonly used is the Galena crystal, which is a natural crystal formation of sulphide of lead, and is found in lead mines. Zincite, bornite, and silicon crystals are also used in some cases. Carborundum crystals are also used in some circuits with a low voltage battery.

Fig. 42 shows a photo of a piece of galena crystal in a mounting or holder, and Fig. 43 shows a sketch of a mounted crystal at A, and at B a complete crystal mounting with its feeler contact or adjustable "cat-whisker," which is used to explore the surface of the crystal for sensitive spots.

When a crystal such as galena is connected in an A. C. circuit, it will allow current to pass through it quite freely in one direction, and will almost entirely prevent its flow in the opposite direction. This

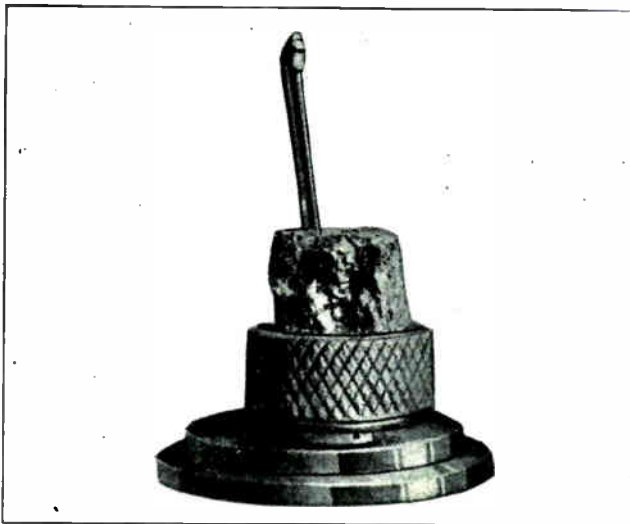

Fig. 42. Photo of a detector crystal fastened in its mounting. Such crystals as this were formerly used very extensively in radio receivers.

is illustrated by the relative size of the current arrows on the wires leading to the crystal at A in Fig. 43.

This rectifier action is thought to be due to either electro-chemical or electro-thermal action between the layers within the crystal structure, or at the point of contact between the tip of the cat-whisker wire and the crystal surface.

42. ACTION OF CRYSTAL DETECTOR IN A RECEIVER CIRCUIT

Fig. 44 shows a method of connecting a crystal and a pair of headphones to a tuning coil to form a simple radio detector or receiver.

When the high frequency waves of a damped wave signal for example, strike against the receiving antenna of such a circuit, they induce alternating voltages in the antenna. This voltage tends to set up in the tuning coil, during each wave train, an alternating current such as illustrated by the curve at A in Fig. 45.

The voltage drop across the coil L in Fig. 44 will cause part of the current to flow through the crystal and headphones.

If the crystal were left out the high frequency current would not produce any sound at the phones, because it could not flow to any appreciable extent through the high impedance of the phone coils which are wound on iron cores. Even if the current did get through the coils in any useful amount the phone diaphragms could not vibrate at such high frequency, nor could the human ear hear it if they did.

With the crystal in the circuit as shown in Fig. 44, however, the current is allowed to flow through it and the phones in only one direction, and is practically all cut off in the reverse direction. This is illustrated by the curves at B in Fig. 45.

Thus practically all that gets through the phones is pulsating D. C. or current in one direction. The current through the phones does not vary with, or follow, each of the high frequency pulsations of these rectified groups, but due to the impedance of the phone coils the current builds up to a sort of average value, in the form of one pulsation for each group or wave train, as illustrated by the large dotted curves at C in Fig. 45.

These longer and slower current impulses through the phone magnets, all in one direction, cause the diaphragms to be attracted and released or vibrated at audio frequency, thus setting up audible signals.

The same general action takes place with modulated C. W. (continuous wave) energy of voice or music reception. The crystal rectifies the energy to high frequency pulsating D. C. by cutting off the flow in one direction. Then the impedance of the phones causes the unidirectional voltage pulsations to build up current through the phone magnets, which does not vary much with each high frequency impulse, but varies or pulsates with the slower variations in value which are due to the audio frequency modulation of the waves, as was shown at C in Fig. 45.

So we find that detection, or the change from radio frequency energy to audio frequency, takes place as a result of the combined rectifying action of the crystal and the choking action of the phones.

43. AMPLIFICATION WITH CRYSTALS AND LOCAL BATTERY

Some crystals such as those made of carborundum can be used with a small amount of current from

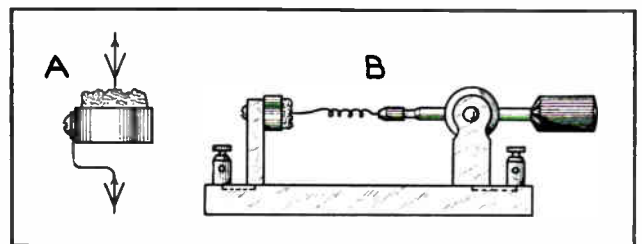

Fig. 43. The sketch at A shows a crystal and illustrates the rectifier effect on the current passing through it. At B is shown a complete crystal mounting with the crystal and cat-whisker in place.

a local battery added to that from the antenna, to obtain a feeble amplification of the signal, through the valve action of the crystal.

Fig. 46 shows a complete circuit diagram for a receiver of this type.

A variable condenser is used for tuning the circuit and a small fixed condenser "C" is connected

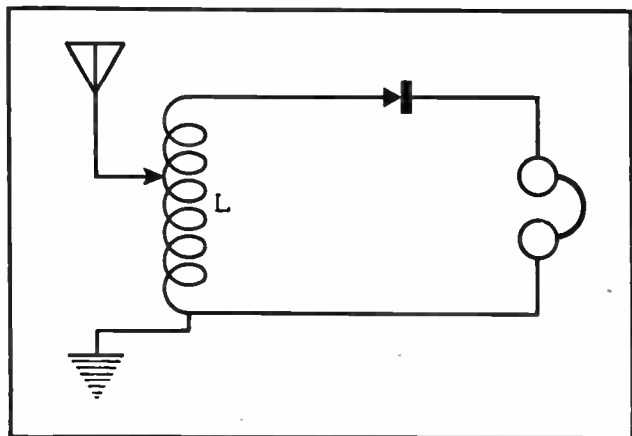

Fig. 44. This sketch shows a circuit for a simple crystal detector radio receiver.

across the phones and battery, to shunt or pass by them, the radio frequency current. This condenser is not large enough, however, to pass the audio frequency variations. Because of its function it is often called a by-pass or bridging condenser.

The amount of battery voltage applied to the crystal and phones is carefully adjusted for best results, by means of a high resistance rheostat or potentiometer P.

44. CARE AND USE OF DETECTOR CRYSTALS

To obtain best results from detector crystals they should be kept clean and free from dust and grease, even being careful not to get the oil from the hands on them by careless handling. Dirty crystal surfaces can be cleaned by washing with alcohol.

When it seems difficult to locate any sensitive spots by feeling or exploring the crystal surface with the point of the cat-whisker, new spots can often be uncovered by carefully chipping away small sections or layers of the galena crystal.

When operating a crystal receiver, one explores the crystal with a cat-whisker while listening with the phones. When a sensitive spot is touched it will be known by a slight hissing sound in the phones. This sound is partly due to static or atmospheric disturbance.

Next adjust the tuning coil and condenser to the wave length of the desired station, tuning it in as loud and clear as possible. Then make a final adjustment of the cat-whisker, or find the spot where the signal is best. A heavier needle or a fixed metal point is used for the contact on carborundum crystals.

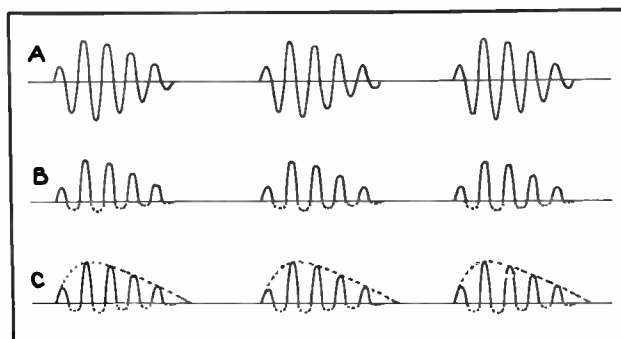

Fig. 45. The curve at A represents the alternating current induced by damped wave-trains striking an aerial. At B is shown the curve for this energy after it has been rectified into pulsating D. C. by the crystal. At C the large dotted curves illustrate how each group of pulsations supply one current impulse to the headphones.

Crystal receivers have received messages and signals from transmitters hundreds of miles distant, will produce very clear and undistorted signals, and are very cheap to construct. But they have the disadvantage of requiring frequent adjustment and being incapable of any great degree of amplification.

Vacuum tube receivers are more dependable, and capable of much greater amplification, therefore they have replaced crystal sets almost entirely, except for experimental sets.

45. RADIO WIRING SYMBOLS

On the following pages are shown the most common symbols which are used for representing various radio devices and parts in circuit wiring diagrams. Carefully study and familiarize yourself with each of these symbols and they will help you to understand the many radio circuit diagrams in following sections, as well as those in any radio magazines or books you may wish to read.

You should also be able to recognize the symbols of parts and trace out the factory diagrams of various receivers or radio equipment which you may be installing and servicing. A knowledge of these symbols and radio circuit diagrams will also enable you to draw up circuits and represent on paper, your own ideas for radio set changes or experimental circuits you might wish to build.

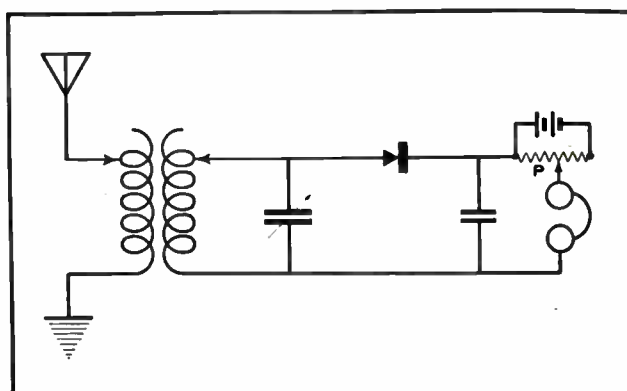

Fig. 46. Sketch of a crystal detector circuit using a battery and potentiometer for applying voltage to the crystal and obtaining slight amplification of the received signal.

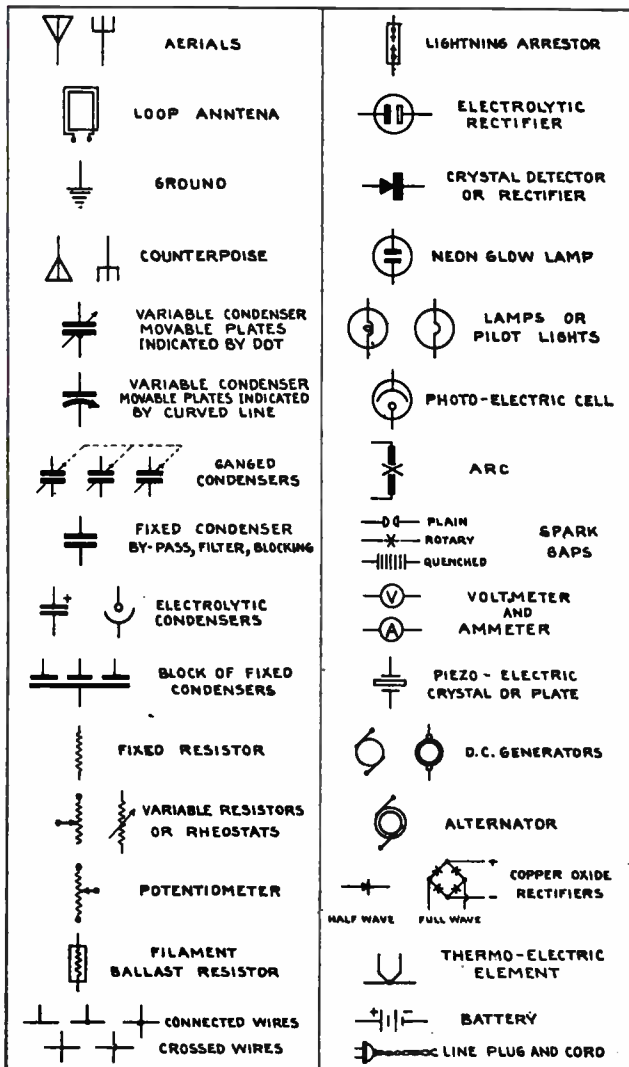

Fig. 47. Radio wiring symbols.

radio receiver, amplifier or transmitter. These little glass or metal bottles with millions of tiny electrons flying around inside them can be made to do remarkable things in radio sets. You will find the following section on vacuum tubes extremely interesting.

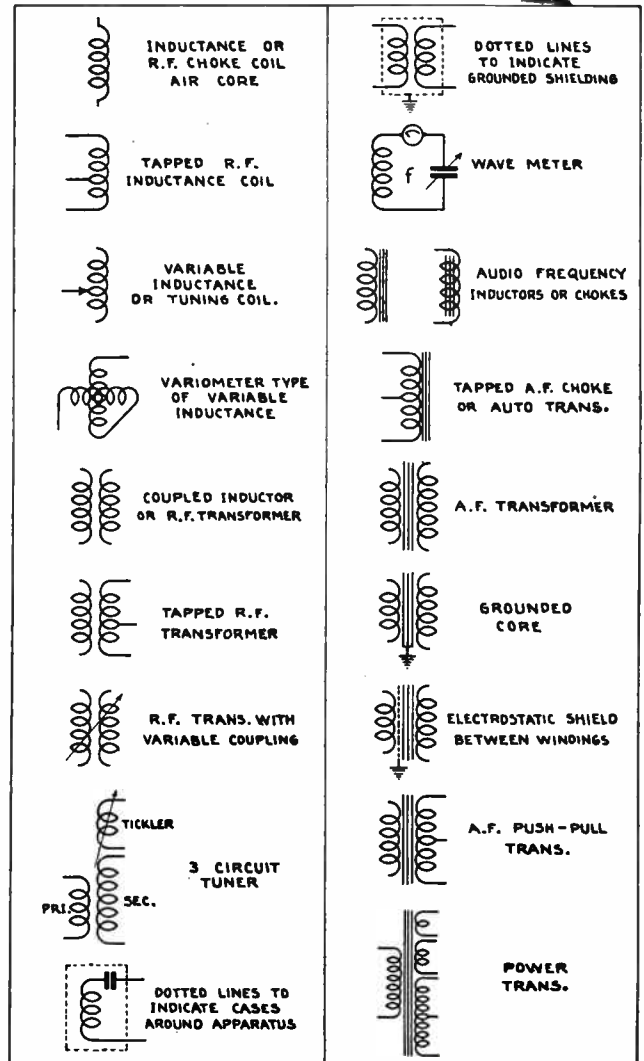

Fig. 48. Radio coil and transformer symbols.

Now if you have thoroughly studied the principles of radio circuit tuning, radio signal detection and the symbols covered in this section, you are ready for the next section on the very interesting and important subject of vacuum tubes.

The vacuum tube is the heart of any modern

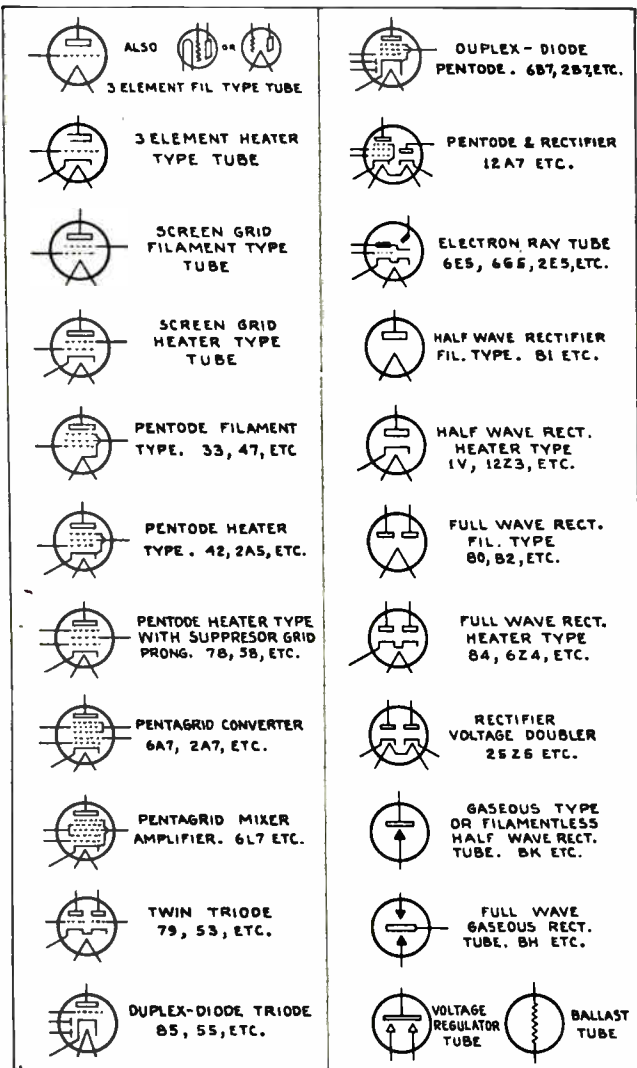

Fig. 49. Radio vacuum tube symbols.

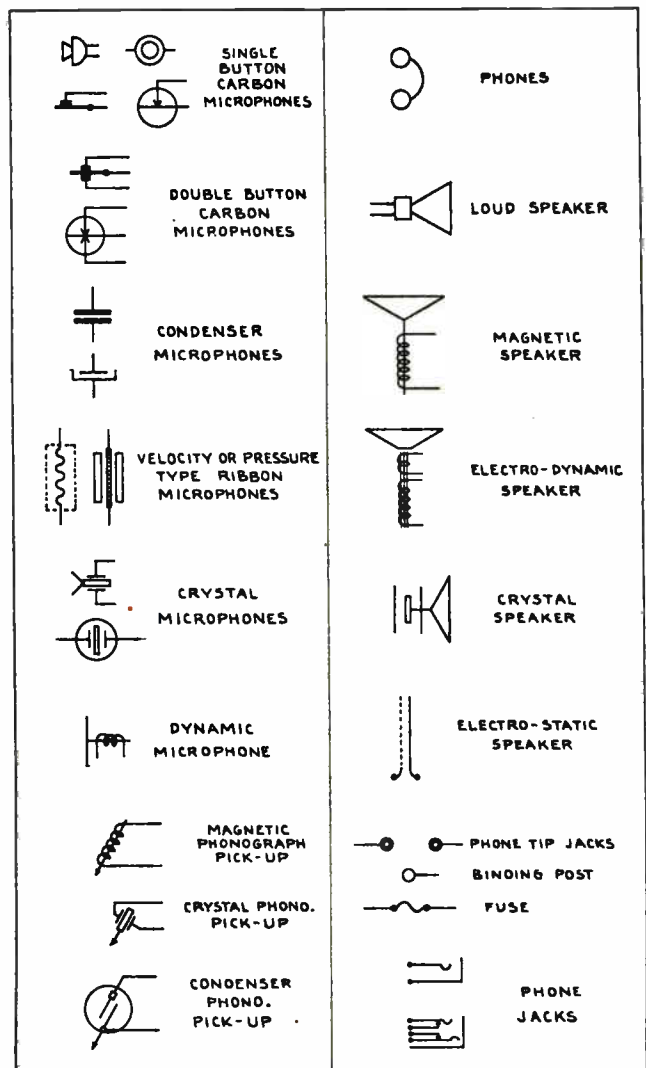

Fig. 50. Microphone, loud speaker and phonograph pick-up symbols.

RADIO VACUUM TUBES

Now that you are familiar with the general nature of radio wave energy and how it is produced and sent out from the transmitter, and also how it is received and detected at the receiver, we are ready to learn more about radio vacuum tubes which are actually the "heart" of any radio transmitter or receiver.

Vacuum tubes play a most important part in practically all modern radio, public address, and television equipment. In fact the vacuum tube is one of the principal items which has made possible the development of radio from the spark and crystal stage to the splendid equipment we have today, with its long range, high tone quality and sharp tuning or selectivity.

We may well marvel when we pause to think that a little evacuated glass or metal bulb enclosing a few small pieces of metal and millions of speeding electrons, can serve to detect and amplify feeble signals of one millionth of a volt or less and bring them out of our radio speakers loud and clear.

Every year new improvements are made in vacuum tubes and new uses are found for them, resulting in constant improvements in radio, sound pictures, public address and television, to say nothing of photo-electric cells and amplifiers used in industry.

Vacuum tubes are made in sizes ranging from the small receiving tube no larger than the end of your thumb and having a fraction of one watt capacity, up to huge transmitting tubes as tall as a man, having a capacity of 100,000 watts or more. See Fig. 51 which shows some of the various types of tubes in common use. They are used in radio receivers as detectors, amplifiers, rectifiers, oscilla-

tors, mixers, tuning indicators, etc., and in radio transmitters as amplifiers, modulators, oscillators, rectifiers, etc. So you can readily see the importance of having a thorough practical understanding of the construction, operation, and characteristics of these highly important radio devices.

You have already learned in radio section number 1 about the general construction of the common three-element vacuum tubes and their function as oscillators, but we will now explain more fully the details of tube construction, operation, and characteristics.

Fig. 53 shows two common types of vacuum tubes such as used in radio receivers. Note the manner in which the filament, grid and plate are mounted inside the tube on support wires which are attached to the glass post. Also note how the connecting wires or leads from these elements of the tube are brought out through the glass to terminal prongs on the base of the tube, and to a metal cap on top of the tube for the control grid connection.

The prongs on the bottom of the tube serve to hold the tubes in their sockets, and also to complete the circuits from the tube elements to the socket contacts and wiring of the receiver.

In recent years, tubes have been developed which use metal jackets or enclosing envelopes instead of glass bulb envelopes. Two of these metal tubes are shown in Fig. 56. Metal tubes have the advantages of being more rugged than glass tubes and more completely shielded from electro-static interference. Note the extra "locator" or guide prong in the center of the bases of these metal tubes, to assist in placing them in the sockets correctly.

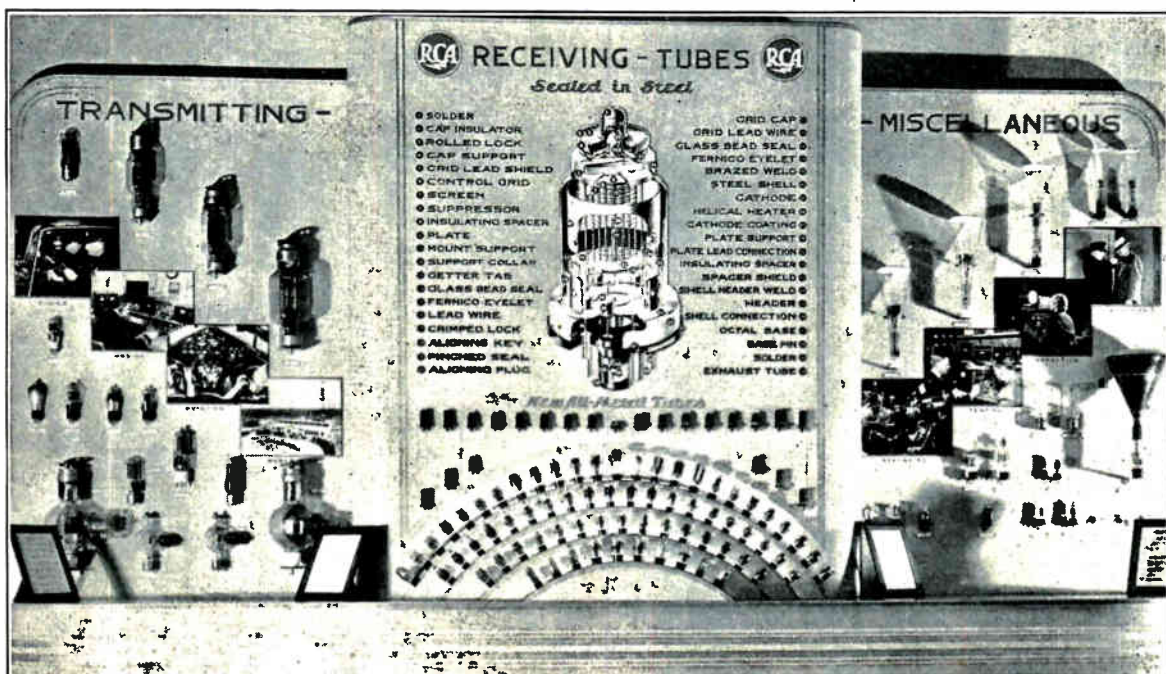

Fig. 51. R. C. A. tube display, showing a few of the many types of tubes now in use.

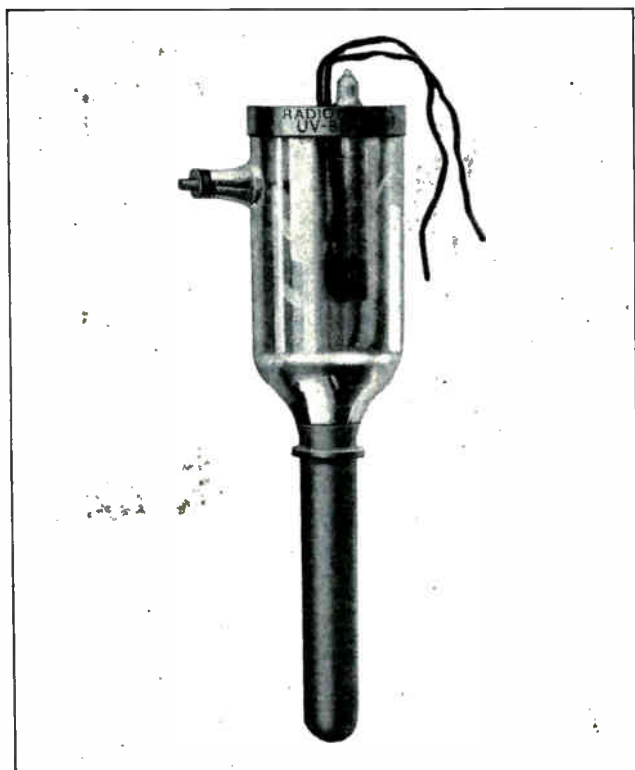

Fig. 52. A 10 Kw water cooled transmitter tube.

There are so many different types of vacuum tubes in use in various models of radio receivers today that the radio service man may have tendency to become somewhat confused at the great number of them. However, many of the different types of tubes are only slightly different from each other in shape, size or the number of grids, plates or filaments they contain. So a thorough understanding of the more common types of tubes should help you to properly select, use and test any of the various types.

46. TUBE CONSTRUCTION AND FUNCTION OF PARTS

You will recall that the three important elements of the simple tube are the filament, grid and plate. The filament being heated to throw off electrons to complete a circuit and establish current flow between the plate and filament; the plate used as a positive electrode to supply current from the B battery; and the grid being used as a control element or shutter to regulate the electron stream and the current flow. Fig. 54 shows these various elements before they are assembled in one of the earlier type tubes, and also shows the completed tube.

The filament is just a simple loop of high resistance tungsten or nickel wire, as shown both with and without its support at A, or in some cases just a single straight strip of this material held in place by a supporting wire, as shown by the right hand one of these filaments at A.

The tungsten filaments of later model tubes are usually treated with thorium, and the nickel wires coated with oxide, to make them emit electrons more freely at lower temperatures. This makes them much more efficient than the older types, as

many of the ordinary small tubes with the thoriated or oxidized filaments only require about .25 ampere, or $\frac{1}{4}$ as much filament current as the older tubes. Many of these new tube filaments operate at such low temperatures that they need only be heated to a dull cherry red, while many of the older tube filaments were operated at white heat or incandescence.

Filaments of tubes in battery operated receivers are heated by current from a low voltage "A" battery, ranging from $1\frac{1}{2}$ to 6 volts, and filaments of A. C. tubes are heated by current from the low voltage secondary winding of a filament or power transformer.

Tube filaments are rather delicate and the tubes should never be roughly handled or the filament wires are likely to become broken or bent into contact with the grid. Filaments are also easily burned out if too high voltage is applied to them.

At B in Fig. 54 is shown the grid of the tube. This grid consists of a coil or spiral of fine nickel wire and is placed around the filament between it and the plate, and supported so that it does not touch either the filament or plate. See Fig. 55. The grid support consists of two small stiff wires which have their lower ends imbedded in the glass of the tube as shown at D in Fig. 54. Here the filament and grid are both shown mounted on their support wires which have been imbedded in the top of the glass post while it was hot and soft.

As previously explained the grid, when positively or negatively charged, acts as a control or shutter to regulate the stream of electrons from the filament to the plate.

The filament electrons being negative will be attracted to the grid when it is positive, and the electron flow thereby increased. When the grid is negative it repels most of the electrons, throwing them back toward the filament, and thus greatly reducing the stream of electrons to the plate.

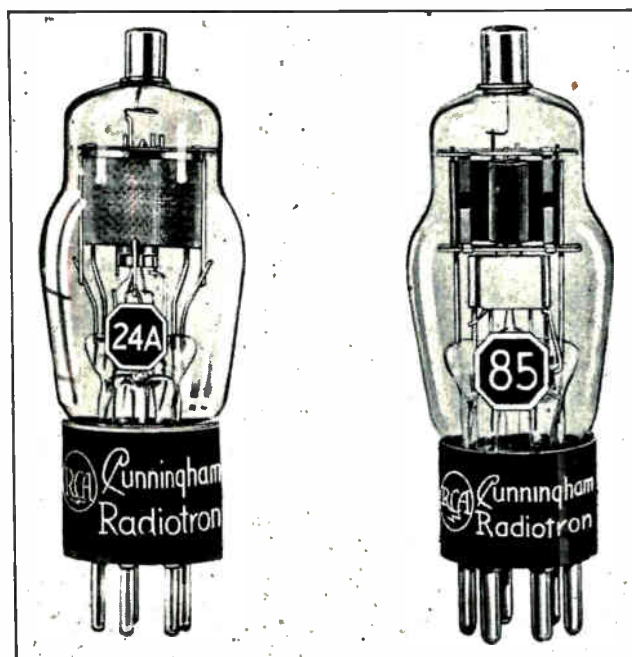

Fig. 53. The 24A tube shown above is a R. F. amplifier tube and the 85 is a duplex tube.

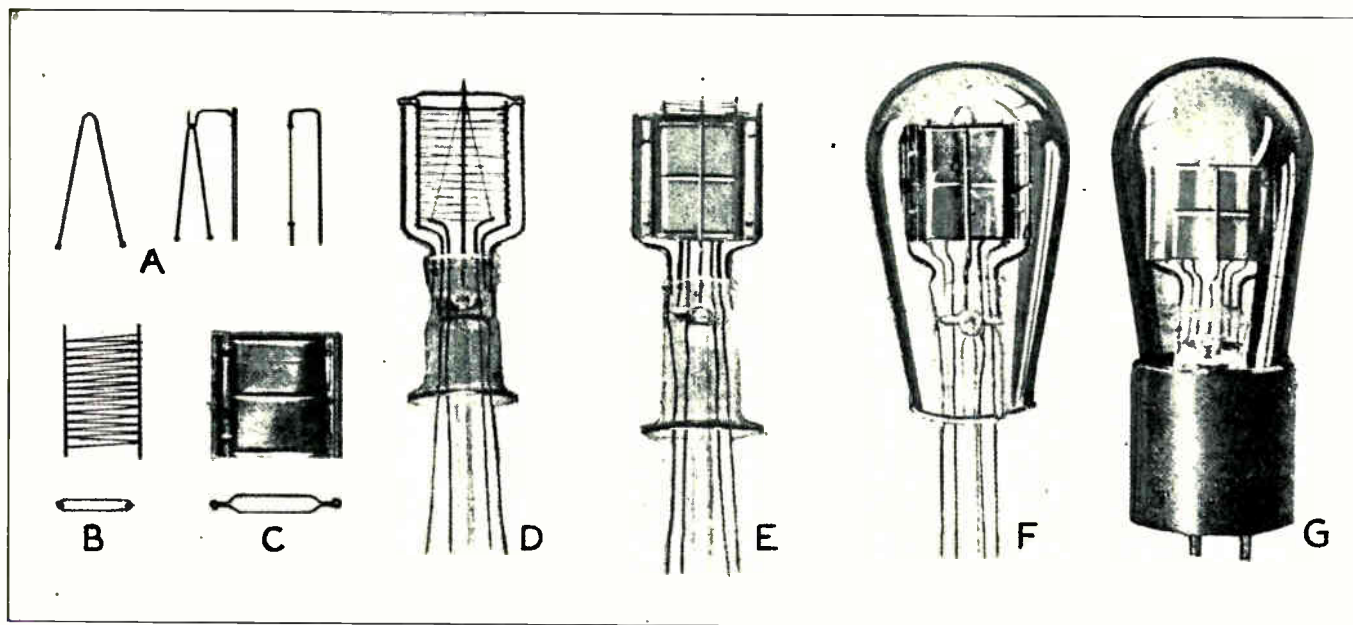

Fig. 54. The above views show the various parts of a vacuum tube and illustrate the manner in which these parts are assembled and mounted in the complete tube. Refer to these views frequently while reading the accompanying paragraphs.

At C in Fig. 54 is shown the plate of the tube. This plate is made of a thin sheet of nickel, formed into a flat, round, or oblong jacket, and when mounted it surrounds the filament and grid as shown at E in Fig. 54. Some plates are heated and oxidized to eliminate gases from the pores of the metal.

Note the wires which are attached to the filament, grid and plate, and taken down through the glass stem of the tube for connection to the tube prongs.

When the plate is connected to a B battery or other source of D. C. voltage, current will flow through the tube and this current is controlled by the number of electrons between the filament and plate. These electrons being controlled by the grid, the grid also controls the plate current flow.

At F is shown the glass bulb placed over the parts and ready to be melted or sealed to the base of the glass inner support, thus making the tube air tight.

Before finally sealing the bulb, it is evacuated or has the air practically all pumped out. After this process it is sealed, fitted with a bakelite base and the lead wires are connected to the prongs in this base.

Evacuating the tubes or removing the air and oxygen from them prevents the rapid burning away or oxidization of the heated filaments, and also makes a lower resistance path for current between the plate and filament.

In certain types of modern vacuum tubes a small cup of magnesium is placed inside the tubes before sealing, and after evacuation and sealing the magnesium is exploded by means of a powerful high frequency field. The burning magnesium absorbs or consumes the small amount of gases left in the tube after evacuation. It is this process which causes the silvery deposit or coating on the inside of certain tubes. The chemical thus used is called the "getter."

The average serviceable life of a good tube with proper treatment should be between 800 and 1,000 hours or more of use.

47. OPERATION OF VACUUM TUBES

In Fig. 58 is shown a sketch of a common type of 3 element vacuum tube. The filament is connected to a low voltage battery ($1\frac{1}{2}$ to 6 volts) called an "A" battery, which supplies current to heat the filament.

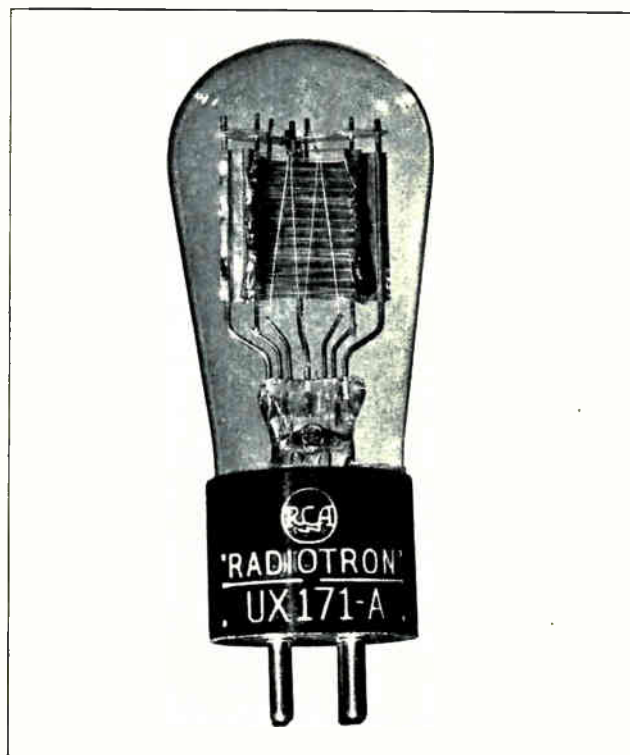

Fig. 55. Photograph of a vacuum tube with the plate opened up on one side to show the location of the grid and filament which are surrounded by the plate.

The plate is connected to a higher voltage battery (22½ to 45 volts) called a "B" battery, which supplies a positive charge to the plate.

The grid of the tube in this case is connected to the center of a potentiometer, which is connected across the filament. This is done to allow an adjustment of the grid potential or voltage, which is obtained from either the positive or negative filament lead.

Note the three circuits thus formed. They are the **grid circuit**, consisting of the grid, grid lead, potentiometer, filament, and the gap from the filament back to the grid; the **filament circuit**, consisting of the filament, "A" battery and rheostat R; and the **plate circuit**, consisting of the plate, plate lead, milliammeter "MA", battery leads, "B" battery, one side of filament, and the gap from the filament back to the plate.

When such a tube is cold and has no current flowing through its filament, no plate current will

If the plate voltage is gradually increased, it also increases the positive attraction for the negative electrons, thereby increasing the number that stream to the plate. Therefore, as the plate voltage is increased, the plate current flow will also increase up to a certain maximum value, where it will not increase appreciably with further plate voltage increase. The reason the plate current will not increase much beyond this point is because the increased plate voltage is drawing all of the available electrons emitted by the filament. This point is called the **saturation point**.

To increase the plate current beyond this value, we would need to increase the electron emission from the filament by increasing its temperature.

Fig. 59 shows a curve which illustrates the manner in which the plate current changes with variation of plate voltage.

This curve is approximate and shows the general plate voltage, plate current characteristics of some common receiving tubes, although its shape would vary a little for different types of tubes.

Note how the plate current increases quite slowly as the voltage is raised from 0 to 60 volts, and then increases very rapidly as the voltage is raised from 60 to 200. Beyond this, however, the plate current increases very little for any further voltage increase.

By careful examination of the curve, tracing up along the 60 volt line to the point where it crosses the curve, then reading to the left along a horizontal line to the left edge of the chart, we find the first 60 volts applied to the plate will only produce about 2½ milliamperes. The next 60 volts, however, will raise the current from 2½ to about 8½ milliamperes, and the next 60 volts brings it up to about 15 milliamperes. From this point on the curve begins to level off, and the next 60 volt increase only raises the plate current from 15 to a little above 18 milliamperes.



Fig. 56. Metal tubes of this type are used in many modern radio receivers.

flow as the gap between the filament and plate is too high resistance.

When the filament is heated by passing current through it, electron emission is set up, and millions of negative electrons are thrown off around it in all directions. Some of these electrons fly across to the plate, due to the attraction of the positive plate for the negative electrons, thus completing a circuit and allowing a very small current to flow from the B battery in the plate circuit. This current can be measured in milli-amperes by the meter MA.

48. PLATE CURRENT

This current which flows in the plate circuit when no signal voltage is applied to the grid, or when the grid is at normal potential, is called the **normal plate current**. The amount of normal plate current flow will depend on the type of tube, upon the electron emission from the filament, and upon the voltage applied to the plate. It generally ranges from 4 to 40 milliamperes in common receiving tubes.

49. CONTROL ACTION OF GRID

In Fig. 58 the grid lead of the tube is connected through a potentiometer to the filament, and the grid kept about at zero potential. The plate current flow is simply due to the moderate amount of

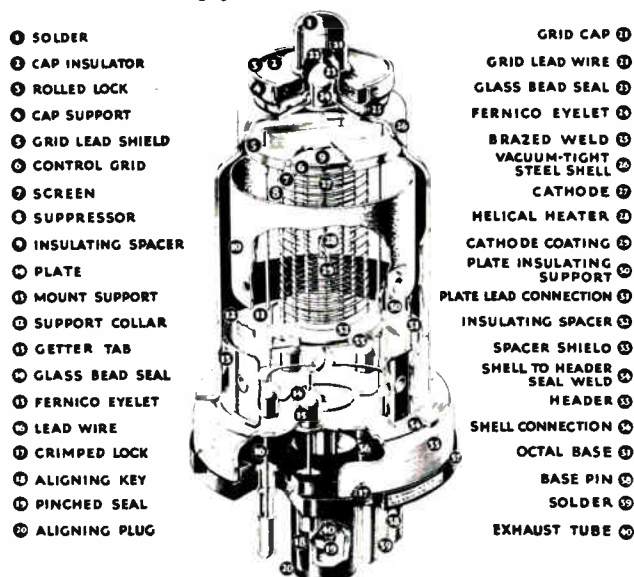

Fig. 57. This figure shows the structure of an all-metal tube.

electrons drawn from the filament to the plate by its positive attraction.

In Fig. 60 is shown another sketch of a tube with the grid positively charged by means of a low voltage battery connected in its circuit.

In this case the grid return lead is connected to the positive filament lead to prevent the A battery from applying negative potential which would overcome the effect of the cell in the grid circuit.

When the grid is positively charged in this manner, even at very low potential, being very close to the filament it exerts a great attractive force on the negative electrons from the filament, and causes them to stream toward it in great quantities. When these electrons reach the grid, a few strike and cling to it, but because they are then getting near to the plate which is of much greater positive potential, most of the electrons fly right on through the grid to the plate, as shown in Fig. 60. Compare the number of electrons between filament and plate in this sketch with the number in Fig. 58, where the grid is at zero voltage.

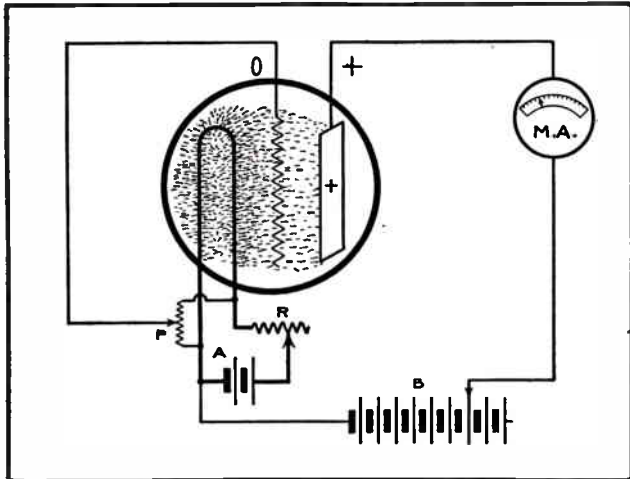

Fig. 58. This sketch illustrates the electron flow from the filament to the plate of a vacuum tube when no potential is applied to the grid. You will note that only a moderate amount of electrons are attracted to the plate while the grid is in this condition.

The greatly increased stream of electrons when the grid is positively charged as in Fig. 60, causes a corresponding increase in plate current, as shown by the milliammeter in the plate circuit. Compare its reading with that of the one in Fig. 58.

In Fig. 61 is shown another sketch of a tube with the grid negatively charged, by reversing the polarity of the battery cell connected in its circuit and having the grid return connected to the negative side of the filament. In this case the negative charge on the grid repels the negative electrons from the filament, throwing most of them back toward the filament and allowing only a very few to get through to the plate.

This nearly complete shutting off of the electron stream in the gap between the filament and plate, reduces the plate current nearly to zero, as shown by the milliammeter in the plate circuit in Fig. 61.

Compare very carefully figures 58, 60, and 61, until you are sure you fully understand the effect of the grid in controlling the plate current as the grid potential is varied or reversed.

50. VALVE AND DETECTOR ACTION OF TUBES

We have found that the tube acts as a very sensitive valve, with the grid controlling the current in the plate circuit. It only requires a very small change of potential on the grid to make a much greater change in the plate current. So vacuum tubes also have an amplifying function, due to the fact that a very small amount of energy on the grid, even as small as a few millionths of a watt, will release and control much greater amounts of energy from the B battery.

As the plate current is direct current supplied by the B battery, and only flows in one direction, we also find that a tube connected in such circuits will act as a rectifier. Or in other words, we can supply feeble alternating voltage to the grid circuit and have strong direct current pulsations set up in the plate circuit of the tube.

As explained in an earlier article, rectification of the received high frequency energy is necessary to accomplish detection and to enable the headphones to produce audible signals.

From the foregoing we find this rectification and detection can be accomplished with vacuum tubes as well as with crystals.

In Fig. 62 a vacuum tube is shown connected in a simple detector circuit for receiving radio signals. The grid circuit is connected through a grid resistance and condenser, L and C, to the secondary winding of the antenna coupling-coil or R. F. transformer T, and then back to the filament. The grid resistance and condenser will be explained later.

A variable condenser is connected across the R. F. transformer for tuning the circuit to the proper wave length. A pair of headphones and a bypass condenser are now connected in the plate circuit in place of the millammeter shown in the previous circuits.

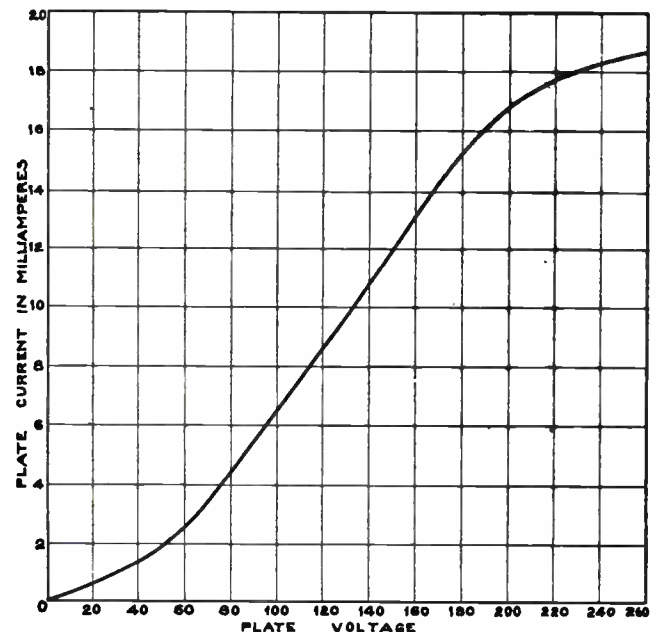

Fig. 59. Curve showing the manner in which the plate current of a vacuum tube varies with changes of the plate voltage.

51. RECTIFIER ACTION

When the antenna and grid circuits are tuned to receive signals from a transmitter, high frequency A. C. is induced in the grid circuit and this alternating voltage is applied to the grid.

Each time the grid becomes negative the electron stream is diminished and the plate current reduced below normal. Each time the grid becomes positive the electrons are allowed to reach the plate in greater numbers and the plate current is greatly increased. Thus the application of high frequency A. C. causes pulsating D. C. to flow in the plate circuit.

If the incoming carrier wave is modulated by voice or code signals, the variations in the value of the A C. voltage applied to the grid will cause corresponding audio frequency variations in the pulsations in the plate circuit. This in turn sets up vibrations of the headphone diaphragms and reproduces the sound.

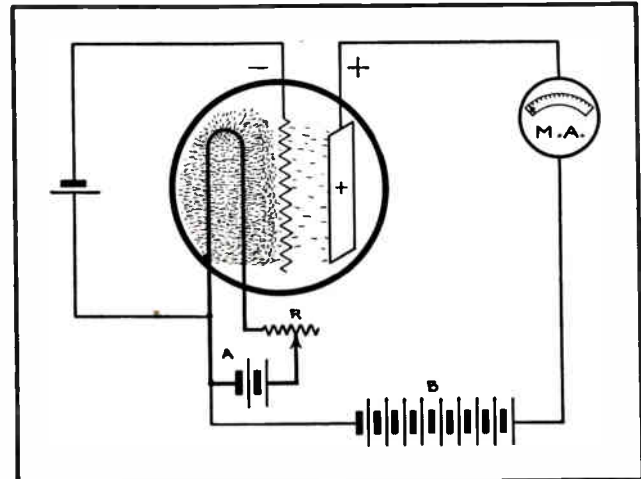

Fig. 61. The above diagram shows the manner in which the electron flow from filament to plate is almost entirely shut off when the grid of the tube is negatively charged. Compare this sketch with those in Figs. 58 and 60.

This point of maximum effectiveness of the tube as a detector is illustrated by Fig. 63, which shows the grid voltage, plate current curve or characteristic of a tube. This curve shows the manner in which the plate current of a common type of detector tube will vary with changes in grid voltage.

Note that as the grid voltage is reduced from about 8 volts negative to zero potential, the plate current only increases very little, or from zero to about 1½ milliamperes. As the grid voltage swings past zero and becomes positive, the plate current increases very rapidly for each volt of increase in positive grid potential, up to the point where it nears saturation.

By using 22½ volts on the plate of this tube, the lower knee or bend of the curve is kept about at the point of zero grid potential, as shown by the vertical dotted line crossing the curve about at this knee. The normal plate current which flows at zero grid voltage is indicated by the horizontal dotted line. Changing the plate voltage will change the shape of the curve somewhat. Increasing the plate voltage will cause a greater change in plate current for each volt of change in grid potential, and will cause the plate current curve to shift so that the zero grid voltage line will cross it at a point farther out in the straight portion.

If a detector tube is worked with the zero grid voltage point at the knee of the curve as shown in Fig. 63, the alternating voltage applied to the grid will cause the pulsations of plate current to rise farther above normal value than they fall below. This is illustrated in Fig. 64. Here a section of a plate current curve is shown from A to B, the alternating grid voltage curve of an incoming damped wave signal from G1 to G6, and the resulting curve of the pulsating plate current from P1 to P6.

The voltage values of the alternations applied to the grid can be determined by the figures at the tops of vertical dotted lines, and the current values of the D. C. pulsations set up in the plate circuit can be determined by the figures at the left ends of the horizontal dotted lines.

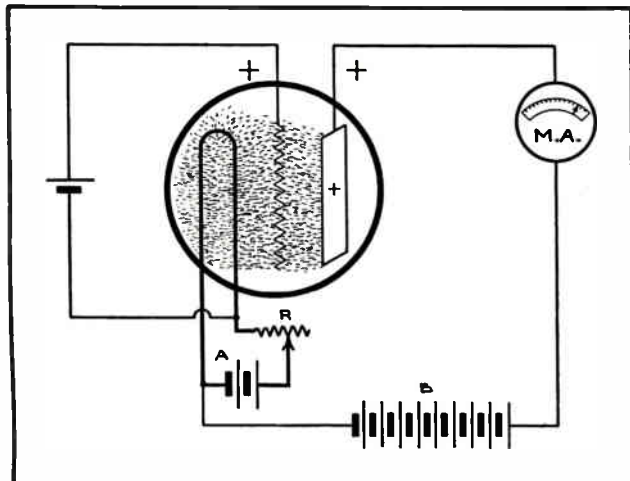

Fig. 60. This sketch shows the greatly increased flow of electrons from the filament to the plate of a vacuum tube when the grid is positively charged at very low potential.

Fig. 45 in section one showed the audio frequency pulsations resulting from rectified groups of the high frequency waves of code signals, and while these groups were rectified by a crystal detector we now find that vacuum tubes will produce the same result. Vacuum tubes are much more sensitive as detectors than crystals are, because the tubes can use such very feeble voltages on the grid to control strong impulses from the B battery through the headphones.

52. OPERATION OF DETECTOR TUBE. GRID VOLTAGE, PLATE CURRENT CURVE

The detector action of vacuum tubes can be greatly improved by taking advantage of a known characteristic of the tube and using just the right grid and plate voltages to work the tube at a certain point on its grid-voltage plate-current curve. At this particular point the pulsations will be more pronounced in one direction from normal plate current, thus producing greater variations in the pull on the phone diaphragms and greater signal strength.

The normal plate current which flows at zero grid potential is shown by the heavy solid and dotted horizontal line. By following the vertical dotted line down from the tip of any alternation of the grid voltage to the point at which it strikes the plate current characteristic curve AB, and then following the horizontal line to the right, the plate current pulsation curve for that grid voltage is found. Then by looking to the left margin the current value of the plate pulsation or impulse can be determined.

You will note that while the positive and negative grid voltage alternations are equal in value or amplitude, the positives cause the plate current to rise about three times as far above normal as the negatives cause it to fall below normal. This results in an average current increase or one long pulsation through the headphones. See the curved dotted line which indicates this.

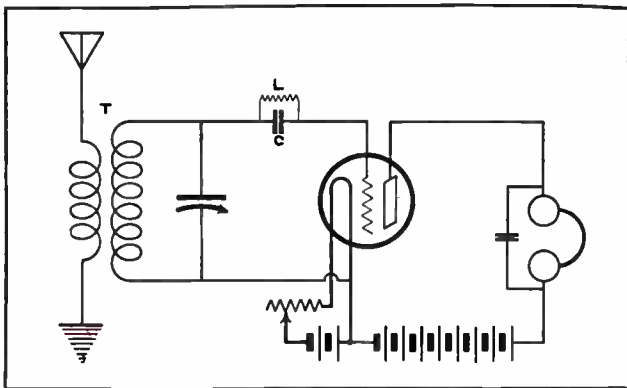

Fig. 62. Diagram of a simple single tube detector circuit using a grid leak and condenser to obtain detector action.

In this diagram only three complete alternations are shown for the damped wave signal, but an actual wave group of this kind would probably consist of 12 to 30 or more oscillations, and the entire group of pulsations set up by them would be used to make up one of the audio frequency pulsations through the headphones.

53. GRID BIAS VOLTAGE

We have already stated that a detector tube can be worked at its most efficient point, for detector action, by using the proper plate voltage to bring the bend or knee of the plate current curve at about zero grid potential. This condition was shown in Fig. 64.

Another method of obtaining rectification or detector action, with maximum variations in plate current for each change of signal voltage on the grid, and thereby producing greater movement and sound from the phone diaphragms, is by giving the grid a negative bias. This means applying or keeping a negative potential on the grid at all times. This is often called power detection.

This negative potential or bias can be obtained in several different ways. One way being to connect the grid return lead to a point between the filament rheostat and the negative side of the A battery, as at X in Fig. 65A. This causes a negative potential equal to the voltage drop in the negative side of the filament plus that in the rheostat, to be applied to the grid.

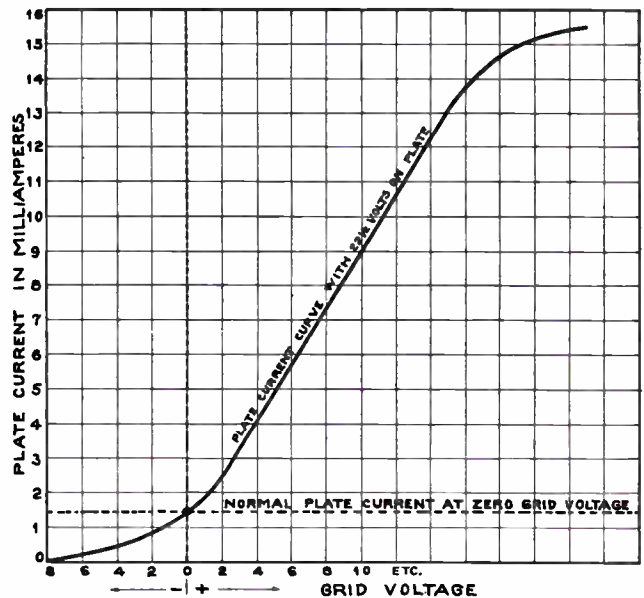

Fig. 63. The above curve shows the manner in which the plate current of a vacuum tube changes with variations of the grid voltage.

Another method is by use of a "C" battery or biasing battery as shown in Fig. 65B. Here a low voltage battery C1 is connected in the grid return with its negative terminal toward the grid and its positive terminal to the filament lead. A small by-pass condenser C2 is often connected in parallel with this battery to allow the high frequency signal energy in the grid circuit to pass directly to the filament lead.

At C in Fig. 65 is shown a method of using a potentiometer or variable high resistance P, connected across the C battery for varying the negative biasing voltage applied to the grid. Here again the by-pass condenser C2 is used to keep the feeble signal energy from having to pass through this high resistance in order to get to the filament and complete the grid circuit.

54. GRID LEAK AND CONDENSER

At D in Fig. 65 the negative grid bias is obtained by means of a grid condenser and leak, GC and GL, which you may recall were also shown in the detector circuit in Fig. 62. These devices accomplish the biasing of the grid in the following manner:

When the tube is in operation some of the negative electrons thrown off by the filament strike the grid and cling to it, thus tending to build up a slight negative charge on the grid. If the grid return is connected to one side of the filament as is generally the case, these negative electrons will flow right back to the filament or their source. If the grid lead was not connected to anything, the electrons not being able to drain or flow off from it would soon accumulate in sufficient amount to build up a considerable negative potential on the grid, and stop practically all flow of electrons from filament to plate, by the repelling action of this negative charge on the grid.

Now if we had some way of holding just the proper amount of this negative charge on the grid and allowing the rest to escape, we could give the grid the desired negative bias in this manner. That

is exactly what we do with the grid condenser and grid leak.

The grid condenser, while allowing the high frequency A. C. signal energy to pass through it to the grid, will not allow the direct current flow of electrons or grid current to pass through it from grid to filament, around the grid circuit. Thus it acts as a blocking condenser to store up electrons and negative charge or bias on the grid.

Now to prevent this charge becoming too high we place a high resistance "leak" across the condenser to allow the excess electrons to leak back to the filament whenever the grid potential gets high enough.

By selecting the proper sizes of grid condenser and leak for various tubes or circuit conditions the detector tubes can be properly biased for operation at the best point on their curves, and maximum signal strength thus obtained at the headphones. The size of grid condenser commonly used is about .00025 microfarad (mf.), and the grid leaks vary from about .5 to 10 megohms, the 2 megohm size being the most common.

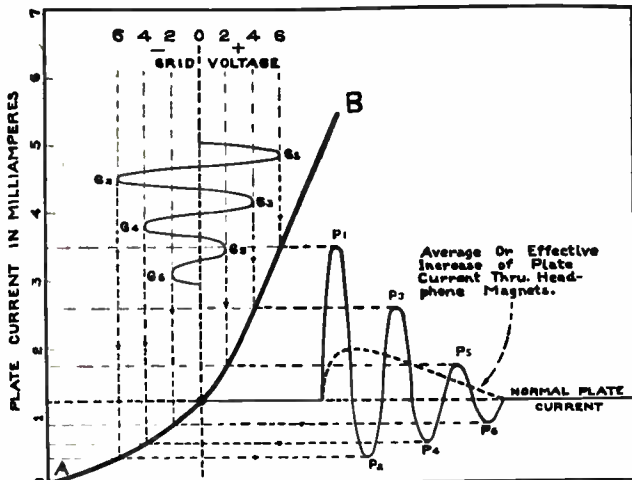

Fig. 64. Curves showing the manner in which the signal voltage of a damped wave train is applied to the grid of a tube, and is both amplified and rectified in the resulting plate current impulses. Study this action carefully in the accompanying paragraphs.

A low resistance leak allows the electrons forming the grid current to flow away from the grid more rapidly, thus maintaining lower negative potential or bias on the grid. A high resistance leak tends to hold back the electrons and grid current flow until greater negative potential is built up on the grid to force them to flow through the resistance back to the filament, and thus the higher resistance maintains a greater negative grid bias.

Too high grid leak resistance may cause the tube to become inoperative or "paralyzed," by storing up such a high negative potential on the grid that it stops practically all flow of electrons from filament to plate. This would be particularly true with strong signals.

Some grid leaks consist of a thin metallized or graphite coating applied in liquid form and dried and baked on the inside of a glass tube, or on a slender insulator element in the tube. Others consist of a composition rod of carbon or graphite mixed with powdered insulation and bound together with cement.

The grid leak method of detection is more sensitive than the power detector and is therefore best to use for very weak signals. The power detector method is best for handling strong signals, as there is less liability of overloading the tube. One advantage of the grid leak method is that a leak of proper resistance will automatically control or adjust the grid bias for variations in signal strength. This can be understood by applying Ohms Law. We know that the current flow through any certain resistance will be proportional to the voltage applied. So whenever the electrons tend to build up a higher negative potential on the grid, this higher potential speeds up the rate of flow through the grid leak and keeps the negative bias quite well controlled.

55. EFFECT OF NEGATIVE BIAS

Now let us see just what effect this negative bias has on the operation of a detector tube.

First of all it allows the use of much higher plate voltages, to obtain greater output from the tube and stronger signals at the headphones or loud speaker. Then by biasing the grid with a negative potential the incoming signal oscillations simply cause the grid potential to become more or less negative, instead of positive and negative. This in turn causes all the variations or changes in plate current to be below normal instead of part above and part below, as when the grid is operated at zero potential.

Operating the tube with a negative grid bias, or keeping the grid always at some negative potential, also prevents the grid from attracting to itself such large numbers of electrons from the filament and thereby reduces the grid current. Excessive grid current is very objectionable as it robs the plate circuit of some of its current thereby reducing the tube efficiency. It also tends to cause distortion of the signals.

The manner in which a negative grid bias or potential reduces the grid current can be readily understood by keeping in mind that if the grid is always slightly negative it will not attract negative electrons to itself, even though it will allow them to pass through between the grid wires to the plate if the positive plate voltage is kept high enough

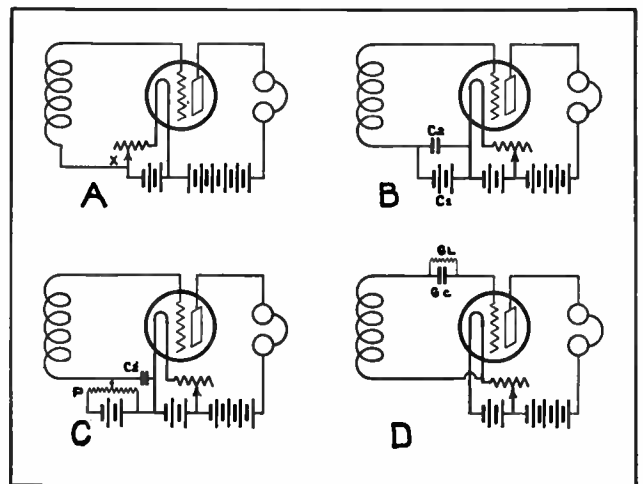

Fig. 65. The above sketches show four common methods of biasing the grid of a vacuum tube with a low negative potential.

to draw them on through. On the other hand, if the grid is not biased and is allowed to become positive on every other alternation of the applied signal voltage, it then attracts negative electrons to the grid wires, robbing the plate of that amount, and setting up grid current flow in the grid and filament circuit.

Fig. 66 shows the plate current curve of a tube which has higher plate voltage applied, and illustrates the manner in which a constant 3 volt negative grid bias from a C battery or some D. C. source is used to work the tube at the proper point or knee of the curve for detection.

The use of the higher plate voltage causes the plate current curve to shift over so that the point of zero grid voltage comes in the straight portion of the curve, as shown by the light dotted vertical line running down from zero grid voltage. The horizontal line X would represent the normal plate current at zero grid voltage.

By using the 3 volt grid bias the working point of the grid voltage is shifted to the left of zero as shown by the heavy dotted vertical line. The normal plate current with the grid bias in use is represented by the horizontal line X1.

The curves G and G1 represent two groups of I. C. W. or interrupted continuous wave signal voltages applied to the grid. This signal voltage being alternating and of 3 volts amplitude, swings back and forth from 3 volts positive to 3 volts negative. But on account of the 3 volts bias the grid signal voltage starts at 3 volts negative and causes the grid voltage to swing from zero to 6 volts negative and back again, but never positive.

The resulting pulsations or variations in the plate current as shown by the curves P and P1, increase and decrease from about 2.2 to .4 milliamperes, but never rise above the line X or what would be the normal current at zero grid voltage.

The average plate current or the audio frequency pulsations which flow through the headphones are shown by the dotted curves.

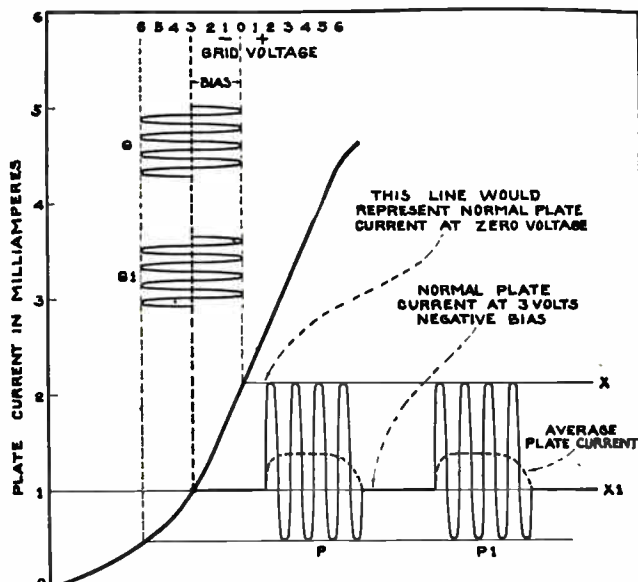

Fig. 66. These curves illustrate the rectifier or detector action obtained from a tube operating with a negative bias on the grid. This sketch shows I.C.W. signals applied to the grid, instead of damped wave signals as shown in Fig. 64.

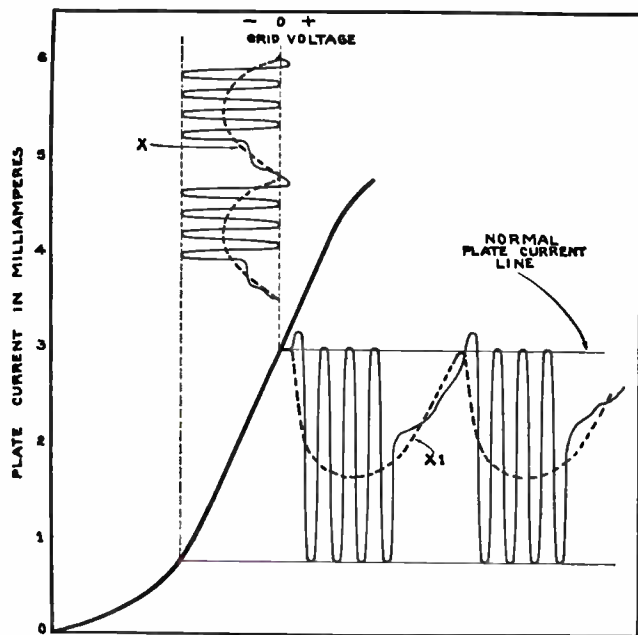

Fig. 67. Curves illustrating detector action of a tube using a grid leak and condenser to obtain maximum rectification with plate current impulses falling below the normal plate current.

56. EFFECT OF GRID LEAK AND CONDENSER ON SIGNAL STRENGTH

Fig. 67 illustrates approximately the operation of a tube using the grid leak and condenser method of biasing the grid. In this case the negative bias is not constant as with the C battery, but builds up during each signal group due to the grid accumulating more and more electrons as each positive alternation of the signal voltage is applied to it. This causes the bias voltage to swing from zero over to negative about as shown by the dotted curve X. This is due to the negative electrons accumulating on the grid a little faster than they can leak off during the signal. Then during the idle period between groups of alternations the leak drains the grid potential down to zero again, as shown in Fig. 67 by the dotted curve X falling back to the vertical zero line each time between signal groups.

However, the fact that the biasing voltage keeps practically all of the grid voltage variations on the negative side, the pulsations of plate current are practically all downward from the normal plate current. The dotted curve X1 shows the approximate average plate current, and you will note the very decided decrease from normal during each signal group. This decrease of current through the phone magnets releases their diaphragms, and then as the average current rises back toward normal between signal groups the diaphragms are again attracted, thus causing strong vibration.

You will also note that this form of bias allows the tube to be worked on a straight portion of the steeper curve above the bend or knee, thus making the full swing or change of grid voltage much more effective in producing variations in the plate current. This is one of the reasons for the extreme sensitivity of the grid condenser and leak method of detection.

Be sure you have a good understanding of the preceding articles, as vacuum tubes are a vital part

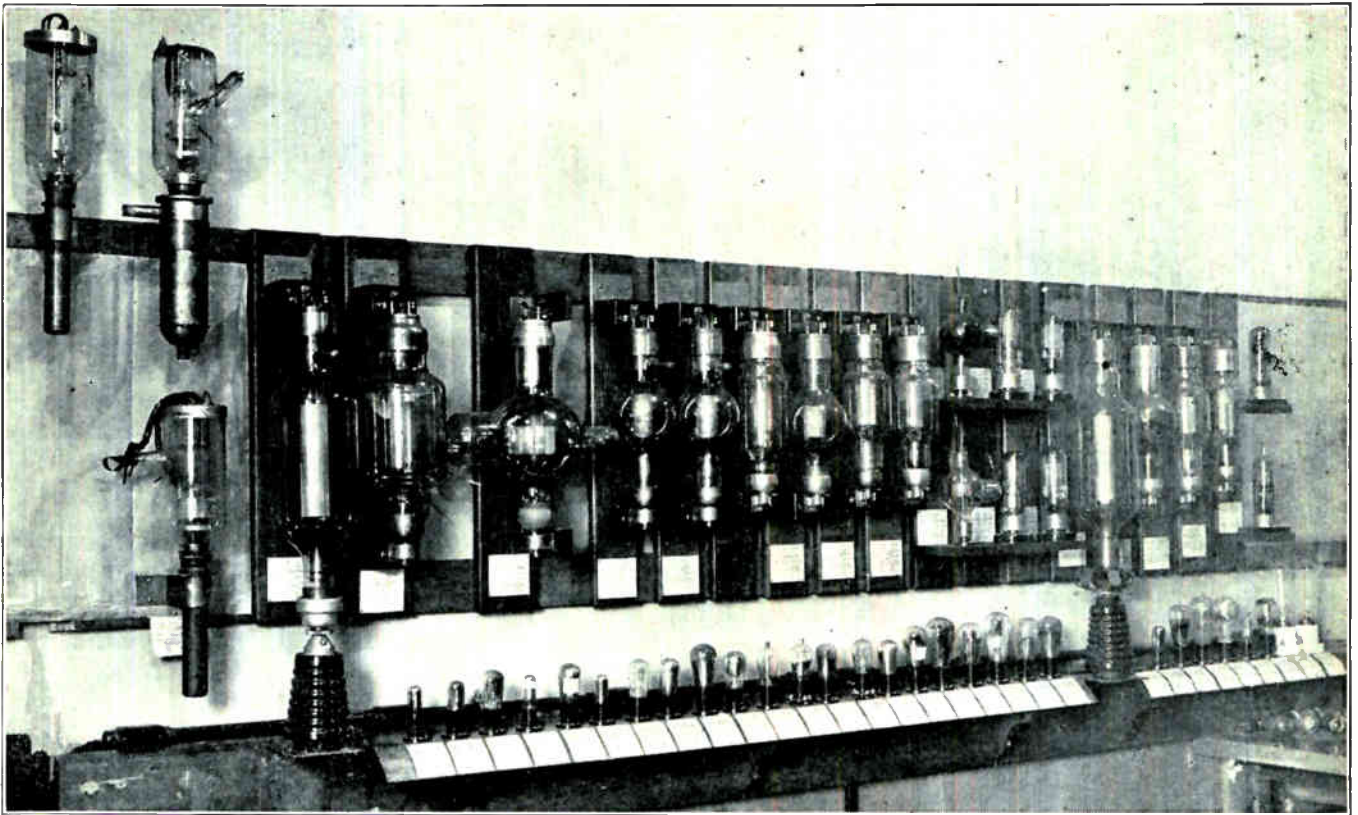

Fig. 68. Note the number of different types and sizes of radio receiving and transmitting tubes shown in this view.

of all modern radio transmitting and receiving equipment.

57. VACUUM TUBES AS AMPLIFIERS

One of the most remarkable things about the modern radio receiver is its ability to amplify weak signals millions of times and build up their energy to a point where it will operate loud speakers with sufficient sound volume to fill a large room, or with thunderous volume for large outdoor public address equipment. This feature of radio receivers and public address amplifiers is made possible by the vacuum tube.

We have already learned that vacuum tubes can be used for amplifiers as well as for detectors, because of the fact that a small change in grid voltage and power will cause a much greater change in plate current and power.

For amplification we operate the tube on the straight portion of the characteristic plate current curve so that all variations or increases and decreases of grid voltage will be amplified equally, and the waves or impulses kept unchanged in shape and merely increased in amplitude or volume.

Fig. 69 illustrates this amplifier action of a vacuum tube. The average voltage or output impulses of the detector tube are applied to the grid of this amplifier tube as shown at X. These are greatly amplified in the pulsations of plate current in the amplifier tube as shown at XI, but you will note that they retain their original shape or form.

In Fig. 70 is shown a circuit by means of which the output of the detector tube is fed to the grid of an amplifier tube through an audio frequency

transformer. The output of this amplifier tube is then fed to the grid or input of another tube for still further amplification if desired. This would be referred to as two stages of Audio Frequency amplification, as these amplifier tubes only handle the energy after it is detected and converted into A. F. pulsating D. C., by the detector tube and impedance of the first transformer primary. Each separate amplifier tube with its transformer and circuit is called one stage of amplification.

The peaks in the horizontal line above the circuit diagram in Fig. 70 illustrate how the signal strength is increased by the amplification effect of the detector tube and by both of the amplifier tubes.

The output of the detector tube is pulsating D. C., but by passing this through the primary of the first A. F. transformer it sets up A. C. in the secondary and in the grid circuit of the first amplifier tube.

This alternating current, however, carries the same general wave form and variations in value as the pulsating D. C., and thus conveys the signal to the grid of the amplifier tube. Here again it is amplified and rectified to pulsating D. C., and then passed on through the next A. F. transformer to the next amplifier tube, etc.

The audio frequency transformers not only serve as a means of coupling the tubes and circuits together but also serve to aid amplification by increasing the voltage on the grids of following tubes, as these transformers are generally wound with a step-up ratio of about 1 to 2 or 1 to 3.

Other types of amplifier circuits and coupling will be shown and explained in a later lesson on receiver circuits.

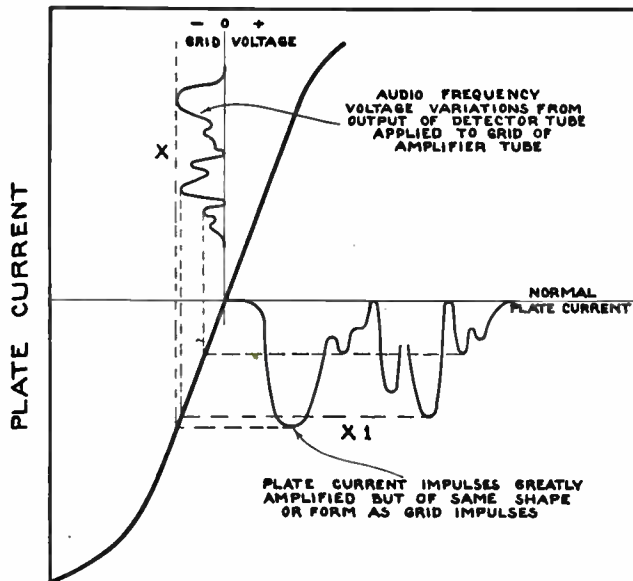

Fig. 69. Amplifier action illustrated with audio frequency curves of the average variations caused in the grid voltage and plate current by the voice modulation on the carrier wave.

In many radio receivers amplifier tubes are also used to increase the strength of the signal before it reaches the detector tube. This is called R. F. or radio frequency amplification as it is done before the energy is rectified and converted to audio frequency. Fig. 71 shows the manner in which an R. F. amplifier tube increases the voltage or amplitude of the incoming R. F. signal without rectifying or changing the shape of the R. F. waves.

In this figure we see how a signal is applied to the grid and what effect it has on the plate current. When amplifying radio signals, the variations in plate current must have the same form as the changes in grid voltage, so it is necessary to operate the amplifier tube within the limits of the straight portion of the characteristic curve. This will require a fixed negative grid bias, in order to locate the operating point on the curve in such a position that variation of the grid voltage, due to the applied signal, will cause changes in plate current which are of exactly the same form as the signal, only greatly enlarged or amplified.

We must not allow the grid signal to become too great or we will be operating the tube in the bend or knee region of the curve causing the output wave form to change from that of the original signal, resulting in distortion of the waves form and the sound at the speaker. Also too much or too little grid bias will shift the operating point one way or the other, thereby limiting the grid signal which can be applied, to somewhere below normal in order to keep from getting off the straight portion of the curve.

Different types of tubes require different values of bias depending on their characteristics.

58. METHODS OF BIASING AMPLIFIER TUBES

In the preceding articles we have discussed the reasons for providing negative biasing voltages

on the grids of detector and amplifier tubes. The "C" battery and the grid leak and condenser methods of obtaining this biasing voltage were also explained.

Another method of biasing commonly used in radio receiver and amplifier circuits is the self-biasing method, in which the negative potential for the grid is obtained by utilizing the voltage drop through a resistor "R" as shown in Fig. 72-A and 72-B. At "A" the resistor is shown connected between the center tap of the filament transformer and negative terminal of the plate current supply. At "B" the resistor is connected between the cathode or electron emitting element of an indirect heater type A. C. tube and the negative terminal of the plate current supply.

In either case, the plate current through the tube passes from the filament or cathode, down through the resistor "R," causing a voltage drop in this resistor and setting up positive potential at its upper end and negative potential at its lower end. The grid circuit being connected through the secondary of the coupling transformer and to the negative end of the resistor thus supplies the grid with negative biasing voltage.

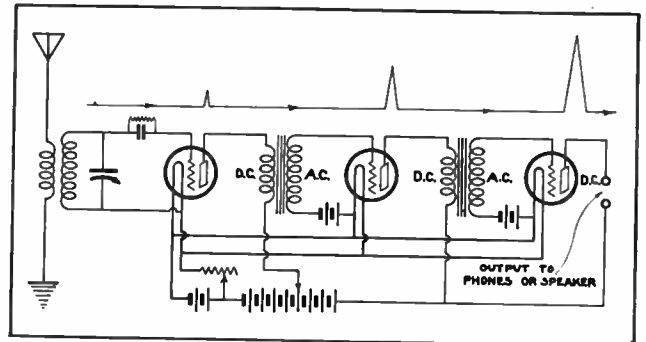

Fig. 70. Circuit diagram of a simple 3 tube receiver with one tube used as a detector and two as amplifiers. Note how the signal strength is increased by each tube.

As the voltage drop in resistor "R" will be proportional to the flow of plate current through it, and to the resistance in ohms of the resistor "R," the amount of negative grid bias voltage applied to the grid will remain at proper value as long as the plate current flow is normal.

Another method of obtaining the negative grid biasing voltage is shown in Fig. 73. This diagram shows a section of a push-pull amplifier circuit and two power amplifier tubes at the upper right. At the lower left side is shown the power supply transformer, rectifier tubes, filter and biasing resistor.

The upper rectifier tube "E" and the filter chokes and condensers "C" are in the power supply circuit for the plates of the power amplifier tubes "P." The lower rectifier tube and biasing resistor "R" supply the biasing voltage for the grids of the power amplifier tubes.

The lower rectifier tube supplies rectified or direct current which flows in this circuit as shown by the arrows. In passing through the resistor, this current flow causes voltage drop in the resistor and sets up negative biasing potential on the top end to which the grid wires are connected, through the section of the coupling transformer "T."

Another method of biasing the grids of amplifier tubes utilizes the voltage drop or potential set up in a resistor "R," or a choke coil or speaker field coil "D" which carries the total plate current load of the receiver as shown in Fig. 74—A, B and C. These resistors or chokes are connected in series with the negative return circuit of the plate supply or B—, so that the total plate current load of the entire receiver passes through them and affects the amount of voltage drop and the biasing potential applied to the grids of the tubes.

The point at which the grid circuit connects in each of these circuits is negative with respect to its own electron emitting element.

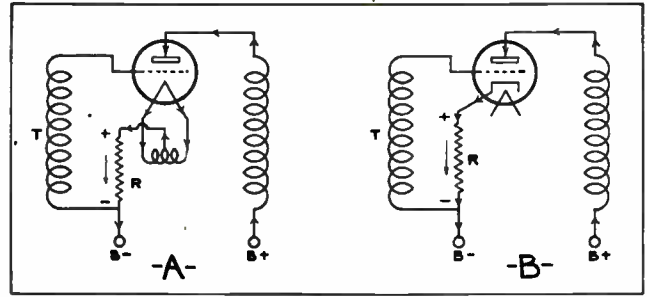

Fig. 72. Diagrams showing method of obtaining negative bias voltages for grids of amplifier tubes of the filament and heater element types, by means of the voltage drop across resistor "R."

The amplification factor of a tube is determined by comparing the amount of plate voltage increase required to make a certain change in plate current, with the change of grid voltage required to make the same amount of change in plate current.

For example, if a 3 volt change in grid voltage makes a change of 10 milliamperes in the plate current, and it requires a change of 30 volts on the plate to make the 10 milliamperes variation in plate current, then the amplification factor of that tube will be $30 \div 3$ or 10. The amplification factor of ordinary tubes such as the 27 or 56 types usually ranges from 6 to 10 although special high Mu tubes are made with amplification factor of up to 200.

Amplifier tubes are used for **Voltage Amplification** in some parts of radio receivers, and for **Power Amplification** in other parts. Voltage amplification to merely increase the voltage on the grid of each successive tube, is commonly used in radio frequency stages and in the first audio frequency stages, while power amplification which increases both voltage and current is used in the final audio frequency stages.

For power amplification we use larger tubes of special construction, having lower internal resistance and greater capacity in milliamperes or watts.

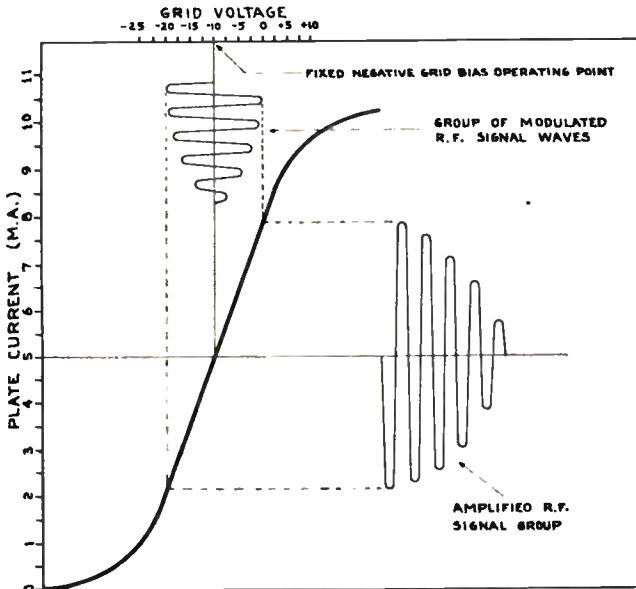

Fig. 71. Curves illustrating amplifier action of a vacuum tube. Note that the grid voltage impulses are greatly amplified or increased in the plate current impulses, but are kept in the same form instead of being rectified.

59. AMPLIFICATION FACTOR

Some vacuum tubes are better amplifiers than others, depending upon their construction, and in particular upon the size and spacing of the grid wires and the distance between the grid and plate. Using small diameter grid wires, closely spaced, and placing the grid closer to the plate increases the amplifying ability of a tube.

The term **Amplification Factor** is used to express the amount of amplification that can be obtained with a certain tube. The Greek letter Mu (μ) is used as a symbol for amplification factor, and the expression "low Mu" or "high Mu" is often used in connection with amplifier tubes to express their ability as amplifiers.

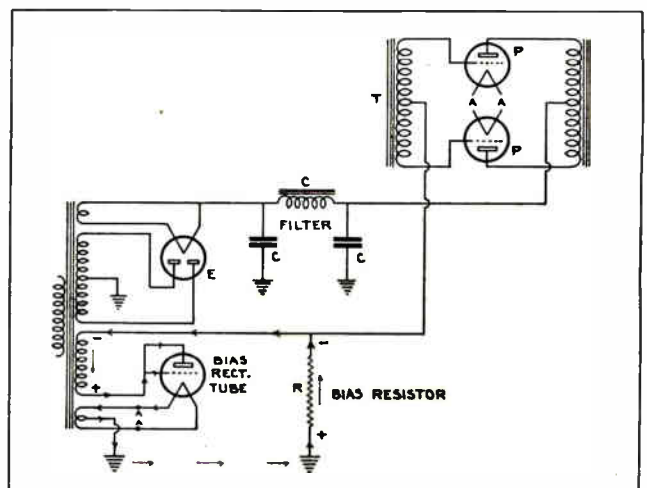

Fig. 73. Another method of obtaining grid bias voltage for power amplifier tubes. Examine this circuit carefully while studying the lesson.

These power tubes provide the energy required for operation of large loud speakers and for better reproduction of the heavy bass notes of music. Power tubes are very similar to ordinary amplifiers, except that their elements are larger, and they are designed for much higher plate voltages and current. Fig. 75 shows a power tube which has a capacity of 34 milliamperes plate current, or over 1.6 watts without distortion.

60. SPACE CHARGE

The cloud or stream of negative electrons which are thrown off by a tube filament into the space between the filament and plate, create an electron cloud or negative charge in this space. This is called the **Space Charge** in a tube.

The space charge tends to prevent free emission of electrons from the filament, as the negative charge or electrons already in the space tend to repel and throw back the fresh electrons coming from the filament or cathode. The space charge is of course greatly reduced by the positively charged plate and also by the grid at any time it becomes positive, because they tend to attract the electrons, drawing them away from the filament more rapidly.

One way of further reducing the space charge is to equip a tube with an extra grid located between the regular grid and the plate, and by keeping this grid at some positive potential to aid the plate in attracting the negative electrons.



Fig. 75. Photo of power amplifier tube such as used for obtaining great amplification and handling larger amounts of plate current for producing stronger signals from radio receivers. (Photo courtesy of R. C. A. Radiotron Co., Inc.)

This extra grid is called a **screen grid** or **shield grid** and will be more fully described in later paragraphs.

61. INTERNAL CAPACITY EFFECT IN TUBES

There is a small amount of capacity or condenser effect between the metal elements inside a vacuum tube, as these parts being separated by gas or vacuum and supplied with varying voltages, act as plates of a small condenser.

The capacity between the grid and filament and between the plate and filament is generally about 5 M. M. F. (micro-micro-farads), or small enough so it does not interfere with the tube operation to any great extent. The capacity between the plate and grid however, is about 8 M. M. F. in common detector and amplifier tubes, and may have a decided effect on the operation of the tube.

This capacity is extremely small when compared with most of the condensers used in radio circuits, one micro-micro-farad being only one millionth part of a micro-farad. But even this small amount of 8 M. M. F. in a tube is sufficient to create enough capacity coupling between the input and output circuits of the tube at radio frequencies, to set up a feed back from the plate or output to the grid or input circuit. This often results in bad oscillation of the circuit and howling in the phones or speaker. In other cases the capacity between the tube electrodes causes absorption of energy from the input circuit by the output circuit.

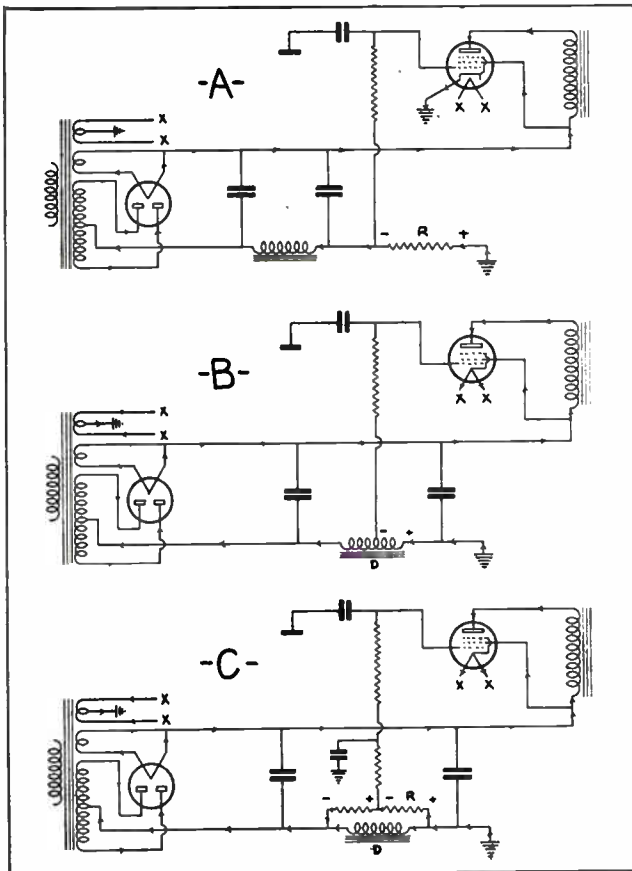

Fig. 74. Circuits showing three additional methods of obtaining grid bias voltage for amplifier tubes.

There is also a certain amount of capacity between the socket terminals and wiring of tubes to add to this undesirable coupling effect through the tube.

In order to prevent oscillation and howling, and reduced efficiency of the tube and its circuits, this tube capacity must either be neutralized in some manner, or reduced to a minimum by special construction within the tube. A method of neutralizing it by means of a small condenser outside the tube will be explained later. A method of reducing the capacity effect in later type tubes is by the use of the extra grid or screened grid which has already been mentioned for reducing space charge.

62. SCREEN GRID TUBES

The screen grid, we have now found, will serve a double purpose of reducing the space charge and also reducing the interelectrode capacity of tubes.

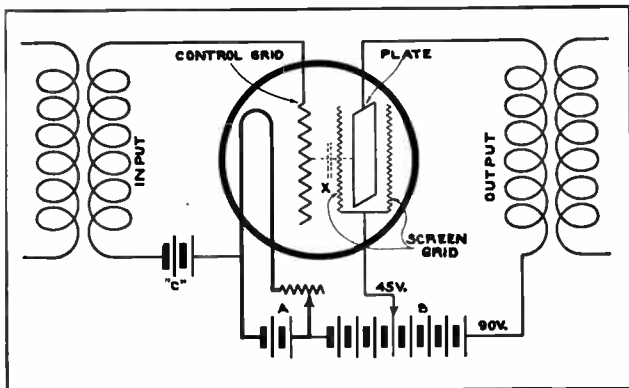

Fig. 76. Diagram of a screen-grid tube showing the connection of the screen grid, and illustrating the manner in which it reduces the capacity between the control grid and plate.

Fig. 76 shows a diagram of a screen grid tube connected in one stage of a radio receiver. This sketch shows the screen grid connected to the B battery or plate current supply, at a point which will supply it with from 22 to 45 volts positive potential. It is this positive potential which causes the screen grid to attract negative electrons toward itself and toward the plate which is charged positive at 90 to 135 volts or more, and draws most of the electrons on through to itself. In this manner the screen grid helps to reduce the space charge, thereby greatly increasing the efficiency and the amplification factor of the tube.

Amplification of 30 to 200 times can be obtained with screen grid tubes, as compared with 6 to 10 times for ordinary tubes without this extra grid.

You will note in Fig. 76 that the screen grid is made in two parts, one of which is between the control grid and the plate, and the other on the outside of the plate so that a complete shield is formed around the plate.

The capacity between the control grid and plate in a tube without the screen grid, would be as shown by the dotted condenser X. But when the screen grid is inserted it acts as a shield between the grid

and the electrostatic field around the plate and thereby reduces the capacity effect between grid and plate to about .01 M. M. F. as compared with 8 to 10 M. M. F. in ordinary tubes.

This very great reduction of grid to plate capacity of the tube almost entirely prevents objectionable oscillation and feed back.

The inner section of the screen grid consists of a spiral of closely spaced fine wires, very much like the regular control grid. The outer shield or section of the screen grid surrounding the plate consists of a screen mesh or a perforated band of sheet metal.

Fig. 77 shows a screen grid tube with part of the outer screen and plate cut away to show the inner construction. Note the inner section of the screen grid which surrounds the filament and control grid, and which is located between the control grid and the plate.

The screen grid lead is brought out to the regular grid prong on the tube base, and the control grid lead on this type of tube is brought out to the small metal cap on top of the tube.

Screen grid tubes being very sensitive to outside capacity influence require good shielding from other stages and parts of the circuit. Where complete interstage shielding is not provided the tubes themselves are often equipped with grounded metal shields or hoods.

Screen grid tubes are largely used as R. F. amplifiers, although in some cases they are used as detectors, and A. F. amplifiers.

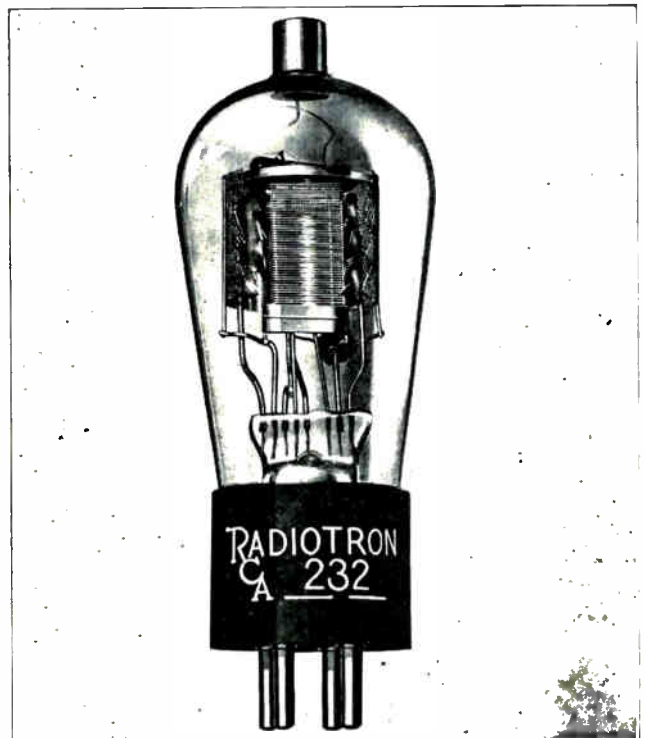

Fig. 77. This excellent photograph shows a vacuum tube with part of the outer screen grid and part of the plate removed, to clearly show the inner screen grid in its position between the control grid and plate. (Photo courtesy of R. C. A. Radiotron Co., Inc.)

63. PLATE RESISTANCE AND MUTUAL CONDUCTANCE

The internal resistance or plate circuit resistance of a vacuum tube depends upon several factors in the tube design, such as (a) spacing between tube elements, (b) length and area of filament, (c) filament condition or temperature and efficiency of electron emitting surface, (d) area of plate, (e) amplification factor, and (f) applied voltages.

This plate resistance of course causes a certain amount of loss in the tube, proportional to the amount of resistance. It is, therefore, desirable to keep the plate resistance as low as possible without changing the tube design in such a manner that it interferes with other desirable characteristics.

For example, a tube which is constructed with the proper spacing between grid wires and between the grid and plate, to obtain a high amplification factor, generally also has a high plate resistance.

The plate circuit resistance to D. C. can be easily determined according to Ohms law, by dividing

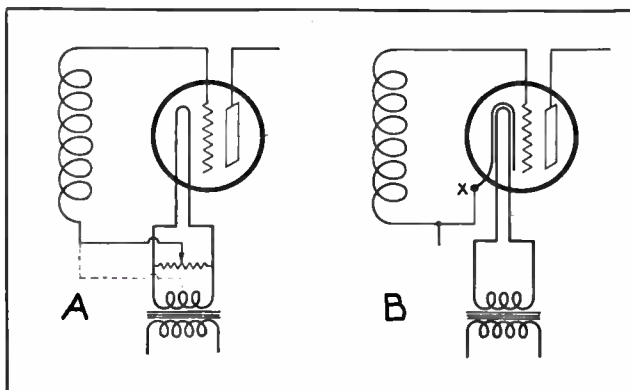

Fig. 78. At A is shown a vacuum tube using A. C. to heat the filament, and having the grid return lead connected to the center of a potentiometer. At B is shown an A. C. heater-element type tube using A. C. for the filament and having a separate cathode which is heated by the filament.

the plate voltage by the plate current. For example, if a certain tube has 45 volts applied to its plate and shows a plate current flow of 1.7 milliamperes or .0017 amperes, then as

$$R = \frac{E_p}{I_p}$$

$$= \frac{45}{.0017}$$

the resistance will be $\frac{45}{.0017}$ or 26,470+ ohms.

Plate resistance is generally expressed in Ohms resistance to the A. C. component of the pulsating D. C. plate current, and as this value is approximately one half that of the D. C. resistance, it is easy to determine the A. C. resistance by calculating the D. C. resistance and dividing it by 2. The term plate impedance was formerly extensively used for A. C. resistance, but the latter term is now more generally used.

As both the plate resistance and the amplification factor of a tube greatly affect its performance, the

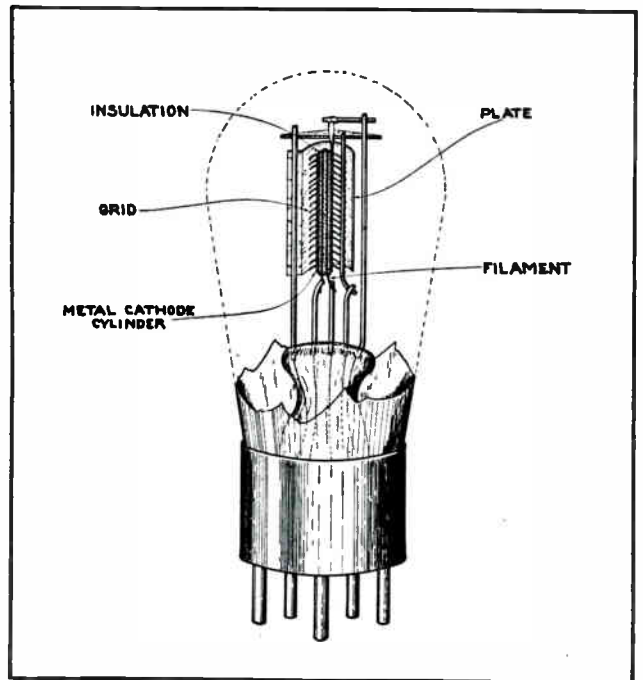

Fig. 79. This sketch gives a sectional view of an A. C. tube and shows the construction of the heater element, its insulator, the cathode, grid, and plate of the tube.

term Mutual Conductance which considers both of these factors, is quite generally used in expressing or comparing the values of tubes of the same general type.

Mutual conductance is expressed in Micromhos, and is found by dividing the amplification factor of a tube by its plate resistance, or

$$GM = \frac{\mu}{rp}$$

In which GM = Mutual Conductance in micromhos
 μ = Mu or amplification factor
 rp = plate resistance

In general, tubes with high mutual conductance are more efficient amplifiers than those of similar types having lower mutual conductance (GM). One should be sure, however, that the comparison is made between tubes of the same general type or tubes designed for the same service, and with similar characteristics in other respects. This is because tubes of a different type having more of certain other characteristics might be better under certain conditions.

64. A. C. TUBES

Early types of vacuum tubes were all developed with filaments designed for heating with D. C. from low voltage A batteries, and great quantities of D. C. operated tubes are still made for use in battery operated sets in farm homes and places where electric power supply is not yet available. Most modern radio sets for use in city homes and places where 110 volt A. C. power is available, are made

with A. C. tubes, which have their filaments heated by current from the low voltage secondary of a transformer. This is a great convenience as it eliminates the necessity of the messy and bulky wet storage batteries formerly used for filament power.

A. C. tubes are of two general types known as **Filament Type** and **Heater Element Type**.

A. C. "filament type" tubes have simple filaments very much like those of D. C. tubes, except that they are generally made of a shorter and heavier wire. This enables them to hold their heat a little longer and does not allow the heat to vary so much with the rise and fall of the A. C. voltage.

In filament type A. C. tubes the filament serves as the cathode or electron emitter the same as in D. C. tubes.

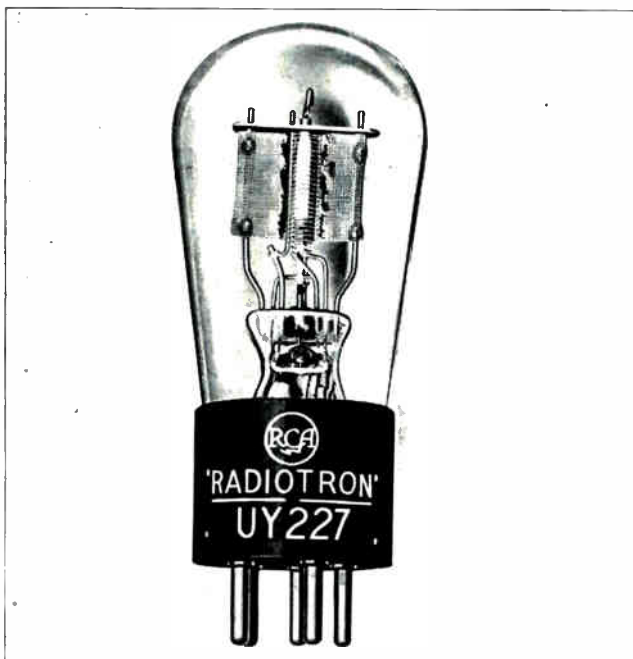

Fig. 80. Photograph of an A. C. heater-element vacuum tube with part of the plate removed to show the grid and the cathode inside of which the heater element or filament, is located. (Photo courtesy of R. C. A. Radiotron Co., Inc.)

In order to avoid very objectionable hum from the variations in the A. C. voltage, it is necessary to connect the grid return on these tubes to a center point on the filament circuit, so that the voltage drop is equally balanced on each side of this connection. This is done either by using the center tap on a resistance unit connected across the filament terminals, or by use of a center tap sometimes provided on the secondary of the filament transformer. At A in Fig. 78 is a sketch showing how this connection is made to the center tap of a resistor, and the dotted lines show how it would be made to a center tap on the transformer. Use of a resistance with a variable center tap allows the grid connection to be adjusted to the point of best balance and least hum.

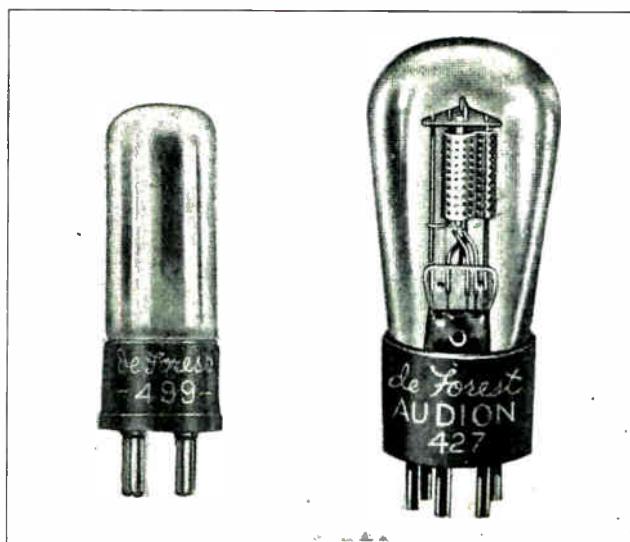

Fig. 81. Photo showing two different types of vacuum tubes for use in radio receivers. The filament of the small tube on the left can be operated on dry cells thus making it very good for use in portable sets. (Photo courtesy of DeForest Radio Co.)

Filament type A. C. tubes are only used as amplifiers and oscillators but not for detectors, because even with the most careful selection of the neutral point for the grid return, considerable hum will be set up if they are used as detectors.

65. HEATER ELEMENT TUBES

Heater element type A. C. tubes use a small oxide coated nickel cylinder as the cathode or electron emitter, and this cathode is heated by a filament which is placed inside the cylinder but is insulated from it. In these tubes the filament serves only as the heater element and not as the cathode or electron emitter, and can therefore be made of ordinary tungsten wire.

The filament being entirely insulated from the cathode or electron emitting element, practically none of the influence of the A. C. voltage variations

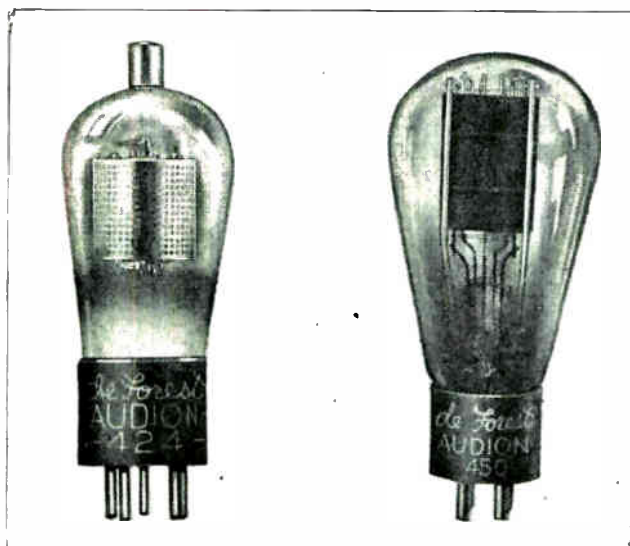

Fig. 82. On the left is shown a screen grid amplifier tube, and on the right a power amplifier tube. (Photo courtesy of DeForest Radio Co.)

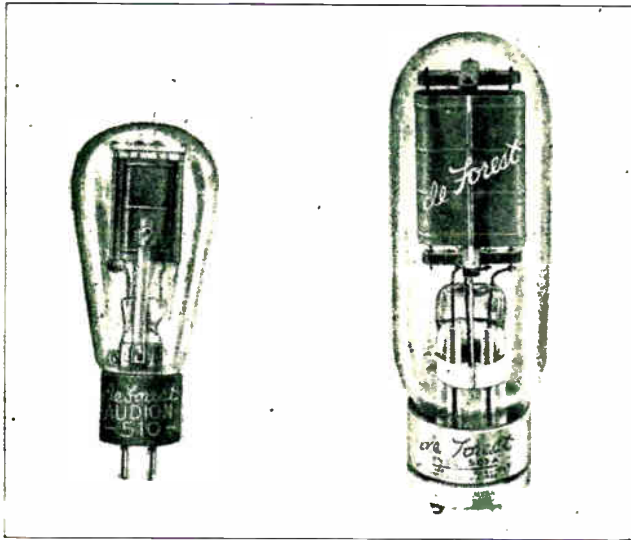

Fig. 83. This photo shows a 15 watt transmitter tube on the left, and a 50 watt transmitter tube on the right. These tubes are constructed very similarly to those for receivers except that they have larger elements spaced farther apart to handle the greater plate currents at higher voltages. (Photo courtesy of DeForest Radio Co.)

is allowed to affect the cathode. In this manner practically all A. C. hum is eliminated.

The grid return lead on these tubes is connected to the cathode lead which is brought out to an extra prong on the bases used for these tubes. Fig. 78-B shows the connection of the grid return to the cathode lead at X. Fig. 79 shows a sketch of a heater element type A. C. tube, showing a sectional view of the elements. Note the location of the filament or heater wire inside the insulator which separates it from the cylindrical cathode. This view clearly shows how the cathode is heated by heat from the filament passing through the insulator to the cathode, and also how the insulator separates the filament and cathode electrically, thus preventing A. C. hum.

The grid and plate are also shown in sectional view in this sketch.

Fig. 80 shows a photo of an A. C. heater element tube with part of the special mesh type plate torn away to show the grid and cathode inside.

A. C. tubes of the heater element type generally require a few seconds to heat up and become operative, as it takes a little time for the heat from the filament to pass through the insulating tube to the cathode. This time lag in the heat change is desirable, however, as it also works the other way, requiring a short period for the cathode to cool off, and thus making the tube less sensitive to momentary voltage variations and to the continuous variations in the A. C. voltage due to its alternations.

A. C. tubes of the heater element type are used both for detectors and amplifiers. Their filaments operate on about 2.5 to 25 volts, depending on the type of the tube.

66. TYPES OF VACUUM TUBES

Vacuum tubes for receivers are made in a wide variety of types and sizes, ranging from the little dry cell operated detectors and amplifiers up to power amplifiers capable of handling several watts.

For transmitting purposes, amplifier, modulator and oscillator tubes are made in sizes ranging from 15 watts to 100,000 watts.

On the left in Fig. 81 is shown a "99" tube of the dry cell operated tube for use in portable receiving sets or sets for use in places where A. C. power supply is not available and where storage batteries are undesirable. These tubes use less than .07 amp. at 3 volts for their filaments, so can be operated on a few dry cells for several months of ordinary use.

On the right in Fig. 81 is shown a "27" tube such as used for either detector or amplifier duty. This is an A. C. tube of the heater element type.

On the left in Fig. 82 is shown a "24" tube of high Mu or high amplification factor. This is an A. C. heater element screen grid tube.

On the right in Fig. 82 is shown a "50" power amplifier tube which operates with a filament voltage of 7.5 volts, filament current of 1.25 amperes, plate voltage of 250 to 450 volts, and is capable of handling 4.6 watts of undistorted power output.

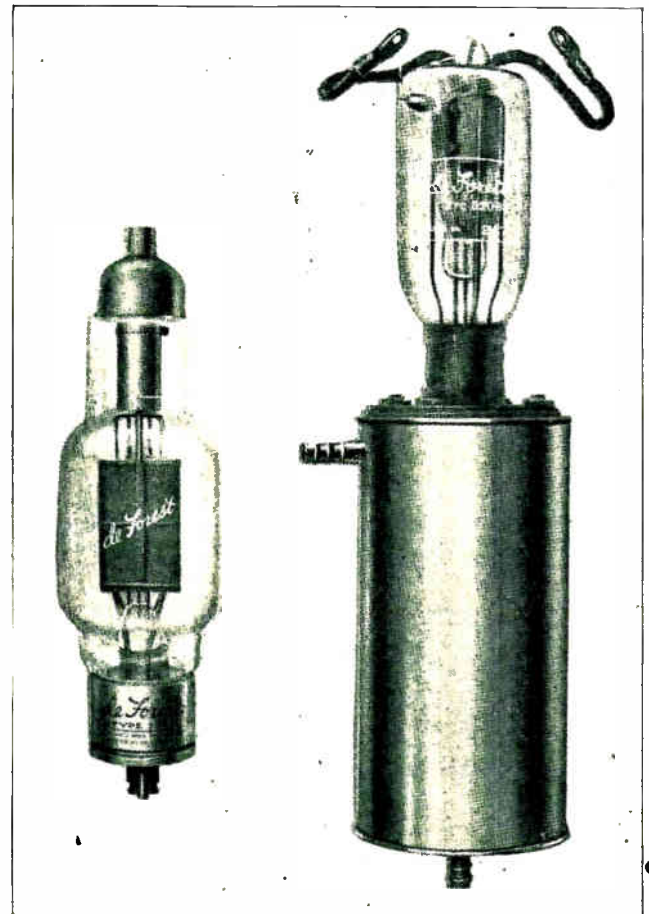

Fig. 84. The tube on the left in this photo is a 250 watt transmitter tube, and the one on the right is a water-cooled 5000 watt tube for large radio transmitter. (Photo courtesy of DeForest Radio Co.)

Fig. 83 shows a 15 watt transmitter tube on the left and a 50 watt tube on the right. Fig. 84 shows a 250 watt transmitter tube on the left and a 5,000 watt transmitter tube on the right. This 5,000 watt tube is water cooled by circulating cool water through the large metal jacket attached to the tube.

In addition to the tubes previously mentioned, there are today many other types, both for general use as detectors, amplifiers, oscillators, and rectifiers in radio sets, and also for special applications such as automatic volume controls, tuning indicators, ballast tubes, voltage regulator tubes, etc. These various tubes are classified as diodes, (meaning two elements), triodes, (three elements), tetrodes, (four elements), pentodes, (five elements), beam power, pentagrid converters and various multi-electrode or multi-unit tubes. They are made with either a glass

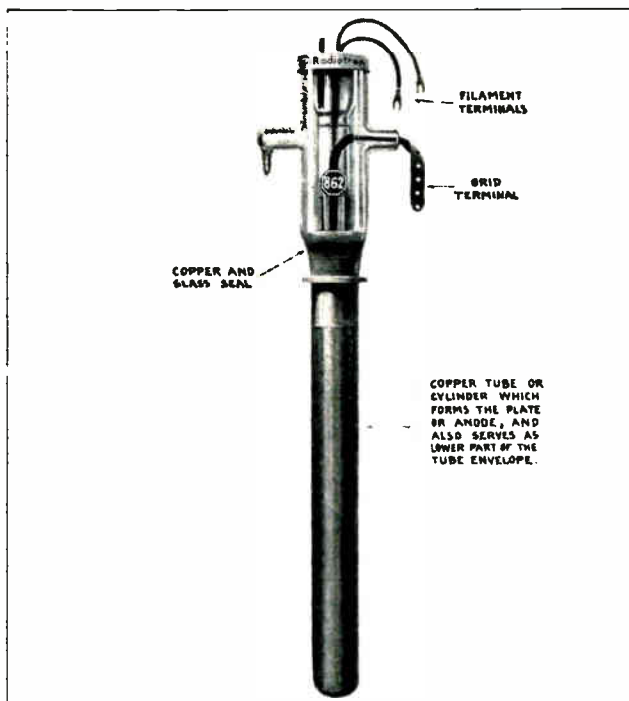

Fig. 85. Photo of a 100 K. W. water cooled power tube for use in large broadcast transmitter. The copper tube at the lower end is sealed to the glass top and forms the plate or anode of the tube. The filament and grid are inside this tubular anode, and when in operation a water jacket surrounds the anode.

enclosing envelope or if they are of the metal tube variety, the tube elements are sealed in a metal shell as previously explained.

There are a great many different models of tubes on the market but if you are thoroughly familiar with the general principles and applications of the most common types, the others should not be confusing to you when you find them in receivers or in set diagrams.

67. TUBE NUMBERING SYSTEM.

The various types of vacuum tubes are identified by numbers and letters such as the type 27, 56, 6K7, 25Z5, etc. This system simplifies the ordering and selection of proper tubes for replacing any which may become defective in a radio set. It also makes it very convenient to specify certain tubes with proper characteristics for use in any certain type of radio circuit.

For example, you will find by reference to the tube characteristics charts in the later pages of this section, that type 27, 30, and 56 tubes are all used as detectors or amplifiers; while type 80, 81 and 6Z4, tubes are rectifiers; type 10, 50, and 6V6G tubes are power amplifiers, etc.

With the newer number and letter system of tube identification, the various numbers and letters each indicate certain features or characteristics of the tubes. For example, with a 6K7 tube, the first figure 6 indicates that the filament uses approximately 6 volts (6.3 volts to be exact). The letter "K" indicates that this tube is an R. F. amplifier. The last figure 7 indicates that the tube has 7 elements.

With the 25Z5 tube, the figure 25 again indicates a 25 volt filament, the letter Z indicates a rectifier tube, and the figure 5 indicates a 5 element tube, etc.

By careful and continued reference to the tube charts whenever you have need to select tubes for any given purpose you will soon learn the meaning of the tube numbers and letters for at least the most commonly used tubes.

It is not at all necessary to try to memorize all the many different types of tubes, as about 12 or 15 of the most commonly used tubes will cover the great majority of those used in recent model receivers.

The diode or two element tube is the simplest form of radio tube, and contains two electrodes, the cathode or filament and plate. Such tubes are commonly used as half wave rectifiers, while if another plate is introduced in the tube we have a full wave rectifier, such as the 80, 5Z4, 6H6, and others.

In some rectifier tubes, the effect of the space charge in limiting current flow through the tube, is overcome by placing the elements very close to each other, thus allowing low voltage operation. The 25Z5 tube with only two-hundredths of an inch spacing between plate and cathode, is an example of this type.

Under the triode classification comes any of the three element tubes, such as the 27, 6C5, 37, 56, etc., having a cathode, grid and plate. Adding another tube element called a screen grid, brings us into the tetrode or four element tube class, typical examples of which are the 32, 24A, 35, and 44 tubes.

68. SECONDARY EMISSION.

Pentode tubes were developed to overcome what is called "secondary emission." In any tube, electrons striking the plate may, if moving at sufficient speed, dislodge or knock loose other electrons. In two and three electrode types, these secondary electrons will cause no trouble as there is no positive element other than the plate itself to attract them. However, in tubes having a screen grid, the positive charge on this electrode will attract these secondary electrons, and particularly so if the plate voltage, during the signal cycle, swings lower than the screen voltage. This lowers the plate current and limits the permissible signal amplitude these tubes may handle.

The effects of secondary emission can be removed by a fifth electrode, known as the **suppressor grid** which is placed in the tube between the screen

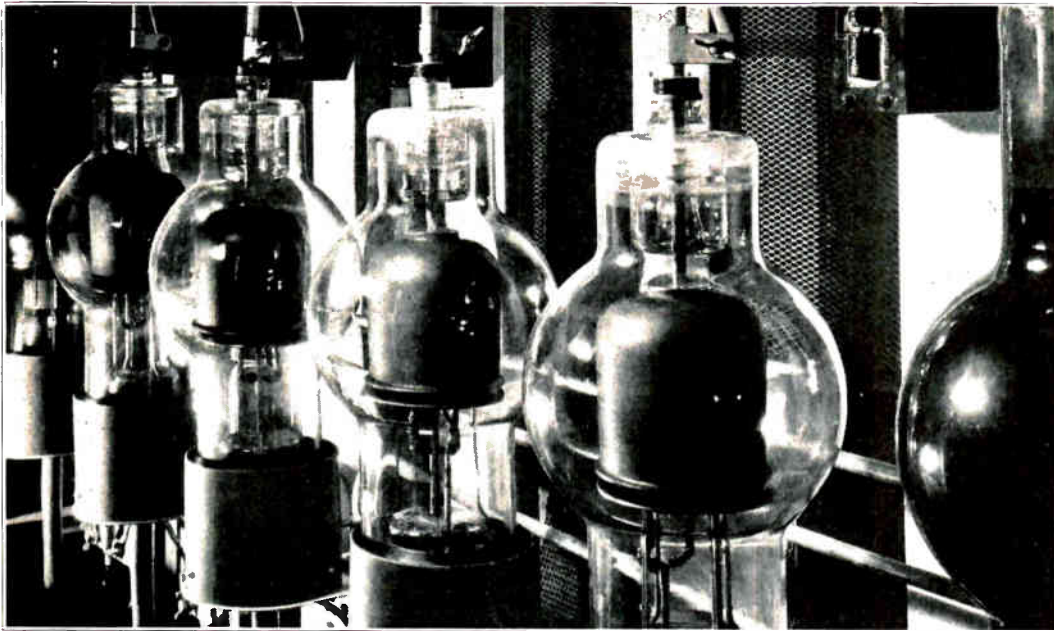

Fig. 86. This photograph shows a bank of heavy duty mercury vapor rectifier tubes in a modern high power radio station. Courtesy WLW Crosley Radio Station.

and plate. This element is usually connected to the cathode and since it has a negative potential with respect to the plate, it diverts the flight of secondary electrons back to the plate, where they will cause no trouble.

Tubes in the power output pentode class are capable of large power output and high gain or amplification; the 42, 43, 6L6, 2A5, and 6F6 being tubes of this type. In radio frequency amplifier pentodes we find the 6K7 and 6J7 which give high voltage amplification at moderate plate potentials.

69. BEAM POWER TUBES

The beam power tube makes use of a different method for suppressing secondary emission. This tube contains a cathode, grid, screen grid and plate as shown in Fig. 87. The spiral wires of the screen are so wound and placed that they are directly in line with and shaded by the grid wires. Two beam forming plates, having a negative potential, are placed on either side between the screen and plate to concentrate the electrons into beams, this action being further aided by the placement of the grid structures.

Because of this design, when the plate voltage is low, the electrons slow down on their way to the plate, to almost zero velocity in a certain region between screen and plate. This causes a cloud of electrons or a space charge to form, which effectively repels secondary electrons back to the plate, thus suppressing secondary emission. This tube has a high power output, high sensitivity and high efficiency. The 6L6 and 25L6 tubes are of this type.

The pentagrid converter tube is of the multi-electrode class, having seven elements, all acting on the same electron stream to perform two functions simultaneously. The 6A7 and 6A8, used as combined mixer and oscillator in a superheterodyne receiver are examples of this class.

Other multi-electrode and multi-unit tubes such as 6L7, 6A7 and 2A7 are used as mixers in superheterodyne circuits which will be explained later. The 6Q7 is an example of the multi-unit tube being

of the duplex-diode triode type. In the duplex-diode pentode types are the 6B8 and 6B7 tubes. In spite of the long technical sounding names given to these tubes, just keep in mind that they are merely tubes with extra sets of elements, or extra cathodes, grids and plates for special or combination duty and service.

70. VACUUM TUBE TERMINALS.

Fig. 88-A shows a symbol such as used in circuit diagrams, for representing a pentode tube of the heater type. Note the letters which are commonly used to indicate the various filament, grid and plate terminals. Also note that the numbers 1, 2, 3, etc., which are used to indicate the position of the several grids with respect to the cathode.

The letters commonly used to designate tube elements are as follows:

- | | |
|------------|------------------------|
| F—Filament | TA—Target |
| G—Grid | PBF—Beam forming plate |
| P—Plate | NC—No connection |
| H—Heater | S—Shell |
| K—Cathode | |

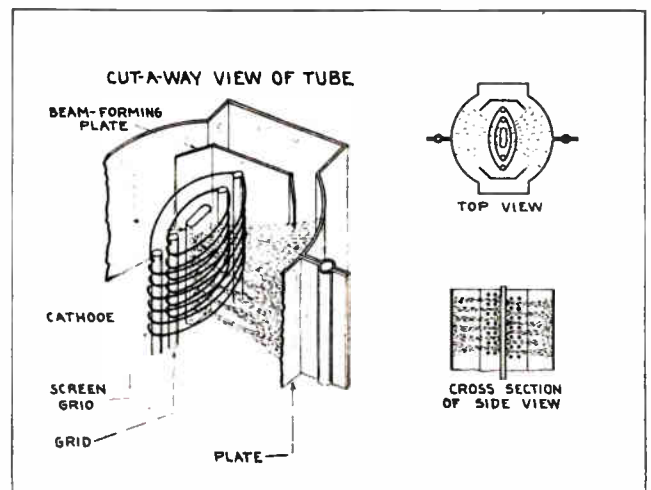

Fig. 87. Diagrams showing several views of a beam power tube in which electron streams are concentrated in beams to obtain high efficiency and high power output with low secondary emission.

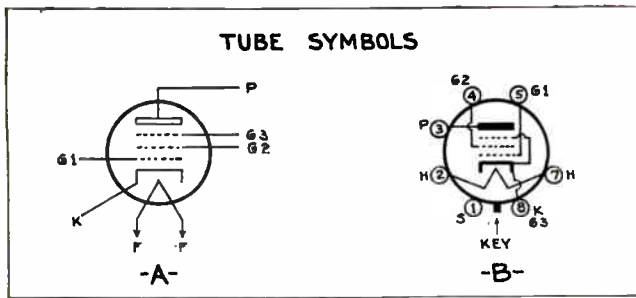

Fig. 88. Diagrams showing tube terminal and socket terminal arrangement and numbering system for a 6K7, R. F. amplifier pentode tube.

Figure 88-B shows a combined tube and socket layout diagram for a metal tube. This type of symbol shows the tube terminal or socket connections for the various elements, as viewed from the bottom. Such symbols when used in circuit diagrams greatly aid in tracing the circuits and in wiring or testing radio receivers. Note that the tube prong or socket terminal numbers start with number 1 to the left of the aligning key and number around to the right or clockwise.

71. RECTIFIER TUBES.

Any ordinary 3 element vacuum tube can be used as a rectifier to convert A. C. to D. C., because with A. C. applied to the plate circuit of such a tube, current will only flow from the plate to the filament during the half cycle when the plate is positive. During the other half cycle when the plate is negative, it repels the electrons from the filament or cathode and stops the current flow.

Special vacuum tubes are made for use as rectifiers to furnish D. C. for the plate supply and grid biasing voltages in electric sets that are to be operated on the common 110 volt A. C. wiring systems in homes. Fig. 89 shows on the left a half-wave rectifier tube of the 81 type, and on the right a full-wave rectifier of the 80 type.

The 481 tube on the left will deliver 110 milliamperes of half-wave or pulsating D. C., and the

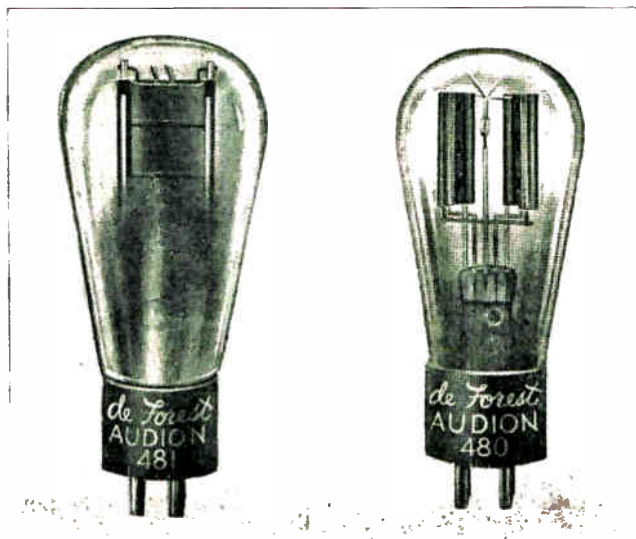

Fig. 89. On the left is shown a half-wave rectifier tube and the one on the right is a full-wave rectifier. Such tubes are used in the power supply units of A. C. receivers. Courtesy DeForest Radio Co.

480 tube will handle 125 M. A. of full-wave rectified D. C.

The general principles of vacuum tube rectifiers was explained in A. C. section 6, articles 245 to 249. You will recall that a heated filament or cathode serves as an electron emitter to throw off negative electrons which reach the plate and allow current to flow when the plate is positive. When the plate is negative the electrons are repelled and current stops flowing, so the current can only flow through the tube in one direction—from plate or anode to filament or cathode.

By using two plates as in the tube on the right in Fig. 89, both halves of the A. C. cycle can be used and passed through the tube in one direction, alternately from first one plate and then the other, to the cathode. This type of rectifier is much more efficient than the half-wave type and is quite com-



Fig. 90. Another type of half-wave rectifier tube for use with higher voltages such as required for the plates of power output tube. Courtesy R. C. A. Radiotron Company, Inc.

monly used in the power supply units of A. C. receivers.

Fig. 90 shows another rectifier tube of the half-wave type which you will note is constructed somewhat different from the one on the left in Fig. 89. The tube in Fig. 90 operates on the same principle but is designed for handling higher voltages for the plate supply to power amplifier tubes.

72. MERCURY VAPOR RECTIFIER TUBES.

In addition to the ordinary vacuum tube rectifier just described, and in which the conduction is by means of the electronic stream, evacuated tubes

which contain a small quantity of mercury, are also used as rectifiers in radio equipment. In this type of tube, the mercury vaporizes when the cathode reaches operating temperature.

The presence of the mercury vapor in the tube greatly reduces the resistance of the tube to current flow, thereby reducing the voltage drop in the tube and increasing the efficiency of this type of tube above that of ordinary vacuum tube rectifiers.

Mercury vapor rectifier tubes of this type also have the advantage of better voltage regulation with varying loads. The voltage drop through this type of tube remains at about 15 volts regardless of the amount of load current.

The amount of voltage that can be handled by these tubes depends on the spacing of their elements and upon the operating temperature of the tube. If too high voltages are applied to such tubes, they will "arc back" and the tube will be destroyed. Mercury vapor rectifiers develop considerable heat when operating under load, so they should always have ample cooling air circulation space around them.

If mercury vapor tubes are overloaded with more current than they are rated to carry the tube will generally be ruined. If heavy overloads are placed on these tubes for even short periods, the positive ions of the mercury vapor are attracted to the cathode with such force that they actually knock off the coating of emitting material of the cathode.

The type 82, 83, 866 and 872 are popular types of mercury vapor rectifier tubes. Fig. 91-A shows the circuit of a half-wave mercury vapor rectifier. Fig. 91-B shows a full-wave mercury vapor rectifier connection, and Fig. 91-C shows a bridge type rectifier circuit using mercury vapor tubes.

73. GASEOUS RECTIFIERS.

In addition to the rectifier tubes of high vacuum and mercury vapor types which use hot filaments or cathodes as a source of electrons, another type of rectifier known as the Raytheon gaseous rectifier tube, uses no filament or hot cathode. Instead, these tubes are filled with argon, neon or other gases to reduce their resistance to electric current flow. They make use of the well-known principle that Electricity will flow from a small or sharp pointed electrode through space to a larger electrode quite easily, but will not flow as readily from the large electrode through space to the small one.

Full-wave Raytheon rectifiers have the large electrodes made in a tubular or cup-shaped form, inside of which are located two small electrodes in the form of little rods or wires, as shown on the left in Fig. 92. These are sealed inside a gas-filled bulb with leads brought to the outside terminals. The leads are connected to the terminals of a power transformer and filter as shown on the right in Fig. 92.

The small electrodes are connected to the outside ends of the power transformer secondary and the large electrode is connected to the positive lead of the filter.

When alternating voltage is induced in the transformer secondary, these small electrodes alternately become positive and negative. During the periods of the cycle when they are positive, current will

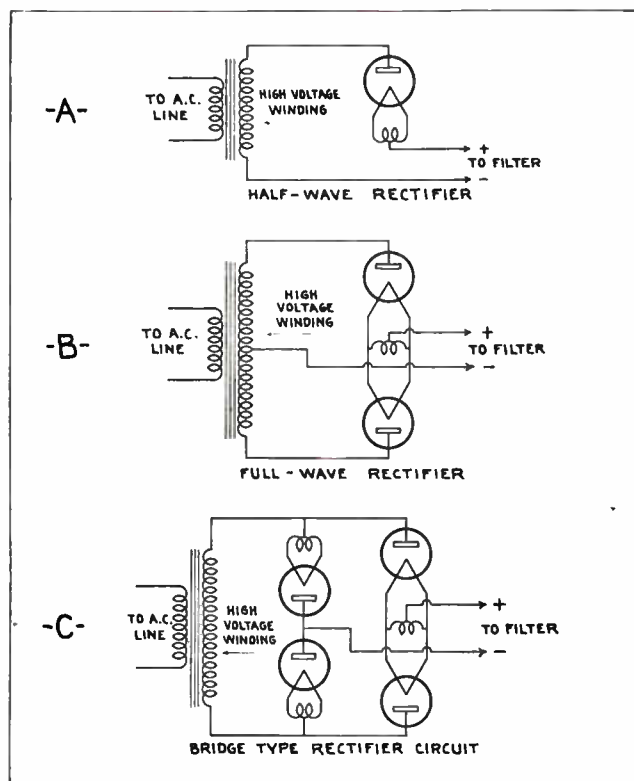

Fig. 91. The above diagrams show circuit connections for half-wave, full-wave and bridge type rectifiers with the tubes connected to their power supply transformers.

flow from them, through the ionized gas to the large electrode and out on the positive lead to the filter, through the receiver, and back on the negative lead to the center tap of the transformer secondary.

When the polarity reverses so that the large electrode is positive with respect to its small electrode, the current is then almost entirely cut off, only a few millionths of an ampere flowing. When either of the small electrodes are positive, many thousandths of an ampere will flow.

Even though one of the small electrodes is positive while the other is negative, practically no current will flow between them because of their distance from each other, and also because current cannot easily flow thru a gas or space to any small electrode.

When voltage is first applied to a Raytheon rectifier tube it may require a few seconds for the gas to become fully ionized and for the current to build up to its full value or to the current capacity of the tube.

74. CATHODE RAY TUNING INDICATOR TUBES.

Another type of vacuum tube which has come into excessive use in modern radios is the cathode ray or electron-ray tube which is used as a tuning indicator to show when the set is accurately tuned to the station wavelength. This tube is often called the "Magic Eye."

Fig. 93 shows a sketch of such a tube mounted in its holder and equipped with a shadow shield which aids in seeing its pale green glow in a lighted room. Fig. 94 shows in the upper view, a diagram of the

important elements of this tube, and in the lower view are shown the tube symbol and connections.

This type of tube uses a hot cathode to throw off negative electrons which are attracted by a coating of fluorescent material on a target or cone-shaped metal element in the end of the tube.

The term "Fluorescent" means material that glows when excited or struck by the stream of electrons. The material used in these tubes gives off a pale greenish glow when the speeding negative electrons strike it. The target is positively charged by a connection to B+ as shown in the lower sketch, Fig. 94. This causes the target to attract the negative electrons from the cathode.

To produce the shadow for the tuning indication, a ray-control-electrode is located between the cathode and the target as shown in the upper view in Fig. 94, and given a varying negative charge according to the strength of the signal to which the set is being tuned.

When this ray-control electrode is negative with respect to the target, it repels or deflects some of the electrons and prevents them from striking the target behind it, thus causing a dark spot or shadow on the target which does not glow.

The more negative the charge on the ray-control electrode, the more it repels the electrons which come near it and the wider the shadow it causes.

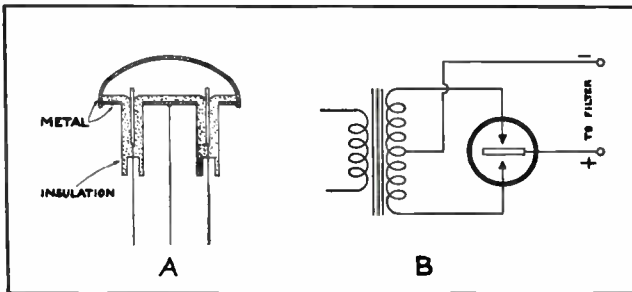

Fig. 92. On the left is shown a sketch of the anode and cathodes of a full-wave gaseous rectifier tube. On the right is shown a connection diagram for a tube of this type as used in the power supply of A. C. receivers.

Thus when the set is tuned so that this shadow is narrowest, the receiver is accurately tuned to the desired station.

More about the circuit connection of these tubes will be given later under radio receiving circuits. The 6E5 and 6G5 are tuning indicator tubes of this type.

75. CARE OF VACUUM TUBES.

Most modern vacuum tubes are made to give 1,000 hours or more of operation or service, provided they are operated under the proper voltages, loads and conditions for which they are intended. The rated filament and plate voltages and currents of various common tubes are specified in the tube data charts in the latter pages of this lesson.

In order to secure satisfactory operation and normal life of these tubes, they should be operated at their rated voltages and currents. If excessive voltage is applied to the filament or plate of a vacuum tube, it will likely overheat and burn out, or its life will be greatly shortened.

If the filament and plate voltages are too low, the tubes will not operate satisfactorily. In other

words, they will not be as sensitive when used as detectors and they will not deliver proper output to the speaker when used as amplifiers.

Never use high plate voltages on tubes without being sure that the proper negative bias voltage is applied to the grids of the tubes. In the case of battery operated receivers always see that the D. C. filament connections are made with the right polarity, as reversed polarity of the filament leads of a D. C. tube will reduce the efficiency and effectiveness of its operation.

76. SELECTION OF VACUUM TUBES.

Certain types of vacuum tubes are constructed so that they are better detectors while other tubes are constructed for best results when used as amplifiers. We have also learned that some tubes are made with a number of extra or special elements to fit them for combination service such as mixers and second detector in super-hetrodyne sets, etc.

In some cases, the difference in construction and operation of two or more different models of vacuum tubes may be very little and they can be interchanged or substituted for other tubes of similar characteristics, in case of emergencies where the proper tubes are not available. However, it is best as a general rule to replace defective tubes with those of the same model or number. In some cases if tubes are inter-changed or placed in the wrong sockets in a receiver they will immediately burn out because of the great difference in voltages or currents in various parts of the circuit.

By careful reference to the tube charts on following pages, you will find a number of tubes which have similar operating voltages and which are marked for the same general class of service such as detector, amplifier, oscillator, rectifier, etc.

Certain defects such as short circuits, defective resistors, condensers, transformers or speakers in radio sets, may cause abnormal operating voltages or current and damage the tubes.

After a vacuum tube has been operated for a certain number of hours, nearly equal to its normal life, its efficiency may drop to a point that will greatly interfere with proper operation of the receiver and cause the set to become noisy, or the sound at the speaker to become mushy or distorted, or it may greatly reduce the sensitivity or volume of the set. For best radio reception or sound amplification vacuum tubes that are old and weak should be replaced with new ones.

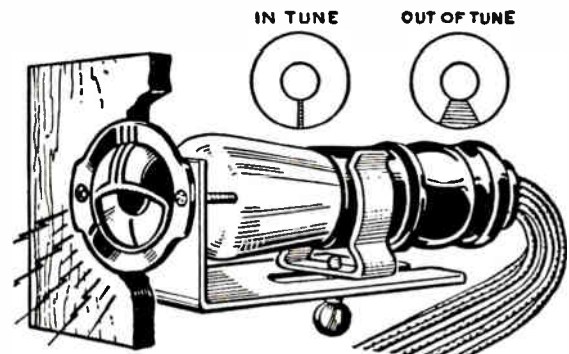

Fig. 93. Sketch of a cathode ray tuning indicator tube mounted in its support behind a shadow shield on the panel of a radio set. Courtesy Radolek Company.

While modern vacuum tubes are very well constructed mechanically, they contain a number of very small, delicate and closely spaced elements and should therefore be handled with care. They should not be sharply jarred or subjected to unnecessary vibration. For this reason tube sockets or entire radio chassis are often suspended in rubber or spring type shock absorbing mountings. This is particularly necessary in automobile and airplane radios.

Vacuum tubes of the hot filament or cathode type all produce a certain amount of heat. This heat is developed both by current flow through high resistance filament or heater element, and from the flow of plate current through the evacuated or gaseous space in the tube. Therefore, provision must be made for proper cooling or ventilation of radio sets and amplifiers. Otherwise if this heat is kept confined within the chassis or cabinet the set would soon become so hot that insulation would be destroyed and parts burned out. Bad fires have resulted from enclosing radio receivers or amplifiers in cabinets, drawers or closets without proper ventilation.

Large tubes used for transmitting purposes are often water cooled. Tubes of this type were shown in the preceding lesson.

Carefully examine the tube charts and socket diagrams shown on the following pages, to become familiar with the characteristics, applications or uses, and the terminal arrangements of some of the more commonly used vacuum tubes. Then refer to these charts from time to time when selecting proper tubes for replacement purposes or for the design or construction of receiving or amplifying circuits.

Additional tube data charts can be obtained from tube dealers or manufacturers from time to time,

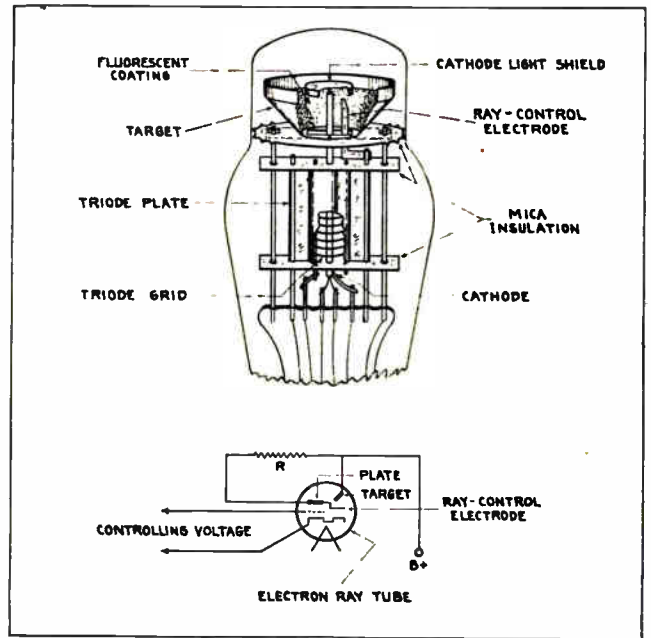

Fig. 94. Diagrams showing construction and circuit of a cathode ray tuning indicator tube, or "magic eye" as these tubes are often called.

in order to keep your tube service data up to date with the current changes in vacuum tubes.

Now before proceeding to your next very important section on receiving circuits let us remind you once again of the great importance of vacuum tubes in radio equipment, and advise you to be thoroughly familiar with the material covered in this section. Review this section on vacuum tubes if necessary and then you will be ready for the valuable and interesting sections which follow on receiver and amplifier circuits, radio test equipment and service methods.

PLUG-IN RESISTORS FOR AC-DC HEATERS WITH 200 MILLIAMPERE SERIES CONNECTED HEATERS. (NORMAL LINE VOLTAGE - 117.5 V. 1/2)

TYPE	TYPICAL TUBE IN SHEET TYPES	TOTAL DROP IN TUBE VOLTS	TOTAL DROP IN RESISTOR VOLTS	NUMBER AND PANEL LAMPS	CIRCUIT AND BASE	REPLACEMENT TYPES
L50B	5	81.5	46.3	1-250	B-OCTAL	L50B, L50B
42A	4	75.2	46.3	0	A-OCTAL	K42A, 42A2, K42AG, K42A
42A1	4	75.2	46.3	0	A-OCTAL	KY42B
42B2	4	75.2	46.3	2-150	B-OCTAL	K42B1
42B2	4	75.2	46.3	2-150	C-OCTAL	KY42C
K42B	4	75.2	46.3	2-150	B-OCTAL	K42B, K42B2, K42B, 135KL
3K42B	HAS BALLASTING ACTION FOR PANEL LAMP TAP					K42B
K42C	4	75.2	46.3	2-150	C-OCTAL	K42C, BK42C, #5E2, K40C, 5516, 5630
K42D	4	75.2	46.3	2-150	D-OCTAL	K42D, BK42D, K40D, X42B
K42E	4	75.2	46.3	3-150	E-OCTAL	K42E1
L42B	4	75.2	46.3	1-250	B-OCTAL	BL42B, L42B2, 5547
L42C	4	75.2	46.3	2-250	C-OCTAL	BL42C, L42C2, 69-2037, 5648
L42D	4	75.2	46.3	2-250	D-OCTAL	BL42D, L42D2, 5549
L42E	4	75.2	46.3	3-250	E-OCTAL	K42E, K42E1, K50A
49A	3	68.9	48.6	0	A-OCTAL	KY49A
49A1	3	68.9	48.6	0	A-OCTAL	KY49A1
49A2	3	68.9	48.6	1-150	B-OCTAL	KY49B
49B	3	68.9	48.6	1-150	B-OCTAL	KY49C
K49B	3	68.9	48.6	1-150	B-OCTAL	BK49B, 49B2, K49B2, 165KB, W43307, 115.41, 8C33, 160KB, 5625
K49C	3	68.9	48.6	2-150	C-OCTAL	49C, BK49C, 116C60, K50C, B1966-2, 5C34
3K49C/K49C	HAS BALLASTING ACTION FOR PANEL LAMP TAP					
K49D	3	68.9	48.6	2-150	D-OCTAL	49KD, BK49D, BK49D-10, 5633, 5518, 69116, 115.28, 3334, 3334A
L49B	3	68.9	48.6	1-250	B-OCTAL	49LB, BL49B, 2UR224, 165LB, 160LB, 89.2033, 5560, 5511
L49C	3	68.9	48.6	2-250	C-OCTAL	49LC, 160C, 155LC, L49-3, 5C, BL49C, 295B, 8662
L49D	3	68.9	48.6	2-250	D-OCTAL	3CR-241, 49LD, BL49D, 5567
55A1	2	62.6	54.9	0	A-OCTAL	KY55A
55A2	2	62.6	54.9	1-150	B-OCTAL	KY55B
55B2	2	62.6	54.9	2-150	C-OCTAL	KY55C
K55B	2	62.6	54.9	1-150	B-OCTAL	55KB, K55B2, K54B, 180KB, 185KB, BK55B, 3613, 5519, 5536
K55C	2	62.6	54.9	2-150	C-OCTAL	BK55C, 185CD, 115.22
K55D	2	62.6	54.9	2-150	D-OCTAL	BK55D, 185CD, 115.22
L55B	2	62.6	54.9	1-250	B-OCTAL	2V4215, 165LB, 2003, 5586, 8598
L55C	2	62.6	54.9	2-250	C-OCTAL	751C, 165-3, 5C, 1851C, 2904
L55D	2	62.6	54.9	2-250	D-OCTAL	851D, 1851D
60R300	SPECIAL	96.9	17.6	1-150	B-OCTAL	
H75B	3	75.2	46.3	1-200	B-OCTAL	
140B	4	75.2	46.3	1-150	A-OX	
140B4	4	75.2	46.3	1-150	B-OX	
140B5	4	75.2	46.3	2-150	C-OX	
1561A	3	68.9	48.6	0-250	B-OX	
165B	3	68.9	48.6	0	A-OX	
165B4	3	68.9	48.6	1-150	B-OX	
165B5	3	68.9	48.6	1-150	C-OX	
185B	2	62.6	54.9	0	A-OX	
185B4	2	62.6	54.9	1-150	B-OX	
185B5	2	62.6	54.9	2-150	C-OX	
185B6	2	62.6	54.9	1-150	B-OX	
185B7	2	62.6	54.9	2-150	C-OX	
185B8	2	62.6	54.9	1-150	B-OX	
185B9	2	62.6	54.9	2-150	C-OX	
185B10	2	62.6	54.9	1-150	B-OX	
185B11	2	62.6	54.9	2-150	C-OX	
185B12	2	62.6	54.9	1-150	B-OX	
185B13	2	62.6	54.9	2-150	C-OX	
185B14	2	62.6	54.9	1-150	B-OX	
185B15	2	62.6	54.9	2-150	C-OX	
185B16	2	62.6	54.9	1-150	B-OX	
185B17	2	62.6	54.9	2-150	C-OX	
185B18	2	62.6	54.9	1-150	B-OX	
185B19	2	62.6	54.9	2-150	C-OX	
185B20	2	62.6	54.9	1-150	B-OX	
185B21	2	62.6	54.9	2-150	C-OX	
185B22	2	62.6	54.9	1-150	B-OX	
185B23	2	62.6	54.9	2-150	C-OX	
185B24	2	62.6	54.9	1-150	B-OX	
185B25	2	62.6	54.9	2-150	C-OX	
185B26	2	62.6	54.9	1-150	B-OX	
185B27	2	62.6	54.9	2-150	C-OX	
185B28	2	62.6	54.9	1-150	B-OX	
185B29	2	62.6	54.9	2-150	C-OX	
185B30	2	62.6	54.9	1-150	B-OX	
185B31	2	62.6	54.9	2-150	C-OX	
185B32	2	62.6	54.9	1-150	B-OX	
185B33	2	62.6	54.9	2-150	C-OX	
185B34	2	62.6	54.9	1-150	B-OX	
185B35	2	62.6	54.9	2-150	C-OX	
185B36	2	62.6	54.9	1-150	B-OX	
185B37	2	62.6	54.9	2-150	C-OX	
185B38	2	62.6	54.9	1-150	B-OX	
185B39	2	62.6	54.9	2-150	C-OX	
185B40	2	62.6	54.9	1-150	B-OX	
185B41	2	62.6	54.9	2-150	C-OX	
185B42	2	62.6	54.9	1-150	B-OX	
185B43	2	62.6	54.9	2-150	C-OX	
185B44	2	62.6	54.9	1-150	B-OX	
185B45	2	62.6	54.9	2-150	C-OX	
185B46	2	62.6	54.9	1-150	B-OX	
185B47	2	62.6	54.9	2-150	C-OX	
185B48	2	62.6	54.9	1-150	B-OX	
185B49	2	62.6	54.9	2-150	C-OX	
185B50	2	62.6	54.9	1-150	B-OX	
185B51	2	62.6	54.9	2-150	C-OX	
185B52	2	62.6	54.9	1-150	B-OX	
185B53	2	62.6	54.9	2-150	C-OX	
185B54	2	62.6	54.9	1-150	B-OX	
185B55	2	62.6	54.9	2-150	C-OX	
185B56	2	62.6	54.9	1-150	B-OX	
185B57	2	62.6	54.9	2-150	C-OX	
185B58	2	62.6	54.9	1-150	B-OX	
185B59	2	62.6	54.9	2-150	C-OX	
185B60	2	62.6	54.9	1-150	B-OX	
185B61	2	62.6	54.9	2-150	C-OX	
185B62	2	62.6	54.9	1-150	B-OX	
185B63	2	62.6	54.9	2-150	C-OX	
185B64	2	62.6	54.9	1-150	B-OX	
185B65	2	62.6	54.9	2-150	C-OX	
185B66	2	62.6	54.9	1-150	B-OX	
185B67	2	62.6	54.9	2-150	C-OX	
185B68	2	62.6	54.9	1-150	B-OX	
185B69	2	62.6	54.9	2-150	C-OX	
185B70	2	62.6	54.9	1-150	B-OX	
185B71	2	62.6	54.9	2-150	C-OX	
185B72	2	62.6	54.9	1-150	B-OX	
185B73	2	62.6	54.9	2-150	C-OX	
185B74	2	62.6	54.9	1-150	B-OX	
185B75	2	62.6	54.9	2-150	C-OX	
185B76	2	62.6	54.9	1-150	B-OX	
185B77	2	62.6	54.9	2-150	C-OX	
185B78	2	62.6	54.9	1-150	B-OX	
185B79	2	62.6	54.9	2-150	C-OX	
185B80	2	62.6	54.9	1-150	B-OX	
185B81	2	62.6	54.9	2-150	C-OX	
185B82	2	62.6	54.9	1-150	B-OX	
185B83	2	62.6	54.9	2-150	C-OX	
185B84	2	62.6	54.9	1-150	B-OX	
185B85	2	62.6	54.9	2-150	C-OX	
185B86	2	62.6	54.9	1-150	B-OX	
185B87	2	62.6	54.9	2-150	C-OX	
185B88	2	62.6	54.9	1-150	B-OX	
185B89	2	62.6	54.9	2-150	C-OX	
185B90	2	62.6	54.9	1-150	B-OX	
185B91	2	62.6	54.9	2-150	C-OX	
185B92	2	62.6	54.9	1-150	B-OX	
185B93	2	62.6	54.9	2-150	C-OX	
185B94	2	62.6	54.9	1-150	B-OX	
185B95	2	62.6	54.9	2-150	C-OX	
185B96	2	62.6	54.9	1-150	B-OX	
185B97	2	62.6	54.9	2-150	C-OX	
185B98	2	62.6	54.9	1-150	B-OX	
185B99	2	62.6	54.9	2-150	C-OX	
185B100	2	62.6	54.9	1-150	B-OX	

THE FOLLOWING TYPES ARE FOR USE IN BATTERY OPERATED RECEIVERS USING 2 VOLT TUBES WITH FILAMENTS IN PARALLEL.

TOTAL CURRENT DRAIN OF TUBE.

TYPE	TYPE	TYPE	TYPE	TYPE
1A1	800	2	1	A-OX
1B1	360	2	1	A-OX
1N1	300	2	1	A-OX
1N2	360	2	1	A-OX
1N3	480	2	1	A-OX
1N4	480	2	1	A-OX
1N5	640	2	1	A-OX
1N6	600	2	1	A-OX
1N7	600	2	1	A-OX
1N8	780	2	1	A-OX

ALL NB TYPES USE BAWN. DIAGRAM INDICATED TOGETHER WITH LEVELLED BASE VIEW, DEPENDING UPON THE WAY IN WHICH IT IS INSERTED IN THE SPECIAL 3-KEYWAY OCTAL SOCKET, AN NB TYPE MAY BE USED WITH SETS OBTAINING FILAMENT SUPPLY FROM EITHER A DRY CELL, AIR CELL BATTERY OR STORAGE BATTERY. COMPLETE DATA AND APPLICATION INFORMATION IS AVAILABLE UPON REQUEST.

(FOR PANEL LAMP DATA SEE PAGE 1151)

*PANEL LAMPS TO BE USED WITH THESE PLUG-IN RESISTORS MUST HAVE THE CURRENT RATING SHOWN. THE ACTUAL TYPE WILL DEPEND UPON THE TYPE OF BIASING. FIG. 94D MAY BE OBTAINED FROM THE PANEL LAMP DATA IN THIS CHART.

TYPE	DESIGN	CATHODE HTR OR FIL		BASING DATA	MAX SIZE VIEW	CAPACITIES			USED AS	PLATE VOLTS	GRID VOLTS	SCR VOLTS	PLATE MA	SCR MA	AMP FACT	PLATE RESIS OHMS	MUT COND μMHO	OUT PUT WATTS	LOAD RESIS OHMS	CUT OFF VOLTS	TYPE	
		TYP	AMPS			C-P μFDS	IN μFDS	OUT μFDS														
00A	TRIODE	FIL	5.0	.25	4D-SM4B	14B	8.5	3.1	2.2	DETECTOR	45	0	1.5	20	30000	666					00A	
01A	TRIODE	FIL	5.0	.25	4D-SM4B	14D	8.1	3.1	2.2	AMP CL A	135	-9	3	8	10000	800					01A	
0A4G	OAS TRI	COLD			4V-OS6	12E				RELAY TUBE	MAX PEAK CATHODE CURRENT 100ma, MAX DC CATHODE CURRENT 25ma, STARTER ANODE DROP APPROX 60V, ANODE DROP APPROX 70V											0A4G
0Z4 0Z4G	TWIN DIODE	COLD			4R-OW6 4R-OTS	8D 7A				FULL WAVE RECTIFIER	300 RMS MAX 75 ma MAX-30 ma MIN TUBE DROP 24v											0Z4 0Z4G
1A4-T	TETRODE	FIL	2.0	.06	4K-SS4	12H	.010*	5.0	11	AMP CL A	180	-3	67.5	2.3	0.7	720	.96MEG	750			-16	1A4-T
1A5G 1A5GT	PENTODE	FIL	1.4	.05	6X-OS7 6X-00T7	9N 9H				POWER AMP CLASS A	90 85	-4.5 -4.5	90 85	4.0 3.5	0.8 0.7	.3 MEG .3 MEG	850 800	.115 .100	25000			1A5G 1A5GT
1A6	HEPTODE	FIL	2.0	.06	6L-SS6	12E	.25*	10.5	9.0	OSC SECT MIXER	135S 180	.05MEG -3	67.5	2.3 1.3	2.4	GRID #2 RES .5 MEG	3000	.02 MEG				1A6
1A7G 1A7GT	HEPTODE	FIL	1.4	.05	7Z-OS8 7Z-OW8	9P 9F	.30*	6.5*	11*	OSC SECT MIXER	90 90	.2 MEG 0	45	1.2 0.55	0.6	.8 MEG	2500				-3	1A7G 1A7GT
1B4/951	PENTODE	FIL	2.0	.06	4M-SS4	12H	.007*	5.0	11	AMP CL A	180 90	-3 -3	67.5 67.5	1.7 1.6	0.6 0.7	1000 550	1.5MEG 1 MEG	650 600			-8 -8	1B4/951
1B5/256	DUO-DI TRIODE	FIL	2.0	.06	6M-SS6	12B	3.6	1.6	1.9	AMPLIFIER CLASS A	135	-3		0.8		20	35000	575				1B5/256
1B7G	HEPTODE	FIL	1.4	.1	7Z-OS8	9P	.34*	7.0*	7.5*	OSC SECT MIXER	90 90	.2 MEG 0	45	1.6 1.5	1.3	.35MEG	3500				-14.5	1B7G
1C5G 1C5GT	PENTODE	FIL	1.4	.1	6X-OS7 6X-00T7	9N 9H				POWER AMP CLASS A	90 83	-7.5 -7	90 83	7.5 7.0	1.6 1.6	.12MEG .11MEG	1550 1500	.240 .200	8000 9000			1C5G 1C5GT
1C6 1C7G	HEPTODE	FIL	2.0	.12	6L-SS6 7Z-OS8	12H 12F	.3*	10*	10*	OSC SECT MIXER	180S 180	.05MEG -3	67.5	4.0 1.5	2.0	GRID #2 RES .7 MEG	3250	.02 MEG			-14	1C6 1C7G
1D5G-P	PENTODE	FIL	2.0	.06	5Y-OS7	12F	.007*	5.0*	11*	AMPLIFIER CLASS A	180 90	-3 -3	67.5 67.5	2.3 2.2	0.8 0.9	750 425	1 MEG .6 MEG	750 720			-15 -15	1D5G-P
1D7G	HEPTODE	FIL	2.0	.06	7Z-OS8	12F	.30*	10*	14*	OSC SECT MIXER	180S 180	.05MEG -3	67.5	2.3 1.3	2.4	GRID #2 RES .5 MEG	3000	.02 MEG			-22.5	1D7G
1D6GT	DI-TRI PENTODE	FIL	1.4	.1	8AJ-00T8	9J				TRI CL A PENT CL A	90 90	0 -9	90	1.1 5.0	1.0	25 .2 MEG	43500 925	.575 .200	12000			1D6GT
1E4G	TRIODE	FIL	1.4	.05	5S-OS7	9N	2.4	2.4	6.0	AMPLIFIER CLASS A	90 90	-3 0		1.5 4.5		14 14.5	17000 11000	825 1325				1E4G
1E5G-P	PENTODE	FIL	2.0	.06	5Y-OS7	12F	.007*	5.5*	12*	AMPLIFIER CLASS A	180 90	-3 -3	67.5 67.5	1.7 1.6	0.6 0.7	1000 550	1.5MEG 1 MEG	650 600			-8 -8	1E5G-P
1E7G	TWIN	FIL	2.0	.24	8C-OS8	12E				CL A 1 SECT CL A 2 SECT	135 135	-4.5 -7.5	135 135	7.5 14	2.2 4.0	.26MEG	1425	.290 .575	16000 24000			1E7G
1F4 1F5G	PENTODE	FIL	2.0	.12	5K-SM5 6X-0M7	12D 14C				PR AMP CL A CL AB 2 TUBE	135 180	-4.5 -7.5	135 180	8.0 19	2.4 5.5	.20MEG	1700	.310 1.25	16000 20000			1F4 1F5G
1F6 1F7G-H	DUO-DI PENTODE	FIL	2.0	.06	6W-SS6 7AD-OS8	12H 12F	.007* .01*	4 3.8*	9 9.5*	AMPLIFIER CLASS A	180	-1.5	67.5	2.2	0.7	1 MEG	650				-12	1F6 1F7G-H

TYPE	DESIGN	CATHODE HTR OR FIL		BASING DATA	MAX SIZE VIEW	CAPACITIES			USED AS	PLATE VOLTS	GRID VOLTS	SCR VOLTS	PLATE MA	SCR MA	AMP FACT	PLATE RESIS OHMS	MUT COND μMHO	OUT PUT WATTS	LOAD RESIS OHMS	CUT OFF VOLTS	TYPE		
		TYP	AMPS			C-P μFDS	IN μFDS	OUT μFDS															
1G4G	TRIODE	FIL	1.4	.05	5S-OS7	9N				AMP CL A	90	-6		2.3		8.8	825					1G4G	
1G5G	PENTODE	FIL	2.0	.12	6X-0M7	14C				POWER AMP CLASS A	135 90	-13.5 -6	135 90	8.7 8.5	2.5 2.5	.16MEG .13MEG	1500	.550 .250	9000 8500			1G5G	
1G6G	TWIN TRIODE	FIL	1.4	.1	7AB-OS8	9N				CL A 1 SECT CL B 2 SECT	90 90	0 0		1.0 2.0		30 45000	675					1G6G	
1H4G	TRIODE	FIL	2.0	.06	5S-OS6	12E	3.6*	5.0*	5.5*	AMPLIFIER CL B 2 TUBE	180 157.5	-13.5 -15		3.1 1.0		9.3	10300	900	(SEE TYPE 30 2.1	ALSO) 8000		1H4G	
1H5G 1H5GT	DIODE TRIODE	FIL	1.4	.05	5Z-OS7 5Z-0W7	9P 9F	1.1	.36	4.0	AMPLIFIER CLASS A	90	0		0.15		65	.24MEG	275				1H5G 1H5GT	
1H6G	DUO-DI TRIODE	FIL	2.0	.06	7AA-OS8	12E	3.6*	2.0*	3.0*	AMPLIFIER CLASS A	135	-3		0.8		20	35000	575				1H6G	
1J5G	PENTODE	FIL	2.0	.12	6X-0M7	14C				PR AMP CL A	135	-16.5	135	7.0	2.0	100		950	.45	13500		1J5G	
1J6G	TWIN TR	FIL	2.0	.84	7AB-OS8	12E				CLASS B TWO SECT	135 135	0 -6		10 NO SIG 0.2 NO SIG				2.1 1.6	10000 10000			1J6G	
1LA4	PENTODE	FIL	1.4	.05	5AD-L8	9A				PR AMP CL A	CHARACTERISTICS SAME AS FOR TYPE 1A5G											1LA4	
1LA6	HEPTODE	FIL	1.4	.05	7AK-L8	9A	.40	7.7	5.0	OSC MIXER	CHARACTERISTICS SAME AS FOR TYPE 1A70											1LA6	
1LN4	DI-TRI	FIL	1.4	.05	5AG-L8	9A	1.2	2.0	2.4	AMP CL A	CHARACTERISTICS SAME AS FOR TYPE 1H5G											1LN4	
1LN5	PENTODE	FIL	1.4	.05	7AO-L8	9A	.007	3.5	9.0	AMP CL A	90	0	90	1.6	0.35	880	1.1MEG	800				-4.5	1LN5
1N5G 1N5GT	PENTODE	FIL	1.4	.05	5Y-OS7 5Y-0W7	9P 9F	.007*	2.2	9.0	AMP CL A	90	0	90	1.2	0.3	1160	1.5MEG	750				-4	1N5G 1N5GT
1N6G	DI-PENT	FIL	1.4	.05	7AM-OS8	9N				PR AMP CL A	90	-4.5	90	3.1	0.6		.3 MEG	800	.10	25000		1N6G	
1P5G	PENTODE	FIL	1.4	.05	5Y-OS7	9P	.007*	2.2	9.0	AMP CL A	90	0	90	2.3	0.7	640	.8 MEG	800				-12	1P5G
1Q5G 1Q5GT	BEAM PWR AMP	FIL	1.4	.1	6AF-OS7 6AF-00T7	9N 9H				POWER AMP CLASS A	90 85	-4.5 -4.5	90 85	9.5 8.2	1.6 1.4		2100 1950	.27 .225	8000 8000				1Q5G 1Q5GT
1T5GT	BM PWR	FIL	1.4	.05	6X-00T7	9H				PR AMP CL A	90	-6	90	6.5	1.4			1150	.17	14000		1T5GT	
1-V	DIODE	HTR	6.3	.3	40-SS4	12B				H W RECT	325 RMS MAX 45 DC MAX TUBE DROP 20v AT 90ma DC											1-V	
2A3	TRIODE	FIL	2.5	2.5	4D-SM4	16B				PR AMP CL A PUSH-PULL CL AB 2 TUBE	250 300 300	-45 -82 SELP		60 80 80		4.2 15 780 OHM BIAS RES	800 5250	3.5 15 10	2500 3000 5000			2A3	
2A4G	OAS TRI	FIL	2.5	2.5	5S-OS7	12E				THYRATRON	200 RMS MAX 100 DC MAX TUBE DROP 12v											-9	2A4G
2A5	PENTODE	HTR	2.5	1.75	6B-SM6	14D				TRIODE CONNECTION	PR AMP CL A CL AB 2 TUBE	250 350	-20 -38	250	31 46	6.8 (SEE TYPE 6P6G ALSO)	2600 6P6G	.85 13	4000 6000			2A5	
2A6	DUO-DI TRIODE	HTR	2.5	.8	60-8S6	12H	1.7	1.7	3.8	AMPLIFIER CLASS A	250	-2		0.9		100	91000	1100				2A6	
2A7 2A7B	HEPTODE	HTR	2.5	.8	7C-8S7 7C-8S7	12H	.3*	8.5	9.0	OSC SECT MIXER	250S 250	.05MEG -3	100	4.0 3.5	2.7	GRID #2 RES .36MEG	1500	.02 MEG			-35	2A7 2A7B	

Fig. 95. Vacuum tube data chart.

TYPE	DESIGN	CATHODE		BASING DATA	MAX SIZE VIEW	CAPACITIES			USED AS	PLATE VOLTS	GRID VOLTS	SCR VOLTS	PLATE MA	SCR MA	AMP FACT	PLATE RESIS OHMS	MUT COND μMHO	OUT PUT WATTS	LOAD RESIS OHMS	CUT OFF VOLTS	TYPE	
		HTR OR FIL TYPE	FIL VOLTS			FIL AMPS	G-P μFDS	IN μFDS														OUT μFDS
2B7 2B7S	DUO-DI PENTODE	HTR	2.5	.8	7D-SS7 7D-SS7	12H	.007*	3.5	9.5	AMPLIFIER CLASS A	250 650	-3 -3	125 100	9.0 6.0	2.3 1.5	.65MEG .90MEG	1125 1000			-21 -17	2B7 2B7S	
2E5	ELEC RAY	HTR	2.5	.8	6R-SS6	12B				TUNING IND	CHARACTERISTICS SAME AS FOR TYPE 6E5										2E5	
2B/4S	DUO DIODE	HTR	2.5	1.35	5D-SS6					DETECTOR	40 APPROX PER PLATE AT 50V DC										2B/4S	
2Z2/GB4	DIODE	FIL	2.4	1.5	4B-SS4	12B				HALF WAVE RECTIFIER	CHARACTERISTIC SIMILAR TO THOSE OF TYPE 1-V										2Z2,GB4	
3ABGT	DI-TRI PENTODE	FIL	1.4 or 2.8	.1 .05	8AS-OOT8	9K	2.2*	2.6*	4.6*	TRI CL A PENT CL A	90 90	-FIL -FIL	90	0.15 1.2	0.3	.24MEG .6 MEG	275 750					3ABGT
3Q5GT	6M PWR	FIL	1.4 or 1.1	.1	*AP-OOT7	9H	PARALLEL FIL SERIES FIL			PR AMP CL A	90 90	-4.5 -4.5	90 90	9.5 8.0	1.6 1.0	.1 MEG .11MEG	2100 1950	.270 .230	8000 8000			3Q5GT
4A6G	TWIN TRIODE	FIL	2.0 or 4.0	.12 .06	8L-OS8	12E				CL A 1 SECT CL B 2 SECT	90 90	-1.5 -1.5		1.1 1.1	20	26000 11MEG	750 1950		8000			4A6G
5T4	TWIN DIODE	FIL	5.0	2.0	5T-OW5	10C				FULL WAVE RECTIFIER	450 550	RMS MAX RMS MAX	COND IN MAX CHOKE IN	225 DC 225 DC	MAX MAX	TUBE DROP 45v AT	225ma DC					5T4
5U4G	TWIN DIODE	FIL	5.0	3.0	5T-OW8	16A				FULL WAVE RECTIFIER	450 550	RMS MAX RMS MAX	COND IN MAX CHOKE IN	225 DC 225 DC	MAX MAX	TUBE DROP 56v AT	225ma DC					5U4G
5V4G	TWIN DIODE	HTR	5.0	2.0	5L-OW5	14C				FULL WAVE RECTIFIER	375 500	RMS MAX RMS MAX	COND IN MAX CHOKE IN	175 DC 175 DC	MAX MAX	TUBE DROP 23v AT	175ma DC					5V4G
5W4 5W4G	TWIN DIODE	FIL	5.0	1.5	5T-OW5	8H 14C				FULL WAVE RECTIFIER	350 500	RMS MAX RMS MAX	COND IN MAX CHOKE IN	100 DC 100 DC	MAX MAX	TUBE DROP 45v AT	100ma DC					5W4 5W4G
5X4G	TWIN DI	FIL	5.0	3.0	5q-OW8	16A				F W RECT	CHARACTERISTICS SAME AS FOR TYPE 5U4G										5X4G	
5Y3G 5Y4G	TWIN DIODE	FIL	5.0	2.0	5T-OW5 5q-OW8	14C 14C				FULL WAVE RECTIFIER	350 500	RMS MAX RMS MAX	COND IN MAX CHOKE IN	125 DC 125 DC	MAX MAX	TUBE DROP 30v AT	125ma DC					5Y3G 5Y4G
5Z3	TWIN DI	FIL	5.0	3.0	4C-SM4	16B				F W RECT	CHARACTERISTICS SAME AS FOR TYPE 5U4G										5Z3	
5Z4 5Z4MG	TWIN DIODE	HTR	5.0	2.0	5L-OW5 5L-OW5	8H 10D				FULL WAVE RECTIFIER	350 500	RMS MAX RMS MAX	COND IN MAX CHOKE IN	125 DC 125 DC	MAX MAX	TUBE DROP 20v AT	125ma DC					5Z4 5Z4MG
6A3	TRIODE	FIL	6.3	1.0	4D-SM4	16B	16	7	5	PR AMP CL A PUSH-PULL CL AB 2 TUBE	CHARACTERISTICS SAME AS FOR TYPE 5B4G										6A3	
6A4/LA	PENTODE	FIL	6.3	.5	5B-SM5	14D				PR AMP CL A PUSH-PULL CL AB 2 TUBE	180 250	-12 SELP	180 230	22 32	3.9 700	100 OHM BIAS RES	4500 2200	1.4 4.2	8000 16000			6A4/LA
6A5G	TRIODE	HTR	6.3	1.25	6T-OW8	16A	16	7	5	PR AMP CL A PUSH-PULL CL AB 2 TUBE	250 325 325	-45 -68 SELP	60 80 80		4.2 800	800	5250	3.75 15 10	2500 3000 5000			6A5G
6A6	TWIN TRIODE	HTR	6.3	.8	7B-SM7	14D	(SEE TYPE 6N7G ALSO)			AMP CL A TRI IN PAR'L	294 250	-6 -6	7 6		35 35	11000 11300	3200 3100					6A6

TYPE	DESIGN	CATHODE		BASING DATA	MAX SIZE VIEW	CAPACITIES			USED AS	PLATE VOLTS	GRID VOLTS	SCR VOLTS	PLATE MA	SCR MA	AMP FACT	PLATE RESIS OHMS	MUT COND μMHO	OUT PUT WATTS	LOAD RESIS OHMS	CUT OFF VOLTS	TYPE		
		HTR OR FIL TYPE	FIL VOLTS			FIL AMPS	G-P μFDS	IN μFDS														OUT μFDS	
6A7 6A7S 6A8 6A8G 6A8GT	HEPTODE	HTR	6.3	.3	7C-SS7 7C-SS7 8A-OW8 8A-OW8 8A-OW8 8A-OW8	12H	.3*	8.5	9.0	OSC SECT	250 1500	.65MEG .05MEG		4.0 2.0								6A7 6A7S 6A8 6A8G 6A8GT	
6A8S	ELEC RAY	HTR	6.3	.15	6R-SS6	9R				TUNING IND	135 THRU .25 MEG, TARGET 135v, GRID OV FOR 90°, -7.5v FOR 0°										6A8S		
6A87/RK1853	PENTODE	HTR	6.3	.45	8N-OW8	8E	.015	8	5	HIGH FREQ AMPLIFIER	300 300	-3 -3	200 300	12.5 THRU .03 MEG	3.2 (OTHER VALUES SAME AS ABOVE)	.7 MEG	5000			-15 -22.5	6A87/RK1853		
6AC5G	TRIODE	HTR	6.3	.4	6q-OS6	12E	ONE 76 DRIVER TWO 76 DRIVERS			DIR CIPID AMP PUSH PULL CL B 2 TUBE	250 250	SUPPLIED BY DRIVERS	32 54	125	36700	3400	3.7 9.6	7000 10000				6AC5G	
6AC7/RK1852	PENTODE	HTR	6.3	.45	8N-OW8	8E	.15	11	5	HIGH FREQ AMPLIFIER	300	SELP	150 300	10 THRU .06 MEG	2.5 (OTHER VALUES SAME AS ABOVE)	.75MEG	9000	160 OHM BIAS RES				6AC7/RK1852	
6AD6G	TWIN ELEC RAY	HTR	6.3	.15	7AG-OW7	9C				TUNING INDICATOR	TARGET 150v CONTROL ELECTRODE 75v AT 0°, 8v AT 90°, -50v AT 135° TARGET 100v CONTROL ELECTRODE 45v AT 0°, 0v AT 90°, -23v AT 135°										6AD6G		
6AE5G	TRIODE	HTR	6.3	.3	6q-OS6	12E				AMP CL A	95	-15		7		4.2	3500	1200				6AE5G	
6AE6G	DUO TRIODE	HTR	6.3	.15	7AH-OS7	12E				CONTROL FOR 6AD6G-6AF6G	250 250	-1.5 -1.5		6.5 4.5	25 33	1000 950	PLATE R PLATE L		-35 -9.5			6AE6G	
6AF5G	TRIODE	HTR	6.3	.3	6q-OS6	12E				AMP CL A	180	-18		7		7.4	4900	1500				6AF5G	
6AF6G	TWIN ELEC RAY	HTR	6.3	.15	7J-OS7	9M				TUNING INDICATOR	TARGET 135v CONTROL ELECTRODE 81v AT 0°, 0v AT 100° TARGET 100v CONTROL ELECTRODE 60v AT 0°, 0v AT 100°										6AF6G		
6AL6G	BEAM PWR AMP	HTR	6.3	.9	6AM-OW7	16C				POWER AMP CLASS A	250 250	-14 SELP	250 250	72 75	5 6.4	17*	2500 OHM BIAS RES	6000 6.5	2500 2500			6AL6G	
6B4G	TRIODE	FIL	6.3	1.0	5E-OW8	16A	16	7	5	PR AMP CL A PUSH PULL CL AB 2 TUBE	250 325 325	-45 -68 SELP	60 80 80		4.2 800	800	5250	3.7 15 10	2500 3000 5000			6B4G	
6B5	DUO-TRI TRIODE	HTR	6.3	.8	6AS-SM6	14D				DIR CIPID AMP	300	0	300	42	9	59	24000	2400	4	7000			6B5
6B6G	DUO-DI PENTODE	HTR	6.3	.3	7V-OS7	12F	1.7	1.7	3.8	AMPLIFIER CLASS A	250	-2		0.9		100	91000	1100				6B6G	
6B7 6B7S	DUO-DI PENTODE	HTR	6.3	.3	7D-SS7 7D-SS7	12H	.007*	3.5	9.5	AMPLIFIER CLASS A	250 250	-3 -3	125 100	9.0 6.0	2.3 1.5	.6 MEG .8 MEG	1125 1000			-21 -17	6B7 6B7S		
6B8 6B8G	DUO-DI PENTODE	HTR	6.3	.3	8E-OW8 8E-OW8	8F	.005 .01*	6 3.6*	9.5*	AMPLIFIER CLASS A	250 250	-3 -3	125 100	2.3 1.5	2.3 .8	.6 MEG .8 MEG	1325			-21	6B8 6B8G		
6C5 6C5G	TRIODE	HTR	6.3	.3	6q-OW6 6q-OW6	8D 12E	2.0 4.4*	3.0 11*	11*	AMPLIFIER CLASS A	250	-8		8		20	10000	2000				6C5 6C5G	
6C6	PENTODE	HTR	6.3	.3	6F-SS6	12J	.007*	8.0	6.5	AMPLIFIER CLASS A	250 100	-3 -3	100 100	2.0 2.0	.8 .5	1.1MEG 1 MEG	1226 1185			-7 -7	6C6		
6C7	DUO-DI TRIODE	HTR	6.3	.3	7G-SS7					AMP CL A	250	-9		5.5		20	16000	1250				6C7	
6C8G	TWIN TR	HTR	6.3	.3	8Q-OS8	18F				CL A 1 SECT	250	-4.5		3.2		30	28500	1800				6C8G	

Fig. 96. Vacuum tube data chart.

TYPE	DESIGN	CATHODE		BASING DATA	MAX SIZE VIEW	CAPACITIES			USED AS	PLATE VOLTS	GRID VOLTS	SCR VOLTS	PLATE MA	SCR MA	AMP FACT	PLATE RESIS OHMS	MUT COND μMHO	OUT PUT WATTS	LOAD RESIS OHMS	CUT OFF VOLTS	TYPE	
		HTR OR FIL	FIL AMPS			G-P μFDS	IN μFDS	OUT μFDS														
6D6	PENTODE	HTR	6.3 .3	6P-SS6	12J	.007*	4.7	6.5	AMP CL A	CHARACTERISTICS SAME AS FOR TYPE 6U7G										6D6		
6D7	PENTODE	HTR	6.3 .3	7H-SS7					AMP CL A	CHARACTERISTICS SAME AS FOR TYPE 6C6										6D7		
6D8G	HEPTODE	HTR	6.3 .15	8A-OS8	12F	.2*	8.0*	11*	OSC SECT MIXER	250S 250	.05MEG -3	100	4.3 3.5	2.6		GRID #2 RES .02 MEG .4 MEG 550C					-35	6D8G
6E5	ELEC RAY	HTR	6.3 .3	6R-SS6	12B				TUNING IND	250 THRU 1 MEG, TARGET 250v, GRID Ov FOR 90°, -8v FOR 0°										6E5		
6E6	TWIN TR	HTR	6.3 .6	7B-SM7	14D				PUSH PULL	250 250	-27.5 -27.5		18 36		6	3500	1700	1.6	14000			6E6
6E7	PENTODE	HTR	6.3 .3	7H-SS7					AMP CL A	CHARACTERISTICS SAME AS FOR TYPE 6U7G										6E7		
6F5 6F5G 6F5GT	TRIODE	HTR	6.3 .3	5M-OW5 5M-OS5 5M-OW5	8F 12F 9F	2.0 2.0	5.0 2.5	12 3.5	AMPLIFIER CLASS A	250	-2		0.9		100	66000	1500					6F5 6F5G 6F5GT
6F6 6F6G	PENTODE	HTR	6.3 .7	7S-OW7 7S-OW7	8H 14C				PENTODE CONNECTION	285 250 375 315	-20 -16.5 -25 -24	285 250 250 285	38 34 34 62	7 6.5 5 12		78000 80000	2550 2500	4.8 3.2 15.5 11	7000 7000 10000 10000			6F6 6F6G
6F7 6F7S	TRIODE PENTODE	HTR	6.3 .3	7E-SS7	12H	2.0 .007*	2.5 3.2	3.0 12.5	TRI CL A PENT CL A	100 250	-3 -3	100	3.5 6.5	1.5	8 900	18000 .95MEG	500 110C			(SEE 6P7G ALSO)	-35	6F7 6F7S
6F8G	TWIN TR	HTR	6.3 .6	8O-OS8	12F	4.0L 3.6R	3.2L 3.0R	3.2L 3.8R	AMP CL A ONE SECT	250 90	-8		9.0 10.0		20 20	770C 670C	2600 3000					6F8G
6G6G	PENTODE	HTR	6.3 .15	7S-OS7	12E				POWER AMP CLASS A	180 135	-9 -6	180 135	15 11.5	2.5 2.0	400 360	.16MEG .17MEG	230C 2100	1.1 0.6	10000 12000			6G6G
6H4GT	DIODE	HTR	6.3 .15	5AF-OOT5	9H				DETECTOR	100 MAX 4 MAX 1000 AT .25ma										6H4GT		
6H6 6H6G 6H6GT	TWIN DIODE	HTR	6.3 .3	7Q-OW7 7Q-OS7 7Q-OW7	8C 12E 9E	.05 .1 P-P	3 3.1 P-K	3.4 4.0 P-K	DETECTOR	117 MAX 4 MAX EACH DIODE										6H6 6H6G 6H6GT		
6J5 6J5G 6J5GT	TRIODE	HTR	6.3 .3	6Q-OW6 6Q-OS6 6Q-OW6	8E 12E 9E	3.4 4.0*	3.4 4.2*	3.6 5.0*	AMPLIFIER CLASS A	250 90	-8 0		9.0 10.0		20 20	7700 6700	2600 3000					6J5 6J5G 6J5GT
6J7 6J7G 6J7GT	PENTODE	HTR	6.3 .3	7R-OW7 7R-OS7 7R-OW7	8F 12F 9F	.005 .007*	7 4.6*	12 12*	AMP CL A PENT CONN TRI CONN	250 100 250	-3 -3 -8	100 100	2.0 2.0 6.5	0.5 0.5		1.5MEG 1.0MEG	1225 1165				-7 -7	6J7 6J7G 6J7GT
6J8G	TRIODE HEPTODE	HTR	6.3 .3	8H-OS8	12F	.01*	4.6*	10.5*	OSC-TRIODE MIXER HEPT	250S 250	.05MEG -3	100	5.0 1.7	2.9		TRIODE PLATE RESISTOR 4 MEG 290C	.02 MEG				-20	6J8G
6K5G	TRIODE	HTR	6.3 .3	5U-OS7	12F	2.0	2.4	3.6	AMP CL A	250	-3		1.1		70	50000	1400					6K5G
6K6G 6K6GT	PENTODE	HTR	6.3 .4	7S-OS7 7S-OOT7	12E 9H				POWER AMP CLASS A	315 250	-21 -18	250 250	25.5 22.5	4.0 4.0		75000 68000	2100 2300	4.5 3.4	9000 7600			6K6G 6K6GT
6K7 6K7G 6K7GT	PENTODE	HTR	6.3 .3	7R-OW7 7R-OS7 7R-OW7	8F 12F 9F	.005 .007*	7 7*	12 12*	AMPLIFIER CLASS A	250 250 90	-3 -3 -3	125 100 90	10.5 7.0 5.4	2.6 1.7 1.3		.6 MEG .8 MEG .3 MEG	1650 1450 1275				-52.5 -42.5 -35.5	6K7 6K7G 6K7GT

TYPE	DESIGN	CATHODE		BASING DATA	MAX SIZE VIEW	CAPACITIES			USED AS	PLATE VOLTS	GRID VOLTS	SCR VOLTS	PLATE MA	SCR MA	AMP FACT	PLATE RESIS OHMS	MUT COND μMHO	OUT PUT WATTS	LOAD RESIS OHMS	CUT OFF VOLTS	TYPE	
		HTR OR FIL	FIL AMPS			G-P μFDS	IN μFDS	OUT μFDS														
6K8 6K8G 6K8GT	TRIODE HEXODE	HTR	6.3 .3	8K-OW8 8K-OS8 8K-OW8	8F 12F 9F	.03 .08* .03*	6.6 4.6* 4.0*	3.5 4.8* 4.5*	OSC-TRIODE MIXER HEX	100 250 100	.05MEG -3 -3	100 100	3.8 2.5 2.3	6.0 6.2		.6 MEG .4 MEG	3000 350C 325C			(TRIODE GRID Ov)	-30 -30	6K8 6K8G 6K8GT
6L5G	TRIODE	HTR	6.3 .15	6Q-OS6	12E	2.7*	3*	5*	AMP CL A	250	-9		8		17	8900	1900				-20	6L5G
6L6 6L6G	BEAM PWR AMP	HTR	6.3 .9	7AC-OW7 7AC-OW8	10C 16A				POWER AMP CLASS A PP CL A PP CL AB PP CL AB	350 250 270 360 360	-18 -14 -17.5 -22.5 -22.5	250 250 270 270 270	54 72 134 88 88	2.5 5.0 11 5 5		33000 22500 23500	5200 6000 5700	10.8 6.5 17.5 26.5 47	4200 2500 5000 6800 3800			6L6 6L6G
6L7 6L7G	HEPTODE	HTR	6.3 .3	7T-OW7 7T-OS7	8F 12F	.001 .005*	7.5 6*	11 10*	AMP CL A MIXER	250 250	-3 -6	100 150	5.3 3.3	6.5 9.2	670	.6 MEG 1 MEG	1100 3500	33 AT 33 AT	-3v -15v	-15 -45	6L7 6L7G	
6N5 6N6G 6N6GT	ELEC RAY DUO TRI	HTR	6.3 .15	6R-SS6 7AU-OW7 7AU-OW7	12B 14C 10B				TUNING IND DIR COUP PWR AMP	136 THRU .25 MEG, TARGET 135v, GRID Cv FOR 90°, -12v FOR 0°										6N5 6N6G 6N6GT		
6N7 6N7G	TWIN TRIODE	HTR	6.3 .8	8B-OW8 8B-OW8	8H			(SEE TYPE 6A6 ALSO)	POWER AMP CL B 2 SECT	300	0		35		PL CUR-MAX SIO	-70ma	10	8000				6N7 6N7G
6P5G 6P5GT	TRIODE	HTR	6.3 .3	6Q-OS6 6Q-OOT6	12E 9H	3.4*	3.6*	5.5*	AMPLIFIER CLASS A	250 100	-13.5 5		5 2.5		13.8 13.8	9500 12000	1460 1150					6P5G 6P5GT
6P7G	TRIODE- PENTODE	HTR	6.3 .3	7U-OS8	12F	2.0* .008*	3.5* 3.5*	3.0* 12*	OSC-TRIODE MIXER PENT	100 250	-10	100	2.4 2.8	0.6		2 MEG	300C			(SEE TYPE 6P7 ALSO)		6P7G
6Q7 6Q7G 6Q7GT	DUO- DIODE TRIODE	HTR	6.3 .3	7V-OW7 7V-OS7 7V-OW7	8F 12F 9F	1.5 1.3	2.5 2.7	5.0 4.5	AMPLIFIER CLASS A	250 100	-3 -1.5		1.1 0.35		70	58000 87500	1200 800					6Q7 6Q7G 6Q7GT
6R7 6R7G	DUO DI TRIODE	HTR	6.3 .3	7V-OW7 7V-OS7	8F 12F	2.5 3.5	5.5 2.5	4.0 4.5	AMPLIFIER CLASS A	250	-9		9.5		16	8500	1900	.28	10000			6R7 6R7G
6S7 6S7G	PENTODE	HTR	6.3 .15	7R-OW7 7R-OS7	8G 12F	.005 .008*	6.5 4.4*	10.5 8.0*	AMPLIFIER CLASS A	250 135	-3 -3	100 87.5	8.5 3.7	2.0 0.9		1 MEG 1 MEG	1750 1250				-38.5 -25	6S7 6S7G
6S8T 6S8GT	HEPTODE	HTR	6.3 .3	8R-OW8 8AD-OW8	8E	.13 .13	9.5 10.5	12 12	OSC SECT MIXER	OSC GRID RES 250	-.02 MEG 0	100	3.4	8	OSC GRID CUR -.8 MEG 450C						-35	6S8T 6S8GT
6SCT	TWIN TR	HTR	6.3 .3	8S-OW8	8E				CL A 1 SECT	250	-2		2		70	53000	1325					6SCT
6SF5 6SF5GT	TRIODE	HTR	6.3 .3	6AB-OW6 6AB-OOT6	8E 9H	2.6	4.2	3.8	AMPLIFIER CLASS A	250	-2		0.9		100	66000	1500					6SF5 6SF5GT
6SJ7 6SJ7GT	PENTODE	HTR	6.3 .3	8N-OW8 8N-OW8	8E 9E	.005	6.0	7.0	AMPLIFIER CLASS A	250 100	-3 -3	100 100	3.0 2.9	0.8 0.9	2500 1100	1.5MEG 0.7MEG	1650 1575					6SJ7 6SJ7GT
6SK7 6SK7GT	PENTODE	HTR	6.3 .3	8N-OW8 8N-OW8	8E 9E	.005*	6.0*	7.0*	AMPLIFIER CLASS A	250 100	-3 -3	100 100	9.2 8.9	2.4 2.6	1600 475	0.8MEG .25MEG	2000 1900				-35	6SK7 6SK7GT
6SQ7 6SQ7GT	DUO-DI TRIODE	HTR	6.3 .3	8Q-OW8 8Q-OOT8	8E 9H	1.8	4.2	3.4	AMPLIFIER CLASS A	250	-2		0.8		100	91000	1100					6SQ7 6SQ7GT
6T7G/6Q6G	DUO DI TRIODE	HTR	6.3 .15	7V-OS7	12F	1.3	2.7	4.5	AMPLIFIER CLASS A	250 135	-3 -1.5		1.2 0.9		65 65	62000 85000	1050 1000					6T7G/6Q6G

Fig. 97. Vacuum tube data chart.

Vacuum Tubes.

TYPE	DESIGN	CATHODE HTR OR FIL TYPE	HTR VOLTS	FIL AMPS	BASING DATA	MAX SIZE VIEW	CAPACITIES			USED AS	PLATE VOLTS	GRID VOLTS	SCR VOLTS	PLATE MA	SCR MA	AMP FACT	PLATE RES OHMS	MUT COND μMHO	OUT PUT WATTS	LOAD RES OHMS	CUT OFF VOLTS	TYPE		
							G-P μFDS	IN μFDS	OUT μFDS															
6U5/6G5	ELEC RAY	HTR	6.3	.3	6R-SS6	9R				TUNING IND	250 THRU 100	1 MEG TARGET	250V, 3RD GRID Ov FOR 90°, -22v FOR 0°									6U5/6G5		
6U7G	PENTODE	HTR	6.3	.3	7R-OS7	12L	.007*	5*	9*	AMP CL A	250 100	-3 -3	100 100	8.2 8.0	2.0 2.2	.8 MEG .25MEG	1600 1500				-50 -50	6U7G		
6V6 6V6G 6V6GT	BEAM POWER AMP	HTR	6.3	.45	7AC-OW7 7AC-OW7 7AC-OW7	9H 14C 9H				AMPLIFIER CLASS A PP CL AB	315 250 250	-13 -12.5 -15	225 250 250	34 45 70	2.2 4.5 5.0	77000 52000 60000	3750 4100 3750	5.5 4.5 10	8500 5000 10000			6V6 6V6G 6V6GT		
6V7G	DUO-DI TRIODE	HTR	6.3	.3	7V-OS7	12F	1.7	2.0	3.5	AMPLIFIER CLASS A	250 180	-20 -13.5		8 6		8.3 7500 8500	1100 975	.35 .16	20000 23000			6V7G		
6W5G	TWIN DI	HTR	6.3	.9	6S-OS6	12E				FULL WAVE RECTIFIER	325 RMS MAX 450 RMS MAX	COND IN 90 DC MAX	IN 90 DC MAX									TUBE DROP 24v AT 90ma DC	6W5G	
6W7G	PENTODE	HTR	6.3	.15	7R-OS7	12F	.007*	5.0*	8.5*	AMP CL A	250	-3	100	2.0	0.5	1.5MEG	1225					-7	6W7G	
6X5 6X5G 6X5GT	TWIN DIODE	HTR	6.3	.6	6S-OW6 6S-OS6 6S-OGT6	8H 12E 9H				FULL WAVE RECTIFIER	325 RMS MAX 450 RMS MAX	COND IN 70 DC MAX	IN 70 DC MAX										TUBE DROP 22v AT 70ma DC	6X5 6X5G 6X5GT
6Y5	TWIN DI	HTR	6.3	.8	6J-SS6	6J	(MERCURY VAPOR)			F W RECT	1500 PEAK			200 DC MAX									TUBE DROP 15v	6Y5
6Y6G	BEAM PWR AMP	HTR	6.3	1.25	7AC-OW7	14C				POWER AMP CLASS A	200 135	-14 -13.5	135 135	61 58	2.2 3.5	18300 9300	7100 7000	6.0 3.6	2600 2000			6Y6G		
6Y7G	TWIN TRIODE	HTR	6.3	.6	9B-OS8	12E				CL B AMP 2 SECTIONS	250 190	0 0		10.0 7.5	NO SIG NO SIG			8 5.5	14000 7000			6Y7G		
6Z5	TWIN DIODE	HTR	12.6 or 6.3	.4 .8	6K-SS6	12B				FULL WAVE RECTIFIER	1500 PEAK			60 DC MAX									6Z5	
6Z7G	TWIN TRIODE	HTR	16.3	.3	8B-OS8	12E				CL B AMP 2 SECTIONS	180 135	0 0		8.4 6.0	NO SIG NO SIG			4.2 2.8	12000 9000			6Z7G		
6Z5G	TWIN DI	HTR	6.3	.3	6S-OS6	12E				FULL WAVE RECTIFIER	325 RMS MAX 450 RMS MAX	COND IN 40 DC MAX	IN 40 DC MAX										TUBE DROP 18v AT 40ma DC	6Z5G
7A4	TRIODE	HTR	6.3	.3	5AC-L8	9A	4	3.4	3.0	AMPLIFIER CLASS A	250 90	-8 0		9 10		7700 6700	2600 3000					7A4		
7A5	PENTODE	HTR	6.3	.7	6AT-L8	9B				POWER AMP CLASS A	125 110	-9 -7.5	125 110	37.5 35	3.2 3.0	17000 16700	6100 6000	1.9 1.4	2700 2500			7A5		
7A6	DUO-DI	HTR	6.3	.15	7AJ-L8	9A	.05PP			DETECTOR	150 RMS MAX			10 DC MAX									TUBE DROP 8v AT 10ma DC	7A6
7A7	PENTODE	HTR	6.3	.3	8V-L8	9A	.005	6.0	7.0	AMP CL A	250	-3	100	8.6	2.0	1600	.8 MEG	2000				-35	7A7	
7A8	OCTODE	HTR	6.3	.15	8U-L8	9A	.15	7.5	9.0	OSC SECT MIXER	250S 250	.05MEG -3	100	4.5 3.0		GRID #2 RES .7 MEG	5500	.02 MEG				-30	7A8	
7B5	PENTODE	HTR	6.3	.4	6AE-L8	9B				POWER AMP CLASS A	250 100	-18 -7	250 100	32 9.0	5.5 1.6	68000 .1 MEG	2300 1500	3.4 .35	7600 12000			7B5		
7B6	DUO-DI TRIODE	HTR	6.3	.3	8W-L8	9A	1.5	3.0	3.0	AMPLIFIER CLASS A	250	-2		C.9		100	91000	1100					7B6	
7B7	PENTODE	HTR	6.3	.15	8V-L8	9A	.005	5.0	7.0	AMP CL A	250	-3	100	8.5	2.0	1200	.7 MEG	1700				-40	7B7	

TYPE	DESIGN	CATHODE HTR OR FIL TYPE	HTR VOLTS	FIL AMPS	BASING DATA	MAX SIZE VIEW	CAPACITIES			USED AS	PLATE VOLTS	GRID VOLTS	SCR VOLTS	PLATE MA	SCR MA	AMP FACT	PLATE RES OHMS	MUT COND μMHO	OUT PUT WATTS	LOAD RES OHMS	CUT OFF VOLTS	TYPE		
							G-P μFDS	IN μFDS	OUT μFDS															
7B8	HEPTODE	HTR	6.3	.3	8X-L8	9A	.03	9.5	9.0	OSC SECT MIXER	250S 250	.05MEG -3	100	4.0 3.5	2.7		GRID #2 RES .36MEG	5500	.02 MEG			-35	7B8	
7C5	BEAM PWR AMP	HTR	6.3	.45	6AT-L8	9B				PUSH PULL PR AMP CL A CL AB 2 TUBE	250 250	-12.5 -15	250 250	45 70	4.5 5.0		52000 60000	4100 3750	4.5 1.0	5000 10000			7C5	
7C6	DUO-DI TRIODE	HTR	6.3	.15	8W-L8	9A	1.4	2.4	3.0	AMPLIFIER CLASS A	250	0		1.3*		100	.1 MEG	1000	10 MEG	GRID RES			7C6	
7C7	PENTODE	HTR	6.3	.15	8V-L8	9A	.007*	5.5*	6.5*	AMPLIFIER CLASS A	250 100	-3 -3	100 100	2.0 1.8	0.5 0.4	2 MEG 1.2MEG	1300 1225					7C7		
7E6	DUO-DI TRIODE	HTR	6.3	.3	8W-L8	9A	1.5	3.0	3.4	AMP CL A	250	-9		9.5		16	8500	1900					7E6	
7E7	DUO-DI PENTODE	HTR	6.3	.3	8AE-L8	9A	.005*	4.6*	9.5*	AMPLIFIER CLASS A	250	-3	100	7.5	1.6		.7 MEG	1300				-42.5	7E7	
7F7	TWIN TR	HTR	6.3	.3	8AC-L8	9A				CL A 1 SECT	250	-2		2.3		70	44000	1600					7F7	
7J7	TRI HEX	HTR	6.3	.3	8AR-L8	9A	.01*	5.5*	7.5*	OSC-TRIODE MIXER HEX	250S 250	.05MEG -3	100	5.7 1.4		TRIODE PLATE RESISTOR	1.5MEG 310C	.02 MEG				-20	7J7	
7Q7	HEPTODE	HTR	6.3	.3	8AL-L8	9A	.1*	9.5*	9.0*	OSC SECT MIXER	OSC GRID RES 250	0		-0.2 MEG 3.4	OSC CUR .5ma	8	GRID RES .8 MEG	450C				-35	7Q7	
7Y4	TWIN DI	HTR	6.3	.5	5AB-L8	9A				F W RECT	350 RMS MAX			60 DC MAX									TUBE DROP 18 AT 60ma DC	7Y4
10	TRIODE	FIL	7.5	1.25	4D-SM4	16B	7	4	3	POWER AMP CLASS A	425 250	-40 -23.5		18 10		8 8	5000 6000	1600 1330	1.6 0.4	10200 13000			10	
WD11 WX12	TRIODE	FIL	1.1	.25	4F-WD4 4D-SK4B	8B 10A	3.3	2.5	2.5	AMPLIFIER CLASS A	135 90	-10.5 -4.5		3 2.5		6.6 6.6	15000 15200	440 425					WD11 WX12	
12A	TRIODE	FIL	5.0	.25	4D-SK4B	14D	8.5	4.0	2.0	AMPLIFIER CLASS A	180 135	-13.5 -9		7.7 6.2		8.5 8.5	4700 5100	1800 1650	.285 .130	10650 9000			12A	
12A5	PENTODE	HTR	12.6 or 6.3	.3 .6	7F-SS7	12B				POWER AMP CLASS A	180 100	-25 -15	180 100	45 17	8 3		35000 50000	2400 1700	3.4 0.8	3300 4500			12A5	
12A7	DIODE PENTODE	HTR	12.6	.3	7K-SS7	12H				H W RECT AMP CL A	125 RMS MAX 135	-13.5	135	30 DC MAX 9									TUBE DROP 15v AT 60ma DC	12A7
12ABGT	HEPTODE	HTR	12.6	.15	8A-OW8	9F				OSC MIXER	CHARACTERISTICS SAME AS FOR TYPE 6ABGT											12ABGT		
12B7	PENTODE	HTR	12.6	.15	9V-L8	9A	.005*	5.5*	7.0*	AMPLIFIER CLASS A	250 100	-3	100 100	9.2 8.9	2.4 2.6		.8 MEG .25MEG	2000 1900				-35	12B7	
12B8GT	TRIODE PENTODE	HTR	12.6	.3	8T-00T8	9L				AMP TRIODE CLASS A AMP PENT CLASS A	100 90 100	-1 0 -3	100 90 90	0.6 2.5 2		110 90 360	73000 37000 2100	1500 2400 2100				-2.5 -2.6 -42.5	12B8GT	
12C8	DUO-DI	HTR	12.6	.15	8E-OW7	9F	.005	6	9	AMPLIFIER CLASS A	250 250	-3 -3	125 100	2.3 6.8	2.3 1.5		.6 MEG .8 MEG	1325 1150				-21 -17	12C8	
12F5GT	TRIODE	HTR	12.6	.15	5V-OW5	9F				AMP CL A	CHARACTERISTICS SAME AS FOR TYPE 6F5GT											12F5GT		
12J5GT	TRIODE	HTR	12.6	.15	6Q-OW6	9E				AMP CL A	CHARACTERISTICS SAME AS TYPE 6J5GT											12J5GT		

Fig. 98. Vacuum tube data chart.

Vacuum Tubes.

TYPE	DESIGN	CATHODE NTR OR FIL	FIL VOLTS	FIL AMPS	BASING DATA	MAX SIZE VIEW	CAPACITIES			USED AS	PLATE VOLTS	GRID VOLTS	SCR VOLTS	PLATE MA	SCR MA	AMP FACT	PLATE RES OHMS	MUT COND μMHO	OUT PUT WATTS	LOAD RESIS OHMS	CUT OFF VOLTS	TYPE
							C-P μFDS	IN μFDS	OUT μFDS													
12J7GT	PENTODE	HTR	12.6	.15	7R-0W7	9F				AMP CL A	CHARACTERISTICS SAME AS FOR TYPE 6J7GT										12J7GT	
12K7GT	PENTODE	HTR	12.6	.15	7R-0W7	9F				AMP CL A	CHARACTERISTICS SAME AS FOR TYPE 6K7GT										12K7GT	
12Q7GT	DUO-DI TRIODE	HTR	12.6	.15	7V-0W7	9F				AMP CL A	CHARACTERISTICS SAME AS FOR TYPE 6Q7GT										12Q7GT	
12SA7 12SA7GT	HEPTODE	HTR	12.6	.15	8R-0W6 8AD-0W6	8E	.13*	9.5*	12*	OSC-MIXER	CHARACTERISTICS SAME AS FOR TYPE 6SA7										12SA7 12SA7GT	
12SC7	TWIN TRI	HTR	12.6	.15	8S-0W6	8E				AMP CL A	CHARACTERISTICS SAME AS FOR TYPE 6SC7										12SC7	
12SF5GT	TRIODE	HTR	12.6	.15	6AB-00T6	8H				AMP CL A	CHARACTERISTICS SAME AS FOR TYPE 6SF5GT										12SF5GT	
12SJ7 12SJ7GT	PENTODE	HTR	12.6	.15	8N-0W6 8N-0W6	8E	.005	6.0	7.0	AMPLIFIER CLASS A	CHARACTERISTICS SAME AS FOR TYPE 6SJ7										12SJ7 12SJ7GT	
12SK7 12SK7GT	PENTODE	HTR	12.6	.15	8N-0W6 8N-0W6	8E	.005	6.0	7.0	AMPLIFIER CLASS A	CHARACTERISTICS SAME AS FOR TYPE 6SK7										12SK7 12SK7GT	
12SQ7 12SQ7GT	DUO-DI TRIODE	HTR	12.6	.15	9Q-0W6 9Q-00T6	8E	1.8	4.2	3.4	AMPLIFIER CLASS A	CHARACTERISTICS SAME AS FOR TYPE 6SQ7										12SQ7 12SQ7GT	
12Z3	DIODE	HTR	12.6	.3	40-SS4	12B				H W RECT	235 RMS MAX	55 DC MAX	TUBE DROP 17v AT 110ma DC									12Z3
15	PENTODE	HTR	2.0	.22	5F-SS5	12E	.01*	2.4	7.8	AMPLIFIER CLASS A	135 67.5	-1.5 -1.5	67.5 67.5	1.85 1.85	0.3 .3	600 450	.8 MEG .63MEG	750 710				15
19	TWIN TR	FIL	2.0	.26	6C-SS6	12B				CL B 2 SECT	CHARACTERISTICS SAME AS FOR TYPE 1J6G										19	
20	TRIODE	FIL	3.3	.132	4D-SS4	9Q	4.1	2.0	2.3	FR AMP CL A	135	-22.5		6.5		3.3	6300	525	.11	6500		20
22	TETRODE	FIL	3.3	.132	4K-SM4	14E	.02*	4.0	10	AMP CL A	135	-1.5	67.5	5.7	1.3		.33MEG	500				22
24A 24B	TETRODE	HTR	2.5	1.75	5E-SM5 5E-SM5	14E	.007*	5.3	10.5	AMPLIFIER CLASS A	250 180	-3 -3	90 90	4 4	1.7 1.7	630 460	.6 MEG .4 MEG	1050 1000				24A 24B
25A6 25A6G 25A6GT	PENTODE	HTR	25	.3	7S-0W7 7S-0M7 7S-0W7	8H 14C 9F				AMPLIFIER CLASS A	160 135 95	-18 -20 -15	120 135 95	33 37 20	6.5 8 4		42000 35000 45000	2375 2450 2000	2.2 2.0 0.9	5000 4000 4500		25A6 25A6G 25A6GT
25A7G 25A7GT	DIODE PENTODE	HTR	25	.3	8P-0W6 8P-00T6	14C 9H				H W RECT AMP CL A	125 RMS MAX 100	-15	100	75 DC MAX 20.5	4	90	50000	1800	.77	4500		25A7G 25A7GT
25AC5G	TRIODE	HTR	25	.3	6Q-0S6	12K				6AE5G DRIVER DIR C'P'D AMP	110 FROM DRIVER		45						2	2000		25AC5G
25B6G	PENTODE	HTR	25	.3	7S-0M7	14C				POWER AMP CLASS A	200 135 105	-23 -22 -16	135 135 105	62 61 48	1.8 2.5 2.0		18000 15000 15500	5000 4800	7.1 4.3 2.4	2500 1700 1700		25B6G
25B9GT	TRIODE PENTODE	HTR	25	.15	8T-00T6	9L				CL A TRIODE CL A PENT	100 100	-1 -3	100	0.6 7.5	2.0	113 .08MEG .19MEG	1500 2000				-2.5 -41	25B9GT
25C6B	EM PWR	HTR	25	.3	7AD-0M7	14C				FR AMP CL A	CHARACTERISTICS SAME AS FOR TYPE 6Y6G										25C6B	
25L6 25L6G 25L6GT	BEAM PWR AMP	HTR	25	.3	7AC-0W7 7AC-0M7 7AC-00T7	8H 14C 9H				POWER AMP CLASS A	110	-7.5	110	49	4	82	10000	8200	2.2 2.1	2000 1500		25L6 25L6G 25L6GT

TYPE	DESIGN	CATHODE NTR OR FIL	FIL VOLTS	FIL AMPS	BASING DATA	MAX SIZE VIEW	CAPACITIES			USED AS	PLATE VOLTS	GRID VOLTS	SCR VOLTS	PLATE MA	SCR MA	AMP FACT	PLATE RES OHMS	MUT COND μMHO	OUT PUT WATTS	LOAD RESIS OHMS	CUT OFF VOLTS	TYPE
							C-P μFDS	IN μFDS	OUT μFDS													
25Z5 25Z5G 25Z5GT	TWIN DIODE	HTR	25	.3	6E-SS6 7Q-0W7 7Q-0S7 7Q-00T7	12B 8H 12E 9E				H W RECT V DOUBLER	235 RMS MAX 117 RMS MAX			75 DC MAX 75 DC MAX							TUBE DROP 22v AT 150ma DC	25Z5 25Z5G 25Z5GT
26	TRIODE	FIL	1.5	1.05	4D-SM4	14D	8.1	2.8	2.5	AMP CL A	180	-14.5		6.2	14D	8.3	7300	1140				26
27 27B	TRIODE	HTR	2.5	1.75	5A-SS5 5A-SS5	12B	3.3	3.1	2.3	AMPLIFIER CLASS A	250 135	-21 -13		5.2 4.5	9	9250 9000	975 1000					27 27B
30	TRIODE	FIL	2.0	.06	4D-SS4	12B	6.0	5.0	2.1	AMP CL A BIAS DET	180 180	-13.5 -18		3.1 0.2 WITH NO SIGNAL	9.3	10300	900	(SEE 1H4G ALSO)				30
31	TRIODE	FIL	2.0	.15	4D-SS4	12B	5.7	3.5	2.7	AMPLIFIER CLASS A	180 135	-30 -22.5		12.3 8		3.8 4.100	3600 4100	1050 .185	5700 7000			31
32	TETRODE	FIL	2.0	.06	4K-SM4	14E	.015*	5.3	10.5	AMPLIFIER CLASS A	180 135	-3 -5	67.5 67.5	1.7 1.7	0.4 0.4	780 610	1.2MEG .95MEG	650 640				32
32L7GT	DIODE EM PWR	HTR	32.5	.3	8Z-00T6	9H				H W RECT POWER AMP CLASS A	125 RMS MAX 110 90	-7.5 -7	110 27	40 3 2		15000 17000	8000 4800	1.5 1.0	2500 2600			32L7GT
33	PENTODE	FIL	2.0	.26	5K-SM5	14D				POWER AMP CLASS A	180 135	-18 -13.5	180 135	22 14.5	5 3	90 70	55000 50000	1700 1450	1.4 0.7	8000 7000		33
34	PENTODE	FIL	2.0	.06	4M-SM4	14E	.015*	6.0	11.5	AMPLIFIER CLASS A	180 67.5	-3 -3	67.5 67.5	2.8 2.7	1.0 1.1	620 224	1 MEG 0.4MEG	620 560			-22.5 -22.5	34
35/51 35B/51B	TETRODE	HTR	2.5	1.75	5E-SM5 5E-SM5	14E	.007*	5.3	10.5	AMPLIFIER CLASS A	250 180	-3 -3	90 90	6.5 6.5	2.5 2.5	420 305	0.4MEG 0.3MEG	1050 1020			-42.5 -42.5	35/51 35B/51B
35A5	EM PWR	HTR	35	.15	5AT-L6	9B				FR AMP CL A	110	-7.5	110	35	2.8		25000	5500	1.4	2500		35A5
35L6GT	EM PWR	HTR	35	.15	7AC-00T7	9H				FR AMP CL A	110	-7.5	110	40	3		13800	5800	1.5	2500		35L6GT
35Z3	DIODE	HTR	35	.15	4Z-L6	9B				H W RECT	250 RMS MAX			110 DC MAX							TUBE DROP 22v AT 200ma DC	35Z3
35Z4GT	DIODE	HTR	35	.15	5AA-00T6	9H				H W RECT	125 RMS MAX			110 DC MAX							TUBE DROP 16v AT 200ma DC	35Z4GT
35Z6GT	DIODE	HTR TAP	35 7.5	.15 .15	6AD-00T6	9H				H W RECT LAMP TAP	125 RMS MAX			100 DC MAX OR 60 DC MAX WITH PANEL LAMP								35Z6GT
36	TETRODE	HTR	6.3	.3	5E-SS5	12H	.007*	3.7	9.2	AMP CL A BIAS DET	250 250	-3 -8	90 90	3.2 0.1 WITH NO SIGNAL	1.7 1.55MEG	595	.65MEG	1080				36
37	TRIODE	HTR	6.3	.3	5A-SS5	12B	2.0	3.5	2.9	AMP CL A BIAS DET	250 250	-18 -28		7.5 .2 WITH NO SIGNAL	9.2	8400	1100					37
38	PENTODE	HTR	6.3	.3	5F-SS5	12H	.3	3.5	7.5	POWER AMP CLASS A	250 135	-25 -13.5	250 135	22 9	3.8 1.5	120 .13MEG	1200 925	2.5 0.65	10000 13500			38
38/44	PENTODE	HTR	6.3	.3	5F-SS5	12H	.007*	3.5	10	AMPLIFIER CLASS A	250 90	-3 -3	90 90	5.8 5.8	1.4 1.6	1050 350	1.0MEG .38MEG	1050 950			-42.5 -42.5	38/44
40	TRIODE	FIL	5.0	.25	4D-SM4	14D	8.0	2.8	2.2	AMP CL A	180	-3		0.2		50	.15MEG	200 PL RESISTOR	.25MEG			40
41	PENTODE	HTR	6.3	.4	6B-SS6	12B				FR AMP CL A	CHARACTERISTICS SAME AS FOR TYPE 6K6G										41	

Fig. 99. Vacuum tube data chart.

TYPE	DESIGN	CATHODE TYPE	HTR OR FIL VOLTS	FIL AMPS	BASING DATA	MAX SIZE VIEW	CAPACITIES			USED AS	PLATE VOLTS	GRID VOLTS	SCR VOLTS	PLATE MA	SCR MA	AMP FACT	PLATE RESIS OHMS	MUT COND μMHO	OUT PUT WATTS	LOAD RESIS OHMS	CUT OFF VOLTS	TYPE
							G-P μFDS	IN μFDS	OUT μFDS													
42	PENTODE	HTR	6.3	.7	6B-SM6	14D				POWER AMP	CHARACTERISTICS SAME AS FOR TYPE 6F6G											42
43	PENTODE	HTR	25	.3	6B-SM6	14D				POWER AMP	CHARACTERISTICS SAME AS FOR TYPE 25AGG											43
45	TRIODE	FIL	2.5	1.5	4D-SM4	14D		7	4	3												45
45Z9GT	DIODE	HTR	45	.15	6AD-00T6	9H																45Z9GT
46	DUAL GRID TRIODE	FIL	2.5	1.75	5C-SM5	16B		G2 TIED TO P														46
47	PENTODE	FIL	2.5	1.75	5B-SM5	16B																47
48	PENTODE	HTR	30	.4	6E-SM6	16B																48
49	DUAL GRID TRIODE	FIL	2.0	.12	5C-SM5	14D		G2 TIED TO P														49
50	TRIODE	FIL	7.5	1.25	4D-SM4B	19A		7.1	4.2	3.4												50
50C6G	BM FWR	HTR	50	.15	7AC-0M7	14C																50C6G
50L6GT	BM FWR	HTR	50	.15	7AC-00T7	9H																50L6GT
52	2 GRID TRIODE	FIL	6.3	.3	5C-SM5	14D		G2 TIED TO P														52
53	TWIN TRIODE	HTR	2.5	2.0	7B-SM7	14D																53
55 55B	DUO-DI TRIODE	HTR	2.5	1.0	6G-SS6 6G-SS6	12H		1.5	1.5	4.3												55 55B
56 56B 56AS	TRIODE	HTR	2.5 2.5 6.3	1.0 1.0 .3	5A-SS5 5A-SS5 5A-SS5	12B		3.2	3.2	2.2												56 56B 56AS
57 57B 57AS	PENTODE	HTR	2.5 2.5 6.3	1.0 1.0 .4	6F-SS6 6F-SS6 6F-SS6	12J		.007*	5.0	6.5												57 57B 57AS
58 58B 58AS	PENTODE	HTR	2.5 2.5 6.3	1.0 1.0 .4	6F-SS6 6F-SS6 6F-SS6	12J		.007*	4.7	6.3												58 58B 58AS
59	PENTODE	HTR	2.5	2.0	7A-SM7	16B		G2, G3 TO PL 2 TUBES G3 TO P,														59
70L7GT	DIODE BM FWR	HTR	70	.15	8AA-00T8	9H																70L7GT

TYPE	DESIGN	CATHODE TYPE	HTR OR FIL VOLTS	FIL AMPS	BASING DATA	MAX SIZE VIEW	CAPACITIES			USED AS	PLATE VOLTS	GRID VOLTS	SCR VOLTS	PLATE MA	SCR MA	AMP FACT	PLATE RESIS OHMS	MUT COND μMHO	OUT PUT WATTS	LOAD RESIS OHMS	CUT OFF VOLTS	TYPE
							G-P μFDS	IN μFDS	OUT μFDS													
71A	TRIODE	FIL	5	.25	4D-SM4B	14D				POWER AMP CLASS A	180	-40.5	20	10	3	1750	1700	.79	4800			71A
75 75B	DUO-DI TRIODE	HTR	6.3	.3	6G-SS6 6G-SS6	12H		1.7	1.7	3.8												75 75B
76	TRIODE	HTR	6.3	.3	5A-SS5	12B																76
77	PENTODE	HTR	6.3	.3	6F-SS6	12H		.007*	4.7	11												77
78	PENTODE	HTR	6.3	.3	6F-SS6	12H		.007*	4.5	11												78
79	TWIN TR	HTR	6.3	.6	6H-SS6	12H																79
80	TWIN DI	FIL	5.0	2.0	4C-SM4	14D																80
81	DIODE	FIL	7.5	1.25	4B-SM4	16B																81
82	TWIN DI	FIL	2.5	3.0	4C-SM4	14D																82
83	TWIN DI	FIL	5.0	3.0	4C-SM4	16B																83
83V	TWIN DI	HTR	5.0	2.0	4AD-SM4	14D																83V
84/824	TWIN DI	HTR	6.3	.5	5D-SS5	12B																84/824
85	DUO-DI TRIODE	HTR	6.3	.3	6G-SS6	12H		1.5	1.5	4.3												85
85AS	DUO-DI TRIODE	HTR	6.3	0.3	6G-SS6	12H																85AS
89	PENTODE	HTR	6.3	.4	6F-SS6	12H		G3 TIED TO K														89
V99 X99	TRIODE	FIL	3.3	.063	4E-SV4 4D-SB4	8A 9A		3.3	2.5	2.5												V99 X99
117Z6G 117Z6GT	TWIN DIODE	HTR	117 58.5	.075 .15	7AR-0S7 7AR-00T7	9H 9H																117Z6G 117Z6GT
182B/482B	TRIODE	FIL	5.0	1.25	4D-SM4	14D																182B/482B
183/483	TRIODE	FIL	5.0	1.25	4D-SM4	14D																183/483
488	TRIODE	HTR	3.0	1.25	5A-SS5	12B																488
950	PENTODE	FIL	2.0	.12	5K-SM5	14D																950
1232	PENTODE	HTR	6.3	.45	8V-L8	9A		.007*	9.0*	7.0*												1232

Fig. 100. Vacuum tube data chart.

RADIO RECEIVING CIRCUITS

Now if you have obtained a good general knowledge of radio principles, tuning devices and vacuum tubes as explained in the preceding sections, we are ready to take up common types of radio receiving circuits.

Most radio receivers consist primarily of tuning coils, transformers, tubes, condensers, resistors and connecting wires. These parts are properly mounted on a base or chassis frame, and connected up with wires and then attached to the speaker. Even the most complicated 20 or 30 tube, all wave superheterodyne sets consist of these same parts, except more of each kind of parts are used.

The manner in which these parts are arranged and connected or the type of circuit used is highly important. Some receiving circuits are designed to give maximum volume or power output from a few tubes, while other circuits give better sensitivity and selectivity, or better tone quality, and require more tubes.

While there are many dozens of different receiver circuits in use, the majority of popular radio receivers made today, follow the basic outline of a few common types of circuits, such as the tuned radio frequency (T. R. F.), the superheterodyne (super), the neutrodyne, the regenerative circuits, etc.

These circuits are modified to include power packs, rectifiers, filters, automatic volume control (A. V. C.), automatic frequency control (A. F. C.) all wave switching arrangements, electric tuning indicators, and other special features.

However, if you get a good understanding of the operating principles of the several more common types of circuits you should be able to understand and service most any type of radio receiver. Here is where your knowledge of circuit tracing, obtained from your study of electrical equipment, will prove of great value to you.

One of the simplest forms of vacuum tube radio receivers is the plain single tube detector set, such as shown in Fig. 102.

You have of course learned that any practical radio receiver must at least consist of a detector circuit, to convert the radio frequency energy into audio frequency impulses capable of operating the headphones and making audible sounds. Most sets have several stages of amplification in addition to the detector, as the detector alone can only receive signals from a limited distance, and can usually only supply power enough to operate headphones.

Examine Fig. 102 again and we find that its important parts are the R. F. coupling transformer "A", tuning condenser "B", grid leak and condenser "C", tube "D", rheostat "E", phones "F", bypass condenser "G", and the A and B batteries.

The purpose and function of each of these parts has been generally explained already. It will be

well, however, to bring out certain points more in detail at this time.

The R. F. transformer is used to couple the antenna circuit to the grid circuit of the tube by magnetic induction. Inductive coupling of this type is extensively used in receivers as it gives much sharper tuning than direct conductive coupling. By adjusting the spacing between the primary and secondary coils the sharpness of tuning can be varied. Tuning becomes sharper as the coils are moved farther apart or more loosely coupled, and it becomes broader as the coils are more closely coupled.

Close coupling can be used for receiving very weak signals, and loose coupling for receiving stronger signals and keeping out other undesired signals from near by stations, and also to reduce static and other interference.

R. F. transformers or tuners with variable coupling are made in a number of forms, some with a

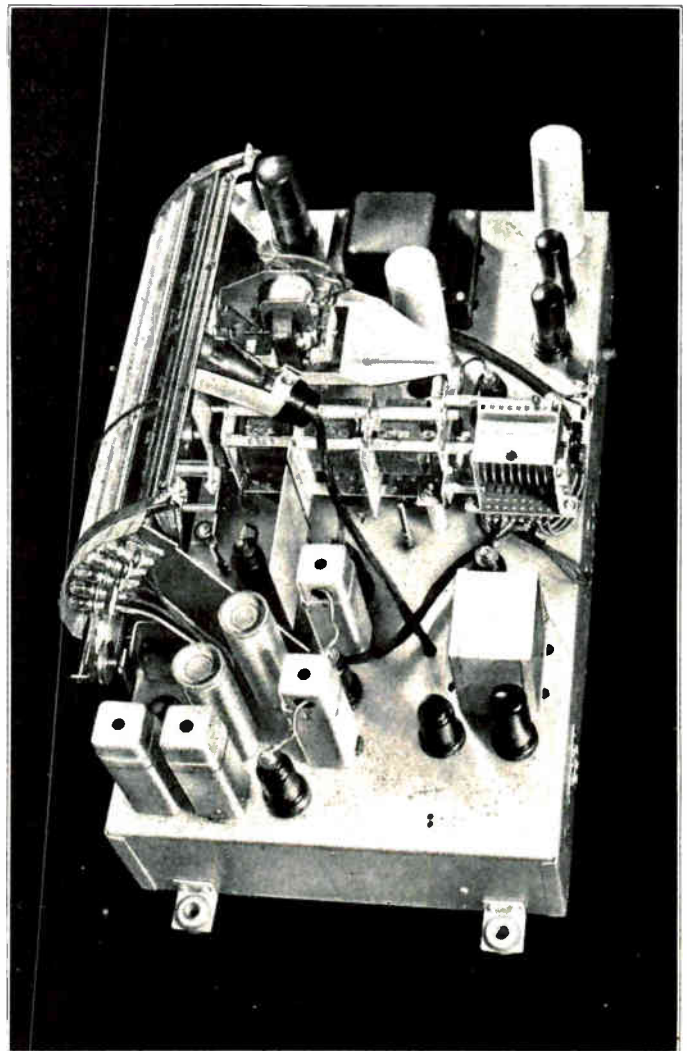

Fig. 101. Chassis of a modern Radio set showing the arrangement of coils, condensers, tubes, and power transformer. (Courtesy R.C.A.)

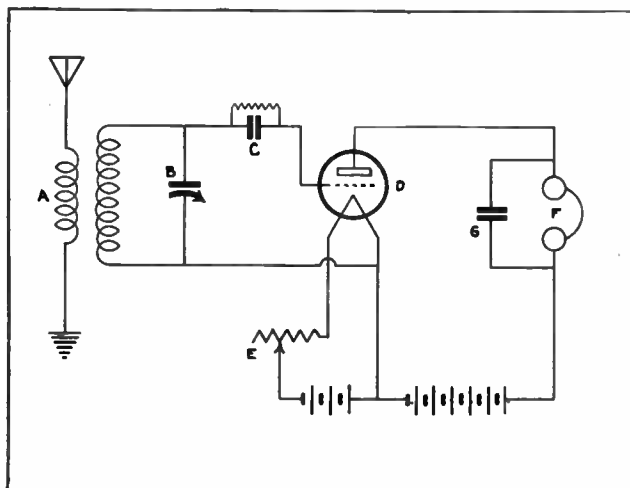

Fig. 102. A simple one tube Radio receiving circuit.

rotating secondary coil and others with a hinged coil, while some have sliding coils. All serve the same general purpose, however.

These coupling transformers also serve to step up the signal voltage applied to the grids of the tubes, as their primary coils are generally wound with fewer turns than the secondaries. Tuning inductances or R. F. transformers for ordinary broadcast wave lengths generally have about 15 to 20 turns of about #28 cotton or silk covered wire on their primaries, and about 45 to 75 turns of #28 on their secondaries.

R. F. transformers are generally constructed in a manner to keep the distributed capacity in the coils at a minimum. This capacity is very undesirable in an inductance because of the losses it causes by the absorption of R. F. energy in the capacity effect. In order to reduce distributed capacity in inductances for radio work they are often wound with the turns spaced apart, or crossed at an angle when in more than one layer.

Many inductance coils of this type are covered over with a layer of insulating varnish which holds the turns in place and prevents moisture and dirt from affecting the insulation and inductance of the coil to such an extent as they often do untreated coils.

On the left in Fig. 103 is shown an adjustable type of R. F. transformer with the primary on the small movable form, and the secondary mounted stationary. With this type of transformer or tuner the coupling can be adjusted or set at the best point for the stations desired. The tuner on the right in this figure will be explained later.

The tuning condenser should be carefully chosen to fit the wave length to be received and to match the inductance of the coils. A variable condenser of about .00035 mfd. is quite commonly used for ordinary broadcast wave lengths.

The grid leak is generally about 1 to 2 megohms and the grid condenser about .00025 M. F. Any good detector tube such as the 01A, 12A or the type 30, with a D. C. operated filament can be used in a battery set of this type. The headphones should be good ones of about 2000 to 3000 ohms resistance or more, and the bypass condenser .002 M. F. The A battery should be from 2 to 6 volts according to the type of tube used, and the rheostat from 10 to 25 ohms according to the filament current required by the tube. The B battery should be from 45 to 90 volts according to the type of tube used. A number of these values can be found in the tube chart, by noting the data given for the tube selected.

A detector of the type shown in Fig. 102 is extremely simple to tune and operate. One good point to keep in mind is to adjust the rheostat to operate the tube at as low filament voltage as possible with good signal strength in the phones. Burning the filament at excessive temperature does not usually improve the signal and sometimes actually makes it weaker, and it also shortens the life of the tube.

77. REGENERATIVE DETECTOR CIRCUITS

Special circuits using regenerative or reflex principles are sometimes used to get maximum results from one tube. This is often a decided advantage in portable receivers, but generally such circuits have some disadvantages such as objectionable oscillation or producing poorer quality signals.

Fig. 104 shows a diagram of a feed-back or regen-

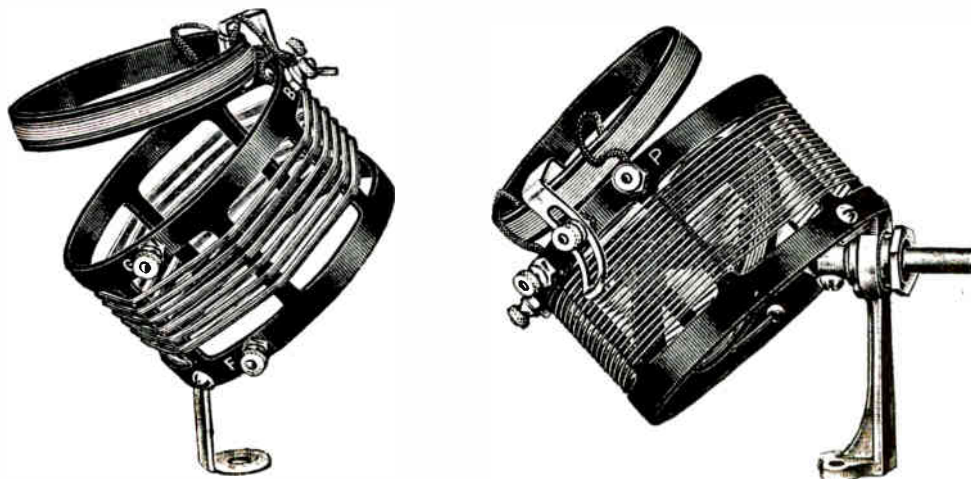

Fig. 103. On the left is shown a tuning coil or antenna coupling transformer with a movable primary for adjusting the coupling. On the right is a three circuit tuner or set of coils used for antenna coupling and regeneration. The small movable coil on the top is the primary, the large stationary coil the secondary, and the inner movable coil the "tickler" or feed back coil.

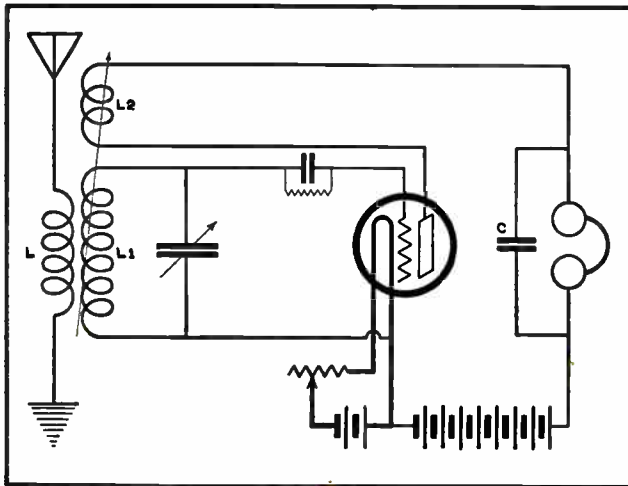

Fig. 104. This diagram shows the circuit of a regenerative detector for obtaining maximum signal strength with one tube. The tuner on the right in Fig. 3 could be used for the coils L, L1 and L2 in this figure.

erative detector circuit, which can be used either in single tube sets or in the detector of a set with amplifier stages.

This circuit makes use of part of the plate current to strengthen the charge on the grid, by induction between a coil L2 in the plate circuit and the grid coil L1. By tracing this circuit you will find that the plate current passes through coil L2.

The radio frequency variations of current which exist in the plate circuit, and which are passed around the phones by the bypass condenser C, set up high frequency flux around coil L2. The strength of this flux varies in proportion to the signal strength on the grid, which causes the pulsations in plate current. This varying flux around coil L2 induces voltage in coil L1 which will aid that induced by the antenna coil L, providing coil L2 is connected with the proper polarity. If this coil is connected wrong its flux will oppose that of coil L1, and the leads of coil L2 should be reversed.

The audio frequency variations in the plate circuit do not affect the grid voltage much by regeneration because the air core R. F. transformer coils L1 and L2 operate most effectively on high frequency. Furthermore, any slight audio frequency which might be induced in the coil L1 cannot pass through the grid condenser as it is too small to pass much energy at low frequency.

As these circuits depend on the R. F. component of the plate current for their regenerative effects the bypass condenser C is very necessary to allow this R. F. energy to flow past the impedance of the phones.

The coil L2 is often called a tickler coil because of its boosting effect on the voltage of coil L1 and the grid circuit. The tickler coil is often arranged so it can be adjusted with respect to coil L1, so the amount of feed-back from the plate to grid circuit can be varied by rotating or moving the tickler closer to or farther from the grid coil. In other cases the tickler coil is fixed or stationary and a variable condenser is connected across it to control regeneration.

On the right in Fig. 103 is shown a 3 circuit tuner for use in regenerative detectors. The primary is the small coil on top, the secondary is the large stationary coil, and the movable tickler coil can be seen inside the secondary.

By using the energy fed back from the plate circuit to strengthen the signal voltages on the grid in this manner, such regenerative circuits give considerably more amplification and will receive weaker signals than a non-regenerative set.

78. OSCILLATION AND HETERODYNING OF REGENERATIVE CIRCUITS

Regenerative circuits are also useful for receiving continuous wave code signals, as these sets can be adjusted to oscillate at a frequency of their own and thus set up an audible beat note with the received C. W. signal.

Beat notes are produced by waves of different frequencies first aiding and then opposing each other at regular intervals and thus setting up a resulting wave of still another frequency, known as the beat note or frequency. This beat note is always of a frequency equal to the difference between the two frequencies used to produce it.

This mixing of two different frequencies to produce a beat note is also called heterodyning.

Fig. 105 illustrates the manner in which a wave of 1,000,000 cycles and one of 999,000 cycles blend together to create a beat note of 1,000 cycles.

You will note that the first waves A and A1 of number 1 and 2 sets of curves are in phase, and unite to make one larger wave A2 in number 3 set of curves. As the waves of the upper two sets progress, however, they get more and more out of phase, until at B and B1 they are in almost exact opposition to each other, or 180 degrees out of phase, and the result shown at B2 is practically zero.

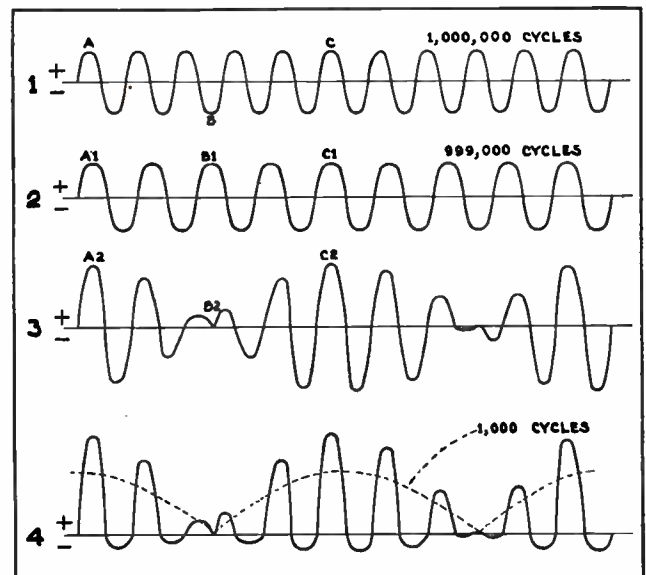

Fig. 105. The above curves illustrate the manner in which energy at two frequencies (1 and 2), can be mixed or heterodyned to produce waves of varying amplitude at 3, which result in a third frequency or beat note as shown by the dotted curve at 4.

Then as the waves come nearer into phase again the resultant wave builds up greater and greater until at C and C1 where the waves of different frequency are again in phase with each other they build up to maximum value in the circuit again as shown at C2, and so on.

When the resulting wave is rectified by detector action of the tube, the result is shown at number 4, and you will note that the average value then produces a low frequency audible beat note, as shown by the dotted curves.

This same beat note principle is also used in superheterodyne receivers which will be explained later.

One of the disadvantages or objections to the use of regenerative receivers is that they often oscillate when not intended to, and set up oscillations in the antenna circuit which transmit continuous waves that heterodyne and interfere with other near by receivers.

79. REFLEX CIRCUITS

Another method of obtaining maximum results and signal strength from one tube, is by the reflex circuit shown in Fig. 106. This circuit makes the vacuum tube do double duty or serve as both an R. F. and A. F. amplifier, and uses a crystal as a detector. Or if desired, another tube can be used as the detector.

Both R. F. and A. F. currents are handled in reflex circuits by providing two paths, one of low impedance to the R. F. currents and one of low impedance to the A. F. currents. Thus the two frequencies can be separated where desired, and again mixed or handled together where desired.

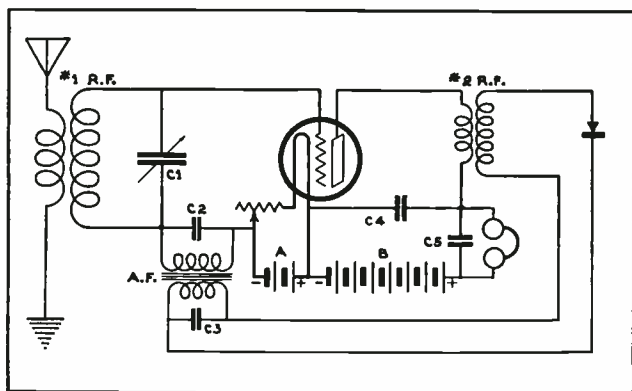

Fig. 106. Circuit diagram of a reflex receiver, in which the one vacuum tube is made to serve both as an R. F. and A. F. amplifier, and a crystal is used as the detector.

We know that high inductances such as coils of iron core transformers or headphones will offer high impedance to R. F. currents, and less impedance to A. F. currents; while condensers offer more impedance to A. F. currents and less impedance to R. F. currents.

With a reflex circuit such as shown in Fig. 106, the R. F. currents in the antenna circuit and primary coil of the first R. F. transformer, induce the R. F. signal energy into the secondary of this transformer, which applies this voltage to the grid of the tube. The grid circuit is completed from this

transformer secondary by a direct connection from the top of the coil to the grid, and from the bottom of the coil through the bypass condenser C2 to the filament rheostat and filament. The condenser C2 is connected across the secondary of the A. F. transformer to pass the R. F. currents around the impedance of the transformer secondary.

The tube acts as an R. F. amplifier to this incoming signal energy, and produces much stronger R. F. impulses in the plate circuit. These amplified

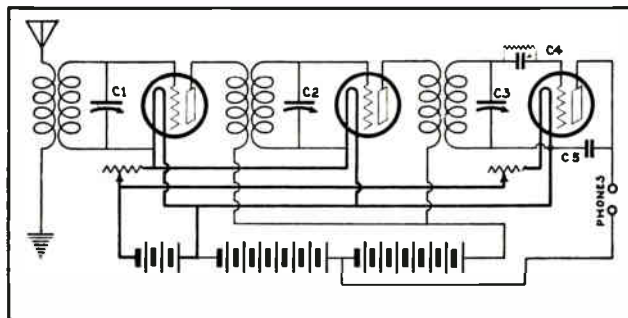

Fig. 107. Circuit diagram of a three tube receiver using two stages of R. F. (radio frequency) amplification and a detector.

R. F. impulses pass from the positive of the B battery through the bypass condenser C5, across the phones, and through the primary of the second R. F. transformer to the plate, returning through the tube and filament to B negative.

These strengthened R. F. impulses through the second R. F. transformer primary, induce still higher voltage in its secondary on account of the step up ratio of the transformer. This energy from the secondary is next passed through the crystal detector and rectified to bring out the audio frequency signal variations or pulsations, and this A. F. energy is passed through the primary of the A. F. transformer. This induces A. F. impulses of still higher voltage in the secondary of this step up transformer, and from the secondary they are again applied to the grid of the tube, which now acts as an audio frequency amplifier.

When these A. F. impulses are thus amplified again due to the grid of the tube controlling much stronger impulses in the plate circuit, this audio frequency plate current now passes through the phones which offer less impedance to the low frequencies than does the small bypass condenser C5.

Even though the R. F. and A. F. impulses are mixed in the tube and both being handled at once, we find this is entirely possible and practical with an ordinary amplifier tube. By use of proper bypass condensers and parts in the circuit, to prevent distortion by passing the R. F. currents around the high impedance devices, and by proper tuning adjustment, fairly clear, strong signals can be obtained with these reflex circuits.

However, reflex circuits are used very little in modern sets because the double duty placed on the tube tends to overload it and make it difficult to obtain the best tone quality in voice and music reproduction. The action in reflex circuits is really quite similar to that of regenerative circuits, except that it is audio frequency energy which is fed back through the tube.

The principles of this circuit are explained to help you understand these receivers in case you might be called on to service one, and also because some of the principles used in separating the high and low frequencies are valuable for the radio man to know.

80. RADIO FREQUENCY AMPLIFICATION

Multiple tube sets of more than 3 tubes generally use both radio frequency and audio frequency amplification. The term radio frequency "R. F." amplification applies to all stages ahead of the detector tubes, as these stages handle and amplify the incoming signal energy at radio frequency. The term audio frequency "A. F." amplification applies to all stages following the detector as these stages handle and amplify the rectified audio frequency energy. Fig. 107 shows a diagram of a receiver using two stages of R. F. amplification and a detector. The circuit is very easy to trace and its operation is simple.

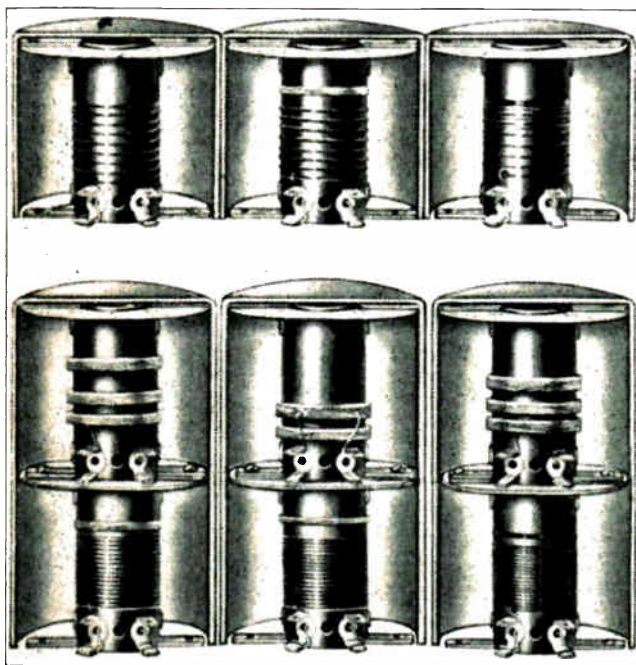

Fig. 108. Several types of R. F. coils or transformers, used for coupling R. F. stages together, or passing the signal energy from the output of one tube to the input of the next.

The R. F. signal energy in the antenna circuit is stepped up in voltage by the first R. F. transformer and applied to the grid of the first amplifier tube. The increased energy in the plate circuit of this tube is passed on through the second R. F. transformer to the grid of the second tube. Here it is further amplified and applied to the grid of the detector tube, which can be easily identified by its grid leak and condenser. From the detector tube the output energy in the plate circuit is applied to the phones, and is very much stronger than if the R. F. stages had not been used.

For example, if the first tube amplifies the signal about 20 times, and the second tube amplifies the output of the first 20 times again, this produces a signal 20×20 or 400 times as strong, without counting any amplification which may take place

in the detector. Another R. F. stage would increase the signal to 20×400 or 8,000 times its original value. More than three stages of R. F. amplification are rarely used because of distortion and losses due to the leakage and capacity coupling between circuits carrying R. F. currents.

R. F. feedback due to this capacity coupling often results in severe oscillation and howling unless it is prevented by neutralizing the circuit as will be explained later, or by use of screen grid tubes and shielding as is done in later type sets.

Screen grid tubes have such low internal capacity that they do not permit any appreciable feed back through them and are therefore excellent for use in R. F. amplifier stages. If stages using screen grid tubes are properly shielded with grounded aluminum or copper partitions around and between them, objectionable feed back, oscillation, and interstage interference, can be almost entirely eliminated.

The R. F. transformers used to couple the stages of radio frequency amplifiers are generally wound with about 15 to 20 turns on the primaries and 50 to 80 turns on the secondaries, or a step up ratio of about 1 to $3\frac{1}{2}$. These windings are usually wound in plain solenoid form on fibre or bakelite tubing, with the primaries and secondaries spaced a small distance apart on the same tubular form, or on two separate forms one within the other. In some cases the coils are coated with a cement like insulating compound which holds the coils in shape so the forms can be removed. Fig. 108 shows several types of R. F. transformers.

Transformers of this type are often called air core transformers and are designed to handle R. F. currents only.

In the circuit in Fig. 107 a variable condenser is connected across the secondary of each of the R. F. transformers to tune each stage to the same frequency, as all R. F. stages should be tuned to the wave length or frequency being received, in order to obtain efficient operation and maximum signal strength.

The rotors of all of these condensers can be connected together on one shaft, or by other mechanical means so that they can be operated by one dial, and thus simplify the tuning controls. In order to do this, however, the circuits of all stages must be accurately matched in inductance and capacity. Small trimming condensers not shown in Fig. 107 are often provided and connected across the main tuning condensers to balance up slight inequalities in the circuits, in an original adjustment when the set is tested and installed. These trimmer condensers are shown by dotted lines in Fig. 109.

One advantage of R. F. amplification is that it amplifies the signals without amplifying so much, certain classes of static, audio frequency interference, and microphonic noises, which are amplified by audio frequency stages.

Note that the amplifier tubes in Fig. 107 both have their filaments controlled by one rheostat, and have full B voltage applied to their plates, while the detector has its separate filament rheostat and a lower voltage plate tap on the B battery.

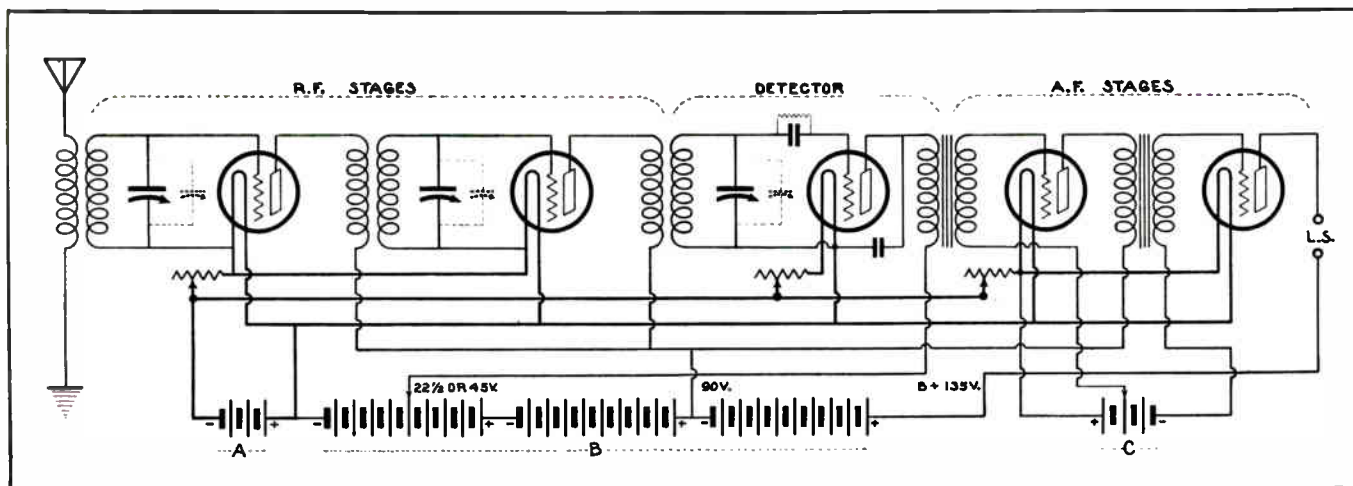

Fig. 109. Circuit diagram of a simple five tube receiver, using two stages of R. F. amplification, a detector, and two stages of A. F. (audio frequency) amplification. Study this circuit carefully, as it illustrates the general arrangement of many common receivers. Carefully trace the coupling circuits from stage to stage, and also the filament and plate circuits of all tubes.

81. AUDIO FREQUENCY AMPLIFICATION

Two stages of audio frequency are very commonly used to further increase the signal energy after it leaves the detector. Fig. 109 shows a diagram of a five tube receiver with two stages of audio frequency amplification in addition to the R. F. stages and detector.

Audio frequency stages use iron core transformers for handling the low frequency pulsating D. C. currents after the detector. The straight lines between the coils in the diagram indicate iron cores in the transformers. These transformers are much more efficient than R. F. transformers, and if properly constructed they will handle the energy from stage to stage with very little distortion. A. F. transformers are wound with several thousand turns on their primaries and secondaries and with ratios of from 1 to 1, up to 1 to 6 or higher. Thus the transformers also aid in increasing the voltage applied to the grids of the tubes. Ratios higher than 1 to 3 1/2 are seldom used, however, as they tend to produce distortion.

Fig. 110 shows an iron core A. F. transformer and Fig. 111 shows how the primary and secondary leads are arranged and marked for proper connection.

Good audio transformers should be designed to amplify as near equally as possible, all audio frequencies from 150 to 5000 cycles, and thus avoid distortion and produce as true reproduction as possible of the words and music. A. F. transformers of course handle frequencies from 20 to 10,000 cycles per second, but most of the notes of voice and music come in the range between 150 and 5000 cycles, so a transformer that handles these frequencies well gives good results.

Good A. F. transformers must have large enough iron cores so that the plate currents they are to handle will not set up sufficient flux to saturate them. When a transformer core is saturated a further increase of current will not produce a proportional flux increase, and thus the output or secondary voltage does not vary in proportion to the primary input, and distortion results.

The primary winding of an A. F. transformer should have an impedance at least equal to that of the plate circuit of the tube to which its primary connects.

As the A. F. stages handle only low frequency currents no tuning condensers are needed. One of the reasons for A. F. transformers being of higher efficiency than R. F. transformers, is that the former use greater numbers of ampere turns in their windings, and low reluctance iron cores. These low reluctance iron cores also confine the flux to the transformer more and prevent so much leakage of stray flux.

There is some leakage of flux around A. F. transformers, however, and to prevent interference from it they can be spaced several inches apart or turned with their cores at right angles to each other. A. F. transformers often have thin metal shields around their cores and windings, and those which do not, have their own shields generally have shielding

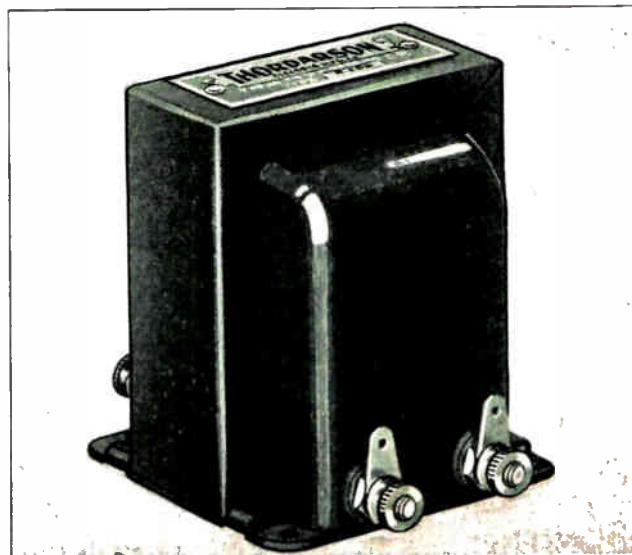

Fig. 110. Photo of a common type of iron-core audio frequency transformer, with a metal case or shield enclosing the core and coils. Transformers of this type are used for coupling between A. F. amplified stages. (Photo courtesy of Thordarson Electric Mfg. Co.)

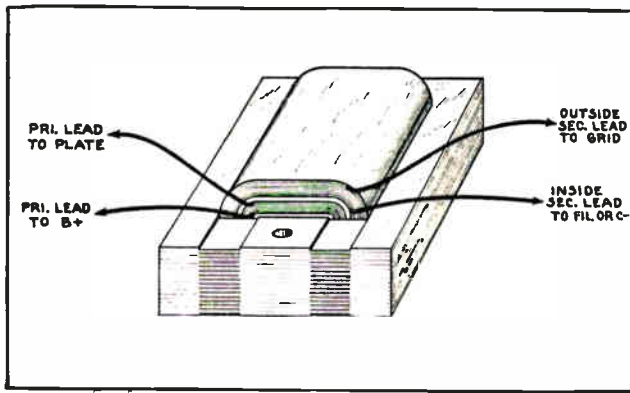

Fig. 111. This sketch shows the common arrangement of the primary and secondary coils and leads of A. F. transformers, and also shows the manner in which these leads should connect to the other devices in the circuit.

placed between them in the set to minimize inductive interference.

It is possible to obtain an increase of 400 times in signal strength with the amplification of the tubes and step up ratios of the transformers in two stages of A. F. amplification.

The arrangement of the audio frequency amplifier stages shown in Fig. 109 is known as a **cascade connection**, because of the manner in which the energy passes on through one stage after another.

More than two stages of A. F. amplification are seldom used on account of increasing distortion with greater numbers of stages.

82. A. F. TRANSFORMER AND AMPLIFIER CONNECTIONS

In Fig. 111 you will note that the outer lead on the secondary coil is marked for connection to the grid of the tube which this secondary feeds. It is very important to get this proper lead connected to the grid, because the inner lead is closer to the grounded transformer core and thus is more closely coupled to the core and ground by capacity. As the grid of a tube is fundamentally a voltage operated device, we should use the transformer lead which is farthest removed and at highest potential from ground. This lead to the grid should also be kept as short as possible.

The other secondary lead should connect to the filament terminal or to the negative terminal of the C battery when one is used. Note the C battery connections to the grids of the two tubes in the A. F. stages in Fig. 109. The primary terminals are connected to the plate of the tube and to the positive terminal to the B battery respectively.

The primary and secondary leads of A. F. transformers are often marked "P" for plate connection, "G" for grid connection, "B+" for plate battery of power supply lead, and "F" for filament, to make it convenient to connect them properly.

In Fig. 109 you will note again that the detector tube is supplied with lower plate voltage than the amplifier tubes, in order not to overload the detector tube and cause distortion. You will recall that the use of proper voltage on the detector, works it at the proper point on its plate current curve to give maximum rectification and best detector action. In some later type sets, however, a form of detection called **power detection** is used, and higher voltages

are used on the detector tubes by using the proper negative bias on the grid. This bias is obtained from a "C" battery or from the voltage drop in a resistor in the circuit, as explained in an earlier lesson.

In Fig. 109 you will note that the plates of R. F. amplifier tubes use voltage somewhat higher than that on the detector tube, and that the A. F. tubes can use still higher voltage without overloading, because of the C battery negative bias used on their grids. The proper plate voltages and grid bias voltages for various detector and amplifier tubes are given in the tube characteristics chart in section 2.

83. PUSH PULL AMPLIFICATION

The five tube circuit shown in Fig. 109 will ordinarily give plenty of amplification and power output to operate a loud speaker, on signals from powerful stations or stations not too far distant.

When it is desired to operate a loud speaker with considerable volume it may require more power from the receiver than can be handled without distortion by a single ordinary amplifier tube, such as used in the last stages of the circuit in Fig. 109.

In order to obtain increased volume and improved quality two amplifier tubes can be connected in a parallel arrangement in the last stage, as shown in Fig. 113. This arrangement is called a **Push-Pull amplifier connection**.

By examining Fig. 113 you will find that a push-pull amplifier stage makes use of audio frequency transformers with center taps on their windings. The secondary of the input transformer feeding the push-pull tubes is tapped, and the primary of the output transformer which couples the set to the loud speaker is tapped. The center tap on the secondary of transformer number two connects to

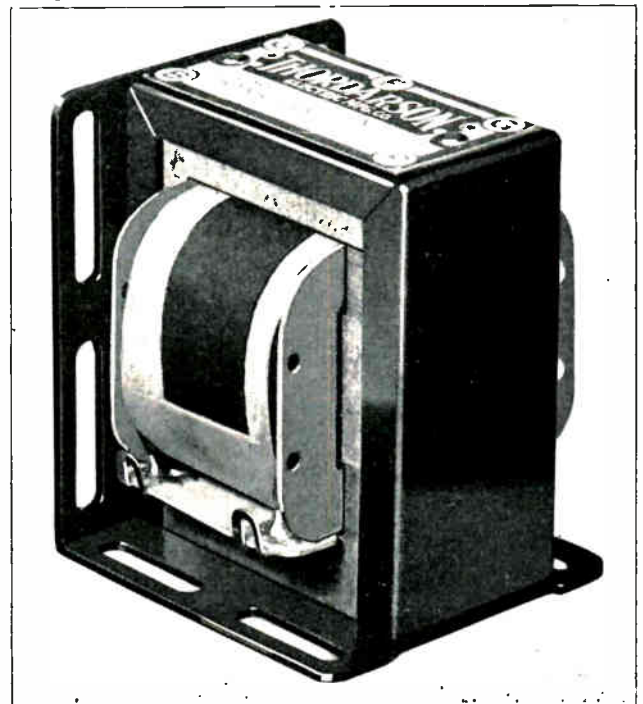

Fig. 112. Audio frequency transformer with sides of metal shield removed to show insulation around coils. This unit is equipped with brackets and slots for convenient mounting either on a horizontal or vertical panel. (Photo courtesy of Thordarson Electric Mfg. Co.)

the filaments of both tubes, providing a filament return circuit for both grids which are connected to opposite ends of this transformer secondary. A "C" battery can be connected in the grid return lead at X to bias the grids if desired.

With the grids connected in this manner, when alternating voltage is induced in the secondary of number two transformer, first one grid is positive and the other negative, and then the other grid becomes positive and the first one negative. Thus each tube handles one half of every cycle, or handles every other alternation.

The positive lead from the "B" battery connects to the center tap of the output transformer primary, and the ends of this split primary connect to the plates of the tubes as shown.

With the grid of first one tube and then the other becoming negative at alternate intervals, the "B" battery feeds current first to one plate and then the other, thus supplying two full plate current impulses to the primary of the output transformer during each cycle. These alternate impulses are in opposite directions through the two halves of the split primary, however, and thus cause a much greater voltage and flux change in this winding than the mere rise and fall of the plate current of a single

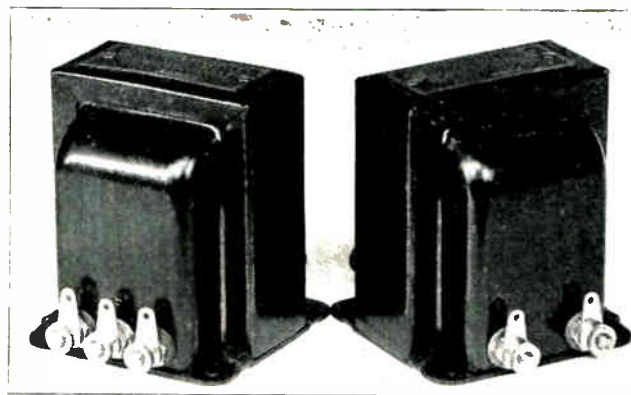

Fig. 114. Photo showing opposite sides of two push-pull A. F. transformers. Note the three terminals on the side with the center-tapped coil. (Photo courtesy of Thordarson Electric Mfg. Co.)

Fig. 115 shows a photo of a complete audio frequency amplifier for using two number 210 power tubes in push-pull in the last stage, fed by a 227. The 281 sockets are for half-wave rectifier tubes for the power unit. Note the push-pull transformers on the right near the panel or terminal board, and the smaller A. F. transformers to the left.

The sockets and wiring can be clearly seen in this photo, and you will also note the power supply transformer, condenser and choke coil, which will be explained a little later.

84. POWER AMPLIFICATION

We have already referred to the use of power tubes where great volume of sound is desired from loud speakers, and some of the figures in the section on vacuum tubes showed tubes of this type. The chart on tube characteristics in section 2 also gives the complete data on various power tubes. Power amplification simply means using power tubes of the proper size in the final stage or stages of audio frequency amplifiers. The circuits and connections are practically the same as those of the straight audio or cascade, and push-pull amplifiers already shown, except that higher plate voltages and negative grid bias voltages are used on the power tubes. The voltage and current required by their filaments is also greater, so separate filament resistors are used for power tubes.

Even where the sound volume requirements of a receiver or amplifier are not so great, one stage of moderate power amplification is often used to provide plenty of undistorted power to faithfully reproduce all notes of voice and music, and thus obtain much better tone quality in the reproduced sound.

The heavy bass notes of music require much more energy to fully reproduce with a loud speaker diaphragm than the higher pitched notes do, and the recent development of power tubes and amplifiers has greatly improved the tone quality of radio sets and speech amplification equipment such as used in talking picture installation and public address systems.

As a comparison of the greater amount of power available from power tubes, the ordinary 201-A or 301-A tube has a maximum undistorted plate power output of about 55 milli-watts, as compared with 5 to 8 watts output for some of the modern power tubes. This you will note is about 145 times as

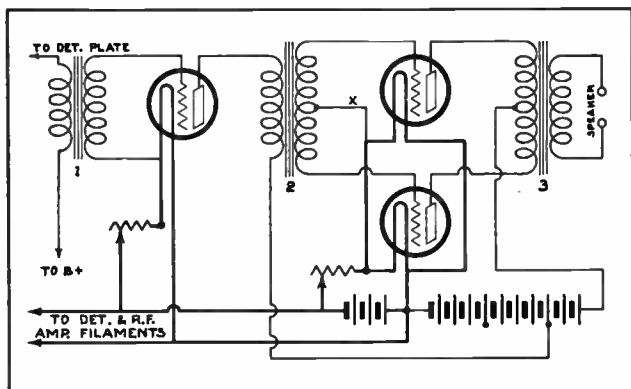

Fig. 113. Diagram showing the connections of a push-pull amplifier, using two tubes in the last stage, to increase the volume and improve the quality of the set.

tube would. Thus the output of both tubes is combined in the primary of the output transformer to deliver greatly increased energy from its secondary to the loud speaker.

Two stages of push-pull amplification, often called double push-pull, are sometimes used, and in such circuits a push-pull interstage transformer with center taps on both primary and secondary is used.

Push-pull amplification with the small amplifier tubes is not so necessary in some modern receivers because the development of power tubes with much greater output capacity has made it unnecessary. But even power tubes are often connected push-pull in the last one or two stages of heavy duty power amplifiers, used for operating large speakers in public address and theatre installations where great volume is needed to carry the sound throughout a large hall or auditorium.

Fig. 114 is a photo of two push-pull transformers with their opposite sides shown in this view. Note the three terminals from the winding with the center tap.

much power output from the large tube, and you can readily understand what an improvement in tone quality, and increase in sound volume this should make possible.

Fig. 116 shows a complete compact power amplifier designed for use where great volume is required. This amplifier can be connected to the output of an ordinary radio receiver, to a microphone or electric phonograph pick-up, or to the pre-amplifier from the sound head of a talking picture machine, and can be used to amplify the audio frequency energy to a point where it will operate very large speakers and fill a large room or hall with sound.

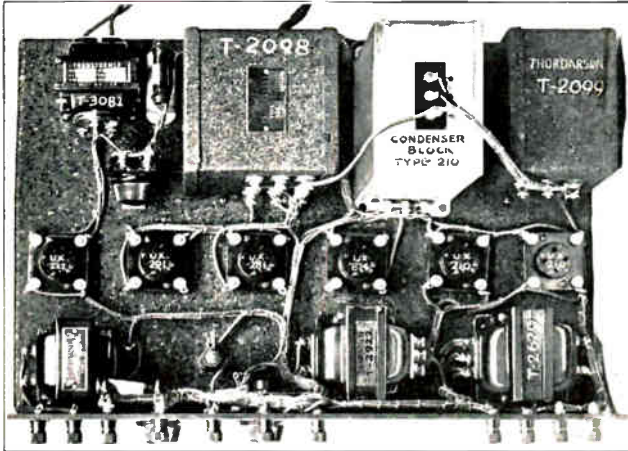

Fig. 115. This photograph shows the wiring and arrangement of parts in a complete power amplifier without the tubes. Two number "210" power tubes are used in push-pull in the last stage of this amplifier. It also contains its own power supply unit. (Photo courtesy of Thordarson Electric Mfg. Co.)

This particular type of amplifier is so constructed that several of them can be connected in parallel to give as great volume as required for most any purpose.

85. VOLUME CONTROL

Where radio sets have considerable reserve capacity it is very desirable to have some form of volume control to prevent excessive sound, or "blasting" of the speaker when receiving nearby stations.

Sometimes the volume is controlled by adjusting the filament rheostat of the detector tube, but this is not such good practice and the detector filament rheostat should only be used to adjust the filament temperature of this tube to a point where the signal is clearest and best. On modern A. C. receivers no detector filament rheostat is provided, but they are in use on some battery operated sets.

When a filament rheostat is used for volume control its principle of operation is easily understood. Increasing the resistance in series with the filament decreases the filament current and temperature, thereby reducing the electron emission and amount of plate current flow.

Some receivers use a potentiometer or variable high resistance of 100,000 ohms or more, connected across the secondary of the first A. F. transformer to control the volume of the set. When the resistance of the potentiometer is reduced it simply shunts part of the energy from the transformer secondary away from the grid of the first A. F. ampli-

fier tube, and thereby reduces the voltage applied to that grid. This in turn reduces the output of that tube and results in less energy and amplification in the remaining stages, and less volume at the speaker.

Some receivers obtain their volume control in the R.F. stages, by use of potentiometers of several hundred thousand ohms resistance, shunted either across the primary of the first R. F. transformer or across the secondary of one or more of the R. F. interstage transformers, as shown at B and C in Fig. 117.

Any of these methods simply cause a loss of part of the signal energy through the potentiometer resistance, and thus reduce the energy in the circuits and stages from that point on throughout the set.

Volume control can also be obtained by varying the amount of negative bias on any of the tubes, by means of an adjustable resistance across the C battery, or by variable voltage taps on the C battery or negative bias supply. See Fig. 117-D.

Some older type receivers use potentiometers in series with the plate circuits of one or more R. F. tubes, to reduce the plate voltages applied to these tubes, and thereby reduce their output. See Fig. 117-E.

A. C. receivers with screen grid tubes frequently use potentiometers in series with the leads from the B battery or D. C. supply to the screen grids of these tubes. Varying the positive potential of these screen grids varies the space charge and electron flow as previously explained, and thereby controls the plate current and power output of the tubes. This method of volume control is illustrated for one tube in the sketch in Fig. 117-F.

It is easy for one with a knowledge of vacuum tube and amplifier principles to understand how any of these methods explained will effect volume control.

Volume control in the R. F. stages or first audio stage is generally considered to be better than in the last audio stages, because if the volume is reduced in the R. F. stages it prevents overloading of the detector and audio amplifier tubes. There is very little possibility of R. F. tubes ever becoming overloaded when supplied with proper voltages, because the signal energy is too small until after it has been amplified by several stages.

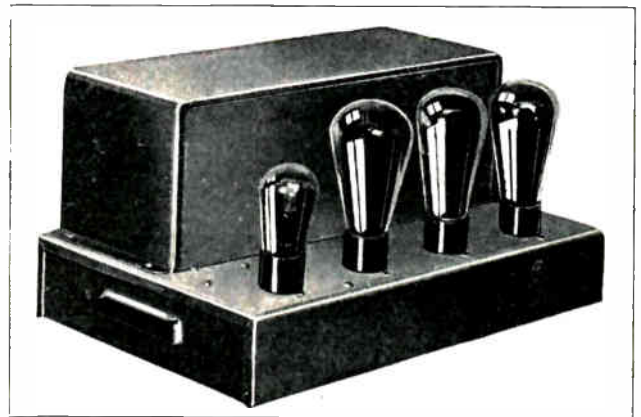

Fig. 116. Photo of a neat and compact power amplifier which can be connected to the output of an ordinary receiver, an electric pickup on a phonograph, or to a microphone of a public address system, and will supply power enough to operate large loudspeakers. (Photo courtesy of Thordarson Electric Mfg. Co.)

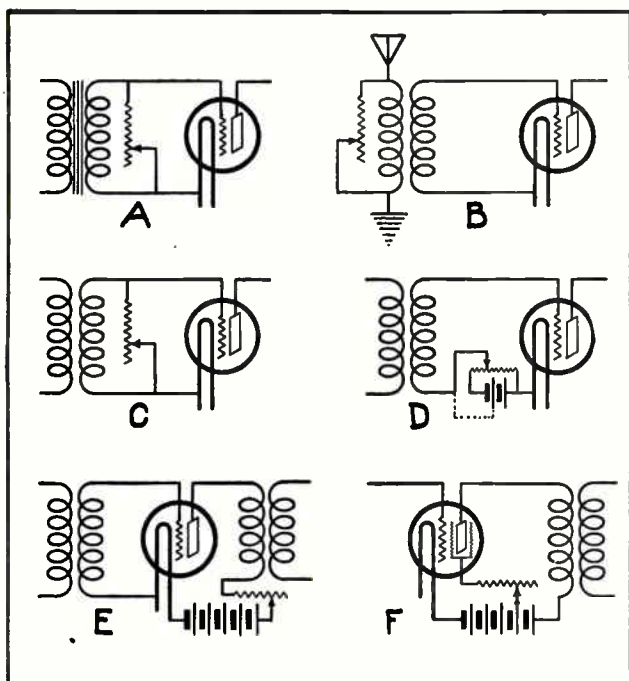

Fig. 117. The above sketches show six different methods of obtaining volume control in the R. F. or A. F. stages of radio receivers and amplifiers.

of maximum plate current during any pulsation or cycle. Therefore, the voltage induced in the secondary and applied to the speaker coil is considerably less than half of the full plate voltage.

Most loud speakers are so designed that they will operate best when used with transformers of a certain impedance, so the impedance of the output transformer should be matched to the design of speaker used. Many loud speakers are built with their coupling transformers attached directly to the speaker base and furnished as a part of the speaker.

Another method of coupling loud speakers to the output of amplifiers is the choke or impedance method illustrated on the right in Fig. 118.

Here a large condenser of 4 to 8 M. F. capacity is connected in series with one lead to the speaker, and the speaker leads then connected across a choke coil which is in series with the plate circuit of the last tube.

The amount of voltage and current supplied to the speaker depends upon the voltage drop across the choke coil and the charging current drawn by the condenser. As the condenser charging current depends upon the voltage drop across the choke coil, and this voltage drop in turn depends on the amount of variation of plate current through the choke, the speaker armature and diaphragm will vibrate in proportion to the plate current pulsations and reproduce the sound accordingly.

Another very important reason for using some form of coupling between the plate circuits of the tubes and certain types of speakers, is to get sufficient impedance in the plate circuits. The impedance of the operating coils in many loud speakers is not enough to make efficient use of the plate circuit energy, but the impedance of the primary of an iron core coupling transformer, or the coil of a coupling impedance can be made high enough to match the impedance of the plate circuit.

Some earlier radio receivers were equipped with switches for cutting out one or more R. F. or A. F. stages, or with jacks to enable the speaker to be plugged in ahead of the last one or two A. F. stages in order to operate at lower volume.

86. MAGNETIC SPEAKER COUPLING

The armature coils of loud speakers are not usually designed to operate on voltages above 180 volts, and as large power tubes are designed to operate with plate voltages from 135 to 450 volts, some form of transformer coupling must be provided to reduce this output voltage to the speaker.

One of the most common forms of loud speaker coupling for magnetic speakers is a simple output transformer or audio transformer of 1 to 1 ratio, connected as shown on the left in Fig. 118.

At first thought it might seem that a 1 to 1 ratio transformer would not reduce the voltage applied to the speaker. However, we can readily see that if the speaker armature were connected directly in the plate circuit in place of the coupling transformer primary, it would have the full 450 volt potential applied to its end attached to the positive B supply lead.

With the speaker connected to the secondary of the output transformer it will only receive that voltage which is induced in the secondary winding. The voltage induced in the secondary of a transformer depends upon the amount of voltage drop across its primary and the rate at which the primary voltage and current change.

Only part of the plate circuit voltage drop occurs across the primary of the output transformer, and the rest occurs in the plate circuit resistance inside the tube. Furthermore, as the plate current is pulsating D. C. and never falls quite to zero as long as the tube is operating, we do not have 100% change

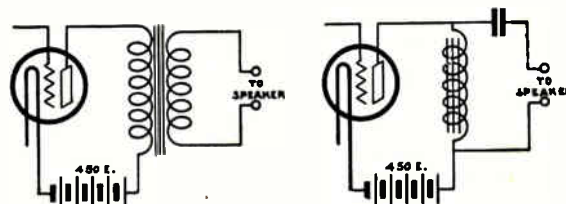

Fig. 118. The sketch on the left shows the transformer method of coupling a loudspeaker to the output or plate circuit of the last tube. On the right is shown the impedance method of speaker coupling.

87. RESISTANCE COUPLED AMPLIFIERS

We have previously discussed the transformer method of coupling the amplifiers to the detector and connecting the various stages of amplification together.

We are now ready to consider another method of coupling where transformers are not used.

This method, known as resistance or impedance coupling, is accomplished by use of condensers and resistors, or condensers and impedance units.

Resistance coupled amplifiers are often used for short wave receivers and in television equipment, and in audio frequency stages of certain receivers where high tone quality and absolute freedom from distortion is desired.

One advantage of resistance coupled amplification is that there are no inductance coils nor iron cores in such circuits to set up magnetic induction or eddy currents, which might cause distortion, and extremely high impedance to the very high frequencies of short wave signals.

Fig. 120 shows a diagram of a detector and three stage resistance coupled amplifier. The R. F. stages are not shown in this diagram. Resistance coupled amplification is not often used in R. F. stages.

The principle of operation of this method of coupling is as follows: When signal energy is applied to the grid of the detector tube in Fig. 120, it causes pulsations or variations in the plate current in the usual manner.

Instead of a transformer primary in this plate circuit we now have a fixed resistance R1, of about 100,000 ohms. You have already learned that the voltage drop through any resistor is proportional to the resistance in ohms and to the current in amperes. The resistance in this case remains constant but as the plate current varies through resistor R1 the voltage drop across it varies proportionately.

This varying voltage drop across resistor R1 causes corresponding variations in the positive voltage applied to the condenser C1, which is connected between the plate of the detector tube and the grid of the first A. F. amplifier tube. The varying positive potential applied to the plate of this condenser which connects to resistor R1 and the plate of the detector, causes a varying negative potential to be induced on its opposite plate which connects to the grid of the first A. F. amplifier tube.

You will recall from an earlier section that when one plate of a condenser has voltage of a certain polarity applied to it, the other plate always takes on an electro-statically induced charge of opposite polarity.

The varying negative potential thus induced on the right hand plate of this condenser C1 is applied

to the grid of the first A. F. amplifier tube. This causes pulsations of increased strength in the plate circuit of that tube and through resistor R3, which in turn changes the voltage applied to condenser C2 and the grid of the next amplifier tube, etc.

The condensers are necessary between the plates and grids of successive tubes to prevent the positive "B" potential from being applied to the grids.

The resistors R2, R4 and R6 are merely grid leak resistors to drain away excessive negative charges which would otherwise be stored up on the grids by the blocking effects of the condensers which are in the normal grid return leads. In transformer coupled sets this negative charge can leak off through the secondaries of the transformers and back to the filaments.

The coupling resistors R1, R3 and R5 are all of the same size and usually of about 100,000 ohms regardless of the number of stages. The leak resistors vary in resistance, however, getting lower as the stages progress and the signal strength and grid voltages increase. For three stages of resistance coupled amplification these leaks are generally of 1 megohm for R2 or the first stage, $\frac{1}{2}$ megohm for R4 or the second stage, and $\frac{1}{4}$ megohm for R6 or the third stage.

The size or capacity of the coupling condenser is not very critical, ranging from .01 to 1.0 mfd., a very commonly used size being the .1 mfd. condenser.

Fig. 121 shows several types of condensers such as are commonly used for coupling purposes and also for bypass and other uses in radio sets. Some of these condensers are made with flat sheets of tin foil and mica pressed together and moulded in bakelite or hard insulating compound, after the alternate foil strips are equipped with projecting terminals or connector lugs which project out through the insulation. Others of these condensers are made with waxed or oiled paper insulation between the

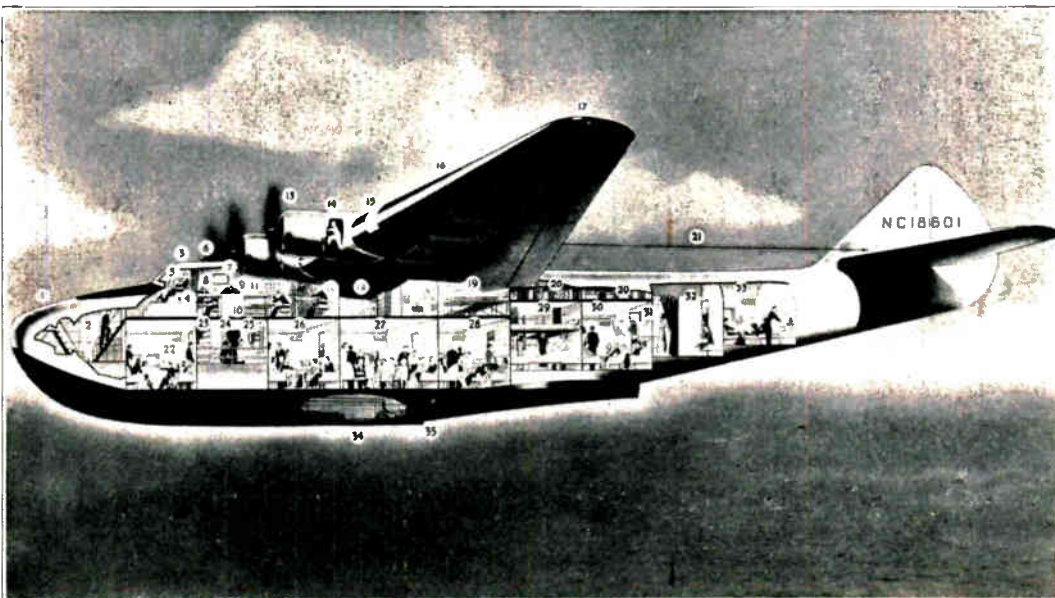

Fig. 119. Large modern planes as shown above are equipped with both Radio receiving and sending equipment. The Radio Direction Finder loop is located at "6," the radio officers post at "8," and the Antenna at "21." (Courtesy Boeing Aircraft Co.)

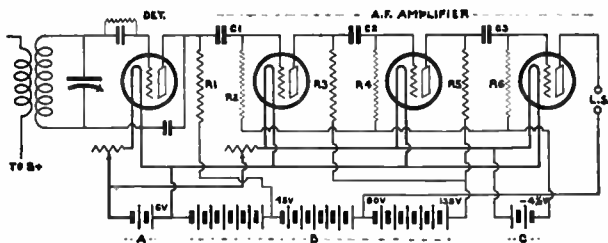

Fig. 120. Circuit diagram of a detector and three-stage resistance coupled amplifier. Carefully study the principles of this circuit with the accompanying explanations.

foil, and are either of flat pressed or rolled construction, and then the entire element enclosed in a moisture proof metal case which is filled with oil or wax.

Fig. 122 shows several types of resistors which are used for coupling resistors in the plate circuits of resistance coupled amplifiers, for grid leaks, and other purposes in radio receivers and amplifiers. Note that most of these resistors are made in a sort of cartridge unit or tubular form for convenient mounting in spring clips in the set. This enables them to be easily and quickly changed or replaced with resistors of different values when necessary. At the lower left in Fig. 122 is shown a base and the spring clips for mounting a single resistor unit, and at the lower right in this same figure two resistor units are shown in the clips of a double unit mounting.

In some cases condensers are equipped with these spring clips attached to them so the resistors and condensers can be mounted and connected as a unit, thus saving space and wire.

On account of the voltage drop in the plate circuit resistors it is necessary to use somewhat higher B battery voltages to get the proper voltage applied to the plates. Resistance coupled amplifiers gen-

erally require about 135 to 150 volts plate supply instead of 67 to 90 as in ordinary transformer coupled amplifiers. One of the disadvantages of resistance coupled amplifiers is their inefficiency due to the losses occurring in the plate circuit resistors.

Where several stages of resistance coupling are used for audio frequency amplification, as in Fig. 120,

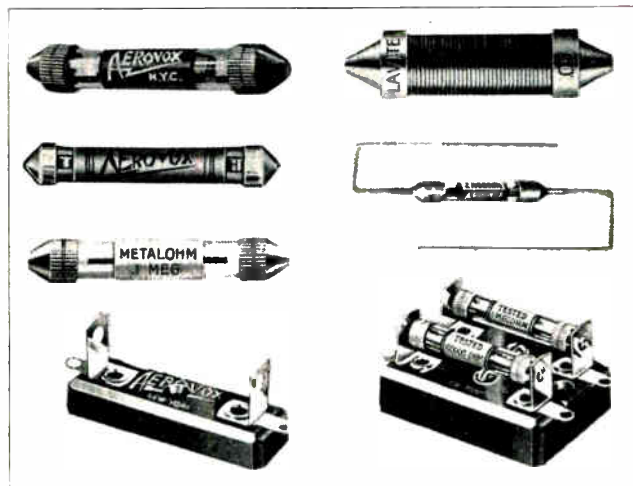

Fig. 122. Photos of several styles of fixed resistor units and mountings, for use in resistance coupled amplifiers, and for grid leaks, and other purposes in radio receivers. (Photo courtesy of Aerovox Wireless Corp.)

the voltage applied to the plate of the last tube is generally somewhat lower than that used on the other stages, as the last stage has no resistor in its plate circuit to cause any voltage drop, and the coils of the loudspeaker have only a small amount of resistance as compared with the regular plate circuit resistors.

Some radio sets use just one or two stages of resistance coupled amplification with one or more stages of transformer coupled amplification. In some cases where little or no R. F. amplification is used, the first stage of A. F. amplification is transformer coupled, because the plate current of the detector tube is likely to be so small on weak signals that it would not cause sufficient voltage drop in a coupling resistor if such were used in the first stage.

88. IMPEDANCE COUPLING

Some amplifiers use impedance coupling which is very similar to resistance coupling except that an impedance or choke coil is used instead of a resistor in the plate circuit of each tube.

If the resistors R1, R3 and R5 in Fig. 2 were replaced by iron core choke coils, we would then have a circuit for a detector and three stage impedance coupled amplifier. The diagram of impedance coupling for loud speakers which was shown on the right in Fig. 118 shows the use of an iron core choke coil or impedance of the type used in impedance coupled amplifiers. These coils are also often called plate reactors.

The coupling condensers and grid leaks in impedance coupled amplifiers are the same as with resistance coupled amplifiers. The operating prin-



Fig. 121. Above are shown several types of fixed condensers used for coupling radio circuits and for bypassing certain frequencies around some of the inductive or high resistance devices in the circuits. (Photo courtesy of Aerovox Wireless Corp.)

ciples of the two types of amplifiers are fundamentally the same. With an impedance or plate reactor of the proper value in the plate circuit of an amplifier tube, the plate current will flow through it quite freely but the varying flux due to plate current pulsations will induce counter E.M.F. in the coil. The voltage drop due to this impedance or counter E.M.F. varies the voltage applied to the coupling condenser and to the grid of the following tube, etc.

In order to develop sufficient voltage drop with the low frequency currents or pulsations in audio frequency stages, the plate reactors or impedance coils must be of the iron core type. In radio frequency stages, however, air core impedance coils can be used and will develop sufficient counter E.M.F. and voltage drop due to the high frequency energy passed through them.

The inductance of the choke coils used in the plate circuit of impedance coupled amplifiers varies from 100 to 300 henries, and their impedance from 20,000 to 60,000 ohms, according to the types of tubes used and their location in the amplifier. The impedance of these coils is generally quite high with respect to that of the plate circuit of the tube, often from 3 to 5 times as high in ohms as the A. C. resistance or impedance of the plate circuit in which the coil is connected.

89. NEURODYNE CIRCUITS AND NEUTRALIZING

In earlier paragraphs we mentioned the necessity of neutralizing or balancing out the capacity between tube electrodes and leads to prevent oscillation and feed back in R. F. stages. There are several different methods of accomplishing this, but they all work on about the same general principle of supplying a small capacity or condenser outside the tube to balance that within the tube itself, and also that of its terminals and wiring.

One of the methods which has been very commonly used in earlier makes of battery operated sets is shown in the R. F. stages of the circuit in Fig. 124 on page 15. This circuit is commonly known as the Neurodyne circuit and was very popular a few years back.

Screen grid tubes have now made neutralizing of this type unnecessary in modern receivers, but there are many neurodyne sets still in use, and it will be well for any radio service man to have an understanding of their principles and adjustment.

In Fig. 124 you will note the two small neutralizing condensers connected from the grid to the output transformer secondary of each R. F. stage. These condensers and the specially tapped secondaries of the R. F. transformers to which they attach are about the only differences between this neurodyne circuit and an ordinary five tube set with two R. F. stages, detector and two stages of audio frequency amplification.

The principle of this neurodyne circuit or of neutralizing undesirable tube capacity in any R. F. amplifier is as follows: First we know that the

feed-back and oscillation troubles which often occur in R. F. stages without screen grid tubes, are caused by energy feeding back through capacity from the plate to the grid. This changes the grid potential, and causes another surge of plate current which again imparts a potential change to the grid by capacity, and thus sets up oscillation or a continuous repetition of this action.

Now if we connect a small external condenser of just the right size, from the plate circuit back to the grid of the same tube, and in such a manner that it will always supply voltage of opposite polarity to that applied to the grid by plate capacity within the tube, the two voltages should balance or neutralize and destroy each other. That is just what happens with the connections shown in Fig. 124 if the condensers NC are of the proper size.

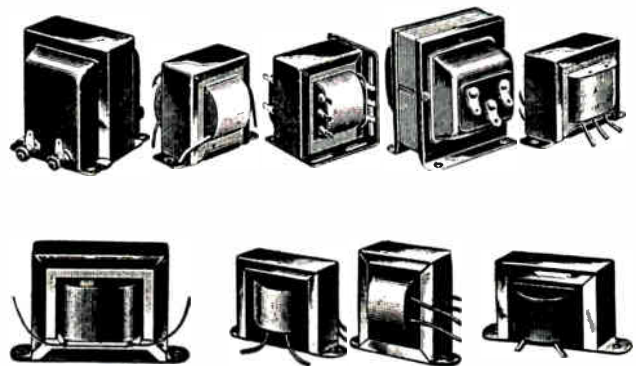

Fig. 123. Several transformers and choke coils such as used for coupling purposes.

One plate of the neutralizing condenser NC connects to the grid of the tube, and the other plate connects to a point on the secondary of the output transformer where it obtains a small voltage of opposite polarity to that supplied to the plate through the primary. Therefore, the charge imparted to the grid through condenser NC is just opposite to that supplied by capacity from the plate, and the two neutralize and cancel each other, thus preventing any change of grid potential from either source and thereby eliminating objectionable oscillation.

Of course the capacity of NC must be just right to balance that between the respective tube elements, and as the capacity of different tubes usually varies a little, these neutralizing condensers are adjustable so they can be set at the proper values to match the tubes they are used with. Their capacity is only very small and generally ranges from one to thirty m.m.f. (micro-microfarads).

These little condensers are of various construction, some being merely two pieces of stiff wire pushed into a fibre or glass insulating tube until their ends nearly meet, and with a metal sleeve placed over the outside of the insulating sleeve. In this type the capacity effect between the wires and the outer metal sleeve creates two small condensers in series. Such neutralizing condensers can be adjusted by sliding the sleeve back and forth on the wire ends, but of course never allowing the wire ends to touch each other.

Some neutralizing condensers consist of two small flat strips of metal separated by insulation, and have a screw adjustment for moving one of these plates closer to or farther from the other. For adjusting this type a screw driver made of bakelite or some such insulating material should be used, in order to avoid the effect of body capacity which would be conveyed through the metal of an ordinary screw driver to the condenser.

Some neutralizing condensers are of the single plate rotary or variable type, made in a very small size known as midget condensers.

90. NEUTRALIZING PROCEDURE

A battery operated neutrodyne may be neutrolyzed without the use of an oscillator, by proceeding as follows. First tune the receiver to some local or nearby station and adjust the tuning dials and rheostats to the point of greatest undistorted volume.

Then remove the first R.F. amplifier tube and wrap a piece of thin but tough waxed tissue paper around its filament prongs, so the filament will not light when the tube is replaced.

With the tube back in place in its socket but with its filament not heated, again adjust the receiver to the point of greatest volume, and the signal now heard will be coming through this tube by capacity coupling.

Next adjust the neutralizing condenser of this tube until the signal disappears or is brought to the lowest volume possible by this adjustment.

Then remove the paper from the tube prongs and put this tube back in service and proceed in the same manner on each of the remaining R.F. tubes.

In some cases it is not possible to make the signals completely disappear when neutralizing a tube, because of inductive and capacity coupling between wiring and parts of the set.

It is more desirable when possible to use a modulated oscillator to excite a receiver during neutralizing adjustments, instead of tuning it to some station. A modulated oscillator is simply a portable oscillator set which is constructed to give off a

continuous wave which is modulated at an audible frequency. When such an oscillator is placed near the antenna of the receiver to be neutralized, the receiver will deliver a note of constant value which is much better than ordinary music when making adjustments on the set.

Instead of wrapping the tube filament prongs with paper, a tube of the same type with one filament prong cut off close to the base is often used to replace the other tubes one at a time while neutralizing each stage.

The potentiometer P in Fig. 124 is connected across the filament supply leads and used to obtain the proper negative bias for the R.F. tubes, by connecting their return leads to the sliding arm of this resistance. A "C" battery is used to get the negative bias for the first audio tube and the power tube in the last stage.

The detector tube in this circuit has a filament rheostat but the filament circuits of all the amplifier tubes are equipped with fixed resistor units called ballast resistors, which are of the proper resistance for each tube.

91. PHONES AND LOUDSPEAKERS

So far we have learned how radio energy is produced, transmitted, received, detected, and amplified. Now in order to reproduce at the receiver the audible sounds which were impressed on the carrier wave at the transmitter, we must use a pair of phones or a loudspeaker. Radio headphones operate on the same general principle as a telephone receiver, and by means of magnetic action on a diaphragm convert the electrical impulses from the amplifier output back into air waves or audible sound.

The construction and operation of telephone receivers have been explained in earlier sections, so we need not go into great detail on those principles here.

Ear phones for use with radio receivers are generally made in pairs and fastened together with a head band as shown in Fig. 125. The two units are connected in series and equipped with a cord with metal tips or plugs for convenient connection to the set.

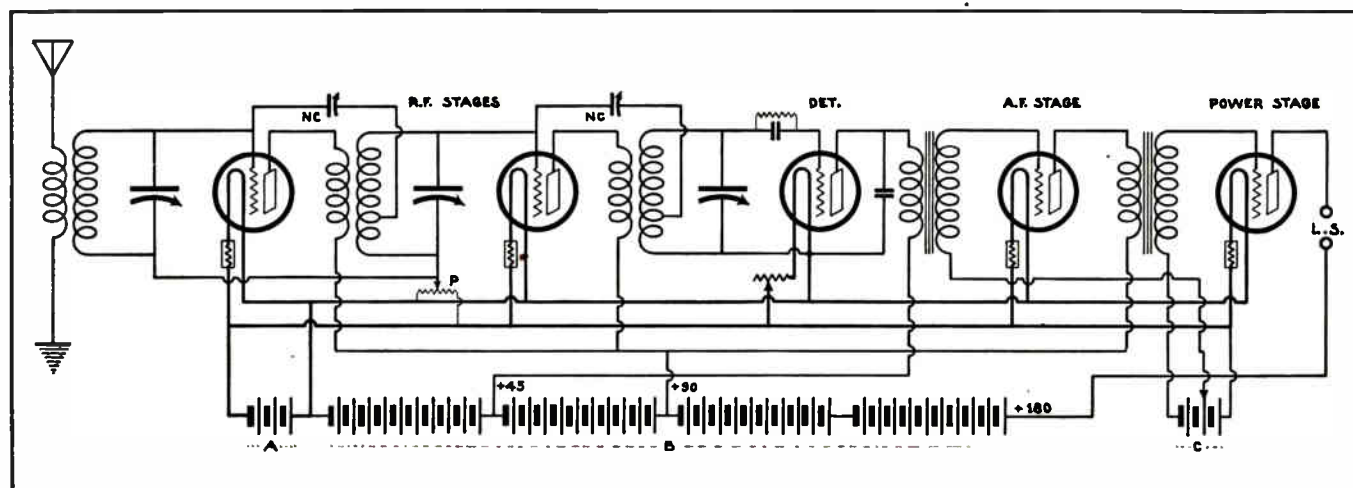

Fig. 124. Circuit diagram of a five tube neutrodyne receiver. Note the two neutralizing condensers N. C. connected across the R. F. amplifier tubes for balancing out the effect of the tube capacity. Also note the tapped secondaries of the special R. F. transformers or "neutroformers," to which one lead from each neutralizing condenser connects.

Ear phones for radio use are made in thin flat units like a telephone operator's head set, and are made as light in weight as possible for comfort to radio operators or testers who may wear them for long periods. The upper view in Fig. 126 shows a head set with the rubber cover and the diaphragm removed from one of the phones to show the magnets and coils inside. The lower view shows a slightly different phone unit for use with small loudspeaker horns.

The coils of the electro-magnets in these phones are usually wound with several thousand turns of very fine enameled copper wire, and good headphone sets have a resistance of 2,000 to 5,000 ohms. The amount of current supplied by radio receivers is very small, so the phone magnets should have a great number of turns to give them as many ampere turns magnetic strength as possible with the small currents which operate them. This is particularly true of phones to be used with crystal



Fig. 125. This photo shows a pair of earphones or headphones as they are often called. Phones of this type are very useful for receiving weak signals that are not strong enough to operate a speaker, and also for testing radio devices and circuits.

receivers and single tube or small low cost receivers, where the phones must be extremely sensitive. It is also desirable to use phones with large numbers of turns on their coils when the phones are to be used with vacuum tube receivers, because if the impedance of the phones is about the same as that of the tube plate circuit, best results will be obtained from the tube.

Most earphones have a ring shaped or horseshoe shaped permanent magnet in the case, and the coils of the electro-magnets are usually placed over the ends or poles of these permanent magnets, as shown in Fig. 127.

In this sketch a sectional view of the ring shaped permanent magnet is shown at P, with the pole pieces N and S attached. The coils C are placed over these pole pieces as shown.

When no current is flowing through the coils the permanent magnet poles hold the thin iron diaphragm slightly attracted as at D. When current is passed through the electro-magnet coils it sets up flux and polarity which either aids or opposes that of the permanent magnets, according to the direc-

tion of current flow. If this current is either A. C. or pulsating D. C. it will cause the diaphragm to vibrate and produce sound waves.

When a pair of phones is connected in the plate circuit of a vacuum tube, a small amount of current (the normal plate current) flows through them all the time the tube filament is lighted. When signal variations are impressed on the grid of the tube the plate current pulsates or decreases and increases, and the pulsating D. C. causes the phone diaphragms to vibrate, as shown by the dotted lines in Fig. 127, and thus reproduce the sound.

When a loudspeaker or phones are connected to the secondary of an output transformer, instead of directly in the plate circuit, the current flowing through them will be alternating, but will also vary in value with the signal variations, so the phone or speaker diaphragm will still vibrate and reproduce the sound.

When handling headphones care should be taken not to allow the diaphragms to become permanently bent or loose. Sometimes a piece of dirt or magnetic material will become lodged between one of the magnet poles and the diaphragm and will interfere with the operation of the phone. The cap can be unscrewed and the diaphragm carefully removed and the dirt cleaned out.

Great care should be used in cleaning or working around the coils as their wires and connections are so fine that they are easily broken. Headphones can be quickly and easily tested for open circuits by connecting them directly across a $1\frac{1}{2}$ volt dry cell. If the circuit is complete a click should be heard in the phones when the connection to the cell is made and broken. Headphones are very useful with small low power receivers, for receiving very weak signals from distant stations, and also for testing receivers. Headphones were used exclusively for radio reception before the development of loud speakers.



Fig. 126. The top photo shows a pair of phones with the cover and diaphragm removed from one to show the magnets, and below is shown an open view of a single large phone unit for use on a speaker horn.

92. LOUDSPEAKERS

Where radio receivers are operated in homes and for entertainment purposes it is usually desired to have the sound spread throughout the room so it can be heard by several people anywhere in the room, without the inconvenience of having to sit near the receiver and wear uncomfortable headphones.

To accomplish this we must use a loudspeaker or special reproducing unit which usually has a larger diaphragm than headphones have. It is not practical to try to use ordinary headphones for this purpose, because even if they were supplied with sufficient power from the output of the receiver, their diaphragms are not large enough to produce the desired volume of sound without distortion and chattering.

Early types of loudspeakers, some of which are still in use with old receivers, merely used a large sized phone unit very similar to the ones just described, except with larger diaphragms. Such units are attached to the base or throat of a large horn. Fig. 128 shows a speaker of this type and also a large phone or reproducing unit without the horn.

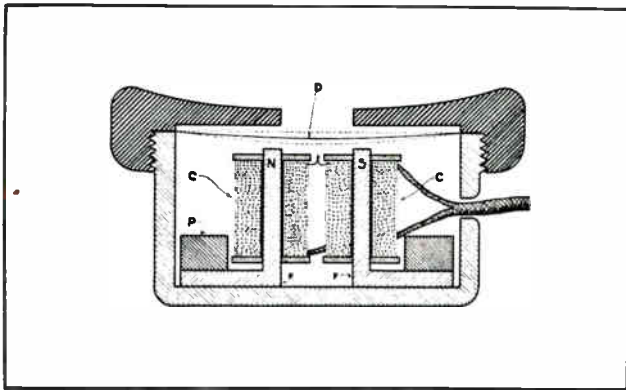

Fig. 127. Sectional sketch showing the construction and operation of an earphone unit. Note the arrangement of the permanent magnet and the electro-magnet coils.

The horn serves to give the diaphragm a better "grip" or control of the larger volume of air necessary to move for the louder sound. Speaker horns are often made of wood, fibre, paper mache or such non-resonant materials, to avoid vibration of the horn, and "tinny" effects such as would be obtained if metal were used.

Another type of loudspeaker reproducing unit known as the balanced armature type, is shown in the larger sketch in Fig. 129. In this type of unit a large horseshoe permanent magnet is used to provide a field in which a small balanced iron armature moves. This armature is pivoted at its center and has a thin rod or stiff wire connecting its end to the diaphragm.

The movable armature has a small light weight coil wound on it, or in some cases around it in solenoid form, but not touching it. In either case this coil is connected to the radio receiver output and when current flows through it in the direction indicated by the arrows, it creates N and S magnetic poles in the armature as shown, causing its right end to swing down and its left end up, because of

the attraction and repulsion of the poles of the horseshoe magnet. If pulsating D. C. or alternating current is passed through this armature coil it will rapidly change the magnetic strength of the armature and cause the armature and diaphragm to vibrate.

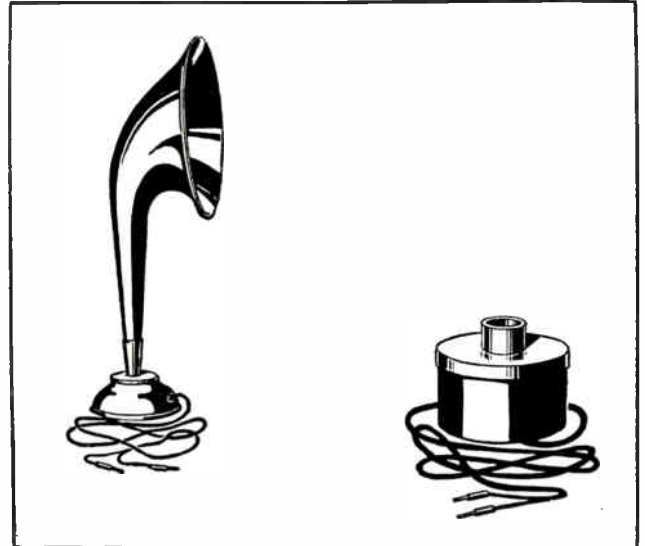

Fig. 128. A simple horn-type loudspeaker is shown on the left, and a reproducer unit similar to a large phone is shown on the right.

In another unit of very similar design the coils are wound on the pole tips of the permanent magnet as shown in the small sketch at B in Fig. 129. Pulsating current through these coils causes certain poles to be strengthened and others to be weakened, and the shifting flux causes the armature core to be vibrated as before.

Another type of speaker unit operating on this principle is constructed as shown at C in Fig. 129 and uses a stationary solenoid coil to induce the magnetic polarity in the iron armature. This relieves the armature of all unnecessary weight and

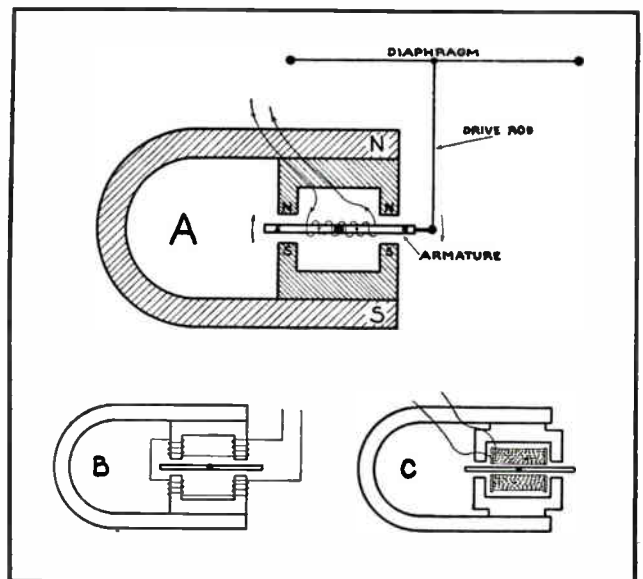

Fig. 129. These sketches show the construction of loudspeaker driving units or reproducers of the balanced armature type.

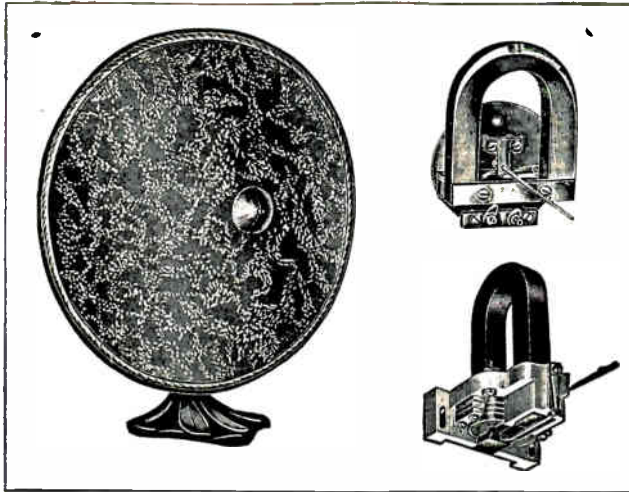

Fig. 130. A cone type speaker is shown on the left in this figure, and on the right are shown two types of driving units or reproducers of the balanced armature type.

eliminates the necessity of having a moving coil, with its possibility of breaking the flexible connections, etc.

The diaphragms used with speaker units of this type do not need to be metal as there is no direct magnetic pull on them so they are generally made of non-magnetic materials.

In one type of speaker called the cone type, the driving rod of the speaker unit is connected to the center of a large cone instead of to a small flat diaphragm. These cones are made of paper, fibre, treated cloth, etc.

Cone speakers are capable of moving large volumes of air and of producing great sound volume with very good tone quality. They reproduce the low frequency bass notes of music much better than the small horn speakers. Fig. 130 shows a cone speaker on the left, and two types of cone speaker reproducing units on the right.

93. DYNAMIC SPEAKERS

One of the best and most popular types of loudspeakers developed in recent years is the dynamic speaker, which is used on the great majority of modern radio receivers. Fig. 131 shows three views of dynamic speakers, and Fig. 132 is a sketch illustrating the construction and operation of this type speaker.

The unit consists essentially of a powerful electro-magnet for producing a magnetic field, and a small cone coil or "voice coil" attached to the apex or point of a stiff paper cone.

The electro-magnet or field magnet is wound with a great number of turns of wire around a heavy iron core. When the unit is in operation the coil of this magnet is excited by D. C. either from the power supply unit of the receiver or from a separate rectifier. The rectifier is usually of the dry copper oxide type, or a rectifier tube, and is often attached directly to the speaker. This direct current sets up a powerful magnetic field around the end of the iron core, and across the turns of the small movable cone coil. Dynamic speaker fields operate on D. C. voltages ranging from 6 volts on auto radios to 250 volts on A. C. receivers for home use.

When pulsating or alternating current from the receiver output is passed through the cone coil, the reaction between the flux of its turns and that of the field magnet exerts a varying force to vibrate the small coil.

As this coil is attached to the cone it causes the cone to vibrate also. The edge of the cone is cemented to a flexible soft leather or buckskin ring or edging, which in turn is fastened to the frame ring of the unit. See the lower view in Fig. 131.

The cones are often ribbed or corrugated as shown in the two upper views in Fig. 131. The rectifier units can be seen attached to these two speakers.

The large coil of a dynamic speaker not only serves as a field coil, but also acts as a very effective filter choke to smooth out the ripple in the D. C. from the rectifier. When these units are built into a radio receiver, this coil often serves as one of the choke coils in the power pack filter. When used with a separate rectifier of its own, the speaker is equipped with filter condensers connected across its own field coil to filter out the pulsations of the rectified D. C. Fig. 133 shows a dynamic speaker with its field coil connected in series with the B— return lead of the power unit, and serving as one of the filter chokes.

The voice coil or cone coil is connected to the secondary of the output transformer from the power tube of the receiver. The balance of the receiver is not shown.

94. VOICE COILS AND HUM BUCKING COILS

The voice coils of dynamic speakers consist of only a few turns of wire, in some cases only one

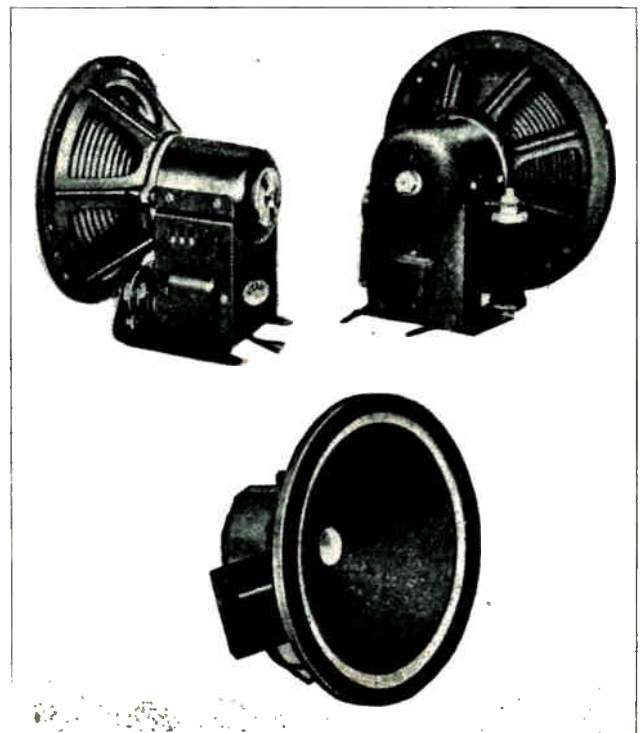

Fig. 131. This photo shows several views of dynamic speakers such as are very commonly used with modern radio receivers.

turn, and therefore have very low impedance of somewhere between one ohm and thirty ohms, the average limits being from two to six ohms. In order to effectively transfer the energy from the high impedance plate circuit of a vacuum tube to the voice coil, it is necessary that a step down transformer be used. This is really a device to match impedances, giving a good transfer of audio frequency

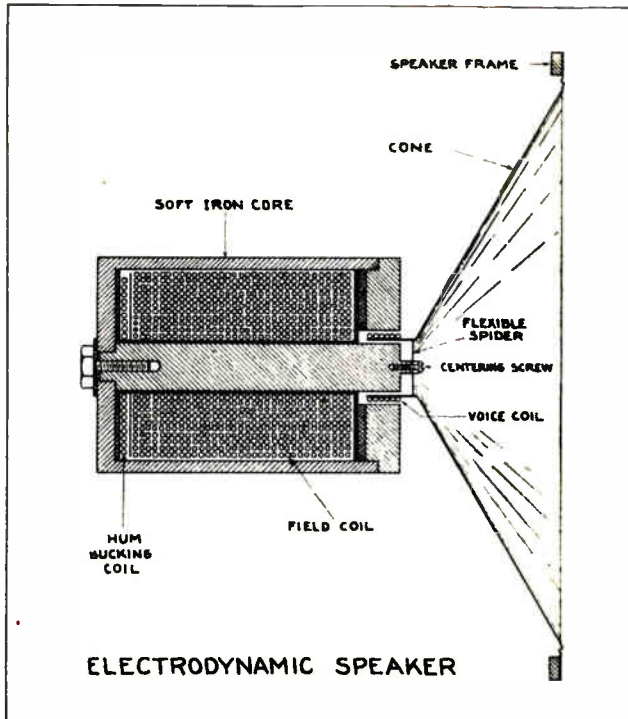

Fig. 132. This sketch shows the construction of a dynamic speaker. Note the large field coil, the small voice coil, the core, cone, etc.

energy with least distortion. The connection of such a transformer can be seen in Fig. 134. Here also is shown a hum bucking coil as found on some types of speakers.

In cases where the speaker field coil is used as a choke in the filtering system of the power pack, there may be a slight pulsation of the D. C. thru this coil, setting up a small A. C. voltage in the voice coil. This will cause a steady hum to be heard from the speaker. The hum bucking coil, consisting of a few turns of wire, is placed next to the field coil as shown on the left in Fig. 14, and has induced in it a small A. C. voltage equal to that existing in the voice coil. By use of a series connection with the voice coil and transformer secondary the A. C. from the hum bucking coil is made to buck out or neutralize the A. C. in the voice coil, thereby eliminating the speaker hum. See Fig. 134.

One type of dynamic speaker has no field coil, a permanent magnet being used to furnish the magnetic field. This type is used to advantage in battery operated sets, where the additional current required by a field coil is a major factor.

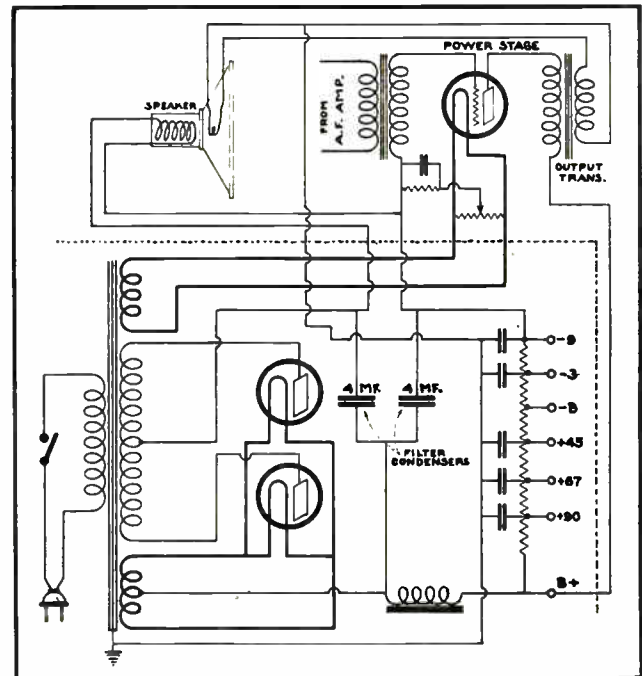

Fig. 133. Diagram of a power supply unit, dynamic speaker, and the last stage of power amplification of a receiver. Note that the field coil of the speaker is connected in series with the negative lead of the D. C. plate supply and serves as one of the filter chokes. Also note the connection of the cone coil, or "voice coil," to the secondary of the output or speaker coupling transformer.

For the reproduction of the extreme upper range of audio frequencies, in high fidelity sound, an additional speaker is often used and is known as a "tweeter". Such a unit is helpful, due to the fact that the average speaker reproduces more efficiently the lower and middle range of frequencies. One very popular type of "tweeter" is known as the crystal speaker. It employs the principle of operation that certain crystals when subjected to an electrostatic field change their shape slightly. This crystal motion is transferred to a diaphragm mounted at the small end of a bell shaped horn, for most efficient radiation of the sound waves.

95. SPEAKER Baffles

In order to more faithfully reproduce the low notes, the dynamic speaker is generally mounted on a baffle. This may consist of a large piece of non-

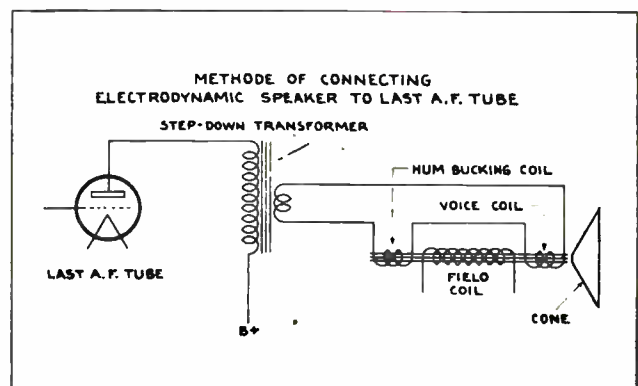

Fig. 134. This figure shows a dynamic speaker connected to the last stage of a Radio receiver. Note how the hum bucking coil is connected in series with the voice coil.

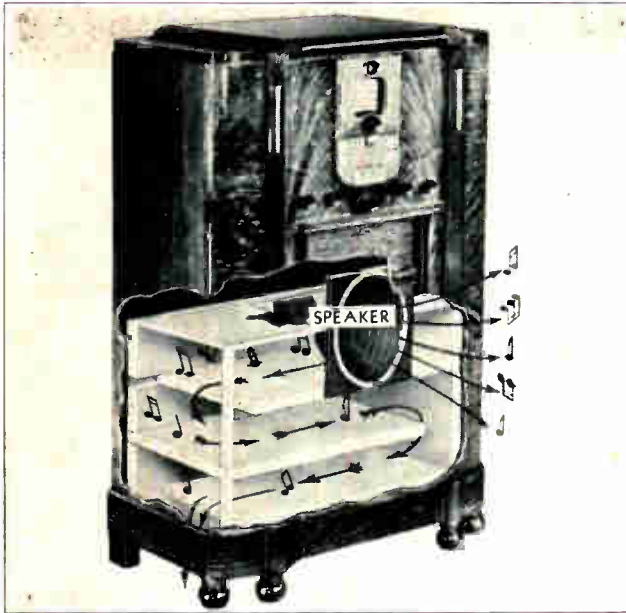

Fig. 135. Console Radio Cabinet equipped with extra built-in baffle boards to increase the distance between the back and the front of the speaker. (Courtesy Stromberg Carlson Co.)

resonant material with a circular opening at the center, just large enough to fit the outer edge of the cone. In many cases the radio cabinet itself is used as the baffle. The purpose of the baffle is to provide a long path for the low notes, emanating from the front of the speaker, to travel before they can reach the rear of the speaker.

The action of the speaker cone is similar to that of a piston since it moves forward and backward, pushing the air as it goes and setting up air waves, which reach our ears as sound. When the cone moves forward it pushes the air out in front of it and at the same time creates a partial vacuum at the rear of the cone. If no baffle is used, the air compressed in front has a tendency to immediately flow around to the back of the cone and fill in the space formed by the vacuum. Such an action would prevent the low frequency sound waves from traveling ahead to the listener.

The higher frequencies would be adequately reproduced as the cone is large enough to act as its own baffle for these higher frequencies. For faithful reproduction of the extremely low notes, say down to 40 cycles per second, an external baffle must be used, measuring 15 feet from front cone center to rear center by the shortest path. From the above explanation we can see why speakers mounted in large console cabinets reproduce with greater fidelity than those in small mantel type housings.

In dynamic speakers one of the most common troubles is due to the voice coil being off center and rubbing on the pole faces of the field magnet. An inspection of the opening in which the voice coil moves will reveal that the clearances are very small, consequently the coil must be exactly located or it may rub, setting up a distinct distortion in the sound output.

If a speaker is suspected of this trouble, disconnect it from the set and very gently push the cone up and down, by placing the fingertips on either

side of center and near the outer edge. If the voice coil is rubbing, a scraping movement will be felt. Now loosen the centering screw and insert, through the spider openings, speaker shims equally spaced and so located that they pass between the center pole and voice coil form. All shims must be the same size and must have a snug fit. Tighten the centering screw, remove the shims and the speaker is ready for trial.

Occasionally dirt or metal filings will lodge in the voice coil opening and these may be cleaned out by the use of compressed air or in some cases it may be necessary to entirely remove the cone and voice coil while the foreign material is forced out with a piece of stiff wire or other prod.

Dynamic speakers are made in various sizes for ordinary receivers in homes and for power amplifiers in large halls, theatres, etc. Dynamic reproducer units are also made for use with large horns of the type extensively used in sound picture and public address systems.

It has been found that long throated horns of special design are ideal for handling large volumes of sound in "power jobs".

Fig. 137 shows several horns of this type with both round and square openings. These horns are known as exponential and orthophonic types, according to their shape and design. Some of the large ones have a "tone travel" or length of 12 feet or more.

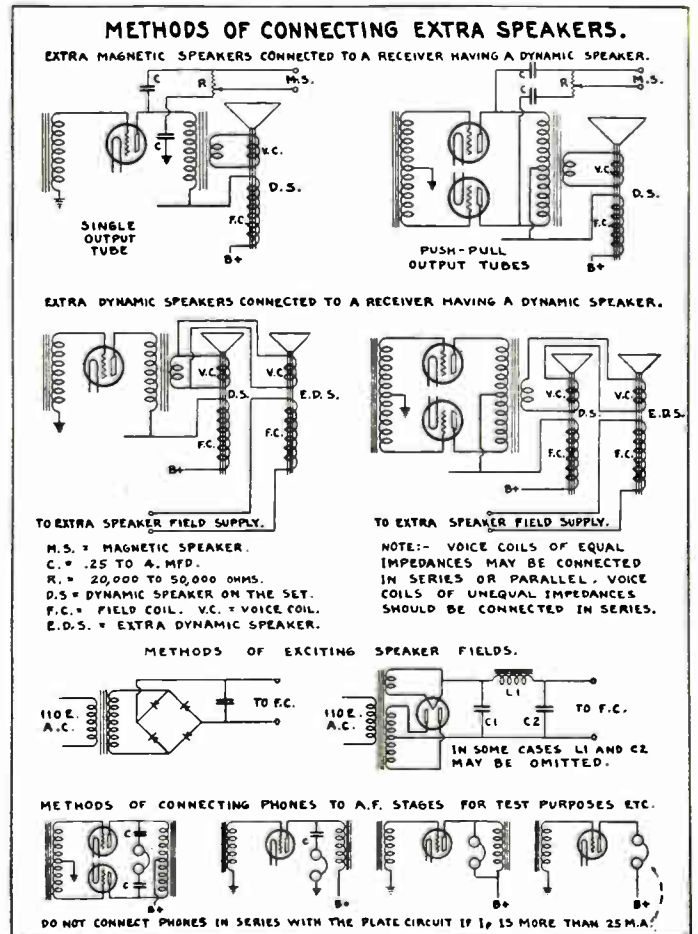

Fig. 136. Several practical methods for connecting extra loud speakers.

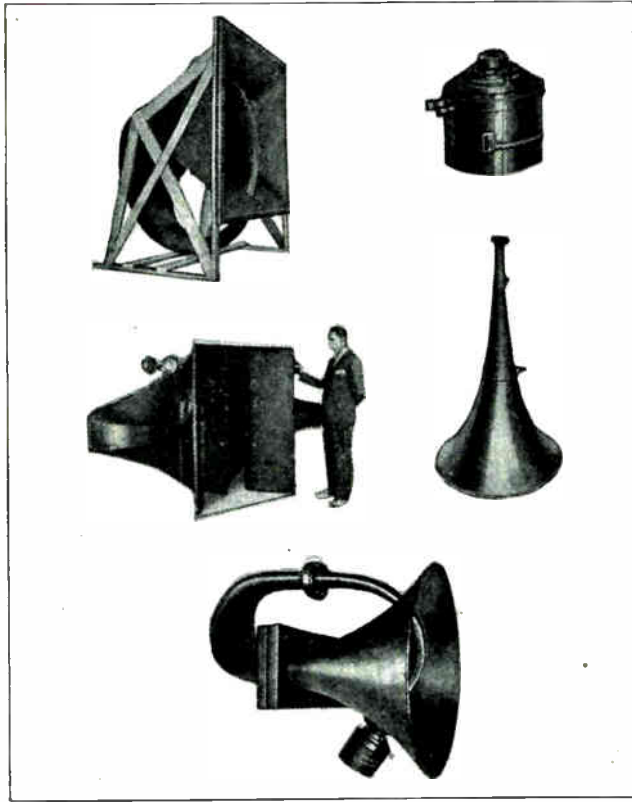

Fig. 137. Several types of large power speaker horns, and a large dynamic reproducer unit such as used with these horns. Horns of the above type are called exponential and orthophonic horns according to their design.

Another type speaker which has been used to a limited extent is known as the electrostatic or condenser type. These speakers consist of two thin sheets of metal with a sheet of insulation between them, or in some cases one thin slotted plate of aluminum on one side of the insulator and a sprayed metallic coating on the opposite side.

When the pulsating voltage output of the receiver is applied to these plates it causes the movable one to vibrate, due to electrostatic attraction between them. A D. C. bias of several hundred volts on their metal surfaces often improves the operation of these speakers.

Condenser type speakers reproduce very faithfully all notes of music, with very little of the distortion which some other types of speakers produce.

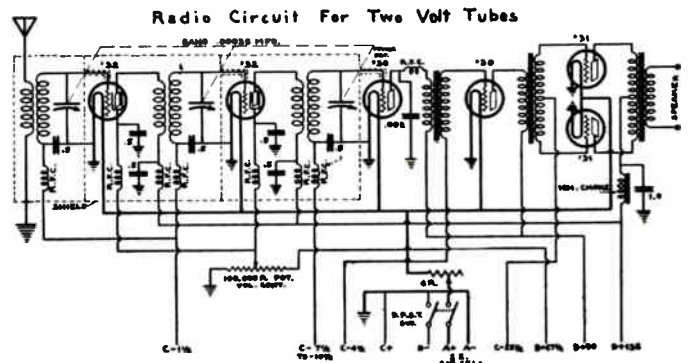

Fig. 138. A modern 6 tube battery operated set designed for use with an air cell "A" battery.

A.C. RECEIVERS

In order to make it easier to trace and understand the complete circuit diagrams studied so far, we have shown batteries as the current or power source.

However, although this was done purposely to aid you in your study of circuits in these earlier lessons, it must be remembered that battery operated radio receivers still occupy an important place in the radio field. There are still, and undoubtedly will be for some time to come, many thousands of battery operated radio receivers in use in localities where regular electrical power lines are not yet installed. This is particularly true in many rural districts and farm homes not yet reached by rural electrification development.

And, of course, automobile and airplane radios are also battery operated. So you can readily see that there is still a great deal of repair and service work on battery operated radios available to the man equipped with this type of training.

Back in the early days of radio all types of radio receivers used batteries almost exclusively for their source of power, as at that time all radio tubes were designed for D. C. operation.

Because batteries supply smooth constant value

D. C., as long as their voltage or state of charge is up to normal, they were very convenient for radio use in these early radio receivers and still possess these same advantages for operating radio receivers designed for use in localities and homes where no other electrical current supply is available.

Wet storage batteries of the 6-volt automobile type are used for filament supply on some battery operated receivers, while other sets use a 2-volt AIR CELL battery which is not rechargeable but has replaceable elements. Some small portable sets use tubes having filaments for dry cell operation. Dry "B" batteries consisting of a number of small cells connected in series are used for plate supply.

Some of the disadvantages of batteries, however, are their cost and weight, the fact that they discharge or run down and need to be replaced or recharged frequently, and in some cases cause corrosion and mess from acid fumes, etc.

Most modern sets made for use in towns and homes supplied with electricity are made for operation with current from the light socket or convenience outlet. As most of this current supplied in homes for lighting is A.C., most of these receivers are designed for A.C. operation and are com-

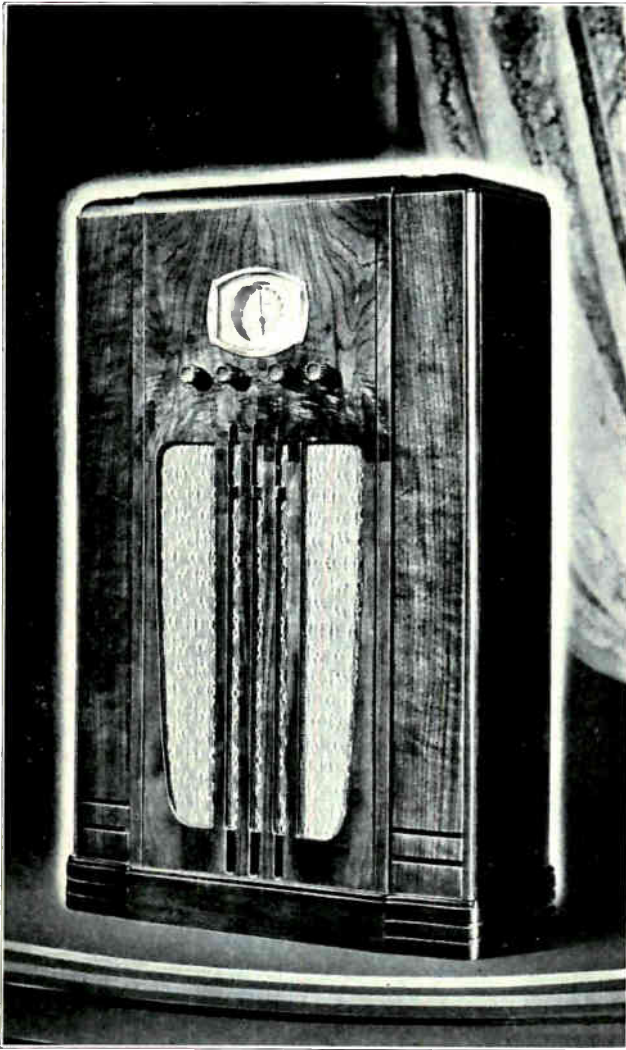

Fig. 139. A modern console type A.C., operated Radio Receiving set. (Courtesy Stewart-Warner.)

monly called A.C. receivers. However, some "all electric" sets are made for operation on D.C., where homes are supplied with 110 or 220-volt D.C. for lighting.

The general operation of A.C. sets is the same as that of battery sets, and the circuits and parts are much the same, except that A.C. filament type or heater element tubes are used in A.C. sets, and a "power pack" or power supply unit is used in place of the batteries.

All receiver tubes require D.C. for their plate circuits, even though the filaments of modern A.C. tubes can be operated on alternating current.

The power pack or unit of an A.C. receiver, therefore, must operate on the 110-volt A.C. supplied by the ordinary socket or outlet in the home, and it must supply the proper voltages and currents for the various circuits in the receiver.

The section of the power unit which supplies the low voltage A.C. filament current consists merely of a step down transformer. The section which supplies the high voltage D.C. current for the plates of the tubes, consist of a step up transformer, rectifier, and filter. The power unit will be described more in detail a little later.

96. SIMPLE FIVE TUBE A.C. CIRCUIT

Fig. 140 shows a circuit diagram of a five tube A.C. receiver without the power unit. The tubes used in this circuit are all A.C. type 27 tubes which are used both for detector and amplifier duty. These tubes are of the heater element type with five prong bases, as described in the articles on vacuum tubes in radio section 2.

The circuit shown in Fig. 140 is a very simple one, making it easy to compare the A.C. receiver circuits with the battery operated types already shown.

In battery sets rheostats are used in the filament circuits of the tubes, to keep the filament voltage properly adjusted as the battery voltage changes slightly during discharge.

Such filament rheostats are not necessary in A.C. receivers as the line voltage supplied to the filament supply transformers usually remains about constant, so the transformer secondary delivers steady voltage of the proper value to the filaments at all times. In case the primary voltage does at times fluctuate with the load on the line the transformer voltage can be adjusted by a compensating device in its primary circuit. Note that the filaments of all tubes in Fig. 140 are simply connected in parallel to the 2½-volt A.C. filament supply leads.

In circuits using heater element type tubes as shown in Fig. 140, the grid returns are connected to the cathode terminals as shown. This cathode instead of the filament is the electron emitting element in these tubes.

The plate circuits are also completed through the cathodes. Note that all plate leads connect to the positive terminals of the "B" power supply. The plates of the amplifiers connecting to the 90-volt terminal, and the plate of the detector to the 45-volt terminal. The current flow can be traced from the positive terminal of the power unit, through any plate, through the electron stream to the cathode and then back to the negative (B-) terminal of the plate power supply, which is connected to all cathodes.

The variable condensers used for tuning the R.F. stages in Fig. 140, are shown connected together by a dotted line, which indicates that their rotors are all located on one shaft or operated from one dial. This is called single dial tuning control and is the method used on most modern receivers.

97. A.C. CIRCUIT WITH SCREEN GRID R.F. AMPLIFIERS AND PUSH-PULL POWER STAGE

Fig. 141 shows a very practical circuit for a 6 tube A.C. receiver using screen grid tubes in the R.F. stages, and two power tubes in push-pull in the last A.F. stage.

With the high amplification factors of the screen grid tubes, and the large undistorted power capacity of the "45" power tubes in push-pull, a receiver of this type will give good selectivity, sensitivity, and plenty of volume of good quality sound to meet ordinary requirements for a home set.

The R.F. amplifier tubes, detector, and first audio amplifier are all A. C. heater element type tubes

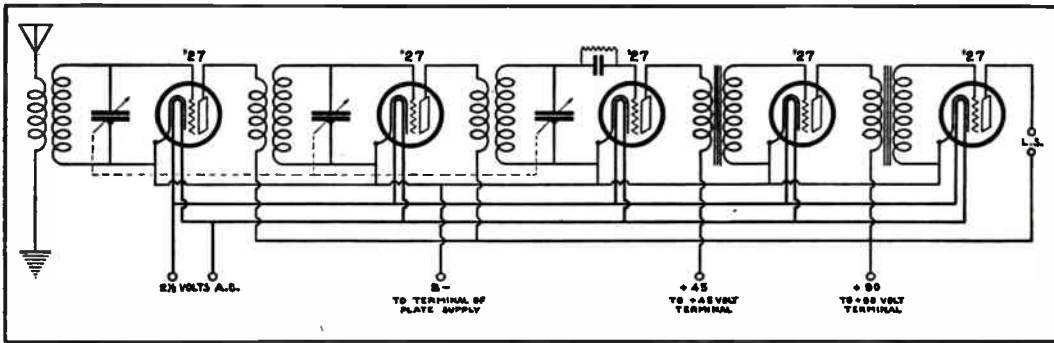

Fig. 140. Circuit diagram of a five tube A.C. receiver, using A.C. heater-element tubes. The "27" type tubes as shown above are used in both the R.F. and A.F. amplifiers and in the detector stage. Note the connections of the cathodes of the heater element tubes to the B- terminal.

and the power tubes in the last audio stage are A.C. "filament type". All of these tubes, however, use the same filament or heater element voltage which simplifies the wiring and power supply considerably.

The screen grids of the "24" tubes in the R.F. stages, connect to a 75-volt positive terminal of the plate power supply unit. A small bypass condenser C is usually connected between this screen grid lead and the negative B lead which connects to all cathodes of the heater element tubes.

Three volts negative bias is used on the control grids of the "24" tubes, 9 volts bias on the grids of the "27" tubes, and 45 volts bias on the grids of the "45" power tubes.

A variable high resistance is shown connected across the primary of the first R.F. transformer or aerial coupler, to be used as a volume control. As this resistor shunts more or less of the received signal energy around the primary of this transformer and thereby controls the amount of energy applied to the grid of the first R.F. tube, this of course controls the volume throughout the rest of the set and at the speaker. This circuit shown in Fig. 141 is very similar to those used in some of the earlier types of A.C. receivers.

The power supply unit is not shown, so in tracing the various circuits just start at a positive supply terminal and trace through to negative, etc.

98. A.C. CIRCUIT WITH FILAMENT TYPE AMPLIFIER TUBES

Fig. 142 shows a circuit diagram of a simple 5 tube A.C. receiver. This is one of the earlier type A.C. sets and is shown because of its simplicity as a circuit in which to trace out the power pack connections. Two of the "26" type tubes are used as

R. F. amplifiers, and one "26" tube and one "71" power tube for A.F. amplifiers. These four tubes are all of the A.C. filament type. The detector is a "27" heater element type A.C. tube. The "80" tube shown in the power unit at the lower part of the diagram is a full wave rectifier tube.

The negative bias voltage for the amplifier tubes of this circuit is obtained from the voltage drop in a resistor placed in series with the negative return of the plate current supply. This resistor is shown on the lower right. The grid returns of the R.F. amplifier tubes and the first A.F. amplifier are all connected together to the C-9 volt tap on the bias resistor. The grid return of the power tube in the last audio stage is connected to the C-40 volt point on this resistor.

The voltage drop in this bias resistor sets up a difference in potential between the grids of the tubes and the center taps of the resistors R and R1, from which the negative return is taken to the B- and C+ connection of the power supply, and through which the plate current returns.

The plate current of the A.C. filament type tubes flows from the positive terminal of the plate supply through the transformer primaries to the plates, through the electron streams in the tubes, down whichever side of the filaments the A.C. filament current happens to be flowing at that instant, and then through one half of the resistor R or R1 to the center tap, and from there back to B-.

You will note that the plate of the detector tube is supplied with 45 volts, those of the two R.F. amplifiers and the first audio amplifier with 90 volts, and that of the "71" power tube with 180 volts.

These different voltages are obtained from various points along a voltage divider resistor R2, shown near the right side of the diagram in Fig. 142.

Fig. 141. Circuit diagram of a simple six tube A.C. receiver, with screen grid R.F. amplifier tubes, and two power tubes used in push-pull in the last A.F. amplifier stage. A.C. heater element tubes are used for the R.F. amplifiers, detector, and first A.F. amplifier. The power tubes in the push-pull stage are "filament type" tubes with the filaments serving as the cathodes, and the filaments of these "45" tubes operating on the same voltage as the heater elements of the other tubes. Note the high C voltage used for negative grid bias on the power tubes, and note also the various terminals where the leads of this receiver connect to the power supply unit.

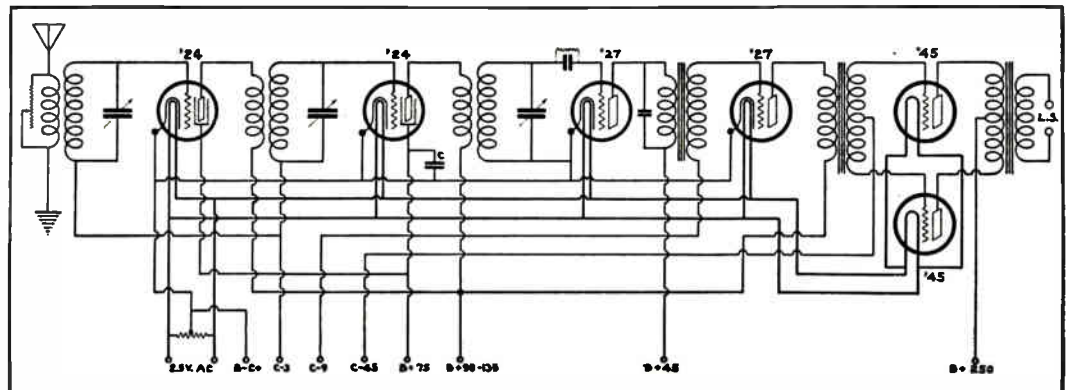

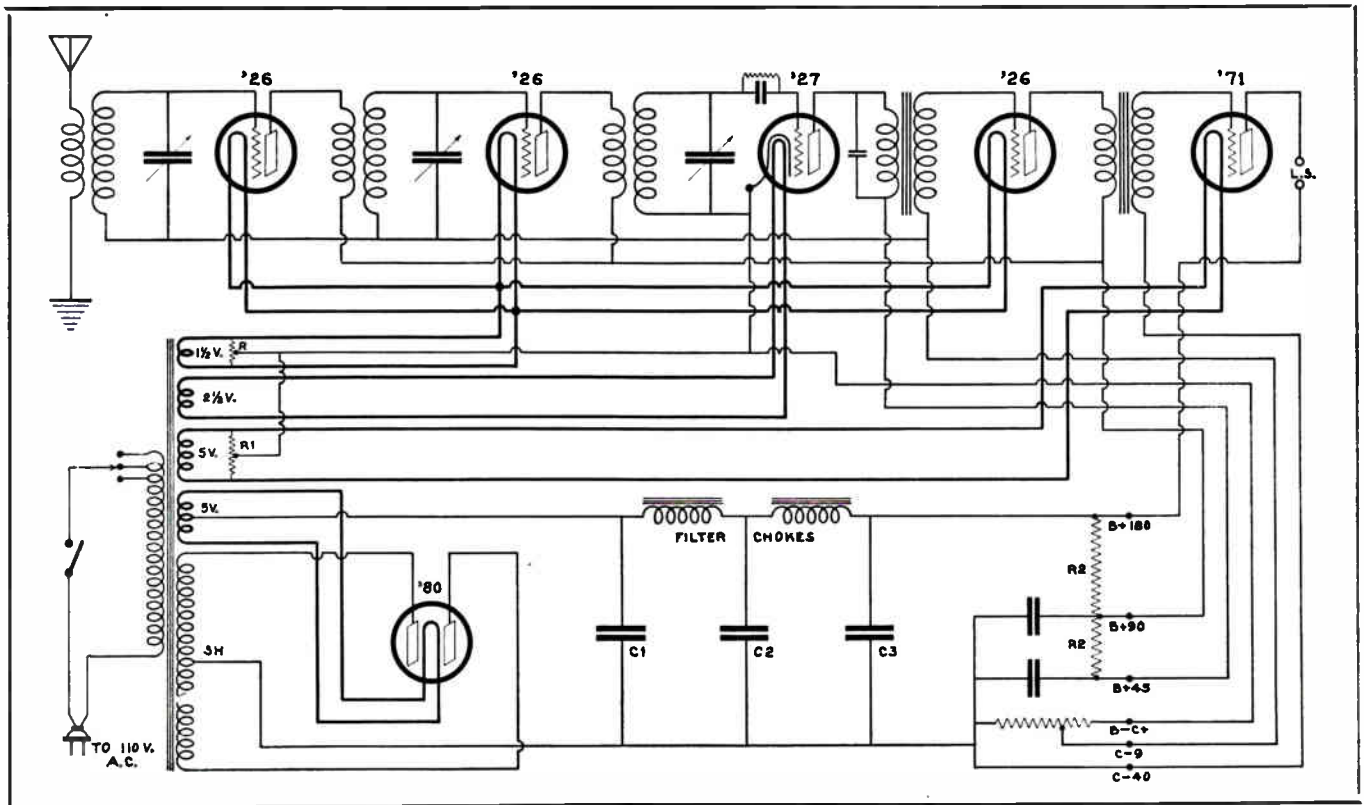

Fig. 142. Complete circuit diagram of a simple five tube A. C. receiver and its "power pack" or power supply unit.

This resistor and the plate circuit terminals are fed with rectified D.C. which comes through the filter chokes from the rectifier tube.

The high voltage secondary S H of the power transformer supplies A.C. to the rectifier tube, which converts it to pulsating D.C. Practically all of the ripple or pulsation of this D.C. voltage is then smoothed out by the filter system consisting of the filter chokes and the condensers C1, C2, and C3. The lower 5 volt winding on the transformer secondary supplies A.C. to the filament of the rectifier tube, and the upper 5 volt winding supplies the filament of the power tube. The 2½-volt secondary supplies A.C. to the heater element of the detector tube, and the 1½-volt winding supplies A.C. filament current to the R.F. amplifier tubes and first audio amplifier tube.

99. POWER UNITS FOR A.C. RECEIVERS

The power supply unit or power pack in an A.C. receiver is usually mounted with the rest of the parts of the receiver on one main frame or chassis. The power unit is often mistaken for part of the amplifying equipment.

Fig. 143 shows a photo of a modern A.C. receiver without its cabinet.

On the left side of the chassis you will note the power transformer and the large full wave rectifier tube. The filter condenser can also be seen. The voltage divider resistors are located underneath the chassis.

Also note the variable, 3 gang tuning condenser, the metal tubes, and the condensers and R.F. transformers which are inside the bright metal shield cans.

Fig. 144 shows a circuit diagram of a complete power supply unit a little different from the one shown in Fig. 142.

The primary of the power transformer is connected to the 110-volt supply by means of the plug and cord shown on the left. The lower secondary coil supplies low voltage (7 volt) A.C. to heat the filaments of the two half-wave rectifier tubes. This winding also has a center tap to be used as the positive lead for the plate supply.

The top secondary coil furnishes 2½ volts A.C. for the filaments and heater elements of the tubes in the receiver. The main center section of the secondary supplies high voltage A.C. to the plates of the rectifier tubes.

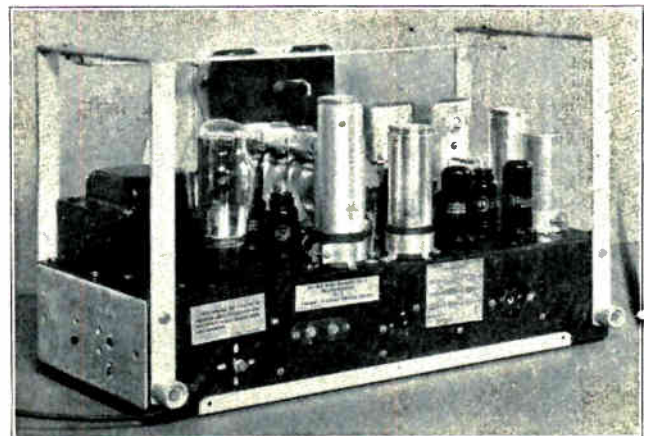

Fig. 143. Photo of a modern A. C. receiver chassis showing power transformers, rectifier tube, tuning condenser, detector and amplifier tubes, and shielded condensers and R. F. transformers. Courtesy Stromberg Carlson Co.

The entire power unit consists of four sections, marked A, B, C, and D in Fig. 144. Section A is the power transformer which supplies the various A.C. voltages required. It steps the voltage down from the 110 volts on the primary, to the coils of few turns on its secondary for the filament supply. It also steps up the voltage on its high voltage secondary which supplies current to the rectifier tubes.

This high voltage secondary winding is designed according to the types of tubes used in the receiver, and the plate voltages required by them. When this winding feeds a full wave rectifier as in Fig. 144, only half of the winding is in use at any one time, each half feeding its respective tube during every other alternation. Therefore, each half of this winding must develop the full voltage required by the

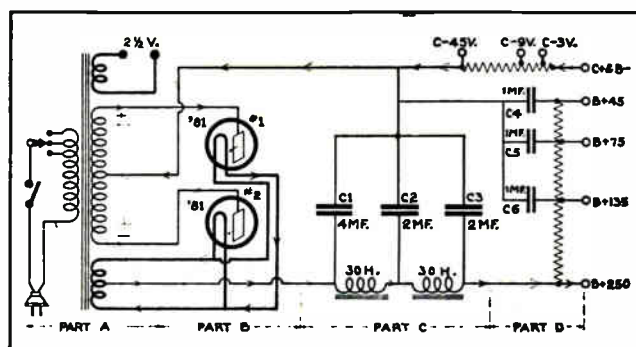

Fig. 144. Wiring diagram of a power supply unit showing the transformer, rectifier, filter, and voltage divider sections. Observe this diagram carefully and make sure you thoroughly understand the use and operation of each part.

rectifier tubes and the highest voltage required by the plates of the power amplifier tubes in the receiver. Note that this secondary has a center tap for the negative B return lead.

Section B of this power unit consists of the two half wave rectifier tubes connected for full wave rectification. Their plates are connected to opposite ends of the high voltage transformer winding, and when alternating voltage is induced in this winding first one rectifier plate becomes positive and then the other.

When either of these plates is positive it attracts negative electrons from the filament, thus completing the circuit and allowing current to flow from its plate to the filament, but never in the opposite direction.

During the alternation when the upper end of the transformer secondary is positive, current will flow as shown by the solid arrows, out from this positive lead through the upper rectifier tube, on from the filament of the tube through one half of the lower transformer coil, out through the chokes and filter system to B+, then to the tube plates, through the tubes and back to B- which returns to the center of the transformer secondary.

During the next alternation current will flow from the lower end of the winding as shown by the dotted arrows, through the lower rectifier tube, and out along its filament lead through one half of the lower secondary coil, and out on B+ in the same direction as the other alternation.

So we find that the rectifier tubes change the A.C. from the transformer into pulsating D.C. for

the plate supply, the center tap on the low voltage winding being the positive lead from the rectifiers, and the center tap on the high voltage winding being the negative return.

The rectified D.C. is pulsating as shown by the curve at A in Fig. 145, and varies too much to be suitable for use on the plates of the receiver tubes.

100. FILTER

The filter unit in Section C, of Fig. 144, consisting of two chokes in series and 3 condensers in parallel with the plate supply, smooths out this pulsating current about as shown by the curve at B in Fig. 145. This is accomplished by the combined action of the choke coils and condensers.

The choke coils which have a very high inductance of about 30 henries, consist of several thousand turns of fine wire wound on iron cores, and are connected in series with the positive lead from the rectifier.

As the voltage of the rectifier current starts to rise during any pulsation, it builds up current in the choke coils and sets up a flux around them which generates in their turns a counter E. M. F. which opposes or limits the building up of this current. During this period of rising voltage the condensers are receiving a charge and are absorbing the peaks of the voltage and energy waves which are blocked and held back by the chokes.

When the voltage of a pulsation from the rectifier starts to decrease toward zero the strong flux already built up around the chokes now collapses and induces in their turns a voltage which tends to keep the current flowing. As soon as this voltage starts to lower the condensers also start to discharge and supply current through the chokes and to the plate circuits of the receiver tubes.

Thus the peaks of the waves or pulsations are blocked by the chokes and stored by the condensers and then fed back into the hollows, smoothing out nearly all of the ripple or pulsations in the D.C. plate supply. Thus the name "filter" given to this part of the power unit.

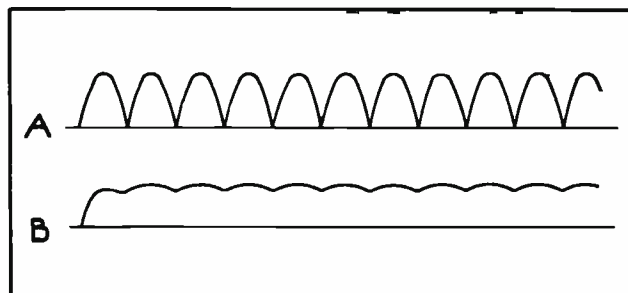

Fig. 145. Curves showing pulsating D.C. as it comes from the rectifier, and also after the ripples have been smoothed out by the filter.

101. VOLTAGE DIVIDER

Section D in Fig. 144 is the voltage divider consisting of a high resistance tapped at several points, and having several fixed condensers connected in parallel with its various sections.

The purpose of this resistor is to lower the voltage from the filter to the desired value for the plates of the various tubes. This is accomplished by the



Fig. 146. Photo showing several types of fixed condensers used for filter condensers in power supply units. The condensers in the top row are paper and mica types, while those below are electrolytic types. (Photo courtesy of Aerovox Wireless Corp.)

plate current flowing through the sections of this high resistance and causing a voltage drop.

The output voltage of the filter of a power unit should be just high enough for the plate of the power tube, or the highest plate voltage required by the receiver. In Fig. 144 this is the voltage obtained between the terminals B+ 250 and B—. This voltage is too high for the plates of the amplifier and detector tubes, so these tubes get their plate voltages at the taps along the resistor or "voltage divider", as at B+ 135 and B+ 45. The B+ 75 terminal is for the screen grids of screen grid amplifier tubes.

The fixed condensers connected between the taps on the resistor and the negative lead to the filter, are for the purpose of storing up a charge of energy or current during periods of normal plate current flow, to be delivered to the tube plates when the signal changes on the grids cause the plates to draw more current. If it were not for these condensers, during periods of heavy plate current flow the increased current through the resistor would cause increased voltage drop and thereby reduce the plate voltage temporarily.

This would tend to distort the signal and also reduce the amplification of the tube. With the condensers used as shown, when the voltage lowers slightly due to increased current demand and voltage drop, the condenser immediately begins to discharge and thus supplies the extra current required. Thus nearly a constant voltage is maintained at the plate lead terminal during all normal variations of plate current.

Fig. 146 shows several types of filter condensers including three of the electrolytic type in the lower part of the figure.

The proper resistance for each section of a voltage divider of a power unit can be simply and easily calculated by Ohms Law. For example, suppose the receiver supplied by the unit shown in Fig. 144 con-

sists of two 24 screen grid R. F. amplifier tubes, a 27 detector, another 27 for the first audio stage, and two 45 power tubes in push pull for the last A. F. stage.

The two 24 tubes each require about .004 ampere plate current and about .012 ampere each on their screen grids, the 27 tube used as detector requires about .003 ampere plate current, and the 27 tube used as first A. F. amplifier uses about .005 ampere plate current. This totals .040 ampere or 40 milliamperes, to go through the first section of the resistor.

We do not need to include the plate current of the power tubes as their current does not pass through the resistor but goes direct from the B+ 250 terminal to their plates.

As the voltage drop required in this first section is 250 — 135, or 115 volts, and as $E \div I = R$, then $115 \div .040 = 2875$ ohms resistance needed, to cause the voltage drop and get 135 volts at this terminal for the plates of the two R. F. amplifiers and the first A. F. amplifier.

To reduce the voltage from 135 to 75 volts or a drop of 60 volts, we find the current through the next resistor section is only that of the screen grids for the 24 tubes and the plate current for the detector, or .027 ampere. Then $60 \div .027 = 2222$ ohms, resistance required in this section.

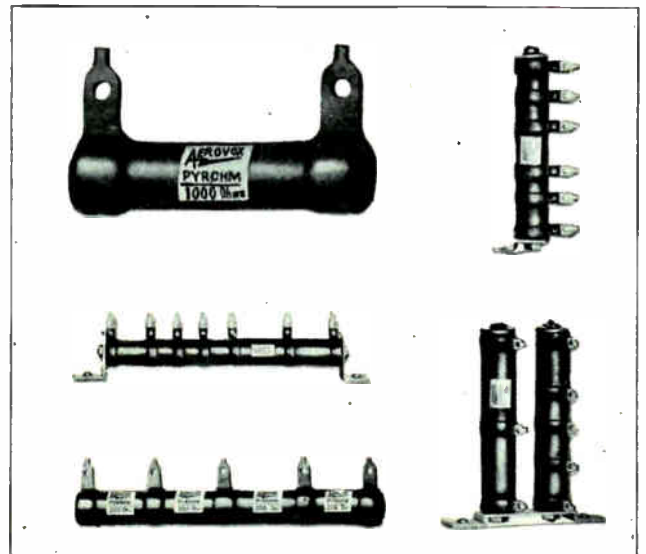

Fig. 147. This photo shows a number of convenient tapped resistor units used for voltage dividers, C bias resistors, etc., in power supply units. (Photo courtesy of Aerovox Wireless Corp.)

The last section of resistance carries only the plate current of the detector, and must cause a voltage drop from 75 to 45, or 30 volts, so $30 \div .003 = 10,000$ ohms resistance required. Convenient resistor units such as shown in Fig. 147, and with different values in ohms, can be purchased for use as voltage dividers in power packs.

102. GRID BIAS RESISTOR

The tapped resistance in series with the negative B lead of the filter in Fig. 144, is for the purpose of obtaining the negative grid bias voltages for the various tubes.

All of the current from the plate and screen grid circuits of the receiver tubes must return through this resistor on its way back to the rectifier. This causes a proportional voltage drop of different amounts at the various taps along the resistor.

The negative lead C+ and B- on this resistor which is connected to the B- terminal on the receiver, is negative to the positive taps B+ 45, B+ 75, B+ 135, and B+ 250, but this same terminal is positive to the taps C-3, C-9, and C-45 on the bias resistor. So the negative grid bias voltages can be obtained from the taps on this resistor, and the C+ or grid return lead from the filament is connected to the B- terminal of the power supply unit.

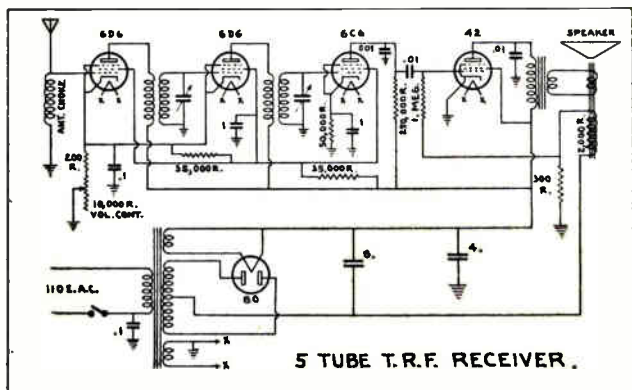

Fig. 148. Circuit diagram of a popular type 5 tube A. C. midget receiver. Note the pentode tubes used for two R. F. amplifiers, detector and one A. F. amplifier. Carefully trace the receiver and power pack circuits, and note the ground connections to the chassis, which completes various circuits.

The amount of resistance to be used to get the proper voltage drop in the various sections of this grid bias resistor can be determined by the same rule or method as that used for the voltage divider, except that in this case we include the plate current of the two power tubes with the plate and screen grid current of the other tubes, as it all flows back

through the bias resistor. The plate current of a 45 power tube is about 30 milliamperes; so for two of these tubes we would add .060 ampere to the .040 for the other tubes, making a total of .1 ampere or 100 milliamperes.

103. RESISTORS AND THEIR COLOR CODE

We have found that resistors are used in many places in radio receiver circuits. These resistors are of many different types and sizes. The resistance may range from several ohms to several megohms (1 megohm=1,000,000 ohms). One has only to look under the radio chassis of any radio receiver such as shown in Fig. 150, to realize the importance of fixed resistors in the construction of these receivers. Resistors are used to limit current flow or to cause voltage drop in filament or cathode circuits, grid circuits, power supply units, etc.

There are two types of fixed resistors in common use today; the composition type and the wire wound type.

The carbon composition type resistor is generally used in circuits where little current is involved and where the accuracy of the resistance is not of too great importance. These resistors have a tolerance of 10% above or below the resistance rating of the resistor. That is, if you purchase a carbon composition type resistor of a specified value of 10,000 ohms you may get a resistor with a value anywhere between 9,000 and 11,000 ohms.

The wattage rating of the carbon type resistor is rather low, ranging between one-fifth of a watt and approximately three watts. The cross sectional area and the length of the carbon type resistor increases with increase of wattage rating, so it is rather easy to determine the approximate wattage rating of the resistor by size. Fig. 151 shows four composition resistors of 2 watt, 1 watt, 1/2 watt, and 1/3 watt sizes. The two resistors on the right are wire wound types.

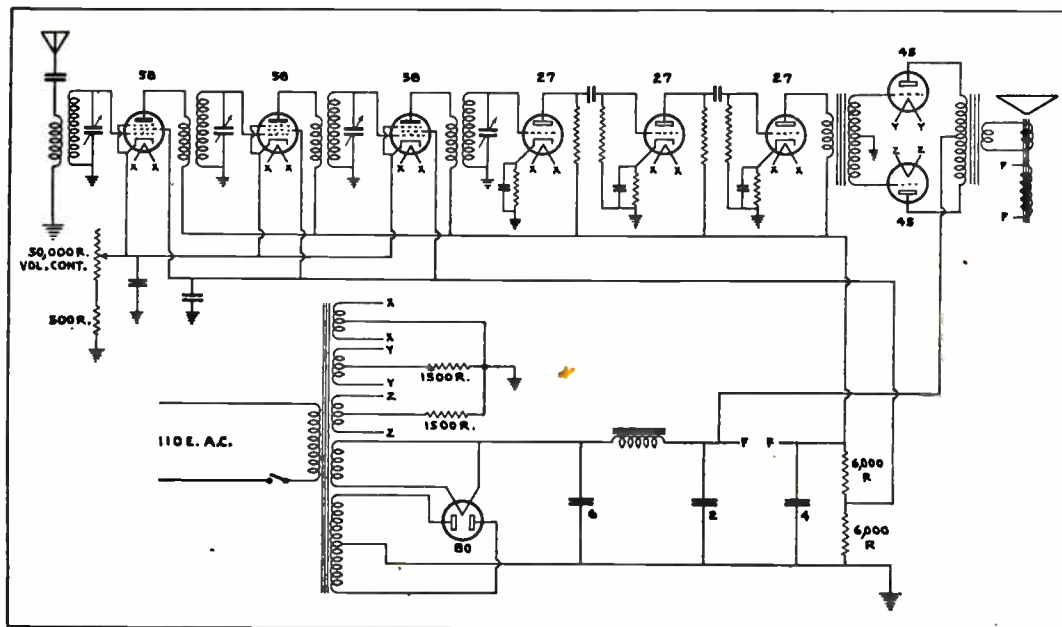

Fig. 149. Circuit diagram of a 9 tube tuned Radio Frequency A. C. receiver, using three stages of T. R. F. amplification, power detector, two stages of resistance coupled A. F. amplification, and one stage of push-pull audio amplification. Trace all of the above circuits carefully.

Carbon and graphite are generally used for the conducting element and are mixed with a binder of insulating material of suitable proportion to form resistors of the desired values.

The resistance of the carbon composition type resistor is not uniform, but varies somewhat with changes of temperature and applied voltage. The resistance of a poor grade of carbon resistor may vary as much as twenty per cent, so these resistors are not always the most desirable type to use. When

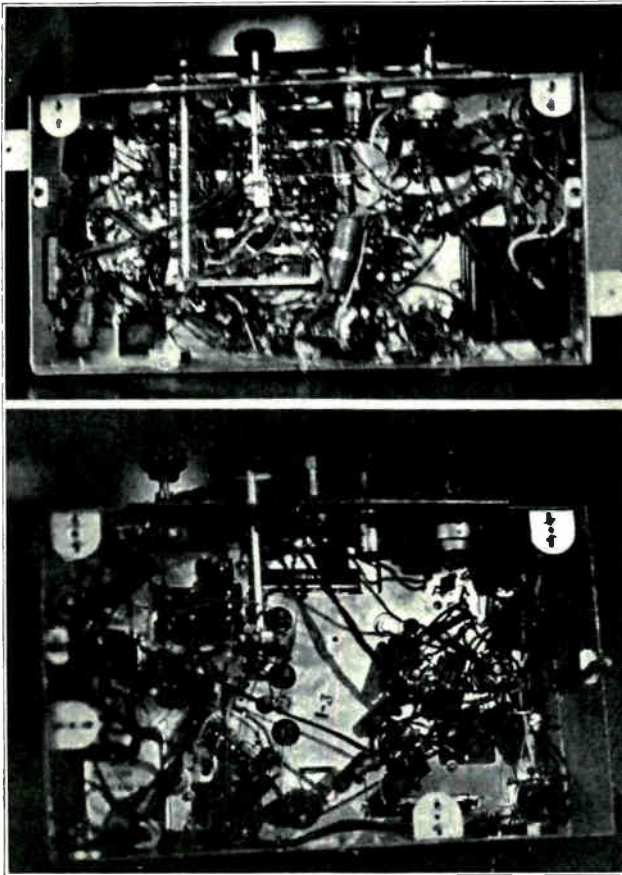

Fig. 150. Small condensers and resistors are usually located with the wiring, on the under side of the radio chassis as shown on the above sets.

a greater degree of accuracy is desired the wire wound resistor should be used.

Wire wound resistors are wound on a form of porcelain or some other ceramic material. Wires of nickel-chromium alloy are generally used for wire wound resistors. The entire resistor, with the exception of the terminals or pigtails, is coated with a vitreous enamel which protects the resistance wire from moisture and mechanical injury and also serves as an excellent heat conductor. The vitreous enamel also serves as a binder, keeping the fine resistance wire in place. See Fig. 147 and also the two resistors on the right in Fig. 151. The enamel and the resistor wire tend to expand and contract together, thus eliminating any mechanical strain on the wire due to the heating and cooling of the resistor.

Wire wound resistors employed in receivers have a tolerance of between two per cent and ten

per cent above or below their rated value. The wattage rating of wire wound resistors commonly ranges from one watt to one hundred watts or more.

104. R. M. A. RESISTOR COLOR CODE

The resistance of composition resistors is generally indicated by a color code or marking, according to the Radio Manufacturers Association (RMA) specifications. By the use of colors it is possible to designate the value of a resistor in ohms, rather than printing the numerical value on the unit itself, although some manufacturers do print the value on the resistor. The color code makes it very convenient to designate the resistance of the resistor regardless of whether it is of the small or large type.

Wire wound resistors are not usually color coded but are marked with metal or paper tags.

All resistors do not follow the R. M. A. code, some being all one color. Resistors colored in this manner are generally the individual manufacturers own system of coding.

105. RESISTOR COLOR MARKING

With resistors using the R. M. A. color code system of marking, the Body color represents the first figure of the resistance. End or tip color represents the second figure of resistance. Dots or narrow bands represent the number of zeros following the first two figures, as shown in the following table:

First Figure Body Color	Second Figure End Color	Dot or Narrow Band Color	
0—black	0—black	none	black
1—brown	1—brown	0	brown
2—red	2—red	00	red
3—orange	3—orange	000	orange
4—yellow	4—yellow	0000	yellow
5—green	5—green	00000	green
6—blue	6—blue	000000	blue
7—purple	7—purple	0000000	purple
8—gray	8—gray	00000000	gray
9—white	9—white	000000000	white

Examples:

If a resistor such as shown in Figure 152-A has a brown body meaning (1), green end (5), yellow dot (0000), it would be a 150,000 ohm resistor.

If a resistor such as shown in Figure 152-B has an orange body (3), red end (2), no other color on the resistor, so the dot space is orange (000), it would be a 32,000 ohm resistor.

If a resistor such as shown in Figure 152-C has a green body (5), no other color on the resistor except a black dot, so the end color is green (5), black dot (no zeros), it would be a 55 ohm resistor.

This color code is not used to designate the values of precision type resistors of odd values, such as one having 1956 ohms. Instead these special values are usually printed on the resistor or on a tag attached.

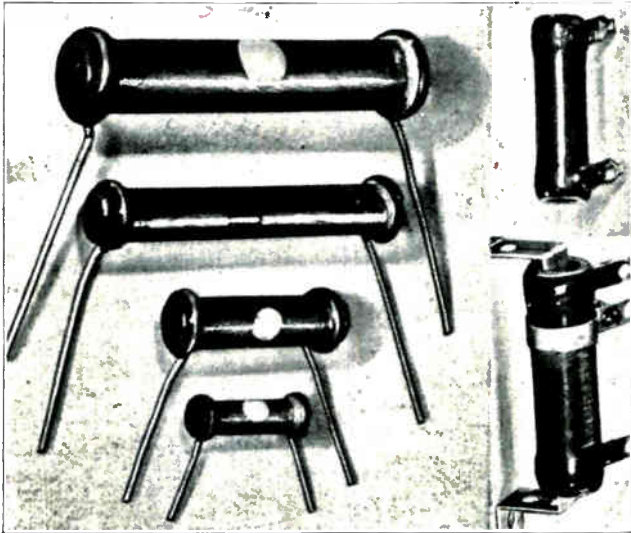

Fig. 151. Several composition type resistors of 2 watt, 1 watt, $\frac{1}{2}$ watt, and $\frac{1}{8}$ watt sizes on the left; and two wire wound resistors on the right.

106. CONDENSERS

We have learned that a number of fixed condensers or capacitors of various types and sizes are used in various parts of the circuits of modern radio receivers.

Just how important condensers are in circuit design may be readily seen from the number of ways in which they are used. Condensers are employed in practically every circuit of a receiver such as the plate, grid, screen grid, cathode, filament, filter, coupling circuits, by-pass circuits, etc. A number of small condensers can be seen in the radio chassis in Figure 150.

There are two common types of fixed condensers in common use. These are the paper and the mica insulated condensers and the electrolytic condensers. Several of each type are shown in Figure 154.

The fixed paper condensers consist of tin foil or aluminum foil conducting plates, separated by different grades of dielectric such as linen paper, wood pulp paper, etc. During manufacture the capacitors have the residual air withdrawn or evacuated and then are made moisture-proof by impregnating

them in hot paraffin or some other special insulating compound that melts under high temperatures. The capacity of the condenser depends upon the total active area in contact with the dielectric, the quality of the dielectric, and the thickness of the dielectric between the plates.

The capacity of the paper type capacitors range from approximately .0001 mfd. to 2 mfd., with voltage ratings from 200 volts to 1500 volts. The voltage on which the condenser may be safely operated depends upon the thickness and the nature of the dielectric. The capacity and the voltage ratings are generally designated on the condensers.

The higher grades of fixed condensers use mica as the dielectric, because mica has a higher breakdown voltage and smaller dielectric losses. Mica is more expensive than the paper dielectric and is not used in the construction of the larger size fixed condensers or capacitors. The mica condenser is constructed by placing alternate layers of tinfoil and mica upon one another, then moulded in a bakelite casing to make it moisture-proof.

The mica condensers range in capacity from approximately .000025 mfd. to .01 mfd. Condensers are constructed within a tolerance of ten per cent plus or minus (over or under) their specified capacity.

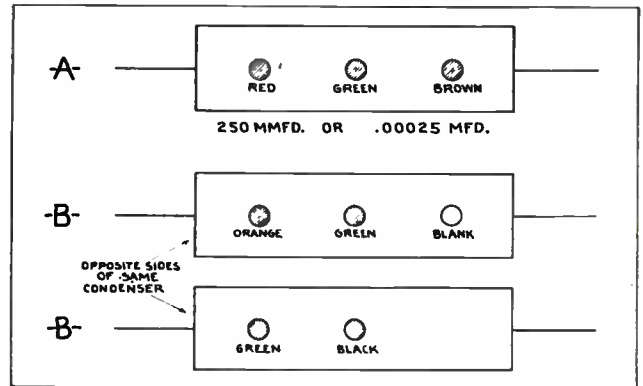

Fig. 153. Diagram showing condenser color code markings. Read the explanations in the lesson material.

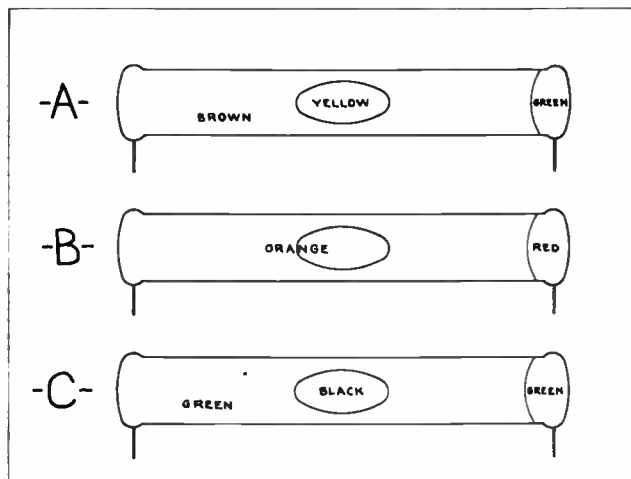

Fig. 152. Sketch showing color code markings used to indicate the resistance values of various resistors. Examine each one carefully while reading the instruction material which explains this color code.

107. ELECTROLYTIC CAPACITORS OR CONDENSERS

Electrolytic capacitors are more commonly employed in the filter circuits of the power supply and as cathode by-pass condensers in the A.F. section of the receiver.

These condensers are designed in two types, the wet and dry electrolytic condensers.

The wet type electrolytic condenser consists of an aluminum electrode which acts as the positive plate and terminal, immersed in an electrolytic solution such as borax or boric acid. The electrolytic solution acts as the negative plate of the capacitor and is contacted by a copper or aluminum container which serves as the negative terminal. The positive electrode is designed in different forms to increase the active area of the plate, thus increasing the capacity of the condenser.

A microscopic film forms electrochemically on the surface of the positive plate, and this film acts as the dielectric of the capacitor. Due to the extremely thin dielectric film formed on the positive

anode, it is possible to obtain large capacities in a small amount of space, which is one of the major reasons for the popularity of electrolytic condensers in receivers. For example, comparing an electrolytic and a fixed paper capacitor of equal capacity and voltage rating, the former is much smaller in size and weight.

The electrolytic capacitors are self-healing in case of breakdown, due to over voltage. The film is restored back to the normal operating characteristic of the capacitor, when the high voltage that caused the breakdown of the dielectric is removed. The capacitor may break down a number of times before being discarded. Whereas in a paper condenser a break down generally means a permanent short circuit and makes necessary the replacement of the condenser. Electrolytic capacitors are available at a considerably lower price than the paper type of the same capacity.

Electrolytic condensers are polarized and are **NOT TO BE USED IN ALTERNATING CURRENT CIRCUITS**. The positive side of the condenser must be connected to the positive side of the supply, and the negative side of the condenser to

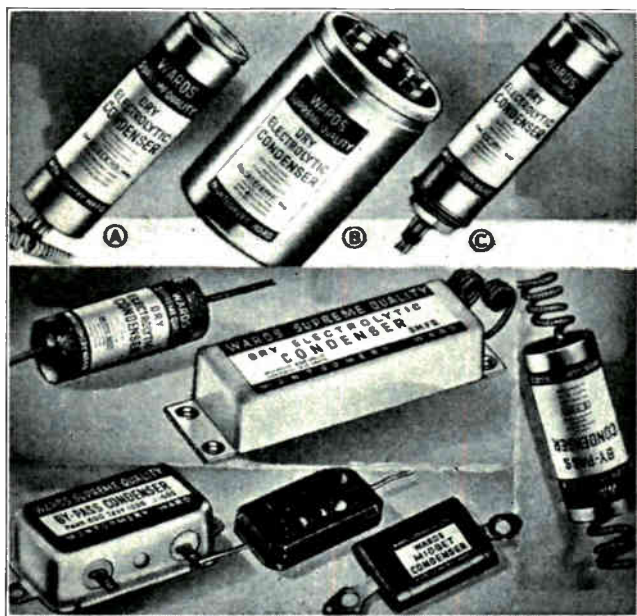

Fig. 154. Several types of electrolytic condensers are shown at the top of this illustration and several paper and mica type condensers below. (Courtesy Montgomery Ward.)

the negative terminal of the supply. The polarities are generally designated on the condensers.

The dry-type electrolytic capacitor is constructed of two aluminum electrodes, one of which acts as the positive plate and the other the negative plate. A layer or two of gauze is saturated with an electrolytic solution and placed between the two plates and the whole element rolled up into a compact unit.

Electrolytic condensers range in capacity from one mfd. to fifty mfd., with voltage ratings from twenty-five volts to six hundred volts.

The dry-type electrolytic capacitors are placed in cardboard and aluminum containers and may be mounted in any position, whereas the wet-type should be mounted in an upright position. It is

not unusual to find three or more capacitors in one container, especially the dry-type in cardboard containers, employed mainly in the midget type receivers.

108. CONDENSER COLOR CODE

The capacity rating of mica type condensers is generally indicated by color markings on the condenser. The capacitor color code is the same as the resistor color code, but the number designated refers to micro-micro-farads (MMFD).

The colors are read from left to right or the trademark side.

Examples:

A fixed mica capacitor has three colored dots on one side, the red dot meaning (2), green dot (5), brown dot (0). The capacity would be 250 mmfd. or .00025 mfd. See Figure 15A.

Some capacitors have the capacity represented by two colored dots and the third left blank on the trademark side, and the remaining code on the other side.

Suppose a fixed mica capacitor has three dots on one side and two dots on the other, as shown in Figure 153-B. Trademark side dots are orange, meaning (3), green (5), and a blank dot; reverse side is green (5), black (none), answer 355 mmfd. or .000355 mfd.

109. CONDENSER TESTING

The occasion may sometimes arise for testing a condenser that is suspected of being faulty, when no condenser tester is available at the time. If one has on hand the usual meters used for service work and a $\frac{1}{4}$ watt neon lamp, a series of simple test circuits may be set up, which will enable us to determine the condition of the capacitor in question.

First let us assume we wish to check a paper or mica dielectric condenser. The circuit of Figure 155-A is first set up using the $\frac{1}{4}$ watt neon glow lamp in series with 100 or 250 volts D.C. This source of D.C. voltage may be a "B" eliminator, "B" batteries, or from the power unit of a radio set, just so it is a smooth D.C. and not pulsating. When the connections are first made the neon lamp should flash once and then remain dark, providing the condenser is a good one and has no leakage. If the unit leaks the glow lamp will flicker and the more rapid this flicker the greater the leakage. A rate of one flicker or flash per second is the maximum allowable for most condensers, while for coupling condensers there should be no indication of leakage whatsoever.

If the neon lamp remains lighted continuously the condenser is shorted. An ohmmeter may also be used to check for a shorted condenser, as well. If the condenser gives no indications at all, on the neon lamp test, it may be open. We will now connect our circuit across the 110 volt A.C. line, as shown in Figure 155-B, and make a test for open. If the condenser is good, the neon lamp will give a steady glow, but if it remains dark the condenser is open.

If we have an electrolytic condenser we wish to check, we may use the circuit shown in Figure 155-C to test for both open and short. Use the same source of D.C. voltage as before, only be sure you

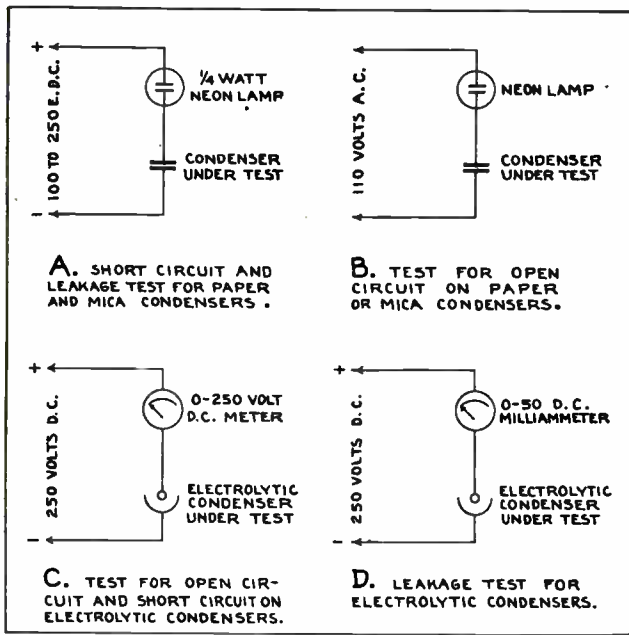

Fig. 155. The above sketches show connections for testing paper type or electrolytic type condensers for opens, shorts, and leakage.

observe the polarities of the condenser. If it is a wet electrolytic, the metal container is negative, while the dry or cardboard cased units usually have the polarities marked on them. On first connecting

the circuit the meter will read full scale and then drop back. This indicates the unit is not shorted or open. A shorted condenser will cause the meter to continue to read full scale (voltage of D.C. source) while an open condenser will give a zero reading.

If the electrolytic condenser is not open or shorted we can check it for leakage by using the circuit of Figure 155-D. Be sure you wait until the meter needle comes to rest before taking the reading. The maximum allowable leakage is 1/2 ma. for each mfd. of capacity. For example; a 10 mfd. condenser could have a leakage of 5 ma. or less, and be O.K. A leakage of over 5 ma. in this case would be too much and the unit should be discarded and replaced. However, these leakage currents must not be taken too literally as so many factors enter into the consideration that a condenser that has an excessive leakage for one receiver may be alright for another set of different design. The values given above are about average and these leakage currents should not be exceeded.

Now let us remind you once more that the important parts of any radio set are the tubes, sockets, transformers, condensers, resistors, the speaker, and the wiring. Keep this well in mind and you will have a good idea where to look for troubles in any receiver.

Now we are ready to take up the very important and interesting subject of superheterodyne receivers and automatic volume control in the next section.

THE SUPERHETERODYNE RECEIVER

You are now ready to learn about the most popular and common type of modern radio receiver circuit, namely, the Superterodyne.

Most of the radio receivers produced today and in the past few years are of the superheterodyne type, although several of the so-called "midget" receivers utilize the TRF circuit. While it is true that the superheterodyne is not a development of recent years, it is only in the past few years, with the introduction of newer type vacuum tubes, that this circuit has been so highly developed to its present day status and popularity. We now recognize it as the leading type of receiver employed for most all radio work, whether it be a short-wave set built by some experimenter, an ordinary home radio for broadcast reception, or the most elaborate type of communications receiver.

Superheterodyne receivers were used during the world war, where a need for greater sensitivity and increased selectivity was very urgent, and it can be said that the development of this circuit dates back to that time. Strange as it may seem, present day circuits still resemble those of the earlier type, despite numerous design developments, for the basic principle of operation remains the same. Superhet' receivers of several years ago had long panels with numerous controls mounted on them. Today a small cabinet with two or three controls typifies the modern superhet' receiver.

One of the greatest advantages of the superheterodyne receiver is its remarkable sensitivity and high selectivity. No other type of circuit has yet been able to equal the super' in selectivity (sharp tuning) and sensitivity (distance range). True, some TRF (tuned radio frequency) circuits have been developed which show high selectivity and good sensitivity, but usually the tuning range was restricted to one or two bands, and several continuously tuned circuits were required. The super' can do all of that and more, and still use fewer continuously variable circuits. This is very important for convenient operation.

110. SUPERHETERODYNE PRINCIPLES

Now let us see just how this circuit operates and how it differs from the regular type of TRF circuit. You will recall that in the TRF receiver, the signal received from the antenna was merely passed through each succeeding RF stage, being amplified as it went along, yet retaining the original carrier frequency and audio modulation characteristics up to the detector. At this point, the demodulating action of the detector separated the audio or modulation component (part) from the RF carrier, and then this audio signal was passed on into the AF section of the receiver.

The superheterodyne action is different, in that the carrier frequency, after being passed through the RF amplifier stages, is next sent through a

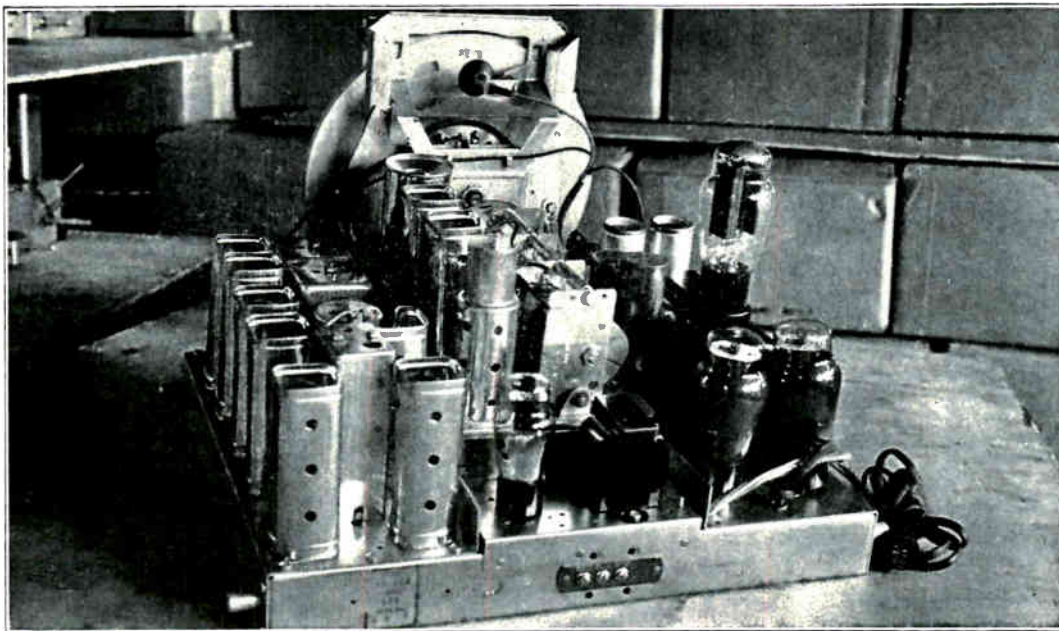

Fig. 156. View of a modern Radio receiver chassis of the type in which superheterodyne circuits are commonly used. Millions of popular receivers now use the superheterodyne circuits, which are explained in this lesson. Courtesy Philco Radio & Television Corporation.

first detector or mixing stage where it is mixed with another high frequency wave, which is generated by an extra oscillator tube within the receiver. Fig. 157 shows a block diagram or simplified layout of the important sections of a superheterodyne receiver.

In the superheterodyne receiver, the additional oscillator tube and circuit is used to set up a continuous wave of slightly different frequency from that of the received signal. This new wave is mixed or heterodyned with the signal carrier at the mixer or first detector, after it has passed through the RF amplifier stages. The heterodyne principle was explained in Art. 78 of this section, which we suggest that you review at this time.

This mixing of the two different frequencies produces a beat note or intermediate frequency (IF) wave, which can then be amplified through several more stages of IF or lower frequency amplification. Amplification of this IF energy can be accomplished with much less loss than at the higher radio signal or carrier wave frequencies, and with much less distortion than at audio frequencies.

In Fig. 157, the block marked "RF" represents one or more complete stages of tuned RF. The mixer is also a complete tuned stage and is sometimes referred to as the first detector. The "Osc" section in Fig. 157 represents a local RF oscillator for generating the high frequency heterodyning wave. These three blocks or stages are all controlled or tuned by the receiver gang condenser which is operated by the tuning dial, as shown in the diagram.

After the modulator comes the "IF" amplifier section. This IF or intermediate frequency amplifier is nothing more than a semi-fixed tuned RF amplifier, and in our example is tuned to 460 kc. After this comes the demodulator, often called the second detector, where the audio signal component is separated from the IF wave. Following this is the conventional "AF" or audio frequency amplifier with which you are already familiar.

The heart of the whole circuit is the IF section, which is actually a semi-fixed tuned, low radio frequency amplifier, which operates on a much lower frequency than that of the received signal. It is a well known fact that RF amplifiers are much more sensitive and selective when operating at low frequency RF than if they were handling higher frequencies. These two characteristics are utilized in a very great degree in the superheterodyne IF section, due to the fact that it can be permanently adjusted to one frequency for greatest efficiency. For our example we have taken 460 kc. as the IF frequency, although in commercial practice other frequencies are also used, such as 456 kc., 260 kc., 175 kc., etc.

Now that we have a very efficient IF amplifier ahead of our demodulator tube, and tuned to a fixed frequency of 460 kc., it is only necessary to arrange the variable tuned circuits ahead of it, so that we can change our received signal over to this low frequency, and utilize the capabilities of the IF amplifier to the utmost. To make this change, we make use of the heterodyning action or mixing of two frequencies together as previously explained.

Whenever two different frequencies are mixed together, there will be produced a new frequency equal to the difference between the two originals. Thus, if we mix together a frequency of 1000 kc.

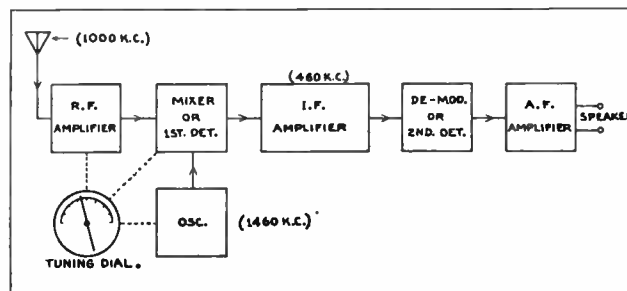

Fig. 157. Simple block diagram showing the important parts or sections of a superheterodyne receiver, and the order in which signals must pass through this type of set.

and one of 1460 kc., a new one of 460 kc. will result. That is, 1460 minus 1000 equals 460. You will notice that the new frequency produced is much lower than either of the two originals.

In our diagram, the signal from the antenna will be the 1000 kc. frequency, while a local oscillator built in the receiver, will furnish the 1460 kc. signal. The two are mixed together in the mixer stage and the resultant new frequency of 460 kc. is passed on into the IF to be further amplified, before the audio component is removed in the demodulator stage.

Remember, that the signal from the antenna is a modulated RF carrier, or in other words the amplitude of the carrier varies at an audio rate. We might picture this RF carrier as being molded up and down by the audio signal, as described in Art. 11, Radio Section 1. When this modulated signal of 1000 kc. is mixed with the oscillator signal of 1460 kc., the new low frequency (460 kc.) will still retain the audio modulation. This modulation is of course what we are interested in separating from the RF and passing through the audio amplifier to the speaker.

In the superhet' circuit the RF and mixer stages are tuned to the signal frequency by the movement of the gang condenser. The oscillator is also tuned by a section of this gang condenser, but the circuit is so arranged that it will always tune 460 kc. higher than the received signal, assuming of course that the IF is 460 kc.

The IF section remains tuned to one frequency at all times. This makes possible the use of sharply tuned transformers in the IF stages. These IF transformers may be of the air-core type, or in some cases they have a very small iron core in the coils. In either case, they are sharply tuned by using just the right number of turns, and by means of small adjustable trimmer condensers. This is one of the reasons for the high selectivity or sharp tuning of superheterodyne receivers.

Now that we understand the principle of operation, we will briefly review again the advantages of the superheterodyne receiver.

First, since the major portion of the amplification takes place in the IF section at a fixed frequency, more uniform amplification may be secured over any tuning band.

Second, since the IF section operates at a fixed frequency, as well as at a lower frequency than that of the received signal, it is possible to obtain maximum amplification without loss of stability.

Third, since most of the amplification is in the IF section, it is possible to design this section of the receiver so it will be either very sharp tuning or else broad tuning, giving a band pass effect to the signals of sharp or broad tuning, as desired.

Fourth, increased selectivity results from the process of mixing the two frequencies together or in frequency conversion, giving a frequency separation of 5 to 10 per cent in the super', as against a frequency separation of 1 to 2 per cent in the TRF receiver.

Fig. 158 shows a simple nine tube superheterodyne receiver circuit, which is easy to compare with the block diagram shown in Fig. 157. Note the RF section, oscillator, first detector or mixer, IF section, second detector or demodulator, and the AF amplifier section in this receiver circuit.

Also note the variable condensers for tuning the RF stages to the desired signals, and for tuning the oscillator to produce the proper beat frequency for each different station tuned in. These condensers are all ganged together so that each time a new station is tuned in, the oscillator circuit is automatically adjusted to produce the proper beat frequency. This keeps the IF frequency at constant value at all times. Keep well in mind this fundamental principle of the superheterodyne circuit.

The circuit shown in Fig. 158 has two stages of R.F. amplification using 6K7 tubes, a first detector or modulator using a 6L7 tube, one stage of I.F. amplification using a 6K7 tube, and a diode or power detector using a 6H6 tube which merely acts as a rectifier to bring out the audio portion of the signal. This circuit also has one direct coupled

Fig. 158. Circuit diagram of a simple nine tube superheterodyne receiver. Carefully examine and trace all parts of this circuit, particularly the coupling or path of the signals through the R. F. stages, first detector, I. F. stage, second detector, and two A. F. stages. The tube filament or heater circuits are not shown in this diagram.

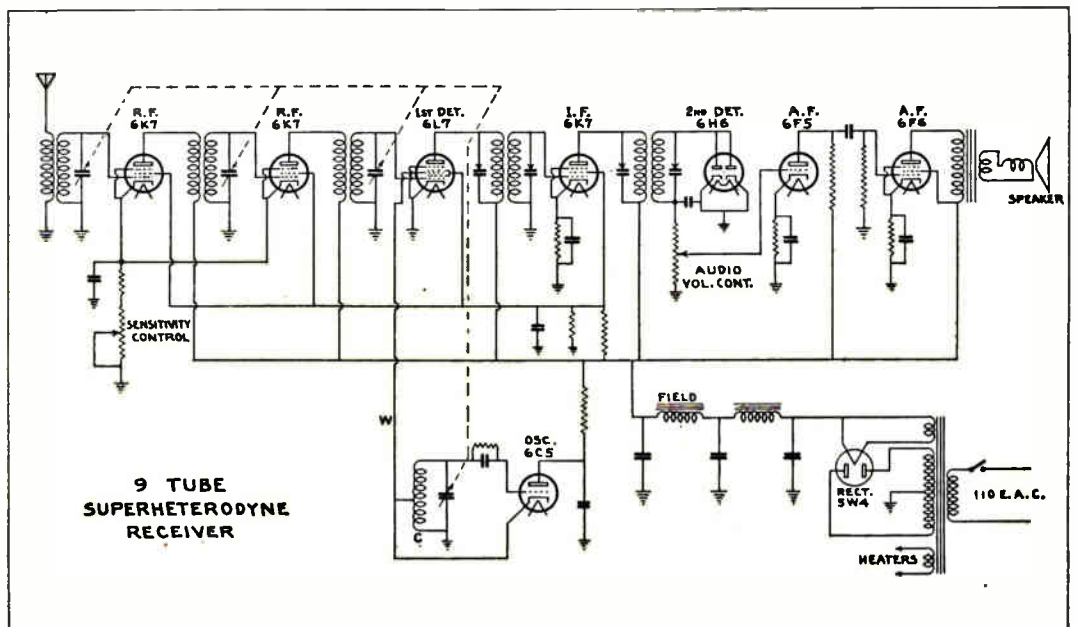

audio stage using the 6F5 tube, and one resistance coupled audio stage using a 6F6 tube.

The oscillator tube is a 6C5 type. The circuit of this tube is self oscillating due to the feedback coupling between the plate and grid circuits, at the upper and lower sections of the coil "C." In tracing the plate current from plate to cathode, etc., we find that this current must pass on from the cathode through the lower half of coil "C" to ground or B— return. Induction from this part of the coil excites the upper half which connects back to the grid, and thus sets up oscillation.

The output of the oscillator tube is coupled to the grid of the mixer or first detector by the wire "W" from the plate coil connection of the oscillator.

Fig. 159 on this page shows a circuit diagram of a commercial type superheterodyne. This circuit is similar to many other receivers of this type, being one of the all-wave sets now so popular. Note the band switches in the RF stage and oscillator section for selecting various sections of the RF coils for tuning stations in the various frequency bands. These will be more fully explained later. Other circuits will differ somewhat in tube line up, but the general layout will be the same. Some receivers may employ only one stage of IF amplification, others more. Some may not have any RF ahead of

the first detector, and others may combine the mixer and oscillator stages in one tube.

Carefully examine all parts and stages of this circuit in Fig. 159. The aligning data given in this diagram will be explained later.

Later model superheterodynes use a diode tube as the second detector. This diode circuit has the advantage of undistorted output at both high and low signals, as well as furnishing a voltage for automatic volume control.

111. DOUBLE PURPOSE TUBES

The 6A7, or pentagrid converter tube was designed for the dual purpose of functioning as a mixer and as an oscillator in superhet' circuits. Referring to the diagram of this tube circuit in Fig. 160 we find that grids 1 and 2, together with the cathode, function as the oscillator. Grid 2 is really acting as a plate since it has a positive potential applied to it in this oscillator circuit. Grids 3, 4, and 5, and the plate and cathode are serving as the first detector. Grid 4 is the control grid, while grids 3 and 5 act as a screen grid. The plate is the same as the plate in any tube.

The antenna signal is applied to the detector section of the 6A7, and the local oscillations are produced in the oscillator section. Since the same

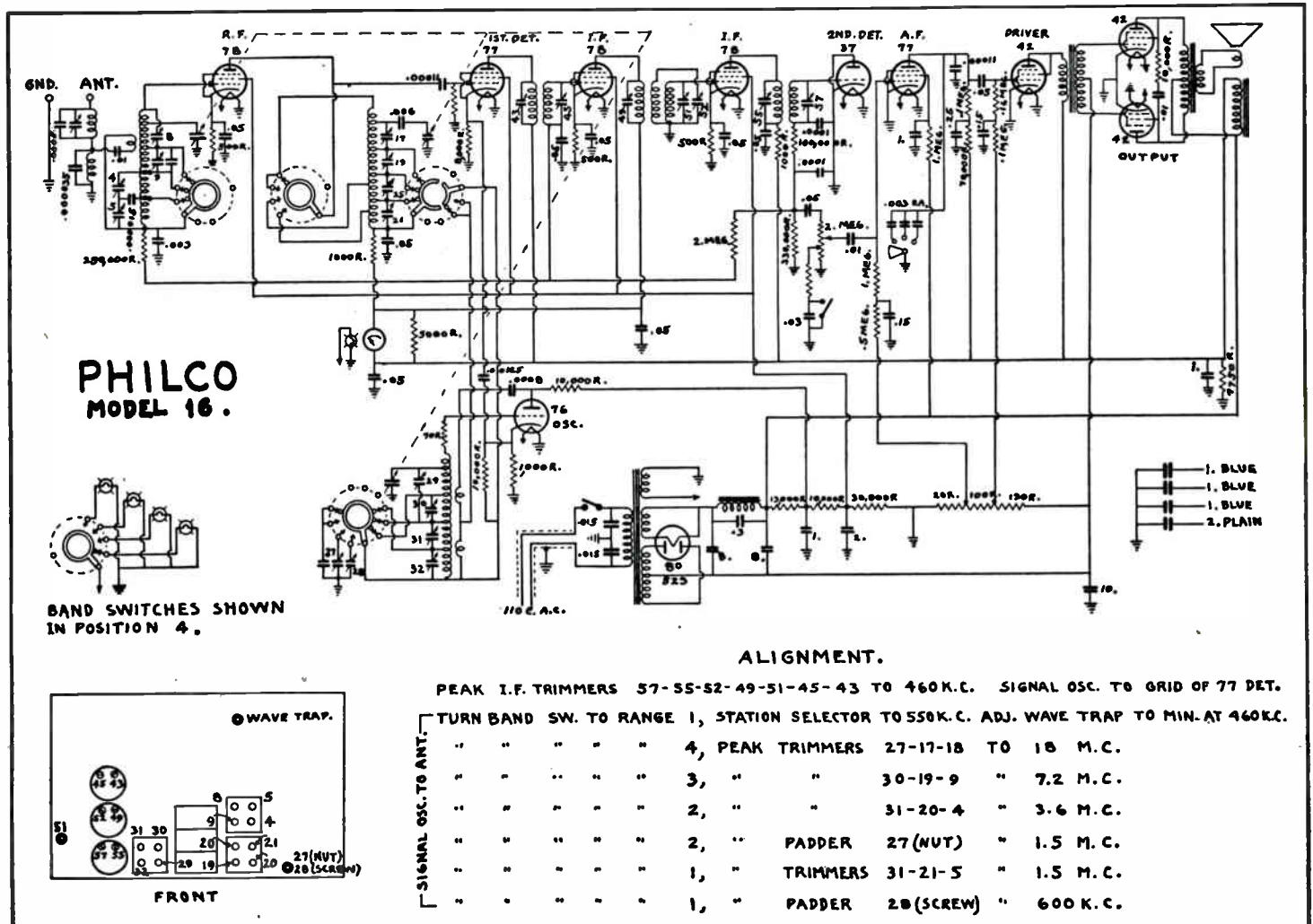

Fig. 159. Circuit diagram of an all-wave "super". Carefully examine all stages, and the oscillator and power pack circuits.

stream of electrons from the cathode, passes through both sections of the tube on its way to the plate, the two sections of the tube are said to be electron coupled. The mixing of the two frequencies is done right in the electron stream itself. This tube has the advantage of simplified circuit construction, economy and efficient mixing action.

112. GRID BIAS AND DIODE DETECTORS

In addition to the grid leak type of detector, which has already been explained in an earlier lesson, there are two other types of detectors in use today, one being the grid bias detector and the other the diode detector. The bias detector is shown in Fig. 161-A, and is sometimes called a power detector. Its circuit is so arranged that it is biased negatively to such an extent that the operating point comes at the lower knee of the characteristic curve, as shown at B in Fig. 162. Rectification of the RF signal takes place by suppression of the negative half cycles, allowing only the positive half cycles to be amplified. This causes an increase of plate current when a signal is received. This circuit

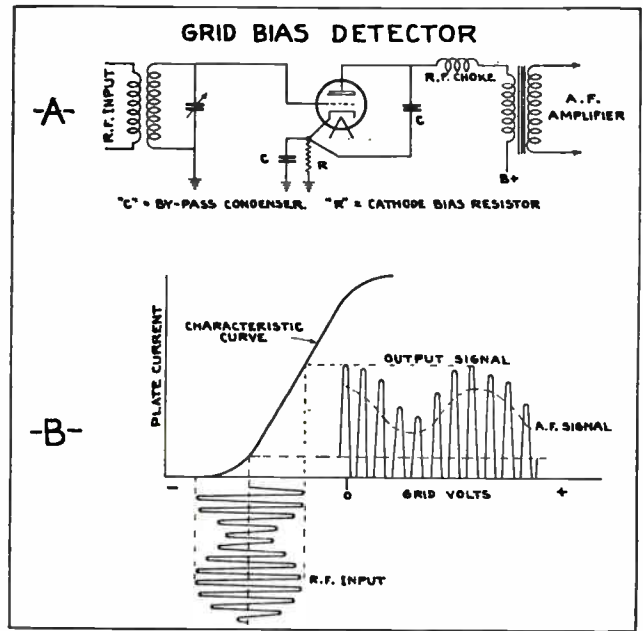

Fig. 161. Connections for grid bias detector, with characteristic operating curve shown below.

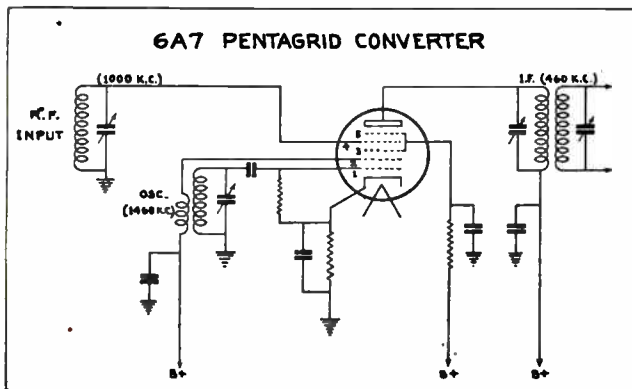

Fig. 160. Circuit connections for 6A7 pentagrid converter tube such as often used in modern superheterodyne receiver circuits.

113. AUTOMATIC VOLUME CONTROL

Most superheterodyne receivers of today are equipped with automatic volume control, or AVC as it is commonly called. The purpose of AVC is to reduce the amplification in the IF section on strong signals, and yet not have it reduced on weak ones. This will tend to give a uniform output from the loudspeaker as the volume would be automatically reduced for strong signals, but not for very weak ones. The diagram of the IF stages and second detector shown in Fig. 163 shows how this can be accomplished.

We can vary the grid bias on the IF tubes and in that way change their amplification ability, since increasing the negative bias of a tube decreases its amplification. In this circuit, we obtain the addi-

offers the advantage of amplification of the received signal, as well as its ability to handle strong signals. It is not sensitive to weak signals.

The diode detector such as shown in Fig. 162, was designed for use in superhets where the signal applied to the second detector is fairly large in value. It will also handle weak signals satisfactorily although it does not possess any amplifying characteristics. It functions either as a half-wave or as a full-wave rectifier, utilizing the principle that a vacuum tube will pass current in one direction only.

In Fig. 162-A and B, R is the load resistor across which the rectified signal voltage appears. This voltage will be in the form of pulsating DC, the pulsations representing the audio signal. It is this audio signal which is fed into the AF section of the receiver and amplified for reproduction from the speaker.

Some tubes such as the type 85, 75, and others, are designed to perform the dual functions of diode detector and first audio amplifier. See Fig. 162-C. In some circuits a triode tube may be used as a diode, the grid being connected to the plate, giving the effect of a two element tube.

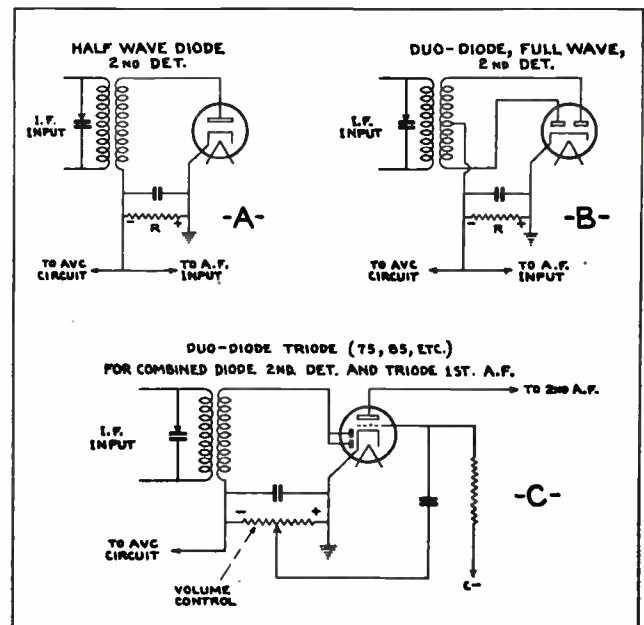

Fig. 162. The above sketches show connections for half-wave and full-wave rectifier type detectors at A and B, and for a double purpose combination detector and first A. F. amplifier tube at C.

tional grid bias for the IF tubes from the DC potential produced across resistor R, due to the flow of rectified signal current. With no signal, there will be no voltage across R, and therefore no more than the normal bias on the IF tubes, thus causing these tubes to have maximum sensitivity. With a signal applied to the second detector, a DC voltage will appear across R, and this voltage is fed back to the grid return circuits as an additional negative grid bias.

This causes a reduction in the amplification of the signal passing through the IF section. The greater the received signal, the more will be the increase of bias on the IF tubes, causing more of a reduction in amplification, with a consequent leveling off of the signal from the loudspeaker. Weak signals will not materially affect the bias or reduce the amplification through the IF, with the result that they are amplified to a greater degree and give normal loud-speaker output.

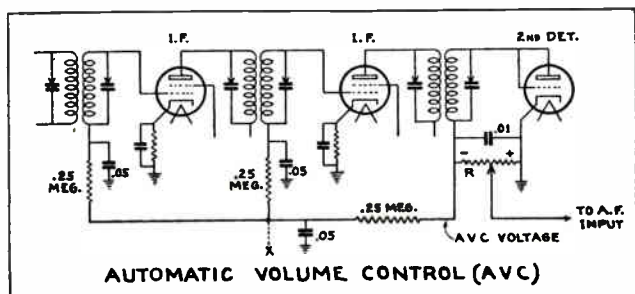

Fig. 163. Carefully examine this automatic volume control circuit while studying the accompanying explanation in the lesson.

Since the D.C. voltage appearing across R is pulsating, a filtering system, consisting of high values of resistance and small filter condensers, is placed in the grid return leads, so that the AVC voltage actually applied to the grid circuits of the tubes will be a smooth, well-filtered D. C.

114. CATHODE RAY TUNING INDICATORS

In Article 72, Section 2, the cathode ray tuning indicator, or "magic eye" tube was explained. By

reviewing this article you will find that the beam or shadow of this tube is controlled by negative voltage applied to the ray-control electrode of the tube.

From the explanation of AVC in the preceding article, we can now see how this varying negative potential for the cathode ray tube can be obtained from the negative bias of the AVC circuit, at the point marked X in Fig. 163.

By referring again to the lower view in Fig. 94, in Section 2, you will note the control grid connection of the cathode ray tube. This grid wire connects to the receiver AVC line, as marked at X in Fig. 163 of this section.

When there is no signal and the AVC voltage is zero, the grid of the cathode ray tube is also at zero potential and the plate current of the cathode ray tube is maximum, causing the greatest difference in potential between the target and the control electrode. This in turn causes the greatest shadow angle to be produced, as explained in Article 72, Section 2. If a signal is received, AVC voltage will be produced, making the grid of the cathode ray tube negative and narrowing down the shadow.

Tubes of the 6E5 type, operate so as to close the shadow with only a small value of AVC voltage, while the 6G5 is of the remote cut off type, and therefore the shadow angle closes on a relatively large AVC potential. As a visual indicator, this tube has the advantage that it does not draw current from the circuit to which it is connected, and from which the grid receives its signal or control voltage.

115. ALIGNING SUPERHETERODYNE RECEIVERS

We have seen from our previous study of the superheterodyne that there are a number of semi-fixed tuned circuits in the receiver, as well as the continuously variable circuits, such as those controlled by the gang condenser. The proper adjustment of the I.F. or semi-fixed tuned circuits in the superheterodyne receiver is so important that

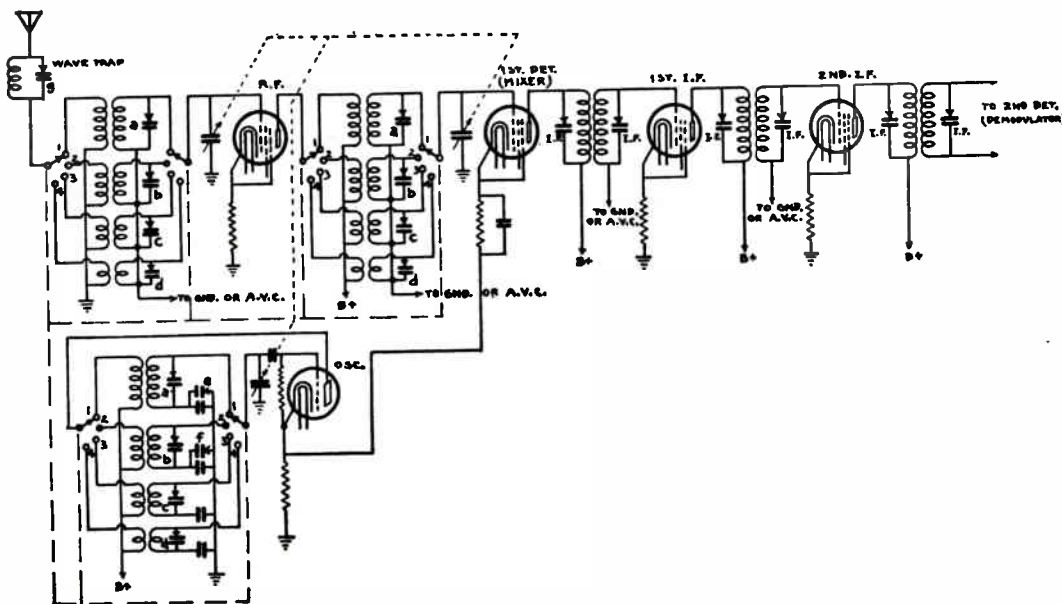

Fig. 164. Circuit diagram of the R. F. stages, first detector, I. F. stages and oscillator sections of an all-wave receiver. Refer to this diagram while studying the instruction on aligning "supers."

every radio service man should be thoroughly familiar with the proper procedure and equipment for balancing, phasing or aligning these circuits.

If a superheterodyne receiver is out of proper balance or alignment, it may be indicated by one or more of the following symptoms: (1) incorrect dial readings for the frequency of the signal tuned in; (2) the receiver may oscillate at certain dial settings but not at others; (3) stations may be received satisfactorily over a portion of the tuning band and not over the remainder of the band; (4) broad tuning or poor selectivity.

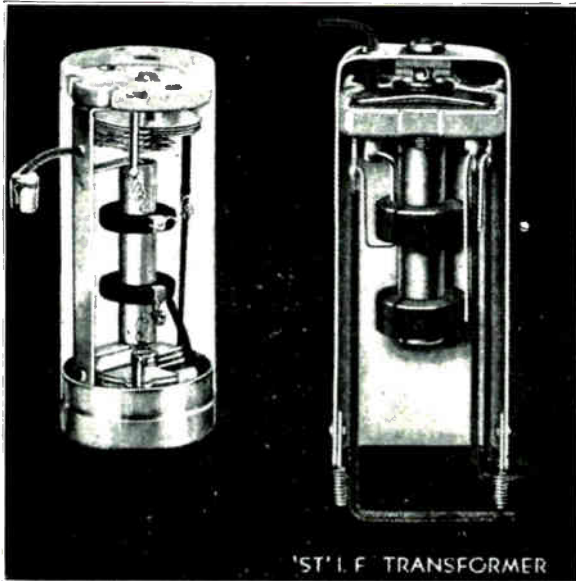

Fig. 165. Two types of I. F. transformers. The one on the left has an air type, variable trimmer condenser, while the one on the right has a mica type, screw-adjusted trimmer condenser in the top section.

Detailed information on the procedure for alignment of most receivers may of course be obtained direct from the manufacturer or from one of standard radio service manuals, which a service man should have on hand. In this lesson, however, we will take up the general method of alignment, leaving the minor details of each individual receiver to be taken care of at the proper time.

Referring to the block diagram of the superhet in Fig. 157, we see that the I.F. is that section of the receiver, with adjustable circuits, immediately ahead of the demodulator tube. We can also see that the I.F. must be in proper working order before we can hope to get any signals through from the RF and mixer stages.

Therefore our first step in the alignment of any superheterodyne receiver is to align the I.F. For our example, we will assume the intermediate frequency to be 460 kc., and that we are to tune or balance the I.F. to this frequency. Referring to Fig. 164, you will note there are two I.F. stages using a total of three I.F. transformers.

These transformers are really R.F. transformers which are tunable over a narrow range by the trimmer condensers shown connected across the primary and secondary windings and marked "I.F." These condensers as well as the other trimmers are of very small capacity and are generally varied by a screw adjustment. Usually the primary and

secondary windings of each transformer are mounted in a shield can, together with the two trimmer condensers. These units can be seen in Fig. 156 in the second row from the left, or the units with the small nuts on the top of the shields.

Figs. 165 and 166 show cut away views of several types of I.F. transformers. Note the trimmer condensers in the top of each transformer. Also see the several trimmer condensers shown separately in Fig. 167.

116. ALIGNING PROCEDURE. SIGNAL GENERATORS

In order to tune a number of R.F. circuits to the same frequency, it is necessary to apply an R. F. signal, of the correct frequency, and then adjust these circuits for maximum output from the amplifier. The source of R.F. signals used in alignment work is usually a signal generator, which produces R.F. signals of a known frequency, either modulated or unmodulated. This generator has a dial which is accurately calibrated in kilocycles and megacycles so that the operator may set the instrument correctly to any frequency he desires. Controls are also provided to regulate the output energy. See Figs. 168 and 169.

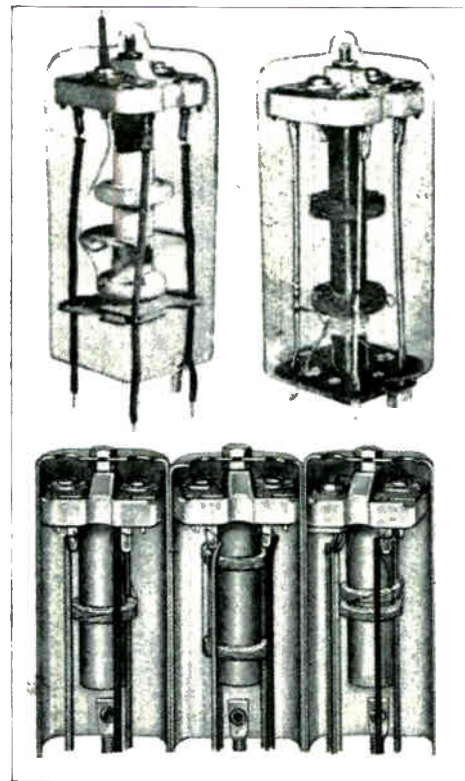

Fig. 166. Several more types of I. F. transformers, showing coils and trimmer condensers. The trimmers are located underneath the adjusting screws on top of the porcelain sections.

For our first step we will set our signal generator at 460 kc., with the modulation on, and feed its energy into the I.F. amplifier of the receiver. The ground lead from the generator should be connected to the metal chassis of the receiver, and the antenna lead connected to the control grid of the mixer tube. Be sure to lift off the grid lead from this tube before connecting the generator's antenna lead.

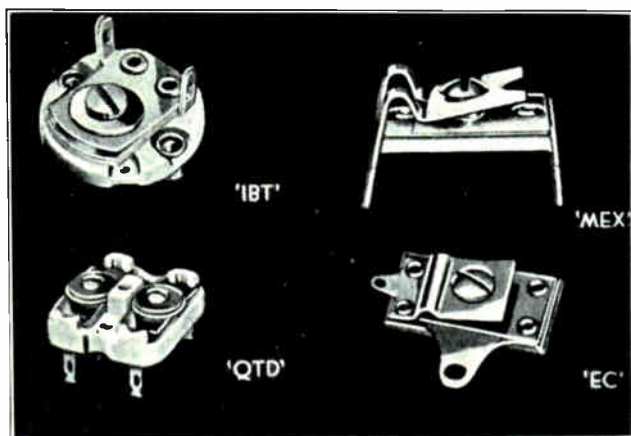

Fig. 167. Several types of trimmer condensers such as used on I. F. and R. F. transformers for aligning or balancing their circuits. The movable plate or strip is moved closer to, or farther from, the stationary plate by turning the adjusting screws.

Now before making any adjustments, turn the volume control of the receiver on fully and leave it there until the set is all aligned. Any adjustment for signal volume is now made at the generator. In this way we avoid overloading of tube circuits and prevent A.V.C. action and consequent broad tuning of circuits.

Then, with an insulated aligning tool, such as shown in Fig. 170, adjust the I.F. trimmer condensers for maximum output from the receiver, starting with the one next to the second detector and aligning them all in order, back to the mixer tube. These adjustments are quite critical and extreme care should be exercised during this procedure, always using the smallest amount of energy from the signal generator, that it is possible to work with.

117. ALIGNING R.F. STAGES AND OSCILLATORS

Now that the I.F. is aligned, transfer the signal generator leads to the antenna and ground posts of the receiver, and replace the grid lead on the mixer tube. We will now proceed to balance the high

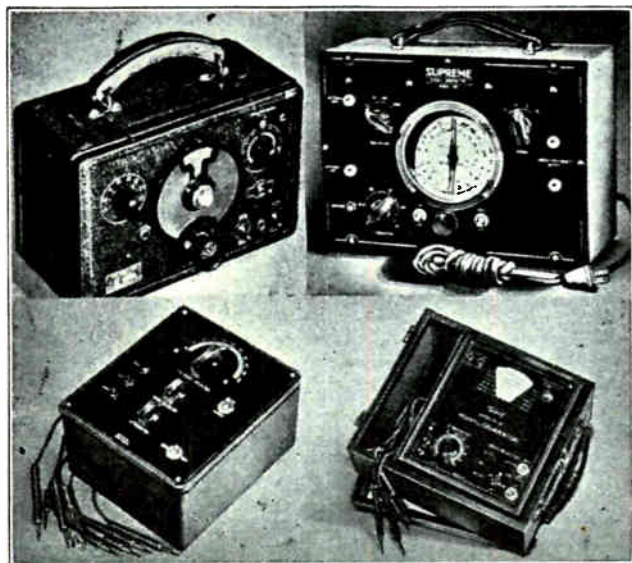

Fig. 168. This view shows several types of signal generators such as used for aligning "supers."

frequency portion of the receiver on the broadcast band, there being two aligning points, one at the high and one at the low frequency end of the dial. The adjustments on the high end of the dial, usually at 1400 kc., should be made first.

To do this, set the receiver dial to 1400 kc. and the signal generator to the same frequency. In Fig. 164, there are three high frequency trimmer condensers marked with the letter "a," one on the oscillator, one on the mixer and one on the R.F. stage. These condensers should now be adjusted, in the order named, until maximum output is obtained at the speaker terminals.

For alignment of the low frequency end of the dial set the signal generator and the receiver dial to 600 kc. and adjust the oscillators low frequency padder condenser, labeled "e" in the diagram, for maximum output at the speaker terminals of the receiver.

On sets having a wavetrap, set the dial of the receiver to 550 kc. and adjust the frequency of the generator to that of the I.F. Then adjust the wavetrap condenser for minimum output. The purpose of the wavetrap is to reject any signal having a frequency the same or near that of the I.F. fre-

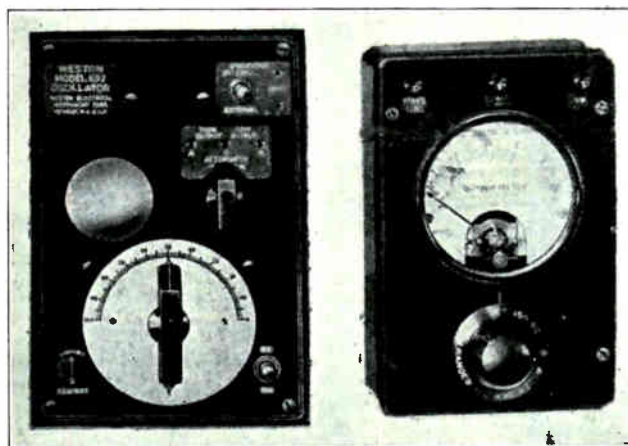

Fig. 169. On the left is shown another type of signal generator, and on the right is an output meter for checking the receiver output while balancing or aligning.

quency. For example, beacon or commercial code station signals, which if quite strong, would force their way through the R.F. and mixer stages and get into the I.F., where they would be amplified along with any other signal we wished to receive. This would, of course, cause interference with reception, and thus we see it is the purpose of the wavetrap to suppress these undesired signals. That is why we adjust the wavetrap for minimum output at the I.F. frequency.

On all-wave receivers, there will be additional aligning adjustments to be made on the short wave bands. The procedure is very similar to that used on the broadcast band, and for most accurate alignment these adjustments should be made by following the manufacturers instructions. Note the aligning data or instructions shown in Fig. 159 for that particular receiver.

It is possible to align a receiver by ear, using the volume of sound from the loudspeaker as our indication of set output, but a much more accurate

method is to use an output meter or visual indicator such as shown on the right in Fig. 169. This output meter may consist of a dry disk type rectifier connected to a low reading D.C. milliammeter. The rectifier is used to rectify the applied A.F. signal so that it will operate the D.C. meter.

Connections of this output meter to the A.F. stages may be made in several ways as shown by the dotted lines in the diagrams in Figs. 171-B and C. Perhaps the handiest method is to connect it directly across the voice coil terminals, as these are usually accessible on the rear of the speaker.

118. ALIGNING WITH A "TUNING WAND"

The "tuning wand" is a tool that may be used to determine the correctness of the receiver alignment without disturbing the adjustments of the trimmer condensers. This can be done by supplying the receiver with a signal from the signal generator, and inserting the "tuning wand" through the opening provided in the shield over the I.F. transformers.

The "tuning wand" consists of a non-metallic rod of bakelite or rubber, having a brass cylinder attached to one end and a small core of finely divided iron on the opposite end. See Fig. 170.

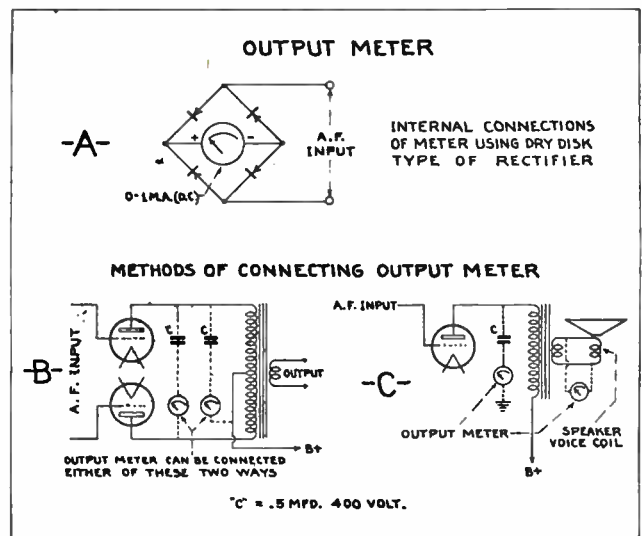

Fig. 171. At "A" are shown the connections of an output meter and its rectifier. At "B" and "C" are shown methods of connecting output meters to receivers when aligning "supers."

Inserting the brass cylinder into the coil will lower the inductance, and increase its resonant frequency.

Inserting the iron end will increase the inductance of the coil, and decrease its resonant frequency.

The trimmer capacity should be increased when the signal increases by inserting the iron end. If the signal increases by inserting the brass cylinder, then the trimmer capacity should be decreased. A decrease in the signal by inserting either end indicates correct alignment and therefore the trimmers do not need adjusting in this case.

Necessary Adjustment Indicated "by the Tuning Wand"

End of wand inserted	Effect on signal	Capacity adjustment required
Brass end	Increase	Decrease capacity
Iron end	Decrease	
Brass end	Decrease	Increase capacity
Iron end	Increase	
Brass end	Decrease	None
Iron end	Decrease	

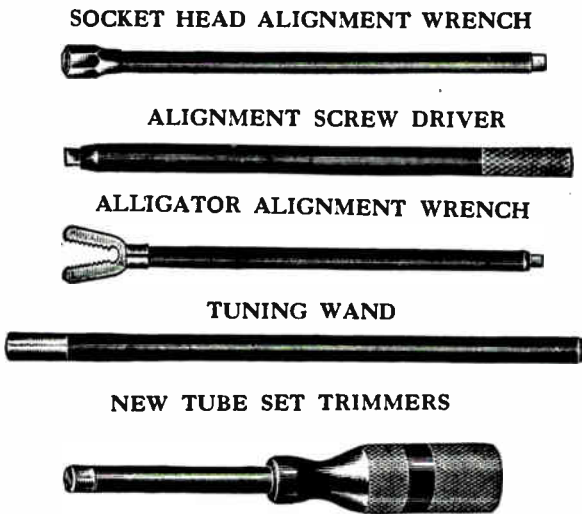

Fig. 170. Several types of aligning wrenches and screwdrivers, and also a tuning wand for aligning "supers."

RADIO PANEL LAMPS

Type No.	Volts	Amps.	C. P.	Bulb	Base	Bead Color	L.C.L. Inches	M.O.L. Inches
40	6-8	0.15	0.5	T-3 1/4	Min. Screw	Brown	29/32	1 1/8
40-A	6-8	0.15	0.5	T-3 1/4	Min. Bayonet	Brown	23/32	1 1/8
41	2.5	0.5	0.5	T-3 1/4	Min. Screw	White	29/32	1 1/8
42	3.2	0.5	0.75	T-3 1/4	Min. Screw	Green	29/32	1 1/8
43	2.5	0.5	0.5	T-3 1/4	Min. Bayonet	White	23/32	1 1/8
44	6-8	0.25	0.8	T-3 1/4	Min. Bayonet	Blue	23/32	1 1/8
45	3.2	0.5	0.75	T-3 1/4	Min. Bayonet	Green	23/32	1 1/8
46	6-8	0.25	0.8	T-3 1/4	Min. Screw	Blue	29/32	1 1/8
48	2.0	0.06	0.03	T-3 1/4	Min. Screw	Pink	29/32	1 1/8
49	2.0	0.06	0.03	T-3 1/4	Min. Bayonet	Pink	23/32	1 1/8
49-A	2.1	0.12	0.07	T-3 1/4	Min. Bayonet	White	23/32	1 1/8
50	6-8	0.2	1.0	G-3 1/2	Min. Screw	White	23/32	15/16
292	2.9	0.17	0.3	T-3 1/4	Min. Screw	White	29/32	1 1/8
292-A	2.9	0.17	0.3	T-3 1/4	Min. Bayonet	White	23/32	1 1/8

AUTOMOBILE MINIATURE TYPES

51	6-8	0.2	1.0	G-3 1/2	Min. Bayonet	White	1/2	15/16
55	6-8	0.4	1.5	G-4 1/2	Min. Bayonet	White	1/2	1 1/16

AUTOMATIC TUNING AUTOMATIC FREQUENCY CONTROL ALL WAVE RECEIVERS

Tuning of radio receivers has been so greatly simplified in the last few years that it seems a long step from the earlier sets, with their numerous controls and dials, to the present day receiver with its push button tuning. Formerly we were very content with single dial operation, but today we have available a still easier method of dialing, merely that of pushing one of several buttons on the front of the receiver, each labeled with the call letters of your favorite station, as shown in Figs. 172 and 174.

Going a step further, we find arm chair controls, consisting of extended hidden cables from the radio console receiver, and terminating in a small control block about the size of a book. This block has a duplicate set of push buttons all labeled the same as those on the receiver, so that the set may be remotely tuned while sitting in an easy chair across the room.

All such additional automatic tuning apparatus tends to make radio receivers more popular and more convenient to operate. It also makes added work for the trained service man, in adjusting and servicing such mechanisms.

119. MOTOR OPERATED TUNING SYSTEMS

Two of the common systems of electric push button tuning in general use today, both utilize a small electric motor to rotate the gang condensers in tuning the receiver. These systems differ only in the manner in which selective control is accomplished.

First, let us consider the simplified diagram of the system shown in Fig. 173. At the upper left, we see a motor coupled to a shaft, carrying several selector disks, the other end of the shaft being coupled to the tuning condenser gang. A side view of one selector is also shown at the upper right. "C" is a round disk having a small slot cut in the edge at "K". The slot is just large enough to allow the end of arm "A" to drop in. When arm "A" drops, contact "X" will open the motor circuit. "P" is the control push button and when pushed in will allow "A" to drop down, when "K" is in the proper position. With "P" out, arm "A" cannot drop down, even if slot "K" does come into position.

Disk "C" may be rotated to any desired station position on the shaft and then clamped to the shaft by means of a set screw, at the time the set is installed. Thus, we may set the selector disk in such a manner that the motor will rotate the shaft and gang condensers to a certain point or station, at which time arm "A" drops down into slot "K", instantly shutting off the current to the motor and locking the shaft in position to prevent it from coasting on past the proper point. As many as 16 selector positions are used in some models, permitting us to select 16 different positions to which the condensers may be turned, or in other words,

we may tune in 16 different stations by means of a push button control. Each selector button and switch arm is identical, and all the contacts "X" are connected in series so that breaking any one contact will stop the motor. The push buttons are so arranged that pushing any one button in, automatically resets any button previously depressed.

The second general system is similar to the first, only the selector disk arrangement is somewhat different. In the lower view in Fig. 173 we see a metal selector disk carrying an insulated segment "R". On the edge of this disk rides the contact arm "H". Pushing a button "P" will close the motor circuit through "H" to the disk, causing the shaft to rotate until "R" comes under "H" and breaks the circuit, stopping the motor.

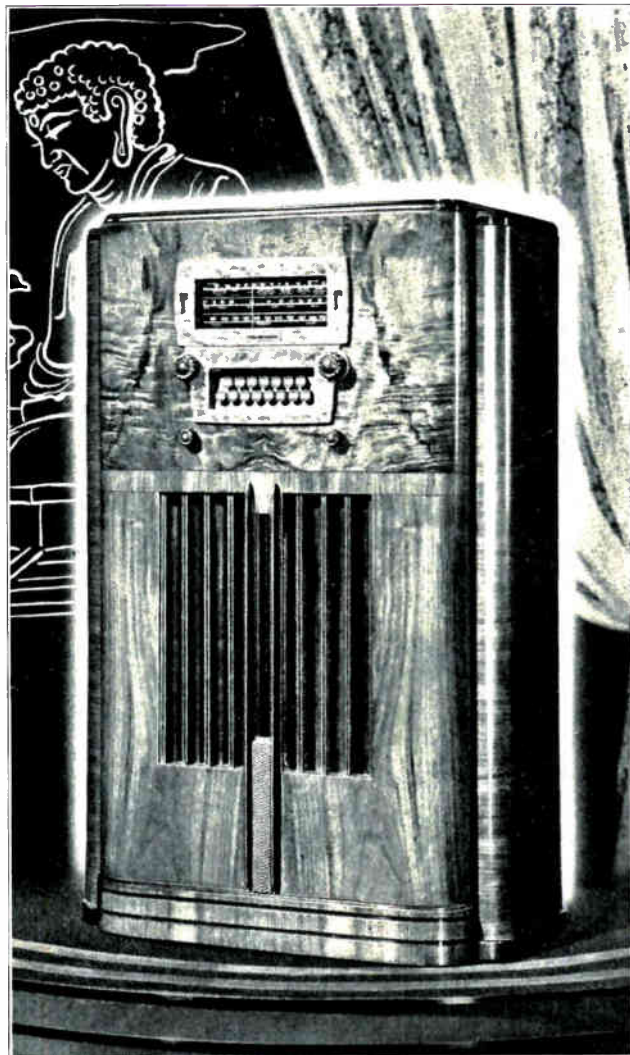

Fig. 172. Photo of a modern console type radio receiver, equipped with automatic tuning. Note the push buttons for quickly tuning in various stations by merely pressing the proper buttons. (Courtesy Stewart-Warner Company.)

Some means of quick, electrically controlled braking is employed to stop the shaft rotation precisely at the desired position, just as soon as the circuit is opened. A motor reversing switch also comes into action at the extreme end of the 180 degree arc through which the gang condenser moves. In this system also, a separate selector disk is used and pre-set for each station or push button control position. Fig. 174 shows a good view of the motor and disk selector mechanism and the push buttons of an automatic tuning unit for a modern receiver.

120. MANUAL AUTOMATIC TUNERS

Some sets use simpler manual automatic tuners, usually consisting of a series of push buttons set around the outer edge of the tuning dial, and so arranged that the operator merely pushes in a button and then pulls the dial around to a stop pin or position, at which point the desired station is tuned in. See Fig. 175.

One such system consists of a mechanical pin and stop mechanism so arranged that depressing

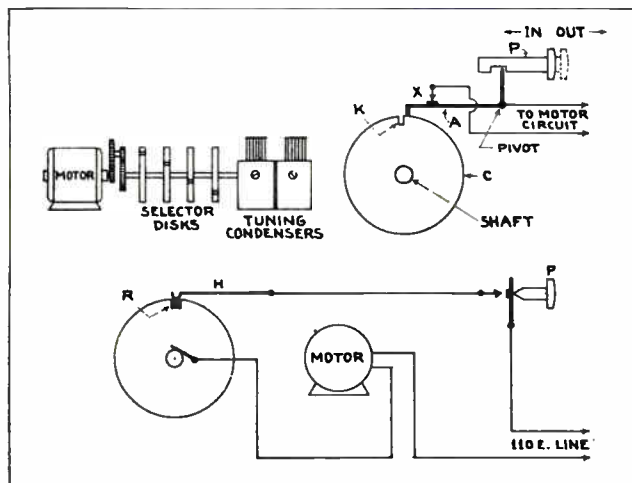

Fig. 173. The above diagrams illustrate principles of two types of automatic tuning systems which are explained in this lesson.

a button pushes out a pin in the rear of the dial, and as the dial is rotated this pin moves to the stop position. Here a locking latch catches and holds the pin, stopping the dial at a pre-determined point, thus tuning in the desired station.

Most of these systems employ a means of silencing the receiver during rotation of the dial, to eliminate several stations popping in and out as the dial is tuned from one setting to another. Many of the higher grade sets also employ automatic frequency control, while in the lower-priced receiver, a means is provided to broaden out the tuning whenever the push button feature is used. All of these sets may also be tuned by the usual manual tuning control.

121. AUTOMATIC TUNING BY CONDENSER SWITCHING

Still another method using push buttons for tuning control, is one utilizing several small semi-variable condensers which are switched in and out each time the high frequency circuits of the super-

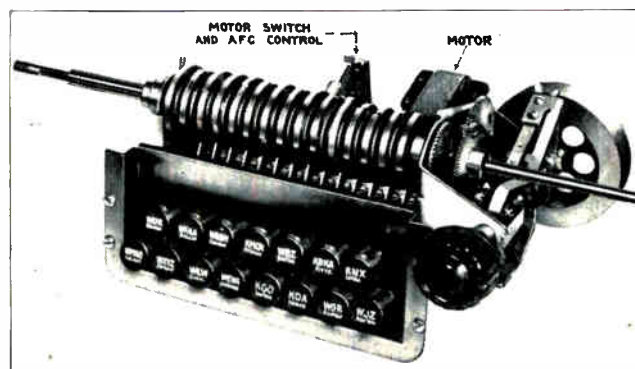

Fig. 174. This excellent photo shows the automatic tuning mechanism of a modern radio. Note the push buttons which energize the motor, which in turn rotates the gang condenser shaft until the proper disk or cam allows its catch to drop in the slot. Courtesy Stewart-Warner Company.

heterodyne receiver are to be tuned to another frequency. One set, usually three to a set, of pre-tuned condensers are used for each station desired. Pushing a button merely switches in another set of condensers resulting in the circuit being tuned to another frequency.

All of these various tuning systems, whether electrical or mechanical, require a qualified service man to make the initial adjustment necessary to pre-set each selector position of the push button tuning system. These adjustments are of a rather delicate nature and require precise settings, resulting in a job for the service man on the radio before it is placed in operation, as well as other calls of the usual service nature, later on.

We have previously explained how the selector disks on motor operated tuners can be carefully pre-set on the shaft by loosening their set screws, or in some cases by loosening a clutch, then tuning the set to each desired station by hand, and locking the disks in place.

Make sure these selector disks are accurately set, even if several repeat adjustments are necessary, as a receiver that does not tune accurately to the desired stations will produce poor tone quality and very unsatisfactory operation.

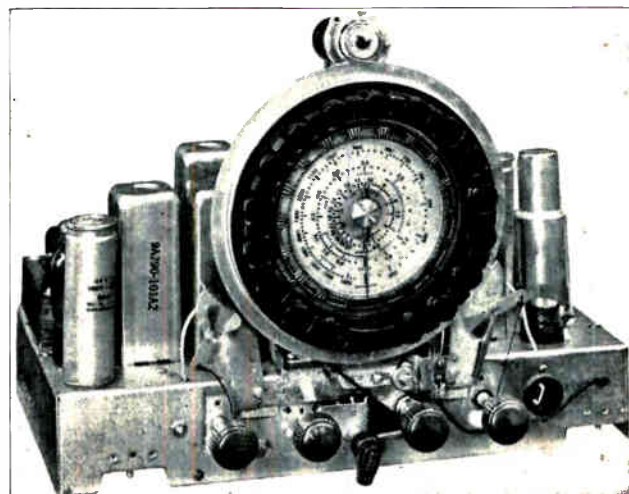

Fig. 175. A good view of the push button dial of the manual automatic tuning system used on another modern type of radio. Courtesy Wells-Garnder Company.

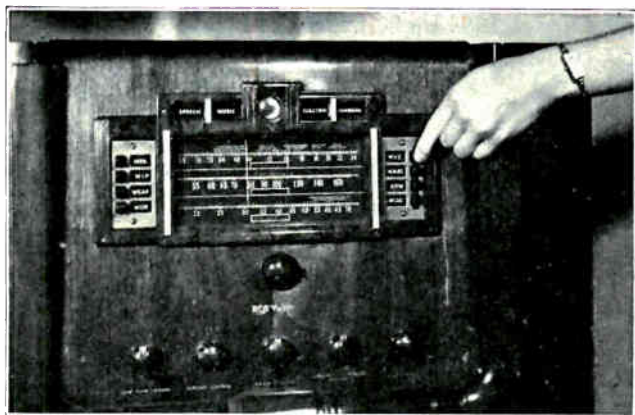

Fig. 176. Note the push buttons for automatic tuning on this console type receiver, and also the kilocycle and megacycle scales for the broadcast and short wave stations, the cathode ray tuning indicator above the scales, and the manual tuning knob below the scales. Courtesy R.C.A. Victor Corporation.

Most of the manual automatic tuning sets have simple instructions furnished with the set by the manufacturer or dealer. By careful examination of the tuning mechanism and these instructions you should be able to easily set the stop pins or buttons on the desired stations. Here again, however, be sure to set them carefully and accurately for sharp tuning and clear reception.

On receivers using fixed condensers for each separate station, the tuning adjustment can be made by cutting in or out one or more of the condensers in the block, and by small adjusting screws that slightly change the capacity of one or more of these condensers.

122. AUTOMATIC FREQUENCY CONTROL

In recent years, radio receivers have been made very selective, or "sharp tuning," thus making the correct tuning of the set a rather critical operation, if undistorted audio reproduction is to be enjoyed. To overcome any reasonable error the average operator may make in tuning in a signal, a system called automatic frequency control, or A.F.C., has been devised.

The action of this circuit is such that when tuning a receiver that is equipped with A.F.C., as the point is approached on the dial where a particular station or signal is ordinarily received, the signal will automatically be suddenly tuned in sharply,



Fig. 177. The above radio made by Stromberg-Carlson Company features "quick as a wink" automatic tuning. (Photo Courtesy of Stromberg-Carlson Company.)

and remain so even until the dial is moved a short distance past the station point. So accurate is this A.F.C. action that a 5000 micro-volt signal in the broadcast band will be pulled within 500 cycles, or $\frac{1}{2}$ kilocycle of resonance, when the dial is tuned to within 7 KC of the correct point. This is more accurate than a skillful operator will normally tune the receiver. It is interesting to note that the stronger the signal the greater the distance, from resonance, that the A.F.C. action will "pull" the receiver into correct tuning or resonance.

As with most developments in receiver design in the last few years, A.F.C. is used in conjunction with the superheterodyne circuit. Since A.F.C. effects the tuning of the receiver, whenever the tuning is changed either manually or automatically, the resulting I.F. signal must be kept at exactly the correct frequency for undistorted audio reproduction. For example, in a superhet receiver, if the I.F. transformers are tuned to 460 KC, the I.F. signal

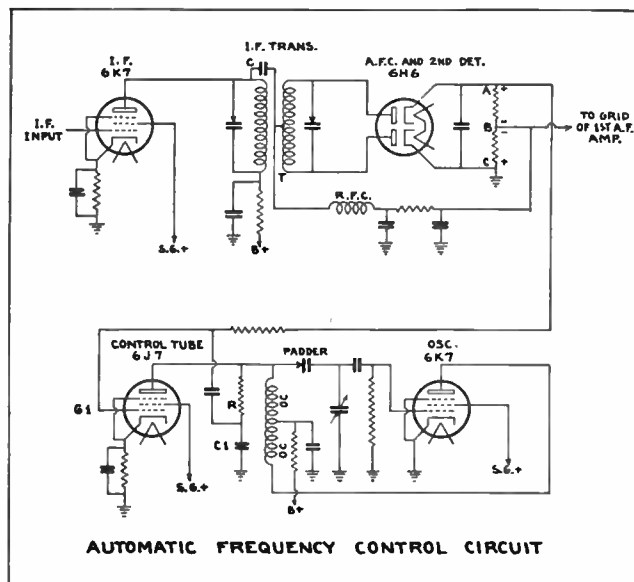

Fig. 178. Examine and trace out this automatic frequency control circuit very carefully while reading the explanation on these pages.

must always be of this value, and not three or four KC above or below this amount.

123. A.F.C. CIRCUIT AND PRINCIPLES

In Fig. 178 we see a simplified circuit of the A.F.C. section of a receiver. In addition to the last I.F. tube (6K7) the second detector (6H6) and the oscillator tube (6K7) of the regular superhet circuit, you will also note a "control tube" (6J7), which has been added for the A.F.C. The rest of the receiver circuit is not shown.

The control tube, is connected across the oscillator tuned circuit so as to change the frequency of oscillations, as required. This effect is controlled by varying the grid bias of the control tube to cause either an increase or decrease in oscillator frequency. This bias is supplied by the voltage drop existing between points "A" and "C."

From the diagram we see that the resistors between "A" and "B" and between "B" and "C," are diode load resistors connected across the cathodes of the 6H6 tube. If the current supplied by each

diode section of this tube is equal, no matter what the voltage drop across each resistor may be, the total voltage from "A" to "C" will be zero. This is due to the fact that the polarities across the two resistor sections are opposite as shown in the diagram, and will therefore neutralize or cancel each other if they are equal.

However, if the top diode section supplies more current to its load resistor "AB," than the other diode supplies to resistor "BC," the resulting bias

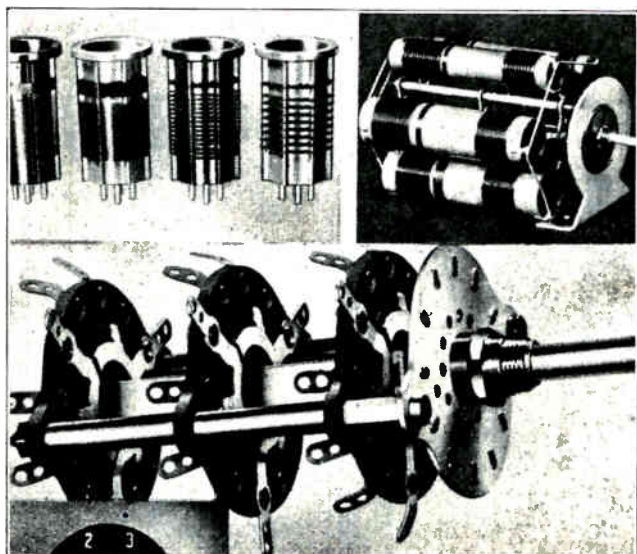

Fig. 179. At the upper left are shown several plug-in type coils, and at the upper right a set of coils and selector switch assembly for quickly changing wave lengths on all wave sets. In the lower view is shown a 3-gang, multi-point selector switch such as used for changing the coil connections on all wave receivers. Courtesy Montgomery-Ward & Company.

voltage from "A" to "C" will have a positive value, the negative end being to ground. On the other hand, if the lower diode supplied the most current, the bias voltage will have a negative value.

In order to obtain this varying bias voltage, the circuit from the 6K7 to the 6H6 tube has been made both inductively coupled through the I.F. transformer "T," and capacity coupled through condenser "C." By means of this condenser the R.F. signal across the primary of the I.F. transformer, also appears across the R.F. choke, marked R.F.C. This voltage is always in series with the secondary voltage supplied to the 6H6 diode tube plates, and when this circuit is at resonance both diodes are supplied with equal voltages.

Now, if the I.F. signal is less than 460 KC the induced voltage at the top half of the I.F. transformer secondary will lag behind the current more than it normally does, while the voltage at the bottom half leads the current more than normally. Adding each secondary voltage vectorially to that existing across the choke, gives us a greater net voltage applied to the top diode than to the lower, and consequently more voltage appears across resistor "AB" than across "BC." The resulting bias voltage supplied to the control tube will then be positive.

Naturally the more "off resonance" this I.F. signal is, the greater is the bias voltage generated.

If a signal above 460 KC is applied, the vector addition will now result in a negative grid bias being generated. We now have a means of supplying a varying grid bias to the control tube, as the receiver tuning is varied, and thereby changing the plate current of this control tube.

124. CHANGING THE OSCILLATOR FREQUENCY

Now if we use this plate current of the control tube to vary the effective inductance of the oscillator coil circuit, we can thus change the frequency output of the oscillator tube circuit. In the circuit shown in Fig. 178, the plate current of the control tube acts as an apparent inductance; connected across the oscillator coils which are marked O.C. If two inductances are placed in parallel the net result is a total inductance value less than the smallest original one. Thus, in a tuned circuit we can change the inductance or resonant point by connecting an additional inductance across the tuning coil. The smaller this added inductance, the greater will be the frequency change.

The grid "G" of the control tube is excited by the oscillator frequency, utilizing the voltage drop existing across C1, which lags behind the oscillator voltage by nearly 90 degrees. This causes the tube to draw a lagging plate current, which passes from B+ through the upper oscillator coil. This added current through the oscillator coil produces the effect of an added inductance connected across the oscillator tuned circuit.

If the grid bias of the control tube changes so as to cause a heavy lagging current to flow, we have the same effect as lowering the circuit inductance and thus raising the frequency of oscillation. A

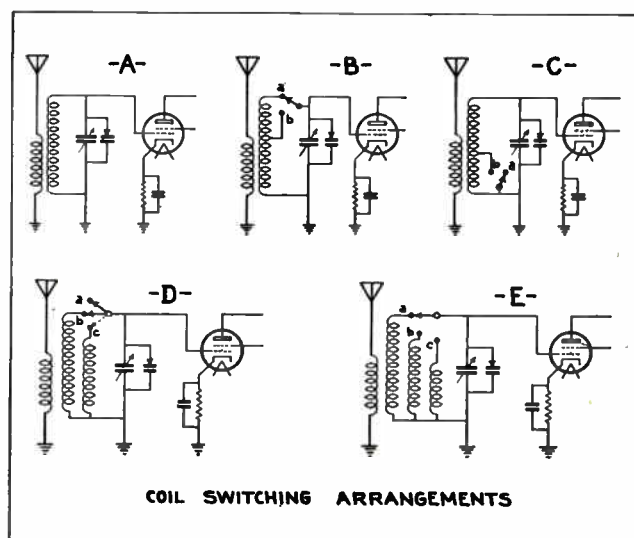

Fig. 180. The above sketches show several different methods of using tapped coils or separate coils, with different inductance values, for changing the frequency bands or wavelengths of receivers.

decrease in lagging current on the other hand will shift the oscillator to a lower frequency. Since the oscillator frequency is varied to obtain the correct I.F. signal for any given carrier, we find that as a signal is tuned in, the frequency of the oscillator is now automatically changed by the control tube until the bias voltage between "A" and "C" drops

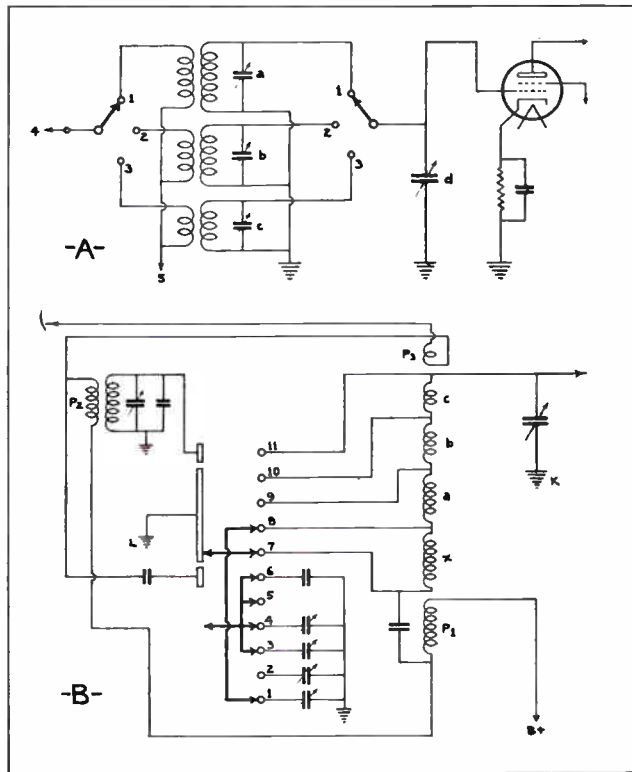

Fig. 181. These sketches show additional methods of switching coils for tuning different frequency bands on modern receivers.

to nearly zero, at which time the I.F. frequency will be of the correct value. This action takes place very rapidly and gives an apparent broad tuning on stations which are strong enough to bring the A.F.C. into action. In actual use, a switch is generally provided on the receiver for turning this circuit action on or off as desired.

So we can see that the purpose and advantage of the automatic frequency control tube and circuit in a receiver, is to automatically provide sharper tuning and clearer reception than the average set operator would obtain by manual adjustment of the tuning dial. This A.F.C. feature also greatly aids in securing proper tuning and clearer reception on sets equipped with automatic tuning, in case the tuning mechanism is not accurately set on certain stations.

125. TONE CONTROL

Most modern radio receivers are equipped with what is known as tone control, for regulating the proportionate strength of the high or low notes of voice or music delivered by the loud speaker.

Speech amplification equipment for public address systems and sound picture installations is also generally equipped with tone control.

Tone control can be accomplished by connecting across one of the audio frequency transformers, a condenser of the right capacity to absorb some of the energy of the high frequency notes, thus reducing their strength, without materially reducing the low frequency notes.

One system uses a variable resistor of about 100,000 ohms connected in series with the condenser to regulate the amount of control or absorption of high notes as desired. The condenser used for

this purpose is usually about .004 to .01 mfd. capacity. A choke coil in series with a variable resistor can also be used across the audio circuit, to absorb or shunt out some of the energy of low frequency or bass notes, without greatly affecting the higher frequencies.

You have learned that it requires much more energy to reproduce the low frequency notes than is required for those of higher pitch, so in some cases simple resistance type volume control is used to cut down the energy or volume, and thus reduce the low notes more than the high ones.

With certain voices or musical notes, and with certain acoustical conditions in rooms or auditoriums, it is often a great advantage to have tone control to make the reproduction of the voice or music more natural and pleasing.

Another system of tone control for reducing the higher audio frequencies uses a block of small fixed condensers, one or more of which can be connected across one of the audio stages by means of a multi-point tap switch. These condensers range in size from .001 to .006 mfd.

126. ALL WAVE RECEIVERS

In addition to the radio receivers which are made for receiving just the ordinary broadcast band of frequencies, there are also many receivers which are so constructed that they will receive signals in several different frequency bands, such as broadcast stations, police stations, aircraft and airport stations, special short wave broadcast and foreign stations, or amateur stations. These sets are known as all wave receivers or three band receivers, four band receivers, etc.

One common method of equipping radio receivers to bring in signals over several widely varying frequencies, is to provide tapped coils or extra sets of coils in the antenna coupling and R.F. transformer stages. These extra coils, having different numbers of turns for the various frequency bands, may be of the interchangeable plug-in types such as shown in the upper left of Fig. 179, or they may be permanently mounted in the receiver and

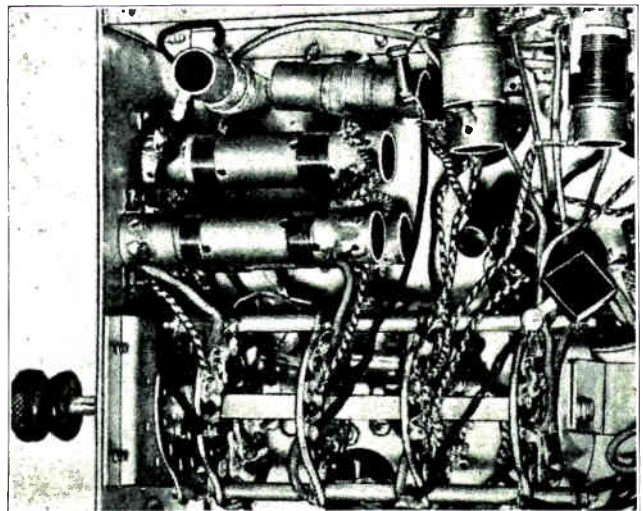

Fig. 182. This view of the under side of a radio chassis shows the gang selector switch and multi-wave coils of an all-wave receiver. Note that the four sections of the rotary multi-point switch are all ganged together on one shaft, for operation by the single knob shown on the left. Courtesy Short-Wave Craft.

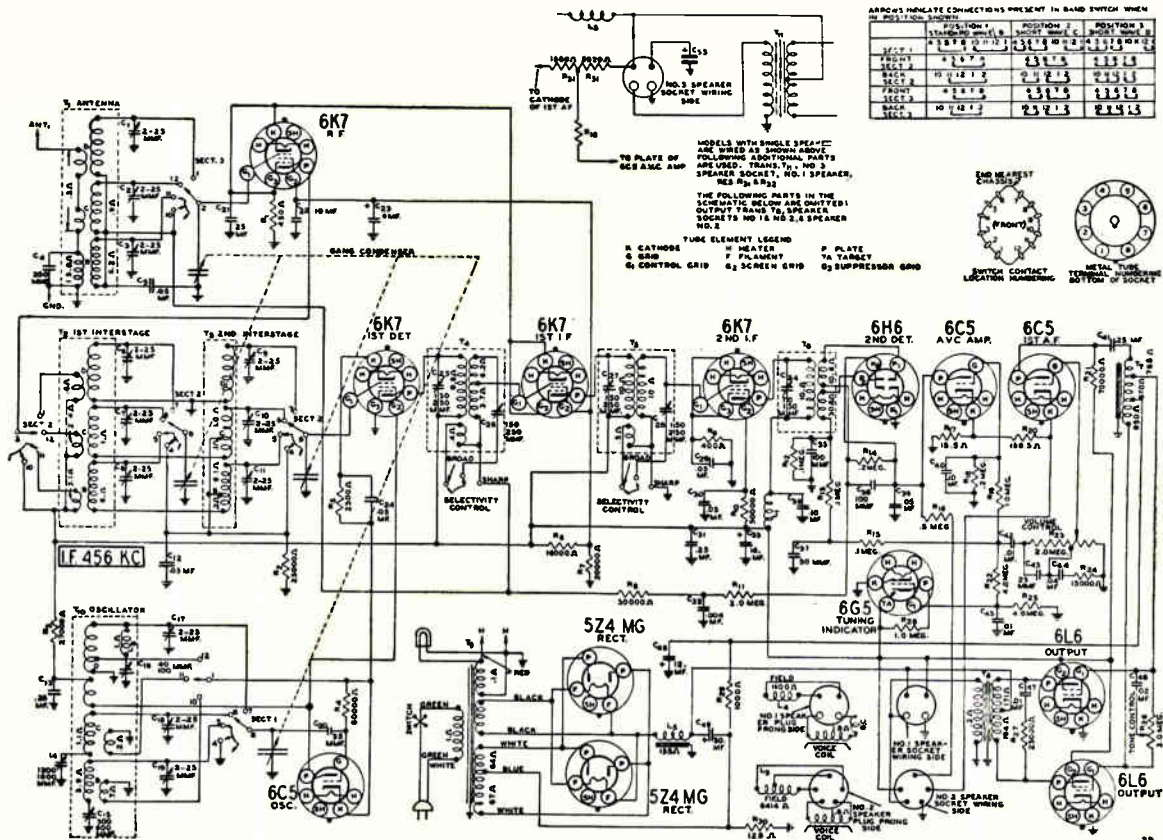

Fig. 183. Wiring diagram of another type of all-wave superheterodyne receiver, showing multiple band coils and selector switches. This is a good circuit to observe and trace carefully.

equipped with taps and with gang selector switches for cutting the proper coils or number of turns in and out of the circuit. See the coils in the upper right of Fig. 179, and also the multipoint or gang selector switch shown in the lower part of Fig. 179.

The plug-in type coils are often used in commercial and amateur type receivers, because of their greater accuracy. The multiple coil and gang selector switch arrangement is commonly used in household type receivers, because of their greater convenience, due to the single knob control for quickly changing to stations on different frequency bands.

127. TAPPED COILS AND BAND SWITCHES

The sketch shown at "A" in Fig. 180 shows the usual antenna coupling coils, condenser and first R.F. tube of an ordinary broadcast band receiver, which in some cases will also receive some of the police station signals. The tuning range of such a single coil and condenser will usually only cover frequencies ranging from about 550 to 1500 K.C.

The sketch at "B" in Fig. 180 shows a tapped coil arrangement by which the receiver can be tuned to cover either the broadcast band or one group of the shorter waves or higher frequencies, by merely shifting band switch (b). When the movable arm of switch (b) is thrown up to contact (a) the entire number of turns or inductance of the antenna transformer secondary is in the circuit, and the set will receive the broadcast frequencies. Changing the switch arm to contact (b) will cut out part of the turns of the coil, reducing its inductance and wave length, and the set will then receive short wave signals of higher frequency.

At "C" in Fig. 180 is shown another switching arrangement for a two-band receiver. When the switch arm is in contact with (b), it will short out the lower section of the coil and enable the set to be tuned to the higher frequencies. Shorting out the unused section of the coil in this manner eliminates dead ends of the winding and prevents losses due to absorption of signal energy in the dead turns. Placing the switch arm at (a) puts the entire coil in service for receiving broadcast signals.

128. MULTIPLE COILS AND SELECTOR SWITCHES

At "D" in Fig. 180 is shown another type of tuning arrangement in which one coil is used alone when the switch is in the upper position, or both coils are connected in parallel when the switch is in the lower position and in contact with (b) and (c). Connecting the two coils in parallel reduces their total inductance and enables the set to receive the higher frequencies. Additional coils can be provided and several more wave bands covered by this type of switching system.

The arrangement shown at "E" in Fig. 180 is one of the most common switching systems used on all wave sets. Each band has a separate coil with the proper number of turns. With the switch at (a), the set will receive broadcast frequencies. When the switch arm is moved to (b) the set can be tuned to shorter wavelengths, and at (c) still shorter wavelengths or higher frequencies will be received.

At "A" in Fig. 181, separate coils or transformers are used for each of the wave bands covered, thus eliminating the dead end losses of tapped coils.

ever, because numerous manufacturers are now turning out all kinds of receivers in attractive cabinets, and cheaper and better than the average individual can build them.

A general knowledge of the proper methods of set construction may be very useful to the trained radio man, however, in case he may desire to build experimental radio equipment, and it is also useful in making repairs to defective sets.

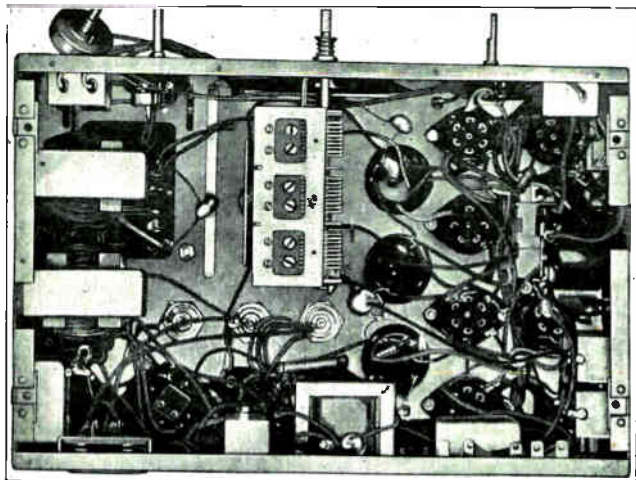

Fig. 186. View of the under side of a radio chassis, showing the wiring of the tube sockets, condensers, transformers, etc.

One of the first rules for building a good receiver or amplifier is to use good parts. Good quality transformers, condensers, and tubes should give efficient and dependable operation if carefully assembled and wired in a good circuit.

Parts should always be neatly and carefully arranged according to their order in the circuit, to keep the connections as short as possible, and yet have proper spacing between parts to prevent interference.

Transformers, sockets, and stationary parts are usually lined up on a chassis or base of bakelite or metal. Bakelite has the advantage of being easy to mount and fasten the parts on, while metal aids in shielding the parts and provides convenient common ground connections for various parts of the circuit.

The sub-panel is very often mounted several inches above the bottom edge of the chassis to permit parts to be mounted both above and beneath it for compactness of the set.

R.F. transformers and parts should be spaced several inches apart, or else shielded from each other by enclosing them in partitions or "cans" of sheet copper or aluminum about $\frac{1}{82}$ " thick.

Proper shielding enables the set to be more compactly built and prevents interference between parts and stages. Shields should surround the parts as completely as possible, in order to entirely prevent inductive interference and distortion. See Fig. 185, which shows a photo of a modern receiver, with shields around the tubes and R.F. transformers.

Never use iron or any magnetic materials, or any very thin high resistance metals for shielding. Shields should be kept about one-half inch from the sides of R.F. coils and an inch from their tops.

Parts in separate circuits or stages should be enclosed in separate shielding compartments. Any parts which are mounted on the shields should be carefully insulated from them, unless the part is supposed to be connected or grounded to the shield, in which case a secure dependable connection should be made.

Take particular care to see that any uninsulated wires or terminals do not touch the shields. See that all shields are well fitted and fastened securely so they cannot vibrate, and make sure that they are all well grounded. The grounded metal chassis and shields of modern sets are generally used as a common ground for all negative return leads.

If audio transformers are not shielded, and if they are to be mounted very close together, it is well to mount them with their cores at right angles to each other to prevent magnetic linking of their fields.

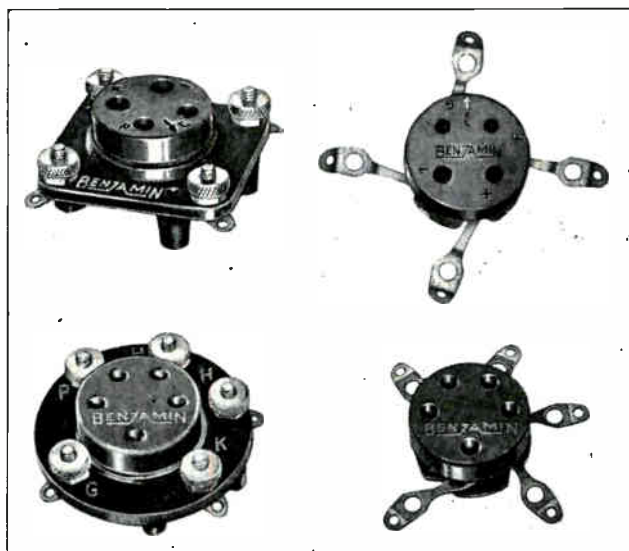
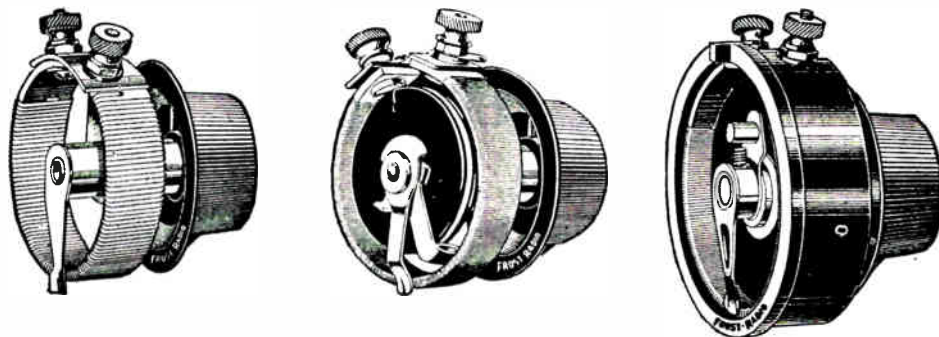

Fig. 187. Several types of tube sockets for both four and five prong tube bases. Note the connection terminals and goldering lugs for securely attaching the wires. (Photo courtesy of Benjamin Electric Mfg. Co.)

Fig. 188. At the right are shown several types of variable resistors such as are used for filament rheostats, volume controls, biasing potentiometers, etc.



130. RECEIVER WIRING

Radio set wiring was formerly extensively done with stiff, bare, nickel plated copper wires of about No. 14 B & S gauge, known as bus wire. This form of wiring if properly done, makes a neat and impressive appearing job, but it is no better and in some cases not as good as the wiring with flexible insulated wires, which are used almost exclusively in modern sets. Fig. 186 shows a good job of wiring of the tube sockets, condensers, resistors, and transformers on the under side of a metal chassis.

The flexible wiring is much quicker and cheaper, more compact, and fully as efficient if properly done. The wire used for this purpose is usually a flexible wire of number 14, 16, or 18 size, and insulated with rubber or waxed cotton covering.

All joints and connections whether made between wires, or between wires and terminals on parts and devices, should be carefully and securely made, and then well soldered. This is extremely important because the energy in some of the circuits is so small that any appreciable resistance in

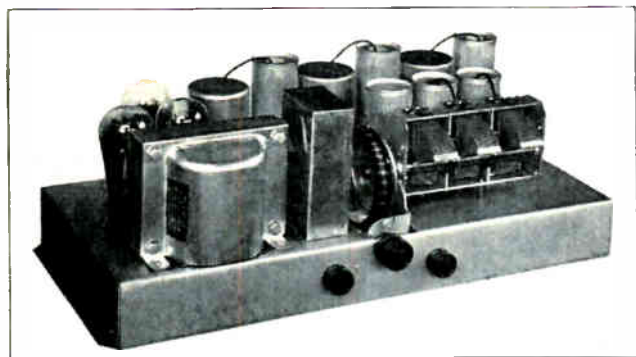

Fig. 189. This photo shows another view of compact, factory made receiver with the power unit located on the left. Note the arrangement and shielding of parts. The wiring, A. F. transformers, and some other small parts are located beneath the sub-panel.

the connections will greatly reduce the efficiency of the receiver. It is also important because joints or connections, which work loose even slightly, will cause a lot of crashing and sputtering noises in a receiver when the set or wires are vibrated or jarred.

Radio parts are usually equipped with connection terminals or soldering lugs. Fig. 187 shows several tube sockets with their soldering lugs and terminal nuts for attaching the wires to them. Fig. 188 shows several rheostats with terminal nuts or "binding posts."

When soldering joints and connections in radio receivers or amplifiers, always use a good non-corrosive flux, and take pains to do a neat and thorough job. Make sure the splice is well cleaned, well heated, and fluxed so that the solder when applied will flow freely and neatly, and make a permanent low resistance connection. "Resin joints" or soldered connections which appear good on the outside, but from which the flux was not thoroughly heated or boiled out, are often the cause of failures in radio receivers.

When wiring a receiver never run grid and plate wires parallel or close to each other, on account of the objectionable feed back coupling and distortion this will cause. Also avoid running parallel to each other any conductors which carry high frequency

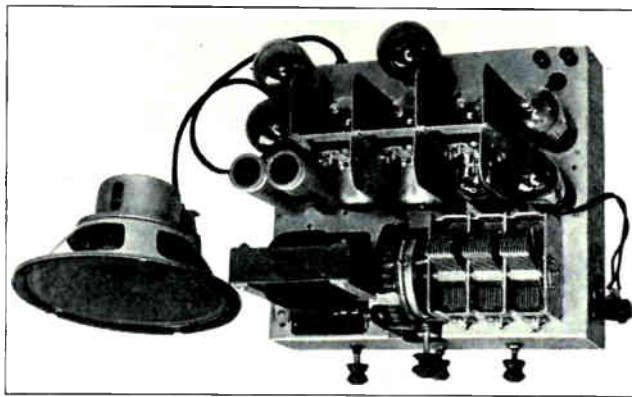

Fig. 190. This photo shows a top view of an A. C. receiver of still different construction and shielding than either of those shown in Figures 185 or 189.

currents, unless these wires are separated an inch or more apart, or are shielded.

Fig. 189 shows a front view of a factory-made A.C. set. The power pack is on the left and the gang condensers with the front of their shield removed, are shown to the right of the tuning dial. Note the arrangement of the shielded tubes and R.F. transformers at the rear. The tube shields can be distinguished by their perforations to let out the heat. The non-perforated "cans" contain the R.F. transformers. The A.F. transformers are under the sub-panel on this set.

Fig. 190 shows still another arrangement of tubes, R.F. transformers and shielding of a factory-built chassis. Note the power transformer, tubular electrolytic filter condensers, and rectifier tubes of the power pack on the left. Also note the screen grid tubes, distinguishable by their top connections, the large power tube at the rear, the tuning condensers, tuning dial, etc.

Fig. 191 shows the under side of the sub-panel of one type of chassis and part of the set wiring.

These various views give a general idea of the type of construction, wiring, and shielding of some makes of factory-built sets. You can readily see how sets of this type should if properly built, give better results than home-made sets will, unless considerable time and trouble is spent on the shielding and wiring of the home built receiver.

Many good receivers, amplifiers, and special experimental radio devices can be built in the home or small shop, however, if the parts are properly spaced, or shielded, and if the general rules just given are carefully followed.

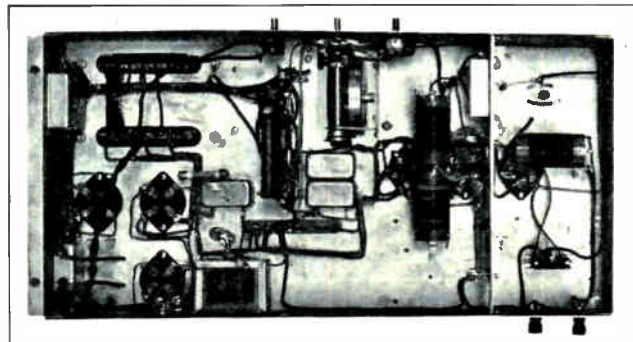

Fig. 191. This view shows the under side of the sub-panel of a factory made receiver. Note the wiring and parts which are conveniently arranged beneath this panel. (Photo courtesy of Silver Marshall Inc.)

130A. FREQUENCY MODULATION

A system of modulation called "Frequency Modulation" (F. M.) has recently been developed and installed by a number of broadcast stations. It is very popular for short range transmission, due to increased quality and lower noise level as compared to amplitude modulation (A. M.).

The F. M. system maintains a constant amplitude carrier, while the frequency of the carrier varies in accordance with the audio energy.

The difference in the two systems of modulation is—with A. M. the amplitude varies and the frequency remains constant; with F. M. the frequency varies and the amplitude remains constant.

For an example of F. M., we shall assume that an audio frequency of 500 C. P. S. is impressed on a 40 M. C. carrier. The frequency of the carrier would be continually shifting above and below 40 M. C. at the rate of 500 times per sec. The amount of the frequency shift would be governed by the strength of the audio signal.

The circuits required for F. M. transmission and reception are different than those required for A. M., as illustrated in figures 191A and 191B. This means

High quality is obtained because the width of the transmitter channel is not affected by the frequency of the audio energy. Due to this fact, it is possible to modulate the carrier with all the audible frequencies in the range of the human ear.

Reproduction of sound practically, free of static is obtained by the use of a "Limiter Circuit," shown in the upper part of Fig. 191B. Static causes the

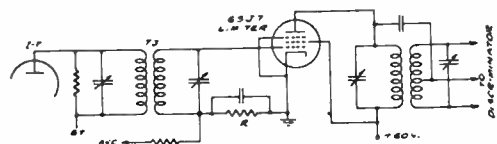

THE LIMITER STAGE IS USED IN F.M. RECEIVERS TO REMOVE VARIATIONS IN AMPLITUDE OF THE FREQUENCY-MODULATED WAVE. LOW PLATE AND SCREEN VOLTAGES ARE EMPLOYED SO THAT THE LIMITER OVERLOADS EVEN WHEN THE INPUT SIGNAL IS WEAK. THE OUTPUT AND TO THE DISCRIMINATOR IS THEREBY MAINTAINED CONSTANT REGARDLESS OF VARIATIONS IN THE STRENGTH OF THE INCOMING SIGNAL DUE TO NOISE OR OTHER CAUSES. THE LIMITER IS NOT USED IN A.M. RECEIVERS.

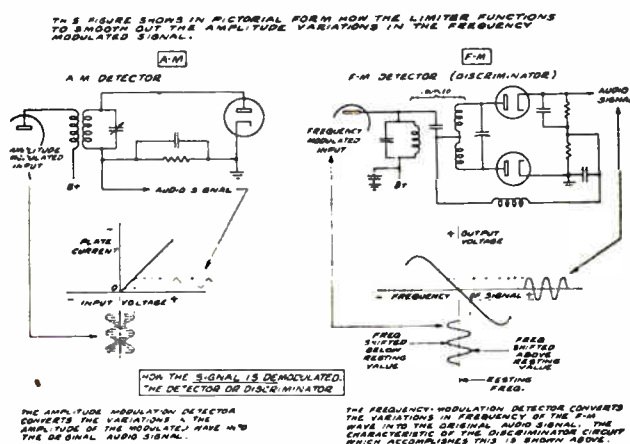
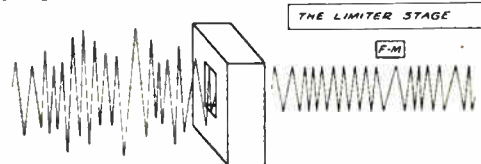

Fig. 191B. Top, circuit of F.M. limiter stage, center, illustration of limiter stage operation. Bottom, comparison of A.M. detector and F.M. detector or discriminator circuits.

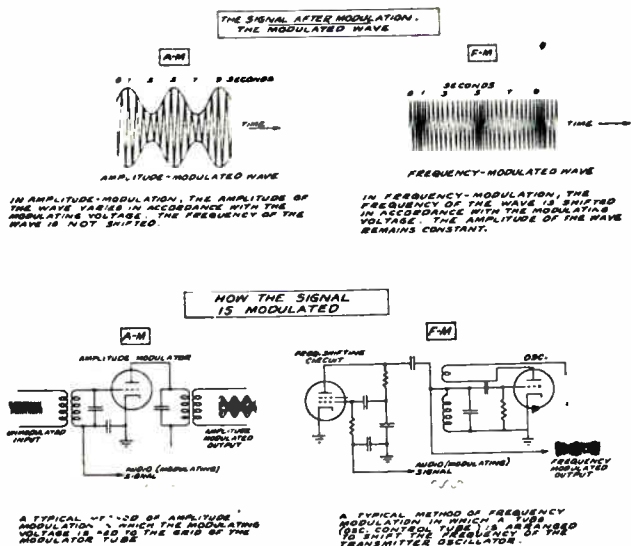

Fig. 191A. This diagram illustrates the difference between A.M. and F.M. modulated waves above, and modulating circuits below.

that a receiver designed for A. M. reception will not receive F. M.; however, F. M. converter units are manufactured, enabling the reception of F. M. on high quality A. M. receivers. Combination A. M. and F. M. receivers are also made with the change-over accomplished by the band-switch

F. M. transmitters operate on ultra-short waves around 42 M. C., which limits the dependable range to a straight line of vision distance.

amplitude of a carrier wave to vary. When the signal is passed through the limiter circuit, the peaks of the carrier are clipped off, thus reducing the carrier to a constant amplitude, which eliminates the static, but in no way affects the audio energy.

On account of the above mentioned advantages Frequency Modulation has developed rapidly and will no doubt become very extensively used in the future.

With an understanding of the basic difference in circuits and principles of F. M. receivers, much of the information on radio servicing covered in the following pages can be applied to F. M. receivers as well as to A. M. units, as their fundamental parts and troubles are very much the same.

RADIO SERVICING

Radio servicing is one of the largest and most profitable branches of work for trained radio men, who have a thorough knowledge of radio principles, sets and circuits, and who know how to use modern service methods and instruments to quickly locate and repair radio troubles.

There are in use in this country over 28,000,000 household radio receivers, over 8,000,000 auto radios, and hundreds of thousands of public address, sound amplifier units, and radio inter-communication systems. Naturally many of these sets require occasional service and repairs to keep them in good operating condition.

Radio manufacturers, dealers and service shops, department stores, electric shops, hardware stores, and garages employ thousands of trained radio service men. Many independent radio service men operate profitable service shops and businesses of their own.

There was a time a few years ago when radio receivers were simple enough so that their owners or almost anyone with a little radio knowledge, could make many of the simpler needed repairs. Modern radio receivers, however, have been equipped with so many added features and circuits, and are so accurately constructed and delicately adjusted that a trained radio service man is required to make most of the repairs and adjustments.

Many of the older radio service men who have not had fundamental training in Electricity and Radio, are no longer able to properly or efficiently service modern radios. Here is where thorough practical training gives you the advantage, and should enable you to earn good money servicing radio sets that many other service men cannot handle.

The radio field has never been overcrowded with thoroughly competent service men. Many well trained radio men hold good jobs or operate a profitable service business in localities where other less efficient radio men say there is no opportunity to make money at this work. Keep this fact well in mind as you study and build up your knowledge to prepare yourself to do better work than the average and to make your services in demand where others fail to get the jobs or business.

A radio service man also has many opportunities to make extra money on sales of repair parts, additional improvements on sets, and the sale of new sets where old ones have become obsolete or worn out. This is where your special business course instruction will enable you to make extra profits which are often over-looked by the average service man.

Radio trouble shooting and service work can be both easy and interesting, as well as profitable, for one who has a good general knowledge of radio principles, circuits and devices as covered in your course.

131. COMMON RADIO TROUBLES

When starting to look for trouble in any radio receiver, always use a definite systematic method of testing each part and circuit, and keep well in mind what we have emphasized before, that any trouble or fault can be located by careful and systematic testing.

Remember the following fact at all times. No matter how complicated any type or size of radio may appear at first glance, any set is merely an assembly of tubes, transformers, condensers, resistors, sockets, switches and circuits. Therefore, a good knowledge of the operation and testing of each of these individual parts, applied with thorough, systematic test procedure and the proper test instruments, should locate any fault or defective part in any radio.

There are, of course, many possible causes of trouble in radio sets, but the most frequent and common troubles are generally caused by a few things, such as failure of power supply, (may be due to a blown fuse or a loose plug on the power supply cord) defective power transformer, rectifier or filter, defective tubes, defective condensers, resistors or transformers; circuits out of balance or alignment; or an open circuit, short circuit, ground or loose connection in some part of the set wiring.

Common Radio set troubles can be divided into four general classes as follows: (1) complete failure to produce any signals, (2) signals weaker than normal, (3) signals distorted from normal tone quality, (4) noisy reception.

In some cases, more than one of these troubles may occur at the same time. For example, when a receiver gives abnormally weak signals, distortion and noise will often accompany them.

Distortion can be divided into several classes as follows: Loss of low notes, producing "tinny," high pitched reproduction; coarse or rattling reproduction; loss of high notes, producing muffled reproduction. Noise can be divided into the following types: Hum, static, motor-boating, whistling or squealing, and microphonic noise.

Experience and practice will often enable one to recognize certain common radio troubles by the sounds or symptoms they cause. For example there is a certain characteristic howl of a microphonic tube; a certain type of hissing and crackling noise caused by weak A or B batteries on battery sets; certain classes of distortion due to defective tubes in detector or first A. F. stages, or defective A. F. transformers; low pitched 60 cycle hum due to defects in power supply unit, defective by-pass condenser or open grid circuit on first A. F. tube. Other symptoms of this nature will be explained later.

132. PRELIMINARY SERVICE INSPECTION

In starting to locate trouble in a radio receiver, if some familiar symptom does not indicate just about where the trouble is, you should first make a quick general examination of the tubes, antenna and ground connections, speaker connections, the plug, cord and 110 volt power supply for A. C. electric receivers, or the batteries of battery operated receivers.

If this general examination does not show up the trouble, you should then try to localize the trouble and determine whether it is in the antenna circuit, R.F. stages, I.F. stages, detector, A.F. stages oscillator section, power unit, or speaker.

If no signals are obtainable from the set, the trouble will usually be found in some part of the antenna circuit or in the power supply.

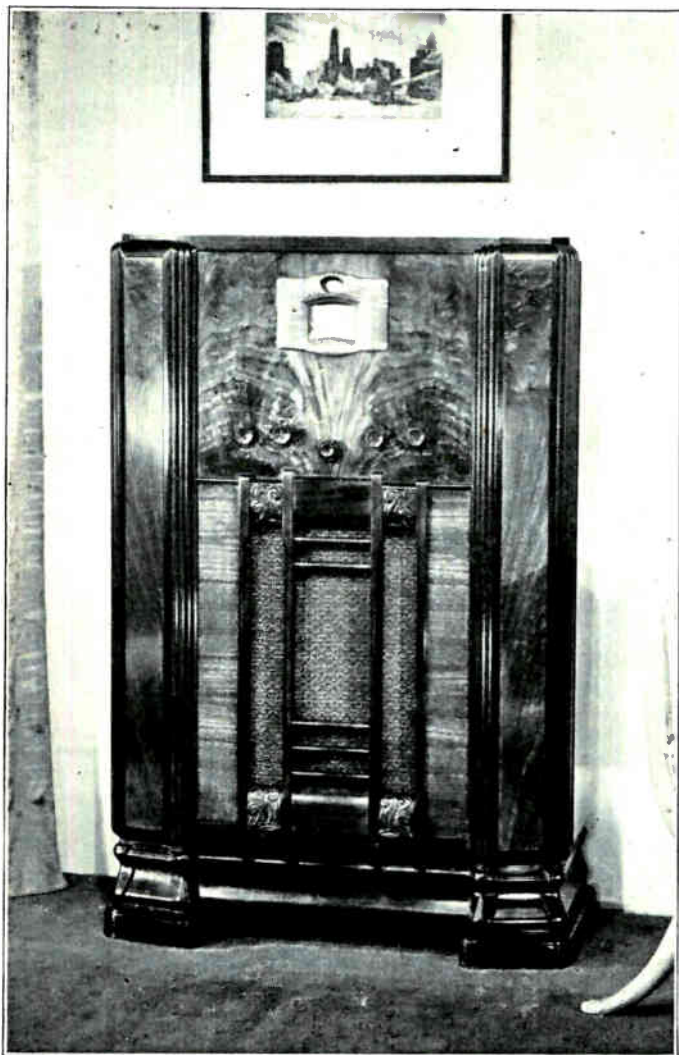

Fig. 192. A modern radio receiver of the type shown here can be a great source of pride, entertainment and education to the owner, providing the receiver is kept in first-class operating condition. To keep radio receivers in good condition requires occasional inspection, cleaning, and adjustment, and at times repair or replacement of electrical parts which get out of order. To properly service these modern radios, a serviceman must have thorough practical training and up-to-date test equipment and tools. Courtesy Stromberg-Carlson Co.

If all of the tubes heat up and if a noticeable click is heard in the speaker when the last audio tube is removed from its socket, it is quite likely that the power supply is all right, and that the trouble is elsewhere. The click heard when the last audio tube is removed indicates that the plate circuits of the receiver are supplied with power.

If any of the tubes in an A. C. receiver heat up to their normal temperature, it is a further indication that the primary of the power transformer is all right.

If all but one or two tubes heat up, those which do not are probably burned out, although their failure may also be due to an open circuit in some part of the filament wiring.

The power supply unit is a very vital part of the receiver and is more apt than almost any other part to cause complete failure of the receiver.

If the signals are noisy and distorted from their natural tone, the cause of the trouble will often be found in the A. F. stages, although either the

aerial system, or the R. F. or I. F. stages may at times be to blame for noise and distortion.

After one becomes familiar with the various forms of distortion, you can often determine about where the trouble is.

If the audio stages are suspected, a simple test to determine if the fault is in them, can be made by removing the second detector tube from its socket. If the noise still continues, the trouble is probably in the A. F. stages. It does not, however, always indicate that the audio stages are all right if the noise stops upon removal of the detector tube.

If all the tubes heat up, but we nevertheless suspect that a defective tube is the cause of the trouble, and if no tube tester is available, the tubes may be replaced one at a time with good ones until the defective one is located.

It is not advisable to replace the rectifier tube without first testing the receiver, as a short circuit in the power pack or receiver might burn out the new tube.

If all circuit voltages appear to be normal and all tubes are good, then the trouble may be caused by the set being out of balance or alignment, as previously explained under aligning superheterodyne receivers.

133. LOCALIZING THE TROUBLE

If a receiver does not operate or give any signals at all, then a definite systematic inspection and test is necessary to locate the trouble. Before starting detailed tests of the internal parts and wiring of the set, always remember to carefully check the antenna circuit, tubes, power unit or batteries, and the speaker.

In checking the antenna circuit, make sure that the antenna and ground connections are clean and tight at the set, and that the ground connection to the water pipe or ground rod is also clean and tight. See that the antenna is not down, or grounded by contact with some other wire or metal structure.

See that all tubes heat up, and test the tubes in a set analyzer or tube tester, or by replacing them with good ones. If all tubes fail to heat up, the trouble is almost certain to be in the power unit, or filament switch or wiring, or in the "A" battery if the receiver is of the battery operated type. It may also be possible that all tubes are burned out due to some wiring defect or wrong connection having placed the plate voltage on their filaments or heater elements.

In checking an "A" battery, test it with a hydrometer for state of charge, and carefully check for corroded terminals. In checking a power pack, first see that the light circuit to which it is plugged is alive, by testing with an A. C. voltmeter or 110 volt test lamp. Examine the cord to see that the wires are not broken under the insulation, and see that the plug and all connections are tight. Test the filament voltage supply terminals with a low reading voltmeter and the plate voltage supply terminals with a high reading voltmeter.

In checking the speaker, see that its cord is not broken or shorted, and see that the connections both at the output of the set and at the speaker



Fig. 193. This photo shows a very popular and convenient type of modern arm-chair radio. Owners of sets of this class are usually glad to pay a fair price for intelligent and efficient service to keep the set in A-1 operating condition. Courtesy Stewart-Warner Company.

unit are secure. See that the diaphragm or cone is not jammed, bent or torn.

If the speaker is of the dynamic type, the field coil can be tested by holding a nail, screwdriver or some magnetic object, near the end of the iron core inside the cone, while the set is turned on. If the coil is alive a strong magnetic pull will be felt. Examine or test the flexible fine wire leads to the voice coil as these often get broken.

An ordinary magnetic speaker having only two leads can be quickly tested by tapping its terminals on a low voltage battery, which should result in a loud click. With dynamic speakers, the same test can be made with the voice coil leads, assuming of course that the field coil is supplied with power and is energized. Do not leave the speaker voice coil connected to a battery or this coil may be burned out. Any of these coils or circuit connections may also be tested by means of a continuity test which will be explained later.

134. CIRCUIT DISTURBANCE TEST

The fault in a radio receiver can often be approximately located by what is called a **circuit disturbance test**. This test is made by starting at the last audio stage and removing one tube at a time and observing the click which this causes at the speaker. By removing the tubes in reverse order, back toward the antenna or first R. F. stage, when a tube is found that gives no click upon removal, it indicates that the fault is probably at this tube or between it and the last tube which caused a click at the speaker.

We should then test the socket terminals of this last tube removed, for proper voltages. Also run a continuity test on the parts of the circuit between

this tube and the next one following it in the regular order of the circuit.

On most receivers, it is easier to merely remove the grid cap lead and touch it to the grid terminal, to produce the same click as removing the tube from its socket.

135. FAULT LOCALIZING WITH AN OSCILLATOR

Another good method of localizing radio troubles, or determining what section or stage they are in, is by use of a test oscillator or signal generator, such as previously described and shown in section 3, on aligning superheterodyne receivers.

To make this localizing test, the oscillator ground lead is connected to the metal chassis of the receiver, and the receiver is then switched on or put in operation.

With the oscillator adjusted to produce an audio signal, and a .5 mfd., 600 volt condenser connected in series with its antenna lead, touch this lead first to the plate terminal and then to the grid terminal of each tube, starting with the last audio output tube.

When the oscillator lead is touched to the plate terminal of the last tube, a signal should be heard in the speaker. If no signal is heard, the fault may be in the speaker field or voice coil, or in the output coupling transformer.

If a signal is heard, then touch the oscillator lead to the grid terminal of this last audio tube. If the tube is good, and supplied with proper filament and plate voltages, the signal should pass through the tube and be heard in the speaker somewhat louder than when testing at the plate terminal.

Proceed to test each tube in this manner, from the last audio tube to first R. F. tube, until a point is found where the signal does not go through. This will localize the trouble to that tube or stage last tested.

When making this test, after passing the detector tube, if the set is a super with I. F. stages, the oscillator must be adjusted to give the proper I. F. signal for these stages. Then when testing the

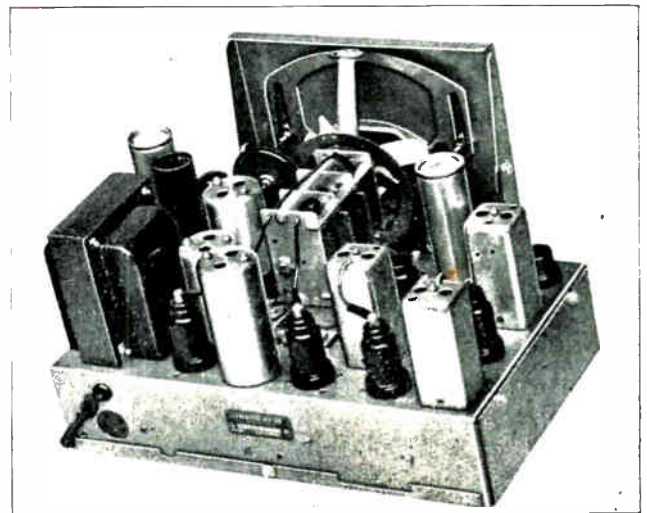

Fig. 194. This view shows the chassis of a radio receiver and illustrates how the serviceman can easily get at the tubes, R.F. and I.F. transformers, tuning condenser and tuning mechanism, and the power transformer. To reach the resistors, condensers and circuit connections on the under side of this set, the chassis must be removed from the cabinet and turned on its side or up side down.

R. F. tubes, again adjust the oscillator to produce an R. F. signal for testing these stages.

You can readily see the advantage of making such fault localizing tests to approximately locate the trouble in a certain section of the receiver, before spending a lot of time in making detailed circuit tests of the entire receiver.

136. CONTINUITY TESTS

After localizing the trouble, or determining, by one of the methods just described, which section of the receiver the fault is located in, the individual resistors, condensers, transformers and circuit wires and connections of that particular section of the receiver can then be given a continuity test, to locate any burned out units or open or loose connections which may be causing the trouble.

The purpose of the continuity test is to determine if the circuit through each device or part of the suspected section of the receiver is continuous

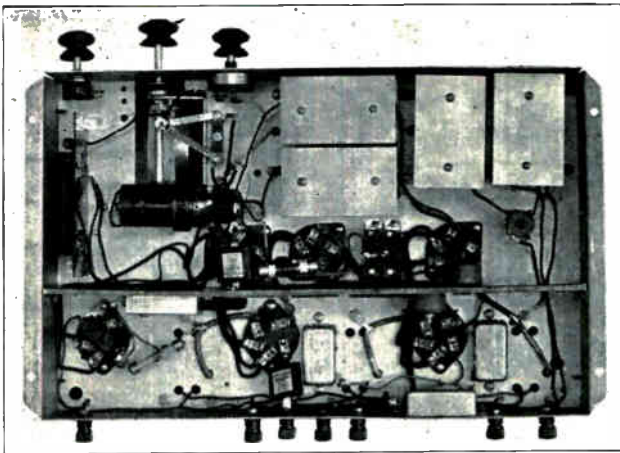

Fig. 195. This view shows a receiver chassis turned up in position for testing tube socket terminals, resistors, condensers, volume control, switch and circuit connections. Courtesy Silver Marshall Incorporated.

and of proper normal resistance, because an open circuit, loose connection, or wrong resistance of any part may be the cause of the trouble.

Continuity tests can be made with a small portable voltmeter or milliammeter connected in series with a battery and a pair of test points or prods as shown in Fig. 196. A portable ohm-meter with a self-contained battery and a selector switch for high or low readings, is also a very convenient instrument for making continuity tests. See Fig. 197. Fig. 198 shows two views of a very compact and convenient radio test instrument which has the multi-range meter, selector switch, resistors, rectifier and small dry battery, all built into a neat, small case, with pin jacks for attaching the test leads.

An instrument of this type is one of the most useful and necessary, and yet least expensive units of the radio service man's test equipment. With it one can make dozens of different trouble shooting tests to locate defective receiver parts or circuit faults.

A complete radio analyzer such as shown in Fig. 199 can also be used for making continuity tests, circuit voltage tests, and for testing tubes, resistors, condensers, and almost every part of the receiver.

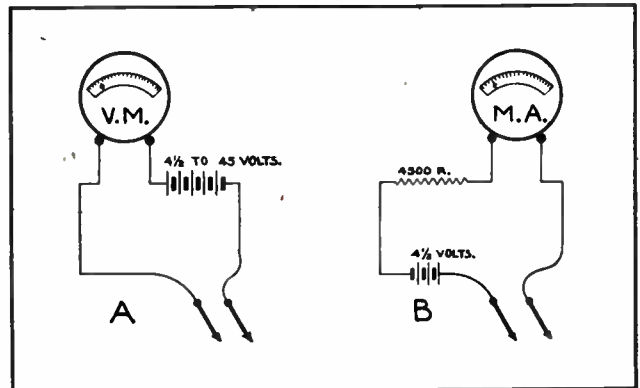

Fig. 196. The sketch at A shows the connections for using a low reading voltmeter for making continuity tests, and the one at B shows the connections for using a milliammeter for this purpose.

These instruments and their use will be explained later.

When making continuity tests, unless you are thoroughly familiar with the receiver being tested, it is well to refer to a circuit diagram of the set, in order to make sure that each device and part of the circuit are thoroughly tested. Such circuit diagrams can be obtained from the manufacturer of the receiver, or from a service manual containing diagrams and detailed service information for all the leading makes of receivers.

Such service manuals and manufacturers' service charts are a great help to the radio service man and should always be on hand in the service shop or tool kit. These charts give the correct voltages and resistance values for each part of the receiver circuit, and are, therefore, a great aid and time-saver in analyzing various radio troubles.

When making continuity tests, make each test thorough and complete, as every wire and part in a radio circuit has a function to perform, and it requires only one invisible open or short circuit,

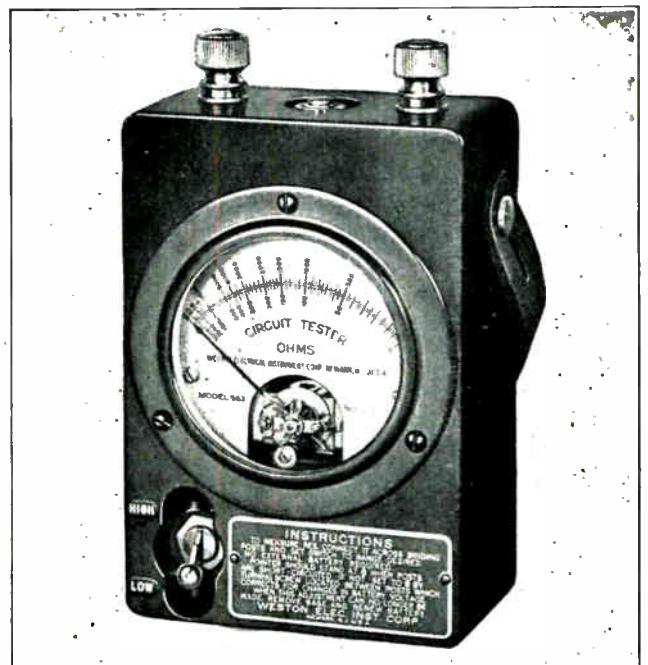

Fig. 197. Convenient Ohmmeter or circuit tester which is also very valuable for continuity testing and radio trouble shooting. (Photo courtesy of Weston Electrical Instrument Co.)

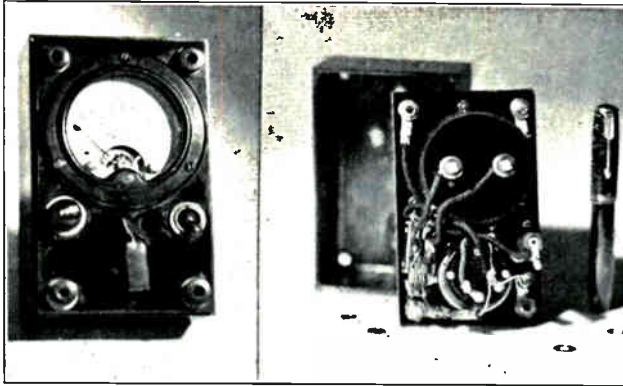

Fig. 198. This photograph shows two views of a very compact and convenient ohmmeter or multi-range meter for radio testing. On the right is shown a view of the back of the instrument opened up so the meter terminals, selector switch, rectifier and resistors can be seen. Note the fountain pen standing on the right to give an idea of the compact size of this unit.

or high resistance connection, to prevent proper operation of the entire receiver.

In some cases, an "intermittent open" circuit may cause trouble in a receiver at times, while at other times, the set may operate all right. An "intermittent open" may be caused by a loose connection that opens and closes the circuit irregularly when the set is jarred, or when the parts expand and contract as the set warms up and cools off.

As each device, circuit or stage of a receiver is tested and found to be normal, that part can be eliminated as a possible cause of the trouble.

Before starting a continuity test, the receiver should be disconnected from the power supply or batteries, so the receiver will be entirely dead. This is necessary to prevent obtaining false readings and also to prevent possible damage to the test instrument or receiver tubes, when various wires and leads are touched with the test points. It is also advisable to disconnect any suspected part from its circuit for making the final resistance tests.

When a milliammeter or voltmeter is used for continuity testing the resistor or the battery voltage should be adjusted so that when the test prods are shorted together, the meter will give nearly full scale reading. Then when testing across wiring joints or connections or at the terminals of low resistance coils or devices, the reading should still be nearly full scale. When testing very high resistance parts such as potentiometers, grid leaks or coupling resistors of thousands of ohms resistance, the reading will drop in proportion to the resistance. The resistance of windings of R. F. or I. F. transformers is not high enough to make much difference in the reading of the meter. An open circuit will give no reading.

A shorted condenser will give a full scale reading. If it is a fixed condenser, it must be replaced. If it is a variable condenser the trouble may be corrected. Condensers should always be disconnected from their circuit before testing or a false reading will be obtained from attached closed circuits.

When using a voltmeter for continuity tests, the meter should be of the proper rating or design to give a full, or nearly full scale reading with the voltage of the battery used, when the test points are shorted together. When the test points are

then applied to circuits and devices, the reduced meter reading indicates the voltage drop through them. Testing across wiring joints or terminals, or across R. F. coils or transformers and other low resistance devices, should show no appreciable voltage drop unless there is some high resistance fault or open circuit in them.

When using an ohmmeter for continuity testing, the instrument reads directly the resistance of any circuit or part being tested, and thus gives very reliable and easily understood indications. After performing a number of continuity tests one gets to know just about what readings to expect from the tests on various parts in good condition, even without the manufacturers' data, and even though the readings may vary slightly on different makes of equipment.

137. TUBE AND VOLTAGE TROUBLES

When testing the plate, grid and filament voltages of tube sockets with an analyzer or test instrument, these values should be very close to those given in the manufacturers test data for the tubes. The plate current may, however, vary some for the same tubes when used in different receivers, but if it is very much off there is probably some fault causing it.

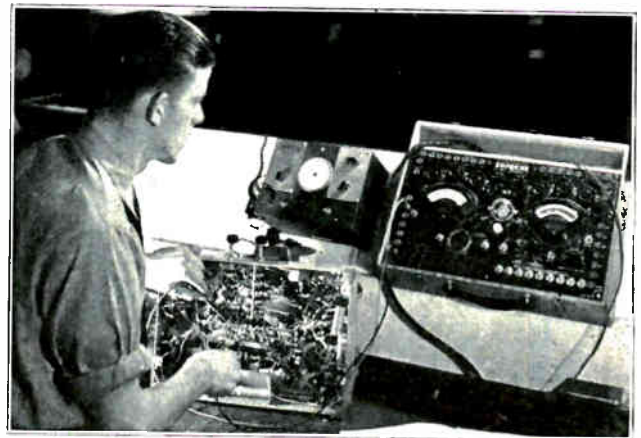

Fig. 199. This view shows an analyzer in use for testing parts and circuits on the under side of a radio chassis. Note the meters, selector switches, pin jacks and tube sockets on this complete analyzer, and also the oscillator or signal generator on the left. The operator is using a pair of test prods for checking resistances and continuity of various parts of the receiver circuit.

Some of the common causes of wrong voltage and current on tubes are as follows: Excessive plate current may be caused by too high plate voltage; too low grid bias voltage; too high filament voltage; leaky condenser or poor circuit insulation; or a defective tube. Insufficient plate current may be caused by too low plate voltage; grid bias voltage too high; low filament voltage; or defective tube.

If a test with a meter shows that the plate voltage is excessive, this may be due to an open circuit in the negative end of the voltage divider in the power unit, to excessive negative grid bias; to low filament voltage; or a defective tube. Too low plate voltage may be due to failure of the power transformer, rectifier, filter condensers or chokes of the power supply unit, or it may be due to low negative grid bias; too high filament voltage; or a defective tube.

If the grid biasing voltage is found to be too

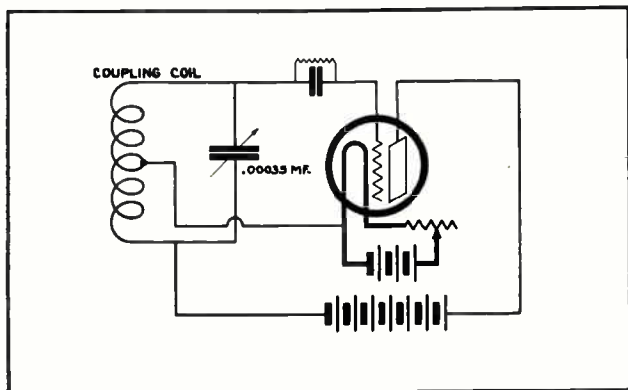

Fig. 200. Circuit diagram of an inexpensive portable modulated oscillator which can be easily made, and which is very useful for testing, balancing and neutralizing radio receivers.

low, too high or reversed, this may be due to an open circuit at the bias resistor, or "C" battery; a shorted by-pass condenser; leaky insulation or leaky blocking condenser between grid and plate supply circuit; open transformer secondary in the grid circuit, or a defective tube socket.

If the filament voltage is wrong, it may be due to a defect in the power transformer or a weak "A" battery, or to loose, corroded connections; an overload or partial short on the filament circuit; or improper line voltage on the house circuit to which the power unit is plugged.

A defective tube may cause wrong readings due to loss of vacuum, which will generally cause a bluish glow in the tube; a dead or deactivated filament; or to a short circuit in the tube, caused by the grid touching the plate or filament.

Some tubes are **microphonic** and produce a howl at the speaker every time the receiver is vibrated slightly. This vibration causes a loose filament or grid to vibrate, and the changes in spacing between them and the plate cause corresponding plate current changes and sound variations. Microphonic tubes should be replaced, or a temporary remedy can be effected by fitting a piece of rubber inner tubing tightly over the top of the tube to dampen its vibrations.

138. COMMON TROUBLES IN R.F. STAGES, DETECTOR AND AUDIO STAGES

Lack of sensitivity in the R.F. stages of a receiver may be caused by poorly balanced tuning condensers; an open or shorted R.F. transformer coil; open or shorted by-pass condenser; defective tube; wrong filament, grid, or plate voltages; or a high resistance antenna or ground connection. Dampness or moisture absorbed by R.F. coils and condensers may also be a cause.

A continuity test will usually locate any faulty device or circuit, and repairs or replacement can be made according to the nature of the trouble.

Broad tuning or lack of selectivity may be due to most any of the causes of poor sensitivity just mentioned; or it may be due to too long an antenna; wrong grid bias voltage on the tubes; or to some trouble in the circuit or volume control. Sometimes broad tuning is blamed on the receiver when it is really caused by some powerful local station.

In such cases, if the undesired station cannot be tuned out by the receiver, when it is in good con-

dition and fairly selective on other stations, a wave trap consisting of an auxiliary tuner or variable condenser and inductance, can be shunted across the antenna and ground terminals of the receiver and used to tune out the undesired station.

Oscillation in R.F. stages may be due to poor shielding; careless wiring; defective volume control; set not properly aligned or neutralized; bad tube; or wrong voltages.

Foreign noise in R.F. stages is generally due to loose connections in the wiring, or at the terminals of condensers, sockets, rheostats, etc., or to loose shield cans; rubbing condenser plates; or defective volume controls or filament rheostats.

Troubles in I.F. stages may be due to defective transformers, defective tubes or sockets, faulty condensers; wrong grid, plate or filament voltages, or circuits out of alignment.

Trouble in the detector circuit may be due to a defective tube; wrong voltages; loose connections; wrong grid leak resistance or C bias, etc.

Lack of sensitivity in detectors is often due to a bad tube; wrong plate or filament voltages; or an open circuited grid lead, condenser or "C" battery.

Noise from the detector may be caused by a microphonic tube; dirty or loose tube socket connections, or to a poor or loose grid leak resistor. Too high resistance in the grid leak will cause "motor boating," or a "put put" sound like an engine exhaust. A. C. hum may be caused by poor shielding; lack of proper by-pass condensers in grid and plate circuits; or to induction from nearby A.C. circuits.

Troubles in audio stages may be due to poor tubes; defective A.F. transformers; wrong voltages on tubes; defects in wiring; wrong grid bias voltages, or defective by-pass condensers. An open coupling transformer primary will cut off the plate voltage to the tube preceding it, or in whose plate circuit the primary is connected. An open coupling transformer secondary will cut off the grid voltage

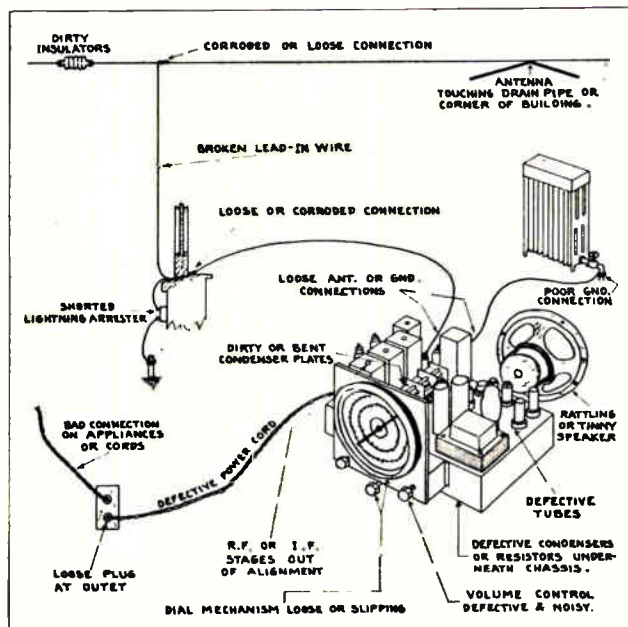

Fig. 201. The above diagram shows a number of points to examine in preliminary inspection on a radio service call. Examine this diagram carefully and keep these important points in mind when making radio service calls.

to the tube following it, or in whose grid circuit the secondary is connected.

Open, shorted, or burned out A.F. transformers can be easily located by a continuity test, and should be replaced by ones of the same general type and the same ratio.

Loose connections in A.F. transformers will often cause a lot of noise when the set is jarred or vibrated.

139. POWER SUPPLY FAILURE

Troubles in power supply units may cause complete failure of the receiver, wrong tube socket voltages, or bad A.C. hum.

Complete failure is generally due to an open in the 110 volt supply line or power transformer windings; to a defective rectifier tube; shorted filter condenser; or to an open circuit in a filter choke or in the wiring. A continuity test will locate any of these faults.

Wrong tube socket voltages may be caused by a bad rectifier tube; open circuit in the voltage divider resistor; shorted or open condensers or chokes; overload on the power unit due to shorts in the receiver; or to incorrect supply line voltage.

If the line voltage is too high or too low, it can usually be corrected by adjustment of the line ballast resistor or by taps in the circuit of the power transformer primary.

Rectifier tubes have a limited useful life and should, therefore, be tested or compared with a new tube when suspected of causing trouble.

Defective resistors, condensers or chokes should be replaced, unless the defect is merely a broken connection at the terminal.

140. MECHANICAL AND GENERAL TROUBLES

All moving parts such as variable condensers, rheostats, potentiometers, etc., in defective radio receivers, should be carefully examined for damage due to mechanical wear, or for parts or flexible connections having become loose.

Variable condensers should also be checked to see that none of the plates have become bent so they touch, or that dirt of a conductive nature is not partially shorting the plates. Bent or rubbing condenser plates will usually be indicated by a harsh, scratching sound when the condenser is rotated during operation of the receiver.

Very weak signals are often caused by gang condensers being out of balance, and in such cases they should be carefully re-balanced by adjusting the small single plate balancing or trimming condensers while listening to the output reception of a local station, or with the set excited from a modulated oscillator. An output meter on a set analyzer is a great help to balance condensers more accurately.

Spring contacts in tube sockets sometimes become bent or corroded so that they do not make contact, or only make a poor high resistance connection to tube prongs. These contacts can usually be bent back into firm connection with the tube prongs, and cleaned with a narrow strip of sandpaper or emery cloth held over the end of a flat pointed stick. Sometimes, on tubes in the old style sockets where the tube prongs only make contact at their tips, these tips may need to be brightened

and have corrosion removed from them by moving the tube back and forth in the socket, or by removing it and lightly polishing the prong tips with fine sandpaper or a fine file.

Audio transformers sometimes develop open circuits due to corrosion from soldering flux eating away the fine coil-lead wires near their terminals. A transformer with an open or burned out winding should be replaced with a new one of the same type and ratio.

141. SPEAKER TROUBLES

Trouble in magnetic type speakers may be caused by loose connections; jammed or bent diaphragms or cones; loose armatures of the balanced type striking the pole tips; loose driving rod or parts; collection of iron filings or magnetic particles in the narrow gaps between poles and armature or diaphragm.

Damaged cones or diaphragms usually cause a weak tinny sound, and when found should generally be replaced instead of trying to repair them. Loud chattering sounds are caused by the armature striking the pole tips. Rasping, scratching sounds are caused by dirt or magnetic particles rubbing on the armature or diaphragm. Light rattling sounds are generally caused by a loose driving rod or parts.

Poor volume may be due to a weak permanent magnet; open or short in a coil; or to defective insulation on the speaker cord. A broken connection at one of the electro-magnet coils may cause a permanent open, or it may cause a lot of noise as the speaker vibrates slightly.

Trouble in dynamic speakers may be caused by an open field magnet coil; by failure of voltage supply to field coil, due to defective rectifier tube, defective dry oxide rectifier, or defective filter condenser or transformer of separate speaker power supply unit. Dynamic speaker troubles may also be caused by a shorted or open voice coil; damaged cone; filings or dirt stuck between magnet and voice coil; or cone off center.

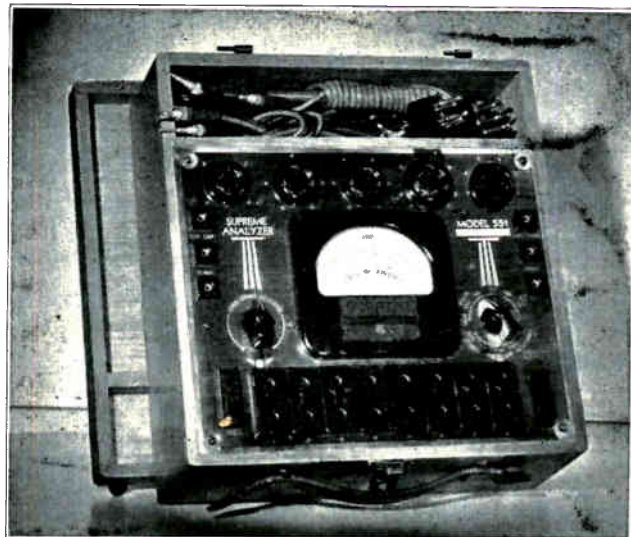

Fig. 202. Photograph of a compact radio analyzer and tube tester. Note the multi-range meter for checking resistance, voltage, and current in various parts of a receiver. Also note the pin jacks for connection of test leads for making various tests. The cord and plugs shown in the upper compartment of this instrument may be used for taking convenient readings of voltages at the tube sockets of receivers. Courtesy Supreme Instrument Co.

Failure of the field magnet coil is usually indicated by weak, raspy reproduction and almost no bass notes. This field magnet can be tested as previously mentioned by holding some clean iron object near its center pole to note the strong magnetic pull, if the coil is operating properly.

An open circuit in the voice coil will stop all reproduction, and a partial short of this coil will cause reduction of bass notes and poor sound reproduction. These voice coils often become shorted by being off center and rubbing on the field magnet poles. Their flexible leads also become broken occasionally by vibration or abuse.

If iron filings are found in the magnetic gap they should be cleaned out by collecting them on a pointed magnetic tool, or with a stiff piece of paper. If necessary the cone can be removed and the filings and dirt wiped out with a cloth or brush.

If the cone becomes broken or damaged very badly, it is usually best to replace it.

On dynamic speakers which have their own power units for supplying D. C. to the field coil, the rectifier tube may become defective or entirely dead, or the dry oxide rectifier, if one is used, may have reached the end of its useful life and if so should be replaced. A shorted filter condenser will cause failure of the current supply to the field coil, and an open circuited filter condenser will cause 60 cycle hum in the speaker. An open in the transformer or cord, or failure of the 110 volt supply will of course cause the speaker to fail.

Some dynamic speakers use a means of balancing out 60 cycle hum by feeding a small amount of the pulsating field current into the voice coil through a variable resistor. By adjusting this resistor, the hum can be completely balanced out when the speaker is in good condition.

142. MODULATED OSCILLATOR

We have previously mentioned oscillators and their use for aligning superhetrodyne receivers, as explained in Articles 115, 116, and 117 of section 3. The use of the test oscillator for localizing radio troubles has also been explained in Article 135 of this section.

There are many types of oscillators on the market, which are designed to produce R. F., I. F. or audio signals for testing and aligning radio receivers, and the well equipped service man should have one of these instruments on hand.

If you cannot afford to purchase one of the better makes of oscillators when first starting to service radios, a simple and inexpensive modulated audio oscillator can be built according to the diagram in Fig. 200. This oscillator will produce a high frequency wave that is modulated by the "spill over" action of the grid leak and condenser, to produce an audible note in the speaker of the receiver under test.

The parts needed for this simple oscillator are as follows: an 01-A tube and socket, grid leak and condenser, a center tapped inductance coil of about 100 turns of #24 wire on a 1½" form, a .00035 mfd. variable condenser, tube filament rheostat and the necessary filament and plate batteries or power supply.

This type of oscillator can be connected to the receiver by a short length of wire leading to the

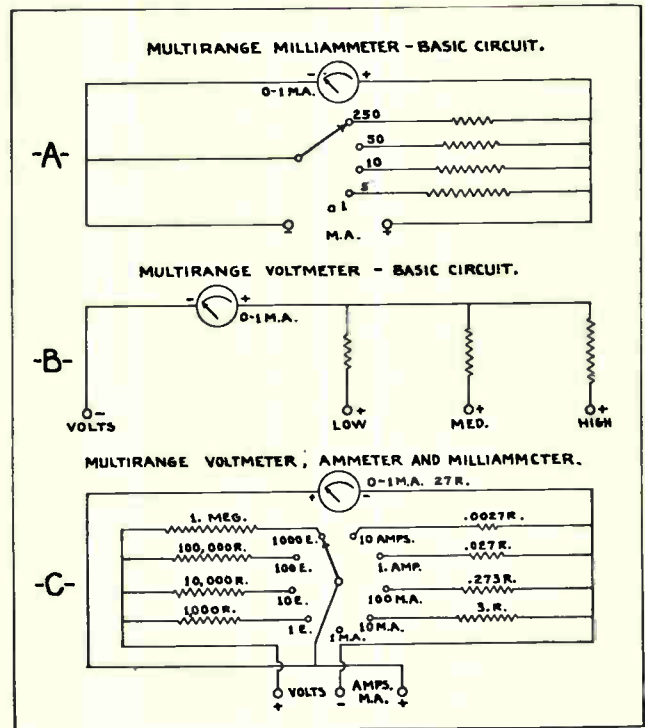

Fig. 203. The above diagram shows the wiring and connections for a multi-range milliammeter, voltmeter and a combination voltmeter, ammeter and milliammeter, such as commonly used for radio service tests.

receiver antenna terminal, or looped around the R. F. coil under test. Or in some cases the receiver will pick up enough of the oscillator signal energy by merely setting the oscillator close to the receiver.

When using an oscillator of this type to balance the tuning condensers of a set, the oscillator can be connected or coupled to the antenna circuit or first R. F. coil, and adjusted to about 200 meters or 1,500 kilocycles by setting the dial of the receiver at this point. Then adjust the oscillator until it gives maximum sound at the speaker, or maximum reading on an output meter connected to the receiver in place of the speaker. If the maximum sound or reading is too great when the receiver and oscillator are tuned to resonance, reduce the filament temperature of the oscillator tube by means of its rheostat.

Now with the receiver operating from the oscillator, adjust the receiver gang condenser to maximum volume as indicated by the speaker or output meter. Then adjust each of the small balancing or trimmer condensers to the point where they give best results or increase the output to maximum. The condensers will then be balanced for that wave length.

Next set the receiver dial at about 500 meters or 600 kilocycles and adjust the trimmer or balancing condensers to get maximum output from the receiver. But when adjusting them this time, if it requires a change from their former setting to get best results, carefully note just how much change is required by counting the turns of the adjusting screw or noting their positions, and then set each trimmer back just half way between their best positions for the two different wave lengths. This will balance the gang condenser for best average results over the broadcast band.

The output meter mentioned is simply an A. C. voltmeter which reads the signal variations in the plate circuit of the receiver output.

143. RADIO ANALYZERS

All radio circuits are made up of various parts having capacity, inductance and resistance. To these circuits are applied both A. C. and D. C. voltages of different values. If the capacity, inductance or resistance of any of these parts is off from normal value, or if any of the voltages are wrong, faulty operation of the receiver, or complete failure to operate may result. This is why we must have trained service men with their modern servicing equipment.

One of the most useful pieces of radio testing apparatus is the analyzer, which is used primarily for voltage, current and resistance measurements of receiver circuits and parts. Fig. 202 shows one popular type of analyzer, and Fig. 199 shows an analyzer in use for testing circuits and parts underneath a radio chassis. These instruments are made in various types, ranging from the simplest single unit voltmeter to the more complex combination analyzer. Some complete laboratory type analyzers are also equipped to test tubes and condensers.

In many of these instruments a single multi-range meter is used to indicate both milliamperes and volts, over several different ranges, all values being read from the one meter. This is possible because only one measurement is made at a time, whether it be volts, ohms, or milliamperes. The different readings can be taken by cutting various calibrated resistors in or out of the meter circuit by means of selector switches or pin jacks, which can be seen on the analyzers in Figs. 199 and 202.

The basic diagram of a D. C. multi-range milliammeter is shown in Fig. 203-A. Here we see an O-1 MA, D. C. meter used with four shunts and a selector switch to give us four corresponding current ranges. It is very common practice, as well as good economy, to use an O-1 MA meter movement in analyzer construction, although movements having greater sensitivity are available, some of them requiring as little as 50 micro-amperes to move them full scale.

In Fig. 203-B we have a basic diagram of the same meter used as a voltage indicating device, and arranged with three different sized resistors to give the various corresponding voltage ranges. We can also combine the milliammeter and voltmeter into one circuit as shown in Fig. 203-C. This is similar to many multimeter circuits now in use in radio analyzers, and is very useful in radio testing, as the one instrument is made to function as several meters, merely by turning the selector switch. With this instrument we are able to measure both D. C. volts and D. C. current, but not A. C.

144. ANALYZER METERS AND RECTIFIERS

For A. C. measurements we have available two types of instruments, one of low sensitivity requiring rather high current to operate the meter element, the other of high sensitivity, requiring a very small current. The first meter is the movable iron vane type, which is used extensively for A. C. in-

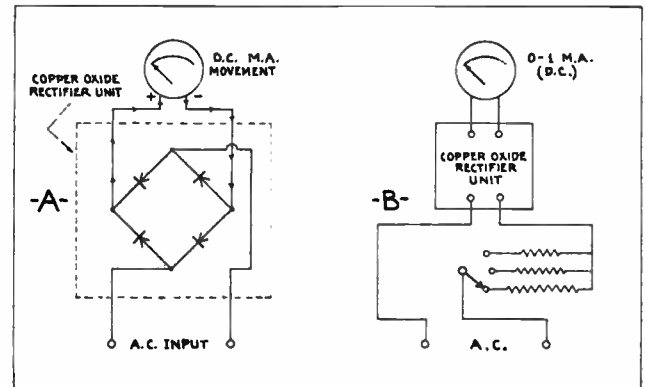

Fig. 204. This diagram shows two methods of connecting rectifiers to radio test meters for taking either D.C. or A.C. readings. The circuit at "B" shows how a milliammeter can be used as a multi-range A.C. voltmeter, by use of the rectifier and proper resistors.

struments. This type of meter was fully explained in A. C. section 2 on A. C. meters.

This type meter will operate on either D. C. or A. C., but has the disadvantage of requiring a rather large current drain, usually between 15 and 150 MA, depending on the design. For power work, this current drain is negligible, but for radio tests, such current values might impose too great a load on the circuit under test, giving a lower voltage reading than actually exists at the measuring points.

To overcome this disadvantage, we can use a small copper-oxide rectifier designed for use in conjunction with a low current operated D. C. meter, such as an O-1 milliammeter. This type of rectifier consists of discs of copper-oxide held in contact with discs of copper. It will allow current to flow easily in the direction from copper-oxide to copper, but not in the reverse direction, and thus it acts as a rectifier. By connecting this unit to an O-1 MA, D. C. meter, we can use it in analyzer circuits to read A. C. voltage or current values, with only a very small current drain from the circuit, to move the meter. Fig. 204-A and B shows connections for meters using copper-oxide rectifiers.

Since the use of the rectifier will allow us to change our D. C. instrument over to read A. C., we can combine the two circuits into one multi-range meter for both A. C. and D. C. readings. This is often done in commercial analyzers. One precaution must be observed in the use of the copper-oxide rectifier. Never permit more current to pass through it than that value for which the rectifier is rated, or it will become overheated and damaged.

145. ANALYZER OHMMETER CONNECTIONS

As previously explained in Article 136, we can use an ohmmeter to measure the resistance of radio circuits or parts in ohms. There are three general types of ohmmeters in use today, (1) the series type, (2) the shunt type, and (3) the combination of the series and shunt type.

In Fig. 205-A is shown the fundamental circuit of a series type ohmmeter. Its principle of operation depends upon the variation in current flow through the circuit, as indicated on the milliammeter, due to the various values of resistance RX connected in series in the circuit. However, if, instead of using the meter to read the value of current flowing in the circuit, we calibrate it to read in ohms what-

ever value of resistance is connected at RX, we will have a series type ohmmeter. In this circuit the higher the resistance, the lower will be the current flow from the battery, making the readings just the reverse of the usual meter scale markings.

In Fig. 205-B is shown the circuit diagram of another series type ohmmeter. Note the "zero" adjuster "R", which is used to set the meter reading to zero ohms when the terminals "T" are shorted together. To obtain readings of low values of resistance, two shunts have been provided, while an additional 45 volt battery and series resistor provide a high range. This meter will measure from .1 ohm to 1,000,000 ohms.

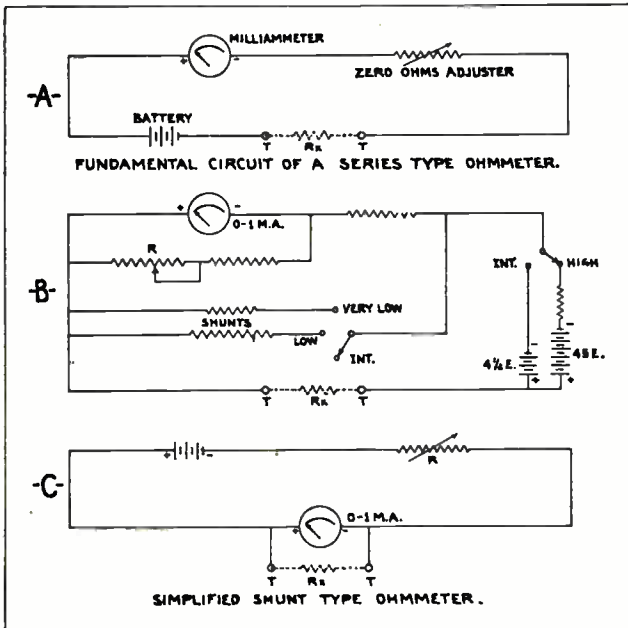

Fig. 205. These sketches show the connections for a series type ohmmeter at "A", a shunt type ohmmeter at "C" and a multi-range milliammeter or ohmmeter at "B".

An ohmmeter using the shunt circuit is shown in simplified form in Fig. 205-C. The resistor "R" is first adjusted to make the meter read full scale with terminals "T" open. Now any resistance shunted across the terminals will cause part of the current to flow through it and the meter current will decrease. The scale is calibrated in ohms as before, only in this case the zero reading comes at the left side. This type circuit has the advantage of measuring very low values of resistance without excessive battery drain.

In commercial instruments, the circuit is usually arranged to utilize the series type of ohmmeter connection for high resistance measurements, and the shunt connection for the lower ranges, thus making it a combination meter.

Several precautions should be observed in checking with the ohmmeter. First, be sure the receiver is turned off before measuring resistors, as they usually have a D. C. voltage drop across them which will affect the ohmmeter readings very greatly. Second, before using the meter, short the test leads or terminals together and adjust the meter to full scale deflection, as aging batteries will change the zero setting. Third, do not allow your hands to come in contact with the metal ends of the test prods, as the body resistance may cause an appreciable meter error. And last, it is usually

best to disconnect one end of a resistor from the circuit before checking it, as coils or leaky condensers in parallel with it will have an effect on the true resistance readings.

146. CONDENSER TEST UNITS

As many types of condensers are employed in radio work, and since their condition will affect the proper operation of the circuit, condenser testers and capacity meters have been developed to check these units. In Fig. 206-A is shown the fundamental circuit of a simple capacity meter. The meter measures the current flow through the condenser and may be calibrated in MFD.

The operation of this circuit depends on the reactance offered by the condenser to the flow of current, the larger the condenser the lower the reactance and consequently the greater will be the meter reading. This type of circuit is suitable for measurement of all condensers except the electrolytic type.

For capacity tests of electrolytic condensers, a circuit employing low voltage A. C. is often used, to overcome the disturbing effect of the high leakage current inherent in this type capacitor. Such a circuit as developed by Aerovox Company is shown in Fig. 206-B. Many set analyzers are so constructed as to check all sizes and types of condensers, and there are also available many condenser testers especially designed for this type work. In addition to indicating the capacity of a condenser under test, provisions are also made to test them for opens, shorts and leakage, as these factors have a decided bearing on proper circuit operation. Also see Article 106 in Section 3 for additional instructions on condenser tests.

So we see that the standard milliammeter unit can be used to check voltages, currents, resistances, and condenser capacities, merely by equipping it with the proper resistors, shunts, scales, and selector switches or pin jack terminals. Fig. 207 shows a diagram of such a meter or analyzer, equipped for making many of these common radio trouble tests.

Some types of radio analyzers are also equipped with a multi-wire cord and plug arrangement, so that the plug prongs can be inserted in the various tube sockets of the receiver, for making quick, convenient tests of tube socket voltages for filament, heater, cathode, grid and plate circuits. These cords and plugs can be seen with the analyzers shown in Figs. 199 and 202.

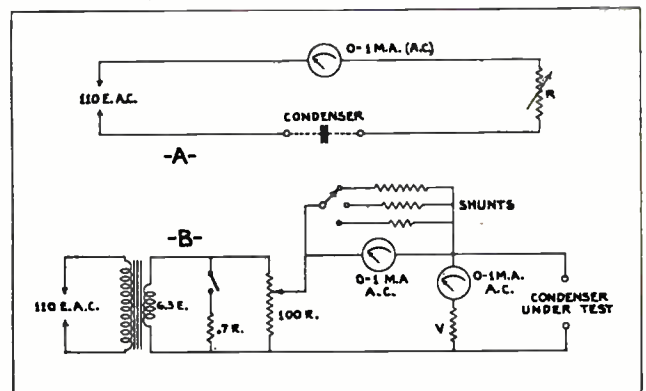

Fig. 206. Circuit diagrams for two common types of condenser test instruments which are very useful in checking condensers in radio service work.

147. VOLTAGE ANALYSIS OR POINT TO POINT TESTS

We have explained the importance of analyzing or checking the **voltage, resistance** and **current** values of various parts of receiver circuits, as a means of locating troubles in the receiver. Also the convenience of having the manufacturers or service manual diagrams and service charts, with which to compare the analyzer readings to determine whether they are correct or incorrect, and thus recognize faults when they are indicated by wrong voltage, resistance or current indications.

The point to point or voltage method of analysis is perhaps one of the most widely used methods of receiver trouble shooting. By a proper sequence of voltage tests, the service man can eliminate a great deal of unnecessary tests, although the nature of trouble largely determines the proper procedure of checking.

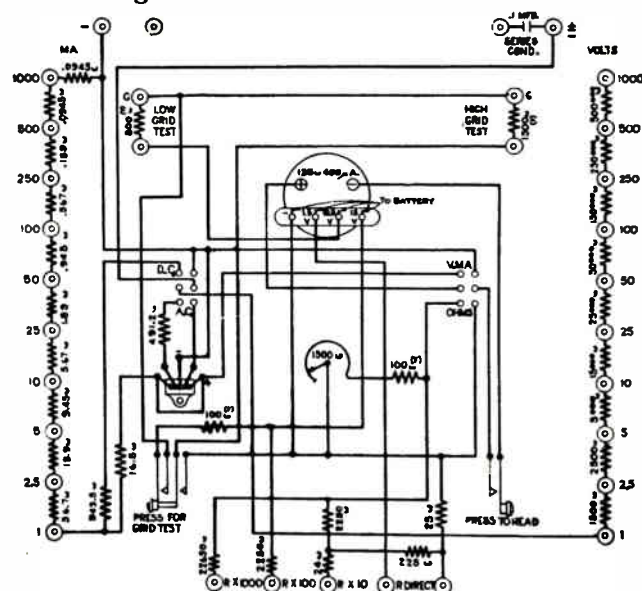

Fig. 207. Circuit diagram of a convenient portable radio analyzer, showing the connections of the meter, rectifier, pin jacks and resistors for checking various voltages, currents, and resistances on a radio receiver. Courtesy Weston Electrical Instrument Company.

If the complaint is a dead receiver, the following points should be checked first, as they do not require much time and may prevent other unnecessary tests. Check the speaker and see that it is connected to the receiver, because if the speaker is not connected to the set there is no means of reproducing the sound. In case of an electrodynamic speaker, the field is frequently employed as a choke coil in the power pack and must be connected in the circuit to complete the "B" voltage supply circuit, and at the same time excite the speaker field coil.

Be sure that the speaker is connected to the receiver before turning the set on. Failure to observe this rule may ruin the filter condensers by permitting excessively high voltage to build up when the speaker load is not in the circuit.

Some receivers have a separate power pack and must be coupled to the set to supply the "B" voltage. In case of a battery operated receiver, see that all batteries are connected to the proper terminals. Now turn the receiver switch on and observe the tubes to see if they light up, assuming that all

tubes are in their respective sockets and the receiver connected to the source of power supply, either batteries or 110 volt A. C. or D. C., etc.

In case the receiver is operated from a D. C. line, be sure that the receiver plug is connected to the supply correctly, because if the line plug is placed in the receptacle incorrectly the plates and the screen grids will not receive any "B" voltage.

Any tube that does not heat up should be replaced with another good tube, with the exception of the rectifier tube. If the rectifier tube is burned out, it may have been caused by an overload such as a shorted filter condenser, shorted filter choke from "B" positive to "B" negative, a partial short from "B" positive to "B" negative, shorted power transformer, etc.

Before replacing the rectifier tube, check the resistance between the electron emitting element of the rectifier tube (the filament of the 80 tube in the set shown in Fig. 208-A) and "B" negative which is generally the chassis or the center tap of the high voltage winding of the power transformer.

In Fig. 208-A you will notice the resistance values and capacitor sizes are marked beside their respective parts. A resistance value of approximately 24,000 ohms should be indicated by the ohmmeter if the voltage divider is not defective.

This resistance reading is through the speaker field of 1500 ohms, the screen grid voltage reducing resistor of 12,500 ohms, and the bleeder resistor of 10,000 ohms, giving a total resistance of 24,000 ohms. If the resistance of an A. C. receiver checks 5000 ohms or more, and the universal (A. C.-D. C.) receiver 3000 ohms or more by this test, it is all right to replace the rectifier tube and turn the set on. If the resistance shown by the test is much lower than this value, the operation of the receiver may cause excessive heating of the power transformer and rectifier, which should be checked by a point to point resistance test.

When metal tubes are used in the receiver, the tubes may be touched by the hand to note their temperature, to determine whether they are getting any voltage. The tubes should get warm or hot, depending upon the type and use of the tube. If the tube is cold, it is probably burned out and should be tested or replaced.

Failure of the tubes in the receiver to heat up may also be caused by a defective fuse, ballast tube, power cord, plug, or receptacle, receiver switch, or open filament or heater circuits in the receiver.

Assuming that all the tube filaments are hot, next try tuning in a broadcast signal with the antenna and ground connected to the receiver. Some receivers do not have a ground terminal and on such sets no ground should be used. If no signal comes through, then disconnect the antenna and connect about 12 or 15 ft. of wire to the antenna terminal. If the signal now comes through satisfactorily, the antenna is at fault. If this does not bring in a signal, it is probably due to a defect in the receiver.

148. VOLTAGE TESTS. POWER SUPPLY VOLTAGE TROUBLES

To make further tests on the receiver, the service man can use the voltage method of testing for incorrect voltages in the respective circuits. A port-

able voltmeter, or an analyzer voltmeter with different ranges for at least 500 volts D. C., and an A. C. voltmeter of approximately 1000 volts, should be employed in the voltage tests. The positive side of a D. C. voltmeter should always be connected to the positive point and the negative side of the meter to the negative point. **The side at which the current enters a resistor or coil is positive and the side at which the current leaves is negative.**

The highest D. C. voltage available in the circuit is directly across the output of the 80 rectifier. The positive side of the voltmeter is connected to the filament and the negative side of the chassis. If no D. C. voltage is available at the output of the rectifier, connect the voltmeter first as shown at "F" in Fig. 208-B, and then disconnect the following points until a reading is indicated. First, disconnect points X1 and X2. A short circuit through condenser C1, or from the speaker field to ground will short the "B" supply, and will generally cause the rectifier tube to overheat and burn out. This trouble is indicated by the plates of the rectifier tube getting red hot.

If disconnecting at X1 and X2 does not bring back the voltage, then connect a wire from the center tap of the transformer high voltage winding X3 to ground, to check for an open. If this brings back the voltage, it indicates that there is an open in the B— return wire or ground connection.

In case voltage exists between the output wire "G" of the rectifier, and ground, but does not show up beyond the choke or speaker field, or on the voltmeter connected at "H", this indicates an open in the speaker field or choke, or possibly a shorted condenser C2. Short circuit the speaker field from point X2 to X4 and see if this brings the voltage through to wire "I." If it does, this proves that the open was in the speaker field or choke.

A short circuit in condenser C2 will still give a voltage reading on the voltmeter at F because of the resistance of the speaker field.

If shorting the field coil or choke with a wire does not show voltage on the meter at "H", it is probably due to a shorted filter condenser C2, which can be checked by disconnecting the condenser at the point X5 and leaving the voltmeter connected to the circuit as shown at "H". If disconnecting the condenser C2 brings back voltage on the meter at "H", then we know the trouble was in the condenser.

A shorted tube may also be the cause of no voltage on the meter at "H". To check for a shorted tube, remove the tubes one by one, replacing in the sockets those that do not increase the voltage on the voltmeter when they are removed, as these tubes are not the cause of the trouble. When a tube is removed which raises the voltage at "H", this is the defective tube. (Do not remove the 80 rectifier tube or it may cause high voltage surges.) If the condenser C3 is shorted, the voltage will increase on the voltmeter when disconnecting this condenser from the circuit.

149. PLATE VOLTAGE TESTS

If voltage is available from point X4 to ground or chassis, then check the plate circuit of each tube by placing the voltmeter between the plates of the tubes and the chassis as shown in Fig. 208-B at J,

K, L, and M. No voltage on the plate of any tube indicates an open somewhere between this point and X4, because we have already checked the circuit for shorts. You will remember we did get a voltmeter reading from X4 to the chassis, so now if we do not get a reading from any tube plate terminal to the chassis, it is no doubt caused by an open circuit in the primary P1, resistor P2, or the wires leading to them.

If voltage is available from the plates to the chassis, the coils, resistor and wires in series with these circuits are probably all right.

If an open is suspected in any unit, that unit may be shorted with a jumper wire temporarily to see if a reading is then indicated on the voltmeter.

A short circuit in the condenser C4 will short the plate supply of the detector tube only, and can be tested by connecting the voltmeter to the plate of the detector tube and the chassis as at "K". Then disconnecting the condenser C4 should apply a voltage to the plate.

150. SCREEN GRID AND CATHODE VOLTAGE TESTS

With voltages on the plates of all tubes, the next step is to check the Screen Grid voltages by connecting the voltmeter between the point X7 and chassis, as shown in Fig. 208-C. No voltage on the screen grids is probably due to an open in the screen grid voltage reducing resistor of 12,500 ohms, or to a shorted .1 mfd. condenser between the screen grids and the chassis.

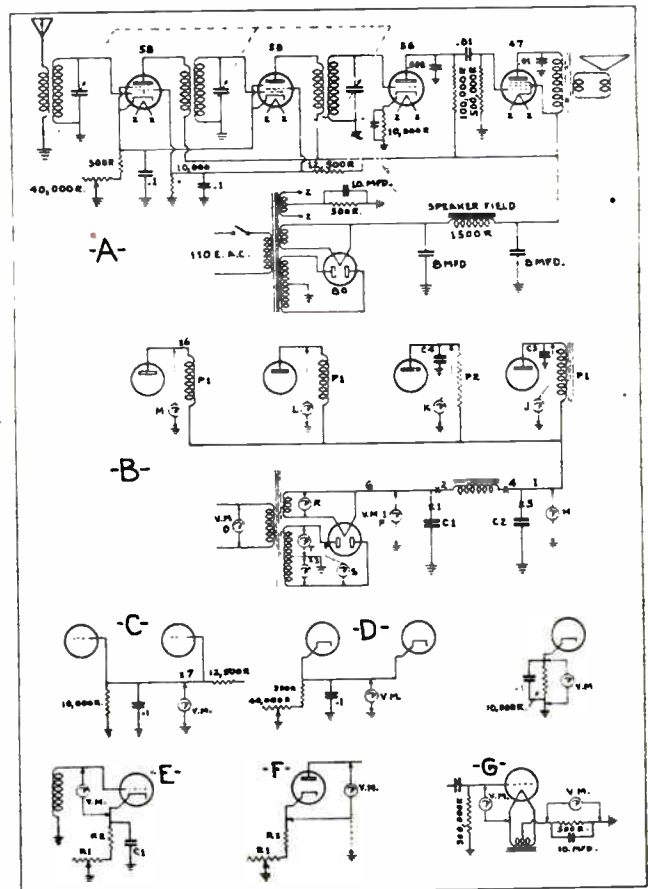

Fig. 208. Carefully refer to the above partial circuit diagrams of this receiver while reading the instructions on radio service tests as illustrated in these sketches.

With the voltmeter connected in the circuit as shown in Fig. 208-C, short the 12,500 ohm resistor temporarily to check it for an open. A reading should then appear on the meter if the resistor is open. If this does not give any reading on the meter, remove the short and disconnect the .1 mfd. condenser.

To check the cathode voltage, the voltmeter may be connected between the cathode and ground as shown in Fig. 208-D. No voltage on the voltmeter will probably be due to a shorted .1 mfd. condenser. The condenser can be checked by disconnecting it from the circuit, to see if voltage is then indicated on the meter.

If the cathode voltage reads high, it is probably due to an open cathode circuit or an open grid circuit. The grid circuit may be checked by connecting the voltmeter between the cathode and the grid of the tube as shown in Fig. 208-E. No reading on the voltmeter will indicate an open grid circuit, assuming that the condenser C1 was checked and found good. A short in this cathode by-pass condenser C1, will give the same indication because it will short the resistors R1 and R2, giving no voltage drop across them. The cathode circuits and the grid circuits of the other tubes are checked by the same procedure.

Another method for determining if there is an open in the cathode circuit, is as follows: If no voltmeter reading is obtained from plate to the cathode, as in Fig. 208-F, but a reading is shown on the meter when it is connected between the plate and chassis, it indicates an open cathode circuit. The resistors in the cathode circuit can be checked by temporarily shorting them out, or by placing another good resistor in parallel with the suspected resistor. The one that gives a voltmeter reading, when shorting the resistor, with the meter connected between the plate and cathode, is the defective unit. The 500 ohm resistor shown in Fig. 208-G is the grid bias resistor for the 47 type output tube.

Referring to Fig. 208-G you will notice that the meter connections are somewhat the same with the exception of the filament connection. The filament type tube does not have a separate cathode such as used with the heater type tube, so the meter will be connected to the filament. When measuring the grid voltage on the 47 tube, there will not be a very high reading on the voltmeter because of the high resistance connected from the grid to the chassis. If in doubt about this resistor being defective, connect another resistor in place of the suspected one and check the voltage again.

151. TESTING THE A.C. VOLTAGES ON THE POWER TRANSFORMER

In testing the power transformer A. C. voltages, we will begin with the primary. Connect the voltmeter with the proper range across the primary as shown at "O" in Fig. 208-B. If the primary voltage shown is low, the voltage on the secondary side will also be low.

Next we will test the filament windings by connecting the meter across the filament terminals as shown at "R" in Fig. 208-B. Low voltage here may be due to a shorted secondary winding, and in this case the transformer must be replaced. No voltage

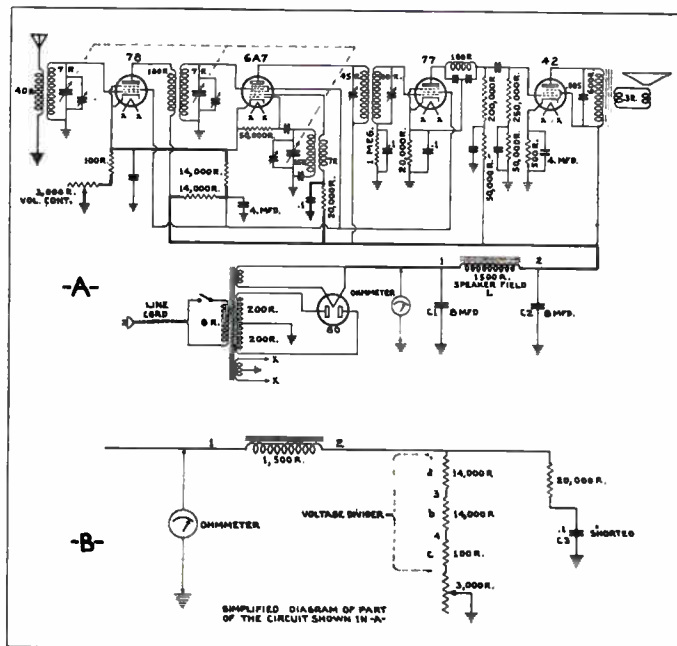

Fig. 209. The diagram at "A" shows the circuit of a modern radio receiver, with the correct values of various resistors and condensers marked. Observe this diagram carefully while reading the instructions on various service tests for this receiver. The sketch at "B" shows a simplified view of part of the wiring of the complete circuit at "A". Compare the lower sketch with the same section of the circuit above.

across the terminals of the filament winding is likely to be due to an open. If the open cannot be reached readily without unwinding the transformer, then the transformer should be replaced.

The high voltage winding is checked by connecting the high voltage range of the A. C. voltmeter from plate to plate of the rectifier, as shown at "S" in Fig. 208-B. Next test the voltage from one plate to the center tap or chassis as at "T" in Fig. 208-B, which should give a reading of one-half the voltage measured across the high voltage winding. The voltages should test the same from both plates to the center tap. Any noticeable difference in voltage between the two is no doubt due to shorted transformer secondary turns.

152. RECEIVER ANALYSIS BY RESISTANCE TESTS

The resistance method of analysis is also one of the commonly used methods for determining the location of the defective part or parts in radio receivers. A serviceman employing this method of locating defective parts must be able to interpret the meter readings by carefully tracing each circuit, and determine whether they indicate normal or abnormal conditions. If one does not know what the correct resistance values should be, the resistance measurements are of no real value with the exception of checking the continuity of the circuit.

Most of the receiver manufacturers furnish diagrams giving the resistance values of all the parts employed in the receiver, which makes this method of testing rather accurate. Here again, is where the manufacturers service charts, or the diagrams in a radio service manual are very helpful.

Upon examination of a wiring diagram of an electric receiver you will notice that the chassis, ground terminal or "B" negative is common to all circuits

in the receiver, with the exception of the voice coil of the speaker, which is not always grounded.

However, having a receiver wiring diagram with the electrical values of the parts marked on it, one can check the electrical values of the different parts and sections, as well as the continuity of a circuit.

A serviceman should have a fairly accurate ohmmeter capable of measuring the resistance value of the parts being checked. One must also be careful not to have too much resistance in the circuit, so that an accurate reading can be obtained by the ohmmeter. If too much resistance is in the circuit, the ohmmeter may not give any resistance reading or it may be near the high resistance end of the scale, on which the calibration markings are crowded close together. **When checking low resistance parts or circuits, use a low range ohmmeter, and for high resistance use a high range ohmmeter.**

153. RESISTANCE ANALYSIS EXAMPLE

Referring to the receiver wiring diagram in Fig. 209, for example, one should make the following resistance tests. **The line cord should be disconnected from the A. C. supply, or whatever power supply is used for the receiver. That is, no voltage should be applied to the receiver when making resistance tests with an ohmmeter.**

Connecting the ohmmeter between point 1 and ground as shown in Fig. 209, the resistance indicated by the ohmmeter should normally be 1500 ohms plus 14,000 ohms, plus 14,000 ohms, plus 100 ohms, or 29,600 ohms with the volume control turned to the right. If the volume control is turned to the left, the resistance would be 29,600 ohms plus 3000 ohms, giving a total resistance of 32,600 ohms. This circuit is drawn in heavy lines.

Resistors employed in the receivers have a tolerance of 10% plus or minus their rated resistance. So do not expect the resistance reading to be exactly as marked for the various resistors in the receiver wiring diagram.

When placing the ohmmeter in the circuit, be sure the positive side of the meter is connected to the positive side of the supply and the negative side of the meter to the negative side of supply, or otherwise an incorrect reading will be obtained if the receiver employs electrolytic condensers.

If the ohmmeter gives full scale deflection or zero ohms between point 1 and ground, it is generally due to a shorted filter condenser C1 or a grounded speaker field "L". With a little reasoning one can see that the short is not beyond the 1500 ohm speaker field, as if it was the resistance reading would be higher than zero ohms.

To check the condenser C1 for a short, disconnect one end and take another resistance test. The resistance of the circuit should now be normal if the condenser was defective. The ohmmeter may also be connected across the condenser terminals to check for a short. The ohmmeter will give a full scale reading or zero ohms if the condenser is shorted.

The speaker field "L" is checked by disconnecting number 1 side. No reading on the ohmmeter when connected to this point 1, will indicate a grounded speaker field (assuming that the wiring

isn't grounded.) To check the resistance of the speaker field, connect the ohmmeter between points 1 and 2.

154. RESISTANCE TESTS FOR SHORTED CONDENSERS

A reading of 1500 ohms between point 1 and ground in Fig. 209-A, indicates a short in condenser C2. If a zero reading is indicated with the ohmmeter connected to point 2 and ground, it is further proof that condenser C2 is shorted, assuming that the speaker field "L" is not grounded. Additional tests may be made by disconnecting the condenser as explained previously.

With condenser C3 shorted, as shown in Fig. 209-B, it forms a parallel circuit connecting the 20,000 ohm resistor in parallel with resistors a, b, and c. The resistance from point 2 to ground will now be approximately 11,935 ohms. With the ohmmeter connected from point 1 to ground as shown, the resistance reading will be approximately 11,935 ohms plus the 1500 ohms of the speaker coil, giving a total resistance of 13,435 ohms. So you can readily see the importance of interpreting the amount of resistance in the circuit.

The defective condenser may be easily found by connecting the ohmmeter across condenser C3 which if shorted will give a zero reading. Similar tests for short circuits, can be made with the ohmmeter

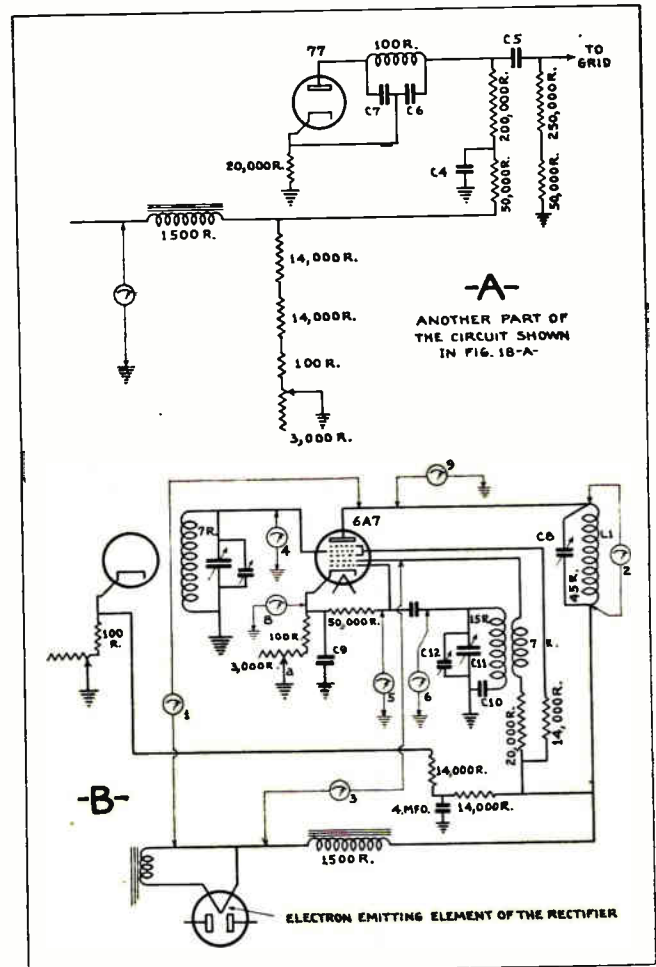

Fig. 210. These partial circuit sketches of the receiver shown in Fig. 209 illustrate the methods of making various service tests, explained in the accompanying pages.

connected in parallel with condensers C4, C5, C6, or C7, in Fig. 210-A, but the resistance readings will be proportionately higher because higher resistances are connected in the circuit.

Let us assume that resistor "B" in Fig. 209-B is open. Our first test will be from point 1 to ground and we know we should get approximately 29,600 ohms, but the ohmmeter does not indicate any resistance. This is a good indication of an open circuit in the voltage divider. The open is found by contacting the ungrounded side of the ohmmeter to points 2, 3, and 4 until a reading is given on the ohmmeter.

If there is no reading from 3 and a reading is obtained at 4, the trouble is located between these two points. The ohmmeter can then be connected directly across the 14,000 ohm resistor to check for an open. No reading indicates an open resistor.

155. RESISTANCE TESTS ON PLATE AND SCREEN GRID CIRCUITS

The plate circuits can be checked for resistance and continuity by connecting the ohmmeter as shown in position 1 in Fig. 210-B, to the plate contact on the tube socket, and to the filament contact or electron emitting element of the rectifier tube. The resistance reading should be 1545 ohms, because we are now measuring the resistance of the 1500 ohm speaker field and the 45 ohm primary L-1.

The speaker field and L-1 may be checked separately for resistance, by placing the ohmmeter across the part being checked. Suppose we measure the resistance of L-1 with the ohmmeter 2 connected as shown, and find that the ohmmeter reads zero ohms. The trouble would be a shorted I. F. trimmer condenser C8. The trimmer condenser may be adjusted in and out to see if the trouble disappears. If the trouble still remains then the condenser should be disconnected from the coil and checked again, and replaced if defective.

The plate circuit of the oscillator section is also checked in a similar manner by placing the ohmmeter 3 between the grid that acts as the plate of the oscillator, and the electron emitting element of the rectifier as shown in Fig. 210-B. We know the reading should be approximately 21,507 ohms, but let us assume that we do not get a reading, which means we have an open in the circuit. The wiring and each part may be checked separately, or by moving one lead of the ohmmeter along the circuit toward the other ohmmeter lead until the open is found.

The plate and screen grid circuits can also be checked by using the ground as common. For instance, checking the resistance from the plate of the 6A7 mixer tube to ground as shown by ohmmeter 9, the reading should be 28,145 ohms. The grid circuits are checked by placing the ohmmeter 4 as shown, and the reading should be 7 ohms. In case of a zero reading, rotate the tuning condenser and also adjust the trimmer to see if a normal reading will then appear. In some cases it is necessary to disconnect one side of the condenser from the circuit to get a satisfactory check.

The resistance reading from the grid of the oscillator section to ground, as shown by ohmmeter 5, will normally be 50,100 ohms. This reading should increase up to 53,100 ohms by varying the resis-

tance of the volume control "a". If no variation is noticeable when the volume control is adjusted, it is probably due to a shorted cathode by-pass condenser C9.

To complete the checking of the oscillator grid circuit, connect the ohmmeter 6 as shown, and there should be no reading. If the resistance reading is 15 ohms, then the condenser C10 is shorted. If the reading is zero ohms, it would be due to shorted tuning or trimmer condenser plates. There should be no reading with the ohmmeter connected as shown. If a reading is noted, it may be due to a short in the tuning condenser C11 or its trimmer condenser C12.

The cathode circuit reading should be 100 ohms with the ohmmeter 8 connected as shown. Zero reading means a shorted cathode by-pass condenser C9. No reading is due to an open 100 ohm resistor or volume control "a". All other circuits are tested in a similar manner.

The foregoing instruction covers the methods of making many of the most common radio trouble tests. If carefully reviewed and visualized step by step, and then applied in actual tests on receivers, it should be a very valuable guide in radio service work.

155A. TROUBLE SHOOTING WITH SIGNAL TRACING UNITS

Signal tracing is the name applied to the process of feeding a signal into the antenna circuit of a receiver and then following this signal through the various sections of the receiver, using a special instrument capable of indicating the presence of this signal. These instruments are called signal tracing units. They contain the principal parts of a standard radio receiver such as the R. F. section, detector section and A. F. section. In fact, a standard radio receiver may be converted into a simple signal tracing unit by inserting phone jacks at the input and output circuits of each section.

The signal tracing unit is used in the following manner. A signal generator is set up to feed a signal of 1400 K. C. into the antenna and ground circuits of the receiver under test. Test leads are inserted into the R. F. input jack of the signal tracing unit and the external end of the leads are placed across the primary of the antenna coil. Both the receiver under test and the signal tracing unit must be tuned to 1400 K. C. The presence of the signal across the primary of the antenna coil will be indicated by means of a magic eye, headphones, or a combination of both on the output of the signal tracing unit. Then the test leads are placed across the secondary of the antenna coil, then across the primary of the first R. F. coil, then across the secondary of the R. F. coil, etc. By this method, the signal can be followed through from stage to stage, giving the service man a check on the actual operating efficiency of each individual section. The test leads must be shifted to the A. F. input jacks when testing for signal in the A. F. section of the defective receiver.

The best signal tracing units incorporate a vacuum tube voltmeter and magic eye with a system of level controls, enabling the user to determine the gain or loss in any section of the receiver and also make a voltage analysis of the entire receiver.

AUTOMOBILE RADIO INSTALLATION AND SERVICING

During the past several years, auto radios have become very popular and several million automobiles have already been equipped with such receivers. A number of busses and trucks also carry radio receivers. There are still many millions of automobiles to be equipped with radios. Recent improvements and refinements in tone quality, compactness and convenience have greatly increased the popularity of these units.

A good auto radio, properly installed and serviced can be a great source of comfort and companionship to relieve the monotony of long drives, by providing music and entertainment, as well as news items, baseball, football and other sports announcements, speeches, educational broadcasts, etc.

Some auto manufacturers are now equipping their cars with radio receivers as standard accessories. However, many cars are sold without radios and the owners later decide to have them installed. Owners of thousands of older cars are also willing to have an auto radio installed, providing a neat and efficient installation is offered at a reasonable price.

This branch of work offers interesting and good paying jobs to hundreds of trained radio men. Many radio dealers, garages, and auto service stations employ trained auto radio men both for installing and servicing these sets.

Automobile radios require careful and intelligent installation by trained men who have some knowledge of the ignition equipment and other electrical circuits on the car, in order to avoid and eliminate radio interference noises and static which originate in a number of the electrical devices on the modern automobile. Here is where you can make excellent use of your combination electrical, auto ignition and radio training.

156. AUTO RADIO SERVICE CONDITIONS AND REQUIREMENTS

Auto radios also require frequent and intelligent servicing, due to the rather severe conditions under which they operate. For example, auto radios are subjected to a great deal of vibration, extreme temperature changes, moisture or humidity and electrical interference which household radios do not have to contend with. Auto radios may be subjected to temperatures ranging from sub-zero winter atmosphere to temperatures of 100 to 140 degrees F., resulting from combined hot summer atmosphere and engine heat.

Modern automobile radios are very well made to meet these conditions, by being housed in metal containers and having the chassis mounted on rubber, springs, or other shock absorbing materials. The metal housings provide a certain amount of shielding from electrical interference and considerable protection from mechanical abuse and moisture. Nevertheless they should be installed with due regard for these important factors which so materially affect the operation of the rather delicate and critical parts of any radio receiver.

Your knowledge of auto radio installation and servicing may also be applied to air craft radio equipment, due to the similarity of construction and service conditions of these systems. Therefore, you can see that practical training in this field opens up great opportunities for well qualified radio service men. Most all of the radio knowledge you have gained so far from earlier lessons can be applied to auto radio work.

Fig. 212 shows a compact auto radio receiver which has the chassis and speaker both mounted in the metal cabinet. In this same figure are shown several types of auto radio control units which are made for mounting on the instrument panel of the car.

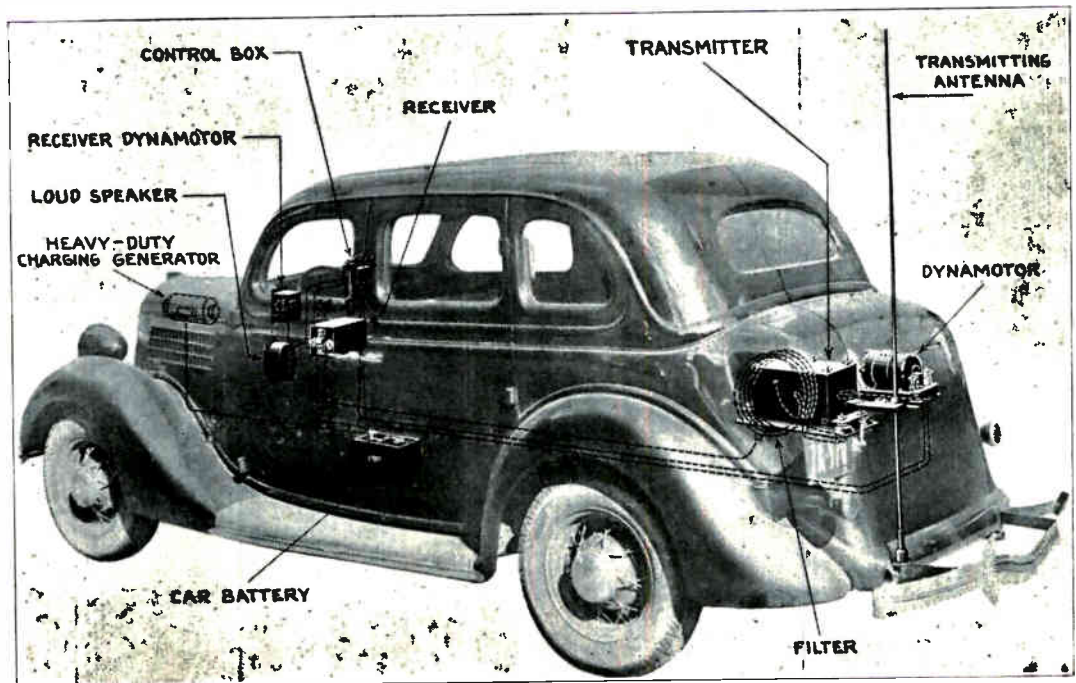

Fig. 211. Photo diagram showing the installation of a complete radio transmitter and receiver in a police car. Thousands of police cars are now being equipped with such two-way radio communication. Installation and servicing of such equipment provides good jobs for many trained radio men. Courtesy General Electric Company.

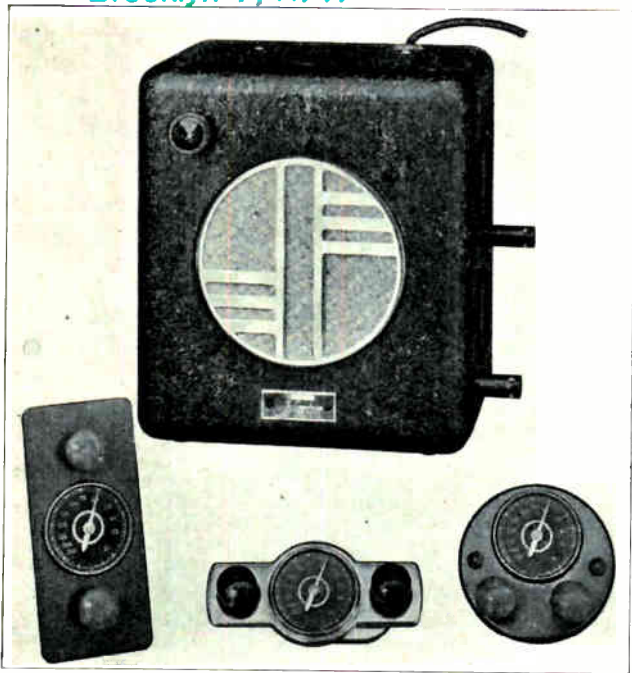

Fig. 212. Compact modern auto radio receiver with speaker located in the same cabinet with the receiver chassis. Note the two connections for control cables on the right of the cabinet. In the lower view are shown several types of control heads or panels for use with auto radios. Courtesy Wells-Gardner Company.

Some auto radio controls are mounted on the steering column beneath the steering wheel, by means of a metal strap or clamp. Auto radio controls are connected to the switch, volume control, tone control and tuning condensers of the receiver by means of small flexible cables enclosed in tubular metal or fabric shields.

157. LOCATION AND MOUNTING OF RECEIVER

The radio receiver is generally mounted underneath the cowl or back of the instrument panel of the car, although in some cases they may be mounted under the hood in the engine compartment. Two advantages of mounting the receiver inside the car body and behind the bulkhead panel are: that in this position, the radio is not subjected to the high engine temperatures, dirt, oil and moisture which are often present around the engine; and the metal bulkhead panel in modern cars affords a certain amount of shielding from ignition interference which is produced at the spark plugs, ignition wiring, generator and starting motor.

In selecting a location for the auto radio, one should try to place it where it will not interfere with the operation or free movement of gear shift, brake lever, clutch and brake pedals or other operating controls of the car. It should also be located out of the way of the feet of passengers or driver, and where it will not be rubbed or bumped by metal parts, control rods or wiring under the cowl, as these things will cause electrical interference noises in the receiver if they touch the receiver cabinet.

The receiver should also be mounted where it can easily be removed for inspection or service, and where it will not prevent access to important instruments or wiring on the automobile. Avoid placing the radio underneath the cowl ventilator, or it may be damaged by water during rain storms.

Some auto radios have the speaker built in the receiver cabinet as shown in Fig. 212 while others have the speaker mounted separately, either behind the instrument panel or in the roof of the car, and connected to the receiver by means of a shielded cable. If a separate speaker is mounted on the bulkhead panel, it is advisable to cut several large holes through the panel back of the speaker to act as sound openings and prevent muffled tone of the speaker. Cover these openings with fine copper screen.

Auto radio manufacturers generally supply instruction sheets, and a template or cardboard pattern with which to lay out the holes to be drilled in the bulkhead for the radio mounting bolts.

158. GENERAL CONNECTIONS

Earlier models of auto radios were operated by batteries, the regular six volt storage battery of the car being used for tube filament or heater current supply, and dry "B" batteries being used for plate voltage supply. Practically all modern auto radios are equipped with a vibrator rectifier and step up transformer to obtain plate voltage from the regular six volt auto battery. This rectifier being mounted right in the cabinet with the receiver, eliminates much of the wiring which was formerly necessary to connect up external "B" batteries.

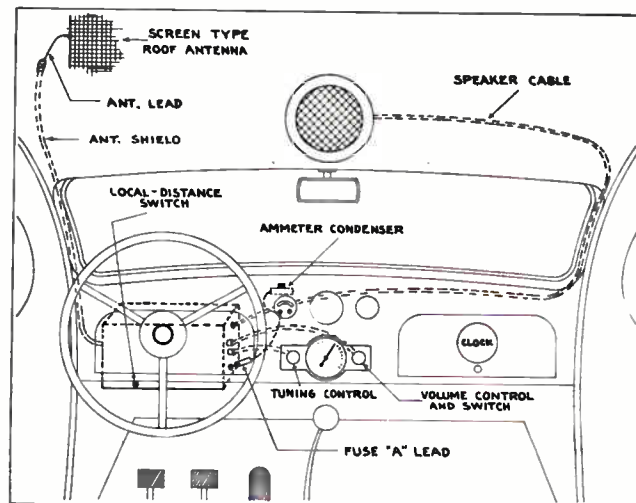

Fig. 213. This diagram shows the location and connections of an auto radio receiver, speaker, control head and antenna. Examine each part of the diagram carefully.

Thus about the only wiring and connections necessary for the modern auto radio are the antenna and ground connections, control cables, and a single wire connection from the car ammeter terminal to supply the source of current from the car battery. The return for this circuit is through the radio ground connection and metal chassis of the car, the same as for all car lights, ignition and other circuits.

In case the speaker is mounted separately this of course requires one additional connection. If the speaker is mounted in the roof of the car as shown in Fig. 213, the connecting cable is usually drawn up through the hollow corner post at the side of the windshield, by means of a pull cord attached to the end of the speaker cable.

Some auto radios have the control knobs right

on the front of the cabinet and are made for mounting directly behind the instrument panel, and therefore do not require any control cables. Many modern cars are fitted with a special opening or removable piece in the instrument panel for the mounting of the radio control head. In some cases the ash tray is removed to provide a place for the control head.

159. AUTO RADIO ANTENNAS

There are several different types of auto radio antennas in use today, the ones most commonly used being car top antennas, roof type antennas, running board type, under-car type, rod type antennas and insulated front or rear bumpers.

The car-top antenna is often used in cars that do not have all-metal tops, and generally consists of a fine copper wire screen or galvanized poultry wire mesh mounted between the roof of the car and the inner cloth covering or ceiling upholstery as shown in Figs. 213 and 215. Or it may be an insulated wire which is laced back and forth between the top cross bows as shown in Fig. 216-A, or woven into the top fabric as shown in Fig. 216-B. Many modern automobiles are equipped with roof type antennas right at the factory, even though the car may not be equipped with a radio when sold.

On cars having built-in antennas, the antenna lead in wire will usually be found coiled up and tucked under the dash near one front corner post.

If the car has no built-in antenna, the inner cloth top covering can be removed to allow the installation of a screen or wire type antenna. Or it may often be easier to install a running board antenna underneath one or both of the running boards.

When installing screen type antennas in the car top the screen should be cut away around the dome light, and also away from the dome light wire which leads to the switch on the door column. See Fig. 215-A. The screen should not be closer than three or four inches from this wire or the dome

light, or the antenna may pick up considerable ignition interference which is radiated back along this wire from the ignition wiring in the front of the car. The same care should be observed when installing insulated wire antennas in the car roof, to keep these wires several inches away from the dome light and its circuit.

In cars having wooden slats or crossbows in the top, the wire screen antenna can be securely tacked, or laced with cord to these crossbows. Care should be taken to see that no part of the wire mesh antenna touches the metal edges of the car top or body frame. If a car is already equipped with wire screen in the roof, and this screen appears to be grounded, a test can be made with an ohmmeter or test lamp to determine whether it is grounded or not. Another test can be made by touching the antenna lead to the ammeter terminal. If the antenna is grounded this will cause a spark.

160. ANTENNA LEAD-IN WIRES

The lead-in wire from a roof type antenna should be soldered along the entire front edge of the screen to form a good connection with all of the screen wires. The lead-in should be kept as short as possible and should be shielded with metal shielding from the point where it leaves the antenna to the point where it attaches to the receiver.

The metal shielding should be cut back a couple of inches where the lead-in wire connects to the antenna wire, and this bare end of wire taped to prevent the shielding from contacting the antenna. The lead-in wire should then be pulled down through a hollow corner post, or run underneath the upholstery to a point where it goes behind the instrument panel. The lead-in shield should be grounded at both ends by soldering or other secure connection to the grounded radio cabinet and to the grounded metal of the car body. When splicing lead-in wires to the antenna wire on the receiver, be sure to draw the metal shields together

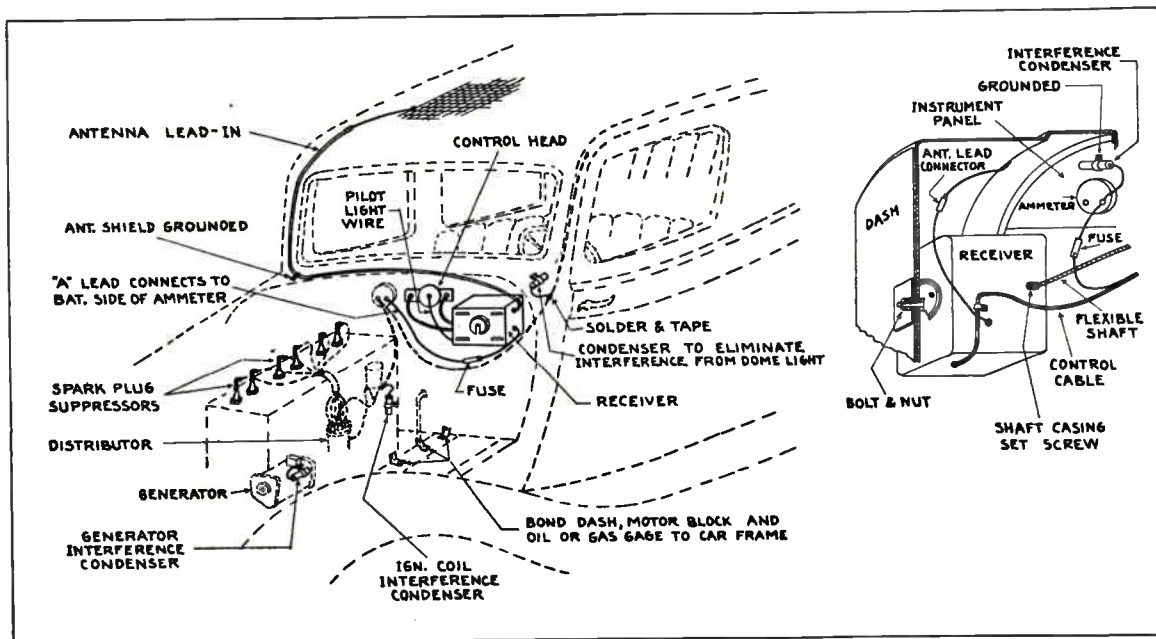

Fig. 214. Diagram showing method of installation and wiring for an auto radio receiver, including suppressors for elimination of ignition interference. On the right is shown another view of the connections from the receiver to the antenna, car ammeter, and control cables. Study these diagrams carefully while reading the instruction in this section.

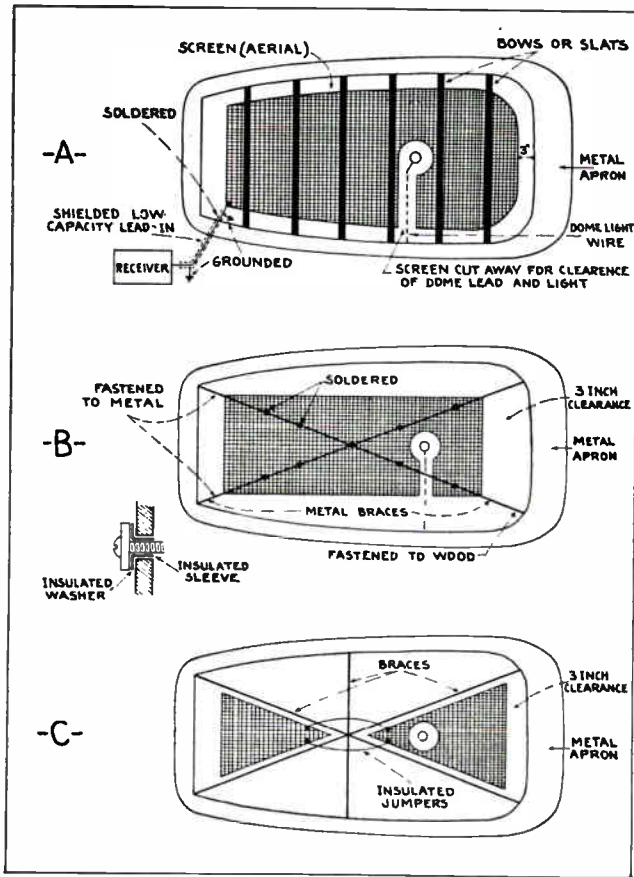

Fig. 215. The above views show several different methods of installing antennas in the roofs or tops of automobiles. Each of these methods is fully explained on the accompanying pages.

over the soldered and taped splice, and solder the shields together to form one complete grounded shield.

In cars having fabric tops, muslin support strips are sometimes used above the wood crossbows. The antenna screen wire can be laid above these muslin strips.

161. SPECIAL CAR TOP ANTENNAS

In cars having metal top bows, these bows are bonded or grounded to the frame of the car and the antenna should not be allowed to touch them. In such cars, the headlining can be removed to expose the car top and permit screw eyes or staples to be attached to the wooden frame underneath the metal apron. A number 18 stranded wire with rubber insulation can then be threaded through these eyes and back and forth across the car top. The screw eyes or staples should be spaced two or three inches apart and at least two or three inches away from the metal cross bows as shown in Fig. 216-A. The lead-in wire can be run from this antenna to the receiver as previously explained.

Some car tops have two metal braces extending diagonally from corner to corner as shown in Fig. 215-B and C. These metal braces can be insulated at their ends by drilling larger holes in the metal frame and using fibre or rubber sleeves and washers to insulate the rod and nut from the metal frame. See the small sketch in Fig. 215. A wire screen antenna can then be laid above these brace rods and soldered to them at a number of points as shown in Fig. 215-B.

Or, if preferred, the antenna screen can be cut in two sections and fitted between the brace rods as shown in Fig. 215-C. In this case, be careful to see that the edges of the screen are kept several inches away from the rods and the dome light.

In roadsters and sport cars having folding or collapsible tops, a flexible antenna or wire can be installed by removing the top material and exposing the cloth quarter-deck pads on each side of the top bows. Eight or more rows of number 18 rubber covered stranded wire may be woven back and forth on these cloth pads and spaced from 2 to 3 inches apart. The wire can be held in place by tying with cord every six inches or so.

In some cases it may be more convenient to use a piece of muslin to support the antenna. Holes can be punched about 10 inches apart and in rows in the muslin, and the antenna wire woven back and forth through these holes as shown in Fig. 216B.

162. RUNNING BOARD ANTENNAS

On cars having all metal tops, the roof type antenna may not be so efficient due to the shielding effect of the grounded metal top. Running board aeriels are very efficient and popular in this type of car. These aeriels consist of metallic conductors or rods encased in rubber or water-proof material and may be mounted underneath the running board by means of clamps, screws or bolts. See Fig. 217.

Sometimes only one running board aerial is used, while in other cases, two may be used with a switching arrangement to connect either one or both to the receiver, for local or distance reception. Shielded lead-in wire can be run from such aeriels underneath the car frame or floor boards and then brought through a hole in the floor and up along the front side wall to the radio back of the instrument panel.

Running board aeriels should be about 3 inches below the running board for best efficiency.

Under car antennas often consist of flexible metallic conductor enclosed in rubber or water-proof fabric covering and suspended underneath the chassis from front to rear axle. Or they may be

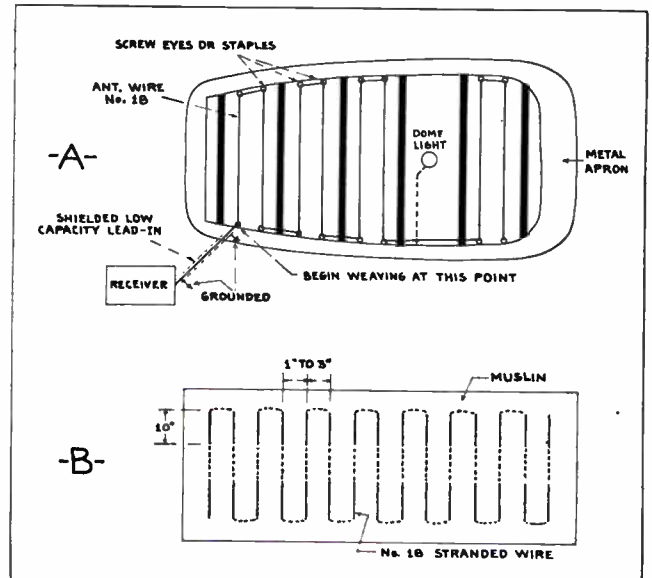

Fig. 216. Diagrams showing two additional methods of installing auto radio antennas in car tops.

run in a triangular pattern and attached to the "U" bolts which hold the chassis to the rear axle and flywheel housing. See Fig. 217.

163. ROOF AND ROD TYPE ANTENNAS

Outside roof type antennas may consist of metallic tubing 7 or 8 feet long, which is mounted on the top of the car by rubber standoff insulators of the suction cup type. This eliminates the necessity of drilling the metal car roof. See Figs. 217 and 218.

Rod type antennas, consisting of adjustable telescoping metallic rods, similar to a metal fishing rod are sometimes mounted at the front or rear end of the car by means of special insulated brackets or clamps. Several antennas of this type are also shown in Figs. 217 and 218.

Sometimes the front or rear bumper may be insulated from the car frame by heavy rubber insulators, and the metal bumper will then act as an antenna. Shielded lead-in wires with the metal shielding grounded to the metal car frame at both ends, or at several points along their length, should be used.

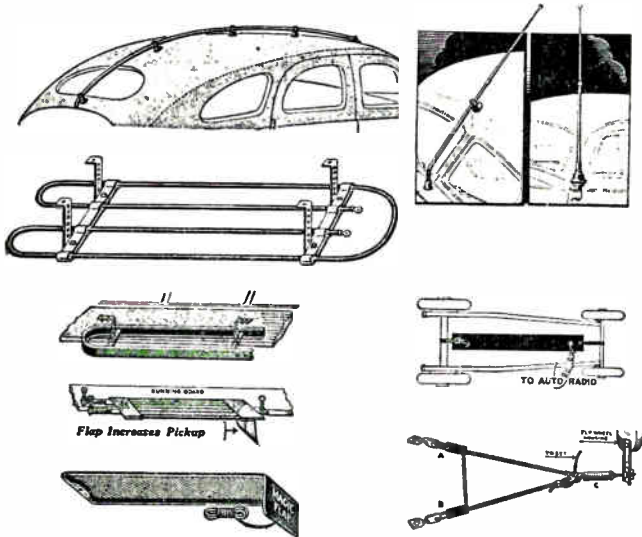

Fig. 217. The above views show several different types of car top, running board, and under-car auto radio antennas and their methods of installation.

164. INSTALLATION OF AUTO RADIOS

The actual mounting or installing of the auto radio receiver is not particularly difficult for one who is used to handling tools, providing a few general precautions are observed.

First select the location for the receiver, where it will not interfere with other parts of the car mechanism or controls, or with the driver's feet. Try to locate the receiver where it will be accessible, but get it up out of sight and out of the way as much as possible. Usually somewhere on the vertical bulkhead panel which separates the engine compartment from the driver's compartment.

Try to locate the radio where the antenna and battery leads and control cable connections can be conveniently made. Avoid any sharp bends or kinks in control cables, as the controls may bind or work hard if these cables are sharply bent.

If the control cables are of the twisted spring wire type and are to be shortened by cutting, always securely braise or solder all those wires together

at the point where they are to be cut or they will unwind and ruin the cable. The brazing should be done before cutting the inner control cable, and at a point close to where the cut is to be made, and so that when the free end is cut off the remaining end which is to be attached to the control head or knob, will be the end that is brazed. Some control cables are made with swaged spots every few inches for cutting.

The trouble of cutting control cables can often be avoided by mounting the radio a little farther toward one side of the dash, and farther away from the control head. Or the standard length control cables can be exchanged for cables of shorter length. Cables can be looped to take up slack, providing the loops are arranged with gradual curves and no sharp bends.

As previously mentioned, auto radios are generally supplied with paper templates to use in marking or laying out the mounting holes. After marking these holes carefully, drill them through the panel with a drill of proper size to accommodate the mounting bolts.

The receiver should be mounted upright and level and with proper clearance for ventilator and speaker openings. In some cases, mounting brackets are used instead of bolting the receiver directly to the bulkhead panel, especially if the panel is on a slant.

The paint should be thoroughly scraped off the metal panel where the mounting bolt washers and nuts are to fit, in order to provide a good ground for the set.

165. CONNECTING UP THE RECEIVER

It is usually best to attach the control cables and set wires and adjust the trimmer condensers before permanently tightening the mounting bolts. If the chassis is provided with a ground wire or strip, be sure this is securely grounded.

The antenna lead wire should be connected to the set and the lead-in wire shield grounded to the chassis or metal box.

The "A" lead or power wire may be connected to the ammeter terminal, usually on the battery side so that the radio current will not pass through the ammeter. This "A" lead or cable usually has a fuse installed in a receptacle located right in the cable, as shown in Fig. 219.

If the receiver is provided with a pilot lamp on the control head or panel, the wire from this lamp should be plugged into the jack or receptacle provided for it on the chassis, as shown in Fig. 219. If this wire is too long, loop and tie up the extra length, but do not cut it off. It is best to remove

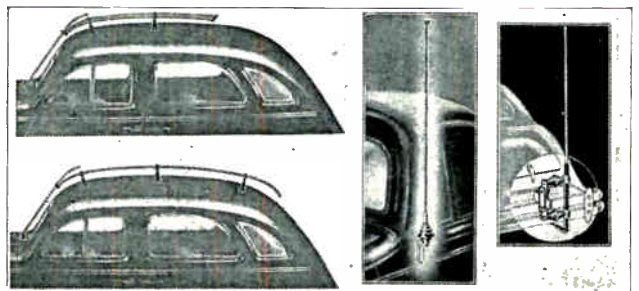

Fig. 218. Additional views showing mounting of car top and rod type auto radio antennas. Courtesy Radolek Company.

the car fuse while connecting up the radio, or otherwise this fuse may be blown by accidental contacts of tools with the wiring.

166. CONTROL CABLE CONNECTIONS

On some of the earlier model auto radios considerable care was required to connect up the control cables properly to the receiver and control head. On such sets the tuning condenser plates should be turned all the way out of mesh or counter clockwise, and the tuning knob and pointer all the way counter clockwise, or to the high frequency end of the dial.

Then insert the control cable ends in the openings or slots at the condenser shaft and tuning knob couplings and tighten the set screws onto the cable. Sometimes it may be necessary to loosen one set screw and reset the control once or twice to get it in the proper position.

On the later model auto radios, having Universal control heads such as shown in the upper view in Fig. 219, the one end of the control cable can be first attached to the condenser shaft, and the other end inserted into the control head coupling slot, with the condenser in any position.

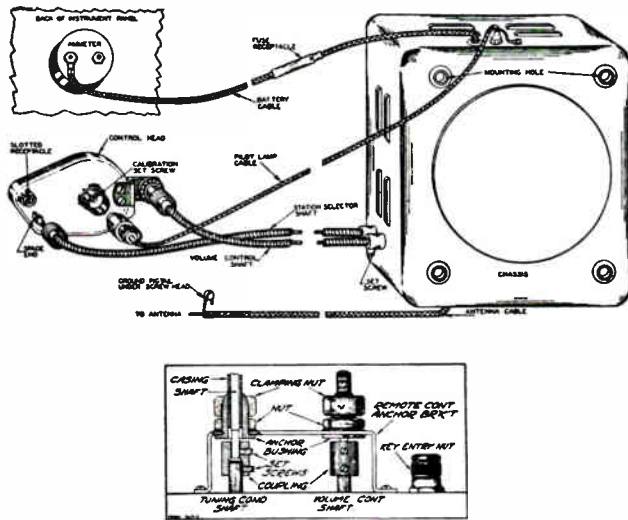

Fig. 219. The top diagram shows the method of connecting the control cables, pilot lamp and battery cable from an auto radio receiver to the car ammeter and to the control head on the instrument panel. The lower view shows the connections for the control cables and their sheaths. Courtesy Wells-Gardner Company.

Then tune in a station of some particular frequency and set the dial pointer to this frequency calibration by turning the small calibration set screw shown in the upper view in Fig. 219. This screw is located in the pilot lamp socket and the pilot lamp bulb must be removed to get at the screw with a small screw driver.

The sheath or outer covering of the control cable should have both ends securely clamped in the clamping nuts at the receiver chassis and control head. Before attaching the cable from the switch and volume control, turn this knob all the way to the left and turn off the switch at the radio. Then connect the cable ends and tighten the set screws. Also note the cable sheath couplings shown in the lower view in Fig. 219.

167. AUTO RADIO INTERFERENCE AND SUPPRESSORS

The elimination of ignition noises and other electrical interference from various points on the car, is one of the most important and critical jobs in connection with a good auto radio installation.

Some of the most common and troublesome sources of static or radio interference on the car, are the ignition coil, distributor, spark plugs, high voltage wiring, generator, cutout, starting motor, dome light and dome light wire. Other sources are wheel static, poor bonding or grounding of engine and body parts to frame, tail light, stop light, heater, windshield wipers, cigar lighter, etc.

Wherever sparks occur at spark plugs or at the interruption of any circuit, high frequency oscillations are likely to be set up due to the inductance and capacity of the circuits. These high frequency oscillations or current surges set up radio waves, similar to those radiated by old style spark radio transmitters.

Spark plug and distributor interference can be reduced or largely eliminated by use of suppressors or resistors in series with these leads. Several types of these resistors are shown in Fig. 220. These suppressors may be either of the carbon composition resistor type, or of the wire wound inductive type.

The resistance of such suppressors ranges from 3,000 to 25,000 ohms or more. On some of the older model cars suppressors of 15,000 to 25,000 ohms resistance may be required to eliminate ignition interference noises. On later model cars, due to improvements in ignition equipment and shielding, suppressors of 3,000 to 5,000 ohms resistance may be sufficient.

Never use any more suppressors than necessary, or any higher resistance suppressors than needed, because suppressor resistance causes some reduction of the ignition spark efficiency. Suppressors are usually more effective if mounted at right angles to the spark plugs.



Fig. 220. These views show several different types of suppressors for elimination of auto radio interference from spark plugs, distributor and ignition wiring. Courtesy Radolek Company.

168. IGNITION INTERFERENCE

On some cars, no ignition interference suppressors may be needed. After installing the receiver, turn it on and listen to a station. Then start the engine. If the running engine causes an objectionable spark popping noise which rises to a roar as the engine is speeded up, then first place a single suppressor in the center high tension lead to the distributor cap.

Try the radio again and if this does not reduce the ignition noise enough, then place suppressors at each spark plug. When testing a radio for interference, be sure the car hood is down and securely latched. You will note that the suppressors shown in Fig. 220 are of both straight and elbow types, and fitted with clips for attaching to spark plug terminals, or with sharp pointed screws to screw directly into the ends of ignition cables.

The one with the spring attached is a high resistance distributor rotor brush for Ford V8 cars. Fig. 221 shows distributor and spark plug resistors installed. The view on the left in this figure also shows a filter condenser on the car generator.

Cleaning and properly adjusting spark plug points will often greatly reduce auto radio interference. Cleaning or replacing distributor breaker points will also help in many cases. A defective breaker point condenser is often the cause of severe radio interference. Some spark plugs have suppressors built in the plug body.

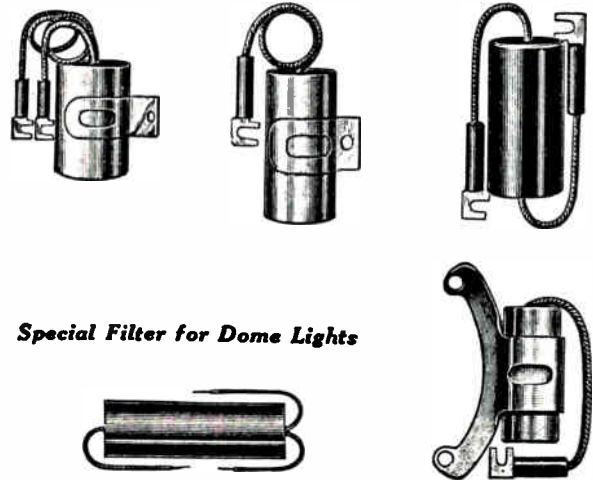

Fig. 222. Several different types of filter condensers for elimination of radio interference from car generator, dome light, stop light and other circuits.

mutators clean and brushes well fitted and with proper spring tension helps to prevent interference from this source.

Starting motors sometimes cause bad radio interference when starting the engine, due to sparking at the commutator and brushes. Cleaning the commutator, refitting the brushes or adjusting defective brush springs to reduce sparking will help to cure this interference. Or a condenser can be connected from the starter terminal to ground on the starting motor or car frame. Starter noise is generally not so objectionable because it is only noticeable for a few seconds when starting the engine. It is best policy to switch off the radio when using the starter, as otherwise the vibrator points may become burned and stuck due to the voltage drop when the starting motor is used.

The dome light wire which leads from the ammeter to the dome light often picks up some of the interference radiated by ignition circuits, and carries it to the antenna, especially if a car top antenna is used.

Interference from this circuit or from stop light, tail light, electric heater motor, or electric windshield wiper can generally be greatly reduced by connecting 1/2 to 1 mfd. filter condensers from each of such circuits to ground. If these condensers do not reduce the interference sufficiently, an R.F. choke coil consisting of about 20 turns of number 18 wire on a 1/2 inch form, or special filter chokes made for this purpose can be connected in series with such troublesome light or motor circuits.

Connecting 1/2 mfd. filter condensers from ammeter terminals to ground and from ignition coil battery lead to ground as shown in Figs. 223-B, C, D, and E, may also help to reduce interference from these various circuits. An R.F. choke or "A" filter choke should be connected in series with the "A" lead as close to the receiver as possible.

If the dome light wire still gives interference after attaching the condenser to ground as mentioned above, it may then be necessary to shield the dome light wire with grounded metal sheath, or to remove this wire from the ammeter connection and front of the car entirely, and run it down the side door post and directly to the battery.

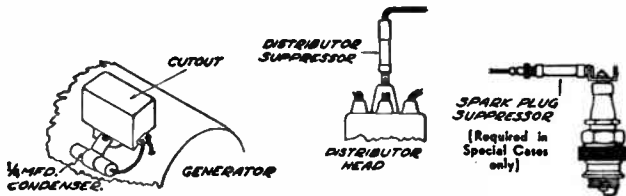

Fig. 221. The above sketches show how ignition interference suppressors should be installed at spark plugs, distributors, and generators to reduce radio interference from each of these sources.

169. GENERATOR, STARTER AND DOME LIGHT INTERFERENCE

Generator interference may be caused by sparking at the brushes and by "commutator ripple" or voltage variations at the commutator. The generator interference has a different sound from the regular rapid popping or roar of ignition interference. Generator noise sounds more like commutator hum, with perhaps some occasional scratching or spitting noise from commutator sparks.

Much of the generator interference can be eliminated by connecting a metal shell condenser of about 1/4 to 1 mfd., from the cut-out terminal to the generator frame as shown in Figs. 221 and 223. The wire on the condenser connects to the cut-out terminal which connects to the car battery. In some cases it may be more effective to connect the condenser to the opposite cut-out terminal. The metal shell acts as the other terminal of this condenser and grounds it to the generator frame. Be sure the paint, dirt and grease are scraped off the strap and housing to make a good ground connection.

Several types of interference filter condensers are shown in Fig. 222. Keeping generator com-

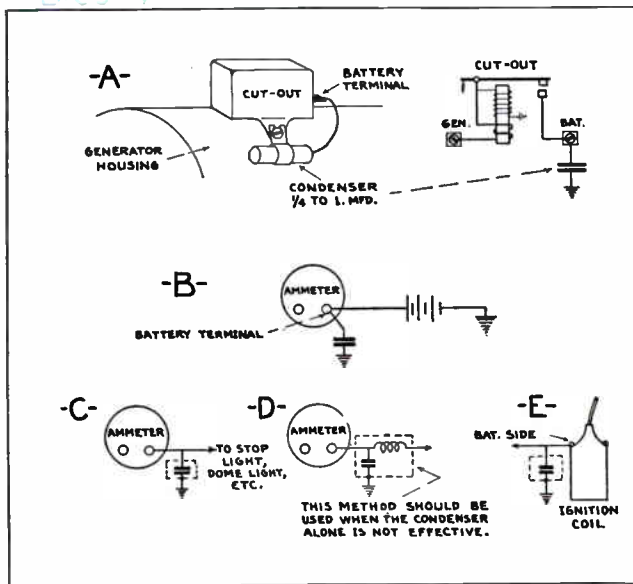

Fig. 223. These sketches show various places where filter condensers may be connected to eliminate radio interference from different sources on the automobile.

170. OTHER SOURCES OF INTERFERENCE

If ignition interference still persists after the above suppression methods have all been tried, then check the ground on the radio chassis to be sure it is a good low resistance connection. Also make sure that the engine is thoroughly grounded at both ends to the car frame by means of heavy flexible copper braid or a piece of cable shielding.

Also try grounding all control rods and metal tubes which come through the dash, and all brake and clutch pedals and levers, by bonding them all together with a piece of flexible copper braid, well soldered to each one and then grounded. Be sure to leave enough slack in these ground wire connections to permit free movement of control rods.

In some cases, providing an extra ground connection from the metal dash, the car hood, and the radiator to the car frame will greatly reduce radio interference. The ground contact of these parts is sometimes of high resistance due to grease, dirt and rust getting between them and the car frame. Placing a grounded metal wire screen underneath the floor mat will often help to reduce interference on cars with wooden floor boards.

In stubborn cases of auto radio interference, always check for dirty, leaky or incorrectly spaced spark plugs; for dirty, leaky or cracked distributor cap; for defective condenser across breaker points; for dirty or burned breaker points, etc.

Too much spacing between the distributor rotor arm and the stationary contacts often increases radio interference. These points should be kept clean and free from scale or pitting. If too short, the rotor arm can be replaced or the metal tip can be lengthened slightly by laying it on a flat metal plate and carefully peening or drawing it out with a hammer.

In some cases, it may be necessary to place a grounded shield over the ignition coil.

If high voltage and low voltage ignition wires are run through the same metal tube or manifold on the engine, it often helps to separate these wires

by removing the low voltage ones from this metal tubing.

Static interference on car radios may be produced by the wheels and friction of tires over dry pavements, by rubbing brake bands, and by loose fenders, bumpers, brake rods, etc. Such interference shows up when the car is in motion, even with the engine shut off.

Spiral coil springs placed against the inner side of the metal hub cap and in contact with the end of the axle shaft will often greatly reduce wheel static. Applying brake juice to brake bands or readjusting brakes will often reduce static from this source. Bonding loose rods, bumpers, fenders or other parts to the car frame to thoroughly ground them, also helps to reduce static interference.

171. AUTO RADIO VIBRATOR—RECTIFIER UNITS

To avoid the necessity of having extra "B" batteries for plate voltage supply, modern auto radios are equipped with vibrator interrupters and step up

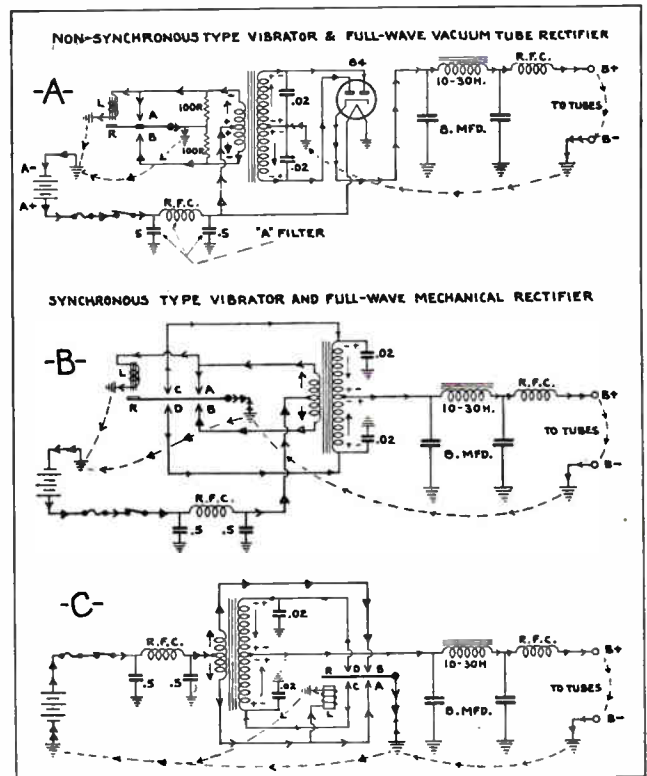

Fig. 224. Wiring diagrams of synchronous and non-synchronous types of auto radio vibrators and rectifiers, such as used to provide high voltage plate supply, from the car storage battery. Trace each of these circuits carefully while reading the accompanying explanation.

transformers to raise the voltage from the six volt car battery to the higher values needed for plate and screen grid circuits.

The vibrator interrupter changes the D.C. current from the battery to pulsating D.C., which will operate the transformer to step up the voltage. High voltage A.C. will then be taken from the transformer secondary. This must of course again be rectified to smooth D.C. for plate supply.

This rectification can be accomplished either with a full wave or half wave rectifier tube such as you are already familiar with, or by means of a set of

mechanical vibrator rectifier contacts in connection with the interrupter unit.

172. NON-SYNCHRONOUS VIBRATOR UNIT

The type of vibrator unit which uses a rectifier tube and on which the magnetically operated vibrating reed contacts are merely used as interrupters to provide pulsating D.C. for the transformer, is known as a non-synchronous vibrator.

Fig. 224-A shows the circuit diagram of a vibrator power supply unit of this type. Current flows from the positive side of the battery as shown by the large open arrows, through the fuse, R.F. choke, upper half of the transformer primary, through coil "L" of the vibrator magnet, and through the ground connection to battery negative.

This excites the upper section of the transformer primary and also energizes coil "L" and its magnet core, causing the vibrator reed "R" to be attracted and close contacts "A". This allows current to flow through the vibrator reed to ground and shorts out coil "L", thus releasing the reed "R". The spring action and the momentum of the weighted end of reed "R" cause it to then close contacts "B" and permit current to flow through the lower half of the transformer primary as shown by the large closed arrows.

Thus we see that as the reed "R" is caused to vibrate by magnet "L", it causes current to flow in opposite directions, first through the upper half and then the lower half of the transformer primary. This induces alternating voltage of higher value in the secondary, the ends of which connect to the plates of the full wave rectifier tube. So current will flow first from one plate and then the other, to the cathode, and then through the filter choke to the B plus terminal for the plate circuits of the receiver tubes. The return for this circuit is through the receiver chassis ground to the secondary center tap as shown by the dotted line.

The resistors shown across the transformer primary are used to stabilize the circuit and improve filtering action. The R.F. choke and the .5 mfd. con-

denser is to filter out radio interference from the vibrator contacts.

173. SYNCHRONOUS VIBRATOR UNIT

Fig. 214-B shows a diagram of an auto radio power unit using a synchronous vibrator which has a double set of contacts which operate in synchronism, and serve both as interrupters for the transformer primary current, and as rectifiers for the secondary current.

The current flow from the battery through first the upper and then the lower sections of the transformer primary can again be traced by the large open and closed arrows, the same as in Fig. 224-A. However, with the synchronous vibrator—rectifier unit shown at "B", you will note that the center tap of the transformer secondary forms the positive connection for the plate supply to the tubes.

When the vibrating reed "R" is up, closing contacts "A" and "C", primary current flows through the upper half of the transformer primary coil. Secondary current flows out of the secondary center tap, through the filter to the tube plates, back through the chassis ground to the grounded end of reed "R", then through contact "C" to the top half of the secondary coil, as shown by the small open arrows.

When the vibrating reed "R" is down, closing contacts "D" and "B", primary current flows through the lower section of the transformer primary. Secondary current flows out at the center tap of the secondary winding, through the tubes, back through ground to reed "R", through contact "D" to the lower end of the secondary coil as shown by the small closed arrows.

Another way of representing this same type of circuit is shown in Fig. 224-C. Trace the operation and current flow of this circuit also.

If the battery leads are connected to a synchronous vibrator rectifier with wrong polarity, the receiver will not operate because the plates will then be supplied with negative voltage. To remedy this, merely reverse the battery leads at the rectifier

Fig. 225. Circuit diagram of a popular six tube superheterodyne auto radio receiver. Examine this circuit carefully to become familiar with all of the important parts of such receivers. Note the similarity to household radio receivers and also note the vibrator and rectifier circuit. Courtesy Wells-Gardner Company.

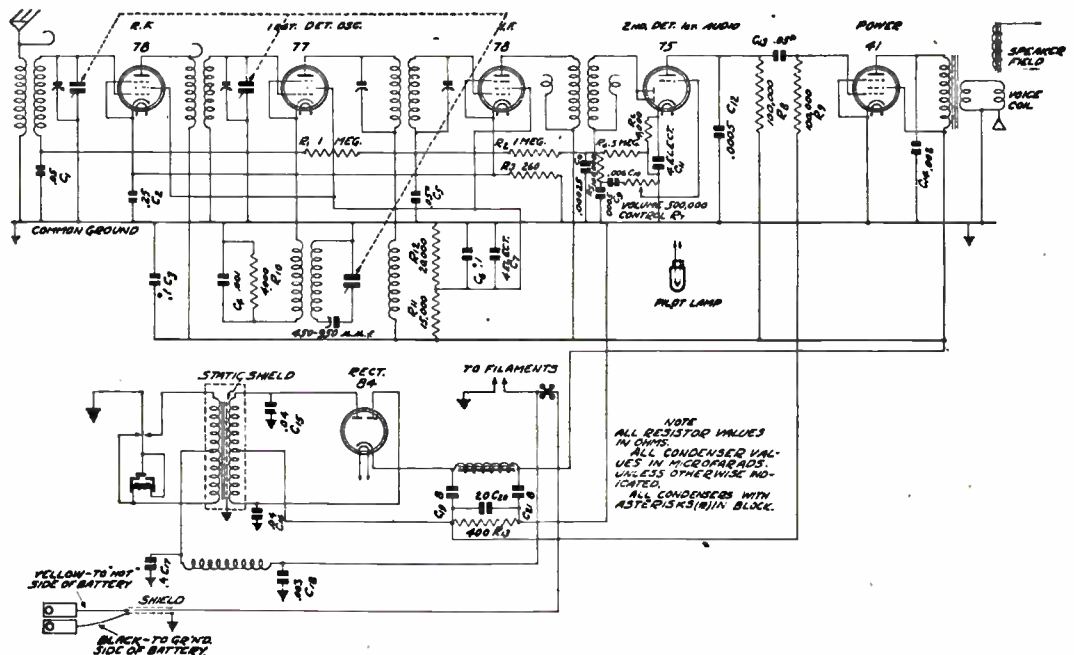

primary. Some rectifiers are provided with reversing switches for this purpose. On others, it is necessary to disconnect and reverse the primary leads. On synchronous vibrator units having plug-in type vibrators, the vibrator can be removed from its socket and reversed to correct wrong polarity.

174. VIBRATOR UNIT TROUBLES

Vibrator rectifier troubles may be caused by dirty or pitted vibrator contacts, poor adjustment of vibrator reeds or springs, or by overloads due to short circuits in the receiver or to defective buffer condensers across the secondary winding. A defective vibrator is generally indicated by no vibrator hum at the speaker when the set is turned on, by unsteady power output and speaker volume, or by complete failure of the receiver to operate. Listening for vibrator hum by placing a screw driver against the chassis and the handle against your ear, is also a good way to check to see if vibrator is operating.

In some cases this can be remedied by cleaning the vibrator contacts or readjusting the springs or reeds. In many cases, however, it is simpler and cheaper to replace the vibrator unit. Many auto radios have the vibrator unit fitted with prongs and plugged into a socket to permit quick and convenient replacement.

With the exception of the vibrator unit, auto radio troubles and servicing, are the same as those for household sets. The fault localizing test, and the voltage and resistance methods of analysis which you have already learned can be applied to these receivers.

Figs. 225 and 226 shows circuit diagrams of two different popular makes of auto radio receivers, which use power supply units with rectifier tubes and non-synchronous vibrators of a slightly differ-

ent type from those shown in Fig. 224. Examine and trace these diagrams carefully to become familiar with common auto radio receiver circuits.

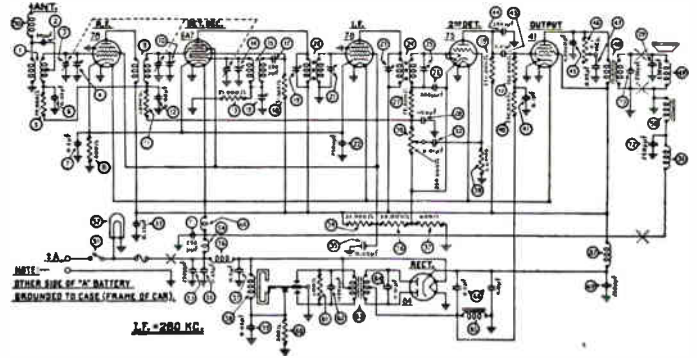

PARTS LIST

No.	Description	Part No.	Description	Part No.
1	Apr. Trans. Transformer	22-1414	Condenser (.1 mfd.)	30-1122
2	Inductor (50 mhd.)	17-17	Resistor (500,000 ohms)	40-7
3	Tuning Condenser	31-1113	Condenser (.01 mfd.)	30-1112
4	First Padler (500 ohms)	33-1115	Condenser (.025 mfd.)	30-1021
5	Resistor (17,000 ohms)	33-1115	Condenser (.005 mfd.)	30-1113
6	Condenser (.05 mfd.)	30-1020	Tone Control	33-1101
7	Condenser (.5 mfd.)	30-1027	Condenser (.05 mfd.)	30-1012
8	Resistor (500 ohms)	33-1209	Power Transformer	33-1101
9	P. F. Transformer	22-1419	Chin. A. Valve Prod.	36-2120
10	Second Padler (500 ohms)	33-1115	Fixed Coil Assembly	30-1025
11	Resistor (1,000,000 ohms)	33-1096	"50" "A" "DE" Switch Arm.	43-5252
12	Condenser (.05 mfd.)	30-1020	Pilot Lamp	31-1022
13	Resistor (51,000 ohms)	30-1026	Condenser (.05 mfd.)	30-1022
14	Third Padler (500 ohms)	33-1115	"A" Choke	30-1114
15	Rectifier Transformer	22-1420	Condenser (.25 mfd.)	30-1114
16	Fourth Padler (500 ohms)	33-1115	Vibrator Choke	30-1117
17	Condenser (.25 mfd.)	30-1113	Condenser (.5 mfd.)	30-1027
18	Resistor (51,000 ohms)	33-1115	Vibrator	30-1026
19	Padler (170, 1st I. F. Trns.)	33-1115	Condenser (.02 mfd.)	30-1021
20	First I. F. Transformer	22-1421	Resistor (300 ohms)	33-1010
21	Padler (170, 2nd I. F. Trns.)	33-1115	Resistor (200 ohms)	33-1117
22	Condenser (.1 mfd.)	30-1021	Condenser (.15 mfd.)	30-1023
23	Padler (170, 3rd I. F. Trns.)	33-1115	Power Transformer	33-1101
24	Condenser (.1 mfd.)	30-1021	Condenser (.01 mfd.)	30-1021
25	Padler (170, 4th I. F. Trns.)	33-1115	Filter Choke	30-1101
26	Condenser (.1 mfd.)	30-1021	"A" Choke	30-1114
27	Padler (170, 5th I. F. Trns.)	33-1115	Condenser (.25 mfd.)	30-1022
28	Condenser (.1 mfd.)	30-1021	Antenna Choke	30-1021
29	Padler (170, 6th I. F. Trns.)	33-1115	Condenser (.25 mfd.)	30-1022
30	Condenser (.1 mfd.)	30-1021	Condenser (.25 mfd.)	30-1022
31	Padler (170, 7th I. F. Trns.)	33-1115	Condenser (.25 mfd.)	30-1022
32	Condenser (.1 mfd.)	30-1021	Control Assembly	43-5252
33	Padler (170, 8th I. F. Trns.)	33-1115	Glass and Dial	37-1010
34	Condenser (.1 mfd.)	30-1021	Pointer Assembly	43-5252
35	Padler (170, 9th I. F. Trns.)	33-1115	Bracket Plate	37-1100
36	Condenser (.1 mfd.)	30-1021	Knob (Tuning & Volume)	37-1101
37	Padler (170, 10th I. F. Trns.)	33-1115	Knob (Vol. 10)	37-1102
38	Condenser (.1 mfd.)	30-1021	Control Mounting Bracket	37-1101

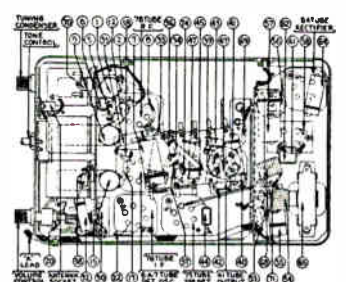

Fig. 226. Circuit diagram of another popular type of auto radio receiver with chassis layout diagram shown below. Note each of the parts of this receiver which are numbered and listed above. Courtesy Philco Radio & Television Corp.

PUBLIC ADDRESS SYSTEMS

During recent years public address units and systems have come into very extensive use, wherever speeches, announcements, music, etc., are to be given to large audiences.

The purpose of public address equipment is to amplify the sound so it can be clearly heard by large audiences either indoors or outdoors. A simple public address (P.A.) unit would consist of a microphone, and audio amplifier and a loudspeaker, while more complete P.A. systems may employ several microphones, phonograph pick-ups, a control or monitoring panel, several separate channel amplifiers, and a number of loud speakers.

P.A. systems range in size from the small portable units which can be carried in a suitcase, to large installations which fill an entire large room with their numerous amplifiers, control panels, record turntables and pick-up heads, etc.

P.A. systems are now commonly used in schools, colleges, athletic fields, boxing arenas, railroad depots, airports, churches, hotels, theatres, restaurants, factories, department stores, broadcast studios, sound trucks and call systems. So you can readily see that public address has become a very large and

important branch of work for trained radio and sound men.

Hundreds of trained men are making good money selling, renting, installing and servicing public address equipment. Many stores frequently rent or hire portable P.A. systems or sound trucks to advertise special sales. Political speakers, picnic groups, state fairs, and athletic fields often rent temporary P.A. systems at a good figure. There are thousands of opportunities to install permanent P.A. systems in schools, churches, stores, factories, and theatres which are not yet equipped with such systems.

175. PUBLIC ADDRESS APPLICATIONS

P.A. systems enable a speaker to address much larger audiences than his voice could possibly reach without the aid of amplification. By means of a P.A. system in a large school the principal, superintendent, or any special speaker can address all classes at once by means of loud speakers located in each classroom. They also make possible the use of recorded lectures from other schools.

Some such P.A. systems are equipped for two

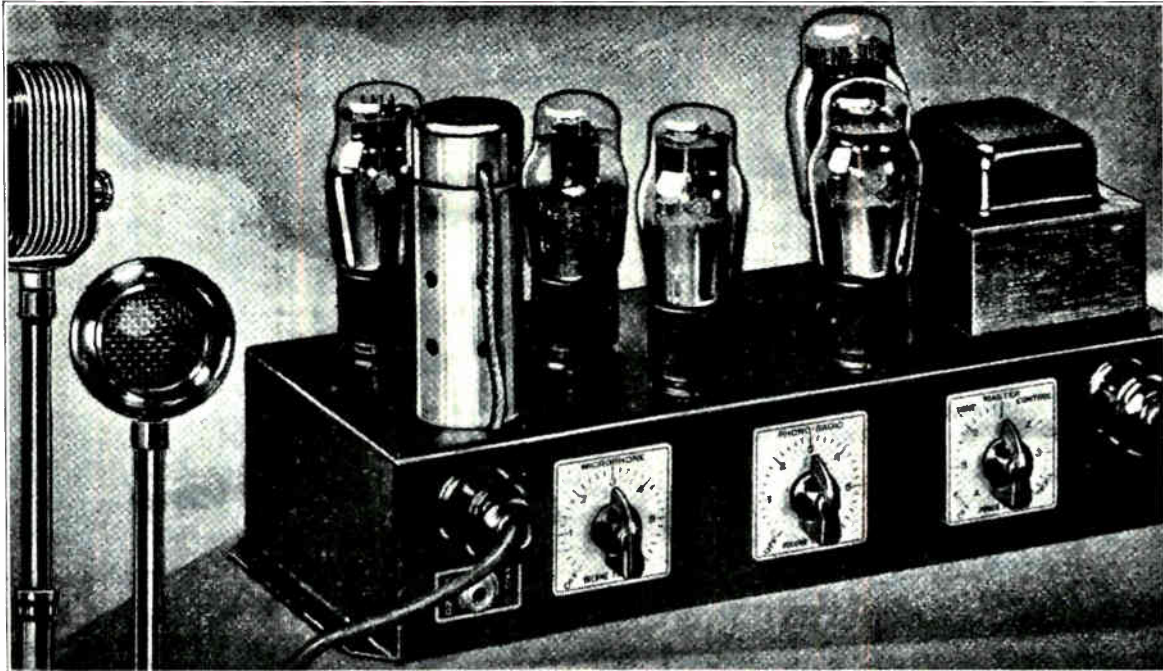

Fig. 227. Photograph of a compact public address amplifier unit. Note the separate controls for microphone, phonograph and radio signal input and also the master tone control. Thousands of P.A. units of this type are now being used in sound trucks, schools, churches, offices, auditoriums, and factories throughout the country. Courtesy Montgomery-Ward Company.

way communication, with combination speaker-microphones in the classrooms to permit teachers to talk to principal, or the principal to listen to class work in progress.

P.A. systems at depots and air ports make possible more effective announcements of plane and train arrivals and departures.

P.A. systems in department stores permit announcements of special sales, paging or calling of any employee or customer, or music to pep up employees and customers toward the close of the day.

P.A. systems in factories permit calling any employee or foreman to the office, issuing orders or instructions to all employees without shutting down the machinery, or snappy music from radio or records, to break the monotony of routine production work.

Some factory and office P.A. systems are also equipped for two-way communication so that various foreman or department heads can converse with each other.

Public address equipment really covers more of a commercial application of radio and sound amplification equipment, and is, therefore, often more profitable than household radio servicing. Every well trained radio man should always be on the alert for every opportunity to sell, install, or service a P.A. system.

176. POWER SUPPLY UNITS FOR P.A. SYSTEMS

Since P.A. systems consist of an amplifier, similar to the audio frequency amplifier used in a Radio receiving set, including vacuum tubes, transformers, resistors, condensers, microphones, volume controls, speakers, and such units with which you are already familiar, you can apply your radio knowledge from earlier lessons to this field also.

Permanent or portable P.A. systems used inside

of buildings, generally get their power supply from the nearest electrical outlet. Such units are equipped with a power pack, consisting of a transformer, rectifier and filter such as previously explained, only larger. The units shown in Figs. 227, 228 and 230, all have their own power transformers and rectifiers built in the amplifier chassis.

Portable P.A. units for use in autos, sound trucks or outdoors where no A.C. line is available, may get their power from batteries, small gasoline en-

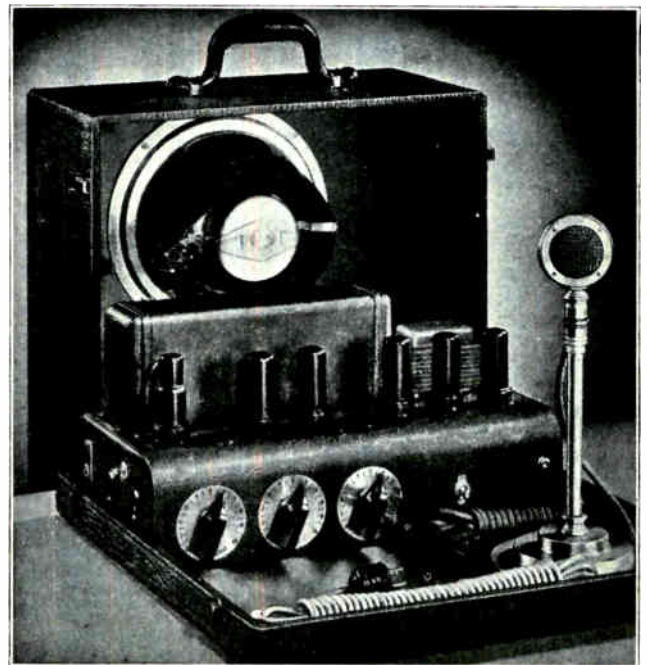

Fig. 228. Compact portable public address unit showing amplifier, speaker, microphone and connecting cables all neatly arranged in a convenient carrying case. Courtesy Montgomery-Ward.

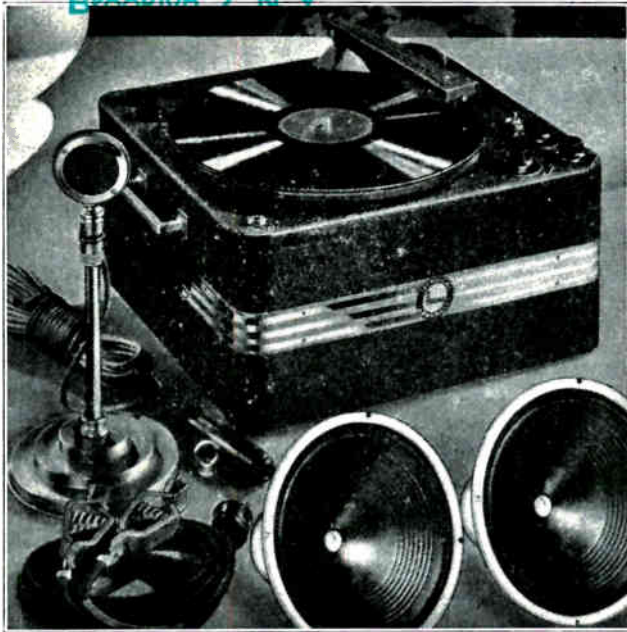

Fig. 229. Phonograph or record turn table and pick-up head with amplifier enclosed in the same compact cabinet. Note the microphone and dynamic speakers which are used with this unit. Courtesy Montgomery-Ward.

gine-driven generator, or from a small battery operated motor generator set such as shown in Figs. 231 and 232.

P.A. units for outdoor use generally require more power than those for indoor use, due to the higher sound level or volume requirements in the unlimited outdoor space. Indoor units generally range from 5 to 100 watts in size, while outdoor units may range from 25 to 500 watts.

The principal requirements of a good P.A. system are that it should give sufficient volume to enable the entire audience to hear and clearly understand the speech or music delivered, the tone quality should be natural and undistorted, and it should be free of echos, reverberation or feed-back from loudspeakers to the microphone.

The ideal P.A. system would be one with which the audience is not conscious that any amplification is being used. To accomplish this result requires good quality microphones and amplifiers and careful location of microphones and loudspeakers. Concealing microphones and speakers, and placing speakers so that their sound reaches the listeners at the same time as the voice of the person talking, helps to produce the desired effects.

If the distance from loudspeakers to listeners differs by more than 55 feet, from the distance between the microphone and the listeners, there will be a noticeable time lag or difference between the original voice waves and the speaker output, and this destroys the proper natural effects.

177. ACCOUSTICAL TREATMENT

We have already learned in earlier sections that sound is energy in wave form in the air. We also know that the pitch of sound, or high and low notes, are controlled by wave frequency.

The frequencies within the range of the human ear range from 16 to 15,000 cycles per second, and those most commonly encountered with speech or

music are from about 45 to 6,000 cycles per second. This is the range that P.A. units should be designed to handle efficiently.

The sound volume is controlled by the amount of energy or power of the waves.

Sound waves will be reflected from smooth, hard surfaces, or absorbed by soft, porous surfaces. Sound waves can be broadcast in all directions from their source, or they can be focused and concentrated in a narrow area by the shape of speaker cone or horn. See Fig. 233.

Therefore, undesirable echos, reverberation, feedback, etc., can usually be eliminated by proper accoustical treatment of room walls and ceilings and proper selection and placement of speakers and microphones.

Celotex or other forms of soft, fibrous or porous panel board is often used to cover walls or ceilings in large rooms, to prevent echos and reverberation. Heavy draperies and soft curtains are often used over windows and certain wall sections. Carpeting of floors and overstuffing or padding of chairs and furniture greatly improve the accoustical properties of the floor and lower areas of large rooms.

The bodies of the persons in an audience will also soften or absorb sound waves to a great extent. For example, if a P.A. system was set up and tested at a certain volume in an empty hall, it may be found necessary to add considerably to the volume or sound output when the hall is filled with people.

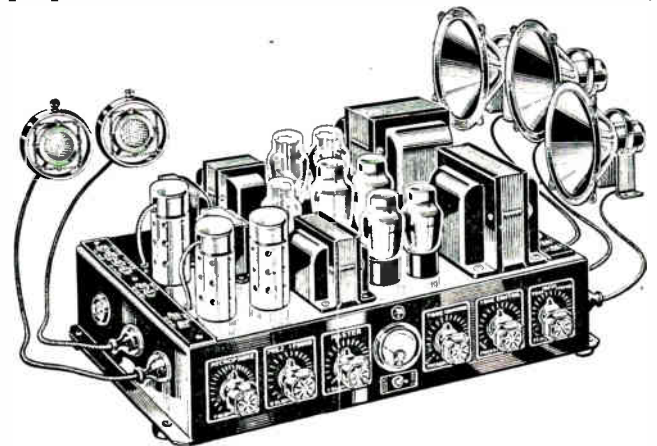

Fig. 230. Another view of a very popular type of P.A. unit showing the power amplifier, power supply transformers, controls, microphones and speakers for a complete installation. Courtesy Radolek Company.

Walls or ceilings with broken or irregular surfaces reflect much less sound than plain flat surfaces.

Accoustical treatment is generally more effective at the rear of a hall or room where most of the direct sound waves strike. Ceiling drops or baffles of heavy drapery material, suspended across the room part way down from the ceiling at intervals, are also helpful in reducing ceiling reflection. Wall drapes should be loose or have heavy folds, and should not be directly against the wall, but hung out an inch or so.

When installing P.A. systems in rooms that are not accoustically treated, one or two of the above mentioned types of treatment can be tried out first on part of the wall or ceiling areas. Then add more

complete treatment if later tests show they are needed. In this manner the expense can be kept at a minimum. Too much sound absorbing material may be objectionable, as it may give the sound a rather "dead" effect. A small amount of sound reflection adds life or tone to certain sounds, and provides more even sound distribution.

The following formula can be used for determining the time of reverberation in rooms of various sizes with various types of wall surfaces or sound treatment.

$$T = \frac{.05 \times V}{A}$$

T = time of reverberation in seconds (time required for sound to die out, after original source ceases.)

V = cubic feet of air in the room (length x width x height.)

A = total number of absorption units in the room.

The number of absorption units can be determined by referring to the table on "coefficients of absorption" at the bottom of Fig. 241. Multiply the number of sq. ft. of each material used by its coefficient of absorption. Then total these figures for all materials used on the ceiling, wall and floor surfaces of the room. In figuring floor area, only use 1/4 of the space occupied by chairs, as 3/4 of this space is assumed to be covered by the chairs.

On some indoor installations, the P.A. amplifier must be operated at rather high volume levels to counteract residual noises from the audience, ventilating fans, machinery, air ducts, outside traffic noises, etc. Other installations such as in churches, funeral parlors, studios, etc., require very low volume levels.

On outdoor P.A. installations, due to the greater distances covered and the higher background noises, the loudspeakers are usually operated at very high volume levels, and directional horns or baffles are used to direct or concentrate the sound over the area occupied by the audience.

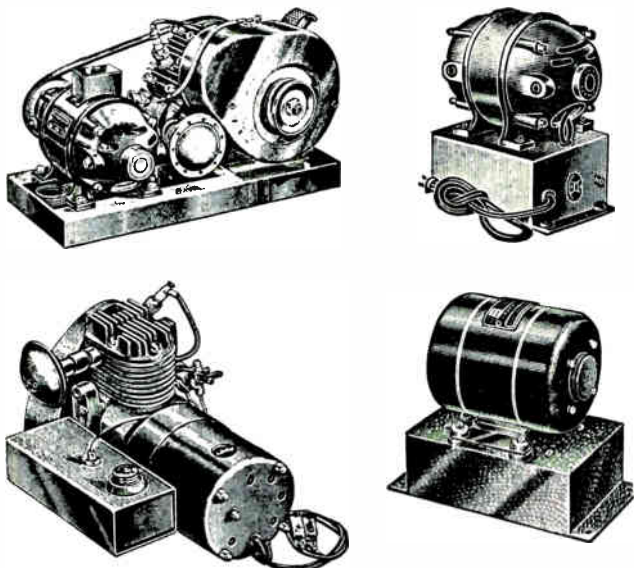

Fig. 231. The two views on the left above show compact portable gasoline engine driven generators for supplying the power to portable public address equipment. On the right are shown two types of battery operated motor generators and filter units, for supplying high voltage plate current from six volt storage batteries. Courtesy Radolek Company.

178. TYPES OF P.A. SYSTEMS

Public address equipment may be classified in four different types. (1) one unit type, (2) portable type, (3) separate power supply type, (4) separate units type.

The first two types refer to the popular small self-contained low power units, in which the amplifier and power supply unit are all built on the one chassis. See Figs. 227, 228 and 230. The microphone and speakers may of course be operated at short distances from the amplifier, by means of proper connecting cords or cables. On units of this type, since the first stages are usually of the "high gain" type, good shielding must be used to reduce hum pick-up from the A.C. power supply circuits.

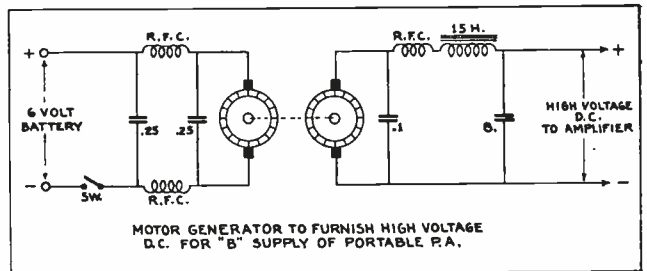

Fig. 232. Diagram showing the connections of battery operated motor generator power supply units such as were shown on the right in Fig. 231. Note the filter circuits used to provide smooth D.C. for the tube plates and also to eliminate commutator hum or interference.

On larger units of the separate power supply type, the power supply is often built in a separate unit to reduce hum pick-up from the A.C. circuits in the power unit, and to make the installation more convenient. Even these units should be very carefully shielded from stray electrical fields and interference.

For very large and elaborate P.A. systems such as used in some hotels, schools and studios, the amplifiers are often divided into high gain sections and power output sections, with separate power supply units for each section. Sometimes several high gain amplifier sections are used to feed a multiple bank of power output sections, for greater wattage output.

By referring to the P.A. amplifier circuit diagrams shown in Fig. 234, you will note that the first high gain tubes are generally resistance coupled. This type of coupling is economical and helps to eliminate magnetic hum pick-up that might occur with iron core transformers.

The power output circuits or stages are usually transformer coupled for greater efficiency, and the use of coupling transformers from the output stage to the loudspeaker voice coils is necessary for proper impedance matching of these circuits.

179. VOLUME CONTROLS AND MIXER PANELS

Where several input circuits are used from several different microphones or phonograph pick-up heads, some means must be provided to regulate the amount of energy fed from each microphone or pick-up to the amplifier. For example, several microphones may be used to obtain properly balanced pick-up from a large orchestra. A volume control on each microphone circuit will then permit the amount of pick-up from various instruments

or sections to be varied to obtain proper balance of the orchestra music at the loudspeaker, or to single out one instrument for solo effects.

These mixer controls should permit the adjustment of energy fed from one circuit, without affecting any of the other circuits. To accomplish this result, we often use circuits of the constant impedance type, or electronic mixer circuits such as shown in Figs. 235 and 236.

The constant impedance control circuits shown in Fig. 235-C and in Fig. 236 permit the operator to control the volume of the signal pick-up, and still maintain the proper impedance matching of the pick-up circuit or line with the impedance of the input transformer, which is necessary for efficient operation.

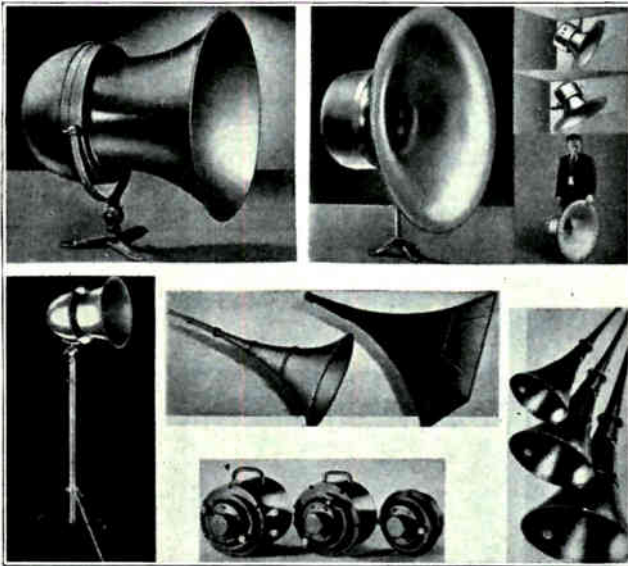

Fig. 233. Above are shown several different types of loudspeaker units and horns such as used for both indoor and outdoor public address installations. Note the different shapes of horns used for wide angle or narrow angle sound projection. Courtesy Montgomery-Ward.

Where long lines are used from the microphones or other pick-up devices to the amplifiers, matched transformers of 500 ohms impedance are often used at both ends of the pick-up line, in order to keep current values low and reduce inductive losses and voltage drop in the lines.

180. PICK-UP UNITS FOR P.A. SYSTEMS

Public address units may obtain their signal input or pick-up, from microphones, phonograph pick-up heads and records, a radio receiver, or from photo-electric cells operated from a sound film.

On low cost P.A. units, carbon type microphones are often used, while on high grade units, microphones of the crystal, condenser, ribbon velocity type or dynamic type may be used. These various types of microphones and their coupling circuits and pre-amplifiers are explained in a later article.

Where the microphone is located near to the loud speakers, accoustical feedback may result and set up a howl from the loudspeakers. If a velocity microphone is used, its directional pick-up properties can be utilized to eliminate this feedback howl, by turning the "mike" at an angle where it picks up the least amount of sound from the speakers. In other cases, it may be necessary to shield

the microphone from the loudspeaker sound waves by some sort of directional housing or baffle.

Electric pick-up heads for use with sound recordings are of two general types, known as the electro-mechanical type and the crystal type. See Fig. 237 which shows several styles of pick-up heads and motor operated turn-tables for reproducing sound from records.

The electro-mechanical type of pick-up head has a small armature which is caused to move or vibrate in a magnetic field, by the vibrations of the needle riding in the record groove. This moving iron armature varies the magnetic flux and causes voltage to be induced in a small pick-up coil which is placed in the field of the magnet.

The crystal type pick-up head operates on the piezo-electric effect, or the feeble voltages produced by certain crystals when they are subjected to vibration or mechanical pressure. In this case, the pick-up needle being vibrated by the sound track variations in the record grooves, applies varying pressure to a crystal, which in turn gives off corresponding voltage impulses which are amplified by the P.A. amplifier and converted into sound at the speaker. Such pick-up heads and record turntables are quite extensively used in P.A. systems, and in broadcast stations where sound recordings or electrical transcriptions are used on parts of the program.

The output of the audio detector of a radio

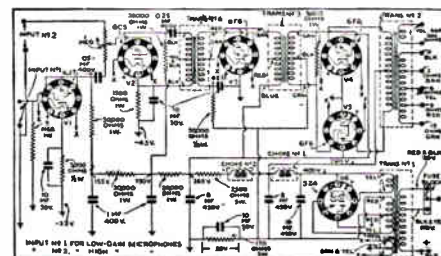
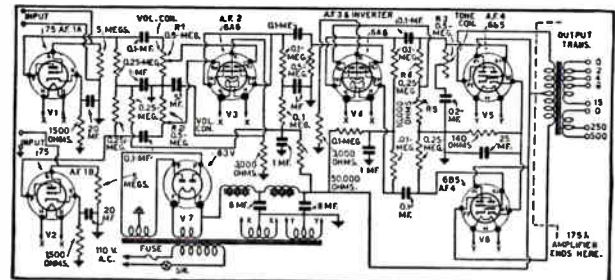
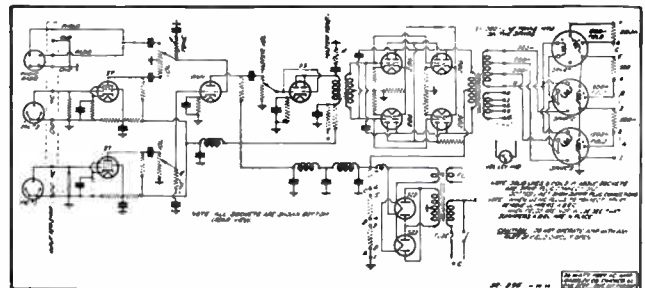

Fig. 234. The above three diagrams show circuits of popular type P.A. amplifiers. The top circuit is for a 36 watt amplifier such as made by Radolek Company, Chicago. The middle diagram shows the circuit of a 15 watt P.A. amplifier, while the lower diagram shows the circuit of a compact six tube amplifier with its power supply unit and two input circuits. Courtesy RadioCraft Magazine.

receiver can also be coupled to the input of a P.A. unit, to further amplify the radio program for delivery to large audiences.

Photo-electric cells are used to pick up varying light rays from the sound track on films and convert these light impulses into electrical impulses, which can be amplified by P.A. units or theatre sound equipment.

181. SOUND PICTURE UNITS

The sound amplification equipment in motion picture theatres is very similar to that of ordinary high grade P.A. systems, and requires the same general care and service.

Fig. 238 shows a diagram of a wide range theatre amplifier, using two photo-cells to pick up the sound from the light passed through the sound track on the film. The sound image or track being photographed or printed on the same film with the pictures, and synchronized with them, gives the effect of actual voices of the actors, when reproduced by the amplifier on the sound projector machine.

The electrical output of photo-cells is so small that very sensitive pre-amplifiers are generally used between the cell and the main amplifier. These pre-amplifiers must be well shielded and mounted to avoid pick up of electrical hum or interference and mechanical vibrations.

When testing sound picture units, one should first check the light source from the exciter lamp, the focus of this narrow light beam on the film sound track by the lens, then the photo-cells, pre-amplifier, main amplifier and speakers.

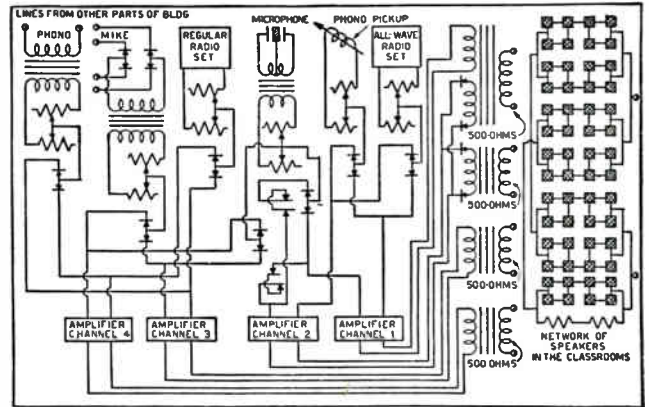

Fig. 236. Block and schematic diagram of a four panel P.A. system for a school installation, showing constant impedance controls for regulating the volume from six different pick-ups or sources of input. Courtesy RadioCraft Magazine.

The loudspeakers in theatre installations are generally placed behind the screen, which is perforated with thousands of small openings to permit the sound waves to pass through it, and give the effect of voices or music coming from the screen.

182. SPEAKERS FOR P.A. SYSTEMS

Dynamic speakers are used almost entirely with P.A. systems, due to their high sound output ability and low distortion factor. For indoor work, both flat baffles and directional baffles or horns are used. For outdoor work, directional baffles or horns of either wide angle or narrow angle, or both, are used to direct the sound where it is desired. Fig. 233 shows a number of speaker and horn units of this type, and dynamic speakers are shown with the P.A. units in Figs. 228 and 230. This type of speaker was also explained in an earlier lesson.

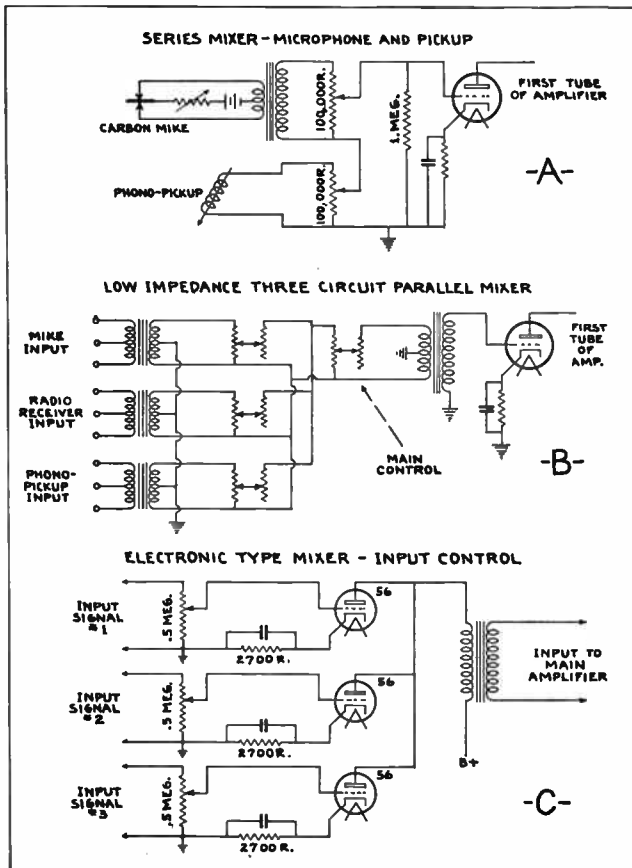

Fig. 235. The above diagram shows several different types of constant impedance volume and mixer controls for use with public address amplifiers.

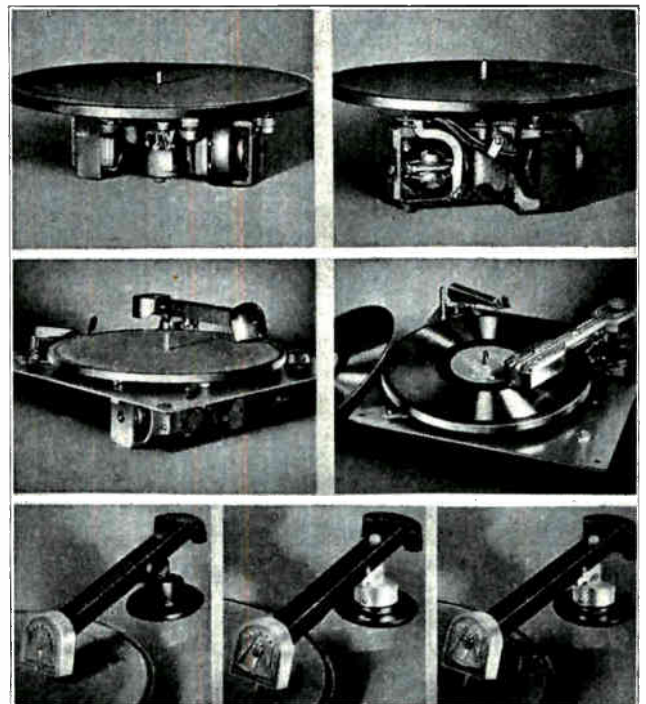

Fig. 237. Above are shown several types of motor driven turn tables and pickup heads for feeding recorded sound programs to public address units. Courtesy Montgomery-Ward.

For high fidelity sound reproduction special "tweeter" horns or speakers are also used with the dynamic units, to reproduce the higher audio frequencies more efficiently and lend brilliance and realism to the sound output. See Fig. 239. Some of these small high frequency speakers are of the dynamic type and some are of the crystal type. The dynamic type requires a filter to keep out the low notes, while the crystal type acts as its own filter.

183. PHASING DYNAMIC SPEAKERS

Many receivers and public address systems employ two or more dynamic speakers, all operating from the same output transformer, so it is very necessary that the speakers be correctly phased, or that the voice coils be connected properly so that the cones move in and out in unison.

We have already learned that the cone of a dynamic speaker acts as a piston, increasing the air pressure in front of it on the forward motion, and decreasing the normal air pressure on the backward motion. If the cones of the speakers all move in and out, in step with each other, the compressions and rarefactions from each one will reach the listener all at the same time, giving the impression of correct sound distribution.

However, if one speaker cone is moving backward while the rest are moving forward, then the rarefaction of this one speaker will reach the listener at the same instant as the compression from the other units. Neutralization of the sound waves will then result, giving the effect of dead spots at certain locations in front of the speakers. The remedy is, of course, to properly phase all the speakers and this can be done very easily with the aid of an ordinary 1½ volt dry cell.

First disconnect the leads of the speaker voice coils from the secondary leads of the output transformer, and connect the dry cell across the voice coil leads. At the moment contact is made, all the cones should move in, or out, together. This is easily determined by placing the fingers lightly on each cone, in turn, and feeling the cone movement. If one cone moves in while the remainder move out, reverse the voice coil leads to this unit.

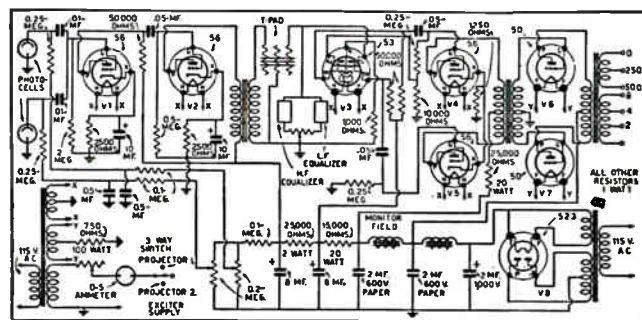

Fig. 238. Circuit diagram of an amplifier such as used with sound picture installations. Note the photo-cell pick-ups and the "T" pad type of volume control. Also note the power supply unit and the push-pull stages of power amplification to the output. Courtesy RadioCraft Magazine.

184. MATCHING OF SPEAKER IMPEDANCES

Where several loudspeakers are connected to the output of a P.A. amplifier, it is also important to see that the total impedance of the several speaker circuits matches that of the output transformer secondary. For example, two 10 ohm speaker coils

connected in parallel would give a total impedance of only 5 ohms, while, if these same two speaker coils were connected in series, their combined impedance would be 20 ohms.

Note: It is not good practice to connect all speakers of a system in series, as an open circuit in any speaker coil would then cause all speakers to fail.

In case it is not possible to exactly match the impedances of the output transformer and the speaker load, it is better to have the load impedance slightly higher than that of the output transformer, rather than the output impedance higher than that of the load.

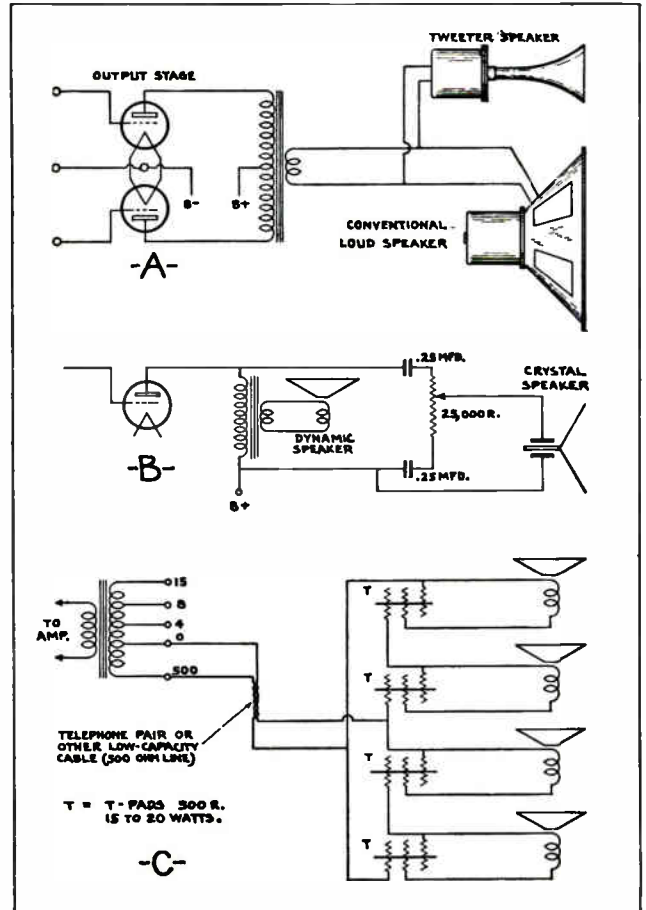

Fig. 239. These diagrams show several different methods of connecting loudspeakers to public address amplifiers. Note the type of volume controls used in these circuits.

In case it is desired to switch off certain speakers at times and operate the remainder, then, in order to maintain proper impedance balance in the output circuit, a dummy load or coil can be cut in to the circuit in place of the speaker that is removed. This is often done by remote control by means of a relay at the speaker, operated from the control panel.

Separate volume controls are sometimes located at each speaker, and sometimes they are located at the control panel.

Where speakers are located considerable distance from the amplifier, special transmission lines with matched coupling transformers of 500 ohm impedance at each end, are often used to couple the amplifier output to the speakers. If the volume is to be adjusted at the speakers, then constant imped-

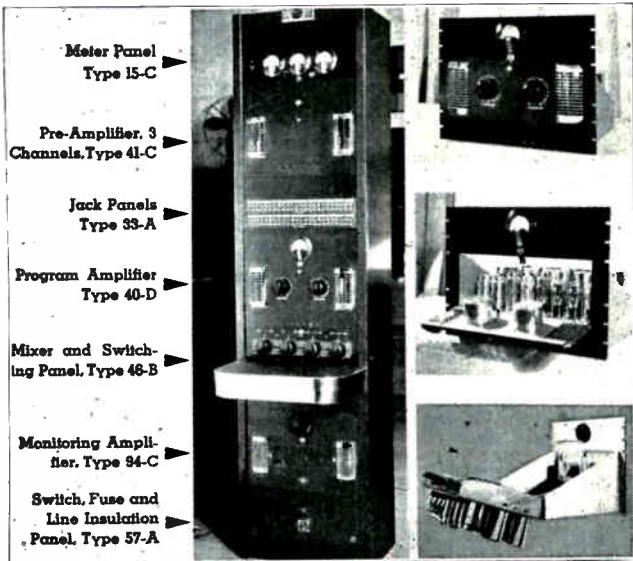

Fig. 240. The above view shows a large rack and panel type public address amplifier, with some of the separate units removed from the panel and shown separately on the right. This is a very popular type of construction for large permanent public address installations in schools, offices, studios, etc. Courtesy R. C. A.

ance volume controls are used at the speakers to prevent unbalancing the impedance. See Fig. 239-C.

185. P. A. AMPLIFIER CAPACITY RATINGS

Public address amplifiers of various sizes and types may be rated in watts output, or according to decibel gain. As previously mentioned, P.A. units range in size from 5 watts to 500 watts or more.

The term "decibel" (DB) refers to the unit of sound volume measurement or ratio, which is based on audibility or the response of the human ear. Zero decibels refers to the smallest sound that can be heard by the average human ear. Louder sounds than this may be expressed as +10DB, or equivalent to the sound of rustling leaves; or +20DB, average whisper at 4 ft. distance; or +50DB, quiet automobile; or +100DB, riveting hammer at 35 ft., etc.

The chart shown in Fig. 241 gives decibel values of sounds above zero DB, and energy of circuits and devices below zero or in the minus (-D.B.) range. This chart also shows the comparison between decibels and watts, milliwatts, microwatts, etc.

The small chart at the upper right in Fig. 241 shows the proper wattage or size of P.A. amplifier to use for various sized rooms and audiences. The chart at the upper left shows optimum or permissible reverberation time, or the time required for sound echos to die out in rooms of various sizes. At the bottom of this chart is shown the sound absorption coefficients of various sound treatment materials and objects. Study these charts carefully as they provide very valuable information for use in P. A. work.

When servicing P.A. equipment, keep in mind that the troubles of these units are very similar to those of the audio amplifier section of radio receivers. Check the tubes, transformers, resistors, condensers, speakers, and circuits in the same manner as previously described under Radio Servicing.

186. MICROPHONES

The five most common types of microphones used for P.A. systems and broadcast studio work are:— the carbon, condenser, ribbon or velocity, dynamic or moving coil, and crystal type microphones. See Figs. 242 and 243. Each one has its advantages and disadvantages and so we shall consider each type in the order named.

The carbon microphone depends for its operation on the varying resistance of a carbon element when subjected to varying pressure. Since sound waves are really air pressure variations, a diaphragm placed in the sound field, will vibrate accordingly. In the carbon microphone, this motion of the diaphragm produces a corresponding change in pres-

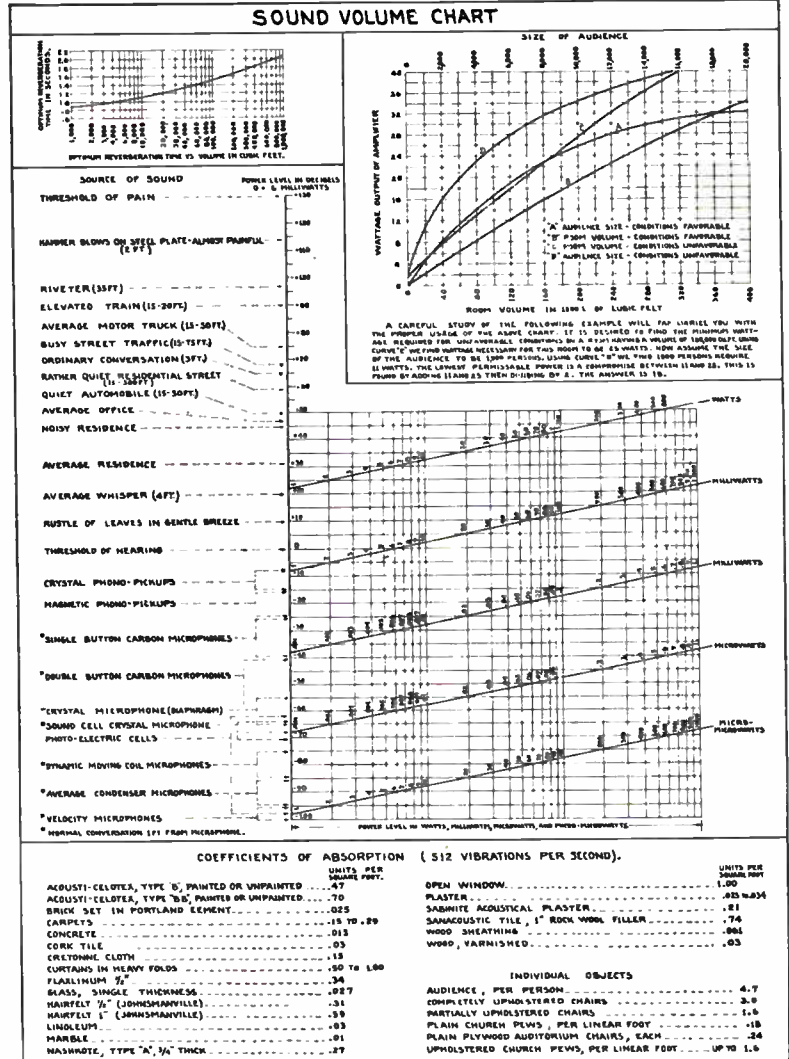

Fig. 241. The above chart gives a great deal of valuable information on the size and output requirements of P.A. systems for various sized rooms and audiences, and also the characteristics of various sound absorbing materials. Also note the output volume levels shown on the decibel scale for various types of microphones. Study each section of this chart carefully and refer to it frequently when planning any P.A. system installations.

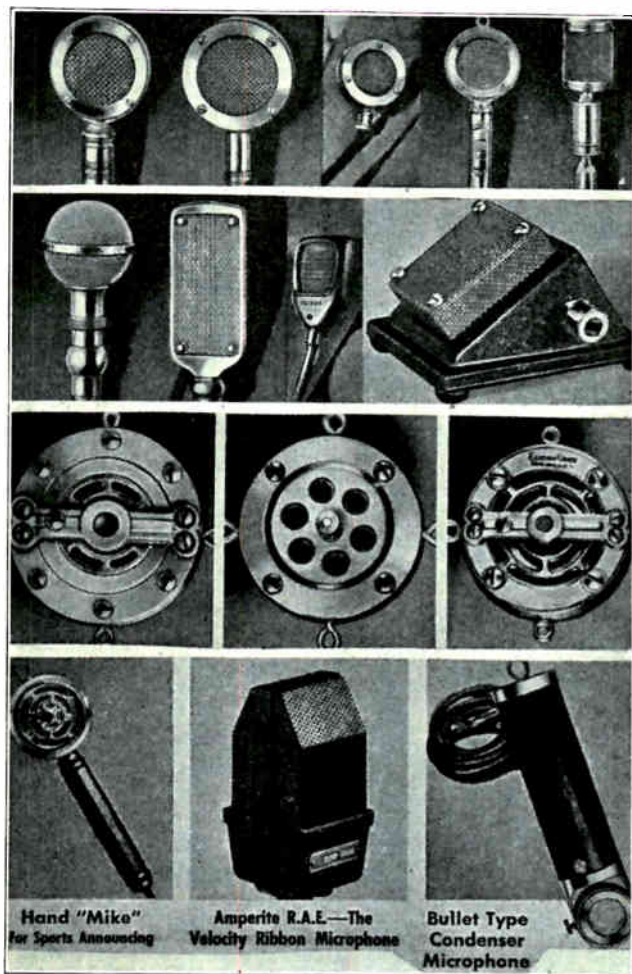

Fig. 242. Above are shown a number of different types of microphones such as commonly used with P.A. systems and in broadcast stations or recording studios. Those in the top row are crystal type microphones, and those in the second row sound-cell crystal type units. The third row shows various views of carbon type microphones and below are shown a portable hand "mike," a ribbon velocity microphone, and a condenser type microphone. Courtesy Montgomery-Ward.

sure and resistance of a carbon element made up of small carbon granules.

This carbon element is connected in an electrical circuit as shown in the two top views in Fig. 243. This circuit includes a battery and the primary of a microphone coupling transformer, so that a variation in current flow through the primary will take place whenever sound waves actuate the diaphragm. This induces in the transformer secondary, an alternating voltage of audio frequency, which may be impressed on the amplifier.

The usual arrangement of this type unit, for best fidelity, consists of two carbon buttons one on either side of the diaphragm. This metal diaphragm is stretched and air damped so that the effects of self-resonance vibrations are negligible, giving a reasonably uniform output at all ordinary audio frequencies.

This unit has the disadvantage of a background noise called carbon hiss, which is caused by the passage of current through the granules. It has a high maintenance factor and must be handled with care. On the other hand it has the advantage of a very good power output level of -30DB , together with low output impedance, making it possible to

have the microphone some distance from the amplifier.

187. CONDENSER MICROPHONES

The diaphragm of the condenser microphone constitutes one of the plates of a variable air condenser, while the back plate, which is separated from the diaphragm by a film of air about one-thousandth of an inch thick, acts as the other plate. See the view at the center right in Fig. 243. Capacity variations of this condenser will be produced as the diaphragm vibrates in response to the sound pressure fluctuations upon it. With an increase in capacity, more charging current will flow into the condenser, while a decrease in capacity will produce a flow in the opposite direction.

These current changes are very minute, consequently the energy output of the condenser element is extremely low and it is necessary to provide additional amplification in the form of a one or two stage head amplifier as shown in Fig. 244-B. This amplifier is also necessary in order to prevent stray pick-up of interference from mixing with the minute microphone signal currents. In actual practice, the condenser and head amplifier are all housed in the same case and the whole unit is called a condenser microphone.

After the signal leaves the head amplifier, it has about the same output level as that of a double button carbon type. The same principle of stretching and damping the diaphragm is applied to the condenser type as is used in the carbon microphone, thus giving about the same fidelity of output. However, there is a noticeable absence of background hiss, and the ruggedness of the unit is a decided advantage. Due to the integral (build in) head amplifier required, the physical size is somewhat larger than any of the other types.

188. RIBBON OR VELOCITY MICROPHONES

The ribbon type microphone is so named because the armature is a light corrugated ribbon of aluminum alloy. See the center left view in Fig. 243. This type is also called a velocity microphone because the voltage induced in the ribbon is proportional to the instantaneous velocity of the air in the sound wave. The aluminum ribbon is suspended in the field of a permanent magnet and when sound waves strike the ribbon it vibrates, cutting the magnetic lines of force.

Whenever a moving conductor cuts lines of magnetic force, an electromotive force is induced in the conductor. Thus in this case we will have set up in the ribbon a small E.M.F. whenever it vibrates. Since the mass of the ribbon is extremely low, an excellent frequency response is obtained, extending well beyond the upper limits of the regular stretched diaphragm type microphone. This extended range of audio response is not very important as far as speech is concerned but does add brilliance to the reproduction of sound from musical instruments.

The output of this unit is approximately the same as that of a condenser type microphone, so it also requires a two stage amplifier to bring the output level up to about -30DB . See Fig. 244.

The velocity microphone is a low impedance device, but it always has a coupling transformer

mounted right in the microphone case. By matching the line impedance to that of this coupling transformer, the amplifier may be located some distance from the unit itself, providing the connecting cable is properly shielded.

This type microphone is of a rugged nature and also possesses a very marked directional effect, the greatest response being obtained at right angles to the plane of the ribbon. The construction of the microphone is of such a nature that its operation is very quiet and free from noise or hiss.

189. DYNAMIC TYPE MICROPHONES

The operation of the moving coil or dynamic microphone is fundamentally that of a conductor moving in a magnetic field, thus generating an E.M.F. in the conductor. The lower left hand view in Fig. 243 shows the actual construction, which looks somewhat like a dynamic speaker unit. The diaphragm is made of thin duralumin which is pressed into a dome shape for stiffening to secure a piston action over the audio frequency range.

The moving coil is made from thin aluminum ribbon cemented to the diaphragm, and moves in the air gap between the pole pieces. The permanent magnet is composed of cobalt alloy steel, which will remain magnetized for a long period of time.

The moving coil microphone is quite rugged and is not affected by climatic conditions. Its output level is approximately 10DB higher than that of

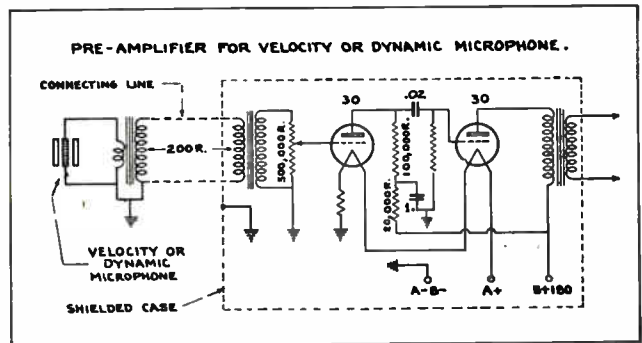

Fig. 244. This diagram shows the connections of a pre-amplifier which can be used for either velocity or dynamic type microphones. The output of this pre-amplifier feeds the first stage of the public address amplifier.

the condenser type microphone, or about—80DB. A circuit for a dynamic microphone pre-amplifier is shown in Fig. 244.

The low impedance of the dynamic microphone makes it possible to locate the pre-amplifier some distance from the microphone itself. The frequency characteristic of the dynamic microphone is quite uniform from 35 to 10,000 cycles, so it has very good fidelity response to sounds in the normal audio range. This type unit has no inherent noise, and due to its very rugged construction can stand quite a bit of rough handling.

190. CRYSTAL MICROPHONES

Two types of crystal microphones are in common use today; first the sound-cell type in which the sound waves act directly upon the crystal, and secondly, the diaphragm type which uses a diaphragm, to the center of which the crystal is attached by means of a mechanical link. See Fig. 243, lower right hand views. In either of these units, the principle of operation depends upon the piezo-electric effect or voltage produced in certain crystals when subjected to mechanical stress.

The sound cell unit shown at the lower right in Fig. 243, is an assembly of two bimorph Rochelle salt crystal elements in a bakelite frame. The bimorph elements, in turn, are each made up of two crystal plates with electrodes attached, cemented together so that an applied sound will cause a bending of the assembly, and produce a voltage. The mounting is such that mechanical shocks have little effect on the unit. No diaphragm is used, the sound impulses actuating the crystal elements directly.

An exceptionally wide frequency range, even into the super-audible band and on down to zero frequency, may be obtained from this unit. Of the two types of crystal microphones, the sound cell has the better frequency characteristics. Its output is very low, however, so it requires greater amplification. The diaphragm type will give much greater output, eliminating in most cases the need for a pre-amplifier, but it has the disadvantage of limited frequency response. This type is most used for voice work, while for full range musical pick-up the sound-cell type is usually employed.

Now if you have studied this section thoroughly you should find profitable use for your knowledge of public address units, in the installation and servicing of such equipment in the many places where it is needed.

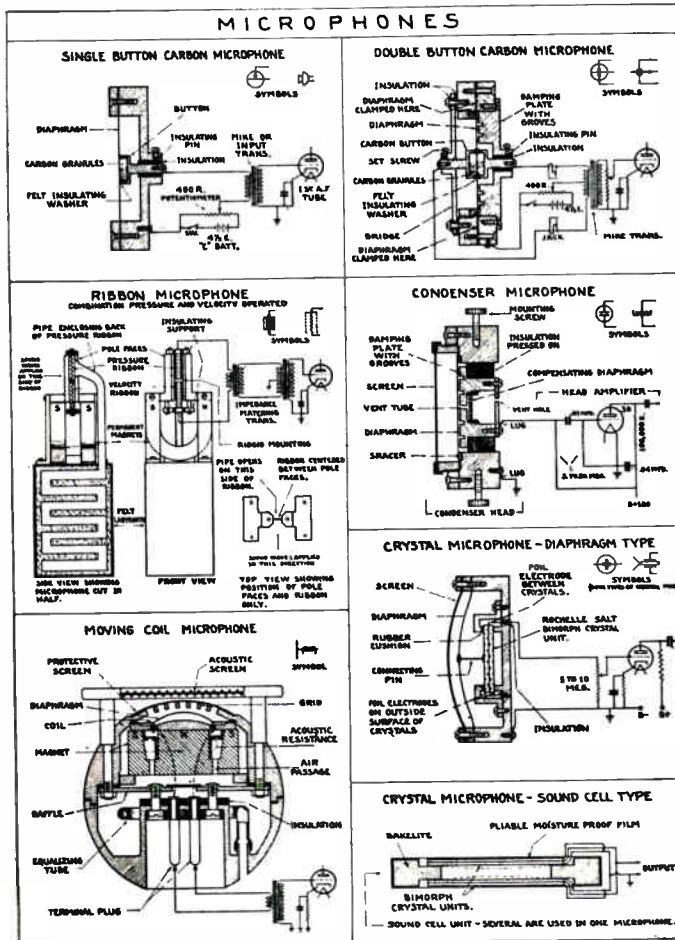

Fig. 243. The above sketches show the construction and connections of carbon, condenser, crystal, and ribbon and dynamic type microphones. Study each view carefully while reading the accompanying explanations.

CATHODE RAY OSCILLOSCOPE

One of the very important instruments which has been more recently developed for radio service and test work is the cathode ray oscillograph, or oscilloscope as it is often called. See Fig. 245. This rather remarkable device makes use of a cathode ray tube which actually traces out voltage wave forms on a fluorescent screen by means of a controlled stream of electrons.

This makes it possible to actually see the voltage or current curves, or the shape of sound waves in action at various stages of the receiver, and enables the trained service man to quickly determine whether conditions in the set are normal or out of order. The cathode ray oscilloscope might also be called a visual voltmeter, which draws a moving picture of voltage curves, showing both the amount or value of voltage and the time duration of each curve. It permits viewing the action of electrical circuits and wave form energy at frequencies even up to one million cycles per second.

Cathode ray oscillographs are also used in observing voltage and current waves in electrical power circuits, and for studying the action of circuit breakers, arcs, high voltage discharges and transient or harmonic impulses set up in certain electrical

circuits. Cathode ray tubes have also become an important part of television transmitting and receiving equipment.

Fig. 245 shows a cathode ray oscilloscope with the end of the cathode ray tube showing at the top center of the panel, and the various control knobs and switches on the front panel. Fig. 246 shows three views of the front of an oscilloscope with alternating voltage curves appearing on the ends of the cathode ray tubes.

191. CATHODE RAY TUBES

The heart of the cathode ray oscilloscope is the cathode ray tube, or electron gun, shown in Figs. 247 and 248. This tube is a specially constructed, funnel shaped vacuum tube equipped with an electron emitter or cathode, which fires a stream of electrons through a path between deflecting plates, to strike upon the inner surface of the front end of the tube, where they cause a glow to appear on a fluorescent screen or coating.

Carefully examine the views of the tube and parts shown in Fig. 247, and note the important parts which are numbered in Fig. 248-A and B. These parts are:—(1) heater, (2) cathode, (3) beam intensity control, (4) beam focusing anode, (5) high voltage electron accelerating anode, (6) vertical deflecting plates, (7) horizontal deflecting plates, (8) fluorescent screen. Terminals from each of these elements are brought out through the base of the tube and through the sides of the tube as shown in Fig. 247. The later type tubes have all terminals brought out at the tube base.



Fig. 245. Photograph of a modern cathode ray oscilloscope of a type now becoming very popular as a radio service instrument. Note the end of the cathode ray tube near the top center of the panel. Also note the various control knobs and switches used for adjusting and operating this instrument. Courtesy Supreme Instrument Company.

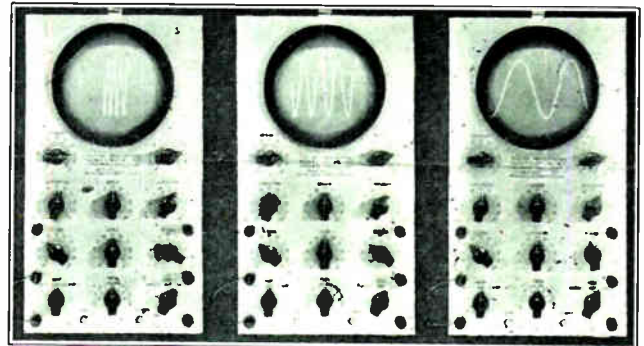

Fig. 246. Above are shown three views of the front of a cathode ray oscilloscope with alternating voltage curves appearing on the ends of the cathode ray tubes. Instruments of this type enable the trained serviceman to visualize and accurately check circuit conditions in the modern radio receiver. Courtesy Du-Mont Laboratories.

As in ordinary vacuum tubes which you have previously studied, the heater element (1) in Fig. 248 is heated by low voltage A.C., and serves to heat the cathode or electron emitting element, (2) which supplies a stream of electrons for the beam.

The intensity control element (3) is supplied with negative voltage which can be varied to control the number of electrons which will pass into the beam, and thereby control the intensity of the glowing spot on the screen inside the end of the tube. The oscilloscope is provided with a control for changing the amount of negative bias, to permit more or less electrons to pass through the intensity control element.

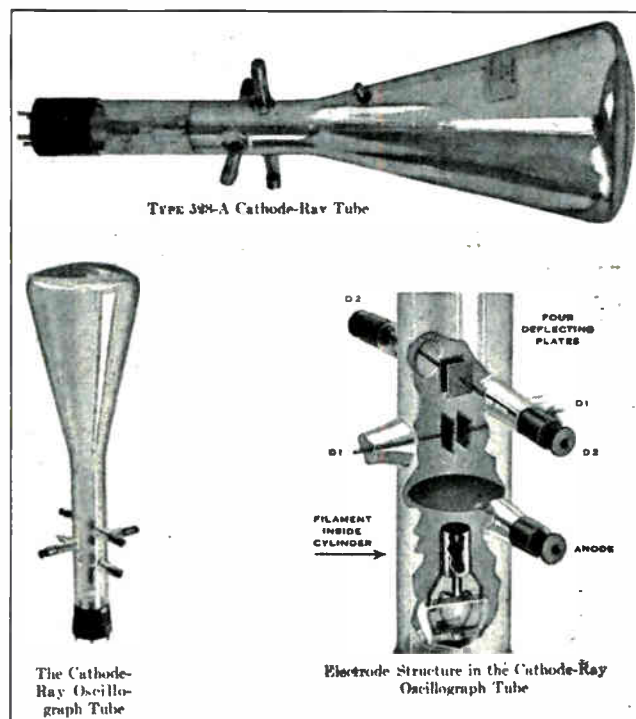

Fig. 247. These views show the construction and parts of a common type of cathode ray tube such as used with oscilloscopes. Note the tube elements and deflector plates, and also the fluorescent screen on the end of the tube. Tubes of a similar type are also used for television equipment. Courtesy General Radio Corporation.

You will recall that a negatively charged electrode will repel negative electrons, in proportion to the amount of negative voltage on the electrode. So we see that the intensity of the spot on the screen can be controlled by adjusting the negative bias on the intensity control element.

The focusing anode (4) is supplied with variable positive voltage of about 200 to 600 volts, and serves to focus the electrons into a concentrated beam to produce a sharply defined spot on the screen. The high positive voltage charge on this anode tends to accelerate the electrons and draw many of them toward the small openings in the center of the anode.

Some of the negative electrons will be attracted to this positive anode, but those that are traveling in line with the openings will shoot on through at increased velocity to the accelerating anode (5) and on to the screen. The focusing of the electron stream, and the size of spot on the screen is controlled by adjusting the positive voltage on anode (4).

The accelerating anode (5) is also supplied with high positive potential of from 1,000 to 4,000 volts, and serves to further speed up the electrons which shoot through the opening in its center.

The horizontal and vertical deflecting plates can be supplied with positive voltage on one plate and negative on the opposite plate, or with alternating voltages of various values and frequencies. The attraction and repulsion of the positive or negative charges on these plates serves to deflect or bend the stream of negative electrons slightly from its straight path, and thereby cause the spot to move up, down or sidewise on the screen. This will be explained more fully a little later.

The fluorescent screen is produced by sandblasting or roughening the inner surface of the broad flattened end of the tube, and coating it with one of several substances such as zinc silicate, willemit, calcium tungstate, cadmium tungstate, etc. These materials will fluoresce or glow and give off a pale green or blue light when they are struck by electrons moving at high velocity.

Therefore, if we focus a beam of electrons on this screen and then bend the electron stream vertically and horizontally we can make it trace out the shape of the applied voltage or current waves in a moving line of light.

Cathode ray tubes are commonly made in sizes ranging from tubes with a one inch diameter face or screen end, up to 9" or more in diameter. They are made with different fluorescent materials in the screen, to produce light lines of green, yellow, white or other colors.

The complete cathode ray oscilloscope includes a power supply unit to furnish the various A.C. and D.C. voltages for operation of the heater, intensity control electrode and the anodes. It also includes controls for adjusting these voltages and for adjusting the amount of external circuit voltages which are applied to the deflecting plates. A special oscillator circuit for producing "saw tooth" shaped waves for moving the electron beam horizontally, is also built in many oscilloscopes. Some instruments also include amplifiers for increasing the control voltage impulses from external circuits under test.

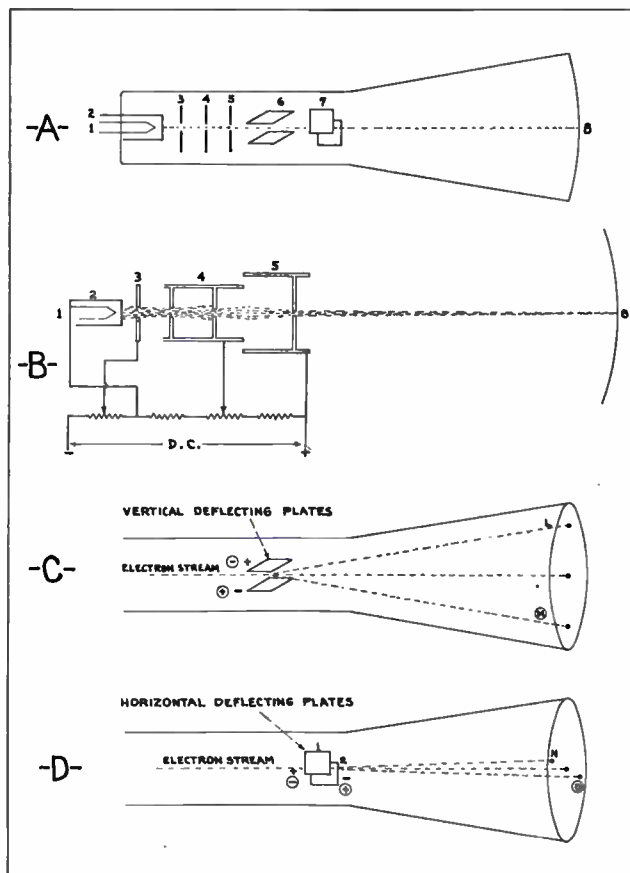

Fig. 248. The above diagrams show several views of cathode ray tubes and illustrate the principle of operation of the electron beam which traces the image of voltage or current waves on the fluorescent screen. Carefully note the various important parts of the tube which are numbered and explained in the instruction material on these pages.

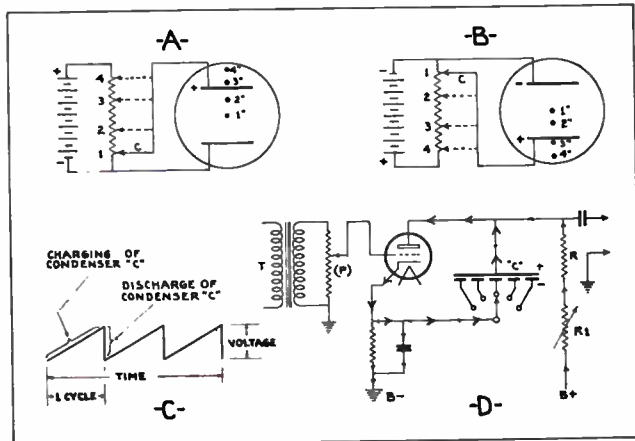

Fig. 249. The sketches at A and B illustrate the manner in which the electron beam is deflected in proportion to the voltage applied to the deflecting plates. The diagram at D shows the circuit of the "sweep" oscillator used with some cathode ray oscilloscopes, and at C is shown the shape of the saw-tooth wave produced by such oscillators.

Some types of cathode ray tubes use a set of electro-magnet coils at the sides of the tube, instead of deflecting plates, to control the electron stream. Electrons can be made to change their path by means of magnetic fields as well as by positive and negative electro-static fields, or repulsion and attraction.

192. OPERATION OF DEFLECTING PLATES

Referring to Fig. 248-A, let us assume that the tube is operating with proper voltages applied to the intensity control element and to the anodes, but with no external control or test voltage applied to the deflecting plates. The beam should then be straight and the light spot should be at the center of the screen as shown in Fig. 248-A. Now, if we apply a positive voltage to the top vertical deflecting plate and negative voltage to the bottom plate, the electron beam passing between the plates will be attracted by the top plate and repelled by the bottom one, and bent upward, causing the spot to move upward as shown at "L" in Fig. 248-C.

Then, if we reverse the polarity on these plates, so that the bottom one becomes positive and the top negative, the beam will be deflected downward and the spot will move downward on the screen as shown at "M" in Fig. 248-C.

The amount of deflection and the distance the spot will move will depend upon the value of the voltage applied to the deflecting plates at any instant. Thus by the use of calibrated lines on a celluloid screen in front of the tube as shown in Fig. 245, we can actually measure the voltage by the distance the spot moves up or down from its normal position in the center of the screen.

If alternating voltage is applied to the deflecting plates, the spot will move up and down exactly as the voltage rises and falls and reverses in the A.C. circuit under test. If the frequency of the A.C. is more than 15 cycles per second, we will see a vertical line of light on the screen, due to the "persistence" of vision of the human eye. In other words, the light spot moves up and down so rapidly that we seem to see it continuously over the entire path it travels.

The response or movement of the electron beam to any change of voltage applied to the deflecting

plates, is so extremely rapid or instantaneous, that it will accurately follow voltage variations or alternations up to 1,000,000 cycles or more per second.

Now, if we were to apply changing or alternating voltages to the horizontal deflecting plates, the beam and light spot will move horizontally across the screen in the same manner. For example, if we apply positive voltage to the plate No. 1 in Fig. 248-D, the beam and spot will be deflected to the left side of the screen as shown at "N". If the polarity is reversed so that plate No. 2 becomes positive and No. 1 negative, the beam will be deflected to the right of the screen as shown at "O" in Fig. 248-D.

Another illustration of the manner in which the position of the electron beam and light spot will accurately follow any variations of voltage applied to the deflecting plates, is shown in Figs. 249-A and B. Here a source of D.C. voltage is used with a variable resistor or potentiometer for a voltage divider.

With the control arm "C" in position (1) there will be no difference of potential between the top and bottom deflecting plates, and the spot will appear in the center of the screen as at (1').

Moving the control arm "C" to position (2) will make the top plate slightly positive with respect to the lower one, and the spot will move to position (2'). If the movement of the control arm is continued upward, the spot will move upward to positions (3') and (4'), etc.

In Fig. 249-B the polarity of the D.C. supply is reversed, making the lower plate positive and deflecting the beam and spot downward on the screen as shown.

An external voltage from some radio receiver or other circuit under test is usually applied to these vertical deflecting plates. This, however, only gives us a vertical line on the screen, indicating the amount of voltage variation. Now if we were to

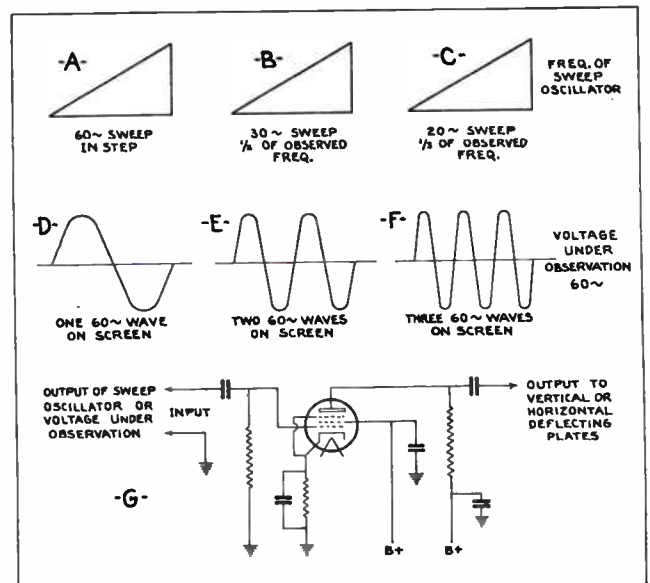

Fig. 250. The sketches at D, E and F in this figure show the types of curves which will be produced by an oscilloscope with the sweep oscillator adjusted to different frequencies with respect to the frequency of the alternating voltage being observed. The diagram at G shows the circuit of a resistance coupled amplifier used to increase the voltages applied to the deflecting plates, in case the receiver circuit voltages are too low to produce normal deflection without amplification.

apply to the horizontal plates at the same time, an accurately controlled timing wave, or varying voltage of some constant frequency, we can make the spot move vertically and horizontally at the same time, and produce on the screen an image of the wave form as shown in Fig. 246, or other wave patterns which will be shown later.

193. SWEEP CIRCUIT OSCILLATOR

To produce this timing voltage wave for the horizontal deflection of the beam, we use what is known as a **sweep circuit oscillator**, also sometimes called a **saw tooth oscillator** because of the saw tooth shape of the wave it produces. See Fig. 249-C, which shows the shape of this wave, and Fig. 249-D which shows the sweep oscillator circuit.

The curve at Fig. 249-C shows a voltage which starts at zero and builds up slowly at a constant rate of increase, and then dies off with a snap, or instantaneously to zero, and repeats this process over and over.

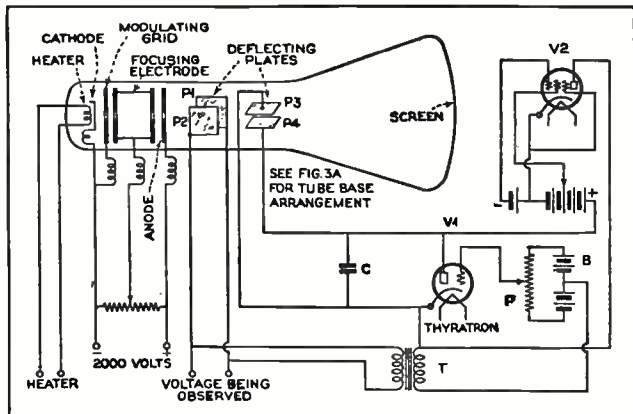

Fig. 251. Diagram of a simple fundamental circuit of a cathode ray oscilloscope showing the connections to the various elements of the tube. Courtesy Radio News Magazine.

To produce this type of voltage wave, we gradually charge a condenser "C," Fig. 249-D, up to a certain voltage, and then suddenly discharge it through a type 885 Thyratron tube. This tube normally has a very high internal resistance until a certain critical voltage is applied, at which time the gas in the tube suddenly ionizes and breaks down the resistance, allowing the tube to spill the charge applied by the condenser, and thus drop the circuit voltage instantaneously to nearly zero.

As soon as the condenser has discharged and the voltage has dropped low enough, the control grid of the thyratron tube again takes effect, increasing the tube resistance and the condenser charge starts to build up again, until it once more reaches the "spill over" value.

The direction of current flow during the condenser charging period is shown by the small arrows in Fig. 249-D. The direction of flow during discharge is shown by the large arrows. The period of time required for the condenser to discharge when the resistance of the thyratron tube breaks down, is only a small fraction of a micro-second (less than one-millionth part of a second) and is, therefore, negligible.

Thus we see that the sweep circuit oscillator supplies the horizontal deflecting plates of the cathode

ray tube, with a continuously varying voltage, which builds up gradually and dies off instantly. This causes the spot on the screen to move across in one direction rapidly but at constant velocity, and then snap back instantly to the other side of the screen to start its travel over again. This horizontal movement combined with the vertical movement due to the test circuit voltages, produces the wave form curves which we desire.

194. SWEEP CIRCUIT FREQUENCY

To prevent the wave form of the frequency under test from moving off the screen of the tube, a low voltage, called the synchronizing or control voltage, is fed to the grid circuit of the oscillator tube from the circuit under observation, by way of the transformer "T" in Fig. 249-D. The amount of control voltage can be governed by the potentiometer "P".

The frequency at which the sweep circuit will oscillate depends principally on the size of the condenser "C" in Fig. 249-D. The larger the condenser, the longer it requires to become fully charged from the B plus voltage applied through the resistors "R" and "R'". In some oscilloscopes the condenser charging current is passed through the resistance of a vacuum tube instead of a fixed resistor. This gives a more constant rate of charge and more uniform rate of increase of the sweep circuit voltage wave. This condenser is made up of a number of different sized fixed condensers so that the sweep frequency can be varied.

The frequency of the sweep oscillator must have a definite relationship to the frequency of the circuit under test. For example, suppose we wish to examine one cycle of a 60 cycle wave, then the sweep frequency must also be of 60 cycles as shown in Fig. 250-A, in order to allow the vertical movement of the spot to travel just one complete cycle up and down, in the same period that the sweep voltage cycle draws the spot once across the tube face horizontally.

The sweep circuit will then allow the spot to snap back to start over from the left side of the screen every time a new cycle starts in the circuit under test. This will produce the curve shown at Fig. 250-D.

If we wish to observe two cycles of a 60 cycle wave, the sweep frequency must then be 30 cycles, or one-half that of the circuit under test. This will permit the vertical travel of the spot to make two complete cycles or up and down movements, during each horizontal trip of the spot due to the sweep frequency, and will produce a curve such as shown at Fig. 250-E.

For observing three cycles of the wave from the circuit under test the sweep frequency should be one-third that of the test circuit frequency, and would then produce curves such as shown at Fig. 250-F.

The shape of all three curves would be uniform if the cycle produced by the sweep oscillator was perfectly linear, or in other words if its rate of voltage build up was absolutely uniform from zero to point of discharge. This is not always the case, as the sweep wave has a tendency to slope off a little near the discharge point.

195. CATHODE RAY TUBE SENSITIVITY

Cathode ray tubes are rated at different degrees of sensitivity, depending upon the amount of voltage required to deflect the beam one inch at the screen. The less voltage required to produce this deflection, the more sensitive is the tube. Cathode ray tubes such as commonly used in radio service oscillographs have a sensitivity of about 70 to 75 volts per inch of beam deflection.

Tubes with 3" to 5" diameter screens are very commonly used, and a number of the less expensive oscilloscopes use 1" diameter tubes. In some cases, a magnifying glass is mounted in front of the tube screen to enlarge the view of the wave under observation. Due to the very low voltages encountered in some circuits of radio receivers, additional amplifiers of the high gain, wide frequency range are often used with oscilloscopes to increase the test circuit voltages enough to give suitable vertical and horizontal deflection on the cathode ray tube screen.

These amplifiers are of the resistance coupled type such as shown in Fig. 250-G, and have a very high gain or amplification factor, and a flat frequency range between 20 and 90,000 cycles, plus or minus 10%. The sensitivity of the oscilloscope may be increased by the use of these auxiliary amplifiers, to about one volt D.C. or two volts A.C. per inch of deflection on both horizontal and vertical beam travel.

196. CATHODE RAY TUBE POWER SUPPLY UNITS

As previously mentioned, the complete cathode ray oscilloscope, contains its own power supply unit. This unit supplies about 1000 to 4000 volts D.C. to the high voltage accelerating anode, and lower voltages from a voltage divider resistor, for the focusing anode and beam control grid or electrode.

It also supplies low voltage A.C. for the heater element.

One power supply transformer generally supplies voltages to two separate rectifiers and filters, which

are used for the cathode ray tube and the sweep oscillator. The power transformer is generally large size or of liberal core design to prevent stray magnetic leakage fields that would otherwise occur and interfere with proper operation of the cathode ray tube.

Fig. 251 shows a simple fundamental circuit of a cathode ray oscilloscope, and Fig. 252 shows a complete circuit of a commercial type oscilloscope, using a type 906 tube with a 3" screen.

197. USE OF CATHODE RAY OSCILLOSCOPE IN RADIO SERVICE WORK

The cathode ray oscillograph is a highly practical and convenient instrument for radio service work. It can be used for measuring voltages and currents in various parts of receiver circuits, for checking the amount of gain or amplification in various stages, for locating distortion, for visual alignment of R.F. and I.F. stages, for checking tubes, condensers, etc.

When used as a voltmeter or ammeter the oscillograph has several advantages over ordinary meters, in that it has no delicate coils to burn out and no meter needles to be bent or broken against the side of the case if over voltage is applied.

When used for measuring voltages a calibrated scale of transparent celluloid is used over the screen end of the cathode ray tube. This screen can be calibrated by applying known voltages to the cathode ray tube. The oscilloscope may be used either with or without the amplifier, depending on the value of the voltage to be measured.

The voltage of the circuit under tests is usually applied to the vertical deflecting plates. The amount of deflection or movement of the spot on the screen will be proportional to the voltage applied. The polarity of the voltage applied will be indicated by the direction of movement of the spot. Application of positive potential to the top deflecting plate will cause the beam or spot to move upward.

When D.C. voltage is applied, the spot will rise

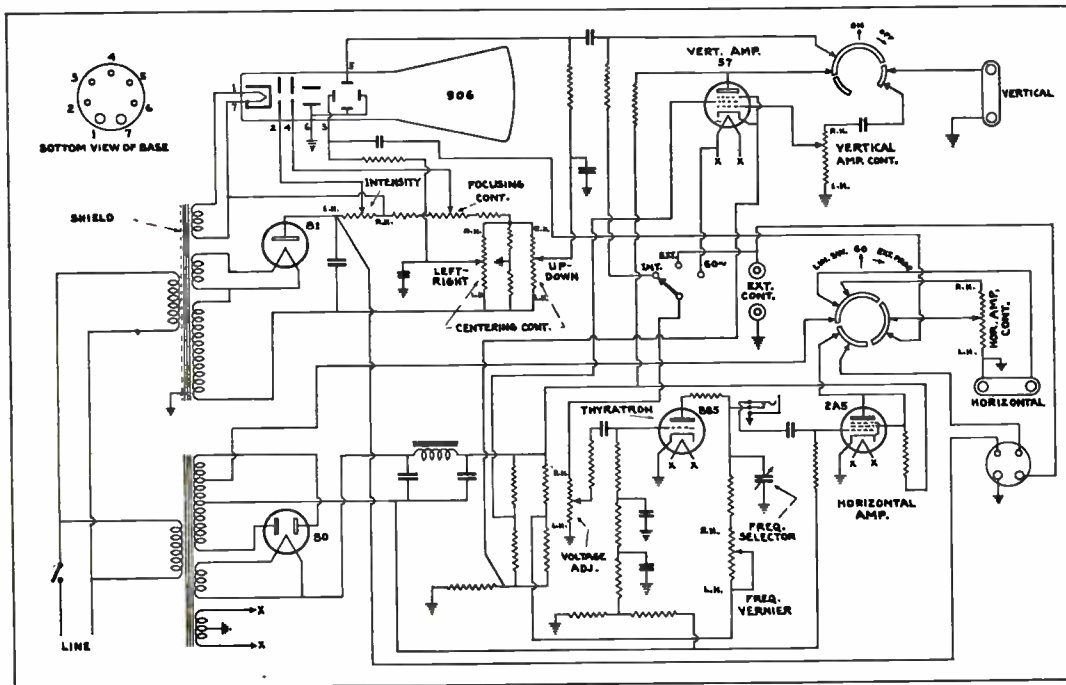

Fig. 252. This diagram shows the complete circuit of a commercial type oscilloscope using a type 906 cathode ray tube. Carefully observe and trace all parts of this circuit including the power supply unit, sweep oscillators, and amplifier.

or fall a distance proportional to the voltage, and remain until the voltage is removed. If A.C. voltage is applied the spot will vibrate rapidly up and down and appear as a vertical line, showing both the positive and negative halves of the cycle.

The cathode ray beam indicates the maximum voltage of an A.C. wave, instead of the effective value as indicated by ordinary meters. To determine the effective A.C. voltage value indicated by the oscilloscope we multiply the sensitivity of the tube in volts per inch, by the length in inches of the line on the screen. Then divide this by two to get the maximum value of one-half of the wave, and next divide by 1.414 to get the effective value.

The amount of direct current flowing in any part of a radio circuit of known resistance can be determined by connecting the vertical plates of the cathode ray tube across the resistance, and then dividing the voltage indicated on the screen by the resistance.

198. CHECKING AMPLIFIER GAIN WITH OSCILLOSCOPE

In a previous section, we learned that one good method of locating radio receiver faults or troubles was to check the gain or amplification at each stage, to determine which stage, if any, was not performing its proper function.

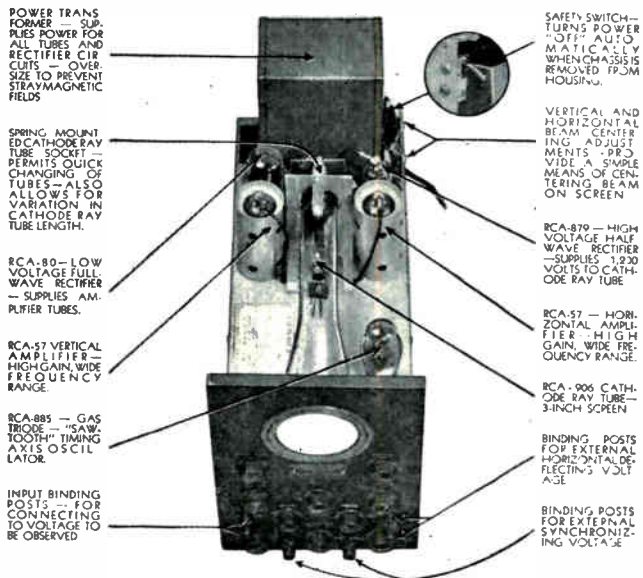

Fig. 253. Carefully observe this very fine view of a cathode ray oscilloscope and the descriptions of each of the parts shown in this figure. Courtesy R. C. A.

This test can be made very easily and accurately with the cathode ray oscilloscope, by connecting it to the output of each successive R.F., I.F. and A.F. stage, while the receiver is being fed a signal from a 400 cycle modulated signal generator. See Fig. 255-B.

The normal height and shape of the signal generator wave form should first be carefully observed for purposes of comparison with the wave shown when testing through various stages of the receiver. This can be done by connecting the output of the generator, with volume control set at maximum, directly to the vertical deflecting plates of the oscilloscope, and applying the saw tooth oscillator to the horizontal plates.

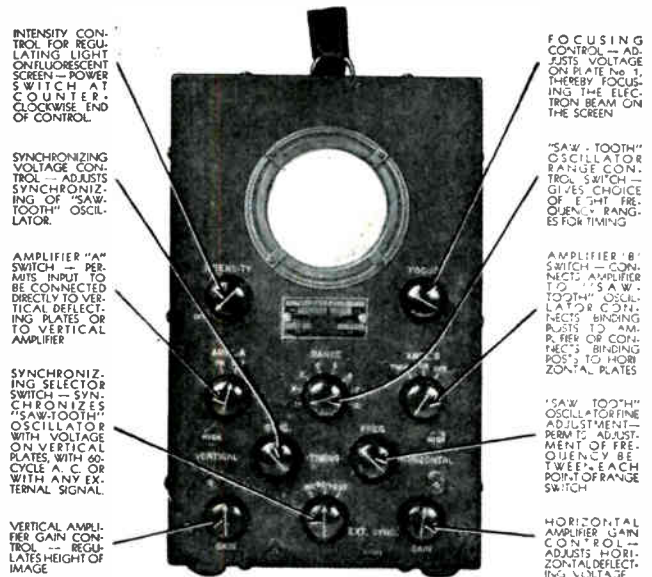

Fig. 254. Another excellent view of a modern cathode ray oscilloscope, showing the various important controls and connections. Study this view very carefully to become familiar with this important type of instrument. Courtesy R. C. A.

The gain of any stage of the receiver can then be determined by connecting the signal generator output to the input of the stage under test, and with one of the oscilloscope vertical plate terminals grounded, connect the other one to the plate of the tube of the stage being tested. Be sure that suitable frequency is used from the signal generator, to suit the particular R.F., I.F. or A.F. stage under test.

Compare the wave form now shown by the oscilloscope, with the original reference wave form. If the receiver stage is properly functioning, the height of the wave should be noticeably increased by the resulting amplification. If there is no increase in the height of the wave there is probably a fault in this stage of the receiver.

If the vacuum tube is suspected of being the cause, it can easily be replaced with a new tube. Then note the oscilloscope wave. If the new tube caused a considerable increase in the height of the wave this shows the old tube was defective. We can, therefore, see that the oscilloscope also provides a method of testing tubes, by comparing their output wave forms with those of good tubes. Tubes which give the wave of greatest height without distortion, are desirable.

If the output of the signal generator is not great enough, an R.F. or A.F. amplifier may have to be used to build up this signal strength for oscilloscope tests.

199. CHECKING OTHER CIRCUIT TROUBLES

If changing the tube does not cause an increase in the height of the wave shown on the oscilloscope, then the defect is probably in some other part of the circuit, such as a condenser, transformer or resistor. The receiver circuit can be further tested by contacting the undergrounded vertical deflector plate lead of the oscilloscope to points 1, 2, 3, 4, and 5 shown in Fig. 255-B.

As the oscilloscope lead is touched to each of these points in succession, a small wave form should

appear on the screen, providing the receiver circuit is normal. When contacting the defective circuit no wave, or a smaller wave, will appear, thus indicating that the fault is in this part of the circuit.

The tuning condenser and trimmer can be tested for shorted plates, by rotating the tuning condenser to several different settings, and adjusting the signal generator to the frequency of each setting. A wave form should appear on the screen for all settings unless the condenser plates touch or short circuit at some point.

Defective by-pass or blocking condensers can be tested by placing the vertical deflecting plate leads

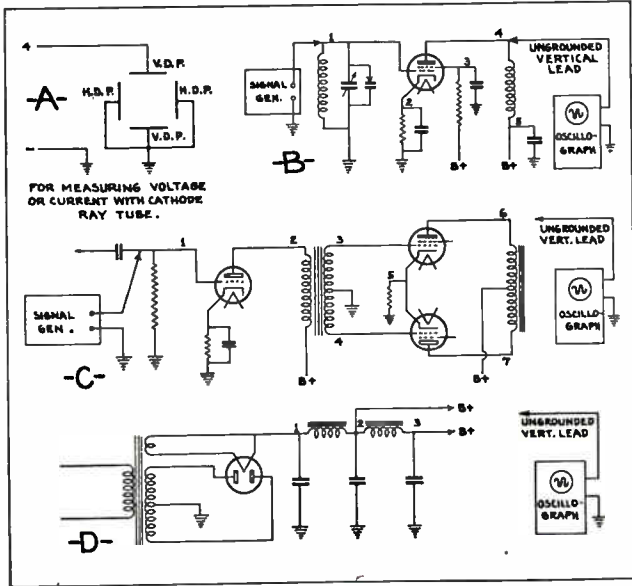

Fig. 255. Above are shown various methods of connecting the deflector leads of an oscilloscope to the different parts of a radio receiver circuit for testing the gain at each stage, for checking tubes and condensers, for locating distortion in the radio receiver, and for checking A.C. ripple in the power supply.

across the condenser terminals, while the receiver circuit is being fed by the signal generator. A good condenser should show a wave form. A shorted condenser will short out the vertical deflecting voltage and show no wave form. An open condenser will show an irregular shape of wave form. A condenser with an intermittent open would alternately show normal and irregular shaped wave forms as the circuit opens and closes.

Audio stages can be tested in a similar manner for loss of signal voltage or quality, by connecting the ungrounded vertical deflecting plate lead of the oscilloscope to points 1, 2, 3, 4, 5, 6 and 7 as shown in Fig. 255-C. The signal generator should be connected as shown and adjusted to give an audio signal.

200. CHECKING DISTORTION

One very annoying trouble arising in radio receivers is the overloading of audio amplifier stages with resulting distortion of tone quality. To check for this condition connect the signal generator across the receiver antenna and ground terminals, and connect the vertical deflecting plates of the oscilloscope across the speaker voice coil terminals or the secondary of the output transformer. The wave form of the receiver output should now appear on the oscilloscope screen.

Next increase the output of the signal generator

to a point where the wave form shows distortion by changing from its original shape, or the peak of the wave becomes flat. The offending stage can then be found by connecting the ungrounded vertical plate terminal of the oscilloscope progressively to the output of each amplifier stage as at points 2, 6, and 7 in Fig. 255-C.

201. OSCILLOSCOPE TESTS ON FILTER CIRCUITS

An oscilloscope is also useful for measuring the amount of ripple or voltage fluctuations in the power supply of radio receivers. The effectiveness of the filter unit can be determined by connecting the ungrounded vertical deflecting plate lead of the oscilloscope to points 1, 2, and 3 of Fig. 255-D.

The A.C. ripple across the output of the rectifier will be of rather high amplitude, and by connecting the vertical plate leads of the oscilloscope between point 1 and ground should show a rather large ripple wave on the screen. Connecting the leads between point 2 and ground should decrease the ripple wave considerably, and between point 3 and ground it should be barely noticeable.

202. ALIGNING RECEIVER WITH AN OSCILLOSCOPE

Another important use to which the cathode ray oscilloscope may be applied is the visual alignment of radio receivers. Some means must be employed to modulate or vary the frequency of the signal generator which is to be used for such visual alignment. In other words the signal generator frequency must be made to periodically increase and decrease slightly. A device known as a frequency modulator or "wobbler" is used for this purpose. The "wobbler" consists of a very small electric motor which rotates a small variable condenser, which is connected in parallel with the main tuning condenser of the signal generator, and thus varies the radio frequency signal at a uniform rate.

When this modulated signal is applied to any R.F. or I.F. stage of a receiver, a selectivity curve of that stage will appear on the screen if the oscil-

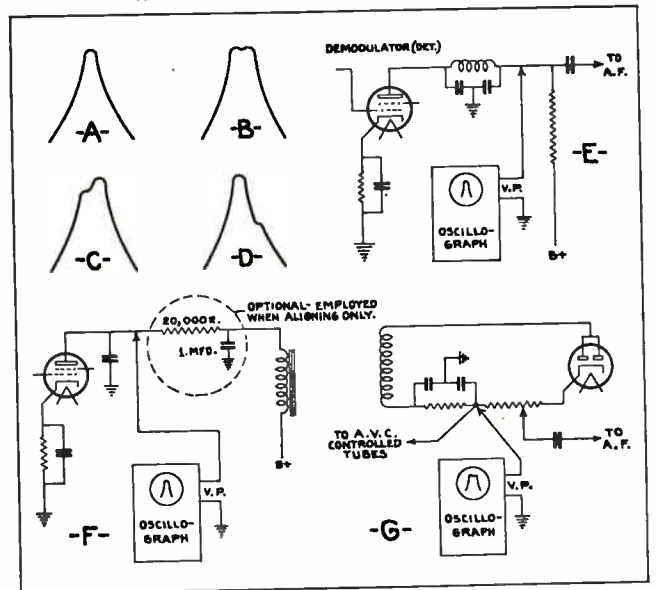

Fig. 256. The top views A to D show normal curves and distorted curves of radio receiver signal output. At E, F, and G are shown the methods of connecting the deflector plate leads when using an oscilloscope for aligning radio receivers.

oscope leads are connected across the output of the detector. The horizontal deflecting plate leads should be excited by the sweep circuit voltage, which is set at the same frequency as the rotating "wobbler" condenser. This curve should appear as shown at "A" in Fig. 256, or possibly a curve with a slight double hump as shown at "B". These two curves indicate correct alignment of the receiver. The curves shown at "C" and "D" in Fig. 256 indicate improper alignment.

The frequency modulator or "wobbler" should be connected to the receiver in the same manner as the ordinary type of signal generator.

It is important when using an oscilloscope for aligning, to see that the vertical deflector plate leads are properly connected to the output of the demodulator tube in the receiver. If the set is of the grid leak or power detector type, these vertical plate leads should be connected between the plate circuit and ground on the filtered side of the R.F. filter, if such a filter is used. See Fig. 256-E. With sets

using resistance coupling, the vertical plate leads V.P. should be connected between the plate of the demodulator tube and ground as shown at "E" in Fig. 256.

With sets using transformer or impedance coupling between the demodulator and first A.F. tubes, it is necessary to insert a 20,000 ohm resistor between the plate and the inductance, and also to connect a 1 mfd. condenser from this circuit to ground as shown at "F" in Fig. 256. Then the vertical plate leads of the oscilloscope are connected as shown in this same figure, with the top plate lead between the plate of the demodulator tube and the inserted resistor.

In diode detector circuits the vertical plate leads of the oscilloscope should be connected to the load resistor and ground as shown in Fig. 256-G.

This visual method of aligning radio receivers with the oscilloscope is one of the most accurate methods in use and is, therefore, well worth careful study.

TELEVISION

One of the more recent applications of radio principles and equipment which promises tremendous future expansion and opportunities, is in the field of television. The term "television" applies to the transmission by radio, of visual images of persons such as announcers, speakers, singers, actors, etc.

It may also include the transmission of moving images of action scenes in baseball games, football games, boxing matches, hockey matches, and other sports events. Or we can televise and transmit by radio a complete motion picture film.

Any method of electrically transmitting visual images or pictures instantaneously from one point to another, either by wire or radio may be called television.

You can readily imagine the tremendous future possibilities of such an industry or field, through which people will be enabled to see as well as hear their favorite announcers, singers, speakers, sports events, news events, etc.

Television has already been developed to a point where very good moving images, ranging from several inches to several feet square, can be transmitted and received by radio over distances of 30 to 70 miles. See Fig. 257. Improvements are constantly being made in this remarkable equipment, by the engineers of large radio corporations and by private experimenters. Note the difference between the pictures in Figs. 257 and 258.

The great expense of establishing special television transmitters and programs, the problem of sponsorship by advertisers or manufacturers, and the problem of standardizing the several types of television receivers to receive images from different stations, have been some of the factors which have so far delayed the large scale commercial development of television.

However, these difficulties are certain to be overcome, just as many great obstacles were overcome in the development of the radio broadcast industry to its present vast size and activity. Many trained radio men who are wise enough to acquaint themselves with the general principles of television to-

day, and then follow the current developments through radio journal articles and manufacturers' bulletins, will undoubtedly have splendid opportunities to cash in on this knowledge in the near future.

Keep in mind the fact that television is very largely accomplished by means of radio equipment and devices with which you are already familiar, except that television transmitting, receiving and amplifying units operate on shorter wave lengths or higher frequencies, and cover a wider band of frequencies in each station channel, than used for radio transmission of sound.

In addition to vacuum tubes, condensers, resistors, transformers, and complete transmitters, receivers and amplifiers, television also requires a light source, scanning mechanism, optical lenses, photo-electric cells and cathode ray tubes.

One very practical use of television principles which is already in commercial use, is for the transmission of photos by wire or radio, over what is



Fig. 257. This view shows an actual photograph of a television image on the screen of a cathode ray type television receiver. Compare this view with the one shown in Fig. 258, and note the great improvement and progress made in television equipment during recent years. Courtesy Radio Craft Magazine.

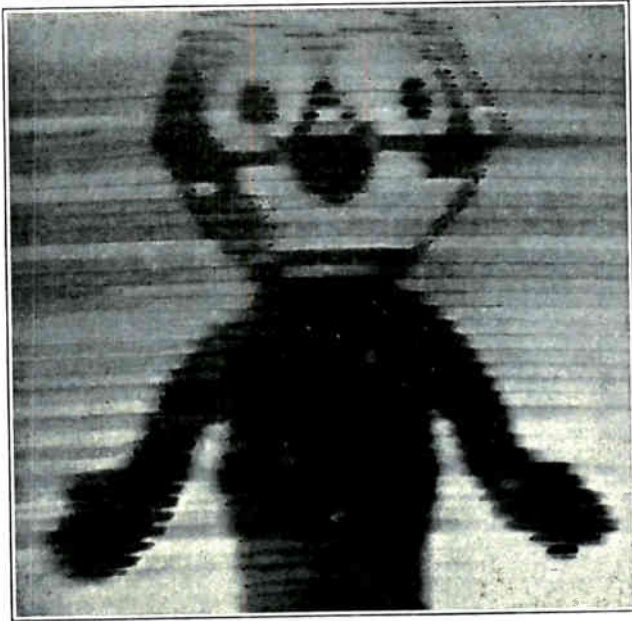

Fig. 258. This view shows a very poor image of a cartoon such as produced by early types of television receivers having very few lines per image. Courtesy Radio Craft Magazine.

known as radio or wire "facsimile" equipment. With this system news photos, photos of criminals, or important documents can be transmitted in a few minutes from one side of the continent to the other, or from across an ocean. Newspapers, Government bureaus and police departments and other organizations are now using this system daily.

It is entirely possible that we may receive our newspapers or bulletins in our homes by this method at some future date.

203. TELEVISION IMAGE SCANNING

In order to televise or transmit an image by television with present day methods it is necessary to first break up the image into thousands of small sections or elements, each of which will reflect more or less light according to its color or shading. The varying light impulses reflected from these elements or minute image sections, are then passed through a focusing lens to a photo-electric cell or a cathode ray pick-up camera which converts these varying light impulses into varying electrical impulses. These electrical impulses are then amplified and transmitted over a radio frequency carrier wave much the same as sound wave electrical impulses are modulated onto the carrier frequency in ordinary radio broadcasting.

At the receiving end, the signal impulses are amplified and applied to a cathode ray tube, or used to control a light source, for converting them back to varying light impulses. These light impulses are then passed through another lens system and scanning mechanism and again re-assembled into a complete visual image. See Figs. 259 and 260.

At present television scanning systems are of two types, known as the mechanical disc or drum scanner and the cathode ray scanning tube or "iconoscope." Each system has its advantages and disadvantages, and both have possibilities of much more development and improvement.

The scanning disc was invented by Paul Nipkow and has been used by the Peck Television Corp.,

and also in the Jenkins televisors. The cathode ray scanning system has been developed by Pharnsworth, Philco Radio & Television Corp., and R.C.A.

The process of scanning an image or a subject for television amounts to breaking the image or view up into narrow lines of varying degrees of light and shadow, transmitting the light variations from these strips by electrical impulses, and then reassembling them into a complete image by a synchronized scanner at the receiver.

By referring to Fig. 259, we can see that the simple mechanical scanner consists of a motor driven disc with a set of small holes or perforations arranged in a spiral row around the disc. A mask or frame is set in front of the disc so that the holes in the disc will revolve past this frame or aperture. Light reflected from the image or subject falls on this mask opening, and is scanned or permitted to pass through in lines as the small disc openings pass by the mask opening.

The size of the mask and the spacing of the disc holes are such that only one hole can appear in the mask opening at any time. Just as one hole leaves

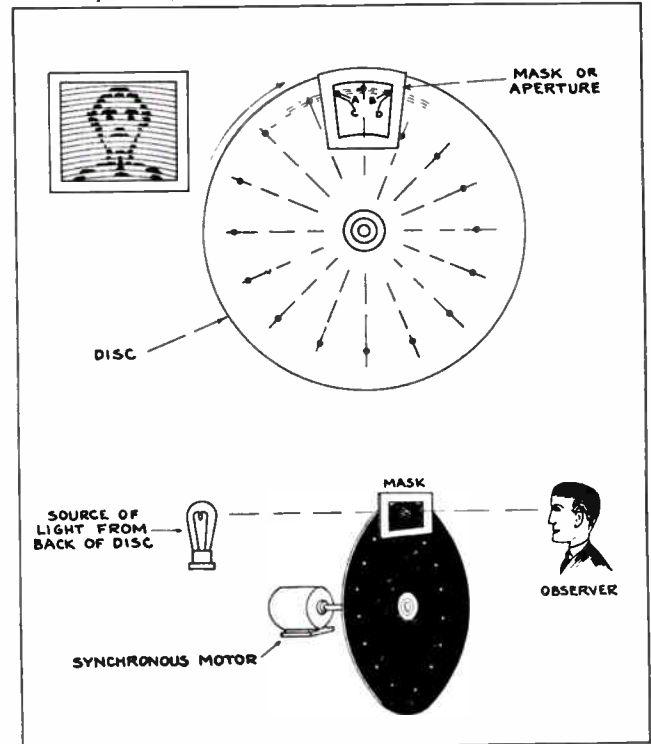

Fig. 259. The above sketch illustrates the mechanical method of scanning a television image. Note the motor driven scanning disk, the mask or aperture, and the light source. Observe this sketch carefully while reading the accompanying explanation on these pages.

the side of the mask aperture the next hole enters the opposite side. Each disc hole is set closer to the center of the disc by an amount equal to the width of one hole. Thus the first hole will trace a line or path from A to B, in Fig. 259, and the second hole a path from C to D, just one line below the first, etc.

This process is carried quickly from the top to the bottom of the mask opening each time the disk makes one revolution. If the disc had 20 holes the opening in the mask would have 20 lines traced across it from top to bottom for each revolution of the disc. If the disc with the light behind it as

shown in the lower view in Fig. 259, were revolved fast enough, when viewed from the front the persistency of vision of the human eye would make the mask opening appear to be filled with light, even though there is only one very small spot of light in the opening at any instant.

Another illustration of the principle of scanning may be had by considering the path followed by your eyes as you read this printed paragraph or page. Your eye follows one line word by word, from left to right, and then your vision shifts quickly to the left and follows the next line to the right. This is repeated over and over until you have scanned or read the entire page, much the same as the television scanner covers the mask opening and the light reflected into this opening from any image.

In television practice, 45 or more holes or lines are used, and the disc is revolved at high enough speed to scan the opening 15 or more times per second, to produce the effect of continuous vision of the image.

In order to produce a fairly even field of light over the entire mask opening, the holes must be laid out very accurately on the disc, so that the edge of one light line exactly meets the edge of the next line, etc. To reduce the shadowy lines or amount of light variation the holes are sometimes arranged so that the lines of their edges will slightly overlap. Some scanning discs are made with larger openings and have each opening fitted with a lens to improve the accuracy of matching the light lines and to improve the clearness of the image.

204. DIRECT PICK-UP TELEVISION CAMERA

The upper diagram in Fig. 260 illustrates the principles of a simple direct pick-up type of television transmitting and receiving unit. At the transmitter on the left, the object to be televised is illuminated by flood lights, so that its image will be reflected to the camera lens. This lens will focus the image

onto the perforated section of the scanning disc which is revolved at constant speed by a synchronous motor.

The image is broken up by the scanning disk, into strips or lines of varying light intensity, which are traced across the mask or aperture. The amount of light passing through the holes will fluctuate directly in proportion to the amount of reflection from the light and dark areas of the object being televised.

This rapidly varying light is passed through the condenser lens to the photo electric cell which converts the light impulses into corresponding electrical impulses. As we have previously learned, the photo-cell is an evacuated or gas filled bulb having an electrode or part of the glass surface coated with a special substance such as cesium oxide or potassium which emits electrons or feeble electric currents when light rays strike this coating.

205. GLOW LAMPS AND SYNCHRONIZATION OF SCANNERS

The electrical impulses from the photo cell are next amplified by the special resistance coupled pre-amplifier and main amplifier, and used to modulate the radio frequency carrier wave of the short-wave radio transmitter.

At the receiving end, the signal is picked up by the antenna and fed to a special resistance coupled receiver and amplifier which separates the light modulated component of the signal from the R.F. carrier wave, amplifies it and feeds it to the plates of a special neon glow lamp.

This glow lamp has two metal plates about 1 1/4" square, mounted in a bulb filled with neon gas. When proper voltage is applied to these plates, the entire surface of the negative plate will glow with a uniform field of pink light. The intensity of this light will vary instantaneously and proportionately with any changes in the voltage applied to the lamp. Therefore, if the amplified signal is applied to this lamp, its light will increase and decrease exactly as the light beam striking the photo cell at the transmitter varies in intensity. So if we view this varying light source through the scanning disc at the receiver, we will see a reproduction of the image at the transmitter.

The neon glow lamp is located behind an aperture and another scanning disc which has the same number of holes and is rotated at exactly the same speed as the disc at the transmitter. These scanning discs at the transmitting and receiving units must be kept perfectly synchronized or in absolute step with each other, so that, for example, if they were operated side by side their holes would line up at all times. This can be accomplished by means of synchronous motors operated on the same power system lines, or by means of special synchronizing impulses sent over the carrier wave from the transmitter, amplified at the receiver and used to control the motor speed.

Some television receiving units of the mechanical scanner type use a crater type neon lamp and a lens disc for projecting enlarged images onto a screen. The crater type lamp produces a very intense light from a small point or source which can be readily focused by the lenses of the scanning discs. The

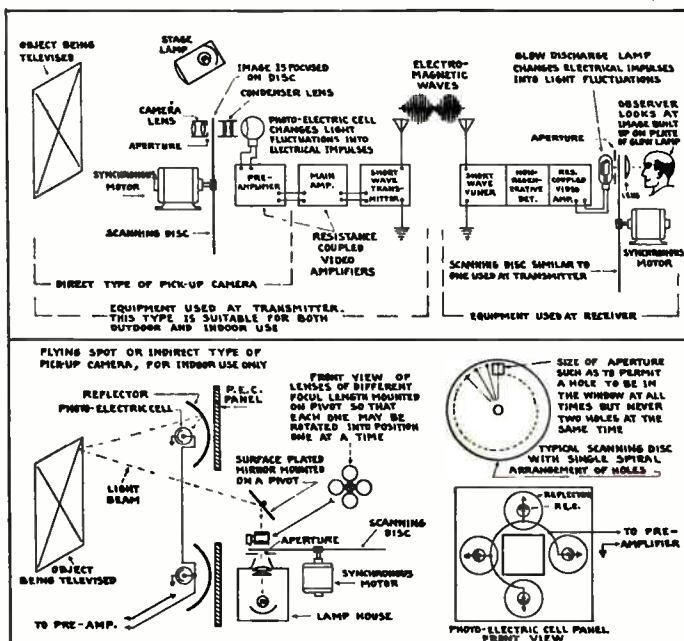

Fig. 260. The top diagrams illustrate the principle of the direct pick-up type of television camera, and the lower diagrams show the principle of the flying spot pick-up system. Refer to these diagrams frequently while reading the accompanying instruction material.

intensity of the light varies with the fluctuations of the applied voltage, similarly to that of the ordinary neon lamp previously described.

206. IMAGE DEFINITION OR QUALITY

Early television experimenters used scanning discs with 40 to 60 holes or lenses, revolving at 900 or 1200 R.P.M. The clearness or detail of images made up of so few lines was not at all satisfactory. The images appeared coarse and spotty and outlines were not sharp or clear. Compare the photo of the older 60 line image in Fig. 258 with the later 441 line image shown in Fig. 257.

If you will closely examine the halftone photo reproductions in a newspaper, you will find that they are made up of many rows of very small black dots of different sizes. Where the dots are heavy, the picture looks quite black and where the dots are smaller, the picture appears lighter. This should help to illustrate how pictures or images can be made up of small spots of varying light and shadow, with television equipment.

You may note, however, that newspaper illustrations often have from 80 to 100 lines of dots per inch, in order to produce a fairly good picture. And so with television, to get good images, we must transmit hundreds of thousands of these picture "elements," or individual light impulses or spots to produce one single image. Then to obtain moving images of live subjects, we must repeat this process about 30 times per second, in order that our persistency of vision will enable us to see smooth motion effects.

Later type television equipment uses 441 line images, produced by electrical scanning, and mechanical scanners now use discs revolving in a vacuum at 6000 R.P.M., in order to obtain greatly improved television images.

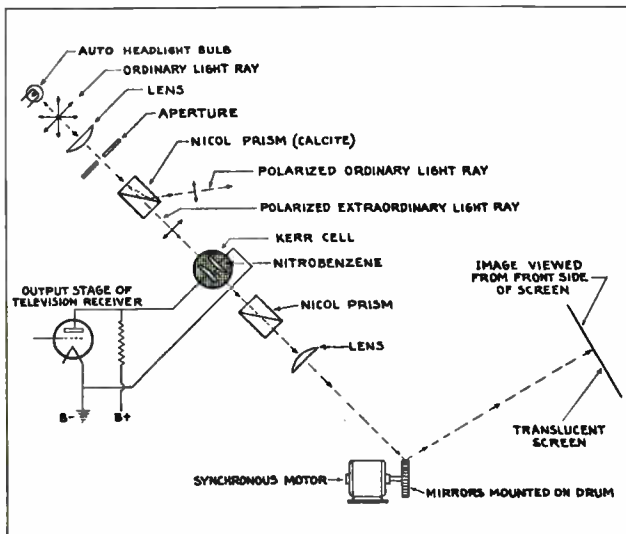

Fig. 261. This figure shows the operation of the Kerr cell and Nicol prism arrangement used for polarizing and controlling a light beam for projecting enlarged television images. Observe each of the parts carefully while reading the explanation of their functions in the instruction material. Also note the drum type scanner which is used instead of the scanning disk.

207. FLYING SPOT PICK-UP SYSTEM

The lower diagram in Fig. 260 illustrates the principles of a somewhat different television system known as the flying spot type of pick-up. With this system, the light source is placed behind the scan-

ning disc in such a manner that the object to be televised will be illuminated or scanned by flying spots or lines of light, coming through the holes in the disc. Actually only one tiny spot of the object is illuminated at any instant, but this spot of light scans or travels over the object so fast and so often that it appears to be entirely illuminated with a rather dim light.

The varying amounts of light reflected from the light and dark areas of the object being televised, are reflected to the photo-electric cells on the panel shown in the lower diagram in Fig. 260. This type



Fig. 262. Photograph of a large cathode ray tube such as used in some of the later type television receivers. This tube has a 12" diameter screen and is capable of producing television images similar to the one shown in Fig. 257. Courtesy DuMont Laboratories.

of television camera is used in a dark room. A surface plated mirror and a set of revolving or changeable lenses are used to keep the camera in focus with the subject being televised. This system has the advantage of not requiring the subject to be illuminated with the very intense light required for the direct pick-up system.

208. TELEVISION PROJECTORS USING POLARIZED LIGHT

Some television receiving systems use a strong steady polarized light source instead of a neon glow lamp, in order to project larger images onto a screen. An ordinary automobile headlight lamp can be used as the light source in such units. See Fig. 261.

Ordinary light rays consist of electromagnetic stresses which radiate equally at right angles to the light ray. The "nicol" prism allows only light rays having radiations in one plane to pass through it. This is called polarized light. These polarized light rays are then passed through a special light control valve, known as a Kerr cell, and shown in Fig. 261.

This cell or light valve consists of two electrostatic plates immersed in a solution of nitro-benzene which acts as a di-electric between the plates. The polarized light ray which is passed between these plates can be twisted or bent from its normal plane by applying the television signal voltages to the plates of the cell. This twisting of the plane of the polarized light ray prevents part of it from passing through the second nicol prism. In this manner the Kerr cell and nicol prisms act as an instantaneous light valve to control or modulate the light to correspond to the television signal variations.

These fluctuating light rays leaving the second "nicol" prism are then passed through a lens to a

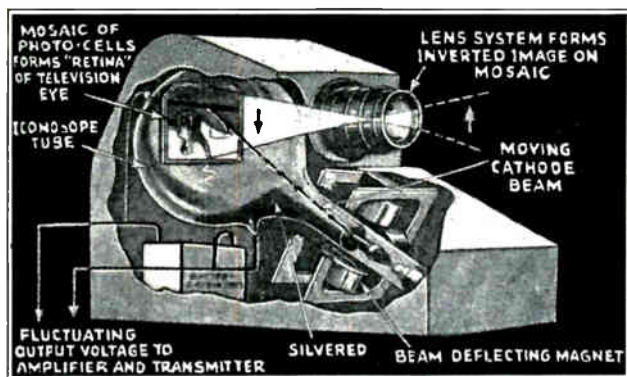

Fig. 265. This view shows how the iconoscope tube is mounted behind the lens in a television pick-up camera. Courtesy Radio Craft Magazine.

transmitted along with the television signals, are used to control the frequency output of the saw tooth oscillator.

The horizontal deflectors move the electron beam across the end of the tube from left to right to trace each line of the image. As soon as each line is thus traced across the tube, the beam returns instantaneously to the left side to start the next lower line. During this process, the vertical deflectors, operating on a lower frequency, cause the beam and its horizontal lines to shift gradually downward from top to bottom of the tube screen until the image is fully traced. Then the beam is moved instantaneously back to the top of the tube to start tracing the next image.

The variation in light intensity of the lines or image is accomplished by applying the amplified signals to the control grid of the cathode ray tube. This control grid regulates the number of electrons in the beam and the intensity of the spot it produces on the screen, according to the signal voltage applied to the grid.

The number of lines per picture, and the number of pictures per second which can be received by such a cathode ray tube are innumerable, as the response of the electron stream is instantaneous or incredibly fast, and the saw tooth oscillators can be adjusted to suit the line and image frequency characteristics of the transmitter. Fig. 262 shows a view of a 12 inch diameter cathode ray tube for television use.

Fig. 263 shows a kinescope tube with its power supply circuit and signal amplifier or "video" amplifier circuit in the upper view. The two lower views show circuit diagrams of the saw tooth oscillator circuits used for supplying the vertical and horizontal deflecting coils of this type of cathode ray tube when used for reproducing television images.

211. CATHODE RAY PICK-UP CAMERA OR ICONOSCOPE

For pick-up of high definition television pictures using 300 to 450 lines per image, mechanical scanning is not generally used because of design difficulties with discs using so many holes or lenses. Instead, another special type of cathode ray tube, known as an "iconoscope" is used in the pick-up camera.

Fig. 264 shows a tube of this type and Fig. 265

shows how it is mounted in the pick-up camera with a lens in front to focus the image of the object onto a special mosaic plate or screen inside the tube. This mosaic signal plate consists of a sheet of mica, which is covered on one side with tiny goblets of silver-oxide which is sensitized with caesium. This actually forms thousands of tiny photo-electric cells on this plate, and each of these cells will produce an electrical charge when light strikes it. Back of the mica plate is a copper sheet which serves as the opposite plate of a condenser. The silver-oxide caesium coating forms the other plate and the mica acts as the di-electric of this condenser.

The action of this mosaic plate is quite similar to that of the retina of the human eye. When an image is focused on the plate or "retina" each tiny P.E. cell develops an electrical charge proportional to the amount of light that strikes it.

A cathode ray beam is then caused to scan this mosaic and as it passes over each of the minute cells which is receiving light, it neutralizes their positive charge. As the beam leaves each of the cells, they immediately throw off a few more electrons and become charged again. Wires connected to the copper plate and to a metallic coating on the stem of the tube conduct these electrical charges through a grid resistor which converts them into voltage variations which are applied to the signal amplifier and transmitter. See Figs. 266 and 267.

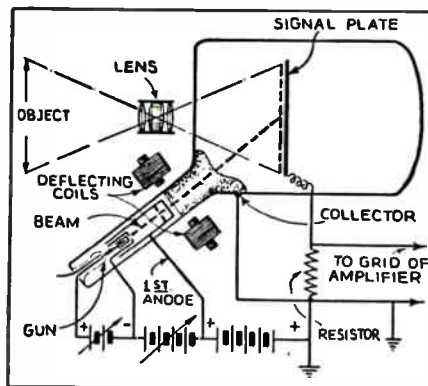

Fig. 266. This sketch shows the connections from an iconoscope tube to the signal amplifier of a television pick-up unit. Courtesy Radio Craft Magazine.

This cathode ray iconoscope pick-up camera is the type used in some of the more recent television demonstrations, with the proposed standard images of 441 lines per image, 586 divisions per line, 30 images or frames per second, and 60 fields per second. The number of divisions per line is governed by the size or width of the beam spot.

212. TELEVISION FREQUENCIES

The voltage impulses or signals from such pick-up units are amplified and then transmitted over carrier waves of very high frequency, or wave lengths of 6 to 7 meters. Separate frequency bands, within a channel 4 mego-cycles wide, are used for both sight and sound transmission. This is known as the "associated" system and permits both images and sound to be received with a single dial tuning unit. Carefully observe Fig. 268.

We have learned that as a scanning beam passes

over light and dark areas of the image being scanned, it produces a corresponding change of voltage at the photo-electric cell or cathode ray tube. As the beam travels from a light to a dark area and back to a light area again, or vice versa, it will produce one complete cycle in the signal voltage.

With 441 lines and 586 divisions per line, there is a maximum possibility of over 250,000 elements per picture, or 125,000 signal cycles per picture. Then, with 30 pictures per second, this gives a possible maximum signal frequency or picture frequency of 3,750,000 cycles.

Comparing this with high fidelity radio sound transmission of 8000 cycles audio frequency, we can see that a very large band width is required in the radio spectrum for television transmission at these proposed standards. The carrier wave frequency must also be several times higher than the signal frequency. The only place such wide bands of frequencies are available is in the ultra high frequencies around 6 to 7 meters.

As these very high frequency waves have much the same characteristics as light waves, and travel in a straight line instead of following the curvature of the earth's surface as ordinary broadcast frequencies do, the present consistent range of television seems to be about 25 to 70 miles, depending on the height and location of the transmitter. Thus with present equipment, it would require a large number of transmitters to cover the entire country.

cies needed for television signals. Some of the principal differences between the television receiver and the ordinary radio sound receiver are as follows: The television receiver must be broad tuning to cover the wide frequency range of television signals; it must respond to the ultra short waves or high frequency used for the television carrier wave; the "video" amplifier must have a response broad enough to amplify equally all frequencies from 30 C.P.S. (cycles per sec.) to 2500 K.C.P.S. (kilocycles per sec.); and it must produce the right polarity of signal output for a positive image. The detector circuit of a television receiver should be non-regenerative.

Fig. 269 shows the circuit diagram of a 5 meter superheterodyne television receiver and power supply unit which meets the above requirements, and which is designed for use with the kinescope or cathode ray type of scanner shown in Fig. 263.

Most high fidelity visual transmitters operate in the range of 40 to 65 megacycles. In order to respond to these very high frequencies the antenna and oscillator coils of this receiver have only 5 and 4 turns respectively, and are both tuned with very small condensers of about 35 M.M.F. (micro-microfarad.)

This receiver uses the heterodyne principle to bring the carrier frequency down to about 13 megacycles, to which the I.F. transformers are broadly tuned. By tuning the plate and grid coils to slightly different frequencies the range of response of the transformers can be greatly increased. The individual stages may also be "staggered" or slightly detuned from each other to further increase the frequency range or broad tuning characteristics of the entire amplifier.

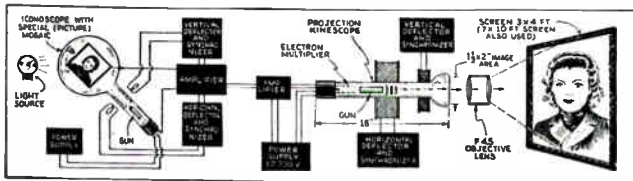

Fig. 267. Block diagram of a complete television transmitting and receiving system, using an iconoscope pick-up camera and a cathode ray receiver. Courtesy Radio Craft Magazine.

However, one transmitter can cover an entire large city, and the area around it, and smaller transmitters located in the smaller towns can be fed television signals by wire, over what is called a "coaxial" cable. Such cables consist of a wire centered within a metal tube, and are in use now by telephone companies for transmitting wire photos and a number of phone messages at different frequencies simultaneously over the same cable.

Television systems can also be adapted to transmission of motion picture films. A powerful light is placed behind the film so as to shine through it, and the film is moved downward in front of a lens and scanning disc or iconoscope tube. The light impulses from the film are converted into electrical impulses by the photo cell or iconoscope, amplified and transmitted the same as direct pick-up television images. The sound impulses from the sound track of the film can be transmitted at the same time on a separate frequency band. See the lower view in Fig. 268.

213. TELEVISION RECEIVER DESIGN

The receivers and amplifiers used for television are in reality just radio receivers which are designed with somewhat different circuit characteristics to adapt them to the wider range of higher frequen-

214. SIDE BAND RECEPTION

The side bands which extend out from each side of the normal carrier wave due to signal frequency

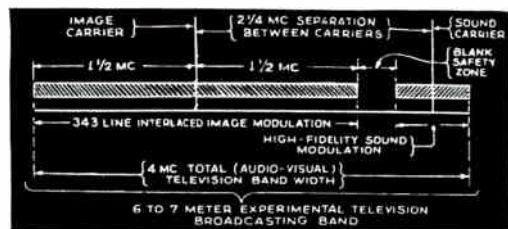
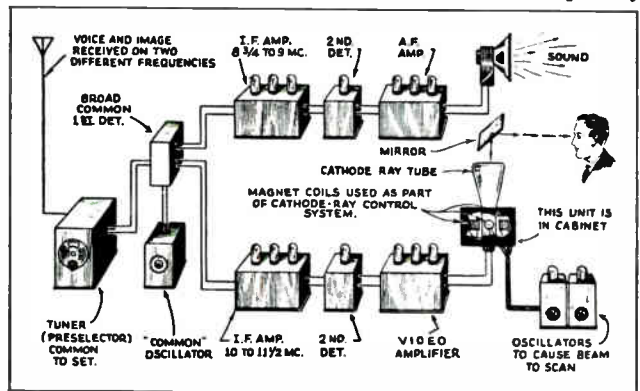

Fig. 268. The above views illustrate the manner in which both sound and television images can be transmitted simultaneously over one television channel, and received by a single receiver. Courtesy Radio Craft Magazine.

modulation, on visual transmitters may occupy a channel up to 5 megacycles wide. Therefore, to pick up both side bands of a television signal the I.F. amplifier would need to respond to a channel of the above width. However, it is possible to obtain good images with an I.F. amplifier which responds to a frequency range only slightly wider than the carrier and one side band.

The receiver is then slightly detuned from exact resonance so that it will pick up all of the frequencies in one side band only. This method is called "signal side band reception" and is being practiced by some television experimenters.

Due to the very broad tuning of the I.F. transformers of television receivers, the amplification factor per stage is only about 5, as compared with 100 per stage for ordinary sound radio receivers. It is, therefore, necessary to use 5 stages of I.F. amplification to bring the sensitivity of the receiver up to the required value.

The detector must be non-regenerative, as regenerative circuits always sharpen the tuning of a receiver, and television receivers must be broad tuning.

215. VIDEO AMPLIFIER

The amplifier following the detector is called the "video" amplifier, as it must amplify all of the visual or image element frequencies that make up the picture. Since this amplifier must respond to a wide band of frequencies, a resistance coupled circuit is used, as shown in Fig. 269.

The coupling condensers must be large, in order to effectively transfer some of the very low signal frequencies. The plate coupling resistor must be of relatively low resistance so that the capacitive reactance, due to capacity between wires and ground and the internal capacity of tubes, will be considerably higher than the resistance value at the maximum frequencies to be amplified.

These capacities from the plate circuit to ground will produce greater losses at high frequency than at low frequency. To compensate for this frequency discrimination, a small R.F. choke coil is

placed in series with the plate resistor. This choke coil is so small that it will not have any noticeable effect on the voltage variations across the plate circuit at the very low frequencies, but it will increase the voltage variations across this plate circuit at high frequencies.

216. PHASING OF TELEVISION RECEIVERS

If the signal output of a television receiver is not of proper polarity, or properly phased with the light and dark elements of the image being scanned at the transmitter, a negative image will be produced. That is an image in which the light and dark areas are reversed, as in a negative of a photograph film.

Some television transmitters send out negative images while others send positive images. If the amplitude of the carrier wave decreases during the time that a light area is being scanned, the transmission will be negative. However, regardless of the type of signal transmitted the receiver can be easily constructed or arranged to give a positive image.

The signal polarity is reversed or shifted 180 degrees as it passes from each resistance coupled stage to the next. Therefore, we need only add or remove one stage of the video amplifier to reverse the signal polarity, or change it from negative to positive.

A power detector will produce an image opposite to that of a grid leak and condenser type detector, so changing the type of detector will also reverse the image.

The power supply unit of a television receiver such as shown in Fig. 269 uses a three section filter to provide very smooth or steady D.C. voltage, which is required for television receivers and for the deflecting circuits of the kinescope tube. The slightest ripple or fluctuation in this voltage will distort the image.

Low voltage windings are supplied for all tube heaters, and the power supply unit should be thoroughly shielded from the rest of the circuits to prevent pick up of 60 cycle power disturbance by the receiver.

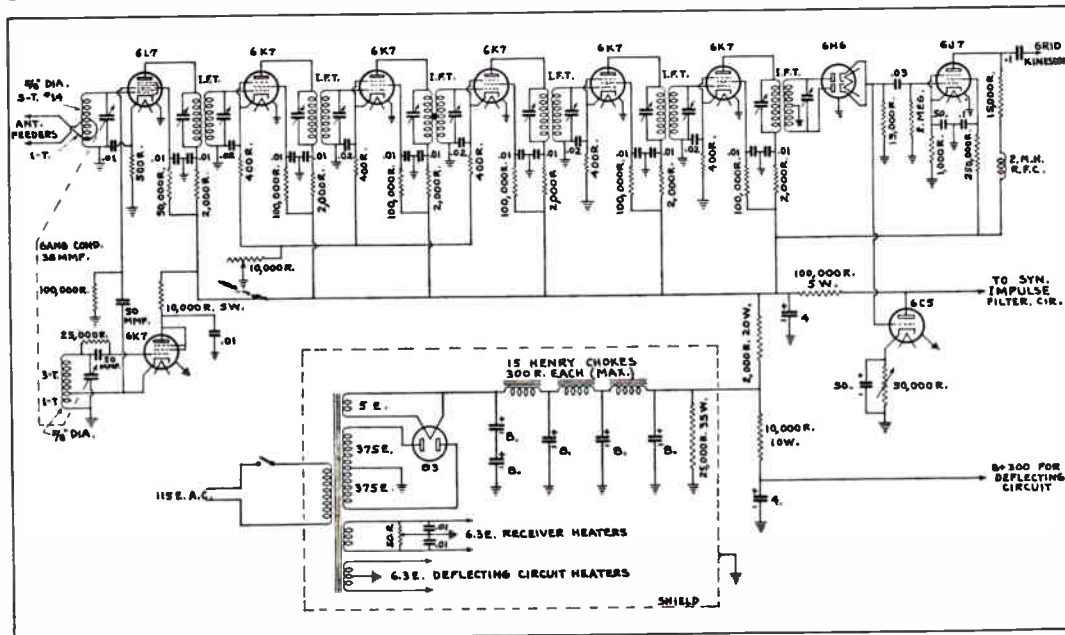

Fig. 269. Circuit diagram of a 5 meter superheterodyne television receiver and power supply unit suitable for use with cathode ray type scanners such as shown in Fig. 263.

RADIO INTERFERENCE

The radio service man is often called upon to locate and stop radio interference from sources outside the receiver, which cause so much noise or man-made static in the set that it makes good reception impossible.

Radio interference may be caused by nearby electrical machines or equipment, such as D.C. motors with sparking brushes, X-ray or high frequency machines, arc lights, gasoline engines with electric ignition, sign flashers, nearby power lines or A.C. circuits in the building, defective insulators on high voltage lines, or from other radio receivers which are in a state of oscillation.

Then, of course, there is also the interference from natural static or atmospheric electricity, and from powerful nearby radio transmitters. Even door bells and signal buzzers, and the switching on and off of lights in a building will often cause considerable interference in sensitive radio receivers.

A great many noises from such outside interferences are often blamed on the receiver, by those who are not able to recognize the sounds. Any high voltage sparks or arcs such as those caused by X-ray machines, ignition equipment, sparking mo-

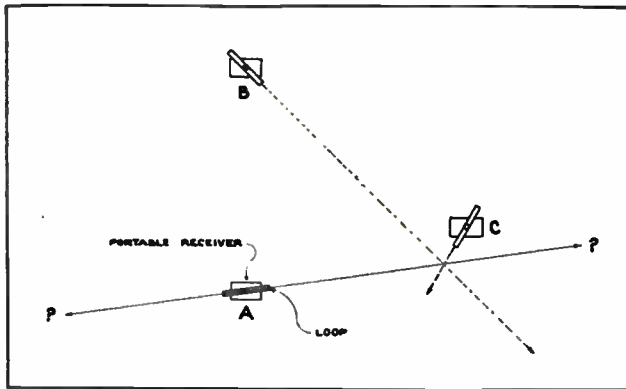

Fig. 270. This sketch illustrates the method of locating a source of radio interference with a portable receiver and a loop aerial.

tors or trolleys, arc lamps, or leaky power line insulators, are radiators of high frequency energy and serious offenders in the matter of radio interference. They produce high frequency energy by oscillations set up between the arc or spark and the inductance and capacity of the circuit in which the arc occurs.

X-ray machines generally cause a loud hissing or crashing sound in the speaker for intervals of a few seconds to a few minutes in length. About the best way to prevent radiation of interference from X-rays is to completely shield the machine or the room it is in, with wire screen or sheet metal on the walls and then thoroughly ground this metal shield.

Ignition equipment usually causes a continuous put, put, or clicking sound for single cylinder engines, or a rapid and regular sputtering for multiple cylinder engines, such as automobile or airplane types. Ignition interference can usually be prevented by shielding the spark plugs and ignition coils with sheet metal, and the high voltage conductors with tubular copper braid, and then grounding these shields. A condenser with a grounded case, connected across the make-and-break contacts in the ignition coil primary will also help to eliminate interference from this source.

Either D.C. or A.C. motors of the commutator type are common sources of radio interference, much of it coming from small motors on washing machines, oil burners, refrigerators, fans, etc.

Interference from this source can be quite effectively prevented by connecting two condensers of the proper voltage rating, and from 2 to 6 mfd. capacity, across the line to the motor, and then grounding the connection between them as shown in Fig. 271-A. One or more choke coils in series with the supply line will also help to cure the trouble.

The condensers tend to absorb the high frequencies and pass them to ground, and the choke coils block the high frequencies preventing them from being carried out on the line and radiated as from an antenna. The chokes do not interfere at all with the passage of D.C. power current, nor do they appreciably affect the passage of 60 cycle A.C. They must be made of large enough wire, however, to carry the line current without overheating or causing appreciable resistance voltage drop.

The interference filters should be located as close to the motors or sources of trouble as possible to prevent radiation of the R.F. energy from the lines.

Interference from sign flashers and certain other sources can be largely eliminated by means of a filter such as shown for the motor in Fig. 271-A, by simply connecting this filter in and across the line leads as shown.

Where interference is not filtered out at its source, it will travel over the line or the light or power wires, as a sort of "wired wireless" for considerable distance, and either by radiation or conduction will get into any receivers attached to, or near to that line. When a line to which a receiver is attached seems to be full of such interference energy, a filter such as shown in Fig. 271-B can be installed between the outlet and the receiver to greatly reduce the amount of interference reaching the set. This filter consists of both R.F. and A.F. chokes in series with the line, and condensers across the line. In many cases a less elaborate filter or interference eliminator, consisting of two chokes and a pair of grounded condensers, will be sufficient or will greatly improve the condition.

Conductors carrying large amounts of alternating current will often induce considerable A.C.

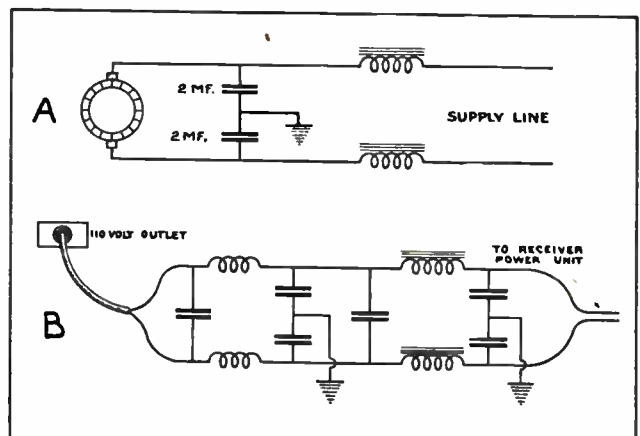

Fig. 271. Two types of filter circuits for interference elimination, or for reducing radio interference caused by electrical disturbances near the receiver.

hum in a nearby receiver, by ordinary low frequency magnetic induction. Wires run in grounded conduit rarely cause this trouble.

If the source or sources of radio interference are in the same building with the radio set, they can often be located by a general inspection of the premises.

If the interference seems to be coming from outside the building and no nearby electrical machinery can be located, then the trouble may come from a

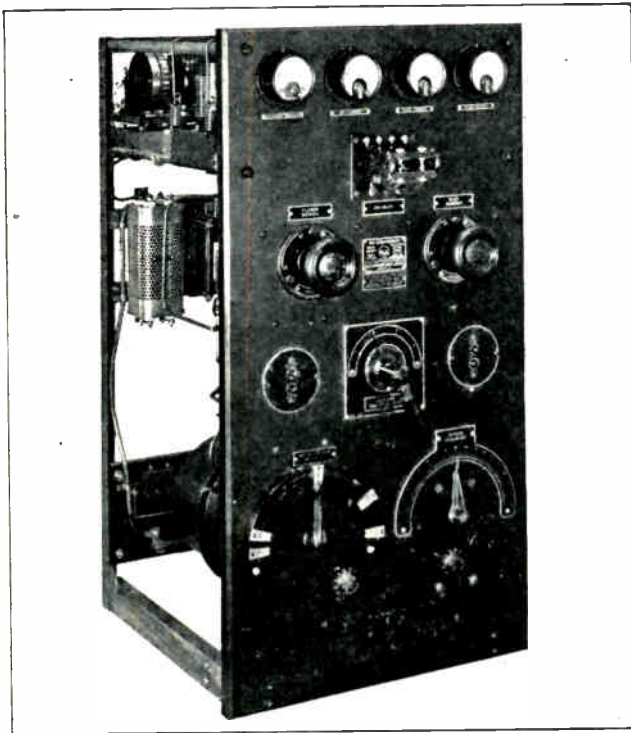

Fig. 272. Front view of a marine type vacuum tube transmitter for use on ships for communication and distress signal uses. Vacuum tube transmitters of this type are rapidly replacing all spark transmitters. (Photo courtesy of Radiomarine Corp. of America.)

nearby high voltage power line, distribution line, or arc light circuit. Leaky insulators which occasionally or continuously spark over, transformers with poor insulation, arc lamps in operation, or even incandescent street lamps of the series type with film cutouts, are all common causes of radio interference.

The source of bad interference, even though it is at some distance, can be quite easily located by the use of a portable receiver and a loop aerial, with its directional characteristics. By carrying the receiver to a location where the interference can be heard, and then rotating the loop to a point where the sound is loudest, we know that the plane of the loop will point in the direction of the source, or that the source of interference lies in line with the loop in one direction or the other. This is shown by the set and loop at A in Fig. 270, and by the solid line pointing each way from the edges of the loop.

Lay out this line on a sketch or map of the territory and then carry the receiver off a distance of a block or so at right angles to the first line, as shown at B, and again set the loop for loudest reception of the interference. This time we know in which direction from the loop edge the source of

interference lies, because it must be the direction toward one of the other lines as shown by the light dotted line in Fig. 270.

Lay out this line on the map and note where it crosses the other, and you will know just about where the trouble comes from.

Then by going close to this spot and testing once or twice more from different angles as shown at C, the loop will point as shown by the short, heavy dotted line, to the very building, transformer, line insulator, street light, or whatever it is that the interference comes from.

Local power companies are usually glad to cooperate in eliminating interference if it is proven to be coming from their equipment.

The portable set and loop direction finder can also be used for locating badly oscillating regenerative receivers, which radiate serious interference that sets up a continuous howl in other receivers even a half mile or more away. Radio amateurs or experimenters who may be transmitting code without a license, or on a poorly tuned transmitter can also be located in this manner, and a report to the nearest radio inspector will put a stop to their interference.

Observers may think you are looking for a buried treasure or a lost radio program, but your search will usually be worth while.

Get the habit of regularly looking in this reference set for any practical electrical or radio information you want, and never allow any dust to collect on it.

You'll find it like a good tool on the job, very valuable if you use it at every opportunity until you are really familiar with its every possible use, but of not much value if allowed to lay and gather rust (or dust) and until you forget where it is.

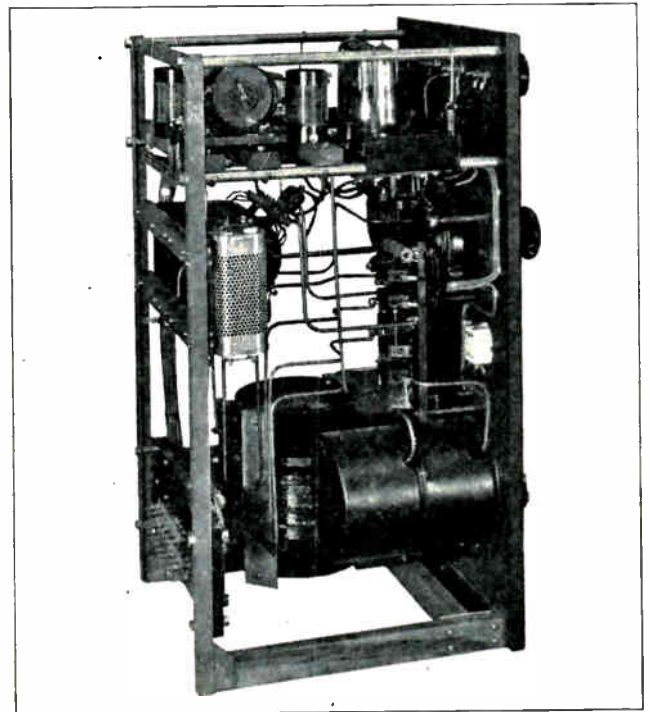

Fig. 273. Side view of marine type vacuum transmitter such as shown in Fig. 272. (Photo courtesy of Radiomarine Corp. of America.)