

150

*Radio
Television*

**PICTURE
PATTERNS
and
DIAGRAMS**

EXPLAINED



Emerson

Westinghouse

THE EXCLUSIVE STROMBERG-CARLSON

BROADCAST INSTALLATION

TRANSMITTER CIRCUITS

Model 441-1
PHILCO

STEWART-WARNER II

Motorola
Model 42-B

ZENITH RADIO CORP.
CHICAGO, ILL.

630T

6V6

785
OSC.

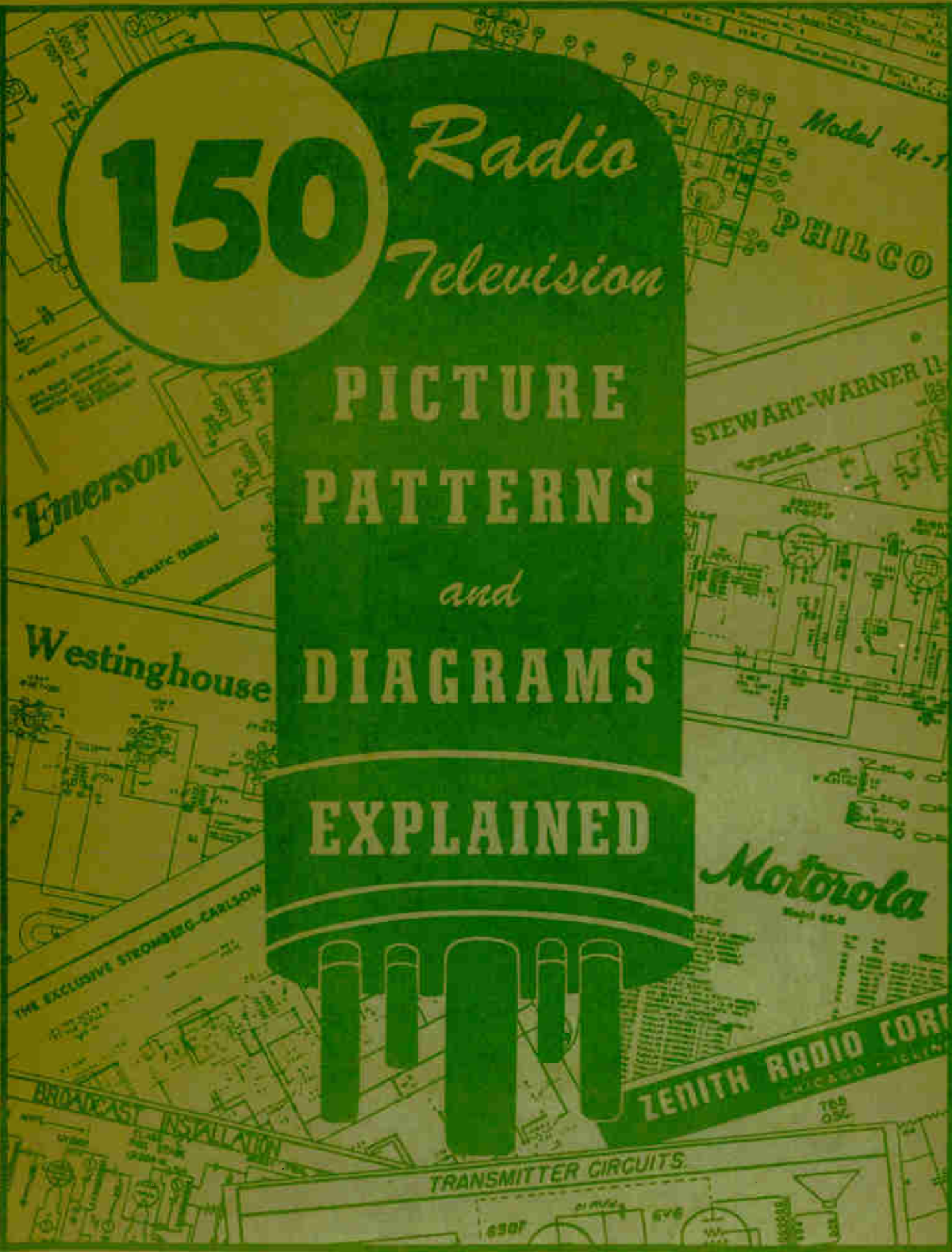

*New Radio—Television
Picture Patterns and
Diagrams Explained*

An Instruction and Reference
Book on Radio and Television

Copyright, 1960, by
COYNE ELECTRICAL SCHOOL,
1501 W. Congress Pkway.
Chicago, Illinois

All rights reserved. This book or any parts
thereof may not be reproduced in any form
without written permission of the Publishers.



1963 Printing
Coyne School Publications, Inc.

Printed in the United States of America

FOREWORD

THE successful Radio-TV Serviceman is the man who can read diagrams—the fellow who understands symbols, circuits and details of Radio and Television construction.

A knowledge of circuit tracing and diagram analysis is to the serviceman what a knowledge of mathematics is to an accountant. This book contains diagrams of modern radio and television sets. These diagrams have been supplied to the Educational Book Publishing Division of The Coyne Electrical School by the leading Radio and Television manufacturers of the United States. They represent an effort on the part of the Industry to help Coyne put out a practical book on **How to Read Diagrams**.

Reading radio and television diagrams can be as easy as reading a newspaper if a man has a clear conception of the various signs, and the symbols used in these diagrams.

It is the purpose of this book to make clear and easy to understand these different terms and symbols that represent the component parts of radio sets, their connections and the tracing of the current thru these parts as well as other phases of scientific radio circuit tracing.

Common terms such as circuit, current, resistance and difference of potential are often used when talking about radio.

In every case as we come upon a new symbol in the special series of instructional diagrams we have especially selected to explain modern diagram analysis, we will follow this practice:

First, we will give the definition, then we will give an illustration in everyday language. We will compare the purpose of the radio or television component with something you see in everyday life. Following this practice, you will better understand the reason for the various parts in a radio set as well as the way they “dovetail” with all other parts.

We will break down every part of the circuits so that you can follow the logical path of the current flowing through the radio.

Many of the diagrams in this book have been prepared by the staff of Coyne School for instructional purposes. These diagrams have special notes and analyzing instructions that make them amazingly easy to understand. These diagrams have been **SHOP TESTED** by actual on the job use. That eliminates any possibility of any technical errors.

Regardless of whether you are a “beginner” or an experienced radio man you should find the material in this book of extreme value to you. We have put a great deal of up-to-date instruction methods in Radio circuit and diagram reading in this book along with dozens of valuable commercial radio diagrams.

Radio-TV diagram reading is the same as any other reading—the more you do of it the more expert you become. To succeed in Radio and Television you must know circuit tracing so give the specially prepared material in this book careful study—it can help you increase your speed and accuracy in reading diagrams.

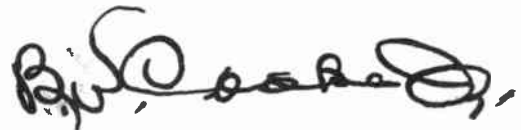

B. W. COOKE, JR., President
Coyne Electrical School

Table of Contents

| | |
|--|--|
| SECTION I—Schematic Diagrams and How to Read Them..... | |
| SECTION II—Component Identification, Charts, Nomographs, Audio Data | |
| SECTION III—Special Purpose Units, Alignment Methods. Ratio De- tector Analysis..... | |
| SECTION IV—TV Servicing with Picture Tube Patterns..... | |
| SECTION V—TV Waveforms | |
| SECTION VI—Typical Commercial Schematic Diagrams (See listing at front of section for specific make and model)..... | |

SECTION I

Schematic Diagrams and How to Read Them

Suppose then we start with the most common expression used in radio—a radio circuit.

By definition “a circuit is the complete or closed path taken by an electrical current in flowing through a conductor from one terminal of the source of supply to the other.”

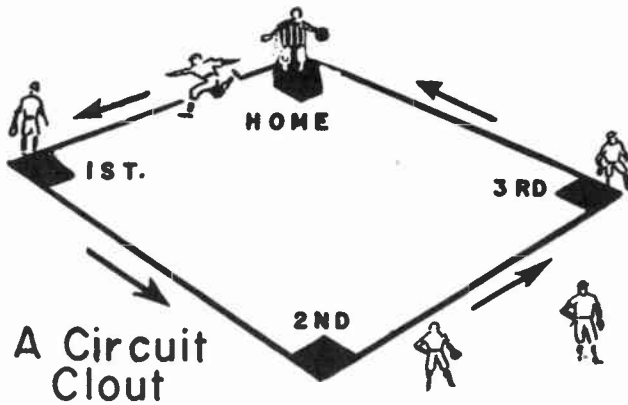

No doubt you have often heard the expression “a circuit clout.” This is used in baseball when a batter hits a home-run. It means the ball has been driven far enough to enable the batter to complete the “circuit” of bases. The bases form a closed loop or path for the batter to take, just as connecting wires form a closed loop or path for the current to take.

The resistance is the substance which resists or opposes the flow of current through it.

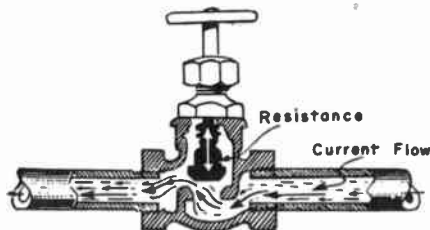

It can be compared to a valve in a water pipe to limit the flow of water.

A difference of potential or difference of pressure is the difference between the potentials or pressures at two points in a circuit.

To better understand this let's assume that we are looking at a two-story building. In measuring the distance between the street and the first floor we found it to be 10' and the measurement to the roof was 30'. It would be correct to say that the distance between point “A” and point “B” is 10' or that point “B” is 10' higher than point “A”. In order to make a

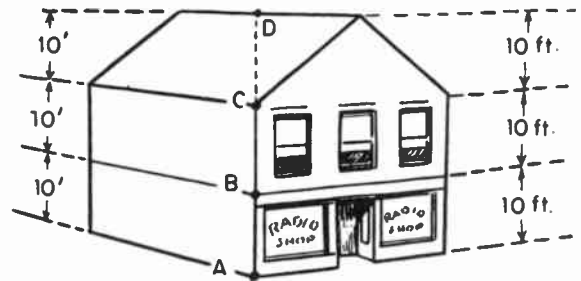

measurement we must refer one point to another. It would not be correct to say that point “C” measures 20' because we are not sure whether the point to be measured is from “B” or “A”. Point “C” does measure 20' if we are referring it to point “A” as the other point, but it is only 10' from point “B” or point “D”.

The same thing holds true in electrical circuits. The difference of potential is a measurement between a lower and a higher point in a circuit. One point is at a higher electrical degree than the other. The higher point having a deficiency of electrons while the lower point has an excess of electrons. It is the movement of these electrons that constitutes a flow of current in an electrical circuit.

The difference of potential and the opposition are circuit properties. In fact they are the determining factors as far as the current is concerned. When the opposition in any circuit is not sufficient to limit the current, wires may burn or the units connected in the circuit may be ruined beyond repair. That is the reason why they put fuses in the branch circuits in homes. To protect the conducting wires from excess current.

Diagrams are used in Radio just as blue prints are used in construction work. They tell a complete story that might otherwise require thousands of words of explanation.

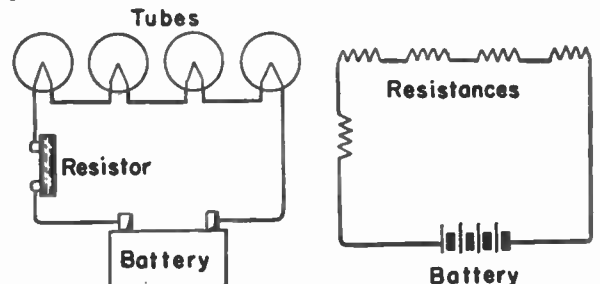

Elements of a series circuit.

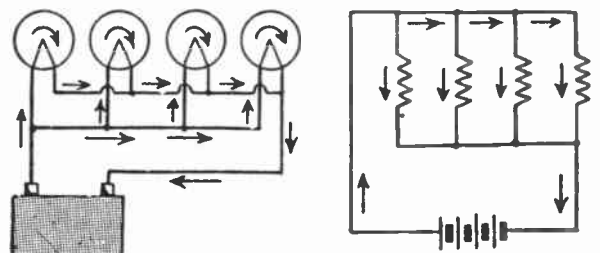

Elements of a parallel circuit.

There are several types of diagrams used, just as there are different types of maps available for the man preparing to go on a journey. He may have a "pictorial diagram" which is a diagram pertaining to or illustrated through pictures. They make the same type of diagram in Radio for the beginner as illustrated below.

Consequently, certain signs, marks or symbols, easy for all of us to duplicate, have been adapted and made standard. They represent the component parts and were originated in order that we may convey or impart our information to others, quickly.

In radio a schematic diagram shows the electrical connections of a circuit by means of symbols used in

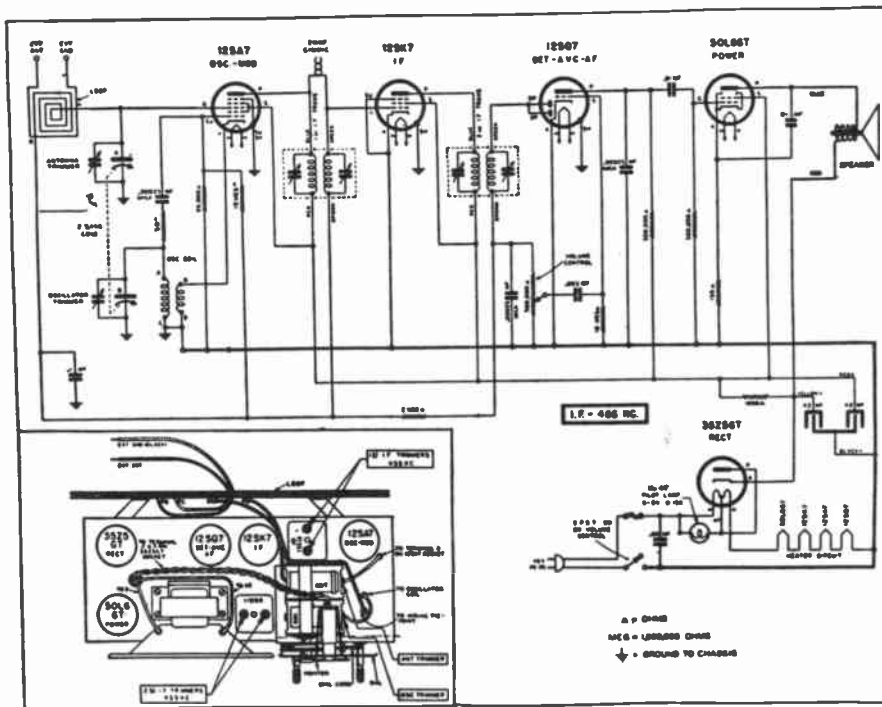
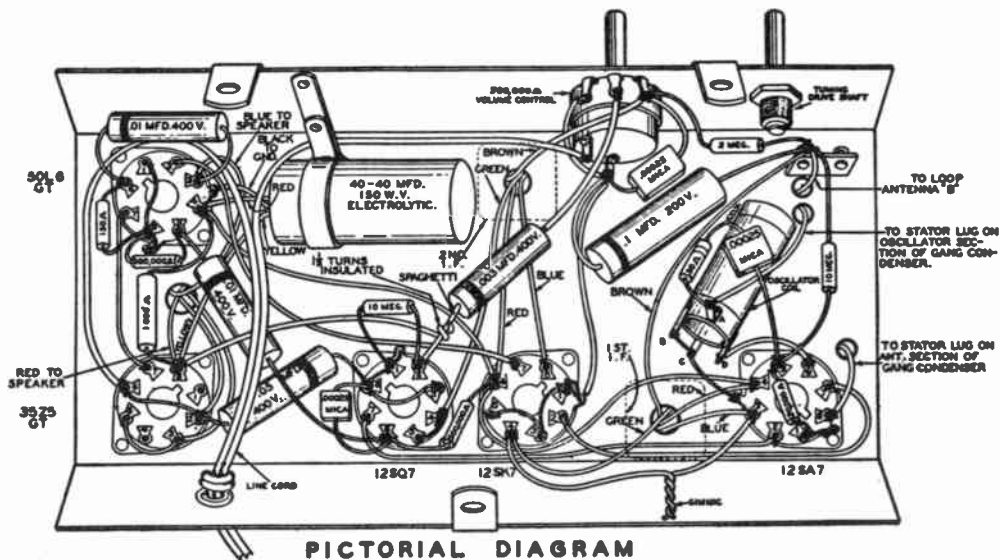

Such a diagram enables us to quickly determine the layout of all the parts. The question then arises, since a pictorial diagram has these advantages, why not use them exclusively? If we sit back for a moment and think about it, the answer would be obvious. To use these diagrams we all must be skilled or gifted with artistic talents, it takes a great deal of time and effort to put down on paper any part of the above two diagrams for the sole purpose of explaining either of them.

place of the actual parts. Symbols to represent the different parts are simple signs, marks, or characters used as an abbreviation. It is important to learn these symbols so that all the parts may be readily identified.

Of course, it would be impossible to expect a beginner to memorize all the existing symbols in a short time, but by constant reference to radio diagrams in magazines or books you will be surprised

to note how quickly and easily you have learned to identify these symbols.

Still another type of diagram is known as a "block diagram."



In the above diagram only the states are shown and the roads to take to get to them. Likewise in radio, a block diagram merely shows the connections of the different stages in block-form.

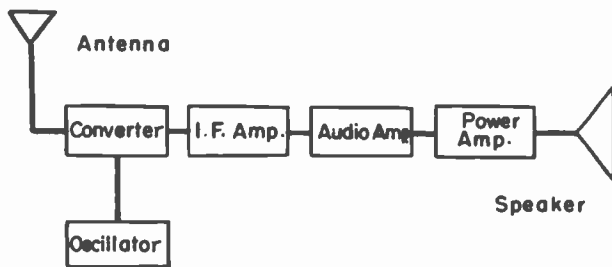

The diagram above is the easiest of all to explain in that the function of each stage is omitted, just as the road map above would be simple to direct a person interested to get at a certain point without explaining the different rivers he would have to cross and the cities that he would pass, etc.

For instance, in that block diagram the electromagnetic waves radiated by means of a transmitting antenna cut the stationary conductor called the receiving antenna. These waves cause a difference of potential to be induced in the receiving antenna referred to as a signal. The converter stage receives the signal and mixes with a signal generated by the oscillator. The difference of these two signals is sent on to the I.F. stage where it is amplified, and sent to the audio stage where it is changed to an audio signal and amplified. It is received by the power amplifier where it is further amplified and moved on to the speaker.

The signal strikes a diaphragm in the speaker causing it to vibrate, thus changing the electrical impulses into sound.

We can safely say then that block diagrams are used to give a general idea of the operating principles in a condensed form.

It would be well at this time to introduce some of the symbols used and show what the actual parts look like.

The antenna or aerial is a conductor used to pick up radio signals. The outdoor antenna, usually

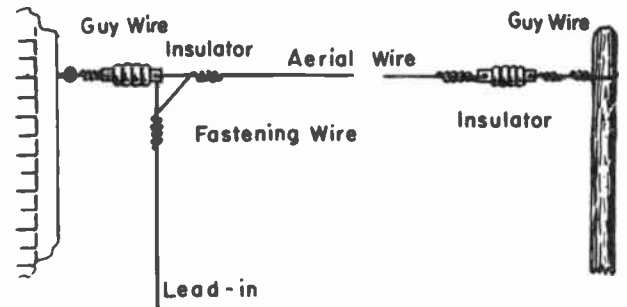

mounted on a structure or roof is a bare wire of pre-determined length. The vertical line represents the lead-in wire which makes connection between the antenna and the receiver. This type of antenna is no longer used for radio reception, but the symbol indicates an antenna regardless of design.

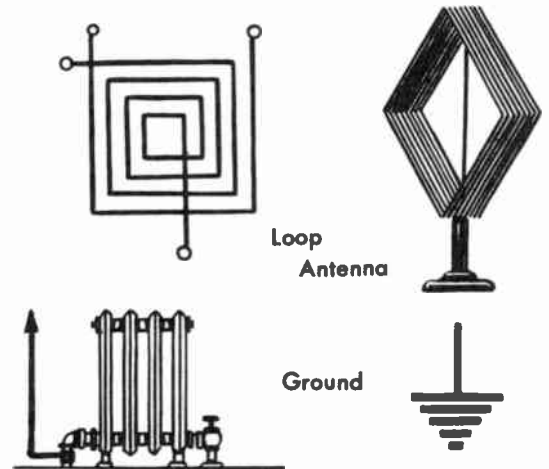

The loop antenna or aerial consists of complete turns of wire spaced on a rectangular frame of wood or attached to a cardboard. It is built into a receiver cabinet.

The ground connection is an earth connection. It may be a water pipe, a radiator or any pipe driven into the earth to insure good contact with the moist earth. It also indicates a connection to the chassis of the receiver.

This symbol is often used to simplify diagrams by eliminating unnecessary lines. The symbol shows the common connections in the circuit.

There are various types of capacitors used.

A capacitor consists of two conductors separated from each other by an insulator called a dielectric, such as air, oil, paper, glass, ceramic

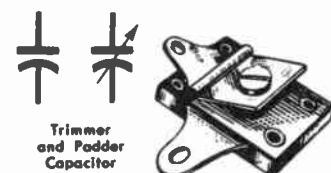

capable of storing electrical energy. They block the flow of direct current while allowing alternating and pulsating currents to pass.

Variable capacitors are used in Radio frequency and oscillator circuits. Their capacity may be conveniently varied. They are usually found in the form of a movable and fixed set of plates. The movable plates are called the rotor and the fixed plates called the stator. Air is used as a dielectric. Their main purpose is to adjust the circuits to resonance.

Padder and trimmer capacitors sometimes are mounted on the variable and can be adjusted with a screwdriver. They permit accurate alignment of the radio frequency and oscillator circuits.

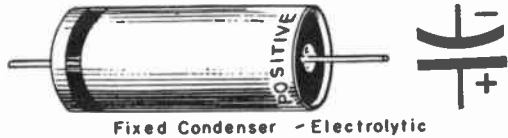

Fixed Condenser - Electrolytic

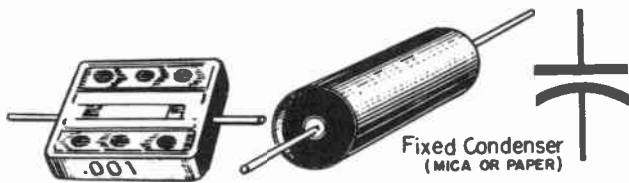

Fixed Condenser (MICA OR PAPER)

Electrolytic capacitors are a special type of fixed capacitors used in direct current circuits only. The polarity of these capacitors is clearly marked and must be observed.

These capacitors are usually found in the power supply circuit. Mica and paper capacitors are other types found in radio. The mica will be found in the radio frequency circuit, while the paper capacitor will be found almost anywhere from the low radio frequency circuits to the audio stage.



FIXED RESISTOR

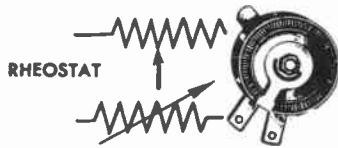

RHEOSTAT

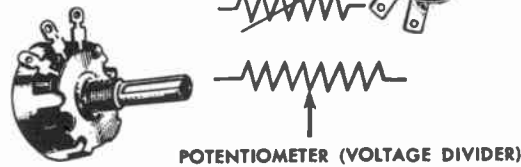

POTENTIOMETER (VOLTAGE DIVIDER)

Resistors, rheostats and potentiometers are designed to oppose the flow of current whether it be direct or alternating currents.

A resistor whose value remains constant is called a fixed resistor. On the other hand if the value can be changed during operation it is known as a variable resistor.

Rheostats and potentiometers are variable resistors. The rheostat can be identified by its two terminals. The potentiometers have three terminals.

There is another important property in radio circuits called inductance. It is a measure of the ability of a conductor to produce a magnetic field.

Inductance may be introduced in a circuit in the form of coils and transformers.

This property of inductance is present in a circuit only when the current changes. That is, when it is of alternating nature. As the current changes from zero to maximum the magnetic field also changes and in so doing cuts the conductor and induces in it a counter voltage which tends to oppose the change in current. You will find some type of inductance in all stages of a radio circuit.

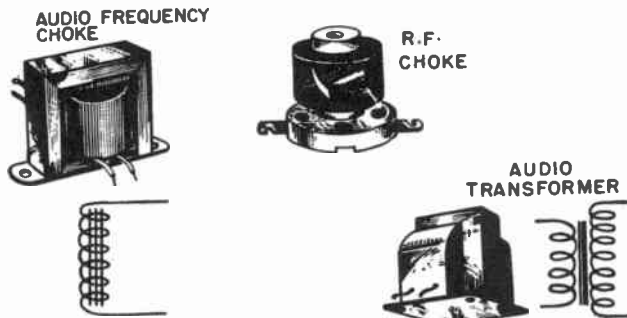

A wide variety of tubes are used in radio today. The ones most frequently encountered are the diode, the triode, the tetrode and the pentode.

Sometimes when space is limited in a radio, tubes are used that have the elements of two tubes combined in one envelope. Examples of these are the duo-diode, the twin-triode, the duplex-diode pentode, etc.

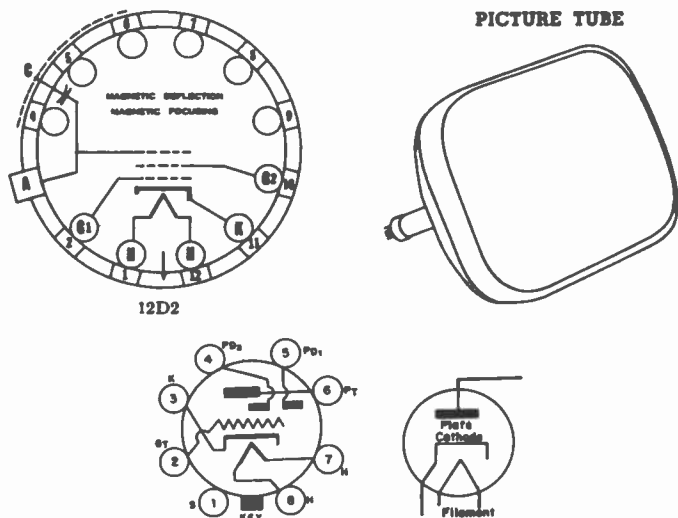

PICTURE TUBE

The schematic symbol of a tube is usually shown by the base of the socket of the tube. The tube has a marker or key that fits into a similar marker in the socket. The reason for this being a precaution against burning the elements in the tube. In this manner the tube must be inserted always in the same way. The marker or key as it is sometimes called is clearly shown at the bottom of the circle representing the tube socket. Terminals of the elements within the

tube are indicated and numbered. The numbers being in a counter clockwise direction with number one located to the left of the key.

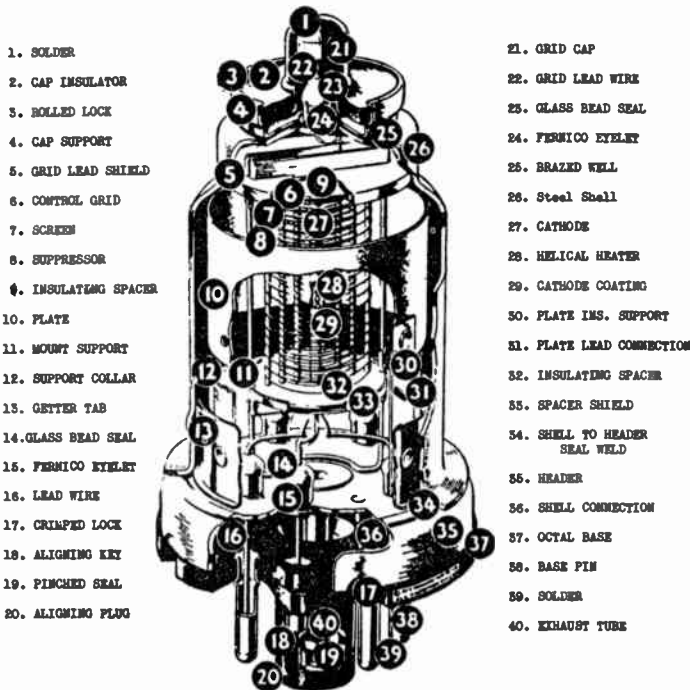

Cross-section of a typical RCA Metal Tube.

This diagram illustrates in detail the construction of a modern radio tube. All elements are clearly indicated. The complexity of the modern tube is here readily apparent. A good basic understanding of tube design and function is essential to good radio building.

Now that we have been introduced to the actual parts and the symbols that represent those parts let us look at the schematic below and see just how many symbols we can identify.

Of course a good idea would be to make a note of the symbols you did not recognize and refer to them until you are sure you will not have that difficulty again.

Our next step would be to know the different circuits in the radio so that we can trace the current through these circuits.

Let's start with the filament circuit in our schematic which is located in the lower left hand corner of our diagram. Incidentally those filaments are located within the tubes, but to make the diagram clearer by eliminating a lot of lines the filament circuit is usually shown in some corner of the diagram.

The first symbol we see is that of a male plug that fits into any wall receptacle. Then there are two lines that make connection to the plug. Starting along the bottom line we come to the switch. Its purpose is to turn the radio on or off. Above the switch is the symbol for a fuse.

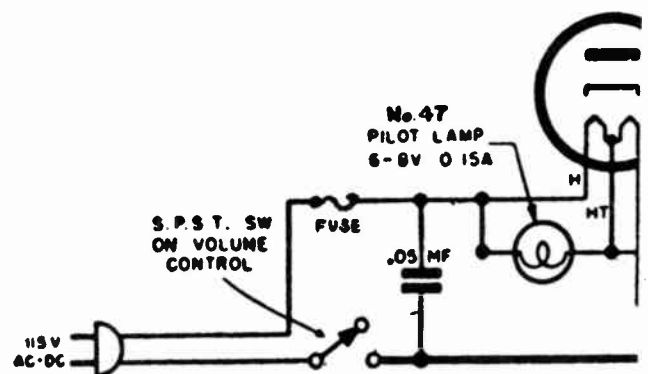

It protects the parts in the radio in case of a short circuit.

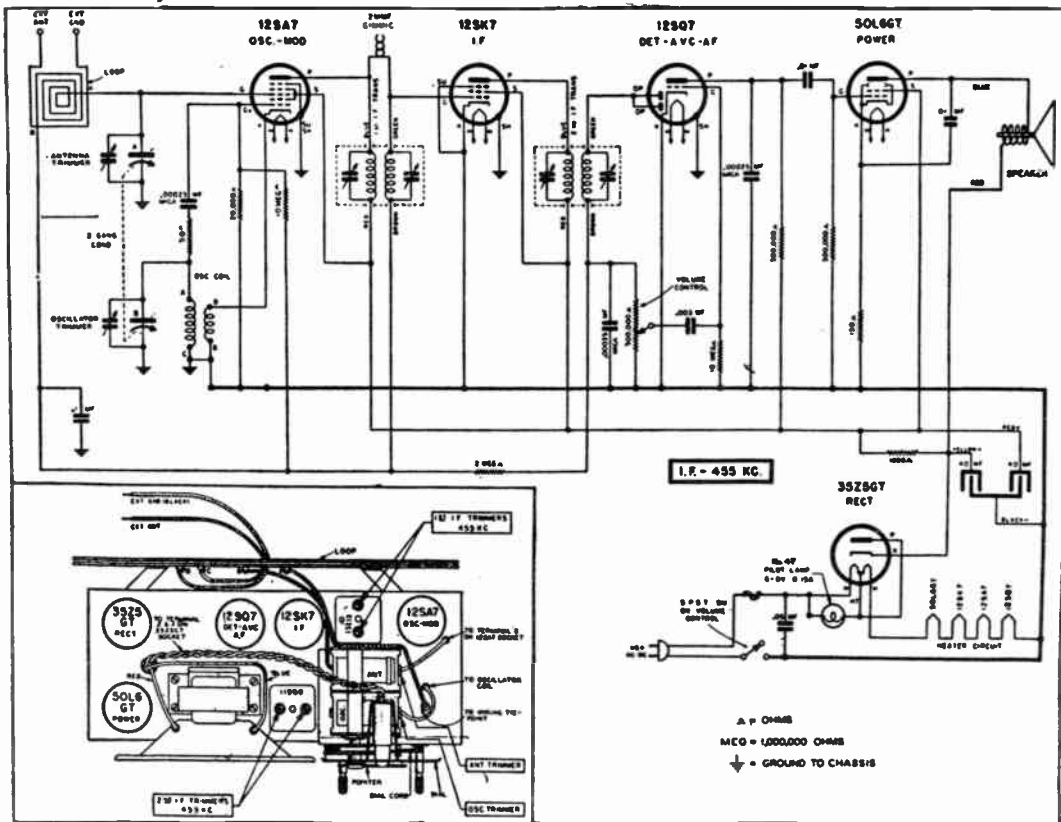

Then we see a capacitor.

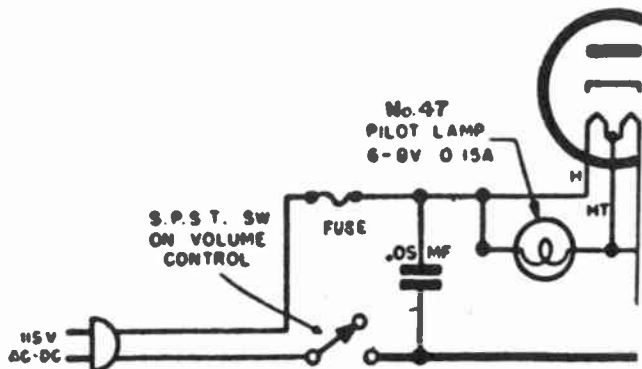

We can tell it is connected across the line because of the heavy dots. When one line crosses another and no connection is intended then there is no heavy dot. Moving along the bottom line again we come to the second dot. Let's move up now and to the left to the first filament which is the 12 S Q 7. Suppose we look at the 12 S Q 7 tube and see if we can locate the terminals that connect this filament.

From the symbol we see that the external terminals are number seven and number eight. As we go on tracing the circuit, we pass the filaments of the 12 SA 7, the 12 SK 7 the 50L6 and the 35Z5 tubes

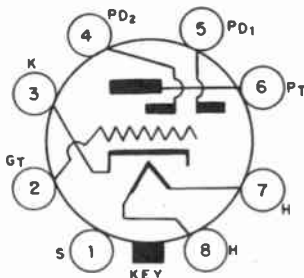

through the fuse and back to the plug. That completes the filament circuit.

It does seem strange to have wires inserted within the tubes and tied together to form a closed loop for no apparent reason. Any substance whether it be in a solid, liquid, or gaseous state offers resistance to the flow of current. Then why do we need a filament circuit in a radio? This same circuit is often referred to as the heater circuit and its function is to heat the cathode. The cathode plays an important part — it supplies the electrons necessary to operate the tube. It consists of a thin metal sleeve coated with electron-emitting material. The filament, or heater, is placed within the sleeve, and is insulated from it. In operation, the filament heats both the cathode sleeve and the coating to the electron-emitting temperature.

Referring to our diagram again you will notice that the filament is the only element within the tube that has two external terminals. All the rest have only one terminal to make connection with. We pointed out earlier in our explanation that in order to have a flow of current we needed a closed loop. Then something must take place within the tubes to complete the remaining circuits. The simple schematic dia-

gram below shows a plate, a filament and a cathode.

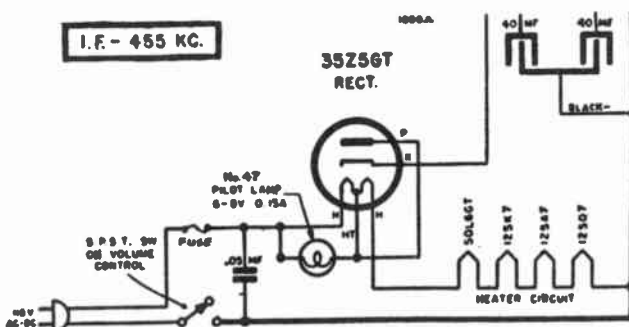

The plate is at a higher potential than the cathode. When the filament heats the cathode to the emitting temperature, the electrons move at a high velocity thru the vacuum of the tube to the plate. To illustrate

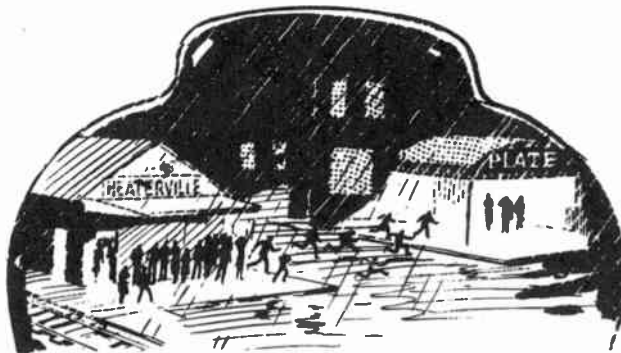

the above explanation, let's assume that a number of people are stranded on the platform of a railroad station and it is raining quite hard. To add to their misery the overhead shelter is not long enough to accommodate them all. Some of them are getting wet, therefore the general tension increases. Anxiously they look around and in the distance they see a brightly illuminated marquee. Since they notice that not many people are under it they start for it. Others that never saw the shelter join in because they think it is the wise thing to do. In the same way the electrons all rush to the brightly illuminated plate because of its higher potential. In tracing the plate circuits of all the tubes, you will notice that they all connect to one common point. The electrons then move from this common point to the cathode of the 35Z5. They go on to the plate of that tube and back to the source of supply.

The screen grid follows the same path as the plate and is used to shield the grid from the plate. The screen supplies an electrostatic force pulling electrons from the cathode to the plate. It is mounted between the control grid and plate for the purpose of reducing the capacity between those two electrodes

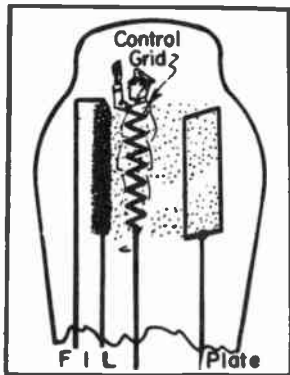
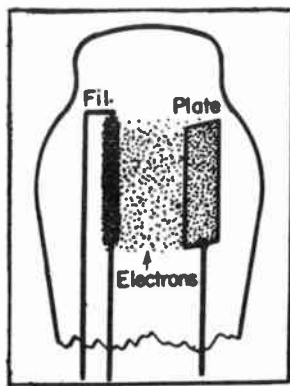

The control grid has the most effective control over the flow of electrons thru the tube. It is like the traffic cop on the corner. He blows his whistle and puts up his hand to stop the traffic. Then he signals the traffic to move on again. In the same way the control grid signals the traffic of electrons to move. Sometimes more electrons move to the plate while other times there are less. It all depends upon the potential of the grid. Because of this varying voltage, an A. C. component is impressed on the D. C. potential of the plate. This changes the D. C. voltage to a pulsating D. C. The primary of a transformer is usually connected to the plate of the R.F. stage. Since the current in the plate circuit is varying it induces a voltage into the secondary of the transformer and that voltage is applied to the grid of the next tube.

Now that we have this information let's trace the signal from the antenna to the speaker.

The electro-magnetic waves thru the air strike the antenna and induce a voltage in it. This voltage is applied to the control grid of the first tube. Being of alternating nature it controls the flow of electrons thru the tube. At the same time the oscillator generates a voltage and is also applied to the same tube. The difference of these two voltages causes the change in current in the plate circuit. This change in current induces a voltage in the secondary of the transformer which is applied to the grid of the I.F. tube. As the signal is applied from stage to stage, it is amplified many times over. When it reaches the next stage the I.F. signal is changed to an audio note. It is then applied to the grid of the output tube. From there, the electrical impulses vibrate the diaphragm of the speaker. In doing so, these impulses are changed to sound, and we hear our radio programs.

The diagram we have taken you through step by step is similar to any other radio diagram you may ever be called upon to analyze.

In some sets you will find additional circuits for automatic push button tuning or combination phonograph and radio. These things are merely additions to a basic radio circuit arrangement such as we have just explained. You can trace out the circuits for these additional features in a set the same way you have checked the preceding diagrams.

The balance of this book is composed of data and diagrams. The data section includes specially prepared material to explain many important phases of servicing. You will find explanations of such things as Impedance, Inductance, Reactance, Frequency Modulation, Resonance and dozens of other important subjects.

Several pages of the book are devoted to explaining how to read and use nomograms.

The second portion of the book contains diagrams of Radio, Television sets and Public Address equipment. We have had the cooperation of the Industry in compiling this valuable collection of modern diagrams and in addition to giving you practical material for on the job servicing these diagrams also provide material you need to learn diagram tracing. With the instructions you have had you should not have any difficulty analyzing these diagrams.

SECTION II

Component Identification, Charts, Nomographs, Audio Data

RESISTOR COLOR CODE

| Preferred Values of Resistance | | | Old Standard Resistance Values | Color Coding | | | Preferred Values of Resistance | | | Old Standard Resistance Values | Color Coding | | |
|--------------------------------|------------------|---------------|--------------------------------|--------------|--------|--------|--------------------------------|------------------|---------------|--------------------------------|--------------|--------|--------|
| ±20% D=no col. | ±10% D=silver | ±5% D=gold | | A | B | C | ±20% D=no col. | ±10% D=silver | ±5% D=gold | | A | B | C |
| | | 51 | 50 | Green | Black | Black | | | | 25,000 | Red | Green | Orange |
| | 56 | 56 | | Green | Brown | Black | | 27,000 | 27,000 | 30,000 | Red | Violet | Orange |
| | 62 | 62 | | Blue | Blue | Black | | 30,000 | 30,000 | 33,000 | Orange | Black | Orange |
| 68 | 68 | 68 | | Blue | Red | Black | 33,000 | 33,000 | 33,000 | 36,000 | Orange | Orange | Orange |
| | 75 | 75 | 75 | Blue | Gray | Black | | 36,000 | 36,000 | 39,000 | Orange | Blue | Orange |
| | 82 | 82 | | Violet | Green | Black | | 39,000 | 39,000 | 40,000 | Orange | White | Orange |
| | 91 | 91 | | Gray | Red | Black | | | | 43,000 | Yellow | Orange | Orange |
| 100 | 100 | 100 | 100 | White | Brown | Black | | 43,000 | 43,000 | 47,000 | Yellow | Orange | Orange |
| | 110 | 110 | | Brown | Black | Brown | 47,000 | 47,000 | 47,000 | 50,000 | Yellow | Violet | Orange |
| | 120 | 120 | | Brown | Brown | Brown | | | | 51,000 | Green | Black | Orange |
| | 130 | 130 | | Brown | Red | Brown | | | | 56,000 | Green | Brown | Orange |
| 150 | 150 | 150 | 150 | Brown | Orange | Brown | | 56,000 | 56,000 | 60,000 | Blue | Black | Orange |
| | 160 | 160 | | Brown | Green | Brown | | | | 62,000 | Blue | Red | Orange |
| | 180 | 180 | | Brown | Blue | Brown | | | | 68,000 | Blue | Gray | Orange |
| 220 | 220 | 200 | 200 | Brown | Gray | Brown | 68,000 | 68,000 | 68,000 | 75,000 | Violet | Green | Orange |
| | 220 | 220 | | Red | Black | Brown | | 75,000 | 75,000 | 78,000 | Red | Red | Orange |
| | 240 | 240 | | Red | Red | Brown | | 82,000 | 82,000 | 91,000 | Red | Gray | Orange |
| | | | 250 | Red | Yellow | Brown | | 91,000 | 91,000 | 100,000 | Red | White | Orange |
| | 270 | 270 | | Red | Green | Brown | 100,000 | 100,000 | 100,000 | 100,000 | Brown | Black | Yellow |
| | 300 | 300 | 300 | Red | Violet | Brown | | 110,000 | 110,000 | 120,000 | Brown | Brown | Yellow |
| | 330 | 330 | | Orange | Black | Brown | | 120,000 | 120,000 | 130,000 | Brown | Red | Yellow |
| | 330 | 330 | 350 | Orange | Orange | Brown | | 130,000 | 130,000 | 150,000 | Brown | Orange | Orange |
| | | | 360 | Orange | Green | Brown | 150,000 | 150,000 | 150,000 | 150,000 | Brown | Green | Yellow |
| | 390 | 390 | | Orange | Blue | Brown | | 160,000 | 160,000 | 180,000 | Brown | Blue | Yellow |
| | | | 400 | Orange | White | Brown | | 180,000 | 180,000 | 200,000 | Brown | Gray | Yellow |
| | 430 | 430 | | Yellow | Black | Brown | | 200,000 | 200,000 | 220,000 | Red | Black | Yellow |
| | 470 | 470 | 450 | Yellow | Orange | Brown | 220,000 | 220,000 | 220,000 | 220,000 | Red | Red | Yellow |
| | 470 | 470 | | Yellow | Green | Brown | | 240,000 | 240,000 | 250,000 | Red | Yellow | Yellow |
| | | | 500 | Yellow | Violet | Brown | | | | 270,000 | Red | Green | Yellow |
| | | 510 | | Green | Black | Brown | | 270,000 | 270,000 | 300,000 | Red | Violet | Yellow |
| | 560 | 560 | | Green | Brown | Brown | | 300,000 | 300,000 | 330,000 | Orange | Black | Yellow |
| | | | 600 | Green | Blue | Brown | 330,000 | 330,000 | 330,000 | 360,000 | Orange | Orange | Yellow |
| | | 620 | | Blue | Black | Brown | | 360,000 | 360,000 | 390,000 | Orange | Blue | Yellow |
| 680 | 680 | 680 | | Blue | Red | Brown | | 390,000 | 390,000 | 400,000 | Orange | White | Yellow |
| | | 750 | 750 | Blue | Gray | Brown | | | | 430,000 | Yellow | Orange | Yellow |
| | 820 | 820 | | Violet | Green | Brown | | 430,000 | 430,000 | 470,000 | Yellow | Orange | Yellow |
| | | 910 | | Gray | Red | Brown | 470,000 | 470,000 | 470,000 | 500,000 | Yellow | Violet | Yellow |
| 1000 | 1000 | 1000 | 1000 | White | Brown | Brown | | 510,000 | 510,000 | 560,000 | Green | Black | Yellow |
| | | 1100 | | Brown | Black | Red | | 560,000 | 560,000 | 600,000 | Green | Brown | Yellow |
| | 1200 | 1200 | 1200 | Brown | Brown | Red | | | | 620,000 | Blue | Black | Yellow |
| | 1300 | 1300 | | Brown | Red | Red | | | | 680,000 | Blue | Red | Yellow |
| 1500 | 1500 | 1500 | 1500 | Brown | Orange | Red | 680,000 | 680,000 | 680,000 | 750,000 | Blue | Gray | Yellow |
| | 1600 | 1600 | | Brown | Green | Red | | 750,000 | 750,000 | 820,000 | Violet | Green | Yellow |
| | 1800 | 1800 | | Brown | Blue | Red | | 820,000 | 820,000 | 910,000 | Gray | Red | Yellow |
| 2200 | 2200 | 2000 | 2000 | Red | Gray | Red | 1.0 Meg. | 1.0 Meg. | 1.0 Meg. | 1.0 Meg. | White | Brown | Green |
| | | 2400 | | Red | Black | Red | | | | 1.1 Meg. | Brown | Black | Green |
| | | | 2500 | Red | Red | Red | | 1.1 Meg. | 1.1 Meg. | 1.2 Meg. | Brown | Brown | Green |
| | 2700 | 2700 | | Red | Yellow | Red | | 1.2 Meg. | 1.2 Meg. | 1.3 Meg. | Red | Orange | Green |
| | | 3000 | 3000 | Red | Green | Red | | 1.3 Meg. | 1.3 Meg. | 1.5 Meg. | Brown | Green | Green |
| 3300 | 3300 | 3300 | | Orange | Violet | Red | 1.5 Meg. | 1.5 Meg. | 1.5 Meg. | 1.6 Meg. | Brown | Blue | Green |
| | | | 3500 | Orange | Black | Red | | 1.6 Meg. | 1.6 Meg. | 1.8 Meg. | Brown | Gray | Green |
| | | 3600 | | Orange | Orange | Red | | 1.8 Meg. | 1.8 Meg. | 2.0 Meg. | Red | Black | Green |
| | 3900 | 3900 | | Orange | Green | Red | | 2.0 Meg. | 2.0 Meg. | 2.2 Meg. | Red | Red | Green |
| | | | 4000 | Orange | Blue | Red | 2.2 Meg. | 2.2 Meg. | 2.2 Meg. | 2.4 Meg. | Red | Yellow | Green |
| | | 4300 | | Orange | White | Red | | 2.4 Meg. | 2.4 Meg. | 2.7 Meg. | Red | Black | Green |
| 4700 | 4700 | 4700 | 4700 | Yellow | Black | Red | | 2.7 Meg. | 2.7 Meg. | 3.0 Meg. | Red | Red | Green |
| | | | 5000 | Yellow | Orange | Red | | 3.0 Meg. | 3.0 Meg. | 3.3 Meg. | Orange | Black | Green |
| | | 5100 | | Green | Violet | Red | 3.3 Meg. | 3.3 Meg. | 3.3 Meg. | 3.6 Meg. | Orange | Orange | Green |
| | 5600 | 5600 | | Green | Black | Red | | 3.6 Meg. | 3.6 Meg. | 3.9 Meg. | Orange | Blue | Green |
| | | 6200 | | Green | Brown | Red | | 3.9 Meg. | 3.9 Meg. | 4.3 Meg. | Orange | White | Green |
| 6800 | 6800 | 6800 | | Blue | Blue | Red | | 4.3 Meg. | 4.3 Meg. | 4.7 Meg. | Yellow | Black | Green |
| | | 7500 | 7500 | Blue | Red | Red | | 4.7 Meg. | 4.7 Meg. | 5.1 Meg. | Yellow | Orange | Green |
| | 8200 | 8200 | | Violet | Gray | Red | 4.7 Meg. | 4.7 Meg. | 4.7 Meg. | 5.6 Meg. | Green | Violet | Green |
| | | 9100 | | Gray | Green | Red | | 5.1 Meg. | 5.1 Meg. | 5.6 Meg. | Green | Black | Green |
| 10,000 | 10,000 | 10,000 | 10,000 | White | Red | Red | | 5.6 Meg. | 5.6 Meg. | 6.2 Meg. | Green | Brown | Green |
| | | 11,000 | | Brown | Brown | Orange | | 6.2 Meg. | 6.2 Meg. | 6.8 Meg. | Blue | Blue | Green |
| | 12,000 | 12,000 | 12,000 | Brown | Black | Orange | | 6.8 Meg. | 6.8 Meg. | 7.5 Meg. | Blue | Red | Green |
| | | 13,000 | 15,000 | Brown | Red | Orange | 6.8 Meg. | 6.8 Meg. | 6.8 Meg. | 8.2 Meg. | Blue | Gray | Green |
| 15,000 | 15,000 | 15,000 | 15,000 | Brown | Orange | Orange | | 7.5 Meg. | 7.5 Meg. | 8.2 Meg. | Violet | Black | Green |
| | | 16,000 | | Brown | Green | Orange | | 8.2 Meg. | 8.2 Meg. | 9.0 Meg. | Violet | Green | Green |
| | 18,000 | 18,000 | | Brown | Blue | Orange | | 8.2 Meg. | 8.2 Meg. | 9.1 Meg. | Gray | Black | Green |
| | | 20,000 | 20,000 | Brown | Gray | Orange | | 9.1 Meg. | 9.1 Meg. | 10 Meg. | Gray | Red | Green |
| 22,000 | 22,000 | 22,000 | | Red | Black | Orange | | 10 Meg. | 10 Meg. | 10 Meg. | White | Black | Green |
| | | 24,000 | | Red | Red | Orange | | | | 10 Meg. | White | Brown | Green |
| | | | | Red | Yellow | Orange | | | | 10 Meg. | Brown | Black | Blue |

Standardized coding for resistance value identification is confined to ten colors and figures as shown:

| Figure | Color |
|--------|--------|
| 0 | Black |
| 1 | Brown |
| 2 | Red |
| 3 | Orange |
| 4 | Yellow |
| 5 | Green |
| 6 | Blue |
| 7 | Violet |
| 8 | Gray |
| 9 | White |

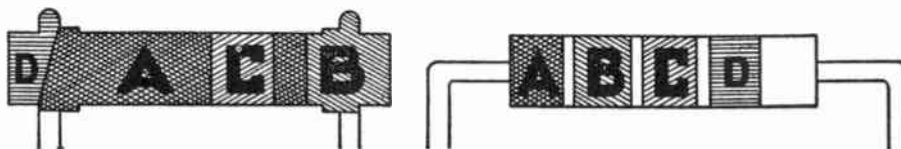

The body (A) of the resistor is colored to represent the first figure of the resistance value. One end (B) of the resistor is colored to represent the second figure. A band, or dot (C) of color, representing the number of ciphers following the first two figures, is located within the body color. The two diagrams illustrate two interpretations of this standard method of coding resistance value.

The color "D" appearing on the body of the axial lead resistor and on the end of the radial lead type, is used to indicate tolerance value.

If no color appears in the position shown on the resistors, the tolerance is $\pm 20\%$. If the resistor has a silver dot or band, the tolerance is $\pm 10\%$, while if a gold color is employed, the resistor is within $\pm 5\%$ of the specified value.

A DECIBEL NOMOGRAM

Most useful of graphic charts, the nomogram is "equivalent to an infinite number of graphs." This one can be used to find a number of solutions to decibel problems

MANY problems may be solved by graphical means. An advantage of such representations is the bird's-eye view which results. To connect two variables it is common to plot a chart which is a line or curve, every point of which indicates one variable in terms of the other. Charts may be designed to correlate frequency vs. dial setting, antenna length vs. reactance, plate voltage vs. plate current, etc.

Another type of graph is the nomograph, which is useful in certain types of problems. This is usually designed to contain three lines or curves, each calibrated in terms of a variable. The nomograph differs from the ordinary chart in that the reader supplies his own indication by the use of a straight-edge, preferably a celluloid or other transparent ruler.

Suppose we wish to show the variation of three quantities: Two may be shown on a chart, but there is no way of showing the third, which will have to be assumed constant. We would need an infinite number of curves on our chart, each corresponding to some value of the third variable. A nomograph is therefore equal to an infinite number of graphs. This is the key to its usefulness.

A useful nomograph is that relating db gain or loss to voltage or power ratio. The three variables are input, output and decibels. In the figure, the left-hand scale is calibrated in values from 1 microvolt to 100 volts in two sections, A and B. The right-hand scale indicates from one-half volt to 500 volts. The center scale shows decibels in two sections, C corresponding to A and D corresponding to B.

As the nomograph stands it indicates voltage gain or loss, but since current varies directly with voltage in any constant impedance circuit, amperes may be substituted for volts and microamperes for microvolts. To extend to power values the center scale must be divided by two for all readings.

To work out a problem, connect the larger of the two voltages, currents or powers at scale E with the smaller at either A or B by means of the ruler. If the output is larger there is a gain, otherwise a loss. The answer is read off at C or D.

Four lines are shown on the figure as examples.

1—We wish to find the voltage gain

of an audio amplifier. Making measurements with a v.t.v.m. we find the output is 55 volts when the input is .15 volt. There is a GAIN of 51.3 db (Line A).

2—We have an r.f. tuner and after repairing and aligning we wish to find its amplification. Applying a signal generator to an artificial antenna we find an output of 3 volts when 1600

microvolts is measured at the input. The GAIN is 65 db (Line B).

3—How much attenuation must we use to obtain an output of .51 volt when 20 volts is applied to the attenuator? All impedances are assumed matched. We must design an attenuator to have a 31.9 db loss (Line C). The same line may be used to show the output when the input and the attenuation are known.

4—As mentioned before, power calculations are the same except that the db scale is read off as one-half its value. The catalog lists a particular amplifier as having 10 watts output. What is its power gain (above 6 milliwatts)? Connect 10 at E with 6000 at A. The gain is 64.2 divided by 2, equals 32.1 db (Line D).

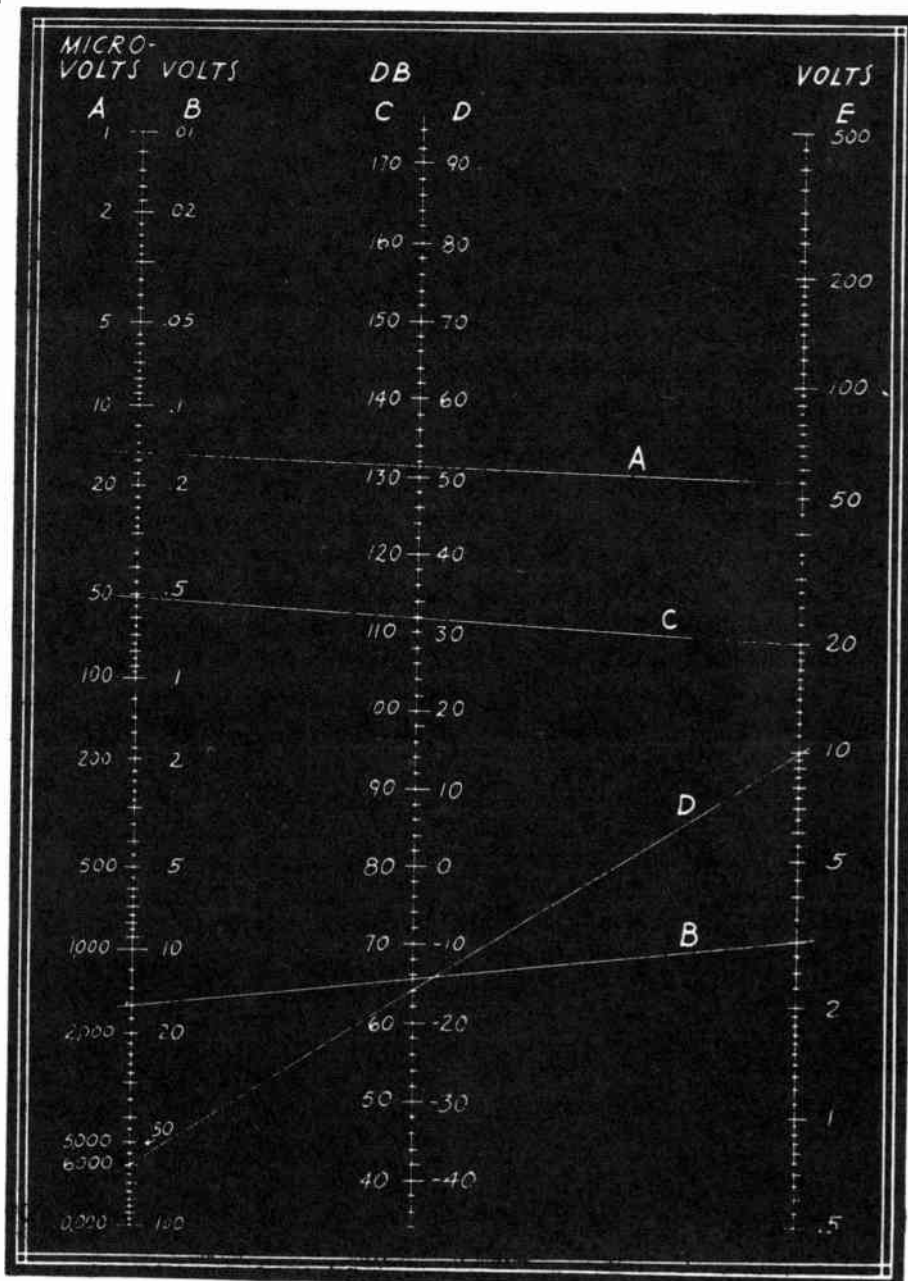

SOUND VOLUME CHART

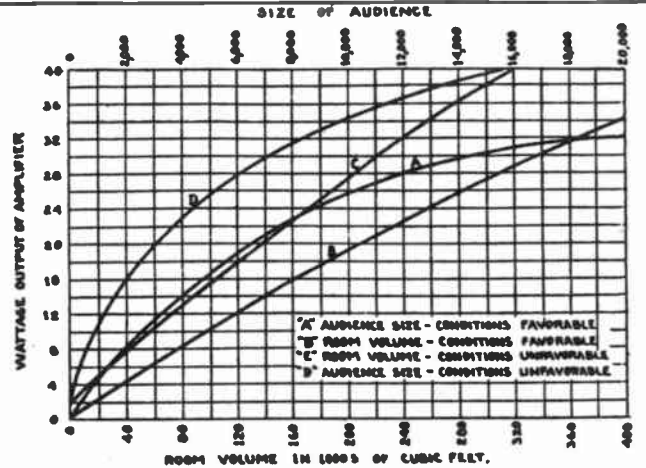
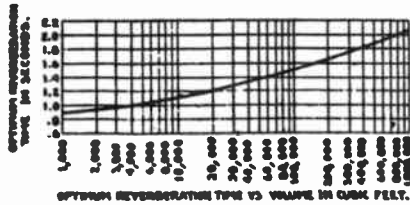

A CAREFUL STUDY OF THE FOLLOWING EXAMPLE WILL FAMILIARIZE YOU WITH THE PROPER USAGE OF THE ABOVE CHART. IT IS DESIRED TO FIND THE MINIMUM WATTAGE REQUIRED FOR UNFAVORABLE CONDITIONS IN A ROOM HAVING A VOLUME OF 10,000 CU. FT. USING CURVE "C" WE FIND THE POINT NEAREST FOR THIS ROOM TO BE 80 WATTS. NOW ASSUME THE SIZE OF THE AUDIENCE TO BE 1000 PERSONS, USING CURVE "D" WE FIND 1000 PERSONS REQUIRE 11 WATTS. THE LOWEST PERMISSIBLE POWER IS A COMPROMISE BETWEEN 11 AND 80. THIS IS FOUND BY ADDING 11 AND 25 THEN DIVIDING BY 2. THE ANSWER IS 18.

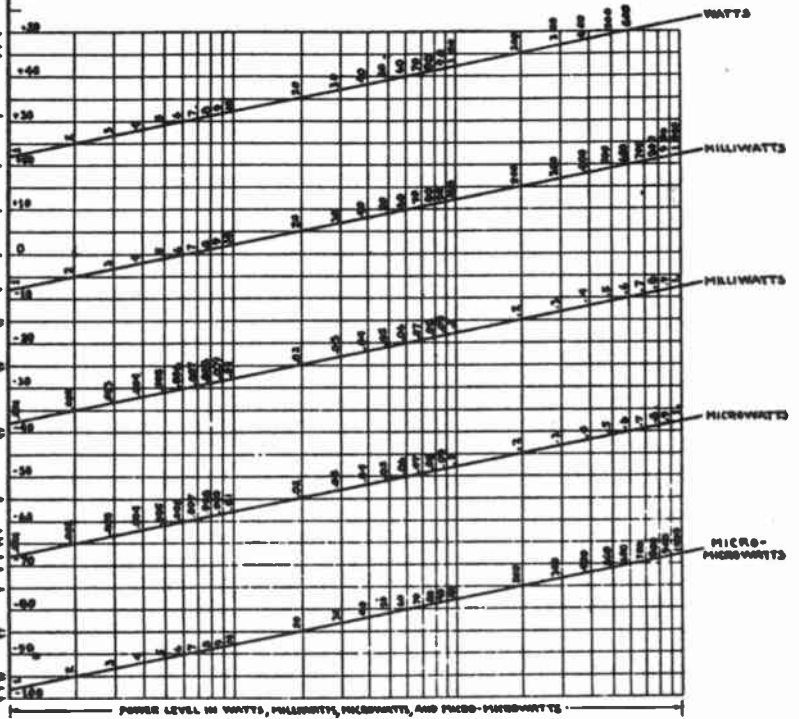
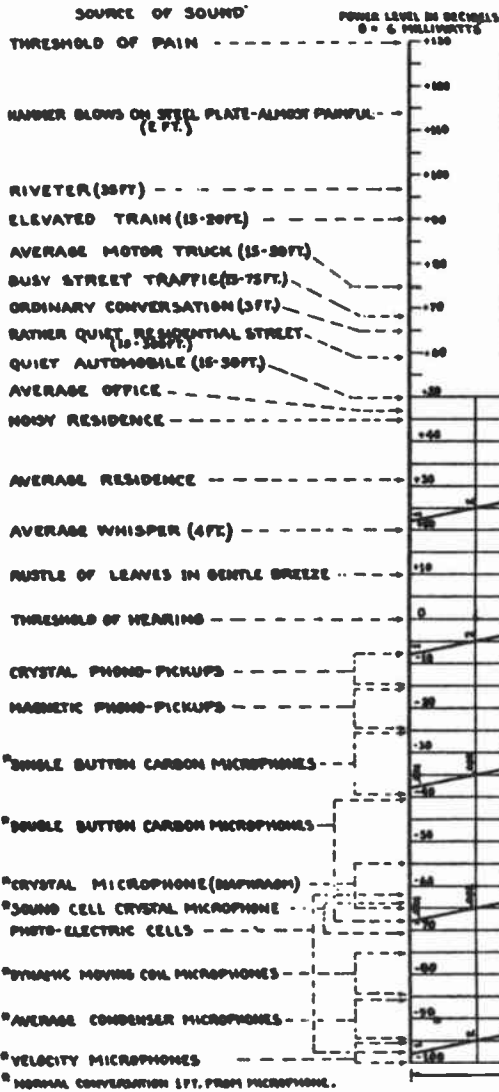

COEFFICIENTS OF ABSORPTION (512 VIBRATIONS PER SECOND).

| | UNITS PER SQUARE FOOT. | UNITS PER SQUARE FOOT |
|--|------------------------|-----------------------|
| ACOUSTI-CELOTEX, TYPE "B", PAINTED OR UNPAINTED | .47 | 1.00 |
| ACOUSTI-CELOTEX, TYPE "BB", PAINTED OR UNPAINTED | .70 | .025 to .034 |
| BRICK SET IN PORTLAND CEMENT | .025 | .21 |
| CARPETS | .15 TO .29 | .74 |
| CONCRETE | .015 | .061 |
| CORK TILE | .03 | .03 |
| CRETONNE CLOTH | .15 | |
| CURTAINS IN HEAVY FOLDS | .50 TO 1.00 | |
| FLUXLINUM 1/2" | .34 | |
| GLASS, SINGLE THICKNESS | .027 | |
| HAIRFELT 1/2" (JOHNSMANNVILLE) | .31 | |
| HAIRFELT 1" (JOHNSMANNVILLE) | .59 | |
| LINOLEUM | .03 | |
| MARBLE | .01 | |
| MASKNOTE, TYPE "A", 3/4" THICK | .27 | |
| OPEN WINDOW | | 1.00 |
| PLASTER | | .025 to .034 |
| SABINITE ACOUSTICAL PLASTER | | .21 |
| SANACOUSTIC TILE, 1" ROCK WOOL FILLER | | .74 |
| WOOD SHEATHING | | .061 |
| WOOD, VARNISHED | | .03 |

| INDIVIDUAL OBJECTS | |
|--|-----------|
| AUDIENCE, PER PERSON | .7 |
| COMPLETELY UPHOLSTERED CHAIRS | 3.0 |
| PARTIALLY UPHOLSTERED CHAIRS | 1.6 |
| PLAIN CHURCH PEWS, PER LINEAR FOOT | .18 |
| PLAIN PLYWOOD AUDITORIUM CHAIRS, EACH | .24 |
| UPHOLSTERED CHURCH PEWS, PER LINEAR FOOT | UP TO 1.0 |

SOUND PRINCIPLES

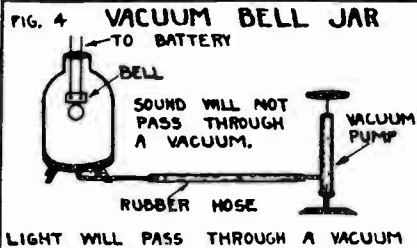
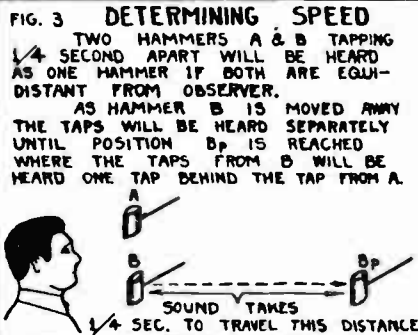
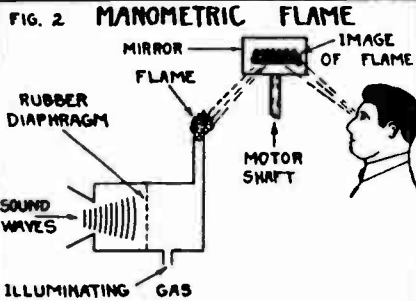
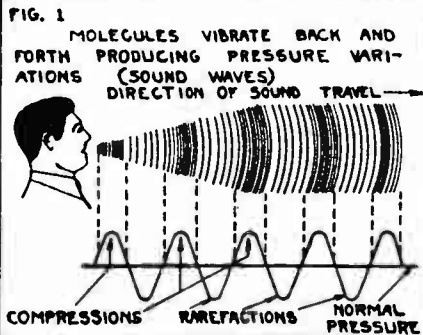

FIG. 5 VELOCITY OF SOUND IN VARIOUS MATERIALS

$$V = \sqrt{\frac{E}{d}}$$

WHERE V=VELOCITY
E=ELASTICITY
d=DENSITY

| MATERIAL | VELOCITY FEET PER SEC. | DENSITY GRAMS/C.C. |
|---------------|------------------------|--------------------|
| AIR | 1130 | .001205 |
| HYDROGEN | 4138 | .00009 |
| MERCURY | 4615 | 13.6 |
| WATER | 4725 | 1.0 |
| BRICK | 11979 | 2.0 |
| CORK | 1374 | .2 |
| IRON | 16225 | 7.8 |
| ELM (WOOD) | 3411 | .54 |
| GLASS (FLINT) | 13120 | 3.0 |

FIG. 9 VOLUME LEVEL IN DECIBELS

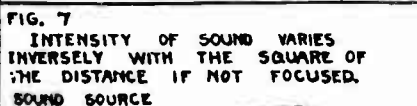
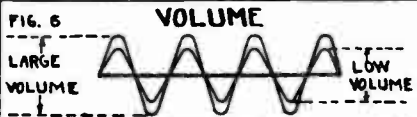
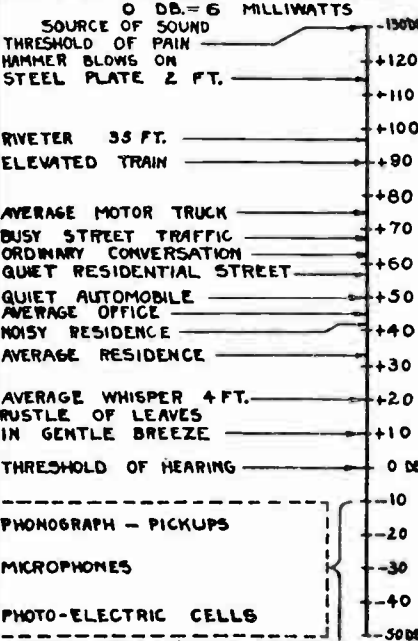

FIG. 8 DECIBEL CONVERSION CHART

CHANGE IN DB. = 10 X LOG₁₀ P/P₁ WHERE P & P₁ ARE IN WATTS.

DECREASE OF 1 DB. = WATTS X 4/5
" " 2 " = WATTS X 2/3
" " 3 " = WATTS X 1/2
" " 10 " = WATTS X 1/10

FOR INCREASE OF GIVEN DB.
INVERT FRACTION AND MULTIPLY.
TO FIND FRACTION FOR 7 DB.
DECREASE - FOLLOW PROCEDURE SHOWN BELOW

$$7DB. = 2DB. + 2DB. + 3DB. = 2/3 \times 2/3 \times 3/2 = 2/9$$

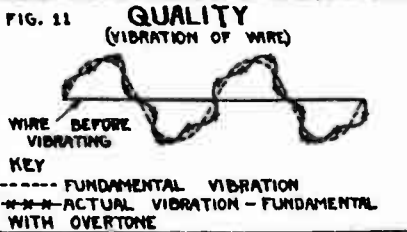
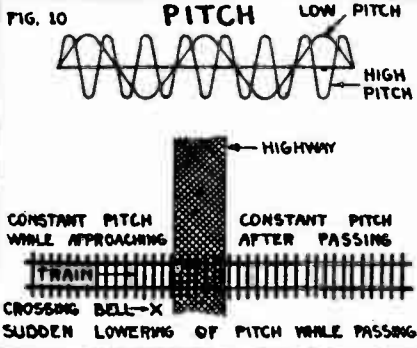

FIG. 12 REFLECTION OF SOUND FROM A FLAT SURFACE

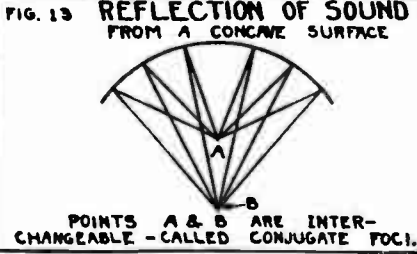
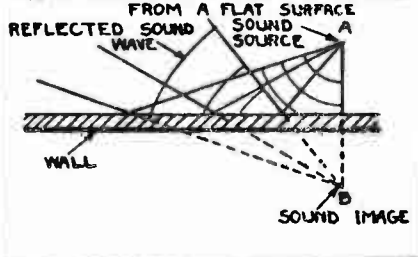

FIG. 14 REFRACTION OF SOUND WHEN PASSING THROUGH A BUBBLE OF GAS HEAVIER THAN AIR.

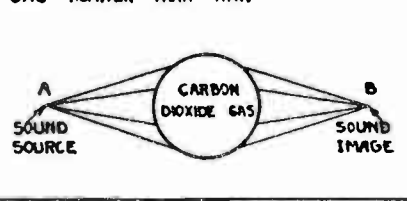

FIG. 15 REFRACTION OF SOUND WHEN PASSING THROUGH A BUBBLE OF GAS LIGHTER THAN AIR.

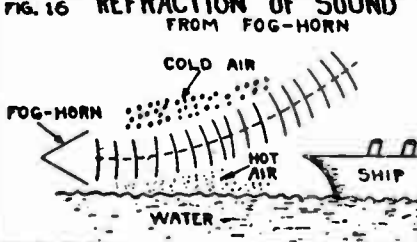
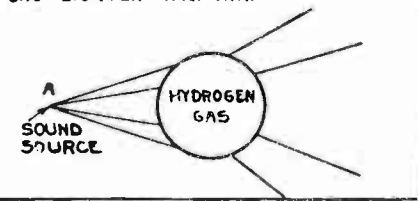

FIG. 17 REFRACTION OF LIGHT MAKES PUDDLES OF WATER APPEAR ON ROAD-BED.

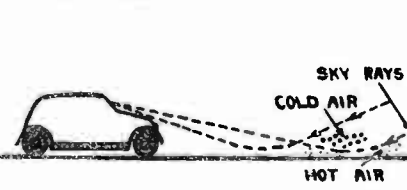

FIG. 18 REFRACTION OF LIGHT ON A DESERT MAY CAUSE A MIRAGE

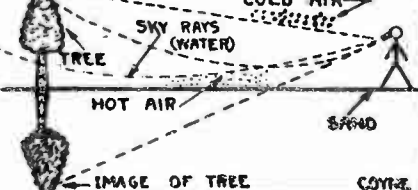
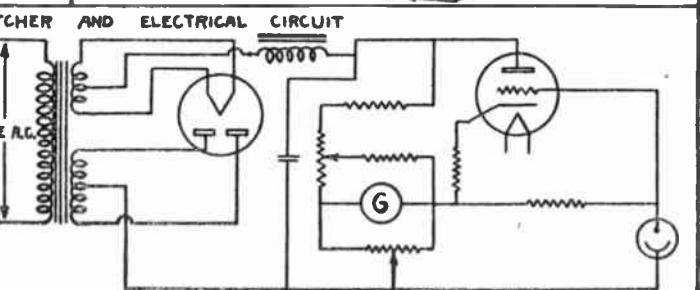
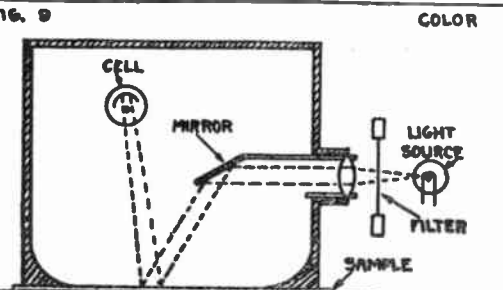
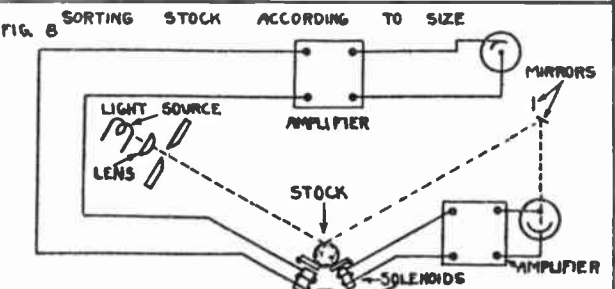
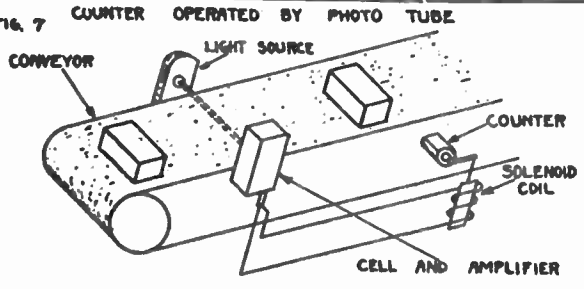
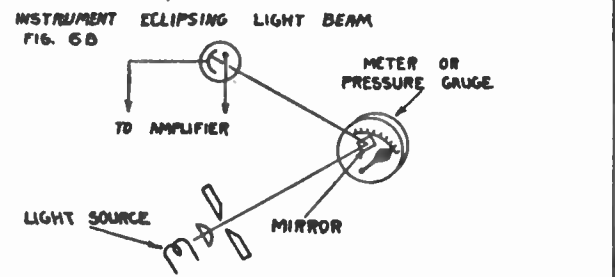
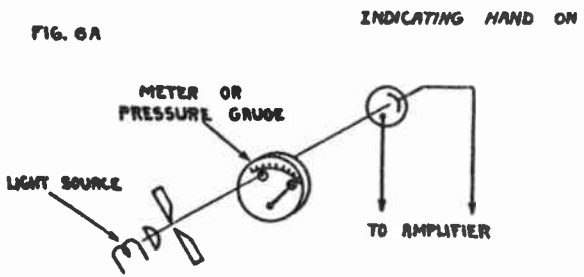
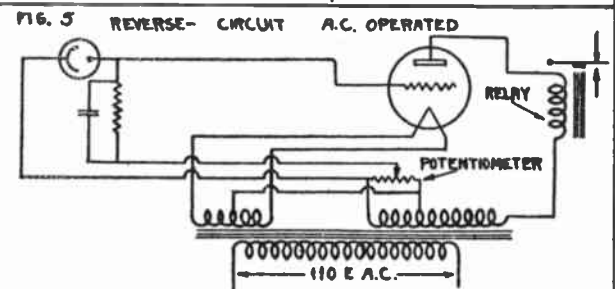
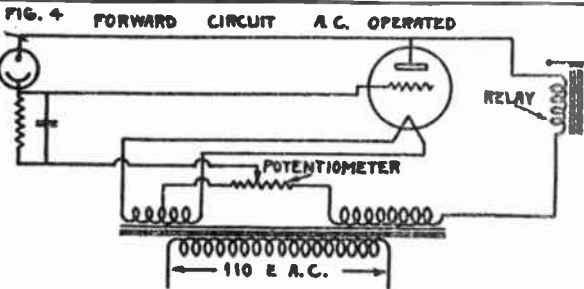
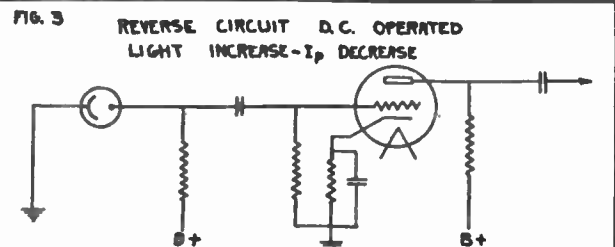
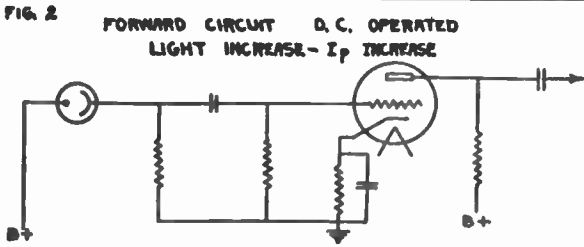
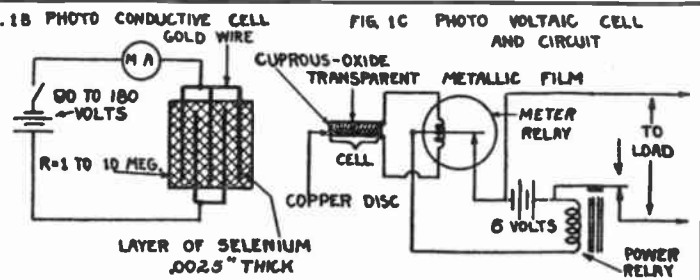
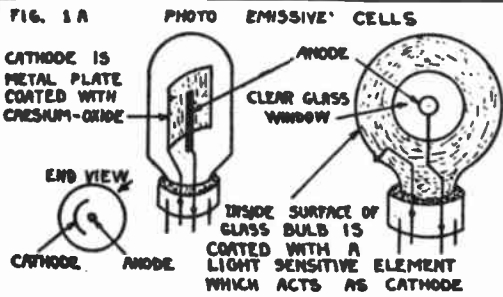

PHOTO ELECTRIC CELLS, CIRCUITS AND APPLICATIONS



Applications for Phototubes

Burglar Alarm . . .

The phototube can be used to operate an alarm system when its light beam is cut off by an undesired entry of someone. It can be a fairly simple arrangement, as shown in the diagram, or quite complicated, depending on the installation. External alarms require fairly rugged weather-proof equipment and consideration must be given to operation under various weather conditions. All of the visible light from the light source can be eliminated by the use of an infra-red filter.

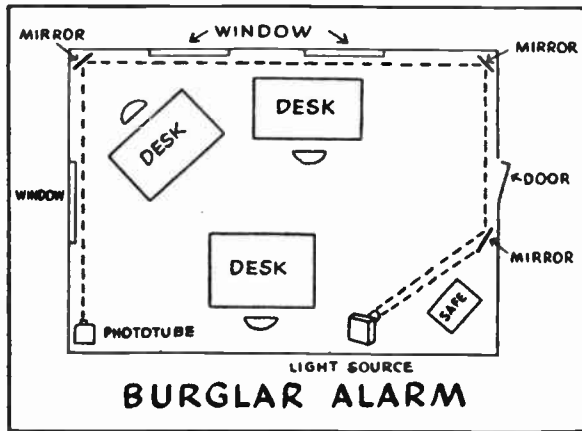

Water Level Gauge . . .

By means of a column of phototubes, a simple and reliable gauge to indicate the level of water or other liquid can be constructed, as shown in the diagram. When a beam of light shines through a column of liquid, it is refracted. By virtue of this fact, the beams of the light source of this water level gauge are adjusted so that they do not strike the phototubes unless there is liquid to refract them. Any desired number of tubes may be used. A meter connected to the output will read in direct proportion with the number of tubes illuminated.

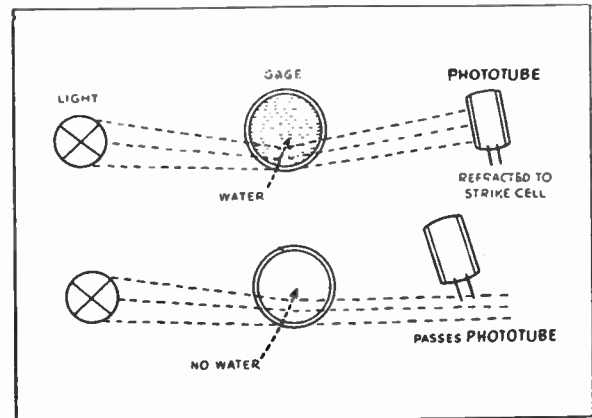

Opening and Closing Doors . . .

Mechanical door openers employing the action of opening and closing doors can be made completely automatic by the use of phototube control. This automatic device is especially suitable for garage door, restaurant kitchen door, and similar places, for the sake of convenience and time-saving.

Mechanically operated garage doors are equipped with one push button for opening and another for closing. A phototube in a light-on energized circuit with its relay connected across the terminals of the opening push button may be used as a controlling device. The car driver simply shines the headlights on the phototube which energizes the circuit, operates the relay and opens the garage door.

For swinging doors in restaurants or bars, a different arrangement and circuit are to be used. Three phototubes in series are to be installed as in the diagram. Tubes 1 and 2 are operated from either approach, and tube 3 is used to hold door open when someone remains in the doorway. When the door closes, tube 3 is short-circuited by switch 4. Since the dark resistance of a tube is several times greater than that of a tube when illuminated, blocking the light beam of either tube 1 or 2 which are connected in series will greatly reduce the current output and thus operate the relay.

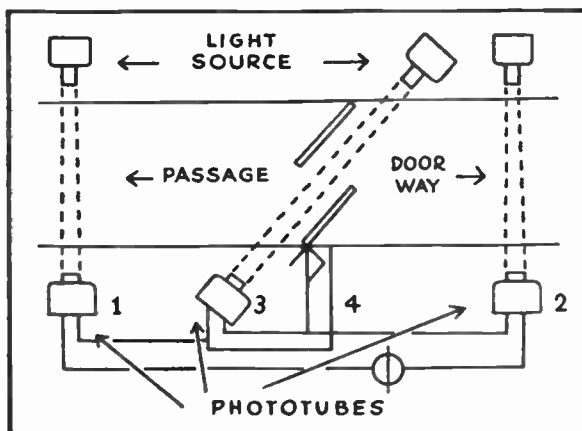

Relay Circuit Energized by Increase in Light . . .

In using this circuit, adjust R_3 so that the bias voltage is just negative enough to prevent the thyatron, 2051, from conducting, at a predetermined light level. When there is an increase in light, the increase of current in the phototube, in turn, reduces the negative grid voltage through the voltage drop across R_4 . The 2051 conducts and closes the relay. R_4 is to be selected according to the desired sensitivity of the circuit. The function of R_3 is to keep the current within the current rating of the relay and the 2051. It is not needed, if the relay has a sufficiently high resistance. The condenser is to prevent the relay from chattering.

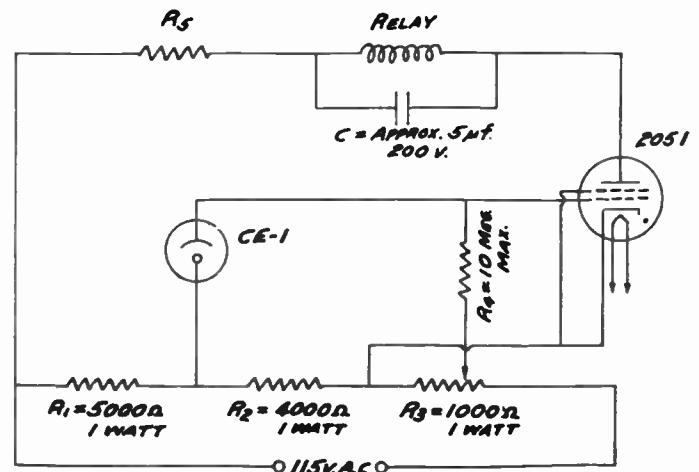

Counting . . .

The simplest use of phototubes is that of counting, with the aid of relay and counter. A beam of light shines across a conveyor belt into a phototube which is used in a light-off energized circuit. When the light beam is intercepted by the object on the conveyor belt, the change in current actuates the relay which, in turn, operates the counter. If two objects of different sizes are to be counted, two phototubes may be arranged at different heights. The top beam is high enough so the large object will intercept it. When the large object cuts the top beam and the bottom beam, the phototube operates one counter. In doing so, it opens the relay of the second counter. Only when the bottom beam is cut by the small object, the second counter registers. With the same principle, three or more objects of different sizes on the same conveyor belt can be counted.

If a mechanism operated by the same relays is mounted to separate the two objects, the counting system may serve, at the same time, as a sorting system.

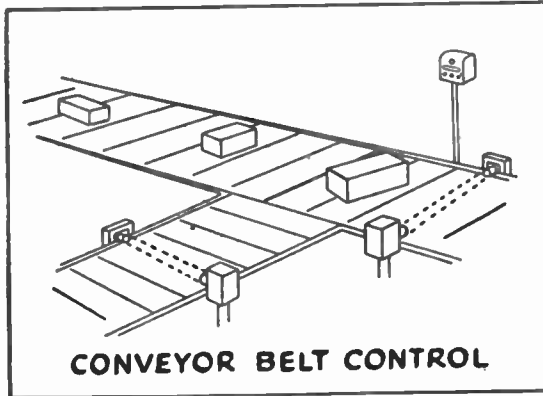

Turbidity Control . . .

In the process of manufacture or purification of liquids, an automatic system can be set up to inspect the clarity or turbidity of liquid. Foreign matters picked up by rapidly moving liquid may cause contamination if they are not detected and eliminated immediately. The arrangement of this automatic system is very similar to that of smoke control.

The diameter of the pipe where the phototube is to be installed should preferably be fairly large. Arrangement as in sketch is recommended if the pipe is rather small.

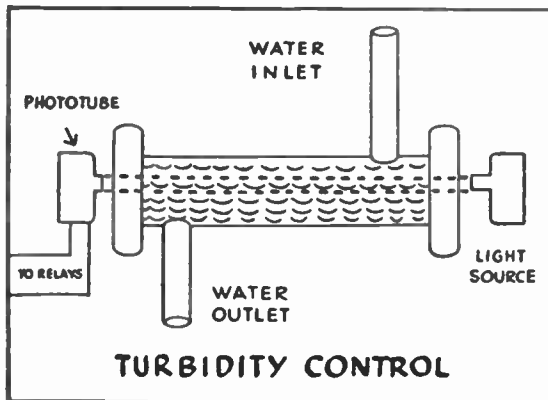

Smoke Control . . .

By virtue of the fact that the current of phototubes varies in proportion with intensity of light beam, many phototube control units have been designed to control, indicate, or adjust smoke density of industrial stacks. Aside from the fact that operating companies are required to comply with the smoke ordinances, improper combustion results in a waste of fuel. The phototube control may be used to indicate smoke density or to register a continuous or permanent record or to operate a mechanism that controls fuel feeding. Generally, when smoke density exceeds a predetermined density, an alarm is set off by the change of current in phototube.

To install a smoke indicator, two openings are cut in opposite sides of the stack. In one opening a phototube is installed and in the other a light source which directs a beam against the tube. The intensity of the beam of light transversing the stack is determined by the density of smoke, and the corresponding current in the phototube with the aid of an amplifier can be used to operate an alarm system or adjust directly the fueling mechanism. The indicating or recording instrument is usually calibrated into Rengelmann smoke units.

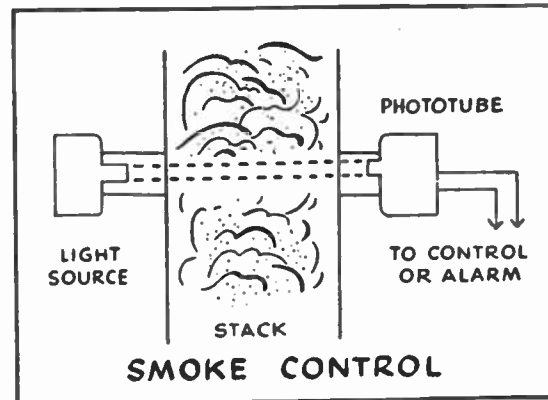

Traffic Control

By means of phototube-controlled traffic lights, 20% of car-seconds were saved. When riding on a major highway, it is annoying as well as wasteful of time to stop at a red traffic light when there is no car travelling on the minor highway. The phototube control makes it possible to give the major highway green light all the time except when there is a car approaching the traffic light on the minor highway.

The arrangement of light sources and phototube units is shown in the diagram. The light source, quite similar to automobile spotlight, sends a beam of light across the street to the phototube unit which was equipped with a lens to permit only the beam from light source to shine on the phototube surface.

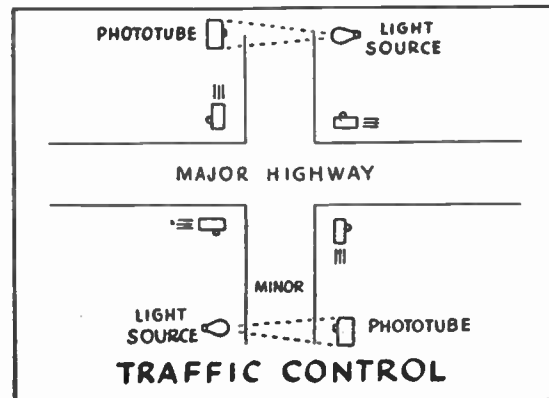

Boat Radios

You cannot simply resign yourself to getting your feet wet, and then get out to push the boat. And you just don't handcrank a large marine engine.

Before selling and installing that radio, check the boat's storage battery capacity against its lights and contemplated radio drain. Additional storage batteries, in some cases, may not be the best solution.

Weight is important aboard ship. The deeper in the water the boat sits, the harder it's going to be to move her. If this factor is not too important, however, an additional battery may be installed, and the generator's rate of charge stepped up correspondingly. Otherwise, a dry-battery portable receiver may be needed.

Connecting the radio to the boat's power supply will introduce ignition noise, and probably auxiliary motor noise. This interference may be treated in the same fashion it would be treated ashore with one basic difference . . . don't use spark plug suppressors!

Why Suppressors Are Out

Suppressors should never be installed in a marine engine. In most cases, the inclusion of a resistance in the spark circuit will ruin the engine. The number of times suppressors may be used with impunity are so few that suppressors may be considered non-existent aboard ship.

The reason is this: suppressors will not interfere with the starting and running of an engine. However, at full load, or close to full load, the resistors will cut down the amount of spark and prevent complete combustion.

The unburnt gasoline will foul the combustion chamber and eventually dilute the crankcase oil to the point where the bearings and associated parts will burn up. The gasoline is not readily detected on the oil gauge stick or pressure gauge. However, the tachometer will show low RPM.

Suppressors can be used without ill effect on most cars, since they are very seldom, and then for a short period only, operated at full power. The modern car engine is "revved up" to full power only when the car pushes ninety, or when it is raced up a steep hill in second gear. These periods are too short to permit the gasoline to accumulate dangerously in the crankcase.

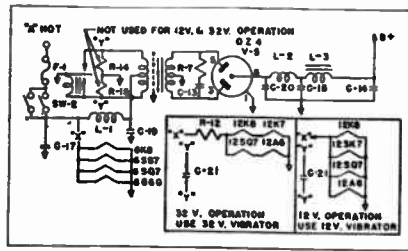

"Buccaneer" power supply for 6V, 12V, 32V., showing vibrator used off boat's starting battery.

However, when a boat owner installs a hundred horse motor in his boat he uses that full hundred a great deal of the time he is under way. To double the speed of a boat you have to square the power. From this, derives the natural tendency to open the throttle and let it run.

Ignition interference, a major problem only in 2-way radiotelephone jobs, may safely be suppressed by means of complete metal shielding. A wall of metal as heavy and of as low electrical resistance as is practical is thrown around the entire ignition system, and is grounded to the engine at one, or as close to one point as possible. The high tension

primary is filtered. The plugs, distributor, ignition coil are all inside the shield.

Commercial suppressor "packages," designed to be easily installed on a variety of standard marine engines, are available. They run about \$150. installed. Care must be exercised in the design to include plenty of insulation and ventilation. The instantaneous voltages run upwards of fifteen thousand volts, and the ozone generated by the electric arcing across the points induces corrosion and needs to be let out.

Copper screening tacked to the inside of the engine box and bonded to form one continuous wall will sometimes help enormously. A ground plate has been found to be very ineffective so far as reception and noise suppression is concerned. It should not be resorted to except as a final measure or when needed to counterpoise a transmitting antenna.

The generator may be filtered by means of a bypass capacitor and filter choke. The same holds true for the water closet bowl, sump pump, ventilating and other auxiliary motors aboard the ship. It is almost all cut and try work. No two ships, even sister ships, built by the same company on the same day have been found to respond exactly alike.

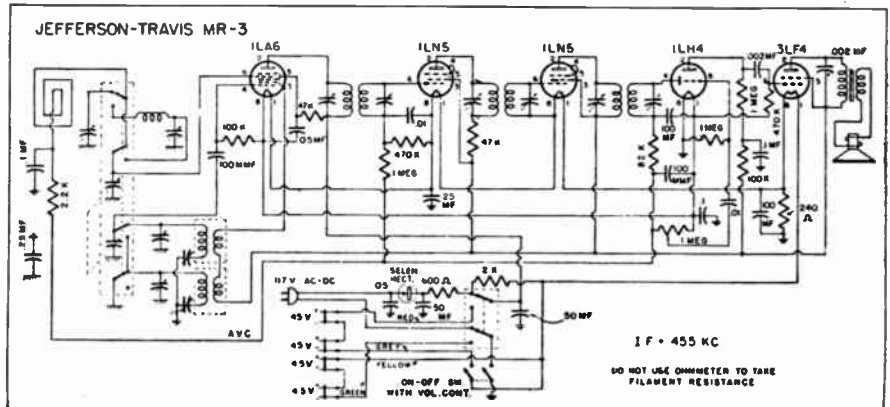

Jefferson-Travis model MR-3 is an example of an ac-dc-battery portable designed for shipboard installation.

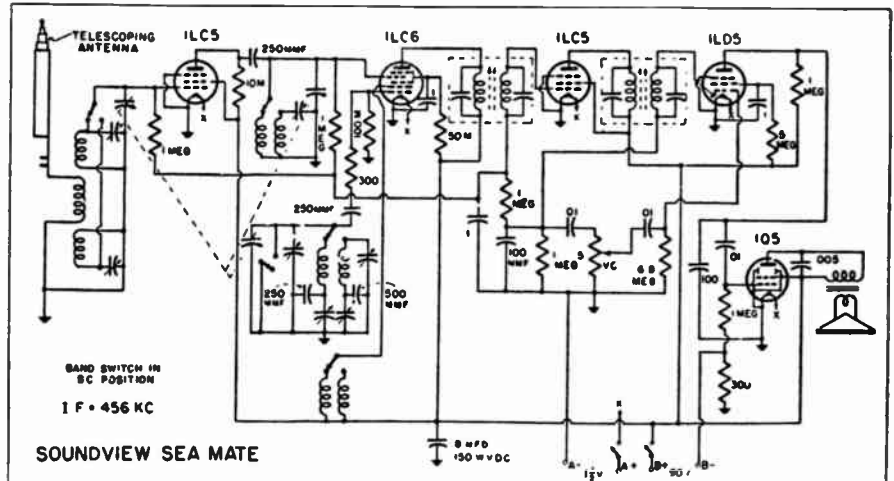

Typical marine dry battery portable, with broadcast band and 2000 kc to 6600 kc maritime band.

TV Service Hints

Coupling Sweep and Marker Generators to Receiver

When using a sweep generator, marker generator and oscilloscope to check the I-F response curves of a television receiver, it is sometimes difficult to obtain the correct balance between sweep output and marker output. This is particularly true when the ranges of the individual attenuators are limited. For best results, the amplitude of the

band, and 2 mmf. for stubs used in the high frequency band. This gives a series parallel tuned trap which is much sharper in response and will not affect the response curve of the head-end unit unless the stub is tuned directly in the channel.

The capacitors in the tuning stubs result in a longer piece of line being used for a particular frequency. The best method of determining the proper length of line is to clip off small portions until maximum attenuation is obtained.

—Courtesy General Electric Co.

Matching 72 Ohm Coax Cable to 300 Ohm Balanced Input

In some areas it may be desirable to use 72 ohm coaxial cable as a transmission line between the antenna and the receiver in order to reduce noise pickup. The problem of matching the coaxial cable to the receiver input in such installations can be solved as shown.

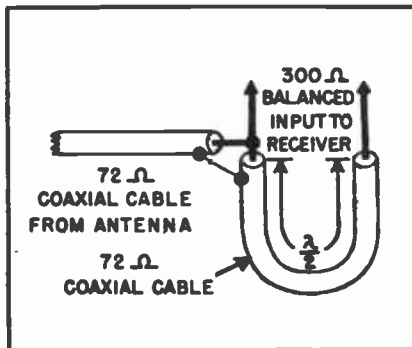

The matching section should be one half wavelength long at the most critical frequency. If reception is possible on one channel only, cut the matching section to the video carrier frequency of that channel. If operation on more than one channel is possible, cut the matching section to the video carrier frequency of the weakest signal.—Courtesy Westinghouse.

Ground Connection to Aquadag

Wear or vibration may sometimes develop a poor connection between the outside coating of the cathode ray tube and its grounding springs. The attendant arcing at that point can result in tearing of the picture and insufficient picture width.

To insure a permanent ground contact, a piece of aluminum foil may be inserted between the aquadag and the grounding springs. This foil, one side of which is coated with adhesive, is

first cut to size of 1" x 1½". One edge is then folded ¼" over the adhesive side of the foil. Finally, the foil is placed between the aquadag and the grounding spring in such a manner that adhesive holds the foil to the aquadag, the spring bears against the uncoated side of the foil, and the uncoated side of the ¼" fold bears tightly against the aquadag.—Courtesy Westinghouse.

Shielded 300-Ohm Line

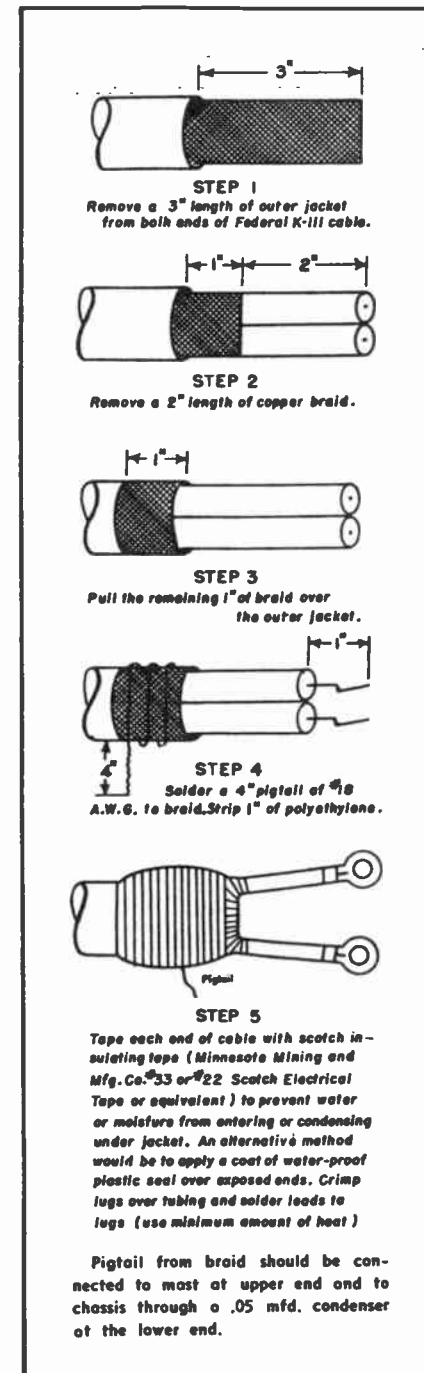

—Courtesy Federal Telephone & Radio Co.

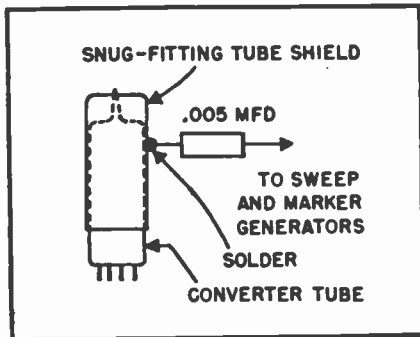

applied sweep voltage as well as that of the marker voltage must be adjusted to a fairly critical level.

The coupling method shown above provides additional control of the sweep and marker voltages. By sliding the tube shield up or down on the tube, the capacitance between the shield and the tube elements is varied, and the coupling can be adjusted as desired. Another advantage of this method is that it is not necessary to make a direct connection to the circuit under test; simply slide the tube shield over the converter tube. Any tube shield can be used provided that it fits the tube snugly and does not ground to the chassis. Courtesy Westinghouse.

Antenna Stubs

Occasionally we hear of or recommend the use of a quarter-wave stub of transmission line for trapping out unwanted signals or partially attenuating powerful interfering nearby TV stations. This is satisfactory as far as the reduction or elimination of the undesired signal is concerned, but it will also cause a change in the R-F response curve of the head-end unit on channels close to the tuned frequency of the stub. This may result in a serious impairment of the picture detail due to smearing.

It has been found that it is much more desirable to insert a small capacitor in series with each line of the stub at the point where the stub fastens to the head-end terminals. These capacitors should be 5 mmf. for stubs in the low frequency TV spectrum and the FM

TRANSISTORS

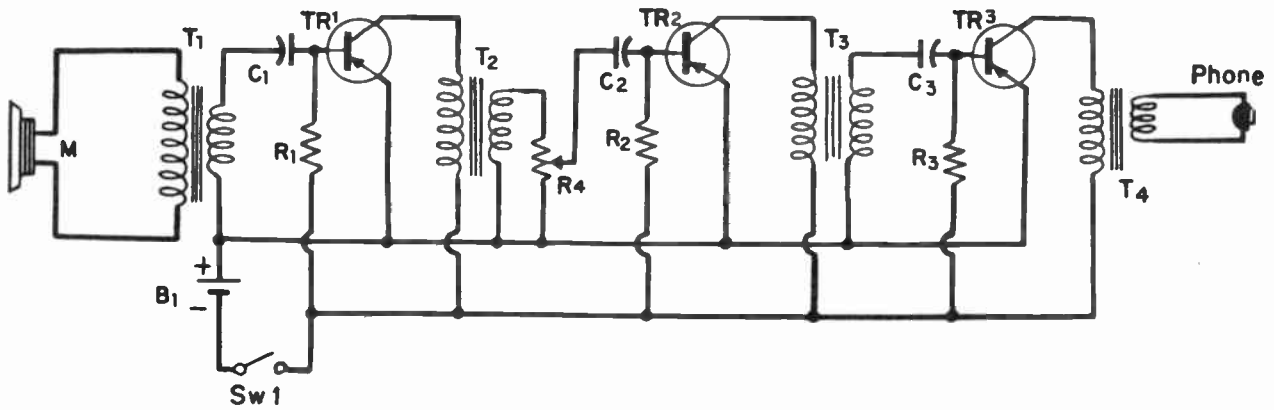

Figure 9-3. A transistorized hearing aid circuit. Parts values are as follows:

- TR₁, TR₂ - RAYTHEON type CK718 PNP junction transistors.
- TR₃ - RAYTHEON type CK718 or CK721 PNP junction transistors.
- T₁ - STANCOR type UM112 transistor transformer.
- T₂, T₃ - STANCOR type UM110 transistor transformer.
- T₄ - STANCOR type UM111 transistor transformer.
- R₁, R₂ - 10K-15K resistors*.
- R₃ - 50K-100K resistor*.
- R₄ - VOLUME control - 4K-6K.
- C₁, C₂, C₃ - Large interstage coupling capacitors - 2-5 mfd.
- M - High impedance microphone (crystal or dynamic).
- B₁ - Power supply battery . . . 1.5 to 6.3 volts.
- Sw₁ - SPST "Off-On" switch.
- PHONE - Low impedance hearing aid type earphone.

*These resistor values will vary with battery voltage and transistors used. Choose final values experimentally for best operation.

CREDIT: Circuit Courtesy STANCOR.

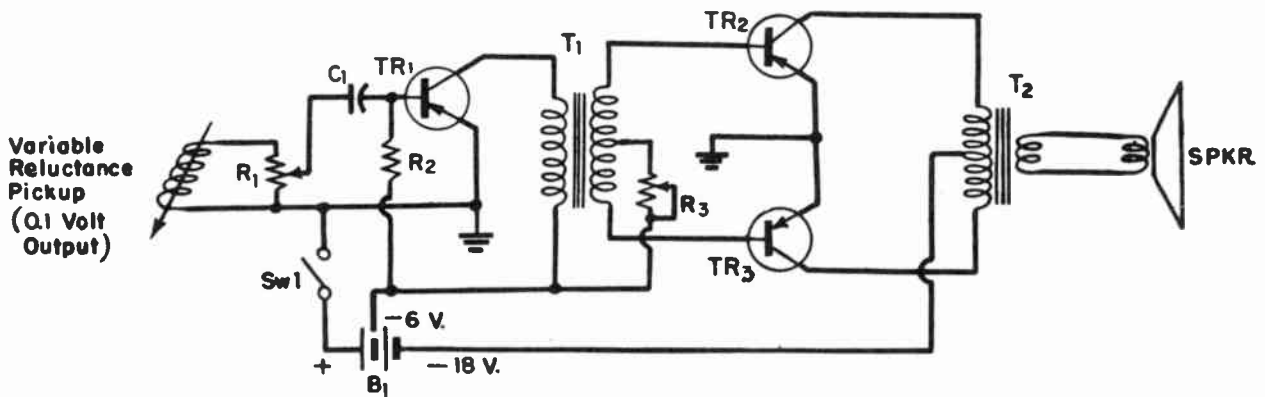
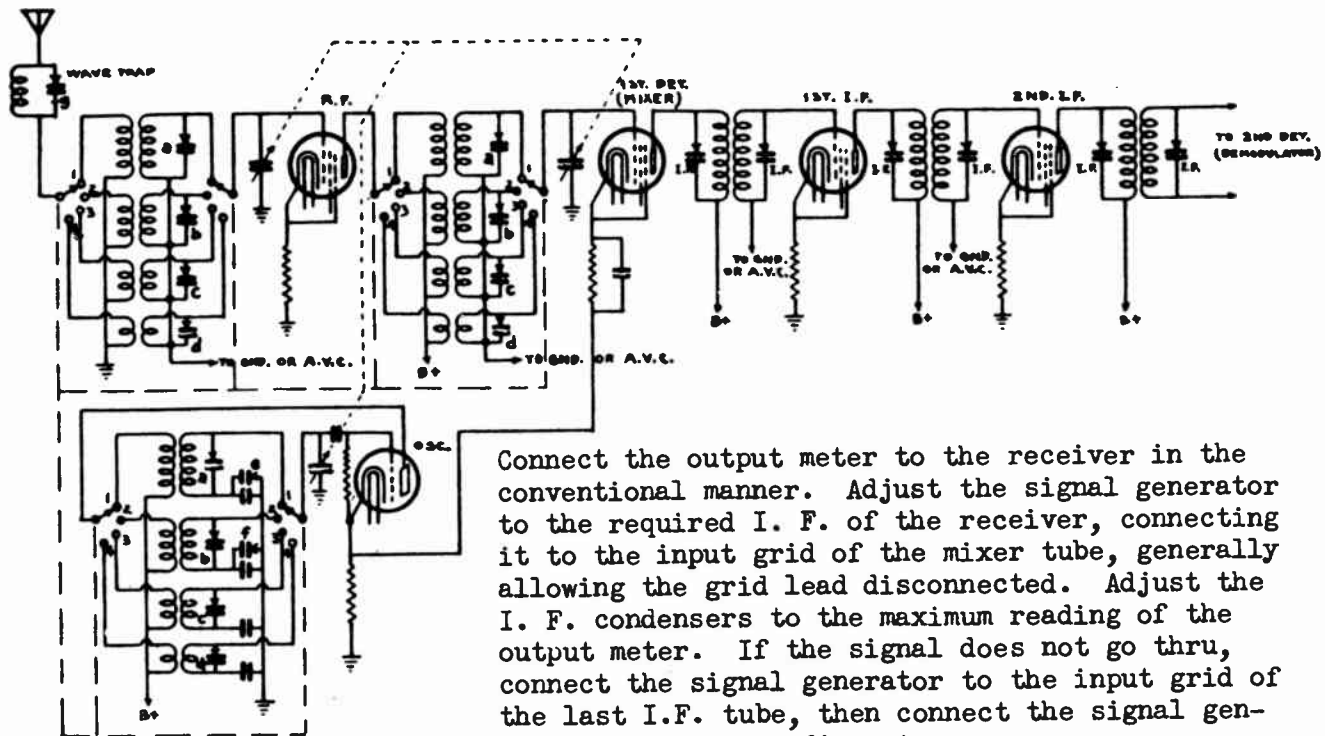

Figure 9-2. A transistor-operated phonograph amplifier. Parts values are as follows:

- TR₁ - CBS-HYTRON type 2N36 PNP junction transistor.
- TR₂, TR₃ - CBS-HYTRON type 2N37 PNP junction transistors.
- R₁ - VOLUME control, 10K.
- R₂ - 100K resistor.
- R₃ - Output bias control, 25K.
- C₁ - 1 mfd.
- T₁ - Interstage Transformer; 3:2 turn ratio.
- T₂ - Output transformer; 4000 ohms to speaker voice coil.
- Sw₁ - SPST "Off-On" Switch.
- B₁ - Tapped battery . . . or separate batteries providing 6 and 18 volts.

CREDIT: Circuit courtesy CBS-HYTRON

ALIGNING SUPERHETERODYNE RECEIVERS.



Transfer the signal generator connections to the antenna and ground of the receiver.

Tune the receiver to band #1 (generally the broadcast band). If the receiver has a wave trap, the trimmer (g) is adjusted to minimum reading of the output meter, when the signal generator is tuned to the I. F. and the tuning condensers are tuned to the low frequency end of the broadcast band.

Adjust the signal generator and the receiver to 1400 k.c. Adjust the high frequency trimmers (a) to maximum reading of the output meter.

Adjust the signal generator and the receiver to 600 k.c. Adjust the low frequency trimmer (e) to maximum reading of the output meter.

Tune the receiver to band #2 (generally the first short wave band)

Adjust the signal generator and the receiver to the required frequency of band #2. Adjust the high frequency trimmers (b) to the maximum reading of the output meter.

Adjust the signal generator and the receiver to the required low frequency and adjust the low frequency trimmer to the maximum reading of the output meter.

The same procedure is followed with bands #3 and #4, the high frequency trimmers (c) and (d) are adjusted for maximum reading of the output meter in their respective bands.

NOTE: Keep output of the signal generator low in value, allowing just enough signal to give a readable induction on the output meter. Above frequencies do not apply to all receivers, check with manufacturers aligning data.

THE RATIO DETECTOR

The ratio detector, appearing first in RCA f-m receivers, is a device for converting a frequency modulated carrier to an audio signal, while at the same time offering a high degree of attenuation to any incident amplitude modulation. The relative insensitivity to amplitude variations, which is an inherent characteristic of ratio detectors, enables them to be used without the usual preceding limiter stage, thus affording the use of a high gain i-f stage instead of the low-gain limiter.

Theory of Operation

A brief review of the theory of the discriminator detector will help the serviceman to understand the action of the ratio detector.

Figure 1 portrays a conventional discriminator stage, and it can be seen that it consists essentially of two diode rectifiers which are differentially connected so that the d-c potentials across their respective load resistors are subtractive. These two d-c voltages (across R1 and R2 in Figure 1) are proportional to the a-c voltages applied to the diodes. The a-c voltage applied to each diode is the vector sum of E1 and the voltage across that half of L1 which is connected to the diode plate, as shown in the diagrams of Figure 4. E1 has practically the same amplitude and phase as the voltage across the tank in the limiter plate circuit. The current in this same tank circuit induces a voltage in L1, which causes a circulating current to flow in the resonant circuit composed of L1 and C1. E2 and E3 are the voltage drops which occur across each half of L1 as a result of this circulating current. When the carrier frequency is equal to the frequency at which the discriminator transformer is tuned (Fig. 4A), the a-c voltage applied to diode 1 equals that applied to diode 2, therefore the rectified voltages are equal and since they are bucking voltages, the output of the discriminator is zero.

When the carrier frequency increases during a half cycle of modulation, the phase relations between E1, E2 and E3 change in accordance with Figure 4B, and it is evident that the vector sum of the voltages applied to diode 1, resulting in a higher rectified voltage across R2 than across R1. The instantaneous difference of the rectified voltages appears as a negative voltage in the discriminator output. Figure 4C shows the condition occurring when the carrier frequency swings below the resonant frequency of the discriminator transformer, the end result being a positive voltage at the output of the discriminator.

The important fact in discriminator action is that the output voltage is proportional to the difference between E_{diode 1} and E_{diode 2}. This is true because the d-c voltages appearing across R1 and R2 vary directly with E_{diode 1} and E_{diode 2}, respectively, and the instantaneous output voltage is the difference between the rectified voltage drops.

In considering the effect of amplitude variation on discriminator output, refer again to the vector diagrams of Figure 4. An increase in the amplitude of the voltage applied to the discriminator would increase all of the vectors in the diagram proportionately. In other words, the effect would be as though the vector diagrams were enlarged photographically. It can be seen that while the phase relationships would remain the same, the difference between E_{diode 1} and E_{diode 2} would increase, so long as the frequency of the applied voltage differed even slightly from the receiver i-f. Thus components of amplitude modulation would be detected and passed on to the audio amplifier. Ordinarily, discriminators are preceded by limiters which remove most of the amplitude variation from the f-m carrier, but the discriminator itself is not a device capable of rejecting amplitude modulation, except when the instantaneous frequency of the applied carrier is exactly equal to the resonant frequency of the discriminator transformer. This condition occurs only twice in every modulation cycle.

Note that while an increase in the amplitudes of the vectors in Figure 4 results in a proportionate increase in the difference between E_{diode 1} and E_{diode 2} for off-resonant conditions, the ratio of E_{diode 1} to E_{diode 2} is a constant, as far as amplitude variations are concerned. Therefore, a detector responsive only to changes in the ratio of E_{diode 1} to E_{diode 2}, and insensitive to changes in the difference between these voltages would be a detector capable not only of converting frequency variations to audio variations, but of rejecting any amplitude modulation. Such a detector is the ratio detector.

DISCRIMINATOR

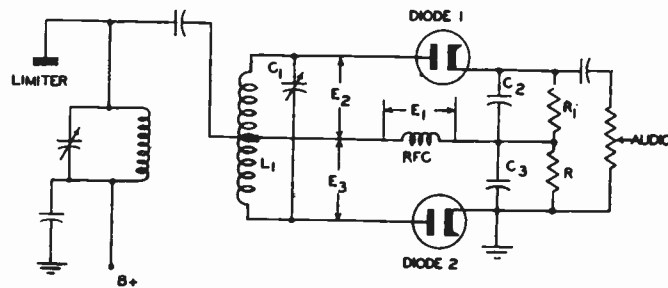

FIG. 1

RATIO DETECTOR

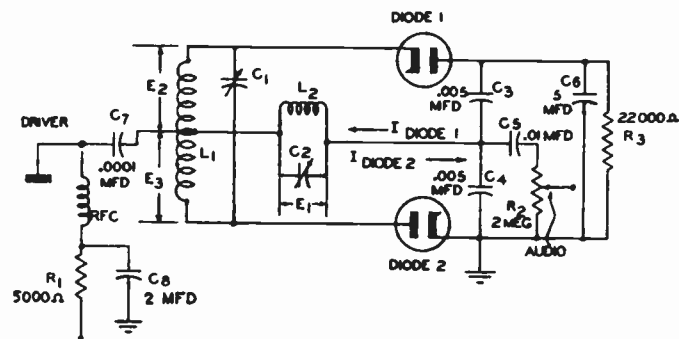

FIG. 2

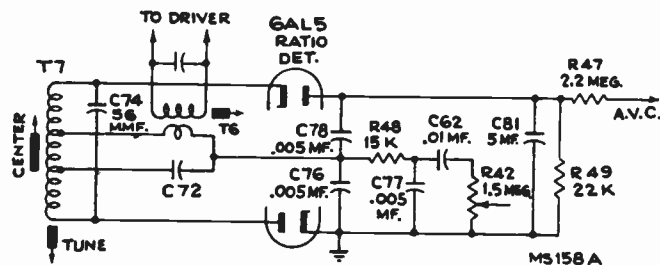

FIG. 3 - RATIO DETECTOR

A schematic of the fundamental ratio detector is shown in Figure 2. C7 and C4 have very little reactance at the intermediate frequency, so it is evident that the parallel resonant circuit L2 C2 is the true load for the driver stage, this stage being shunt fed. A driver stage, in this case, is nothing more than a conventional i-f amplifier preceding the ratio detector. L2 is inductively coupled to L1, therefore a comparison of Figures 1 and 2 will show that as far as the a-c voltages applied to the diodes are concerned, these circuits are almost exactly similar, indeed, the same vector diagrams used in the analysis of Figure 1 can be used to portray the a-c voltages across the diodes in Figure 2. Here the similarity ends, because the ratio detector method of extracting intelligence from the f-m carrier differs greatly from previously used methods. Diode 1, R3, and diode 2 complete a series circuit fed by the a-c voltage across L1. Since the two diodes are in series, they will conduct on the same half cycle, and the rectified current through R3 will cause a negative potential to appear at the plate of diode 1. The time constant of R3 C6 is usually about 0.2 second, so that the negative potential at the plate of diode 1 will remain constant even at the lowest audio frequencies to be reproduced.

ELECTRONIC PHOTOFLASH UNITS

In servicing or experimenting with photoflash equipment, it must be remembered at all times that capacitors are charged at high voltages and very dangerous unless extreme care is taken to be sure they are properly discharged before touching terminals or leads.

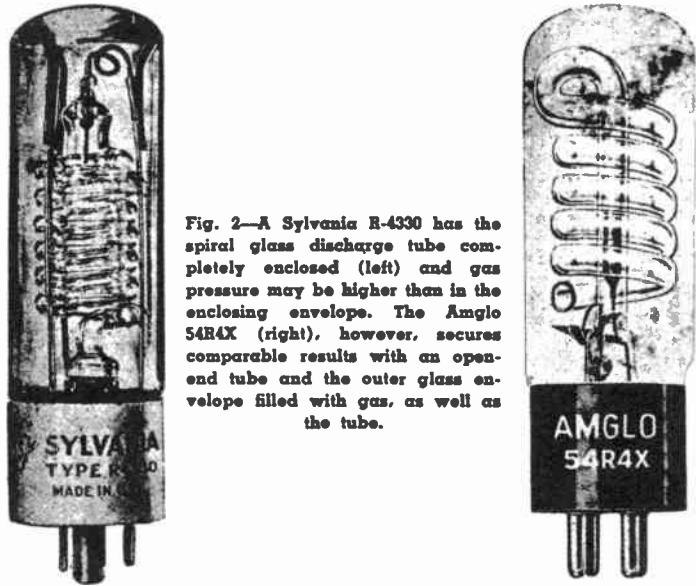

Fig. 2—A Sylvania R-4330 has the spiral glass discharge tube completely enclosed (left) and gas pressure may be higher than in the enclosing envelope. The Amglo 54R4X (right), however, secures comparable results with an open-end tube and the outer glass envelope filled with gas, as well as the tube.

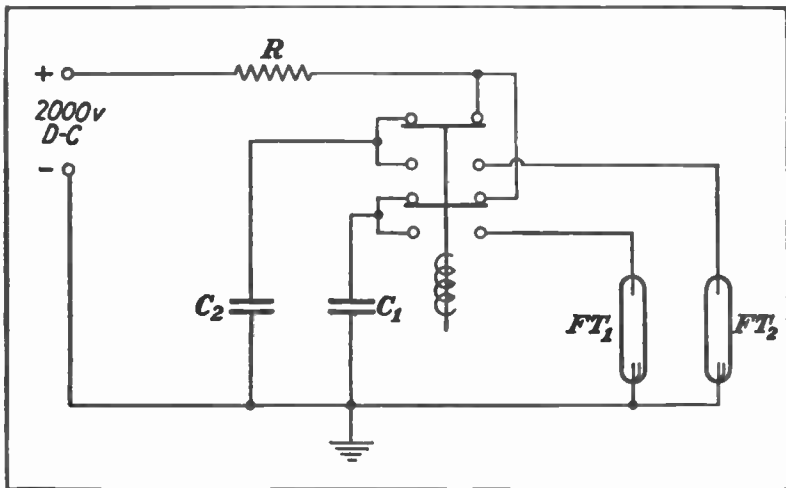

Fig. 4—Arrangement for charging capacitors in parallel but discharging them through individual flashtubes by means of a transfer relay.

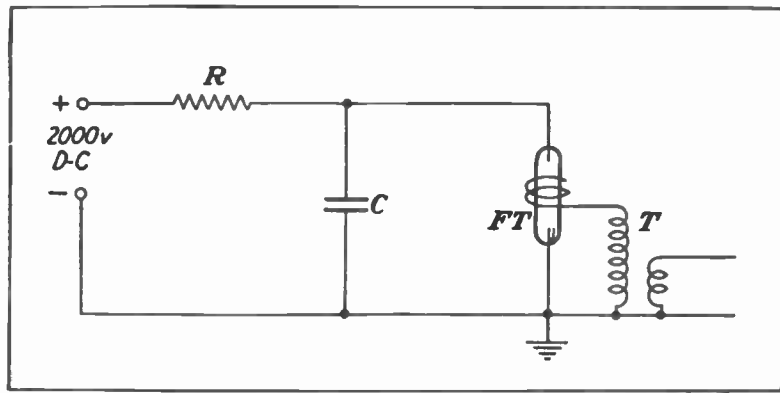

Fig. 5—The basic circuit used in G-E and Sylvania flashtubes. Gas in the tube is ionized by a high voltage between an external electrode and grounded terminal.

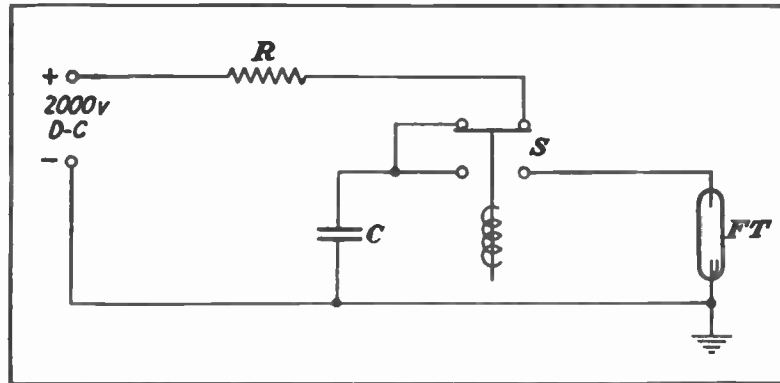

Fig. 3—Basic circuit of the flashtube with capacitor C charged from d-c source and discharged through relay S into the flashtube FT.

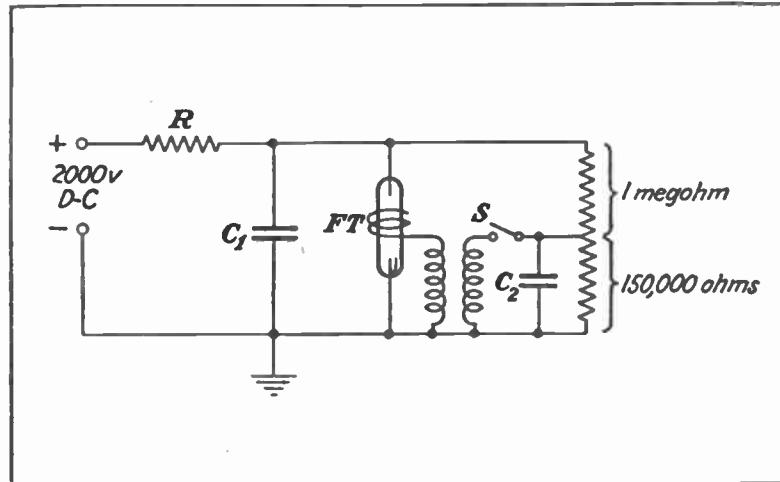

Fig. 6—Ionizing voltage may come instead from the discharge of a small condenser charged through a potentiometer from the main d-c supply.

SECTION IV

TV SERVICING

with

PICTURE TUBE PATTERNS



Analysis of differences between abnormal and normal test patterns or television pictures often enables a serviceman to determine the kinds of troubles which may be causing the faulty reproduction. Many of the picture patterns that appear on TV receivers and the relation of these pictures to trouble shooting are described in this book.

On the following pages under the names ordinarily used to describe the appearance, due to faulty reproduction, are lists of troubles and photographs illustrating these abnormal patterns. The photographs have been provided through the courtesy of Allen B. DuMont Laboratories, Admiral Corporation, RCA, General Electric Company, Philco Corporation, Sentinel Radio Corporation and Radio Electronics Magazine.

Coyne definitely cautions any inexperienced individual against attempting to service a Television receiver. While certain adjustments for a better picture can be made from the "dials on the front" under no circumstances should anyone but a qualified TV serviceman attempt to service a television set. Even qualified servicemen are advised to observe the following precautions.

1. Extreme caution should be taken in handling the picture tube. The mounting of picture tube is usually constructed to provide adequate protection against implosion while the tube is in the receiver. Extreme caution is recommended when removal or installation of a picture tube is necessary. Here are several things to keep in mind.
2. Shut off power.
3. At no time rest the tube in the deflection yoke.
4. Wear heavy gloves and shatterproof glasses.
5. Advise everyone except qualified servicemen to stay at least 8 feet away from the set while the installing or removal of a picture tube is being done.

In any probing or testing in any part of the set it is recommended that (a) well insulated wire and hooded test clips be used; (b) use good test instruments with all lead wires adequately insulated for the voltages to be encountered. You should use extreme caution in working in or near the high voltage section; (c) do not take anything for granted—test everything—that is the only way to be sure.

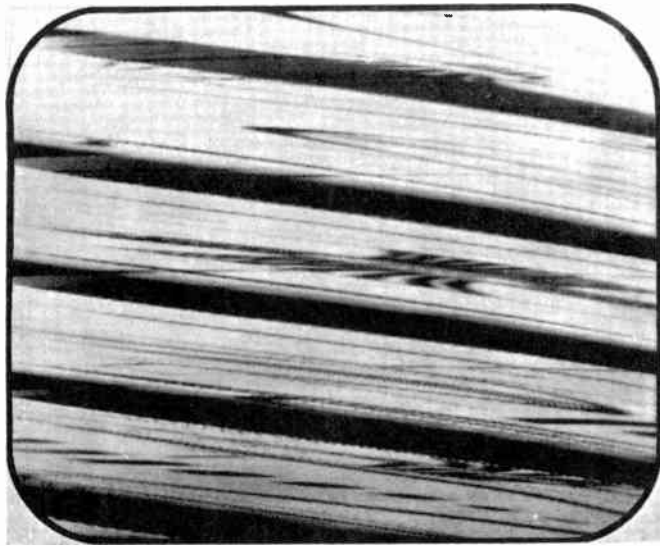

Fig. 131-3.—Bars, Sloping.

The bars change their degree of slope, their number, and their positions as the horizontal hold control is altered.

Causes for trouble.

Horizontal hold control incorrectly adjusted.

Faulty connections, resistors, or capacitors in circuits for horizontal hold control or for horizontal automatic control of sweep frequency.

See also troubles listed under *Movement, Horizontal*.



Fig. 131-16.—Linearity Poor, Vertical

With poor vertical linearity the pattern or picture is compressed or flattened from above, below, or from both directions.

Causes for trouble.

Vertical linearity control wrongly adjusted.

Defective capacitors or resistors, fixed or adjustable, in vertical linearity control circuits.

Vertical sweep oscillator tube defective, or supplied with wrong voltages.

Vertical sweep amplifier tube defective, or supplied with incorrect voltages.

Trouble in any parts which follow the vertical sweep oscillator, and which carry sawtooth voltages and currents.

Vertical sweep output transformer defective.

Shorted turns in a vertical deflection coil.

Poor filtering of low-voltage B-power supply.

FOLDS, HORIZONTAL. Figs. 8 and 9.

Only part of the picture or pattern is clearly recognizable, although more or less distorted and compressed horizontally. The remainder, usually less than half, appears to be stretched horizontally and folded back over the first portion. The folded part is indistinct, usually with only shadowy out-

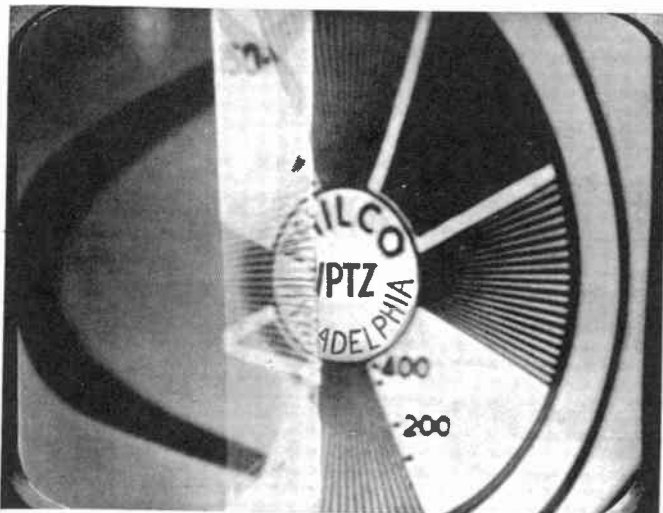

Fig. 8. The pattern is folded horizontally.

lines. There may be only one fold (Fig. 8) or there may be several (Fig. 9) to give the distinct portion of the picture a corrugated appearance.

The horizontal retrace time, due to discharge of the sawtooth capacitor in the horizontal oscillator-discharge tube circuit, actually is longer than the time allowed for horizontal retrace in received signals. The folded portions of pictures, which are indistinct and shadowy, occur during periods in which the picture tube beam should be blanked.

Damper Tube And Circuit.

Tube defective.

Capacitor on low-side circuit of damper open or disconnected.

Linearity control inductor in damper circuit shorted, otherwise defective of wrong type or wrong inductance.

Lead from horizontal output transformer and damper to the deflecting yoke has poor connections or is allowing leakage of current through faulty insulation.

Damper plate or cathode, depending on type of circuit, connected to a tap on the horizontal output transformer at which horizontal pulse voltages are not strong enough for rapid damping and retrace.

Boosted B-voltage to the horizontal output transformer and amplifier plate too low.

Frequency Control Circuits.

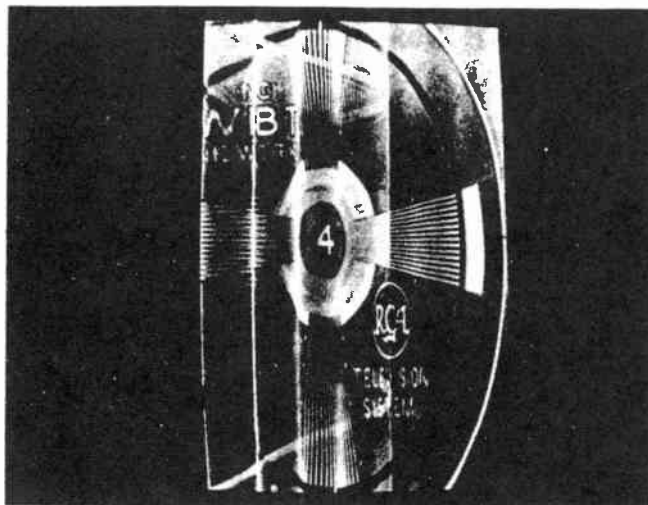

Fig. 9. One large horizontal fold and several minor ones.

Afc tube weak or otherwise defective.

Afc control misadjusted. This is a control which operates in the circuits of the afc tube, or between that tube and the horizontal oscillator.

Too much resistance in the grid return lead of the horizontal output amplifier.

Too much capacitance has been connected across part of the horizontal output transformer or across a width control inductor when increasing the width of pictures.

Unbalance in resistors on the two sections of a horizontal phase detector or discriminator, or resistors connected wrong.

Insufficient feedback to afc tube from horizontal sweep circuit. Series capacitor too small, or shunt capacitor too large. Series resistor too great, or shunt resistor too small. The feedback lead may be connected to the wrong point on the horizontal output transformer or other parts of the sweep circuits.

Vertical hold control fixed resistors or potentiometer of wrong values or defective.



Fig. 131-16.—Linearity Poor, Vertical

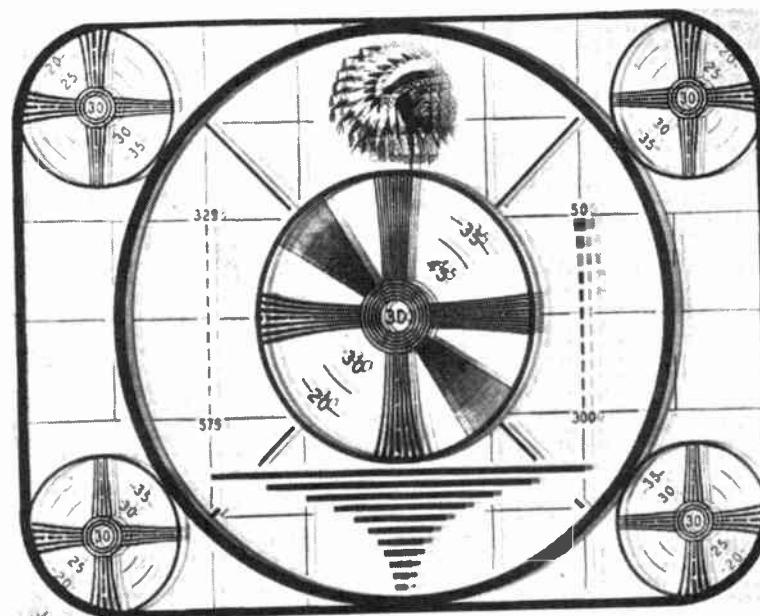

Fig. 131-13.—Ghosts.

With poor vertical linearity the pattern or picture is compressed or flattened from above, below, or from both directions.

Causes for trouble.

Vertical linearity control wrongly adjusted.

Defective capacitors or resistors, fixed or adjustable, in vertical linearity control circuits.

Vertical sweep oscillator tube defective, or supplied with wrong voltages.

Vertical sweep amplifier tube defective, or supplied with incorrect voltages.

Trouble in any parts which follow the vertical sweep oscillator, and which carry sawtooth voltages and currents.

Vertical sweep output transformer defective.

Shorted turns in a vertical deflection coil.

Poor filtering of low-voltage B-power supply.

There are multiple images in the test pattern or picture. The displaced images, of which there may be one or more, may be so close to the principal image or may be so faint as to cause only a blurring effect. In other cases the displaced images may be at a considerable fraction of inch from the principal image, and may be distinct.

Causes for trouble.

Part of the transmitted signal is being reflected from large conductive or semi-conductive objects, such as buildings, bridges, tanks, or steep hills, and the reflected portion is reaching the receiver antenna a fraction of a second later than the direct signal. Try rotating the receiving antenna to reject the reflected signal without too much loss of direct signal. Fit a reflector, and possibly also a director, on the antenna. Try the antenna in various locations.

Incorrect matching of impedances between antenna and transmission line, or between transmission line and receiver input. There are standing waves on the line. Use antenna and transmission line whose impedances match that of the receiver and of each other.

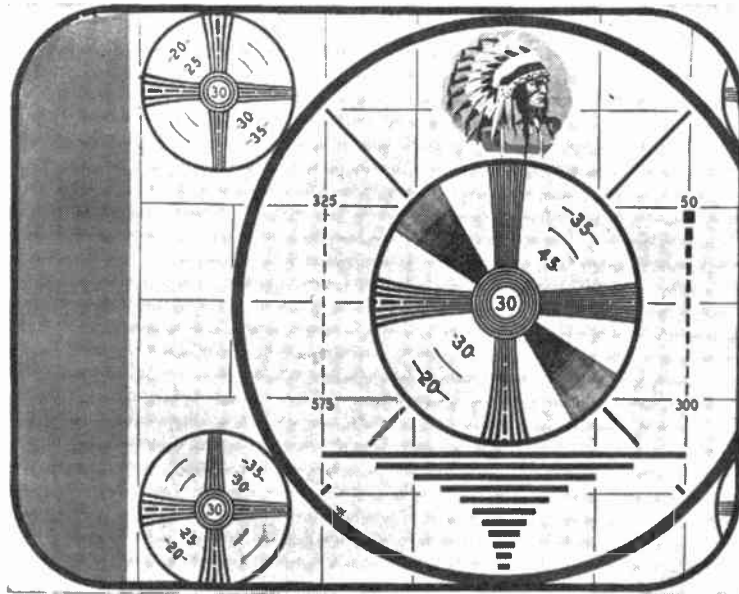

Fig. 131-6.—Centering Incorrect.

Picture or pattern may be too high or too low, incorrect vertical centering, or it may be too far to the right or left, incorrect horizontal centering, or there may be incorrect centering in both directions at once, as in the photograph.

Causes for trouble. Magnetic deflection.

Focusing control wrongly adjusted.

Ion trap magnet in wrong position on picture tube neck, or weak.

Horizontal hold control misadjusted.

Focusing coil axis direction requires adjustment. Should be in line with picture tube axis.

Focusing coil too far forward or back. Usually should be $\frac{1}{4}$ to $\frac{3}{8}$ inch from the deflection yoke.

Focusing coil short circuited.

Deflection yoke too far back on neck of picture tube, or not centered around neck.

Defective bypass capacitor on focusing control.

Causes for trouble. Electrostatic deflection.

Centering control or controls wrongly adjusted.

Horizontal hold control misadjusted.

Picture tube shield magnetized.

Leaky capacitor or capacitors between outputs of deflection amplifiers or oscillators and the picture tube deflection plates. WorldRadioHistory

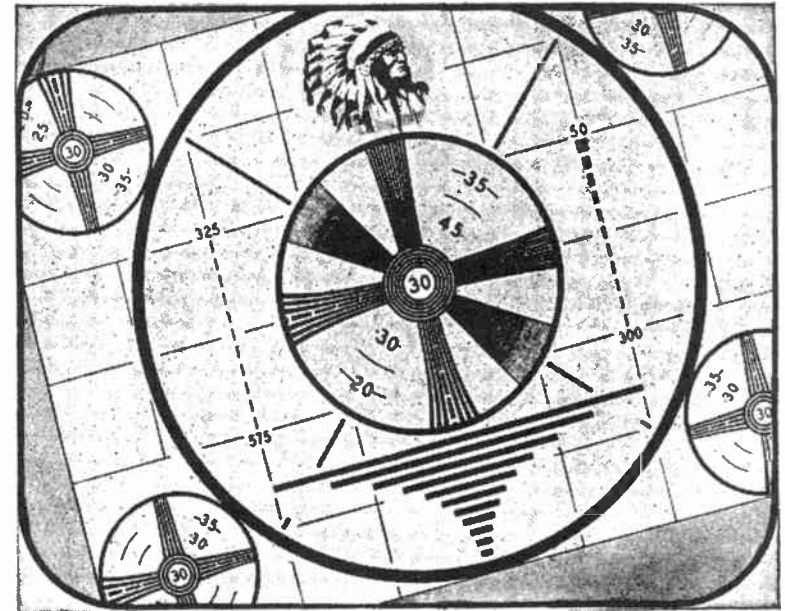

Fig. 131-30.—Tilting in Mask.

Causes for trouble.

Incorrect position of magnetic deflection yoke. Loosen the yoke fastening while rotating the yoke around the picture tube neck to straighten the pattern.

Incorrect position of electrostatic tube. Rotate the entire tube around its axis to straighten the pattern.

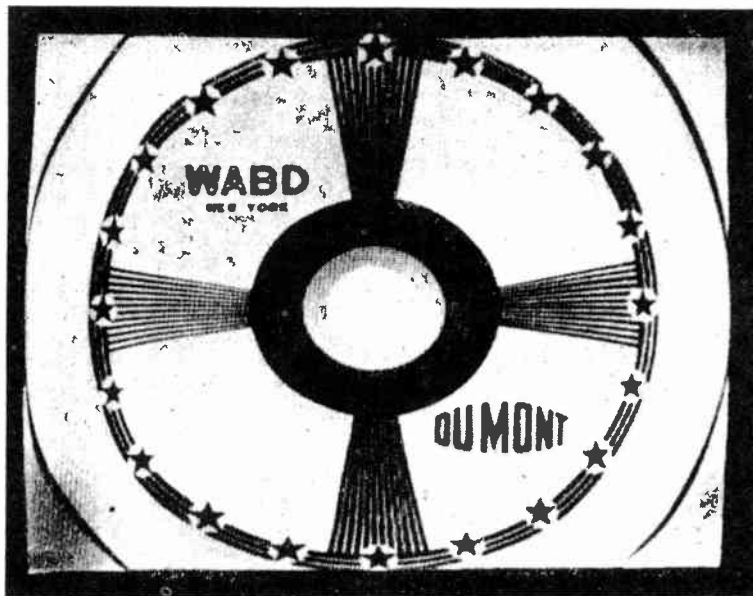

Fig. 131-18.—Lines, Narrow, Allover Pattern.

Due to beat interference from radio frequency and television frequency signals or voltages originating from outside or within the receiver. The number of cycles per second of the interfering frequency is equal approximately to the number of lines, either light or dark, but not both, multiplied by 15,750. The lines may lie vertically or diagonally on the picture tube screen. They weave or ripple and change their direction.

Causes for trouble.

Interference from f-m radio broadcasting stations operating in the area where the receiver is located. Change the direction of the receiving antenna. Tune an antenna trap to the interfering frequency. Check the transmission line for possible signal pickup.

Interference from nearby short-wave transmitters. Same remedies as for f-m interference.

Interference from television channels other than the one to which the receiver is tuned. Try adjusting the fine tuning control.

Beating frequency of 4.5 megacycles from sound section of a receiver having intercarrier sound system, or getting past the sound takeoff and reaching the picture tube grid cathode circuit through all or part of the video amplifier. Check dressing of all grid and plate leads following the takeoff.



Fig. 131-12.—Folded Pattern, Vertically.

Causes for trouble.

Vertical hold control incorrectly adjusted.

Faults in vertical hold control circuit causing vertical deflection frequency which is too high.

SECTION V

Waveforms

The preferred method of analyzing the operation of a TV receiver is through the use of an oscilloscope. The waveforms reproduced in this Section are typical of those found in a well-performing commercial receiver. It must be understood that circuit variations exist between different manufacturers and that the waveforms obtained will be dependent upon these circuit variations as well as the signal conditions and the quality of the oscilloscope being used.

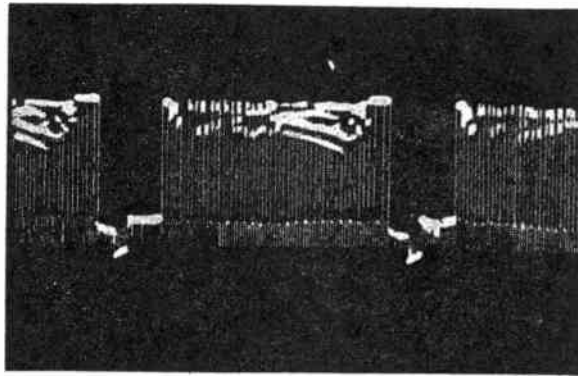

Fig. 139-1.

Fig. 139-1: Taken at the top of the video detector load resistor. This is the output of the video detector and the input to the grid circuit of the video amplifier. Here appears the entire composite television signal with picture variations, positive, at the top and with sync pulses, negative, at the bottom. Two vertical blanking intervals are plainly visible between the fields. During each blanking interval there appear in order, from left to right, the equalizing pulses which follow one field, then the vertical sync pulses at the bottom-most points along the trace, and finally the remaining equalizing and horizontal sync pulses which precede the next field.

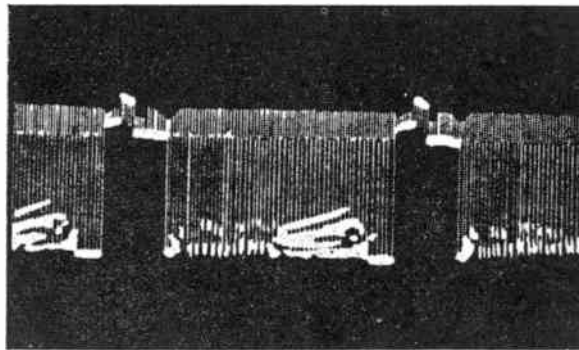

Fig. 139-2.

Fig. 139-2: Taken at the plate of the video amplifier tube. Here again is the complete composite signal, but now the polarity has been inverted to make sync pulses positive and picture variations negative. This waveform is applied to the cathode of the picture tube, which is the point of signal input to the picture tube of this particular receiver.

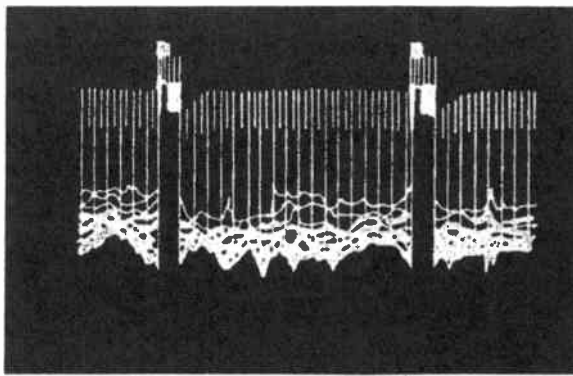

Fig. 139-3.

Fig. 139-3: Taken at the grid of the first tube in the sync section, which is a sync amplifier. The signal shown here comes from the output of the video amplifier, and accordingly is of the same polarity and has the same general characteristics as shown in Fig. 139-2.

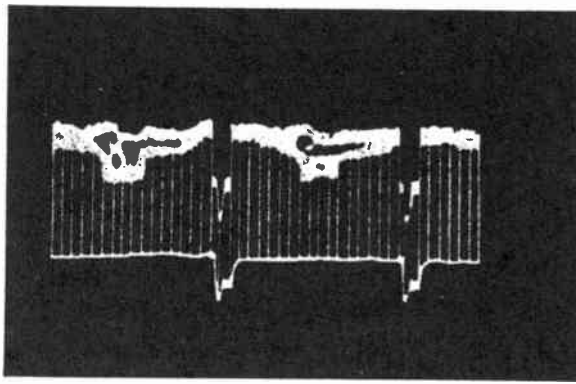

Fig. 139-4.

Fig. 139-4: Taken at the plate of the sync amplifier tube. The polarity has been inverted with respect to polarity in Fig. 139-3. The peak-to-peak voltage of this amplifier output waveform actually is about four times as great as voltage at the input to the tube.

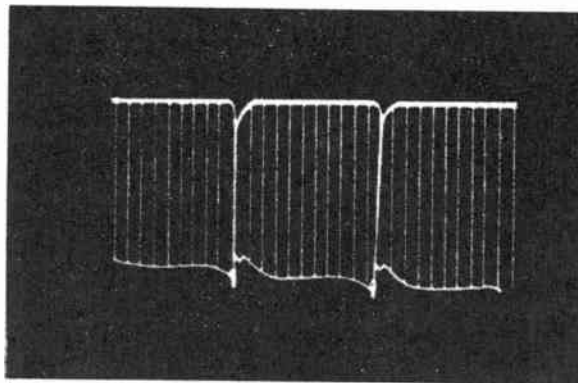

Fig. 139-5.

Fig. 139-5: Taken at the plate of the second tube in the sync section, which is operated as a separator. Picture variations have all but disappeared from the signal, while the vertical sync pulses have been retained. Polarity has not been inverted, because signal input is to the cathode rather than the grid of this separator.

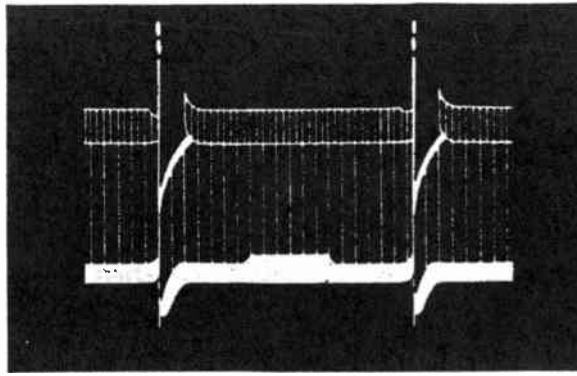

Fig. 139-6.

Fig. 139-6: Taken at the plate of the third tube in the sync section, which is operated as a clipper. Polarity has been inverted with respect to that of Fig. 139-5. Vertical sync pulse voltage peaks have become very pronounced. This is the signal which goes to the integrating filter located between the sync clipper and the input for the vertical sweep oscillator.

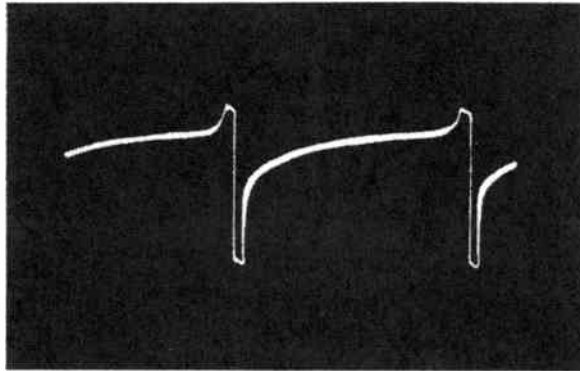

Fig. 139-7.

Fig. 139-7: Taken at the grid of the vertical sweep oscillator, which is a blocking type. Note the sudden changes of potential in the negative direction, downward on the trace, as the oscillator blocks. Then comes the quick partial recovery in the positive direction and the more gradual change preceding the positive peak that triggers this oscillator.

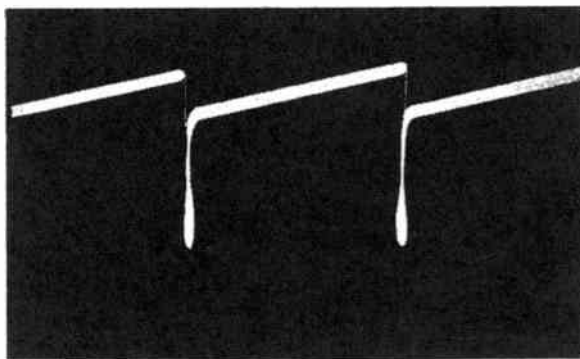

Fig. 139-8.

Fig. 139-8: Taken at the grid of the vertical sweep amplifier which follows the vertical oscillator. This is the sawtooth voltage combined with negative (downward) peaks as required for magnetic deflection.

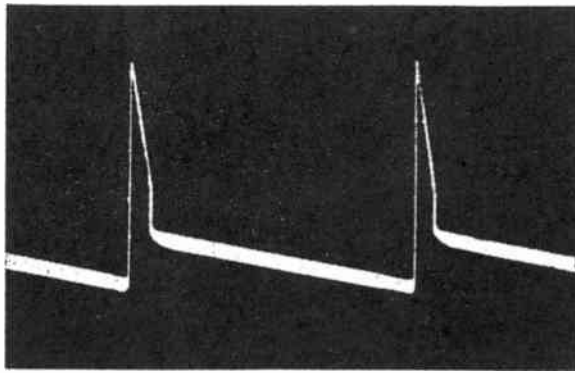

Fig. 139-9.

Fig. 139-9: Taken at the plate of the vertical sweep amplifier. Polarity has been inverted with respect to the previous trace, taken at the grid of the same tube. Peak-to-peak voltage here is about 18 times as great as at the grid.

Fig. 139-10: This final trace for the vertical deflection system is taken from the circuit which includes the secondary winding of the vertical output transformer and the two ver-

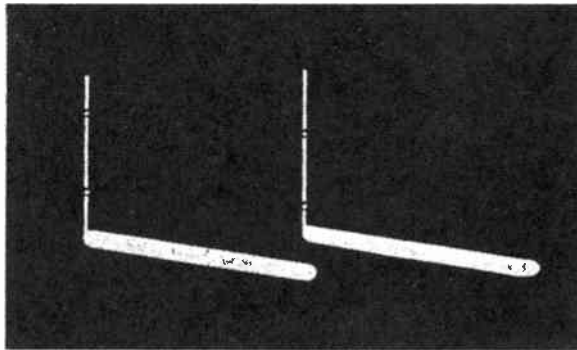

Fig. 139-10.

tical deflection coils of the yoke on the picture tube. Peak-to-peak voltage is between one-ninth and one-tenth of that at the plate of the vertical sweep amplifier, which connects to the primary of the output transformer.

Traces which are to follow in Figs. 139-11 to 139-24 are taken with the internal sweep of the oscilloscope adjusted for 7,875 cycles per second or to the frequency which produces two horizontal line periods.

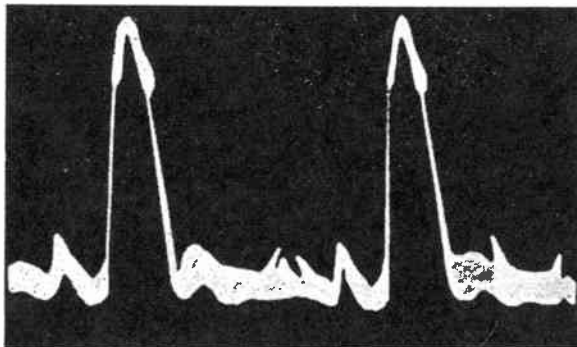

Fig. 139-12.

Fig. 139-12: From the plate of the video amplifier tube. Except for inversion of polarity this trace is similar to the one taken from the grid of this tube. Peak-to-peak voltage has been increased about nine times.

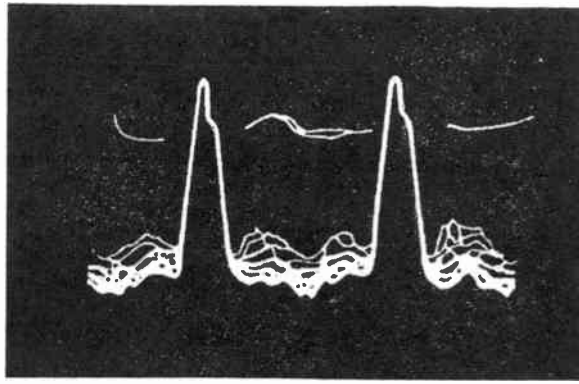

Fig. 139-13.

Fig. 139-13: From the grid of the sync amplifier, the first tube in the sync section. This signal comes from the output of the video amplifier, and is of the same polarity as in Fig. 139-12.

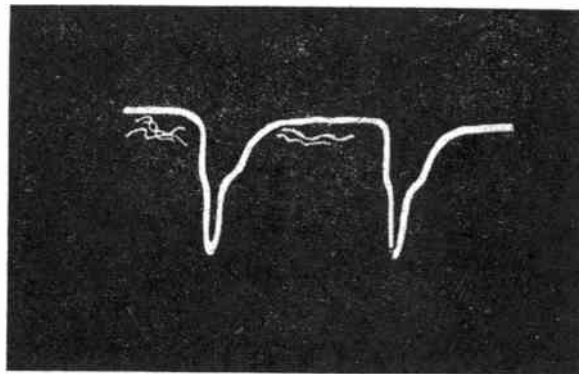

Fig. 139-14.

Fig. 139-14: From the plate of the sync amplifier. Polarity has been inverted. Voltages for picture variations have very nearly disappeared, while horizontal sync pulses have become distinct.

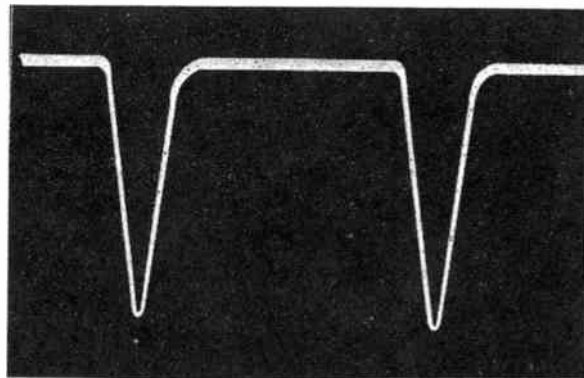

Fig. 139-15.

Fig. 139-15: From the plate of the sync separator tube. Only the horizontal sync pulses now remain. There has been no inversion of polarity, due to use of cathode input to this tube.

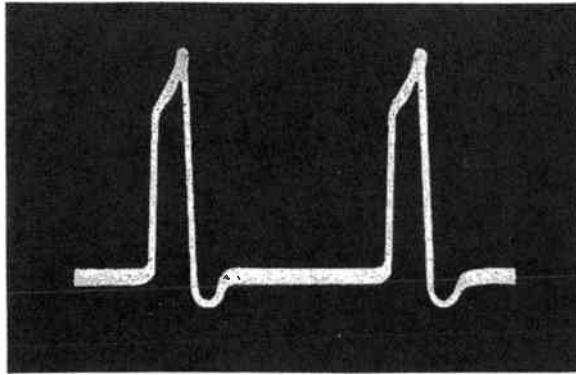

Fig. 139-16.

Fig. 139-16: From the plate of the sync clipper tube. This waveform is the input to the differentiating filter located between the clipper and the horizontal oscillator control tube of the horizontal afc system.

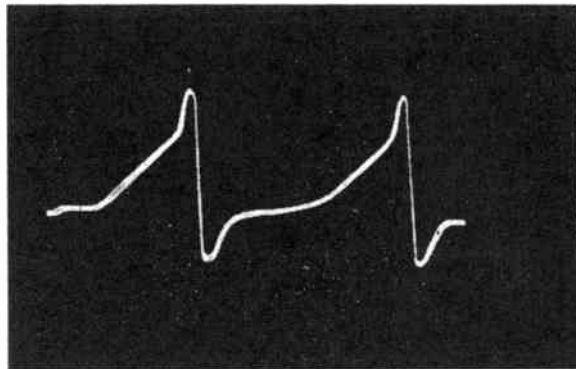

Fig. 139-17.

Fig. 139-17: From the top (ungrounded side) of the lock-in control capacitor in the grid circuit of the control tube of the horizontal afc system. This voltage results from combination of the output from the differentiating filter and a feedback voltage from the horizontal sweep output circuit, as required for this method of oscillator control. The waveform shown here is taken while a transmitted television signal is being received. The sharp or narrow positive peaks represent synchronizing voltages which result from horizontal sync pulses in the signal.

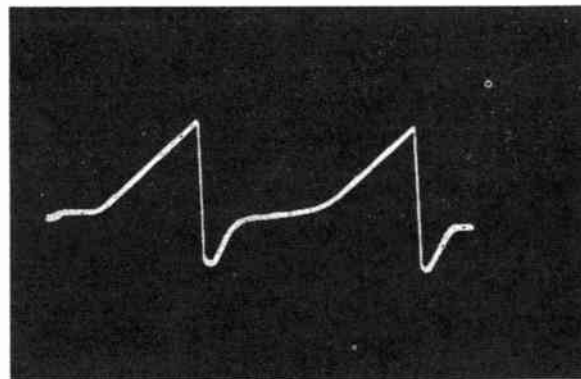

Fig. 139-18.

Fig. 139-18: This is the same as the previous trace, except that it is taken while no transmitted signal is being received. Note the absence of positive synchronizing peaks at the tops of the sawtooth portions of the wave.

SECTION VI

TYPICAL SCHEMATIC DIAGRAMS

The Diagrams reproduced on the following pages are Electronic Technician Circuit digest sheets, prepared by the Technical Staff of Electronics Technician Magazine. Diagrams covering essential Service Data on several popular TV Receivers, Transistorized Radio Receivers - including Portable and Auto Radios, as well as examples of Stereo, Hi-Fi and Printed Circuit Units are included in this section.

INDEX of SCHEMATICS

| | |
|--|---------|
| ADMIRAL; Tr Rad 6S2 | 404 |
| " " Ch 7M1, 7M11, 12, 14, 16. | 417 |
| TV 16AF1. | 417 |
| DELCO; Auto Rad 987727. | 410 |
| " Olds, 989131 | 414 |
| " 988977. | 418 |
| DUMONT; TV- RA 406/407. | 405 |
| " RA 502/503. | 407 |
| EMERSON; Tr-Rad 12374. | 406 |
| FIRESTONE; AM-FM Rad Phono 334-8-OA16A 5P10A. | 418 |
| GENERAL ELECTRIC; TV - M4 - 21T2425-21T2426 | 403 |
| TR Rad, P725-726A. | 406 |
| TR Port Rad P755A | 418 |
| HOTPOINT; TV Q3, 145208-9 UHF. | 413-415 |
| MAGNAVOX; AM-FM RAD 55-01-00. | 413 |
| MONTGOMERY WARD; TR RAD 75X GEN 1106A | 405 |
| PACKARD-BELL; TV CH 98D4, | 416 |
| PHILCO; TR-RAD-T-9 | 408 |
| TR RAD T4-T4J | 413 |
| PILOT; Stereo, Preamp SP 215 | 411 |
| RCA; TV KCS 122, A, B, C, D, E, F, H, J, K, L, M, N, P, R, AD, AE | 410 |
| WESTINGHOUSE; TR RAD V2393-1 | 409 |
| ZENITH; TR RAD 8AT41Z2. | 415 |

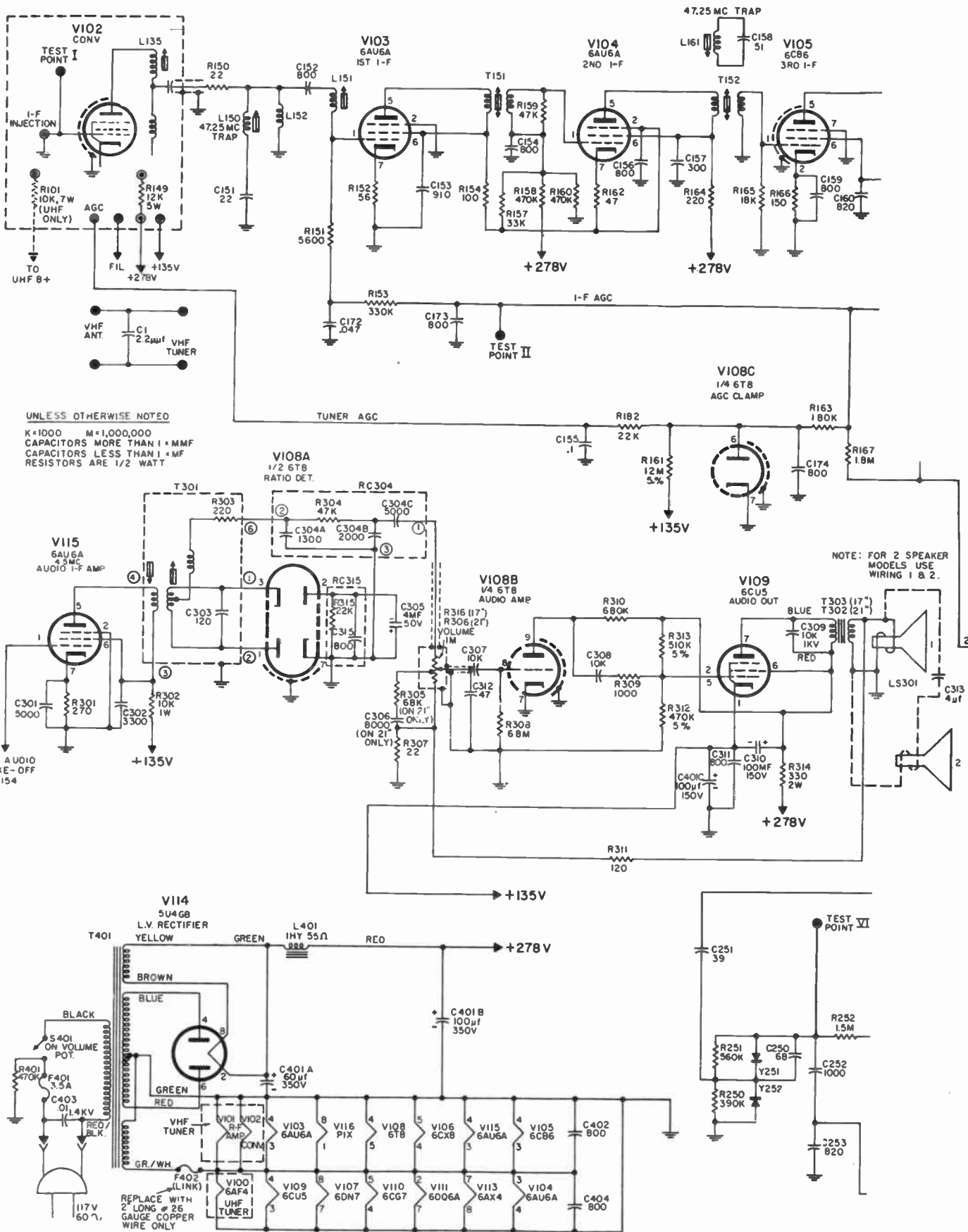

UNLESS OTHERWISE NOTED
 K = 1000 M = 1,000,000
 CAPACITORS MORE THAN 1 = MF
 CAPACITORS LESS THAN 1 = MF
 RESISTORS ARE 1/2 WATT

NOTE: FOR 2 SPEAKER
 MODELS USE
 WIRING 1 & 2.

CONTINUED ON NEXT PAGE →

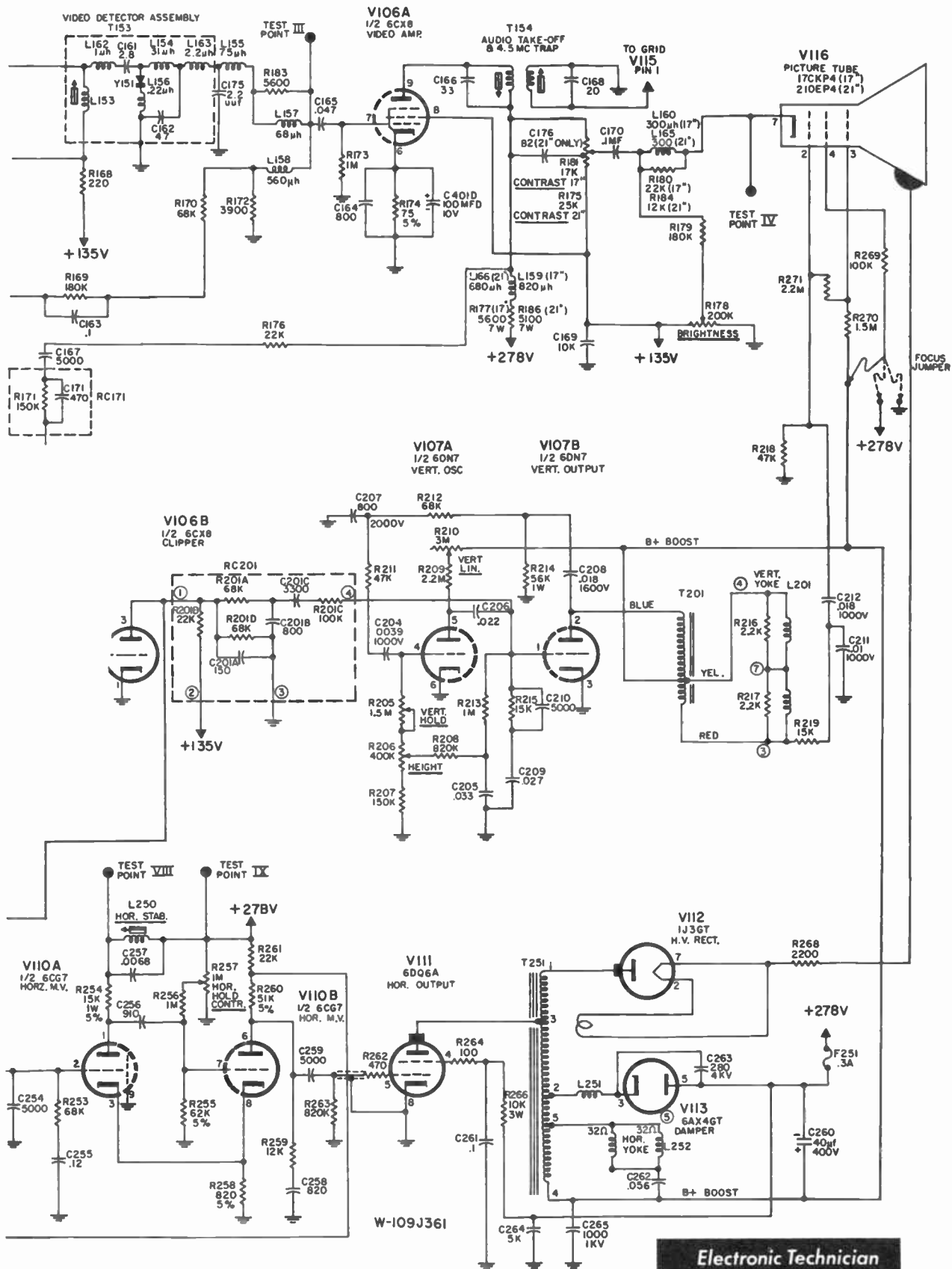

Electronic Technician
**CIRCUIT
DIGEST**

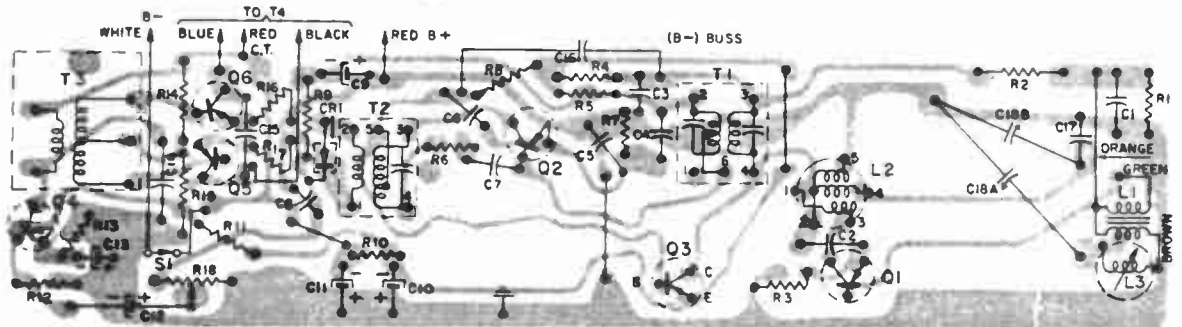
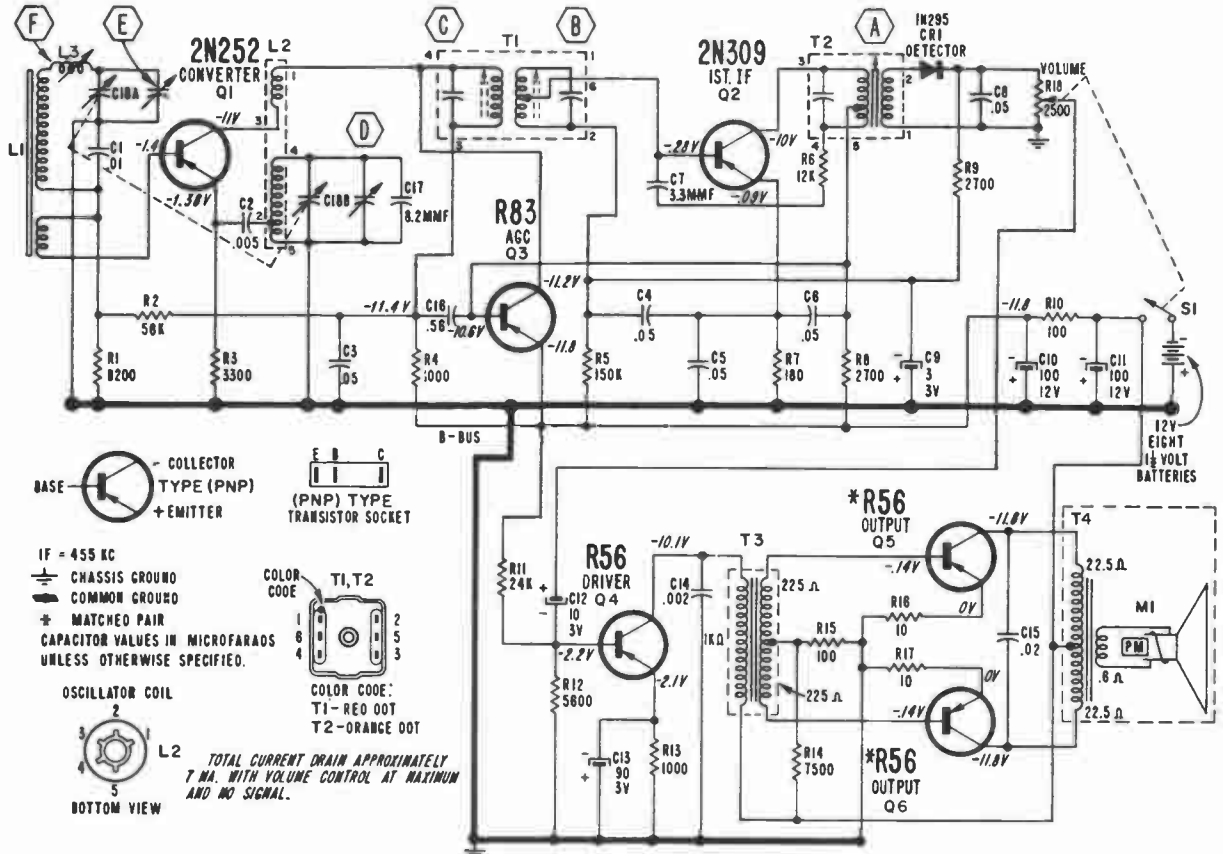

View of Printed Wiring Board. NOTE: Gray area represents printed wiring, black symbols and lines represent components, wiring and connections on opposite side.

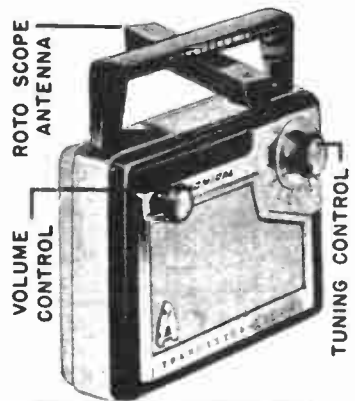

Electronic Technician
**CIRCUIT
DIGEST**

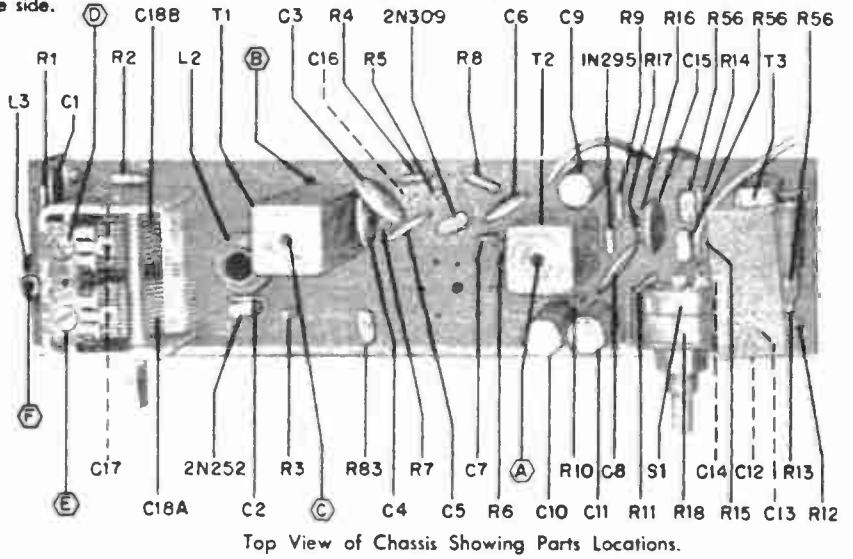

Top View of Chassis Showing Parts Locations.



BROADCAST Ant., R-F, Osc. and Mixer Circuits (SW1 and SW2 are similar except for Coils and Trimmers)

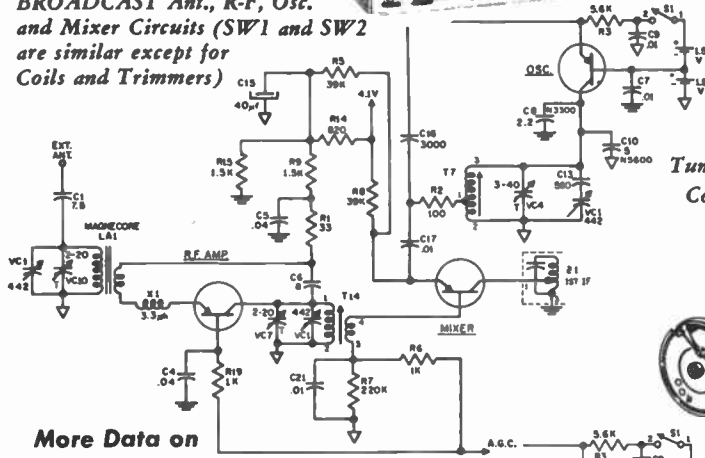

More Data on
Opposite Page

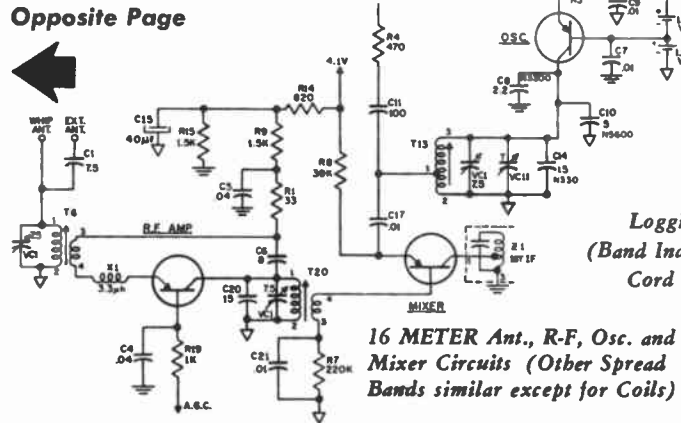

16 METER Ant., R-F, Osc. and Mixer Circuits (Other Spread Bands similar except for Coils)

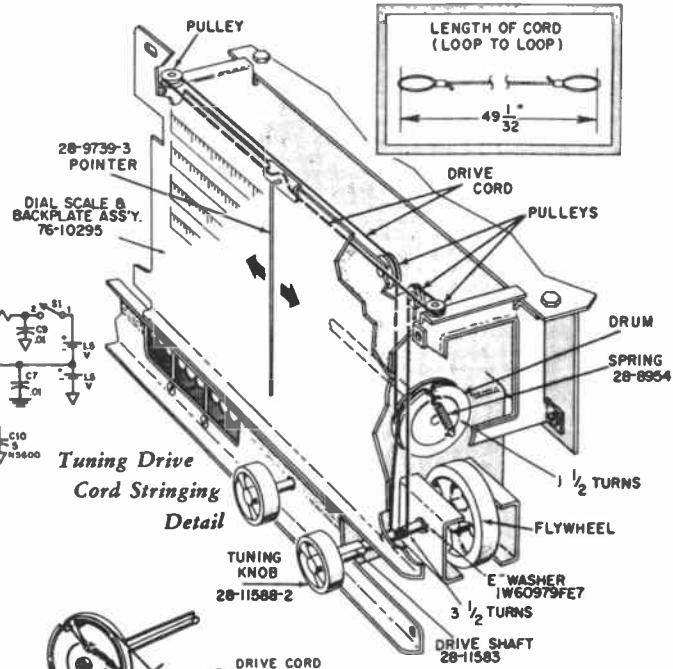

Tuning Drive Cord Stringing Detail

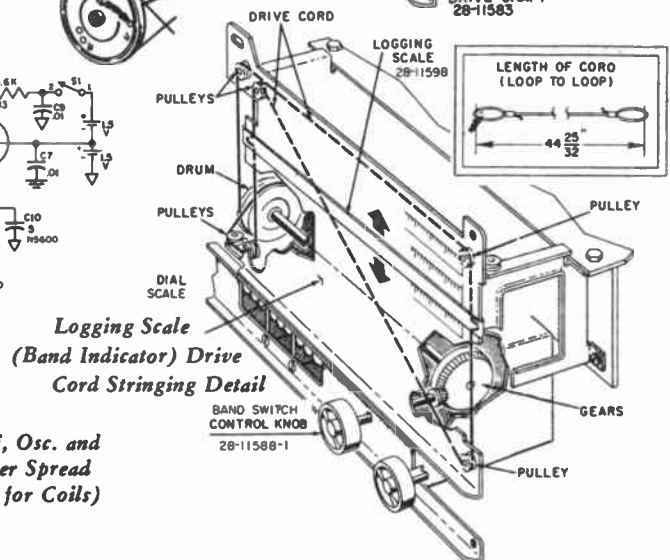

Logging Scale (Band Indicator) Drive Cord Stringing Detail

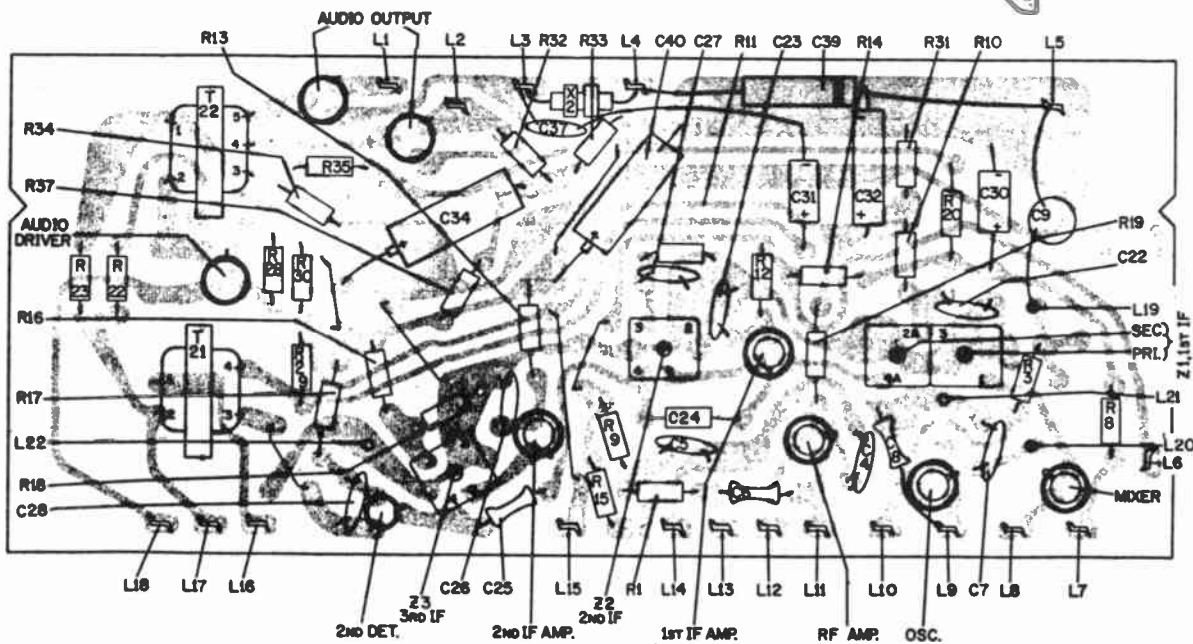
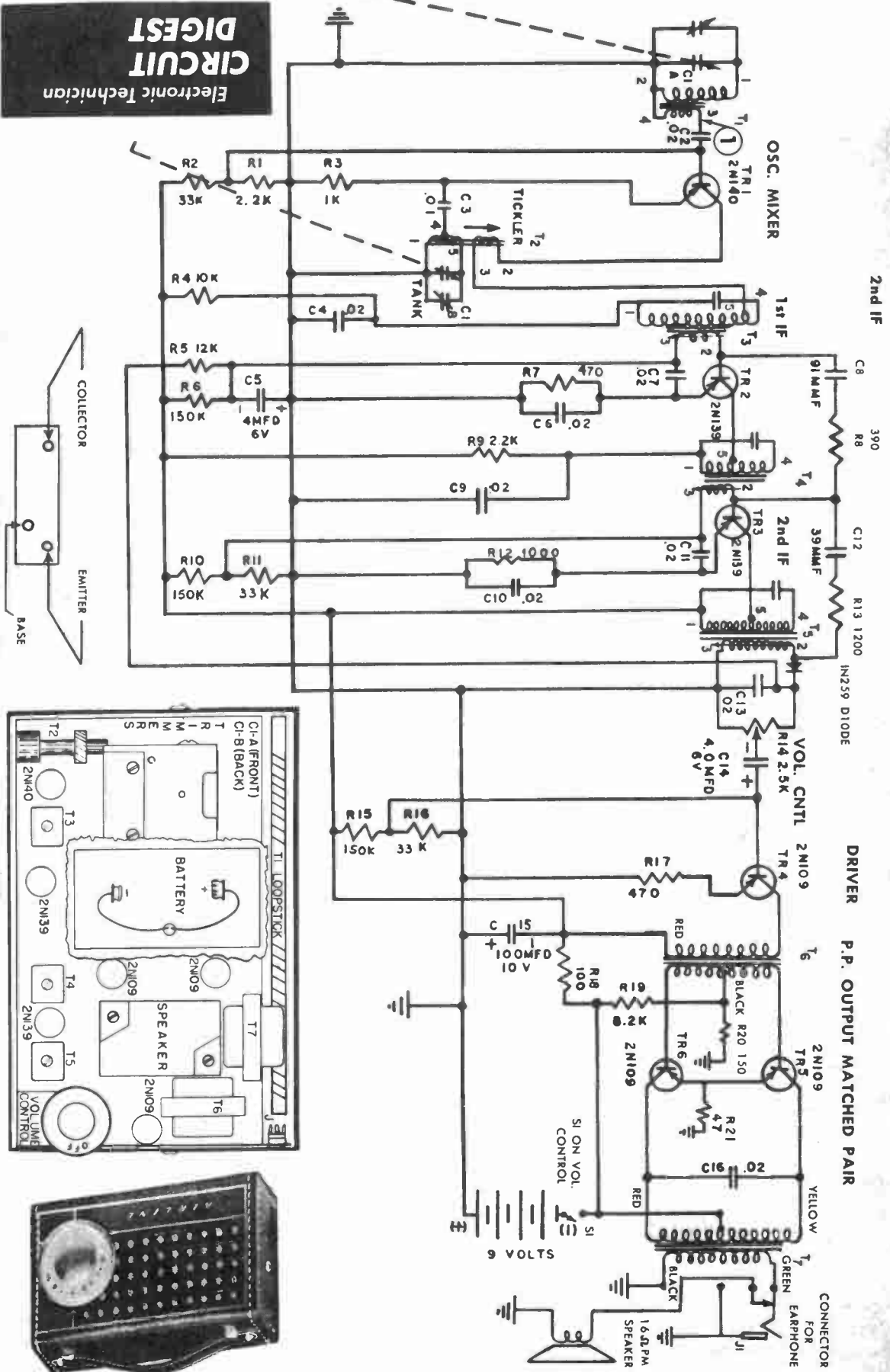

Figure 7. Composite Panel View — Showing Parts Placement

ELECTRONIC TECHNICIAN CIRCUIT DIGEST

MONTGOMERY WARD
Transistor Radio
Serial No. 75X
Model GEN-1106A

405



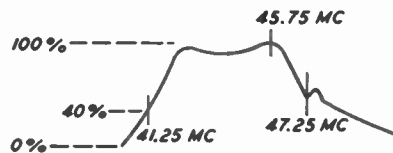
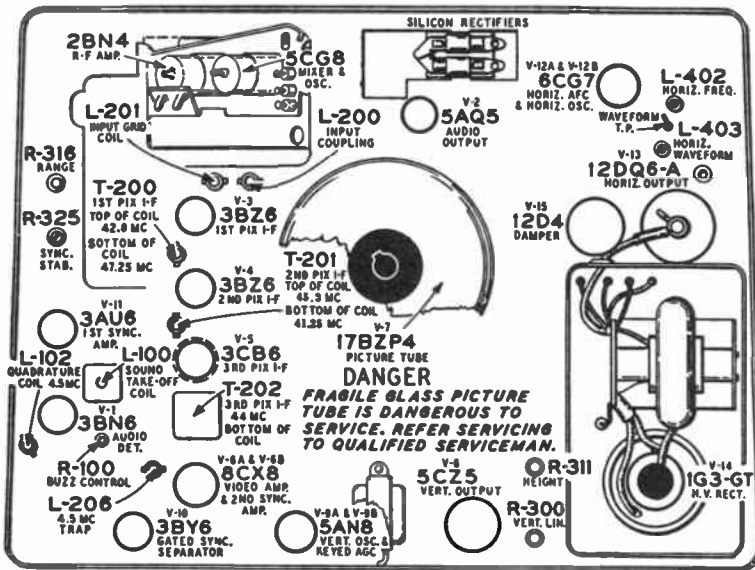
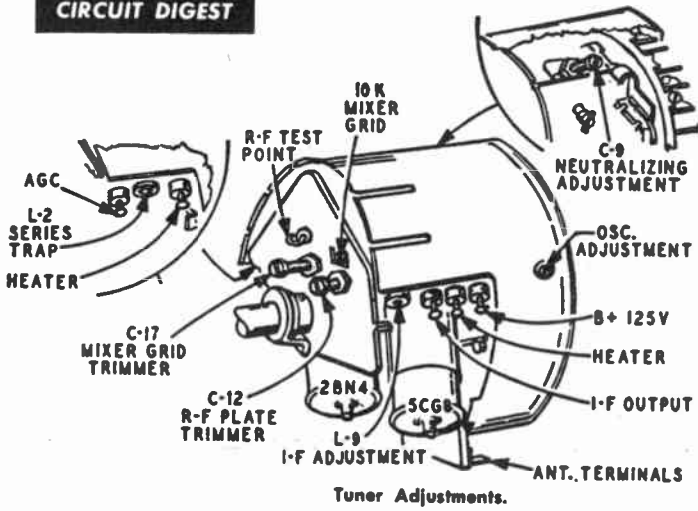
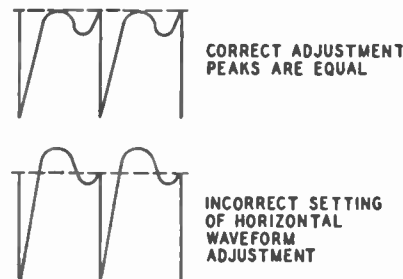
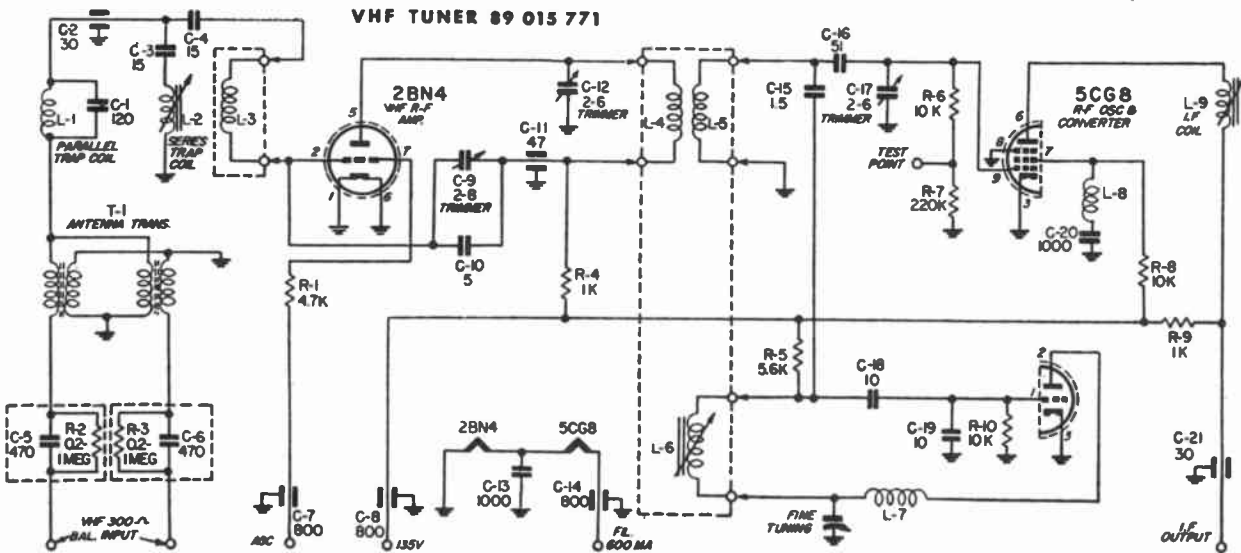

Figure 4. Bandpass Curve.



Proper and improper horizontal wave forms.



ELECTRONIC TECHNICIAN CIRCUIT DIGEST

WESTINGHOUSE
Transistor Radio
Chassis V-2393-1
Model H655P5, H656P5

409

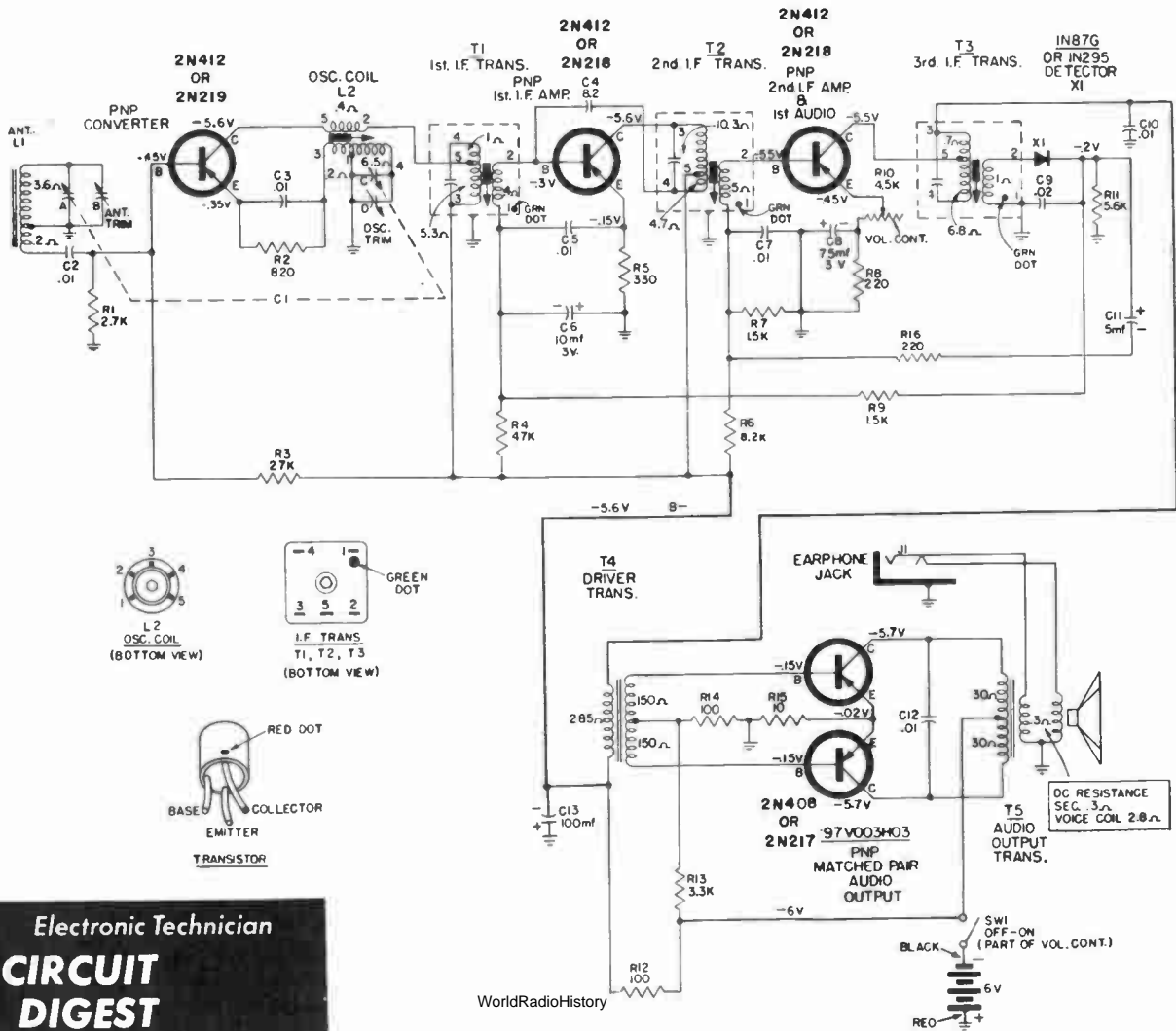
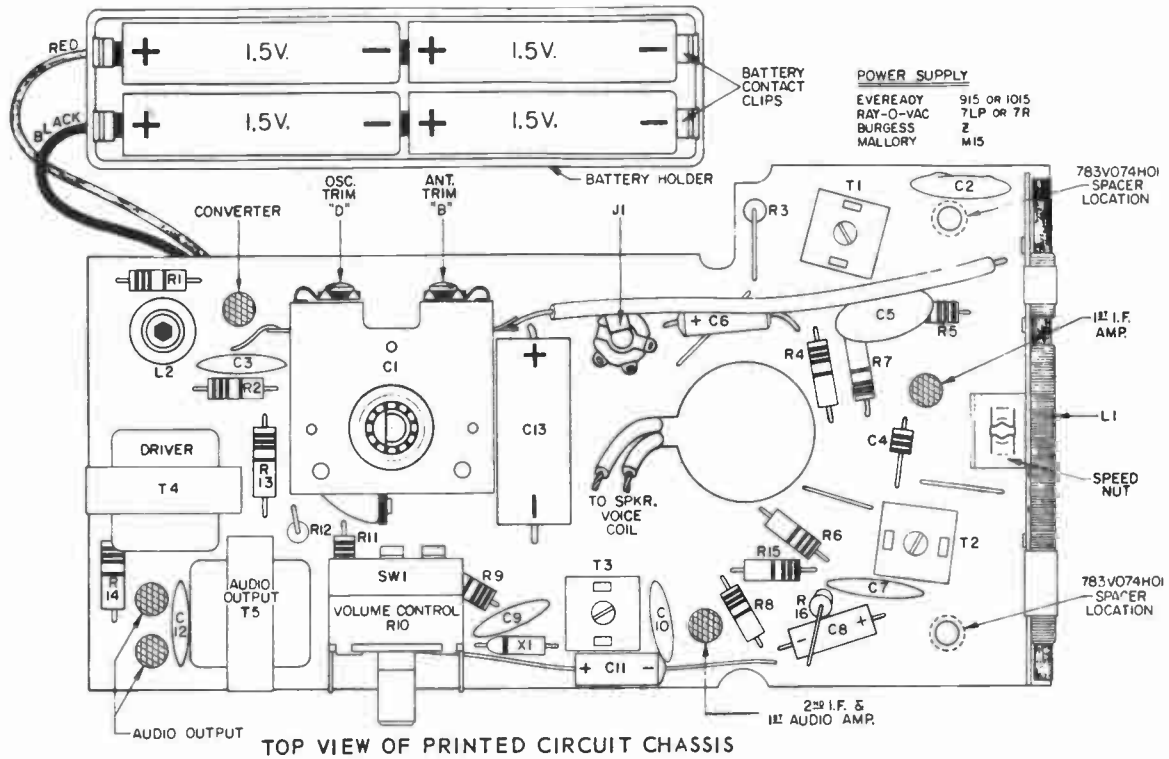

Electronic Technician
**CIRCUIT
DIGEST**

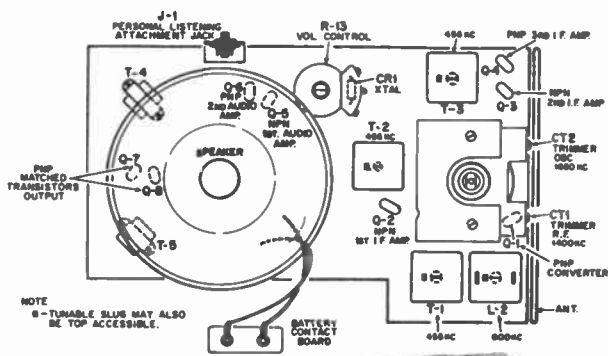

NOTE: B-TUNABLE SLUG MAY ALSO BE TOP ACCESSIBLE.



MODEL 888 (PIONEER)



VANGUARD



SATELLITE

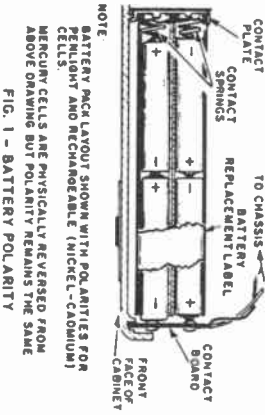

NOTE: BATTERY PACK LAYOUT SHOWS WITH POLARITIES FOR PENLIGHT AND RECHARGEABLE (NICKEL-CADMIUM) CELLS. MERCURY CELLS ARE PHYSICALLY REVERSED FROM ABOVE DRAWING BUT POLARITY REMAINS THE SAME.

FIG. 1 - BATTERY POLARITY

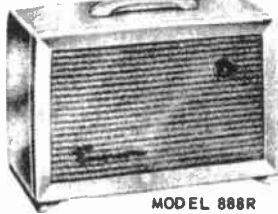

MODEL 888R

| FOR | USE | TRANSISTOR NOS. |
|---------|------------|-----------------|
| 815026B | 815026D | Q2/Q3 |
| 815026A | 815026E | Q2/Q3 |
| 815026C | No. Subst. | Q2/Q3 |

| FOR | USE | TRANSISTOR NOS. |
|---------|--------|-----------------|
| 815026F | 815028 | Q2/Q3 |
| 815028 | 815032 | Q5 |
| 815028 | 815032 | Q5 |

| FOR | USE | TRANSISTOR NOS. |
|--------|--------|-----------------|
| 815033 | 815032 | Q5 |
| 815034 | 815032 | Q5 |
| 815035 | 815032 | Q5 |

| TRANSISTOR PAIRS | ASSOCIATED R12 |
|------------------|----------------|
| Q2 | 880 |
| 815026C | 880 |
| 815026B | 880 |
| 815026A | 880 |
| 815026D | 330 |

| TRANSISTOR PAIRS | ASSOCIATED R12 |
|------------------|----------------|
| Q2 | 880 |
| 815026C | 880 |
| 815026B | 880 |
| 815026A | 880 |
| 815026D | 330 |

| TRANSISTOR PAIRS | ASSOCIATED R14 |
|------------------|----------------|
| Q3 | 3000 |
| 815031 | 8200 |
| 815028 | 4700 |
| 815032 | 4700 |

| TRANSISTOR PAIRS | ASSOCIATED R14 |
|------------------|----------------|
| Q5 | 8800 |
| 815033 | 8200 |
| 815034 | 10,000 |
| 815035 | 10,000 |

NOTES: 1-Because of the small physical size of the transistors, the 1st three digits, "815", have been replaced by the letter, "E" for Emerson.
2-To improve the operation of Q1, at the high end, a resistor 680K, $\pm 10\%$, $\frac{1}{2}W$, is added across pins 1 and 2 of L-2.

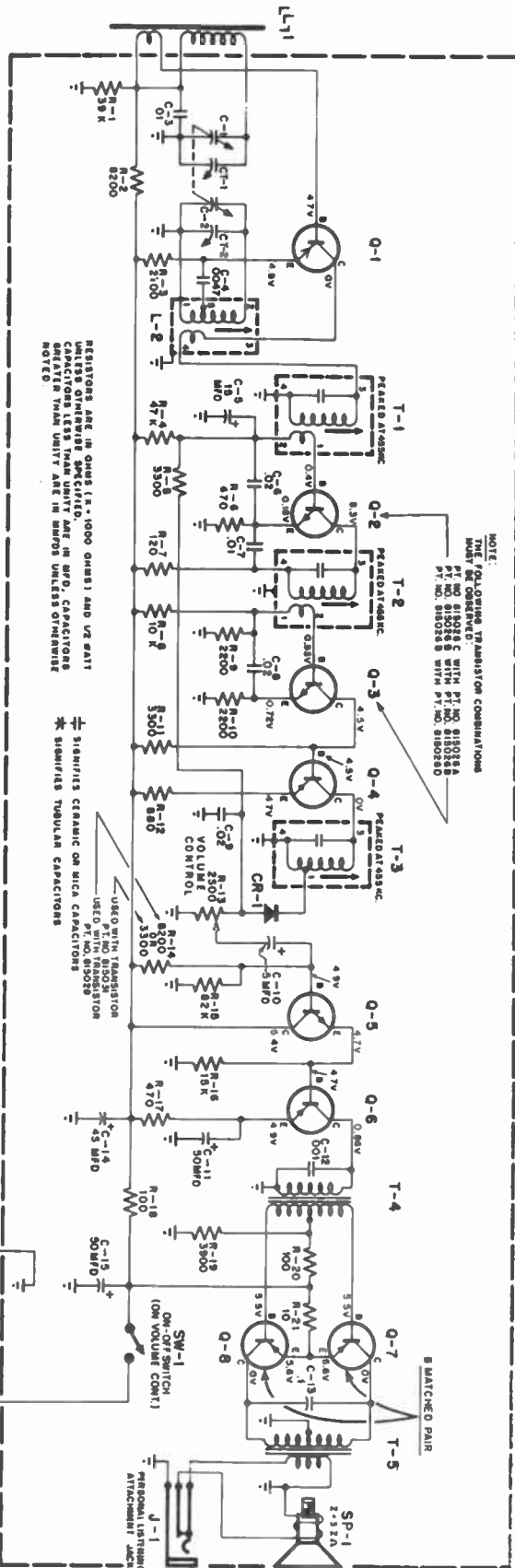

NOTE: THE FOLLOWING TRANSISTOR COMBINATIONS MUST BE OBSERVED:
PT. NO. 815026 C WITH PT. NO. 815028 B
PT. NO. 815026 B WITH PT. NO. 815028 B
PT. NO. 815026 A WITH PT. NO. 815028 B
PT. NO. 815026 D WITH PT. NO. 815028 B

RESISTORS ARE IN OHMS (i.e., 1000 OHMS) AND VC MEANS VOLTAGE COEFFICIENT SPECIFIED. \pm IN OHM CAPACITORS GREATER THAN 1000 ARE IN MICRO UNLESS OTHERWISE NOTED.
* SIGNIFIES CERAMIC OR MICA CAPACITORS
* SIGNIFIES TUBULAR CAPACITORS

USED WITH TRANSISTOR PT. NO. 815031
USED PT. NO. 815028

BATTERY - 6 VOLT
(4 PENLIGHT CELLS)

ELECTRONIC TECHNICIAN CIRCUIT DIGEST

GENERAL ELECTRIC
Transistor Radio
Models P725A, P726A

Electronic Technician
**CIRCUIT
DIGEST**

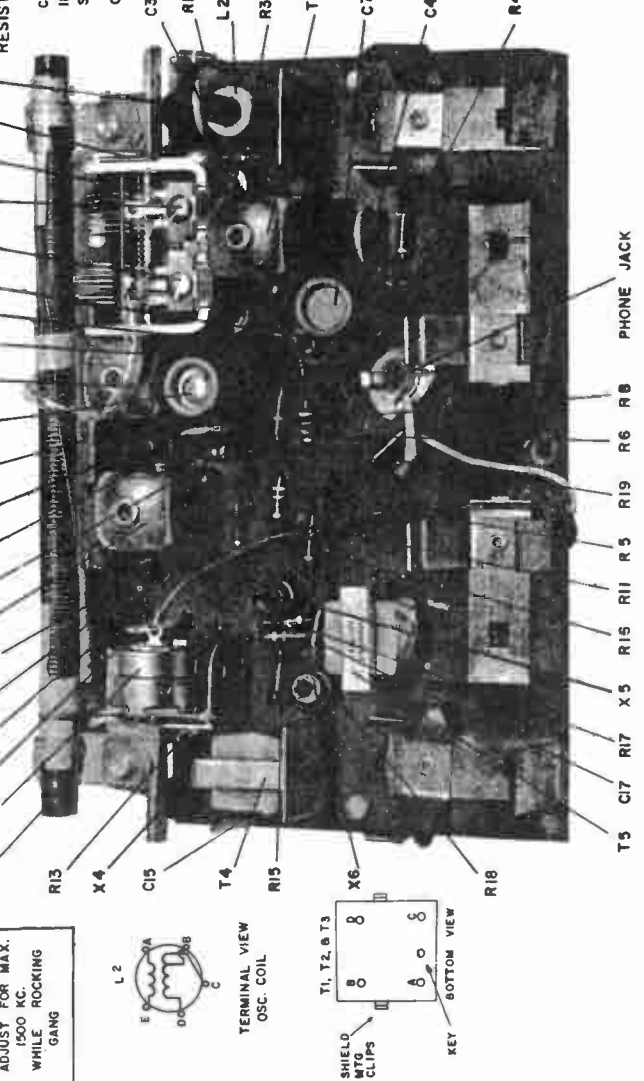
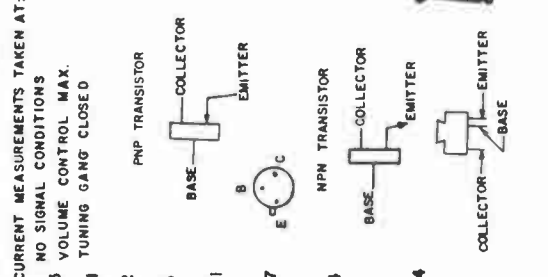
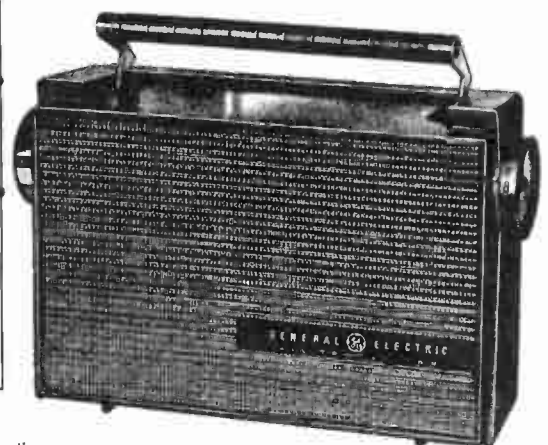
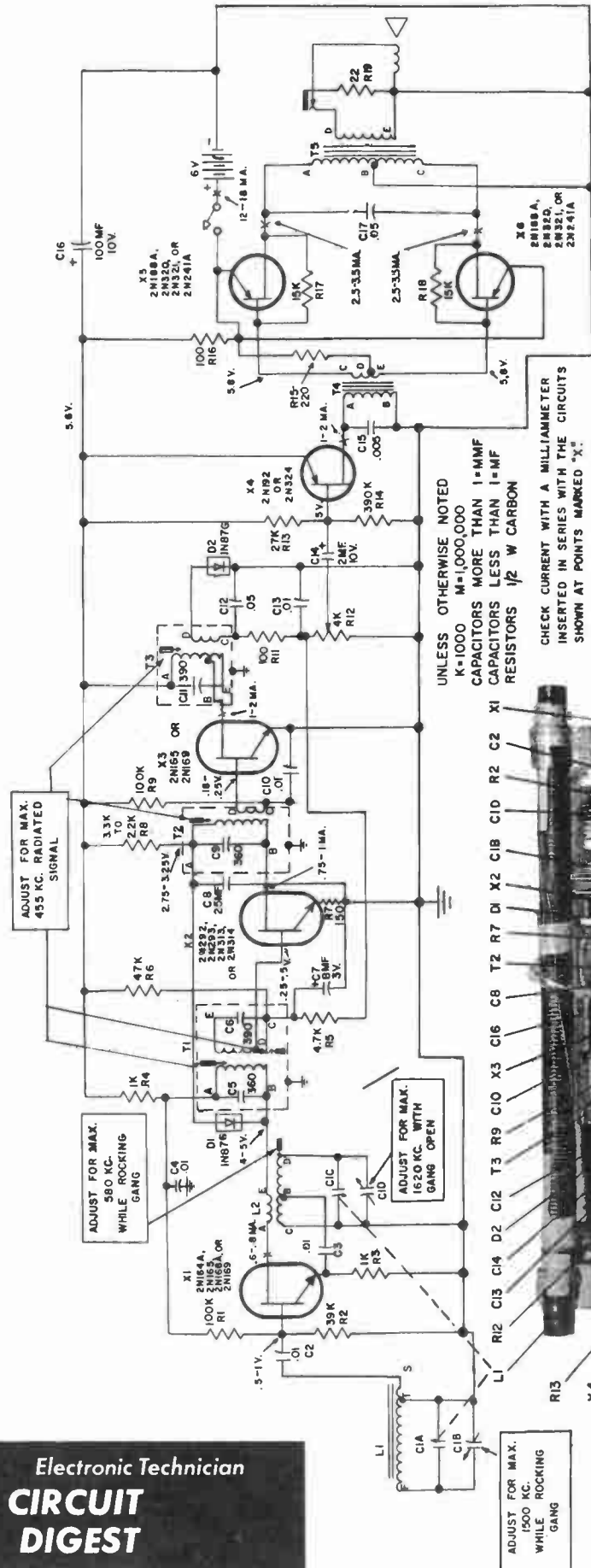

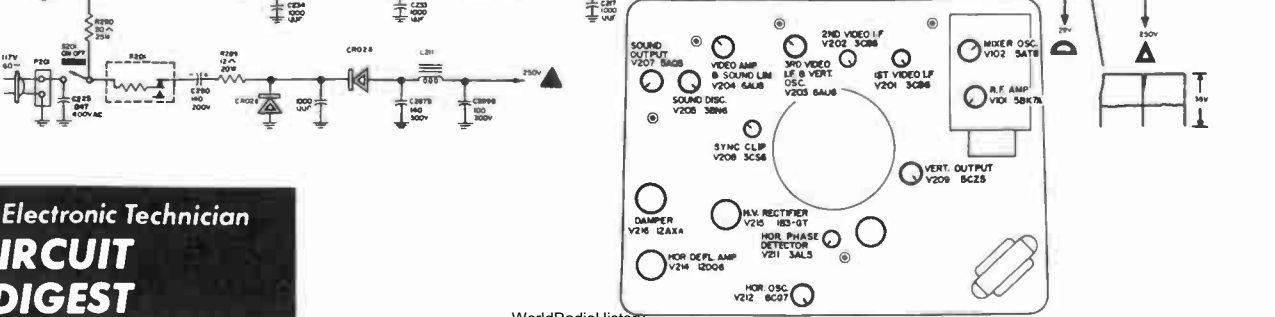
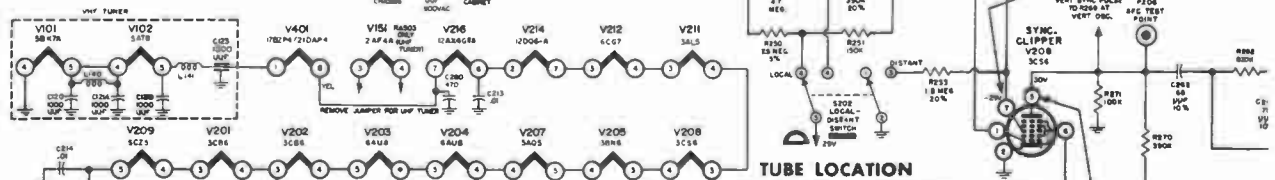
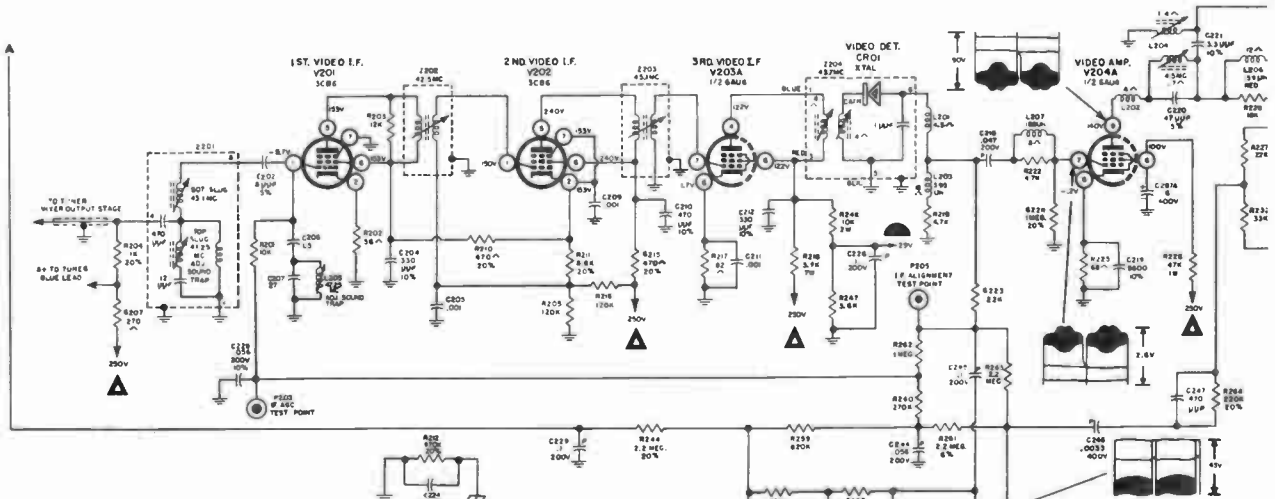
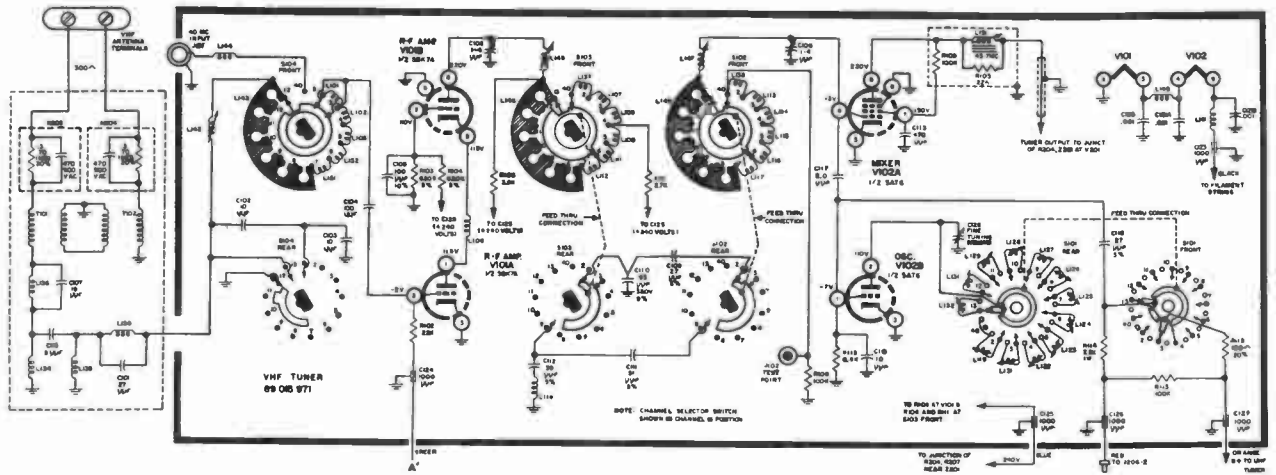

Electronic Technician
**CIRCUIT
DIGEST**

WorldRadioHistory

CONTINUED ON NEXT PAGE →

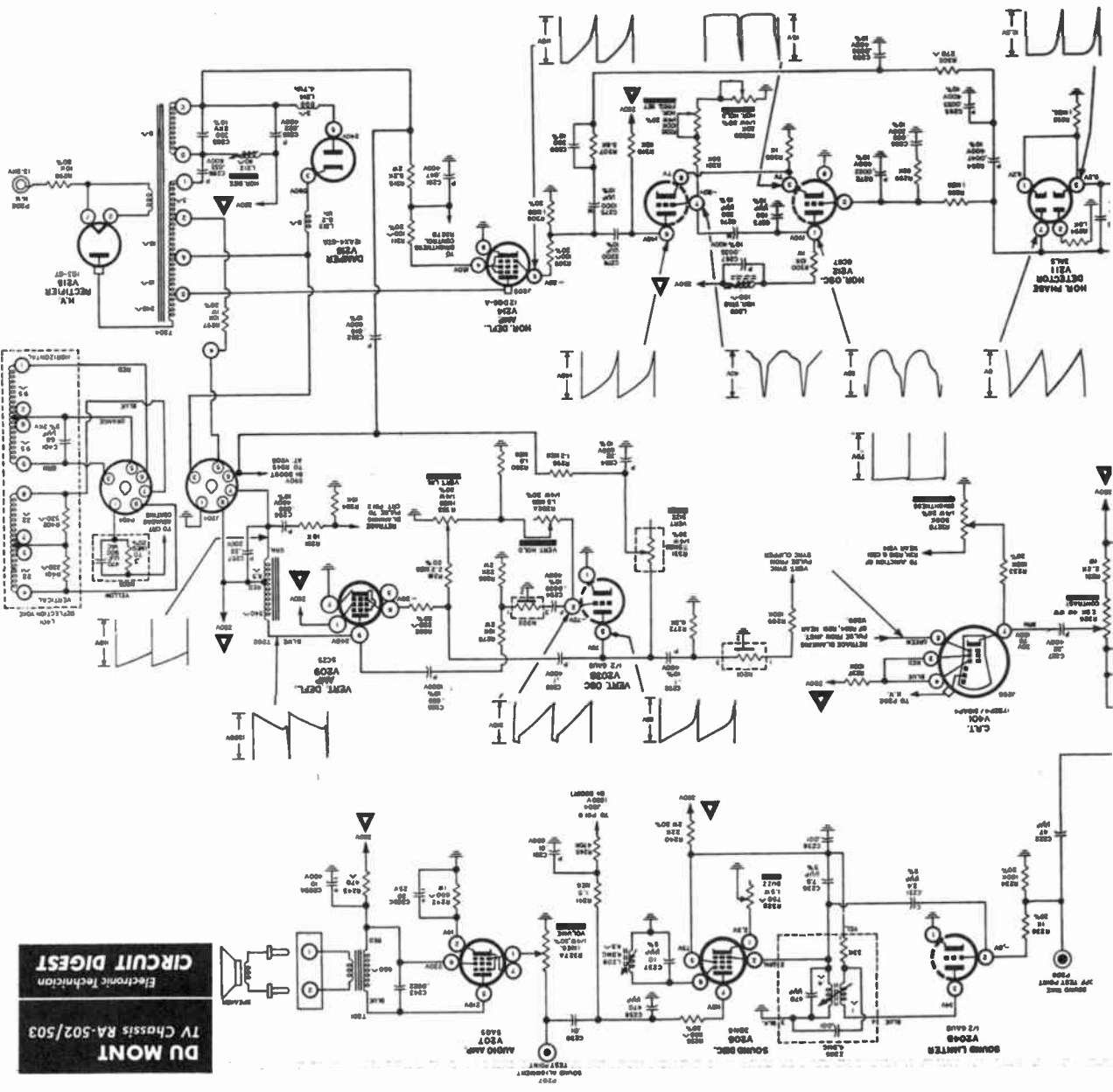

DU MONT
 TV Chassis RA-502/503
 Electronic Technician
CIRCUIT DIGEST

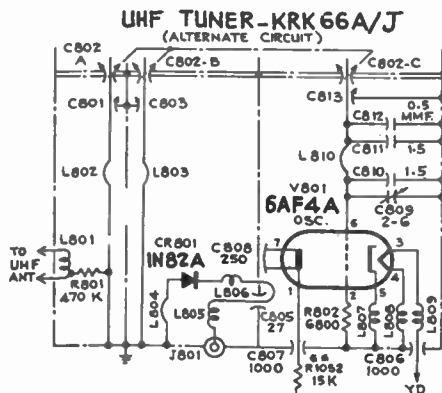
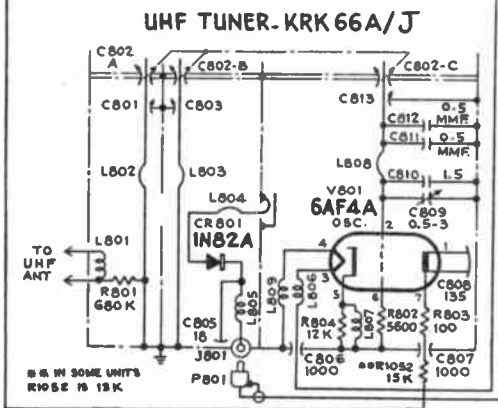
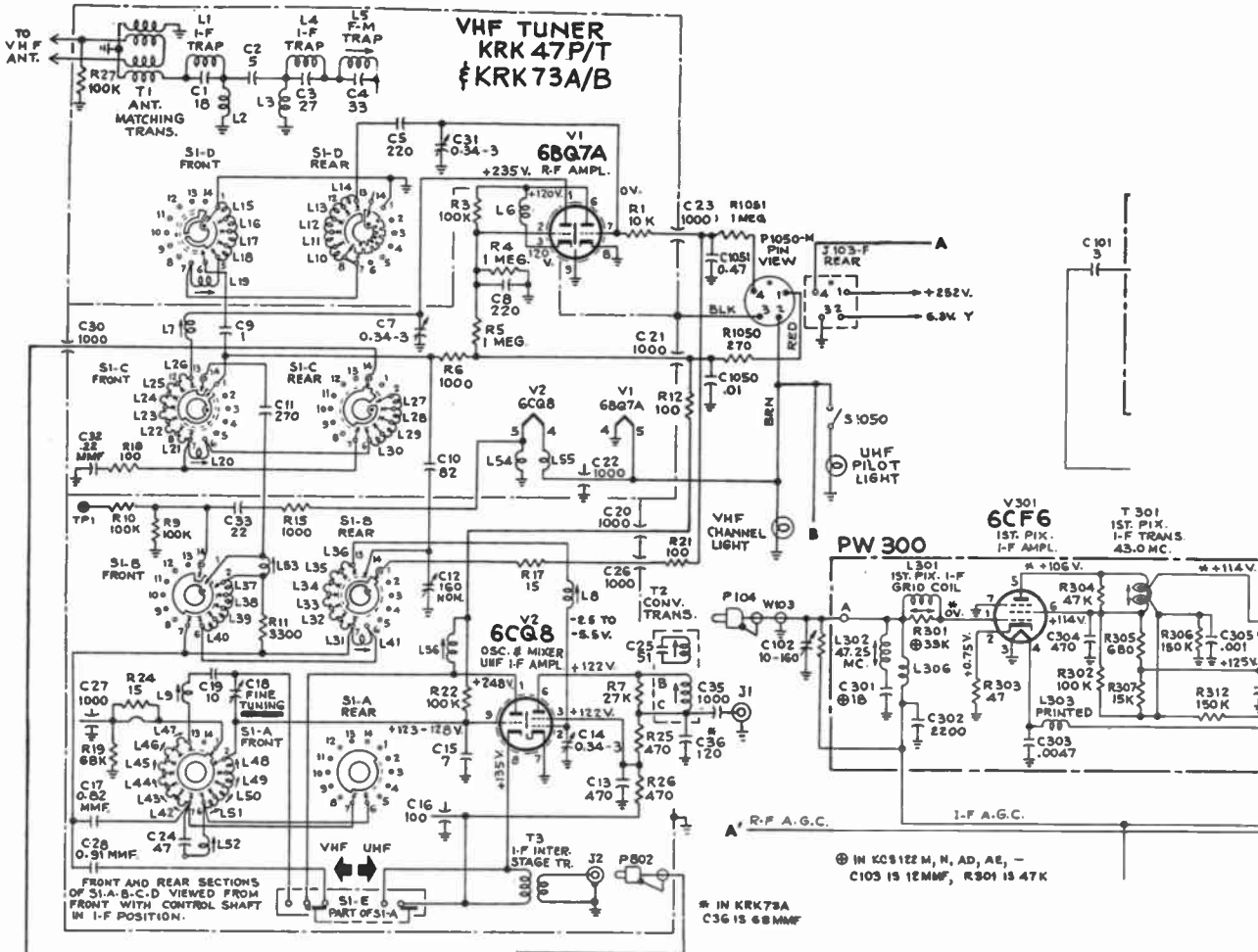

All resistance value in ohms. K = 1000.

All capacitance values less than 1 in MF and above 1 in MMF unless otherwise noted.

Direction of arrows at controls indicates clockwise rotation.

All voltages measured with "Volt-Ohmyst" and with no signal input. Voltages should hold within $\pm 20\%$ with 117 v. a-c supply.

*Measured with 1 megohm, $\frac{1}{2}$ watt resistor in series with probe.

Balloons ① ② etc., shown on schematic indicate points of observation of the waveforms shown

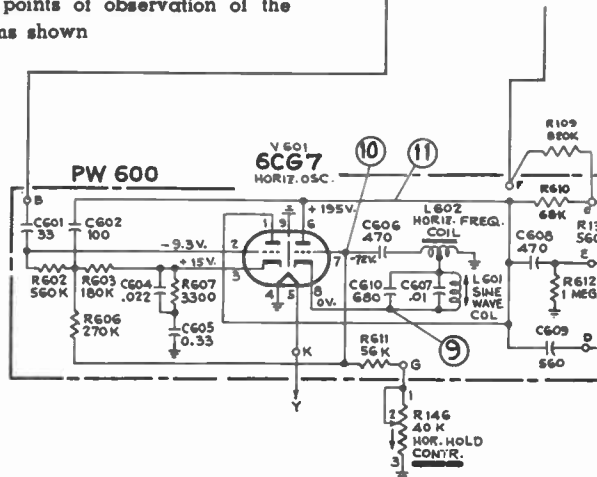
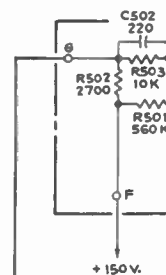

CONTINUED ON NEXT PAGE →

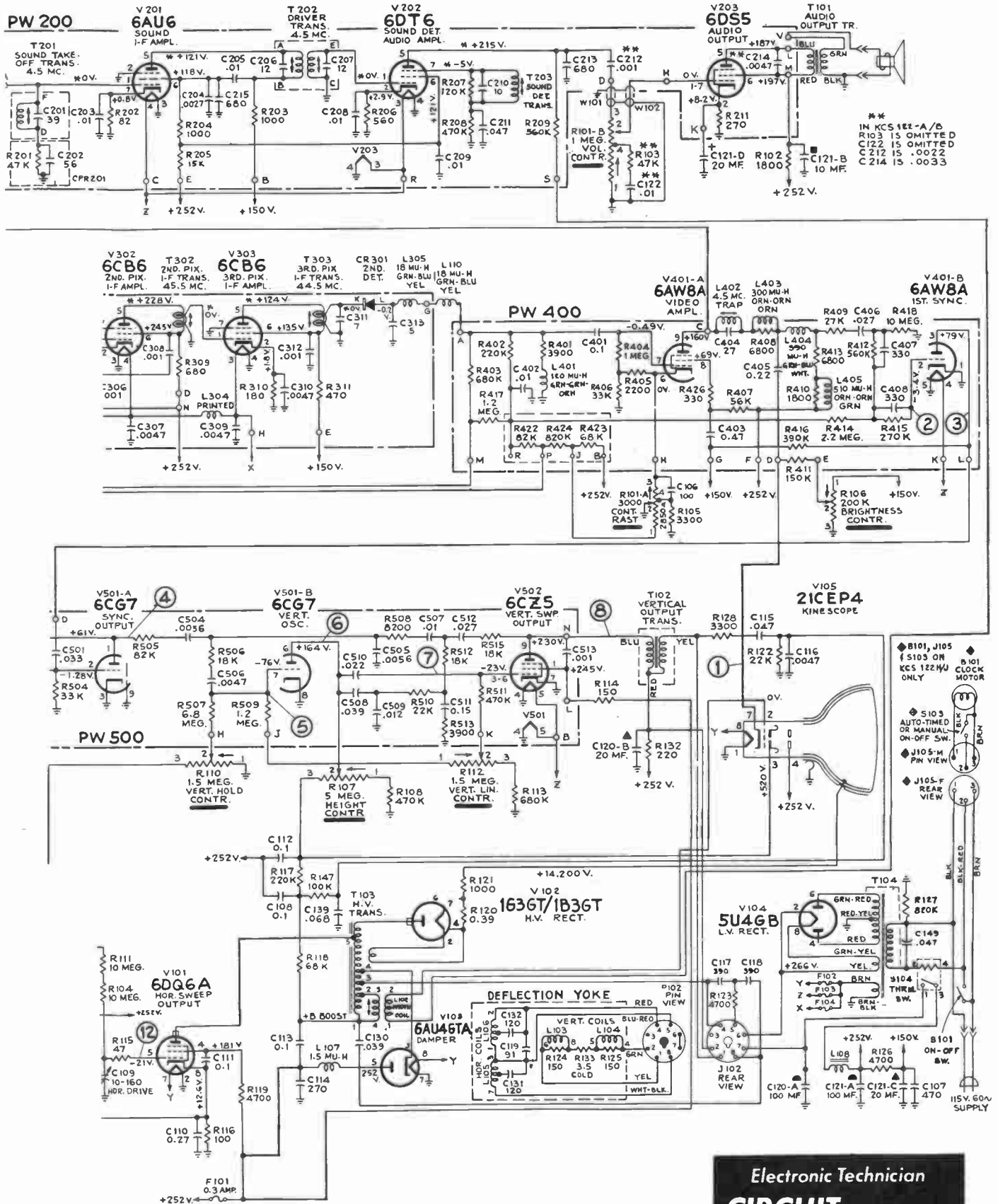

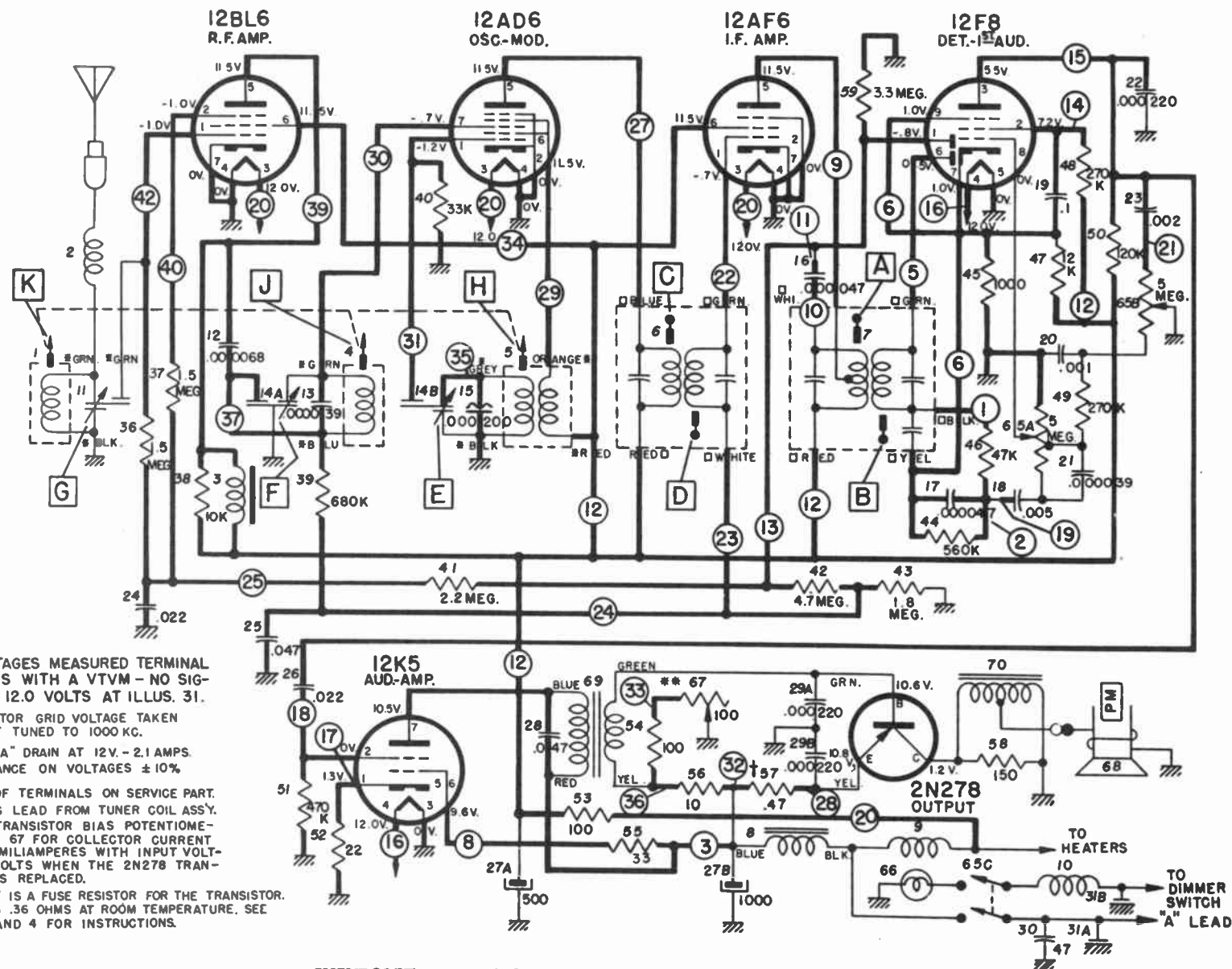

VOLTAGES MEASURED TERMINAL TO CHASSIS WITH A VTVM - NO SIGNAL AND 12.0 VOLTS AT ILLUS. 31.

OSCILLATOR GRID VOLTAGE TAKEN WITH SET TUNED TO 1000 KC.

TOTAL "A" DRAIN AT 12V. - 2.1 AMPS. TOLERANCE ON VOLTAGES $\pm 10\%$

- - COLORS OF TERMINALS ON SERVICE PART.
- * - INDICATES LEAD FROM TUNER COIL ASS'Y.
- ** - ADJUST TRANSISTOR BIAS POTENTIOMETER ITEM 67 FOR COLLECTOR CURRENT OF 930 MILLIAMPERES WITH INPUT VOLTAGE 12 VOLTS WHEN THE 2N278 TRANSISTOR IS REPLACED.

† - ILLUS. 57 IS A FUSE RESISTOR FOR THE TRANSISTOR. VALUE IS .36 OHMS AT ROOM TEMPERATURE. SEE PAGE 2 AND 4 FOR INSTRUCTIONS.

CHEVROLET 987727—PRINTED CIRCUIT SHOWN IN HEAVY LINES.

DELCO
Chevrolet Auto
Radio Model 987727
Electronic Technician
CIRCUIT DIGEST

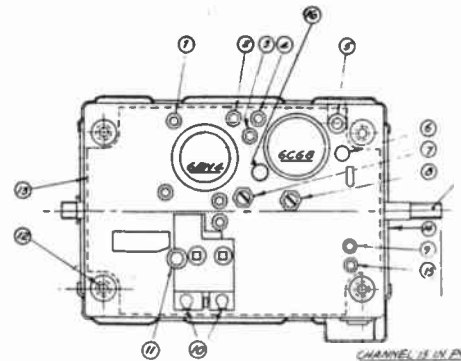
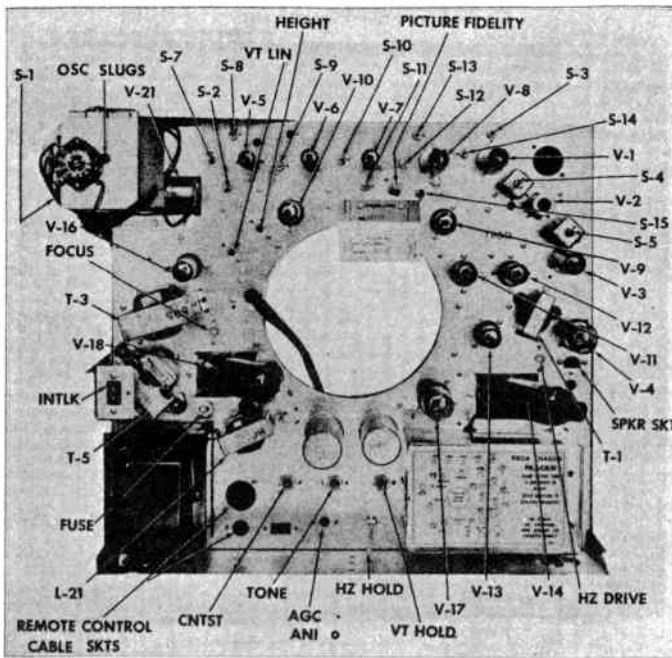

| ITEM NO | DESCRIPTION |
|---------|-----------------------|
| 1 | A.G.C. |
| 2 | RF TEST. |
| 3 | B + 135V. |
| 4 | HEATER. |
| 5 | I.F. ADJUST. |
| 6 | I.F. TERMINAL. |
| 7 | RF TRIM. |
| 8 | MIXER TRIM. |
| 9 | FINE TUNING. |
| 10 | ANTENNA. |
| 11 | SERIES ADJUST. |
| 12 | Ø-32 TAP & HOLES. |
| 13 | MOUNTING CLEARANCE. |
| 14 | OSC. SLUG ADJUST. |
| 15 | Ø-260V. |
| 16 | ACCESS TO MIXER GRID. |

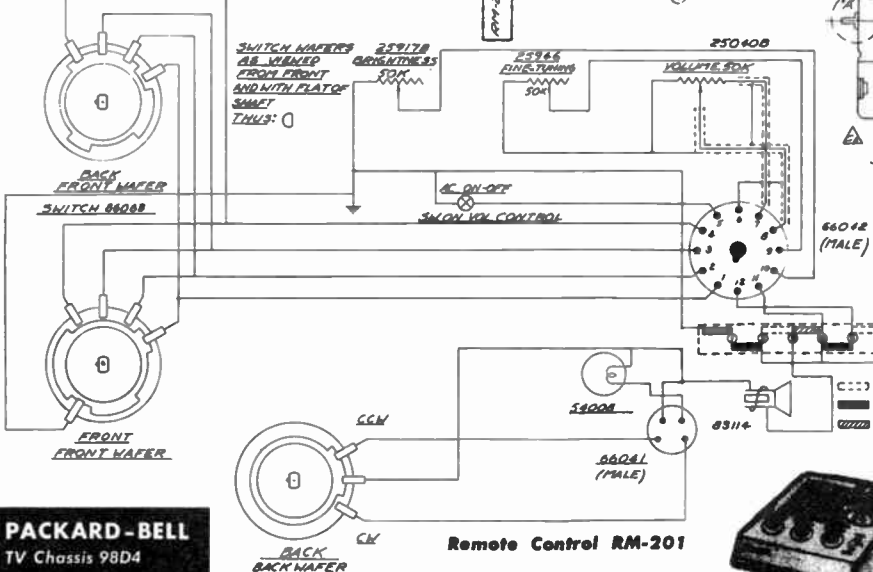
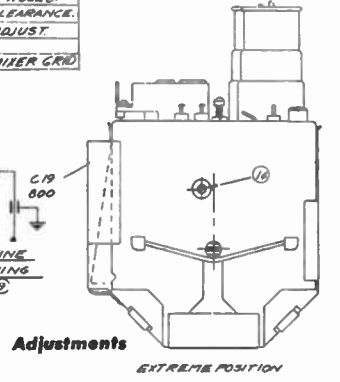
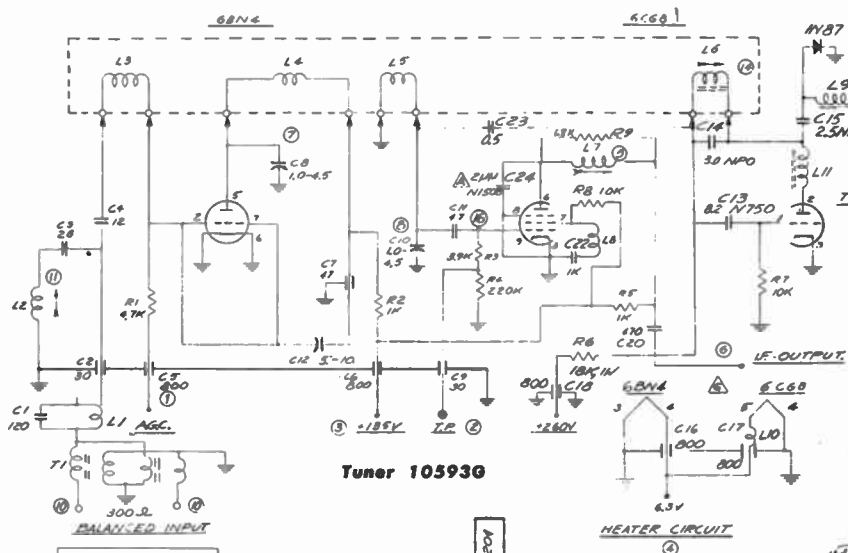
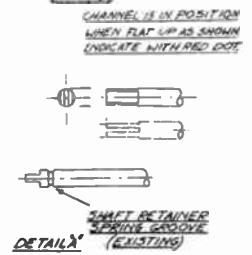

- NOTES:**
- 1-MFD BY STANDARD COIL CO. PART NO. TX-N4A-84
 - 2-DETENTS FOR 12 CHANNELS
 - 3-TORQUE: V.H.F. 120 IN.OZ
 - 4-3-TAMP PACKARD BELL PART NO. ISSUE LETTER (MFR'S LD MARK ON PART.)
 - 5-FINE TUNING SLEEP: 137K MIN ON CHANNEL 2.-21K ON CHANNEL 13.
 - 6-OSCILLATOR INJECTION ON ANY CHANNEL SHALL NOT BE LESS THAN TWO VOLTS WITH FINE-TUNING ADJUSTED FOR LOWEST INJECTION

PACKARD-BELL
TV Chassis 98D4

Electronic Technician
CIRCUIT DIGEST

More Data on Opposite Page

** SCOPE SYNCED AT 1/2 VERT. FREQUENCY.
 *** SCOPE SYNCED AT 1/2 HORIZ. FREQUENCY.
 WAVE SHAPES TAKEN WITH NORMAL CONTROL SETTINGS & NORMAL SIGNAL APPLIED.
 VOLTAGE MEASUREMENTS ARE IN RESPECT TO CHASSIS WITH A 20,000 Ω VOLT METER WITH CONTROLS SET FOR NORMAL OPERATION, NO SIGNAL APPLIED, UNLESS OTHERWISE NOTED.
 ▲ MEASURED WITH VTVM.
 ● VARIES WITH CONTROL SETTINGS.
 RESISTANCE MEASUREMENTS MADE WITH COMPONENTS DISCONNECTED.
 UNLESS OTHERWISE NOTED
 K=1,000 M=1,000,000
 CAPACITORS MORE THAN 1 = μuf
 CAPACITORS LESS THAN 1 = pf
 RESISTORS ARE 1/2 WATT
 // DENOTES CABINET

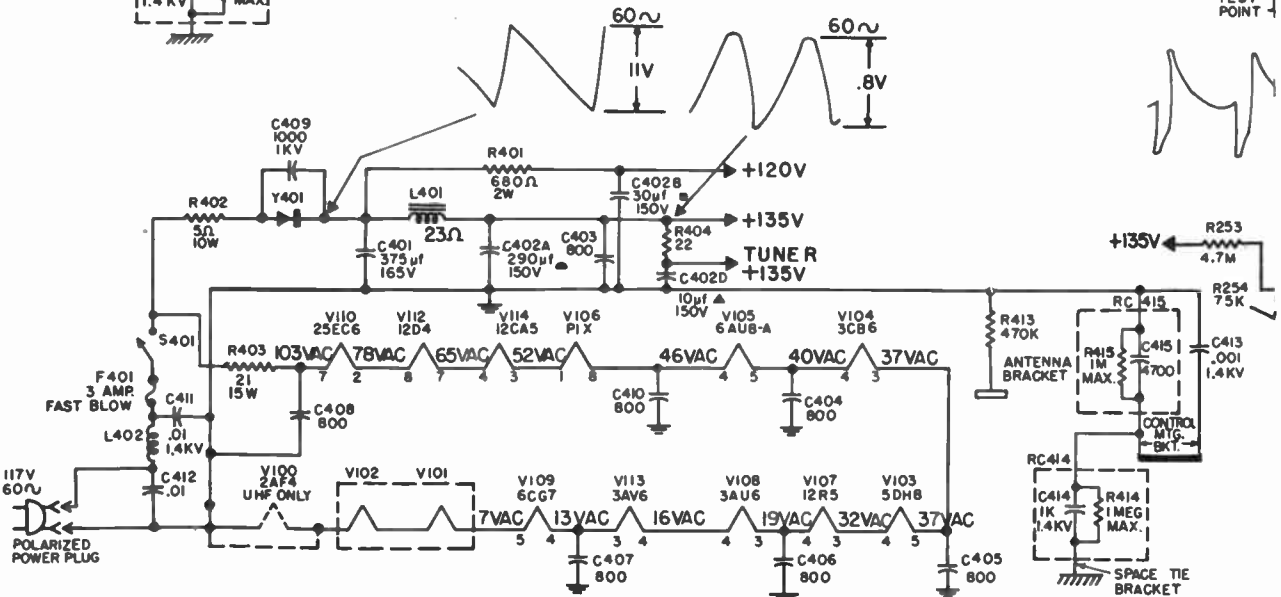
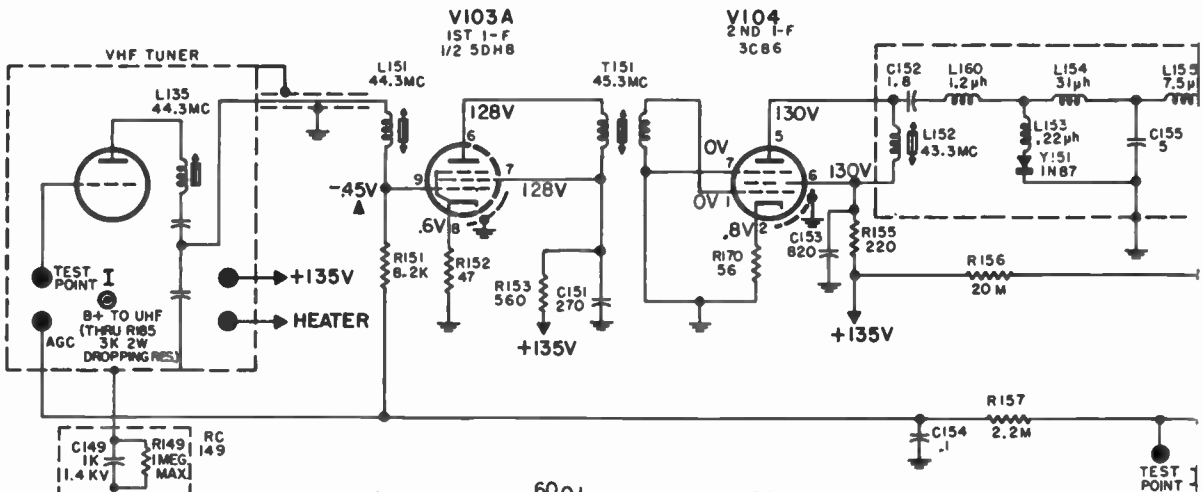
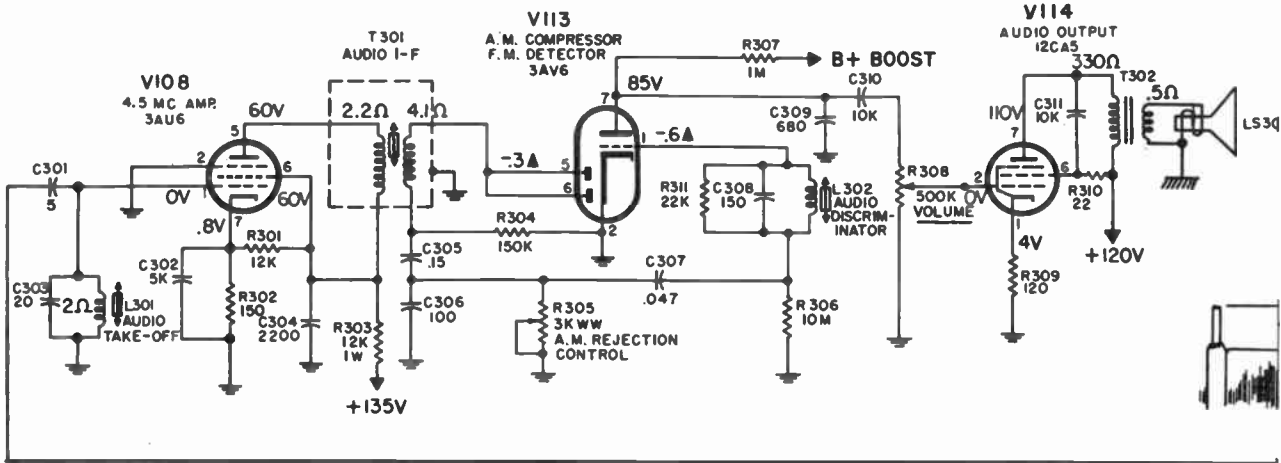
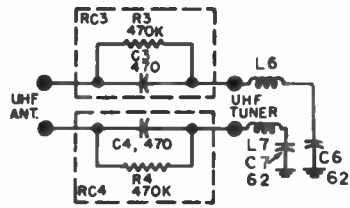
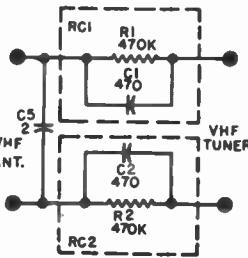

CONTINUED ON NEXT PAGE →

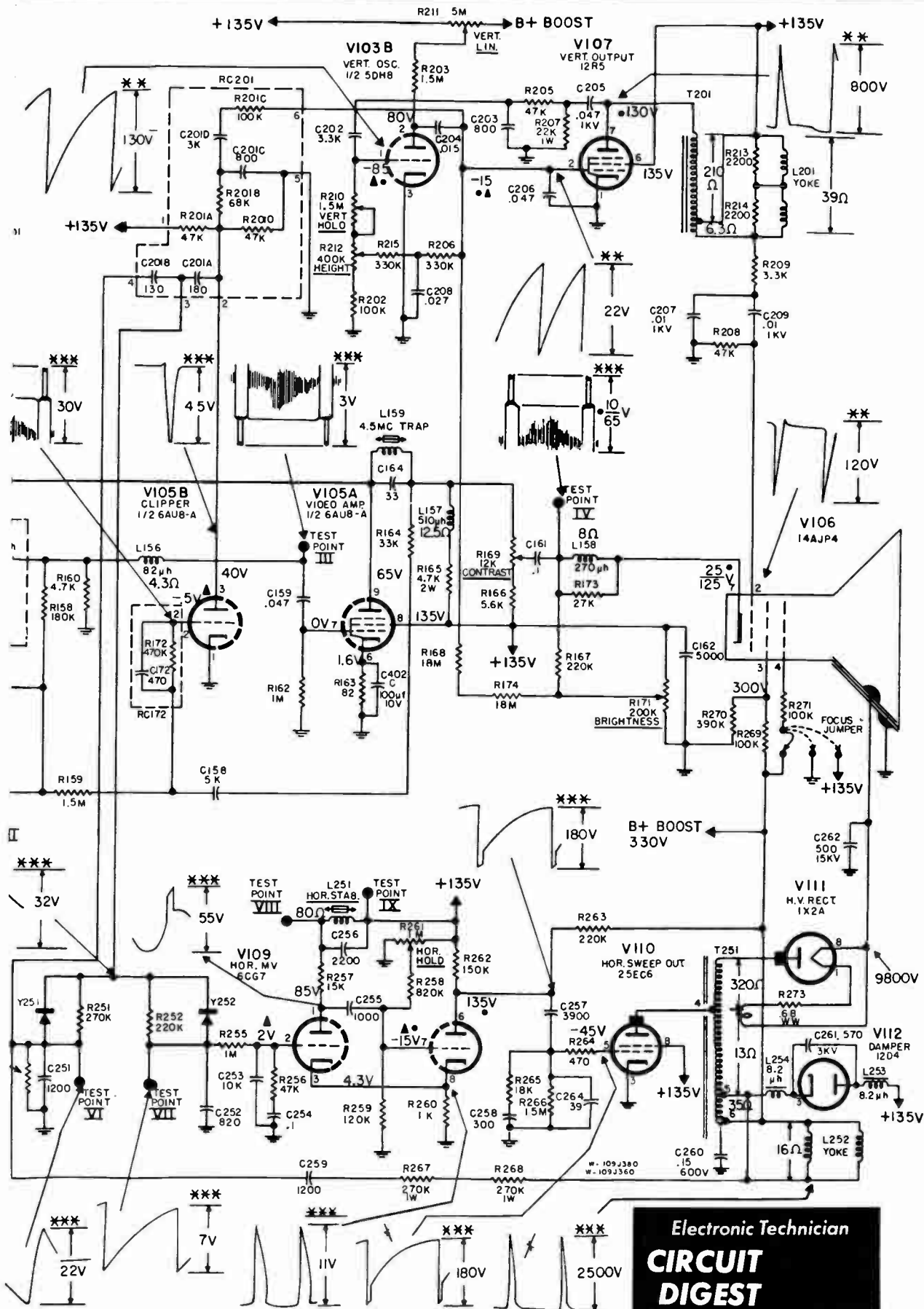

SCHEMATIC DIAGRAM (55-01-00 & 10)

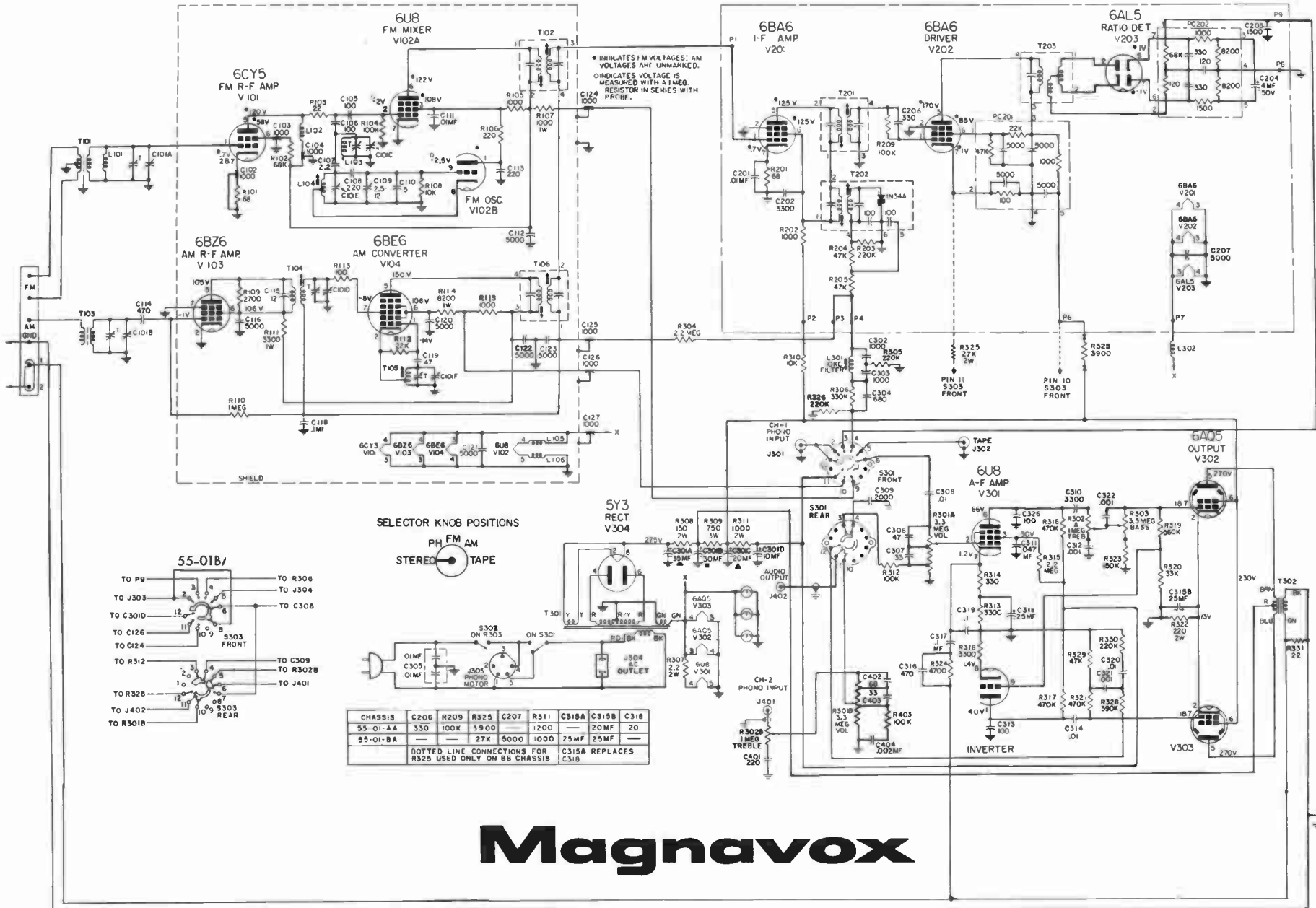

Magnavox

ELECTRONIC TECHNICIAN CIRCUIT DIGEST

PHILCO Transistor Radio Models T-4, T-4J

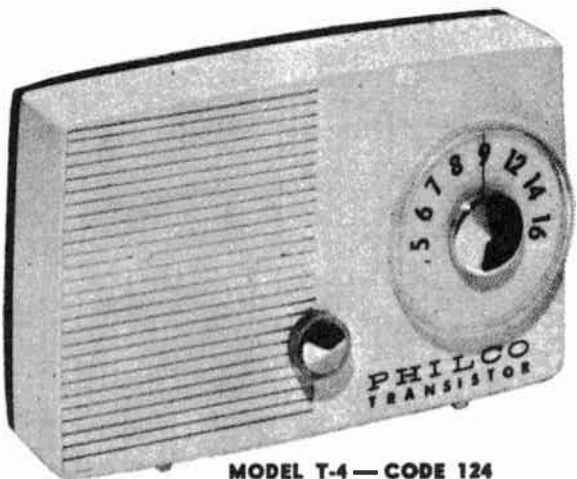

MODEL T-4 — CODE 124

Models T-4 & T-4J — Code 124

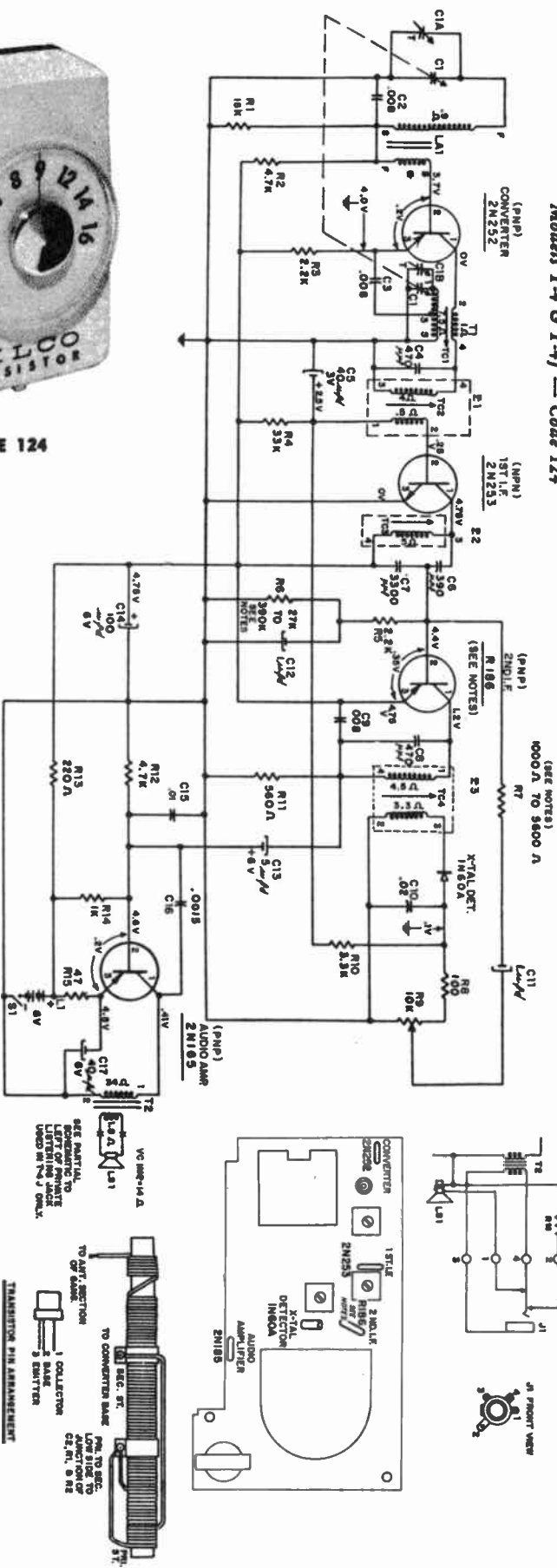

T-4J PRIVATE LISTENING JACK TERMINAL LEADS

Terminal 1—Brown lead to speaker.
Terminal 2—One end of R16, P.L. shunt resistor.
Terminal 3—Black ground lead to on-off switch and other end of R16.
Terminal 4—Green lead of T3.

SERVICE NOTES

When signal tracing, inject signal at transistor collector and limit input to keep signal across speaker below 0.275 volts. Normally, the transistors should be the last item suspected.

SCHEMATIC NOTES

Due to 2nd IF transistor variations the values of resistors R6 and R7 must be selected, within limits, for optimum performance.
When transistor R186 is defective, kit number 324-0003 must be ordered. This kit contains a R186 transistor and two resistors (R6 and R7) properly matched. All three components must be replaced.

The stage may be checked as follows:

The value of R6 is selected to allow the 2nd IF transistor collector to draw 2 milliamperes. This is checked by measuring the voltage across R11, the 560 ohm collector return resistor. This voltage should be 1.12 volts, with a tolerance of approximately ± 0.12 volts. The value of R6 falls within the limits of 27K to 390K.

All resistors are 1/2 watt, 10%, carbon.

Coil resistances read with coil in circuit.

Voice coil impedance = 14 ohms.

Voltages measured to ground with a 20,000 ohm/volt meter under no signal condition.

Emitter to base voltages were measured with positive lead to emitter, except for the 1st IF which is an NPN type and measured with the positive lead to the base.

Run #51 — to improve low end sensitivity. The value of R1 was changed to 15,000 ohms, part number 66-3158340. Some few sets may have a 10,000 ohm resistor for R1.

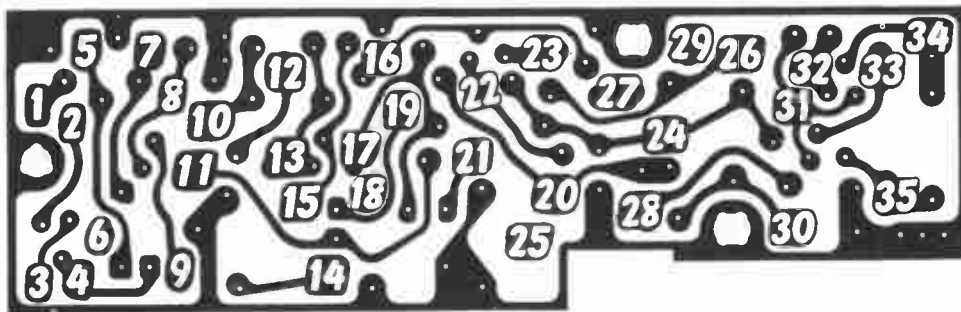
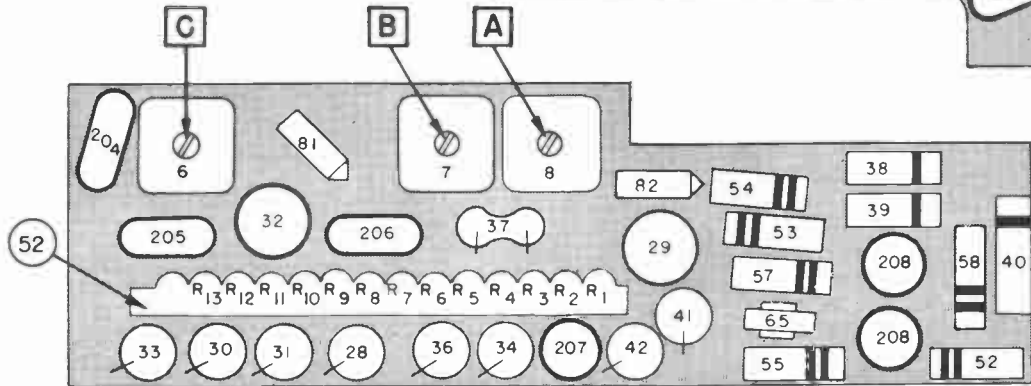
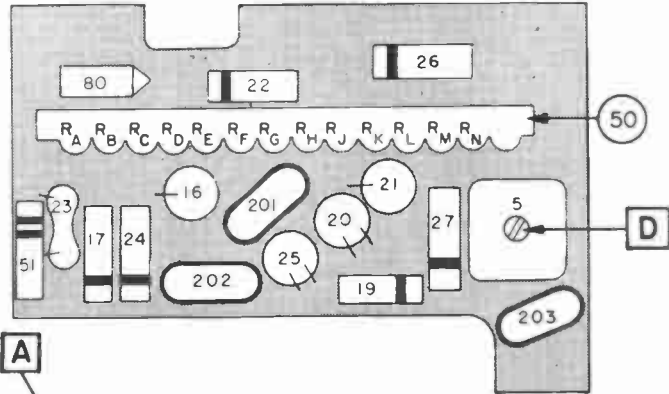
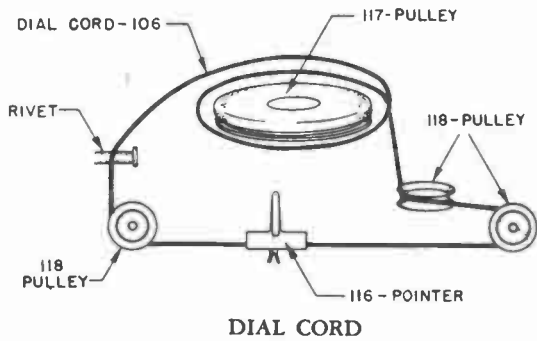
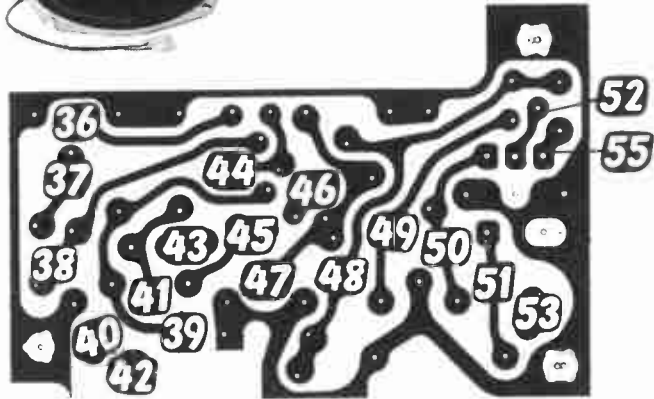
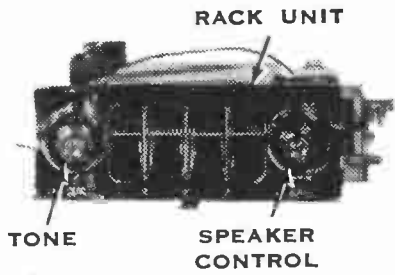

SCHEMATIC DATA

Voltages measured terminal to chassis with a VTVM—no signal. The portable unit voltages are taken with a battery voltage of 5.3 volts. Rack unit voltages taken with 12 volts at Illus. 46. Oscillator Base voltage taken with set tuned to 1000 Kc.

Total "A" Drain in Car 1.3 amps.
 Total "A" Drain of Portable 7.6 ma.
 Tolerance on Voltage $\pm 10\%$

Resistances are $\pm 20\%$. Ohmmeter reading in transistor circuits are affected by meter battery polarity. Check in both directions and use highest reading.

PRINTED CIRCUIT SHOWN IN HEAVY LINES

ALL TRANSISTORS ARE
 SELECTED FOR APPLICATION AND
 ORIGINAL EQUIPMENT PART
 SHOULD BE USED.

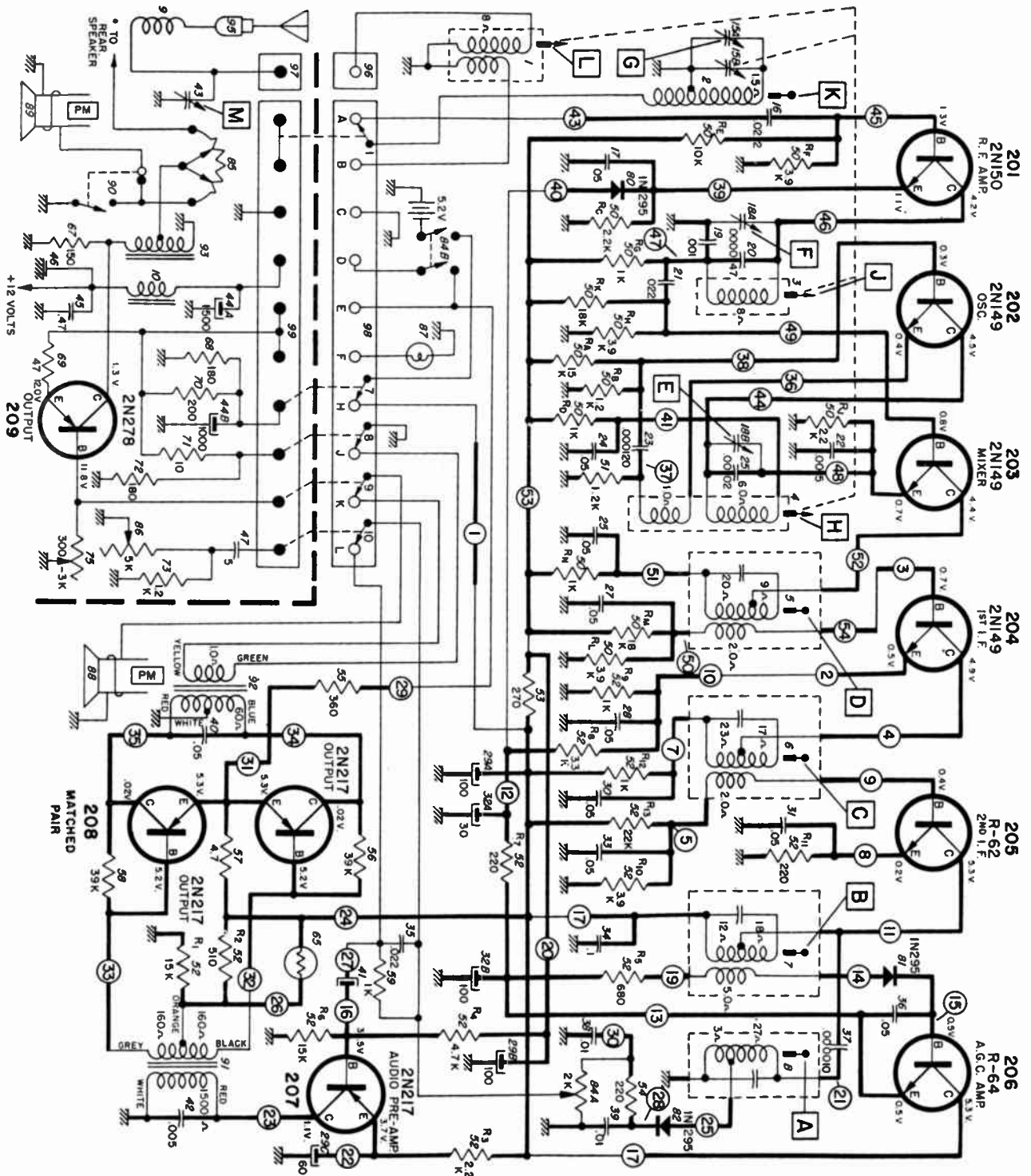

**RJX-099 &
RJX-100
ADJUSTMENTS**

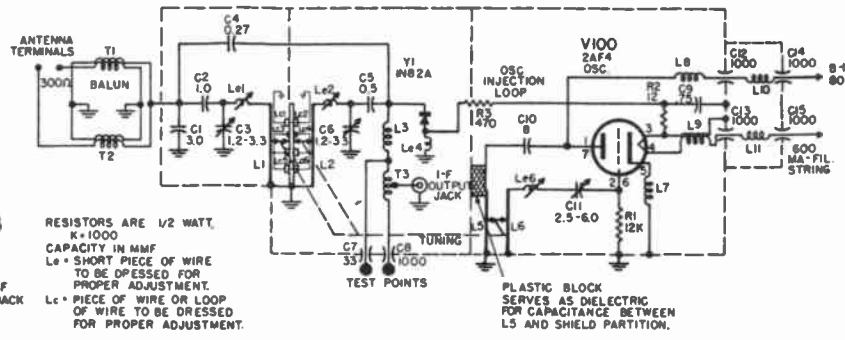
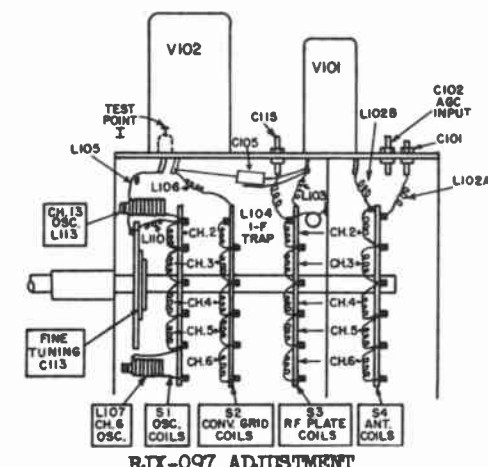
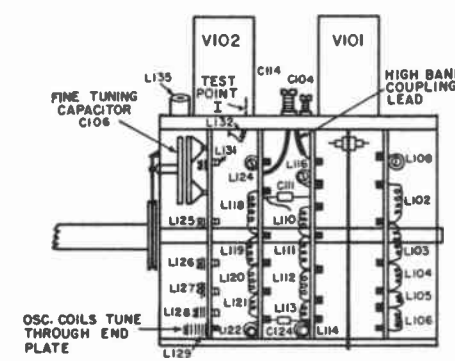
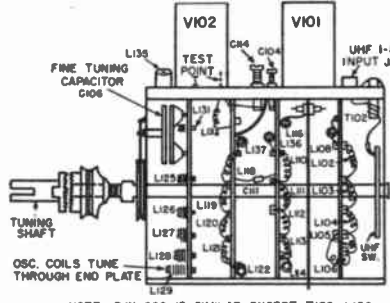

SCHEMATIC DIAGRAM UHF TUNER WT85X21

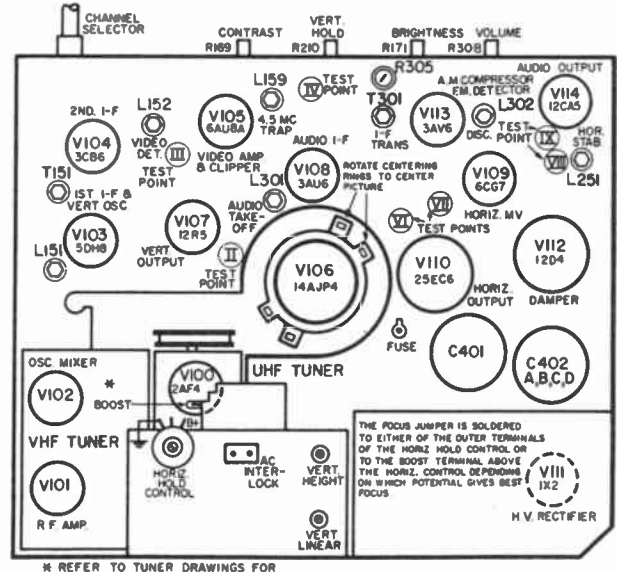
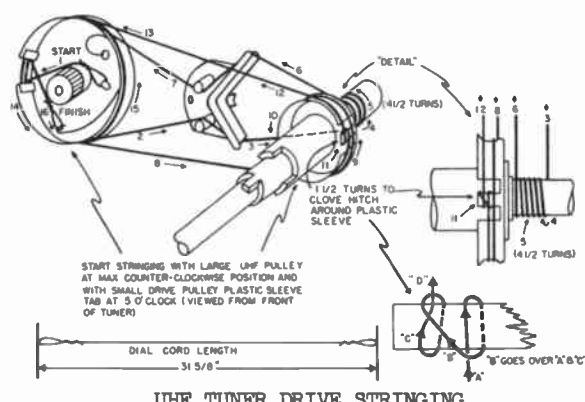

VHF-UHF TUNER ASSEMBLY

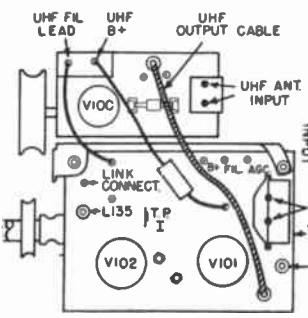

TOP VIEW UHF TUNER

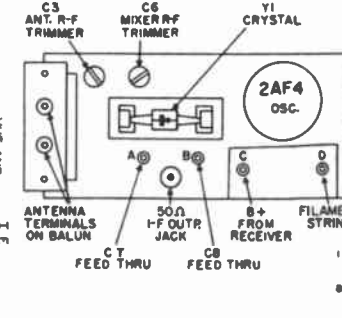

COMPONENT WIRING

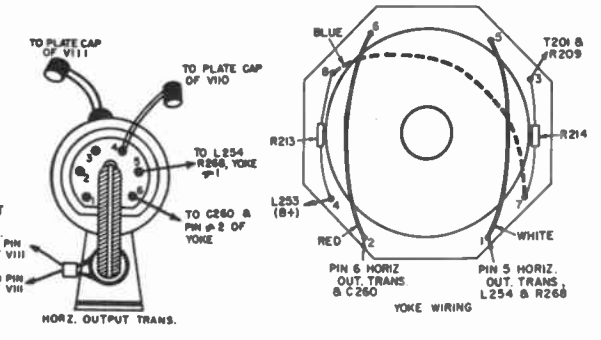

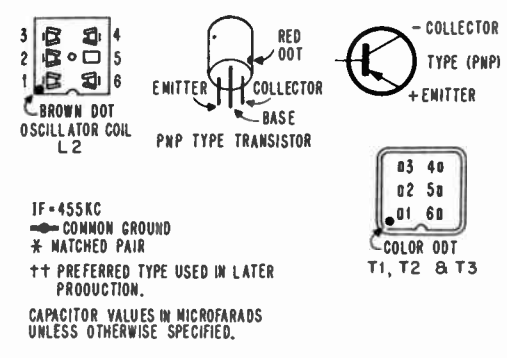
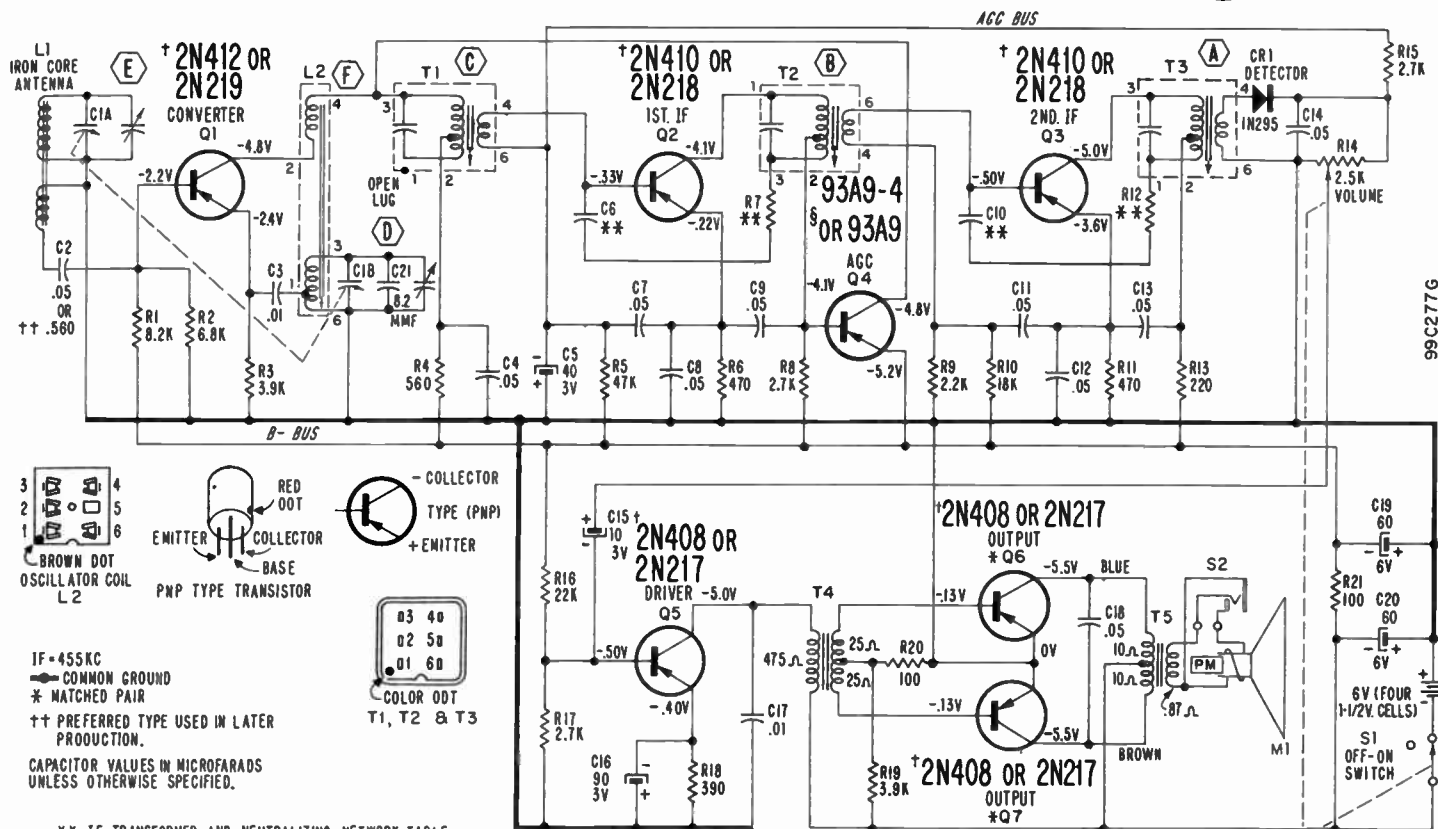

IF-455KC
 COMMON GROUND
 * MATCHED PAIR
 † † PREFERRED TYPE USED IN LATER PRODUCTION.
 CAPACITOR VALUES IN MICROFARADS UNLESS OTHERWISE SPECIFIED.

**** IF TRANSFORMER AND NEUTRALIZING NETWORK TABLE**

| C6 | C10 | R7 | R12 | T1 | T2 | T3 | COMMENTS |
|---------|---------|------|------|----------|----------|----------|-----------------------|
| 4 MMF | 8 MMF | 6.8K | 3.3K | 72C182-1 | 72C182-2 | 72C182-3 | INITIAL PRODUCTION |
| 5.5 MMF | 3 MMF | 15 K | 39 K | 72C182-4 | 72C182-5 | 72C182-6 | 1ST PRODUCTION CHANGE |
| 11 MMF | 5.5 MMF | 3 K | 16 K | 72C182-4 | 72C182-5 | 72C182-6 | 2ND PRODUCTION CHANGE |

NOTE: WHEN REPLACING INDIVIDUAL COMPONENTS LISTED IN ABOVE TABLE, DO NOT INTERMIX VALUES OR TYPES NOT LISTED ON THE SAME LINE. ALWAYS REPLACE WITH SAME TYPE OR VALUE USED IN SET.

† 400 SERIES TRANSISTORS USED IN LATER PRODUCTION CHASSIS. INTERCHANGEABLE WITH CORRESPONDING 200 SERIES SHOWN.
 § 93A9-4 TRANSISTOR USED IN LATER PRODUCTION CHASSIS. INTERCHANGEABLE WITH 93A9.

TOTAL CURRENT DRAIN WITH NO SIGNAL & VOLUME CONTROL SET AT MINIMUM, 85MA.

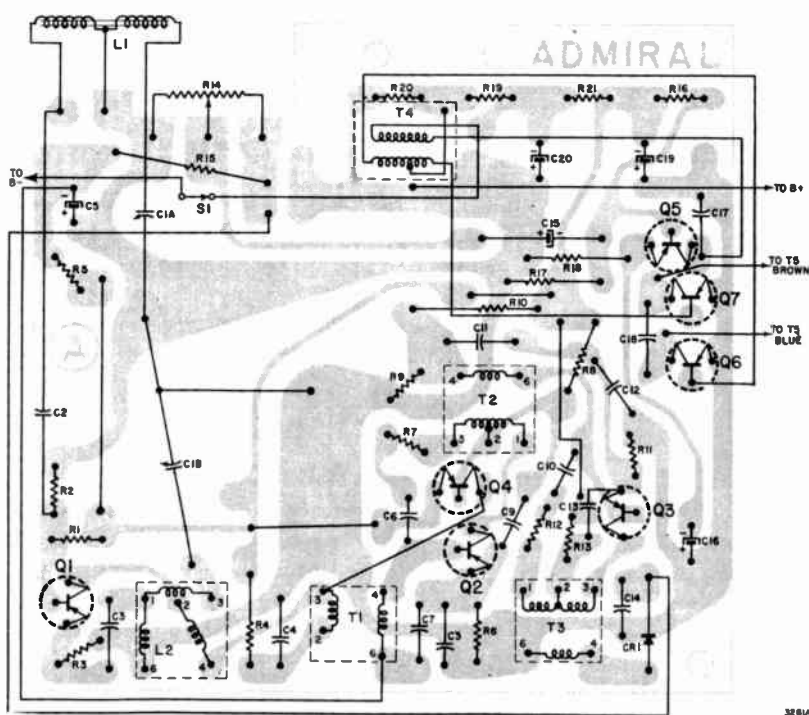

View of Printed Wiring Board. NOTE: Gray area represents printed wiring, black symbols and lines represent components, wiring and connections on opposite side.

- MISCELLANEOUS CHASSIS PARTS**
- S2 Earphone Jack 88B 39-3
 - Bracket, Volume Control Mtg. 15B 1513
 - Operating Instructions 41C 20-168
 - Rivet, Battery Contact Spring Mtg. 6B 1-13-24
 - Screw, Speaker Mtg. (4-40x1/4 BHMS PH) 345-250-C2-24
 - Screw, Volume Control Knob (2-56 x 3/16 BHMS PH) 325-187-C2-24
 - Speaker Mounting Pad 43A 285
 - Spring, Battery Contact, Single 18A 173
 - Spring, Battery Contact, Double 18A 174

- CABINET PARTS**
- Cabinet Back Assembly
 - Red (7M12) A5582
 - Tan (7M14) A5650
 - Turquoise (7M18) A5651
 - Yellow (7M16) A5652
 - Cabinet Front Assembly
 - White (7M12, 7M18) 34E 115-10
 - Cover, Battery Compartment
 - Red (7M12) A5583
 - Tan (7M14) A5646
 - Yellow (7M16) A5648
 - Turquoise (7M18) A5647
 - Escutcheon, Cabinet 23D 280
 - Grille, Metal, Black 36B 75-1
 - Handle, Gold 37A 155-1

Admiral

VOLTAGE DATA

- Voltages shown measured with no signal, using fresh batteries.
- Volume control at minimum; dial set at low frequency end.
- All readings made between transistor lead terminals and B plus (ground).
- All voltage readings are negative.

PARTS LIST

| Sym. | Description | Part No. |
|-------|--|-----------|
| R1 | 8,200 ohms, $\frac{1}{2}$ watt | 60B 8-822 |
| R2 | 6,800 ohms, $\frac{1}{2}$ watt | 60B 8-682 |
| R3 | 3,900 ohms, $\frac{1}{2}$ watt | 60B 8-392 |
| R4 | 560 ohms, $\frac{1}{2}$ watt | 60B 8-561 |
| R5 | 47,000 ohms, $\frac{1}{2}$ watt, 5% | 60B 7-473 |
| R6 | 470 ohms, $\frac{1}{2}$ watt | 60B 8-471 |
| **R7 | 6,800 ohms, $\frac{1}{2}$ watt | 60B 8-682 |
| | 15,000 ohms, $\frac{1}{2}$ watt | 60B 8-153 |
| | 3,000 ohms, $\frac{1}{2}$ watt, 5% | 60B 7-302 |
| R8 | 2,700 ohms, $\frac{1}{2}$ watt | 60B 8-272 |
| R9 | 2,200 ohms, $\frac{1}{2}$ watt | 60B 8-222 |
| R10 | 18,000 ohms, $\frac{1}{2}$ watt | 60B 8-183 |
| R11 | 470 ohms, $\frac{1}{2}$ watt | 60B 8-471 |
| **R12 | 3,300 ohms, $\frac{1}{2}$ watt | 60B 8-332 |
| | 39,000 ohms, $\frac{1}{2}$ watt, 5% | 60B 7-393 |
| R13 | 16,000 ohms, $\frac{1}{2}$ watt, 5% | 60B 7-163 |
| | 220 ohms, $\frac{1}{2}$ watt | 60B 8-221 |
| R14 | 2,500 ohms, Volume control (includes switch S1) | 75B 36-1 |
| R15 | 2,700 ohms, $\frac{1}{2}$ watt | 60B 8-272 |
| R16 | 22,000 ohms, $\frac{1}{2}$ watt | 60B 8-223 |
| R17 | 2,700 ohms, $\frac{1}{2}$ watt | 60B 8-272 |
| R18 | 390 ohms, $\frac{1}{2}$ watt | 60B 8-391 |
| R19 | 3,900 ohms, $\frac{1}{2}$ watt | 60B 8-392 |
| R20 | 100 ohms, $\frac{1}{2}$ watt | 60B 8-101 |
| R21 | 100 ohms, $\frac{1}{2}$ watt | 60B 8-101 |

CAPACITORS

| Sym. | Description | Part No. |
|-------|---|------------|
| C1A | 123.1 mmf, max. ant. } gang ... | 68B 67-1 |
| C1B | 78.2 mmf, max. osc. } | |
| C2 | .560 mf, 1.5 volts, ceramic | 65B 45-12 |
| C3 | .01 mf, 600 volt, cer. disc | 65D 10-41 |
| C4 | .05 mf, 30 volts, ceramic | 65B 45-6 |
| C5 | 40 mf, 3 volts, electrolytic | 67B 32-9 |
| **C6 | 4 mmf, 500 volts, ceramic | |
| | NPO temp. coeff. | 65D 6-124 |
| | 5.1 mmf, 5%, 500 volts, cer. | 65D 6-1 |
| C7 | 11 mmf, 5%, 500 volts, cer. | 65D 10-175 |
| | .05 mf, 30 volts, ceramic | 65B 45-6 |
| C8 | .05 mf, 30 volts, ceramic | 65B 45-6 |
| C9 | .05 mf, 30 volts, ceramic | 65B 45-6 |
| **C10 | 8 mmf, 500 volts, ceramic | |
| | NPO temp. coeff. | 65D 6-125 |
| | 3 mmf, 500 volts, ceramic | |
| C11 | NPO temp. coeff. | 65D 6-97 |
| | 5.6 mmf, 5%, 500 volts, cer. | 65D 10-176 |
| C12 | .05 mf, 30 volts, ceramic | 65B 45-6 |
| C13 | .05 mf, 30 volts, ceramic | 65B 45-6 |
| C14 | .05 mf, 30 volts, ceramic | 65B 45-6 |
| C15 | 10 mf, 3 volts, electrolytic | 67B 35-6 |
| C16 | 90 mf, 3 volts, electrolytic | 67B 32-10 |
| C17 | .01 mf, 600 volts, cer. disc | 65D 10-41 |
| C18 | .05 mf, 30 volts, ceramic | 65B 45-6 |
| C19 | 60 mf, 6 volts, electrolytic | 67B 32-8 |
| C20 | 60 mf, 6 volts, electrolytic | 67B 32-8 |
| C21 | 8.2 mmf, 5%, 500 volts, ceramic, NPO temp. coeff. | 65D 10-131 |

COILS, TRANSFORMERS, ETC.

| | | |
|------|---------------------|-----------------------------|
| L1 | Antenna, Iron Core | 69B 218-3 |
| L2 | Oscillator Coil | 69B 213-2 |
| **T1 | Transformer, 1st IF | { 72C 182-1 or 72C 182-4 |
| **T2 | Transformer, 2nd IF | { 72C 182-2 or 72C 182-5 |
| **T3 | Transformer, 3rd IF | { 72C 182-3 or 72C 182-6 |
| T4 | Transformer, Driver | 79B 67-3 |
| T5 | Transformer, Output | 79B 68-4 |
| M1 | Speaker, 2-3/4" PM | 78B 125 |
| S1 | Switch, On-Off | Part of R14 |

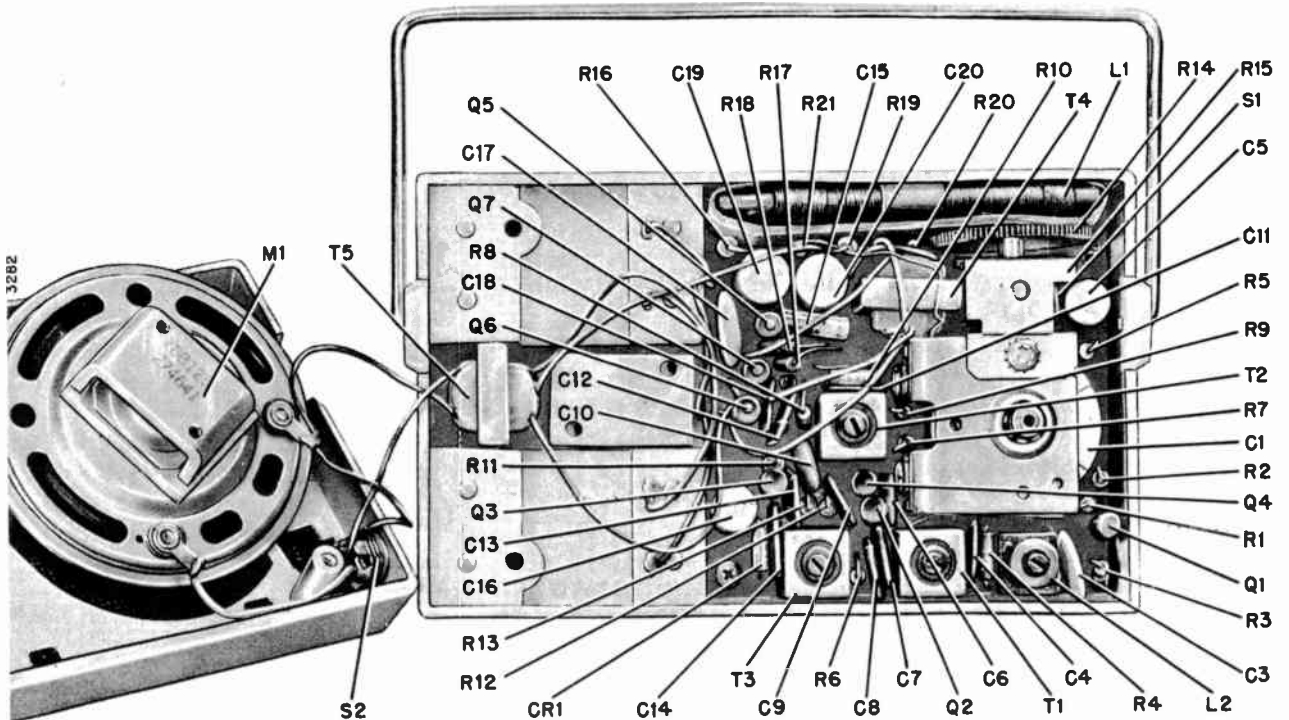

WorldRadioHistory
Top View of Chassis Showing Parts Locations.

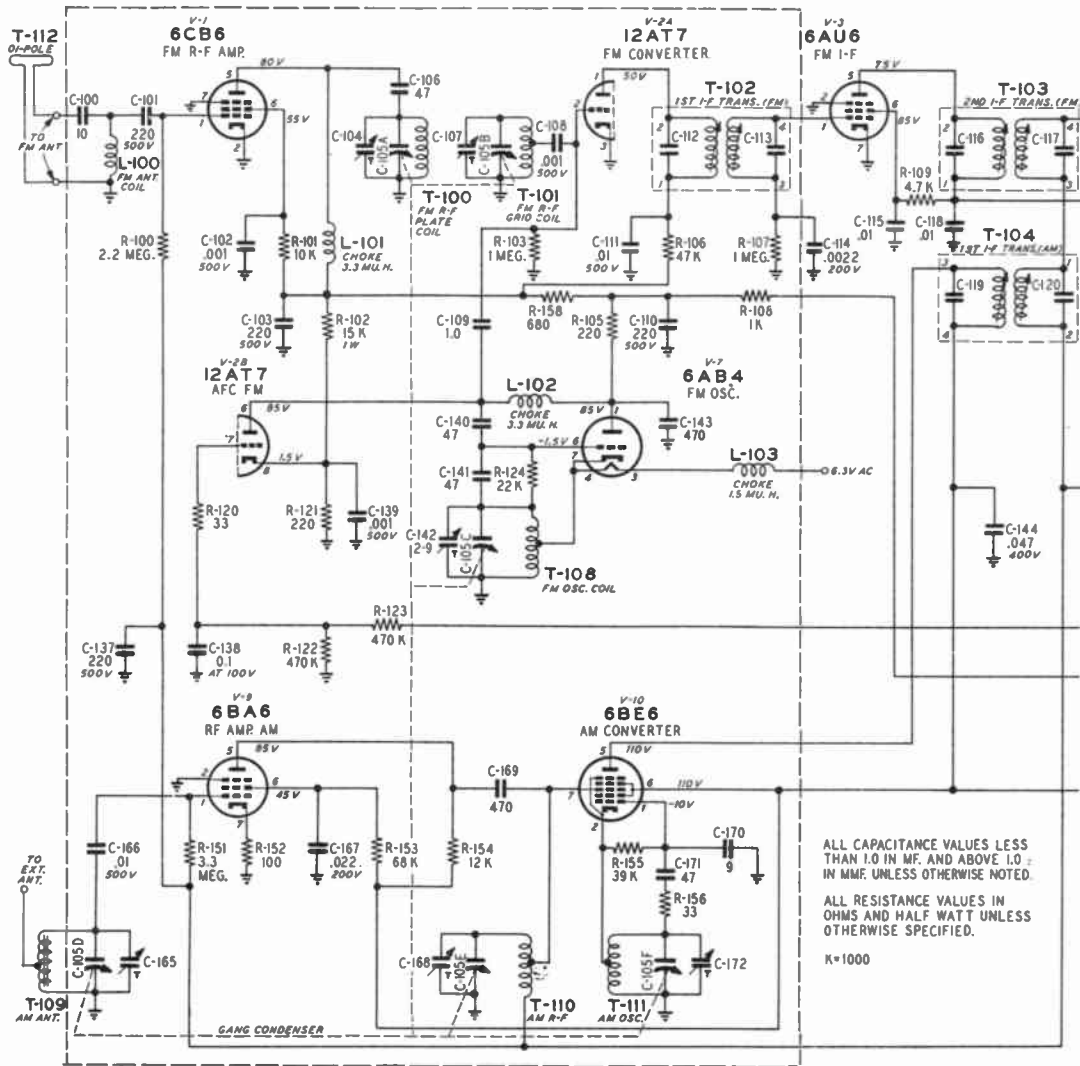

Firestone

AM-FM HIGH FIDELITY RADIO PHONOGRAPH

STOCK No. 4-H-3

CODE NO. 334-8-0A16A/5P10A

CONTINUED ON NEXT PAGE →

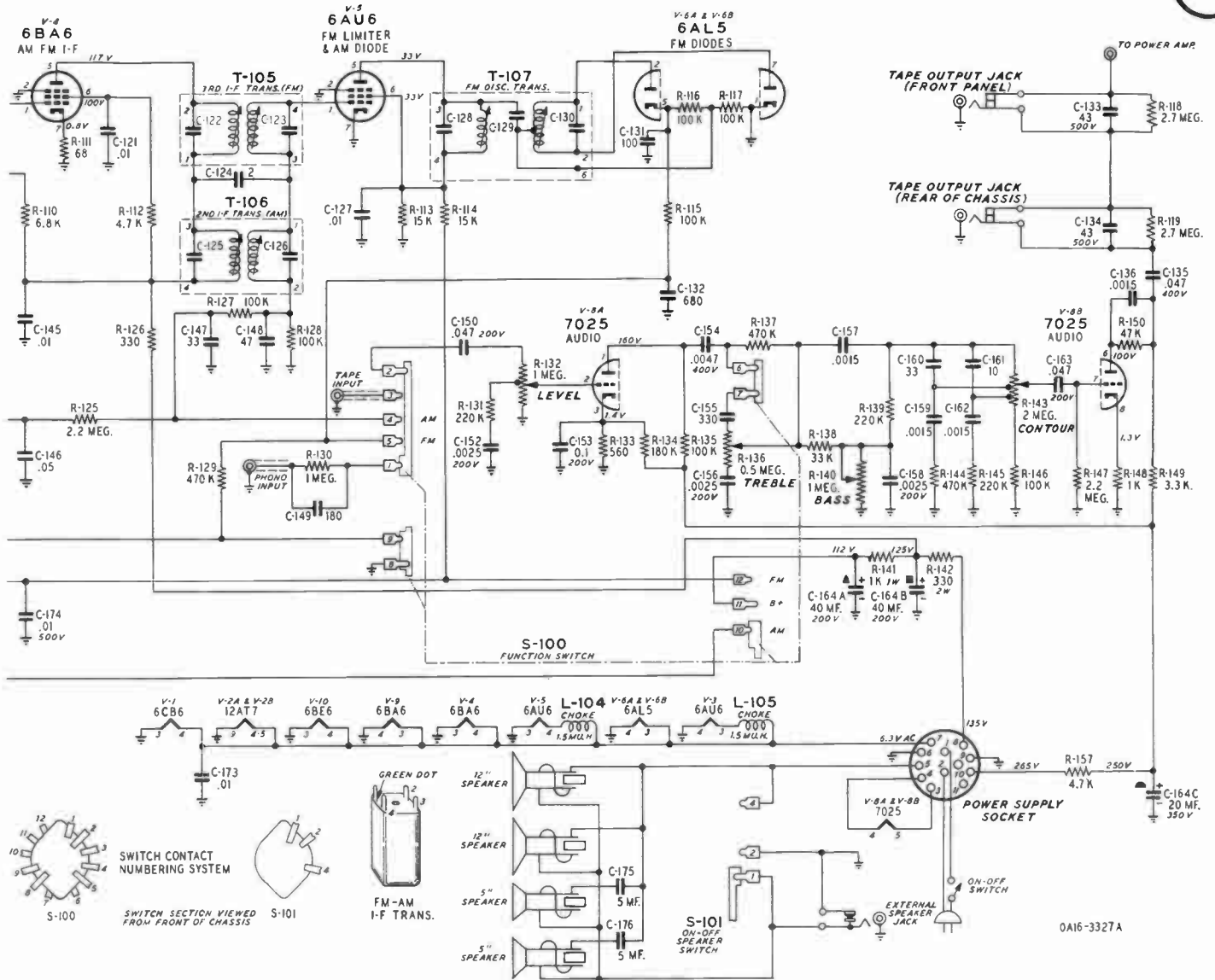

AM-FM TUNER

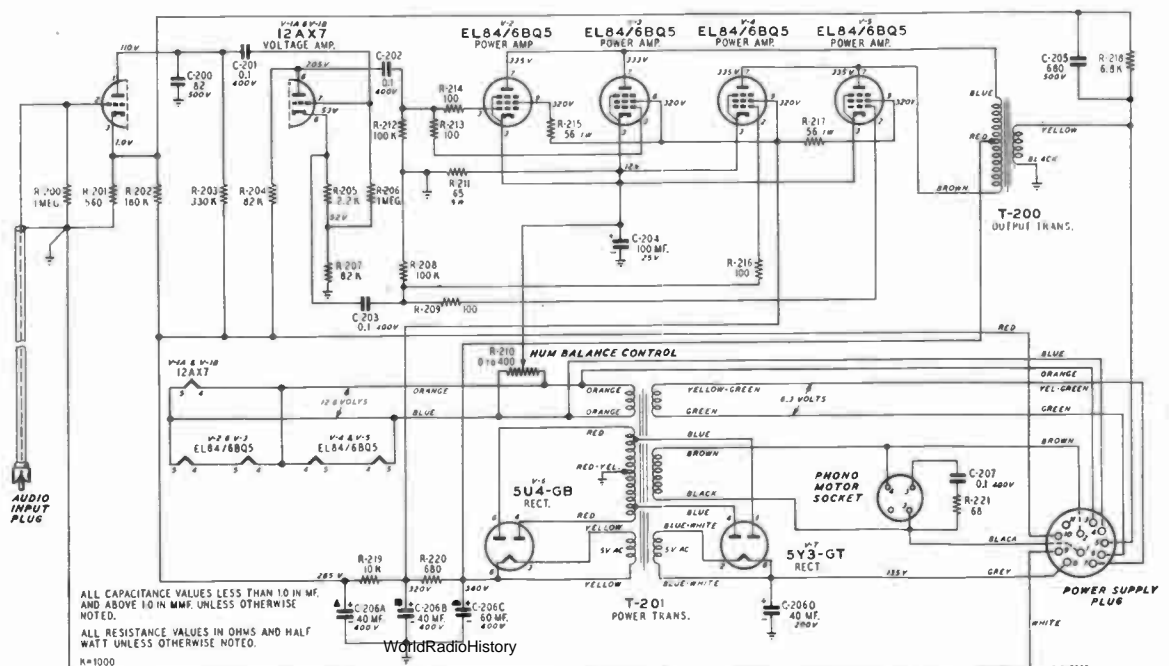

ALL CAPACITANCE VALUES LESS THAN 10 IN MF. AND ABOVE 10 IN MMF. UNLESS OTHERWISE NOTED.
 ALL RESISTANCE VALUES IN OHMS AND HALF WATT UNLESS OTHERWISE NOTED.
 R=1000

WorldRadioHistory

POWER SUPPLY AND POWER AMPLIFIER

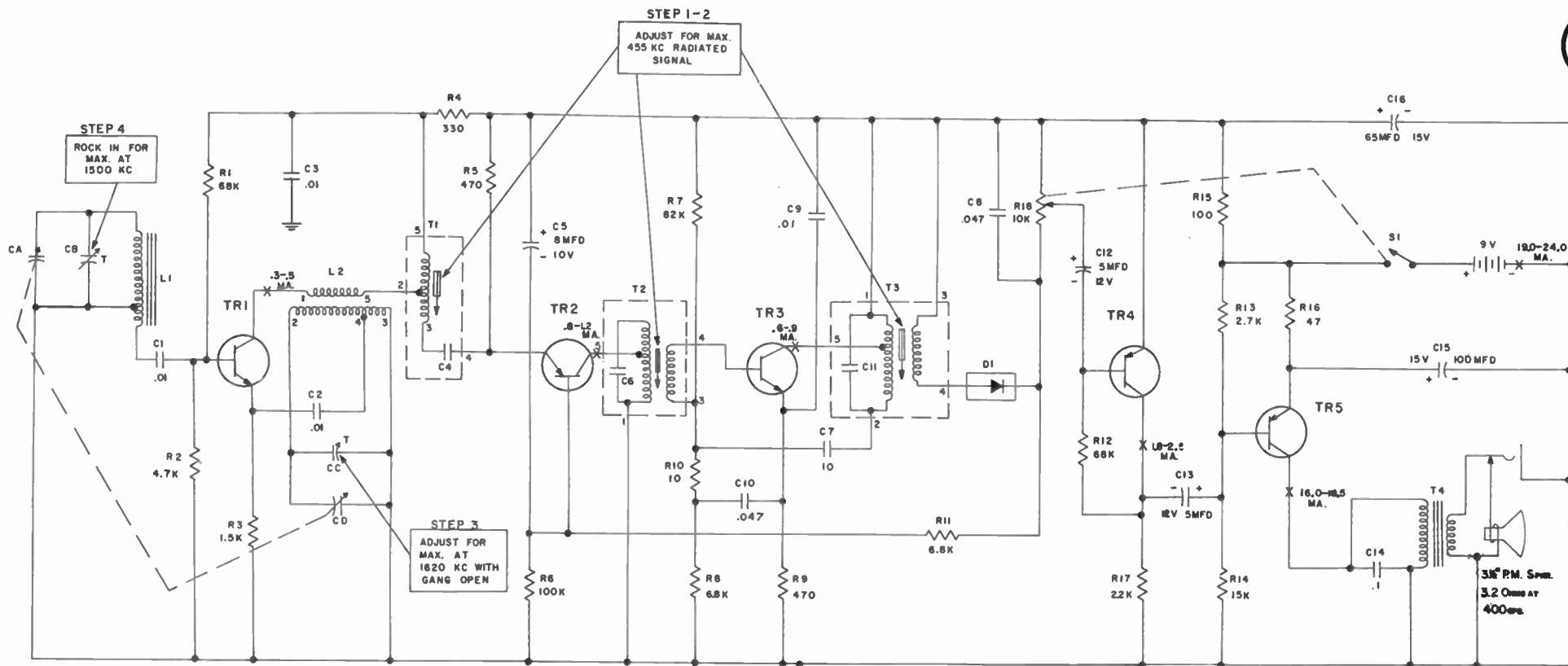

L.F. TRANSFORMER



TR1, TR2, TR3

OSCILLATOR TRANSFORMER L2



BOTTOM VIEWS

TRANSISTOR MOUNTING



ALIGNMENT
 SET VOLUME CONTROL AT MAXIMUM.
 CONNECT OUTPUT METER OR SCOPE
 ACROSS VOICE COIL.
 INDUCTIVELY COUPLE SIGNAL GENERATOR
 TO RECEIVER.
 STEP 1 & 2 - SET SIG. GEN. AT 455 KC,
 WITH RECEIVER TUNING GANG OPEN.
 STEP 3 - SET SIG. GEN. AT 1620 KC,
 WITH RECEIVER TUNING GANG OPEN.
 STEP 4 - SET SIG. GEN. AT 1500 KC.
 TUNE RECEIVER TO 1500 KC.

UNLESS OTHERWISE NOTED -
 CAPACITORS MORE THAN 1+MMF
 CAPACITORS LESS THAN 1+MMF
 RESISTORS ARE 1/2 WATT K=1000
 MEASURE COLLECTOR CURRENTS WITH A
 MILLIAMMETER INSERTED IN SERIES WITH
 THE CIRCUITS MARKED "X" AND ALSO
 BATTERY CURRENT AT POINT MARKED "X"
 IN BATTERY CIRCUIT.

GENERAL ELECTRIC

TRANSISTOR PORTABLE

MODEL
 P755A

DELCO

DELUXE ELECTRAMATIC MODEL 988977
with Automatic Tuning

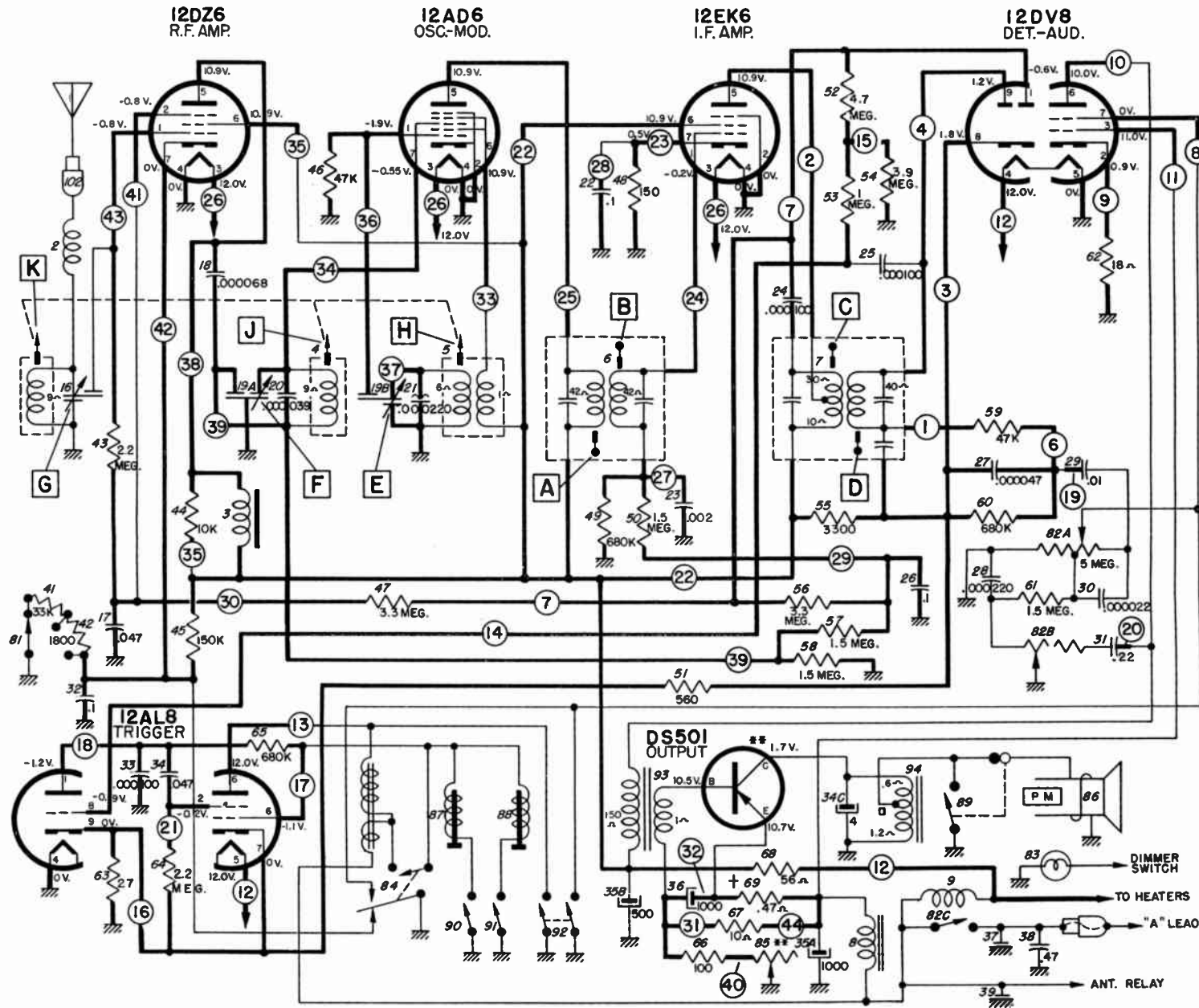

WHEN RADIO IS OPERATED ON BATTERY ELIMINATOR,
THE TUNER MAY STOP SEEKING EVERY TIME A SOL-
ENOID ENERGIZES, DUE TO LARGE VOLTAGE DROP.

IMPORTANT!

— TUNER CIRCUIT COMPONENTS

PONTIAC MODEL 988977
PRINTED CIRCUIT SHOWN IN HEAVY LINES