

THE THOUGHT IS IN THE QUESTION THE INFORMATION IS IN THE ANSWER

HAWKINS  
**ELECTRICAL GUIDE**

NUMBER  
**NINE**



**QUESTIONS  
ANSWERS  
&  
ILLUSTRATIONS**

A PROGRESSIVE COURSE OF STUDY  
FOR ENGINEERS, ELECTRICIANS, STUDENTS  
AND THOSE DESIRING TO ACQUIRE A  
WORKING KNOWLEDGE OF

**ELECTRICITY AND ITS APPLICATIONS**

A PRACTICAL TREATISE

HAWKINS  AND STAFF

THEO. AUDEL & CO. 72 FIFTH AVE. NEW YORK.

IMPRESSION 1923

COPYRIGHTED, 1917,  
BY  
THEO. AUDEL & CO.,  
NEW YORK

Printed in the United States

# TABLE OF CONTENTS

## GUIDE NO. 9

### ELECTRIC RAILWAYS - - - - - 2,533 to 2,672

Classification of the subject—**power systems**—direct current transmission and distribution; *diagram*—use of boosters—standard voltages—**alternating current transmission, direct current distribution**; *diagram*—substations—**alternating current transmission and distribution**—kind of motor used on single phase systems—adaptation of single phase system—**comparison of the various systems**—map showing route of the Indianapolis and Louisville railway—interior power station at Scottsburg (I. & L. R.R.)—power house, car barn, and artificial lake (I. & L. R.R.)—overhead construction I. & L. 1200 volt line—**current collecting devices**—trolley wheel and harp—section through trolley showing lubricating bushing—trolley base—**overhead trolley system**—pantograph trolley—**surface contact system**—**third rail system**—details of Manhattan Elevated Railway third rail—details N. Y. Central inverted third rail—location of third rail relative to track—**underground trolley or conduit system**—Third Ave. R.R., New York, conduit system—comparison conduit and overhead systems—requirements conduit system—**motors**—d. c. railway motor—principal requirements—d. c. split frame motor—G. E. standard box frame motor—motor classification—**forced circulation** method of forced ventilation; with internal air; with external air—**natural ventilation**—**motor suspension**—frame heads of General Electric box type motor—cradle, nose, yoke, parallel bar or side, and twin motor suspension—frame heads G. E. split frame motor—armature construction G. E. ventilated motor—motor gearing and case—G. E. split frame motor—various construction details G. E. commutating pole motor—**motor control systems**—classification—ordinary rheostatic controller—hand control—detail of G. E. magnetic blow out—automatic control—multi-unit or so called multiple unit control—rheostatic control—

ELECTRIC RAILWAYS—*Continued.*

field control—detail of G. E. type K controller construction—**series parallel system of control**—mode of transition—power off method—series resistance transition—bridge transition—diagrams of series parallel two and four motor control—advantage of bridge transition—diagrams of G. E. type K, two and four motor control connections—wiring diagram G. E. contactor equipment—Westinghouse K-12 and K-35 controlling connections—**alternating current control systems**—single phase motor control by compensator method—objections to induction regulator method—Westinghouse auxiliary contactor equipment—**three phase induction motor control**—rheostat control applied to three phase induction motors; type of motor used—kind of resistance used—Westinghouse unit switch control—changeable pole method; advantages—cascade operation—cascade method; single control; parallel single control—Westinghouse standard reverser—combination of changeable pole and cascade methods—Westinghouse standard resistance grids—**combined direct current and alternating current control**—Westinghouse master controller—Westinghouse control resistor—**electric locomotives—classification**—gearless and geared locomotives—G. E. 100 ton locomotive for moderate speed heavy duty service—side rod drivers—various locomotives—Westinghouse mine locomotive—**the running gear**—M. C. B. truck—Brill maximum traction truck; service suitable for—tandem and inside hung motors—use of M. C. B. trucks—Westinghouse self-lubricating bearing—G. E. storage battery locomotive—G. E. gas-electric motor car—G. E. gas-electric direct connected set for motor car—**brakes**—hand brake—diagram of hand brake system showing stresses—air brakes—geared brake—“straight air”—diagram of automatic air brake system—automatic air—**car lighting**—diagram showing head lights in series with interior lamps—historical note—**“axle” lighting of cars**—the Stone system—Safety Lighting Co. axle driven dynamo—method of dynamo suspension in Stone system—McElroy system—S. L. Co. dynamo suspension—S. L. Co. lamp regulator; *wiring diagram*—**car heating**—heater coils and case—location of panel heater—under seat type heater—construction of Gold two coil heater unit—points on heaters—regulation of heat—six heater equipment—**track construction for electric railways**—rail bonding—various rail bonds—cable bond—ribbon bond—typical car tracks with T rails—advantages of T rails—**conduit or underground trolley systems**—section of underground conduit showing hand hole—yoke

ELECTRIC RAILWAYS—*Continued.*

construction—**third rail construction**—cross section of protected top contact third rail—exposed type—protected type—details of protected bottom contact third rail—**trolley line construction**—bracket catenary construction—single and double catenary—anchorage for double track span wire catenary construction—bridge type catenary construction for double track road—length of hangers—single catenary curve construction—detail of bracket arm—messenger cable—catenary construction at anchor span—installation of messenger cable and trolley wire—trolley deflector construction at switch—four track double catenary with bridge supports—**signal apparatus**—*classification*—automatic block signal system—non-controlled manually operated signals—controlled manually operated signals—automatic operator system—staff system—tracks used for block signal circuits—method of applying bond wires—insulated rail joint—method of connecting a relay between insulated joints of track—**bell and relay circuits**—simple track circuit signal operated by train in block—universal train annunciator—three position universal annunciator diagram—**relays**—polarized relay—slow release vertical relay—glass enclosed interlocking relays—Chicago time relay—**signal circuits**—frog bonding—**electric interlocking**—interlocking relay—interlocking feature of universal crossing bell relay—advanced block signal—distant signal and electric circuit—electric interlocking—dispatchers selector system—**blocks**—road conditions requiring long blocks—intersection of two double track lines—standard house and distant semaphore signals—three spectacle automatic double round house and distant semaphore signal—**management**—scope of the subject—motorman duties on large roads; on small roads—experience necessary—**trolley car operation**—starting—shutting of the circuit—too much current—violent stops—approaching curves—running down grades—steep grades—failure of brakes—running up heavy grades—starting on heavy up grades—slipping of wheels—use of sand—failure of power—failure to start—fuse—dead rail—peculiar jumping action—bringing car into house—**points relating to controller operation**—controlling manipulation—climbing grades—curves showing advantage of using controller correctly—**failure of car to start**—blown fuse—dust on track—Westinghouse multi-unit system—track conditions—condition of brushes—rough or burned contact fingers—loose or broken cable connection—burned rheostat—**abnormal starting**—speed increase beyond normal—starting with a jerk—flashing—

## ELECTRIC RAILWAYS—Continued.

**faulty operation**—Westinghouse interpole motor—**motor troubles**—sharp rattling noise—flats—dull thumping noise—heating, etc.—**before starting a train**—starting a train with master control—why controller button is held down—to start slowly—running positions—**reversing**—train fails to start—failure of power—fault in master control circuit; in motor control current—non-release of brakes—how to detect failure of power—detection of loose cable jumper—complete wiring diagram of Westinghouse type HL control for four 50 h.p. 500 volt motors—detection of grounded cable—systematic diagram of Westinghouse type of HL. control for four 75 h. p. 500 volt motors—detection of ground in train cable—poor contact in master controller—blown master controller fuse—faults in motor control circuit—**electric ship propulsion**—inherent defect of turbine for driving propeller—requirements in ship propulsion—nature of the turbine—*object of electric drive*—various systems—*elementary diagram illustrating the essentials of electric ship propulsion*—Hobart's alter-cycle control—Menless system—views of the author.

## MOTION PICTURES - - - - 2,673 to 2,732

Introduction—**optics**—light—mirrors—formation of images on mirrors; why inverted—**laws of reflection**—spherical mirrors—focus of curved mirror—multi-images—parabolic mirrors—refraction—**laws of refraction**—critical angle—effect of refraction—total refraction—construction of refracted ray—**LENSES**—classification—**foci in double convex lenses**—principal foci—conjugate foci—virtual foci—**foci in double concave lenses**—experimental determination of the principal focus of lenses—**optical center, secondary axis**—**formation of images by double convex lenses**—image at twice, more than twice, and less than twice the focal distance—**formation of images by double concave lenses**—effect on rays—the image—**formulæ relating to lenses**—**spherical aberration; caustics**—effect of large aperture—ill effect of spherical aberration, how avoided—stops—caustics—**chromatic aberration**—white light—dispersion—**achromatic lenses**—**PRINCIPLES OF OPTICAL PROJECTION**—relative positions of the arc, condenser, and objective—lantern slides and motion picture films used interchangeably—**how to select a lens**—the equivalent focus—standard projection lens—variation of size of image with respect to focal length—

## MOTION PICTURES—Continued

precautions in selecting a lens—kind of picture most desirable—two forms of condenser—**RULES: Size of image, focal length, distance from slide to screen**—table showing size of screen image when moving picture films are projected—table showing size of screen image when lantern slides are projected—**Motion picture machines**—optical system—intermittent film feed system—persistence of vision—*elementary moving picture machine without case, showing essential parts*—operation of elementary motion picture machine—construction details of film gate—construction details of intermittent movement—object of upper and lower feed loops—function of the film gate—**the intermittent movement**—Geneva intermittent motion—diagram showing progressively the action of the intermittent movement—“threading” a typical motion picture machine—relative periods of rest and motion, how varied—**illumination for motion picture projection; the electric arc**—kind of current used—adjustment of carbons for direct current—multi-tip acetylene burner—carbon adjustment for direct current stereopticon arc—the advance displacement—troubles encountered with alternating current arcs—kind of carbon used for alternating current arcs—angular settings—how to center the light—lamp adjustments—starting, or *striking* the arc—characteristics of a long arc—**auxiliary apparatus**—alternating current arc setting with cored carbons—tilted setting for alternating current arc carbons—90 degree angle arc lamp—Bausch and Lomb diagrams illustrating results of defective centering of the arc—various arc lamps—**the film**—how treated—precautions to be taken with films—rheostats—transformers—how film is repaired—the splice—various film perforations—arc controller—splice in frame—splice out of frame—**Motion picture cameras**—elementary diagram showing essential parts—operation—how to take motion pictures—various motion picture cameras—shutter requirements.

## GAS ENGINE IGNITION - - - - 2,733 to 2,792

Fundamental electrical principles necessary for an understanding of ignition: **electricity**—currents—conductors—resistance—volts—amperes—insulation—short circuit—metallic, and ground circuits—direct and alternating currents—high tension and low tension currents—induced currents—**magnetism**—magnetic poles—magnetic fields—**induction**—induction coils—**methods of producing elec-**

## GAS ENGINE IGNITION—Continued

**tricity**; chemical; mechanical—cells, primary and secondary—dynamos—magnetos—**ignition**—various methods of ignition: naked flame; hot tube; hot ball; electric *make and break*; electric *jump spark*—**point of ignition**—how much advance desirable—**hot tube igniter**—two cycle oil engine with hot ball igniter—**electrical ignition systems**—classification—**current for ignition**—**primary cells**—hydraulic analogies—“**dry**” cells—**points relating to primary cells**—**secondary cells**—Edison cells—**points relating to secondary or storage batteries**—difference between a dynamo and a magneto—**mechanical generators**—**dynamos**—friction drive—how a dynamo is generally used—**magnetos**—classification—**inductor magnetos**—elementary diagram of double ignition system with magneto and battery ignition—**low tension magnetos**—**high tension magnetos**—elementary diagram—oscillating type—so-called high tension magnetos—**synchronous drive for magnetos**—magneto timing diagrams—**low tension ignition**—igniters—magnetic spark plug—elements in a low tension circuit—circuit diagrams—how the spark is produced in low tension systems—inductance—primary induction coil—adaptation of low tension ignition—hammer break igniter—wipe contact igniter—**igniter with inductor magneto**—**high tension ignition**—wiring diagram—circuits necessary for the production of the jump spark—general principles of high tension ignition—automatic spark advance—**high tension ignition devices**; secondary induction coils; timers (contact makers, tremblers, contact breakers, interrupters;) distributors—spark plug—**various high tension ignition systems**—ignition with plain coils, with mechanical vibrators, with vibrator coils, with master vibrator—**synchronous ignition**—**magneto ignition**—points on magnetos—**dual ignition**—**double ignition**—**ignition with special devices**—single break system—coil wiring diagram—**ignition troubles**; how to cope with—wiring diagrams—how to adjust a vibrating coil—testing the spark plug—**faults**—complete break in the wiring—partial break—primary short circuits—secondary short circuits—primary connections—vibration—timers—coils—igniters—wiring diagrams—spark plugs—engine misfires and finally stops—engine suddenly stops, does not start, runs fitfully—pre-ignition—misfiring—knocks—loss of power—explosion in the muffler.



## SELF-STARTERS AND LIGHTING SYSTEMS FOR AUTOMOBILES - 2,793 to 2,814

Classes of starter: mechanical; compressed air; gas; **electric**—classes of **electric starter**—storage battery required—data on storage battery—state of charge as measured by hydrometer—different types of storage battery—**choice of voltage**—advantage of low voltage—**voltage of units**—their general combinations—**one unit systems**—wiring diagrams—**two unit systems**—so-called two unit system—Leece-Neville two unit systems—Wagner dynamo and cut out—Gray and Davis system—Westinghouse system—**three unit systems**—Disco system—Westinghouse diagram—**Methods of control**—thermal method—Ward Leonard controller—diagram Rushmore system—discriminating cut out—essential requirement in battery charging—Rushmore ballast coil.

## ELECTRIC VEHICLES - - - - 2,815 to 2,854

The term electric vehicle—principal types—**electricity as a motive power**—**light electric vehicles**—Baker electric roadster—**electric trucks for city service**—electric winch on truck—relative merits of gasoline and electric trucks—plan of electric chassis—**gasoline electric vehicles**—object of the carbureter—interior Waverly brougham—**electric vehicle essentials**—various losses—wind pressure—tire friction—losses in the motor—**motors for electric vehicles**—Rauch and Lang motor—Waverly motor—features to be avoided in vehicle design—considerations with respect to friction in bearing—**the drive or transmission**—**herringbone drive**—method of attaching—Waverly double reduction drive—**chain drive**—objections—diagram of chain action—cause of climbing the teeth—double chain drive—advantage of chain drive—two kinds of chain—snap and rattling—attention required—how to clean a chain—chain adjustment—chain and sprocket double reduction gear for heavy trucks—**combination chain and gear drive**—**worm drive**—Baker R & L worm and gear—worm drive transmission unit—storage battery for electric vehicles—how weight is reduced—**mileage and battery**—**points relating to storage batteries**—wiring diagram of Baker electric—Gould cell—**battery capacity**—high charging rates—normal charging rates—battery data—

**ELECTRIC VEHICLES—Continued**

**electric vehicle controllers**—diagrams—Baker R and L selective dual controller—controller diagrams—**electric vehicle circuits**—arrangement of circuits with two batteries and two motors—four unit one motor circuit—speed changing diagrams—**how to operate an electric vehicle**—charging an electric in front of city residence—**electric vehicle troubles**—various faults and remedies.

## CHAPTER LXXIII

# ELECTRIC RAILWAYS

Any system of electric car propulsion includes besides the back and rolling stock suitable apparatus: 1, to produce the current, and 2, to transmit and distribute it to the electric motors on the cars where it is transformed into mechanical energy to give motion to the car.

The extensive development of the electric railway has given rise to numerous systems. which may be classified in several ways, as

1. With respect to the current, as

- a. Direct;
- b. Alternating;

2. With respect to the method of current generation, as

- a. Mechanical  $\left\{ \begin{array}{l} \text{steam;} \\ \text{hydraulic;} \\ \text{gas engine.} \end{array} \right.$
- b. Chemical  $\left\{ \text{storage battery.} \right.$

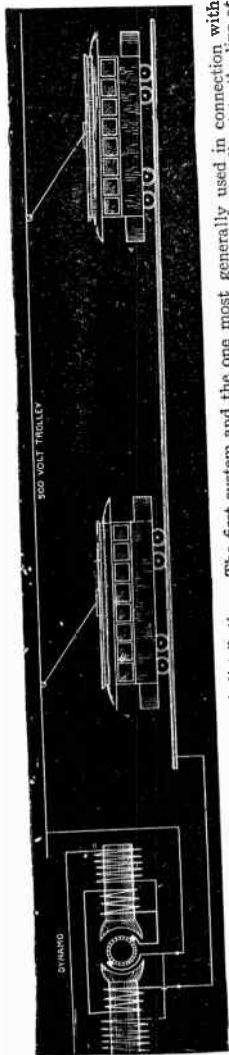
3. With respect to the power system, as

- a. Direct current transmission and distribution;
- b. Alternating current transmission, direct current distribution;
- c. Alternating current transmission and distribution.

4. With respect to the current collecting devices, as
- a. Trolley;
  - b. Surface Contact;
  - c. Third rail;
  - d. Conduit.
5. With respect to the location of the electrical source, as
- a. External { power station.
  - b. On the car { storage battery;  
gas-electric plant.
6. With respect to the distribution pressure, as
- a. Low tension { pressures  
up to  
600 volts.
  - b. High tension { pressures  
above  
600 volts.
7. With respect to the service, as
- a. City lines { elevated;  
surface;  
subway.
  - b. Interurban or suburban;
  - c. Long distance lines;
  - d. Industrial short lines.

**Power Systems.**—There are three types of motor in use for electric railways; the direct current motor, the single phase commutator motor, and the three phase induction motor.

The various transmission and distribution systems which may be successfully employed are here described and illustrated in the accompanying diagrams.



**FIG. 3,486—Direct current transmission and distribution.** The first system and the one most generally used in connection with city or short lines having a radius of 5 to 8 miles from the power house. The dynamo delivers current direct to the line at 550 volts, with the distribution system designed to deliver as nearly as possible 500 volts direct current at the motors on the cars. This system operates very satisfactorily and economically where the power is not transmitted further than mentioned above, but when it becomes necessary to extend the railway lines to greater distances into suburban districts and elsewhere, the excessive amount of copper required to transmit the power at the low voltage and maintain the proper voltage at the cars necessitates the use of *boosters* for increasing the voltage on the feeders in proportion to the demand, as shown by **fig. 3,487.**

**Direct Current Transmission and Distribution.**—This system is especially well adapted for densely populated sections as in large cities. It is not well adapted to the operation of roads covering large areas and is becoming obsolete, owing to the great amount of feeder copper required to transmit large amounts of energy at 600 volts, which is the standard pressure used.

**Ques.** Why is the use of boosters objectionable on these lines?

**Ans.** They add largely to the fuel expense.

A floating storage battery at the end of a long feeder is sometimes more expensive to install and operate than some of the other systems later described.

**Ques.** What are the standard voltages?

**Ans.** 600, 1,200, 1,500 and 2,400.

**Ques.** How are the motors operated at these various pressures?

**Ans.** The motors for the 600 volt system are designed for full

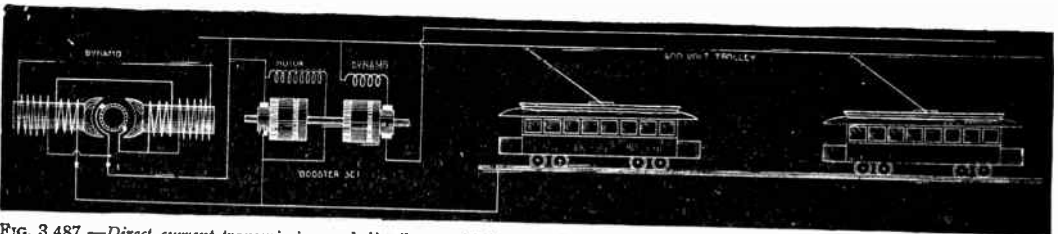


Fig. 3,487.—*Direct current transmission and distributor with booster.* 650 volts at the dynamo, radius 7 to 15 miles from the power station. The booster, which consists, usually, of a series wound dynamo driven by an engine or a motor is connected directly in series with the feeder on which it is desired to raise the voltage. Its economy is due to the fact that the cost of the power for raising the voltage sufficiently to maintain the proper voltage at the end of the feeder is less than the interest charge on the larger amount of copper which would be required to accomplish the same result with the normal voltage loss of the system. The booster has the additional advantage, that in the case of a motor driven outfit, its loss varies substantially with the demand for current, whereas if copper were used, it would be necessary to employ a sufficient amount to take care of the maximum demand and still give normal voltage at the end of the line. In addition to boosters of the motor-generator type, some generating stations employ storage batteries to take care of peak loads and the sudden fluctuations of load characteristic of electric railway work. Batteries are used also in substations at distant points on the system, where by means of reversible boosters, the battery is caused to take current from the power house feeder at time when the power demand is low on the section supplied for the sub-station, thus storing up current which it subsequently delivers to the line when the power demand is heavy. In some cases the batteries are simply floated on the line and tend to equalize the demand and the voltage. By these means the radius of successful operation of direct current systems is extended to about 15 miles from the power house.

trolley voltage. For the 1,200 volt system, both 1,200 volt and 600 volt motors are used, in the latter case, the motors are series connected in pairs. For the 2,400 volt system 1,200 volt motors are used, being series connected in pairs.

### Alternating Current Transmission, Direct Current Distribution.

—This system is in general use for suburban roads and the larger city systems. The advantages accruing from the use of both alternating and direct current must be evident, thus, a large amount of power can be transmitted by alternating current at high voltage reducing the cost of copper to a minimum, and by means of rotary converters, converted into direct

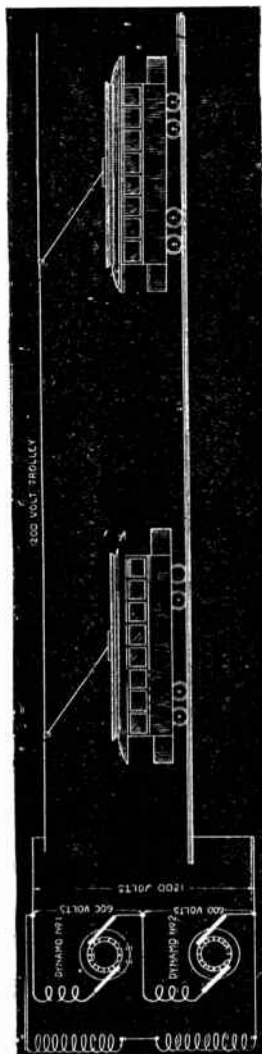
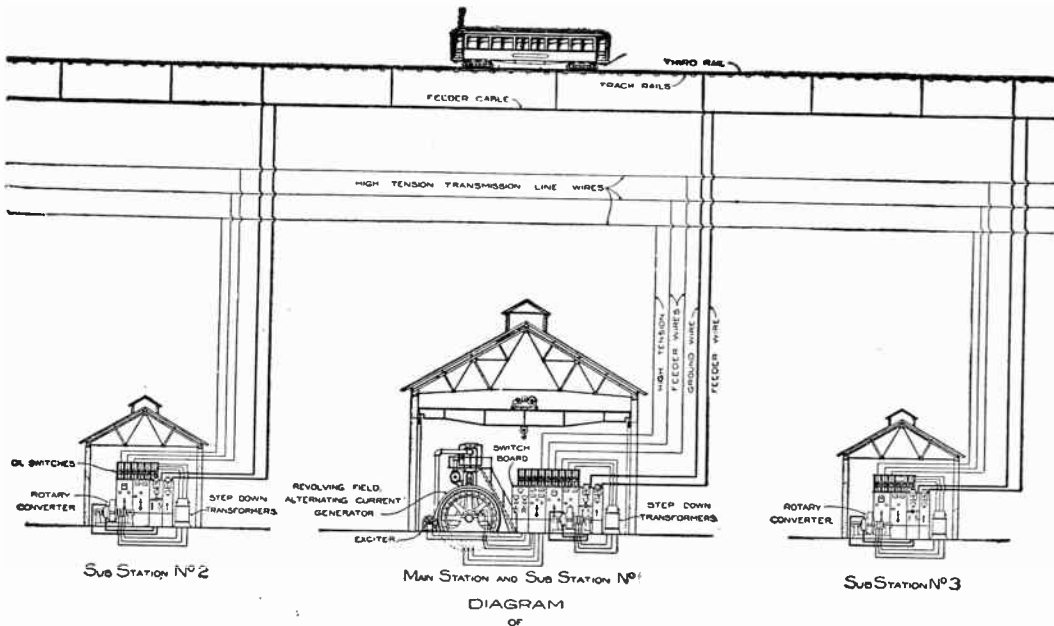


FIG. 3,488.—*Direct current transmission and distribution; 1,200 volt two stage generation, radius 10 to 20 miles from the power station. The generating plant consists of two 600 volt dynamos operated normally in series, thus feeding into the trolley at 1,200 volts. Either 1,200 volt or 600 volt motors may be used; in the latter instance the motors are series connected in pairs. Most of the roads equipped with 1,200 volt apparatus have employed motors wound for 600 volts and insulated for 1,200 volts, two motors connected in series. When this arrangement is adopted with four motor equipments, the pairs are connected in series and parallel to give the excellent result obtained by series parallel control.*

current of suitable working voltage for the motors at the distribution points.

New York City is fed entirely from rotary converters which receive their power from alternators and alternating current transmission lines at 6,600 and 11,000 volts.

**Alternating Current Transmission and Distribution.**—The first practical application of the alternating current for both transmission and distribution involved the use of the induction motor. This system required the use of two trolley wires with the ground as the third wire of a three phase distributing system. The motors were usually wound for the trolley voltage and for operating at half speed or slower, the current induced in the secondary of one motor was fed into the primary of a second motor, and resistance was placed in the secondary circuit of the latter for reducing the speed still further. Owing to the complicated overhead construction due to



FIGS. 3,489 to 3,491.—*Alternating current transmission, direct current distribution.* The diagram shows the main station and two sub-stations with apparatus and connections to the line. In the system here shown three phase current is generated at the main station, where it passes to *step up* transformers to increase the pressure a suitable amount for economical transmission. At various points along the railway line are *sub-stations*, where the three phase current is reduced in pressure to 500 or 600 volts by *step down* transformers, and converted into direct current by rotary converters. The relatively low pressure direct current is then conveyed by *feeders* to the rails, resulting in a considerable saving in copper in moderate and long distance lines.



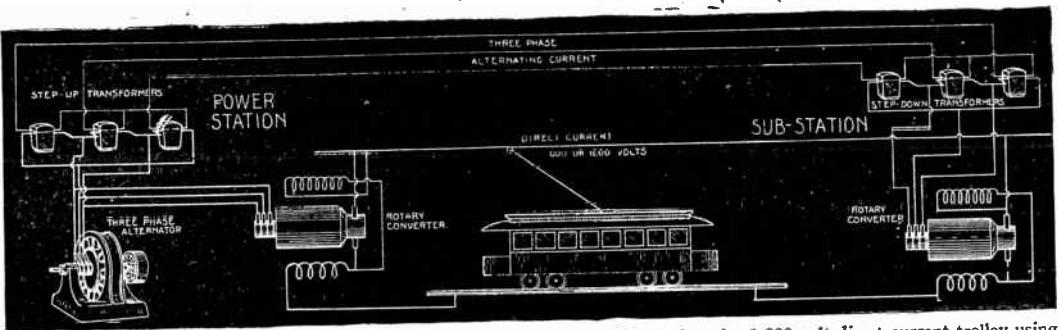


FIG. 3,492.—*Alternating current transmission, direct current distribution.* Sub-stations for 1,200 volt direct current trolley using two rotaries in series. Alternating current radius depends on the transmission voltage. *The system shown consists of three phase 25 cycle alternators, wound for 360 to 390 volts, depending on the direct current voltage desired; step up transformers for raising the generated voltage to the voltage necessary to transmission; sub-stations each having one or more rotary converters, with each converter having a set of three step down transformers for lowering the alternating current voltage to the proper value for reception by the converter for conversion to the proper direct current voltage supplied by it to the trolley, and in some cases the installation of rotary converters in the power station, as shown at A, for taking current directly from the generators without transformation.* In cases where a large amount of direct current is required near the power station, and for plants of moderate capacity where the transmission pressure is higher than 13,500 volts it is desirable to have the alternators wound for the low voltage stated; but for cases where the transmission on voltage does not exceed 13,500 volts, the use of the step up transformer may be avoided by winding the alternators for the high voltage; while for cases where the units of power handled at the switchboard exceed 1,500 kilowatts it is almost essential that the generated voltage should be higher than 390 volts. *This system may be varied in several ways* to satisfy special conditions, for example; 60 cycles may be used where the general lighting circuits are supplied from the same power house, and storage batteries may be installed in the sub-stations for equalizing the demand and reducing the rotary converter capacity necessary to take care of the load. The primary elements of all such installations are practically the same, however, and the sub-stations are usually placed from 10 to 15 miles apart, depending on the character of the road and the traffic.

the use of two trolley wires, combined with the fact that the performance of the induction motor does not give the best results in traction work, the practical application of this system is confined to a comparatively few special cases among the European electric railways.

Amore successful alternating current system is shown by fig. 3,493. As practically applied at the present time on all installations in this country the

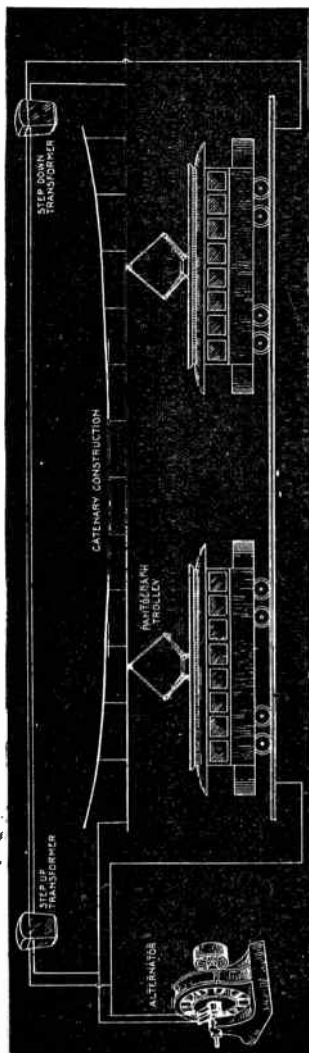


FIG. 3,493.—*An alternating current transmission and distribution. For current supply a single phase alternator may be used, or one leg of a three phase machine. For short lines the alternator may be wound for the trolley voltage, but for long lines a high pressure machine must be used in connection with step down transformer sub-stations or a medium pressure machine with step up and step down transformer as here shown. A three phase alternator is used to advantage in cases where it is desirable to furnish polyphase current for stationary power service, one leg being used to furnish single phase current to the railway, and the two other legs to furnish current for the stationary service. Trolley voltages of 3,300, 6,600, 11,000, and as high as 13,000 are in use, but the usual pressure is 6,600 volts for ordinary trolley roads, and 11,000 for the electrification of existing steam railways.*

usual trolley voltages are 6,600 and 11,000 volts.\*

**Ques.** What kind of motor is used on the single phase system?

**Ans.** The series single phase motor.

In construction it is very similar to the ordinary direct current motor, except that the entire field is made of laminated steel and an auxiliary or compensating winding is placed in the slots between the poles to secure good commutation with alternating currents. The motors are usually wound for 240 volts to which value the trolley voltage is reduced by an auto transformer placed on the car.

As in the case of the direct current motor, the speed of the single phase motor varies with the voltage at its terminals, therefore, by simply

\*NOTE.—For a single phase system the alternators are usually wound for the trolley voltage and feed directly into the line without transformation, thus supplying the whole of the road. Where the length of the road exceeds 35 or 40 miles, it is equipped with step down transformers to lower the transmission voltage to that of the trolley. In cases where it is desirable to furnish polyphase current for stationary power service, and for the operation of rotary converters, three phase alternators having one phase the full capacity required, and utilizing only one of the three phases for railway work. The cost of such installation does not differ materially from that of installations having single phase generators.

connecting the motor to different taps on the auto-transformers, for operating at slower speeds, or any voltages higher than the normal in an emergency requiring a higher speed.

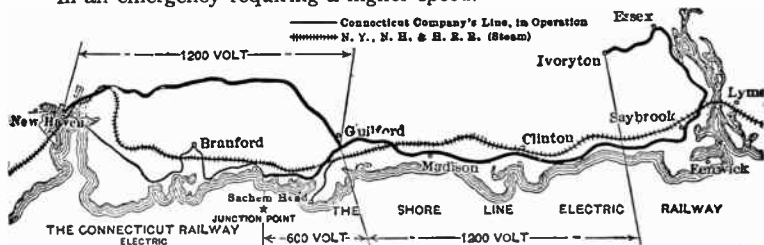
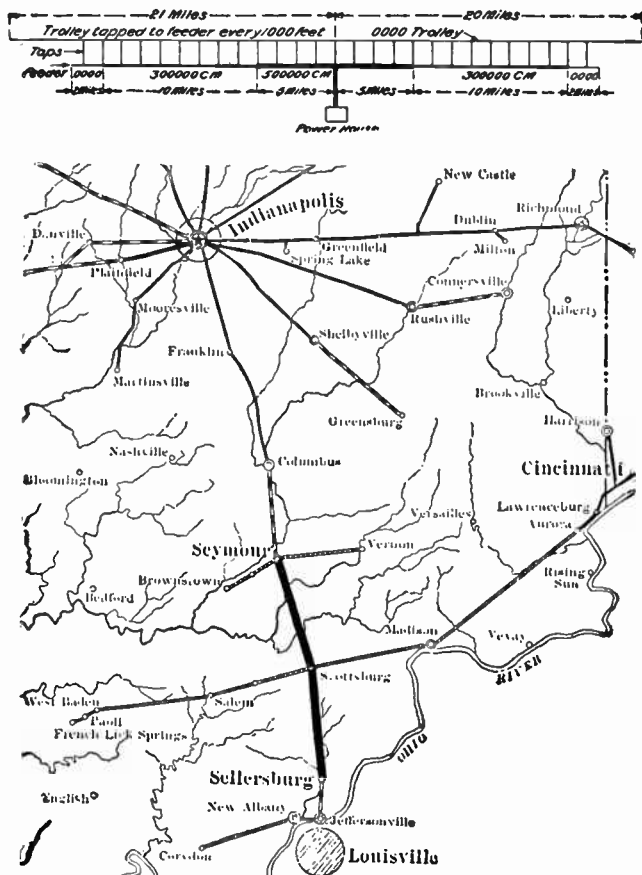


FIG. 3,494.—Map of the Shore Line Electric Railway. This line follows the Connecticut shore of Long Island Sound connecting New Haven with the towns situated along the lower end of the Connecticut river and passing through the numerous summer resorts which line the coast between Stony creek and old Saybrook. The energy for operating the system is generated at Saybrook by three phase Curtis turbines wound for 11,000 volts, 25 cycles, and is transmitted at the same voltage to two sub-stations, one at the car barn about a mile distant from the power house and the other at Guilford which supply 1,200 volts direct current to the entire 52 miles of line. **The power house** is built on the banks of the Connecticut River about a mile distant from the town of Saybrook. **The prime movers** are Curtis steam turbines of the vertical type. At present, two of these units are installed, each of 1,500 kw. capacity. They are designed to operate at a gauge pressure of 160 lb., and with a vacuum of approximately 28½ inches. The station is designed for an ultimate equipment of four of these turbines. There are two exciter sets, one a Curtis turbine set and the other a motor generator set. The former, consisting of a type CC two pole, 35 kw, 125 volt dynamo, coupled to a Curtis steam turbine unit, runs at 3,600 r.p.m. This exciter set operates non-condensing. The other set is composed of a CLB six pole, 35 kw., 125 volt compound wound dynamo direct connected to a four pole, 50 h.p., 440 volt Form K induction motor. The speed of this set is 750 r.p.m. Current at 440 volts is supplied to the motor generator sets through the medium of three type H 20 kv-a., 11,000/400 volt, 25 cycle, oil cooled transformers. **The switchboard** for the power house consists of one three phase induction motor and transformer panel, two three phase turbine generator panels, two blank panels for future generators, two three phase outgoing line panels, a swinging bracket provided with synchronous indicator and voltmeter for the exciter sets, and one two circuit exciter panel. **Lightning arresters** of the electrolytic type are provided to protect the apparatus in the power house. **The boilers** are of the water tube type. There are three 625 h.p. boilers at present and provision is made for a fourth.

**Comparison of the Various Systems.**—For ordinary street railway service the 600 volt direct current system is almost universally employed, but for interurban and trunk line service there is a great difference of opinion as to which of the various systems is the most economical when all the factors are taken into account. The factors which must be considered in comparing the three systems in any particular case are the following:

1. For a given weight and length of trolley or third rail the per cent. power loss for a given amount of power transmitted varies inversely as the square of the trolley or third rail voltage.



FIGS. 3,495 and 3,496.—Map showing route of the Indianapolis and Louisville electric railway and connections, and diagram of feeder layout. The lines of this road extend from Seymour to Sellersburg, a little over 41 miles. The company also operates cars between Louisville and Indianapolis, a distance of 110 miles. The general scheme of electrification is of special interest, owing to its simplicity. The power house is located between Seymour and Sellersburg; it feeds the 41 mile line without sub-stations. The arrangement of the feeders is shown in fig. 3,496, and is symmetrical in each direction, so that it is only necessary to consider a half section. For the first five miles from the power house, the feeder has a capacity of 500,000 cir. mils.; for the next ten miles, 300,000 cir. mils., and after that, 211,000 cir. mils. for two miles. The feeder and trolley are joined every 1,000 feet.

2. The higher the trolley or third rail voltage the fewer are the number of sub-station required for the same efficiency of distribution and weight of conductor.

3. The higher the trolley or third rail voltage the more costly is the insulation and supporting structure, and also the greater is the cost of maintenance of the distribution system.

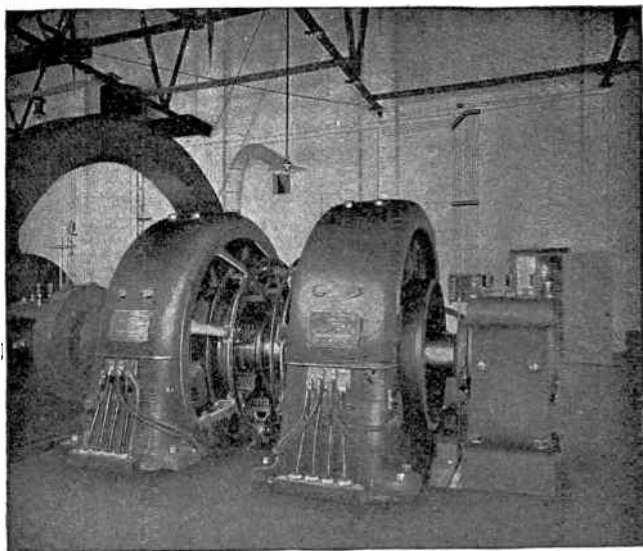


FIG. 3,497.—Interior of power station at Scottsburg (Indianapolis & Louisville line), showing direct connected two stage units. The two dynamos as shown are mounted on the extended shaft of each engine (there being two sets), and the armatures are connected in series to give 1,200 volts. The fields are connected in series on the ground sides. The switchboard consists of two dynamo panels, two feeder panels, and two exciter panels. The switches are all of the knife pattern. The control is of the automatic Sprague-General Electric parallel unit type. The commutating switch used on these equipments is located on the car platform beside the master controller for convenience in operation. The operating mechanism of the contactors is similar to those used on standard 600 volt equipments, the only difference being that additional insulation is used. The protective devices are similar to those on standard 600 volt equipment with the exception of additional blowout capacity in the main fuse bores. As is usual on 1,200 volt equipments, a dynamotor is provided to supply 600 volts for the auxiliary circuits, including the secondary control, lighting and compressor circuits.

4. Both the first cost and annual expense of the sub-stations are less for the alternating current systems than for the direct current systems, since for the former static transformers only are required whereas for the latter rotary converters must be used.

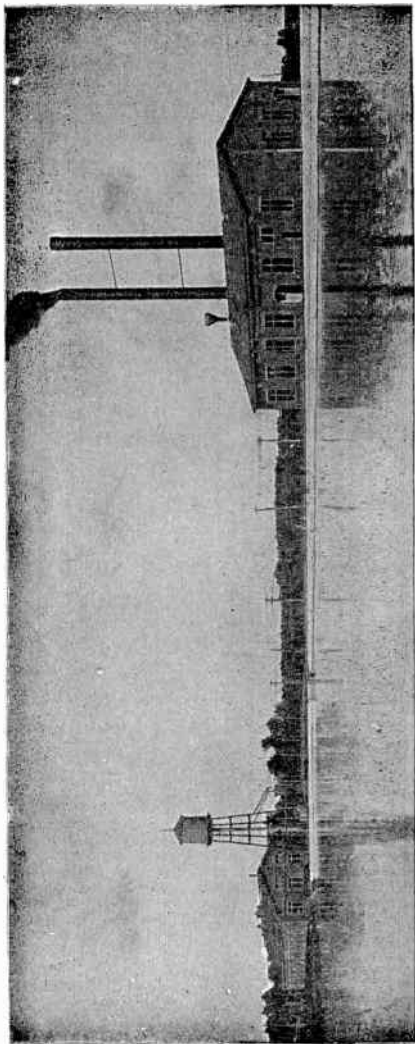


FIG. 3,498.—Power house, car barn, and artificial lake, Indianapolis and Louisville line. The power house, which is located at Scollsburg, Ind., is equipped with two single cylinder 750 horse power Corliss engines, and the boiler plant consists of four 300 horse power Babcock & Wilcox water tube boilers. The electrical equipment includes four General Electric 600 volt compound wound dynamos. Two of these units are mounted on the extended shaft of each engine, and their armatures are connected in series to give 1,200 volts. The fields are also connected in series on the ground side. The switchboard consists of two generator panels, two feeder panels, and two exciter panels. The switches are all of the knife pattern.

5. The relatively low power factor of alternating current motors (80 to 90 per cent.) as well as the relatively low power factor of the line (due to the reactance of the trolley wire and track return) gives rise to a greater power loss in the alternating current distribution system for the same power delivered than in the case of the direct current system, and this great loss and lower power factor make necessary the employment of generating apparatus of greater kva. capacity.

6. The 600 volt direct current motor, for the same horse power rating and speed, costs less, weighs less, and occupies less space than either type of alternating current motor. The high voltage direct current motors cost more, weigh more, and occupy more space than the 600 volt type.

7. With the alternating current motors, transformers are required on the locomotives, which add to the cost and weight of the locomotive equipment.

8. The 600 volt direct current motor costs less to maintain and is liable to fewer operating troubles than any of the other motors.

9. With the commutating type of alternating current motor the power lost in the control equipment is practically negligible, since the pressure type of control can be used. For both the direct current motor and the induction motor a resistance control is necessary, with consequent loss in power.

10. The induction motor is inherently a constant speed machine, and consequently the power input varies directly as the opposing resistance. The direct current motor and the alternating current commutator motor are inherently variable speed machines, and the



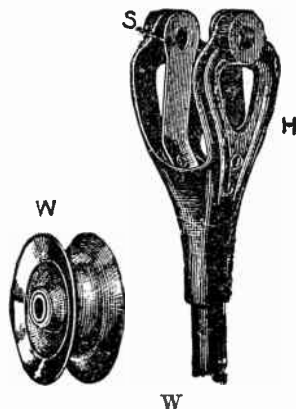
Figs. 3,499 and 3,500.—Overhead construction on the Indianapolis & Louisville 1,200 volt line. The line throughout is of the single bracket construction on tangents, as shown in fig. 3,499 and of the span type at curves, as in fig. 3,500. The poles are spaced 90 ft. apart on tangents and 60 ft. on curves. A single No. 0000 trolley wire of grooved section is used, and is held in alignment by 8 in. four screw clamps reinforced with soldered strain guys every half mile. Lightning arresters are installed every 1,000 ft., and are tapped alternately to the trolley and feeder. Telephones have been installed throughout the system, and jack boxes are attached to the poles at all sidings and at half-mile intervals.

power input varies approximately as the square root of the opposing resistance, the speed at the same time falling off.

11. The three phase induction motor, when kept connected electrically to the source of power, automatically operates as an alternator when the train is going down grade at a speed greater than the synchronous speed of the motor, the motor thus returning power to the line and at the same time acting as a brake preventing any considerable

increase in speed. *Regeneration*, as this action is called, can also be obtained with the other types of motor, but only at increased expense for the additional control equipment required.

**Current Collecting Devices.**—The various electric traction systems in successful use as distinguished by the mechanical means provided and special methods adopted for supplying

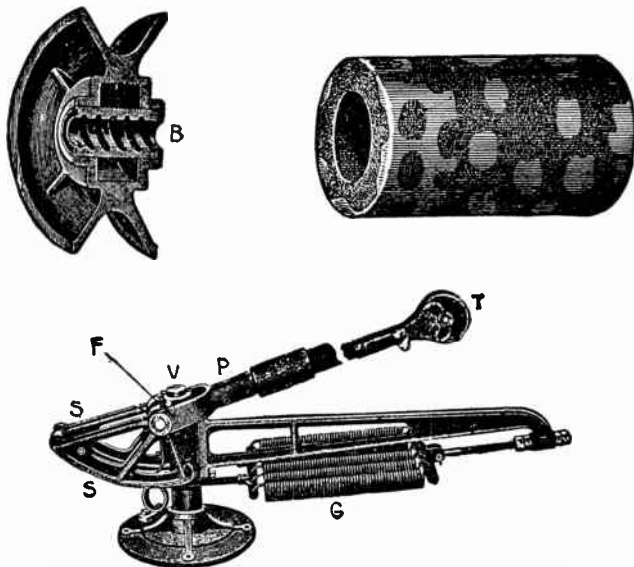


**FIGS. 3,501 and 3,502.**—Trolley wheel and harp. The word trolley signifies the wheel which is supported at the top of the trolley pole, and which makes rolling contact with the overhead conductor. As shown, the trolley consists of a light wheel W, usually of bronze, supported in a frame or *harp* H, and revolving freely on a spindle, the latter not shown in the figure. The grooved form given to the wheel not only serves the purpose of securing additional contact surface, but prevents the trolley slipping off the wire. The spring S, pressing against the side of the trolley maintains good electrical contact between the wheel and insulated wire which passes down through the trolley pole to the car. For city service the wheel principally used on the large city systems runs to fairly uniform practice being  $4\frac{1}{2}$  inches outside diameter, with a  $\frac{3}{4}$  inch V groove,  $1\frac{1}{2} \times 1\frac{1}{2}$  in., bronze and graphite bushing, and weighing from 2 to 4 lbs.;  $1\frac{1}{2} \times \frac{1}{2}$  in. bushings are largely employed on city roads. For interurban service trolleys of from  $4\frac{1}{2}$  to  $8\frac{1}{2}$  in. outside diameter are used. In general the larger the diameter the greater the mileage. Mr. Chas. A. Ingle, Electric Railway Journal, 1914, states as follows: "For the past year the Rockford & Interurban Railway, Rockford, Ills., has been able to average approximately 10,000 miles on its trolley wheels by getting the maximum possible wear out of them. We use a 6 in., 4 lb. wheel with a  $\frac{3}{8}$  in. hollow shaft, for which we pay \$1.05. The new wheels are installed in interurban service, and as they wear down are transferred to city car until worn out. We had much trouble at first because the hub would become badly worn before the rim. Now when this occurs we bore out the hub  $1\frac{1}{8}$  inch scant and press in a  $\frac{3}{8}$  in. inside diameter,  $1\frac{1}{8}$  in. outside diameter phosphor bronze bushing, which is swaged at both ends with a tapered pin ( $\frac{1}{8}$  in. taper to fit). This makes the bushing tight in the wheel and allows it to run freely on the  $\frac{3}{8}$  in. axle. At a cost of 7 cents for labor and material we frequently obtain from 3,000 to 4,000 miles additional life from a wheel, and in all cases we obtain the limit of wear." Other companies report wear from 2,800 miles in interurban service, to 25,000 or 30,000 miles in city service.



current to the motors are, as already mentioned, divided into four classes:

1. Overhead trolley system;
2. Surface contact system;
3. Third rail system;
4. Underground rail or conduit system.



FIGS. 3,503 and 3,504.—Section through trolley showing lubricating bushing, and view of bushing removed from trolley. Since trolleys revolve at a very high speed, some unusual means of lubrication must be provided, as shown in fig. 3,503. The trolley hub is fitted with a brass bushing, having a spiral groove into which is pressed graphite which acts to fill the pores of the metal, thus giving a smooth surface which reduces the friction. Roller bearing wheels have been used to a limited extent with considerable success. On some lines a very long journal is used instead of the usual short brass graphite bushing.

FIG. 3,505.—Trolley base. As shown, the Pole P terminates in a fork F, attached to a pair of sector S, S, forming a frame, capable of revolving about a vertical axis V, so as to accommodate the pole and trolley to turns or curves in the track and trolley wire. The spiral springs G maintain a tension upon these sectors binding to force the pole P upward. This tension has screw adjustment behind the springs. In order to use the trolley when the direction of the car is reversed, the pole is pulled down by a rope attached near the trolley, and then swung around the vertical pivot V, when it is allowed to re-engage with the wire in the opposite direction.

**The Overhead Trolley System.**—In this arrangement which is largely used in towns and cities, the current for the motors is taken from an overhead wire by means of a "trolley" with grooved wheels, which is held up against the wire by a flexible pole. The wires from the contact wheels pass down the pole to the car controller and thence to the motor, the return circuit usually being through the rails.

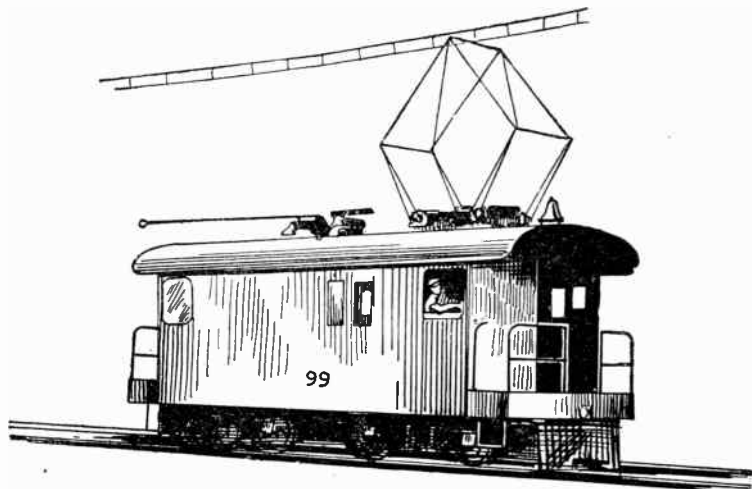
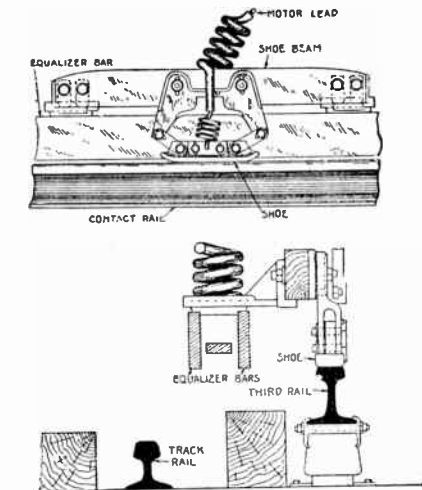


FIG. 3,506.—Pantograph trolley; view of motor car showing trolley raised. For use on high speed roads operating at high pressures a pneumatically operated pantograph trolley has been devised which can readily be raised or lowered by the motorman without leaving his cab. In trains of several motor cars, moreover, the trolleys on the entire train may be simultaneously controlled from any one point. This trolley is normally held against the wire by means of a spring, but is lowered and automatically locked down by the application of compressed air. Application of the air to another point will then unlock the trolley and allow it to rise.

**The Surface Contact System.**—This system may be advantageously used in some industrial works where an overhead trolley is objectionable, and a third rail is not permissible. The Westinghouse surface contact system requires no poles or overhead wires and leaves yards and buildings free of all obstructions. The current is supplied to the motors through contact buttons

which are connected to a feeder cable laid along the track, through electromagnetic switches; the buttons are "dead" except those directly under the motor cars or locomotives.

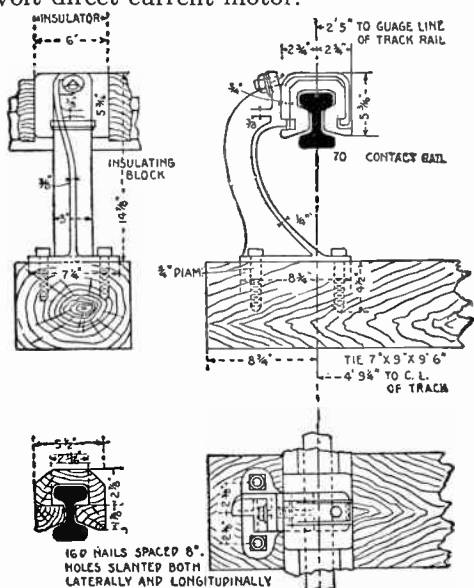
**The Third Rail System.**—In this system a rail called the "third rail" is laid outside the track rails. The current is taken



FIGS. 3,507 and 3,508.—Construction details of third rail and contact shoe as used on the Manhattan Elevated Railway, New York City. As shown, the shoe is attached to the coil spring seat of the truck, and the shoe proper, which is suspended by two links from the yoke, which is in turn bolted to castings on the shoe beam. This type of shoe has a tendency to ride on its nose when the speed is high, and does not permit of adequate protection of the rail from the weather.

by means of a suitable contact shoe which slides along the rail, and the car is controlled by the motorman as in the case of a trolley car. This system is extensively used on elevated railways, subway systems, and on those roads which have a private right of way, as in the case of electrified steam roads, which operate heavy trains at high speed.

By means of the third rail it is possible to successfully deliver to the cars much heavier currents, and to operate the cars safely at higher speeds than is possible with the ordinary type of overhead or underground trolley construction, two important features which serve to greatly expand the field of application of the 500 volt direct current motor.



**FIGS. 3,509 to 3,512.**—Construction details of New York Central Railroad inverted third rail. As shown, the rail is supported from above every eleven feet by iron brackets, which hold the insulation blocks by special clamps. These blocks, which are in two pieces, are  $6 \times \frac{3}{4}$  in., and are interchangeable. Between supporting brackets the upper part of the rail is covered by wooden sheathing, which is applied in three parts and nailed together. At the joints where the third rail is bonded, and at the feeder taps, the wooden sheathing is mortised. This rail is given a little play in the insulators for expansion, except at certain points, where it is anchored. The rail is of special section and composition and has a conductivity of about  $\frac{1}{2}$  that of copper. The under, or contact surface is placed  $2\frac{3}{4}$  inches above the top of the service rail, and its center is 4 ft.  $9\frac{1}{2}$  ins. from the center line of the service track, or 2 ft. 5 ins. from the gauge line of the near rail.

**\*NOTE.**—The location of the third rail with reference to the track rails has been different with each road using it. The Pennsylvania, Long Island, New York Central and Interborough Rapid Transit railroads have agreed upon a location which will not interfere with the passage of any of their rolling stock, either passenger or freight, viz: "The third rail shall be located outside of and parallel to the track rails so that its center line shall be 27 inches from the track gauge line and its upper face  $3\frac{1}{2}$  inches above the top of the track rail."

**The Underground Trolley or Conduit System.**—Previous to 1893 many patents were granted on conduit or other sub-surface systems of carrying the conductors for electric railroads, but it was not until after that year that capitalists began to expend enough money to make a really successfully operating road. In the conduit system the conductor carrying the current is supported in conduits and the current is taken from it by means of a trolley which extends from the motor car into the

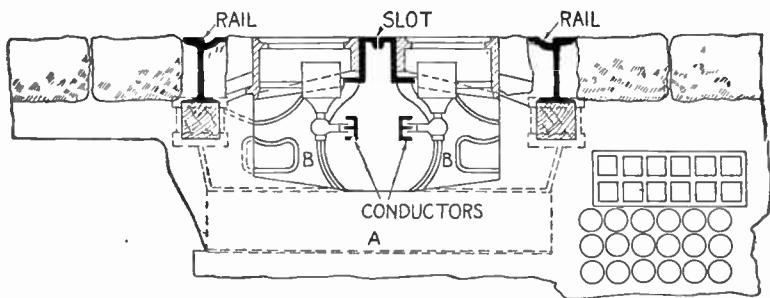


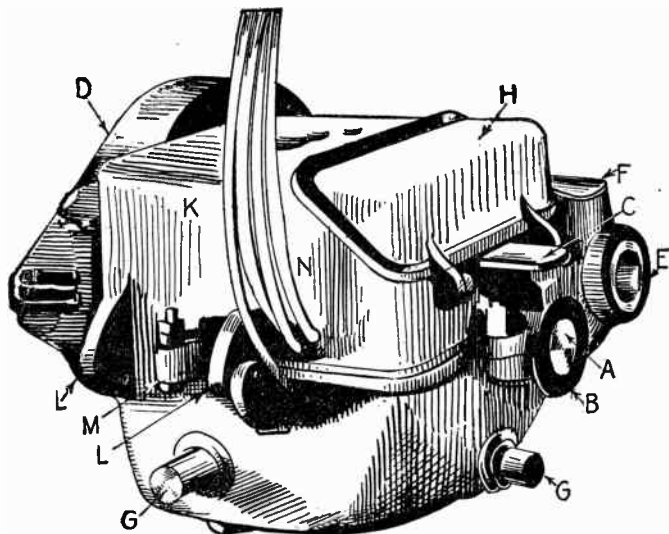
FIG. 3,513.—Sectional view showing construction details of conduit system of the Third Ave. Street Railway, New York City. A 4 inch layer of concrete forms a surface on which to align the iron work, all of which is assembled before the main body of concrete is installed. The track rails and slot rails are supported on iron yokes spaced 3 feet apart and made up in three pieces, which is a new feature in such work. The three members are a steel I beam A and two cast iron side pieces B, weighing about 125 pounds each. The yokes rest on the 4 inch concrete bottom, and the space between the yokes, the center of which space is the conduit proper, is filled with concrete that must be put in after the iron is in place, because the throat of the yoke dictates the general shape of the concrete part of the conduit. In order to shape the walls between the yokes, iron linings are used to support the concrete until it has set. These linings are made so that they can be freely drawn through the slot either way, and they are forced into position by means of a folding form operated by a lever. The track rails are 9 inch grooved girders 107 pounds to the yard, in 60 foot lengths, laid on pine stringers. This stringer construction is in accordance with the idea held by many engineers that a rigid support for the rails does not afford an easy riding track.

conduit through a central slot and makes a sliding contact with the conductor.

This system is used in the streets of large cities where the use of overhead trolley wires are objectionable, but the cost of construction is very great.

**Ques.** How does the conduit system differ from the overhead system electrically?

**Ans.** The conduit system has a metallic circuit (two insulated conductors) while the overhead trolley has a ground return, that is to say, the track rails which are not insulated from the ground are used as the return.



**FIG. 3,514.**—Direct current railway motor, casing closed; as shown, the armature shaft A, projects through its bearing B, lubricated by the grease box C, and is connected with the car axle by gear wheels enclosed in the gear cover D. The gears serve to reduce the speed of the car, and also to increase the effective pull of the motor. The car axle passes through the bearing E, lubricated by the grease box F. The motor is supported on the truck by the lugs G G. The commutator door H gives access to the brushes, while a more complete inspection of the working parts may be obtained by throwing back the upper half of the casing K upon the hinges L L, after unscrewing two bolts, one of which is shown at M. The insulated cables shown at N, pass through the casing and supply current to the motor.

**Ques.** What are the requirements of a conduit system?

**Ans.** Perfect drainage; conductor inaccessible from surface to anything except the contact shoes; good insulation of the

conductors; provisions for expansion and contraction; accessibility for repairs.

**Motors.**—The severe operating conditions of railway service demand a motor differing in many respects from the ordinary machine. The principal requirements are: 1, that it shall be dust and water proof because of its exposed location beneath

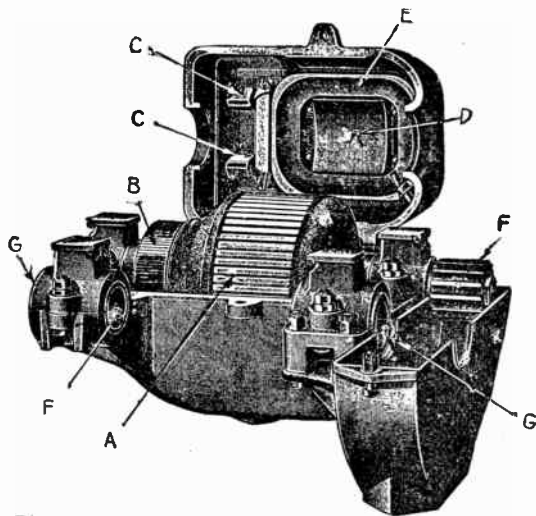


FIG. 3,515.—Direct current railway motor, casing open; as shown, the essential working part of the motor consists of an armature A, with a commutator at B; the brushes C C, which serve to carry the current from the trolley line into and out of the armature; and the four poles between which the armature rotates. One of the poles is shown in the upper half of the casing at D, surrounded by the upper field coil E. The pinion F secured to one end of the armature shaft engages with a gear wheel on the car axle, which passes through the bearings G G, corresponding to the bearings designated E in fig. 3,514.

the car; 2, it must be capable of very heavy overloads to secure quick acceleration at starting; 3, it must be compact because of the limited space available; 4, large bearings with efficient self-oiling devices must be provided to secure long operating

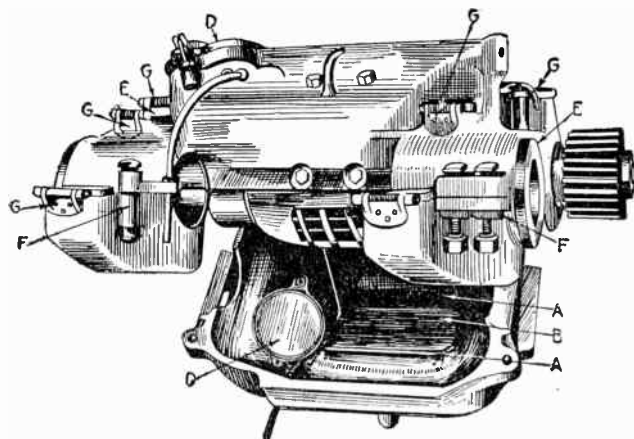


FIG. 3,516.—Direct current split frame motor which allows the lower part to be swung down into a pit for the inspection or renewal of the working parts. The main exciting pole pieces two of which are shown at AA, are bolted to the frame at an angle of 45 degrees to the horizontal. The commutating pole pieces one of which is shown at B, are bolted to the frame at points midway between the main exciting poles. Commutator doors DD, fitted with malleable iron covers and gaskets are provided at both ends of the motor to permit of the inspection or ventilation of the working parts under service conditions. They are inclined at any angle so as to allow of the brush holders being readily reached either from under the car, or through a trap door in the floor of the car. The covers for these openings are held in place by a readily adjustable cone locking device. Supporting brackets EE for the armature shaft, and brackets FF for the axle bearings are located on the outside top magnet frame. The linings are held rigidly in the supporting brackets by means of caps bolted tightly against them. The armature shaft linings consist of bronze sleeves soldered in place. The layer of babbit metal is so thin that the armature will not rub against the pole pieces in case it is melted out by overheating. All bearings are designed for oil and waste lubrication in a manner similar to the standard box journal bearing. The oil wells are reached through large hand holes protected by strong springs, as shown. Waste oil from the armature shaft bearings is prevented entering the inside of motor casing or frame by deflectors which divert the oil into grooves which conduct it away. The main field coils and the commutating coils are of the type and are wound with either copper wire or strip as may be necessary. The strip is insulated between turns with asbestos and the sections are separated from each other by an insulating partition of oiled asbestos and mica. All coils, whether of wire or strip are first provided with a wrapping of cotton tape and are thoroughly filled with an insulating compound by the vacuum process. They are then thoroughly insulated with several wrappings of specially prepared tape, and finally given a wrapping of heavy cotton webbing thoroughly filled with japan to protect them against mechanical injury. The coils are securely clamped to the frame when the pole pieces are bolted in. The armature core is built up of laminations of soft iron interspaced with ventilating ducts. The armature coils are of the formed type, and the windings at both ends are covered with a strong canvas dressing securely bound in place. The commutator segments are made of hard drawn copper insulated throughout with mica. The cone micas are built up and pressed hard and compact in steam moulds. The mica between the segments is made of softer quality, so that it will wear evenly with the copper. The shells and caps are of cast steel or malleable iron in strong sections which serve to prevent breakage and preserve the proper shape of the commutator. The brush holders, two in number, are made of cast bronze and hold from two to four carbon brushes each, according to the size of the motor. The brushes slide in finished ways, and are pressed against the commutator by



periods without attention. The first requirement calls for enclosed construction, thus instead of a frame as in the ordinary motor, this number takes the form of a case or the "iron clad" construction.

To permit the heavy overloads necessary at starting as well as the heavy duty running conditions, the proportion of parts comprising the electrical circuits, as inductors, field coils,

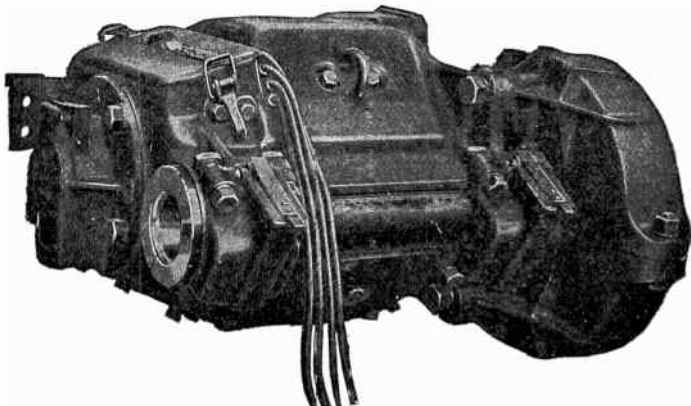


FIG. 3,517.—General Electric standard box frame motor. In this type the magnet frame is one piece of cast steel, and, as shown, is approximately octagonal in shape. The frame is provided with bored openings at each end, through which the armature, pole pieces, and field coils can be inserted or removed through the pinion end opening. Bails are cast on the frame at convenient points to facilitate handling. The opening through the frame over the commutator is large and inclined at an angle to allow easy access to the commutator and brush holders. Hand hole openings are located at points most convenient for the inspection of the interior of the motor. Drain holes are drilled in the lower side of the motor frame. The axle caps (which are inclined at an angle of approximately 60 degrees to the horizontal) are tongued and bolted to machined surfaces on the magnet frame.

FIG. 3,516.—Description continued.

independent fingers, which exert a uniform pressure throughout the working range of the brushes. A "pig tail" or shunt is inserted between the fingers and the brush holder body to prevent current passing through the spring which actuates the fingers, or through the pivoting pins. The brush holders are adjustable in position to allow for wear of the commutator, and can be readily removed through the commutator door. The three point suspension is a salient feature in the designing of these motors. In the box frame type the front of the frame or casing is provided with a lug which rests on a bracket secured to the truck transom. The motor is kept from rising by means of a forged strap bolted over the top of the lug. When the truck is out from under the body of the car, the motors can be mounted on or taken off the truck from above, no pit being required. In the split frame motors, lugs are cast on the upper half of the frame to which a suspension bar is bolted.

commutation segments, brushes, must be increased to proper size for the heavy current. A similar increase of dimension of the bearings, shaft, pinion, etc., must be made to secure proper working stresses. These requirements together with the fact that the construction must be compact, result in a design of motor considerably different in appearance from the ordinary motor for stationary service.

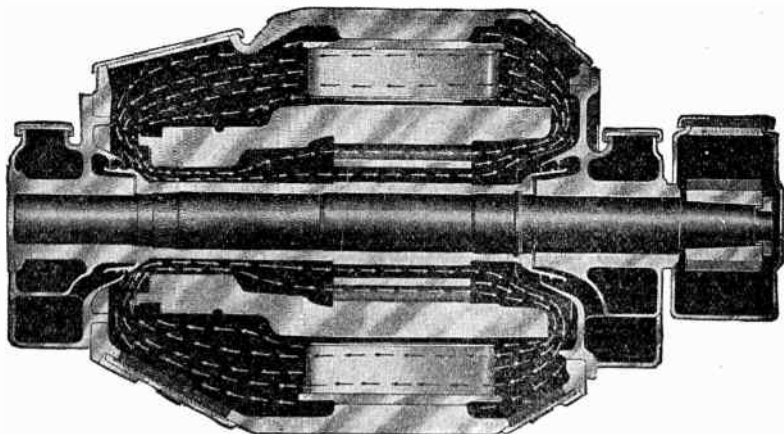


FIG. 3,518.—Method of forced ventilation with internal air. In this arrangement there are no ventilation openings to the outside air, the air being circulated internally in the motor, as shown.

**Ques.** Name an important provision that should be made in railway motor design.

**Ans.** Some means of ventilation should be provided especially for motors to be operated in warm climates.

**Ques.** Name two methods of ventilation.

**Ans.** Natural, and forced.

**Natural Ventilation.**—This may be secured either by *internal circulation* or *circulation of outside air*. In the first

mentioned method, the heat is distributed by keeping the warm air stirred up through the ducts.

The method of circulating the external air through the interior of the casing may be used in warm weather but with caution when there is much dust in the air.

**Forced Circulation.**—This may be secured by a fan located either within or outside the motor. The fan is usually

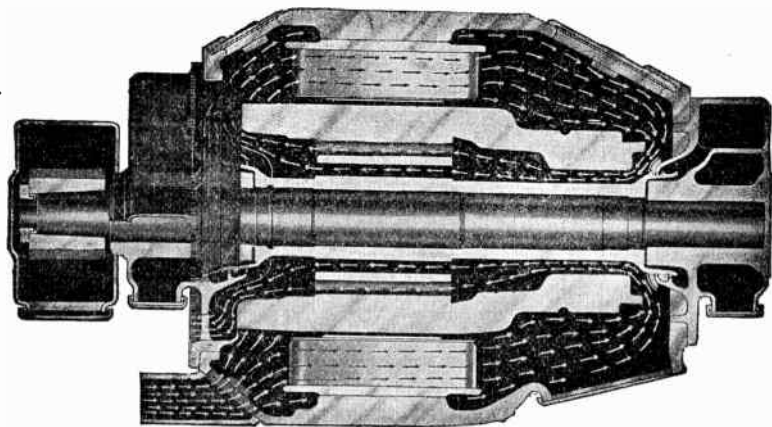


FIG. 3,519.—Method of forced ventilation with external air. *In construction*, the fan is cast integral with the pinion end armature head, which draws air in through a screened inlet. *In operation*, the air passes around field coils, over and through the commutator and armature coil, carrying the heat from the interior, and thus increasing the service capacity of the motor.

mounted on the armature shaft at the pinion end and inside the casing. This fan drives air out of the motor through openings in the pinion end of the motor which is replaced by external air entering through a screened opening over the armature and field coils, under and through the commutator and then through longitudinal ducts in the armature core.

**Motor Classification.**—There are several types of motor used for railway service, and these may be classified

1. With respect to the kind of current used, as

- a. Direct;
- b. Alternating  $\left\{ \begin{array}{l} \text{single phase;} \\ \text{polyphase.} \end{array} \right.$

2. With respect to the pressure of the current, as

- a. Low pressure  $\left\{ \begin{array}{l} 50 \text{ volts} \\ \text{to} \\ 220 \text{ volts;} \end{array} \right.$
- b. Medium pressure  $\left\{ \begin{array}{l} 250 \text{ volts} \\ \text{to} \\ 550 \text{ volts;} \end{array} \right.$
- c. High pressure  $\left\{ \begin{array}{l} 600 \text{ volts} \\ \text{to} \\ 2400 \text{ volts.} \end{array} \right.$

3. With respect to winding and operating principle, as

- a. Series direct current;
- b. Series single phase;
- c. Induction, three phase.

4. With respect to the method of ventilation, as

- a. Natural ventilation  $\left\{ \begin{array}{l} \text{internal circulation;} \\ \text{external circulation.} \end{array} \right.$
- b. Forced ventilation  $\left\{ \begin{array}{l} \text{self-contained fan;} \\ \text{external fan.} \end{array} \right.$

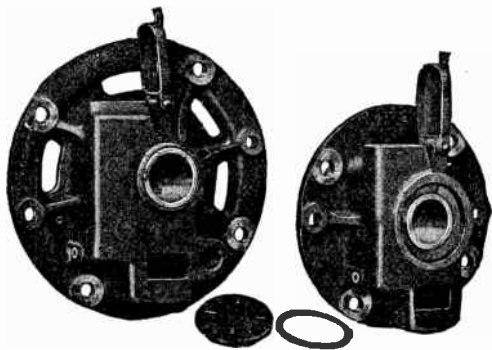
5. With respect to the transmission, as

- a. Direct drive;
- b. Geared drive.

The various types of motor and their principles have already been treated at such length (see Guide No. 2 for direct current motors, and Guide No. 6 for alternating current motors) that it is not necessary to add anything here, save to treat of the peculiarity of construction, behavior, methods of placement, etc.

**Motor Suspension.**—An important point in railway motor design is the method of suspending the motor and usually much care is devoted to the selection of the best arrangement.

Usually the motor is constructed with a set of bearing on one side of the frame, in which bearings the axle of the car wheels rotate. Mounted upon this axle is a large gear which meshes with the pinion gear on the end of the armature shaft, the gears being protected from dust, etc., by a casing. The side of the motor opposite to that containing the car axle is usually fastened



Figs. 3,520 to 3,523.—Frame heads for General Electric box type motor.

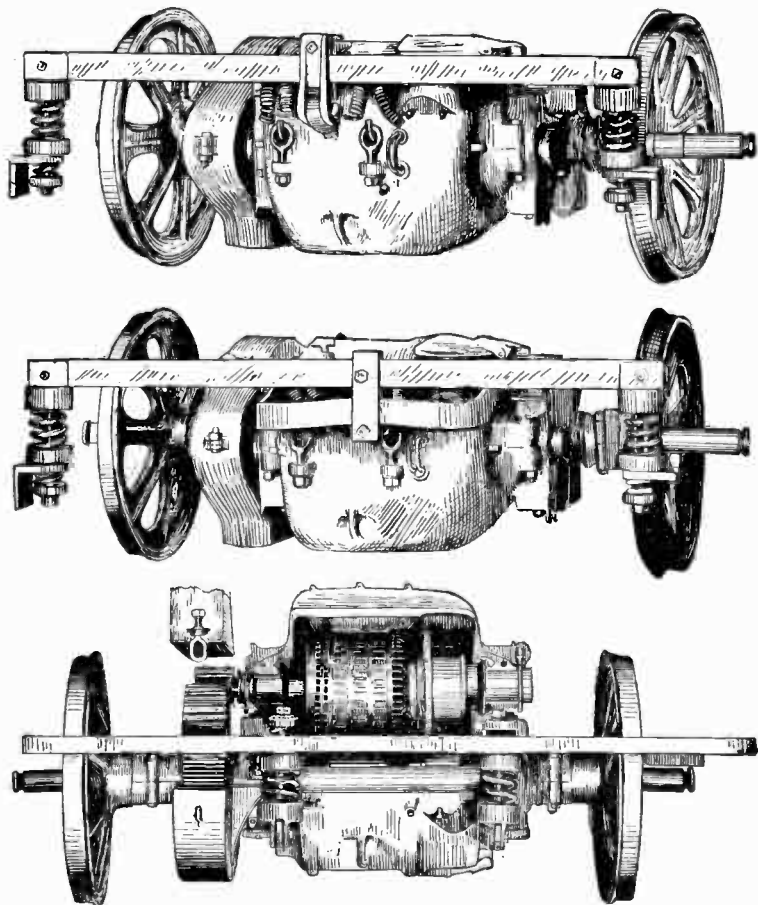
to a bar, which in turn is mounted upon springs connecting it to the car truck.

There are numerous forms of suspension, and these may be classed as

1. Cradle suspension;
2. Nose suspension;
3. Yoke suspension;
4. Parallel bar or side suspension;
5. Twin motor suspension.

**Ques.** Describe the cradle suspension.

**Ans.** It consists of a U shaped bar fastened to the truck at the middle of the U, as shown in fig. 3,525.

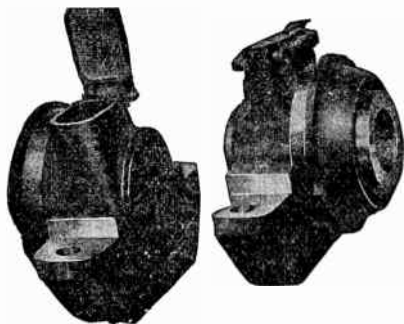


FIGS. 3,524 to 3,526.—Various motor suspensions. Fig. 3,524, nose suspension; fig. 3,525, cradle suspension; fig. 3,526 parallel bar suspension.

The cradle suspension is intended to relieve the bearings of the weight of the motor. The total weight of the motor is hung by lugs on either side from a longitudinal horizontal bar which at the back end is spring supported from lugs on the arm which carries the axle bearing and at the front end by a cross and beam truck frame. This type of suspension is now semi-obsolete.

**Ques. Describe the nose suspension.**

**Ans.** This method consists of casting a projection or "nose" on the motor frame, and fastening it to the motor truck by means of a heavy link.



**FIGS. 3,527 and 3,528.**—Frame heads for General Electric split frame motor. These heads are of the solid type and special provision is made to secure good lubrication.

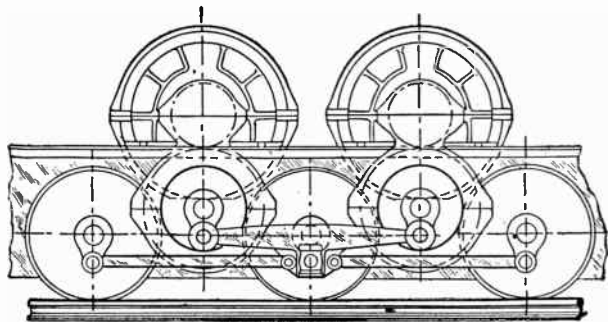
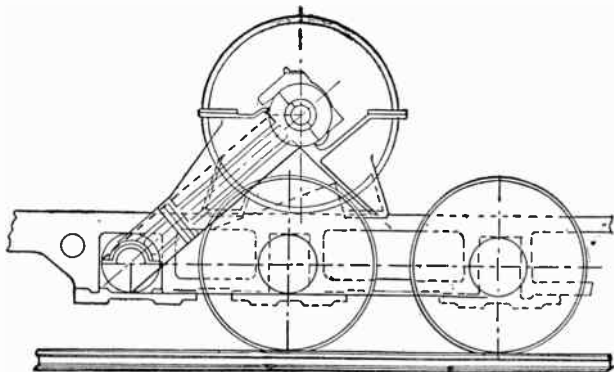
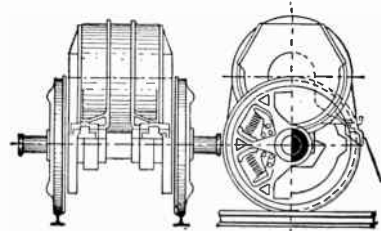
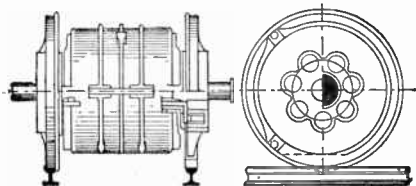
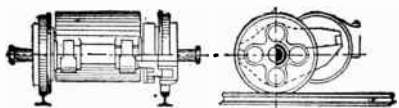
The object of nose suspension is to distribute the weight of the motor between the car axle and the truck. This is the most used method. In operation the springs in the nose suspension lessen shocks during starting or sudden changes of torque, about 60 per cent. of the weight of the motor being carried directly on the axles without spring support.

**Ques. Describe yoke suspension.**

**Ans.** In this method a cross bar is rigidly bolted on to seats cast on the motor casing, and the ends of these bars are spring supported on the truck frame.

**Ques. Describe parallel bar or side suspension.**

**Ans.** This consists of two parallel bars fastened to the car truck supporting the motor on springs at its center of gravity.



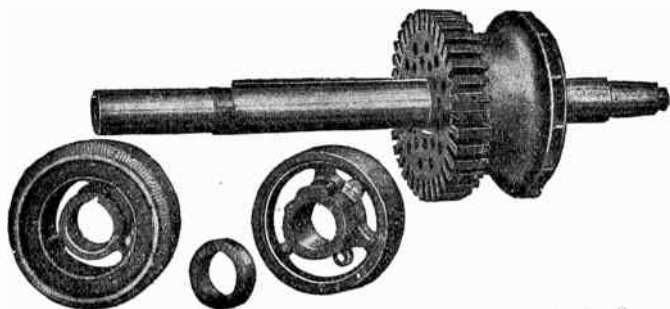
FIGS. 3,529 to 3,533.—Various motor suspensions. Fig. 3,529, New Haven geared motor; fig. 3,530, New Haven gearless motor; fig. 3,531, New Haven topgeared motor; fig. 3,532, Pennsylvania gearless motor with connecting rods; fig. 3,533, geared motors with yoke, or erroneously called Scotch yoke.



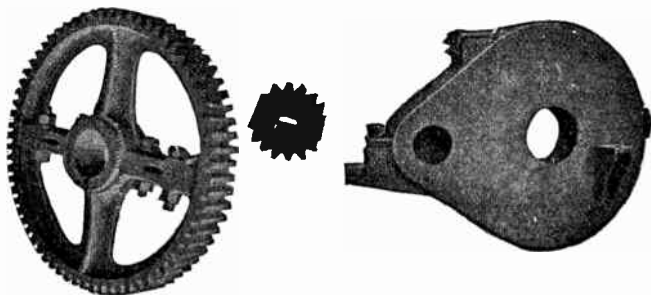
### Ques. Describe twin motor suspension.

Ans. In this arrangement two motors of equal capacity are mounted above each axle. Each motor is provided with a pinion and the two pinions of the pair of motor mesh with a single gear which is mounted on a quill surrounding the driving axle.

By this method, two small motors, each having twice the rotative speed of one large motor, may be used. Since each little motor is about



FIGS. 3,534 to 3,537.—Armature construction of General Electric ventilated railway motor. The core is built up of laminations mounted upon and keyed to the armature shaft. The armature is so constructed that the shaft can be removed without disturbing the windings or connections to the commutator. The laminations are punched and assembled with the holes in alignment so as to provide longitudinal holes through the core structure. The pinion end thrust collar has two oil throws, and the commutator end thrust collar, three, so designed as to prevent oil reaching the interior of the motor.



FIGS. 3,538 to 3,540.—Railway motor gearing and case. Fig. 3,538 large gear, which is attached to the car wheel axle; fig. 3,539 pinion, which meshes with the large gear, and which is attached to one end of the motor shaft; 3,540 gear case to protect large gear and pinion from dust, etc.

half the diameter of one motor of capacity equivalent to that of the pair, the pair may be mounted on a lighter frame and the weight of the end housings may be reduced. The width of the gear required on each axle is but half that required with one large motor of equivalent capacity. Hence the weight of the gear is reduced and a larger and more economical design of motor is made possible.

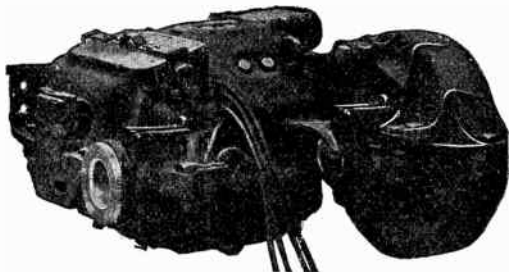


FIG. 3,541.—General Electric split frame motor. The frame is split horizontally with the suspension on the top half. The bottom half is arranged to drop to permit inspection of the interior of the motor from a pit. The armature bearing frame heads are of the solid head type giving the same qualities of oil lubrication as are obtained in the standard box frame motors. The upper and lower halves of the frame are held together by four bolts and two hinge bolts, and each frame head is firmly secured to the upper frame by bolts which are easily accessible from a pit. By removing these bolts (excepting the hinge bolts) and the lower half of the gear case, the armature can be removed. The upper and lower magnet frames are provided with machined surfaces fitting closely around the bearing heads, which act as keys in securing the alignment of the upper and lower halves of the motor frame. The axle bearing caps are bolted to planed surfaces on the top half of the frame and all the bolts are accessible from a pit. The armature is so constructed that the shaft can be removed without disturbing the windings or connections.



FIGS. 3,542 to 3,547.—Various construction details of General Electric commutating pole railway motor, fig. 3,542, exciting field coil and supports; figs. 3,543 to 3,545 details of commutating field coil and supports; fig. 3,546, brush holders; fig. 3,547, malleable iron gear case.

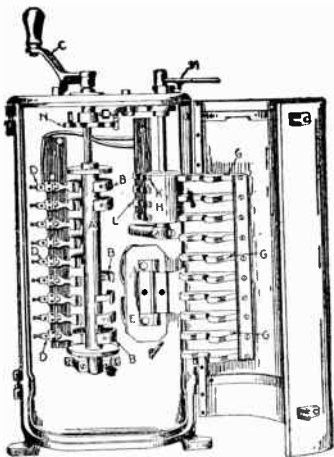
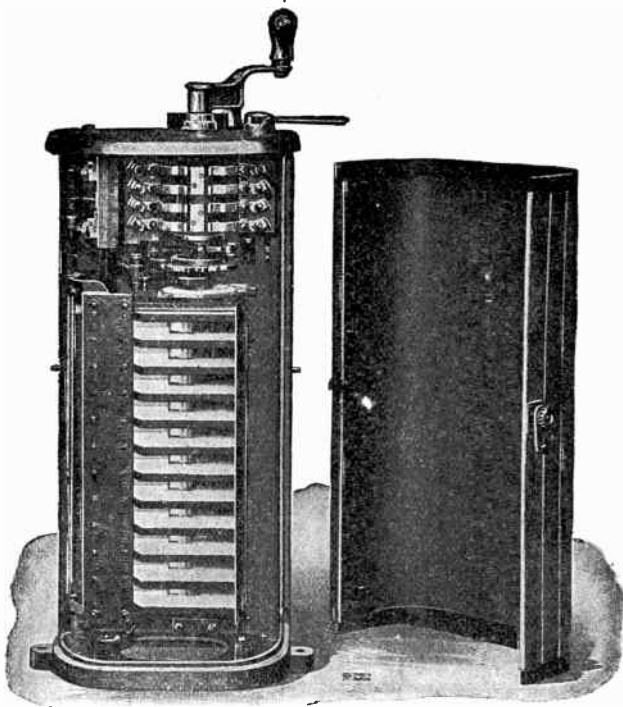


FIG. 3,548.—Ordinary rheostatic controller, designed to control one or more motors by means of resistance only. As shown, it consists of a switch cylinder A, carrying nine insulating supports upon which are mounted nine metallic conducting segments B, B, B. These segments differ in length and position, and when the cylinder is turned by means of the handle C, they come in contact at different times with the nine fixed contact springs D, D, D, which effect the changes in the connection by which more or less resistance is brought into or out of the motor circuit, thereby producing a change in the speed of the car. It is evident that after contact has been made between the motor and the trolley, an electric arc, very destructive to the breaking contact within the controller would be established unless some means were provided for breaking the arc at the instant of its formation. This is accomplished by means of a magnetic blow out device consisting of the magnet E and its pole piece, carrying the polar ridges G, G, G, which rest close to the contact springs D, D, D, when the pole pieces are placed in normal position. **In operation,** the current passing through the motor passes through the coils of the magnet E, and converts its core into an electromagnet which produces a powerful magnetic flux around the contact surfaces of the springs D, D, D. At the instant the circuit is broken either in changing connections or when the current is entirely shut off, the irresistible influence of this powerful magnetic flux prevents the severe sparking which would naturally occur otherwise by blowing out the arcs as soon as they are formed. The reversing cylinder H, carries four conducting segments K, and a corresponding number of contact spring L. By moving the handle M through an arc of about 60 degrees, the segments in contact with the springs L, can be changed and the direction of the current through the armature of the motor reversed, thereby causing it to rotate in the opposite direction and back the car. As the reversing operation cannot be safely accomplished while the motor is running, the handles C and M are made interlocking so that the latter cannot be moved unless the former be in the "off position." In other words the current must first be shut off before the direction of the car can be reversed. This prevents any arcing on the contacts of the reversing cylinder. The proper operation of a controller requires that all the successive contacts be made and none omitted. This is insured by the action of the star wheel located at N. Rheostatic controllers may be used for single motor railway equipments, single or double motor mining equipments, and for crane, etc. It is important to have a full knowledge of all the requirements of any particular service before selecting the controller. For service requiring frequent motor reversals, a controller with a single handle, with the motor circuits so arranged as to perform the function of the reverser, is found more convenient than a controller with a separate reversing handle. Controllers with single handles are usually employed to operate travelling cranes, turn tables, stationary and portable hoists, etc., while those having two handles are generally used with street railway and mining equipments.

**Motor Control Systems.**—In the case of nearly all railway motors of both the direct current and alternating current types, the speed of the motor varies with the voltage impressed upon its terminals. In other words, by increasing or decreasing the



**Figs. 3,549 and 3,550.**—General Electric series parallel controller. In this type, of which there are several forms, the power circuits are not broken during transition from series to parallel connections. The series parallel controller, as is well known, is used to control two motors, or two pairs of motor, and serves to connect these motors in series or in parallel relation. By means of these connections a car may be run economically at a medium speed, as well as at full speed, and can be accelerated to full speed more efficiently than is possible with a simple rheostatic controller. Hence, the practically universal adoption of the series parallel controller in railway service. The older forms of K controller were designed for operation on a normal line pressure of approximately 500 volts. With the advent of the commutating pole railway motor, the use of higher operating pressures, 600 to 650 volts, became possible and is now common practice, especially on interurban lines. To successfully operate on these higher voltages, individual blow outs and other features were introduced.

voltage applied to the terminals of a motor its speed may be correspondingly increased or decreased.

It is evident that one of the principal requirements in the operation of electric cars is that they should not only be capable of being started, run up to full speed, slowed down and stopped gradually, but should also be capable of being stopped suddenly and their direction of motion reversed in emergency.

These various speed requirements give rise to several control systems, and the apparatus employed to effect the proper sequence of connection corresponding to the system of control adopted is known as a controller. A comprehensive classification would divide the various systems

1. With respect to the method of operation, as

- a. Hand control;
- b. Automatic control;
- c. Master control.

2. With respect to the current, as

- a. Direct;
- b. Alternating.

3. With respect to character and sequence of connections, as

- |                        |   |  |              |   |   |             |   |  |
|------------------------|---|--|--------------|---|---|-------------|---|--|
| a. Direct current      | { | rheostatic;<br>field;<br>series parallel;<br>multi-unit (master control).  |              |   |   |             |   |  |
| b. Alternating current | { | <table border="0" style="border-left: 1px solid black; padding-left: 10px;"> <tr> <td style="vertical-align: middle;">single phase</td> <td style="font-size: 2em; vertical-align: middle;">{</td> <td style="vertical-align: middle;">rheostatic;<br/>compensator;<br/>induction regulator;</td> </tr> <tr> <td style="vertical-align: middle;">three phase</td> <td style="font-size: 2em; vertical-align: middle;">{</td> <td style="vertical-align: middle;">rheostatic;<br/>changeable pole;<br/>cascade { single;<br/>parallel single;<br/>combined changeable<br/>pole and cascade.</td> </tr> </table> | single phase | { | rheostatic;<br>compensator;<br>induction regulator; | three phase | { | rheostatic;<br>changeable pole;<br>cascade { single;<br>parallel single;<br>combined changeable<br>pole and cascade. |
| single phase           | { | rheostatic;<br>compensator;<br>induction regulator;  |              |   |   |             |   |  |
| three phase            | { | rheostatic;<br>changeable pole;<br>cascade { single;<br>parallel single;<br>combined changeable<br>pole and cascade.   |              |   |   |             |   |  |

4. With respect to the method of transition, as

- a. With power off;
- b. With series resistance;
- c. Bridge.

The various systems in general use are illustrated in the accompanying cuts.

### Ques. Define hand control.

Ans. In this system the motorman, by moving the controller handle, can vary the current value without any time limit device.

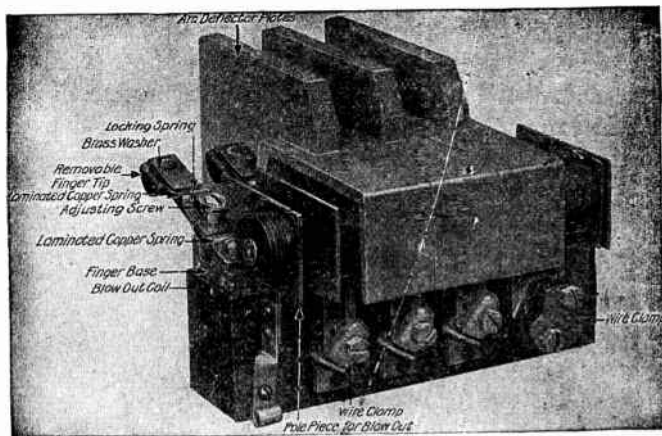


FIG. 3,551.—Detail of General Electric type K magnetic blow out showing main finger and wire clamps. The figure shows the construction of blow outs used in forms K-34, K-35, K-36 and K-44 controller. Each finger is supplied with a separate magnetic blow out, consisting of a complete magnetic circuit, blow out coils and arc deflecting chutes. In this illustration one of the iron plates forming part of the magnetic circuit is removed to show the finger and blow out coil. The current entering at the clamp terminal passes through the blow out coil, through the finger to the segment, generating a strong magnetic field across the space between the arc deflector plates, so that when the circuit is broken the arc is blown in an outward direction, away from the cylinder. In order to extend the pole pieces to a point where arcing occurs, between the finger and segment, iron plates are imbedded in the insulation of the arc chutes. The arc chutes are made of a special moulded insulation compound, which does not carbonize under the influence of an arc. Ample space is provided in these chutes for the expansion of the arc when breaking a circuit. As the arc is projected away from the cylinder, the danger from short circuiting, which occurred with the older form of blow out, has been eliminated. In the older controllers, the magnetic blow out is composed of one magnetic field, extending the full length of the cylinder, and produced by a single coil. The effect of this field is to extinguish the arcs by blowing them either up or down against the deflector plates, and not directly away from the cylinder.

### Ques. Define automatic control.

Ans. This system includes certain automatic devices which

prevent the motorman applying to the motors a current greater than a predetermined value.

Thus, the motor starts with a proper current and as soon as the current has decreased to a specified value, the connections are automatically changed so that the rate of acceleration and the current are kept practically uniform throughout the period of control.

**Ques. Define master or multi-unit control.**

Ans. This system, ill advisedly called multiple unit control, is one in which the motors on each car of a train of several cars are controlled from one master controller.

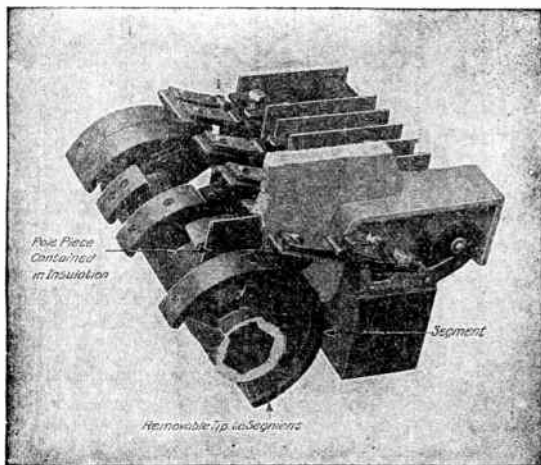


FIG. 3,552.—Detail of General Electric type K magnetic blow out showing pole piece, segment and removable tip.

The principal object of multi-unit control is in service requiring that cars be operated singly or several coupled together in a train and operated simultaneously, the connection being so arranged, when several cars are coupled together, that the motors on all of the cars may be controlled from either end of any car by a single operator.

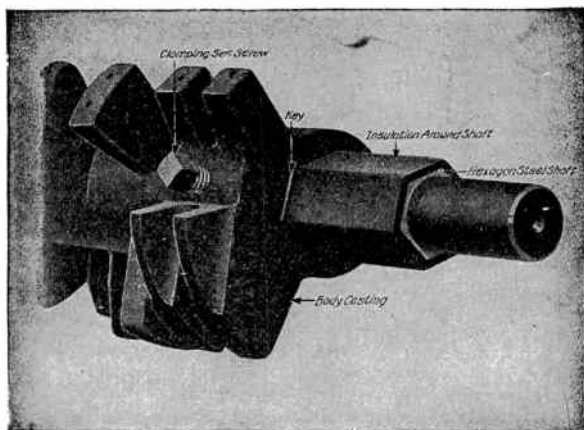
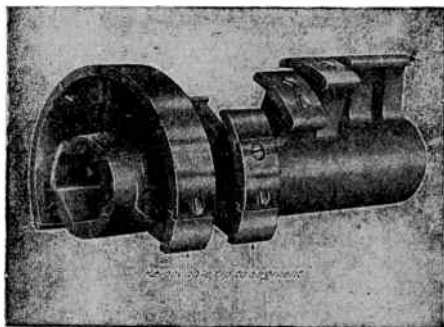
**Ques. Describe rheostatic control.**

Ans. This consists of progressively cutting out sections of resistance connected in series with the motor.

An ordinary rheostat is used and the method is confined to single motor installations as in mining or other small industrial locomotives.

**Ques. Describe field control.**

**Ans.** This method consists in varying the intensity of the motor field magnets, by dividing the coils into two sections and arranging the controller to give a proper sequence of connection.



**FIGS. 3,553 and 3,554.**—Details of General Electric type K controller construction. **Fig. 3,553,** method of fastening tips to segments; **fig. 3,554,** detail of cylinder casting assembly.



Thus, when the two sections of the motor field winding are connected in series, a strong field is obtained, and therefore slow speed. By arranging the second step of the controller to cut out one field section the speed is increased. The complete sequence of connection gives two series running positions and two parallel running positions, thus making four running positions.

**Ques. What control system is very largely used?**

Ans. The series parallel.

**Ques. Describe this method.**

Ans. This method is used with two or four motor equipments. The sequence of connection for a two motor car during the control period is as follows: 1, both motors connected in series with control resistance, 2, control resistance progressively reduced, 3, control resistance again put in circuit in series with parallel connection of motors, 4, control resistance progressively reduced, 5, both motors in parallel with control, no resistance.

**Ques. What feature of series parallel control divides this method into several types?**

Ans. The mode of transition.

**Ques. Describe the power off method of transition.**

Ans. In this method the controller is so arranged that the power is cut off from both motors in changing the motor connections from series to parallel.

This was formerly used for large size motors and locomotives but is not used much at present.

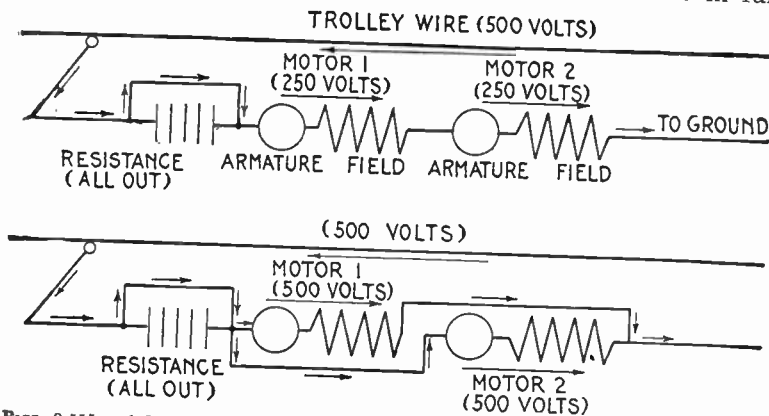
**Ques. Explain series resistance transition.**

Ans. During the transition from series to parallel, a resistance is placed in series with one motor and the other motor is first short circuited, then disconnected from the main circuit, and finally placed in parallel with the other motor.

This method is in general use in equipments of small motors with the so called type K controller.

### Ques. What is bridge transition?

Ans. This method consists in grouping the motors and their resistances like the arms of a **Christie**, or erroneously called Wheatstone bridge,\* so that after the two motors are in full

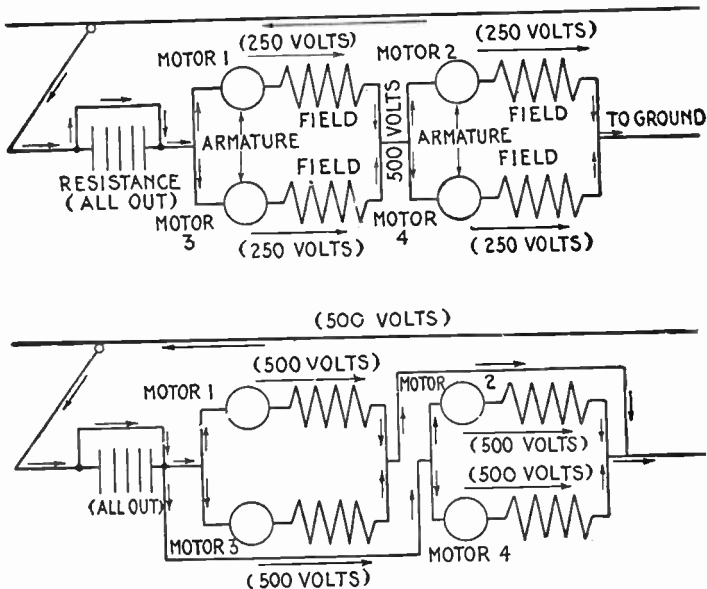


Figs. 3,555 and 3,556.—Diagrams of series parallel two motor control. Fig. 3,555, series running position, all resistance cut out; fig. 3,556, parallel running position, all resistance cut out. When the controller handle is in the series running position, fig. 3,555, the motors are in series, and with a 500 volt trolley circuit, each motor therefore operates at 250 volts. In fig. 3,556, both motors are in parallel under the full 500 volt pressure. The two positives here shown are with resistance all out. A number of intermediate positions may be obtained in both series and parallel positions by progressively cutting out a series resistance. When a rheostatic controller is used with, for example, a two motor equipment, the motors are connected permanently in parallel, and the current divides into two branches, one of which passes through each motor, before they become joined again in a single circuit, passing to the ground. Under this condition the amount of current required by each motor is double that which would be required by one of the motors to move its share of the load. As all this current has to flow through the resistance of the rheostat, the volts dropped in the rheostat constitute a loss, since they do no work, but are wasted in the form of heat. Series parallel operation prevents some of this loss as the motors are in series at starting and the same current which starts one motor passes through and starts the other, thereby taking only one-half as much current from the line as when a rheostatic controller is used. The final or full speed connections are the same in both methods, the motors operating in parallel at the full trolley line voltages with all resistance cut out of the circuit. In selecting a series parallel controller, as in the case of any other similar apparatus, it is important to consider the nature of the circuit, whether wholly metallic or ground return, the number of motor per equipment, and the capacity of each, and the character of the service required of the controller, whether for simple series parallel operation, series parallel control with emergency electric brake, or series parallel control with electric brake for regular operation. The controller should not only be of sufficient capacity, but should be arranged for the number of motor operated. For example: a series parallel controller designed for two 100 H. P. motors is not suitable for an equipment of four 50 H. P. motors, as the reversing switch must have separate connections for each motor. Furthermore, controllers of either the rheostatic or series parallel type for operation with electric brakes for either emergency or regular service should have the necessary contacts and connections for the operation of the brakes.

series position, the resistances may be placed in circuit again in parallel with the motors without opening the circuit. The two motors are then connected in parallel with each other and each in series with its own resistance.

**Ques.** What is the advantage of bridge transition?

**Ans.** There is no noticeable jerk as both motors are in

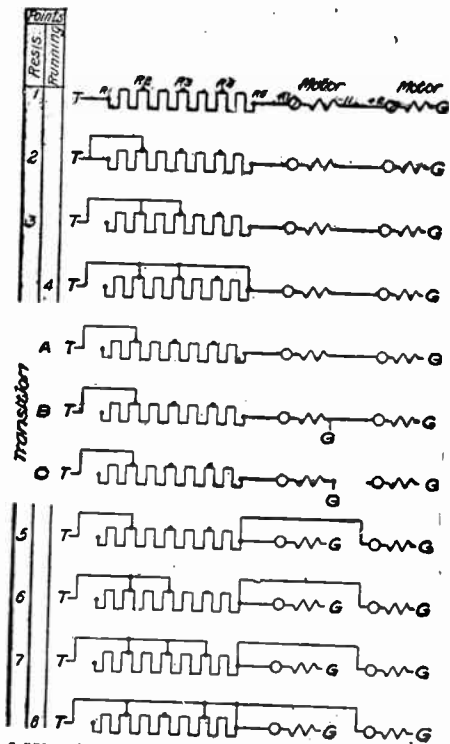


**Figs. 3,557 and 3,558.**—Diagrams of series parallel four motor control. Fig. 3,557 series running position, all resistance cut out; fig. 3,558, parallel running position, all resistance cut out.

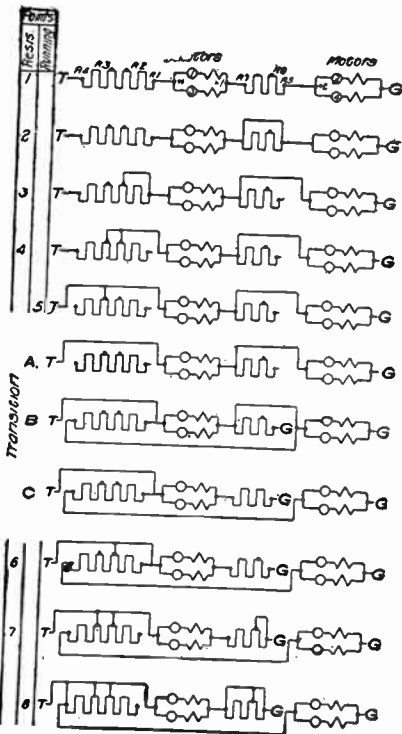
operation throughout control period and it is not necessary to open the circuit which would cause flashing at the switches.

This method is used mostly on multi-unit control equipments, particularly for large size units.

\*NOTE.—See note page 2,239.



Figs. 3,559 to 3,569.—Diagrams showing control connections of General Electric type K series parallel two motor controller.



Figs. 3,570 to 3,580.—Diagrams showing control connections of General Electric type K series parallel four motor controller.

**Ques.** How is series parallel control applied to four motor equipments?

**Ans.** By connecting the motors in parallel in pairs and treating each pair as a unit.

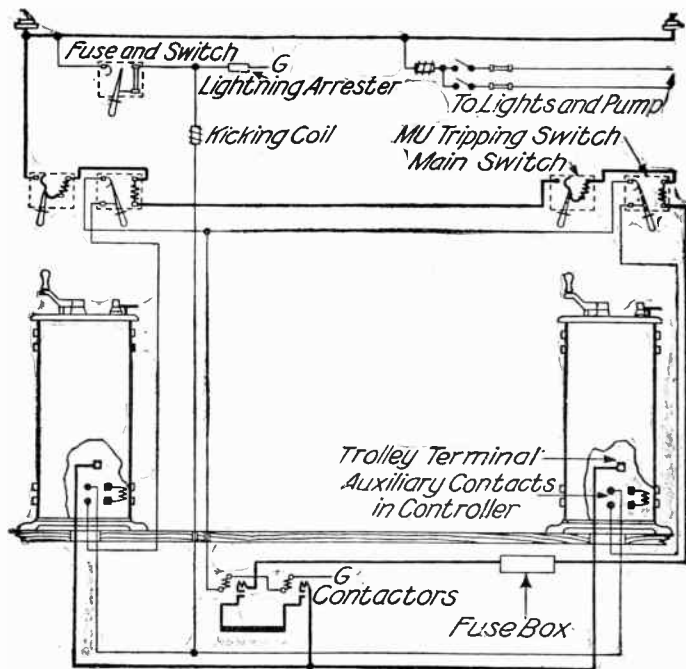
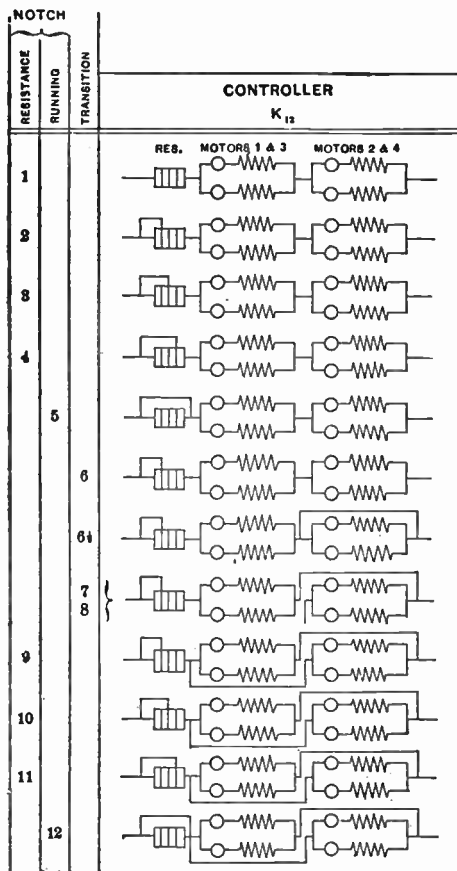


FIG. 3.581.—Wiring diagram of General Electric contactor equipment, designed to eliminate all destructive arcing from the car platform, by opening and closing the main power circuit with contactors located underneath the car body. Two of these contactors are connected in series in the main circuit between the trolley base and the controller and are enclosed in an iron box for protection. Additional contacts are provided in the controller for opening and closing the operating circuit of the contactors when the controller is turned off or on respectively. By this arrangement heavy arcing is avoided at the controller. This equipment also includes overload devices, tripping switches for interrupting the energizing circuit of the contactor coils in case of overload. These switches perform the function of the circuit breakers ordinarily used, and are located in the cab convenient for operation by the motorman. They are adjusted, set and tripped the same as a circuit breaker but only open the small energizing current of the contact coils. A combined switch and fuse is connected in the contactor operating coil circuit. Where the auxiliary contactor equipment is used, the car circuit breakers are usually replaced with non-automatic magnetic blowout switches, for opening the main circuit when desired.



FIGS. 3,582 to 3,593.—Westinghouse type K-12 controller connections. In changing the motor connections from series to parallel, it will be noted that the controller short circuits one pair of motor, but the current continues to flow to the other pair. The **series method** here employed consists in connecting the total amount of resistance in series and then progressively short circuiting the various connections until all are cut out.

**Alternating Current Control Systems.**—The single phase motor used on alternating current roads has a commutator, and in fact is almost identical with the series direct current motor, save that all the iron in the magnetic circuit is laminated, and there is a compensating winding in the field magnet whose office it is to neutralize the inductance of the armature caused by the alternating current flowing therein.

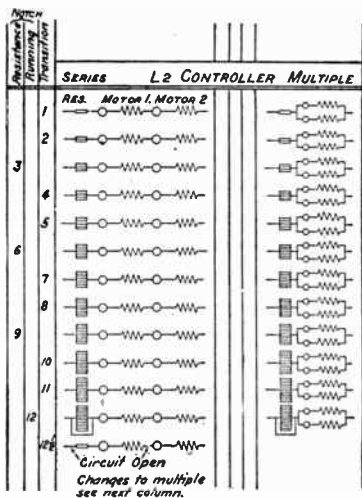
**Ques. How are single phase motors controlled by the compensator method?**

**Ans.** The impressed pressure is gradually increased by progressively cutting out sections of the compensator or auto-transformer.

**Ques.** What is the objection to rheostatic control as compared with the compensator method?

**Ans.** The compensator method is the more efficient.

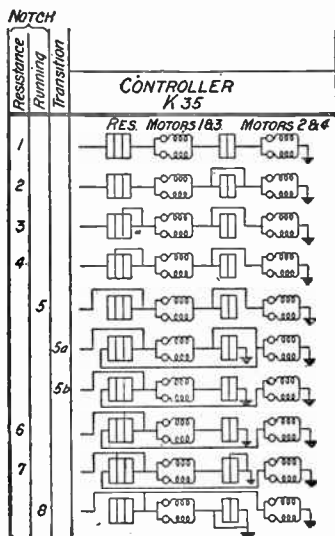
**Ques.** Describe the induction regulator method of control.



**FIGS. 3,594 to 3,618**—Westinghouse type L-2 controller connections. This type controller opens the circuits to both motors before making the change from series to parallel. In this parallel method additional sections of resistance are connected in parallel with the first section on each successive step. The value of the resistance in circuit is decreased as each new section is added in parallel with the first section and, finally on the last step the entire group is short circuited.

**NOTE.**—*Jones three speed control system.*—This control which is used on the Pittsburgh low floor cars, provides three running points, one full series, one series—parallel and one parallel, the points between, where there are one or more idle motors, being simply transition points. This arrangement makes possible the changing of the motors from the full series to full parallel relation without breaking the initial series connections between the motors. These original connections are maintained and the various changes effected by short circuiting one or more motors and establishing circuit connections of a character to cause the current to flow through both the fields and armatures of some of the motors in a direction reversed to that in which it flowed in the series position. On the first point all four motors are connected in series through a resistance, on the second point this resistance is cut out, which, on a 600 volt circuit, makes 150, volts drop across each motor and makes the second point on the control a running point. The third point is made by manipulating two switches which short circuits two motors and place 300 volts across each of the other two. The fourth point simply closes the ground connection to the two idle motors which makes 300 volts across all four motors and parallels the two pairs. Transition is made from this fourth point, which is a running point, to the next running point, which is the seventh, by first providing connections which short circuit one motor and place one across 600 volts in parallel with the other two in series with 300 volts across each; then short circuiting another motor circuit beyond the first controller position, it thus also reduces the weight of resistances which must be carried on the car.

Ans. An induction regulator (fully described in Chapter LX, Guide No. 7) consists of two coils: a primary, and a secondary, which are wound upon separate cores and are capable of angular adjustment for changing the direction of the flux from the primary through the secondary so that the voltage generated in the secondary increases or decreases the voltage supplied to the motors by the auto-transformer according to the relative angular position of the secondary to the primary.



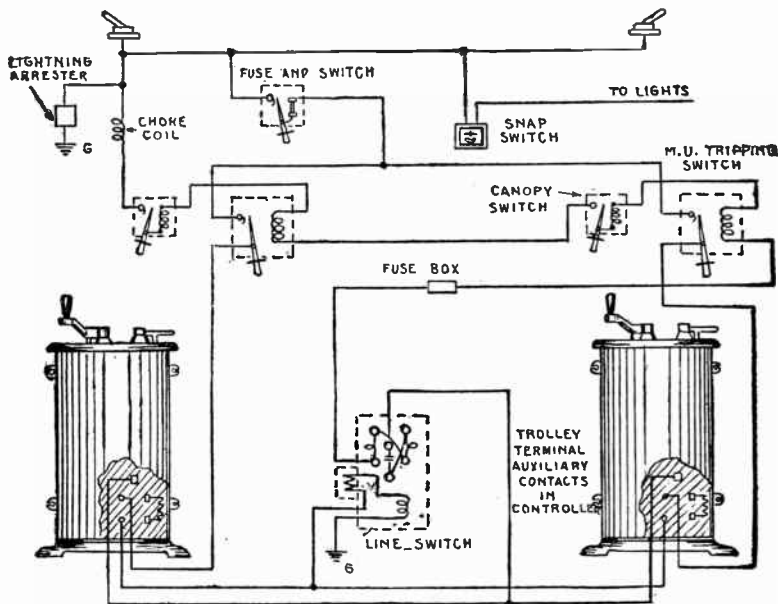
Figs. 3,619 to 3,628.—Westinghouse type K-35 controller connections.

Clearly, the voltage induced in the secondary of the regulator may be made to buck or boost the voltage applied to the motor from the auto-transformer, by any amount within the range of the regulator. By making the range of the regulator equal to one step of the auto-transformer, full control is secured without shock; thus, the first position of the regulator lowers the transformer voltage by one half step. On turning the regulator the voltage reduction gradually drops to zero; as the turning is continued, the regulator delivers a rising additional voltage which gradually reaches the value of one half step, and this equals the next higher step on the transformer.

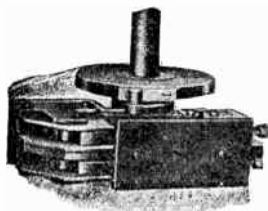
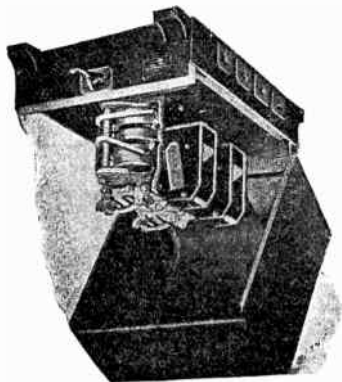
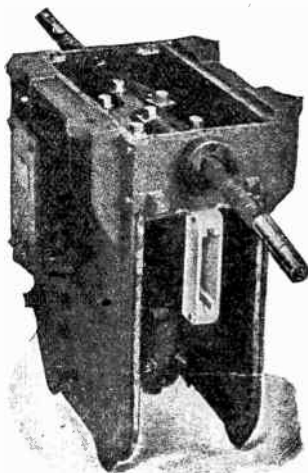
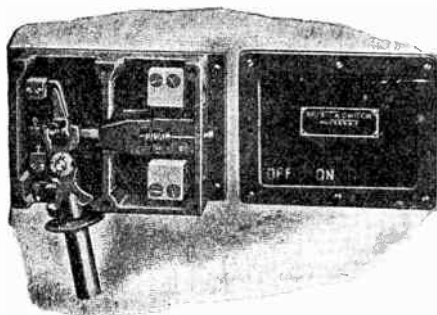


**Ques.** What are the objections to the induction regulator method?

**Ans.** Considerable weight, low power factor, and complexity of the apparatus as compared with the compensator method.

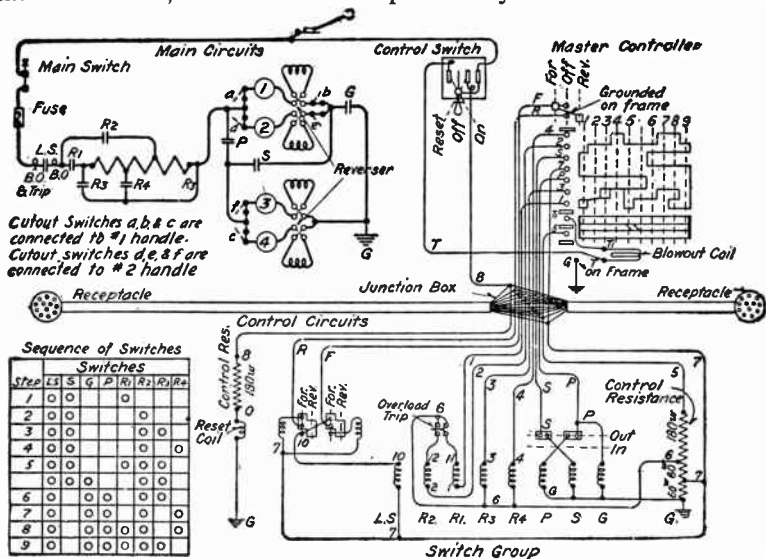


**FIG. 3,629.**—Diagram of connections of Westinghouse auxiliary contactor equipment. The wear and tear on drum controllers may be reduced and life of the contacts increased by the use of auxiliary contactor equipments. A contactor equipment consists of a powerful pneumatically operated switch, or "contactor," mounted beneath the car and connected to the main reservoir of the air brake system. The switch is controlled by means of a magnet valve, which is operated by current from the trolley. The circuit of this magnet valve is carried through a pair of auxiliary contacts located on the drum of the controller. When the handle is moved toward the off position, the circuit of the auxiliary contacts, and hence the circuit of the magnet valve is broken before the main power circuits are broken, and thus the main power circuit is always opened by the pneumatically operated switch beneath the car rather than by the controller contacts. The auxiliary circuit is carried also to a small tripping switch, located near each controller, and corresponding to the usual car circuit breaker. This switch is so arranged that an overload or "short" in the main circuit will release the handle of the tripping switch, thus opening the auxiliary circuit and causing the contactor beneath the car to open the main circuit. The air supply for operating the contactor is carried through an auxiliary reservoir and a check valve before going to the pneumatic cylinder.



FIGS. 3,630 TO 3,633.—Construction details of Westinghouse auxiliary contactor equipment. Fig. 3,630, tripping switch; fig. 3,631, pneumatically operated line switch; fig. 3,632, electrically operated contactor in iron box; fig. 3,633, auxiliary contact attachment for type K-28 controller. The electrically operated contactor shown in fig. 3,632 is used in cases where a supply of compressed air is not available; it operates in the same way as the pneumatic type, except that the auxiliary circuit closes the switch directly by means of a magnet coil, instead of operating a magnet valve.

**Three Phase Induction Motor Control.**—As outlined in the classification of control system, there are four methods of control for three phase induction motors. The changeable pole and cascade methods were extensively tried out by German manufacturers, and have been practically abandoned because



**FIG. 3,634.**—Diagram of connections Westinghouse unit switch control (type HL) for quadruple equipment of 75 horse power motors or less. In type HL control the various main circuit connections between trolley, starting resistors and motors (which, in drum type control, are made by the overhead circuit breaker and the power drum and contact fingers of the controller) are made by pneumatically operated switches assembled in a common frame designated as a switch group, which is located underneath the car. Each switch is closed when desired by compressed air from the brake system, acting on a piston. The reversing connections ordinarily made by the reverse drum of the platform controller are made by a reverse drum similar to that of the controller, but of more substantial construction, pneumatically operated and mounted in a separate case underneath the car. The complete reverse drum with its operating mechanism is termed a reverser. The admission or release of compressed air to the pistons for operation of the switches and reverser is regulated by means of electrically operated magnet valves, one of which is attached to each piston cylinder. The circuits from the various magnet valves are controlled by a master controller on either car platform through a control train line, which extends the length of the car and terminates at each end in a twelve conductor train line receptacle. By moving the handle of the master controller from notch to notch, the various switches in the switch group are operated and the proper motor connections are established. If the adjacent train line receptacles on two or more cars be connected by suitable train line jumpers, the operation of either master controller on any car will cause the various switches on all of the cars to close or open simultaneously for train operation.

of their complications. In addition to the complications, the rheostatic method must also be used with them to provide the smaller gradations of speed.

**Ques. How is rheostatic control applied to three phase induction motors?**

**Ans.** By arranging a variable resistance in series with the

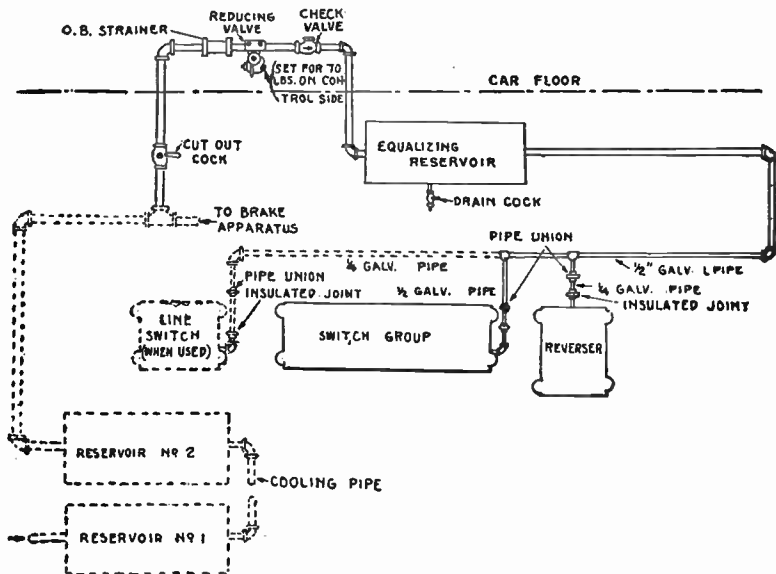


FIG. 3,635.—Arrangement of piping of Westinghouse unit switch control, type HL. The piping here shown is for the compressed air which operates the control apparatus, the air supply being taken from the brake system. The air passes through a cut out cock for shutting off the supply if desired, a hair strainer for removing dirt or scale, and a reducing valve, with equalizing reservoir and check valve for maintaining a uniform pressure. The amount of air required for operating the switches is so small compared to that required by the brakes and whistle that it is practically negligible.

armature winding and progressively reducing it as the motor speeds up, till at full speed or the last step of the control all the resistance is cut out.

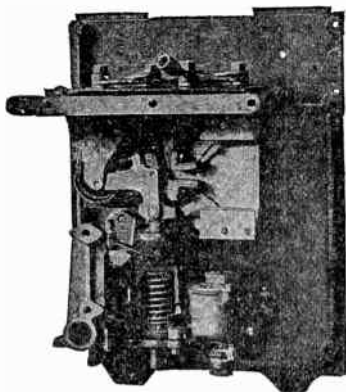
**Ques. What type of motor is used for rheostatic control?**

Ans. The slip ring or external resistance form of induction motor.

**Ques. What kind of resistance is used?**

Ans. Resistance in the form of grids or liquid.

In the case of liquid resistance, the electrodes which dip into the liquid are held stationary and in the process of reducing the resistance, the level of the liquid is raised by compressed air, the influx of which is regulated by an air valve controlled by a magnet in the motor circuit.



**FIG. 3 636.**—Westinghouse unit switch with sides of box, arc chute, cylinder and valve cut away. The construction of the switch includes two stationary copper castings, one of which forms directly the upper or fixed contact, while the other serves as a support for the lower or movable contact. The current carrying parts are enclosed in an insulating box of moulded material, in addition to which the jaws of the switch are further surrounded by an arc chute slipped inside of the switch box to protect the latter from the arc. The switch secured to the base plate of the switch group by two copper bolts, one of which is screwed into each of the stationary castings; and these same bolts serve as terminals to carry the current. By merely removing these two bolts the entire switch unit, complete with insulating box and arc chute, can be readily taken out. The force with which the switches operate is independent of the force with which the magnet valves operate. As long as the trolley voltage is sufficiently high to operate the magnet valves at all (200 volts), the switches close and remain closed with the same certainty and power as when the full normal voltage of 600, or more is available.

Finally the resistance is automatically short circuited by a switch governed by a float. To cut in the resistance the liquid is depressed by air pressure.

**Ques. Describe the changeable pole method.**

Ans. In this method the number of pole may be altered to

secure variable torque either by providing the motor with independent field windings, or by regrouping the field coils.

**Ques. Which changeable pole method is preferable and why?**

Ans. The regrouping method because it utilizes all the winding.

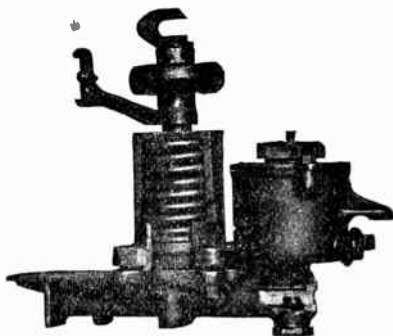


FIG. 3,637.—Westinghouse cylinder and magnet valve cut to show working parts. *In operating* the reaction of the spring, when compressed by the admission of air to the cylinder, is 120 pounds and the leverage is such that the pressure of 100 pounds appears at the switch jaws for forcing them apart. The same construction which secures the wiping action of the contact tips when the switch is closing is also of considerable benefit when it is opening, and an efficient application of the above force is obtained. The size of the air cylinder is such that the net pressure at the jaws for closing the switch is also approximately 100 pounds at all times of operation. The low voltage current from the trolley, through the control resistor, for operation of the valves is so small as to permit their arrangement for operation under a wide variation of trolley voltages. The assembled unit of cylinder and magnet valve is so secured to the frame of the switch group by means of two bolts that, like every other part of the group, it can be easily removed and replaced, should this become necessary.

**Ques. What other names are given to cascade operation?**

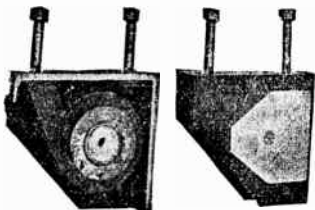
Ans. Concatenation, and tandem control.

**Ques. What is cascade operation?**

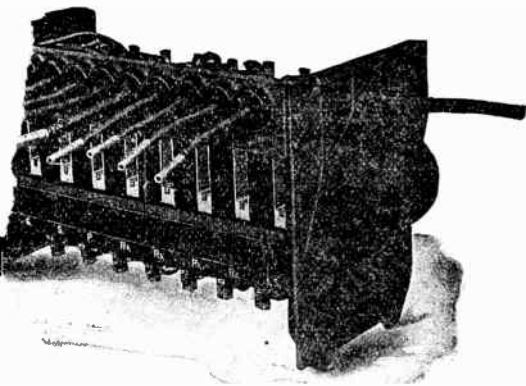
Ans. The various combinations of connection of two motors.

In the concatenation of two railway motors, the armatures are mechanically connected, the field of the first is connected to the supply and the armature to the field of the second motor: the armature of the

connected to the external resistance at start. As the the external resistance is cut out till armature of second recruited. For motors of equal number of pole, after m speed, they may be separated and each, having l in its armature circuit, may have its field connected



restinghouse blow out coil. Fig. 3,638 view with side of box cut away; with pole piece. Each blow out coil consists of a number of turn of in an insulating box similar to the switch box. Each coil is secure switch group by two copper bolts, in the same way as the switches.



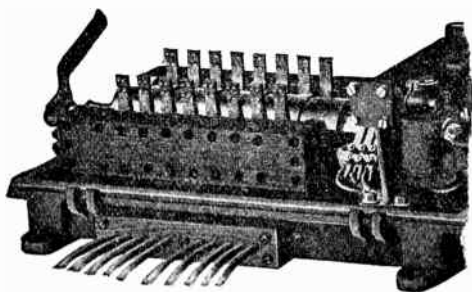
group, covers removed, front view. The most important e switch group. This consists of a cast and malleable iron itches are mounted, completely enclosed by three easily ow out coil is located at the side of each switch in order he switch is opened under load. The motor cut out na! board are located in a suitable compartment or 'rip, when not mounted on a line switch, is on the o this system of control signifies that the funda- ranged on the unit plan, so that any worn, or A switch group, for instance, is made up by ir different units, known respectively as the blow out coil, these being described in the

to the supply. For maximum effort the external be progressively cut out resulting in full parallel c

**Ques.** Describe the single control cas

**Ans.** In this method the second motor is period of concatenation.

**Ques.** Describe parallel single cascade



**FIG. 3,641.**—Westinghouse standard reverser, covers removed. The number of copper fingers mounted on a stationary base, and presence of two sets of movable contact carried on a wooden drum. The forward or the reverse position by one or the other of two pneumatically controlled by a magnet valve similar to those in the switch group. Powering those for operating the switches, are used for moving the reverser on the fingers and firm contacts are thus secured. This construction overload capacity for taking care of heavy current rushes. No reverser cylinders and the drum, when moved to one position by action of the magnets, remains in that position until the circuit of the other. Suitable small fingers mounted upon the reverser frame, and pressing movable contact pieces on the reverser shaft, establish the necessary connections. The reverser parts are built upon a skeleton cast iron frame with sheet iron covers.

**Ans.** In this method motors are employed number of pole, or different gear ratios.

In operation, when the motor with the greater synchronism, it is cut out. If the motor with the lesser pole be cut out instead, the train will correspond to concatenation and the motor with the lesser number of poles

**Ques.** How are the changes combined?

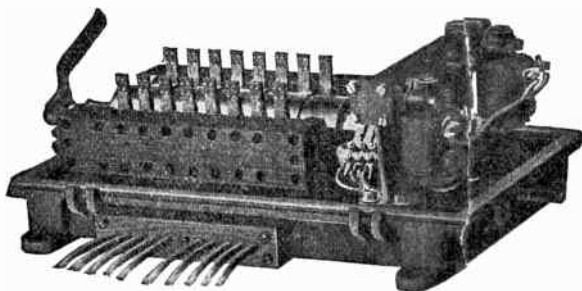


to the supply. For maximum effort the external resistances may now be progressively cut out resulting in full parallel operation.

**Ques.** Describe the single control cascade method.

**Ans.** In this method the second motor is cut out after the period of concatenation.

**Ques.** Describe parallel single cascade control.



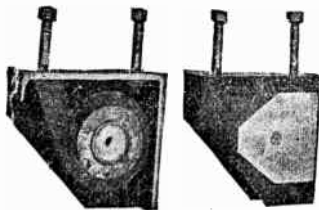
**FIG. 3,641.**—Westinghouse standard reverser, covers removed. The reverser comprises a number of copper fingers mounted on a stationary base, and pressing on one or the other of two sets of movable contact carried on a wooden drum. The drum is revolved to the forward or the reverse position by one or the other of two pneumatic cylinders, each controlled by a magnet valve similar to those in the switch group. Powerful forces approximating those for operating the switches, are used for moving the reverser, so that heavy pressures on the fingers and firm contacts are thus secured. This construction gives the reverser large overload capacity for taking care of heavy current rushes. No springs are used in the reverser cylinders and the drum, when moved to one position by closing the circuit of one of the magnets, remains in that position until the circuit of the other magnet is closed. Suitable small fingers mounted upon the reverser frame, and pressing upon corresponding movable contact pieces on the reverser shaft, establish the necessary interlocking connections. The reverser parts are built upon a skeleton cast iron frame and enclosed by removable sheet iron covers.

**Ans.** In this method motors are employed having a different number of pole, or different gear ratios.

In operation, when the motor with the greater number of pole reaches synchronism, it is cut out. If the motor with the lesser number of pole be cut out instead, the train will operate at a speed between that corresponding to concatenation and that for the free running of the motor with the lesser number of pole with armature short circuited.

**Ques.** How are the changeable pole and cascade methods combined?

second motor is connected to the external resistance at start. As the motors speed up, the external resistance is cut out till armature of second motor is short circuited. For motors of equal number of pole, after reaching maximum speed, they may be separated and each, having resistance inserted in its armature circuit, may have its field connected



FIGS. 3,638 and 3,639.—Westinghouse blow out coil. Fig. 3,638 view with side of box cut away; fig. 3,639, complete with pole piece. Each blow out coil consists of a number of turns of copper strap enclosed in an insulating box similar to the switch box. Each coil is secured to the base plate of the switch group by two copper bolts, in the same way as the switches.

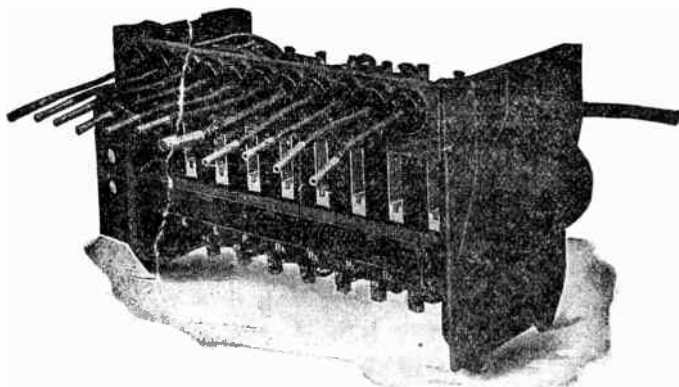


FIG. 3,640.—Westinghouse switch group, covers removed, front view. The most important item of a control equipment is the switch group. This consists of a cast and malleable iron frame upon which the various switches are mounted, completely enclosed by three easily removable sheet iron covers. A blow out coil is located at the side of each switch in order to extinguish the arc formed when the switch is opened under load. The motor cut out switches and the control circuit terminal board are located in a suitable compartment on one end of the group and the overload trip, when not mounted on a line switch, is on the other. The term unit switch as applied to this system of control signifies that the fundamental pieces of apparatus have all parts arranged on the unit plan, so that any worn, or damaged part may be removed and replaced. A switch group, for instance, is made up by assembling the requisite number of each of four different units, known respectively as the *switch*, the *cylinder*, the *magnet valve* and the *blow out coil*, these being described in the accompanying cuts

Ans. By first making the sequence of pole change and then applying either of the cascade methods, thus giving several speeds.

**Combined Direct Current and Alternating Current Control.**—In changing from alternating current to direct current (or from direct to alternating) it is necessary to guard against the possibility of wrong connections upon the car for

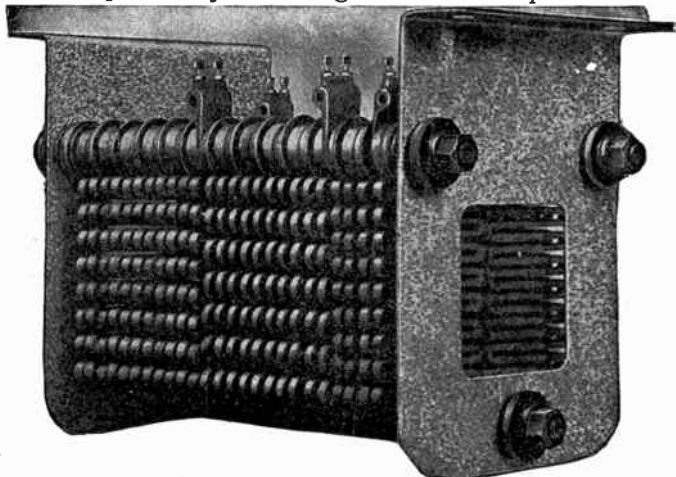
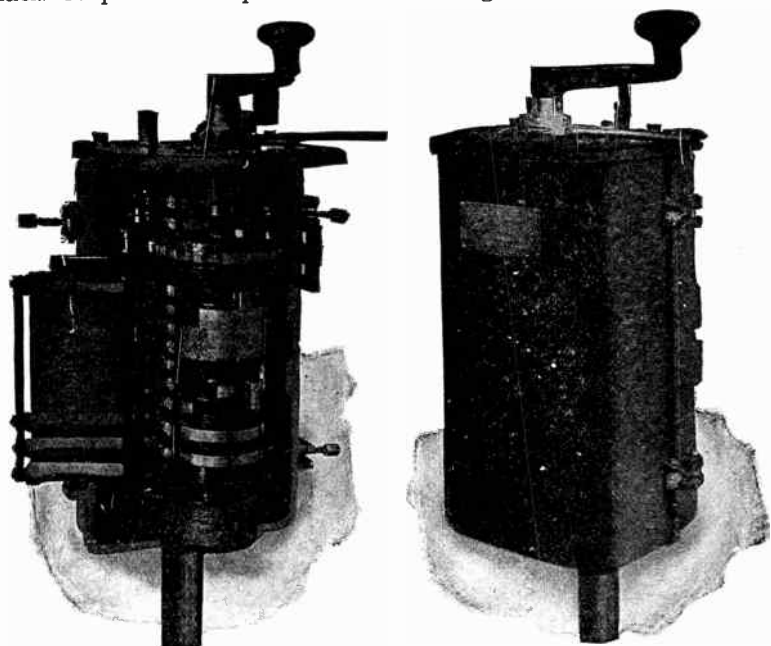


FIG. 3,642.—Westinghouse standard resistance grids for railway service. These grids are designed with the object of providing ample mechanical strength and liberal current carrying capacity. Individual grids of sufficient section to resist breakage are used; and this, together with the triangular arrangement of the tie rods, makes the assembled frames strong and solid.

the current received, that is, to prevent disaster should connections be made for 600 volts direct current operation and accidental contact be made with 6,600 volts alternating current trolley. To guard against this, the main switch of the direct current and alternating current car equipment is provided with a retaining coil so designed that it will open when the motor current is interrupted. Where alternating current and direct current trolley sections adjoin, a dead section is left between

the two for a length not exceeding a car length, so that a car may pass from one section to the other at full speed, in which case the main ca. switch opens on the dead section through lack of power to operate the retaining coil, and will reset



FIGS. 3,643 and 3,644.—Westinghouse master controller. Fig. 3,643 view with cover removed; fig. 3,644 with cover in place. The master controller contains the usual power and reverse handles, mutually interlocked. Except for the smallest sizes of equipments, it is arranged with five notches in series and four in parallel. The position of the notches is indicated on the cap plate of the master controller and also by a suitable star wheel inside of the case.

automatically for alternating or direct current operation as the case may be, after leaving the dead section.

**Electric Locomotives.**—Numerous types of electric locomotive have been built for a variety of purpose, from yard switching

to the hauling of heavy passenger trains at high speeds  
They may be classed

1. With respect to service, as
  - a. Switching;
  - b. Freight;
  - c. Passenger;
  - d. Industrial;
2. With respect to the running gear, as
  - a. Single truck;
  - b. Double truck;
  - c. Double truck with trailers;
  - d. Articulated, etc.;

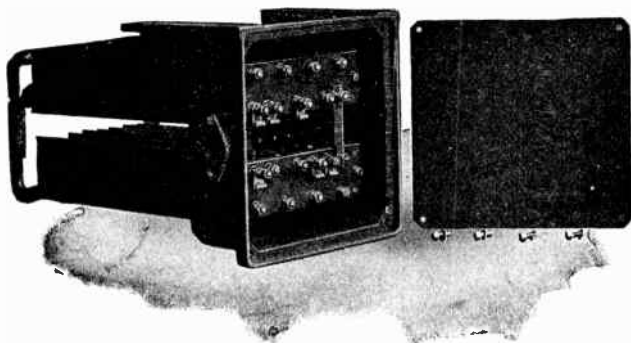


FIG. 3,645.—Westinghouse control resistor. This is used to reduce the trolley voltage for operating the magnet valves. The resistance element is of the slotted ribbon type, and is iron clad to protect it from the weather.

3. With respect to the transmission, as
  - a. Gearless;
  - b. Geared;
  - c. Connecting rods;
  - d. Scotch yoke;
  - e. Combination gear and connecting rods;
4. With respect to the power source, as
  - a. External;
  - b. Storage battery;
  - c. Gas electric.

The accompanying cuts give example of various types of electric locomotive construction.

**Ques. What is a gearless locomotive?**

Ans. One having the armatures built on the axles of the driving wheels.

**Ques. What is a geared locomotive?**

Ans. One in which the motor drive is through gears.



FIG. 3,646.—General Electric 100 ton locomotive for moderate speed heavy passenger and freight service. There are four 300 horse power motors of the box frame, commutating pole forced ventilated type. Each of these motors at its one hour rating will develop a torque of 4,000 lb. at a one foot radius. The gearing between the motor and driving axle has a 4.37 reduction and the driving wheels are 48 in. in diameter. With this reduction each motor will develop a tractive effort of 8,750 lb. at the rail head, which gives a total tractive effort for the four motors of 35,000 lb. This tractive effort will be developed at a speed of 12 miles per hour. The four motors have an overload capacity sufficient to slip the driving wheels and can develop under maximum conditions a momentary tractive effort of 50,000 lb. to 60,000 lb. The maximum safe speed of the locomotive running light is 35 to 40 miles per hour. The gears are shrunk on to an extension of the driving wheel hub and there are two gears and two pinions per motor, one at each end of the armature shaft. This form of construction is adopted on account of the unusually heavy torque and the excessive overloads to which the motors are liable to be subjected in heavy railroad service. The control comprises two master controllers located in the cab. There are two four wheel trucks with articulated coupling.

**Ques. Describe the side rod driver.**

Ans. In this method, the motors are placed in the cab and the driving torque communicated to the drivers by means of connecting rods.

# Various Electric Locomotives

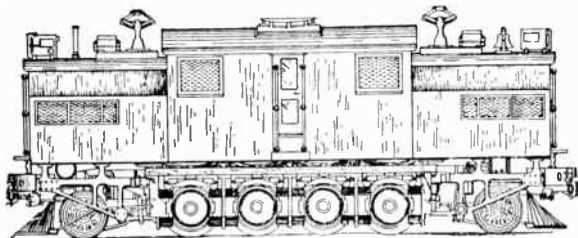


FIG. 3,647.—New York Central 1-4-1 locomotive.

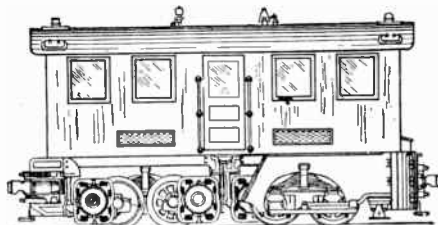


FIG. 3,649.—Ordinary form of locomotive.

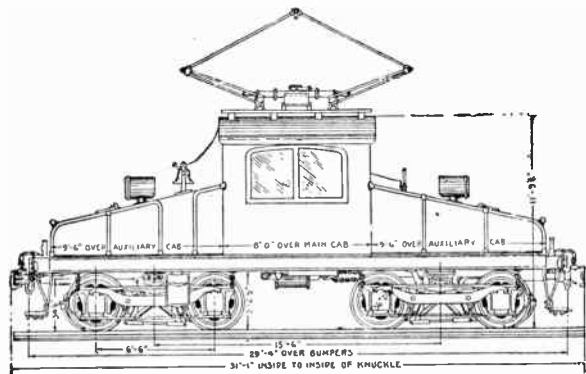


FIG. 3,648.—Baltimore and Ohio 160,000 lb. 0-4-0 locomotive.

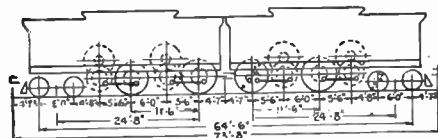


FIG. 3,650.—Combination car and side rod locomotive.

**Main line passenger locomotives** are required to operate safely at speeds of 60 to 75 miles per hour, and the heaviest service requires that trailing loads of 1,000 tons be handled at these high speeds in order to meet the requirements.

**Main line freight locomotives** are proportioned for speeds to meet requirements, but in general for mountain grades the speed will approximate 15 miles per hour on ruling grade with rated tonnage and will reach a maximum of from 25 to 30 miles per hour on level tangent track.

**Ques.** Describe the Scotch yoke arrangement.

**Ans.** The yoke drives one axle through a sliding block and the others through rods connected to the yoke by knuckle pins.

**Ques.** Describe the combination gear and connecting rods.

**Ans.** In this drive the motors are geared to jack shafts which in turn transmit the power to the drivers by means of connecting rods.

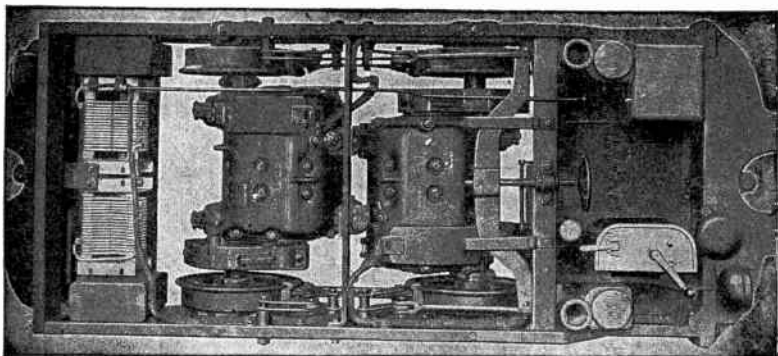


FIG. 3,651.—Plan view of a Westinghouse mine locomotive showing two motor equipment, geared drive, brakes, controller, resistance grids, etc.

**The Running Gear.**—There are two general types of truck for electric cars: 1, those in which the car body rests upon the truck bolster or side bearings which are supported by springs for the side frames carried by the axle journal boxes as in the case of the Brill *maximum traction* truck shown in fig. 3,652, and 2, those in which the car body rests upon the truck bolster supported from the truck frame which rests upon springs carried by equalizer bars resting on the axle journal boxes, as in the case of M. C. B. or Master Car Builders type of truck shown in fig. 3,653.



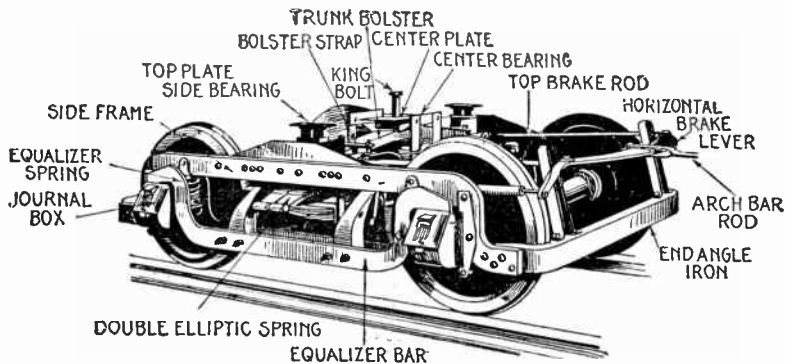
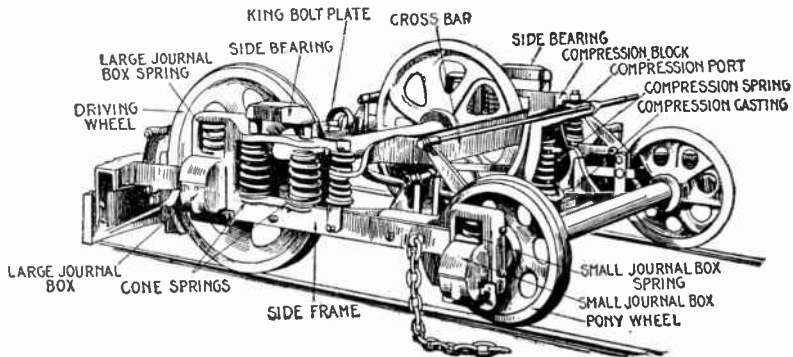


FIG. 3,653.—Standard motor Co. M.C.B. type high speed truck.

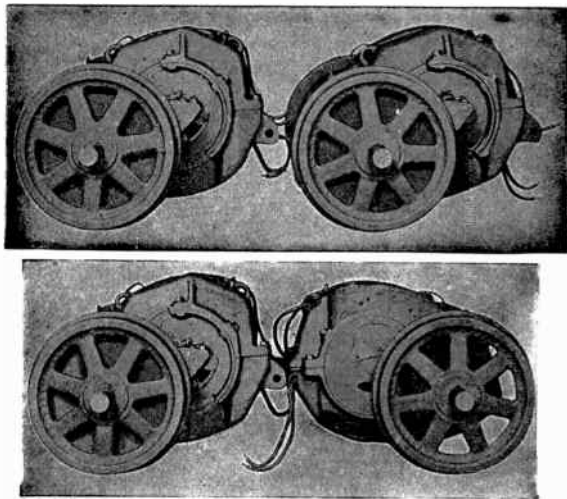
FIG. 3,652.—Brill maximum traction truck. On tangent track 75 per cent. of the weight of this truck comes on the motor axle which has the large wheels. When on a curve, part of this weight is shifted to the trailing wheels. This type is used extensively in city street car service and is not adapted to high speed. One motor is used on each truck.



**Ques.** For what service are maximum traction trucks extensively used?

**Ans.** For city street railway cars where the numerous stops required demand a high rate of acceleration.

This is secured by supporting the weight of the car body between the center of the truck and the axle carrying the motor so that seventy five per cent. of the total weight of the car falls on the larger or driving



**Figs. 3,654 and 3,655.**—Two arrangements of motors. Fig. 3,654, tandem hung; fig. 3,655 inside hung. The tandem method permits a locomotive to be made with a short wheel base and at the same time with good riding qualities. The average gauge, track, and curve limitations of mine service make this the prevailing arrangement. Where a locomotive car has a large wheel base, the inside lining arrangement is generally used, as under such conditions the weight is better distributed.

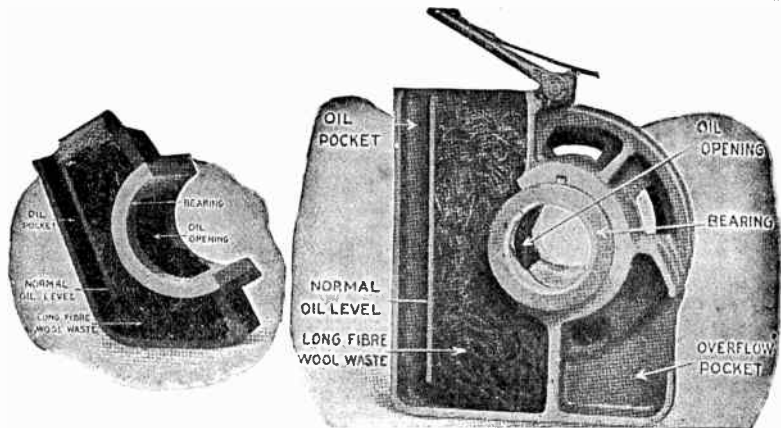
wheels of the truck. The idle wheels, which are commonly known as the pony or guiding wheels are made of much smaller diameter than the driving wheels in order to permit them to clear the under frame of the car when the truck swivels on curves.

**Ques.** What use is made of the M. C. B. type of truck?

**Ans.** They have been designed to satisfy the greater weight

and higher speed requirements of the rapidly extending inter-urban electric railways.

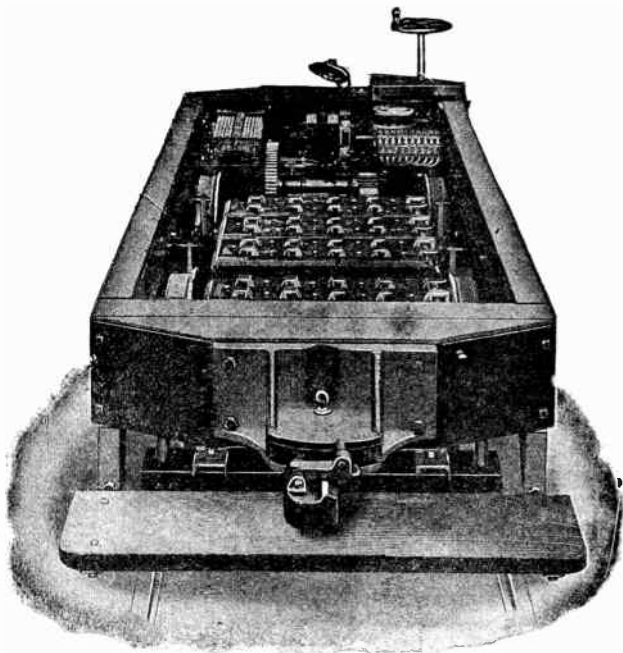
So long as the weight of the cars and the power required to propel them remained comparatively small, the designs for electric car trucks were naturally developed entirely from street railway practice but when it became necessary to apply as much as 400 horse power to a truck, it was quickly recognized that the solution of the problem depended upon the correct application of the principles which have been so carefully and thoroughly worked out on steam locomotives. It must be understood, however, that the conditions are not exactly the same in the two cases. For instance, in the electric motor truck the driving



FIGS. 3,656 and 3,657.—Westinghouse self-lubricating bearing. Fig. 3,656 type used on box frame motor; fig. 3,657 type used on split frame motor. As shown in the sectional views, the bearing housing has a separate oil pocket from which the oil is fed and which may, at any time, be gauged. With this arrangement there is no excuse for wasting oil. The inspector pours only enough oil into the chamber to bring the free oil up to a predetermined depth. With the supply of free oil normally below the level of the opening in the bearing there is no oil wasted when the motors are at rest through dripping or draining. The bearing is provided with suitable wiper rings, that prevent an over supply of oil working into the motor and damaging the windings. In addition, it has an easily accessible drain chamber, that catches the oil as it works out of the bearings. There is no variation in saturation of the waste. In modern Westinghouse motors the armature bearings are lubricated on the low pressure side. With this type of bearing it is usually sufficient to renew the oil once a month.

wheels and the truck wheels are combined, and are necessarily much smaller than the driving wheels of a locomotive. Furthermore, the high speed motor truck cannot have any other guiding wheels other than the driving wheels themselves, and must possess good riding qualities for the protection of the electrical apparatus.

**Brakes.**—Next to the controller, the brake is the most important device provided for controlling the motion of a car. Its function is to slow down or stop a car at any desired place,



**FIG. 3,658.**—Internal arrangement of General Electric platform type storage battery locomotive. Since the energy required for propelling the locomotive is obtained from storage batteries and is, of necessity, limited in amount by the space which is available for installing such a battery, it is desirable to keep the speed of such machine comparatively low in order that the pulling power may be retained to a value within the limits of the battery capacity. The cost for power will vary from 50c to probably \$2.50 per charge per locomotive, depending upon the type, size and efficiency of the batteries furnished, as well as the efficiency of the charging equipment: The cost of power is here considered at 5 cents per kw. hr. The frequency of charge will depend on the severity and conditions of service.

after the power has been cut off and the car is being propelled by its own momentum. As this momentum is overcome by

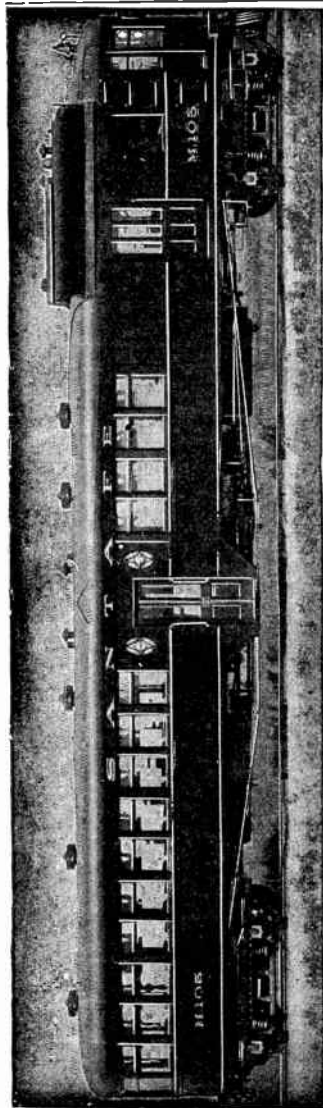


FIG. 3,659.—General Electric gas-electric motor car. Method of control is by voltage variation.

The prime mover is a gas engine direct connected to a dynamo. The friction of the brake shoe on the car wheels, it is obvious that the longer the interval of time allowed between the cutting off of the power and the application of the brake, the less will be the labor required of the motorman to apply the brake; while the wear and tear on the rolling stock and the amount of power wasted would be correspondingly reduced. Therefore, in order to operate a car successfully, that is, to maintain the schedule time with a minimum power consumption, the controller and the brake should be used in connection with each other, intelligently and with good judgment.

There are several types of brake used on electric cars:

1. Hand brakes;
2. Air brakes;
3. Electric brakes.

**Ques.** Describe a hand brake.

**Ans.** It consists of a vertical *brake staff* secured to the

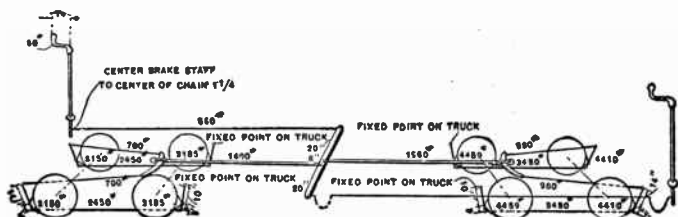


FIG. 3,660.—Diagram of hand brake system showing the chain of connection from the brake handle to the brake shoes, and the leverage employed at the various points in the hand brake system most commonly used on trolley cars. The tensions in the connections and the brake shoe pressures are those resulting from the application of 50 pounds of pressure at right angles to the horizontal arm of the brake handle. One of the objectionable features of this arrangement is the use of a single *sway, bar* and *floating lever*, which results in the application of the greater braking pressure to the rear wheels or truck instead of to the front wheels or trucks where it should be applied to secure the most effective braking, as shown in fig. 3,667.

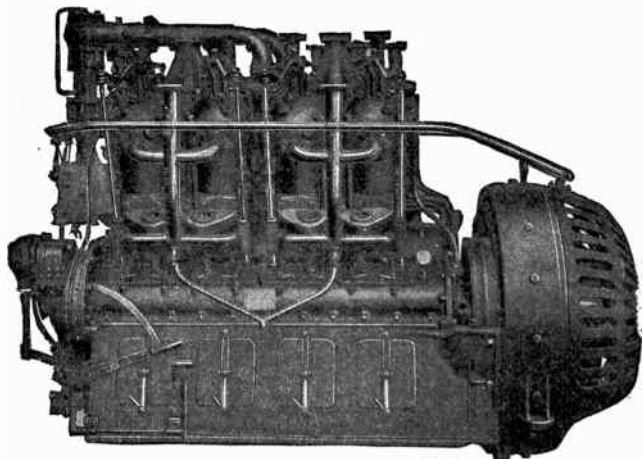


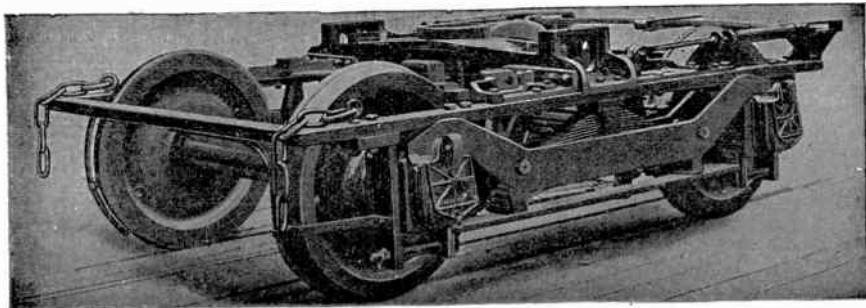
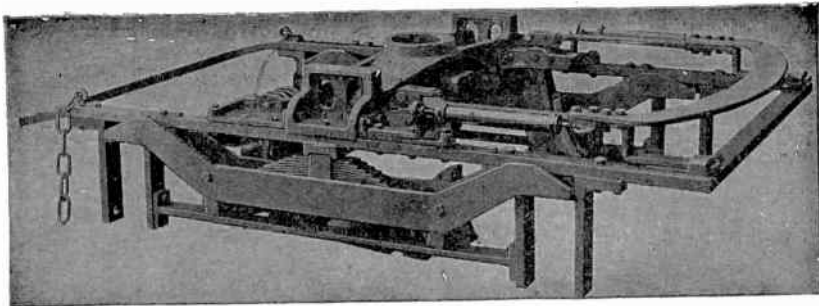
FIG. 3,661.—General Electric gas-electric direct connected set for gas-electric motor car showing control levers. It consists of an eight cylinder, 550 r.p.m., four cycle, gas engine of the V type, direct connected to the dynamo. Cylinders, 8 in. diameter, 10 in. stroke. This set supplies power for the motors and compressed air for braking and air start. Starting is accomplished by compressed air. A two cylinder, auxiliary gas engine with integral air compressor provides an initial charge of compressed air for air start and braking reservoirs. A dynamo, direct connected, supplies current for car illumination and headlights. The controller regulates the voltage and in addition places the motors progressively in series and parallel. Located on the controller are also separate handles for throttling the engine and reversing the driving motors. Two standard type, 600 volt, box frame, railway motors, 100 horse power each, are mounted on the axles of the front trucks, are inside hung and equipped with standard gears and gear cases. The trucks are of the high speed, ail steel, swing bolster, equalized type. Wheels, 33 in. diameter with M.C.B. bearings, wedges, treads and flanges. A fin tube radiator is mounted on cab roof, thermo-syphon circulation. The gasoline tank has a capacity of 150 gals.

**Figs. 3,662 and 3,663.**—

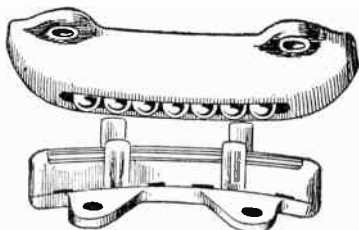
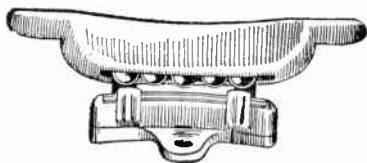
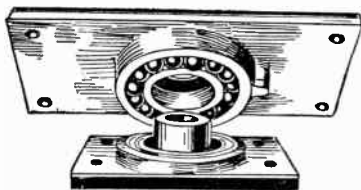
Baldwin truck frame, and truck complete equipped with Westinghouse motors. For electric locomotives weighing from 20 to 65 tons, it is usually preferable to use two 4 wheeled trucks. This arrangement provides a sufficiently long wheel base to insure steady riding and give a satisfactory weight distribution, while at the same time the locomotive can easily

enter sharp curves and switches when running in either direction. The trucks must be designed to perform the double function of carrying the locomotive and also of transmitting to the main frame the tractive force developed by the motors. This tractive force is transmitted through the wheels and journals to the truck frame, and thence through the bolster and center pin to the main frame and to the drawbar. The most important characteristic of a locomotive truck is ability to "stand up" in service. Riding qualities are very important but are necessarily secondary to endurance. The tractive force developed in a locomotive is high, and a strong durable construction is necessary. This is obtained by securing the bolster rigidly to the truck frames. Easy riding qualities are essential in so far as they affect track

maintenance. In Baldwin-Westinghouse locomotives the trucks ordinarily used are of the M.C.D. equalized type, in which the boxes are allowed a vertical play in the pedestals. The truck frame is of iron, forged in one piece. The transom is a steel casting of ample strength, securely bolted to the frames and reinforced at the ends by steel gussets.



end of the car, at the dash board and to the left of the controller. The upper end of the staff carries a crank or wheel by means of which it may be rotated by the motorman so as to wind around its lower end a short length of chain connected to the brake lever system through which the manual force exerted on the



**Figs. 3,664 to 3,666.**—Center and side bearings. Fig. 3,664 center bearing for city and interurban service; fig. 3,665, side bearing with 9 inch travel; fig. 3,666, side bearing with 12 inch travel for interurban cars operating on short curves. The center and side bearings of a truck form the contact points between itself and the car body. The car body is practically carried on the center plates on the truck bolster and comes in contact with the truck only at this point; but in order to prevent more than a slight displacement of the car body from the vertical, side bearings are placed over the side frames of the trucks, and so adjusted as to leave sufficient space between side bearing top plate and the plate on the car to take up the maximum compression of the springs when the car is fully loaded. It is a fact, however, that owing to a lack of adjustment, or from the displacement of the car body from the vertical when rounding curves due to the excessive elevation of the outer rail, the side bearings on one side may be brought into solid contact with the car body. In order to facilitate the swivelling of trucks when rounding curves ball bearings are frequently used in place of the ordinary bearing plates.

brake handle is multiplied in amount to the desired direction, and applied to the brake shoes which press against the wheels of the car.

Fig. 3,660 shows a typical hand brake system.



### Ques. How do air brakes operate?

Ans. By power derived from compressed air and applied to the brake levers by means of a brake cylinder.

There are two systems of air brake, which are distinguished from each other by the method employed for admitting the compressed air to the brake cylinder.

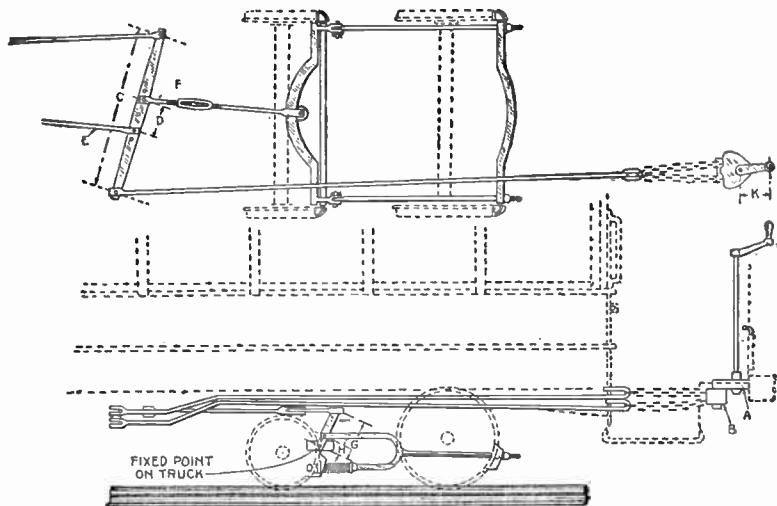


FIG. 3,667.—Geared brake. This apparatus has a pinion A, on the lower end of the brake staff, which engages a gear B, made in one piece with a double sprocket wheel. The two chain loops running through these sprocket wheels engage two hooks formed on the end of the brake rod, or two separate brake rods which are attached at the same point the sway bar. The upper chain is the only one used in braking, the other being left slack and held in reserve for use if the first set fail to work. When the brake is applied to a car mounted on maximum traction trucks as shown, the difference in pressure between the brake shoes on the driving wheels and those on the pony wheels is obtained by means of a spring interposed between the brake system and the pony wheel brake shoes. The dimensions of the different levers are as follows: Length of sway bar C is 48 inches; distance D between pins for the arch bar rods E and F is 9 inches; length truck lever B is 13 inches; and length of horizontal part of brake handle K is 15 inches. With levers of these dimensions a force of 65 pounds applied at the brake handle gives a total braking pressure of 29,000 pounds, or an amount exceeding the weight of an empty car. The best proportion of the lever is secured when,  $(C + D) \times (G \times H) \times 85k = \text{total weight of the empty car}$ .

In the "straight air" brake system, the air from the reservoir is piped to the motorman's valve, which is so designed that when the valve is turned to the position for applying the brakes, the air passes into the pipe running directly to the brake cylinder.

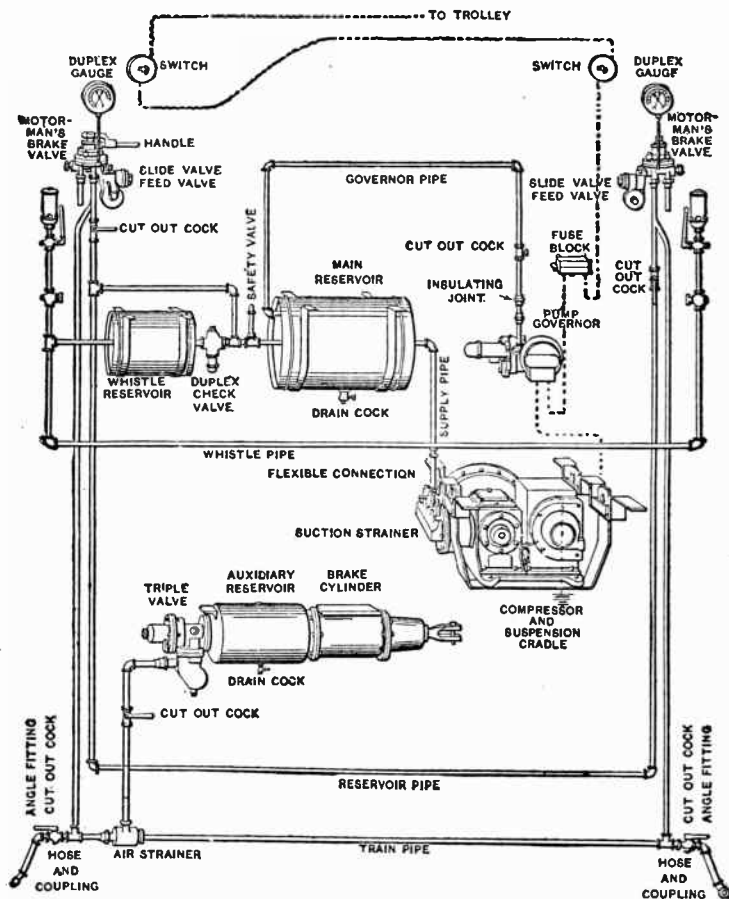
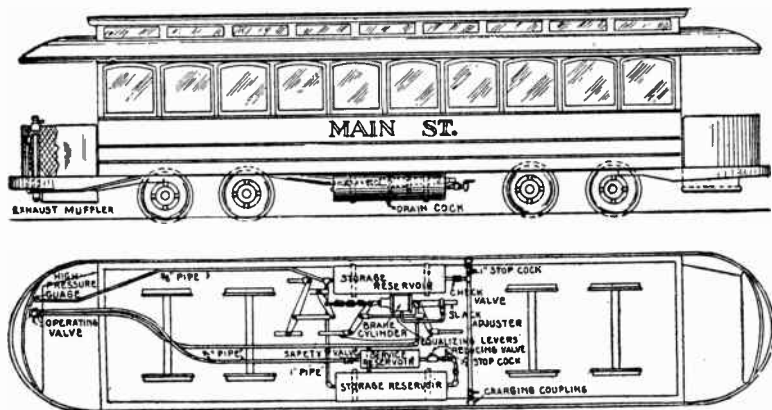


FIG. 3,668.—Diagram of automatic air brake system. This arrangement is very similar to that used on steam railway trains and is adopted for use on electric railway trains composed of more than two cars. It differs from the straight air brake in that the compressed air instead of passing directly from the air reservoir through the train pipe, to the various brake cylinders, passes from the train pipe into auxiliary reservoirs connected with each brake cylinder, as here shown, where it is stored and automatically operates the brake mechanism in response to the movements of the motorman's valve handle. When the motorman turns the valve handle to the position which allows the air to pass from the main reservoir into the train pipe, the triple valve on the several cars allow the air to flow into the auxiliary reservoirs. The system is now in the proper condition for

In the "automatic air" brake system the air from the reservoir is admitted to auxiliary reservoirs which are connected to the brake cylinder by means of special devices called the "triple valve."

The straight air brake system is adopted to single cars or short trains composed of motor car and one or two trailers. It is not suitable for longer trains on account of the objectionable length of time which would be required to supply the quantity of air necessary to fill the brake cylinder.

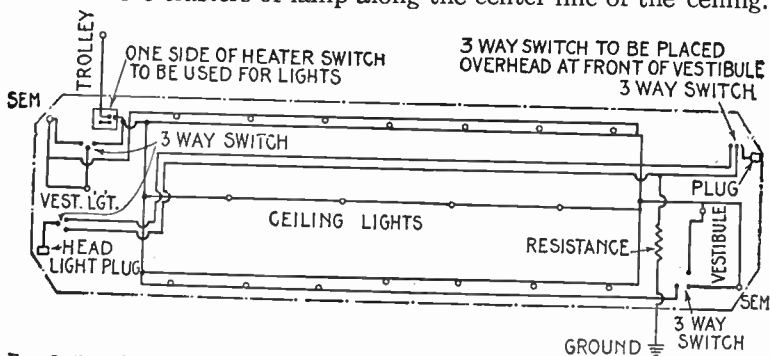


FIGS. 3,669 and 3,670.—Elevation and inverted plan of storage air brake equipment as installed on car.

FIG. 3,668.—Description continued.

setting and releasing the brakes. When the motorman moves the valve handle to the position for setting the brakes, the action of the valve cuts the communication with main reservoirs and permits the air to escape from the train pipe. The consequent reduction of pressure in the train pipe causes the triple valves to open a connection between the auxiliary reservoirs and the brake cylinders, which allows the air to enter the latter and set the brakes. To release the brakes the motorman must again turn the valve handle to the position for admitting air from the main reservoir to the train pipe. The pressure in the train pipe being thus increased above that remaining in the auxiliary reservoirs causes the triple valves to take a position which allows the air in the train pipe to pass into the auxiliary reservoirs, while at the same time the air in the brake cylinder is allowed to escape to the atmosphere through the triple valve exhaust posts, thus releasing the brakes. From the foregoing descriptions, it will be noted that in the straight air system, air is admitted to the train pipe to set the brakes, while in the automatic air brake system air is admitted to the train pipe to release the brakes. In the straight air system the train pipe is never under pressure except during the time the brakes are applied, while in the automatic system is always under pressure, which is greatest when the brakes are released.

**Car Lighting.**—This is largely a matter of taste and judgment, the arrangement and power of the lamps depending upon the size of the car and the character of the service. Incandescent lamps are used almost universally for both interior illumination and for headlights. Cars of ordinary size usually have a cluster of three lamps in the center of the ceiling and one at each end. Larger cars have a row of single lamp placed at a convenient height above the seats, and an additional row, or one or more clusters of lamp along the center line of the ceiling.



**FIG. 3,671.**—Car lighting wiring diagram showing head light in series with interior lamps. In this case there are five circuits of four 16 c.p. 110 volt,  $\frac{1}{2}$  amp. lamps each, operating on a trolley voltage of 550 volts, therefore, 110 volts from each circuit goes to the head light, thereby giving  $2\frac{1}{2}$  amp. of current which is sufficient for a 80 c.p. incandescent lamp for city cars, or a  $2\frac{1}{2}$  ampere arc lamp for interurban cars. The wiring diagram shows 7 lamps on each side, 4 lamps on the ceiling, one lamp in each vestibule and one lamp for the illuminated sign at each end of the car. A three way switch is located in each vestibule by means of which either the vestibule light, or the sign light at either end may be cut out of circuit, thus keeping only 20 lamps in service at any one time. A three way switch for cutting out either head light is also provided at each end of the car. When neither of the head lights is in use, a small resistance inserted in the ground connection is cut into circuit to take up the  $2\frac{1}{2}$  amperes usually taken by the head light.

These lamps are, usually, connected in series on a special lamp circuit with the trolley, the wiring being very much the same as in the case of ordinary house lighting. The lamp on each platform is usually wired in series with the head light on the other end of the car, and a change over switch is provided for throwing into circuit the proper platform lamp and head light whenever the running direction of the car is changed.

It is quite practicable, however, to connect the head light to the interior lamp circuit as shown in fig. 3,671, thus eliminating the resistance used with the independently wired head light and effecting a great saving of current.

The following brief descriptions give the essential features of some typical axle lighting systems.

**The Stone System.**—This equipment was invented in 1895 by Mr. A. B. Gill, and was developed and improved by Messrs. J. Stone & Co., of Deptford, England, hence is known as the Stone system. It has reached almost universal adoption on the English railways.

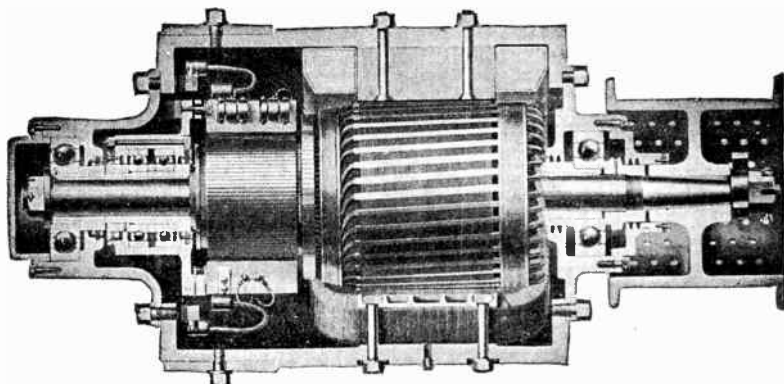


FIG. 3,672.—Safety Lighting Co. axle driven dynamo. It is a four pole machine, with single shunt winding designed to give sparkless commutation at varying speeds and varying loads met with in car lighting. The frame is a one piece steel casting, the supporting lugs being cast solid with the frame. Annular ball bearings are used. Space is provided around the bearings for grease for lubrication. Grease grooves and felt washers prevent the entrance of dirt into the bearings and the leakage of grease into portions of the dynamo where it should not go.

NOTE.—It is a tradition that the honor of first lighting railway cars belongs to one Thos. Dixon, the driver of the *Experiment*, as the coach was called, on the Stockton & Darlington Railway, England, in 1825. It is said that on the dark winter nights, out of pure goodness of heart, he used to bring in a penny candle and set it on the rough oak board that served as a table in the center of the coach. In those days the railway companies made no effort to light their cars except to offer candles for sale to passengers. Gradually times changed and the railway companies furnished a few smoky candles to be placed in each car. This was only to enable the passenger to find his way in and out of the car and took no thought of his real comfort and accommodation. Later, oil lamps were substituted in place of the candles, and these, though at first only a slight improvement over candles, were improved and developed to give a fairly good light as the railway practice developed. Car lighting has followed the same general lines of development as have the common methods of house and street illumination, but at no time till within the last few years has any method of railway car lighting been equal to that employed in houses or public places. The reason for this is obviously in the great difficulty of adapting any method of illumination to the severe conditions of railway service. But, nevertheless, practically all of the house and street illuminants have been utilized in lighting railway trains and in addition to this the vast application of compressed Pintsch gas for lighting railway cars has been developed, and later, various systems of electric lighting.

The characteristic feature of the equipment is that each car is a unit by itself, thus affording a much more flexible system than that of the earlier systems of England, where the dynamo was located in the guard's van, this being suitable for block trains only. The equipment consists essentially of a dynamo, a storage battery to act as auxiliary when the dynamo is inoperative, and an automatic switch to close the dynamo circuit when the critical speed has been attained.

The principle underlying the operation of this equipment is that regulation is obtained by allowing the belt to slip. As the speed of the train rises the dynamo voltage will tend to rise proportionally, this causing a great battery charging current to flow, thus increasing the dynamo output and belt pull. The method of mounting the dynamo is shown in fig. 3,673.

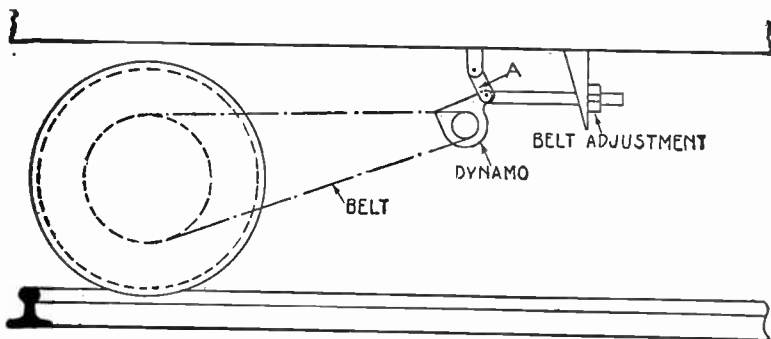
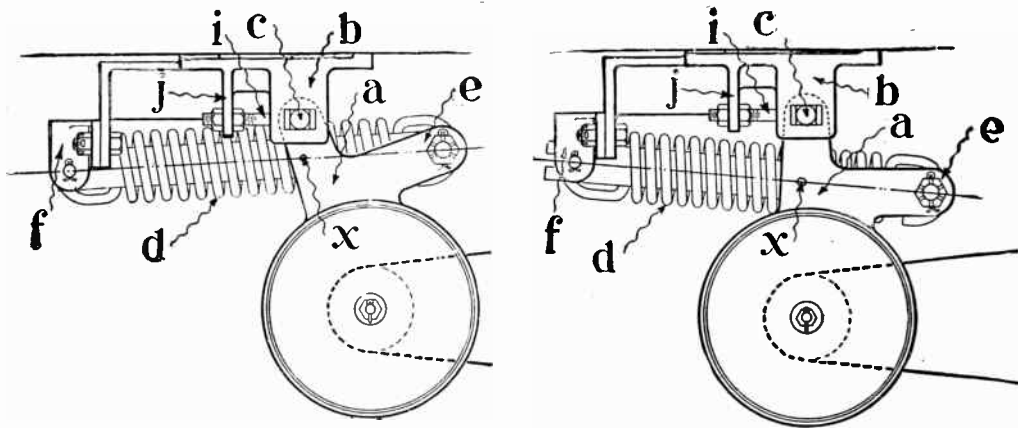


FIG. 3,673.—Method of dynamo suspension in Stone system. As shown, the dynamo is supported at one corner of its frame by the adjustable link A, in such a manner that it is free to swing toward or away from the driving axle. The suspending link is so placed that the belt draws the dynamo out of the diagonal position in which it would naturally hang, thus putting a definite tension on the belt, just sufficient to absorb the power required. It is obvious that when the pull on the belt exceeds that due to the offset suspension of the dynamo that the dynamo will be drawn toward the axle and the belt allowed to slip. Thus the dynamo will run at practically constant speed for all values of train speed above the critical value. A strong mechanical governor automatically closes the dynamo circuit when critical speed has been reached. A storage battery is suspended underneath the car to act as auxiliary in lighting the lights when the dynamo is inoperative. Another function of the storage battery is that it acts as a ballast or regulator to keep the lights constant, absorbing all the variations of dynamo output. The lubrication of the dynamo is effected by means of an electrically controlled oil supply so adjusted that when the dynamo is in operation oil will flow from the oil tank, but when the dynamo is inoperative, the supply is cut off and no waste takes place. The predetermined speed of dynamo was 915, at which it delivered 20 amperes.

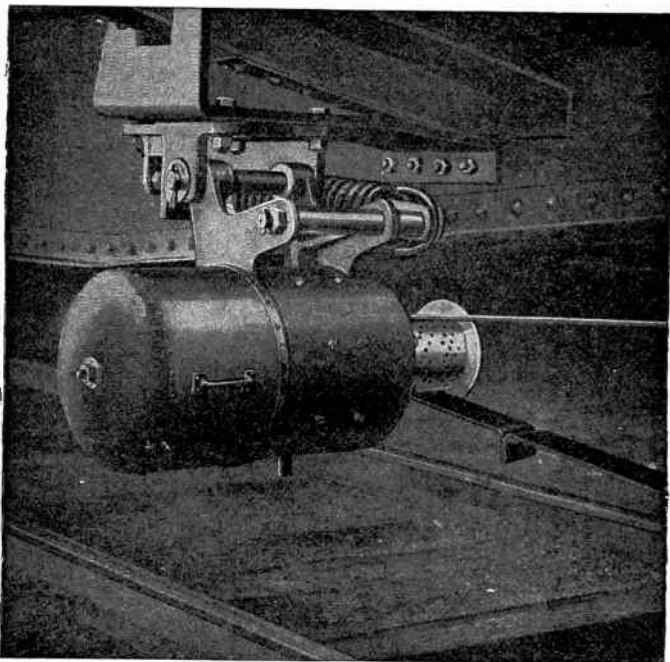
**McElroy System.**—In this system the dynamo is mounted directly on the trucks and is driven by a gear and pinion similar to those used on the motors of trolley cars; these being enclosed in a wrought iron gear case which is made dust proof with leather packing.



FIGS. 3,674 and 3,675.—Safety Lighting Cc. dynamo suspension. Fig. 3,674, position of dynamo when distance between axle pulley and the suspension is shortened; fig. 3,675, position of dynamo when distance between axle pulley and the suspension is lengthened. *In construction* there are two carrying lugs *a* cast on the dynamo frame and which are pivoted to the supporting lugs *b* on the suspension casting by the suspension bar *c*. The suspension casting is to be bolted to a suitable plate secured to the car under frame. Belt tension is maintained by the weight of the dynamo and by the tension spring which engages at one end with the lug *e* on the dynamo frame, and at the other end with the bracket *f*, fastened to the suspension casting. The parts are so designed that the sum of these two varying factors is constant. When the dynamo is hanging as in fig. 3,675, so that its center of gravity is directly under the supporting bar *c*, the weight adds nothing to the belt tension, but the spring *d* has its greatest effect, since the leverage on which the spring acts (the distance between *c* and *x*) is greatest. If the dynamo be swung as in fig. 3,674, the weight of the dynamo is giving tension, but the pull of the spring is decreased as the leverage *cx* is shortened; the sum of the two tensions being the same as in the first position. Ample latitude is provided between the two extreme positions of the dynamo (figs. 3,674 and 3,675) to take care of belt stretch and the variation in distance between the dynamo and axle when the car is on a curved track. The tension spring is assembled on a carrier under the proper tension, so that to apply it to the suspension it is only necessary to slip the two pins through the holes and in the carrier and corresponding holes in generator lug *e* and in the suspension bracket *f*. The arrangement for lining the dynamo with the car axle is simple. The hole in the lug *b* for the supporting bar *c* is slotted, and the position of the bar can be adjusted and locked by means of the bolt *i* which is provided with locknuts on either side of the lug *i*.

**Ques. Describe a common defect in car illumination.**

**Ans.** The use of lamps of high intrinsic brilliancy produces glaring effects which are hard on the eyes especially when reading.



**FIG. 3,676.**—One method of installing Safety Lighting Co. dynamo under a steel car. The dynamo is a four pole shunt wound machine and has a capacity of 3 kw. or 75 amperes at 40 volts. It is of the enclosed type to secure protection from dust, flying gravel, etc. The armature is fitted with ball bearings, space being provided around the bearings for lubricating grease. The direction of current from the dynamo is kept constant by rotating the brushes through an angle of 90 degrees whenever the direction of rotation of the armature is changed. The four brush boxes are mounted on a brush rocker and are insulated from it by mica bushings and mica washers with large creepage surfaces. This brush rocker is mounted on ball bearings, and is free to rotate between two stops, 90 degrees apart, on the head. While running in one direction, the friction caused by the pressure of the brushes against the commutator holds the brush rocker against one of the stops, with the brushes in the proper position for sparkless commutation for this direction of rotation. Reversing the direction of rotation causes the brush rocker to be turned over against the other stop, changing the position of the brushes 90 degrees. The dynamo then gives the same polarity, although the direction of rotation has been reversed.



The intrinsic brilliancy of a lamp is the intensity of the light emitted divided by the area of the source emitting the light. For example: of two lights of equal candle power the one having the shorter or more closely coiled filament and smaller bulb is the more brilliant, and is the one that will have the greater tiring effect on the eyes. For the same reason a large number of low candle power lights distributed through a car will give a more useful illumination than a few high candle power lights.

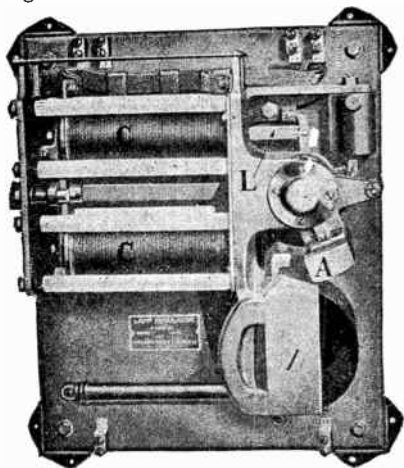


FIG. 3,677.—Safety Lighting Co., type F, lamp regulator. It consists of two piles of carbon discs in series with the lamps; the two piles being in parallel. The pressure on these carbons, and therefore their resistance, is determined by the armature of a magnet, the windings of which receive lamp voltage. By a unique design of magnet and levers, a high degree of accuracy in voltage regulation is accomplished without the use of any auxiliary control. The carbons *C*, are compressed by an adjustable spring connected to the link *L*, acting through a toggle. The pull of the spring is opposed by the pull of the electro-magnet which is connected directly across the lamp mains and is so designed that the armature *A* will stay in any position through its stroke when the lamp voltage is right. When the lamp voltage is high the magnet becomes stronger and pulls armature *A* down against the pull of the spring and reduces the pressure upon the carbons *C*, increasing their resistance and bringing the lamp voltage back to normal. If the lamp voltage be low, the magnet becomes weakened, the spring pulls armature *A* back, and through the toggle exerts enough pressure on the carbon piles to decrease their resistance and bring the lamp voltage back to normal. An air dash pot of the same type as used on the dynamo regulator is employed on the lamp regulator.

**“Axle” Lighting of Cars.**—This method of car lighting is one now being very generally adopted on steam railways, and in brief, it consists of a dynamo belted to the axle, storage battery, and necessary auxiliaries for proper control.

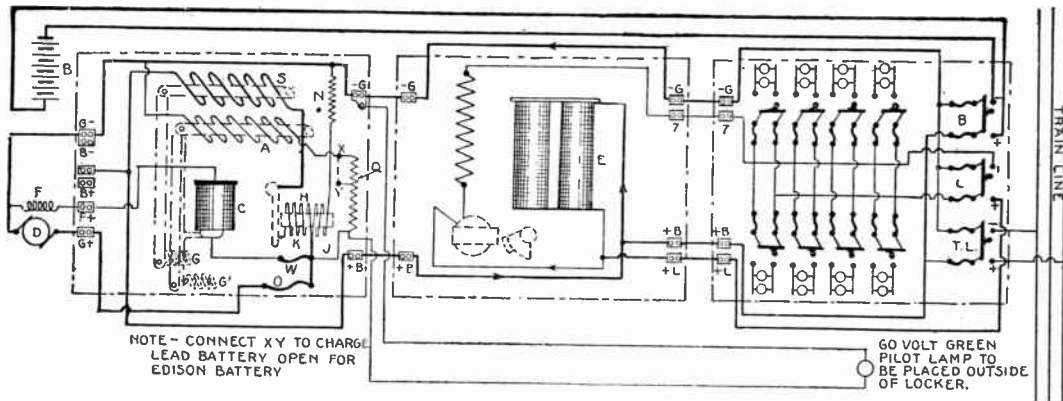


FIG. 3,678.—Wiring diagram of Safety Lighting Co. 40 volt, type F regulator. *In operation*, the dynamo is controlled to give the proper output through changes in speed and battery conditions, by the amount of current supplied to the shunt field. This field current is controlled by the resistance of the carbon pile C in series with the field. The resistance of this carbon is determined by the pressure exerted on it by levers operated by the plungers of magnets A and S. The winding of S carries the total current output of the dynamo; if the current output tend to rise above that for which the regulator is set, the plunger of the coil S, through its lever, reduces the pressure on the carbon pile C, reducing the field current and holding the current output to its proper value. If the voltage tend to rise above that for which the regulator is set, the plunger of the coil A, through its lever reduces the pressure on the carbon pile C, and holds the voltage to its proper value. The coil S is set to hold the current value to the full output of the dynamo. The voltage coil A is set for a maximum voltage of 2.45 volts per cell, or 30 volts on a 16 cell lead battery. With this as a maximum voltage overcharging of the batteries will not take place, since the current to the batteries will automatically taper down to a low value as the cells become fully charged. As the output of the dynamo is limited to its full output by the series coil S, the dynamo cannot be overloaded either by lamp load or charging an exhausted battery. At the same time the full output of the dynamo is available for battery or lamp load whenever it be needed. An equipment with this system of regulation with a dynamo of a given size will maintain the service with a higher lighting load than with a system in which the regulator maintains the battery current constant, regardless of lamp load. The auto-switch is of the closed magnetic circuit type with pivoted armature. It has a dynamo shunt lifting coil which, when the dynamo voltage equals the battery voltage, lifts the armature, bringing into action the series coil, which holds the switch tightly closed and assists in opening the switch when the dynamo voltage falls below battery voltage. Carbon contacts are provided to prevent arcing at the main brushes.

Within the dynamo compartment is a mechanical device that determines the polarity of the circuit on reversal of the direction of motion of the car.

A battery auxiliary is supplied as in all other axle devices. This equipment is one of the type that controls by varying field resistance. The regulator is the characteristic part of the equipment and consists essentially of a compound solenoid controlling a motor, which in turn operates a field rheostat.

The compound solenoid is a part of the equipment that deserves special consideration. It consists essentially of a series coil of heavy wire placed in the battery circuit, and in addition to this a shunt coil which is connected directly across the dynamo terminals. Thus the control is one combined for voltage and current regulation and appears at least partially to eliminate the evils of the control by constant current.

By a proper adjustment of the ratio of ampere turns of the shunt coil to those of the series coil, the regulator may be made to protect the batteries from the destructive overcharge which is so often experienced when a constant current regulator is employed.

This, from a battery standpoint, is a very commendable improvement over the principle of control by constant current regulation and deserves special emphasis.

In explanation of the operation of this solenoid, assume actual operating conditions; there being 16 cells in the storage battery, the dynamo voltage then varies between 32 and 42 volts at different points of the battery charge. Accordingly the magnetic flux in the solenoid due to the shunt coil would vary proportionally to this pressure. This might be expressed as a variation from 320 to 420 ampere turns. Assuming that the series coil had been adjusted so that normal charging current would develop 110 ampere turns, this making a total number of 320 plus 110 equals 430 ampere turns in the solenoid when charge was first commenced. Now as the batteries become charged the voltage rises and the shunt coil magnetism is increased, thus requiring less magnetic pull from the series coil to regulate. It should be noted that the magnetic pull which balances the pull of the adjustable regulator spring is the sum of the magnetic pull due to the shunt coil combined with that due to the battery current flowing through the series coil, and that as the one increases the other must decrease to maintain equilibrium. When charged condition is obtained, the 430 ampere turns total in the solenoid would consist of 420 ampere turns due to the shunt coil, and only 10 ampere turns due to the series coil, thus the charging current has been reduced to only 9% of its normal maximum value. It is obvious that by a suitable proportion of ampere turns due to the series and shunt coils the battery overcharge may be reduced to any desired value.

In regard to the detail operation of the controlling apparatus, the compound solenoid moves an iron plunger back and forth, which in turn makes contact through the armature of a small motor, causing it

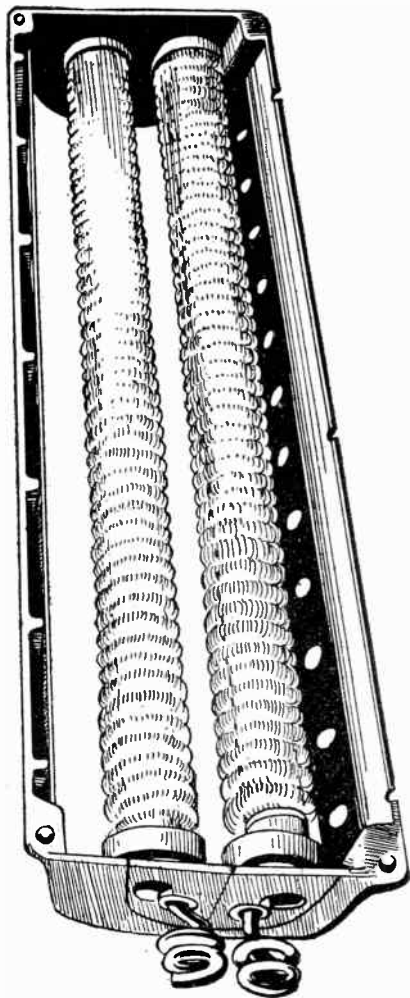


FIG. 3,679.—Electric heater coils and case. There are two coil units, as shown; the coil terminals are led out through insulating bushings and the front of the coil is covered with a wire grating or equivalent to prevent the clothes of passengers coming in contact with the coils, which under certain circumstances may rise to a dangerously high temperature. This type of heater is commonly known as a *panel heater*, as it is usually installed in a panel in the side of the car.

to rotate backward or forward, cutting in or out a field rheostat as may be required to regulate the dynamo voltage. A lamp resistance is also inserted in each lamp circuit by this motor when the dynamo becomes operative. The motor serves also to close the dynamo circuit when the critical speed is attained, thus an automatic switch is not required.

In this regulator the motor runs only when regulation is necessary, so that a minimum wear on moving parts is obtained.

Due to the series coil of the regulator being placed in the battery circuit, the batteries will be charged entirely irrespective of whether or not the lamps are lit, so that, though the lamp resistance be in circuit, the rise in charging voltage of the battery will cause a proportionate rise in voltage at the lamps.

This could be largely eliminated by a slight modification of the regulator solenoid, if another series coil were added to the solenoid and this placed in the lamp circuit so that when the lamps are turned on the current through this coil will create a magnetic flux which will largely replace that of the battery charging current.

This would cause a

large decrease in the battery current when all the lamps are turned on, and would accordingly require that the charging be done largely during the day. This in many cases would be a serious disadvantage, but when installed on a car making at least a part of its run during the day it might be made to operate satisfactorily.

**Car Heating.**—This may be accomplished by means of stoves, hot water heaters and electric heaters. Systems using either stove or hot water heaters are undoubtedly cheaper than those employing electric heaters.

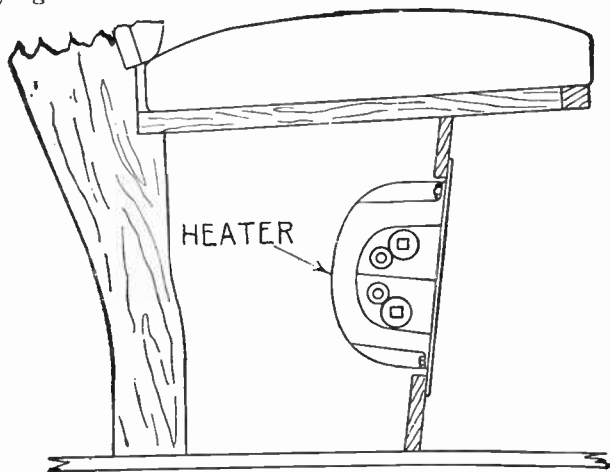


FIG. 3,680.—Section through car seat, showing location of panel heater of the system shown in fig. 3,679.

The amount of power consumed by electric heaters naturally varies with the climatic condition, but for cars ranging from 24 to 34 feet in length the power consumption for average and severe weather conditions varies from 5 to 7 kilowatts, respectively, so that the electric heater loads on both street railway and interurban systems compose a very large part of the total energy consumed. It is well known that on many well equipped electric railway systems, the amount of power consumed in

heating and lighting the cars during very cold weather exceeds 20 per cent. of the power supplied to propel them. Both stove and hot water systems however possess several disadvantages. They occupy useful space, require special attention, and introduce dust smoke and dirt into the car.

In the case of the stove, the heat is principally developed in the upper part of the car, leaving the air near the floor comparatively cold. Furthermore, in the case of cars used for

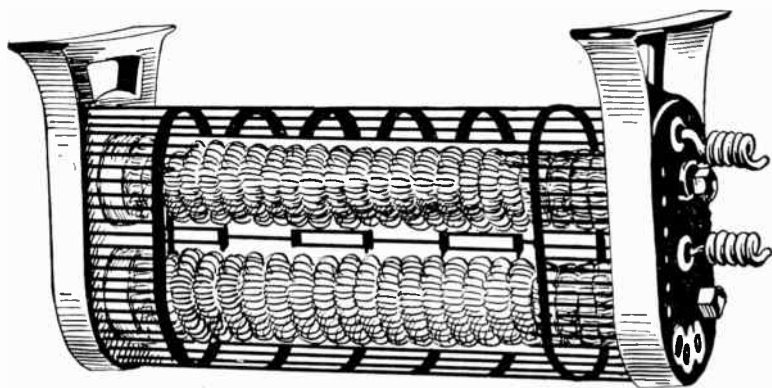


FIG. 3,681.—Type of electric heater suitable for installation under cross seats of car.

heavy city service, where vestibules are not used and the cars are not run as frequently in one direction as the other, it is practically impossible to heat them by any other system than that of electric heaters.

**Ques. Describe an electric heater.**

**Ans.** An electric heater consists of a resistance in the form of a coil of wire, usually of galvanized iron, wrapped in the form of a close spiral around a porcelain tube.

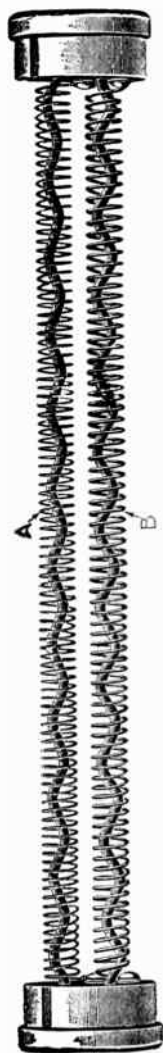


FIG. 3,682.—View showing construction of Gold two coil heater unit. The coils are so designed as to insure a circulation of air. In this heater the coils are wound around wavy metal rods as shown. The smaller coil A provides one-third the heat and the larger coil B, two-thirds, thus making it possible to obtain three variations in the amount of heat furnished, to meet changes in air temperature conditions.

Usually, two such coils are mounted in a metallic case as shown by fig. 3,679, and the entire arrangement secured to the risers under the seat as shown, fig. 3,680.

### Ques. What important point should be considered in the design of electric heaters?

Ans. Special provision should be made to secure good circulation of air around the resistance coils so as to transfer the heat from their radiating surfaces as rapidly as possible into the space to be heated.

Unless this arrangement be effective, the heat given out will not be uniform, and a large amount is apt to be lost through the back of the casing. Furthermore, if the heaters be installed too near the edges of the seats, they are liable to become muffled by the clothing of the passengers resting against the perforated front of the heater case, thus arresting the air circulation, and causing the temperature of the coils to rise to a degree sufficient to scorch the clothes, or to set fire to the woodwork of the car.

### Ques. How may the amount of heat furnished by six single coil heaters be varied?

Ans. This may be done by means of a temperature regulating switch.

Usually, this switch has five positions. When it is turned to the first position all the heaters are connected in series between the trolley and the track, the resistance in the heater circuit is greatest, and consequently the heat radiated is least. When the switch is turned to the fifth position the heaters are connected

in three parallel groups of two each, the maximum current is allowed to pass through them, consequently the greatest amount of heat is obtained. In the intermediate position of the switch, one or more of the heaters are entirely cut out of circuit at will.

**Track Construction for Electric Railways.**—This varies in design according to the character of the service and the traction system or method of power transmission employed.

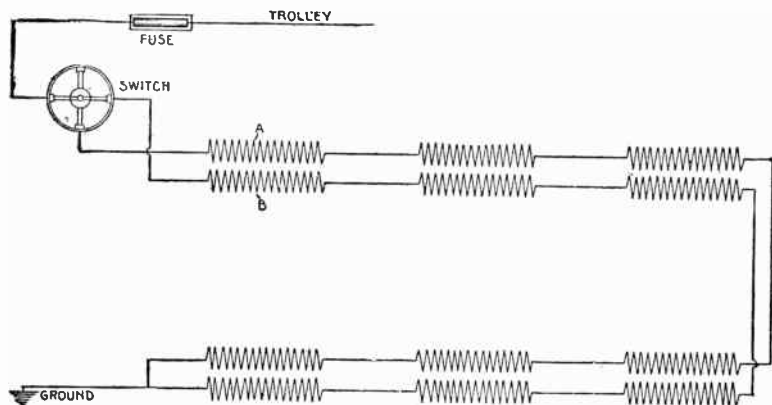


FIG. 3,683.—Wiring diagram of six heater equipment with type of heater shown in fig. 3,682. Three variations in the amount of heat furnished may be obtained with this arrangement, a suitable switch being provided by means of which either the smaller, or the larger coils (see fig. 3,682), or all the heaters may be turned on at a time, or both sets of coil may be operated at the same time.

The track construction for overhead trolley line systems differs but little from other forms of railway construction, with the exception of the *bonding* of the rail joints. With the use of a ground return this is absolutely necessary to secure a continuous metallic path, thereby reducing the resistance which would otherwise be introduced into the circuit.

Rail bonding is accomplished by a variety of method. A common form of rail bond used on trolley roads consists of a copper wire, which





FIGS. 3,684 to 3,687.—Various rail bonds. Fig. 3,684 steel expansion pin; fig. 3,685 and fig. 3,686 two forms of cable band; fig. 3,687 ribbon bond. The steel expansion pin shown in fig. 3,684 as used in type of cable band having holes drilled through the shanks. These shanks are inserted in the holes in the rails and then expanded to a tight fit by the tapered steel pins which are driven in the shank holes.

is passed twice through holes in the rail on each side of a fish plate. At intervals the wire is led directly across the track and attached to the other rail, thus effectively connecting the two rails together. Copper wedges are driven into the holes in the rails to effectually wedge the wire against the rails. In the case of double track roads both tracks are connected together in a similar manner. This type of bond is commonly known as the *solid wire bond*, and when made in short lengths breaks easily from track vibration.

### Ques. Describe the cable bond.

Ans. The cable bond consists of a bundle of copper wires the ends of which are soldered together and to terminals by which it is attached to the rails outside the fish plates. In some forms, the terminals have holes drilled through the center of the shanks. These shanks are inserted in the holes in the rails and then expanded to a tight fit therewith by beveled steel pins driven into the holes.

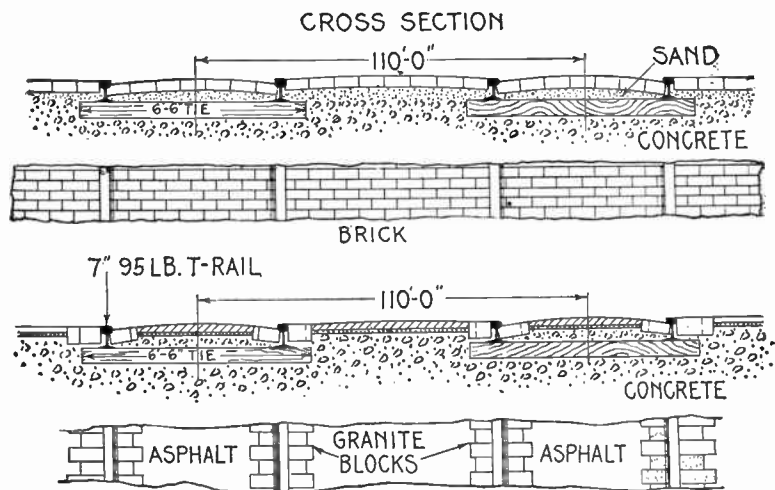
### Ques. Describe the ribbon bond.

Ans. The ribbon bond consists of a series of lamination or thin strips of copper, about

.023 inch thick, bent into various forms to give the greatest possible degree of flexibility.

In the *soldered type* of ribbon bond, the ends of the laminations are separately tinned, clamped together, and after being dipped in solder or welded together, are covered with wrappers. The terminals thus formed may be soldered to the head of the rail, or to the base of the rail.

**Ques.** What advantages are claimed for the T form of rail, as compared with the girder or grooved rail?



FIGS. 3,688 to 3,691.—Cross sections and plans of typical car tracks with T rails in paved street. The height of the rail used in any particular case will depend on the character of the paving. In some cases it might be necessary to use an excessively heavy standard rail weighing from 90 to 100 lbs. per yard, but in most cases the necessary height can be secured by using a high T rail of lighter section. The cost of this form of construction with the paving strip 8 ft. wide will vary from 5 to 7 dollars per lineal foot of single track, according to the cost of material, weight of rail, wages and character of labor, etc.

**Ans.** 1, It is designed on better mechanical lines, and there is not eccentric loading as in the grooved rail, 2, there is not excessive waste of material in rails required for heavy traffic and large wheel flanges. Grooved rail weighing from 125 to 150 lbs. per yard, are being used in many cities, where T-rail

weighing 80 to 90 lbs. per yard, would be amply sufficient, 3, the flangeway is always ready for an increase in the size of wheel flanges of local cars, or for the large wheel flanges of high speed interurban cars, 4, the T rail is not as noisy as the girder or grooved rail, 5, it has a longer life than any other type of rail, particularly at the joints which are the vital points in any rail, and 6, it is cheaper, more easily handled, and does not require the use of high priced shop curves.

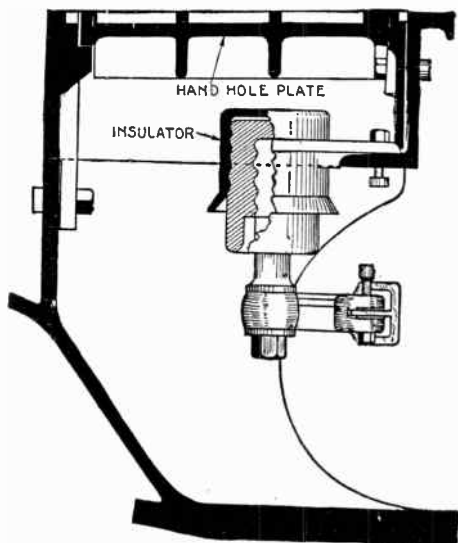


FIG. 3,692.—Section of underground conduit showing handhole at each insulator; these are located 15 feet apart, manholes being provided every 150 ft.

Figs. 3,688 to 3,691 show cross sections and plans of typical track construction with high T rails in paved streets.

**Conduit or Underground Trolley Systems.**—The kind of construction employed largely depends upon the local conditions and requirements. In general it consists of a series of

iron yoke embedded in a concrete sub-surface structure which forms the conduit from the underground conductors. The type of yoke used in the construction of the track of the Lenox Avenue line of the Metropolitan Street Railway Company of New York City, is shown by fig. 3,693.

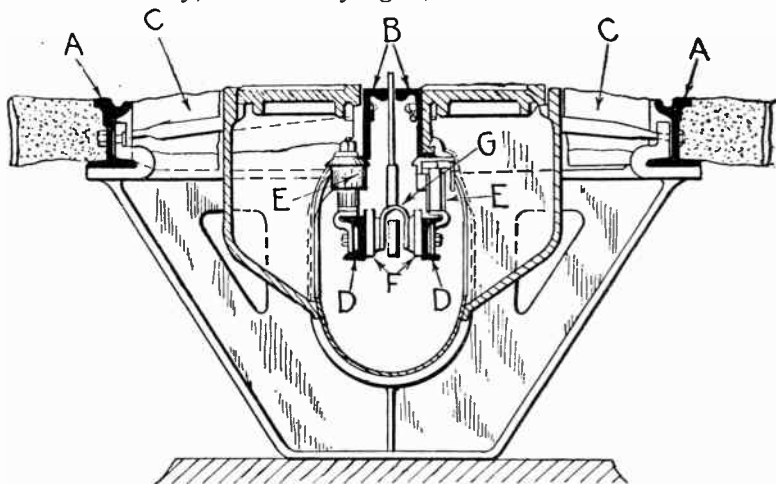


FIG. 3,693.—Yoke construction for conduit or underground trolley, as installed on Metropolitan Railways, New York City. These yokes were placed 5 feet apart in an excavation made through the street. The track rails A, A, and the slot rails B, B, were then laid on the yokes, and the ties C, C, inserted. The whole structure was then blocked up, surfaced and lined, and constituted the track construction. The conductors consist of two channel beams, D, D, placed 6 inches apart and supported by insulators E, E, at each yoke. The contact rail joints are bonded in a manner somewhat similar to ordinary rail bonding, and from a complete metallic circuit having a pressure of 500 volts between the conductors. The current from these conductors passes through the slot or opening between the slot rails and extends into the conduit to a distance sufficient to bring the plow contacts or shoes F, against the conductors. The spring G, tends to keep the shoes normally about 8 inches apart, so that when they are pressed into the G inch space between the conductors, they maintain a firm sliding contact with the latter. The yokes used on some of the lines constructed later are practically the same, but T iron conductors are used instead of the channel beams. In order to provide of expansion and contraction the center of each section of rail is fastened solidly to an insulator at that point, and the ends of each rail are slotted and bonded with a flexible bond. Hand hole provided with iron covers are placed about 15 feet apart directly over the insulators. The manholes are placed about 150 feet apart, and usually between the tracks. Arrangements are made at these points to drain the conduit into the sewers. The bottom of the conduit is given a minimum grade of 2 inches to 100 feet, so as to insure proper drainage on sections of level track. The contact rails are treated like a double trolley wire, and the feeders and mains are laid in underground conduits. This system is so expensive to install that its use is limited to only a few of the largest cities where for various reasons the use of the overhead trolley is objectionable and prohibited.

**Third Rail Construction.**—There are two types of third rail in general use:

1. Exposed type;
2. Protected type { top contact;  
bottom contact.

The third rail is usually placed outside the rack rails on insulators mounted on the ties, and is either entirely exposed as on the lines of the Manhattan Elevated Railway, or protected by wooden shields carried

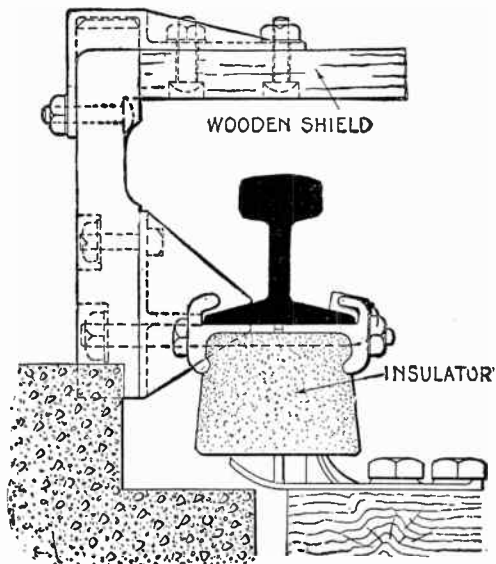
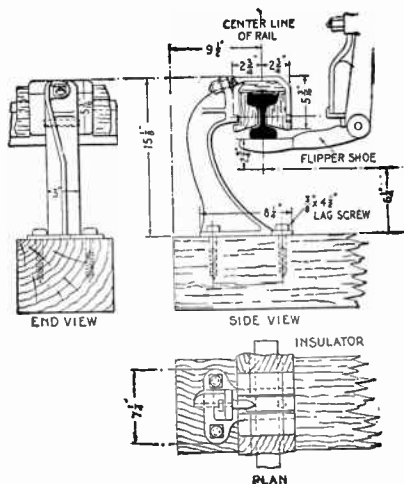


FIG. 3,694.—Cross section showing cartruck of protected top contact third rail.

by yokes from the rail itself, as on the lines of the Interborough Rapid Transit Company of New York, as shown in fig. 3,694. These represent the simplest type of third rail construction, but while they give good service with the special condition under which they are used, it has been found that in many ways the top contact rail is not suitable for interurban railway systems or for the electrification of existing steam railroads. The principal objection is that as its lower part is only about four inches above the ties, it cannot be effectively protected from accumulations of snow, ice, dirt, etc., which tend to cause serious ground and excessive leakage. This objection is almost entirely

eliminated in the protected third rail system which has been adopted on the tracks of the New York Central Railway, the Philadelphia Rapid Transit system, and a number of other roads, as shown in figs. 3,695 to 3,697.

**Trolley Line Construction.**—The various methods of trolley line construction may be divided into two classes



**Figs. 3,695 to 3,697.**—Details of protected bottom contact third rail. It consists of a series of iron bracket carried on ties, to the tongued vertical face of which are clamped non-charring moisture proof insulating blocks which loosely embrace the head of the rail. Intermediates between the insulators the rail carries an insulating sheathing which embraces the head and reaches down nearly to the bottom face of the rail, but extends outward from the web so as to form a petticoat protection against snow and sleet. The position of the rail depends upon the clearance requirements. To meet the ordinary trunk line conditions, the bracket height is made such that the under-contact surface of the third rail is  $2\frac{3}{4}$  inches above the surface of the track rail and the center of the rail is  $27\frac{1}{4}$  inches from the rail gauge line. With this arrangement the height of the third rail above the ties and ballast is about 5 inches more than it would be in the case of ordinary top contact rail construction. On crossings, the horizontally extending slipper shoe, which is normally pressed upwards by the spring, lifts and clears the track rail by a safe margin.

according to the method employed for suspending the trolley wire,

1. Bracket construction;
2. Span wire construction.

In both classes, the trolley wire may be supported either directly from the insulators carried by the brackets or spans, or from a steel cable or *messenger cable* which in turn is supported by insulators carried by the brackets or spans. The former is the old and familiar method of construction employed

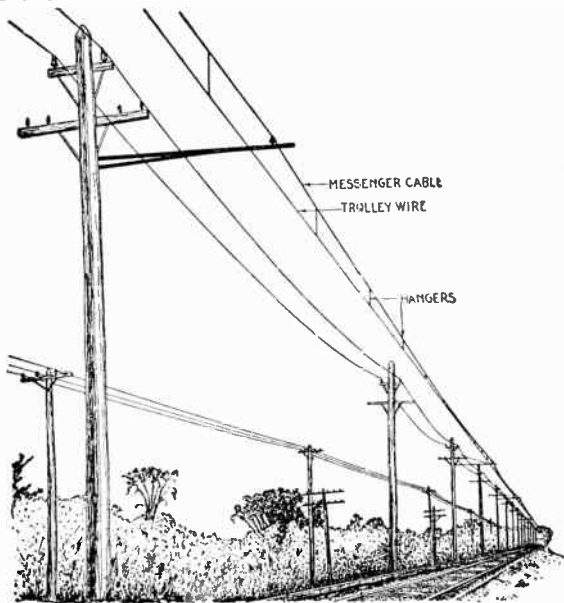


FIG. 3,698.—Eleven point bracket catenary construction for single track. The bracket type of construction is the cheapest and is the one generally used for ordinary interurban service. On double track lines the poles carrying the brackets are placed on each side of the right of way.

for direct current lines, and the latter is the new method commonly known as *catenary line construction*.

Although the catenary type of construction has been developed to meet conditions incidental to the distribution of high tension alternating current for the operation of interurban electric railways, the marked mechanical improvement obtained both in the strength and durability of the overhead structure, and in the maintenance of a

straight trolley wire, at a cost less than that of the older type, tend to make the catenary the standard practice, not only for alternating current work, but also for low and high voltage direct current work, even on lines of limited extent.

The catenary type of construction was originally designed by the Westinghouse Company in connection with their single phase railway equipment designed for operation with line pressures from 3,300 to 11,000 volts.

There are two general classes of catenary construction: the single catenary, and the double catenary. In both of these the principal object aimed at is the maintenance of the trolley wire at a constant distance from the top of the rails.

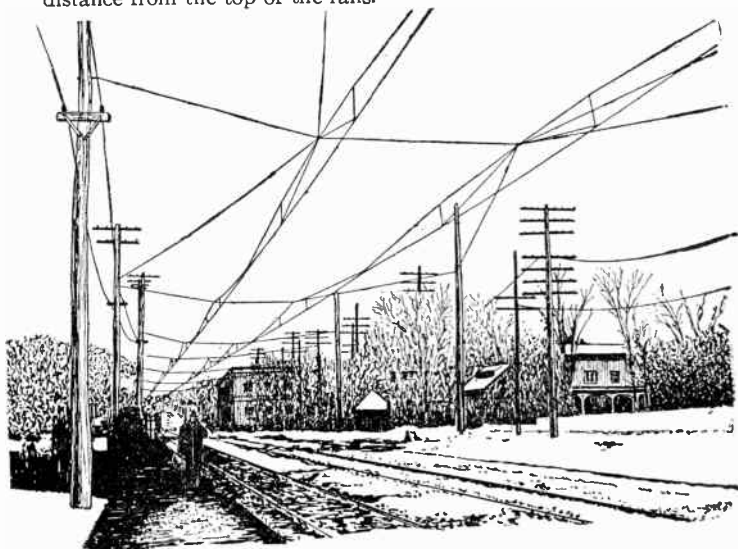


FIG. 3,699.—Anchorage for double track span wire catenary construction. The span wire construction is more expensive than the bracket construction and not as satisfactory, as it requires longer poles and produces a more severe loading of the poles, than bracket suspension. It is used only where the local conditions make its use absolutely necessary as in the case of section of track passing through very wide streets or roadways of country lawns.

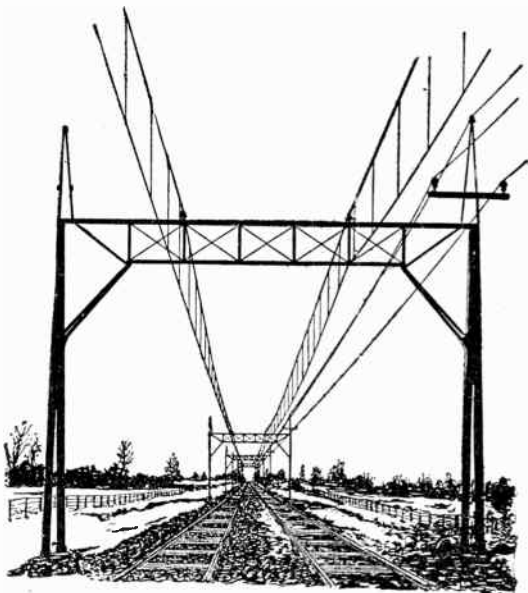
**Ques.** How is the wire supported in the single catenary construction?

**Ans.** By a single messenger cable carried by the brackets, spans, or bridges.



Fig. 3,698, shows an example of 11 point bracket catenary construction for a single track line. Fig. 3,699, shows the anchorage, for a double track span wire catenary as designed by the General Electric Co. Fig. 3,700, shows a bridge supported catenary for a double track line.

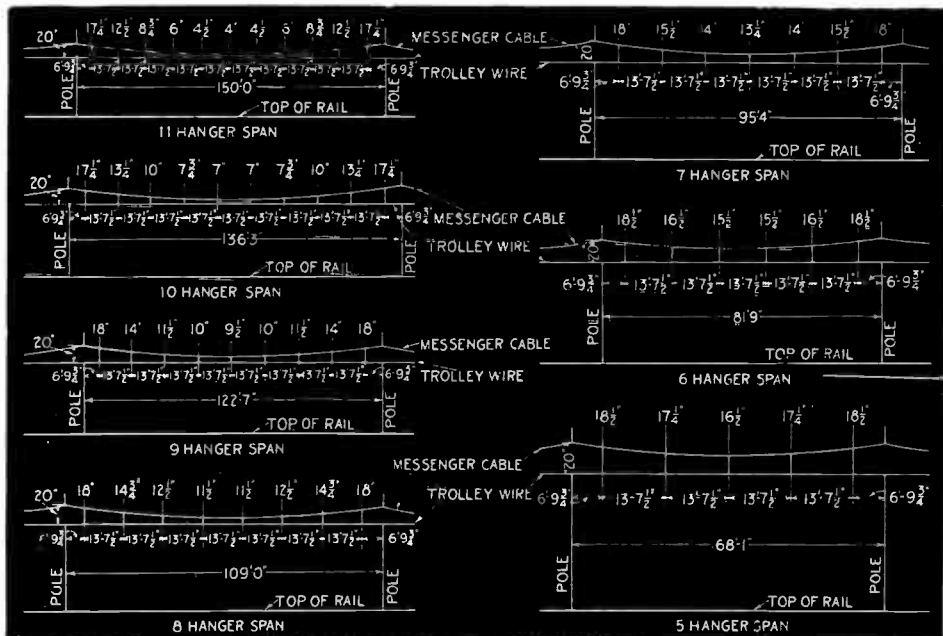
**Ques.** What strain is brought on the trolley wire in catenary construction?



**FIG. 3,700.**—Bridge type single catenary construction for double track road. In this arrangement the trolley wire is suspended from a messenger cable supported on bridges spanning the tracks and supported by towers on each side. This type of construction is seldom used for anything but the heaviest class of service, such as electrified steam railroads, and substantial interurban roads handling heavy freight traffic as well as heavy passenger traffic.

**Ans.** The trolley wire has to support its own weight, only, in the short spans between the hangers.

Accordingly, it can be selected with regard to its electrical carrying capacity and regardless of its tensile strength; but in order to keep the deflection in these spans at a minimum, the trolley wire is usually strung with a tension of about 1,000 lbs., thereby serving also to stiffen the structure and prevent the trolley pushing it over to one side.



Figs. 3,701 to 3,707.—Diagrams showing length of hangers for spans with 13 ft., 7 1/2 in. hanger spacing, based on a span length of 150 feet on tangents. The sag of the messenger cable is proportioned to balance the pull of adjoining spans, and is based on a temperature of 60 degrees Fahr., but the amount of sag in any particular case should be modified to suit local temperature conditions. On tangents, the spacing of the hangers depends largely upon the character of the service. For speeds up to 65 miles per hour, with trolley wheel collectors, the hangers may be placed 30 feet apart, giving a 3 point suspension between poles placed 150 feet apart. A straight or stiffer trolley wire is necessary, however, with the sliding pantograph or bow trolleys which are of relatively sluggish action, and experiments show that a 11 point suspension, giving a hanger spacing of 13 ft., 7 1/4 inches on 150 spans, is the most satisfactory in such cases.

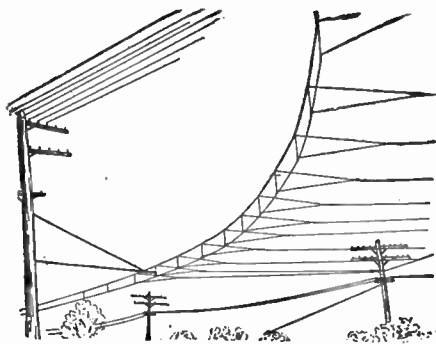
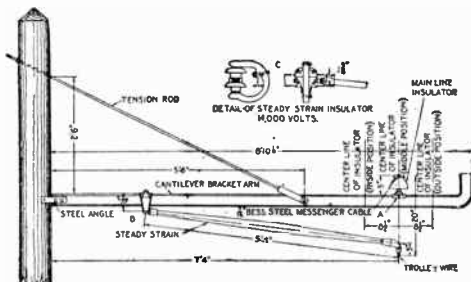


FIG 3,708.—Single catenary curve construction. *In locating* the bracket arms on poles and the poles on curves, the effect of super-elevation and the lateral overhang of the cars or locomotives must be allowed for, as well as the position of the current collector. *Anchor spans* should be placed at the ends of curves and at frequent intervals on tangents.



FIGS. 3,709 to 3,711.—Detail of bracket arm with steady strain. The bracket arm is constructed of a 3 inch I-beam, the outer end of which is bent upward, to prevent the messenger cable falling if it should happen to become detached from the insulator. The I-beam is secured to the pole by means of a tension rod and steel angles. The regular distance from the center of the track to the pole is 7 ft., 4 ins., which is sufficient to provide ample clearance on tangent for all types of equipment. It may be found necessary, however, to increase this distance on sharp curves, to allow for the overhang of large cars, and the bracket arm can be readily lengthened to cars for any degree of super-elevation. The steady strain and insulator are secured to the bracket arm by hook bolts and malleable iron clamps so that they can be shifted to stagger the trolley wire, a maximum throw of  $8\frac{1}{2}$  inches being possible on each side of the center line. This staggering is essential where pantograph or bow trolleys are used, but may be omitted on lines using wheel trolleys. The steady strains are placed upon every fourth or sixth bracket arm on tangents, and upon every bracket arm on curves. The insulators which support the messenger cable are of porcelain with brown glaze, and are proportioned for the operating line voltage. The form of the vital points in high voltage trolley line construction here shown is the skirt type; it is secured to the bracket arm by a malleable iron clamp and hook bolt, as shown at A, fig. 3,711. The steady strain which prevents the trolley wire swinging laterally, consists of treated hardwood rod with substantial end sockets, one end being adapted to clamp the trolley wire, and the other secured either to the bracket arm for pressures up to 6,600 volts, as shown at B, or to an insulator and bracket, for higher pressures, as shown at C, fig. 3,709

### Ques. What kind of messenger cable is used?

Ans. The messenger, or supporting cable is usually a  $\frac{1}{16}$  inch seven wire galvanized steel strand. Bessemer steel is used for spans up to a maximum of 120 feet, and Siemen's-Martin steel for longer spans.

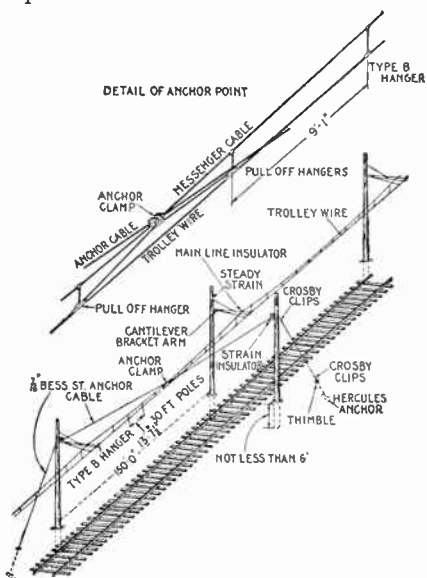
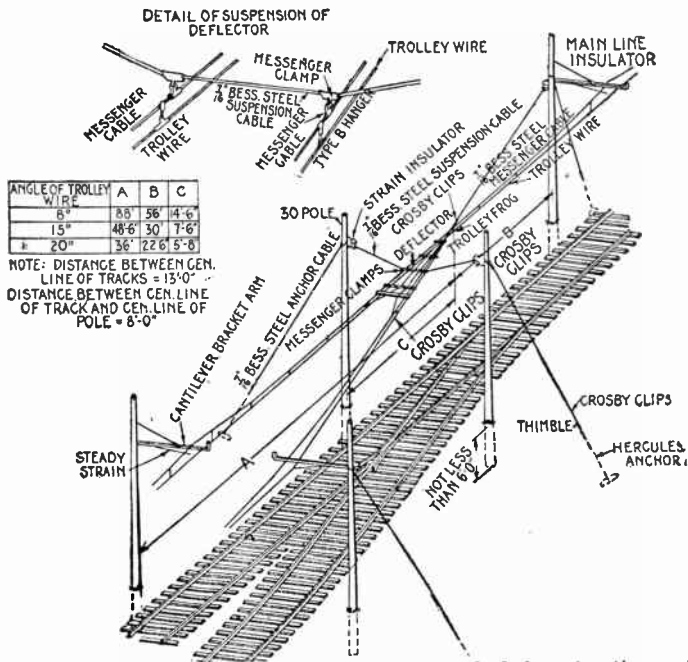


FIG. 3.712.—Catenary construction at anchor span. *In erecting*, the clamp used for the messenger cable is placed at the center of a span, so as to grip both the messenger cable and the diagonal anchor cable. Two pull off hangers are placed each side of the messenger anchor clamp, replacing the ordinary hangers, and a short piece of strand wire is used to tie these pull off hangers to each other and the anchor clamp. The anchor wire is pulled between a pole and an anchor pole on the opposite side of the track, both of which are guyed, and the anchor cable is dead ended on the strain insulators.

The messenger cable should be of sufficient strength to support the span under the most severe weather conditions. The cable is run out in long lengths and then pulled up to a uniform tension in all spans.

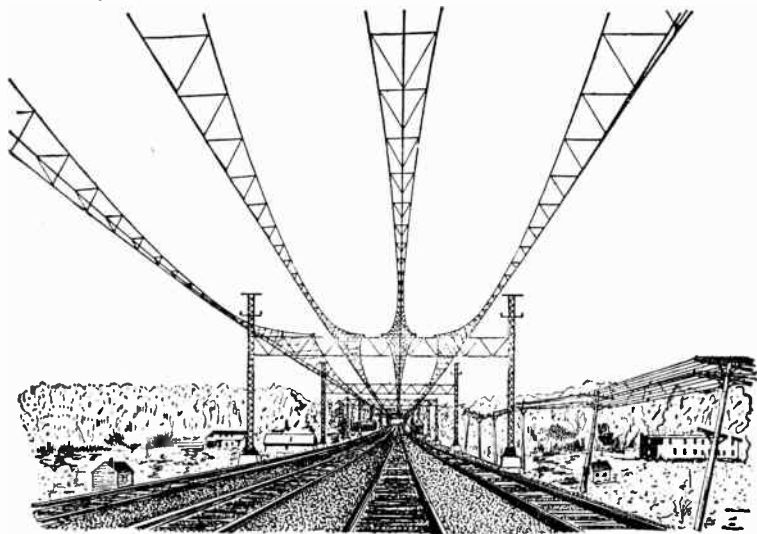
**Ques. In erection how are the trolley wire and messenger cable installed?**

Ans. It is usually found convenient to run out the trolley wire and messenger cable together, laying them on the bracket arms for support until the messenger cable can be pulled up and tied to the insulators; the trolley wire is then stretched and hung. Tower line cars or wagons of the usual design are used in this work.



**FIG. 3.713.**—Trolley deflector construction at switch. *The method of construction* employed at turnouts and sidings depends upon the type of current collector used. For the wheel trolley, the siding trolley wire is brought to the main line at the switch, and then carried down the main line, parallel to and at a distance of 12 inches from the main line trolley wire, to a distance of about 200 feet. For the pantograph trolley, a so called *deflector set* is used to prevent the trolley becoming caught. The layout of the poles and line and the construction of the deflector are here shown. The deflector consists of number of trolley wires held in place by ordinary trolley ears which are bolted to cross bars spaced about 3 feet apart and supported by the main line and siding trolley wires. The ends of these rods are raised about 4 or 5 inches above the siding and the main line trolley wires so that no possibility of the ends of the pantograph becoming caught in them. The siding trolley wire is carried over that of the main line to an anchorage on the farther side.

**Signal Apparatus.**—The selection of proper signal apparatus for an electric railway is governed by many conditions: whether the system be single or double track, city, suburban, or inter-urban; whether the track be straight, or have many curves, be level, or of many grades; whether direct or alternating current be used for train propulsion, etc. There are two general classes of railway signal:



**FIG. 3,714.**—Four track double catenary construction with bridge supports. *In this construction*, the trolley wire is carried by two messenger cables supported on bridge of substantial construction spanning the tracks at intervals of 300 feet or more, as here shown. This type of construction represents the highest development of the art of line construction for electric railways. It produces a very rigid structure which is not subject to undue lateral vibration for wind pressure, but is very flexible with regard to vertical pressures exerted by the current collectors. Owing to its great cost, however, it is used only in the electrification of lines of the heaviest class.

1. Block system;
2. Interlocking system.

Block signaling has to do with keeping trains which are running on the same track, at a proper distance apart.

Inter-locking signaling is for the control of trains over tracks which intersect at points of crossing or divergence, and has for its object the prevention of conflicting movements, the proper routing of trains, and the insurance that the movable parts of the track are in their right positions before the signals governing movement over them can be made to give a proceed indication.

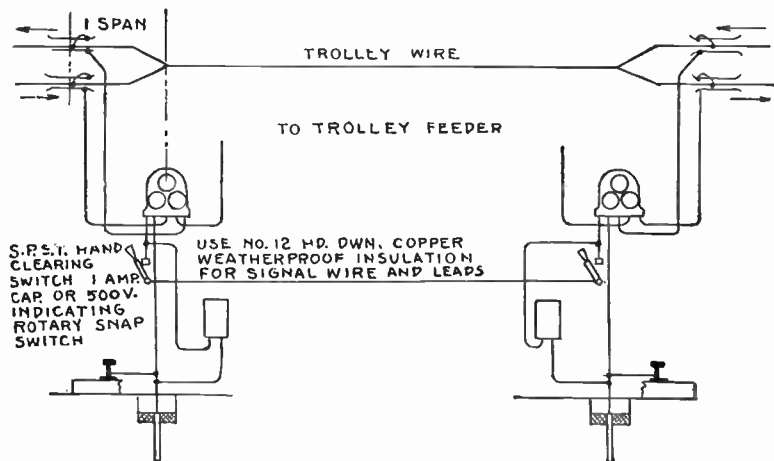


FIG. 3,715.—Automatic block signal system. This system comprises a signal box with white and red lights, located at the end of each block provided with corresponding red and white semaphore discs; a set of trolley switches by means of which the signal boxes are automatically operated.

Block signals may be classed as

1. Non-automatic;
  - a. Non-controlled manually operated;
  - b. Controlled manually operated;
  - c. Staff system.
2. Automatic.

**Ques.** Where are non-controlled manually operated signals used?

**Ans.** At passenger stations, junctions or other convenient points where operators are convenient in connection with the telephone or telegraph blocks.

They are put in the proceed position to permit a train to enter the next block when information has been received by the operator from

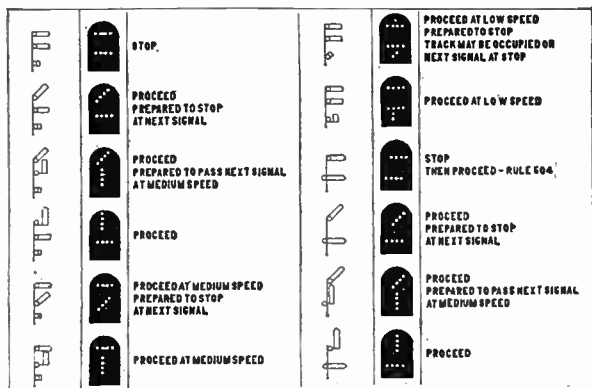


FIG. 3,716.—Corresponding aspects of semaphore and position light signals with their indications. Early in 1914 Dr. Churchill of the Corning Glass Company, while working on some of the electric headlight troubles of the western railroads, discovered that it was possible to secure very long range from a small light source located in the exact focal point of a small wide angle lens, and in talking the matter over with A. H. Rudd, signal engineer of the Pennsylvania, it was seen to be altogether practicable to combine these small separate units into rows of lights which would have the effect of the present semaphore arm and would do away with the color scheme altogether. Thus was evolved the position light signal, which has now been covered by various patent applications. It was, of course, a long way from the conception of the idea to the perfection of the design, and it was not until the summer of 1914 that the signal was considered satisfactory enough to adopt. The principal experiments were conducted at Wayne and later at Paoli.

the next station in the direction of traffic that the preceding train has passed out of the block. They are placed in the stop position on the passage of the train.

**Ques.** What is the objection to non-controlled manually operated signals?

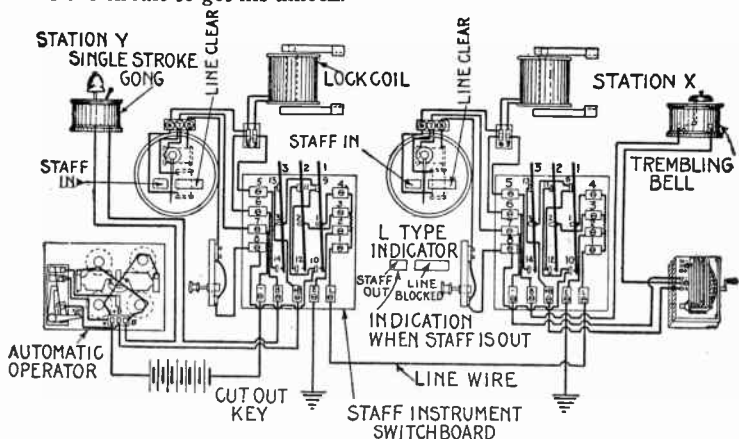
**Ans.** Misunderstandings, and the dangers resulting therefrom.



**Ques.** What provision is made in controlled manually operated signals?

**Ans.** Electric locks are applied to the levers operating the manual signals.

The locks are included in circuits running between block stations, and are so arranged that when an operator wishes to place a signal in the proceed position he has first to ask (by bell signal or otherwise) for an unlock from the next station in the direction of traffic, and cooperate with the operator at that station in the proper manipulation of the circuit to get his unlock.



**FIG. 3,717.**—Wiring diagram of automatic operator system. By using the automatic operator connected as shown, it is possible to operate a staff block without an operator at either station. Twenty dry cells of battery are generally used to furnish current for the operation of each automatic operator. When current is passed through the line the armature is rotated in a direction to cause it to lift the weight on which the normally closed contact is fixed. When current through the line is broken this weight causes the armature to rotate in the opposite direction a sufficient distance to close the other contact and cut in a local battery. Current from this battery passes through a pair of coil holding the armature in this position and releases the staff at opposite ends of the block. When the circuit is again broken, battery is cut off the line.

**Ques.** Describe the staff system.

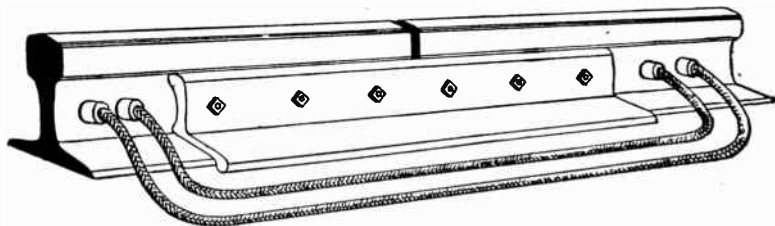
**Ans.** In this system the possession of a small metal cylinder, or "staff" gives the engineer permission to run through a block.

These staffs are normally in one or the other of a pair of instrument call staff instruments, one of a pair being at each end of a block. Only

one staff can be taken from a pair of instrument at a time because of their locking features, controlled by circuits between the instruments, requiring the co-operation of two people, one at each instrument, to abstract a staff. Until this staff is replaced in one or the other instrument, no other staff can be withdrawn.

**Ques.** What provision must be made for tracks used for block signal circuits?

**Ans.** They must be insulated from the ground by fibre, so that the electric current will not dissipate into the ground.



**FIG. 3,718.**—Method of applying bond wires to two butting rail ends. Two wires, which are usually No. 8 B. W. G. galvanized E. B. B. iron, are shunted across the fish plate, connection being made by means of channel pins.

Where rails are joined they must have extra electrical connections, that is, be bonded so as to overcome the open break between the rails.

The block sections of track must be insulated from the rest of the track at these terminals as shown in fig. 3,719.

**Bell and Relay Circuits.**—For the operation of bells or relays, there is the two rail circuit and the single rail circuit. The rail or track circuit is that which is affected by the presence of a train within a block. Where the railroad is equipped for third rail electrical propulsion the single rail system is generally used; when steam engines are employed the double track system is used.

**Railway Signals.**—These consist of colored lights, colored flags or by metal signal banners. Some roads use a green signal for precaution while others use a yellow signal. Red is the danger signal.

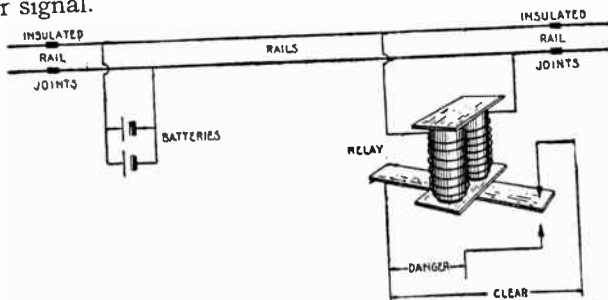


FIG. 3,719.—Insulated rail joint at end of a block section of track. A type used for heavy main line traffic. Insulating fibre is placed between the rail ends and clamped between the rail and the joint plates and insulated bushings are placed around the bolts.

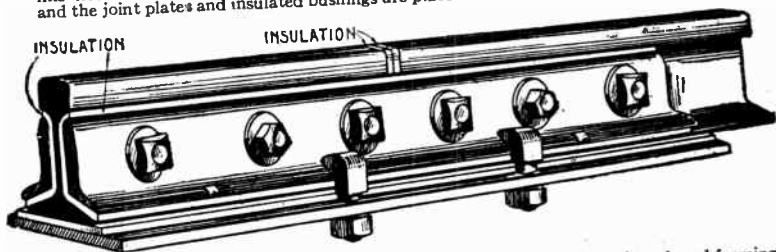


FIG. 3,720.—Simple method of connecting a relay between insulated joints of track and forming a block signal, the circuit being closed by the train as it passes over that section of track.

**Ques.** Name three kinds of signals in general use.

**Ans.** Caution, stop, and proceed signals.

Distant block signals are sometimes used in connection with home block signals to signify the approach of a train.

**Ques.** What kind of signals are used during the day and at night?

**Ans.** Flags or metal signals during the day and lights of various color at night.

Disc signals are displayed by movable shutters or discs in front of a fixed background; semaphore signals, by the position of a movable

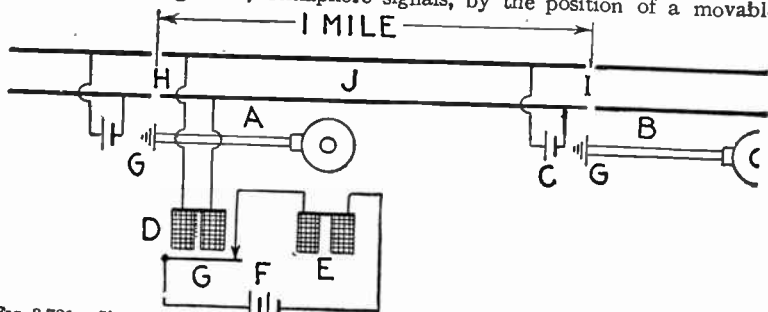
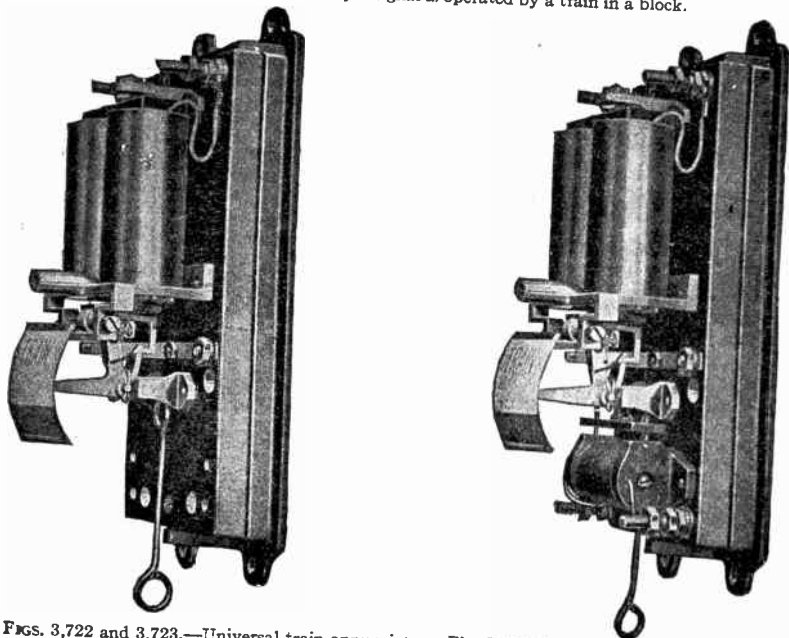
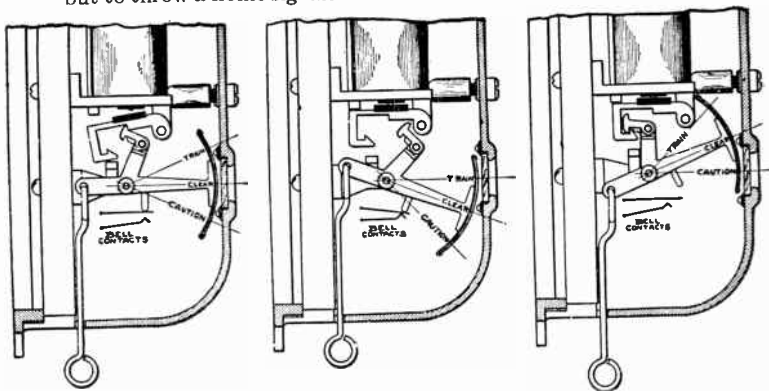


FIG. 3,721.—Simple track circuit whereby a signal is operated by a train in a block.



FIGS. 3,722 and 3,723.—Universal train annunciator. Fig. 3,722 shows annunciator equipped with manual reset, and fig. 3,723, with magnetic reset. The indications displayed by either type are shown in figs. 3,724 to 3,726.

arm in a plane at right angles to the track and mounted on a high pole. The semaphore arms of distant signals have notched ends while the home signals have straight ends. When a home semaphore signal is *up* it means to stop; danger ahead. When a distant semaphore signal is *up* it means to proceed with caution and the next home station signal will indicate if the block be clear. Whether or not a relay be used in the track circuit a bell is generally rung. At distant crossings only the bell is used, but near stations the relay is used to not only ring a bell but to throw a home signal.

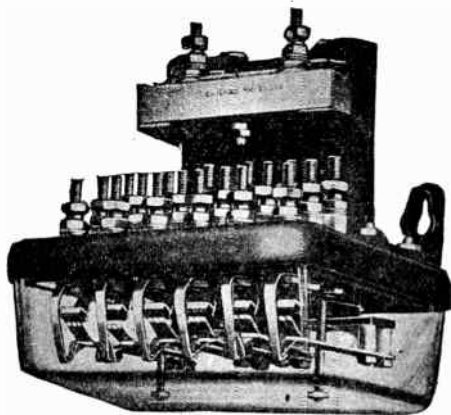


FIGS. 3,724 to 3,726.—Diagrams showing operation of three position universal annunciator. Fig. 3,724, *normal position*: card displaying *clear*, local bell contacts open; fig. 3,725, *train in circuit position*: card showing *train*, local bell contacts closed; fig. 3,726, *restored position*—showing *red color*—this is done while train is on circuit; local bell contacts open. The bell works on open circuit; the spring contacts being closed only when the train is on the track. If it be desired to stop the ringing of this bell and reset the annunciator while the train is still in the block, the lever is pulled down and the indicator shows a red color signal which remains in view until the train has left the block, when it automatically restores to the position showing *clear*, as in fig. 3,726.

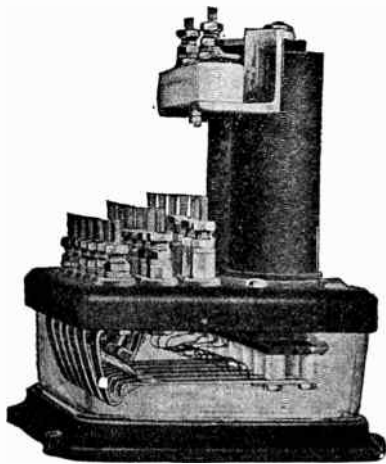
**Relays for Railway Signals.**—There are four kinds of relay used for signaling, these are classed as

1. Polarized;
2. Neutral;
3. Interlocking;
4. Time.

These are shown in the accompanying illustrations. Polarized relays and neutral relays have much the same kind of electromagnets as are used in the construction of crossing bells and are used in the simplest



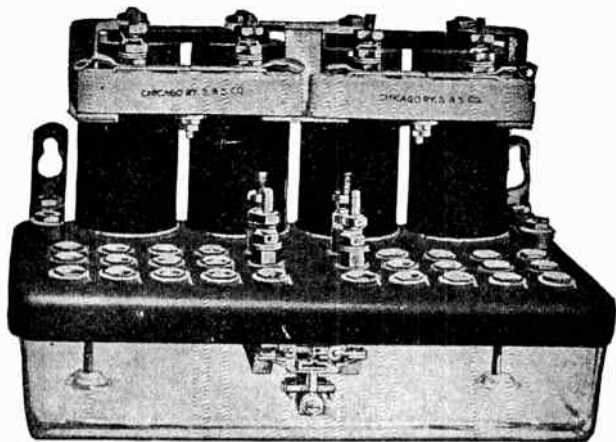
**FIG. 3,727.**—Polarized relay, wall type, with four front and four back neutral contacts and two front and two back polar contacts. The armature of this relay is itself a permanent magnet and swings back and forth to either pole of the electromagnet as the current attracts and repels it or whenever the polarity of the relay magnet changes.



**FIG. 3,728.**—Slow release neutral relay with six front and back contacts. This relay is equipped with extra large magnets having the slow release feature added as sometimes required by polarized wireless rail circuits when it is necessary to prevent the opening of signal circuits during the reversal of current through the polarized track relay. This slow release relay is also used when line wire circuits controlling annunciators or indicators are used with track instruments or short rail sections to prevent the circuit being opened or closed with the passing of each car.

bell circuits. Interlocking relay magnets are similar to double polarized or neutral relay magnets. Time relay magnets consist of a single coil of wire.

**Signal Circuits.**—On electric railways equipped with a trolley or third rail alternating current supply, direct current must be used to operate the signals and the apparatus described will work well on a single rail circuit, but where the road



**FIG. 3,729.**—Glass enclosed interlocking relay; wall type with interlocking contact. Interlocking relays are in reality a combination of two relays in one and are used in connection with two track circuits. The entire operation is actuated by gravity and without springs. Fig. 3,734 shows the interlocking relay connected to the track of an unoccupied block; fig. 3,735 shows the condition of the relay as the train enters it; fig. 3,736 shows the train between the relay connections and fig. 3,737 shows the condition of the relay when the train has passed into a second block

is equipped with a trolley or third rail direct current supply, *alternating current must be used to operate the signals on a single rail circuit.*

The trolley railway is in this case supplied by direct current which is fed by the trolley wire. After passing through the car motors it passes to the grounded rails and thence back to the power house from whence it came.

One part of the track is insulated from the rest of it between the joints in two places, which part represents the terminals of a block.

The other track remains grounded and uninsulated, and to it is attached one end of an alternating current relay winding, the other end being connected to the insulated section. This relay, which is generally known to signalmen as the polyphase relay is connected between the insulated and the uninsulated tracks as is also the secondary winding of an alternating current transformer. The primary coil of this transformer is connected to an alternator. A second smaller transformer has one winding connected across the alternator mains and the other winding connected to the signal circuit.

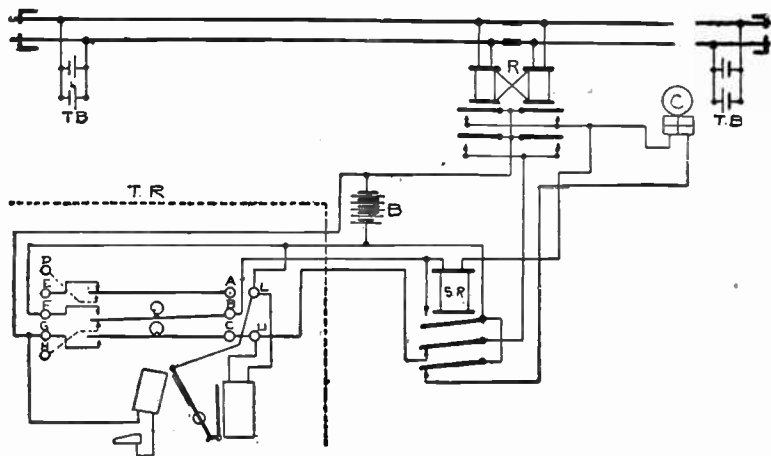


FIG. 3,730.—A crossing bell circuit showing application of Chicago time relay (shown in fig. 3,731). There is a wide variety of application for this type of relay, including wire operating crossing bells, locking and release circuits.

Across the alternating circuit relay winding is shunted, or connected in parallel, a low resistance reactance coil for the purpose of absorbing some of the alternating current. The relay works on closed circuit.

When there is no train in the block the drop in voltage of the direct propulsion current is divided between the two insulated ends of track in proportion to the resistance of the apparatus connected across the track, there being practically no drop of voltage in the block rail. Such is the case also when a train is in the middle of the block. However,



when a train is just entering the block near the relay both rails are at the same pressure at that point because they are connected by the wheels and axles, which cuts out the relay and renders it inoperative, allowing the alternating current to flow full into the danger signal lamp.

The drop in direct current is then at the transformer which is very unfavorable for the operation of the transformer, which then receives the maximum direct current from the track while delivering alternating current to work the relay.

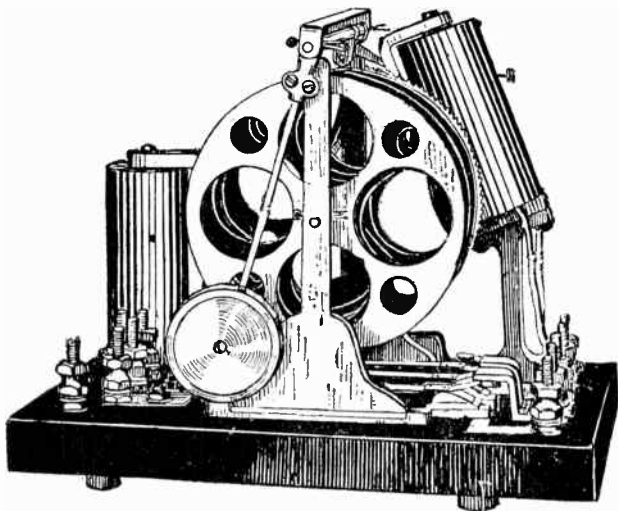


FIG. 3,731.—Rear view of Chicago time relay. A time relay is used when electrically controlled time signals are required, such as line wire operated crossing bells. When current is sent into the high resistance of the releasing magnet the armature is attracted, which allows the pendulum to swing toward the other magnet of the relay. Then it is automatically pushed back again and so is kept oscillating back and forth like the pendulum of an electrically operated clock. This may continue for a minute or a minute and a half, according to how the mechanism is set.

When the train is at the other end of the block and about to leave it, the transformer receives no direct current and can deliver a maximum of alternating current and at the same time the relay receives direct current and is properly rendered inoperative but the danger signal lamp glows bright.

This single rail alternating current signal circuit is used with marked success in the New York subway.

The automatic block signals, the automatic train stops and the interlocking switches there are of the electro-pneumatic type.

The track block relays control circuits which in turn control magnetically operated pin valves governing the admission of air to the cylinders which actuate the signals and train stops.

It is possible to use the *double rail* return system for signaling where the railroad uses direct current for propulsion and alternating current for signal operation, by the use of balanced inductive bonds connected across the rail insulations at the ends of the blocks. This double rail circuit is a feature of the signaling operation of the New York, New Haven and Hartford Railroad.

In the New York subway tunnel, home signals consist of a series of regulated lights whose source of electrical supply is governed by the action of the track circuit.

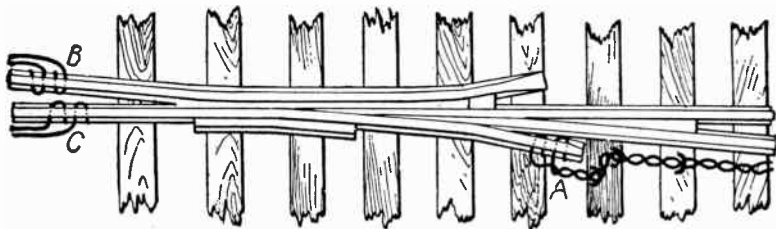


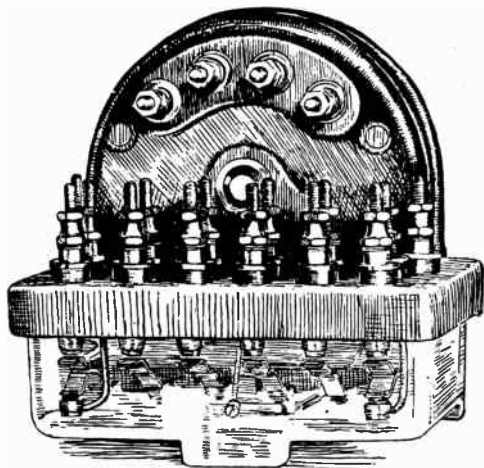
FIG. 3,732.—A method of frog bonding. There are many good foremen in charge of construction forces bonding frogs, but there are no two who have the same ideas as to the best method. It is the custom to put the holes in the rail where it is most convenient and to put the channel pins on the side on which the bond wire is put through the hole. This is done because it is impossible to drive in the pin securely where the rail leads are close together. The man driving the pins often bends the wire away from the pin so as not to strike it. To get around this method drill 4 instead of 2 holes and put the bond wire through the hole and then bend back with a loop, and bond from the outside; this does away with all chances of striking the bond wire. In the majority of cases copper clad wire is used to bond in frogs, which is not difficult to bend, as shown. In bonding around the frog it is advisable to twist the wires and staples about 6 inches from the rail. This leaves the wire so the section man does not interfere with it when he draws spikes. At the points A, B, and C it would be difficult to drive the pins if not put in as described above.

The home relay control circuit is fed from a secondary track relay circuit ahead, to and through a secondary track relay circuit at the place where it energizes the home relay.

A train passing into the block governed by this signal causes the track closed circuit to open and the home danger signal to show.

The distant signal circuits are so arranged that when the distant relay is energized a circuit is completed to the home relay which throws a caution signal.

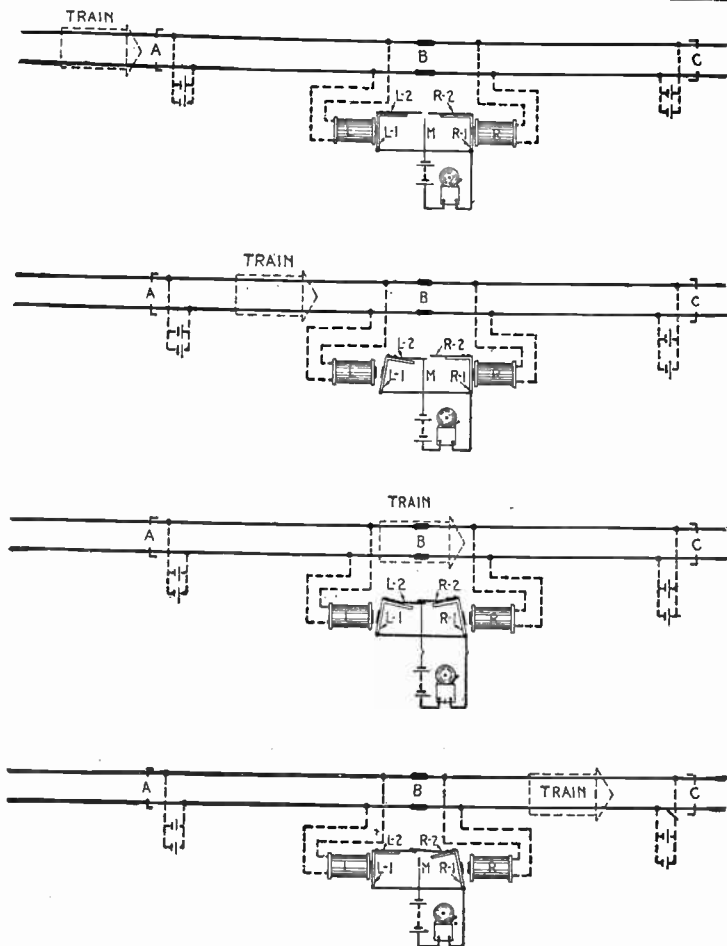
**Electric Interlocking.**—When a switch lever in a tower is manually moved from normal to reverse, the locking between it and the signal lever controlling the governing movements of the signal over the switch reversed is instantly released, but when electric power is used for operating the switches, the movement of the lever merely turns on the power and it is not safe to assume that the switch follows the movement of the lever because the circuit may be open at any place. For this



**FIG. 3,733.**—Interlocking relay for alternating current. The contact springs are glass enclosed. Each armature may be equipped with as many as three extra front and back contacts in addition to interlocking contacts, of which there may be as many as four. It is an improved type of polyphase relay.

reason the lever movement is divided into two parts: 1, the movement which causes the closing of the operating circuit, and 2, the movement which causes the interlocking of other levers.

The first important step toward the development of a practical system of electric interlocking was when a means was discovered for making use of a current of electricity which could be generated by the switch operating motor itself.



Figs. 3,734 to 3,737.—Diagrammatic sketches illustrating the interlocking feature of universal crossing bell relay. Fig. 3,734 track circuit A B and B C unoccupied, bell circuit open; fig. 3,735 train has entered track circuit. A B relay magnet L. De-energized armature L-1 causes contact finger L-2 to make contact with M bell circuit closed; fig. 3,736, train in track circuit A B and B C (at crossing) relay magnet R de-energized contact finger R-2 resting on L-2 bell circuit closed; fig. 3,737, train in track circuit B C relay magnet L energized contact finger R-2 resting on L-2 bell circuit open. When train passes out of track circuit B C all parts normal as in fig. 3,734, operation similar in either direction.

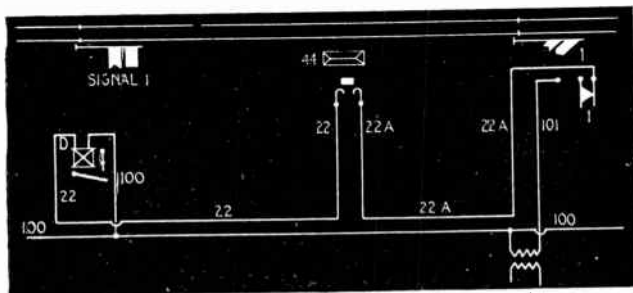


FIG. 3,738.—Advanced block distant signal. *In operation* when the towerman pulls a lever numbered the same as the distant signal he desires to operate, he completes a circuit between the two springs which causes the distant signal blade to clear.

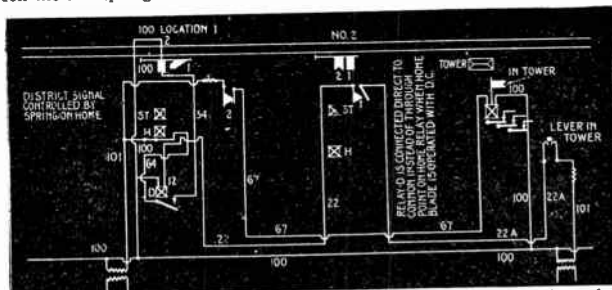


FIG. 3,739.—Distant signal and repeater circuit. Here, through a lever connection, when the lever is pulled out in the tower, current is allowed to flow to and complete a circuit through a contact spring operated by the signal mechanism. As soon as the distant blade clears, according to this circuit, a repeater located in the tower is de-energized and drops its armature, which shows the position of the blade whose action governs its source of energy.

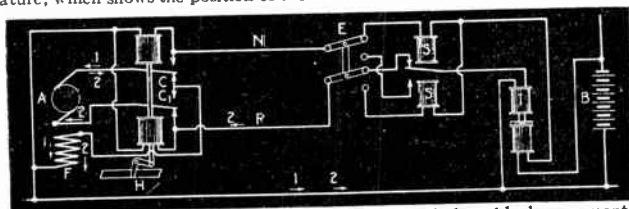
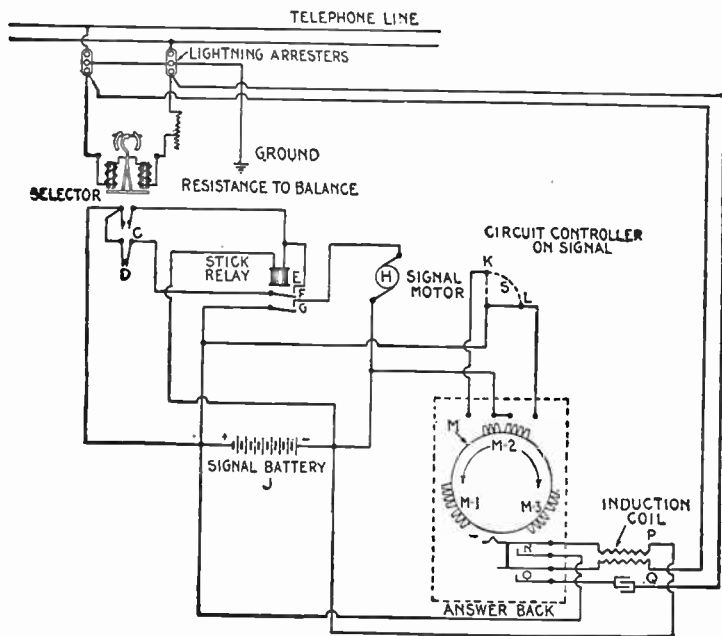


FIG. 3,740.—Diagram illustrating electric interlocking. A switch and lock movement is driven by a direct current motor, the shaft of which is connected by a magnetic clutch to an extension working a cam drum which operates the switch and lock. When the drum is revolved by the motor, first the lock rod and then the switch move in proper operation. After the switch has been moved against the stock rail it is automatically locked and a knife switch throws open the control circuits and closes the indication circuit. The direction of rotation for reversing the switch is controlled by a double field winding in the motor, one part of which is cut out while the other is in circuit.

**Blocks.**—The length of block sections of any railroad will vary anywhere from one to two miles. To secure a maximum capacity for train movements the maximum distance required for the stopping of any train on the road should first be decided. There are various conditions to be considered in fixing the length of block.



**FIG. 3,741.**—Train dispatcher's selector system. *This is used to indicate to the train engineer whether he is to proceed on the main line or to take a side track. The indication may be in the form of a disc, a light, a semaphore, or any prescribed signal. When the indicator signal is turned from the normal to the reverse position a special "answer back" device is also operated, which makes an audible noise and informs the dispatcher that the signal has operated properly. This device is controlled by a commutator operating on the signal mechanism in connection with an induction coil. To display a "take siding" signal the dispatcher turns a switch or depresses a key which operates the selector by closing the normally open contacts marked C. The "stick relay" throws signal battery current into a motor which operates the signal. To restore the signal to normal position the dispatcher operates the selector in the reverse direction, which opens the contacts marked C. This causes the "stick relay" to restore to normal position and throws a reverse signal back to the dispatcher. This system is semi-automatic.*

### Ques. What road conditions require long blocks?

Ans. Blocks should be longer on a descending grade than on an up grade because it is more difficult to stop a train on a descending grade.

Another feature involved is the curvature of the road or obstructions to view, such as bridges. In every case the block represents the space between home signals, the distant signals acting only as repeaters for the home signals and indicated by notched semaphores.

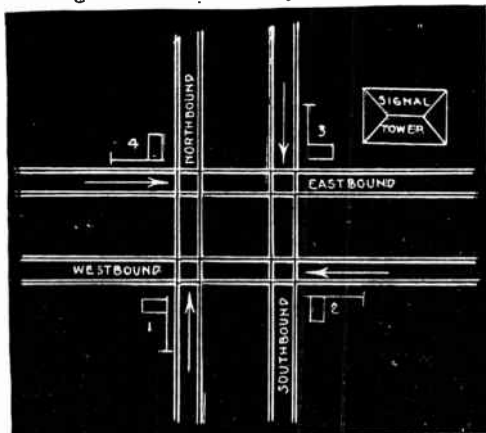


FIG. 3,742.—Intersection of two double track lines, with their respective signals. If these be automatic track relays properly interconnected, they can be readily arranged to give the protection desired. If they be semi-automatic, electric interlocking will be introduced to prevent conflict of routes. Thus, when signal 3 is at clear, to allow a south bound train to pass, 2, and 4, must be locked in the normal or stop position when electric locking or interlocking is used and prevented moving to clear if the ordinary automatic system be employed.

**Management.**—This relates, not only to the necessary conditions of operation and control, but also to the numerous disorders and mishaps likely to be encountered. The motor-man or repair man who possesses a thorough knowledge of the construction and working principles of all the car mechanism is well equipped to cope with the ordinary faults arising in operation, especially when some practical experience is coupled with the theoretical knowledge.

On many large roads the motormen are expected to do nothing beyond operating their cars and whenever trouble occurs to a car on the road it is pushed in by the next car and the repair men at the barn make the necessary repairs.

There are, however, many small roads where a knowledge of how to remedy trouble is needed, and even on the large roads, the man who understands his car can save many delays if he know how to intelligently report troubles.

In enumerating many of the troubles to which cars and motors are subject, the reader should not think that, without practical experience, by simply reading these lines, he can manage a car as well as a man

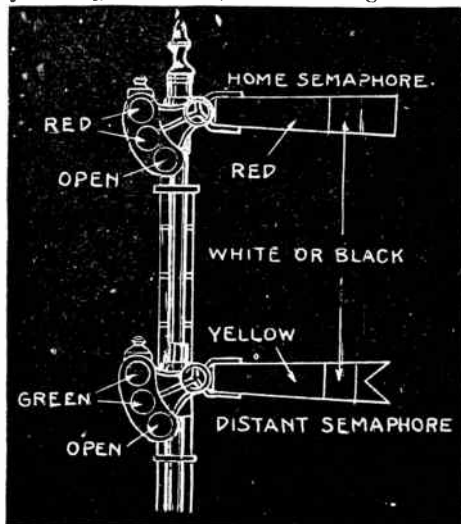


FIG. 3,743.—Standard home and distant semaphore signals. In operation, until either blade has reached a position approximately 30 degrees from the vertical it will indicate the same as though at the full horizontal position. This is effected by using several spectacles, each held in place by independent bezel rings, semaphores vary in length from 4 to 5 feet, about 4½ being regarded as standard.

who has been operating one for years. Practical experience is absolutely necessary, but in connection with it the information here given will be very helpful to the motorman.

A great deal must be learned by actual experience, and success in economical operation on a car line depends partly on the watchfulness of the motorman. While operating his controller he can readily detect irregularities, first, by the way the motors take the current when the controller is operated, and secondly when the car is under way, by the sound of the motors.



The economy which can thus be accomplished lies in the fact that loose bolts, a loose connection and the like are easily tightened. These are small troubles, caused by constant jarring of the car, which are easily attended to. However, if the car be not watched, bolts will be lost, bearings will come loose, the armature revolving at a high rate of speed may be rubbing against the field magnet poles, or a wire working out of its connection may cause a short circuit and blow the fuse, etc. It will be readily seen that these small troubles, if not attended to in time, are the causes of others far more serious, yet a turn of the wrench or the screwdriver in proper time may easily prevent such troubles on the road.

**Trolley Car Operation.**—To start the car, see that the brakes are off, the canopy switches closed; then move the controller handle to the first notch. After the car is well started, move to the second notch, and after a short time to the third, and so on to the last. Don't stop the handle between notches, and don't move it too slowly. On the other hand, do not move too rapidly from the first notch to the second.

Always wait for the car to get up to the speed corresponding to the notch the controller handle is on before going to the next notch, otherwise more current will be used than is necessary.

In shutting off the current the handle may be moved around as rapidly as desired to "off" from whatever position it may happen to be on. When stopping at any point, the reverse lever is sometimes used to make the car go backwards. Never reverse while the car is running, unless to avoid an accident. But if it be absolutely necessary to stop the car quickly, pull the brake on with the right hand and shut off the current with the left at the same time; then with the right hand free, throw the reverse lever and turn on a very little current.

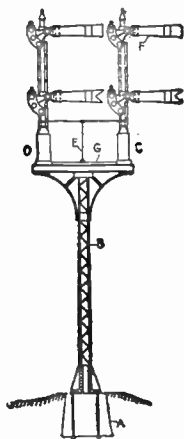
If too much current be turned on, the wheels will lose their adhesion to the rails and spin backwards, which will increase the minimum distance in which the car may be possibly stopped.

Sometimes a very violent stop must be made, when the brakes fail, possibly, or the trolley comes off, in which case reverse and put the

controller handle on the highest point of the controller. This causes an interaction between the motors which brings them to a standstill. It may damage the apparatus, however, and should only be used in rare emergencies; this method is only available when there are two motors on the car.

When approaching curves or turnouts the power should be turned off, applying such power upon reaching the curves as may be necessary to carry the car easily around.

The conductor should be on the rear platform with the trolley rope in his hand, ready to give the signal in case the trolley jumps the wire,



**FIG. 3,744.**—Three spectacle automatic double route home and distant semaphore signal. The post B consists of two lengths of channel iron strengthened by a lattice structure, the base being bolted to, or incorporated with a foundation of concrete, A. The top consists of a platform G, railing E, semaphores F, being pivoted to short posts and operated by motors and accessories housed in watertight base boxes C D. This arrangement protects two tracks having trains running in the same direction.

in which case the motorman should move the controller handle to "off" until he is notified to go ahead. The motorman should never stop on curves unless absolutely necessary.

In running down grades, always have the trolley on the wire, the controller handle at "off," and the brake arranged so that it can be applied instantly.

Before going down a steep grade slow up the car, and set the brakes gradually. If the wheels slide, loosen the brakes to allow them to get hold of the track; then apply the brakes again. If the brakes then fail, reverse the motors. If, in the meantime, the trolley leave the wire, so that there be no power, reverse and throw the controller handle to the last notch, which will make the car come to a standstill.

In running up heavy grades, get the car up to speed, if possible, before reaching the grade so that it will not require so much current to climb up.

If the car be started while on a heavy grade, it will require a very large amount of current. Whether to climb these grades in series or parallel positions is a question on which instructions are given in each individual case. If the wheels slip on the rails, the sand box can often be used to advantage; but always be sure, especially in wet weather, that the sand is dry. Do not use the sand too freely, as you may run short just when it is needed most.

If the power give out, notice if the other cars experience the same trouble, as it may be due to an open circuit on the line; if so, throw the controller handle to "off," close the lamp circuit and wait until the lamps light up.

If, when the lamps light up, the equipment will not move the controller handle on the first point, the motorman should first look to see whether his fuse has blown or burned out; if so, open the head switch, or tie down the trolley pole and replace the fuse.

If the fuse be not blown, the rails may be dirty and the car insulated from the rails.

In this case have the conductor jam the switch bar between the wheel and rail, while the motorman starts the car.

In rare instances there is a case of dead rail.

A length of wire should be kept in the car where possible, and one end placed on the rail back of the car toward the power station, and one on any exposed part of the iron truck. Always place the end on the rail first, otherwise a shock will be received.

In case, as the car goes along, a peculiar jumping action occur, known as the bucking of motors, the motor affected should be cut out by means of the motor switches in the controller.

Instructions are given the motorman how the motors are cut out on each different type of controller. For remedies for more troublesome accidents see below.

After bringing the car into the car house have the controller at "off," take off the controller handles, pull down the trolley and tie it a few inches below the trolley wire.

**Points Relating to Controller Operation.**—The question of the proper handling of the controller is one in which grades, the weight of equipment, motors and controller, all enter. It is the usual practice to instruct motormen to handle their controller so as to get the equipment up to full speed in a certain time; but they should be fully instructed to realize the difference between the time when they are operating near the power station, or at the end of the line, where the voltage drop is greater. In this case the acceleration is slower, and to turn the controller on too fast will increase the drop on the line and decrease the acceleration of the motor.

In climbing grades the question arises whether the motors should be in parallel or in series. This depends largely on the location of the car with respect to the voltage delivery to the trolley at this point. If the voltage drop be considerable with the motors in parallel, the series position will be found more economical, and the available energy for the equipment greater. It has been proven beyond a doubt that the proper handling of the controller will save as much as 20 per cent. in the coal bill. The curves (Fig. 3,745) show some data obtained from the Chicago Street Railway, illustrating the difference in power consumption between a rapid start and a slow start.

**Failure to Start Car.**—If the car fail to start when the controller is “on” and both overhead switches are closed, the trouble is due to an open circuit, and probably to one of the following causes:

1. The fuse may have blown or melted. Open an overhead switch or pull off the trolley and put in a new fuse, removing the burned ends from under the binding posts before doing so. Never put in a heavier fuse than that specified by the company, as it might result in damage

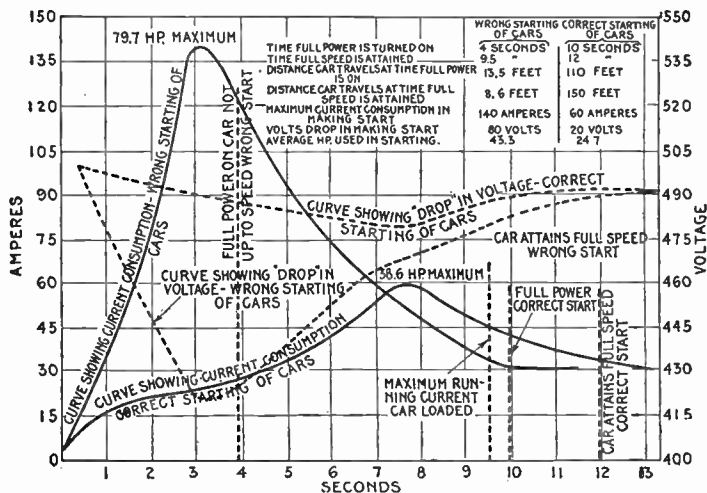
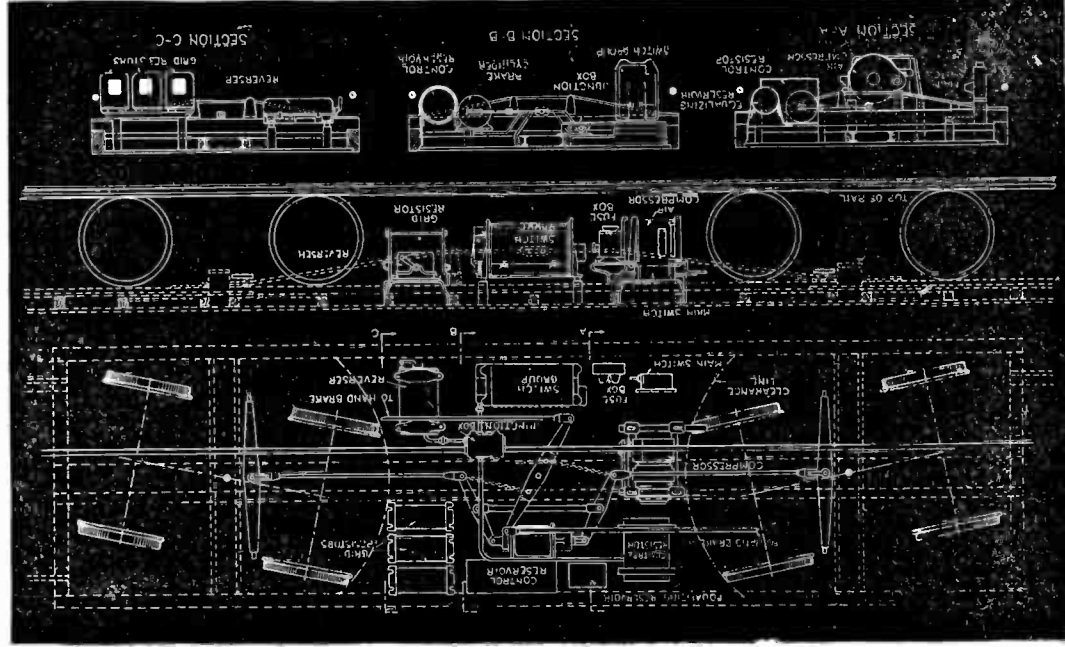


FIG. 3,745.—Curves showing advantage of using controller correctly.

to the equipment by allowing too large a current to flow. The fuse may blow because of some trouble on the car, as will be explained a little further on.

2. On a dry summer day, when there is much fine dust on the track, it happens that the car wheels do not make proper contact with the rail and the car fails to start. In such a case try to establish contact by rocking the car body. Should this fail to work, the conductor should take the switch bar or a piece of wire and, holding one end firmly on a clean place on the rail, hold the other against the wheel or truck. This will make temporary connection until the car has started. The conductor should be sure to make his rail contact first and keep it firm during this operation or he may receive a shock.



Figs. 3,746 to 3,750.—Westinghouse multi-unit system; diagram showing placement of apparatus under car.

3. If the track conditions be apparently good, it may be that the car stands on a piece of dead rail, a piece of rail on which the bonding has been destroyed. In that case the car conductor would have to go to the next rail section with a piece of wire to connect the two rails and then order the motorman to start his car.

4. A brush or two may not have been placed, or, if placed, may fit too tightly in the brush holder, so that the springs do not establish contact between the brush and the commutator. If this be the case, remove the brushes and sandpaper them until they go into the brush holder easily.

5. The contact fingers on a controller are rough, burnt, and perhaps bent so that the drum cannot make contact. It may also be due to wear on both the contact surfaces of the drum and the finger, which may have been burnt and worn away to such an extent that contact is not established when the controller handle is placed in the first notch. Try to smooth the burnt surface with sandpaper and bend the fingers or contact into their proper position. Should this fail, then operate the car with the other controller. In this case the conductor should be on the front platform to handle the brake and give orders to the motorman when to start and stop, as the occasion requires. Under these conditions the car should never be allowed to travel at a high speed.

6. A loose or broken cable connection. This can be located and placed and fastened in its position. It is, in most instances, a cable connected to one of the motors, rheostat or lightning arrester, and very seldom in the controller stand.

7. A burnt rheostat. A rheostat may have received too great a current for some time and the first contact terminal may be broken. In such a case, if temporary connection cannot conveniently be established, the car will not start at the first notch, but at the second it will start with a jerk.

8. If the car refuse to start on the first contact, but start all right on the second and acts normal thereafter, then there is an open circuit in the rheostat, either internally, or the first cable connection is broken.

**Abnormal Starting.**—Sometimes a car will start with a jerk, but afterwards run smooth and normal. This indicates a short circuit in the rheostat. Examine the rheostat terminals, as the trouble may be due to the crossing of the cables or a loose cable touching another terminal of the rheostat; do not touch it but run car back to barn.

**Ques.** What causes a motor to increase speed beyond normal?

Ans. This may be due to a short circuited or burned out field magnet coil.

The motor should be cut out.

**Ques.** What causes a car to start with a jerk and the gears to make considerable noise?

Ans. This may be due to worn pinion teeth, or worn bearing permitting loose meshing of teeth, or the key seat on the armature shaft may have become wider by the constant wear of a loose key.

**Ques.** What should be done if the motors start with a jerk or do not run smoothly?

Ans. The conductor should lift one of the trap doors at a time, while the car is running to examine the commutator and brushes of each motor.

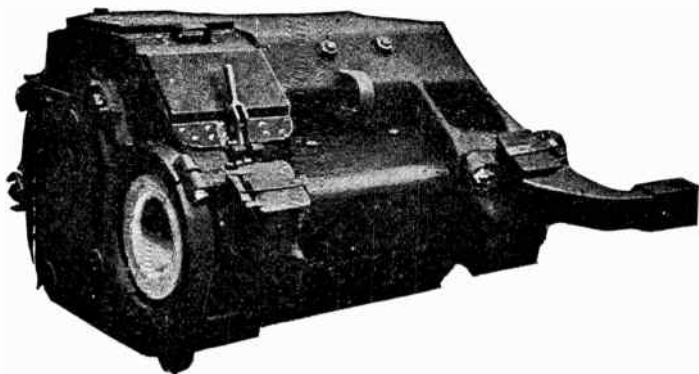
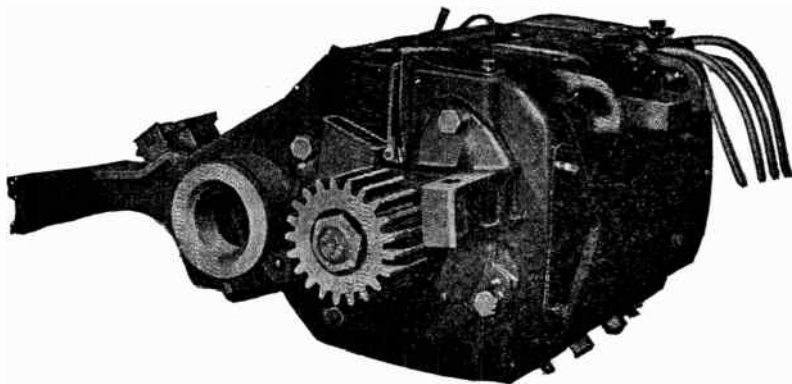
Should there be seen a flash all around the commutator or connecting two brushes, there is an open circuit in the armature. Cut out the motor.

**Faulty Operation.**—Heavy flashing and smoking in the controller is due to dirt, moisture, metal dust in the controller, or the too slow turning off of the controller. Open the overhead switch and blow out the dust from the ring terminals, also remove all dust at the lower ends of the controller and see that it is dry.

Should the lamps not light upon turning the lamp switch examine lamp circuit fuse.

If fuse be not blown, either a lamp is not screwed up or one is burned out. In either case none will burn because they are connected in series.





FIGS. 3,751 and 3,752.—Westinghouse interpole motor as used on Piedmont railway. Fig. 3,751 pinion end of motor; fig. 3,752 commutator end. The motor is rated at 110 horse power at 750 volts. Two motors are connected in series for 1,500 volt operation. These motors are geared to 36 inch wheels with a 20 tooth pinion and 57 tooth gear. The cars, weighing complete without load, approximately 41 tons, are operated at a schedule speed of 34 miles per hour. The weight of the motor complete is 4,150 pounds. The armature is especially designed to withstand the higher voltage, being insulated with mica, and having liberal creepage distances provided at the end of the commutator. The brush holders have extra heavy porcelain insulators. The length of the dust ring at the end of the commutator, and the clearances from the line parts of the motor to the ground are greater than in ordinary designs.

**Motor Troubles.**—A few motor troubles often met with are given here: for a full treatment of the subject in general, see Guide No. 3.

A sharp rattling noise when the car is traveling at high speed is the consequence of an uneven commutator.

A commutator that is flat in places, or a few bars that have become loose and project slightly, cause the brushes to be quickly forced away from the commutator by the high bars, and to be forced back onto the lower ones by the brush holder spring as soon as a high bar has passed. This causes heavy sparking at the brushes and excessive heating of the commutator segments, besides the rapid wearing down of the brushes. The rapid succession of these changes causes the noise, and this can be remedied only in the repair shop. It should be reported.

A dull thumping noise, also connected with sparking at the brushes, may be due to the armature striking or rubbing against the pole pieces. If this be due to loose bearings the cap bolts should be tightened, but if, on account of worn out boxes, the car should be taken to the barn at a reduced speed.

Abnormal heating of one of the motor armatures may be due to its striking the field poles when rotating.

Heating of the motor may also be due to a defective brake, caused by weak release springs or too short a brake chain.

Again, heating may be due to the oil or grease used which does not melt properly, if at all.

A full grease or oil cup is no sign of proper lubrication.

If it be found that bearings heat, in spite of full grease cups, take a clean stick, make a hole through the grease down to the shaft, pour in soft oil and go ahead.

It may be well occasionally to feel the car axle bearings, which get pretty warm when insufficiently supplied with oil.

**Before Starting a Train.**—When the train is turned over to the motorman he should:

1. Pass along the outside and carefully examine the bus line and cable jumpers between cars, to assure himself that all connections are properly made and that the main switches are closed;

2. Pass through the train, closing air compressor and third rail

switches in each car, and opening master control switches in all cars except head car or car from which train is to be operated;

3. Pass along outside the train again and satisfy himself that the air compressors are working properly;

4. Take position in the motorman's compartment at forward end of train and note the brake pipe pressure, and close master controller switch;

5. Set circuit breakers by moving the circuit breaker switch over the master controller to the on position, holding it there about one second to allow time for all circuit breakers to set;

6. Test the air brakes, and if same work satisfactorily, the train is ready to start.

**Starting a Train with Master Control.**—After receiving the signal to start, press down the button in the controller handle, insert the handle key and give it a quarter turn.

**Ques. Why should the button in the controller handle be held down?**

Ans. To prevent the pilot valve in the controller operating and applying the brakes.

**Ques. What next should be done?**

Ans. Move the controller handle to the left as far as it will go, holding it there against the spring, which tends to return it to the "off" position.

The motor control will then notch up to full speed position by the automatic progression of the contactors in successive steps, under the control of the current limit relay. In this position it is not necessary to hold the button down to prevent application of the brakes.

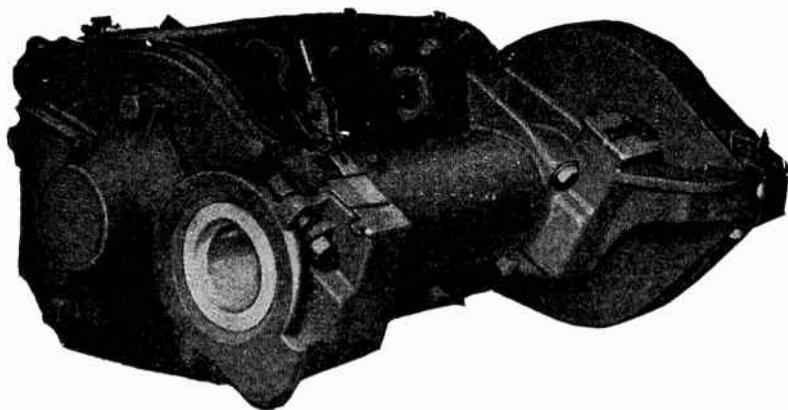
**To Start Slowly.**—Move controller handle to the left to first point. In this position both motors on each car are

connected in series with all resistance in circuit and the motor control will not notch up to higher speed.

**Ques.** How is the speed increased slightly?

**Ans.** By moving the controller handle to the second point and quickly returning it to the first point.

**Ques.** What will happen if the controller handle be left in second point?



**FIG. 3,753.**—Westinghouse interpole 750 volt railway motor, showing axle caps and axle dust guard in place. This is another view of the motor used on the Piedmont locomotives as shown in figs. 3,751 and 3,752.

**Ans.** All resistance will be progressively cut out giving full series or half speed.

**Ques.** What are the running positions?

**Ans.** The second and fourth notches.

The train should not be operated for more than a few minutes at a time on the other or intermediate notches.

**Reversing.**—When the train has come to a stop it may be reversed by moving the controller handle to the right to the first point. This connects the motors in reverse direction in series with all resistance in circuit.

**Ques. How fast can the train be run in reverse direction?**

Ans. Up to half speed.

**Ques. How can higher speed be obtained in reverse direction?**

Ans. By operating the master controller at the other end of the train.

This, of course, strictly speaking, is not reverse operation, but forward operation, considering the rear car as the front end of the train.

**Train Fails to Start.**—If, when all the connections are made and the controlling handle operated properly, the train do not start, the fault may be due to various causes, as

1. Failure of power;
2. Fault in master control circuit;
3. Fault in motor control circuit;
4. Non-release of air brakes.

**Ques. How may a failure of power be detected?**

Ans. By turning on the lights; if lights do not burn, the current is off.

**Ques. Name some faults liable to occur in the master control circuit.**

Ans. Loose cable jumper; grounded train cable; poor contact in master controller; master control fuse blown.

**Ques. How is a loose cable jumper detected?**

Ans. By noting if the contactors on each car be working while the train is accelerating.

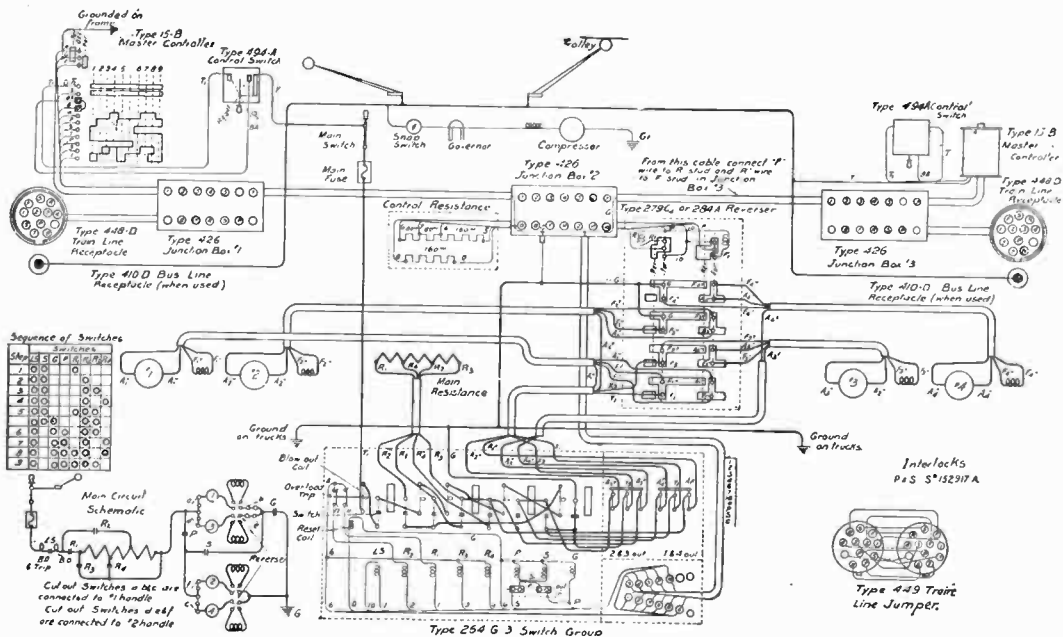


FIG. 3,754.—Complete wiring diagram of Westinghouse type HL control for four 50 horse power 500 volt motors.

The trainmen should make the observations. If there be a loose cable jumper, all cars ahead of the jumper will operate.

### Ques. How is a grounded cable detected?

Ans. By operating the master controller; if the master controller fuse blow, it indicates that one or more wires of the train cable are grounded.

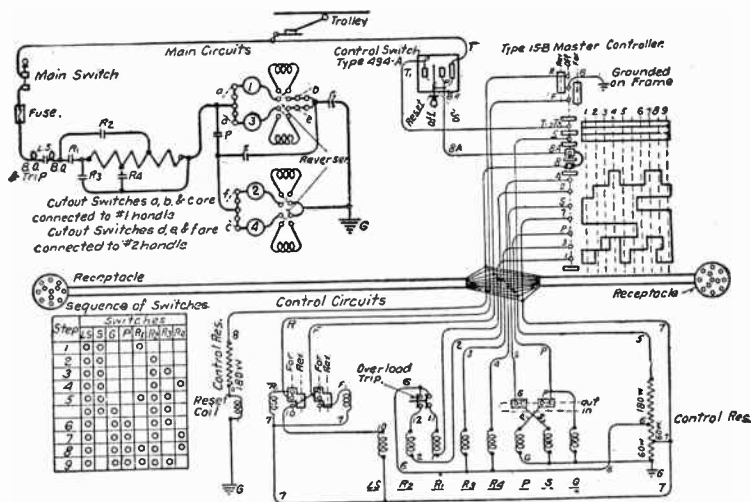


FIG. 3,755.—Schematic diagram of connections type HL control for four 75 horse power 500 volt motors.

### Ques. How is a ground in the train cable located?

Ans. Disconnect train cable on operating car from rest of train by removing train cable jumper from its socket on second car. If the fuse now blow, when the controller handle is operated, it indicates that the ground is either in the operating car or its train cable jumper.

To determine which be grounded, remove jumper, if fuse blow when the controller handle is operated, the ground is in the car; if it do not blow, the ground is in the jumper.

**Ques. How is poor contact in the master controller detected?**

Ans. Open master controller switch, remove cover from the controller and turn the handle slowly, noting if each finger make good contact with the drive.

**Ques. What indicates a blown master controller fuse?**

Ans. If, in turning the master controller handle to the first notch and thus opening the master controller switch, no arcing occur, the fuse is blown or is imperfect.

**Ques. Name some faults liable to occur in the motor control circuit.**

Ans. Main fuse blown; shoe or trolley fuses blown; bus fuses blown; loose or disconnected bus jumper; circuit breakers open.

**The blowing of the main fuses** should not occur often. It is caused by short circuit or grounding in the motor circuit. Before renewing main fuse open the main switch.

The grounding or short circuiting of the wiring on a car or truck may cause **the trolley fuse to blow**. The trolley or trolleys should be pulled down and trolley switch opened before replacing trolley fuse.

A **shoe fuse** may blow for short circuit, grounding of the car wiring on some part of the car or truck, or may be caused by a contact shoe on the car or train grounding. In replacing fuse, first open the third rail switch and insert the wooden paddles, provided for that purpose between all shoes on that car that are in contact with the third rail.

A **loose or disconnected bus jumper** may be detected when the train is at a crossover and current cannot be obtained on operating cars, although other cars of the train have current, thus indicating **blown fuse or fuses, or that a bus line jumper is loose or disconnected between the operating and adjacent cars.**



**Electric Ship Propulsion.**—Although the steam turbine is extensively used for propelling vessels of various kind it is subject to certain limitations which detract from its value, especially for heavy marine work such as battleships.

For instance, while the turbine operates at its highest efficiency when driven at a very high rate of speed, the screw propeller of the ship attains its maximum efficiency when turning at a speed relatively very low—about 160 revolutions per minute. This means the introduction of gearing or some other mechanism to reduce the speed of the turbine to that best adapted to the propeller.

Furthermore since the turbine runs inherently in one direction only, means must be provided for reversing the propeller, either by providing a reverse gear, or by installing on the turbine shaft an extra set of vane for backing. The latter method is the one generally used, although the backing turbine is driven idle by the ahead turbine, thus increasing the cost weight and space of the unit while decreasing its mechanical efficiency.

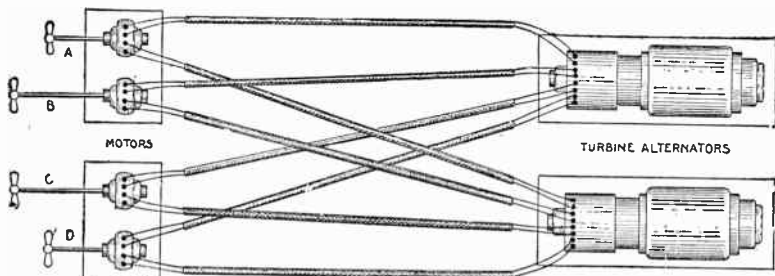
Flexibility of control in both backward and forward movements is of the highest importance in the fighting ship and for this reason the builders have been forced to employ a driving mechanism embodying every possible feature of advantage regardless of the cost of installation and subsequent operation.

Another essential in the propulsion of a battleship is that it shall be capable of cruising day in and day out at about three quarter speed and at the same time be able to make a sudden, though perhaps long continued spurt at its maximum speed.

The turbine is essentially a one speed machine and its ideal operating speed is a high one. In order, therefore, that it be made capable of attaining the higher speed, it must be operated for the greater part of the time (while cruising) at comparatively low efficiency.

The object of the electric drive is to overcome the inherent defects or limitations of the turbine, that is to say, its function is similar to the so called "transmission" of an automobile in that it gives flexibility of control and permits the turbine to run at its most economical speed.

Various combinations of machinery for electric propulsion have been worked out, being suggested by plans and principles of proved appropriateness which have been employed in electric power plants on land. These various systems have been proposed by Emmet, Mavor, Durtnall, Hobart, Day, and others. The problem has been to so combine generating units with



**FIG. 3,756**—Elementary diagram illustrating the essentials of electric ship propulsion. Two turbine alternator units are shown on the right which are wired for various connections with the motors; the latter operate the propellers A, B, C, and D.

motors that the maximum efficiency of the turbine could be obtained under all working conditions of the vessel, as in maneuvering, cruising at low or moderate speed, and when being driven at high speed.

An examination of the simple diagram, fig. 3,756, will serve to make clear the plan of the driving mechanism. The generating plant is composed of two independent turbine alternators, each of which is capable of delivering one-half of the total power necessary to run the ship at maximum speed. The driving motors are of the three phase variety and each motor

is equipped with two sets of pole piece—one of twenty-four poles and the other of thirty-six. By operating the motors on one or the other set of pole, the speed is changed without impairing the efficiency in any way. The plan of operation is to drive the motors at the lower speed for cruising with only one turbine alternator in operation, while for the greater speed the two alternators would be operated in tandem with the motors arranged to run at their maximum speed. Thus it will be seen that when cruising, the one alternator is running at its full efficiency as are also the motors, while the second alternator

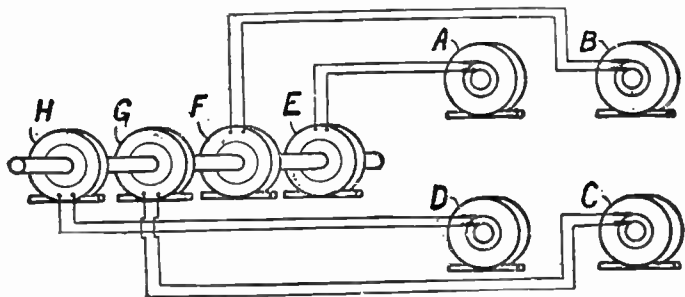


FIG. 3,757.—Hobart's alter-cycle control of induction motors for electric ship propulsion. There are four motors E, F, G and H, wound respectively for 24, 36, 48, and 72 poles. The maximum speed of the propeller shaft is 100 r.p.m. with full power of all the motors. To run the motors at 100 r.p.m. requires frequencies of 20 cycles for the 24 pole motor, 30, for the 36 pole motor, 40, for the 48 pole motor, and 60 for the 72 pole motor. Thus to obtain equal r.p.m. the frequencies of the four alternators A, B, C, D are respectively made 20, 30, 40, and 60. To obtain these frequencies when the alternators are down say to 600 r.p.m. requires respectively 4, 6, 8, and 12 poles for the alternators A, B, C, and D. To drive the ship at two thirds speed, motors F and H are connected to alternators A and C, which provide respectively  $\frac{2}{3}$  of the frequencies of B and D, to which F and H were connected for full speed running. Since for the lower speed only about  $\frac{2}{3}$  as much power is required as for top speed, alternators B and D, and motor E and G are shut down. For half speed a single motor is sufficient; this can be provided by operating motor H from alternator B, or G from A. One third speed is obtained by operating H from A.

is idle. Likewise, when full speed is required, the second alternator is started and run also at its peak of efficiency.

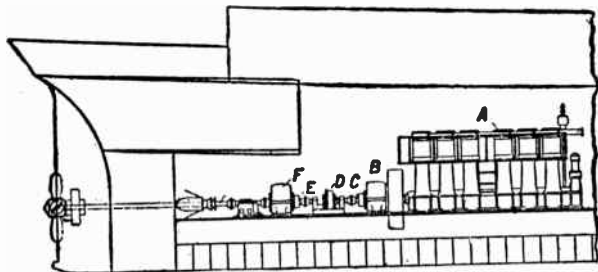
The following description of the machinery for electric propulsion in the new battleship *California* will illustrate more in detail the features of electric propulsion:

The outfit consists essentially of a port and a starboard unit, each consisting of a turbine driven, two pole, quarter phase alternator and two double squirrel cage induction motors. Direct current field excitation, at 230 volts, for the alternator, is supplied from a turbine driven alternator in the engine room, or, if desired, is obtained from the ship's mains.

Conversely, the two exciters may be used in port to supply power to the ship's mains, and thus form two valuable additions to the vessel's power plant.

The motors have two possible arrangements of pole, the change from 36 poles to 24 poles being accomplished by simply throwing a switch. There is one motor in a separate compartment for each of the four shafts.

For 21 knots both turbine units are run and the four motors are used in their 24 pole rig (low gear). This reduces the full turbine speed of 2,000 r. p. m. to 165 r. p. m. of motor or propeller.



**FIG. 3,758.**—The Menlees system of propelling ships by gas engines. In the figure A is a six cylinder gas engine coupled to a dynamo B. The shaft C of the dynamo and engine is adapted to be connected by a clutch D with the shaft E of the electric motor F, which is connected with the propeller shaft. *In operation*, at all ahead ship speeds direct driving may be employed, but, for speeds less than half, the electrical transmission may be used, the motor F, receiving electrical energy from the dynamo B. The drive may also be employed for reversing the astern speed by not greater than half the full ahead speed, suitable switches and gear being provided.

At cruising speeds one turbine is connected to the four motors in their 36 pole rig (high gear). Thus either turbine at 2,000 r. p. m. drives four motors at 110 r. p. m. The other turbine is meanwhile not in use.

When the motors are not connected, the turbine runs at no load and the motors stand idle. If connected to one alternator, all the motors turn (if in the same pole setting) at the same speed, although, if it be desired to back the port and at the same time stop or go ahead on the starboard motors, this is possible. In other words, when in cruising rig the ship can be quickly started, stopped, or turned by various combinations of the four motors driven by one turbine, and power for 15 knots is available.

Speed control with either one or two alternators running is entirely by turbine throttle or on the so called "variable-frequency" principle.

It is at once evident that the electricity between turbine shaft and propeller shaft simply performs the same function that a clutch and gear box do on an automobile. The electric machinery simply makes it possible to reverse the propeller shafts and keep the turbine running in the same direction, and also gives two gear ratios between turbine shaft and propeller shafts.

The electric rig does not have a "direct drive," as does an automobile, because this is just what is not wanted in a ship. On the other hand, the electric rig gives two speed ratios ahead and two backing, while the automobile gives usually two ahead (besides "direct") and

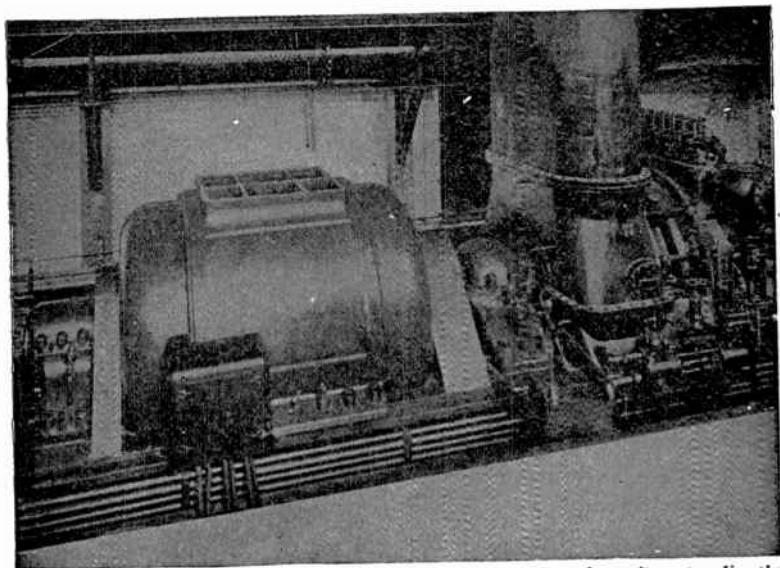


FIG. 3,759.—Generating unit of U. S. Collier Jupiter, consisting of an alternator directly connected to a turbine.

one backing. Being in any gear setting with either ship or automobile, *to go faster, speed up the engine; to slow, slow the engine.* Without "shifting gear" *speed changes can be made in no other way.* In the automobile the clutch can at any time be thrown out and leave the engine running; with the ship, the motors may be disconnected electrically and leave the turbine running.

Between the exciter and the alternator there are, besides the usual protective circuit breakers, one switch and one rheostat. As has been said, the ship's circuit can be used for supplying excitation for the alternators, or in port the exciters, which are of about 300 kw. capacity, can be used for supplying power to the ship's mains.

The four main leads from the armature of, say, the port alternator go through a four pole switch to the port bus bars. As this switch is opened only when no power is on the system, it is of the usual knife type. The two port motors are connected in parallel and then through either one of two electrically actuated main oil switches to the bus bars.

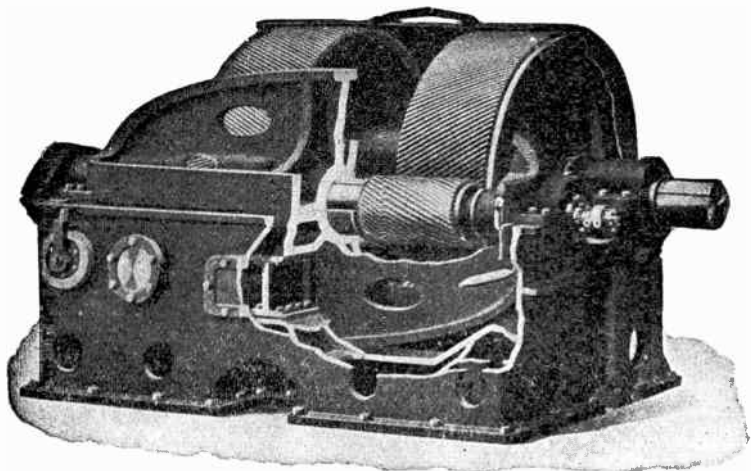


FIG. 3,780.—View of 6,000 horse power Melville-MacAlpine speed reduction gear with case broken away showing construction. It is a double helical spur gear, designed with involute teeth, and a transmission capacity of 6,000 horse power at a pinion speed of 1,500 *r.p.m.* The pinions have 35 teeth, the spur wheels 176 teeth. The 176th tooth constitutes a bunting cog and equalizes the wear. The pitch circle diameters are 14 ins. and 70 ins. respectively. The reduction ratio is thus practically 5 to 1, hence the power is delivered from the gear at a speed of only 300 *r.p.m.* The pitch line speed is 5,500 ft. per minute and the design is based on a limiting pressure of 450 lbs. per inch of tooth contact. Provision is made for the liberal use of lubricating and machine oil. Rear-Admiral Melville writing in Proc. Inst. Civil Engineer, Feb., 1910, states as follows: A full power test of 6,500 horse power was carried out for a period of 40 hours from 2.30 P.M. on Oct. 16, 1909, till 6.30 A.M. Oct. 18. At the close of this test the gear was found to be in excellent condition and without any sign of wear. This established without question the fact that gearing could be made to transmit such large powers continuously at high speed.

When closed, one of these oil switches connects the pair of motor for "ahead" operation; and when closed, the other switch connects the motors for "astern" operation. Only one of these switches can be

closed at a time, and the closed switch is locked so that it cannot be opened until after the alternator field switch is open. This last provision makes it impossible to break the main circuit until the current in it practically ceases to flow.

In each motor circuit there is a four pole, double throw switch. One closed position of this switch connects the motor for 36 poles, the other closed position for 24 poles. As the pole changing switches are never used with power on the circuit, they are simply knife switches.

When in cruising rig with all four motors driven by one turbine unit, the port and starboard bus bars are connected together. At all

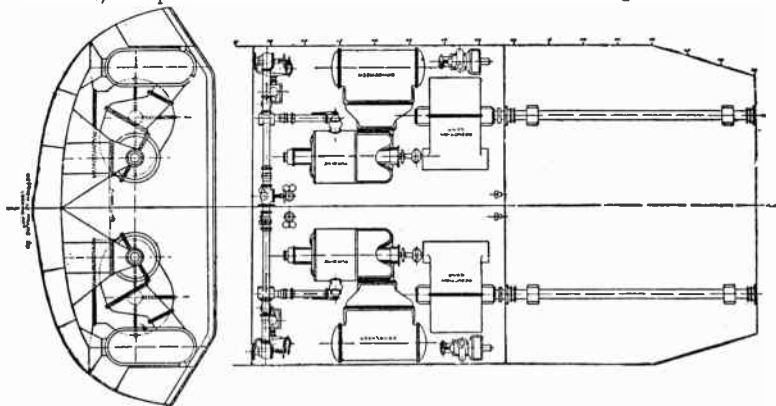


FIG. 0,000.—Arrangement of Westinghouse marine steam turbines with Melville-MacAlpine reduction gear, proposed for U. S. S. Baltimore. The entire equipment is shown as if installed in one of the two engine rooms occupied by the reciprocating engines with which this vessel was actually fitted. Since the gearing is of 98½ per cent or conservatively 98 % efficiency, the output for a group of turbine such as would drive the Mauretania at a speed of 25 knots would be  $60,500 \div .98 = 62,000$  horse power, requiring an estimated weight of 260 tons. The weight of gearing for a ship of the Mauretania's displacement and speed would amount to some 300 tons in place of a weight of some 1,100 tons of machinery which would be saved. The turbines of the Mauretania are rated at 70,000 shaft horse power. Even the comparatively low speed at which these turbines run is too high for maximum propeller efficiency. It is hardly possible that the propeller efficiency exceeds 55 per cent, which means that the actual effective propelling power is only about 38,500 horse power. At a lower speed well within the capabilities of the reduction gear, a propeller could be made that would have an efficiency of not less than 65 per cent. With this improved efficiency, the shaft horse power required for the same effective propelling power would be somewhat less than 57,000, a saving of almost 15 per cent. With the turbine and propeller direct connected so that both revolve at the same speed, not only is it necessary to sacrifice the efficiency of the propeller, but also the efficiency of the turbines.

other times the port and starboard sides of the ship are not electrically connected.

As the alternator field switch, the main switches, and even the turbine governors will in all probability be electrically operated, two master

contollers, one in front of the instrument board in each engine room, will suffice for handling the entire main propelling plant.

The author believes the time and money spent in devising such complication of machinery to secure flexibility of control and to obtain the necessary speed reduction between high speed turbines and low speed propellers could have been employed more profitably in perfecting a two speed and reverse gear, or more especially in seeking a commercially successful method of generating steam at considerably higher pressures and degrees of superheat than are common at present, for use in triple or quadruple expansion engines.

In view of the economic results obtained in the White system and in the various "locomobiles," a quadruple expansion condensing engine, not handicapped with the present boiler limitations, and operating under favorable conditions, that is to say, under desirable initial and terminal pressures, and with a sufficient degree of superheating and reheating to secure passage of the steam through the cylinders without condensation, should produce an indicated horse power on five pounds of water per hour, or about one third the amount now required.

In devising any new method of steam making, a study of Prof. Carpenter's tests on the White steam generator will show the marked effect of rapid circulation in reducing the heating surface necessary for a given output.



## CHAPTER LXXIV

## MOTION PICTURES

The subject of motion pictures may be included with propriety in a work on electricity because of the electric arc generally used for illumination and the auxiliary apparatus necessary for the proper working of the arc; in some installations the generating machinery being included, comprising an isolated plant.

While arc lighting has been treated at considerable length in the chapter on electric lighting, the special adaptation of the arc for moving picture machines is best explained in a separate chapter. For completeness, the subject of motion pictures is treated at length with respect both to its electrical and non-electrical features. With this in view, a comprehensive explanation of motion pictures is naturally given in the order of the outline below which is followed in part.

1. Optics;
2. The film;
3. Motion picture cameras;
4. Taking the pictures;
5. Developing;
6. The electric arc;
7. Auxiliary apparatus;
8. Motion picture machine;
9. Projection;
10. Reproducing the pictures on the screen;
11. Stage effects;
12. Motion picture theatres;
13. Theatre lighting;
14. Installation;
15. Operation;
16. Care and repair.

**Optics.**—By definition, *that part of physics which deals with the property of light is known as optics.*

### Ques. What is light?

Ans. Various hypotheses have been made, the most important of which are the emission or corpuscular theory, and the undulatory or wave theory.

*The emission theory* assumes that luminous bodies emit, in all directions, an imponderable substance which consists of molecules of an extreme degree of tenuity. These are propagated in right lines with an almost infinite velocity. Penetrating into the eye, they act on the retina and produce a sensation which is called *vision*.

*The undulatory theory* assumes that all bodies, as well as the celestial spaces are filled with an extremely subtle elastic medium,

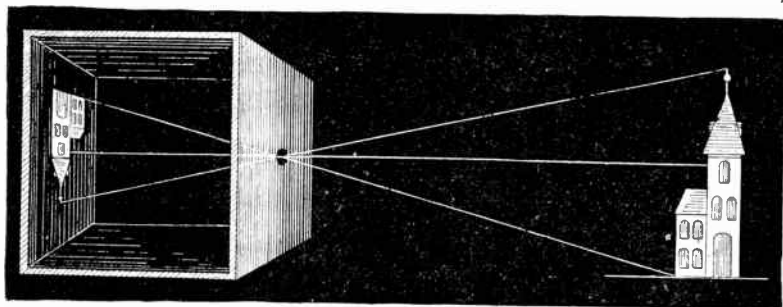


FIG. 3,762.—Images produced by small apertures showing the luminous rays at the aperture causing inversion of the image.

called the luminiferous ether, the luminosity of a body being due to an infinitely rapid vibratory motion of its molecules, which, when communicated to the ether, is propagated in all directions in the form of spherical waves, and this vibratory motion, being thus transmitted to the retina, produces the sensation called *vision*.

### Ques. What is an image?

Ans. An image is the appearance of an object at a place where no object exists.

### Ques. What is the difference between a real and a virtual image?

Ans. A real image is formed when the rays *actually* meet; a virtual image is formed when the rays only *appear* to meet.

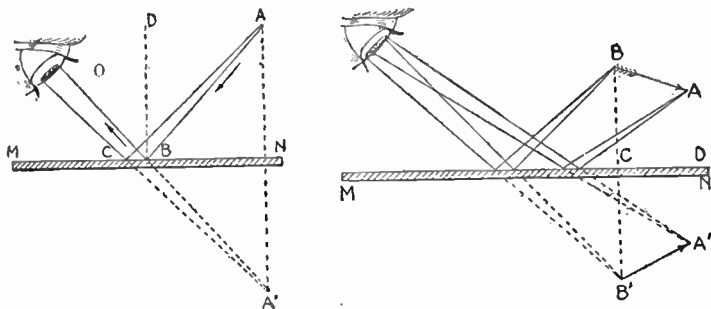
### Ques. What is a mirror?

Ans. A polished surface which reflects objects placed before it.

According to their shape, mirrors are called plane, concave, convex, spherical, parabolic, conical, etc.

### Ques. What kind of image is seen in a plane mirror?

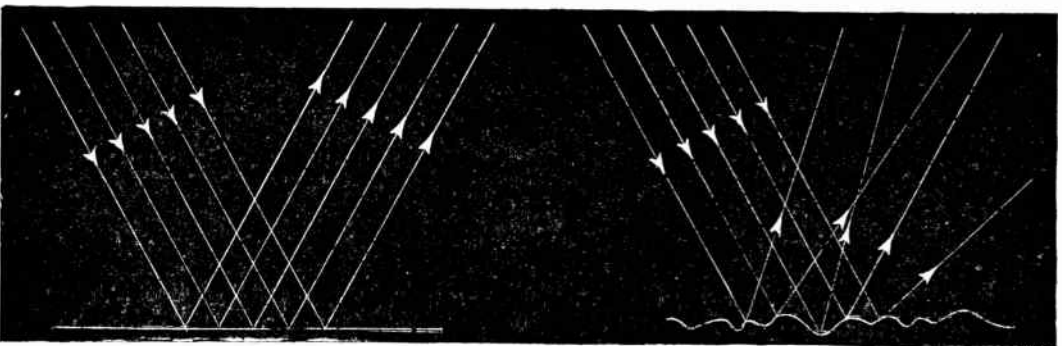
Ans. A virtual image.



FIGS. 3,763 and 3,764.—Formation of images by plane mirrors. The determination of the position and size of image resolves itself into investigating the images of a series of points. CASE I. Single point A placed in front of a plane mirror, as in fig. 3,763. Any ray AB, incident from this point on the mirror is reflected in the direction BO, making the angle of reflection DBO equal to the angle of incidence DBA. If a perpendicular AN, be let fall from the point A over the mirror, and if the ray OB, be prolonged below the mirror until it meets this perpendicular in the point A', two triangles are formed, ABN and BNA', which are equal, for they have the side BN common to both, and the angles ANB, ABN, equal to the angles A'NB, A'BN; for the angles ANB and A'NB are right angles, and the angles ABN and A'BN are each equal to the angle OBN. From the equality of these triangles, it follows that A'N is equal to AN; that is, that any ray AB, takes such a direction after being reflected, that its prolongation below the mirror cuts the perpendicular AA' in the point A', which is at the same distance from the mirror as the point A. This applies also to the case of any other ray from the point A, as AC. It follows, that all rays from the point A, reflected from the mirror, follow after reflection, the same direction as if they had all proceeded from the point A'. The eye is deceived, and sees the point A at A', as if it were really situated at A'. Hence, in plane mirrors, the image of any point is formed behind the mirror at a distance equal to that of the given point, and on the perpendicular let fall from this point on the mirror. CASE II: Object AB placed in front of the mirror, as in fig. 3,764. The image of any object will be obtained by constructing the image of each of its points, or at least, of those which are sufficient to determine its form. Fig. 3,764 shows how the image A'B' of any object AB is formed.

### Ques. How are images produced by small apertures?

Ans. When luminous rays, which pass through a small aperture into a dark chamber, are received upon a screen, they form



**Figs. 3,765 and 3,766.**—Reflection from polished and unpolished surfaces. The difference between a smooth (polished) and a rough (unpolished) reflecting surface is here greatly exaggerated. In both cases the law of reflection for each ray of light is precisely the same, that is, the *angle of incidence is equal to the angle of reflection*. In the first case all portions of the reflecting surface are parallel to one another, and therefore reflect in the same direction all the rays which fall upon them from a given direction; in the second case, the elements of the surface are turned in a great variety of way and hence the reflected rays pass off in every direction. Even the smoothest surfaces which can be made diffuse light to a slight extent.

images of external objects as shown in fig. 3,762.

**Ques.** Why are these images inverted?

**Ans.** Because the luminous rays proceeding from external objects, and penetrating into the chamber, cross one another in passing the aperture as shown in fig. 3,762.

**Ques.** What is reflection?

**Ans.** The change of direction experienced by a ray of light, or of other radiant energy, when it strikes a surface and is thrown back or reflected, as shown in fig. 3,767.

**Laws of Reflection.**—When a ray of light meets a polished surface, it is reflected according to the two following laws:

1. The angle of reflection is equal to the angle of incidence.
2. The incident and the reflected rays are both in the same plane which is perpendicular to the reflecting surface.

**Ques.** Describe a spherical mirror.

Ans. If a segment were cut from a hollow sphere and the surfaces were silvered or polished, each side of the segment would be a spherical mirror.

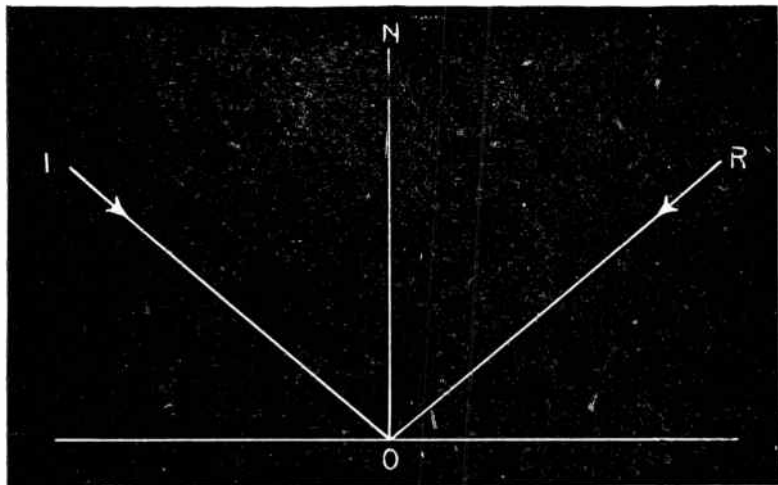


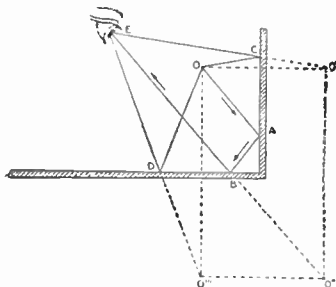
FIG. 3,767.—Angles of incidence and reflection. LAW: *the angle of reflection is equal to the angle of incidence.* The ray IO is called the incident ray; OR, reflected ray; angle ION, angle of incidence; angle NOR, angle of reflection; NO, normal or perpendicular to the reflecting surface.

The inner side is a *concave* spherical mirror, and the outer side, a *convex* spherical mirror.

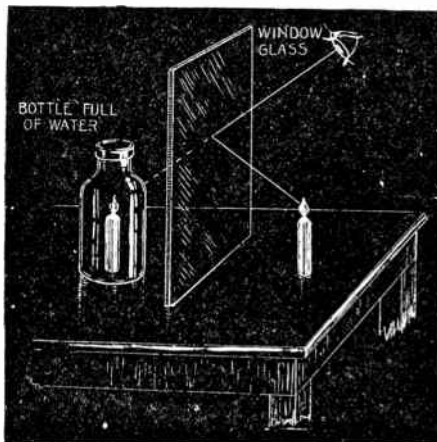
**Ques.** What is the focus of a curved mirror?

Ans. A point where the reflected rays meet or tend to meet if produced either backward or forward.

There is a real or principal focus, a virtual focus, and conjugate foci. The principal and the conjugate foci are always on the same



**FIG. 3,768.**—Multi-image formed by two mirrors. When an object is placed between two plane mirrors, which form an angle with each other, either right or acute, images of the object are formed, the number of which increases with the inclination of the mirrors. If they be at right angles to each other, three images are seen, arranged as represented in the figure. The rays OC and OD from the point O, after a single reflection, give the one, an image O', and the other an image O'', while the ray OA, which has undergone two reflections at A and B, gives the third image O'''. When the angle of the mirror is 60°, five images are produced, and seven if it be 45°. The number of image continues to increase in proportion as the angle diminishes, and when it is zero (mirrors parallel), the number of image is infinite. *In general*, if two mirrors be inclined to each other, the number of image they produce is equal to the number of times the angle between them is contained in 360.



**FIG. 3,769.**—Position of image in a plain mirror. Let a candle be placed exactly as far in front of a pane of window glass as a bottle full of water is behind it, both objects being on a perpendicular drawn through the glass. The candle will appear to be burning inside the water. This experiment explains a large number of familiar optical illusions, such as "the figure suspended in mid-air," "bust of person without trunk," "stage ghost," etc. In the last case the illusion is produced by causing the audience to look at the actors obliquely through a sheet of very clear plate glass, the edges of which are concealed by draperies. Images of strongly illuminated figures at one side appear to the audience to be in the midst of the actors.

side of the mirror as the luminous point, while the virtual focus is always on the other side of the mirror. The distinction between these various foci is illustrated in the accompanying cuts.

### Ques. What is a parabolic mirror?

Ans. A concave mirror whose surface is generated by the revolution of the arc of a parabola AC about its axis AB as in fig. 3,770.

### Ques. What is avoided by the use of parabolic mirrors?

Ans. Spherical aberration.

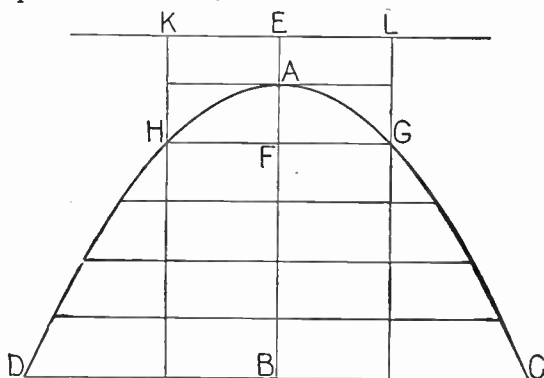


FIG. 3,770.—The parabola. A parabola DAC is a curve such that every point in the curve is equally distant from the directrix KL and the focus F. The focus lies in the axis AB, drawn from the vertex or head of the curve A, so as to divide the figure into two equal parts. The vertex A, is equidistant from the directrix and the focus or  $AE = AF$ . Any line parallel to the axis is a diameter. A straight line, as HG or DC, drawn across the figure at right angles to the axis HFG drawn through the focus, is called the parameter of the axis. The ordinate to the axis is a double ordinate, and either half of it is an ordinate. The ordinate to the axis, reckoned from the vertex, is an abscissa of the axis, and it is an abscissa of the ordinate drawn from the base of the abscissa. Thus AB is an abscissa of the ordinate BC. Abscissæ of a parabola are as the square of their ordinates.

### Ques. What is refraction?

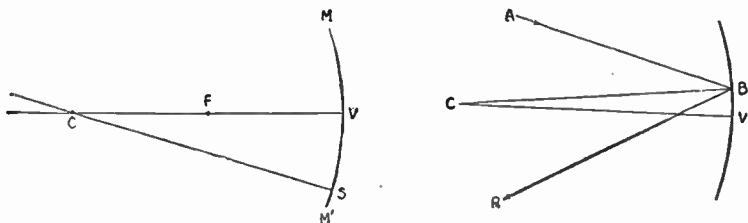
Ans. The change of direction which a ray of light undergoes upon entering obliquely a medium of different density from that through which it has been passing, as in fig. 3,773.

If the incident ray be perpendicular to the surface separating the two media, it is not bent, but continues its course in a right line.

According as the refracted ray approaches or deviates from the normal, the second medium is said to be more or less *refracting*, or *refracting* than the first.

Mathematical analysis shows that the direction of refraction depends on the relative velocity of light in the two media.

**Ques.** Define the index of refraction, or refractive index.



FIGS. 3,771 and 3,772.—Concave spherical mirror; definitions. In the diagram V is the vertex; MM', the aperture; CV, the principal axis; CS, a secondary axis; C, center of curvature; F, principal focus (midway between V and C). Any line drawn from C to the mirror will be perpendicular to the mirror at that point. This line then will always be the normal which will be used in making the angle of incidence equal to the angle of reflection. Now in fig. 3,772, if AB be an incident ray of light, the angle ABC is the *angle of incidence*. To find the direction of the reflected ray draw BR so that the angle CBR equals angle ABC, then will BR be the direction of the reflected ray.

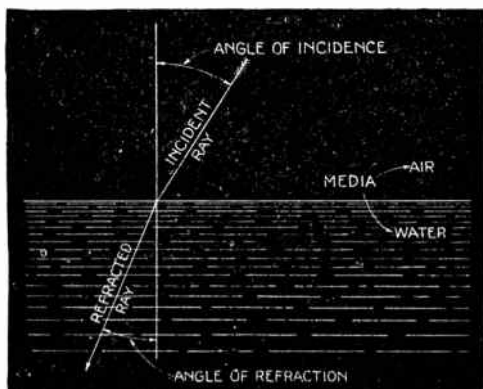


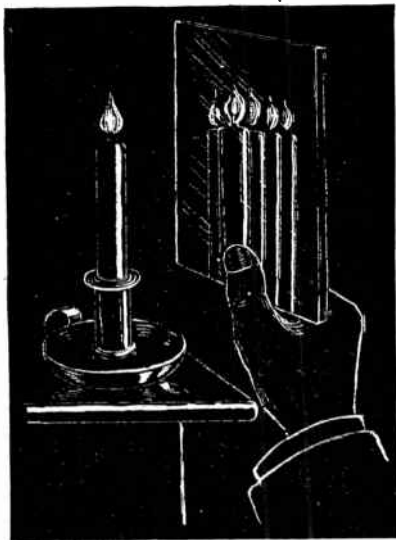
FIG. 3,773.—Diagram illustrating refraction definitions. All the light which falls on a refracting surface does not completely pass into it; one part is reflected and scattered, while the other penetrates into the medium. **According to the undulatory theory**, the more highly refracting media is that in which the velocity of propagation is least. In uncrystallized media, such as air, liquids, ordinary glass, the luminous ray is singly refracted; but in certain crystallized bodies, such as Iceland spar, selenite, etc., the incident ray gives rise to two refracted rays. The latter phenomenon is called *double refraction*.



Ans. It is the ratio between the sines of the incident and refracted angles.

It varies with the media, for instance from air to glass it is  $\frac{3}{2}$ ; from air to water,  $\frac{4}{3}$ .

Indices of a few common substances are as follows: alcohol 1.36; crown glass 1.53; turpentine 1.47; diamond 1.67; flint glass 2.47.



**FIG. 3,774.**—Experiment illustrating multi-image in ordinary mirror. Let the flame of a candle be observed very obliquely in an ordinary mirror. From four to ten images of the flame may be seen arranged in a row, as here shown. The second image of the series will be by far the most brilliant.

**Laws of Refraction.**—When a luminous ray is refracted in passing from one medium into another of different refractive power the following laws obtain:

1. *Light is refracted whenever it passes obliquely from one medium to another of different optical density;*
2. *The index of refraction for a given substance is a constant quantity whatever be the angle of incidence;*

3. The refracted ray lies in the plane of the incident ray and the normal;

4. Light rays are bent toward the normal when they enter a more refractive medium, and from the normal when they enter a less refractive medium.

**Ques.** Define the critical angle.

**Ans.** In fig. 3,775, let CD be a surface separating two transparent media, the lower one being the denser of the two (as air

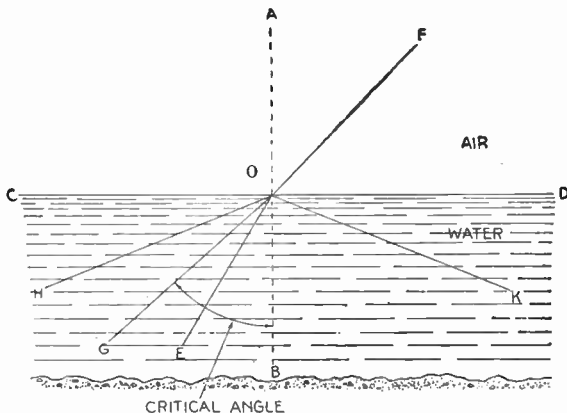


FIG.—3,775.—Diagram illustrating the *critical angle* or that angle between the incident ray and the perpendicular drawn to the surface in the medium of smaller velocity at the point at which total reflection begins to occur; the diagram is explained in the accompanying text,

and water). If a ray EO strike the surface it will be bent away from the normal AOB, along the line OF, in accordance with the law of refraction  $\sin AOF = \mu \sin EOB$ . If now the angle EOB be increased, AOF will go on increasing until  $\sin AOF = 1$ , and the refracted ray passes along OD; in this case the ray in the dense medium makes an angle BOG with the normal such

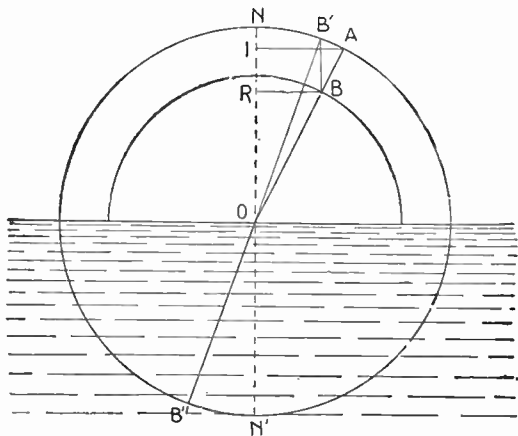
**NOTE.—Effect produced by refraction.** Bodies immersed in a medium more highly refracting than air appear nearer the surface of this medium, but they appear to be more distant if immersed in a less refracting medium. A stick plunged obliquely into water appears bent, the immersed part appearing raised. Owing to refraction stars are visible even when they are below the horizon.

that  $\mu \sin \text{BOG} = 1$ , from which,  $\sin \text{BOG} = 1 \div \mu$ . This angle  $\text{BOG}$  is the *critical angle*.

The critical angle varies with the nature of the substance: thus, for water and air, it is about  $48.5^\circ$ ; for crown glass,  $42.5^\circ$ ; for flint glass,  $38.6^\circ$ ; for diamond,  $23.7^\circ$ .

**Ques. What is total reflection?**

**Ans.** When the angle of incidence is greater than the critical



**FIG 3,776.**—Construction of refracted ray. Let  $AO$  be a ray of light passing through air and entering water at  $O$ . The index is  $\frac{4}{3}$ . Draw two circles with centers at  $O$  and with radii whose lengths are as  $4 : 3$ . Draw  $AI$  and  $BR$  perpendicular to the normal  $NN'$ . Since  $AO : BO = 4 : 3$ , then  $AI : BR = 4 : 3$ . Hence if  $AI$  be the sine of the angle of incidence,  $BR$  is the sine of the angle of refraction. If then,  $BB'$  be drawn parallel to the normal, and a straight ruler be placed on the points  $B'$  and  $O$ , the line  $OB'$ , the refracted ray may be drawn.

angle, none of the light will emerge into the adjacent medium, but all will be reflected; this is called total reflection.

Total reflection can take place only when light traveling in any medium meets another medium in which the speed is greater.

**Ques. How do external objects appear to an eye under water?**

Ans. They appear to lie within a cone whose angle is  $97^\circ$ , as explained in fig. 3,777.

**Lenses.**—A lens may be defined as, *a piece of glass or other transparent substance with one or both sides curved.* Both sides may be curved, or one curved and the other flat.

*The object of a lens is to change the direction of rays of light, and thus magnify objects, or otherwise modify vision.*

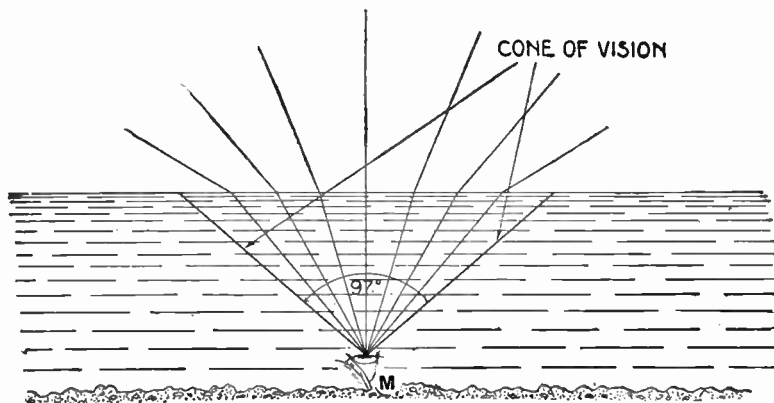


FIG. 3,777.—Appearance of external objects to an eye under water. Since the critical angle for water is  $48\frac{1}{2}^\circ$ , an eye located at M will see objects above the water as though located within a cone whose angle is  $2 \times 48\frac{1}{2}^\circ = 97^\circ$ . The reason for this is because if the eye look toward the surface at an angle greater than  $48\frac{1}{2}^\circ$  it can see nothing but the reflection from the bottom of the water.

There are various kinds of lens and they may be classed as:

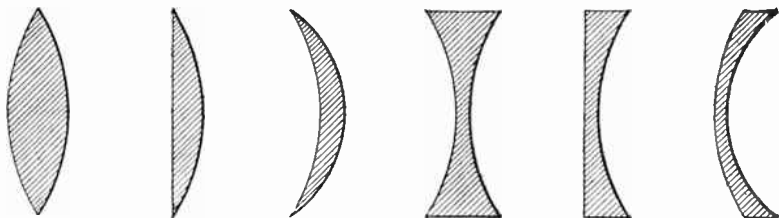
1. Convex.

- a. double convex;
- b. plano convex;
- c. concavo convex.

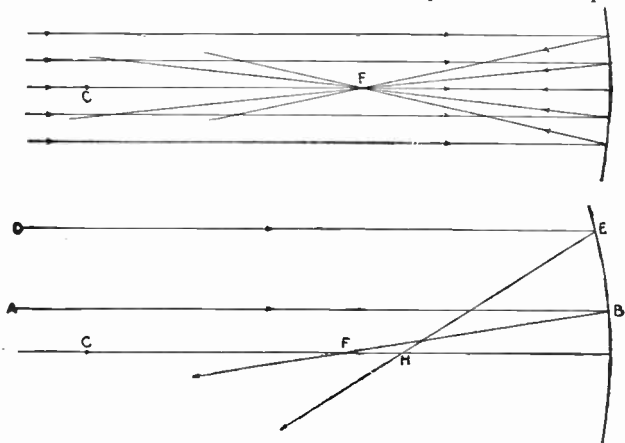
2. Concave.

- a. double concave;
- b. plano concave;
- c. convexo concave.

These various types of lens are illustrated in figs. 3,778 to 3,783, which give a better idea of the numerous combinations of curved and plane surface than is obtained by definition.



FIGS. 3,778 to 3,783.—Various lenses. *The first three* are thicker at the center than at the borders, and are called *converging*; *the second three*, which are thinner at the center are called *diverging*. In lenses whose two surfaces are spherical, the centers of these surfaces are called centers of curvature, and the right line which passes through these two centers is the principal axis. In a plano-concave or plano-convex lens, the principal axis is the perpendicular let fall from the center of curvature of the spherical face on the plane face.



FIGS. 3,784 and 3,785.—The principal focus. *By definition*, it is, *that point where all the rays parallel to the principal axis meet after reflection*, as, for instance, the rays from a source of light at an infinite distance from the mirror. The sun is so far distant that its rays are practically parallel. When they are reflected upon a concave mirror they are reflected to the principal focus *F*; forming a point of intense light and heat.

**Foci in Double Convex Lenses.**—*The focus of a lens is the point where the refracted rays, or their prolongations meet.* Double convex lenses have both real and virtual foci, like concave mirrors.

**Principal Foci.**—Fig. 3,786 shows the case in which the luminous rays which fall on the lens are parallel to its principal axis.

In the figure, any incident ray as LB, in approaching the normal of the point of incidence B, and in diverging from it at the point of emergence D, is twice refracted toward the axis which it cuts at F. Since all rays parallel to the axis are refracted in the same manner it can be

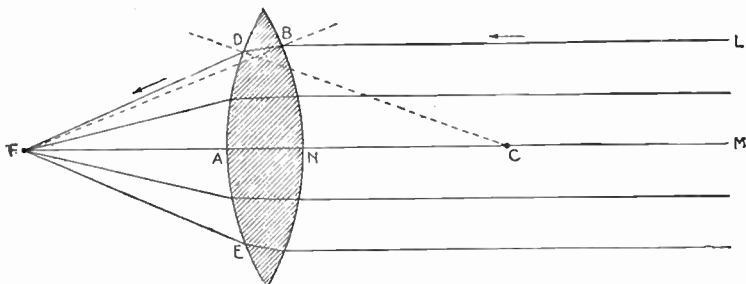


FIG. 3,786.—Principal focus in double convex lens. CASE I: Rays from luminous source parallel to the principal axis.

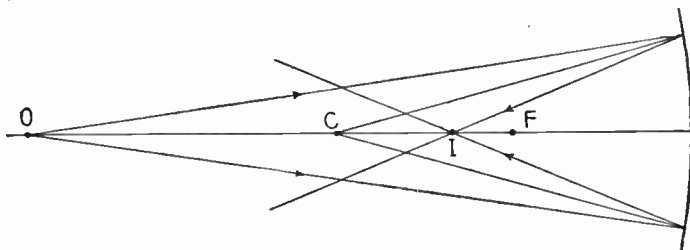


FIG. 3,787.—Conjugate foci. *By definition, when two points are so related that object and image may exchange places, they are called conjugate foci.* If a luminous object be placed at the point O, it projects divergent light rays upon the mirror. These rays will focus at a point I, a little further from the mirror than the principal focus F. If the source of light be now placed at I, the rays will pass back over the same paths and will come to a focus at O; the points I and O thus related to each other are called *conjugate foci*. Concave mirrors make divergent rays less divergent, parallel or convergent; parallel rays, convergent; convergent rays more convergent.

shown by calculation that they all pass very nearly through the point F, so long as the arc DE does not exceed  $10^\circ$  to  $12^\circ$ . This point is the principal focus and the distance FA, the principal focal distance.

Fig. 3,788 shows the case in which the luminous source is outside the principal focus, but so near that all incident rays form a divergent pencil.

**Virtual Foci.**—A double convex lens has a virtual focus when the luminous object is placed between the lens and the principal focus, as shown in fig. 3,790.

In this case the incident rays make with the normal greater angles than those made with the rays FI from the principal focus. Accordingly,

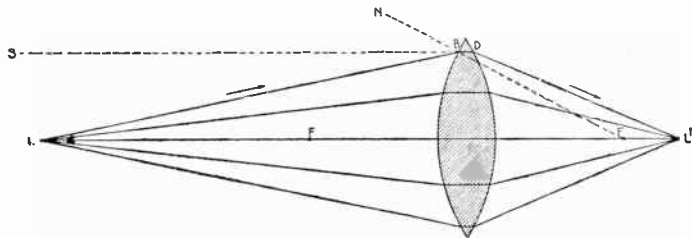


FIG. 3,788.—**Principal focus** in double curve lenses. CASE II: *Divergent rays from luminous source.* In the figure the luminous source being at L, by comparing the path of a diverging ray LB, with that of a ray SB, parallel to the axis, the former is found to make with the normal, an angle LBN, greater than the angle SBN, hence, after traversing the lens, the ray cuts the axis at a point L', which is more distant than the principal focus F. As all rays from the point L intersect approximately in the same point L', this latter is the conjugate focus of the point L. This term has the same meaning here as in the case of mirrors, and expresses the relation existing between the two points L and L', which is of such a nature that, if the luminous point be moved to L', the focus passes to L.

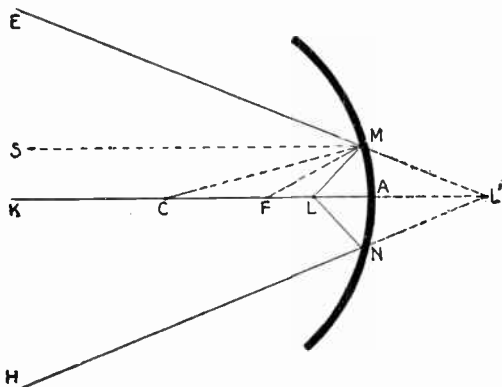


FIG. 3,789.—**The virtual focus.** If a source of light be placed at L, between the principal focus F, and the mirror, any ray LM emitted from L, makes with the normal CM, an angle of incidence LMC, greater than FMC. The angle of reflection must be greater than CMS, and therefore the reflected ray ME diverges from the axis AK. This is also the case with all rays from the point L, and hence these rays do not intersect, thus forming no conjugate focus. If they be regarded as being prolonged on the other side of the mirror, their prolongations will intersect in a point L', on the axis, giving the same effect to the eye as though the rays were emitted from the point L', this point being called the *virtual focus*.

when the former rays emerge, they move farther from the axis than the latter, and form a diverging pencil HK, GM. These rays cannot produce a real focus, but their prolongations intersect in some point  $L'$ , on the axis, and this point is the virtual focus of the point L.

**Foci in Double Concave Lenses.**—In lenses of this form, *there are only virtual foci*, whatever be the distance of the object.

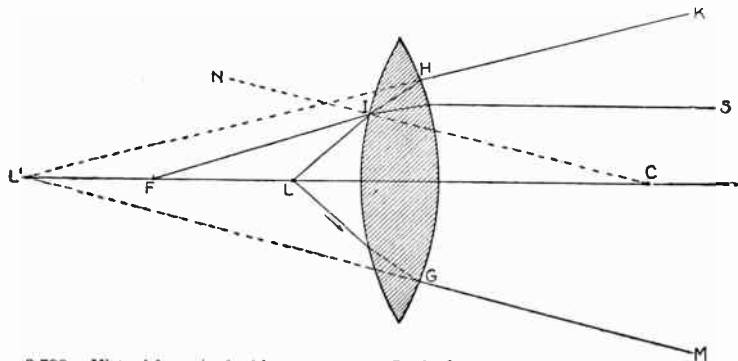


FIG. 3,790.—Virtual focus in double convex lens. In the figure, L is the position of the luminous source between the principal focus and the lens; F is the principal focus, and  $L'$ , the virtual focus corresponding to the position L of the luminous source.

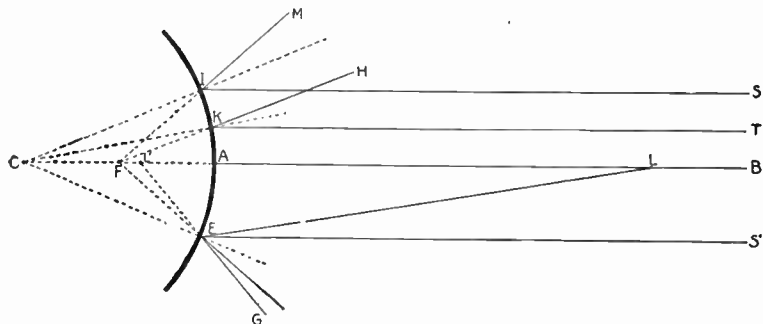


FIG. 3,791.—Foci of convex mirrors. This type of mirror has only virtual foci. Let SI, and TK be rays parallel to the principal axis of a convex mirror. These rays, after reflection, take the diverging directions IM, KH, which, when continued, meet at a point F, which is the *principal virtual focus*. In the triangle CKF, it may be shown, in the same manner as with concave mirrors, that the point F is approximately the center of the radius of curvature CA. If the incident luminous rays, instead of being parallel to the axis, proceed from a point L, situated on the axis at a finite distance, a virtual focus will be formed at a point  $L'$ , between the principal virtual focus and the mirror.



In fig. 3,792 let  $SS'$  be any pencil of ray parallel to the axis. Any ray  $SI$  is refracted at the point of incidence  $I$ , and approaches the normal  $CI$ . At the point of emergence it is also refracted, but diverges from the normal  $GC'$ , so that it is twice refracted in a direction which moves it from the axis  $CC'$ . Since the same conditions obtain for every other ray,  $S'KMN$ , it follows that the rays, after traversing the lens, form a diverging pencil,  $GHMN$ . Hence, there is no real focus, but the prolongations of these rays cut one another in a point  $F$ , which is the principal virtual focus.

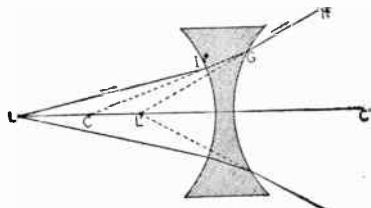
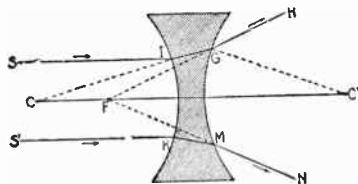


FIG. 3,792.—Virtual focus in double concave lens. CASE I: *Parallel incident rays.*

FIG. 3,793.—Virtual focus in double concave lens. CASE II: *Divergent incident rays.* In this case where the rays radiate from a point  $L$  on the axis, it is found by the same construction that a virtual focus is formed at  $L'$ , which is between the principal focus and the lens.

**Experimental Determination of the Principal Focus of Lenses.**—To determine the principal focus of a convex lens, it

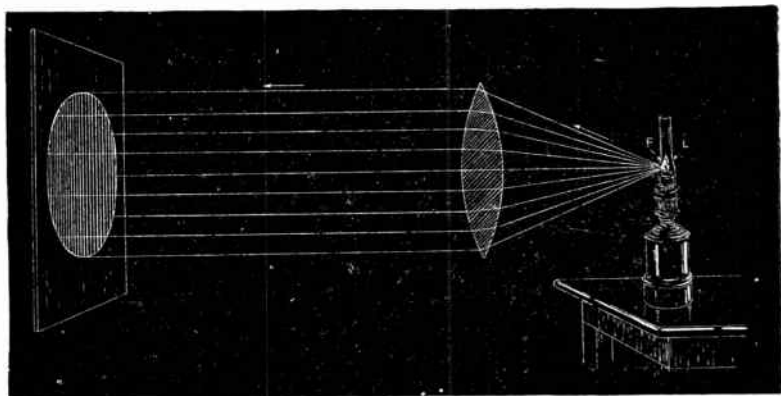


FIG. 3,794.—Effect of placing luminous source at the principal focus of a double convex lens. As the point of light comes near the lens, the convergence of the emergent rays decreases, and the conjugate focus  $L'$  (fig. 3,788) becomes more distant. When the source of light  $L$  coincides with the principal focus  $F$ , as shown above, the conjugate focus is at an infinite distance, that is to say, the emergent rays are parallel. When this condition obtains, the intensity of light decreases slowly, thus, a small lamp can illuminate considerable distance.

may be exposed to the sun's rays so that they are "parallel" to its axis. The emergent pencil being received on a ground glass screen, the point to which the rays converge or the principal focus is readily seen.

Fig. 3,795 shows the experimental determination of the principal focus of a double concave lens.

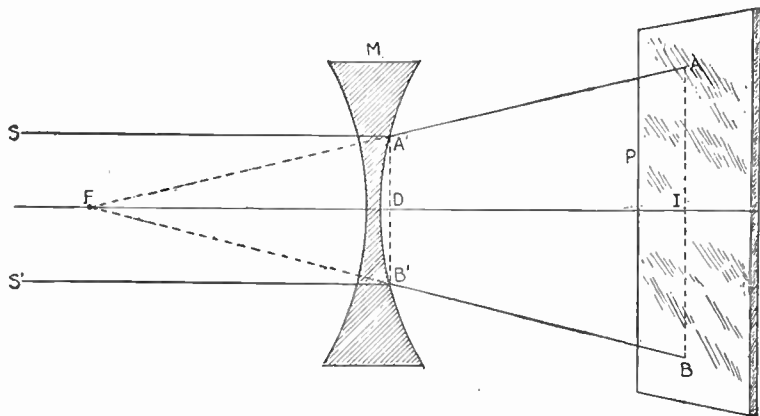


FIG. 3,795.—Experimental determination of the principal focus of a double concave lens. The face AB is covered with an opaque substance, such as lamp black, two small apertures, A and B, being left in the same principal section and at an equal distance from the axis. A pencil of sunlight is then received on the other face, and the screen P, which receives the emergent rays, is moved toward or away from the lens until A and B, the spots of light from the small apertures, are distant from each other by twice  $A'B'$ . The distance  $DI$  is then equal to the focal distance  $FD$ , because the triangles  $FA'B'$  and  $FAB$  are similar.

**Optical Center; Secondary Axis.**—In or near every lens there is a point called the optical center, which is located on the axis, and which has the property that *any luminous ray passing through it experiences no angular deviation*, that is to say, the emergent ray is parallel to the incident ray. The existence of this point is demonstrated as in fig. 3,796.

By definition, a secondary axis is *any right line* (as  $PP'$ , fig. 3,797), which passes through the optical center of a lens without passing through the centers of curvature. From this property of the optical center, every

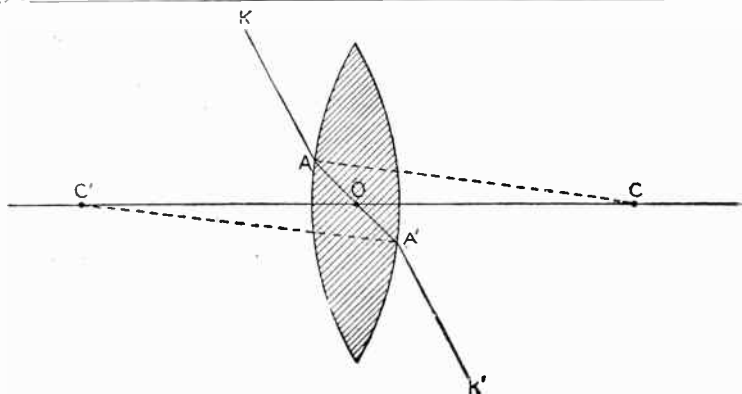


FIG. 3,796.—**Optical center.** Let two parallel radii or curvature  $CA$  and  $C'A'$  be drawn to the two surfaces of a double convex lens. Since the two plane elements of the lens  $A$  and  $A'$  are parallel, as being perpendicular to two parallel right lines, it is evident that the refracted ray  $AA'$  is propagated in a medium with parallel faces. Hence a ray  $KA$ , which reaches  $A$  at such an inclination that after refraction it takes the direction  $AA'$ , will emerge parallel to its first direction. The point  $O$  at which the right line cuts the axis is therefore the optical center. The position of this point may be determined from the case in which the curvature of the two faces is the same, which is the usual condition, by observing that the triangles  $COA$  and  $C'OA'$  are equal, and therefore that  $OC = OC'$ , which gives the point  $O$ . If the curvatures be unequal, the triangles  $COA$  and  $C'OA'$  are similar, and either  $CO$  or  $C'O$  may be found, and therefore also the point  $O$ . In double concave or concavo-convex lenses, the optical center may be determined by the same construction. In lenses with a plane face, this point is at the intersection of the axis by the curved face.

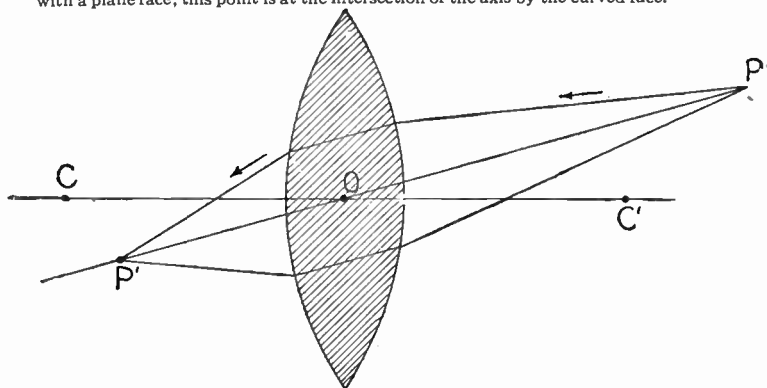


FIG. 3,797.—**Secondary axis.** This is any right line passing through the optical center, but not through the centers of curvature. Rays emitted from a point  $P$  on the secondary axis  $PP'$  nearly converge to a center point  $P'$  on the axis  $PP'$ , and according as the distance from the point  $P$  to the lens is greater or less than the principal focal distance, the focus thus formed will be conjugate or virtual. The formation of image is in accordance with this principle.

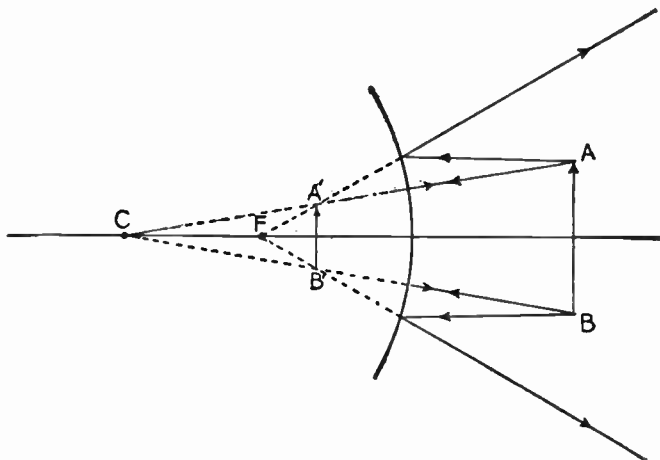


FIG. 3,789.—Image in convex mirror. Let  $AB$  be the object; draw two lines from  $A$ , and two from  $B$ , to the convex side of the mirror. Draw lines from  $C$  through these points. These lines are the normals. Construct the angles of reflection and extend the rays until they meet. It is found in this case that the image  $A'B'$  is virtual, erect, smaller than the object, and located on the opposite side of the mirror. *The effect of a convex mirror* is to make convergent rays less convergent, parallel, or divergent; parallel rays, divergent, and divergent rays, more divergent. *In general*, the concave mirror tends to collect the rays, and the convex mirror tends to scatter them.

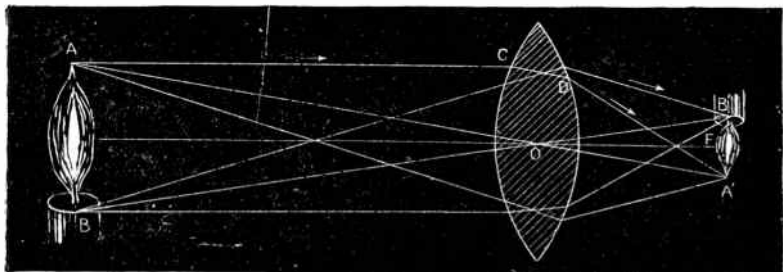


FIG. 3,799.—Formation of real image by double convex lens. Let  $AB$  be placed beyond the principal focus. If a secondary axis  $AA'$  be drawn from the outside point  $A$ , any ray  $AC$  from this point will be twice refracted at  $C$  and  $D$ , and both turning in the same direction, approaching the secondary axis, which it cuts at  $A'$ , the other rays from the point  $A$  will intersect in the point  $A'$  which is accordingly the conjugate focus of the point  $A$ . If the secondary axis be drawn from the point  $B$ , it will be seen that the rays from this point intersect in the point  $B'$ , and as the points between  $A$  and  $B$  have their foci between  $A'$  and  $B'$ , a real and inverted image of  $AB$  will be formed at  $A'B'$ . To see this image it may be received on a white screen, on which it will be depicted, so the eye may be placed in the path of the rays emerging from it. Again, if  $A'B'$  were the luminous object, its image would be formed at  $AB$ .

secondary axis represents a luminous rectilinear ray passing from this point because, from the slight thickness of the lens, it may be assumed that rays passing through the optical center are on a right line.

**Formation of Images by Double Convex Lenses.**—In lenses as well as in mirrors, the image of an object is the collection of the foci of its several point. Accordingly images furnished by lenses are real or virtual in the same case as the foci, and their construction resolves itself into determining the position of a series of point.

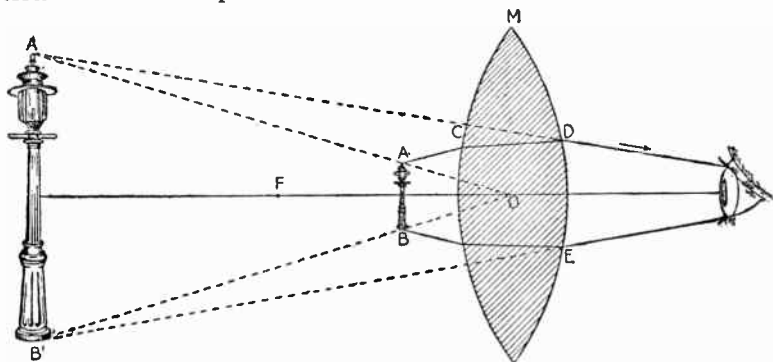
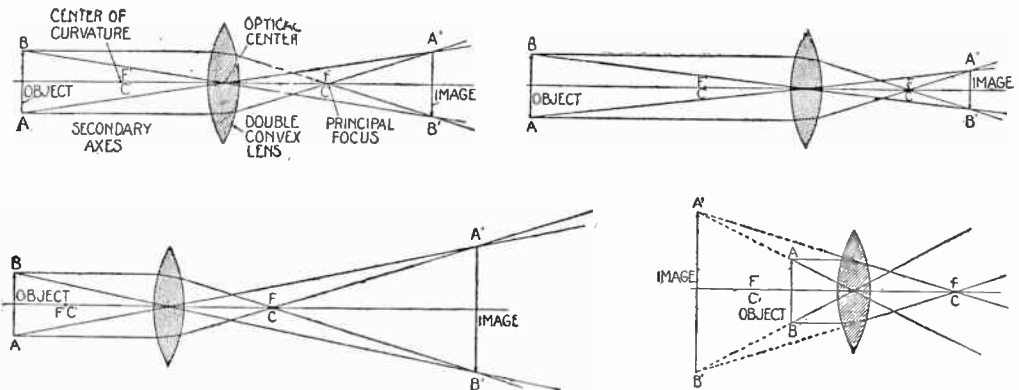


FIG. 3,800.—Formation of virtual image by double convex lens; object AB, placed between the lens and its principal focus. If a secondary axis  $OA'$  be drawn from the point A, every ray AC, after having been twice refracted, diverges from this axis on emerging, since the point A is at a less distance than the principal focal distance, this ray, continued in an opposite direction, will cut the axis  $OA'$  in the point  $A'$ , which is the virtual focus of the point A. Tracing the secondary axis of the point B, it will be found in the same manner, that the virtual focus of this point is formed at  $B'$ . There is, therefore, an image of AB at  $A'B'$ . This is a virtual image; it is erect and larger than the object. The magnifying power is greater in proportion as the lens is more convex, and the object nearer the principal focus.

Fig. 3,799 shows the formation of a real image, and fig. 3,800, the formation of a virtual image.

**Ques.** Describe the image formed with object at twice the focal distance.

**Ans.** The image is real, inverted, same size as the object, and at the same distance from the lens.



Figs. 3,801 to 3,804.—Images formed by double convex lens with object at various distances from the lens. Fig. 3,801, object at twice the focal distance; fig. 3,802, object more than twice focal distance; fig. 3,803, object at a distance less than twice the focal distance; fig. 3,804, object at a distance less than the focal distance. *In the construction of these figures, two rays from any point are all that are needed to locate the image. The two most convenient are, one parallel to the principal axis and the other through the optical center. The former will, after refraction, pass through the principal focus, which in cases here considered is at the center of curvature, and the latter will pass through the lens without change of direction.*

**Ques.** Describe image formed with object at more than twice focal distance.

**Ans.** The image is real, inverted, smaller than the object, and beyond the principal focus.

**Ques.** Describe image formed with object at less than twice the focal distance and greater than focal distance.

**Ans.** Image is real, inverted, larger than the object, and more than twice the focal distance from the lens.

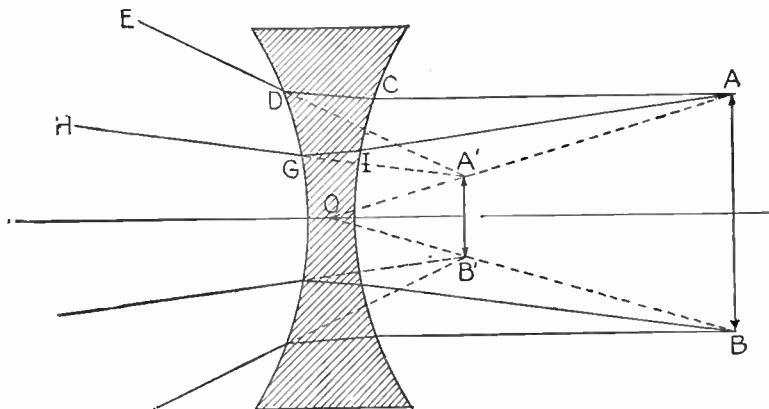
When the object is at the principal focus, the rays after passing through the lens will be parallel, and no image will be formed.

**Ques.** Describe image formed when the object is between the principal focus and the lens.

**Ans.** The image is virtual, erect and larger than the object.

In this case the rays are made less divergent but not convergent.

**Formation of Images by Double Concave Lenses.**—These lenses like convex mirrors give only virtual images, whatever be the distance of the object.



**FIG. 3,805.**—Formation of virtual image in double concave lens; no real image is formed with this type of lens. Let  $AB$  be an object placed in front of the lens. If the secondary axis  $AO$  be drawn from the point  $A$ , all rays  $AC, AD, AE, \dots$ , from this point are twice refracted in the same direction, diverging from the axis  $AO$ , so that the eye receiving the emergent rays  $DE$  and  $GH$ , supposes them to proceed from the point where their prolongations cut the secondary axis  $AO$  in the point  $A'$ . Similarly, drawing a secondary axis from the point  $B$ , the rays from this point form a pencil of divergent rays, the directions of which, prolonged, intersect in  $B'$ . Accordingly the eye sees at  $A'B'$ , a virtual image of  $AB$ , which is *always erect, and smaller than the object*.

**Ques.** How are rays affected by double concave lenses?

**Ans.** Diverging rays are always made more divergent.

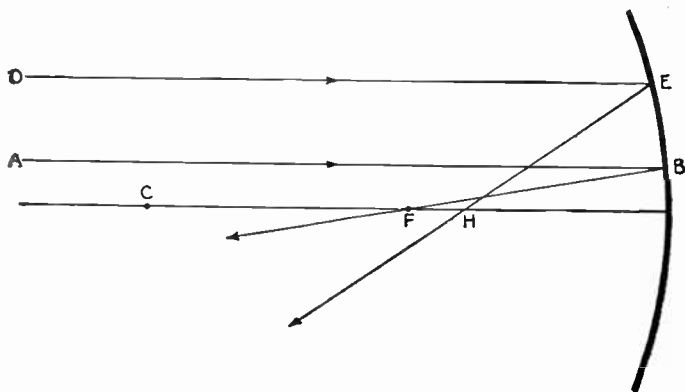
**Ques.** Describe the image formed.

**Ans.** It is virtual, erect, and smaller than the object.

**Formulae Relating to Lenses.**—In all these lenses the relations between the distances of the image and object, principal focus, also radii of curvature, the refractive index, etc., may be expressed by a formula.

If  $O$  be distance of the object from the lens,  $I$  the distance of the image, and  $F$ , the principal focal distance, then

$$\frac{1}{O} + \frac{1}{I} = \frac{1}{F} \dots \dots \dots (1)$$



**FIG. 3,806.—Spherical aberration.** The reflected rays of concave spherical mirrors do not meet at exactly the same point. For instance, the ray  $AB$ , will be reflected to  $F$ , but  $DE$  will be reflected to  $H$ , a point closer to the mirror. This is called *spherical aberration*. It has been observed that the reflected rays only pass through a single point when the aperture of the mirror does not exceed 8 or 10 degrees. A larger aperture causes spherical aberration, producing a lack of "sharpness." Every reflected ray cuts the one next to it, and their points of intersection form in space a curved surface which is called the *caustic by reflection*. **By experiment**, when the light of a candle is reflected from the inside of a tea cup or a glass tumbler, a section of the caustic surface can be seen by partly filling the cup or tumbler with milk. Spherical aberration may be avoided by the use of a parabolic mirror. The point  $C$  is the center of curvature.

From the equation it is seen that if any two of the distances are given the other can be found. Thus solving (1).

$$\frac{1}{I} = \frac{1}{F} - \frac{1}{O} \dots \dots \dots (2)$$

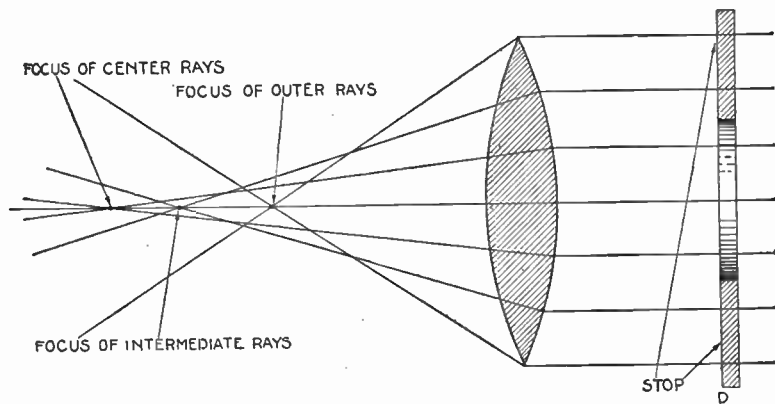
$$\frac{1}{O} = \frac{1}{F} - \frac{1}{I} \dots \dots \dots (3)$$



**Spherical Aberration; Caustics.**—The assumption that rays emitted from a single point intersect also after refracting in a single point is virtually correct with a lens whose aperture, that is, the angle obtained by joining the edges to the principal focus, does not exceed  $10^\circ$  or  $12^\circ$ .

**Ques. What is the effect of a larger aperture?**

**Ans.** The rays which traverse the lens near the edge are refracted to a point F on the principal axis nearer the lens than the focus of the rays G which pass near the axis.



**FIG. 3,807.**—*Effect of spherical aberration: it produces a lack of sharpness and definition of an image.* If a ground glass screen be placed exactly in the focus of a lens, the image of an object will be sharply defined in the center but indistinct at the edges, and if sharp at the edges, it will be indistinct at the center. This effect is very objectionable, especially in photographic lenses. To avoid this, a disc D with a hole in the center is placed concentric with the principal axis of the lens, thus only the central part of the lens is used.

That is to say, the rays farther from the principal axis are refracted more than those near this axis.

**Ques. What ill effect is due to spherical aberration?**

**Ans.** The image is slightly blurred.

**Ques. How may this be avoided?**

Ans. By means of a "stop," that is to say, a disc with a small hole in it placed in the path of light, as shown in fig. 3,807.

**Ques.** What name is given to the luminous surfaces produced by the intersecting of the refracted rays?

Ans. Caustics by refraction.

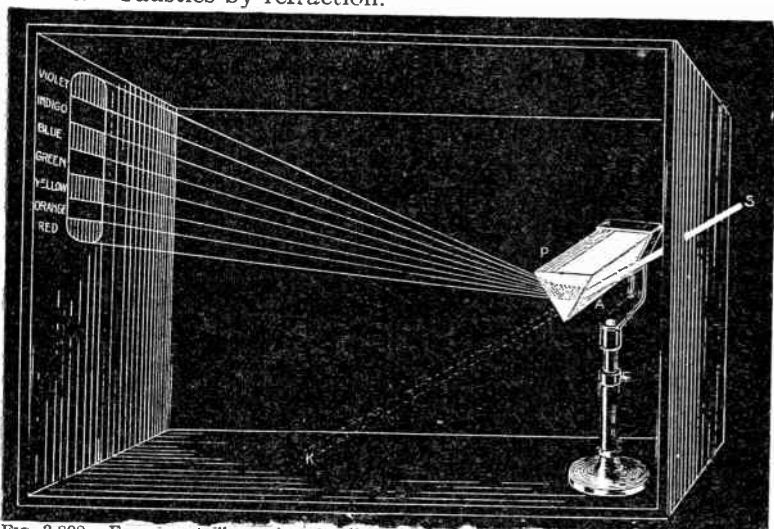


FIG. 3,808.—Experiment illustrating the dispersion or decomposition by refraction of white light. If a pencil of the sun's rays SA be allowed to pass through a small aperture in the window shutter of a dark chamber, this pencil tends to form a round and colorless image of the sun at K, but if a flint glass prism arranged horizontally, be interposed in its path, the beam, on emerging from the prism, becomes refracted toward its base, and produces on a distant screen a vertical band rounded at the ends, colored in all the tints of the rainbow, which is called the solar spectrum. In this spectrum there is virtually an infinity of different tint, which merge into each other, but it is customary to distinguish seven principal colors, viz: violet, indigo, blue, green, yellow, orange, red; they are arranged in this order in the spectrum, the violet being the most refrangible, and the red the least. They do not all occupy an equal extent in the spectrum, violet having the greatest extent, and orange the least.

**Chromatic Aberration.**—When white light is passed through a spherical lens, *both refraction and dispersion occur.*

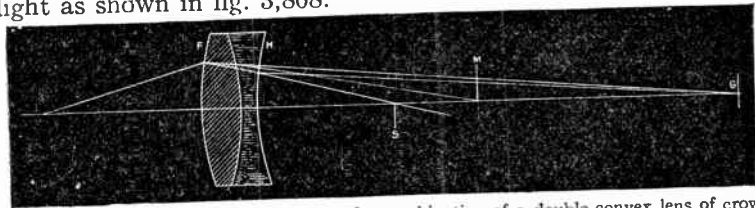
This causes a separation of the white light into its various colors and causes images to have colored edges. This defect which is most observable in condensing lenses is due to the unequal refrangibility of the simple colors, and is called chromatic aberration.

**Ques.** What is white light?

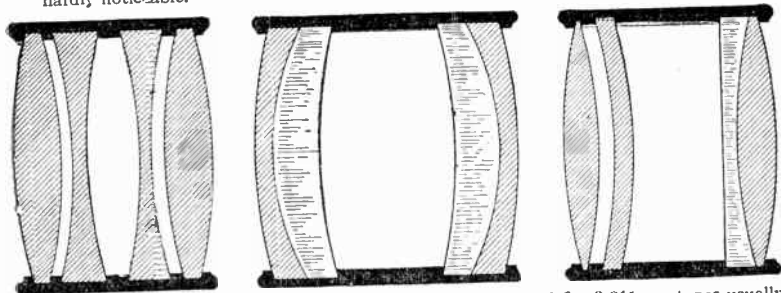
**Ans.** The light from the sun, the electric arc, etc.

**Ques.** What is dispersion?

**Ans.** The decomposition of white light into several kinds of light as shown in fig. 3,808.



**FIG. 3,809.**—Achromatic lens, consisting of a combination of a double convex lens of crown glass, and a double concave lens of flint glass. Whenever it is desired to project especially good pictures upon a screen, lenses are often combined as shown in the figure. Here M indicates the line through the principal axis, at which the red rays reflected by the double convex lens would strike, and S, the line where the violet rays would be projected. The addition of the double concave lens brings the red and violet together again at G. A combination of two such lenses F H, placed the proper distance apart and the surfaces properly proportioned, may be made to combine any two of the colors of the spectrum. Accordingly even with these connected lenses there is always some coloring on the screen, although hardly noticeable.



**FIGS. 3,810 to 3,812.**—Various achromatic lenses. Fig. 3,810 and fig. 3,811 are types usually used in photography, and fig. 3,812, a combination used in motion picture and stereopticon projection.

**Achromatic Lenses.**—The color effect caused by the chromatic aberration of a simple lens greatly impairs its usefulness. This may be overcome by combining into one lens, a convex lens of crown glass and a concave lens of flint glass.

**Ques.** What is the action of the first lens?

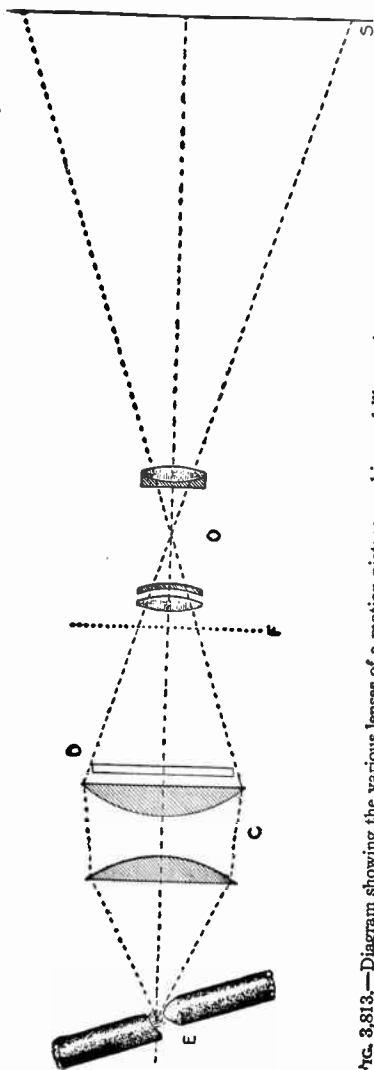


FIG. 3,813.—Diagram showing the various lenses of a motion picture machine and illustrating the principles of optical projection.

Ans. It produces both bending and dispersion.

**Ques. What is accomplished by the second lens?**

Ans. It almost completely overcomes the dispersion without entirely overcoming the bending.

**Principles of Optical Projection.**—The process is almost the reverse of ordinary photography.

For instance in photographing a scene by means of the photographic objective or lens, a reduced image is obtained on ground glass. This glass is replaced by a sensitized plate, and by the use of chemicals the image is fixed thereon.

In projection the process is reversed, that is, a transparent slide is made from the picture made with the lens, or the roll of film taken with a motion picture camera is developed and used in the projection lantern or "motion picture machine" as it is usually called.

By means of a condensed light these are strongly illuminated, and with an objective lens, an enlarged image is projected upon the screen; this screen image corresponding to the real objects photographed.

The principles of optical projection for both lantern slide and motion picture apparatus will readily be understood from the diagram fig. 3,813.

At E is an electric light or other suitable illuminant the light from which is caught up by the condensing lenses or condenser C; this condenser is an arrangement of lenses so constructed as firstly, to gather up as great a volume of light as possible and secondly, to concentrate the light which it gathers at the center or diaphragm plane of the objective when the objective is located at the proper distance from the slide or film, which distance is determined by the focal length of the objective.

The slide or film should be placed at such a point that the entire area of the opening is fully illuminated, and it should also be placed so that the greatest number of light ray possible should pass through it. Taking into consideration the fact that the opening in the mat in the lantern slide is  $2\frac{3}{4} \times 3$  inches and in the motion picture film is  $1\frac{1}{16} \times 1\frac{15}{16}$  inches, it will at once be evident that the slide must be placed at the point D in the diagram in order that its entire area be covered, and the moving picture film must be located at the point F, in order that it may take in the greatest number of light ray.

Proceeding from the slide or film, the light passes through the objective O, where the rays cross and the object is therefore reversed; by means of the objective, the object is also imaged or delineated upon the screen S, the degree of sharpness or flatness of the image depends upon the optical connection of the lens.

**Ques. What must be the relative positions of the arc, condenser and objective?**

Ans. They must be so placed that an image of the light source will be formed at the diaphragm of the objective.

Under these conditions all light coming from the condenser is utilized and the image on the screen is at its brightest.

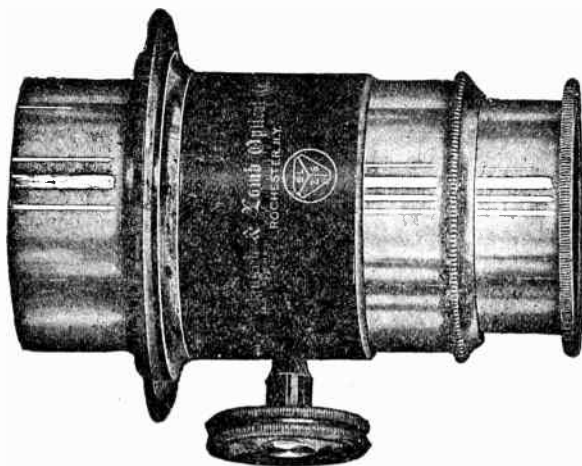
**Ques. What provision should be made where lantern slide and motion picture films are to be used interchangeably?**

Ans. Since the opening in the slide mat is approximately three times that of the moving picture film, it is therefore necessary

to have a lens for lantern slides about three times the focal length of that of the lens used for films.

*It should be noted* that it is possible to match the size of the image in *one dimension only* (either width or height) because the two openings are not proportionate in size; **accordingly, it is necessary in ordering lenses to specify whether the images are to be the same height or width.**

**How to Select a Lens.**—The lens is probably the most important consideration in projection work, for on its selection depend the quality and size of the image on the screen. Not



**FIG. 3,814.**—Bausch & Lomb standard projection lens. *It consists of two combinations fitted into a cell and mounted in a brass tube which slides through a brass tube or sleeve. The focusing is by rack and prism, as shown. Connection is made for spherical and achromatic aberration. Equivalent focus  $2\frac{1}{2}$  to 32 inches, and back focus  $1\frac{1}{4}$  to 30 inches; corresponding diameter of lenses  $1\frac{1}{8}$  to  $2\frac{1}{16}$ .*

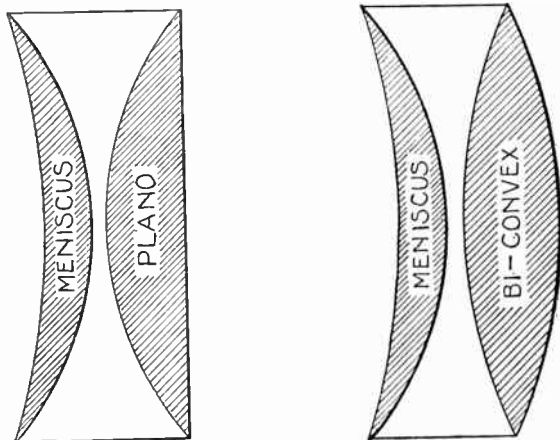
the lens mounting, nor even the diameter of the lens itself, but **its equivalent focus**, and *distance from the screen*, determine the size of the image.

**Ques.** At a given distance how does the size of the image on the screen vary with the focal length?

Ans. The greater the focal length the smaller the image.  
Accordingly short focus lenses give large images.

**Ques. What precaution should be taken in selecting a lens?**

Ans. The lens should not be of such short focus that the magnification will be so great as to sacrifice definition and perspective when viewed by an observer near the screen.



**FIGS. 3.815 and 3.816.**—Two forms of condenser. Owing to its form, the meniscus condenser will intercept and utilize a larger percentage of light ray from the arc than the plano, which means that more light will be transmitted to the film, when a meniscus condenser is used. The meniscus, however, because of being closer to the heat of the arc, is more liable to breakage. A combination consisting of one meniscus, and one bi-convex condenser is recommended.

**Ques. What kind of picture is most desirable?**

Ans. Brilliant pictures of medium size.

**Ques. How should the projection distance be measured?**

Ans. From the slide or film to the screen.

The accompanying tables show the size of image obtained with lenses of different focal length at varying distances. Other sizes, focal lengths and distances can be computed as follows:

**Size of Image.** RULE: *Multiply the difference between the distance from the lens to screen and the focal length of the objective, by the size of the slide and divide the product by the focal length.*

EXAMPLE.—Let  $L$  be the projection distance, 40 feet or 480 inches;  $S$ , the slide mat 3 inches;  $F$ , the focus of the lens 12 inches. The formula for size of image, is

$$d = \frac{S(L-F)}{F}$$

where  $d$  = size of image substituting the given data

$$d = \frac{3(480-12)}{12} = 117 \text{ ins. or } 9\frac{3}{4} \text{ ft.}$$

**Focal Length.** RULE: *Multiply the size of the slide or film opening by the distance from the lens to screen, and divide the product by the sum of the size of the image and the size of the slide.*

Expressed as a formula

$$F = \frac{S \times L}{d + S}$$

substituting the values previously given

$$F = \frac{3 \times 480}{117 + 3} = \frac{1,440}{120} = 12 \text{ ins.}$$

**Distance from Slide to Screen.** RULE: *Multiply the sum of the size of the image and size of slide mat, by the focal length, and divide this product by the size of the slide mat.*

Expressed as a formula

$$L = \frac{F(d+S)}{S}$$

substituting the values previously given

$$L = \frac{12(117+3)}{3} = 480 \text{ ins., or } 40 \text{ ft.}$$



Table showing size of screen image when moving picture films are projected.

Size of Mat opening  $1\frac{1}{2} \times 1\frac{1}{8}$  inch

Equip. Focus Inches	15 ft.	20 ft.	25 ft.	30 ft.	35 ft.	40 ft.	45 ft.	50 ft.	60 ft.	70 ft.	80 ft.	80 ft.	100 ft.
2½	4.8	6.4	8.0	9.6	11.3	12.9	14.5	16.1					
	6.5	8.7	11.0	13.2	15.4	17.6	19.8	22.0					
3½		5.4	6.8	8.2	9.6	10.9	12.3	13.7	16.4				
		7.4	8.3	11.2	13.1	14.9	16.8	18.7	22.4				
8		4.5	5.7	6.8	8.0	9.1	10.3	11.4	13.7	18.0			
		6.2	7.7	9.3	10.9	12.4	14.0	15.6	18.7	21.8			
9½		4.8	5.8	6.8	7.8	8.8	9.8	11.7	13.7	15.7			
		6.6	8.0	9.3	10.6	12.0	13.3	16.0	18.7	21.4			
8		4.2	5.1	6.0	6.8	7.7	8.5	10.3	12.0	13.7	15.4		
		5.8	7.0	8.1	9.3	10.5	11.6	14.0	16.3	18.7	21.0		
11½		4.5	5.3	6.2	6.8	7.7	9.1	10.6	12.2	13.7	15.4		
		6.2	7.2	8.4	9.3	10.5	12.4	14.5	16.6	18.7	21.0		
8		4.8	5.4	6.1	6.8	8.2	9.6	10.9	12.3	13.7			
		6.5	7.4	8.4	9.3	11.2	13.0	14.9	16.8	18.7			
11½		4.3	4.9	5.6	6.2	7.4	8.7	9.9	11.2	12.4			
		5.9	6.7	7.6	8.4	10.2	11.9	13.6	15.3	17.0			
8			4.5	5.1	5.7	6.8	8.0	9.1	10.3	11.4			
			6.2	7.0	7.7	9.3	10.9	12.4	14.0	15.6			
11½			4.7	5.2	6.3	7.3	8.4	9.6	10.6				
				8.4	7.1	8.6	10.0	11.4	13.0	14.5			
8			4.4	4.9	5.8	6.8	7.8	8.8	9.8				
				6.0	6.6	8.0	9.3	10.6	12.0	13.3			
11½				4.5	5.4	6.4	7.3	8.2	9.1				
				6.2	7.4	8.7	10.0	11.2	12.3				
8					5.1	6.0	6.8	7.7	8.5				
					7.0	8.1	9.3	10.5	11.8				

EXAMPLE: With a lens of 5½ inch focus at a distance of 36 ft. the screen image will be 4.3 x 5.9; at 40 ft., 4.9 x 6.7; at 45 ft., 5.6 x 7.6 etc.

Table showing size of screen image when lantern-slides are projected.

Size of Mat opening 2¼ x 3 inches

Equip. Focus Inches	15 ft.	20 ft.	25 ft.	30 ft.	35 ft.	40 ft.	45 ft.	50 ft.	60 ft.	70 ft.	80 ft.	90 ft.	100 ft.
5	8.0	10.8	13.5	16.3	19.0								
	9.8	11.8	14.8	17.8	20.8								
5½	7.3	9.8	12.3	14.8	17.3	19.8							
	7.8	10.7	12.4	16.1	18.8	21.8							
6	6.8	8.8	11.2	13.5	15.8	18.1	20.4						
	7.3	9.8	12.3	14.8	17.3	19.8	22.3						
6½	6.1	8.2	10.4	12.5	14.6	16.7	18.8						
	6.7	8.0	11.3	13.6	15.9	18.2	20.5						
7	5.7	7.6	9.6	11.6	13.5	15.5	17.5	19.4					
	6.2	8.3	10.5	12.6	14.8	16.9	19.0	21.2					
7½	5.3	7.1	8.9	10.8	12.6	14.4	16.3	18.1					
	5.8	7.8	9.8	11.8	13.8	15.8	17.8	19.8					
8	6.0	8.4	10.1	11.8	13.5	15.2	17.0	20.4					
	7.3	9.1	11.0	12.9	14.8	16.6	18.5	22.3					
8½	6.2	7.9	9.5	11.1	12.7	14.3	16.0	18.2					
	6.8	8.6	10.3	12.1	13.8	15.6	17.4	20.9					
9	5.9	7.4	8.9	10.5	12.0	13.5	15.1	18.1	21.1				
	6.4	8.1	9.8	11.4	13.1	14.8	16.4	19.8	23.1				
9½	5.6	7.0	8.5	9.9	11.4	12.8	14.2	17.1	20.0				
	6.1	7.6	9.2	10.8	12.4	14.0	15.5	18.7	21.8				
10	5.3	6.6	8.0	9.4	10.8	12.2	13.5	16.3	19.0	21.8			
	5.8	7.3	8.8	10.3	11.8	13.3	14.8	17.8	20.9	23.8			
11		5.5	6.6	7.8	8.8	10.1	11.2	13.5	15.6	18.1	20.4		
		6.0	7.3	8.5	9.9	11.0	12.3	14.9	17.3	19.8	22.3		
11½			5.6	6.6	7.6	8.6	9.9	11.6	13.5	15.5	17.5	19.4	
			6.2	7.3	8.3	9.4	10.5	12.6	14.6	16.9	19.0	21.2	
12			5.8	6.6	7.5	8.4	10.1	11.6	13.5	15.2	17.0		
			6.3	7.3	8.2	9.1	11.0	12.9	14.8	16.8	18.8		
12½			5.1	5.8	6.6	7.4	8.8	10.5	12.0	13.5	15.1		
			5.8	6.4	7.3	8.1	9.8	11.4	13.1	14.8	16.4		
13				5.3	6.0	6.8	8.0	9.4	10.6	12.2	13.5		
				5.8	6.5	7.3	8.8	10.3	11.9	13.3	14.8		
13½				5.4	6.0	7.3	8.5	9.8	11.0	12.3			
				5.9	6.6	7.9	9.3	10.7	12.0	13.6			
14					5.5	6.6	7.8	8.9	10.1	11.2			
					6.0	7.3	8.5	9.8	11.0	12.3			

EXAMPLE: With a lens of 10-inch focus at a distance of 20 ft. the screen image will be 5.3 x 5.8; at 25 ft., 6.6 x 7.3; at 30 ft., 8.0 x 8.8; at 50 ft., 13.5 x 14.8 etc.

**Motion Picture Machines.**—The term motion picture machine is the proper name of the apparatus used in projecting motion picture film upon a screen; the use of such expressions as projector, graphoscope, etc., should be avoided.

The function of a moving picture machine, as stated, is to project motion pictures upon a screen, in distinction from a motion picture camera used for motion picture photography. Some of the "coined expressions" are both ill advisedly and erroneously used.

A motion picture machine may be said to consist of:

1. An optical system, comprising

a. Source of light;

b. Lens { condenser;  
objective.

2. Intermittent film feed system, comprising

a. Upper reel;

b. Upper steady feed sprocket;

c. Steady drum;

d. Film gate;

e. Intermittent sprocket;

f. Intermittent movement;

g. Shutter;

h. Lower steady feed sprocket;

i. Lower reel;

j. Lower reel drive;

k. Operating crank and drive;

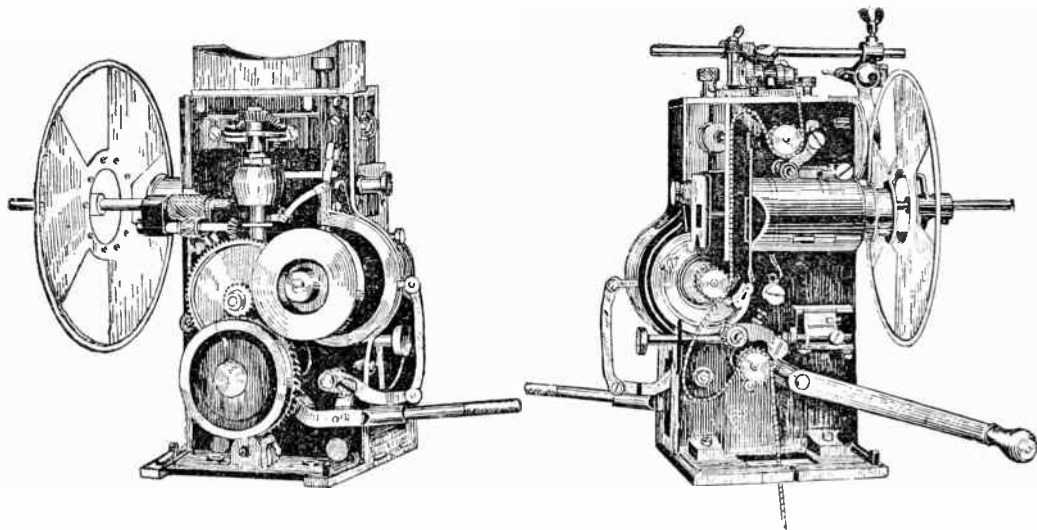
l. Numerous presser rollers.

Besides these various essential parts, safety devices such as, fire shutter, fire valves, film shields, etc., are provided.

The elementary moving picture machine shown in fig. 3,819 is so drawn that every part can be seen; it does not represent any particular machine but is intended to give a clear idea of how the film is fed across the film gate intermittently and the synchronous operation of the shutter whereby the light is cut off from the screen during each movement of the film, with alternate "on" intervals while the film is at rest.

**Ques.** Upon what property of vision is moving picture projection based?

Ans. Upon the "*persistence of vision.*"



Figs. 3,817 and 3,818.—Simplex motion picture machine. Fig. 3,817 shows the right side with film covers and upper magazine fire valve removed from the top. The valve consists of one large steel roller and two smaller ones which are set at an angle of 45 degrees. They bear against the film top and bottom, and protect the reel from fire. Fig. 3,817 shows also the revolving shutter and shutter mechanism. The three wing shutter shown is used with direct current, but on A. C. circuits of 60 cycles or less a two wing shutter is recommended as it does not intercept the light periods in step with the alternation of the arc. A three wing shutter used with alternating current is liable to get into synchronism with the alternations of the arc and cause a wavy effect in the light similar to a bad flicker. The shutter may be set during operation by turning the knurled knob located alongside the framing handle, thus avoiding ghosts or white streaks. Fig. 3,818 shows right side of machine with fireproof covers removed; it also shows clearly the path of the film through the machine.

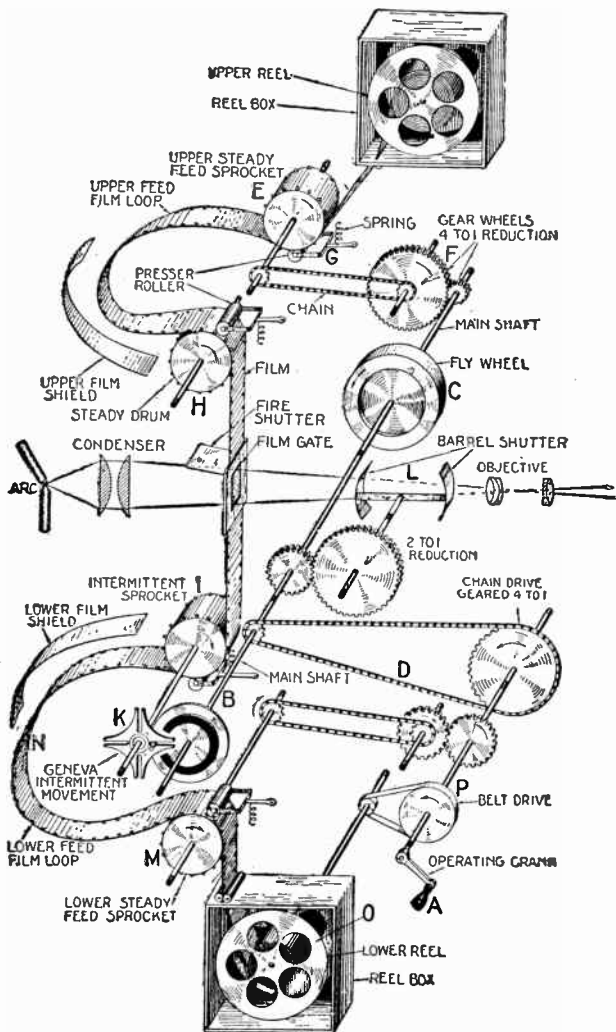


FIG. 3,519.—Elementary moving picture machine without case, showing essential parts.

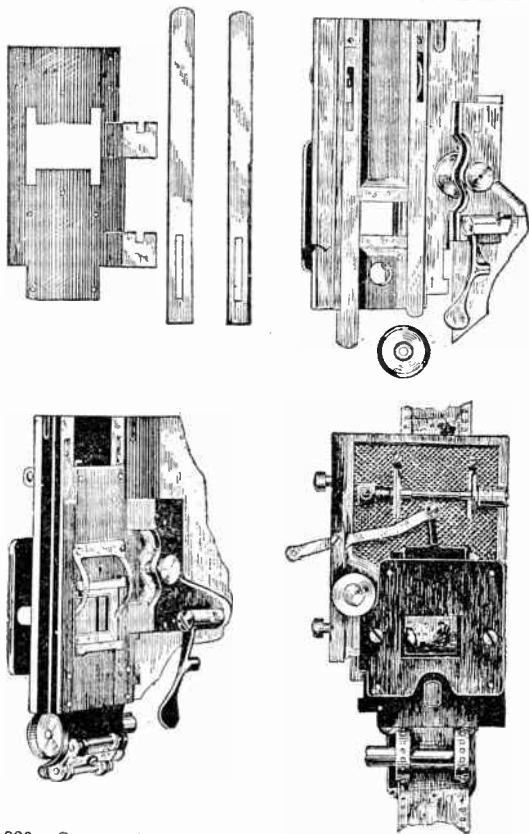
**Ques. Define persistence of vision.**

Ans. It is that property of the eye by which vision remains or *persists* for a short interval after the thing viewed has vanished.

Owing to the persistence of vision, when two views are seen with an interval of not more than one fiftieth of a second between the two, the eye blends the two and accordingly does not appreciate the interval of darkness which has occurred between the two, as is demonstrated in moving picture projection.

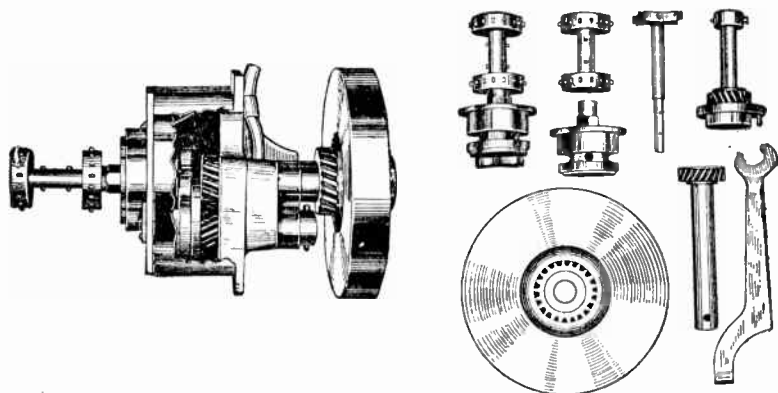
**Ques. Describe briefly the operation of the elementary motion picture machine shown in fig. 3,819.**

Ans. By turning the operating crank A, counter clockwise, the main shaft B, is driven through the 4 to 1 reduction chain drive D, a steady turning motion being caused by the fly wheel C, this in turn operates the upper steady feed sprocket E, through the 4 to 1 reduction gear F, thus the teeth of E sprocket which mesh with the perforations in the film, feed the film at a constant rate, the film being held against E by pressure roller G. A film loop or length of loose film is thus maintained between E and the steady drum H. The film is fed past the film gate intermittently by the intermittent sprocket I, operated by the Geneva movement K, the latter producing a quick quarter turn of I, followed by a relatively long rest during which the main shaft B, makes one revolution. The barrel shutter L, by a 2 to 1 gear with the main shaft and proper timing, operates to cut off the light rays from the screen during each movement of the intermittent sprocket I, and to admit the light during the intervals that I remains stationary. The synchronous operation of the intermittent sprocket and the shutter is very clearly shown in the diagram. A lower steady feed sprocket M, which operates at the same speed as the upper sprocket E, maintains a lower feed film loop N, and feeds the film to the lower reel O. Because of the increasing diameter of the roll of film due to winding the film on reel O, the velocity of rotation of O must be



**Figs. 3,820 to 3,826.**—Construction details of Simplex film gate. It is made of machine steel, the lugs securing the gate to the holder being electrically welded. Fig. 3,820 represents milled surfaces. The film trap shoes (figs. 3,820, 3,825), are of steel ground on both sides and beveled (fig. 3,820) to permit sliding into the dove tail slots (fig. 3,823). The lateral guide rollers (fig. 3,824 and 3,826) are of steel hardened and ground; the film cannot pass the guide rollers unless it be set between the two. If it should not be, it automatically rights itself. The distance between the rollers is adjustable by a set collar (fig. 3,826). The gate (fig. 3,825) is opened for threading by a light inward pressure on a thimble (fig. 3,826), and is closed by releasing the film trap door trip lever (fig. 3,825). Thus, in threading, there are only two operations: one to open, and one to close the gate. The intermittent sprocket tension shoe is made of ten pieces of hardened tool steel. The two inside shoes are offset and do not touch the film. The cooling plate (fig. 3,826) is made of two pieces of sheet steel separated  $\frac{1}{4}$  inch, which arrests the heat by radiation and protects the fire shutter and aperture side of the film trap. The air space between the film trap is  $\frac{1}{2}$  inch.

allowed to vary; this is accomplished by means of the belt drive P, the belt permitting slippage below the maximum speed. *It should be carefully noted that the total revolutions made by each of the three sprockets E, I, and M, is the same, the only difference being that the motion of E and M is constant while that of I is intermittent.*



**FIGS. 3,827 to 3,835.**—Construction details of an intermittent sprocket and intermittent movement. Fig. 3,827, intermittent sprocket and intermittent movement with case broken to show interior; figs. 3,828 to 3,835, parts. The intermittent movement is of the Geneva type arranged to run in oil. The case is in two pieces, consisting of box and screw cover, as shown in fig. 3,827. "Framing" of the film is accomplished by advancing or retarding the intermittent movement by a device for turning the intermittent box forward or backward. The revolving shutter synchronizes automatically by a cam system.

**Ques.** What is the object of the upper and lower feed loops.

**Ans.** To lessen the inertia of the film by reducing the length of film subject to the sudden intermittent motion.

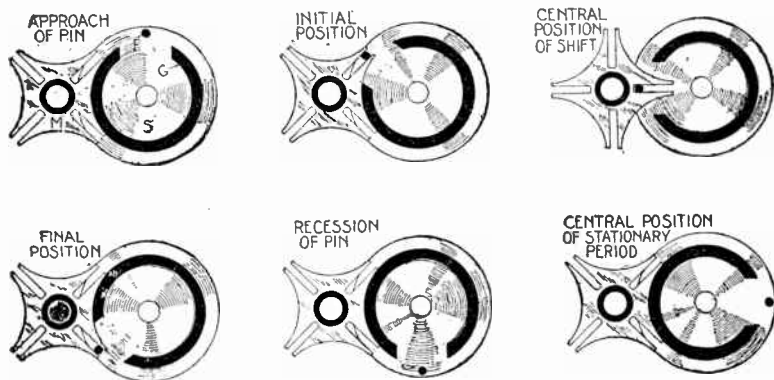
**Ques.** What duties are performed by the film gate?

**Ans.** It guides the film so as to prevent any lateral motion,

flattens the film, and by frictional resistance, prevents the momentum of the film causing any up and down vibration.

**The Intermittent Movement.**—Various devices have been introduced for producing the intermittent movement necessary in projecting motion pictures. The movement consists essentially of an intermittent sprocket and intermittent gear.

The sprocket is a cylinder with teeth at each end, or for very light construction, it may consist of two hubs provided with teeth and



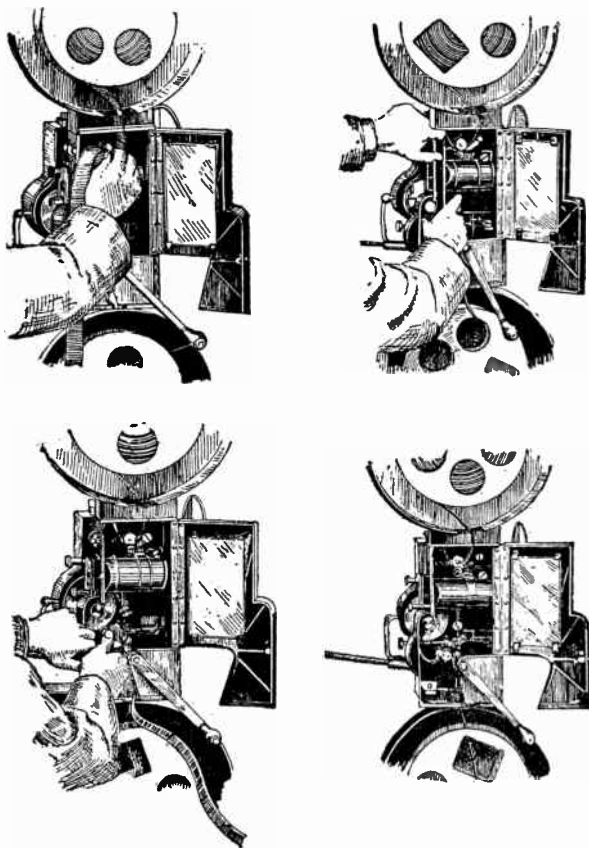
**Figs. 3,836 to 3,841.**—Diagrams showing progressively the operations of the Geneva intermittent movement. Fig. 3,836, approach of pin; fig. 3,837, initial position or beginning of the movement; fig. 3,838, mid-position; fig. 3,839, final position or end of the movement; fig. 3,840, recession of the pin; fig. 3,841, mid-position of stationary period. The Geneva movement consists of a maltese cross M and a disc S provided with a pin F and circular guide G. *In operation*, the pin disc S is in continuous motion and the pin is so located that it enters one slot of the cross M, and carries it along with it, thus causing one-quarter revolution. The circular guide G is cut away sufficiently to allow the cross to make a quarter revolution, but when it registers with the cross it holds the latter securely until the pin rotates around to the next slot.

properly spaced on a shaft to take the film. The teeth mesh with perforations of the film and thus secure a positive movement.

Of the various intermittent movements, the Geneva is extensively used and easily understood. Its operation is shown progressively in figs. 3,836 to 3,841.

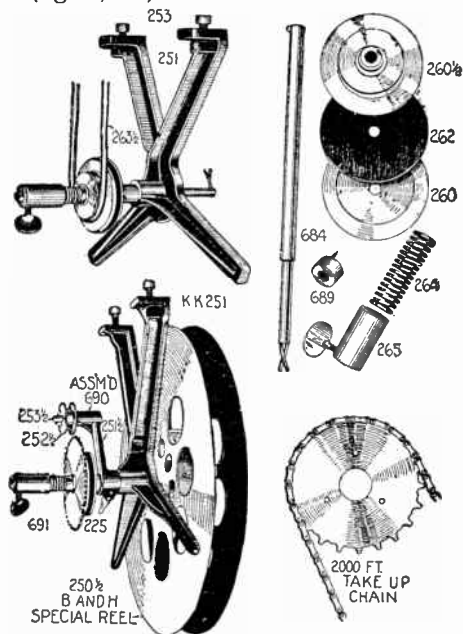
**Ques.** What is the nature of the Geneva intermittent motion?





**Figs. 3,842 to 3,845.**—“Threading” a typical motion picture machine. Fig. 3,842 illustrates the method of threading the film through the film trap by forming the upper loop with the second finger of the left hand and gripping the film below the intermittent sprocket with the first finger. Fig. 3,843 illustrates how the film is threaded through the film trap by forming the upper loop with the second finger of the left hand and gripping the film below the intermittent sprocket with the first and third fingers of the right hand and closing the film trap gate by tripping the film trip lever with second finger. Fig. 3,844 illustrates the method of forming the lower loop, threading the film over the lower feed sprocket and closing the lower feed sprocket roll arm by a downward pressure with the first finger of the right hand. The film is then inserted through the fire valve by means of the slot in the base of the mechanism and is then fastened on to the lower reel so as to rewind to the right. Fig. 3,845 shows the machine completely threaded from the top reel to the feed sprocket through the film trap and on to the lower feed sprocket and the take up reel.

Ans. The motion begins slowly, (fig. 3,837), accelerates to a maximum at the mid position (fig. 3,838) and gradually slows down to zero (fig. 3,839).



**Figs. 3,846 to 3,855.**—Simplex take up device. Fig. 3,846 belt drive for small reels; fig. 3,854, chain drive for large reels; figs. 3,847 to 3,853, parts. The take up is the equivalent of the belt drive P, fig. 3,819, that is, it performs the same function, viz.: to rotate at variable speed the lower reel upon which the film is wound. Instead of securing the variable speed by belt slippage, a friction disc clutch is provided. Part 260 is the driving side of the disc and is directly connected to the take up shaft 684. The leather friction washer 262 is 3" diameter by  $\frac{1}{4}$ " thick; it operates between friction disc 260 and pulley 260 $\frac{1}{2}$ . The driving pulley 260 $\frac{1}{2}$ , driven by belt 263 $\frac{1}{2}$ , is forced to bear against leather washer 262 by spring 264, which is kept in place by a thimble and set screw 265.

**Ques.** Describe a variation in construction details.

Ans. Instead of only one pin on the disc, there are sometimes two.

**Ques.** How may the relative periods of rest and motion be varied?

Ans. By making the disc large in proportion to the cross.

The interval of movement can be reduced as much as desired in proportion to the interval of rest, but the characteristic features of starting and stopping the film gradually will be lost directly in proportion as the ratio between disc and cross sizes is increased.

**Ques. How is the Geneva movement sometimes arranged in construction?**

Ans. Provision is sometimes made for the movement to be run in oil.

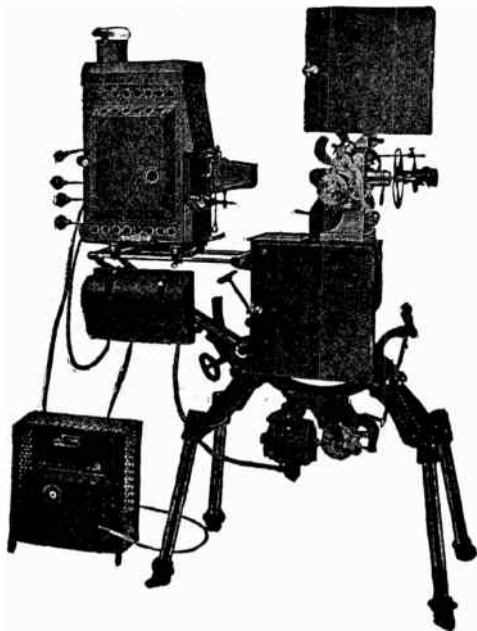


FIG. 3,856.—Power's motion picture machine or Cameragraph; view showing lamp house and machine with covers removed, exposing mechanism.

**Illumination for Motion Picture Projection.**—Both gas and electricity are used to produce illumination for motion picture projection. The electric arc is universally employed wherever electric current is available, but in many rural districts where

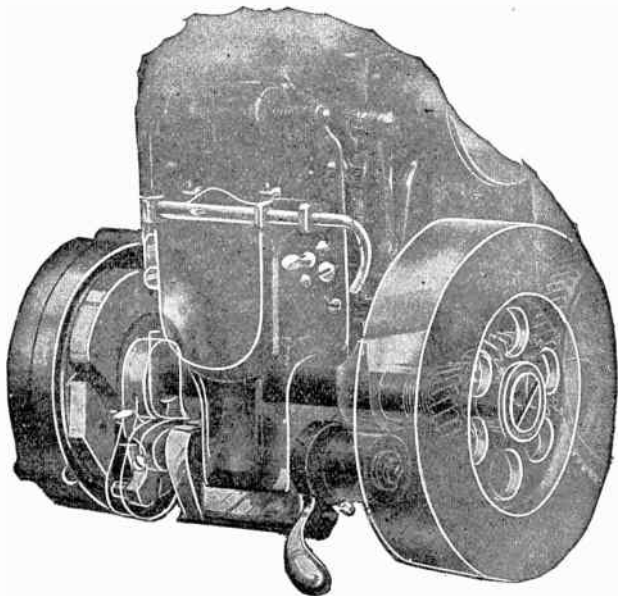


FIG. 3,857.—Powers' intermittent movement. The driving element is a diamond-shaped revolving surface which projects from the disc, the latter being attached to the main spindle or shaft. A locking ring for the driven element is also formed on the face of the disc in such relation to the diamond that the driven element passes from engagement with the diamond to engagement with the ring. The driven element consists of a cross as shown with intermittent sprocket spindle formed out of a block of drop forged tool steel. The intermittent movement is arranged to run in oil.

electricity cannot be obtained, gas is used and gives satisfactory results. Several kinds of gas are used for illumination.

Burners for use with these gases are shown in the accompanying cuts, also some types of generator or gas making outfit.

**The Electric Arc.**—The subject of electric arcs has been presented at length in Guide No. 9, and it is only necessary to treat here of its special adaptation to optical projection.

The only modification of the ordinary arc required to adapt it for use in the optical lantern is to make it as much one sided as possible, that is to say, to so arrange it that *as much of the light as possible will be thrown toward the condensers.*

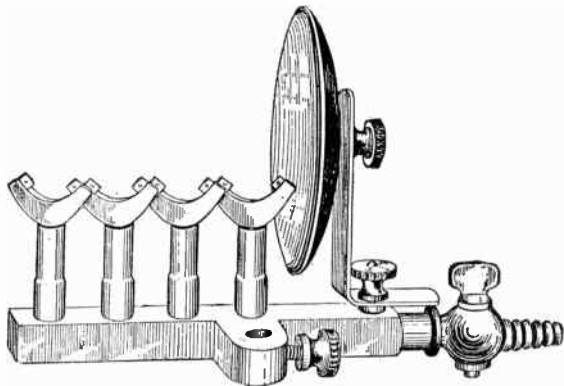


FIG. 3,858.—Challenge multi-tip acetylene burner. It has eight tips set in pairs at an angle. The gas comes from each set at an upward and inward angle, meeting to form one flame.

**Ques.** What kind of current is used for the arc?

Ans. Either direct or alternating

**Ques.** How is the direct current arc connected?

Ans. The positive pole is connected to the upper carbon of the lamp and the negative pole to the lower carbon.

**Ques.** How are the carbons adjusted for direct current motion picture arc?

Ans. The carbons are placed end to end in a straight line except that the axis of the lower one is slightly in advance of that of the upper one as in fig. 3,859. To bring the maximum light upon the condensers the carbon must be inclined about  $25^{\circ}$ .

If inclined too much, the end of the lower carbon will throw a shadow upon the condenser; if not enough, the maximum light is not projected upon the condenser.

**Ques. How are carbons adjusted for direct current stereopticon arc?**

**Ans.** The carbons are set at right angles, positive carbon horizontal, and negative carbon vertical, as in fig. 3,860.

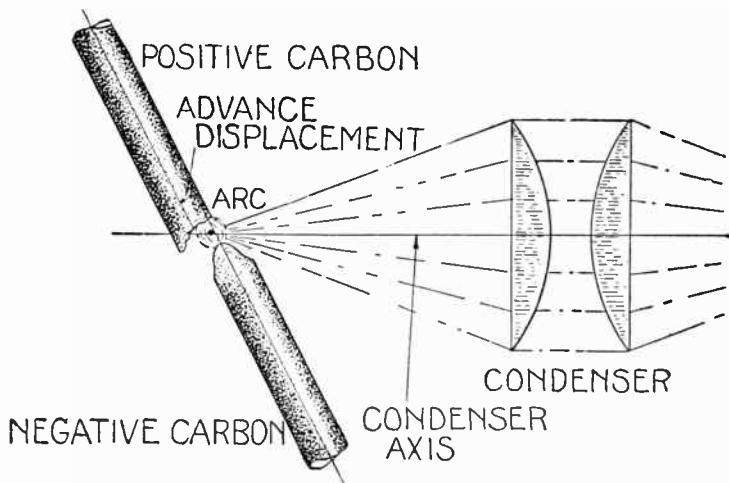


FIG. 3,859.—Motion picture arc for direct current. *The advance displacement, say  $\frac{1}{8}$  inch, causes the upper carbon to burn with a diagonal end containing the brilliant crater and the light is accordingly thrown toward the condenser.*

That is to say, the positive carbon is set in the axis of the condenser with the negative carbon at right angles.

**Ques. What troubles are encountered with alternating current arcs?**

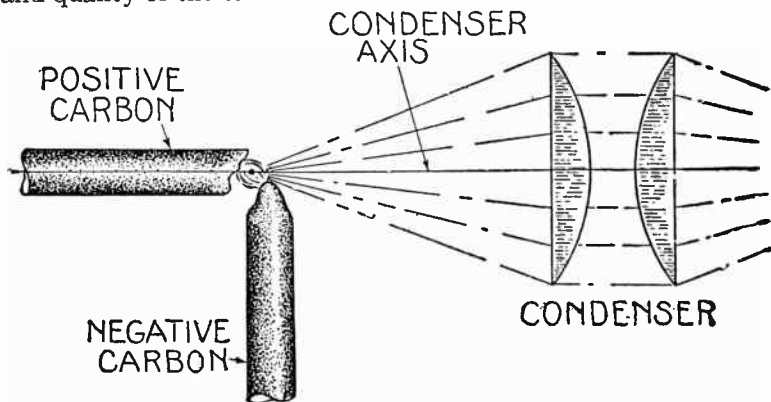
**Ans.** Two craters are formed and if the light from both is to be used, a very careful setting and adjustment is necessary to avoid poor illumination and a double spot at the center of the screen.

**Ques.** What kind of carbon should be used for alternating current arcs?

**Ans.** Cored carbons.

**Ques.** For angular settings, how does the angle of carbon vary?

**Ans.** It varies with the amount of current used, and the size and quality of the carbon.



**FIG. 3,860.**—Stereopticon arc for direct current. *This setting* does not give as brilliant an arc as fig. 3,859, when a long arc is used, but for a short arc the carbons become so near that an arc of more brilliancy than fig. 3,859 is obtained.

**Ques.** In operation how is the proper angle secured?

**Ans.** By varying the angle, that is "rocking" the carbons while watching the screen till the best illumination is secured.

**Ques.** How is the light centered?

**Ans.** By moving the arc in a direction opposite to that in which it is desired to move the bright spot on the screen.

**Ques.** Describe the lamp adjustments.

**Ans.** There are four adjustments: 1, vertical, 2, lateral, 3, focusing, and 4, feed.

### Ques. How is the arc started or "struck?"

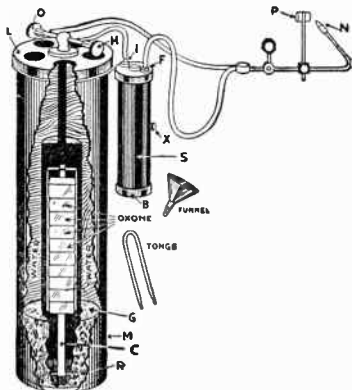
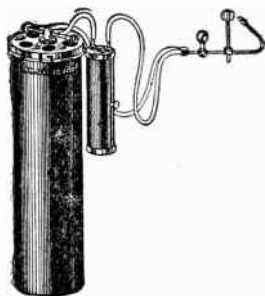
Ans. Bring the carbons together by turning the proper knob, then reverse and draw them apart until the proper arc is secured.

### Ques. What is a proper arc?

Ans. An arc of medium length.



FIG. 3,861.—Fulco pastil adapter. By means of this device the Guil pastil may be used with any calcium burner. The main portion of the adapter is a hollow shell which serves as a receptacle for the pastil when not in use.



FIGS. 3,862 to 3,865.—The Economic calcium light; makes its own gas automatically from oxone and ether. Fig. 3,863 shows section view of interior of outfit. The parts are: M, main tank; L, cover for tank; G, gas bell or chamber; C, container for holding charge of oxone; R, wire rod for supporting container in position; O, needle valve controlling flow of oxygen gas direct to burner; H, needle valve controlling flow of gas through saturator S which causes ether vapor (hydro-carbon gas) to flow to burner; S, saturator; I, inlet connecting with nipple of needle valve H; F, filler plug; X, overflow; B, bottom cap of saturator; P, pastil; N, nozzle of burner.



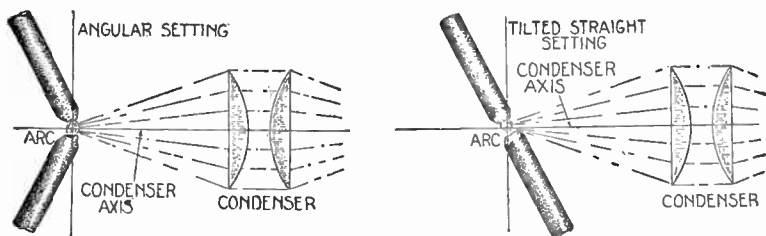
### Ques. What are the characteristics of a long arc?

Ans. The crater is at less than maximum brilliancy and the current is reduced.

### Ques. How is the feeding of the carbon gauged?

Ans. By observation through the peep hole in the lamp house, or by the sound produced by the arc.

**Auxiliary Apparatus.**—Various devices are necessary for the proper and safe control of the electric arc used in motion picture projection.



**FIG. 3,866.**—Arc setting for alternating current arc with cored carbons. When cored carbons are used, the crater will form in the end of the core, keeping in the center of the carbon pencil, and the vapor of the soft core will hold the arc between alternations. Without cored carbons, an alternating current arc has a tendency to run to the nearer edges of the carbons with loss of brilliancy upon the condensers.

**FIG. 3,867.**—Tilted straight setting for alternating current arc carbons. The lower carbon is placed a little ahead of the upper carbon. This tends to draw the crater of the upper carbon forward, thus improving the light on the condenser, but if the carbons be tilted too much the lower carbon will obstruct light from the lower part of the lens. The carbons must be in perfect alignment in a vertical plane, passing through the arc and axis of condenser.

Each installation will require proper fuses and switches in accordance with the Underwriters' regulations.

Rheostats are required with direct current to regulate the voltage so as to obtain best results with the arc. Rheostats should never be used on alternating current circuits for permanent installation as they are very wasteful in comparison with transformers.

On alternating current circuits when it is considered that the hand feed arc lamp used requires only about 30 to 35 volts, while the alternating current is supplied at from 104 to 250 volts, it is obvious that there is a large percentage of current wasted unless a transformer having a proper transformation ratio be used.

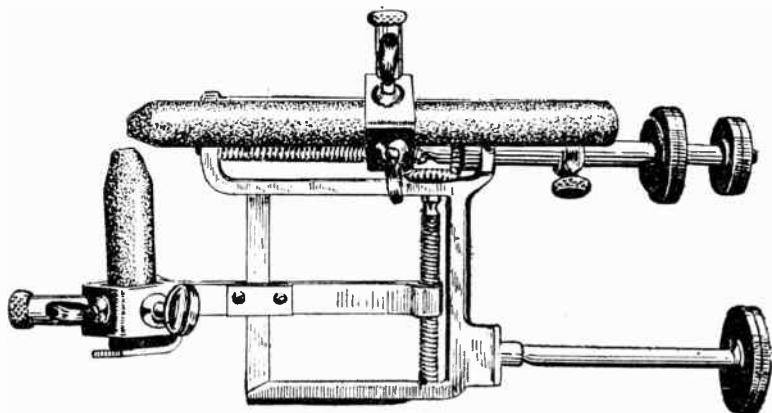
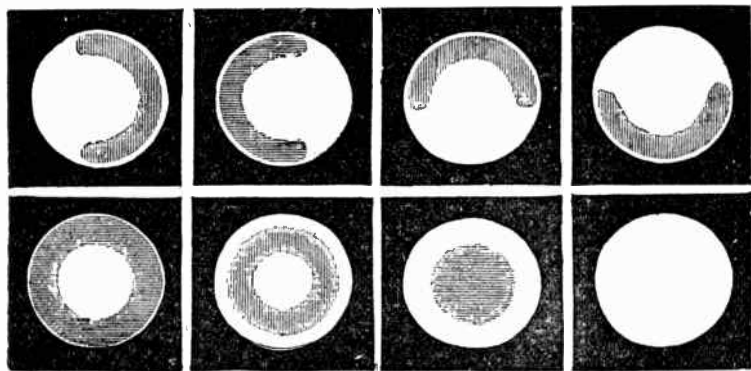
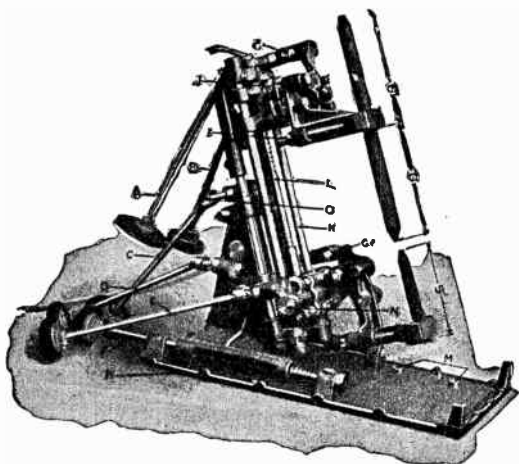


FIG. 3,868.—Ninety degree or right angle arc lamp. With the  $90^\circ$  setting, the arc can be kept nearer in line with the center of the lenses for a greater length of time, without re-adjusting the carbons, because of the horizontal carbon being in line with the principal optical axis and fed directly toward the center of the condenser.



FIGS. 3,869 to 3,876.—Bausch & Lomb diagrams illustrating the results of defective centering, that is, the shadows produced. Successful results in projection depend largely upon the correct adjustment of the lamp, which must throw a brilliantly illuminated circle upon the screen. After the objective is focused, as will be evidenced by a sharp, clear image on the screen, remove slide and slide holder, and examine the illuminated circle. If the light be centered and the lamp correctly adjusted, the circle will be entirely free from coloration or shadows. In figs. 3,869 and 3,870, the crater needs to be properly adjusted laterally, it being as shown too far to the right or left; figs. 3,871 and 3,872, show the crater too high or too low; in figs. 3,873 to 3,875, it is too near or too far from the condenser's fig. 3,876 shows it to be in correct position, the field being entirely clear.



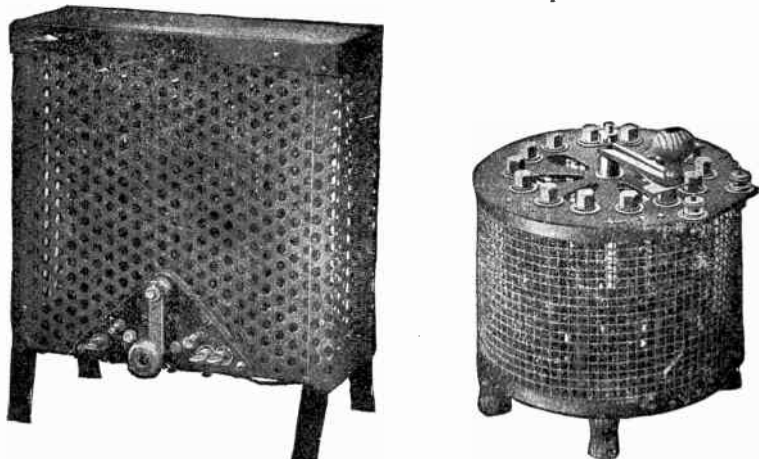
**FIG. 3,877.**—Simplex arc lamp. The carbon holders are furnished to accommodate carbons of  $\frac{1}{2}$ " to  $\frac{1}{4}$ " diameter and 12" upper and 6" lower in length, carrying capacity 75 amperes. There are eight adjustments, six being accessible from the back of the lamp house; and two, to alter the angle of the carbon, from the inside. The lamp can be withdrawn from the back of the lamp house, so that all parts are readily accessible.



**FIG. 3,878.** Powers' arc lamp. Carrying capacity 100 amperes. All adjustments are accomplished from the outside of the lamp house. Carbon range from  $\frac{3}{8}$ " to  $\frac{1}{4}$ " in diameter, 6" length for lower and 12" length for upper carbon. The carbon may be placed at any angle desired, and can be moved independently of each other, forward, backward and sideways, or the whole lamp can be swung forward or backward, laterally, and up and down.

**The Film.**—This is made of celluloid, being similar to the film used in ordinary cameras, excepting that it comes in long strips, one thousand or more feet in length.

The size of each picture on the film is  $\frac{1\frac{1}{16}}$  inch high by  $\frac{1\frac{5}{16}}$  inch wide. The film is  $1\frac{3}{8}$  wide which leaves a margin on each side of the pictures for the holes which mesh with the sprocket teeth. These



FIGS. 3,879 and 3,880.—Powers' rheostats. The type shown in fig. 3,879 is designed for use on 110 volt circuits and will carry 25 amperes without overheating. The coils are so supported that any of them may be replaced when desired. Adjustment is effected by means of a lever switch. Fig. 3,880 shows Underwriters' pattern rheostat of 25 amperes capacity. It is designed for 110 volts and is not adjustable.

holes are about  $\frac{3}{16}$  inch apart. At present there is no standard as to the spacing of the holes, but as in other lines, the makers will sooner or later adopt a standard.

**Ques.** How is film treated by the manufacturer before shipment?

**Ans.** It is treated with glycerine.

This keeps the film pliable, and delays drying out.

**Ques.** What precaution should be taken with film?

Ans. Because of its inflammable character it must always be kept in fire proof enclosures.

**Ques. How is film repaired?**

Ans. Usually by cutting out the defective part and splicing the ends together.



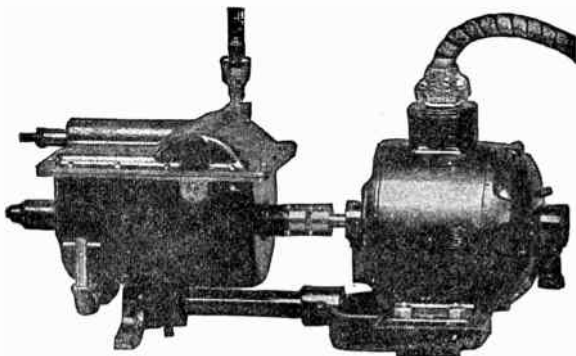
**FIG. 3,881.**—Powers' multi-tap transformer. It is without casing and is mounted on heavy legs which support it several inches above the floor. The numerous leads are properly marked as shown, to distinguish them.

**Ques. How is a splice made?**

Ans. Cut one end on the line between pictures and cut the other end with a quarter picture on; thus in cutting a film there will be three quarters of a picture cut out, a picture and three quarters, etc. Moisten the gelatine on the quarter picture and scrape it clean, also scrape the celluloid side of the other end



**Figs. 3,882 to 3,884.**—Various film perforations. These are called: fig. 3,882, round; fig. 3,883, square; fig. 3,884, barrel. The square and barrel holes seem to be more durable than the round hole. The shape of the holes should correspond to the shape of the sprocket teeth. A standard perforation is four pairs of holes per picture, each hole being approximately  $\frac{1}{16} \times \frac{3}{32}$ , spaced along the edges of the film  $\frac{1}{16}$  inch apart, making four holes at each edge for a  $\frac{3}{4}$  inch motion picture image.



**FIG. 3,885.**—The arc controller or device designed to control the rate of feed of the carbons of an arc lamp, with the object of maintaining at all times a predetermined size of arc. *It consists* of the controller proper, direct coupled to a fractional horse power motor. There are two shafts, primary and secondary. The former, which is direct coupled to the motor, carries governor parts, and rotates constantly at the motor speed. The secondary, to which the telescope rod is geared, remains idle until the speed of the primary shaft exceeds the point of adjustment. The adjustment for any preferable size of arc is made with a brass adjusting nut upon a rod projecting from the cover of the controller. The inner end of the rod is connected through a heavy wire spring to a pawl, the function of which is to "step in" and transmit the power to the primary, through differential gearing to the secondary shaft, at the slightest tendency of the arc to become wider than the predetermined size adjusted for. The installation of the arc controller does not interfere with any of the lamp adjustments already provided. The operator may trim as he pleases, and feed by hand if he choose, by loosening a thumb screw at the feed handle gearing. Having loosened the thumb screw and trimmed the lamp, the operator strikes the arc by hand and makes the original and only feeding adjustment, by parting the carbons to the size of arc that he wishes to maintain; he then tightens thumb screw, and sets adjusting nut at the controller so that feeds do not occur below that size; the controller will then feed the carbons to that certain size of arc without further attention. To increase size of arc, tighten adjusting nut; to decrease size, loosen nut.

clean. Spread cement on the cleaned quarter picture space and fit it on the back of the other end, sticking the two ends together with the picture lines matching and the sprocket holes matching. Cut either through a sprocket hole or midway between sprocket holes straight across the film.

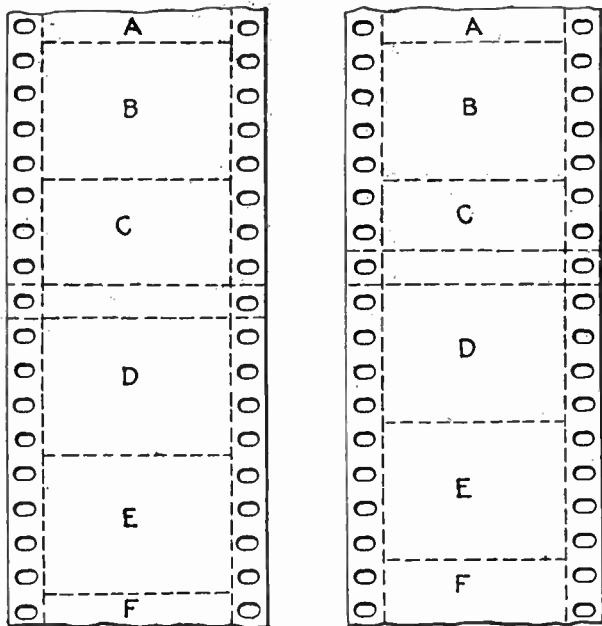
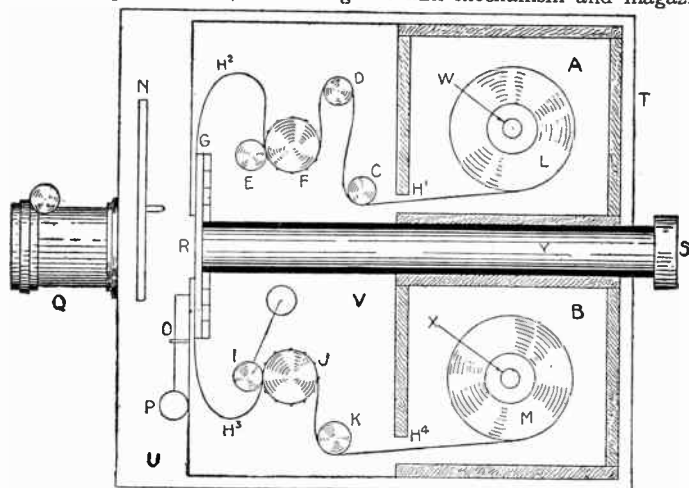


FIG. 3.886.—Splice in frame. The picture C has four holes at the side, just as have the pictures A, B, D, E, etc., and when that film is passed through the film gate and intermittent mechanism, the framing will be preserved, because mechanically the film is the same in distribution of pictures and of sprocket holes as though no splice had been made. The difference is found in the "jump" of the pictures when one or more pictures have been omitted, but the "frame" will not be disturbed as the splice passes.

FIG. 3.887.—Splice out of frame. The picture C has but three holes at the side. Hence, when the picture B is pulled out of the film window and C is pulled in, the intermittent sprocket pulling down four holes will pull into the film window the three-quarter picture C, and also the top quarter of the whole picture D. At the next shift, the intermittent sprocket pulls down another four holes, pulling into the film window the remaining three-quarters of D, and the top quarter of E, etc. This continues until the operator notices the screen and frames with his lever. This is called a splice "out of frame" because the splice throws the picture out of frame in passing.

**Motion Picture Cameras.**—Apparatus for taking motion pictures differs in many ways from ordinary cameras. Fig. 3,888 is a diagram showing the essential parts of a motion picture camera.

There are three compartments: 1, a front compartment U containing a rotating shutter N, pin mechanism OP, and other parts not shown; 2, a compartment V, containing the film mechanism and magazines,



**FIG. 3,888.**—Diagram of motion picture camera showing the essential parts. Cameras are built for various numbers of picture per turn of the crank; four, six, and eight are common. An eight picture camera should be run at a speed of almost one hundred turns per minute. To operate at this speed, get a watch ticking 300 ticks per minute and learn to count one, two, three; one, two, three, etc., just as fast as the watch ticks, turning the crank one revolution for every one, two, three counted; that is to say, one revolution per every three ticks of the watch.

and 3, a compartment on the opposite side containing mechanism communicating with the spools in the magazines, with the sprocket wheels, and the points in the first compartment.

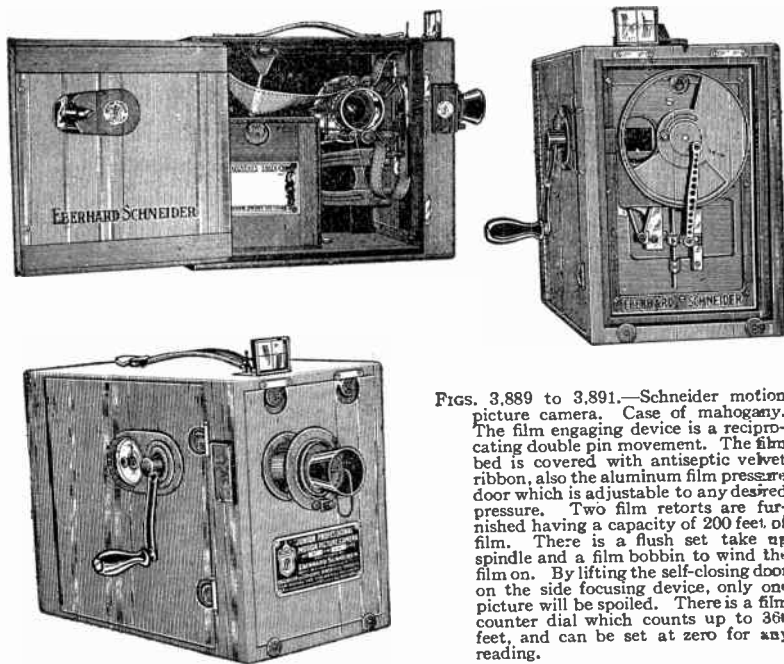
The two magazines A, B, consisting of light boxes, fit into the back portion, and carry reels, W, X, on which the film is wound.

**In operation,** the roll of unexposed film L, which passes out of a small aperture H' at the corner of the top magazine A, around guide rollers C, D, engages by its perforations with the sprocket wheel F, to which it is kept by the roller E. The film forms a loop at H<sup>2</sup> and passes downward through the guide grooves made in the gate G.



Continuing, it passes out past the bottom of the gate, forming a second loop  $H^3$ , and then passes between a spring roller I and sprocket J, under the guide roller K, and enters at  $H^4$  the lower magazine B when it is wound up on the bobbin X.

The sprocket wheels rotate continuously drawing the film from the supply at L and taking it up at M.



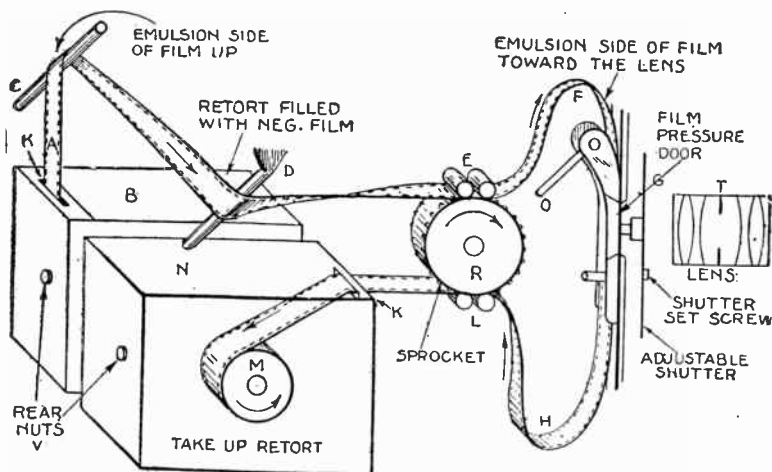
FIGS. 3,889 to 3,891.—Schneider motion picture camera. Case of mahogany. The film engaging device is a reciprocating double pin movement. The film bed is covered with antiseptic velvet ribbon, also the aluminum film pressure door which is adjustable to any desired pressure. Two film retorts are furnished having a capacity of 200 feet of film. There is a flush set take up spindle and a film bobbin to wind the film on. By lifting the self-closing door on the side focusing device, only one picture will be spoiled. There is a film counter dial which counts up to 360 feet, and can be set at zero for any reading.

The motion of the film in the gate G, however, is intermittent. During the period of rest, a surplus loop of film forms at  $H^2$ , which is then pulled down through the gate by the action of the pin O, engaging with the perforations.

The whole mechanism is so arranged and geared together that, while the film is being shifted, the light is excluded from the lens, and admitted during the stationary periods.

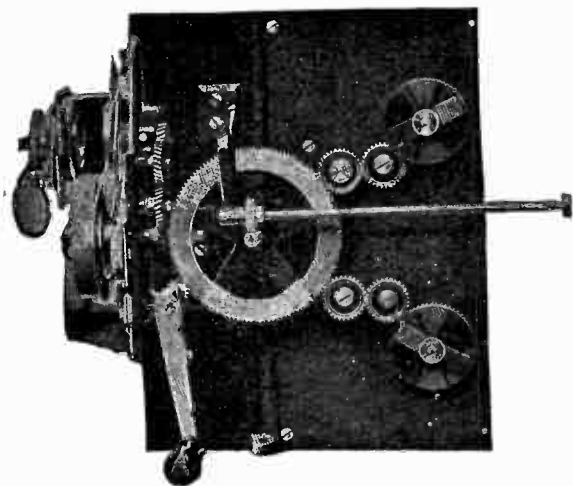
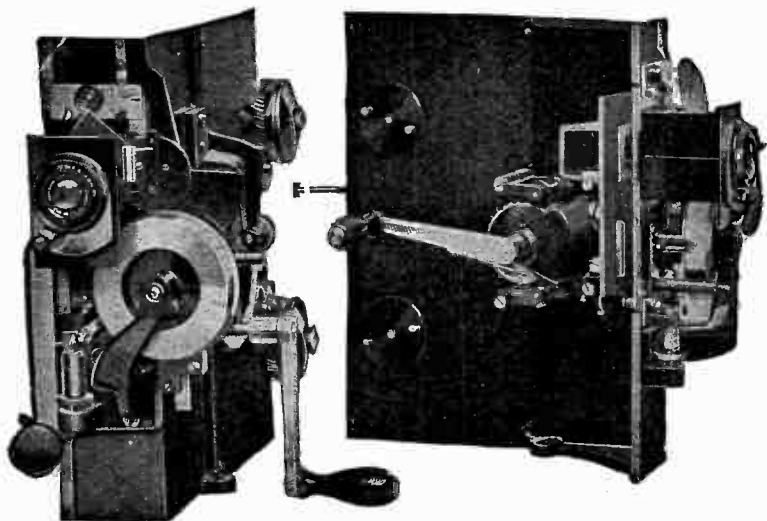
A long tube V extends through the center of the camera, and is provided with a detachable cap at S. This tube forms the sight hole for inspecting the image on the film, prior to exposure.

The gate G is a kind of hinged door with an aperture in it, and its function is to keep the film flat and vertical during exposure and also to act as a channel or guide.



**FIG. 3,892.**—How to use the Schneider camera. Open the doors on both sides of the camera by opening locks, fill retort B in dark room with perforated, sensitive negative film A of reliable manufacture, close cover and secure retort B, with nut, screw V into the camera box; lead film A through film gate K of retort B, with nut, screw V into the camera box; in passing over guide roller C. Now lead the film under guide roller D so the emulsion side of the film will lay against this roller D, then lead the film over the large sprocket R under the two film pressure rollers E and be sure that the teeth engage the holes in the film and not between the holes, also make sure that the film lays straight over the large sprocket R make a few turns of the sprocket to obtain more slack of film, lift pressure door G with the ring finger of right hand and place the film straight into the aperture track, leave enough slack for loop F and let the door go, but make sure that the door presses on the film. Now leave enough slack for under loop H and pass the film between sprocket and pressure rollers L through retort gate K on to bobbin M of retort N. Make another turn of sprocket R and see that the film is guided properly between all members and that the loops are there and that bobbin M takes up the film. Place the cover on retort N and fasten same into the rear wall by rear nuts V, close all camera doors and set the film counter to zero. The camera has either a fixed or an adjustable focus lens (the latter preferred) either lens has a diaphragm. The camera can be focused for either the inside or outside.

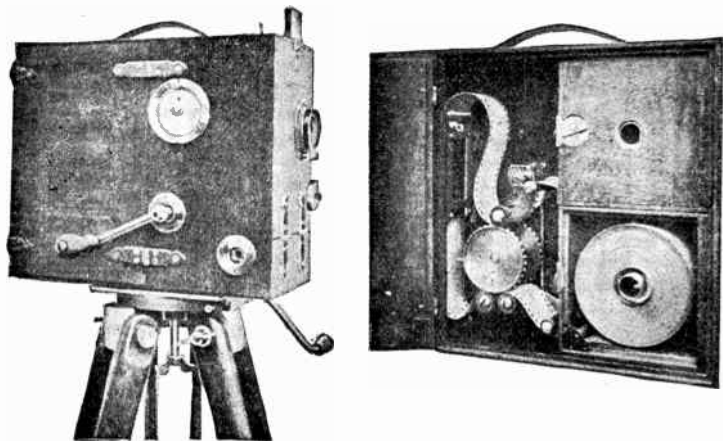
*After taking a subject*, the operator presses a button, and in so doing punches a hole in the film at a point just above the gate, thus indicating the end of the subject and beginning of the next subject.



FIGS. 3,893 TO 3895.—Views of Universal motion picture camera. Fig. 3,893 front view showing lens, fly wheel, shutter, and aperture adjustment; fig. 3895, right side showing film channel sprocket wheel and shuttle movement. The adjustable shutter may be set for from 25% to 50% exposure. Under ordinary day light conditions and ordinary speed,  $37\frac{1}{2}\%$  (about  $\frac{1}{4}$ th second) is found to be the correct time of exposure; fig. 3,894, left side showing arrangement of take up mechanism and stop picture shaft.

**Ques.** What requirement should be fulfilled by the shutter?

**Ans.** It should be adjustable to give a variable ratio between the open time and closed time.



**Figs. 3,896 and 3,897.**—Exterior and interior views of Angelus motion picture camera. The frame is made of pressed steel with table bronze bearings, claw movement is of the finger type, counterbalanced, and feeds film forward or backward equally well. Take up is of the pulley type with spring belt and adjustable tension; takes up in both directions, forward or backward. Punch or film marker is placed on one side so as to notch edge of film instead of punching hole in center.

**Ques.** Can a motion picture machine be used as a camera?

**Ans.** Yes.

Pictures may be taken by constructing a light tight box for the motion head of the machine. Such an arrangement is, however, rather bulky in comparison to a regular motion picture camera.

## CHAPTER LXXV

## GAS ENGINE IGNITION

Most treatises on ignition begin with an explanation of electrical principles and considerable space is thus taken up, which, if confined to the main subject, would be of greater value to the reader, assuming that he either has an elementary knowledge of electricity, or that he will acquire this knowledge elsewhere.

The author especially recommends that the reader at least acquaint himself with fundamental electrical principles before taking up the study of ignition, so that he can, with greater ease, become familiar with the working principles of the multiplicity of ignition apparatus now in use. This preliminary knowledge may be obtained by consulting the preceding Guides, however, for convenience, a summary or condensed outline of elementary electricity is here given.

**Electricity.**—The name electricity is applied to an invisible agent known only by the effects which it produces, and the various ways in which it manifests itself.

Electrical *currents* are said to flow through *conductors*. These offer more or less *resistance* to the flow, depending on the material. Copper wire is generally used as it offers little resistance to the flow of the current.

The current must have pressure to overcome the resistance of the conductor and flow. This pressure is called *voltage* caused by what is known as *difference of pressure* between the source and terminal.

An electric current has often been compared to water flowing through a pipe. The pressure under which the current flows is measured in *volts* and the quantity that passes in *amperes*. The resistance with which the current meets in flowing along the conductor is measured in *ohms*.

The flow of the current is proportional to the voltage and inversely proportional to the resistance. The latter depends upon the material, length and diameter of the conductor.

Since the current will always flow along the path of least resistance it must be so guarded that there will be no leakage. Hence to prevent leakage, wires are *insulated*, that is, covered by wrapping them with cotton or silk thread or other non-conducting materials. If the insulation be not effective, the current may leak, and so return to the source without doing its work. This is known as a *short circuit*.

The conductor which receives the current from the source is called the *lead* and the one by which it flows back, the *return*.

When wires are used for both lead and return, it is called a *metallic circuit*; when the metal of the engine is used for the return, it is called a *grounded circuit*, the term originating in telegraphy, where the earth is used for the return.

In ignition diagrams, then, the expression "to ground" means *to the metal of the engine*.

An electric current may do work of various kinds, but the one property which makes it available for ignition is the fact that whenever its motion is stopped by interposing a resistance, the energy of its flow is converted into heat. In practice this is accomplished in two ways: 1, by suddenly breaking a circuit; 2, by placing in the circuit a permanent *air gap* which the current must jump. In either case, the intense heat caused by the enormous resistance interposed, produces a spark which is utilized to ignite the charge. The first method is known as the *make and break* or *low tension* and the second, the *jump spark* or *high tension*.

An electric current is said to be: 1, *direct*, when it is of unvarying direction; 2, *alternating* when it flows rapidly to and fro in opposite directions; 3, *primary*, when it comes directly from the source; 4, *secondary*, when the voltage and amperage of a primary current have been changed by an *induction coil*.

A current is spoken of as *low tension*, or *high tension*, according as the voltage is low or high.

A *high tension current* is capable of forcing its way against considerable resistance, whereas, a *low tension current* must have its path made easy. A continuous metal path is an easy one, but an interruption in the metal, as, the permanent air gap of a spark plug, is difficult to bridge, because air is a very poor conductor. Air is such a poor conductor that it is usually, though erroneously, spoken of as a *non-conductor*; it is properly an insulator.

The low tension current is only able to produce a spark when parts are provided in the path, so arranged that they may be in contact and then suddenly separated. The low tension current will, as the separation occurs, tear off very small metallic particles and use these as a *bridge* to keep the path complete. Such a bridge is called an *arc*, the heat of which is used for ignition.

**Magnetism.**—The ancients applied the word "magnet," *magnes lapes*, to certain hard black stones which possess the property of attracting small pieces of iron, and as discovered later, to have the still more remarkable property of pointing north and south when hung up by a string; at this time the magnet received the name *lodestone*. The automobile word *magneto* is derived, as may easily be understood, from the word *magnet*.

Magnets have two opposite kinds of magnetism or magnetic poles, which attract or repel each other in much the same way as would two opposite kinds of electrification.

One of these kinds of magnetism has a tendency to move toward the north and the other, toward the south.

The two regions, in which the magnetic property is strongest, are called the *poles*. In a long shaped magnet it resides in the ends, while all around the magnet half way between the poles there is no attraction at all. The poles of a magnet are usually spoken of as *north pole* and *south pole*.

When a current of electricity passes through a wire, a certain change is produced in the surrounding space producing what is known as a *magnetic field*.

If the wire be insulated with a covering and coiled around a soft iron rod, it becomes an electromagnet having a north and south pole, so long as the current continues to flow. The magnetic strength increases with the number of turn of the coil, for each turn adds its magnetic field to that of the other turns.

**Induction.**—If a second coil of wire be wound around the coil of an electromagnet, but not touching it, an *induced current* is produced in this second coil by what is known as *induction*, each time the current in the inside coil begins or ceases flowing. The inside coil is called the *primary winding* and the outside coil the *secondary winding*. Similarly, the current passing through the inside coil is called the *primary current* and that in the outside coil the *secondary* or *induced current*.

It has been found that by varying the ratio of the number of turn in the two coils, the ratio of voltage of the two currents is changed approximately proportionately. That is, if the primary winding be composed of ten turns and the secondary, of one hundred, the voltage of the secondary current is increased approximately ten times that of the primary. This principle is employed to produce the extremely high tension current necessary with the jump spark method of ignition.

**Methods of Producing Electricity.**—Currents are produced by, 1, chemical, and 2, mechanical means. In the first method, two dissimilar metals such as copper and zinc called *electrodes* are immersed in an exciting fluid or *dielectric*. When the electrodes are connected at their terminals by a wire or conductor, a chemical action takes place, producing a current which flows in the external circuit from the copper to the zinc. This device is called a *cell*, and the combination of two or more of them connected so as to form a unit, is known as a *battery*.

The word battery is frequently used *incorrectly* for a single cell. That terminal of the copper electrode from which the current flows is called a *plus* or *positive pole* and the zinc electrode terminal a *negative pole*. It should be carefully noted, however, that the copper electrode itself is negative and the zinc electrode, positive.

Cells are said to be *primary* or *secondary* according as they generate a current of themselves or first require to be charged from an external source, storing up a current supply which is afterwards yielded in the reverse direction to that of the charging current.

There are two methods of producing an electric current by mechanical means, 1, by a *dynamo*, and 2, by a *magneto*. A dynamo has an *electromagnet* which is known as a *field magnet* to produce a *magnetic field* and an armature which when revolved in the magnetic field develops electric current. A magneto has a permanent magnet to produce the magnetic field and an armature which is usually arranged to revolve between the poles of the magnet.

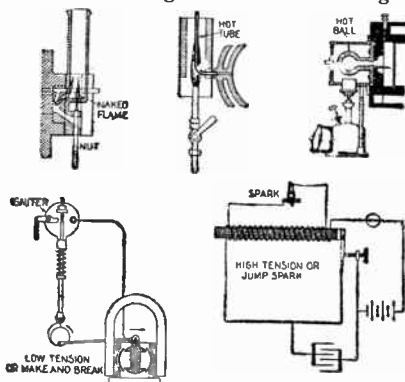
The basic principles upon which dynamos and magnetos operate are the same.

Magnetos are divided into two classes, 1, *low tension*, and 2, *high tension* according as they generate a current of low or high voltage. Low tension magnetos are used for make and break ignition and the high tension type for the jump spark system. There are numerous so called high tension magnetos on the market each consisting of a low tension magneto in combination with a secondary induction coil used to produce a high tension spark.

**Ignition.**—A thorough knowledge of ignition is of prime importance to any operator of a gas engine, whether it be stationary, marine, or automobile type. Many of the troubles still encountered, notwithstanding numerous improvements, have arisen from failure of the ignition system to perform its proper function. The engine may operate with an imperfect

fuel mixture, if the ignition system be in working order, but any defect in the latter will in nearly every case cause the engine to misfire or stop.

Numerous devices have been tried to fire the charge in gas engines. In the early days, a flame behind a shutter was used, the latter being opened at the proper moment. Sometimes the flame was blown out by a too violent explosion, so this method gave way to a porcelain tube that was kept at white heat by an interior flame. Tube being subject to breakage, spongy platinum, heated by compression, was next tried and found to work, if not too moist from watery vapor in the gas mixture, or if the engine speed were not too high. Electricity is now universally used. Hence, in order to gain an understanding of ignition principles,



**Figs. 3,898 to 3,902.**—Various methods of ignition. Fig. 3,898, naked flame; fig. 3,899, hot tube; fig. 3,900, hot ball; fig. 3,901, low tension electric or make and break; fig. 3,902, high tension electric or jump spark.

it is necessary to have at least an elementary knowledge of electricity, as previously mentioned, and because of which, the preceding electrical introduction will be found of value.

**Methods of Ignition.**—The charge in the cylinder of a gas engine may be ignited in several ways, as

1. By means of a naked flame;
2. By means of a highly heated metallic surface;
3. By an electric spark;
4. By the heat of very high compression.



The naked flame is practically obsolete, and the hot surface or hot tube is used to a very limited extent, except in the case of some types of oil engine. Many builders of standard engine, however, are prepared to furnish hot tube ignition.

**Point of Ignition.**—The "timing" or selection of the point of the stroke at which ignition shall take place is an important factor in the application of any method.

Obviously the amount of "advance," that is to say, the pre-dead center angular position of the crank selected for firing the charge, will vary in different types of engine and in the same engine under different

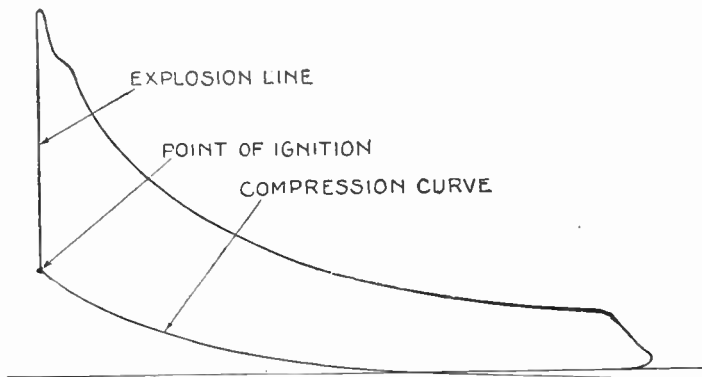


FIG. 3,903.—Indicator card for gas engine illustrating the "point of ignition". It will be noted that compression continued to the end of the stroke, before the compression curve made an abrupt change into a nearly vertical line, the point of ignition, that is, the piston position at the instant of the spark, the nearly vertical "explosion" line with the high peak coming almost to a point, denotes a strong mixture and a quick explosion.

running conditions; thus, noting that there is an appreciable time interval between the spark and the maximum pressure of combustion, it is clear that the spark should be advanced more for an engine running at high speed than for one running at low speed.

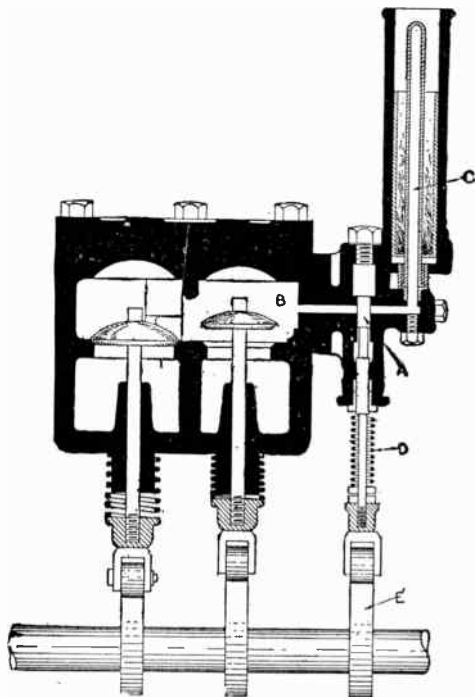
**Ques.** In general how much should the spark be advanced?

**Ans.** As much as possible, consistent with smooth running and economy.

### Ques. Why?

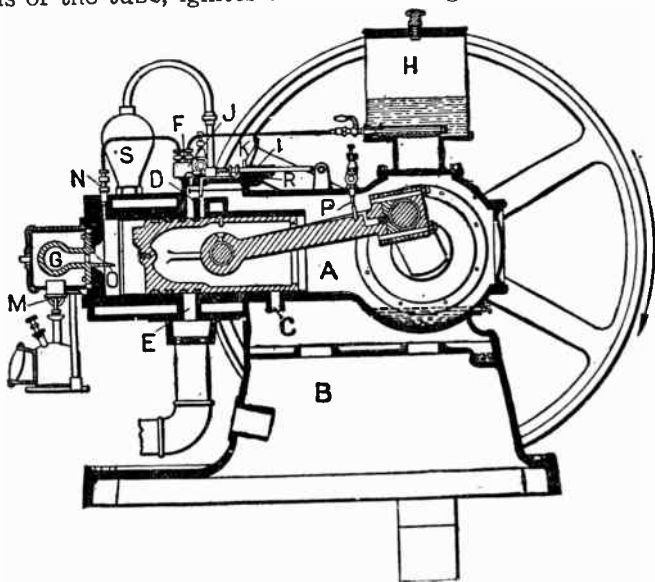
Ans. In order that the temperature at release, that is to say, when exhaust begins, should not be high enough to injure the exhaust valves.

If more attention were paid to this, especially by automobilists, there would not be the need for such frequent grinding of the exhaust valves.



**FIG. 3,904.**—Sectional view through valves of engine showing hot tube method of ignition. This is a modification of the method described in the accompanying text and is more exact and satisfactory. *In construction*, a valve A, commonly called the timing valve, is provided, and which is interposed between the admission valve chamber B (communicating with the clearance space of the cylinder) and the interior of the hot tube C. This valve is normally held closed by the spring D. When the piston reaches its inner dead point at the end of the compression stroke, a cam E, on the secondary shaft, opens the valve and allows a portion of the compressed charge to pass into the hot tube where it ignites. The timing valve is held open throughout the power and exhaust strokes, thus permitting the products of combustion to be carried out of the tube with the exhaust.

**Hot Tube Ignition.**—This method consists of a short tube of metal or porcelain which is maintained at a dull red heat by contact with a gas flame, and which is attached to the engine cylinder in such a manner that a portion of the explosive charge is forced into it, this, being ignited by contact with the hot walls of the tube, ignites the whole charge.



**FIG. 3,905.**—Meitz and Weiss two cycle oil engine with hot ball igniter. *In operation*, air is drawn into the closed crank chamber A, from the interior of the base B, through the port C, in the lower part of the cylinder. On the outward stroke of the piston, this air is compressed, and the opening of a port D, by the piston, allows the air, together with the steam generated in the water jacket, to pass into the combustion space of the cylinder. At the same time, the exhaust port E, having been overrun, and thus opened by the piston, discharges the products of combustion of the previous charge into the exhaust pipe. The fuel is injected into the cylinder by the pump F, and mixes with the air and steam previously admitted from the crank chamber, so that on the compression stroke, the charge is automatically ignited by contact with the heated walls of the hollow igniter ball G. This ball, made of cast iron, is located in the projection attached to the cylinder head, as shown. A charge is compressed at every revolution of the crank shaft, and compressed by the piston into the compression space of the cylinder and the interior of the igniter ball where it is ignited. *Before starting*, the igniter ball is heated for a few minutes by a small oil jet from the burner M. The oil jet from the injection nozzle N, strikes the projection O, extending from the igniter ball and is sprayed, vaporized and mixed with the air and steam in the compression space. The igniter ball is maintained at a dull red heat by the heat of the explosives.

In the ordinary arrangement, the time of ignition depends upon the degree of compression. The products of combustion remain in the tube and mix with the succeeding fresh charge, so that varying degrees of compression cause ignition at different points of the piston stroke or cycle of operation. Under these conditions, the moment of ignition becomes later and later as the amount of compression decreases, until the compression becomes so weak as to produce failure to ignite.

**Electrical Ignition Systems.**—There is a multiplicity of method for using electricity for ignition. A classification of these various system, would divide them

1. With respect to the generation of the current, as
  - a. Primary battery;
  - b. Storage battery;
  - c. Dynamo;
  - d. Magneto.
  
2. With respect to the spark, as
  - a. Low tension;
  - b. High tension.
  
3. With respect to the nature of the sparking device, as
  - a. Make and break;
  - b. Jump spark.
  
4. With respect to the induction coil, as
  - a. Primary coil;
  - b. Secondary coil { multi-coil;  
single coil (*synchronous ignition*).
  
5. With respect to the primary circuit control, as
  - a. Contact maker;
  - b. Contact breaker;
  - c. Mechanical vibrator;
  - d. Magnetic vibrator { individual vibrator;  
master vibrator.

6. With respect to the magneto, as
  - a. Low tension;
  - b. So called high tension;
  - c. True high tension.
  
7. With respect to extra or duplicate apparatus, as
  - a. Dual;
  - b. Duplex;
  - c. Double.
  
8. With respect to circuit arrangement, as
  - a. One wire (grounded);
  - b. Two wire (metallic).
  
9. With respect to special spark plug construction, as
  - a. Magnetic spark plug;
  - b. Coil spark plug;
  - c. Multi-point spark plug.

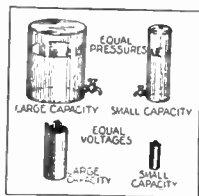
**Current for Ignition.**—The electric current used for igniting the charge may be produced either by chemical, or mechanical means, or it may be generated mechanically and stored chemically. The apparatus required for these various methods consist of primary and secondary cells, dynamos and magnetos.

**Primary Cells.**—Two types of cell are in general use for ignition, namely, liquid cells and the so called dry cells.

Liquid cells are used extensively for stationary engines and for some classes of marine work.

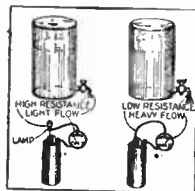
In purchasing a set of wet cell, the following points should be noted:  
1. They should be substantial and constructed so that the chemicals will not creep over the edge of the jar or evaporate; 2, They should be slop proof and all renewals required should be easily obtainable.

When space allows and first cost is not of great importance, wet cells give excellent service. The advantage of these cells is that they give



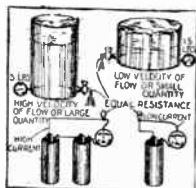
Figs. 3,906 to 3,909.—*Hydraulic analogy of capacity.* Figs. 3,906 and 3,907 show two tanks of water of different sizes (capacities). The head of water is the same in each and consequently the pressure in the stop cock is the same in each, irrespective of the fact that they are of different capacities. The two dry cells shown have the same voltage even though they are of different size. The difference in size, however, means that they contain different amounts of electricity. The voltage of a dry cell does not depend on its size. It is about 1.5 volts.

Figs. 3,910 to 3,913.—*Hydraulic analogy of pressure.* Fig. 3,910 shows three tanks connected in *series*. The total head and therefore, the pressure on the stop cock is three times that of a single tank. When three cells are connected in *series*, as in fig. 3,911, the terminal voltage is increased three times, in a like manner. Fig. 3,912 shows three tanks connected in *parallel*. Here the pressure is the same as if there were only one tank. When three cells are connected in *parallel*, as in fig. 3,913, the *voltage* remains the same as that of a *single* cell.

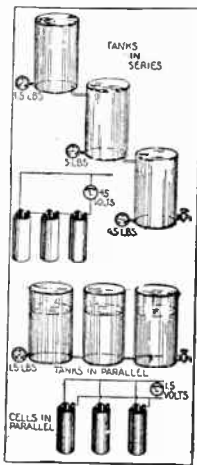


Figs. 3,914 to 3,917.—*Hydraulic analogy of resistance.* Figs. 3,914 and 3,915 show two tanks, having equal depths of water, and consequently equal pressures in the discharge cocks. The left tank has a small cock (*high resistance*) and the other has a large cock (*low resistance*). It is obvious that the flow from the first will be less than the flow from the second. In an analogous manner it may be seen that the two dry cell circuits have equal voltages

applied and that the circuit of high resistance (fig. 3,916), permits less current to flow than does the circuit of low resistance, fig. 3,917. It is apparent that both these conditions show the current to depend on the voltage and resistance, in accordance with Ohm's law.

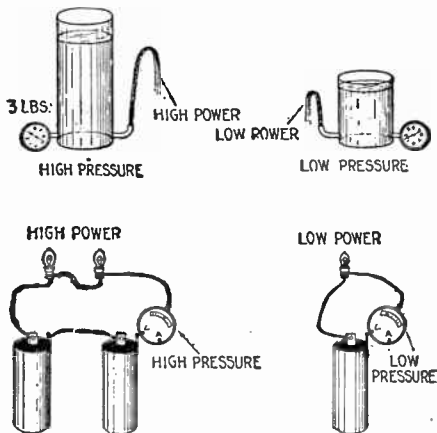


Figs. 3,918 to 3,921.—*Hydraulic analogy of current.* Figs. 3,918 and 3,919 show two tanks with discharge cocks of the same size (*equal resistances*). Obviously the higher pressure in tank fig. 3,918 will cause a greater flow through its cock than will the low pressure in tank, fig. 3,919. The analogous electrical condition is shown in figs. 3,920 and 3,921. Assuming the *internal* resistance of each cell to be zero and each circuit to have an equal external resistance, the current in fig. 3,920 will be two times stronger than in fig. 3,921. **It should be noted** that in an actual circuit the *internal* resistance of the cells must be considered. Thus, an ammeter connected across the end terminals of the cells in figs. 3,920 and 3,921 will give the same reading because the internal resistance of a battery of cells in series increases in proportion to the number of cells.



constant current, moreover the liquid or electrolyte may be renewed so that it is not necessary to buy a new battery when it becomes exhausted.

**"Dry" Cells.**—The so called dry cell consists usually of a carbon and zinc element immersed in moistened salts.



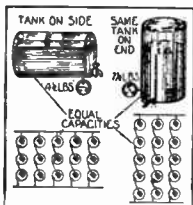
**Figs. 3,922 to 3,925.**—*Hydraulic analogy of power.* Figs. 3,922 and 3,923 show two tanks with equal flows at different pressures. In both, the same number of pound of water is discharged per second, but in the high pressure tank this amount is lifted higher than in the low pressure tank, and consequently the first jet has more *power*, because it raises the same amount of water higher in the same time. Power, accordingly, increases with pressure, as well as with flow. The electrical case is analogous. In fig. 3,924, the circuit has 3 volts applied to two  $1\frac{1}{2}$  ohm lamps, thus, according to Ohm's law, one ampere is flowing. Fig. 3,925 shows a circuit having  $1\frac{1}{2}$  volts applied to one  $1\frac{1}{2}$  ohm lamp so that here also one ampere is flowing. The candle power, however, of the two lamps in fig. 3,924 is two times that of the lamp in fig. 3,925.

For full description of dry cell and points relating to same, see Guide No. 1.

Since the gasoline engine has come into prominence and the demand for an efficient, reliable and inexpensive source of current supply has been created, the dry cell has been brought to a high state of efficiency.

An ammeter test should be made of each dry cell before purchasing. The ignition size cell should test at least 25 amperes; to avoid waste of current, make the ammeter test as quickly as possible.

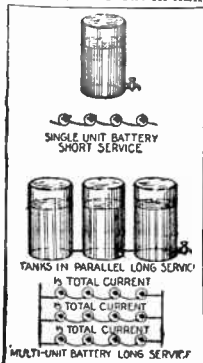
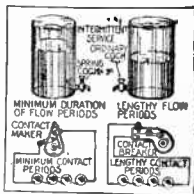
**Points Relating to Primary Cells.**—In order to obtain satisfactory results in battery systems of ignition, the following suggestions should be carefully noted and followed:



same way, if the batteries be discharged to the same end point, more unavailable energy will remain in the left-hand than in the right-hand battery.

Figs. 3,930 to 3,933.—*Hydraulic analogy of useful service.*

Service is usually expressed as the length of time a cell or battery will continue to operate a given apparatus, that is until the voltage falls to a definite value. It is evident that with a lower cut off voltage more current can be obtained, just as lowering the limit of the water level in a tank allows more water to be withdrawn. It is also evident that the lighter the flow from a given tank, the longer will be the service. This is true to an even greater extent in the case of dry cells on account of the characteristic that the lower the current drain the greater becomes the useful life. The length of service is increased, then, for two reasons; first, because energy is withdrawn more slowly, and second, because the capacity is increased. Thus, if the current drain be cut in half, the length of the service will be considerably increased.



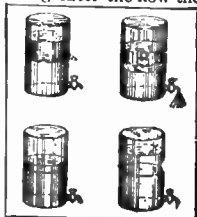
Figs. 3,934 to 3,937.—*Hydraulic analogy of parallel connection.*

Figs. 3,934 and 3,936 show conditions of a single tank, and three tanks in parallel, furnishing equal flows. It is apparent that in the case of the parallel tanks, each is furnishing only one-third the total flow, while the single tank has to furnish it all. The parallel connection for dry cells has the same effect of dividing the current, giving triple the length of service.

Figs. 3,938 to 3,941.—*Hydraulic analogy of recuperation.*

The power of recuperation and some other phenomena may be illustrated by an analogy in the form of such a tank as is shown in fig. 3,938, containing an internal diaphragm pierced by a small hole. When the tank is in the condition of fig. 3,938, with no water flowing, the pressure on the stop cock is due to the head of water all the way to the top level. This corresponds to the *open circuit voltage* of a cell. When, however, the stop cock is opened, as in fig. 3,939 and water flows out of the lower compartment faster than it can flow in from the upper, the pressure immediately drops just as the voltage of a cell drops under a heavy current drain. The greater the flow the

less of the total water in the tank that can be used before the lower (useful) compartment becomes exhausted. With a lighter flow more opportunity would be afforded to use water from the upper tank, thus increasing the effective capacity. If now the flow be stopped, the tank will "recuperate" to the condition of fig. 3,940, so that it can once more be used, but the "initial pressure" will be less than formerly and the recuperation after a second discharge will not be as rapid as before. Finally, when the upper compartment is emptied the recuperative power fails altogether and the tank becomes "dead." In the case of very light flow from the lower chamber, as in fig. 3,941, the recuperation may be able to keep up with the discharge in which case the initial and working pressures remain approximately equal.



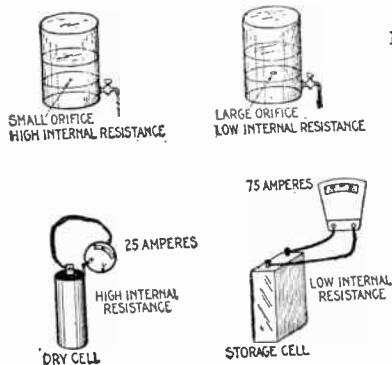


1. In connecting up cells the terminals and connecting wires should be scrupulously clean and bright, using sand paper or a scraper if necessary. All terminal nuts should be screwed down tightly so as to make a firm connection and reduce the resistance of the joint to a minimum.

2. Batteries consisting of two or more series connected units should not be used with series parallel connection except in case of emergency because the units are never of exactly the same voltage, hence the storage set tends to discharge through the weaker.

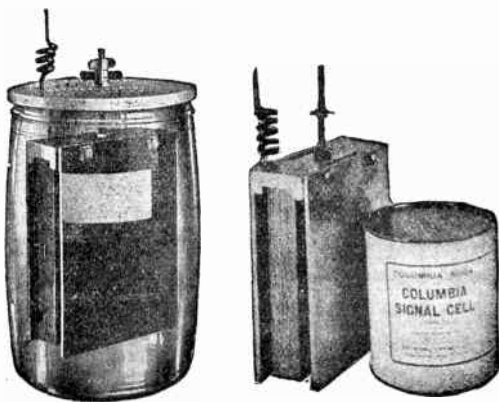
3. Never use more cells than necessary, because an excess of current will flow, thus reducing the life of the battery.

4. In general four dry cells are sufficient for automobile ignition, and six for marine ignition.



FIGS. 3,942 to 3,945.—*Hydraulic analogy of internal resistance.* Figs. 3,942 and 3,943 show two tanks (cells) both having discharge pipes (external circuits) of practically no resistance. The internal resistances of the tanks are represented by a large and small orifice through which the tanks must discharge. It is evident that the flow in one case will be high, and in the other case low, corresponding to initial currents of cells of low and high internal resistances. It is certain that on ordinary work either of these tanks would give equally good service if the flow required be less than the initial flow of the high resistance tank. This is true of dry cells. The required drain in any kind of work is less than the lowest initial current; hence, a low current cell may give just as good or better service results than a very high current cell.

FIGS. 3,946 and 3,947.—Columbia R. S. A. signal cell, type 72. It conforms to the R. R. S. A. specifications for copper oxide, zinc and soda primary battery. The cell is self-oiling and does not require the shipping or handling of any oil. A protecting layer of oil automatically forms on the surface of the solution within a comparatively short time after the element is immersed. A sand blasted space on jar is provided for record. Although primarily designed for signal work the cell is also satisfactory for gas engine ignition.



5. Weak dry cells can be strengthened by removing the paper jacket and punching the metal caps full of small holes, then placing in a weak solution of sal-ammoniac, allowing the cells to absorb all they will take up. Do this only in emergency; if the holes be closed by soldering, the cells will last longer.

6. Extra service may be obtained by two run down series connected units by connecting them in series parallel.

7. Extra service may be obtained by closer adjustment of the vibrator coil or reducing the distance between the spark plug points.

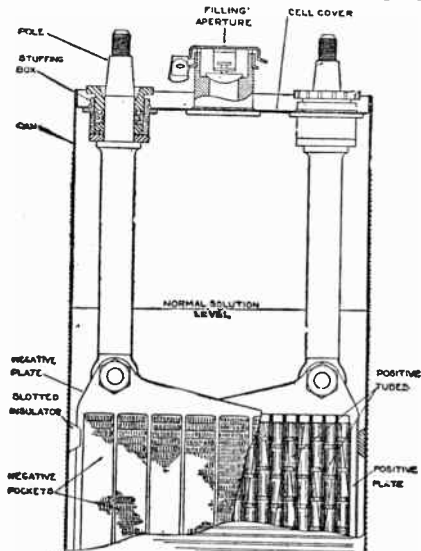


FIG. 3,948.—Sectional view showing construction of Edison cell. The solution should be maintained  $2\frac{3}{4}$  inches above plates. If solution level be low in any cell, hold battery out of service until renewal solution can be obtained. **Normal charge.** After battery has been practically discharged, the normal charge is for seven hours at normal rate. Charging resistance should be adjusted from time to time to keep current normal. If this be impracticable, set resistance so that current is about 50 per cent. above normal at the start. It should taper off by rise in battery voltage so that the average current will be at normal rate. If battery be only half discharged, recharge for half of seven hours at normal rate; if only one quarter discharged, charge for a quarter of seven hours, etc. **Low rate charge.** To secure best results on five hour or eight hour discharge, charge at not less than the normal rate. If, however, the cells be discharged at a very low rate, a charging rate lower than normal can be used with satisfactory results. **Ampere hour meter.** An ampere hour meter, if used, should be set to recharge 25 per cent. in excess of discharge. **Discharge rate.** The size of cell used should be such that the continuous discharge does not exceed 25 per cent. above normal rate. **Water.** Replenish cells with distilled water as frequently as is necessary to keep solution level above tops of plate. When adding water do so before charging. **Changing solution.** After about every nine or ten months of continuous daily service, test solution with hydrometer after a full charge. If it read below about 1.160, the solution should be changed.

**Secondary Cells.**—A second chemical means of producing electricity for ignition is the *storage battery* which consists of two or more secondary cells contained in a carrying case or box usually of wood or hard rubber. A secondary cell is made up of a positive and a negative set of plate (usually of lead) immersed in an electrolyte of dilute sulphuric acid. The plates are spaced apart by insulating separators. The proportion of acid to water is about one part acid to three and one-half parts water. In preparing the electrolyte, acid should always be added to the water—*not water to acid*.

In passing an electric current through a cell, the plates undergo a chemical change; when this is complete the cell is said to be *charged*. A quantity of electricity has been stored in the cell, hence the name, *storage battery*. The cell after being charged will deliver a current in a reverse direction because during the discharge a reverse chemical action takes place which causes the plates to resume their original condition. When fully charged the positive plates are coated with peroxide of lead and are brown in color and the negative plates gray.

For a very extended treatment of the subject of storage batteries see Guide No. 4

**Points Relating to Secondary Batteries.**—Many storage batteries are ruined after short service by neglect or ignorance in caring for them; accordingly, the following items should be carefully noted.

1. The water in the electrolyte evaporates but the acid never does.
2. Keep plates well covered with electrolyte.
3. To replace loss by evaporation *add only distilled water, or clean rain water which has been collected in a non-metallic vessel*. The water must positively be chemically pure or the battery will be ruined within a short time.
4. The battery capacity is rated in *ampere hours*. Thus a fifty ampere hour battery means that with full charge it will give an ampere for 50 hours.
5. *Never test a storage battery with an ammeter*. The internal resistance of battery being very low, a very large current flows on short circuit, hence, an ordinary pocket ammeter would probably be injured—use a volt meter and take readings while the battery is delivering current, not when the circuit is open.
6. The capacity of a battery is independent of its voltage.

7. Don't take it for granted that the wiring on automobile lighting and starting systems is of large enough size to carry current of a short circuited storage battery without excessive heating—such short circuit in the vicinity of a leaking carburetter is not to be recommended (though only so called "gasoline" be used), especially in the case of makeshift rigs installed by amateurs.

8. Except for stationary service, keep battery securely fastened in place.

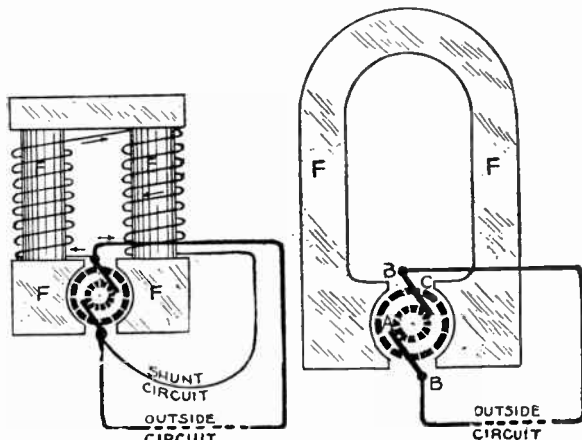
9. Keep battery and interior of battery compartment wiped clean and dry.

10. Do not permit an open flame near the battery

11. Keep terminals and connections coated with vaseline or grease.

12. Test specific gravity of each cell regularly with a hydrometer.

13. When all cells are in good order the gravity will test about the same (within 25 degrees) in all.



**FIGS. 3,949 and 3,950.**—Circuit diagrams to illustrate the difference between a dynamo and a magneto. The former has its field magnets FF magnetized by means of a small current flowing around a shunt circuit. In a magneto the field magnets are permanently magnetized. The strength of the magnetic field of a magneto is constant while that of a dynamo varies with the output, hence, a magneto may be run at a widely varying speed and meet ignition requirements, but a dynamo must have its speed maintained approximately constant to keep the voltage within limits.

14. A dead battery tests 1,150; when fully charged 1,275 to 1,300.

15. A battery which is to stand idle should be fully charged.

16. A battery should not remain idle for more than six months without recharging.

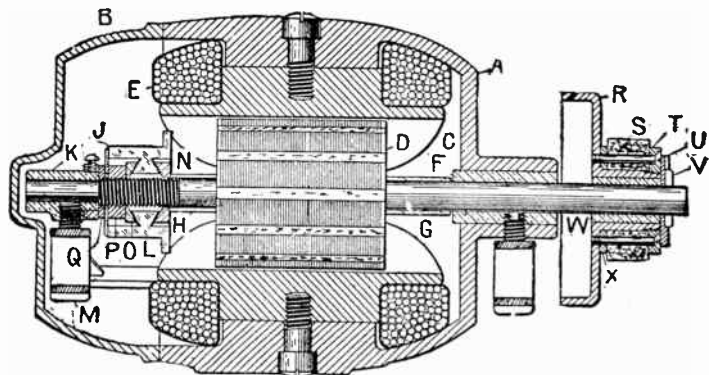
17. Disconnect the leads from an idle battery to avoid any slight leak in the external circuit.

18. *Many batteries are ruined by entrusting their care to incompetent garage men.*

**Mechanical Generators.**—The two methods of producing a current by mechanical means are by the use of dynamos or magnetos.

**Ques. How does a dynamo differ from a magneto?**

**Ans.** Chiefly in that the dynamo has field magnets of soft iron or mild steel, wound with wire through which circulates the whole, or a portion of the current generated by the machine;



**FIG. 3,951.**—Sectional diagram of the Apple igniting dynamo. The parts shown are: A, cast iron body containing the moving parts; B, the hinged lid of the body; C, the one pole piece of one of the field magnets; F, brass bearing of the armature spindle; G and H, fibre tubes surrounding the spindle; K, brass spider supporting the spindle; L, commutator; M, wick feed oil cup; N, beveled nut supporting the commutator; O, P, Q, supports of the commutator; R, the driving disc; S, lever friction pinion. This machine can generate a direct current at 8 volts at a speed of between 1,000 and 1,200 revolutions per minute. It is provided with a simple centrifugal governor that automatically interrupts the driving connections when a certain speed has been exceeded.

whereas, a magneto has field magnets constructed of steel and permanently magnetized, no part of the current adding to the magnetism.

The circuit diagrams, figs. 3,949 and 3,950, illustrate this difference. In the dynamo the field magnets FF are magnetized by means of a small current flowing around a shunt circuit; that is, a certain amount of current is taken from the system and used to magnetize the field. The remainder of the current generated is used in the outside circuit,

**Dynamos.**—The field magnets of a dynamo increase in strength as the current which passes around them increases.

Moreover, as the magnetic strength increases, the voltage of the generated current also becomes stronger. Hence, it is evident that a dynamo is not self-regulating, and if run at too high speed is liable to be overheated or even burned out in its effort to furnish a current beyond its capabilities, on account of this faculty of automatically strengthening its own fields.

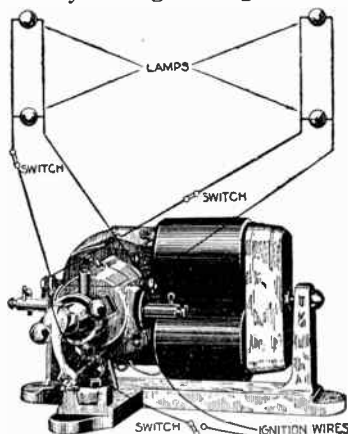


FIG. 3,952.—Motzinger "Auto Sparker" friction drive dynamo. The small friction pulley gives sufficient speed to ignite the charge when engine is turned slowly as in cranking. After the engine is under motion, the governor on the shaft of the dynamo limits its speed so as not to obtain an excessive voltage. This is accomplished by mounting the dynamo on its base so that it can oscillate on an axis, the small friction wheel making and breaking contact with the engine fly wheel. *In operation*, when normal speed is exceeded, the governor weights fly out and draw the friction wheel away from the fly wheel, one spring serving the double purpose of pushing the friction pulley against the fly wheel and acting as a tension on the governor. By increasing or diminishing the tension on the governor spring by means of a thumb nut provided for the purpose, the speed of the dynamo may be increased or diminished, which in turn increases or diminishes the volume of current and size of spark. By screwing up on this thumb nut the position of the dynamo is not changed, but the contact of the pulley and tension of the governor are increased. Thus, by adjusting the thumb nut, the size of the spark may be regulated at will.

**Ques.** Describe the friction drive for a dynamo.

**Ans.** In this form of drive, motion is transmitted through a very small wheel in frictional contact with the fly wheel of the engine.

This frictional wheel is small enough to run the dynamo at full speed when the engine is turned slowly, as in cranking. As the engine speed increases, the governor acts, and maintains the speed of the dynamo unchanged.

### Ques. How is a dynamo generally used?

Ans. In connection with a storage battery, the current for ignition being supplied by the battery, which, in turn, is con-

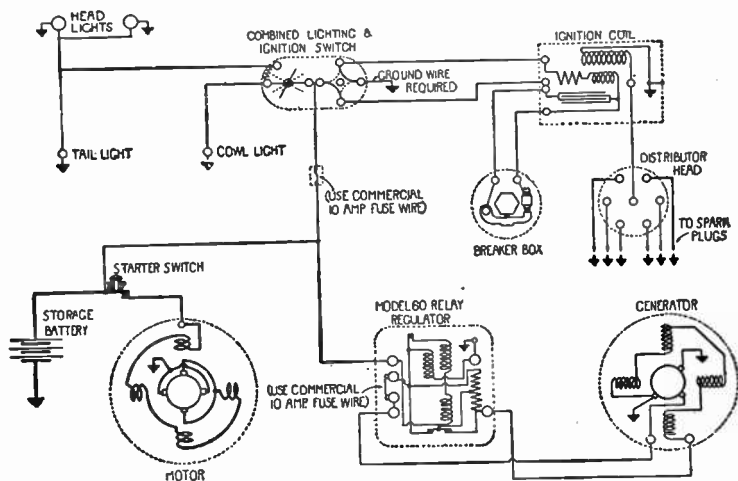


FIG. 3,953.—Wiring diagram of Remy ignition, lighting and starting system as installed on Oakland automobiles. The 6 volt dynamo is a four pole shunt wound machine driven at  $1\frac{1}{2}$  crank speed. A discriminating cut out controls its connection with the battery in charging. The ignition distributor which is a part of the dynamo distributes the high tension current to the cylinders in proper sequence. The interrupter contact points are made of silver.

stantly charged by the dynamo to replace the energy drawn from the battery.

A discriminating cut out or reverse current circuit breaker (erroneously called relay) disconnects the dynamo from the battery when the voltage of the former becomes equal to, or less than that of the latter and this prevents the battery discharging through the dynamo.

**Magnetos.**—There are many types of magneto in use for ignition. They may be classified,

1. With respect to the armature, as
  - a. Stationary;
  - b. Oscillating;
  - c. Rotating.
2. With respect to the kind of current generated, as
  - a. Low tension;
  - b. So called high tension { with separate coil;  
with self-contained coil.
  - c. True high tension.

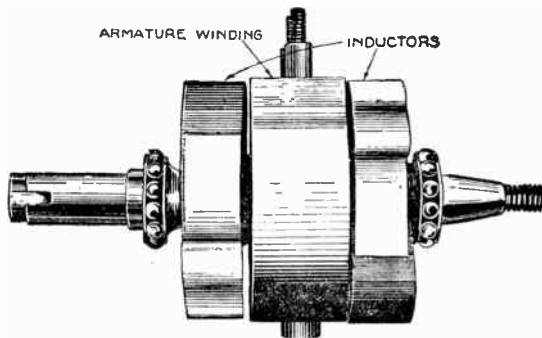
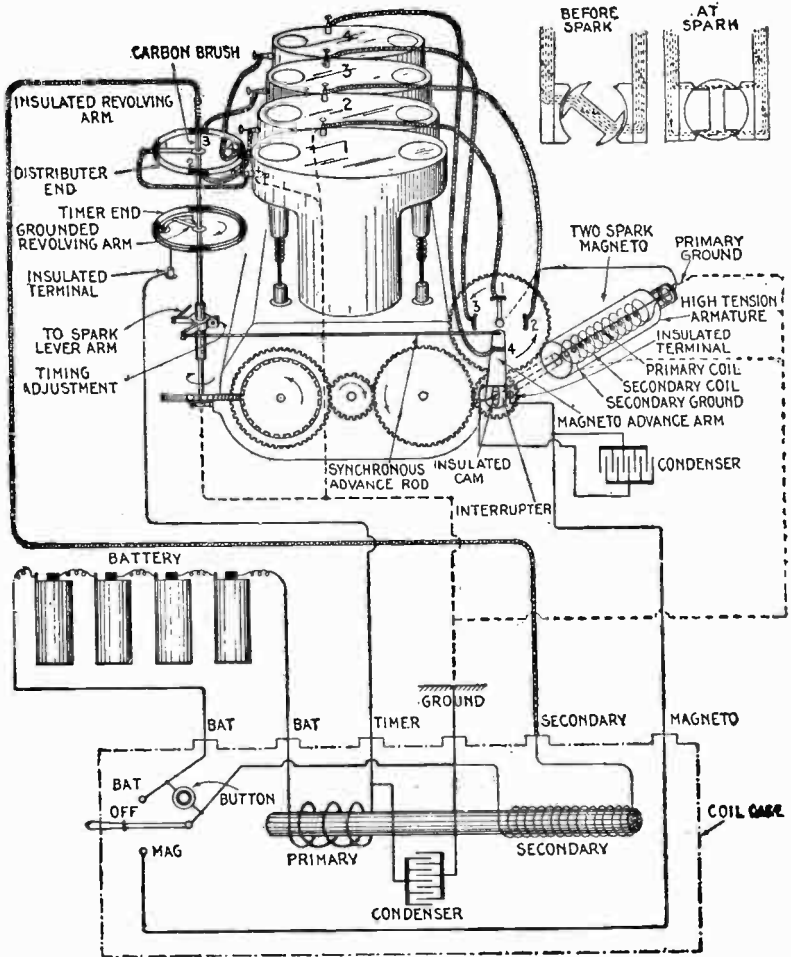


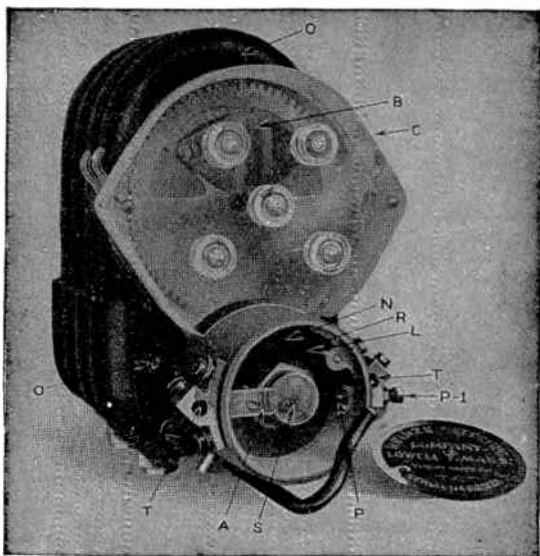
FIG. 3,954.—Remy ball bearing shaft showing inductors and stationary armature of inductor magneto. This type of magneto consists of a winding which is held stationary between the pole pieces, on either side of which revolves a *laminated steel inductor*. Inasmuch as the winding is held rigidly stationary, such construction eliminates all revolving or moving wires, all sliding or wiping contacts, collector rings, etc. This design permits of rugged electrical, as well as mechanical, construction. *In operation*, at each half turn of the inductor shaft, the direction of flow of the lines of force through the winding is reversed, producing in the winding two electrical impulses for each complete revolution. The stationary winding is directly connected through the magneto circuit breaker with the primary of the secondary coil used with the magneto. The timing of the spark is accomplished by shifting the circuit breaker around the inductor shaft, to which is attached the circuit breaker cam. The timing range is 35 degrees.

**Inductor Magnetos.**—In this class of magneto, the armature is fixed so that it does not revolve and is located with the sector shaped heads of the core at right angles to the line joining the field poles. This position of the core furnishes the least magnetically conducting path. An annular space between the





**FIG. 3,955 to 3,957.**—Double ignition consisting of a two spark high tension magneto system, and a battery synchronous ignition system with engine driven distributor. Fig. 3,955 elementary diagram of connections; fig. 3,956, position of magneto armature just before time of spark; fig. 3,957, position of armature at time of spark.



**FIG. 3,956.**—Heinze low tension magneto. The reason round magnets are used is because it is claimed better contact is thus obtained with the pole pieces or by carefully grinding the ends of the magnets and reaming the holes in pole pieces. **Magneto instructions:** 1, Keep interior of breaker box clean; 2, keep phosphor bronze studs on end of armature clean; 3, keep steel plate in breaker box clean; 4, keep platinum points clean and surfaces flat; 5, use nothing but emery paper or fine file on platinum points; 6, be sure all leads are soldered in terminals or rigidly connected; 7, platinum points should be adjusted to .02 of an inch; 8, lubricate bearing in interrupter lever with one drop of very light oil every two or three thousand miles; 9, spark plug gap should be adjusted to a minimum of .02 inch and maximum of .025 inch; 10, connect dry cells so as to produce not more than 3 or 4 volts; 11, never leave switch on battery point for any length of time either when engine is idle or running, as this causes excessive battery current and will injure the platinum points; 12, magnetos are considered running clockwise looking at the driving end. **How to efficiently operate a Heinze magneto.** In the figure the distributor cover C, and brush arm A, are shown semi-transparent so as to distinguish parts behind them. Be sure magneto is securely fastened to base and driving shaft is in perfect alignment. Be sure all connections are soldered or otherwise positively connected. Keep interior of breaker box clean. Keep phosphor bronze studs S clean and lubricate occasionally with a few drops of very thin oil. Keep inside surface of brush arm A, clean, as studs S make contact on this. Keep platinum points P, clean and surfaces of same flat. Use only emery cloth or fine file for this purpose. Platinum points should be adjusted to .02 of an inch separation when open. Gauge furnished on small wrench with magneto is proper thickness for this purpose. Adjust by turning platinum point screw P1 in or out as necessary. Lubricate bearing in make and break lever L, with one drop of very thin oil every two weeks when magneto is in continuous use. If make and break lever roll R, should become flat from wear, loosen nut N, and turn roll slightly to present a new surface to cam, and then tighten again. Be sure leads are rigidly connected in terminals TT. Leads must be long enough to allow free movement of breaker box. Remove distributor cover C occasionally and wipe out interior of same, also clean off any carbon dust or dirt from distributor brush B. Magneto bearings should be lubricated by oiling at 000 every week when magneto is in continuous use. Two or three drops are enough at a time. There is one oiler at rear end which does not show in cut.

armature and the field poles is provided for the rotation of an *inductor*. This consists of two diametrically opposite cylindrical segments of soft iron supported and carried by a shaft located at the center of the circle described by the segments.

The magnetic condition of the armature core depends entirely upon the position of the inductor. The latter is arranged, 1, to revolve continuously with a gear drive from the engine, or 2, to rotate to and fro through a small arc by link connection to the half time shaft.

**Low Tension Magnetos.**—Generators of this class may be used to supply a current of low voltage for, 1, make and break ignition or for, 2, high tension ignition with induction coils or coil spark plugs. A low tension magneto has an armature winding consisting of about 150 to 200 turns of fairly thick wire, covered with a double layer of insulating material.

One end of the winding is grounded to the armature core and the other, brought to a single insulated terminal. When this terminal is connected to any metal part of the magneto or engine (since the latter is in metallic contact with the base of the magneto), the circuit is complete. The wiring therefore is very simple, which is one of the advantages of the system.

The "live end" of the armature winding is brought out by means of a metallic rod passing lengthways through the shaft of the armature; a hard rubber bushing is provided as insulation between the shaft and the rod. The live end of the winding is located at one end of the armature shaft, from which the current flows to an insulated terminal by means of a metal contact which is pressed against the revolving rod by a spring.

**High Tension Magnetos.**—These are *erroneously* divided into three classes, viz: 1, those in which the induction secondary wiring is wound directly on the armature; 2, those having a secondary induction coil contained within the magneto, and 3, those having the coil in a separate box usually placed on the dash.

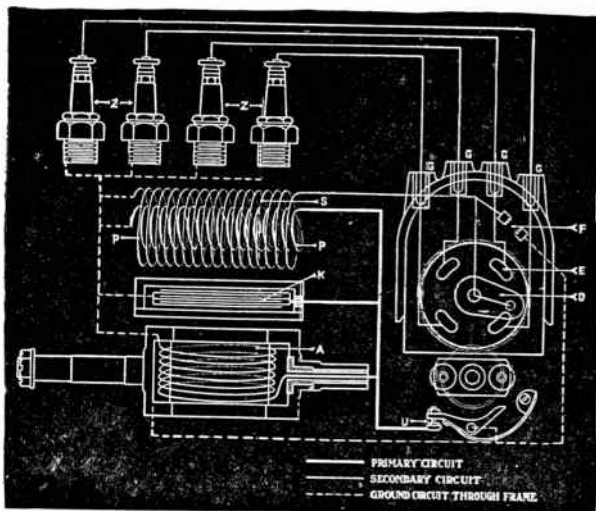


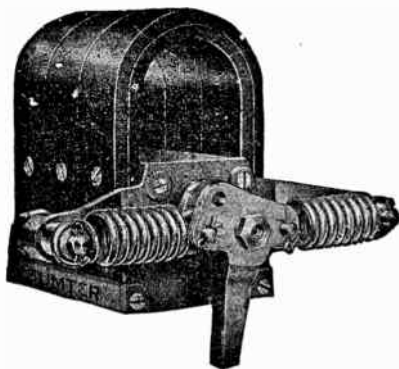
FIG. 3,959.—Circuit diagram of a magneto with self contained coil. A is the armature winding; P, primary of transformer; S, secondary of transformer; D, distributing brush carrier; E, contact segments; F, safety spark gap; G, terminals to plugs; U, interrupter; Z, spark plugs. **In operation**, alternating current flows from the armature having two points of maximum pressure in each armature revolution. As the current leaves the armature, it is offered two paths: 1, the shorter through the interrupter U to the ground, and 2, the longer through the primary P of the induction coil to the ground. A third path through the condenser K is only apparently available; it is obstructed by the refusal of the condenser to permit the passage of the current, as the condenser will merely absorb a certain amount of current at the proper moment, that is at the instant of the opening of the interrupter. The interrupter being closed the greater part of the time, allows the primary current to avail itself of the short path it offers. At the instant at which the greatest current intensity exists in the armature, the interrupter is opened mechanically so that the primary current has no choice but must take the path through the primary P of the induction coil. A certain amount of current is at this instant also absorbed by the condenser K. This sudden rush of current into the primary P of the induction coil, induces a high tension current in the secondary winding S of the coil which has sufficient pressure to bridge the air gap of the spark plug. The sharper the rush of current into the primary winding P, the more easily will the necessary intensity of current for a jump spark be induced in the secondary winding S. **The distribution of the current** in proper sequence to the various engine cylinders is accomplished as follows: the high tension current induced in the secondary S of the induction coil is delivered to a distributing brush carrier D that rotates in the magneto at half the speed of the crank shaft of the engine. This brush carrier slides over insulated metal segments E—there being one for each cylinder. Each of these segments E connects with one of the terminal sockets that are connected by cable with the spark plugs as shown. **At the instant of interruption of the primary current**, the distributing brush is in contact with one of the metal segments E and so completes a circuit to that spark plug connected with this segment. Should the spark plug be too great to permit a spark to jump, or the resistance of the spark plug is introduced. This will allow the current to rise only to a certain maximum, after which discharges will take place through this gap. **In construction** the spark discharges over this gap are visible through a small glass window conveniently located.

The first mentioned type constitutes the only real high tension magnetos.

**Ques.** How does a magneto deliver current to the cylinders in proper sequence?

**Ans.** By means of a self-contained distributor.

**Ques.** Describe briefly a so called high tension magneto with self-contained coil.



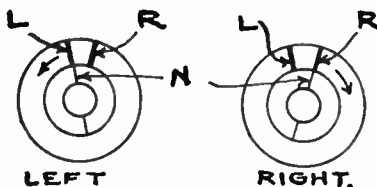
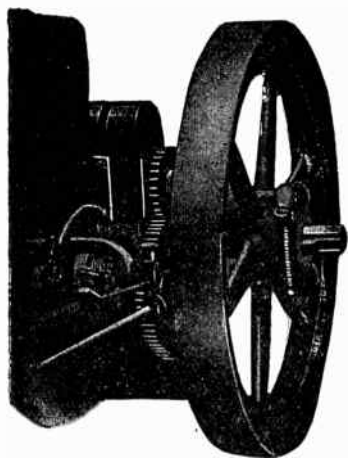
**FIG. 3,960.**—Sumter low tension oscillating magneto. In this type the armature does not revolve continuously but oscillates back and forth through an angle of about 90°.

**Ans.** The essential features are a low tension armature arranged to revolve in a permanent magnet field and provided with interrupter, secondary coil, condenser, and distributor. The construction and operation of this type magneto is clearly shown in fig. 3,959.

**Synchronous Drive for Magnetos.**—Ignition magnetos are generally constructed to deliver an alternating current, that is,

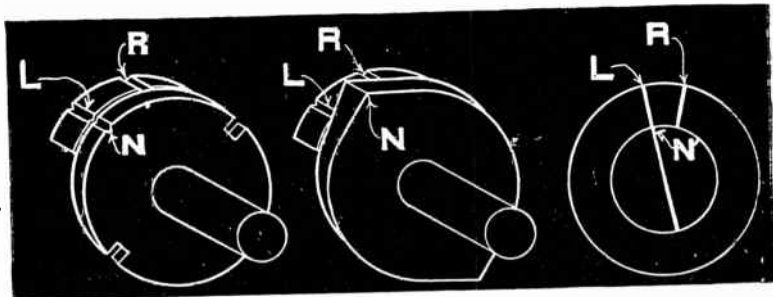
a current consisting of a succession of regularly alternating electrical impulses, varying in intensity from a plus maximum to a negative maximum, and separated by points of zero pressure depending upon the armature position with respect to the field.

Hence, it is necessary that the generator, unless geared to run at high speed, should be driven **synchronously**, that is, at a speed in a definite rate to that of the engine, in order that the periods when a spark is desired shall coincide with the periods when sufficient voltage is being developed, as otherwise the sparking periods might occur with a zero point of electrical generation, and no spark would be produced.



**FIGS. 3,961 and 3,962.**—Scumter low tension magneto installed on stationary engine, and marking on the ends of shaft and bearing for timing. *To time*, turn engine over in *running* direction until igniter snaps; be careful not to turn past this point. With gear on magneto shaft, turn the magneto in *running* direction until timing mark N on the shaft is in line with mark L, if rotation be left hand, or R, if rotation be right hand. Now mesh the gears, *without moving the timing*; this is accomplished by a proper location of the keyway in the magneto gear in relation to a marked tooth on same. The teeth on the engine driving gear meshing with marked tooth on magneto gear should also be marked, and after this marking is once determined all keyways may be cut in proper relation to the marked tooth, thus making all magnetos on the same type of engine interchangeable. These magnetos are usually driven at engine speed, but may be driven at other speeds.

To meet these conditions, the drive must be positive and may consist of either toothed wheel gears or chain and sprocket; the former is more desirable, since, with a chain and sprocket drive, there is sufficient



FIGS. 3,963 to 3,965.—Timing Sumter low tension magnetos. Type "Imp" is timed as in figs. 3,963 and 3,964, the end of shaft and bearings being marked as in fig. 3,965. All other Sumter magnetos are timed as shown in figs. 3,963 or 3,964. Some machines have the notched disc as per fig. 3,963; others, the pointed disc, fig. 3,964. In either case, the timing is exactly the same. With the pointed disc, use the point to time with instead of the notch. **Speed:** On single cylinder 2 and 4 cycle engines, magnetos may be run at engine speed, or  $1\frac{1}{4}$ ,  $1\frac{1}{2}$ ,  $1\frac{3}{4}$ , or twice engine speed. In the majority of cases, engine speed is most desirable, although other speeds result in reversing the current through igniter points, preventing pitting, which is advantageous. On two and four cylinder, 4 cycle engines, run magneto at engine speed. Three cylinders, at  $1\frac{1}{2}$  times engine speed. **For fixed ignition,** turn the engine in the direction in which it runs until the igniter snaps. **Do not turn past this point.** Observe the setting disc on the magneto shaft, and so mesh the magneto driving gear with gear on engine that either small notch N (see cut) is exactly in line with the mark R on the end plate if rotation be right hand, or L, if rotation be left hand, looking at magneto from gear end. Where timing discs have points like fig. 3,964 set either point in line with the proper mark. **For variable ignition,** where the range is not excessive, place the spark lever in the starting position, and then time the magneto as described above. Some engine builders prefer to reverse this order, giving the best spark for the advance or running position, although for starting on magneto it is preferable in most cases to use the best spark for starting. These are matters which have to be tested out by the manufacturer, and the engine dealer and user should be particular not to change the speed or method of timing on the engine as originally furnished. When magneto is properly timed, it is necessary to secure the magneto gear against slipping. The gear should be marked and keyway cut to register with keyway in armature shaft. As the keyway is the same in all armature shafts, the gears may also be keyed and marked alike, and by simply meshing the marked tooth on magneto gear with marked tooth on driving gear, the correct timing will be obtained without the necessity of setting each magneto. The driving gear should be so meshed that there is a very small amount of play. Otherwise, destructive wear of magneto bearings will take place. The amount of play is sometimes provided for by the engine manufacturer, by adjusting collars in the magneto bracket, or is easily accomplished by shimming either the magneto itself or the bracket. **In old engines,** when checking timing, it is best to note that the magneto marks line up when the piston is in the proper firing position, as it is possible that the igniter may have gotten out of time with the piston through wear. If so, the igniter should be properly adjusted, so that it will snap in time with the magneto. Sometimes the magneto is suspected of being out of time, when as a matter of fact it is the igniter. Igniters should be so adjusted that the points remain closed as much as possible, and open only to make a spark. This not only keeps the points from getting dirty, but also gives the magneto time to "build up" and produce its maximum current.

**NOTE.—Sumter reversing attachment.** Many marine engines are reversed "on the spark," and to accomplish this, a special attachment is necessary. This consists of a collar on magneto shaft carrying the gear and having a pin engaging a cutaway shoulder on the collar. This arrangement allows sufficient lost motion between the gear and collar so that, when the engine is reversed, the magneto is brought in time with the snapping of the igniter.

lost motion when the chain is loose enough for smooth running to prevent the accurate timing of the spark.

The friction gear drive or belt and pulley are alike objectionable, from the fact that no slipping or variation is permissible. While some recent forms of high tension magneto are advertised to operate **asynchronously**, that is, not speeded in definite ratio to the engine, the common types are so made that the spark shall occur in the cylinder at precisely the moment the magneto armature is at a certain point in its rotation. If, therefore, this condition be not strictly observed, the spark will be of defective intensity.

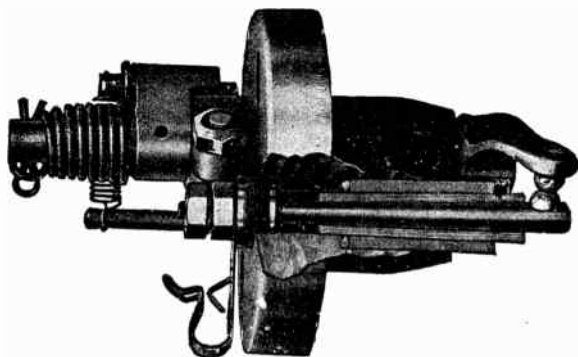


FIG. 3,966.—Sumter electrode for make and break ignition. *In construction*, the stem is insulated with rolled mica, which does not have any upturned edges in the combustion chamber. The taper arrangement makes it impossible to loosen or pull out the insulation. A copper gasket inside the igniter casting makes a gas tight joint. The stem is long enough to take care of igniter castings of various thickness, and the superfluous portion may be cut off.

**Ignition Systems.**—There are two systems in general use for igniting the charge by electricity:

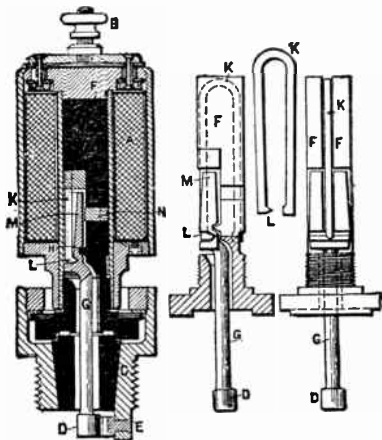
1. The low tension or *make and break*.
2. The high tension or *jump spark*.

**Ques.** What are the characteristic features of each system?

**Ans.** The low tension system is electrically simple and mechanically complex, while the high tension system is electrically complicated and mechanically simple.



**Low Tension Ignition.**—In this system there is a device known as an *igniter*, placed in the combustion space of the engine cylinder. This consists of two electrodes, one of which is stationary and the other movable. The stationary electrode is insulated, while the other, having an arm within the cylinder and placed conveniently near, is capable of being moved from the outside so that the arm comes into contact with the stationary electrode and separates from the latter with great rapidity.



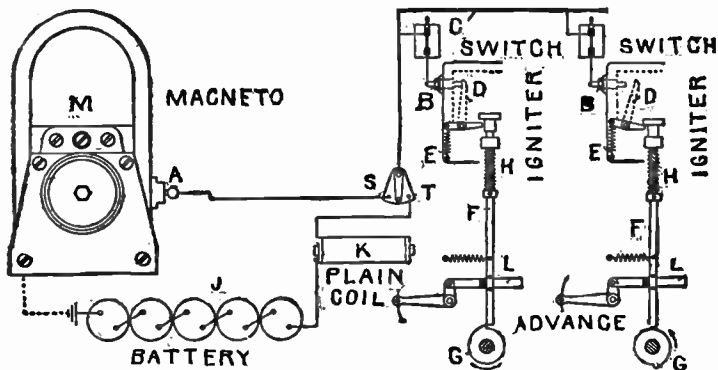
FIGS. 3,967 to 3,970.—Bosch magnetic spark plug. This consists of a coil A having one end connected to a terminal B, and the other to the plug casing C. A spark is produced when a separation takes place between the moving contact D and the stationary contact E. Within the plug is a metal core F and a swinging lever G, which lever pivots on the projection H which is a part of the core F. K shows a portion of a hair-pin spring, the end L of which rests in a recess within the lever G, the ordinary tension of the spring tending to hold the lower end of the lever G carrying the contact D against the stationary contact piece E.

This sudden breaking of the circuit produces an electric arc or *primary spark* caused by the inductance—that is, by the “inertia” or tendency of the current to continue flowing after the separation of the contact points.

The current may be derived from either a primary battery, storage battery, or low tension magneto.

**Ques.** Name the elements in a low tension circuit.

**Ans.** 1, a source of current supply consisting of either a primary battery, storage battery, or low tension magneto, 2, a primary induction coil when a battery is used, 3, an igniter,

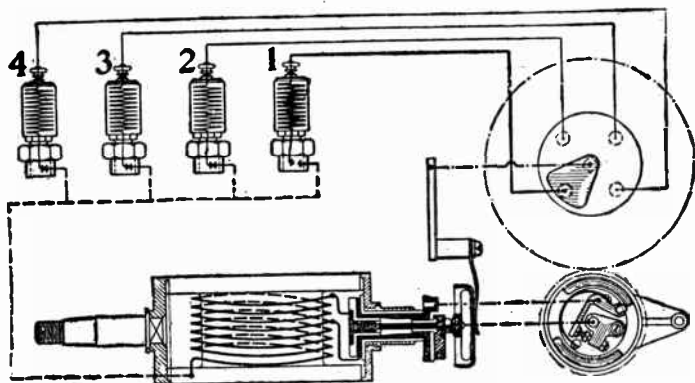


**FIG. 3,971.**—Low tension or make and break system. Two sources of current supply are provided: a dry battery and a magneto. One terminal of both the battery and magneto is grounded; the other terminal A, of the magneto M, is connected to the point S, of a two way switch. The cells comprising the battery J, are connected in series and the terminal not grounded is connected to a primary induction coil K, and thence to the point T of the two way switch. By moving the arm of this switch to the right or left, current may be had from the battery or magneto respectively. A conductor C, connects the third point of the switch to the stationary or insulated electrode of each igniter, a single throw switch being placed at each igniter which allows either or both cylinders to be thrown out of the circuit at will. The movable electrodes and metal of the engine furnishes the ground return to the battery and magneto. On a multi-cylinder engine it is evident that no other contact can be made at the moment of break in one cylinder since the current would then flow through any other igniter that might be in contact instead of producing a spark at the break. The operation of the make and break system is as follows: *Starting, say on the battery*, the arm of the two way switch is turned upon point T. The movable electrode D, of the first cylinder being in contact with the insulated electrode B, by the spring E, the current will flow from the battery J through the coil K, thence through the two way switch and the single throw switch to the insulated electrode B. The movable electrode D, being in contact with the insulated electrode B, the current returns to the battery through D and the metal of the engine, thus completing the circuit. As the cam G revolves in the direction indicated by the arrow, its nose passes from under the lower end of F, the latter drops with great rapidity by the action of spring H and in so doing a shoulder at the upper end of F, strikes the external arm of D a blow causing the contact point of D to be *quickly snapped* apart from B, producing an arc which ignites the charge. This cycle of operations is repeated by the ignition mechanism of each cylinder in rotation.

4, a switch for breaking the circuit, and an additional switch to alternate between the battery and the magneto when both means of furnishing the current are provided, and 5, connecting wires, as shown in fig. 3,971.

**Ques.** How is the spark produced in the low tension system?

**Ans.** The sudden breaking of the circuit by the quick separation of the electrodes produces an electric arc or **primary**



**FIG. 3,972.**—Wiring diagram of a low tension system with magnetic spark plugs. A portion of the wiring of the magneto armature is short circuited by the platinum points of the interrupter, and when the circuit is broken the resulting armature reaction has the effect of raising the armature voltage sufficiently to operate the plugs.

**spark** caused by the **inductance**—that is, by the “inertia” or tendency of the current to continue flowing after the separation of the contact points.

**Ques.** What is the object of the primary induction coil?

**Ans.** To intensify the spark.

When a magneto is used, a coil is not necessary, as the armature winding serves the same purpose. A magneto furnishing either direct

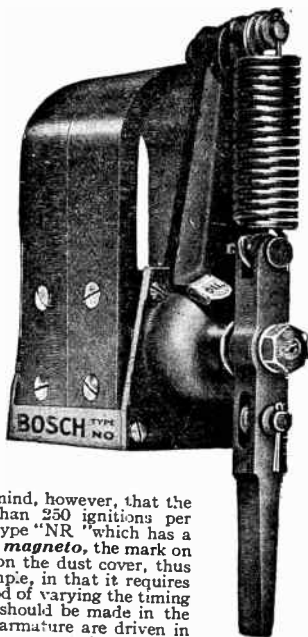
or alternating current may be used; the voltage will depend on the armature speed and the strength of the magnets.

**Ques.** What is used for the electrode contact points?

Ans. Iridium or platinum, as these metals resist the oxidizing effect of electricity and heat better than others.

**Ques.** What is the action of the current in low tension ignition?

Ans. A considerable interval of time is required for the current to rise to its full value, and the time of separation of the electrodes should not be sooner than the moment when the maximum current strength has been attained. When a magneto

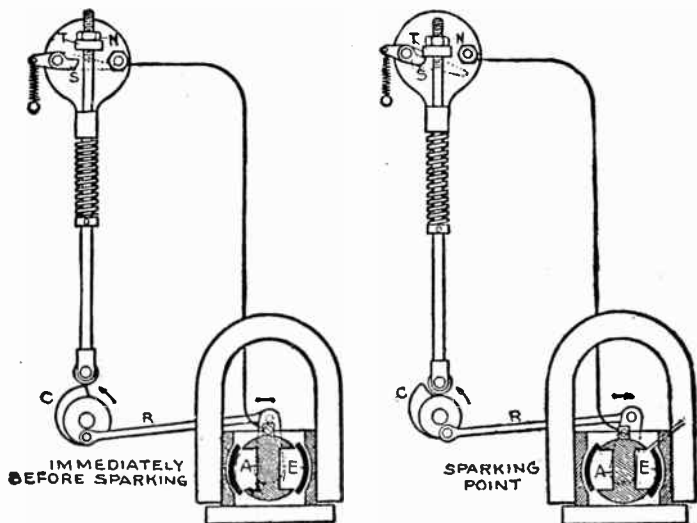


**FIG. 3,973.**—Bosch low tension, type NO, oscillating magneto used in connection with mechanical make and break igniters. A current wave being produced by each oscillation of the armature, it is necessary to drive the magneto in a fixed relation to the engine crank shaft. The magneto trip lever should be mechanically connected to the movable igniter on the engine, as in this way only can proper synchronism be obtained. It should be borne in mind, however, that the type "NO" cannot be used at speeds greater than 250 ignitions per minute, and where a greater speed is desired, the type "NR" which has a rotating armature, should be used. *In timing the magneto*, the mark on the armature should register with the proper mark on the dust cover, thus making the timing for either rotation extremely simple, in that it requires no disassembling of the instrument. Since no method of varying the timing of the spark is provided, arrangements to this end should be made in the tripping mechanism, and since the igniter and the armature are driven in synchronism by the trip lever, the instrument is always operated at its point of maximum efficiency regardless of whether the spark be retarded or advanced. In order to obtain proper results, the trip lever should be deflected through an angle of 30 degrees before it is released, and, since the spark is produced by spring action rather than directly through the speed of the engine and therefore is independent of the latter, no battery is necessary for starting, and in ordinary cases one turn of the fly wheel will be sufficient, provided, of course, that a proper gas mixture be present.

is used, the current strength increases with the speed, hence the contact interval can be shorter at high speeds than when a battery is used.

**Ques.** In low tension ignition, what is necessary in order to produce a good spark?

**Ans.** The "break" or separation of the contact points of the igniter should take place with extreme rapidity, that is, the spring H (fig. 3,971) should be sufficiently strong to cause the shoulder or rod F, when it falls, to strike the igniter arm a decided blow, thus quickly snapping apart the contact points.



**FIGS. 3,974 and 3,975.**—Low tension ignition system with inductor magneto. Fig. 3,974, position immediately before sparking; fig. 3,975, position immediately after sparking. **In construction**, the cam which operates the make and break igniter has a link connection to the inductor crank of the magneto which gives an oscillating motion to the inductor. The connection is such that at the instant of "break" the inductor cuts through the greatest number of magnetic line. **In operation**, the cam C, on the half time shaft, makes a contact just before sparking, and immediately breaks it again by permitting the hammer T to fall on the cam S. A spark is produced at the instant of break of contact at N. The winding of the armature A has one end grounded through the base of the magneto, the current returning through the engine to the point S; the other end of the winding is led through an insulated post to the nut N by which it is connected with a stud brought through the cylinder wall, where a wiper, indicated by dotted outline, normally rests against it by means of a spring.

**Ques.** State some disadvantages of low tension ignition.

Ans. Mechanical complication, excessive noise, wear of the igniter points, and possible leakage through the igniter.

Ques. For what service is low tension ignition especially suited?

Ans. For marine service especially in open, off shore fishing boats, such as Cape Cod dories, Sea Bright skiffs, etc.

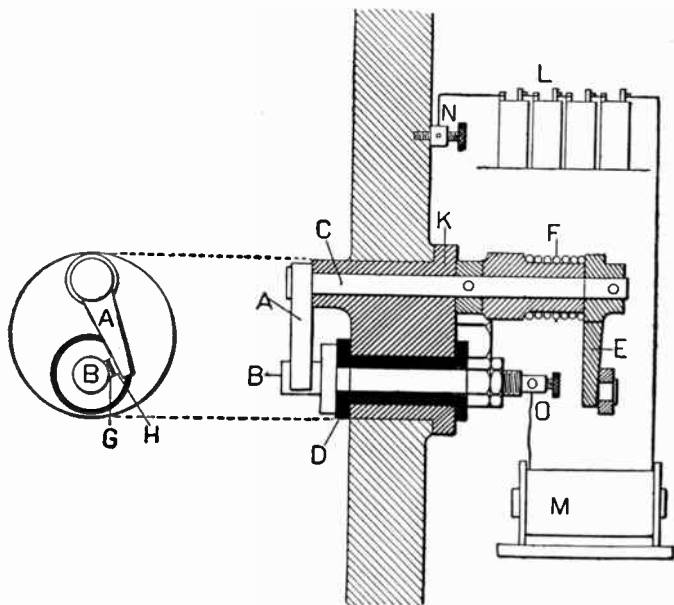
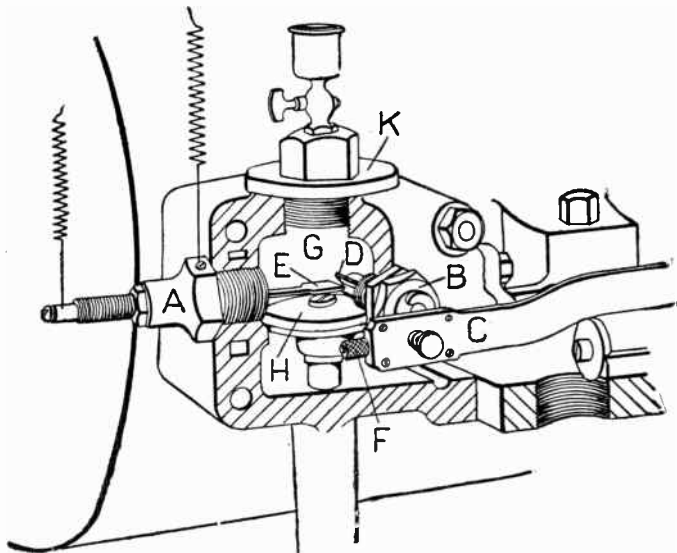


FIG. 3,976.—Hammer break igniter. *It consists of two metallic terminals A and B. The terminal A is mounted on a movable shaft C, while B is stationary and insulated from the cylinder wall by the lava bushing D. A suitable cam rod, attached to the crank E, provides the means for rocking the terminal A, so as to bring it in contact with the terminal B, and then quickly separate the terminals to produce the spark. The helical spring F provides a semiflexible connection between the shaft C, and the crank E. The contact points of the two terminals are tipped with two small pieces of platinum G and H, and both terminals are mounted in the removable plug K, which is usually inserted through the wall of the cylinder head, so that the igniter points extend into the compression space of the cylinder. In the circuit is a battery L, and primary spark coil M. In operation, when the igniter terminals are brought together, the circuit is closed through the battery and the spark coil, and when the terminals are quickly separated, the self induction of the coil causes an electric arc between the igniter terminals which ignites the charge.*

**Ignition with Inductor Magneto.**—In this system of low tension ignition, the current is furnished by a magneto having a stationary armature and a rotating inductor as before described.

The inductor is arranged to either revolve continuously or to oscillate through a small arc. An example of the latter type for low tension ignition is shown in figs. 3,974 and 3,975 which illustrates the Simms-Bosch system.

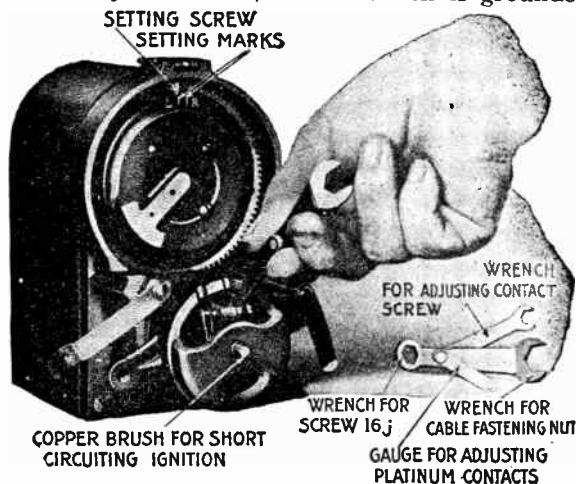


**FIG. 3,977.**—Wipe contact igniter. *It consists of two independent electrodes, the stationary electrode A, and the movable electrode B. The igniter is located in the inlet chamber G, directly over the head of the admission valve H, and either one of the electrodes can be reached for inspection or removal independently by removing the cap K. In operation, when B is revolved by the motion of the igniter rod C, the revolving blade D, is brought into contact with the spring E, at each rotation and produces the spark. A feature of this type of igniter is that the wiping contact prevents the accumulation of burnt carbon on the contact surfaces and this serves to reduce the resistance of the closed circuit. It is subject however to wear of the contact surface, and breakage of the spring. In adjusting the timing can be changed during operation by turning thumb screw F, on the end of the igniter rod, advancing or retarding the arc.*

**Low Tension or Make and Break Igniters.**—These devices may be divided into two general types according to the manner

of separating the terminals, that is to say, according to the method of break, as hammer break, and wipe contact (figs. 3,976 and 3,977.)

**High Tension Ignition.**—In this method of producing a spark, a device called a *spark plug* is employed. It consists of two stationary electrodes, one of which is grounded to the



**Figs. 3,978 and 3,979.**—Eisemann type G4 magneto showing method of timing and special wrench. **Timing the magneto:** As the spark occurs when the primary circuit is broken by the opening of the platinum contacts in the make and break mechanism, it is necessary that the magneto will be so timed that at full retard position of the timing lever body, the platinum contacts will open when the respective piston of the engine has reached the top point on the firing stroke. Turn engine by hand until piston of No. 1 cylinder is on the upper dead center; remove distributor plate from magneto and turn the driving axle of the armature until the setting mark on the distributor disc is in line with the setting screw as shown. (For clockwise rotation use mark R, for counter clockwise, use mark L). With the armature in this position, the platinum contacts are just opening, and the metal insert of the distributor disc is in connection with carbon for No. 1 cylinder. The driving medium must now be fixed to the armature axle without disturbing the position of the latter, and the cables connected to the spark plugs.

**NOTE.—Primary Induction Coils.** When an electric current flows along a coiled conductor, an inductive effect is produced which opposes any rapid change in the current strength. This principle is employed in low tension ignition to intensify the spark when a battery forms the current source. The device which accomplishes this effect is known as a *primary induction coil* and consists of a long iron core wound with a considerable length of low resistance copper wire, the length of the core and the number of turns of the insulated winding determining the efficiency. The current passing through the winding magnetizes the soft iron, and a self-induced current is generated. When the circuit is broken, the magnetic reactance tends to continue the flow of current, despite the break in the circuit, and occasions a spark of great heat and brilliancy. *The spark occurs at the moment of breaking the circuit, not at the moment of making.*



engine cylinder and the other insulated. The points of the electrodes are permanently separated from each other by about  $\frac{1}{32}$  of an inch, the space between the points being known as an *air gap*. This space offers so much resistance to the flow of an electric current that a very high pressure is required to cause the current to burst through the air gap and produce a spark, hence the term "high tension ignition," meaning *high pressure ignition*.

Since the spark jumps from one electrode to the other, this method of igniting the charge is also known as the *jump spark*

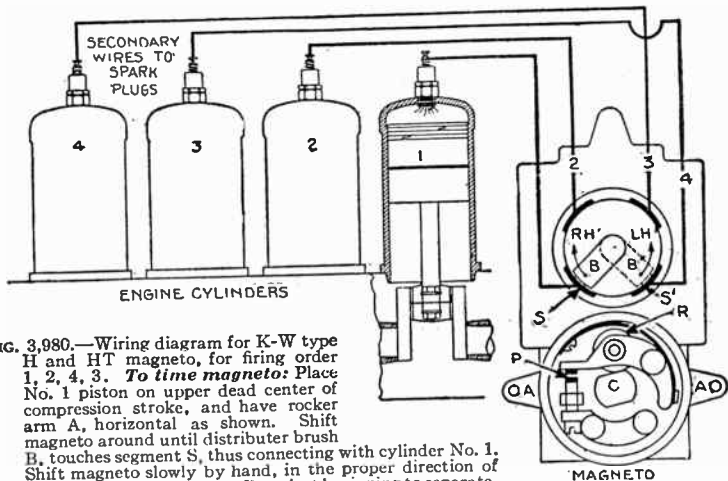


FIG. 3,980.—Wiring diagram for K-W type H and HT magneto, for firing order 1, 2, 4, 3. **To time magneto:** Place No. 1 piston on upper dead center of compression stroke, and have rocker arm A, horizontal as shown. Shift magneto around until distributor brush B, touches segment S, thus connecting with cylinder No. 1.

Shift magneto slowly by hand, in the proper direction of rotation, until the contacts P are just beginning to separate. At this point secure magneto shaft to gear or coupling with set screws. When one cylinder is timed, proceed to connect the others as follows: Ascertain the firing order of the engine then crank engine slowly and connect plug cable from next cylinder that fires to distributor segment No. 2 and so on until all the plug cables are connected. The secondary connections on the hard rubber distributor block are numbered in consecutive order, 1, 2, 3, 4, etc. These numbers do not refer to the engine cylinders, and it is necessary to determine the order in which the cylinders fire and connect secondary cables accordingly. Replace parts on the magneto and start the engine to test the setting. See that all nuts and connections are tight, also that retainer spring has been replaced. There should be a tendency for the engine to kick back slightly when starting, and if it do not, advance magneto until it does kick slightly. To advance, shift coupling against direction of rotation. To retard, shift coupling with direction of rotation. Shift slightly each time until correct position is obtained. Pin magneto shaft to gear or coupling with taper pin. do not depend on a set screw, as it will surely work loose in time.

system. The spark itself is properly described by the prefix *high tension* or *secondary*.

In the production of the spark two distinct circuits are necessary; 1, a low tension or *primary* circuit and 2, a high tension or *secondary* circuit. The current which flows through the low tension circuit is called the *primary current* and that which it *induces* in the high tension circuit, the *secondary current*.

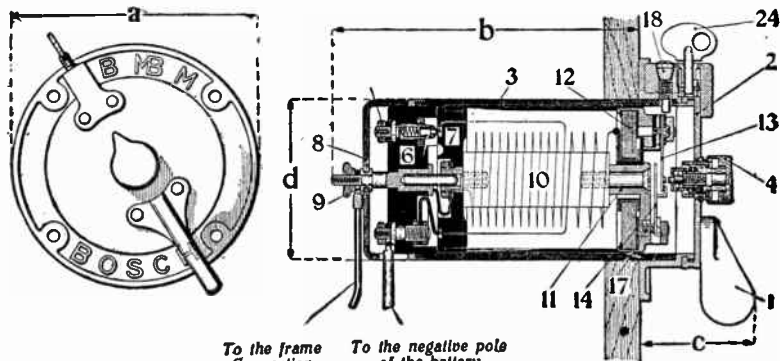
In order to obtain the high pressure required to produce a spark, a device known as a *secondary induction coil* is used which transforms the primary current of low voltage and high amperage into a secondary current of high voltage and low amperage, that is, the quantity of the current is decreased and its pressure increased.

The general principles upon which high tension or jump spark ignition is based are as follows:

An automatic device is placed in the primary circuit which closes and opens it at the time a spark is required. When the circuit is closed, the primary current flows through the primary winding of the coil and



**FIG. 3,981.**—Automatic spark advance mechanism and armature of Eisemann magneto. The automatic advance is accomplished by the action of centrifugal force on a pair of weight attached at one end to a sleeve through which runs the shaft of the magneto, and hinged at the other end of the armature. Along the armature shaft, run two helicoidal ridges which engage with similarly shaped splines in the sleeve. *In operation*, the rotation of the armature causes the weights to spread and exert a longitudinal pull on the sleeve which in turn changes the position of the armature with reference to the pole pieces. Thus, the moment of greatest induction is advanced or retarded and with it the break in the primary circuit, for the segments (or cams) which left the circuit breaker and cause the break in the primary circuit are *fixed* in the correct position and thus the break occurs only at the moment when the current in the winding is strongest. On other magnetos it is the segments or cams that are moved forward or back as the case may be. To apply the automatic control principle to any engine, there have been produced spindles of varying pitches; spindles that will give 19, 25, 38, 45 and 60 degrees advance. For use in connection with these spindles, there are sixteen different springs. With these parts, in connection with the governor mechanism, 160 advance curves can be produced. By varying the length of the stop on the bronze nut, more may be obtained. Many engines require a great deal of advance, others will not permit of more than 20 to 25 degrees. It is necessary to take into consideration the size and shape of the combustion chamber, the compression, the position of the spark plugs and the speed of the motor. It is also universally acknowledged that an engine of high compression will give a quicker burning mixture and will not require, or in some cases, stand, as early a spark as one of lower compression.



1. Switch handle.
2. Movable cover.
3. Coil housing.
4. Starting press button.
6. Fixed connection plate.
7. Movable switch plate.
8. Cable cover.

To the frame Connection  
To the negative pole of the battery

9. Milled edged nut.
10. Iron core.
11. Plate carrying the starting arrangement and the condenser.
12. Condenser.
13. Contact spring.
14. Vibrator.

15. } Auxiliary contact breaker.
16. } Vibrator spring.
17. } Stop screw for switch handle.
24. Locking key.

### Dimensions

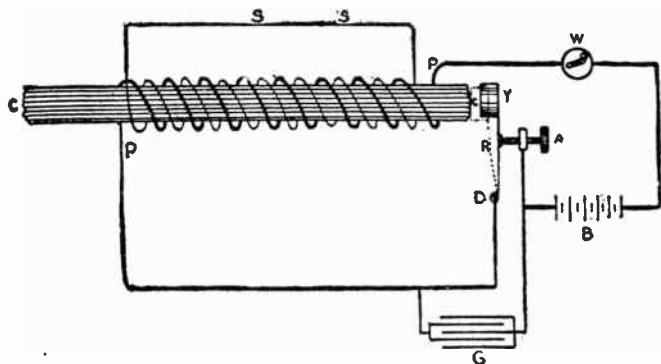
a =	105 mm
b =	135 "
d =	50 "
d =	71 "

### Horizontal Coil Type "C".

**FIGS. 3,982 and 3,983.**—Bosch type C horizontal secondary coil. *In construction*, a movable brass cover 2 carries the switch handle 1, and is attached to the cylindrical coil housing 3 by means of a bayonet joint. The press button used for starting projects from the center of the cover. A pin set on the coil end plate engages an opening in the cover, which causes the coil and cover to move together. The switch contacts being located on the other end plate of the coil, this permits the operation of the switch by the movement of the cover. **Switch positions:** Four positions are provided, 1, O, off, 2, B, battery, 3, MB, magneto and battery, 4, M, magneto. The base of the coil housing is formed by the stationary switch plate 6, and the contacts carried on it register with the contacts of the movable switch plate 7. The partial rotation of the coil by the movement of the cover plate causes the different switch contacts to engage. The coil body consists of a cylindrical iron core 10, upon which are wound the primary and secondary windings; the former consists of a few layers of heavy wire, and the latter of many layers of fine wire. One end of the primary winding is connected to a segment on switch plate 7, while the other end leads to the vibrator, from whence it passes to ground. The iron core 10, carries the condenser 12, and to it is screwed the end plate 11 that supports the starting device. The parts of the starting device are the brass button 4, the contact spring 13, and the vibrator blade 14. When the switch handle is turned to either of the battery positions, a pressure on button 4, will complete the primary circuit by causing the contact pin to touch the platinum point carried on spring 13. This contact will be in parallel with the primary timer, and the current will flow from the blade 14, to the end plate 11, to the iron core 10, and by binding post 9, to ground. **Lock:** The coil is provided with a key lock, which may be operated only when the coil is in the "Off" position. This prevents the unauthorized use of the engine, and by making it impossible to lock the switch in any of the operative positions, renders unlikely that the switch will be left unintentionally on one of the battery positions to the injury of the battery. **Battery voltage:** The coils are wound for a current of six volts, and a six volt, sixty ampere hour storage battery is recommended. If it be necessary to use dry cells, ten should be provided for a 4 cylinder system, and twelve for 6 cylinders, connected in series parallel. They should be divided into two groups of five or six cells each; the cells of each group should be connected in series, and the groups connected together in parallel.

causes a secondary current to be induced in the secondary winding. The spark plug being included in the secondary circuit opposes the flow of the current by the high resistance of its air gap. Since the pressure of the secondary current is sufficient to overcome this resistance, it flows or "jumps" across the gap and in so doing, intense heat is produced resulting in a spark.

Sometimes the spark is obtained by keeping the primary circuit closed except during the brief interval necessary for the passage of the spark at the plug points. A secondary spark, then, may be produced by either open or closed circuit working, that is, the primary circuit may be kept either opened or closed during the intervals between sparks.



**FIG. 3,984.**—Diagram of a secondary, vibrator type induction coil. *The parts are as follows:* A, contact screw; B, battery; C, core; D, vibrator terminal; G, condenser; P, primary winding; S, secondary winding; W, switch; Y, vibrator. *In operation*, when the switch is closed, the following cycle of action takes place: *a*, the primary current flows and magnetizes core; *b*, magnetized core attracts the vibrator and breaks primary circuit; *c*, the magnetism vanishes, inducing a momentary high tension current in the secondary winding, producing a spark at the air gap; *d*, magnetic attraction of the core having ceased, vibrator spring re-establishes contact; *e*, primary circuit is again completed and the cycle begins anew.

The automatic device which controls the primary current to produce a spark by the first method is called a *contact maker*, and by the second method, a *contact breaker*. A closed primary circuit with a contact breaker is used to advantage on small engines run at very high speed as it allows time for the magnetism or magnetic flux in the core of the coil to attain a density sufficient to produce a good spark. The word *timer* is usually applied to any device which controls the primary current, when it controls both the primary and secondary currents, as in *synchronous ignition*, it is called a *distributor*. Before explaining the different systems of high tension ignition the several devices used, such as induction coils, spark plugs, etc., will be described in some detail.

Among the various devices used in high tension ignition the following are of importance and the function and construction of each should be clearly understood.

**Secondary Induction Coils.**—In order to obtain the high voltage necessary to produce a secondary (jump) spark, a secondary induction coil is used: it is a species of transformer and transforms the primary low tension current into a secondary high tension current. It consists essentially of four main parts: 1, an iron core; 2, primary winding; 3, secondary winding, and 4, condenser.

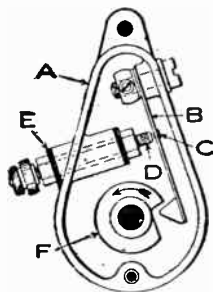


FIG. 3,985.—Contact maker and mechanical vibrator. The case, A, is usually attached to the gear box of the engine; B, is the vibrator blade; C, a platinum contact point; D, an insulated adjusting screw; E, a bushing with insulation; F, the operating cam. As this cam revolves the weight on the end of blade, B, drops into the recess on the cam causing the blade to vibrate and make a number of contacts with D, thus producing a series of sparks when in operation.

**Timers.**—These devices are simply revolving switches operated by the engine and so adjusted that the primary circuit is made and broken in proper sequence with the engine cycle, so that the spark may occur at the proper point with respect to the crank position. A timer is geared to revolve at one half engine speed for a four cycle engine, and at engine speed for a two cycle engine. *The distinction between timers and distributors should be carefully noted, to avoid the usual erroneous use of these terms.*

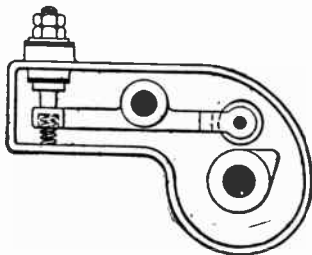
**Special Forms of Timer.**—In order to meet certain conditions of operation, special timer construction is sometimes used, giving rise to types of timer which are known as:

1. Contact makers;
2. Mechanical vibrators, or *tremblers*;
3. Contact breakers;
4. Interrupters.

A *contact maker* keeps the circuit closed for only a short interval, whereas, a *contact breaker* keeps the circuit open for only a short interval. A contact breaker is intended to meet the conditions of extreme high speed, that is, by keeping the primary circuit closed except during the brief interval necessary for the passage of the spark, sufficient time is given for the magnetic flux of the core of the magnet to attain a sufficient density to induce a secondary current of the required strength.

An interrupter is virtually a contact maker located on a magneto and forming a part of the latter machine.

**Distributers.**—When one secondary coil only is used with a multi-cylinder engine as in synchronous ignition, a device called a distributor is a necessary part of the system. Its use is to direct the discharge of a single coil to the spark plug of each cylinder in rotation. A distributor



**FIG. 3,986.**—Contact breaker. This device keeps the circuit closed at all times except during the brief interval necessary for the passage of the spark at the plug points. It is used to advantage on engines running at very high speeds, as it allows time for the magnetic flux in the core of the coil to attain a density sufficient to produce a good spark.

consists of a timer for the primary current, and a similar device for the secondary current working synchronously, that is, in step with the timer and which switches the secondary current to the various spark plugs in the proper order of firing.

In other words, a distributor is a combination of two timing devices working in unison with each other; one makes and breaks the primary

**NOTE.**—*The primary element of a distributor* contains as many stationary contacts as there are cylinders and a revolving arm or rotor which in its revolution touches each of the stationary contact so that the primary circuit is made and broken once for each cylinder during one revolution of the arm. *The secondary element* is above and concentric with the primary part. It has a rotor and the same number of stationary contact as the primary element; the parts of both elements are arranged symmetrically with each other and are contained in a compact cylindrical casing. A shaft geared to the engine operates both the primary and secondary rotors. The primary rotor is in metallic contact with the shaft and forms with it and the engine a ground return for the primary circuit. The secondary rotor is carefully insulated. All the primary stationary contacts are connected to one common terminal which receives the primary lead. A binding post is provided for each of the secondary stationary contacts and one for the secondary rotor. These binding posts are usually placed on the top part of the casing.

circuit, while the other makes and breaks the secondary circuit and in so doing distributes the current to the several cylinders in correct sequence.

**Spark Plugs.**—In all high tension ignition systems a *permanent air gap* is placed in the secondary circuit across which the current must jump to produce a spark. The device by which this permanent air gap is maintained is called a *spark plug*. There are several varieties

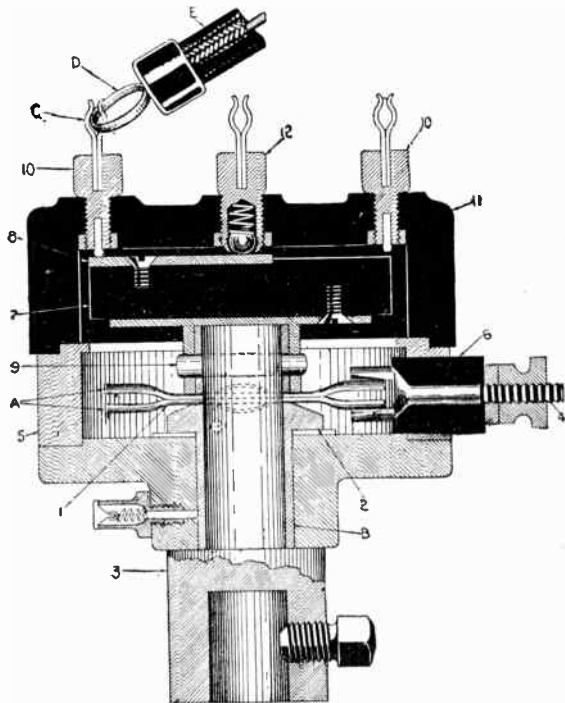
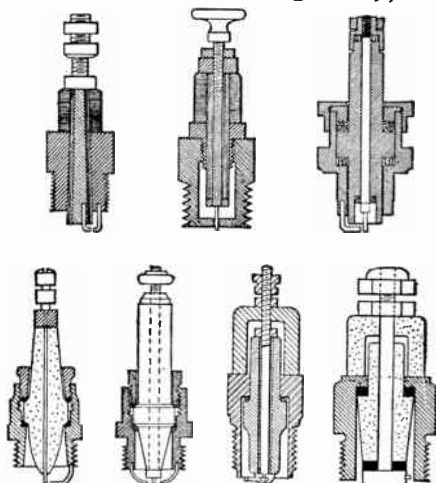


FIG. 3,987.—Sectional view of the Pittsfield distributor. In this device several revolving contacts are employed instead of one; these consist of a double spring making sliding contact at the portions, A. **The parts are:** 1, contact springs; 2, shaft; 3, bushing; 4, stationary terminal; 5, timer ring; 6, stationary contact insulation; 7, distributor plate; 8, secondary revolving contact segment; 9, taper pin; 10, secondary stationary terminals; 11, casing; 12, secondary terminal for lead to coil; B, slide bearing; C, hook; D, eye; E, secondary cable. The principles of distributor operations are plainly shown in fig. 3,998.

of spark plug, of which the following are extensively used: 1, *primary*, or magnetic make and break plugs, 2, *secondary*, or jump spark plugs, including plain and special forms such as coil plugs.

**Various High Tension Ignition Systems.**—There are a number of satisfactory method for producing a secondary or high tension spark, such as ignition

1. With plain coils;
2. With vibrator coils;
3. With master vibrator;
4. With single coil (synchronous ignition);



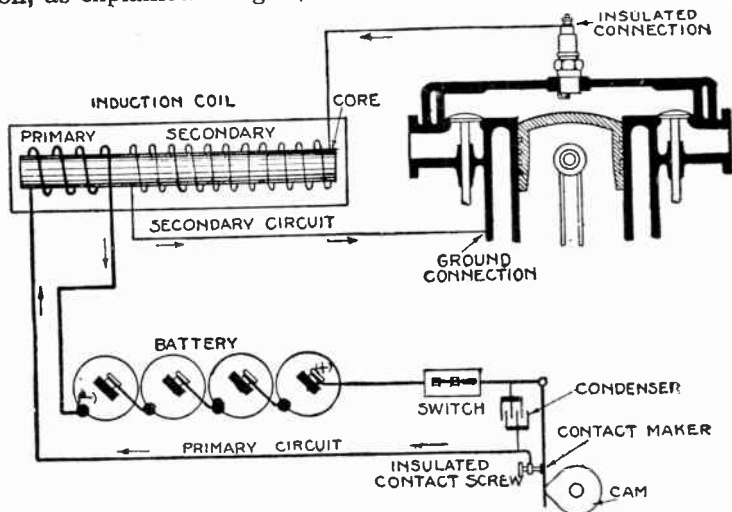
Figs. 3,988 to 3,994.—Sections of well known spark plugs. The first five have porcelain insulation; the last two, mica.

5. With dynamo and storage battery;
6. With magneto;
7. With special igniting devices.

**NOTE.**—*Sparkling pressure.* A current of very high voltage is required to produce a secondary or jump spark on account of the great resistance of the air gap and compression pressure which oppose the current flow. The required voltage will depend on the length of the air gap and the intensity of the pressure inside the cylinder. For ordinary spark plugs in air the sparking pressure will vary from about 3,000 to 5,000 volts according to the length of the gap, but to produce a spark in an engine cylinder where the mixture has been compressed to four or five times the atmospheric pressure, will require from 10,000 to 20,000 volts. *When a spark plug will not work,* the electrodes and insulating material should be thoroughly cleaned with fine sandpaper and the distance between the points adjusted to about one thirty-second of an inch, or the thickness of a ten cent silver piece. If the battery be weak, the gap may be made smaller.



**Ignition with Plain Coils.**—The first high tension system to attain popularity was the single spark system using a plain coil and contact maker. This being the simplest method of producing a secondary spark, it will serve to illustrate the several principles involved in jump spark or high tension ignition, as explained in fig. 3,995.



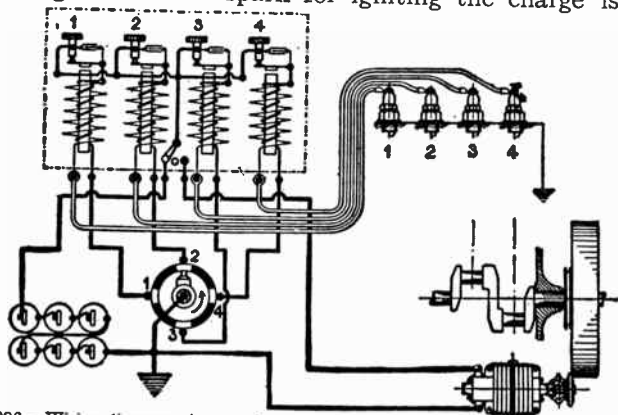
**FIG. 3,995.**—Diagram illustrating the principles of high tension or jump spark ignition. The nose of the cam in revolving engages the contact maker which completes the primary circuit and allows current to flow from the battery through the primary winding of the coil; this magnetizes the core. The primary circuit is now broken by the action of the cam and magnetic changes take place in the coil which induce a momentary high tension current in the secondary circuit. The great pressure of this current forces it across the air gap of the spark plug and as it bridges the gap a spark is produced. The arrows indicate the paths of the currents. At break, the primary current is "slowed down" by the condenser, thus preventing an arc between contact breaker contacts.

**Ignition with Mechanical Vibrators.**—The view held by some that a series of spark closely following each other is more effective for ignition than a single spark, led first to the introduction of the mechanical vibrator. This system employs a plain coil and is identical with the one just described with the

exception that in place of the make or break timing device, a mechanical vibrator is used which gives a succession of spark for firing each charge.

As the rotor of the timer revolves, it touches each of the stationary contact and in so doing, the above cycle is repeated for each cylinder in the order of firing, as wired.

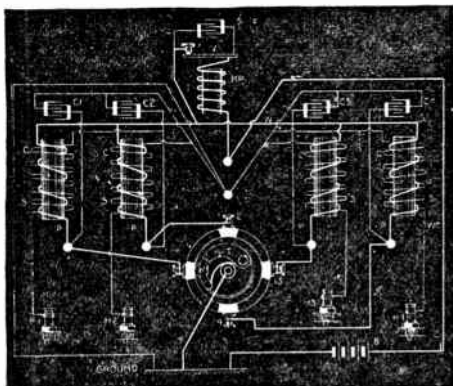
**Ignition with Vibrator Coils.**—A more refined method of producing a series of spark for igniting the charge is by the



**FIG. 3,996.**—Wiring diagram of a dual jump spark system for a four cylinder, four cycle engine. A dry battery and low tension magneto form the two sources of current supply. The primary, or low tension circuit is shown by heavy lines, the secondary or high tension circuit by fine lines, and the leads to spark plugs by the double lines. The dotted rectangle represents the outline of a four unit dash coil. *In the coil connections* it should be noted that the adjustable contact screw of each vibrator is connected by a common wire terminating at the two way switch; also, in each unit one end of the secondary winding is connected to that end of the primary, leading to the vibrator blade. These common connections simplify the external wiring, as otherwise there would be four binding posts for each unit. The two way switch just referred to permits the current supply to be taken from either of two sources, such as a battery and a magneto. Current is supplied by the battery when the switch is in the position shown in the figure. By turning the switch to the right, a current from the magneto will be furnished. With the battery in the circuit and the timer in the position shown, *the operation is as follows:* Current flows from the positive terminal of the battery, to the switch, thence, to the contact screw of coil number two. From here, it flows through the vibrator blade, primary winding of the coil timer and the metal of the engine, and returns to the battery. The primary circuit is alternately opened and closed with great rapidity by the vibrator so long as the rotor of the timer is in contact with terminal 2. During this interval, a series of high tension current is induced in the secondary circuit producing a series of spark. The current which flows through the secondary winding is in a direction opposite to that of the primary current. At each interruption of the primary current, an induced high tension current flows through the secondary winding, to the spark plug, across the gap, producing a spark and returns through the metal of the engine, timer, and back to the coil.

use of a vibrator coil. The magnetic vibrator is a marked improvement on the mechanically operated device as it vibrates with greater rapidity and is capable of delicate adjustment. This system which is extensively used is illustrated in fig. 3,996, which is a wiring diagram for a four cylinder engine.

**Ignition with a Master Vibrator.**—In a multi-unit coil there is a vibrator for each unit, all of which may be operated by a single or master vibrator. The advantage of such a system



**FIG. 3,997.**—Circuit diagram of a master vibrator coil. B, is the battery; C, the unit coils; C1, C2, etc., the condensers; P, the primary windings and S, the secondary windings; H1, H2, etc., the spark plugs; T, the timer; MP, the master primary; V, the vibrator; W, the common primary connection; 1, 2, etc., the stationary contacts of the timer. The primary windings are all united in parallel at the top by a wire W, and with the lower winding ends connecting respectively with the segments of the timer T. The primary winding MP which operates the vibrator V is in series with this winding, the wire WT connecting from the battery and passing directly through the master primary MP. The four condensers, C1, C2, C3 and C4, are in parallel with the primary windings. Each of the secondary windings S connects direct to the spark plugs, designated respectively H1, H2, H3 and H4.

is that there is but one vibrator to keep in adjustment, since this vibrator serves for all the cylinders; whereas, with one for each unit, all have to be kept in adjustment and the difficulty of keeping the several adjustments is a considerable factor. The diagram, fig. 3,997, illustrates the circuit and operation of a master vibrator.

**Synchronous Ignition.**—This system employs a distributor and a single coil for a number of cylinder. It is called "synchronous" for the following reason: when a multi-cylinder engine has a coil unit for each cylinder, it requires the adjustment of several vibrators. Now, the time required by the vibrator to act is variable with the adjustment and with slight differences

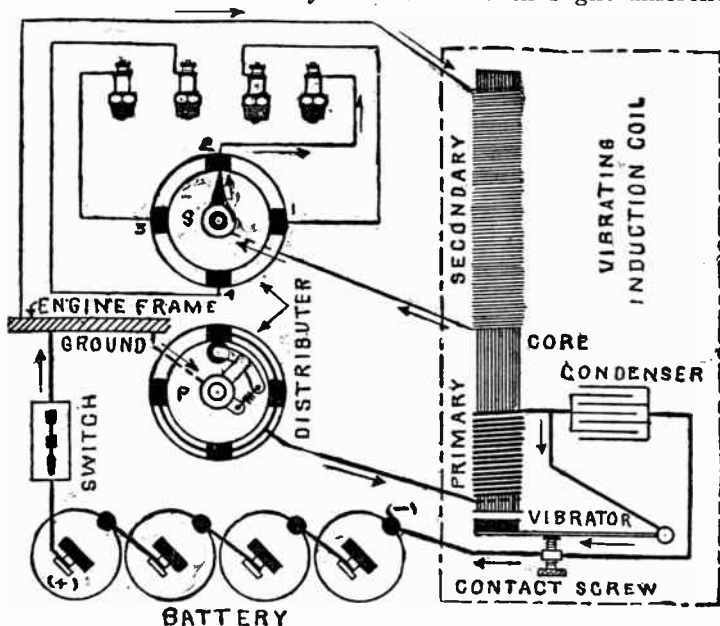


FIG. 3,998.—Diagram illustrating the principles of synchronous ignition. For clearness the primary and secondary elements of both the coil and the distributor are shown separated. When the primary rotor of the distributor completes the primary circuit, current from the battery flows and the vibrator operates, making and breaking the current with great frequency. A high tension current, made up of a series of impulses, is induced in the secondary circuit and distributed by the rotor arm during its revolution to the several cylinders in the proper order of firing. Each secondary segment of the distributor being wired to one of the spark plugs, the rotor during its revolution brings each plug into the secondary circuit in the order indicated in the diagram. As shown, the secondary rotor is in contact with segment number two which causes the induced current to flow from the secondary winding, through the distributor. One end of the secondary winding is usually connected to one end of the primary winding instead of making a separate connection to the metal of the engine. This simplifies the wiring by having one common ground connection.

in construction, hence, of the several vibrators, perhaps no two will act in exactly the same time. Consequently, though in the ordinary multi-unit coil system, the closing of the primary circuits may occur at exactly corresponding moments for all cylinders, the production of the spark will be more or less "out," owing to the variation in the "lag" of the different vibrator.

With a distributor and single coil, the lag is the same for all the cylinders, hence, the application of the word *synchronous*.

Fig. 3,998 is a wiring diagram showing the connections of a synchronous system; for clearness, the two windings of the coil are shown separated from each other and for the same reason also the primary and secondary elements of the distributor are separated.

**Magneto Ignition.**—There are numerous types of magneto used for igniting purposes. In the several systems, therefore, different methods of wiring are required. In the true high tension and the self-contained types where the coil and condenser are a part of the magneto, the number of external connection is less than with those having the coil in a separate box.

In starting an engine equipped solely with a magneto, it is necessary to turn the crank much faster than when a battery is used, because the armature must be turned at a certain speed to generate the required current. Due to the refinement of design this factor has been reduced and most magnetos will give a spark sufficient for ignition even if the armature be revolved quite slowly.

To secure satisfactory ignition with a magneto it is very essential that the various joints of the primary circuit be kept in perfect condition,

---

NOTE.—In connecting up batteries and coils it is recommended that the vibrator screws be made "positive," so that whatever platinum is carried away by the arc may be taken from the screw and deposited upon the contact point of the vibrator. The theory is that the screw is cheaper and easier to replace than is the vibrator, and that, with this arrangement, the vibrator point builds up rather than wears away, requiring only the smoothing of the extra metal deposited upon it to keep it in condition.

NOTE.—The very slight wear produced upon vibrators operated from non-synchronous alternating current magnetos from which the current is in each direction for one-half of the time, in the aggregate, is well known. Hence, when a battery is used, if the operator would periodically change the direction of the current flow by reversing the two battery wires connecting the one which has gone to the positive pole, to the negative and vice versa, he will find that the wear of the vibrator points is reduced to a minimum.

that is to say: all terminals should be clean, bright, and firmly connected.

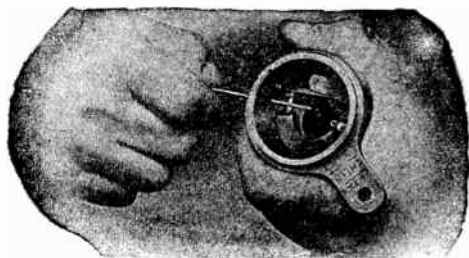
*The interrupter contacts should be kept clean and true* using a fine file to square the surface, so that the entire surface of one contact will touch the other.

The two brushes leading to armature coil must be kept clean, free of oil and springs adjusted to secure good contact.

Most operators pay too little attention to the secondary circuit contacts. These also should be kept clean, true, and springs properly adjusted.

When an engine will not start on the magneto or requires unusually rapid spinning to effect ignition, it is a strong indication that the primary and secondary contacts are not in proper condition.

When a magneto ignition system fails, the trouble is almost always due to faulty condition of the contacts.



**FIG. 3,999.**—Filing slot for cleaning platinum contacts of Connecticut magneto interrupter. The cup holding the interrupter or primary circuit breaker may be withdrawn from its housing. The slot serves as a guide for a small flat file for cleaning and squaring the contact points. By means of an adjustable gauge furnished with the magneto, the correct opening of the contact points may be determined. The interrupter is provided with a single roller bearing against the cam pins, thus insuring accurate timing at any speed and unaffected by centrifugal force. The advance lever can be connected at either side of the magneto as the interrupter housing is reversible. The cams are renewable by a half turn with a screw driver.

**Dual Ignition.**—As defined, a dual ignition system is *one having two separate current sources with some parts of the ignition apparatus in common*. Most magneto systems are examples of dual ignition, that is the distributor which forms a part of the magneto is used to distribute the current from either the magneto or a battery. Thus, if a short circuit occur in the armature, by turning a switch, current may be *furnished* by the battery and *distributed* by the magneto. Moreover, because of the difficulty of cranking an engine fast enough to start on the magneto,

the battery is usually used for starting and the magneto for running. An example of dual ignition is shown in fig. 4,000.

**Double Ignition.**—An extreme provision against failure in operation consists in providing two entirely independent ignition systems. For some installations both make and break and jump spark systems are provided, in others, two high tension systems. Such practice is not to be recommended, especially in view of the very efficient and dependable apparatus that can now be obtained.

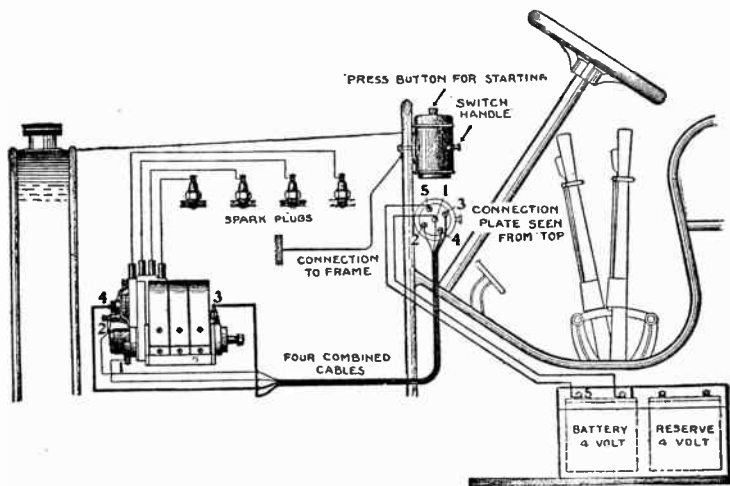
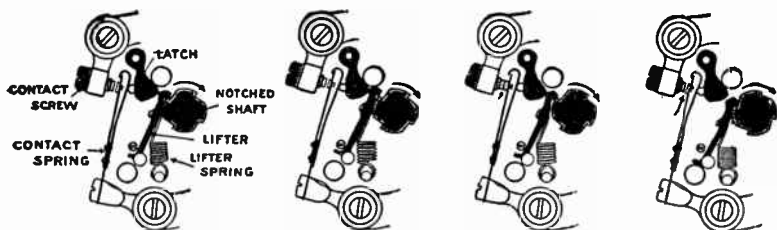


Fig. 4,000.—Wiring diagram of Bosch *dual* ignition system, using one set of spark plug. A special coil is provided with self-contained switch, and a button for bringing a magnetic vibrator into the circuit when desired. **Combined cables:** 1, thin blue cable is for contact breaker; 2, thin red cable for short circuiting terminal; 3, thin white cable for high tension terminal; 4, thick brown cable for distributor terminal. **Single connections,** 1 and 5 are battery leads. At back of coil is connection to frame.

**Ignition with Special Devices.**—The fact that ignition could be made reliable and certain, as well as more nearly synchronous, by the single spark as produced by the magneto, has influenced

several seekers after battery economy with coil ignition to develop and place on the market devices in which a single break in the primary circuit is caused mechanically at each instant at which it is desired to ignite the charge within the engine cylinders.

These "single-break" coil systems embody, in their most highly developed forms, a single plain coil, a secondary timing device for the induced high tension current and a timer or circuit breaker which causes a sharp break in the circuit of the primary coil winding each time an ignition spark is required. After the coil itself, the circuit breaker is the chief component of single coil systems with distributor, designed to produce but one spark per ignition. Upon it depends the effectiveness



**Figs. 4,001 to 4,004.**—Principle of the Atwater-Kent ignition system. The so called "unisarker" consists of a notched shaft, one notch for each cylinder, which rotates at one-half the engine speed, a lifter or trigger which is pulled forward by the rotation of the shaft and a spring which pulls the lifter back to its original position. A hardened steel latch and a pair of contact point complete the device. The figures show the operation of the contact maker very clearly. It will be noted that in fig. 4,001 the lifter is being pulled forward by the notched shaft. When pulled forward as far as the shaft will carry it fig. 4,002, the lifter is suddenly pulled back by the recoil of the lifter spring. In returning, it strikes against the latch, throwing this against the contact spring and closing the contact for a very brief instant—too quickly for the eye to follow the movement (fig. 4,003). Fig 4,004 shows the lifter ready to be pulled forward by the next notch. Note that the circuit is closed only an instant preceding the spark. No current can flow at any other time, not even if the switch be left "On" when the engine is not running. Note that no matter how slow or how fast the shaft is turning, the lifter spring will always pull the lifter back at exactly the same speed, so that the operation of the contact, and therefore the spark, will always be the same, no matter how fast or how slow the engine be running. The contact points are adjustable only for normal wear. By means of the distributor, which forms the upper part of the unisarker, the high tension current from the coil is conveyed by the rotating distributor block, which seats on the end of the unisarker, to each of the four spark plug terminals in the order of firing.



of the spark, and in some measure also the current consumed in the coil in producing it.

In consideration of battery economy, it is necessary that the circuit breaker make only a sufficiently long contact to secure the proper building up of the magnetic field about the coil windings, before the occurrence of the break. Because of this, it is usual to so set the adjustable point of the breaker that the contact duration is the minimum with which a proper igniting spark can be secured. The author objects to primary battery systems, except on some single cylinder engines, because the current is of constantly decreasing strength and batteries of short life, necessitating frequent renewal.

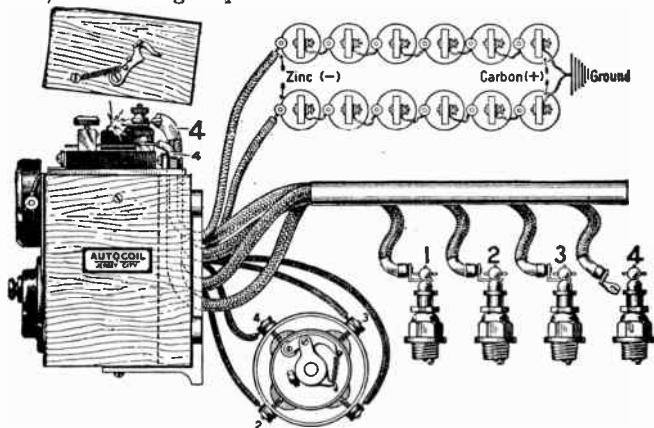
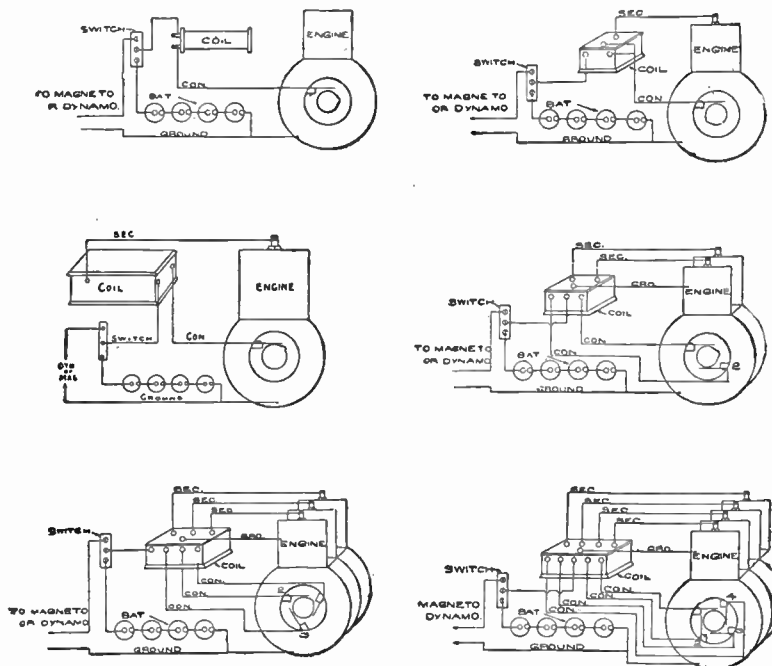


FIG. 4,005.—Auto coil wiring diagram showing coil box and connections. The picture shows clearly how to bring the battery, timer and plug wires to the coil. The wires can enter through the middle back or from the bottom of the coil box, through holes provided for the purpose. It is important to connect the zinc or (—) battery wires to coil, the carbon or (+) wires being connected to ground or frame of engine. It is also important to shave or pare back the braid on the secondary or high tension wires as shown in picture. If the braid be connected to any metallic portion of the wire or terminal clip, there will be a noticeable leak on damp days, as the oil in the braid sooner or later dies out, and the braid quickly absorbs moisture, and moist braid will cause the high tension current to escape to the frame of the engine.

**Ignition Troubles.**—To successfully cope with ignition troubles there are two requisites: 1, a thorough knowledge of the system used, and 2, a well ordered course of procedure in looking for the cause of the trouble.

In many ignition systems the chief difficulty encountered in the location of defects arises from the fact that faults in different



**FIGS. 4,006 to 4,011.**—Knoblock coil wiring diagrams. Fig. 4,006, connections for make and break engine, showing battery, magneto and double switch. If magneto be not installed, use a single switch in place of the double switch; Fig. 4,007, connections for single cylinder jump spark engine using either vibrator or non-vibrator coil; fig. 4,008, connections for jump spark coil with three terminals; fig. 4,009, connections for two cylinder jump spark coil; fig. 4,010, connections for three cylinder jump spark coil; fig. 4,011, connections for four cylinder jump spark coil.

**NOTE.**—*How to adjust a vibrating coil.* Good coils, when properly adjusted, consume about one-quarter to one-half ampere for each engine cylinder. By screwing down the points too close, the current consumption may be greatly increased to the detriment of the mileage and without any advantage. Therefore, it is advisable to see that the coil is adjusted so as to take no more current than is necessary. To do this connect an ammeter in the place usually left for a connection on a coil, or insert the ammeter in the battery connection, so that the current flows from the battery through the ammeter to the coil. Place a piece of paper under all but one of the vibrator points with the engine running. Adjust this point until the current taken by its cylinder is a minimum, without, however, any tendency to miss explosions. If the engine will not run with only one cylinder working, the current taken by each contact point may be determined by blocking this one point off with a piece of paper and noting the change in the current that this causes. Adjust the point and try this again, until the lowest current consumption on which the engine will run properly is obtained. The proper voltage for a battery in most cases is 6 volts.

portions of the circuit sometimes make themselves manifest by the same symptoms. If each defect had its individual symptom, locating the trouble would be comparatively easy, but, as it is, it is sometimes quite difficult to find the defective parts. In general, the following method, should be adopted to locate ignition troubles:

1. The source of current supply should be examined; if a battery, each cell should be tested separately, and any one found to be weak, removed. If a magneto be used, it should be disconnected, and the armature turned by hand; in case the field magnets have not lost their proper strength, the armature should turn perceptibly hard during certain portions of each revolution.

2. The primary circuit should be examined for breaks; all connections made bright and secured firmly by the binding screws, and the timer contacts cleaned.

3. The spark plug points should be cleaned and the air gap made the proper length—about one thirty-second of an inch.

4. The vibrator contacts should be made flat and clean, and the vibrator properly adjusted.

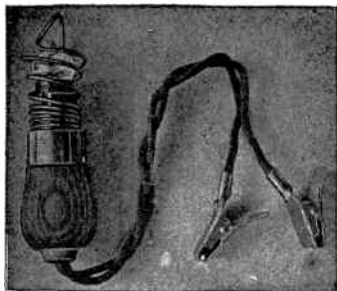
**Testing the Spark Plug.**—The spark plug should be unscrewed and placed on the cylinder without disconnecting the wire to the insulated electrode: the body of the plug only should touch the metal of the cylinder. On cranking the engine the spark should be "fat" if everything be in good condition; if a weak spark be produced it may be due to either a loose terminal, run down battery, or badly adjusted vibrator. When no spark can be obtained the entire system must be examined and tested, beginning at the battery.

**Plug Testing in Multi-Cylinder Engines.**—All nuts are removed from the plug, leaving the high tension wires in place. After starting the engine, all wires are grounded except one, thus running the engine on one cylinder. In case there be no misfiring after testing at various engine speeds, it can be taken for granted that the plug is sound. The remaining plugs are tested in the same manner. When a multi-unit coil is used, a faulty plug may be located by holding down all the vibrator blades but one, so that only one spark plug operates. Running each cylinder separately by this means, it can easily be ascertained

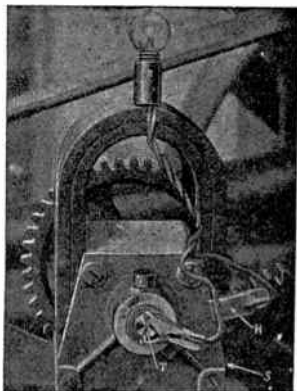
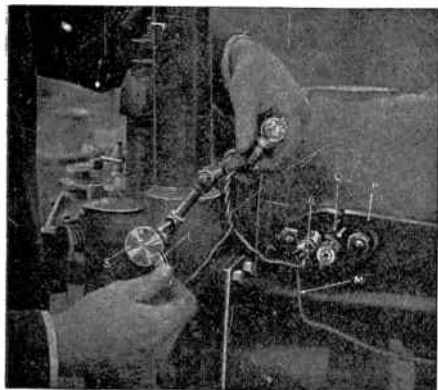
which plug is defective. Some coils are provided with little knobs for cutting out cylinders in the manner just described.

**Complete Break in the Wiring.**—The engine is placed upon the sparking point, the primary switch closed, and the two terminals of the suspected wire touched with a test wire. A current indicates a break.

**Partial Break in the Wiring.**—A partial break, or one held together by the insulation, may sometimes be located by bending the wire sharply at successive points along its length, the engine being at the sparking point and the switch closed as before.



**Primary Short Circuits.**—The primary wires should be disconnected from the coil, leaving the ends out of contact with anything. There is a short circuit if on touching the switch points momentarily a spark appear. A short circuit may sometimes be overcome by clearing all wires of contact with metallic bodies, and pulling each wire away from the others which were formerly in contact with it.



FIGS. 4,012 and 4,014.—Sumter testing device for testing low tension circuits. To test magneto, snap the clips on terminals after disconnecting it from circuit. The condition of magneto is evidenced by the brilliancy of lamp. To test a make and break ignitor, snap one clip on insulated terminal and the other on the engine frame. A little practice enables the conditions to be determined by noting the varying brilliancy of the lamp.

**Secondary Short Circuits.**—The secondary lead from the spark plug should be disconnected. Under this condition the high tension current may sometimes be heard or seen discharging from the secondary

wire to some metallic portion of the car. Water in contact with the secondary wire will sometimes cause a short circuit unless the insulation be of the best quality.

**The Primary Switch.**—This portion of the primary circuit sometimes causes trouble by making poor contact. This is generally due to the deterioration of the spring portion of the metal, which gradually loses its resiliency. Snap switches sometimes fail through the weakening of the springs which hold them in the "on" or "off" position. The contacts of a switch should be kept in good condition.

**Primary Connections.**—All binding posts and their connections should be clean and bright. The wires should be firmly secured to the binding posts, as a loose connection in the primary circuit is often the cause of irregular misfiring or the stopping of the engine.

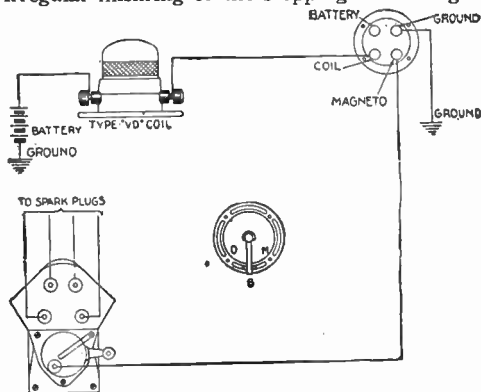


FIG. 4,015.—Bosch vibrating duplex ignition; arrangement when employing battery of a grounded lighting or starting system, or separate battery for ignition.

**NOTE.—Bosch vibrating duplex ignition.** In the operation of this system the arrangement is such that, while the magneto circuit is independent and complete in itself, the battery circuit includes both the coil and the magneto. With the switch in the battery position, the battery and coil are in series with the primary winding of the magneto armature, and the current for the battery supplements that generated by the magneto. Thus there is induced in the secondary winding of the magneto armature, a very powerful current, which, on account of vibration action of the coil appears not as a single spark but as a series of spark, the current is distributed in the usual way by the magneto distributor. The battery side is not intended to be used as a separate ignition system, but merely as an auxiliary to the magneto to insure positive starting when conditions are not of the best. The battery and coil are used in connection with the magneto only when starting, while for regular running the magneto operates as an independent ignition system. The coil is designed to operate over a range of from eight to sixteen volts, so that cars provided with a storage battery for lighting, starting, or other purposes, if within the voltages mentioned, can employ the same battery for the Bosch vibrating duplex system. If only a 6 volt storage battery be provided, this can be utilized in connection with the system by adding three dry cells in series with the storage battery. Where no storage battery is available, or where it is desired to keep the ignition battery separate from the starting or lighting battery, dry cells alone may be used to operate the system; in such case it is advisable that the battery consist of eight or ten dry cells (preferably ten), connected in series.

**Vibration.**—Since the wires are subject to constant vibration, a number of strand of fine wire is better than a single heavy wire, as the latter is more liable to be broken. In securing the wire to a binding post, care should be taken that all the strands are bound.

**Timers.**—These may give trouble by: 1, presence of dirt, 2, loose contacts, or 3, division of the spark; this latter effect is sometimes caused by metallic particles wearing off the revolving part forming a path so that the spark passes from the revolving part to more than one contact segment.

**Coils.**—The part of a coil which requires most frequent attention is the vibrator. The contact points are subject to deterioration on account of the small spark always present between the points when the coil is in operation. In time, the points become corroded and

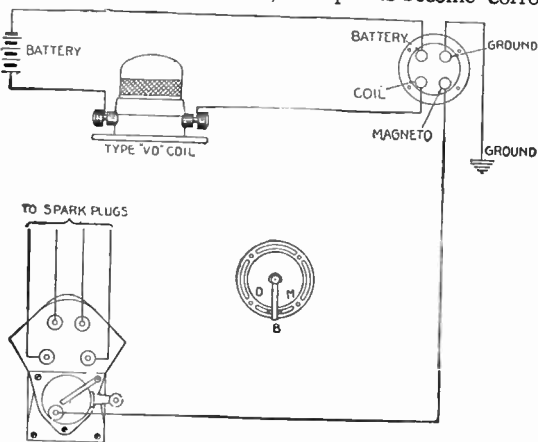


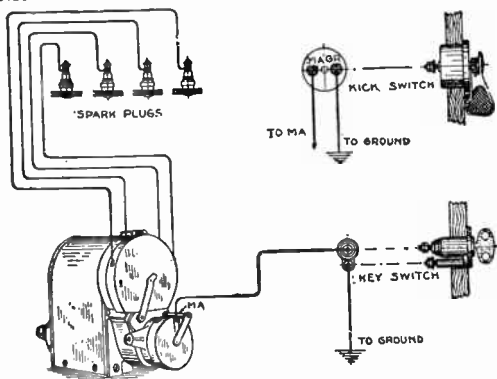
FIG. 4,016.—Bosch vibrating duplex ignition; arrangement when employing battery of an ungrounded lighting or starting system.

burned, and therefore require to be resurfaced by smoothing with a fine file. A faulty connection to the condenser is at once shown by large sparks at the vibrator points. Any repairs to a coil, aside from the vibrator, should be done by an expert, as the construction is very delicate.

**Igniters.**—In make and break ignition, a failure to get a spark, especially with a weak battery, is frequently due to the tappet spring. This spring must be quite stiff so as to cause the break to take place with considerable rapidity; **the more rapid the break, the better is the quality of the spark.** The contact points of the igniter electrodes are subject to corrosion and wear. When they become pitted the contact surfaces should be filed smooth.

**Spark Plugs.**—Repeated failure to start when the coil vibrator operates, indicates a faulty spark plug. A rich gasoline mixture often leaves a carbon deposit, and being a partial conductor short circuits the plug. The porcelain insulation, on account of its brittleness, may crack inside the sleeve, allowing a spark to pass there instead of at the gap. Mica insulation sometimes becomes saturated with oil, causing the layers to separate, permitting a short circuit.

**Engine Misfires and Finally Stops.**—This may be due to exhaustion of the battery, and is indicated by a weak spark and very faint vibrator action.



**Figs. 4,017 and 4018.**—Wiring diagram of Eisemann type G4 magneto. **Troubles and remedies.** If the engine misfire or refuse to start, it should be found out first whether the trouble lie in the magneto or in the spark plugs. The latter should be examined first, as they are the most frequent cause of trouble. If the missing be in one cylinder only, or in different cylinders, the corresponding spark plug should be examined to see that the gap be not too large. This gap between the electrodes should be approximately  $\frac{1}{8}$  of an inch. Also the spark plug may be short circuited through carbon, or the insulation may be cracked. Cleaning with gasoline or replacing is the remedy. The wiring should be very carefully examined and checked in accordance with the firing order of the engine. If cables be cracked or worn, they should be replaced. Clean same with gasoline until the contact surface appears quite white, or if pitted use a fine file—a manicure file will serve the purpose very well—but file very carefully, so that the surfaces will remain square to each other. The correct gap of the contact points is  $\frac{1}{16}$ " and in no case should it be more than  $\frac{1}{8}$ ". As these contacts wear away in time, they should be regulated by giving the adjustable screw "U" a forward turn, care being taken to securely tighten the lock nut "V". This can be accomplished without removing the timing lever or make and break mechanism, as shown in figs. 3,978 and 3,979. The cut also shows the combination wrench which is furnished with each magneto and which includes a gauge for the regulation of the gap between the platinum contacts ( $\frac{1}{16}$ "). If the platinum contact riveted to the contact spring "17m", or that of the adjustable screw "U" should be worn down entirely, it would necessitate a change of either or both. When the adjustable screw "U" is replaced or adjusted, care must be taken that the lock nut is securely tightened in place. If after following these instructions, the engine still refuse to start, the magneto should then be tested by removing the distributor plate and resting a screw driver on the gear casing holding same about  $\frac{1}{8}$ " from the collector ring. Then, if upon rotating the armature, a spark jump across the  $\frac{1}{8}$ " gap, it shows that the trouble does not lie in the magneto, but in some other part of the engine, possibly the carburetter. If a spark do not jump across the  $\frac{1}{8}$ " gap previously mentioned, the magneto should be examined by an expert.

**Engine Suddenly Stops.**—This is generally caused by a broken wire or loose switch which does not stay closed. In the case of a single cylinder, the broken wire may be either in the primary or secondary circuit; if a multi-cylinder engine, the break is in the primary circuit.

**Engine Does Not Start.**—Usually caused by: 1, primary switch not closed, 2, battery weak or exhausted, 3, entire or partial break in wire, 4, loose terminal, 5, moisture on spark plug, 6, fouled plug, 7, spark too far retarded or advanced, or 8, too slow cranking with magneto ignition.

**Engine Runs Fitfully.**—Frequently results from a partial break in the wiring, especially in the primary circuit.

**Pre-ignition.**—Caused by: 1, some small particle in the cylinder becoming heated to incandescence, 2, the electrodes of the spark plug becoming red hot, or 3, intermittent short circuit in the primary.

**Engine Runs with Switch Open.**—Usually caused by: 1, overheated engine or plug points, 2, defective switch, 3, an incandescent particle inside the cylinder.

**Engine Misfires.**—This may be caused by: 1, weak battery, 2, partial break in conductor, 3, loose or disconnected terminal, 4, intermittent short circuit in the secondary, 5, faulty action of either timer or vibrator contacts, 6, bent vibrator blade, 7, faulty spark plug, or 8, air gap too large.

**Knocking of Engine.**—Too much advance of the spark sometimes produces this effect.

**Knocking in the Cylinder.**—The form of unusual noise commonly described as "knocking" consists of a regular and continuous tapping in the cylinder, which is so unlike any sound usual and normal to operation, that, once heard, it cannot be mistaken. Too much advance of the spark sometimes produces this result. As mentioned by numerous authorities, the placing of the spark plug in the exact center of the combustion space occasions a peculiarly sharp knock, which may be stopped by advancing or retarding the spark from the one point of trouble. This explanation of the trouble is questioned by others, and is probably over rated.

**Knocking in Cylinder when Ascending Hills.**—*Carbonized cylinder.*

**Loss of Power Without Misfires.**—This may be due to badly adjusted coil contacts, poor spark, or incorrect timing.

**Explosions in the Muffler.**—These are usually caused by misfiring, partially charged storage battery, or by one cylinder not working.



## CHAPTER LXXVI

**SELF-STARTERS AND LIGHTING SYSTEMS  
FOR AUTOMOBILES**

In summing up the merits of the gas engine as a prime mover, there is one inherent defect that cannot be overlooked—the fact that, on account of the nature of its cycle of operation, it is not self-starting. It must be turned by some external force until the proper mixture has been drawn into the cylinder; compressed and ignited before it will start, unless perchance an unignited mixture be left in the cylinder and the piston be in the proper position; then by igniting the unburned charge the engine will usually start.

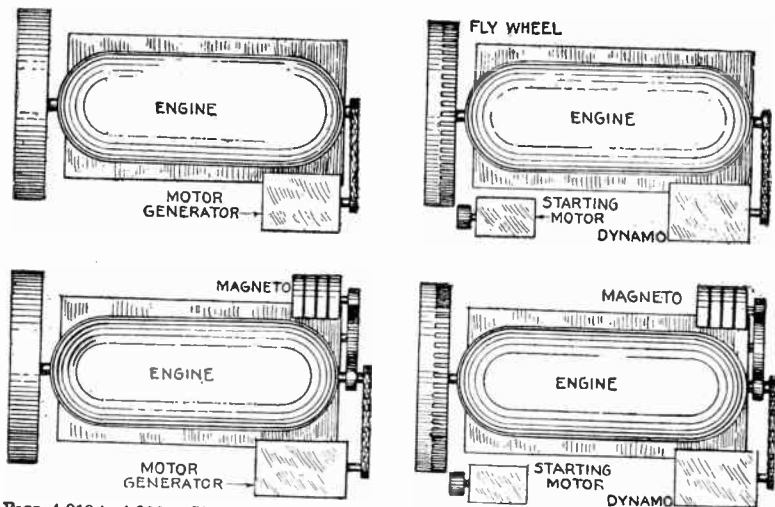
**Classes of Starter.**—The engine starting mechanism requires deep thought and engineering skill to properly apply it to an automobile, that is, making it an integral part of the car, preferably a part of the engine mechanism.

The various starting systems are classed, according to the kind of power used, as: 1, mechanical; 2, compressed air; 3, gas; and 4, electric.

The employment of electricity for starting has the advantage of also supplying current for lighting and ignition as well, and this has led to the development of systems involving various combinations. It would seem, therefore, that electricity would be universally used for starters, save for the fact that there are some objections, such as high cost, maintenance, and the considerable mechanism necessary, that offset more or less the advantages accruing from its threefold uses.

**Classes of Electric Starter.**—There are numerous electric starting systems, and they may be classified according to the methods of obtaining current for starting and ignition, and the power element of the starter, as:

1. One unit systems;
2. Two unit systems;
3. Three unit systems.



Figs. 4,019 to 4,022.—Classes of starter systems. Fig. 4,019, one unit system; fig. 4,020, two unit system; fig. 4,021 so called two unit system; fig. 4,022, so called three unit system.

These several systems comprise respectively:

1. A motor-dynamo;
2. A motor and a dynamo;
3. A motor, a dynamo, and magneto all separate.

NOTE.—There are two classes of two unit systems as explained on page 2,802; a two unit system and a so called two unit system. There is some confusion in classification, chiefly because of the close relationship between the starter lighting and ignition systems. *One unit* properly indicates a system with a motor generator and *two unit*, a system with motor and dynamo separate.

**Electric Starters Require a Storage Battery.**—In any electric system a storage battery is always necessary; for, in order to crank a gasoline engine there must be some source of electrical energy from which the cranking motor may draw its supply of electricity. Without it there would be no electric cranking

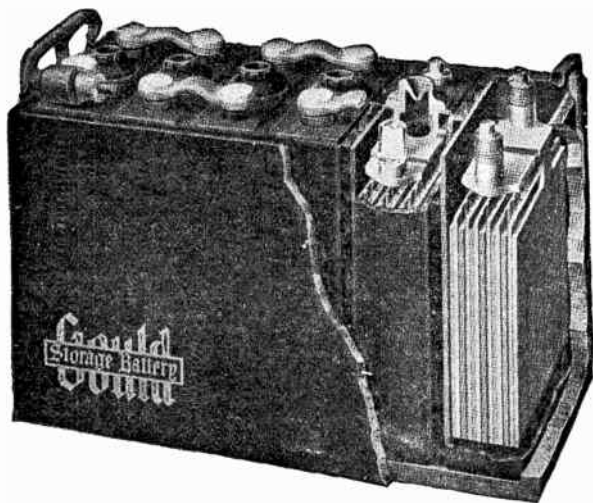
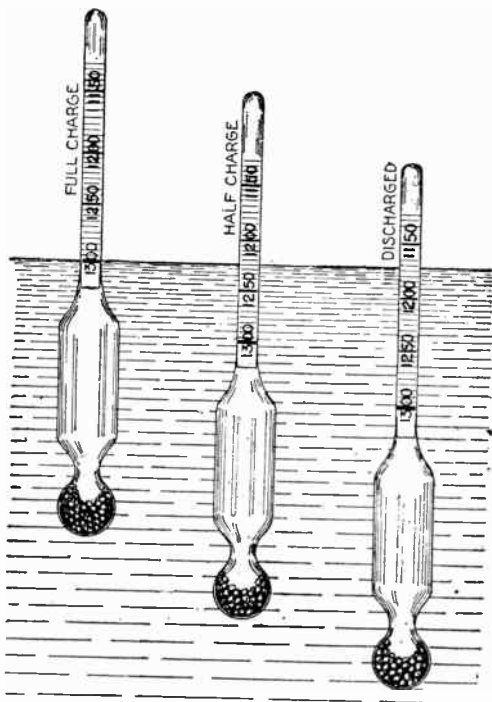


FIG. 4,023—Gould type B storage battery for starting and lighting systems. Plates  $4\frac{1}{8} \times 5\frac{3}{4}$  7 to 15 plates per cell. Battery units for 6, 8, 12, 16, 18 and 24 volts.

devices. The first function, therefore, which the storage battery serves is to supply electricity for starting purposes.

NOTE.—The oxide battery plates are of the grid type. The grid is made of a stiff lead alloy which supports the active material in the form of a series of vertical strip held between the grid bars and locked in place by horizontal surface ribs which are staggered on the opposite sides. After the grids are cast, they are "pasted" with oxides of lead made into a paste of special composition which sets in drying like cement. The plates then go through an electric chemical process which converts the material of the positives into brown peroxide of lead and that of the negatives into gray spongy lead. Both the positive and negative plates are provided with lugs and in assembly the positives and negatives are separated by wood separators ribbed on the side against the positive. A positive and negative group, together with the separators constitute an *element*. A rubber jar of special composition is used as a cell container. The plates rest on stiff ribs or bridges in the bottom of the jar.



**Figs. 4,024 to 4,026.**—State of charge of cell as indicated by the density of the solution. Fig. 4,024, cell fully charged; fig. 4,025, cell about half charged; fig. 4,026, cell almost discharged.

**How to test with hydrometer:** Remove vent caps from the cells. To use hydrometer, squeeze the rubber bulb, then insert the end of the rubber tube in the cell and well below the surface of the liquid; slowly release bulb, drawing the solution into the glass chamber until the hydrometer floats freely. Note the point at which the hydrometer stem emerges from the solution. Then slowly withdraw the tube from the solution and squeeze the bulb to return the solution in the hydrometer set to the cell. The point at which the hydrometer stem emerges from the solution denotes the density thereof. When the cells are in good condition the density of the solution denotes the state of charge thereof. The readings for various conditions of charge are 1,300, 1,225, and 1,150 for full, half, and no charge respectively. **In taking readings,** to prevent the hydrometer sticking to the side of the barrel, it should be held in a vertical position, the reading being taken at the surface of the electrolyte when there is no compression on the bulb. **In reading the gravity** of the different cells, it is customary to begin with the cell at the positive end. **When readings have been taken** be careful to replace the electrolyte into the same cell from which it was taken. Failure to do this often leads to trouble, that is, electrolyte is often taken out of one cell, the gravity noted and the electrolyte put back into another cell. The result is that the amount of electrolyte taken out of the first cell is eventually replaced with water, leaving the electrolyte weaker; whereas the electrolyte which was taken out and put into another cell would make the electrolyte of that cell stronger, resulting in irregularity in the different cells.

When the car comes from the manufacturer, the storage battery will be filled with electricity, and it must be kept charged. If a dynamo be provided on the car, this may serve to charge the battery whenever the car is in use. Unless such a generator be supplied, it will be necessary to periodically recharge the battery.

Batteries designed solely for ignition or lighting are not capable of taking care of the sudden and large demand for current to operate a starter.

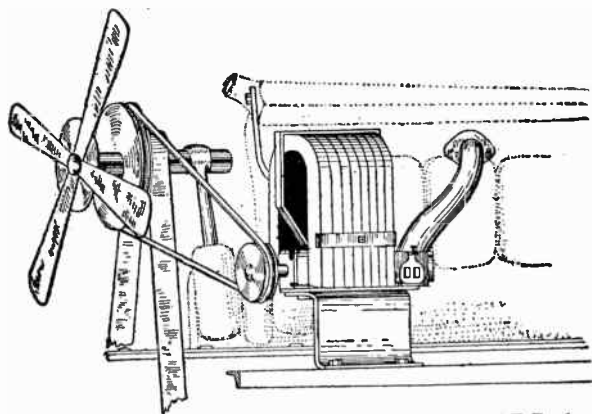


FIG. 4,027.—Holtzer-Cabot lighting magneto as installed on model T Ford car. It must be driven from the fan pulley. A special fan with magneto pulley is furnished with the magneto. The battery is mounted under rear seat on right side; the usual running board mounting is not recommended. A 60 ampere hour storage battery, if fully charged, will operate the side and tail lamps (6 candle power total) for approximately 50 hours, or the head and tail lamps (34 candle power) for approximately 10 hours. Turn off head lights when car is standing.

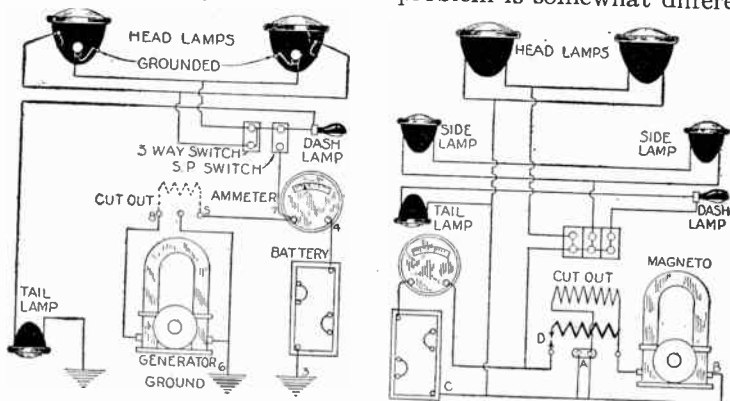
**Ques.** What is the principal difference in storage batteries intended for ignition, lighting, and starting?

**Ans.** Capacity.

The ignition battery is inapplicable to either lighting or starting duty. Just as the lighting battery lacks capacity for starting purposes, so does the one used for ignition purposes, only that the latter is lacking in a greater degree than the former.

The construction of the ignition battery prohibits its use for starting purposes; however, there is little difference in the construction of lighting and starting batteries, hence a large lighting battery may be used for starting.

**Choice of Voltage.**—In designing starters there are several conditions to be considered in determining what voltage shall be used, especially as the starter problem is somewhat different



Figs. 4,028 and 4,029.—Holtzer-Cabot lighting magneto outfit installation, views showing location of switch, ammeter, cut out and their connections. Fig. 4,028, one wire system is applied to double bulb or turn down head lamps; fig. 4,229, two wire system, suitable also as a general guide for motor boat wiring.

from the ignition and lighting requirements as to voltage, and one battery is generally employed for all.

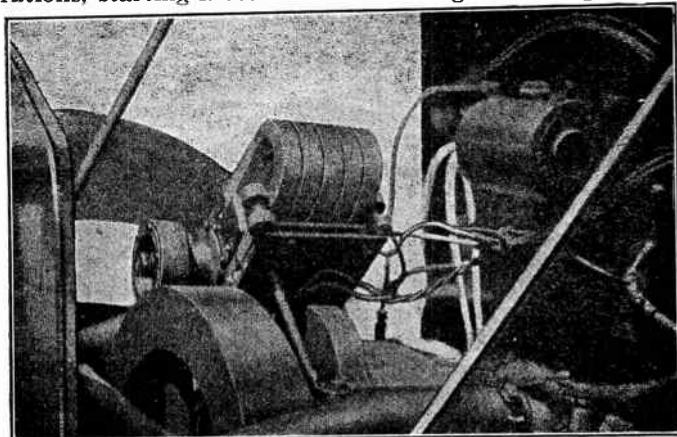
The pressure used on the different lighting and ignition systems is six volts, and were it not for the problem of cranking, there probably would not be any reason to change.

**NOTE.**—The essential requirement for rapid discharging is large plate area per ampere discharged. This is just what is accomplished by the use of thin plates; for when two plates replace one, the effective area is doubled. In practice this doubling of area is accompanied by the reduction in thickness of plate, in order to keep the size of the battery about the same as before. It also has an important bearing on the discharge rate which may be obtained from a battery, and also the capacity or length of time that the battery will give this discharge. The gain is due to the shortening of the distance which the electrolyte has to travel to reach the center of the plate.

**Ques. What is the advantage of low voltage?**

**Ans.** The circuits are easily protected from electrical leakage. Low pressure lamps are manufactured with less difficulty than those designed for higher pressure.

**Voltage of Units.**—The weight of six volt batteries is less than that of the higher voltage type. Were it not for these considerations, starting motors would be designed for high pressure,



**FIG. 4,030.**—Method of driving a generator direct from engine fly wheel by friction pulley with spring or cushion base; the latter relieves the stress on the shaft from excessive vibration. The governor regulates the speed of the machine and prevents burning out of the lamps. The illustration shows a K-W magneto installed on an early Maxwell car.

as they are smaller and consequently lighter. High voltage for the motor does not necessarily mean high voltage for the dynamo and lights.

There are three general combinations:

1. All one voltage, either 6, 12, 16, or 18 volts;
2. Generating and starting at 12, 16, or 18 volts, and lighting at 6, 8, and 16 volts respectively.
3. Generating and lighting at 6 volts, and starting at 24 or 30 volts.

**One Unit Systems.**—The term “one unit” as applied to an electric starting system means that there is a motor and dynamo combined in one machine, or motor dynamo, as it is called, the dynamo furnishing current for the starter, and for charging the storage battery.

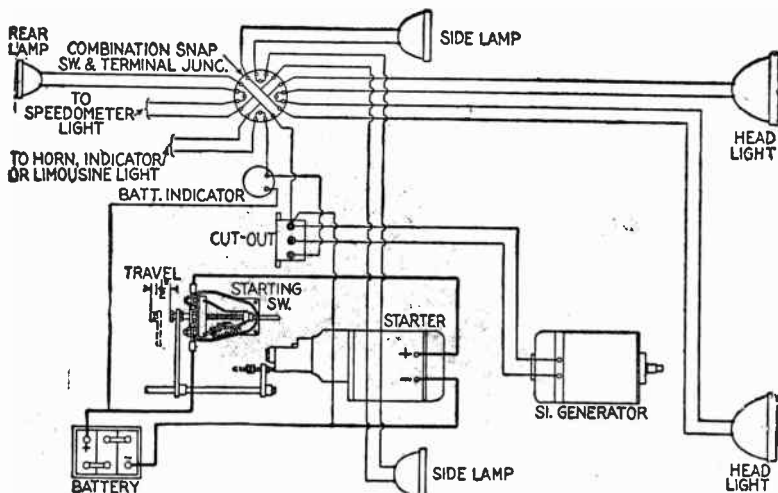
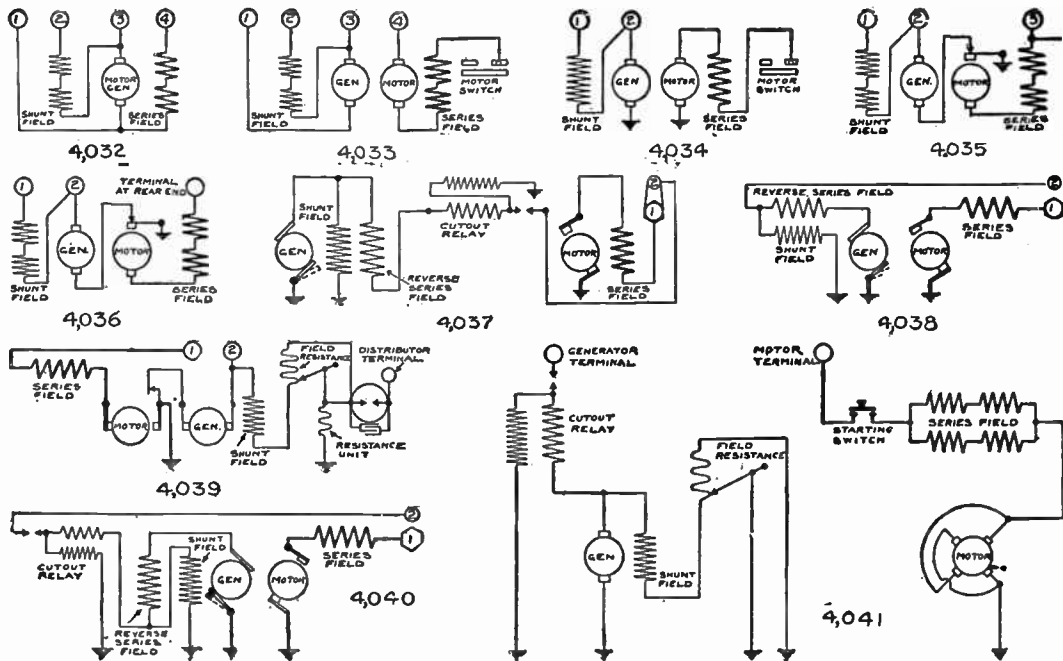


FIG. 4.031.—Wiring diagram of Deaco single unit starting and lighting system. Heavy lines indicate No. 4 B. & S. stranded cable. Medium lines from motor generator and starting switch to combination snap switch and terminal junction indicate No. 10 B. & S. gauge duplex wire. Fine lines in lamp circuit indicate No. 12 B. & S. gauge duplex wire.

**NOTE.**—An example of the one unit arrangement is the Electro system, which has a combined motor and dynamo, the latter furnishing current for starting ignition and lighting. It is necessary to arrange the motor with a short driving shaft integral with the motor case, driven either through the timing gears or silent chain and connecting to the starter with an Oldham coupling. The motor dynamo is always in operation. When turning below 380 revolutions per minute it is a motor, and when turning above that rate, a dynamo. The compound differential winding takes care of the output from the generator. No discriminating cut out or reverse current circuit breaker is provided to disconnect the battery from the motor dynamo entirely at very low speeds. Instead of this, the ignition switch breaks the line between the battery and generator when the engine is stopped by cutting off the ignition. The system operates on 24 volts, but charges the battery at six volts. The amperage drawn by the 24 volt motor when turning over the gasoline engine varies with the size of the motor as in all systems. The gear reduction between the motor dynamo and the engine is twenty-five to one when starting but changes automatically to a direct drive when the engine starts running.





FIGS. 4,032 to 4,041.—Internal circuits of motors, generators, and motor generators in Delco Systems (Phillips and Copland diagrams). Fig. 4,032, 1912 Cadillac, 1913 Cole, Hudson, Oakland and Oldsmobile. Fig. 4,033, 1913 Cadillac and Packard 13-38. Fig. 4,034, Buick 14-54, 55, Oldsmobile 6-54, Oakland 43, 48, 62, Cole 4-40, 4-50, 6-60, Moon 4-42, 6-50. Fig. 4,035, 1914 Cadillac. Fig. 4,036, 1914 Hudson 6-54. Fig. 4,037, 1914 Buick 24, 25, 36, 37, Cartercar 7, Paterson, Oakland 36, Hudson 6-40. Fig. 4,038, 1915 Buick, 24, 25, Cartercar-9. Fig. 4,039 Buick 36, 37, 54, 55, Cadillac 8, Cole 6-50, Hudson 6-40, Moon 6-40, 6-60, Oakland 37, 49, Oldsmobile 42. Paterson and Westcott Model U. Fig. 4,040, 1915 Westcott 4. Fig. 4,041, 1915 Cole 8.

In classifying a system as having one or more units, it means that the apparatus provided for generating the current and the motor for starting the engine consists of one or more parts.

Thus, as just stated, in the one unit system there is a combination dynamo and motor forming one machine, or "one unit."

**Two Unit Systems.**—This classification indicates that the motor and dynamo are separate units, as distinguished from the

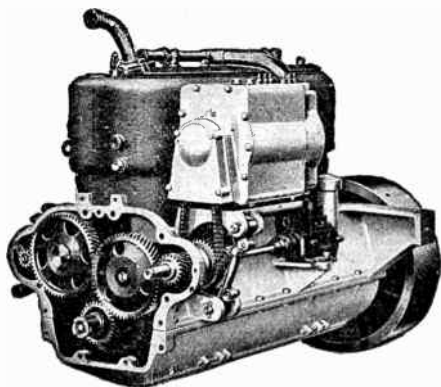
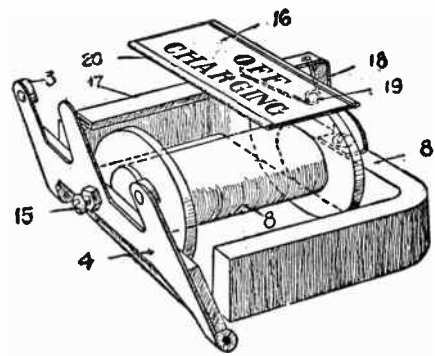
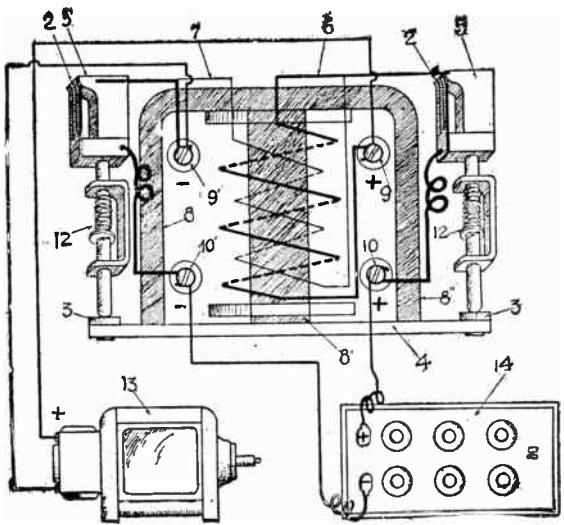


FIG. 4,042.—Entz single unit starting and lighting system. View showing mounting of motor generator on engine and so called silent chain drive.

one unit system in which they are combined. There is another system, ill advisedly called two unit, consisting of a motor dynamo, and a magneto. The reason for this confusion is because some dynamos are arranged to furnish current for ignition when not charging the battery, thus ignition has to be considered in the classification to distinguish the last mentioned system from the arrangement of three independent units.

The Westinghouse system is an example of the first mentioned class of two unit systems in which the cranking motor and dynamo are



FIGS. 4,043 and 4,044.—Leece-Neville two unit electric starting and lighting system. Breaker contacts 1, 2 and 5 are shown closed as when the generator is charging the battery. Indicating target omitted for the sake of clearness. The electric generating and storage plant commences operation as soon as the engine starts by generating current in the generator. This first current flows from the

generator through the winding 7 on the magnet 8 until the energy is sufficient to attract and close the armature 4. This action closes the charging contacts 1, 2, and 5, when the bulk of the current flows through the heavy wire winding 6, to the battery and the energy is there stored for use in cranking, lighting, etc. When the armature closes it also operates the indicating target and shows the word "charging" on the face of circuit breaker to the operator. When the generator stops running, the magnet 8 is no longer energized and springs 12 push the armature back and open the charging contacts 1, 2 and 5, thus breaking the electric connection between generator and battery on both the positive and negative sides. At the same time spring 19 operates the indicating target to show "off" on the circuit breaker to the operator. The indicating target shows the word "off" in the little window of its case when generator is not charging, and when the generator is "charging," this word is shown instead of "off." The wiring diagram shows the generator connected through the circuit breaker to the storage battery and the battery connected to the motor through the motor switch and the lamps through the lighting switch. Standard 6 volt lamps are used in connection with the 12 volt battery by connecting them thereto by a three wire system. All the lamps are connected on one side through the lighting switch to a central terminal on the battery and on the other side one-half of the lamps are connected to the positive pole of the battery and the other half of the lamps are connected to the negative pole. Thus the 12 volt battery is divided into two 6 volt batteries for lighting without in any way interfering with its being charged by the generator at 12 volts or discharged through the motor at 12 volts.

separate machines. The latter not only charges the storage battery but also furnishes direct a supply of current for ignition. The dynamo is of the slow speed type and turns at crank shaft speed on four cylinder engines and  $1\frac{1}{2}$  crank shaft speed on six cylinder engines.

The battery circuit is cut in above 10 miles an hour and is cut out below 7 miles per hour. This difference prevents the switch cutting in and cutting out continuously when the speed of the car is at one particular point.

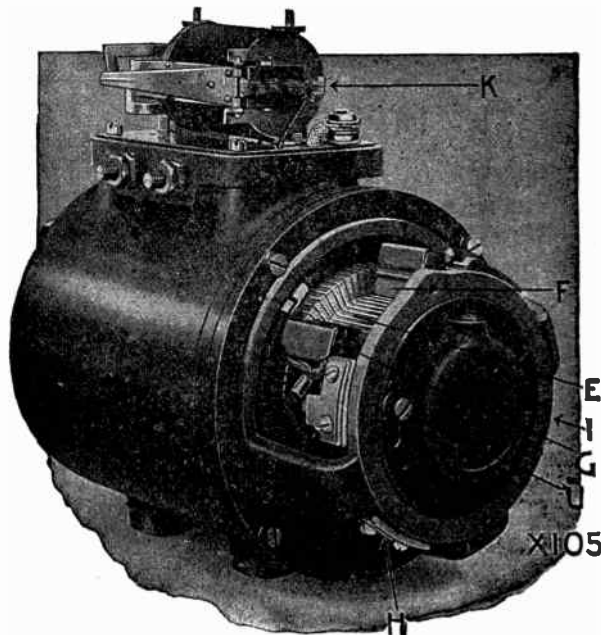


FIG. 4.045.—Wagner dynamo of two unit starting and lighting system. The drive is through a train of gear or equivalent. The windings and internal connections are of such character that no regulating devices are required except a cut out. *In construction*, the commutator E and brushes F, G, H, and I, are located under the cover which in this cut is removed. The brushes H and I collect the current from the commutator and furnish this current for charging the battery through the cut out K. The brushes F and G collect the current from the commutator and furnish this current for exciting the fields. The cut out K is shown in detail in fig. 4.046.

A feature of the Westinghouse system is that the output of the generator varies with the load. When the lamps are switched on, the output of the dynamo becomes great enough to take care of the added

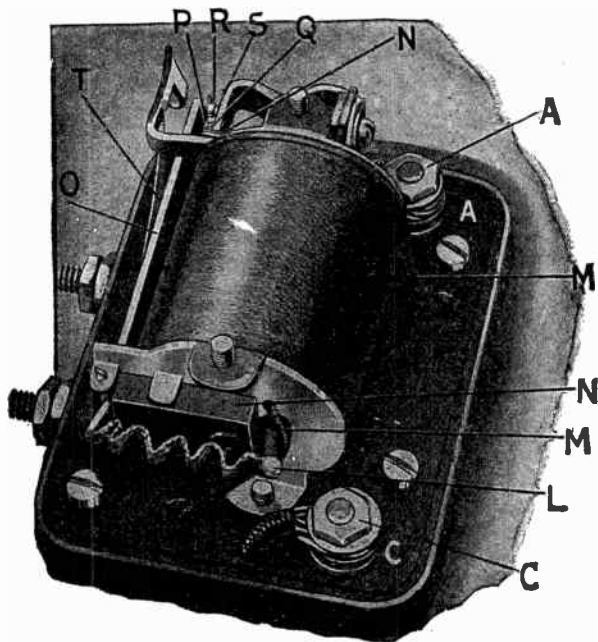


Fig. 4,046.—Wagner cut out of two unit starting and lighting system. It consists of two magnet coils L and M, wound on an iron core N, which attracts and repels an iron lever O. At the end of O are two main contact points P and Q at which the contact between the dynamo and battery is made and broken. There are also supplied two auxiliary contact points R and S which are for the purpose of minimizing sparking at the main contact points P and Q. The coil M called the *shunt coil* is connected directly across the two brushes H and I, and therefore the full dynamo voltage is impressed across the ends of this coil. The coil L, called the *series coil*, is connected in series with the battery and dynamo and therefore this coil carries the charging current when the battery is being charged. *In operation*, when the engine is started, the dynamo is driven by the engine and it, therefore, increases and decreases in speed with the engine. When the engine is speeded up, the dynamo follows with corresponding increase in speed and the voltage of the dynamo rises as the speed increases. As soon as the dynamo voltage gets to a point above the voltage of the battery, which is approximately six volts, the coil M pulls the iron lever O toward the magnet core, thereby closing the contact at the points P and Q-R and S. As soon as this contact is made, the dynamo is connected to the battery, and a charging current will flow from the dynamo to the battery through the series coil L, which is in series with the dynamo and battery. The dynamo continues to charge as long as these contact points P and Q-R and S remain together, but when the engine speed is decreased, so that the dynamo voltage falls below the battery voltage, the battery will discharge through the dynamo and therefore through the coil L. This discharge current, being in the opposite direction from the charging current, will neutralize the effect of coil M and allow the spring T to pull lever O away from the magnet core, thereby opening the contact at the points P and Q-R and S. As soon as these contacts open, the battery is off charge. The engine speed at which this relay closes corresponds to a car speed of 7 to 10 miles per hour.

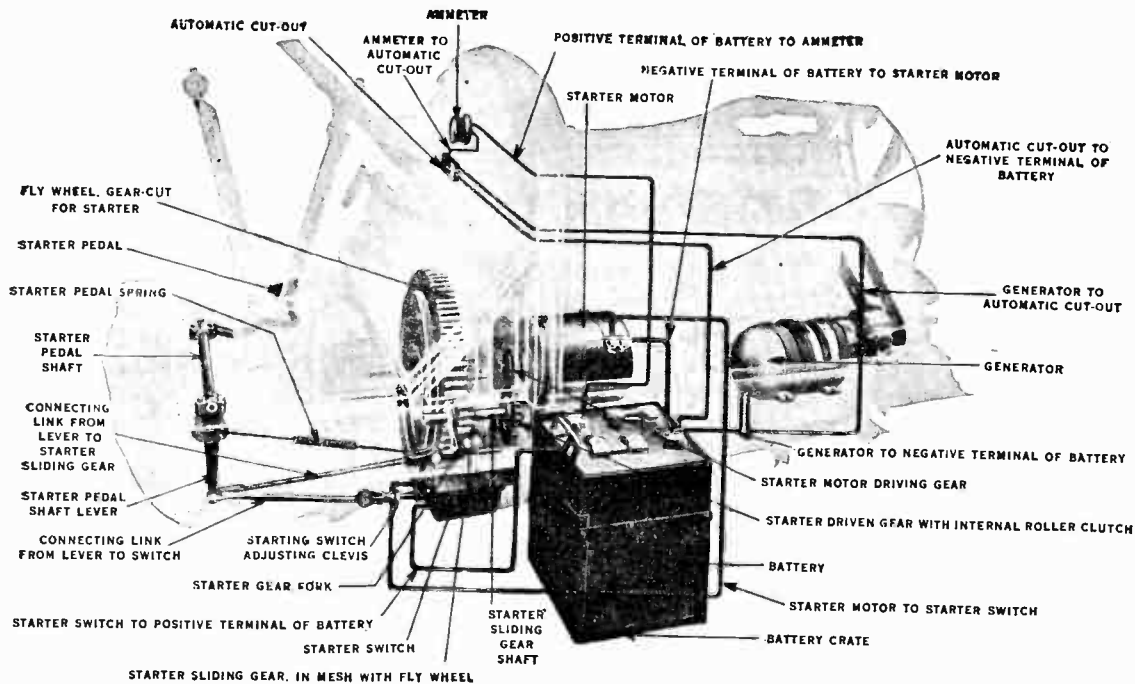
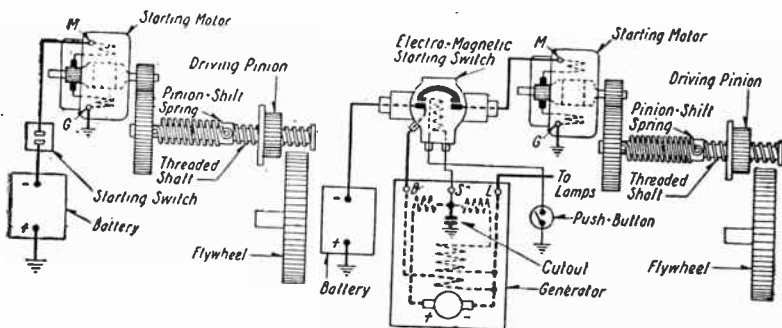


FIG. 4,047.—Gray and Davis self-starter as installed on the Lozier car. This is a two-unit system, and comprises a dynamo storage battery, discriminating cut out, motor and resistance switch.

load. This is accomplished by having the battery current go through a series field on its way to the lamps, thus assisting instead of bucking or neutralizing the shunt field.

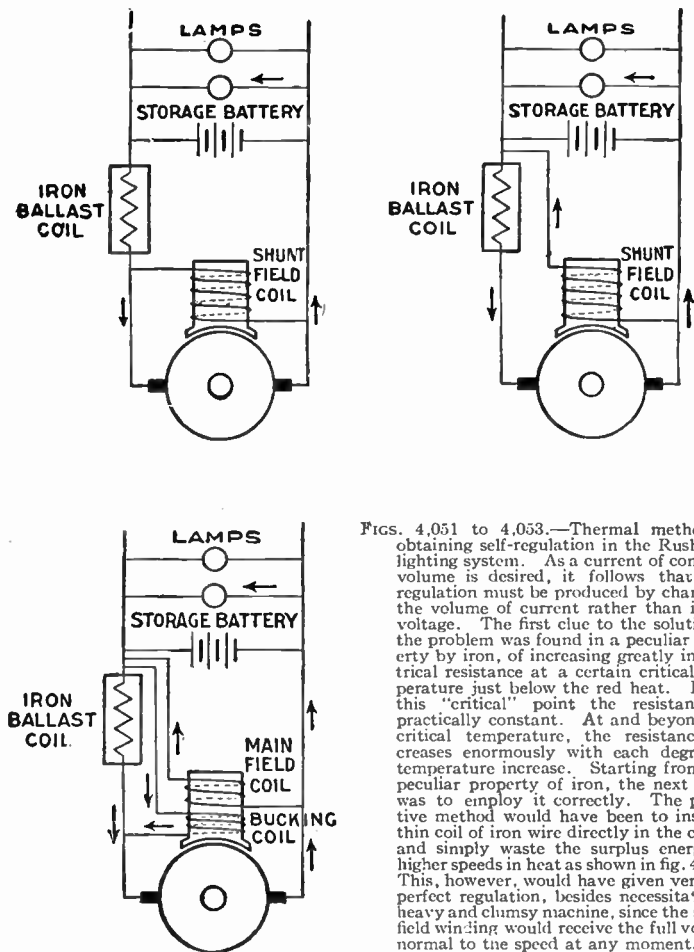
The reduction between the motor and the engine varies between ten to one and twenty-two to one. The amperage on the jump or when the starting switch is thrown in depends on the resistance opposed to revolving the engine, but will in the average case of a large four or small six cylinder motor be 200 on the jump and about 80 for a running amperage. The motor is series wound and is generally geared to the fly wheel; it is operated by a switch which throws the gears into engagement for starting, by first meshing them and then spinning the engine. The motor is automatically thrown out of engagement when the engine operates under its own power.



FIGS. 4,048 and 4,049.—Diagrams of Westinghouse electrical and mechanical connections of double reduction motor and switch for automatic screw pinion shaft. Fig. 4,048, with hand or foot operated starting switch; fig. 4,049, with electro magnetically operated starting switch controlled by push button. In the figures, when the starting switch is closed, the full battery voltage is impressed on the motor, and it starts immediately. The pinion, when the motor is at rest, is within the screw shift housing and entirely away from the flywheel gear. The threaded shaft is connected to the reduction gear shaft by a spring which thus forms a flexible coupling. As the load is not large enough to compress the spring when the motor starts, the threaded shaft is immediately revolved by the spring in released position. The pinion moves out on its shaft by virtue of the revolving threads, until it reaches the flywheel. If the teeth of the pinion and flywheel meet instead of meshing, the spring allows the pinion to revolve until it meshes with the flywheel. When the pinion is fully meshed into the flywheel teeth, the spring compresses and the pinion is then revolved by the motor as through a continuous shaft, turning the engine over. When the engine fires and the flywheel peripheral speed continuously exceeds that of the driving pinion, it forces the latter out of mesh, and it is returned to its original position in the screw shaft housing. During the periods immediately after the engine has passed over any one of the points of maximum compression, the spring offers an elastic cushion between the flywheel and the reduction gear so that the pinion will not be thrown out of mesh.

the voltage tends to exceed the value for which the regulator is set, the regulating contact open, opening the direct shunt field circuit and cutting in the regulating resistance. This causes a momentary drop in voltage so that the contacts close again. This opening and closing of the contacts is repeated so rapidly as to be imperceptible to the eye, and holds the voltage constant.

The "Apco" is a so called two unit system in which the motor and the dynamo are contained in one unit and the magnets forms the second

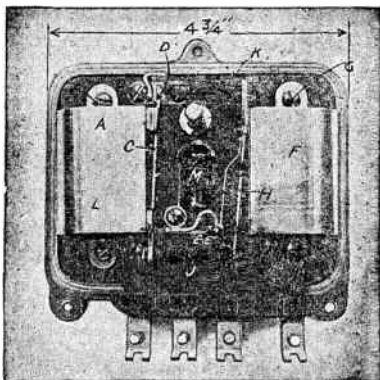


Figs. 4,051 to 4,053.—Thermal method of obtaining self-regulation in the Rushmore lighting system. As a current of constant volume is desired, it follows that self-regulation must be produced by change in the volume of current rather than in the voltage. The first clue to the solution of the problem was found in a peculiar property by iron, of increasing greatly in electrical resistance at a certain critical temperature just below the red heat. Below this "critical" point the resistance is practically constant. At and beyond the critical temperature, the resistance increases enormously with each degree of temperature increase. Starting from this peculiar property of iron, the next thing was to employ it correctly. The primitive method would have been to insert a thin coil of iron wire directly in the circuit and simply waste the surplus energy at higher speeds in heat as shown in fig. 4,051. This, however, would have given very imperfect regulation, besides necessitating a heavy and clumsy machine, since the shunt field winding would receive the full voltage normal to the speed at any moment. To

keep down the strength of the current in the shunt field coil one terminal of the latter may be connected beyond the iron "ballast" coil instead of between that and the armature and the "ballast" coil as in fig. 4,052. With this arrangement better results are obtained, but, as the field excitation remains constant, an excessive voltage will still be generated at high speeds. To counteract this, a bucking coil is added, as shown in fig. 4,053, which reduces the field excitation.



**Methods of Control.**—In any electric system where there is a dynamo and a storage battery, two control elements are necessary for the proper working of the system:

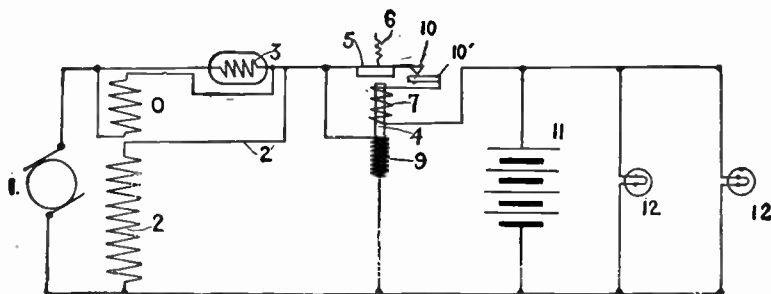


**FIG. 4,054.**—Ward Leonard automatic controller for automatically regulating the charging of the battery. When the car speed becomes approximately seven miles per hour, the dynamo armature will give a voltage sufficient to charge the batteries. The circuit between the dynamo and the batteries is normally open, but when the voltage of the dynamo becomes proper for charging, the coil A on the magnet core B, magnetizes the core sufficiently to attract the arm C. This arm moves toward the core B and thus two spark proof points D D' are brought together, establishing the circuit between the battery and the dynamo, and the dynamo begins to charge the batteries. In a dynamo the dynamo voltage increases with the speed unless a method of controlling it be adopted. The dynamo should charge at about seven miles per hour, but it is desirable that when the car runs at a much higher speed, as 15 to 60 miles per hour, the dynamo voltage shall not increase. If allowed to increase, such an excessive dynamo voltage would tend to cause sparking at the brushes, excess current and consequent trouble at the commutator and excessive wear and heating of the bearings. It would also cause an excessive amount of current to flow through the battery. To prevent this, the strength of the dynamo field, and consequently the output of the dynamo, is made dependent on the touching of the two points E E'. The coil F on the magnet core G carries the armature current, and if this current become a certain amount (usually in practice 10 amperes) the core becomes sufficiently magnetized to attract the finger H. This separates the contacts E E' and a resistance M is inserted in the field circuit, weakening it. This causes the amperes flowing through the battery to decrease. When the current decreases to a predetermined amount (say 9 amperes), the coil F does not magnetize the core G enough to overcome the pull of the spring J. The spring J pulls together the points E E', the full field strength is restored and the current tends to increase. Under operating conditions, the finger H vibrates so rapidly as to keep the current constant. As a result the dynamo will never charge above a predetermined amount (10 amperes), no matter how high the speed of the car, but at all speeds greater than a predetermined speed (about 15 miles per hour in practice), the dynamo will charge at a varying rate, which has a maximum of 10 amperes and a minimum of 9 amperes. In case the engine speed become so low that the dynamo cannot charge the battery, the magnetism caused by the coil A is weakened so that the spring K pulls the contacts D D' apart. Thus the circuit between the dynamo and battery is opened when the dynamo speed is too low for the dynamo to charge. The auxiliary series coil L on core B acts to insure the perfect demagnetization of the core B on reversal of current.

1. Means for preventing reversal of current when the dynamo is charging the battery;
2. Means for limiting the dynamo voltage.

**Ques.** When dynamo is charging the battery and the engine is slowed down, what happens?

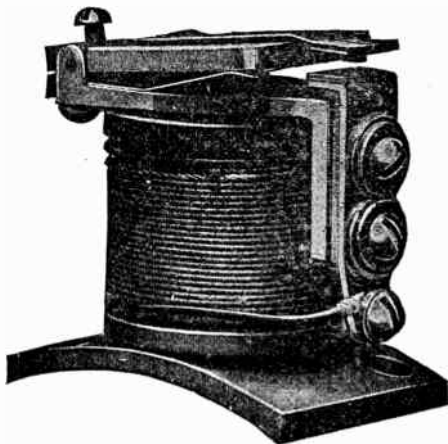
**Ans.** Reducing the speed reduces the pressure induced in the dynamo armature, hence, in slowing down beyond a certain



**FIG. 4,055.**—Diagram showing circuit connection of Rushmore dynamo with automatic cut out. The construction of the cut out is shown on fig. 4,056. The shunt field coil is connected beyond the ballast coil so that it receives current at all times at the constant voltage of the battery, and another winding is added to the field. This is what electricians call a "bucking" coil, that is a coil so connected as to oppose the main shunt field coil. This bucking coil, the effect of which is to reduce the field excitation, is connected as a shunt across the iron ballast coil. Its resistance is considerably greater than that of the ballast coil when the latter is cold or only warm, so that at low engine speeds practically all of the current generated passes directly to the battery and lamps and the machine acts as a simple unhampered shunt dynamo. However, the iron wire will allow only a certain number of amperes to pass, after which it suddenly increases in resistance, so that any excess current cannot pass, but must go through the field bucking coil which thus, only at high speeds, comes into action and chokes down the dynamo excitation. It will thus be seen that the output of the dynamo may be adjusted to any value desired by simply employing an iron wire of suitable diameter in the ballast coil. At car speeds below 15 miles an hour, the dynamo acts as a simple uncontrolled shunt wound machine, while at the higher speeds, owing to the counter effect of the bucking coil, the resultant excitation is less than the excitation due to the main shunt field coil alone. In order to keep the current in the main shunt field coil as nearly constant as possible, it is connected at a point beyond the ballast coil instead of directly across the brushes; then it does not feel the fluctuations of voltage at the brushes. The effect of controlling the bucking coil by the current output is to produce an approximately constant current at the higher speeds. The voltage is determined by the storage battery, and is simply the voltage required to force the specified current against the reverse pressure, plus the small internal resistance of the battery. Assuming the battery to be in good condition, the dynamo voltage will be slightly in excess of the open circuit voltage of the battery, from about  $6\frac{1}{4}$  to  $6\frac{1}{2}$  volts, depending upon the state of charge. The battery is necessary to control the voltage of any automobile lighting dynamo, and must never be disconnected therefrom while the dynamo is in use.

point, the pressure induced in the armature will become less than the battery pressure against which it must force the current in charging, and accordingly, unless some automatic device be provided to break the circuit when such condition obtains, the current will reverse and flow out of the battery.

**Ques.** What is the automatic device called?



**FIG. 4,056.**—Automatic cut out as used for Rushmore electric car lighting system.

**Ans.** It is properly called a discriminating cut out or reverse current circuit breaker, and *erroneously* a relay.

**Ques.** Describe a discriminating cut out.

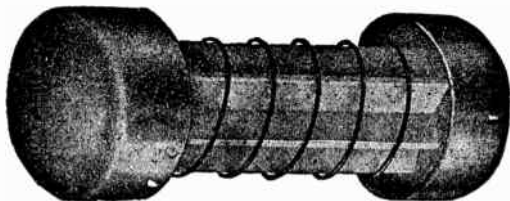
**Ans.** It consists of an electromagnet connected in the dynamo circuit, which, when the dynamo generates sufficient pressure to charge the battery, will attract an armature and close the circuit between the dynamo and battery, and which will also open the circuit when the battery pressure becomes greater than that induced in the dynamo.

**Ques.** What requirement is essential in charging a battery?

**Ans.** The voltage of the dynamo must not exceed a certain maximum, so that the charging rates do not become higher than that proper for the battery.

**Ques.** How is this condition obtained?

**Ans.** By automatic regulation of the dynamo voltage.



**FIG. 4.057.**—Rushmore ballast coil with cover removed to show the iron wire; illustration full size.

There are several ways of effecting this regulation:

1. Mechanically;
2. Electrically;
3. Thermally.

These several methods are illustrated in the accompanying cuts.

An example of mechanical control is the Gray & Davis system, where a clutch and centrifugal governor are used.

The Ward-Leonard has electromagnet control, and in the Westinghouse there are two electrical fields, which oppose one another as the speed of the dynamo increases.

The Rushmore system furnishes an example of thermal control.

## CHAPTER LXXVII

## ELECTRIC VEHICLES

The term *electric vehicle*, is generally applied to a great variety of either passenger or freight carrying machines which are propelled by electric energy supplied usually from storage batteries, and in some cases from dynamos direct connected to gas engines; the latter type, however, does not include gas electric combinations used on some electric railroads.

The principal types of electric vehicle which are commercially successful at the present time are:

1. Electric automobiles, represented by various types of roadster, coupe, phaeton, cab, etc., suitable for the use of physicians, business men and others, in city service.

2. Electric trucks and vans for moving merchandise, and for delivering purposes.

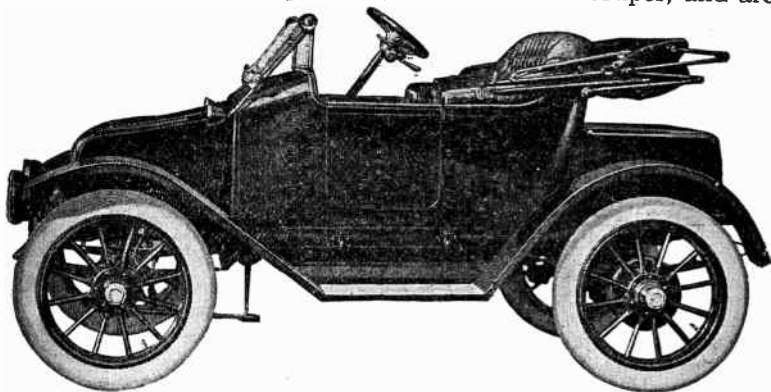
3. Gasoline-electric trucks, which represent an attempt to overcome the lack of flexibility of internal combustion engine by combining it with a dynamo and storage battery.

**Electricity as a Motive Power.**—Vehicles propelled by electric motors, whose energy is derived from secondary batteries, are preferred by some on account of the combined advantages in point of cleanliness, safety and ease of manipulation. When well constructed and well cared for, they are also less liable to get out of order from ordinary causes. Among their disadvantages, however, may be mentioned the fact that the storage battery must be periodically recharged from some primary electrical source, which fact greatly reduces their sphere of efficient operation.

Since electric vehicles are not the prevailing type, charging stations are in some localities few and far between which would make it impossible under these conditions to make an extended tour from the base of supplies. This difficulty cannot be overcome by carrying an extra battery since the additional weight would curtail the speed and carrying power of the vehicle.

It is impracticable to propel a vehicle by a battery of primary cell, since such a battery of sufficient power would have little, if any, advantage in point of endurance over secondary cells, and when once exhausted must be entirely replaced.

**Light Electric Vehicles.**—These are of various types, such as roadsters, victorias, phaetons, runabouts and coupes, and are



**Fig. 4,058.**—Baker electric roadster. The general specifications are as follows: frame, pressed steel; wheel base, 83 ins.; tread, 50 ins.; steering mechanism, two types, one with wheel steer, the other with lever steer; controller, continuous torque type, six speeds forward and three reverse; springs, semi-elliptic and full elliptic rear; battery, 3½ cells, 13 MV thin plate Exide, standard; tires, 32×4 special electric pneumatic front and rear or 34×4 cushion front and rear; brakes, two sets of internal expanding on rear wheels, operated independently by two foot pedals; body aluminum, with side doors, open top, nickel and black metal finishings throughout; painting, body black, blue, green, or maroon panels, striping to match; upholstery, blue, green, or maroon leathers, or imported broadcloths, standard; fenders, full skirted metal curved fenders; equipment, two head lamps, two side lamps, tail lamp, side and storm curtains; volt ammeter and shaft odometer, full kit of tools, special adjustable clear vision wind shield, electric horn.

equipped with batteries which have a capacity ranging from 75 to 100 miles per charge, with controller arrangements for providing speeds varying from 6 to 25 miles per hour. In these cases the number of cell in each battery may vary from 10 to 30 according

to the make and number of plate in each cell. The number of plate in each cell may vary to suit special conditions.

**Electric Trucks for City Service.**—Under certain traffic conditions and surface requirements, the superior mobility of the gasoline engine truck effects a saving in drivers sufficient to compensate for the higher maintenance charges, but when the number

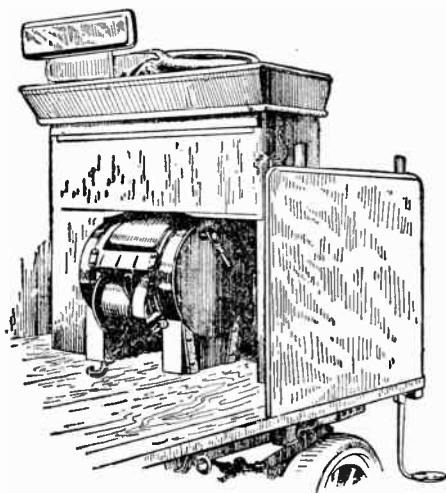


FIG. 4,059.—View of front portion of electric truck showing electric winch which provides mechanical means for loading or unloading, consequently reducing the time necessary for this performance, especially in the case of bulky and heavy articles, thus in some instances increasing the total utility of the machine and operator.

of active truck is the same in each case, the electric truck is sometimes the more economical.

The gasoline engine truck has the advantage in all classes of service requiring a greater mileage than that which is conveniently obtainable with the electric truck, but the greater portion of city delivery service is well within the limits of the safe operative mileage radius of the electric truck built at the present time.

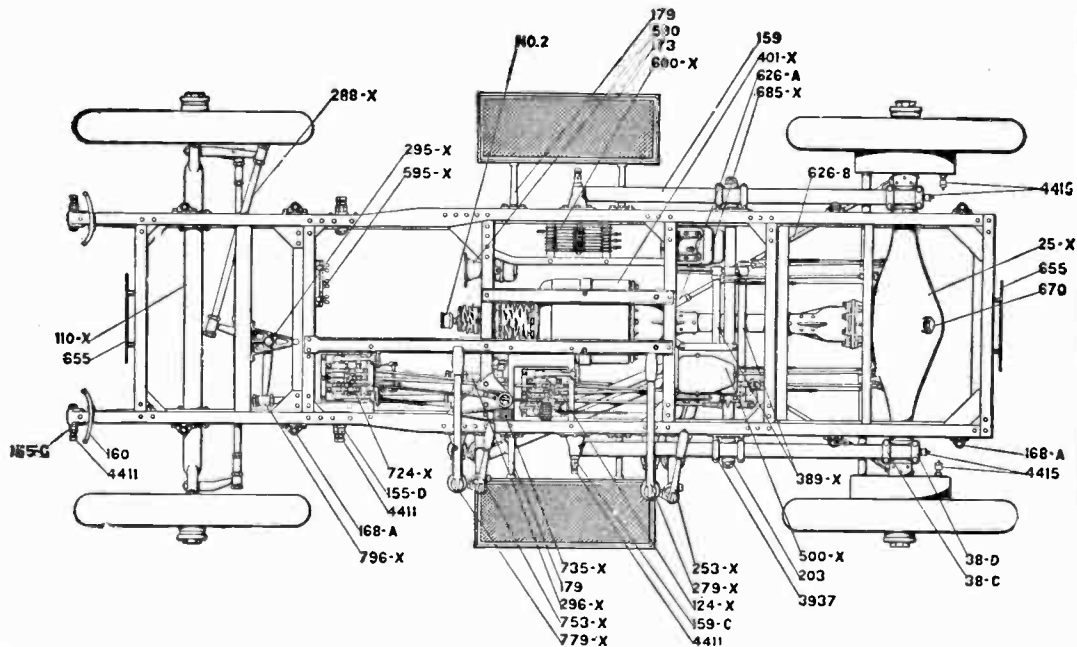
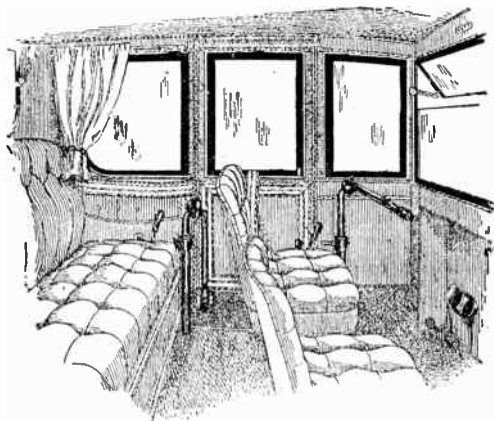


FIG. 4,060.—Plan view of Bakcr electric chassis. The parts are: 25-X, rear axle; 38-D, rear spring yoke rear; 110-X, front axle; 124-X, front levers, rear; 155-C, front spring bolt, front; 155-D, front spring bolt, rear; 159, rear spring; 159-C, rear spring bolt; 160, head lamp bracket; 168, A, fender bracket; 173, step pad; 179, step bracket; 203, rear spring seat, center; 253-X, rear control mast; 279-X, steering mast, rear; 288-X, lower steering rod, mast to mast; 296-X, lower steering rod, bell crank to spindle; 295-X, bell crank; 296-X, lower steering rod, mast to mast; 389-X, brake shaft; 401-X, motor; 500-X, controller; 590, horn; 595-X, fusc box; 600-X, resistance; 626-A, brace rod clevis; 626-B, brace rod; 655, license bracket; 670, oil inlet; 685-X, contactor; 724-X, foot levers, front; 735-X, interlock; 753-X, front control mast; 779-X, steering mast, front; 796-X, lower steering rod, mast to bell crank; 3,937, rear spring clip; 4,411, 4,415, No. 2 grease cups.



**Gasoline-Electric Vehicles.**—The principal disadvantage of the gas engine for self-propelled vehicles is its lack of flexibility; while on the other hand, the principal disadvantage of the electric vehicle operated by means of storage batteries is its lack of mobility. It is evident that the short coming in each case can be overcome only by combining the gas engine with a dynamo connected to a storage battery, for supplying the power required by the electric motors.



**FIG. 4,061.**—Interior Waverly front and rear drive electric brougham. The seating arrangement of this type of electric duplicates that of the Waverly front drive four with the addition of separate steering and controlling levers, and a separate set of brake pedal at the left of the rear seat. The car in this way gains the advantage of dual driving systems, a feature sometimes desired.

Such a combination will operate at practically constant speed at all loads, as the dynamo with the storage battery serves to furnish the necessary overload, or consumes that portion of the energy which is not needed. Furthermore, the transmission will be entirely electrical and will possess the simplicity and flexibility of electric control; while the use of a motor will allow the attainment of various speeds by series-parallel combinations.

Vehicles of this type are built in the form of omnibuses, surface cars and trucks for city service and freight and passenger cars for interurban railway service. The arrangement appears better adapted to the latter service, than for propelling pleasure vehicles.

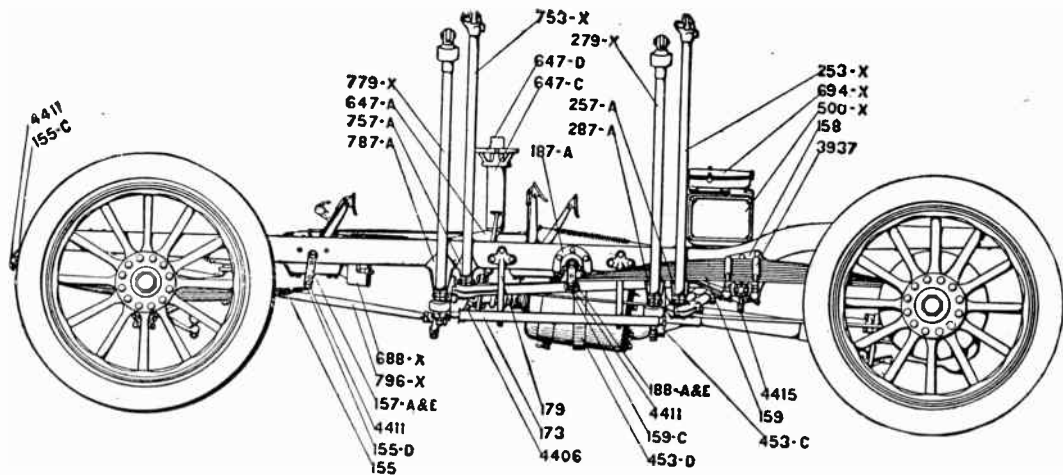
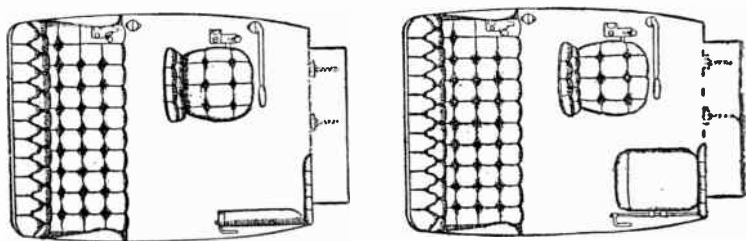


FIG. 4.062.—Side view of Baker electric chassis. The parts are: 155, front spring; 155-C, front spring bolt, front; 155-D, front spring bolt rear; 157-A, front spring shackle; 157-E, front spring shackle lock plate; 158, rear spring bracket center; 159, rear spring; 159-C, rear spring bolt; 173, step pad; 179, step bracket; 187-A, front hanger for rear spring; 188-A, rear spring shackle; 188-E, rear spring shackle lock plate; 253-X, rear control mast; 257-A, rear control mast bracket, lower; 279-X, steering mast, rear; 287-A, steering mast bracket, rear; 453-C, safety loop, short; 453-D, safety loop, long; 500-X, controller; 647-A, seat pedestal bracket, left; 647-C, seat pedestal tube, left; 647-D, seat pedestal stop cup; 688-X, opening switch; 694-X, closing switch; 753-X, front control mast; 757-A, front control mast bracket, lower; 779-X, steering mast, front; 787-A, steering mast bracket, front; 796-X, lower steering rod, mast to bell crank; 3,937, rear spring clip, 4,406, 4,411, 4,415, grease cups.

**Electric Vehicle Essentials.**—The three essential features which convert a vehicle into an electric automobile are the battery, the motor and the system of transmitting power from the motor to the propelling wheels.

In order to move a body from one point to another, it is necessary to apply power to overcome the various opposing forces that always exist. In putting any body, say a carriage, into motion, the effect of its weight, called inertia, opposes the force producing the motion. Inertia requires an application of



Figs. 4,063 and 4,064.—Waverly alternative seating arrangements.

force directly proportional to the rate at which the vehicle is accelerated. Besides this, there are several forces which are active not only on starting and increasing the speed, but when a uniform motion has been attained. These forces are: 1, wind pressure; 2, internal friction of tires; 3, losses in the various moving parts; 4, electrical losses in battery; 5, electrical losses in wiring and motor; 6, gravity in ascending hills.

All these forces which are met when the vehicle is under motion absorb more or less power, and, as in an electric machine the quantity of energy that can be stored is limited, it is of the greatest importance that the designing engineer should bear in mind the vital necessity of cutting down these opposing forces as much as he possibly can.

**Wind Pressure.**—The resistance of the air encountered by a vehicle at normal speed is not a very serious matter, but with an increase of speed or with a head wind, the loss becomes quite large and racing cars are built with the idea in view of reducing the area exposed to the wind and so shaping the exposed parts that the machine will cut its way through with the smallest amount of retardation.

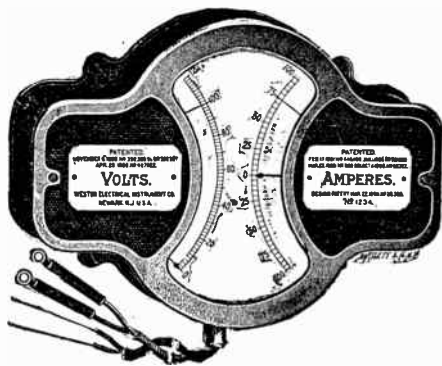


FIG. 4,065.—Weston volt ammeter of the type used on electric vehicles. In some types, the index is side by side instead of end to end.

**Tire Friction.**—The most important loss, perhaps, and one that is least understood is the effect of tires.

It is clear that the portion of any tire which is in contact with the earth must be flattened, but in order to do this, not only must some other parts of the outer surface of the tire assume a deformed shape by creeping, but there must be a change in the relative position of the internal particles. If the tire be a double tube, pneumatic, the inner tube will rub against the casing and the casing will have more or less play against its fastening.

In every pneumatic tire, besides the rubber composition there must be a certain amount of tough cotton fabric which gives the entire structure its strength. In most tires of standard make this material is inserted in the shape of canvas fairly closely woven and quite stiff. In these tires the elasticity of the rubber is restrained and controlled by this

cloth, and it is readily seen that there is but little of the power of flattening or adapting itself to the road that would be possible by the same tire were rubber used alone.

Thread and cord fabric tires have been developed with the intention of retaining the strength of the cotton and at the same time permit of more freedom of motion than canvas will allow. The idea is to use independent threads or cords and surround them with rubber. The one layer of such threads being wound in the direction of the thread on a right hand screw and the next layer at right angles to these. The action of all the threads will then resemble very much a strip of loosely woven cloth cut bias.

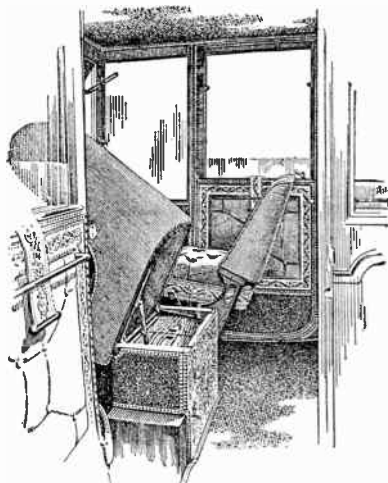
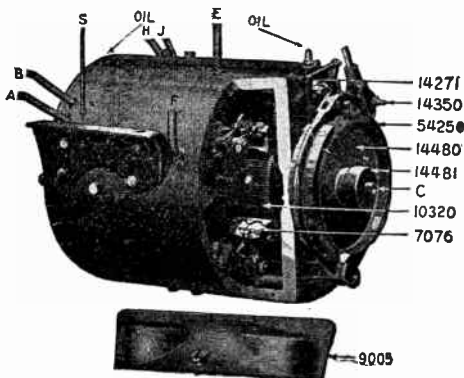


FIG. 4,066.—Interior of Borland electric. The driving seat is tilted forward to show the means of ready access to controller through the box-like base beneath the seat.

There are losses in the electric motor, controller and wiring which in importance rank next to tire losses; besides the design of the motor should be such that outside of the question of its own efficiency its propelling power should be so regulated that the maximum distance may be covered on a single charge.

In the design of electric vehicle the object of the builders should be to attain the greatest possible mileage consistent with durability; also lightness, combined with strength and efficiency in every part. To this end manganese bronze, aluminum, seamless tubing and drop-forged steel are the materials that are largely used.

**Motors for Electric Vehicles.**—These are of the enclosed type of construction, which of necessity they must be, in order to protect them from dust, etc., in their exposed positions under the car. They are designed for heavy overloads.



**FIG. 4,067.**—Raach and Lang electric vehicle motor. *Instructions for care of motor:* The two oil covers lead to the ball bearings in the motor yokes. A good grade of light cylinder oil is recommended for these bearings. The commutator, 10,320, should be at all times kept clean, free from any gummy or gritty substance. The carbon brushes 7,076 should make perfect contact with the surface of the commutator and should be replaced with new ones when worn out. These brushes are originally  $1\frac{1}{8}$  inches long and should be replaced with new ones as soon as the measurement is reduced to  $1\frac{1}{4}$  inches. It is safer to replace these brushes often, rather than allow them to become too short. Very serious damage may result from using brushes that are too short or ones that make poor contact with the commutator. Brushes that are too short or that are making poor contact will pit, burn and blacken the surface of the commutator. Replacement of brushes should be made only by an experienced person. The motor leads are lead out of motor through insulated holes. These holes, lettered J, H, B, A, S, E and F correspond to the letter contacts on the controller into which they are connected. The motor brake may be adjusted for wear by means of the winged nut 14,350. Clearance between brake jaws and wheel may be adjusted by means of the screw 14,271. To remove brake wheel from armature shaft, take the  $\frac{1}{8}$  inch screw C out of the cap 14,481. A  $\frac{1}{2}$  inch, 12 pitch bolt, 3 inches or longer, or a cap screw may then be screwed through the threads in the cap and up against the end of the armature shaft. Continue to turn this screw and the pulley will be drawn off the shaft.

When a vehicle is started or its speed increased, a certain amount of energy is absorbed to produce this acceleration. The total amount of energy required is in proportion to the total weight and to the square of the velocity, so that to double the

weight of a vehicle means doubling the power required for starting, and doubling the velocity means four times the power. Accordingly, to meet these conditions, especially when starting under severe conditions, as on a sandy road, or in ascending a hill, the electric vehicle motor is constructed for a 200% or more overload.

As stated by one manufacturer, a motor for a two passenger runabout rated at  $2\frac{1}{2}$  horse power consumes 6,800 watts in ascending an 11 per

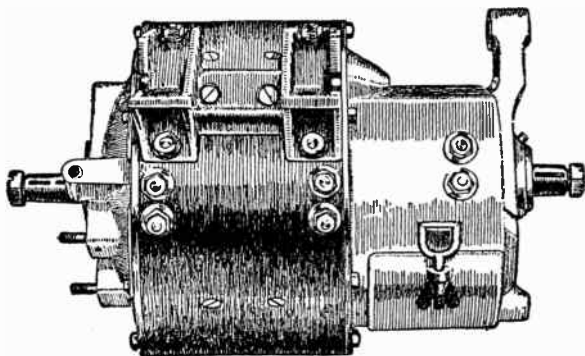


FIG. 4,068.—Waverly 80 volt motor. *In construction* it is series wound medium speed. The armature rotates on ball bearings; four poles are used.

cent. grade at 7 miles per hour, although no more than 360 watts are required to propel the vehicle on an even asphalt roadway at  $8\frac{1}{2}$  miles per hour. These figures represent an effective power range of between  $\frac{1}{2}$  horse power and over 9 horse power.

There seems to be some uncertainty as to the precise power rating of vehicle motors, but, as a matter of fact, they are wound to develop the highest constant power output at the highest voltage used, with a high overload capacity for short spurts, as in hill climbing, etc.

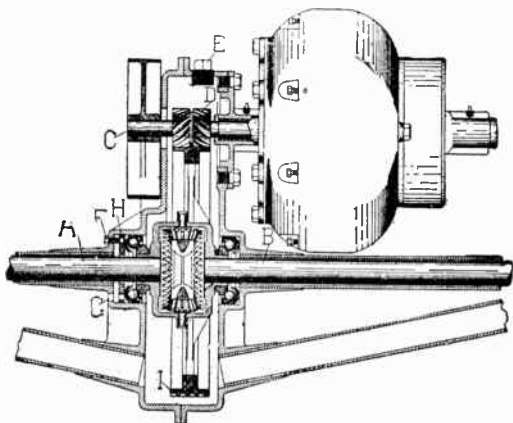
**Ques.** What objectionable feature should be avoided in electric vehicle design?

**Ans.** Very quick acceleration. because a vehicle. constructed

with this feature, not only gives the passenger an unpleasant jerk, but puts a heavy overdraft on the battery.

**Ques.** What are the considerations with respect to friction in the bearings?

**Ans.** Since the amount of power lost by friction in the bearings requires that much more power to be carried by the vehicle, in order to attain the desired mileage or speed, it is very essential to reduce frictional losses to a minimum by using approved forms of ball and roller bearing.



**FIG. 4,069.**—Diagram of a single motor attached to rear axle through "herringbone" single reducing gears. A, is the left hand section of the divided rear axle; B, the right hand section of the rear axle; C, the brake drum; D, the spiral pinion on the motor shaft driving the worm gear, I, on the differential; E, plug for greasing gears; F, set screw for locking ball race; G, slot for wrench to adjust threaded ring, H, against ball bearings.

**The Drive or Transmission.**—Because of the relatively high speed of the motor as compared with that of the rear wheels of the car, a system of gearing is necessary between the motor and rear axle to obtain the necessary velocity reduction. Moreover, in some cases, other gears must be provided so that



the power may be applied to the rear shaft when the motor shaft and rear shaft are at right angles to each other.

There are several forms of drive, as by

1. Herringbone gear;
2. Chain gear;
3. Worm gear.

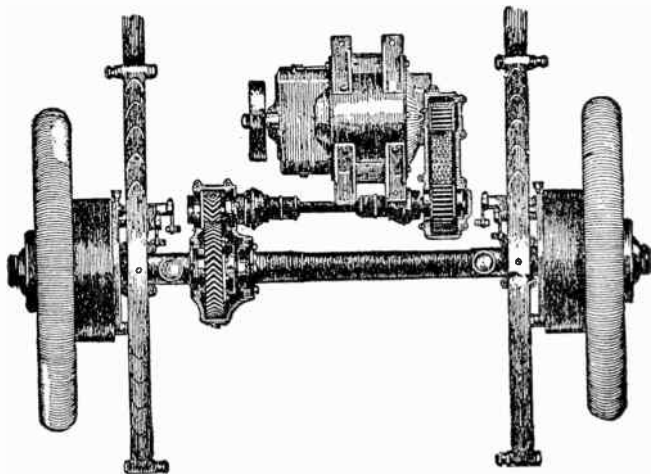


FIG. 4,070.—Waverly double reduction gear or combination herringbone gear and "silent" chain. *In construction* the motor shaft is parallel to the intermediate or jack shaft and drive shaft. Two universal joints are used, so as to give freedom of motion in any direction. The motor weight is above the springs. The first reduction is by the silent chain enclosed in a casing at end of motor; the second reduction is through the herringbone gear in the axle.

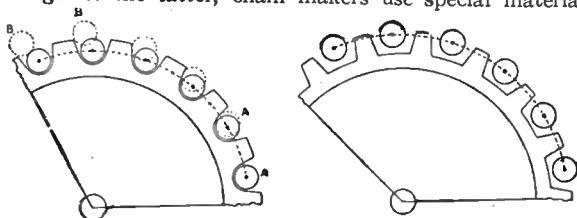
**Herringbone Drive.**—This type of drive gear is extensively used.

The method of attaching a single motor to the rear axle through herringbone single reducing gears is shown in fig. 4,069. A and B, are the two sections of the divided rear axle. The spiral pinion D on the motor shaft drives the worm gear I, on the differential. C represents the brake drum; E, the plug for greasing gears; F, the set screw for locking ball race; and G, the slot for wrench for adjusting threaded ring H, against the ball bearings.

The advantages of this sort of drive are its freedom from noise, its simplicity and durability owing to the parts being enclosed.

**Chain Drive.**—This form of drive is desirable for heavy service, as on very large trucks. It is a noisy and dirty mode of power transmission, and when not enclosed is subject to rapid wear.

In chain drives there is more or less elongation of the chain due to the wear of the rivets and bearings or to stretch of the material. To guard against the latter, chain makers use special material of high



**Figs. 4,071 and 4,072.**—Diagrams showing the behavior of a chain on a sprocket of equal pitch, and on one of properly unequal pitch. The following quotation from an English authority explains the action: "A chain can never be in true pitch with its sprocket. A pair of spur gears tend, to a certain extent, to wear into a good running fit with each other, but a chain, if made to fit its sprocket when new, does not continue do to so a moment after being made, as wear at once throws it out. This being so, it must be put up with, and involves the consequence that a chain can only drive with one tooth at a time, supplemented by any frictional 'bite' the other links may have on the base of the tooth interspaces. If the chain be made to fit these accurately (taking a roller chain for illustration), it is obvious that the least stretch will cause the rollers AA to begin to ride on the teeth as at BB. If, however, the teeth be made narrow compared with the spaces between the rollers, a considerable stretch may occur without this taking place. The roller interspaces, then, should be long, to permit the teeth to have some play in them, while retaining sufficient strength, as shown in fig. 4,072. In order that the driving sprocket may receive each incoming link of the chain without its having to slide up the tooth face, it should be of a somewhat longer pitch than its chain, the result being that the bottom tooth takes the drive, this being permitted by the tooth play shown in fig. 4,072. This difference, of course, gradually disappears as the chain stretches. The back wheel sprocket, on the other hand, should take the drive with its topmost tooth, and hence should be of slightly less pitch than the chain, but as the pitch of the latter constantly increases, it may be originally of the same pitch. The only remaining point with regard to design, and one which the owner of a car may easily ensure, is that the number of teeth in the sprockets should be prime to that of the links in the chain."

tensile strength, but if, for any reason, a link elongates unduly, it should be replaced at once, as one long link will eventually ruin a chain. Such elongation sometimes results from a sudden application of the load.

To prevent undue interference between the chain and sprocket as the result of elongation, the sprockets are not cut to fit the chain accurately but with a certain amount of pitch line clearance.

**Ques.** State a very objectionable feature of chain drives?

**Ans.** The chain sometimes climbs the sprocket teeth.

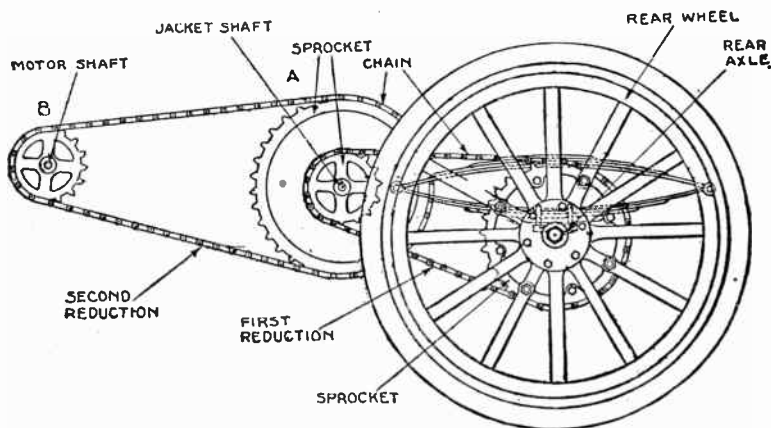
**Ques.** What is the cause of this?

**Ans.** Considerable wear or too little clearance.

If a sprocket were cut without clearance, an elongated chain would climb the teeth and the latter would exert a wedging effect, thus subjecting the chain to excessive strains. In design the amount of clearance should be as large as is consistent with the proper strength of the teeth.

**Ques.** Under what conditions should a chain operate?

**Ans.** It should work in oil, in a dust tight case.



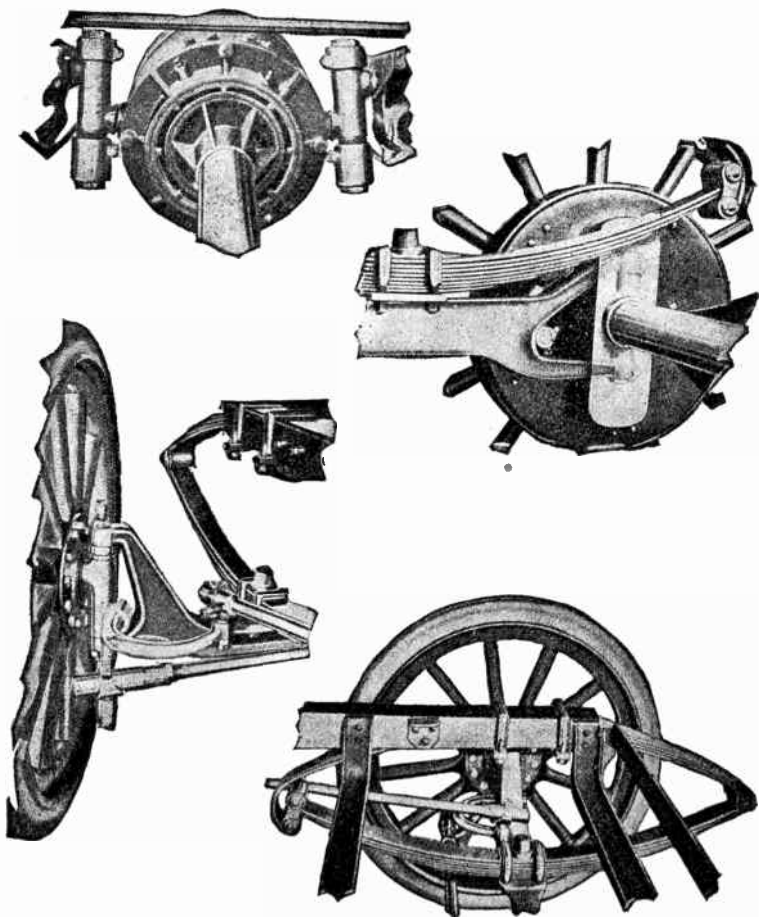
**FIG. 4,073.**—Double chain drive. The rear axle is of the "dead" type and each rear wheel has a sprocket with which the chains mesh. The jack shaft is parallel to the rear axle and upon the maintenance of parallelism between the two axles depends the satisfactory working of the chain. The cut illustrates single and double reduction chain drive. For single reduction the motor would be located at A, and for double reduction, at B.

**Ques.** What is the advantage of the chain drive?

**Ans.** The greater portion of the weight of the drive mechanism is supported by the frame instead of the rear axle housing; it is thus cushioned from shocks due to uneven road.

**Ques.** What two kinds of chain are used?

**Ans.** Block chain and roller chain.



FIGS. 4,074 to 4,077.—Details of Wood's electric vehicle construction. Fig. 4,074, *motor suspension* showing detail of the hangers between which the motor is suspended; fig. 4,075, *radius rod connection*, showing phantom view of radius rod and how attached to rear axle housing. Also mounting of rear spring or radius rod forward to rear axle; fig. 4,076, *steering knuckle*, showing connections and half of front spring; fig. 4,077, *front spring* showing full elliptical design and method of attaching springs to main chassis frame.

**Ques. Describe a block chain.**

Ans. A block chain is made of a series of block, properly shaped to fit the teeth of the sprocket, each joined to similar blocks before and after by side links bolted through the body of the block.

**Ques. Describe a roller chain.**

Ans. A roller chain is composed of a series of roller, known as center blocks, joined by side links. Each roller rotates on a hollow core which is turned to smaller diameter at either end, to fit a perforated side piece joining the rollers into pairs. The side links are set over these side pieces and bolted in place through the cores.

**Ques. How do the two types compare in operation?**

Ans. A block chain with generous slack is liable to meet the sprocket with a continual clapping, which at high speed, becomes a continuous rattle. A roller chain is comparatively free from the trouble.

**Ques. What causes the snap and rattle of a chain?**

Ans. The fact that even with the best designed sprocket, as each tooth in turn passes out of engagement with the chain, the next roller must be drawn forward through an appreciable distance before engaging a tooth. This action not only produces the noise, but it is a factor in waste of driving power.

**Ques. What attention should chains receive to maintain a proper working condition?**

Ans. The principal points to be observed in the use and care of sprocket driving chains are: 1, to maintain the proper tension in order to avoid "whipping"—which, particularly with a long one, is liable to result in snapping of the chain,—and, at best, involves a loss of driving efficiency. The chain should not be drawn too tight, lest a similar disaster result. Some slack

must always be allowed, 2, two sprockets should always be kept in alignment. In the case of a double chain drive, from a counter shaft parallel to the rear axle, care should be exercised to maintain the parallelism, even preferring a somewhat loose chain to a tight one that strains the countershaft, 3, if a link show signs of elongation, it should be

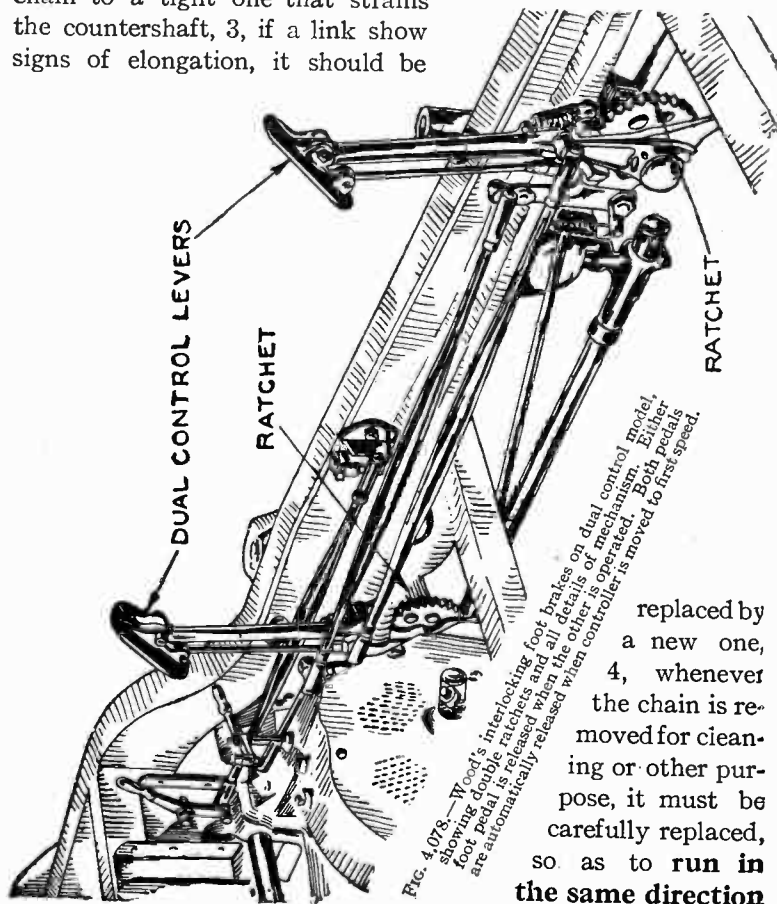


FIG. 4,078.—Wood's interlocking foot brakes on dual control model, showing double ratchets and all details of mechanism. Either foot pedal is released when the other is operated. Both pedals are automatically released when controller is moved to first speed.

replaced by a new one, 4, whenever the chain is removed for cleaning or other purpose, it must be carefully replaced, so as to run in the same direction

as formerly, and **with the same side up**. The chain should never be turned around, or its direction between the sprockets reversed, 5, a new chain should not be put on a much worn sprocket, 6, a chain should be frequently cleaned and rubbed with graphite, because the chief difficulty involved in the use of driving chains is the liability to clog and grind with sand, dust, and other abrasants, and 7, after steady use for a more or less extended period, the chain should be removed and cleaned throughout.

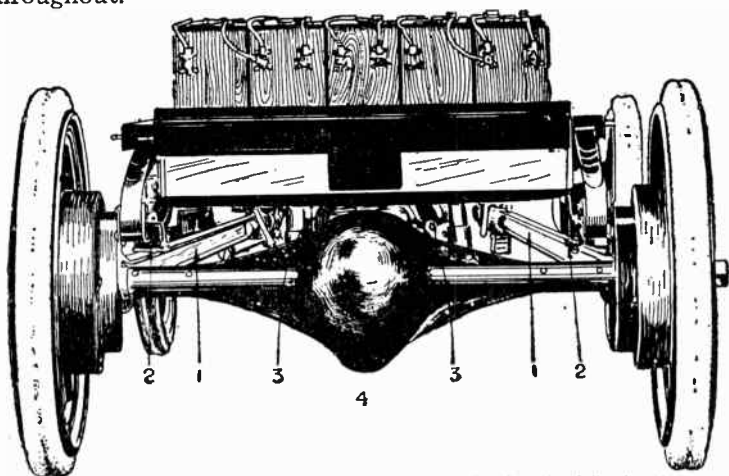


FIG. 4,079.—Rear view of Wood's chassis with battery showing the following *features of construction*: 1, radius rods extending from rear axle to sub-chassis frame; 2, rear springs rest on radius rods, instead of on rear axle; 3, motor, showing ball and socket spring suspension; 4, worm drive, showing location of worm below rear axle.

### Ques. How may a chain be best cleaned?

Ans. After removing it from the sprockets, cleanse first in boiling water, then in gasoline, in order to remove all grease and dirt. The common practice is next to boil the chain for about half an hour in mutton tallow, which is thereby permitted to penetrate all the chinks between rolling surfaces forming an

excellent inside lubricant. After boiling, the chain is hung up until thoroughly cool, at which time the tallow is hardened. It may then be wiped off clean and treated with a preparation of graphite, or a graphite alcohol solution on its inner surface.

Some authorities recommend that the chain, after it is cleaned in boiling water and gasoline, should be soaked, first, in melted paraffin for an hour at least, and then in a mixture of melted mutton tallow and graphite. After each soaking, it is dried and wiped clean. With either process, a daily application of graphite is desirable.

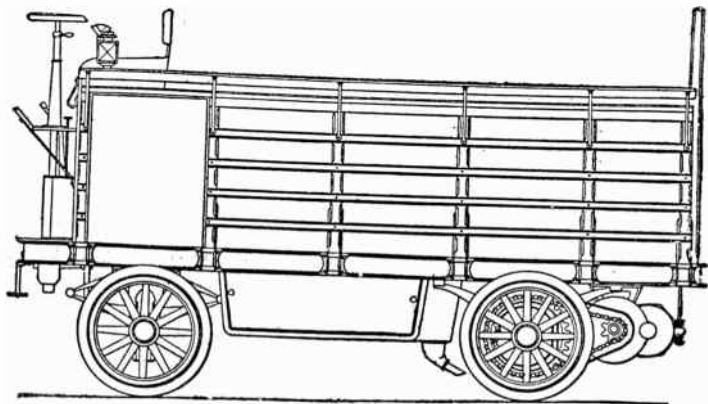


FIG. 4,080.—Chain and sprocket double reduction gear for heavy trucks. As here shown, the motor is hung above the springs, missing the jars of travel.

**Ques.** Is it necessary that both chains be of equal tightness?

**Ans.** No; the differential gear on the jack shaft will counteract this and cause each chain to do its share of the driving.

**Ques.** What adjustment is important with a chain drive?

**Ans.** The jack shaft and rear axle should be made parallel



by adjusting the radius rods to secure the proper engagement of the chain with the sprockets.



FIG. 4,081.—Baker R and L worm and gear.

**Combination Chain and Gear Drive.**—For very heavy trucks where a considerable reduction in speed is required between the motor and wheels, a double reduction is sometimes used as shown in fig. 4,080.

The motor is usually hung above the springs, thus being protected from the jars of travel.

There are several forms of double reduction using light high speed motors by means of various combinations of

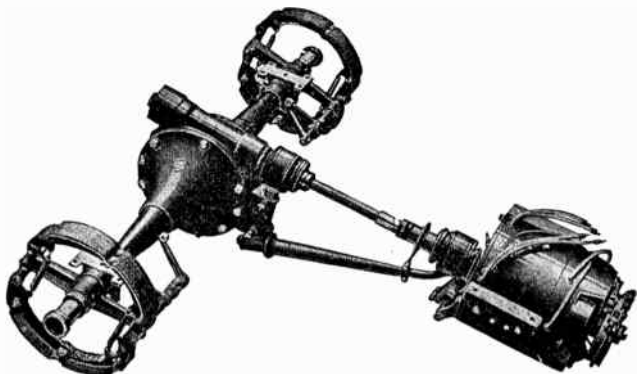


FIG. 4,082.—Baker R and L motor, propeller shaft, universal joints, worm and gear. This is the straight type top mounted worm drive.

gear and chain, with silent, roller chains or herringbone gears for the first reduction, and single or double roller chains, bevel gears or herringbone gears for the second reduction.

**Worm Drive.**—This is a very popular drive for trucks and pleasure cars propelled by electric motors, because of the very large reduction possible on single gear. It has the advantages of silence in operation and great durability.

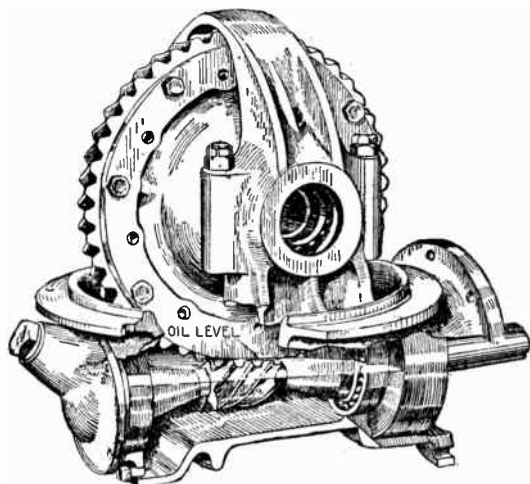
**Ques.** Describe a typical modern worm drive rear axle construction.



**FIG. 4,083.**—Baker R and L worm drive transmission unit.

**Ans.** The worm wheel and differential gearing are assembled as a unit with the cover of the axle housing. This housing carries all of the weight, the driving shafts being full floating and transmitting only the driving power to the wheels. A torque rod takes all driving and braking torsional strain, while two side radius rods relieve the rear springs of all tractive effort. Annular ball bearings are used to take the radial and thrust loads of the worm and wheel, while the road wheels run on conical roller bearings.

**Storage Batteries for Electric Vehicles.**—The storage battery has been modified in various ways to adapt it to automobile use, the problem being to secure the greatest specific energy with the least bulk and weight. Its efficiency, or the amount of electrical energy it will discharge in proportion to the amount it takes to charge it is also an important consideration. Average figures run between 70 and 90 per cent.



**FIG. 4,084.**—Lanchester type of worm drive as used on some electrics. An advantage claimed for this form of worm drive is the fact that mounting the worm below the ring gear permits it to be placed in a bath of oil, assuring constant and ample lubrication.

The storage batteries which have proved most successful in connection with electric vehicles are the lead sulphuric acid type, and the iron nickel battery, commonly known as the Edison battery.

**Ques.** What construction is employed to reduce the weight of battery for use in electric vehicles?

**Ans.** The plate surface is finely divided.

The following methods are those most common: scoring, grooving, laminating, casting, pressing and by the use of a lead wool.

The Faure, or pasted type plates are usually lighter and of higher capacity than the Plante, but have a tendency to shed the material for the grid thus making the battery useless.

**Mileage and Battery.**—If the proper mileage per charge be not obtained when all mechanical parts of the car are in good order, it is undoubtedly due to the battery being undercharged and not brought up to full voltage as indicated on the meter.

In this case it is best to discharge the battery until voltage indicates 1.8 per cell; open the hoods over the battery, remove plugs from cells

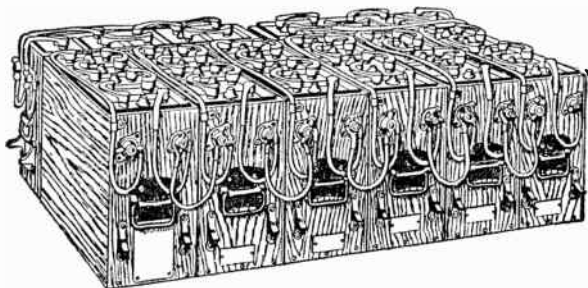


FIG. 4,085.—Waverly 42 cell lead battery. All battery cells are accessible from outside of car by raising the hoods. The battery compartments are lined with acid proof material to prevent acid reaching the paint, the running gear or other parts.

and cover the plates with *distilled* water to within one-half inch of the inside top cover. Charge the battery in the usual way until it reaches a maximum voltage as given on charging card, then charge four hours longer at the lowest rate shown on the card. Try battery; if this do not improve the mileage sufficiently, repeat the operation as before. If after repeating the operation three times, normal mileage be not obtained, and trouble be not found elsewhere the maker of the battery should be consulted at once.

**\* Points Relating to Storage Batteries.**—The following important directions should be carefully followed to obtain satisfactory service for a storage battery:

• NOTE.—For a full treatment of the subject of storage batteries, see Guide No. 4.

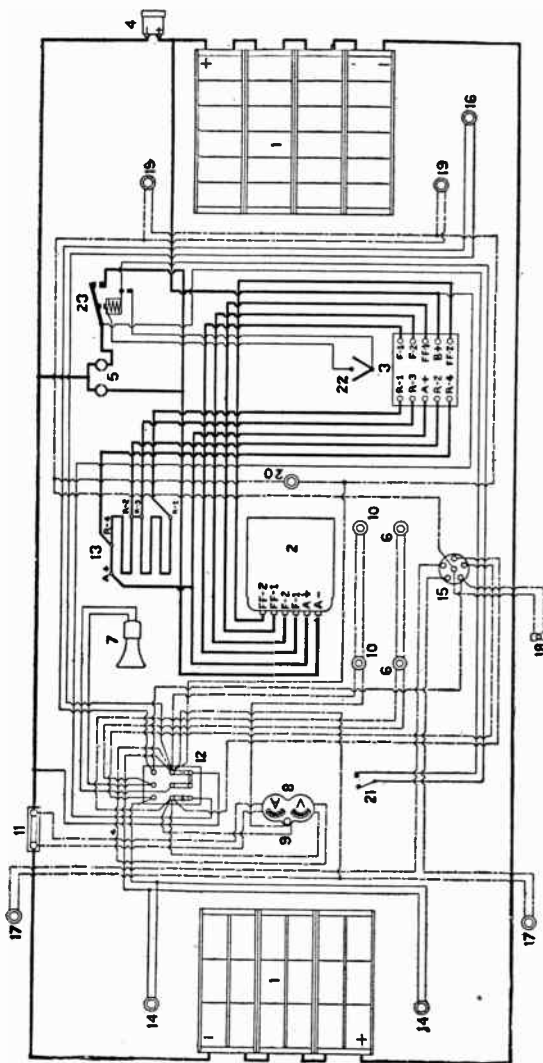


FIG. 4.086.—Wiring diagram of Baker electric: 1, batteries; 2, motor; 3, controller; 4, charging receptacle; 5, starting plug receptacle; 6, signal button; 7, horn; 8, volt ammeter; 9, meter light; 10, meter light button; 11, shunt for volt ammeter; 12, fuse box; 13, resistance guides; 14, head light wires; 15, light switch; 16, tail light wires; 17, side light wires; 18, door jamb switch; 19, inside rear corner lights; 20, dome light; 21, opening switch; 22, closing switch; 23, contactor.

1. Keep the battery and connections clean.
2. Go over the same and see that they are bolted up tight.
3. If there be any low cells in the battery, attend to them at once.
4. Keep the electrolyte, or battery solution, at the proper height above the tops of the plates.
5. Keep the density of the electrolyte, or battery solution, at the proper point.
6. Do not charge at a rate that will make the cells exceed 100 degrees F. in temperature.
7. A battery can be ruined in three hours after it has been put in use by being left on charge at a high rate after it is full.

8. The user of the vehicle should keep careful track of the charging and, if possible, watch it personally.
9. In all cases follow strictly the instructions furnished by the maker.
10. Do not let battery stand completely discharged.
11. Do not let battery fully discharge in cold weather.
12. Do not let battery stand in a partly discharged condition long.
13. Do not go away on a visit and allow battery to stand inactive.
14. A battery must be worked constantly to get satisfactory service and when going away for two weeks or more, it is best to make arrangements to have the battery looked after by someone familiar with it.
15. In charging, always connect the positive wire of the charging source to the positive terminal of the battery and vice versa.
16. If the battery become dead, or lose mileage, consult the makers.
17. Charge battery in a warm room in winter.
18. In consulting the makers, be sure to give full particulars.

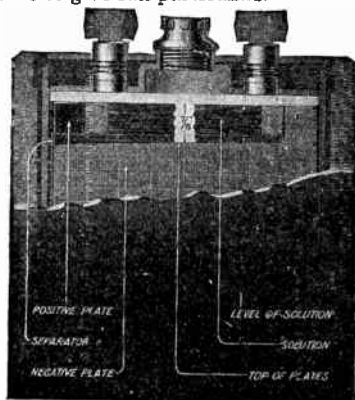
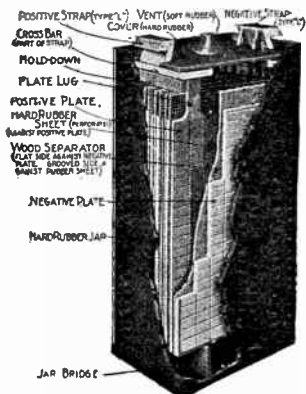


FIG. 4.079.—Gould cell showing parts.

FIG. 4.088.—Sectional view showing height to fill Gould starting and lighting type of cell.

**Battery Capacity.**—As there is no sure way for the automobilist to estimate the discharge capacity of his battery, he is obliged to base such calculations as he makes on the figures furnished by the manufacturers. With the help of his indicating instruments, the voltmeter and ammeter.

Apart from any considerations of efficiency, the driver of an electric carriage should carefully bear in mind the figures supplied by the manufacturers of the type of battery he uses, in order to judge:

1. How long the present charge will last;
2. Whether he be exceeding the normal rate of discharge, and thus contributing to the unnecessary waste of his battery and incurring other dangers that may involve unnecessary expense.

As a general rule the 1 hour discharge rate is four times that of the normal, or 8 hour discharge, and considerations of economy and prudence suggest that it should never be exceeded, if, indeed, it be ever employed. The 3 hour discharge, which is normally twice that of the 8 hour, is usually the highest that is prudent while the 4 hour discharge is the one most often employed for average high speed riding; batteries give only the 3 and 4 hour discharge rates in specifying the capacity of their products.

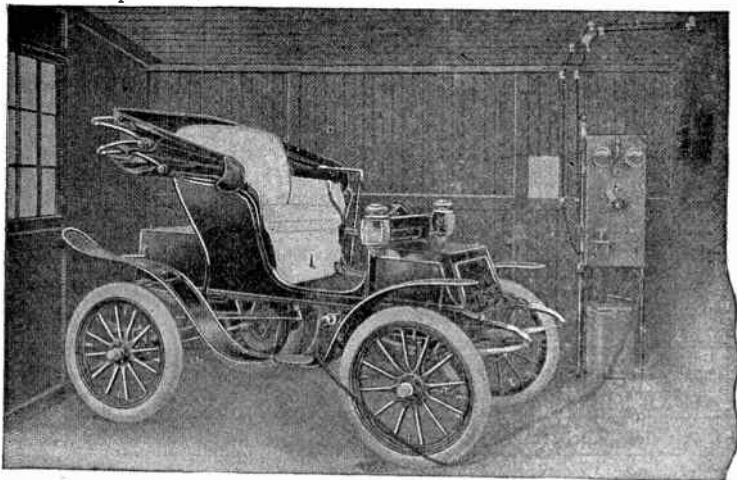


FIG. 4,089.—View showing Studebaker electric in home garage connected to rectifier charging outfit. The subject of rectifiers has been treated at such length in Guide No. 6, that no further explanation is here necessary.

**NOTE.—High Charging Rates.**—Occasionally it is desirable to charge a battery as quickly as possible, in order to save time, as when belated and far from home with an electric vehicle that has almost reached its limit. As a general rule, such a procedure should not be adopted unless the battery be thoroughly discharged. In charging a battery at a high rate, the danger to be avoided is the tendency of the cells to heat. A battery should never be charged at a high rate unless it be completely exhausted, since it is a fact that the rate of charge that it will absorb is dependent upon the amount of energy already absorbed. As shown in the table of high charging rates, the 96 ampere hour cell requires, for charging in three hours: For the first half hour, 70 amperes; for the second, 40 amperes; for the third, 30 amperes; for the fourth, 20 amperes, and during the last hour, 10 amperes. It may also be charged at the following rate in 45 minutes: 140 amperes for the first 20 minutes; 100 amperes for the next 5 minutes; 70 amperes for the next 5 minutes; 30 amperes for the next 10 minutes; 10 amperes for the last five minutes. This is the rate to be followed when the battery is completely discharged.

The following data on sizes suitable for automobile use will be found useful.

Discharge in Amperes Per Hour During			Ampere Hour Capacity When Discharged			Normal Charging Rate	Outside Dimensions of Jar in Inches		
8 Hrs.	5 Hrs.	3 Hrs.	8 Hrs.	5 Hrs.	3 Hrs.		Height	Length	Width
6½	8¾	12½	50	43¾	37½	6½	10½	5¼	4¼
7½	10½	15	60	52½	45	7½	11	7⅞	4¾
8¾	12¼	17½	70	61¼	52½	8¾	12½	7⅞	4¾
10	14	20	80	70	60	10	12	6¾	7
12½	17½	25	100	87½	75	12½	12	6¾	7
15	21	30	120	105	90	15	12½	6¾	7
17½	24½	35	140	122½	105	17½	12½	6¾	7
20	28	40	160	140	120	20	12½	9⅞	5¾
22½	31½	45	180	157½	135	22½	12½	9	6½
25	35	50	200	175	150	25	12½	9	6½
27½	38½	55	220	192½	165	27½	12½	9	6½
30	42	60	240	210	180	30	12½	9	6½
37½	52½	75	300	262½	225	37½	12½	9⅞	7¾
45	63	90	360	315	270	45	12½	9	8⅞
52½	73½	105	420	367½	315	52½	12½	11⅞	8

NOTE.—The figures will vary for different rates largely due to the number of plate per jar and to other points of construction.

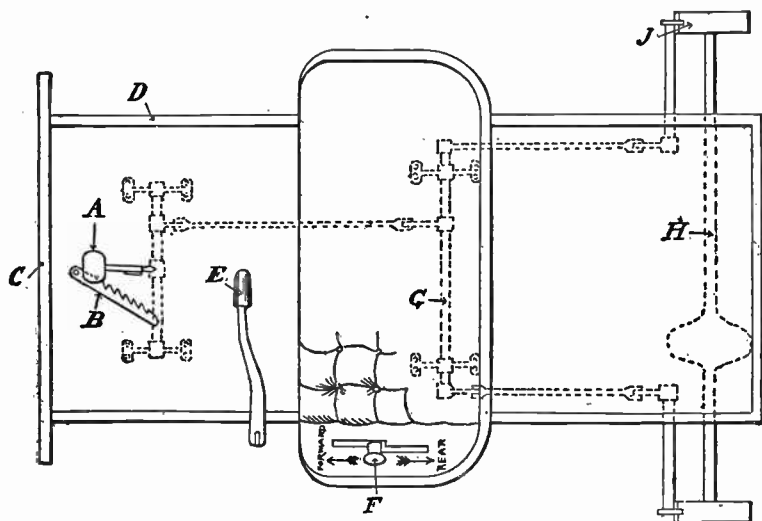
As given by a well known vehicle manufacturer, the following data on discharging and rapid charging of a given make of battery will be found typical:

Ampere Hour Capacity Discharged					Normal Charging Rate	Rate in Amperes for a 3 Hour Charge					Rate in Amperes for a 45 Minute Charge				
3 Hr.	4 Hr.	5 Hr.	6 Hr.	8 Hr.		½ Hr.	¾ Hr.	1 Hr.	1 ¼ Hr.	1 ½ Hr.	20 M.	5 M.	5 M.	10 M.	5 M.
34	38	40	42	48	6	36	20	16	10	5	72	52	36	16	5
45	50	53	55	64	8	48	28	20	16	7	96	68	48	20	7
66	73	78	81	96	12	70	40	30	20	10	140	100	70	30	10
112	124	132	137	160	20	128	68	52	32	17	238	170	119	51	17
140	155	165	171	200	25	150	86	62	42	21	300	214	150	64	21
168	186	198	206	240	30	178	102	76	50	26	356	254	178	76	26
196	217	231	240	280	35	208	118	90	60	30	420	300	210	90	30

NOTE.—It is customary to state the normal capacity of a cell in ampere hours, based upon the current which it will discharge at a constant rate for eight hours. Thus a cell which will discharge at 10 amperes for 8 hours *without the voltage falling below 1.75 per cell* is said to have a capacity of 80 ampere hours. It does not follow that 80 amperes would be secured if the cell were discharged in 1 hour. It is safe to say that not more than 40 amperes would be the result with this rapid discharge. *The ampere hour capacity decreases with the increase in current output.* Generally speaking, the voltage during discharge is an indication of the quantity of electricity remaining within the cell.

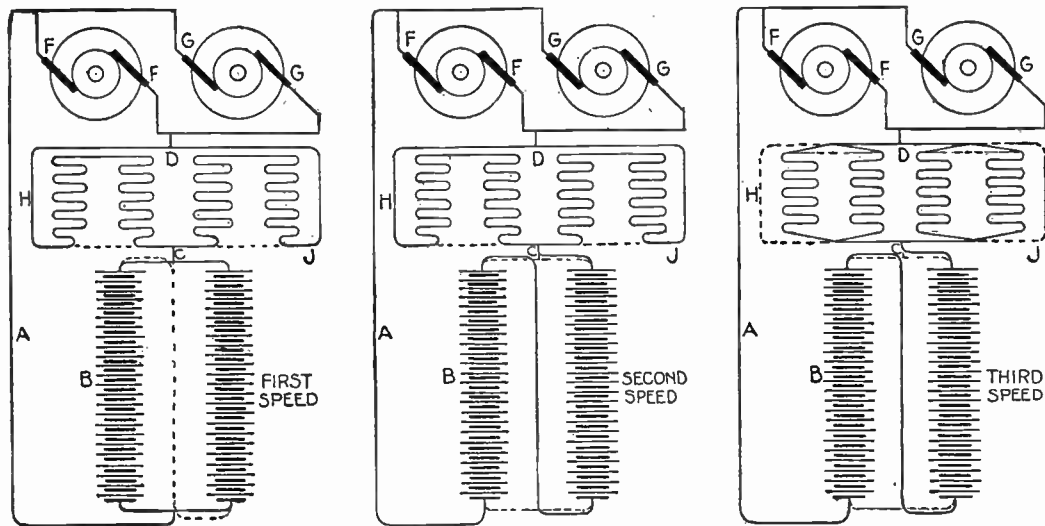


**Electric Vehicle Controllers.**—The form of controller adapted to electric vehicle use consists of a rotatable insulated cylinder carrying on its circumference a number of contact, arranged to make the desired connections with the terminals of the various apparatus in the circuit through a wide range of variation.



**FIG. 4,090.**—Diagram of the controlling apparatus of a light electric vehicle. A, brake pedal; B, ratchet retaining pedal in place, operated by left foot; C, dash board; D, body sill; E, steering handle; F, controller handle; G, rocker shaft for setting hub brakes; J, brake band on wheel hub; H, rear axle.

Some controllers are constructed with a cylindrical surface, upon which bear single leaf springs, the desired electrical connections being made by suitably connected conducting surfaces on the cylinder circumference, and cut outs being similarly



FIGS. 4,091 to 4,093.—Diagrams of the circuit changing arrangements of a typical electrical vehicle. The full lines in these diagrams indicate the closed or active circuits; the dotted lines the open, or inactive circuits. As may be readily understood, the whole scheme of the circuit changing depends on employing several different circuit connections between battery and motor, which may be opened and closed, as desired. Here A and C are the lead wires between battery, B, and motor brushes, FF and GG, and the field windings H and J, and the wire D. Fig. 4,091 shows first speed; two units of the battery B are connected in parallel, which means that the voltage is reduced to the lowest point. The wire C, connected to the bridge between the positive poles of the battery, leads the current to the field windings, H and J, which, in this figure, are connected in series-parallel, which gives the lowest speed and power efficiency of the motors. By the wire, D, the current is carried to the brushes, FF and GG, which, according to this scheme, are permanently connected in parallel, the return path to the negative pole of the battery being through the wire A. In fig. 4,092, the circuit is varied so as to connect the two units, so as to give its highest pressure efficiency. But, since the field windings of the motors are also connected in series, or in series parallel, as in this case, the efficiency in speed and power is reduced nearly one-half. In fig. 4,093, the two units of the battery are connected in series, which, as in the former case, indicates the greatest efficiency in power output; but the field windings are connected in parallel, which means that the voltage generated by their operation is equivalent to the voltage of only one motor, with the result that the speed and power efficiency is raised to its highest point.



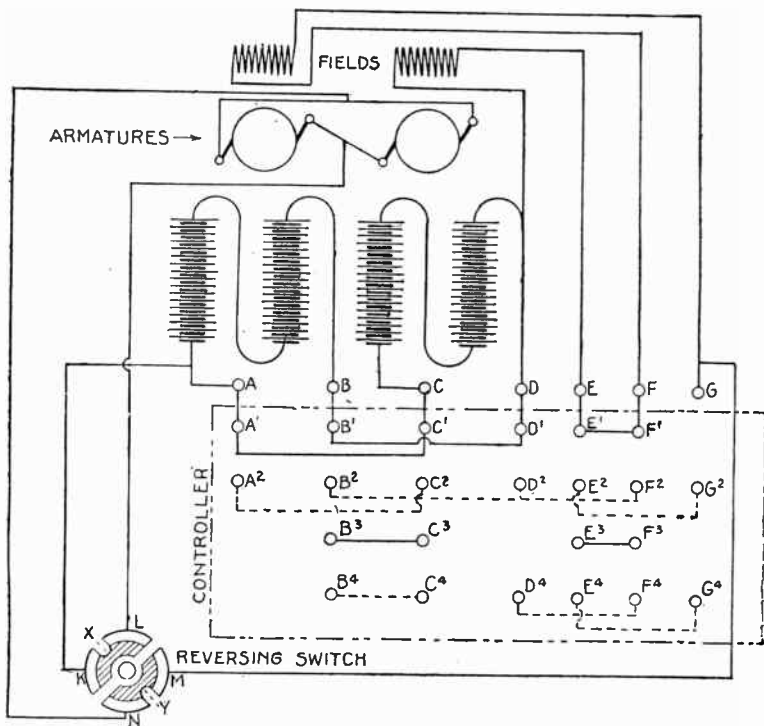
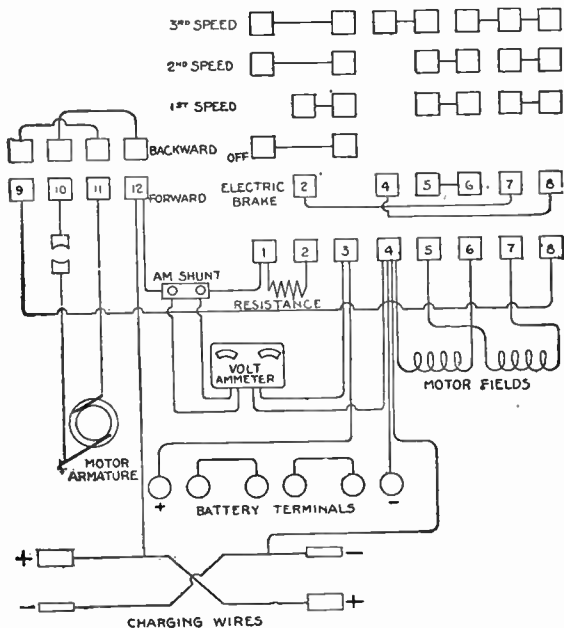


Fig. 4,096.—Diagram plan of the several parts of an electric vehicle driving circuit. The field windings and armatures are shown projected, the proper wiring connections being indicated. The periphery of the controller is laid out within the broken line rectangle, the contacts and connections through it for varying the circuits through four speeds being shown. **For first speed** the controller is rotated so that the row of terminal points, A, B, C, D, E, F, G, are brought into electrical contact with the row of terminal points, on the controller, A', B', C', D', E', F', G'; this connects the two unit battery in parallel and the field windings of the two motors in series. A further movement of the controller, bringing the points, A, B, C, etc., into contact with A<sup>2</sup>, B<sup>2</sup>, C<sup>2</sup>, etc., gives **second speed**, the batteries now being in parallel and the fields in series parallel. **For third speed**, the points B and C are brought into contact with B<sup>3</sup> and C<sup>3</sup>, and E and F with E<sup>3</sup> and F<sup>3</sup>, which means that the batteries are connected in series, and the fields in series. Similarly, for fourth speed, the points B and C are brought into contact with B<sup>4</sup> and C<sup>4</sup>, and D, E, F, G, with D<sup>4</sup>, E<sup>4</sup>, F<sup>4</sup>, G<sup>4</sup>, which means that the batteries are in series and the fields in parallel. The connections between the battery, the armature brushes, and the motor fields, are made as indicated through the rotary reversing switch by the terminals, K, L, M, N. This switch may effect the reversal of the motors by giving a quarter turn to its spindle, which means that the contacts of segment X, will be shifted from L and K to K and N, and the contacts of segment Y, shifted from M and N to L and M, thus reversing the direction of the current.

**Electric Vehicle Circuits.**—The methods employed to vary the speed and power output of an electric vehicle motor consist briefly in such variation of the electric circuits as will modify the pressure of the batteries on the one hand, and the operative efficiency of the motors on the other.



**FIG. 4,097.**—Diagram of controller connections of a one unit, one motor circuit, with variable fields.

The cells comprising the storage battery are so arranged as to form a number of unit, being so wired that by the use of a form of switch known as a controller, the connections may be varied from series to parallel, or the reverse, as desired. The same arrangement for varying the circuit connections is used for the field windings.

The wiring diagrams, figs. 4,091 to 4,093, show one arrangement. The dotted lines on each figure indicate the circuits that are cut out or open, and the full lines those that are active or closed.

**Ques.** How may the circuits be arranged with two batteries and two motors?

**Ans.** For this combination, as shown in figs. 4,102 to 4,104, it is possible to eliminate the resistance coil altogether and depend entirely upon the circuit shifting for regulating the

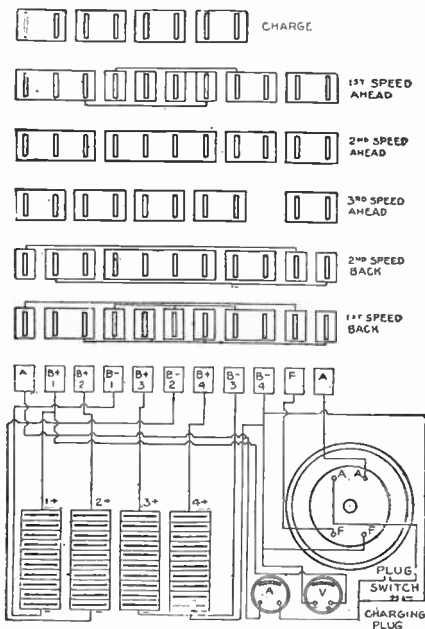
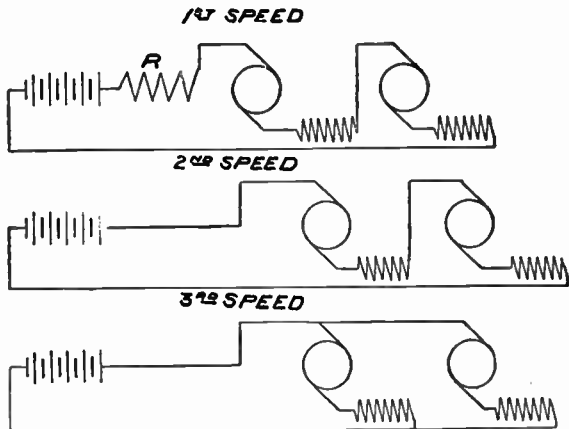
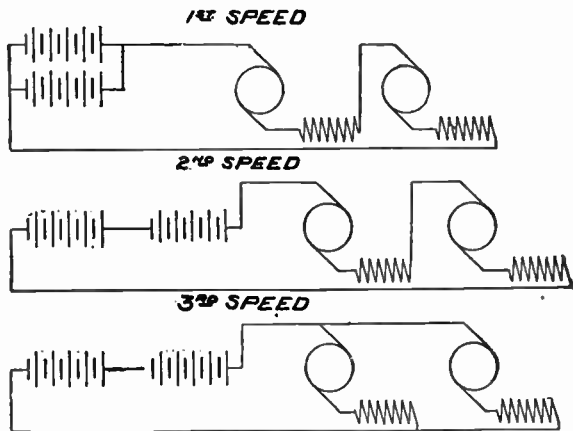


FIG. 4,098.—Diagram of controller connections of a four unit one motor circuit, with constant series connections for fields and armatures in forward and backward speeds.

voltage and power. Accordingly, *for the first speed* the batteries are connected in parallel, and the armatures and windings of the two motors in series. *For the second speed*, the series connections are adopted for both batteries and motors, while *for the third speed* the batteries are in series, with the motors in parallel.



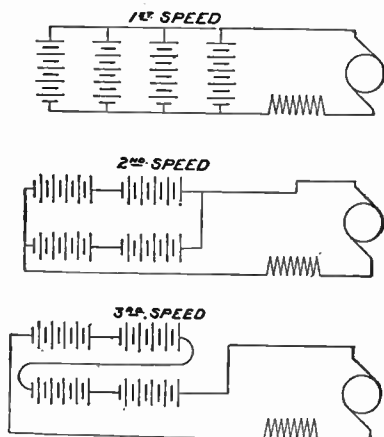
FIGS. 4,099 to 4,101.—Diagrams showing methods of speed changing in a typical one battery unit, two motor circuit. *The first speed* shows the two motors in series, with a resistance coil interposed; *the second*, the motors in series, without the resistance; *the third*, the motors in parallel.



FIGS. 4,102 to 4,104.—Diagram showing methods of speed changing in a two battery unit, two motor circuit, showing combinations for three speeds. *The first speed* is obtained with the battery units in parallel, and the motors in series; *the second*, with the battery units in series and the motors in series; *the third*, with the battery units in series and the motors in parallel.

**How to Operate an Electric Vehicle.**—The following instructions, which are given by one maker, will be found to apply for the most part to any car.

1. Be seated.
2. Place steering lever in position to give ready control.
3. Insert key in controller handle and unlock.
4. Pull controller handle back to brake or off position and raise slide. (This closes the circuit and electric is ready to move.)
5. Be sure that the foot brake is released.



**FIGS. 4,105 to 4,107.**—Diagrams showing combinations for three speeds in a typical four battery unit, single motor circuit. The only changes made in these circuits are in the battery connections. **For the first speed** the battery units are in parallel **for the second**, in series parallel, **for the third**, in series. The motor connections are not varied.

6. Forward movement of the controller handle gives two starting speeds and three running speeds.

7. To stop electric, pull controller handle backward past off position. First the electric brake will come into action and then a mechanical motor brake.

8. To reverse, bring electric to standstill. Press down the foot lever. Move controller handle forward same as when running forward. Two starting and one running speed will be obtained when backing.

9. To stop reversing, pull controller handle to extreme backward position. Take foot off reverse lever, which will automatically return



to forward position and electric is ready to be operated in a forward direction.

10. Steering: Push steering arm from you to turn to the left and pull steering arm toward you to turn to the right.

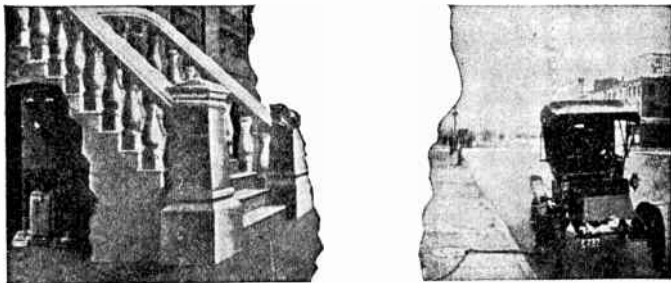
11. When leaving the electric, be sure to always force down slide of controller handle and take key out of lock.

12. Release foot brake before applying power.

13. To charge batteries:

a. Be sure that slide of controller handle is down and key out of lock.

b. Insert charging plug in socket at rear of electric and if the connections from the plug to the charging source be correct the ammeter should show reading below the zero on the scale.



FIGS. 4,108 and 4,109.—Charging an electric in front of city residence; fig. 4,108 shows mercury rectifier located in basement under steps. With this arrangement the car may be charged at the curb during idle hours of the day.

c. Follow the instructions for charging and care of battery that are furnished by the manufacturers of the battery.

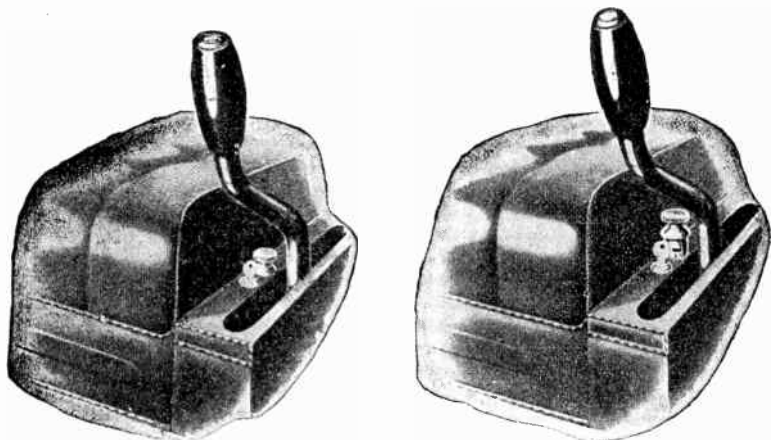
NOTE.—There are two push buttons in the floor of the car that may be operated by a slight pressure of the left foot. One increases the speed of the car and the other lights the meter lamp.

NOTE.—*Baker R and L motor and control.* The motor is designed to receive the combined voltage of all the cells in the battery, i. e., the battery is at all times in series and as the voltage is 2 volts per cell, the running voltage of the models equipped with 41 cells would be 82 volts and on those models having 42 cells the voltage would be 84 volts. The object of this is to eliminate the usual troubles caused by all unbalanced conditions of the battery as when several sections are operated in parallel. *The first speed* includes a high resistance and is intended for starting duty alone. *The second speed* has less resistance and although intended to grade the starting is convenient for occasional use in congested districts, but too slow for ordinary running. *The next stop* cuts out all the resistance and the motor runs on the series fields alone, the two sections being in series. *The next or fourth speed* parallels the two sections of series field. *On the fifth speed* the series fields are in parallel with an external shunt resistance across them. This weakens the strength of the series fields and reduces the resistance of the circuit. *The sixth or highest speed* of the car is obtained by means of an *accelerator button* located in the floor of the car. Its action is that of a switch closing the circuit of a light shunt field on the motor. The direction of the flow of current in this field is such that its strength opposes that of a series, thus weakening it and producing an increase of speed on light running; but due to the differential action between the two, a very great dropping off in speed occurs when climbing a grade or traveling a heavy road. In this manner great driving power and low current consumption is obtained on the grades on the high speed.

**Electric Vehicle Troubles.**—In order to properly cope with the numerous disorders and mishaps likely to be encountered, the following points relating to troubles may be found helpful.

1. If vehicle run too slow, look for the following:

- a. Deflated tires.
- b. Slow tires, due to other makes having been substituted for those furnished by the manufacturer of the vehicle.
- c. Broken bearings in wheels, countershaft or motor.
- d. Shoes not making perfect contact on face of controller.



FIGS. 4,110 and 4,111 Broc control lever lock. Fig. 4,110, locked, safety plunger pushed down; fig. 4,111, ready to operate safety plunger raised. *To unlock*, insert and turn the key, move control lever back to power off position, and pull up safety plunger.

- e. Brushes not making perfect contact on commutator due to being too short, or commutator being dirty.
- f. Broken battery jar, solution having partly leaked out.
- g. Brakes rubbing when they are supposed to be thrown off.
- h. Battery exhausted.

2. If the current be higher than usual when running on the level, look for the following:

- a. Tight bearings.
- b. Brakes rubbing.
- c. Silent chains too tight.
- d. Front wheels out of alignment.
- e. Tires deflated.

3. If needle on ammeter vibrate more than usual, moving up and down very rapidly, look for the following:

- a. Blackened commutator.
- b. Commutator brushes worn too short.
- c. Loose connections at battery terminals or at connections on controller.
- d. Broken wire leading to meter.

4. If vehicle refuse to run, look for the following:

- a. Broken jar in battery.
- b. Broken connections between cells.

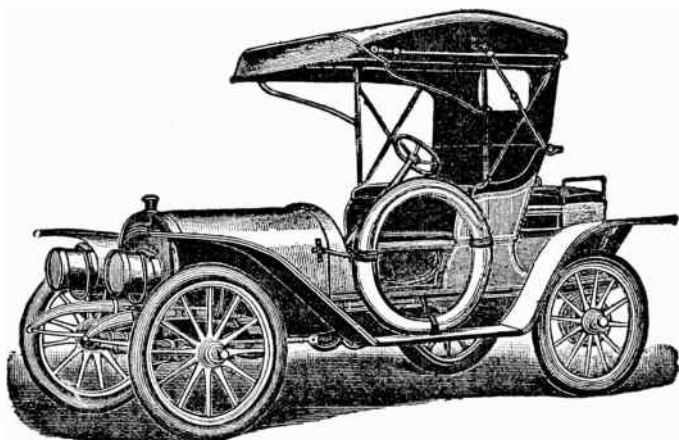


FIG. 4,112.—The Babcock electric roadster. This car is provided with a battery of forty two cells, which it is claimed, gives one hundred miles at seventeen miles per hour on one charge. The controller provides for five speeds forward and two reverse. The motor develops fifteen horse power, which will run the car over thirty miles per hour.

- c. Broken terminals.
- d. Open motor leads.
- e. Broken connections on any part of vehicle.

5. In case vehicle do not run on any of the speeds, first examine those connections that are easiest to get at, viz:

- a. Those at the end of the batteries.
- b. The connecting straps, connecting one cell to another.
- c. The wires going into the circuit closing switch.
- d. The springs on the controller arm and the copper shoes. Be sure that they make contact with plates on the controller face.
- e. See that there are no wires hanging loose, that appear to belong in the controller.
- f. If the trouble be not found in some one of these points, it would be best to have an expert examine the machine.

6. If the usual graduation of speed be not obtained when running on the level, read carefully the instructions of maker relating to controller.

7. If ammeter on the vehicle do not register properly, look for the following:

- a. Broken or partly broken connections in the wire leading from meter to shunt block, under floor of carriage.
- b. The ammeter pointer sticking or working irregularly, due to dirt inside of ammeter, in which case it must go to the factory.

8. If the voltmeter do not register at all, look for broken connections in wires leading to connection points under floor.

9. If voltmeter read too high, there is something wrong inside; it should immediately be sent to the factory.

10. If the lights do not burn and the bell refuse to ring, look for a burnt fuse wire.

11. If one light refuse to burn while the others are working correctly, try a new lamp, or examine connecting theater plug that connects body wiring to chassis wiring.

12. If both side lights refuse to burn, all other lamps being in working order, the trouble is in the connector.

13. If bell refuse to ring, all lamps being in working order, examine the theater plug connecting body and chassis wiring and make sure that the wires leading to the switch contacts at bottom of controller handle have not been taken out or broken off.

---

NOTE.—The bell can be tested by disconnecting from it the wires that are there, connecting two temporary wires to these same binding posts and touching these to the battery terminals. If the bell do not ring then it should be taken off and replaced with a new one or readjusted.

---

NOTE.—No meter on an electric vehicle is infallible as the service is very hard and the adjustments liable to get loose; and, as the general instructions as to care of battery, especially in charging, are to charge until voltage reads a certain amount, it is of the highest importance that the meter should read correctly. As soon as any irregularities are noticed in its readings, have it examined immediately by an expert, or send it to the factory. When it is necessary to return it to the factory, be sure to send the shunt block with it, as this is part of the meter. Even if no irregularities be noticed it would be well to have the meter examined at the factory and recalibrated once every year.