

THE THOUGHT IS IN THE QUESTION THE INFORMATION IS IN THE ANSWER

HAWKINS

ELECTRICAL GUIDE

NUMBER
TEN

QUESTIONS
ANSWERS
&

ILLUSTRATIONS

A PROGRESSIVE COURSE OF STUDY
FOR ENGINEERS, ELECTRICIANS, STUDENTS
AND THOSE DESIRING TO ACQUIRE A
WORKING KNOWLEDGE OF

ELECTRICITY AND ITS APPLICATIONS

A PRACTICAL TREATISE

HAWKINS  AND STAFF

THEO. AUDEL & CO. 72 FIFTH AVE. NEW YORK.

I M P R E S S I O N 1 9 2 3

COPYRIGHTED, 1917,
BY
THEO. AUDEL & CO.,
NEW YORK

Printed in the United States

TABLE OF CONTENTS

GUIDE No. 10

ELECTRIC ELEVATORS - - - - 2,855 to 2,934

Electricity as a motive power—classification of electric elevators—**drum elevators**—application of power—over and under mounted types—adaptation—**traction elevators** 1 to 1, 2 to 1, and multi-reduction types—advantages—**the car**—typical elevator car layouts—construction of freight elevator platform—typical modern passenger car—**the shaft**—multi-shaft open iron work—general requirements—motors for electric elevators—horse-power diagram—kind of current suitable—Warner direct current and alternating current motors—**elevator controllers**—classification—**non-reversible and reversible controllers**—simplest type—**full magnet direct current control**—arrangement of switches—diagrams—how excessive currents are guarded against—speed control—diagrams—speed variation by shunt field resistance—push button control—slow down control—diagrams—two types of resistance explained—control apparatus—**the mechanical, and dynamic brakes**—**try out switch**—diagrams—service switch—heavy load lifting device—machine type limit switch—shaft limit switches—diagrams—safety switch—**alternating current controller**—description of various alternating current controllers—diagrams—current relay acceleration—functions of the relay—various auxiliary apparatus—**the transmission**—definition—**gearing between motor and drum**—**belt drive**—horse power of belts—objections to belt drive—**chain drive**—**spur gear drive**—gear tooth parts—strength of gear teeth—horse power transmitted—herringbone gear drive—Gurney herringbone gear—action of herringbone gear teeth—**worm gear drive**—single gear—objection to single gear—thrust bearing—double worm gear; two types—**double reduction worm and internal gear drive**

ELECTRIC ELEVATORS—Continued

—why an internal gear is used—Warner internal spur gear freight elevator machine—**drums, cables, pulleys, counterweights**—lifting and counter weights, how attached—idler pulley—“scores”—arrangement of counterweights—compensating chains—elevator safety—**how to run an elevator**—before starting—starting—stopping—sudden reversal—machine limit stop—motor starter contacts—Gurney centrifugal safety governor—caution in adjusting—**car stops**—car stops between landings—slack cable switch—Warner worm drive machine—car beyond control—limit stops—Otis spring return oil buffer or cushion—caution while car is in motion—leaving car for the night.

ELECTRIC CRANES - - - - - 2,935 to 2,962

Definition—**classification**—crane types defined: swinging, jib, column, pillar, pillar jib, derrick, walking, locomotive, bridge, tram, traveling, gantry, and rotary bridge cranes—**essentials of rotary cranes**—locomotive jib crane—Niles crane construction: bridge ends or trucks—area served by locomotive jib crane—effective radius—**essentials of rectilinear cranes**—diagram of traveling crane—bridge girders—motor location—the cage—**essentials of combined rotary and rectilinear cranes**—standard grab bucket trolley—**essential of transporters**—diagram of transportor—operation—the grab load—**crane motors**—conditions to be met—Shaw crane motor—**automatic electro-magnetic brakes**—operation—Niles electric brake—**automatic mechanical brake**—**eddy current brake**—rheostatic brake—brake points—controlling connections—**overhead wharf crane**—Shaw wharf crane—half gantry crane—**regenerative control**—kind of motor used—advantage—connection for control—**collector gear**—size of wires used—trolley wheels—**controllers**—types used—Palmer safety limit stop—contact type limit switch—**power required to drive cranes**—**telpherage**—definition name introduced by Fleeming—automatic telfers—adaptation—non-automatic telfers—Shaw mono-rail system—telpher suspension and drive—arrangement of mono-rail tracks—power features—**telpher motors**—load factor—Brown motor driven trolley—**brakes**—types used—**trackage**—**essentials of cableways**—diagram of cableways—range of the apparatus—telpher performance.

ELECTRIC PUMPS - - - - - 2,963 to 3,022

Hydraulics—definition—**water**—relative volumes of water at different temperatures—*hydraulic principle I*—most remarkable characteristic of water—weight of water per cu. ft. at different temperatures—weight per gallon—**head and pressure**—head and lift graphically defined—static and dynamic head—friction of water in pipes—friction of water in elbows—pressure per lb. per sq. in. corresponding to various heads of water—head in feet corresponding to various pressures—the total static and dynamic head—**lift**—effect of the barometer and temperature—practical limit of lift—*hydraulic principle II*—condition requiring short lifts—*hydraulic principle III*—*hydraulic principle IV*—*hydraulic principle V*—theoretical lifts for various temperatures—**elementary pumps** classification—**lift pumps**—elementary diagram—**force pumps**—elementary diagram—**single acting force pumps**—plunger pumps—difference between a piston and plunger—**double acting force pumps**—**air chambers**—function—capacity—proportions—**capacity of pump**—theoretical and actual, or net capacity—slip—when leakage is likely to occur—two kinds of leakage—**how to figure capacity**—RULE:—example—actual, sometimes more than theoretical capacity—**horse power of pump**—**theoretical horse power at the water end**—example—**horse power absorbed at the water end**—**the electrical horse power**—work to be done—example—**how to figure the cost of electric pumping**—formulæ—example—**ELECTRIC PUMPS**—classification—**reciprocating pumps**—water ends—**pump valves**—arrangement size—number of valve unit—single and double acting outside packed plunger water ends—various details of pump valve construction—jig for removing valve seats—detail of stuffing box—**rotary pumps**—various types of rotary pump—Taber rotary pump—Deming rotary pump—**centrifugal pumps**—classification—ordinary centrifugal pump—Gwynne's conoidal type—various types of impeller—single suction volute pump—methods of priming centrifugal pumps—characteristic performance curves of single stage double suction centrifugal pump—importance of correct head determination—three stage turbine pump—**motors for reciprocating pumps**—**motors for centrifugal pumps**—operating conditions—**the drive**: belt, spur, herringbone, silent chain, double reduction spur, combination short belt and spur, long belt and spur, and worm gear types of drive—**control devices; water end**—automatic pressure regulators and by pass—by pass control—

ELECTRIC PUMPS—Continued.

control devices; power end—float switch, diaphragm switch—Hill tank pump with pressure control.

AIR COMPRESSORS - - - - - 3,023 to 3,046

Field for use of compressed air—the **compression of air**—Boyle's law—Charles' law—effect of heat—free air—Ingersoll-Rand air compressor cylinder with Corliss inlet valves—gauge pressure and absolute pressure—air compression characteristics—the **heat of compression**—principal source of loss—views of inlet and discharge valves—parts—**simple compression**—spray injection—hurricane type inlet valves—dry or jacketed compressor process—**compound compression** cylinder—diameter of compound compressor—cycle of compound compressor—*elementary compound compressor and auxiliary apparatus*—three stage compressor—compression curves—principal advantage of compound compression—**control method**—unloading devices—Ingersoll-Rand unloader—**intercoolers**—intermediate separator—starting a power driven compressor—**intercooler**—its functions—capacity—construction—**air receivers**—**after coolers**—**the saving due to compounding**—work lost in terms of isothermal compression—**altitude compression**—volumetric efficiency—example.

ELECTRIC HEATING - - - - - 3,047 to 3,066

Advantages of electricity for heating—**production of the heat**—resistance wires—properties of various resistance wires—Simplex electric coffee percolator—**heating units**—classification—details of construction of various heating units—**temperature regulation in electric heaters**—arrangement of internal circuit for heaters giving three heating values—internal heating circuits—**room heating**—where desirable—economy of electric heating—**loss of heat**—loss by leakage—wiring diagram for heaters along truss plank in car heating—loss of heat per sq. ft. of surface through walls, windows, etc.—how to compute loss of heat in a room—**example**—**electric water heaters**—classification—Simplex electric immersion heater—electric geyser—cost of heating water—**electric cooking appliances**—plan of an all electric kitchen—**electric flat iron**—details of construction—**electric soldering bits**—forms most commonly used—the heating element—thawing of frozen water pipes—diagram and example—**wiring for heating and cooking**—extra receptacle for heating purposes—difficulty with electric heating devices.

SOLDERING AND BRAZING - - 3,067 to 3,106

Solder—kind used for electrical work—soft and hard solder—melting points of tin lead solders—necessary relation between solder and metals to be united—increasing the fusibility of a solder—**soft solders**—kinds—half and half solder—melting points and hardness of tin lead solders—soft solders for various metals—**hard solders**—where used—difference between hard soldering and brazing—hard solders for various metals—plumber's gasoline furnace—nature of alloys containing much lead—**miscellaneous solders**—very hard yellow solders—silver solders—solder for silver plated work—solder for silver chains—resoldering silver solders—readily fusible silver solder for ordinary work—pot and ladle—German silver solder—various soldered joints—German silver soldering methods—how to make a round wiped joint—gold solders—methods of wiping a horizontal joint—aluminum solders—**soldering fluxes**—definition of the word flux—its function—method of wiping a vertical joint—various wiped joints—flux permitted by Underwriters' code—various fluxes: resin, chloride of zinc, rosin and tallow, soldering grease, ammonia soap, soldering fat for iron, soldering fat for aluminum, soldering salt, soldering paste, borax, cryolite, Muller's hard soldering liquid, dry soldering preparation—the various fluxes and their adaptations—**soldering bolts or bits**—classifications—gas soldering bits—**tinning the bit**—tinning block for electric soldering bit—**soft soldering**—principle on which it depends—picking up soft solder with the bit—points on soft soldering—soldering with a torch—**sweating**—diagram illustrating the process—**babbiting**—anti-friction metals—babbitted boxes—**brazing**—definition—ordinary mouth blow pipe—theory of brazing—method of using the mouth blow pipe—oxidizing, and the reducing flame—**butt brazing**—how to butt braze two lengths of small pipe—**lap brazing**—method of lap brazing a band saw—**dip brazing**—cast iron soldering—**muffle brazing**—**brazing of copper**—cleaning of copper joints—furnace for brazing—brazing copper flanges—brazing furnace without fire brick—table of brazing solders—miscellaneous brazing solder—**heating methods in brazing**—brazing small chain link in charcoal with a blow pipe—charcoal fire—gas furnace—gasoline torch—air gas torch for brazing—**lead burning**—definition—preparation of butt and lap seams for lead burning—process of burning a butt seam in two sheets of lead—flat butt burning—edge burning.

WELDING - - - - - 3,107 to 3,132

The term *welding*—oxidation of iron—character of oxide

WELDING—Continued

of iron—why it prevents welding—**methods of preventing oxidation**: reducing fire; protective coating—**fluxes**—care required in preparation—fluxes for: cast iron, steel, mild steel and wrought iron, copper; brass, bronze, and aluminum—**various welds**: scarf, butt, lap, cleft or split, jump, and glut welds—fagoting—building up—**forge fuels**—kind of bituminous coal most desirable—difficulty encountered with anthracite—**systems of welding**—making a scarf for a scarf weld—classification of varying systems of welding—correct and incorrect shapes for lap welds—blow pipe welding—character of blow pipe flame—kind of fuel used for blow pipe—autogenous welding—features of the oxyhydrogen and oxy-acetylene flames—adjustment of oxy-acetylene torch—how to handle the torch—weld rod—**thermit welding**—description of the process—mould for thermit welding of locomotive frame—thermit pipe clamps and mould—thermit pipe welding operation—Clark joint—thermit preheating; directions of operating—C and C electric welding apparatus—composition of thermit steel—**electric welding**—best conditions of welding—principle of electric welding—Thomson welder—views of Toledo spot welder—the Thomson process—spot welding—Toledo butt welder—general hints in electric welding—flash weld and upset weld—**Zerener or electric blow pipe process**—Bernardos process—electric blow pipe—**Slavianoff or modified Bernardos process**—Davis-Bournonville oxygraph—**Hoho and Lagrange process**—difficulty in controlling the temperature—modification of the system.

ELECTROLYSIS - - - - - 3,133 to 3,142

Significance of the term electrolysis—the electrolyte—ions: cations, anions—experiment illustrating electrolysis—**industrial electrolysis**—alkali and bleach—**aluminum**—process of aluminum manufacture—**bullion refining**—general principle on which the process depends—electrolysis in lower New York—**chlorates**—production of chlorate of potash or soda—chemical changes—**hypochlorites**—arrangement of the Gibb's process—Gibb's cell and battery of three cell—**organic chemicals**—Aussig bell cell—reductions and oxidations—section of Hargreaves-Bird cell—**oxygen and hydrogen**—primary products—**sodium and potassium**—Sir Humphry Davy's method—a fused electrolyte necessary—Castner cell—**wet extraction processes for metals**—various extractions: copper, nickel, tin, and zinc.

ELECTRO-PLATING - - - - - 3,143 to 3,184

The process in general—essential condition for best results—cleaning the articles to be plated—various dipping baskets—important considerations in electro-plating—stripping—heating tanks—**current supply for electro-plating**—Smee cell—dynamos for electro-plating—characteristics of plating dynamos—**current required and sizes of wire**—amperes required to plate one square foot of various metals—Hanson and Van Winkle motor generator set—electro-plating outfit with two wire system; with three wire system—wiring diagrams—**rheostats and switchboards**—form of rheostat for controlling heavy currents—use of volt meters—voltage regulators—**mechanical electro-plating apparatus—tanks or vats**—two tank installation—iron tanks—wooden tanks—tanks for gilding solutions—**dipping vessels—scouring, swilling and rinsing troughs**—material used—**scouring and washing out brushes**—various brushes—**tumbling or rattling barrels**—speed regulation in tumbling—**steel ball burnishing barrels**—wet grinding or polishing—**polishing powders—rouge**—tripoli—crocus—Vienna lime—pumice stone or rotten stone powder—**solutions for plating with different metals**—24 carat gilding solution—14 carat gold plating solution—best solution for silver plating—nickel plating solution—electro-plating with copper—copper plating solutions—**polishing and grinding machines—polishing wheels**—speed—Hanson and Van Winkle polishing and grinding machine—emery wheels—canvas, wood, felt, and walrus wheels—best speed for buffs—**pickles and dips**—precautions—dipping—black pickle for iron—bright pickle for iron—dip for copper, brass, etc.—cyanide dip for brass—pickle for German silver—**nickel plating**—the process in detail—**anodes—electrotyping—electro-plating barrel—galvanizing.**

ELECTRO-THERAPEUTICS - - - 3,185 to 3,226

Definition—kinds of electric current used—influence machines—Toepler-Holtz machine—precautions in operating influence machines—**induction coils**—use—construction—diagram showing connections—how operated—**high frequency apparatus—interrupters**—types: magnetic, electrolytic, mechanical—Wehnelt interrupter—current regulation—anti-acid interrupter—muffler—mechanical interrupter—construction—**rectifiers**—description and operation—**currents used in electro-therapeutics—selection of electrodes**; choice of various authorities—positive and

ELECTRO-THERAPEUTICS—Continued

negative poles—faradic current—sinusoidal current—copper, zinc, and iron—nickel plated electrodes—block tin, platinum, and carbon—McIntosh universal mode and its modalities—various electrodes: vaginal, intra-uterine, rectal, abdominal, urethral, eye, ear, nose and throat electrodes—epilating needles—summary—McIntosh wall plate—**galvanic therapy**—properties of positive and negative pole—**galvanic technique**: cervical erosions; epilation; internal hemorrhoids; urethral stricture—**sinusoidal therapy**—value of the sinusoidal current—**sinusoidal technique**, giving a multiplicity of cases for treatment of various disorders—sinusoidal controller—high frequency outfit—vacuum electrodes—copper ball electrode—ozone generator—electric light bath cabinet—diagnostic lamp outfit—**vibratory technique**: constipation; mechanical vibration of the eye; splenic congestion—Dr. Abrams reflex set—vibrating chair—**electro-cautery**—cautery transformer—cautery knives—hypersensitive areas—the technique to be used—proctologist's special set—cautery illuminator set.

X RAYS - - - - - 3,227 to 3,242

Roentgen's discovery—nature of X rays—how X rays are produced—old form of Crookes tube—cathode stream—focus tube—single focus tube—**fluorescing screens**—fluoroscope X ray shadow of the bones of the hand and wrist—special coil with anti-acid interrupter for X ray treatment—radiographs—how a radiograph is taken—special radiographic coils—**practical points in X ray photography**—Hulton inductance switch—triple valve tube—portable X ray coil—interrupterless transformer—diagram for distance of X ray tube from plate—stereoscopic angle—X ray bracket stand and patient—dental Roentgenograms—X ray tube—suggestions for using X ray tube—developing plates.

CHAPTER LXXVIII

ELECTRIC ELEVATORS

Electricity has been found to be a very desirable power for operating elevators, and has some inherent advantages which has caused electric elevators to grow rapidly in public favor. Ordinarily electricity is easily obtained, and the flexibility of electric equipment allows it to be installed where little room is available.

There are numerous kinds of electric elevator to meet the various conditions of service, and they may be classed:

1. With respect to the current, as

- a.* Direct;
- b.* Alternating.

2. With respect to service, as

- a.* Passenger;
- b.* Freight.

3. With respect to the transmission, as

- a.* Drawn;
- b.* **Traction.**

4. With respect to the control, as

- a.* Non-reversible;
- b.* Reversible;
- c.* Mechanical;
- d.* Semi-mechanical;
- e.* Semi-magnet;
- f.* Full magnet;
- g.* Push button;
- h.* One speed;
- i.* Two speed.

5. With respect to the location of the power unit, as
 - a. Over mounted (overhead);
 - b. Under mounted (basement).
6. With respect to the velocity ratio between motor and car, as
 - a. Direct drive;
 - b. 2:1 reduction;
 - c. Multi-reduction.
7. With respect to the transmission as
 - a. Belt driven;
 - b. Direct connected.
8. With respect to balancing the load, as
 - a. Counter-balanced;
 - b. Compensated.

After describing the essential features of drum and traction elevators, the numerous devices comprising the mechanism, many common to both systems, will be treated in detail.

Drum Elevators.—The term “drum” applies to all elevators in which the cables leading from the car are **both fastened to and wound upon** a drum. The essential features consist of a drum operated through gearing, and to which is attached the cables which support the car.

Power, when applied to the driving gear, turning it in one direction, winds the cables upon the drum and causes the car to ascend, and when the power is reversed, the drum turns in the opposite direction, paying out the cables, and causing the car to descend.

The weight of the car is balanced by a counterweight, thus reducing the energy to be expended in operating the car. Automatic devices, to be described later, are used to insure the proper and safe control of the movements of the car.

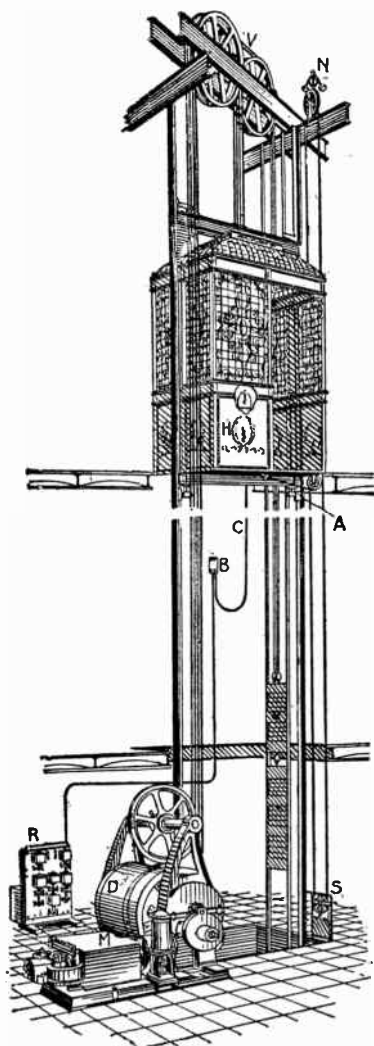

Ques. How is the counter balance usually proportioned for drum elevators?

Ans. It is made heavy enough to balance the car with its average load.

Ques. Why?

Ans. To avoid gravity work as much as possible.

Thus with average load, very little power is required—just enough to overcome the friction of the system. It should be noted that with this arrangement, the counterweight is heavier than the car, and while power will be required to produce a downward movement of the empty car, the work done in raising the car with full load is only equal to the weight of half the load (including friction) plus the distance raised.

Ques. In construction what advantages result from placing the drum overhead?

Ans. It gives direct transmission, that is, no pulleys are

FIG. 4,113.—Undermounted full magnet drum type elevator. The hoisting drum is driven by worm gear from a motor M. The flexible conductors being shown at C running from the car H to a connection block B, and thence to the controller R. The overhead sheaves at V, the counterweight U, and the car safety equipment consisting of the governor N, the idler S, and the guide gripping device at A.

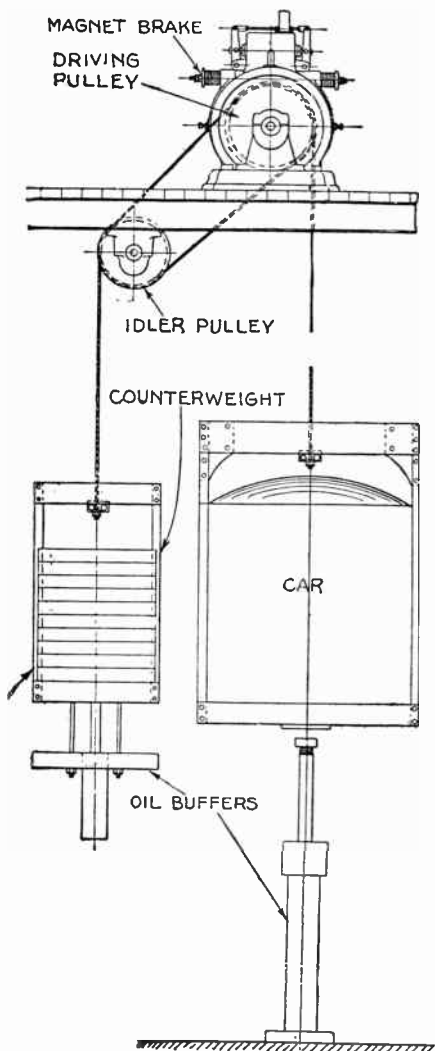

required between drum and car, also the drum may be so located that one face of the drum is over the center of the car, and the other face over the counterbalance, thus allowing the car cables to be fastened at one end of the drum and the counterbalance cables at the other end of the drum grooves, the car cables occupying the entire surface of the drum when the car is up, and the counterbalance cables following along side of them, occupying the entire drum surface when the car is down.

FIG. 4,114.—Diagram of Otis over-mounted 1 to 1 traction elevator. The machine consists essentially of a motor, a traction driving pulley, and a magnetically released spring applied to brake, compactly grouped and mounted on a continuous heavy iron bed. The motor is of the slow speed shunt wound type. The drive from the armature spider to the pulley is effected through a flange integral with the spider and bolted directly to the pulley, thus eliminating torsional strains on the shaft and the use of keys. The control is full magnet, that is, the controller is actuated by a master switch in the car. The object of the oil buffer, is to act as a cushion in bringing either the car or counterweight to a positive stop through the displacement of the oil.

The arrangement of placing the machine or "engine" as it is called, that is, the power unit in the top of the elevator shaft, is peculiarly adapted to electric elevators, when the power is easily conveyed by electric conductors to the motor. The drum machine, whether over or under mounted is nearly always overbalanced as the saving in gravity work compensates for all friction and any extra first cost that might be received.

Ques. State an objection to drum elevators.

Ans. There is lack of absolute means of stopping the drum when the car or counterbalance gets to the top of the shaft.

Automatic safety devices are provided to shut off the power and apply the brake when the car is near its limit of travel. These devices are adjustable, can be removed, and may get out of order when neglected by those in charge.

Ques. For what service are drum elevators not suited, and why?

Ans. For very high lifts, because of the very large size of drum necessary to take the cables.

Traction Elevators.—This type of elevator derives its name from the fact that motion is obtained by means of the *traction*; that is to say, the friction existing between the driving pulley and the hoisting cables. In order to produce the necessary tension for this result, the hoisting cables, from one end of which is suspended the car, and at the other end, the counterweight, pass twice partially around the driving drum and only once around the idler, although frequently, before leading into the shaft, they are deflected by the idler in order to lead them plumb over the counterweight. This accounts for the necessity of having the same number of groove on each drum.

It should be noted that the grooves are straight for traction elevators and spiral for drum elevators.

The term "gearless" is sometimes ill advisedly applied to some form of traction elevator, meaning that the power is

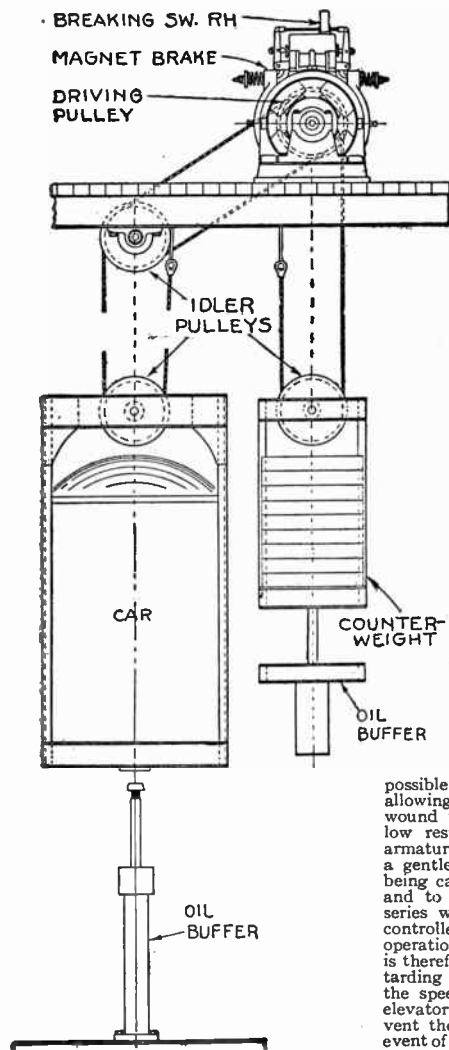

FIG. 4,115.—Diagram of Otis, over-mounted 2 to 1 traction elevator. This machine is similar in appearance to the standard drum machine, except that a multi-grooved driving pulley is mounted in place of the drum, and a non-vibrating idler leading pulley takes the place of the vibrating pulley necessary on the drum type. The car and the counter-balance weight hang directly from the driving pulley, one from either end of the cables in precisely the same manner as with the 1 to 1 drive, the necessary amount of traction being obtained by the extra turn of the cables resulting from passing around the idler pulley. The machine is equipped with a mechanically applied and electrically released double shoe brake. The shoes are applied against a pulley of ample diameter and width to dissipate any heat generated. The brake shoes, normally, are bearing against the pulley with a pressure corresponding to the compression of the two helical springs. When current is admitted to the solenoid brake magnet, and then only, the action of the springs for the time is overcome, so that the shoes are released. It will be seen, therefore, that the brake will apply with full force should a failure of current occur, resulting in an immediate stop of the elevator. The motor is compound wound and runs usually at about eight hundred revolutions per minute at full car speed and load. The series field is used only at starting to obtain a highly saturated field in the shortest possible time, and this is then short circuited, allowing the motor to run as a plain shunt wound type. In stopping, a comparatively low resistance field is thrown across the armature, providing a dynamic brake action and a gentle slowing down of the car, the brake being called upon only to effect the final stop and to hold the load at rest. Resistance in series with this *extra field* as it is called, is controlled by magnets which depend in their operation on the speed of the armature. It is therefore evident that the dynamic or retarding effect of the field is proportional to the speed; and therefore to the load in the elevator. Rope guards are provided to prevent the cables leaving their grooves in the event of either car or counterweight bottoming.

transmitted to the car without toothed gears; it is in fact, transmitted through cables and pulleys which is in fact a form of gear.

There are two forms of the so called gearless traction elevators: the 1 to 1 or direct drive type shown in fig. 4,114 and the

2:1 reduction type shown in fig. 4,115. A third form of traction elevator known as a multi-reduction or worm drive is shown in fig. 4,116, the essential features of each being mentioned under the illustrations.

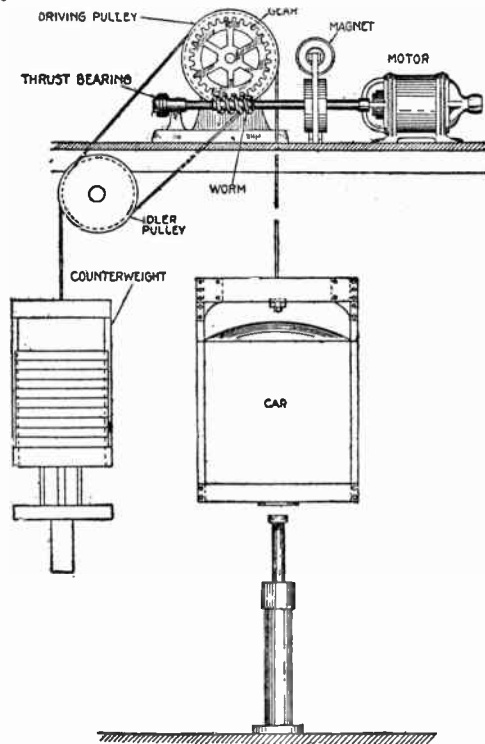
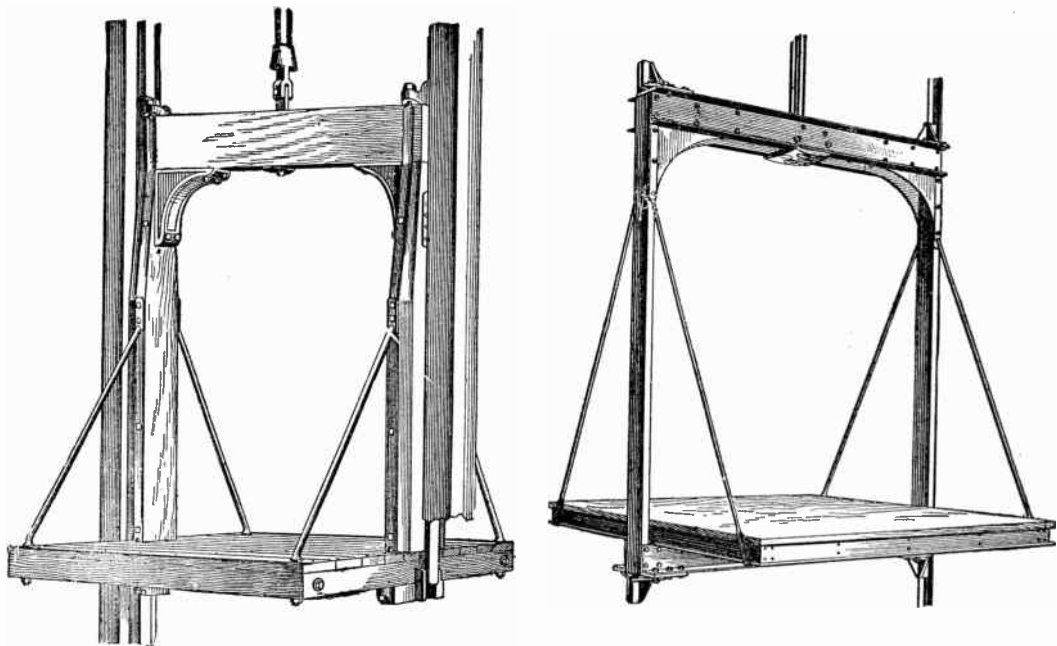

FIG. 4,116.—Diagram of an overmounted traction elevator with multi-reduction or worm drive. The traction feature is identical with fig. 4,115. Attached to the driving pulley is a gear which meshes with the worm underneath, the latter being direct connected to the motor. Clearly, the worm gives a large velocity reduction permitting the use of a high speed motor. The magnetic brake being located to act on a brake pulley attached to the fast revolving motor shaft gives considerable braking power light grip on the brake pulley. The action of the single worm gear is such as to require a thrust bearing, as later explained in detail.

By comparing the three figures it is obvious that the direct drive machine (fig. 4,114) is suitable for high speed service; that the 2:1 reduction machine (fig. 4,115) is an adaptation of the direct drive type permitting of slower car speeds; the multi-reduction type (fig. 4,116), permitting the use of small high speed motor.



FIGS. 4,117 and 4,118.—Two types of freight elevator. The all wood construction, fig. 4,117, because of fire risk, is not so desirable as the composite construction shown in fig. 4,118, the latter being made entirely of metal with exception of the floor boards.

The multi-reduction type of which fig. 4,116 shows one form permits the use of a small high speed motor for operating a slow or comparatively slow car. Because of the high velocity reduction ratio of the worm gear, it is self-locking, that is to say, although the worm and gear unit permits motion to be transmitted from the worm to the gear, no load that could be put on the car would be heavy enough to cause motion to be transmitted from the gear to the worm, thus no change of loading would cause the car to descend, and consequently no car locking device is required.

Ques. State some advantages of traction elevators.

Ans. The traction elevator may be used for lifts of any height, because it does not employ a winding drum whose size has to be considered; the compact and simple arrangement of parts permits of simplicity of installation and economy of space especially when over mounted.

Ques. What difficulty is sometimes experienced with traction elevators?

Ans. Slippage.

With all traction elevators, there is the danger of slippage of the cables on the driving drum, especially if the cables become greasy. This slippage is most noticeable when the operator endeavors to stop in descending with a heavy load, with the result that on high speed cars when attempting to make a quick stop, the car sometimes slides past the landing even to the extent of one or more stories.

The fact that the traction drive is not a positive drive is a safeguard for the reason that cable strains can never increase beyond a certain limit, well within the factor of safety of the cables and fastenings. This means that the danger of the car or weight dropping, as a result of being pulled into the overhead work, and thus breaking cables or fastenings, is eliminated.

The Car.—There are two general classes of elevator car: freight and passenger: these of course vary considerably in design.

Freight elevator cars are made of wood or iron, with iron braces and fixtures; their platforms are seldom enclosed, and their design is usually of the simplest nature. Cars intended for passenger service are enclosed by a cage of wood or iron—preferably of the latter material.

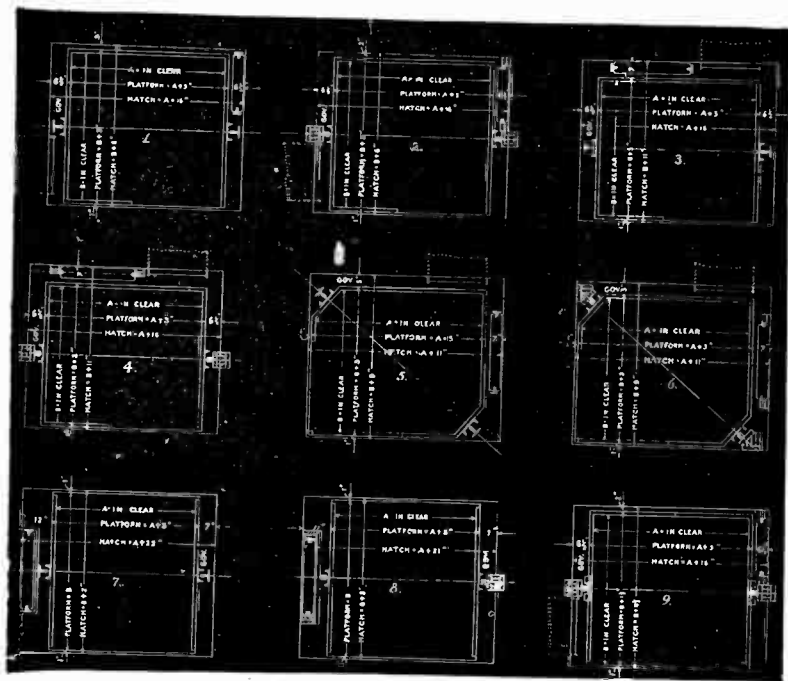

Figs. 4,119 to 4,127.—Typical elevator car layouts as given by Warner Elevator Co., showing relative sizes of shaft and platform for both passenger and freight elevators, the width of entrance being the only difference. **No. 1** side post, steel guides, machine and counterweight at side; **No. 2** side post, wood guides, machine and counterweight at sides; **No. 3** side post, steel guides, machine at back or overhead, counterweight at side; **No. 4** side post, wood guides, machined back or overhead, counterweight at back; **No. 5** corner post, steel guides, machine at back or overhead, counterweight at side; **No. 6** corner post, wood guides, machine at back or overhead, counterweight at side; **No. 7** side post, steel guides, machine overhead, weight at side; **No. 8** side post, wood guides, machine and counterweight at sides. Layouts No. 1, 2 and 9 are to be preferred when machine is erected in basement. Layouts No. 3, 4, 7 and 8 are to be preferred with machine overhead. Height required above top floor when machine is placed in basement is 19 feet. Height required above top floor for overhead constructions is 23 feet. Pits must be made full size of shaft and should be 30 inches deep for speeds under 125 feet per minute, and 48 inches deep for greater speeds. Allow at least 7 feet by 11 feet for machine to permit free access to all parts.

NOTE.—In the construction of a freight elevator platform, oak timber can be recommended for all parts except head beam, which should be structural steel. In best work all joints are tenoned or belted. Tension and brace rods effectually tie the frame together and prevent it getting out of shape. Structural brackets connect head beam with side pieces. Guide brackets at top and bottom of side frame have chilled faces which bear against hardwood guide strips. The platform is thus maintained in proper position and friction of guides reduced to a minimum.

In general, elevator cars should be constructed wholly of metal for safety in case of fire. Wrought iron grill work is largely employed for the sides and top of passenger cars, as it is not only fire proof but provides for ventilation and is ornamental in appearance, and at the same time substantial and of light weight.

In order to guide the car, two guide rails usually and preferably of iron are mounted vertically in the elevator shaft, and over these rails fit guide shoes that are fastened to the car. These guides are usually placed on opposite sides of the car, and in some instances at the diagonally opposite corners. In the former case the installation is said to be of the side post type, and in the latter case, of the corner post type.

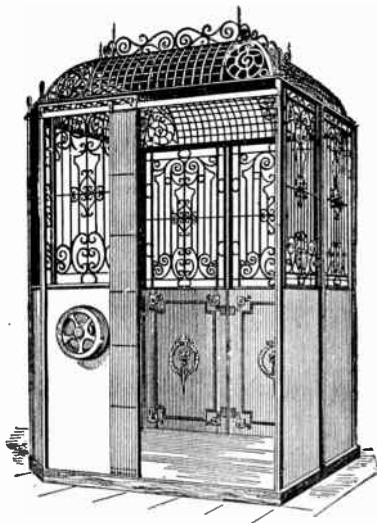

FIG. 4,128.—Typical modern passenger car. Wood or other combustible material is practically eliminated, and with the exception of the floor boards, the construction is all metal. Sheet metal is employed around the lower part and open metal grill work around the upper portion giving a well ventilated and light yet strong car.

Local conditions determine which type to adopt. The various details of car construction are shown in the accompanying cuts.

The Shaft.—The enclosure in which the elevator travels, called the shaft, and sometimes ill advisedly, the hatchway, should be enclosed with iron lattice work or grill work.

The walls should not be solid, because the solid enclosure acts as a chimney, in case of fire causing the fire to work upward from floor to floor, rendering escape by elevator impossible. A better lighted and ventilated shaft is also obtained with openwork construction of the shaft and of the doors or gates opening into it.

That portion of the shaft enclosure at each floor should be carried the full height of the opening between floor and ceiling in order to reduce the possibility of accident. When grill work is used for this portion of the enclosure, there should not be more space than one and one-half inches between the adjacent parts of the grill work to prevent objects being thrust through. Throughout the interior of the shaft there should be no projections.

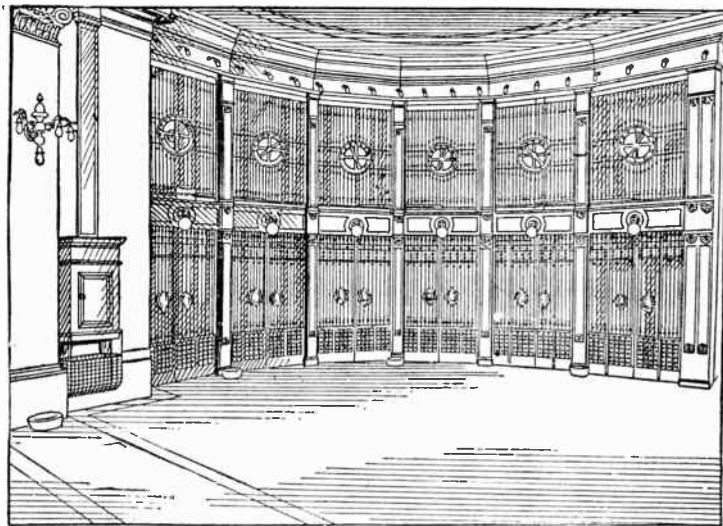

FIG. 4,129.—Semi-circular multi-shaft open iron work. With this grouping of the entrance to cars, the doors of all the cars can then readily be seen by a person entering the hall, and he can therefore ascertain at once which car to enter. This arrangement, however, should not be carried beyond the limits of a semi-circle, as the cars located in the extension are liable to be overlooked, and the efficiency of the system as a whole thus diminished.

In buildings where more than one elevator is installed, it is advisable to enclose each elevator shaft separately and have the stairways cut off from the elevator hallways. While this construction is not usually followed, the reduction in the fire risk that is otherwise present and the elimination of noises caused by the opening and closing of the elevator doors, commend it where the additional expense entailed is not prohibitive.

All doors and gates leading to the shaft at the various floors must be substantially made and locked or bolted on the shaft side so as to be opened only by the operator in the car.

When the car is at the lowest landing, it should rest on spiral springs called bumpers, or on oil bumpers, so as to relieve the tension on the hoisting cables. These bumpers interpose a yielding resistance to the car when settling to rest and thus often prevent severe shocks or jars. Below the lowest landing it is well to have the shaft constructed air tight as far as its walls are concerned, so that it will act as an air cushion in case a car fall into it and thus gradually bring the car to a stop.

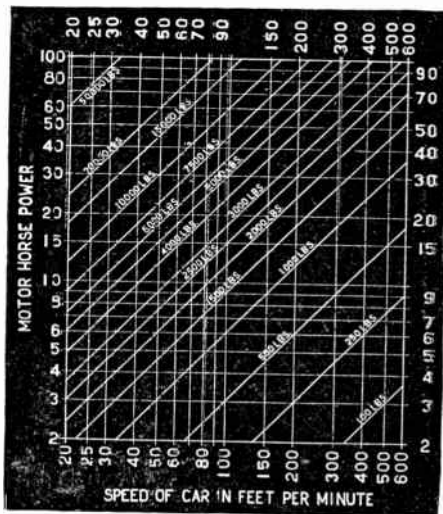

FIG. 4,130.—Elevator motor horse power diagram. Three factors determine the horse power of the motor that should be used, namely, the weight to be hoisted, the speed of travel and the efficiency of the elevator. In the diagram, the efficiency of the elevator is assumed to be 50 per cent. To determine the proper size motor to use in any case follow the diagonal line corresponding to the unbalanced load up to the point where it crosses the vertical line corresponding to the speed desired. The horizontal line at this point will indicate the horse power of motor required.

Motors for Electric Elevators.—In estimating the horse power required for an elevator motor, the load, speed and efficiency of the system must be considered. Since it is customary to counterbalance the weight of the car and part of the load this must be taken into account, that is, only the unbalanced

load is considered. Accordingly the horse power required may be obtained from the following formula:

$$\text{Horse power} = \frac{L \times S}{E \times 33,000}$$

in which

L = unbalanced load in pounds;

S = speed of elevator in feet per minute;

E = efficiency of the system generally taken at 50%.

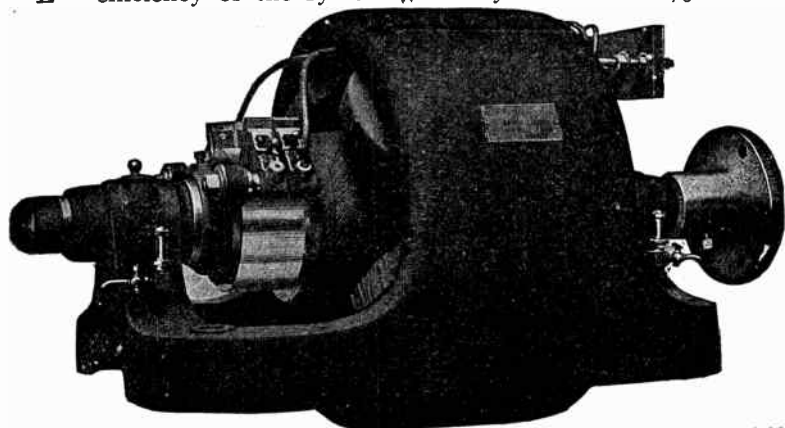

FIG. 4.131.—Warner direct current motor. It is compound wound, having heavy series field windings. The series windings are used for starting only, and are cut out of circuit as the motor attains its normal speed, in order to give the constant speed characteristic of the simple shunt motor. The standard motors up to 40 horse power are variable speed, and have a controllable range from 500 R.P.M. to 800 R.P.M. Another type of Warner direct current motor has interpoles; up to 30 horse power, the range is from 260 R.P.M. to 800 R.P.M., and 40 to 50 horse power the range is 200 R.P.M. to 600 R.P.M.

EXAMPLE.—What size motor will be required for an elevator to operate at a speed of 400 feet per minute with an unbalanced load of 2,000 lbs.?

Substituting the values in the formula,

$$\text{H. P.} = \frac{2,000 \times 400}{.5 \times 33,000} = 48$$

Ques. What kind of current is suitable for elevator motors?

Ans. Either direct or alternating, preferably direct.

Ques. Why?

Ans. Principally, because of the high starting torque of the direct current motor.

The chief difficulty experienced with alternating current motors is this lack of ability to start under heavy loads, and for this reason proportionally larger sizes must be used, the increase in horse power required being fully 33 per cent.

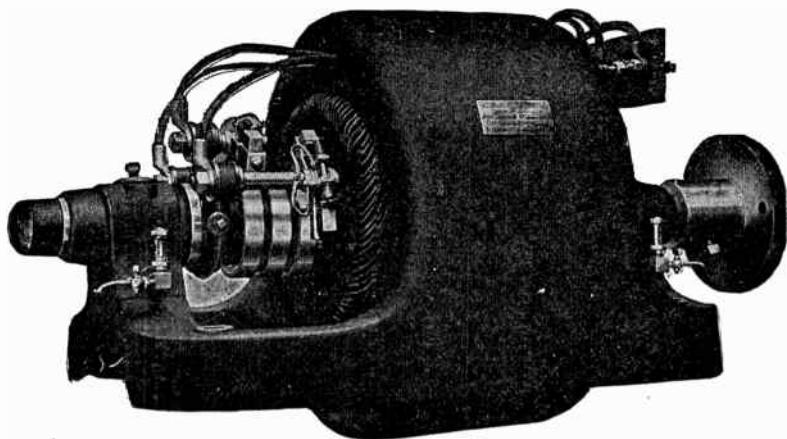

FIG. 4,132.—Warner alternating current motor. It has a standard speed of 900 R.P.M. for 60 cycle circuits, and 750 R.P.M. for 25 cycle circuits, and is of the wound rotor, slip ring type. The slip ring type gives high torque with minimum starting current, and has practically a constant speed regardless of load. An interesting feature of the Warner motors is that the alternating and direct current motors are interchangeable. Thus, an elevator built for direct current can readily be changed to alternating current in cases of a change in power.

Ques. Is the higher cost of the relatively larger size alternating current motor offset in any way?

Ans. Besides giving a heavier starting torque, it furnishes an excess of power which enables the motor to run at full speed without such noticeable fluctuations with changes in load as would be the case with a smaller motor.

Ques. What type of direct current motor gives the best control?

Ans. The adjustable speed motor having a small percentage of compound winding.

The series winding is cut out by the controller at normal speed, but is necessary in starting, insuring a smooth quick start, besides being of value in the subsequent control of the motor.

About 10 to 15 per cent. series field winding give the best results. Where no speed control is provided by shunt field resistance, a compound wound motor is still desirable in order to obtain smooth acceleration.

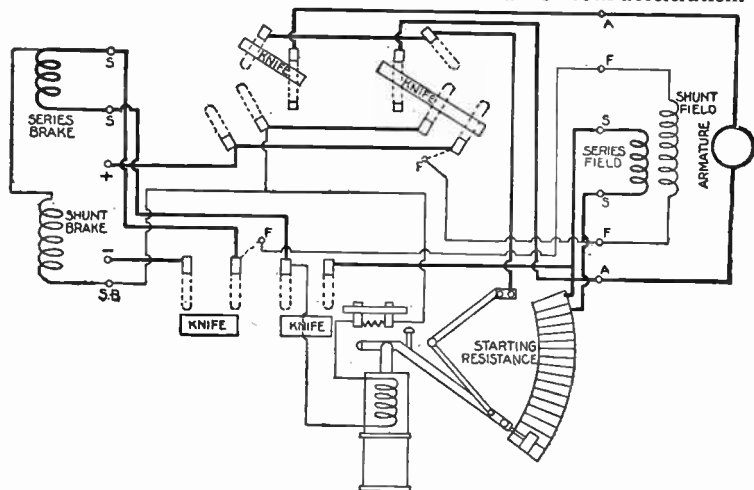

FIG. 4,133.—Diagram of A. B. See No. 4 mechanical controller.

Ques. For what service is the squirrel cage induction motor suited?

Ans. It should be used only for slow and constant speed freight elevators where the impairment of the line regulation, caused by the high starting currents, is not important.

The induction motor is being used more and more for driving elevators and while admirably adapted for some classes of elevator service, it

possesses certain definite limitations which should be taken into account when deciding on the type of motor to use.

It is not possible to vary the speed of the ordinary induction motor under all conditions of load, nor is it ever possible to employ with it the dynamic brake used with the direct current motor.

Accordingly, the use of alternating current motors is limited to slow speed elevators which may be slowed down and stopped by the mechanical brake alone.

Until such time as a variable speed alternating current motor is developed and placed on the market, the use of an induction motor with high speed passenger elevators should not be attempted. In addition, the high torque polyphase squirrel cage motor can be used where

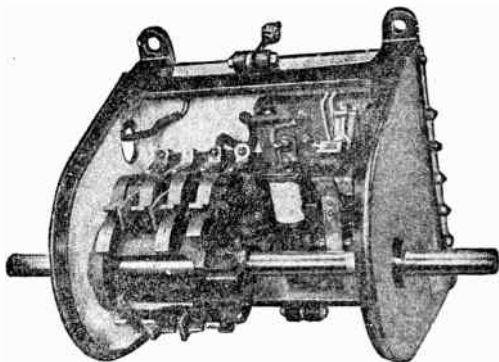

FIG. 4,134.—Cutler-Hammer direct current reversible single speed semi-mechanical controller for short lift sidewalk elevators. The equipment consists of a drum case containing the line and reverse switch and resistance switch, with a space at the back containing the armature starting resistance. Only a single step of starting resistance is provided, and one current relav. Accordingly, the motor is brought up to full speed in two steps, one according to the speed obtained with all resistance in circuit and the other to the speed obtained with all resistance short circuited. The motor is started, stopped and reversed by means of the drum switch which is usually connected directly to the hand cable. At the two limits of travel, the elevator may be stopped by buttons on the cable. All of the operating parts of this controller are enclosed in the drum case and are thus protected from dust and dirt. The space at the back of the frame containing the resistance is ventilated, but the resistance units themselves are of the enclosed, moisture proof type.

sufficient power and line capacity are obtainable, but the current inrushes limit the size of the motor in most cases to less than 20 horse power.

Elevator squirrel cage motors, when thrown across the line, should not take more than $2\frac{1}{2}$ to 3 times the normal current.

Ques. What type of alternating current motor is suitable for elevators of higher speed?

Ans. Polyphase slip ring or external resistance motors.

This type of motor has a high starting torque and suitable secondary control can readily be provided that will insure a smooth acceleration. It will start smoothly under load and without requiring for acceleration more than 150 per cent. of normal current.

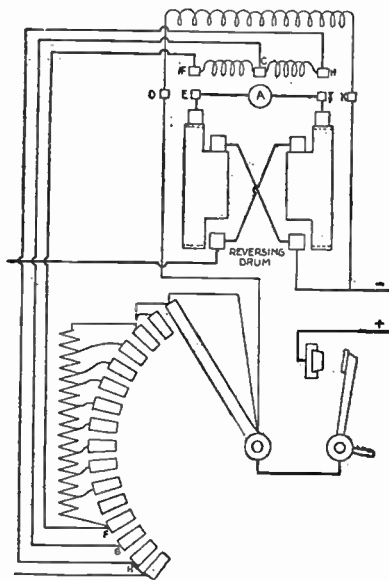

FIG. 4,135.—Diagram of Otis mechanical reversing control with type B reversing switch.

With this type of motor and the proper controlling device it is possible to secure a smooth start and to maintain a constant speed under varying loads. The polyphase, slip ring motor will not run away under conditions where the load tends to drive the motor, but, so far as operating characteristics are concerned, will approximate the performance of a shunt wound, direct current motor.

These motors may be used on two phase or three phase circuits having a frequency of not more than 60 cycles.

Ques. Are single phase motors suitable for elevator service?

Ans. Special elevator type of repulsion induction motors, which absolutely insure reversal of the motor, can be satisfactorily employed.

Standard split phase or standard repulsion induction motors are not suitable for elevator service.

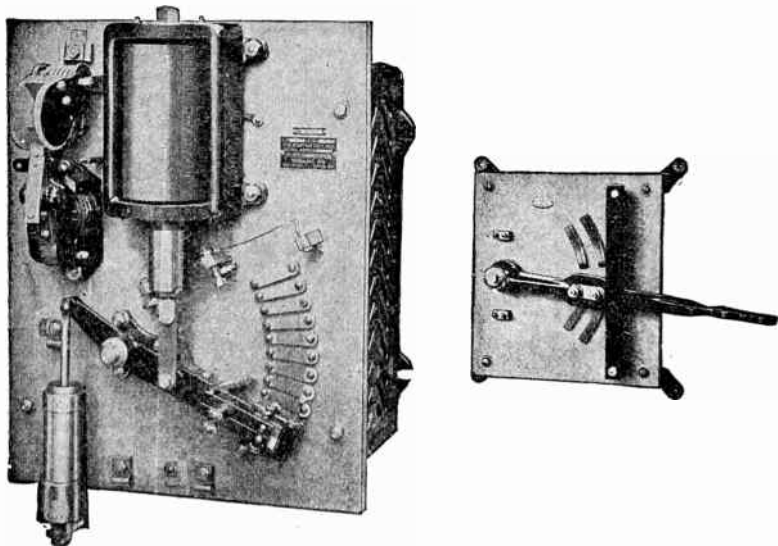

FIGS. 4.136 and 4.137.—Cutler-Hammer direct current non-reversible single speed semi-magnet controller and belt switch for double belt freight elevators. The controller consists of a sliding contact type of self-starter, with main line clapper switch, and a separate belt switch which serves as a pilot switch for the self-starter. The belt switch is designed to be suitably connected to the belt shifting mechanism of the elevator so that the motor is started or stopped whenever the operator manipulates the lever that shifts the belt. The controller can also be operated by a separate hand cable connected to the belt switch only. By this arrangement the motor is started in advance of the elevator and is left running while the elevator is in service.

Elevator Controller.—This is a most important part of an elevator installation, as upon its proper working depends the safe and satisfactory working of the car. It performs a number of

function, such as releasing the brake, starting, accelerating, slowing, and quickly starting the car. The control may be classified:

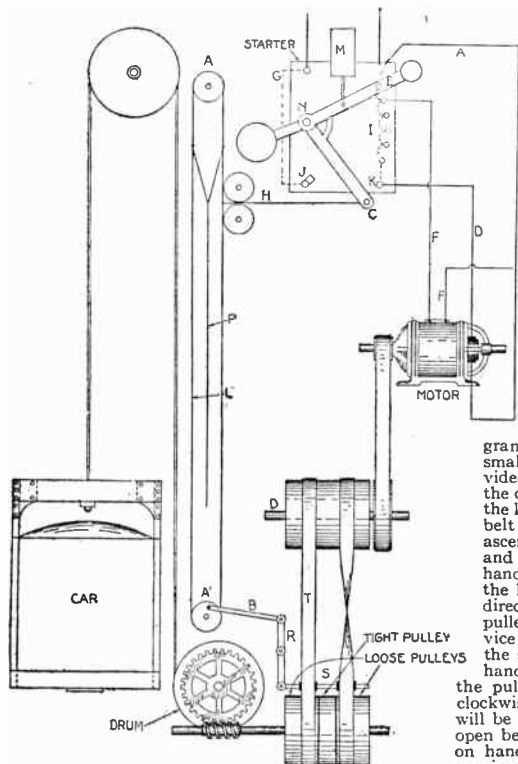

FIG. 4,138.—Continuous operating non-reversible full mechanical belt driven elevator control system. As shown the elevator machine is provided with a tight center pulley and loose pulleys on the two sides. The belts are shown on the loose pulleys, one being open and the other crossed. The countershaft carries a drum wide enough to allow for the side movement of the belts when one or the other is shifted upon the tight center pulley by the belt shifter S. To operate the elevator a hand rope is provided which runs up the elevator shaft at one side of the car from bottom to top of building. This

rope is shown in the diagram at L, and runs around two small pulleys AA'. Pulley A' is provided with a crank pin, which moves the connecting rod B and thus rocks the lever R, and thereby moves the belt shifter S. To cause the car to ascend, hand rope L is pulled down, and to make the car descend, the hand rope is pulled up. Accordingly, the lower pulley will rotate in one direction when the hand rope is pulled to make the car go up and vice versa. Pulley A is shown in the stop position, hence, when the hand rope is pulled down for up trip,

the pulley will turn in a counter-clockwise direction, and thus the belt will be moved to the right, bringing open belt into operation. Pulling up on hand rope rotates A clockwise, moving belt to left and bringing

cross belt into operation, thus causing car to descend. P is a stop rope and is connected with the two sides of the hand rope as shown and if pulled when car is in operation, will bring L to position shown, stopping the car. In operation when the hand rope L is pulled in either direction, H, draws C to the left and contacts with J, thus current passes through starting resistance I to motor armature through D. The field circuit branches off from upper end of I and reaches field coils through P, and reaches return wire through D and thus the opposite side of the circuit. When C is pulled to left, E gradually follows by gravity and dash pot control. The elevator machine is provided with a brake, actuated by the belt shifter S, applying brake when belts are in positions shown; when belt shifter is moved in either direction, brake is released.

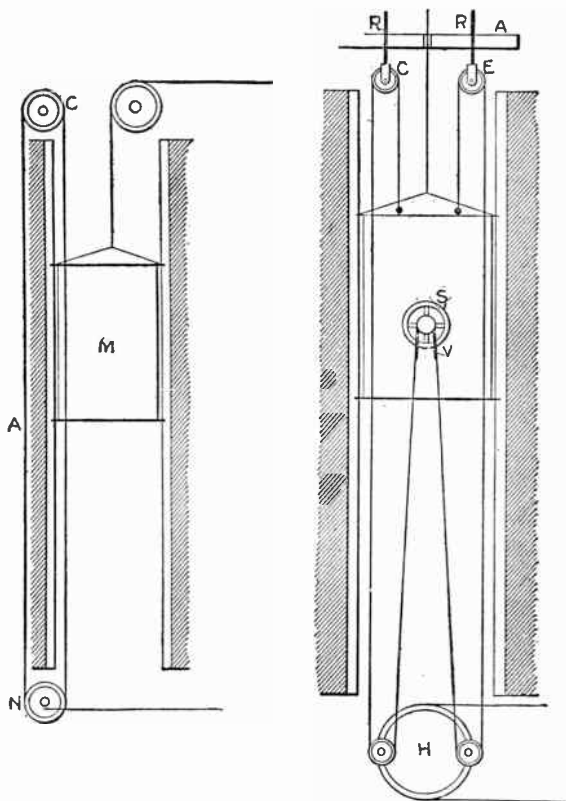

FIG. 4,139.—Mechanical control by shipper cable. *As shown*, an endless cable *A*, known as a shipper cable, is led up one side of the shaft and over a pulley *C*, down through the elevator car *M*, as shown, and around a pulley *N* connected to the switch or regulating apparatus at the motor. If, then, the operator in the car pull that portion of the shipper cable passing through the car, either up or down, he regulates the action of the motor and consequently of the car. For high speeds this style of control is not-satisfactory.

FIG. 4,140.—Mechanical control by wheel; a method suitable for high speed cars. *As shown*, the ends of the shipper cables are fastened to the top of the car. The idlers *C* and *E* over which the cables pass are supplied by springs *RR* on a cross bar *A* which is fastened across the top of the shaft. A pulley *H* is placed at the bottom of the shaft, and a hand wheel *S* is used in the car for control, the shipper cable being roped around the pulleys as shown, that portion of the shipper cable near the hand wheel being replaced by a chain *V* which engages with a sprocket wheel mounted on the same shaft with the hand wheel. *In operation*, turning the control wheel to right or left causes a like movement of the pulley *H*, as is evident, thus transmitting the motion to the motor controller.

1. With respect to the rotation of the motor, as

- a. Non-reversible;
- b. Reversible.

2. With respect to the current, as

- a. Direct;
- b. Alternating.

3. With respect to construction, as

- a. Full mechanical;
- b. Semi-mechanical;
- c. Semi-magnet;
- d. Full magnet.

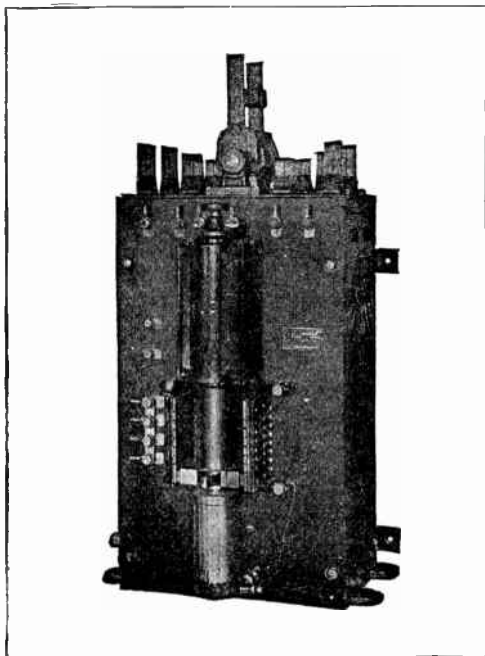

FIG. 4,141.—Cutler-Hammer (Schureman type F) direct current reversible single speed semi-mechanical controller with self-contained reverse switch for belted freight elevators controlled by a hand cable. In this type, the controller, reverse switch, and rheostat are mounted together as a single unit. The reverse switch is of the quick make and break type and cannot be left partly open or closed. The switch revolves 90 degrees each way from center to operate. The rheostat is of the solenoid operated cross head type with self-aligning contacts, the rate of acceleration being governed by a suction air dash pot. The piston is packed with soft leather, held in place by a compression spring and thereby forced gently against the wall of the dash pot. The rate of acceleration can be adjusted by means of a needle valve.

Non-Reversible Controllers.—The simplest way in which a motor can be installed to drive an elevator, is to arrange it so as to drive a counter shaft continuously, in which case the elevator is stopped and started by throwing belts on the tight or loose pulley as in fig. 4,138.

This system may be fully classified as a continuous operating non-reversible full mechanical control system. Obviously the term non-reversible refers to the motor which always runs in one direction as distinguished from motors which reverse their rotation to reverse the motion of the car.

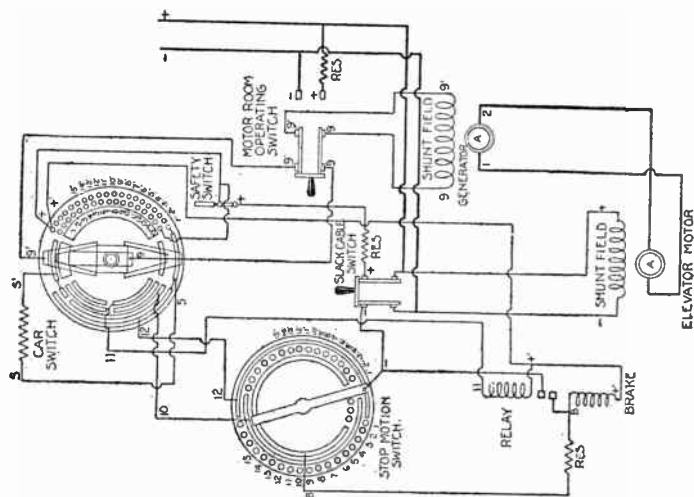

FIG. 4,142.—Diagram of Otis direct current field control (Leonard device).

A full mechanical reversible or "single belt" installation is shown in fig. 4,143. As will be seen, the principal difference in the mechanism is that the tight and loose pulleys are replaced by a single tight pulley and a reversible controller provided.

The foregoing types are simply combinations of an electric motor with a belt drive transmission.

To avoid the inherent defects of belt drive, and for economy of space,

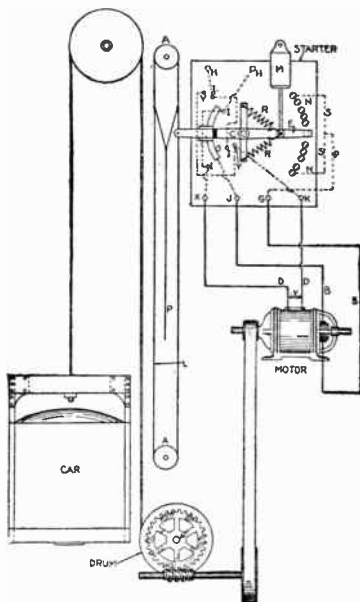

FIG. 4,143.—Reversible full mechanical belt driven elevator control system. *In operation* current from the line wires passes along the dotted connections H H to the contacts I, I, I, I. The upper left hand I contact is connected to the lower right hand contact, and the upper right hand, to the lower left hand. Switch lever C is connected with the starter by means of the two springs R R, so that C may be moved either up or down without carrying E with it. The curved contact O is connected with J, while G is connected with the ends of the starting resistance N N by means of the wires F and S, S. Contacts Y Y are connected to K and the lower left hand contact I, to X. If hand rope L be pulled so as to carry lever C upward, current from the left side line wire will pass through the upper left side contact I to O, thence to J and through B to armature, returning through B to G, thence via F and lower S to lower end of N, over lever E, to inner end of C which will be in contact with the upper right hand I contact and finally to the right side line wire. Current for the field magnet coils will be drawn from upper left side I contact to adjacent Y contact, thence to contact K, through the fields and back to X, finally to the left side line wire. Since lever C has been moved upward, the upper spring R will be compressed and the lower one will be stretched, exerting a force to move E downward over the lower contact N thus cutting out the starting resistance. Retardation is secured by dash pot M, thus cutting out the resistance gradually. To prevent excessive sparking when the switch is opened incandescent lamps V are connected across the terminals of the field circuit. Another method of reducing sparking slightly is by connecting the brake magnet coil with the binding posts X and K, but when the main circuit is opened, the currents flowing in the two coils meet each other at X and K, flowing in opposite directions, hence both follow along the main circuit and try to jump across the gaps at the switch, and thus produce about as much sparking as if they were connected independently of each other. When C is moved downward, the same line wire runs to the lower commutator brush since the connections between the two upper I contacts and the two lower ones are crossed. To reverse the motor, reverse current through armature, that through fields remaining unchanged, accordingly by crossing the connections between the upper and lower I contacts the motor is reversed when lever C is moved in opposite directions.

the motor and winding mechanism are direct connected which is the form in most general use.

The distinction between the various classes of controller, known as non-reversible, reversible, mechanical, semi-mechanical, semi-magnet, full magnet, and push button is illustrated in the accompanying cuts.

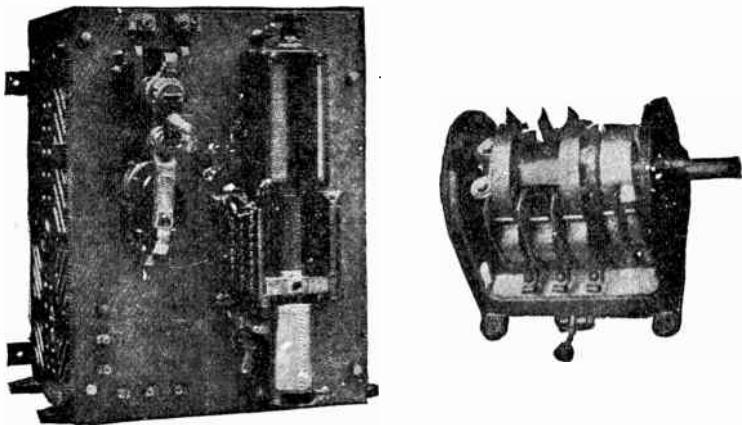

FIG. 4,144 and 4,145.—Cutler Hammer direct current reversible single speed semi-magnet controller with separate reverse switch for slow speed passenger or freight elevator. Fig. 4,144, self starting; fig. 4,145, Schureman type BR reverse switch. The controller consists of a sliding contact controller panel with main line magnetically operated clapper switch, and a separate drum reverse switch. The main clapper switch is controlled directly from the reverse switch by means of suitable auxiliary contacts, the action of the clapper switch being such that the motor circuit is always opened or closed with a snap. The main switch is so interlocked with the rheostat that the motor cannot be started or reversed until all starting resistance is in circuit, insuring smooth acceleration. The reverse switch is of the drum type designed for use with lever, wheel, or crank control, or may be operated by hand cable. The arrangement of contact is such that, although the reverse switch is of the slow break type without a centering spring, the motor circuit is opened at the clapper main switch, thereby eliminating destructive arcing on the reverse switch contacts. A mechanical connection may be made between the traveling nut of the winding drum and the reverse switch which will serve to throw the latter to the off position at either limit of travel. Limit switches may be used, however, and in many cases the use of shelf limit switches will obviate the necessity of installing the more expensive traveling nut device. Where shaft limit switches are used the hand cable is connected to the drum reverse switch only. Two single pole shaft limit switches should be installed, one at either limit of elevator travel. These can be arranged for operation by the car, or may be so installed that one switch is operated by the car and the other by the counterweight. The limit switches should be connected between the drum reverse switch and the controller panel so as to open the circuit of the main switch coil and stop the motor whenever the car arrives at the top or bottom of the shaft. With all semi-magnet controllers the mechanical brake is usually released by the operation of the hand cable. It is possible, however, to use a solenoid operated brake with these controllers by the addition of suitable contacts or relays to the controller. In connection with the hatchway limit switches a brake solenoid and slack cable switch should always be installed.

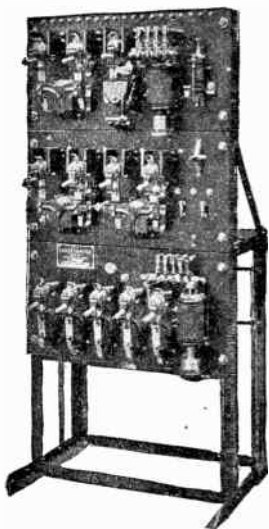

FIG. 4,146.—Cutler Hammer (Schureman type M) direct current reversible one or two speed with slow down full magnet controller for high speed passenger elevators. *Slow down.* This feature gives about one-quarter of the normal speed, the normal speed being for single speed equipment, the running speed, and for two speed equipment, the speed obtained with full field on the motor and all the armature resistance cut out of circuit. *Controller panel.* This is built in three sections in which the necessary armature resistance is mounted. The field and control resistances are mounted in a suitable frame on the back of the control panel. The field resistance has a wide range of adjustment so that the speed of the equipment can be regulated to the desired value. Suitable interlocks are supplied so that the main and reverse switches cannot be energized until all of the starting resistance is inserted in the armature circuit. Similar interlocks are supplied for giving proper sequence in the operation of the switches. *Apparatus on controller panel.* 1, double pole main line magnetically operated switch; 2, double pole magnetically operated direction switches; 1, single pole magnetically operated "slow down," or "dynamic brake" switch; 1, single pole "slow down" relay; 1, acceleration movement consisting of a set of crank switches operated by a solenoid and retarded by a dash pot; 1, try out switch; 2, control fuses; 1, double coil overload movement. In addition to the above, for two speed controllers there is one four step field weakening switch.

Functions of switches. A double pole main line switch breaks both sides of the line and in connection with the direction switches gives four breaks in the armature circuit. The direction switches are mechanically interlocked to prevent their simultaneous operation which would cause a short circuit on the line. These switches will automatically open on abnormal drop in voltage and stop the equipment. The slow down, or dynamic brake switch inserts armature shunt resistance in the slow down position and also keeps this resistance in circuit in the off position until the motor has practically stopped, thus giving a powerful dynamic braking effect. The slow down relay handles the accelerating solenoid current, thus eliminating the arcing on the car switch contacts, which would occur in case the accelerating solenoid was handled directly from the car switch. The time of cutting out the armature resistance is adjusted by means of a needle valve in the bottom of a large vacuum dash pot. The try out switch enables the attendant to run the car directly from the control panel without the necessity of getting into the car. The control fuses are used as a protection to the operating coils of the magnet switches and also afford additional protection to the elevator equipment in the case of grounds or short circuits in the operating cables. The double coil overload movement is arranged to stop the elevator in case of overload and can be automatically reset by throwing the car switch to the off position. This gives a reliable indication as to whether the car is overloaded and by having the resetting feature in the car switch, it is possible to set this overload within the closest limits. This device therefore possesses an advantage over the hand operated circuit breaker in that the operator is not compelled to go to the switchboard in case a slight overload occurs. The only thing necessary is to lighten the load on the elevator. With a manually operated circuit breaker the operator, under these conditions, invariably increases the current setting of the breaker when he goes to the panel to reset it and, in case of continued tripping, eventually ties the breaker in; thus eliminating the overload protection which the circuit breaker is designed to give. The four step field weakening switch which is used on two speed equipments is a weight closed switch controlled by an air dash pot. It is positive in action and is operative both when inserting and when cutting out the field resistance, insuring smooth acceleration and deceleration of the motor.

Full Magnet Direct Current Controllers.—A typical direct current control apparatus of the full magnet type consists of several slate panels, mounted on an angle iron frame with all the connections made on the back of the board.

The solenoid switches mounted on the slate panels are arranged to perform the following functions:

1. To disconnect in the off position both sides of the line from the armature, series field, resistance, and brake magnet.

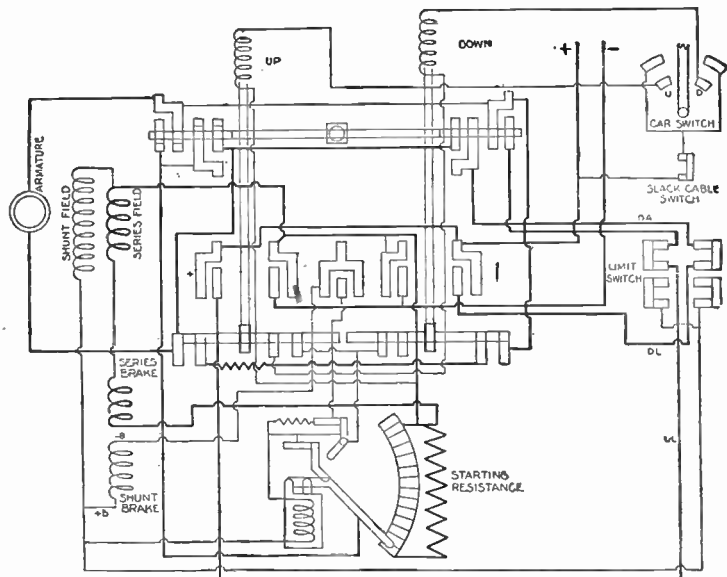

FIG. 4,147.—Diagram of A. B. See No. 4 magnet controller.

2. To accelerate the motor automatically by cutting out the armature starting resistance step by step, and also the series field with the last step of armature resistance (this by means of individual series relay control) giving smooth acceleration under all load conditions.

3. To control the speed of the elevator by cutting resistance in or out of the shunt field circuit of the motor, affording positive speed control under widely varying loads.

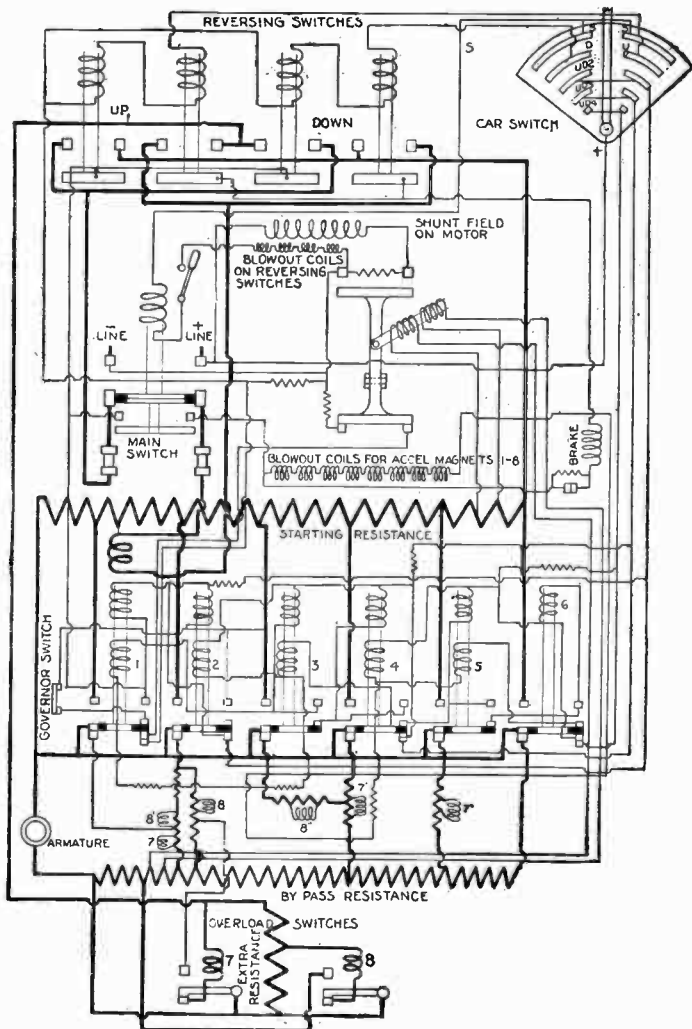

FIG. 4.148.—Diagram of A. B. See traction controller.

4. To bring the elevator quickly, but smoothly, from high to low speeds, regardless of load, making accurate stops at landings an easy matter.
5. To open the circuit to the motor should an overload current flow.
6. To apply the dynamic brake in the off position.
7. To operate the elevator at normal speed from the switchboard for test purposes.

To these seven functions may be added, as a modification of the standard controller equipment:

8. To open the shunt field circuit in the off position of the controller.

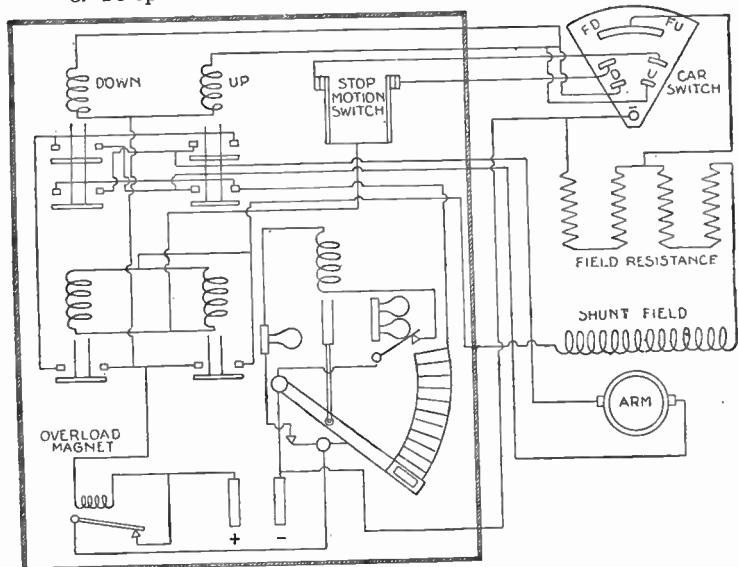

FIG. 4,149.—Diagram of Cutler-Hammer, two speed magnet controller.

Ques. How are excessive currents guarded against during the starting period?

Ans. The acceleration of the motor is governed by current relays so adjusted as to limit to a predetermined value the current taken by the motor.

Any tendency to overload the motor in starting is checked by the current relays which, whenever the current rises above a predetermined value, operate to prevent the cutting out of more resistance until the motor has properly accelerated and the surge of current, which follows the closing of each switch, has decreased.

In addition to the protection afforded by the current relays during the starting period, the motor is insured against overloads while running by an overload, or circuit breaker, relay which operates to open the circuit whenever an abnormal current flows. This circuit breaker relay is interlocked with the car switch in such a way that, should the motor be stopped by the action of the circuit breaker relay, the relay can be

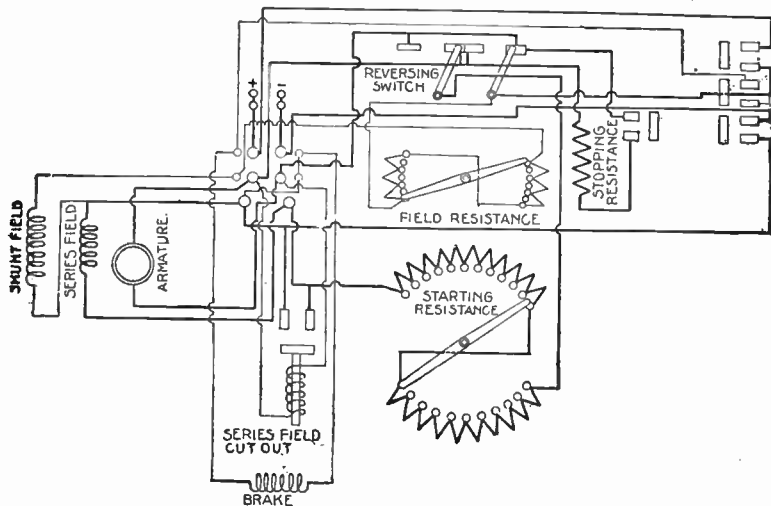

FIG. 4,150.—Diagram of Electron direct current mechanical controller

reset from the car by merely moving the lever of the car switch to the off position. This re-establishes the continuity of the circuit and it is then possible for the operator to start the car again in the usual manner.

Ques. Describe the speed control.

Ans. The controller is arranged usually to give three speeds: 1, slow down speed, 2, normal speed, obtained by cutting out the armature resistance step by step, and 3, high speed, obtained by inserting resistance in the shunt field.

The slow down speed is not a running speed, but is only used for making accurate landings.

Ques. What are the features of speed variation by shunt field resistance?

Ans. It is positive at all loads in the elevator, even under conditions when the car, in descending, tends to drive the motor. It is also very economical

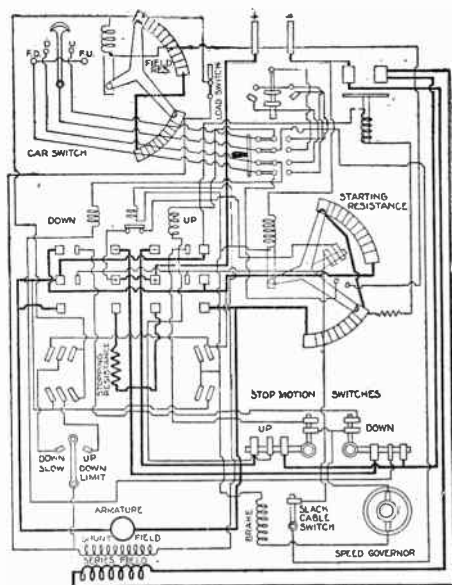

FIG. 4.151.—Diagram of Electron direct current two speed magnet controller.

A further advantage of shunt field control is found in the fact that it permits the car to be slowed down, regardless of load, enabling the operator to make more accurate landings and rendering the operation of the automatic limit switches more certain.

The shunt field resistance is mounted directly on the back of the switchboard panel in a suitable frame and is arranged for a wide range of adjustment to vary the speed in case it is found necessary.

With the slow down control provided with some controllers the speed

FIG. 4,152.—Push button control.

In this system a series of push buttons are placed both in the hallway and in the car. In the hallway there is one button A at each floor to bring the car to that landing. In the car at E there is one button for each floor and also one for stopping the car at any point by cutting off the current. By means of a cut out device on the controller C the circuits to all push buttons are automatically opened after the car starts. It is therefore impossible for a second party to interfere with the movement of the car after it has been started. It is also impossible for a second party to start the car while it is at landing and a passenger is getting in or out, for while any door M to the shaft is open, the controlling circuit is broken. An automatic door fixture is generally used in this system for locking the shaft doors so that none of them can be opened until the car reaches the landing, and then only the door at the landing where the elevator stops. A passenger desiring to go from, say, the second floor to the fourth, would, if the car were not already at the second floor, push the hall button located there in the same manner as he would to ring an electric bell. He need not continue the pressure on the button, nor, in fact, on any of the buttons used in the system, for more than an instant. The car will then rise or descend, depending upon where it may be stationed at the time, until it reaches the second floor where it will stop and automatically unlock the shaft door. The passenger then steps in the car and closes the shaft door. Unless he close this door he will be unable to start the car. Wishing to go to the fourth floor he pushes the button in the car corresponding to that landing, and the car ascends, automatically stopping and unlocking the door at that floor as previously described for the second floor. A simple modification of the automatic system just described is used for dumbwaiters or freight elevators. In this case the car is controlled entirely from the landings.

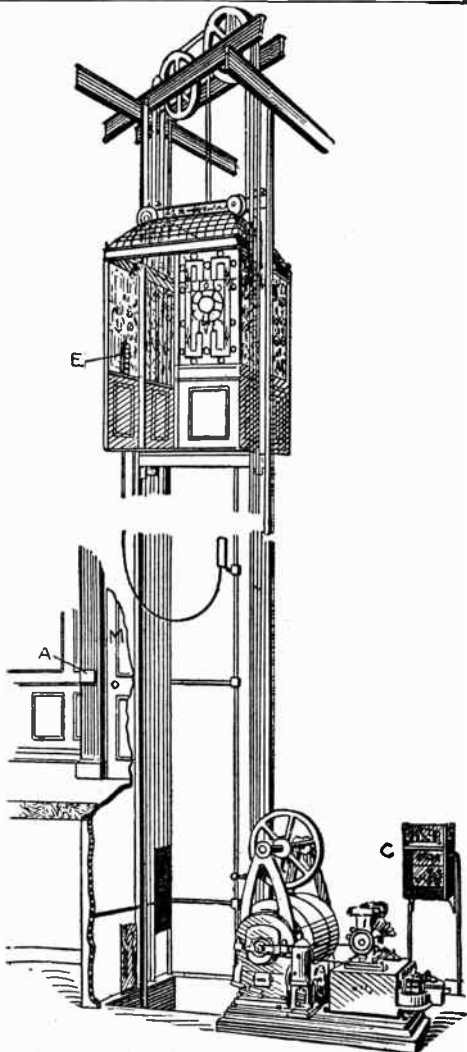

of the car is reduced to approximately 30 per cent. of normal speed and from this slow speed it is very easy to make an accurate landing, the tendency of the car to coast being practically eliminated.

Ques. State an additional advantage of slow down control.

Ans. It reduces the speed of the car at the two limits of travel regardless of load, making it possible to set the brake and adjust the limit switches so that the car will be brought to a full stop

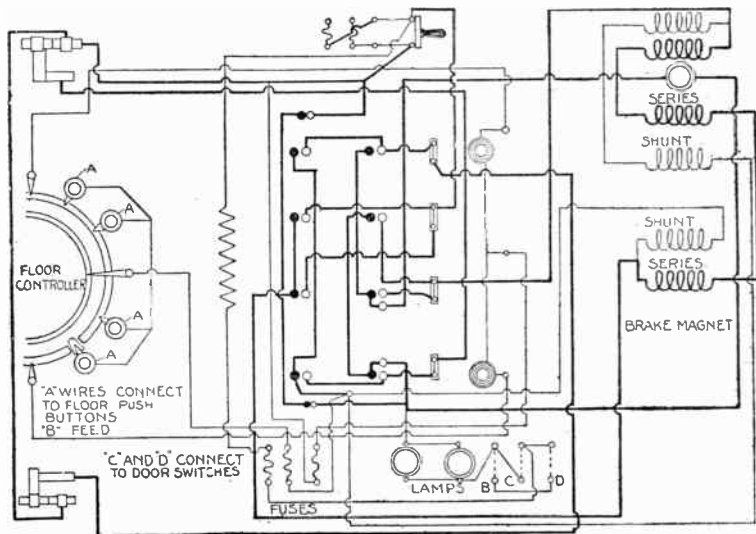

FIG. 4,153.—Diagram of Burdett and Roundtree push button controller for dumbwaiter.

at the last landing, instead of coasting past the limits when light or heavily loaded and hitting the bumpers at the top or bottom of the shaft.

Ques. When is the motor series field winding used?

Ans. It is used while accelerating, being cut out by the controller at normal speed.

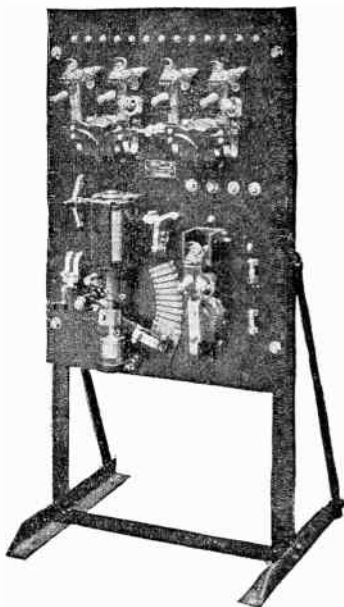

FIG. 4,154.—Cutler-Hammer (Schureman type K) direct current reversible single speed push button controller for passenger elevators or dumb waiters. The push buttons are located on the car or at various landings. The controller is of panel construction, all wiring being exposed on the back. The motor circuits are controlled by means of a single pole magnetically operated main line switch, two double pole magnetically operated direction switches, and a solenoid operated, pivoted arm type rheostat. The main line switch is equipped with a blow out magnet to suppress arcing. An electrical interlock is used to prevent the closure of the main line switch except when all of the starting resistance is in the armature circuit. Push button operated passenger elevators have a gang push switch in the car with a button for each landing. The pressing of any button will automatically send the car to the corresponding landing and bring it to a stop. There is also an individual push switch at each landing, which, when pressed, will automatically bring the car to that landing, provided that all the doors are closed and the car is not in use. An emergency stop switch is mounted in the car to bring the car to a stop at any time. Push button operated dumb waiters usually have a gang switch mounted at each landing so that the car can be brought from or sent to any other landing. Occasionally, however, installations are made in which a gang push switch is mounted at only one landing, from which the car is controlled, and an individual push switch is mounted at each of the other landings to send the car to the control landing, after it has been loaded or unloaded. A floorstop is used to determine the direction of travel and to bring the car to a stop when opposite the desired landing. On passenger elevators, an emergency stop device is used to bring the car to a stop at any time when the emergency stop button in the car is pressed. To prevent operation in case any of the doors be left open, a door safety switch is used; shaft limit switches and a slack cable switch should be used with these controllers to open the control circuit if the car should over travel or become stuck in the guides. When the motor is to be operated from a 500 volt circuit, a low voltage control circuit (115 or 230 volts) must be used. This circuit may be either direct current, or 25 or 60 cycle alternating current.

If the series field be heavy, the speed of the motor will increase very materially when the series winding is cut out, and it may be necessary to provide an extra switch on the controller in order to give smooth acceleration. This is apt to be the case with an old motor.

Ques. Name two types of resistance employed.

Ans. The armature starting resistance and the dynamic brake resistance.

These are of the cast metal grid form.

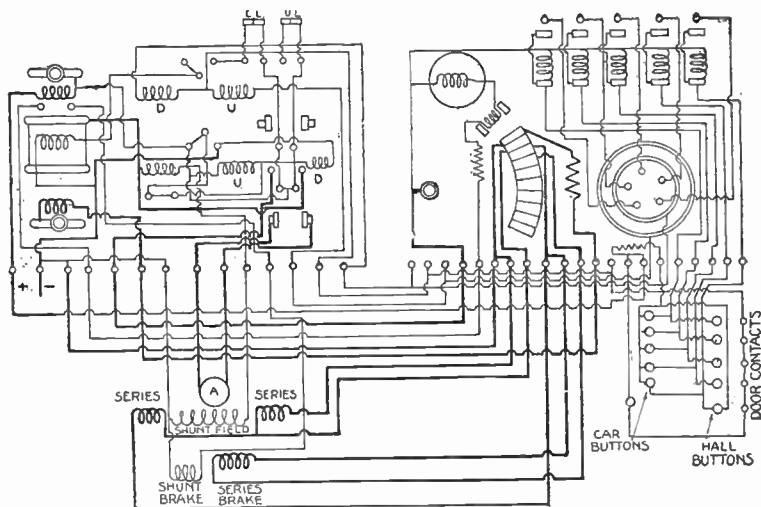

FIG. 4,155.—Diagram of Darrin automatic push button controller.

Ques. How is the armature resistance proportioned and why?

Ans. It is in proportion to the horse power output of the motor at normal speed in order to make the acceleration as smooth as possible and at the same time to reduce the amount of current taken from the line in starting.

The Mechanical Brake.—The proper functioning of the mechanical brake is rendered positive by disconnecting both terminals of the brake magnet winding from the line and from the motor armature in the off position of the controller. This makes it certain that no possible combination of grounds or short circuits can keep the brake magnet energized and the brake released when the car switch is thrown to the off position. So long as the brake mechanism is in good working order mechanically, the positive application of the brake is assured.

The Dynamic Brake.—Power for the operation of the dynamic brake switch is taken from the motor armature and the brake resistance is applied directly across the armature terminals.

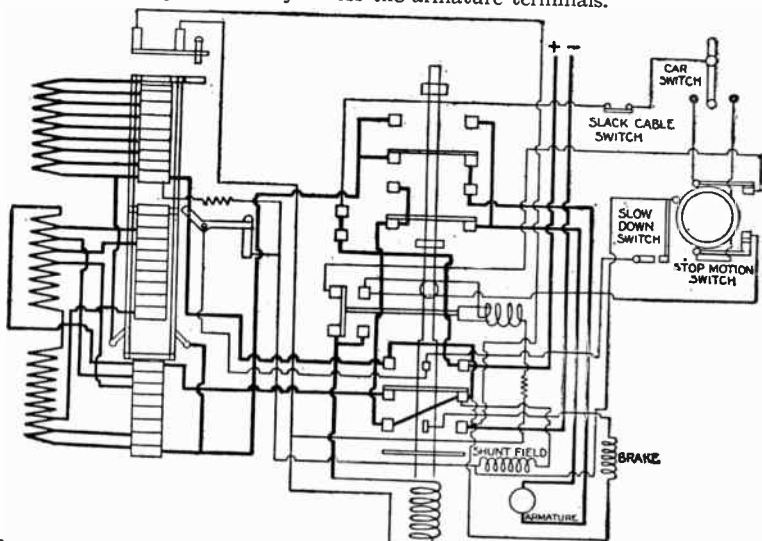

FIG. 4,156.—Diagram of National direct current type A, one speed gravity rheostat controller.

The application of this brake depends, therefore, not on the line voltage but solely on the motion of the armature.

In any form of elevator braking, mechanical or electric, the energy represented by the inertia of the moving parts must be dissipated in the form of heat in order to stop the motor.

In mechanical braking this energy is transformed into heat by the friction of the brake shoe; in electric braking it is transformed into heat by causing the motor to generate current and dissipating this energy in a resistance provided for that purpose—the dynamic brake

resistance. Accordingly, when the dynamic brake is used in connection with the mechanical brake, the effectiveness of the latter is increased since it is not called upon to arrest a full powered motor, but one which has already been deprived of a portion of its energy by having a resistance shunted across its armature terminals.

The Try Out Switch.—Operators are usually instructed to go to the switchboard every morning before entering the car and to test the operation of the elevator by means of a *try out switch*, so as to ascertain

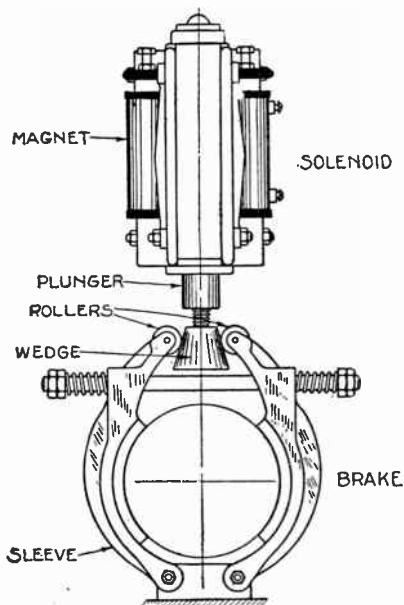

FIG. 4,157.—Typical arrangement of brake magnet having a wedge acting between rollers to release the brake.

that every part of the installation is operating properly. In this way the car can be run up and down the shaft several times each morning, testing not only the control apparatus, but also the motor, limit switches, brake solenoids, etc.

Ques. Describe the try out switch.

Ans. It consists of a single lever normally locked in the central position, and in the position completing the circuit to the car switch.

It is, therefore, not possible to operate the elevator from the car while the try out switch is in use, this fact enabling the try out switch to be used also as a safeguard against the operation of the elevator while the regular operator is absent from the car.

The Service Switch.—It sometimes happens that the main line knife switch ordinarily used as a service switch cannot be so located that it may be conveniently opened at night, or at other times when the elevator is idle for considerable periods. This condition is frequently met with in over mounted installations, and unless some provision be made for opening the circuit to the motor from the car, or from one of the lower floors of the building, the operator will be obliged to leave the elevator at the top of the shaft each night, walking down stairs every evening and up stairs every morning.

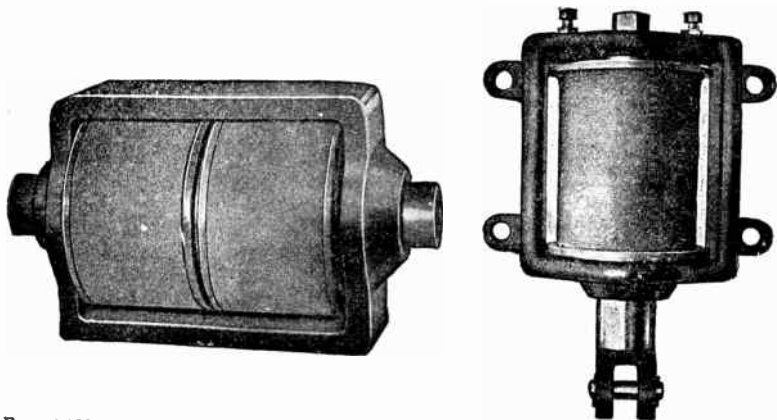

Figs. 4,158 and 4,159.—Cutler-Hammer direct current brake solenoids. Fig 4,158, short pull; fig. 4,159, long pull. **Types of winding.** In the case of the shunt wound solenoid, there is a single coil connected directly across the line to release the brake. The compound wound solenoid has a shunt and a series coil in the same frame. The shunt coil is wound for connection directly across the line. While contributing somewhat to the pull on the plunger, its principal function is to hold the load in the sealed position of the solenoid. The work of retracting the brake is performed principally by the series winding which is so connected as to be cut out of circuit when the motor is running, leaving the shunt winding in circuit to support the load. The brake will therefore be released whenever the circuit of the shunt winding is opened. Owing to the reduced self-induction, compound wound brake magnets are more rapid in action both in releasing and in applying the brake than plain shunt wound solenoids. This characteristic results in the preference being given to compound wound solenoids in all cases where quick starting and stopping is desirable.

Ques. Describe the operation of the service switch.

Ans. It remains closed normally while the elevator is in operation, not being connected in any way to the car switch or other speed regulating portion of the apparatus. Connection to the single pole service switch may be either through the safety switch, installed in the car,

or through any other suitable pilot switch installed on the landing at which the operator usually leaves the elevator for the night. The opening of the switch disconnects one side of the line from the controller switchboard, enabling the operator or janitor of the building to open the circuit to the motor without going to the main line switch. The service switch controls, from one set of contact, the continuity of both the armature and shunt field circuits. This arrangement is necessary for safety, so that it will not be possible to open or close the armature circuit without also opening or closing the shunt field circuit.

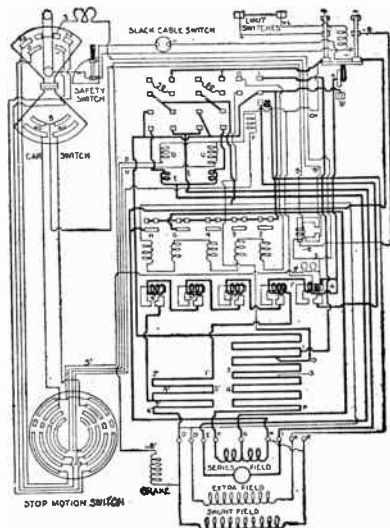

FIG. 4,160.—Diagram of Otis style B, direct current, two speed magnet controller.

Controllers in which the shunt field is always opened when the car switch is thrown to the off position are sometimes called for. This requirement can be met by the addition of relay circuits serving to open the service switch above described whenever the elevator comes to rest.

Unless there be some special reason for desiring this arrangement, however, it is generally advisable not to open the shunt field circuit except when the elevator service is shut down for the day, the reason for this being that some excitation of the shunt field is desirable while the elevator is in service in order to obtain the best results in speed control.

The amount of current saved by opening the shunt field momentarily during stops at landing is not very much, and any gain of this nature is more than offset by the larger armature current taken in starting under these conditions and the greater length of time which is required to bring the car up to full speed.

When the service is discontinued for the day there is then reason for wishing to open the circuit to the shunt field, and this is provided for by the service switch already described.

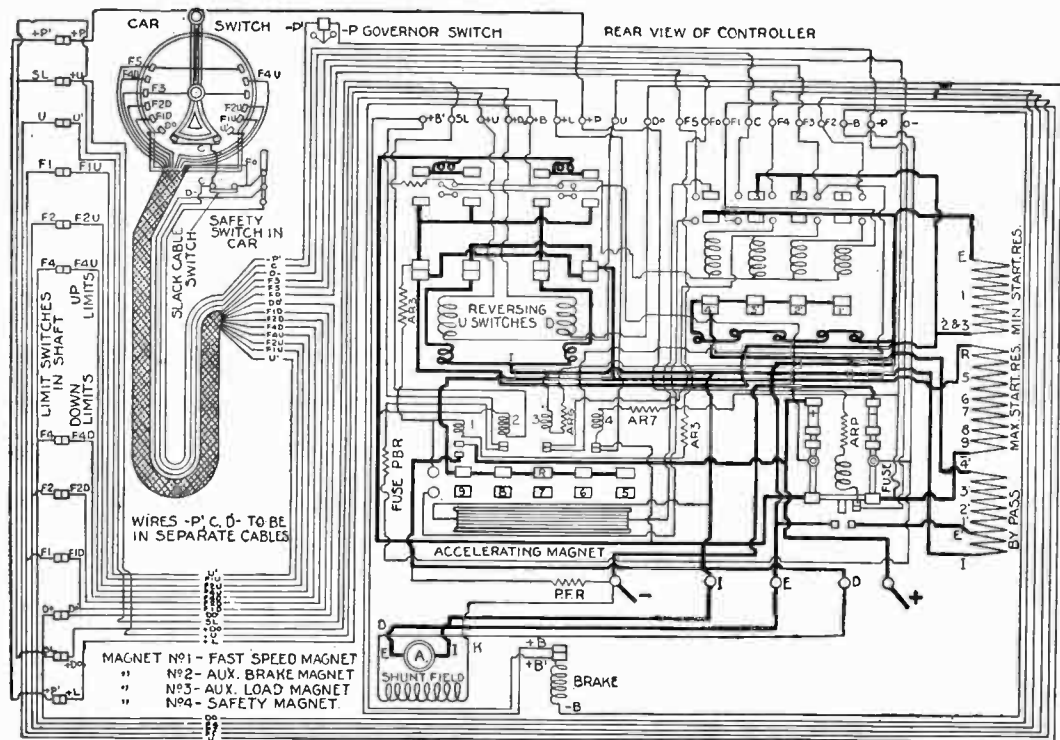

FIG. 4.161.—Diagram of Otis type MF4 direct current magnet controller for traction elevator.

Heavy Load Lifting Device.—It is sometimes desired to have a high speed passenger elevator equipped so that it can be operated at a lower speed as a freight elevator for the purpose of lifting occasional heavy loads such as safes, etc. This has usually been accomplished in the past by means of back gearing, an arrangement which gives a slower speed to the car and a correspondingly greater lifting capacity. Such an arrangement however results in higher initial cost and requires a great deal of time and labor for throwing the back gears in and out. The same result can be accomplished electrically with the elimination of all back gearing. In changing over, the only operation required with this method is the closing or opening of a knife switch on the

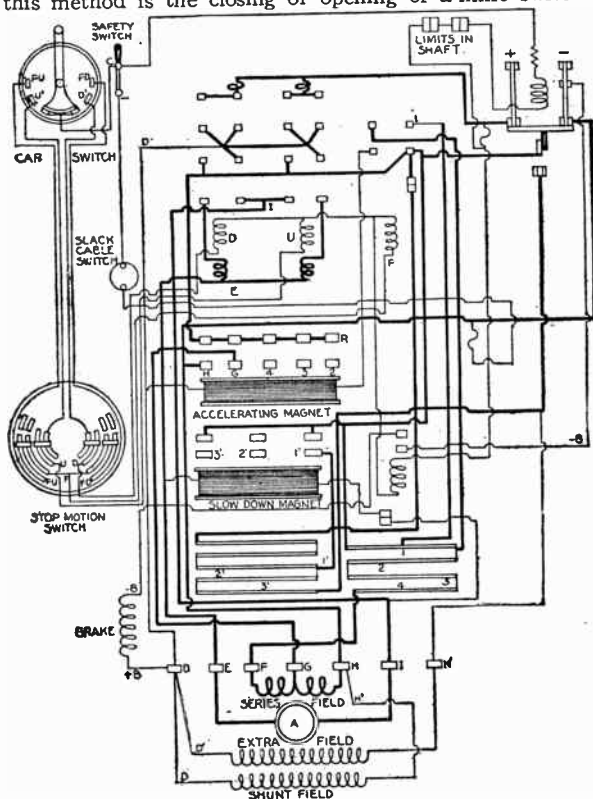

FIG. 4.162.—Diagram of Otis style GS direct current, two speed controller.

controller panel, this simple operation enabling one to lift approximately twice the normal load at half the normal speed.

In order to use this arrangement with a standard Cutler-Hammer controller it is necessary to have a motor with a 2 to 1 speed variation by shunt field resistance.

The knife switch referred to above arranges the armature starting resistance and prevents the weakening of the shunt field. This also adjusts the series relays so that equally good conditions of acceleration are obtained in both methods of operation. The motor will not be worked above its rated capacity in either case.

Machine Type Limit Switch.—This switch is intended to insure the slowing down of the car from any speed not exceeding 300 feet

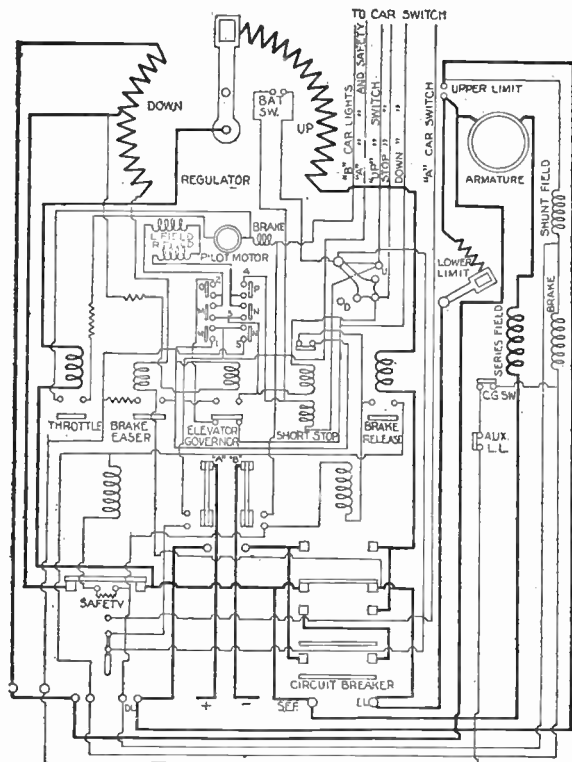

FIG. 4.163.—Diagram of Sprague direct current pilot motor controller for type A Sprague elevator.

minute, and its stoppage at the predetermined limits of elevator travel. The slow down is accomplished by means of single pole switches in the control circuit, while the complete stoppage of the car is brought

about by double pole switches which disconnect both sides of the lines from the control system, thus insuring that the motor will be stopped even under conditions which might otherwise tend to impair the control of the car, such for instance, as grounds or short circuits in some part of the control system.

Connections to the limit switches are so designed that after the car has been stopped automatically at either limit of elevator travel it is possible for the operator to start and immediately accelerate to full speed in the opposite direction.

Shaft Limit Switches.—In addition to the machine type limit switches just referred to, over travel switches should be installed in the elevator shaft as an extra precaution. These shaft limit switches

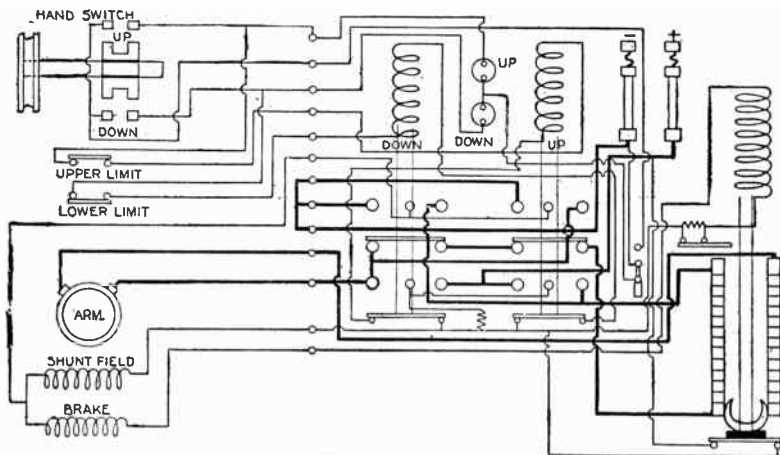

FIG. 4.164.—Diagram of Sprague direct current magnet controller for type T and Y Sprague sidewalk elevator.

are arranged to be operated by the car which, on passing a given point, opens the switch thus introducing an additional break in the control circuit and insuring the stopping of the elevator through the opening of the line and reverse switch.

Shaft limit switches, when used as over travel switches, should be so arranged that it is impossible for the operator to move the car after the switch has opened without first going to the elevator machine, thus insuring attention to the defect which caused the shaft limit switch to operate. These switches are sometimes installed alone in preference to the machine type of limit switch on drum type elevator machines.

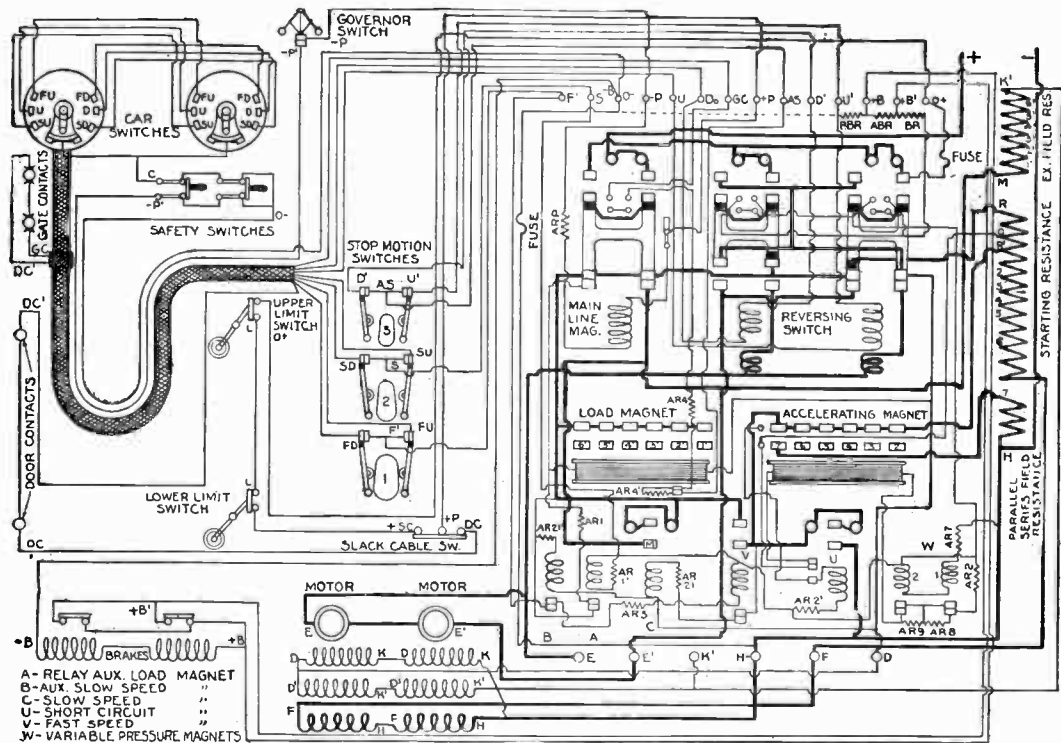

FIG. 4,105.—Diagram of Otis style 7 direct current duplex controller.

On traction type elevator machines they obviously have to be used for both the automatic limits and over travel. For automatically slowing down and stopping the car three single pole shaft switches at either limit of elevator travel should be used, making a total of six switches in all. One switch in each of the two sets of three is used to slow down the car while the other two operate in unison as a double pole switch to bring the car to a stand still.

In addition two single pole shaft limit switches should be used for protection against over travel.

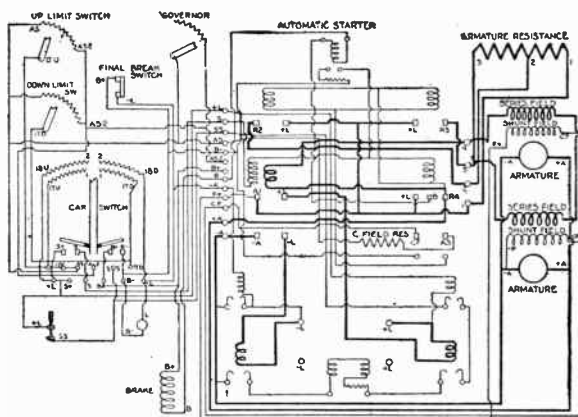

FIG. 4.166.—Diagram of Fraser direct current duplex motor controller.

Shaft limit switches may be installed so as to be operated either by the car or by the counter-weight, or by both.

The Safety Switch.—In order to insure the stopping of the elevator, even should some accident render the regular control from the car switch inoperative, a safety switch should be provided. This consists usually of a single pole switch enclosed in a cast iron box, the handle of the switch projecting through a slot in the enclosing case.

This safety switch is designed to be connected, by means of a separate three wire cable, to that part of the control circuit which is in the side of the line opposite to that in which the car switch is connected. The third wire in this cable is desirable as a spare. The opening of the safety

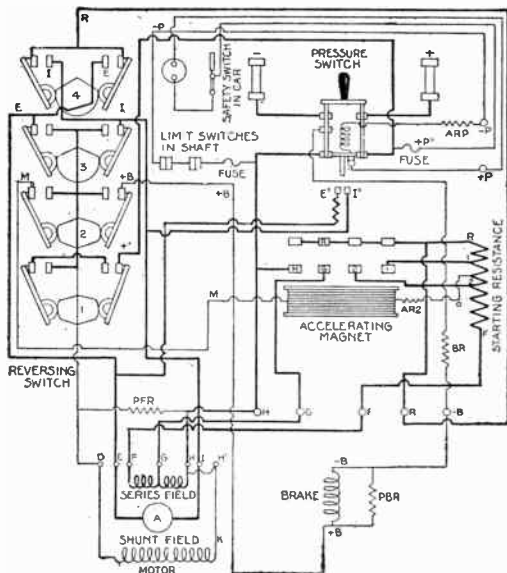

FIG. 4,167.—Diagram of Otis style 2H mechanical reversing switch.

FIG. 4,168.— Cutler-Hammer direct or alternating current elevator car switch. The operating lever and handle are mounted vertically on the front of the switch case, the lever being latched in the central, or off position to prevent the accidental starting of the elevator. **To release the latch** it is necessary to depress the button mounted in the top of the handle, this action occurring naturally when the operator places his hand on the lever to operate it. Should the operator remove his hand from the car switch while the elevator is in motion a centering spring throws the lever to the off position and brings the car to a standstill. This insures constant watchfulness on the part of the operator and serves also as a safeguard against accident should injury or illness befall the operator while the elevator is in motion.



switch will therefore entirely disconnect one side of the control system from the line, and this switch, in connection with the car switch, makes it impossible for any combination of ground or short circuit to prevent the operator stopping the car at will.

Alternating Current Controllers.—There are many types of alternating current controller, the best known being of the full magnet variety.

As previously stated alternating current motors should preferably be limited to moderate speeds, because it is not feasible

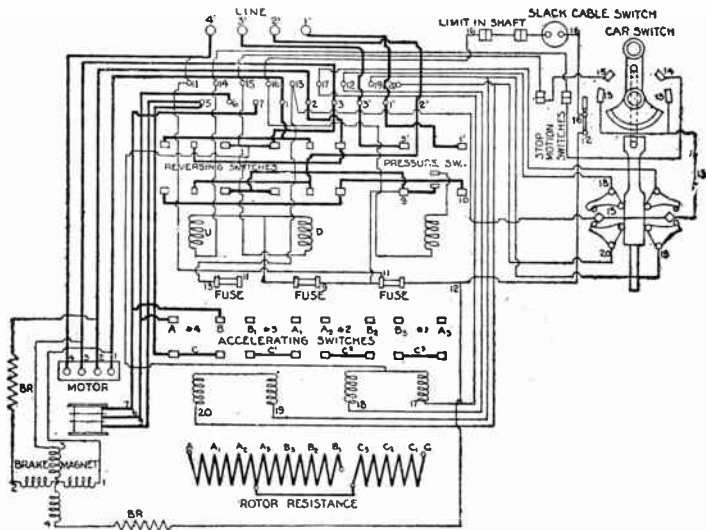

FIG. 4,169.—Diagram of Otis type VAS alternating current, two phase magnet controller.

to employ dynamic braking. This means that the car must be slowed down and stopped by the application of the solenoid brake alone, and the speed must therefore be one that will permit

NOTE.—Where old elevator equipments are being changed over to the full magnet system and the old motor is in such good condition that it is possible to use it with the new equipment, particular attention should be paid to the amount of speed variation that can be obtained from the old motor. Very few of the older elevator motors are designed for a wide range of speed variation by shunt field resistance.

this being done with safety and comfort under all the widely varying conditions met with in elevator service.

A typical alternating current full magnet controller consists of several slate panels mounted on an angle iron frame which serves also as a support for the resistance. Alternating current solenoid switches mounted on the face of the panel and

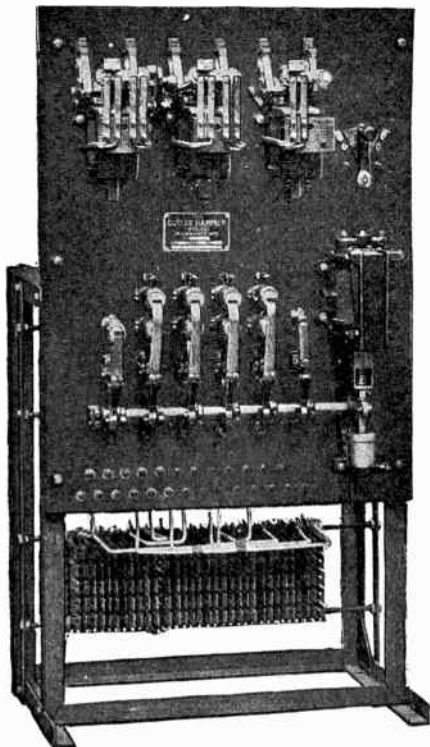
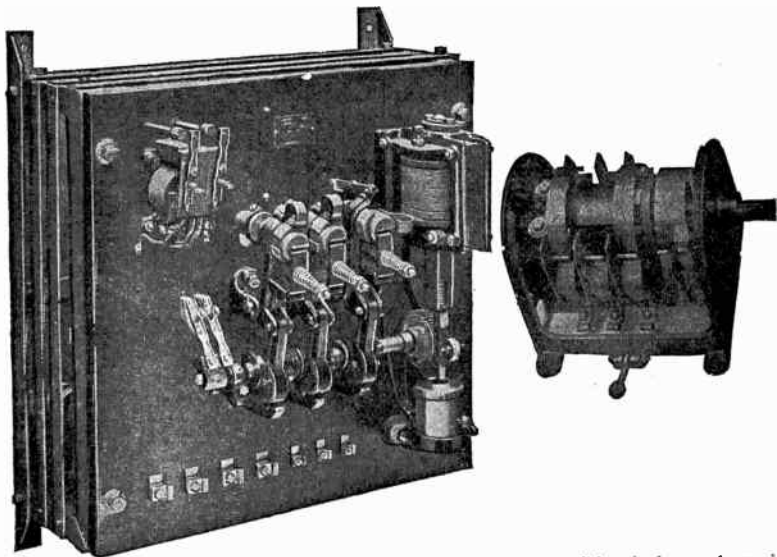

FIG. 4,170.—Cutler-Hammer, alternating current, reversible, single speed full magnet push button controller for slow speed passenger or freight elevators. It is suitable for two or three phase slip ring induction motors, 25 or 50 cycles, and also with self starting, single phase motors. The latter type motor should be provided with an interlocking connection to prevent quick reversals. Since there is no satisfactory and practicable method or reducing the speed of an alternating current motor under varying loads, the speed at which elevator cars may run when driven by such motors is limited and the problem is purely a matter of bringing the car to an easy and accurate stop. There are elevators driven by alternating current motors and operating satisfactorily at car speed of 275 to 300 feet per minute; however, in such cases the brake details have been worked out with extreme care so that a comparatively easy stop is made with widely varying loads, even for such a high speed. Ordinarily, however, it is not good practice to use alternating current elevator controllers for installation when the car speeds are likely to exceed 200 feet per minute. *In construction* of the controller here shown, the primary circuits are controlled by a double pole, solenoid operated main line switch and two double pole solenoid operated direction switches. The rheostat is of the solenoid operated crank acceleration type, retardation being effected by an adjustable vacuum dash pot. The starting resistance is of the cast grid type and is cut out in equal steps in each phase of the rotor winding, thereby keeping the

phases in balance at all times. The rheostat and the main line switch are so interlocked that it is impossible to make a quick reversal with the starting resistance cutout. A mechanical interlock is also provided between the two direction switches so that both cannot be closed at the same time. Test buttons mounted on the panel permit of the car being operated from the switchboard.

connected to the resistance (all connections being made at the back of the board) are arranged to perform the following functions:

1. To disconnect the primary wires from the motor and brake solenoid in the off position of the controller.
2. To accelerate the motor automatically by cutting the starting resistance out of the rotor circuit step by step (using series relay control) and giving smooth acceleration at all loads.
3. To operate the elevator from the switchboard for test purposes.



FIGS. 4,171 and 4,172.—Cutler-Hammer alternating current, reversible, single speed, semi-magnet controller with separate reverse switch for slow speed passenger or freight elevators operated by self-starting, single phase, special elevator type motors. Fig. 4,171, self-starter; fig. 4,172, reverse switch. *In construction*, the self-starter is of the crank acceleration type, using individual carbon contact levers for each step of resistance. The rate of accelerating is under control of a vacuum air dash pot. *In operation* the contacts in the drum reverse switch are not required to break the motor currents, but are used to reverse the motor connections. Auxiliary contacts in the switch, handle, and control circuit of the self-starter and the main circuits are made and broken on a special quick make crank switch actuated by the accelerating solenoid. The special motor which must be used is provided with an interlocking contact on the motor which is closed only after the motor has practically come to a standstill. Connection is made between this contact and the self-starter so as to insure reversal of the motor while running. The ordinary single phase, self-starting motor will not reverse from high speed unless this interlocking be provided. *Adaptation*: 25 to 60 cycles. Shaft limit switches may be installed in the elevator shaft if desired to stop the motor at the travel limits.

The secondary starting resistance is of the cast metal grid type and is mounted in a frame forming part of the switchboard support. Connections between grids and terminals and between the terminals and the various solenoid switches on the controller switchboard are usually made at the factory.

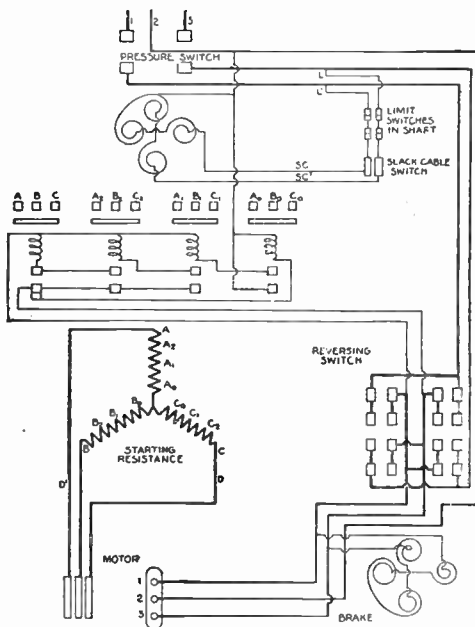

FIG. 4,173.—Diagram of Otis type alternating current two or three phase mechanical controller.

Current Relay Acceleration.—The acceleration of the motor is accomplished by a parallel solenoid self-starter with secondary starting resistance. A suitable number of double pole alternating current solenoid switch are used, these being so connected as to cut a section of resistance out of each of the three phases of the rotor circuit simultaneously, the rate of acceleration being governed automatically by a number of current relay in the rotor circuit. By suitable adjustment of these relays the starting current is limited to a predetermined maximum

Ques. What is the function of the relay?

Ans. It operates to lift and open the circuit to the succeeding switch when the starting current rises as each switch in turn is closed, thus preventing the cutting out of the next step of resistance until the motor has properly accelerated and the surge of current incident to the closing of the previous switch has died down.

In construction each circuit relay has three coils connected between its switch and the three phases of the rotor circuit. These relays govern the acceleration of the motor.

Limit Switches.—The automatic stopping of the car at the two limits of elevator travel, in the case of a drum type elevator machine,

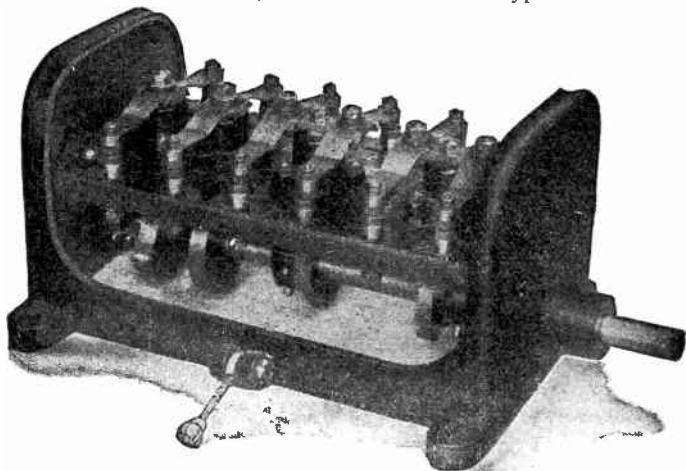

FIG. 4,174.—Cutler-Hammer direct or alternating current rotating cam limit switch for use with controllers in connection with the traveling nut mechanism of the winding drum machine. The limit switch is double pole, and in operating to stop the elevator, disconnects both sides of the control circuit from the line. **In installing** this type of limit switch the switch shaft is geared to the yoke of the traveling nut device on the winding machine, either by spur or bevel gearing. It is essential that a centering device be provided which will return the limit switch and the yoke of the traveling nut mechanism to the central position whenever the car moves away from either limit of its travel. The angular throw of the rotating cam limit switch is limited to approximately 160° on either side of the central position and it is necessary that the ratio of the gears between the traveling nut device and the limit switch be such that the elevator can be slowed down and stopped within this angular movement.

is usually accomplished by a limit switch of the rotating cam or traveling cam type. These switches are designed to open both sides of the control circuit to the solenoid switches on the controller switchboard, thus insuring the stopping of the car through the opening of the motor circuit.

Shaft limit switches may be used in place of the cam type limit switches, if desired, and should be used in the case of traction machines.

Two shaft limit switches should be used as over travel switches, in both cases, and should be so connected in the control circuit as to make it impossible for the operator to move the car in the reverse direction after over traveling without first going to the winding machine. This insures protection against phase reversal.

The Brake Solenoid.—This is designed to be connected directly to the motor terminals. When the circuit to the motor is closed, the solenoid is energized and the brake released. Upon the opening of the main line circuit (whether this be done intentionally in operating the elevator, or is the result of accident) the solenoid is de-energized and the brake applied. The operation of the brake solenoid is very rapid, and

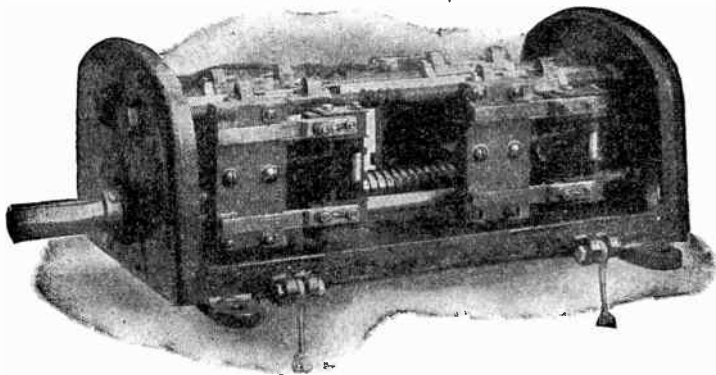

FIG. 4,175.—Cutler-Hammer direct or alternating current traveling cam limit switch for use with controllers. This switch has the traveling nut device incorporated in its own mechanism. It consists of a shaft (designed to be geared directly to the shaft of the winding drum) and threaded so as to drive a nut along its length as the car moves from one limit of its travel to the other. Double pole switches are mounted on rods parallel to the shaft of the limit switch, and adjustable on these rods with reference to the traveling cam. The cam itself follows the motion of the car, and as the latter approaches either limit of its travel, the cam trips out the switches, which in turn slow down the elevator and bring it to rest. The traveling cam limit switches may be mounted in any position but are preferably located above the drum shaft bearing so as to be out of the way of lubrication drippings. With both switches pointing inwardly the maximum number of turn that the shaft of the limit switch can make is 33, and the minimum 30. The best results will be obtained, however, when the switch is so geared to the winding drum that the number of turn made by the limit switch shaft for the full elevator travel is between 18 and 27, which is obtained with one switch pointing out, and one pointing in. With both switches pointing out, the range is from 7 turns to 20 turns of the limit switch shaft for the full elevator travel. The individual snap switches are reversible on their supporting rods, by reversing the corresponding cam at the same time.

the force applied to the brake considerable. It is recommended, therefore, that the parts of the brake mechanism used with these solenoids, be of rugged construction, a simple toggle or wedge mechanism being most desirable. It is desirable also that the brake itself be so

designed as to permit of a gradual, rather than a sudden braking effect, so as to avoid jarring the car by stopping it too quickly.

The Transmission.—The term “transmission,” as generally and erroneously used, denotes the system of gearing between the motor and drum; it properly includes the entire mechanism between the motor and car, that is, the gearing between motor and drum and the “final drive” or drum, cables and pulleys, for all

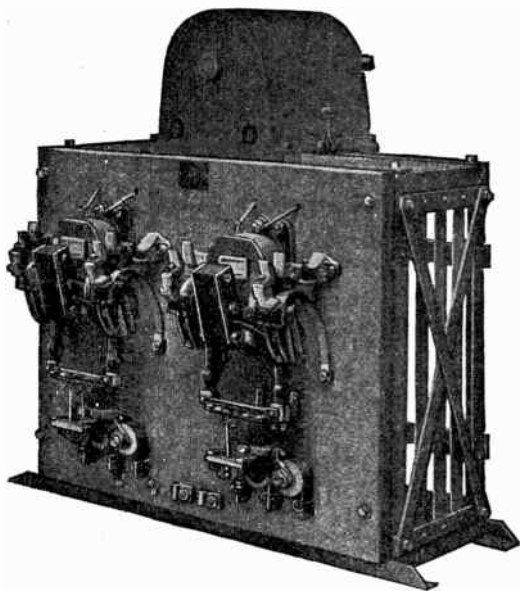

FIG. 4,176.—Cutler-Hammer alternating current, reversible, single speed, semi-mechanical controller with self-contained reverse switch for slow speed passenger or freight elevators; 25 to 60 cycle circuits with two or three phase slip ring induction motors where rated full load rotor circuit does not exceed 150 amperes per phase. *It consists of a three pole drum type reverse switch and a secondary self-starter, the two being assembled on the same frame and inter-connected.* The drum switch, which performs the functions of both line and reverse switch, controls the starting, stopping and reversing of the motor, and is designed to be suitably geared to the operating shaft of the elevator. As the reverse switch affords the only control over the line circuit, it is essential that the operating cable from the car be provided with a centering device. The acceleration of the motor is automatic and is accomplished by the secondary self-starter which is of the series relay type. Automatic stopping at the travel limits must be effected by the traveling nut device on the elevator machine.

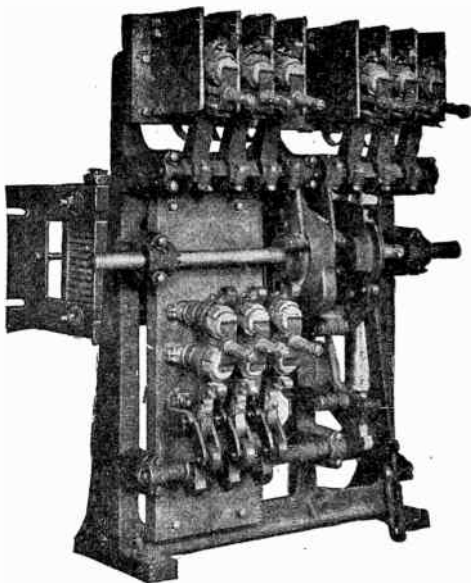

FIG. 4,177.—Cutler-Hammer alternating current, reversible, single speed, full mechanical controller for slow speed freight or passenger elevators; no electro-magnet or sliding contacts are used. It is primarily adapted for use in connection with polyphase alternating current slip ring induction motors and is arranged for rope or lever operation from the car. The operating shaft has an extension at each end so that the controller can be adapted for either right hand or left hand operation. *In construction* two separate panels are mounted on a cast iron frame. The resistance is of the cast grid type. The primary circuit is controlled by two sets of switch, each set consisting of three single pole switches, equipped with arcing shields, the switches being mounted on a square shaft and insulated. Each set is operated by a special internal cam, arranged so as to give an absolute knock out to the switches when opening, and also an absolute lock out for the second set when the first set is thrown in. Secondary resistance is cut out by three triple pole cam operated switches. *In operation*, immediately after the primary switches are thrown, a catch is released, allowing a weight to drop, the motion of which is retarded by a suction dash pot. The weight in turn drives a shaft on which the necessary cams are mounted for throwing in the secondary switches. The secondary resistance is cut out simultaneously in all three phases of the rotor circuit, thus insuring a balanced condition at all times. The secondary resistance is re-inserted upon the opening of the primary switches and a latching arrangement is also provided so as to prevent accidental operation of the controller, if the operating mechanism be not thrown to the central position. *In installing*, it is necessary to place heavy and substantial stops on the elevator machine so as to limit the angular throw of the controller operating shaft to 90 degrees from the central position in either direction of rotation. A notched star wheel gives an accurate indication of the "off" and "running" positions. Stops are provided on the controller in order to keep the parts in proper relation for shipment and to take care of excess overthrow of this shaft. They are not strong enough, however, to take the blow of the operating mechanism, and it is therefore necessary to provide stops of sufficient strength on the elevator machine.

these devices are used to *transmit* power from the motor to the car. The same mistake is made in the case of the automobile by ill advisedly using the word transmission to denote only the gear set, whereas it properly includes the entire system between the engine and rear axle, viz: clutch, gear set, propeller shaft, universal joints, bevel gear and differential.

Accordingly in the case of the elevator, the transmission consists of

1. Gearing between motor and drum;
2. Drum;
3. Cables;
4. Pulleys.

The term "electric engine" is used by elevator manufacturers to denote the motor, controller, drum and gearing between motor and drum. Presumably because these devices are usually incorporated in one unit, arises the erroneous usage of the term transmission.

Gearing between Motor and Drum.—There are several forms of gear used to secure the velocity reduction between the motor and drum, necessary in most types of elevator. These may be classified as

1. Belt;
2. Chain;
3. Spur gear;
4. Herringbone gear;
5. Worm and wheel gear.

Belt Drive.—In factories or other places where line shafting is kept running continuously elevators are sometimes driven from a countershaft, the latter being belted to the line shaft.

Very often the elevator machine is driven directly from the line shaft, and as the line shaft always runs in the same direction the only way in which the elevator machine can be reversed is by the use of two belts, one open and one crossed, as is done in the case of a metal planer in a machine shop; this form of elevator drive has already been described.

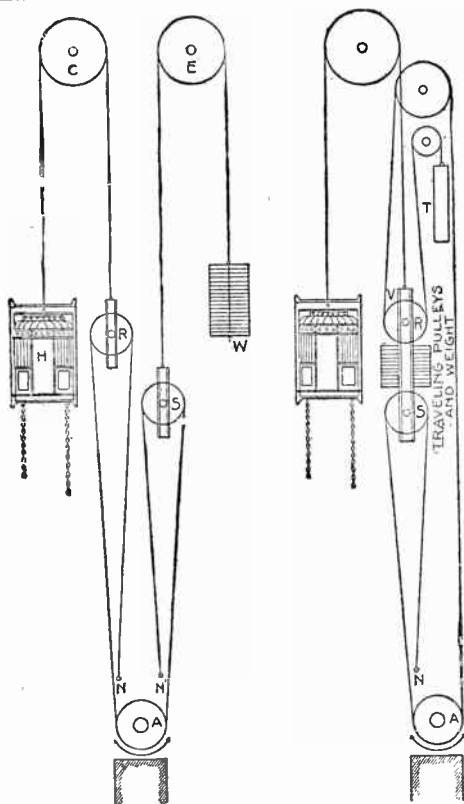

FIGS. 4,178 and 4,179.—Single motor traction drive with traveling pulleys. Fig. 4,178, primary form; fig. 4,179, modified form. This drive differs from the Fraser arrangement in that but one motor is used instead of two. The motor in this system runs at slow speed and, by means of the pulley A on the armature shaft, drives a set of cable, which passes under this pulley, thence over the traveling pulleys R and S, and has its free ends anchored at NN. The frames of the traveling pulleys are respectively connected by cables passing over the upper pulleys C and E with the car H and the counterweight W. *In the modified form*, the two traveling pulleys R and S are combined in a single frame V and a tension weight T is added as shown. *In operation*, the motor is controlled as usual from the car. It must be started to move the car and stopped to bring the car to rest. Both the car and counterweight move at half the peripheral speed of the driving pulley. If, however, the set of driving cable after passing over the pulley R and S be led under a pair of stationary pulley and then have their free ends connected respectively to the traveling frames R, and S, instead of anchored at the fixed points NN, the speed of the car and counterweight would be one-third the peripheral speed of the driving sheave. By further de-veoping this plan, different ratios of car speed to motor speed can be obtained.

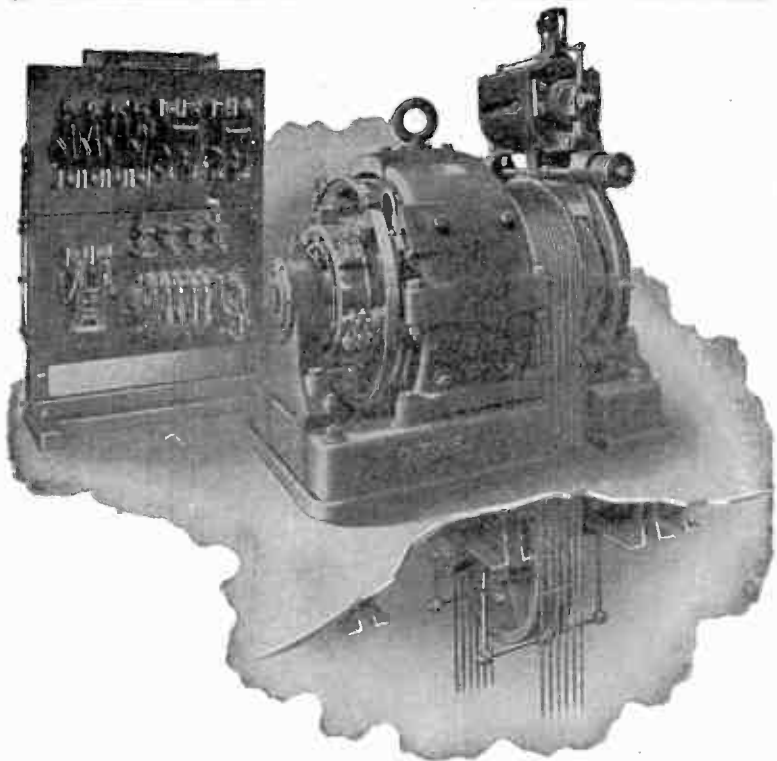
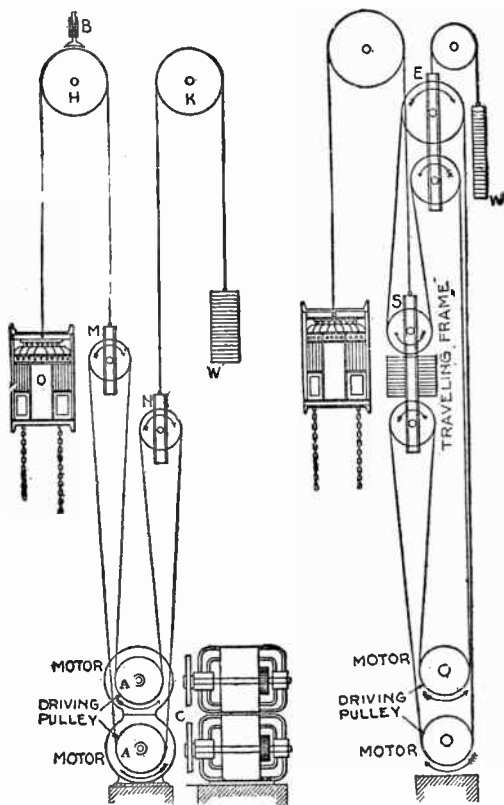

FIG. 4,180.—Otis 1 to 1 over mounted traction elevator machine, consisting essentially of a slow speed shunt wound motor, a traction driving pulley, and a magnetically released spring applied brake. Pull magnet control is used. The motor is so governed as to prevent excessive speed regardless of load. Automatic slow down near the travel limits is secured, attained by two multi-arm switches located on the car, one for the up and one for the down motion. These switches are operated by cams in the shaft that open the contacts, one after the other, as the car approaches the limits of travel. This automatic feature being independent of the operator in the car, is effective even though the car operating device be left in the full speed position. The usual safety devices installed in connection with modern apparatus, are used with this type of elevator, including speed governors, wedge clamp safety devices for gripping the rails in case of the car attaining excessive speed, and pressure switches. One safeguard resulting from the arrangement and the method of driving the cables, is the decrease in traction which follows the bottoming of either the car or the counterweight on their oil buffers. This minimizes the lifting power of the motor, until normal conditions are resumed. Inasmuch as in any properly constructed elevator the roping is so arranged that the counterweight will rest on its oil buffer before the car reaches the overhead work, or vice versa, it therefore will be seen that the above mentioned decrease in tractive effort is a very valuable and effective safety feature inherent in this type of elevator.



Figs. 4,181 and 4,182.—Fraser cable drive, designed to obviate the disadvantage of the large shaft space required for drum elevators in very high buildings, owing to the horizontal travel of the cables when winding. Fig. 4,181 primary form; fig. 4,182, modified form. *In the primary form*, the hoisting machine at C, consists of two motors, superimposed, each driving a set of endless cable by means of a pulley on its armature shaft. Two weighted sliding frames M and N, carrying pulleys, are driven by the endless cable. The frame M is connected to the car O by a cable passing over the upper pulley H, and the frame N is connected to the counterweight W by a cable passing over the upper pulley K. *In the modified form*, the traveling pulleys are combined in a single frame S, the tension on the endless cables being maintained by a weight W, acting on the pulleys in the frame E. *In operation*, when both motors are running at the same speed, and in opposite directions, the driving cables move without raising or lowering the car or counterweight. The motors, therefore, run continuously in the operation of the system regardless of whether the car be moving or standing still. A magnetic brake B, on the overhead pulley H, is operated when the car is to remain motionless, so as to prevent any slight variation in the speed of the

Horse Power of Belts.—There is considerable diversity of opinion in regard to the proper size of belt per horse power transmitted. If the working strain be 60 lbs. per inch of width, a belt one inch wide and traveling 550 ft. per minute will transmit one horse power; if the working strain be 30 lbs. per inch of width, a belt one inch wide traveling 1,100 ft. per minute will transmit one horse power. Numerous rules are given by different writers on belting which vary between these extremes.

A rule commonly used and one which can be recommended to give an amply large single belt for any service is: *a single belt one inch wide traveling 1,000 ft. per minute will transmit one horse power.*

This corresponds to a working strain of 33 pounds per inch of width. For double belts, twice the horse power may be transmitted.

Many writers give a safe practice for single belts in good condition, a working tension of 45 pounds per inch of width.

Ques. Mention some objections to belt drive?

Ans. Slippage, breakage, and running off the pulleys.

Chain Drive.—On some slow speed heavy duty elevators, a double reduction gear is used with chain drive for the first

FIGS. 4,181 and 4,182.—Continued.

motors tending to move the car. When motion is to be imparted to the car, one motor is speeded up, and the other motor is slowed down, thus, there will be a difference in the heights of the two cable loops. This difference is taken up by the motion of the sliding frames which, in turn, transmit their motion to the car and counterweight, raising the one and lowering the other, or vice versa, depending upon which of the two motors be running the faster. The speed of the car in either case will be half the difference of the peripheral speeds of the driving pulleys. The motors are shunt wound, and run normally at 400 revolutions per minute. The speed of either motor can be increased to 520 revolutions per minute or diminished to 280 revolutions per minute by means of a rheostat in the car which introduces resistance in the field of one motor and cuts it out of the field of the other motor. With driving pulleys 19 inches in diameter, the operator can thus vary the speed of the car from zero to 600 feet per minute. Owing to the small diameter of the pulleys, a special kind of cable consisting of a steel wire core covered with manila or hemp is used to secure the requisite strength and flexibility. A diagram showing the connections for this system is given in fig. 4,166. The advantages of the Fraser type of elevator, besides small shaft space required for its operation, are rapid acceleration and quick stopping, and the ability to reverse from full speed in one direction to full speed in the opposite direction without producing excessive strains or shocks in the apparatus. To counterbalance these features are the first cost and the operating cost of the system, both of which are greater than for the drum type of elevator.

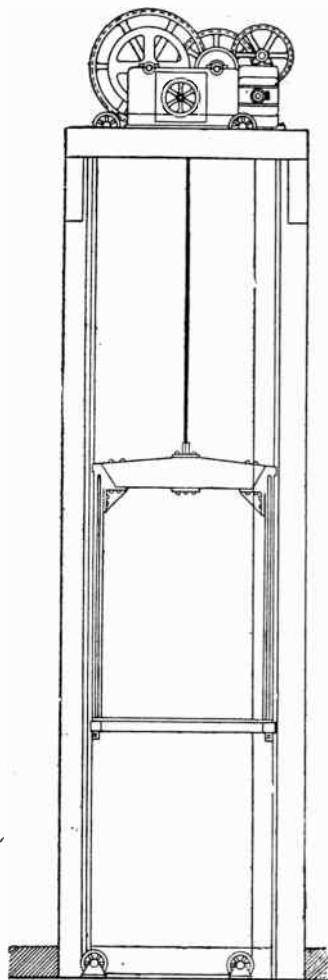

FIG. 4,183.—Northern spur geared elevator machine for freight and foundry elevator. The frame for the hoisting mechanism is self contained. A slow speed motor is used. The machine can be either over or under mounted or below the ceiling of any story with the rope carried over the pulleys.

reduction and worm gear for the second reduction. There are various types of chain that may be used, such as link, roller, and the so called "silent" chain. The latter is extensively used because of its quiet operation, but has the objection that when the multiplicity of toothed bars of which it is composed, become worn, thus unduly elongating the pitch, it must be replaced with a new chain.

Spur Gear Drive.—This well-known method of transmitting power is extensively used in elevator practice. It is a "positive" drive, as distinguished from belt drive which is subject to slippage. For moderate speed motors or machines in which the speed reduction between the motor and drum is not too great, spur gearing is well suited.

Obviously, where great speed reduction is required, as in installation comprising a high speed motor and slow speed elevator it is not so well suited because of the large diameter of the drum gear required or the

extra gears for double reduction necessary to obtain the necessary speed reduction. Clearly, such installations are best fitted with worm gear drive, as any speed reduction is easily obtained without the necessity of double reduction drive.

*Prof. Harkness, as a result of his investigation on the strength of gear teeth, found that all the formulæ on the subject might be expressed in one of three forms, viz:

$$\text{horse power} = \text{CVPF} = \text{CVP}^2 = \text{CVP}^2\text{F}$$

in which C is a coefficient, V=velocity of the pitch line in feet per second, P=pitch in inches, and F=face of tooth in inches.

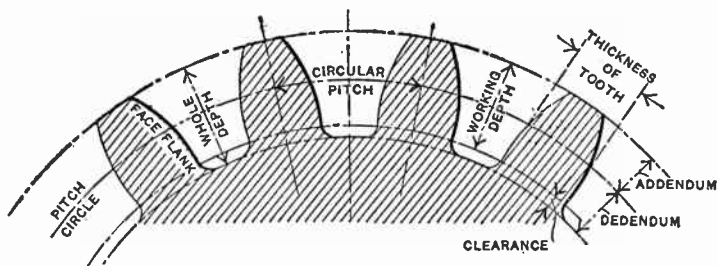

FIG. 4,184.—Gear tooth parts. **Systems of spur gearing.** Two systems of gear tooth are used for spur gears: the *cycloidal* and the *involute*. Of these, the involute system is the one more commonly used, especially for cut gearing. The standard involute gear tooth has a $14\frac{1}{2}$ degree pressure angle, hence the rack meshing with gears cut according to this standard has straight sides inclined $14\frac{1}{2}$ degrees from the vertical. **Definition:** *Circular pitch* is the distance from center to center of two adjacent teeth along the pitch circle. *Diametrical pitch* is a number found by dividing the number of teeth by the pitch diameter; that is, it gives the number of teeth for each inch of pitch diameter. **Internal spur gears.** The dimension of internal spur gears may be found by the same formulæ as those for external spur gears, except for the modification made necessary by the fact that the center distance in internal gearing is equal to the *difference* between the two pitch radii, instead of the *sum*. In addition, the term inside diameter takes the place of the outside diameter of external spur gearing. This diameter, of course, is the diameter of the hole in the blank before the teeth are cut. **In laying out** the shape of teeth for internal gearing, interferences are almost sure to be met with. The points of internal gear teeth must, therefore, be relieved to avoid interference with the flanks of the meshing teeth. **Interference occurs** also when the pinion has too nearly the same number of teeth as the gear. In this case there is a tendency for the points of the pinion and the gear teeth to strike as they roll into and out of engagement. To avoid this interference, the teeth must be cut by specially made cutters or shaped on a gear shaping machine.

NOTE.—The strength of gear teeth and the horse power that may be transmitted by them depend upon so many variable and uncertain factors that it is not surprising that the formulæ and rules given by different writers show a wide variation. In 1879 John H. Cooper (*Jour. Frank. Inst., July, 1879*) found that there were then in existence about 48 well established rules for horse power and working strength, differing from each other in extreme cases about 500 per cent. In 1886 Prof. Wm. Harkness (*Proc. A. A. S. 1886*), from an examination of the bibliography of the subject, beginning in 1796, found that according to the constants and formulæ used by various authors, there were differences of 15 to 1 in the power which could be transmitted by a given pair of geared wheel.

From an examination of precedents he proposed the following formula for cast iron wheels:

$$\text{horse power} = \frac{.91 \text{ VPF}}{\sqrt{1+.65V}}$$

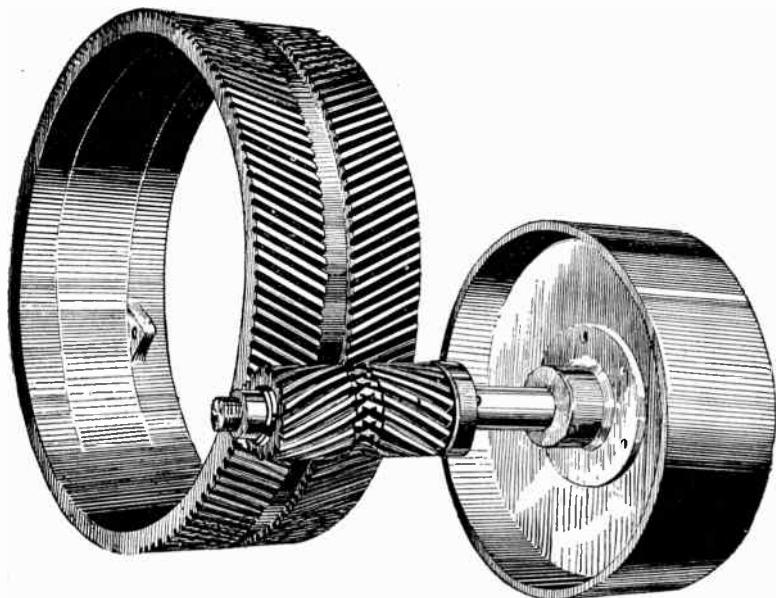

FIG. 4,185.—Gurney nerringbone gear, pinion, and brake pulley. The ratio between gears is about 5 or 7 to 1, and the teeth in gear and pinion converge from the center of its face outward at an angle of about 2½ degrees. There is nothing new about this type of spur gear, as it has been in use for mill purposes for at least a century. It was originally designed to impart a smoother motion to the driven machines and also to give greater strength to the teeth, but until recently the only method of producing it was by casting and, of course, cast gears were not applicable to elevator service. The advantages of the herringbone gear are a minimum of friction as compared with the worm and worm gear; smoother running than with the teeth cut straight across the face; and greater strength due to the diagonal position of the teeth, which allows a greater number of teeth to be in mesh with the pinion at one time.

Herringbone Gear Drive.—This form of gear, sometimes called double helical tooth gear is a type in which right and left hand spiral teeth are both used.

The advantages of herringbone gears may be stated as follows: The action is continuous and smooth; there is no shock when the load is transferred from tooth to tooth, and therefore wear is practically eliminated; the bending action of the load on the teeth is less than with straight spur gearing; the gears work almost silently and without perceptible vibration; back lash is practically absent and herringbone gears can be used for high ratios and for great velocities.



FIG. 4,186.—Detail of Kaestner and Hecht electric brakes. *In operation*, the brake is mechanically closed by the spring shown at the lower end, and electrically released by the solenoid at the top.

NOTE.—The fundamental principle of the action of herringbone gear teeth lies in the fact that all phases of engagement take place simultaneously for every position of pinion and gear, providing the relationship between pitch, width of face and angle of spiral is such that it insures a complete overlap of engagement. Since all the phases of engagement occur simultaneously, it is evident that the load is partly carried by tooth surfaces in sliding contact and partly by surfaces in rolling contact. The portions of the teeth farthest from the pitch line, which engage with sliding action, tend to wear away more rapidly than the portions nearest to the pitch line. The pitch line portion, however, is always carrying part of the load and the effect of wear at the ends of the teeth merely is to throw more load on the center portions, or in other words, there is a constant tendency to concentrate the load near the pitch line.

Ques. Describe the Wuest system of herringbone gears.

Ans. The right and left hand sides of the gears are stepped half a space apart and do not meet at a common apex at the center of the face, as in the usual type of herringbone gear.

This stepped form wears more evenly under extreme loads than the ordinary type.

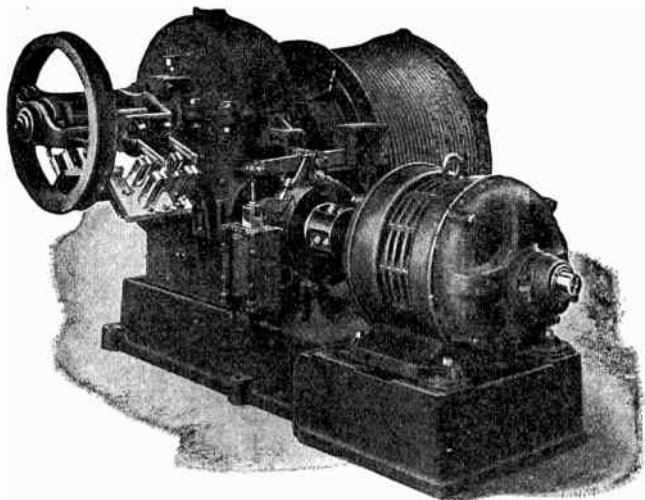

FIG. 4,187.—Albro-Clem internal geared electric elevator engine. This machine is sometimes furnished without internal gears, mounting the drum directly on the worm wheel shaft, using slightly higher pedestal and out board bearing on the drum. Either method being part of standard equipment. The internal geared machine is used for large capacity, slow speed elevators, while the omission of internal gears reduces the capacity and increases the car speed. This machine is built for either a. c. or d. c. current, using either electric or mechanical control in the car.

Worm Gear Drive.—This form of gear is very extensively used and is especially suited to slow speed elevators driven by high speed motors. A feature of worm gear drive is that it is self-locking because of the high velocity ratio, that is to say, no change in the loading of the car will produce movement.

In construction the gearing is enclosed in a cast iron box or casing which serves to protect the gears from dust and also to form a reservoir for oil used for lubrication. The worm is generally placed below the gear, in order that the worm may run in an oil bath. There are two kinds of gear:

1. Single gear;
2. Double or tandem gear.

Ques. Describe the single gear.

Ans. The worm is direct connected to the motor shaft, and in operation when it revolves, the spiral thread of the worm produces an endwise motion similar to that of a screw in a nut, but as the worm is prevented moving sidewise by a *thrust bearing*, it transmits motion to the teeth of the gear with which it meshes and causes it to revolve. This motion is transmitted to the drum which winds and unwinds the hoist cables.

Ques. What is the undesirable feature of single worm drive?

Ans. End thrust.

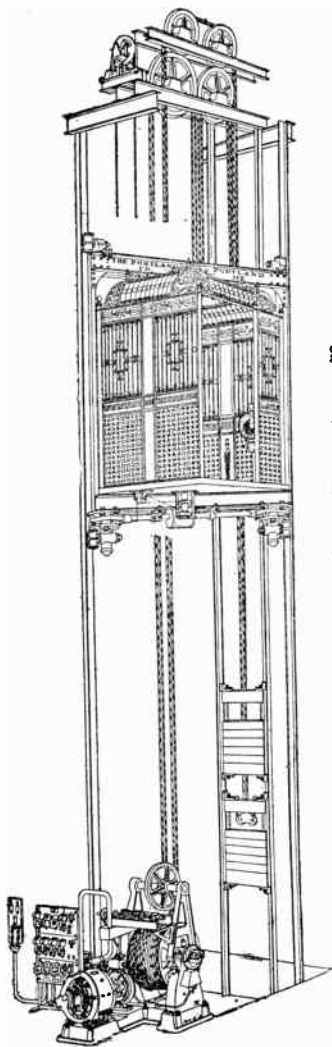
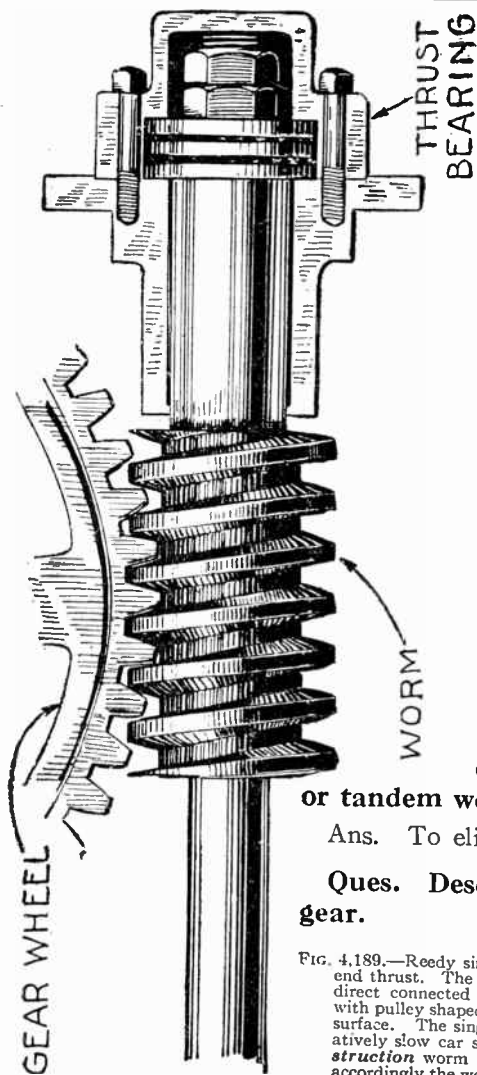

FIG. 4,188.—Portland undermounted worm drive drum elevator showing machine, car, shaft, counterweights, and arrangement of cables and pulleys, also controller and safety devices.



Clearly with a heavy load there is considerable pressure endwise on the threads of the worm which is accompanied by friction (loss of power) and wear, moreover a special form of bearing called a thrust bearing is required to take this end thrust.

Ques. Describe some forms of end thrust bearing.

Ans. For light service, discs of bronze and steel suffice to take the thrust; for medium duty ball bearings should be used; and for heavy duty, roller bearings.

The details of construction are shown in the accompanying cuts.

Ques. What is the object of a double or tandem worm gear?

Ans. To eliminate the end thrust.

Ques. Describe a double worm gear.

FIG. 4,189.—Reedy single worm drive with ball bearing end thrust. The shaft on which the worm is cut is direct connected to the motor through a coupling with pulley shaped flange which is used as a braking surface. The single worm drive is suitable for relatively slow car speed and light loads. In construction worm drives are arranged in oil, accordingly the worm is placed below the gear wheel.

Ans. Two worms, usually forged solid to one shaft are employed; one, a right hand worm, and the other left hand. These worms mesh with two gears of equal size.

As originally designed by the inventors, the worm gears used were made with straight faces, the teeth being cut at the angle of the thread of the worm, and the gears were set so that they meshed together as in fig. 4,190 and 4,191. Later some makers used spur gears in addition to two worm wheels and bolted them together in pairs as in figure 4,192.

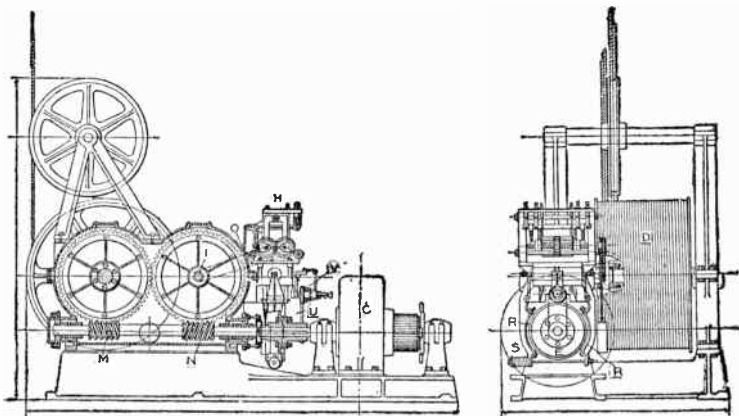

FIGS. 4,190 and 4,191.—Early design of tandem worm drive machinery in which the two gear wheels meshing with the two worms, mesh with each other. *In construction*, the gears are of bronze, cut on a spiral gear cutter, and the worms are a part of the steel worm shaft. The motor C is equipped with self-aligning, self-oiling bearings. Drum D is secured and driven by six coupling bolts fitted into a flange forged to the drum shaft. An electro-mechanical brake is used, the friction arms or shoes, RR, are made of cast iron, lined with cork formed to fit the brake wheel E. The pressure is applied by a spring S and released by energizing the magnet. The limit stop device is mounted on the brake magnet, and is driven by a sprocket chain O from the gear shaft I. The slack cable device consists of a balanced bar under the drum which acts upon the controller to stop the motor upon the slacking of the ropes. A centrifugal governor at V, driven by a belt U, from the worm shaft, applies the brake whenever the normal speed is exceeded. It will be noted that the casing around the worm drive forms a reservoir allowing the worms to run in oil, thus securing the most efficient lubrication.

The spur gears were enough larger in diameter than the worm gears to prevent the latter meshing.

Another and better construction is to use two spiral gears meshing together with the worms driving them.

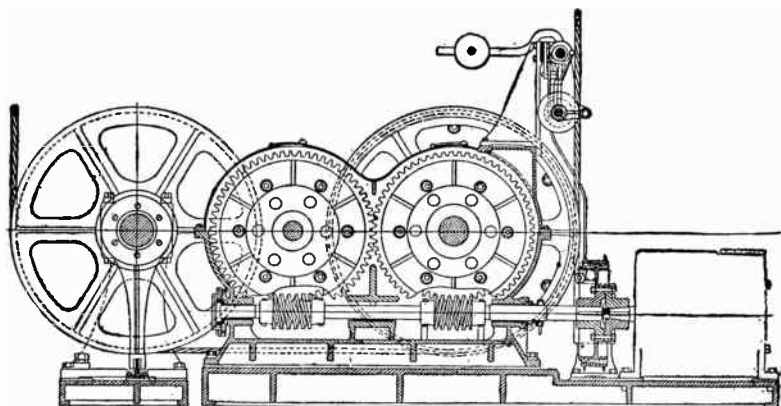

FIG. 4,192.—Tandem worm drive machine with independent concave face gears meshing with the worm as shown by the portions of the larger gears cut away above the worms. As shown, there are four gear wheels bolted together in pairs, the two larger ones meshing with each other, and the two smaller ones with the worms.

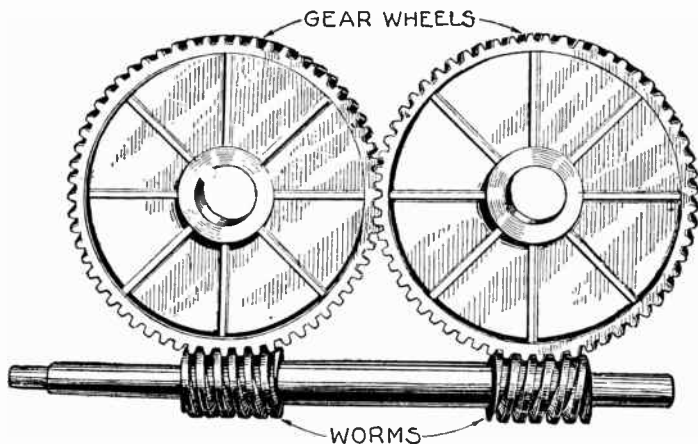

FIG. 4,193.—Reedy tandem worm drive. This type differs essentially from the single worm drive in that intermeshing right and left hand gears are used in place of the single gear. The use of the double gear has the advantage of dividing the pressure between the worm and gear so that greater loads and speeds are obtainable than are advisable with the single gear. The manner in which the gear wheels and worms intermesh produces, moreover, a three point contact which permits the gearing itself to compensate for any end thrust of the worm shaft, thus eliminating the necessity of thrust bearings.

Double Reduction Worm and Internal Gear Drive.—

For very slow heavy duty freight elevators, operated by high speed motors, the excessive speed reduction necessary is best obtained by double reduction drive employing a combination of worm and internal spur gear.

The general arrangement is shown in fig. 4,194, in which the worm drives a large spur gear which has attached to its shaft a pinion meshing with the internal gear on the drum.

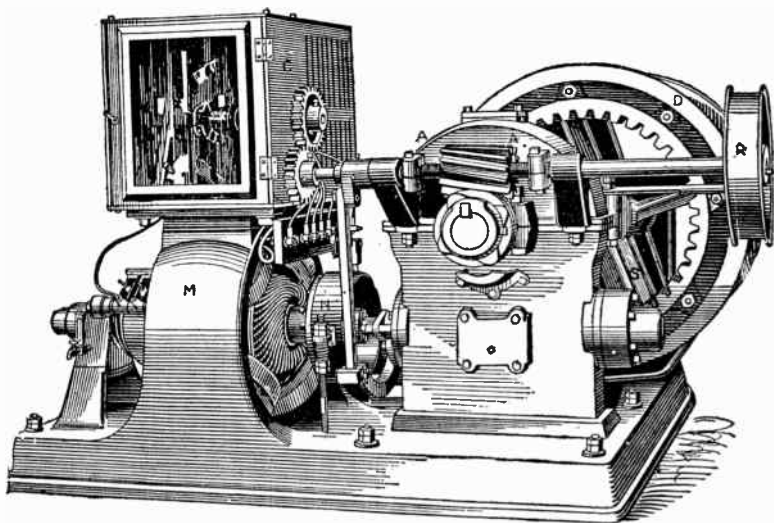

FIG. 4,194.—Warner internal spur gear freight elevator machine, fitted for mechanical control. The gear spider S and drum D are made in one casting with a heavy cast iron neck between them. On top, the motor M, is the controller box C, containing the switches and rheostat. N, is the brake, R, shipper pulley, and A A, the limit stop.

Ques. Why is an internal gear used?

Ans. In order that the drum will rotate in the same direction relative to the worm as in single reduction gear.

It is desirable that the drum in lifting the load should revolve so as to bring the thrust of the end of the worm shaft toward the back end of the gear case.

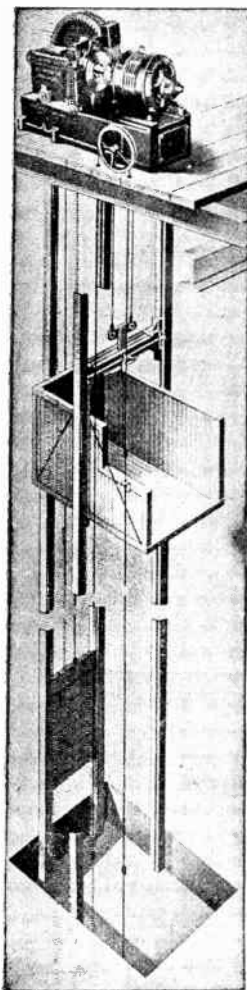

FIG. 4,195.—Albro-Clem internal gear worm drive freight elevator.

Drums, Cables, Pulleys, Counterweights.—These devices constitute that portion of the transmission that may be called the *final drive*.

On winding drum machines, the lifting and counterweight cables are attached to the drum, which is spirally grooved with a concave groove to receive and guide the cables.

The lifting and counterweight cables are so attached to the drum and arranged that, while the lifting cables are being wound up, the counterweight cables are being unwound, as shown in figure 4,188.

The idler pulley slides from side to side as the cables wind on or off. From the illustration it is clear, that they alternately use the same grooves in pairs. These grooves or scores as they are called, are, in the case of the overhead type, so made, that they run from the end of the drum toward the center one groove on each side

Ques. In the case of the overhead type, how are the grooves or "scores" made?

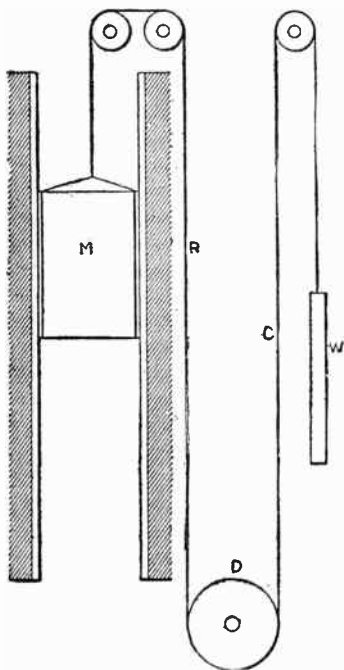

Ans. They are so arranged that they run from the ends of the drum toward the center, one groove on each side.

When the engine is set to one side of the shaft, either on a foundation or a suitable frame on one of the other floors of the building, the grooves run in pairs side by side from one end of the drum to the other and are made to lead right hand or left as the conditions require.

Ques. How are the counterweights arranged?

Ans. Two weights are used, as in fig. 4,188, one, which is attached to the drum to offset a certain percentage of the load to be lifted, and another to counterbalance the car. The latter weight travels in the same runways as the

FIG. 4,196.—Usual method of proving the counterweight. As shown the counterweight *W* is joined to the drum *D* instead of to the car *M*, the connecting cable *C*, being wound around the drum in the opposite direction to that in which the hoisting rope *R* is wound, and anchored thereto. As the drum rotates, the two ropes or sets of rope move in opposite directions; the one set is therefore wound into the grooves on the drum left free by the unwinding of the other set. The counterbalance is generally given a weight equal to the weight of the car and its fixtures plus the weight of the average live load. When the average load is being carried by the car, the elevator is balanced, and the motor need then furnish only sufficient power to start the car and keep it moving against frictional resistances. With a live load in excess of the average, the motor will be required to furnish more power in raising the car and less power in lowering it. Thus, with a load in the car equal in weight to the maximum load, the power supplied by the motor on the up trip must be sufficient to raise the number of pound represented by the difference between the maximum load and the average load. On the down trip, however, the maximum load may be sufficient to lower the car without requiring any power from the motor. On the other hand, if the car be empty on the down trip, the motor must provide sufficient power to raise the weight of the counterbalance which, as previously stated, is generally equal to the weight of the car and its fixtures plus the weight of the average live load. In ordinary passenger service, the average load carried by an elevator is usually less than one-half the maximum load for which the car is designed, very often not more than one-third the maximum load.

Before Starting.—The main switch connecting the motor with the supply circuit must be closed. This switch should not be closed, however, until it is positively known that the hand rope, pilot wheel, lever, or switch of the operating device in the car is in its off position.

Starting.—In all cases in order that a reasonable the acceleration must be

In starting, considerably more normal speed, and the more abrupt the stress in the various parts of the

Stopping.—An abrupt on the braking apparatus.

the car should be started gradually, although average speed be maintained between floors rapid.

power is required than after the car has reached its start the greater this abnormal power and the greater equipment.

stopping of the car produces a severe stress If the stops be made within the distance

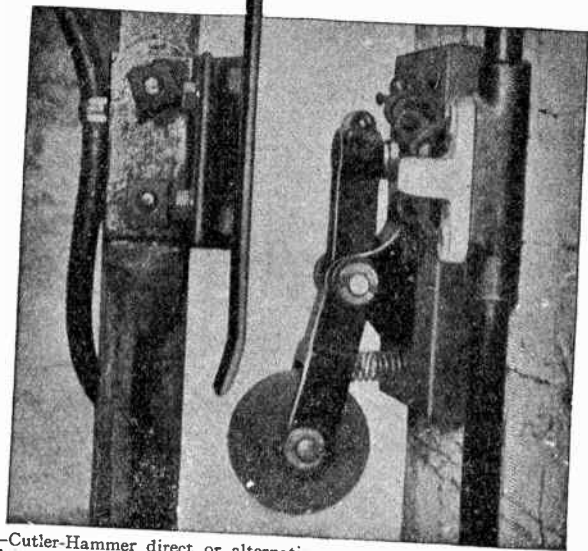

FIG. 4,200.—Cutler-Hammer direct or alternating current single pole shaft limit switch. It consists of a slate base on which is mounted a pivoted arm carrying a large roller at one end and a carbon contact button at the other. A coiled spring, bearing against the roller end of the pivoted arm tends to keep the carbon button in close contact with a stationary carbon contact. When mounted in the shaft, the limit switch is so placed that, should the car fail to stop before reaching the switch, the roller comes in contact with a cam surface on the car and is forced back a little, this slight movement being sufficient, however, to raise the opposite end of the pivoted arm, opening the control circuit. If preferred, the switch can be so placed that it will be operated by the counterweight instead of by the car. Where shaft limits are used throughout as in the case of traction elevators, ordinarily one shaft limit is used for slow down, two for final stop (as this must be double pole). For speeds over 300 feet per minute, additional limit switches should be used for slow down.

that the operator can see the landing at which he aims, the best results will be obtained for moderate speed cars. This allows the operator about eight feet in which to bring the car to a stop from full speed. A skillful operator can readily do this, but an unskillful one may require a much longer distance.

Sudden Reversal.—On account of the waste of power and the strain on the apparatus, it is advisable not to suddenly reverse the direction of travel of the car; also, to bring the floor of the car on a level with the landing at the first stop, not run past and then back up, or stop too soon and thus have to start and stop again.

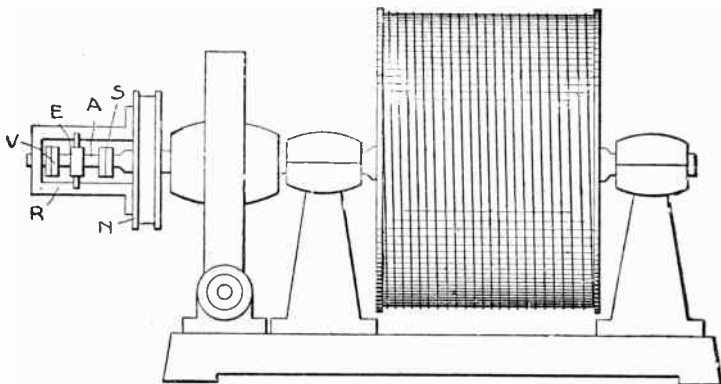

FIG. 4,201.—Machine limit stop or safety device placed on the machine to prevent over travel in case the stops on the shipper rope become inactive by the breaking of the rope. *It consists of* a threaded extension *A* on the drum shaft upon which a traveling nut *E* moves in a fixed ratio to the movement of the car. The shipper rope pulley *N* is on that portion of the drum shaft which is not threaded, and carries a bracket *R* that extends over the threaded portion. Owing to two lugs on the nut *E* which fit in slots in the bracket, the nut can move only parallel with the shaft when the drum rotates unless the shipper rope sheave *N* moves also. On each side of the nut *E* there are claws that engage with similar claws on the inner sides of the nuts *V* and *S* when *E* and *V* or *E* and *S* come together. Check nuts on the outer sides of the nuts *V* and *S* securely clamp the latter to the drum shaft, so that when the nut *E* engages either with *V* or *S* it will, by means of the bracket *S*, shift the shipper rope sheave *N*, thus cutting off the current from the motor and applying the brake. If the nuts *V* and *S* be located on the threaded portion of the shaft so that contact is made between them and the nut *E* when the car reaches its limits of travel, the operation of the device will stop the car automatically at both these points.

By giving attention to these points, not only will the power used, and therefore the operating expense be reduced, but the useful life of the motor starter contacts will be prolonged. These contacts suffer most from the sparking and flashing produced by switching off the current when the motor has just started or while it is running very slowly.

Motor Starter Contacts.—These contacts should always be kept smooth and bright. A piece of fine sand paper rubbed over them is the

best means of producing the desired result. After sand papering, the loose particles should be blown out with a bellows.

The bearings and cams of the motor starter should be kept clean and well oiled, and if a dash pot be provided to prevent the contact arm moving over the contacts faster than is necessary to secure the proper acceleration of the motor, this should be adjusted so that the arm will descend in from five to seven seconds.

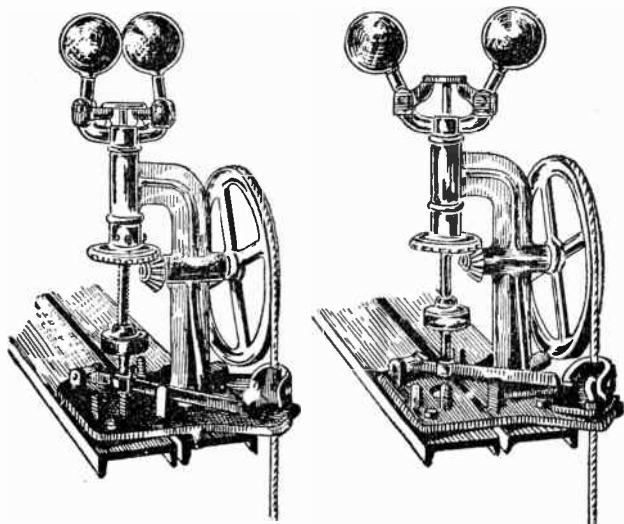

Figs. 4,202 and 4,203.—Gurney centrifugal safety governor. Fig. 4,202, governor under normal operating conditions; fig. 4,203, governor in operation through car exceeding a predetermined speed. The governor is located at the top of the shaft and directly connected to the car safety. *When the car exceeds a predetermined speed*, for which the centrifugal governor is adjusted, the car safety is automatically brought into action, gradually stopping the car and locking it securely to the guides by a powerful gripping pressure. Non-corrosive metal is used for the operating parts of this device, insuring its being in working condition at all times. There are no springs in the governor to assist or retard the action of the balls.

As the retarding action of the dash pot may be overcome by gravity, a spring, magnetic attraction, or by the motion imparted from the motor, the shafting, or the elevator machine, the method of adjustment will depend upon which form of motor starter be used.

Caution in Adjusting.—An important point to remember in connection with the cleaning, oiling, or adjusting of the motor starter,

and in fact in connection with the cleaning, oiling, or adjusting of any parts of the elevator equipment, is to open the main switch connecting the motor to the supply circuit before commencing these operations; this will tend to prevent accidents of an electrical or a mechanical nature.

Car Stops.—If, in the operation of an elevator, the car stop for some unknown reason, the operator should at once shift his controlling device in the car to the off position. If, then, upon shifting the controlling device again to start, the car refuse to move in either direction, some one of the following occurrences has probably taken place: It may be that the car or counter weight has met with some obstruction and the slack cable device has operated; that there is a poor contact in the switch or connections; that the fuse or circuit breaker has opened the

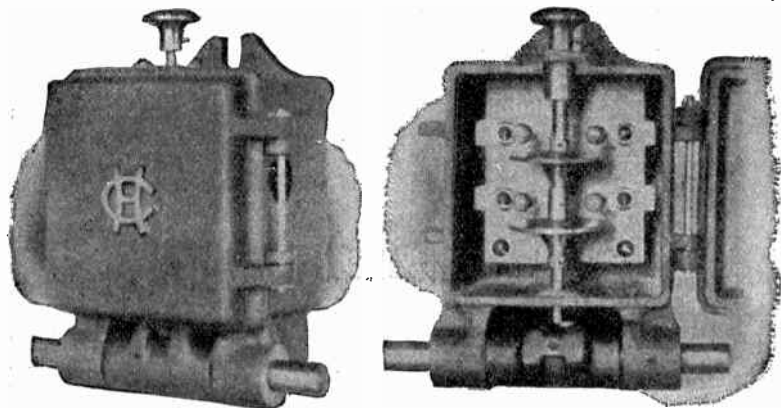

FIGS. 4,204 and 4,205.—Cutler-Hammer direct or alternating current double pole slack cable switch for use with controllers. Fig. 4,204, case closed; fig. 4,205, open. *In construction* the switch is enclosed in a cast iron case from which projects a shaft designed for attachment to the slack cable arm of the winding machine. *In operation* should the cable become slack, the movement of the slack cable arm through an angle of a few degrees in either direction serves to trip the switch, opening both sides of the line to the control system and stopping the car. The slack cable switch cannot be automatically reset, but after having tripped out must be reset by hand, thus compelling the operator to go to the source of the trouble before the elevator can be again operated.

motor circuit; or that the current has been turned off the supply wires. In any case, the motor should be examined before starting, to see that no damage has been done to it.

Car Stops between Landings.—When this happens, owing to a failure in supply of power, an effort should be made to have the main switch opened, the brake released, and the worm shaft turned either by pulling on the brake pulley or with a wrench on the end of the armature shaft so as to bring the car to a floor landing and allow the passengers to get out.

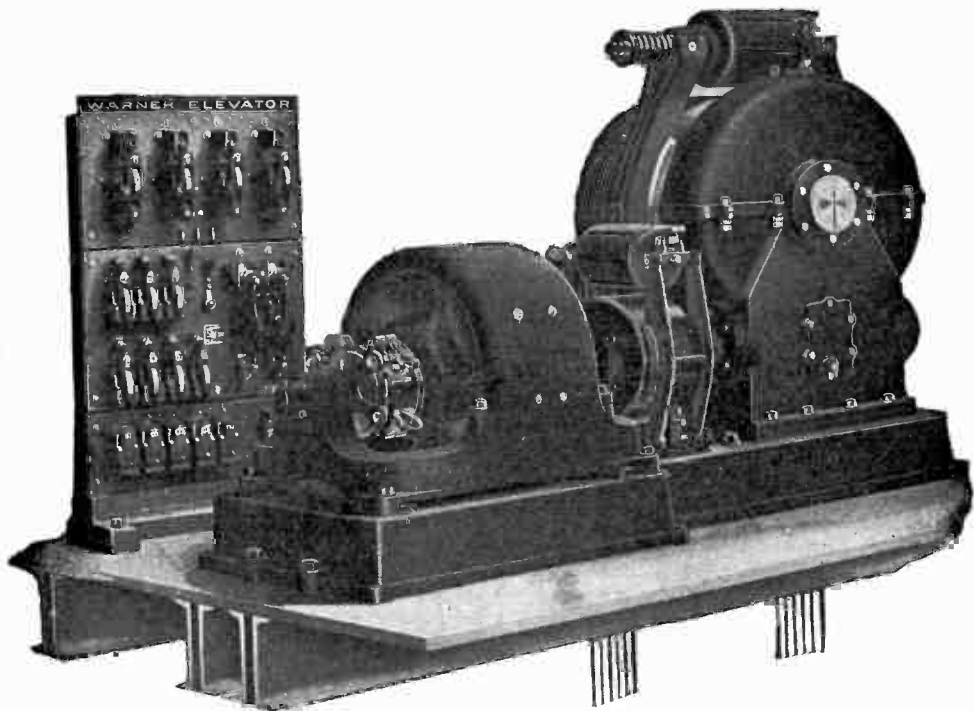

FIG. 4,206.—Warner worm drive over mounted traction elevator machine with control board; for speeds up to 600 feet per minute. The largest machines are ball bearing throughout. The motor is of the interpole type. The switches have metal contacts, except the pressure switch, which has copper and carbon contacts.

In some elevator motors, the free end of the armature shaft is purposely made square to facilitate turning the shaft with a wrench as just mentioned.

Car Beyond Control.—If the operator find he has lost control of the car and cannot stop it, he should not become frightened but allow it to make the full run, relying on the limit stops to automatically bring the car to a standstill at either end of its travel.

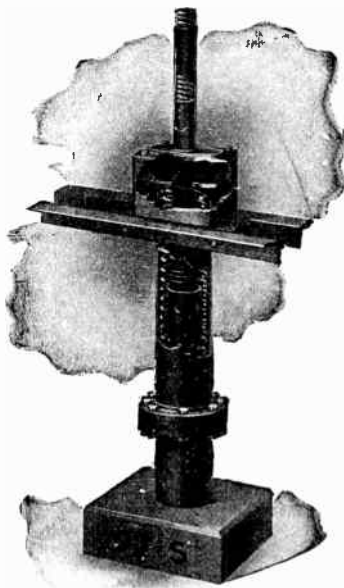

FIG. 4,207.—Otis spring return oil buffer or cushion. These are placed in the shaft one under the car and one under the counterweight, and are arranged to bring either the car or the counterweight to a positive stop, through the telescoping of the buffer—this occurring at a carefully calculated rate of speed, which is regulated by the escape of oil from one chamber of the buffer to another.

Limit Stops.—The operator should not rely on the limit stops to make a top or bottom landing, but should operate the controlling device in the car as he would to make any intermediate landing. It is advisable, however, to test the adjustment of the limit stops and determine if they remain in proper working order by trying them once daily by means of the car.

Caution While Car is in Motion.—The operator should never leave his car while it is in motion, and he in turn should never allow a passenger to enter or leave until the car has stopped at a landing.

The majority of elevator accidents have resulted from carelessness in observing this simple rule, showing that more attention should be given it by operators than heretofore has been the custom. As the operator opens the doors at a landing he should call out "up" or "down," depending upon the direction in which the car is making the trip, and while he should allow ample time for passengers to reach the car from wherever they may be standing, it may be necessary in certain cases to add, "step lively, please."

Leaving Car for the Night.—When the elevator is left for the night, the car should be brought to the lowest landing and allowed to remain there. Care must be taken to open the main switch connecting the motor to the supply circuit, before leaving the premises. In fact, whenever the car is to be left idle for any length of time, this switch should be opened to prevent any possibility of the motor starting up and causing damage.

CHAPTER LXXIX

ELECTRIC CRANES

By definition, a crane is *a machine for lifting, lowering and moving a load in a horizontal direction*, as distinguished from a hoist which simply lifts and lowers a load.

The numerous and diverse conditions of service require a multiplicity of type, and accordingly cranes may be classified:

1 With respect to the motive power, as

- a. Steam;
- b. Pneumatic;
- c. Hydraulic;
- d. *Electric.*

2. With respect to the character of the horizontal motion, as

- | | | |
|-----------|---|--|
| a. Rotary | { | swing cranes;
jib cranes;
column cranes;
pillar cranes;
pillar jib cranes;
derrick cranes;
walking cranes;
locomotive cranes. |
|-----------|---|--|

- | | | |
|----------------|---|---|
| b. Rectilinear | { | bridge cranes;
tram cranes;
traveling cranes;
gantry cranes. |
|----------------|---|---|

- c. Combination rotary and rectilinear.

In addition to these, there are some miscellaneous types known as

1. Sheer legs;
2. Transporters;
3. Telfers {cableways;
mono-rail systems.

The following definitions of the various type show the inherent features of each:

Swinging cranes.—Having rotation, but no trolley motion.

Jib cranes.—Having rotation and a trolley traveling on the jib.

Column cranes.—Identical with the jib cranes, but rotating around a fixed column (which usually supports a floor above).

Pillar cranes.—Having rotation only, the pillar or column being supported entirely from the foundation.

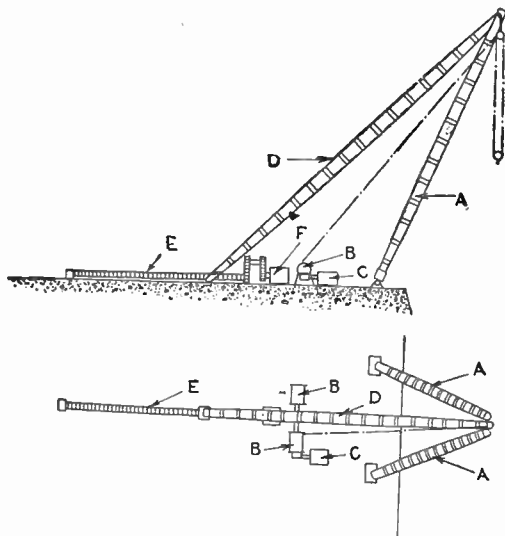

FIGS. 4,208 and 4,209.—Sheer legs. This is a type of lifting appliance used for handling extremely heavy loads such as ship's boilers and heavy guns. The load rope passes over a pulley at the head of the legs A and is led to the winding drum B, which is driven by the motor C. The bottom of the back leg D is traversed by a screw E, driven by the motor F so as to traverse the load in or out. Occasionally a second hoisting drum and motor are provided to handle light loads at quick speeds. It will be noted that with this type of crane, loads can only be picked up and deposited along a horizontal line which is a continuation of the center line of the screw.

Pillar jib cranes.—Identical with the last, except in having a jib and trolley motion.

Derrick cranes.—Identical with jib cranes, except that the head of the mast is held in position by guy rods or stiff legs, instead of by attachment to a roof or ceiling.

Walking cranes.—Consisting of a pillar or jib crane mounted on wheels and arranged to travel longitudinally upon one or more rails.

Locomotive cranes.—Consisting of a pillar crane mounted on a truck, and provided with power capable of propelling and rotating the crane, and of hoisting and lowering the load.

Bridge cranes.—Having a fixed bridge spanning an opening and a trolley moving across the bridge.

Tram cranes.—Consisting of a truck, or short bridge traveling longitudinally on overhead rails, and without trolley motion.

Traveling cranes.—Consisting of a bridge moving longitudinally on overhead tracks, and a trolley moving transversely on the bridge.

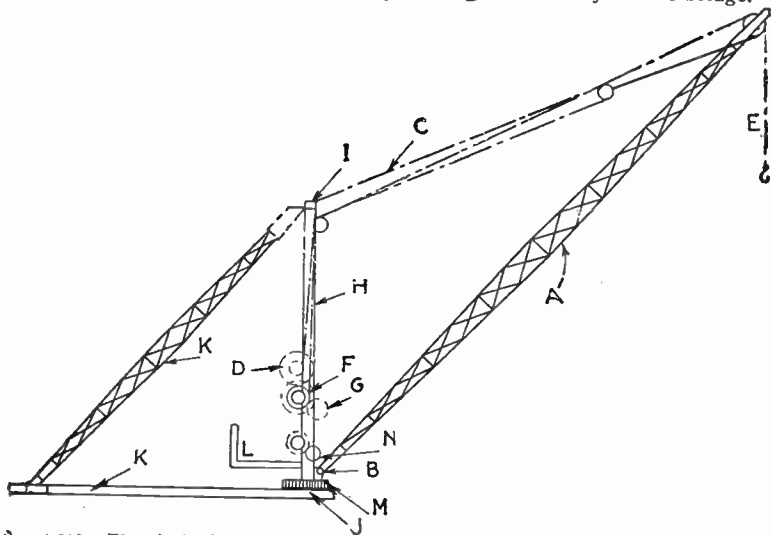

FIG. 4,210.—Electric derrick crane. The load hangs from the end of the jib A, which is supported by the pin B, and rope C, which leads to the jibbing drum D, by which the jib can be lowered. The load rope E, is led to the drum F. Drums D and F are driven by motor G. A clutch is provided by which the drum D may be put in or out of gear with drum F. When D is out of gear, the drum F is used to lift or lower the load. When the two drums are clutched together they run in opposite directions, so that when drum D is hoisting the jib, drum F pays out the load rope, and vice versa. Thus, whether the jib is being lifted or lowered, the load remains steady, and simply runs in or out in a horizontal line. The jib and the motors and gearing are carried by the vertical mast H, which turns in bearings I J in the framing K. The driver's platform L is also attached to the mast, and the various controlling switches and levers are placed on this platform. To slew the mast and jib, a toothed wheel M is fastened to the framing and gearing. With this is provided a pinion, the shaft of which is carried in bearings on the mast, and is driven by the slewing motor N. This type of crane will serve an area having a radius equal to the maximum horizontal radius of the jib, and forming a segment of a circle embracing an arc of rather less than 270 degrees.

Gantry cranes.—The same as a traveling crane except that the bridge member is supported on structural legs of suitable height, which are provided with wheels and suitable gearing, so that the crane may be propelled bodily along the tracks which are on the ground.

Rotary bridge cranes.—Combining rotary and rectilinear movements and consisting of a bridge pivoted at one end to a central pier or post, and supported at the other end on a circular track, provided with a trolley moving transversely on the bridge.

Essentials of Rotary Cranes.—In this type of crane, the construction is such as will permit the load to be lifted, lowered,

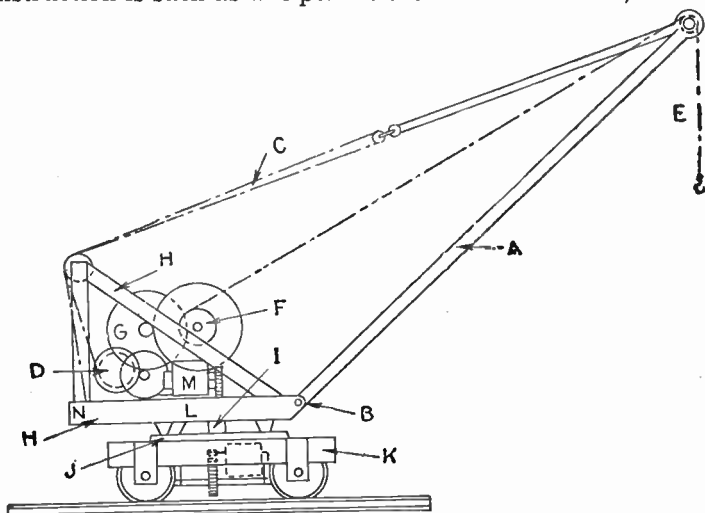

FIG. 4,211.—Electrical locomotive jib crane. The essential parts are: A, jib; B, jib pivot; C, rope gear serving as a brace for jib, and which controls the radial position of jib; D, jib shifting drum; E, hoisting rope leading from hook; F, hoisting drum; G, hoisting motor; H, framing; I, pin; J, turning or slewing wheel; K, truck; L, pinion; M, turning and propelling motor.

and moved radially. An example of rotary crane is shown in fig. 4,211, which illustrates the essential features of a locomotive jib crane.

As shown in the figure, the hook, which engages the load, hangs from the end of the jib A, which is supported by the piece B, and rope C, which leads to the drum D. By winding in or paying out the rope

C, the radius of the jib in the horizontal plane can be increased or diminished.

The rope for hoisting the load is brought over a pulley at the head of the jib and led to the drum F. Drums D and F are usually arranged to be driven from one motor G, clutches being so arranged that when the motor is in gear with the one drum, it is out of gear with the other. The jib and hoisting gear are carried by the framing H, which turns upon the pin I, the turning or slewing being accomplished by means of the wheel J, which is secured to the platform of the truck K and pinion L (carried by bearings in the framing H), which is driven by the motor M.

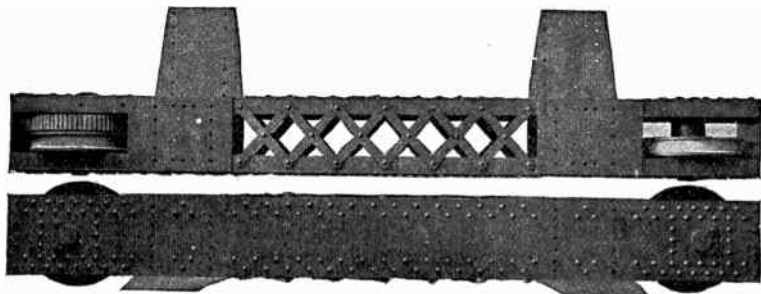

Figs. 4,212 and 4,213.—Niles crane construction: bridge ends or trucks. The bridge ends are built up of plates and angles, as illustrated, or of heavy steel channels or I beams, depending upon the type and capacity of the crane. Heavy gusset plates connect the girders and bridge ends, and prevent the girders getting out of square. All connection holes are drilled and reamed after the parts are assembled and squared. In best construction, finished body bound bolts with lock washers are used for connecting these parts. The truck wheels are bronze bushed, extra heavy, and double flanged, the treads being accurately finished to equal diameters. They revolve on turned steel axles of large diameter, which are fitted in bored holes in the reinforced bridge ends and securely held by key plates. This construction gives large bearing surfaces and extremely low bearing pressure values, ensuring minimum wear. Bronze washers are provided between the hubs of the truck wheels and the web plates. The truck wheel gears have teeth cut from solid stock and are forced by hydraulic pressure on the hub of the truck wheels and keyed. The bridge ends extend beyond the wheel and are capped at the ends with a removable steel plate, provision being made for attaching wooden bumper blocks, which prevent the wheels and gears of two cranes coming in contact when several cranes are on the same runway. The truck wheels may be easily removed by taking off the steel caps, jacking up the bridge ends just enough to remove the weight from the wheel, withdrawing the axle and rolling the wheel out. Lubrication of the truck wheels is provided by internal oiling through the center of the axle. The bridge drive shaft is carried at the ends by self-oiling cap bearings, so located as to eliminate overhung gears or pinions.

It is usual for the framing to be capable of making a complete circle. The motor M is also used to drive the truck along the rails.

A vertical shaft driven from this motor passes through the pin I, and drives one or both of the axles by means of bevel gear. Clutches are provided so that the motor M may be used for slewing or traveling.

The load is balanced by the weight *N*. A foot plate for the operator is provided on the framing just in front of the balance weight, and the controllers and clutch levers are within easy reach.

Ques. What area is served by a locomotive jib crane?

Ans. It is equal to twice the maximum radius of the jib, and a length depending on the length of track laid.

Ques. What is the effective radius of the jib?

Ans. Its projection on the horizontal plane passing through the pivot on the lower end of the jib.

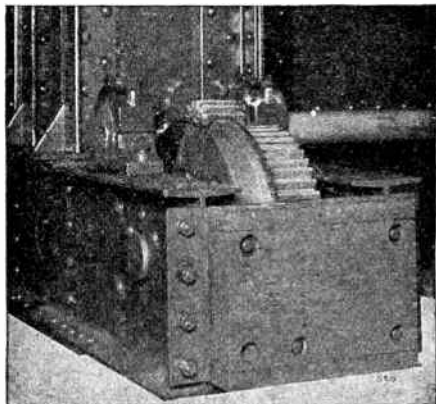

FIG. 4,214.—Niles crane construction: Bridge end trucks showing the two bearings for bridge drive shaft and the steel plate with bumper block at end of truck.

Ques. What is the most economical position of the inclined brace in a jib crane?

Ans. The position in which the inclined brace intersects the jib at a distance from the mast equal to $\frac{4}{5}$ of the effective radius of the jib.

Essentials of Rectilinear Cranes.—This form of crane differs from the preceding type in that the load is moved linearly

instead of radially. The essential features of rectilinear cranes are shown in fig. 4,215, which illustrates a rectilinear crane of the traveling type.

In construction a pair of cross girder AA, known as the bridge, are supported on the end carriages BB. The wheels of the end carriages run on rails mounted on elevated structures or *gantries* CC. The purpose of the crane is to lift, transport, and deposit loads anywhere within an area a little less than the width between the gantries and of a length depending on the length of the gantries. Rails are laid on the cross girders AA, and a crab or trolley runs on these rails.

The trolley has two motions, each driven by its own motor.

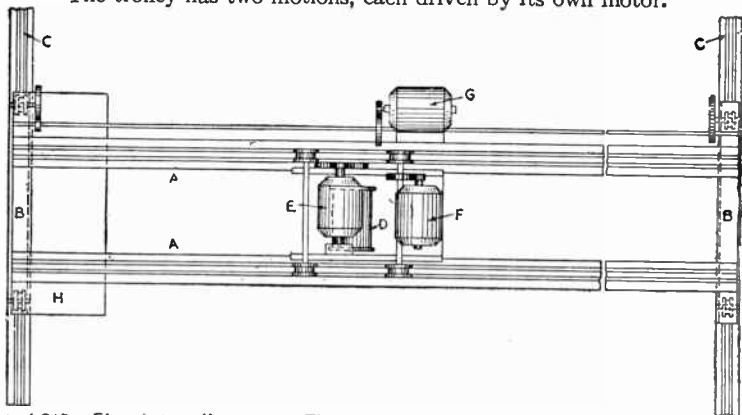

FIG. 4,215.—Electric traveling crane. The parts are: AA, cross girders known as the *bridge*; BB, end carriages; CC, elevated track structure or *gantries*; D, hoisting drum; E, hoisting motor; F, transverse propelling motor; G, longitudinal propelling motor; H, cage or operator's platform.

The hoisting motion, for lifting and lowering the load, consists of the drum D, driven through suitable gearing by the motor E.

To traverse the crab along the cross girders, the motor F drives one pair of wheel through gearing.

For the purpose of traveling the crane along the gantry, the motor G is mounted at the center of one of the cross girders, and from each end of the motor, a shaft is led to drive one wheel in each of the end carriages.

Ques. What is the object of mounting the traveling motor at the center of the cross girders?

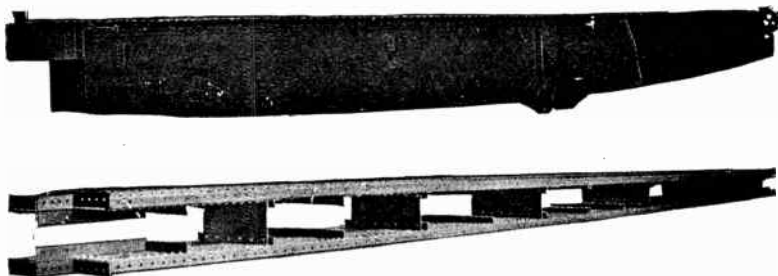

FIGS. 4,216 and 4,217.—Niles crane construction: Box section bridge girders. The standard box section girders are built up of two web plates, four heavy angles and universal mill top and bottom cover plates. The web plates are reinforced at frequent intervals by heavy vertical angles and connected together by diaphragms to prevent vibration and skewing diagonally when the crane is started suddenly. All holes in the angles and plates composing the girders are laid out to templates, and after being assembled, are reamed to the proper size to receive the rivets without the use of drift pins. The bridge motor is bolted in a horizontal position to a heavy structural steel bracket, riveted to the girder adjacent to one set of vertical angles and diaphragm plates connecting the web plates described above, in order to prevent distortion of the girders. At the ends of the girders are placed heavy vertical and horizontal angles which reinforce the webs and serve as a connection to the bridge ends.

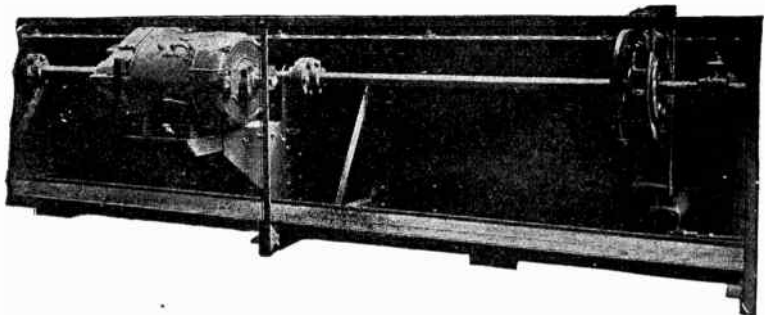

FIG. 4,218.—Niles crane construction: Bridge drive for box section girders. The web plates of the box section girders are reinforced by heavy stiffening angles, placed near the bridge drive motor and are connected by diaphragms, preventing distortion of the girders by motor or gears. The bridge motor is bolted in a horizontal position to a heavy structural steel bracket riveted to the girder. The motor gear and pinion are enclosed and run in self-oiling bearings. The cross shaft is of extra heavy steel and is sufficiently strong to skid the truck wheels with the crane fully loaded, thereby preventing distortion in the shaft due to careless handling. The shaft is supported at uniform intervals by adjustable split babbitted bearings which can be removed without disturbing any other part. They have oil reservoirs and are provided with wick feed lubrication. The truck wheels are extra heavy with double flanges, the treads being accurately machined or ground to equal diameters. A powerful foot brake of the post type is provided, operated by a foot lever conveniently located in the cage. The brake is simple in construction and extremely powerful in action. A substantial platform with angle iron hand rail extends along the girder on the bridge drive side, providing easy access to the bridge motor, gears and bearings.

Ans. To obtain an equal amount of twist in both parts of the shafting, so as to avoid cross wind.

Ques. What is the cage?

Ans. A platform or housing for the operator, and containing the control devices.

Ques. Where is it located?

Ans. It is attached to the bridge at H, fig. 4,215. This position gives the operator a clear view of the hoisting operations.

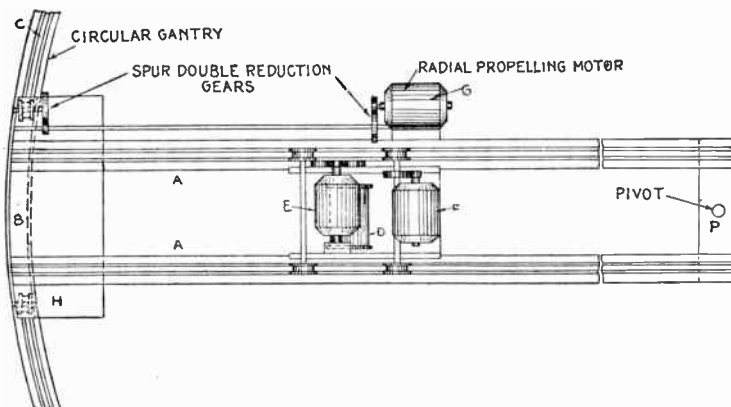

FIG. 4,219.—Electric combined rotary and rectilinear crane. *In construction* most of the parts are identical with those of fig. 4,215, and the letters on these parts are the same for each figure. This type differs from fig. 4,215, in the replacement of one gantry by a pivot P, and the other straight gantry by a circular gantry which may be either an arc or a complete circle as desired.

Essentials of Combined Rotary and Rectilinear Cranes.

—A modification of the traveling crane, which combines the functions of the two classes, rotary and rectilinear, consists in pivoting one end of the bridge of a traveling crane and supporting the other end on a circular gantry as shown in fig. 4,219.

The illustration shows the most of the mechanism to be identical with that of the traveling crane.

One end of the bridge is pivoted at P and at the other end, a section of the circular gantry is shown.

In construction the circular gantry may continue all the way around or only for a short arc, as may be desired. The figure clearly shows that the rotary motion is obtained by operating motor G, and the rectilinear motion, by motor F, while hoisting and lowering is effected by motor E.

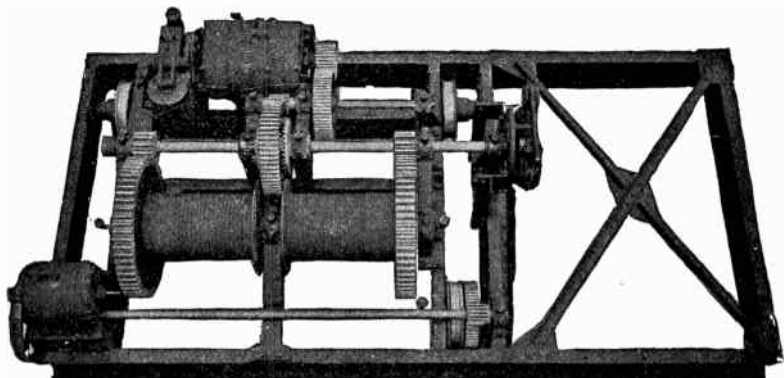

FIG. 4,220.—Niles crane construction: Standard grab bucket trolley suitable for operation with a two rope grab bucket, one rope being attached to bail of bucket and the other attached to the opening mechanism. The trolley framing consists of heavy steel channels securely riveted together, making a self-contained and rigid construction to which the mechanism is attached. The trolley is of the double drum type, each drum being operated independently of the other or in unison through the medium of one train of compensating gears. The hoisting drums are finished all over, and have grooves cut so that the bucket is lifted vertically without twisting, and the load is distributed equally to both bridge girders. The bearings in the drums are bronze bushed and revolve on a steel drum shaft in which allowance has been made for all bending strains and in which all torsional strains have been eliminated. The steel drum gears are forced directly on to the drums and keyed. All shafts run in self-oiling cap bearings with removable bushings. Any shaft may be removed without interfering with any other. One drum is fitted with a powerful foot brake of the post type, perfectly balanced and positively withheld from contact with the brake wheel, except when applied by the operator for the purpose of opening the bucket. The brake is operated by a foot lever conveniently located in the cage. The bucket is held by two sets of rope, the tension in which is always equalized through the compensating gears, avoiding the possibility of slack ropes and insuring the retention of the bucket by one of the ropes should the other break. The hoisting mechanism is controlled by powerful brakes, preventing the dropping of the bucket or running down by gravity under any condition of service. Hoisting, lowering, opening or closing the bucket is under the complete control of the operator at all times. The opening of the bucket or dumping of the load is by the simple application of the foot brake. When the open bucket comes in contact with the material to be handled, the controller is moved to the hoisting position. This closes and thereby fills the bucket, which, without further manipulation, is hoisted to the desired dumping point. The mechanism is always in position to repeat the operation, insuring, by its simplicity, high speed of operation with moderate speed of mechanism. Clutches or other parts liable to excessive wear are eliminated. Regularly built with direct or alternating current motors, which are bolted directly to the steel frame.

Essentials of Transporters.—By definition a transporter is a lifting and transporting machine designed to carry loads between two fixed points. It is used chiefly for handling comparatively light loads at quick speeds and employed largely for the conveyance of materials such as coal in bulk. For the latter service it is provided with an automatic grab instead of a hook. Fig. 4,221 shows the essential features.

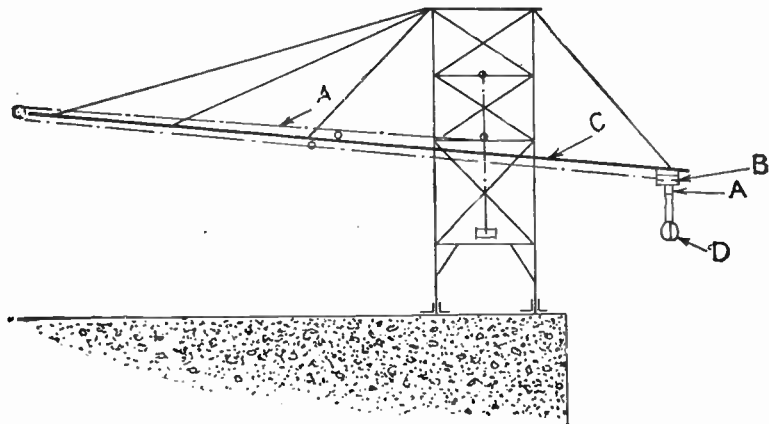

FIG. 4,221.—Electric transporter. The parts are: A, load rope; B, carriage; C, beam; D, grab.

In operation, the grab being full, the electrically driven drum winds in the load rope A. The carriage B, being held by a trigger at the bottom end of the beam C, the winding in of the rope lifts the grab. When it is heaved right up to the carriage, it locks itself to it, and at the same time lets go the trigger.

The carriage is pulled along the beam, but as the rope is now single purchase, the carriage is pulled along at double the speed at which the load was hoisted.

On arriving at the top end, the carriage is held by a trigger and the grab is freed from the carriage. The motor is now reversed, and the grab, after being lowered a given distance, discharges its contents. The motor is again reversed, thus hoisting the grab up to the carriage, to which it locks itself and frees the trigger.

On reversing the motor, the carriage runs down the beam, and at the bottom end is caught by the trigger, while the grab is released and continues to run down till it plunges into the material, thus completing the cycle.

Ques. How long does a complete cycle take in this type of apparatus?

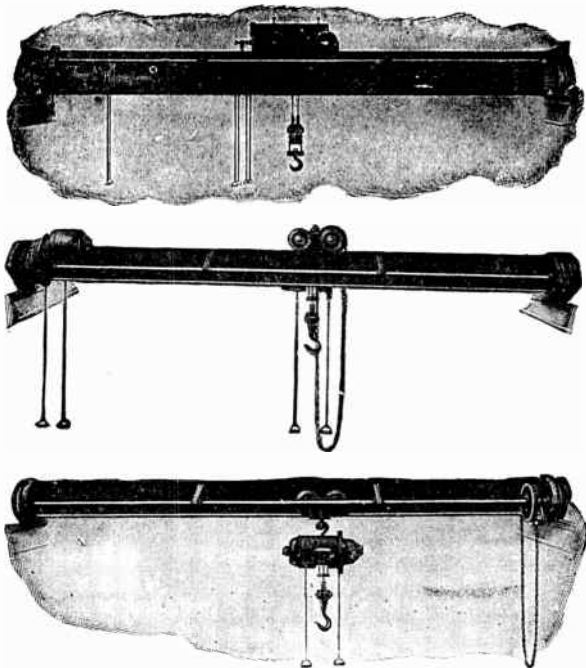

FIGS. 4,222 to 4,224.—Northern low junior and express type electric crane, floor controlled
 Figs. 4,222 and 4,223 showing over mounted trolley; fig. 4,224, under mounted trolley.

Ans. From one-half to one minute.

Ques. What is the grab load?

Ans. From one to one and one-half tons.

Crane Motors.—For driving the traveling, traversing, and slewing motions of crane, series wound motors of a generally similar type to those used for electric traction give satisfactory results, this work being in fact a simple class of electric traction. The driving of the hoisting motion presents a more difficult problem, for though it is easy to lift the load up, it is not always so easy to get it down again in a satisfactory manner.

Automatic Electro-magnetic Brakes.—It is customary to fit the hoisting motion with an electro-magnetic brake. This

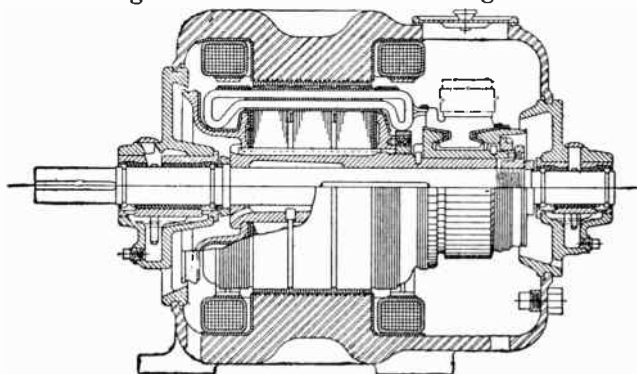

FIG. 4,225.—Sectional view of Shaw type Z Crane motor. The frames are of cast steel split diagonally and when assembled with bearings completely enclose the armature. The motor has four salient poles cast integral with the frame and so shaped that the field coils can easily be put in place. The brake is attached to the lower half of the frame so that the motor can be taken apart without disturbing it except that the band must be removed by taking out the two pins holding same.

may consist of a band brake which is normally kept on by a spring or weight and released by an ironclad solenoid, or it may be a disc brake in which the discs are normally pressed together by a spring, an electro-magnet being provided to pull back the pressure plate and release the discs.

The coil of the solenoid or electro-magnet is in circuit with the hoisting motor, so that when current is switched on to the motor, the brake is released, and when it is switched off, the brake is applied. This makes an excellent safety device, but

as it can only be off or full on, it cannot be used to regulate the descent of the load when lowering.

In cases where the driver has access to the gear, as in locomotive jib cranes and derricks, an addition may be made to the electro-magnetic brake in the form of a hand or foot release lever, by which the brake can be released or its pressure regulated. Loads are then hoisted by the motor, and are allowed to run down by their own weight, the speed of descent being regulated by the brake.

Where the driver operates the gear from a distance, the arrangement just described is not practicable, and some automatic or electrically controlled arrangement must be used to check the speed of descent of the load.

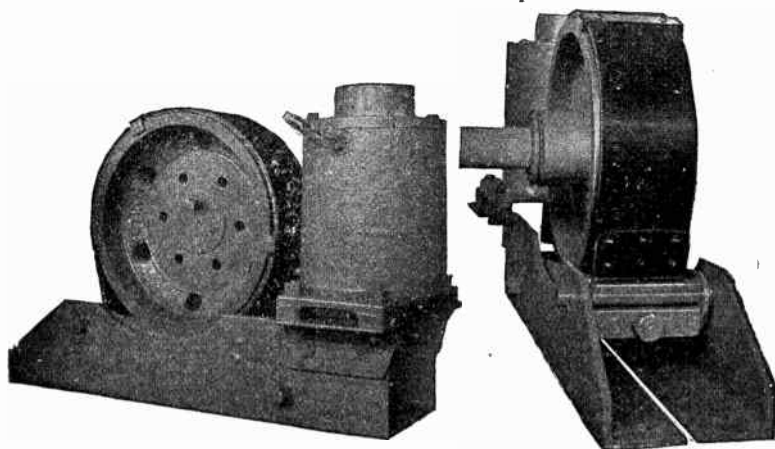

FIGS. 4,226 and 4,227.—Niles crane construction: Electric brake. It is of the ironclad solenoid type and is fitted with a removable brake band which engages almost the entire circumference of a turned and balanced wheel. The band is of special steel and lined with a renewable friction wearing surface. The brake is equally effective in either direction. The brake is always on when there is no current flowing through the motor and is always off when motor is running.

Automatic Mechanical Brake.—A common arrangement is the automatic mechanical brake. The brake is usually of the disc type, and is arranged to allow the gear to run freely in the direction of hoisting, but holds it from running in the opposite direction, being applied by a screw, or it can be arranged to be operated automatically by the load.

The brake is released by running the motor in the direction for lowering. As the motor releases the brake, the load tends to put it on again; consequently the speed of descent depends upon the speed of the motor, and this can, of course, be regulated by the driver by means of the controller.

Eddy Current Brake.—This type of brake is only used to a limited extent. It consists of a wheel, generally of copper or

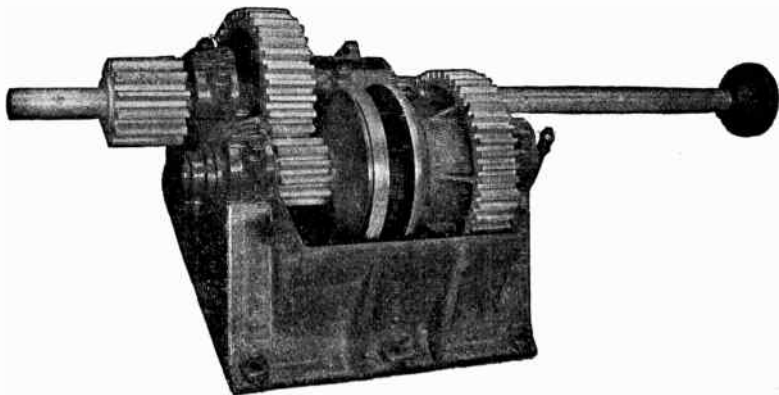

FIG. 4,228.—Niles crane construction: Mechanical load brake. It is of the double disc type with hard bronze wearing surfaces. It is automatic in action and self-contained, all thrusts being taken up within itself. The brake will not permit the load to run down unless the motor is revolved by power in the lowering direction. The brake, together with the intermediate steel gears, runs enclosed in a case, making a self-contained unit, insuring perfect accessibility, ideal lubrication and protection from dust and mechanical injury. The turned steel shafts revolve in self-oiling cap bearings, fitted with removable bronze bushings, the caps being attached by through bolts.

other metal of low electrical resistance, which is arranged to rotate between the poles of an electromagnet. The wheel is driven by the descending load, and eddy currents are generated in it, which give rise to a retarding torque. The eddy currents and the consequent torque are regulated by varying the strength of the magnet by means of a regulating switch and resistance.

Rheostatic Brake.—For this form of braking, the controller is provided with several positions on the lowering side, called *brake points*. In these positions the controller alters the connections of the motor to those of a series dynamo, so that it generates current when driven by the descending load, the

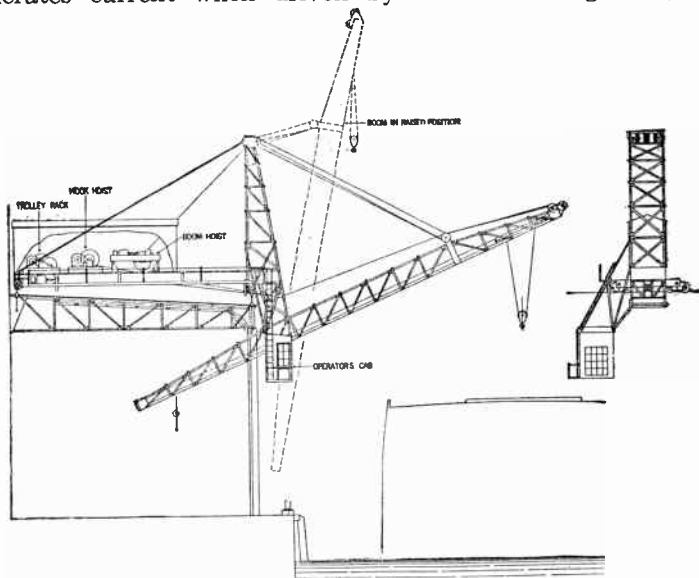

FIG. 4,229.—Shaw overhead wharf crane. The handling of freight at a marine terminal presents two distinct but closely related problems: the loading and unloading of ships and the distribution of freight on the pier. The crane here shown is designed for such service and travels on tracks carried above the roof of the shed. The boom, when in working position, stands with the outer end extending over the ship and the inner end projecting through the doorway into the shed. The usual working angle is 24 to 30 degrees from the horizontal, but this angle can be varied as the height of the boat and other conditions may require. A trolley, comprising merely a light frame with the necessary pulleys and wheels, from which the hoisting block hangs, travels out and in from one end of the boom to the other. When the crane is not in service the boom can be raised to a nearly vertical position, in which position the lower end is withdrawn from the shed and the upper end is removed from over the ship. The shed doors can then be closed, the crane can be moved to another location, and ships can sail or dock without interference with the crane boom. This crane is adapted especially to those terminals in which a railroad track is extended along the edge of the pier. Having no supports outside of the railroad track, the space is clear, so that long material, such as poles, railroad rails and structural steel, can be handled between ships and cars without swiveling. The shed should have a height sufficient to give clearance for handling freight over the sides of the largest ships entering the port when floating light at high tide or river stage. A capacity of 6,000 pounds is considered suitable for most terminals, but this, as well as other details, can be varied to suit local conditions,

energy being absorbed by the controller resistance. The speed of lowering is regulated by varying the resistance.

Regenerative Control.—Instead of a series motor, a shunt wound motor may be used to drive the hoisting motion. A shunt motor has the advantage that its speed can be efficiently

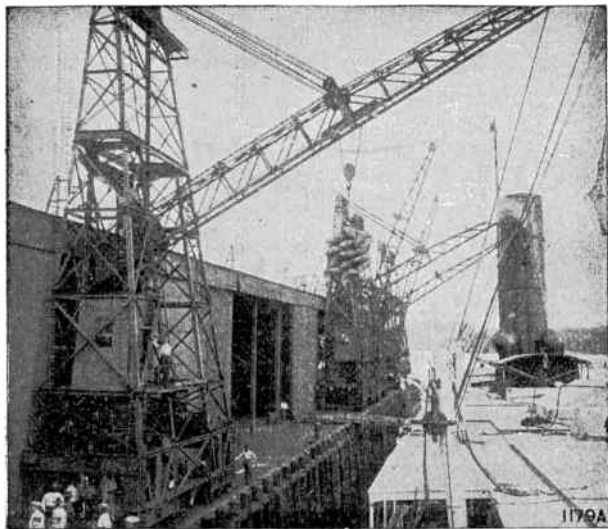
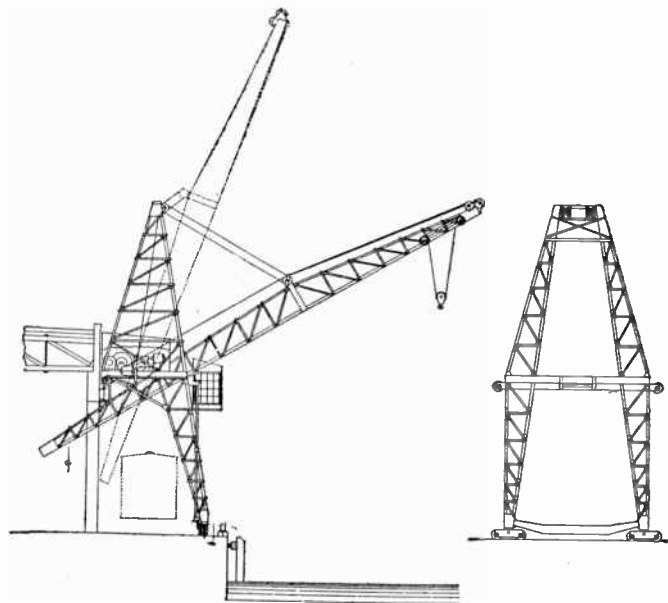

FIG. 4,230.—Shaw gantry wharf cranes as installed for the Panama R. R. Co., Laboca (now Balboa) Panama. These cranes have sloping booms, the upper ends of which are brought over the holds of vessels and the lower ends of which are then within the sheds. This construction permits freight being carried to and fro between ship's hold and inside of shed at a single handling. It carries the freight in a straight line and avoids moving a great mass of structural work or machinery whenever a piece of freight is moved. When it is desired to move the crane along the wharf, the boom is raised to a nearly vertical position. It then clears both the ship's rigging and the columns carrying the shed roof. In its most recent development, the sloping boom wharf crane runs, not on the wharf, but on the shed roof, thus leaving the deck of the wharf entirely free from obstruction.

NOTE.—Cost of Cranes. The cost of cranes depends to so great an extent upon the design, motor equipment, etc., that no reliable average figures can be given. As a rough approximation, the cost of a hand operated traveling crane may be taken at from about 5 to 7 cents per pound of total crane weight and the cost of an electric traveling crane at from about 10 to 13 cents per pound of total crane weight.

regulated over a fairly wide range by inserting resistance in its field circuit. By this means considerable variation of speed in lifting and lowering may be obtained without the necessity of having variable speed gear in the hoisting train, and when lowering, the shunt motor, if overhauled by a load, becomes a



Figs. 4,231 and 4,232.—Shaw half gantry wharf crane suitable for piers on which the sheds are set so far back that it is not practical to reach the ship from overhead tracks. This crane has the same boom and operating machinery as the overhead type shown in fig. 4,229, but travels on one elevated track carried by the building columns and one surface track at the edge of the pier. Such a crane gives the same advantages of direct and rapid handling, but not the unobstructed pier. The leg of the gantry is formed with an opening to allow the freight to pass through. This opening can be made wide enough to permit long material, such as railroad rails, to pass from boat to cars or vice versa without swiveling.

dynamo and feeds current back to the circuit, thus automatically controlling the speed of lowering. This system has been in use to a limited extent for some years.

Collector Gear.—To convey current from the mains to the moving crane a collector gear, generally similar to that used for electric tramway work, is employed. For overhead cranes copper wires about one-quarter to three-eighths inches diameter are stretched along the gantry, being supported at the ends by globe strain insulators. Trolley wheels or slides, mounted on the end carriage, make contact with these wires.

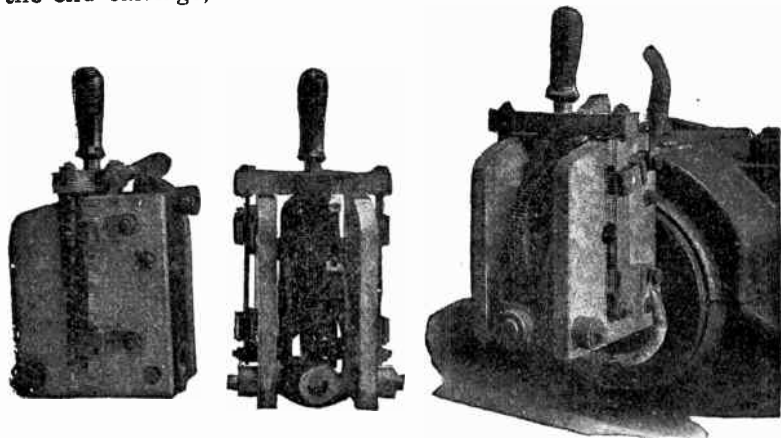

FIGS. 4,233 to 4,235.—Niles crane construction: Contact type limit switch. It consists of a worm wheel with machined teeth actuated by a turned steel worm which is attached directly to the hoisting drum shaft. The body of the switch has heavy soapstone sides between which are located the worm and wheel. The switch blades are of heavy hard drawn copper with ample carrying capacity; the blades are arranged for easy examination and cleaning. The release mechanism is operated by a positive stop on the worm wheel with a by pass attachment which prevents damage to the switch by over hoisting. The switch blades are of a quick break type operated by a powerful spring. When the switch is open the motor cannot be operated until the switch is set by hand, after which the hook can be hoisted to the maximum height in the danger zone. When the hook is out of the danger zone, the release stop is automatically reset.

From trolley wheels or slides, insulated cables are led to the switches and controllers, and to another set of trolley wires on the cross girders. Contact with these wires are made by sliders or trolley wheels on the crab, from which cables are led to the motors.

For locomotive jib cranes overhead or underground collector gear is used, similar to that used for tramway cars. As derrick cranes only swing backwards and forwards through a portion of a circle, collector

gear is not necessary. Connection from the supply mains to the moving part of the crane can be satisfactorily made by means of flexible armoured cable.

Controllers.—The class of controller most commonly used for crane work is that known as the drum, or tramway type. In these controllers the wires and cables are brought to a series of fixed contact, usually arranged in a straight line. A series of corresponding contact are attached to a revolving drum, of corresponding contact are attached to a revolving drum,

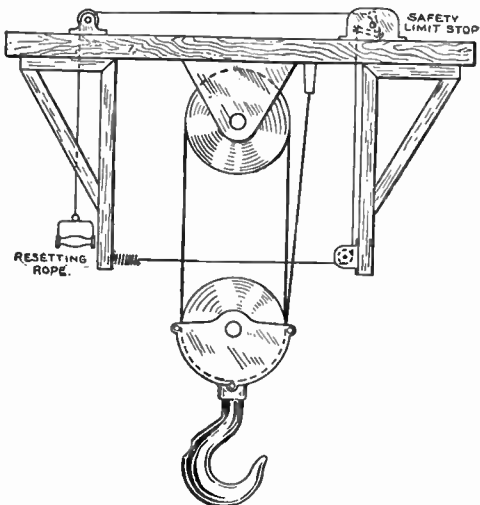

FIG. 4,236.—Diagram showing method of mounting the Palmer safety limit stop. It is not geared to the hoist nor operated by a traveling nut. Instead, a trip rope is used, one end of which is attached to a latch lever inside the enclosing case of the device while the other end, after passing through a pulley, is secured to a fixed support. The trip rope is passed through the hoisting ropes so that the hoist block cannot fail to come in contact with it at the upper limit of travel. Further upward movement of the hoist block strikes the trip rope to trip the latch lever of the limit stop, open the motor circuit, establish a dynamic braking action and bring the motor promptly to rest. When the hoist block strikes the trip rope it is promptly stopped. It cannot be raised further, but can be lowered by simply throwing the controller lever to the reverse position. Resetting of the limit stop device is accomplished by means of the simple arrangement as shown.

the various combinations of connection for hoisting, lowering, etc., being obtained by rotating this drum into different positions.

Power Required to Drive Cranes.—The power required to drive the different parts of a crane is determined by allowing a certain friction percentage over the power required to move the dead load. On hoist motions $33\frac{1}{3}$ per cent. is allowed for friction of the moving parts, thus giving a motor one-third greater capacity than if friction were neglected.

For a bridge and trolley motions, a journal friction of the track wheel axles of 10 per cent. of the total weight of the crane and load is allowed. There is then added an allowance of $33\frac{1}{3}$ per cent. of the horse power required to drive the crane and load plus the track wheel axle friction to cover friction of the gearing.

Telpherage.—This word is defined as: *Automatic aerial transportation as by the aid of electricity, especially that system in which carriages having independent motors are run on a stout wire conducting an electric current.*

Telpherage is a name introduced by the late Prof. Fleeming Jenkin to designate a system devised by him, by which the transmission of a vehicle by electricity to a distance is effected independently of any control exercised from the vehicle; it is an aerial electrical railway.

Telpherage properly includes those systems employing a wire or cable for a track, but the term is erroneously applied to systems using a rail. There are two divisions of telfers.

1. Automatic;
2. Non-automatic.

NOTE.—Power required for travelling cranes and hoists. Ulrich Peters, in *Machinery*, November 1907, develops a series of formulæ for the power required to hoist and to move trolleys on cranes. The following is a brief abstract. Resistance to be overcome in moving a trolley or crane bridge. P_1 = rolling friction of trolley wheels, P_2 = journal friction of wheels or axles, P_3 = inertia of trolley and load. P = sum of these resistances = $P_1 + P_2 + P_3 = (T + L) \left(\frac{F_1 + F_2 d}{D} + \frac{V}{1932t} \right)$ in which T = weight of trolley, L = load, F_1 = coefficient of rolling friction, about .002 (.001 to .003 for cast iron on steel); F_2 = coefficient of journal friction, = .1 for starting and .01 for running, assuming a load on brasses of 1,000 to 3,000 lb. per sq. in.; [F_2 is more apt to be .05 unless the lubrication be perfect]; d = diam. of journal; D = diam. of wheels; V = trolley speed in feet per minute; t = time in seconds in which the trolley under full load is required to come to the maximum speed. Horse power = sum of the resistances \times speed, feet per min. $\div 33,000$. Force required for hoisting and lowering: F_b = actual hoisting force, F_o = theoretical force or pull, L = load, V = speed in feet per min. of the rope or chain, c = hoisting speed of the load L , $c \div V$ = transmission ratio of the hoist, e = efficiency = $F_o \div F_b$. The actual work to raise the load per minute = $F_b V = L c = F_o V \div e$. The efficiency e is the product of the efficiencies of all the several parts of the hoisting mechanism, such as pulleys, windlass, gearing, etc. Methods of calculating these efficiencies, with examples, are given at length in the original paper by Mr. Peters.

Ques. What are automatic telfers?

Ans. Those which are driven by electric motors, the control being apart or remote from the telfer. The original telfers were automatic, the telfer being placed in the middle of the train.

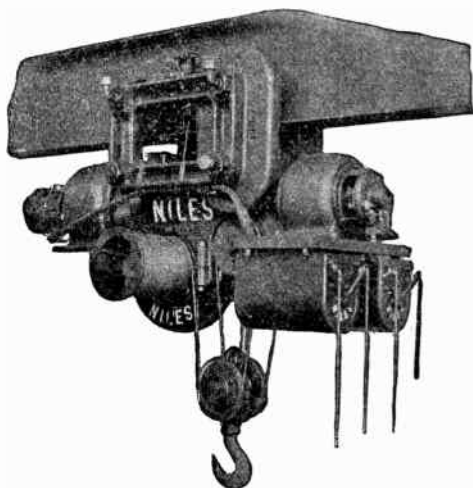

FIG. 4,237.—Niles electric mono-rail hoist, built in capacities from three-quarters to six tons. They will run on straight and curved tracks, and are generally provided with a separate motor for traversing. The hoist is self-contained in one heavy cast iron frame to which the motors are attached end on, and the power is transmitted directly from the armature shaft to the drum shaft through worm and worm wheel. The traversing mechanism is also driven by worm and worm wheel, similarly to the hoisting mechanism except that, when the trolley is arranged to run on a single I beam, a double set of transmission gears is used. The worm gear mechanism is enclosed in oil and dust proof casings, and is noiseless in operation. In addition to the braking effect obtained by use of the worm and worm wheel, a powerful electric brake is attached to the hoist motor. These hoists when mounted on a traveling bridge may be used as small capacity cranes. When used as cranes, the hoists are usually arranged to run between the two I beams or channels of the bridge, and the controllers for raising and lowering the hook and operating the traversing mechanism may be placed either on the hoist or on the bridge, and may be operated by cords from the floor or from an operator's cage attached to the bridge.

Ques. What is the chief use of automatic telfers?

Ans. They are employed for handling coal, ore, and bulk material.

Ques. Define non-automatic telfers.

Ans. Non-automatic telfers are those which are controlled by an operator who travels with the load and who operates both the telfer and hoists from a cab or case which is attached to the telfer or carriage.

Non-automatic telfers are employed for bulk material, like the automatic telfer, and are also used for the hoisting and conveying of

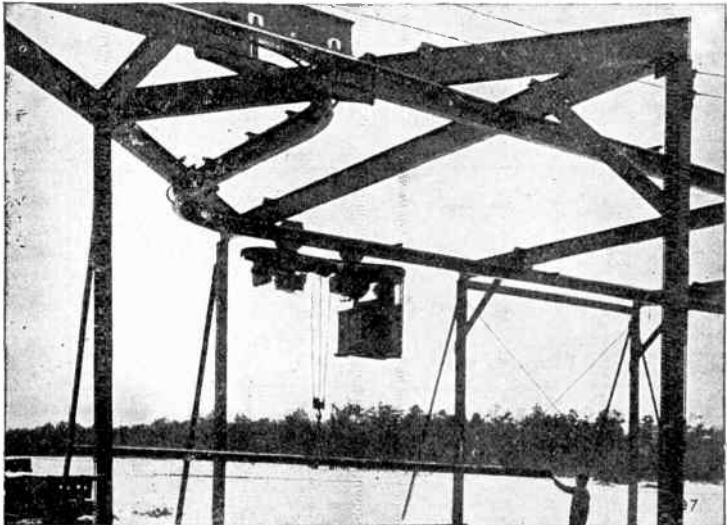

FIG. 4,238.—Shaw mono-rail system, showing fixed tongue track switch in upper foreground. The two I beams, as shown, constituting the main or shaft through track and the third I beam constituting the spur or curved track, terminals near the point of tangency of these center lines and have rigidly secured to each a cast steel extension piece or tongue, the projecting portion of which is on the same level as, and constitutes a continuation of, the bottom flange of the I beam. These tongues are so shaped as to leave between them open slots, through which the truck sides of the trolley pass, as it traverses the track switch. On approaching a track switch at which the operator desires to run from the main to the spur track, he pulls the steering lever, which is located on the trolley, near the controllers. This raises a horizontal roller to a position in which it engages a curved rib on the underside of the central switch tongue and swivels the leading truck, thereby diverting it on to the spur track. By a positive and very simple means, which is not dependent on the operator, the trailing truck is also guided on to the spur track. No steering is necessary to return from the spur to the main track, nor to run through the track switch on the main track in either direction. The hoist motion is equipped with motor and load brakes, the latter being of the multi-disc type and being located in the hoist gear case and lubricated by the same oil as the gears. The travel motion is equipped with a foot brake. An automatic limit stop is provided to prevent the lower block being accidentally wound up into the trolley machinery.

miscellaneous material, boxes, cases and barrels, the package freight of railways and the mixed cargoes of steamships.

Ques. How is a telfer suspended, and driven?

Ans. From one or more wheels in tandem, of which one or all are driven by the electric motor or motors.

In the minimum head room two ton type designed for railway and steamship terminals the vertical space from the underside of the roof girders to the bottom of the hoist hook is 4 ft. 9 in. (144.8 cm.). The

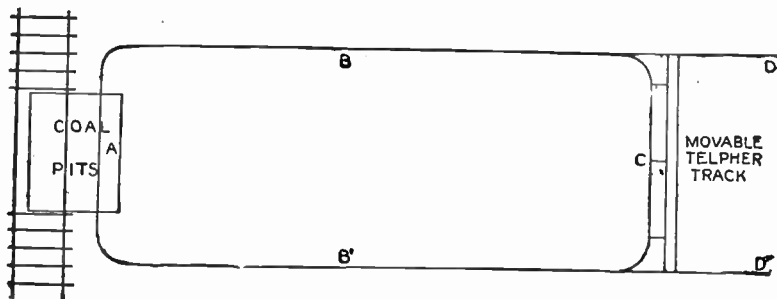

FIG. 4,239.—Typical arrangement of mono-rail tracks. The track is supported on brackets attached to buildings, or is supported on A bents. Supports under straight track are spaced 20 feet apart, and on curves, the spacing is 8 feet. For long spans, cables or trusses are used. The tracks may be either fixed or movable. In the figure, the side tracks BB' are fixed, but C is movable, being attached to a traveling bridge. The speed of this bridge is from 300 ft. to 900 ft. per min. The motor driving this bridge would have a load factor of .16. The telfer train is passed from these side tracks B', by means of a gliding switch upon the movable track C. This track therefore may be placed anywhere over the area between the fixed side tracks. The telfer returns by means of the track B', to its starting point A. By the operation of this movable track all the space can be served; this operation is called transference. The minimum allowable radius of curves is 8 ft.

width of the hoist is 3 ft. 3 in., and 4 ft. 8 inches to the limit line for 10 degrees swing. From the center of the rail to the inner limit of the telfer and hoist is 16 inches.

Ques. Describe the power features.

Ans. Energy in the form of either direct or alternating current is communicated to the motors by conductors which lie

parallel to the track, the contact being made by shoes or wheels. Sometimes storage batteries suspended from the telfer or the carriage are employed. On steep grades the telferage

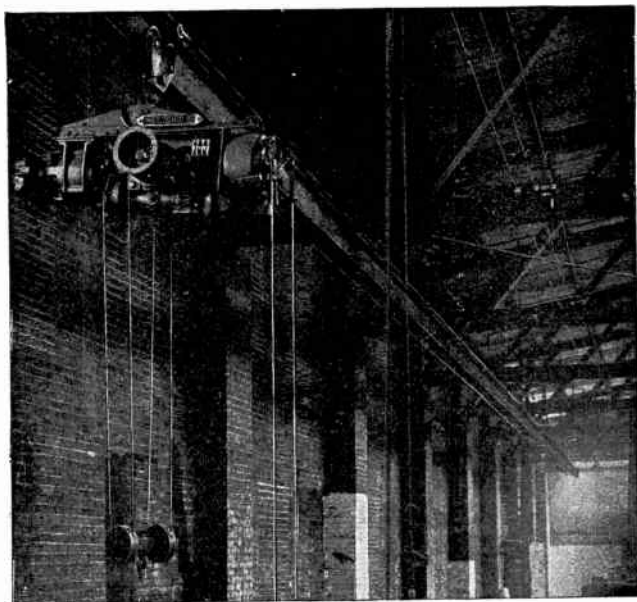

FIG. 4,240.—Brown electric hoist on plain steel plate trolley (clevis connection) as used by Pittsburgh Glass Co., in their warehouse at Cleveland, O. The hoist is operated from the floor and is used for loading, unloading, and transporting boxes of plate glass in the shipping department.

traction, in some installations, has been assisted by supplementary cables, either fixed or movable.

Telfer Motors.—The sizes of motor for telfers and hoists will depend upon the class of work to be done; the motors for telfer tractors vary from 5 to 15 h. p. and for the hoists,

from 3 to 75 h. p., the loads being from 500 lb. to 30,000 lb. The load factor for the tractor motor is .25 and for the hoisting motor .16. The driving wheels and the motors may be connected by gears or by chain drive. The maximum service efficiency of the motors is that corresponding to the efficiency obtained between one half and three-quarters full load. The motors are of slow or medium speed.

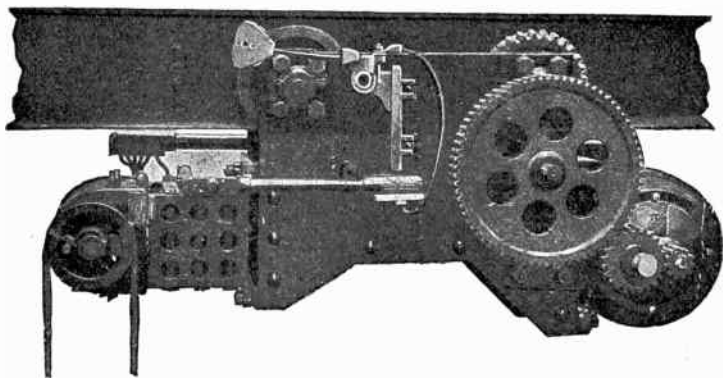

FIG. 4,241.—Brown motor driven trolley. *It consists of two steel side plates connected by separator bolts. The steel pins which serve as axles for the wheels, are supported in castings which in turn are bolted to the side plates. These castings together with steel axles and wheels are easily removed. The wheels are bronze bushed and equipped with lubricating cups. The trolley is equipped with a crane motor for traveling under full load at a rate of 350 feet per minute on straight track. It is provided with a standard type controller with either pendent cords for floor operation, or handles for cab operation. It can be used with an electric hoist either hooked in, with a clevis connection, or built in. Current collectors are provided to take the current from wires or conductor bars strung along the I beam track.*

Direct current 250 volt or, 500 volt series wound motors are preferable for tractors and hoists through alternating current motors afford satisfactory results. The motors should be dust and weather proof, and should have a 50 per cent. reserve in their rating. The average combined efficiency of the motors and gearing, for the tractor and hoist, is from 65 per cent. to 75 per cent.

Brakes.—The mechanical type of telfer brake is used and the hoist brake is of either the electro-mechanical or

electro-dynamic types. Spur gears and chain drive on the tractor transmit the power from motor to track wheels, and either spur or worm gear is used to transmit power to the hoisting drum.

Trackage.—Telfers either run in one direction on a closed track circuit, or to and fro over a single line. On the single line the automatic telfers reverse themselves on completing their trips.

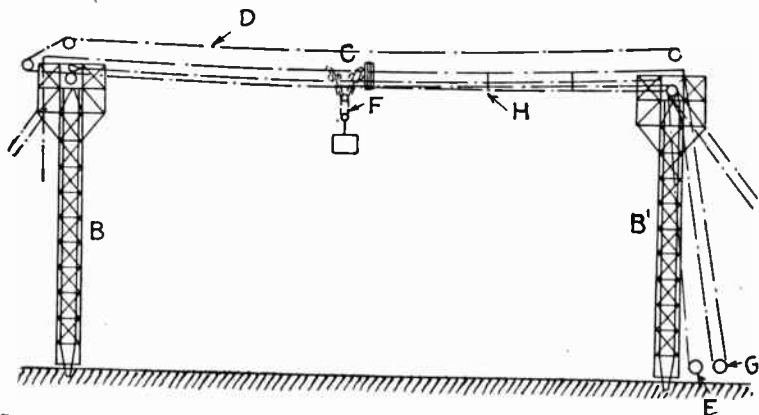

FIG. 4,242.—Cableway. The essential elements of construction are BB' towers; C, cable; D, hauling rope; E, hauling rope drum; F, hoisting rope; G, hoisting drum; H, hoisting rope slack carriers.

Ques. How is the spacing between the cars regulated?

Ans. Automatically by a block system.

Essentials of Cableways.—The term cableway may be defined as a rectilinear *hoisting and conveying apparatus supported by a cable.*

The elements of construction are shown in fig. 4,242. A strong steel wire rope or cable is stretched between the towers BB'. On this rope runs the carriage C, pulled backwards and forwards by the hauling rope

D, which is operated by the capstan drum E. One end of the hoisting rope F is secured to the carriage, and is led round the various pulleys shown and to the hoisting drum G.

The slack of the hoisting rope, when paying out, is supported by the carriers H. These carriers are dropped by the carriage when running from B to B', and are picked up again when returning from their position, being determined by buttons of different size arranged on the rope. Loads are hoisted and lowered by drum G, driver E being held by its brakes.

To travel the load, the two drums are clutched together. Driver E then hauls the carriage along, while drum G takes in or pays out the hoisting rope, so that the vertical position of the load is unaltered.

Ques. What is the range of the apparatus?

Ans. It will take up and deposit loads anywhere along a line directly underneath the main cable, and by means of switch blocks it may be made to serve an area having a width of about 15 feet or so each side of the cable.

NOTE.—Telfer performance. The loads hoisted and conveyed on telfer hoists have been as high as fifteen tons. The maximum speed of conveying on a straight level track is about 1,000 feet per min. The running speed is reduced at curves, according to their radii. For terminal work, the capacity of each hoist is two tons at 60 feet per min. (18.288 m. per min.) Two hoists can be combined so as to raise four tons. The motors being series wound, the speed of hoisting will increase as the load is diminished. For freight, handling from two to four carriage hoists constitute a train which has a total maximum carrying capacity of eight tons. Such trains are used for assorting as well as for distributing, according to consignments.

CHAPTER LXXX

ELECTRIC PUMPS

The electrical engineer or electrician who has to specify or install electric pumps, should not only understand the electrical features, but have a knowledge of the conditions of operation of the "water end" in order to respectively make proper selections and satisfactory installations. Accordingly each should at least be familiar with the elementary principles of hydraulics, of which an outline is here given as an introduction to the main subject.

Hydraulics.—The term *hydraulics* is commonly, though ill advisedly, defined as *the science which treats of liquids, especially water in motion*. **Properly speaking** there are two general divisions of the subject:

1. Hydrostatics;
2. Hydrodynamics.

Hydrostatics refers to liquids *at rest*, and hydrodynamics to liquids *in motion*. The outline here given relates to water.

Water.—Those who have had experience in the design or operation of pumps, have found that water is an unyielding substance when confined in pipes and pump passages, thus necessitating very substantial construction to withstand the pressure, and periodic shocks or water hammer.

Accordingly to Копп, as corrected by Porter, the following table gives the relative volumes of water at different temperatures compared with its volume at its temperature of maximum density or 39.1° Fahr.

Relative Volumes of Water at Different Temperatures

Degrees Fahr.	Volume	Degrees Fahr.	Volume	Degrees Fahr.	Volume
39.1	1.00000	95	1.00586	158	1.02241
41.0	1.00001	104	1.00767	167	1.02548
50.0	1.00025	113	1.00967	176	1.02872
59.0	1.00083	122	1.01186	185	1.03213
68.0	1.00171	131	1.01423	194	1.03570
77.0	1.00286	140	1.01678	203	1.03943
86.0	1.00425	149	1.01951	212	1.04332

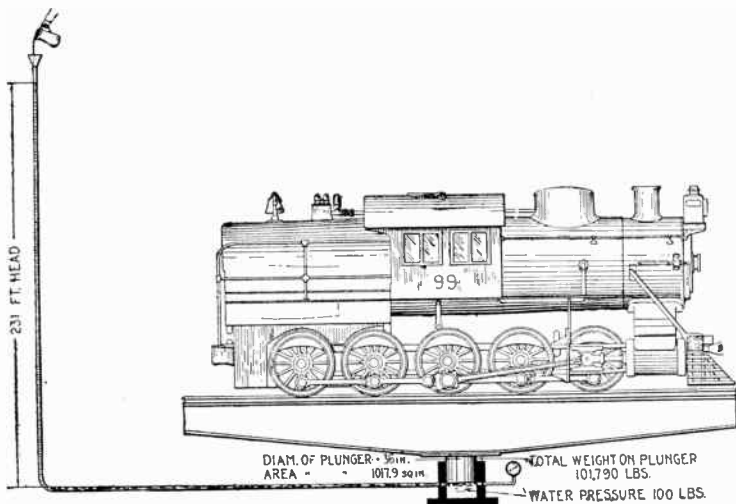

FIG. 4,243.—Hydraulic principles: 1. Any quantity of water however small may be made to balance any weight however great. The figure shows a locomotive on a turn table balanced by a hydraulic pivot or plunger. Assuming no leakage or friction at the joint, and that the vertical pipe leading to the plunger cylinder is very small, it is evident that it could be filled to the elevation shown with a very small quantity of water—say one quart. If the total weight of locomotive, turn table, etc., and the plunger be 101,709 lbs., and the plunger area be 1,017.9 sq. ins., then the water pressure per sq. in. on the piston necessary to balance the load = $101,796 \div 1,017.9 = 100$ lbs. Hence the load will be balanced when the pipe is filled with water to a height of $100 \times 2.31 = 231$ ft.

Ques. What is the most remarkable characteristic of water?

Ans. Water at its maximum density (39.1° Fahr.) will expand as heat is added, and it will also expand slightly as the temperature falls from this point.

Ques. What is the weight of a cubic foot of water at maximum density?

Ans. It is generally taken at the figure given by Rankine, 62.425 lbs. per cu. ft.

Some authorities give as low as 62.379. The figure 62.5 commonly given is approximate. The highest authoritative figure is 62.428. At 62° Fahr., the figures range from 62.291 to 62.36. *The figure 62.355 is generally accepted as the most accurate*, though for ordinary calculations the figure 62.4 is generally taken, this corresponding to the weight at 53° Fahr.

Weight of Water per Cubic Foot at Different Temperatures

Temp. deg. F.	Weight lbs. per cu. ft.	Temp. deg. F.	Weight lbs. per cu. ft.	Temp. deg. F.	Weight lbs. per cu. ft.	Temp. deg. F.	Weight lbs. per cu. ft.
32	62.42	80	62.23	130	61.56	180	60.55
35	62.42	85	62.18	135	61.47	185	60.44
40	62.42	90	62.13	140	61.37	190	60.32
45	62.42	95	62.08	145	61.28	195	60.20
50	62.41	100	62.02	150	61.18	200	60.07
55	62.39	105	61.96	155	61.08	205	59.95
60	62.37	110	61.89	160	60.98	209	59.84
65	62.34	115	61.82	165	60.87	210	59.82
70	62.31	120	61.74	170	60.77	211	59.79
75	62.28	125	61.65	175	60.66	212	59.76

Ques. What is the weight of one gallon of water?

Ans. For a U. S. gallon or 231 cu. ins., it is generally taken at $8\frac{1}{3}$ lbs.

Head and Pressure.—These are the two primary considerations in hydraulics. The word head signifies *the difference in level of water between two points*, and it is usually expressed in feet.

There are two kinds of head:

1. Static head;
2. Dynamic head.

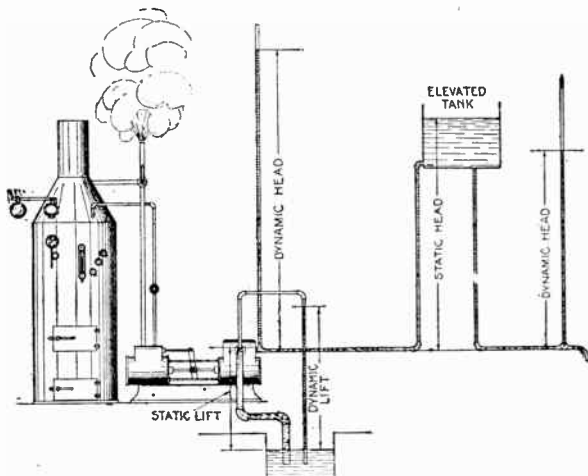

FIG. 4,244.—View of elevated tank with pump in operation maintaining the supply which is being drawn upon as shown, illustrating the terms static lift, dynamic lift, static head, and dynamic head.

The **static head** is the height from a given point of a column, or body of water at rest, considered as causing or measuring pressure.

The **dynamic head** is an equivalent or virtual head of water in motion which represents the resultant pressure due to the height of the water from a given point, and the resistance to flow due to friction.

Thus, when water is made to flow through pipes or nozzles there is a loss of head. These terms are illustrated in fig. 4,244. Here the dynamic head is *greater* than the static head in the supply line to the tank, and *less* in the tank discharge line because of frictional resistance to the flow of the water. The following table gives the loss of head due to friction of water in pipes of various sizes and for various rates of flow.

Friction of Water in Pipes

Loss of head in feet due to Friction, per 100 feet of smooth, straight cast iron pipe

Gallons Per Minute	1/4-Inch Pipe		3/8-Inch Pipe		1-Inch Pipe		1 1/4-Inch Pipe		1 1/2-Inch Pipe		2-Inch Pipe		2 1/2-Inch Pipe		3-Inch Pipe		4-Inch Pipe	
	Vel.	Frict.	Vel.	Frict.	Vel.	Frict.	Vel.	Frict.	Vel.	Frict.	Vel.	Frict.	Vel.	Frict.	Vel.	Frict.	Vel.	Frict.
2	2.10	5.30	1.20	1.40														
3	3.16	11.30	1.80	2.90	1.12	0.90												
4	4.21	19.20	2.41	5.00	1.49	1.52	0.86	0.40	0.63	0.187								
5	5.26	29.00	3.01	7.50	1.86	2.32	1.07	0.60	0.79	0.283								
10	10.52	105.00	6.02	27.10	3.72	8.40	2.14	2.18	1.57	1.02	.51	.09	0.33	0.05				
15			9.02	57.00	5.58	13.80	3.22	4.65	2.72	2.25	1.53	0.81	0.98	0.25	0.68	0.11		
20			12.03	97.00	7.44	30.10	4.29	7.90	3.15	3.70	2.04	1.29	1.31	0.43	0.91	0.18		
25					9.30	45.50	5.36	11.90	4.56	5.60	2.55	1.96	1.63	0.66	1.13	0.27		
30					11.15	64.00	6.43	16.90	4.72	7.80	3.06	2.73	1.96	0.92	1.36	0.38		
35					13.02	85.00	7.51	22.30	5.51	10.30	3.57	3.66	2.29	1.23	1.59	0.51		
40					14.88	109.00	8.58	28.50	6.30	13.30	4.08	4.68	2.62	1.52	1.82	0.65	1.02	0.16
45							9.68	35.20	7.08	16.60	4.60	5.80	2.95	1.97	2.02	0.80	1.17	0.20
50							10.72	43.20	7.87	20.20	5.11	7.10	3.30	2.38	2.27	0.98	1.28	0.24
70							15.01	81.00	11.02	37.60	7.15	13.20	4.60	4.42	3.18	1.83	1.79	0.45
75									11.80	42.70	7.66	14.90	4.93	5.07	3.41	2.11	1.92	0.52
100									15.74	73.00	10.21	25.60	6.54	8.60	4.54	3.52	2.55	0.88
120											12.25	30.00	7.84	12.00	5.45	4.97	3.06	1.22
125											12.75	38.90	8.16	13.01	5.68	5.40	3.19	1.33
150											15.30	54.00	9.80	18.72	6.80	7.72	3.84	1.82
175													11.43	23.70	7.92	9.75	4.45	2.40
200													13.07	30.90	9.08	12.80	5.11	3.12
225														10.42	16.00	6.32	4.72	
250														11.28	19.70	6.40	4.80	
270														12.45	22.70	6.90	5.50	
275														12.70	23.60	7.03	5.71	
300														13.62	27.10	7.66	6.70	
350																8.90	8.80	
400																	10.20	11.30
450																		11.50
470																		12.15
500																		12.30
575																		12.77
700																		17.50
Gallons Per Minute	5-Inch Pipe		6-Inch Pipe		8-Inch Pipe		10-Inch Pipe		12-Inch Pipe		16-Inch Pipe		20-Inch Pipe		24-Inch Pipe		30-Inch Pipe	
	Vel.	Frict.	Vel.	Frict.	Vel.	Frict.	Vel.	Frict.	Vel.	Frict.	Vel.	Frict.	Vel.	Frict.	Vel.	Frict.	Vel.	Frict.
70	1.14	0.15
100	1.63	0.29	1.14	0.10
120	1.96	0.41	1.42	0.18
125	2.04	0.46	1.48	0.20
150	2.45	0.63	1.71	0.23
175	2.86	0.84	2.00	0.34
200	3.27	1.06	2.28	0.44
225	3.67	1.33	2.57	0.53
250	4.08	1.60	2.80	0.66	1.60	0.16
270	4.42	1.86	3.03	0.81	1.70	0.18
275	4.50	1.94	3.06	0.82	1.73	0.19
300	4.90	2.25	3.40	0.92	1.90	0.26
350	5.72	2.99	3.98	1.21	2.20	0.29
400	6.54	3.81	4.54	1.58	2.60	0.40
450	7.35	4.75	5.12	1.96	2.92	0.46	1.80	0.150
470	7.78	5.30	5.49	2.23	3.07	0.55	1.92	0.170
500	8.17	5.80	5.80	2.33	3.20	0.58	2.04	0.200	1.42	0.08
550	8.99	6.80	6.18	2.81	3.52	0.70	2.25	0.236	1.57	0.098
600	9.80	8.10	6.72	3.36	3.84	0.83	2.46	0.282	1.71	0.106
650	10.62	9.40	7.28	3.93	4.18	0.96	2.66	0.327	1.85	0.134
700	11.44	10.80	7.84	4.56	4.46	1.10	2.86	0.368	2.00	0.154
750	12.26	12.30	8.50	5.00	4.80	1.24	3.06	0.422	2.13	0.170
800			9.08	5.84	5.12	1.41	3.28	0.476	2.27	0.196
850			9.58	6.25	5.48	1.63	3.48	0.534	2.41	0.22
900			10.30	7.22	5.75	1.76	3.68	0.592	2.56	0.24
950			10.72	7.65	6.06	2.05	3.88	0.653	2.70	0.25
1000			11.32	8.60	6.40	2.16	4.08	0.718	2.84	0.285
1100			12.50	10.22	7.03	2.51	4.50	0.860	3.13	0.35
1200			13.52	11.92	7.67	3.04	4.91	1.040	3.41	0.41
1500					9.60	4.48	6.10	1.490	4.20	0.61	2.39	0.171
2000					12.70	7.65	8.10	2.500	5.60	1.02	3.19	0.280
2500							10.10	3.810	7.00	1.56	3.99	0.397
3000							12.10	5.300	8.40	2.42	4.79	0.568	3.08	0.191
3500							14.10	7.200	9.80	2.80	5.59	0.745	3.59	0.251
4000									11.35	3.80	6.38	0.956	4.10	0.323
5000									14.20	5.82	7.96	1.144	5.13	0.488	3.55	0.199	2.27	0.067

When pipe is slightly rough, add 15 per cent. When very rough, add 30 per cent.
 Vel.—Velocity feet per second. Frict.—Friction head in feet.

Friction of Water in Elbows

Loss of head in feet, due to friction in various sizes of smooth 90° elbows when discharging the given quantities of water

Gals. per Minute	1-Inch		1½-Inch		2-Inch		2½-Inch		3-Inch		4-Inch		5-Inch		6-Inch		8-Inch		10-Inch		12-Inch	
	Vel.	Frict.	Vel.	Frict.	Vel.	Frict.	Vel.	Frict.	Vel.	Frict.	Vel.	Frict.	Vel.	Frict.	Vel.	Frict.	Vel.	Frict.	Vel.	Frict.	Vel.	Frict.
5	2.04	0.06	1.30	0.14																		
10	4.08	0.22	2.60	0.21																		
15	6.12	0.49	3.90	0.29	2.73	0.09																
20	8.16	0.87	5.20	0.52	3.64	0.16																
25	10.20	1.35	6.50	0.80	4.55	0.24	2.80	0.09														
30	12.24	1.95	7.80	1.15	5.46	0.36	3.06	0.13														
35	14.28	2.65	9.10	1.60	6.37	0.50	3.57	0.18	2.29	0.09												
40	16.32	3.46	10.40	2.05	7.28	0.64	4.05	0.23	2.62	0.11												
45			11.70	2.70	8.19	0.81	4.50	0.29	2.95	0.14												
50					9.10	0.99	5.11	0.35	3.30	0.18	2.02	0.06										
60					12.74	1.98	7.15	0.70	4.60	0.34	3.18	0.19	1.79	0.05								
70							10.20	1.41	6.54	0.74	4.54	0.29	2.55	0.10								
80							12.25	2.24	7.81	1.17	5.45	0.46	3.06	0.15	1.95	0.06						
90							15.30	3.20	9.87	1.58	6.80	0.66	3.84	0.22	2.45	0.09						
100									11.43	2.16	7.92	0.90	4.45	0.30	2.80	0.12	2.00	0.06				
120									13.07	2.90	9.08	1.18	5.11	0.40	3.27	0.16	2.28	0.07				
150											11.28	1.84	6.40	0.62	4.08	0.25	2.80	0.12	1.80	0.04		
175											12.45	2.35	6.90	0.70	4.42	0.25	3.03	0.14	1.70	0.05		
200											13.62	2.63	7.66	0.89	4.90	0.36	3.40	0.18	1.90	0.06		
250											8.90	1.24	5.72	0.50	3.98	0.24	2.20	0.09				
270											10.20	1.59	6.54	0.63	4.54	0.29	2.60	0.10				
300											11.50	2.01	7.35	0.81	5.12	0.39	2.92	0.13	1.80	0.05		
350											12.16	2.26	7.78	0.90	5.49	0.46	3.07	0.14	1.92	0.06		
400											12.77	2.47	8.17	1.01	5.60	0.48	3.20	0.16	2.00	0.07	1.40	0.04
450													12.26	2.24	8.40	1.09	4.80	0.38	3.00	0.15	1.20	0.07
470															12.57	2.41	7.04	0.76	4.40	0.29	3.08	0.14
500															14.10	3.02	8.01	1.00	5.00	0.40	3.50	0.19
550																	8.60	1.44	8.10	0.58	4.20	0.23
600																						
650																						
700																						
750																						
800																						
850																						
900																						

When pipe is slightly rough, add 15 per cent. When very rough, add 30 per cent.
 Vel.—Velocity in feet per second. Frict.—Friction head in feet.
 Table shows loss for one elbow, and is based on Weisbach's Formula for short radius bends.

The term pressure is used in its ordinary sense in terms of pounds per square inch. At 62° Fahr. the pressure per square inch of a column of water of one foot head is .43302, or .433 lbs. At this temperature one cubic foot of water would weigh $.433 \times 144 = 62.352$. On this basis the pressure in pounds per square inch for different heads of water are as given in the following table.

Pressure per Lb. per Sq. Ins. Corresponding to Various Heads of Water

Head feet	0	1	2	3	4	5	6	7	8	9
0		0.433	0.866	1.299	1.732	2.165	2.598	3.031	3.464	3.897
10	4.330	4.763	5.196	5.629	6.062	6.495	6.928	7.361	7.794	8.227
20	8.660	9.093	9.526	9.959	10.392	10.825	11.258	11.691	12.124	12.557
30	12.990	13.423	13.856	14.289	14.722	15.155	15.588	16.021	16.454	16.887
40	17.320	17.753	18.186	18.619	19.052	19.485	19.918	20.351	20.784	21.217
50	21.650	22.083	22.516	22.949	23.382	23.815	24.248	24.681	25.114	25.547
60	25.980	26.413	26.846	27.279	27.712	28.145	28.578	29.011	29.444	29.877
70	30.310	30.743	31.176	31.609	32.042	32.475	32.908	33.341	33.774	34.207
80	34.640	35.073	35.506	35.939	36.372	36.805	37.238	37.671	38.104	38.537
90	38.970	39.403	39.836	40.269	40.702	41.135	41.568	42.001	42.436	42.867

Head in Feet of Water Corresponding to Various Pressures

Pressure	0	1	2	3	4	5	6	7	8	9
0		2.309	4.619	6.928	9.238	11.547	13.857	16.166	18.476	20.785
10	23.0947	25.404	27.714	30.023	32.333	34.642	36.952	39.261	41.570	43.880
20	46.1894	48.499	50.808	53.118	55.427	57.737	60.046	62.356	64.665	66.975
30	69.2841	71.594	73.903	76.213	78.522	80.831	83.141	85.450	87.760	90.069
40	92.3788	94.688	96.998	99.307	101.62	103.93	106.24	108.55	110.85	113.16
50	115.4735	117.78	120.09	122.40	124.71	127.02	129.33	131.64	133.95	136.26
60	138.5682	140.88	143.19	145.50	147.81	150.12	152.42	154.73	157.04	159.35
70	161.6629	163.97	166.28	168.59	170.90	173.21	175.52	177.83	180.14	182.45
80	184.7576	187.07	189.38	191.69	194.00	196.31	198.61	200.92	203.23	205.54
90	207.8523	210.16	212.47	214.78	217.09	219.40	221.71	224.02	226.33	228.64

In ordinary calculation, it is common practice to estimate that every foot head is equal to one-half pound pressure per square inch, as this allows for ordinary friction in pipes.

Ques. In pump operation what is the total static head?

Ans. The static lift plus the static head.

Ques. What is the total dynamic head?

Ans. The dynamic lift plus the dynamic head.

Lift.—When the barometer reads 30 inches at sea level, the pressure of the atmosphere at that elevation is 14.73 lbs. per sq. in., that is to say, this pressure will maintain or balance a column of water 34.019 ft. high when the column is completely exhausted of air, and the water is at a temperature of 62° Fahr. In other words, the pressure of the atmosphere then *lifts* the water to such height as will establish equilibrium between the weight of the water and the pressure of the air. Similarly in pump operation, the receding piston or plunger establishes the vacuum and the pressure of the atmosphere lifts the water from the level of the supply to the level of the pump. Accordingly

lift as relating to pump operation may be defined as *the height in feet from the surface of the intake supply to the pump.*

Strictly speaking, it is the height to which the water is elevated by atmospheric pressure, which in some pumps may be measured by the elevation of the inlet valves and in others by the elevation of the piston.

Ques. What is the practical limit of lift?

Ans. 20 to 25 ft.

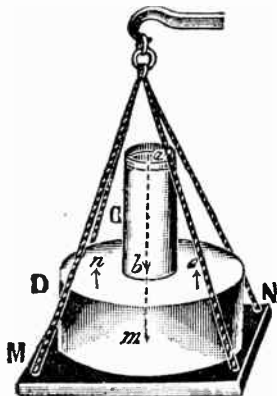

Fig. 4,245.—Hydraulic principles: 2. Pressure exerted anywhere upon a mass of liquid is transmitted undiminished in all directions, and acts with the same force on all equal surfaces, and in a direction at right angles to those surfaces. CD (fig. 4,245) is a vessel composed of two cylindrical parts of unequal diameters, and filled with water to *a*. The bottom of the vessel CD supports the same pressure as if its diameter were everywhere the same as that of its lower part; and it would at first sight seem that the scale MN of the balance in which the vessel CD is placed, ought to show the same weight as if there had been placed in it a cylindrical vessel having the same weight of water, and having the diameter of the part D. But the pressure exerted on the bottom of the vessel is not all transmitted to the scale MN; for the upward pressure upon the surface *no* of the vessel is precisely equal to the weight of the extra quantity of water which a cylindrical vessel would contain, and balances an equal portion of the downward pressure on *m*. Consequently the pressure on the plate MN is simply equal to the weight of the vessel CD and of the water which it contains.

Ques. What conditions would require shorter lifts?

Ans. Long inlet lines, multiplicity of inlet elbows, and high temperature of the water.

Ques. Why must the lift be reduced as the temperature of the water is increased?

Ans. Because the boiling point of water corresponds to the pressure.

Theoretically a perfect pump will draw water from a height of 34 ft. when the barometer reads 30 ins., but since a perfect vacuum cannot be obtained on account of valve leakage, air contained in the water *and the vapor of the water itself*, the actual height is generally less than 30 feet, and for warm or hot water considerably less.

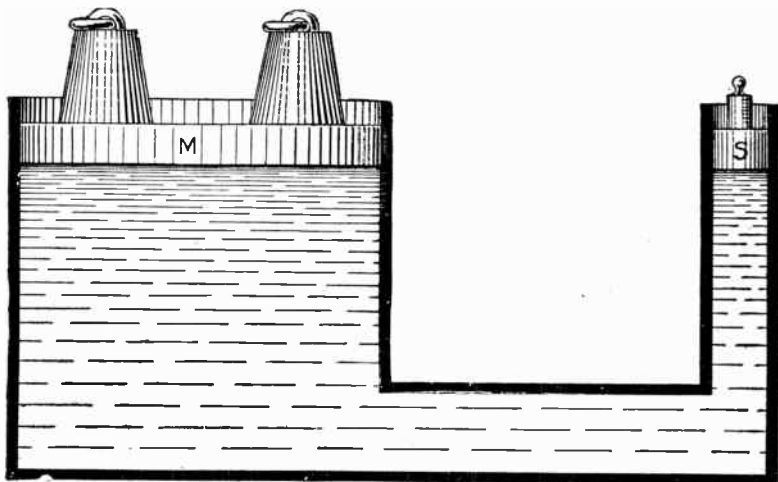

FIG. 4,246.—Hydraulic principles: 3. *The pressure exerted by a liquid on a surface is proportional to the area of the surface.* Two cylinders of different diameter are joined by a tube and filled with water. On the surface of the two pistons M and S, which hermetically close the cylinders, but move without friction. Let the area of the large piston M be, say thirty times that of the smaller one S, and let a weight, say of two pounds, be placed upon the small piston. The pressure will be transmitted to the water and to the large piston, and as this pressure amounts to two pounds in each portion of its surface equal to that of the small piston, the large piston must be exposed to an upward pressure thirty times as much, or 60 lbs. If now a 60 lb. weight be placed upon the large piston, both pistons will remain in equilibrium, but if the weight be greater or less, the equilibrium will be destroyed.

When the water is warm, the height to which it can be lifted decreases, on account of the increased pressure of the vapor. That is to say, for illustration, a boiler feed pump taking water at say 153° Fahr., could not produce a vacuum greater than 21.78 ins., because at that point

the water would begin to boil and fill the pump chamber with steam. Accordingly, the theoretical lift corresponding would be

$$34 \times \frac{21.78}{30} = 24.68 \text{ ft. approximately.}$$

The result is approximate because no correction has been made for the 34 which represents a 34 foot column of water at 62°; of course, at

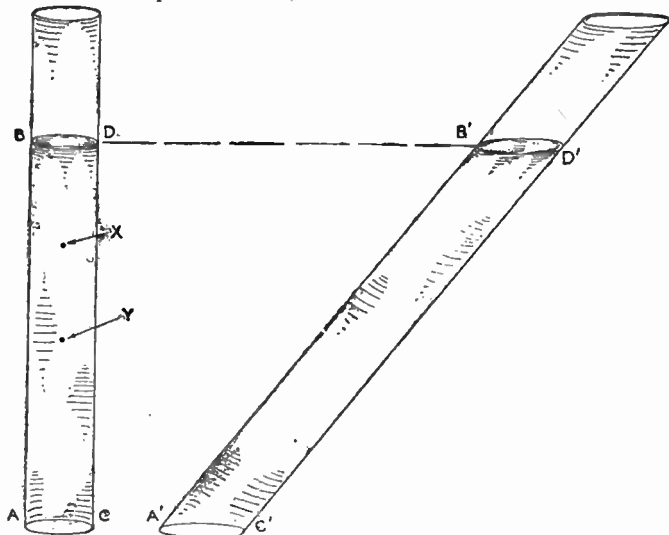

FIGS. 4,247 and 4,248.—*Hydraulic principles:* 4. *The pressure upon any particle of a fluid of uniform density is proportional to its depth below the surface. Example 1.* Let the column of fluid ABCD, fig. 4,247, be perpendicular to the horizon. Take any points, X and Y, at different depths, and conceive the column to be divided into a number of equal space by horizontal planes. Then, since the density of the fluid is uniform throughout, the pressure upon X and Y, respectively, must be in proportion to the number of equal space above them, and consequently in proportion to their depths. *Example 2.* Let the column be of the same perpendicular height as before, but inclined as is fig. 4,248; then its quantity, and of course its weight, is increased in the same ratio as its length exceeds its height; but since the column is partly supported by the plane, like any other heavy body, the force of gravity acting upon it is diminished on this account in the same ratio as its length exceeds its height; therefore as much as the pressure on the base would be augmented by the increased length of the column, just so much it is lessened by the action of the inclined plane, and the pressure of any part of C'D' will be, as before, proportioned to its perpendicular depth, and the pressure of the inclined column A'C'D'B' will be the same as that of the perpendicular column ABCD.

153° the length of such column would be slightly increased.

It should be noted that the figure 24.68 ft. is the *approximate* theoretical lift for water at 153°; the *practical* lift would be considerably less.

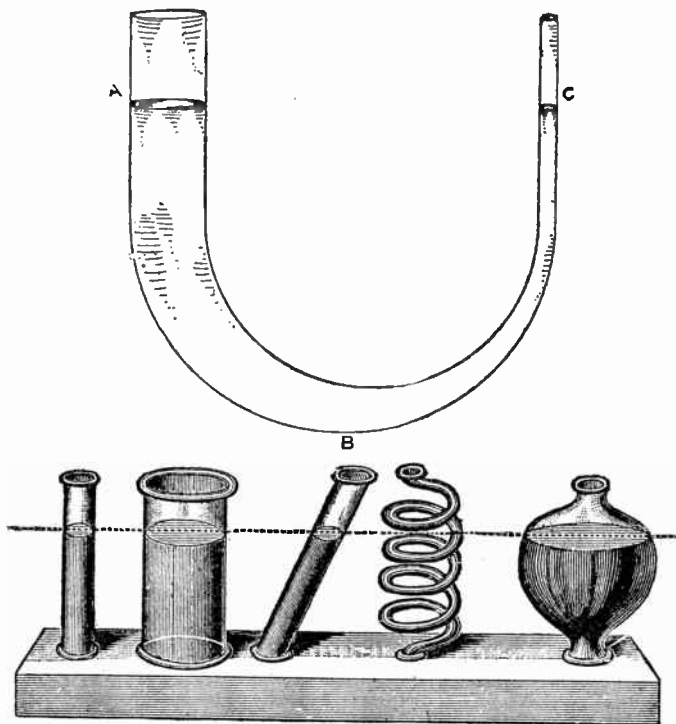

FIGS. 4,249 and 4,250.—*Hydraulic principles:* 5. *Fluids rise to the same level in the opposite arms of a U tube.* Let A B C be a recurved tube; if water be poured into one arm of the tube, it will rise to the same height in the other arm because the pressure acting upon the lowest part at B, in opposite directions, is proportioned to its depth below the surface of the fluid. Therefore, these depths must be equal, that is, the height of the two columns must be equal, in order that the fluid at B may be at rest. Unless this part be at rest, the other parts of the column cannot be at rest. Moreover, since the equilibrium depends on nothing else than the heights of the respective columns, therefore, the opposite columns may differ to any degree in quantity, shape, or inclination to the horizon. Thus, if vessels and tubes vary diversely in shape and capacity, as in fig. 4,250, be connected with a reservoir, and water be poured into any one of them, it will rise to the same level in all of them. The reason of this fact will be further understood from the application of the principle of equal moments, for it will be seen that the velocity of the columns, when in motion, will be as much greater in the smaller than in the larger columns, as the quantity of matter is less; and hence the opposite moments will be constantly equal. Hence, water conveyed in aqueducts or running in natural channels, will rise just as high as its source. Between the place where the water of an aqueduct is delivered and the spring, the ground may rise into hills and descend into valleys, and the pipes which convey the water may follow all the undulations of the country, and the water will run freely, provided no pipe be laid higher than the spring

The following table shows the theoretical maximum lift for different temperatures, leakage not considered.

Theoretical Lift for Various Temperatures

Temp. Fahr.	Absolute pressure of vapor lbs. per sq. ins.	Vacuum in inches of mercury	Lift in feet	Temp. Fahr.	Absolute pressure of vapor lbs. per sq. ins.	Vacuum in inches of mercury	Lift in feet
102.1	1	27.88	31.6	182.9	8	13.63	15.4
126.3	2	25.85	29.3	188.3	9	11.6	13.1
141.6	3	23.83	27	193.2	10	9.56	10.8
153.1	4	21.78	24.7	197.8	11	7.52	8.5
162.3	5	19.74	22.3	202	12	5.49	6.2
170.1	6	17.70	20	205.9	13	3.45	3.9
176.9	7	15.67	17.7	209.6	14	1.41	1.6

Elementary Pumps.—There are three elements necessary for the operation of a pump:

1. Inlet or suction valve;
2. Piston or plunger;
3. Discharge valve.

Simple pumps may be divided into two classes:

1. Lift pumps;
2. Force pumps.

A lift pump is one which does not elevate the water higher than the lift; a force pump operates against both lift and head.

Lift Pumps.—Figs. 4,251 to 4,253 show the essentials and working principle of a simple lift pump.

In construction there are two valves in this type of pump, which are known as the foot valve and the bucket valve. *In operation* during the up stroke the bucket valve is closed and foot valve open, allowing the atmosphere to force the water into the cylinder.

When the piston begins to descend, the foot valve closes and bucket

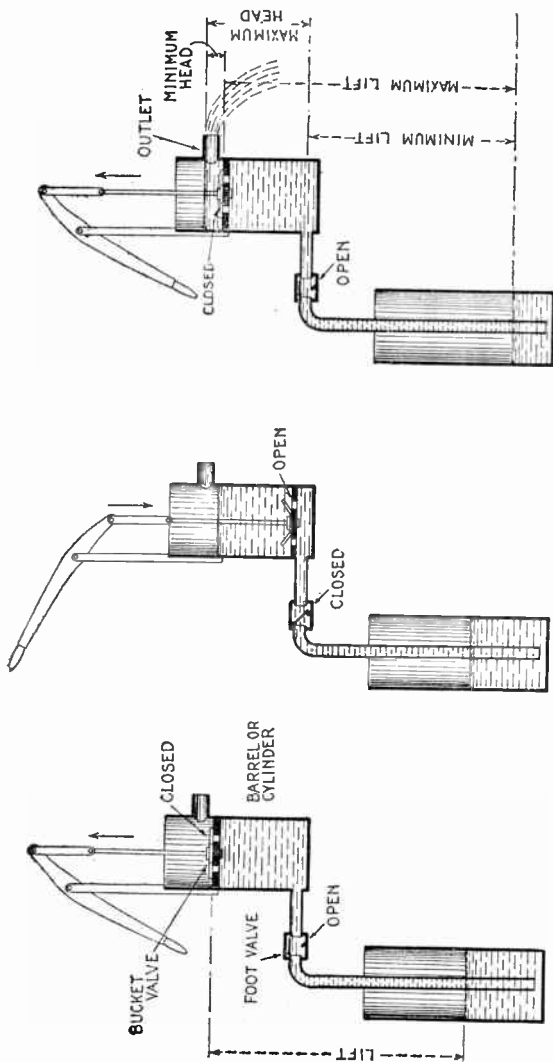

FIGS. 4,251 to 4,253.—Elementary single acting lift pump, showing essential features and cyclic of operation.

valve opens, which transfers the water in the cylinder from the lower side of the piston to the upper side as in fig. 4,252.

During the next up stroke, the water, already transferred to the upper side of the piston, is discharged through the outlet as in fig. 4,253.

It will be noted that as the piston begins the up stroke of discharge it is subject to a small maximum head, and at the end of the up stroke to a minimum head as indicated in fig. 4,253. This variable head is so small in comparison to the head against which a force pump works that it is not ordinarily considered.

F o r c e pumps.—The essential feature of a force

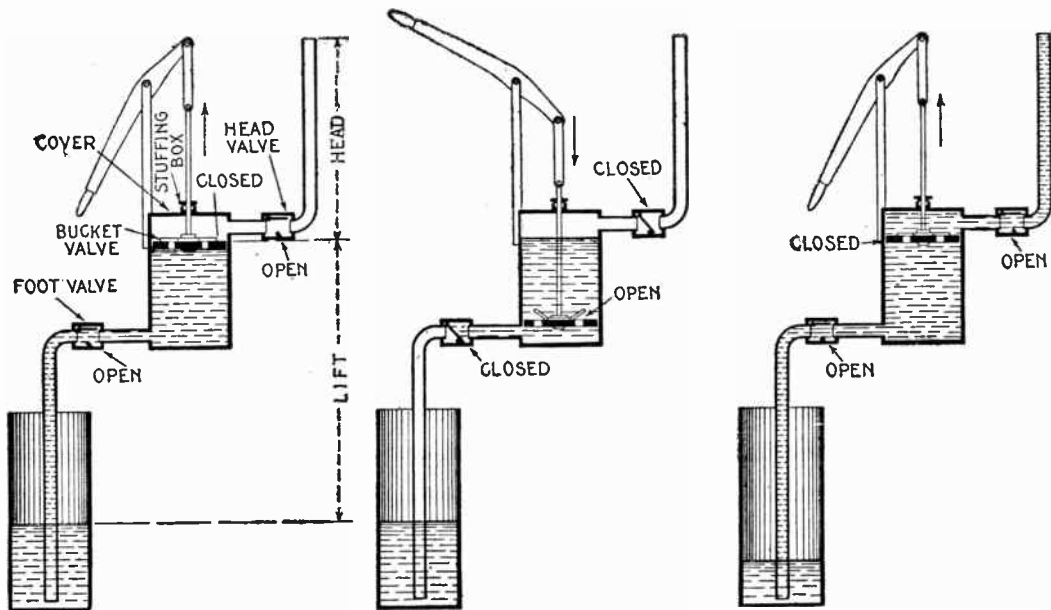

FIGS. 4,254 to 4,256.—Elementary single acting force pump showing distinguishing feature of closed cylinder.

pump which distinguishes it from a lift pump is that *the cylinder is always closed*, whereas in a lift pump it is *alternately closed and open* when the piston is respectively at the upper and lower ends of its stroke.

As shown in figs. 4,254 to 4,256, the cylinder top is closed by a cover, the piston rod passing through a stuffing box; this keeps the cylinder closed.

In addition to the foot and bucket valves of the lift pump, a head valve is provided.

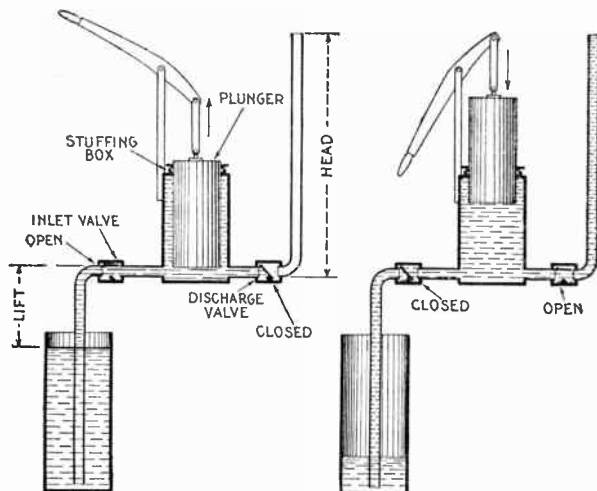

Figs. 4,257 and 4,258.—Elementary single acting plunger pump showing essential parts. The distinction between a plunger and a piston should be carefully noted.

In operation, during the up stroke, atmospheric pressure forces water into the cylinder as in fig. 4,254; during the down stroke this water is transferred from the lower to the upper side of the piston as in fig. 4,255; during the next up stroke, the piston forces the water out of the cylinder through the head valve which closes when the piston reaches the end of the stroke and the cycle is repeated. The positions of the valve are shown in the cuts.

A simple form of force pump, is one known as a single acting plunger pump, a type extensively used, its cycle of operation being shown in figs. 4,257 and 4,258. The figures show the distinguishing features, such as closed cylinder, plunger, and only two valves.

In operation during the up stroke water fills the cylinder, inlet valve opens, and outlet valve closes, as shown in fig. 4,257. During the down stroke, the plunger "displaces" the water in the barrel, forcing it through the discharge valve against the pressure due to the head.

Ques. What is the difference between a piston and a plunger?

Ans. A piston is *shorter* than the stroke, whereas a plunger is *longer* than the stroke.

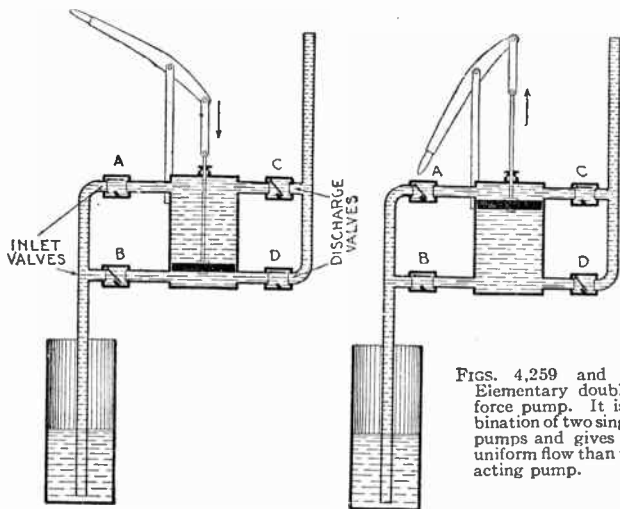

FIGS. 4,259 and 4,260.—Elementary double acting force pump. It is a combination of two single acting pumps and gives a nearer uniform flow than the single acting pump.

The word plunger is very frequently used *erroneously* for piston even by those who ought to know better.

Double Acting Force Pump.—By fitting a set of inlet and outlet valve at each end of a pump cylinder it is rendered **double acting**, that is, a cylinder full of water is pumped each stroke instead of every other stroke.

With this arrangement the piston need have approximately only half the area of the single acting piston for equal displacement, and accordingly the maximum stresses brought on the reciprocating parts are reduced approximately one-half, thus permitting lighter and more compact construction.

In the double acting pump there are no bucket valves, a solid piston being used. The essential features and operation are plainly shown in figs. 4,259 and 4,260. There are two inlet valves A, B, and two discharge valves C, D, the cylinder being closed and provided with a piston.

In operation during the down stroke, water follows the upper face of the piston through valve A. At the same time the previous

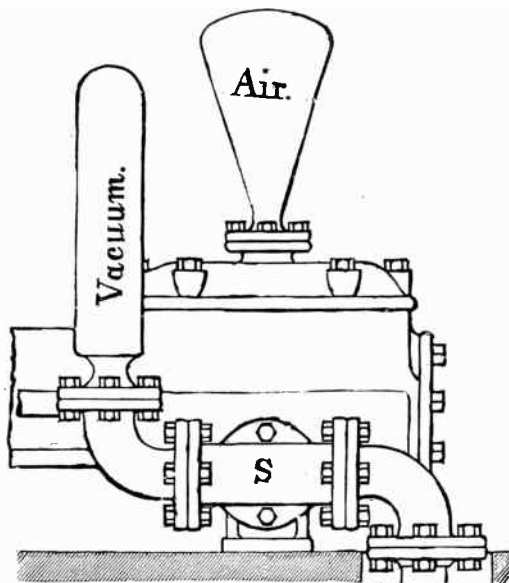
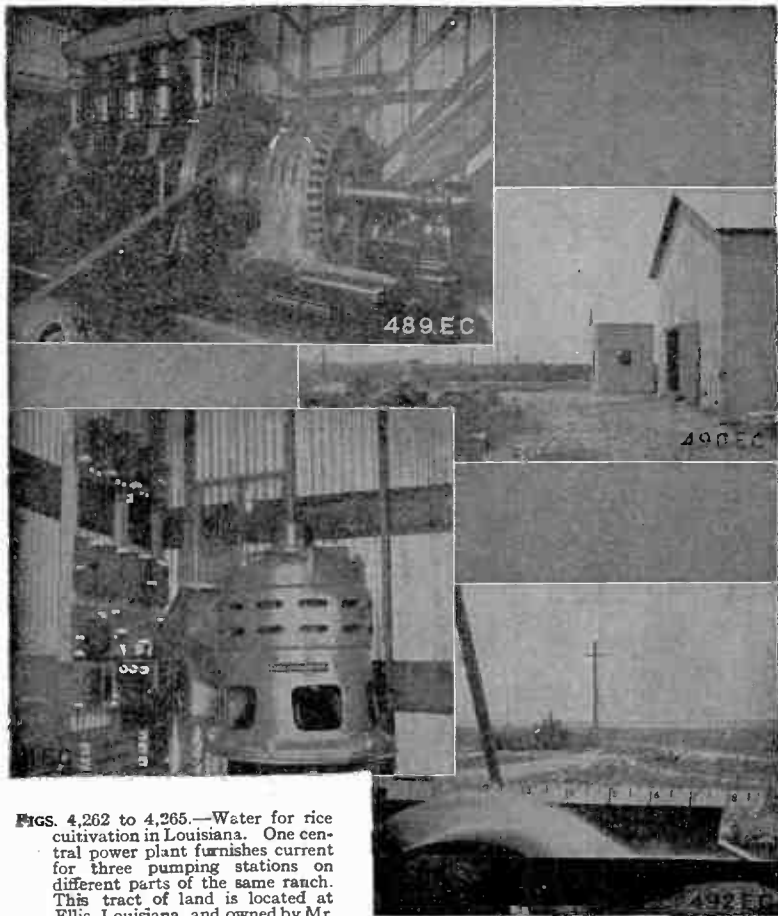

FIG. 4,261.—Air and vacuum chambers. The air chamber is for the purpose of introducing an air cushion to counteract the solidity of the water, thus preventing shocks as the water flows through the valves. Similarly, a vacuum chamber is sometimes attached to the suction pipe. When the column of water in the suction pipe of a pump is once set in motion, it is quite important, especially under high speeds and long intake lines, to keep the water in full motion, and when it is stopped, to stop it gradually and easily. This is accomplished by placing a vacuum chamber on the suction pipe, as shown. *The action of the vacuum chamber is practically the reverse of that of the air chamber.* The object of the vacuum chamber is to facilitate changing continuous into intermittent motion. The moving column of water compresses the air in the vacuum chamber at the ends of the stroke of the piston, and when the piston starts the air expands (thus creating a partial vacuum above the water) and aids the piston in setting the column of water in motion again.

charge is forced out of the cylinder through valve D, by the lower face of the piston. During these simultaneous operations, valves A, and D, remain open, and B, and C, closed, as in fig. 4,259.

During the up stroke, water follows the lower face of the piston through valve B. At the same time, the previous charge is forced out



FIGS. 4,262 to 4,265.—Water for rice cultivation in Louisiana. One central power plant furnishes current for three pumping stations on different parts of the same ranch. This tract of land is located at Ellis, Louisiana, and owned by Mr. Floyd Williams. The motive power is a 200 horse power four cylinder oil engine direct connected to a 170 kva. 2,300 volt alternator. The current at this voltage is distributed over their own transmission line to three pumping stations. One station is located near the power plant, another $\frac{1}{2}$ mile away and the third $1\frac{1}{4}$ miles away. Each pumping plant is equipped with a 75 horse power vertical 2,200 volt motor, direct connected to a vertical centrifugal pump. Each one of these pumps has a capacity of 3,000 to 4,000 gallons per minute, and irrigates about 250 acres of land.

of the cylinder through valve C, by the upper face of the piston. During these simultaneous operations, valves B, and C, remain open, and A, and D, closed.

Air Chambers.—These are placed upon pumps on the head or discharge side of the discharge valve, and contain air for the purpose of introducing an *air cushion* to counteract the solidity of the water, thus preventing shocks or *water hammer* as the water flows through the valves; and also for the purpose of securing a steady discharge of water.

The water being under pressure in the discharge chamber, compresses the air in the air chamber during each stroke of the water piston and, when the piston stops momentarily at the end of the stroke, the air expands to a certain extent and tends to produce a gradual stopping of the flow of water, thus permitting the valves to *seat easily and without shock or jar*.

The capacity of the air chamber varies in different makes of pump from 2 to 3½ times the volume of the water cylinder in single cylinder pumps, and from 1 to 2½ times the volume of the water cylinder in the duplex type. The volume of the water cylinder is represented by the area of the water piston multiplied by the length of stroke.

For single cylinder, boiler feed pumps and those employed for elevator and similar service the volume of the air chamber should be 3 times the volume of the water cylinder, and for duplex pumps, not less than twice the volume of the water cylinder. High speed pumps, such as fire pumps, should be provided with air chambers containing from 5 to 6 times the volume of the water cylinder.

The diameter of the neck should not exceed one-third the diameter of the chamber. When the pumps work under pressure exceeding 80 or 90 pounds per square inch, it is frequently found that the air gradually disappears from the air chamber, the air passing off with the water by absorption. Air should be supplied to the air chamber except at slow speed. At higher speed and with no air in the air chamber

NOTE.—In large pumping plants small air pumps are employed for keeping the air chambers properly charged. In smaller plants an ordinary bicycle pump and a piece of rubber tubing are used to good advantage.

the valves are apt to seat heavily and cause more or less jar and noise, and the flow of water will not be uniform. The water level in the air chamber should be kept down to from $\frac{1}{4}$ to $\frac{1}{3}$ the height of the air chamber for smooth running at medium and high speeds.

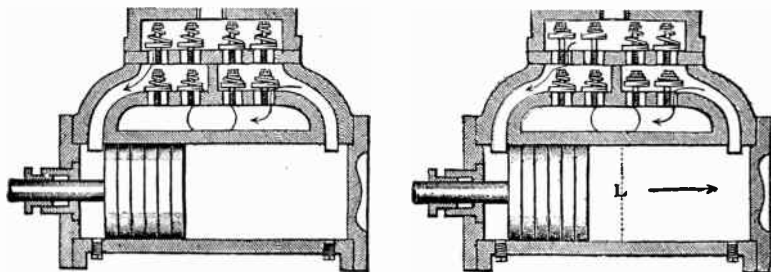

Figs. 4,266 and 4,267.—Sectional view of water end, illustrating lift of valve, and slip. Fig. 4,266, lift for slow or moderate speed; fig. 4,267, lift for high speed. The cuts clearly show the relative position of the suction and discharge valves during the movements of the piston. *Pump slip* or slippage is a term used to denote the difference between the calculated and the actual discharge of a pump, and is generally expressed as a percentage of the calculated discharge. Thus, when the slippage is given as 15 per cent, it indicates that the loss due to slip amounts to 15 per cent. of the calculated discharge. Slippage is due to two causes, the time required for the suction and discharge valves to seat. When pumps run very fast the piston speed is so high that the water cannot enter the pump fast enough to completely fill the cylinder and consequently a partial cylinder full of water is delivered at each stroke. *High speeds also increase slippage*, due to the seating of the valves. Fig. 4,267 represents a sectional view of the water end of a pump, showing the position of the valves during a quick reversal in the direction of the arrows, which illustrates the position of the valves corresponding to high speeds. The valves in a pump, like almost every other part in the operation of machinery, do not act instantaneously, but require time to reach the seats. When pumps run at high speed the piston will move a considerable distance, while the valves are descending to their seats, and water flows back into the pump cylinder until the valves are tightly closed. The valves will remain in the raised position shown in fig. 4,267 until the piston stops at the end of the stroke, and under high speed the piston will reach the position on the return stroke indicated by the dotted line L by the time the valves are closed. The cylinder will be filled up to this point with water from the delivery chamber so that no vacuum can be formed until after the piston reaches this position. The volume of water that can be drawn into the cylinder must necessarily be represented by the cubic inches of space, minus the quantity which flows back during the time the valves are closing. It will thus be seen that the actual volume of water discharged is considerably less than a cylinderful, and the difference, whatever it may prove to be, is called, and is due to slippage. Fig. 4,266 represents the same pump running at a comparatively low speed. It will be noticed that the valves have not been raised as high as in fig. 4,267, because a longer time being allowed for the discharge of the water, a smaller orifice is sufficient. It will be seen also that the piston, moving at a lower velocity, cannot travel as far in fig. 4,266 before the valves seat, and consequently a vacuum can be created in the cylinder earlier in the stroke, and a larger volume of water can therefore be drawn in during the return stroke. In the latter case it is evident that the volume of water drawn into the cylinder will be nearly equal to a cylinderful and consequently the loss by slippage must be correspondingly less. In order to reduce the loss by slippage several valves are used instead of a single valve of equal area. A flat disc valve will rise a distance equal to one-fourth the diameter of the port or of the opening in the seat to discharge the same volume of water that can flow through the port in the same time. In practice the rise exceeds this proportion of one-fourth a trifle, owing to the friction of the water, and this is especially true at high speeds.

Capacity of Pump.—This term relates to the amount of water a pump is able to deliver when operated, at a specified speed. There are two kinds of capacity:

1. Theoretical capacity;
2. Actual or net capacity.

The theoretical capacity represents the pumping ability of a perfect pump, and is expressed as *the volume in cubic feet or gallons displaced by the pump per minute.*

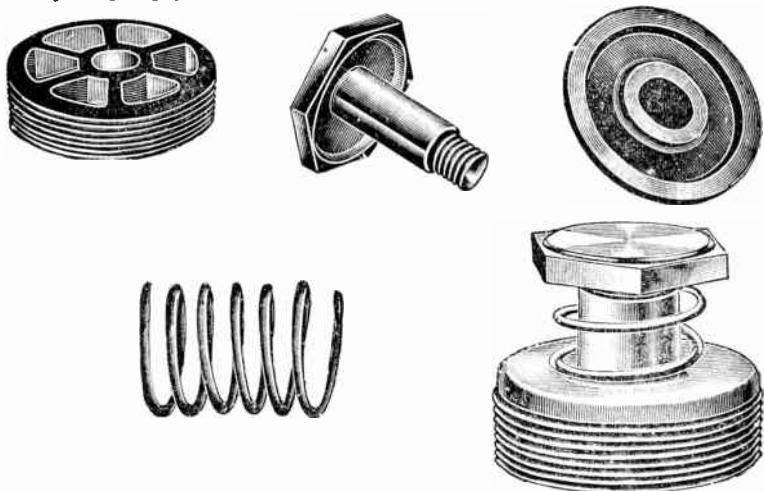

Figs. 4,268 to 4,272.—Metal valve with screw seat details. Fig. 4,268, screw seat; fig. 4,269, stud fig. 4,270, metal valve; fig. 4,271, spring; fig. 4,272, assembly.

Since it is impossible to construct a perfect pump, it is customary in computing capacity, to first calculate the theoretical capacity and then make allowance for the various losses due to slip, leakage, etc.

Ques. What is slip?

Ans. The back flow of water through the valves while they are in the act of closing.

Ques. Where is leakage liable to occur?

Ans. At the stuffing box, valves, piston and joints.

Ques. Name two kinds of leakage?

Ans. Water leakage and air leakage.

How to Figure Capacity.—*RULE:* Multiply the area of the piston in sq. ins. by the length of the stroke in ins., and by the number of delivery strokes per minute; divide the product by 1,728, to obtain the theoretical capacity in cu. ft., or by 231 to obtain theoretical capacity in U. S. gallons. The result thus obtained is to be multiplied by an assumed factor representing the efficiency of the pump to obtain the approximate net capacity.

The rule expressed as a formula is

$$\begin{aligned} \text{Approximately net capacity} &= \frac{.7854 D^2 \times L \times N}{1,728} \times (1-f) \text{ cu. ft., or} \\ &= \frac{.7854 D^2 \times L \times N}{231} \times (1-f) \text{ gallons} \end{aligned}$$

in which

D^2 = square of piston or plunger diameter in sq. ins.;

L = length of stroke in ins.;

N = number of delivery stroke per minute;

f = factor representing assumed slip in per cent. of displacement;

1,728 = cu. ins. in one cu. ft.;

231 = cu. ins. in one U. S. gallon.

EXAMPLE.—What is the approximate net capacity of a 3×5 double acting power pump running at 75 revolutions per minute with an assumed slip of 5 per cent., applying this formula?

$$\begin{aligned} \text{Approximately net capacity} &= \frac{.7854 \times 3^2 \times 5 \times 150}{1,728} \times (1-.05) = 2.91 \text{ cu. ft.} \\ &= \frac{.7854 \times 3^2 \times 5 \times 150}{231} \times (1-.05) = 21.8 \text{ galls.} \end{aligned}$$

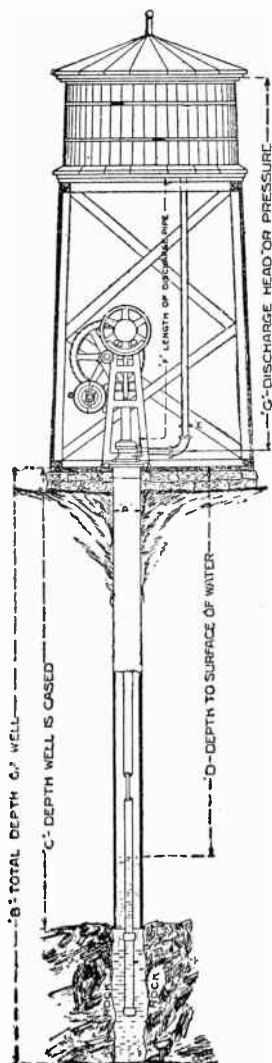

Ques. What kind of a pump will pump more than its theoretical capacity, and why?

Ans. A single acting lift pump having bucket valves, because the column of water does not cease flowing when the bucket descends, that is, especially at high speeds the foot and head valves remain open all the time, and the bucket valve accordingly under such conditions is the only valve essential to operation.

Horse Power of Pump.—The power required to elevate water at a given rate to a given elevation is expressed in horse power, as theoretical or actual, according to whether the various losses are considered. In a pump there is to be

FIG. 4,273.—*Suggestion relating to the installation of deep well pumps.* The cylinder should be placed at such depth as to insure its being constantly submerged, and unless tests show that the water level does not recede materially it is advisable to place the cylinder near the bottom of the well. In placing the cylinder in the well special care should be taken to make all pipe and sucker rod joints tight. For convenience in shipping, cylinders are usually sent with the plunger and lower valve screwed together, and these must be disconnected before lowering the cylinder in the well. The well is supposed to have a straight clear bore of the size specified so that the pump parts will go into it when reasonable clearance is allowed, and also to furnish sufficient clear water to supply the pump. The letters A, B, C, etc., are items necessary to intelligently select the best style of deep well pump. In addition it should be known if the water level recede when pumped, and how much, also capacity in gallons required.

considered the horse power at the water end, and also at the power end. The horse power at the power end represents the actual power to be applied and includes that lost by friction.



Theoretical Horse Power at the Water End.—The theoretical horse power required to raise water at a given rate to a given elevation is obtained by the following formula:

$$\text{T. H. P.} = \frac{V \times W \times (L + H)}{33,000}$$

in which

V = volume in cu. ft. per minute;

W = weight of one cu. ft. of water;

L = lift in ft.;

H = head in ft.

EXAMPLE.—What is the theoretical horse power required to raise 100 cu. ft. of water 200 ft., with a 10 ft. lift when the water is at a temperature of 75° Fahr., and when at 35° Fahr.?

For a temperature of 75°, one cu. ft. of water according to the table (page 2,965) weighs 62.28 lbs. Substituting this and the other data in the formula,

$$\text{T. H. P.} = \frac{100 \times 62.28 \times (10 + 200)}{33,000} = 39.63$$

FIGS. 4,274 and 4,275.—Deming double acting deep well cylinder with ball valves. The inner cylinder is of heavy seamless drawn brass tubing, while the outer casing is of galvanized pipe, and the ball valves, cages and plunger are of brass. The plunger can be readily withdrawn for renewing the leathers without removing the drop pipe. *In operation*, the water is discharged on up stroke through discharge valve D1, which is located in the top of pump plunger. D2 is the discharge valve on down stroke. S1 is the suction valve on down stroke. S2 is the suction valve on up stroke.

Now if the water have a temperature of only 35°, as might be in very cold weather, the weight of one cu. ft. will increase to 62.42, and the horse power would accordingly increase in proportion to the ratio of the two weights, or

$$\text{T. H. P. (at 35° Fahr.)} = 39.63 \times \frac{62.42}{62.28} = 39.7$$

By observing the very slight difference in the two results it will be seen that, for ordinary calculation, the temperature need not be considered, taking the usual value 62.4 lbs.

Horse Power Absorbed at the Water End.—The actual horse power required at the water end of a pump (not including slip or mechanical efficiency) is equal to *the theoretical horse power plus an allowance for the friction of the water through the pipes and pump passages*. The latter being usually very small as compared with the former, may be neglected.

There is also friction of water in the elbows which is usually taken into account.

The tables on pages 2,967 and 2,968 give the approximate friction of water in pipes and elbows, from which the virtual head to be used is easily found and which when inserted in the T. H. P. formula will give the "actual horse power" as above defined.

The Electrical Horse Power.—The number of watt required by the motor of an electric pump must be sufficient to furnish power for:

1. Lifting the water;
2. Loss due to slip;
3. Overcoming the friction of water in traversing the system from intake to point of delivery;
4. Overcoming the friction of pump and gearing;
5. Overcoming the friction of the motor;
6. Electrical losses in motor.

NOTE.—If the quantity of water be given in gallons, W is taken as 8½ lbs., instead of 62.4 lbs.

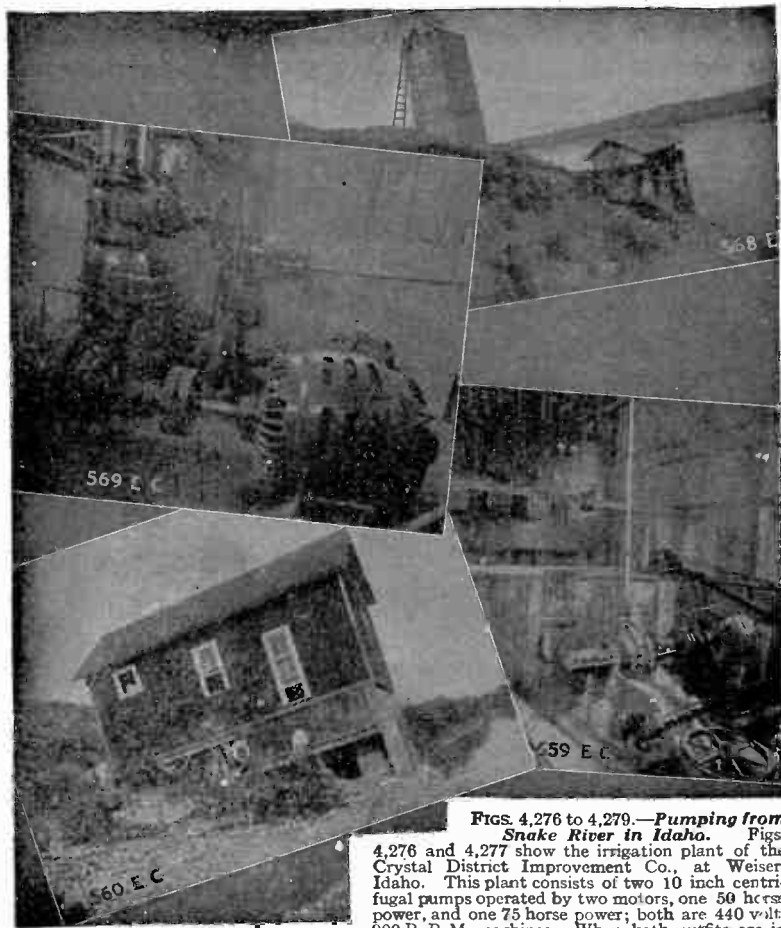

FIGS. 4,276 to 4,279.—Pumping from Snake River in Idaho.

Figs. 4,276 and 4,277 show the irrigation plant of the Crystal District Improvement Co., at Weiser, Idaho. This plant consists of two 10 inch centrifugal pumps operated by two motors, one 50 horse power, and one 75 horse power; both are 440 volt, 900 R. P. M. machines. When both outfits are in operation they deliver nearly 7,000 gallons per minute into the five miles of distributing line which irrigate 1,500 acres of sandy loam. **Figs. 4,278 and 4,279**, illustrate the plant of the Weiser Flat Line Pipe Co., Weiser, Idaho. This plant is similar to the other, and has one 30 horse power motor and 8 inch pump, and one 25 horse power motor and 6 inch pump. The two pumps deliver over 3,000 gallons per minute into three miles of pipe line which is used to irrigate about 500 acres. Before these plants were installed the land was covered with sage brush and now grows alfalfa, grain, etc.

Accordingly, as must be evident, the actual power to be supplied to the motor is considerably less than the theoretical power required to lift the water.

For illustration, assuming that a certain pump have an efficiency of 85 per cent. and the motor which runs it, 88 per cent., then the combined efficiency, or efficiency of the system is $.85 \times .88 = .75$. That is to say, if the electrical power delivered to the motor be 100 horse power and the efficiency of the system be 75 per cent., then only $100 \times .75 = 75$ horse power is available for elevating the water.

How to Figure the Cost of Electric Pumping.—To get the actual electrical power required, first, the theoretical head should be increased by the loss of head in feet due to friction in the pipe line, as determined from the accompanying tables. The result determined in this way must then be considered for the power loss in the pumping unit. This is determined by dividing the theoretical horse power by the efficiency of the system expressed as a decimal, thus :

$$\text{H. P. required by motor} = \frac{W \times H}{33,000 \times E} \dots (1)$$

in which

W = weight of water pumped per minute in pounds;

H = total dynamic head;

E = efficiency of the system comprising pump, motor, and gearing connecting them.

EXAMPLE.—It is required to pump 300 gallons of water per minute against a combined static lift and head of 200 ft. The pipe line is 400 ft. long and contains 5 ninety degree elbows.

From the table showing friction of water in pipes (page 2,967), the friction loss in 100 ft. of 5 in. pipe, discharging 300 gals. per min. is 2.25 ft. Accordingly for 400 ft. it is $4 \times 2.25 = 9$ ft. From the table showing friction of water in elbows (page 2,968), one 5 in. 90° elbow, discharging 300 gals. per min. = .36 ft. Five elbows = $5 \times .36 = 1.8$ ft.

The total dynamic head is therefore, $200+9+1.8=210.8$ ft. Now the weight of water pumped per minute is $8\frac{1}{3}\times 300=2,499$ lbs.

Assuming an efficiency of 75 per cent. for the system, and substituting in (1)

$$\text{H. P.} = \frac{2,499 \times 210.8}{33,000 \times .75} = 21.3 \text{ horse power.}$$

Having determined the actual horse power to be delivered to the motor, the cost per hour for operating the pump can be readily determined by multiplying the horse power just obtained by .746 and by the central station charge per kw. hour. Thus, if the charge be 10c, then

$$\text{Cost of pumping} = 21.3 \times .746 \times .10 = \$1.59 \text{ per hour}$$

Electric Pumps.—Pumping machinery of various form constitutes a part of practically all operations involved in modern industrial development, and in many cases, such as irrigation and drainage projects, sewage disposal, mining, etc., pumps are of vital importance, and in many instances they are operated by electric power to advantage.

To meet the varied conditions of service, there are a multiplicity of type which may be classified:

1. With respect to the cycle of operation, as

- a. Reciprocating { single acting;
double acting;
- b. Rotary;
- c. Centrifugal { single stage;
multi-stage;

2. With respect to the number of cylinder, as

- a. Single cylinder;
- b. Duplex;
- c. Triplex;
- d. Quadruplex, etc.

3. With respect to the reciprocating part, as

- a. Piston;
- b. Plunger.

4. With respect to the stuffing box, as

- a. Inside packed;
- b. Outside packed.

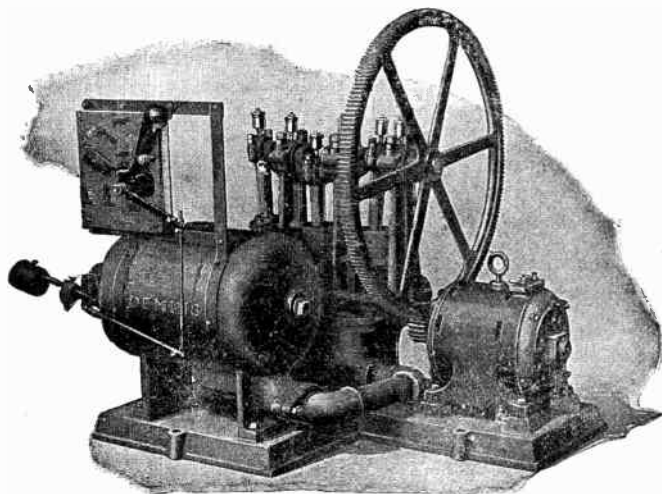

Fig. 4,280.—Deming automatic 3 × 3 triplex piston feed pump and receiver. *It is designed to automatically drain steam coils, radiators, heaters, etc., of the water of condensation constantly collecting therein, and to return this water to the boiler at a temperature otherwise impossible without the use of a special water heater. The outfit includes the pump and cast iron receiver, with a float connected to a lever at the top of the receiver for operating the motor controlling switch. The pump and receiver are mounted on a cast iron bed plate, this being also extended to receive the electric motor, which is connected to the pump by single reduction spur drive. The pump and receiver are set below the water level of the steam coils, so that the condensation will flow to the receiver by gravity. As the water flows into the receiver the float rises, and by moving the lever at the top, starts the motor and pump by throwing in the switch and automatic starter. The pump is also automatically stopped when the water in the receiver is lowered by pumping, the variation of water level being regulated by properly locating the buttons on the chain which passes through the switch lever.*

5. With respect to the valve arrangement, as

- a. Single valve;
- b. Multi-valve;
- c. Bucket valve;
- d. Pot valve.

6. With respect to the pressure, as
- a.* Low pressure;
 - b.* Medium pressure;
 - c.* High pressure.
7. With respect to the velocity of direction of the drive, as
- a.* Single reduction;
 - b.* Double reduction;
 - c.* Multi-reduction.

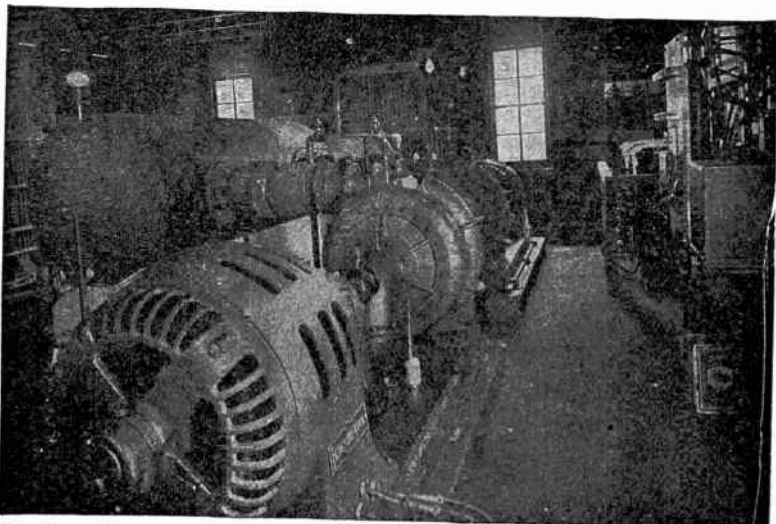

FIG. 4,281.—Fairbanks-Morse electrically driven irrigating plant at Payette river, near Payette, Idaho, which furnishes water to irrigate 600 acres of orchard land. The two 7 inch centrifugal pumps are driven by two 75 horse power induction motors, delivering 2,700 gallons per minute into 660 feet of 30 inch pipe.

8. With respect to the drive construction, as
- a.* Spur gear;
 - b.* Spiral gear;
 - c.* Worm gear;
 - d.* Combination silent chain and toothed gear;
 - e.* Combination belt and toothed gear.

Reciprocating Pumps.—The large variety of pump represented under this heading are used for almost every condition of service. They are either single or double acting, single or multi-cylinder, vertical or horizontal, piston or plunger, etc., as may be best suited to any particular condition of service.

The principles of operation have been given under elementary pumps, and the accompanying cuts illustrate the trend of design and construction

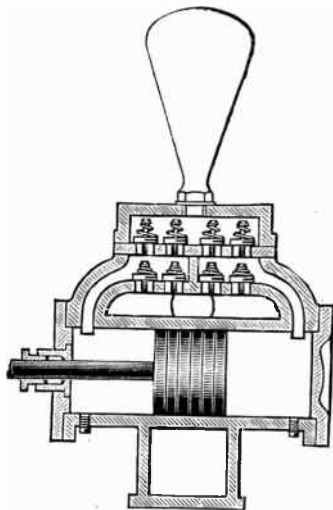

FIG. 4,282.—Double acting piston water end, showing sectional view of piston, cylinder, stuffing box, valves, and water passages. The lower row of valve are the inlet valves, and the upper row the discharge valves.

Water Ends.—There are, properly speaking, four kinds of water end to power pumps:

1. A piston packed with fibrous material within the cylinder, as shown in fig. 4,282. The letter P in fig. 4,283 and the following cuts indicates the plunger.

2. Inside packed plunger, with a stuffing box used for heavy pressures in hydraulic apparatus, or as shown in fig. 4,283 for larger plungers.

3. A single acting outside packed plunger as in fig. 4,284.

4. Two plungers, fig. 4,285, connected outside of the cylinder with a stuffing box in two cylinder heads, through which the plungers work.

The construction of the water ends of single cylinder and duplex pumps is practically the same; any slight differences which may be found are confined to minor details which in no way affect the general design or operation of the pump.

Pump Valves.—The valve apparatus is perhaps the most important part of any form of pump and its design has a material bearing upon its efficiency.

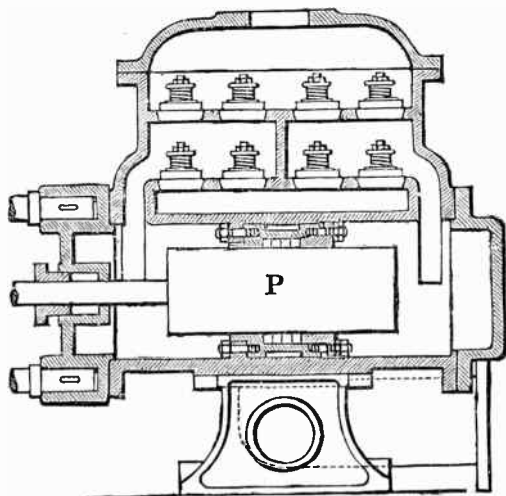

FIG. 4,283.—Double acting inside packed plunger water end showing sectional view of working parts.

The valves shown in fig. 4,282 are carried by two plates or decks, the suction valves being attached to the lower plate and the delivery valves to the upper one. The upper deck, and sometimes both decks, are removable.

The valves are secured to the seats by means of bolts or long screws, which, in turn, are screwed into the seat, as shown in figs. 4,286 and 4,288 or capped as in fig. 4,289.

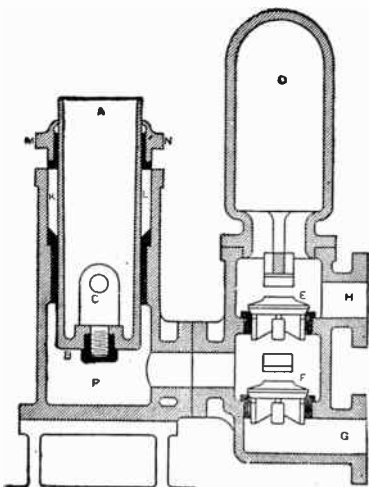

FIG. 4,284.—Single acting outside packed plunger pump. *In construction*, the moving part consists of the plunger AB working in the stuffing box KL. There are two valves or sets of valve, F and E. The stuffing box KL being on the outside can be kept in perfect adjustment, and with proper design the suction and discharge valves may be examined by the simple removal of a bonnet. The strong points of this pump are its simplicity, and the ready accessibility for examination and adjustment of all parts on which the operation of the pump may depend.

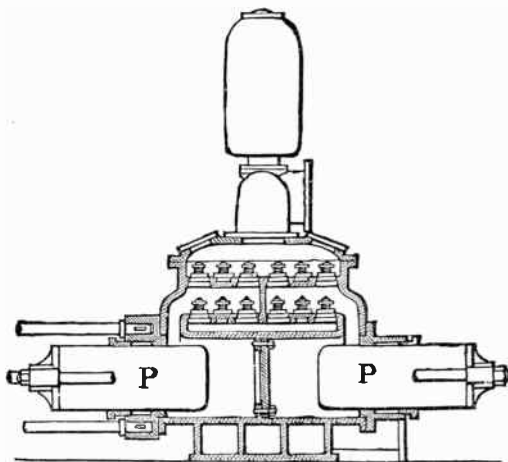
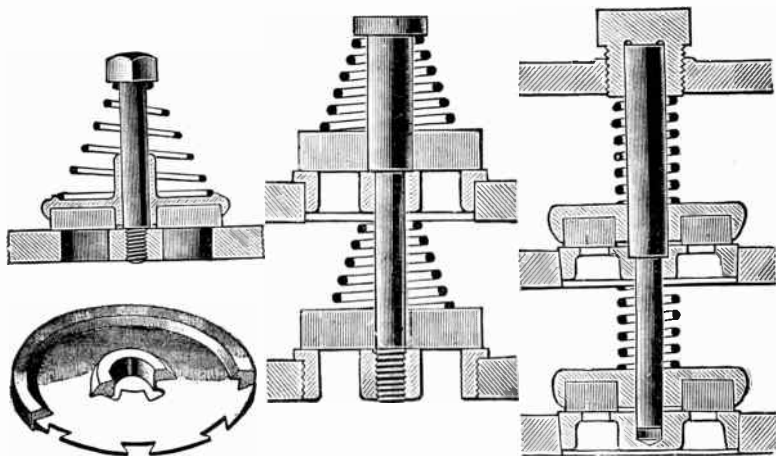

FIG. 4,285.—Double acting outside plunger water end. These plungers are connected by yokes and outside rods, the yokes and a portion of the rods being shown in the figure. The construction is virtually a combination of two single acting plunger pumps so connected as to give the equivalent of a double acting pump cycle.

The valves in all pumps except the large sizes, which may properly be classed with pumping engines, are of the *flat rubber disc type*, with a hole in the center to enable the valve to rise easily on the bolt, the latter serving as a guide.

A *conical spring* is employed to hold the valve firmly to its seat, the spring being held in position by the head of the bolt, or cap, as shown.

Certain improvements in pump valves have been made which tend to increase the durability and to prevent the liability of sticking, which is not an uncommon occurrence after the valves have become badly worn. The improved forms of pump valve are shown in figs. 4,288 and 4,289. When these valves leak, through wear, the disc may be reversed, using the upper side of the disc next to the valve seat. This



FIGS. 4,286 to 4,289.—Various details of pump valve construction.

can be done with ordinary valves also, provided the spring has **not** injured the upper surface of the disc.

Valve seats are generally pressed into the plates, although instances may be found where they are screwed. When pressed in they may be withdrawn by substituting a bolt having longer length of screw thread than the regular bolt, and provided with a nut and yoke, as shown in fig. 4,290. The bolt is slipped through a yoke and screwed into the seat. By turning the nut the seat can generally be started without difficulty.

Fig. 4,291 represents the customary *gland and stuffing box*, in which the gland is adjusted by the nuts C and D upon two studs. After the

adjustment has been properly made, lock nuts are tightened which leaves the gland free, yet preserves the alignment.

It has been proven by practice, after long and costly experiments, that a number of small valve instead of one large valve are more durable. Worthington, Dunham, Leavitt, Holly and other leading pump engineers had occasion to find the truth of this statement early in their careers.

H. F. Dunham confines his practice to four or four and one-half inch valves in all cases except for pumps of very small capacity; the author considers this good practice, as larger valves involve too great lift, and the smaller sizes necessitate an undue multiplicity of valve unit. The "slamming" of large valves under moderate speeds proved itself a

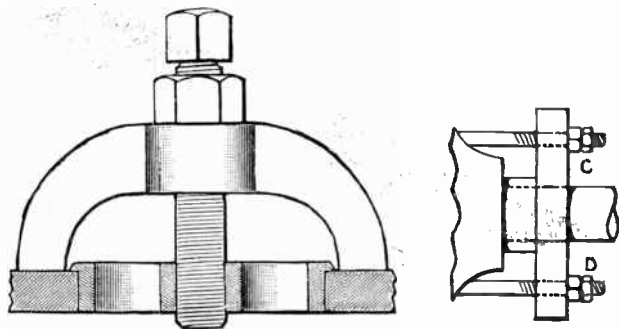
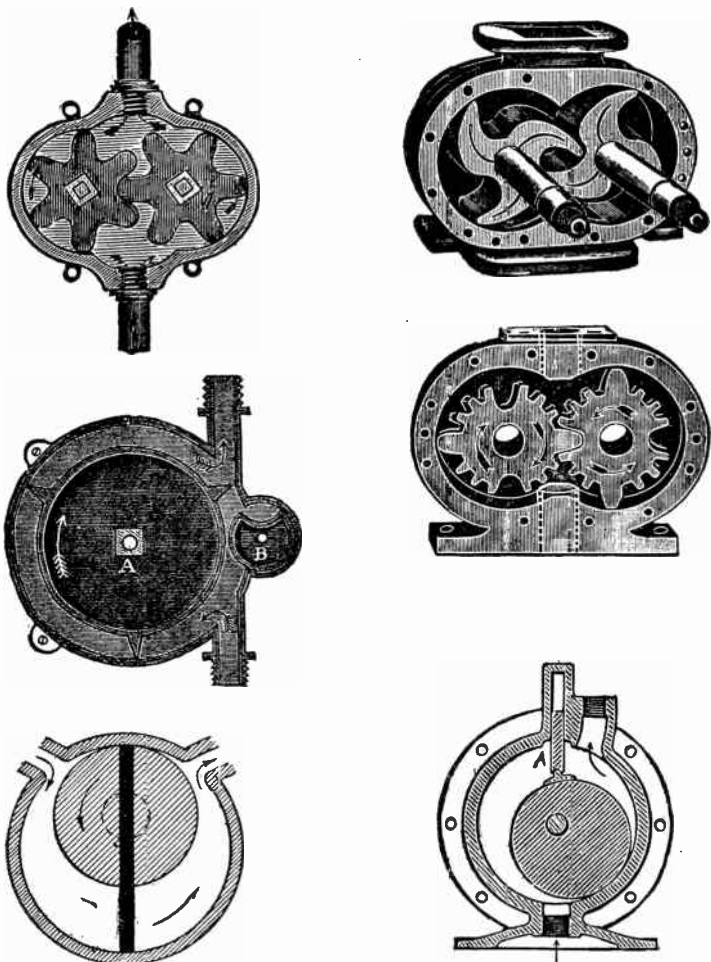

FIG. 4,290.—Jig for removing valve seats of the press fit type. It consists of a bolt with extra length of thread, a yoke and nut as shown. The operation is apparent from the cut.

FIG. 4,291.—Detail of stuffing box for piston pump.

difficulty hard to overcome, until the principle of keeping the valve area as low as possible within reasonable limits had been fully demonstrated.

Rotary Pumps.—This type of pump may be defined, as *one having a revolving piston, or pistons which partake of the nature of cams, rotating upon an axis and being in contact at one or more points with the walls of the enclosing chamber.* In operation, a rotary pump continuously "scoops" the water from its chamber, the operation being somewhat similar to *baiting a boat with a scoop.*



FIGS. 4,292 to 4,297.—Various types of rotary pump. Fig. 4,292 represents one of the oldest and most efficient forms of the rotary pump. Cog wheels, the teeth of which are fitted to work accurately into each other, are enclosed in an elliptical case. The sides of these wheels turn close to those of the case so that water cannot enter between them. The shaft of one of the wheels is continued through one end of the case (which is removed in the figure to show the interior) and the opening made tight by a stuffing box or collar of leather. A crank is applied at the end to turn it, and as one wheel revolves, it necessarily turns the

Rotary pumps may be divided into several classes according to the forms of, and methods of working the pistons or impellers, as they are usually called, that is, according to the construction and arrangement of the abutment.

The abutment receives the force of the water when driven forward by the pistons or impellers and also prevents the water being carried around the cylinder, thus compelling it to enter the delivery pipe.

In the construction of the impellers or pistons, and of the abutments, lie the principal differences in rotary pumps.

In some pumps the abutments are movable, and are arranged to draw back, as shown in fig. 4,297, to allow the piston to pass. In others the pistons give way when passing fixed abutments, and in others the pistons are fitted with a movable wing, as in fig. 4,296, which slides radially in and out when passing the abutment.

Rotary pumps are especially suitable for low pressures, and the absence of close fitting parts renders it possible to handle water containing a considerable quantity of impurity, such as silt, grain and gravel. This type of pump is compact and is generally self-contained, especially in the smaller sizes, and will deliver more water for a given

FIGS. 4,292 to 4,297.—Continued.

other, the direction of their motions being indicated by the arrows. The water that enters the lower part of the case is swept up by the ends of each cog in rotation; and as it cannot return between the wheels in consequence of the cogs being always in contact there, it must necessarily rise in the ascending or forcing pipe. Fig. 4,293 represents a pump similarly constructed to the foregoing, *but having cams*, shaped so as to reduce the wear. *In Eve's pump*, shown in fig. 4,294, a solid or hollow drum, A, revolves in a cylindrical case. On the drum are three projecting pieces, which fit close to the inner periphery of the case. The surface of the drum revolves in contact with that of a smaller cylinder, B, from which a portion is cut off to form a groove or recess sufficiently deep to receive within it each piston as it moves past. The diameter of the small cylinder is just one-third that of the drum. The shafts of both are continued through one or both ends of the case, and the openings made tight with stuffing boxes. On one end of each axle is fixed a toothed wheel of the same diameter as its respective cylinder; and these are so geared into one another, that when the crank attached to the drum axle is turned (in the direction of the arrow) the groove in the small cylinder receives successively each piston, thus affording room for its passage, and at the same time, by the contact of the edge of the piston with its curved part, preventing water passing. *In operation*, the water that enters the lower part of the pump through the suction pipe is forced round and compelled to rise in the discharging one, as indicated by the arrows. Other pumps of the same class have a portion of the small cylinder cut off, so that the concave surface of the remainder forms a continuation of the case in front of the recess while the pistons are passing; and then, by a similar movement to that in the figure described, the convex part is brought in contact with the periphery of the drum until the return of the piston. The next improvement in rotary pumps is shown in fig. 4,295. This type was used for many years as fire pump. The Silsby fire engine is practically this pump in design although it has packing strips in the center of each of the long teeth of the elliptical gears. Fig. 4,296 shows a design with a piston passing through the eccentric rotor. The simplicity, and operation of this type is apparent from the illustration. In the design shown in fig. 4,297, a sliding partition or abutment, A, is used to imprison the water. As the piston or inside cylinder turned around, the abutment was pushed up and fell of its own gravity. A strip of metal supported this abutment and furnished a suitable wearing surface upon the surface of a revolving cylinder and also accommodated itself to the tilting motion introduced by the eccentricity of the revolving cylinder.

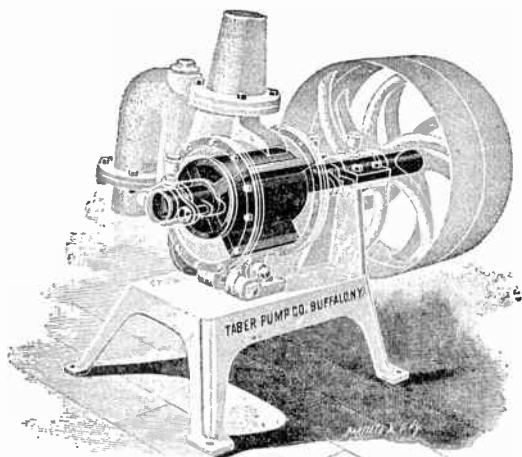

FIG. 4,298.—Transparent view of Taber rotary pump showing all parts. *It consists of a circular barrel containing four vanes or valves projecting through slots of a cylinder eccentric to the circular barrel, and arranged to move in or out to maintain contact with the interior surface of the circular barrel, as shown. In operation, when power is applied to the pulley, the valves automatically adjust themselves to the inside surface of the barrel and create a vacuum which starts the flow of liquid.*

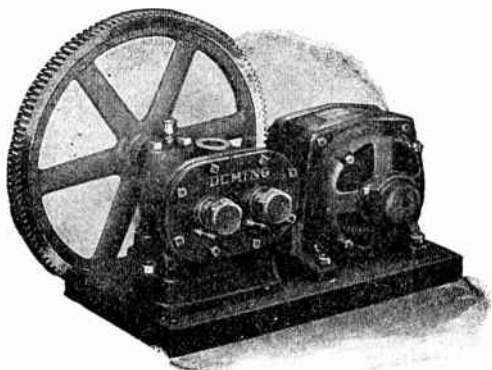
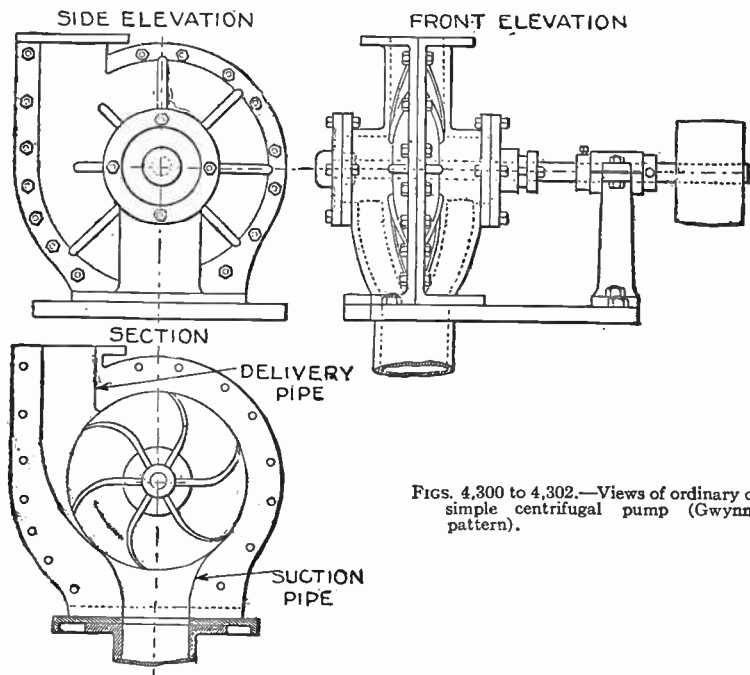

FIG. 4,299.—Deming rotary force pump designed to meet the demand for pumps for pumping small quantities of oil or gasoline. It is also recommended for pumping water for house supply or other purposes where power is available, and the liquid is entirely free from gritty substances. It is simple in construction, consisting of a pair of machine cut gears running together in a tight case. It is mounted on an iron base frame with babbitted bearing for shaft. Suction connection at either side, and discharge at the top.

weight and space occupied than the reciprocating types, while its simplicity of construction not only lessens the liability to derangement, but enables persons having a limited knowledge of machinery to set up and operate these pumps successfully.

Rotary pumps have an advantage over single stage centrifugal pumps in working under widely varying heads. They are usually not eco-



FIGS. 4,300 to 4,302.—Views of ordinary or simple centrifugal pump (Gwynne pattern).

nomical, but when carefully designed with the impellers of the correct cycloidal shape, like those used in positive rotary blowers, they give a moderately high efficiency.

Centrifugal Pumps.—This type of pump may be defined as one in which curved vanes or impellers, rotating inside a close fitting casing, draw in the liquid at the center and, by virtue of

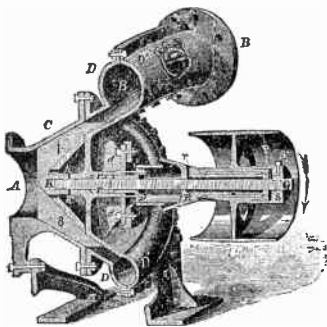
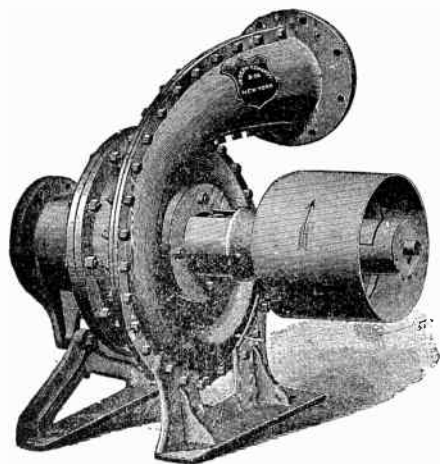

FIGS. 4,303 and 4,304.—Gwynne's conoidal type centrifugal pump and detail of impeller. The arrows indicate the direction in which the impeller turns. *In construction*, A, is the inlet; B, discharge; C, the bottom chamber within which the impeller consisting of disc K, and blades or vanes l to 8, revolve closely without touching the surrounding casing. To chamber C, are attached the conducting case D and D', which form between them an easy curved spiral discharge passage, gradually enlarging toward its outlet B. The shaft G, passes through the stuffing box F, thence through and into the sleeve R, which is securely bolted by wide flanges to the case D', thus forming a central rigid and long bearing for the spindle. The driving pulley P, has its bearing babbitted and runs on the outer diameter of the sleeve R. S is the driving clutch secured to spindle by the feather key and set screw S', and engages by the lugs to the driving pulley. Means of lubrication is afforded by the oil holes r. The vanes on disc K, extend above the disc to exclude dirt from the bearings, and partially relieve the downward pressure upon the disc. The spaces above and below the disc are connected by the holes *kk* through the disc, equalizing the vacuum therein, relieving it from downward pressure, and balancing it so that no lower bearing is required.

centrifugal force, throw out the liquid through an opening at the periphery of the casing.

Centrifugal pumps are divided into four classes:

1. Simple;
2. Conoidal;
3. Volute;
4. Turbine { single stage;
multi-stage.

The simple or ordinary type consists of a series of blade, which are rigidly fixed on a shaft and enclosed in what is called the whirlpool chamber. When the blades are rapidly revolved, the centrifugal force thus created throws the water through the outlet in the casing.

The general appearance of the conoidal pump (named from the cone shaped impeller) is somewhat different from the ordinary centrifugal pump, on account of the widening of the pump chamber to receive a special form of impeller, which consists of a double conical shaped core, on which radial vanes are cast or mounted. The peculiar shape of this

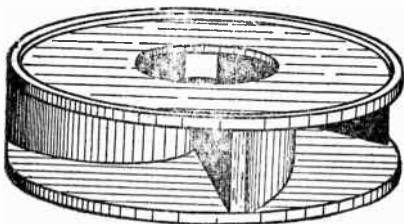
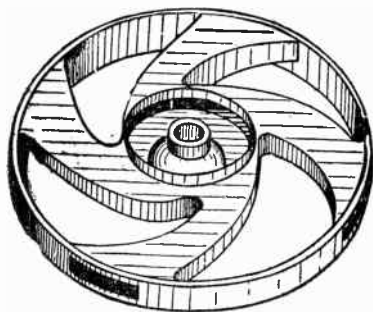
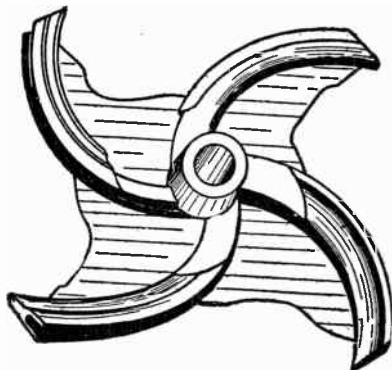

core serves to modify gradually the direction of the incoming current, thereby preventing waste of power. The pump chamber is divided into two parts by a radial partition, which extends entirely around the interior of the chambers and encloses the base of the conoidal impellers. This partition prevents the impingement and consequent disturbance of the two entering columns of water. Conoidal pumps are especially suitable for supplying water to surface condensers, or for irrigation, pumping sewage, or purposes where the liquid pumped is accompanied by sand, mud, silt, etc. They are comparatively inexpensive and the space required by them, relative to the quantity of water delivered, is claimed to be about one half that of a centrifugal pump of the ordinary pattern. They are designed for a maximum head of 30 feet.

Volute pumps are built for medium lifts, but for all capacities. They are desirable for heads up to 70 feet, without necessitating the use of pumps, which are either especially large or very expensive. Volute pumps run at moderate speed.

FIGS. 4,305 to 4,307.—Three styles of impeller for centrifugal pumps. Fig. 4,305, shows a form used for small sizes and for thick liquids; fig. 4,306, is a hollow arm type used in large pumps, and has the advantage that the water is thrown outward without any churning action, and that there are no dead spaces; fig. 4,307 is used for dredges and has the advantage that the sand is prevented grinding between the blades and the casing, yet large openings are free for the passage of sand and mud.

The turbine type may be defined as a *centrifugal pump having stationary guides or diffusion vanes inside the casing*. The diffusion vanes are placed between the periphery of the impeller and the case which take the place of the usual whirlpool chamber and assist in guiding the water to the outlet without internal shock or commotion.

The very limited head at which it was possible to operate the earlier pumps with economy has been overcome by connecting two or more units upon one shaft and operating them in series, that is, passing the water through each unit in succession, thus the head is divided between the units by a multi-stage operation and by providing a sufficient number of units or stages, they may be operated with heads even exceeding two thousand feet without impairing the economy.

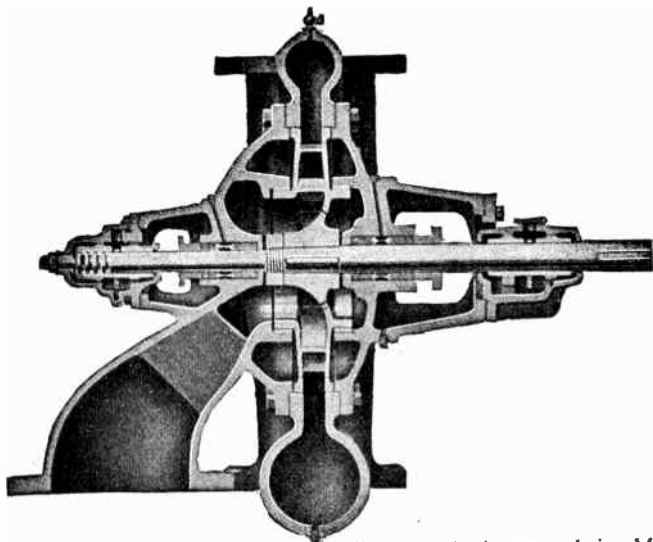
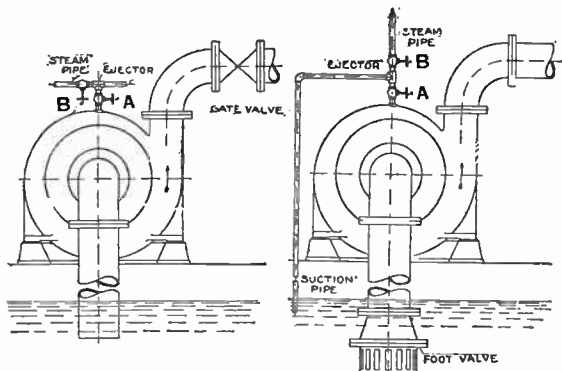

FIG. 4,308.—Sectional view of a typical single suction standard volute pump designed for direct connection to moderate speed motors or for belt or gear drive. A single suction opening is provided on the side furthest from the driving power, thus affording the facility for connecting the suction pipe. The casing is in one piece with feet for mounting on the base plate. The side plates are removable, affording access to the internal parts of the pump. There is a male and female joint between the side plates and casing insuring perfect alignment. The bearings are fastened to brackets cast integral with the side plates, there being a male and female joint between the bracket and bearing body. The impeller is of the enclosed type of cast iron or bronze as required. Alberger regular volute pumps are of the same type and general design, except that the respective sizes are of greater diameter, thus permitting a slower speed for a given head, making this type particularly suitable for engine drive. Standard and regular volutes can be built for heads up to about 85 feet, provided the available speed of the driving power will permit. Standard volute pumps are built in sizes having discharge openings from $1\frac{1}{2}$ inches up to 72 inches in diameter.



FIGS. 4,309 and 4,310.—Method of priming centrifugal pumps. All centrifugal pumps which do not operate with pressure on the suction side, must have the casing and suction pipe filled with the fluid to be pumped, before starting. This priming is accomplished by some combination of the following devices:—hand primer, foot valve, flap valve, check valve or ejector. *If a hand primer be used*, the air cock on the top of the pump is opened, and the primer is worked until water flows through this cock. Then the pump is started. If there be a foot valve on the bottom of the suction pipe, the pump can be primed by running water into it from an overhead tank, hose, city main, etc., as the valve will hold the water in the pump. *Where steam is available* and a foot valve is not used, the pump can be primed by means of an ejector as shown in fig. 4,309. The valve A is opened; then the steam valve B is opened. The current of steam will draw the water up through the suction pipe of the ejector and fill the pump. A and B can then be closed and the pump can be started. *Where a foot valve is used*, a steam ejector can be used as shown in fig. 4,310. The valve A is opened; then the steam valve B is opened. The current of steam in the ejector will draw the air out of the pump casing, and the water will rise through the suction pipe of the pump. When water begins to flow from the ejector pipe, the pump is primed. A and B can be closed and the pump started. When bolting the pump to the foundation, care must be taken not to spring the bed plate. Every joint in the suction pipe should be air tight. The pump should be installed to run in the direction indicated by the arrow on the casing. The stuffing boxes should be packed properly and the water seal ring should be in the proper position. The bearings should be cleaned and filled with a good grade of engine oil. *Long sweep elbows only, and as few of them as possible* should be used in the suction and discharge piping. It is also advisable to use *large pipe lines*, as this reduces the power necessary to drive the pump and will save money in the long run. *To prevent freezing* in cold weather, the pump should always be drained when not in use, by unscrewing the plug in the bottom of the pump casing.

NOTE.—In priming a centrifugal pump where steam is not available and it is impracticable to fill the suction line with water, a hand or power operated air pump should be provided. The use of an air pump requires the placing of a valve on the discharge line of the centrifugal pump. Such a power operated pump should be driven by its individual motor. In priming multi-stage pumps, it is necessary to exhaust the air thoroughly from each stage, and if primed by exhauster, it should be connected to each stage. The pump should be started only after it is entirely filled with water. The pump must not be run empty, as the clearance rings and shaft sleeves, which in good designs have very small clearances, will bind, heat and cut if run dry. When first starting the motor, be sure to see that its direction of rotation agrees with that of the pump, as pump must not run in a direction opposite to that for which it is intended. This will be usually stamped on the casing or may be marked on the blue print of the pump. After the pump is primed, the shaft should be turned over one or two revolutions to allow all air to free itself from the vanes of the impeller.

The turbine pump has created an entirely new field of application for centrifugal pumps, embracing mine drainage, water works, and numerous other services where rotary pumps are desirable but have not been employed, owing to their former limited efficiency at high heads.

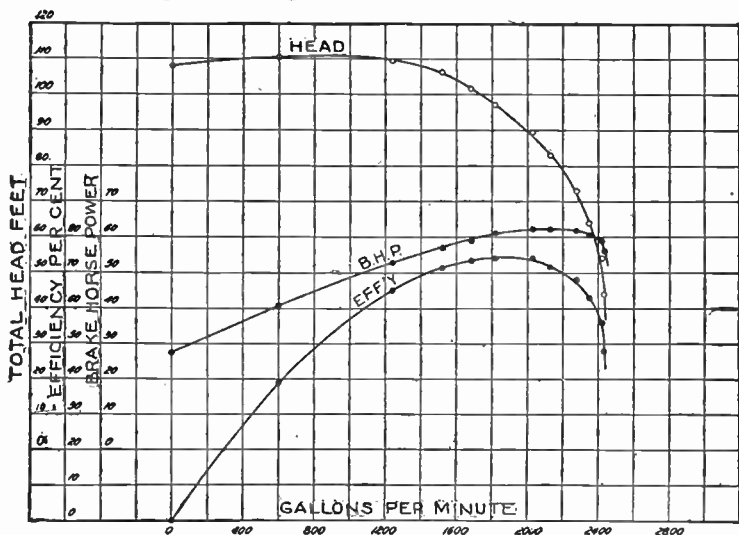

FIG. 4.311.—Characteristic curves of No. 88 Gould single stage double suction centrifugal pump operating at 1,740 R. P. M. constant speed. **Characteristics:** The curve marked *head* shows the variation in total head generated by the pump as the capacity increases from zero to maximum. The B. H. P. curve illustrates the change in horse power input at the pump shaft as the capacity varies, and the *efficiency* curve shows how the efficiency of the pump changes with its output. From inspection of the head curve it is seen that the pump will deliver 2,200 G. P. M. against 79 feet, 2,000 G. P. M. against 90 feet, 1,800 G. P. M. against 97 feet, and that the head at no delivery is above 108 feet. This point is actually somewhat higher, in case pump is driven by an independent motor or turbine, as the speed will increase as the load decreases. From the B. H. P. and Efficiency curves we find that 62 horse power is required to pump 2,200 G. P. M. and that the efficiency of the pump is 70 per cent. under these conditions. Likewise the efficiency is 74 per cent. when pumping 2,000 or 1,800 G. P. M. and 62 B. H. P. and 61 B. H. P. respectively is required. The pump efficiency is 70 per cent. or better over a capacity range of from 1,440 G. P. M. to 2,200 G. P. M. It is further to be noted that the power curve reaches its peak at a point nearly coincident with the maximum efficiency. In other words, if a motor be chosen of just sufficient power to drive the pump at its most efficient capacity—in this case 1,900 G. P. M., that motor cannot be overloaded, or otherwise damaged, by any change in the head against which pump will operate. As the capacity of the pump decreases the power also decreases. Power can therefore be saved by throttling the discharge until just the desired quantity is obtained. At the point of no delivery about 28 H. P. is required to rotate the impeller. The efficiency at this point is, of course, zero, as all the power is absorbed in overcoming friction and no useful work is performed. If the head curve were continued to zero head, about 2,430 G. P. M. would be discharged, and the efficiency would again be zero, as no useful work would be performed under such condition.

As a sinking or station pump for mine service, the turbine pump is ideal. There are no valves, guards or springs, no reciprocating parts, and, most important of all, there is no contact surface in the machine except the shaft and its bearings. The design is such that parts subjected to the action of mine water may be made of acid resisting metal, and, when desired, lead lined.

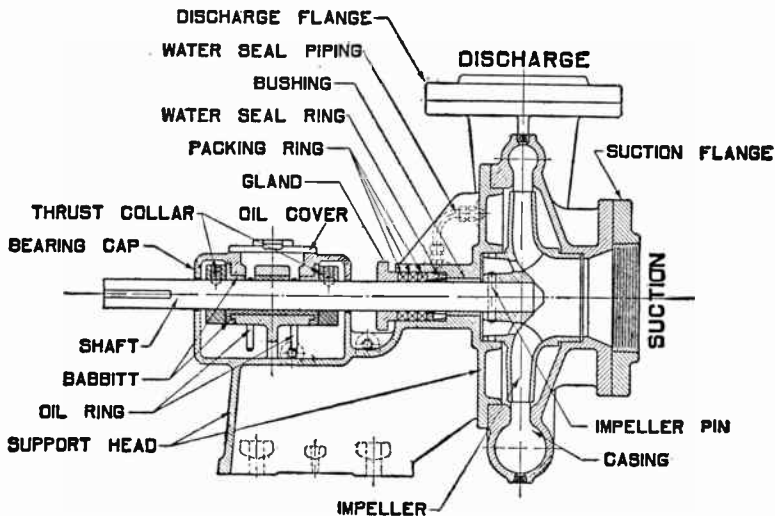

FIG. 4,312.—Section of Goulds single stage single suction centrifugal pump, enclosed impeller type, showing parts.

NOTE.—The importance of correct head determination: In estimating the total head against which a centrifugal pump must operate, use great care and do not resort to guess work; select a motor somewhat larger than apparently necessary so that in case of increased head there will be sufficient power. The total head against which a centrifugal pump operates is made up of the sum of four factors, namely: suction lift, discharge head, friction head (due to losses in pipe line), and velocity head. The suction lift is the vertical distance from the level of the water to be pumped to the floor level of the pump. If the water level be above the center line of the pump, the pump is then said to operate under a suction head, or "flooded suction," and the distance must be subtracted from the sum of the remaining factors. The discharge head is the vertical distance between the floor level of the pump and the level to which the water is elevated. The friction head is determined by referring to tables on pages 2,967 and 2,968 which give the losses in pipe lines and elbows for different sizes. The velocity head (H) in feet is determined by solving for H in the equation $H = V_1^2 \div 64.4$ where V is the velocity in feet per second of the water at the discharge nozzle of the pump. The velocity head need be considered only when the sum of the other factors is less than 20 feet. If the actual head be found to be greater than that for which the pump was designed less than the desired capacity will be discharged. If pump be driven by a direct current motor its speed can be increased so as to discharge more water against the higher head, provided the motor is large enough to carry the increased load. If an induction motor be used, however, it would be necessary to fit the pump with a new impeller and, possibly a larger motor. These brief examples are cited to illustrate the importance of accurately determining the total head.

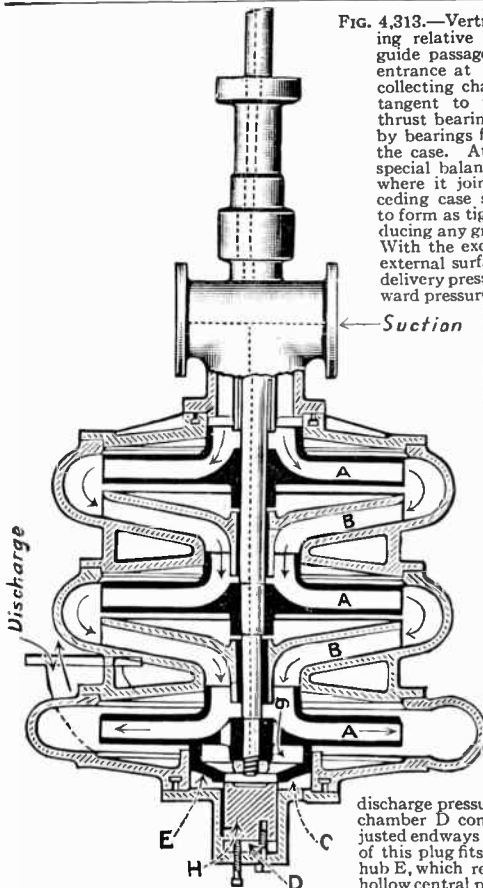

FIG. 4,313.—Vertical three stage turbine pump showing relative arrangement of impellers A, and guide passages B. This pump has the suction entrance at the top; the discharge leaves the collecting chamber of the last (lowest) impeller tangent to the circle. The shaft rests in a thrust bearing at the top, and is further held by bearings formed in the successive sections of the case. At the bottom it is provided with a special balancing arrangement. Each impeller, where it joins the guide passages of the preceding case section, is fitted into the case so as to form as tight a joint as possible without introducing any great frictional resistance to rotation. With the exception of the entrance opening, the external surface of the impeller is exposed to the delivery pressure, so that there is a resultant upward pressure on each impeller, equal to the area of

its entrance multiplied by the difference between the entrance and discharge pressures of that stage. If all the impellers be alike, the total upward thrust is equal to the product of entrance area multiplied by the total head on the pump. The pumps are so proportioned that this upward thrust slightly exceeds the weight of the rotating portion, consisting of impellers and shaft. The excess of upward pressure, however, is relieved by the balancing device located at the lower end of the shaft, with the result that the rotating part is precisely balanced, thus relieving the thrust bearing of all load while the pump is running. The balancing device referred to consists of two chambers, C and D, formed centrally in the bottom of the lowest section of the pump case. The large chamber C encloses a projecting hub E on the lower surface of the impeller. This hub rotates with the impeller, and the joint between the hub and the walls of the chamber is, therefore, loose enough to allow water from the delivery side of the last impeller to leak into chamber C, and establish the full

discharge pressure in that chamber. The small lower chamber D contains a plug H, which may be adjusted endways by means of screws. The forward end of this plug fits closely into a recess in the face of the hub E, which recess communicates, by way of the hollow central part of the hub and the passage g, with

entrance side of the last impeller. In operation, when chamber C becomes filled with water, or rather when leakage through the joint around the tube E has raised the pressure in the chamber C to the delivery pressure, the total upward pressure on the impellers is greater than the total weight of the rotating part of the pump. The rotating element is therefore lifted until the recess in hub E is raised clear of the plug H. In this position the pressure in chamber C is relieved through the passage g, with the result that the rotating element again settles down over the adjusting plug H. As this action tends to recur, a position of equilibrium is established near the point where the plug just enters the recess of the hub E. The precise position of this point may be altered by the adjusting screws of the plug H, thereby adjusting the endwise position of the impellers in the casing. When the pump is not in operation, of course the upward pressure of the water does not act, and the weight of the rotating part must be carried by the thrust bearing.

For mine service, it is preferable that they be driven by electric motors, thereby minimizing space and requiring little attention other than that which is necessary to insure the proper lubrication of the pumps and motors. In addition to the various types of centrifugal pump just described, there are two modifications of design with respect to the inlet feature, namely: the *single inlet*, in which the water enters the case parallel to and in line with its center, and the *double inlet*, in which the suction pipe is divided, forming a U shape, and enters the case at both sides of the center.

Ques. What are the uses of the single and double inlet types?

Ans. The single inlet type is used for clear water only, while the double inlet type will pass everything that enters the suction.

Motors for Reciprocating Pumps.—When direct current motors are used, the compound wound type is generally selected for single acting pumps, on account of the rather pulsating load, but for double and triplex pumps having steadier load

NOTE.—In multi-stage centrifugal pumps and in single stage pumps where the pressure is high, an effective check valve as well as a gate valve should be placed in the discharge line. This should be installed between the gate valve and the pump. In shutting down the pump in cases where there is a foot valve and possibility of water hammer, it is advisable that the discharge valve be first closed before shutting off the power.

NOTE.—Where the suction lift of a centrifugal pump is not very high it is frequently advisable to install a foot valve. By its use, the priming of the pump is simplified, if water be available for that purpose. Care must be taken, however, to keep the foot valve from becoming choked by foreign substances in the water, and for this purpose an efficient strainer should be provided. It is not advisable to use a foot valve where the pump is to work against a very high static head, for instance, into standpipes, reservoirs, etc.; by shutting off the driving power the pump would stop suddenly, and the water rushing back might close the foot valve before the discharge check valve could act, thus producing a very heavy water hammer. The foot valve should be of flap type, rather than multi-spring type, and of ample size so as to introduce no more friction in the suction line than necessary. It is advisable that the suction inlet should be so arranged or placed as to prevent foreign objects being drawn into the pump or clogging up the foot valve. If there be very much refuse or other substances in the water, such as sticks, twigs, leaves, etc., it would be well to have a large outside screen to prevent too frequent stoppage of the water through the strainers. The foot valve or strainer should be placed sufficiently deep in the water to prevent whirl in the surface and consequent drawing in of air.

NOTE.—Before starting a centrifugal pump and its motor, care should be taken to clean the bearings, as dirt and substances may get in during shipment or erection. They should then be filled with a pure, clean mineral oil. This oil should be changed when it becomes dirty and the bearings thoroughly cleaned at the same time. At regular intervals these bearings should be examined.

NOTE.—In operating centrifugal pumps, where there is a considerable amount of air or gases in the water, the air stop cock on top of casing should be opened occasionally; in extreme cases, the cock may be left partially open.

characteristics, the shunt wound type is used to advantage. Both squirrel cage and phase wound induction motors are suitable, the latter as a rule being selected where it is desirable to reduce the starting current to a minimum, or where a somewhat variable speed is required. Synchronous motors may be, and are frequently used for driving large pumps. By pass valves must then, however, be provided for reducing the torque at starting.

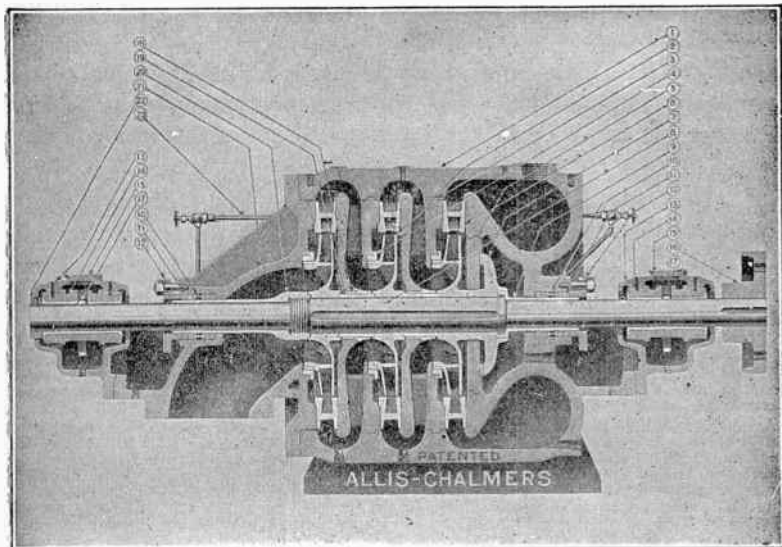

FIG. 4,314.—Sectional view of Allis-Chalmers three stage centrifugal pump showing construction. *The parts are:* 1, cast iron casing; 2, bronze enclosed runner; 3, cast iron return guide; 4, bronze wearing ring; 5, cast iron thrust plate; 6, bronze diffusers; 7, balancing disc; 8, open hearth steel shaft; 9, bronze shaft sleeve; 10, bronze water seal ring; 11, packing; 12, cast iron glands; 13, cast iron bearing cap; 14, cast iron babbitted shell; 15, cast iron hinged lid; 16, cast iron flexible coupling; 17, bronze oiling ring; 18, bronze return guide bushing; 19, bronze spacer sleeve; 20, bronze shaft sleeve; 21, cast iron suction cover; 22, cast iron set collar; 23, water seal piping.

Motors for Centrifugal Pumps.—On account of the peculiar characteristics of the centrifugal pump, special care is required in selecting the type of motor best suited. With a reciprocating



FIG. 4,315.—Rotating element or impellers of Allis-Chalmers five stage centrifugal pump showing runners and balancing disc.

pump operating at constant speed an increase of the resistance increases the pressure and therefore the load on the motor, but with a centrifugal pump, an increase of the resistance reduces the load. The volume of water delivered by a reciprocating pump is not affected by the reduction of the head, but the required power is reduced. A reduction of the head with a centrifugal pump, however, increases the volume of water, and as the efficiency at the same time goes down rapidly, the load increases. It is accordingly of importance to know what this overload, caused by a reduction of the head, amounts to—the duration of this overload. The capacity of the motor should as a rule be governed by the low and not the high head conditions. The condition of starting must also be given careful consideration in selecting the motor.

In starting a centrifugal pump the discharge valve may be closed until the motor comes up to speed, so that the motor may start as nearly light as possible. At rest, the torque required is small, usually from 15 to 25 per cent. of full load torque, and this drops from 5 to 6 per cent. as soon as the machine starts. The pump casing is full of water, however, and as the machine comes up to speed this water is churned around in the casing, causing the motor to load up as it approaches full speed.

when with pumps of the usual design, it takes from 40 to 50 per cent. of full load torque to drive it, even though pumping no water.

Shunt wound direct current motors and either squirrel cage or phase wound induction motors are well adapted for this type of pump and will readily meet the above conditions.

A synchronous motor may lead to difficulties unless proper precautions are taken in designing the starting winding and auxiliary starting equipment.

The Drive.—The reciprocating pump, because of the necessarily low speed at which it must operate requires a high

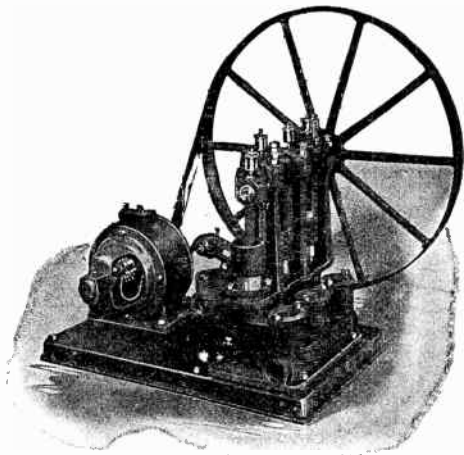

FIG. 4,316.—Deming single acting plunger triplex pump with *single reduction belt drive*. As shown, a short belt is used which runs over an idler having spring tension, the idler serving to maintain the proper belt tension and to give a large arc of contact with the small pulley. This type has the desirable feature of quiet running in addition to its compact arrangement. It makes a desirable arrangement for light service such as tank pumping in residences, apartment houses, hotels, or wherever noise is objectionable.

velocity reduction between the motor and pump. Accordingly some form of gearing which constitutes the “drive” must be interposed between the two machines.

Of the various type of drive, the single reduction belt gear, as shown in fig. 4,316, is the simplest but has the disadvantages of requiring a large pulley and is subject to slippage and breakage of the belt.

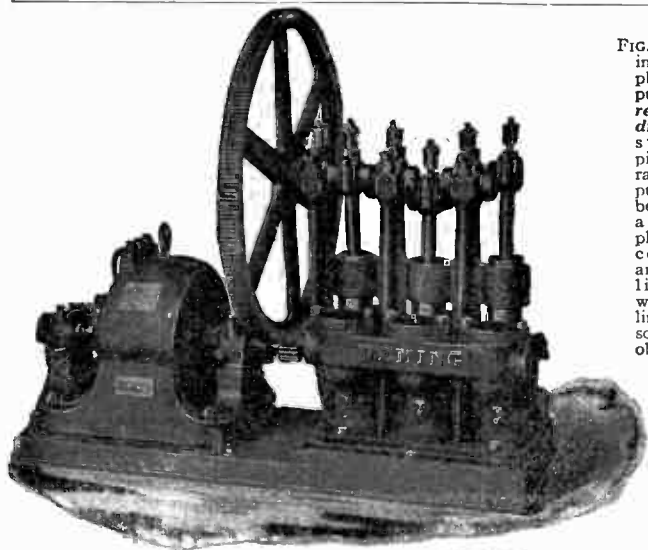
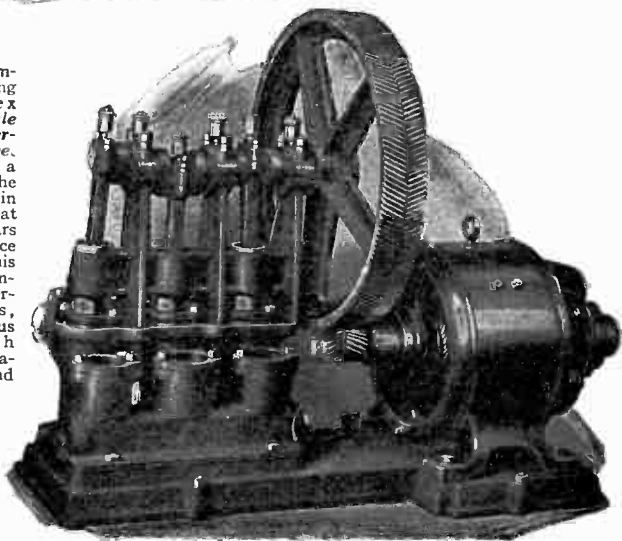

FIG. 4,317.—Deming single acting plunger triplex pump with *single reduction spur drive*. As constructed the pinion is made of rawhide, both pump and motor being mounted on a cast iron bed plate. This is a compact drive and is suitable for light service where space is limited and where some noise is not objectionable.

FIG. 4,318.—Deming single acting plunger triplex pump with *single reduction herringbone drive*. This drive is a refinement of the drive shown in fig. 4,317, in that herringbone gears are used in place of spur gears, this giving the advantages due to herringbone gears, viz.: continuous and smooth action, elimination of shock, and reduced wear.



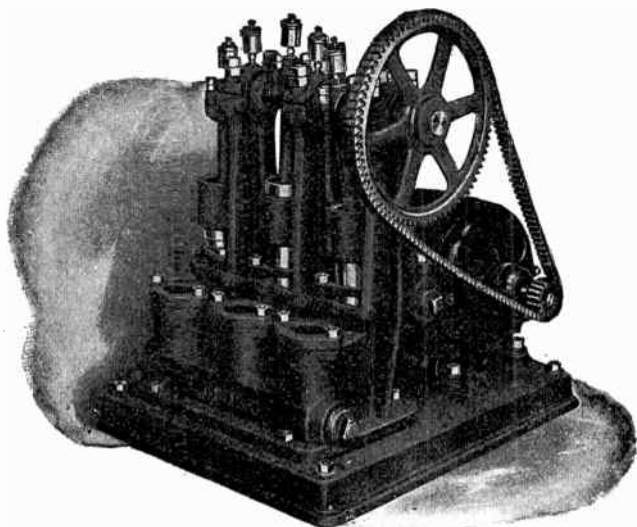

FIG. 4,319.—Deming single acting plunger triplex pump with *single reduction*, so called *silent chain drive*. This drive is desirable where quiet running is essential and space limited. It gives a positive connection between motor and pump, but when worn, the operation of the chain becomes jerky, necessitating replacement.

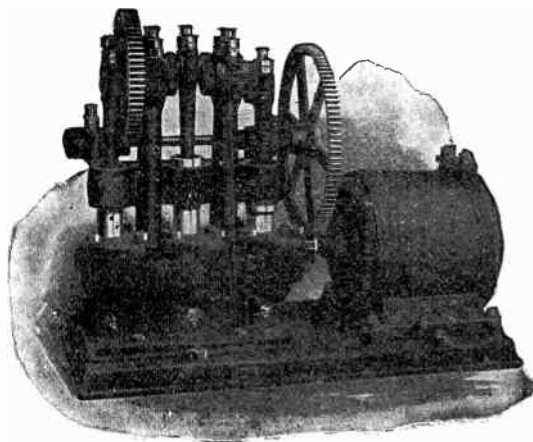

FIG. 4,320.—Deming single acting plunger triplex pump with *double reduction spur gear drive*. As shown, the pinion gear on the motor engages with a large gear on the intermediate shaft which has at its other end a small gear or pinion which engages with a large gear on the pump shaft. As is evident, a large speed reduction between motor and pump is obtained in a small space. The arrangement permits the use of a high speed motor with a heavy duty pump.

The single reduction spur drive shown in fig. 4,317, avoids the large pulley necessary in belt drive, and gives a "positive" connection between motor and pump, but its operation is accompanied by noise which may be more or less objectionable according to location.

A refinement designed to secure quiet running is the herringbone single reduction drive, shown in fig. 4,318, or a so called silent chain as in fig. 4,319. These single reduction drives are suitable for low or moderate pressures, but for heavy duty and large pumps, a higher velocity reduction between motor and pump is desirable, requiring double reduction drives.

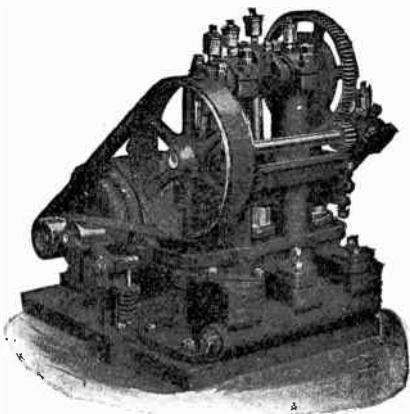

FIG. 4,321.—Deming single acting plunger triplex pump with *double reduction combination short belt and spur gear drive*. This type has the desirable features of quiet running and compactness. When a rawhide pinion is used practically all noise is eliminated. This type of drive is desirable for tank pumping in residences, apartment houses, hotels, or wherever noise is objectionable. The cut shows plainly the idler pulley with its spring holding the belt in proper tension, and also the increased arc of contact secured on the belt pinion by the use of the idler.

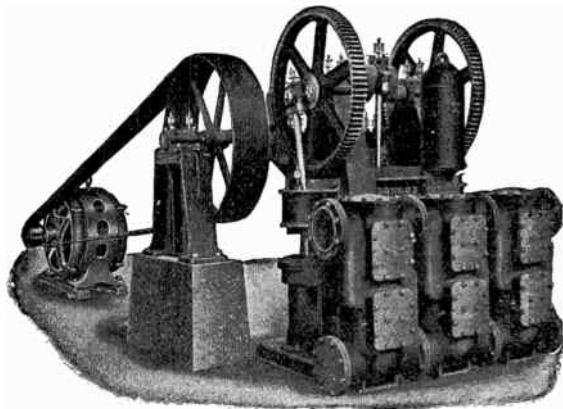

FIG. 4,322.—Goulds double acting piston triplex pump with *double reduction combination long belt and spur gear drive*. As shown, the intermediate shaft carrying the spur pinion gear is extended and supported by outboard bearing for carrying the driving pulley, though on some designs this bearing is integral with the pump structure. The cut clearly shows the long belt connection permitting placement of motor in any desirable location.

Fig. 4,320 shows a double reduction spur gear drive which makes a compact unit, and fig. 4,321, a combination spur gear and belt double reduction drive, the belt rendering the drive less noisy than when both reductions are by spur gear, and yet retaining a high degree of compactness.

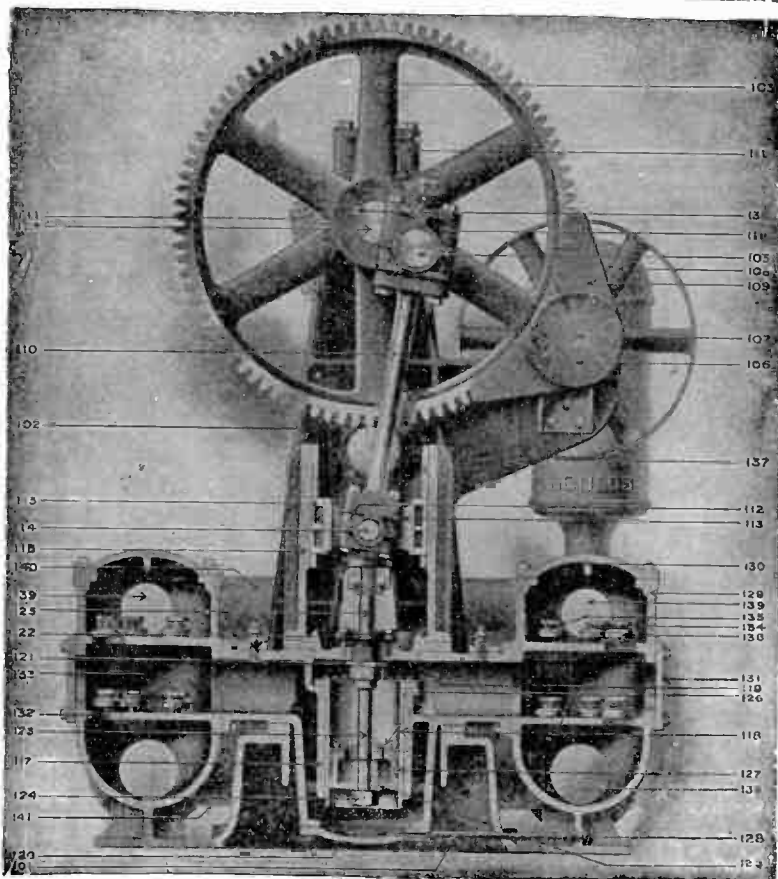

FIG. 4,323.—Sectional view of Goulds double acting piston triplex pump with double reduction combination long bell and spur gear drive, showing construction. *The parts are:* 101, base; 102, standard; 103, main gear; 104, crank shaft; 105, crank pin; 106, main pinion; 107, pinion shaft; 108, pulley; 109, gear guard; 110, connecting rod; 111, upper connecting rod box; 112, lower connecting rod box; 113, cross head; 114, cross head pin; 115, cross head shoe; 116, cross head guide; 117, cylinder; 118, cylinder lining; 119, cylinder head; 120, cylinder bottom flange; 121, stuffing box; 122, gland; 123, piston rod; 124, piston rod nut; 125, piston body; 126, piston follower; 127, piston packing; 128, drain pipe and plug; 129, valve box; 130, valve box cover; 131, hand hole cover; 132, valve seat; 133, valve plate; 134, valve stem; 135, valve spring; 136, rubber valve disc; 137, air chamber; 138, gear key; 139, water passages; 140, discharge pipe; 141, suction pipe.

Where there is ample space and in locations where it is desirable to place the motor at some distance from the pump the type of spur gear and belt drive shown in fig. 4,322 is desirable.

Fig. 4,324 shows a form of worm drive. This gear gives a high velocity ratio on single reduction and is quiet in operation.

Control Devices ; Water End.—For the proper operation of pumps under different conditions various devices have been applied to effect the proper control. Fig. 4,325 shows an automatic pressure regulator and by pass which may be used to

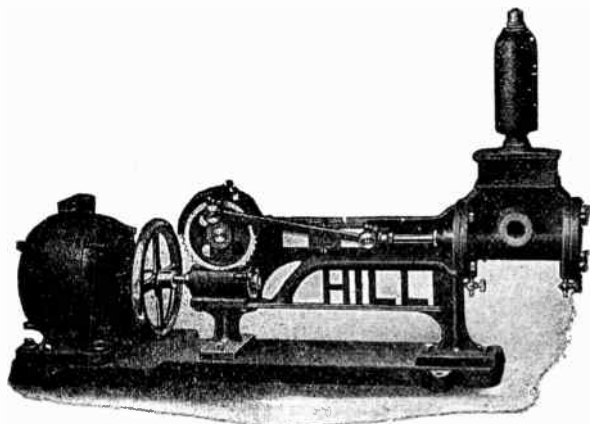

FIG. 4,324.—Hill double acting single cylinder piston pump with *single reduction worm drive*. This form of drive secures practically silent operation, a desirable feature in house tank pumping. The worm is provided with ball bearing thrust collar to reduce end friction. The wheel forming connection between motor and worm shafts also acts as a flywheel as well as a hand wheel for turning around by hand when necessary to pack or work at the machine. Suitable flexible coupling is also formed with this wheel. The position of the worm below the gear wheel allows it to run in an oil bath, thus giving maximum lubrication.

advantage when the demand on the pump is practically constant. The pressure on the pump is controlled by the pressure in a compression tank. The regulator is adjusted to open the by pass valve when the limit pressure is reached. Again, when the pressure begins to drop, the by pass closes and the pump discharges into the tank.

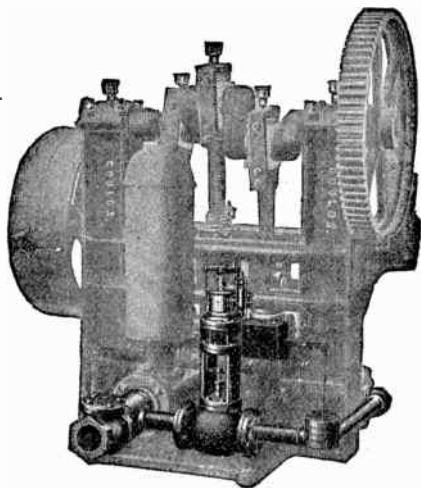

FIG. 4,325.—Goulds type L automatic pressure regulator and by pass.

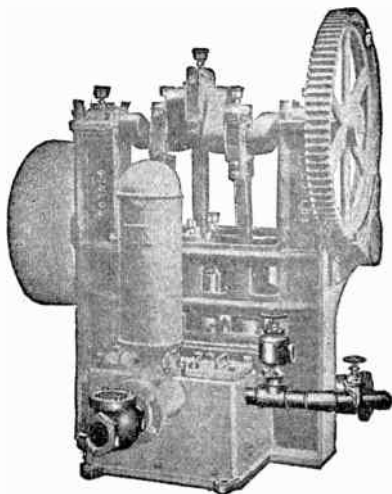
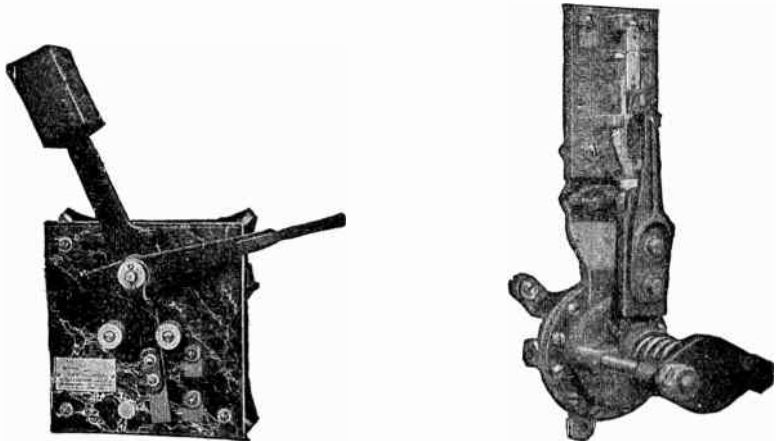

FIG. 4,326.—Goulds type K by pass control consisting of gate valve, discharge check valve, and relief valve.

For boiler feeding, a pump is generally run continuously at a fixed speed, delivering enough water to supply the maximum demands of the boilers, while the actual quantity required may vary. To allow for this variation a by pass should be provided. By means of a gate valve in the by pass pipe the feed may be regulated, the surplus water returning to the source of supply, as shown in fig. 4,326.



FIGS. 4,327 and 4,328.—Deming single pole float switch, and diaphragm pressure regulator. Fig. 4,327, switch; fig. 4,328, regulator. The switch is of the single pole sliding contact type for use with self-starting for automatically starting and stopping the pump motor with open tank systems. This switch is intended to break solenoid currents only and must not be used to handle main line currents. The diaphragm pressure regulator controls a single pole switch designed primarily as a pilot switch for use with a self starter, although it may also be used for throwing a small motor directly on the line in such cases where a single pole switch only is required. Direct or alternating current motors in capacity not over $\frac{1}{4}$ horse power, 110 volts, and $\frac{1}{2}$ horse power, 220 volts to 250 volts can be handled in this way.

Control Devices ; Power End.—There are various devices for automatically starting and stopping the motor when predetermined conditions of pumping are reached. These consist of pressure regulators, float switches, etc.

Fig. 4,329 illustrates the method of automatically controlling an electric house pump when the open tank pumping system is used. The

pump is usually placed in the basement, the discharge pipe passing up through the building to the open tank in the attic, where it is generally located. In the tank is placed a float which follows the water level, and a chain from the float passes over pulleys through the automatic switch arm (the switch being usually located near the tank), and then to a counterweight. Small buttons attached to the chain above and below the switch arm afford a means of regulating the points where

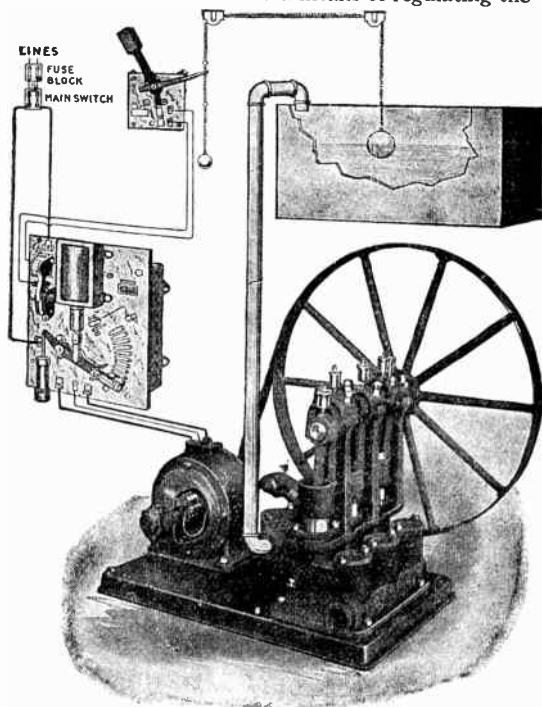
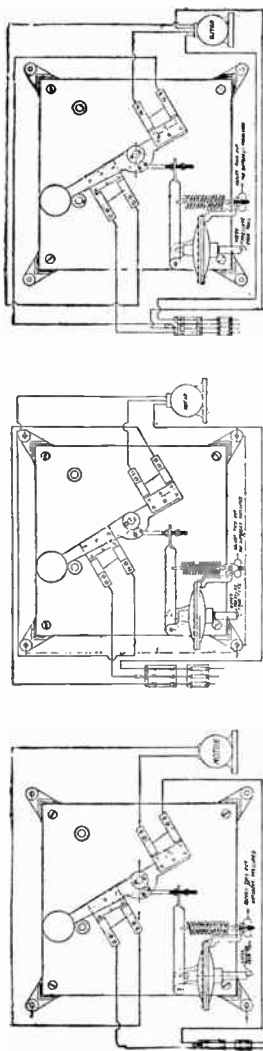

FIG. 4,329.—Automatic control for electric house pump, consisting of float switch, starter, and connection, as shown.

the motor will start and stop. The figure shows the starting rheostat, fuse block, main switch, and wiring.

In place of a tank float, control may be effected by means of the varying pressure of the water due to the head.



FIGS. 4.330 to 4.332.—Wiring diagrams for Hill double pole automatic pressure tank switch. Fig. 4.330, direct, or alternating current, single phase, two wires; fig. 4.331, alternating current, three phase, three wires; fig. 4.332, alternating current, two phase, four wires.

The method, which operates on the same principle as the well known diaphragm damper regulator placed on steam heating boilers, is illustrated in fig. 4,333. The cut shows a switch operated by a pressure diaphragm.

Water is piped to the diaphragm chamber through a quarter inch pipe from tank or discharge of pump.

As pressure rises, diaphragm moves lever until ball falls across center, throwing switch open suddenly.

When pressure in tank decreases, on account of lowering of the water level, lever is moved until ball falls to the opposite side, closing switch and again starting motor and pump. The apparatus is set for different pressures by adjusting the thumb nut shown in the cut. A valve should be placed on the quarter inch pipe to permit water to be shut off in case it be necessary to clean or repair switch.

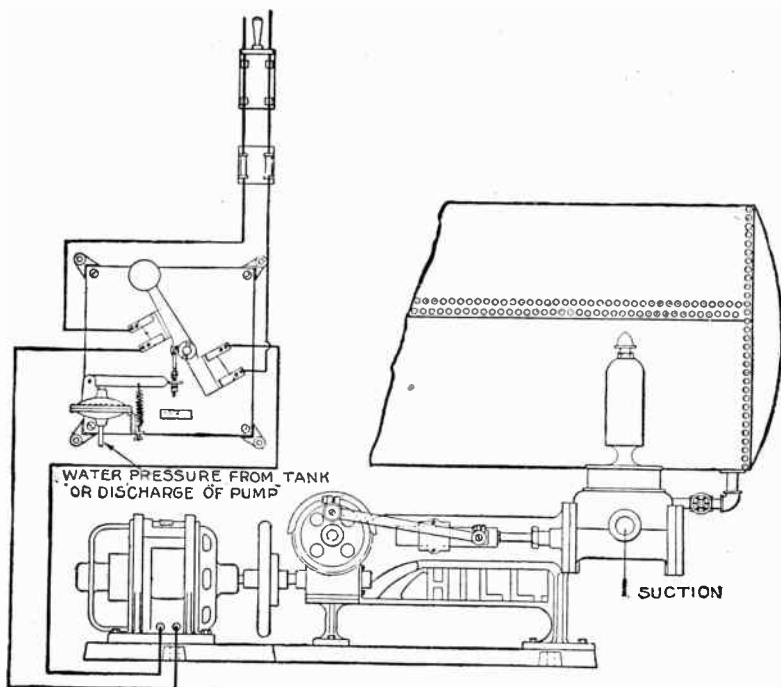

FIG. 4,333.—Hill electric tank pump and *method of pressure control*. The illustration shows a double pole switch connected with a diaphragm pressure regulator, whose operation is described in the accompanying text. The switch here shown is designed for pumps up to $2\frac{1}{2}$ horse power direct current, and 5 horse power alternating current, 110 or 220 volts. The switch is not intended for a closer regulation than about 15 pounds variation in water pressure. That is, if the switch be set to throw at 50 lbs., it will not throw on again and start the motor until pressure in tank has gone down to about 35 lbs. Sometimes closer regulation can be had, but the former serves for most cases, and avoids the too frequent starting and stopping of the motor.

CHAPTER LXXXI

AIR COMPRESSORS

The ever broadening field for the use of compressed air, and the rapid increase of invention of compressed air appliance, have produced a number of change in the design of the earlier compressors the scope of which was confined almost entirely to mine and tunnel work.

Compressed air is used in almost every art known to man, and in many cases its use depends so much upon its economical production, that the modern compressor must embody every refinement which has proved to be of practical value.

The Compression of Air.—When the space occupied by a given volume of air is changed, both its pressure and temperature are changed in accordance with the following laws:

Boyle's law: *At constant temperature, the absolute pressure of a gas varies inversely as its volume.*

Charles' law: *At constant pressure, the volume of a gas is proportional to its absolute temperature.*

In the ordinary process of air compression, therefore, two elements are at work toward the production of a higher pressure:

1. The reduction of volume by the advancing piston;
2. The increasing temperature due to the increasing pressure corresponding to the reduced volume.

The application of the two laws is illustrated in fig. 4,334, which shows a cylinder fitted with an air tight piston. If the cylinder be filled with air at atmospheric pressure (14.7 lbs. per sq. in. absolute) represented by volume A, and the piston

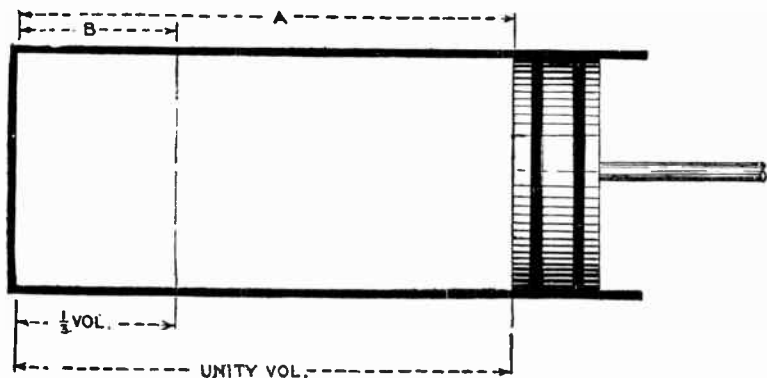

FIG. 4,334.—Elementary air compressor illustrating the phenomena of compression as stated in Boyle's and Charles' laws.

be moved to reduce the volume, say to $\frac{1}{3}$ A, as represented by B, then according to Boyle's law the pressure will be trebled or $= 14.7 \times 3 = 44.1$ lbs. absolute, or $44.1 - 14.7 = 29.4$ gauge pressure. *In reality, however, a pressure gauge on the cylinder would at this time show a higher pressure than 14.7 gauge pressure because of the increase in temperature produced in compressing the air.*

Now, in the actual work of compressing air, it should be carefully noted that *the extra work which must be expended to overcome the excess pressure due to rise of temperature is lost, because after*

the compressed air leaves the cylinder it cools, and the pressure drops to what it would have been if compressed at constant temperature.

Accordingly, in the construction of air compressors, where working efficiency is considered, some means of cooling the cylinder is provided, such as projecting fins, or jackets for the circulation of cooling water.

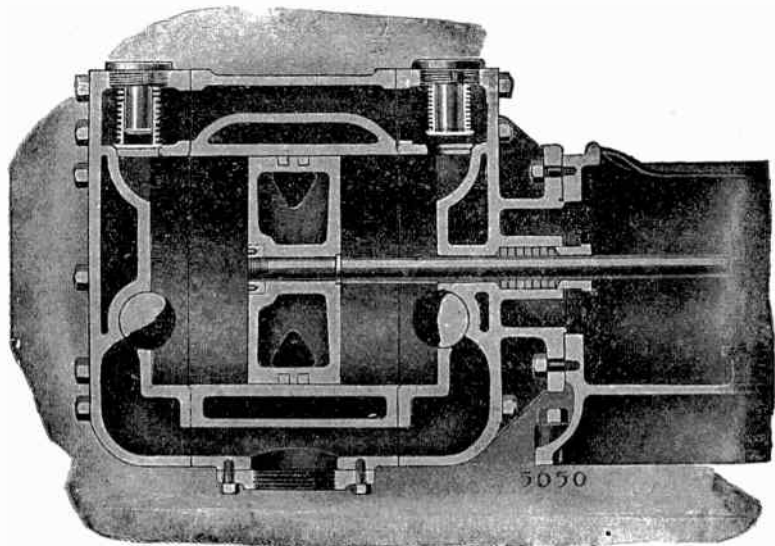

FIG. 4,335.—Ingersoll-Rand imperial air compressor cylinder with Corliss inlet valves, and direct lift discharge valves. The construction provides short, free passages for the entering air and minimizes clearance. The walls of the valve chamber or seat are water jacketed, so that the entering air encounters a cold valve and passage walls.

Ques. What is “free air?”

Ans. Air at ordinary atmospheric pressure and temperature, whatever these may be.

NOTE.—In air compressor problems careful distinction should be made between *gauge pressure* and *absolute pressure*, the former being the pressure as indicated by a pressure gauge, as distinguished from absolute pressure which is the gauge pressure plus 14.72 lbs., the weight of the atmosphere at sea level, when the barometer reads 30 ins. or, for ordinary calculations, 14.7 lbs.

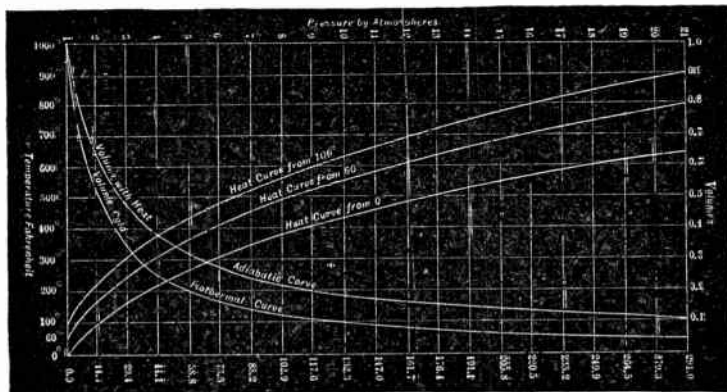
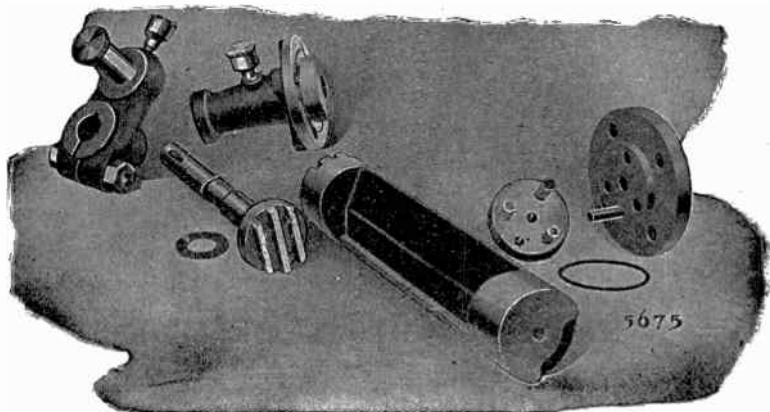

Fig. 4.336.—Air compression characteristics; curves showing the thermal result of air compression and expansion. The simplest application of this diagram is that which gives the gauge pressure represented at different points of the stroke. This is shown in the vertical lines. But in compressing air, heat is produced, and it is important to know the temperature at any given pressure, also the relative volume. All of these are shown in the diagram. The initial volume of air equal to one is taken and divided into ten equal parts. Each division between two horizontal lines, shown by the figures at the right, representing one-tenth of the original volume. The horizontal and vertical lines are the measures of volumes, pressures and temperatures. The figures at the top indicate pressure in atmospheres above a vacuum; the corresponding figures at the bottom denote pressures by the gauge. At the right are volumes from one tenth to one; at the left, degrees of temperature from zero to 1,000 degrees Fahr. The two curves which begin at the upper left hand corner and extend to the lower right are the compression curves. The upper one is the *adiabatic* curve, or that which represents the pressure at any point on the stroke, with the heat developed by compression remaining in the air; the lower is the *isothermal*, or the pressure curve uninfluenced by heat. The three curves which begin at the lower left hand corner and rise to the right are heat curves, and represent the increase of temperature corresponding with different pressures and volumes, assuming in one case that the temperature of the air before admission to the compressor is zero, in another 60 degrees, and in another 100 degrees. Beginning with the adiabatic curve, it will be noted that for one volume of air, when compressed without cooling, the curve intersects the first vertical line at a point between .6 and .7 volume, the gauge pressure being 14.7 pounds. If it be assumed that this air was admitted to the compressor at a temperature of zero, it will reach about 100° when the gauge pressure is 11.7 pounds. If the air had been admitted to the compressor at 60°, it would register about 176° at 14.7 pounds gauge pressure. If the air were 100° before compression, it would go up to about 230° at this pressure. Following this adiabatic curve until it intersects line No. 5, representing a pressure of five atmospheres above a vacuum (53.8 pounds gauge pressure), the total increase of temperature on the zero heat curve is about 270°; for the 60° curve it is about 370°, and for the 100° curve it is 435°. *The diagram shows that* when a volume of air is compressed adiabatically to 21 atmospheres (294 pounds gauge pressure), it will occupy a volume a little more than one tenth; the total increase of temperature with an initial temperature of zero is about 650°; with 60° initial temperature it is 800° and with 100° initial it is 900°. It will be observed that the zero heat curve is flatter than the others, indicating that when free air is admitted to a compressor cold, the relative increase of temperature is less than when the air is hot. This points to the importance of low initial temperature. It is plain that a high initial temperature means a higher temperature throughout the stroke of a compressor. *The diagram gives the loss of temperature during compression, from initial temperatures of 0°, 60°, 100°.* Comparing the compression curve from zero with the compression curve from 100°, it will be noted that in compressing the air from, say, 1 atmosphere to 10 atmospheres, the original difference, which at the start was only 100°, has now been about doubled; that is, it has reached 200°, and in carrying

The Heat of Compression.—This subject has probably received more consideration in air compressor design than any other. The principal losses in the earlier compressors were traceable to this source.



FIGS. 4,337 to 4,344.—Parts of Ingersoll-Rand's *Corliss type inlet valve*. The working pressure is distributed over the entire valve surface, which is almost a half circle. *In operation*, ample port opening is provided at the beginning of the stroke, when the piston is moving most slowly. This opening increases toward mid-stroke; with the piston at its highest speed the port is fully open. The closing of the valve is timed to coincide with the stopping of the piston at the end of the stroke. Thus air is admitted for full stroke and shut off suddenly at the end, so that there can be no escape of free air.

FIG. 4,336.—*Text Continued.*

the compression to 20 atmospheres, the difference now becomes about 250° . Each vertical division represented by the figures at the left is equal to 100° , and the space between any two adjacent vertical lines may be subdivided into 100 equal parts representing 1° each. Where there is a system of cooling the air during compression, the lines on the indicator cards can be traced between the adiabatic and isothermal curves on the diagram. In practice, the best compressors show a line about midway between these two curves. For all practical purposes, in using the diagram it is best to follow the adiabatic curve in all determinations, except where the exact pressure line is known. This diagram will be found convenient to those who are called upon to figure the pressure at different points in the stroke of an air compressor and it points out the common error of neglecting to take into consideration in calculating, the fact that, at the beginning of the stroke, one atmosphere in volume already exists. Beginning at the upper left hand corner, the adiabatic pressure curve intersects the first vertical line at that point in the stroke, when the pressure on the gauge will register 14.7 pounds. The next vertical line shows where the gauge reaches 29.4 pounds, and it is evident here that the piston of an air compressor travels much farther in reaching 14.7 pounds than in doubling that pressure or in reaching 29.4 pounds; thus an air compressor is an engine of unevenly distributed resistance. During the early stages of the stroke it has a slowly accumulating load to carry, while later on this load is multiplied very rapidly. This is one of the reasons for heavy flywheels in air compressors.

By reference to a table giving the temperatures at end of compression for various terminal pressures, it is seen that aside from the injurious effect such high temperatures would have on the lubrication of the cylinder and valves of an air

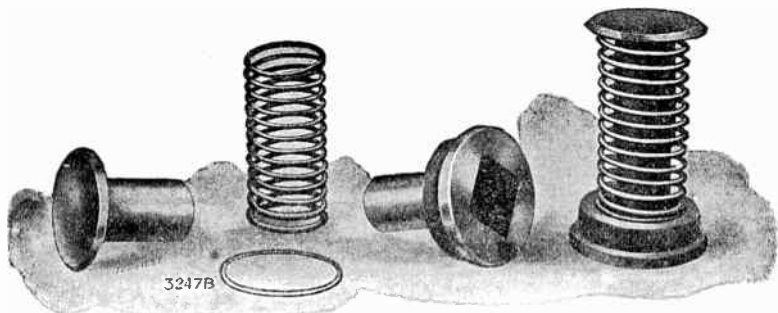

FIGS. 4,345 to 4,349.—Parts of Ingersoll-Rand Imperial *direct lift discharge valve* and assembly. The valve proper is machined from steel and ground to seat; the projecting lip or rim above the seat is caught in the back lash of the compressed air when the piston stops and assists the spring in closing the seat quickly. The valve is cup shaped.

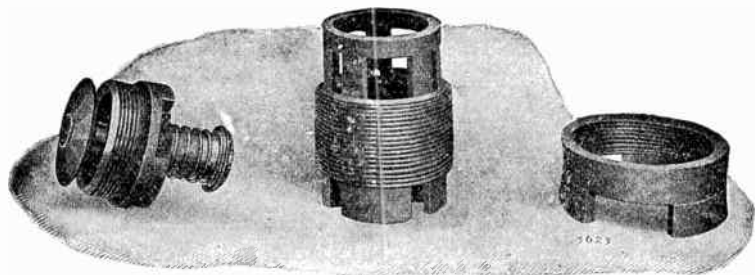

FIGS. 4,350 to 4,352.—Ingersoll-Rand *direct lift inlet valve*, with its bonnet and locking nut. Each unit is self-contained, screwing into place in the cylinder and locked with an auxiliary nut. The valve seats in the cage so that its condition is easily ascertained on the removal of a unit.

compressor, the thermal loss would grow as the pressure increased, if no means were provided for abstracting this heat during compression. It should be noted that the heat of compression, as already explained, represents work done upon the air for which there is

usually no equivalent obtained, since the heat is all lost by radiation, before the air is used.

Simple Compression.—In the earlier compressors, compression was accomplished in one stage or single cylinder machines, and the heat of compression was removed by injecting water into the cylinder in the form of a spray; or, in another type, the water was used as a piston for compressing.

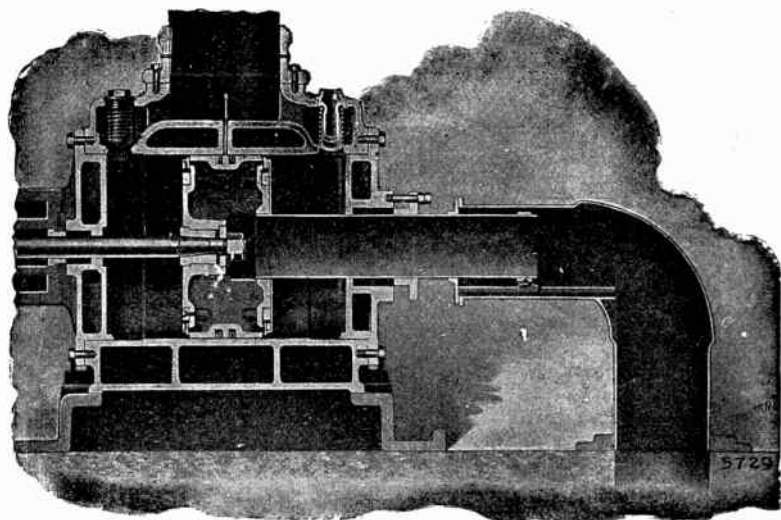

FIG. 4,353.—Ingersoll-Rand air cylinder with *hurricane inlet valves*.

The spray injection cylinder has now given way almost entirely in this country to the dry or jacketed cylinder.

Ques. What are the features of the spray injection process?

Ans. A higher thermal efficiency may be attained than by the dry process, but from a commercial point of view its

ing the loss due to the *heat of compression*.

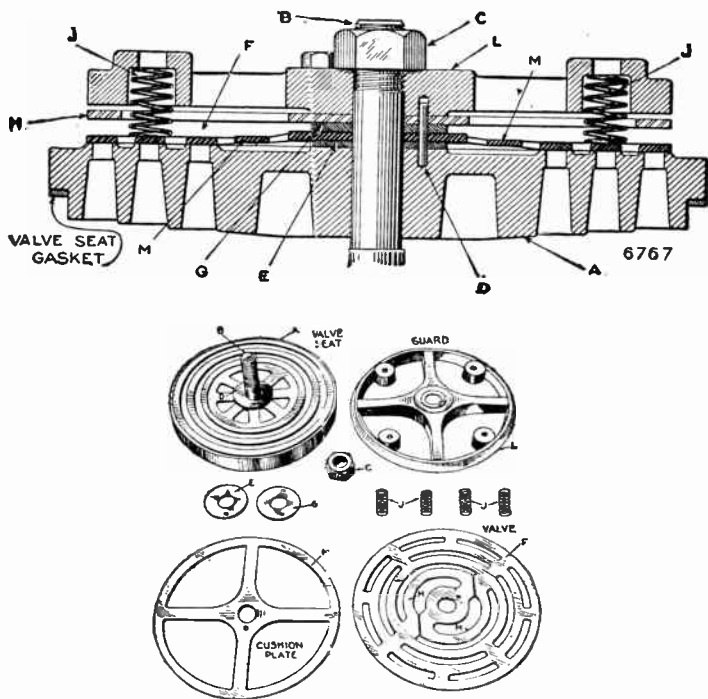

Figs. 4,364 to 4,375.—Cross section of Ingersoll-Rogler valve and parts. *In construction* A is the valve seat; B, the valve bolt; C, the valve bolt nut; E, a washer placed between the valve seat and the valve proper. F is the valve; G a washer placed between the valve and cushion plate H. L is the guard; J, the valve springs, placed inside the four pockets of the guard and which act on the valve. Washers E and G, valve F, and stop plate H, are clamped by means of valve bolt B and kept from turning by a dowel pin D. The portions M of the valve F are integral spring arms. They are ground to about half the thickness of the valve proper, and are made narrow, giving elasticity. The portions M of the valve F are integral spring arms. They are ground to about half the thickness of the valve proper and are made narrow, giving them great elasticity. These portions M should not be confused with the term springs; they are merely connecting arms between the fixed and the moving sections of the valve and serve to hold the valve in one position and seat it always in the same place. With valve at rest, it is held in its seat by the four main springs J, against a slight tension of the integral valve arms M. As soon as the air pressure required to open is reached, the valve opens against these four coil springs to very nearly its full opening. It then comes in contact with the cushion plate H and moves the last $\frac{1}{4}$ inch to $\frac{1}{8}$ inch of its travel against its additional spring tension, the cushion plate having a certain amount of elasticity, it being fixed in the center only. When the piston passes the dead center on the return stroke, the valve closes. The function of the cushion plate is to act as a buffer, absorbing any shock that might otherwise fall on the valve, thus prolonging the life of the valve and reducing the noise.

Ques. How are the cylinder diameters of a compound compressor proportioned?

Ans. They are so proportioned as to divide the work of compression equally between the given number of cylinders.

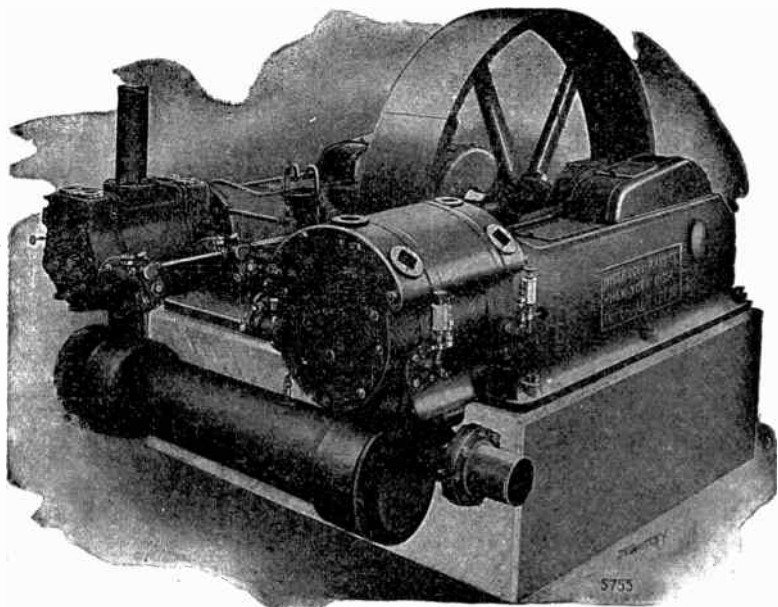

FIG. 4,376.—Ingersoll-Rand Imperial type, compound or two stage duplex belt driven air compressor with underneath intercooler. The cranks are at 90° , thus giving the advantages of stress reduction, and nearer uniform effort inherent in this sequence of crank.

Ques. Describe the cycle of compound compression with intercooling.

Ans. Free air is admitted to the low pressure cylinder, where it is partially compressed, and then forced into an *intercooler*. The intercooler acts as a receiver and at the same time removes the heat of compression of the intake cylinder before the air

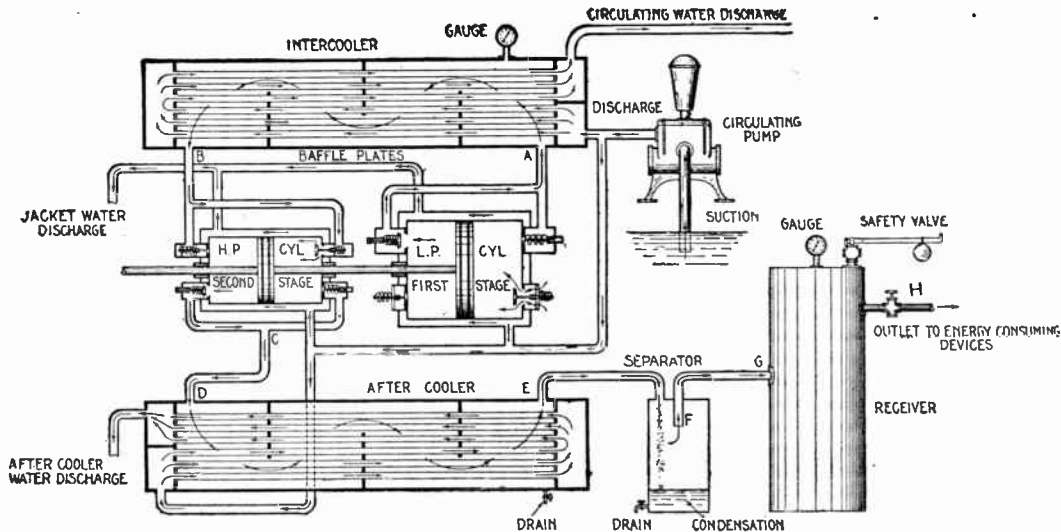

FIG. 4.377.—Elementary compound or two stage air compressor showing all the auxiliary apparatus essential for maximum efficiency in two stage compression. *The cycle of operation* is as follows: Free air is compressed in the *low pressure cylinder* to a moderate pressure and discharged into the intercooler at A, where the *heat of compression* is carried away by the *cooling or circulating water* which flows from the *circulating pump* through the *intercooler cooling tubes*, short circuiting being prevented by the series of *baffle plate*. Passing out of the intercooler at B, it enters the *high pressure cylinder* and is again compressed from moderate to high or working pressure, being discharged at C, into the *after cooler* at D, wherein the heat of the second stage compression is abstracted in precisely the same way as in the intercooler, the circulating water connection being clearly shown. The highly compressed air now leaves the after cooler at E, and passes to the *separator*. The construction of this device, as shown, causes the current of compressed air to suddenly change its direction 180°, thus causing any moisture or water that may be in the air to be hurled to the bottom of the separator by *centrifugal force*. Thus freed of water and moisture, the dry air leaves the separator at F, and enters the *receiver* at G, wherein it is stored, at the working pressure, and is discharged through the outlet H, to perform various kinds of work such as driving rock drills, engines, and all kinds of pneumatic tools. The numerous arrows seen in the diagram show: 1, course of the air in traversing the apparatus; 2, direction of piston movement at the instant depicted; and 3, the direction of water flow: a. through the cylinder jacket; b, through the intercooler; and c, through the after cooler.

is admitted to the second stage cylinder. In the high pressure cylinder the process of compression is completed and the air is delivered to the receiver at the required terminal pressure.

The final temperature in each cylinder will be the same if the work has been divided equally and the intercooler properly designed, but it will be very much lower than if the compression were done in one cylinder. For instance, in compressing air to 100 pounds pressure in a two stage compressor, the air is compressed from atmospheric pressure to, say, $26\frac{1}{2}$ pounds in the intake cylinder and is delivered to the

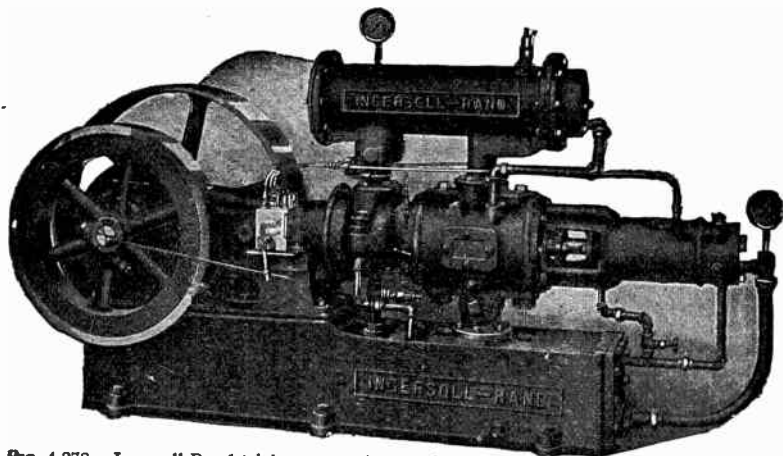

FIG. 4,378.—Ingersoll-Rand triple compression, or three stage high pressure air and gas compressor. Probably the largest demand for high air pressures comes from the mining and contracting fields where pneumatic haulage is employed. Scientific and experimental work calls for still higher pressures in air and gas and the U. S. Government uses high pressure air for a variety of purpose.

intercooler at this pressure and at 240° Fahr.* (atmospheric temperature at 60° Fahr.). If all of the heat of compression be taken out by the intercooler, it is admitted to the high pressure cylinder at atmospheric temperature and is there compressed from $26\frac{1}{2}$ pounds to 100 pounds and delivered to the receiver at 240° Fahr.*

In a single stage compressor the air is compressed from atmospheric pressure to 100 pounds in one cylinder and reaches the receiver at 482° Fahr.*

* NOTE.—Radiation and cooling influence of water jacket not considered.

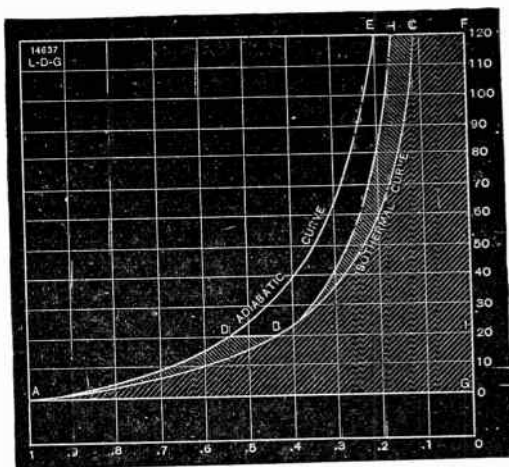

FIG. 4,379.—Compression curves. If the heat of compression be removed as fast as generated, and the compression proceed under a uniform temperature, it is said to be *isothermal*, and the compression curve follows the line A B C in the diagram. If the isothermal compression of air were practicable, and if the heat absorbed from the air by the cooling agent could be applied to the air during its re-expansion in use along a similar isothermal curve, the result would be perfect thermo-dynamic efficiency, and it is toward an approximate realization of these ideal conditions that the best compressor practice is directed. The line A D E in the diagram represents the other extreme, or *adiabatic* compression, during which no heat is removed from the air, and in consequence of which the temperature rises, as indicated in the diagram on page 3,026. The result of this rise of temperature is plain; since a given weight of air at a given pressure occupies a volume proportional to its absolute temperature, the volumes at all pressures are greater in adiabatic than in isothermal compression in a ratio increasing with the pressure, and since the work of compression and discharge is represented by the area in the diagram to the right of the curve along which compression is accomplished, it will be seen that the area A D E C B stands for the waste of energy caused by allowing the heat of compression to remain in the air. *The problem of economy*, therefore, becomes one of the abstraction of the heat generated in the air during the process of compression; and the most obvious solution lies in keeping the air during that period in intimate contact with cold water. *In the early days* of slow running machines the injection of a water spray into the cylinder was attended with success, but the danger and impracticability of such a method with modern speeds must be apparent, and have in fact caused the direct spray to be generally discarded. As a partial substitute for the injection of water, good practice requires the *water jacketing* of the air cylinder, but owing to the short interval within which compression takes place, there is very little actual cooling of the air therein, and the jackets are chiefly useful in keeping the cylinder walls cool enough for effective lubrication, and in the prevention of cumulative heating. At ordinary speeds, the indicator card from an air cylinder in good condition, shows a compression line approaching the adiabatic curve A D E much more closely than the isothermal A B C, so closely indeed, that within the usual and proper ranges of single cylinder compression, no great error is introduced by regarding the compression as adiabatic. Any claims as to approximately isothermal single stage compression must attract suspicion whether supported by cards or not, since such cards can be based only on abnormally slow running, a spray injection, or most probably on leaky suction valves or piston. The loss of energy in adiabatic (approximately single stage) compression is represented by the area A D E C B. The saving effected by two stage compression is, therefore, represented by the unshaded portion D E H B. It is evident that this unshaded area, representing the two stage saving, will increase or decrease with the terminal pressure.

Ques. What is the principal advantage of compound compression over simple compression?

Ans. The reduction of the loss due to the heat of compression.

Other important advantages due to compounding may be enumerated as follows:

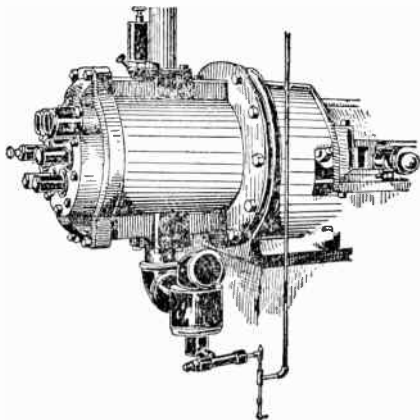

FIG. 4,380.—Rand air cylinder showing control devices. *Unloading device:* The speed of a belt driven air compressor cannot be controlled the same as that of a steam driven machine; its regulation must be accomplished either by throwing off the load, or by stopping the machine during the intervals when there is no demand for compressed air. Accordingly on belt driven compressors a device is provided called an *unloader*, which is placed in the air inlet pipe close to the intake cylinder, and unloads the compressor by cutting off the supply of air. When the unloader is in action, no work is done by the machine excepting that necessary to overcome friction. *Relief starting valve:* This device is used on compressors employing poppet inlet valves. One is placed in each head and consists of a screw, with a knurled handle, threaded into an inlet valve bonnet, and when screwed in, it forces the inlet valve from its seat. By thus holding an inlet valve open in either head, the compressor may be started without load, and when full speed is attained, the valves may be closed, and the compressor permitted to perform its regular work.

1. Cooler intake air;
2. Better lubrication;
3. Reduction of clearance losses;
4. Lower maximum strains and nearer uniform resistance.

The temperature of air leaving the intake cylinder being low, the cooling influence of the jacket is better, the cylinder walls are cooler

between strokes, and the air enters the cylinder cooler than in a single stage compressor. The lubricant for cylinders and valves is not subject to the pernicious influence of high temperatures; and the clearance losses, or losses due to dead spaces, are less in a compound compressor than in a simple compressor. Clearance loss in an air compressor is principally a loss in capacity, and therefore affects only the intake cylinder; it increases with the terminal pressure, but since the terminal



FIG. 4.381.—Ingersoll-Rand Imperial unloader. *It operates* by closing the air intake, and automatically regulates the compressor, maintaining the line pressure within a satisfactory range. *It consists* of a valve on the compressor intake pipe, normally held open by its own weight. When receiver pressure rises above normal this pressure is communicated through a small pipe from the regulating valve, acting to close the valve in the intake pipe, thus shutting off the air supply. The regulating valve can be adjusted for any working pressure by means of a spring adjusting screw.

NOTE.—Air compressor builders and those who use compressed air will agree that the problem of heating or cooling air is a difficult one. Hot air in the cylinder of an air compressor means a reduction in the efficiency of the machine. The trouble is, that there is not sufficient time during the stroke to cool thoroughly by any available means. Water jacketing is the generally accepted practice, but it does not by any means effect thorough cooling. The air in the cylinder is so large in volume that but a fraction of its surface is brought in contact with the jacketed parts. Air is a bad conductor of heat and takes time to change its temperature. The piston while pushing the air toward the head, rapidly drives it away from the jacketed surfaces so that little or no cooling takes place. This is especially true of large cylinders, where the economy effected by water jackets is considerably less than in small cylinders. Engineers who are shown indicator cards from large air compressors with pressure lines running away from the adiabatic, naturally regard them with suspicion, and look for leaks past the piston or through the valves. Such leaks will explain many isothermal cards, and until something better than a water jacket is devised, it is well to seek economy in air compression through compounding. The great advantage of compounding is in the fact that more time is taken to compress a certain volume of air, and that this air while being compressed is brought into contact with a larger percentage of jacketed surfaces.

NOTE.—Since the power driven compressor is almost always a constant speed machine various methods of regulation are employed. Constant speed means constant piston displacement; the problem of delivering a variable volume of air with constant piston displacement, becomes one of making a portion of that displacement non-effective in the compression and delivery of air. Only the fundamental principles of several methods of accomplishing this will here be discussed.

NOTE.—*The first method* is really one of unloading, rather than of regulating. A pressure controlled mechanism is arranged so that when pressure exceeds normal a communication is opened between the two sides of the compressing piston. Usually this is accomplished by opening and holding open one or several of the discharge valves at both ends of the cylinder, the air is then simply swept back and forth from one side of the piston to the other through the open valves and the air discharge passage. When normal pressure is restored, the valves are automatically closed, and compression and delivery are resumed. Evidently this is practically a total unloading of the machine for a longer or shorter period—a sudden release from load and a sudden resumption of load. Moreover, the air which is swept back and forth by the piston in its travel is air under full pressure; so that when the discharge valves suddenly close, the piston at once encounters a full cylinder of air at maximum pressure. These facts limit regulators of this class to machines of comparatively small capacity.

NOTE.—*The second method* provides, by means of a pressure operated device, for the partial or total closing of the compressor intake under reduced load. To avoid the danger attendant upon such an operation acting suddenly, these devices are provided with some damping mechanism so that they are compelled to operate slowly, making the release or resumption of the load gradual. The cutting down of the air intake results in a rarefaction of the air entering the cylinder, and a greater range between initial and discharge pressures, with a corresponding increase in the range of temperatures. This method of regulation, therefore, is not suitable for very great load variations.

NOTE.—*The third method* is very similar to the first, except that here the inlet valve, instead of the discharge valves, are held open when the machine is unloaded, the piston thus simply drawing in and forcing out air at atmospheric pressure. It is open to the same criticism (though in somewhat less degree) as the first method, namely, undue shock and strain on release and resumption of load.

NOTE.—*The fourth method* uses a pressure controlled valve on the compressor discharge of single stage machine, combining also the functions of a check valve to limit the escape of air from the receiver or air line. Excessive pressure blows the discharge to atmosphere, instead of into the line. This arrangement is also used on two stage machines by placing it on the low pressure discharge to the intercooler. Then, when the governor valve is opened by excess pressure, the low pressure cylinder discharges to atmosphere, and the high pressure cylinder acts simply as a low pressure cylinder with intake at atmospheric pressure. This device is more of a relief valve than an unloader, for the piston must continue to compress to a pressure which will open the discharge valves; this volume of compressed air is wasted.

NOTE.—*The fifth method* provides auxiliary clearance spaces, or pockets, at each end of the cylinder, which are successively "cut in" as load diminishes. The excess air is simply compressed into these clearance spaces and expanded on the back stroke. The capacity of the cylinder is reduced without any appreciable waste of power; for the energy used in compressing the clearance air is given back by its expansion.

NOTE.—On power driven compressors with Corliss intake valves, several different methods of unloading or regulating are used. By one method, the Corliss valve is held open for the full admission stroke, and also for a part of the compression stroke, this latter portion being determined by the unloading called for. Evidently this is practically equivalent to a shortening of the stroke of the compressor. By another method the Corliss intake valve is opened full at beginning of admission, but closes later in the admission stroke. The air admitted to that point is expanded or rarefied for the remainder of the compression stroke, and then compressed, the volume of compressed air delivered being of course reduced. This arrangement is productive of an excessive temperature range in the cylinder. Still a third method opens and holds open the intake valves at the end of the cylinder, or at opposite ends in duplex machines. The effect of this is to make ineffective one out of every two strokes. If still further unloading be necessary, the intake valves at the other end of the cylinder or cylinders are opened and held open. The three arrangements just outlined all operate by a pressure controlled mechanism which actuates some form of trip on the Corliss air valve gear.

NOTE.—Three things are to be avoided in the successful unloader or regulator for power driven machines; first, a sudden release or resumption of load, throwing heavy strains on the machine; second, undue rarefaction of the intake air, resulting in a wide range of cylinder pressures and temperatures; third, the blowing off of compressed air to the atmosphere with a waste of power.

pressure of the intake or low pressure cylinder of a compound compressor is much less than the terminal pressure of a simple compressor, the volumetric efficiency of the compound compressor is greater than that of the simple compressor.

The life of a compound compressor is longer than that of a simple compressor for like duty. The maximum strains on most all wearing parts of a compound compressor are less than those of the simple compressor, due to better distribution of pressures, and the resistance due to compression is more uniform, which influence on the power distribution tends to higher steam economy.

Intercoolers.—A properly designed intercooler should reduce the temperature of the air back to the original point, that is,

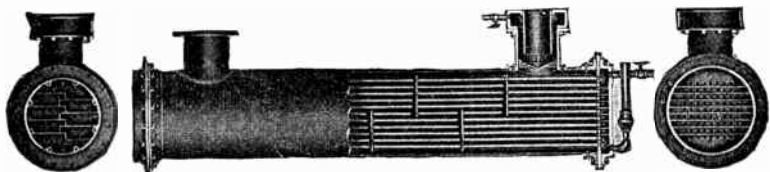

FIGS. 4,382 to 4,384.—Ingersoll-Rand overhead intercooler and intermediate separator. On small sizes it is placed crosswise beneath the air cylinders; in sizes heavy 16 inch and larger the intercooler is crosswise of the compressor and above the air cylinders. **It consists of** a shell containing a nest of galvanized iron tube through which cold water circulates. The discharge from the low pressure cylinder passes over, across, and between these tubes, being directed back and forth transversely by suitable baffle plates. Prolonged contact with cooling surfaces and complete subdivision is obtained by the design of the water heads, which give a lengthened circulation of cooling water, resulting in economical use of water. **In construction** the baffle plates are held in place by a system of spreader, which constitute a frame for the nest of tube. Since the tubes and inside water head are free in the shell, they can expand or contract without causing leakage. The entire set of tube can be withdrawn at one end of the intercooler for cleaning, if necessary. On the overhead intercoolers, the connection between intercooler and high pressure air cylinders forms a water separator through which the air passes. Entrained moisture is caught and drains to the chamber in bottom of the separator, where a drain cock is provided for its removal. This results in the delivery of practically dry air to the high pressure cylinder.

NOTE.—It is usually desirable to start a power driven compressor with no load, throwing on the load gradually after normal speed has been reached. This is in fact essential in machines driven by electric motors, for the heavy inrush of current in starting under load is dangerous, particularly where power is taken from a transmission circuit supplying other motors. Evidently almost any of the unloading devices noted in the previous section can be used for this purpose if properly arranged for manipulation. The usual form, however, is simply a by pass valve to atmosphere on the line close to the compressor protected by a check valve between it and the receiver to prevent the return of air from the line when the starting unloader valve is open. This check valve is essential where several compressors serve one line, permitting cutting in or out any machine without unloading the others. This by pass valve is opened on starting, when the compressor simply compresses to a pressure sufficient to open its discharge valves, this air escaping to atmosphere. When normal speed is reached, the by pass or unloading valve is gradually closed and load resumed. On two stage machines, an unloader valve should be provided on the low pressure discharge to the intercooler, as well as on the high pressure discharge to the line. In the latter case, both cylinders operate momentarily as low pressure cylinders.

to the temperature of the intake air. It can even do more than this, especially in winter, when the water used in the intercooler is of low temperature. A simple coil of pipe submerged in water is not an effective intercooler, because the air passes through the coil too rapidly to be cooled to the core, and such intercoolers do not sufficiently split up the air to enable it to be cooled rapidly. This splitting up of air is an important point. A nest

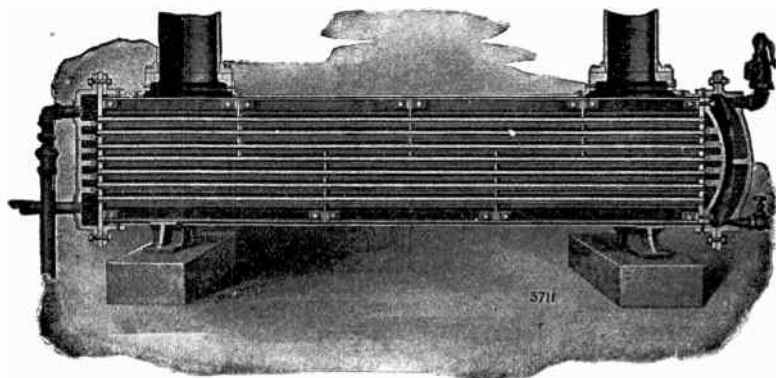

FIG. 4,385.—Ingersoll-Rand horizontal aftercooler with brass tubes. *It consists of a horizontal shell supported on cast foot pieces. Air inlet and discharge connections are usually at the top and the water drain at the bottom. Within the shell is a nest of tinned brass tubes expanded in steel tube plates at each end, an expansion joint being provided at one end. Baffle plates face a cross circulation of the air over the tubes. The cooling water enters the lower set of tube, traversing each row, forward and back, leaving at the top of the one end of the after cooler. In another design galvanized iron pipes are used instead of brass tubes. These pipes are of two sizes, the larger telescoping the smaller and so arranged in pairs that water flows *in* through the inner tube and *out* through the annular space between the inner and outer tubes.*

NOTE.—H. V. Haight in *American Machinist* says: "In multi-stage air compressors, the efficiency is greater the more nearly the temperature of the air leaving the intercooler approaches that of the water entering it. The difference of these temperatures for given temperatures of the entering water and air is diminished by increasing the surface of the intercooler and thereby decreasing the ratio of the quantity of air cooled to the area of cooling surface. Numerous tests of intercoolers with different ratios of quantity of air to area of surface, on being plotted, approximate to a straight line diagram for which the following figures are taken:

Cu. ft. of free air per minute per sq. ft. of air cooling surface . . .	5	10	15.
Diff. of Temp. F. between water entering and air leaving	12.5°	25°	37.5°

of tube carrying water and arranged so that the air is forced between and around the tubes is an efficient form of inter-cooler. If the tubes be close enough together and are kept cold, the air must split up into thin sheets while passing through. Such devices are naturally expensive, but first cost is a small expense when compared with the efficiency of the compressor, measured in terms of coal and water consumed. Receiver inter-coolers are more efficient than those of the common type because

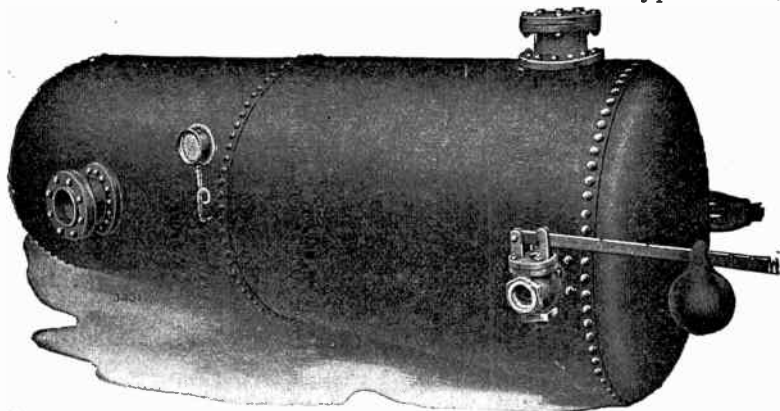
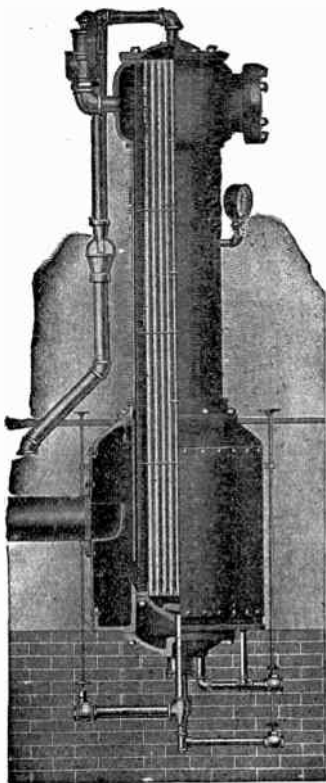

FIG. 4,386.—Horizontal air receivers. The discharge from an air compressor is more or less pulsating in character, and the receiver is analogous to an electrical rectifier, that is it receives and absorbs the pulsations, delivering a steady flow to the pipe line. It is, in a very small degree, an accumulator in which excess energy is momentarily stored and withdrawn. The receiver should be placed as close as possible to the compressor or after-cooler, and it is good practice to make the pipe between the receiver and compressor a size larger than that leaving the receiver. A safety valve and pressure gauge should be provided, and when the receiver is out of doors, the safety valve should be piped back into the compressor room to avoid freezing. There is some cooling of the air in the receiver, and since cooling involves condensation, the receiver should preferably be placed out of doors, where its cooling effect will reduce the moisture in the air. A drain cock should be provided at the lowest point which should be opened often for the discharge of accumulated water. Primary or main receivers, or those next to the compressor, should be so piped up that the air will enter at the top and leave near, but a little above, the bottom. On secondary receivers this arrangement should be reversed. On long pipe line systems small receivers, or moisture traps, should be placed at the low points in the lines, the piping entering and leaving at the top. These will catch the moisture condensed in the lines, which should be withdrawn frequently through a drain cock.

NOTE.—The successful intercooler must provide for a complete and minute subdivision of the air passing through it, that the heat may be dissipated without any dependence upon the heat conducting qualities of the air itself. The air should be split up into thin sheets or streams so as to dissipate its internal heat. There must be an ample cooling surface presented to this subdivided air stream.



the air is given more time to pass through the cooling stages because of the freedom from wire drawing which may take place in intercoolers of small volumetric capacity.

After Coolers.—The function of an after cooler is to *reduce the temperature of the air after the final compression*. In doing this it serves as a drier, reducing the temperature of air to the dew point, thus abstracting moisture before the air is started on its journey. In cold weather, with the air pipes laid over the ground, an after cooler may prevent accumulation of frost in the interior

FIG. 4,387.—Ingersoll-Rand vertical type after cooler, half in section. *In construction*, it has a shell or body made of steel throughout, with the exception of the head, which is an iron casting. Tinned brass tubes expanded in steel tube plates stand vertically in the body with provision for expansion and contraction at the lower end. Water enters at the lower end of the nest of tube leaving at the top. The air enters at the top or head, and leaves at the bottom, surrounding the tubes in transit and traveling counter current to the water. An open funnel in the water discharge shows the flow of water and permits of its proper adjustment. The enlargement of the body at the bottom gives a little receiver capacity and also catches the condensed moisture which may be drained off at

intervals. A plate in front of the air discharge, guards against the escape of water which may be splashed up by the flowing air.

NOTE.—The after cooler has been devised to perform the cooling and drying functions by bringing the hot moist air from the compressor discharge in contact with the water cooled surfaces of such extent and during such a time that the moisture in the air will be condensed and deposited before it can enter the distribution system. Obviously the proper proportioning of the cooling surface and air velocity to volume of air to secure complete after cooling is a rather complex problem which needs a wide experience for its best solution.

NOTE.—After coolers, with adequate cooling surface, and properly supplied with water, will readily reduce the temperature of the compressed air to within 15 or 20 degrees of that of the cooling water. Obviously, the cooler the water supplied, the more complete the cooling and drying effected. The following figures (according to Ingersoll-Rand) are based on good cooling results with air at 80 to 100 lbs. pressure: When the temperature of the cooling water is 50, 60, 70, 80, 90 degrees Fahr., the gallons per hour required per 100 cubic feet of free air per minute, are respectively 120, 140, 160, 180, 200.

walls of the pipes, for where the hot compressed air is allowed to cool gradually, the walls of the pipe in cold weather act like a surface condenser and moisture may be deposited on the inside, for the same reason that frost appears on the inner side of a window pane. Another advantage of the after cooler is that it keeps the temperature of the pipe uniform, otherwise this pipe will be hottest near the compressor, gradually cooling down and being thus subject to irregularities of expansion and contraction.

The Saving Due to Compounding.—The table here given will serve to illustrate the large saving that it is possible to

Work Lost in Terms of Isothermal and Adiabatic Compression

Gauge Pressures	One Stage		Two Stages		Four Stages	
	Percentage of work lost in terms of isothermal compression	Percentage of work lost in terms of adiabatic compression	Percentage of work lost in terms of isothermal compression	Percentage of work lost in terms of adiabatic compression	Percentage of work lost in terms of isothermal compression	Percentage of work lost in terms of adiabatic compression
60	30.00	23.00	13.38	11.80	4.65	4.45
80	34.00	25.26	15.12	13.12	5.04	4.80
100	38.00	27.58	17.10	14.62	8.00	7.41
200	52.35	34.40	23.20	18.88	9.01	8.27
400	68.60	40.75	29.70	22.90	12.40	11.04
600	83.75	44.60	32.65	24.60	15.06	13.10
800	90.00	47.40	35.80	26.33	16.74	14.32
1000	96.80	49.20	39.00	28.10	16.90	14.45
1200	106.15	51.60	40.00	28.60	17.45	14.85
1400	108.00	52.00	41.60	29.40	17.70	15.00
1600	110.00	53.30	42.90	30.00	18.40	15.54
1800	116.80	54.00	44.40	30.60	19.12	16.05
2000	121.70	54.80	44.60	30.80	20.00	16.65

NOTE.—In the above table no account is taken of jacket cooling, it being a well known fact among pneumatic engineers that water jackets, especially cylinder jackets, though useful and perhaps indispensable, are not efficient in cooling, especially so in large compressors. The volume of air is so great in proportion to the surface exposed and the time of compression so short, that very little cooling takes place. Jacketed heads are useful auxiliaries in cooling, but it has become an accepted theory among engineers that compounding or stage compressions is more fertile as a means of economy than any other system that has yet been

effect by compounding. This table gives the percentage of work lost by the heat of compression, taking isothermal compression, or compression without heat, as a base.

Altitude Compression.—The height of the atmosphere surrounding the earth has been variously estimated to extend from fifty miles to twenty thousand miles, and since air has weight it exerts a pressure upon surrounding objects which is equal to the weight of the air column above the object.

Since air is very elastic its weight will cause it to have a variable density throughout its height and exert varying pressures at different altitudes.

At the sea level an atmospheric column balances a column of mercury 30 inches high and of equal area, which corresponds to a pressure of 14.7 pounds per square inch. The variation in pressure for different elevations has been determined by barometric observations and by examining a table of such observations it will be noted that the atmospheric pressure decreases with increasing height, and as a consequence one pound of air occupies a greater volume at an altitude than at the sea level (at the same temperature); or a cubic foot of air weighs less at a higher altitude than at a lower one.

In descending the shaft of a mine the contrary effect is noticed, but in a mine or any level below the sea, increase in density is counterbalanced by increase in temperature as the center of the earth is approached. The temperature of the atmosphere also changes with increasing altitude, but is not always uniform for any two places at the same elevation.

NOTE.—Continued from page 3,044.

devised. The two and four stage figures, as given in this table, are based on reduction to atmospheric temperature 60° Fahr. between stages. This is an important condition, and in order to effect it, much depends on the intercooler. This device represents a case of jacket cooling which in practice has been found to be efficient where engineers specify intercoolers of proper design. While cooling between stages the air may be split up into thin layers and thus cool it efficiently in a short time, a condition not possible during compression. This splitting up process should be done thoroughly, and while it adds to the cost of the plans to provide efficient coolers, it pays in the end. A rule which might be observed to advantage among engineers is to specify that the manufacturers should supply a compressor with coolers provided with one square foot of tube cooling surface for every ten cubic feet of free air per minute furnished by the compressor at its normal speed. Referring again to the table, it will be noted that when air is compressed to 100 pounds pressure per square inch in a single stage compressor without cooling, the heat loss may be 38 per cent. The condition, of course, does not exist in practice, except, perhaps, at exceedingly high speeds, as there will be some absorption of heat by the exposed parts of the machine. It is safe, however, to say that in large air compressors that compress in a single stage up to 100 pounds gauge pressure, the heat loss is 30 per cent. This, as shown in the table, may be cut down more than one-half by compounding or compressing in two stages, and with four stages this loss is brought down to 8 per cent. theoretically, and perhaps to 3 or 5 per cent. in practice. At higher pressures are used, the gain by compounding is greater.

The volumetric efficiency of an air compressor, expressed in terms of *free air*, is the same at all altitudes (for the displacement in a given size of cylinder is the same); but the volumetric efficiency, expressed in terms of *compressed air* at a given pressure, decreases as the altitude increases, for the quantity of air taken into a given cylinder per stroke being less dense at an altitude (due to lower initial or atmospheric pressure) it must be compressed into a smaller space for a given terminal pressure.

Example.—300 cubic feet of air, at atmospheric pressure of 14.7 pounds, compressed to 80 pounds gauge, will represent a volume of $300 \times 14.7 \div 94.7 = 46.6$ cubic feet.

If the atmospheric pressure were 10.1 pounds in the above example, then the volume delivered would be $300 \times 10.1 \div 94.7 = 34.1$ cubic feet; or the volumetric efficiency of a compressor performing the above work at the lower initial pressure would be but 73.2 per cent. of what it would be at the higher initial pressure.

In order, therefore, that an air compressor may deliver, at an altitude corresponding to the lower initial pressure, a volume of compressed air per stroke equal to that which it would deliver at a level corresponding to the higher initial pressure, the corresponding intake cylinder must be proportionately larger for the lower initial pressure as compared with the higher initial pressure.

CHAPTER LXXXII

ELECTRIC HEATING

Electricity is extensively used for heating both for domestic and industrial purposes. Its chief advantages are its cleanliness and the ease with which it can be controlled.

Some of the domestic appliances on the market are not quite satisfactory, but improvements are continually being made.

For instance, some are not sufficiently robust in construction to withstand kitchen wear; in others, the heating elements either soon fail, or else the temperature obtained gradually falls too low to be of practical service. Others have *live* parts that can be easily short circuited. This point should be noted in selecting heating devices.

The *cleanliness* of electric heat is its chief feature, no polluting gas, smoke, or soot being given off; in short, nothing but heat is generated.

With electric heating there is *less waste heat* than with any other method, because the heat can be generated or applied at just those parts of the appliance where it can most effectively do its work. It should be noted, that this does not mean that electric heating is more economical than other methods, for on the contrary it is more expensive except when electricity can be obtained at a very low cost, and moreover, the cost of the heating devices is high.

With an electric cooker, the surrounding atmosphere is not heated to anything like the extent that it is by a coal, gas, or oil cooking stove, and there are no fumes. This is a great advantage, especially during the summer months. As for *control* electric heating may be started and stopped with an ease which is impossible with any other method.



FIG. 4.388.—Simplex electric coffee percolator. Starting with cold water, through the circulating process as shown, drip coffee is ready in a few minutes, depending upon the degree of strength required. Three degrees of heat are provided, permitting quick making, and allowing the coffee to be kept hot at the lowest current consumption.

Production of the Heat.—For domestic and some industrial purposes, heat is produced by electricity by forcing it through resistance wires, raising the temperature of the latter, and applying the heat thus generated to the articles to be heated. Resistance wires are made of special materials and are capable of withstanding high temperatures without deteriorating. Metals and alloys having high specific resistance or low temperature coefficient of resistance are largely used for resistors. The following are the principal resistance wires:

Advance.—This material is a copper nickel alloy, containing no zinc. It is uniform in its composition and constant in its resistance under all conditions of service. It is recommended for apparatus in which the wire is subjected to repeated heating and cooling.

Calido.—This is a high percentage nickel chromium alloy containing a small percentage of iron. The melting point is about 2,822° Fahr. It is recommended for electrically heated devices.

Climax.—This is a high resistance nickel steel alloy. It is well suited for use in rheostats. It is one of the cheapest resistance metals.

Excello.—This is adapted for use in electric heating devices.

Ferro-nickel.—This alloy has a high current carrying capacity, on account of its low specific resistance. As it will rust, it can only be used where it is not attacked by moisture.

German Silver.—This is an alloy of copper, nickel and zinc. The grade of the wire designates the percentage of nickel. The 18 per cent. grade is the most common.

The resistance of any particular grade depends upon the degree of annealing; hard wire is slightly higher in resistance than soft. German silver was for many years the only resistance alloy obtainable, but it is now being generally displaced by materials of the same specific resistance but of superior qualities.

Ia Ia is recommended for use in instruments and electrical devices where a low temperature coefficient is desired.

Ideal.—This is an alloy of nickel and copper, and contains no zinc. The manufacturers state that its temperature coefficient is nil.

It may be used at an incipient red heat of 968° Fahr., and is adapted for resistors and measuring instruments.

Krupp Metal.—This is a special grade of nickel steel adapted for resistors.

Manganin.—This is a material developed by the Reichsanstalt, for use in instruments and standards.

The alloy which was shown to be the best for ordinary purposes is one containing 85 per cent. of copper, 12 per cent. of manganese, and 3 per cent. of nickel.

Monel Metal.—This metal contains approximately three parts nickel to one of copper.

The resistance varies somewhat in different lots, and according to temper. The variation is, however, no greater than that of 18 per cent. German silver.

Nichrome.—This alloy is practically non-corrosive, has an extremely high melting point (about 2,822° Fahr.) and is far superior to nickel in its ability to withstand high temperatures.

It is especially recommended for use in electrically heated appliances and resistance elements generally where extreme conditions are encountered.

Nichrome II. This alloy is strongly resistant to oxidation. It has been especially developed for use in carbon combustion furnaces, and other laboratory furnaces where the more extreme temperatures are to be met.

Nickel.—Due to its high temperature coefficient nickel is very efficient for use in resistance thermometers and owing to its non-corrosive qualities it may be employed for rheostats where acid fumes are to be met with.

Superior.—This is recommended for use in rheostats, arc lamps, resistances, etc.

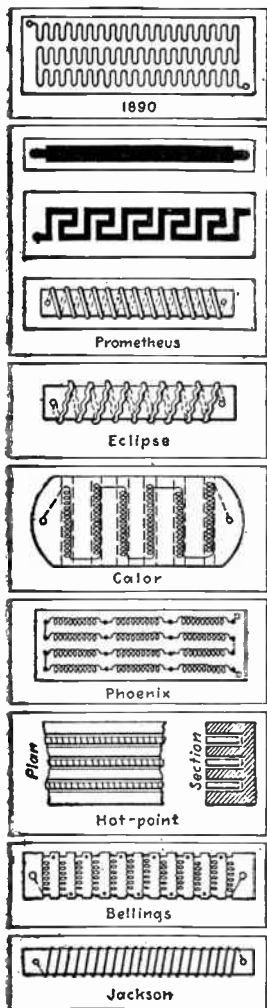

FIGS. 4,389 to 4,399.—Various types of heating unit.

Therio.—An alloy of copper, manganese, and aluminum for work where low thermo-electric effect against copper is demanded. Compared with manganin, this alloy gives a higher specific resistance, does not oxidize so fast, and is more stable in its electrical and mechanical behavior. This material is especially suitable for shunts. Temperature coefficient is $+0.000031$ per 1° Fahr.

Yankee silver.—This is a new alloy with most of the qualities of "18 per cent German silver." It will withstand repeated heating and cooling and often gives satisfactory service where German silver fails.

Heating Units.—The term heating unit is given to that portion of a cooker or heater which gives out the heat for warming an oven or hot plate or for raising the temperature of a room. It consists of some material which is more or less a bad conductor of electricity, and when current is taken through it, by making it form a portion of an electrical circuit, it becomes hot owing to the resistance it sets up to the current. In order to meet the varied conditions of service there are numerous forms of resistor or heating unit, and these may be classified as :

1. Exposed coils of wire or ribbon open to air and wound around insulating material;

2. Wire or ribbon in the form of coil or flat layer embedded in enamel, asbestos, mica, or other insulators;

3. Filling of metal fixed on enamel, mica, or glass;
4. Metallic powder mixed with clay and compressed in forms, and crystallized silica in tubes of glass.
5. Incandescent filaments in vacuum.

A common form of heating unit for use in percolators, chafing dishes, flat irons, etc., is the enclosed disc, the resistor being either a ribbon wound on a mica disc or a grid stamped from a thin sheet of the alloy and mounted between thin sheets of mica.

Electric radiators for room heating consist usually of a resistance wire wound on asbestos tubes covered with a coating of fire proof cementing compound. When air is thus excluded, German silver may be used as a resistor.

The "Cartridge" type of unit is used for grids, broilers, and disc stoves. It consists of a high resistance ribbon wound on a mica cylinder and coated with insulating cement. In placement, it is inserted in a hole in the casting which is to transfer the heat to the point where it is wanted. When a comparatively low operating temperature is required, as in flexible heating pads, asbestos insulated wire woven into a sort of honeycombed mat is used.

The following details are given of some of the heating units in general use:

The Eclipse element consists of high resistance ribbon crimped to give greater length and free air space, wound over mica strips with the ends connected to heavy eyelet terminals.

The Calor element has a base of fireclay with grooves into which spirals of fine high resistance wire are placed.

The Phoenix element has spiral wire coils held lightly at short intervals by porcelain insulators mounted on a suitable base.

The hot point element is made up of nichrome wire or ribbon, wound lightly around thin strips of mica, then further covered with a thin mica covering and inserted very tightly into grooves or slots made in the hot plate or iron base to receive the finished strips.

The Belling element consists of a fire clay strip with spirals of nichrome wire stretched across the width of the base, notches being provided in the base for receiving the ends of the spiral and holding them tightly in position in the manner shown.

The Jackson element has a different class of fire clay base with quite a smooth surface, the section of the strips being a flat oval wire or ribbon of nichrome, is wound tightly over the strip in one continuous length and clamped between heavy terminals at each end.

The Tricity elements consist of nichrome ribbon wound over thin mica and clamped between thin sheets of mica and metal. The method of winding provides for uniform distribution of heat at any loading.

The Bastian or Quartzalite element consists of a spiral of nichrome wire or ribbon coated with a film of oxide insulation. The spiral is held in or on a tube of quartz. The turns of the spiral may be close together without fear of short circuit. This gives it a "hot rod" appearance.

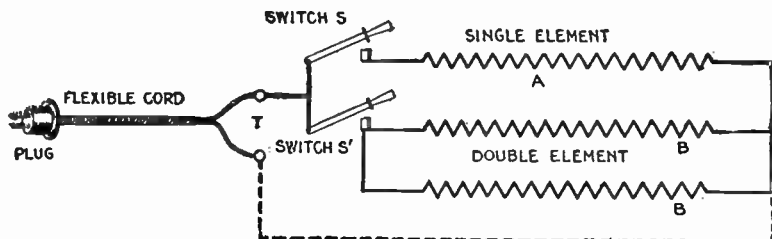

FIG. 4,400.—Arrangement of internal circuit for heaters giving three heating values. In the diagram A, represents one third of the heating circuit; BB, two thirds. With switch S on, one-third of full heat is given; with S', two thirds, while with both S and S' on, the heater works with full power. At T, are two terminals to which the ends of the flexible cord from the plug are secured.

Temperature Regulation in Electric Heaters.—Many appliances have only one internal circuit so that only one heating value can be obtained. There are, however, a great number which have their resistances divided into two or more parts, which can be connected in different ways, so that several heating values can be obtained.

In the simplest case, the internal circuit consists of two parts of equal heating capacity, each being independently controlled by an ordinary switch, or the two by a double switch, thus permitting operation

1. With either circuit on;
2. With both circuits on.

In some cases the internal circuit is divided into two parts of unequal heating capacity so three heating values can be obtained, by operating

1. No. 1 circuit alone;
2. No. 2 circuit alone;
3. Both circuits.

Thus, any degree of refinement of control can be obtained by providing enough internal circuit changes.

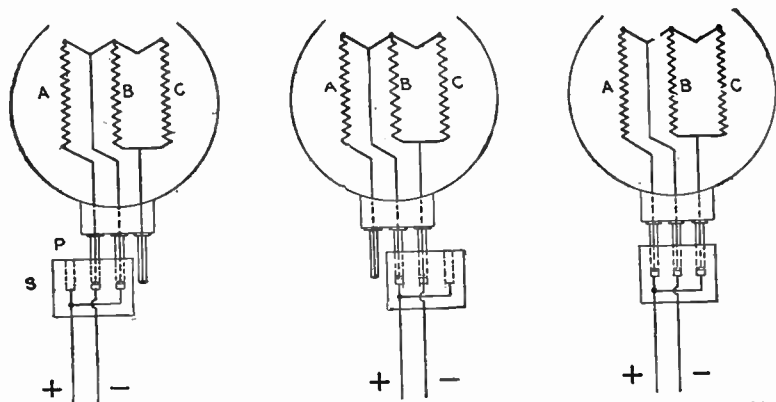

Figs. 4,401 to 4,403.—Internal circuits of heater. As shown the heater wires are divided into three sections: A, B, and C, connected to the external terminals P. A three hole socket S has one conductor of a twin flexible cord connected to the two outer sockets, and the other to the middle socket. The socket piece may thus be put on the pins in three different ways, as shown in the three figures. In fig. 4,401, section A only of the heater is in circuit; in fig. 4,402, sections B and C are connected, and in fig. 4,403, all sections are in circuit. The signs + and - in each figure indicate the heater end of the flexible cord, the other terminating in a plug connection or switch plug on the wall. In some apparatus, a three or four hole socket is made to fit a corresponding number of pins in one position only, and is connected through a triple or quadruple flexible cord to a two or three way switch adjacent. The various degrees of heat are then obtained by altering the position of the switch.

Room Heating.—Only in a comparatively few instances is electricity employed to advantage in the heating of rooms, such practice being confined chiefly to intermittent auxiliary service in offices and dwellings, ticket booths, etc.

The following empirical formula gives the energy required in watts for heating rooms:

$$\text{watts} = \frac{\text{B. t. u. per hour}}{3.41} = \frac{2.71 (T - T_1) N}{3.41}$$

where $T - T_1$ is the temperature difference in degrees Fahr. between the heated surface and the room, and N is the number of square feet of radiating surface. The power required to keep an ordinary sized room warm when the outside air is near the freezing point ranges from about 1 to 2 watts per cubic foot.

Ques. Is electric heating an economical method?

Ans. No.

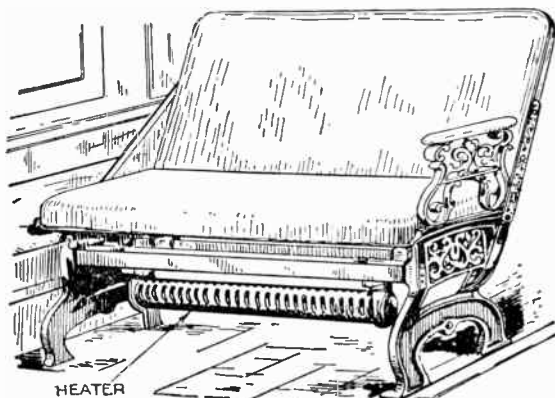
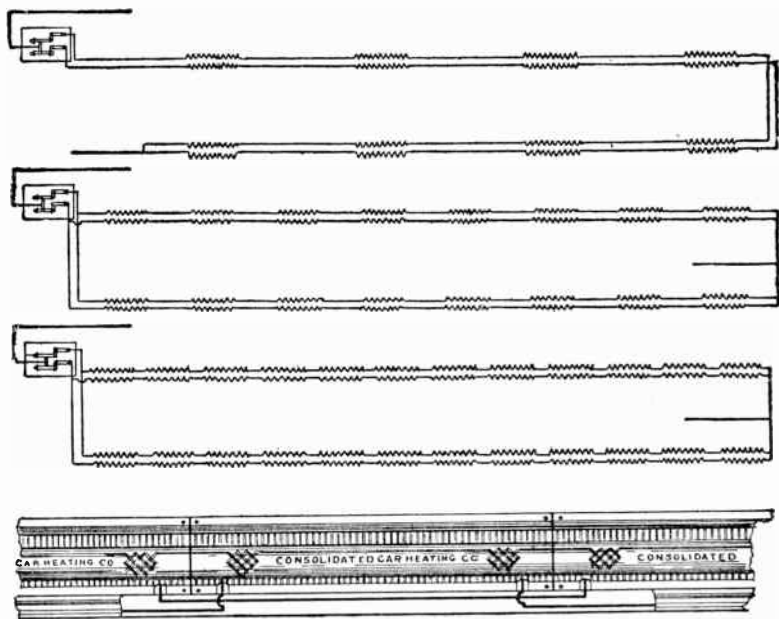

FIG. 4,404.—Underseat method of car heating; view showing seat and placement of heater. At the Montreal meeting of the American Street Railway Association some years ago, Mr. J. F. McElroy read an exhaustive paper on the subject of car heating, from which the following abstracts are taken: In practice it is found that 20,000 B.t.u. are necessary to heat an 18 to 20 foot car in zero weather. When the outside temperature is $12\frac{1}{2}^{\circ}$ Fahr., only 16,000 B.t.u. are required, etc., which shows the necessity of having electric heaters adjustable. The amount of heat necessary in a car to maintain a given inside temperature depends on: 1, the amount of artificial heat which is given to it; 2, the number of passengers carried. The average person is capable of giving out an amount of heat in 24 hours which is equal to 191 B.t.u. This is evidently an error, as Kent says that a person gives out about 400 heat units per hour, and tests by the Bureau of Standards show approximately the same (413) for a person at rest, and about twice that for a man at hard labor (835).

Loss of Heat.—Heat escapes from buildings in two ways: 1, by conduction through the windows, walls, roof, and floor, and 2, by leakage of warm air.

Ques. Upon what does the loss by leakage depend?

Ans. Upon the tightening of the doors and windows, and upon the construction of the walls, floor and roof, especially in wooden buildings.



Figs. 4,405 to 4,408.—Wiring diagrams for Consolidated heaters for use along truss plank, and view of truss plank in position showing wiring in moulding. Fig. 4,405, 8 heater equipment; fig. 4,406, 16 heater equipment; fig. 4,407, 24 heater equipment; fig. 4,408, truss plank heater.

If the outer walls be exposed to wind, the loss of heat by conduction will be increased from 10 to 30 per cent., and if they be not wind tight, the loss by leakage will be increased to an unknown amount.

Ques. What is the law relating to the rate at which heat is lost through walls and windows?

Ans. It is proportional to the difference in temperature between the inside and outside air.

The following table shows the loss of heat per square foot of window and wall surface, for one degree Fahr., difference of inside and outside temperature, the loss being expressed in heat units per hour.

Loss of Heat per Sq. Ft. of Surface

Kind of Surface	B. t. u. per hour	Kind of Surface	B. t. u. per hour
4 in. brick wall.....	.68	Window, single glass....	.776
8 in. brick wall.....	.46	Window, double glass...	.518
12 in. brick wall.....	.32	Skylight, single glass...	1.118
16 in. brick wall.....	.26	Skylight, double glass...	.621
20 in. brick wall.....	.23	Ceilings, fire proof.....	.145
Floors, fire proof.....	.124	Ceilings, wooden beams	.104
Floors, wooden beams..	.683	Ordinary wooden wall, lathed and plastered..	.1

The losses given in the table will be increased under special conditions about as follows:

For northerly exposure, and strong winds, 10 per cent. Building heated during the day only, 10 per cent.; same with northerly exposure and high winds, 30 per cent. Churches, public halls, etc., heated only occasionally, 50 per cent.

Ques. What must be considered in computing the loss of heat in a room.

Ans. All the surfaces must be taken into account, also the surroundings.

If the room be located over a cold cellar, or lower side of floor exposed to cold, proper allowance must be made.

EXAMPLE.—What will be the loss of heat per hour in a single room wooden structure when the temperature inside is maintained at 70° Fahr., while the outside is at 32°. Size of room 10×10×10, having three 3×6 windows. Here all surfaces must be considered.

$$\text{Area of windows} = 3 (3 \times 6) = 54 \text{ sq. ft.}$$

$$\text{Area of walls} = 4 (10 \times 10) - 54 = 346 \text{ sq. ft.}$$

Area of floor = $10 \times 10 = 100$.

B. t. u. lost through windows = $(70 - 32) \times .776 \times 54 = 1,592.4$

B. t. u. lost through walls = $(70 - 32) \times .1 \times 346 = 1,314.8$

B. t. u. lost through floor = $(70 - 32) \times .083 \times 100 = 315.4$

Total loss of heat per hour = 3,222.6 B. t. u.

Electric Water Heaters.—These devices are made in a variety of form to suit different conditions.

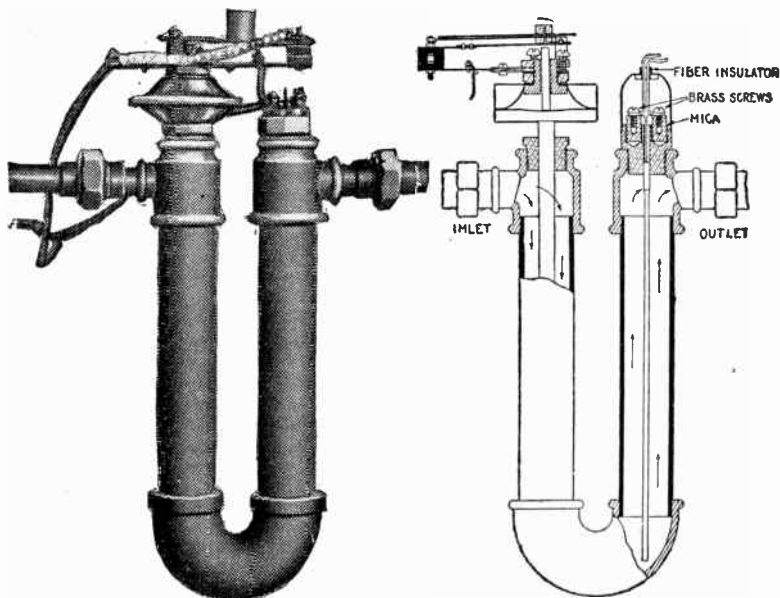

FIGS. 4,409 and 4,410.—Exterior and sectional view of Good Housekeeping electric water heater designed to be connected on the circulation pipe of a kitchen boiler or other storage vessel for hot water. There is a resistance coil using 750 watts per hour (or greater consumption if desired, depending on the hot water requirements). The water is circulated from the bottom of the storage tank through the inlet in the water heater around the heating coil and through the outlet into the top of the storage tank. *In operation*, when all the water in the tank has been heated and the hot water circulates through the inlet of the water heater around the copper tube, the expansion of the liquid in the copper causes the diaphragm to buckle from convex to concave, which turns off the electricity, thus no current will be used until the water in the tank has cooled sufficiently to reduce the pressure, thereby allowing the diaphragm to buckle back and the circuit to be closed. When hot water is drawn from the top of the tank, cold water will replace it through the inlet around the copper tube reducing the pressure, the diaphragm will buckle back thereby closing the circuit, and only sufficient electricity is used to bring the temperature of the cold water up to the predetermined temperature of about 180° Fahr. in the bottom of tank.

The various methods of heating water may be classified

1. With respect to reserve capacity, as

- a. Non-storing;
- b. Storing.

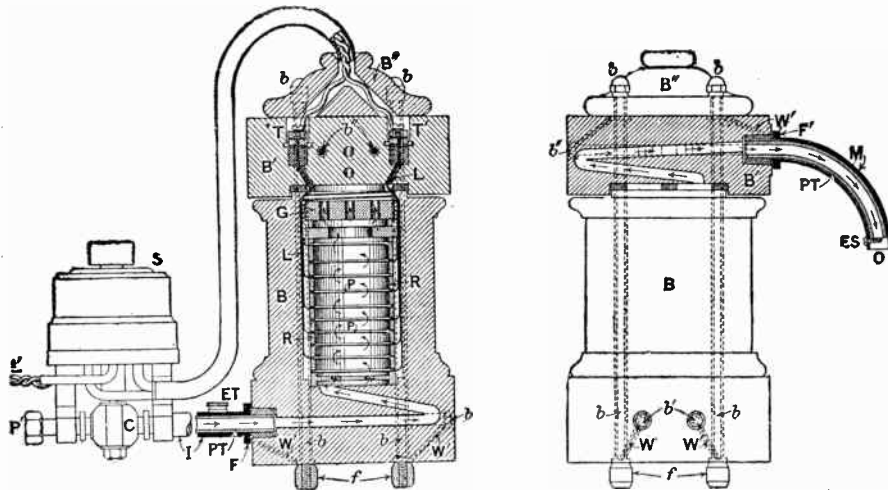

FIG. 4,411.—Simplex electric immersion heater. The most common way of boiling water is to apply heat to the outside of the vessel in which it is contained. But as heat radiates in all directions much of it is lost and only a part is usefully applied in heating the water. In other words when the heating agent surrounds the water only the heat that strikes in is used, that which strikes out is entirely lost. But if the water should surround the heating agent all the heat given off would be used. Advantage is taken of this fact in the Simplex heater by immersing the coil in a vessel of water.

2. With respect to the heating element, as

- a. External element;
- b. Immersed element.

The so called “instantaneous” is an example of the non-storing class and consists of a heating element and coil of pipe through which water passes, the rate of flow, and consequently the temperature being



FIGS. 4,412 and 4,413.—Section of Fuller electric "geyser." *In construction* the body is made of porcelain, and is in three parts, B, B', and B'', the inside of B is hollowed out, and contains a number of platinum diaphragm P, separated from one another by porcelain rings R, and connected alternately with the terminals T, T' by platinum lugs L, L'. Each diaphragm has a hole punched in it for the water to pass through. The stack of diaphragms and rings is tightly compressed by the porcelain grid G, which screws into the top of B. The double pole turn switch S, performs the double function of controlling the current and the water supply. The current flows through the leads L' to the terminals T, T', and so through the water between the + and - connected platinum electrodes. The water enters through a metal or rubber pipe at the point P', and after passing through the cock C (which is actuated by the switch spindle), and traversing the apparatus it emerges by the outlet O. The path of the water through the geyser is indicated by various small arrows, the metal inlet and outlet pipes being insulated by porcelain tubes PT, PT'. At the outlet the water passes an earthing screw ES, so that any electrification it may possess is neutralized. ES is connected through the outlet tube M and wire W' to one of the four bolts b, b. At their lower ends these bolts are similarly connected by wires W', W'', to horizontal bolts b', b', which secure the flange F of the inlet tube I to the body of the geyser. This tube carries an earthing terminal ET, which is generally connected to the water main; though this connection is unnecessary if the supply to the geyser be brought through a continuous metal pipe. The flange F' of M, is bolted to B' by two bolts b'', b'', which are connected by wires to the vertical bolts b, b. Thus every external metal part, including the feet f, is efficiently earthed, and all chance of a shock is avoided.

controlled by a valve. Nothing can be more ridiculous than to call these affairs "instantaneous" heaters, as no physical change takes place instantaneously.

According to the table below prepared by the Simplex Co. the cost for heating water to different temperatures at different rates per kilowatt hour is given, for initial temperature of water 60 degrees Fahr., efficiency of apparatus 85%.

Cost of Heating Water

ONE PINT

Total Temperature	Watts used for				Cost in cents with current at			
	5m.	10m.	20m.	1 hour	3c.	5c.	10c.	20c.
100°F.....	164	82	41.04	13.68	.041	.068	.136	.272
150°.....	372	186	93	31	.093	.155	.31	.62
175°.....	468	234	117	39	.117	.195	.39	.78
200°.....	576	288	144	48	.144	.24	.48	.96
212°.....	624	312	156	52	.156	.26	.52	1.04

ONE QUART

Total Temperature	Watts used for				Cost in cents with current at			
	5m.	10m.	20m.	1 hour	3c.	5c.	10c.	20c.
100°F.....	324	162	81	27	.08	.136	.272	.544
150°.....	744	372	186	62	.186	.31	.62	1.24
175°.....	936	468	234	78	.234	.39	.78	1.56
200°.....	1152	576	288	96	.288	.48	.96	1.92
212°.....	1248	624	312	104	.312	.52	1.04	2.08

ONE GALLON

Total Temperature	Watts used for				Cost in cents with current at			
	5m.	10m.	20m.	1 hour	3c.	5c.	10c.	20c.
100°F.....	1296	648	324	108	.32	.544	1.088	2.17
150°.....	2976	1488	744	248	.74	1.24	2.48	4.96
175°.....	3744	1872	936	312	.94	1.56	3.12	6.24
200°.....	4608	2304	1152	384	1.15	1.92	3.84	7.68
212°.....	4992	2496	1248	416	1.25	2.08	4.16	8.32

A system illustrating the storing class, stores up in a tank, well lagged with insulating material, a small quantity of hot water, a further supply being available very quickly by means of the heating element attached inside. Heaters of the immersion type have a heating element consisting of resistance wire placed in tubing of small diameter, bent into flat or long spirals of varying length, adapting them to shallow or deep vessels. The coils are immersed into the liquid to be heated.

Electric Cooking Appliances.—The multiplicity of cooking appliance now manufactured may be classed as

1. Portable;
2. Stationary.

Portable devices are designed for "cooking at the table." There are any number of such appliance, such as electric coffee pots, toasters, grills, kettles, chafing dishes, frying pans, cake irons,

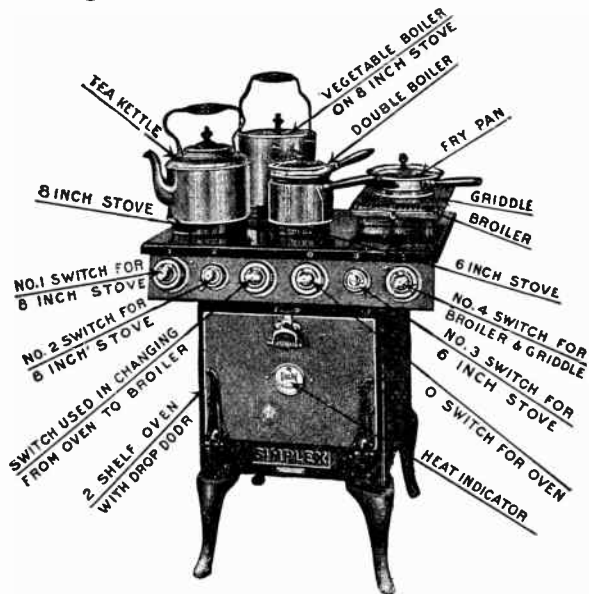

FIG. 4,414.—Simplex electric range consisting of oven, broiler, toaster, and two or more disc heaters with separate cooking utensils. Heating in top and bottom of oven are controlled by a three heat switch. The broiler has a corrugated top slanting slightly toward a grooved end which receives the juices of the meats. A separate smooth top fits on the broiler for making griddle cakes, toast, etc.

etc. With the exception of baking or roasting, a complete meal can be easily cooked at the table with these portable devices, some of which are illustrated in the accompanying cuts.

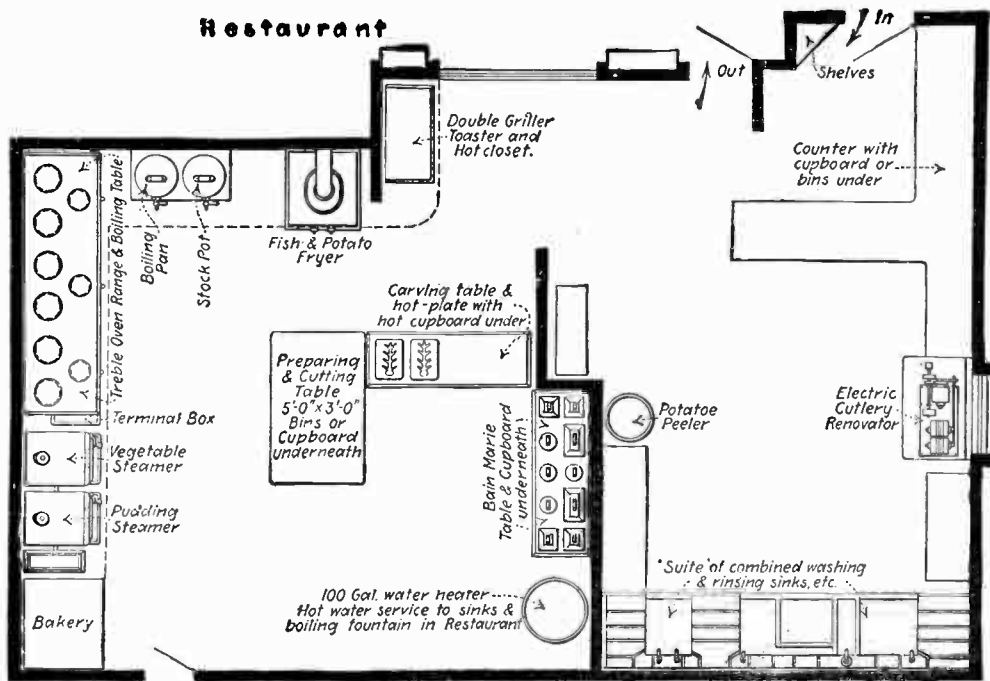
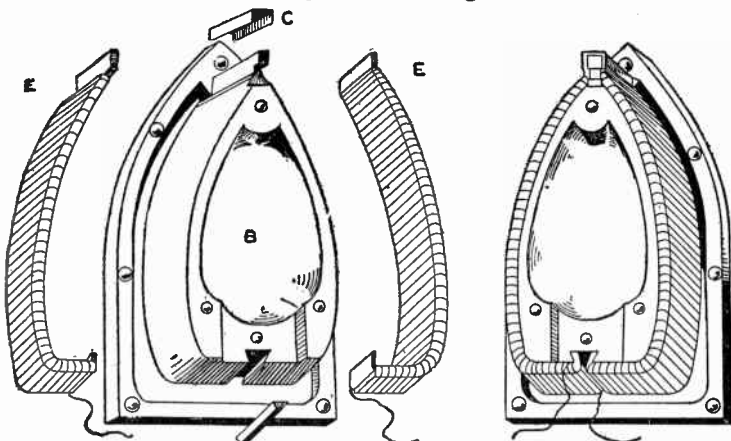

FIG. 4.415.—Plan of an all electric kitchen with bakery, grill, serving, preparing and wash room for a London restaurant. The equipment comprises: Bread and pastry bakers' oven, range of roasting ovens, with boiling table oven, vegetable cooker, pudding cooker, stock pot, boiling pans, fish and potato frier, double grill and toaster (a rack and canopy running the whole length over them with motor and small exhaust fan), carving and serving table, bain Marie, hot cupboards, water heater, scouring and cleaning sinks, polishing and cleaning motors and utensils. The vegetable preparing cleaning and wash room being fitted with vegetable and fruit peelers, plate and dish washers, cutlery and plate polishing tables, washing and rinsing sinks, cupboards, etc., etc.

There are a number of stationary cooking devices, such as complete ranges, or "cookers," ovens, grills, etc., the details of which are illustrated in the accompanying cuts.

Electric Flat Iron.—The most difficult problem in the manufacture of a reliable device of this kind, is the proper construction of the heating elements to withstand the consequence due to the occasional neglect of being allowed to remain in



FIGS. 4,416 TO 4,419.—Details of construction of electric iron. Figs. 4,416 and 4,418, heating elements; fig. 4,417, iron base; fig. 4,419, assembly.

circuit when not in use. Another difficulty is to distribute the heat generated, evenly over the entire working surface of the iron. The design should be such that the iron is quick acting without liability to over-heat. The irons, now turned out by many manufacturers, possess these qualifications in a high degree.

A typical design of electric iron is shown in figs. 4,416 to 4,419.

The heating elements E, E, consist of two resistance wires wound on cores of strip copper, carefully covered with a thoroughly fire-proof insulating material and bent to fit the shape of the iron. A V shaped slot is formed in the head of the central iron B, and the ends of the coils

are wedged lightly into the opening. A sheet of mica is inserted between the central core and the coils, and the coils are then pressed against it and fastened at the iron with a clip C. Another sheet of mica and a thin sheet of copper sheath held in place by a clip at the heel, constitutes the complete heating element of the iron. The coils are detachable and interchangeable. In case of a burn out, only one side need be replaced. By means of a detachable plug the iron can be used in any room wired for electricity, by attachment to any electric lamp socket.

Electric Soldering Bits.—The forms most commonly used are shown in fig. 4,420. The bits here illustrated range in power

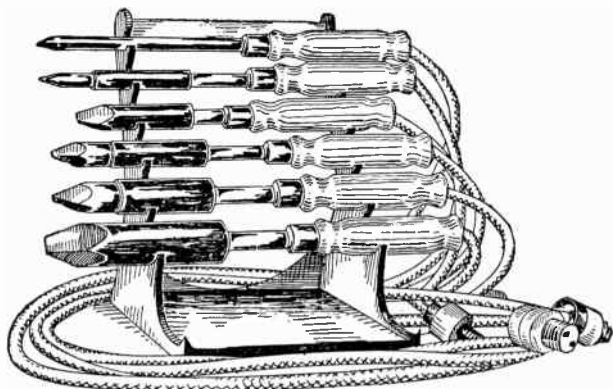

FIG. 4,420.—Nest of electric soldering bits, showing various forms and sizes.

consumption from 55 watts for the small, long, narrow pointed tool, suitable for intermittent telephone switchboard repair work, to 350 watts for the largest size, equal to a 6 pound soldering copper.

The heating element has a copper core with mica insulation, on which the fine wire heating coil is placed, and over which a steel shell is brazed in place. The soldering tip screws on to the copper core with a conical contact, which insures good heat conductivity. The *leading in* wires are taken out to binding posts, located in the interior of the handle, through lavite parts which keep the conductors separated. The handle can be unscrewed over the attachment cord to expose the binding posts.

The Electrical Thawing of Frozen Water Pipes.—A method usually employed in heating frozen pipes is shown in fig. 4,421. A, B, C, represent a line of 2½ inch pipe about 600 to 700 feet long, leading from a stand pipe to the house supply. The section A, B is underground and frozen solid; the section C, B is above ground and frozen to the height of 50 feet. The current is desired from 25 kilowatt lighting transformer; the two ends of the frozen pipe being connected to the secondary

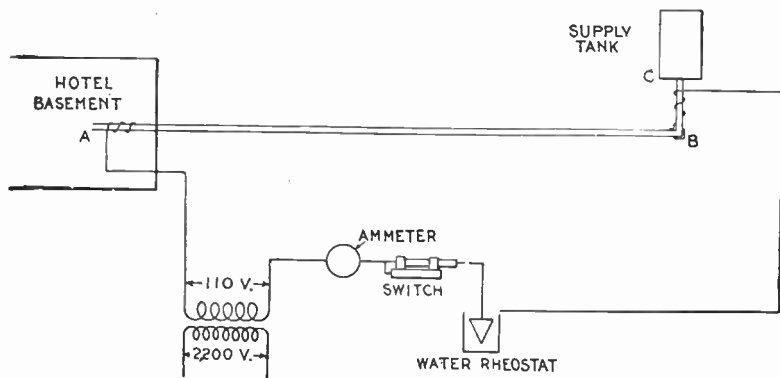

FIG. 4,421.—Diagram illustrating the electrical thawing of frozen water pipe. The description in the accompanying text serves to give an idea of the amount of electrical energy required for a particular installation.

110 volt terminals of the transformer in series with the ammeter, switch and water rheostat as shown, by means of No. 00 cable. The passing of a current of 275 amperes through the pipe for a period of 2½ hours would result in thawing the pipe.

Wiring for Electric Heating and Cooking.—The use of electricity for such service in addition to lighting, necessitates the installation of suitable extra outlets. The proper location of such outlets are matters which should be attended to by the

architect and the owners. However, an extra 25 ampere receptacle and a few feet of wiring, installed as shown in fig. 4,422, solves the problem in many cases.

The Underwriters' rules give the exact requirements necessary to pass inspection.

Most electric heating appliances are connected to the circuit through a length of flexible cord and a plug connection; so that they can be readily disconnected for cleaning purposes, or for moving from one place to another. Generally such appliances, especially radiators and convectors, are sent out by the makers with a length of twin flexible conductor attached ready for joining up to the consumers' plug connections. The plug should have an outer casing of hardwood or something similar,

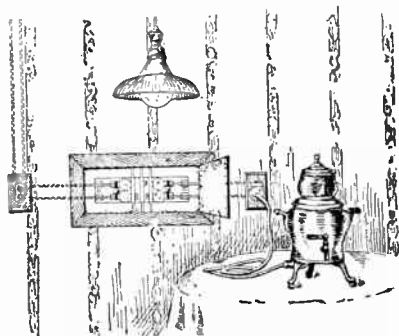

FIG. 4,422.—Extra receptacle for electric heating purposes. It should be carefully determined whether the wiring be of large enough size to carry the maximum current without overheating. See Underwriters' rules.

so that it will not break if dropped; and it should be so constructed that no strain can be thrown on the connections between the flexible conductors and the terminals.

One difficulty with electric heating appliances is the deterioration of the insulation of the flexible cord near the point of attachment to the heater. Owing to the heat developed in the adjacent apparatus, the insulation becomes hard and loses its flexibility; and there is some risk of the flexible conductors short circuiting, or breaking and setting up a momentary arc.

This difficulty arises more particularly with such devices as flat irons, kettles, and cooking appliances. Only the best flexible cord should be used, and when the portion next to the heater has become stiff, it should be cut off and a fresh connection made.

CHAPTER LXXXIII

SOLDERING AND BRAZING

A knowledge of soldering and brazing is useful to the electrician, and the acquirement of proficiency in these operations will be found of value.

Those who have made a first attempt at soldering will agree that it is a distinct art in itself, and while it looks easy, is not; moreover, skill cannot be acquired without considerable practice; however, the information to be obtained in books will be found helpful, not only to the beginner, but also to the experienced workman.

Solder.—The word *solder* is a generic name for fusible alloys used to unite different metal parts. In electrical engineering, the solder used is practically always an alloy of tin and lead. As the electrical conductivity of such an alloy is usually about one seventh that of copper, the best joint between copper conductors is made by bringing the copper surfaces as close together as possible and using a minimum of solder.

For jointing, especially where work has to be done in awkward positions, it is essential that the solder should have a plastic stage between its liquid and solid states.

The curve in fig. 4,423 gives the melting points of *tin lead* solders as a function of the percentage of tin, according to tables published by the Smithsonian Institute.

Ques. Name two classes of solder.

Ans. Soft and hard.

Ques. What is soft solder?

Ans. An alloy composed of lead and tin. Sometimes other metals are added to lower the melting point.

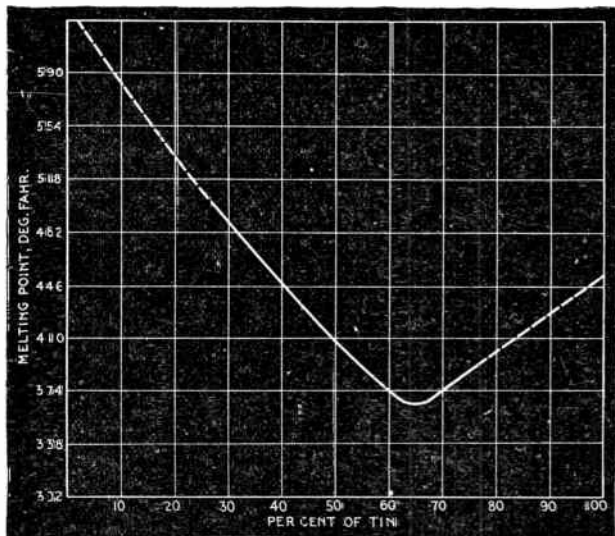

FIG. 4,423.—Characteristic curve showing the melting points of tin lead solders, according to the Smithsonian Institution tables. Authorities differ as to the exact values. Those given in Kemp's handbook result in a curve lying considerably below the curve in the figure, while Hutte's pocketbook gives values resulting in a curve slightly higher. All, however, agree in showing a marked minimum of the melting point with about 60 to 65 per cent. of tin. These differences are doubtless due to the degree of points of the ingredients used. A good electrical solder complying with the conditions mentioned above contains 40 to 45 per cent. of tin, and melts at about 428° to 446° Fahr. with pure ingredients, or lower with commercial samples.

Ques. What is hard solder?

Ans. An alloy composed of copper and zinc, or copper, zinc, and silver.

Hard solder in general is sometimes erroneously called *spelter*.

Ques. What necessary relation must exist between solder and the metals with which it is to unite?

Ans. The solder must have a lower melting point than the metals to be joined to it.

The melting point should approach as nearly as possible that of the metals to be joined so that a more tenacious joint is effected.

Ques. How can the fusibility of a solder be increased?

Ans. By the addition of a small portion of bismuth.

Ques. How do the melting points of soft and hard solder compare?

Ans. Soft solder melts at a low temperature compared to hard solder which melts at a red heat.

Soft Solders.—These consist chiefly of tin and lead, although other metals are occasionally added to lower the melting point. Those containing the most lead are the cheapest and have the highest melting point. According to the tin content they may be classed as

1. Common or plumber's;
2. Medium or fine.

Common or plumber's solder consists of one part of tin to two parts of lead, and melts at 441° Fahr. It is used by plumbers for ordinary work, and occasionally for electrical work where wiped joints are required, for instance, in large lead covered work. Medium or fine solder consists of equal parts of tin and lead, or *half and half*, and melts at 370° Fahr. This solder is always used for soldering joints in copper conductors, and for soldering lead sleeves on lead covered wires.

The following table gives the melting point and relative hardness of various *tin lead* solders.

Melting Points and Hardness of Tin Lead Solders

Percentage		Melting Temp. Deg. F.	Brinell Hardness Test	Percentage		Melting Temp. Deg. F.	Brinell Hardness Test
Tin	Lead			Tin	Lead		
0	100	618.8	3.9	60	40	368.6	14.6
10	90	577.4	10.1	66	34	356.0	16.7
20	80	532.4	12.16	70	30	365.0	15.8
30	70	491.0	14.5	80	20	388.4	15.2
40	60	446.0	15.8	90	10	419.0	13.3
50	50	401.0	15.0	100	0	466.0	4.1

In the table which follows will be found the proper solder and flux to use with various metals.

Soft Solders and Fluxes for Various Metals

Metal to be Soldered	Flux	SOFT SOLDER					
		Tin	Lead	Zinc	Aluminum	Phosphor tin	Bismuth
Aluminum	Stearin	70		25	3	2	
Brass	Chloride of zinc, rosin, or Chloride of ammonia . . .	66	34				
Gun metal		63	37				
Copper		60	40				
Lead	Tallow or rosin	33	67				
Block tin	Chloride of zinc	99	1				
Tinned steel	Chloride of zinc or rosin	64	36				
Galvanized steel	Hydrochloric acid	58	42				
Zinc	Hydrochloric acid	55	45				
Pewter	Gallipoli oil	25	25				50
Iron and steel	Chloride of ammonia . . .	50	50				
Gold	Chloride of zinc	67	33				
Silver	Chloride of zinc	67	33				
Bismuth	Chloride of zinc	33	33				34

Hard Solders.—The various solders known as “hard” solders are used for joining such metals as copper, silver and gold, and such alloys as brass, German silver, gun metal, etc., which require a strong joint, and often a solder the color of which is near that of the metal to be joined.

Ques. What is the difference between hard soldering and brazing?

Ans. According to common usage hard soldering (which is the term used by jewelers) ordinarily means that silver solder is used, whereas, brazing is generally understood to mean the joining of metals by a filler of brass.

A distinguishing characteristic of hard soldering is that a soldering bit cannot be used as in soft soldering because of the excessive temperature (red heat) which necessitates a blow pipe, gas forge, or coke or charcoal fire. The chief advantage of a brazed joint is its superior strength.

The following table gives the various hard solders, proper flux, and metals for which they are suited.

Hard Solders and Fluxes for Various Metals

Metal to be soldered	Flux	HARD SOLDER			
		Copper	Zinc	Silver	Gold
Brass, soft	Borax	22	78		
Brass, hard	Borax	45	55		
Copper	Borax	50	50		
Gold	Borax	22		11	67
Silver	Borax	20	10	70	
Cast iron	Cuprous oxide	55	45		
Iron and steel	Borax	64	36		

As will be noted from the table, most of the hard solders are alloys of copper and zinc. An easily fusible hard solder may be made of one part copper to two parts zinc, this, however, makes a joint that will be weaker than when an alloy more difficult to melt is used.

A hard solder that is readily melted is made of 44% copper, 50% zinc, 4% tin, and 2% lead.

A hard solder for the richer alloy of copper and zinc may be produced from 53 parts copper and 47 parts zinc.

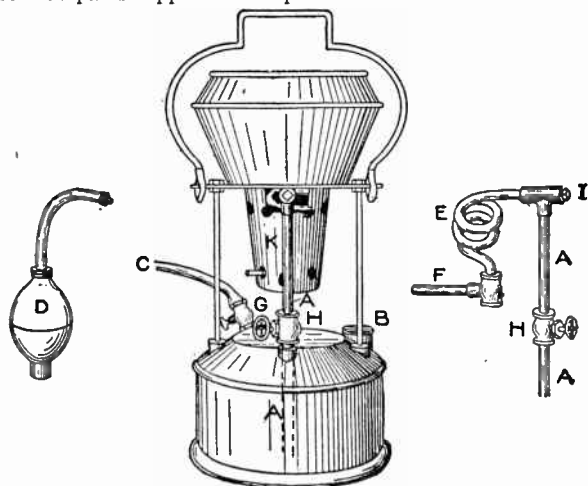

FIG. 4,424.—Plumber's gasoline furnace, adapted to heating soldering pots and copper bolts. *In construction*, the gasoline supply for the blast passes through AA, and is provided with valve H and clean out plug I. The lower end of the supply extends nearly to the bottom of the reservoir. The gasoline passes through coil E, which is partially filled with wire, usually a scrap of small wire cable, to prevent flame running back into the reservoir. The fuel issues from a single small hole at F, which is turned so that the flame will impinge on the coil. Air pressure on top of the gasoline in the reservoir is necessary to make a blast. The air cock is shown at G. For ordinary purposes sufficient pressure can be obtained by blowing air in the hose at C with the lungs, but for a short blast, a bulb containing check valves, shown at D, is used to increase the pressure. The filling plug is at B. *To light the furnace*, valve H is opened and some of the gasoline allowed to play on the coil, from which it falls back into the bottom of cup K. Admit about two tablespoonfuls to cup, close H, and light the gasoline through one of the holes in K. When coil is sufficiently heated, gas instead of liquid will come from the end F, forming a blast which increases in intensity as E becomes hotter. The strength of the blast is regulated by valve H. One pumping keeps the furnace in working order until the lowering of the gasoline level has provided so much room that the pressure of the expanded air is not sufficient to maintain the blast; it then becomes necessary to pump in more air, or to replenish the gasoline and again establish the pressure.

Ques. What is the nature of alloys containing much lead?

Ans. Since lead does not transfuse with brass, the strength of the joint is decreased.

Ques. What is the effect of tin?

Ans. It increases the brittleness of the solder.

Miscellaneous Solders.—In addition to the solders already given, there are a number that are of value for various purposes.

Very Hard Yellow Solders.—The following formulæ make excellent hard solders for all purposes where a high melting point is required:

- No. 1. Copper, 58 parts; zinc, 42 parts.
- No. 2. Sheet brass, 85.42 parts; zinc, 13.58 parts.
- No. 3. Brass, 7 parts; zinc, 1 part.
- No. 4. Copper, 53.3 parts; zinc, 43.1 parts; tin, 1.3 parts; lead, .3 part.

The hardest solders are given first. The following four have lower melting points than those above, and are more suitable where it is desired to solder brass alone.

- No. 5. Brass, 66.66 parts; zinc, 33.34 parts.
- No. 6. Brass, 50 parts; zinc, 50 parts.
- No. 7. Brass, 12 parts; zinc, 4 to 7 parts; tin, 1 part.
- No. 8. Copper, 44 parts; zinc, 49 parts; tin, 3.2 parts; lead, 1.2 parts.

Silver Solders.—These are not, as might be inferred from the name, employed only for the purpose of joining silver, but because of their great strength and resistance are used for many other metals. Like all other solders, they may be divided into the two groups: hard, and soft. Silver solders are usually employed in the shape of wire, narrow strips, or filings. The following are especially adapted to soldering silverware:

Hard Solders

- No. 1. Copper, 1 part; silver, 4 parts.
- No. 2. Copper, 1 part; silver, 20 parts; brass, 9 parts.
- No. 3. Copper, 2 parts; silver, 28 parts; brass, 10 parts.

Soft Solders

- No. 4. Silver, 2 parts; brass, 1 part.
- No. 5. Silver, 3 parts; copper, 2 parts; zinc, 1 part.
- No. 6. Silver, 10 parts; brass, 10 parts; tin, 1 part.

The following silver solders are suitable for cast iron, steel and copper:

- No. 1. Silver, 10 parts; copper, 10 parts.
- No. 2. Silver, 20 parts; copper, 30 parts; zinc, 10 parts.

In addition to the various silver solders already given, two other formulæ should be included.

No. 1. Yellow brass, 70 parts; zinc, 7 parts; tin, $11\frac{1}{2}$ parts.

No. 2. Silver, 145 parts; brass (3 copper, 1 zinc), 73 parts; zinc, 4 parts.

Miscellaneous Silver Solders

Solder for silver plated work: No. 1. Fine silver, 2 parts; bronze, 1 part. No. 2. Silver, 68 parts; copper, 24 parts; zinc, 17 parts.

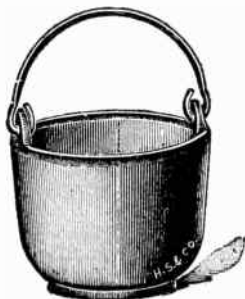

FIG. 4,425.—Soldering pot.

Solder for silver chains: No. 1. Fine silver, 74 parts; copper, 24 parts; orpiment, 2 parts. No. 2. Fine silver, 40 parts; orpiment, 20 parts; copper, 40 parts.



FIG. 4,426.—Ladle for removing solder from soldering pot and for pouring same in making wipe joints, etc.

Resoldering silver solders: These silver solders are for resoldering parts already soldered. No. 1. Silver, 3 parts; copper, 2 parts; zinc, 1 part. No. 2. Silver, 1 part; brass, 1 part; or, silver, 7 parts; copper, 3 parts; zinc, 2 parts.

Readily fusible silver solder for ordinary work: Silver, 5 parts; copper, 6 parts; zinc, 2 parts.

French solders for silver: No. 1, for fine silver work: Fine silver, 87 parts; brass, 13 parts. No. 2, for work 792 fine: Fine silver, 83 parts;

brass, 17 parts. No. 3, for work 712 fine: Fine silver, 75 parts; brass, 25 parts. No. 4, for work 633 fine: Fine silver, 66 parts; brass, 34 parts. No. 5, for work 572 fine: Fine silver, 55 parts; brass, 45 parts.

German Silver solders.—German silver is a very hard alloy of copper (50 to 60%), nickel (15 to 25%), and zinc (15 to 20%). A German silver containing 1 to 2% of tungsten is called *platinoid*. These alloys have a high electrical resistance, platinoid being higher than the other varieties of German silver; the resistance increases uniformly between 32° and 212° Fahr.

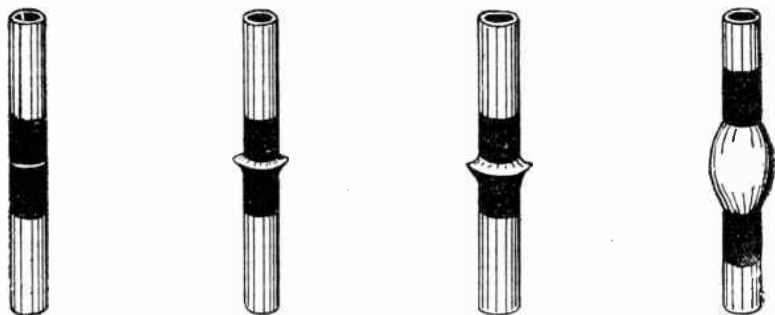

Figs. 4,427 to 4,430.—Various joints. Fig. 4,427, *butt joint* made by squaring the ends, tinning one, and sweating the other to it by heating with torch; this is a comparatively weak joint. Fig. 4,428, *blow joint*; fig. 4,429, *copper bit joint*, the only difference between these is that the solder is floated by a torch in fig. 4,428, and by a bit in fig. 4,429, the latter joint being heavier than the former. Fig. 4,430, round wiped joint.

German silver solders possess considerable strength, and are often used for soldering steel. The color is very similar to that of steel.

In preparing German silver solders, the copper is melted first, and then the zinc and nickel added simultaneously.

Soft German Silver Solders

No. 3. Copper, 4.5 parts; zinc, 7 parts; nickel, 1 part.

No. 4. Copper, 35 parts; zinc, 56.5 parts; nickel, 8.5 parts.

The following No. 5 formulæ given by Kent is similar to No. 4.

No. 5. Copper, 38 parts; zinc, 54 parts; nickel, 8 parts.

Hard German Silver Solders

These solders, sometimes called steel solders, contain a large proportion of nickel and are very strong. They require a very high heat for melting, and usually cannot be fused without the aid of a bellows or blast.

- No. 1. Copper, 35 parts; zinc, 56.5 parts; nickel, 9.5 parts.
 No. 2. Copper, 38 parts; zinc, 50 parts; nickel, 12 parts.

Ques. How is the solder usually applied in soldering German silver articles?

Ans. In the form of a powder or in very small pieces or lumps.

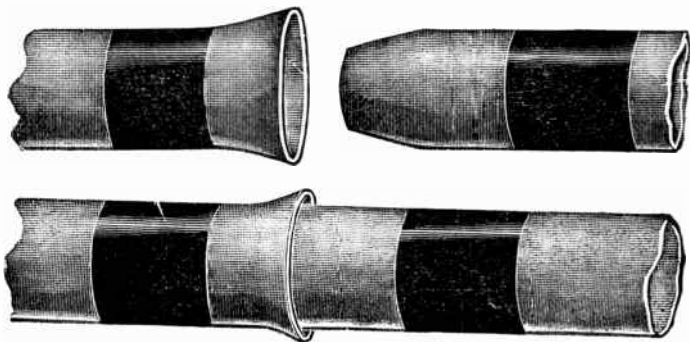

FIGS. 4,431 to 4,433.—Round wiped joint; preparing the pipe ends. These ends to be united are sawed squarely across, to make the joints true with the pipe. It is usual to prepare the female end first, as shown in fig. 4,431. The end is flared or belled out with a *turnpin*, which is a taper boxwood plug, so that the pipe is enlarged a quarter of an inch. The cup thus formed serves to retain the solder. The internal and external surface must be shaved or scraped bright and clean with a *shave hook*, a small tool with a heart shaped blade set at right angles to its stem or handle. Immediately after a little tallow is applied to the parts to preserve them from the oxidizing action of the atmosphere, which would otherwise tarnish the surfaces, and form a film to which the solder cannot adhere. The male end of the pipe is tapered off with a rasp, as shown in fig. 4,432, cleaned with a shave hook and "touched" as before; the two pieces are brought together as in fig. 4,433, and are then ready for the joint.

The solder may be powdered in a mortar if taken from the fire at the right temperature, when it is brittle. This operation is a somewhat difficult one, and so the usual, and perhaps the best plan, is to cast it in the form of a bar or cylinder and then place the latter in a turning lathe, and adjust the tool so that fine shavings are cut off. The shavings are then heated until they become brittle, at which stage they are easily pulverized in a mortar.

Gold Solders.—The hard solder or gold solder which the jeweler frequently requires for the execution of various works, not only serves for soldering gold ware, but is also often employed for soldering fine steel goods, such as spectacles, etc. Fine gold is only used for soldering articles of platinum. The stronger the alloy of the gold, the more fusible must be the solder. Generally the gold solder is a composition of gold, silver, and copper. If it is to be very easily melted, a little zinc may be added. The shade of the solder is regulated by varying the proportions of silver and copper.

No. 1. For 18 carat gold: Gold (18K), 9 parts; silver, 2 parts; copper, 1 part.

No. 2. For 16 carat gold: Gold (16K), 24 parts; silver, 10 parts; copper, 1 part.

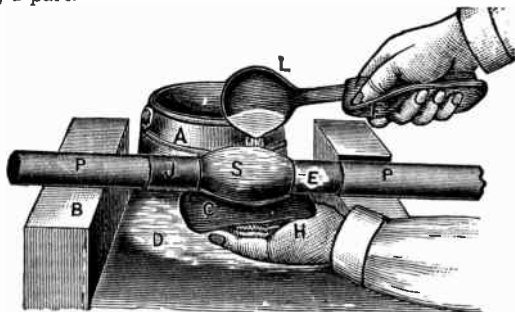

FIG. 4,434.—Method of wiping a horizontal joint. The cloth used for wiping is a pad of moleskin or fustian about four inches square made from a piece twelve inches by nine, folded six times, and sewed to keep it from opening; the side next the pipe is saturated with hot tallow when used. If the lead has been brought to the heat of the solder, and the latter properly manipulated and shaped while in a semi-fluid or plastic condition, the joint gradually assumes the finished egg shaped appearance. In making the joint a quantity of solder is taken from the pot by means of the ladle, the solder being previously heated so hot that the hand can be kept within two inches of its surface. The solder is poured lightly on the joint, the ladle being moved backwards and forwards, so that too much solder is not put in one place. The solder is also poured an inch or two on the soiling, to make the pipe of proper temperature. Naturally the further the heat is run or taken along the pipe, the better the chance of making the joint. The operator keeps pouring and with the left hand holds the cloth to catch the solder, and also to cause the same to tin the lower side of the pipe, and to keep the solder from dropping down. By the process of steady pouring the solder now becomes nice and soft and begins to feel shaped, firm and bulky. When in this shape and in a semi-fluid condition the ladle is put down, and with the left hand, the operation of wiping, as illustrated, is begun working from the soiling towards the top of the bulb. If the lead cool rapidly, it is reheated to a plastic condition by a torch, or a heated iron. When the joint is completed, it is cooled with a water spray, so that the lead shall not have time to alter its shape.

No. 3. For 14 carat gold: Gold (14K), 25 parts; silver, 25 parts; brass, $12\frac{1}{2}$ parts; zinc, 1 part.

Aluminum Solders.—In soldering aluminum it is necessary previously to tin the parts to be soldered. This tinning is done with the iron, using a composition of aluminum and tin. A pure aluminum

soldering bit should be used. To prepare an aluminum solder, first melt the copper, then add the aluminum gradually, stir well with an iron rod, next add the zinc and a little tallow or benzine at the same time. After adding the zinc do not heat too strongly. To avoid volatilization of the zinc, according to *Machinery*, the following aluminum solders have been successfully used:

Aluminum Solders

Tin	Aluminum	Zinc	Copper	Bismuth	Lead	Phosphor Tin*	Silver	Antimony	Cadmium	Magnesium
95.00				5.00						
78.50	2.00	19.00				0.50				
	66.70						33.30			
20.00	70.00						10.00			
97.00				3.00						
	6.00	89.50	4.50							
71.25	2.25	26.00				0.50				
60.00	4.00	8.00	4.00		12.00		12.00			
37.50		25.00	37.50							
	8.00	92.00								
30.00		20.00							50.00	
80.00	2.25	17.00				0.75				
66.00	15.50			9.00				7.00	†	2.25
15.50	2.50	78.25			2.50	1.25				
	20.00	65.00	15.00							
49.05		20.31	1.15		26.06			3.43		
30.00	70.00									
	4.00	94.00	2.00							
85.10	10.80								1.35	2.75
60.00		15.00		5.00	10.00			5.00		†
86.00				14.00						
98.00	1.00			1.00						
20.00	70.00		10.00							
48.00	2.00	27.00			23.00					
90.00	5.00			5.00						
84.95				15.05						

*10% phosphorus.

†This solder also contains 0.25% vanadium.

‡This solder also contains 5% chromium.

Novel's solders for aluminum as given by Kent are as follows:

Tin 100 parts, lead 5 parts; melts at 536° to 572° Fahr.

Tin 100 parts, zinc 5 parts; melts at 536° to 612° Fahr.

Tin 1,000 parts, copper 10 to 15 parts; melts at 662° to 842° Fahr.

Tin 1,000 parts, nickel 10 to 15 parts; melts at 662° to 842° Fahr.

Novel's solder for aluminum bronze: Tin 900 parts; copper 100 parts; bismuth 2 to 3 parts. It is claimed that this solder is also suitable for joining aluminum to copper, brass, zinc, iron and nickel.

Soldering Fluxes.—The word *flux*, means a substance applied to a metal to make solder flow readily on its surface. The action of a flux is largely that of cleaning the surface, and of reducing any oxide on the surface to the metallic state.

If a piece of sheet copper be carefully cleaned by means of emery cloth and heated over a gas flame, the surface will be



FIG. 4,435.—Method of wiping a vertical joint. A small piece of cardboard cut open is placed under the joint to catch excess solder, or as shown, a lead flange cut open is placed around the pipe and held in place by twine.

seen to tarnish rapidly and assume a dark brown appearance. A small piece of resin dropped on the surface will melt, and when the liquid runs, the initial brightness of the surface will be found to reappear.

There are a number of flux suitable for various kind of soldering, but pine amber resin is the best for electrical work as it does not cause corrosion. A corrosive flux, such as zinc chloride

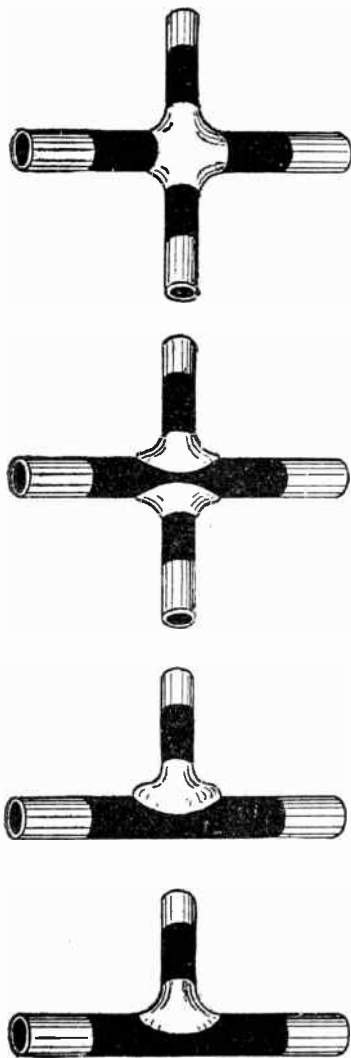

FIG. 4,436 to 4,439.—Various wiped joints. Fig. 4,436, *branch joint with concave neck*; fig. 4,437, *branch joint with swell neck*; this style is much more difficult to wipe than the one shown in fig. 4,436; fig. 4,438, *double branch cross*; this style looks well and is very easy to wipe because one branch may be wiped at a time by protecting the first with chalk or paste; fig. 4,439, *regular cross joint*, more difficult than the double branch because there are four edges to take care of at one heat.

solution (killed spirits) should be strictly excluded from any electrical work.

The Underwriters' code permits the use of a flux composed of chloride of zinc, alcohol, glycerine, and water. This preparation is easily applied and remains in place. It permits the solder to flow freely and is not highly corrosive. This flux is made as follows: Zinc chloride, 5 parts; alcohol, 4 parts; glycerine, 3 parts. Anhydrous zinc chloride crystals should be used dissolved in alcohol. The glycerine makes the flux adhesive. To prevent the alcohol igniting, the mixture may be diluted with water.

There are a number of prepared flux on the market, but are not to be recommended because of the ridiculously high prices demanded.

For electrical work, especially when very small wires are used, rosin should

be insisted upon to avoid any corrosion. No one flux can be assigned to any one metal as being peculiarly adapted or fitted to that metal for all purposes. The nature of the solder often determines the flux. The following fluxes are extensively used.

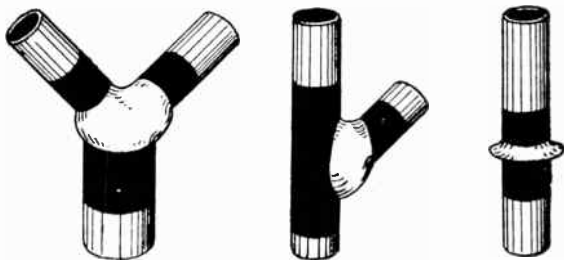
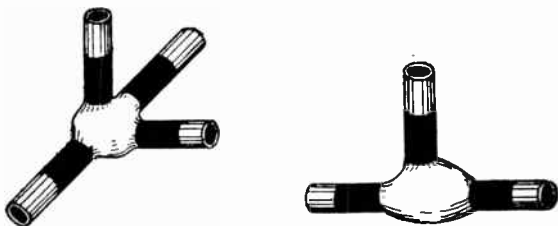

FIGS. 4,440 to 4,444.—Various wiped joints. Fig. 4,440, *angle cross*, a joint more difficult to make than the regular cross; fig. 4,441, *combination branch and round joint*, sometimes made where it is most convenient to have a branch joint come at a point where two ends of the supply line must be joined; fig. 4,442, *V joint*, generally used on telephone branch cables; fig. 4,443, *so called Y joint*, usually made on lead waste pipe; fig. 4,444, *common flange joint*.

Resin.—This substance, one variety being called rosin, is difficult to define. It is undoubtedly an exudation from the trunk and limbs of trees, but these exudations vary so much in all their properties that

the terminology of them is wide, complicated and in some cases, contradictory.

Rosin solidifies after exudation from the tree and is insoluble in water, but soluble in alcohol.

Colophony, or rosin, is the kind of resin used as a flux, and consists of other coagulated exudation obtained from cuts in the bark of trees belonging to several species of *Pinus*, largely grown in America, and on the west coast of France. It comes in lumps but can be granulated by grinding in a coffee grinder or simply by hammering.

The resin may be sprinkled over the surface to be soldered or may be applied in liquid form by dissolving in alcohol. It is used as a flux for brass, copper, gun metal, lead, tinned steel.

Chloride of Zinc.—This flux, which may be used for brass, copper, gun metal, block tin, tinned steel, gold, silver, bismuth, is prepared as follows: Place three parts of hydrochloric (muriatic) acid and one part of water in a glass, wooden, or lead vessel, and add pieces of zinc as long as the acid attacks the zinc. Put in the zinc gradually to prevent "boiling over." Care should be taken to get a saturated solution, that is, to add all the zinc that the solution will dissolve. After settling, the clear solution should be poured off and the latter is then ready for use.

Another flux made with zinc chloride that is especially adapted to the soft soldering of iron and steel (because it does not make rust spots) consists of the ordinary zinc chloride with addition of one-third spirits of sal-ammoniac and one-third part rain water; the mixture is filtered before using.

A formula which dispenses with the use of chloride of zinc consists of: Water, 80%; lactic acid, 10%; glycerine, 10%.

An acid free soldering fluid consists of: 5 parts chloride of zinc, 25 parts of boiling water. Another: 20 parts chloride of zinc; 10 parts ammoniac chloride; 100 parts boiling water. Another formula consists of chloride of zinc, 1 drachm; alcohol, 1 ounce.

Rosin and Tallow.—A mixture commonly used consists of rosin and tallow with the addition of a small quantity of sal-ammoniac. This is adapted to tinned ware, because of the ease with which it may be wiped off the surface after soldering.

Another mixture consists of: 1½ lbs. olive oil; 1½ lbs. tallow; 12 oz. pulverized rosin. Let the mixture boil up and when cool add 1¾ pints of water saturated with pulverized sal-ammoniac, stirring constantly.

Soldering Grease.—In a pot of sufficient size and over a slow fire melt together 500 parts of olive oil and 400 parts of tallow, then stir

in slowly 250 parts of rosin in powder, and let the whole boil up once. After cooling, add 125 parts of saturated solution of sal-ammoniac while stirring; use when cold.

Ammonia Soap.—Mix finely powdered rosin with strong ammonia solution. This is suitable for soldering together copper wires for electrical conduits.

Soldering Fat for Iron.—Olive oil, 50 parts; sal-ammoniac, 50 parts.

Soldering Fat for Aluminum.—Melt together equal parts of rosin and tallow, half the quantity of chloride of zinc being added to the mixture.

Soldering Salt.—Mix equal parts of neutral chloride of zinc, free from acid, and powdered sal-ammoniac. When required for use, 1 part of the salt should be dissolved in 3 or 4 parts of water.

Soldering Paste.—Consists of neutral soldering liquid thickened with starch paste. In using apply more lightly than the soldering liquid.

Borax.—This flux is most frequently used for hard soldering. It should be applied to the soldering seam either dry or stirred to a paste with water. It is advisable to use borax which has been dried by heat (calcined borax).

For soldering steel on steel, or iron on steel, melt in an earthen vessel: borax, 3 parts; colophony, 2 parts; pulverized glass, 3 parts; steel filings, 2 parts; carbonate of potash, 1 part; hard soap, powdered, 1 part. Flow the melted mass on a cold plate of sheet iron, and after cooling, break up the pieces and pulverize them. This powder is thrown on the surfaces a few minutes before the pieces to be soldered are brought together. The borax and glass dissolve, liquefying all impurities, which, if they were shut up between the pieces soldered, might form scales.

Cryolite.—Finely powdered cryolite is suitable for hard soldering copper and copper alloys, or a mixture of 2 parts powdered cryolite, and 1 part phosphoric acid may be used. For hard soldering of aluminum bronze, a mixture of equal parts of cryolite and barium chloride is used.

Muller's Hard Soldering Liquid.—This consists of equal parts of phosphoric acid and alcohol (80 per cent.).

Dry Soldering Preparation.—A good preparation consists of two vials, one of which is filled with chloride of zinc and the other with ammonium chloride. To use, dissolve a little of each salt in water, apply the ammonium chloride to the object to be soldered and heat the latter until it begins to give off vapor of ammonium, then apply the other, maintaining the heat in the meantime. This answers for very soft solder. For a harder solder dissolve the zinc in a very small portion of the ammonium chloride solution (from $\frac{1}{4}$ to $\frac{1}{2}$ pint).

The various fluxes and their use are given in tabular form in the accompanying tables. According to Haswell, the proper fluxes to use are as follows:

For iron, use borax
 " tinned iron, use rosin
 " copper and brass, use sal ammoniac

For zinc, use chloride of zinc
 " lead, use tallow or rosin
 " lead and tin, use rosin and sweet oil

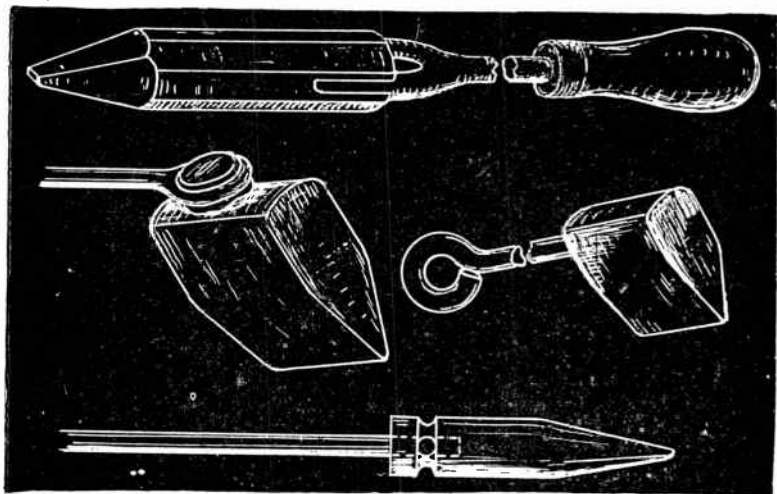

FIGS. 4,445 TO 4,448.—Various soldering bits, or so called "irons." Fig. 4,445, ordinary edge bit; figs. 4,446 and 4,447 hatchet bit; fig. 4,448, pointed bit.

Soldering Bolts or Bits.—The erroneously called soldering "iron" or bit consists of a large piece of copper, drawn to a point or edge and fastened to an iron rod having a wooden handle as shown in fig. 4,445. There are a variety of bit which may be classed

1. With respect to their shape, or construction as

a. Pointed;
 b. Grooved;

c. Hatchet;
 d. Reservoir.

2. With respect to the method of heating, as

a. Externally heated; b. Internally heated { electrically, or by gasoline torch.

The various types of bit are shown in the accompanying cuts.

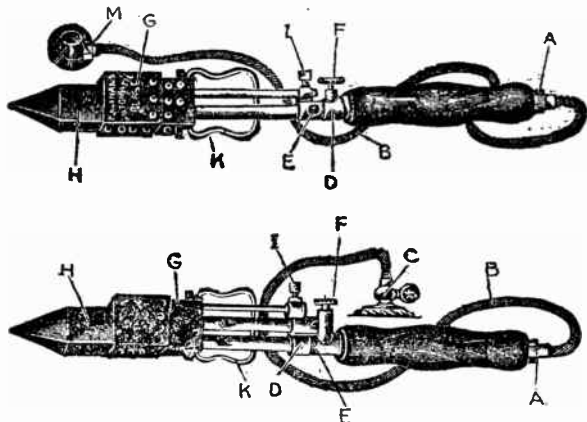

FIGS. 4,449 and 4,450.—Kageman self-heating gas soldering bit for bench work. Fig. 4,449, single torch; fig. 4,450, double torch. Any shape or weight of copper point for any class of work may be easily substituted by means of a set screw I. One end of a flexible tubing is attached to the nozzle or male screw near the handle A, and the other end is connected to the gas main M. ($\frac{3}{8}$ main preferred.) Before lighting, close the Bunsen holes E by means of the air slide D, open the governor F, turn on gas main M, light near copper point at G, and gently open Bunsen holes by means of slide D. If flame appear within chamber E, turn off gas, slightly close holes by means of slide D, and light again. Shut off gas at main cock M. Where the gas main is already installed it is advantageous to bore a hole in the bench near the wall, connect a flexible metallic tubing to the gas main, pass tubing through the hole and fasten tubing to the underside near the outer edge of the bench. In that way the hose will hang freely and will hardly be noticeable. The soldering iron can be used away from the bench at any desired distance, depending upon the length of the tubing. The double torch, fig. 4,450, has two burner tubes generating two short but intensely hot blasts. The double flame is intended to heat heavy coppers quickly, and when the desired temperature is reached one flame is shut off by a half turn of the governor, the remaining flame keeping the point at a steady temperature throughout the day. For smaller coppers one flame is sufficient. When a large heating power is required it is often desirable to use both blasts throughout the day.

A heavy bit is preferable for jointing work, as one weighing less than two pounds does not retain the heat long enough.

Tinning the Bit.—Preliminary to soldering, the bit must be coated with solder, this operation being known as “tinning.” To tin a soldering bit, heat it in a fire or gas flame until hot

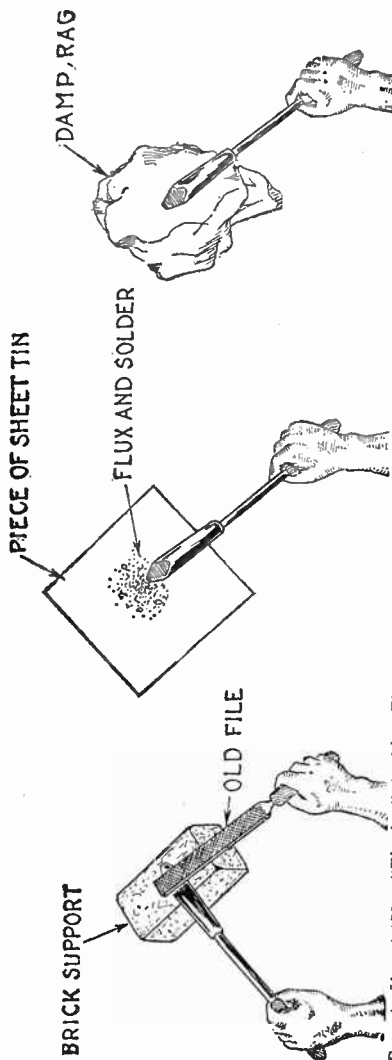

FIGS. 4,451 to 4,453.—"Tinning" the bit. Fig. 4,451, cleaning bit by filing working surfaces with an old file; fig. 4,452, rubbing the bit on the flux and solder, which may be conveniently placed on a piece of sheet tin as shown; fig. 4,453, removing surplus solder by giving each side of the bit a quick stroke over a damp rag.

enough to melt a stick of solder rapidly when it is lightly pressed against it. When the bit is at the right temperature, the heat can be felt when it is held close to the face. When hot enough clean up the surface of the copper with an *old* file. If the temperature be too high, the copper surface will be found to tarnish immediately, in which case the soldering bit must be allowed to cool slightly and the cleaning repeated. When the surface only tarnishes slowly a little flux is sprinkled upon it, it is then rubbed with a stick of solder. After the molten metal has spread over the whole of the surface which it is desired to tin, the superfluous solder is wiped off with a clean damp rag.

The surface should then present a bright silvery appearance when properly tinned.

Once a soldering bit has been well tinned care should be taken not

to overheat it. If the bit at any time reach a red heat it will be necessary to repeat the whole tinning process before it is fit to be used again. No good work can be done with an untinned or badly tinned bit.

Ques. If the bit be forgotten and left in the fire what should be done?

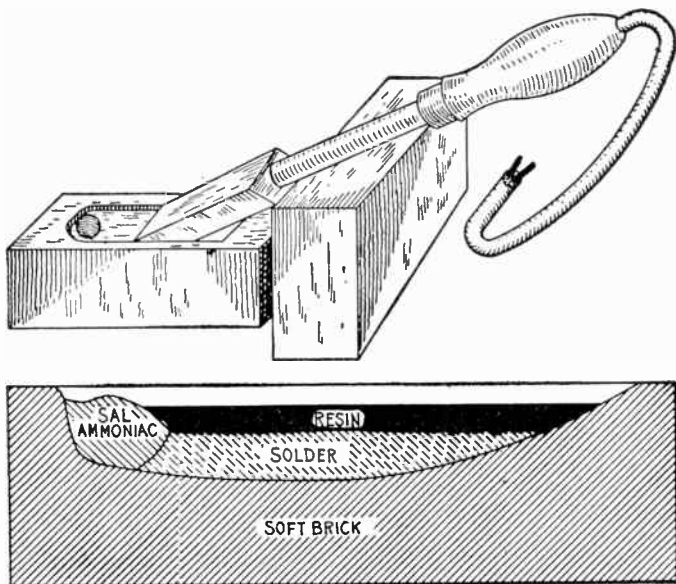

Figs. 4,454 and 4,455.—Tinning block for electric soldering tool. It is made with two soft bricks. One brick is used to support the soldering tool, and the other to contain the tinning material and to furnish a material which will keep the copper bit bright enough to receive its coating of "tin." Fig. 4,455 represents a section of the tinning brick, which is scooped out on top as shown by the lower line. Into one end of the hollow in the brick, some sal-ammoniac is placed to help tin the copper bit. Sal-ammoniac is a natural flux for copper and aids greatly in keeping the tool well tinned. Next, some melted solder is run into the hollow of the brick, and lastly enough resin to fill the cavity nearly to the top. When the tool is not in use, the electricity is switched off and the tool permitted to lie in the resin. If it be desired to repair the tin coating a little when the tool is in use, the latter is rubbed on the brick below the layer of solder, and the layer of resin. If the tool be in very bad condition, it may be pushed into the sal-ammoniac once or twice and then rubbed in the solder again. It requires but little heat to keep the brick and its contents ready for use. In fact, the brick is a fair non-conductor of heat and prevents the escape of heat from one side of the tool. When momentarily not in use, the tool remains in the solder which becomes melted underneath the layer of resin. When the copper bit becomes too hot, it will begin to volatilize the resin, thus calling attention to this fact, whereupon the electricity should be turned off from the tool.

Ans. Heat to redness and then plunge into cold water, when most of the hard oxidized surface will scale off.

Ques. What kind of fire quickly destroys the tinning?

Ans. A soft coal fire.

Soft Soldering.—The theory of soft soldering is that: *as the solder adheres to and unites with the surface of the copper when*

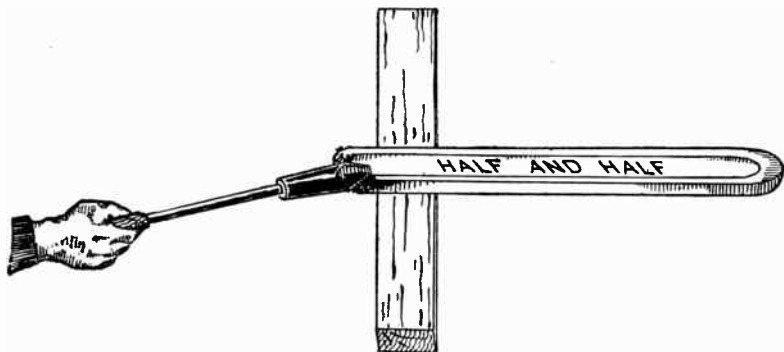

FIG. 4,456.—Picking up solder with a hot bit. This is the proper method for small work. Rest the bar of solder on some support as a brick or piece of wood and touch it with the end of the hot bit. Some of the solder will melt and remain on the bit. It is then transferred to the part to be soldered, and if the surfaces be in proper condition and fluxed when the bit touches the surfaces, the solder will leave the bit and cover the surfaces. **In picking up solder** from the stick, care should be taken not to leave the bit in contact with the solder too long or some of it will drop off. The larger the bit and area tinned, the more solder will the bit hold.

the bit is tinned, so will it adhere to and unite the surfaces of the metals to be soldered.

Soft soldering, as well as hard soldering, or brazing, consists of welding together two or more pieces of similar or dissimilar metals by means of another metal of lower melting point.

In order to solder successfully wire joints, the following instructions should be followed:

1. Clean and tin the bit as previously explained.
2. Heat the bit in the fire until it reaches the right temperature. Do not try to solder a joint with a bit so cool that it only melts the solder slowly, nor with one so hot that it gives dense clouds of smoke when in contact with rosin. Burned rosin must be regarded as dirt.
3. Remove the bit from the fire and hold it, or preferably support it on a brick or block of other material which does not conduct heat readily.
4. Wipe the surface clean with a rag. Apply solder until a pool remains on the flat surface, or in the groove, if a grooved bit be used.
5. Sprinkle with rosin, lay the joint in the pool of solder and again sprinkle with rosin.
6. Rub the joint with a stick of solder so that every crevice is thoroughly filled.
7. Remove the bit, and lightly brush superfluous solder from the bottom of the joint. See that no sharp points of solder remain which may afterwards pierce the insulation.

When the joint is first placed on the bit, the solder should run up into the joint. This will occur only when the joint is well made and thoroughly cleaned, and if the workmanship be perfect it is even possible to fill the joint completely by feeding in solder below the joint as it melts and runs up into the joint.

A well soldered joint should present a smooth, bright appearance like polished silver. Wiping the joint before it cools destroys this appearance, and is also liable to produce roughness, which is detrimental to the insulation.

In order to prevent the insulation on the wire near the joint being damaged, the process of soldering should be carried out as quickly as possible, and for this reason the tendency to burn the insulation is less with a *hot* bit (a quick bit) than with a cooler one.

Ques. How is a joint soldered with a torch?

Ans. The flame is directed on the middle of the joint, and when a sufficient rise of temperature has taken place to melt the solder readily, the joint is rubbed with rosin and solder alternately until it is thoroughly saturated with solder. The usual precaution of brushing any points of solder off the joint with a clean rag must, of course, be taken.

In using the torch there is considerable danger of damaging the insulation with the flame. This may be minimized by wrapping the end

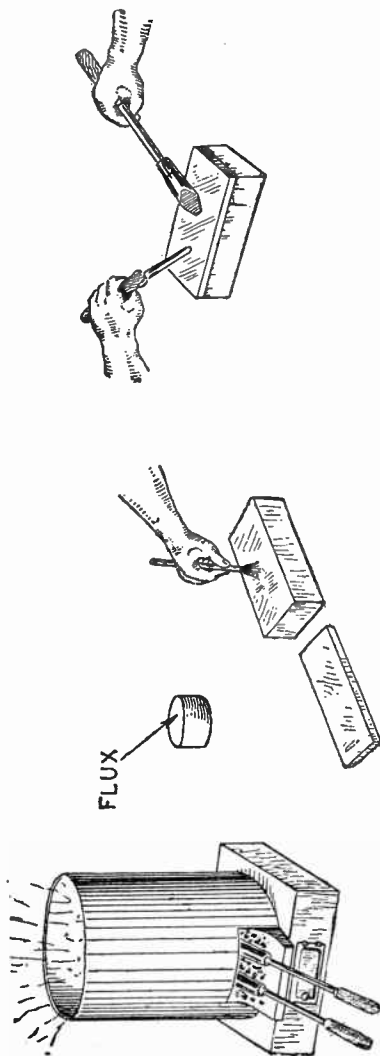

FIGS. 4,457 to 4,461.—*Sweating*. When two surfaces are to be united by sweating, first see that the surfaces are perfectly clean, then flux as in fig. 4,460. Put a piece of tin foil over one surface and the other surface on top. They should be held firmly together by a clamp or other means and heated as in fig. 4,461 by a hot bit, or if the metal have considerable thickness by a torch, until the solder melts. When cool, the surfaces will be found to be firmly united.

of the insulation with seldge tape before soldering. When big joints are being made it is sometimes advisable to wet the tape in order to prevent the conduction of heat along the copper to the insulation.

Sweating.—In this operation the surfaces are cleaned, heated, and covered with a film of solder. The soldered surfaces are then placed together and heated by passing the bit over the outside surface until the solder melts and unites the two surfaces.

Sweating is often employed for the temporary holding together of work which has to be turned or shaped, and which could not be so conveniently held by other methods. After having been turned or shaped, the separation of the parts is readily effected by the aid of heat.

Babbitting Boxes.—

Although some special machines are provided with ball bearings, most dynamos and motors have

plain babbitted bearings, accordingly electricians and repair men should know how to babbitt a box should occasion arise for such operation.

Formerly, bearings for the journals of machinery were constructed of *brass or other alloys*, for the purpose of minimizing friction. Hard cast iron, which afforded an admirable surface becoming glazed over with a sort of skin after a little use, while efficient for sliding surfaces, had to be avoided for journals, as irreparable damage might be done to the bearing when overheated. Later practice evolved the idea

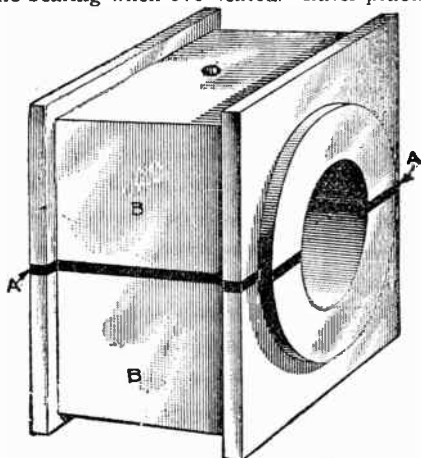

FIG. 4,462.—Sweating brasses. When brasses are sweated together, liners AA, are sometimes placed between them, as shown, to allow for wear when they are in the machine. The faces of the brasses and liners are planed smooth and rubbed bright. They are then heated in the forge, and when hot, the brasses fluxed with sal-ammoniac and tinned by the method employed in tinning the soldering copper. The liners, if of iron, are fluxed with borax and tinned. The pieces are then put together and heated sufficiently to melt the solder. If not heavy enough to make a tight joint, they are weighted down until cold. When the pieces have been bored out and finished in the machine shop, they are melted apart and the liners taken out, a number of thin liners being substituted.

of using a softer or elastic metal, popularly and *erroneously* known as *anti-friction metal*, which would accommodate itself to inequalities of the surfaces in contact, thus working with far less friction than iron or bronze, while on the other hand it would be much cheaper than a copper tin alloy.

Of the various so called anti-friction metals, Babbitt is extensively used. This is a soft white metal composed of tin

copper and antimony. Many different compositions of these metals are used for babbitt metal; the alloy originated by Isaac Babbitt was composed of tin, 45½ parts; copper, 1½ parts; antimony, 13 parts; lead, 40 parts.

At the beginning this proportion was used for all purposes, but it has been found that there is no one composition that will bring equally good results in all kinds of machinery, hence are given the following different proportions:

Babbitt metal for light duty is composed of 89.3 parts of copper, 1.8 parts of antimony, 8.9 parts of lead.

Babbitt metal for heavy bearings is composed of 88.9 parts of copper, 3.7 parts of antimony, 7.4 parts of lead.

Lead and antimony have the property of combining with each other in all proportions without impairing the anti-friction properties of either, the antimony hardens the lead, and when mixed in the proportions of 80 parts lead, by weight, with 20 parts antimony, no other known composition of metals possesses greater anti-friction or wearing properties or will stand a higher speed without heat or abrasion.

The operation of babbitting a box should be done in accordance with the following instructions to obtain good results.

1. Avoid overheating the babbitt, as this is destructive to the qualities of the metal and also entails a considerable loss on account of the dross or scum that has to be skimmed off the ladle.

To ascertain the proper temperature, the time honored test is to try it with a dry pine stick. The temperature should be such that the stick will char without catching fire. Cover the metal with powdered charcoal and put in the ladle a lump of sal-ammoniac.

Of course, it is sometimes necessary to heat the babbitt hotter than this to insure its running to all parts of the box when the section to be filled is thin, but if possible, in such cases, the box should be warmed up to prevent excessive chilling of the metal.

NOTE.—The practice of lining journal boxes with a metal that is sufficiently fusible to be melted in a common ladle is not always so much for the purpose of securing anti-friction properties as for the convenience and cheapness of forming a perfect bearing in line with the shaft without the necessity of boring it. Boxes that are bored, no matter how accurately, require care in fitting and attaching them to the frame or other parts of a machine.

2. If the box is to be babbitted with the shaft in position for a mandrel, be careful to get the shaft properly lined and central in the box.

To hold it in position use an outside support if convenient, but if not, small pieces of lead hammered to the right thickness may be used to hold it at the proper height and in a central position. *It is not good practice*, however, to use the shaft for the purpose of casting the bearings, especially if the shaft be of steel, for the reason that the hot metal is apt to spring it; the better plan is to use a mandrel of the same size or a trifle larger for this purpose. For slow running journals, where the load is moderate, almost any metal that may be conveniently melted and will run free will answer the purpose. For wearing properties with a moderate speed there is probably nothing superior to pure zinc, but when not combined with some other metal it shrinks so much in cooling that it cannot be held firmly in the recess, and soon works loose.

3. The shaft should be smoked or greased so that the babbitt will not adhere to it.

4. The ends of the box should be stopped with clay or cardboard washers cut to snugly encircle the shaft and held to the face of the box, to prevent the babbitt escaping.

Liners made of cardboard should be inserted between the halves of the box and should touch the shaft on each side so that the box can be divided without trouble after the pouring is completed.

5. A small hole at one end will be sufficient to insure the lower part filling properly.

6. With a large box and shaft, it is best to pour the lower part first and then the upper one.

7. Care should be taken that there is no water or dampness in the box, as serious consequences may follow if this precaution be neglected.

A rusty box is likely to throw the babbitt, as water will be liberated when the hot metal is poured on it. A small lump of rosin dropped in the ladle just before pouring increases the fluidity of the metal somewhat and reduces the liability of the babbitt to explode when the interior is slightly damp, although no risks should be taken in this direction.

8. If the oil hole be used to pour through, it will be necessary to drill it out and cut the oil grooves after the box is taken apart.

9. If the babbitt be poured from the side, a plug of pine wood can be inserted in the oil hole down to the shaft to keep it clear.

10. The shaft is sometimes wrapped with a stout cord laid in a spiral direction to get the proper oil runs, but it is usually better to cut them afterwards with a round nose chisel.

Brazing.—This is the art of *uniting metals by means of a hard solder*. Originally, as its name implies, it was devoted to the union of brass or other copper alloys.



FIG. 4,463.—Ordinary mouth blow pipe.

The theory of brazing is *the melting of a low fusing metal against the metals to be united while they are in such a condition of cleanliness and temperature that the metal welds itself to them*.

Brass filings have been generally replaced by *spelter*, which is a composition of about equal parts of copper and zinc; this is used for brass work. For tubes, a composition of 8 parts of brass tube filings to 1 of zinc is used.

Brass or gun metal united by this process will produce a joint as hard as the metal pieces united.

Iron and steel, especially small pieces of finished work, may be united, by the same means. The process of brazing consists essentially of

1. Cleaning the parts to be brazed;
2. Applying the hard solder and flux;
3. Heating.

The work is first carefully cleaned with acid, and some fine spelter is mixed with borax to form a flux, a little water being added to make a paste. The compound is placed between the parts to be united, as much surface as possible being brought in contact, the two being held firmly together, in the case of small pieces by tongs, and heated until the flux and spelter are melted, the parts being held together until the spelter unites with the metal and solidifies.

Sometimes the work cannot be easily gripped, and so, after inserting the spelter and borax as before, the parts are bound with iron wire and

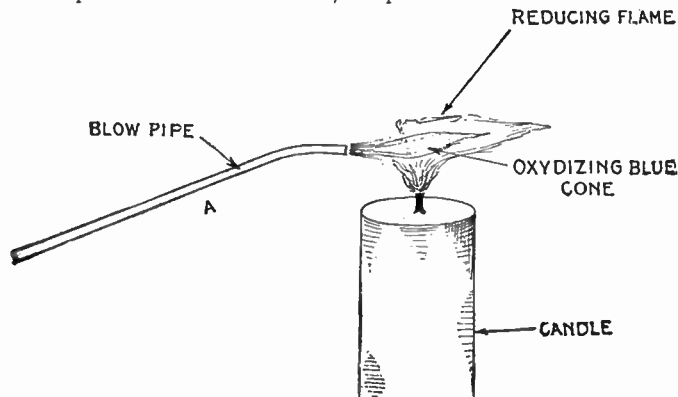

FIG. 4,464.—Method of using the mouth blow pipe. This is for small work, though the intensity of the heat thus produced is very great, the volume of flame is small. Or, some blow pipes a ball or enlargement is made at A to catch any moisture or saliva, thus increasing the efficiency of the instrument. The torch as shown, gives two flames as follows: 1, *oxydizing flame*, commonly caused by the chemical uses of oxygen with another substance. If more oxygen be supplied than is needed for perfect combustion, the free oxygen in excess makes an oxydizing flame, one that rusts or burns the metal. A flame may be oxydized in one place and reducing in another; 2, *reducing flame*, defined as a flame in which the fuel is in excess of the oxygen necessary for perfect combustion. *The tendency of such a flame is to draw some oxygen from the burned parts of the metal.* It prevents burning within its radius.

placed in a clear coke fire until the operation is complete. The superfluous metal around the joint will in each case need to be removed by means of the file.

There are various methods of brazing, such as

1. Butt brazing;
2. Lap brazing;
3. Dip brazing;
4. Muffle brazing.

Butt Brazing.—This method consists of placing the two pieces to be brazed *butt to butt*. If two thin pieces are to be butt brazed, the pieces must be held in position in a bench vise, or clamp, and the heat applied with a torch or blow pipe. The surfaces to be brazed are fluxed and then clamped in position and the proper hard solder, as given in the tables, applied.

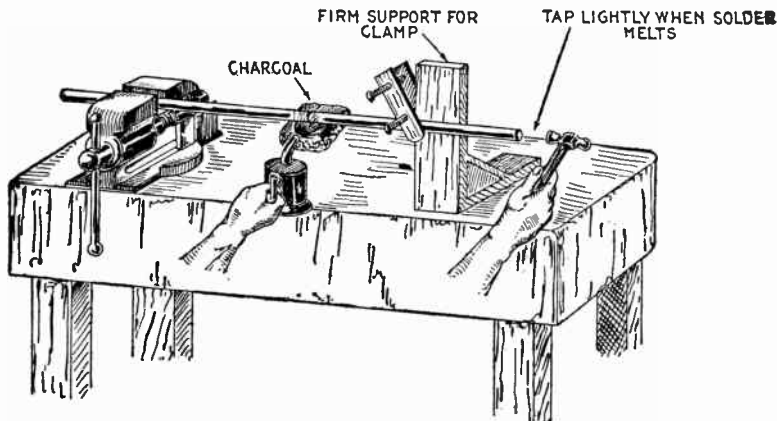

FIG. 4,465.—Butt brazing two lengths of small pipe. After cleaning the ends to be brazed and fluxing, they are clamped in position butt to butt using a vise and clamp as shown, or other means. A little brazing solder is sprinkled over the joint and heat applied. When the pieces are hot enough to melt the solder it must flow into the joint, butt brazing the two pieces. By giving one of the pieces a slight tap on the end, when the solder melts, the surplus solder is squeezed out, making a good and firm joint. If the pipes be large or of considerable length, the heat is quickly conducted away, necessitating a charcoal backing or more adequate means of heating.

Heat is then applied by means of a blow pipe, or Bunsen burner, until the pieces are hot enough to melt the solder, which will then flow into the crack.

By giving one of the pieces a slight tap on the end, they are brought tightly together. After cooling, the superfluous solder is scraped off.

Lap Brazing.—In this method the parts to be brazed are overlapped. Band saws are always lap brazed, the two ends being filed to make an accurate joint. Silver solder is generally used, it being applied between the two surfaces, or the surfaces are coated with borax and the solder allowed to flow into the joint from the edges. The operation of lap brazing a saw is shown in fig. 4,466.

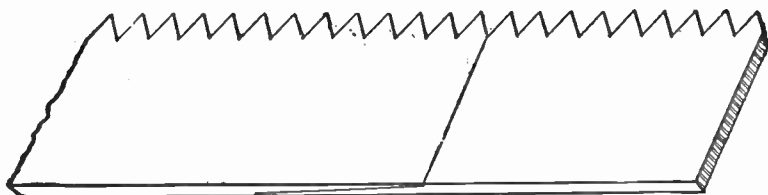

FIG. 4,466.—Lap brazing. A band saw is a good example of this method. In making the lap the two ends are chamfered by filing to make an accurate joint as shown. Silver solder is generally used, it being applied between the two surfaces, or the surfaces are coated with borax and the solder allowed to flow into the joint from the edges. After firmly clamping the parts in position, the solder is laid over the joint, or it may be placed between the two pieces to be united. When the heat is applied, the solder melts and the two pieces must be squeezed tightly together to force out surplus solder. Silver coins contain 10 per cent. of copper and make a good hard solder. When using a coin, pound it until very thin and then place between the two surfaces to be brazed.

Dip Brazing.—This consists of dipping the work into molten solder until the parts are heated sufficiently to be united by it. For duplicate work this method is well suited, and is extensively employed in bicycle manufacture.

NOTE.—Cast iron soldering. A new process consists in decarbonizing the surfaces of the cast iron to be soldered, the molten hard solder being at the same time brought into contact with the red hot metallic surfaces. The admission of air, however, should be carefully guarded against. First pickle the surfaces of the pieces to be soldered, as usual, with acid, and fasten the two pieces together. The place to be soldered is now to be covered with a metallic oxygen compound, and any one of the customary fluxes, and heated until red hot. The preparation best suited for this purpose is a paste made by intimately mingling together cuprous oxide and borax. The latter melts in soldering and protects the pickled surfaces, as well as the cuprous oxide from oxidation through the action of the air. During the heating the cuprous oxide imparts its oxygen to the carbon contained in the cast iron and burns it. Metallic copper separates in fine subdivision. Now apply hard solder to the place to be united, which in melting, forms an alloy with the eliminated copper, the alloy combining with the decarbonized surface of the cast iron.

Muffle Brazing.—As indicated by the title, a tube or *muffle* is used in this method for enclosing the parts to be brazed. The object of the muffle is to insure uniform heating; it is especially adapted to brazing alloys, the melting temperature of which are rather close to that of the solder.

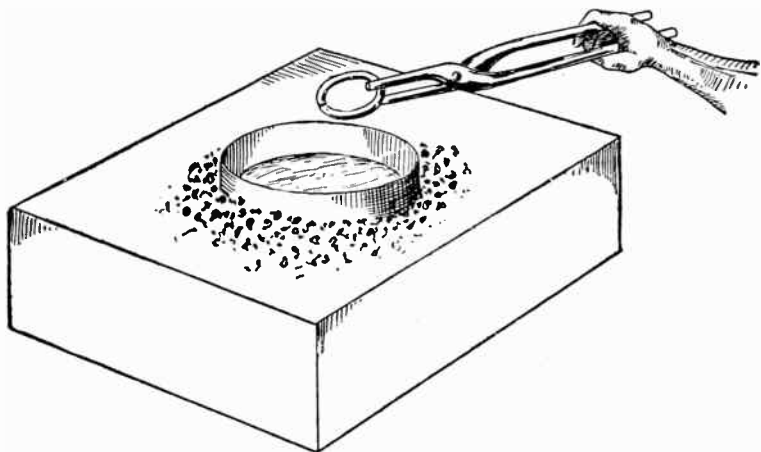

FIG. 4,467.—Brazing by immersion or dipping. The brazing solder is melted in a pot on the coal fire, as shown, or better in a gas furnace, flux being placed on top of the solder. *In brazing*, hold the object first in the flux a little while to heat and coat the article with a film of flux. Then, when it is lowered into the solder, the latter will flow in the joint and firmly attach itself. Before dipping, the article to be brazed is coated with a special anti-flux graphite, covering all the surface except that which is to be brazed. The layer of flux in the pot may be kept from $\frac{1}{2}$ inch to 2 inches deep.

Brazing of Copper.—For coppersmith's work the joints are prepared either by *thinning* or *cramping*. The first process consists simply of scarfing the edges to a long bevel, and is used for heavy material only. The second, a necessity for lighter work, is rather more elaborate; notches are cut at a slight angle into one of the edges to be united, and the teeth thus formed are bent alternately to left and right. The edge of

the other piece is thinned and inserted between the cramp, so that alternate pieces come on opposite sides of the thinned edge, supporting it.

Copper joints to be brazed are cleaned by covering the parts with a strong brine made from salt and water; they are then heated to a cherry red and plunged into clean fresh water, which also has the effect of annealing the copper. Scouring follows with clean water and sand rubbed on with a wad of tow.

The brazing mixture is made of borax and spelter in equal parts, with water, and is preferably made a day or two previously. The

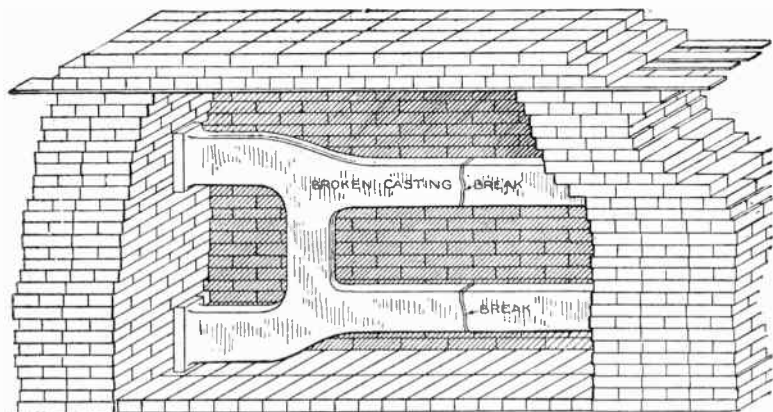

FIG. 4,468.—Quickly constructed furnace for brazing; view showing broken casting in position ready for brazing.

prepared portions of the article to be jointed are placed together and fastened, if for a pipe, by being bound with iron wire. The overlapping edges are closed by means of a mallet on a stake or mandrel.

The mixture is then laid evenly along the joint, and the pipe or other article placed upon a clear coke fire, the temperature of which is easily regulated. Presently, the borax fuses and forms into *drops*, and then the solder melts, which is indicated by blue fumes from the zinc. Probably it will be necessary to sprinkle a little more powdered borax, and the pipe may have to be tapped with a mallet or hammer to cause the

lapped parts to open slightly and permit of the solder flowing readily in between them. Salt is often strewn on the surface immediately after the solder has run, to kill the borax, as it would leave a hard scale interfering with future filing.

All flanges to be brazed to copper pipes must be of copper or what is known as brazing metal, 98 copper to 2 of tin, as gun metal flanges would melt before the spelter ran.

The hole in the flange is slightly tapered, and the end of the pipe also, to form a clearance in which the spelter may flow, a countersink being also formed in the face side of the flange, and the pipe slightly opened to fit it.

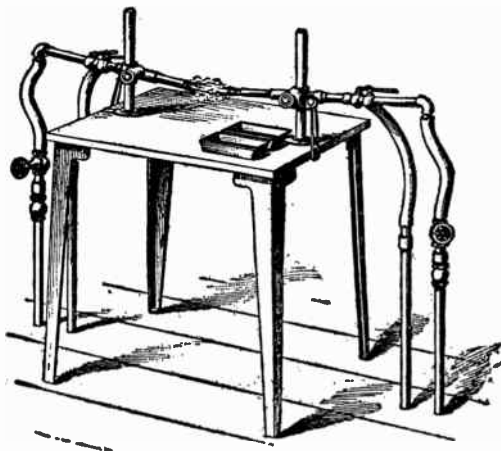

FIG. 4,469.—Brazing furnace without fire bricks. At opposite sides of the top are standards upon which sleeves freely slide, and which are held at any desired height by thumb screws. Each sleeve carries a burner to which gas and air pipes are connected, each pipe being provided with a valve for regulating the flow. The two burners can thus be adjusted so that the meeting points of their flames will be at any desired height above the table.

After the mixture is placed in the joint and the parts put together, the countersink is stopped with clay, to retain the solder. The pipe is then slung vertically over the fire, with the flange underneath, and the previous process carried out.

It will frequently be necessary to close the pipe with a clay tamping or a wooden plug to prevent the heat from going up it. Projections from flanges are protected from the fire by means of a covering of clay.

Table of Brazing Solders

Description	Copper	Zinc	Tin	Lead
Coppersmiths' strong spelter.....	75	25		
Coppersmiths' spelter.....	58	42		
Ordinary refractory spelter.....	50	50		
Hard white solder.....	57½	28	14½	
Half white, easily fusible.....	44	50	4½	1½
Spelter, readily fusible.....	33⅓	66⅔		

A few additional brazing solders are here given with their characteristics and colors.

Miscellaneous Brazing Solders

PERCENTAGE				Characteristics	Color
Copper	Zinc	Tin	Lead		
58	42			Very strong	Reddish yellow
53	47			Strong	Reddish yellow
48	52			Medium	Reddish yellow
54.5	43.5	1.5	0.5	Medium	Reddish yellow
34	66			Easily fusible	White
44	50	4	2	Easily fusible	Gray
55	26	15	4	White solder	White

Heating Methods in Brazing.—On account of the higher temperature required in brazing, a flame is generally used instead of a heated bit. For small work a blow pipe or torch is used, and a forge for large work. A torch alone is ordinarily insufficient as the heat must be put where it is needed and held there. This is usually done by building around the work with charcoal which becomes incandescent from the heat of the gasoline flame, and also gives off some heat from its own combustion.

If the article to be brazed be very small, it can be placed bodily in a hole scooped in a bit of charcoal as shown in fig. 4,470.

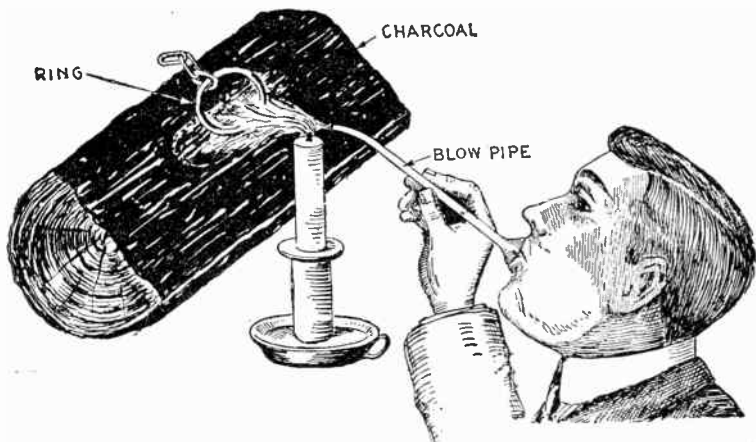

FIG. 4,470.—Brazing a small chain link in charcoal with a blow pipe. Place the broken link in a small hole scooped in the charcoal and heat with the candle flame and blow pipe after applying the solder and flux.

In brazing in the smith's forge it is well to hold the work high up, that is, so that it does not rest on the coal, but is kept suspended between banks of incandescent fuel so that the heating will be as near uniform as possible.



FIG. 4,471.—Brazing the joint of a pair of tweezers. The surfaces to be brazed are cleaned some of the spelter applied to each surface, and the pieces tied together with a fine iron wire and heated sufficiently to melt the spelter. The heat may be applied with a blow pipe or by holding the pieces in a pair of hot tongs. When the spelter is melted the piece is cooled and the iron wire is taken off. When the pieces are clamped in hot tongs, the iron wire is sometimes omitted, the pieces being placed in their proper relation and the tongs depended on to keep them there, or stops may be arranged to determine the location of the pieces.

A charcoal fire should be used, but if bituminous coal be used, coke enough of it to do the work, as the sulphur in the soft coal is to be avoided where good brazing is desired.

A gas furnace is very desirable for brazing. An air blast is necessary as in the forge but a comparatively small blower will suffice.

The accompanying cuts show the various methods of heating in brazing.

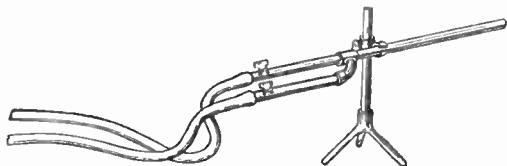

FIG. 4,472.—Air gas torch for brazing.

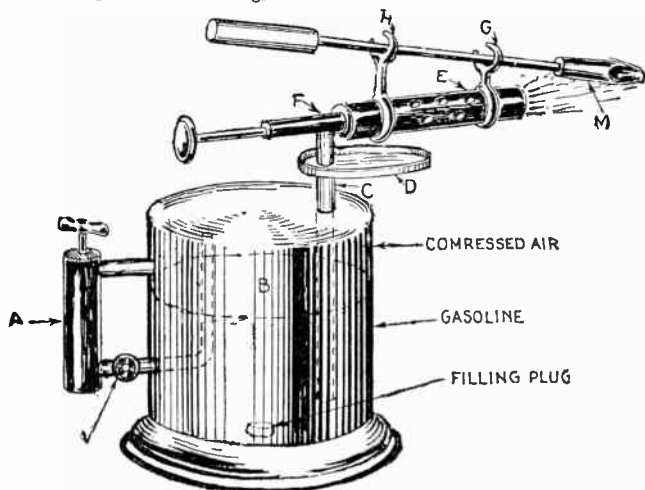
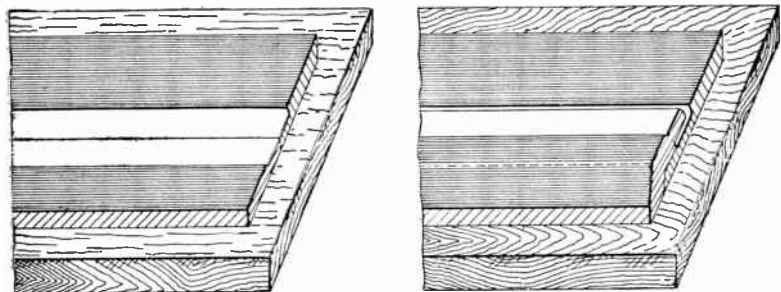

FIG. 4,473.—Gasoline torch with rests for holding soldering bit. *In construction* A is a hand air pump, which may have automatic, or hand operated valve; B is the reservoir containing gasoline and compressed air, the latter being furnished by the pump. A valve V, prevents leakage of the compressed air through pump. A pipe C projects to bottom of reservoir, as indicated by dotted lines, and connects with vaporizer E through needle valve F. A trough D is for holding a small quantity of gasoline to heat vaporizer E in starting. Two supports H and G clamped to the vaporizer support a soldering bit so that it will rest in the flame in heating. *In operation*, the reservoir is filled about two-thirds full through filler plug and the pump given a few strokes to compress air in the top of reservoir. After heating vaporizer E, with a little gasoline placed in D, needle valve F, is opened slightly. The gasoline under pressure in the reservoir will flow through needle valve F, into the vaporizer and ignite. As the vapor becomes hotter the valve may be given more opening and when fully heated an almost colorless flame of great heat will issue from the end of the vaporizer. Air supply is admitted into the vaporizer through the small holes shown. In attaching the supports H, G, care should be taken not to cover any of the air holes, because this will cause a poor flame.

Lead Burning.—This process, sometimes erroneously called autogenous soldering, consists of *joining pieces of lead together by simply placing the edges to be joined close to, or overlapping each other, and then melting them so that they flow and intermingle with each other, forming one piece, and retaining the same condition of unison on solidifying.*

In some cases a strip of lead is melted at the same time as the edges; this makes a raised, and consequently a stronger seam. The process is useful only for joining lead to lead and would not answer so well for joining lead to copper or to brass.



FIGS. 4,474 and 4,475.—Preparation of butt and lap seams for lead burning. Fig. 4,474 shows the edges of a butt seam placed together on a piece of flat board, and the seam shaved ready for burning. The width of the shaving is governed by the thickness of the lead to be joined. For 5 lb. lead the rear should be about $\frac{3}{8}$ inch wide, that is the edge of each piece should be shaved to a width of $\frac{3}{16}$ inch. Fig. 4,475 shows a lapped seam ready for burning. The face of the under side is shaved the width of the seam, and the over lead on the under side, as well as on the upper face, the width being a little less than the width of the seam for butt burning. The shaving is done with an ordinary shave hook and straight edge.

In lead burning, a hydrogen flame is used in connection with a jet of air, the hydrogen being produced in a machine or generator as explained fully in Guide No. 4, page 928, fig. 1,128.

For joining lead sheets together by burning, it is essential that the pieces touch or overlap each other when in the horizontal position, and overlap when in either slanting, upright, or overhead positions. It is not necessary to *soil* the sides of the

seams, because the lead will flow only where it is directed by the flame jet. No fluxes are necessary.

The details of preparation of butt and lap seams are shown in figs. 4,474 and 4,475.

To burn either of these seams, first regulate the gas and air cocks or the gas and oxygen cocks of the generator as the case may be, so as to obtain a "hard solid flame."

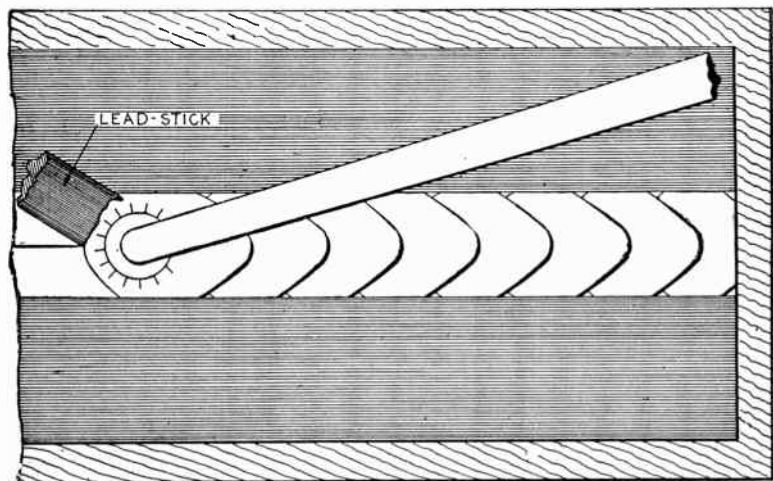

FIG. 4,476.—Process of burning a butt seam in two sheets of lead.

For flat butt burning the end of a stick of lead should be held on the seam so as to be melted at the same time as the other lead, as shown in fig. 4,476.

Before beginning to burn the seam, a stick of lead should be held in the hand and the flame made to play upon it so as to ascertain the hottest part of the flame to apply to the seam.

If the flame tarnish or smoke the lead stick, more air or oxygen should be burned in, but if the lead turn to a silvery brightness, when the flame impinges, the heat will be right and the part of the flame to be used will be ascertained.

Now tack the two ends of the seam by melting little beads on them to hold the pieces in position.

The burning can now be started, beginning being made at the right hand end. The flame is lifted immediately when the metal begins to flow and reapplied at a distance of from $\frac{1}{8}$ to $\frac{1}{2}$ inch, according to the thickness of the lead being joined together, giving the appearance shown in fig. 4,476.

During the process of burning, the sheet lead will be expanded when the heat is applied, and being a poor conductor, the heat is not distributed to the adjoining sides of the seam, hence the heated parts will rise up and leave hollow spaces underneath. When this happens, leaving places where the lead does not rest in the board the lead melts more readily, with the result that a hole is made, through which the molten metal will flow. To prevent this, the lead should be held down with the end of the stick of feeding lead, which is held in the left hand

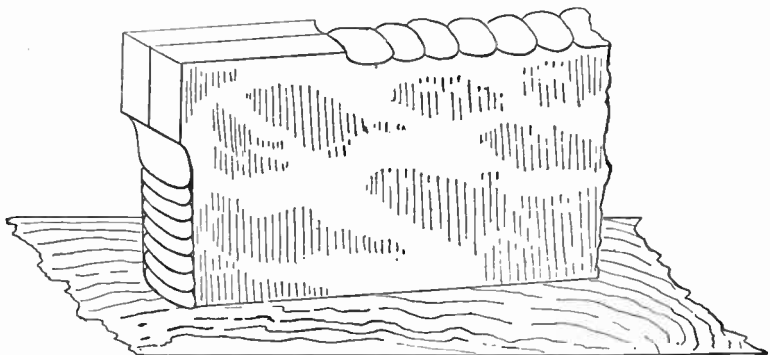

FIG 4,477.—Edge burning. In this case no feed lead is necessary, but a slight jar has to be given to start the first bead on either the vertical or the horizontal seam.

CHAPTER LXXXIV

WELDING

The art of *forcing two pieces of metal into union by means of heat and pressure*, is known as **welding**.

Until the introduction of electric welders, it has always been a difficult process, requiring considerable experience and skill of hand and eye. Not only must the temperature of the heated iron be properly judged for a successful weld, but the metal itself must be protected from the effect of the oxygen in the air.

Oxidation of Iron.—If a piece of iron be heated in contact with air, it will absorb oxygen from the air, thus forming a scale of oxide of iron on the surface. The hotter the iron, the more rapidly will the scale form.

Ques. What is the character of the oxide of iron?

Ans. It is in the form of scale which does not firmly adhere to the iron, and cannot be welded.

Ques. Why does it prevent welding?

Ans. Because it lies between the two surfaces to be united and prevents them coming into contact.

Methods of Preventing Oxidation.—There are two methods used in welding to prevent the formation of oxide of iron, and

both methods are based upon some means of protecting the hot iron from the oxygen in the air.

Oxidation is prevented by using

1. A reducing fire, or
2. A protective coating.

Ques. What is a reducing fire?

Ans. One in which all the oxygen is consumed in the combustion.

Ques. How is the oxygen completely consumed in practice?

Ans. By having a closed thick bed of fire for the air to pass through before coming in contact with the iron and by maintaining a moderate blast.

Care should be used to regulate the air supply so that there will be just enough and no more, otherwise air will be blown through and cause oxidation.

Ques. What is a protective coating?

Ans. A substance containing no oxygen, which is applied to the heated metal, and which possesses certain qualities which prevent oxidation.

Ques. What is the usual name for a protecting coating?

Ans. *Flux*.

Fluxes.—These require considerable care in their preparation. Although their use in greater or less quantity has generally no effect on the composition of the metal, their defective manufacture tends to produce inconvenience when they are used, and in consequence, the bad execution of the weld. The

cleaning fluxes for the various metals are most conveniently used in powdered form.

The usual composition of fluxes for the various metals are as follows:

Cast Iron.—Equal parts of carbonate and bicarbonate of soda to which is added 10 to 15 per cent. of borax and 5 per cent. of precipitated silica. Ordinary table salt may also be used.

Ques. When and how should the cast iron flux be used?

Ans. Only when the metal does not run freely, and then only sparingly.

Ques. What is the effect of too much cast iron flux?

Ans. It causes the metal to harden so that it cannot be drilled or machined.

Steel.—Borax, boracic acid, sodium chloride (salt).

Ques. When should the steel flux be used.

Ans. Only when the metal will not run.

Mild Steel and Wrought Iron.—Same as for steel, used sparingly or not at all.

Copper, Brass, and Bronze.—Same as above. When used for brass make a paste with a little water.

Aluminum.—Flux consists of: 15% lithium chloride; 45% potassium; 30% sodium; 7% potassium fluoride; 3% bisulphate of potassium. Another flux for aluminum is plain borax.

Various Welds.—There are many ways in which the joint between two pieces to be welded can be made, and the selection of the method to be used is made with reference to the use of the finished object, the strains it is to resist, and the equipment for making the weld.

The following are the principal kinds of weld, and are described under the accompanying cuts. These are classified according to the way the ends are formed prior to making the weld, as

1. Scarf weld;
2. Butt weld;
3. Lap weld;

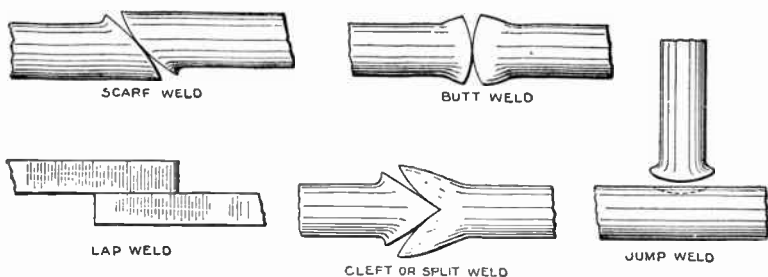

FIGS. 4,478 to 4,482.—Various welds. Fig. 4,478, *scarf weld*. In this weld the two pieces are chamfered, that is beveled. If the iron be of uniform thickness it is first upset at the point where the weld is to be made to make it a little thicker, then it is scarfed. To scarf, the upset end is thinned down, generally with the peen of the hammer, drawing it out thin at the point and crowding the metal together at the stick. The faces to be welded are given a crown shape to facilitate squeezing out of the slag as the weld is closed. Fig. 4,479, *butt weld*. This is an *end to end weld*. Usually the two pieces are upset a little at first, and then ends welded together. They are hammered on end to bring them together, and as this tends to upset the pieces some more, they are drawn out to the required size after the weld has been made. In preparing the ends, the surfaces to be welded are made convex as in the scarf weld, in order to allow the slag to work out. Fig. 4,480, *lap weld*: a weld in which the faces of the two pieces overlap. When the faces are not crowned or rounded care should be taken to begin hammering at the center and work outward to force out all the slag. Fig. 4,481, *cleft or split weld*: a "tongue and groove" form of weld. One of the pieces after upsetting on the end to gain width, is split in the center making a V shaped groove; the other piece is chamfered on both sides bringing it to a point to form a V tongue to fit the groove. In welding the two pieces they are "stuck" together by hammering on the end, and then on the sides of the groove piece to close the weld. The V groove should not have straight sides but slightly rounded as shown so that the slag may be forced out in closing the weld. Fig. 4,482, *jump weld*. A weld formed by bringing the ends of a bar together and jumping them upon the anvil, or with a heavy hammer.

4. Cleft or split weld.
5. Jump weld;
6. Glut weld.

In addition to these there are two processes, known as

1. Fagoting;
2. Building up.

It will be noticed from the illustration of the various weld that *the surfaces are in most cases rounded or curved*. This is done so that when the heated ends are brought together they will unite first in the center. Any slag or dirt which may have adhered to the heated surfaces *will then be forced out as the welding proceeds from the center outward*.

When making a lap weld, the hammering should begin at the center in order to work all the slag out, as the faces in this case are not rounded.

Ques. What is fagoting?

Ans. This operation consists in assembling a quantity of



FIG. 4,483. *Glut weld. A weld in which the ends of the two parts are tapered down, and the angles filled with wedges of iron, the whole being welded together while checking the length with a trammel, excess material being subsequently cut away. This type of weld is generally used in repair work where it is necessary to maintain unchanged the length of the broken part.*

iron junk such as old bolts, pieces of chain, turnings, and other scrap iron, and forging the mass into a billet or slab.

The various articles after being carefully assembled into a firm rectangular pile, usually built up on a flat iron base, is heated in a furnace and then welded under a steam hammer.

Ques. What is "building up"?

Ans. The process of making a multi-piece forging.

That is, a forging built up out of several pieces forged to the approximate shape, and then welded together.

Forge Fuels.—Several kinds of fuel, such as, charcoal, coal, coke, and gas are used for heating metal in welding. Perhaps

bituminous coal is mostly used, though for general work coke is considered the best.

Ques. What kind of bituminous coal or coke is most desirable?

Ans. A grade containing the least percentage of sulphur.

The effect of sulphur is to make iron brittle while hot.

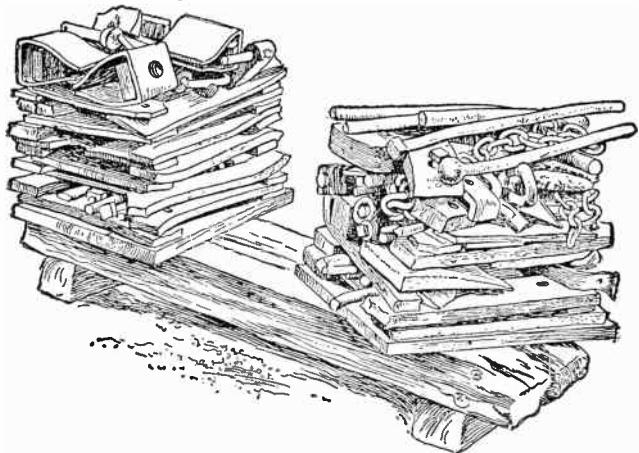

FIG. 4,484.—Fagoting. When a quantity of wrought iron in small pieces, such as scrap iron, turnings, etc., is welded up into a slab or billet, the operation is called *fagoting*. For this, a flat piece of iron, generally fagoted up of small pieces, is laid on a board and the pieces of scrap iron piled on top of this, making a firm rectangular pile with large pieces around the outside and small pieces in the center, or the flat piece on the board may be omitted. It is then heated in a furnace and welded under a steam or a machine hammer.

Ques. What difficulty is encountered with anthracite coal?

Ans. There is trouble in getting a hot enough fire, especially on a small forge.

Ques. What substances should not be in the fuel or fire?

Ans. Lead, sulphur, brass or bronze.

Systems of Welding.—Welding is and has long been a matter of great practical importance, chiefly in the manufacture of iron and steel, and of the various tools, utensils and implements of those metals. Iron has the valuable property of continuing in a kind of pasty condition through quite a wide range of temperature, below its melting point, and this is a circumstance highly favorable to the process of welding. Most metals,

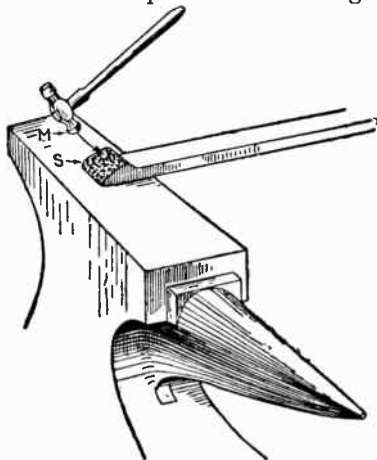

FIG. 4,485.—Making a scarf for a scarf weld. To do this, the upset end is thinned down, generally with the peen of the hammer, drawing it out thin at the point and crowding the metal together at the stock by drawing the hammer as shown at M. The faces to be welded should be rounded as shown at S, so that the pieces first come in contact at the center, in order to give the slag and impurities an opportunity to squeeze out as the weld is being closed.

however, pass quickly, when sufficiently heated, from a solid to a liquid condition, and with such welding is more difficult.

The term welding is more generally used when the junction of the pieces is effected without the actual fusing point of the metal having been reached. Sheets of lead have sometimes been united together by fusing the metal with a blow pipe along the two edges in contact with each other, and this has been called autogenous soldering, or burning if the heating were done with a hot iron.

According to Percy, "the difference between welding and autogenous soldering is only one of degree. The term welding is also used in speaking of the uniting of articles not metallic. Most metals when in the form of powder can be consolidated or welded into a perfectly homogeneous mass by sufficient pressure, without the aid of heat. The same is true of various non-metallic substances, such as graphite, coal, and probably many others.

The various systems of welding may be classified:

1. With respect to the method of working, as

1. Hand welding;
2. Machine welding.

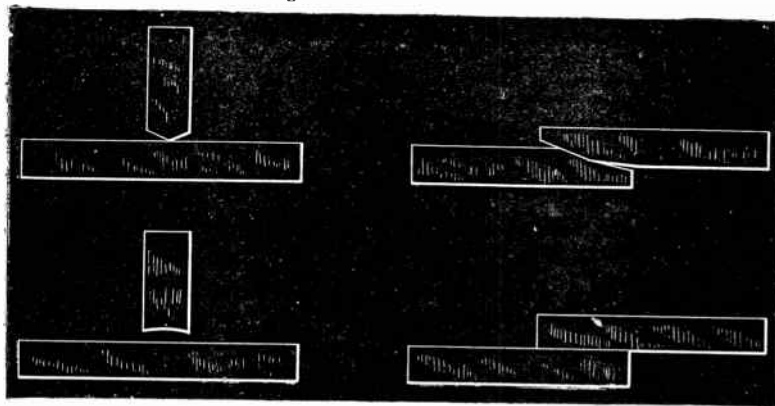

FIGS. 4,486 and 4,487.—Correct shapes for jump and lap welds.

FIG. 4,488 and 4,489.—Incorrect shapes for jump and lap welds.

2. With respect to the treatment of the metal, as

1. By hammering;
2. By fusing (autogenous).

3. With respect to the method of heating, as

1. By forge fire;
2. By blow pipe;
3. By combustible mixture;
4. By *electricity*.

Ques. Define blow pipe welding.

Ans. It consists in uniting the metal pieces by means of a flame of appropriate temperature with the addition of metal of the same composition, the joint thus obtained is called autogenous.

Ques. What is a blow pipe?

Ans. An instrument in which the flames are produced and projected on the metallic parts to be welded.

Ques. What is the character of the flames produced by the blow pipe?

Ans. They are of unusually high temperature.

Ques. What kinds of fuel are used in the blow pipe?

Ans. First oxy-hydrogen was used, then oxy-acetylene, and later, oxygen and coal gas, and oxygen and benzol, etc.

Ques. What is the characteristic of autogenous welding with the blow pipe?

Ans. It looks easy, but isn't, and an inexperienced workman may produce a joint of perfect appearance, though defective under the surface.

Ques. What are the features of the oxy-hydrogen and the oxy-acetylene flames?

Ans. The temperature of the oxy-hydrogen flame is approximately 4,000° Fahr., and the oxy-acetylene flame, 6,300°, giving with the latter flame about five times greater number of B. t. u. per cu. ft., than with the oxy-hydrogen flame.

Ques. How is the oxy-acetylene torch adjusted?

Ans. Before lighting the torch, the regulator on the oxygen tank should be set to give the proper pressure. The average

pressures used are, acetylene, 1 to 8 lbs.; oxygen, 2 to 20 lbs., corresponding to a range of work from $\frac{1}{2}$ " to $1\frac{1}{2}$ " in thicknesses. For greater thicknesses two torches may be used, or preheating of the parts resorted to. The acetylene is lighted first, the regulator being adjusted to the working pressure so that there is a fairly strong flame. The full working pressure of the oxygen is then turned on, after which the pressure is slightly varied by regulation until the two cores which appear in the inner flame at first are merged into one smaller core giving the proper welding flame.

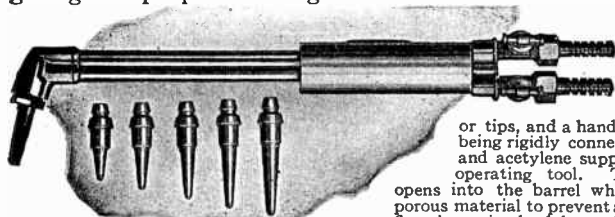

FIG. 4,490.—Davis-Bournonville oxy-acetylene blow-pipe, or "torch." It consists of a head piece for receiving the mixing nozzles

or tips, and a handle or barrel, the two being rigidly connected by the oxygen and acetylene supply pipes to form the operating tool. The acetylene pipe opens into the barrel which is packed with porous material to prevent any possibility of the flame's passing back beyond this point. Inter-

changeable "gas-proportioning and mixing nozzles" of varying capacity are provided, adapting the torch to a large range of work. The mixing of the two gases takes place within these interchangeable tips, each size tip providing a prescribed volume of gases but always in definite proportions which closely approximate the exact theoretical proportions necessary for the combustion reaction, without any excess of either gas, thus providing a neutral flame, or, one to which is fed no excess of either acetylene or oxygen which might change the properties of the metal operated upon. Both gases being admitted to the mixing chamber at appreciable pressure, and at right angles to each other, the maximum of molecular contact of the two gases is secured. The working pressure of both gases are controlled by regulators on the tanks. The type of torch shown, the "positive mixture torch," is for light, medium or heavy welding.

Ques. How is the torch handled in autogenous weld?

Ans. The torch should be given a rotary motion, accompanied by a slight upward and forward movement with each rotation.

This movement assists in blending the metal and reduces the liability of local overheating. It is desirable to keep the metal surrounding the spot operated upon to a fairly high temperature to prevent excessive conduction of heat away from this spot.

Ques. What should be done when fusion occurs?

Ans. New metal should be added from a "weld rod" of suitable composition.

The surface should be thoroughly fused before adding metal from the welding rod, and the latter should be held close to, or in contact with the surface.

Thermit Welding.—This process consists in *pouring super-heated thermit steel around the parts to be united.* This thermit steel is produced by the chemical reaction between finely divided aluminum and iron oxide when ignited. This reaction when started in one spot continues throughout the entire mass, without the supply of heat or power from outside and produces

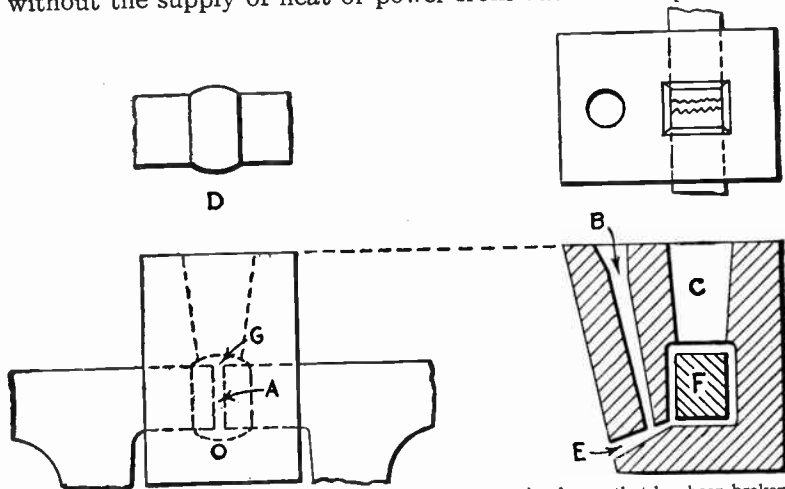

FIGS. 4,491 to 4,493.—Mould for thermit welding of locomotive frame that has been broken between the pedestals at A. The mould surrounding the broken part should be so arranged that the molten thermit will run through a gate to the lowest part of the mould and rise through into a large riser. In the mould here shown the thermit is poured through gate B, and rises into space C, after passing through and between the ends of frame F. The mould must allow for a reinforcing band or collar of thermit steel to be cast around the ends to be welded. Space G, for forming this collar, and the opening between the frame ends must be filled before ramming up the mould. Yellow wax is ordinarily used for this purpose. The shape of this band or collar should be as indicated by the view of the completed weld at D. The thickest part is directly over the fracture and the band overlaps the edges of the break at least one inch. Pattern for the riser, pouring and heating gates can be made of wood. The riser C should be quite large because the steel that first enters the mould is chilled somewhat by coming into contact with the metal, even when pre-heated. This chilling effect is overcome by using enough thermit steel to force the chilled portion up into the riser and replacing it by metal which has practically the full temperature received during reaction. The mould must be of a refractory material owing to the intense heat. When the mould and box are filled and tamped, the wooden runner and riser patterns are withdrawn. The mould is then ready for pre-heating and the drying operation, which causes the wax matrix to melt and run out.

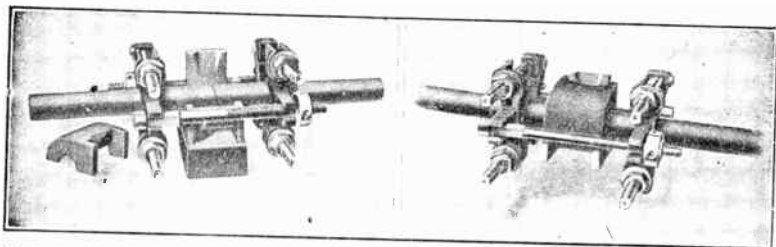

FIGS. 4,492 and 4,493.—Thermite pipe clamps and mould. Fig. 4,492, pipes held in clamps. Mould partly assembled for thermite welding. Fig. 4,493, mould fully assembled ready for weld.

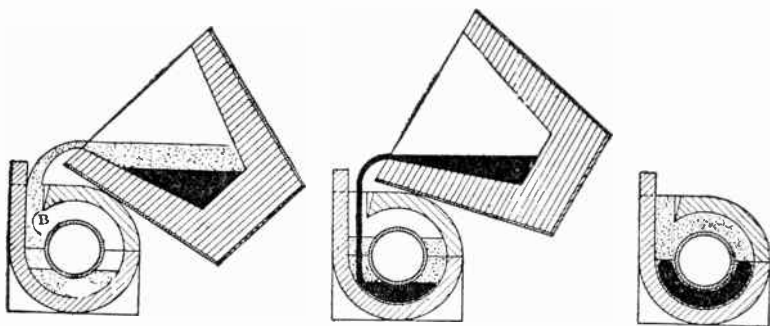

FIGS. 4,494 to 4,496.—Thermite pipe welding operation. Fig. 4,494, slag flowing into mould and coating inside of pipe and inside of mould. Fig. 4,495, slag in mould and steel following, displacing slag in bottom part. Fig. 4,496, both slag and steel in mould but steel separated from pipe and mould by film of slag. In making a butt to butt thermite pipe weld, the pipe ends are first faced very accurately and are then held tightly together by means of clamps. A cast iron mould is then placed around the pipe ends and the proper amount of thermite ignited in a small flat bottom crucible or ladle. As soon as the thermite reaction is over (about $\frac{1}{2}$ minute), the contents of the crucible are poured into the cast iron mould. The liquid alumina or slag which floats on top of the molten mass in the crucible, naturally goes into the mould first and covers the inside of the mould and the outside of the pipes with a protective coating which prevents the superheated liquid steel, which flows in afterwards coming in contact with either. The heat of the entire mass, however, serves to bring the pipe ends up to a welding temperature at which time they are squeezed together by means of the clamps and a butt weld effected. The entire thermite mass can then be knocked away from the pipes and nothing will stick to either the pipe or the mould. A slight upset will be observed on the outside of the welded pipe but the inside diameter is in no way affected. The necessary apparatus, consisting of the pipe facing machine, pipe clamps, crucible and mould are light and portable and can be carried to any point where work is to be done. As no outside power is required, the welding can be executed wherever the pipes are laid. It has been found in practice that two men, one facing the pipe with the pipe facing machine and the other doing the welding, can complete a weld inside of ten minutes and make from 40 to 50 finished pipe welds per day.

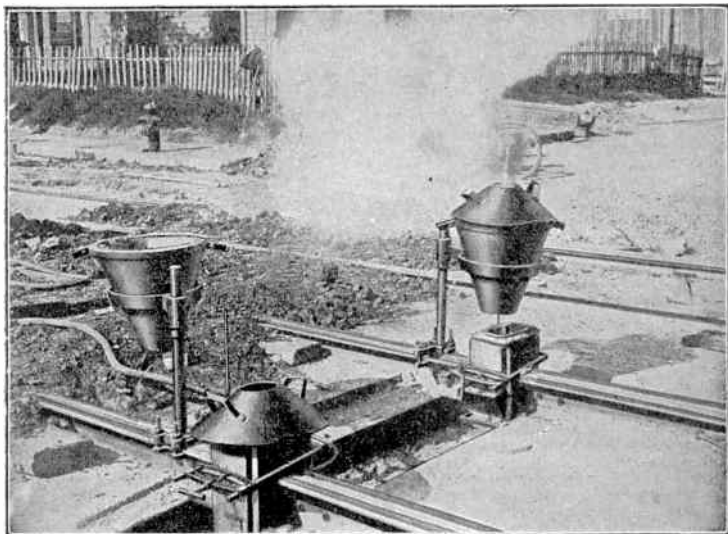

FIG. 4,497.—Open mould and crucible in position for making Clark thermit rail joint. In its original form the Clark joint consisted of a combination of splice bar and thermit steel, it being Mr. Clark's opinion that the head of the rail could be supported by using plates that would come under the ball of the rail. Furthermore, in order to hold the rail rigid, he considered it important that there should be no play in the bolts, so the holes in the plates and rails were drilled round and machine bolts used after reaming for a drive fit. In order to keep the bolts and plates from working loose, and to afford bonding between the rails, a thermit steel shoe was cast around the base. In practice, the rails and splice bars are drilled with holes $\frac{1}{16}$ of an inch less in diameter than the bolt to be used. The splice bar is then applied in the ordinary way and held in place by a couple of temporary bolts, a drift pin being driven into one hole each side of the joint to keep the rails in position. The remaining holes are then reamed with straight end cutting reamers, after which the machined bolts are driven and tightened up in the usual manner. After preheating the rail ends, the thermit steel is run into an open mould surrounding the lower part of the rails. In the latest type of Clark joint, rivets are substituted for the machined bolts, the riveting being accomplished by a pneumatic riveter mounted on a flat car manipulated by means of a small derrick. A modification of the Clark joint has recently been adopted by the United Railways & Electric Co., of Baltimore. The object of the modification was to obtain a larger weld of the base, and in order to do this, the thermit steel was poured into an enclosed mould box instead of into an open mould and the rail ends were preheated to a red heat with the moulds in place before the thermit charge was ignited. Furthermore the design of the fish plates is somewhat changed, being of special design, one inch thick and 32 inches long and so formed as to fit snugly the carbon of the head and base of the rail. At the same time, they provide a minimum amount of space between the web of the rail and the vertical sides of the fish plates. The channel bars and rails are of the same kind of steel (high carbon) and both are punched at the mill with ten $\frac{1}{16}$ inch holes, spaced 3 inch centers and beginning 2 inches from the end of the rail. The joint has been applied thus far exclusively to 7 inch girder groove rail weighing 103 pounds per yard. These 7 inch girder sections are undercut by the manufacturers $\frac{1}{16}$ inch so as to provide a space of $\frac{1}{8}$ inch at the base when the rail ends are butted. This procedure more effectively enables the thermit steel to weld the rail and fish plates into a solid mass at the joints.

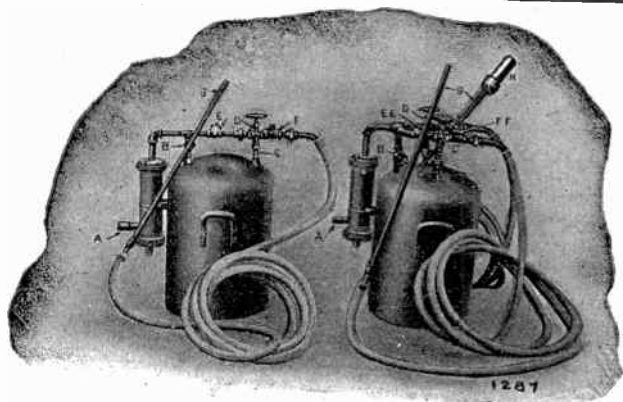

FIG. 4.498.—Thermit preheater. *Directions for operating:* The preheater is connected with compressed air supply at A. The air pressure should be at least 15 lbs. per sq. in., but 50 lbs. or more is recommended. Valve B allows the compressed air to flow into the top of the gasoline tank and places the compressed air to flow into the top of the gasoline tank and places the gasoline contained therein under pressure, driving it up through the pipe C into the needle valve D, which regulates the amount of gasoline to be mixed with the compressed air which flows across by pass E around the needle valve and through the check valve F into the hose and so on to the burner. The gasoline and air become mixed together at the needle valve and also through the passage from D to the burner G. To regulate the torch, use valves D and E, which control the gasoline and the flow of compressed air respectively. In starting the torch, place it in position in front of the heating gate of the mould but about 1 inch away from the mould. Place some oily waste or a flame of some kind at the end of the burner pipe, sufficient to keep the burner lighted until it is satisfactorily regulated. Open the air valve B wide and then open the air valve E from one-half to one full turn according to the air pressure used, and then the gasoline valve D about one-half to three-quarter of a turn, this amount also depending upon the air pressure. The burner will take a few minutes to get properly started because the hose and burner pipe are cold, tending to liquify the gasoline vapor. Gradually as the burner pipe becomes hot the flame will become steady. The burner is lighted more easily if at first an excess of gasoline be used, as the flame becomes more steady this excess should be cut down. Unless the mould be intricate so that a strong flame would tend to break it, the air should be increased after the flame is well started, and then the gasoline increased correspondingly. Too much air will tend to extinguish the flame. Too much gasoline will result in liquid gasoline dripping from the end of the burner pipe. If wax has been used as a pattern it should of course have been provided with a vent connecting the heating gate with the riser. Shortly after the burner is started this wax will melt out, running out of the heating gate and coming from the riser in the form of a heavy white vapor. This heavy white vapor should be ignited at the top of the riser and pouring gate to eliminate the fumes from the room and the burner removed from time to time to allow the liquid wax to run out. If the mixture be right there should be no flame at the end of the burner pipe when it is taken away from the mould. If there should be a flame at the burner pipe the air valve and probably the gasoline valve should be opened wider. After the wax is burned out small sheet iron plates should be placed over the riser and over the pouring gates to hold the heat in the mould. If one part heat more rapidly than another, the heat should be regulated by means of these plates, and by shifting the burner pipe in, out and sideways. Toward the end of the preheating, place the burner in the riser and in the pouring gate so that any loose sand may be blown out through the heating gate. In stopping the burner turn off the gasoline valves D and B completely, but leave the air valve E turned on or perhaps open it wider to blow all gasoline vapor out of the burner pipe. Drain the water out of the water separator from kerosene and to gasoline. All the above applies equally well to

superheated liquid steel and superheated liquid slag (aluminum oxide) at a temperature of approximately 5,400° Fahr. From 30 seconds to one minute is sufficient time to bring into reaction almost any amount of thermit. The thermit steel when poured into a mould surrounding the ends of the sections to be united dissolves the metal with which it comes in contact and amalgamates with it to form a single homogeneous mass when cooled. It is necessary, however, in all cases to preheat the sections



FIGS. 4,499 and 4,500.—C and C electric arc welding apparatus. Fig. 4,499, operator with one type of head shield and combination electrode holder for both metallic and graphite electrodes. Fig. 4,500, graphite electrode holder and hand shield.

before pouring the thermit steel, as otherwise they would exert a chilling effect on the incoming metal and prevent successful fusion.

The essential steps of the operation, therefore, are to clean the sections, and remove enough metal to allow for a free flow of thermit steel, then surround them with a mould, preheat by means of a gasoline torch, ignite the thermit in the crucible suspended over the pouring gate of the mould, and then pour the thermit steel.

Ques. What is the average composition of thermit steel?

Ans. Carbon, .05 to .1; manganese, .08 to .1; silicium, .09 to .2; sulphur, .03 to .04; phosphorus, .04 to .05; aluminum, .07 to .18.

Electric Welding.—By the electric process, all metals and alloys can be welded, and dissimilar metals and alloys united, because the temperature can be maintained or increased while the weld is being made. An ordinary forge fire, involving as it does, the possible inclusion of dirt, irregular heating, difficulty of inspection and control of heat, cannot comply with the best conditions of welding which are:



Fig. 4,501.—Operator using C and C electric arc welding metallic electrode. The electrode itself is melted and supplies the extra metal necessary for welding or building up.

1. The impossibility of introducing foreign matter into the weld.
2. Uniform heating of the area to be welded.
3. Continuous inspection during the process of heating.
4. Early and complete regulation of the heat.

All systems of electric welding are based upon the principle of causing a current of electricity to pass through a high

resistance, thereby generating heat. There are, however, important differences in the manner in which the heat so generated is applied to the welding of metals.

The amount of work done in a given time to force a current through a resistance is

$$\text{watts} = \text{amperes} \times \text{volts}$$

and since by Ohm's law, volts = amperes \times ohms,

$$\text{watts} = \text{amperes}^2 \times \text{ohms}$$

or expressed in the usual symbols

$$W = I^2R$$

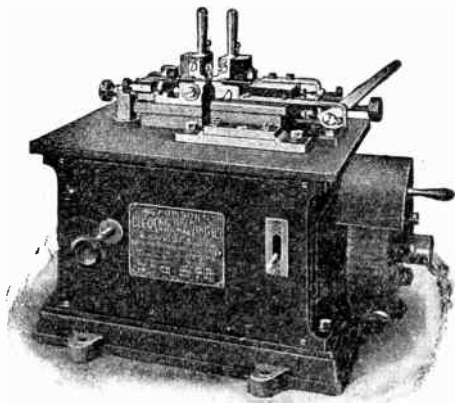
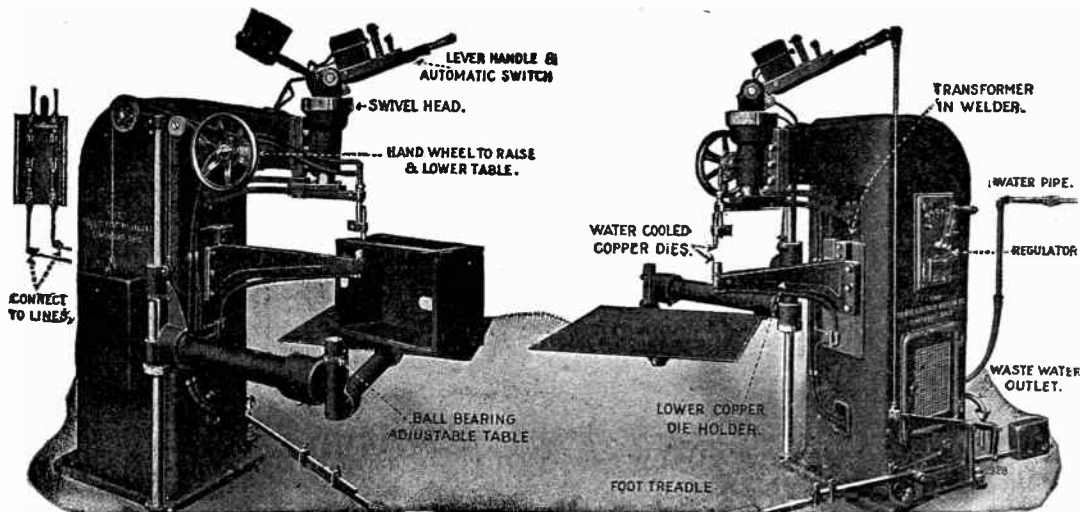

FIG. 4,502.—Thomson welder. Portable, pressure and cut out, mercury slide, with regulator and automatic break switch. Copper wire No. 23 to No. 15. Power 1.5 kw. Time, fraction of second. To operate, move lever at right to position shown; hold back levers at center and insert wire; return lever at right to opposite position; press button and the weld is made.

which shows that in order to obtain a considerable heating effect by means of electricity, it is only necessary to send a large current through a conductor of high resistance.

NOTE.—Prof. Elihu Thomson, in 1877, at the Franklin Institute, Philadelphia, while experimenting with induction coils caused the discharge of a Leyden battery to pass through the fine wire coil, which thus became a high pressure primary, while at the same time the ends of the coarse wire coil were brought into light contact. He noticed that these ends were partially welded together, so that it took some little force to separate them. His invention of electric welding was accordingly the outgrowth of this early observation. In 1881, when it was impossible to obtain copper wire in long lengths for dynamo fields, which necessitated the making of frequent joints in a heavy coil, Prof. Thomson discussed the possibility of electrically welding these wires, and in 1885 he constructed a practical electric welding machine for welding small sections of wire and tools. The various methods of electrical welding are here briefly described.



FIGS. 4,503 and 4,504.—Views of Toledo spot welder showing parts. Two wires run to the machine from the source of supply. Connect these to the wires from the welder marked "line." A half-inch water pipe connected to the city water is ample for cooling.

SIZE WIRE TO USE WHEN WELDER IS NOT MORE THAN 150 FEET FROM SOURCE OF POWER

Kw. capacity	Kva. capacity	110 Volt			220 Volt			440 Volt			Standard dynamo to operate welder	Motor generator set to operate welder	
		Wire No.	Fuses amp.	Switch amp.	Wire No.	Fuses amp.	Switch amp.	Wire No.	Fuses amp.	Switch amp.		H.P. of D. C. motor	A.C. dynamo
5	7.5	6	60	60	8	30	30	10	15	15	7.5 K.V.A.	7.5	7.5 K.V.A.
10	15	2	150	150	6	75	75	8	40	50	15 "	15	15 "
15	20	0	200	200	4	100	100	6	50	50	20 "	20	20 "
20	30	000	300	300	2	150	150	6	75	75	30 "	30	30 "
35	50	00	250	250	2	125	125	50 "	50	50 "

The above is safe carrying capacity for intermittent service, where current is never on more than two to three seconds.

Thomson Process.—This method, invented by Elihu Thomson, appears to be capable of being employed with a variety of metal on a very extensive scale. A current of electricity heats the abutting ends of the two objects which are to be welded, these being pressed together by mechanical force, and so arranged with the electric current that there is great and rapid accumulation of heat at the joint, in consequence of the greater relative conductivity of the rest of the circuit. This method of welding in some cases partakes of the nature of autogenous soldering, the pieces of metal being actually fused while uniting;

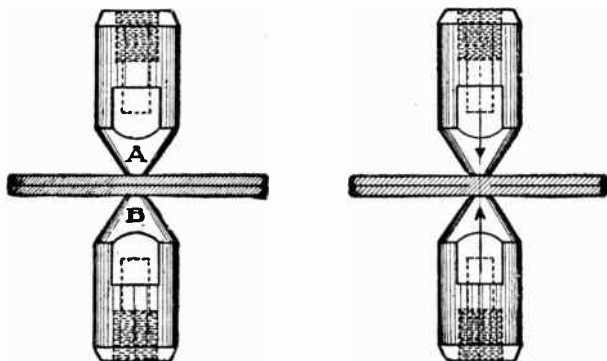

Figs. 4,505 and 4,506.—*Spot welding.*—This is the process of joining or fusing together electrically two or more metal sheets or parts without any preparation of stock. Mechanically it is equivalent to riveting, but it is stronger and can be done much more quickly and economically. The principle of spot welding is simple. Two electrodes, or welding points, A and B, fig. 4,505, are brought to bear on the plates where it is desired to make the weld and a heavy current at a low electrical pressure is passed through the electrodes. The metal plates, as they are much poorer conductors of electricity, offer so great a resistance to the flow of current that they heat to a molten state, and then, by applying pressure on the electrodes, the metals are forced together and the weld is made, as shown in fig. 4,506. **Current.** Single phase, alternating current must be used in electric welding. Where two or three phase current is furnished power must be taken from one phase of the poly-phase system. As pressure is reduced in machines by a transformer to a very low voltage, there is no possibility of the operator receiving a shock. **Weldable materials.** Wrought iron and steel are the best materials for electric welding. Rust, scale and dry paint act as insulators and should be removed from steel before welding so that the current may flow freely. **Grinding or sand blasting** is recommended for this purpose, as pickling causes material to rust very quickly on exposure to the air. Galvanized iron can be welded but the coating must be burned off first, making the operation a trifle slower than with plain sheets. Copper, brass, bronze and aluminum are usually unsatisfactory materials for welding as they are such good conductors of electricity they offer practically no resistance to the flow of current.

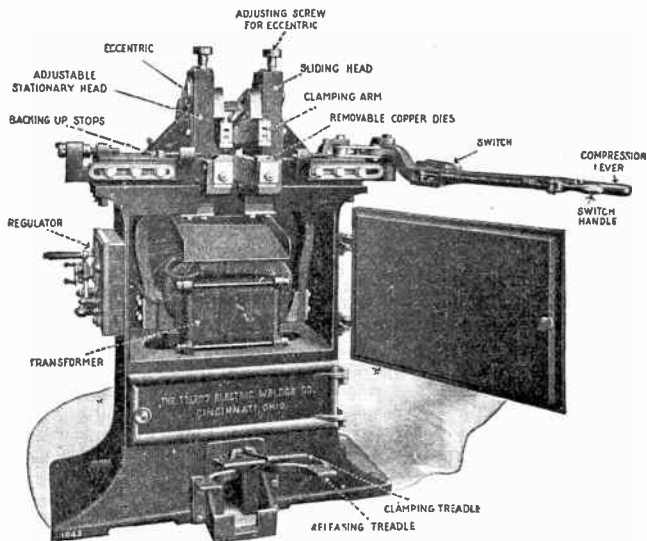
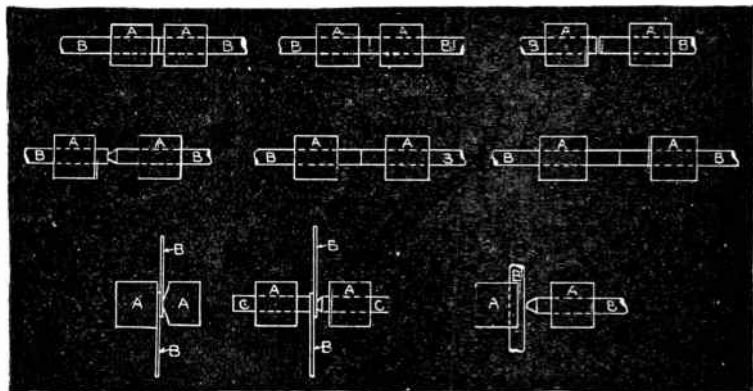

FIG. 4.507.—Toledo butt welder; view showing different parts. There are no auxiliary devices required when installing a welder, except the switch, fuses and water supply. Two wires run to the machine from the source of supply. Connect these to the wires from the welder marked "line." The switch to cut off the current when the machine is not in use and the fuses are usually mounted on the wall. A half-inch water pipe connected to the city water mains will afford an ample supply of water under all conditions. **Instructions for operating:** 1. Set the welder on either a wood or cement foundation and fasten down by lag screws or bolts. If set on wood foundation, the machine should be grounded by connecting a small copper wire from frame of machine to a water or gas pipe. 2. The wiring to the machine should be arranged with fuses and a double pole, single throw switch. 3. The transformer furnished with the machine is located in the base and is used to transform the current from the source of supply (either a dynamo or transformer) to the three to five volts used in the welding operation. The primary coils are connected to the double pole switch at the side of the machine. 4. Rubber tubing is furnished to connect the machine to city water supply and through the dies to the sewer. A globe valve should be inserted ahead of the welder to regulate the flow of water; just enough to keep the dies from becoming excessively heated. The amount of water required for this purpose is small and a ½ inch feed pipe to the welder will be ample. 5. After connecting the machine and water connections, the machine is ready to operate. Set the regulator handle to the extreme left hand side or No. 1, and the double pole, double throw switch to the left. Place two pieces to be welded in the copper dies, which are set from ¼ in. to 1 in. apart, according to the size stock to be welded. Let the ends of the stock touch each other; then turn on the current by means of the switch. If the stock do not heat rapidly enough, turn regulator handle to the right, or No. 2; if not enough heat be obtained at this point, keep on until point No. 5 is reached. If enough heat be not obtained, throw the double pole switch to the right and the lever handle to No. 1. The maximum current is obtained when the regulator is at the right, or at point No. 5, with the switch in the right hand position. A little experimenting will give the correct heat necessary for getting the best results. Copper, brass, tool steel and all other metals that are deteriorated by high temperatures must be heated quickly and pressed together with sufficient force to push out all the burnt metal from the weld. On flash or upset welding of iron or steel, not more than once the diameter of stock is taken up in the weld. For example, in welding two pieces of ½ in. round stock, not more than ¼ in. of each piece is taken up by the weld, or a total of ½ in.



FIGS. 4,508 to 4,516.—General hints on electric welding. **Cast iron** cannot be commercially welded, as it is high in carbon and silicon, and passes suddenly from a crystalline to a fluid condition when brought up to the welding temperature. **Iron or steel.** It is necessary to keep the temperature below the melting point to avoid injury to the metal, and consequently considerable pressure is required to make the weld. The stock should be placed in the dies as shown in fig. 4,508 for a flash weld, and as shown in fig. 4,509 for an upset weld, A representing the dies, and B, the stock to be welded. **High carbon steel** can be welded, but must be annealed after welding to overcome the strains set up by the heat being applied locally at one place. Good commercial results are hard to obtain when the carbon runs as high as point 75 or above, and can only be done by an experienced operator. When below point 25, the operator can always be sure of making a good weld. To weld high carbon steel to low carbon steel, the stock should be clamped in the dies as shown in fig. 4,510, with the low carbon stock extending considerably further out from the dies than the high carbon stock. **Nickel steel.** This welds readily, and a small percentage of nickel materially increases the tensile strength of the metal. **Iron to copper.** These metals can be welded to each other, but it will be found necessary to reduce the cross section of the copper as shown in fig. 4,511. **Copper and brass.** When welding copper and brass the pressure must be less than when welding iron. The metal is allowed to actually fuse or melt at the juncture, and the pressure should only be sufficient to force out the burnt metal. This burnt portion being forced out, accounts for the good results obtained in welding these metals. The current must be cut off the instant the ends of the metal begin to soften. This is done by using an automatic switch which opens at any predetermined point. The sliding head is actuated by either a spring or weight to force the heads together as soon as the metal softens, and this automatically operates the switch. As copper and brass are good conductors of the electric current, a larger volume of current at lower secondary voltage is used and the sliding heads are arranged to move with the least possible friction. The dies should be set apart approximately three times the diameter of the stock for brass and four for copper. See figs 4,512 and 4,513. A represents the dies, and B, the stock to be welded. The welds when properly made will stand the strain of the rolling or drawing process to reduce them to a smaller size. **Spot welding.** To weld two pieces of sheet steel at one small place or spot is called spot welding. For convenience of handling the stock this is usually done in a machine with vertical clamping dies. Where the size and shape of the pieces to be welded will admit, the work can be done in a butt welder equally as well. In this case one of the dies is slightly pointed and the stock welded between the dies as shown in fig. 4,514. Another way is shown by fig. 4,515, where two pieces of copper rod C, one of them slightly pointed, are clamped in the dies A. If galvanized iron is to be welded it will be found necessary to use two pointed dies instead of one flat and one pointed. **Jump welding.** This is for light stock only and the best results are obtained by slightly pointing one of the pieces as shown in fig. 4,516. The other piece is held with a portion extending outside the die, then bring them together, turn on the current and weld quickly.

in other cases, as with iron, nickel, or platinum, the union may take place without fusion, as in ordinary welding.

In electric welding the intensity of the pressure which forces the metallic surfaces together depends on the kind of metal being welded. Copper, brass, tool steel and all other metals that are deteriorated by high temperatures must be heated quickly and pressed together with sufficient force to push out all the burnt metal from the weld. In case of large articles, hydraulic pressure can be used to force their surfaces into contact with each other.



Figs. 4,517 and 4,518.—Flash weld, and upset weld. *A flash weld* is generally used on stock that is wide and thin; where it is rectangular in shape, and where it is not possible to have the welding faces cut square and true. Also in welding tubing to forgings, or tubing to tubing. In all cases where a small amount of stock is to be taken up in welds, or when it is desired to shear or grind off the fin, a flash weld is made. *Upset welding* is used in all cases where the weld is to be hammered, using the heat generated in the welding. Also for small rods or rings where it is not necessary to have a uniform thickness of stock. On brass or copper a flash weld is made. Three times the diameter of stock between the dies should be allowed on brass and four times on copper, but only once the diameter of stock is actually taken up in the weld.

Zerner or Electric Blow Pipe Process—In this method, *an electric arc is drawn between two carbon electrodes*. This arc is then caused to impinge upon the metal surfaces to be welded by means of an electromagnet. The arc is pointed to concentrate the heat, and the metal is fused around its point of contact with the arc. This method is applicable to a rather limited range of small work, such as welding small steel and brass castings, plates, tubes, tanks, etc.

Bernados Process.—*The metal to be welded is connected to one pole of an electric circuit.* When iron or steel is being welded, for which a high temperature is needed, the metal is made the positive and the carbon the negative. In the case of lead, or any metal requiring a comparatively low temperature, this polarity is reversed.

The supply of current is generally furnished by a dynamo, and a series regulating resistance is used for steadying the arc and adjusting the amount of current. This process is of very considerable value in the filling up of blow holes, cracks, etc., in steel castings.

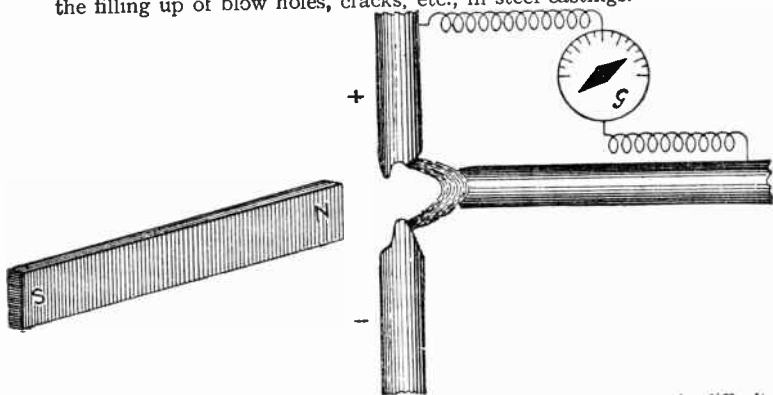
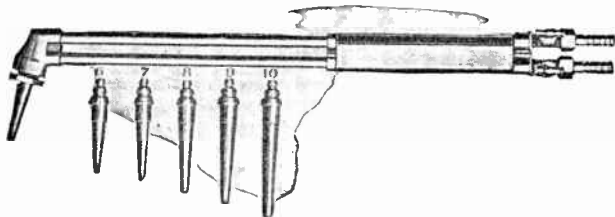

FIG. 4,519.—Diagram illustrating the electric blow pipe. In order to overcome the difficulty in the Bernados process of the extreme concentration of heat in the portion of the metal which forms one pole of the arc, apparatus has been devised by Werdmann, Zerener, and others, in which phenomenon of the magnetic blow pipe is practically applied. It is well known that *when a magnet or electromagnet is brought near an electric arc, the latter is deflected in trying to set itself in a direction at right angles to its length and to the magnetic lines of force*, as shown in the diagram. The apparatus usually consists of two carbon rods, to each of which one pole of the electric circuit is connected, and an electromagnet energized by a shunt current is suspended over the arc. When the current is turned on a strong magnetic field is formed which produces a blow lamp effect on the arc, and by placing the article to be welded or brazed at varying distances from this flame, the heat can be regulated. The various sizes of lamp of the Zerener type require from 25 to 75 amperes or more, at about 70 volts. The Coffin type of lamp consists of two eccentric carbons attached to a suitable handle. Between the two is the iron core of an electromagnet, the winding of which is connected in series with the arc. This apparatus is another form of the electric blow pipe. A different type of electric blow pipe apparatus is that devised by De Tunzelmann. In this there is no magnet or electromagnet, but the two carbon rods are held in a frame nearly at right angles to one another. The feed of the carbons is adjustable, and special carbons are used containing a percentage of metallic oxide. A long arc in the form of a horizontal flame is easily maintained. This apparatus is particularly useful for brazing, and for the welding of thin steel strip. Various sizes of the apparatus are made for currents varying from 25 amperes to 400 amperes or more, at about 55 to 70 volts.

The carbon, which is held in a suitable holder, with hand shield, is placed in contact with the metal and withdrawn a short distance, the arc following and being maintained generally from $\frac{3}{4}$ to $1\frac{1}{2}$ inches in length. By withdrawing the carbon from the work the current ceases. The arc is moved about until the whole surface on which it plays becomes molten, and where necessary additional metal in the form of rod or small pieces is melted in.

Some excellent work has also been done by this process in the way of making longitudinal seams in boats and barrels of thin plate steel. Small pieces of steel scrap are laid over the abutting edges, and by means of the arc are raised to a welding temperature. It is usual to complete the work by hammering.

Another considerable application is the making of a joint by simply fusing the two edges together. An example of this is the dished end of steel barrels. A further important application has been in the welding on of flanges to steam pipes, the manufacture of special tube fittings.



FIGS. 4,520 to 4,525.—Davis-Bournonville long style C welding torch. It is designed for medium and heavy welding, for boiler repairs and for general shop work requiring a strong, rugged torch. Weight, 2 lbs. Length, over-all, 20 inches. Fitted with five tips, Nos. 6, 7, 8, 9, 10, using oxygen pressures of 12, 14, 16, 18, 20 lbs. respectively. This torch is used on metal from $\frac{1}{4}$ " thick upward.

such as tees, elbows, sockets and bends, and in making large pipes out of steel by welding the longitudinal seam.

The *Bernardos* process is of much value in the repair of castings, as it often enables valuable castings which have some small defect to be made quite sound, thereby saving the whole of the cost of labor expended on them. Generators employed for this system are usually compound wound, having a pressure of from 70 to 85 volts.

Slavianoff or Modified Bernardos Process.—In this method, *an electrode which is of the same material as the metal to be welded is used instead of a carbon electrode.*—This change is made so as to prevent the hard welds which sometimes result with the Bernardos or Zerener processes, owing, principally, to the transfer

of carbon from the electrode to the weld. A direct current of about 130 amperes and 24 to 26 volts across the arc is adapted for this process.

The arc is not a long one, as in the Bernardos process, the length being only about $\frac{1}{8}$ or $\frac{3}{16}$ inch. This process is not as rapid as the Bernardos, but, if subsequent machinery be required or the material be thin, it is the better method.

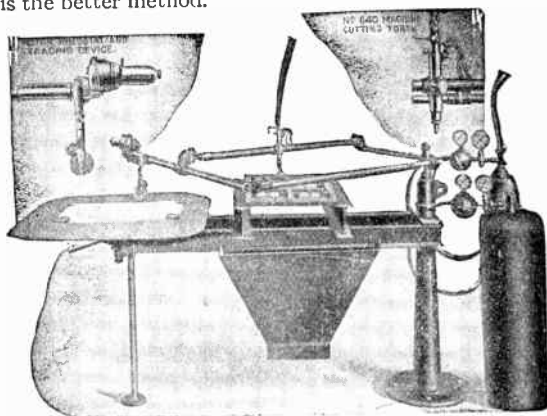

FIGS. 4,526 to 4,528.—Davis-Bournonville oxygraph; fig. 4,526, a motor rheostat and tracing device; fig. 4,527, cutting torch; fig. 4,528, oxygraph. This machine will cut steel up to six inches in thickness, at the rate of three to twelve inches per minute, a larger size cutting up to 18" in thickness, and another modification, for circle or straight line cutting only, taking in armor plate up to 24" thick. It has an electrically propelled rolling tracer, which is guided along the lines of a drawing, and the cutting flame will make an exact reproduction in one machine of one-half the dimensions, in another of the exact size of drawing. Steel can be cleanly and smoothly cut at short angles and of any irregular shape. The machine is desirable for die makers, blanking out connecting rods, crank shafts, etc. The motor can be connected to a lighting circuit or to a battery. The automatic un-interrupted feed adapts the machine to quantity work, and to all work where accuracy, as well as smoothness of cutting surfaces, or roughing out close to the required finished surface are essential.

Hoho and Lagrange Process.—The apparatus used usually consists of a lead-lined wooden tank, filled with an electrolyte of any conducting liquid solution, either alkaline or acid.

The positive pole of a dynamo, giving usually about 200 volts, is connected directly to the inner leaden sheath. The bar of steel or other metal to be heated, is connected to the negative pole and plunged into the bath.

Directly the bar touches the liquid, electrolysis is set up and the water splits up into its component parts, the oxygen going to the leaden sheath and the hydrogen clinging to the metal, forming a complete gaseous envelope around it, and thus preventing the metal actually touching the solution. Here again, a high resistance to the flow of current is offered by the hydrogen sheath, and the electric energy is transformed into heat.

It is difficult with this process to control the temperature, but some practical applications have been made, one of the most successful being the annealing of wire by passing it rapidly through the solution.

A modification of the system consists in replacing the liquid by powdered carbon or charcoal, the article to be heated forming one pole, and the carbon, the other pole. When the article touches, or is inserted in the powdered carbon, the resistance of the latter and its poor contact with the metal generate heat which is conducted to the object.

CHAPTER LXXXV

ELECTROLYSIS

This term signifies the decomposition of a chemical compound in solution, called the *electrolyte*, into its constituent elements, called *ions*, by the passage of an electric current through it.

There are two kinds of ions: 1. The electro-positive ions called *cations* and, 2. The electro-negative ions called *anions*.

The former appear at the cathode and the latter at the anode. The current may be regarded as being carried through the electrolyte by the ions; since an ion is capable of carrying a fixed charge only of + or - electricity, any increase in the current strength necessitates an increase in the number of ions.

An experiment illustrating electrolysis is shown in fig. 4,529. The electrolytic treatment of copper is one of the most important electro-metallurgical processes. Copper thus obtained possesses a purity unattainable by any other means. The electrolytic cell used for this purpose is known as a *copper bath*.

Industrial Electrolysis.—A few applications of electrolysis in various manufacturing enterprises is here given briefly, yet with sufficient detail to give a clear understanding of the principles underlying the use of electricity or electrolysis in the following industries: Alkali and bleach; aluminum; bullion refining, chlorates; hypochlorites, ozone, organic chemicals; oxygen and hydrogen; sodium and potassium; also the wet methods for extracting copper, nickel, tin, and zinc.

Alkali and Bleach.—The term alkali denotes, in the chemical industry, sodium or potassium hydrate or carbonate, while bleach denotes hypochlorite of lime.

When an electric current is passed through a solution of sodium chloride in water, using electrodes which are not attacked by the chloride or by free chlorine, the chloride is split up into its constituent parts, the metal sodium is separated at the cathode, while the gas chlorine

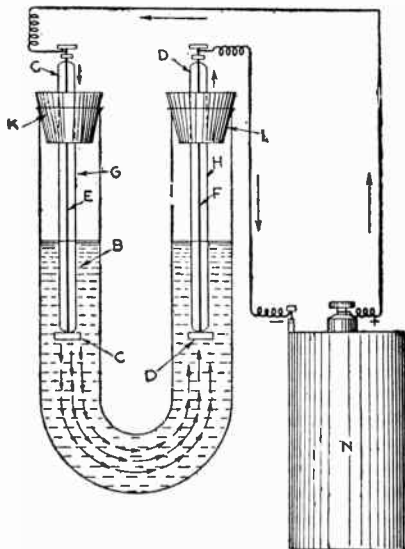

FIG. 4,529.—Electrolysis of copper. Fill the U shaped glass tube shown above, with a solution B, made by dissolving some crystals of copper sulphate or bluestone. Immerse in the solution two platinum electrodes C and D, attached to the copper wires E and F, sealed in the glass tube G and H, which are held in the tube openings by loosely fitting rubber corks K and L. Attach the positive pole of the battery N, to the terminal of the electrode C, and the negative pole of the battery to the upper terminal of the electrode D. The electric current from the battery will then pass through the platinum anode C, through the copper sulphate electrolyte B, to the platinum cathode D, thence to the negative terminal of the battery. The passage of the current through the electrolyte will result in the liberation of the constituent ions of the latter, oxygen gas being liberated at the anode C, metallic copper deposited on the cathode D, and the copper sulphate solution B, changed to sulphuric acid. Allow this action to continue until all the copper has been taken from the electrolyte and deposited on the cathode, completely plating the latter with metallic copper, then reverse the current through the electrolyte by changing the connections at the battery terminals. The copper plated cathode D, will now become a copper anode, with the platinum plate C, for a cathode, and electrolytic action of the current will return the copper deposit on D to the electrolyte, and transfer it to the surface of the platinum plate C.

forms in minute bubbles at the surface of the anode and rises to the surface of the liquid in the cell.

The metal sodium, however, has a great affinity for the hydroxyl constituent of water, and it at once enters into union with this, and produces sodium hydrate and hydrogen gas at the surface of the cathode. These changes are the basis of all the patented processes and cells for the production of alkalis and chlorine products by electrolysis. Both chlorine gas and sodium hydrate are, however, very active chemicals, and the various electrolytic cells and processes for their production differ considerably in the details of cell construction and in the means taken to prevent the sodium hydrate formed at the cathode and the chlorine formed at the anode, entering into further reactions within the cell, or from sharing in the electrolysis in the place of the sodium chloride which it is desired to split up.

Aluminum.—This is the lightest metal known, with the exception of magnesium, and until the year 1891, pure aluminum was produced entirely by chemical and metallurgical methods.

The process of aluminum manufacture consists in the electrolysis of a fused mixture of the fluorides of sodium, calcium and aluminum, in which alumina (aluminum oxide) is dissolved. When an electric current is passed through such a mixture of fused salt, using carbon electrodes, aluminum separates as drops of molten metal at the cathode, while oxygen is liberated at the anode and at once unites with it to form carbonic acid gas. The bath is kept in the fused state by the heating action of the current. The action taking place in the electrolytic bath is therefore, virtually, a reduction of the alumina or aluminum oxide by the carbon of the anode; but this reduction would be impossible without the aid of the current to first separate the oxygen and aluminum, which have great affinity one for the other.

The aluminum separated at the cathode is in the molten state and falls to the bottom of the bath, and it is allowed to collect there, being removed at stated intervals, either by a syphon or by tilting. Fresh alumina is fed into the bath at short intervals to replace that which has been decomposed by the current; and the process is, therefore, a continuous one.

The fused salts employed to dissolve the alumina do not undergo any change; but care must be given to the purity of these and of the alumina used for feeding into the bath, in order to obtain high grade aluminum by this process of manufacture, silicon and iron being the most troublesome impurities.

Bullion Refining.—In the extraction of gold and silver from their ores, and from old articles of plate and jewelry, the

precious metals are generally obtained alloyed with one another, and with copper as an impurity. The technical name for this product is "bullion."

The general principle of electrolytic bullion refining is to use the alloy of precious metals, or bullion, as an anode in an electrolyte which dissolves only one of the two metals to be separated, and to use a sheet of the pure metal that is being deposited, as cathode.

For silver deposition an acid solution of nitrate is employed as the electrolyte (the Moebius process), while for gold an acid solution of gold chloride is found to yield the best results (the Wohlwill process). In the former case, gold and lead remain undissolved, and collect as



FIG. 4,530.—Electrolysis in lower New York. The figure illustrates current movements as discovered. The power house is located near the navy yard in Brooklyn. A portion of the returning currents, as shown by arrows, flows over the New York and Brooklyn bridge to Manhattan, thence north to Williamsburg bridge via underground mains, subway structures, and other metals, and passes over that bridge back to Brooklyn, thence through mains to rails and negatives, to power house. In this case damage may be expected at three points: 1, where currents leave bridge metals on the Manhattan side; 2, where they leave pipes to enter Williamsburg bridge; 3, where they leave same bridge for pipes in Brooklyn side. When the two bridge structures are connected in Manhattan as proposed, then there will be further changes in the direction of current. Before the Williamsburg bridge was built, these currents recrossed through the river bed, leaving mains all along the docks in the Manhattan side, for the river, and leaving the river for mains or other metals along the docks of the Brooklyn side. Traces of these currents have been found as far north as 23d st., a distance of over two miles from the Brooklyn bridge. Since the Williamsburg bridge has been built, nearly all traces of these currents flowing north of it have disappeared, showing that the mass of metal composing the structure acts as a short circuit or path of lower resistance which carries practically all of the returning currents flowing from Manhattan back to Brooklyn.

a slime or mud on the floor of the vat, while in the latter case silver chloride forms, and collects as an insoluble precipitate in the same manner.

Chlorates.—Chlorate of potash or of soda is produced electrolytically by the electrolysis of the corresponding chloride.

The electrolytic and chemical changes which first occur when a solution of sodium or potassium chloride is electrolyzed by the aid of electrodes not acted on by the products of the electrolytic decomposition, have been already described under *Alkali and Bleach*.

Hypochlorites.—Sodium hypochlorite is a compound whose molecule contains two atoms of oxygen less than the chlorate and is expressed chemically by the symbol NaClO . It is produced at some intermediate stages in the electrolytic process for making chlorate.

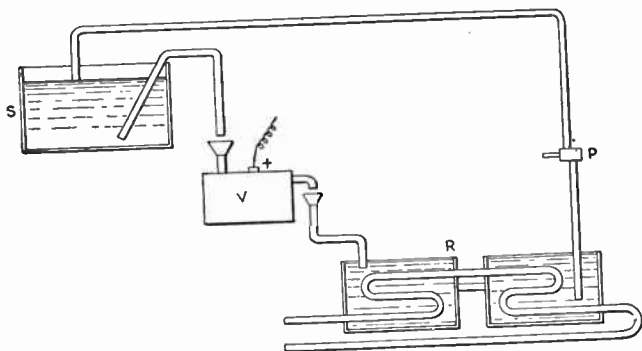

FIG. 4,531.—Arrangement of Gibb's process. The process *consists in* the electrolysis of potassium chloride solutions, using a copper or iron cathode and a platinum anode. S is the supply tank; V, the electrolytic cell; R, the refrigerators; and P, the pump by means of which the exhausted electrolyte is returned to the supply tank, while the chlorate precipitates out as crystals. The reason for using the refrigerator is that in solutions containing only 3 per cent. of chlorate, the latter will not crystallize out upon natural cooling, as it would if present in large quantities. This low percentage of chlorate present is necessary to obtain quick recovery, as otherwise the presence of hydrogen will cause secondary reactions, and cut down the efficiency of the conversion. The pressure employed is about 4 volts per cell, of which 1.4 is required to convert the chloride into chlorate. The circuit density is about 500 amperes per sq. ft. of anode surface.

If the cell designed for chlorate production be worked with a low current density, and at a temperature which does not rise above 68° Fahr., little chlorate will be produced, and sodium hypochlorite will be formed in its place.

Ozone.—This is condensed oxygen, and contains three atoms of this gas in the volume usually occupied by two. It is represented chemically by the symbol O_3 .

Ozone can be produced by chemical methods, but it is also produced by the sparkless discharge of electricity through dry air or oxygen from conductors charged at a high pressure and it is always formed when a frictional electric machine of the old plate type is worked with an air discharge.

Since ozone is a very active oxidizing agent, and is of value for killing the disease germs in contaminated water, the electrostatic method of producing it in air has been developed upon an industrial scale.

A large number of ozonizers have been patented in Europe and America, and some of these are now being employed in connection with water purification and organic chemical works. The principle of the construction is much the same in all, two metallic conductors, kept charged with electricity at a high pressure, being separated by a tube or sheet of glass, and dry air being led through the space thus formed between

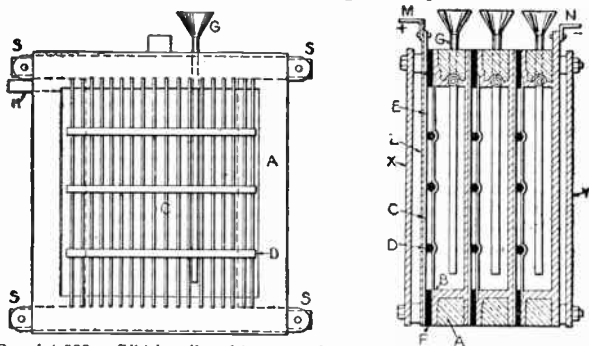

FIGS. 4,532 and 4,533.—Gibb's cell and battery of three cells. The cells consists of a wooden frame A, covered with some metal B, such as lead, not attacked by the electrolyte. The cathode consists of a grid of vertical copper wire C, kept in position by cross bars D, of some insulating material. The grid is placed in a vertical position against one side of the cell frame, and kept in place by the anode of the adjoining cell, from which it is insulated by the strips, F, and bars D. The opposite side of the cell from that occupied by the cathode is partially closed by the anode indicated by dotted lines. This consists of a thick lead plate L, covered with platinum foil on the outer side E, (fig. 4,533), and is held in position by the cathode and framework of the following cell. G is a pipe, reaching to the bottom of the cell, by which the potassium chloride is continuously supplied, and it is the overflow pipe to convey the mixed solution of the chloride and chlorate as well as the liberated hydrogen gas away from the cell. S, S, S, S, are lugs projecting from the framework by means of which any number of cell can be bolted together to form a series of cell. In fig. 4,533, the heavy plates X and Y, are used to close the ends of the wooden framework and form a fully closed series of cell with only the openings at the various supply and overflow points. Current connections are made at the points M and N. **In normal operation**, the cell is continuously fed by each of the supply pipe G, with a solution of potassium chloride, the rate of supply being so regulated as to maintain the temperature of the cell at 122° Fahr., and the amount of chlorate in the discharged solution slightly under 3 per cent. Since the plates C and L, of each cell are in metallic contact, due to the lead lining, the electrolysis occurs between the anode of one cell and the cathode of the following cell (see narrow space between cells), this space being not more than one-eighth inch wide. The fact that the cathode is a grid allows the electrolyte to circulate around it, and all the solution thus passes upwards and out of the cells at H. The percentage of chlorate in the overflow solution is low, and refrigeration is necessary to recover it as shown in fig. 4,531.

them. An induction coil is usually employed for laboratory experiments, to raise the pressure to that required for ozone production (8,000 to 10,000 volts), but transformers are required for large installations.

Organic Chemicals.—In the manufacture of organic chemicals and dyes, there are many stages of chemical change to be passed through before the final product is obtained, and

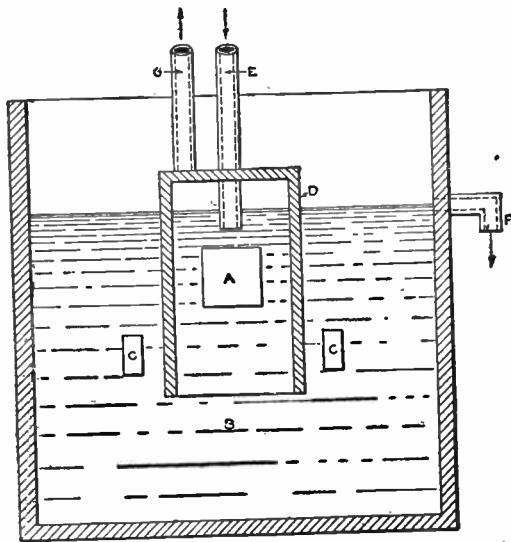

FIG. 4,534.—Aussig bell cell. *The parts are:* A, anode; B, electrolyte; D, bell; E, drive supply pipe; F, overflow pipe; G, chlorine exit pipe; CC, cathodes.

in these, what are called “reductions” and “oxidations” play a leading part. To “reduce” a chemical compound is to bring it to a lower stage of oxidation (*i.e.*, with less oxygen) while to “oxidize” it, is to raise it to a higher stage.

When water, slightly acidified with sulphuric acid, is electrolyzed, oxygen gas is liberated at the anode, and hydrogen gas at the cathode. At a moment of such liberation, these gases are in the ionic or nascent state and they are much more active than when the atoms or ions have

united to form molecules. If, then, the organic compound which it is desired to oxidize be present in the cell near the anode, and the compound which it is desired to reduce be present in the cell near the cathode, and a diaphragm be employed to divide the two compartments of the cell, the nascent oxygen and hydrogen at the moment of their liberation will bring about the desired effects. This, then, is the principle of the use of the electric current for oxidizing and reducing changes in the manufacture of organic chemicals.

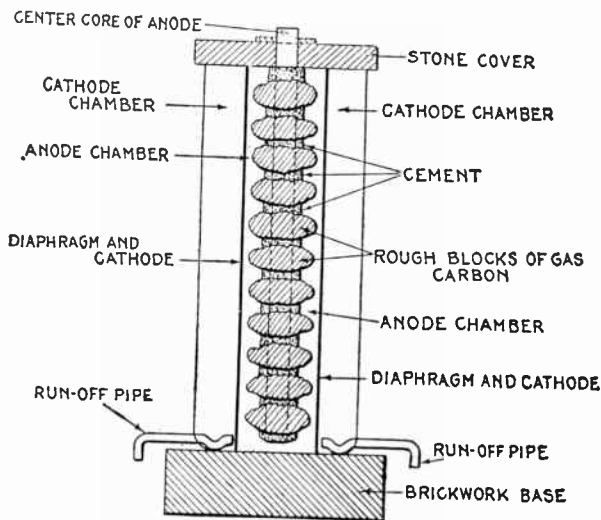

FIG. 4,535.—Section of Hargreaves-Bird cell. This is the diaphragm type of cell, in which a porous diaphragm is placed between the anode and cathode chambers of the cell, and the mixing of the anode and cathode liquids is hindered but not altogether prevented in this way, although the ions, which carry the electric current, have to pass through the diaphragm in their transit from anode to cathode.

Oxygen and Hydrogen.—Dilute sulphuric acid is employed in one form of apparatus as electrolyte, namely, that patented by Schoop, the more customary electrolyte being a solution of caustic soda.

The primary products of electrolysis in this case are hydroxyl (OH) and the metal sodium (Na) but these immediately enter into secondary chemical changes which produce oxygen gas at the anode and hydrogen

gas at the cathode. The gases obtained in this way are not quite free from impurity, but for industrial requirements they are sufficiently pure, and this method of manufacture is much cheaper and more cleanly than the usual chemical methods of production.

Sodium and Potassium.—The method which Sir Humphrey Davy employed to produce a few grains of potassium and sodium is now used to manufacture these metals by the ton.

It is necessary to work with a fused electrolyte in place of an aqueous solution in this case. Owing to the readiness of sodium and potassium to enter into combination with water, the difficulties of operating the process upon a commercial scale are chiefly due to this great chemical activity of the alkali metals.

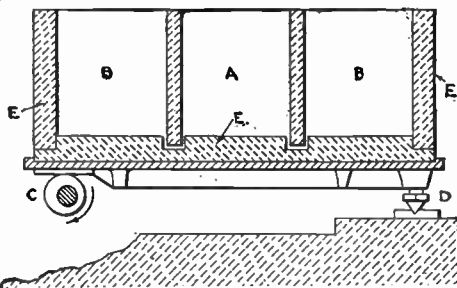

FIG. 4,536.—Castner cell. *The parts are:* A, cathode chamber; BB, anode chambers; C, eccentric for producing a rocking movement of cell; D, pivot support for framework of cell; E, slate walls of cell. The Castner cell is of the mercury type in which advantage is taken of the property possessed by mercury of forming an alloy with sodium, fluid at the ordinary temperature, this alloy being known chemically as an amalgam. When the amalgam is heated with water it is decomposed, and a solution of sodium hydrate is formed, while the mercury is restored to its original condition of purity. Hence, if a layer of mercury be employed as cathode on the floor of a cell in which a solution of sodium chloride is being decomposed by the current, the sodium liberated at the surface of the mercury will at once enter into union with it, and will be kept safe from further chemical or electrolytic changes. The layer of mercury, in fact, acts as a reservoir for the sodium atoms, or ions, brought to its surface, and stores up these until they are wanted.

Wet Extraction Processes for Metals.—Copper, nickel, tin and zinc have all been extracted from their ores or slags by the use of electrolytic processes, and in many cases these processes are still being worked upon an industrial scale.

Copper.—The principle of the wet copper extraction processes is as follows: The ore is roasted to drive off the sulphur, and then leached

in suitable vats with a solution which will dissolve the copper and leave the other metals and impurities undissolved. This solution is then electrolyzed in order to recover the copper as a cathode deposit.

Nickel.—The roasted ore is leached with a solution containing both copper and calcium salts as chlorides, and the copper is first deposited by electrolysis. The last traces of copper are then removed from the electrolyte by chemical means, and the nickel is in turn deposited by use of a higher voltage from the remaining solution.

Tin.—The Böhne process depends upon the use of sulphuric acid as a leaching agent and upon electrolytic deposition of the tin, from the sulphate solution so obtained. In the recovery of tin from old tin cans and tin scrap by electrolysis, sodium hydrate is used as the electrolyte.

Zinc.—A great amount of investigation and large sums of money have been spent upon processes for extracting zinc from its ores, by aid of electrolysis, but only two of these have achieved any industrial success. The Hoepfner process depends upon the use of the waste calcium chloride solution from ammonia soda works, and was worked out chiefly as a process for recovery and utilization of the chlorine from this waste product; zinc, testing 99.96 per cent. purity, and bleach being the products finally obtained. The Swinburne-Ashcroft method (the other successful process) is not a wet extraction process, but depends upon the electrolytic separation of zinc from fused zinc chloride.

CHAPTER LXXXVI

ELECTRO-PLATING

This process consists in obtaining *an electro-deposit of one metal, used as an anode, upon some metallic article which is connected to form the cathode in an electrolytic bath*, that is to say, the substance upon which it is desired to deposit the metal is connected with the negative pole of the source of current, and the metal which is to be plated upon is connected with the positive pole.

The chemical nature of the *electrolyte* employed depends upon the kind of plating. For plating with gold or with silver, the electrolyte is always alkaline, for plating with nickel or with copper, it is usually acid.

Substances other than metal can be electroplated by first coating their surfaces with powdered graphite or plumbago, as in the case of *electrotyping*.

Ques. What is the most essential condition for successful electro-plating.

Ans. Cleanliness.

The merest trace of grease or dirt is sufficient to completely spoil the plating; in fact, the presence of even the small amount of grease caused by handling the article with the naked hand is often sufficient to prevent an adherent deposit.

Ques. How are articles to be plated cleaned?

Ans. This is generally done by means of emery paper or wet sand; the article is also scrubbed with a scratch brush.

Ques. What is the next operation?

Ans. The articles are treated with caustic soda and then thoroughly rinsed in running water.

Ques. What is sometimes done before placing articles in the plating bath, and why?

Ans. They are sometimes dipped in acid; this is partly for cleansing purposes, and partly to slightly roughen or frost the surfaces.

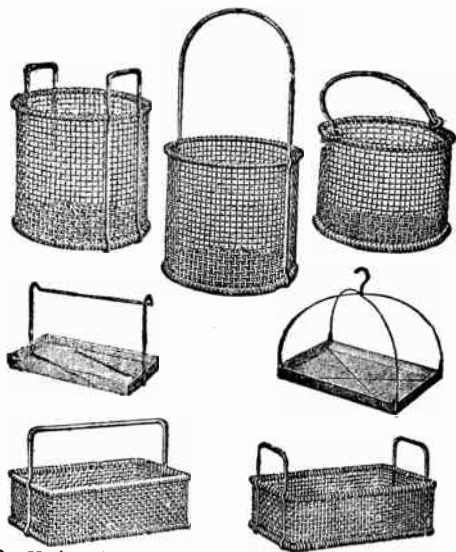

Figs. 4,537 to 4,543.—Various dipping baskets.

Ques. Mention some other important considerations in electro-plating.

Ans. 1, The current density per square foot or square inch of surface; 2, the condition of the anode and its size compared

with that of the cathode; 3, the concentration and composition of the depositing solution; 4, the presence of impurities in the solution.

When the anode is made from impure material, the solution rapidly becomes contaminated with impurities, and gives unsatisfactory results. When the anode is very large in comparison with the cathode, the solution usually becomes too concentrated. When the depositing solution is too strong, the metallic salt often crystallizes out upon the anode and cathode, thus preventing a good deposit and increasing the resistance of the bath.

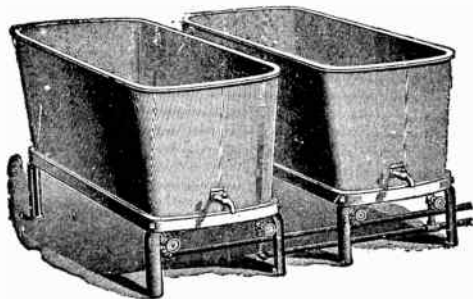

FIG. 4,544.—Heating tanks. Small shops usually depend upon gas or oil stoves placed under the various tanks or jars containing solutions that must be kept hot, such as lye, rinsing water, gold solutions, etc., as either offers a means of keeping up the desired temperature with very little trouble or expense. Larger establishments, however, find it cheaper and better in every way to use steam jacketed tanks, as here shown. These can be purchased in regular sizes, holding from three gallons up to forty gallons, and the smaller and medium

sizes are rapidly finding favor in many machine shops and factories where it is important to cleanse the work quickly and cheaply. Still larger tanks for heavy work are made of boiler iron and heated by a steam coil placed in the bottom of the tank; this usually is allowed to simply lie upon the bottom of the tank, so that it may be readily removed should it become necessary in cleaning the tank or repairing the coil. In arranging the tanks in the plating rooms, much will depend upon the work to be done and the space that is available; the only rule that can be given, therefore, is to follow the order in which the work is handled in both polishing and plating rooms, so that little time and labor will be lost in carrying work back and forth, with the consequent dripping of the lye and acids, etc., upon the floor.

Ques. What is stripping?

Ans. Metals of a like character do not adhere firmly to each other; thus electro-deposited gold will not adhere to a gold surface, and so on. Worn articles of electro-plate, which are to be re-plated, require therefore to have the whole of the previous plating removed before receiving a new coat. This process of removal, which is accomplished by various acids, is technically known as *stripping*.

Current Supply for Electro-plating.—Low pressure direct current is used for this purpose, the pressure used being from 1 to 16 volts, depending upon the nature of the electrolyte employed, and the rate at which the plating is accomplished.

Ques. What are the objections to the use of primary batteries for electro-plating?

Ans. The current furnished is not constant; the increasing internal resistance of the battery causing a gradual diminution

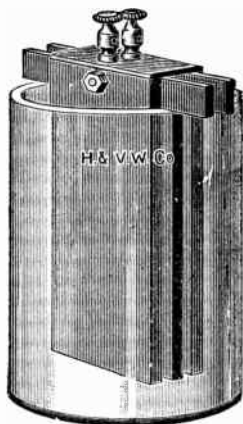

FIG. 4,545.—Smee cell with carbon plates for use with silver and gold plating solutions. *Directions:* Amalgamate the zincs and fill the jar to within about one inch of the wooden support with a mixture of 1 part oil of vitriol to 10 parts water. After using remove zincs and carbon, and wash them in clean water. *Amalgamating solution for cell zincs:* FORMULA: Water, 1 gallon; corrosive sublimate, 1 pound; muriatic acid, 1 pint. Mix in the order named. Dissolve the corrosive sublimate in hot water. The zinc must be thoroughly cleaned before it can be properly amalgamated. This should be done by immersing it in a solution of lye or potash, after which rinse in clean cold water, then place the zinc in the amalgamating solution, and the mercury will readily adhere to it. Another method of amalgamating zinc is to clean it by dipping in dilute sulphuric acid and rubbing on metallic mercury with a cloth or brush. *Electroplating solution:* FORMULA: Water, $\frac{1}{4}$ gallon; oil of vitriol, 1 quart; bichromate soda, pulverized, $1\frac{1}{4}$ lbs. Mix in order named. Pour oil of vitriol slowly in water, and at the same time keep stirring the mixture which will become hot. While the mixture is still hot, stir in the bichromate of soda. When cold, the solution is ready for use.

of the current in the working circuit throughout the period of operation. Furthermore, the high price of zinc and its excitants

make them expensive; they require much time and labor for setting up and removing after the completion of operations; they give off fumes which are injurious to the health, unless they be placed by themselves in properly built and ventilated closets.

The adverse conditions obtaining in the case of batteries, have resulted in the general adoption of suitable types of dynamo especially where the operations require a large and constant current.

There are many cases, however, where the lack of power facilities prevents the advantageous use of dynamos, or motor generator sets,

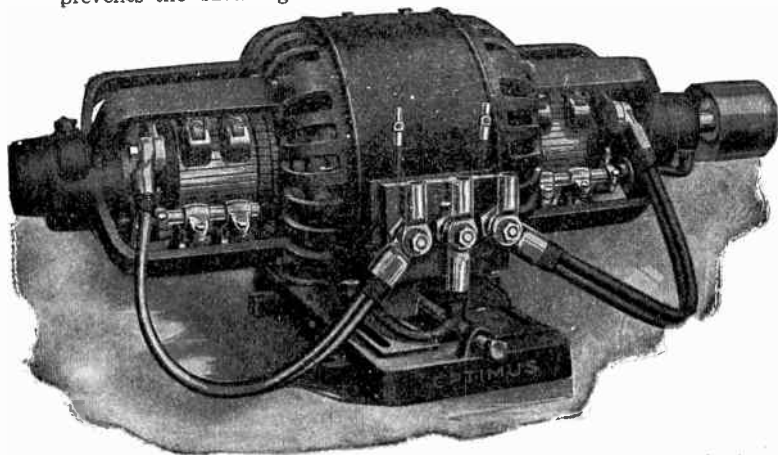

FIG. 4,546.—Optimus double commutator, belt driven electroplating dynamo having a capacity of 750 amperes at 6 volts, or 375 amperes at 12 volts. Two commutators are used in order to keep down the current density in the commutator bars.

so that the use of batteries becomes compulsory. In such cases, several cells of Bunsen, Daniel, or Wallorton type, properly coupled together may be used. As a rule those Bunsen cells having a pressure of 1.8 volts each, will produce sufficient current to run about twenty gallons of nickel electrolyte. Nickel is a very hard metal and cannot be deposited rapidly by low pressure battery currents.

Dynamos for Electro-plating.—Where power is available it is much more economical to employ a dynamo. Although the first cost is greater, the capacity of the outfit is not only

greatly increased, but the work facilitated by the constancy of the current supplied, and comparatively little attention required by the dynamo itself.

Ques. How do plating dynamos differ from those designed for electric lighting and power?

Ans. They are proportioned to deliver a large current at low pressure, instead of a low current at high pressure.

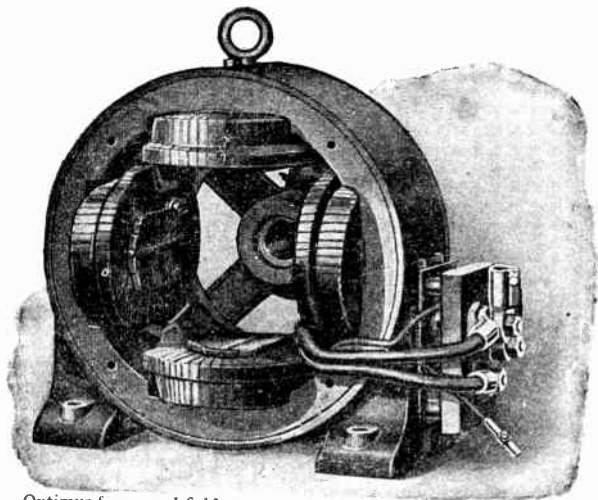

FIG. 4,517.—Optimus frame and field magnets of plating dynamo.

This necessitates large commutators and large brush gear, also large inductors. Some dynamos have double commutators to secure sufficient brush contact area to take care of the large current. The construction of electro-plating dynamos is shown in the accompanying cuts.

Current Required, and Size of Wire.—The amperes required to plate one square foot with a deposit of each of the various metals are given in the following table and will be found useful for determining the capacity of dynamo in square feet

of plated surface, and also for determining the sizes of wire leading from the main lines to the various tanks.

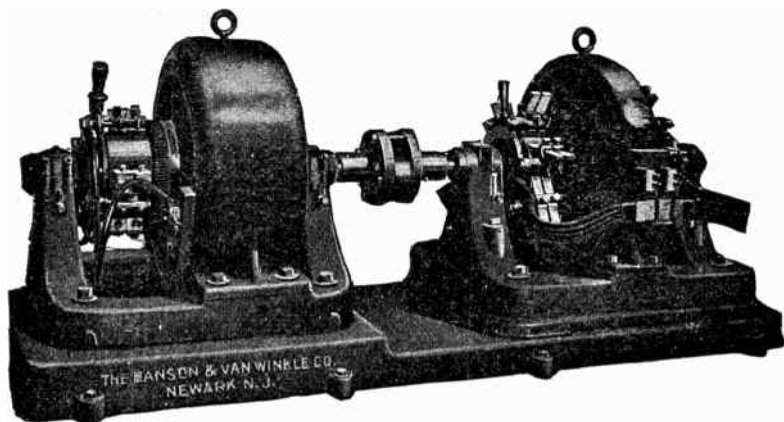

FIG. 4,548.—Hanson and Van Winkle motor generator set consisting of a six volt dynamo and an alternating current motor. For mining and other purposes, recovery of gold, etc., this form of outfit is desirable, as the current to operate the motor can be carried to the point most available for the location of the dynamo, and the expense of maintaining long lines of heavy copper conductors materially reduced.

Amperes required to plate one square foot.

Carrying capacity of copper wire.

Solution and metal.	Average amperes.	Size.	Amperes.
Nickel.....	4	1/16"0625	3
Brass.....	6 to 8	1/8"125	12
Bronze.....	6 to 8	3/16"1875	27
Copper.....	6 to 8	1/4"250	49
		5/16"3125	76
		3/8"375	110
		1/2"500	196
Acid copper.....	10 to 12	5/8"625	306
Silver.....	2	3/4"750	441
Gold.....	1 1/2	7/8"875	601
		1" ... 1.000	785
Zinc.....	10	1 1/8" ... 1.125	994

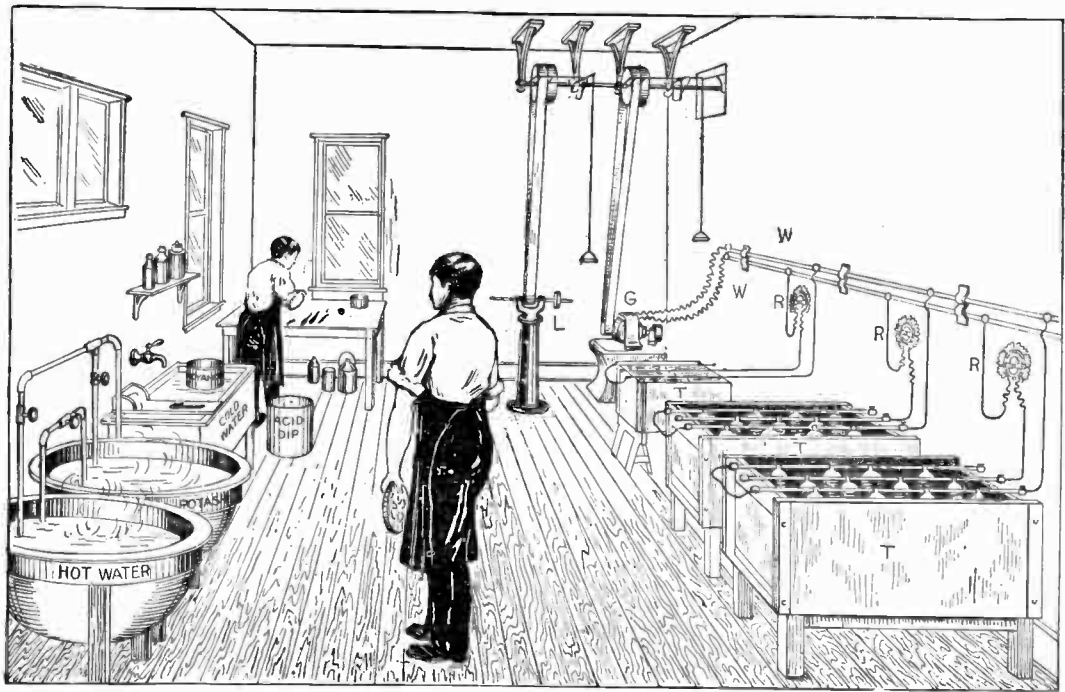

FIG. 4,549.—Electroplating outfit with two wire system of distribution.

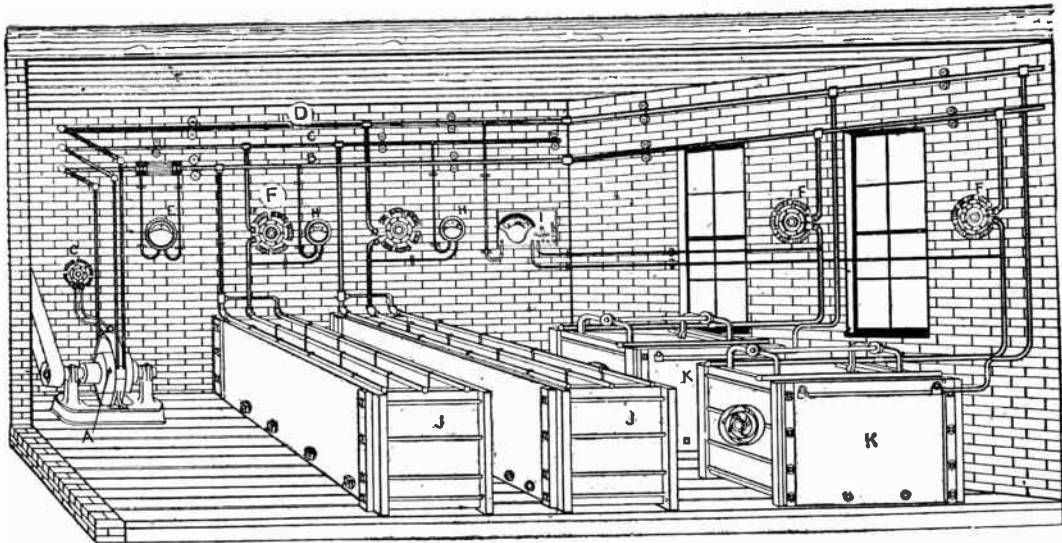
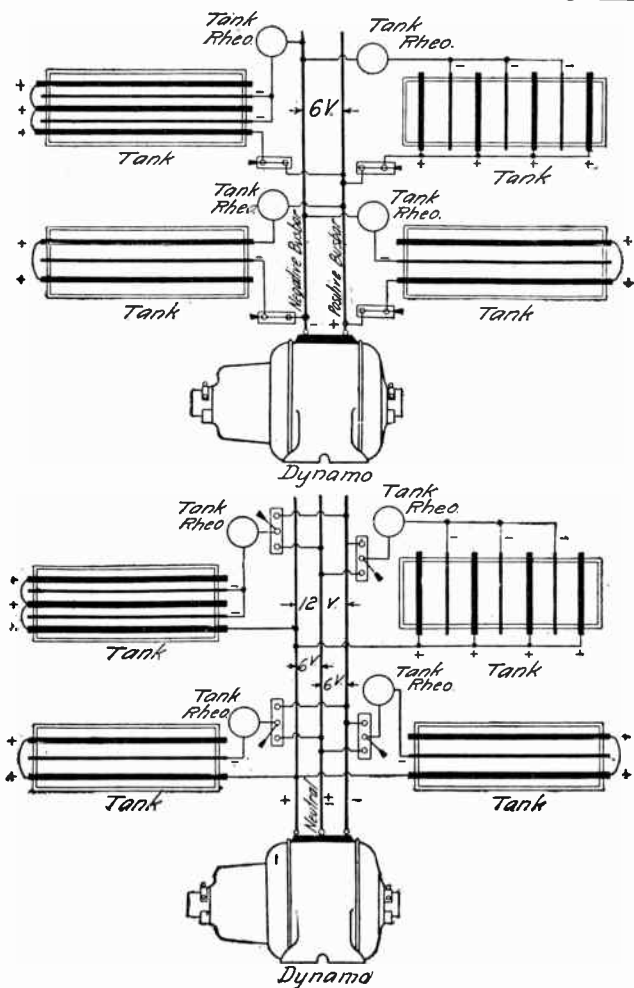

FIG. 4,550.—Electro-plating outfit with three wire system of distribution. The apparatus consists of: A, multipolar dynamo; B, positive line; C, neutral line; D, negative line; E, ammeter; F, tank rheostat; G, field rheostat; H, tank voltmeters; I, Starrett voltmeter; J, still solution; K, plating apparatus. The three wire distributing system is generally employed in the larger electroplating establishments where a variety of solutions are in use, thus necessitating the employment of different voltages in the different solutions. It is well known that a higher voltage and greater current strength can now be advantageously used in many solutions in the working of which it was formerly assumed that only a low voltage could be employed. Furthermore, the necessity for reducing the time of deposition without impairing the quality of the work is desirable for economical reasons, and it is effected by agitating the solution and employing a higher voltage with a proportional increase of the current strength. Since the general run of stock dynamos have capacities ranging from 4 to 6 volts, the three wire system of distribution not only effects a saving of over 37 per cent. in the cost of copper conductors, but permits of desirable voltage variation. For example: with a dynamo capacity of 10 volts, a pressure of 10 volts can be obtained in some of the tanks by connecting them to the outside wires of the system, while five volts can be obtained in other tanks, by connecting the latter to either one of the outside wire and to the neutral wire.



Figs. 4,551 and 4,552.—Optimum wiring diagram for two wire and three wire installations. Fig. 4,551 shows the usual method of connecting tanks with a two wire dynamo; each tank has a separate rheostat, thus permitting independent regulation of voltage for each tank. Fig. 4,552 shows a three wire installation, so wired that each tank can be thrown across the low voltage or across the high voltage line independently of the other tanks.

Special attention should be given to install wires amply large to carry the heavy current. In this connection, it should be noted that a 40 foot conductor must have a cross sectional area equal to one square inch, to carry 1,000 amperes, without heating.

The current density is especially important and varies with different metals. With a high current density the deposit may be crystalline or powdery, and will not adhere well to the cathode. What is required is to regulate the current so that the deposited metal may be smooth and adherent, and capable of being burnished without being detached.

Hard and fast lines cannot be laid down, but, generally speaking, with high current densities the deposit is powdery, and of a dark color, when it is said to be "burnt." Much higher current densities can be employed if the solution be rapidly circulated by means of a pump or agitated by blowing in air.

Electro-plating Outfits.—These vary in general arrangement and equipment according to the character of the work done, its amount, and the source of current supplied. Fig. 4,549, shows the general arrangement of an outfit for plating with three different kinds of metal. The current is distributed on the two wire system, and a rheostat is provided for each tank.

Fig. 4,550, shows the general arrangement of an electro-plating outfit wired for the usual solution tanks and also for the operation of mechanical plating apparatus, on the three wire system of distribution.

Rheostats and Switchboards.—Rheostats are employed for varying the current strength required for working different kinds of solutions or for handling various sizes of baths. When metals such as silver and copper, which require low resistance solutions, are to be deposited in connection with such metals as nickel and brass, which require high resistance solutions, a considerable drop in voltage is required for the former, in order to prevent the blackening of the work.

A rheostat inserted in the field of the dynamo will maintain an initial voltage on the whole system, but rheostats at each tank are necessary to further reduce the current to the proportions required by the solutions in those tanks. While the field rheostat effects the voltage by

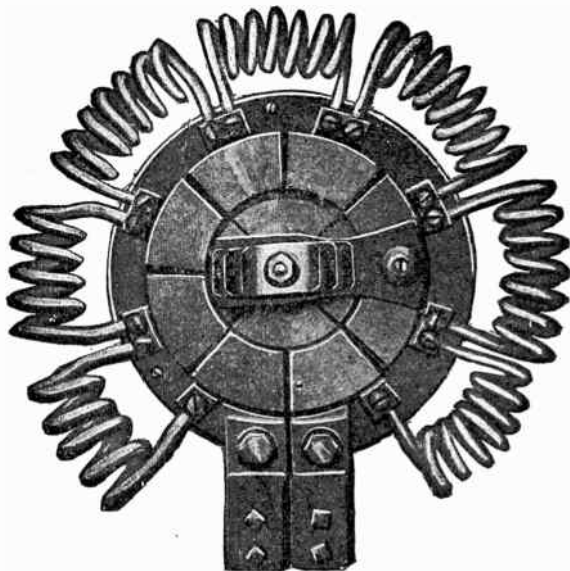

FIG. 4,553.—Form of rheostat for controlling heavy currents. It has a capacity of 800 amperes. The variation of voltage obtainable is 2.1 volts. It is suitable for solutions containing 175 to 200 square feet of nickel, 125 feet of copper or brass work, or 75 feet of zinc work. The capacity of rheostats of this and other types range from a few to many hundreds of amperes, so that no difficulty is experienced in selecting those of proper capacity to suit any combination of tank capacity and character of solution. All platers understand that different voltages are required to operate successfully different kinds of solution, and that when a sufficient voltage is to be generated for a solution of the highest resistance, and at the same time utilized in low resistance solutions, the tank nearest the dynamo, with the customary method, receives the most current, and a tendency to burn and blacken is noticed to a marked degree. When metals such as silver and copper are to be deposited in connection with such metals as nickel and brass, a higher voltage is required, and considerable drop in voltage is demanded in the lower resistance solutions so as not to blacken the work.

NOTE.—The use of voltmeters at each tank is very desirable, as it is well known that the character of the deposit obtained by the use of a certain solution largely depends upon the reproduction of certain voltages and amperage values of the applied current. The ordinary galvanometer, which indicates only a change of polarity, is insufficient for this purpose, while on the other hand a sensitive voltmeter will indicate any irregularity of power, due to the slipping of belts, short circuits in tanks, etc.

setting a fixed resistance in the dynamo field, it does not affect the amperage except to a small extent.

When a rheostat is placed between the main line and the tank, the amperage is reduced in proportion to the reduction of the voltage. Therefore it is necessary that a tank rheostat should be capable of carrying the amperes of current required by the solution in its particular tank, otherwise the proper amount of current will not flow into the tank.

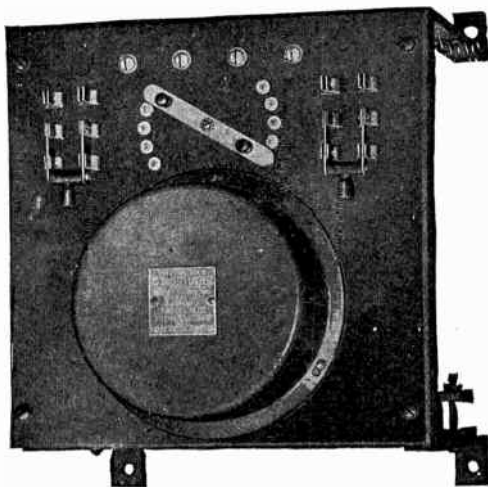

FIG. 4,554.—General Electric voltage regulator for use with electrolytic dynamos. It is sometimes desirable in electro-plating, where more than one tank is operated from a single machine, to maintain a constant voltage under all load conditions without manipulating the field rheostat. To meet these requirements, the regulator here shown has been designed.

Mechanical Electro-plating Apparatus.—A great variety of form have been designed to reduce the cost of plating articles, which in the absence of some form of mechanical plating apparatus must be strung or plated in trays. The cheapening in the

NOTE.—The substitution of steel for the high priced copper or brass has increased the demand for electro-plating more than any other cause. In plating brass or bronze on steel in a stationary tank there is a tendency to an excess or deficiency of the copper. This seems to be overcome in the mechanical plater. The deposit of nickel, brass, copper, zinc, etc., in the mechanical plater is a more protective coating for the same amount of metal used, resembling more a burnished metal.

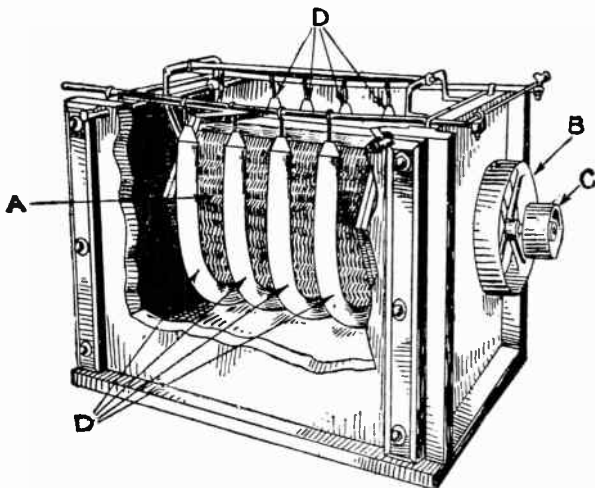

FIG. 4,555.—Mechanical electro-plating apparatus. *It consists of a barrel A, in which are placed the articles to be plated. This barrel is revolved by belt device over the pulleys B or C, which provide two speeds. The barrel is removable at any time without interfering with the device. The anodes D, D, are curved to fit the periphery of the revolving barrel, and when the anodes are hung at each side of the tank, as shown, the work is always equidistant from the anodes, thereby insuring a regular deposit of even depth. In setting up and operating the mechanical electro-plating apparatus, connect the anode rod to the positive wire of the main line, and the cathode rod to the negative wire. Use suitable size wires for this purpose, as shown by the branch holes in the rod connections. Insert a rheostat in the negative line between the tank and the main line. When the barrel is being filled or emptied move the rheostat lever to the off point, so as to prevent the burning or blackening of the work when it is being removed from the tank. This should receive particular attention when a high voltage current is used. All contact points should be kept perfectly clean. A strip of thin sheet lead, or a split length of rubber hose, bent into the shape of a U, should be placed over the entire length of the anode rod to prevent the slop and dirt from the solution impairing the contact of the anode hooks with the positive rod. The revolving barrel may be operated at two speeds. In order to obtain the correct speeds, the countershaft should be driven at the rate of 10 revolutions per minute. The following voltages should be used with the various solutions: Acid copper solution, 18° Baume, 2½ to 5 volts; cyanide copper and brass solution, 12°-15° Baume, 4 to 5 volts; nickel solution, 10° Baume, 4 to 5 volts; zinc solution, 20° Baume, 6 to 10 volts. With the lower speed, almost any kind of article which will not hang to the periphery of the barrel, may be handled with the lower voltages. The higher speed and the higher voltages should be used for round articles, or those having no sharp edges or corners, with a consequent shortening of the time of deposition. The best results are obtained when the articles fill about one-half the barrel. The average length of time required to obtain a good deposit of the different metals under proper working conditions is approximately as follows: Acid copper solution, 20 to 40 minutes; cyanide copper and brass solutions, 30 to 45 minutes; nickel solution on brass, 15 to 30 minutes; nickel solution on steel, 45 to 60 minutes; zinc solution, 1½ to 2 hours. In the case of all solutions, the crystallization of the salts during cold weather tend to give a great deal of trouble. Therefore, all solutions should be kept at a temperature of 70 to 80 degrees Fahr., thereby permitting the use of denser and more highly conductive solutions, with a consequent shortening of the time of deposition. A loop of bare steam pipe immersed in the solution will serve to supply the necessary heat.*

cost of plating has been so marked that mechanical plating apparatus is now recognized as a necessity in the metal manufacturing industry.

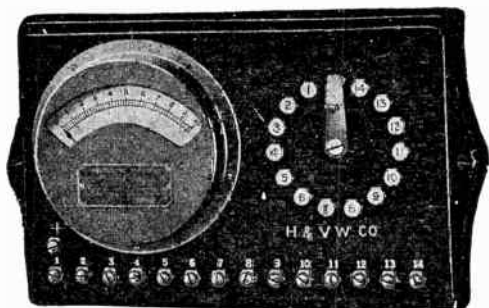

FIG. 4,556.—Waverly voltmeter with binding posts for fourteen tanks, thus enabling the operator to use only one instrument in obtaining the reading of any number of tank up to fourteen, by simply moving the switch lever to the tank numbers indicated on the switch of the instrument, and, when used in connection with tank rheostats, will enable the operator to reproduce at all times the same electrical conditions which by observation and experience he has found necessary in order to obtain a satisfactory deposit of uniform thickness and color in the shortest possible time.



FIG. 4,557.—Connections and manipulation of rheostat on large copper, brass, and bronze solutions where variations of voltage are necessary to secure different colors.

The Tanks, or Vats.—These vessels are for holding the plating solutions, and should be made of well seasoned wood, liquid

Ques. How should gilding solutions be kept?

Ans. In small enamelled iron tanks, provided with legs, so as to permit the placing of a gas burner, lamp, or stove beneath the tank.

A thermometer should be permanently fixed to the tank below the surface of the solution, for ascertaining the right temperature of the latter. The thermometer should be entirely of glass as the presence of any metal attachment will be dissolved by the heat of the gild solution. Thermometers with enamelled scales enclosed in glass tubes are the most suitable.



Figs. 4,560 to 4,562.—Various dipping vessels. Fig. 4,560, deep glazed earthenware dipping basket; fig. 4,561, shallow glazed earthenware dipping basket; fig. 4,562, aluminum wire dipping basket. The aluminum basket is adapted for use in washing and dipping in all acid solutions, but cannot be used in potash solutions. Different shapes and sizes of basket are required for various kinds of work. Successful dipping depends, however, chiefly upon quick and careful handling rather than upon the shapes of the dip, therefore, the holes in these baskets should be as large as possible, so as to allow the acid or cyanide solution to drain out quickly.

Dipping Vessels.—These are employed for holding the articles and dipping them into the various solutions used in cleaning the articles preparatory to the plating.

All dipping vessels used in acid solutions should be made of vitrified or glazed stoneware or glass. Various forms of dipping vessel are shown in the accompanying illustrations.

Scouring, Swilling and Rinsing Troughs.—These are usually made of wood, lined with lead and divided in the middle by a partition, one part being used for scouring and the other for holding clean water for rinsing the articles after they have been scoured clean.

Scouring and Wash Out Brushes.—There are a variety of these, made of various materials, and in many different patterns and sizes suitable for different kinds of work.



FIGS. 4,563 to 4,567—Various brushes. Fig. 4,563, jeweler's shoe handle wash out hand brush; fig. 4,564, flat scouring brush; fig. 4,565, cotton potash brush; fig. 4,566, sawdust brush; fig. 4,567, wire foundry brush.

Fig. 4,563 shows a jeweler's wash out brush. They are made with both straight and curved handles, and of brass or steel wire, bristles and tampico fibre. Extra soft brushes are made of goat's hair.

Fig. 4,564 shows an example of a flat scouring brush of tampico fibre. Their sizes are indicated by the number of knots included in the length, and the number of rows of knots included in the width. The brush shown is 5 rows wide, and 15 knots, about 10 inches long. Flat brushes for nickel scouring are made of extra stiff tampico; they range in width from 2 to 3 rows, and in length from 6 to 8 inches.

Brushes made of cotton and other vegetable fibre are commonly known as potash brushes. They are used for cleaning work requiring

strong alkaline solutions for removing grease. Brushes made of animal fibre cannot be used for this work, as they would soon wear away under the dissolving action of the potash.

Other useful forms of brush are the horse hair sawdust brush shown in fig. 4,566; various forms and sizes of wire foundry brushes shown in fig. 4,567; cup shaped brushes of wire or bristles for watch case work, and steel wire scratch brushes, operated by lathes, for cleaning and removing sand and scale from castings, which cannot be removed by pickling processes. Figs. 4,568 to 4,571 show a circular steel wire casting brush.

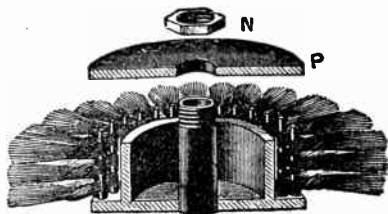

FIGS. 4,568 to 4,571.—Hanson and Van Winkle swing type, circular steel wire, casting brush. The steel wires are twisted in knots and the knots are hung on rods around the hub, as shown in fig. 4,571, so that they will turn around the rods if the work be held too close to the brush wheel. In using the brush the work should be held so as to be just in contact with the ends of the wires. The brush shown is about 15 inches in diameter, and should not be run much faster than at the rate of 1,000 revolutions per minute. If the brush be run too fast, or if the work be held too close, the wires will become crystallized and soon break off. After the brush has been run for a while, the ends of the wires will become bent and drag over the surface of the work; the brush should then be taken off the spindle, turned around, and replaced with the hub next to the collar on the spindle, so that the wire ends will again strike the surface of the work. When the wires are worn out a new set of knot can be readily substituted for the old set by unscrewing the nut N and taking off the hub plate P.

In the packed type of scratch brush, the wires are attached evenly to the surface of the hub. The wires used are stiffer and will wear longer than those of a swing brush, but they are more liable to breakage from careless handling, and do not reach into uneven work as well as the latter.

Tumbling or Rattling Barrels.—Small objects, such as small castings, stampings, etc., that are not required to have

square edges, are best cleaned by tumbling, or rattling, as it is called in foundries. Large quantities of work are thus easily and cheaply cleaned without much manual labor, which is the expensive item in polishing. If rough castings are being worked, the sand, scale, etc., adhering to them is allowed to remain in the barrel, where it acts as a polishing powder, brightening the parts which are not reached by the metal of other castings; but when tumbling for a bright finish, the sand, dirt, etc., are exhausted by means of the blower, so that the surfaces are finely polished by friction only—burnished, as it were, by

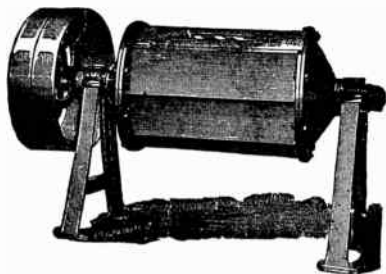

FIG. 4,572.—Hanson and Van Winkle tumbling barrel with convex head for dry tumbling. The type of barrel is especially adapted for removing burrs and for smoothing small castings. This barrel gives three distinct motions to the articles: rolling, shaking, and spreading.

rubbing against other metal of the same kind. A strong exhaust should be kept up when polishing in this way or the finish will be dead instead of bright.

Bright work can only be obtained by long continued tumbling, and the bright finish comes rather quickly after all the pieces in the barrel become smooth, accordingly, it is necessary not to add any pieces once the barrel is charged, or the work will not finish evenly.

Ques. How should the speed be regulated in tumbling?

Ans. The speed should be so adjusted that the articles will have time to "tumble" down upon and slide over each other as much as possible.

If run too fast, centrifugal force will cause the articles to cling to the sides.

Steel Ball Burnishing Barrels.—Burnishing with steel balls is done both on small articles preparatory to plating and also on articles that have been plated and require a highly burnished finish.

This process is intended for burnishing large quantities of small metal articles and for that purpose is more practical, more effective, and more economical than any other method. This process is especially

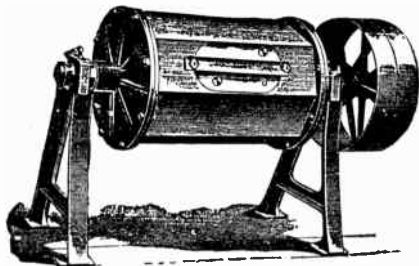

FIG. 4.573.—Hanson and Van Winkle tumbling barrel for wet grinding or polishing. It is intended for sand and water grinding, washing out core sand, etc., and is adapted for brass castings. The barrel is provided with a gland for connecting a water pipe to supply a constant flow of water.

adapted for figured work as the steel balls used readily slide in and out of the crevices, angles, and curves and give the parts being tumbled a high luster that cannot be obtained by any other method.

Almost as fine a surface may be obtained by burnishing in this manner as can be obtained by buffing.

It should be noted that successful burnishing by this method depends upon using enough steel balls of proper size. The balls used run from $\frac{1}{8}$ inch to $\frac{1}{4}$ inch in diameter, but for general use the smaller balls do better work.

As the balls do the burnishing enough should always be used, so that the articles will not rub one another. A good rule is to use two pails of ball for each pail of work and for each pail of work a pail of hot water is needed. Before adding the water dissolve in same about six ounces of borax soap, ivory soap, or some other mild, pure quality soap. Common soaps will not answer as they contain alkalies, etc., which attack both the balls and the work.

Polishing Powders.—In order to hold fine powders on the wheels and buffs, they must be mixed with some medium that will perform this office and at the same time act as a lubricant to the work.

The best powder consists of the largest proportion of powder per part of "binder."

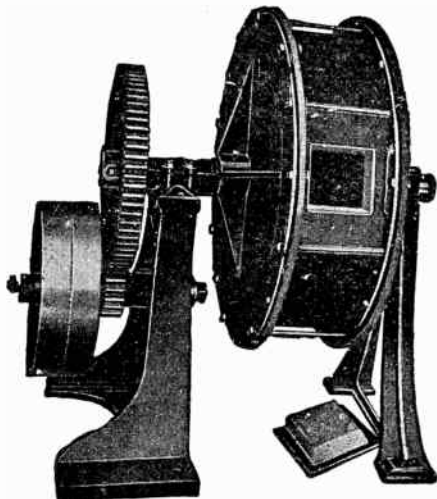

FIG. 4,574.—Hanson and Van Winkle steel ball octagon shape burnishing barrel. It is made of cast iron and has a hard maple lining.

Manufacturers put up powder in the form of a cake that is hard enough so that a small amount of composition may be evenly distributed over the entire cutting surface of the buff by holding the cake against the buff while it is in motion.

Polishes are generally designated by the manufacturer in such a way as to show the metal they are to be used upon, and the grade of polishing material as: Nickel rouge, hard No. 1; nickel rouge, hard No. 2, etc.

The polishing compositions generally employed are various preparations of rouge, tripoli, crocus, white rouge, Vienna lime and powdered pumice stone, described as follows:

Rouge. This is used either in stick or powdered form, the former to remove any scratches and to put on the first polish; the latter mixed to the consistency of their soft paste with alcohol and water for giving the finished polish or color. Rouge is put up in various grades, either in hard or powdered form, suitable for use with different kinds of metal.



FIG. 4,575.—Method of applying lacquers. *Instructions:* Use a glass tumbler or porcelain cup as a container. Apply a flowing coat with a soft brush. A stiff brush will cause foaming or small air bubbles, and will require a heavier body lacquer. Prepare the work the same as for plating. It must be absolutely clean and free from grease or moisture. It requires only the smallest amount of moisture to ruin the work. Use the lacquer as thin as possible without showing iridescent colors. Dry in a temperature of 100° Fahr., if possible, using a thermometer. Brush lacquers will dry in the ordinary temperature, but baking improves the finish. Iridescent colors are in most cases caused by the lacquer being too thin, or by carelessness in removing the polishing composition or rouge from the work. Iridescent colors will often disappear when the article is given a second coating of lacquer after the first has dried. When the body becomes too heavy it needs thinner. *Be sure to use only a thinner of the same grade as the lacquer.*

These various grades are known by the trade as gold rouge, silver rouge, nickel rouge, brass rouge and glass polishing rouge. Gold rouge is the finest of all.

All gold and silver work being finished on buffs should be washed in hot soap suds containing a little ammonia, then rinsed in hot water and dried in *boxwood* sawdust, or with clean soft rags. Other kinds of sawdust are liable to discolor the metal.

Tripoli is used mixed with tallow and beeswax, melted together and run into moulds of convenient size. If made in the shop, care should be taken to avoid the use of an excess of either tallow or beeswax, as the former is liable to stick to the work and may be removed only with great difficulty; while the latter will render the work greasy and dirty, and retard the work of buffing or polishing.

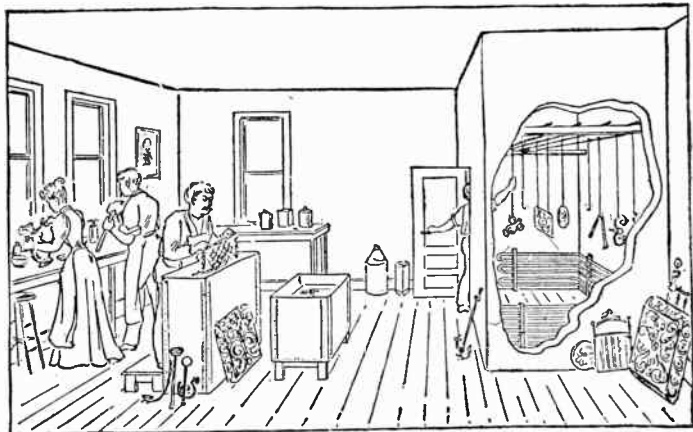

FIG. 4,576.—The lacquer room. When possible, a separate room should be used for lacquering, or a portion of the shop may be partitioned off for the purpose in order to avoid all dust or moisture. If the room be heated by steam pipes, it is advisable to have the regulating valves outside. The lacquer room should be light, dry, and well ventilated. When it is necessary to use artificial light, it is safer and better to use incandescent lamps. Do not have a stove or gaslight near the lacquer room, as both the lacquer and thinner, as well as the gases which arise from them, are very inflammable. The most suitable dryers for this purpose are sheet metal ovens, zinc lined wooden ovens, or wooden closets with dust-proof doors, these to contain a steam radiator with regulating valves on the outside. Rods or hooks can be placed at a convenient height on which to suspend the work with wires. Shelves or racks of wire netting will also be found very convenient. Keep a thermometer in the dryer. Keep the temperature at about 100° Fahr.

Crocus is used mixed with tallow and oil, only a sufficient amount of the latter ingredients being used to allow the mixture to be made into cakes, and to furnish the proper lubrication. Crocus compositions are used chiefly for finishing steel goods such as fine cutlery, surgical instruments, tools, etc., which require a high finish. It is also used for finishing plated articles of brass or nickel.

Vienna lime is used in buffing nickel and silver ware. In order to be effective it must be used while slacking. It is usually put up in the form of pressed bars which are dipped into paraffine and then wrapped in paraffine paper. This treatment makes it air tight, and prevents it slacking until it is being used, when it is disintegrated with slight pressure, and slacking in the air gives the metal a chemically clear surface. It is extensively employed in watch factories.

Pumice stone or rotten stone powder is employed for polishing Britannia metal and other soft metals, which would roughen, become

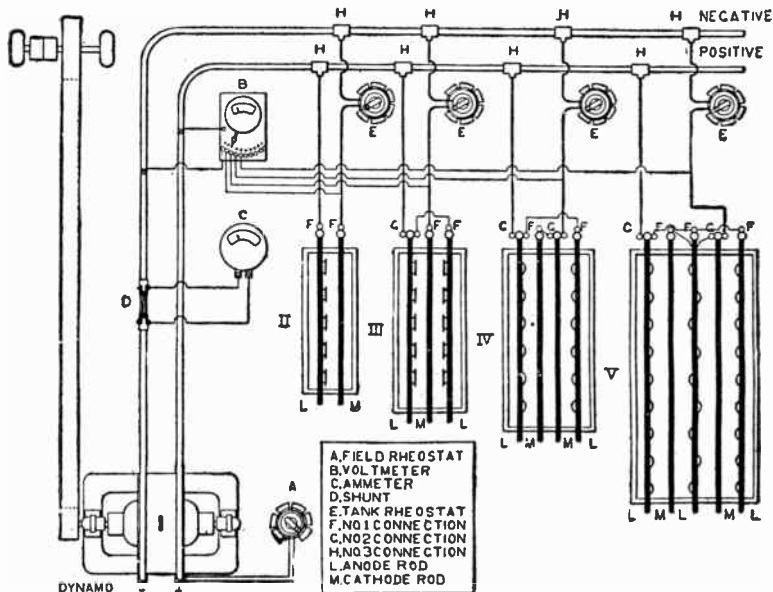

FIG. 4,577.—Wiring details, two wire, four tank installation.

distorted in shape, or melt under the ordinary methods of polishing. Such articles are polished with small leather wheels and bobs of walrus hide, bull neck leather, or sheepskin, according to the requirements of the work, revolving in a box containing the powder mixed with a little oil. The amount of oil used should be just enough to keep down the dust and prevent the powder flying all over the room, but not enough to make the powder lumpy or sticky to the fingers. The polisher holds the work with one hand, so that it will barely touch the wheel, and applies the pumice to the work with the other hand.

Solutions for Electro-plating with Different Metals.—

These may contain the necessary constituents in various percentages. The following solutions are considered the best in general practice.

Twenty-four carat Gilding Solution.—Take 12 pennyweight of pure gold, roll it out as thin as possible with jewelers' rolls. Heat it

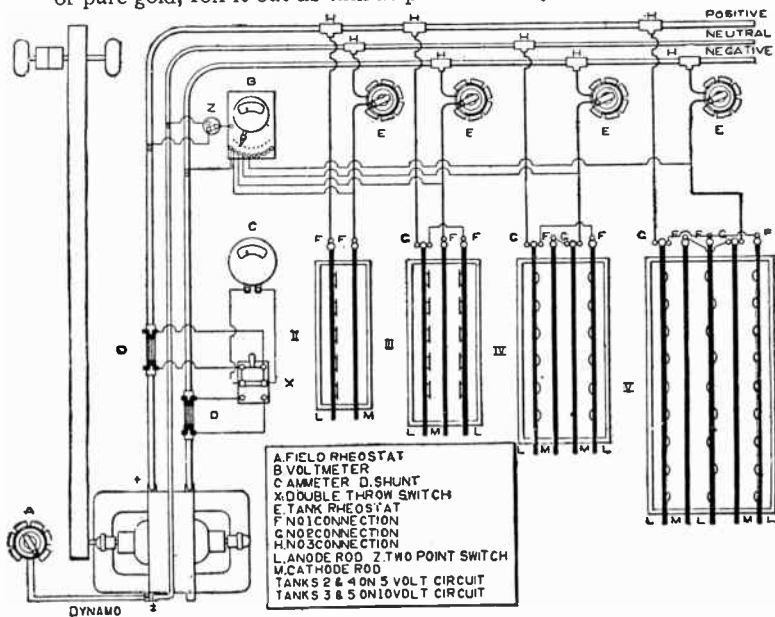

FIG. 4,578.—Wiring details, three wire, four tank installation.

gently with a blow pipe to a red heat, and after it has been allowed to cool, cut it up into small pieces, and place the latter in a porcelain lined evaporating dish. Then pour in two parts C. P. hydrochloric acid, and one part C. P. nitric acid; the latter should be added slowly and stirred with a glass rod. Place the dish in a sand bath over a gentle heat until all the metallic gold disappears, then accelerate the evaporation of the acid by occasionally tipping the dish from side to side until all the acid is evaporated, leaving the chloride of gold on the bottom and sides of the dish, in the form of a brown deposit.

of fine gold and the latter being composed of 80 parts of copper, 83 parts zinc, and 6 parts nickel.

The best solution for silver plating is the double cyanide of silver and potassium solution.

The single cyanide of silver is prepared by adding a solution of cyanide of potassium to a solution of nitrate of silver until a precipitate ceases to form.

The double cyanide of silver and potassium is prepared by dissolving an equivalent of silver cyanide (134 parts) in a solution containing an

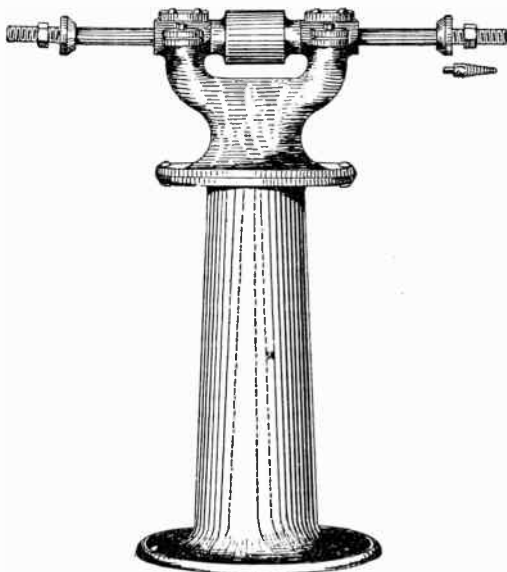

FIG. 4,581.—Polishing and buffing head. Polishing and buffing heads range in size from those sufficiently strong to run wooden polishing wheels up to 16 inches in diameter, and those designed to run 9 or 10 inch buffs at 3,000 revolutions per minute, to those known as light polishing heads, capable of being operated on a bench without the use of a counter shaft.

equivalent of cyanide of potassium (65 parts). The silver plating solution is made up with distilled water, the proportion by weight of silver per gallon of water varying from $\frac{1}{2}$ ounce to 5 ounces or more.

The best nickel plating solution is that which is made up of the double sulphate of nickel and ammonium, in the proportion of 12 ounces to one pound of the double salt to each gallon of solution. The crystals

should be dissolved in boiling water in a wooden tub, frequently stirred and cold water added to make up the desired quantity. After the solution has become cool it should be filtered through a large volume, 1,000 gallons or more, held in large lead lined tanks.

Electro-plating with copper is employed chiefly to form a coating on iron, steel, tin, zinc, lead, Britannia metal and pewter articles preparatory to silver plating the same, for the reason that silver will not adhere perfectly to those metals, while on the other hand, silver will adhere perfectly to copper and copper to the soft metals.

The copper plating solutions employed for this purpose, and for electrotyping are acid solutions of copper sulphate.

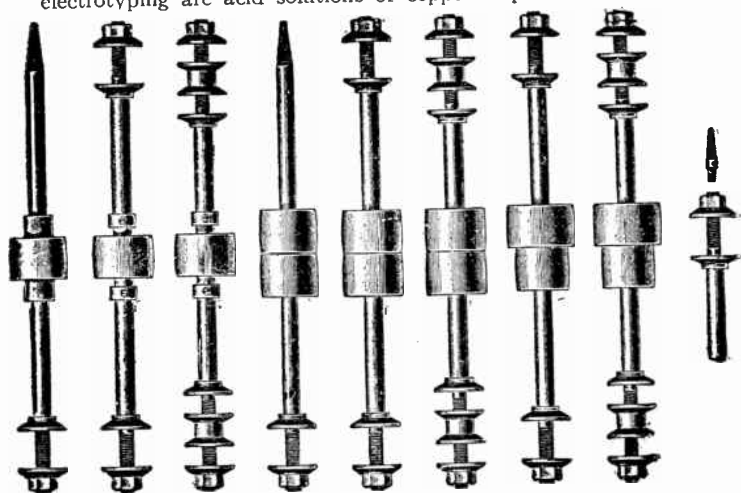

Figs. 4,582 to 4,591.—Steel spindles used with polishing head.

Polishing and Grinding Machines.—These machines, or heads consist of a stand carrying a small pulley between two bearings with shaft extended at each end to take the various buffing, polishing and grinding wheels, brushes, etc.

Fig. 4,581, shows a type of polishing and buffing machine suitable for both light and heavy work. It is provided with tapered steel spindles, wide bearings, and is designed for high speed. The forms of steel spindle used for different kinds of work are shown in figs. 4,582 to 4,591.

Foot power polishing wheels are made in a great variety of form, and are chiefly used in small jewelers' establishments for buffing watch cases, rings and other small articles.

Polishing Wheels.—These are made of canvas, wood, felt, leather, and walrus hide. Rough heavy castings are first ground upon coarse solid emery or carborundum wheels, usually run at a slow speed, not exceeding 1,000 revolutions per minute.

Where no exhaust fan is provided, some form of glass or metal shade

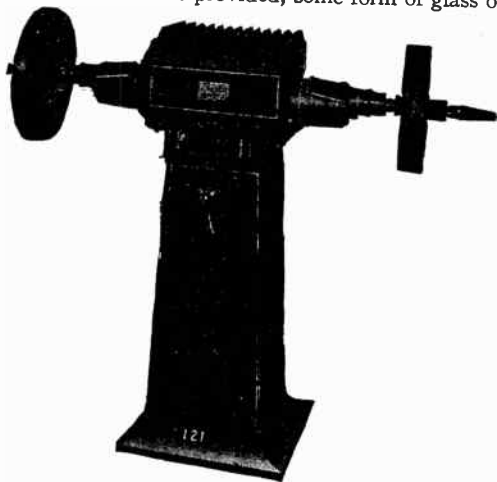

FIG. 4,592.—Hanson and Van Winkle polishing and grinding machine with electric motor drive. The magnetic frame is made of a combination of cast iron and cast steel, having many ribs around the top, back, and bottom to assist in keeping the motor cool under all conditions of load, and enabling it to withstand heavy overloads. The poles are of steel castings, and are of round cross section. The switch, starting box, and regulator are contained within the stand, with the operating handles extending through suitable openings. An important feature of these machines is the ability of operator to regulate the speed of the wheels, running them at the speeds most suitable for the work in hand. This regulation of the speed is accomplished by the simple movement of a handle, the speed remaining practically constant at any point.

should be placed over the wheel for preventing the particles of emery and metal flying into the face and eyes of the workman.

Where emery wheels are continuously used, their grinding surfaces soon become glazed, and tend to cut very slowly. The glaze should be removed by means of an *emery wheel dresser*.

Canvas wheels are commonly called *roughing out wheels*.

The first operation in polishing rough castings after they have been trimmed up and the gates removed, is the use of canvas wheels set up in No. 60 or 70 emery. They are composed of several thicknesses of canvas or duck, cut into discs and glued or cemented together to the required thickness. They are not fitted for working on machine parts, tools, etc., in which sharp edges and square corners are necessary.

Wood wheels are usually employed for roughing out work in which sharp corners and straight edges must be preserved. As these wheels

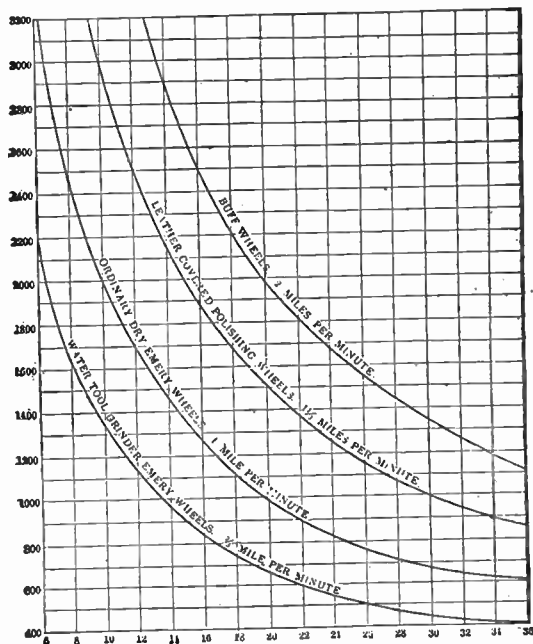

Fig. 4,593.—Speed curves for emery and polishing wheels. There can be no hard and fast rules for the speed of emery and polishing wheels since there is so great a variety in the nature of the work to be done, but a peripheral speed of about a mile a minute for ordinary emery wheels is commonly regarded as good practice. For water tool grinders the speed is usually about two-thirds that of dry grinders, while on the other hand, polishing wheels are generally run at about one and one-half, and buff wheels at twice the speed of dry grinders. The above diagram affords a convenient means for determining the revolutions that will give the above speeds and will be preferred by many to a table of figures. It is only necessary to trace a vertical line from the figure representing the diameter of the wheel to the proper curve and from the intersection point to trace a horizontal line to the figure which will give the revolutions per minute.

are run at speeds ranging from 1,000 to 3,000 revolutions per minute, they are usually built of selected kiln dried lumber one-half inch thick laid up with the grain cross in alternate layers, and then rigidly glued together. They are usually covered with heavy oak tanned leather. They may be used on any work requiring a hard, firm wheel, and they may be set up in any grade of coarse or fine emery.

When the emery begins to wear off, they should be washed in a *wheel washer*, or the old emery and glue may be removed by means of an *emery stick* or buff stick.

Felt wheels are the kind most extensively used, as they are the best suited for general purposes. They can be used for roughing, grinding, polishing and finishing, and when the glue and emery have been



FIG. 4,594.—Walrus or sea horse leather. Walrus leather has a peculiarly tough grain making it especially adapted for polishing wheels. It is extensively used for polishing iron, steel, brass, cutlery, silverware, etc., where a fine polish is required. It can be used with emery, crocus, rouge, or rotten stone and gives a smooth fine finish to the work. The leather is used in the form of solid wheels or cut into strips which are used for covering wood wheels. Walrus hides are invariably uneven in thickness and in order to avoid any misunderstanding as to thickness when purchasing, it has long been a recognized custom of the trade to measure the thickness at the part of the hide marked A.

removed, and a little suitable polishing compound, such as rouge or crocus is applied, they will give the highest polish to nickel plated articles of iron or steel. They are made in several grades, known as Mexican brown, French gray, Spanish white, etc. The Spanish white is the most expensive in first cost, but as it lasts longer and gives better results than the others, it is the cheapest and best in the end.

Walrine wheels made of Walrus hide represent the most efficient type of leather wheel. Their flexibility and elasticity combined with their hardness render them especially suitable for hard grinding. They are made of discs of hide varying from $\frac{3}{4}$ to $1\frac{1}{2}$ inches in thickness. The hides require from three to five years for tanning and possess a very tough grain.

These wheels are used chiefly in giving a fine polish to silverware, brass goods, bicycle parts, stoves, cutlery, edge tools, agricultural implements, etc. They can be used with crocus, emery, rouge, or rotten stone, and give a smooth fine finish to the work.

In using Walrine wheels, screw on pindle only tight enough to hold in place. Any flutter or side motion can be remedied by side pressure of the hand, or by either loosening or tightening the net on the spindle. Always run in the direction indicated by the arrow marked on the face of the wheel.

For silver, nickel, or brass work, use the *soft* and *medium* grades; for stove, axe and plow work, and for saddlery hardware use the medium grade; for gold, brass, emery hard grinding and for grease or oil work use the hard grade.

Ques. How do buffing wheels differ from the various kinds of grinding and polishing wheel?

Ans. They differ in that they are usually made of loose sections of sheep skin, or unbleached cotton cloth or muslin.

Ques. How are they used?

Ans. Various kinds of buffing composition are held against the buff from time to time, for setting them up during the progress of the work.

Ques. At what speed do buffs cut best?

Ans. At a speed that will make them stand up stiffly.

For cutting down work, buffs should be run at speeds ranging from 10,000 to 15,000 feet per minute, rim velocity, while for coloring work, they should be run from 5,000 to 8,000 feet per minute. As a rule, the larger the buff the greater will be the amount of work that may be accomplished in a given time.

Pickles and Dips.—While the best polish is secured by grinding and wheel polishing, many articles are best cleaned chemically by immersing them in solutions which dissolve the scale, grease, etc., adhering to them, leaving a clean but rough surface which must be polished afterwards.

Ques. What are pickles?

Ans. Solutions intended for prolonged action on rough surfaces.

Ques. What are dips?

Ans. Solutions intended for momentary action on a surface already smooth.



FIG. 4,595.—Dipping or immersion; a method of chemically cleaning many articles consisting of dipping them in solutions which dissolve the grease scale, etc. Successful dipping depends chiefly upon quick and careful handling rather than upon the dips themselves, and the holes in these baskets should be as large as possible to allow the rapid escape of acid or cyanide. The usual sizes of hole in dipping baskets are $\frac{1}{8}$, $\frac{1}{4}$, $\frac{3}{8}$, $\frac{1}{2}$, $\frac{5}{8}$, $\frac{3}{4}$, $\frac{7}{8}$, to 1 inch in diameter.

Ques. What precautions should be taken in pickling and dipping?

Ans. The articles to be immersed should be clean and dry.

This is secured by dipping the work in boiling lye and then rinsing in boiling water, shaking a moment to drive off the water and then immersing in the dip.

Black Pickle for Iron:—Sulphuric acid 66° Baume, 1 part; water, 15 parts. Used chiefly for removing scale from castings and forgings.

Bright Pickle for Iron:—Water, 10 quarts; concentrated sulphuric acid, 28 ozs.; zinc, 2 ozs.; nitric acid, 12 ozs. Mix in the order named. The pickle leaves the metal bright.

Dip for Copper, Brass, etc.:—Sulphuric acid, 66° Baume, 50 parts by weight; nitric acid, 36° Baume, 100 parts by weight; common salt, 1 part by weight; lamp black, 1 part by weight. Forgings, punchings, etc., are pickled in dilute sulphuric acid to remove scale, and then cleaned and brightened by dipping in the above solution.

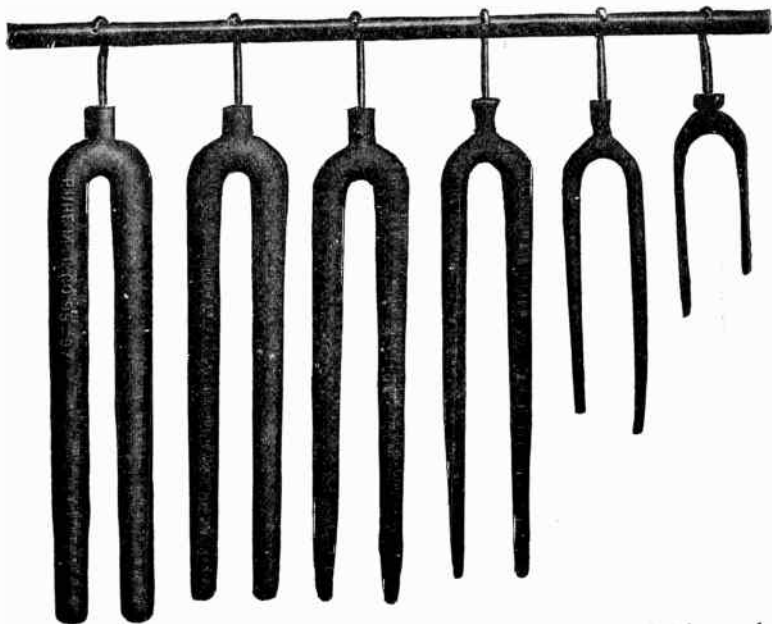

Figs. 4,596 to 4,601.—Characteristic disintegration stages of Munning-Loeb 2 bar anodes. The nickel anode on the left weighed 14 lbs., that on the right in the last stage of disintegration weighed 8½ ounces; 3.8 per cent. waste.

Cyanide Dip for Brass:—Potassium cyanide in ten times its weight of water is used as a preliminary dip when plating articles that would have the polish injured by the acid dips. The work must be allowed to remain longer in this than in the acid solutions.

Pickle for German Silver:—German silver may be cleaned in the bright dip for brass, or in a preliminary pickle of dilute nitric acid and

water (12 to 1), followed by a dip of equal parts of sulphuric and nitric acids, and then by rinsing in boiling water and drying in sawdust. Use sawdust that contains no tannin.

Nickel Plating.—Nickel, when electrolytically deposited is extremely hard and brittle, and it is not at all easy to deposit to any great degree of thickness, as, after a certain amount has

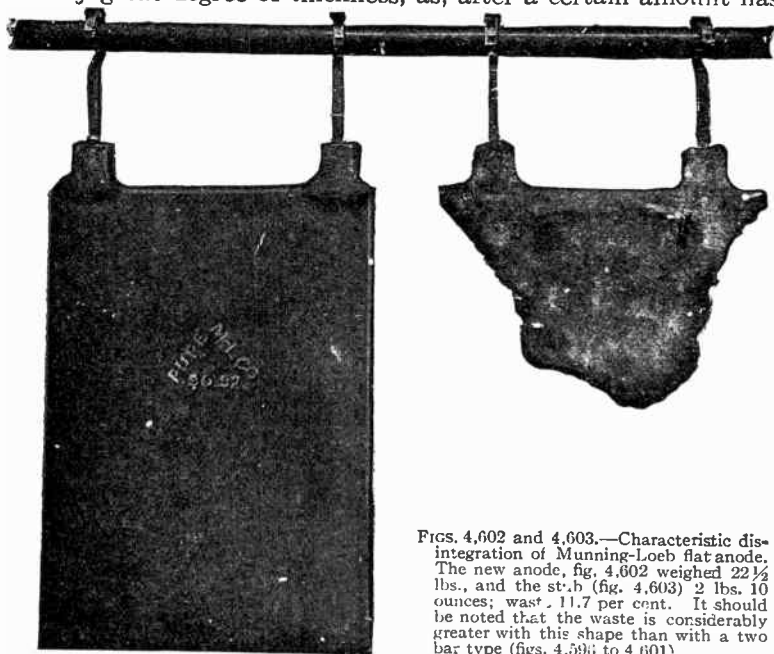

FIGS. 4,602 and 4,603.—Characteristic disintegration of Munning-Loeb flat anode. The new anode, fig. 4,602 weighed $22\frac{1}{2}$ lbs., and the stub (fig. 4,603) 2 lbs. 10 ounces; waste, 11.7 per cent. It should be noted that the waste is considerably greater with this shape than with a two bar type (figs. 4,596 to 4,601).

been plated on, it is inclined to flake off. It does not adhere very well to iron or steel articles, and furthermore, if after being plated upon steel, the article becomes scratched, the steel rusts, and the rust, getting beneath the nickel film, causes it to peel off. It is, therefore, very usual to first coat the iron with a film of copper, which, being a soft metal, is not readily removed by

scratching. The nickel is then deposited upon the copper coating. Nickel cannot be deposited from solutions containing more than a trace of acid; most nickel plating solutions consist of a solution of the double salt of ammonium sulphate and nickel sulphate, which is rendered alkaline with ammonia.

In order to obtain a thoroughly satisfactory and brilliant deposit of nickel, the articles which are to be plated must be very carefully prepared, and should have a burnished surface.

The minutest scratches upon the goods to be plated can be seen even after a considerable thickness of nickel has been deposited. It has been found that the addition of minute quantities of carbon disulphide to the plating bath causes the metal to be deposited in a very brilliant form, the addition of small quantities of boric acid also improved the appearance of the deposited metal.

Since plated nickel has such an extremely hard surface, it is important that the metal should be plated in a brilliant form, because it is extremely difficult to burnish should the deposited metal have a dull appearance.

Electrotyping.—In preparing electrotypes a wax impression is taken of the form, which is made up usually of type, or illustrations, or both. In order to do this a metal plate is evenly coated with a wax composition, and this is placed with the wax face downward upon the form. The form with the wax upon it is then placed in a hydraulic press and subjected to a steady pressure of about two tons to the square inch. To prevent the type adhering to the wax, it is dusted over with finely powdered graphite. After being taken out of the press, the wax is carefully removed from the type, and then graphited in order to render the surface conducting. It is then thoroughly washed with water.

Although graphite will conduct the current by simply placing a prepared plate in the bath, it is not always easy to obtain good contact. It is usual, therefore, to either coat the mould with copper by some chemical process, or to drive little brass nails through the wax in order to make electrical contact with the metal plate at the back, and thereby get the current evenly distributed over the surface. Of course, the

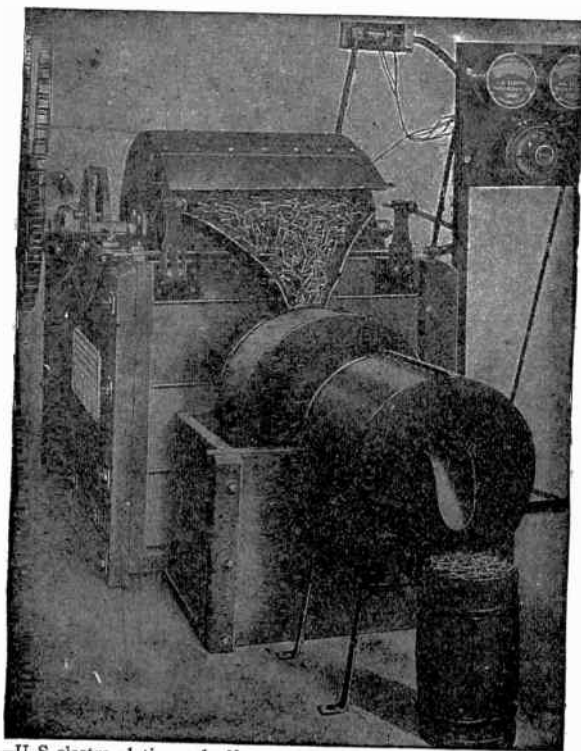
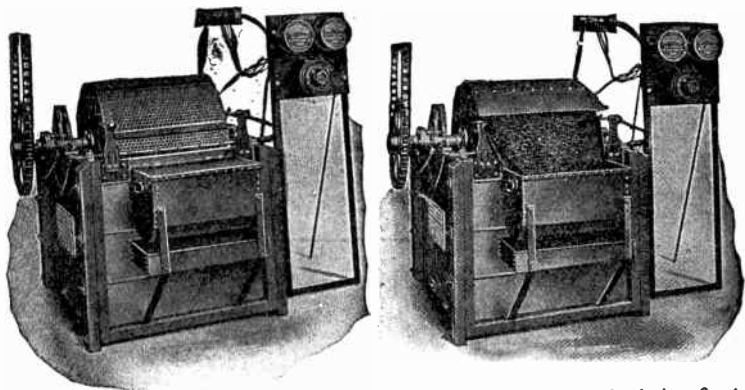

FIG. 4,804.—U. S. electro-plating and self-emptying barrel for brass, nickel, copper, tin, zinc, etc. **Method of galvanizing:** After pickling and cleaning the material the galvanizing barrel is then filled by means of pails, shovels, etc., with from 150 to 200 lbs. of material at a time, and is then started to turn slowly "in the galvanizing direction," and in about 40 to 50 minutes the material is finished. Upon reversing the motion of the barrel, it thereupon empties the galvanized material (in from three to four minutes) into the washing drum of the washing and drying apparatus and gradually goes into draining drum, from there to drying drum, from there into whatever receptacle is placed for receiving the material ready for shipment. **Quality and thickness of coating:** The thickness of the coating can be regulated according to requirements, and depends upon the length of time the material is allowed to remain in the galvanizing barrel while galvanizing. The coating deposited consists of chemically pure zinc, uniformly smooth. With the apparatus, one laborer can attend to two barrels and turn out from 3,000 to 5,000 lbs. of material per day; two men and a boy will be able to attend to about six barrels. **Cost of galvanizing:** This depends on the number of barrel in use, thickness of coating required, and upon the nature of the material treated. It is equivalent to from 25 to 40 cents per 100 lbs. **Range of the barrel:** The barrel will galvanize any kind of small material as, for instance: bolts and nuts (from the smallest size to 8 in. long), nails, rivets, spikes, screws, small castings and fittings, stampings, sash pulleys, lag screws, washers, springs, etc., in fact all such material excepting that having very deep recesses or hollow material which requires inside galvanizing.

nails must only be driven in between spaces, otherwise the impressions of the type would be injured. The chemical method is the better one. The mould, after having been washed, is covered with a solution of copper sulphate and then fine iron filings are sprinkled over it; in about half a minute by this means the whole surface becomes covered with a thin coating of metallic copper. The excess of copper sulphate and the iron filings are washed off with a jet of water, and the mould placed in the depositing vat, being so hung that the coppered part faces the anode.

The time required for the production of the copper shell varies considerably in different establishments. When the electrolyte is in good condition, and is heated to the correct temperature, high current densities may be employed, and a shell of sufficient thickness can be prepared in from 30 to 40 minutes. In most electrotyping works a considerably longer time is, however, employed.



FIGS. 4,605 and 4,606.—U. S. electro-plating barrel. Fig. 4,605, view while plating; fig. 4,606, view while emptying. It empties by lifting a lever which reverses the motion of the barrel.

When a sufficiently thick deposit has been obtained (and this varies with the work for which the electrotype is required) the mould is taken out of the bath, and the shell separated from the wax by pouring hot water on it, or with a jet of steam.

In the case of electrotypes used for lettering or illustrating the outside of books, very heavy deposits are made.

The next process is to pour the backing metal into the copper "shell" to make it a standard thickness. The shell is carefully cleaned and painted over with soldering fluid, and then a double sheet of tin foil spread over it. The shell is now placed on a sheet of iron, and floated upon a bath of melted "stereo" metal. The tin foil melts and produces

an even coating all over the inner surface of the copper mould. As soon as the whole of the foil has melted the plate is removed from the bath and placed on a slightly recessed iron table. "Stereo" metal is now poured in until the shell is completely filled. It is then allowed to cool. The next process consists in planing down the back, bevelling the edges and hammering up any depressions. Any shell spaces which might get in the way during printing are then "routed" out, and the "electro" is mounted "type high" either on metal or on wood, and is now ready for the printing press.

Galvanizing.—A bath containing zinc sulphate, which must only be slightly acid, is employed; as the electrolysis proceeds the solution becomes acid by the zinc being deposited out, and in order to keep the strength of the solution constant, it is circulated through a filter bed containing zinc dust. Zinc anodes are not generally used because they are apt to disintegrate; the anodes usually employed are of lead, but iron is sometimes used. In fact, the presence of a trace of iron in the bath improves the deposit.

CHAPTER LXXXVII

ELECTRO-THERAPEUTICS

By definition electro-therapeutics is *the treatment of disease by electricity*; it embraces the laws, principles, and doctrines of such treatment.

Electricity is of special value in the treatment of various forms of nerve lesion, thus giving a distinct place in the practice of every reputable physician.

The kinds of electricity used may be classed as.

1. So called static;
2. Current;
3. Radiant.

Such terms as *galvanic electricity* (produced by means of a primary battery), and *faradic electricity* (produced by secondary induction coils), are commonly, though ill advisedly, used by the medical profession.

Ques. How is the so called static electricity produced?

Ans. By influence machines.

The principal types of influence machine are the Wimshurst and the Toepler-Holtz.

Fig. 4,607 shows a Baker static machine of the Toepler-Holtz type. The central plate A, is of glass, and is stationary. The outside plates B, one on each side of the plate A, are mounted on a common shaft, rotatable either by a crank handle, as in the smaller machines, or by

electric motor drive in the case of large high speed machines. The outside or revolving plates in this particular machine are constructed of a patent fibrous material in the form of a sheet, which extend over the entire area of the plate and are pinned together in cement and hardened under hydraulic pressure. They are of extremely high insulation and are not resonant like glass and mica. The operation of the machine is explained under the figure.

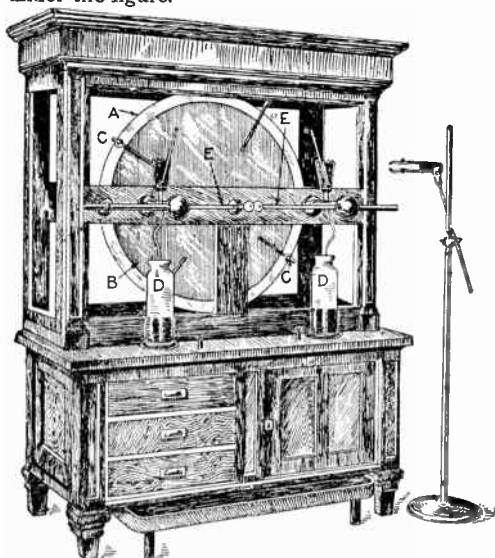

FIG. 4.607.—Toepler-Holtz influence machine. Its principle of operation is induction. *In operation*, an initial charge is required. This is given to one of the metallic surfaced field plates, cemented to the stationary plate. When the outside plates are revolved, the tinfoil buttons—*current carriers*, on their external surfaces become charged inductively as they pass the field plates, a brush of fine brass wire permitting the escape of the electricity of the same kind as that of the charge of the field plate. The carriers thus charged pass the collecting combs, C, C, communicating to the latter a portion of their charges. They are then discharged by a neutralizing brush similar to the brass wire contact brush, already mentioned, and connecting with the field plates, thus increasing the charge of the latter. Since there are two field plates, located opposite each other on the stationary plate, but charged with opposite kinds of electricity, the process of recharge and discharge becomes continuous. The electricity for the collecting combs connecting with the main conductors passes to the Leyden jars D, D, where it is collected in the form of a powerful static charge. The charges on the field plates increase automatically until the leakage between the plates equals the additions to the charges. The leakage, therefore, limits the maximum voltage obtainable. When the discharging rods E, E, are close together, the electrical pressure obtained is lower, due to the smaller pressure required for a spark discharge across the air gap. With a lower pressure, the discharges will occur in rapid succession. Increasing the distance between the knobs of the discharging rods will give an increase of pressure attended by a diminished frequency of discharge. *The effect of the Leyden jars* is to diminish the electrostatic resistance between the main terminals of the machine, thereby enabling a given voltage, to accumulate a greater charge between the terminals.

Ques. What precaution should be taken in operating influence machines?

Ans. Great care should be taken to maintain their insulation, especially during damp weather, so as to reduce the leakage to a minimum. The different parts and conductors, particularly all glass parts which are liable to become coated with conducting films of moisture, should be covered with shellac, varnish or paraffin. The better class of machine is enclosed in a glass

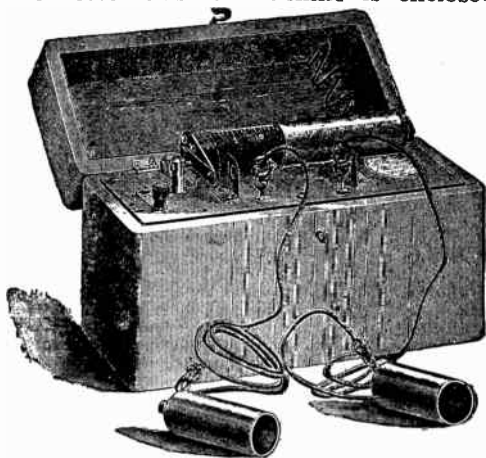

FIG. 4,603.—Medical induction coil, or faradic battery set. *In operation* metallic tube A is moved over the surface of the secondary coil. The latter is practically an independent secondary coil made up of a single turn, having a very low resistance. Its presence has a reactive influence on the primary circuit, which increases the further the tube is pushed over the coil, thereby reducing the induced voltage in the secondary coil. The current through the external circuit, including the body of the patient, when the resistance of the latter and the voltage at the secondary terminals of a coil are known may be determined by Ohm's law as follows: assuming the resistance of the external circuit as 3,000 ohms, and the pressure at the secondary terminals 8 volts, the current through the external circuit will be $(8 \div 3,000) = 2\frac{2}{3}$ milli-amperes.

case, and the air within kept dry by the absorbing property of calcium chloride or other highly hygroscopic substance.

Induction Coils.—These are employed chiefly for the application of currents of varying voltage, strength and

frequency and wave form directly to the patient, and for supplying the high frequency current required for the operation of vacuum tubes.

All medical induction coils are of practically similar construction, consisting of a primary and secondary coil in mutual inductive relation to each other, a core made up of a bundle of soft iron wires, and an interrupter to vary the frequency of the primary current. The number of turn in the primary and secondary coils, the voltage of the primary current, and the

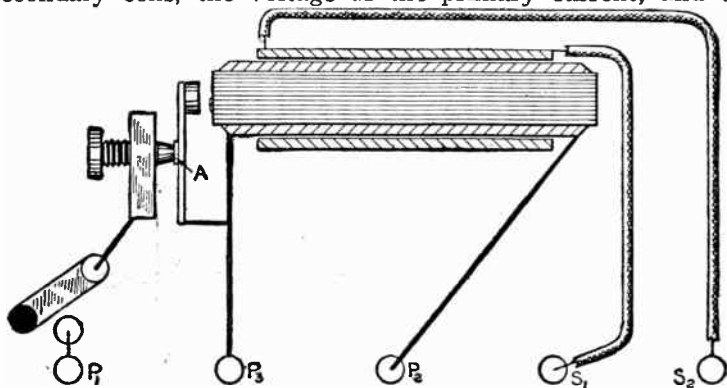

FIG. 4,609.—Diagram showing connections of a medical induction coil. P_1 and P_2 , are the terminals of the primary circuit (including vibrator). S_1 and S_2 , those of the secondary coil. The terminal P_3 , is connected to the vibrating spring or interrupter A . *In operation*, when the vibrator spring breaks the circuit, the pressure in the primary circuit will be generated between the terminals P_2 and P_3 , while that due to mutual induction will be developed between the terminals S_1 and S_2 , of the secondary coil. The voltages supplied from the two sets of terminal are quite different, however, as S_1 and S_2 , will supply the same both at the making and breaking of the primary circuit, in opposite direction, on the other hand, the voltage obtainable from P_2 and P_3 , will be practically zero at making, and rise to its full value suddenly at breaking. The primaries of medical induction coils consist of from 4 to 6 layers of No. 24, 22, or 20 wire, according to the dimensions of the coil, while the secondaries are wound with No. 36, or 34 wire.

manner in which the mutual induction between the coils is varied, depends entirely upon the purpose for which the coil is used.

The value of the voltage induced in the secondary circuit depends on the number of turn in the secondary coil and the frequency of the primary current.

When the interrupter consists of a vibrating spring, alterations of the frequency in the primary circuit are made by means of the spring contact screw. Increasing the tension of the vibrating spring and reducing its range of vibration increases the frequency, and *vice versa*. Ordinary spring vibrators give a frequency of from 150 to 300 cycles per second.

The action of a coil varies greatly, not only with variations in the rate of frequency, but also with the character of the interrupter. The use of slow speed spring vibrators give powerful secondary currents.

The connections of a medical coil is shown in fig. 4,609. Usually, they are so arranged that the pressure induced in either the primary or secondary circuits may be externally used.

Induction coils or spark coils may be operated:

1. By means of either primary batteries or storage batteries, through vibrators or rotary circuit breakers;
2. From direct current electric light circuits operating small motor generators for producing low tension currents;
3. By connecting the primary winding directly to electric light circuits through suitable resistance and contact breakers;
4. From alternating current electric light circuits in connection with an air gap, a *Tesla* coil, and a suitable condenser.

Spark coils are usually rated according to the length of spark. For instance, a two inch coil is one in which the voltage in the circuit is high enough to cause a spark to jump across an air gap of two inches between the knobs of the secondary terminals.

High Frequency Apparatus.—This is used for therapeutic or radiographic purposes, and includes various forms of alternators producing directly frequencies up to 10,000 cycles per second; powerful induction coils charging condenser, which produce high pressures through the discharging circuit, in a manner similar to that of influence machines through the medium of Leyden jars; and suitable influence machines.

Ques. How are high frequency discharges applied in the treatment of diseased parts?

Ans. By means of tubular glass electrodes which are properly shaped to fit the cavities for which they are intended, as shown in figs. 4,610 to 4,616, thus avoiding the possibility of their becoming broken therein.

Interrupters.—For the successful operation of an induction coil, the current must be rapidly interrupted. There are various methods of interrupting the current which may be classed as

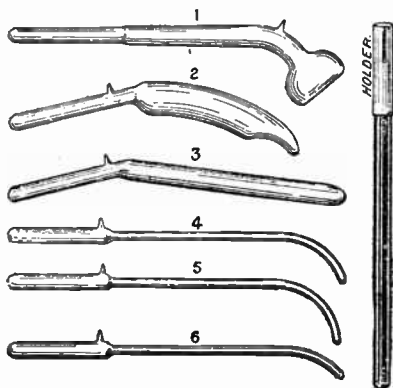

Figs. 4,610 to 4,616.—High frequency electrodes for treatment of diseased parts. The set comprises suitable tubes for vaginal, rectum, throat, nose, and general application, and an insulated universal holder.

1. Magnetic;
2. Electrolytic;
3. Mechanical.

The ordinary "vibrator" placed on many coils, represents the magnetic method, and though called a vibrator, it is in fact a magnetic interrupter.

Ques. Describe the Wehnelt electrolytic interrupter?

Ans. It consists of a porcelain jar, a large lead electrode, a small platinum electrode, and an electrolyte consisting of

dilute sulphuric acid. The platinum parts are mounted on a lead stem and protrude through a porcelain tube.

Ques. Explain its operation?

Ans. When the electric current flows through the electrolyte from the small platinum electrode to the large lead electrode, bubbles of gas form at the platinum point, momentarily stopping

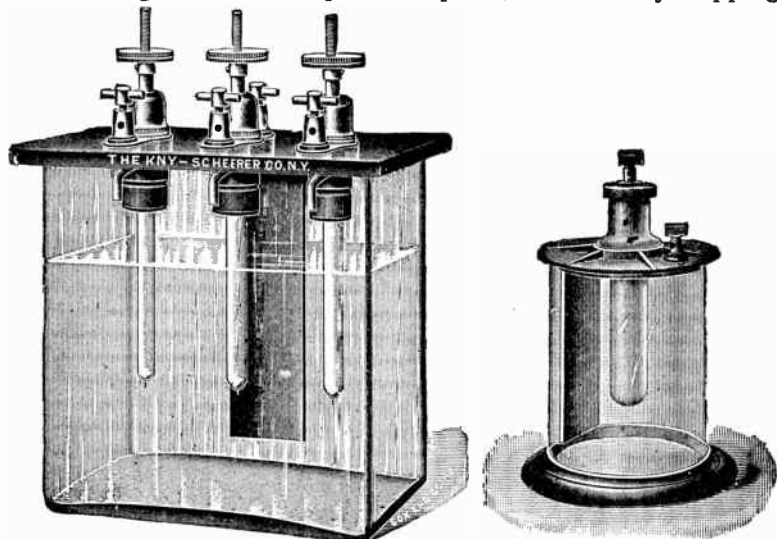

FIGS. 4,617 and 4,618.—Wehnelt electrolytic interrupters. Fig. 4,617, 3 point interrupter; fig. 4,618, 1 point interrupter. In the multi-point type two or more anodes can be used at one time in parallel, thus more current can be passed through the primary.

the passage of the current. The bubbles are absorbed by the electrolytic action and the current flows again and this operation is continually repeated.

Ques. How is the current regulated?

Ans. The amount of current that will pass depends on the size of the platinum point, also on the amount exposed.

For this reason a multi-point interrupter is preferable, allowing a selection of the various sized points.

For practical work the three point type is the more successful. When a great volume of current is necessary for radiographic work, the heavy point is used; for medium or lighter work, the medium point, and for prolonged treatment, the smallest point, which operates the outfit on one-fourth to one-tenth the current consumed by the larger point.

For prolonged use an interrupter should have a metal water jacket to prevent heating.

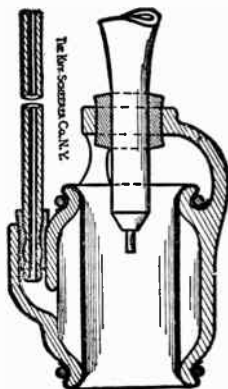

FIG. 4,619—Muffer for Wehnelt electrolytic interrupter. There is a slight noise when the electrolytic interrupter is in action due to the generation of sulphide of hydrogen gas. This is hardly objectionable, but as patients are usually in a nervous condition and a sound may figure as a disturbing factor, a muffer which practically eliminates the noise, is desirable.

Ques. Describe, and explain the action of an anti-acid interrupter.

Ans. As its name implies no acid is used, the electrolyte consisting of an alkaline solution. By using an aluminum plate in place of a lead plate, it acts on alternating current both as a rectifier, and an interrupter.

For continuous service as in treatment, the anti-acid interrupter can be readily substituted for the mercury interrupter, when the latter has been used with a rectifier with indifferent results.

Ques. Describe the construction and operation of the mechanical interrupter shown in figs. 4,620 to 4,622.

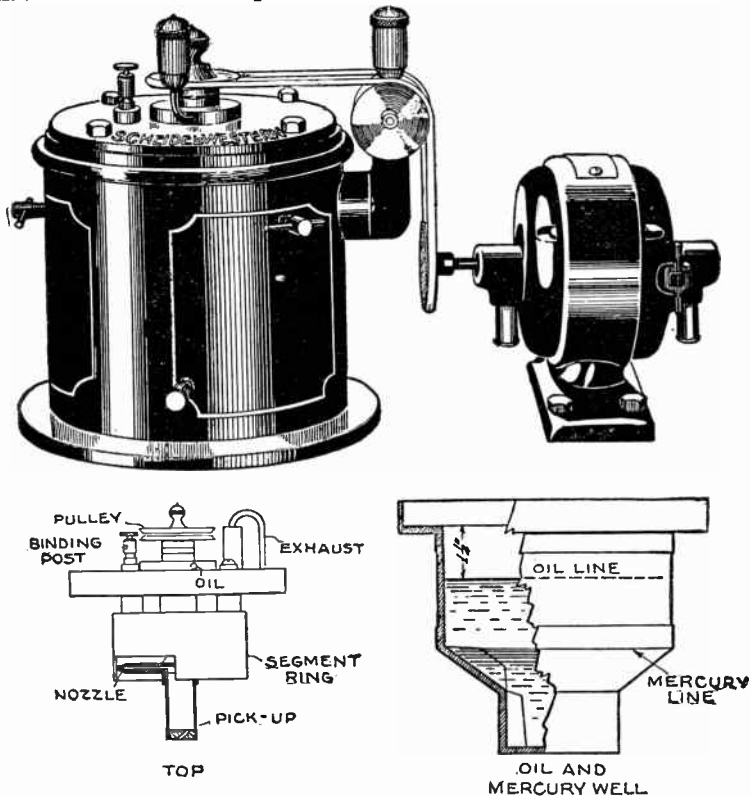

Figs. 4,620 to 4,622.—Scheidel-Western mercury turbine or *mechanical interrupter*. Fig. 4,620, view of interrupter and motor; fig. 4,621, mechanical parts; fig. 4,622, oil and mercury well. When an induction coil is used with direct current for considerable periods for X ray treatment, for fluoroscopic work, or for operating a resonator, a mechanical interrupter will be found more desirable than the electrolytic type. If an electrolytic interrupter be used for such work, the solution heats by continual use, the rate of interruption varies and there is considerable wear on the platinum points. It should be noted, however, that the electrolytic interrupter passes a greater amount of current than is possible with the mercury type, and accordingly is more efficient for rapid radiographic work. The mercury interrupter is not as suitable for alternating as for direct current even if a rectifier be employed; for alternating current an anti-acid interrupter is preferable.

Ans. Mercury is placed in an iron vessel connected by a binding post on the side of the electric current. Through the top is a shaft that is rapidly rotated by a belt from the motor. On the lower end of this shaft is a hollow disc, to which is attached a vertical tube extending to the bottom of the mercury receptacle. This tube is fitted with a screw feed and on one side of the disc is a hole and nozzle connecting directly to the vertical tube. As the shaft revolves, the mercury is lifted through the tube and forced in a stream from the nozzle on the edge of the disc. Just beyond the circle described by this disc is an iron ring insulated from the top, and connected by a binding post on the top to the



FIG. 4,623.—Acid hydrometer for testing the density of the electrolyte of acid electrolytic interrupters. It is important to have the specific gravity of the acid as follows: For a 110 volt current, 1,220; for a 220 volt current 1,070 Baume. *The specific gravity can be approximately obtained* by mixing ingredients according to the formula sent with the interrupter, but as this will vary from the evaporation of the water, it is advisable to use a hydrometer to determine when (*distilled*) water must be added, or when making a new solution. *It should be noted* that the reading of a hydrometer varies with the temperature, accordingly the reading must be corrected. Some hydrometers have a thermometer and correction scale in the neck.

electric current. This ring has two segments opposite each other, extending down below the revolving disc. As the disc revolves, the stream of mercury strikes first one segment, completing the electrical circuit and sending the current through the primary of the coil. It then passes through the open space between the segments, breaking the contact, and striking the other segment, making contact again, and so on, completing the revolution, making and breaking circuit twice. The rate of these interruptions is varied by the speed at which the revolving disc rotates and is controlled through a separate rheostat that varies the speed of the motor.

In order to produce a satisfactory discharge from the secondary of the coil, the interruptions must be very rapid and at perfectly regular intervals.

To prevent oxidation of the mercury from the arc and to make a sharp break, the part of the interrupter above the mercury is partly filled with 175° flash test kerosene oil or Elaine oil.

Rectifiers.—The physician whose office is supplied with alternating current finds it necessary upon the installation of

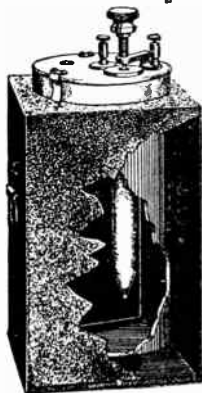

FIG. 4,624.—Scheidel-Western anti-acid interrupter. In this type of interrupter an alkaline solution is used. By using an aluminum plate in place of the lead plate, it acts as the alternating current both as a rectifier and an interrupter.

a wall plate to put in some device to change the alternating current to a direct current possessing the proper proportions for use in galvanic application. Alternating current may be changed into direct current by means of

1. Rotary converters, or
2. Rectifiers.

Both are satisfactory, but the converter is much more expensive to install.

Ques. Describe a rectifier and explain its operation.

Ans. It consists of steel and aluminum electrodes in an

alkaline solution, the combination or cell acts as a valve, permitting the current to pass from the steel to the aluminum plates, but not in the opposite direction (from the aluminum to the steel). In this way a uni-directional current is obtained, on which an electrolytic interrupter will operate.

Currents used in Electro-therapeutics.—Many kinds of electric current are used, to secure different effects, all of which may be classed as

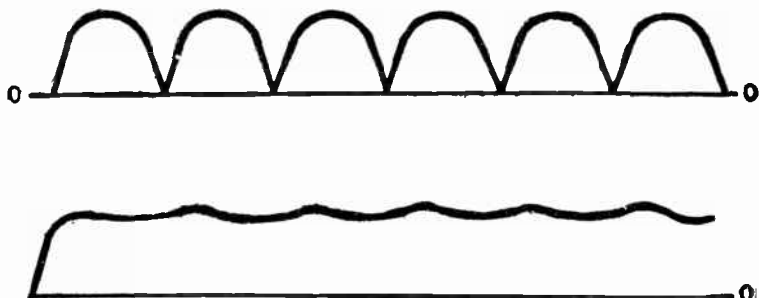

FIGS. 4,625 and 4,626.—Electrolytic rectifier current curves. The electrolytic or chemical rectifier, operating on the principle of transposing one half of the alternating current cycle, delivers a direct current possessing the polar properties required in galvanism, but consisting of a number of minute impulses of current flowing in the same direction and joined together as indicated in fig. 4,625. The current thus produced is capable of producing the same chemical reaction as the current from a dynamo, or battery, although there is quite a noticeable pulsation in the current due to the undulation in voltage as is noted by observing the rise and fall of the pressure as in fig. 4,625. It has been found that by connecting a condenser across the direct current terminals of the rectifier that the undulation of the voltage indicated in fig. 4,625 is equalized as shown in fig. 4,626, so that the current delivered possesses an almost unwavering strength.

1. Direct;
2. Intermittent;
3. Alternating, or some modification formed by combination.

The apparatus used permits of many modifications. Usually a dial selector switch is provided by means of which any of the currents may be obtained, thus producing various changes, as: frequency control: primary faradic wave; secondary faradic

wave, interrupted galvanic wave; combined galvanic and faradic wave, etc.

The Selection of Electrodes.—The physician entering the field of electro-therapeutics finds the selection of suitable electrodes a rather perplexing problem, especially as some writers recommend the use of some favorite metal in almost every conceivable application. Neiswanger is partial to copper, Massey holds fast to zinc, and Martin is a strong advocate of platinum. The matter really resolves itself to the question:

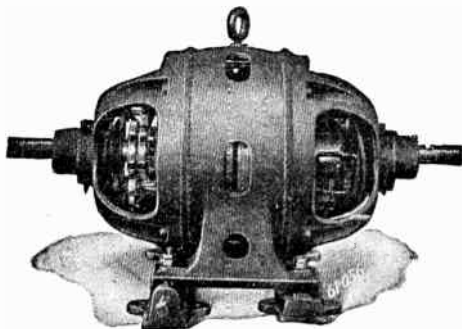

FIG. 4,627.—Scheidel-Western single phase rotary converter for changing alternating current to direct current for operating X ray coils, and other apparatus when a very large amount of current is desired for short periods.

“Shall the particular electrode be soluble or insoluble?” in other words, shall it be immune or subject to the electrolytic decomposition which takes place at the positive pole?

The following items will be found helpful in the matter of selecting electrodes.

The positive pole of the galvanic current liberates and attracts the atoms of oxygen and chlorine found in the fluids of the body which attack the metal composing the electrode; and if it be one of the baser metals, such as copper, zinc, or iron, a salt is readily formed; this constituting the oxy-chloride of the respective metal.

The negative pole gives rise to no such decomposition as takes place at the positive, and hence, the metal is not an important factor, although

nickel plated instruments are usually utilized for special applications with this pole, because they do not tarnish or rust.

The faradic current has no chemical properties and the metal utilized is not an essential item, although nickel plating is preferred.

The sinusoidal current lays no claim to any special polar effects and accommodates itself to the form of electrode most readily available.

Copper, zinc, and iron are used largely for their antiseptic and astringent properties and the former is in popular favor at the present day. A copper electrode is valuable for metallic electrolysis at the positive pole and is useful on the negative pole or with the faradic current.



FIG. 4,628.—McIntosh monomotive rheotome, for interrupting galvanic, faradic, or sinusoidal current for therapeutic application. The range of interruption is from 20 to 400. *The instrument consists of a clock work mechanism with platinum tipped contact, and is wound up with a key, running 45 minutes with a single winding. In adjusting, a lever is turned to the frequency desired; this movement of the lever turns on the clock mechanism, selects the frequency and places the rheotome in the circuit. Turning the lever back to the "off" point similarly cuts it out of circuit and stops the mechanism. The motion of the spring is impeded by a fan, hence the resistance is the same in either horizontal or vertical position. In connecting, it is placed in series between the patient and battery or other apparatus.*

Nickel plated electrodes are designed especially for use with the faradic current or the negative pole in galvanism, and should on no account be employed on the positive pole, as the plating would be stripped; this also applies to gold plated needles, for, it will be recollected, gold is subject to the influence of chlorine.

Block-tin, platinum, and carbon are capable of withstanding the action of the positive pole, being unaffected by either chlorine or oxygen, and therefore may be utilized where the effects of this polar are

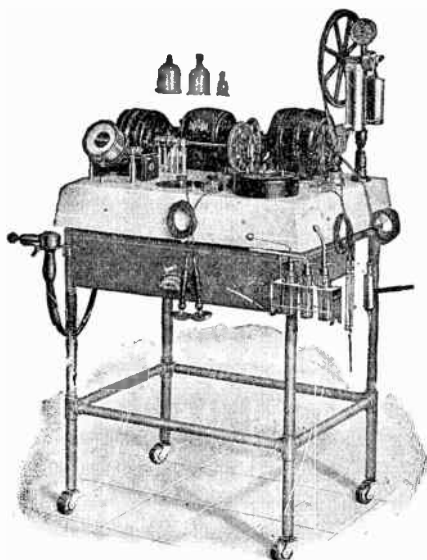
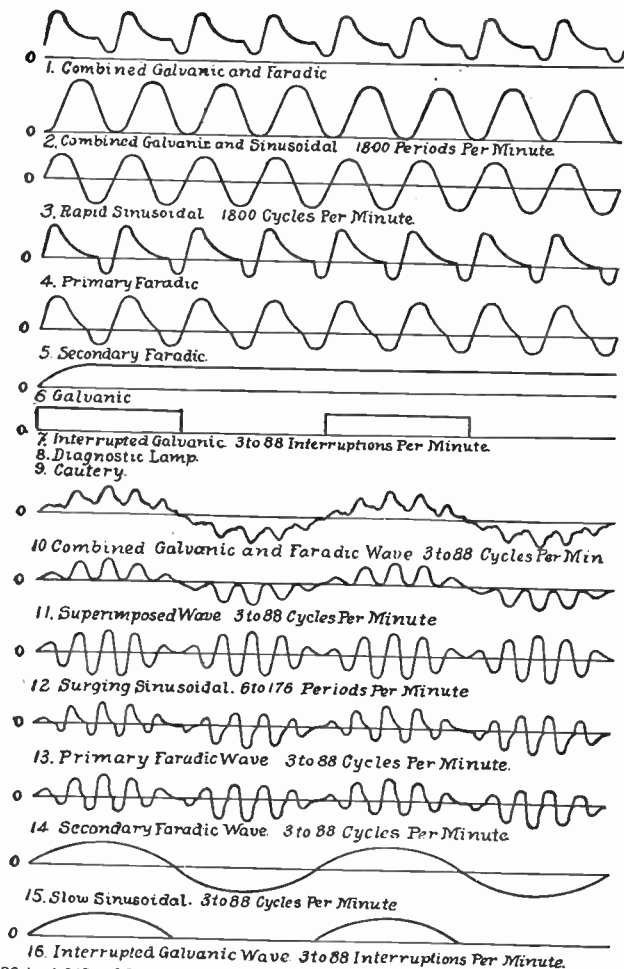

FIG. 4,629.—McIntosh universal mode. The features of the apparatus are as follows: **Dial current selector.** A single knob controls the selection of any one of the sixteen distinctive effects secured, all plainly lettered on the dial. **The sinusoidal current.** Nine varieties of sinusoidal current may be obtained. A friction device controls the frequency of the slow sinusoidal by turning a knob. **The galvanic current.** This current for electrolytes, calaphoreses, gynecology, etc., is generated in the apparatus, having no ground connection, and is controlled by the MacLagan wire rheostat and measured by a milli-ampere meter. **Interrupted galvanism.** This is for muscle and nerve testing in reaction or degeneration and is obtained by a mechanical rotary break from 3 to 88 periods per minute. **The faradic current.** This may be either primary or secondary, with rapid interruptions. It may also be passed through the sinusoidal rotor and delivered in a sine wave. The faradic current may also be combined with the galvanic current. **Electro-cautery points, loops, and snares.** These may be heated with regulation of degree of heat. **Vibrating massage.** When desired for spinal stimulation, inhibition or local effects is secured by fitting a massage cable to the attachment on shaft of motor. **Nasal drilling.** By attaching a suitable cable to shaft of motor, means for nasal drilling is afforded. **Spraying of oils or liquids.** This is accomplished by means of a pump capable of operating against pressures up to 50 lbs. The degree of pressure may be regulated by turning a thumb screw. For massaging the tympanum, the length of stroke can be shortened by adjusting the position of eccentric on the driving wheel. Deep suction, suitable for aspiratory purposes, or for producing hyperemia according to Bier's method is available. **Endoscopic lamps.** These may be illuminated and controlled for diagnostic purposes.

NOTE.—The term sinusoidal current has been used by many manufacturers as a rather vague characterization covering many forms of current having very little in common in the way of physiologic action. The first form of sinusoidal apparatus introduced to the medical profession was of the nature of a magneto with pole pieces cut away so as to produce a gradual rise and fall in the voltage of the current developed. This style of apparatus had among its early advocates Dr. Kellogg of Battle Creek, who has done much to advance the use of this modality, especially in hydrotherapeutic work.



FIGS. 4,630 to 4,643.—Modalities of the McIntosh universal mode. In addition to the sixteen illustrated, the following are also available: 17, mechanical vibratory massage; 18, nasal drilling to remove obstructions; 19, electrically heated air; 20, pneumo-massage of tympanum, eye or skin; 21, spraying of liquids or powder blowing in nose or throat work; 22, vaporizing or nebulizing of oils; 23, deep suction suitable for aspirating in congested sinuses; 24, Bier's hyperemia.

desired in cases where the application of metallic salts is not indicated. Platinum is very costly and carbon is brittle and hard to work, but block tin is more practical as the cost is not prohibitive and it is easy of adaptation.

Vaginal and intra-uterine electrodes are always best of copper, except for faradization or dilating, when nickel plating is preferable.

Rectal electrodes are usually more desirable in copper, as the treatment of hemorrhoids demands this particular metallic salt.

Abdominal electrodes are preferably composed of a block tin plate with a suitable covering.



FIG. 4,644.—Dr. Rice's epilation set comprising electrodes necessary for epilation according to the method introduced by Dr. May Rice of Chicago. The set contains: Face anesthetizer; lip anesthetizer; needle holder with magnifying glass; forceps; hand spongio electrode; bulbous pointed epilator needles; broaches for growths.

Urethral electrodes, if required solely for the treatment of stricture, should be nickel plated, but for the treatment of gleet and kindred ailments copper is indicated.

Eye, ear, nose and throat electrodes are largely called for in copper, but in cases where the faradic or sinusoidal currents are to be employed, nickel plating is more desirable.

Epilating electrodes or needles are usually of steel, as the negative pole is most commonly employed for this purpose.

As a summary it might be said that copper is a very serviceable, all round metal, and can occasionally be replaced by zinc or iron; but nickel plated instruments are in a class of their own, and are unexcelled for certain special applications.



FIG. 4.645.—McIntosh type 12 aseptically porcelainized plate. *Direct current operation.* When the plate is employed with direct current lighting circuit, the galvanic and faradic circuits of the plate are supplied by the direct current; while a motor generator must be employed to transform the *direct* current to an *alternating* current to properly energize the transformer for cautery and sinusoidal currents. In this manner each circuit of the plate is supplied with its appropriate form of energy. *Battery equipment.* With a battery of 50 dry cells and a motor generator the same results can be had as with the direct lighting current, the cells being good for 100 brief cautery operations and several hundred galvanic, faradic and sinusoidal applications. Dry cells, however, constitute an expensive current service. *Alternating current installation.* With the alternating current the rectifier with pressure equalizer is necessary to transform the *alternating* current to a *direct* current in order to operate the galvanic and faradic circuits, while the alternating current in its original form is employed with the transformer for cautery and sinusoidal currents. *The dial current selector.* With one turn of the knob all connections for any given modality are instantly made and the current is ready for use. Eleven distinct modalities are plainly indicated on the dial. When the knob is turned "off", the current is completely cut off from all circuits of the plate. *The rheostat.* This consists of a solid block of porcelain, wound with high grade resistance wire, with a traveling contact which increases or diminishes the current strength imperceptibly controlling the galvanic, faradic and sinusoidal currents. The volt scale shows the voltage of galvanic current used. *Monomotive rheotome.* This is an interrupter, which may be used to interrupt either the galvanic, faradic or sinusoidal currents; being especially valuable with the former in muscular diagnosis. It is wound up as a clock by means of the key accompanying the outfit, and, as its name indicates, requires but *one motion* to start mechanism, select frequency, and close circuit. *The faradic coil.* This is a secondary coil with a primary winding of 230 feet of No. 20, a rather coarse wire; and a secondary of 1,300 feet of No. 30, a comparatively fine wire, thus affording a comprehensive range of induced currents. The slowly interrupted faradic currents are secured with the monomotive rheotome, varying from 20 to 400 per minute. *The transformer.* This transforms alternating current of 110 volts, $1\frac{1}{2}$ amperes, to a cautery current (which is also an alternating current) of 4 volts, 35 amperes, sufficient for all ordinary knives, under perfect control of operator. The sinusoidal current obtained from the transformer is "earth free," having no "ground" connection, and, if desired, may be used in bath tub application, something unattainable with the ordinary wall plate on account of the average bath tub being grounded by the waste pipe connection. This feature is of especial value in a sanitarium. *Milli-ampere meter.* The meter has two scales, one in black figures reading 0-400, suitable for recording heavy dosages, which is placed in service by inserting the hard rubber plug in the socket marked "B;" and one in red figures reading 0-20, adapted to measuring lighter currents, which is in effect when the hard rubber plug is inserted in socket marked "R." The meter reads to right or left according to position of pole changer. Before using meter, the knob on scale pan may be adjusted so that the needle rests exactly at zero.

Galvanic Therapy.—The importance of the galvanic current in gynecology, rectal work, urology and for cosmetic purposes is recognized by all engaged in these branches of practice. The galvanic current possesses the following properties:

Positive pole

1. Oxygen;
2. Acid;
3. Will stop bleeding;
4. Sedative;
5. Hardens tissues;
6. Is an acid caustic and the resultant cicatrix is hard and unyielding;
7. Is a vaso constrictor.

Negative pole

1. Hydrogen;
2. Alkaline;
3. Increases bleeding;
4. Produces hypersensitiveness;
5. Liquefies and disintegrates;
6. Is an alkaline caustic and the resultant cicatrix is soft and pliable;
7. Is a vaso dilator.

Galvanic Technique

Cervical erosions. As erosions are commonly caused by excoriating discharges, they generally heal after the discharge ceases. Should the erosions persist, it is well to give two or three local applications with the Fitz Hugh electrode amalgamated and bare to the erosion. Thirty to forty milli-amperes with the positive pole of the continuous current will saturate the friable tissue with copper salts. This should be given four days to heal, when, if it seem necessary, the cataphoric application may be repeated. Follicular erosions should be opened with a bistoury and then treated with the bare tip of the amalgamated copper sound.

Epilation. (Hayes). Select a fine bulbous pointed steel needle, attach to needle holder, connect to negative pole, turn on about 20 volts and insert in hair follicle, allowing it to find its own way and avoiding perforating the follicle sheath. The patient is instructed to place the hand with gradual pressure on a well moistened pad connected with the positive pole until the circuit is completed, when a white froth at the needle indicates that electrolysis is complete and the hair may be withdrawn without traction.

Internal hemorrhoids. (Neiswanger). Place the patient upon the table in the gynecological position, wet thoroughly a pad as large as the hand, or larger, attach it to the negative terminal of the battery and place upon the abdomen. The positive is connected with the rectal electrode, which is then carefully introduced with the curved side down, pushing up with the electrode any fringe or prolapsed membrane. The current is now turned on by means of the rheostat until ten or fifteen milli-amperes is reached, and allowed to flow for ten minutes.

Urethral stricture. (Neiswanger). The technique is simple and may be briefly given as follows: The caliber of the stricture is taken in the usual manner with any set of urethral sounds, then an olive pointed

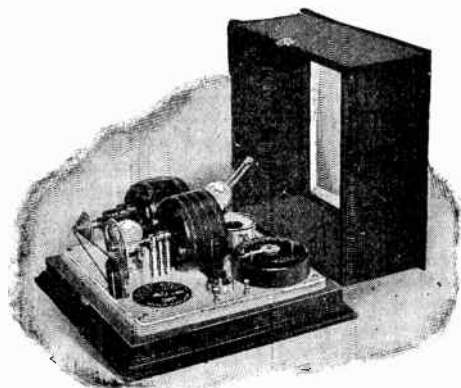

FIG. 4,646.—McIntosh polysine generator. It supplies a slow sine wave ranging from 12 to 120 cycles per minute; a rapid sine wave of 1800 per minute; a superimposed wave consisting of the 1800 cycle rapid sine wave imposed upon the slow wave; a surging sinusoidal, somewhat similar in character to the former; a slow surging galvanic current; a rapid surging galvanic current; a straight galvanic current; a combined galvanic and sinusoidal current; and a current for diagnostic lamps.

electrode about two sizes larger than the caliber of the stricture is attached to the negative pole of a galvanic current and introduced into the urethra so as to engage the stricture. The positive pole may be a pad the size of the hand or larger on some indifferent point. The current is now turned on until five milli-amperes is reached. No appreciable pressure is used, but the electrode is allowed, by its own weight, to slowly pass through the stricture, which it will do in about five minutes. The current is then turned off, the electrode withdrawn and the operation not repeated sooner than five to seven days, at which time a sound two sizes larger is employed.

Sinusoidal Therapy.—The value of the sinusoidal current has been proven in many chronic nervous and muscular conditions not amenable to drug therapy, such as atonic constipation, prostatic hypertrophy, splanchnic engorgement, locomotor ataxia, anterior poliomyelitis, menorrhagia, prolapsed ovaries and many other cases.

The rapid sinusoidal current possesses one feature of the high frequency current; that is, the greater its rate of alternation, the less painful is the current. As in the case of the high frequency current, this is supposed to be because the alternations or vibrations are too rapid for the comprehension of the sensory nerves. Muscular fibres frequently react to the sinusoidal current which fail to respond to the faradic current.

The sinusoidal current increases the elimination of urea, sulphates and phosphates in the urine. Indican, if present, is at first increased, or if not found before, frequently appears after administration of the current. After a number of treatment it is much less evident, as it is looked upon as the product of proteid putrefaction. The inference is that the sinusoidal current tends to lessen toxic intestinal products through improved intra-abdominal circulation. In general terms, it may be said that the sinusoidal current is employed in all cases where faradism is ordinarily employed, following essentially the same technique. In addition there are certain conditions that deserve special mention, which will be classified according to the method of applying the treatment. The usual guide to dosage is the patient's toleration. The current is not caustic.

1. By abdominal applications. Intestinal toxemia, strengthening of the abdominal muscles, prolapsed abdominal viscera, abdominal arterio-sclerosis, diabetes mellitus, disease arising from faulty metabolism of abdominal viscera, diseases caused by portal congestion, neurasthenia, melancholia, conditions arising from venous congestion of the abdomen, constipation, etc.

2. Diseases of the stomach, especially those due to atony and motor insufficiency.

3. Hyperesthesias, neuralgias, muscular rheumatism, headaches and localized pains outside of orifices.

4. Gleet, urethritis, spasmodic strictures, incontinence of urine, endometritis, cervical catarrh, fibroids, etc.

5. Prostatic diseases, hemorrhoids, fissure of anus, prolapse of rectum, inflammation of seminal vesicles, inflammation of bladder in males, etc.

6. Vaginitis, leucorrhea, cystitis in females, relaxed ligaments. etc.

Sinusoidal Technique

Amenorrhœa: Galvanic (Neiswanger.)

Negative galvanism is a vaso motor dilator, bringing increased blood supply to the parts. Vaginal electrode covered with wet cotton pad is used in vault of vagina with positive pad on abdomen. Use 40 ma. ten minutes every second day. The results in one month will restore normal condition.

Aphonia: Galvanic. Sinusoidal.

Cases of simple aphonia. Galvanic: Place a positive felt covered electrode 3 inches by 4 inches at back of neck, bend a flexible electrode over the larynx so that it covers both sides. Wet both sides with sodium bicarbonate solution. Give 15 ma. and treat ten minutes. Next apply

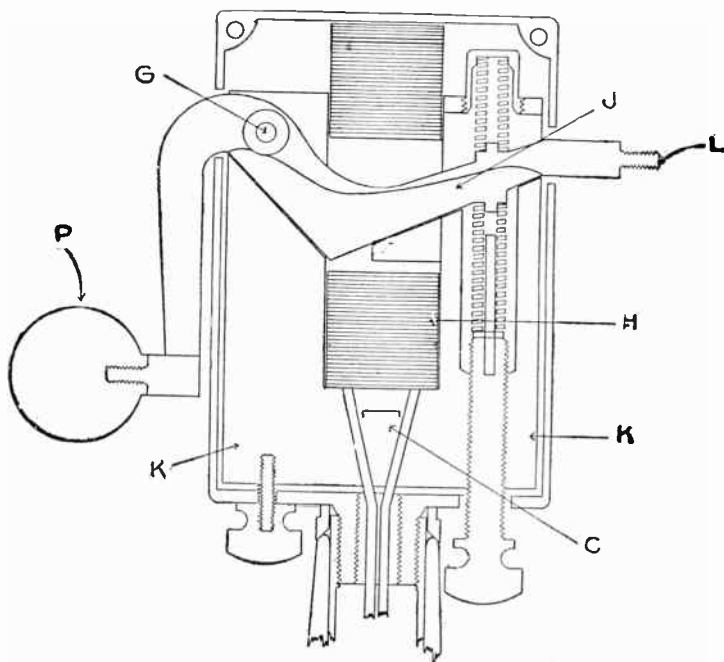

FIG. 4,647.—Diagram of Scheidel-Western vebragenitant. It consists of a synchronized motor geared to a vibrator. Current enters through the leading in wires to the simple switch G and through the coil H. Every alternation of the current causes the armature J, which is pivoted at G, to be pulled toward the field K, imparting a percussion stroke to the applicator at P, and a lateral stroke to the applicator when placed at L.

negative on one side, positive on the opposite side, regardless of polarity.

*Turn the dial selector to "Surging Galvanic," shift the belt to the right to fifth grooves in pulleys, which gives a frequency of 72 per minute, regulate the current so as to cause strong contractions of the vocal apparatus for a few minutes. After five or six treatments with the galvanic current, use low sinusoidal with belt same as for the above treatment, then increase the current from zero through rheostat until strong sensible but painless contractions are secured. The duration of the entire treatment should be about ten minutes, treatment three times per week.

Asthma, bronchial. Rapid Sinusoidal. (Abrams.)

Stimulate lung reflex of contraction. Strong rapid sinusoidal current, one electrode over the spines of the fourth and fifth cervical vertebrae and the other over the sacrum, fifteen minutes to one hour every day. The interrupting electrode may be used over the cervical vertebra.

Catalepsy: Sinusoidal. (Monell.)

Monell gives account of cataleptic patients who refused to respond to all measures resorted to until the current was applied to the left nipple. Try surging sinusoidal current.

Catarrh, cervical: Galvanic. (Neiswanger.)

This disease is more amenable to treatment and results more permanent than curettement. Large copper electrode to positive pole that will fill the cervical canal. Introduce electrode up to internal os and employ current of 30 to 42 ma. Do not move electrode to prevent sticking, for that is what is wanted. Negative to large pad on abdomen. In five minutes the mucous plug will have adhered to electrode and by a little traction may be withdrawn. Slight bleeding is of no consequence.

Constipation: Slow sinusoidal.

One moistened pad electrode on second lumbar spine, other electrode on abdomen from twenty to thirty minutes three times a week.

Diabetes: Slow sinusoidal. (Dugan.)

In diabetes the patient may be so weak that excessive exercise may excite proteid metabolism. From twelve to 120 contractions per minute will exercise the muscles sufficiently without producing the above results. (See Sinusoidal Electric Bath.)

Endocervitis: Galvanic.

Treatment same as Endometritis. The treatment can be followed by rapid sinusoidal current, one pad on abdomen and one to vaginal electrode, fifteen minutes.

Endometritis: Galvanic. (Rice.)

Prepare large pad for negative pole, wet and place over lower part of abdomen. Through the speculum introduce amalgamated sound (see p. 66, Dr. Rice's "Electricity in Gynecology") connect with positive pole, 20 to 50 ma., as the patient can tolerate, five or ten minutes.

NOTE.—The apparatus referred to is the McIntosh (universal mode.)

of treatment fifteen to twenty minutes. In irritable conditions of the kidneys where dilatation is present, the organ can be contracted by applying the sinusoidal current to the twelfth dorsal spine with a pad at the sacrum.

Mammary Glands, Insufficiency of: Rapid sinusoidal. (Dr. Chas. L. Ireland.)

One pad between third and fourth dorsal vertebrae and other over glands. Treatments five to ten minutes daily until normal secretions are obtained.

Cases have been reported where nourishment was impossible in which an abundant secretion of milk followed in two or three days. It is a well known fact that one of the principal causes of infant mortality in America is the almost universal habit of artificial nursing.

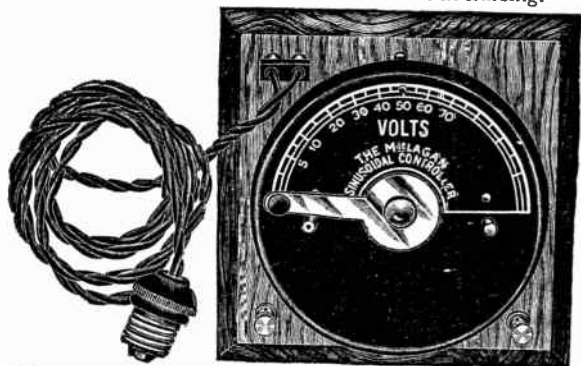

FIG. 4,650.—Maclagan sinusoidal controller for securing a rapid sinusoidal current for connection with 110 volt, alternating current circuit. The apparatus consists of a current controller or rheostat wound with a fine quality of resistance wire controlled by a lever which permits of a gradual increase or decrease of the current strength absolutely without shock. The rapid sinusoidal is desirable in constipation and other gastro-intestinal disorders. In sciatica, lumbago and neuritis it is of great value. This current can be used to elicit the reflexes according to Abrams by applying one electrode to the spinal center and an indifferent pad at the sacrum. At the seventh cervical the heart and aorta are contracted; at the fifth dorsal the pylorus is opened, discharging contents of stomach into duodenum; the twelfth dorsal contracts the prostate; at the seventh and eighth dorsal the abdominal muscles are contracted; and at the second lumbar the uterus and ovaries are contracted.

Melancholia: Slow sinusoidal. (J. J. P. Armstrong, M.D., Douglas, Ariz.)

Cases of melancholia are benefited by this current, especially if due to intestinal disorders. One pad on sacrum, other on abdomen. Seance 15 minutes.

Muscles, Atrophy of: Slow sinusoidal. (Dugan.)

The sinusoidal current will show a rapid muscular development if daily applications are made. If used on the abdominal muscles, we will see

an improvement in the nerves, together with a marked improvement in the tone of the muscles. It has been shown that the sinusoidal current, by contracting the blood vessels of the splanchnic circulation, aids in improving the general blood circulation.

Neuralgia, trigeminal: Slow sinusoidal. (Abrams.)

The slow sinusoidal is fine in cases of trigeminal neuralgia. One pole on back of neck and other on the Gasserian ganglion from ten to twelve minutes.

Neuralgia, visceral: Rapid sinusoidal. (Dugan.)

Visceral neuralgia is relieved by the analgesic effect of this current, as it relieves the congestion. We should use large electrodes and place one

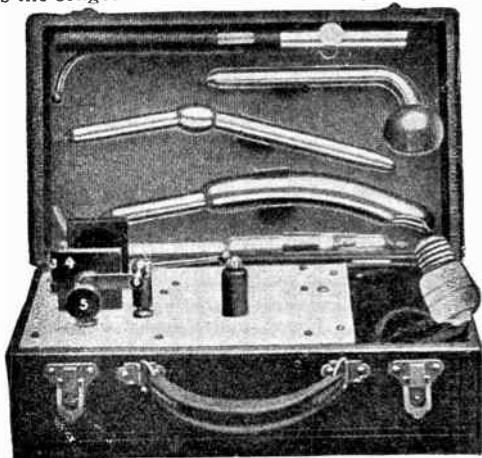

FIG. 4,651.—Columbia high frequency outfit consisting of a coil in carrying case ($7\frac{1}{2} \times 12\frac{1}{2} \times 6\frac{1}{4}$ in.), 8 ft. silk covered cord and plug ready to attach to any light socket. One insulated connecting cord. One set of six vacuum electrodes: No. 1, surface; No. 2, nasal; No. 3, urethral; No. 4, throat; No. 5, rectal; No. 6, vaginal; No. 7, insulated handle with swivel connector and adjustable to different sizes of electrode.

over the lumbar region and the other on the abdomen or over the painful part. Seance ten minutes.

Neurasthenia, intestinal: Superimposed wave. (J. J. P. Armstrong, M.D., Douglas, Ariz.)

The superimposed wave has done fine work in cases of intestinal neurasthenia. Use small pad in intrascapular region and large pad on the abdomen for twelve minutes at a time.

Neurasthenia, splanchnic.

Sinusoidal, slow or rapid, both electrodes. Eighth dorsal twenty minutes once or twice a day.

Neuritis: Rapid sinusoidal. (Dugan.)

In chronic neuritis, lumbago and intercostal neuralgia, the same technique should be followed as in visceral neuralgia.

Obesity: Slow sinusoidal. (Dugan.)

A general application of slow sinusoidal current will cause contraction of the muscles all over the body. In obesity a large amount of muscular activity is needed to burn up the surplus fat. (See Sinusoidal Electric Bath.)

Optic Atrophy: Rapid sinusoidal. (W. Franklin Coleman, M.D.)

Dr. Coleman, in his new book "Electricity in Diseases of the Eye, Ear, Nose and Throat," tabulates many cases of atrophy of the optic nerve

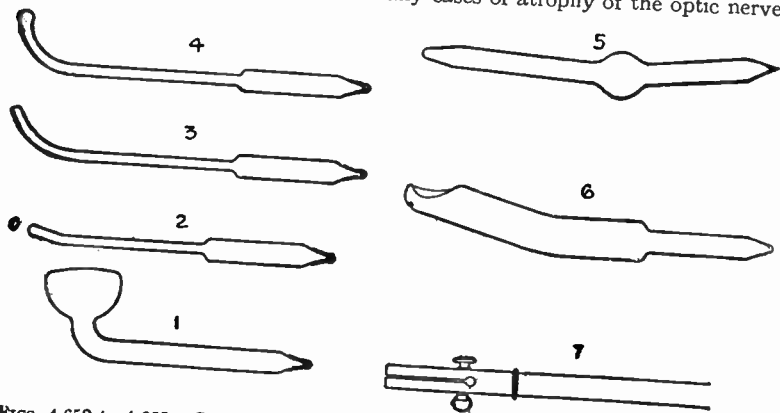

Figs. 4,652 to 4,658.—Columbia vacuum electrodes. 1, surface; 2, nasal; 3, urethral; 4, throat; 5, rectal; 6, vaginal; 7, handle.

where vision was greatly increased by the application of the rapid sinusoidal current with a double eye sponge electrode and an oval pad placed at the nape of the neck. Treatments 20 minutes daily.

Ovarian neuralgia: Slow sinusoidal.

One electrode on tenth dorsal, the other over ovary, twenty minutes every day.

Paralysis: Slow sinusoidal.

Double electrode: For arms, third to seventh dorsal. For limbs, tenth to twelfth dorsal. In some cases the surging sinusoidal current is recommended, being interrupted.

Paralysis due to central lesions: Surging sinusoidal. (A. J. Smith, M.D.)

One electrode in cervical region, other at periphery. Treatments: One

hour every day with a mild current, according to severity. It has been claimed that the stimulation thus set up acts upon the trophic centers in the cord, favoring increased metabolism and carrying away the products of stasis.

Pelvic Diseases: Rapid sinusoidal. (Dugan.)

In pain due to a neuralgic condition of the ovaries or tubes, in cases in which the uterus is very sensitive, but no acute or chronic endometritis is present, the rapid sinusoidal will afford most satisfactory results. Whenever passive congestion is present we should use one electrode on the abdomen and the other applied to the uterus. Use rapid sinusoidal for ten minutes, then use the slow sinusoidal current for five minutes.

Pelvic disease, Neurosis in the woman due to: (A. J. White, M.D.)

(a) Surging sinusoidal. Pad electrode at sacrum, another pad in cervical region.

(b) Galvanism positive. Copper ball electrode in vagina, negative to large pad on abdomen.



FIG. 4.659.—Neiswanger's perforated copper ball electrode for galvanic current. May be used as an irrigating electrode.

Beginning treatment with (a) for tonic effect for 10 minutes, change to (b) for 5 minutes for the local antiseptic effect of the copper salt. Treatments every day for first week, every other day during second week, afterward twice weekly.

Pleurisy: Rapid sinusoidal.

In pleurisy or intercostal pain of the chest wall, use one electrode over the eighth dorsal spine and one over the seat of pain, with stable application for ten minutes. Very efficient in relief of pain.

Ptosis: Surging sinusoidal. (J. F. Roemer, M.D.)

F. B. ———. Farmer, white, aged 66. Poorly nourished. Complains of stomach sore, painful, no appetite, cannot eat, tongue coated, center thick brownish white, edges clear. Likes meat and potatoes but cannot eat much. Heart palpitates, feels it beat all through his body, feet cold, cannot get them warm, blood pressure 166. Difficult breathing, but lungs clear. Sleep, restless, wakes at 1:00 a. m. Dreams all night long, especially if lying on back. Back sore and lame, hips very sore and painful, cannot lie on side, says he is lame and nervous all over, all tissues sore. Frequent urination at night. Painful erections awaken him. Unable to pass water for long time in morning. Examination showed ptosis of all organs. Heart not enlarged, but two inches below normal, stomach below umbilicus in left inguinal region. Spleen easily

palpated. Liver two inches below ribs, and no doubt the inability to pass urine in early morning was due to relaxed condition of walls of bladder. He has complained of the same symptoms for the past twelve years, and has so far received no relief. When I told him of my findings and located his organs for him, he answered: "Yes, that is what Dr. T. said. He told me they were out of place, that they had fallen down." **Enteroptosis**, a good and plenty. **Neurasthenia; treatment:** The indicated remedy, vibrator three times a week for two weeks to start blood current through back, and then applied the surging sinusoidal current for fifteen minutes three times a week. My case book shows he had just 29 treatments. In one week his heart had ceased paining him. In three weeks his stomach was feeling better, tongue had cleaned and he was eating fine, as he expressed it. The nervous feeling persisted longer and gradually left him and after four months have

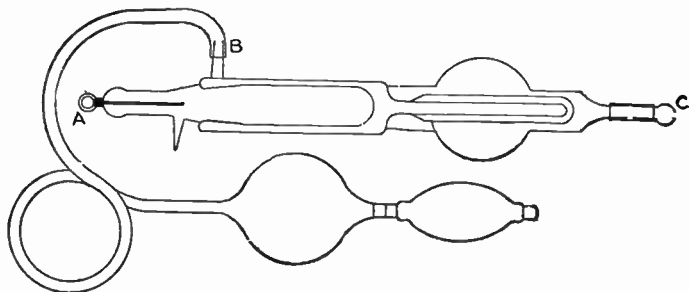

FIG. 4,660.—Columbia ozone generator. *In operation*, a current of air passes through the high frequency discharge and through a reservoir containing oils of eucalyptus and pine needles. The vapor is inhaled by the patient and is said to have an oxydizing and antiseptic effect; desirable in treatment of diseases of the respiratory organs.

elapsed since his last treatment the report from his son is "Father is better than he has been in 16 years. Wants to go back to farming. Is enjoying himself this winter. We are all well pleased over the results." The sinusoidal current was applied from a McIntosh polysine generator, using the surging sinusoidal from 40 to 80 volts, varied as he could endure it or rather as it was comfortable to him, applied by a special electrode made by myself for the purpose, using the ordinary sponge disc electrodes on back but the eight inch spongio-piline electrode on abdomen. I first applied the current for five minutes over the space between the sixth and seventh dorsal vertebræ, one sponge disc on either side. At this point all of the muscles of abdomen and contents can be influenced and the patient feel no pain. None of the fiery burning feeling experienced in other locations. Then I placed the electrodes over the fifth and sixth cervical or, at times, the seventh cervical. Here I got the contracting effect on the neck and shoulder muscles. Then placing the sponge discs far apart I placed them over the third and

fourth lumbar vertebræ, using a bifurcated cord from one binding post of the generator, and with a cord from the other binding post of the generator to the large eight inch pad over the abdomen, using this five minutes. A

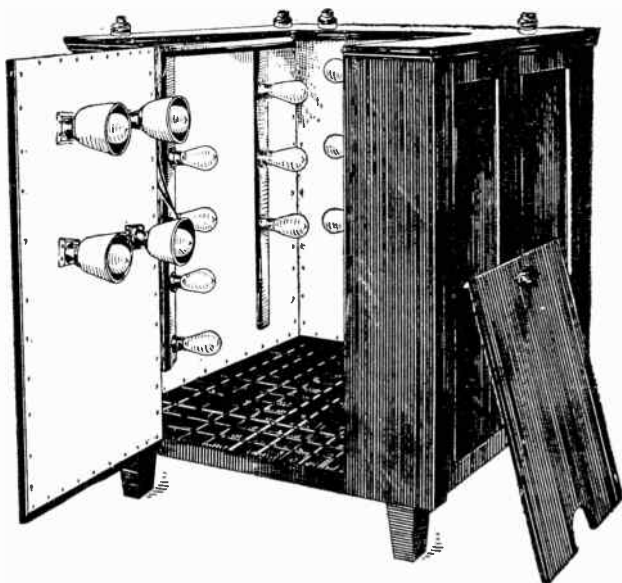

FIG. 4,661.—Columbia electric light bath cabinet. Dr. Otto Juettner in "Modern Physiotherapy" says: "Among the various physical and mechanical therapeutic agents known to modern medicine, light is, in point of clinical usefulness and therapeutic efficiency, surely entitled to a foremost place." Briefly, *the physiological effects of light are as follows*: By stimulating the nerve endings in the skin, the reflex phenomena are: dilating the capillaries, securing local hyperemia, stimulating the circulation of blood and lymph and relieving stasis; increasing the functions of the sweat glands, eliminating toxins; absorbing inflammatory products; increasing nutrition by reflex stimulation of the trophic nerves; raising the temperature en masse and thereby modifying metabolism and nutrition; muscular activity enhanced; the coloring matter of the red corpuscles increased; inhibiting the growth of bacteria, fungi and lower organisms; acting as a germicide and oxygenator, the chemical rays have a disintegrating effect on living tissues and in cutaneous tissue with tubercle bacilli or other germs, oxygen is attracted, and a healthy reaction set up. *In using the light treatment*, it should be borne in mind that the white light, combining as it does all the various rays, is in most general use. The red light, giving the thermal rays, acts as a nerve stimulant, having a special effect on the sympathetic nervous system, and through this on all functions of the animal economy. Used as a general tonic, this is the most satisfactory color and valuable in contusions, bruises, sprains, etc. The green light contains the luminous rays and acts as a mild sedative. Blue light, containing the chemical or actinic rays, is a more pronounced sedative, diminishing pain, rectifying metabolism and is a local anesthetic. The investigation of Professor Minin, of St. Petersburg, has done much to cause this light to be accepted for its chemical and actinic rays. In skin diseases, in old ulcers and certain forms of malnutrition the blue light is worthy of a place in every physician's office.

Uterus, Infantile: (A. J. Smith, M.D.)

(A) Slow or Surging Sinusoidal. Large nickel plated electrode in vagina and pad on abdomen.

(B) Galvanism. Negative electrode in vagina, large pad on abdomen. Treatments: Thirty minutes every other day, alternating between A and B.

Uterus, to increase tone to: (A. J. Smith, M.D.)

(A) Surging or rapid sinusoidal. One electrode on abdomen and a large nickel plated electrode in vagina.

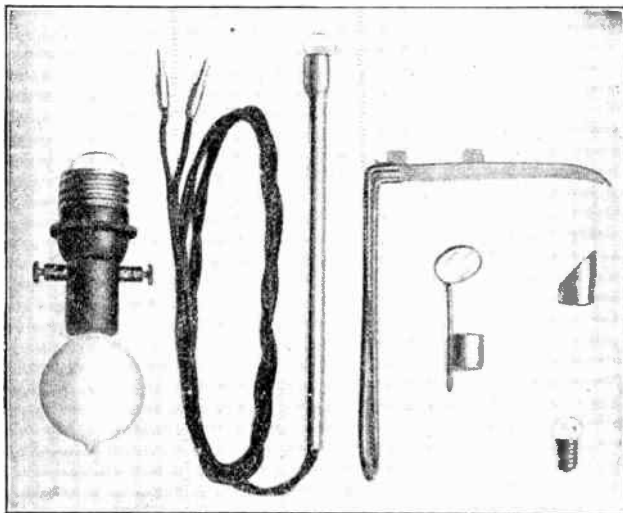

FIGS. 4,668 to 4673.—Columbia diagnostic lamp outfit. *It consists of a* $\frac{1}{4}$ inch nickel plated brass tube 6 inches long, with a socket on end $\frac{1}{16}$ inch in diameter, for standard miniature base lamps. An 8 ft. green silk cord is provided with cord tips to connect to any current controller, series socket, wall cabinet, etc. The $2\frac{3}{4}$ volt lamp bulb has a lens blown in the end.

(B) Galvanism. Copper ball electrode with positive cord in vagina and large negative pad on abdomen. Treatments: Begin with A for thirty minutes for increased tonicity and change to B for five minutes for the local, astringent, prophylactic effect of the copper salts.

Vagus Hypotonia (Low Vagus Tone): Rapid sinusoidal. (Abrams.)

Claud Bernard produced diabetes in the animal by irritating the floor of the fourth ventricle. Since then it has been shown that other parts of the nervous system when irritated will produce diabetes, hence there has arisen a neurotic theory of diabetes which supposes it to be

caused by a vaso-motor paralysis, resulting in a greater quantity of blood flowing through the liver. The tone of the vagus may be permanently increased by applying the rapid sinusoidal current to the seventh cervical spine by means of the double interrupting electrode. Seance from ten to fifteen minutes, being careful not to over stimulate.

Velum, Post-Diphtheritic Paralysis of the: Rapid sinusoidal.

Five cases are reported. In the first three cases the paralysis was of twenty to forty days' standing. After three or four treatments, great improvement was apparent and entire relief resulted after eight to eleven applications. In the fourth case reported the paralysis was of seven years' standing and no benefit resulted. In the fifth case the treatment was begun too soon, on the sixth day while the diphtheritic neuritis was still in progress, and an aggravation of both subjective and objective symptoms was the result. A rapid, intermittent, faradic or alternating sinusoidal current may be used, for fifteen minutes at a time. A large electrode is placed on the back of the neck and the patient's hands or feet are placed in a bowl of water. The treatment should not be painful.

Vomiting in Pregnancy: Rapid sinusoidal. (J. J. P. Armstrong, M. D., Douglas, Ariz.)

I have used the rapid sinusoidal in ten consecutive cases of vomiting in pregnancy with most excellent results and depend on it almost entirely in such cases, especially those of obstinate type.

Wasting of muscles, due to impaired nutrition from pelvic sources:

(A. J. Smith, M. D.)

(A) Superimposed wave. One electrode in cervical region, other over affected region.

(B) Faradic current or rapid sinusoidal: One electrode on abdomen, other in vagina.

Starting with A for 10 minutes, change to B for 10 to 30 minutes, giving treatments every day for the first month, then every other day.

Mechanical Vibration.—This is a remedial agent of proven value. Massage is one of the oldest forms of physical therapy, in fact it is almost as old as medicine itself.

Vibratory Technique

Constipation. (Rice.)

Let the patient lie upon the left side. Place the tip of the dilator, lubricated with tragacanth lubricant, against the sphincter muscle,

turn on the vibrator, gradually increasing the speed and making light pressure at the same time with the dilator until it passes as high up as possible. Turn the vibrator off and wait a moment before again turning it on. Continue turning on and off for about five minutes. Managed gently with interrupted vibrations, there is not the danger of over-exhausting the muscles that there is when the vibrations are continuous. For general stimulation to the gastro-intestinal tract, as well as for systemic effect, it is well to follow this application with interrupted vibration to the spinal column, vibrating from the fourth dorsal to the end of the spine, and also to vibrate the colon through the abdominal walls. In the latter the vibrator should have a long stroke and should be passed over the colon from the right to the left side. The vibratory treatment requires about ten minutes.

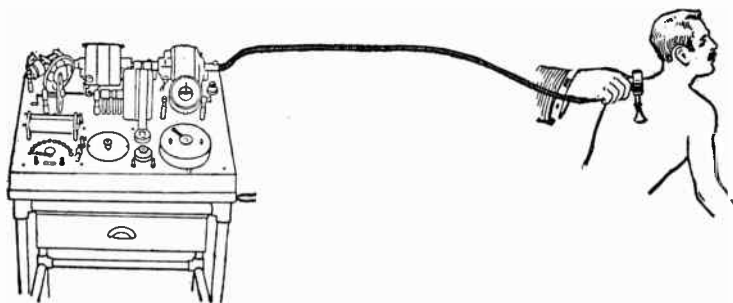

FIG. 4,674.—McIntosh apparatus showing application of mechanical vibration. The effects claimed for mechanical vibration are: 1. Cardiac activity is regulated. Blood pressure may be lowered reflexly. It may be raised also. 2. Contracts arterial blood vessels. If prolonged, dilation results. Pulse rate may be lowered. 3. It induces many reflex effects as well as motor, sensory, secretory and vaso-motor effects. It lessens and removes hyperactivity of nerves. It diminishes pain and relieves congestion not due to organic conditions. 4. Diminishes and relieves muscular pain and stiffness. It can relax tense muscles and cause relaxed and atrophied muscles to become firm and increase in size. It tones up cardiac muscles. 5. Reflexly induces contraction of the lungs. Relieves pain and dyspnoea. Improves respiration. 6. Diminishes size of glands, directly and reflexly. 7. Contracts or dilates the liver, stomach and spleen. 8. Diminishes irritability of the bladder when not due to organic conditions. 9. Induces peristalsis. 10. Increases or diminishes lymphatic circulation according to the vibratory friction given, centripetal or centrifugal. 11. Assists in diminishing intraocular tension. 12. Lessens nasal hyperemia. 13. Suction vibrations are valuable in removing pus from a boil, etc.

Mechanical vibration of the eye is indicated for twitching of the lids. blepharospasm and glaucoma. (Arnold-Snow.)

The greatest gentleness and skill must be employed in the treatment of the eye, avoiding the possibility of causing irreparable injury, such as retinal detachment. In some cases vibratory treatment alone is effective, while in others a combination with other methods gives the best results. As with other affections, treatments should vary from twice a day to once a week, according to the indications of the case.

Mechanical vibration when applied over the eye in the treatment of eye diseases should be employed in the form of a vibra-massage. Make the application for but a short time, 30 seconds to a minute or so, and as a rule only once daily, using a soft rubber cup vibratode with the shortest stroke and no pressure over the eye ball. In all cases indicated constitutional treatment, with due consideration of diet and hygiene, must be observed. A study of the blood pressure should be made in every case.



FIGS. 4,675 to 4,678.—Dr. Abrams' reflex set for the physician who desires to test the value of concussion according to Dr. Abrams' method. The hammer, for evoking vertebral reflexes, is called a *plexor*. It is employed for diagnostic purposes and as a concussion apparatus in spondylotherapy. Many use it exclusively to attain their therapeutic results. *The pleximeter* is of metal, covered at one end with rubber and is employed concurrently with the plexor. *The single pronged instrument* is used for demonstrating areas of paravertebral tenderness. Better than the fingers. *The two pronged instrument* (radicularpressor) is employed for making bilateral pressure on the roots of the spinal nerves at their exit from the intervertebral foramina. The employment of pressure in treatment and the use of these various instruments is explained in Dr. Abrams' book on spondylotherapy. The hammer and pressor instruments are fitted with polished hard rubber handles, while all metal parts are nickel plated.

Splenic congestion. (Arnold-Snow.)

Deep vibratory friction or interrupted vibration with the disc vibratode should be administered over the side of the gland from the ninth to, and including, the eleventh rib between the axillary lines. Reflex contraction of the spleen can be induced by vibrating with the ball

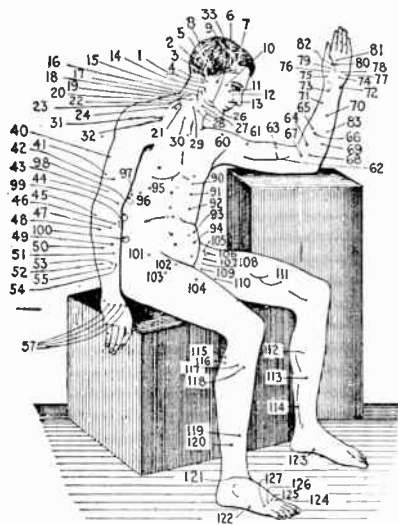

FIG. 4,679.—Diagram showing motor points (after Myer) for testing for reaction of degeneration.

1. Facial nerve at its exit.
2. Auriculo-posterior branch of facial nerve.
3. Branch of facial to occipito-frontalis muscle.
4. Branch of facial to tragus muscle.
5. Auriculo-anterior branch of facial.
6. Branch of facial supplying frontalis muscle.
7. Facial branch to corrugator supercillii.
8. Facial branch to orbicularis palpebrarum.
9. Facial branch to zygomaticus major.
10. Facial branch to zygomaticus minor.
11. Facial branch to levator labii superioris.
12. Facial branch to compressor nasi.
13. Facial branch to levator labii sup. proprius.
14. Buccal branches of the facial.
15. Infra maxillary cutaneous branches.
16. Subcutaneous branches of colli super.
- 17-18. Branches of spinal accessory.
19. Affects the platysma myoides.
20. Branch from cervical plexus to lev. Aug. scap.
21. Phrenic nerve. Respiration.
22. Dorsalis scapula nerves.
23. Posterior thoracic nerve.
24. Supra-scapular nerve.
26. Branch of facial to triangularis menti muscle.
27. Hypoglossus nerve.
28. Motor point of omo-hyoid muscle.
29. Motor point of sterno-thyroid muscle.
30. Motor point of sterno-hyoid muscle.

81. Outer cord of brachial plexus.
32. Anterior thoracic nerve.
33. Branch of facial to depressor labii inf.
40. Branch of radial nerve to triceps.
41. Radial nerve.
42. Radial branch to brachialis ant. muscle.
43. Radial branch to supinator longus muscle.
44. Radial branch to exten. carpi rad. long.
45. Radial branch to anconeus quartus.
46. Nerve to extensor carpi rad. brevior.
47. Nerve to extensor com. digitorum.
48. Nerve supplying the extensor carpi ulnaris.
49. Motor point for abduct. pollicis longus.
50. Motor point for exten. minimi digiti. prop.
51. Motor point for extensor digiti.
52. Motor point for extensor indicis prop.
53. Motor point for extensor pollicis longus.
54. Motor point of extensor pollicis brevis.
57. Motor point of Interossei externi.
60. Branch of ant. thoracic nerve.
61. Musculo-cutaneous nerve.
62. Median nerve.
63. Motor point of brachialis int.
64. Motor point of pronator teres.
- 65, 66. Points of flexor digitor. sub.
71. Branch of median to pollicis longus.
72. Branch of ulnar to palm of hand.
73. (See 62.)
74. Motor point of volaris profundus.
75. Motor point of abduct. pollicis brevis.
76. Motor point of opponens pollicis.
77. Motor point of abductor digiti min.
78. Motor point of flexor digiti min.
79. Motor point of flexor pollicis brevis.
80. Branch of ulnar to abductor pollicis.
- 81-82. Branch of median supplying the lumbricals.
83. Motor point of flexor digitor.
- 90 to 94. Motor point of rectus abdom. ext.
- 95 to 98. Motor point of obliquus abdom. ext.
99. Motor point of transversus abdom.
100. Motor point obl. abdom. inter.
101. Branch of crural to tensor fascia lata.
102. Branch of crural to rectus femoris.
103. Motor point of vastus ext.
104. Motor point of vastus and rectus.
105. Crural nerve.
106. Branch of crural to M. Sartoris.
107. Motor point of pectineus muscle.
108. Motor point of abductor hrevis.
109. Motor point of abductor longus.
110. Motor point of gracilis.
111. Motor point of vastus int.
112. Motor point of soleus.
113. Branch of tibialis to flexor digitor.
114. Tibial nerve.
115. Peroneal nerve.
116. Popliteal nerve.
117. Motor point of ext. digitor com. long.
118. Motor point of tibialis anticus.
119. Motor point of ext. hallucis long.
120. Motor point of peroneus tert.
121. Motor point ext. digitor com.
122. Motor point of abductor digiti. min.
123. Motor point of hallucis.
- 124-127. Motor points of interossei ext.

The motor point of the sciatic nerve (not shown in cut) lies between the trochanter major and tuber. ischi.

between the first and second, and second and third lumbar vertebræ, following Abrams' method of vertebral concussion. The treatment should be prolonged for five, ten, or even fifteen minutes, as the response warrants. This is of value in malaria and pathological states characterized by an enlarged spleen.

Electro-Cautery.—This treatment utilizes the heating effect of the electric current for surgical purposes. Various forms of cautery knife are used, some being shown in figs. 4,682 to 4,686.



FIG. 4,680.—Columbia vibrating chair. In appearance this is a heavy and substantial chair, and there is nothing about it that would give apprehension to the most sensitive patient. Concealed rubber bumpers prevent transmission of the vibration to the floor and prevent noise, so that in operation there is just a slight hum. By means of a simple mechanism the strength and rapidity of the vibration is varied from a very light movement to as heavy a vibration as can be desired. The adjusting device is separate from the chair and may be placed on the physician's desk and the degree of vibration varied by him as desired. A switch is on the chair where the current may be turned off or on. *While taking a treatment* the patient experiences a pleasing sensation, as the circulation is increased and the nervous tension relaxed on account of the rapidity of the vibration, and they nearly all remark: "How is the electricity applied?" as the sensation feels similar to a rapidly interrupted faradic current. The use of the chair is indicated in rheumatism, locomotor ataxia, paralysis agitans, neurasthenia, anemia, constipation, obesity, etc. It is used in many sanitariums where patients are too weak to exercise and where the circulation may be increased without increasing the pulse. The work of Zander, Ling, Grönville, Kellogg and others indicates that this is an effectual method of treatment. No special wiring is required; all that is necessary is to connect to the electric light socket.

They consist of suitably shaped platinum wires which require different amounts of electric energy to render them red hot, depending upon the surface of heated metal which they expose to the air. The broad flat blades requiring more energy than the narrower blades. The broadest blades require from 25 to

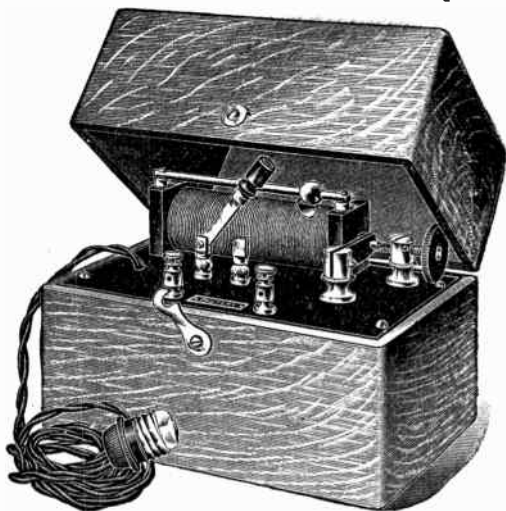
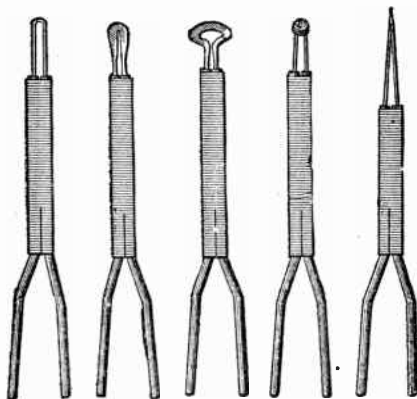

FIG. 4,681.—McIntosh universal cautery transformer, for either alternating or direct current. *It consists of* an open core transformer, in appearance like an induction coil, mounted on a finely finished black enameled slate base and fitted in a highly polished, quarter sawed golden oak case, measuring $9 \times 6 \times 7\frac{1}{2}$ inches. The transformer can be connected to any lamp socket in the office with either direct or alternating current providing the voltage is 110 volts, approximately. For a higher voltage a series lamp and tap can be furnished at a slight additional expense. Control of the heat of the cautery knife is had by sliding the regulating knob on top of coil from left to right, thus increasing the current strength very gradually until the desired heat is obtained. Any electrode from the lightest eye point to the heaviest used in nose or throat work may be employed. Diagnostic lamps of almost any style, ranging from small $3\frac{1}{2}$ volt urethroscopes or auriscopes to heavy trans-illuminators requiring 18 volts, can be illuminated to full brilliance, by proper adjustment of the regulator. A compartment is provided in the lid of box which will hold cautery handle, cords or any accessories desired, a metal plate forming a cover for this section.

35 amperes at one volt, or from 25 to 35 watts. According to E. L. Smith, M.D., the degree of heat of the platinum point is important. Cherry red heat is generally used. The object is

to press the mucous membrane down to the periosteum with the edge of the electrode, with the least amount of cicatrical tissue.

If hypersensitive areas are to be destroyed, then use the electrode flat with white heat and make a superficial burn. When the platinum point comes in contact with the tissues it will be noticed that it lowers the heating point, hence, if a large area is to be treated, it will be necessary to go in with a higher point of heat than is needed.



FIGS. 4,682 to 4,686.—Various electric cautery knives. The snare cautery consisting of a loop of platinum wire which is placed around the growth or part to be removed, then the loop drawn tight and the current passed through it, so that the flowing wire is pulled through the part, consumes a smaller number of watt, but requires a greater voltage to send a sufficient amount of current through the platinum wires. The current for the operation of electric cautery knives may be either continuous or alternating. It may be obtained from either primary batteries or storage batteries, or from alternating current sources of supply, the voltage in the latter case being stepped down by means of suitable transformers to that required for the operation of the knives.

The Technique to be Used.—After selecting an electrode to fit the pathological condition, place the platinum surface on the tissue, but do not press the closing button while the electrode is still. Just before pressing the button to heat the platinum wire, start a gentle to and fro motion over the area to be treated. Do not stop with the current on, as it will adhere and break the eschar and bleed. Remove the platinum point before the heat is turned off. Care should be taken not to allow the cautery point to come in contact with two opposite surfaces,

as they would be very likely to adhere and form a troublesome synechia. This can be avoided by using an electrode where one part is wrapped. When possible, treat only one location at a time. Keep the area well cleaned out with any good alkaline solution and hydrogen peroxide (1 in 5), and the crusts will come off in a week to ten days.



FIG. 4,687.—Protologists' special set. It contains hollow rectal electrode, fistula electrode, rectal stricture set; hydro-electric rectal tube and a sponger pad electrode.

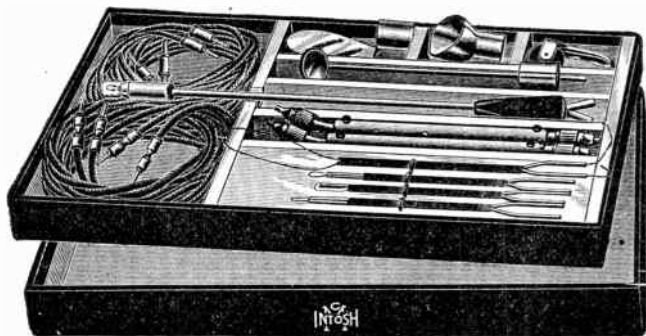

FIG. 4,688.—McIntosh cautery illuminator set comprising a list of attachments for electrocautery and lamp diagnoses. It is suitable to be employed in connection with a transformer, converter or wall plate with cautery.

CHAPTER LXXXVIII

X-RAYS

These rays, discovered by Roentgen were called X-rays because of their unknown real nature. Some scientists have regarded X-rays as light rays of very small wave length, but the sounder theory seems to be that they are instantaneous impulses produced by the impact of electrons upon the anti-cathode. They may be likened to the sound waves produced by rain drops on the roof, not of a definite pitch. The velocity of X-rays is probably the same as that of Hertzian waves.

The exact nature of the X ray is still under discussion. The most commonly accepted explanation is that it is a disturbance of the luminiferous ether similar to visible light, but having much shorter wave length than ultra-violet light.

Ques. What apparatus is necessary for the production of X-rays?

NOTE.—Roentgen spoke of his discovery, made on Nov. 8, 1895, as follows: "I was working with a Crookes tube covered by a shield or screen of black cardboard. A piece of barium platino-cyanide paper lay near by on the table. I had been passing a current through the tube and noticed a peculiar black line across the paper. As this effect could be produced by the passage of light only, and as no light except from the tube could have struck the plate, I made a test at once, and found that some kind of ray actually passed through the black cardboard cover. In a completely darkened room the paper screen washed on one side with barium platino-cyanide lighted up brilliantly, and fluoresced equally well no matter which of its sides was turned towards the tube. This fluorescence was noticeable even at a distance of two meters. The most remarkable thing to me was that this fluorescence passed through the black cardboard cover, which transmits none of the ultra-violet rays of the sun or of the electric arc. I found by experiments that all bodies are transparent to this influence, although in very different degrees."

Ans. A vacuum tube, a battery, and an induction coil with interrupter.

Ques. How are X rays produced?

Ans. If an electrical discharge be passed through a vacuum tube exhausted to a Crookes vacuum (much higher degree of exhaustion than in the tubes of Hillorf, Geissler and Lenard)

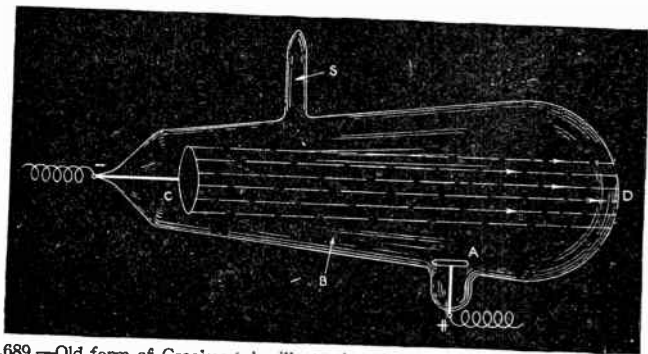

FIG. 4,689.—Old form of Crookes tube illustrating the production of X rays. The anode A and the cathode C, are aluminum plates cemented on the ends of iron or copper rods sealed in the glass bulb B. S is the seal off tube, which is closed after the bulb has been exhausted of air to the desired vacuum. In the various forms of tube used for different purposes, various degrees of vacuum are employed, but complete exhaustion is never used as the electric spark will not pass through an absolute vacuum. *In operation*, when the anode A is connected to the positive terminal, the cathode C to the negative terminal of an induction coil or influence machine, and current turned on the following phenomena will occur: 1. If the vacuum in the tube be low, (not much below the pressure of the atmosphere), the discharge will pass in the form of a spark, between the anode and the cathode, but no cathode rays are found. 2. If the vacuum be sufficiently high to prevent the passage of a spark, no matter how high a pressure may be applied, the bulb will have a dark appearance except around the area D, which will be illuminated by a bright canary yellow light. This light is due to the fluorescence of the glass under the action of the cathode rays emitted in straight lines from the cathode C, as shown by the dotted lines. The cathode rays are generally accepted as a form of radiant matter consisting of streams of negatively electrified material particles either of the air remaining in the bulb after exhaustion, or of particles torn from the cathode, and repelled from the latter at enormous velocity. In other words, the stream of cathode rays is accepted as the equivalent of an electric current. This theory is sustained by the fact that cathode rays are deflected by a magnet, and furthermore, that they are capable of producing marked mechanical, heat, and light effects, in the fluorescence of various solid substances, various kinds of glass, chemical salts and acids, placed in its path. The fluorescence being the actual conversion of the energy and momentum of the cathode stream into light. In 1895, Roentgen accidentally discovered that the surface rendered fluorescent by the action of the cathode rays emitted rays which differed from cathode rays in that they were not deflected by a magnet, and were capable of penetrating opaque objects to a remarkable degree. These rays are now commonly known as Roentgen rays or X rays and the special forms of tube (X ray tubes) employed in their production are merely Crookes tubes having a somewhat higher vacuum than is usually employed for the production of cathode rays.

X rays are produced whenever the cathode stream is arrested by the walls of the tube or metallic objects therein.

Ques. What is the cathode stream?

Ans. This is believed to be a discharge of negatively charged electrons from the surface of the cathode.

Ques. What is a focus tube?

Ans. One in which a concave cathode focuses the cathode stream upon a flat metallic target as shown in fig. 4,690.

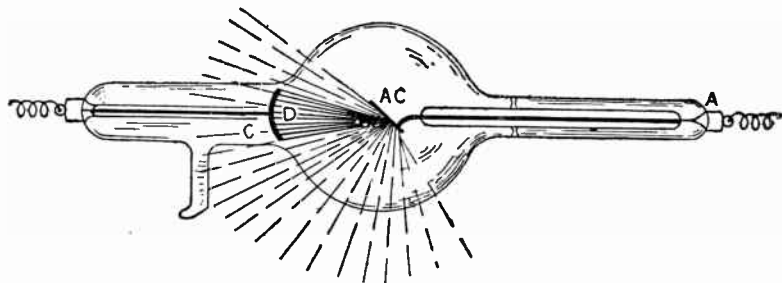

FIG. 4,690.—Single focus X ray tube. This is the simplest form of single focus tube designed for limiting the X ray radiations to a point source, thereby obviating the necessity of placing an object far from the tube when the former cannot be brought close to a fluorescent screen. In other words for the purpose of reducing the time of exposure required for making a radiograph or skiagraph of such an object. In this tube, the copper wire A, is the anode, the cup shaped aluminum plate C, the cathode, and the thin plate of platinum foil A, C, is the anti-cathode. The copper wire connecting the anode with the anti-cathode, makes the latter the anode. In operation, the cathode rays represented by the dark cone D converge onto the inclined surface of the anti-cathode, so that the latter becomes a point source of X ray, the rays being radiated in all directions as shown by the broken lines. The anti-cathode is made of platinum so as to enable it to resist the powerful heating effects of the concentrated cathode rays.

Fluorescing Screens.—Examination of objects, such as the bones of the hand, foreign bodies in the system, etc., are made with the aid of a *fluorescing screen* or *fluoroscope*. This device consists of light tight box A, fig. 4,691, provided with an aperture for the eyes at B, and an opening C, at the opposite end for the

fluorescing screen D. The latter consists of a piece of paper or cardboard coated with platinum-barium cyanide crystals, which fluoresce under the action of X rays. When such a screen is held against the face by means of the handle, and the aperture

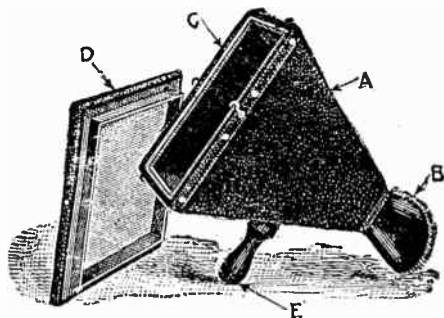

FIG. 4,691.—Fluoroscope. A, box; B, opening for eyes; C, opening for screen; D, screen.

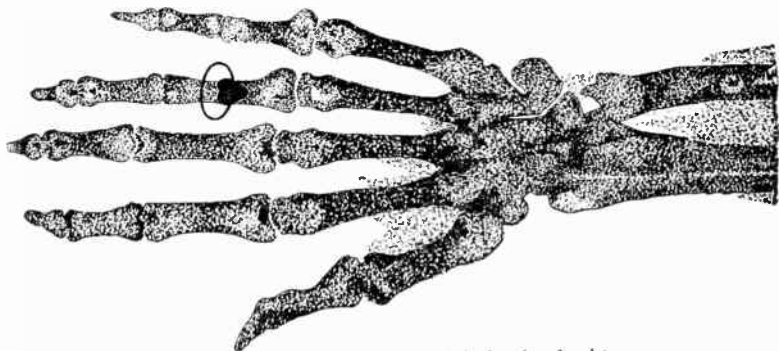

FIG. 4,692.—X ray fluorescent shadow of the bones of the hand and wrist.

B, pressed tightly around the eyes so as to exclude all outside light, and the screen placed near an active X ray tube, the former will fluoresce with a greenish yellow light.

If a hand, for instance, be placed between the screen and the tube, the X rays will pass through the fleshy parts and impinging on the screen

will cause it to fluoresce, but, being intercepted by the bones, will not affect the screen, thus leaving thereon a shadow picture of the bones as shown in fig. 4,692. It is immaterial whether the screen be placed in the holder box with the crystal coated, or opposite side turned to the eye aperture.

The intensity of the illumination produced by the fluorescence on the screen rapidly diminishes with the distance of the screen from the tube, therefore, in order to obtain a maximum illumination and consequently

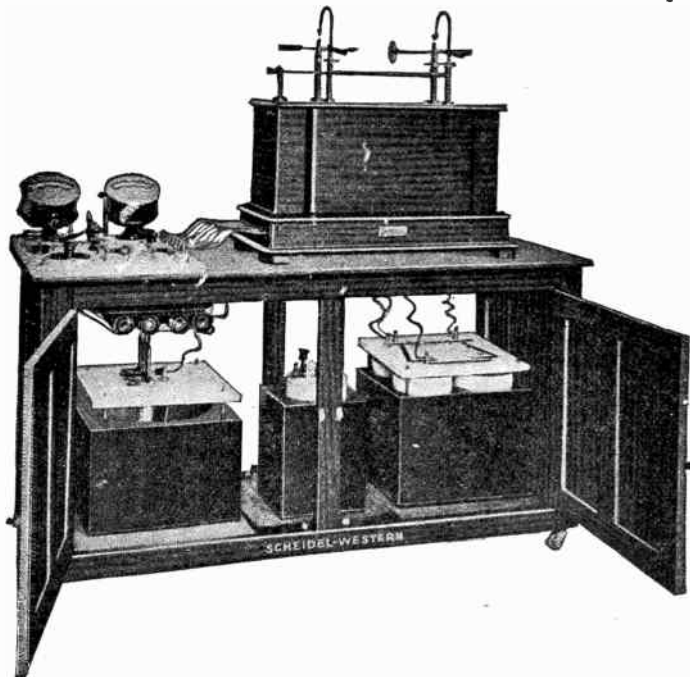

FIG. 4,693.—Scheidel-Western radiographic special coil with anti-acid interrupter for X ray treatment.

a sharply defined shadow, the screen should be held close as possible to the source of X ray, and the hand close to the screen.

Ques. What is a radiograph?

Ans. A picture taken upon a photographic plate by means of X rays.

The picture is usually of an opaque object through which the rays pass.

Ques. How is a radiograph taken?

Ans. Replace the fluorescent screen of the fluoroscope by a suitable photographic plate, give it the proper exposure and develop as in photography.

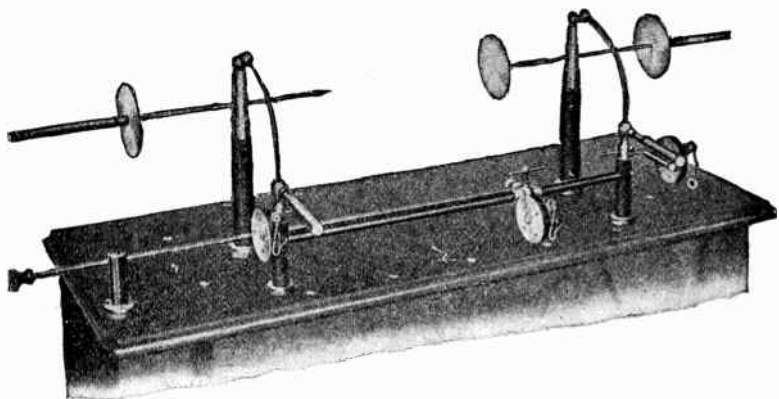

FIG. 4,694.—Scheidel-Western third terminal on radiographic special coils. The third terminal is for regulating the vacuum in X ray tubes, which is accomplished by moving a cord reel that is connected to the regulating bulb of the tube either to or from the negative or positive pole as desired. This transfers the unpleasant regulating spark from near the patient to the coil, several feet away, and enables the vacuum to be regulated without stopping the machine or moving from the switchboard. The series gaps also provide a means for putting into the circuit a double spark gap to eliminate inverse if ever required.

The length of exposure will depend upon the character of the object radiographed, the quality of the X ray tube, and the current strength employed.

Practical Points on X Ray Photography.—1. Radiographs may be made on photographic paper, films, or glass plates. For best results, however, specially prepared X ray plates with double coating should be used.

2. Very rapid plates have not the same advantage over medium or slow plates as they have in ordinary photography.

5. It is of advantage to place a sheet of lead or zinc below the plate on the non-coated side to intensify the contrast, details, etc.

6. The position of the tube in relation to the plate and patient must be minutely observed. Place the tube so that the anode and cathode terminals are in a parallel position. The anti-cathode is then to directly focus the center of the plate. An imaginary line drawn through the anode and cathode should be parallel to the plate at all times. This rule has but one exception, and that is, when taking a radiograph of a frontal sinus. In this case the patient should lie face downward with the forehead and the tip of the nose touching a surface tilted to a 25° angle from the horizontal. The imaginary line of the tube should then be placed parallel to the horizontal plane.

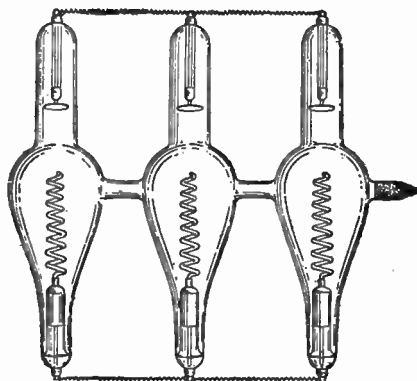

Fig. 4,696.—Scheidel-Western triple valve tube. The valve tube is used as an accessory to the X ray coil for eliminating any inverse current. It assists in obtaining greater definition in the radiograph, and by eliminating the heat rays prolongs the life of the X ray tube.

7. The distance of the tube from the patient or plate must not be too great, as the intensity of the X radiance diminishes unevenly with the distance; if too short, image will appear too large and distorted, moreover, there is some danger of producing dermatitis.

8. The longest distance between anti-cathode and emulsion of plate for thorax, pelvis, etc., need not exceed 20 inches, while the shortest distance of small objects, as teeth, finger, toes, etc., should not be less than 10 inches.

9. Make the patient comfortable so that the part to be radiographed is motionless.

10. Start apparatus once before plate is in position to avoid movement due to possible fright of patient.

11. The object should be as near the plate as possible.

12. If the exposure is to be as short as possible to avoid movements due to respiratory motion, heart action, or with children who cannot be persuaded to keep quiet, a hard tube must be selected unless a photographic or intensifying screen be used with the X ray plate.

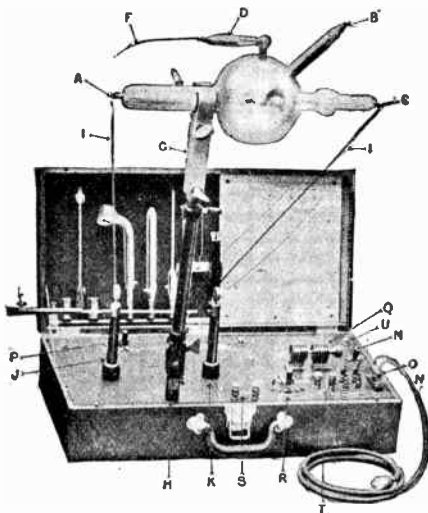
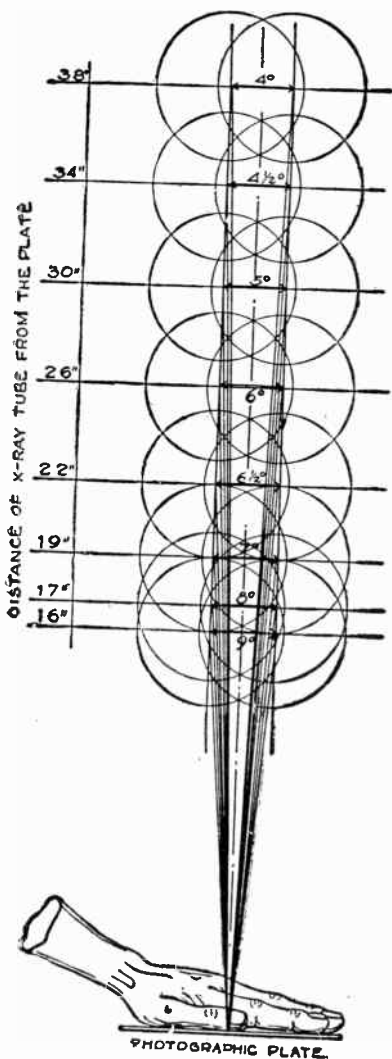

FIG. 4,697.—Scheidel-Western suitcase portable coil. *The parts are:* A, cathode; B, anode; C, assistant anode; D, regulating chamber; F, regulating adjuster; G, tube holder; H, tube holder socket; I, connection tapes; J, left hand terminal post; K, right hand terminal post; L, regulating rod; M, main line switch; N, connecting cord; O, connecting cord sockets; P, selector switch; Q, interrupter spark gap; R, controller switch; S, D'Arsonval; T, cautery and diagnostic lamp; U, sinusoidal current. *To operate,* set the X ray switch at the back to the point marked X ray, or controller switch to any of the six points of varying strength; close the main switch, and adjust the spark gap until the tube is operating satisfactory. Then open the main line switch, and, after the plate is in position, close the switch for the length of time necessary to make the exposure. A radiograph of the hip can be obtained in 45 seconds, or if an intensifying screen be used, the time is reduced to between 10 and 15 seconds; other parts in proportion. The high frequency current may be applied by means of the three vacuum electrodes furnished with the coil, connecting to either of the two main posts. This current has a very high rate of oscillation, making it practically without sensation. The D'Arsonval current is applied by connecting to the two binding posts marked "D'Arsonval" and the strength of this current is regulated in the same manner as is the high frequency, by the setting of the controller switch and spark gap. The cautery is used by connecting handle and electrodes furnished with the outfit to the binding posts marked *cautery*, and varying the amount of current with the controller switch. A diagnostic lamp on a long handle is supplied and the amount of current controlled by varying the strength with the main controlling switch. Any electric lighted diagnostic instruments may be used with this coil. The sinusoidal current for inducing muscular contraction without pain is applied by means of metal or moist electrodes, connections being made to the two binding posts marked *sinusoidal*.



16. The easiest parts to photograph are the hands, elbows and feet. Next come the knee, head, thorax, and shoulders. The most difficult part is the abdomen, and the task to prove the presence and position of stones in the kidneys, the ureters, etc. It must be remembered that only bodies whose atomic weight differs from the surroundings in which they are embedded, can be detected. The heart produces a shadow because it is filled with blood and surrounded by the lighter lung filled with air. Tuberculosis patches in the lungs appear darker because there is less air than in healthy parts, or even pus. Stones containing phosphate and lime will give some shadows, whereas gall stones or uric acid calculi give practically none.

17. To verify an exposure for stones, either part of a rib or part of the spine should appear on the negative, so as to show whether the exposure and development have been correct. If the transverse processes of the vertebra are clearly shown together with muscular details, most stones will also be shown. Failures are frequent in cases of stout patients and it is sometimes hopeless to verify stones.

FIG. 4,700.—Diagram for estimating the stereoscopic angle when tube is shifted $2\frac{1}{2}$ inches. **Example:** If distance from tube be 30 ins., shift tube $1\frac{1}{2}$ inch to either side of center and tilt it $2\frac{1}{2}^\circ$ either way toward center line. The greater the distance between the plate and the tube, the less the necessity of tilting it.

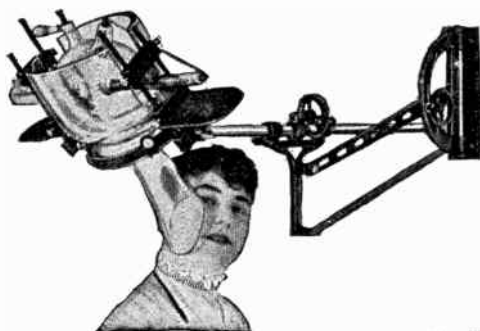
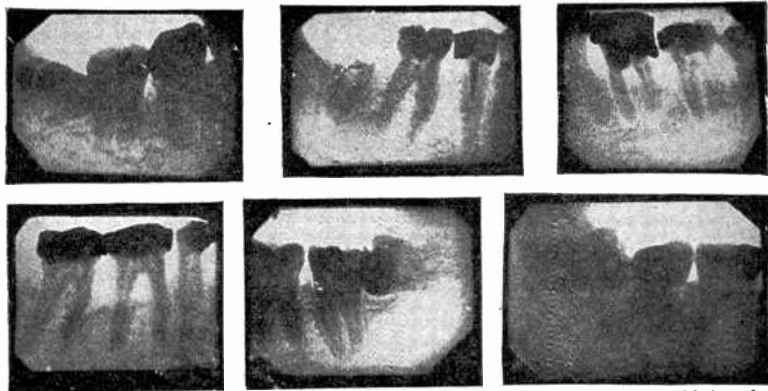

FIG. 4,701.—Scheidel-Western X ray bracket stand and patient. The illustrations show the bracket fastened to the wall by means of screws or bolts through a heavy plate to which is attached an arc that swings from side to side. To this arc is attached the arm supporting the tube and protection bowl. It will be noted in the illustration that a separate connecting rod keeps this bearing so that the tube is horizontal at any height. The tube bowl is mounted in a special saddle that may be tilted from side to side. As this can be revolved, also, every adjustment desired can be obtained, quickly. The tube is held in position securely by rubber and fibre clamps. It will be noted in the illustration that this bracket stand may be used for making Roentgenograms from either side of the head without moving the patient. The tube travel is from $30\frac{1}{2}$ inches from the wall to a maximum of $52\frac{1}{2}$ inches, and the up and down motion is 38 inches.



FIGS. 4,702 to 4,707.—Dental Roentgenograms. Fig 4,702, unerupted lower third molar, abscessed anterior root of 12 year molar due to pressure from third molar, and imperfect fitting crown of 12 year molar with abscessed distal root; fig. 4,703, both roots of 12 year molar remaining after attempted extraction. This was completely hidden by gum tissue, the patient suffering great pain from abscess; fig. 4,704, abscessed anterior and posterior roots of lower 6 year molar, the result of imperfect root filling, alloy filling extending into bifurcation, and region between teeth; fig. 4,705, poorly fitting crowns; fig. 4,706, impacted lower third molar; fig. 4,707, impacted lower third, and irreparable injury to second molar.

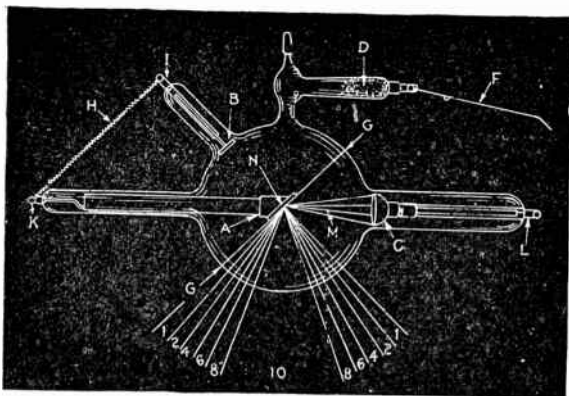

FIG. 4,708.—X ray tube. **The parts are:** A, anode; B, assistant anode; C, cathode; D, regulating chamber; F, regulating adjuster; G, hemisphere; H, connection wire; I, assistant anode cap; K, anode cap; L, cathode cap; M, cathode stream; N, focal point.

SUGGESTIONS FOR USING X RAY TUBES: Connecting X ray tubes: The positive pole of the coil is connected with the anode cap K and the negative pole to the cathode cap L. The current passes from the anode A to the cathode C and is reflected back as the invisible cathode stream M to the focal point N, producing the X ray which passes through the walls of the tube. **Strength of ray:** The most rapid and effective rays are those reflected at right angles from the cathode stream forming a focal point on the anode surface and shown graphically by the heavy cone No. 10. The strength of the rays gradually decreases, as indicated by the numbers 8-6-4, etc. **Adjustment:** Before passing the current through the tube, set the regulating adjuster F, if this be on the tube so that its end is from one and one-half to three inches from cathode cap L, according to the vacuum desired. **Visible hemisphere of green fluorescence.** **Regulation:** If sparks pass between the regulating adjuster F and the cathode cap L, it means the vacuum is high. If too high for the work to be done, allow the sparks to continue reducing the vacuum until the right degree is reached. When the vacuum is right, raise the regulating adjuster until the sparks cease to pass. Never permit the regulating adjuster F, to touch cathode cap L, as so many sparks would pass into the chemicals in the regulating chamber D, and so much gas would be driven off that the vacuum would be destroyed, or at least be too low for effective work. **To raise the vacuum in the tube:** If tube be warm it will generally be higher in vacuum than when cold. Reverse the connections, connecting the positive pole to the assistant anode cap I, and the negative pole to anode cap K. First removing the connecting wire H, and using a light current, permit it to pass for one or two minutes. The two cords connecting I, and K, to the coil should be so arranged that before reaching the connections on the tube, they will be closer together than the distance between any part of the glass surrounding anode K, and the assistant anode cap I, or there will be danger of sparks jumping from assistant anode cap I, through glass to anode. After operating tube with a light current in this manner for a short time, change the connections, connecting up in the regular way, and the tube will be found to have a higher vacuum. Repeat the operation if not high enough. Be careful in doing this not to raise the vacuum too high, for if this method is used very much, it has a tendency to make the tubes iracky. **High frequency tubes:** When using these tubes be sure that the connection wire II, is removed. In the illustration of the ordinary tube the point marked B, is called the assistant anode. In the high frequency tubes it is really the anode, and frequently the position of B, and K, are reversed. Connect one wire to the cap I, and the other wire to cap L, and be sure the tube is so adjusted that the wire connected to I, does not pass close to anode stem K, as there would be a leakage of current from the wire to anode stem which might puncture the tube.

A cylinder diaphragm compressor, is of great advantage in all abdominal cases.

18. The essential factor for radiographic results is the vacuum of the tube; select a "seasoned" tube so the vacuum and relative penetration will not change during the time of exposure. By far shorter exposures must be given where a larger amount of current passes through the X ray tube. X ray as well as outdoor photography requires correctly exposed plates. The amateur outdoor worker usually underexposes while the X ray beginner overexposes his plates.

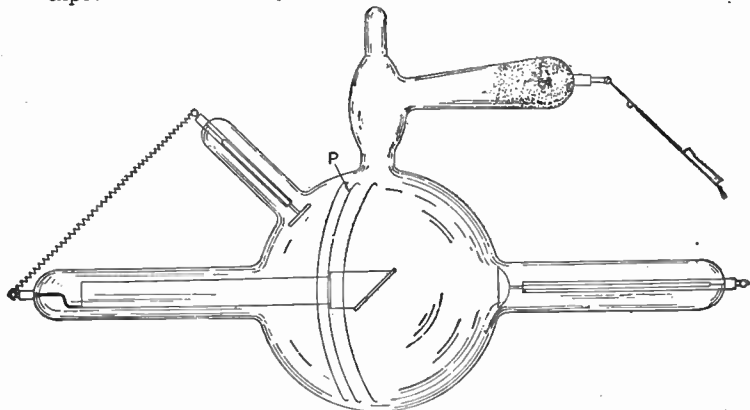
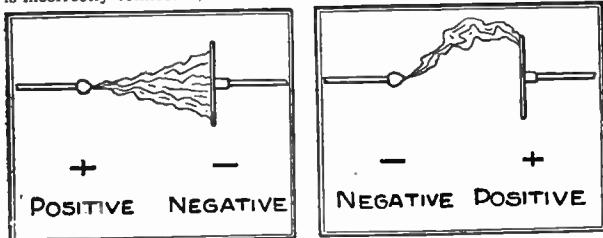

FIG. 4,709.—Suggestion for using X ray tubes: *Inverse*. At times, in addition to the hemisphere of brilliant green fluorescence there will be bands of green fluorescence on the bulb back of the anode, as shown in the illustration at P and parallel with cathode. This indicates, either that the tube is of low vacuum, or improper adjustment of the machine used for exciting it. In this case, go over the adjustment of the coil, or raise the vacuum of the tube. If only the green rings show and there is no hemisphere it indicates that the tube is incorrectly connected, and to remedy this reverse the connections.



FIGS. 4,710 and 4,711.—Suggestion for using X ray tubes: *Positive and negative poles*. This is determined by the action of the spark on the disc connected to the poles. If the sparks appear to come from the edge of the disc, the disc is positive and the point negative. If the sparks appear to come from the center of the disc, the disc is negative and the point positive. Do not use a flame or heavy spark while making this test.

19. Development is an art and considerable time should be given to this work to become proficient.

20. A correctly timed plate will show black during development in parts which have not been covered by the patient's body. Bones will appear fairly clear and the soft parts will show contrast and detail.

21. An under exposed plate will appear gray in portions not covered by the patient's body; the shadows of the bones will be white and the soft parts will show faint details. If the under exposure be excessive, they will also appear white.

22. An over exposed plate will be gray all over; bones will be only a slightly lighter shade of gray than the soft parts, and there will be a general fog with neither contrasts nor details in soft parts. To this type belong the majority of negatives. The fault is due to excessive length of the exposure, or more frequently to the fact that tubes have been employed which were too hard and required a relatively shorter time.

23. All developers work best at a temperature of 65° to 70° Fahr.

24. A concentrated developer works fast and with much density.

25. A diluted developer works slower but with finer details and is best for short exposures.

26. If the developer be too concentrated or too warm it will produce fog, unless it be restrained by the addition of bromide of potassium solution.

27. If too diluted, the developer will produce stains by the long immersion required.

28. Some developers, as for instance Eikonogen, Hydrochinone and Metol, when used fresh, require the addition of a few drops of bromide of potassium solution or some old developer to work perfectly clear. A small quantity of contrast developer may be added for the same purpose.

INDEX

NOTE.—This Index has been planned to render easily accessible all the vast amount of information contained in the 10 Electrical Guides. A feature of the Index, which contains over thirteen thousand five hundred items, is the fullness of its cross references. A very considerable amount of information will be found under the numerous illustrations.



A and B switchboard, telephone, operating, 2,140.

Abdominal treatment, current for, 3,205.

Aberration, achromatic, 2,702.
chromatic, 2,698.
spherical, 2,679, *ills.*, 2,696, 2,697, 2,702.

A. B. See No. 4, magnet control, *ills.*, 2,881.

Absolute and gauge pressure, distinction, 3,025.

Absorption, self-induced current, 147.
light, loss prevented, 2,519.

Accumulator(s), care and management of, 918.
charged, during night, 929.
charge indications, 926.
 every two weeks, 918.
 through lamp bank, *ills.*, 922.
 through rheostat, *ills.*, 922.
charging, current, effect of varying, 921.
 induction motor for, *ills.*, 915.
 time required for, 915.
danger of explosion of, 921.
first charge, regulated voltage during, 918.
parts, Champion, *ills.*, 909.
voltage shown by cadmium test, 919.

Accumulator(s), *continued*,
 weighted, used with step bearing, *ills.*, 1,181.

Acetic acid in battery electrolyte, 910.

Acetylene, burner, Challenge, multi-tip, *ills.*, 2,717.
 flame, candle power of, 2,521.
 oxy-, features of, 3,115.
 torch, oxy-, adjustment of, 3,115.

Achromatic aberration, 2,702.
 connection for in lens, 2,702.

Achromatic lens, 2,699.

Acid, acetic, in battery electrolyte, 910.
 copper, electro-plating, current for, 3,149.
 density of charged battery, 908.
 dilute sulphuric, strength of, 965.
 dipping baskets, electro-plating, *ills.*, 3,144, 3,160.
 effect of adding water to, 40.
 hydrofluoric, electro-plating, 3,158.
 hydrometers, *ills.*, 907, 3,194.
 nitric, electro-plating, 3,169.
 use in depolarizing, 41.
 solution, conductivity of, 69.
 effect of in cell, 40.
 specific gravity of, table, 906.
 tested with hydrometer, 905.
 sulphuric, and water, 904.
 characteristics of, 964.
 how to mix with water, 55, 905.
 liberation of gas from, 38.
 proportion used in cell, 53.
 testing set for accumulator, 921.
 vapor in battery rooms, 957.

Acousticon, battery, *ills.*, 2,199.
 sound regulator, *ills.*, 2,199.
 station sets, *ills.*, 2,199.
 telephone, *ills.*, 2,197.
 transmitters, *ills.*, 2,198.

Acting forces, on dynamo armature, *ills.*, 594.
 on tangent galvanometer, *ills.*, 444.

Action, chemical, in storage battery, 899.
 in motor armature winding, 1,494.

Alternating current(s).—*Continued.*

elevator motor, ills., 2,869.
 feeder regulation, 1,715, 1,716.
 field, ring armature in, ills., 1,351.
 generating set, Engberg, ills., 1,145.
 guided in external circuit, 162.
 heating effect of, ills., 1,015.
 heating of wires, 1,899.
 high voltage overload relays, ills., 1,649.
 indicating devices, 1,777-1,838.
 induced, where, 171.
 interlocking relay, 2,643.
 Kapp coefficient, 1,220.
 lag, ills., 1,050.
 lightning arrester, ills., 2,023.
 line curve, ills., 1,777.
 low voltage relays, General Electric, ills., 1,657.
 parallel circuit, ills., 1,540.
 parallel series circuit, ills., 1,541.
 power factor, 1,101.
 principles, 1,001.
 properties of, 997.
 pumps, various 2,999.
 switch, ills., 3,022.
 railway signals, 2,639.
 rectifier, Edison, ills., 942.
 parts of, ills., 944.
 relay, ills., 1,647.
 reverse phase, ills., 1,652.
 sine curve, ills., 168.
 single phase, 1,020,
 elementary, one loop alternator,
 and sine curve, ills., 1,020,
 for railway operation, 1,552.
 hydraulic analogy diag., 1,021.
 skin effect on wire, ills., 1,065.
 starting polyphase converter, 2,069.
 strength, rate of change in, ills., 1,068.
 three phase, 1,026-1,028.
 elementary three loop alternator
 and sine curves, ills., 1,026.
 hydraulic analogy, ills., 1,027.
 number of wires used, 1,028.
 trans. and dist. for railways, ills.,
 2,534-2,540.
 transmission, 1,532.
 for railways, ills., 2,536.
 two phase, 1,021-1,026.
 alternator armatures, how wound,
 1,025.
 elementary two loop alternator,
 ills., 1,022.
 hydraulic analogy, ills., 1,023.
 various two phase armature con-
 nection diags., 1,025.
 three wire dist., ills., 1,024.
 variation of, how shown, 168.
 virtual value, 1,777.
 voltage, effect of regulating pole con-
 verter on, 1,478.
 wave, equation, ills., 1,000, 1,002,
 various forms of, ills., 1,016.

Alternating current(s).—*Continued.*

wires, resistance, 1,896.
 Alternating current arc, 2,441.
 carbon, action, 2,442,
 for, 2,719.
 characteristics of, 2,442.
 current consumed in, 2,442.
 enclosed, ills., 2,441.
 humming and hissing, causes, 2,443.
 light distribution, ills., 2,478.
 troubles with, 2,718.
 Alternating current arc lamp(s), 2,444.
 Adams-Bagnall, ills., 2,433.
 cut out for, ills., 2,439.
 adjusting weight for, ills., 2,436.
 forced carbons for, 2,424.
 laminated parts, 2,444.
 Westinghouse, ills., 2,448.
 Alternating current bell(s), 2,365.
 operation of, ills., 2,367.
 transformer circuit, ills., 2,397.
 with permanent magnet armature, ills.,
 2,366.
 Alternating current circuit(s), capacity effect
 in, ills., 1,039, 1,040.
 capacity in, hyd. analogy, 1,041.
 condenser, ills., 1,046.
 containing capacity, ills., 1,047.
 direct current motor, 1,349.
 forms of, 1,537.
 frequencies, 1,991.
 ills., 1,098.
 impedance, 1,897.
 open, 1,040.
 self-induction in, ills., 1,028.
 series parallel, 1,542.
 with inductance, ills., 1,038.
 Alternating current diagram(s), composition
 of forces, 1,072, 1,073.
 active, and self-induced pressures,
 1,075.
 angle of lag, 1,079.
 illustrating capacity in series, and in
 parallel, 1,084.
 impedance, 1,081, 1,083, 1,093, 1,097.
 impressed pressure, 1,076, 1,077, 1,080,
 1,087, 1,089, 1,099.
 inductance and capacity, 1,090-1,092.
 lag, 1,083.
 ohmic drop, 1,079.
 parallelogram of forces, 1,074.
 properties of right angle triangle, diag.,
 1,070.
 reactance drop, 1,078.
 representation of forces by lines, ills.,
 1,072.
 Alternating current motor(s), 1,267-1,376.
 and alternator, 2,058.
 Arago's rotations, explanations, ills.,
 1,296.
 armature, built up core construction,
 ills., 1,325.
 commutator motor, Wagner, ills.,
 1,353.

Alternating current motor(s), armature,—
Continued.

- slip ring, Richmond, 1337
- W. E., ills., 1,336, 1,337.
- armature, squirrel cage, Allis-Chalmers construction, ills., 1,322.
- end rings, method of casting Fairbanks-Morse, ills., 1,375.
- evolution of, ills., 1,319-1,325.
- Fairbanks-Morse, ills., 1,326, 1,373.
- G. E. end ring construction, ills., 1,324.
- polyphase, Wagner, ills., 1,328.
- Richmond, ills., 1,329.
- Triumph, ills., 1,323.
- W. E., ills., 1,328, 1,331.
- armature, wound, for internal resistance motor, ills., 1,336.
- slip ring, Allis-Chalmers, ills., 1,339.
- Wagner polyphase induction motor, armature, ills., 1,335.
- auxiliary coils, 1,345.
- closed coil, action of, in rotating field, 1,349-1,355.
- commutator motor(s), 1,348-1,372.
- adjustable speed G. E., ills., 1,359.
- field of, Sprague, ills., 1,356.
- generated pressure, de., 1,352.
- high resistance connection, diag., 1,358.
- local armature currents, 1,355-1,357.
- operation, Wagner, diag., 1,350.
- principles, ills., 1,351.
- self-induction pressure, 1,352.
- short circuiting device, Bell, ills., 1,357.
- single phase compensated repulsion, G. E., ills., 1,354, 1,355.
- transformer pressure, 1,351.
- nature of, 1,352.
- variable speed, Wagner, ills., 1,349.
- compensated repulsion motor, parts of, G. E., ills., 1,366.
- copper ring, effect of alternating field on, ills., 1,365.
- Faraday's experiment, ills., 1,297.
- field magnet, 1,326-1,331.
- three phase, 6 pole, ills., 1,310.
- field winding two phase eight pole, ills., 1,301.
- two phase, 6 pole, ills., 1,300.
- induction asynchronous, des., 1287.
- Crocker Wheeler, magnetic bridge type, ills., 1,330.
- G. E. fractional horse power, ills., 1,288.

Alternating current motor(s), induction,
General Electric,—Continued.

- terminals, ills., 1,286.
- vertical type, ills., 1,314, 1,283.
- internal resistance, 1,334-1,336.
- when desirable, 1,336.
- polyphase, 1,292-1,338.
- Allis-Chalmers, parts of, 1,312.
- Holtzer Cabot set, ills., 1,332.
- operation, 1,287.
- Richmond field construction, ills., 1,327.
- power factor of, 1,373-1,375.
- principle of, ills., 1,311.
- Reliance polyphase, ills., 1,292.
- single phase, 1,338-1,348.
- clutch type, Sprague, ills., 1,342.
- disassembled clutch, G. E., ills., 1,348.
- G. E. fractional h. p., ills., 1,344.
- G. E., ills., 1,341.
- operation, 1,284, 1,285.
- phase splitting, diag., 1,341.
- slip, 1,310-1,319.
- slip ring connections, diag., 1,339.
- split phase, stationary armature, Fort Wayne, ills., 1,347.
- starting, 1,331-1,348.
- with auto-transformer, ills., 1,334.
- with field resistance, 1,332.
- squirrel cage, clutch type, G. E. ills., 1,343.
- Fairbanks-Morse, ills., 1,374.
- table, of slip, 1,318.
- of synchronous speeds, 1,317.
- three phase, four pole Y connected, ills., 1,305.
- mill type, W. E., ills., 1,340.
- W. E. frame and punchings, ills., 1,287.
- Westinghouse, auto-starter, ills., 1,333.
- squirrel cage armature, ills., 1,319.
- oscillating field, production of, 1,343-1,347.
- phase splitting, 1,343-1,347.
- character of starting torque, 1,346.
- production of a rotating magnetic field, 1,294-1,298.

- Alternating current motor(s), production of a rotating magnetic field,—Continued.**
 four pole, two phase motor, ills., 1,299.
 six pole, three, phase motor, ills., 1,306.
 three phase, ills., 1,304–1,309.
 two phase, ills., 1,298–1,304.
 series motor(s), 1,359–1,362.
 characteristics, 1,360.
 neutralized, 1,361.
 conductive method, diag., 1,361.
 inductive method, diag., 1,362.
 shading coils, action of, diag., 1,347.
 for starting, ills., 1,346.
 shunt motor(s), 1,362–1,364.
 compensated, diag., 1,363.
 Fynn's, diag., 1,364, 1,367.
 simple, diag., 1,363.
 slip, 1,310–1,319.
 sector, method of measuring, ills., 1,318.
 table of, 1,318.
 variation, 1,317.
 speed and torque, 1,375, 1,376.
 starting coils, 1,345.
 synchronous and induction motors, comp., 1,280.
 synchronous motor(s), 1,268–1,282.
 adaptation, 1,279.
 advantages, 1,278.
 as condenser, ills., 1,281.
 characteristics, 1,282.
 disadvantages, 1,277.
 mech. analogy of hunting, ills., 1,280.
 Westinghouse, self-starting, 1,279.
 synchronous motor principles, ills., I. to VIII., 1,268–1,276
 repulsion motor(s), 1,364–1,372.
 compensated, adaptation, 1,372.
 brushes, 1,371.
 parts of G.E., ills., 1,366.
 reversing, Sprague, diag., 1,371.
 Sprague, diag., 1,368.
 variable speed, Sprague, 1,370.
 repulsion motor, simple, des., 1,369.
 rotating magnetic field, moving picture view, ills., 1,304.
 objection to high speed, 1,329.
 three phase, physical conception of, ills., 1,308, 1,309.
 two phase, physical conception of, ills., 1,302, 1,303.
 Tesla's, ills., 1,293.
 Thompson's, experiment, alternating field, 1,364.
 motor, difficulty with, 1,368.
 torque and speed, 1,375, 1,376.
- Alternating current motor(s),—Continued.**
 two phase, resultant poles, ills., 1,300.
 variable speed machine, 2,545.
 Alternating current systems, 1,531–1,586.
 angle tower with G. E. strain insulators, ills., 1,552.
 change of frequency, 1,568–1,571.
 delta and star connection comp., 1,567.
 delta connection, 1,566.
 diag. of parallel series circuit, 1,541.
 diametrical connection, diag., 1,575.
 electric railway system, diag., 1,584.
 forms of circuit, 1,537.
 G. E. standard h. t. three phase tower, ills., 1,580, 1,581.
 transposition h. t. three phase tower, ills., 1,580.
 mixed current systems, 1,585, 1,586.
 monocyclic system, diag., 1,554.
 objections to single phase systems, 1,551.
 parallel circuits, 1,540, 1,541.
 pump, various, 2,999.
 switch, ills., 3,022.
 relative weights of copper required by polyphase systems, diag., 1,576–1,580.
 saving due to, 1,575, 1,576.
 Schaghticoke-Schenectady line, beginning, ills., 1,570.
 ills., 1,569.
 top of power house, ills., 1,571.
 Schenectady Power Co., line crossing, R. R. tracks, ills., 1,582.
 Scott connection, diag., 1,573.
 series circuits, 1,537.
 series parallel circuits, 1,541.
 single phase, 1,546–1,553.
 low pressure alternator with step up transformer, diag., 1,551.
 two wire trans., three wire dist. diag., 1,547, 1,550.
 star connection, 1,565.
 sub-station converter, Brooklyn Edison Co., ills., 1,585.
 T connection, diag., 1,567, 1,568.
 three phase, delta connected alternator, diag., 1,566.
 four wire, star con., diag., 1,565.
 long dist. trans. and dist., diag., 1,562.
 six wire, diag., 1,563.
 star and delta connections, diag., 1,560.
 star connected alternator, diag., 1,565.
 three phase, systems, 1,561–1,568.
 three wire, evolution, diags., 1,564.

Alternating current systems, 3, ph.,—Cont'd.

- T, connection of transformer
diag., ills., 1,567.
- 2,300 volt line at Chazy, N. Y.,
1,583.
- transformation of phases, 1,571-1,576.
 - classification, 1,571, 1,572.
 - Scott connection, 1,573.
 - three phase, to one phase, 1,572.
 - to six phase, diag., 1,575.
 - to two phase, 1,572.
diag., 1,574.
- transformer system, transformer at distribution center, diag., 1,544.
 - with individual transformers,
diag., 1,543.
- twin circuit aermotor towers (44,000-volt line) Southern Power Co.,
ills., 1,579.
- two phase, five wire, diag., 1,560, 1,561.
 - four wire, diag., 1,555.
 - trans., three wire dist. diag.,
1,559.
 - systems, 1,555-1,561.
 - three wire, diag., 1,556.
 - trans., diag., 1,557, 1,558.
- typical isolated plant, ills., 1,549.
 - 6,600 volt single phase trolley
line, ills., 1,539.
- use of step up and step down transformers,
diag., 1,545.
- usual transmission voltages, 1,582.
- various forms of circuit, 1,537.
- 44,000 volt lines at Gastonia, S. C.,
ills., 1,542.
- 100,000 volt Milliken towers, Southern
Power Co., ills., 1,548.

Alternating current wiring, 1,885-1,914.

- a. c. diagrams for impedance, impressed
pressure, etc., 1,897, 1,899.
- capacity effect, 1,890, 1,892.
 - single phase, diag., 1,890.
 - three phase, diag., 1,890.
 - per mile, three phase system
table, 1,891.
- corona effect, 1,894.
- critical voltage, 1,895.
- effect of self-induction, diag., 1,886.
- electromagnetic and electrostatic fields,
surrounding conductors, ills.,
1,895.
- frequency, 1,892.
- inductance per mile of three phase circuit
table, 1,889.
 - when considered, diag., 1,901.
 - when negligible, diags., 1,901.
- induction, 1,885.
- induction motors, approx. amperes per
terminal, table, 1,900.
- impedance, 1,897, 1,898.
- mutual induction, 1,887.
 - how caused, 1,887.

Alternating current wiring,—Continued.

- power factor(s), 1,898-1,900.
 - mechanical analogies, 1,898.
 - on commercial circuits, 1,900.
- properties of copper wire, table, 1907-
1909.
- resistance of wires, 1,896.
- skin effect, diag., 1,893, 1,894.
 - how calculated, 1,894.
 - ratio factor table, 1,894.
 - when negligible, 1,893.
- spacing of wires, 1,896.
 - for various voltages, table, 1,896.
- stranded copper cables, ills., 1,903.
- transpositions, diags., 1,888, 1,890
- wire calculation (s), 1,900-1,914.
 - current, 1,912, 1,913.
 - drop, 1,909-1,911.
 - miscellaneous formulæ, 1,906.
 - size of wire, 1,902-1,907.
 - values of, M, table, 1,904.
 - S for 25 cycles, 1,911.
 - S for 60 cycle table, 1,910.
 - T, table, 1,905.
 - wire equivalents, table, 1,913.
- Alternation of current explained, ills., 1,003.
- Alternative compound winding, 195.
- Alternator(s), 1,125-1,186.
 - Allis-Chalmers, ills., 1,190, 1,200.
 - amortisseur winding, 2,039.
 - amortisseur wound, Westinghouse, ills.,
1,154, 1,155.
 - and alternating current motor, 2,058.
 - and dynamo, difference in current, 171.
 - and gas engine direct connected, ills.,
1,956.
 - and induction motor, 2,058.
 - and synchronous motors, location of,
ills., 1,766.
 - armature connections, three phase, delta,
ills., 1,560.
 - three phase, star, ills., 1,560.
 - armature, revolving, 6 pole, ills., 1,234.
 - self-excited, ills., 1,189.
 - windings, classified, 1,210.
 - asynchronous, 1,183.
 - automatic voltage regulator, for, 1,748.
- average volts of, 1,010.
- belt driven, ills., 1,135.
 - separately excited, Fort Wayne,
ills., 1,163. 2,010.
- belt tightened, 1,136.
- brought in phase, 2,034.
 - brush, rigging, ills, 1,262.
 - holder, slip rings, ills., 1,202.
- chain driven, ills., 1,135.
- classes of, 1,126.
- coils, lap wound, ills., 1,222.
- winding, distributed, 1,218.
- collection of armature currents, 171.

Alternator(s),—Continued.

- compositely excited, 1,191-1,193.
- compound, synchronized, ills., 2,046.
- concentrated coil for, ills., 1,218.
- concentrated winding, wave form with, 1,217.
- constant current, advantage of, 1,540.
 - voltage high when circuit is open, 1,539.
- construction of, 1,187-1,266.
- coupled, Crocker-Wheeler, ills., 1,142.
- cut out with main switch, 2,043.
- developed view of, ills., 1,128, 1,130.
- device for moving, 1,136.
- direct connected, ills., 1,141.
 - to engine, ills., 1,174.
- direction of current in, ills., 163.
 - Fleming's rule, 163.
- distributed coil for, ills., 1,218.
- dynamo ring wound, converted into, ills., 1,144.
- electromotive force in, ills., 166.
- elementary, construction of, 162, 163.
- engine type ills., 1,141.
- excitation test, ills., 2,084.
- exciter location, 2,009.
 - transformer and converter connected, ills., 2,062.
- features of revolving field, 1,149.
- field(s) circuit, rheostat in, 2,019.
 - magnets of, 1,187, 1,189.
 - self-excited, ills., 1,168.
 - superposition of, ills., 1,164.
- flywheel, General Electric, ills., 1,175.
- four pole, single phase, ills., 1,127.
 - three phase, ills., 1,131.
 - two phase, ills., 1,129.
- frame, General Electric, ills., 1,208.
- frequencies made the same, 2,034.
- heteropolar inductor, ills., 1,153.
- high frequency, 1,185.
- high pressure, synchronized, ills., 2,038.
 - transmission, ills., 1,550.
- high speed, ills., 1,176.
- homopolar inductor, ills., 1,153.
- horizontal water wheel, ills., 1,177.
- hunting, 1,151. 2,045.
- image current, 1,183.
 - circuits, ills., 1,184.
- inductor, ills., 1,150, 1,152.
 - classes of, 1,153.
 - compared with others, 1,151.
- in parallel, ills., 2,032, 2,033.
- in series, 2,045.
- installed, Crocker-Wheeler, ills., 1,174.
 - Curtis turbine, ills., 1,182.
 - load test, three phase, 2,085.
 - low pressure transmission, ills., 1,547.

Alternator(s),—Continued.

- low voltage, low frequency, ills., 1,553.
- magnetic leakage of, 1,165.
- maximum volts of, 1,010.
- monocyclic, ills., 1,158.
 - circuits, ills., 1,156.
 - connections, ills., 1,159.
 - teaser coil, 1,554.
- moving device, 1,136
- multiphase revolving armature, ills., 1,203.
- Murray, with high speed Corliss engine, ills., 1,979.
- operation of, 2,031.
- parts of Allis-Chalmers, ills., 1,251.
- pedestal, bearing, Westinghouse, ills., 1,260.
 - type, belted, ills., 1,137.
- pole pieces of, ills., 1,188.
- polyphase, 1,129.
 - Westinghouse, ills., 1,169.
- pressures induced in, diagram of, ills., 1,232.
- principle of, 2,412.
- rated, 1,121.
- rectifier, ills., 1,193.
- regulating devices, 1,715-1,762.
- reversal of current in, ills., 165-166.
- revolving armature, ills., 1,143.
- revolving field, ills., 1,146, 1,148.
 - belt driven, ills., 1,139.
 - for Allis-Chalmers, ills., 1,179.
 - Lincoln, ills., 1,167.
 - separately excited, Westinghouse, ills., 1,172.
- saturation curve, how obtained, ills., 1,991.
- section of General Electric, ills., 1,207.
- self-exciting image current, 1,185, 1,186.
- separately excited, ills., 1,191.
- shaft, slip rings for, 1,195.
 - ills., 1,201.
- single phase, 1,127.
- slow speed, ills., 1,173.
- spider used on, 1,199.
- star connected, merits of, 1,567.
 - three phase, 4 wire, ills., 1,565.
- starting several at once, 2,039.
- stationary armature, Western Electric, ills., 1,149, 1,203.
- stationary field of Fort Wayne, ills., 1,195.
- stator and rotor, 1,148.
- synchronized, 2,034.
 - three phase, 2,041, ills., 2,042.
- synchronizing lamp, ills., 2,033, 2,035.
- temperature test, three phase, ills., 2,086, 2,087.
- three bearing, ills., 1,190.
- three loop, ills., 1,026.
- three phase, sine curves, ills., 1,132.
 - delta connected, ills., 1,566.

Alternator(s), three phase,—Continued.

- for single phase circuits, 1,550.
 - turbine driven, 1,181.
 - two bearing, ills., 1,200.
 - units, turbine, ills., 2,666.
 - use of, 1,125.
 - vertical water wheel, ills., 1,178.
 - virtual pressure of, 1,010.
 - voltage adjusted by varying field excitation, 2,039.
 - water wheel, ills., 1,177.
 - revolving field for, ills., 1,179.
 - section of, ills., 1,257.
 - Westinghouse, stationary armature, ills., 1,264.
 - three phase composite wound, ills., 1,253.
 - winding(s), damper, ills., 1,155.
 - fully distributed, ills., 1,219.
 - lap and wave, 1,213.
 - multi-coil, 1,218.
 - partially distributed, ills., 1,219.
 - single phase, 1,233.
 - squirrel cage, ills., 1,155.
 - turbine, driven, ills., 1,180.
 - ills., 1,263.
 - with amortisseur winding, Fort Wayne, ills., 1,154.
 - Westinghouse, 1,155.
 - with direct connected exciter, Fort Wayne, ills., 1,171.
- Altitude compression, 3,045.
- Aluminum, conductor of electricity, 69.

- electrolysis of, 3,135.
 - electrolytic arrester, 1,696, ills., 1,697.
 - parts of, ills., 1,698.
 - manufacture of, 3,135.
 - overhead wires, 800.
 - pointer, tubular, for meters, Wagner, ills., 1,778.
 - rectifier cathode, 1,496.
 - soldering fat for, 3,083.
 - solders, 3,077, 3,078.
 - welding flux for, 3,109.
- Amalgamated zinc, action of, 64, 65.
- Amalgamating solution, electro-plating, 3,146.

Amber as insulator, 70.

- Amenorrhoea, treatment for, 3,206.
- American, cells, electrical data on, 959.

- form of Grenet cell, ills., 52.
- standard wire gauge, ills., 73E, 739.
- wire splice, ills., 818.

Ammeter(s), and voltmeter, difference between, 544.

- and volt meter, windings, 541.
- automobile, defective, cause, 2,854.
- contact making, ills.G. E., 1,749.
- electro-magnetic, ills., 1,781.
- electro-plating outfit, ills., 3,151, 3,168, 3,169.
- experiment battery, and motor, 359.

Ammeter(s)—Continued.

- Hoskins, ills., 1,790.
 - h. p. reading, how obtained, 385.
 - illuminated, Weston, ills., 558.
 - inclined coil, ills., 548, 549.
 - jack plug switch, ills., 1,592.
 - milli-, des., 358.
 - panel board, ills., 1,880.
 - plunger, 544.
 - qualities essential, 537.
 - radial switch, Crouse-Hinds, ills., 1,883.
 - wiring, Crouse-Hinds, ills., 1,884.
 - readings, 385.
 - 2,098, 2,099,
 - recording, G. E., record from, ills., 565.
 - series and shunt, 542.
 - series, connections, ills., 542.
 - shunt(s), connections, ills., 542.
 - connected to bus bars, 543.
 - solenoid or plunger type, ills., 544, 546.
 - test, dry cells, 61.
 - with Queen Acme set, 510.
 - Thompson inclined coil, ills., 548.
 - types of various, 537.
 - voltmeter, a special form of, 542.
 - and wattmeters, 537-572.
 - volt-, Weston, ills., 2,822.
 - wattmeter and voltmeter connected, ills., 2,074.
 - Weston, construction, ills., 545.
- Amortisseur winding, action of, 2,041.
- Fort Wayne alternator, ills., 1,154.
- of alternator, 2,039.
- on synchronous condenser field, General Electric, ills., 2,041.
- Westinghouse alternator, ills., 1,155.
- Ampere(s), 2,733.**
- and coulombs, hydraulic analogy, ills., 468.
 - difference between, 470.
 - and volts, effective, 1,013.
 - virtual, ills., 1,012.
 - capacity of insulated wire, 731.
 - coil and volt coil meter, ills., 556.
 - consumed by series dynamo, 186.
 - definition of, 29.
 - demand measured, 557.
 - foot, measuring of, 736.
 - formula to determine, 29.
 - hour(s), amount of electrolyte, 908.
 - battery charging capacity, 916.
 - definition of, 86.
 - capacity of storage cell, 938.
 - rate of battery capacity discharge, 941.
 - how determined, 29.
 - how differs from coulomb, 87.
 - how produced, 29.
 - international, with silver voltmeter, 472.
 - kilovolt, 1,121.

Arc(s),—Continued.

- effect of carbons in contact at starting, 2,432.
 - effect of too much current in, 2,422.
 - effect on, of increasing distance between carbons, 2,422.
 - efficiency of, 2,426.
 - enclosed, 2,439.
 - bulbs for, 2,439.
 - carbon a. c., ills., 2,441.
 - globes for, 2,439.
 - light distribution of, 2,440.
 - with solid carbons, ills., 2,416.
 - energy consumed, ills., 2,417, 2,419.
 - flame, description of, 2,418.
 - flickering of light, cause of, 2,424.
 - general appearance of, ills., 2,426.
 - general characteristics of, 2,417.
 - heat of, 2,426.
 - hissing in, cause, 2,422.
 - intensity of light in, 2,417.
 - lead burning outfit, ills., 927.
 - luminosity increased, 2,418.
 - luminous, 2,461.
 - maintenance of, 2,415.
 - mercury rectifier, bulbs, General Electric, ills., 1,523.
 - connections, ills., 1,517.
 - construction and operation, 1,517.
 - double tube, ills., 1513-1514.
 - outfit, General Electric, ills., 1,522.
 - series, General Electric, ills., 1520-1,524.
 - spark, 1,512.
 - starting, 1,521.
 - three phase, ills., 1,509.
 - tube, General Electric, ills., 1,516.
- metallic oxide, advantages of, ills., 2,464.
- most luminous part, 2,422.
- motion picture, 2,717.
 - current for, 2,717.
 - how started, 2,720.
 - proper arc for, 2,720.
- photometric characteristics of, ills., 2,511.
- proper, per cent of light furnished by, 2,426.
- resistance of, how increased, 2,432.
- resistance rate, 2,421.
 - solid carbons, ills., 2,419.
 - varies with current, ills., 2,420.
- rupturing arrester apparatus, ills., 889.
- semi-enclosed, voltage of, 2,441.
- setting for a.c., cored carbons, ills., 2,439.
- small open, on constant pressure systems, 2,426.

Arc(s),—Continued.

- stereopticon, d. c., carbon adjustment ills., 2,718, 2,719.
 - for direct current, ills., 2,719.
 - stream, description of, 2,418.
 - modifying to increase luminosity, 2,418.
 - temperature produced by, 2,419.
 - voltage, adjustment of, 2,447.
 - and current waves, ills., 1,869.
 - lamp, to reduce, 2,458.
 - reduced, use of cored carbon, 2,423.
 - regulating with adjusting weight, 2,437.
 - watts consumed by different current strength, ills., 2,118.
 - consumed for different lengths, 2,417.
 - welding, C. and C., ills., 3,121.
 - electrode for, ills., 3,122.
- Arc lamp(s), Adams-Bagnall, ills., 2,433.**
- adjusting weight, Adams-Bagnall, ills., 2,436.
 - special design, 2,447.
 - adjustment of carbons, 2,422.
 - air circulation, ills., 2,464.
 - alternating current, 2,444.
 - diff. control, Adams-Bagnall, ills., 2,447.
 - diff. control, Westinghouse, ills., 2,448.
 - focusing mechanism, 2,443.
 - laminated parts, for, 2,444.
 - bad feeding from excessive current, 649.
 - carbon clutch, Fort Wayne, 2,455, ills., 2,455.
 - carbon, high tension, 2,425, holder carrier, Ft. Wayne, ills., 2,455.
 - cause of flaming, 2,426.
 - circuits, 2,445.
 - constant current, 757.
 - constant voltage, 757.
 - parallel, 757.
 - series, 757.
 - clutch, Adams-Bagnall, ills., 2,432.
 - operation in, 2,433.
 - compound wound solenoid in, ills., 2,438.
 - conduit outlet, condulet for, ills., 793.
 - construction details, ills., 2,465.
 - cost of operating, 2,423.
 - c. p. distributing curve, 2,425.
 - current adjustment, 2,457.
 - consumption of, 2,426.
 - excessive, 649.
 - Westinghouse, ills., 2,452.
 - cut out, ills., 2,438.
 - Adams-Bagnall, ills., 2,439.
 - and substitutional resistance, ills., 2,437, 2,438.
 - cut out dash pot(s), and adjusting weights, 2,435.

Arc lamp(s).—*Continued.*

- cut out, retarding medium, 2,436.
- differential, ills., 2,430, 2,431.
 - Westinghouse, 2,448.
 - with cut out, ills., 2,438.
 - with rod feed, ills., 2,438.
- diffusers, for, ills., 2,518, 2,519.
- direct current enclosed, 2,440.
 - series, constant current in, 2,449.
 - Westinghouse, ills., 2,456.
- effect of too great voltage in, 2,426.
- electricity consumed by, 470.
- enclosed, advantages of, 2,440.
 - Ft. Wayne, ills., 2,450.
 - Westinghouse, ills., 2,452.
- expense saved, 2,440.
- flaming, 2,466.
 - efficiency increased, 2,418.
 - Lord, ills., 2,469.
 - mechanism of, ills., 2,467.
 - transformer, Moloney, ills., 1,454.
- flickering, 2,437.
- focusing, ills., 2,471.
- gas cap, ills., 2,459.
- globes, 2,516.
- hand feed, ills., 2,472.
 - for lantern work, ills., 2,471.
- impedance coil, Fort Wayne, ills., 2,454.
- indirect system of lighting, 2,509.
- installation, and carc, 2,476.
 - and incandescent wiring, 2,459.
- inverted, ills., 2,470.
- loss of light prevented in, 2,519.
- low tension, carbon for, 2,425.
- magnetite, principle of, 2,463.
- mechanism of, 2,427.
- metallic flame, electrode arrangement, ills., 2,466.
 - ills., 2,462.
- motion picture, defective centering, ills., 2,722.
 - Power's, ills., 2,723.
 - right angle, ills., 2,722.
 - Simplex, ills., 2,723.
- open, compared with enclosed, 2,440.
- outrigger suspension for, 2,507.
- parallel, 2,452.
- parallel circuit, Ft. Wayne, ills., 2,451, 2,453.
- retrimming, 2,479.
- series, 2,446.
 - Adams-Bagnall clutch for, ills., 2,432.
- series control, ills., 2,428.
 - Ft. Wayne, ills., 2,451.
 - Westinghouse, ills., 2,456.
 - with rod feed, ills., 2,435.
- series parallel, 2,461.
 - ills., 2,463.
- shunt coil, action of, ills., 2,429, 2,431.

Arc lamp(s).—*Continued.*

- size of carbons for, 2,425.
 - sodium flame, 2,424.
 - special forms, ills., 2,471.
 - starting resistance, Adams-Bagnall, ills., 2,440.
 - titanium, principle of, 2,463.
 - Toening inverted, ills., 2,470.
 - unpacking, 2,476.
 - voltage adjustment, 2,457.
 - Westinghouse, ills., 2,452.
 - voltages for, 2,426.
 - voltage Ft. Wayne, d. c., series, ills., 2,450.
 - vs. Cooper-Hewitt lamp, 2,485.
 - Westinghouse auto-transformer, ills., 2,452.
 - differential control, ills., 2,460.
 - enclosed, parallel circuit, ills., 2,456.
 - parallel circuit, ills., 2,462.
 - with single acting dash pot, ills., 2,437.
- Arc light,** cut out and substitutional resistance, 2,437.
- enclosed, nature of, 2,454.
 - motion picture, how centered, 2,719.
 - steadiness in, 2,479.
 - water resistance for, ills., 2,777.
- Arc lighting,** a. c., fuses for, ills., 2,444.
- Adams-Bagnall oil switch, ills., 2,444.
 - regulator, ills., 2,444.
 - carbon feed for search light, ills., 2,475.
 - carbons, defective, 2,479.
 - size of, 2,423.
 - used in, 2,422.
 - circuit, size of wire for, 2,449.
 - constant pressure transformer for, ills., 2,444.
 - copper saving in, 2,449.
 - globes for, 2,516.
 - intensity table, 2,524.
 - intrinsic brilliancy table, 2,521.
 - parallel a. c. system, ills., 2,458.
 - resistance of carbons in, 2,423.
 - search light projectors, 2,472.
 - series, advantages of, 2,449.
 - circuit, ills., 698.
 - disadvantages of, 2,450.
 - dynamo in, 185.
 - mercury vapor rectifier for, 1,515.
 - methods of control, 2,452.
 - wound dynamo for, ills., 184.
 - shades and reflectors for, 2,516.
 - system(s), Adams-Bagnall a. c., series, ills., 2,444.
 - series circuit, ills., 698.
 - danger of, 698.
 - ills., 1,510.
 - testing and adjusting, 2,478.
 - wiring diagram, 100 light transformer, ills., 2,445.

Arc lighting, wiring diagram,—Continued.

- high voltage, 778.
- low voltage, 778.
- Arm(s), bridge, table, 502.**
- cross, for insulator pins, 805.
- holding brushes in large dynamos, 320.
- lever, of brake test, 379.
- of Wheatstone bridge, reversing of.
 - ills., 493.
- rocker, brush holders carried by, 319.
 - of speed motor, ills., 688.
 - telephone, cross, 805.
- Armature, 221-228.**
- alternator, revolving, six pole, ills., 1,234.
- and field coils in closed circuit, 675.
- reversed connections between, 589.
- and field magnet, how different, 159.
- and magnetic field, relative positions, 169.
- relative position, ills., 169.
- and shunt field control combined, 690.
- at rest, magnetic flux through, 263.
 - ills., 262.
- attachment of commutator to, 172.
- axis of, ills., 267.
- back head of, ills., 337.
- bar, back end, meaning of, 229.
- front end, meaning of, 229.
 - Siemens', ills., 339.
- barrel wound, Holtzer Cabot, ills., 334.
 - Western Electric, ills., 333.
 - Westinghouse, ills., 340.
- bearings, hot, cause, 565.
 - lubrication of, 2,595.
 - self-aligning, ills., 656.
 - self-oiling, ills., 656.
- bell, too rapid vibration, 2,396.
 - momentum of, how absorbed, 2,342.
 - reduction of, 2,367.
- booster converter, Westinghouse synchronous, ills., 1,483.
- brushes, adjustment, 611-612.
 - amperage through, 251.
 - carton, 306.
 - classification of, 303.
 - effect of reduction, ills., 253.
 - laminated, 305.
 - size of, 311.
- care in handling, necessary, 394.
- chord winding, ills., 246.
- circuit(s), break in, 635.
 - breaks, sparking at brushes, 650.
 - repaired, 634.
 - dynamo, resistance in, 605.
 - number of, 253.
- Commercial voltages at moderate speed of, 182.**

Armature,—Continued.

- commutator, and brushes, heating of, 655.
 - bars, ills., 224.
 - Bissell, ills., 646.
 - turned on lathe, 645.
 - concentrated coil, Westinghouse single phase, ills., 1,217.
 - connectors, high resistance, ills., 1,358.
 - spiral, 336.
 - cross magnetism of, ills., 262, 263.
 - dead turns of, 278, 279.
 - definition of, 159.
 - delta connected and collector rings, ills., 1,254.
 - difference between elementary and commercial, 221.
 - disc(s) for alternator, ills., 1,204.
 - connections of, ills., 228.
 - of Niaudet machine, ills., 228.
 - Watson, ills., 617.
 - double winding, 243.
 - driven, type for alternator, ills., 1,204.
 - dynamo, 160.
 - acting forces on, ills., 504.
 - current in, ills., 262, 263.
 - easy removal of, ills., 156.
 - of what made, 221.
 - dynamo, three wire, ills., 198.
 - dynamometer, Wagner, ills., 1,794.
 - elementary, coil added to, 221.
 - dynamo, ills., 173.
 - producing pulsating current, 221.
 - end ring, soldered form, General Electric, ills., 1,324.
 - welded form, General Electric, ills., 1,324.
 - end of ring winding, ills., 230.
 - evolute connectors, 337.
 - Fairbanks-Morse, ills., 360.
 - field, and interpoles of motor, ills., 385.
 - symmetry in, 255.
 - former wound, 158.
 - four coil, action of, ills., 179.
 - friction varies with load, 282.
 - General Electric, ills., 348.
 - ills., 1,206.
 - Gramme, original ring, ills., 223.
 - ills., 1,250.
 - four coils, ills., 177.
 - one coil, 174.
 - grounded, magnet test for, 633.
 - in, 632.
 - hand winding of, 336.
 - heating, causes of, 332.
 - Holtzer Cabot, rear view, ills., 337.
 - induction motor, slip of, 1,313.
 - inductors, drag on, ills., 275.
 - in transit, ills., 2,001.
 - laminated, sectional view of, ills., 324.
 - smooth core, ills., 323.
 - with retaining bolts, ills., 325.

Armature, laminated,—Continued.

- with retaining plates, ills., 324.
- lap winding of, ills., 236.
- large, for direct connected dynamo, ills., 348.
- lead, test for break in, ills., 625.
- losses, mechanical and electrical, 281.
- magnetic drag on, 274.
- mica insulated, 2,657.
- motor, drop in, 380.
 - open coil, Thomson's, 1,368, 1,369.
 - polyphase induction, ills., 1,335.
 - winding, action in, 1,494.
- moving, friction of air on, 2,113.
 - iron, ills., 1,781.
- moving of, ills., 2,001.
- not centered, 659.
- Or field currents reversed, reverse motor rotation, 361.
- open, temporary clearing of trouble, 617.
- partial short circuits in, 630.
- paths of current through, 261.
- pitch(es) average, 253.
 - alike in sign, 256.
- polarized relay, 2,638.
- protection, 2,001.
- pulsations produced by, 176.
- railway motor overheated, 2,658.
- repulsion induction commutator motor, ills., 1,353.
- resistance, elevator, 2,889.
- resistance, loss, 2,114.
 - regulation by, 683.
- revolving, alternator, ills., 1,143.
 - multiphase alternator, ills., 1,203.
- six coil, ills., 1,234.
- three coil, ills., 1,235.
- ring, and drum, compared, 223.
 - described, 224.
 - diagram showing distribution of current in, ills., 259.
 - distribution of current in, illustrated by battery analogy, ills., 258.
 - for alternator, ills., 1,204.
 - Gramme's invention of, ills., 176.
- in alternating current field, ills., 1,351.
- of commutator motor, section of, ills., 1,358.
- of four pole dynamo, ills., 222.
- producing high voltage, 225.
- sections held by spider, 330.
- rotation, continuous, given by commutator, 360.
 - direction of, 577.
- section of monocyclic alternator, ills., 1,157.

Armature,—Continued.

- segments, sectional view of, ills., 298.
 - brush in contact with, 289.
 - two, covered by brush, ills., 296.
- self-excited alternator, ills., 1,189.
- shaft, attached to core, 322.
 - end nut, ills., 688.
 - shoulders on, 322.
 - steel, 321.
 - typical, ills., 322.
- short circuited, 624, 659.
 - sparkling at brushes, 650.
- Siemens' wood core, 226.
 - winding, 243, 244, 246.
- simplest form, 159.
- sine curve applied to, ills., 163-170.
- sling for handling, ills., 405.
- slots, number of, 256.
- slotted, advantages and defects of, 328.
 - core, 1,206.
 - retaining wedges in, 348.
 - smooth and slotted, 276.
 - squirrel cage, ills., 1,343.
- spider for rotary converter, Westinghouse, ills., 1,466.
- squirrel cage, Allis-Chalmers, ills., 1,322.
 - end rings, cast on, ills., 1,375.
 - evolution of, 1,319, 1,321.
 - Fairbanks-Morse, ills., 1,326, 1,373.
 - induction motor, ills., 1,291.
 - Richmond, ills., 1,329.
 - Triumph, ills., 1,323.
 - Wagner, ills., 1,328.
 - Western Electric, ills., 1,328, 1,331.
- stationary, alternator, Western Electric, ills., 1,149.
 - section of General Electric, ills., 1,209.
 - section of Western Electric, ills., 1,211.
 - Western Electric alternator, ills., 1,203.
- steam given off from, 659.
- steel shaft, ills., 224.
- sticking to core (bell) cause of, 2,394.
- symmetrical winding of, 240.
- tangential brushes, 305.
- theory of, 257-282.
- troubles, 623.
- two phase, 1,025.
- various, Sprague, field, ills., 1,338.
- ventilating ducts, ills., 1,213.
- ventilation of, 332.
- wattmeter, torque of, 563.
- Watson, complete, ills., 621.
- wave barrel wound, Westinghouse, ills., 341.
- wave winding, developed view of, ills., 241.
- wedges made of baked hard wood, 348.

Armature, —Continued.

- weight, how reduced, *ills.*, 2,367, 2,368.
- wooden core, *ills.*, 234.
- Y connected and collector rings, *ills.*, 1,255.
- Armature coil(s), adjacent, short circuits between, *ills.*, 628,
 - break(s) in, 659.
 - causes flat commutator, 643.
 - burning of, 631, 657.
 - construction of, *ills.*, 1,225.
 - damaged, cut-out, 631.
 - evolute, described, 343.
 - faulty, locating, 624.
 - grounded, locating, *ills.*, 632.
 - guard of, *ills.*, 337.
 - lap winding of, 233.
 - moisture in, 659.
 - number of, depends on number of segments, 300.
 - open, repaired, 617.
 - path of first, *ills.*, 237.
 - rotary converter, Westinghouse, *ills.*, 1,465.
 - series connected, *ills.*, 244.
 - series, developed view of, *ills.*, 245.
 - shellac varnish for, 626.
 - short circuited by brushes, *ills.*, 222.
 - path of second, *ills.*, 237.
 - retaining devices, 347.
 - self-induction in, 279.
 - short circuits in, test for, *ills.*, 624.
 - taping machines, *ills.*, 346, 347.
 - temperature of, 590.
 - testing for breaks in, *ills.*, 630.
 - uneven number of, 240.
 - variable voltage in, 257.
 - wave winding of, 233.
- Armature coil winding(s), creeping, 1,260.
 - fed in, 1,258.
 - imbricated, 1,259.
 - mummified, 1,259.
 - practical, 241.
 - shuttle, 1,260.
 - skew, *ills.*, 1,258.
 - spiral, *ills.*, 1,259.
- Armature connections, for converter booster, 1,482.
 - polyphase converter, 1,463.
 - three phase delta alternator, *ills.*, 1,560.
 - three phase star alternator, *ills.*, 1,560.
- Armature construction, 321-348.
 - Allis-Chalmers, *ills.*, 1,223.
 - dynamotor, 2,059.
 - requirements, 299, 300.
 - split frame, railway motor, 2,554.
 - ventilated railway motor, *ills.*, 2,563.
- Armature core, 1,204.
 - built up, with spider, *ills.*, 331.
 - construction, *ills.*, 1,325.
 - discs, method of assembling, 579.

Armature core, —Continued.

- insulation of, 333.
- laminated, few eddy currents induced in, *ills.*, 273.
- laminated, treated by hydraulic pressure, 274.
- large, sections of, *ills.*, 1,205.
- locating short circuited coils through, *ills.*, 629.
- magnetic hysteresis in, *ills.*, 277, 279.
- notched, 328.
- slotted, 323.
- solid, eddy currents induced in, *ills.*, 272.
- stamping, *ills.*, 1,229.
- wooden, skeleton view of, *ills.*, 237.
- Armature, current(s), direction of, *ills.*, 355.
 - distribution in, 257.
 - dynamo, distribution of, *ills.*, 252.
 - in repulsion motor, 1,355.
 - local, reduction of, 1,357.
 - sparking of, 1,356.
 - strength of, 1,356.
 - starting and stopping, 293.
- Armature reaction, 263.
 - demagnetizing effect of, *ills.*, 268, 269.
 - effect, Lenz's law, 265.
 - ills.*, 262.
 - in motors, 363.
 - of inductors, *ills.*, 1,160.
 - requires more driving power, 265.
 - weakened field, *ills.*, 1,161.
- Armature teeth, enclosed type, *ills.*, 328.
 - notched and projecting, *ills.*, 329.
 - object of notches in, 328.
 - projecting, 327.
 - various forms of, *ills.*, 328.
 - width of, 328.
 - with inclined sides, 327.
- Armature winding(s), 229-256, 334.
 - 1206-1209.
 - back pitch of, *ills.*, 246.
 - barrel, *ills.*, 339.
 - bastard, 340.
 - binding of before handling, *ills.*, 633.
 - brushes required for, 150.
 - connected to equalizer rings, 254.
 - connections of induction motors, 1,337.
 - connectors, evolute, 336.
 - involute, 336.
 - delta connection of three phase on slot, *ills.*, 1,246.
 - drum, completed, *ills.*, 238.
 - duplex, 149.
 - alternator classified, 1,210.
 - dynamo, self-induction in, 136.
 - former, 341.
 - half coil, 1,214.
 - hemitropic, 1,214.
 - multiplex, 247, 248.
 - large machine, 230.

Armature winding(s),—Continued.

- pitch of, 231.
- quadruplex, 149.
- single phase, ills., 1,237.
- table, 234.
- three phase, 1,239–1,241.
- triplex, 149.
- two phase, ills., 1,237, 1,238.
- two range, ills., 1,238.
- whole coil, 1,214.
- Y connection of three phase one slot, ills., 1,246.

Armoured cable, comparative cost of, 798.

- features of, 796.
- flexible, 796.
- installation of, 798.
- lead covered, Greenfield, ills., 796.
- submarine, ills., 729.
- wiring, 796.

Arrester, aluminum electrolytic, ills., 1,696,

- 1,698.
- air gap, ills., 887.
- 1,678.
- and magneto telephone, ills., 2,180.
- apparatus for breaking arc, 889.
- arc extinguished, 1,682.
- box, pole, Westinghouse, ills., 1,688.

- breaking back effect, 1,683.
- carbon, ills., 891.
- cells, electrolyte in, 1,699.
- charging operation, 1,703.
- critical voltage, 1,698.
- cumulative effect, 1,683.
- discharge, oscillograph record, ills., 1,681.
- electrolytic, 1,696, 1,697.
- horn gaps for, ills., 1,702.
- station, Westinghouse, ills., 1,705.
- Westinghouse, ills., 1,700.
- for high power trans., ills., 1,576.
- for telephone, ills., 2,163.
- frequency, effect in, 1,682.
- gaps, sparking at, ills., 1,680, 1,681.
- Garton-Daniels, ills., 2,023.
- graded shunt resistances, ills., 1,683.

ground connection for, ills., 890–892.

- horn gap, ills., 1,691.
- ills., 1,692.
- mounted, ills., 1,694.
- objections, 1,691.
- on series circuits, ills., 1,693.
- horn pole, General Electric, ills., 1,695.

- horn type, ills., 890.
- line magnetic blow out, General Electric, ills., 1,708.
- low equivalent, ills., 1,687.
- Mason multi-discharge, ills., 888.
- mounted, 2,025.
- multi-gap, ills., 1,679, 1,687.
- connections, ills., 1,685.

Arrester, connections,—Continued

- General Electric, ills., 1,680, 1,681.
- installation, General Electric, ills., 1,686.
- low equivalent, ills., 1,679.
- Westinghouse, ills., 1,680, 1,690.
- multiplex, connection 1,689.
- non-arcing multi-gap, ills., 1,678.
- plates, teeth on, 888.
- principle of air gap, ills., 886.
- railway magnetic blow out, General Electric, ills., 1,707.
- spark gaps, adjustment of, 1,694.
- trays, electrolytic, Westinghouse, ills., 1,701.
- vacuum tube, General Electric, ills., 1,703.
- wiring, kinks in avoided, 890.
- Arrow or needle drop annunciator, ills., 2,390.
- Asbestos, commutator insulated, 652.
- Astatic galvanometer, double coil ills., 439.
- needles, ills., 437.
- reflecting, ills., 440.
- single coil, ills., 438.
- use of, 440.
- instrument, Thompson, ills., 3,552.
- meter, Thompson, ills., 552.
- needles, ills., 439.
- Asthma, treatment for, 3,207.
- Asynchronous alternators, 1,183.
- induction motor called, 1,287.
- operation of magnetos def., 2,760.
- Atmospheric, column and mercury, pressure, 3,045.
- electricity, definition of, 4.
- pressure, variation of, 3,045.
- temperature, variation of, 3,045.
- Atom, definition of, 84.
- Attraction, and repulsion, ills., 5, 6.
- 360.
- of unlike poles, ills., 110.
- Audion detector, wireless tel., 2,321.
- valve, 1,504.
- Auger, post hole, ills., 801, 803.
- Auris telephone transmitter, ills., 2,198.
- Aussig bell cell, electrolysis, 3,139.
- "Autex," cells, data on, 960, 961.
- Willard storage battery, parts of, ills., 902.
- Auto-coil ignition wiring diagram, 2,785.
- Automatic, air brake system, ills., 2,602, 2,603.
- burglar alarm circuit, gravity drop, ills., 2,405.
- central telephone system, 2,151–2,157.
- circuit breaker operation, 1,625.
- coin machine circuit, ills., 2,154.

Automatic,--Continued.

- control, pumps, ills., 3,020,
railway motor, 2,508.
 - controlled circuit breaker, ills., 1,632.
 - cut out of dynamos, 604.
 - disc telephone selector, ills., 2,155.
 - earth leakage cut out, Wallis-Jones,
ills., 1,838.
 - exchange groupings, ills., 2,156.
 - fire alarm signals, 2,262.
 - ground detector, 2,262.
 - impulse springs, ills., 2,154.
 - induction regulator connections, ills.,
1730, 1731.
 - intercommunicating telephone, systems,
2,150, 2,151.
Western Electric, ills., 2,161.
 - mechanical brake, crane, ills., 2,948,
2,949.
 - motor starter, ills., 674.
Allen-Bradley, ills., 673.
 - operated induction regulator, 1,727.
 - overload circuit breaker, ills., 418.
 - printing press starter, ills., 674.
 - regulator, direct current, General Elec-
tric, ills, 2,028, 2,029.
 - repeater, description of, ills., 2,219,
2,220.
how operated, 2,219.
 - spark advance, Eisemann igniter mag-
neto, ills., 2,770.
 - starter with relay, ills., 674.
 - tape winder, Bunnell, ills., 2,250.
 - telegraph, repeater, Ghegan, ills., 2,220,
2,247.
sending tape, 2,247.
 - telegraphy, 2,247.
 - telephone circuit, of operator, ills.,
2,153.
of subscriber, ills., 2,152,
switch, 2,115.
system, Western Elec., 2,151.
 - telpher, def., 2,956.
 - trunk, selector system, ills., 2,156.
 - voltage regulation, 1749.
for alternators, 1,748.
G. E., ills., 1,748, 1,750.
mounted, G. E., ills., 2,026.
switchboard, General Electric,
ills., 2,022, 2,024.
with line drop compensator,
ills., 1,754.
- Automobile(s), ammeter, defective, 2,854.**
Babcock electric roadster, ills., 2,853,
2,820.
Baker electric chassis, side view, ills.,
2,820.
bearings, defective, effect 2,852.
friction in, 2,826.
bell, defective, cause, 2,854.
brake(s) apparatus, ills., 2,843.
defective, effect, 2,852, 2,853,
2,853.
- cable, ills., 729.

Automobile(s),--Continued.

- chain(s), and gear drive combined,
2,835.
care of, 2,831.
drive, silent, ills., 2,827.
lubrication, 2,834.
various, 2,831.
- charging, mercury rectifier, ills., 2,851,
2,839.
outfit, ills., 2,841.
plug, 2,851.
rates, 2,841, 2,842.
receptacle, wiring diagram, ills.,
2,839.
- chassis, plan of, ills., 2,818.
- circuits, ills., 2,801, 2,847, 2,848,
2,844.
charging diagram, ills., 2,844.
various connections, ills., 2,847-
2,850.
- coil, bucking, ills., 2,810.
iron ballast, ills., 2,810.
- connections defective, effect, 2,853,
2,854.
- contact shoes, defective, effect, 2,852.
- controller, ills., 694. 2,843.
Baker selective dual, ills., 2,845,
2,847.
one unit, one motor connection,
ills., 2,847.
operation of, 2,850, 2,851.
wiring diagram, ills., 2,839.
- current too high, cause, 2,852.
- double chain drive, ills., 2,829.
- double reduction herringbone gear, ills.,
2,827.
- dry cells for, ills., 59-61.
- failure to start, cause, 2,863.
- gasoline electric, 2,819.
- gear, lubrication of, ills., 2,829, 2,837,
2,837.
reduction, various forms, 2,826-
2,837.
worm, Baker, R. & L., 2,835.
- high tension cable, ills., 70.
- lighting, and ignition, pressure for,
2,798.
- lighting defective, cause, 2,854.
- magnetic, diagrams, H.-C., 2,798.
- magneto, H.-C., ills., 2,797.
- storage battery for, ills., 996.
- wiring diagram, Baker, 2,839.
- materials used in construction, 2,823.
- meter, defective, 2,854.
- motor, 2,824.
dynamo, Electro, 2,800.
leads open, effect, 2,853.
motor, single reduction, herring-
bone gear, ills., 2,826.
Rauch and Lang, ills., 2,824.
reversal, 2,845.
- one and two unit systems, def., 2,794.
- one unit, Deaco system, ills., 2,800.

Automobile(s),—Continued.

- operation of, 2,850, 2,851.
 - opposing forces, 2,821.
 - power consumed, 2,825.
- points, in design of, 2,823, 2,825.
- propeller shaft, Baker, ills., 2,835.
- rectifier charging outfit, ills., 2,841.
- resistance coil eliminated, 2,848.
- running too slow, cause, 2,852, overload, 2,825.
- parts, controlling apparatus, ills., 2,843.
 - defective, 2,852-2,854, ills., 2,818, 2,820.
 - operation of, 2,850, 2,851.
 - wiring diagram, ills., 2,839.
- safety plunger, ills., 2,852.
- signal button, wiring diagram, ills., 2,839.
- speeds, Baker R. & L., 2,851, diagram(s), ills., 2,847-2,850, failure to regulate, cause, 2,854.
- starting plug receptacle, wiring diagram, ills., 2,839.
- steering, 2,851.
- storage batteries, 2,837.
- Studebaker, with charging outfit, ills., 2,841.
- switch(es), ills., 2,848.
 - wiring, diag., ills., 2,839, 2,846.
- theater plug, 2,854.
- tire friction, 2,822.
- transmission defined, 2,909.
- truck, gear, chain, ills., 2,834.
 - for heavy, 2,835.
- various types, 2,815.
- voltage, advantage of low, 2,799, combinations, 2,799.
- vs. ship propulsion, 2,669.
- Waverly 80 volt motor, ills., 2,825, seating plan, ills., 2,821.
- wheels out of alignment, effect, 2,852.
- wiring, diagram, Baker, ills., 2,839.
 - loose, effect of, 2,853.
- Woods, construction, ills., 2,830, motor suspension, 2,830, ills., worm drive, 2,836.
 - Manchester, type, ills., 2,837.
- Automobile battery**, arrangement, Baker, ills., 2,839.
 - box, Willard, ills., 932.
 - cells, parts of, ills., 902.
 - capacity of, 2,840.
 - charged, 930, 931.
 - charging, 2,797.
 - cell, Gould, ills., 2,840.
 - controller, Ward Leonard, ills., 2,811.
 - defective, effect, 2,852, 2,853, ignition, inapplicable, 2,797.
 - overdraft, cause of, 2,826.
 - storage, for starting and lighting, ills., 2,795.
- Waverly**, 42 cell, ills., 2,838.

- Autoraobile starting and lighting (systems)**, 2,793-2,813.
 - ballast coil, ills., 2,814.
 - battery charging, 2,814.
 - battery circuit, 2,804.
 - Entz, ills., 2,802.
 - Gray and Davis, ills., 2,806.
 - hydrometer test, ills., 2,796.
 - Rushmore cut out, ills., 2,813, single unit, ills., 2,802.
 - thermal control, 2,813, 2,814, three unit, 2,808, 2,809.
 - two unit, ills., 2,802-2,808, voltage for, 2,798.
 - Wagner cut out, ills., 2,804, 2,805, dynamo, ills., 2,804.
- Autoplex transmitter**, Bunnell, ills. 2,229.
- Auto-transformer(s)**, compared with two winding transformer, ills., 1,422.
 - induction motor starter, ills., 1,334, in three wire circuit, 1,548.
 - principle of, ills., 1,421.
 - to reduce trolley voltage, 2,540.
 - Westinghouse arc lamp, ills., 2,452.
- Auxiliary**, and main bus bars, ills., 719.
 - apparatus, 1,587, 1,588, for motors, 407-430.
 - bus bar(s), object of, 720, carries highest voltage, 719, used instead of booster, 720.
 - circuit, closing switch, General Electric, ills., 1,635.
 - opening switch, General Electric, ills., 1,635.
 - trip, 1,634.
 - coils of motor, 1,345.
 - commutating motor field, 385.
 - dynamo 3 wire system, ills., 709.
 - motor flux, 385.
 - power, double throw switches for, ills., 849.
 - resistance with meter, 540.
 - telephone bell open, 2,170.
- Axle**, bearings, trolley car, overheated, 2,658.
 - dead type, chain drive, ills., 2,829.
 - lighting of cars, 2,609, 2,610-2,613.
- Axis**, line of sine curve, ills., 170.
 - of armature, ills., 267.
 - secondary, ills., 2,690, 2,691.
- Ayrton-Mather galvanometer shunt**, ills., 463.
- Ayrton and Sumpner method of measuring power**, ills., 1,121.

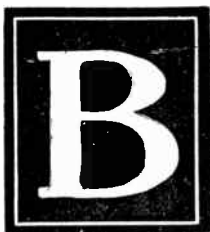

- Babbitt, composition of, 3,091.
 Babbitted bearings, Niles crane, 2,942.
 Babbitting, 3,090.
 Babcock and Wilcox boilers in railway power house, 2,544.
 Babcock, electric roadster, ills., 2,853.
 Backing, cap and tongue of moulding, ills., 774.
 Back, end of armature bar, meaning of, 229.
 geared motor(s), G. E., ills., 403.
 polyphase induction, Triumph, ills., 1,315.
 to drive slow machines, 403.
 head of armature, ills., 337.
 loading motor or dynamo temperature test, ills., 2,091.
 pitch, and front, must differ, 256.
 unequal, 256.
 of armature winding, ills., 246.
 Baffle plates, air compressor, 3,034.
 Bag, depolarizer, 43.
 Bain telegraph code, 2,246.
 Baker electric, chassis, plan, ills., 2,818.
 parts, 2,820.
 side view, ills., 2,820.
 roadster, ills., 2,816.
 wiring diagram, ills., 2,839.
 Baker R. & L., controller, ills., 2,845.
 motor, ills., 2,835.
 and control, 2,851.
 speeds of, 2,851.
 worm, drive transmission unit, 2,836.
 gear, 2,835.
 Baker static machine, ills., 3,185, 3,186.
 Balanced three wire system, ills., 706.
 Balancer(s), General Electric, set, ills., 1,492.
 in three wire system, ills., 712.
 set, three wire dynamo substitute for, 198.
 speed of, 1,492, 1,493.
 Balancing coil(s), action of, 716.
 for three wire system, ills., 714.
 impedance of, 717.
 system, operation of, 717.
 Balancing set three wire motor dynamo, ills., 713.
- Baldwin truck, ills., 2,599.
 Ballast coil, Rushmore, ills., 2,814.
 Ball bearings of motor, ills., 688.
 Ball clutch, carbon feed, ills., 2,434.
 Ballistic, galvanometer(s), 453.
 current measurement with, 454.
 method of measuring waves, ills., 1,846.
 reflecting galvanometer, Queen, ills., 454.
 B and A switchboard operation, 2,140.
 Band(s), brass, on smooth core armatures, 347.
 iron clad armature, Holtzer-Cabot, ills., 335.
 Bar(s), and blocks connected with plugs, ills., 495.
 armature, back end, meaning of, 229.
 front end, meaning of, 229.
 Siemens', ills., 339.
 bus, main and auxiliary, ills., 719.
 commutator, burned, ills., 647.
 of armature, ills., 224.
 copper, inductors, objection to, 335.
 digging, ills., 801.
 equalizing, action of, 609.
 inductor, ills., 1,229.
 key of Adams-Bagnall adjusting weight, 2,436.
 magnet, ills., 106.
 Barrel, and bastard winding combination, Westinghouse, ills., 344.
 armature winding, ills., 339.
 burnishing, electro-plating, ills., 3,164, 3,165.
 electroplating, ills., 3,183.
 self emptying, ills., 3,182.
 galvanizing, ills., 3,182.
 shutter, motion picture machine, ills., 2,208.
 tumbling, electro-plating, 3,162.
 windings, straight out coils best for, 345.
 Barrel wound armature, Holtzer-Cabot, ills., 334.
 Western Electric, ills., 333.
 Westinghouse, ills., 340.
 Bar, strap and wire coil windings, 1,225.
 tamping, wood handle, ills., 801.
 to bar test for open coil, 626.
 Base, and cap of metal moulding, ills., 775.
 and shunt coil of Sangamo meter, ills., 1,818.
 board, and wire outlet pocket, ills., 855.
 wire outlet through, ills., 856.
 of belt drive machine, ills., 2,002.
 of induction motor, ills., 1,284.
 Basket(s), acid dipping for electro-plating, ills., 3,144.
 electro-plating, dipping, ills., 3,160.
 hole size, 3,178.

Basket(s),—*Continued.*

- or chain winding, ills., 1,256.
- Bastard, and barrel winding combination, Westinghouse, ills., 344.
- armature winding, 340.
- Bastian heating element, 3,052.
- Bath cabinet, electric light, Columbia, ills., 3,215.
- sinusoidal electric, 3,216.
- Battery, 2,735.
 - acid, density of charged, 908.
 - ampere hour, charging capacity, 916.
 - and coil connection, 2,781,
 - for spark ignition, motor cycle, 142.
 - and dynamo for boat, ills., 950.
 - in parallel, ills., 971.
 - and mileage, electric vehicles, 2,838.
 - and motor, galvanometer in circuit with, 350.
 - arrangement, Baker automobile, ills., 2,839.
 - attendants, storage, 946.
 - automobile, defective, effect, 2,852.
 - undercharged, remedy, 2,838.
- Aussig bell cell, electrolysis, ills., 3,139.
- auxiliary, axle lighting, 2,611.
- binding post, 153.
- box, automobile, Willard, ills., 932.
- capacity, automobile, 2,840.
 - increased, 939.
 - depends on plates, 938.
 - storage, lack of, 958, 959.
 - with reversible booster, 988.
- care of, 62.
- cause of running down, vibrator adjustment, 153.
- circuit, starting and lighting system, 2,804.
- clamps, paraffin treatment of, 952.
- common, switchboards, 2,136,
 - system, 2,175.
 - telephone system, 2,135.
- compensating resistance, 2,243.
- compounded by differential booster for constant pressure, 991.
 - by series booster, 983, 984.
- connections, 65-67.
 - and circuit control apparatus, 972-974.
 - for ground return, 2,385.
 - series, ills., 65.
 - spark coil, ills., 153.
- connector remover, Exide, ills., 939.
- inverted T, ills., 951.
- construction, storage, Northwestern, ills., 930.
- control, storage, 975.
- controller, Ward Leonard, automobile, ills., 2,811.
- counter pressure, 996.
- current, distribution in ring armature, analogy, ills., 258.

Battery, current,—*Continued.*

- through series field, effect, 2,807.
- def. of, 27, 35.
- discharge, automobile, 2,841.
 - maximum rate of, 941.
 - rates, capacity variation, 939.
- dry, 59, ills., 60, 61.
 - Blue Bell cells, ills., 2,179.
 - current how tested, 62.
- Edison, for electric vehicles, 2,837.
- effect of in regulating dynamo load, ills., 972.
- effect on of too much current, 60.
- electro-magnetic rectifier, ills., 1,529.
- equipment for residence lighting, ills., 977.
- erroneous use of the term, 2,735.
- escape to ground, 2,190.
- Exide, duplex sparking, charging connections for, ills., 924.
 - ignition, ills., 911.
- fault finder, connected with telephone buzzer and coil, 522.
- feed, open and E key, 2,179.
 - telephone, grounded, 2,174.
 - open, 2,174, 2,176.
 - wire, ills., 2,394.
- floating, on the line, 972.
 - storage, for railways, disadvantage of, 2,535.
- for acousticon, ills., 2,199.
- Gibbs electrolysis process, 3,137.
- Gould, unformed plate of, ills., 896.
- hydrometer syringe, ills., 908.
- ignition weak, emergency connection for, ills., 920.
- incorrect wiring of, ills., 67.
- in parallel, charging, ills., 979.
- iron nickel, for electric vehicles, 2,837.
- jars, plates placed in, ills., 957.
 - precaution taken with, 966.
- lack of capacity of, 960.
- lead sulphuric acid, for electric vehicles, 2,837.
- light, for electric vehicles, 2,837.
 - local, telephone circuits, ills., 2,145.
 - long end and short end of, 2,241.
 - motor, and ammeter, exp. with, 359.
- new, boils more than old, 928.
 - capacity of, 933.
 - period of charging, 932.
- one fluid primary, ills., 32.
- out of commission, re-assembling of, 967.
 - vehicle charged, 930-931.
- overcharge reduced, axle lighting, 2,611.
- parts of Exide storage, ills., 913.
 - Witherbee, ills., 946.
- polar duplex tel. system, ills., 2,236.
- pressure with voltmeter, 467.
 - motor driven bells, 2,371.

Battery,—Continued.

- primary, for electro-plating, undesirable, 3,146.
 - Volta's invention, 2,411,
 - room, acid vapor in, 957.
 - equipment, storage, 946.
 - magnetic cut outs in, 948.
 - storage, interior of, ills., 947.
 - sunlight excluded from, 943.
 - wooden stringers in, 948.
 - running down, cause of, 61.
 - secondary, charge indications, 926,
 - charging, frequency of, 919.
 - in motor vehicles, 2,815.
 - should not remain discharged, 943.
 - small, charged from lighting circuit, 931.
 - Smee, electro-plating, ills., 3,146.
 - sparking, Exide, phantom view, ills., 911.
 - specific gravity, 908.
 - taking voltage reading, 934.
 - tap wire, 2,241.
 - resistance in, 2,241.
 - terminals, storage, verdigris on, 949.
 - testing, silver chloride, ills., 503.
 - storage, portable instruments for, 921.
 - to correct reversed field, 588.
 - troubles, storage, 953.
 - used with fault finder, ills., 522.
 - various cells, electro-plating, 3,147.
 - voltage, ignition, 2,786.
 - Waverly 42 cell lead, ills., 2,838.
 - workmen, clothing of, 946.
 - zincs and carbons, 61-63.
- Battery cell(s), arrangement of, 951.**
- automobile, parts of, ills., 902.
 - connected reverse pressure, ills., 981.
 - connecting of, 951.
 - connectors, spring snap, 2,401.
 - ills., 2,402.
 - Willard storage, ills., 904.
 - connections, storage, 952.
 - Hargreaves-Bird electrolysis, ills., 3,140.
 - joining terminals of, 951.
 - on stand, ills., 953.
 - placed on insulators, 948.
 - plates, unformed lead, 981.
 - precautions in unpacking, 949.
 - short circuited, treatment of, 954.
 - storage, assembled, 950.
 - disconnected, 963.
 - two connected, ills., 951.
 - weak, treatment of, 962.
 - well insulated, 949.
- Battery charge, automobile, life of, 2,841,**
- indications of, 921.
 - scales formed on plates during, 923.
- Battery charging, and lighting lamps, circuit,**
- ills., 990.
 - automobile, ills., 2,851.
 - voltage limit, 2,814.

Battery charging,—Continued.

- best results obtained in, 923.
 - board, Witham, ills., 966.
 - constant current for, 924.
 - constant voltage for, 924.
 - current kept constant, 925.
 - "Champion," ills., 949.
 - outfit, for boats, ills., 950.
 - precaution in, 921.
 - rate high, 933.
 - rates, 2,841, 2,842.
 - storage, switchboard for, ills., 914.
 - switch, ills., 975.
 - voltage used in, 924.
- Battery electrolyte, becomes hot, 905.,**
- acetic acid in, 910.
 - chlorine in, 909.
 - copper in, 910.
 - density of, 908.
 - impurities in, 909.
 - iron in, 910.
 - mercury in, 910.
 - nitrate in, 909.
 - platinum in, 910.
 - thermometer for, 921.
 - used again, 911.
- Battery plate(s), Faure, 903, 2,838,**
- imperfect sulphation of, 923.
 - injured by rapid discharge, 941.
 - Plante, 2,838.
 - made efficient, 903.
 - separators, wood, 966.
 - storage, Edison, ills., 895.
 - sulphation of, 956, 957.
 - thin, for rapid discharging, 2,798.
- Battery, storage, 893-968,**
- and dry cells connected, 920.
 - automobile, charging, 2,797.
 - booster system, ills., 984.
 - buckling of, 955.
 - cells filled, 907.
 - Champion, ills., 909.
 - charge indications, 926.
 - charged, during night, 929.
 - every two weeks, 918.
 - too rapidly, 929.
 - charging of, 914.
 - chemical action in, 899.
 - chloride cells of, ills., 925.
 - circuit breaker, ills., 1,673.
 - condensed rules for care of, 967, 968.
 - connections for charging, 912, 913.
 - controlled by end cell switches, 977.
 - decrease of capacity, 942.
 - depth of vessel, 906.
 - des., 2,747.
 - directions for, 2,839.
 - discharge, 939.
 - discharging in series, ills., 980.
 - electrolyte, 904.
 - boiling of, 927.
 - used in, 898.
 - Exide plates, ills., 897.
 - floating of, 971, 972.
 - for electric vehicles, 2,837.
 - for small loads, 969.

Battery, storage.—Continued.

- for starting and lighting, ills., 2,795,
- for telephone, 2,959.
- Gould cell, ills., 910.
- idle, loses power, 959.
- ignition, lighting, starting, 2,797,
- in motor vehicles, 2,815.
- induction motor for, ills., 915,
- in series, 920.
- negative plates, gray, 923.
- occasionally used, 959.
- overdischarge of, 955.
- parts of Willard Autex, ills., 902,
- parts relating to, 2,838.
- plates of Edison, ills., 916.
- positive plates dark brown, 923.
- prime condition for operation, 899.
- rectifier for charging, 1,526.
- regulation by variable resistance, ills., 976.
- systems, 969-996..
- short circuits, 954.
- theory of, 896.
- taken apart when not in use, 965.
- three wire system, 709.
- to carry peak of load, 895.
- voltage of, 911, 912.
- Battleship propulsion, 2,665, 2,667.**
- Bausch and Lomb, diagrams defective centering, ills., 2,722.**
- lens, ills., 2,702.
- Beam(s) floor, wires between, 781.**
- light definition of, 2,505.
- walking, telegraph pole changer, Foote Pierson, ills., 2,239.
- ills., 2,234.
- Bearing(s), armature, self-aligning, ills., 656.**
- self-oiling, ills., 656.
- unequal wearing of, 659,
- automobile, defective, effect, 2,852.
- friction in, 2,826.
- ball, of motor, ills., 688.
- box, sliding thrust, motor, ills., 688,
- bronze bushed, crane trolley, 2,944.
- bushing of motor, ills., 688.
- caps of, and journals, 573.
- for city and interurban railways, ills., 2,600.
- grit in, 656.
- hot, various causes, 656.
- points relating to, 657.
- motor, Westinghouse, self lubricating, ills., 2,595.
- not in line, 656.
- of brushes on commutator, 574.
- of Sangamo meter, ills., 1,814.
- of Westinghouse meter, ills., 1,804.
- oil leakage from, 591.
- self oiling, ills., 1,996.
- self-aligning, ills., 1,997,
- shaft, lubrication of, ills., 592.
- thrust, elevator, ills., 2,920.
- too tight, 656.

- Beck flaming arc lamp mechanism, ills., 2,467.
- Bedding coil windings, order of, ills., 218,
- Begole and Langsdorf frequency meter, ills., 1,830.
- Behavior of, current when circuit is broken, 1,589.
- direct and a. c., difference in, 1,056,
- rotary converter when hunting, 1,487,
- shunt dynamo when used as motor, 363.
- Bell(s), adjustment, telephone, ills., 2,182.**
- alarm for school, ills., 2,349.
- alternating current, 2,365.
- operation of, ills., 2,367.
- permanent magnet armature, ills., 2,366.
- and buzzer circuit connections, ills., 2,402.
- difference between, 2,356.
- and push button, wiring of 25, ills., 2,403.
- armature, effect of too rapid vibration, 2,396.
- momentum, how absorbed, 2,342,
- weight reduction, ills., 2,367.
- 2,368.
- automobile, defective, cause, 2,854,
- bi-polar receiver, ills., 2,120.
- box circuit, standard, ills., 2,123.
- Holtzer-Cabot, ills., 2,128.
- telephonic, ills., 2,121.
- burglar alarm continuous ringing, ills., 2,352.
- clapper, disc type, ills., 2,372.
- vibration of, ills., 2,369.
- classified, 2,339.
- coil(s), connection of, ills., 2,377.
- reducing resistance of, ills., 2,377.
- combination, single stroke, constant ringing, ills., 2,374.
- vibrating and single stroke, ills., 2,345, 2,346.
- combined differential and alternate, ills., 2,360.
- condenser action, pneumatic analogy of, ills., 2,364.
- constant ring drop, burglar alarm, 2,407.
- with maintainer, ills., 2,355.
- contact adjustment of, 2,341.
- continuous ringing, 2,350.
- ills., 2,373.
- of burglar alarm, ills., 2,405.
- proper use of, 2,407.
- relay, ills., 2,376.
- types, 2,351.
- with circuit maintainer, ills., 2,352.
- cover for exposed, ills., 2,351.

Bell(s).—*Continued.*

- current, alternating, for large buildings, 2,401.
- differential description, 2,356,
 - good design, ills., 2,357, 2,358.
- displaced contact screw, 2,396.
- double acting, ills., 2,369, 2,370.
- current flow in, ills., 2,370.
- magnet, ills., 2,369, 2,370.
- spring in, ills., 2,370.
- polarity in, ills., 2,370.
- Edwards, weatherproof, ills., 2,372.
- effect on, of too much battery power, 2,396.
 - of weak spring, 2,396.
- electro-mechanical, 2,371-2,374.
 - air vane of, ills., 2,372, 2,373.
 - circuit, maintainer for, ills., 2,355.
- elevator wiring, ills., 2,393, 2,395.
- enclosed weatherproof, ills., 2,372.
- faults in, 2,394, 2,395.
- gear, electro-mechanical, ills., 2,371.
- gong, cow, ills., 2,361.
 - dinner, ills., 2,361.
 - regular, ills., 2,361.
 - sleigh, ills., 2,361.
- heavy duty, high voltage, ills., 2,362.
- high frequency in, 2,367.
- high voltage, ills., 2,362.
 - limiting current in, 2,363.
 - sparking prevented, ills., 2,363.
- iron box, Bunnell, ills., 2,347.
- kind most extensively used, ills., 2,340, 2,341.
- kind of in parallel connection, 2,386.
- lighting current used for, 2,402.
- magneto night alarm, 2,190.
- main spring of, ills., 2,371, 2,373.
- mechanical, circuit maintainer for, 2,351.
- Mesco single stroke, ills., 2,345.
- metallic circuit, ills., 2,384.
- motor driven, ills., 2,370-2,372.
- parallel connected, ills., 2,386.
 - push buttons, ills., 2,385.
- Patrick and Wilkins emergency gong, ills., 2,349.
- parts, proportion of, 2,342.
- pawl wheel, 2,371, ills., 2,373.
- polarized and high frequency current, 2,366.
- prevention of sparking, ills., 2,365.
- railway signal circuit, 2,634.
- ratchet of, ills., 2,371, 2,373.
- re-adjustment of contact screws, 2,396.
- relay, and relay operation, 2,377.
 - current in, ills., 2,374-2,376.
- revolving strike, ills., 2,371.
- ringing, current supply, ills., 2,400-2,404.
 - transformer, 2,394.
 - "Cadet type." ills., 2,397.

Bell(s) ringing, transformer.—*Continued.*

- ills., 2,397.
 - Western elec., ills., 2,404.
- school gong, ills., 2,349.
- series, oper. of, ills., 2,340, 2,341.
- short circuit, adaptation, 2,350.
- shunt, 2,347, 2,349, 2,350.
 - operation, ills., 2,347, 2,348.
 - vibrating and single stroke, ills., 2,350.
- signal, motor dr., ills., 2,370-2,372.
- single phase repulsion induction motor.
 - parts of, ills., 1,357.
- single stroke, ills., 2,343, 2,344.
- skeleton frame, Holtzer-Cabot, ills., 2,359.
- single stroke, in series connection, ills., 2,386.
 - and vibrating, com., 2,343.
 - or vibrating gong, ills., 2,349.
- table of proportion of parts, 2,343.
- telephone, 2,117.
 - auxiliary open, 2,170.
 - call, ills., 2,121, 2,127-2,128.
 - open, 2,170.
 - out of adjustment, 2,170.
 - patent, 2,115.
 - party, with pulsating current, 2,147.
 - with superimposed current, 2,148-2,150.
 - rings without cause, 2,172.
 - troubles, 2,170.
- trembling, in series, ills., 2,386.
 - or vibrating, 2,340, ills., 2,341.
- troubles, 2,394, 2,395.
- vibrating, Bunnell, ills., 2,342.
 - changed to single stroke, ills., 2,346.
 - dry cells used for, 2,400.
 - differential, ills., 2,358.
 - vibration, how governed, 2,341.
 - watchman's alarm, continuous ringing, ills., 2,352.
- water tight, H.-C., ills., 2,359.
- wire(s), crossed, test, ills., 2,396, 2,397.
 - how concealed, 2,382.
 - varieties of, 2,381.
- wiring, 2,382, ills., 2,383-2,387.
 - apartment house, ills., 2,394-2,396.
 - joints, 2,381, ills., 2,383.
 - wood box type, Patrick and Wilkins, ills., 2,361.
- Bell circuit(s), crossing, railway signal, ills., 2,640, 2,644.
 - current, decrease in, cause of, 2,396.
 - reversal in, ills., 2,369.
 - detail of maintainer for, ills., 2,354.
 - faults in, 2,396, ills., 2,397, 2,398.

- Bell circuit(s)**,—*Continued.*
 increased resistance in, cause of, 2,396,
 magnet arrangement, ills., 2,369, 2,370,
 maintainer, for, 2,351, 2,353.
 object of spring in, ills., 2,370.
 sounder in, 2,380.
 test for break in, ills., 2,398,
 troubles, 2,170.
 two way switch, ills., 2,369, 2,370,
 with ground return, ills., 2,384.
- Belting** heating element, 3,051.
- Belt(s)** alternator tightened, 1,136.
 appearance of, 2,012.
 bad joint in, 643.
 clamp holding ends, 398.
 home made, ills., 2,004.
 connected and direct connected ma-
 chines, 396.
 cotton, 2,010.
 double and quarter turn, 401.
 effect of water and moisture on, 402.
 elevator shifting, ills., 2,874.
 fasteners, why they give way, 401.
 friction on leather, 401.
 gear driven exciter, 1,171.
 horse power of, 2,913.
 transmitted by, ills., 2,011.
 laced and endless, 2,013.
 ills., 2,005.
 leather, 2,010.
 margin for adhesion of, 402.
 methods of lacing, ills., 399.
 placed on pulley, 2,013.
 points relating to, 401.
 power of transmission, 401.
 pulley, rules for size and speed, 402.
 put on pulley, ills., 2,059.
 rope and rubber, 2,010.
 running of, ills., 2,012.
 run, right way, ills., 401.
 wrong way, ills., 400.
 shifting, elevator, ills., 2,874.
 should not wobble, 401.
 size of, rule for determining, 400.
 slipper, ills., 2,059.
 softening of, 2,013.
- Belt speed**, proper for, 401.
- Belt drive**, best with pulleys at same level,
 2,014,
 disadvantages of, 399.
 elevator, 2,909.
 features of, 398.
 machine base, ills., 2,002.
 objections to, 2,913.
 plan of station, ills., 1,947.
 plant, 1,948.
 with countershaft, ills., 1,938.
- Belt driven**, alternator, ills., 1,135.
 separately excited, Fort Wayne,
 ills., 1,163.
 ills., 2,010.
 tandem generators, ills., 2,008.
- Belt trans.**, double pulley dr., ills., 2,009.
- Belt transmission**,—*Continued.*
 floor economy with, 2,009.
 horse power, rule for, ills., 1,138.
- Belted alternator**, pedestal type, ills., 1,137.
- Bender**, conduit, or hickey, ills., 795.
- Bends**, sharp, in lighting rods to be avoided,
 886.
- Benjamin Franklin's** experiments, 3.
- Bernados** process, electric welding, 3,129,
 3,130.
- Berrycombination** transformer, ills., 1,391.
- Betts'** monogram time flasher, ills., 882.
 script sign flash breaker, ills., 875.
- Beveled** rims, thin, of core end plates, 325.
- Biasing** spring, telephone, 2,172.
 cell, Fuller, ills., 48, 49.
 Grenet, ills., 51-53.
- Bichromate** potassium, 41.
- Bijur's** storage battery system, ills., 984.
- Binding** armature winding before handling,
 ills., 633.
 post of ignition coil, 153.
 ribbons, armature, 347.
 wires, short circuits, 629.
- Bipolar** dynamo, 182.
 field magnet, ills., 201.
 machine(s), disadvantage of, 183.
 lap winding for, ills., 240.
 ring windings for, 229.
- receiver**, Adler, 2,121.
 Bell, ills., 2,120.
- Birmingham** wire gauge, 739.
- Bismuth**, as conductor of electricity, 69.
 in caustic potash, 102.
 in contact with zinc, 44.
 in hydrochloric acid, 102.
 in sulphuric acid, 102.
- Bissell** armature commutators, ills., 646.
 double brush holder, ills., 313.
 dynamo brush gear, ills., 637.
- Bit(s)**, soldering, electric, ills., 3,064, 3,084-
 3,088.
 tinning, ills., 3,085-3,087.
 various, ills., 3,085.
- Black**, film on commutator, 657.
 oxide of copper plates in Edison cell,
 ills., 50.
 pickle, iron, electro-plating, 3,178.
- Bladder** disease, treatment for, 3,705.
- Blade** holder, swivel switch, ills., 1,597.
- Blade(s)**, of Parsons turbine, ills., 1,963.
 switch, cross sectional area of, 410.
- Blake**-microphone transmitter, ills., 2,126.
 telephone transmitter, ills., 2,124, 2,126.
- Blast**, air, transformers, and blowers, ills.,
 2,049.
 curve, Westinghouse, ills.,
 2,048.
 ills., 1,407.
 in sub-station, plan, ills.,
 1,981.
 water cooled, and oil cooled trans-
 formers compared, 1,439.

- bleach and alkali, 3,134.
Block(s), and fall, lineman's, ills., 817.
 carbon, soldered to cable, ills., 576.
 circular fixture for ceiling wire outlet,
 ills., 779.
 chain, 2,829, 2,831.
 vs. roller chain, 2,831.
 for sandpaper, ills., 651.
 for tinning soldering tool, ills., 580.
 fuse, transformer, 1,420.
 Westinghouse, ills., 1,406.
 railway signal system, ills., 2,631.
 resistances connected between, ills.,
 495.
 sections, railway, 2,646.
 system spacing telpher cars, 2,961.
 terminal, Westinghouse transformer,
 ills., 1,404.
Slow, joint, soldering, ills., 3,075.
Blow out, circuit breaker, magnetic, ills.,
 1,620, 1,622.
 coils, magnetic of controller, 694.
 Westinghouse, ills., 2,585.
 fuse, magnetic, 1,616.
Blow pipe, described, 3,115.
 butt brazing, 3,096.
 fuel for, 3,115.
 oxy-acetylene, D.-B., ills., 3,116.
 soldering, ills., 3,094, 3,095.
 welding, ills., 3,115, 3,129.
 Zerener, welding, 3,124.
Blower(s), and air blast transformers, ills.,
 2,049.
 organ, motor speed regulator, ills., 692.
Blowing of fuses caused by short circuit,
 619.
 "Blue Bell" battery dry cells, ills., 2,179.
 Blue rays, effect passing through water,
 2,277.
Blue stone, (blue vitriol), in Daniell cell, 54.
Board(s), for battery charging, Witham,
 ills., 966.
 panel, in large building, 852.
 toll, in main telephone office, 2,166.
 lighting outfit, Dayton, ills., 983.
 motor, wiring diagram, 2,798.
Böhne process, wet extraction of tin, 3,142.
Boiler(s), Babcock & Wilcox, in railway
 power house, 2,544.
 feeding, speed of pump, 3,019.
 header connected to, ills., 1,944.
 horizontal, dry pipe, ills., 1,943.
 in central station, 1,941.
 room forced draft, ills., 1,959.
Boiling of, new battery greater than old,
 928.
 battery electrolyte, 927.
Boit's experiment, ills., 8.
Bolts, anchor, concrete foundation for, ills.,
 1,952.
 template for locating centers, ills.,
 1,953.
 retaining, laminated armature with,
 ills., 325.
Bond, frog, railway, ills., 2,642.
 wire for insulated rails, ills., 2,634.
Bones, hand, X ray shadow of, ills., 3,230.
Bonnet of inlet valve, ills., 3,028.
Booster, auxiliary bus bar used in place of
 720.
 compound, machines, 988.
 connections, compound, ills., 988.
 differential, ills., 991.
 converter, adaptation, 1,484.
 armature connections, 1,482.
 field connections, 1,482.
 current, motor driven, 718.
 railway system, 2,057.
 use of, 718.
 differential, ills., 991, 992.
 dynamo in series circuit, 982.
 field controlled with rheostat, 986.
 rheostat, ills., 977.
 motor driven, 982.
 non-reversible shunt and battery sys-
 tem, ills., 987.
 reversible, battery capacity with, 988
 use of, 991.
 separately excited, Hubbard, ills., 991.
 series, characteristics, 985.
 compound battery, 983, 984.
 dynamo used as, 185.
 used on, ills., 184.
 operation, 984.
 with synchronous converter, Gen-
 eral Electric, ills., 2,064.
set(s), a. c. motor for, 2,058.
 for railways, ills., 2,536.
 for railway station, ills., 1,491.
 induction motor for, 2,058,
 series motors for, 2,057.
 shunt wound, G. E., ills., 1,491.
telephone, 2,142.
 circuits, ills., 2,145.
 shunt, characteristics, 985.
 diagram of load for, ills., 985.
 not used for sudden fluctuating
 circuits, 987.
 reversible, 987.
 static, diagram, ills., 1,456.
 storage battery system, ills., 984.
 synchronous converter, 1,481.
 Westinghouse armature and field,
 ills., 1,483.
 synchronous, rotary converter, West-
 ington, ills., 1,482.
 system, carbon pile, ills., 986.
 constant current, ills., 995.
 non-reversible, ills., 993, 994.
 reversible, 988, 995.
 shunt, 987.
Borax soldering flux, 3,083.
Borland electric, interior, 2,823.
Bosch, dual ignition system, ills., 2,783.
 ignition system, vibrating, duplex, ills.,
 2,789.
 low tension, oscillating magneto, ills.,
 2,764.

Bosch—Continued.

- magnetic spark plug, ills., 2,761.
- secondary coil, ignition, ills., 2,771.
- Boston Edison Co., turbine central station, ills., 1,926, 1,971.
- Bottle zinc, ills., 61.
- Bougie decimale, lighting standard, 2,508.
- Board electricity, definition of, 9.
- Box, babbitting, 3,090.
- brush holder, W. E., ills., 308.
- case for wires on wall, ills., 769.
- conduit, construction of, ills., 786.
- expanding, spacer, ills., 784.
- fire alarm, 2,262.
- for pole arrester, Westinghouse, ills., 1,688.
- fuse, and service switch, Palmer, ills., 1,591.
- transformer, ills., 1,420.
- journal, lining with metal, 3,092.
- junction, General Electric, ills., 843.
- kick, to protect wires, ills., 776.
- outlet, and cover, ills., 778.
- pull, for conduit work, ills., 791.
- resistance, for portable voltmeters, ills., 478, 479, 553.
- megohm, ills., 486.
- portable, ills., 554.
- shunt, galvanometer, ills., 462, 463.
- single switch, ills., 784.
- standard resistance, ills., 487.
- starting, for motor, why used, 422.
- connected to motor, 422.
- switch, for concealed wiring, ills., 784.
- to protect bent wires, ills., 791.
- two switch gang, ills., 784.
- water rheostat, ills., 2,108.
- Boyle's law, for gases, ills., 3,023, 3,024.
- Brace, inclined, jib crane, 2,940.
- Bracket, arm, trolley line con., ills., 2,627.
- construction, trolley line, ills., 2,622, 2,627, 2,645, 2,677.
- insulator, ills., 801.
- Braided, conductors, double, for unlined conduit, 786.
- cotton covered wire, 726.
- Brake(s)**, air, ills., 2,601-2,603.
- automobile, defective, effect, 2,852.
- foot, 2,830, 2,851.
- Woods interlocking, 2,832.
- crane, automatic, 2,948, 2,949.
- disc, Niles crane const., 2,948.
- eddy current, 2,949.
- foot, 2,942.
- mechanical load, on, ills., 2,949.
- rheostatic, 2,950.
- Elevator**, dynamic, 2,890.
- and mech., 2,891.
- Kaestner and Hecht, electric, ills., 2,917.
- magnet for, ills., 2,891.
- mechanical, 2,890.

Brake(s), elevator—Continued.

- point in design, 2,906.
- hand, ills., 2,597, 2,598.
- horse power, by prony brake, ills., 378.
- formula, 379, 380.
- meaning of, 378.
- quantities, 379.
- magnet, elevator, ills., 2,858, 2,860.
- pedal, automobile, ills., 2,843.
- pipe pressure, 2,659.
- railway, ills., 2,596-2,603.
- geared, ills., 2,601.
- release solenoid, elevator, 2,917.
- solenoid(s), elevator, 2,906.
- ills., 2,892.
- with shaft limit switch, 2,879.
- straight air system, 2,601.
- telpher, 2,960.
- test, lever arm of, 379.
- motor, apparatus for, ills., 378.
- trolley car, operation of, 2,649-2,655.
- 2,658.
- Branch, circuit diagram of, ills., 743.
- definition of, 743.
- exchange, private. circuits, ills., 2,130-2,133.
- private, emergency machine wiring, ills., 2,146.
- joint, soldering, ills., 3,080, 3,081.
- Brass**, as conductor of electricity, 69.
- bands on smooth core armatures, 347.
- electro-plating current, 3,149, 3,157.
- rheostat, ills., 3,154, 3,157.
- dips for, 3,179.
- barrel for, ills., 3,182.
- tank for, 3,159.
- polish rouge, 3,160.
- sweating, ills., 3,091.
- transfusion with lead, 3,072.
- welding, ills., 3,127.
- flux for, 3,109.
- pressure, 3,128.
- with zinc, conductivity of, 723.
- Brazing**, blow pipe method, ills., 3,102.
- butt, ills., 3,096.
- dip, ills., 3,097, 3,098.
- furnaces, ills., 3,072, 3,099, 3,100.
- heating methods, ills., 3,101, 3,103.
- joint, advantage of, 3,071.
- lap, ills., 3,097, 3,104.
- muffle, 3,098.
- preparations, various, 3,082, 3,084.
- solders, 3,101.
- torch, ills., 3,103.
- various articles, ills., 3,102.
- Break(s)**, air, switch, enclosed, 1,596.
- circuit, forms of, 1,592.
- double, pole switch, Baum, ills., 1,596.
- down switch, wire circuit, ills., 752.
- grounds and crosses in cables, 535.
- hammer, construction of, ills., 151.
- horn switch, ills., 1,598, 1,600.

Break(s),—*Continued.*

- in armature circuit, 633.
- cause sparking at brushes, 650.
- coil causes flat commutator, 643.
- coils, 659.
- testing for, ills., 630.
- lead, test for, ills., 625.
- in field circuit causes sparking at brushes, 651.
- in shunt coil, 616.
- of current, spark produced at, 145.
- oil, nature of, 1,604.
- open air, objection to, 1,594.
- partial, in coil detected, 651.
- quick, fuse, ills., 1,617.
- knife switch, ills., 411.
- switch, con., 411, 412.
- repaired in armature circuit, 634.
- switch, single and double, 407.

Breaker(s), circuit, 1,621, 1,622.

- automatic operation, 1,625, 1,632.
 - carbon discs, Condit, ills., 1,624.
 - Condit, ills., 1,648, 1,650.
 - contact, telegraph transmitter, ills., 2,228.
 - control, electro-magnetic, ills., 1,630.
 - General Electric, ills., 1,629, 1,636.
 - instantaneous, 1,612.
 - I-T-E con., ills., 1,664-1,666.
 - ills., 1,622.
 - magnetic blowout, G. E., ills., 1,621.
 - Westinghouse, ills., 1,620.
 - no voltage trip, 1,633.
 - operation, ills., 1,626.
 - overload, General Electric, ills., 1,640.
 - ills., 1,627.
 - parts, General Electric, 1,629.
 - pneumatic, Condit, ills., 1,663.
 - position, of current coil, 1,633.
 - of pressure coil, 1,633.
 - thermal overload, ills., 1,623.
 - trip attachments, G. E., ills., 1,634.
 - underload trip, 1,633.
 - with generator, ills., 1,674.
 - with overload coils, ills., 1,628.
 - with pull down handles, ills., 1,628.
 - Breaking back arrester effect, 1,683.
 - Breast plate transmitter, ills., 2,139.
 - Brett, experiments of, 2,413.
 - Bregnet upright galvanometer, ills., 435.
 - Brick(s) heat loss, table, 3,056.
 - wall, wires installed on, 776.
- Bridge**, Anthony, modified, ills., 491.
- arm, table, 502.
 - Christie, 2,413.
 - coil table, 502.
 - commutator, plugs in, 502.
 - cranes, 2,937.
 - const., def., ills., 2,941.
 - decade method, advantages of, 297.
 - duplex telegraph system, ills., 2,238.
 - 2,240.
 - ends, Niles crane, ills., 2,939, 2,940.

Bridge,—*Continued.*

- girders, crane, box section, ills., 2,942.
 - Kelvin, circuits, ills., 507.
 - principle of, ills., 506.
 - Leeds and Northrup, for testing power circuits, ills., 534.
 - magnetic, of Crocker-Wheeler induction motor, ills., 1,330.
 - motor transition, advantage of, 2,573.
 - resistance units with Varley loop, 517.
 - system, three wire, 709.
 - testing, slide wire, ills., 504.
 - plug out and plug in, ills., 498.
 - with minimum number of coils, ills., 496.
 - transition, 2,571.
 - type catenary construction, ills., 2,625.
- Wheatstone**, diag. of, ills., 489-490.
- dial, Leeds and Northrup, ills., 497.
 - erroneously named*, 2,413.
 - INF. marking on, 493.
 - testing method, ills., 488, 492.
 - with resistances, ills., 491.
 - wire, table for, 757.
 - wiring diagram, ills., 758.
- Bridgework**, porcelain, for underground conductors, ills., 834.
- Brill** maximum traction truck, ills., 2,593.
- Brilliance**, intrinsic, definition of, 2,609.
- intrinsic, of light sources, 2,521.
- Brilliant lamp** synchronizing method, ills., 2,037.
- British thermal unit**, definition of, 91.
- Broc** control lever, automobile, ills., 2,852.
- Broiler**, heating, unit for, 3,051.
- Brooklyn Edison Co.** converter sub-station, ills., 1,585.
- Brougham**, Waverly electric, 2,819.
- Brown and Sharpe** flat wire gauge, ills., 738.
- Brown** electric hoist, ills., 2,959.
- trolley, motor driven, ills., 2,960.
- Bronze**, electro-plating, current for, 3,149.
- 3,151.
 - siliceous, conductivity of, 723.
 - welding flux for, 2,109.
- Brush(es)**, adjustment of, 574.
- for field distortion, ills., 286.
 - for self-induction, ills., 287.
 - improper, ills., 290-291. 639, 640.
 - allowable amperage for, 657.
 - and brush gear, 303-320.
 - and brush holders, 574.
 - Triumph, ills., 1,255.
 - and commutator, care of, 635-652.
 - and knife flashers, 869.
 - angle between, 251.
 - angles of contact, ills., 312.

Brush(es),—Continued.

- armature, amperage through, 251.
- effect of, *ills.*, 253.
- joining series dynamo, 185.
- not properly adjusted, 611-612.
- sets of, 311.
- size of, 311.
- attention given to, 636.
- bad condition of, *ills.*, 641.
- bearing on commutator, 574.
- carbon, adjustment of, 307.
- allowable current for, 657.
- armature, 306.
- decomposed by heat, 657.
- different grades of, 308.
- extensively used, 308.
- fed by spring holder, 307.
- for fluctuating currents, 310.
- high conductivity of, 657.
- length of reduced, 657.
- merit of, 309.
- objections to, 310.
- of automobile motor, 2,824.
- possess high resistance, 295.
- reinforced, 657.
- too hot, 657.
- usual form of, 307.
- varied construction 309, 310.
- commutator, and armature, heating of, 655.
- connected, directly with main conductors, 319.
- for 4 pole dynamo, *ills.*, 260.
- how affects voltage, 260.
- contact(s), automobile, defective, effect, 2,852.
- bad, 641.
- effect of increasing degree of, 297.
- of Wimshurst machine, *ills.*, 26.
- oily, 612.
- proper, securing of, 577.
- resistance theory of commutation, *ills.*, 296.
- copper, and carbon compared, 309.
- in Faraday's machine, *ills.*, 126.
- used for high amperage and low voltage, 311.
- covering 2 armature segs., *ills.*, 296.
- dimensions of, 311.
- dynamo, electro-plating, 3,148.
- various, *ills.*, 3,159, 3,161, 3,162.
- lead small, 589.
- rocking of, 640.
- effect of charged wires, 1,894.
- of lead of, 269.
- ends, carbon, treatment of, 308.
- excessive sparking of, 591.
- false position, causes sparking, 289.
- filing clamp, metal, *ills.*, 638.
- machine, jig for, *ills.*, 638.
- fixed position of, 294.
- friction of, 314. 2,113.

Brush(es),—Continued.

- gauze, construction, 303.
- features of, 304.
- gear, dynamo, Bissell, *ills.*, 637.
- for large plating dynamos, 320.
- multipolar generator, 320.
- Western Electric, 314.
- heat due to great pressure, 658.
- held by arms in large dynamos, 320.
- holder(s), 315.
- and brushes, 574.
- and slip rings, *ills.*, 1,202.
- box, Western Electric, *ills.*, 308.
- carried by rocker arm, 319.
- Crocker-Wheeler, *ills.*, 306.
- double, Bissell, *ills.*, 313.
- General Electric, *ills.*, 305.
- ills.*, 315, 316.
- multiple, Holtzer-Cabot, 310.
- requirements, 315, 316.
- short circuit at, 620.
- testing of, 620.
- trouble with, 319.
- types, 318.
- Western Electric, *ills.*, 318.
- parallel spring, *ills.*, 319.
- Westinghouse, *ills.*, 309.
- in series dynamo, sparking at, 187.
- jumping of, causes flat commutator, 643.
- laminated, armature, 305.
- lead, effect of, 294.
- of the, 266.
- lifting device on rotary converter, Westinghouse, *ills.*, 1,472.
- machine, cleaning of, 595.
- making bad contact, *ills.*, 641.
- metal strip with frayed ends, 637.
- metallic, in alternator, *ills.*, 162, 163.
- motor, sparking at, 388.
- number of, in each set, 311.
- number reduced, lap winding, 251.
- of dynamo, 160.
- sparking at, cause, 136.
- prevented, 388.
- spark when connections are loose, 649.
- of series dynamo, 590.
- of watt hour meter, *ills.*, 562.
- of West. rot. converter, *ills.*, 1,475.
- pilot, and voltmeter, 261.
- position, influence of, on shunt motor, 373.
- for heavy load, 269.
- for light load, 269.
- pressure on commutator, 577.
- proper, adjustment of, 577.
- pitch of, 640.
- raised from commutator, 582.
- required for armature windings, 150.
- reversing contact with segments, *ills.*, 172.
- rigging for large revolving field alternators, *ills.*, 1,262.
- rot. converter, West., *ills.*, 1,469.

Brush(es),—Continued.

- rocker ring rotated by worm gear, 320.
- scratch, electro-plating, 3,162.
- sparking at, caused by breaks, in armature circuit, 650.
- in field circuit, 651.
- by short circuited armature, 650.
- causes, 640.
- prevented, 294.
- sparking, dynamo, 136. 638.
- setting marks cut in collar of commutator, 575.
- steel wire, electro-plating, ills., 3,162.
- sub-division of, 311.
- swing, electro-plating, ills., 3,162.
- tampico fibre, H. & V., ills., 3,161.
- tangential, armature, 305.
- thin, objection to, 294.
- three dynamo, 3 wire system, 709.
- tinsel, Toepler-Holtz machine, 24.
- type flasher, Reynolds', ills., 868.
- variation of position, 187.
- voltage drop at, 313, 314.
- watts lost at, 314.
- width of, 311, 312.
- period of commutation dependent upon, 283.
- wire, 304.
- B** telephone switchboard, 2,165.
- Bubbles, gas, bad conductors, 40.
- gas in storage battery, 917.
- Buckeye mobile engine, ills., 1,979.
- Bucket(s), Doble, water wheel, ills., 2,054.
- fire, in central station, 2,016.
- valves, 2,977.
- Bucking, coil of Rushmore dyn. ills., 2,812.
- transformer temp. test, ills., 2,097.
- Buckingham-Barclay tel. system, 2,256.
- Buckled plate straightened, ills., 955.
- Buckling of storage battery, 955.
- Buffer, oil, elevator, ills., 2,858, 2,860.
- Otis spring return, ills., 2,933.
- Bufs, polishing, electro-plating, 3,177.
- Buick, automobile circuit diagram, 2,801.
- Buildings, wiring of, 845-864.
- Built in, cable system, 826.
- wooden conduits, ills., 833.
- Built up armature core, ills., 331.
- Bulb(s), for enclosed arc, 2,439.
- incandescent lamp, 2,486.
- mercury arc, G. E., ills., 1,523.
- rectifier tilted, 1,512.
- mercury vapor rectifier, Westinghouse Cooper-Hewitt, ills., 1,511.
- rectifier, heat in, cooled, 1,524, 1,525.
- Bull's eye cord signal sticks, 2,175.
- Bullion refining, 3,135.
- Bumper, elevator, 2,866.
- Bunnell, adjustable tel. conden., ills., 2,233.
- automatic tape winder, ills., 2,250.
- detector galvanometer, ills., 434.
- galvanometer, ills., 436.
- horizontal galvanometer, ills., 435.

Bunnell,—Continued.

- iron box bell, ills., 2,347.
- Jupiter fire alarm box, ills., 2,409.
- pole changing telegraph transmitter, ills., 2,235.
- special telegraph relay, ills., 2,222.
- spring contact telegraph repeater, ills., 2,223.
- tangent galvanometer, ills., 442.
- telegraph, recorder, ills., 2,257.
- transmitting typewriter, ills., 2,255.
- tongue contact telegraph repeater, ills., 2,222.
- vibrating bell, ills., 2,342.
- Bunsen, burner in brazing, 3,096.
- cell, description of, 51.
- electro-plating, 3,147.
- ills., 53.
- used for experiments, ills., 53.
- holes of soldering bit, ills., 3,085.
- photometer, ills., 2,513.
- Burdett and Roundtree, dumbwaiter, controller, ills., 2,887.
- Burglar alarm, circuit with gravity drop, ills., 2,405.
- continuous ringing bell, ills., 2,352.
- floor tread, ills., 2,405.
- ills., 2,404-2,410.
- switch, Yale lock, ills., 2,404.
- system in house, ills., 2,406.
- molestation determined, 2,410.
- ills., 2,408.
- trap, ills., 2,406.
- with string balance, ills., 2,407.
- window switch, ills., 2,408.
- wires, concealing of, 2,409.
- wiring, metal moulding for, 2,409.
- Burner, acetylene, Challenge multi-tip, ills., 2,717.
- Burnham split pole rot. converter, 1,476.
- Burnishing barrel, electro-plating, ills., 3,164.
- 3,165.
- Bus bar(s), ammeter shunts connected to, 543.
- auxiliary, 719.
- object of, 720.
- used instead of booster, 720.
- common negative, 720.
- main and auxiliary, ills., 719.
- ship propulsion, 2,670.
- shunt coils, direct connected, 602.
- shunt dynamo, connected to, 604.
- Bus capacity, method of obtaining, 1,878.
- Bus transfer plug switch, ills., 1,592.
- Bushing, insulated for rail, joints, 2,635.
- interior, for wire, ills., 773.
- lava, of Ft. Wayne arc lamp, 2,453.
- lubricating, of trolley, 2,547.
- motor bearing, ills., 688.
- Westinghouse transformer, ills., 1,405.
- Butt, brazing, ills., 3,096.
- joint, soldering, ills., 3,075.

Butt,—*Continued*.
seam, lead burning, ills., 3,104, 3,105.

weld, ills., 3,110.
welder, Toledo, ills., 3,126.

Butterfly wind'g, evolve connectors, 337.
Buttner valve, 1,505.

Button, ceiling lamp, ills., 846,
inserted in battery plate, ills., 894,
how operated, 2,219,
push, ills., 2,378.
motor switches, ills., 675.
switch telegraph repeater circuit, ills.,
2,214.

tel. repeater circuits, ills., 2,216.
repeater operation, 2,215.
vulcanite, Edison cells, 51.

Buzzer(s), and bell, circuit, ills., 2,402.
and bell, difference between, 2,356.
and push buttons, wiring of 25, ills.,
2,403.
attached to annunciator, ills., 2,390,
circuits for apartment house, ills., 2,394,
2,396.

contact spring open, 2,176.
def. of, 2,354.
key, switchboard wiring, ills., 2,130-
2,133.

in push button, ills., 2,379.

Buzzer, ringer coils open, 2,174.
relay, at switchboard, open, 2,176.
contact open, 2,174.
for P. B. X. switchboard, ills.,
2,166.

sectional view of, 2,357.
use of, 2,402.

telephone and coil connected with
fault finder battery, 522.

By pass, in shunt dynamo, 189.
pump control, Gould, ills., 3,018.
valve(s), air compressor, 3,040,
reciprocating pumps, 3,010.



Cable(s), armoured, cost of, 798.
features of, 796.
flexible, 796.
installation of, 798.
submarine, ills., 729.

Cable(s),—*Continued*.
automobile, high tension, ills., 70,
bond, for rail, ills., 2,617.
built-in system, 826.
capacities, concealed work, 753.
open work, 753.
table of, 753.

catenary construction, 2,628.
circuit, submarine tel., ills., 2,253.
color code, telephone, 2,160.
conduits, 826, 827.

connected to pot head, 844.
connecting, box, outdoor, ills., 2,165.
motor wound with marlin, ills.,
578.

copper, rope stranded, 1,912.
device, elevator, defective, 2,931.
drawing in system, 826.
drive, Fraser elevator, ills., 2,912.
Edison underground, ills., 842.
elevator, ills., 724, 2,919.
hand, with shaft limit switch,
2,879.

ends, stranded copper, ills., 1,903.
fault in, determining distance, 516.
for elev. annun., ills., 724, 2,393.

gas engine ignition, ills., 729.
grounded, detection of, 2,663.
guy, 811.

hanger, Harvard, ills., 821.
hoisting of trac. elev., 2,859, 2,924.
insulation testing, 487.
jumper, loose, 2,661.

lead encased in ground, 826.
locating distance of fault in, 536.
messenger for trolley, ills., 2,628.
of different cross sections, locating faults
in, 535.

overhead construction, ills., 821.
shipper, elev. control, ills., 2,875.
soldered to carbon block, ills., 576.
stranded copper, 1,903.

submarine telegraph, 2,252.
telephone, forming and installing, ills.,
2,186.

laced, ills., 2,160.
lead encased, ills., 729.
telephone switchboard, ills., 2,164.
terminal, tcl. exten., ills., 2,164.
testing set, portable, Fischer, ills., 535.

underground, 840.
porcelain bridgework for, ills.,
834.

three wire, ills., 840, 841.
winding with marlin, 578.
wiring, armoured, 796.

Cableway, def., 2,961.
hoisting, ills., 2,961.

range of, 2,962.

Cadillac automobile circuit, diag., 2,801.

Cadmium, in caustic potash, 102.
in contact with zinc, 44.
in hydrochloric acid, 102,
in sulphuric acid, 102.

- Cadmium**,—*Continued.*
 readings of storage cells, 925.
 test of accumulator voltage, 919.
- Cage**, crane const., 2,943.
 squirrel, alter. winding, ills., 1,155.
- Calcium burner**, Guil pastil adapter for, ills., 2,720.
 light, "Economic," ills., 2,720.:
 salts carbon cores, 2,467.
- Calculation(s)**, curves, lighting, 2,523,
 factors, wire, 744, 745.
 for three wire circuit, 761.
 lighting, point by point method, ills., 2,524, 2,525.
 rapid method, 2,526.
 skin effect, 1,891.
 speed and size of belt pulley, 402.
 synchronous condenser, 1,771, 1,774, 1,775.
 wire, 1,901.
 examples of, 763,
 for motors, 758,
 gauge, ills., 740.
- Calibrate**, def., 544.
- Calibrated**, galvanometer, 442.
 scale, ills., 1,780.
- Calibrating a wattmeter**, ills., 2,094.
- Calido resistance wire**, comp., 3,049.
- Call**, bells, telephone, ills., 2,127-2,128.
 box, messenger, ills., 2,258.
 carriage, keyboard for, ills., 881.
 sign, monogram for, ills., 880.
- Calland star carbon**, ills., 62.
- Callender tube conduit system**, 839.
- Calor heating element**, 3,051.
- Cam clutch**, carbon feed, ills., 2,434.
- Camera**, motion picture, Universal, ills., 2,731.
 Angelus, ills., 2,732.
 machine used as, 2,732.
 operation of, ills., 2,728.
 Power's, ills., 2,715.
 Schneider, ills., 2,729, 2,730.
- cinematograph**, for oscillograph, ills., 1,866.
 falling plate oscillograph, 1,866.
- C. and C. electric arc welding**, ills., 3,121.
- Can. oil**, non-magnetic, 593.
- Candle**, English standard, 2,508.
 foot, definition of, 2,510, 2,523.
 German, lighting standard, 2,508.
 international, 2,507.
 meter, ills., 2,510.
 multi-image exper., ills., 2,681.
 per cent. of light from, 2,426.
 position of image, ills., 2,681.
 power, a. c. arc, 2,443.
 definition of, 2,506, 2,507.
 dist. curve for arc lamp, 2,425.
 incandescent lamp, 2,488,
 maximum, 2,511.
 mean, conical, 2,510,
 hemispherical, 2,513,
 horizontal, 2,514,
 spherical, 2,512, 2,515,
 Moore vacuum lamp, 2,482.
- Candle, power**,—*Continued.*
 Nernst lamp, 2,501.
 nominal, 2,511.
 of search lights, 2,475,
 tungsten lamps, 2,498.
 various light sources, 2,521.
- Canopy insulator fitting**, ills., 788.
- Cant hook**, ills., 803.
- Canvas**, for field coil insulation, 217.
 wheel, for polishing, 3,175.
- Cap(s)**, and base metal moulding, ills., 775.
 for conduit end, ills., 792, 793.
 for telephone receiver, ills., 2,120.
 motor shaft end, ills., 688.
 of bearings and journals, 573.
 vent, of Witherbee bat., ills., 940.
- Capacity**, 1,892.
 ampere, of insulated wire, 731.
 analogy, hyd., ills., 2,742.
 equal, ills., 2,744.
 in a. c. circuit, ills., 1,041.
 and head, pumps, centrifugal, 3,011.
 and inductance, 1,091,
 in circuit, ills., 1,059, 1,084,
 mutual effect, 1,064.
 bus, method of obtaining, 1,878.
 cable, table of, 753.
 causes, current lead, 1,049.
 charging battery, ampere hour, 916.
 condenser, depends on size, 1,043,
 in a. c. circuit, 1,041,
 of one microfarad, ills., 1,043.
 tested with charge and discharge
 key, ills., 477.
 decrease of storage battery, 942.
 effect, mech. analogy, ills., 1,040.
 in single phase transmission line,
 ills., 1,890.
 equal, hyd. analogy, ills., 2,744.
 hydraulic analogy, ills., 1,041.
 inductance, and non-inductance in cir-
 cuit, ills., 1,060.
 and resistance, in circuit, ills.,
 1,058.
 in series, ills., 1,096.
 loss in air compressor, 3,038.
 measured by farads, 92.
 microfarad table, 1,891.
 of battery, depends on plates, 938,
 new, 933,
 with reversible booster, 988,
 increased, 939.
 lack of, 960.
 of dynamos and motors, 390.
 of motor, General Electric, 377.
 of pump, 2,983, 2,985.
 ex., 2,984.
 rule, 2,984.
 of rectifier tube, 1,526.
 of storage cell, unit of, 938.
 of synchronizing lamp, 2,037.
 of transformer(s), for induction motors,
 1,451.
 for motors, 1,449.
 ohmic value of, 1,045, 1,046.

Capacity,—*Continued.*

- opposite to inductance, 1,040.
- pressure, and applied pressure, phase relation between, 1,086, or reactance drop, 1,088.
- reactance, 1,054, 1,055, effect of, 1,117, given negative sign, 1,062, symbol, 1,048.
- reduces lag on long lines, 1,054.
- resistance and inductance, circuits containing, 1,092, 1,093.
- rupturing, of oil switches, 1,609.
- safe carrying, of wire, 730, table, 731.
- specific inductive, 1,043, of air, 1,044.
- storage battery, lack of, 958, 959.
- tests, 1,044.
- theoretical, of pump, 2,983.
- unit of, farad, 1,041.
- var. for diff. bat. disch. rates, 939.

Car. apparatus, Westinghouse multi-unit, ills., 2,654.

- elevator, ills., 2,863-2,865, layout (Warner), ills., 2,864.
- heater coils, ills., 2,612, 2,613, design, 2,615, installation of, 2,615, underseat, ills., 2,614, wiring diagram, 2,616.
- heating, ills., 2,612-2,616, power consumption, 2,613, truss plank, wiring diagram, ills., 3,055, underseat method, 3,054.
- lighting, defective, 2,608, McElroy system, 2,606, Stone sys., ills., 2,605, 2,606.
- motor troubles, 2,658, operation, 2,649, 2,658, propulsion, series motor, 371, track, third rail const., 2,621, 2,622, trouble in starting, 2,653, 2,656.

Carbon(s), a. c. arc, action of, 2,442.

- and copper brushes compared, 309, angle variation, 2,719.
- armature brushes, 306.
- block soldered to cable, ills., 576.
- brushes, adjustment of, 307, allowable current for, 657, automobile motor, 2,824, decomposed by heat, 657, different grades of, 308, ends, treatment of, 308, extensively used, 308, fed by spring holder, 307, for fluctuating currents, 310, high conductivity of, 657, length of reduced, 657, merit of, 309, objections to, 310, possess, high resistance, 295, reinforced, 657, too hot, 657, usual form of, 307.

Carbon(s), brushes,—*Continued.*

- varied const. of, 309, 310, where used, 310.
- calcium salts cores, 2,467.
- Calland star, ills., 62.
- candle power of various, 2,521.
- cell, ills., 42, Hercules, ills., 42, Law, ills., 42, National, ills., 42, Sampson, ills., 42, Standard, ills., 42.
- classes of, 2,422.
- clutch(es), 2,432, feed, var. forms, ills., 2,434, Ft. Wayne arc lamp, ills., 2,455.
- conductivity of, 69, constant cur. series arc circs., 2,424, consumption, how increased, 2,426, copper plated, 2,424, conductivity of, 2,424, cored, arc setting, a. c., ills., 2,721, description of, 2,423, for a. c. arc, 2,442, 2,719.
- corrugated, merit of, 42.
- cylindrical, ills., 42, 62, defective, 2,479, difference of temperature in, 2,420, dioxide, formation in arc, 2,418, discs, Condit circuit br'k'r, ills., 1,624, disulphide in nickel plating, 3,181, effect of wrong inclination, 2,718, electrodes, medical, 3,198, electric light flasher, ills., 866, enclosed a. c. arc, ills., 2,441, enclosed arc, action of, 2,439, lamp(s), arrangement, 2,440, life of, 2,440.
- feed, automatic, kinds of, 2,429, how gauged, 2,721, mechanisms, 2,428, ills., 2,475.
- flasher, Dull's, wir. diag., ills., 867.
- filament, lamps, 2,486.
- fluted, merit of, 42.
- forced, 2,424, for const. pressure lamps, 2,425, granulated, in dry cells, 2,401, holder carrier, Ft. Wayne arc lamp, ills., 2,455, how to cut, 2,425, 2,476, in arc lamp, adjustment of, 2,422, in contact at starting, 2,432, in telephone transmitter, 2,172, lamp, consumption of, 2,532, properties of, 2,529, treated, 2,492, lasting qualities of, 2,424, lightning arrester, ills., 891, long flame arc, life of, 2,443, monoxide, formation in arc, 2,418, motion picture d. c. arc., ills., 2,717, 2,718, lamp, ills., 2,723, moulded, 2,424.

- Carbon(s)**,—*Continued*.
 negative, temperature of, 2,420.
 operating, conditions of, 2,427.
 pile booster system, ills., 986.
 plate of dry cell, 2,401.
 pliers, ills., 2,476.
 proper sizes of, 2,425.
 resistance of in arc lighting, 2,423.
 rocking, 2,719.
 rods, shape at tips, 2,421.
 vaporization of, 2,416.
 series feed, ills., 2,423, 2,429.
 size of, in arc lighting, 2,423.
 slender, when used, 2,440, 2,441.
 solid, in arc lighting, 2,422.
 how differ, 2,423.
 tips, various air gaps, 2,422.
 to prevent polarization, 42.
 transmitter cup, ills., 2,118.
 vapor, how produced, 2,416.
 vaporized, how varies, 2,419.
 various, ills., 62.
 vertical, form of arc between, 2,412.
 wheel, ills., 62.
- Carbonized**, cylinder, 2,792.
 poles, 802.
- Carborundum**, of wave meter, ills., 2,285.
 wireless detector, 2,314.
- Carcel** standard of lighting, 2,507, 2,508.
- Card(s)**, indicator, gas engine, ills., 2,737.
 steam engine, ills., 1,779.
- Care**, and management, accumulators, 948.
 in use of weather proof wires, 726.
 of commutator and brushes, 635-652.
 of motors, 687.
 of potentiometer, 533.
 of primary cells, 62.
 of storage bat., rules, 967, 968.
- Carlisle and Nicholson**, experiments, 98.
- Carriage** call, operating keyboard, 881.
 sign, monogram for, ills., 880.
- Carriers**, 23.
 on Holtz machine, ills., 24.
 porcelain, for underground conductors,
 ills., 834.
- Carrying** hook, ills., 801.
- Cartercar**, circuit diagrams, 2,801.
- Cartridge**, fuses, ills., 413.
 heating unit, 3,051.
- Cascade**, and synchronous converters com-
 pared, 1,494.
 connection, condensers, ills., 1,045.
 method, single control, 2,586.
 motor generator set, ills., 1,490.
 operation, 2,584, 2,586.
 rotary converter, ills., 1,490.
- Case**, and cover of meters, 1,821.
 box, for wires on wall, ills., 769.
- Cast**, end rings on squirrel cage armature,
 ills., 1,375.
 iron, conduit, advantage of, 837.
 for core construction, 206.
 pipe conduits, 836.
 welding flux, 3,109.
 yokes, ills., 204.
- Cast**,—*Continued*.
 welded laminated poles, ills., 213.
 steel yokes, ills., 204.
 Castner cell, in electrolysis, 3,141.
 Catalepsy, treatment for, 3,207.
 Catarrh, treatment for, 3,205, 3,207.
 Catenary, anchorage for, ills., 2,624.
 bracket, ills., 2,623.
 bridge type, 2,625.
 cable for, 2,628.
 hangers for spans, ills., 2,626.
 single, 2,624, ills., 2,625, 2,627.
- Cathode**, alum., electrolytic rect., 1,496.
 and anode, relation, 3,145.
 definition of, 98.
 mercury, of rectifier, 936.
 of voltmeter, 471.
 ray, oscillograph, 1,852.
 rectifier, mercury, why used, 1,523.
 rod, electro-plat., ills., 3,168, 3,169.
 storage battery, 899.
 stream, X rays, ills., 3,229.
- Cations**, def., 3,133.
- Caustic(s)**, acid, current, 3,203.
 alkaline, current, 3,203.
 by refraction, 2,698.
 potash in Edison cell, ills., 50.
 series metals in solution, 102.
 surface, sp. aberration, 2,696.
- Cautery**, electro-, 3,223.
 illuminator set, McIntosh, 3,226.
 knives, various, ills., 3,225.
 technique, 3,225.
 transformer, McIntosh, ills., 3,224.
- Ceiling**, lamp(s), button, ills., 846.
 controlled by switch, 846.
 motors suspended from, 686.
 moulding, treatment of, ills., 777.
 outlet for wires, ills., 855, 856.
- Cell(s)**, 2,735.
 "American," electrical data on, 959.
 and porous cup, Leclanche, ills., 46.
 arrester, electrolyte in, 1,699.
 Aussig bell, electrolysis, ills., 3,139.
 "Autex," electrical data on, 960, 961.
 automobile battery, parts of, ills., 902.
- Bunsen**, description of, 51.
 electromotive force of, 53.
 use of in experiments, 53.
- Carbon**, electromotive force of, 42.
 closed circuit, Partz acid gravity,
 57.
- Castner**, electrolysis, 3,141.
 connected in series, ills., 65.
 connection of, 65-67.
 storage battery, 952.
- connectors**, of "National" battery, ills.,
 963.
 spring snap, ills., 2,401, 2,402.
 Willard storage bat., ills., 904.
- construction of, ills., 32.
 continuous current furnished by, 35.
 covers, paper, effect of water on, 60.
 crowfoot, copper element, ills., 64.

Cell(s).—Continued.

- Daniell, const. of, ills., 54, 55, 56.
 adaptation, 54, 55.
 electromotive force of, 131.
 location of poles, 2,387.
 diaphragm type, ills., 3,140.
 double, action secured by, 41.
 use in depolarizing, 41.
dry, ills., 59-61.
 amperage of, 61.
 when new, 2,743.
 average voltage of, 61.
 des., 2,743.
 for automobiles, ills., 59, 60.
 for marine ignition, 59-61.
 for vibrating bells, 2,400.
 pole location, 2,387.
 restoring, 2,400.
 test by ammeter, 61.
Edison, description of, 50.
 electrical data for, 918.
 for electro-plating, ills., 50.
 for fire alarms, ills., 50.
 ills., 2,746.
 railroad signals, 50.
 storage battery, ills., 918.
 telephone circuits, ills., 50.
 type R.-R., ills., 50.
 use of for ignition, ills., 50.
 electrolytic, arrester connect. 1,699.
 Gibbs, ills., 3,138.
 for incandescent lamps, ills., 49.
 for motors, ills., 49.
 for standard internat'l volt, ills., 467.
 for telephone, ills., 49.
Fuller, bichromate, 48, 49.
 const., ills., 48, 49.
 electromotive force of, 49.
 how, to set up, 49.
 use of, in plating, ills., 49.
 for telephone, 49.
Gould, automobile bat., ills., 2,840.
gravity, 56, 57.
 location of poles, 2,387.
Grenet bichromate, 51-53.
 American form, ills., 52.
 French form, ills., 52.
Grove, electromotive force of, 53.
 use of in experiments, 53.
Hargreaves-Bird, ills., 3,140.
 hydrometer test, ills., 2,796.
 internal resistance of measured, 509.
Leclanche, carbon cylinder, ills., 42.
 how to set up, 48.
 invention of, 47.
 location of poles, 2,387.
 objections to, 48.
 polarization of, 48.
 multiple-series connection, ills., 66.
 "National," electrical data on, 958.
 of battery, and stand, ills., 953.
 arrangement of, 951.
 connecting of, 951.
 joining terminals of, 951.
 placed on insulators, 948.
 weak, treatment of, 902.

Cell(s).—Continued.

- of battery, well insulated, 949.
 of chloride storage bat., ills., 925.
 of Edison storage battery, 918.
 of Gould storage battery, ills., 910.
 of "National" storage bat. ills., 962.
 of Plante storage battery, 900.
 of storage bat. disconnected, 963.
 open circuit, Leclanche, ills., 46.
 prevent polarization of, 43.
 primary, use of, 35.
 Partz acid gravity, ills., 57.
 Leclanche, 46.
 parallel connection of, ills., 66.
 prevention of polarization, 43.
 primary, 35-67.
 best results from, 62.
 care of, 62.
 elements of, ills., 37.
 def., 32.
 ignition, 2,741.
 points on 10, 2,741-2,746.
 use of, 35.
 proportion of, for spark coil, 154.
 requirements of, 45.
 secondary, action of, 2,747.
 def., 32.
 des., 2,747.
 voltage of, 911, 912.
 series-multiple connection, ills., 66.
 series connection of, ills., 65.
 simple, connecting electrodes, 39.
 unsuited to practical work, 39.
 simplest, polarization of, 41.
 signal, Columbia, ills., 2,745.
 single fluid, Edison, ills., 50.
Smee, corrugating electrode of, 41.
 for electro-plating, ills., 3,146.
 standard, setting, 531.
 storage battery, assembled, 950.
 briefly described, 897.
 capacity of, def., 938.
 filed, 907.
 plate or grid, ills., 894.
 switches, end, 977.
 terminals, ills., 2,401, 2,402.
 two fluid, Daniell gravity, 56, 57.
 depolarization in, 45.
 Fuller, ills., 49.
 various, for electro-plating, 3,147.
 Volta's single fluid, 45.
 voltage by potentiometer, ills., 530.
 weak, how strengthened, 61.
 Weston normal, 467.
 Wheelock, construction of, ills., 58.
Cellar(s), distribution center in, 845.
 tel. lightning arrester in, ills., 2,163.
 terminals of tel. wires in, ills., 2,162.
Cement, iron pipe conduit laid in, 835.
 lined iron pipe, 836.
Center(s), dead, of synchronous motor,
 1,274.
 distribution of circuit, ills., 736.
 in cellar, 845.
 of regular circuit, ills., 737.
 electrical distribution, 704.

- Center(s)**,—*Continued*.
of gravity, electrical, 704.
optical, ills., 2,690, 2,691.
- Central**, automatic tel. sys., 2,151, 2,157, .
energy, switchboards, 2,136.
telephone system, 2,135.
office, exchange equipment, 2,139.
Scientific tang. galv., ills., 441, 449,
- Central station(s)**, 1915, 1916.
at Derby, section, ills., 1,921.
boilers, 1,941.
coal supply, ills., 1,925.
doors, 1,941.
efficiency, examples, 1,933. .
engine, 1,941.
fire buckets, 2,016.
G.E. motor generator set, ills., 1,486,
generated current, 1,586.
interior, ills., 1,940.
land, 1,920.
load curve, ills., 1,932,
location, ills., 1,917, 1,920.
management, 1,989-2,114.
motor generators in, 1,485.
oil switches in tanks, ills., 1,602,
plan, ills., 1,939.
size of, 1,930.
small, exterior, ills., 1,918.
steam pipes, 1,941, 1,942.
transformer, Wag., ills., 1,408, 1,446,
turbine, Boston Edison Co., ills., 1,926.
Waterside, ills., 1,922.
water supply, ills., 1,923, 1,924.
- Central supply system**, choice of, 1,927.
- Central trunk jack**, telephone, ills., 2,141.
- Centrifugal**, elev. governor, ills., 2,930.
force, reduced by modified small field,
ills., 1,266.
- Centrifugal pumps**, Allis-Chalmers, five stage,
motor, ills., 3,011,
capacity and head, 3,011.
classification, 3,002.
def. and des., 3,001, 3,002.
double inlet, 3,009.
Gould's single stage, ills., 3,007.
Gwynne, ills., 3,001.
head for, note, 3,001.
how to prime, ills., 3,005.
motors, 3,010, 3,011.
multi-stage, notes, 3,009.
prime without steam, note, 3,005.
single inlet, uses, 3,009.
starting, 3,011, 3,012.
3 stage Allis-Chalmers, ills., 3,010.
turbine, single inlet, 3,009.
vertical 3 stage turbine, ills., 3,008.
- Chafing dish**, heating unit for, 3,051.
- Chain**, and gear drive, 2,835.
automobile, adjustment, 2,834.
block vs. roller, 2,831.
care of, 2,831.
cleaning, 2,834.
rattle and snap, 2,831,
- Chain, automobile**,—*Continued*.
silent, ills., 2,827.
whipping prevented, 2,831.
block, 2,829, 2,831.
drive, advantages of, 1,140.
ills., 2,829,
care of, 2,828, 2,832.
climbing the teeth, 2,828.
doub. automobile, ills., 2,829.
electric vehicle, 2,828.
motion picture machine, ills.,
2,708, 2,709, 2,714.
objections to, 1,140. 2,828.
driven alternator, ills., 1,135.
elevator compensating, 2,926.
operating conditions, 2,829.
or basket winding, ills., 1,256.
roller, 2,829, 2,831.
silent, automobile, ills., 2,827.
vibrating, Columbia, ills., 3,223.
- Challenge acetylene burner**, multi-tip, ills.,
2,717.
- Chambers**, air and vacuum, ills., 2,979.
- Champion**, accumulator parts, ills., 909. .
battery, charging, of ills., 949.
plug for, 949.
electriclight bat.char.outfit, ills., 950.
storage battery, ills., 909.
- Change(s)**, chemical, simple cell, 37,
in strength a. c., rate, ills., 1,068.
of current frequency, 1,568.
- Changeable pole method**, railway motor,
2,583, 2,586.
- Charcoal**, conductivity of, 69.
Davy's experiment with, 2,411,
forsoldering and brazing, ills., 3,101. .
- Charge**, and discharge key to test condenser
capacity, ills., 477.
battery, indications of, 921.
detected by gold leaf electroscope, 11.
distribution of, 7.
on various conductors, ills., 9.
effect of on temp. of conductors, 72
experiment deter. nature of, 12.
first, battery, voltage during, 918.
how affected by neighboring charge of
opposite kind, 9.
how induced, 125.
indications of storage bat., 921, 926,
induced by lightning, 892.
nature of, ills., 15.
machines for producing, 23.
maximum, of condenser, 1,047.
negative, on Wimshurst machine, 26,
of battery, scales formed, 923,
of box covered with tin foil, 13,
of resinous substance, 17.
of storage battery, duration, 915.
on electrified surface, 7.
positive, on Wimshurst machine, 26,
resides on surface, ills., 7, 8.
static, causes, 1,677.
disposed of, 39.
unlimited number of, ills., 16, 17,
voltage of accumulator, 924.

- Charged, automobile battery, 930, 931.**
 battery acid, density of, 908.
 coil, effect of on needle, ills., 432.
 conductor, discharging of, 20, ills., 21.
 loop, effect of on needle, ills., 432.
 resinous substance, ills., 17.
 wire(s), corona effect, 1,894.
 dir. magnetic field, ills., 114.
 near compass needle, ills., 431.
 spacing, 1,896.
- Charging, accumulator, induction motor for,**
 ills., 915.
 through lamp bank, and rheostat,
 ills., 922.
 with motor dynamo, ills., 914.
- battery, automobile, 2,851.**
 during night, 929,
 in parallel groups, ills., 979.
 precaution in, 921.
- board for battery, Witham, ills., 966.**
- Champion battery, ills., 949.**
- connections for Exide duplex sparking
 battery, ills., 924.**
- current, of accumulator varied, 921.**
 of batteries kept constant, 925.
- electric machine, damp weather, 25.**
- gas engine storage bat., ills., 919.**
- Leyden jar, 23.**
- new battery, period of, 932.**
- operation for arrester, 1,703.**
- outfit for boat batteries, ills., 950.**
- plug, automobile, 2,851.**
 for "Champion" battery, 949.
- rate(s), automobile, 2,841, 2,842.**
 of battery high, 933.
- receptacle, ills., 2,839.**
- secondary battery, how often, 919.**
- set(s), mercury arc, G. E., ills., 1,522.**
- small bat. from lighting cir., 931.**
- storage batteries, 914.**
 connections for, 912, 913.
 small, 931.
 switchboard for, ills., 914.
 with rectifier, 1,526.
- Charles' law air compression, ills., 3,023,**
 3,024.
- Chaser, electric light flasher, ills., 876.**
 wiring for two snake, ills., 877.
- Chassis, attaching springs, Woods, 2,830.**
 Baker electric, plan, ills., 2,818.
 side view, ills., 2,820.
- parts of, ills., 2,818, 2,820.**
- Chemical(s), action, law of in cell, 45.**
 and dyes, 3,139.
 changes, simple cell, 37.
 effect of current, 97.
 in storage battery, 899.
 methods in depolarizing, 41.
 rectifier, ills., 1,498.
- Chicago time relay, ills., 2,610, 2,641.**
- Chimney(s), and mec draft comp., ills.,**
 1,960.
 metallic flame arc lamp, ills., 2,465.
 of electrical station, 1,957.
 temperatures in, table, 1,955.
- Chlorates, by electrolysis, 3,136.**
- Chloride, cells of storage battery, ills., 925.**
 of gold, electro-plating, 3,169.
 of zinc, soldering flux, 3,082.
 silver, testing battery, ills., 503.
- Chlorine, in battery electrolyte, 909.**
- Choke coil, air cooled, Westinghouse, ills.,**
 1,712, 1,713.
 and condenser, ills., 1,714.
 G. E., ills., 1,036. 1,710.
 high pressure, Westinghouse, ills., 1,711.
- ills., 1,061.
 in circuit, ills., 1,034.
 in lighting circuit, ills., 1,063,
 line suspension, ills., 1,709,
 mounted, 2,025.
 object of, 1,710.
 oil cooled, 1,712.
 resonance with avoided, 1,710.
- Chopper, wireless tel., 2,284.**
- Chord winding, des., 247.**
 of armature, ills., 246.
- Christie bridge, 2,413.**
- Chromatic aberration, 2,698.**
- Chromic acid cell, ills., 48, 49.**
- Churcher valve, ills., 1,503.**
- Churchill's railway signal, ills., 2,632.**
- Cinematograph camera for oscillograph, ills.,**
 1,866.
- Circuit(s), alternating current, ills., 1,098.**
 impedance, 1,897.
 self-induction in, 1,028.
- alternator field, rheostat in, 2,019.**
- image current, ills., 1,184.**
- analogy bet. mag. and elec., 121.**
- annunciator, for one elev., ills., 2,395,**
 for two elev., ills., 2,391-2,395.
 with b'rg. alarm sw., ills., 2,408.
- arc lamp, 2,445.**
 constant, current, 757.
 voltage, 757.
- armature, break in, 633, 650.**
 breaks in repaired, 634.
- automobile, ills., 2,847-2,850.**
 four unit, one motor, 2,848.
- battery, result of opening and closing in
 mutual induction, 139.**
- starting and lighting system,**
 2,804.
- bell, apartment house, ills., 2,394, 2,396.**
- crossed wires, ills., 2,396, 2,397.**
 current reversal in, ills., 2,369.
- faults in, ills., 2,396-2,398.**
 increased resistance, 2,396.
 magnet arrangement, ills., 2,369,
 2,370.
- metallic, ills., 2,384.**
 series connection, ills., 2,386.
 two way switch, ills., 2,369, 2,370.
- with ground return, ills., 2,384.**
- break down switch, 3 wire, ills., 752.**
 forms of, 1,592.

Circuit(s),—Continued.

- break down switch, 752.
- break in primary, effect of, 146.
- broken, behavior of current, 1,589.
- calculations for three wire, 761.
- cause of spark in breaking of, 138.
- center of distribution of, 736.
- closing auxiliary switch, General Electric, ills., 1,635.
- closing relay(s), ills., 1,646, 1,661.
 - operation, ills., 1,641.
- constant, pressure series feed, 2,430.
 - voltage, shunt dynamo, ills., 189, 190.
- containing, induct. and cap., 1,091.
 - resistance and capacity, ills., 1,084.
 - resistance, inductance and capacity, 1,092, 1,093.
- control apparatus and battery connections, 972-974.
- current, induced around, 132.
 - how induced in, 130.
- determining current in, 29.
- divided, hydraulic analogy, ills., 78, 79, 80.
- drop of voltage in, ills., 33, 34.
- external, current guided in, 165, 174.
 - path of current in, 165.
- fall of potential in, 33.
- field, breaks in cause sparking, 651.
 - broken, 615.
 - magnet, of dynamo, 573.
- forms of alternating current, 1,537.
- frequencies, alternating, 1,991.
- grounded, 2,734.
 - def., 30.
 - neutral, 1,704, 1,705.
- irregular, center of dist., ills., 737.
- light and power, wiring table, 750.
- lighting, choke coil in, ills., 1,063.
 - wasted electricity in, 570.
- line drop compensator, ills., 1,751.
- magnetic, described, 111.
 - magnetic lines of force, altering, 126.
 - of meter, 1,813.
 - resistance in, on what depends, 122.
- maintainer, ills., 2,354.
 - electrical for bell, ills., 2,353.
 - electro-mechanical ills., 2,355.
 - mechanical, for bell, ills., 2,352.
- master controller, 2,661.
- metallic, 2,734.
 - definition of, 30.
 - of magneto switchboard, ills., 2,129.
- motor control, faults in, 2,664.
- moved without altering lines of force, ills., 128.
- moving, action of current induced by, 127.
- mutual induction between, 138.
- non-grounded neutral, 1,704, 1,705.

Circuit(s),—Continued.

- non-inductive coil in, ills., 1,034.
 - number of armature, 253.
 - one wire series, ills., 698.
 - open, alternating current, 1,040.
 - location of, 522.
 - telegraph system, ills., 2,207.
 - opening, aux. switch G.E., ills., 1,635.
 - relay, ills., 1,644, 1,645.
 - parallel, a. c., ills., 1,540.
 - arc lamp, 757.
 - drop in voltage of, 700.
 - ills., 79.
 - series a. c., ills., 1,541.
 - potential difference in, ills., 33.
 - power, tested with Leeds and Northrup bridge, ills., 534.
 - preserving continuity of, 2,410.
 - pressure, by voltmeter, ills., 544.
 - primary, broken in vibrator, ills., 150.
 - in mutual induction, 139.
 - ills., 138.
 - mechanical vibrator in, 146.
 - suddenly breaking, 144.
 - railway signal, 2,639.
 - resonant, ills., 1,062.
 - retarding coil in, 1,034.
 - semi-closed, cell suited to, 49.
 - series arc lamp, ills., 698, 757.
 - series, horn gap arresters, ills., 1,693.
 - short, cause of, 2,398.
 - how caused, 30.
 - indication of in field coils, 662.
 - shunt, in dynamo, ills., 183.
 - resistance of, 190.
 - single phase, with 3 phase alter., 1,550.
 - single, self-induction in, 138.
 - standard bell box, ills., 2,123.
 - sub-feeder distribution, ills., 756.
 - telephone, Edison cell for, ills., 50.
 - Fuller cell for, 49.
 - testing device, ignition, ills., 2,788.
 - 3 phase, inductance per mile, 1,889.
 - three way lighting, with switches, ills., 847.
 - three wire, panel board, ills., 762.
 - trip, auxiliary, 1,634.
 - twin aeromotor towers, ills., 1,579.
 - two bells one push, ills., 2,386.
 - two phase, protection, 1,662.
 - used for shunt bell, 2,349.
 - with capacity, a. c., ills., 1,039.
 - with inductance, a. c., ills., 1,038.
 - with primary coil, closing of, 138.
- Circuit breaker(s), and switches, choice between, 415.**
- automatic, operation, 1,625.
 - overload, ills., 418.
 - automatically controlled, ills., 1,632.
 - carbon discs, Condit, ills., 1,624.
 - Condit, ills., 1,648-1,650.
 - construction of, 415.
 - control, electro-magnetic, ills., 1,630.
 - discriminating, Apico, 2,808.
 - elevator, defective, effect, 2,931.

Circuit breaker(s),—Continued.

- fitted with current dampers, 420.
- for storage battery, ills., 1,673.
- General Electric, ills., 1,629, 1,636.
- how to set, 2,659.
- instantaneous, 1,612.
- intermediate contacts, 1,624.
- I-T-E, connections, ills., 1,664, 1,665.
- magnetic blow out, ills., 1,622.
- General Electric, ills., 1,621.
- Westinghouse, ills., 1,620.
- main contacts, 1,624.
- on panel, ills., 1,880.
- operation, ills., 1,626.
- overload, 1,627.
- General Electric, ills., 1,640.
- ills., 1,627.
- parts, General Electric, 1,629.
- plain overload, ills., 419.
- pneumatic, Condit, ills., 1,663.
- position of, current coil, ills., 1,633.
- pressure coil, ills., 1,633.
- relay, elevator motor, 2,884.
- reverse current, ills., 417-420.
- Roller-Smith overload, ills., 430.
- solenoid, ills., 417-420.
- thermal overload, ills., 1,623.
- time limit attachments, 420.
- trip attachments, G. E., ills., 1,634.
- trip, no voltage, underload, 1,633.
- two way, on transmitter, ills., 2,229.
- underload and overload, ills., 419.
- use of, in circuit, 195.
- with generators, ills., 1,674.
- with overload coils, ills., 1,628.
- with pull down handles, ills., 1,628.

Circuit diagram(s), driving, automobile, ills., 2,846.

- heater, ills., 3,052-3,055.
- ignition systems, 2,777-2,780.
- of branch, ills., 743.
- of feeder, ills., 743.
- of main, ills., 743.
- of magneto and dynamo, 183.
- of sub-feeder, ills., 743.
- of tap, ills., 743.
- thawing, water pipes, ills., 3,065.

Circular, loop, lines of force in, ills., 114.

- mils, formula for finding, 748.
- of wire, ills., 732.

Clamp(s), belt, holding ends, 398.

- belt, home made, ills., 2,004.
- commutator, ills., 639.
- insulated, segments held by, 299.
- metal, for brush filing, ills., 638.
- of battery paraffin, treated, 952.
- wire, come along, 817.
- wire twisting, McIntire's, ills., 819.

Clapper, bell, disc type, ills., 2,372.

- vibration of, ills., 2,369.

Clark, cell, volt standard, ills., 466.

- electrical machine, 2,413.

Clark's antihum, ills., 822.

- thermit rail joint, ills., 3,119.

Classes of, alternator, 1,126,

- dynamo, 181-198.

Classes of,—Continued.

- galvanometer, 437.
- inductor alternator, 1,153.
- magneto, 2,735.

Classification(of), alternator armature wind-

- ings, 1,210.
- armature brushes, 303.
- centrifugal pumps, 3,002.
- electric pumps, 2,990-2,992.
- microphone transmitters, 2,124.
- motors, 368.
- primary cells, 35.
- pump water ends, 2,993, 2,994.
- telegraph systems, 2,202.
- transformers, 1,385.

Clay, pipe conduit, vitrified, ills., 827.

- vitrified, trough conduit, ills., 829.

Cleaning, and smoothing the commutator,

- 647.
- batteries, 62.
- dynamos and motors, 595.
- machine brushes, 595.
- rough meter commutator, 568.

Clearance, in sprocket design, 2,829.

- loss in air compressor, 3,038.

Cleat(s), and knobs, porcelain, ills., 772.

- fibre, for securing wires, 2,409.
- standard 2 wire porcelain, ills., 72.

Cleft or split weld, ills., 3,110.

- Climax, resistance wire, 3,049.

Climbers, pole, eastern, ills., 813.

- Clock, brush holder, 318.
- monogram flasher, ills., 882.

Closed, circuit, cells, one fluid, 35.

- Partz acid gravity, ills., 57.
- polarization prev., 43.
- two fluid, 35.
- of field and arm. coils, 675.
- primary cells, use of, 35.
- telegraph system, 2,206.
- with Edison cell, 50.

action of, 1,349,

- coil rotating in alternating field,

Clutch(es), Adams-Bagnall, arc lamp, ills.,

- 2,432.
- carbon, 2,432.
- Ft. Wayne arc lamp, ills., 2,455.
- carbon feed, ball, ills., 2,434.
- rod, ills., 2,435.
- mechanism, Hill, Smith type, ills., 2,015.
- motion picture friction disc, ills., 2,714.
- of clutch type motor, ills., 1,348.
- operation in arc lamp, 2,433.
- pulley, friction, for power control, ills., 2,013.
- Hill mechanism, ills., 2,014.

Clutch type induc. motor, ills., 1,342.

- clutch of, ills., 1,348.
- starting of, 1,348.

Coal, anthracite, difficulty with, 3,112.

- for welding, most desirable, 3,112.
- supply for central station, ills., 1,925.

Coal—Continued.

transporter, 2,945.

grab load, 2,946.

Code(s), color, telephone cable, 2,160.

rules, wireless telegraph, 2,271.

secret wireless, 2,272.

telegraph, 2,246.

explained, 2,245.

how to learn, 2,246, 2,271-2,273.

wireless telegraph, 2,270a, 2,270b.

standard, 2,271.

Coefficient, Kapp, for a. c., 1,220.

M value, 1,904.

S value, 1,910, 1,911.

T value, 1,905.

Coffee percolator, Simplex, ills., 3,048.**Coherer**, Branley tube ills., 2,270.

mercury, Lodge Muirhead wireless, ills.,

2,289.

Coil(s), adj., short circuits bet., ills., 627.

armature, breaks in, 643, 659.

burned, 631, 657.

construction of, ills., 1,225.

evolute, described, 343.

faulty, locating, 624.

grounded, locating, ills., 632.

lap winding of, 233.

lap wound, ills., 1,222.

moisture in, 659.

open, repaired, 617.

retaining devices, 346-347.

rotary converter, Westinghouse,

ills., 1,465.

short circuits test for, ills., 624,

temperature of, 590.

testing for breaks in, ills., 630.

uneven number of, 240.

variable voltage in, 257.

wave winding of, 233.

armature winding, creeping, 1,260.

fed-in, 1,258.

imbricated, 1,259.

shuttle, 1,260.

skew, ills., 1,258.

spiral, ills., 1,259.

mummified, 1,259.

auxiliary, of motor, 1,345.

bad, operation of dynamo with, 617.

balancing, action of, 716.

connected to dyn., ills., 716.

for 3 wire system, ills., 714.

impedance of, 717.

system, operation of, 717.

ballast, Rushmore, ills., 2,814.

bell, reducing resistance, ills., 2,377.

Bosch, ignition, ills., 2,770.

bridge, table, 502.

bucking, Rushmore dynamo, 2,812.

car heater; ills., 2,612, 2,613.

choke, air cooled, West., ills., 1,712,

and condenser, ills., 1,714.

G. E., ills., 1,036. 1,710.

high pres., West., ills., 1,711,

in lighting circuit, ills., 1,063.

mounted, 2,025.

Coil(s), Choke—Continued.

object of, 1,710.

oil cooled, 1,712.

resonance avoided, 1,710.

Westinghouse, ills., 1,712-1,713.

closed, in a. c. field, action of, 1,349.

compensating, with differential booster,

ills., 992.

concentrated, alternator, ills., 1,218,

connected for demons., 143.

continuous, in armature, 176.

core and edge strip, ills., 216.

current, consumption, 2,786.

in two turn, 173.

limiting, location of, 1,620.

of circuit breaker, ills., 1,633.

strength in, 120.

D'Arsonval galv., how affected, 459.

damaged armature, cut out, 631.

damping, and damping discs for galva-

nometers, 457.

dash, wiring diagrams of, ills., 153.

differential galv., adjustment of, 453.

dimensions, induction, table of, 152.

distributed, ills., 1,220, 1,221,

spreading of, 1,220.

effect of breadth of, ills., 1,224.

rotating, 128.

ends, how brought out, ills., 215-217,

treatment of, ills., 1,240, 1,241.

evolute, how placed on core, 344.

method of winding, ills., 343.

peculiarity of, 343.

placed like straight out, 346.

field, and arm., in closed cir., 675.

reversed, 585, 587.

short circuits in, 662.

large, heat dissipated in, 220.

magnet, coupling of, 396.

moisture detected in, 661.

of dynamos connected in parallel,

600, 601.

of railway motor, ills., 2,564.

test, with pocket compass, 587.

with telephone, ills., 620.

Watson, ills., 631.

floating, on regulators, 1,735, 1,736.

form wound assembled, ills., 1,212.

former, advantage of, 342.

construction of, 215.

des., 342.

straight out winding 344.

wound interchangeable, 340.

galvanometer, ills., 444-453.

Gramme's ring armature, ills., 176.

guard of armature, ills., 337.

half, arm. winding, ills., 1,214-1,215.

concentrated wind., ills., 1,216.

heating unit, ills., 3,050, 3,051.

high resistance, for voltmeter, 542.

ignition, 2,790.

connections of, ills., 153.

points relating to, 152.

impedance for Ft. Wayne arc lamp,

2,454, ills., 2,454.

Coil(s)—Continued.

inclined, meter, ills., 1,783.
 instrument, 547.
 inductance, limits a. c., 1,619.
 induction, 137-154. 2,735.
 classified, 137.
 for wireless, ills., 2,314.
 in wireless telegraphy, 137.
 in X ray work, 137.
 Rhumkorff, ills., 145.
 rule for voltage relation, 141.
 short circuited, 2,171.
 telephone, 2,117, ills., 2,121.
 voltage in, 140.
 voltage regulator, ills., 1,716.
 windings, 2,124.
 with air core, ills., 1,032.
 with iron core, ills., 1,032.
 iron wire core of, 1,035.
 junction of, pressure at, 177.
 jump spark, motor cycle, ills., 142.
 kinds of, for galvanometers, 435.
 Knoblock, ignition, 2,786.
 laminated iron core in, ills., 1,061.
 line suspension choke, ills., 1,709.
 magnetic blowout, controller, 694.
 magnetizing, object of, 214.
 power of, 120.
 medical, and attachments, ills., 144.
 induction, ills., 3,187, 3,188.
 spark, 3,189.
 meter, currents in displaced, 1,809.
 movable, on sine galvanometer, 449.
 moving in magnetic field, 131.
 oscillograph, 1,857.
 Duddell, ills., 1,858.
 G. E., ills., 1,852, 1,853.
 Siemens-Blondel, 1,856.
 type meter, ills., 539.
 multi-unit, adjustment, 154.
 non-inductive, ills., 1,032, 1,034.
 non-vibrator, six-terminal, ills., 153.
 number of turns in, 120.
 of two turns, in series, ills., 173.
 in parallel, ills., 173.
 open, bar to bar test, 626.
 overload, with cir. br'k'r, ills., 1,628.
 pancake transformer, ills., 1,381.
 partial break in detected, 651.
 path of, armature, ills., 237.
 per phase per pole, 1,019.
 phase, transformer damaged, 1,395.
 plain, ignition with, 2,777.
 secondary, description of, 143.
 pressure, depends on number, 175.
 of circuit breaker, ills., 1,633.
 primary, description of, 140.
 induction, efficiency, 140.
 ignition, 2,768.
 when used, 138.
 of telephone, open, 2,171.
 reversed, 2,172.
 superposed, ills., 1,380.
 production of spark in, 141.
 ratio of Christie bridge, ills., 492.
 reactance, in sub-stations, 1,984.

Coil(s), reactance.—Continued.

limits a. c., 1,619.
 of rectifier, effect, ills., 1,521.
 of signal relay, 2,640.
 release, low voltage, G. E., ills., 1,638..
 repeating, Pupin, 2,169.
 repulsion, trans., ills., 1,505-1,506.
 resistance, switchboard open, 2,176.
 elimination of, 2,848.
 with Varley loop, 517.
 retardation, telegraph, 2,233.
 retarding, in circuit, 1,034.
 ringer, at switchboard open, 2,174.
 sec. and pri., induction, ills., 141.
 induction, classified, 142.
 description of, 140.
 ignition, 2,773.
 of telephone, open, 2,170.
 reversed, 2,171.
 Rhumkorff, 145.
 vibrator, ignition, 2,772.
 self-induction in, 279.
 cause of sparking, 291, 91.
 three wire dynamo, ills., 708.
 series, armature, ills., 245.
 connected armature, ills., 244.
 short circuits, between, through binding
 wires, 629.
 located through armature core,
 ills., 629.
 single, break, ignition, 2,784.
 windings, 1,230.
 size of, for motorcycle, 143.
 smaller than pole pieces, 208.
 spark, battery connection, ills., 153.
 for wireless, ills., 2,314.
 points relating to, 152.
 Splitdorf master vibrator, ills., 150.
 spool wound, construction, ills., 215.
 spurious resistance in, 279-281.
 standard of volts, 154.
 steadiness of current, 180.
 straightout, ills., 345.
 how to wind, ills., 345, 346.
 placed like evolute coils, 346.
 suited for barrel windings, 345.
 taping machine, ills., 346, 347.
 teaser, monocyclic alternator, 1,554,
 to equalize load, ills., 716.
 transformer, Wag., ills., 1,381, 1,382,
 turns of wire in, 1,035.
 two slot, for alter. wind., ills., 1,226,
 unit, in master vibrator, ills., 149,
 vibrating, adjustment, 2,786.
 vibrator, condenser, use of, 146.
 double, ills., 153.
 four terminal, ills., 153.
 ignition with, ills., 2,778.
 quadruple, ills., 153.
 three terminal, ills., 153.
 triple, ills., 153.
 W. E. former wound, ills. 219.
 blow out, ills., 2,585.
 whole, arm. wind., ills., 1,214, 1,215,
 concentrated winding, ills., 1,216.

Coil(s), whole—Continued.

- windings, two ph., ills., 1,236
- winding(s), alter., dist., 1,218
- bedding of, ills., 218.
- multi-slot, 1,230.
- practical armature, 241.
- single phase, ills., 1,222.
- strap arrangement, ills., 1,231.
- with laminated core, ills., 1,217.
- X-ray, portable, S.-W., ills., 3,235.
- radio., S.-W., ills., 3,231.
- 3rd term. on, ills., 3,232.
- rotary converter, ills., 3,197.
- triple valve tube for, 3,234.

Coin, machine, circuit, ills., 2,154.

returned by central, 2,154.

Coke, as conductor of electricity, 69.

for welding, most desirable, 3,112.

ground, used in dry cell, 59.

Cole, automobile circuit diagram, 2,801.**Collars, thrust, 688.****Collector(s), gear, crane, 2,951.**

on Winthurst mach., ills., 26.

rings, and com., dyn. with, ills., 714.

and delta connected armature, ills., 1,254.

and Y con. arm., ills., 1,255.

of West. dyn. arm., ills., 198.

Collins' wireless experiments, 2,329.**Color, code, telephone cable, 2,160.**

reflection coef. slighting, 2,525, 2,527.

Colored lights, railway signals, 2,635.

Colophony or resin soldering flux, 3,082.**Columbia, bath cabinet, ills., 3,215.**

high frequency outfit, ills., 3,211.

signal cell, ills., 2,745.

wattmeter construction, ills., 570.

Column cranes, 2,936.**Combs, metallic, 24.****Come along, wire clamp, 817.**

stretcher, ills., 815.

Common, battery, telephone, wiring, plan 3,

ills., 2,142.

plan 5, ills., 2,143.

plan 8, ills., 2,143.

plan 10, ills., 2,144.

switchboards, 2,136.

system, 2,117.

telephone system, 2,135.

Commutation, and field distortion, 789,

and the commutator, 283-302.

current in motor, ills., 288, 365.

period of, 283.

progressively shown, ills., 292, 293,

sparkless, plane for, 267.

theory, brush contact ills., 296.

Commutating, plane, 266, 284, 287,

of motor, ills., 365.

of sparkless commutation, 267.

pole, rotary converter, Westinghouse,

ills., 1,470, 1,471.

Commutator, action of, 171.

and brushes, care of, 635-652,

and collector rings, ills., 714.

and commutation, 283-302,

armature and brushes, heating, 655.

Commutator,—Continued.

Bissell, ills., 646.

turned on lathe, 645.

bad condition of, 639.

bars of armature, ills., 224.

repairing, burned hole, ills., 647.

black film on heating, 657,

bridge, plugs in, 502.

brushes, bearing on, 574.

filng and adjusting of, 576.

raised from, 582.

setting of, ills., 575.

clamp, ills., 639.

cleaning and smoothing, 647.

connection, of inductors, ills., 172.

spark coil, 153.

construction of, 171.

ills., 297-298.

def., 162.

dynamo, ventilated, ills., 655.

electro-plating dynamo, 3,148,

end yoke, ills., 688,

flat, caused by, defect in belt, 643,

break in armature coil, 643.

jumping of brushes, 643.

for closed coil armatures, 301.

for letter flasher, 884.

for open coil armatures, 307.

forced on shaft by press, ills., 664.

four part, method of measuring waves, ills., 1,845.

grooves cut in ridges, cause of, 636,

in bad condition, ills., 641, 642.

inspection of, 574.

insulated with asbestos, 652.

insulation, 302.

lubricated with mineral oil, 646.

meter, 1,804,

mineral oil for, 636.

motor, ills., 1,349.

repulsion induction, Wagner, ills.,

1,352.

armatures of, ills., 1,353.

section of ring armature of, ills.,

1,358.

simple shunt, ills., 1,363.

single phase series, diag., 1,360.

moving, friction of brushes, 2,113.

of dynamo, 160.

of meter, rough, cleaning of, 568.

part of armature, 221.

pitch of machine, 235.

plug testing arrangement, ills., 505.

Pohl, ills., 477.

pressure of brushes on, 577.

rough, feeling with finger nail, 636.

sandpaper, block for, ills., 651.

holder for, ills., 650.

segments, deep, 301.

low, treatment of, 645.

metallic dust between, 652.

successive, variation of voltage be-

tween, 262.

- Commutator**,—*Continued.*
 short circuit in, 153. 652.
 smoothed with white sandstone, ills., 648.
 speed limit, rotary converter, 2,065.
 truing device, Ft. Wayne, ills., 618.
 uneven, railway motor, 2,658,
 untrue, detected, 642.
 variation of voltage around, 261.
 voltage, measured with pilot brush and
 voltmeter, ills., 261.
 Morday's method of measuring,
 261.
 Wagner dynamo, ills., 2,804.
 Watson, various sizes of, ills., 691.
 Western Electric, ills., 299.
 where placed, 172.
- Compass**, deflection, Amper's rule, 431.
 needle at rest, 431.
 charged wire near, ills., 431.
 current in, coil near, ills., 433.
 loop near, ills., 432.
 wire near, ills., 431.
 pocket, field coil test, 587.
 simple, construction of, ills., 105.
- Compensated**, repulsion motor, single phase,
 ills., 1,354.
 Sprague, ills., 1,368.
 starting of, 1,371.
 with series transformer, 1,372.
 shunt induction motor, Fynn's, ills.,
 1,367.
 ills., 1,363.
 single phase repulsion motor, General
 Electric, ills., 1,366.
- Compensating**, battery resistance, 2,243.
 coil differential, booster, ills., 992.
 starter, 3 ph. induc. motor, ills., 1,334.
- Compensation shunt**, adj., G.E., ills., 1,724.
- Compensator(s)**, circuit, ills., 1,751.
 elevator, chains, ills., 2,926.
 friction, of meter, 1,818.
 line drop, 1,751.
 General Electric, ills., 1,752.
 Westinghouse, ills., 1,753.
 with automatic voltage regulator,
 ills., 1,754.
 or reactance coil at dynamo, 197.
 starting, 1,755.
 circuits, G. E., ills., 1,755-1,757,
 1,759.
 three phase, ills., 1,758.
 synchronous, ills., 1,281.
 three phase starting, G.E., ills., 1,762.
 three wire system, ills., 709, 710.
 winding taps, 1,758.
- Complex**, curves resolved into sine curves,
 ills., 1,017.
 phantom circuits, ills., 2,169.
- Component**, active, current, 1,114-1,116.
 forces, ills., 1,074.
 pressures, resultant of, ills., 1,536.
 wattless, dif. power factors, 1,776.
- Compositely excited alternator**, ills., 1,191-
 1,193.
- Composition of forces**, 1,072.
- Compound(s)**, air compression, 3,031.
 compression vs. simple, 3,037.
 with intercooling, 3,033.
 alternators syn., ills., 2,046.
 and shunt dynamos in parallel, 610.
 booster, connections, ills., 988.
 dynamo(s), ills., 191, 193.
 characteristics of, 191.
 correcting reversed polarity in,
 ills., 588.
 curves, ills., 2,112.
 exter. char. test, ills., 2,092.
 field magnet winding, ills., 191.
 for country plants, 195.
 how excited, 193.
 in parallel, ills., 607, 608.
 in series, ills., 605, 606.
 load equalized, 609.
 two, in parallel, ills., 583.
 fireproof, on wire, ills., 727
 impregnating, use of, 73.
 machine, starting of, 583.
 motor, characteristics of, 375.
 merits of, 374.
 rheostat, ills., 609.
 speed regulators, 690.
 speed of varied, 681.
 starter, ills., 609.
 with no voltage release, ills.,
 424, 425.
 with constant speed, 680.
 rubber, insulation, 725.
 series and shunt dynamos, uses, 392.
 speed regulator, C-H, ills., 685.
 starter, Cutler-Hammer, ills., 684,
 winding, alternative, 196.
 wound, dynamos, polarity of reversed
 while stopping, 649.
 field coil, Ft. Wayne, ills., 220.
- Compressed air**, characteristic curves, 3,026,
 3,036.
 field for use, 3,023.
- Compression**, air, compound, 3,031.
 altitude, 3,045.
 curves, 3,036.
 laws, ills., 3,023, 3,024,
 simple, 3,029.
 spring of motor adjuster, ills., 688.
 type resistance units, ills., 672.
- Compressor(s)**, air, 3,023.
 dry or jacketed, feature, 3,031.
- Concave**, lens(es), double, virtual focus in,
 ills., 2,689
 double, principal focus, 2,690,
 foci in, ills., 2,688, 2,689.
 mirror, 2,677, 2,679,
 properties of, 2,686.
 spherical, ills., 2,680.
- Concealed**, and exposed motor wiring, 405.
 knob and tube wiring, ills., 780.
 wires between floor beams, 781.
 fixture outlets from, ills., 781.
 wiring, surface switch, 783.
 wiring, switch, ills., 783.
 switch and wire receptacle outlet
 from, ills., 782.

- Concealed, wiring**.—*Continued*.
switch boxes for, ills., 784.
- Concentrated, armature coil** 1,214.
coil, arm., sin. ph., West., ills., 1,217, .
for alternator, ills., 1,218.
half coil winding, ills., 1,216.
whole coil winding, ills., 1,216.
winding of alternator, wave form with,
1,217.
- Concentric diffusers for arc lamps**, 2,518.
- Concrete, building, reinforced, conduit wiring in**, 792.
sheet iron tubes in, 792.
direct conduits, 830, 831.
duct conduits, ills., 830.
foundation for anchor bolts, ills., 1,952.
holes reinforced, 804.
settings for poles, 802.
walls, exposed wiring on, 792.
- Condenser(s), 22**.
action of, 1,085.
pneumatic analogy, ills., 2,364,
prevents sparking, ills., 2,363.
affects phase difference, 1,086,
and choke coil, ills., 1,714.
and engine, ills., 1,942.
arc, and objective relative positions of,
2,701.
capacity, in a. c., circuit, 1,041.
method of testing, ills., 477.
coil vibrator, use of, 146.
description of, 146.
discharge of, 23.
curves, ills., 1,864.
for voltage regulator, ills., 1,746.
for induction coil(s), ills., 147.
usual form of, ills., 147, 148.
ills., 146.
in a. c., circuit, ills., 1,046.
in direct current circuit, 1,046.
in parallel, ills., 1,044.
in series, ills., 1,045.
Leyden jar, ills., 22.
loss of power in, 1,118.
maximum charge of, 1,047.
of trunk line open, 2,176.
one microfarad capacity, ills., 1,043.
plates, material between 1,043.
pressure ahead of current, 1,085.
formula, 1,048.
rotary, ills., 1,281.
short circuited, trunk line, 2,177.
short wireless wave, ills., 2,306.
standard capacity tests with, 1,044.
synchronous, 1,763-1,776.
at Kennett, Cal., 1,768.
calculations, 1,771, 1,774, 1,775.
cost, 1,770.
field amortisseur winding, General
Electric, ills., 2,041.
field, ills., 1,767.
General Electric, ills., 1,765.
location, 1,773.
motor used as, ills., 1,281.
- Condenser(s), synchronous**.—*Continued*.
speed power factor curves, 1,772,
telegraph, Bunnell, ills., 2,233.
object of, 2,231.
telephone, ills., 2,117, 2,121.
open, 2,170.
testing apparatus, 1,045,
variable, for wireless, 2,326.
- Condit, circuit breaker carbon discs, ills.**,
1,624.
pneumatic cir. breaker, ills., 1,663.
relay, curves of, ills., 1,654.
circuits, ills., 1,653.
selective relay, ills., 1,655.
time limit relay attach., ills., 1,656,
ills., 1,671.
- Conductance, joint, rule for finding**, 81.
- Conducting loop(s), relation, voltage**, 162.
loss of heat by, 3,055.
- Conducting, path, suitable**, 31.
power, effect of heat on, 71.
of moisture, 74.
- Conductivity, and resistance**, 75-82.
high, of carbon brushes, 657.
joint, 79, 81.
of alloy, 723.
of brass with zinc, 723.
of copper, 78.
plated carbons, 2,424.
with nickel, 723.
of forced carbons, 2,424.
of metals, and alloys, 723,
and liquids, 76.
of phosphor bronze, 723.
of pure, copper, 723.
lead, 723.
nickel, 723.
platinum, 723.
silver, 723.
water, 76.
zinc, 723.
of siliceous bronze, 723.
of Swedish iron, 723.
relative, definition of, 77.
silver, standard of, 75.
specific, definition of, 77.
table of metals, 78.
- Conductor(s), 2,733**.
and insulators, ills., 68-74.
table of, 69-70.
armoured, lead covered, Greenfield ~~flex-~~
ible steel, ills., 796.
charged, spacing, 1,896.
copper wire, 799.
current carrying, force exerted on, in
magnetic field, ills., 354.
difference of potential, ills., 33, 34.
double braided, 786.
elevated, in wireless tel., 2,281,
experiment showing direction of mag-
netic field, ills., 113.
fairly good, table of, 69.
gas bubbles, bad, 40
gases not good, 76,
good, table of, 69.

Conductor(s),—Continued.

- how cuts lines of force, 126,
 - in magnetic field, ills., 350,
 - lead, definition of, 30,
 - lines of force unaltered by, 128,
 - outside, materials for, 799,
 - partial, table of, 69,
 - resistance affected by kind, 30,
 - return, definition of, 30,
 - rubber covered, 725,
 - silver, standard, 75,
 - square, measurement of, ills., 733,
 - stranded wire, 724,
 - to end cell switch, ills., 978, 979,
 - underground, 825,
 - porcelain bridgework, ills., 834,
 - water as, 74,
 - weather proof, 726,
 - precaution in use of, 726,
 - wire, insulated, 724.
- Conduit(s), advantage of cast iron, 837.**
 and overhead systems, 2,552.
 and tubing, flexible, compared, 789.
 bender or hickey, ills., 795.
 bends, offsets, and elbows, 794,
 box, construction of, ills., 786.
 cable, 826-827.
 cast iron pipe, 836.
 circuit breaker, ills., 1,648-1,650.
 concrete duct, ills., 830, 831.
 fibre, pipe, ills., 837, 839.
 flexible, advantages of, 790.
 Greenfield fish pig, ills., 790.
 tools, ills., 797.
- how laid, 828.
 installed, in fireproof building, ills.,
 792.
 iron pipe laid in cement, ills., 835,
 iron, wires in, 1,886.
 large, bent, ills., 795.
 lead encased wires in, 792.
 lined, tube in, 785.
 multiple duct, 828,
 joints in, ills., 831.
 or tube, underground, 825.
 or underground trolley, 2,551.
 outlet, conduit, ills., 793.
 pipes dipped in tar, 836.
 railway, construction, ills., 2,620,
 railway system, 2,552,
 requirements of, 2,552.
 should be continuous, 791.
 single, use of, 828.
 single duct, how laid, 828,
 steel, flexible, Greenfield single and dou-
 ble strip, ills., 787.
 subject to inspection, 785.
 terminal, panel box or switch, 793.
 tube(s), interior, placing of, 792,
 system, Edison, 839.
 underground, section of, ills., 2,619,
 unlined, enameled, 785,
 use of, 787.
 vertical run, fishing, 789.
 vitrified clay pipe, ills., 827,
 trough, ills., 829.

Conduit(s),—Continued.

- wiring, flexible, 787,
 - house plan of, ills., 858.
 - in rein. concrete b'ld'g, 792.
 - practical points relating to, 791-
794.
 - rigid, 784,
 - wooden built-in, ills., 831-833.
 - wood pulp, ills., 837.
 - work, pull box for, ills., 791.
 - wrought iron pipe, 834.
- Condulet for arc lamp, ills., 793.**
Cone, of vision, ills., 2,684,
 unit, definition of, ills., 2,510.
- Connection(s), alternator, monocyclic, ills.,
1,159.**
 ammeter, series, ills., 542,
 shunt, ills., 542,
 anti-parallel feeder, 701.
 armature, discs, ills., 228,
 polyphase converter, 1,463,
 arrester, multiplex, 1,689.
 graded sh. resis., ills., 1,685.
 battery, 65-67,
 and circuit control apparatus,
 972-974.
 and dynamo, ills., 971,
 cells, 951,
 storage, 952,
 Exide duplex, ills., 924,
 charging, storage, 912, 913,
 battery, ign., ills., 920,
 of spark coil, ills., 153,
 bell coils, ills., 2,377.
 booster, compound, ills., 988,
 brushes, how affects voltage, 260,
 charging, storage bat., 912, 913.
 clevis, Brown electric hoist, 2,959.
 cir. breakers, I-T-E, ills., 1,664-1,666,
 coil(s), spark, commutator, ills., 153,
 commutator, spark coil, ills., 153,
 condensers, in parallel, ills., 1,044,
 in series, ills., 1,045.
 converter, rotary chart, ills., 2,060,
 synchronous, ills., 2,065.
 dynamo(s), 395, 598,
 and battery, ills., 971,
 balancing coils, ills., 716,
 heating of, 654.
 loose, cause sparking 649.
 in series and parallel, 597,
 test, ills., 2,109.
 two in par., ills., 583,
 wrong, 621.
 electrical machines, 405.
 electric vehicles, defective, effect, 2,853,
 2,854.
 emergency, weak ignition, ills., 920,
 equalizing, effect of, 601.
 exciter, diag., G. E., ills., 2,020.
 feeder, anti-, and parallel, 701,
 field coils, wrong, 622,
 generator panel, ills., 1,877,
 ground, 1,706-1,708.
 ignition outfit, ills., 975.
 internal, Duncan meter, ills., 571,

Connection(s),—Continued.

lamp socket and tubing, ills., 779,
lightning arrester ground, ills., 890-892.

spark coil, ills., 153.

meter, Sangamo, ills., 1,820, 1,821.

monocyclic alternator, ills., 1,159.

motor, changed, ills., 372.

controller, ills., 695.

external res. induc., ills., 1,339.

reversing, repulsion, Sprague,
1,371.

series wound, ills., 368.

shunt wound, ills., 370.

slip ring induction, ills., 1,339.

variable speed repulsion, Sprague,
ills., 1,370.

multiple, ills., 66.

multiplex arrester, 1,689.

oscillograph, Duddell, ills., 1,862-1,863.

parallel, ills., 66.

feeder, 701.

hydraulic anal., ills., 2,744.

of dynamo and bat., ills., 971.

plug with spark coil, ills., 153.

polyphase converter arm., 1,463.

pot head with cable, 844.

principles of switchboard, 1,871, ills.,
1,872.

rectifier, Edison, ills., 945.

regulator, equalizing, G. E., ills., 2,032.

pole, G. E., ills., 1,739.

voltage, G. E., ills., 1,750.

reversed between field coils and arma-
ture, 589.

reversed field from line, 588.

rheostat, diagram of, 421.

shunt field, ills., 194.

with field winding, ills., 188.

series, battery, ills., 65.

multiple, wrong wiring, ills., 67.

shunt, coils direct to bus bars, 602.

field rheostat, ills., 194.

wound motor, ills., 370.

single ph. transf., ills., 1,426-1,427.

slip ring induction motor, ills., 1,339.

solenoid switches, ills., 1,609.

star, two phase, 1,243, 1,245.

switch, remote control, ills., 1,607.

series multiple, 67.

solenoid operated, ills., 1,609.

two way, in, 67.

with spark coil, ills., 153.

voltmeter, ills., 429.

switchboard instruments, 427.

principles, 1,871.

synchroscope, G. E., ills., 1,834.

telephone, exchanges, 2,164.

night through P. B. X., 2,141, 2,179.

standard magnets, 2,183.

transformer(s), for motors, ills., 1,451-
1,453.

secondary, 1,429.

Connection(s), transformer(s),—Continued.

single phase, ills., 1,426, 1,427.

standard, ills., 1,440.

three phase, feeder panel, ills., 1,881.

mesh, 1,247.

voltmeter, 543.

ills., 33.

two scale, 2,085.

wattmeter, Duncan, ills., 571.

Sangamo, ills., 569.

dial regulator, West, ills., 1,738.

wattmeter, multiphase, Fort Wayne,
ills., 1,807.

Wheatstone bridge, ills., 489.

wire, lamp socket tubing, ills., 779.

Connector(s), armature evolute, 337.

battery, inverted T, ills., 951.

cell, Willard storage bat. ills., 904.

evolute, armature winding, 336.

butterfly winding, 337.

for lap or wave winding, 339.

high resistance armature, ills., 1,358.

involute armature winding, 336.

"National" battery cells, ills., 963.

remover of battery, ills., 939.

spiral, armature, 336.

spring snap, ills., 2,401, 2,406.

two storage battery cells, ills., 951.

Conoidal, centrifugal pump, ills., 3,002.

Consequent, field magnets, ills., 202.

pole of field magnet, ills., 201.

poles of magnet, ills., 108.

Constant(s), galvanometer, 447, 461.

load armature speed varied for, 187.

motor speed, variable torque, 381.

motor torque, at variable speed, 381.

voltmeter, 2,102.

Constant cur. alternator, 1,539, 1,540.

arc lamp circuits, 757.

arc lighting, d. c. series, 2,449.

battery charging, 924.

booster system, ills., 993.

definition of, 2,446.

distributing sys., ills., 698.

1,506.

series, arc circuits, carbons for, 2,424.

circuit, ills., 1,538.

transf., air cooled, G. E., ills., 1,424.

series arc lighting, ills., 1,423.

Constant pressure, parallel circuit, ills., 1,538.

series parallel circuit, ills., 1,538.

system, 700.

transformer, ills., 2,444.

Constipation, treatment for, 3,207, 3,219,

3,223.

Contact(s), vibrator, ills., 148, 151, 152.

adjustment of electric bell, 2,341.

arc lamp cut out, ills., 2,439.

angles of different brushes, ills., 312.

breaker, ignition, def., 2,772.

ills., 2,774, 2,775.

spring, of adjustment, 2,346.

object of, 2,342.

teleg. transmitter, ills., 2,228.

Contact(s)—Continued.

- brush(es), Wimshurst machine, *ills.*; 26.
 intermediate, circuit breaker, 1,624.
 key, double, *ills.*, 472, 473.
 limit switch for, crane, *ills.*, 2,953.
 main, of circuit breaker, 1,624.
 maker, A. K., ignition, *ills.*, 2,784,
 ignition, *def.*, 2,772.
ills., 2,773.
 of differential bell, *ills.*, 2,357,
 2,358.
 mercury, flasher, *ills.*, 883.
 metals, series, Pfaff, 44.
 of bell, dirty and loose, 2,396,
 differential, *ills.*, 2,357, 2,358.
 of brush(es) oily, 612.
 with armature segments, 289.
 of buzzer relay open, 2,174.
 of cord relay crossed, 2,175.
 of machine defective, 612.
 of master control, 2,664.
 of metals, effect, 43.
 of ringing keys, crossed, 2,175,
 open, 2,178.
 of station jack open, 2,178.
 of telephone switchboard listening key
 open, 2,177.
 of wires, how to secure good, 62.
 open at tel. hook, 2,171.
 burned, cause of, 153.
 ignition, 2,764.
- Contact point(s), proper, of brushes, 577.
 Contactor, automobile wir. diag., 2,839.
 equipment, G. E., railway, *ills.*, 2,575..
 West., *ills.*, 2,579, 2,580.
- Continental Morse code, 2,270a.
- Control, arm. and shunt field comb., 690.
 automobile starting and lighting, 2,811.
 battery, storage, 975-979.
 combined a. c. and d. c., railway, 2,587.
 crane, regenerative, 2,951,
 electro-magnetic, of cir. bkr., *ills.*, 1,630.
 elevator, 2,870.
 kinds of, 2,855.
 slow down, 2,887.
 speed, 2,884.
 field, railway motor, 2,570.
 induction regulator method, 2,577,
 lever(s), automobile, Broc, *ills.*, 2,852,
 gas-electric motor car, 2,598.
 motor(s), series parallel, *ills.*, 2,572,
 2,573, 2,574.
 shunt from, distance, 677.
 pressure, of tank pump, *ills.*, 3,022.
 railway, a. c., 2,576.
 automatic, 2,568.
 compensator, vs. rheostatic meth-
 ods, 2,577.
 hand, 2,568.
 Jones system, 2,577.
 master or multi unit, 2,569.

Control, railway,—Continued.

- systems of, 2,567.
 three phase induction, 2,581.
 Westinghouse master, *ills.*, 2,588.
- remote, hand operated oil switch, West-
 inghouse, *ills.*, 1,610.
 oil switches, *ills.*, 1,605-1,607.
 remote, switch connections, *ills.*,
 1,607.
 resistor, Westinghouse, *ills.*, 2,589.
 rheostatic, motor used for, 2,582,
 railway motor, 2,569.
 rotary converter with multi-tap trans-
 former, 1,481.
 solenoid, oil switch, *ills.*, 1,606.
 system, railway, a. c., 2,576.
 switch(es), Kelman, *ills.*, 1,604.
 lever locking, *ills.*, 675.
 Monitor, *ills.*, 675.
 safety lever, *ills.*, 675.
- Control device(s), Hill, pressure control, *ills.*,
 3,022.
 pumps, diaphragm reg., *ills.*, 3,019,
 float switch, *ills.*, 3,019.
 Gould's, by pass, *ills.*, 3,018.
 pressure regulator and by
 pass, *ills.*, 3,018.
 Hill, automatic pressure tank switch,
ills., 3,021.
 power end, 3,019-3,022.
 water end, 3,017-3,019.
- Controller, arcing at, 2,575.
 automobile, *ills.*, 2,843, *ills.*, 2,823.
 4 unit, one motor, diag., *ills.*, 2,848.
 1 unit, 1 motor con., *ills.*, 2,847.
 operation of, 2,850, 2,851.
 wiring diagram, *ills.*, 2,839.
 connections, West., *ills.*, 2,576, 2,578..
 crane, 2,954.
 dumbwaiter, Burdett and Roundtree,
 p. b., *ills.*, 2,887.
 electric vehicle, operation of, 2,850,
 2,851.
 Rauch and Lang, *ills.*, 694.
 flat radial, *ills.*, 694.
 fuse, master, blown, 2,664.
 lever in off position, 695.
 magnetic blow out coils, 694.
 master, contact poor in, 2,664,
 starting train with, 2,659.
 to detect grounded cable, 2,663.
- Monitor printing press, *ills.*, 676, 678.
 motor connections, *ills.*, 695,
 flat radial, *ills.*, 694.
 General Electric, *ills.*, 693.
 panel, elevator, Cutler-Hammer, full
 magnet, *ills.*, 2,880,
 railway, curves, *ills.*, 2,653.
 motor, *ills.*, 2,565,
 G. E. series parallel, *ills.*,
 2,566.
 operation of, 2,649-2,658.

Controller, —Continued.

- selective dual, B.R. & L., ills., 2,845.
- series parallel, 383.
- sinusoidal, MacLagan, ills., 3,210.
- trolley car, operation, 2,649-2,658.
- Westinghouse, ills., 2,662, 2,663.
- K-35 connections, ills., 2,578.
- L2 connections, ills., 2,577.
- with mechanical interlocks, 695.
- with separate revers. cylinders, 695.
- A. B. See, magnet, ills., 2,881.
- mechanical, ills., 2,870.
- traction, 2,882.

Controller, elevator, reversing, Otis, ills., 2,872.

- belt driven, full mech., ills., 2,878.
- non-reversible, ills., 2,874.
- box for, ills., 2,923.
- C.-H. with load device, 2,896.
- Darrin, automatic, ills., 2,889.
- diagram A. B. See No. 4, 2,870.
- non-reversible, 2,877.
- operation, 2,931.
- push button, ills., 2,886.
- shipper cable, ills., 2,875.
- special type, 2,893.
- speed, 2,884.
- two speed magnet, ills., 2,883.
- wheel, ills., 2,875.

Controller, elevator, a. c., full magnet, 2,901, 2,902.

- full mech., C.-H., a. c., ills., 2,908.
- semi-magnet, ills., 2,903.
- semi-mech., C.-H., ills., 2,907.
- two or three ph., Otis, ills., 2,904.
- two phase, mag., Otis, ills., 2,901.

Controller, elevator, d. c., duplex, Fraser, ills., 2,899.

- full magnet, 2,881, ills., 2,880.
- gravity, National, ills., 2,890.
- magnet, Sprague, ills., 2,897.
- mech., Electron, ills., 2,884.
- Otis, diagram, ills., 2,877.
- pilot, Sprague, ills., 2,876.
- p. b., Schureman, type, ills., 2,888.
- semi-magnet, ills., 2,873.
- non-reversible, ills., 2,873.
- reversible, 2,879.
- semi-mech., ills., 2,871.
- Schureman, ills., 2,876.
- traction, magnet, Otis, ills., 2,894.

- two speed mag., electron, ills., 2,885.
- Otis, ills., 2,893, 2,895.

Converter(s), alternator, exciter and transformer connected, ills., 2,062.

- booster, adaptation, 1,484.
- armature connections, 1,482.
- field connections, 1,482.
- synchronous, 1,481.
- cascade and synchronous, compared, 1,494.
- compounding, 1,480.
- connections, diametrical, ills., 1,575.
- current, 1,457-1,494.

Converter(s), current, —Continued.

- reactance, 1,480.
- direct current, 1,458.
- field, strength, effect of, 1,466.
- strengthened, 1,986.
- weakened, 1,985.
- frequency, 1,459.
- hunting, 2,079.
- prevented, 2,080.
- by damping meth., 2,081.
- inverted rotary, 1,461.
- levelling device, West., ills., 1,988.
- motor, 1,458.
- induction, ills., 2,071.
- pole regulating field, ills., 1,476.
- polyphase, arm. connections, 1,463.
- started with a. c., 2,069.
- portable sub-sta., West., ills., 1,986.
- rating of, 1,488.
- railway syn., protection, ills., 1,642.
- regulated, effect of on volt., 1,478.
- regulating poles, location, ills., 1,479.
- single ph. rot., not self-starting, 2,063.
- speed, 1,492, 1,493.
- started with direct current, 2,068.
- starting of, 1,494.
- sub-station of Brooklyn Edison Co., ills., 1,585.
- unity power factor, adv., of, 1,466.
- vertical syn., G. E., ills., 2,072.
- voltage diagram for, 1,477.
- voltage regulation of, 1,472.
- Westinghouse mechanical oscillator, ills., 1,481.

Converter(s), rotary, 1,459. 2,061-2,063,

- and rectifier compared, 1,526.
- and transformers con., ills., 1,462.
- armature construction, Westinghouse, ills., 1,465, 1,466.
- behavior of when hunting, 1,487.
- brush, lifting device, Westinghouse, ills., 1,472.
- rigging, West., ills., 1,469.
- Westinghouse, ills., 1,475.
- Burnham split pole, 1,476.
- cascade, ills., 1,490.
- commutating pole, West., ills., 1,470.
- compounding of, 1,468.
- connection chart, ills., 2,060.
- construction of, 1,467.
- control with multi-tap trans., 1,481.
- current and voltage, table, 1,464.
- efficiency, 2,066.
- equalizer con., West., ills., 1,467.
- operation of, 1,460.
- overloaded, 2,067.
- phase, 1,459.
- regulation, 2,066.
- regulating pole, General Electric, ills., 1,474, 1,475.
- ring wound single phase, ills., 1,459.
- speed of, 1,460.
- speed limit of commutator, 2,065.
- starting, 2,067.
- phase relation, ills., 2,070.

- Converter(s) rotary**,—*Continued.*
 three phase, ills., 1,461.
 two phase, ills., 1,460.
 Westinghouse commutating pole, ills.,
 1,471, 1,480.
 syn. booster, ills., 1,482.
 Woodbridge split pole, ills., 1,473.
 X ray coils, ills., 3,197.
- Converter(s), synchronous**, 1,458,
 booster, West., field, ills., 1,483.
 armature, ills., 1,483,
 connections, G. E., ills., 2,065,
 three wire, ills., 2,067.
 transformer connections, ills., 2,105,
 with series booster, G. E., ills., 2,064,
 two and three wire system, ills., 850.
- Convex lens**, double, foci in, ills., 2,685, 2,686,
 2,688.
 image various distances, ills., 2,694,
 2,695.
 principal focus in, ills., 2,689.
 real image in, ills., 2,692,
 virtual image in, ills., 2,693.
- Convex mirror**, 2,677.
 effect of, 2,692.
 foci of, ills., 2,688.
 image in, 2,692.
- Cooking and heating elements**, various, 3,051,
 3,058.
 heating unit, ills., 3,050, 3,051.
 resistance wires for, 3,048-3,050.
 Underwriters rules, 3,066.
 water heaters, Good Housekeeping, ills.,
 3,057, 3,058.
 wiring for, ills., 3,065, 3,066.
- Cooking appliances**, 3,061.
 coffee percolator, Simplex, ills., 3,048.
 insulation deterioration, 3,066.
 overheating, caution, 3,066.
 plan of elec. kitchen, 3,062.
 portable, 3,061.
 points in selecting, 3,047.
 range, Simplex, ills., 3,061.
 short circuiting of, 3,047.
 water heaters, ills., 3,057, 3,058.
 wiring for, ills., 3,065, 3,066.
- Cooled, air, choke coil**, West., ills., 1,712.
 transformers, 1,405, 1,408.
 constant current, General
 Electric, ills., 1,424.
 oil, transformer, G. E., ills., 1,395,
 Wagner, ills., 1,410.
 rectifier bulb, 1,524-1,525.
 transformer(s), water, General Electric,
 ills., 1,414.
 water, ills., 1,412-1,413.
 water, oil and air blast transformers
 compared, 1,439.
- Coolers, air, compressor**, 3,040.
 rule for, 3,045.
- Cooper, gear teeth strength**, 2,915.
- Cooper-Hewitt, lamp(s)**, c. p., 2,521.
 in series, ills., 2,484.
 mercury vap., a. c., ills., 2,483.
 vs. arc lamp, 2,485.
- Cooper-Hewitt**,—*Continued.*
 rectifier, mercury vapor, ills., 1,508.
- Copper**, and carbon brushes comp., 309.
 and zinc, of cell, care of, 62.
 bar inductors, objection to, 335.
 best metal conductor, 70.
 bit joint, soldering, ills., 3,075.
 brass or zinc oil cans, 593.
 brazing, 3,098.
 brushes, Faraday's machine, ills., 126,
 use of, 311.
 cable(s), ends, stranded, ills., 1,903,
 rope stranded, 1,912,
 stranded, 1,903.
 commutator const., 171,
 conductivity of, 69, 78. 723,
 contact with zinc, 44.
 core, amount required for, 207.
 disc wattmeter armature, ills., 569.
 economy of a. c., systems, ills., 1,578.
 electrode, polarity, 2,735.
 electro-plating, current, 3,149, 3,157.
 dips for, 3,179,
 rheostat for, ills., 3,154, 3,157.
 electrolysis of, ills., 3,134.
 element for crowfoot cell, ills., 64.
 field magnets, use for, 203.
 fuses, objection to, 415.
 galvanizing barrel for, ills., 3,182.
 in battery electrolyte, 910,
 in caustic potash, 102.
 in hydrochloric acid, 102.
 in sulphuric acid, 102.
 inductor in dynamo, 127.
 loss, transformer test for, ills., 1,444.
 transformer test, ills., 2,095.
 nickel, conductivity of, 723.
 oxide of, in depolarizing, 46.
 plate, black oxide of, Edison cell, ills.,
 50.
 plated carbons, 2,424, 2,424B.
 plating, 3,173.
 tank for, 3,159.
 point soldering bits, ills., 3,085,
 pure, conductivity of, 723.
 relative weights of, required by poly-
 phase systems, 1,576.
 resistance of, 78.
 ribbon in dynamo circuit, 610.
 saving, series arc light, 2,449.
 sheet, hood over pot head, 844.
 shell, electrotyping, 3,183.
 signal pan bottom, ills., 64.
 soldering flux for, 3,084.
 standard of ampere, 29.
 sulphate, electro-plating, 3,173,
 electrotyping, 3,183.
 solution, effect of current, 100.
 transformer losses, 1,402.
 voltameter, 469.
 welding, ills., 3,127.
 flux for, 3,109.
 pressure, 3,128.
 wet extraction of, 3,141.
 wire(s), of shunt dynamo, 189.
 as conductor, 2,738.

Copper, wires,—Continued.

conductors, 799,
 current collector, crane, 2,953,
 economy, 3 wire system, 707,
 for annunciator work, 2,392,
 formulæ, miscellaneous, 1,906,
 hard drawn, 721.
 highly conductive, 721,
 properties of, 749.
 table, 1,907-1,909.
 pure annealed, 722.
 resistance (of), 28. 734.
 standard (of), 722.

Matthiessen's, 723,
 tensile strength of, 800,
 tinned, rubber covered, 725.
 vibration in, 60,
 weight of, 749.

Cord(s), and plug pairs, ills., 2,127.
 and Siemens' winding, difference be-
 tween, ills., 246, 247.
 elastic, magnetic lines like, 275.
 plugs, switchboard removed and inserted
 in jack, ills., 2,190.
 short circuited, 2,175.
 relay contacts crossed, 2,175.
 signal, bull's eye, sticks, 2,175.
 switchboard, repaired, Western Electric,
 ills., 2,189.

or plug, open, 2,178.

Core, air, action of, ills., 118.
 inductive coil, ills., 1,032.
 and pole piece, combined, ills., 211,
 Lundell, ills., 214.
 and shell, transformers, 2,052.
 combination, ills., 1,390, 1,391.
 and windings, how kept cool, 158.
 armature, 1,204.
 built up, with spider, ills., 331.
 laminated, few eddy currents in-
 duced in, ills., 273.
 hydraulic pressure, 274.
 large, sections of, ills., 1,205,
 magnetic hysteresis in, ills., 277,
 ills., 279.

notched, 328.
 of Holtzer-Cabot dynamo, 156.
 slotted, 323. 1,206.
 stamping, ills., 1,229,
 wooden, ills., 237.

attaching, key for, 325.
 method of, ills., 205.

carbon, object of, 2,423,
 coil(s), iron wire, 1,035.

laminated, ills., 1,217.
 plain secondary, 143.

cylindrical, advantage of, 207.
 discs, insulation of, 326.

solid and ventilated, ills., 326.
 stamped in one piece, 326.

eddy currents in, prevented by lamina-
 tions, 324.

field magnet, effect of absence of resid-
 ual magnetism, 124,
 ills., 200.

held on shaft by key, ills., 323, 325.

Core,—Continued.

iron, action of in solenoid, 117.
 inductive coil, ills., 1,032.
 to increase magnetic power of
 solenoid, ills., 117, 118.

laminated armature, treated by hydrau-
 lic pressure, 274.

coils with, ills., 1,217.
 iron, in coil, ills., 1,061.

of transformer, ills., 1,389.

laminating, disadvantage of, 214.

loss, iron, by eddy currents and hystere-
 sis, 278.

of dynamo, 2,113.

of transformers, 1,545.
 determined, ills., 1,443.
 ills., 2,093.

non-continuous, transformer, 1,378,
 requiring least copper, 207.

seat(s), machined, ills., 205.
 on yoke of dynamo, ills., 203.

slotted armature, W. E., ills., 327,
 construction of, ills., 330.

smooth, armature lam., ills., 323,
 squirrel cage arm., ills., 1,343.

type of, obsolete, 323.

transformer, G. E., ills., 1,392,
 Moloney, ills., 1,390.

soft iron, 1,398.

triangular, of transf., ills., 1,396.
 type transformer, ills., 1,388.

wires, how to protect, 140,
 wooden, armature, ills., 234.

Siemens', ills., 226.

Cored carbon(s), description of, 2,423.
 for a. c. arc, 2,719.

in arc lighting, 2,422.

Corkscrew rule, ills., 112.

Corliss engine(s), valve gear, dash pot used on,
 2,435.

high speed, with Murray alternator,
 ills., 1,979.

in railway power house, 750h.p., 2,544.

inlet valve, I.-R., parts of, 3,027,
 on air compressor cylinder, ills.,
 3,025.

operation, air compres., 3,039.
 poles guded, ills., 812.

Corona effect of charged wires, 1,894.
Corpuscular theory of light, 2,674.

Corrugated, carbon, merit of, 42.
 cylinder fuse, ills., 414.

Corrugating electrode in depolarizing, 11.

Corundum wheel, grinding, ills., 3,170.

Cosmetic work, current for, 3,203.

Cotton, belts, 2,010.

braided, covered wire, 726.

conductor of electricity, 69.

covered wire inflammable, 726.

electrification of, 7.

Coulomb(s), and ampere, dif., 87. 470,

hydraulic analogy, ills., 468.

volt, definition of, 86.

Counter-, balanced torque of meter, 1,813.

Counter,—Continued.

- pressure battery system, 996.
- shaft, belt drive with, ills., 1,938.
- torque of wattmeter, 1,804.
- sink in soldering and brazing, 3,100.
- weight, elevator, arrangement, 2,925, ills., 2,858, 2,860, 2,861, 2,919, 2,924, 2,926.
- defective, effect, 2,931.
- proving, ills., 2,925.

Coupling, compound dynamos, in parallel, 607, ills., 607, 608.

in series, 605, 606, ills., 606.

cut off, ills., 2,051.

dynamos, 597-610.

series, in parallel, ills., 600,

shunt, in par., ills., 600, 601.

in series, ills., 601, 602.

field magnet coils, 396.

Course of Schaghticoke-Schenectady transmission line, ills., 1,569.

Covered wire(s), braided cotton, 726.

conductors, 724.

ills., 70.

lamp table, 746.

Crab or trolley of crane, 2,941.

Cradle suspension, railway motor, ills., 2,560.

Cranes, 2,935-2,962.

brake, automatic mechanical, ills., 2,948, 2,949.

eddy current, 2,949.

foot, 2,942.

iron clad solenoid, ills., 2,948,

telephone, 2,960,

various, 2,948.

bridge, 2,937.

def., ills., 2,941.

cableway, def., ills., 2,961, 2,962,

cage, def., 2,943.

collector gear, 2,951.

column, 2,936.

controllers, 2,954.

cost of, 2,951

derrick, collector gear not necessary, 2,953.

ills., 2,936, 2,937.

express type, Northern, ills., 2,946.

gantry, 2,938.

circular, const., 2,944.

wharf, Shaw, ills., 2,951.

half gantry, wharf, Shaw, ills., 2,952.

hoist, Brown, electric, ills., 2,959,

jib, ills., 2,936, 2,938,

locomotive, 2,937,

area served, 2,940.

current collector, 2,953,

jib, ills., 2,938, 2,948.

mono-rail trolley system, ills., 2,956-2,958.

motor for, 2,951.

ills., 2,947,

traveling, mounting, 2,941,

Niles, const., ills., 2,939, 2,940, 2,942, 2,944, 2,953.

Cranes,—Continued.

Northern low junior and express, ills., 2,946.

overhead wharf, Shaw, ills., 2,950,

pillar jib, 2,936.

power to drive, 2,955.

rectilinear, essentials of, 2,940,

regenerative control, 2,951,

rotary, and rectilinear, ills., 2,943.

bridge, 2,938.

essentials of, ills., 2,938.

sheer legs, 2,936.

small traveling, ills., 1,999.

swinging, 2,936.

switch, contact limit, Niles, ills., 2,953.

telpher performance, 2,962.

trackage, 2,961,

telpherage, 2,955.

tram, def., 2,937.

transporters, essentials of, 2,945.

grab load, 2,946.

traveling, ills., 2,937, 2,941.

large, ills., 2,000.

trolley, grab bucket, ills., 2,944,

motor driven, ills., 2,960,

or crab, 2,941.

various types, def., 2,936-2,938.

walking, 2,937.

Crater, on carbon, 2,442, ills., 2,426.

Creeping, apparent distillation, 103,

armature coil winding, 1,260.

prevention, 55, 63,

salts, effect of, 51.

winding, diagram of, ills., 1,261.

Creosoted poles, 802.

Critical, alternating voltage, 1,895.

angle for various substances, 2,683, ills., 2,682.

frequency curve, ills., 1,064.

determination of, 1,065.

voltage at arrester, 1,698.

Crocker-Wheeler, alternators installed, ills., 1,174.

brush holder, ills., 306, 307.

coupled alternator, ills., 1,142.

magnetic bridge, ills., 1,330.

motor-dynamo set, ills., 718.

slow speed alternator, ills., 1,173,

Crocus polish, electro-plating, 3,167.

Crompton, tube conduit system, 839,

potentiometer circuit, ills., 529

Crookes, X-ray tube, ills., 3,228.

Cross, arm(s), for insulator, ills., 805, 806.

bar telegraph switchboard. Western Union, ills., 2,231.

telephone, ills., 2,164,

grounds and breaks in cables, 535,

joint, soldering, ills., 3,080, 3,081.

magnetism, armature, ills., 262, 263.

magnetizing force, effect on motor field, 365.

of motor changed, 364.

magnetizing turns, ills., 268, 269.

Crow and digging bar, ills., 801.

Crowfoot, cell, copper element, ills., 64,

Crowfoot, cell,—Continued.

- Daniell, ills., 56.
- zinc, 63.
- "Crown of Cups," ills., 32.
- Crouse-Hinds, radial switch, ills., 1,883.
- wiring, ills., 1,876, 1,884.
- voltmeter and ground detector radial switch, ills., 1,875.
- Cull poles, for guy stubs, 807.
- with small tops, 807.
- Cup(s), porous, core of, 62.
- Current(s), 1,911-1,912.
 - acid, caustic, 3,203.
 - action, on various substances, 68.
 - active component of, 1,114-1,116.
 - alkaline, caustic, 3,203.
 - allowable for carbon brush, 657.
 - alternation explained, ills., 1,003.
 - Fleming's rule for direction of, ills., 163, 164.
 - reversal, ills., 165.
 - amplitude explained, ills., 1,003.
 - and pressure, curves, ills., 1,085.
 - limiting devices, 1,613-1,676.
 - reverse, ills., 1,069.
 - synchronism of, ills., 1,105.
 - waves, ills., 1,847.
 - and voltage, arc waves, ills., 1,869.
 - of rotary converters, table, 1,464.
 - relations of delta connected three wire system, 1,566.
 - armature, collection of in alternator, 171.
 - direction of, ills., 355.
 - in repulsion motor, 1,355.
 - starting or stopping, 293.
 - behaviour, circuit broken, 1,589.
 - booster, motor driven, 718.
 - railway system, 2,057.
 - use of, 718.
 - chemical effect of, 97.
 - collector gear for crane, 2,953.
 - collecting devices, railway, 2,546.
 - commutation, ills., 172.
 - in motor, ills., 365.
 - converters, 1,457-1,494.
 - curves, and pressure, ills., 1,008.
 - illus. lag, ills., 1,049, 1,050.
 - speed, of syn. conden., 1,772.
 - dampers fitted to cir. breakers, 420.
 - density, electro-plating, 3,144.
 - developed by heat, ills., 96.
 - effect(s), 93-104.
 - on frog's legs, ills., 103.
 - magnetic needle, ills., 431.
 - of passage, through copper sulphate solution, 100.
 - through water, 100.
 - polarization of cell, 40.
 - electrolytic rectifier, curves, ills., 3,196.
 - electro-plating, 3,146, 3,148, 3,149.
 - density of, 3,153.
 - electrotyping, distribution, 3,181.
 - energy at reversal wasted, 280.

Current(s)—Continued.

- excessive, arc lamp, 649.
- due to overloaded dyn., 655.
- dynamo field, 661.
- effect on battery, 60.
- incandescent lamps, 649.
- injury to dynamo, 592.
- field, coils, how varied, ills., 190, 191.
- frequency, change of, 1,568.
- ills., 1,004.
- transformer laminæ, 1,399.
- galvanic, 3,198-3,200.
- properties of, 3,203.
- generated, at central station, 1,586.
- by heat energy, 33.
- in conductors, 125.
- generation of 3 ph., ills., 1,026, 1,028.
- of two phase, ills., 1,024.
- heating effect of, 72.
- high, copper brushes for, 311.
- outfit, ills., 3,211.
- hydraulic analogy, ills., 31, 2,742.
- ignition coil, increase, ills., 153.
- image, alternators, 1,183, 1,184.
- self-exciting, ills., 1,185, 1,186.
- induced, 127, 2,735.
- around a circuit, 132.
- by moving circuit, 127.
- Fleming's rule for direction of, ills., 133, 135.
- palm rule for direction of, ills., 135, 136.
- rules for direction of, 134.
- induction, 130, 172, 2,412.
- essential condition, 129.
- in dynamo arm., ills., 262, 263.
- lag, caused by inductance, 1,050.
- lead, caused by capacity, 1,049.
- leakage, cause, 60.
- Lenz's law of direction, ills., 131.
- limiting, 2,363.
- coil, location of, 1,620.
- inductances, 1,618.
- reactance, G. E., ills., 1,619.
- local armature, reduction of, 1,357.
- sparking of, 1,356.
- strength of, 1,356.
- losses, arc lamp, avoided, 2,448.
- low, frequency, indicated, ills., 2,368.
- tension, def., 30, 2,734.
- nature of, 2,734.
- with carbon brushes, 310.
- magnetic effect of, 97, 112.
- magnetizing, 674.
- measure of heat given off, ills., 94.
- measurement, 469.
- with ballistic galv., 454.
- with galvanometer, 450.
- with potentiometer, ills., 533.
- mechanical generation of, 33.
- meter coils displaced, 1,809.
- mixed, distribution systems, 1,585.
- motion picture arc, 2,717.
- muscular contractions, ills., 103.
- neutral, of three wire system, 198.

Current(s),—Continued.

- opposition of, by inertia, 288,
 - or voltage limiting devices, 1,587,
 - path(s), in external circuit, 165,
 - least resistance, 295.
 - through armature, 261.
 - through dynamo brushes, ills., 262, 263.
 - polarization of bat. weakens, 40.
 - pulsating, for telephone party bell ringing, 2,147.
 - def., 174.
 - produced by elementary armature, 221.
 - rectified, diagram of, 1,496.
 - rectifiers, 1,495-1,530.
 - regulating devices, 1,588.
 - relative direction of, rule, ills., 112.
 - secondary, def., 30, 2,734.
 - Seebeck effect on, ills., 95.
 - self-induced, how absorbed, 147.
 - sinusoidal, 3,193-3,200.
 - skin effect, 1,893.
 - steadiness, on what depends, 180.
 - superimposed, for party telephone bell ringing, 2,148-2,150.
 - telephone, waves, ills., 1,870.
 - three phase, sine curves of, ills., 1,308, 1,309.
 - through electrolyte, effect of, 898.
 - transformer(s), 1,377-1,456,
 - magnetizing, 1,383.
 - no load, 1,400.
 - two paths, in shunt dynamo, 189.
 - two phase, 1,020.
 - hydraulic analogy, ills., 1,023..
 - sine curves, ills., 1,302, 1,303.
 - unequal, galvanometer coils, 453.
 - wattless, ills., 1,110, 1,111.
 - mech. analogy, ills., 1,113.
 - wave(s), ills., 1,868,
 - of a. c. arc, 2,442.
 - universalnode, 3,200.
- Current(s), alternating, 997-1,066.**
- advantages of, 997-999.
 - apparatus operated by, ills., 998.
 - changed to direct, 172.
 - circuit, ills., 1,098.
 - with capacity, ills., 1,039.
 - with inductance, ills., 1,038.
 - complex properties of, 997.
 - danger vs. direct, 999.
 - def., 30, 997, 2,734.
 - diagrams, 1,067-1,100.
 - economy of, 1,575.
 - feeder regulation, 1,715, 1,716.
 - for starting polyph. converter, 2,069.
 - power factor, 1,101.
 - principles, 1,001.
 - rectifier, Edison, ills., 942, 944.
 - sine curve, ills., 168-170.
 - skin effect on wire, ills., 1,065.
 - strength change, rate, 1,065, 1,068.
 - systems, 1,531-1,586.
 - relative cop. econ., ills., 1,578.
 - two phase, ills., 1,022.

Current(s), alternating,—Continued.

- variation of, how shown, 168.
 - virtual value, 1,777.
 - voltage, effect of reg. converter, 1,478.
 - where induced, 171.
 - wiring, 1,885-1,914.
- Current, constant, alternator, advantage of, 1,540.**
- alternator voltage high, 1,539.
 - arc lamp circuits, 757.
 - arc lighting, d. c. series, 2,449.
 - booster system, ills., 993.
 - def. of, 2,446.
 - for battery charging, 924.
 - transformer, 1,505, 1,506.
 - air cooled, G. E., ills., 1,424, 1,425.
 - for series arc lighting, ills., 1,423.
 - ills., 1,505, 1,506.
- Current(s), direct and alternating, difference in behaviour of, 1,056.**
- measured by voltmeter, 2,095.
 - apparatus operated by, ills., 998.
 - automatic reg., G. E., ills., 2,028, 2,029.
 - def. 30, 2,734.
 - for starting converter, 2,068.
 - how obtained in dynamo, 173.
 - how produced, 155.
 - indicated by sine curve, ills., 174.
 - motor run by a. c., 1,349.
 - voltage on traction lines, 1,586.
 - voltage reg., cir., G. E., ills., 1,729.
 - condenser, ills., 1,746.
 - connections, ills., 1,745.
 - General Electric, ills., 1,725.
- Current distribution, in armatures, 257.**
- in Gramme ring, ills., 257, 258.
 - ills., 259.
 - in ring arm., bat. analogy, ills., 258.
 - of three phase, ills., 1,026, 1,028.
 - of two phase, 1,025.
 - ills., 1,024.
- Current(s), eddy, Arago's exp., ills., 270.**
- armature affected by, 658.
 - cause heat, 658.
 - causes of in pole pieces, 661.
 - detected in armature, 658.
 - formation of, ills., 271.
 - induced in lam. arm. core, ills., 273.
 - in solid arm core, ills., 272.
 - in pole pieces, 209.
 - loss in transformer, 1,402.
 - reduced, 249.
 - prevented in cores, 324.
 - reduced by lamination, 272.
 - transformer, 1,398.
- Current phase(s), difference, 1,002, 1,008.**
- displacement, 1,007.
 - explained, ills., 1,006.
 - motors in step with, 1,269.
 - transformation of, 1,571.
- Current strength, arc, watts consumed by various, ills., 2,418.**

- Current strength**,—*Continued*.
 def., 33.
 divided circuit, law, 78.
 formula to determine, 29.
 in coil, to what proportional, 120.
 Ohm's law, 75.
- Curtis**, horizontal turbine and dynamo, General Electric, ills., 2,044.
 steam turbine(s), 1,971.
 turbine, alternators, installed, ills., 1,182,
 generator ills., 2,050.
- Curvature**, radii of, 2,696.
- Curves**, air compression, characteristic, 3,026,
 3,036.
 a. c., in opposition, ills., 1,009.
 in phase, ills., 1,009.
 in quadrature, ills., 1,009.
 complex, resolved into sine curves, ills.,
 1,017.
 condenser discharge, ills., 1,864.
 dynamo, characteristic, series dynamo,
 ills., 2,106.
 compound, ills., 2,112.
 shunt, ills., 2,111.
 efficiency, of dynamos, ills., 391.
 incandescent lamps, distribution of,
 2,528.
 illumination, calculation, 2,523.
 Mazda lamp, ills., 2,525.
 impedance, ills., 1,061.
 lag, current, ills., 1,049, 1,050.
 load, dynamo and battery, ills., 970.
 for one day, ills., 1,930.
 for one year, ills., 1,931.
 of plant, ills., 1,932.
 magnetization test, ills., 2,084.
 performance, Holtzer-Cab., ills., 392.
 of induction motor, ills., 1,112.
 power, drawing of, ills., 1,104,
 explained, ills., 1,103.
 power factor, ills., 1,122.
 pressure, lag, ills., 1,049, 1,050.
 pump, char., Gould, ills., 3,006.
 relay, Condit, char., ills., 1,654.
 sine, bell circuit, ills., 2,367.
 construction of, 168.
 equation of, ills., 1,002.
 Gramme ring armature of six coils,
 ills., 178-180.
 3 ph. current, ills., 1,308, 1,309.
 2 ph. current, ills., 1,302, 1,303.
 wave, ills., 1,000.
 super-imposed harmonic, ills., 1,018.
 transformer efficiency, ills., 1,418.
 West. air blast, ills., 2,048.
- Curved**, magnetic lines, 130.
 mirror, 2,677.
- Cushion**, air, pump, 2,981.
- Cutler-Hammer**, compound, speed regulator,
 ills., 685.
 starter, ills., 684.
- elevator**, brake solenoids, ills., 2,892.
 controller, full mech., a. c., ills.,
 2,908.
- Cutler-Hammer**, elevator controller,—*Cont'd*.
 full magnet, Schureman
 type, ills., 2,880,
 ills., 2,883.
 p. b., Schureman type, ills.,
 2,888.
 semi-magnet, a. c., ills., 2,903.
 d. c., ills., 2,873.
 d. c., reversible, ills.,
 2,879.
 semi-mech., a. c., ills., 2,907.
 d. c., ills., 2,871.
 Schureman, ills., 2,876.
 switch, d. c. or a. c., ills.,
 2,900.
 switch, rotating cam limit,
 2,905.
 shaft limit, ills., 2,928.
 slack cable, ills., 2,931.
 traveling cam limit, ills.,
 2,906.
 float switch, ills., 1,611.
 motor starter, ills., 666.
 multiple switch starter, ills., 682.
 reversible starter, ills., 689.
 rheostats, ills., 671.
 speed regulator, ills., 683.
 switch, star delta, ills., 1,761.
- Cut** or electro, manufacture of, 3,183, 3,184.
- Cut out(s)**, and substitutional resistance, ills.,
 2,437, 2,438.
 arc lamp, ills., 2,438.
 Adams-Bagnall, ills., 2,439.
 discriminating, 418.
 disadvantages of, 420.
 dynamos, automatic, 604.
 magnetic, in battery room, 948.
 relay, high vol., G. E., ills., 1,735.
 reverse cur., Aplco system, 2,808.
 Rushmore automobile lighting system,
 ills., 2,813.
 switchboard receiver cord, 2,176.
 telephone desk stand cord, 2,172.
 receiver cord, 2,171.
 transmitter cord, 2,172.
 Wagner dynamo, ills., 2,804, 2,805.
 Wallis-Jones automatic earth leakage,
 ills., 1,838.
- Cyanide**, dip for brass, electro-plating, 3,179.
 of potassium for electro-plating, 3,172.
 of silver for electro-plating, 3,172.
- Cycle**, of a. c., sine curve applied, 170.
- Cylinder(s)**, air compressor, adequacy of,
 3,046.
 Corliss inlet valve, 3,025.
 hurricane inlet valve, 3,029.
 with control, Rand, ills., 3,037.
 and magnet valve, West., ills., 2,584.

Cylinder(s),—Continued.

- carbon, ills., 42.
- ills., 62.
- comp. air, water jacketing, 3,036
- controllers with sep. reversing, 695,
- core, advantage, 207.
- diameters, air compressor, compound,
- 3,033.
- Dewey, deep well, double acting, pump,
- ills., 2,986.
- dry or jacketed, air comp., 3,029.
- duplex compressor, valve placing, ills.,
- 3,031.
- knocking in, ignition, 2,792.
- metal, effect of electrification on, ills.,
- 16.
- spray injection, air, comp., 3,029,
- thermal flasher, 879.
- water, volume of, 2,981.
- cycloidal spur gearing, 2,915.
- Cryolite, soldering flux, 3,083,
- Cystitis, treatment for, 3,205.



- Dam, power house, ills., 1,977.
- Damp, air, effect of on electrification, 20.
- Damper(s) alternator winding, ills., 1,155,
- current, fitted to cir. breakers, 420.
- Damping, discs and coils for gal., 457.
- effect in galvanometer, 454.
- method to prevent hunting, 2,081.
- of galvanometer, 456.
- Daniell cell, 41, 53-56, 57, 59, 61.
- Darin elevator controller, automatic, p. b.,
- ills., 2,889.
- D'Arsonval galvanometer, 457-459, 461.
- Dark lamp synchronizing, ills., 2,033.
- Dash coils, wiring diag., 153.
- Dash pot(s), and adjusting weights, 2,435,
- arc lamp, retarding medium, 2,436.
- vacuum type, ills., 2,460.
- of elevator starter, 2,876, 2,878.
- single acting, on series lamp, ills., 2,437.
- Davis-Bourmonville, oxy-acetylene blow pipe,
- ills., 2,116.
- oxygraph, ills., 3,131.
- welding torch style C, ills., 3,130.
- Davy's, battery experiment, 893,
- experiment in lighting, 2,411.
- Day, efficiency, 2,047, 2,048.
- one, load curve for, ills., 1,930.
- system, ship propulsion, 2,666.
- Dayton launch lighting outfit, ills., 983.
- Deaco starting and lighting system, one unit,
- 2,800.
- Dead, beat, gal., cause of, 454, 459, 461,
- centers of syn., inotors, 1,274.
- men, pole hoists called, 811,
- moulding, ills., 777.
- turns of armature, 278, 279.
- Deaf man's telephone, ills., 2,197.
- Decade plan of combining resistance coils,
- ills., 494-497.
- Decohering, how accomplished, 2,270.
- Decomposition of, light, 2,698, 2,699,
- water, 97.
- in battery electrolyte, 898.
- Deep well, cyl., Deming, ills., 2,986.
- pumps, installation of, ills., 2,985.
- De Faria valve, ills., 1,504.
- Deflection, method of testing, direct, 503,
- of testing resistances, ills.,
- 476, 477.
- of testing different from zero
- method, 482.
- of compass, Ampere's rule for, 431,
- tangent of angle, galvanometer, 443.
- Deflector, trolley, const. of, ills., 2,629.
- De Forest's wireless, experiments, 2,329,
- telegraph system, ills., 2,293.
- Delaney multiplex telegraph, 2,249.
- De la Rue's battery experiment, 894.
- De Laval steam turbine, 1,969.
- Delco systems, automobile circuit diagram,
- 2,801.
- Delta, connected, alternator, three phase,
- ills., 1,566.
- armature and collector rings, ills.,
- 1,254.
- connection of three phase one slot wind-
- ing, ills., 1,246, 1,247.
- grouping, three phase, ills., 1,247.
- open, transf. method, ills., 1,568.
- star, starting switches, 1,769.
- switch, C-11, ills., 1,761,
- transformer connection, ills., 1,432,
- 3 phase armature con, ills., 1,560.
- Demagnetizing, effect, described, 269.
- of armature reaction, ills., 268.
- 269.
- of shunt dynamo, 190.
- turns, breadth of belt, ills., 268, 269.
- Demand indicator, Wright, ills., 557.
- Deming, deep well pump cyclinder, ills.,
- 2,986.
- float switch and regulator, 3,019.
- pump, diaphragm reg., ills., 3,019.
- double reduction short belt and spur
- gear drive, ills., 3,015.
- float switch, ills., 3,019.
- single reduction, belt dr. ills., 3,012,
- silent chain drive, ills., 3,014.
- spur drive, ills., 3,012.
- rotary, ills., 3,000.

- Drain cock**, ills., 1,996.
- Draught**, forced, to boiler room, ills., 1,959, 1,961.
transformer, ills., 1,406, 1,407.
- induced, 1,960.
mechanical, ills., 1,957-1,960.
natural, air cooled trans., 1,406.
pressure in chimneys, 1,955.
- Drawn shell motor**, 1,288, 1,344, 1,345.
- Drive**, belt, conditions best for, 2,014.
features of, 398, 399.
machine base, ills., 2,002.
motion picture, ills., 2,714.
objections to, 2,913.
plant, ills., 1,947, 1,948,
tandem generators, ills., 2,008,
with countershaft, ills., 1,938.
- chain**, adjustment, ills., 2,834.
adv., and disadv. 1,140,
1,948, 1,950. 2,828.
care of, 2,832.
double, ills., 2,829.
elevator, 2,913.
silent, automobile, 2,827.
- direct**, features of, 398.
plant, ills., 1,916, 1,948, 1,949.
ship propulsion, 2,669.
pulley, belt trans., ills., 2,009.
- dynamo or motor**, 396.
elevator, cable, Fraser, ills., 2,912.
herringbone, Gurney, ills., 2,916,
2,917.
single motor, traction, 2,910.
worm tandem, ills., 2,922.
- gear reduction**, var. forms, 2,835.
- gear**, series motors best for, 370.
- herringbone**, advantage, 3,015.
automobile, ills., 2,826, 2,827.
- pump(s)**, Deming single and double reductions, ills., 3,012, 3,014, 3,015.
reciprocating, 3,012-3,017.
quill transmission, ills., 2,052.
- rope**, motors, advantages of, 403.
- single reduction spur**, adv., 3,015.
- synchronous** for magnetos, 2,757, 2,760.
- worm, automobile, 2,836,
pump, ills., 3,017.
- Driving horns** on smooth core arm., 347.
- Drop**, formula, 1,914.
in motor armature, 380.
line, compensator, various, ills., 1,751-1,754.
method of measuring resistance, ills., 483. 2,073.
negligible, table for wires at, 757.
of voltage in circuit, ills., 33. 747.
- diagram meas. of, ills., 544,
of shunt dynamo, 190. 313,
314. 700.
- ohmic, explained, ills., 1,079, 1,087.
- Drum**, and ring armatures compared, 223.
- Drum**,—Continued.
armature(s), 223-226.
distribution of field magnetism
through, ills., 281.
for alternator, ills., 1,204,
varying brush position in, 187.
windings, 238, 335.
- Drum elevator(s)**, 2,924, 2,856.
counterbalance proportion, 2,857.
objection to, 2,859.
over and undermounted, ills., 2,857.
- Drum winding**, condition of, 227, 239.
parallel, 235.
requirements, 255.
series, 241.
Siemen's, ills., 226.
- Dry cell**, ill., 59-61.
and storage bat. connected, 920.
construction of, 2,401.
des., 2,743.
uses of, ills., 59-61. 2,400.
how to renew, 60.
leakage in and restoring, 2,400.
testing with ammeter, 61.
- Dual**, ignition, ills., 2,782-2,783.
jump spark ignition system, 2,778.
- Duct** conduits, concrete, ills., 830.
multiple, ills., 828, 829, 830, 831.
single, 828.
wooden, ills., 831, 832.
- Ducts**, ventilating, of arm., ills., 1,213,
spacing of, 333.
- Duddell oscillograph**, ills., 1,858-1,865.
- Dull's carbon flasher**, ills., 866, 874.
- Dumb waiter(s)**, controller, Burdett and Roundtree, p. b., 2,887.
wiring of, ills., 2,393, 2,394.
- Duncan wattmeter**, ills., 571.
- Dunham**, H. F., valve practice, 2,997.
- Duplex**, air compressor, I.-R., ills., 3,031-3,033.
armature winding, 149.
battery, sparking, charging connections, ills., 924.
elevator contr., Fraser, ills., 2,899.
covered wire, ills., 70.
ignition, vibrating, Bosch, ills., 2,789.
repeater, Postal direct point, ills., 2,219.
telegraph, 2,226-2,240.
- Duplexing**, cable, submarine, ills., 2,252, 2,253.
- Durnall system**, ship propulsion, 2,666.
- Dust**, metallic, bet. com. segments, 652.
- Dyes and chemicals**, 3,139.
- Dynamic**, brake, 2,889, 2,890.
head, ills., 2,966.
total, 2,969.
- Dynamo(s)**, 155-198.
action of magnetic force in, ills., 353,
and battery in par., ills., 970, 971,
and engine, aligning of, ills., 402,
ills., 1,979.
and horizontal Curtis turbine, G. E.,
ills., 2,044.

Dynamo(s),—Continued.
 and magneto, dif., ills., 183. 2,748.
 and motors care of, 595, 596.
 construction, operation, ills., 159,
 349-389, 395.
 rotation, direction, ills., 362.
 selec. and install., 389-406.
Apple ignition, 2,749.
 arc, effect of high resistance, 2,431.
 Thomson-Houston, 306.
armature, construction, 221.
 definition of, 321.
 disc., Niaudet, ills., 228.
 effect of current in, ills., 262.
 forces acting on, ills., 594.
 circuit, resistance in, 605.
 currents, dis. of, ills., 252.
 auxiliary, three wire system, ills., 709.
 balancing coil connection, ills., 716.
 basic principles of, 161-170.
 bipolar, 182, 183.
 booster, in series circuit, 982.
 brush gear, ills., 637, 638.
 brushes, connected, 222.
 lead small, 589, 590.
 rocking of, 640.
 building up of, 583.
 circuits open, 614, 615.
 classes of, 181-198.
 commutator, pitch of, 235.
 ventilated, ills., 655.
 compound, characteristics, 191, 195.
 char. curves, ills., 2,112.
 connected in parallel, ills., 583.
 coupled, ills., 605, 606, 607.
 load equalized, 609.
 rever. polar. corrected, ills., 588.
 test external char., ills., 2,092.
 wound, polarity reversed, 649.
 connecting, 395. 621.
 connections, shunt, 606.
 heating of, 649, 654.
 core loss, 2,113.
 coupling of, 597-610.
 current commutation, ills., 171-180,
 254. 604.
 def., 155. 2,735.
 direct con., large arm., for, ills., 348.
 discriminating cut out, 2,751.
 double, 3 wire system, ills., 709, 710.
 drive, 396.
 effect on, of residual magnetism, 124.
 efficiency at av. load, 391. 597.
 electro-plating, ills., 3,147, 3,150, 3,152,
 3,168, 3,169.
 magnets of Optimus, 3,148.
 equalizer, 601.
 essential parts, 157, 161.
 examination of, 573.
 exciter water wheel driven, ills., 2,056,
 failure to excite, 619.
 Faraday's, ills., 126. 2,412.
 field, coils, in parallel, 600, 601,
 remagnetized, 587,

Dynamo(s), field,—Continued.
 distortion of, ills., 262.
 magnet circuit of, 573.
 windings, classes of, 182.
 Fort Wayne, ills., 317.
 foundation for, ills., 395.
 four pole, connection of brushes, ills.,
 260.
 ring armature, ills., 222, 230, 231,
 friction drive, 2,750, 2,751.
 General Electric, 157. 2,544.
 heat of, 332.
 hub and shaft design, ills., 332.
 ignition, des., 2,750, 2,751.
 incandescent lighting, 192.
 in series and parallel, 597, 598.
 inspection of, 573.
 installation, 389-406.
 car lighting, 2,606-2,608.
 large, armature windings, 230.
 brushes held by arms, 320.
 effect of battery in regulating, ills.,
 972.
 load reduced before stopping, 594.
 M type, Holtzer-Cabot, ills., 156.
 motor-, automobile, 2,800.
 series, direction, 361.
 sets, distribution of, ills., 715.
 multipolar, 182. ills., 1,005.
 new, heat easily, 593.
 Niaudet, disc armature of, ills., 228,
 operating above rated voltage, 659.
 operation, 155. 573-596, 617.
 effect on, of differential lamps,
 2,432.
 of self-induction, 280.
 over compounded, 192, 193.
 overheated, detecting, 653.
 overloaded, 655.
 origin of, 2,413.
 parallel con., unequal voltage, 600.
 polar duplex system, ills., 2,237,
 power loss, 2,113.
 principle of, like pump, 157.
 protection, three wire, ills., 1,675.
 regulation, automatic devices necessary,
 186.
 reversed, 589.
 ring wound, converted into alternator,
 ills., 1,144.
 rule, different from motor rule, 364.
 for direction of induced current,
 ills., 134.
 running, attention, 589.
 Rushmore, circuit con., ills., 2,812.
 Safety Lighting Co., axle driven, ills.,
 2,605.
 selection of, 389-406.
 self exciting, 124, 184.
 separately excited, ills., 196, 197.
 similar to motor, 356.
 starting, 580, 581, 582.
 difficulty in, 2,431.

Dynamo(s),—*Continued.*

- suspension, car lighting, *ills.*, 2,606–2,608.
- switchboard for, *ills.*, 428.
- table of amperes for, 760.
- telegraph, 2,254.
- temperature, rise, allowable, 654.
- test, *ills.*, 2,091.
- terminals, short circuit at, 619.
- tested for short circuits, *ills.*, 616.
- testing, *ills.*, 2,092, 2,107, 2,109.
- with main leads out, 619.
- three brush, two wire system, 709.
- three wire, of Dobrowolski, *ills.*, 197.
- system, 708.
- turbine rotor, West., *ills.*, 1,998.
- two, in par., unequal voltage of, 600.
- switchboard for, *ills.*, 428.
- types of, 181.
- variation of field strength in, 187.
- various, *ills.*, 198. 2,804, 2,908.
- voltage unequal, two parallel, 600.
- wiring, size of wire for, 406.
- with commutator and collector rings, *ills.*, 714.
- with four consequent field magnets, *ills.*, 202.
- series**, affected by open ext. cir., 619.
- and shunt, difference, 189.
- arc lighting, *ills.*, 184.
- characteristic curves, *ills.*, 2,106.
- connections, 597.
- coupled in parallel, 598–600.
- ills.*, 184–187.
- in series, *ills.*, 598, 599.
- current supplied, effect, 361.
- disadvantage of, 186.
- effect of winding of, 185.
- magnetism in, how diminished, 186.
- motor sets in, *ills.*, 715.
- polarity reversed while stopping, 649.
- regulation of, 186.
- use of, 392.
- strut**, and compound, in par., 610.
- behavior of, when used as motor, 363.
- building up of, 585.
- characteristic curve, *ills.*, 2,111.
- characteristics of, 189.
- compound, double long connections, 606.
- connected, in series, *ills.*, 582.
- to bus bars, 604.
- to three wire system, *ills.*, 582.
- coupled, *ills.*, 601, 604.
- double short connections, 606.
- external characteristic test, *ills.*, 2,089.
- for incandescent lighting, *ills.*, 189, 190, 191.

Dynamo(s), skunt,—*Continued.*

- motor, acting as, 2,952.
- plant, dividing load, 605.
- point of voltage decrease, 190.
- slow speed of, 585.
- two, connected in parallel, *ills.*, 581.
- use of, *ills.*, 189, 190.
- used as motor, 363.
- Dynamometer(s)**, construction, 1,793.
- small, *ills.*, 1,797.
- without iron magnet, 1,797.
- Dynamotors**, features, 2,058, 2,061.
- Holtzer-Cabot, *ills.*, 982.
- in railway power house, 2,543.
- starting, 2,061.
- use, *ills.*, 711, 712.
- Dyne**, force of in magnetic field, 111.

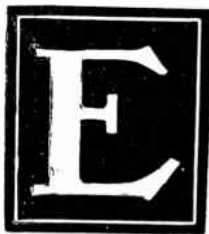

- Ears**, trolley, of deflector, *ills.*, 2,629.
- Earth**, conductivity of moist, 69.
- leakage automatic cut out. Wallis-Jones, *ills.*, 1,838.
- Earthenware** trough conduit, *ills.*, 829.
- Eastern pole** climbers, *ills.*, 813.
- Ebonite**, as insulator, 70.
- rod, electrification of, *ills.*, 15.
- Eck-Manchester** small motor, *ills.*, 658.
- Eclipse** heating element, 3,051.
- "Economic" calcium light, *ills.*, 2,720.
- Economy**, rel., a. c. systems, *ills.*, 1,578.
- Eddy current(s)**, and hysteresis, effect, *ills.*, 278.
- causes of, in pole pieces, 661.
- crane brake, 2,919.
- disc motion opposed by, *ills.*, 270.
- experiment, Arago's, *ills.*, 270.
- formation of, *ills.*, 271.
- in cores, 273, 324.
- induced, arm. core, lam., *ills.*, 273.
- solid, *ills.*, 272.
- in pole pieces, 209, *ills.*, 210.
- in transformer, 1,398.
- in wire, 1,066.
- loss, in transformer, 1,402.
- reduced, 249.
- Edge strip** winding of coils, *ills.*, 216.
- Edison**, and Phelps tel., induction, 2,266.
- battery for electric vehicles, 2,837.

Edison, —Continued.

- cables, underground, *ills.*, 842.
 - cell, 50. 918. 2,746.
 - effect, incandescent lamp, 2,486.
 - rectifier, a. c., *ills.*, 942-945.
 - storage bat., complete, *ills.*, 916-918.
 - three wire system, 704.
 - tube conduit system, *ills.*, 839, 840.
- Edwards, electro-mech. cong.**, *ills.*, 2,372.
- Eel, electric**, *ills.*, 4.
- Effective, and virtual pressure**, *ills.*, 1,013.
- current, 1,054.
 - pressure in syn. motor, 1,271, 1,272.
 - sinusoidal voltages, sparking distances, 152.
 - volts and amperes, 1,013.
- Efficiency (of), dynamo, curves**, *ills.*, 391.
- maximum, 597.
 - dynamotors, 2,061.
 - generator, 1,997-1,998.
 - commercial, 2,110.
 - motor, 384.
 - plant, examples, 1,933.
 - rotary converter, 2,066.
 - transformer, 1,417. 2,047.
 - curves, *ills.*, 1,418. 2,048.
 - all day, 1,419.
- Eisemann, ign. magneto**, *ills.*, 2,768, 2,770.
- magneto wiring diagram, 2,791.
- Electric, air compressors**, 3,023-3,047.
- arc, 2,415.
 - bells, 2,339-2,410.
 - cooking, 3,047-3,066.
 - cranes, 2,935-2,962.
 - eel, *ills.*, 4.
 - elevators, 2,855-2,934.
 - heating, 3,047-3,066.
 - indicating devices, 1,777-1,838.
 - lighting, 2,411-2,532.
 - lightning protection devices, 885-892.
 - 1,677-1,714.
 - limiting devices, 1,613-1,676.
 - machine, 23-26.
 - static, *ills.*, 3,185.
 - Toepler Holtz, 24.
 - Wimshurst, *ills.*, 25, 26.
- motors**, 349-388.
- a. c., 1,267-1,376.
 - d. c., 349-406.
 - operation, 663-696.
- power stations**, 1,915-1,988.
- pumps, 2,963-3,022.
 - railways, 2,533-2,672.
 - regulating devices, 1,715-1,762.
 - ship propulsion, *ills.*, 2,865-5,672.
 - sign flashers, 865-884.
 - starting and lighting systems, 2,793-2,814.
 - switching devices, 1,589-1,612.
 - truck for city service, 2,817.
 - typewriter, Postal Teleg. Co., 2,256.
 - valve, Giles, 1,505.
 - vehicles, 2,815-2,854.
 - wave(s), form, measurement, 1,839-1,870.
 - ills.*, 2,274, 2,276.

Electric, wave(s), —Continued.

- method, wireless telegraphy, *ills.*, 2,275, 2,281.
 - radiation, 2,280, 2,281.
 - welding, 3,107-3,132.
 - whirl, *ills.*, 9, 10.
 - wind, 9.
 - windmill, *ills.*, 9, 10.
 - wiring, a. c., 1,885-1,914.
 - d. c., 721-764.
 - buildings, 845-864.
 - inside, 765-798.
 - outside, 799-815.
 - underground, 816-844.
 - writing machine and telephone, *ills.*, 2,157, 2,161, 2,167.
- Electrical, and mech. losses comp.**, 282.
- and mechanical energy, 83-92.
 - attraction and repulsion, *ills.*, 5, 6.
 - center of, distribution, *ills.*, 736.
 - gravity, 704.
 - current, effects of, 93-104.
 - energy, 26, 161.
 - horse power, 91.
 - formula, 385. 1,913.
 - ignition sys., class., 2,740, 2,741.
 - machine(s), connections, 405.
 - foundation for, *ills.*, 395.
 - original, 2,411, 2,413.
 - measuring instruments, 2,081, 2,082.
- osmose, cause of, 102.
 - plants, units for, 390.
 - solder, 3,068.
 - unit of, power, def. of, 88.
- Electricity, measured by electroscopes**, 13.
- atmospheric, def. of, 4.
 - bound, def. of, 9.
 - classified according to motion, 2.
 - chemically produced, 2,735.
 - coulomb of, *ills.*, 1,042.
 - current, def., 3.
 - def. of, 84. 2,733.
 - developed by friction, 5.
 - different from magnetism, 85.
 - displ., of, Wimshurst mach., *ills.*, 26.
 - dissipated by flame, 7.
 - dynamic, def. of, 3.
 - effect of in flame, 7.
 - faradic, 3,185, 3,198-3,200.
 - free, def. of, 9.
 - frictional, def. of, 4.
 - function of, 84.
 - galvanic, 3,185, 3,198-3,200.
 - kind of, ind. by electroscopes, 12.
 - mechanically produced, 2,735.
 - medical, 3,185.
 - production, method, 2,735.
 - nature and source of, 1.
 - positive and negative, def. of, 3.
 - quantity measurement, 29, 87.
 - radiated, def. of, 3.
 - resinous, def. of, 4.
 - resistance of, how deter., 29, 76.
 - laws of, 76.
 - static, def. of, 2, 5. 3,185, ...

- Electricity**,—*Continued.*
 vitreous, def. of, 4,
 vs. gas, 92.
 wasted in lighting circuits, 570.
- Electrification**, detected by gold leaf electro-
 scope, ills., 11,
 lines of, ills., 19,
 negative, 5,
 of dissimilar bodies, ills., 13,
 of ebonite rod, ills., 15,
 of glass and leather, ills., 13,
 of metal cylinders, ills., 16,
 of substance, resinous, 17,
 of various subs., 7, 12, 13, 16, 17,
 on hollow sphere, ills., 12,
 positive, 5.
- Electro(-)**, manufacture of, 3,183, 3,184,
 cauterizing, 3,223.
 chemical, depolarizing, 41.
 series, arrangement of, 101.
 dynamometer, ills., 556.
 L. and N., ills., 1,797.
 Siemens's, ills., 555, 556, 558.
- Electrode(s)**, 2,735,
 carbon, ills., 2,421.
 connections, 139.
 contact points, ignition, 2,764,
 copper, polarity of, 2,735,
 low tension ignition, 2,761,
 medical, copper ball, Neiswangers, 3,213,
 high frequency, ills., 3,190,
 irrigating, 3,213,
 proctologists' set, ills., 3,226,
 selection of, ills., 3,197, 3,198,
 3,201.
 vacuum, Columbia, 3,212,
 platinum, use of, 99,
 resistance, negative, of rectifier, 1,512.
 telephone transmitter, 2,119.
- Electrolysis**, alkali and bleach, 3,134,
 aluminum, 3,135,
 cells, various, ills., 3,138-3,140,
 copper, ills., 3,134.
 decomposing fluid by, ills., 99.
 Faraday's, definition of, 98.
 Gibbs' process, ills., 3,137,
 Grothuss' theory of, ills., 100,
 in lower New York, ills., 3,136,
 various metals, ills., 3,134, 3,135,
 wet extraction process, 3,141.
- Electrolyte**, 908.
 behavior during discharge, 926,
 boiling, of storage battery, 927,
 composition of, 904, 909, 910,
 effect of, current, 898,
 in cell, 40.
 evaporation of, 63.
 hot, 905.
 introduced in arrester cells, 1,699,
 rectifier, 1,502,
 specific gravity, change, 915,
 low, 962,
 testing, 921.
- Electrolytic, arrester(s)**, 1,696, 1,697.
 aluminum, ills., 1,696-1,698.
- Electrolytic, arrester(s)**,—*Continued.*
 cells connection, 1,699,
 horn gaps, G. E., ills., 1,702,
 bullion refining, 3,135,
 cell, ills., 98.
 rectifier(s), Mohawk, ills., 1,501,
 ills., 1,495, 1,496, 1,498, 1,500,
 1,501.
 Westinghouse, ills., 1,705.
- Electromagnet(s)** (of), annunciator, ills.,
 2,388.
 consequent pole, ills., 201.
 construction, 199.
 core(s), 200.
 const., ills., 206.
 current adjustment, 199.
 magnetic effect, 199,
 pole pieces, ills., 207-214,
 salient pole, ills., 200, 201,
 signal relays, 2,637,
 yoke, const., 200, 204, 205.
 vs. permanent magnets, 199.
- Electromagnet coils**, attach. of, ills., 218,
 connections, 219.
 former wound, 215.
 spool wound, ills., 215.
 ventilation, ills., 220.
- Electro-magnetic, field surrounding charged**
 conductor, ills., 1,895,
 induction, 125-136. ills., 2,412,
 inertia, definition of, 136, 137,
 measuring instruments, 1,780,
 meter, ills., 1,783, 1,784,
 rectifier, ills., 1,527-1,529,
 waves, 1.
 for wireless telegraphy, 2,278.
- Electro-mechanical**, bell 2,371-2,374,
 circuit maintainer ills., 2,355.
- Electromotive force(s)**, analogous to water
 pressure, 465.
 def. of, 28.
 formula, 29.
- Electron elevator controller**, d. c. mechanical,
 ills., 2,884, 2,885.
- Electrophorus**, ills., 16, 17, 18, 23.
- Electro-plating**, 3,143-3,183,
 acid dipping baskets, ills., 3,144,
 adherence of metals, 3,145,
 ammeter, ills., 3,151, 3,168, 3,169
 anodes, ills., 3,144, 3,145, 3,168, 3,169,
 3,179, 3,180.
 apparatus, mechanical, 3,156,
 articles not metal, 3,143,
 barrel, burnishing, ills., 3,164, 3,165,
 self-emptying, ills., 3,182,
 tumbling, ills., 3,162, 3,163, 3,183,
 baskets, dipping, ills., 3,160,
 batteries for, 3,146, 3,147,
 blackening prevented, 3,153,
 brushes, various, ills., 3,159, 3,161,
 3,162.
 buffing wheel, 3,177.
 burnishing barrel, steel ball, ills., 3,164,
 3,165.

Electro-plating, —Continued.

- cell(s), various, 49, 50, 54.
 ills., 3,145, 3,146.
 cleaning methods, ills., 3,143, 3,144,
 3,158, 3,178, 3,179.
 color, varying, 3,157.
 work, buff speed, 3,177.
 copper, 3,173.
 current, density, 3,144, 3,153.
 rheostat for ills., 3,154.
 supply for, 3,146, 3,148, 3,149.
 deposit "burnt," 3,153.
 depositing solution, cond. of, 3,145
 dips and pickle, 3,177, 3,179.
 dynamos and connections, ills., 3,147-
 3,152, 3,168, 3,169.
 electrolyte, nature of, 3,143.
 fining wheel, ills., 3,171, 3,176.
 galvanizing barrel, ills., 3,182.
 generators, large, brush gear 320.
 grinding wheel, 3,170.
 heating tanks, ills., 3,145.
 lacquering, ills., 3,166, 3,167.
 motor gen. set, H. & V., ills., 3,149.
 nickel, plating, 3,180, 3,181.
 properties of, 3,147, 3,149.
 outfits, 3,150, 3,151, 3,168, 3,169.
 pickle(s), and dips, 3,177.
 for silver, 3,178, 3,179.
 polish, crocus, 3,167.
 various, 3,166, 3,167, 3,168.
 polishing and buffing, head, 3,172.
 wheel(s), H. & V. univ., ills.,
 3,171.
 spaced curves, ills., 3,175.
 var., ills., 3,174-3,176.
 process explained, 104.
 rattling barrel, 3,162.
 rheostat, ills., 3,150, 3,151, 3,154, 3,168,
 3,169.
 connection, ills., 3,152.
 roughing wheel, H. & V. univ., ills.,
 3,171, 3,175, 3,176.
 solution(s), amalgamating, 3,146.
 electropoison, 3,146.
 hydrofluoric acid, 3,158.
 nickel, 3,181.
 nitric acid, 3,169.
 pickle(s), and dips, 3,177-3,179.
 various metals, 3,169, 3,170, 3,172.
 stripping, 3,145.
 tank(s), iron, 3,159.
 or vats, 3,157, 3,159.
 rinsing, ills., 3,159, 3,161.
 wooden, ills., 3,159.
 time required, various sol., 3,156.
 tumbling barrel, ills., 3,162, 3,163, 3,183.
 2 and 3 wire diag., Optimus, 3,152.
 two, tank installation, ills., 3,158.
 wire, 4 tank, diag., ills., 3,168.
 vessels, dipping, ills., 3,160.
 voltmeter, ills., 3,151, 3,154, 3,168,
 3,157, 3,169.

Electro-plating, —Continued.

- wheel washer, 3,176.
 wire used for, 3,149
 wiring for, 3,153, . . .
 Electropoison, 36, 49. . . . 3,146.
 Electropositive substance, 41.
 Electroscope(s), ills., 5, 6, 15, 20.
 Electrostatic, field surrounding charged con-
 ductor, ills., 1,895.
 ground detector, West., ills., 1,837,
 induction, def. of, 125.
 instruments, 550.
 strain, 19.
 voltmeter, ills., 550, 551,
 Kelvin, ills., 551.
 Electro-therapeutic(s), cautery tech., 3,225.
 coil(s), induction, ills., 3,187-3,189,
 spark, 3,187-3,189.
 X ray, converter, 3,197.
 current(s), for various diseases, 3,199-
 3,220.
 galvanic, 3,198-3,200, 3,203,
 inter., rheotome, ills., 3,198,
 sinusoidal, 3,193-3,200.
 diseases, treatment, (current) for
 abdominal, 3,205.
 amenorrhea, 3,206,
 analgesia, 3,216.
 aphonia, 3,206, 3,207.
 ataxia, locomotor, 3,209.
 atrophy, optic, 3,212, .
 asthma, 3,207.
 bladder disease, 3,205,
 blepharospasm, 3,220.
 catalepsy, 3,207.
 catarrh, 3,207.
 central lesions, 3,212.
 cervical erosions, 3,203.
 congestion, portal, 3,205,
 splenic, 3,220.
 constipation, 3,205, 3,207, .
 cystitis, 3,205.
 erosions, 3,203.
 endocervicitis, 3,207.
 endometritis, 3,207.
 enteroptosis, 3,214.
 fissure of anus, 3,205.
 gastrectasis, 3,208.
 gastritis, 3,208.
 glaucoma, 3,220.
 gleet, 3,205.
 headache, 3,208.
 hemorrhoids, 3,204, 3,205, 3,208.
 hyperesthesias, 3,205.
 incontinence of urine, 3,205.
 infantile paralysis, 3,208.
 infantile uterus, 3,218,
 insomnia, 3,209.
 intestinal neuralgia, 3,211.
 leucorrhoea, 3,205.
 ligaments, relaxed, 3,205.
 locomotor ataxia, 3,209.
 lumbago, 3,209.
 melancholia, 3,205.

- Elevator controller.**—*Continued.*
 semi-mech., C.-H., ills., 2,907,
 2 or 3 phase, Otis, ills., 2,904.
- Elevator controller, d. c., duplex, Otis, diag.,**
 2,898.
 mech. Electron, diag., 2,884.
 gravity, diag., 2,890.
 National, ills., 2,890.
 mag., Electron, diag., 2,885,
 Otis, diag., 2,877, 2,890.
 pilot, Sprague, diag., 2,896.
 semi-magnet, C.-H., ills., 2,873,
 semi-mech., C.-H., ills., 2,871.
 Schureman, ills., 2,876,
 two speed, Otis, diag., 2,895.
- Elevators, drum, cable drive, ills., 2,912,**
 cables, 2,924.
 counterbalance propor., 2,857.
 counterweights, 2,924,
 description, 2,856,
 gear, internal, 2,923,
 single, 2,919.
 gearing, 2,907.
 objection to, 2,859,
 overmounted, advantage, 2,857,
 pulleys, 2,924,
 spiral grooves, 2,859,
 transmission, 2,907.
 undermounted, full mag., ills., 2,857.
- Elevator gear(s), concave face, ills., 2,922,**
 end thrust, ills., 2,919.
 herringbone, Gur., ills., 2,916, 2,917.
 kinds of, 2,916.
 Wuest, 2,918.
 internal, spur, ills., 2,923.
 old forms, ills., 2,921, 2,922,
 spur, ills., 2,915.
 spiral, 2,921.
 teeth, parts, ills., 2,915.
 strength, formula, 2,915,
 wheel, h. p. formula, 2,916, 2,917.
 worm, 2,918, 2,919.
 double or tandem, ills., 2,920,
 2,922,
 lubrication, 2,921.
 tandem, Reedy, ills., 2,922.
- Elevator motor(s), acceleration, 2,904,**
 a. c. Warner, ills., 2,869,
 current for, 2,868,
 d. c., adjustable speed, 2,870,
 gear drive of, 404,
 h. p. diagram, ills., 2,867,
 formula, 2,868,
 leaving for night, 2,934,
 old style, 2,901,
 polyphase slip ring, 2,872,
 relays, 2,884,
 repulsion induction, 2,873,
 series field winding, 2,887,
 single phase, suitability, 2,873,
 standard split phase, undesirable, 2,873,
 squirrel cage, h. p. of, 2,871,
 induction, 2,870.
- Elevator operation, 2,926,**
- Elevator operation.**—*Continued.*
 car stops between landings, 2,931, 2,933.
 caution, 2,933,
 car beyond control, 2,933,
 leaving car for night, 2,933,
 reversal, 2,929,
 starting, 2,928,
 stopping, 2,928.
- Elevator switch, a. c. or d. c., C.-H., ills.,**
 2,900.
 belt freight, ills., 2,873.
 contacts of, 2,932.
 knife, 2,896,
 limit, 2,905.
 cam, rot., C.-H., ills., 2,905,
 trav., C.-H., ills., 2,906,
 machine type, ills., 2,896,
 mech. rev., Otis, ills., 2,900,
 operation of, 2,880,
 pilot, 2,893.
 reverse, C.-H., ills., 2,903,
 drum, three pole, 2,907,
 semi-mech. controller, 2,876,
 safety, 2,899,
 shaft, single pole, 2,899,
 limit, 2,897, 2,899, 2,928,
 C.-H., ills., 2,906,
 slack cable, C.-H., ills., 2,906,
 solenoid operation, 2,881,
 triple pole, cam, 2,908,
 try out, 2,891.
- Elevators, traction, 2,859, 2,863,**
 gearless, 2,861,
 hoisting cables, 2,859,
 Otis, 1 to 1, ills., 2,857, 2,858,
 2 to 1, ills., 2,860.
 straight grooves, 2,859.
- Emmet system, ship propulsion, 2,666,**
Emery wheel, speed curves for, ills., 3,175,
Enclosed, arc(s), 2,439, 2,441
End, cell switch(es), ills., 977-979,
 ring(s), armature, G. E., ills., 1,324.
Endocervicitis, treatment for, 3,207,
Endometritis, treatment 3,205, 3,207.
Energy, central, switchboards, 2,135, 2,136,
- chemical, 28.
 def., 83.
 dissipated by mag. subs., 124.
 electrical, 26,
 amount; on what depends, 161.
 heat, in generating current, 33.
 kinetic, definition of, 83.
 loss due to hysteresis, 123.
 mechanical and electrical, 83-92,
 how converted, 155,
 potential, def., 83.
- Engberg a. c., generating set, ills., 1,145,**
 railway car lighting, 2,605.
- Engine, backward motion of, 594.**
 Corliss high speed, ills., 1,979,
 in railway power house, 2,544,
 direct con. alternators, ills., 1,174,
 gas, and alter., dir. con., ills., 1,956,
 and dynamo, West., ills., 1,979.

Engine,—Continued.

- in central station, 1,941,
M. and W., 2 cycle, ills., 2,739.
pulley diameter, 2,004.
steam, anal. of cur. flow, ills., 1,053,
of power fac., ills., 1,109,
indicator cards, ills., 1,779,
type alternator, ills., 1,141.
- English candle, lighting standard, 2,508.
- Entz', booster sys. carbon pile, ills., 986,
starting and lighting sys., ills., 2,802.
- Epilation work, ills., 3,201, 3,203.
- Equivalent, focus, 2,702,
Joules, 91,
ohmic, of inductance, 1,038.
wire, table, 751, 752, 1,913.
- Equalizer, connections of rotary converter,
Westinghouse, ills., 1,467.
dynamo, 601.
dynamotor, ills., 711,
regulator connec., ills., 2,031, 2,032,
rings, ills., 254.
- Erg, def. of, 123.
- Erman's battery experiment, 893.
- Erosions treatment for, 3,203.
- Ether, luminiferous, 2,674.
waves, 2,274-2,279.
- European telegraph system, ills., 2,207.
- Evaporation factors of, table, 1,934.
of electrified fluids, 102.
of electrolyte, 63.
- Evershed portable ohmmeter set, ills., 509.
- Evolute, armature, coil described, 343,
connectors, 336, 337.
coils, winding of, ills., 343, 344.
placed on core, 346.
winding, ills., 337-339.
- Evolution (of), squir. cage armature, ills.,
1,319-1,321.
3 phase 3 wire system, ills., 1,564,
three wire system, ills., 705.
- Excello resistance wire, comp. of, 3,049.
- Exchange, automatic groupings, ills., 2,156.
circuits, private branch, ills., 2,130-
2,133,
connecting, telephone, 2,164.
equipment, central office, 2,139.
ground, telephone, ills., 2,187.
- Exciter, alternator, location, 2,009,
transformer and converter con-
nected, ills., 2,062,
belt driven, 1,171.
connections, G. E. diag., 2,020,
direct connected, ills., 1,169-1,171,
for shunt fields of several dyn., 197.
- Exide storage bat., cons., ills., 912, 913,
duplex sparking, ills., 924,
ignition, ills., 911,
plates, 2,795, 897.
- Expulsion fuse, 1,616.
- Extension, circuits, priv. line, ills., 2,144,
from P. B. X. switchboard, 2,141.
- Extraction, metal, wet processes, 3,141.
- Ewing's definition, hysteresis, 123.
- Eye, mech. vibration treatment, 3,220.



- Factor(s), diversity, diag., ills., 1,929.
form, peaked wave, 1,015,
load, 1,931-1,932,
of evaporation, table, 1,934,
power, CHAPTER XLVIII, 1,101-1,124.
- Fagoting meth., of weld., 3,110, ills., 3,112.
- Fairbanks-Morse, armature, ills., 360.
squirrel cage, ills., 1,326, 1,373,
field coil and pole piece, ills., 359,
irrigation plant, 2,992,
lighting outfit, ills., 989.
motor inductors, ills., 361,
standard, ills., 358.
- Fall of potential, hydrostatic analogy, 33,
measure of, ills., 33, 34, 480,
testing method, 505.
- Fan motor, single phase, ills., 1,346.
- Farad, ills., 92, 1,041, 1,042.
- Faraday's, battery experiment, 894,
disc meter, elem., ills., 1,822, 1,825,
discovery of electro-mag. induc., 125,
dynamo, separately excited, 196, ills.,
126, 2,412.
electro-magnetic exper., ills., 1,297,
experiment, principle of, 127,
ice pail experiment, ills., 21,
machine, construction of, 126.
mercury motor meter, ills., 1,824.
meter operation, 1,823.
test of charge, 13.
- Faradic, current, 3,198-3,200,
electricity, 3,185, 3,198-3,200.
- Fault finder, battery connections, 522,
L. and N., ills., 510, 511,
measuring resis., L. and N., ills., 512.
test, cable wire, L. and N., ills., 524, 525.
- Murray loop, ills., 516,
special loop, ills., 520, 521.
Varley loop, ills., 519.
- Faure's battery, experiment, 894,
plates, constr., 903, 2,838.
- Feeder(s), and mains in parallel, ills., 701,
battery, storage, ills., 995,
connection, anti-parallel, 701,
parallel, 701.
current, pressure, how increased, 185,
def. of, 743.

- Feeder(s)**,—*Continued.*
 distributing panel, 854.
 layout, Ind. and L. Ry., ills., 2,542.
 motor and lighting separated, 853.
 panel, board, ills., 1,880
 connections, 3 ph., ills., 1,881.
 regulation, a. c., 1,715, 1,716.
 regulator, voltage, 1,742.
 subdivided electric, 853.
 system, plan for hotel, ills., 863.
 tube, Edison, ills., 840.
 wires installed on walls, 772, 778.
 wiring, electric light, ills., 745.
- Ferro-nickel**, resistance wire, 3,049.
- Fessenden sliding half waves**, ills., 2,280.
- Fibre**, conduit, screw joint ills., 837-839.
 sleeve joint, ills., 838.
 insulation, for rail joints, 2,635.
 suspension, galv., torsion in, 441.
 vulcanized, for field coil ills., 217.
- Fibroids**, treatment for, 3,205.
- Field**, a. c., rotation of closed coil in, 1,349.
 alternator, revolving, Lincoln, ills., 1,167.
 superposition of, ills., 1,164.
 commutating, nature of, 387.
 object of, 387.
 produced by interpoles, 387.
 conductor in, ills., 350, 352.
 control, railway motor, 2570.
 current, excessive, of dynamo, 661.
 def., 2,734.
 distorted, by reaction in motor, 363.
 by arm. reaction, ills., 1,160.
 distortion shown by iron filings, ills., 264, 265.
 distortion, brush adj., ills., 286.
 dynamo, ills., 262.
 remedies for, 265.
 effect on, of moving circuit, 127.
 eight pole two phase, ills., 1,301.
 electro-magnetic, 125-136.
 surrounding charged conductor ills., 1,895.
 excitation, 181, 2,039.
 extent and character of, 108.
 flux, inductor influence on, 1,150.
 four pole, devel. view of, ills., 232.
 three phase, ills., 1,305.
 lateral, bet. adj. poles, ills., 1,165.
 or armature currents reversed, 361.
 regulation, series motor, ills., 382.
 regulator open, 612, 615.
 resistance loss, 2,114.
 reversed, causes, 588.
 rotating magnetic, 1294-1309.
 three phase, ills., 1304-1309.
 two phase, ills., 1298-1304
 self-excited, alternator, ills., 1,168.
 self-exciting dyn., strengthening 184.
 series, in compound motor, 375.
 short circuit in, 620.
 shunt, and arm. control comb., 690.
 in compound motor, 375.
 resistance, reg. of motor, 685.
 six pole, three phase, ills., 1,310.
- Field**, six pole,—*Continued.*
 two phase, ills., 1,300.
 stray, between adj. poles, ills., 1,166.
 strength, rise of, how indicated, 185.
 of converter, effect of, 1,466.
 of magnet, unit of, 111.
 of motor, 355.
 of synchronous motor, 1,277.
 strengthened, cur. lead, ills., 1,162.
 surrounding conductor, 274.
 two pole, slot, ills., 1,265.
 three phase, ills., 1,306.
 varied by rheostat, ills., 190, 191.
 weakened by arm. react., ills., 1,161.
 winding(s), automobile, 2,847.
 of dynamo, choice of, 392.
 ratio between, 192.
 sections of short circuited, ills., 681.
- Field coil(s)**, and armature, reversed connections between, 589.
 and pole piece, Fairbanks-Morse, ills., 359.
 attached, ills., 218.
 comp. wound, Ft. Wayne, ills., 220.
 connections wrong, 622.
 current, variation of, ills., 190, 191.
 dynamo(s), con. in parallel, 600.
 remagnetized, 587.
 former wound, W. E., ills., 219.
 grounds located in, 627.
 heat dissipated in, 220.
 improperly connected, 585.
 insulation of, 216, 217.
 moisture detected in, 661.
 railway motor, ills., 2,564.
 reversed, finding of, 587.
 short circuits in, indications, 662.
 test, with pocket compass, 587.
 for short circuit, 620.
 with telephone, ills., 620.
 Watson, ills., 631.
- Field magnet(s)**, 199-220.
 alternators, 1,187, 1,189.
 and armature, how differ, 159.
 bipolar, in dynamo, 182.
 circuit of dynamo, 573.
 coils, coupling of, 396.
 core, residual magnetism in, 124.
 heating of, 661.
 object of, 159.
 over exciting, 648.
 polarized by motor current, 359.
- Field**, magnetic, rotating, alternator, A.-C., ills., 1,179.
 belt driven, ills., 1,139.
 brush rigging for, ills., 1,262.
 ills., 1,146, 1,148, 1,149.
 separately excited, Westinghouse, ills., 1,172.
 experimental, ills., 1,295.
 induction motor, 1,313.
 production of, 1,295.
 by polyphase current, 1,287.
 by 3 ph. cur., ills., 1,304, 1,305.
 by 2 phase cur., 1,298, 1,299.

Field magnetic, rotating.—Continued.

- resultant flux of, ills., 1,294,
 Tesla's, ills., 1,293.
 3 ph., physical concep. cf, ills. 1,308,
 1,309.
 2 ph., physical concep., ills., 1,302,
 1,303.
- Filament, lamp, carbon, 2,486,**
 double, 2,501.
 helion, 2,492.
 incandescent, ills., 2,531,
 forms of, ills., 2,489,
 size of, 2,488.
 iridium, 2,499.
 metallized, 2,492.
 squirted, 2,485.
 tantalum, ills., 2,495. 6.
 tungsten, Kuzel process, 2,497.
- Filing and adjusting com. brushes, 576,**
 clamp, brush, metal, ills., 638.
 high segments, 643.
 machine brushes, jig for, ills., 638.
- Filings, and magnet, exper., ills., 109,**
 Branly's exper., ills., 2,270.
 showing distort. of mag. flux, ills., 265.
- Film, black, on commutator, heating, 657,**
 of idle rectifier lost, 1,501.
 Nodon, valve, efficiency of, 1,499,
 oscillograph records, ills., 1,867.
- Film, motion picture, 2,724,**
 action of, 2,708, 2,709.
 feed system, 2,706.
 framing, 2,711.
 gate, function of, 2,711.
 Simplex, ills., 2,710.
 lens for, 2,701.
 perforations, ills., 2,726.
 repairing, 2,725.
 splice, ills., 2,725, 2,729.
 take up device, ills., 2,714.
- Fire call annun. system, W. E., ills., 2,393.**
- Fire, insurance rule electric wires, 97,**
 proof, bld., conduit, ills., 792,
 compound on wire, ills., 727,
 reducing, welding, 3,108.
- Fire alarm(s), automatic signals, 2,262,**
 boxes, 2,262,
 Jupiter, ills., 2,409.
 circuit, ills., 2,261,
 Edison cell for, 50.
 telegraphy, 2,261.
 zinc, 63.
- Fish plug for flexible conduit, ills., 790.**
- Fischer cable setting set, ills., 535.**
- Fishing wires, ills., 787, 789.**
- Fissure of anus, treatment for, 3,205.**
- Fitting(s), canopy insulator, ills., 788,**
 ground, Westinghouse, ills., 1,706,
 insulated wire joint, ills., 788,
 machine special, 1,993,
 standard, 1,993.
- Five, wire distribution, system, 711,**
 two phase, ills., 1,561.
- Fixed position of brushes, 294.**
- Flag, electric light, wir. diag., ills., 872.**
- Flame, as conductor of electricity, 69,**

Flame.—Continued.

- effect of on electricity, 7.
 lamp, Adams-Bagnall, ills., 2,433,
 near accumulator, danger of, 921,
 oxy-acetylene, features of, 3,115.
- Flaming arc lamp, 2,466,**
 efficiency increased, 2,418.
 Helios, 2,468,
 operating cost, 2,423,
 principle of, 2,463.
 steadiness in, 2,479.
 transformer, Moloney, ills., 1,454.
- Flange, joint soldering, ills., 3,081.**
- Flash weld, ills., 3,128.**
- Flasher(s), brush and knife, 869,**
 brush type, Reynolds', ills., 868,
 carbon, Dull's, ills., 866, 867,
 chaser, Reynolds', ills., 876,
 clock monogram, ills., 882,
 commutator for letter, 884,
 cylinder thermal, ills., 879,
 high speed, wiring plan, ills., 873,
 Dull's, ills., 871.
 knife type, Reynolds', ills., 868,
 lightning Dull's, ills., 874.
 on and off double pole, ills., 870.
 script sign breaker, Bett's, ills., 875,
 sign, 865-892.
 transmission gear, ills., 869,
 slow speed, ills., 878, 879.
 snake, wiring, ills., 877.
 talking sign, 883, 884.
 thermal, G. E., ills., 879,
 two way, ills., 883.
 thermo-contact, ills., 878, 879.
 torch, wiring for, ills., 873.
- Flat(s), commutator, causes of, 643,**
 iron, electric, ills., 3,063,
 heating unit for, 3,051,
 on commutator, 643.
 radial controller, ills., 694.
 wire gauge, B. & S., ills., 738.
- Fleming's, meth. of meas. power, ills., 1,123,**
 oscillation valve, ills., 1,502.
 rule for dir. of cur. in alt., ills., 163, 164,
 for dir. of ind. cur., ills., 133, 135.
- Flexible, armoured cable, 796.**
- Float switch, Cutler-Hammer, ills., 1,611,**
 pump, ills., 3,019.
- Floating, coils on regulators, 1,735, 1,736,**
 the storage battery, 971, 972.
- Floor tread burglar alarm, ills., 2,405.**
- Flow, double, steam turbine, ills., 1,967,**
 inward, reaction turbines, 1,978.
 outward, reaction turbines, 1,978.
 parallel, reaction turbines, 1,978.
 positive, both plates negatively electri-
 fied, 40.
 semi-double, steam turbine, ills., 1,968.
- Fluid(s), decom. by electrolysis, ills., 99.**
- Fluorescence, def. of, 2,506.**
 shadow, hand bones, ills., 3,230,
 screen, X-rays, ills., 3,229, 3,230.
- Fluoroscope, X-ray, ills., 3,229, 3,230.**
- Flux, density, effect of increase, 120,**

- Flux, density**,—*Continued*,
 ratio to magnetizing force, 118,
 field, inductor influence on, 1150,
 in Faraday disc meter, 1,825,
 in gap of dynamo, ills., 208,
 motor, auxiliary, 385,
 soldering, various, 3,079, 3,083, 3,084,
 welding, 3,108.
- Flyer**, electric, ills., 9, 10.
- Focal length**, rule for, 2,704.
- Focus(i)**, concave lenses, double, ills., 2,688,
 2,689,
 conjugate, 2,677, ills., 2,686,
 convex lenses, double, ills., 2,688,
 equivalent, 2,702,
 principal, lens, ills., 2,685-2,687,
 or real, of mirror, 2,677,
 tube, X-ray, ills., 3,229,
 virtual, lens, ills., 2,687, 2,688,
 mirror, 2,677.
- Foot**, ampere, meaning of, 736.
 brake of automobile, 2,850, 2,851,
 candle, ills., 2,510, 2,523,
 lamp, meaning of, ills., 735,
 mil, of wire, 734.
 pound, def. of, 86, 376,
 relation to watt, 91,
 valves, 2,977.
- Foot-Pierson**, telegraph relay, ills., 2,209,
 walking beam pole changer, ills., 2,239.
- Force(s)**, centrifugal, in pumps, 3,002,
 component, ills., 1,074,
 composition of, 1,072,
 cross magnetizing, effect, 364,
 driving, of motor, 351,
 dyne unit, 111,
 electro-magnetic, 1,178,
 electromotive, def., 28,
 magnetomotive, def. of, 120,
 parallelogr. of, ills., 1,534, 1,073,
 representation of, ills., 1,072,
 resultant, ills., 1,074,
 reversal, dynamo used as motor, 356,
 two, phase difference of, 1,535,
 lines of, 13,
 altered, ills., 129,
 by moving circuit, 127,
 in non-uniform field, ills., 130,
 distribution of, ills., 115,
 in circular loop, ills., 114, 115,
 rate of cutting, 1,019,
 solenoid, 115,
 tracing experiment, ills., 109.
- Force**, magnetic, action in dynamo and motor,
 ills., 353,
 laws of, 111,
 lines of, cutting, 126,
 direction, ills., 113,
 number, how altered, 126,
 Ohm's law applied to, 121,
 to what proportional, 130,
- Force pumps**, des., 2,975,
 distinguishing feature, 2,977,
 doubleact., des., 2,978, 2,979, 2,981.
- Force pumps**,—*Continued*,
 elementary single act., ills., 2,976,
 2,977,
 Forced, carbon(s), 2,424,
 circulation of air, arma. vent., 333,
 draught, 1,961,
 air cooled transformer, 1,406,
 boiler room ills., 1,959,
 plant, ills., 1,959-1,961,
 transformer, ills., 1,407,
 system of lubrication, ills., 660.
- Forgings**, electro-plating, pickle, 3,176.
- Form factor**, of peaked wave, 1,015,
 of curve, ills., 1,014.
- Former coils**, 215, 342.
- Formula**, amperes, 29,
 brake horse power, 379, 380,
 condenser pressure, 1,048,
 cranes and hoists, power, 2,955,
 current, pressure, active, 1,087,
 resistance, 29,
 joint, 81.
- Electrical horse power**, 385,
 electromotive force, 29,
 factor, of evaporation, 1,933,
 farads, 1,042,
 generator, com. efficiency, 2,110,
 henry, 1,031,
 impedance, 1,081,
 inductance in, coil, 1,035,
 ohmic equivalent of, 1,038,
 horse power, 376,
 brake, 380,
 electrical, 385,
 motor, elevator, 2,868,
 theoretical pump, 2,986,
 wheels, cast iron, 2,916,
 lamps, deter. number of, 2,529;
 lens, focal distance, 2,696,
 focal length, 2,704,
 microfarads, 1,042,
 motion pictures, distance slide to screen,
 2,704,
 image size, 2,704,
 motor, efficiency, 380,
 elevator, size, 2,868.
- Ohm's law**, 29,
 drop, 1,089,
 power, cranes and hoists, 2,955,
 pump capacity, 2,984,
 reactance, 1,055,
 capacity, 1,063,
 inductance, 1,063, 1,091,
 resistance bridge arms, 502,
 divided circuits, joint, 81,
 fall of potential, 480,
 slip, 1,315,
 synchronous speed, 1,315,
 voltage, 29,
 watt loss at brushes, 314,
 wires, copper, 1,906,
 area, transverse, 734,
 resistance, 734, 746,
 size, 1,902,
 lamp, 748, 763,
 motors, 758, 759.

Formula,—Continued.

wireless wave length, 2,286.

wiring drop, 1,911.

flow in circuit, 1,912.

two wire circuit, 1,904.

Fort Wayne, alternator, revolving armature, ills., 1,203.

revolving field, ills., 1,201.

separately exc't. belt driven, ills., 1,163.

stationary field of, ills., 1,195.

with amortis. wind. ills., 1,154.

with dir. con. exc., ills., 1,171.

arc lamp, carbon clutch, ills., 2,455.

c. p. distributing curve, 2,425.

gas cap for, ills., 2,459.

parallel cir., d. c., ills., 2,451.

enclosed, ills., 2,453.

series, diff., d. c., ills., 2,450.

coil, impedance, ills., 2,451.

comp. wound field, ills., 220.

commutator truing device, ills., 618.**core** laminated, ills., 212.**dynamo**, ills., 317.**meter** induc. watthour, ills., 1,805.

interior, ills., 1,808, 1,809.

motor split phase induc., ills., 1,347.**pole** piece, laminated, ills., 211.**switchboard** panels, ills., 1,873.**transformer**, distrib., ills., 1,384.

ills., 1,398.

regulation curves, ills., 1,411, 2,446.**wattmeter**, multiphase, ills., 1,806, 1,807.

single phase induction, ills., 1,810.

Foucault's exper. velocity light, 2,276.**Foundation(s)**, concrete, ills., 1,952.

footing angle, ills., 1,951.

for dynamos and motors, 394.

for electrical machines, ills., 395.

Frahm res. freq. meter, ills., 1,827.**Franklin's experiments**, 3.**Fraser** elevator, cable drive, ills., 2,912.

controller, d. c., duplex, ills., 2,899.

"Free," air, def., 3,025.

electricity, def. of, 9.

wave theory, 2,280.

Frequency(ies), 1,892.

adjustment of meter, 1,821.

changers, par. oper. of, 1,489, 1,490.

rotating elements of motor and generator, 1,570.

changing sets, ills., 1,488, 1,489.

converter, 1,459.

critical, curve, ills., 1,064.

determination of, 1,065.

def., 1,004.

effect on wave length, 2,278.

high, alternators, 1,185.

oscillations, 1,677.

indicator(s), 1,825.

inductance affected by, 1,892.

low, advantages of, 1,006.

meter, induction, West., ills., 1,829.

G. E., ills., 1,830.

Frequency(ies), meter,—Continued.

Langsdorf & Begole, ills., 1,830.

of ether waves, 2,277, 2,278.

reduction by chopper, wireless, tel., 2,284.

variation, 2,079.

Friction, automobile bearings, 2,826.

belt, on leather covered pulleys, 401.

clutch pulley, Hill, ills., 2,013, 2,014.

compensator of meter, 1,818.

contact pressure and resistance of

brushes compared, 313.

disc clutch, motion pict., ills., 2,714.

drive dyn., Motsinger, ills., 2,750.

of ignition dyn., 2,750, 2,751.

electricity developed by, 5.

heat produced by, ills., 89.

motor drive, 404.

of brushes, 314.

of water, in elbows, 2,968.

in pipes, 2,967.

Frictional electricity, def. of, 4.**Frog(s)**, bond, railway, ills., 2,642.

legs, current effect of, 103.

Fuel, for blow pipe, 3,115.

for welding, 3,111.

Fulco pastil adapter, ills., 2,720.**Fulcrum** pin lever of motor, ills. 688.**Fuller**, bichromate cell, 48, 49.

electrolyte, 49.

electric geyser, ills., 3,059.

two-fluid cell, ills., 49.

zinc, ills., 61.

Furnace, brazing, ills., 3,099, 3,100.

gasoline, plumbers, ills., 3,072.

grate surface, 1,935.

Fuse(s), advan. and disadvan., 1,615.

and main circuit, ills., 744.

blocks, transformer, 1,420.

Westinghouse, ills., 1,406.

blown, master controller, 2,664.

box(es), and service switch, Palmer

ills., 1,591.

transformer, ills., 1,420.

cartridge, ills., 413.

connec. to transf., 3 wire, ills., 1,435.

copper, objection to, 415.

Edison, ills., 416.

elevator, defective, 2,931.

enclosed, end ferrule, ills., 1,616.

ills., 1,614.

expulsion, 1,616.

indicator, ills., 415.

interior construction of, ills., 414.

large, objection to, 1,614.

magnetic blow out, 1,616.

mounting of, 415.

multiple, better than single, 413.

notched end, ills., 1,618.

open, various, ills., 416.

placing of, 413.

plug, ills., 1,615.

quick break, ills., 1,617.

switch(es), 1,593.

metal, objection to, 1,590.

telephone, ills., 416.

- General electric, gas-elec. motor car,—Cont'd.**
 generating set, ills., 1,980.
 generator, marine, ills., 397.
 locomotive, 10 ton, 2,590, ills., 2,590,
 platform type, ills., 2,596.
 manhole, ills., 843.
 motor, adj. speed repul., ills., 1,359.
 back geared, ills., 403.
 capacity of, 377.
 car, gas-electric, ills., 2,597.
 com. pole railway, ills., 2,564.
 controller, ills., 693.
 type K, ills., 2,570, 2,574.
 drawn shell induc., ills., 1,344.
 frame heads, ills., 2,561.
 2,559.
 generators, ills., 1,484, 1,485, 1,492.
 generator set installed in central
 station, ills., 1,486.
 induc., drawn shell, ills., 1,345.
 small, ills., 1,316.
 vertical, ills., 1,314.
 railway, ventilated, 2,563.
 single phase, compensated repul-
 sion, ills., 1,354, 1,366.
 induction, ills., 1,341.
 slow speed, ills., 369.
 split frame railway, ills., 2,564.
 synchronous, ills., 1,765.
 ventilated arm. const., 2,563.
 oscillograph, moving coil, ills., 1,852,
 1,853.
 reactance, cur. limiting, ills., 1,619.
 rectifier, electro-magnetic, ills., 1,529.
 ills., 1,513, 1,514.
 mercury arc, double tube, ills.,
 1,519.
 outfit, ills., 1,522.
 series, ills., 1,520-1,524.
 single tube, ills., 1,518.
 tube, ills., 1,516, 1,525.
regulator, current, d. c. diag., 2,028,
 equalizer, ills., 2,031, 2,032,
 voltage, automatic, d. c. diag.,
 2,029.
 diag., 1,750,
 ills., 1,748,
 switchbd. diag., 2,022, 2,024,
 d. c., form S diag., 1,729,
 ills., 1,725,
 electroplating, 3,155.
 pole type, 1,739-1,744.
 wiring, ills., 2,030.
relay, d. c., differential, ills., 1,670,
 reverse cur., ills., 1,669,
 high voltage cutout, ills., 1,735,
 instantaneous, ills., 1,668,
 low voltage a. c., ills., 1,657,
 time limit, ills., 1,658,
 overload, ills., 1,760,
 shunt adj. compen., ills., 1,724
switch, cir. closing aux., ills., 1,635,
 cir. opening aux., ills., 1,635,
 oil, ills., 1,602,
- General Electric, switch,—Continued,**
 solenoid operated remote control,
 ills., 1,590,
 switchboard, small plant, ills., 1,874.
 synchronism indic. con., ills., 1,834.
 synchroscope, ills., 1,832, 1,834,
 thermal flasher, ills., 879.
 transformer, air cooled constant current,
 ills., 1,424.
 connections, 3 wire, ills., 1,438,
 core, ills., 1,392.
 ills., 1,399.
 water cooled, ills., 1,414, 1,415,
 transmission towers, ills., 1,580,
 wave meas. rec., ills., 1,840, 1,841.
 General Storage Bat., system, ills., 984.
 Generator(s), Curtis turbine, ills., 2,050,
 def., 155.
 double current, 1,461.
 driving direct from engine fly wheel,
 ills., 2,799.
 magneto, ills., 2,128.
 mechanical, 2,749.
 medical, Columbia, ozone, ills., 3,214,
 polysine, McIntosh, ills., 3,204,
 modalities of, ills., 3,217.
 Triumph, with upright slide valve
 engine, ills., 1,979.
 White, 2,672.
 Geneva intermittent movement, action of,
 ills., 2,708, 2,709, 2,712,
 const., 2,715.
 German candle, lighting standard, 2,508.
 German silver, as conductor, 69.
 electro-plating pickle, 3,179.
 shunts, use of in dynamo, 157,
 resistance of, 78.
 resistance wire, composition, 3,049,
 wire, resistance of, 722.
 Geysler, Fuller electric, ills., 3,059.
 Ghegan aut. telegr. repeater, ills., 2,220,
 Gibbs process electrolysis, ills., 3,137, 3,138,
 Gilbert, def. of, 120, 122.
 Gilding solution, 24 carat, 3,169.
 14 carat, 3,170.
 Giles electric valve, 1,505.
 Glass, as insulator, 70.
 battery jars durability, 948.
 critical angle for, 2,683.
 electrification of, 7.
 heat loss, table, 3,056,
 insulator, ills., 804.
 refractive index of, 2,681,
 rouge polish, electro-plating, 3,166.
 wire insulators, ills., 820,
 Gleet, treatment for, 3,205.
 Globe(s), and reflectors, holophane, 2,518,
 arc lamps, 2,516,
 enclosed, 2,439.
 holophane, ills., 2,519, 2,520.
 dist. of light by, ills., 2,522.
 section of, ills., 2,530.

Globe(s)—Continued.

- outer for outdoor lighting, 2,516.
screen, arc lamp, ills., 2,465.
- Glower**, life of, ills., 2,502, 2,503.
Nernst lamp, ills., 2,501, 2,502.
- Glut weld**, ills., 3,110.
- Gold**, heater unit, two coi., ills., 2,615,
in sulphuric acid, 102,
leaf electroscope, ills., 11, 13,
resistance of, 78.
solders, 3,077.
- Gold**, electro-plating, adherence, 3,145,
chloride, how made, 3,169.
current for, 3,149.
rouge polish, 3,166.
solution, 14 K, 3,170.
24 K, 3,169.
tank, 3,159.
- Gongs**, various types, ills., 2,349, 2,361, 2,371,
2,374.
- Good Housekeeping water heaters**, ills., 3,057,
3,057.
- Gould**, battery, informed plate, ills., 896.
cell, automobile, ills., 2,840,
pump, by pass control, ills., 3,018.
centrifugal curves, ills., 3,006.
one st., ills., 3,007-3,009.
double act. triplex, ills., 3,015.
double reduc. long belt and spur
gear drive, ills., 3,015,
pump pressure regulator and by
pass, ills., 3,018.
storage battery cell, ills., 910.
- Governor**, elevator safety, ills., 2,927.
- Gower receiver**, 2,121.
- Grab load**, transporter, 2,946.
- Gramme ring armature**, construction of origi-
nal, ills., 223.
current distrib. in, ills., 257-259,
ills., 174, 176, 177, 178, 1,250.
lines of force through, ills., 225.
- Graphite**, anodes of mer. arc rectifier, 936.
electrotyping, use in, 3,181,
in contact with zinc, 44.
powdered, in electroplating, 3,143.
- Graphoscope motion picture machine**, 2,706.
- Grate surface**, furnace, table, 1,935.
- Gravity**, cells, 56, 57,
center of, electrical, 704.
specific, of acid, table, 906.
of acid tested, 905.
of battery, rise and fall of, 908.
of electrolyte low, 962.
scales, comparison of, 964,
tester, specific, for accumulator, 921.
- Gray and Davis self starter**, ills., 2,806.
- Gray**, Stephen, discoveries by, 68.
- Greenfield flexible conductors**, ills., 796.
- Grenet bichromate cell**, ills., 51-53.
- Grids**, construction of, 2,795.
heating unit, 3,051.
or plate of storage cell, ills., 894,
resistance unit, metal, ills., 665.
West., railway, ills., 2,587.
- Grisson valve**, 1,504.
- Grit in bearings**, 656.
- Grooved**, insulators, ills., 71.
pulley for rope driven motors, 403,
rail for car track, 2,618.
- Ground**, connection(s), 1,706-1,708,
bell wiring, ills., 2,384.
for lightning ar., ills., 890-892.
spark coil, ills., 153.
circuit, def. of, 30.
detector(s), and voltmeter radial switch,
Crouse-Hinds, ills., 1,875,
at switchboard, ills., 585,
automatic, 2,262.
electrostatic, 1,837.
Westinghouse, ills., 1,837.
fittings, Westinghouse, ills., 1,706.
in field coils, locating, 627.
leakage, automatic cut out, Wallis-
Jones, ills., 1,838,
return, battery con. for, 2,385.
of overhead trolley sys., 2,552.
swinging, on ring side of line, 2,172.
telephone, located, 2,173.
- Grounded**, armature(s), coil, ills., 632,
magneto test for, 633,
cable, detected, 2,663.
circuit(s), 2,734.
neutral, 1,704, 1,705.
telegraph system, ills., 2,207.
telephone battery feed, 2,174.
transformer secondary, 1,448.
- Grouping**, (of) phases, 1,243.
three phase mesh, ills., 1,247,
star, ills., 1,245.
two phase mesh, ills., 1,244,
star, ills., 1,244.
selectors, automatic, ills., 2,156.
- Grove(s)**, battery experiment, 893.
cell, ills., 53.
- Guericke's electrical machine**, 2,411.
- Guide**, rails, elevator, 2,365.
shoes, elevator, 2,865.
- Guil pastil for calcium burner**, ills., 2,720.
- Gurney**, elevator safety gov., ills., 2,930,
herringbone gear, ills., 2,913, 2,917.
- Gusset plates**, crane const., 2,939.
- Gutta percha as insulator**, 70,
electrification of, 7.
- Guy**, anchor log in position, ills., 809,
Sombaugh, ills., 809.
cables, 811.
stubs and anchor logs, 813,
cull poles for, 807.
- Gwynne's conoidal centrifugal pump**, ills.,
3,002.



- Hammer**, break, igniter, ills., 2,766.
vibrator, construction of, ills., 151.
- Hand**, brake, 2,597, ills., 2,598.
control, railway motor, 2,568.
winding of armature, 336.
- Hanson and Van Winkle**, electro-plating,
brushes, ills., 3,159, 3,161,
3,162, 3,181.
burnishing barrel, ills., 3,164.
generator set, 3,149.
tumbling barrel, ills., 3,163, 3,164.
- Hargreaves-Bird** cell, ills., 3,140.
- Harkness'** formula, gear teeth, 2,915.
- Harp** and trolley wheel, ills., 2,546.
- Hawksbee**, vacuum tube lamp, 2,481.
- Headache**, treatment for, 3,205, 3,208.
- Head**, and capacity, pumps, centrif. 3,011.
ordinary value per foot, 2,969.
polishing, electro-plating, 3,172.
receiver, 2,122.
total, dynamic, 2,969.
static, 2,969.
valve, 2,977.
water, corres. to var. pres., 2,969.
- Header** connected to boiler, ills., 1,944.
- Heat**, air compression, 3,027.
and light waves, difference, 2,502.
by friction, Tyndall's ex., ills., 89.
caused by, eddy currents, 658.
hysteresis, 123.
rapid charging of battery, 929.
curves, air compression, 3,026.
definition of, 90.
dissipated in large field coils, 220.
effect, conductivity, 71, 76.
energy in generating current, 33.
generated, by arc, 2,419.
in coils dissipated, 219.
given off by current, measure of, ills.,
94.
how produced for igniter, 2,734.
in dynamo, ills., 210.
in rectifier bulb, cooled, 1,524, 1,525.
loss, 3,054-3,057.
measurement, 90.
mechanical equivalent of, def., 89, 91.
of compression, efficiency loss reduced,
3,031, 3,037.
of electric arc, 2,426.
- Heat**,—Continued.
of transformers, 1,397.
production, electric, 3,048.
units, Joules' law, 96.
waves, definition of, 2,274.
frequency of, 2,278.
length of, 2,278.
- Heater**, car, cons., and op., ills., 2,612-2,616.
circuit diag., 3 valve, ills., 3,052.
temperature regulation, 3,052.
water, Fuller elec. geyser, ills., 3,059.
Good Housek'ping, ills., 3,057.
immersion, des., 3,060.
- Heating**, 3,047-3,066.
appliances, wir. diag., ills., 859, 861,
points in selecting, 3,047,
short circuiting of, 3,047,
current, 72.
direct current, ills., 1,015.
effect, of a. c., ills., 1,015.
elements, various, 3,051, 3,058.
leakage in, 3,055.
loss in, 3,054, 3,057.
of armature, causes of, 658.
effect, 332.
of brushes cause, 658.
commutator and arm., 655,
of commutator, cause of, 2,658,
of dynamo, abnormal, 593,
allowable degree, 593.
methods for welding, 3,114.
soldering and brazing, 3,101,
of dynamo, connections, 654.
new, 593.
parts, 653-662.
of electrolyte in battery, 905.
in rectifier, 1,503,
of field magnets, 661.
of motor, railway, abnormal, 2,658,
of wires by alternating current, 1,899,
oil, 2,050.
power formulæ, 3,054.
pre-, before welding, 3,120.
resistance wires for, 3,048, 3,049, 3,050.
rooms, 3,053.
tanks, electro-plating, ills., 3,145,
units, various, ills., 3,050, 3,051.
water, cost table, Simplex, 3,060,
various methods, 3,058,
wiring for, 3,065.
- Hefner** standard of lighting, 2,507, 2,508.
- Heinze** low tension magneto, ills., 2,754.
- Helion** filament for lamp, 2,492.
- Helios** flaming arc lamp, ills., 2,468.
- Hemitropic** armature winding, 1,214.
- Hemorrhoids**, 3,204, 3,205, 3,208.
- Henry**, diagram illustrating, ills., 1,031,
def., 1,030, 1,031.
Joseph, history of, 1,032.
- Herringbone** drive, advantage, 3,015.
gear, automobile, dou. red., Waverly,
ills., 2,827.

- Herringbone drive, gear,—Continued.**
 automobile, single reduction ills.,
 2,826, 2,827,
 elevator, kinds of, 2,919,
 Gurney, ills., 2,916, 2,917.
- Wuest system, 2,918.
- Hertz', electro-mag theory of light, 2,280,**
 oscillator, and resonator, ills., 2,268,
 for wireless telegraphy, 2,279,
 resonator, oscillation of, ills., 2,283,
 2,285.
 wireless detector, ills., 2,268.
- Hertzian waves, des., 2,275.**
 effect on filings, 2,270.
 velocity of, 2,269, 2,277.
 vibration of, 2,269.
 when visible, 2,277.
- Heteropolar inductor alter., ills., 1,153.**
- Hickey or conduit bender, ills., 795.**
- High frequency, alternators, 1,185.**
 current, in bell circuit, 2,367.
 electrodes, medical, ills., 3,190,
 oscillations, 1,677.
- High tension, current, definition of, 30,**
 2,734.
 ignition, 2,734, 2,768-2,772.
- Highland Park sub-station, ills., 1,704.**
- Hill, tank switch, ills., 3,021.**
 clutch mechanism, ills., 2,014.
 mech., Smith type, ills., 2,015,
 pulley, friction, ills., 2,013.
 pump pressure control, ills., 3,022,
 single reduction worm drive, ills.,
 3,017.
- Hobart system, ship propulsion, ills., 2,666,**
 2,667.
- Hoho and Lagrange welding process, 3,131.**
- Hoist(s), brakes, 2,948.**
 Brown, electric, ills., 2,959.
 various types cranes, 2,936-2,938.
 mono rail, Niles, ills., 2,956,
 motor, ills., 2,947.
 pole, called dead men, 811.
 power to drive, 2,955.
- Hoisting, power required for, 2,955.**
- Holder(s), brush, Triumph, ills., 1,255,**
 C.-W., ills., 306,
 G. E., ills., 305,
 ills., 315.
 short circuit at, 620,
 testing of, 620,
 trouble with, 319.
 Western Electric, ills., 318.
 Westinghouse, ills., 309.
- Holly, pump valve practice, 2,907.**
- Holophane globes and reflectors, 2,518.**
 construction of, ills., 2,519, 2,520,
 distribution of light by, ills., 2,522,
 pendent and upright, 2,522.
- Holtz machine, ills., 24.**
- Holtzer-Cabot, armature, ironclad band, ills.,**
 335.
 rear view, ills., 337.
 barrel wound armature, ills., 334.
- Holtzer-Cabot,—Continued.**
 bell box, ills., 2,128.
 ills., 2,359.
 brush holder, ills., 310.
 dynamo, ills., 156.
 dynamotor, ills., 982.
 magneto, ills., 2,128.
 lighting, ills., 2,797.
 motor, induction, ills., 1,332.
 shunt, ills., 686, 687.
 single phase, ills., 2,006.
 performance curves, ills., 392.
- Home signals, railway, ills., 2,647, 2,648.**
- Homopolar inductor alternator, ills., 1,158.**
- Hook, and tackle, wireman's, ills., 816,**
 cant, ills., 803.
 carrying, ills., 801.
 receiver, telephone, 2,117.
- Horn, break switch, ills., 1,598, 1,600,**
 driving, on smooth core arm., 347.
- Horn gap arrester(s), diag., 890, 1,691.**
 G. E., aluminum, ills., 1,702,
 G. E., ills., 1,692.
 mounted, ills., 1,694.
 objections, 1,691.
 on series circuits, ills., 1,693.
 pole arrester, G. E., ills., 1,695,
 pieces of separated, ills., 209.
- Horse power (of), belt, ills., 2,011,**
 2,913.
 rule for, ills., 1,138,
 brake formula, 379, 380,
 meaning of, 378.
 quantities, 379.
 definition of, 87.
 electrical, 91.
 formula, 385.
 hour, definition of, 88.
 of motor, 376.
 elevator, diag., 2,867, 2,862.
 squirrel cage, 2,871.
 pumps, at water end, 2,987.
 electrical, 2,985-2,989.
 relation to kilowatt, 91.
 ship propulsion, 2,670-2,672.
- Horseshoe magnet, ills., 106.**
- Hoskins, ammeter, ills., 1,790.**
 induction meter, ills., 1,789,
 meters, ills., 1,790, 1,791.
 voltmeters, ills., 1,790.
- Hospitalier ondograph, ills., 1,849-1,851.**
- Hot, bearings, causes of, 656.**
 point heating element, 3051.
 tube ignition, 2,739, 2,740.
 wire instruments, Whitney, 549-550,
 meters, 1,786.
 elementary, ills., 1,787.
 Whitney, ills., 550.
 principle of, 548.
 voltmeter, 548-550.
- Hours, kilowatt, 561.**
- House wiring, apartment switchboard, ills.,**
 2,130-2,133,
 burglar alarm, ills., 2,406.
 conduit, ills., 858.

House wiring,—*Continued.*
 heating, circuits, ills., 860, 861.
 Hubbard sep. excited booster, ills., 994.
 Hudson, automobile, circuit diag., 2,801.
 Hutton, X-ray switch, ills., 3,233.
 Hunting (of), alternator, 1,154.
 cause, 2,045.
 converter, cause, 2,079.
 prevented, 2,081.
 rotary, 1,487.
 motor(s), mech. analogy, ills., 1,280.
 synchronous, 1,280.
 prevented, 2,080.
 Hurricane inlet valve and piston, I.-R., ills., 3,030.
 Hydraulic analogy, amperes and coulombs, mech. inductance, ills., 1,033.
 Hydraulic principles, I, 2,964.
 II, 2,970.
 III, 2,971.
 IV, 2,972.
 V, 2,973.
 Hydraulics, def., 2,963.
 Hydrochloric acid, series metals in solution, 102.
 Hydrodynamics, def., 2,963.
 Hydro-electric, plant, ills., 1,978.
 system, map, ills., 1,919.
 Hydrofluoric acid, electro-plating, 3,158.
 Hydrometer, acid, ills., 907. 3,194.
 syringe, for accumulator, 921.
 for battery, ills., 908.
 testing with, ills., 2,796.
 Hydrogen, accumulation prevented, 41, 42.
 amount of zinc dissolved by, 45.
 and oxygen, in storage battery, 899.
 production of, 3,140.
 deposit, result of, 59.
 effect of, on current, 41.
 evolution of, caused by vacuum, 65.
 gas, generator for lead burning, ills., 928.
 lib. from sulphuric acid, 38.
 oxy-, flame, features of, 3,116.
 producing difference of potential, 41.
 Hydrostatic analogy, fall of potential, 33.
 def., 2,963.
 Hylo turn down incan. lamp, ills. 2,500.
 Hypochlorites, produced by electrolysis, 3,136.
 Hyperesthesias, treatment, 3,205.
 Hysteresis, and eddy currents produce iron core loss, 278.
 cause of, 123.
 definition of, 123.
 dielectric, 1,118.
 in armature core, ills., 277, 279.
 of transformer, 1,397.



Ia Ia resistance wire, comp., 3,049.
 Ideal resistance wire, comp., 3,049.
 Idler pulley, elevator, ills., 2,858, 2,860, 2,861, 2,924.
 Igniters, 2,790.
 Ignition, 2,733-2,792.
 air gap, 2,769.
 auto coil wiring diagram, 2,785.
 battery, Exide, ills., 911.
 weak, emergency connections for ills., 920.
 secondary, points on, 2,747.
 coil(s), 2,790.
 connections of, ills., 153.
 induction, adapted to, 137.
 points relating to, 152.
 primary induction, 2,763.
 secondary induc., 2,770, 2,773.
 Bosch, ills., 2,771.
 vibrating diag., 2,772.
 terminals of, 152.
 vibrator, current required in adjusting, 153.
 wiring diag., Knoblock, 2,786.
 contact, breaker, def., 2,772.
 maker, def., 2,772, ills., 2,773.
 current for, 2,741.
 distributers, ills., 2,774, 2,775.
 distribution, def., 2,772.
 double, 2,783.
 dynamos, 2,750, 2,751.
 electrical principles, 2,733.
 electrode contact points, 2,764.
 elements in prim'y cir., 2,762, 2,763.
 Edison cell used for, ills., 50.
 engine misfires and stops, 2,791.
 trouble with, 2,792.
 hammer breakignition, ills., 2,766.
 hot tube, des., 2,739, 2,740.
 ills., 2,758.
 igniter, wipe contact, ills., 2,767.
 jump spark, des., 2,769.
 lighting and starting system, Remy, ills., 2,751.
 timer(s), 2,772, 2,773, 2,790.
 Ignition, high tension or jump spark, 2,734, as applied to motor cycle, 142.
 circuits necessary to produce, 2,770,

- Ignition, high tension.**—*Continued.*
 coil for motor cycle, ills., 142,
 how obtained, 2,772.
 ills., 2,776-2,778.
- Ignition, low tension, or make and break,**
 adaptation, 2,766,
 des., 2,761-2,766.
 circuit, diag., 2,762.
 action, 2,764.
 current source, 2,761.
 disadvantages of, 2,765, 2,766.
 electrodes, 2,761.
 induction magneto sys., ills., 2,765.
 mag., spark plug sys. diag., 2,763.
 spark, how produced, 2,763, 2,765.
 use of primary coil in, 140.
- Ignition, magneto, 2,781.**
 automatic adv., Eisemann, 2,770.
 classification, 2,752.
 Eisemann, ills., 2,768.
 high tension, class., 2,755-2,757,
 interrupter for, ills., 2,782.
 low tension, des., 2,755.
 operation, 2,757.
 self-contained coil, 2,755-2,757.
 synchronous drive, 2,757-2,760.
 wiring diagram, Eisemann, 2,791,
 K.-W., 2,769.
- Ignition system(s), At.-Kent, ills., 2,784.**
 characteristic features, 2,760.
 classification, 2,740, 2,741, 2,760.
 double, elementary diagram, 2,753.
 dual, 2,782.
 Bosch, ills., 2,783.
 duplex vibrating, Bosch, ills., 2,789.
 gas engine, with stor. bat., ills., 919.
 ills., 2,734, 2,768, 2,776-2,785.
 low tension, 2,761-2,766.
 primary induction coil used in, 138,
 with inductor magneto, ills., 1,151.
 2,765.
 short circuits, 2,788.
 wiring diagrams, 2,777-2,780, 2,783,
 2,786, 2,789-2,791.
 troubles, 2,785-2,787.
 wipe contact igniter, ills., 2,767.
- Illumination, 2,411-2,532.**
 arc, 2,416-2,427.
 calculation of, ills., 2,523.
 point by point meth., ills., 2,524.
 rapid method, 2,526.
 candle power, ills., 2,506-2,514.
 color reflection coeffs., 2,525, 2,527.
 curves, Mazda lamp, ills., 2,525,
 def., 2,411, 2,504.
 diffusion, 2,518, ills., 2,519,
 indirect system of, ills., 2,509.
 intensity of, def., table, 2,506.
 international candle, 2,507.
 intrinsic brilliancy table, 2,521.
 lamps, arc, 2,426-2,434,
 diffusers and reflectors, ills., 2,517,
 2,518, 2,531.
 globes for, 2,516.
 incandescent, ills., 2,485-2,503,
 law of inverse squares, ills., 2,505,
- Illumination.**—*Continued.*
 light, def., 2,504,
 dist. of, ills., 2,515, 2,522,
 measuring standard of, 2,506,
 motion picture projection, 2,716,
 nomenclature of, 2,505.
 photometer, integrating, def., 2,515,
 railway car, ills., 2,604-2,613,
 refraction, cause of, ills., 2,522.
 requirements for good, 2,519.
 sources of elec. light, 2,415.
 spacing table, 2,532.
 standards of, 2,507, 2,508,
 terms used in, 2,505, 2,506.
 units, size determined, 2,531.
 spacing of, 2,532.
- Image, cur., alternator circuits, ills., 1,184.**
 self-exciting, ills., 1,185, 1,186,
 def. of, 2,674,
 in convex mirror, 2,692,
 in plane mirror, 2,678.
 inversion of, ills., 2,674, 2,676.
 multi-, ills., 2,678, 2,681.
 object at various focal distances, ills.,
 2,694, 2,695.
 real, 2,674,
 doub. convex lens, ills., 2,692.
 size, rule for, 2,704.
 virtual, 2,674, 2,675.
 double convex lens, ills., 2,693.
- Imbricated armature coil winding, 1,259.**
- Immersion, brazing, ills., 3,098.**
 water heater, description, 3,060,
 Simplex, ills., 3,058.
- Impedance, coil, Pt. Wayne, 104 volt circuit,**
 ills., 2,454.
 in circuit, ills., 1,034.
 curve, ills., 1,061,
 def., 1,057.
 diagrams, 1,093-1,094.
 explained, ills., 1,081, 1,082
 of balancing coils, 717.
 problems, 1,071.
 synchronous test, ills., 2,085.
- Impeller or piston, rotary pumps, 2,999.**
- Impregnating compounds, use of, 73.**
- Impressed pressure, 1,067.**
 diagram, 1,089,
 examples, 1,090, 1,099, 1,100.
 explained, ills., 1,080,
 formula, 1,087, 1,088.
 in circuit, ills., 1,076, 1,077,
 in synchronous motor, 1,271, 1,272,
 waves of rectifier, ills., 1,515.
- Impulse, and reaction, steam turbines, 1,964,**
 1,965.
- Incandescent, electric lamps, various, des.,**
 ills., performance curves,
 tables, etc., 2,485-2,503.
 lighting, dynamo, series, ills., 184, 185,
 shunt, ills., 189, 190.
- Incidence, angle of, ills., 2,676, 2,677.**
- Incident, ray(s), direction of, 2,679.**
 divergent, ills., 2,689,
 parallel, ills., 2,689.
- Inclined coil, ammeter, ills., 3,548, 3,549.**

- Inclined coil**,—*Continued*.
 electromagnetic meter, ills., 1,783.
 instrument, 547.
 meter, portable, ills., 549.
- Index of refraction**, 2,680, 2,681.
- Indianapolis and Louisville Elec. Ry. map**,
 2,542.
 overhead construction, ills., 2,545.
 power house, ills., 2,543, 2,544.
- Indicating devices**, 537, 1,588.
 a. c., 1,777-1,838.
- Indicator(s)**, cond. gas engine, ills., 2,737,
 steam engine, ills., 1,779.
 frequency, 1,825.
 synchronous motor, 1,826.
 fuse, ills., 415.
 or annunciators, ills., 2,387-2,395,
 pendulum, use of, 2,389.
 power factor, 1,835.
 Westinghouse, ills., 1,835.
 speed, for dynamo testing, 2,107,
 Starrett's, ills., 2,003.
 synchronism, 1,831.
 connections, G. E., ills., 1,834,
 G. E., ills., 1,832.
 Westinghouse, ills., 1,831.
 train, ills., 2,636, 2,637.
 Wright demand, ills., 557.
- Indirect lighting system**, ills., 2,509.
- Indoor transformer**, Moloney, ills., 1,449.
- Induced, charge, nature of**, ills., 16.
 current(s), 2,735.
 dir., Fleming's rule, ills., 134, 135,
 Ohm's law applied to, 133..
 eddy, ills., 210.
 draught, 1,960.
 voltage in transformer, 1,380.
- Inductance**, aerial, Marconi, 2,306.
 analogy, hyd.-mech., ills., 1,033.
 current limiting, 1,618.
 coil, with alternator, 1,619,
 defined, 1,030.
 explained, 1,028,
 in a. c. circuit, ills., 1,038..
 in d. c. circuit, ills., 1,037.
 milli-henry unit of, 1,036,
 negligible in wires, ills., 1,901,
 ohmic value of, 1,037.
 per mile of three-phase circuit, 1,889.
 reactance, 1,038, 1,054, 1,055.
 switch, X-ray, ills., 3,233,
 test, ills., 1,030.
 unit, 1,030.
- Inductance, resistance and capacity, circuits**
 containing, 1,092, 1,093.
 in circuit, ills., 1,058,
 in series, ills., 1,096.
- Induction**, det., 125.
 electrification by, ills., 14.
 electro-magnetic, 125-136.
 current induced by, 128.
 def. of, 125.
 discovery, Faraday's, ills., 125,
 126.
 law(s) of, 130.
- Induction, electrification by, law(s) of**,—*Con.*
 Lenz', ills., 131,
 principle, Faraday's, 127,
 electro-static, 125.
 experiment illustrating, ills., 15.
 maximum, normal plane of, 286, 287,
 meter(s), 1,787.
 frequency, 1,829.
 Westinghouse, ills., 1,829.
 Hoskins, ills., 1,789.
 rotary field, 1,791.
 shielded pole, ills., 1,788,
 motors, various, des., ills., rotating
 magnetic field, slip, synchro-
 nous speed, tables, diagrams,
 etc., 1,283-1,348.
 mutual, 1,887.
 def. and diag., 138, 139.
 self-, 136-138.
 to dissipate heat in coils, 219.
- Induction coils**, 137, 154,
 condenser for, ills., 147,
 dimensions, table of, 152,
 primary, des., 138-140.
 igniter, note, 2,768.
 object, 2,763.
 principle of, ills., 140.
 winding, 2,735.
 secondary and primary, ills., 141,
 description of, 140,
 ignition, 2,770,
 winding, 2,735.
 transformation ratio, 2,735.
 use of, in ignition, 137,
 in wireless tel., 137, 2,314,
 in X-ray work, 137.
- Induction regulator(s)**, ills., 1,717,
 method of control, 2,577.
 operation, 1,718, 1,719.
 automatic, 1,727.
 hand, West., ills., 1,722,
 polyphase, 1,723, 1,725.
 relay contacts, vibration at, 1,730..
 single phase, 1,721.
 heteropolar, ills., 1,153.
 homopolar, ills., 1,153.
 ills., 1,150, 1,152.
- Inductor, armature, drag on**, ills., 275..
 reaction of, ills., 1,160..
 copper bars, objection to, 335.
 def., 127, 172.
 Fairbanks-Morse motor, ills., 361,
 multi-wire, ills., 1,226, 1,228,
 of electrical machines, 23,
 size of wire used for, 335.
 strap, ills., 1,229.
 synchroscope, 2,036,
 tinfoil, 23, ills., 24.
- Inertia, electro-magnetic**, def. of, 136, 137,
 opposition of current by, 288.
- Infantile paralysis, treatment for**, 3,208.
- Ingersoll-Rand air compressor**, 3,025-3,027-
 3,033, 3,035, 3,038.
 aftercooler, 3,041.
 intercooler, 3,040,
 air receivers, 3,042, 3,043.

- inside, wiring, 765-798.
 Insomnia, treatment for, 3,209.
 Instruments, indicating, d. c., 537-572.
 a. c., 1,777-1,838.
 Insulated wire(s), 2,734.
 Insulation (of), armature core, 333.
 cable, testing, 487.
 underground, 825.
 coils, between series and shunt, 217.
 effect of moisture on, 661.
 field, 216, 217.
 commutator, 302.
 with asbestos, 652.
 core disc, 326.
 deterioration, 3,066.
 ineffective, 30.
 mica, for armature, 2,657.
 for commutator, 302.
 reinforced with mica, 156.
 rubber, adv. and disadv., 725.
 compound, 725.
 test(s), machine parts, 596.
 transformer, ills., 2,098-2,099.
 internal, ills., 2,100.
 resistance, ills., 2,101.
 track, for block signals, 2,634, 2,635.
 ills.,
 transformer, 1,414, 1,415.
 major, 1,415.
 minor, 1,415.
 wire, 770.
 method of testing with voltmeter,
 487.
 Insulator(s), and conductors, 68-74, ills., 70-
 71.
 table of, 69, 70.
 battery cells placed on, 948.
 bracket, ills., 804.
 canopy, fitting, ills., 788.
 glass, ills., 804.
 grooved, ills., 71.
 oil, for storage battery, ills., 956.
 petticoat, des. of, 822.
 pin, ills., 804.
 properties of, 73.
 standard porcelain, ills., 71.
 table of, 70.
 Integrating, photometer, 2,515.
 wattmeters, 1,799.
 Intercommunicating, self-restoring telephone
 keys, 2,151.
 switching devices, 2,129.
 telephone, automatic, 2,150, 2,151.
 De Veau, ills., 2,155, 2,157.
 residence, N. Y. T. Co., ills.,
 2,156, 2,158.
 Intercooler, air compressor, correct type,
 3,042.
 function of, 3,040.
 inadequate, 3,041.
 I.-R., ills., 3,033.
 receiver, advantage, 3,042.
 air compression, rule for, 3,045.
 Interlock(s), controller, elevator, 2,888.
 mechanical, 695.
 Interlocking, electric, ills., 2,643, 2,645.
 Interlocking,—Continued.
 relay, railway signals, ills., 2,637, 2,639,
 2,643, 2,644.
 switches, N. Y. subway, 2,641, 2,642.
 Intermittent, film iced system, 2,706.
 movement, Geneva, action of, ills.,
 2,708, 2,709, 2,712.
 Internal, gear, Albro-Clem elevator, 2,924.
 resistance, hydr. anal., ills., 2,745.
 spur gear, elevator, ills., 2,923.
 International, ampere measured with silver
 voltmeter, 472.
 candle, 2,507.
 Morse code, 2,270a.
 ohm, ills., 474.
 volt defined, 468.
 standard cell, ills., 466, 467.
 Interpole, motor, 385-388.
 West., ills., 2,657, 2,660.
 Interrupter, anti-acid, of radiograph, ills.,
 3,231, 3,232.
 circuits, W. E., ills., 2,195.
 electrolytic, ills., 3,191, 3,192.
 magneto ignition, ills., 2,782.
 mercury turbine, ills., 3,193.
 sparking at, prevention of, 2,363.
 static, ills., 1,714.
 Intrinsic brilliancy, def. of, 2,609.
 of light sources, 2,521.
 Inverse, squares, law of ills., 2,505.
 time limit relay, 1,667.
 Involute, spur gearing, 2,915.
 Ions, Faraday's def. of, 101, 102.
 Iron(s), annealed, in magnet core, 124.
 cast, conduit, adv. of, 837.
 soldering, 3,097.
 welding flux, 3,109.
 conductivity of, 69.
 conduits, wires in, 1,886.
 core, action, in sol. ills., 117, 118.
 laminated, in coil, ills., 1,061.
 loss by eddy currents and hysteresis,
 278.
 effect of sulphur in, 3,112.
 electro-plating, adherence of nickel to,
 3,180.
 pickles for, 3,178, 3,179.
 filings showing distortion of magnetic
 field, ills., 265.
 flat-, electric, ills., 3,063.
 magnetized, 124.
 or steel pipe conduit, 834.
 oxidation of, 3,107.
 permeability of, comp. with air, 118.
 pipe conduits, cast, 836.
 laid in cement, ills., 835.
 lined with cement, 836.
 resistance of, 78.
 sheet, tubes in concrete building, 792.
 soft, effect of magnet on, 14.
 transformer cores, 1,398.
 soldering fat for, 3,083.
 flux for, 3,084.
 ills., 3,084, 3,088.
 tinning, ills., 3,086.
 various, gas, ills., 3,085.

Iron(s)—Continued.

- Swedish, conductivity of, 723.
welding of, 3,127.
wire(s), best, 722.
 core of coil, 1,035.
 extra best, 722.
wrought, pipe, (so called) standard, properties of, 1,995.
Irrigation plant at Ellis, La., ills., 2,980.
Isolated plants, ills., 1,549, 1,980.
Isothermal air compress. loss table, 3,044, curve, 3,026, 3,036.
I-T-E circuit breakers, connections, ills., 1,664-1,666.
Ivory, electrification of, 7.



- Jack, ammeter, plug switch, ills., 1,592, and drop combined, ills., 2,141, with mag. teleph., ills., 2,170.
circuits, magneto, ills., 2,135.
switchboard, connected, ills., 2,133, multiple, 2,132-2,134.
 removing and inserting cord plugs in, ills., 2,190.
telephone extension station, 2,141.
trunk, switchboard wire open, 2,176.

- Jackson heating element, 3,051.
Jenkin's telpherage system, 2,955.
Jenny pole support, ills., 808.
Jet as insulator, 70.
Jewelers' brush, wash, H. & V., ills., 3,161.
Jib crane(s), ills., 2,936, 2,938, inclined brace, best position, 2,940, locomotive, area served, 2,940, current collector gear, 2,953, ills., 2,938, 2,948.
Jib, effective radius of, crane, 2,940, jibbing drum, crane, 2,937.
Johnson's, hydro-electric rectal tube, ills., 3,209.
Joint(s), broken, between commutator segment and lug, ills., 644, conductivity, 79, 81, fitting, insulated wire, ills., 788, hor., method of wiping, ills., 3,077, in conduit, ills., 830, 831, pole crossing of two lines, ills., 824,

Joint(s)—Continued.

- resistance, ex. and rule, ills., 79, 81, screw, type of fibre conduit, ills., 839, sleeve McIntire, ills., 818, fibre conduit, ills., 838, socket, fibre conduit, ills., 837, 838, soldering, various, ills., 3,075-3,081, vertical, meth. of wiping, ills., 3,079, wiped, ills., 3,076, 3,077, ladle for, 3,074, wire, ills., 2,381, 2,383, soldering, 3,089, Western Union, ills., 818.
Jones three speed control, 2,577.
Joubert's wave meas., ills., 1,843, 1,844.
Joule(s), equivalent, 91, ills., 90, James P., physicist, 89, law of heat developed by current, 96
Journal and caps of bearings, 573.
Journal boxes; lining with metal, 3,092, Junction, box, G. E., ills., 843, of coils, pressure in, 177.
Jumps, bus, loose, 2,664.
Jump, spark ignition, 2,734, weld, ills., 3,110, 3,114, correct and incorrect shapes, 3,114, welding, 3,127.
Jumper, cable, tram, 2,663, wires, ills., 2,194.
Jupiter fire alarm box, ills., 2,409.

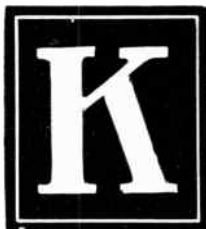

- Kaestner and Hecht elevator brake, ills., 2,917.
Kageman, gas soldering bits, ills., 3,085.
Kapp's c. coefficient, 1,220.
Kathion, Faraday's definition of, 101.
Keeper of horseshoe magnet, ills., 106.
Kelman, switch control, ills., 1,604, switching mechanism, ills., 1,600.
Kelvin, bridge, circuits, ills., 507, principle of, ills., 506, electrostatic voltmeter, ills., 551.
Kennedy tube conduit system, 839.
Key, and sounder, Morse, 2,203, 2,204, battery, in galv. test., 492, buzzer, switchb'd., ills., 2,130-2,133, charge and disch., cond., ills., 477, combination bat. and galv., 473,

Key—Continued.

- contact, double, ills., 473.
 ills., 472.
 single, ills., 473.
 emergency, teleph., ills., 2,130-2,133.
- hole saw, use of, ills., 854.
- Key**, telegraph, 2,201.
 operation, ills., 2,204.
 polar, 2,243.
 relays operated by, 2,229.
 submarine, 2,252.
 switches, 2,211.
 voltaplex, ills., 2,232.
- Key**, telephone, listening, 2,177.
 night, switchboard wir., ills., 2,130-2,133.
 generator, switchb'd. wiring, ills., 2,130-2,133.
 ringing, ills., 2,134.
- Keystone**, dynamometer, ills., 1,796.
 moving element, ills., 1,795.
 meter, construction of, 541.
 moving element, ills., 541.
 voltmeter, ills., 540. 1,796.
- Kick**, box, to protect wires, ills., 770.
 or swing of galv. needle, 454.
- Kilovolt**, ampere, 1,121.
 def. of, 88.
 hour, 561.
 relation to horse power, 91.
- Kinetic energy**, def. of, 83.
- Kittons** three wire repeater, ills., 2,218.
- Knife**, and brush flashers, 869.
 cautery, various, ills., 3,225.
 switch, Adams' single throw, ills., 408.
 control rheostat, ills., 674.
 des. and ills., 409.
 for switchboards, 428.
 quick break, ills., 411.
 type flasher, Reynolds', ills., 868.
- Knob**, and cleats, porcelain, ills., 772.
 concealed, and tube wiring, ills., 780.
- Knoblock** coil ignition wiring diag., 2,786.
- Knuckle**, steering, Woods, ills., 2,830.
 Krupp metal, resistance wire, 3,049.
 Kuzel process, tungsten filament, 2,497.
- K-W**, magneto wiring diag., 2,769.
- Kyanized** poles, 802.



- Lacquer, method of applying, 3,166.
- Lacquering room, ills., 3,167.
- Lag, and lead, effect of on power, ills., 1,103, 1,107, 1,108.
 ills., 1,049-1,054, 1,103, 1,108, 1,109.
 angle of, examples, ills., 1,052, 1,083, explained, ills., 1,079.
 maximum, 1,053.
 def., 1,050.
 measured in degrees, 1,051.
 mech. analogy of, ills., 1,051.
 on long lincs reduced by capac., 1,054.
 physical meaning of, 1,052.
- Laminæ, and yoke, induc. motor, 1,327.
- Lamination, effect on eidy cur., 272, 324.
- Lamp(s), adjustment, motion pic., 2,719.
 carbon, consumption of, 2,532.
 properties of, 2,529.
 waves, ills., 1,870.
 consumption of various, 2,532.
 enclosed arc, 2,440.
 filament, double, 2,501.
 squirted, 2,485.
 tantalum, ills., 2,495.
 frosted, reflectors for, 2,521.
 foot, meaning of, ills., 735.
 gen, consumption of, 2,532.
 properties of, 2,529.
 glow, Nernst, ills., 2,501, 2,502.
 Mazda, 2,525, 2,529, 2,532.
 medical, diagnostic, ills., 3,218.
 mercury vapor, a. c., Cooper-Hewitt, ills., 2,483.
 d. c., C.-H., ills., 2,481, 2,482.
 large, Cooper-Hewitt, 2,484.
 meter, of automobile, 2,851.
 motion picture, 2,722, 2,723.
 Nernst, ills., 2,501, 2,502.
 oil, candle power of, 2,521.
 placing of, 2,521.
 properties of various, 2,529.
 reflector, 2,531, 2,532.
 regulator, ills., 2,609, 2,610.
 synchronizing, 2,035, 2,037.
 capacity, 2,037.
 method of, ills., 2,042.
 treated carbon, 2,492.
 trolley car, 2,656.

Lamp(s),—*Continued.*

- vacuum tube, Moore, *ills.*, 2,480-2,483.
- voltage, formulæ, 755, 763.
- Lamp, arc**, adjusting weight for, *ills.*, 2,436.
- carbon, clutches, 2,432.
 - feed mechanisms, 2,428,
 - operating conditions of, 2,427,
 - resistance, 2,423.
 - sizes, 2,423, 2,425.
- current, adjustment, 2,457.
 - consumption of, 2,426.
 - excessive, 649.
 - various, table, 2,532.
- cut out, 2,438.
 - and subs. resistance, 2,437.
- dash pots and adj. weights, 2,435.
- differential control, *ills.*, 2,430, 2,431.
 - rod feed; cut out, *ills.*, 2,438.
- electrode arr., met. flame, *ills.*, 2,466, enclosed, 2,439, 2,440.
- flaming, 2,466-2,469.
- focusing, *ills.*, 2,471.
- installation and care, 2,476.
- inverted, *ills.*, 2,470.
- luminous, various, 2,463.
- motion picture, Powers, 2,723, Simplex, *ills.*, 2,723.
- parallel, *ills.*, 2,446, 2,452-2,460.
 - a. c., enclosed, *ills.*, 2,452, series, 2,441.
- retrimming, 2,479.
- series, 2,446-2,452.
 - control, West., *ills.*, 2,448.
 - parallel, 2,461, *ills.*, 2,463.
- starting resis. A.-B., *ills.*, 2,440.
- shades and reflectors for, 2,516.
- short trim, 2,447.
- shunt, *ills.*, 2,429, 2,431.
- special forms, *ills.*, 2,471.
- testing and adjusting, 2,478.
- titanium, principle of, 2,463.
- voltage, adjustment, 2,457.
 - excessive, effect, 2,426.
- vs. Cooper-Hewitt, 2,485.
- Lamp, arc, a. c.**, Adams-Bag., *ills.*, 2,433.
- carbon clutch for, Ft. W., 2,455.
- current consumed in, 2,442.
- cut out, A.-B., *ills.*, 2,439.
- diff., Adams-Bagnall, *ills.*, 2,447.
 - series, *ills.*, 2,447.
- enclosed, cost of oper. table, 2,423.
 - Ft. W. imp. coil, *ills.*, 2,454.
- parallel, West., *ills.*, 2,452, 2,453.
- regenerative flame, *ills.*, 2,433.
- series, diff., Westinghouse, 2,448.
- slotted solenoid spools, 2,445.
- Lamp arc d. c.**, cost of oper., table, 2,423.
- connection of, 2,476.
- electrode appearance, 2,426.
- flaming, 2,466.
 - Lord, *ills.*, 2,469.
- series diff., Ft. Wayne, *ills.*, 2,450.
- series par., diff., West., *ills.*, 2,460.
- Ft. Wayne, *ills.*, 2,451.
- Lamp, incandescent**, 2,485.

Lamp,—*Continued.*

- base, *ills.*, 2,493.
- calculations, *ills.*, 754, 755.
- candle power, 2,488.
- car lighting, 2,604.
- carbon, filament, classified, 2,486.
 - des., *ills.*, 2,486-2,490.
 - metallized, 2,486, 2,491, 2,492.
- construction of, *ills.*, 2,487.
- current excessive, cause, 649.
- distribution, *ills.*, 754.
- filament(s), *ills.*, 2,531.
 - double, 2,501.
 - forms of, *ills.*, 2,489.
 - helion, 2,492.
 - iridium, 2,490.
 - size of, 2,488.
 - various, *ills.*, 2,531.
- intrinsic brilliancy of, 2,521.
- iridium, 2,499.
- Mazda, consumption of, 2,532.
 - illumination curves, *ills.*, 2,525.
 - properties of, 2,529.
 - sign lighting, *ills.*, 2,499.
- metallized carbon or gem, 2,491.
- Nernst, *ills.*, 2,501, 2,502.
- nitrogen filled, *ills.*, 2,503.
- non-carbon, classified, 2,486.
- osmium, *ills.*, 2,493-2,495.
- pressure limit, 701.
- tantalum, *ills.*, 2,494, 2,532.
 - performance curves, *ills.*, 2,497.
 - properties of, 2,529.
- tungsten, 2,496-2,499.
 - candle power, 2,498.
- turn down, *ills.*, 2,500.
- various, *ills.*, 2,491.
- voltage, 2,488.
- wiring, wall socket, 769.
- Lanchester type worm drive, *ills.*, 2,837.
- Langsdorf and Begole fr. meter, *ills.*, 1,830.
- Lantern, slides, lens for, 2,701.
 - screen image sizes, 2,705.
- Tap, def. and *ills.*, 74b.
- Launch lighting outfit, Dayton, *ills.*, 983.
- Lava bushing, Ft. Wayne arc lamp, 2,453.
- Law(s), Boyle's, 3,023.
 - Charles', 3,023.
 - chemical action in cell, 45.
 - coulomb, 2,505.
 - electrolysis, 100.
 - Faraday's, 125.
 - illumination, 2,505.
 - inverse squares, 2,505.
 - Joules, 89.
 - Lenz's, direction of current, 131.
 - of armature reaction, 265.
 - of electrical resistance, 76.
 - of electro-magnetic induction, 130.
 - of magnetic force, 111.
 - Ohm's, and the ohm, 472.
 - reflection, 2,676.
 - tangent, illustrated, 445.
 - mechanical expl. of, *ills.*, 447.
 - Volta's, position of metals, 44.

- Lead**, 2,734.
 and antimony, transfusion of, 3,092.
 burning, butt and lap seams, *ills.*, 3,104,
 3,105.
 edge burning, *ills.*, 3,106.
 hydrogen gas generator for, 927,
ills., 928.
 conductivity of, 69. 723.
 dust, inhaled poisonous, 961.
 galvanizing anodes, 3,184.
 in caustic potash, 102.
 in contact with zinc, 44.
 in hydrochloric acid, 102.
 in sulphuric acid, 102.
 peroxide, in depolarizing, 46.
 wireless detector, 2,314.
 plate, unformed, battery cells, 981.
 poison prevented, 961.
 resistance of, 78.
 salts poisonous, 961.
 soldering flux for, 3,084
 transfusion with brass, 3,072.
- Lead(s)**, angle of, 267, 268.
 armature, test for break in, *ills.*, 625.
 def., 30.
 due to capacity, 1,049.
 effect of on power factor, *ills.*, 1,108.
 main, open, testing dynamo, 619.
 negative, of motor, *ills.*, 364, 365.
 of brushes, 266.
 dynamo, small, 589.
 effect of, 269, 294.
 of current caused by capacity, 1,049.
 strengthens field, *ills.*, 1,162.
 or lag, eff. on power fac., 1,103, 1,107.
 secondary, in Wag. transf. *ills.*, 1,403.
- Leakage**, earth, automatic cut out, Wallis-
 Jones, *ills.*, 1,838.
 magnetic, of alternators, 1,165.
 of transformer, 1,379.
 through core reduced, 329.
 of current, 30, 60.
 of oil from bearings, 591.
 of pump, when likely, 2,983, 2,984.
 two kinds, 2,984.
 transformer core, test, *ills.*, 2,093,
 reduced, 1,379.
- Leather**, and glass, electrif. of, *ills.*, 13.
 belts, 2,010.
 covered pulleys, belt friction, 401.
 dry, as insulator, 70.
 polishing wheel, 3,176.
- Leclanche cell**, construction of, *ills.*, 46, 47.
 hemp cylinder, 43.
 how to set up, 48.
 objections to, 48.
- Leece-Neville starting and lighting**, 2 unit,
 2,803.
- Leeds and Northrup**, bridge for testing power
 circuits, *ills.*, 534.
 decade method, *ills.*, 496.
 dial Wheatstone bridge, *ills.*, 497.
 fault finder, *ills.*, 510-525.
 galvanometer, *ills.*, 484.
 photometer, *ills.*, 2,514.
 diag. of, 526, 527.
- Leeds and Northrup**,—*Continued.*
 potentiometer rheostat connections
ills., 528.
 with volt box, *ills.*, 532,
 resistance, *ills.*, 475.
- Left**, and right hand winding, *ills.*, 251.
 hand rule for direction of motion in
 motors, *ills.*, 363.
- Lens(es)**, achromatic, *ills.*, 2,699.
 Bausch and Lomb, *ills.*, 2,702.
 choosing of, 2,702, 2,703.
 concave, double, foci in, *ills.*, 2,688,
 2,689.
 converging, *ills.*, 2,685.
 convex, double, foci in, *ills.*, 2,685,
 2,686, 2,688.
 real image, *ills.*, 2,692.
 image various distances, *ills.*,
 2,694, 2,695.
 crown glass, 2,699.
 diverging, *ills.*, 2,685.
 flint glass, 2,699.
 for lantern slides and films, 2,701.
 formulæ for, 2,696.
 principal focus, *ills.*, 2,689, 2,690,
 various, *ills.*, 2,684, 2,685.
 motion pic. mach., *ills.*, 2,700.
- Lenz's, app.**, for meas. heat cur. *ills.*, 94.
 law, direction of cur., 131.
 of arm. reaction effect, 265.
 of retard gr'th field, *ills.*, 132.
- Leonard elev. control**, d. c., *ills.*, 2,877.
- Lever**, arm of brake test, 379.
- Leyden jar(s)**, and discharger, *ills.*, 22, 23.
 effect of in T.-H. static mach., 3,186.
 experiment in resonance, *ills.*, 2,281.
 syntonic, *ills.*, 2,282.
 Toepfer-Holtz machine, *ills.*, 24,
 to charge, 23.
- Lift**, 2,969. 2,970.
 for warm water, 2,971.
 governed by temp. of water, 2,971.
 of valve, *ills.*, 2,982.
 practical limit, 2,970.
 pump(s), des., 2,974.
 elementary single acting, lift, *ills.*,
 2,975.
 static for 30 inch barometer, 2,969,
 theoretical, 2,971.
 for various temp., 2,974.
- Ligaments**, relaxed, treatment for, 3,205.
- Light**, and heat waves, difference, 2,502.
 arc, steadiness in, 2,479.
 bath cabinet, *ills.*, 3,215.
 decomposition of, 2,690, 2,699.
 definition of, 2,502. 2,674.
 diffusion holoph. globes, *ills.*, 2,522,
 diagram, *ills.*, 2,517,
 dispersion of, 2,699.
 diffraction defined, 2,505.
 distrib., a. c., arc, *ills.*, 2,478, 2,479,
 of enclosed arc lamp, 2,440.
 electric, sources of, 2,415.
 emission theory, 2,674.
 flickering, cause of, 2,424.
 fluorescence defined, 2,506.

Light.—Continued.

glow, oscillograph, 1,855.
 Hertz' electromag. theory, 2,280.
 intensity of, how measured, 2,514.
 in arc, 2,417.

on what depends, 2,506,
 intrinsic brilliancy of, 2,521,
 lumen of, def., 2,509.
 lux, def., 2,509.
 motion pic., how centered, 2,719.
 physiological effects of, 3,215.
 red, produced in arc, 2,417.
 reflection of, diagram, ills., 2,517.
 refraction of defined, ills., 2,522.
 double, 2,680.
 ills., 2,679-2,681.

signal, N. Y. subway tunnel, 2,642.
 undulatory theory, 2,674.
 variation in differential lamp, 2,432.
 violet produced in arc, 2,417.

wave(s), 1.
 and atmospheric air, 2,277.
 def. of, 2,274.
 effect on, passing through water,
 2,277.
 frequency of, 2,278.
 propagation of, 2,502.
 velocity, 2,269, 2,276, 2,277.

white, def., 2,699.

yellow, produced in arc, 2,417.

Lighting, and ignition systems, 2,798.
 and motor feeders separated, 853.
 and starting autom., 2,793-2,813.
 battery for, 2,795.
 ignition bat. not adap., 2,797.
 automobile, defective, cause, 2,854.
 storage battery for, ills., 996.
 wiring diagram, ills., 2,839.
 axle, of cars, 2,609, 2,611-2,613.
 bougie decimale standard, 2,508.
 calculation, curves, 2,523,
 ills., 2,523.
 point by point method, ills.,
 2,524, 2,525.

rapid method, 2,526.

andle, foot defined, 2,510.
 power, def., 2,506, 2,507.
 maximum, 2,511.
 mean, conical, 2,510.
 hemispherical, 3,513.
 horizontal, 2,514.
 spherical, 2,512, 2,515,
 nominal, 2,511.

car, defective, 2,608.
 Pintsch gas for, 2,605.
 system, McElroy, 2,606.
 English, 2,605.
 Stone, ills., 2,605, 2,606.
 wiring diagram, ills., 2,604.

Carcel standard of, 2,507, 2,508.
 color reflection coeffs., 2,525, 2,527
 continuous spectrum, 2,521.
 curves, Mazda lamp, ills., 2,525.
 Davy's experiment, 2,411.
 diffusion, 2,518, ills., 2,519.
 distribution curves, ills., 2,515.

Lighting.—Continued.

electrodes or carbons, 2,421.
 English candle standard, 2,508.
 foot candle, ills., 2,510.
 gas flame, light radiated from, 2,426,
 Pintsch, 2,605.
 use of Leclanche cell in, 46.
 German candle standard, 2,508.
 Hefner standard, 2,507, 2,508.
 holophane globe, ills., 2,530.
 incandescent, 2,485.
 dynamo for, ills., 189, 190, 192.
 for cars, 2,604.
 efficiency of, 2,426.

indirect, ills., 2,509.
 Toening lamp for, ills., 2,470.
 intensity, of light, degree of, 2,506.
 table, 2,524, 2,526.

international candle, 2,507.
 intrinsic brilliancy, 2,521, 2,609.
 large areas, globes used, ills., 2,522.
 interiors, best light, 2,454.
 law of inverse squares, ills., 2,505.
 luminous defined, 2,505.
 magnesium light, efficiency of, 2,426.
 maximum candle power, 2,511.
 measurement, 2,506.
 medium defined, 2,505.

meter candle, ills., 2,510.
 nomenclature of, 2,505.
 nominal candle power, 2,511.
 opaque def., 2,506.
 outfit, Fairbanks-Morse, ills., 989.
 for launch, Dayton, ills., 983.

parallel arc lamps, 2,452.
 pencil def., 2,505.
 pentane standard, 2,507, 2,508.
 phosphorescence defined, 2,506.
 photometer, Bunsen's, ills., 2,513.
 integrating, 2,515.
 Rumford's, ills., 2,512.

railway car, ills., 2,604-2,613.
 ray, def., 2,505.
 requirements for good, 2,519.
 shadow defined, 2,506.
 show window, 2,424.
 size of units how determined, 2,531.
 spacing units, table of, 2,532.
 standards of, 2,507, 2,508.
 table of increase, 2,529.
 translucent, def., 2,506.
 transparent, def., 2,506.
 uniform, spacing for, table, 2,532.
 violette unit, 2,508.

Welsbach light, eff. of, 2,426.
Lighting, arc(s), copper saving in, 2,449.
 diffusers for, ills., 2,518, 2,519.
 efficiency of the arc, 2,426.
 enclosed, 2,439.

a. c., ills., 2,441.
 intrinsic brilliancy table, 2,521.
 loss of light prevented, 2,519.
 photometric char., ills., 2,511.
 size of wire, 2,449.
 testing, 2,478.
 water resistance for, ills., 2,477.

- Lightning**, displ. flasher, Dull's, ills., 874.
duration of discharge, 87.
protection, 885-892.
 devices, 1,587, 1,617, 1,714,
 quantity of electricity in, 87.
 rod erection, 886.
- Lightning arrester(s)**, principles, construction,
various types etc., ills., 885-
892.
- Lignum vitæ**, conductivity of, 69.
- Lincoln**, revolv. field alternator, ills., 1,167,
synchronizer, ills., 2,040, 2,043.
- Line(s)**, con., trolley, ills., 2,622-2,630.
phantom circuit, ills., 2,168,
physical circuit, ills., 2,168.
private exten. circuits, ills., 2,144.
single, Morse, 2,203.
transmission, high power, ills., 1,542.
 of Schenectady Power Co., ills.,
 1,582.
 of Sou. Power Co., ills., 1,546,
 transposition of, ills., 819, 820.
 trolley, overhead sin-ph., ills., 1,539.
- Lines** of force, 13.
absence in steady electric field, 19,
action on of moving circuit, 127.
distorted, ills., 275, 352.
distribution, ills., 115.
effect of altering, ills., 128-132.
ills., 13.
in alternator, ills., 163.
of circular loop, ills., 114, 115.
on what depend, 121.
rate of cutting, 134.
 ills., 166, 167. 1,019.
solenoid, 115.
through Gramme ring, ills., 225.
tracing, experiment, ills., 109, 1.
unaltered by rotating conduc., 128.
- Lineman(s)**, block and fall, ills., 817.
portable pole platform, ills., 807.
strap, portable vice with, ills., 813.
tools, ills., 813.
- Listening key**, open, 2,177.
trouble on telephone plans, 2,182.
- Litharge** artificially made, 958.
- Load**, curve(s), for dyn. and bat., ills., 970.
 for one day, ills., 1,930.
 for one year, ills., 1,931,
 of plant, ills., 1,932.
 of dynamo, effects heat, 332.
 reduced before stopping, 594.
 reg., effect on bat., diag., 972.
 shunt plant, dividing, 605.
 relation to current, 190.
 of motor(s), field will vary with, 387.
 induction, 1,764.
 synchronous, 1,273.
 peak, explained, 1,931.
 power, nature of, 1,931.
- Lock(s)**, burglar alarm circuit, ills., 2,404.
control lever, auto., ills., 2,852.
nuts in cross connec. box, ills., 2,164.
of normal signal, 2,633.
- Locomotor ataxia**, treat., 3,209, 3,223.
- Locomotive**, B. and O., ills., 2,591,
cranes, 2,937.
frame thermit welding, ills., 3,117.
freight, 2,591.
geared, 2,590.
gearless, 2,590.
jib crane, area served, 2,940,
 current collector gear, 2,953.
 ills., 2,938, 2,948.
N. Y. C., ills., 2,591.
passenger, 2,591.
railway, 2,588.
storage battery, ills., 2,596.
trucks for, ills., 2,599.
various, ills., 2,591.
Westinghouse mine, ills., 2,592.
- Lodestone**, 105.
- Lodge**, exper. in resonance, ills., 2,282,
Muirhead mer. coherer, ills., 2,289.
- London** wire gauge, 740.
- Loop(s)**, closed, lines of force as, ills., 115.
conducting, action of dyn. on, 161,
drip, of wire, ills., 773.
feed, motion pict. machine, 2,711.
lines of force in, ills., 114.
Murray, with L. and N. fault finder,
 ills., 516.
near compass needle, ills., 432.
revolving, in field, ills., 166, 167.
service connection, series, ills., 823.
single, pulsations produced by, 175.
 turn, ills., 173.
test(s), diag. of, ills., 514.
 for teleph. or telcgr. line, 515,
 Murray, diag. of, ills., 515,
 special, 519.
 with L. and N. faultfinder,
 ills., 520-521.
Varley, with bridge resistance
 units, 517.
 with L. and N. fault finder,
 ills., 519.
 three, of alternator, ills., 1,026.
 wiring: right method of, ills., 759.
- Lord** flaming arc lamp, ills., 2,469.
- Loss**, arm., mech. and elec., 281, 282.
in transformer, 1,395.
 cores, 1,545.
 determined, ills., 1,443,
 resistance deter., ills., 1,444.
 iron, of transformer, 1,400.
 of power found by Ohm's law, 282.
 in condenser, 1,118.
 of synchronism, 1,008.
 of voltage in wire circuit, 747.
 transformer core, test, ills., 2,093.
- Lover's**, telegraph, 2,115.
telephone, ills., 2,117.
- Low**, com. segment(s), pulled out, 645,
frequency, advantages of, 1,006.
 low volt. alternator, ills., 1,553.
 improves power factor, 1,359.
 power factor, effect of, 1,358.
 resistance measurement, ills., 506.
- Low tension**, ignition, 2,734, 2,761-2,768.

- Low tension, —Continued.**
 magneto(s), 2,755.
 Lowell dam power house, ills., 1,977.
Lubrication, armature bearings, 2,595,
 forced system, ills., 660.
 gearing of automobile, 2,837.
 insufficient, 593,
 of shaft bearings, ills., 592.
 of trolley, 2,547.
 railway motor, 2,658.
 wick feed, crane const., 2,942.
 worm gear, 2,921.
- Lumbago, treatment for, 3,209.**
Lumen, def. of, 2,528.
Luminiferous ether, 2,674.
Lundell's core and pole piece, ills., 214.
 pole piece, ills., 208.
Lux, definition of, 2,509.



- McElroy system car lighting, 2,606.**
McIntire, sleeve, joint, ills., 818.
 splice, ills., 818.
 wire twisting clamp, ills., 819.
McIntosh, aseptic plate, 3,202.
 caution illuminator set, ills., 3,226.
 monomotive rheo tone, ills., 3,198.
 polysine generator, ills., 3,204.
 modalities of, ills., 3,217.
 universal mode and modalities, ills.,
 3,199, 3,200.
MacLagan sinusoidal controller, ills., 3,210.

- Magnesium light, efficiency of, 2,426.**
Magnet(s), 106-124.
 abnormal, ills., 108.
 action of, ills., 110.
 and filing, exper. with, ills., 109.
 bar, ills., 106.
 bipolar field in dynamo, 182.
 brake, elevator, ills., 2,858, 2,860.
 coil(s), ends, how brought out, ills.,
 2'5-217.
 effect of, breaking, ills., 108.
 electro-, first use of, 2,413.
 field, 199, 220.
 connections of coils, 219,
 dynamo circuit, 573,
 ills., 183.
 heating of, 661.

- Magnet(s), field, —Continued.**
 multi-pole, advantage, 182.
 frame of railway motor, ills., 2,555.
 horseshoe, ills., 106.
 influence of, 108.
 permanent, ills., 106.
 how differs from solenoid, 116.
 induction, 2,367, ills., 2,368,
 meter, 1,815.
 poles, motion of disc between, opposed
 by eddy currents, ills., 270.
 properties of, 2,734.
 spool, ills., 215.
 state of saturation, 119.
- Magnetic, and electric circuits, anal., 124.**
 circuit, des., 111.
 of dynamo, ills., 213.
 of meter, 1,813.
 reluctance, law of, 122.
 resistance in, law of, 121.
 drag on armature, 274.
 effect, of current, 97, 112.
 flux, armature at rest, 262.
 def. of, 111.
 density, ratio of, 118.
 induced by dynamo, 161, 162.
 measure of, 111.
 fringe of generator, ills., 209.
 hysteresis in arm. core, ills., 277, 279.
 induction, def. of, 125.
 leakage of alternators, 1,165.
 of transformer reduced, 1,379.
 through core reduced, 329.
 meridian, ills., 106.
 needle, effect of, charge coil, ills. 432.
 of current on, ills., 431.
 permeability, 118, 119.
 poles, ills., 107, 108, 111.
 pressure in ampere turn, 120.
 resistance, def. of, 120.
 saturation, def. of, 119.
 strength of solenoid, 116.
 whirls around galv. coil, ills., 444.
 direction of, ills., 114.
- Magnetic field, conductor in, ills., 350.**
 def. of, 97,
 2,734.
 des. of, 109, 111.
 direction of current, ills., 114.
 distortion of, ills., 264, 265.
 dynamo, strength of, 183.
 effect on, of moving circuit, 127.
 extent and character of, 108.
 force exerted on current carrying con-
 ductor in, ills., 354.
 ills., 108, 109.
 intensity of, 111, 183.
 rotating, resultant flux, ills., 1,294.
 Tesla's, ills., 1,293.
 two phase currents, ills., 1,298,
 1,299.
 surrounding conductor, 274.
 variable, result of, ills., 129, 130.
 rotary, motion, exper., ills., 1,304.
- Magnetic lines, analogy elastic cord, 275,**
 curved complex, 120.
 cutting, 126, 131, ills., 166, 167.

- Magnetic lines**,—*Continued*.
 direc., rules and exp. ils., 112, 113.
 distorted, ils., 351, 352.
 ils., 108, 109.
 increasing and dimin., effect of, 132.
 number, how altered, 126.
 Ohm's law applied to, 121.
 poles formed by, ils., 114.
- Magnetism**, 105-124, 2,734.
 cross, of armature, ils., 262, 263.
 dist. of in magnet, ils., 107.
 in drum armature, 281.
 in ring armature, ils., 280.
 how induced, 125.
 hysteresis, or lagging of, 123.
 lagging, behind force, 278.
 molecular theory of, 108.
 residual, def. of, 124.
 strength where greatest, 107.
- Magnetite arc lamp**, principle of, 2,463.
- Magnetization**, cross, ils., 262.
 curve test, ils., 2,084.
 double reversal of, 124.
 highest degree, 119.
 state of magnet immed. after, 119.
 test, direct motor or dyn., 2,088.
- Magnetizing**, coils, object of, 214.
 power of coil, 120.
 turns, cross, ils., 268, 269.
- Magneto**, Alliance, 2,413.
 and dynamo, difference, ils., 183.
 ils., 2,748.
 automobile lighting, H.-C., 2,798.
 classes of, 2,735, 2,752.
 Connecticut, ils., 1,194.
 def., 2,735.
 Eiseman, wiring diag. of, 2,791.
 Heinze, low tension, ils., 2,754.
 high tension, class., 2,755-2,757.
 history of, 2,413.
 Holtzer-Cabot, ils., 2,128.
 ignition, 2,781.
 high tension, 2,757.
 inductor, des., 2,767.
 low tension, ils., 1,151.
 K.-W., timing, diag., 2,769.
 operation, 2,757.
 with self-contained coil, diag.,
 2,755-2,757.
 inductor, ignition, des., 2,752-2,755.
 jack circuits, ils., 2,135.
 low tension, oscillating, Bosch, ils.,
 2,764.
 operator's circuit, ils., 2,172.
 oscillating low tension, ils., 2,757.
 Remey, inductor, ils., 2,752.
 short circuits, 2,190.
 Sumter low tension, ils., 2,758.
 timing diag., 2,759.
 test for grounded armatures, 633.
- Magneto**, telephone, 2,122.
 closed, ils., 2,123.
 open, ils., 2,123.
 plan, wiring, ils., 2,125.
 short circuited, 2,189.
 standard, circuit, ils., 2,183.
- Magneto**, telephone,—*Continued*
 switchboard, 2,127. ils., 2,184.
 theory, 2,122.
 troubles, 2,185-2,196.
- Magnetomotive force**, 120, 122.
- Main**, def. of, 743.
 fuse, blown, 2,664.
- Major transformer insulation**, 1,415.
- Make and break ignition**, 2,734.
 igniters, des., 2,767, 2,768.
- Mammary glands**, insuf. treat., 3,210.
- Mandrel**, babbitting, 3,093.
- Manganese**, dioxide of, in dry cell, 59,
 ore in contact with zinc, 44.
 oxide, in depolarizing, 46.
 in dry cell construction, 2,401.
- Manganin resistance wire**, 3,049,
 Manhole, G. E., ils., 843.
- Manual**, or button repeater, oper., 2,219.
 railway signal, 2,632.
- Marble**, conductivity of, 69.
- Marconi**, aerial inductance, 2,306.
 wave meter, ils., 2,284, 2,285.
 wireless telegraph(y), 2,263,
 ils., 2,286.
 operation, 2,329.
 wireless telephone, 2,329.
- Marianini's battery experiment**, 893.
- Marine**, portable transformer, ils., 1,984.
 search light, ils., 2,474.
 steam turbine, West., ils., 2,671.
 view showing motion, ils., 1,147.
- Marlin cable winding**, ils., 578.
- Mason multi-discharge arrester**, ils., 888.
- Massage**, electrical, 3,219, ils., 3,220.
 control, railway motor, 2,569.
- Master Car Builders truck**, ils., 2,593.
- Matter**, def. of, 84.
- Matthiessen's copper wire standard**, 723.
- Mavor system**, ship propulsion, 2,666.
- Maxwell's**, battery experiment, 894.
 corkscrew rule, ils., 112.
 def. of, 111.
- Mazda lamps**, various, properties of, ils.,
 2,499, 2,525, 2,529, 2,532.
- Measuring instruments**, electrical, 431-572
 2,081, 2,082.
 electromagnetic, 1,780.
 moving coil, ils., 539, 1,857.
 moving iron, ils., 538, 1,780.
 portable, 2,089.
- Mechanical**, and electrical armature losses,
 281, 282.
 and electrical energy, 83-92.
 brake, elevator, 2,890.
 circuit maintainer for bell, ils., 2,351,
 2,352.
 draught, and chimney, comp., ils., 1,958,
 1,960.
 for station, 1,957.
 electro-plating, 3,155.
 equivalent of heat, 89, 91.
 generation of current, 33.
 interlocks, controllers with, 695.
 rectifiers, ils., 1,495, 1,497.
 vibration, 3,219, ils., 3,220.

Mechanical analogy, cur., a. c., pres., effect, 1,779.
 capacity, a. c., ills., 1,040.
 lag, ills., 1,051.
 wattless, 1,113.
 hunting of motors, ills., 1,280.
 pressure, back, a. c., current, 1,779.
 effective, a. c. current, 1,779.
 virtual, a. c. current, 1,779.
 steam engine, current flow, 1,053.
 power factor, 1,109.
 tuning, 2,278.

Medical electricity, 3,185-3,242.

Medium, homogeneous, velocity, ether waves in, 2,276.
 wireless telegraphy, 2,264.

Meitz and Weiss, 2 cycle eng., ills., 2,739.

Megohm(s), meaning of, 78, 434.
 resistance box, ills., 486.

Melancholia, treatment for, 3,210.

Melville-MacAlpine ship speed gear, ills., 2,670, 2,671.

Meniscus lenses, ills., 2,703.

Menlees system ship propul., ills., 2,668.

Mercury, bulb(s), G. E., ills., 1,523.
 conductivity of, 69.
 effect of addition of zinc, 65.
 in battery electrolyte, 910.
 motor amp. meter, ills., 1,822-1,824.
 resistance of, 78.
 standard of ohm, 29.
 turbine or interrupt., S. W., ills., 3,193.
 vapor lamp, C.-H., a. c., ills., 2,483.
 C.-H., a. c. series, ills., 2,484.
 C.-H., d. c., ills., 2,481.

Mercury rectifier, 1,507-1,526.

Meridian, magnetic, ills., 106.

Mesh grouping, six ph. winding, ills., 1,133.
 three phase, ills., 1,247.
 two phase, ills., 1,244.

Messenger, cable in trol. line, ills., 2,628.
 telegraph call box, ills., 2,258.

Metal(s), aluminum, solder for, 3,077.
 and alloys, conduc. of, 723.
 anti-friction, 3,091, 3,092.
 Babbitt, compo. of, 3,091, 3,092.
 brass, sweating, ills., 3,091.
 composition, various, 3,048, 3,049.
 conductivity of, 76.
 contact of, 43.
 copper, brazing of, 3,098.
 difference of potential, Volta, 44.
 electrification of, 7.
 electrolysis of, 3,133-3,142.
 electroplating, 3,143-3,184.
 gold, solder for, 3,077.
 grid resistance unit, ills., 665.
 in solution, series of, 102.
 iridium for lamp filaments, 2,499.
 Krupp, composition of, 3,049.
 liberation of in double cells, 41.
 monel, composition of, 3,049.
 moulding, base and cap, ills., 775.
 Raff's contact series of, 44.
 resistance, table, 78.
 wires, various, 3,048, 3,049.

Metal(s),—Continued.

resistors in electric heating, 3,048.
 stereo, electrotyping, 3,183.
 silver, solder for, 3,073.
 solders for var., 3,070, 3,071, 3,073.
 strip brushes with frayed ends, 637.
 tantalum, 2,496.
 tungsten, 2,496.
 Volta's, 44.
 wet extraction of, 3,141, 3,142.
 wire fuse, 1,617, 1,618.

Metallic, circuit, 2,734.
 combs, on Holtz machine, ills., 24.
 dust bet. commutator segments, 652.
 flame arc lamp, ills., 2,462.
 ores, conductivity of, 69.

Metallized filament, 2,492.

Metallurgy, 3,143, 3,184.

Meter, astatic, Thompson, ills., 552.
 automobile, defective, 2,854.
 bearings, ills., 1,804, 1,814.
 candle, ills., 2,510.
 commutator, 1,804.
 rough, cleaning of, 568.
 compensator, friction, 1,818.
 connex., Sangamo, ills., 1,820-1,821.
 disc, Faraday, ills., 1,813, 1,823.
 magnetic vane, ills., 1,784.
 electrostatic, 530.
 element producing field, 1,808.
 elementary Faraday disc, ills., 1,822.
 fast running, 568.
 Faraday disc, ills., 1,824.
 flux in Faraday disc, 1,825.
 frequency, adjustment, 1,821.
 G. E., ills., 1,830.
 Langsdorff and Beg., ills., 1,830.
 Hoskins, ills., 1,790-1,791.
 hot wire, 1,786, 548, 1,787.
 how to read, ills., 561.
 illuminated dial station, ills., 558.
 induction, 1,787.
 frequency, 1,829.
 Westinghouse, ills., 1,829.
 Hoskins, ills., 1,789.
 pole, shielded, ills., 1,788.
 rotary field, 1,791.
 watt hour, Fort Wayne, ills., 1,805.
 inclined coil, ills., 1,783.
 Keystone, construction of, 541.
 magnets, Sangamo, ills., 1,819.
 magnetic, circuit, 1,813.
 vane, ills., 546-547, 1,785.
 Wagner, ills., 1,784.
 mercury motor ampere, ills., 1,822.
 Faraday, ills., 1,824.
 moving, coil type, ills., 539.
 iron, ills., 538.
 objections to, 1,781.
 permanent magnets, 1,815.
 plumbing of, 564, 1,782.
 plunger, 546, 1,782.
 portable inclined coil, ills., 549.
 power factor, 1,835.
 adjustment, 1,820.

Meter, power factor,--Continued.

- Westinghouse, ills., 1,835.
 reading, 561.
 register dials of Sangamo, ills., 1,816
 1,817.
 resonance, freq., Frahm, ills., 1,827.
 reeds, ills., 1,828.
 retarding element, 1,815.
 slow running, 568.
 testing, 568.
 transformer shunts, 2,100.
 Wagner, ills., 1,798.
 watt hour, 1,799.
 slow speed of, 562.
 Thompson, ills., 559, 560.
 Westinghouse, ills., 566.
 wave, ills., 2,284, 2,285.
 voltage, how indicated, 2,285.
 Whitney hot wire, ills., 549, 550.
- Mica**, as insulator, 70.
 for commutator insulation, 302.
 for transformer insulation, 1,416.
- Micro-**, amperes, meaning of, 434.
 farad, def. of, 92.
- Micromh**, meaning of, 78.
- Micrometer wire gauge**, ills., 739.
- Microphone transmitter(s)**, 2,124, 2,126.
 classified,
- Mil(s)**, circular, formula for finding, 748.
 foot, 734.
 square, ills., 733.
- Milli-**, ammeter, des., 538.
 henry, unit of inductance, 1,036.
 voltmeter, des., 538.
- Milliken**, telegr. repeater syst., ills., 2,221.
 wire towers, ills., 1,548.
- Milonite tacks for wire**, 2,399, 2,409.
- Mineral oil**, for commutator, 636.
 for lubricating commutator, 646.
 used in transformer, 1,410.
- Minor transformer insulation**, 1,415.
- Mirror**, concave, 2,677.
 properties of, 2,686.
 spherical, ills., 2,680,
 convex, 2,677.
 image in, 2,692.
 curved, 2,677.
 des., 2,675.
 galv. for telegraph, 2,251.
 multi-image, 2,678, 2,681.
 parabolic, 2,679.
 plane, ills., 2,675.
 position of image in, 2,678.
 reflector Thompson galv., ills., 455.
 spherical, 2,677.
 vibrating, ills., 1,865.
- Mobile engine**, Buckeye, ills., 1,979.
- Modalities of universal mode**, 3,200.
- Moebius process**, silver deposition, 3,136.
- Mohawk elec. rect.**, ills., 1,500, 1,501.
- Moist earth**, conductivity of, 69.
- Moisture**, conducting power of, 74.
 detected, in field coils, 661.
 in mineral oil, 2,049.
 effect of on coil insulation, 661.
 in armature coils, 659.

- Molecule(s)**, behaviour of, 84.
- Molecular**, theory of magnetism, ills., 123.
- Moloney**, transformer cores, ills., 1,390, 1,397,
 1,447-1,449, 1,454.
- Monel metal**, resistance wire, 3,049.
- Monitor**, automatic starter, ills., 674.
 control, switches, ills., 675, 676.
 printing press controller, ills., 678.
- Monocyclic**, arm. and tr. cons, ills., 1,156.
 motor and transf., cir., ills., 1,453,
 system, ills., 1,554.
 with transformer, ills., 1,157.
- Monocyclic alternator**, connections, ills.,
 1,159.
 G. E., ills., 1,158,
 teaser coil, 1,554.
- Monomotive rheo.**, McIntosh, ills., 3,198.
- Monophase** or single phase current, 1,020.
- Mono-rail**, hoist, Niles, ills., 2,956-2,958.
- Moore**, vacuum tube lamp, ills., 2,480.
 candle power of, 2,482.
- Morday's method** com. voltage, 261.
- Morse**, code, telegraph, 2,246.
 wireless, 2,270A.
 experiments, wireless, ills., 2,265.
 key and sounder, 2,203-2,204.
 single line telegraph, 2,203.
 telegr. and teleph., ills., 2,162.
- Motion picture(s)**, 2,673.
 arc, controller, ills., 2,726.
 auxiliary apparatus, 2,721.
 carbon, adjustment, 2,719.
 feeding, 2,721.
 centering defective, ills., 2,722.
 film, 2,724.
 splice, ills., 2,727.
 friction disc clutch, ills., 2,714.
 lamp(s), various, ills., 2,722, 2,723.
 lenses, achromatic, ills., 2,699.
 optics, 2,673.
 persistence of vision, 2,706, 2,709.
 Power's rheostat, ills., 2,724.
 projection, illumination for, 2,716.
 screen image sizes, table, 2,705.
 size of on film, 2,724.
 take up device, ills., 2,714.
 thimble, ills., 2,714.
 transformer, Power's, 2,725.
 Underwriters' regulations, 2,721.
- Motion picture camera**, op., ills., 2,728.
 Powers, ills., 2,715.
 Schneider, ills., 2,729, 2,730,
 Universal, ills., 2,731.
- Motion picture machine(s) (parts)**, 2,703.
 condenser, ills., 2,708.
 elementary, ills., 2,708, 2,709.
 feed sprocket, ills., 2,708.
 film, feed system, 2,706.
 intermittent movement, 2,712.
 lamp house, ills., 2,715.
 optical system, 2,706.
 pastil adapter for, 2,720.
 Power's, ills., 2,715.
 rheostat, 2,721.
 safety devices of, 2,706,
 Simplex, ills., 2,707.

Motion picture machine(s) (parts),—Continued.

threading, 2,712.
transformer, 2,721.
used as camera, 2,732.
various lenses, ills., 2,700.

Motor(s), a. c., 1,267-1,376.
automobile, 2,823.
auxiliary apparatus for, 407-430.
Baker R. & L., ills., 2,835.
box frame, bearing for, ills., 2,595.
brake test, apparatus for, ills., 378.
brush(es), sparking at, 388.
car, gas electric, set, ills., 2,597, 2,598,
care of, 687.
cascade method, 2,586.
classification of, 368.
clutch type, ills., 1,348.
commutating plane of, ills., 365.
commutator, ills., 1,349.
compen. repul., Sprague, ills., 1,368,
1371, 1372.
compound, char. of, 374, 375.
 connec. with rheostat, ills., 374.
 rheostat, ills., 669.
 speed regulators, 690.
 speed of varied, 681.
 starter, ills., 669.
connection(s), changed, ills., 372.
controller, various types, 663-696.
converter, 1,458.
 induction, ills., 2,071.
crane, Shaw, ills., 2,947.
 trolley, d. c., or a. c., 2,944.
d. c., 349-406. 663-696.
 direc. of motion, rule for, ills., 363.
 drive, friction, 404.
 dynamo, automobile, 2,800.
 efficiency of, 384.
 electric vehicle, 2,824.
 electro-plating, generator set, H. & V.,
 ills., 3,149.
fan, single phase, ills., 1,346.
field, auxiliary commutating, 385.
flux, auxiliary, 385.
foundation for, ills., 395.
fractional horse power, ills., 2,726.
geared, to jack shafts, 2,592.
General Electric, adjust., speed, repul-
 sion, ills., 1,359.
 back geared, ills., 403.
 capacity of, 377.
 car, gas electric, ills., 2,597.
 com. pole railway, ills., 2,564.
 controller, ills., 693.
 generators, ills., 1,484, 1,485,
 1,492.
 ills., 377.
 induc. dr'n. shell, ills., 1,344, 1,345.
 small, ills., 1,316.
 railway, ventilated, 2,563.
 single phase, compensated repul-
 sion, ills., 1,354, 1,366.
 induction, ills., 1,341.
 slow speed, ills., 369.
 split frame railway, ills., 2,564.

Motor(s), General Electric,—Continued.

synchronous, ills., 1,765.
type K, ills., 2,570, 2,574.
ventilated arm. const., 2,563.
vertical, ills., 1,314.
 hunting of, mech. anal., ills., 1,280.
 in watt hour meter, 1,802.
 inside hung, ills., 2,594.
 lead negative, ills., 364, 365.
 load and torque equal, 355.
 location and setting of, 686.
 mercury ampere meter, ills., 1,822,
 Faraday, ills., 1,824.
 monocyc. and transf., cir., ills., 1,453.
 octagonal shaped, ills., 367.
 oiling of, 687.
 operation, 663-696.
 parts of, ills., 358.
 power of, 375-376.
 power for hoisting, 2,955.
 principle of, ills., 364.
 synchronous, ills., 1,268-1,276.
 pump, centrifugal, 3,010, 3,011.
 reciprocating, 3,009, 3,010.
 reaction of armature in, 363.
 reg. by shunt fld. resis., 685.
 reversal of rotation, 361.
 reverse voltage, 350.
 reversible starter, ills., 689.
 rheostat, compound, ills., 669,
 function of, 367.
 rheostatic control, 2,582.
 rope driven, 403.
 rotation of, 360, 361.
 salient poles of, ills., 2,947.
 separately excited, ills., 362.
 single phase, comp. repul., ills., 1,354,
 slip, induction, variation of, 1,317.
 slip ring, wound rotor type, ills., 2,869.

slow speed, wiring, ills., 2,007.
small, Eck Manchester, ills., 658.
small, started without resist., 667.
starting (of), affected by reversed
 voltage, 668.
 operation of, 664.
 panel, ills., 670.
 rheostats, ills., 669.
 switch, West., ills., 1,598,
 through resistance, 663.
stopping of, 687, 696.
suspension, from ceiling, 686.
telpher, 2,959.
temperatures of, 687.
test, loaded, 2,076.
 single phase, ills., 2,076.
 three phase, ills., 2,077, 2,078,
 2,080-2,082.
torque, and speed, relations of, 381.
traction, speed regulation of, 693.
trolley car, trouble with, 2,656, 2,658.
vertical, Watson, ills., 404.
Waverly, 80 volt, ills., 2,825.
Western Electric, slip ring, ills., 1,337.
 squirrel cage ills., 1,283.

- Motor, asynchronous or induction, 1,267-**
 1,348.
 amperes per terminal, table, 1,900.
 clutch type s. p., Sprague, ills., 1,342.
 compen. sh., ills., 1,363, 1,367.
 control, three phase, 2,581.
 converter, ills., 2,071.
 core construction, ills., 1,290.
 Holtzer-Cabot, ills., 1,332.
 internal resistance, 1,334, ills., 1,336.
 magnetic bridge C.-W., ills., 1,330.
 operation, ills., 1,311, 1,313.
 performance curves of, ills., 1,112.
 polyphase, 1,292-1,338.
 Richmond, ills., 1,285.
 single phase, starting of, 1,286.
 ills., 1,341-1,342.
 slip of, ills., 1,313, 1,318.
 slip ring, ills., 1,340, 1,339.
 split phase, Fort Wayne, ills., 1,347.
 squirrel cage, arm. of, ills., 1,291.
 two phase, West., ills., 1,333.
 W. E., ills., 1,283.
 starting, 1,331, 1,332.
 single phase, ills., 1,341, 1,342.
 temperature test, ills., 2,083.
 three phase, for railway, 2,545.
 two phase, ills., 1,289.
- Motor, elevator, accel., 2,883, 2,904,**
 a. c. for slow speed, 2,871.
 compound wound, ills., 2,868.
 high torque polyphase, 2,871.
 h. p. diagram, ills., 2,867.
 induction, speed varying, 2,871.
 leaving for night, 2,934.
 non-reversible, 2,877.
 polyphase slip ring, 2,872.
 repulsion, induction, 2,873.
 series field winding, 2,887.
 single phase, suitability, 2,873.
 speed of, 2,869.
 squirrel cage, induction, 2,870.
 stopping, 2,890.
- Motor generators, 2,055-2,056,**
 combinations, 1,485.
 for emergency machine, ills., 2,166.
 in central stations, 1,485.
 set(s), cascade, ills., 1,490.
 ills., 1,484, 1,485.
 for increasing freq., 1,569.
 speed of, 1,492, 1,493.
- Motor, railway, 2,544.**
 armature, construction, 2,563.
 overheated, 2,658.
 bridge transition, 2,571, 2,573.
 car, G. E., gas-electric, ills., 2,597.
 classification of, 2,558.
 closed, ills., 366.
 commutating pole, ills., 2,564.
 d. c., ills., 2,552, 2,553, 2,554.
 split frame, ills., 2,554, 2,555.
 geared and gearless, 2,562.
 gearing and case, ills., 2,563.
 lubrication of, 2,595.
 open, ills., 367.
 operation, at various pres., 2,535.
- Motor, railway,—Continued.**
 cascade 2,584, 2,586.
 changeable pole, 2,583, 2,586.
 concatenation, 2,584, 2,586.
 tandem control, 2,584, 2,586.
 series, resistance transition, 2,571.
 wound, 367.
 troubles, 2,658.
 West. interpole, ills., 2,657, 2,660.
 ventilation methods, ills., 2,556, 2,557.
- Motor, railway, control, series parallel, ills.,**
 2,572, 2,573, 2,574.
 systems of, 2,566, 2,567.
 induction, regulator, 2,577.
 three phase, 2,581.
 rheostatic vs. compen., 2,577.
 West., H. L., ills., 2,662, 2,663.
- Motor, railway, controller, G. E., ills., 693.**
 type K, ills., 2,570, 2,574.
 ills., 2,565.
 series parallel, 2,571.
 trolley cars, 2,649-2,658.
 Westinghouse type K12, ills., 2,576.
 type K 35, ills., 2,578.
 type L2, ills., 2,577.
- Motor, railway, suspension, ills., 2,559-2,564,**
 cradle, ills., 2,560.
 nose, ills., 2,560, 2,561.
 parallel bar or side, ills., 2,561.
 twin, 2,563.
 yoke, 2,561.
- Motor, repulsion, action of, 1,369.**
 armature currents in, 1,355.
 principle of, ills., 1,365.
 reversing type, Sprague, ills., 1,371.
 speed adjustable, G. E., ills., 1,359.
 start and induction operation, 1,352.
 variable speed, connection of Sprague,
 ills., 1,370.
- Motors, series, advantages and disadvantages,**
 393.
 alternating current, 1,359,
 and rheostat, ills., 368.
 conditions at starting, 667.
 def., 368.
 direction of reversed, ills., 372,
 for booster sets, 2,057.
 neutralized, conductive method, ills.,
 1,361.
 inductive method, ills., 1,362.
- revolving strike bell, ills., 2,371,
 shunt motor starts like, 375.
 single phase for railways, 2,540.
 speed of, doubled by direct field varia-
 tion, 383.
 varied, 681.
 speed regulation of, ills., 679, 680.
 starter for, ills., 422.
 unsuited for varying load, 369.
 variable field regulation of, ills., 382.
- Motor, shunt, adv., and disadv., 393.**
 circuits suitable for, 393.

- Motor, Shunt**,—*Continued.*
 conductive single phase, Fynn's, ills., 1,364.
 connections, diag., 370.
 control, 677.
 crane, 2,951.
 d. c., load and speed test, ills., 2,090,
 rotation, direction, 362.
 direction reversed, 372.
 speed, variation, 373.
 regulation, 371. ills., 679, 681.
 starter with voltage release, ills., 423.
 starting, 373. 668.
 used as dynamo, 2,952.
- Motor starter, automatic, Allen-Bradley, ills., 673.**
 compound, ills., 669.
 with no voltage release, ills., 424,
 425.
 connected to motor, 422.
 Cutler-Hammer, ills., 666.
 for series motor, ills., 422.
 induction, auto-transformer, ills., 1,334.
 lever, operation of, 667.
 multiple switch type, ills., 668.
 no voltage, ills., 669.
 overload release, ills., 669.
 overheating of, 690.
 shunt, with voltage release, ills., 423.
 contact, sliding, ills., 667.
 two phase induction, Westinghouse,
 ills., 1,333.
- Motor, synchronous, as frequency indicator, 1,826.**
 adv. and disadv. 1,278.
 dead centers, 1,274.
 characteristics of, 1,281.
 explained, 1,269.
 for high voltage, 1,279.
 G. E., ills., 1,765.
 hunting of, 1,280.
 over excited, 1,763.
 reverse pressure, 1,271,
 reverse voltage, 1,272.
 rotation, 1,275.
 self-starting, Westinghouse, ills., 1,279.
 temperature test, ills., 2,086, 2,087.
 used as condenser, ills., 1,281.
 with vibrating mirror for oscillograph,
 ills., 1,865.
- Moulding(s), and flexible tubing or conduit combination in non-fireproof building, ills., 862.**
 backing, cap and tongue, 774.
 ceiling, treatment of, ills., 777.
 dead, ills., 777.
 metal, base and cap, ills., 775.
 wiring, 2,409.
 standard wooden, ills., 774.
 wires run in, 773.
- Muffle brazing, 3,098.**
Muffler, explosions in, 2,792.
- Muller's soldering liquid, 3,083.
 Multiple, brush holder Holtzer-Cabot, ills., 310.
 connection, 66.
 jack magneto circuit, ills., 2,135.
 switchboard drops, ills., 2,134.
 jacks, 2,132-2,134.
- Multiplier(s), electrical, ills., 2,207, 2,208,**
 for portable voltmeters, ills., 553, 554.
 with L. and N. potentiometer, 532.
- Multiplex, armature winding, 247, 248.**
 arrester connection, 1,689,
 telegraph, Delaney, 2,249.
 Rowland, 2,249.
 wireless, Slaby-Arco, 2,289.
 windings, number of, 249.
- Mummified armature coil winding, 1,259.**
Murray, alternator with dir. con., 1,979,
 and Varley loops illustrated, 514,
 loop, test circuit, ills., 515.
 with fault finder, ills., 516.
- Muscles, atrophy of, treatment, 3,210,**
 wasting of, treatment for, 3,219.
- Muscular contractions, ills., 103.**
Musschenbrock and the Leyden jar, 22,
 Mutual induction, 1,887.

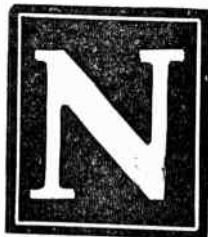

- Nails, milonite, ills., 2,409.**
National, carriage call key'rd, ills., 881.
 cells, electrical data on, 958.
 elev. cont. d. c. gravity, ills., 2,890.
 storage battery cells, ills., 962, 963.
- Natural sines, and tangents, table of, 451.**
Needle(s), astatic, galvanometer, ills., 437, 439.
 compass, 431,
 galvanometer, 493.
 swing or kick of, 454.
 magnetic, between two coils, 453.
 horizontal, ills., 106.
 moving, Keystone meter, ills., 541.
 soft iron, of meter, 538.
- Negative, charge, neutralizing of, 19, 20,**
 on Wimshurst machine, 26.
 electrification, 5, 7.
 electricity, def. of, 3.

Negative,—Continued.

- elements, how distinguished, 37.
- lead of motor, 364, *ills.*, 365.
- plates, of storage battery, 923.
- pole, 107.
 - def. of, 32, 2,735.
 - location of, 2,386.
- sign given to cap. reactance, 1,062.
- Neiswanger technique, 3,204, 3,206, 3,207, 3,213.
- Nernst, lamp, 2,501.
 - diag., *ills.*, 2,502.
 - light curve, *ills.*, 2,515.
- Neuralgia, treatment for, 3,205, 3,211.
 - ovarian, 3,212.
- Neurasthenia, treatment for, 3,211, 3,214, 3,223.
- Neuritis, treatment for, 3,212.
- Neurosis, treatment for, 3,213.
- Neutral, bodies, 14.
 - grounded and non-grounded circuits, 1,704, 1,705.
 - plane, 287.
 - normal, 266, *ills.*, 267, 285.
 - relay, railway signals, 2,037, *ills.*, 2,638.
 - wire, of three wire system, *ills.*, 706.
- Neutralized field magnetism, 587.
- New British standard wire gauge, 740.
- New Haven motors, *ills.*, 2,562.
- N. Y. Central inverted 3rd. rail, *ills.*, 2,550.
- N. Y. City, railway, power, 2,537.
 - railway, Third Ave. system, *ills.*, 2,551.
 - third rail system, *ills.*, 2,549.
 - subway, signal system, 2,641, 2,642.
- N. key oper. at P. B. X. switchbd, 2,179.
- Niaudet's, battery experiment, 894.
 - machine disc armature of, *ills.*, 228.
- Niblett's battery experiment, 894.
- Nicholson and Carlisle experiments of, 98.
- Nichrome resistance wire, 3,049.
- Nickel, anode two bar, 3,179.
 - conductivity of, 69, 723.
 - electro-plating, 3,180.
 - current for, 3,149.
 - rheostat for, *ills.*, 3,154.
 - galvanizing barrel for, *ills.*, 3,182.
 - in caustic potash, 102.
 - in hydrochloric acid, 102.
 - in sulphuric acid, 102.
 - plating, 3,180, 3,181.
 - properties of, 3,147, 3,149.
 - resistance wire, properties of, 3,049.
 - rouge polish, electro plating, 3,166.
 - wet extraction of, 3,142.
- Nitrates in battery electrolyte, 909.
- Nitric acid for electro-plating, 3,169.
 - use in depolarizing, 41.
- Nitrogen filled lamp, *ills.*, 2,503.
- Noark enclosed fuse, *ills.*, 1,614.
- Nodon valve, action of, 1,497, 1,499.
- Non-conductor(s), def. of, 68.
 - incorrect term, 10.
 - made conductors by heating, 72.
 - properties to be desired in, 73.

Non-conductor(s),—Continued.

- table of, 70.
- Non-induc., and induc. resis., *ills.*, 1,029.
- capacity an induc. in cir., *ills.*, 1,060.
- coil, *ills.*, 1,032.
- Non-luminous, def., 2,506.
- Normal, neutral plane, 266, *ills.*, 267, 285.
 - plane of maximum induction, 286.
- Northern cranes, *ills.*, 2,946.
- Northrup electro-dyn., *ills.*, 1,797.
- Novel's solders, aluminum, 3,078.
- Nozzle(s), needle, water discharging from, *ills.*, 1,975.
 - steam, of turbine, 1,973.



- Oakland automobile circuit diag., 2,801.
- Obesity, treatment of, 3,212, 3,223.
- Objective, arc, condenser, 2,701.
- Oerstead, discovery by, 112.
 - def., 121.
- Offsets, elbows and conduit bends, 794.
- Ohm(s), 29.
 - 472-474, 2,733.
 - ampere and volt. relation, *ills.*, 468.
 - comparison, table, 475.
 - formula to determine, 29.
 - hydraulic analogy, 2,733.
- Ohm's law, 29.
 - applied to, dir. of cur., 133.
 - heat developed by current, 96.
 - loss of power found by, 282.
 - magnetic lines of force, 121.
 - when not applicable, 2,420.
- Ohmmeter, portable, Evershed, *ills.*, 509.
 - testing set, *ills.*, 504.
- Ohmic, drop, explained, *ills.*, 1,079.
 - resistance, 1,029.
 - value, of capacity, 1,045, 1,046.
 - of inductance, 1,037.
- Oil, bath, break, nature of, 1,604.
 - buffer, elevator, *ills.*, 2,858, 2,860.
 - Otis spring return, *ills.*, 2,933.
 - bumper, elevator, 2,866.
 - can non-magnetic, 593.
 - drying, Westinghouse meth., 2,050.
 - heavy, best for machinery, 660.
 - insulator, 70.
 - leakage from bearings, 591.
 - lubricating properties, loss of, 660.
 - mineral, for commutator, 636, 646.

- Oil, Mineral.**—*Continued.*
 used in transformer, 1,410.
 paraffin, use of in Edison cell, 51.
 rings, ills., 1,996.
 use of in dynamo, 156
 transformer, 1,410, 1,411.
Oil switch(es), 1,601–1,603.
 Adams-Bagnall ills., 2,444,
 G. E., ills., 1,602.
 motor operated, G. E., ills., 1,608.
 remote control, 1,605.
 hand oper., West., ills., 1,610.
 ills., 1,605–1,607.
 rupturing capacity, 1,609.
 tank central station, ills., 1,602.
 weatherproof, Pacific, ills., 1,601.
 Westinghouse, ills., 1,603.
 with solenoid control, ills., 1,606.
Old English wire gauge, 740.
Oldsmobile circuit diagram, 2,801.
Omnigraph telegraph apparatus, 2,271.
One fluid, closed circuit cells, 35.
 primary battery, ills., 32.
Onesti's experiments, wireless, 2,269.
Ondograph, Hospitalier, 1,849–1,851.
Opaque, def. of, 2,506.
Optic atrophy, treatment of, 3,212.
Optic, def. of, 2,673.
Optical, center, ills., 2,690, 2,691.
 projection, electric arc in, 2,717.
 system, motion pic. machine, 2,706.
Optimus electroplating dynamo, 3,147.
Organic chemicals and dyes, 3,139.
Oscillating, low tension magneto, Bosch, ills.,
 2,764.
 Sumter, ills., 2,757.
Oscillation(s), high frequency, 1,677,
 2,283.
 of ring shaped Hertz resonator, ills.,
 2,283, 2,285.
 valve, Fleming, ills., 1,502.
Oscillator, and res., Hertz', ills., 2,268.
 mech., on West. conv., ills., 1,481.
 wireless teleg., original type, 2,283.
Oscillatory currents, wireless, 2,281.
Oscillograms, ills., 1,842, 1,843, 1,857.
 Duddell oscillograph, 1,860.
 of d. c. pressure, ills., 1,851.
Oscillograph, camera used on, ills., 1,866.
 cathode ray, 1,852.
 connec., Duddell, ills., 1,862, 1,863.
 glow light, 1,855.
 moving coil, 1,857.
 Duddell, ills., 1,858.
 G. E., ills., 1,852, 1,853.
 Siemens-Blondel, ills., 1,856.
 moving iron, 1,855.
 permanent mag., Duddell, ills., 1,861.
 record, ills., 1,867.
 from Nodon valve, ills., 1,498.
 of arrester disch., ills., 1,681.
 of curves, ills., 1,018.
 recording ap., Duddell, 1,865.
 syn. motor with vibr. mir., ills., 1,865.
 time scale, 1,864.
 vibrator, Duddell, ills., 1,859.
- Osmium Lamps.**—*Continued.*
Osmium lamps, 2,493.
 light curve, ills., 2,515.
Osmose, electrical, cause of, 102.
 Porret's discovery, 102.
Otis elevator, machine, over mounted, trac-
 tion, ills., 2,911.
 traction, overmounted, 1 to 1, ills.,
 2,857, 2,858.
 2 to 1, 2,860.
Otis elevator controller, a. c., full magnet,
 ills., 2,901.
 2 or 3 phase, ills., 2,904,
 d. c., diag., 2,877.
 duplex, ills., 2,898.
 traction, magnet, ills., 2,894,
 two speed, ills., 2,895.
 mag., ills., 2,893.
 mech. reversing, ills., 2,872.
Ovarian neuralgia, treatment for, 3,212.
Over compounded dynamo, 192.
Overhead, aluminum wires, 800.
 cable construction, ills., 821.
 trolley system, 2,548.
 single phase line, 1,539,
 wharf crane, Shaw, ills., 2,950.
 wire cables, hanging of, ills., 821.
Overheated dynamo, 653.
Overheating of motor starters, 690.
Overload, and underload cir.brkr, ills., 419.
Over voltage relays, 1,650.
Oxidation (of), hydrogen, depolarizing, 41.
 iron, 3,107.
Oxide(s) (of), iron, character of, 3,107,
 lead, artificially made, 958,
 manganese in depolarizing, 46.
 dry cell construction, 2,401,
 plumbic, artificially made, 958,
 pure, in storage battery, 960.
Oxidizing of brass, 98.
Oxy-acetylene, flame, features of, 3,115,
 torch, adjustment of, 3,115,
 and hydrogen, 899, 3,140.
 production of, 3,140.
Oxygraph, Davis-Bour, ills., 3,131,
 of copper in depolarizing, 46.
Ozone, composition of, 3,137, 3,138.
 generator, Columbia, ills., 3,214,
 water purifying with, 3,138.
Ozonizer, construction of, 3,138.



Pacific switches, ills., 1,597, 1,601.
 Packard automobile circuit diag., 2,801.
 Palladium in contact with zinc, 44.
 Palm rule, dir. of ind. cur., ills., 135, 136.
 Palmer, hoisting safety limit stop, 2,954.
 service sw. and fuse box, ills., 1,591.
 Pan cake transformer coils, ills., 1,381.
 Panel(s), feeder distribution from, 854, ills., 1,880.
 heater, car, ills., 2,612, 2,613.
 Fort Wayne, ills., 1,873.
 joined, ills., 2,016.
 telephone, 2,133.
 Pantograph trolley, ills., 2,540, 2,548.
 Paper, as insulator, 70.
 sectors, 23, 24.
 Parabola, ills., 2,679.
 Parabolic mirror, 2,679.
 Paraffin, oil, use of in Edison cell, 51.
 treatment of battery clamps, 952.
 wax as insulator, 70.
 prevent creeping, 55.
 Parallel, arc lamp(s), 2,452.
 circuits, 757.
 a. c., West., ills., 2,452.
 d. c., Fort Wayne, ills., 2,451.
 circuit, ills., 79.
 a. c., ills., 1,540.
 constant pressure, ills., 1,538.
 drop in voltage of, 700.
 system, various, ills., 702.
 connection (of), bells, ills., 2,386.
 coils, ills., 2,377.
 condensers, ills., 1,044, ills., 66.
 dynamo(s), cut out of circuit, 608.
 field coils, 600, 601.
 shunt and comp., 610.
 two, compound, 583.
 two shunt, ills., 581.
 series, 598.
 feeder, 701.
 hydraulic analogy, ills., 2,744.
 push buttons, ills., 2,385.
 drum winding, 235.
 flow reaction turbines, 1,978.
 operation of r. changers, 1,489, 1,490.
 paths, in simplex winding, 253.

Parallel paths.—*Continued.*
 number of increased, 259.
 series, controller, 383.
 system, of dis., ills., 703.
 system, application of, 699, 701.
 transformers, 2,053, ills., 1,543.
 Parallelogram of forces, ills., 1,073, 1,074, 1,534.
 Paralysis, treatment for, 3,212.
 agitans, 3,223.
 infantile, 3,208.
 of velum, 3,219.
 Parsons steam turbine, ills., 1,962, 1,963.
 Parsons-Westinghouse turbine, ills., 1,966.
 Partial, conductors, table of, 69.
 short circuits in armatures, 630.
 Partrick and Wilkins bells and gongs, various, ills., 2,351, 2,361.
 Party lines, telephone, 2,145-2,149.
 Partz acid gravity cell, ills., 57.
 Pastil adapter, Fulco, ills., 2,720.
 Paterson, automobile circuit diag., 2,801.
 Pawlowski valve, 1,504.
 P. B. X., emergency machine, 2,144.
 circuits, ills., 2,146.
 night connections, 2,141.
 switchboard, buz. relay, ills., 2,166.
 circuits, ills., 2,130-2,133.
 extensions, 2,141.
 jacks, 2,141.
 night connections, 2,179.
 troubles, 2,173-2,179.
 telephone cables, 2,164.
 Peak load, explained, 1,931.
 carried by storage battery, 895.
 Peaked wave, ills., 1,843.
 Peavey socket, ills., 803.
 Pelton-Francis turbines, 1,976.
 Pelvic diseases, treatment for, 3,213.
 Pencil, light, definition of, 2,505.
 Pendulum signals, use of, 2,389.
 Pennsylvania gearless motor, ills., 2,562, 2,563.
 Pentane standard of lighting, 2,507, 2,508.
 Percolator, coffee, Simplex electric, ills., 3,048-3,051.
 Period, def., 1,004.
 of charging new battery, 932.
 of commutation, 283.
 Periodicity, def., 1,004.
 Permanent magnet(s), ills., 106.
 Permeability, 118, 119.
 of iron, 1,034.
 Peroxide of lead, in depolarizing, 46.
 in storage battery, 960.
 Persistence of vision, 2,706, 2,709.
 Petticoat insulator described, 822.
 Pfaff, contact series of metals, 44.
 Phantom circuits, complex, ills., 2,169.
 Phase(s), alternators brought in, 2,034.
 curves of a. c., ills., 1,009.
 difference, aff. by condenser, 1,085.
 grouping of, 1,243.
 machines usually out of, 1,008.
 relation, between applied pressure and capacity pressure, 1,086.

Phase(s), relation,—Continued.

- between cur. and reverse pres. of self-induc., ills., 1,069.
- reverse, a. c., relay, ills., 1,652.
- single, alternating cur. ills., 1,020.
- rotary converter, 1,459.
- six, winding, ills., 1,133.
- split., induc. motor, Ft. W., ills., 1,347.
- splitting, 1,343-1344.
- three, alternator and sine curves, ills., 1,132.
- connections, mesh, 1,247.
- star, 1,243.
- power meas., ills., 1,124.
- reaction, 1,165.
- system, four wire, 1,551.
- six wire, ills., 1,563.
- 3 wire, evol., ills., 1,564.
- twelve, winding with star grouping, ills., 1,134.
- two, alternating current, ills., 1,020.
- 1,022.
- sine curves of, ills., 1,302-1,303.
- mesh grouping, ills., 1,244.
- star group., ills., 1,243, 1,244.
- system, five wire, ills., 1,561.
- four wire, ills., 1,555.
- three wire, ills., 1,556, 1,557.
- Phelps and Edison**, induction telegraph, 2,266.
- Phillips and Copland** auto. cir., 2,301.
- Phoenix** heating element, 3,051.
- Phonograph and dictograph**, 2,200.
- Phosphor-bronze**, conductivity of, 723.
- Phosphorescence**, definition of, 2,506.
- Photography**, lenses for, ills., 2,699.
- vs. optical projection, 2,700.
- X-ray, 3,232.
- Photometer**, Bunsen's, ills., 2,513.
- integrating, 2,515.
- L. and N., ills., 2,514.
- Rumfords, ills., 2,512.
- Photometry**, def. of, 2,514.
- Pick**, tamping, ills., 801.
- Pickle**, electro-plating, 3,178, 3,179.
- Piedmont railway**, West. motor, ills., 2,657.
- Pig tail** or shunt of railway motor, 2,555.
- Pike pole**, ills., 803.
- Pillar cranes**, 2,936.
- Pilot**, brush and voltmeter, ills., 261.
- lamp, to indicate field strength, 185.
- valve in master controller, 2,659.
- Pin**, expansion, rail bonding, ills., 2,617.
- insulator, ills., 804.
- Pinion and yoke** of speed motor, ills., 638.
- Pintsch gas** for car lighting, 2,605.
- Pipe**, blow, des., 3,115.
- fuel for, 3,115.
- oxy-acet., D. B., ills., 3,116.
- soldering, ills., 3,094, 3,095.
- lead, 3,113.
- welding, 3,115, 3,129.
- Zerener, welding, 3,128.
- clamps for welding, ills., 3,118.
- conduit, iron, 834-836.

Pipe, conduit,—Continued.

- vitrified clay, ills., 827.
- wooden, ills., 832.
- cutters, wheel and roller, ills., 1,994.
- dry, in horizontal boiler, ills., 1,943.
- friction of water in, table, 2,967.
- iron, standard properties of, 1,995.
- steam, connected, ills., 1,945.
- in central station, 1,941, 1,942.
- water, thawing, frozen, ills., 3,065.
- welding, ills., 3,118.
- Piston**, distinguishing feature, 2,978.
- inlet valve, operation of, 2,027.
- or impeller, rotary pumps, 2,999.
- pump, water end, ills., 2,993.
- Pitch** (of), armature winding, 231.
- angular, 233, 235.
- average, 255.
- front and back, 246, 256.
- proper, of brushes, 640.
- short, winding, 246.
- used in dry cell, 59.
- Pith ball(s)**, on metal cylinders, ills., 16.
- Pittsfield distributor**, ills., 2,775.
- Pixii**, devel. of elec. machine, 2,413.
- Plane**, commutating, 266, 284.
- different from neutral planes, 287.
- for sparkless com., 267, ills., 284, 285.
- of motor, ills., 365.
- position of, 284.
- Plane(s)**, distinguishing, 287.
- maximum induction, def., 287.
- neutral, def., ills., 284, 285.
- normal, max. induction, def., 286.
- neutral, def., ills., 284, 285, 286.
- 287.
- mirror, ills., 2,675.
- Plant(s)**, electric, country, ills., 1,549.
- hydro electric, ills., 1,975, 1,978.
- isolated, 1,980.
- power, 1,915-1,988.
- small, switch, G. E., ills., 1,874.
- Plante**, battery, cell, storage, 900.
- experiment, 894.
- plates, 903. 2,838.
- Plating**, electro-, 3,143-3,183.
- Platinoid**, conductivity of, 69.
- Platinum**, conductivity of, 69. 723.
- contact(s), magneto, ills., 2,782.
- electrodes, medical, 99. 3,198.
- in battery electrolyte, 910.
- in sulphuric acid, 102.
- melting point of, 2,419.
- use of, by Grove, 53.
- in vibrator, 147.
- wires, use of, 99.
- Pleurisy**, treatment for, 3,213.
- Pleximeter** of reflex set, ills., 3,221.
- Plexor** of reflex set, ills., 3,221.
- Pliers**, carbon, ills., 2,476.
- Plotted saturation curve**, ills., 1,992.
- Plug**, Bosch magnetic spark, ills., 2,761.
- fish, for flexible conduit, ills., 790.
- fuse, ills., 1,615.
- spark, def., 2,791.

- Plug**,—Continued.
switch(es), arc lighting, A.-B., 2,444.
- Plumbago**, conductivity of, 69.
in electroplating, 3,314.
- Plumbic dioxide**, 958, 960.
- Plunger**, and solenoid, ills. 1,785.
ammeter, 544.
distinguishing feature, 2,978.
erroneously called, 2,978.
meter, diag. of, 546. 1,782.
safety, automobile, ills., 2,852.
- Plus pole**, def., 32, 2,735.
- Pneumatic tire**, const., 2,822.
- Pohl commutator**, ills., 477.
- Poison**, lead, prevented, 961.
- Polar**, duplex, battery system, ills., 2,236.
dynamo system, ills., 2,237.
- edge** of motor, leading, ills., 362.
trailing, ills., 362.
- system of duplex telegr., ills., 2,244.
telegraph, key, 2,243.
relay, 2,243.
- Polarity**, in bell circuit, ills., 2,368.
in ground return, 2,385.
of dynamo, reversed, 588, 649.
of solenoid, right hand rule, ills., 117.
of transf., instantaneous, ills., 1,430.
reversed, meth. of correct g., ills., 586.
test of transformer, 2,054, 2,103.
- Polarization**, avoiding, 41.
of cell, effects of, 40.
of field mag. by motor current, 359.
prevented in open circuit cells, 43.
primary cell, 38.
- Polarized**, relay operation, ills., 2,226.
- Pole(s)**, anchor for, ills., 1,571.
burnettized, 802.
carbonized, 802.
climbers, Eastern, ills., 813.
concrete settings for, 802.
creosoted, 802.
cull, for guy stubs, 807.
erection of in ground, 507, 808.
for light and power wires, 807.
guys for, 811.
guyed, corner, ills., 812.
on hillside, ills., 812.
hoists, 811.
joint crossing of two lines, ills., 824.
kyanized, 802.
laminated, cast welded, ills., 213.
definition of, 211.
lightning arrester, ills., 890.
line construction tools, ills., 803.
method of raising, ills., 810.
painting of, 807.
raising fork, ills., 808.
regulator, G. E., ills., 1,740, 1,741.
1,743, 1,744.
reinforced concrete, 804.
spacing of, 808.
sterilized by antiseptic, 802.
support, jenny, ills., 808.
mule, ills., 808.
transmission lines, 800.
transformer, Fort Wayne, ills., 1,384.
- Pole(s)**,—Continued.
vulcanized, 802.
- Pole(s)**, electrical, adjacent, lateral field between, ills., 1,165.
stray field between, ills., 1,166.
changer, telegraph, F.-P., ills., 2,239.
telegr., walk beam, ills., 2,234.
transmitter, 2,243.
- commutating, rotary converter, 1,470, 1,471.
- consequent, of field magnet, ills., 201.
of magnet, ills., 108.
- location, 2,386.
in Daniel cell, 2,387.
in dry cell, 2,387.
- negative, 32, 107. 2,735.
- piece(s), alternators, ills., 1,188.
eddy currents in, 209, 661.
laminated, ills., 211.
various forms of, ills., 207.
- plus or positive, def., 32. 2,755.
- regulating, rotary converter, 1,474.
relays, 1,661.
salient, magneto, ills., 200, 201.
shielded, induction meter, ills., 1,788.
single, discon. sw., West., ills., 1,594.
switch, single and double, 407.
triple, relays, 1,661.
twin and single circuit, ills., 1,546.
- Polishes**, electro-plating, various, 3,165-3,168.
- Polyphase**, alternators, 1,134, 1,129.
converter, connection diag., 1,462.
induction, motor, des., ills., const., oper., etc., 1,202-1,338.
systems, relative copper, 1,576.
transformer(s), 1,392. ills., 1,394, 1,574, 1,575.
- Polysine generator**, ills., 3,204.
McIntosh, modalities, ills., 3,217.
- Porcelain**, as insulator, ills., 70, 71.
tubes, for wires, ills., 770, 773.
- Porous cup(s)**, and cell, Leclanche, ills., 46.
core of, 62.
- Porret's discovery** of electrical osmose, 102.
- Portland elev.**, worm drive, ills., 3,199.
- Positive**, electricity, definition of, 3.
electrification, 5, 7.
elements, how distinguished, 37.
flow, negative plates, analogy, 40.
pole, 32, 107. 2,386.
- Postal Telegr. Co.**, typewriter, 2,256.
repeater system, ills., 2,219.
- Potash**, caustic, series metals in, 102.
chlorate of, production, 3,136.
- Potassium**, and sodium, mfg. of, 3,141.
bichromate, use in depolarizing, 41.
chloride sol., electrolysis, ills., 3,137.
cyanide, for electro-plating, 3,172.
- Potential**, difference of, ills., 28.
energy, definition of, 83.
fall of, hydrostatic analogy, 33.
- Potentiometer meas.**, ills., 513, 520, -527, 534.
- Pot head(s)**, of cables, ills., 843, 844.
wires, ills., 730.
- Poulsen Wireless Co.**, system, 2,284.

- Powder, polishing, electro-plating, 3,165.
 Power, and light cir., table of wir., 750.
 curve, ills., 1,103, 1,104.
 def., 87.
 electrical unit of, 88.
 horse, def. of, 87.
 electrical, 91.
 how obtained, 385.
 trans. by belt, ills., 2,011.
 house, I. and L. Ry., ills., 2,543, 2,544.
 Lowel dam, 1,977.
 Shore Line Elec. Ry., 2,542.
 hydraulic analogy of, ills., 2,743.
 magnetic, solenoid, ills., 116, 117, 118.
 measurement, Ayrton and Sumpner
 method, ills., 1,121.
 Fleming's method, ills., 1,123.
 meters connected, ills., 2,074.
 three phase, ills., 1,124.
 mechanical unit of, 87.
 stations, 1,915-1,988.
 systems, electric railways, 2,534.
 unit established by James Watt, 376.
- Power factor**, affected by induction motor
 loads, 1,764.
 analogy, marine, ills., 1,102.
 mechanical, ills., 1,898.
 steam engine, ills., 1,109.
 curves, ills., 1,122.
 showing rel. of loads, 1,776.
 speed, syn. condenser, 1,772.
 improved by low frequency, 1,359.
 indicators, ills., 1,835.
 lead or lag effects, 1,103, 1,108.
 low, effect of, 1,358.
 frequency improves, 1,359.
 lagging, effect of, 1,767.
 meaning of, 1,102.
 meter adjustment, 1,820.
 single phase, ills., 1,836.
 of induction motors, 1,373.
 regulating devices, 1,588.
 unity, of converter, 1,466.
 value of, 1,119.
 variation, 1,103.
 zero, 1,110, 1,111.
- Power's, motion pic.**, arc lamp, ills., 2,723.
 intermit. move't, ills., 2,716.
 machine, ills., 2,715.
 multi-tap transformer, ills., 2,725.
 rheostat, ills., 2,724.
- Prece**, experiments by, 2,266.
Preheater, thermit, welding, ills., 3,120.
Pre-ignition, cause, 2,792.
Premier Ampero mag. rectifier, ills., 1,528.
Pre-payment wattmeter, ills., 567.
Press, printing, motor controller, ills., 678.
- Pressure (of)**, 28.
 active, or ohmic drop, 1,087.
 to overcome resist., ills., 1,075.
 air, laws, ills., 3,023, 3,024.
 alternator, average, 1,010.
 induced in, diag., 1,232.
 maximum, 1,010.
 virtual, 1,010.
 analogy of air and electricity, 40.
- Pressure (of)**,—*Continued.*
 and cur. curves, ills., 1,008, 1,085,
 limiting devices, 1,613-1,676,
 synchronism of, ills., 1,105.
 waves, ills., 1,847.
 atmospheric, variation of, 3,045.
 volume, ex., 3,046.
 brushes, on commutator, 577, 658.
 coil of cir. brkr. position, ills., 1,633.
 condenser, ahead of current, 1,085.
 constant, parallel circuit, ills., 1,538.
 control, Hill pump, ills., 3,022.
 tank pump, ills., 3,022.
 counter, battery system, 996.
 current, measurement of, 28.
 curves illustrating lag, 1,049, 1,050.
 difference of, 2,733.
 effective, in syn. motor, 1,271.
 gauge and absolute, distinct, 3,025.
 hydraulic analogy, ills., 2,742.
 induced in secondary circuit, 144.
 impressed, def., 1,067.
 diag., 1,076-1,080, 1,099, 1,100.
 in synchronous motor, 1,271.
 maximum, point of, ills., 168.
 resultant, component, ills., 1,536.
 reverse, 1,067, ills., 1,069, 1,271.
 self-induction, defined, 1,352.
 transformer, defined, 1,351.
 virtual and effective, ills., 1,013.
 working, of steam turbines, 1,968.
 zero, line of, sine curve, ills., 168.
- Primary**, cells, various, des., ills., electrolytes,
 elements, connections, etc.,
 35-67 2,741-2,746.
 coils, various, des., ills., connections,
 etc., 137-154, 1,378,
 1,718. 2,171. 2,763.
- Principal**, focus, 2,677.
 convex lens, 2,689.
- Private**, br. exch., circ., ills., 2,130-2,133.
 troubles, 2,173-2,179.
 line extension circuits, ills., 2,144.
- Proctologists' set**, ills., 3,226.
- Progressive wave winding**, ills., 248.
- Projection lens**, B. and L., ills., 2,702.
 motion pic., on what based, 2,706.
 optical, principles of, ills., 2,700.
- Projector or motion picture mach.**, 2,706.
- Prony brake**, ills., 378.
- Propeller**, ship, speed of, 2,665, 2,671.
- Propelling drag**, 351.
- Prostatic diseases**, treatment for, 3,205.
- Protection**, lightning, 885-892.
 dev., ills., 1,587, 1,677-1,714.
- Protective relays**, 1,640, 1,641.
- Ptoisis**, treatment for, 3,213.
- Pull**, box for conduit work, ills., 791.
- Pulley(s)**, belts placed on, 2,013, 2,059.
 belt, rules for size and speed of, 402.
 diameter, engine, 2,004.
 double, drive trans., ills., 2,009.
 driving, elevator, ills., 2,858, 2,860,
 2,861, 2,924.
 speed, 2,005.

Valley(s),—Continued.

elevator, arr. of, ills., 2,919.
 grooved, for rope driven motors, 403.
 idler, elevator, ills., 2,858, 2,860, 2,861,
 2,924.

leather covered, belt friction, 401.
 shipper, elevator mach., ills., 2,923..

Pulsating current, def. of, 174.

for party bell ringing, 2,147.

Pumice stone polish, electro-pl., 3,168.

Pumps, air, and vac. chambers, ills., 2,979.
 chambers, capacity, 2,981.
 cushion, 2,781.

capacity, 2,983-2,985.

control automatic, ills., 3,020.

by pass, Goulds, ills., 3,018.

dev., power end, 3,019-3,022.

water end, 3,017-3,019.

deep well, installation, ills., 2,985.

diaphragm regulator, ills., 3,019.

double, acting plunger, ills., 2,994.

inlet, 3,009.

drive, various, ills., 3,012-3,017.

electric, 2,963 to 3,022.

classification, 2,990-2,992.

electrical horse power, 2,987-2,989.

elementary, 2,974.

force, ills., 2,976-2,978.

lift, ills., 2,975.

plunger, ills., 2,977.

flat rubber disc valves, 2,996.

float switch, ills., 3,019.

force, des., 2,975.

distinguishing feature, 2,977.

doub. act., 2,978, 2,979-2,981.

h. p., water end, 2,985-2,987.

leakage, two kinds, 2,984.

where likely, 2,983, 2,984.

lift, des., 2,974.

single acting, el., ills., 2,975.

metal valve details, ills., 2,983.

outside packed, d. a., ills., 2,995.

pres. control, Hill, ills., 3,021, 3,022.

single acting plunger, ills., 2,995.

slip, def., 2,983.

speed for boiler feeding, 3,019.

stuffing box, ills., 2,997.

switch, automatic, Hill, ills., 3,021.

triplex feed, Denung, ills., 2,991.

valve(s), action, 2,981, 2,982.

construction, ills., 2,996.

des., 2,994-2,997.

practice. H. F. Dunham, 2,997.

seats, jig for remov., ills., 2,997..

spring, 2,996.

vertical 3 stage turbine, ills., 3,008..

water end, class., 2,993, 2,994.

ills., 2,982.

water hammer prevented, 2,981.

worm drive, 3,017.

Pumps, centrifugal, Allis-Chalmers, five stage

rotor, ills., 3,011.

capacity and head, 3,011.

char. curve, Gould's, ills., 3,006.

classification, 3,002.

Pumps, centrifugal,—Continued.

conoidal, des., 3,002-3,003.

head for, note, 3,007.

motors, 3,010-3,011.

multi-stage, instal., notes, 3,009.

priming, ills., 3,005.

starting, 3,011-3,012.

Pumps, reciprocating, by pass valv., 3,010..

drive, 3,012-3,017.

herringbone advan., 3,015.

single reduction, belt, Deming,

ills., 3,012.

silent chain ills., 3,014..

spur, adv., 3,015.

Pumps, rotary, classification, 2,999.

def. and des., 2,997-3,001.

pistons or impellers, 2,999.

Taber, ills., 3,000.

various types, ills., 2,998.

Pumps, turbine, 3,004-3,009.

diffusion blades, 3,004.

for mine service, 3,007-3,009.

limited head, 3,004.

multi-stage, 3,004.

three stage, vertical, ills., 3,008.

Push button(s), various kinds, ills., 2,378-

2,385, 2,400, 2,403.

elevator controller, ills., 2,886.



Quadruplex, armature winding, 149.

telegraph, system, ills., 2,242.

Queen, Acme, testing set, ills., 498, 499.

ammeter test with, 510.

checking voltmeter, 507.

operation of, 500.

dial, decade port. set, ills., 501.

galvanometer, dead beat, ills., 454.

reflecting astatic, ills., 440.

ballistic, ills., 454.

tangent and sine, ills., 448.

telescope, ills., 458.

Quill transmission drive, ills., 2,052.



- Radial**, ammeter switches, C.-H., ills., 1,875, 1,883, 1,884.
- Radiant energy**, def. of, 2,274.
- Radiated electricity**, def. of, 3.
- Radiator**, heating unit for, 3,051.
- Radiograph**, X-ray, 3,232.
- Rail(s)**, bond, ills., 2,617, 2,617.
- dead, trolley car oper., 2,651, 2,655.
- girder or grooved, 2,618.
- guide, elevator, 2,865.
- insulated, bond wire for, ills., 2,634.
- joints, bonding of, 2,616.
- T form, ills., 2,618.
- welding, Clark thermit, ills., 3,119.
- Railway(s)**, a. c., control system, 2,576.
- trans. and dist., 2,537, 2,540.
- d. c., distribution, ills., 2,536, 2,538, 2,539.
- arrester, G. E., ills., 1,707.
- block signals, 2,631.
- brakes, ills., 2,596-2,603.
- car equipment, multi-unit, 2,654.
- car heater installation, 2,615.
- car lighting, ills., 2,604-2,613.
- catenary constr., ills., 2,623-2,630.
- city street, trucks used for, 2,594.
- conduit system, ills., 2,619.
- contactor equip., G. E., ills., 2,575.
- West., ills., 2,579, 2,580.
- control, comb., d. c. and a. c., 2,587.
- systems, 2,566.
- current, booster system, 2,057.
- collecting devices, 2,546.
- dispatcher's selector system, ills., 2,646.
- English, system of lighting, 2,605.
- frog bonding, ills., 2,642.
- heating, car, ills., 3,054, 3,055.
- I. and L., Elec. Ry., ills., 2,542, 2,544.
- lighting, 2,605, 2,606, 2,609, 2,611-2,613.
- locomotives, 2,588.
- various, ills., 2,591.
- operation, 2,647-2,664.
- overhead, cons. I. & L. Ry., 2,545.
- trolley system, 2,548.
- pantograph trol., ills., 2,540, 2,548.
- power house switchboard, 2,544.
- power systems, 2,534.
- Railway(s)**.—*Continued.*
- pressure, standard, 2,535.
- signal(s), ap., ills., 2,630-2,649.
- surface contact system, 2,548.
- systems, 2,533, 2,547.
- comparison, 2,541, 2,552.
- for suburban roads, 2,536.
- New York City, 2,537.
- surface contact, West., 2,548.
- third rail, ills., 2,549, 2,550.
- underground or conduit, 2,551.
- three phase distribution, ills., 2,538.
- track, construction, ills., 2,616-2,622.
- train starting, 2,659.
- trolley, car operation, 2,649-2,658.
- construction, ills., 2,547.
- line cons., 2,622-2,630, 2,645.
- trucks for electric cars, ills., 2,592-2,595, 2,599.
- use of boosters, 2,535, ills., 2,536.
- Railway motor(s)**, 2,544.
- armature construction, 2,563.
- car, G. E., gas-electric, ills., 2,597.
- classification, 2,558.
- closed, ills., 366.
- commutating pole, ills., 2,564.
- d. c., ills., 2,552, 2,553, 2,554.
- split frame, ills., 2,554, 2,555.
- geared and gearless, 2,562.
- gearing and case, ills., 2,563.
- lubrication of, 2,595.
- open, ills., 367.
- standard box frame, ills., 2,555.
- troubles, 2,658.
- West. interpole, ills., 2,657, 2,660.
- ventilation ills., 2,556, 2,557.
- Railway motor, control, bridge transition**, 2,571, 2,573.
- field control, 2,570.
- rheostatic control, 2,582.
- operation, at var. pressures, 2,535.
- cascade, 2,584, 2,586.
- changeable pole, 2,583, 2,586.
- concatenation, 2,584, 2,586.
- tandem control, 2,584, 2,586.
- series, par., ills., 2,572, 2,573, 2,574.
- resistance transition, 2,571.
- systems of, 2,566, 2,567.
- induction regulator, 2,577.
- induction, three phase, 2,581.
- rheostatic vs. compen., 2,577.
- West., H. L., ills., 2,662, 2,663.
- Railway motor controllers**, G. E., ills., 693.
- type K, ills., 2,570, 2,574.
- Westinghouse type K12, ills., 2,576.
- type K 35, ills., 2,578.
- type L2, ills., 2,577.
- Railway motor suspen.**, ills., 2,559-2,564.
- cradle, ills., 2,560.
- nose, ills., 2,560, 2,561.
- parallel bar or side, ills., 2,561.
- twin, 2,563.
- yoke, 2,561.
- Range**, Simplex elec., ills., 3,061.
- Ray(s)**, cathode oscillograph, 1,852.

Ray(s)—*Continued.*

- def., of, 2,505.
- divergent incident, ills., 2,689.
- effect on of concave lens, 2,695.
- incident, direction of, 2,679.
- luminous ills., 2,674, 2,675.
- parallel incident, ills., 2,689.
- radial, from searchlight, ills., 2,473.
- refracted, 2,682, ills., 2,683.
- Reactance**, capacity, 1,054-1,055.
 - effect of, 1,117.
 - coil(s), ills., 1,061. 1,984.
 - current limiting, G. E., ills., 1,619.
 - def., 1,055.
 - drop, ills., 1,078.
 - inductance, 1,038, 1,054, 1,055.
- Reaction**, armature, ills., 268-269.
 - of inductors, ills., 1,160.
- Receiver**, bi-polar Adler, 2,121.
 - Bell, ills., 2,120.
 - circuit troubles, 2,170.
 - diaphragms, teleph., ills., 2,119, 2,120.
 - Gower, 2,121.
 - head, 2,122.
 - intercooler, air compressor, 3,042.
 - telephone, 2,117.
 - open, 2,170.
 - trouble, switchboard, 2,177.
 - watch case, 2,122.
 - wireless telegraph, ills., 2,326.
- Reciprocal** of a number, def. 79.
- Reciprocating** pump, drive, 3,012-3,017.
 - motors, 3,009, 3,010.
- Recorder**, telegraph, Bunnell, ills., 2,257.
 - siphon, Thomson, 2,251.
- Recording**, ammeter, record, ills., 565.
 - wattmeter checking, ills., 2,094.
- Rectal**, diseases, treatment for, 3,203.
 - tube, Johnson's ills., 3,209.
 - ulcer, treatment for, 3,216.
- Rectified** currents, diagram of, 1,496.
- Rectifier(s)**, analogy, air receiver, 3,042.
 - auto. shaking dev., ills., 1,513-1,514.
 - charging outfit, ills., 2,841.
 - condenser, West. C.-H., 1,513.
 - connections, mercury arc, ills., 1,517.
 - current, 1,495-1,530.
 - Edison a. c., ills., 942-945.
 - electrolyte, 1,502, 1,503.
 - current curves, 3,196.
 - electro-magnetic, 1,527.
 - G. E., ills., 1,529.
 - Premier Ampero, ills., 1,528.
 - mechanical, 1,495, ills., 1,497.
 - mercury arc, con. and op., 936.. 1,517.
 - diagram of, ills., 936.
 - double tube, ills., 1,513, 1,514.
 - series, G. E., 1,520, 1,524,
 - spark, 1,512.
 - starting of, 937. 1,521.
 - three phase, ills., 1,509.
 - mercury vapor, 1,505-1,515.
 - arc lighting, series, 1,515.
 - circuit, W.-C.-H., ills., 1,507, .
 - self-starting, 1,513.

Rectifier(s)—*Continued.*

- reactance coil, effect of, ills., 1,521.
- shaking device, ills., 1,513, 1,514.
- starting mercury arc, 1,521.
- tube, capacity of, 1,526.
- waves, impressed pres., ills., 1,515.
- Westinghouse-C.-H., ills., 1,505, 1,506.
- Recuperation**, hydraulic anal., ills., 2,744.
- Reduction**, gear, various forms, 2,835.
- Reedy** elevator, worm gear, ills., 2,920.
 - tandem, ills., 2,922.
- Re-entrant** simplex wave winding, 252.
- Refining**, bullion, 3,135.
- Reflection**, angle of, ills., 2,676, 2,677.
 - def. and laws, ills., 2,676.
 - of color, coef., table, 2,525, 2,527.
 - of light, diag., ills., 2,517.
 - total, 2,683.
- Reflectors**, and shades for arc lamps, 2,516.
 - holophane, 2,518.
 - table of unit spacing, 2,532.
- Reflex** set, Dr. Abrams, ills., 3,221.
- Refraction** of light, caustics by, 2,698.
 - def., ills., 2,522. 2,679-2,681.
- Refractive** index various sub., 2,681.
- Refringent**, definition of, 2,680.
- Regulating**, devices, 1,715-1,762.
 - power factor, 1,588.
- Regulation** (of), by arm. resistance, 683.
 - a. c. feeder, 1,715-1,716.
 - field, two path method, ills., 188.
 - machines, 1,999.
 - motor speed, 382. 677.
 - rotary converter, 2,066.
 - series dynamo, 186.
 - storage battery by var. resis., ills., 976.
 - transformers, 1,767. 2,051.
 - circuit, ills., 1,456.
 - inherent, 1,425.
 - test, ills., 1,445.
- Regulator(s)**, 1,715-1,762.
 - air compressor, ills., 3,038, 3,039.
 - arc lighting, ills., 2,444, 2,445.
 - automatic voltage connections, G. E., ills., 1,750.
 - for alternators, 1,748.
 - with linedrop comp., ills., 1,754.
 - compound motor speed, 690.
 - equalizer, con., G. E., ills., 2,032.
 - field, 612.
 - floating coils on, 1,735-1,736.
 - induction, application, ills., 1,717.
 - automatically operated, 1,727.
 - coil voltage, ills., 1,716.
 - hand operated, West., ills., 1,722.
 - operation of, 1,719.
 - pole, G. E., ills., 1,740, 1,741, 1,743, 1,744.
 - polyphase induction, 1,723.
 - pressure, pump, 3,017.
 - single phase induction, 1,721.
 - service of, 666.
- Regulator(s)**, voltage, d. c. con., ills., 1,745.
 - drum var. transf., West., ills., 1,732.

- Regulator(s), voltage**.—*Continued.*
 electro-plating, G. E., 3,155.
 small feeder, 1,742.
 variable ratio transf., 1,733, 1,734.
- Relay(s), a. c. and d. c. compared**, 1,643.
 acceleration, elevator, 2,904, 2,905.
 alternating current, ills., 1,647.
 low voltage, G. E., ills., 1,657.
 automatic track, 2,647.
 bell, 2,374, ills., 2,375, 2,377.
 Chicago, time, 2,640.
 circuit, breaker, elev. motor, 2,884.
 closing, ills., 1,646, 1,661.
 opening, ills., 1,644, 1,645.
 current, elevator motor, 2,884.
 def., 2,375.
 differential balance, 1,676.
 differentially wound, ills., 2,224.
 d. c., ills., 1,668.
 discriminating, ills., 1,668.
 double pole, 1,661.
 instantaneous, 1,653, 1,668.
 reverse current, 1,676.
 interlocking for railway signal, ills.,
 2,637, 2,639, 2,643, 2,644.
 inverse time limit, ills., 1,656.
 low voltage, 1,650.
 neutral, 2,637, ills., 2,638.
 telegraph transmitter, 2,243.
 open, positive supervision, 2,178.
 overload, high pres., a. c., ills., 1,649.
 over voltage, 1,650.
 polarized, operation, ills., 2,226.
 for ry. signal, 2,637, ills., 2,638.
 polyphase, for railway signal, 2,640.
 protective, 1,640, 1,641.
 railway signal, 2,634, 2,640.
 regulative, 1,641, 1,642.
 reverse, current, 1,662, ills., 1,668.
 energy, 1,651.
 phase, 1,672, ills., 1,652.
 selection of, 1,639, 1,661.
 selective, Condit, ills., 1,655.
 semi-automatic track, 2,647.
 solenoid, d. c., ills., 1,651.
 telegraph, Bunnell special, ills., 2,222.
 elementary, ills., 2,208.
 time limit, 1,654.
 for railway signal, ills., 2,637,
 2,640, 2,641.
 mechanism, 1,655.
 overload, G. E., ills., 1,760.
 triple pole, 1,661.
 underload, 1,650.
- Reliance adjustable speed motor**, ills., 688.
- Reluctance, air gap, reduced**, 207.
 def., 120, 122.
 yoke joint, how reduced, 205.
- Remote control switch(es), connections**, ills.,
 1,605-1,607, 1,610,
 solenoid operated, G. E., ills., 1,590.
- Remy, induct. ignit. magneto**, ills., 2,752.
 ignition, lighting and starting wiring
 diag. 2,751.
- Repeater, telegr., and transmitter**, 2,230,
 automatic, how operated, 2,219.
- Repeater, telegraph**.—*Continued.*
 Bunnell, ills., 2,222, 2,223.
 button, ills., 2,215, 2,216, 2,219.
 circuit, ills., 2,213, 2,216.
 Ghegan automatic, ills., 2,220.
 Kitton's three wire, ills., 2,218.
 Milliken system, ills., 2,221.
 Postal direct pt. duplex, ills., 2,219.
 simple auto., 2,219, ills., 2,220.
 Repulsion motors, principles, const.,
 operation, 1,364-1,372. **and**
 Residual magnetism, def., 124.
 insufficient, overcome, ills., 614.
 nature of field due to, 184.
- Resin, as insulator**, 70.
 soldering flux, 3,079, 3,081.
- Resinous electricity**, def. of, 4.
- Resiliency, vibration gov. by**, ills., 2,278.
- Resistance**, 27, 2,733.
 alloys, various, 3,048-3,050.
 and capacity in circuit, ills., 1,084.
 and inductance in circuit, ills., 1,059.
 in parallel, ills., 1,095.
 box, ills., 478, 479.
 megohm, ills., 486.
 portable, ills., 554.
 standard, ills., 487.
 with Wheatstone br., ills., 491.
 carbons in arc lighting, 2,423.
 coil(s), decade plan, ills., 494, 495.
 compensating, of battery, 2,243.
 def. of, 75.
 high, measurement of, 486, 522.
 hydraulic analogy, ills., 2,741.
 induc. and capac. in circ., ills., 1,058.
 internal, hydraulic anal., ills., 2,745.
 of cell measured, 509.
 joint, example of, ills., 79.
 rule for finding, 81.
 laws of, 76.
 liquid, measurement, 535.
 loss in transformer, ills., 1,444.
 in armature, 2,114.
 in field, 2,114.
 low, measurement, ills., 506.
 measurement (of), 28, 476.
 by drop method, ills., 2,073.
 L. and N. fault finder, ills., 512.
 substitution method, ills., 478.
 transformer, ills., 2,095.
 metal(s), grid unit, ills., 665,
 various, 3,048, 3,049, 3,050.
 of wire, copper, 28, 734.
 German silver, 722.
 ohmic, 1,029.
 Ohm's law, 75.
 specific, def., 78.
 table of metals, 78.
 spurious, 281, 1,029.
 standard(s), (of), 476.
 copper wire, 722.
 sets, ills., 479.
 test, direct deflection method, 477.
 drop method, ills., 483.
 fall of potential method, 479.

- Resistance, test,—Continued.**
 with voltmeters, ills., 480, 481.
 zero method, 432.
 units, starting, various, ills., 665.
 water, for arc light, ills., 2,477.
 wires, various, 3,048, 3,049, 3,050.
- Resistor, railway control, ills., 2,589.**
 electric heating, alloys for, 3,048.
- Resonance, 1,062, 1,063.**
 freq. meter, Frahm, ills., 1,827, 1,828.
- Resonant circuit, ills., 1,062.**
- Resonator, and oscillator, Hertz, 2,268.**
- Retardation coil, ills., 1,061.**
 telegraph, 2,233.
- Retarding, element of meter, 1,815.**
 medium, arc lamp, dash pot, 2,436.
 torque of meter, 1,815.
- Retrogressive wave winding, ills., 249.**
- Return conductor, def., 30.**
- Reverse, current, cir. br., ills., 417-420.**
 relays, 1,662, ills., 1,668, 1,669.
 instantaneous, 1,676.
 energy relays, 1,651.
 phase relays, 1,672.
 pressure, 1,067, ills., 1,069.
- Reverser, railway, West., ills., 2,586.**
 switch contr., ills., 2,581-2,583.
- Reynolds' flashers, ills., 868, 870.**
- Rheostat(s), and starters, selection of, 690.**
 box, water, 2,108.
 connections, diag. of, 421.
 construction of, 422.
 Cutler-Hammer, ills., 671.
 electro-pl., ills., 3,150-3,158, 3,168.
 essentials of, 604.
 function of, 421.
 how connec. with field, ills., 190, 191.
 with series motor field, ills., 381.
 motion pic. mach., 2,721, ills., 2,724.
 resistance wires for, 3,048, 3,049.
 use of, field, 193.
 water, construction of, 954.
 heating apparatus, 3,065.
- Rheotome, monomotive, ills., 3,198.**
- Rheumatism, treat. of, 3,205, 3,223.**
- Rhumkorff secondary coil, ills., 145.**
- Ribbon(s), binding, on armatures, 347.**
 bond for rail, ills., 2,617, 2,618.
 copper, resis. in dyn. circuit, 610.
- Richmond, induction motor, ills., 1,285.**
 slip ring motor, ills., 1,337.
 squirrel cage armature, ills., 1,329.
- Right hand rules, ills., 113, 117, 133-135.**
- Ring, armature(s), 223, 224.**
 cur., dist., anal., ills., 258, 259.
 Gramme, ills., 176, 223, 225.
 258. 1,250. 1,458.
 collector, and arm., ills., 1,254, 1,255.
 equalizer, 254.
 to balance dyn. cur., ills., 254.
 slip, for alter., 1,198, ills., 1,201,
 induc. motor con., ills., 1,339.
- Ring key(s), telephone, ills., 2,134.**
- Ritter's battery experiment, 893.**
- Rock crystal electrification of, 7.**
- Rocker, arm, for brush holders, 319.**
- Rocker, arm,—Continued.**
 of speed motor, ills., 688.
- Rod(s), lightning, 885.**
- Roebing wire gauge, 740.**
- Roentgen, and X-ray discovery, 3,227.**
 rays, 3,227.
- Roller chain, 2,829, 2,831.**
- Roller-Smith overload cir. br., ills., 430.**
- Rope, belts, 2,010.**
 driven motors, 403.
 stranded copper cable, 1,912.
- Rosewood, conductivity of, 69.**
- Rotary, condenser, ills., 1,281.**
 converter(s), principles, construction,
 ills., operation, regulation,
 etc., 1,459-1,484.
 cranes, ills., 2,938.
 phase converter, 1,459.
 pumps,, 2,997-3001.
- Rotation(s), Arago's, explanation of, ills.,**
 1,296.
- Rotor, meaning of, 159.**
- Rouge, polish, electro-plating, 3,166.**
- Roughing, wheel, electro-pl., 3,171, 3,175.**
- Round meter, ills., 1,798.**
- Rowland, multiplex telegraph, 2,249.**
 typewriting telegraph, 2,256.
- Rubber, belts, 2,010.**
 covered, conductors, 725, 766.
 insulation, advantage of, 725,
 pump valves, flat disc, 2,999,
 pure, vs. compound, 725.
- Running gear, railways, 2,592.**
- Rumford's photometer, ills., 2,512.**
- Rushmore automobile, bal. coil, ills., 2,814.**
 lighting, cut out, ills., 2,813, '



- S coefficient value, 1,910-1,911.**
- Safety devices, elevator, ills., 2,899, 2,927,**
 2,929.
- Safety Lighting Co., railway, car lighting,**
 ills., 2,605, 2,607-2,610.
- Sag (of), wire, 815, table, 816.**
- Sal-ammoniac, use of in cells, 42.**
- Salient pole, magnet, ills., 200-201.**
- Saline solution, conductivity of, 69.**
- Salt(s), creeping, effect of, 51.**
 soldering, 3,083.
- Sampson, vertical turbine, ills., 1,974.**

3,350 Sin. Spa

INDEX

- Single phase, motor,**—*Continued.*
 induction, 1,338-1,348,
 synchronous, 1,267-1,282,
 power factor meter, ills., 1,836,
 systems compared, with two, 1,905,
 transformers, 1,437,
 transmission line, ills., 1,890,
 long distance, ills., 1,550,
 trolley line, overhead, ills., 1,539,
 windings, ills., 1,233-1,235, 1,237.
- Sinusoidal, contr.,** MacLagan, ills., 3,210.
 current, 3,198-3,200.
 therapy, 3,205-3,221.
 voltages, sparking distances for, 152.
 Sinsteden, experiments of, 2,413.
- Siphon telegr. recorder,** Thomson, 2,251.
- Six, phase winding, with ills.,** 1,133.
- Pole field, 3 phase, ills.,** 1,306, 1,310,
 two phase, ills., 1,300.
 wire three phase system, ills., 1,563.
- Skew armature coil winding, ills.,** 1,258.
- Skin effect, calculation, 1,894,**
 des., ills., 1,065.
 explained, 1,066.
 ills., 1,893,
 wire, 1,066.
- Slaby-Arco multiplex wireless, 2,289.**
- Slack cable device, elev., defective, 2,931.**
- Slag, thermit welding, 3,118.**
- Slamming of large pump valves, 2,997.**
- Slate, as insulator, 70.**
- Sleeve joint McIntire, ills., 818,**
 type of fibre conduit, ills., 838.
- Sleigh gong, P. and W., ills., 2,361.**
- Slide wire, bridge, Queen, ills., 508,**
 potentiometer, ills., 530,
 testing set, ills., 508.
- Sling for handling armatures, ills., 405.**
- Slip, of induction motor, 1,313-1,319,**
 of pump, def., 2,983.
- Slip ring(s), alter. shaft, ills., 1,198, 1,201,**
 induction motor cons., ills., 1,339.
- Slipper, belt, ills., 2,059.**
- Smee cell, corrugating electrode of, 41.**
- Smooth, armature, 276,**
 core obsolete, 323.
- Snap switch, ills., 411.**
- Socket, joint fibre conduit, ills., 837, 838,**
 lamp, tubing and wire con., ills., 779,
 peavey, ills., 803.
- Soda, chlorate of, production, 3,136.**
- Sodium, and potassium, mfg. of, 3,141,**
 chlorite, 3,137,
 flame arc lamp, 2,424.
- Solder(s), aluminum, 3,077, 3,078,**
 effect of tin in, 3,073.
 fluxes for, 3,079.
 fusibility increased, 3,069.
 gold, 3,077.
 hard, 3,068-3,076,
 medium or fine, 3,069.
 melting, points of, ills., 3,068-3,070,
 method of picking up, 3,088,
 plumbers' or common, 3,069.
 silver, 3,074,
 soft, 3,068-3,076.
- Solder(s),—Continued.**
 tin lead melting point, 3,070,
 yellow, 3,173.
- Soldering, and brazing, 3,067-3,106,**
 difference, 3,071,
 and welding, difference, 3,114,
 autogenous, 3,113.
 bell wires, 2,382, ills., 2,383,
 bits, ills., 3,064, 3,084.
 various, ills., 3,085.
 cable to carbon block, 576.
 cast iron, 3,097.
 flux, 3,079, 3,083, 3,084.
 furnace, ills., 3,072.
 joints, various, ills., 3,075-3,081,
 jointing, 3,067, 3,075-3,077, 3,080,
 ladle, ills., 3,074.
 metals, sold. for, 3,070, 3,071, 3,073,
 paste, 3,083.
 pot, ills., 3,074.
 preparations, various, 3,082, 3,084.
 resoldering, 3,074.
 solders, 3,067-3,078, 3,101.
 tool, electric, tinning, ills., 580.
- Solenoid(s), brake, elev., ills., 2,892, 2,906,**
 with sh. limit sw., 2,879,
 release, 2,917.
 circuit, breaker, ills., 417, 420.
 maintainer, ills., 2,354.
 compound, axle lighting, 2,611,
 in arc lamp, ills., 2,438,
 current, effect on, ills., 119,
 def., 115.
 differential lamp, ills., 2,430, 2,431.
 iron core in, 117, ills., 118.
 lines of force, character of, 115.
 magnetic, action of, 121,
 field of, ills., 116,
 power on what depends, 117,
 magnetism under control in, 116.
 magnetizing power, 117, ills., 118.
 mutual action of, ills., 121.
 properties of, 116,
 propor. cur. to mag. strength, 116.
 relay, direct current, ills., 1,651.
 shunt, opposite series, ills., 2,433.
 switch, connections, ills., 1,609,
 oil, ills., 1,606.
 remote contr., G.E., ills., 1,590.
- Sound waves, def. of, 2,274.**
- Sounder, telegraph, 2,201,**
 elementary, ills., 2,205,
 Morse lines, 2,203.
- Southern Power Co. trans. lines, ills., 1,546.**
- Spacing of wires, 767-768, 1,896.**
- Spark, def., 1,679,**
 gap(s), arrester, adjustment, 1,694,
 safety, West., ills., 1,684,
 wireless telegraph, 3,229,
 good, conditions for, 145.
 ignition, advance, 2,737,
 best quality, 2,790,
 how much to advance, 2,757,
 jump, how obtained, 2,772.

- Spark**,—*Continued.*
 mercury arc rectifier, 1,512.
 series rapid, how obtained, 46.
- Spark plug(s)**, Bosch, mag., ills., 2,761.
 defective, 2,776, 2,791.
 ignition, 2,768, 2,575, ills., 2,576,
 ills., 2,763, 2,776, 2,785, 2,791,
 sparking pressure, 2,776.
 testing, 2,787.
 various, 2,741.
- Sparking at brushes**, dynamo, 638.
 excessive, 591.
 prevented, 294.
 railway motor, 2,658.
 result of false position, 289.
- Specific**, conductivity, def. of, 77,
 inductive capacity, 1,043.
 of air, 1,044.
 resistance, def. of, 78.
- Specific gravity**, acid, 905, 906.
 battery, rise and fall of, 908.
 electrolyte affected, 915.
 electrolyte low, 902.
 scales, comparison of, 964.
 tester for accumulator, 921.
- Spectrum**, invisible, shortest waves of, 2,278.
- Spherical**, aberration, 2,679, ills., 2,696.
 connection for in lens, 2,702.
 effect of, ills., 2,697.
- Spider**, arm., const., 330-332, ills., 1,466.
- Spiral**, armature, coil winding, ills., 1,259,
 connectors, 336.
- Splenic congestion**, treatment for, 3,221.
- Splice(s)**, and tap, difference between, 859,
 film, motion pic., ills., 2,725, 2,727.
 wire(s), ills., 767.
 American, ills., 818.
 insulated with tape, 860.
 McIntire sleeve, ills., 818,
 soldered, 859.
 W.U. ills., 818. 2,382, 2,383.
- Split**, frame railway motor, ills., 2,554.
 phase induc. motor, Ft. W., ills., 1,347.
 pole rotary converter, 1,476.
 Woodbridge, ills., 1,473
 yoke of dynamo, ills., 203.
- Splitdorf** master vibrator coil, ills., 150.
- Spot**, welding, method, ills., 3,125, 3,127.
- Sprague**, contr. ry. power house, ills., 2,543.
 elev. contr., d. c. magnet, ills., 2,897.
 d. c., pilot, ills., 2,896.
 motor, induction, ills., 1,342.
 repulsion, ills., 1,368.
 reversing type, ills., 1,371,
 var. speed, ills., 1,370.
 field, var. armatures, ills., 1,338.
- Spray** injection, compression, 3,036.
- Sprocket**, and chain, ills., 2,828, 2,829.
- Spur gear** elevator machine, ills., 2,914.
- Spurious** resistance, 281, 1,029.
 in coils, 279-281.
 measurement of, ills., 733.
- Squirrel cage**, armature, evolution of, ills.,
 1,319-1,321.
 various, 1,319-1,323, 1,328-1,331.
- Squirrel cage, armature, various**,—*Continued.*
 1,343, 1,373-1,375.
 motors, 1,283-1,334, 1,374.
- Staff system** railway block signal, 2,633.
- Stamping**, armature core, ills., 1,229.
- Standard(s)**, Am. wire gauge, ills., 738-739.
 bell box circuit, ills., 2,123.
 cell, internat. volt, ills., 466, 467.
 condensers, capacity tests, 1,044.
 copper wire, Matthiessen's, 723.
 lighting, comparison of, 2,507, 2,508.
 machine, frequencies, 1,005.
 magneto teleph. circuit, ills., 2,183.
 of illumination, 2,507, 2,508.
 of luminous flux, 2,509.
 pressure of railways, 2,535.
 resistance(s), 476.
 copper wire, 722.
 sets, ills., 479.
 transformer, cons., ills., 1,440.
 ratios, 1,583.
 transmission voltages, 1,583.
 U. S. wire gauge, ills., 740.
 V.-H. pentane flame, 2,508.
 vibrator coil, wiring of, ills., 153.
 wooden moulding, ills., 774.
 wrought iron pipe properties, 1,995.
- Star** delta connection, switch(es), 1,759.
 Cutler-Hammer, ills., 1,761.
 transformer, ills., 1,432, 1,433.
- Star** connection, 3 ph., 1,245. 1,567.
 transformer, ills., 1,432, 1,433.
 1,574.
 twelve phase, ills., 1,134.
 two phase, 1,243.
- Starrett's**, speed indicator, ills., 2,003.
 voltmeter, electro-plating, 3,151.
- Starting and l'ing**, auto., bat., diff., 2,797,
 control methods, 2,811.
 Rushmore, ills., 2810, 2,812,
 Ward Leonard, ills., 2,811.
 voltage for, 2,798.
 systems, 2,793-2,813.
 internal cir., var., ills., 2,801.
 single unit, Deaco, ills., 2,800.
 Electro, 2,800.
 Entz, ills., 2,802.
 three unit, 2,808.
 ignition Disco, 2,808.
 two unit, Aplco, 2,808.
 def., 2,802-2,808.
 G. and D., ills., 2,806.
 Leece Neville, ills., 2,803.
 Wag., ills., 2,804, 2,805.
 West., ills., 2,807.
 various, ills., 2,794.
- Starter(s)**, and rheostats, selection of, 690.
 automatic, for print. press, ills., 674.
 Monitor, ills., 674.
 motor, automatic, ills., 673.
 induction, three ph., ills., 1,334.
- Starting**, and shading coils of motor, 1,345,
 box, no voltage release, 425.
 overload release, 425.
 connected to motor, 422.

- Starting, box.**—*Continued.*
 essentials of, 664.
 why used with motor, 422.
 centrifugal pumps, 3,011, 3,012.
 coils on s. p. fan motor, ills., 1,346.
 compensators, 1,755.
 G. E., ills., 1,757-1,759.
 three phase, G. E., ills., 1,762,
 ills., 1,758.
 converter, 1,494.
 polyphase with a. c., 2,069.
 with direct current, 2,068.
 dynamo, 580, 581.
 dynamotor, 2,061.
 machine, compound, 583.
 series, 582.
 shunt, 583.
 motor, 664, 666.
 compensated repulsion, 1,371.
 compound, 375.
 induction, 1,286, 1,331, 1,332.
 inspection before, 663.
 method of, 366.
 series, 375.
 shunt, 668.
 by exciting of field coils, 373.
 through resistance, 663.
 rectifier, mercury arc, 937, 1,521.
 resistance, arc lamp, ills., 2,440,
 units, various, ills., 665.
 with converter, 2,072.
 rheostats, motor, ills., 669.
 rotary converter, 2,067.
 trolley car, 2,653, 2,655.
Static, charges, causes, 1,677.
 discharges in telegraphy, 2,254.
 electricity, 1-26. 3,185.
 head, def., 2,966, 2,969.
 interrupters, 1,713, ills., 1,714,
 machine, 23.
 Toep.-Holtz, 3,185, ills., 3,186.
 voltmeter, 466.
Station (central or power), 1,915-1,988.
 arrangement, general, 1,936.
 boilers, 1,941.
 chimney, 1,957.
 coal supply, ills., 1,925.
 construction, 1,950.
 doors, 1,941.
 efficiency, examples, 1,933.
 fire buckets, 2 016.
 floor(s), 1,954.
 plan, 1,937.
 belt drive, ills., 1,947.
 direct current, ills., 1,949.
 foundation, 1,950-1,951.
 hydro-electric, 1,975, ills., 1,978.
 load curves, ills., 1,930, 1,932.
 location, ills., 1,917.
 management, 1,989-2,114.
 mechanical draught, 1,957.
 motor generators, 1,485.
 roof, ills., 1,954.
 size of, 1,930.
 steam pipes, 1,941, 1,942.
 turbines, ills., 1,961.
Station (central or power).—*Continued.*
 water supply, 1,923, ills., 1,924.
 Steam, engine, analogy, p. f., ills., 1,109.
 of current flow at zero pres-
 sure, ills., 1,053.
 indicator cards, ills., 1,779.
 generator, White, 2,672.
 nozzles of turbine, 1,973.
 pipes, connected, ills., 1,945,
 in central station, 1,941, 1,942.
 super-heated, 1,945.
 turbines, principles, construction, oper-
 etc., ills., 1,961-1,970.
 Stearns diff. duplex teleg. sys., ills., 2,227.
 Steel, Bessemer, for cable, 2,628.
 electro plating, with nickel, 3,180.
 Siemen's-Martin, for cable, 2,628.
 soldering flux for, 3,083.
 sub., for copper and brass, 3,155.
 used for field magnets, 203.
 welding tool, pressure, 3,128.
 flux for, 3,109.
 wire, brush, electro-pl., ills., 3,162.
 gauge, Stubs' table, 741.
 Steinheil's experiment, wireless, ills., 2,204.
 Step down, transformers, 1,386, 1,545.
 Step up trans., ills., 1,386, 1,545.
 Stereo metal, electrotyping, 3,183.
 Stillwell voltage reg., cir., ills., 1,733.
 Stock Exchange station circuit, ills., 2,150.
 Stomach diseases, treatment for, 3,205.
 Stombaugh guy anchor, ills., 809.
 Stone sys. car lighting, 2,605, ills., 2,606.
 Stop valves, sections, ills., 1,946.
 Storage air brake system, ills., 2,603.
 Storage batteries, various, principles, construc-
 tion, points relating to, charging, connec-
 tions, troubles, etc., ills., 893-
 968. 2,747, 2,795, 2,815,
 2,829, 2,837.
 Stove(s), electric, heating of, 97.
 unit for, 3,051. 3,051.
 Straight, air brake system, 2,601.
 Strain insulators ills., 1,552.
 Stranded, copper, cables, 1,903
 rope cable, 1,912.
 wire conductors, 724.
 Strap, coil winding, ills., 1,231.
 inductor, ills., 1,229.
 lineman's, port. vice with, ills., 813.
 wire, and bar coil windings, 1,225.
 telephone bell open, 2,170.
 Stream, cathode, X-rays, 3,279.
 Strength (of), a.c., change, rate, ills., 1,068,
 current, def. of, 29, 33.
 field, unit, gauss, 111.
 magnet, on what depends, 188.
 Stress, state of, about mag., ills., 108, 109,
 static, distribution, 1,680.
 Strictures, treatment for, 3,205.
 Stripping, electro-plating, 3,145.
 Stubs, guy, 807, 813.
 steel wire gauge, table, 741.
 wire gauge, 739.
 Studebaker charging outfit, ills., 2,841.
 Sub-feeder, circuit diagram of, ills., 743

Submarine, armoured cable, ills., 729,
 telegraph, 2,249-2,250.
 cable(s), 2,252.
 circuit, ills., 2,253.
 duplex, 2,252.

Subscriber's, teleph. cir., auto., ills., 2,152,
 ills., 2,122.
 troubles, 2,170-2,173.

Sub-station, at Highland Park, ills., 1,704.
 Brooklyn, Ed. Co., ills., 1,585.
 plan, with air transf., ills., 1,981.
 with oil transf., ills., 1,982, 1,983.
 portable, 1,986-1,987.

Substitution, meth. of meas. resis. ills., 478.

Substitutional resistance, and cut out, 2,437,
 ills., 2,438.

Sulphate, copper, electro-plating, 3,173.
 zinc, 38, 40.

Sulphation, battery plates, 955-957.
 imperfect, 923.

Sulpho-chromic salt in cell, ills., 57.

Sulphur, as insulator, 70.
 effect of in iron welding, 3,112.
 electrification of, 7.

Sulphuric acid, characteristics of, 964.
 charging, 923.
 diluted, strength of, 965.
 how to mix, 53, 55.
 liberation of hydrogen gas from, 38.
 preparing electrolyte, 904, 905.
 series, metals in solution, 102.
 specific gravity of, 906.
 storage battery electrolyte, 903.

Summation, vector, 1,533.

Sumter, circuit testing device, ills., 2,788.
 electrde for m. and b. ign., ills., 2,760.

magneto, low tension, ills., 2,758.
 oscillating, ills., 2,757.
 reversing attach., ign., note, 2,759.

Sun, candle power of, 2,521.

Super-heated steam, 1,945.

"Superior," resistance wire, 3,049.

Suspension, fibre, galv., torsion in, 441.
 motor, heavy trucks, 2,835.
 Woods elec. vehic. ills., 2,830.
 railway, 2,559.
 cradle, 2,560.
 nose, 2,560.
 parallel bar, ills., 2,561.
 yoke, 2,551.

out rigger, for arc lamp, ills., 2,507.
 telpher, and driving, 2,958.

Sweating, (soldering), ills., 3,090, 3,091.

Swedish iron, conductivity of, 723.

Swing or kick of galvanometer needle, 454.

Swinging cranes, 2,936.

Switch(es), air brake, 1,596.
 and cir. brkrs., choice between, 415.
 automatic, telephone, 2,117.
 battery charging, ills., 975.
 box, ills., 784.
 break down, 3 wire circuit, ills., 752.
 burglar alarm, 2,404-2,407, 2,408.
 button, telegraph, ills., 2,214.
 circuit breaker, operation of, 2,659.
 commutator, construction of, 171.

Switch(es),—Continued.
 construction of, 409-410.
 control, ceiling lamps, 846.
 relay bell, ills., 2,376.
 safety lever, ills., 675.

control, electric, Kelman, ills., 1,604,
 West, ills., 2,581, 2,582, 2,583.

crane, cont. lim., Niles, ills., 2,953.
 def., 1,589.
 disconnec., ills., 1,594, 1,595, 1,599.

double, break, pole, ills., 1,596.
 throw, 407.
 for aux. power, ills., 849.

electro-pneumatic, 2,641, 2,642.

elevator, a. c., sol., 2,902, 2,903,
 belt, freight, ills., 2,873.
 d. c. or a. c., C. H., ills., 2,900.
 knife, 2,896.
 limit, 2,905.
 pilot, 2,893.
 reverse, C. H., ills., 2,903.
 rotat. cam limit, ills., 2,905.
 safety, 2,899.
 service, 2,892.
 shaft limit, 2,897, 2,899.
 slack cable, C. H., ills., 2,931.
 solenoid, operation, 2,881.
 trav. cam limit, ills., 2,906.
 triple pole, cam, 2,908.
 try out, 2,891.

end cell, conductors to, ills., 978.

float, Cutler-Hammer, ills., 1,611.

fuses for, 1,593.

heater circuit, 3,052, 3,053.

horn break, ills., 1,598, 1,600.

inductance, Hutton, ills., 3,233.

knife, described, 409.
 double throw, 410.
 quick break, ills., 411.
 single thr., with fuse, ills., 408.

lever locking control, ills., 675.

main, to cut out alternator, 2,043.

metal fuse, objection to, 1,599.

motor flashing at, how caused, 2,573.
 operated, 1,607.
 push button, ills., 675.

oil, 1,601-1,603.
 motor oper., G. E. ills., 1,608.
 remote cont., ills., 1,605-1,607.
 rupturing capacity, 1,609.

plug, ammeter jack, ills., 1,592.
 bus transfer, ills., 1,592.
 defined, 1,591.

pole top, Pacific, ills., 1,597.

primary, ignition system, 2,789.
 proportioning of, 409.
 quick break, 412.

radial, Crouse-Hinds, ills., 1,875.
 remote control, ills., 1,605, 1,607.
 reversing, elec. vehicles, ills., 2,846.
 service, ills., 823.

sequence, automatic teleph., 2,153.
 single, and double break, 407.
 throw, 407.

scrap, 411.

solenoid operated, ills., 1,609.

- Switch(es), solenoid operated.**—*Continued.*
 remote contr., G. E., ills., 1,590.
 starting, star delta, 1,759.
 telegraph keys, 2,211.
 three heat, elec. range, 3,061.
 trolley, deflector at, 2,629.
 signal box, ills., 2,631.
 voltmeter, 429.
- Switchboard(s), 1,871-1,884.**
 arr., ills., 426, 427. 1,879.
 connections, prin., ills., 1,871, 1,872.
 des. of, 428.
 instruments, connections of, 427.
 knife switch for, 428.
 location, power, 1,915-1,946.
 material for, 427.
 panels joined, ills., 2,016.
 small, for two dynamos, ills., 428.
 G. E., ills., 1,874.
 telephone, central energy, 2,136.
 circuits, apartment house, ills.,
 2,130-2,133.
 pos. supervision, ills., 2,131.
 P. B. X.(1), ills., 2,130-2,133,
 panels, 2,133.
- Switching, devices, 1,589-1,612.**
 classified, 1,587.
- Symbols and signs, front part.**
- Synchronism, cur. pres., ills., 1,105, 1,107,**
 indicators, 1,831.
 loss of, 1,008.
- Synchronized, alternators, 2,034.**
 high pressure, ills., 2,038.
 three phase, ills., 2,041, 2,042.
- Synchronizer, construction of, ills., 2,040,**
 operation of Lincoln, 2,043.
- Synchronizing, alternators, diag., 2,038.**
 method, lamp dark, 2,033, 2,035.
 lamp brilliant, diag., 2,037.
 three phase alternators, diag., 2,042.
- Synchronous, compensator, ills., 1,281,**
 condensers, 1,763-1,776.
 converter, 1,458.
 drive for magnetos, 2,757-2,760.
 ignition, ills., 2,780.
 impedance test, ills., 2,085.
 motors, principles, construction, oper.
 etc., ills., 1,267-1,282.
- Synchroscope, G. E., ills., 1,832-1,834,**
 inductor, ills., 2,036
 Lincoln, ills., 2,040.
 principle of rotating field, 1,833.
 Westinghouse, ills., 1,831.
- Syntonic, Leyden jars, ills., 2,282.**
 wireless telegraphy, 2,281.
- Syringe hydrometer for bat., ills., 908, 921.**
- System(s), a. c., ills., 1,531-1,586.**
 d. c., ills., 697-720.
 ignition, 2,700-2,785.
 lighting and star, auto., ills., 2,794.
 railways ills., 2,533-2,553.
 storage battery, ills., 969-996.
 telegraph, classification, 2,202.
 wireless, classification, 2,263.
 telephone, ills., 2,122-2,169.
- System(s).**—*Continued.*
 wiring, inside, ills., 765-798,
 of buildings, ills., 815-864,
 outside, ills., 799-824.
 underground, ills., 825-844.
- System, three wire, aux. dyn., ills., 709,**
 balancer in, ills., 712.
 balanced, ills., 706.
 balancing coils for, ills., 714,
 bridge, 709.
 compensator, ills., 709, 710.
 copper wire, economy in, 707.
 distribution, ills., 704-711.
 Dobrowski, ills., 708, 709.
 double dynamo, ills., 709, 710,
 dynamotor, ills., 711.
 Edison, 704.
 evolution of ills., 705.
 modified, 708.
 neutral current, 198. ills., 706,
 principle of, 706.
 saves wire, 705.
 storage battery, 709.
 three, brush dynamo, 709.
 phase, evolution, ills., 1,564,
 transformer connections, ills., 1,438,
 two, phase, ills., 1,556.
 shunt dyna., con. to, ills., 582.
 with one dynamo, 708.

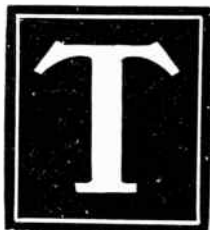

- Table, amperes, per dynamo, 760,**
 per motor, 760.
 bridge arms, 502.
 cable capacities, 753.
 copper wire, properties, 1,907-1,909,
 draught pressure, chimneys, 1,955,
 evaporation factors, 1,934.
 galvanometer constants, 447.
 induction coil dimensions, 152.
 natural sines and tangents, 451.
 sparking distance in air, 152.
 specific gravity of acid, 906.
 synchronous speeds, 1,317.
 voltage, a. c. vs. d. c., conver., 1,464.
 discharge rate, 967.
 water, friction, in elbows, 2,968,
 pipes, 2,967.
 weight per cu. ft., diff. temp.,
 2,965.

Table, water,—Continued.

- weir, 1,973.
- pressure for various heads, 2,968.
- water volumes (Kopp), 2,964.
- wattmeter errors, 2,075.
- wire(s), bridges, 757.
 - capacity, safe carrying, 731.
 - equiv., 751, 752, 1,913.
 - gauges, various, 742
 - lamp, 746, 747.
 - negligible drop, 757.
 - sag, 816.
 - taps, 757.
- wiring for light and power cir., 750.
- Tangent(s)** and sines, table of, 451.
- galvanometer, principles, const., oper., etc., ills., 441-448.
- law, ills., 445.
- mechanical expl., of, ills., 447.
- Tank(s)**, electro-plating, 3,157.
- heating, ills., 3,145.
- various, 3,159-3,161.
- switch, Cutler-Hammer, ills., 1,611.
- Tantalum**, lamps, 2,495.
- filament, ills., 2,495, 2,496.
- life curves, 2,494.
- Tap**, def., diag., 743.
- table for, 757.
- Tape**, insulating, ills., 2,399.
- paper, winder, Bunnell, ills., 2,250.
- telegraph, ills., 2,247, 2,248.
- Taping machine**, arm. coil, ills., 346, 347.
- Teak wood**, conductivity of, 69.
- Teaser**, coil of monocyclic alter., 1,554.
- transformer ratio, 1,573.
- wire connections, ills., 1,156, 1,157.
- Teeth**, armature, various forms, ills., 326-328, ills., 329.
- arrester plates, 888.
- X-ray photograph of, ills., 3,239.
- Telegram**, 2,201.
- Telegraph**, 2,201, 2,262.
 - alphabets, 2,246, 2,270.
 - apparatus, uses of, 2,243.
 - automatic, Wheatstone, 2,247.
 - circuit closed, ills., 2,206.
 - codes, 2,245, 2,246.
 - how to learn, 2,246, 2,271-2,273.
 - wireless, 2,270.
 - combined with telephone, ills., 2,162.
 - condensers, object of, 2,231.
 - def., 2,201.
 - dynamos, 2,254.
 - key, operation, ills., 2,204.
 - transmitting, 2,201.
 - voltaplex, ills., 2,232.
 - messenger call, ills., 2,258.
 - principle of, 2,201.
 - printing and typewriting, Buckingham-Barclay, 2,256.
 - receiver or sounder, 2,201.
 - recorder, Bunnell, ills., 2,257.
 - register, Bunnell, ills., 2,257.
 - relay, elementary, ills., 2,208.
 - Foote-Pierson, ills., 2,209.

Telegraph, relay,—Continued.

- operation, ills., 2,207, 2,208.
- repeater, 2,211-2,221.
- Bunnell, ills., 2,222, 2,223.
- circuit, ills., 2,213.
- Kitton's three wire, ills., 2,218.
- operation, ills., 2,211, 2,212.
- simple automatic, ills., 2,219-2,221.
- sounder, 2,201, 2,203, ills., 2,204, 2,205.
- stock tickers, 2,256, 2,257.
- student's omnigraph, 2,271.
- submarine cable circuit, ills., 2,253.
- duplex, 2,252.
- key, 2,252.
- switchboard, cross bar, W. U., ills., 2,231.
- tape, sending, receiving, ills., 2,247, 2,448.
- tests and troubles, 2,253.
- time signals, Western Union, 2,259.
- transmitter details, ills., 2,230.
- pole changing, 2,243.
- repeater, Toye, ills., 2,217.
- Wheatstone, 2,248.
- walking beam p. changer, ills., 2,234.
- Telegraph systems classified**, 2,202.
 - duplex, 2,226-2,240.
 - bridge, ills., 2,239, 2,240.
 - differential, ills., 2,226-2,228.
 - polar, ills., 2,233-2,239.
 - Stearns, ills., 2,227.
 - fire alarm, ills., 2,261.
 - grounded, ills., 2,207.
 - multiplex, Delaney, 2,249.
 - open, 2,206, ills., 2,207.
 - Rowland, 2,249.
 - quadruplex, ills., 2,240-2,245.
 - adjustment of, 2,243.
 - devices, 2,241.
 - ills., 2,242.
 - simul. telegr. and teleph., ills., 2,263.
 - short line, 2,205, 2,203, 2,207, 2,210.
 - single line, Morse, 2,203.
 - Wheatstone, how operated, 2,248.
- Telegraph, wireless, alphabet**, 2,270a-b.
 - apparatus, 2,278.
 - anchor gaps, ills., 2,302, 2,303.
 - Marconi, 2,297-2,302, 2,307.
 - ills., 2,312.
 - circuits, diag., 2,307-2,310.
 - code, 2,270a-b.
 - rules, 2,271.
 - emergency set, 2,304.
 - history of, 2,263-2,271.
 - small station, 2,322, ills., 2,328.
 - spark gap, 2,329.
 - syntonic, 2,281.
 - teleph. receivers and detectors, ills., 2,311, 2,322.
 - theory elementary, 2,273.
 - use of induction coils in, 137.
 - waves, ills., 2,274-2,278.
 - measured, 2,284-2,286.
- Telegraph, wireless, systems, class.**, 2,263.

Telegraph, wireless, systems,—Continued.

- De Forest, ills., 2,293.
 - Fessenden, 2,288, ills., 2,290.
 - Lodge-Muirhead, ills., 2,288, 2,289.
 - Marconi, ills., 2,286.
 - Phelps and Edison, induction, 2,266.
 - Telefunken, 2,289.
 - various, 2,294, 2,295, 2,296.
- Telephone, 2,115-2,200.**
- apparatus, types, ills., 2,116.
 - attachments, special, 2,157.
 - bell, ills., 2,117, 2,121,
 - adjustment, ills., 2,182.
 - box, ills., 2,121.
 - call, ills., 2,127-2,128.
 - rings without cause, 2,172.
 - trouble, plan 3 or 5, 2,182.
 - booster set, 2,142.
 - circuits, ills., 2,145.
 - cable, color code, 2,160.
 - circuit(s), operator's, ills., 2,153.
 - independent bat., ills., 2,145.
 - subscriber's, ills., 2,122, 2,152.
 - transfer, ills., 2,140.
 - condenser, 2,117, ills., 2,121.
 - cross arms, 805.
 - current waves, ills., 1,870.
 - def., 2,115.
 - exchange(s), connecting, 2,164.
 - ground, ills., 2,187.
 - toll service, 2,164.
 - extension cable terminal, ills., 2,164.
 - for deaf, ills., 2,197.
 - for wireless receiving, 2,326.
 - fuse, ills., 416.
 - induction coil, 2,117, ills., 2,121.
 - magneto, 2,122.
 - circuit, ills., 2,124.
 - closed, open, ills., 2,123.
 - open, ills., 2,123.
 - plan, 3 wiring, ills., 2,125.
 - 5 wiring, 2,125.
 - short circuited, 2,188.
 - standard con., ills., 2,183.
 - switchboard, ills., 2,184.
 - theory, 2,122.
 - troubles, 2,185-2,196.
 - Mershon's, use of, 1,849.
 - party lines, 2,145-2,146.
 - patent, Bell's, 2,115.
 - principle of, 2,115.
 - receiver, 2,117, 2,119, 2,122.
 - troubles, 2,170.
 - ringing, current machine, ills., 2,166.
 - keys, ills., 2,134.
 - set(s), auto. intercom., ills., 2,161.
 - portable, ills., 2,116.
 - subscribers, ap., 2,116, 2,117.
 - system(s), automatic intercommunicat-
 - ing, 2,150, 2,151.
 - central energy, 2,135.
 - common battery, 2,135.
 - direct line selective, 2,142.
 - intercom., 2,150, 2,154.
 - trans-Atlantic, 2,169.
 - trans-continental, 2,168.

Telephone,—Continued.

- transmitter, 2,117.
- Blake, ills., 2,124, 2,126.
- troubles, 2,170-2,196.
 - located, ills., 2,173.
 - magneto, 2,185-2,196.
 - P. B. X., 2,173-2,179.
 - plan, 2,179-2,183.
 - subscribers, 2,170-2,173.
 - wireless, Marconi, 2,329.
- Tellurium in contact with zinc, 44.
- Telpher, automatic, def., 2,956.
 - brake, 2,960.
 - cableway, def., ills., 2,961.
 - range of, 2,962.
 - mono-rail tracks, ills., 2,958.
 - motors, 2,959.
 - non-automatic, def., 2,957.
 - performance, 2,962.
 - power features of, 2,958.
 - storage-battery for, 2,959.
 - suspension and driving, 2,958.
 - trackage, 2,961.
- Telpherage, def., 2,955.
 - trolley, motor driven, Brown, 2,960.
- Tensile strength of copper wire, 800.
- Terminal(s), battery, cells, joining of, 951.
 - spring snap connectors, 2,401,
 - ills., 2,402.
 - pressure, air compressor, 3,038.
- Tesla, coil, medical elec., 3,189.
- Test(ing) (of), acid, specific gravity, 905.
- alternator, excitation, ills., 2,084.
 - load, three phase, 2,085.
 - temp., 3 ph., ills., 2,086, 2,087.
- ammeter, with Queen Acme set, 510.
- apparatus, 465-536.
- armature lead, break in, ills., 1,625.
- battery, silver chloride, ills., 503.
 - storage, instruments for, 921.
- bell circuit, ills., 2,397, 2,398.
- brake, lever arm of, 379.
- brush holders, 620.
- insulation, 487.
- cadmium, 919.
- capacity, with st. condensers, 1,044.
- coil, armature, break in, ills., 630.
 - open, bar to bar, 626.
 - short circuit, ills., 624.
- field, ills., 620.
 - pocket compass, 587.
- current for resistances, 485.
- deflection method, 482.
- dynamo, 2,107.
 - comp., ext. char., ills., 2,092.
 - magnetization, ills., 2,088.
 - open circuit, ills., 613.
 - short circuits, ills., 616.
 - shunt, ext. char., ills., 2,089.
 - temp., loading back, ills., 2,091.
 - with main leads out, 619.
- external char. dyn. ills., 2,089, 2,092.
- fall of potential, 505.
- generators, 2,105-2,107.
- inductance, ills., 1,030.
- insulation of parts of machine, 596.

Test(ing) (of),—Continued.

- loop, diagrams of, ills., 514.
- for teleph. or telegr. line, 515.
- Murray, diag., 515.
- special, 519.
- Varley, circuits of, ills., 518.
- magneto, for grounded arm., 633.
- lines, 2,195, 2,196.
- meter, 568.
- motor, brake, app. for, ills., 378.
- loaded, 2,076.
- magnetization, 2,088.
- rheostatic control app., 2,582.
- single phase, ills., 2,076.
- temp., induction, ills., 2,083.
- loading back, ills., 2,091.
- synchronous, ills., 2,087.
- three phase, ills., 2,077-2,082.
- resistance, 476.
- telephone grounds, 2,173.
- transformer, 2,094.
- copper loss, ills., 2,095.
- core loss, ills., 2,093.
- insulation, ills., 2,098, 2,099.
- internal, ills., 2,100.
- resistance, ills., 2,101.
- polarity, 2,054, 2,103.
- ratio, ills., 2,102.
- regulation, ills., 1,445.
- temperature, ills., 2,096, 2,097.
- winding, ills., 2,102.
- vibrator, 153.
- zero method, 482.
- chawing, frozen water pipes, ills., 3,065.
- ferro resistance wire, 3,049.
- hermit, pipe clamps, ills., 3,118.
- preheater for welding, ills., 3,120.
- rail joint, Clark, mould, ills., 3,119.
- steel, average composition, 3,121.
- welding, 3,117-3,122.
- locomotive frame, ills., 3,117.
- pipe, ills., 3,118.
- thermo contact light flasher, ills., 878.
- thermometer, for battery electrolyte, 921.
- filmbe, motion pictures, ills., 2,714.
- third rail, system, ills., 2,549.
- Thompson, amm., inc., coil, ills., 548, 549.
- astatic meter, ills., 552.
- galvanometer, ills., 455.
- lecture on Faraday's machine, 126.
- wattmeter, ills., 559-567.
- welder, ills., 3,123.
- welding process, 3,125.
- Three phase, alternators, ills., 1,131, 1,132.
- 1,549, 1,553, 2,041.
- 2,042, 2,085, 2,087.
- connections, diag., 1,245-1,250, 1,560.
- 1,565, 1,566. 1,881, 1,882.
- current, trans. and dist., ills., 1,026-1,028, 1,165, 1,561-1,568, 1,584, 2,538.
- transformation, ills., 1,571-1,575.
- motor, ills., 1,285, 1,334, 1,450.
- 2,077, 2,080, 2,082,

Three phase,—Continued.

- power measurement, ills., 1,124.
- rectifier, mercury arc, ills., 1,509.
- rotary converter, ills., 1,461, 1,462.
- starting compen., ills., 1,758, 1,762.
- transformer, ills., 1,394, 1,396, 1,431, 1,432, 1,435-1,437, 1,439, 1,443.
- windings, 1,239, 1,242, 1,249, 1,253.
- Ticker, stock market system, 2,256.
- limit devices, 420, 421.
- Time, relays, ills., 1,654-1,658.
- signals, telegraph, W. U., 2,259.
- standard, by telegraph, 2,259.
- Timer(s), ignition, 2,772, 2,773, 2,790.
- Tin, conductivity of, 69.
- galvanizing barrel for, ills., 3,182.
- in caustic potash, 102.
- in contact with zinc, 44.
- in acid, 102.
- wet extraction of, 3,142.
- Tinfoil, button current carriers, 3,186.
- experiment with, 13.
- inductors, 23, 24.
- Tinning, bit, soldering, 3,085.
- block, soldering bit, ills., 3,087.
- soldering bit, ills., 3,086, 3,087.
- Tire automobile, defective, 2,852.
- friction, 2,822.
- pneumatic, construction of, 2,822.
- Titanium arc lamp, 2,463.
- Toening inverted arc lamp, ills., 2,470.
- Toepler-Holtz machine, 23-25. 3,185, 3,186.
- Toledo, butt welder, ills., 3,126.
- spot welder, ills., 3,124.
- Toll, board in main teleph. office, 2,166.
- service, telephone exch., 2,164.
- Torch, air gas, for brazing, ills., 3,103.
- cutting, ills., 3,131.
- flasher, wiring for, ills., 873.
- oxy-acetylene, D.-B., ills., 3,116.
- soldering joint with, 3,089.
- welding, D.-B., style C., ills., 3,130.
- Torque, motor, 1,375.
- synchronous, 1,276.
- wattmeter, 562, 563.
- Total, pressure, def., 1,067.
- reflection, 2,683.
- static head, 2,969.
- Tower(s), aeromotor, twin cir., ills., 1,579.
- angle, strain insul., G. E., ills., 1,552.
- three phase trans., G. E., ills., 1,580.
- wire, Milliken, ills., 1,548.
- Toye telegr., transmitter rep., ills., 2,217.
- Track(s), const., ry., ills., 2,616-2,622.
- girder or grooved rail, 2,618.
- intersection and signals, ills., 2,647.
- mono-rail, teleph., ills., 2,958.
- signals, 2,647.
- third rail const., ills., 2,621, 2,622.
- Traction, elevators, 2,859-2,863.
- Trans-Atlantic telephony, 2,169.
- Trans-continental telephony, 2,168.
- Transformer(s), air, cooled, 1,405.
- all day efficiency, 1,419.

Transformer(s),—Continued.

- auto, principle of, ills., 1,421.
- bell ringing, 2,394, ills., 2,397.
- capacity for motors, 1,449, 1,451.
- cautery, McIntosh, ills., 3,224.
- central station, Wagner, ills., 1,408.
- circuits, s. p., ills., 1,426-1,427.
- classification, 1,385.
- coils, pan cake, ills., 1,381.
- comb. core and shell, ills., 1,390, 1,391.
- connected in parallel, ills., 1,543.
- connection(s), for interphone bells, ills., 2,397.
- for motors, ills., 1,451, 1,452-1,453.
- for 3 wire system, ills., 1,438.
- Scott, ills., 1,573.
- single phase, 1,426-1,427.
- two and three phase, 1,431.
- Constant current**, 1,505-1,506.
- air cooled, G. E., ills., 1,424-1,425.
- for series arc, ills., 1,423.
- cooling of, 1,404.
- copper loss(es), 1,402, ills., 1,444.
- test, ills., 2,095.
- core**, G. E., ills., 1,392.
- laminated, ills., 1,389.
- loss, ills., 1,443, 1,545.
- test, ills., 2,093.
- type, ills., 1,388.
- current**, 1,377-1,456.
- curve, West. air blast, ills., 2,048.
- delta connection, ills., 1,432.
- delta-star connection, ills., 1,432.
- drum, voltage regulator, 1,735.
- eddy currents, 1,398, 1,402.
- efficiency of, 1,417, 2,047.
- elementary, ills., 1,378.
- forced draught, ills., 1,407.
- Fort Wayne, ills., 1,398.
- G. E., ills., 1,399.
- heat of, 1,397.
- hysteresis, 1,397.
- induced voltage in, 1,380.
- information, general, 1,442.
- inherent regulation, 1,425.
- in parallel, 2,053.
- insulation**, 1,414-1,416.
- tests, ills., 2,098-2,101.
- iron loss**, 1,400.
- losses, 1,395.
- magnetic leakage reduced, 1,379.
- magnetizing current, 1,383.
- main, ratio, 1,573.
- no load current, 1,400.
- oil, cooled, 1,408.
- insulated, 1,417.
- operation**, 1,442.
- with grounded sec., 1,448.
- outdoor**, advantages, 1,988.
- polarity**, instantaneous, ills., 1,430.
- test, 2,054, 2,103.
- pole type**, Moloney, ills., 1,397.
- polyphase**, ills., 1,394.
- principles**, 1,377.

Transformer(s),—Continued.

- primary, 1,378.
- ratios, standard, 1,583.
- resistance loss, 1,402.
- measurement, ills., 2,095.
- secondary, 1,378.
- shell and core, 2,052.
- standard, connections of, ills., 1,440.
- star connection, ills., 1,432, 1,433.
- step, down, ills., 1,386.
- up, ills., 1,386.
- teaser, ratio, 1,573.
- temperature test, ills., 2,097.
- testing, 2,094.
- three phase, connections, ills., 1,432.
- triangular cores, ills., 1,396.
- two phase connections, ills., 1,433.
- water cooled, ills., 1,414, 1,415.
- Westinghouse outdoor, ills., 1,416.
- windings, 2,053.
- X-ray, interrupterless, ills., 3,236.
- Transformation**, current phases, 1,571.
- three ph., to one ph., ills., 1,572.
- to six phase, ills., 1,575.
- to two phase, ills., 1,573-1,574.
- Transition**, bridge, 2,571.
- power off method, 2,571.
- series resistance, 2,571.
- Translucent**, def. of, 2,506.
- Transmitter**, telegraph, dif. from repeater, 2,230.
- pole changing, 2,243.
- Wheatstone, 2,248.
- Transmitter**, telephone, Acousticon and dictograph, ills., 2,198.
- auris, ills., 2,198.
- breast plate, ills., 2,139.
- carbon cup, ills., 2,118.
- diaphragm, telephone, ills., 2,118.
- electrodes, 2,119.
- microphone, Blake, ills., 2,126.
- classified, 2,124.
- solid back, ills., 2,118.
- Transmission**, alternating current, 1,532.
- and dist. 3 ph. long dist., ills., 1,562.
- automobile, 2,909.
- belt, double pulley drive, ills., 2,009.
- current, with step up transformer ills., 1,551.
- elevator, 2,855, 2,907.
- four wire, and three wire distribution, ills., 1,559.
- gear of sign flasher, ills., 869.
- long distance, ills., 1,928.
- pole lines, 800.
- quill drive, ills., 2,052.
- rural line, ills., 1,583.
- single phase, two wire and three wire distribution, ills., 1,547.
- towers, 3 phase, G. E., ills., 1,580.
- two phase, three wire, ills., 1,557.
- voltage**, choice of, 1,581.
- standard, 1,583.
- usual, 1,582.

Transmission,—*Continued.*
 Transparent, def. of, 2,506.
 Transporter, coal, 2,945.
 grab load, 2,946.
 Transposition of line wires, ills., 819.
 1,888.
 Transverse area of wire, 734.
 Traveling cranes, def., 2,937.
 Treatment various diseases, 3,205-3,221.
 Trembler, ignition, ills., 2,773.
 used in decohering, 2,270.
 Triangles, properties of, 1,069, 1,070.
 Tri-city heating element, 3,052.
 Trip circuit breaker, 1,630.
 Triplex, armature winding, 149.
 pump and receiver, Dem., ills., 2,991.
 Tripoli polish, electro-plating, 3,167.
 Triumph, brush and holder, ills., 1,255.
 dyn. and engine, dir. con., ills., 1,979.
 motor, polyphase, incl., ills., 1,315.
 squirrel cage armature, ills., 1,323.
 Trolley, car app., multi unit, ills., 2,654.
 operation, 2,649-2,658.
 3 phase dist. sys., ills., 1,584.
 fuse, blown, 2,664.
 line construction, 2,622-2,630.
 overhead s. p., ills., 1,539.
 track const., ills., 2,616-2,622.
 lubrication of, 2,547.
 pantograph, ills., 2,540, 2,548.
 systems, 2,547.
 overhead, 2,547.
 surface contact, 2,548.
 third rail, ills., 2,549.
 underground, 2,551, 2,619.
 wheel and harp, ills., 2,546.
 Trucks, for city service, 2,817.
 gasoline, 2,815.
 Trucks, railway, 2,592-2,595.
 Baldwin, ills., 2,599.
 city street use, 2,594.
 high speed, M. C. B., ills., 2,593.
 interurban, 2,595.
 maximum traction, Brill, ills., 2,593.
 Trunk, selector automatic sys., ills., 2,156.
 Tudor positive battery plate, ills., 895.
 Tungsten, in contact with zinc, 44.
 melting point of, 2,498.
 lamps, 2,496-2,499.
 Tuning, coil, wireless receiving, ills., 2,314.
 def. of, ills., 2,278.
 Turbine(s), alternators, Curtis, ills., 1,182.
 winding, ills., 1,263.
 blades of Parsons steam, ills., 1,963.
 Curtis, and dyn., G. E., ills., 2,044.
 double flow, ills., 1,967.
 dynamo rotor, West., ills., 1,998.
 generator, Curtis, ills., 2,050.
 high speed, De Laval, des., 1,969.
 impulse, 1,964, 1,976.
 mercury, inter., S. W., 3,193.
 Parsons-Westinghouse, ills., 1,966.
 Turbine pumps, ills., 3,004-3,008.
 Turns, ampere, def., 120,

Turns,—*Continued.*
 cross magnetizing, ills., 268, 269.
 dead, of armature, 278-279.
 demagnetizing, ills., 268-270.
 Twleve phase winding, ills., 1,134.
 Two fluid cell, 45.
 motor equipment reg., ills., 695.
 party J and R teleph. cir., ills., 2,147.
 path method, field reg., ills., 188.
 Two phase, ills., 1,020, 1,022.
 connec., star and delta, 1,243, 1,244.
 current distribution, ills., 1,024.
 Tyndall's exper., heat by friction, ills., 89.
 Typewriter, electric, P. T. Co., 2,256.
 telegraph, Bunnell, ills., 2,255.
 Wright, 2,256.



Underground, cables, 840.
 Edison, ills., 842.
 conductor(s), 825.
 tube or conduit, 825. ills., 2,619.
 wiring, 825-844.
 Underload, and overload cir. br., ills., 419.
 trip, 1,633.
 relays, 1,650.
 trip, G. E., ills., 1,631.
 Underwriters', requirements, 785.
 Undulatory theory of light, 2,674.
 Unformed lead plate battery cells, 981.
 Union lightning arrester, ills., 887.
 Unit(s), British thermal, 90, 91.
 capacity, farad, def., 1,041, 1,042.
 circular, ills., 732.
 cone, illumination, def., ills., 2,510.
 electrical, volt coulomb, 86.
 electromotive force, volt, 131.
 field strength, gauss, 111.
 heat, proportion to resistance, 96.
 heating, various, ills., 3,050, 3,051.
 inductance or henry, 1,030.
 milli-henry, 1,036.
 magnetic, flux, maxwell, def., 111.
 pressure, 120.
 resist., compr. type, A.-B., ills., 672.
 various starting, ills., 665.
 with Varley loop, 517.
 work, foot pound, 376.
 U. S. electro-plating barrel, ills., 3,183.
 gallon, cu. ins., and weight, 2,965;

U. S.,—Continued.

- standard wire gauge, *ills.*, 740
 wireman's calc. gauge, *ills.*, 740.
Unity, power factor, *ills.*, 1,106.
 kept near, 1,119-1,120.
Universal, crossing bell relay, *ills.*, 2,640,
 motion picture camera, *ills.*, 2,731.
 train annunciator, *ills.*, 2,636, 2,637.
Universalmode, McIntosh, *ills.*, 3,199.
 modalities for, *ills.*, 3,200.
Unloader, air, compressor, *ills.*, 3,038.
Uraniur, in contact with zinc, 44.
Urethral stricture, treatment for, 3,204.
Urethritis, treatment for, 3,205.
Urinary diseases, treatment for, 3,205.
Urology, treatment for, 3,203.
Uterus, treatment of, 3,218.



- Vacuum**, reluctance of, how meas., 121
Vaginitis, treatment for, 3,205.
Vagus, treatment of, 3,218.
Valve(s), air com, *ills.*, 3,027-3,032, 3,040,
 audion, electrolytic, 1,504.
 bucket pump, 2,977.
 Buttner, electrolytic, 1,505.
 Churcher, electrolytic, *ills.*, 1,503.
 De Faria, electrolytic, *ills.*, 1,504,
 discharge, direct lift, I.-R., 3,028.
 pump, *ills.*, 2,982.
 foot, pump, 2,977.
 Giles electrolytic, 1,505.
 Grisson, electrolytic, 1,504.
 head, pump, 2,973.
 inlet, air com., 3,025, 3,027-3,031.
 lift, of pump, 2,982.
 needle, motion picture, 2,720.
 Nodon, des., operation, 1,497.
 oscillation, Fleming, elec., *ills.*, 1,502.
 Pawlowski, electrolytic, 1,504.
 pump, discharge and suc., *ills.*, 2,982.
 flat rubber disc, 2,996.
 ills., 2,974, 2,991, 2,994-2,997.
 slip, def., 2,982.
 springs, 2,996.
 triple, air brake, 2,603.
Van Ryselbeeghe telegr. exper., 2,260.
Van Subricke, experiments of, 2,274.
Van Trostwyk's experiments, 97.
Vapor, and arc terms, 1,517.

Vapor,—Continued.

- acid, in battery rooms, 957.
 carbon, how produced, 2,416.
Varley, loops illustrated, 514.
 test, circuits of, *ills.*, 518.
 with bridge resis. units, 517,
 with fault finder, *ills.*, 519.
Varnish, shellac, for armature coils, 626.
Vaso constrictor, current, 3,203.
Vector, summation, 1,533.
Vegetable matter, conductivity of, 69.
Verdigris on storage bat. terminals, 949.
Vehicles, electric, 2,814-2,854.
 Babcock roadster, *ills.*, 2,853.
 Baker electric roadster, *ills.*, 2,816.
 bat., *ills.*, 2,826, 2,830-2,840, 2,852.
 brake, *ills.*, 2,843, 2,852, 2,853.
 chain drive, *ills.*, 2,827, 2,835.
 chains, various, 2,831.
 chassis, *ills.*, 2,818, 2,830.
 circuits, *ills.*, 2,844 to 2,850,
 contact shoes, defective, 2,852.
 controllers, *ills.*, 2,839-2,851.
 Rauch and Lang, *ills.*, 694.
 friction in bearings, 2,826.
 gear, 2,827 to 2,835.
 lubrication of, 2,829, 2,837-
 reduction, 2,826, 2,837.
 worm, Baker R. & L., 2,835.
 mileage and battery, 2,838.
 motors, *ills.*, 2,824-2,826, 2,845.
 operation of, 2,850, 2,851.
 speed, diagram, *ills.*, 2,847-2,856.
 starting, failure in, 2,853.
 tire friction, 2,822.
 transmission defined, 2,909.
 troubles, 2,852-2,854.
 worm drive, 2,836, 2,837.
Velum, paralysis of, treatment, 3,219.
Vent caps of Witherbee battery, *ills.*, 940.
Ventilated and solid core discs, *ills.*, 326.
Ventilating ducts, arm., *ills.*, 1,213, 333.
Ventilated dynamo commutator, *ills.*, 655.
Ventilation, ry. motors, *ills.*, 2,556, 2,557.
Vernon-Harcourt pentane stan., 2,508.
Vibragenitant, Scheidel-Western, 3,206.
Vibration, molecular, intensified, 2,122,
 Duddell oscillograph, *ills.*, 1,859.
Vibrator, mechanical, use of, 146.
 condenser coil, use of, 146.
 coil, ignition with, *ills.*, 2,778.
 master, circuit of, *ills.*, 149.
 quality of spark in, 151.
 used in decohering, 2,270.
Vienna lime polish, electro-plating, 3,168.
Violet, light produced in arc, 2,417,
 rays, passing through water, 2,277.
Violle unit of light, 2,508.
Virtual, focus(i), *ills.*, 2,677, 2,687, 2,688.
 in d. cc. lens, 2,688-2,689.
 in d. cv. lens, 2,687, *ills.*, 2,688.
 def., 2,674, 2,675.
 pressure, 1,010.
 value of alternating current, 1,777.
 volts and amperes, *ills.*, 1,012.
Visc. portable *ills.* 813

Vision, cone of, ills., 2,684.
 def. of, 2,074.
 persistence of, def., 2,706, 2,709.

Vitreous electricity, def. of, 4.

Vitrified clay conduits, ills., 827, 829.

Vitriol, oil of, electro-plating, 3,146.

Volt(s), 2,733.
 alternator, average, 1,010.
 maximum, 1,010.
 ampere, and ohm, ills., 468.
 effective, 1,013.
 virtual, ills., 1,012.
 coulomb, def., 86.
 def., 28, 131.
 formula to determine, 29.
 how obtained, 32.
 international, def., 468.
 standard cell, ills., 466, 467.

Volta's battery experiment, 893.
 contact law, 43.
 "Crown of Cups," ills., 32.
 electrophorus, ills., 17.
 in primary battery, 2,411.
 single fluid cell, 45.

Voltage(s), 2,733.
 battery charging, 924.
 cadmium test, 919.
 choice of transmission, 1,581.
 critical, 1,698. 1,895.
 curves illust. lag, ills., 1,049-1,050.
 d. c., traction lines, 1,586.
 discharge rate, table of, 967.
 drop, at brushes, 313-314.
 shunt dynamo 190.
 transformer, 2,051.
 wire circuit, 747.
 electro-plat., var. met., 3,149, 3,156.
 formula, 1,533, 1,536. 1,914.
 impressed, 1,067.
 in residual field, 184.
 induced in transformer, 1,380.
 limiting devices, 1,587.
 loss in wire circuit, 747.
 lowered by hydrogen deposit, 59.
 maximum, how determined, 169.
 proportion of current flow to, 29.
 ratio of sparking distances of, 152.
 regulation, alternators, auto., 1,749.
 incoming, 2,039.
 bat. cell, during charge, 918.
 converter, 1,472.
 dynamo, 2,814.

regulator, auto., alter., G. E., 1,748.
 line drop comp., ills., 1,754.
 small feeder, 1,742.
 variable transformer, 1,734.
 wiring, G. E., ills., 2,030.

residual field, weak, 184.
 reverse, 1,067.
 self-induction, defined, 1,352.
 standard, of railways, 2,535.
 transmission, 1,583.
 starting and lighting, 2,798.
 storage battery, 911-912.
 transformer, defined, 1,351.

Voltage(s),—Continued.
 transmission, usual, 1,582.
 unknown, measured, 531.

Voltagex telegraph key, ills., 2,232.

Voltmeter, weight, Queen, ills., 469.
 treatment of plates of, 471.

Voltmeter(s), amm., wattmtr., 537-572.
 difference, 541, 544.
 automobile, defective, cause, 2,854.
 battery testing, low reading, 921.
 connection, 543.
 electro-plating, 3,152.
 two tank connec., ills., 3,158.
 Waverly, ills., 3,157.

electrostatic, ills., 550, 551.
 Faraday's def., 102.
 high resistance coil, 542.
 Hoskins, ills., 1,790.
 hot wire type, ills., 548-550.
 Kelvin, electrostatic, ills., 551.
 Keystone, ills., 540. 1,796.
 low reading for accumulator, 921.
 panel board, ills., 1,880.
 portable, multipliers, ills., 553, 554.
 readings, for errors, 2,103.
 of storage cells, 925.
 resistance, boxes, ills., 553.
 static, 466.
 tested and corrected, 2,100-2,104.
 types of various, 537.
 use of, 185.

Volume, air compression, diagram, 3,026.

Volute pump, 3,003.

Vomiting, treatment for, 3,219.

Vulcabeston solenoid spools, 2,448.

Vulcanite buttons, Edison cell, 51.



Wagner, armature, squir. cage, ills., 1,328.
 dynamo, automobiles and l., 2,804.
 dynamometer, ills., 1,793.
 magnetic vane meter, ills., 1,784.
 measuring instruments, ills., 1,798.
 meters, ills., 1,798.
 motor, polyphase arm. ind., 1,335.
 repulsion induc., ills., 1,352.

transformer, ills., 1,408, 1,446.
 coil, ills., 1,381, 1,382.
 ills., 1,794.

- Wagner, transformer**.—*Continued*.
oil cooled, ills., 1,410.
secondary leads in, ills., 1,403.
series, ills., 1,786.
- Wallis-Jones automatic earth leakage cut out**, ills., 1,838.
- Walrus leather polishing wheel**, 3,176.
- Ward Leonard controller**, 2,811, 2,814.
- Warner, d. c. elevator motor**, ills., 2,868.
elevator, car layouts, ills., 2,864.
machine, internal gear, 2,923.
worm gear, ills., 2,932.
- Washburn and Moen's wire gauge**, 740.
- Water**, added to acid, effect of, 40.
and moisture effect on belts, 402.
and sulphuric acid, 904.
as a conductor, 69, 74.
critical angle for, 2,683.
decomposed by discharge, 97.
disch. from needle noz., ills., 1,975.
dispersion property of, 2,277.
effect on of current, 100.
flow, anal. of, to elect. cur., ills., 28.
friction of in elbows, 2,968.
in pipes, table, 2,967.
hammer, prevention of, 2,981.
head coros. to var. pressures, 2,969.
heating, cost table, 3,060.
various methods, 3,058.
jacketing, air compression, 3,038.
maximum density, 2,955.
medium for wireless telegr., 2,264.
pressure coros. to var. heads, 2,968.
how expressed, 2,968.
proof rubber insulation, 725.
pure, conductivity of, 76.
refractive index of, 2,681.
sulphuric acid poured into, 905.
sup. for cen. stat., ills., 1,923, 1,924.
volumes at var. temperatures, 2,964.
weight per cu. ft., def. temp., 2,965.
- Watson, armature complete**, ills., 621.
commutator, ills., 691.
field coils, ills., 631.
vertical motor, ills., 404.
- Watt(s)**, def. of, 88.
formula, 1,914.
hour, def. of, 88.
meters, 1,799.
James, established power unit, 376.
loss at brushes, 314.
measured by wattmeter, 1,101.
- Wattless, components at dif. p. f.**, 1,776.
current, ills., 1,110-1,111, 1,113.
- Wattmeter, calibrating**, ills., 2,094.
checking, ills., 2,094.
Duncan, internal con., ills., 571.
error table, 2,075.
friction in, 1,803.
installation of, 563.
integrating, 1,799.
iron vane, 2,075.
moving ele., Weston, ills., 1,801.
multi-phase, Fort Wayne, ills., 1,806.
measuring transformer losses, 1,418.
pre-payment, Thompson, ills., 567.
- Wattmeter**.—*Continued*.
single ph. induc., F. W., ills., 1,810.
Weston, ills., 1,799.
Thompson recording, 563.
torque, speed proportional to, 562.
- Wave(s)**, air, exper. with guitar, 2,277.
a. c., ills., 1,000, 1,016.
and lap alternator windings, 1,213.
detached theory, 2,279.
distorted, ills., 1,843.
drum winding, 241.
electric, def. of, 2,274.
- Wave. form(s)**, determination of, 1,019.
factor of, ills., 1,014.
ills., 1,843.
measurement, 1,839-1,870.
free, theory, 2,280.
half, Fessenden sliding, 2,280.
heat definition of, 2,274.
Hertzian, velocity of, 2,277.
lengths, measurement of, 2,284.
light.
def. of, 2,274.
velocity of, 2,276, 2,777.
meas., bal. galv. meth., ills., 1,846.
part com. meth., ills., 1,845.
Joubert's method, ills., 1,844.
zero method, ills., 1,848, 1,849.
- meter, Marconi**, ills., 2,284.
peaked, ills., 1,843.
sine, ills., 1,843.
sound, def. of, 2,274.
- Waverly electric brougham**, 2,819.
electro-pl. voltmeter, ills., 3,157.
motor, 80 volt, ills., 2,825.
- Wax, impression, electrotyping**, 3,181.
paraffin, as insulator, 70.
prevent creeping, 55.
- Weather proof, conductors**, 726.
slow burning wire, 730.
twisted wires, ills., 726.
wires for outside wiring, 727.
- Weight, adjusting, arc lamp, special design**, 2,447.
of copper, relative, required by poly-phase systems, 1,576.
of copper wire, 749.
voltmeter, 471.
Queen, ills., 469.
- Weiny-Phillips telegraph sys.**, ills., 2,224.
- Weir, construction**, ills., 1,972.
table, 1,973.
- Welds, various**, 3,109.
flash, ills., 3,127, 3,128.
jump, cor. and incor. shapes, 3,114.
lap, cor. and incorrect shapes, 3,114.
upset, ills., 3,127, 3,128.
- Welder, Thomson**, ills., 3,123.
Toledo butt, ills., 3,126.
spot, ills., 3,124.
- Welding**, 3,107-3,132.
and soldering, difference, 3,114.
autogenous, 3,115, 3,116.
blow pipe, 3,115.
electric, arc, C. and C., ills., 3,121.
Bernados pro., 3,129, 3,130.

Welding, electric,—Continued.

- Slovianoff process, 3,130.
- flux for various metals, 3,108.
- forge fuels, 3,111.
- Hoho and Lagrange process, 3,131.
- jump, 3,127.
- oxygen consumption, 3,108.
- oxygraph, ills., 3,131.
- processes, 3,111, 3,113.
- rail, Clark, thermit, ills., 3,119.
- spot method, ills., 3,125, 3,127.
- systems of, 3,113.
- thermit, 3,117-3,122.
- Thomson process, 3,123, 3,125.
- torch, cutting, ills., 3,131.
- D.-B., style C., ills., 3,130.
- various welds, 3,109.
- Zerener, 3,128.
- Welsbach light, 2,426, ills., 2,515.
- Wehnelt interrupter, ills., 3,191, 3,192.
- Western Electric, annunciator sys., ills., 2,393.
- armature, barrel wound, ills., 333.
- squirrel cage, ills., 1,328, 1,331.
- stationary, ills., 1,211.
- brush gear, ills., 314.
- commutator, ills., 299.
- distributing frame parts, ills., 2,194.
- field coils, 219.
- interrupter circuits, ills., 2,195.
- shunts, portable, ills., 555.
- telephone, automatic, 2,151.
- intercom., ills., 2,161.
- transformer, bell ringing, ills., 2,404.
- Western Union joint, ills., 818.
- splice, 2,382, ills., 2,383.
- switchboard, telegraph, ills., 2,231.
- time signals, 2,259.
- wire splice, ills., 818.
- Westinghouse, alter., polyph., ills., 1,169.**
 - stationary arm., ills., 1,264.
 - 3 ph., composite ills., 1,253.
 - 2 phase compos. w. ills., 1,252.
- arc lamp, diff. control, ills., 2,460.**
 - series parallel, ills., 2,463.
 - air, circulation of, ills., 2,464.
 - a. c. series, ills., 2,448.
- arc lighting, series sys., ills., 1,510.**
 - with amort. winding, ills., 1,155.
- armature, barrel wound, ills., 340.**
 - s. ph. concen. coil, ills., 1,217.
 - wave, barrel wound, ills., 341.
- brush holder, ills., 309.**
- cir. maker, mag. blow out, ills., 1,620.**
- coil blow out, ills., 2,585.**
- choke, ills., 1,711-1,713.**
- compensator, line drop, ills., 1,753.**
- controller, ry., H. L., ills., 2,662, 2,663.**
 - K12, connections, ills., 2,576.
 - K-35, connections, ills., 2,578.
 - L-2, connections, ills., 2,577.
 - master, ills., 2,588.
- converter rotary, ills., 1,474.**
 - com. pole of, ills., 1,470, 1,471.
 - mech. oscillator, ills., 1,481.
 - syn. booster, ills., 1,482, 1,483.
- cylinder and magnet valve, 2,584.**

Westinghouse,—Continued.

- dynamo, automobile, ills., 2,809.
- three wire, ills., 198.
- ground fittings, ills., 1,706.
- locomotive, mine, ills., 2,592.
- meter bearings, ills., 1,804.
- induc. frequency, ills., 1,829.
- motor double reduction, ills., 2,807.**
 - interpole, ry., ills., 2,657, 2,660.
 - self-starting syn., ills., 1,279.
 - starter, ills., 1,332.
- regulator dial, ills., 1,736, 1,738.**
 - induction, hand of, ills., 1,722.
 - voltage, unit sw., ills., 1,747.
 - var., trans., ills., 1,732.
- reverser, standard, ills., 2,586.**
- spark gaps, ills., 1,684.**
- starting and lighting sys., 2,802.**
- steam turbine, marine, ills., 2,671.**
- surface contact system, 2,548.**
- switch group, ills., 2,585.**
 - oil, ills., 1,603.
 - single pole disc., ills., 1,554.
 - starting, ills., 1,593.
- synchronism indicator, ills., 1,831.**
- synchroscope, ills., 1,831.**
- transformer bushings, ills., 1,405.**
 - curve, air blast, ills., 2,048.
 - fuse blocks, ills., 1,406.
 - outdoor, ills., 1,416.
 - terminal blocks, ills., 1,404.
 - type S, ills., 1,409.
- valve gear, ills., 1,969, 1,970.**
- watt meter, ills., 566.**
 - electro-mag. cir., ills., 1,803.
 - polyphase induc., ills., 1,802.
 - single phase induc., ills., 1,800.
- Westinghouse-C. H., rect., 1,505, 1,506.**
- Weston, ammeter construction, ills., 545.**
 - cell, cadmium ills., 467.
 - normal, ills., 467.
 - illuminated meters, ills., 558.
 - portable voltmeter, ills., 545.
 - volt ammeter, ills., 2,822.
 - wattmeter, moving el., ills., 1,801.
 - single phase, ills., 1,799.
- Wharf crane, Shaw overhead, ills., 2,050.**
- Wheatstone, exper. of, 894.**
 - 2,413.
 - telegraph system operation of, 2,248.
- Wheatstone bridge, 488.**
 - connections of, ills., 489.
 - diag. of, ills., 489, 490.
 - dial, L. and N., ills., 497.
 - erroneously named, 2,413.
 - for measuring resistance, 620.
 - key, ills., 473.
 - ratio coils, ills., 492.
 - reversing arms of, ills., 493.
 - testing, ills., 488, 492.
 - with resistances, ills., 491.
- Wheel(s), and rol. pipe cutters, ills., 1,994.**
 - buffing, electro-plating, 3,177.
 - emery and corundum 3,170.
 - felt, electro-plating, 3,170.
 - fining, electro-plating, ills., 3,171.
 - polishing, H. & V. 3,174-3,176.

Wheel(s).—Continued.

- roughing, ills., 3,171, 3,175, 3,176,
- trolley, and harp, ills., 2,546.
- truck, crane const., 2,942.
- washer, electro-plating, 3,176.
- Wheelock cell, ills., 58,
- Whirls, magnetic, ills., 114. 444
- White, light, def., 2,699,
- steam generator, 2,672,
- Whitney hot wire instruments, 548-550.
- Wilde, experiments of, 2,413,
- separately excited dynamo, 196.
- Willard, "Autex" storage bat., ills., 902,
- cell connectors, ills., 904,
- plates, ills., 901.
- Wimshurst mach., ills., 25, 26. 3,185.
- Wind, electric, 9.
- Windings, 229-256, 335-345. 1,210-1,259,
- 1,307, 2,363,
- alternator classified, 1,210,
- fully distributed, 1,219,
- lap and wave, 1,213,
- partially distr., ills., 1,219.
- amortisseur, action of, 2,041,
- of alternator, 2,039.
- barrel, ills., 339,
- with bastard, West., ills., 344,
- straight out coils best, 345.
- bastard, 340.
- butterfly, evolute connectors, 337,
- chain or basket, ills., 1,256.
- chord, described, 247.
- coil, bedding of, ills., 218,
- single phase, ills., 1,222,
- straight out former, 344.
- concentrated armature coil, 1,214,
- connected to equalizer rings, 254,
- connectors, evolute, 336,
- involute, 336.
- creeping, 1,260, 1,261.
- distributed alternator coil, 1,218,
- double, 243,
- drum, condition of, 239.
- duplex, 249.
- edge strip of, ills., 216,
- evolute coils, method of, ills., 343,
- fed-in armature coil, 1,258,
- field, of dynamo, choice of, 392,
- half coil concentrated, ills., 1,216,
- hand of, 336.
- hemitropic, 1,214.
- imbricated coil, 1,259.
- lap, developed view of, ills., 239,
- drum, 235,
- for bipolar machine, ills., 240,
- illustrated, ills., 236, 342,
- left and right hand, ills., 251.
- magnet, of bell, propor., 2,363.
- multi-coil alternator, 1,218,
- multiplex, 247-249.
- multi-slot coil, 1,230.
- mummified coil, 1,259.
- parallel, 235.
- paths in cord, 247.
- primary induction coil, 140,
- requirements, drum, 255.

Windings.—Continued.

- ring, 225,
- developed view of, ills., 233,
- series, drum, 241, ills., 362,
- short and back pitch, ills., 246.
- shunt, of motor, ills., 362,
- pressure applied through, 194.
- shuttle, armature coil, 1,260,
- Siemens' ills., 226, 245, 246,
- simplex, wave, ills., 242,
- single, coil, 1,230,
- phase alternator, 1,233.
- six phase, ills., 1,133,
- skew, ills., 1,258,
- spiral, ills., 1,259,
- straight out coils, ills., 345, 346,
- strap coil, arr., ills., 1,231,
- symmetrical, 240,
- three phase, lap, ills., 1,248,
- wave, ills., 1,249.
- transformer, 2,053,
- triplex, 149.
- turbine alternator, ills., 1,263.
- twelve phase, ills., 1,134.
- two phase whole coil, ills., 1,236,
- wave, developed view of, ills., 243,
- ills., 342,
- progressive, ills., 248,
- retrogressive, ills., 249,
- simplex re-entrant, 252,
- whole coil ills., 1,214-1,216, 1,236.
- Windmill, electric, ills., 9, 10.
- Wire(s), annealing, 3,132.
- bell, how concealed, 2,382,
- crossed, 2,396, ills., 2,397,
- locating break in, ills., 2,398,
- varieties of, 2,381,
- braided cotton covered, 726.
- broken held by insulation, 616.
- brushes, 304.
- calculations, 1,901.
- charged, corona effect, 1,894,
- dir., of magnetic field, ills., 114,
- near compass needle, ills., 431,
- spacing, 1,896.
- conductors insulated, 724.
- copper, annunciator work, 2,392,
- conductors, 799. 2,733,
- current capacity table, 3,149.
- Matthiessen's stan., 722, 723,
- miscellaneous formula, 1,906,
- properties of, 749.
- resistance of, 28,
- standard, 722, 723, 734,
- soldering flux, 3,083.
- tensile strength of, 800,
- vibration effect, 60.
- cotton covered inflammable, 726,
- crossing of, ills., 768,
- drip loop, ills., 773,
- duplex covered, ills., 70,
- eddy currents in, 1,066.
- electro-plating, kind for, 3,149,
- feeder, installed on walls, 772,
- outlet taps for, ills., 778.
- fire and weatherproof, ills., 728,

Rogers Machinists Guide \$2.

*An hour with a book would have brought to your mind,
The secret that took the whole year to find;
The facts that you learned at enormous expense,
Were all on a library shelf to commence.*

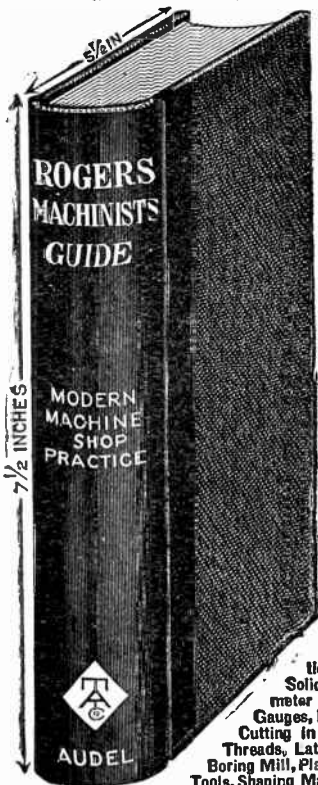

COVERS modern shop practice, thoroughly teaching you in plain language to get ready for better chances ahead.

672 Pages
700 Illustrations
1800 References

Handsomely bound in navy blue cloth with leather back, printed on fine paper in large type. In every way a generously good book.

PART 1.

Materials and their Properties, Metals, Alloys, Gravity Laws, Strength of Materials, Table of Melting Points, Weights and Measures Linear, Square, and Solid Units and Tables, Free Hand Drawing, Section Lining, Dimensioning, How to Read Working Drawings, Geometrical Drawing, Gear Wheels, Various Gears, Designing, Tempering and Hardening Metals, Case Hardening, Annealing, Vise and Bench Work, Tools, Methods of Drilling, Drifting, Screw Cutting, Taps, Dies, Pipe Threading Tools, Lath Tools, Mandrels, Centering, Planing, Turning, Lathe Speed, Chuck and Face Plate Work, Boxing, Various Tables.

PART 2.

Arithmetic, Square Root, Involutions, Metric System, Mensuration, Solids Measuring Machines, Micrometer Devices, Outside and Inside Gauges, Drill Gauges, The Vernier, Screw Cutting in the Lathe, Chasers, Internal Threads, Lathe Gears, Index Plate, Boring, Boring Mill, Planing Machines, Cutting Angle of Tools, Shaping Machines, Slotting Machines, Milling Machines, Dividing Head, Speed of Cutters, Milling Operators, Drilling Operators, Speed of Drills, Emery wheels, Methods of Grinding, Punching and Shearing, Machine Bolt Cutting, Cutting off Machines, Arbor Press, Shaft straightening, Turret and Key Seating Machines, Dressing Tools, Block and Fall, Cranes, Grindstones, Shop Management, Piece Work, Organization Management, Equipment, Useful Recipes, Machinist's Tables, Extensive Index. **PRICE POSTPAID TO ANY ADDRESS. MONEY BACK IF NOT PLEASED.**

THEO. AUDEL & CO., Publishers,
72 FIFTH AVENUE, NEW YORK

\$2

"ON INDICATOR CARDS," \$1

Tells You How to Use an Indicator for Economical and Correct Steam Engine Operation, Written so You Can Understand.

THIS work is designed for the use of Erecting and Operating Engineers, Superintendents and Students of Steam Engineering, explaining, as it does, the economical use of steam.

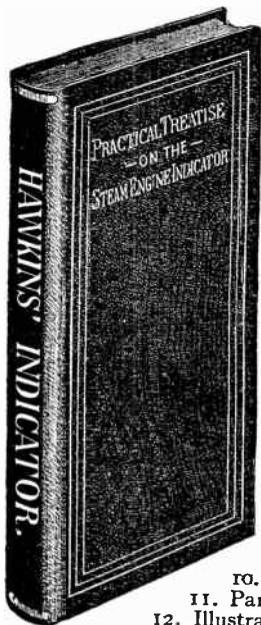

This knowledge is necessary to the engineer, and constitutes a stepping-stone toward promotion or better conditions.

The following is a general outline of the subjects defined, fully illustrated, and presented most helpfully in the book:

1. Preparing the Indicator for Use.
2. Reducing Motions.
3. Piping up Indicator.
4. Taking Indicator Cards.
5. The Diagram.
6. Figuring Steam Consumption by the Diagram.
7. Examples of Diagrams.
8. Description of Indicators.
9. Measuring Diagram by Ordinates.
10. Planimeters.
11. Pantagraphs.
12. Illustrated with cards taken from practical everyday use, with clear and valuable lessons drawn from the diagrams; such as showing whether the valves are properly set or not.
13. Tables.
14. Ready Reference Index.

The book is handsomely bound in cloth, with titles and edges in gold, and is uniform in style with Hawkins' other books. Price \$1 Postpaid.

ENGINEERS' EXAMINATIONS, \$2

**These Questions and Answers Will Help You
Get Your Engineer's License.**

This work is an important aid to engineers of all grades, and is undoubtedly the most helpful ever issued relating to a safe and sure preparation for examination. It presents in a condensed form the most approved practice in the care and management of Steam Boilers, Engines, Pumps, Electrical and Refrigerating Machines.

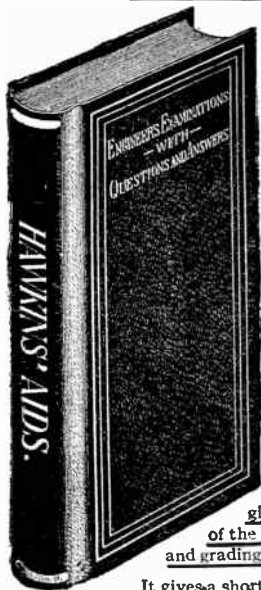

It gives plain rules of arithmetic, with examples of how to work the problems relating to the safety valve, strength of boilers and horse power of the Steam Engine and Boiler.

The main subjects treated, upon which is given detailed information with questions and answers, are as follows:

The Steam Boiler, Boiler Braces, Incrustation and Scale, Firing of Steam Boilers, Water Circulation in Boilers, Construction and Strength of Boilers, The Steam Engine, Engine and Boiler Fittings, Pumps, The Injector, Electricity and Electric Machines, Steam Heating, Refrigeration, Valve Setting, etc.

It contains numerous rules, regulations and laws of large cities for the examination of boilers, and the licensing of engineers, and the laws and regulations of the United States for the examination and grading of all marine engineers.

It gives a short chapter on the "Key to Success" in obtaining knowledge necessary for advancement in engineering. **This is a very important section.**

The book gives the underlying principles of steam engineering in plain language, with many sample questions and answers likely to be asked by the examiner.

This indispensable volume contains 200 pages of valuable information not elsewhere obtainable; it is bound in rich red leather, with full gold edges and titles. Handy to go in your pocket.

Price \$2 postpaid. Money refunded if not satisfactory.

Refrigeration Machinery \$2.

THIS helpful book will tell you in plain language all about the theory, construction, care and operation of an **ICE OR REFRIGERATING PLANT** of any type or capacity.

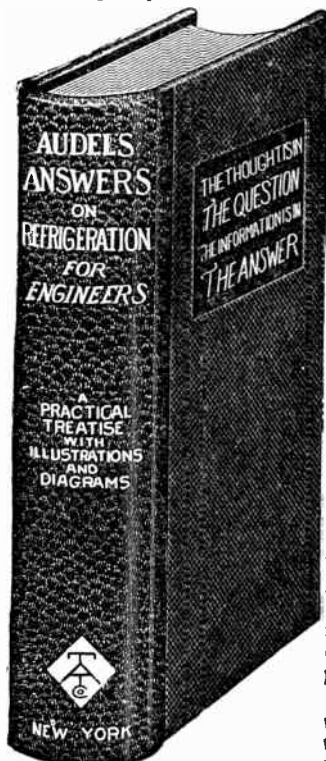

It is a Complete Analysis of the Subject; an Easy Guide for Study; A Ready Reference.

The subjects are arranged in convenient form of "QUESTIONS and ANSWERS," thus giving in plain language information for successfully and economically operating a plant.

It gives the latest improvements in established applications on refrigeration; the practical handling of the machines and apparatus, together with useful and **VALUABLE DATA** regarding the manufacture of ice; and the preservation of food products.

The 250 illustrations and descriptive diagrams (of which nearly 100 are full page) are explicit, and a valuable aid to a full comprehension of the science of refrigeration; contains **700 pages**, durably bound in half leather, delivered to any address, upon receipt of **PRICE \$2.**

PUMPS AND HYDRAULICS (IN TWO PARTS), \$3

These Two Volumes Written so You Can Understand. Contain Practical Information on the Construction, Care and Management of all Types of PUMPS AND PUMPING MACHINERY, also Explaining the Complete Science of Hydraulics and Hydraulic Machinery. Give full Instructions in Valve Setting and are also a Mine of Up-to-Date Valuable information, illustrated with nearly 700 illustrations.

It is with pleasure we call your attention to this recent publication on pumping machinery. This work, issued under the title of "ROGERS' PUMPS AND HYDRAULICS," is a complete and practical hand-book, treating on the construction, operation, care and management of pumping machinery; the principles of hydraulics being also thoroughly explained. The work is illustrated with cuts, diagrams and drawings of work actually constructed and in operation; the rules and explanations of the examples shown are taken from every day practice. No expense has been spared in the endeavor to make this a most helpful instructor on the subject, useful to all pump attendants, engineers, machinists and superintendents.

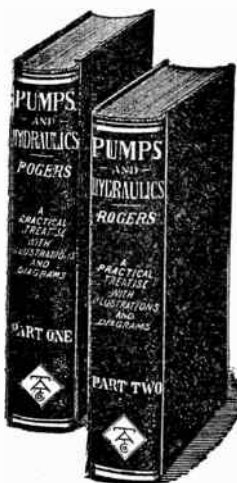

Part One The divisions of Part One are represented by the following headings: each subject is fully treated and illustrated:

Pump and Hydraulic Terms; Historical Introduction; Elementary Hydraulics; Flow of Water Under Pressure; Water Pressure Machines; Water Wheels; Turbine Water Wheels; Turbine Pumps; Water Pressure Engines; Hydraulic Motors; Hydraulic Apparatus; Hydraulic Jack; Hydraulic Press; Hydraulic Accumulator; Hydraulic Ram; Pumps as Hydraulic Apparatus; Classification of Pumps, Hand Pumps; Power Pumps; Belled Pumps; The Electric Pump; The Steam Pump; The Duplex Pump; Underwriter Fire Pumps; Specifications of the National Board of Fire Underwriters relating to the Duplex Fire Pumps, etc., etc.

Part Two The divisions of Part Two are represented by the following headings: each subject is fully treated and illustrated:

Introduction to Part Two; The Air Pump; Air and Vacuum Pumps; Air Compressors; The Air Lift Pump; The Steam Fire Engine; Miscellaneous Pumps; Mining Pumps; Marine Pumps; "Sugar-House" Pumps; Circulating Pumps; Atmospheric Pumps; Ammonia or Acid Pumps; The Screw Pump; Aermotor Pumps; Rotary and Centrifugal Pumps; Turbine Pumps; Injectors and Ejectors; Pulsometer Aqua-Thruster; Pump Speed Governors; Condensing Apparatus; Utilities and Attachments; Tools, Valves and Pipes; Pipes, Joints and Fittings; Useful Notes, Tables and Data, etc., etc.

HANDY READY REFERENCE INDEX.

These books are in every way up to date. The two volumes contain nearly 900 pages, strongly and handsomely bound. Price \$3. postpaid.

HAWKINS' MECHANICAL DICTIONARY \$2

This volume is the most useful book in Mechanical Literature. If constantly referred to will enable the

student to acquire a correct knowledge of the words, terms and phrases in use in Mechanical Engineering and its various branches.

Its great value lies in this: that no man representing the mechanical profession can find excuse for not knowing the use and meaning of the terms used in his work.

Hawkins' Mechanical Dictionary

explains and defines in plain language the use of words and terms now used or heretofore used in the **Mechanic Arts, Trades and Sciences.**

It is an unequalled reference work, and is the one book of permanent value no student or expert should dispense with. Complete from A to Z. Highly endorsed. Price, \$2. postpaid.

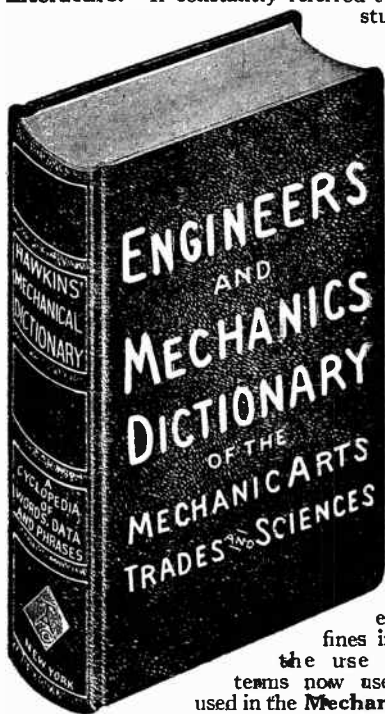

AUDELS ANSWERS ON Practical Engineering

When you spend your good hard earned money for books, always make sure that you are going to receive something that will assist you in bettering your position.

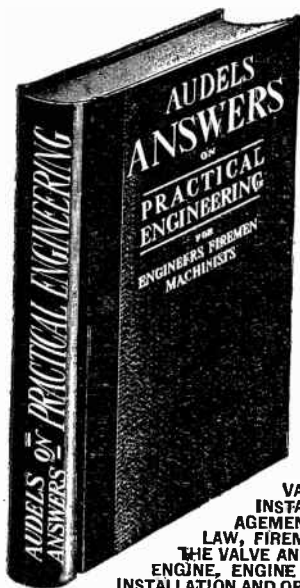

THIS book deals largely with the foundation principles which govern the practice of steam engineering. Nothing so soon condemns the applicant as want of knowledge of the every day practice and simple laws relating to the care and management of a steam plant.

No one is expected to know everything, but all are required to be familiar with certain facts which may be called "the beginning of things."

The lack of knowledge of the small things carries conviction of the same lack in the larger.

Plain facts, that you should know, are plainly explained in **AUDELS ANSWERS ON PRACTICAL ENGINEERING,** answering your questions on

AIR, WATER, STEAM, FUEL AND HEAT, STEAM BOILERS, BOILER CONSTRUCTION, WATER TUBE BOILERS, THE STEAM GAUGE, THE SAFETY VALVE, PROPERTIES OF STEAM, INSTALLATION OF BOILERS, MANAGEMENT OF BOILERS, ENGINEERS' LAW, FIREMEN'S LAW, STEAM ENGINES, THE VALVE AND VALVE GEAR, THE CORLISS ENGINE, ENGINE ARITHMETIC, LUBRICATORS, INSTALLATION AND OPERATION OF ENGINES, STEAM PUMPS, INJECTORS, FEED WATER HEATERS, STEAM HEATING, STEAM TRAPS, BELTS, GEARS AND PULLEYS, STEAM TURBINES, REFRIGERATION, PRACTICAL ELECTRICITY, ELEVATORS.

Understand the framework of which your works but a cross bar. Know something of the cause of which your work is but an effect. Know something of the effect of which your work is the cause. And, above all, know why it is done one way and not another.

LEARN THE THEORY UNDERLYING THE WORK.

Practical Engineering contains 288 pages fully illustrated, handsomely bound and printed and is in every way a first class book.

**PRICE POSTPAID TO ANY ADDRESS,
MONEY BACK IF NOT PLEASED.**

**THEO. AUDEL & CO., Publishers,
72 FIFTH AVENUE, NEW YORK.**

\$1

AUTOMOBILE GUIDE \$1.50

LATE—CONCISE—PRACTICAL

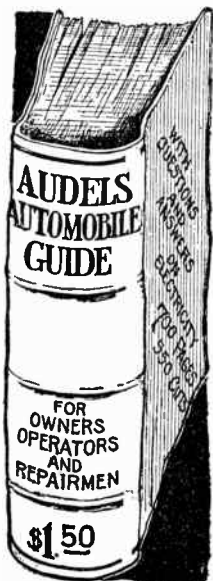

THE object of this book is to give, in the easiest understood form, the information necessary for the proper operation, care and maintenance of an automobile.

To adapt the book to many needs the subject matter is presented in the form of questions and answers. Technical terms are explained or made clear by the wording of the answer, which is always brief and direct.

Any one of the definite chapters on Carburettors, Ignition, Gas Engine Operation, How to Run an Automobile, Overhauling the Car, Battery Troubles, or Starting and Lighting Systems, are alone worth the price asked for the 30 complete chapters contained in this book of 700 pages, illustrated by 550 illustrations.

The form and size are such that it is convenient to handle and study.

This book is a self-educator, hence, "He who runs may read" and improve his present knowledge of automobile engineering and proficiency.

**A GOOD BOOK FOR OWNERS, OPERATORS AND
MACHINIST—OR INTENDING PURCHASER.**

HAWKINS PRACTICAL LIBRARY OF ELECTRICITY

IN HANDY POCKET FORM

PRICE, \$1 EACH

They are not only the best, but the cheapest work published on Electricity. Each number being complete in itself. Separate numbers sent postpaid to any address on receipt of price. Catalog of series will be mailed free.

GUIDE No. 1 Treating on electrical signs and symbols—static and current electricity—primary cells—conductors and insulators—resistance and conductivity—effects of the current—magnetism—electro-magnetic induction—induction coils—dynamo principles—classes of dynamo—field magnets—Armatures—armature windings—armature theory—commutation and the commutator—brushes and the brush gear—armature construction.

GUIDE No. 2 Motor principles—armature reaction in motors—starting a motor—motor calculations—brake horse power—selection and installation of dynamos and motors—performance curves—location—foundation—belts—auxiliary machines—Galvanometer—standard cells—current measurement—resistance measurement—Christie bridge—testing sets—loop tests—potentiometer—armature voltmeter and wattmeter—multipliers—electro-dynamometers—demand indicators—watt hour meters—operation of dynamos—lubrication—troubles—coupling of dynamos—armature troubles—care of commutator and brushes—heating—operating of motors—starters—speed regulators.

GUIDE No. 3 Distribution systems—boosters—wires and wire calculations—inside, outside, and underground wiring—wiring of buildings—sign flashers—lightning protection—storage battery—rectifiers—storage battery systems.

GUIDE No. 4 Alternating current principles—alternating current diagrams—the power factor—alternator principles—alternator construction—alternator windings.

GUIDE No. 5 Alternating current motors—synchronous and induction motor principles—construction of alternating current motors—A. C. commutator motors—power factor of induction motors—transformers—transformer losses—transformer construction—transformer connections—transformer tests—converters—rectifiers—alternating current systems.

GUIDE No. 6 Transformation of phases—switching devices—circuit breakers—relays—lightning projector apparatus—regulating devices—synchronous condensers—indicating devices—meters—power factor indicators—Wave form measurement—switchboards.

GUIDE No. 7 Alternating current wiring—properties of copper wire power stations—power station calculations—turbine practice—management—embracing: selection, location, erection, testing, running, care and repair—telephones.

GUIDE No. 8 Telegraph—simultaneous telegraphy and telephony—wireless—electric bells—electric lighting—photometry.

GUIDE No. 9 Electric railways—electric locomotives—car lighting—trolley car operation—miscellaneous applications—motion pictures—gas engine ignition—automobile self-starters—and lighting systems—electric vehicles.

GUIDE No. 10 Elevators—cranes—pumps—air compressors—electric heating—electric welding—soldering and brazing—industrial electrolysis—electro-plating—electro-therapeutics, X-rays, etc. This number contains a complete ready reference index of the complete library.

Theo. Audel & Co., Publishers.

**72 FIFTH AVENUE,
NEW YORK**

