

TELEVISION

FEBRUARY, 1950

ENGINEERING



*Inspector of complete electron guns
produced for TV picture tubes.*



OF THE *Cathode-Ray* TUBE!

The HAYDU Electron Gun

Efficient mass production of today's cathode-ray picture tubes has been one of the outstanding contributors to the phenomenal growth of this new American industry. But no amount of production skill could have made this possible without the precise standardization of tube components such as the gun mount.

Haydu Brothers has made its contribution through the manufacture of more than ONE-THIRD MILLION electron guns, those all-important precision components which are the key to the cathode-ray picture tube — the heart of the television industry.

Look for the rugged, 3-pillar construction, and the imprint, "HB," the identifying mark of superior electron guns.

- A few of our many satisfied customers include:
- Capehart-Farnsworth Corp. Ft. Wayne
 - Tel-O-Tube Corp. Paterson
 - Thomas Electronics, Inc. Passaic
 - National Video Corp. Chicago

Be sure to see our exhibit at
I. R. E. SHOW
BOOTH 318
Grand Central Palace
March 6-9



HAYDU BROTHERS

PLAINFIELD • NEW JERSEY

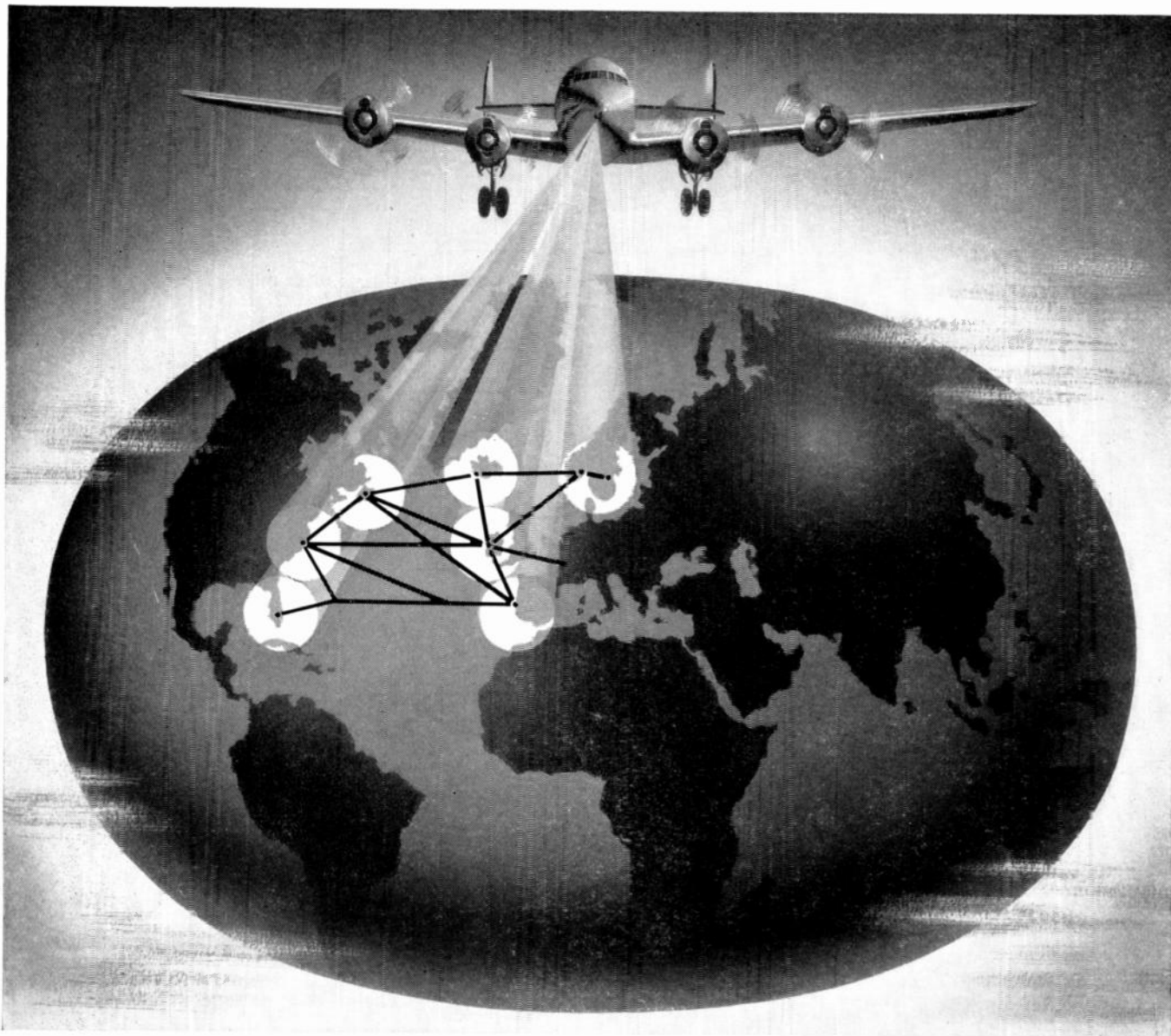

WILCOX ...First Choice for Transatlantic Airline Communication

The whirling propellers of the international airlines make daily mockery of the vast space of the Atlantic Ocean. Intercontinental passengers and cargo come and go hourly at New York, Miami, Gander, Shannon, Ireland, and Lisbon, Portugal. These European and American airports are equipped with modern long-range, multichannel WILCOX Transmitters.

Oslo, Norway, and Stockholm, Sweden, use WILCOX Transmitters as basic communications

equipment, and radio beacon service is provided at Reykjavik, Iceland, by WILCOX Type 96-200 Transmitters.

Thus, the giant airliners of the world's major airways are protected in flight and guided safely to the runways of Europe's and America's principal ports of entry.

WRITE TODAY...for complete information on air-borne, ground station, point-to-point, or shore-to-ship communications equipment.



WILCOX ELECTRIC COMPANY
KANSAS CITY MISSOURI

TELEVISION ENGINEERING

Including Radio Engineering, Communications and Broadcast Engineering. Registered U. S. Patent Office.

VOLUME 1

FEBRUARY, 1950

NUMBER 2

Quality Control in TV Receiver Production.....	<i>L. Lutzker</i>	6
<small>Statistical Techniques, Using P and C Type Control Charts and Sampling Inspection, Found to Reduce Costs About 25% and Expedite Location of Trouble Areas Throughout Plant.</small>		
Application of Germanium Diodes in Veryhigh and Ultrahigh TV Sets	<i>J. H. Sweeney</i>	10
<small>Properties of Passive Elements Which Must Be Evaluated for Video Detector and DC Restorer Circuitry.</small>		
Principles of FM Detection.....	<i>Herbert J. Scott</i>	12
<small>Simplified Analysis of Requirements Which Must Be Met in Order That Detection May Take Place in Any FM System.</small>		
TV Tube Developments.....		14
<small>Installation and Circuitry Requirements of Wide Angle 16-Inch Rectangular and Circular Picture Tubes.</small>		
Mass Processing of TV Picture Tubes.....		17
<small>Procedure and Equipment Required to Produce at 1000-a-Day Rate.</small>		
Going on the Air With the Last TV Channel.....	<i>Ira Kamen</i>	18
<small>Results of Viewing Survey of WOR-TV, the Last Station to Go on the Air in New York City, Discloses That Many Pickup Problems Prevail at Receivers Installed and Adjusted for Other Channels Placed on the Air Prior to Inauguration of New Station.</small>		
TV Camera Tube Design.....	<i>Allan Lytel</i>	22
<small>Part II . . . Operation of Iconoscope Mosaic . . . Keystoning . . . Shading Signals . . . Low Resolution Pickups, etc.</small>		
A Line Equalizer.....	<i>Herbert G. Eidson</i>	26
<small>Loop Equalizer, Employing Parallel Anti-Resonant Circuit Providing Choice of 5 and 10 kc Peaks, Permits Equalization of Telephone Loops for Remote, Program Loops, etc.</small>		
Network Feeding From a Small Station.....	<i>Elliott Full</i>	31
<small>Novel Audio Facilities Developed by Low Power Station to Provide Comparatively Good Quality Signals on Schedule D Type Lines.</small>		

MONTHLY FEATURES

Viewpoints	<i>Lewis Winner</i>	5
TV Tube Developments.....		14
Instrument News		28
TV Parts and Accessory Review.....		33
TV Sound Activities.....		33
Veteran Wireless Operators' Association News.....		34
Personals		35
Industry Literature		35
Briefly Speaking.....		40
Advertising Index		40

Cover Illustration

Final inspection of TV picture-tube electron guns, where each glass stem is checked for stresses and strains. *(Courtesy Hayden Brothers)*

Editor: LEWIS WINNER



Published monthly by Bryan Davis Publishing Co., Inc., 52 Vanderbilt Avenue, New York 17, N. Y. Telephone: MURRAY Hill 4-0170.

Bryan S. Davis, President. Paul S. Weil, Vice-Pres.-Gen. Mgr. Lewis Winner, Editorial Director. F. Walen, Secretary. A. Goebel, Circulation Manager.

Eastern Representative: J. J. Brookman, 52 Vanderbilt Avenue, New York 17, N. Y.
 East-Central Representative: James C. Munn, 2253 Delaware Drive, Cleveland 6, Ohio. Telephone: ERievew 1726.
 Pacific Coast Representative: Brand & Brand, 1052 West 8th Street, Los Angeles 14, Cal. Telephone: Michigam 1732.
 Suite 1204, Russ Building, San Francisco 4, Cal. Telephone: SUTter 1-2251.

Entered as second-class matter October 1, 1937 at the Post Office at New York, N. Y., under the act of March 3, 1879. Subscription Price: \$3.00 per year in the United States of America and Canada; 50c per copy. \$4.00 per year in foreign countries; 60c per copy.

Té Aro Book Depot: Wellington, New Zealand. McGill's Agency: Melbourne, Australia.

TELEVISION ENGINEERING is indexed in the Engineering Index.
 Entire Contents Copyright 1950, Bryan Davis Publishing Co., Inc.

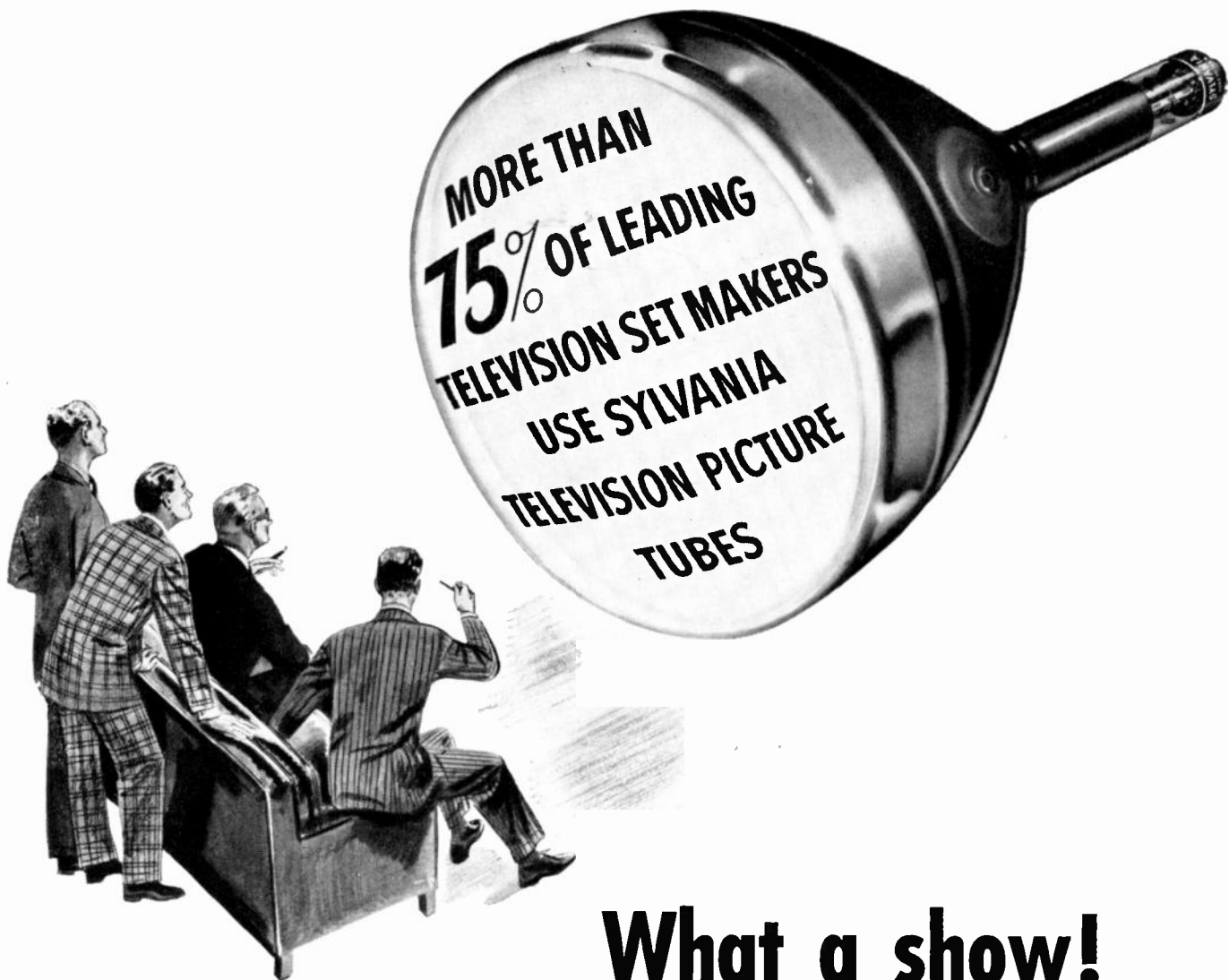

What a show!

A recent intensive survey discloses that among the major television set manufacturers, more than 75% use Sylvania cathode ray tubes!

This impressive showing is a tribute to the research and quality production techniques employed by Sylvania in the making of picture tubes that are unsurpassed.

If you wish full information about the entire Sylvania line of television picture tubes made by the manufacturers of highest quality radio tubes and electronic equipment, write Sylvania Electric Products Inc., Dept. R-2602, Emporium, Pa.

These leading television set manufacturers use Sylvania Television Picture Tubes

Admiral • Air King • Andrea • Ansley • Automatic
 Bendix • Crosley • DeWald • Emerson • Fada
 Farnsworth • Garod • Hallicrafters • Hoffman
 Magnavox • Midwest • Motorola • National • Olympic
 Packard-Bell • Philca • Pilot • Raytheon-Belmont
 Regal • Scott • Sentinel • Silvertone • Sperton
 Stromberg-Carlson • Tele-King • Tele-tone • Temple
 Trav-ler • Westinghouse

SYLVANIA ELECTRIC

CATHODE RAY TUBES; RADIO TUBES; ELECTRONIC DEVICES; FLUORESCENT LAMPS, FIXTURES, WIRING DEVICES, SIGN TUBING; LIGHT BULBS; PHOTOLAMPS

Before Any Other Consideration

Integrity of Circulation

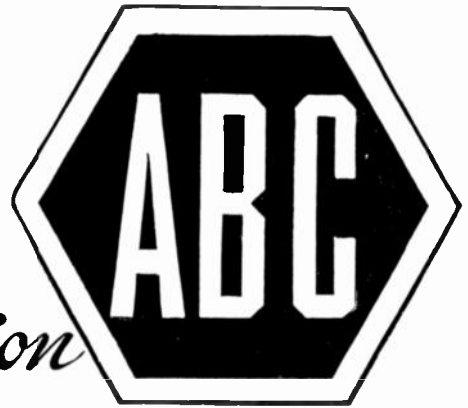

OF THE several factors that enter into the use of published media, the distribution of the advertisers' sales messages, as governed by the selection of media, can of itself decide the success or failure of the advertising investment. That is why integrity of circulation is the first consideration with experienced space buyers.

The emblem shown above stands for the FACTS that make it possible for advertisers to select the right media and to know what they get for their money when they invest in publication advertising. It is the emblem of membership in the Audit Bureau of Circulations, a cooperative and nonprofit association of 3300 advertisers, agencies and publishers.

Working together, these buyers and sellers of advertising have established standards for circulation

values and a definition for paid circulation, just as there are standards of weight and measure for purchasing agents to use in selecting merchandise and equipment. In other words, A.B.C. is a bureau of standards for the advertising and publishing industry.

A.B.C. maintains a staff of specially trained auditors who make annual audits of the circulations of the publisher members. Information thus obtained is issued in A.B.C. reports for use in buying and selling space. All advertising in printed media should be bought on the basis of facts in these reports.

This business paper is a member of the Audit Bureau of Circulations because we want our advertisers to know what they get for their money when they advertise in these pages. Our A.B.C. report gives the facts. Ask for a copy and then study it.

SOME OF THE AUDITED INFORMATION

IN A.B.C. BUSINESS PAPER REPORTS

SEND THE RIGHT MESSAGE TO THE RIGHT PEOPLE

Paid subscriptions and renewals, as defined by A.B.C. standards, indicate a reader audience that has responded to a publication's editorial appeal. With the interests of readers thus identified, it becomes possible to reach specialized groups effectively with specialized advertising appeals.

- How much paid circulation.
- How much unpaid circulation.
- Prices paid by subscribers.
- How the circulation was obtained.
- Whether or not premiums were used as circulation inducements.
- Where the circulation goes.
- A breakdown of subscribers by occupation or business.
- How many subscribers renewed.
- How many are in arrears.



COMMUNICATIONS

A.B.C. REPORTS — FACTS AS THE BASIC MEASURE OF ADVERTISING VALUE

February, 1950

The Freeze Blockade

WITH THE SEVEN appraisers of TV's future scheduled to re-enter, perhaps the final and *harmonious* phase of the hearings, and begin probing the all-important allocation situation, the original intent of the sessions, there is a fervent hope on all fronts that, that vital issue, the freeze, will once and for all receive the immediate attention it merits.

Over sixteen months in duration, the continued freeze has placed road blocks on too many avenues of activities. With the original reason for the freeze, interference between too-closely-spaced stations operating on the same channel, solved by a variety of technical developments of the last year, as the Ad Hoc and many other reports disclosed, there is bewilderment everywhere as to why this clamp remains, and precious time is devoted to other transmission projects. There is no denying that all the facets of the art should be scrutinized in a complete study, but when solutions to problems, originally posed as quite basic to the program, do come to a point of fruition, winning the acceptance of general industry, one becomes quite puzzled as to why these helpful, vital suggestions should be pigeon-holed.

The next few weeks in Washington should be quite revealing, offering perhaps a cue as to the formula for the days to come. All hope that the legislators will use the specific information disclosed in industry probes, revealing quite clearly why the road blocks should be discarded.

The recent TBA survey, among a group of ninety, is an illustration of the type of data available to the group of seven who control the destiny of the video art. Surveying operating stations and applicants and asking the question . . . Would you favor utilization of the assigned *uhf* band at this time for six-mc TV service to provide channels for a fully competitive service or would you prefer reserving some space in the assigned *uhf* band for continued experimentation in wider band TV . . . TBA learned that the majority preferred the reservation of space in the higher bands.

In another inquiry which asked . . . How many TV channels do you feel are required in each of the major market areas of the country to provide a fully competitive service . . . it was found that most preferred four or five depending on the number of networks available. The use of three, six, seven or eight to ten channels was not looked upon with too much favor by those polled.

The color situation was also included in the quiz with the question . . . Would you favor separation of the color issue from that of allocations by urging the FCC to set

standards broad enough within the six-mc band to encompass future improvements in image clarity and integration of color. The ayes were practically unanimous in reply to the query.

There are volumes of other vital statistics which could be used to answer those questions which appear to be so puzzling to our government representatives, detailing why that freeze blockade should be removed now.

Applause For the Kinescope

THAT COMPLEX PROBLEM of the TVcaster, involving interconnection, received a judicious analysis at the recent TBA clinic, by Paul Adanti of WHEN, Syracuse.

Said Adanti: "Interconnection is the magic word that opens doors to new business, breaks down buyer's resistance and most of all removes the psychological block that everyone, including even agency and network people, seem to have about the non-interconnected station. . . . There are several misconceptions that bear reconsideration in the light of present day TV. The greatest of these concerns that much maligned mainstay of the non-interconnected station, the kinescope. In '48 and early '49 the tube was worse, if that's possible, than some of the old relics of early sound movies. When we opened in December of '48, we ordered quite a few kinescopes but had to take them off a few weeks later. In the early spring of last year, however, somebody got the hypo out and things began to happen. The sound track stopped sounding like a vertical transcription being played with a lateral pickup head. Film densities became more uniform, but most important of all the picture fed to the tube, from which the film was being made, received a thorough going over. I'm not sure whether it was the use of the new orthicon, the increased attention to lighting, or the increased proficiency of all operating personnel that turned the trick, but the fact still remains that our live pictures are immensely better than they were just a few short months ago. . . . Television pictures today have regained the snap and quality they had in the early days of TV with a good iconoscope and with about 1500 candles of light. . . . Today it appears possible to achieve a fairly accurate facsimile of interconnected operation with kinescopes, but to do it requires the cooperation of the station and the networks, as well as, of course, the advertisers."

The picture tube appears to have really hit a golden peak.—L. W.

Quality Control in TV Receiver Production

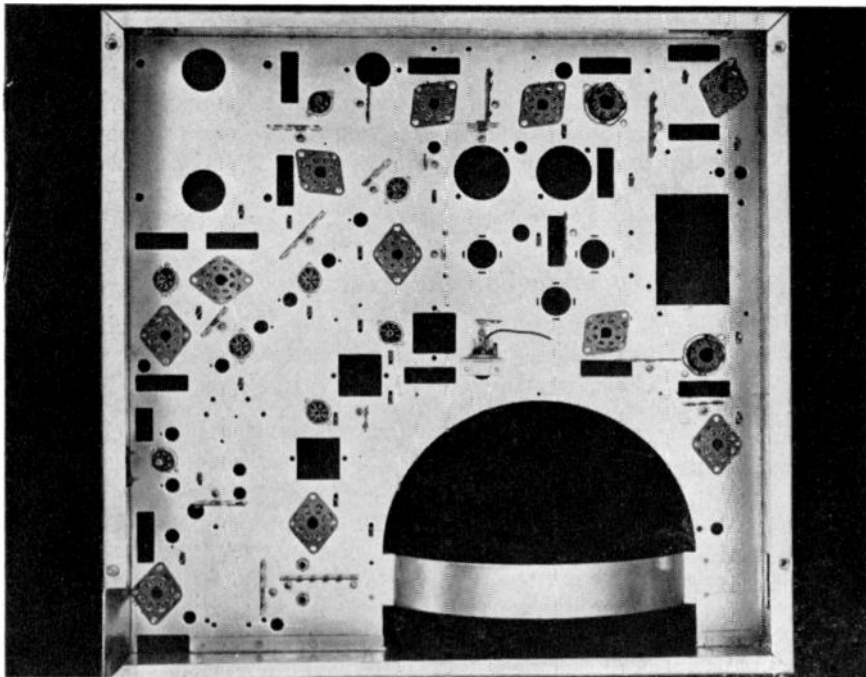

Figure 1

A bottom view of a television receiver chassis after it has passed through the riveting process.

Figure 2

A view of the area in which the chassis are riveted.



IN THE PAST, many industries have experimented with statistical quality-control techniques. Although many of the problems encountered in installing these techniques are common to most industries, there are always those specific situations, encountered in each industry, which require specialized consideration. In a study of quality control, at our plant, several unique factors presented themselves.

In the application of quality control in the *riveting section* of our television receiver manufacturing division, it was necessary, for instance, to determine what procedure would provide the most effective control over the quantity of radio tube sockets, terminal boards and miscellaneous parts which have to be riveted to a steel chassis.

The statistical technique that was chosen involved the use of the control chart for fraction defective, often called a *p* chart. This control chart is a graph of the fraction defective *p*, observed in consecutive samples of inspected items and the limits between which these fractions may vary, if the process is in control. A process can be said to be controlled when, through the use of past experience, it is possible to predict the limits within which the process may be expected to vary in the future. Predictions within limits means that a statement can be made about the approximate probability that the observed process will fall within the given limits.¹ These limits are called *control limits* and are based on the mathematics of probability.

Before use of the *p* chart was started, inspection results for the preceding month were analyzed for daily fraction defective. [Fraction defective has been defined as the ratio of the number of defective chassis found during inspection to the total number of chassis

¹Shewhart, W. A., *Economic Control of Quality of Manufactured Product*. D. Van Nostrand & Co., Inc., p. 6; 1931.

²Grant, E. L., *Statistical Quality Control*, McGraw-Hill Book Company, Inc., p. 254; 1946.

Use of Statistical Techniques Involving *P* and *C* Type Control Charts and Sampling Inspection Found to Reduce Inspection Costs About 25%, Provide Morale Assurance to Personnel Revealing the Extent of Their Quality Level and a Means of Detecting Trouble Rapidly, So Quality Products Can Be Made More Economically.

by **L. LUTZKER**, Quality Control Engineer, Allen B. DuMont Laboratories, Inc.

actually inspected.^{2]} The control limits for the chart were then determined from the following expressions and plotted on the chart:

$$\begin{aligned} \text{Upper Control Limit (UCL)} \\ &= \bar{p} + 3\sqrt{\bar{p}(1-\bar{p})/n} \\ \text{Lower Control Limit (LCL)} \\ &= \bar{p} - 3\sqrt{\bar{p}(1-\bar{p})/n} \end{aligned}$$

Where:

\bar{p} = the process average fraction defective.
 n = the number of chassis inspected in the sample; one sample per day in this case.

The process average-fraction defective and the control limits are computed in terms of decimals but, since it is easier for the average person to interpret per cent figures, these decimal values are usually converted to percentages for graphing.

Each morning the preceding day's results were charted and the progress of the chart discussed with the foreman of the riveting section. The chart was maintained for two weeks during which members of the production and inspection sections became acquainted with it. The process inspection supervisor then requested that the chart be changed from one showing percent defective units to one showing average number of defects per unit. Inasmuch as many of the defective units were rejected for more than one defect, it was felt that the chart for defects would reflect the cost of rejects more accurately than the chart for percent defective.

Our next procedure problem, concerned the possible use of a c^3 type chart. Before c chart could be applied, it was necessary to determine whether this chart was applicable from the viewpoint of statistical theory. The c chart is based on the *Poisson*^{2a} distribution which, in turn, is based on the premises that the opportunity for a given event to occur is very large, but that the likelihood of occurrence is very small. Thus, if the event is the occurrence of a defect in a manufactured product and the process is such that the

premises, on which the Poisson distribution is based, are satisfied, it is statistically correct to apply the control chart for defects.

As the data then being recorded included the number of defects found on each defective chassis, as well as the number of defective chassis found during the day's inspection, it was a simple matter to change from a p chart to a c chart.^{3a}

Following the change to the chart for defects per unit, the chart was posted near the riveting machines in full view of the operators. A history of the process during the first four months of operation with the c chart appears in Figure 3. Although the actual quality of the riveting did not improve, the

immediate effect of the control chart was to make the operators conscious of the high rate of defects produced. They began to correct the conspicuous defects before passing a chassis on for further processing.

The sharp reduction in defects reaching inspection between subgroups 30 and 40 indicate when the operators began to correct their own defects. The rise in the graph between subgroups 41 and 55 was due to a supply of defective material reaching the plant from a vendor. The material was not obviously defective and consequently passed by the operators.

The control chart for defects was continued for about six months. During this time, production had been rising steadily and the need for sampling inspection became more and more acute. The procedure followed in setting up the control sampling inspection involved three steps:

(1) A comprehensive list of defects for which the chassis could be rejected

^{2a}Molina, E. C., *Poisson's Exponential Binomial Limit*. D. Van Nostrand Co., Inc.; 1947.

³The c chart or control chart for defects is a graph of the defects per unit or number of defects observed in consecutive samples of inspected items and the limits between which the plotted points may vary if the process is in control.

^{3a}An excellent treatment of p and c charts, and their bases, appears in chapter 9, 10 and 31 of *Statistical Quality Control* by E. L. Grant.

Figure 3
A control chart of riveting inspection results for the first four months of operation with control charts.

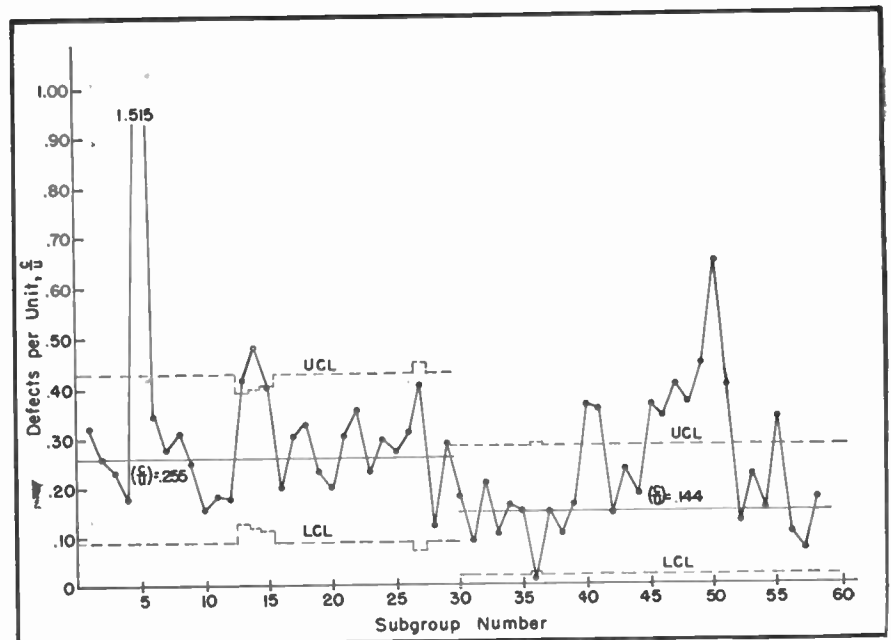

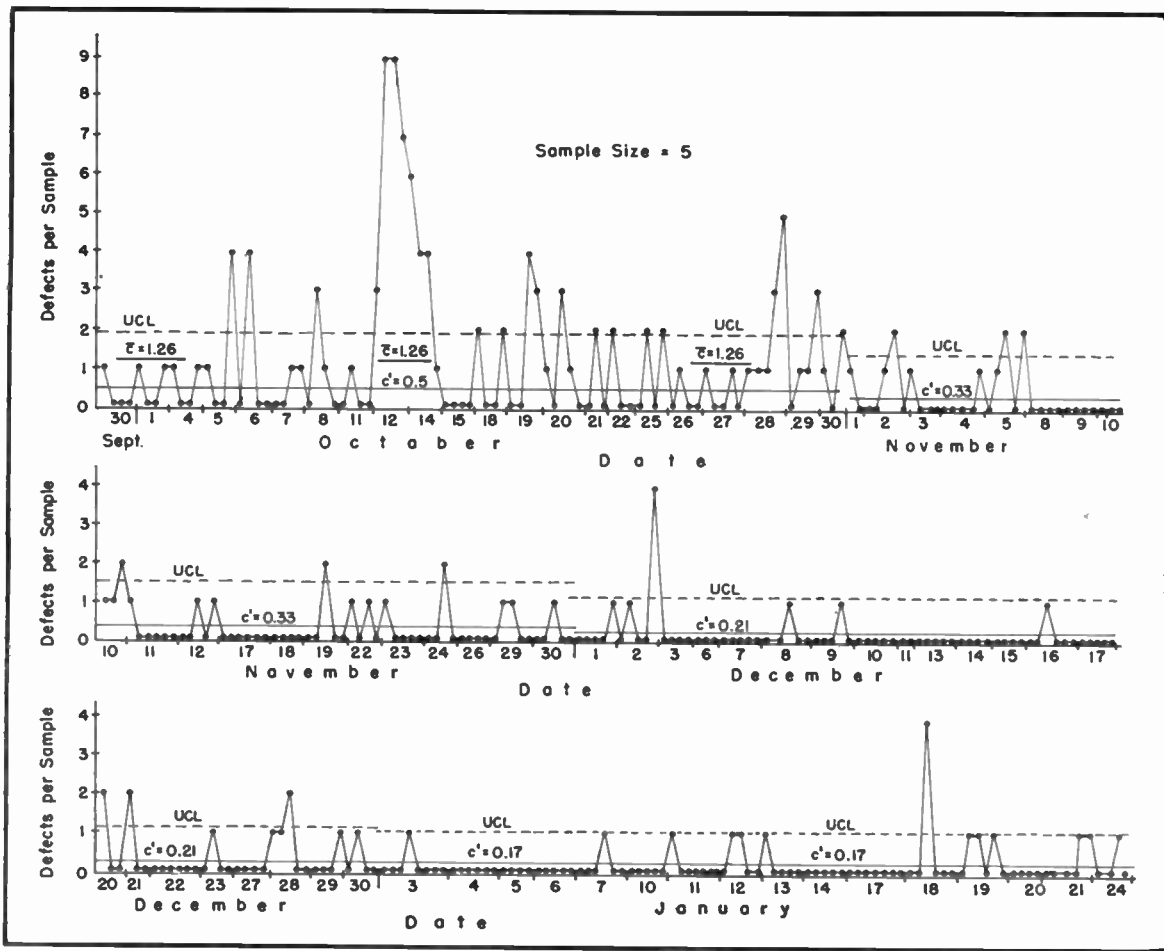

Figure 4
Control chart of riveting inspection results during the first four months of operation of control sampling and inspection.

was compiled and issued as a written inspection specification.

(2) A study was made of the physical layout of the process to determine a convenient sample size and the best way of taking the sample.

(3) A procedure was written for all parties concerned with the inspection. This included:

- (a) Description of how to take a sample
- (b) Sample size
- (c) Time interval between samples
- (d) Duties and responsibilities of all parties concerned with the functioning of the inspection and the searching for trouble when the control chart indicated a need for such action.

The preparation for the installation of control sampling was culminated in a meeting of the representatives of those sections which were going to put the plan in operation. Attending this meeting were the *production manager, methods manager and methods engineer, process inspection supervisor, factory inspection manager, factory engineer, foreman of the riveting line, and the riveting inspector.*

The meeting opened with a lecture and demonstration on control sampling.

utilizing the control chart for defects. Each man's responsibilities were then reviewed and the meeting was concluded with a group discussion of the system and its operation. After the meeting, the managers of *production, methods, and factory inspection* indicated their approval of the procedure written by countersigning it. The next day, the procedure was formally issued and control sampling inspection went into operation. In *appendix II* appears a copy of the original procedure written. Since the promulgation of this procedure, the forms have been revised for use with other applications of the *c* chart.

A history of the riveting inspection results for the first four months of operation under control sampling inspection appears in Figure 4. Control limits were calculated from the expressions:

$$UCL = \bar{c} + 2\sqrt{c}$$

$$LCL = \bar{c} - 2\sqrt{c}$$

Where:

\bar{c} = process average defects per sample.
 σ = standard deviation of the distribution on which the *c* chart is based and is equal to \sqrt{c} .

The 2σ limits were used since experi-

ence had indicated that production personnel were slow in seeking trouble when the control chart indicated the need for such action. To speed the elimination of trouble from the process, tighter limits were placed on the control chart.

Control sampling had hardly begun when trouble struck. Most of the difficulty could be traced to one part, a moulded miniature tube socket. The sockets were apparently satisfactory when they were inspected at incoming inspection, but during the riveting process the pine of the socket had a tendency to fall out. Incoming inspection was alerted and proceeded to give this material a much more rigorous test than had hitherto been the practice. In addition, the vendor was notified and asked to correct the difficulty. Another important cause of defects was the inexperience of newly hired operators. Missing and incorrectly positioned parts helped to account for the sharp rise in defects observed during the months of October as the plot shows.

When it was found that the established procedure was not functioning as intended, the *manufacturing manager*⁴ decided to call a meeting of those

who had attended the lecture-demonstration. A plan of attacking the trouble was outlined and periodic conferences scheduled until the situation could be brought under control.

The results of the action taken as a consequence of those conferences are illustrated in Figure 4. It will be noted that a steady improvement in quality began to appear in the following months of November, December and January. When the line ran out of control a second time, the conference method was used again with success. Though the responsibilities outlined in the procedure were not changed, it was found that calling the conferences accelerated the elimination of trouble.

High Producer's Risks

As the process continued to improve after November, it became apparent that the upper control limit was going to fall below 1 defect per sample. This, it was felt, would result in a high producer's risk. Producer's risk may be defined as the probability that a sample, coming from a lot having the same number of defects per unit as the value of the process average defects per unit, will yield a number of defects in excess of the upper control limit or less than the lower control limit. Since such a sample is out-of-control and the cause is usually sought in such a case, a high producer's risk would result in a high cost of unnecessary troubleshooting.

An investigation of the probabilities of points out-of-control at various process averages indicated that 2σ control limits were unsatisfactory, since they resulted in abnormally high producer's risks at low process averages when small sample sizes were used. The decision was made to use control limits that confined the producer's risk between .02 and .05. This would mean that production would not be searching for trouble which did not exist more than 5% of the time. To facilitate the assignment of control limits for a process, a procedure was written describing the method of arriving at the proper control limits. Accompanying this procedure was a table of process averages with corresponding control limits.⁵

Sampling Inspection Results

The original intention in installing control sampling inspection was to cut inspection costs and still maintain a

⁵At Du Mont, the manufacturing manager coordinates the activities of production, inspection and engineering design and development.

Figure 5
Standard forms QC-c-6 and QC-c-6a used for tabulating data gathered from inspection for defects; form QC-c-6 being used when the list of defects is long, and form QC-c-6a used when the list of defects is short.

check on the quality of the manufactured product. In addition to reducing the inspection cost to about 25% of what it had been just prior to the installation of sampling, we benefited from the by-products that usually accompany an application of statistical quality control. These included assurance to manufacturing personnel of what their quality level was, a tool for rapid detection of trouble, and last, but by no means least, improved quality. After the difficulties which occurred at the inception of control sampling had been eliminated, quality improved from a process average of .5 defects per sample of 5 to .17 defects per sample of 5. Today, control charts for defects are being applied to other points in the production line in an effort to produce a high quality television receiver economically.

⁵Procedure and table will appear in an early issue of TELEVISION ENGINEERING.

*Freeman, Friedman, Mosteller, and Wallis. *Sampling Inspection*. McGraw-Hill Book Company, Inc., p. 383; 1948.

**Shewhart, W. A., *Economic Control of Quality of Manufactured Product*. D. Van Nostrand & Co., Inc., p. 7; 1931.

****Ibid*, page 6.

APPENDIX I

Glossary of Terms

Assignable Cause: Cause of process variation of quality which, if sought out, may be eliminated without a fundamental change in the process.

Attributes, Inspection By: Inspection in which the characteristic of an item is not quantitatively measured but is classified as defective or non-defective.*

c chart: A graph of the defects per unit or number of defects observed in consecutive samples of inspected items and the limits between which the plotted points may vary if the process is in control.

Chance Cause: Any unknown cause of process variation.**

Control (as applied to a process): A process is said to be controlled when, through the use of past experience, we can predict the limits within which the process may be expected to vary in the future. Prediction within limits means that a statement can be made about the approximate probability that the observed process variation will fall within the given limits.***

Defect: "Any deviation from the requirements of the specification, drawing, contract, or order."* Also, any imperfection in a product which is considered undesirable from a consumer's viewpoint.

(Continued on page 37)

Figure 6
Forms QC-c-2 and 2a used for plotting and analyzing data gathered from inspection for defects. Form QC-c-2 is an Ozalid transparency used when the charts must be reproduced for distribution. Form QC-c-2a is a white print with a light grid and used directly on the production lines when one copy of the chart is sufficient.

Application of Germanium Diodes in

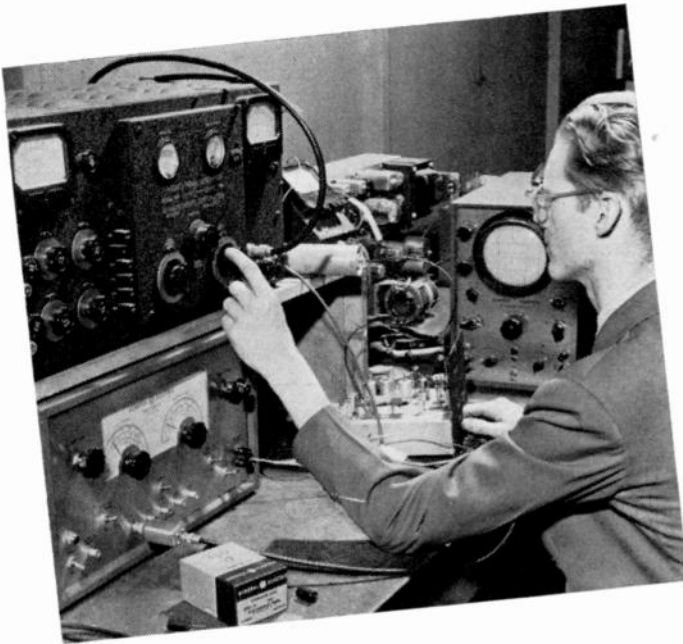

By J. H. SWEENEY

Commercial Equipment Division
Electronics Department
General Electric Company

Testing a uhf type diode† for noise, sensitivity and peak-inverse voltage.

WITH MOST TV receiver manufacturers probing the problems of weight, size and tube complements, in an effort to produce lower-priced models, the variety of components employed are receiving closer electrical and physical scrutiny than ever.

One item which, it has been found, can contribute substantially to the smaller-set lighter-weight program is the germanium diode. Not only does the crystal element possess physical advantages, but many electrical features, too. Filament hum prevalent with series filament wiring can be eliminated; heat from filaments can be reduced; feedback can be more easily controlled; longer, reliable life can be obtained, particularly for *uhf* converters,¹ and in many cases greater output can be obtained.

Until several years ago, germanium as a semi-conductor was little studied. During the war it came into prominence when it was investigated for possible use in mixers for *uhf* reception.

Germanium,² like boron, silicon, selenium, and others, is an element which exhibits properties of conduction

intermediate between conductors and non-conductors in that its current-voltage characteristic does not follow Ohm's law.

The typical current-voltage characteristic of a 1N48 germanium diode appears in Figure 1. The flow of electrons to one polarity of voltage on the diode is many times that of the flow to the opposite polarity.

Diode Classifications

Four general-purpose and two television-type diodes are now being processed at our plant. The general-purpose diodes are classified according to forward and back resistance and inverse peak voltage ratings; types 1N51, 1N48, 1N52, and 1N63, listed in order of increasing back resistance. The TV diodes are the 1N64, a video detector grade, and the 1N65, a *dc* restorer type.

The small physical size of the units permit soldering or clipping into any

tight corner of a chassis assembly or even in a shielding can. An insulated case removes any possibility of its contacting other circuit elements.

The most widely accepted application of the germanium diode in the TV receiver thus far is as a video detector. The function of the video detector is to demodulate the high frequency *if* signal to obtain the video modulation. Until recently, the most common element used for this purpose has been half of a 6AL5 double diode. With only minor circuit changes it has been found possible to substitute for the tube detector. The substitution, however, in many cases has led to the problem of how to eliminate the other half of the diode to dispense with the tube, its socket, and associated wiring. Where the problem could not be solved in model redesign, the use of another germanium diode has been found effective.

Germanium and Tube Diode Differences

In analyzing the differences between the crystal and tube diodes, we find that the germanium unit has greater forward conductance than the tube, which in-

Figure 1
A typical current-voltage characteristic plot of a 1N48 germanium diode.

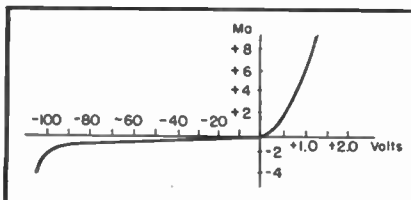

†G.E. type G7.

¹Lingel, F. J., *Germanium Diodes for UHF TV*; TELEVISION ENGINEERING, January, 1950.

²The germanium used in commercial diodes is obtained by reducing germanium dioxide in hydrogen ovens and forming germanium ingots. These ingots are sawed into pellets .050" square by .020" thick and each one soldered to a small brass pin with a tinned pigtail, forming a pellet assembly. The rectifying property is obtained by point to plane contact. In the construction of diodes at G.E. a fine platinum alloy wire .003" in diameter, with a chisel point, is used as a whisker. This wire which is specially formed is welded to a pin and tinned pigtail forming a whisker assembly. With the pellet assembly fixed in a plastic case, the whisker assembly is advanced into the case until contact is made and then a current of several hundred milliamps is passed through the diode forming a weld of the platinum wire to the germanium pellet. The unit is then cemented, vacuum wax impregnated and classified according to test limits.

Figure 2
Simple diode-detector circuits: (a) series setup and (b) shunt system.

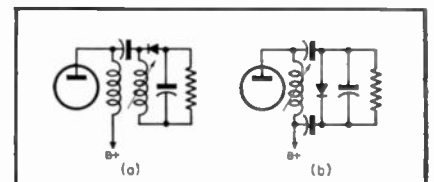

Veryhigh and Ultrahigh TV Sets*

Use of Crystal Diodes as Video Detectors and DC Restorers in TV Sets Involves Careful Evaluation of the Properties of the Germanium and Tube Diodes, the Passive Element Having a Zero Current Flow at Zero Voltage, Greater Forward Conductance and Less Shunt Capacity, With However a Forward and Back Resistance Which Varies With a Change in Temperature and Between Units.

variably has been found to be a distinct advantage. Yet, unlike the tube, it has finite back resistance which must be provided for in the circuit design. The germanium diode has less shunt capacity and also because it is a passive element has zero current flow at zero voltage, both of which are advantages. On the other hand, both the forward and back resistance of the germanium diode varies with a change in temperature and also varies between units. As long as these properties are understood, however, their effect can be compensated for in the circuit design.

To illustrate a circuit application, let us consider the series and shunt-type diode detectors; Figures 2a (series) 2b (shunt). Both types of circuits have been widely used and perform equally well. The shunt circuit is used primarily when a closely coupled *if* transformer is used, and capacitive coupling to the detector is necessary to prevent B+ voltages from being present on the diode. The diode in shunt provides its own *dc* return path, normally restricted by the coupling capacitor in the series hookup. In either circuit, load im-

pedances are determined primarily by video-bandwidth requirements and must necessarily be relatively low values. The load capacitor must be small enough to prevent a reasonably high impedance to the highest video frequency of 4 mc, and yet be large enough to hold the charge from one peak to the next of the 25- or 45-mc *if* signal. The load resistor must be large enough so as not to lower the impedance of the capacitor and yet be small enough to allow the capacitor to discharge at the video frequencies. Usual values are 5 to 10-mmfed capacitance and 1500 to 5000-ohms resistance. In the series-type circuit, the forward dynamic resistance of the diode is important, since it can be large enough in comparison to the load to form a voltage divider and reduce the output voltage. Since germanium diodes have lower dynamic resistance than vacuum tubes, additional gain can be realized. The *Q* or sharpness of resonance of the tuned circuit, however, will be broadened due to the lower resistance of the germanium diode over the vacuum tube, reducing the gain of the last *if* stage. It must be restored by an increase in the load resistance.

In the shunt circuit, the back resistance characteristic of the diode becomes the predominant characteristic. It is necessary that this back resistance be at least ten times that of the load to maintain gain. However, very high values of back resistance may sharpen the *Q* of the tuned circuit. Bandwidth can then be restored by a change of

the coupling capacitor or compensating choke.

It should be realized that wider variations in the dynamic resistance of germanium diodes will be encountered than in vacuum tubes. However, detector type of germanium diodes are selected in their manufacture by test, in an actual video detector circuit, to assure uniformity of performance. Also, circuit values can be so chosen as to minimize the diode variations. The improved linearity of germanium diodes at low voltages and the absence of contact potentials provide improved video output with reduced distortion in the low modulation regions. This means that the quality of the signal representing white will be improved and hence, the overall picture will have a more natural rendition of the various shades of white to black.

The DC Restorer

The function of the *dc* restorer is to reestablish the correct *dc* operating level of the video signal, arriving at the picture tube grid, to maintain a uniformity
(Continued on page 36)

Figure 3
A diode installed as a peak rectifier in the grid circuit of a picture tube which adds a *dc* bias, dependent on the peak voltage of sync pulses and maintains the tips of pulses at a fixed *dc* level.

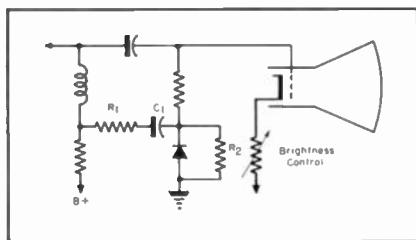
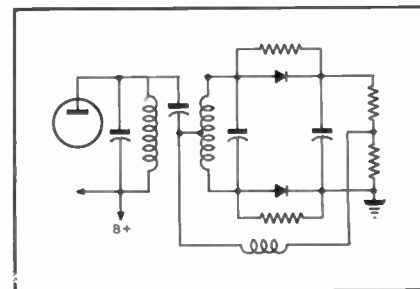

Figure 4
The Foster-Seeley discriminator circuit using germanium diodes.



*From a paper presented before the Winter Meeting of the AIEE.

Principles of FM DETECTION

Simplified Analysis of Requirements, Which Must Be Met in Order That Detection May Take Place in Any FM System, Reveals That Solution to the Problem Is in the Insertion into the System of a Network Which Will Produce Two Voltage Vectors $(2n + 1) \pi/2$ Radians Out of Phase with Each Other at the Undisturbed Carrier Frequency, the Phase Angle Between the Two Vectors Varying Proportionately with the Change in Frequency of the FM Wave Above and Below the Carrier Frequency. The Vector Sum of These Two Voltage Vectors Can Then Be Applied to an Ordinary Rectifying Device Which Then Converts the Variations in Frequency into Corresponding Variations in Amplitude.

by **HERBERT J. SCOTT**, Associate Professor, Electrical Engineering, University of California

A CARRIER WAVE modulated in such a manner as to cause the instantaneous frequency of the wave to vary in accordance with the modulating intelligence, while the amplitude of the wave remains constant, is called a frequency-modulated wave. This is expressed in the well known form

$$e = E \sin(\omega_0 t + m \sin \lambda t) \quad (1)$$

Where:

$\omega_0/2\pi$ = undisturbed carrier frequency

m = modulating coefficient

$\lambda/2\pi$ = modulating frequency

Equation (1) may also be written

$$e = E \sin(\omega_0 t + \phi) \quad (2)$$

Where:

ϕ = time varying phase angle = $m \sin \lambda t$

To recover the original modulating signal implicit in equation (2), it is necessary for the FM detecting circuit to respond to the change in frequency produced by modulation and to convert this change in frequency into a corresponding change in amplitude.

The instantaneous frequency from equation (2) is

$$\omega_1 = (d/dt)(\omega_0 t + \phi) = \omega_0 + d\phi/dt \quad (3)$$

which may be written

$$\omega_1 = \omega_0 + \Delta\omega_0$$

Where:

$$\Delta\omega_0 = d\phi/dt = \lambda m \cos \lambda t \quad (4)$$

From equations (2), (3) and (4) it is evident that any device which produces an output voltage proportional to the rate of change of the time-varying phase angle of the applied voltage will, in the ordinary sense, detect an FM wave and recover the original intelligence modulated on the carrier thereby rendering it explicit.¹

The foregoing is simply a statement of the problem of detecting an FM wave. The solution of the problem resolves itself into the development of a circuit or circuits, the output amplitude of which will be proportional to $d\phi/dt$.

Let us now consider a bridge or lattice structure, as illustrated in Figure 1.

$$e/E = \frac{(R^2 - X^2) + j2RX}{R^2 + X^2} = 1/\phi$$

Where:

$$\phi = \arctan \frac{2RX}{R^2 - X^2}$$

as indicated in Figure 2.

If ω_0 is the angular frequency at which $X = R$, X being $1/\omega C$, then $\omega_0 = 1/RC$ and the angle ϕ may be expressed entirely in terms of ω and ω_0 , or,

$$\phi = \arctan \frac{2(\omega_0/\omega)}{1 - (\omega_0/\omega)^2}$$

Figure 3 shows the relationship between the vectors representing E and e as the frequency $\omega/2\pi$ is varied, E being taken as the reference voltage. It will be noted that the voltage vector, e , remains constant in magnitude but changes in phase with respect to E as ω is varied, and is perpendicular to E at $\omega = \omega_0$.

Referring now to Figure 4 it will be seen that E and e have been joined together at (a) and (b) resulting in a voltage E' at (c) and (d) given by

Figure 4 (right)
A circuit in which the voltage E' is the vector sum of the voltages E and e .

Figure 1
Bridge circuit and its equivalent lattice structure used as a phase shifting network.

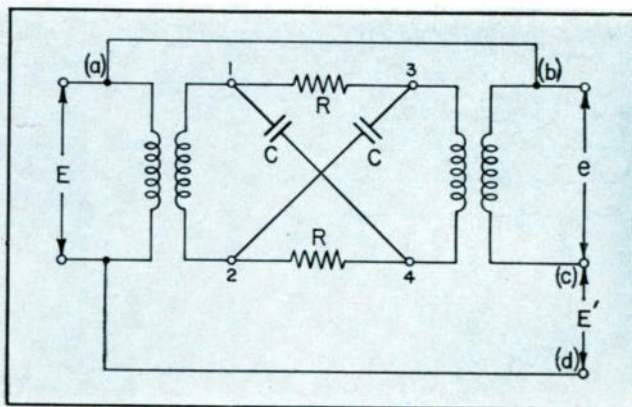
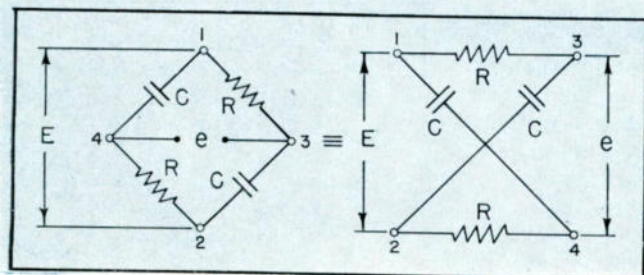

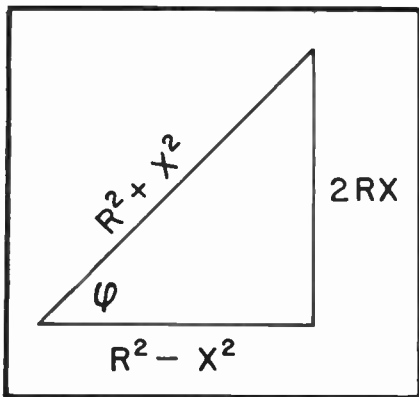

Figure 2 (left)
Phase angle ϕ between E and e of Figure 1, in terms of R and X .

$$E' = E/O + e/180 - \phi$$

as shown in Figure 5.

If E' is expressed in terms of E , e , and ϕ we have,

$$E' = \sqrt{E^2 + e^2 - 2Ee \cos \phi}$$

which, since $E = e$ may be written

$$E' = E\sqrt{2 - 2 \cos \phi}$$

However, from Figure 2

$$\cos \phi = \frac{R^2 + X^2}{R^2 - X^2} = \frac{1 - (\omega_o/\omega)^2}{1 + (\omega_o/\omega)^2}$$

so that

$$E' = 2E \sqrt{\frac{(\omega_o/\omega)^2}{1 + (\omega_o/\omega)^2}}$$

$$= 2E (\omega_o/\omega) \left(\frac{1}{\sqrt{1 + (\omega_o/\omega)^2}} \right)$$

which, for small variations in ω about ω_o , such that in the radical we may consider $\omega_o/\omega = 1$, gives $E' = \sqrt{2} E(\omega_o/\omega)$. Hence for small variations in ω_o/ω E' is proportional to ω_o/ω . This is indicated in Figure 6 which shows both ϕ and e'/E as functions of ω_o/ω for the circuit of Figure 4.

The variation in E' as the phase angle ϕ is varied about the 90° position corresponding to $\omega_o/\omega = 1$ is shown graphically in Figure 7.

To utilize this variation in E' with ϕ it remains only to connect a rectifying device such as, for instance, a diode to the points (c) and (d) of Figure 4, as indicated in Figure 8. In this figure, E_{AC} is proportional to E' and will vary in the same manner as E' varies. The voltage E_{BC} from which has been subtracted the steady dc value corresponding to E' at $\omega_o/\omega = 1$. Hence, E_{BC} is the output voltage which varies in the same manner as ω_o/ω varies. If now the variation in ω_o/ω is that due to the modulation of an FM wave, it is evident that E_{BC} represents the recovery of the original modulating signal. The variation of both E_{AC} and E_{BC} with ω_o/ω is shown in Figure 9.

The mechanism whereby the modulating intelligence in an FM wave may be recovered has been indicated and will now be explored further. For various reasons, the circuit of Figure 4 is not the most desirable circuit to use since among other reasons, the changes in ϕ and in E' as functions of ω_o/ω are not very rapid. It does serve, however, as a simple circuit to investigate and indicates the manner in which a circuit

Figure 7 (left)

Vector representation of the variation in voltage E' of Figure 4 with phase angle ϕ .

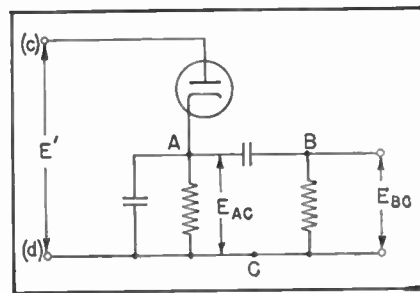

Figure 8
Conventional diode detector circuit.

must perform in order that the desired results may be obtained. It is possible to proceed immediately from the particular circuit of Figure 4 to the more general circuit of Figure 10.

The phase-shifting network indicated by (N) of Figure 10 (p. 38) may be any type of lattice, tee, pi, or other structure including a transmission line provided only that in the region of interest around $\omega_o/\omega = 1$ the phase shift between 1 and e shall

- (a) be $(2n + 1) \frac{\pi}{2}$ radians at $\omega_o/\omega = 1$. ($n = 0, 1, 2$, etc.)
- (b) be reasonably linear with ω_o/ω in this region.

In addition, e should remain substantially constant in this same region, and the phase shift should be quite rapid.

There are a wide variety of networks (N) which will result in satisfactory operation, ranging all the way from simple tuned circuits to more complex structures. One such structure which suggests itself immediately is a suitable filter in which the attenuation through the pass region is essentially constant so that e may be considered constant, and in which the phase shift through the pass region is relatively rapid. The

(Continued on page 38)

Figure 9
Variation of voltages E_{AC} and E_{BC} of Figure 9 as a function of ω_o/ω .

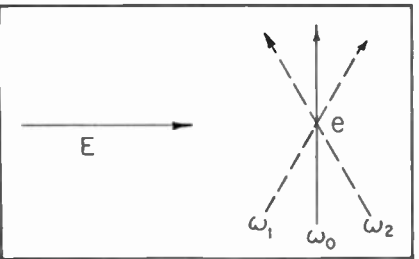
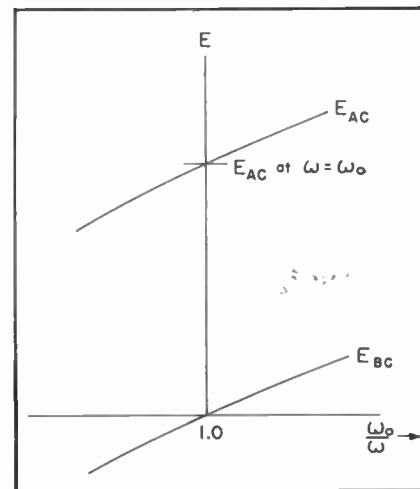

Figure 3 (above)
Relative voltages E and e of Figure 1 and their phase with respect to each other for frequencies corresponding to $\omega_o, \omega_1, \omega_2$.

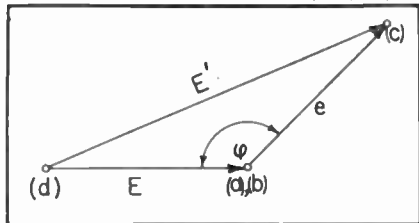

Figure 5 (above)
Vector representation of voltages E' , E , and e of Fig. 4: $E' = E/O + e/180 - \phi$.

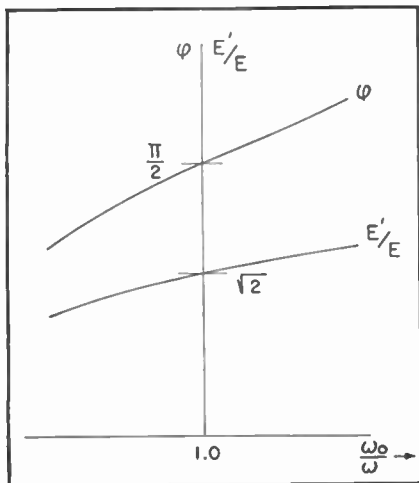
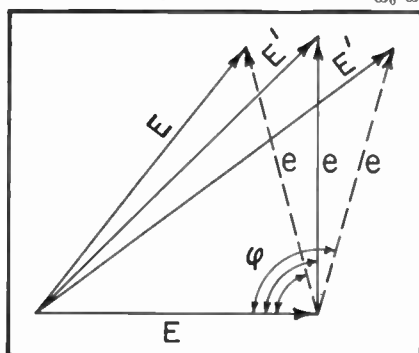

Figure 6 (above)
Variation of phase angle ϕ and voltage E' in the circuit of Fig. 4 as a function of ω_o/ω .



TV TUBE Developments

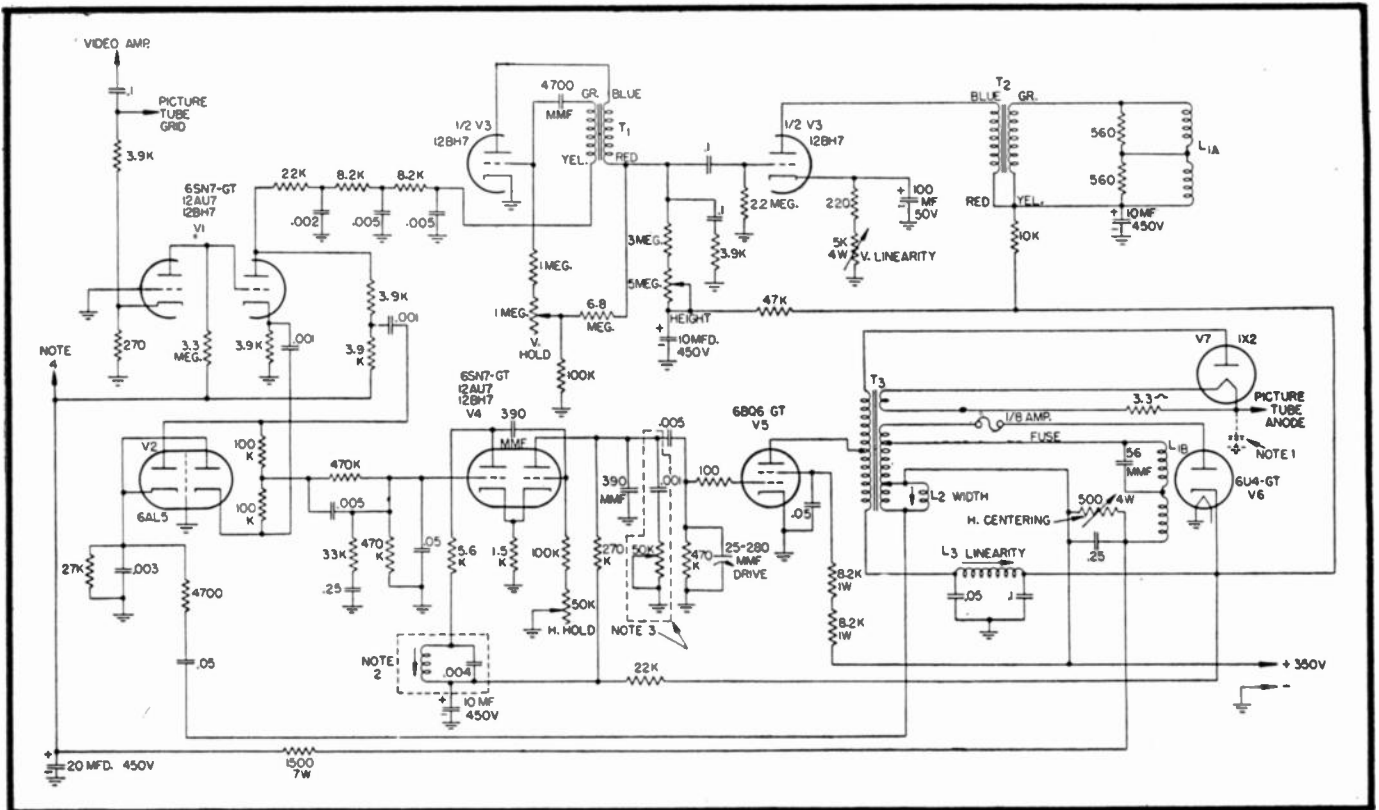

Figure 1

Rectangular tube deflection system circuit. V_1 is the dc restorer, sync clipper and amplifier; V_2 , phase detector; V_3 vertical oscillator-amplifier; V_4 horizontal oscillator; V_5 horizontal amplifier; V_6 damper and V_7 high-voltage rectifier.

At note 1 is indicated the picture tube inner and outer coating which may be used as a filter capacitance, providing an interlock is used on the back panel. At 2 appears an LC network which must resonate at 15,750. The coil should have a Q of 40 to 50, while the capacitor-inductance combination must be temperature compensated. In addition the coil must be kept away from the strong horizontal field. The capacitance-resistance network, indicated at 3, is the peaking network and should be adjusted in design for optimum 6BQ6GT efficiency. A fixed resistor has been found satisfactory in standard production work. At 4 we have the point which feeds the if, screen of the video amplifier, plate and screen of the ratio detector driver, and the first audio. This circuit provides the required drain through the yoke and transformer so that horizontal centering results. To some degree this circuit also decreases the magnetization of the core of the horizontal output transformer.

THE ADVENT of the rectangular-type picture tubes such as the 16RP4 and 16TP4, featuring a 65° deflection angle, has prompted the development of special circuits which can accommodate the increased deflection angle and the proportionate increase in deflection current, as well as the additional sweep power required by the higher operating anode potential of the picture tube.

In Figure 1 appears one such circuit,* with which it has been possible to secure a second-anode voltage of 12 kv with a fully-synchronized picture from a primary supply of 350 volts. The 12-kv voltage was found to be the minimum anode potential required for both the 16RP4 and 16TP4 tubes, which because of a neutral-density face plate have a 35% loss in light transmission as compared with clear-faced tubes having an average of somewhat less

than 10% loss. This reduction in light output has been found to be, however, more than made up by the increase in contrast.

Use of 6BQ6GT

The circuit features a 6BQ6GT as the horizontal-deflection amplifier tube, which was found to have quite a low-internal tube drop, as well as a high peak plate current with zero potential on the grid. Grid-circuit peaking was found to be most desirable and together with the horizontal oscillator shown provided ample grid drive for the 6BQ6GT.

According to the lab which evolved the circuit, the improvement in the efficiency of this circuit was not due solely to the tube used, but because of the

*From application notes prepared by the commercial engineering department of Hytron.

selected transformers and better matching the tube's characteristics. Further improvement in efficiency was found to be possible by grounding the cathode, thereby eliminating the usual cathode-bias resistor and its associated bypass capacitor.

Protection of the 6BQ6GT, in the event of failure of the horizontal oscillator, has been afforded by a 1/8 ampere fuse. Because of the relatively low mu of the 6BQ6GT under a condition of zero bias (i.e. no excitation), the plate current has been found sufficient to blow such a fuse in 5 to 10 seconds (measurements at normal line potential). Furthermore this fuse protects the rest of the circuit in case of failure of either 6BQ6GT or 6U4GT due to break-down.

The vertical-deflection circuit in the Figure 1 system utilizes a 12BH7 twin

Installation and Circuiting Requirements of Wide Deflection Angle 16" Rectangular and Circular Picture Tubes.

triode, with one section functioning as a blocking oscillator and the other section as a vertical sweep amplifier. The self-discharging blocking-oscillator circuit is conventional. The output amplifier will develop sufficient vertical sweep with a primary supply voltage measured at the B+ end of the transformer as low as 325 (normal line conditions) scanning either a 16TP4 or a 16RP4 at second-anode potentials up to approximately 12 kv. A full vertical sweep will also be had at a line voltage of 105 with reasonable linearity.

Picture-Tube Capacitance

Utilization of the capacitance between the picture tube anode and its outer coating has been found to eliminate a separate high-voltage capacitor, although at some sacrifice of high voltage output. Tests showed that approximately 11 kv could be obtained by using this capacitance, while approximately 12 kv was available when an external capacitor was used with its low side connected to the damper plate, thus taking advantage of an additional potential existing in this circuit. A 1X2 rectifier was found adequate for this application. With a negative pulse approximately 25% of the forward pulse, the inverse potential was found to be 15 kv, which does not exceed the design-center maximum rating.

Wide-Angle Yokes

In the lab studies it was found that the deflection yoke must be of the *wide angle type*, sometimes designated as 70°. With the increased deflection angle it follows that the beam must be deflected a greater amount. If a standard 52° yoke (which is longer) is used, the deflection of the beam starts at a point too far back and before it is deflected 65°, it will hit against the inside wall of the picture tube bulb causing shadowing. Therefore the deflection of the beam must start nearer the screen; hence the yoke winding must be shorter in length as well as being formed at the funnel end, so as to follow exactly the outer curvature of the tube. These two changes in the yoke provide for moving the effective center of deflection nearer the screen to

provide the necessary clearance at the reference line of the bulb. Wide-angle yokes with 8.3 millihenry inductance were found to meet the requirements for the wider deflection angle.

Focus Coil Designs

The use of the newer thin focus coils either of the electromagnetic or permomagnetic type, represented another picture-tube factor requiring special consideration. Due to the shorter neck length of both the 16RP4, and 16TP4, it will be found possible to install the wide-angle deflection coil, a thin focus coil, and an ion-trap magnet, but sometimes not the older thick focus coil. The labs found that this restriction is not serious, since the thin focus coil is in production and is currently used by many manufacturers.

Ion-Trap Structure

Due to differences in construction of the electron guns in the rectangular tubes, different types of ion traps are required. The 16RP4 uses a *straight* electron gun, similar to that used in the 12LP4 and 16AP4 which required a double magnet ion trap. The 16TP4 uses a *tilted beam* gun, designed to use a single magnet ion trap having somewhat greater field strength.

The use of the tilted-beam gun with the single-magnet ion trap has been found to permit a reduction of $\frac{5}{8}$ " in the over-all length, making the 16TP4 $18\frac{1}{8}$ " (nominal) over-all as against $18\frac{3}{4}$ " for the 16RP4.

Multivibrator Circuits

A multivibrator type of vertical oscillator driving a triode or triode-connected pentode amplifier is shown in Figure 2 (p. 16). This particular circuit, although it requires both a double triode and a separate amplifier, has found favor among those who have designed circuits in which the final vertical syn-

chronizing pulse is of negative polarity. A blocking oscillator transformer is not required. In addition to the tubes previously mentioned, it is possible to replace the single section of the 12BH7 vertical sweep output amplifier with a triode-connected 6V6GT, a triode connected 6K6GT, or parallel-connected 6SN7GT. In the horizontal oscillator circuit, the 12BH7 can be replaced by a 6SN7GT or a 12AU7; the same is true of the vertical multivibrator.

The 16GP4**

The 16GP4, also a wide-deflection angle type of tube (70°), using however a circular type face, has also had several interesting circuits developed for its application.

DC Voltage Supply

The *dc* voltage supply is one example of this special type of circuitry, with low-energy power supplies suggested. The supply for the anode may be of the pulse-operated or *rf* type; the voltage for grid No. 2 may be obtained from a potentiometer in the voltage divider connected across the anode supply, or it may be obtained from the amplifier voltage supply; and a variable *dc* voltage for grid No. 1 may be obtained from a potentiometer in the voltage divider across the amplifier voltage supply. In some cases it has been found more convenient to operate grid No. 1 at ground potential in a signal circuit and to bias the cathode positive with respect to ground by means of the amplifier voltage supply.

Focus Controls

A small amount of voltage regulation in the anode supply acts to maintain sharp focus as the average beam current is changed. At high beam current, a relatively higher focusing-field strength is required to maintain sharp focus, but provision for such an increase is impractical in commercial receivers. Therefore, the same effect as would be produced by increased focusing-field strength can be achieved auto-

(Continued on page 16)

**From copyrighted data prepared by the tube department of RCA.

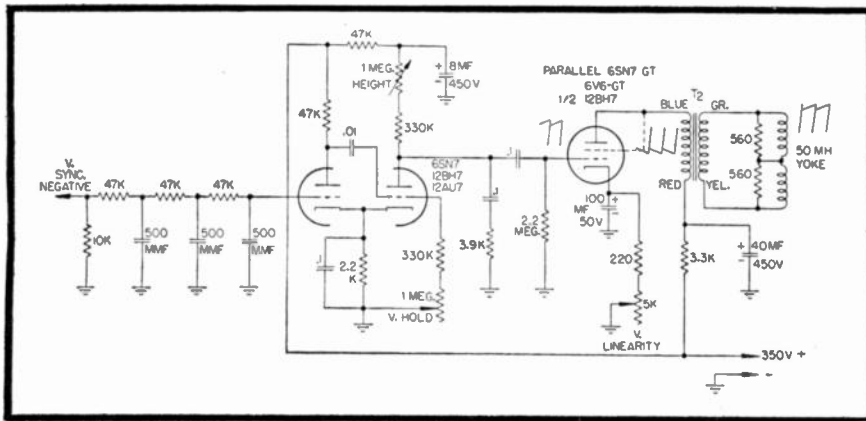

Figure 2

A vertical deflection system circuit using a multivibrator-amplifier.

matically by reduction of anode voltage due to regulation. A regulation corresponding to that provided by an equivalent internal resistance of the rectifier system of 1 megohm has been found to provide good compensation. Such compensation is effective, in general, only for slow changes in current as determined by the time constant of the filter circuit.

Short-Circuit Current

Tests have indicated that the inherent regulation of the limited-energy power supply should limit the continuous short-circuit current to 5 milliamperes. If the regulation of the supply permits the instantaneous short-circuit current to exceed 1 ampere, or if the power-supply output capacitor is capable of storing more than 250 microcoulombs, then provision must be made to protect the tube electrodes connected to that supply. For this purpose, resistors must be connected between the electrodes and the output capacitor of the power supply. According to the manufacturers, an occasional internal arc will not damage the 16GP4 if the current is limited.

Deflecting Yoke Length

The 16GP4 has a short length and therefore the electron beam must be deflected through a wide angle. To scan the screen area determined by the minimum-useful-screen diameter, it is necessary to deflect the beam through an angle of 67°. If, however, the entire screen surface is to be scanned, a de-

flexion angle of 70° is required. The deflecting yoke must have an effective length of not more than 1 11/16" and be designed so that, for the maximum deflection angle, the effective center of deflection of the beam is about 1.15" from the reference line. This requirement has been found necessary to prevent the beam from striking the neck when deflection is sufficient to reach the edge of the screen.

Pattern Centering

Centering of the pattern is preferably accomplished by passing *dc* of the required value through each pair of deflecting coils. When this method of centering is not used, the yoke circuits must filter out the *dc* component of the deflecting currents. Then, the small amount of centering needed to position the pattern in the mask and to correct for small alignment errors can be provided by displacing the focusing field from its optimum position. Both de-centering and tilting of the focusing field change the raster position but the former has been found generally preferred because it produces less distortion.

Spot Size and Intensity Control

Adjustment of spot sizes and intensity can be made by varying the focus and anode current. The current to the anode may be increased by decreasing the bias applied to grid No. 1. Also, an increase in the voltage applied to grid No. 2 increases the anode current

as well as the sharpness of focus and, therefore, the spot intensity.

High-Definition Operation

In applications where high definition is the principal requirement, the 16GP4 can be operated with the maximum anode and grid-No. 2 voltages, and the lowest value of anode current consistent with the desired brightness. Higher anode voltages have been found to be not always desirable because they reduce deflection sensitivity. Higher grid-No. 2 voltages require higher values of grid-No. 1 voltage for beam cutoff and higher grid-No. 1 drive to provide a given brightness.

Cathode Connections

In the 16GP4, the cathode is connected to base pin No. 11 to which the grid-No. 1, grid-No. 2, and circuit returns must be made.

Use of Grid No. 2

Grid No. 2 has been incorporated to prevent interaction between the fields produced by grid No. 1 and anode. Grid No. 2 can also be used to compensate for the normal variation to be expected in the grid-No. 1 voltage for cutoff in individual tubes. By adjusting the voltage applied to grid No. 2, with due consideration to its maximum rated value, it has been found possible to fix the grid-No. 1 bias at a desired value, and obtain approximately the same anode-current characteristics for individual tubes having different cutoff voltages.

Reducing Anode-Current Variations

Adjusting grid No. 1 cutoff as suggested above not only makes grid drive more uniform, but also reduces variations in the anode current. Since grid No. 2 draws only negligible current, its voltage may be obtained from a potentiometer in the voltage divider connected across the anode supply, or from a separate source.

Mass Processing of TV Picture Tubes

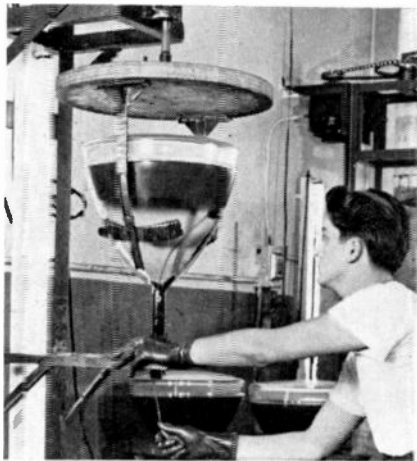

Variety of Specially Developed Procedures and Equipment Required to Produce Tubes, at 1000-a-Day Rate.*

(Left)

Applying interior conductive coating to the tube where precise control is required to give correct brilliance of picture. This coating forms what is commonly called the beam intensifier anode.

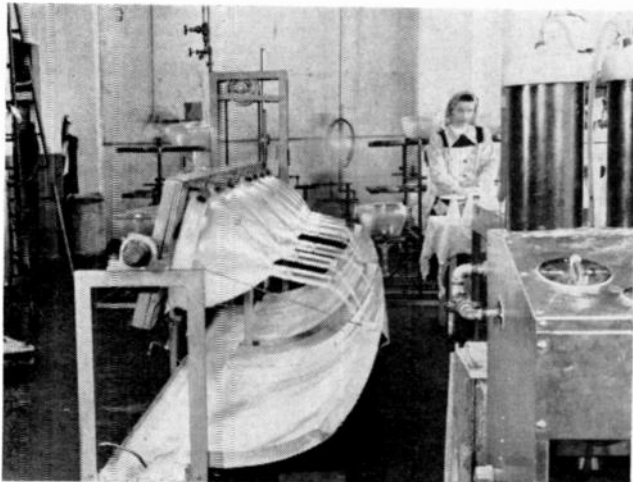

Following settling of the tube's screen materials is the pour off, in which the settling solution is poured off in such a manner as to leave the screen materials undisturbed. Careful inspection follows the pour-off to eliminate any holes in the screen surface.

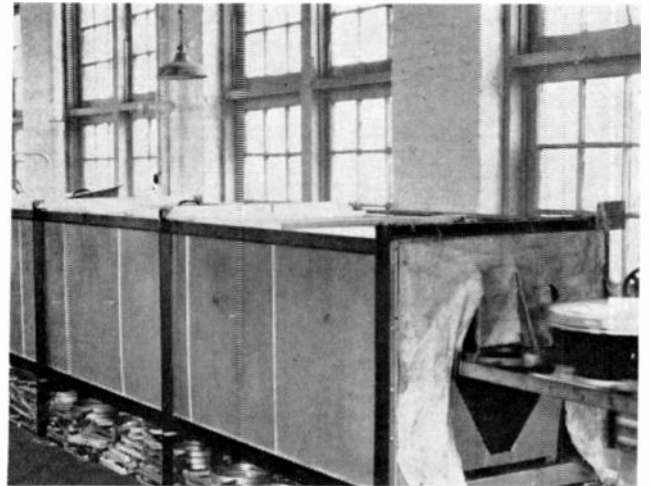

Electronically controlled oven (over 80' long) which bakes out the screen material and the conductive coating to remove all impurities prior to exhaust. If these impurities are not removed, poor performance and a shortened tube life result.

One of the sealing positions, used for production runs where the electron gun is sealed into the tube neck by a glass-to-glass bond under terrific heat.

Final test position where the tube is subjected to a series of rigid mechanical and electrical tests.

Exhaust system, which consists of eighty separate exhaust units, each one entirely automatic except for the tip-off position shown, the critical point in tube manufacture.

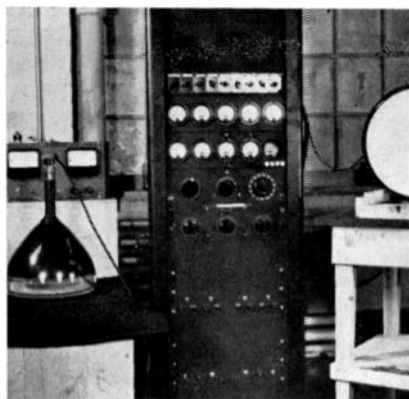
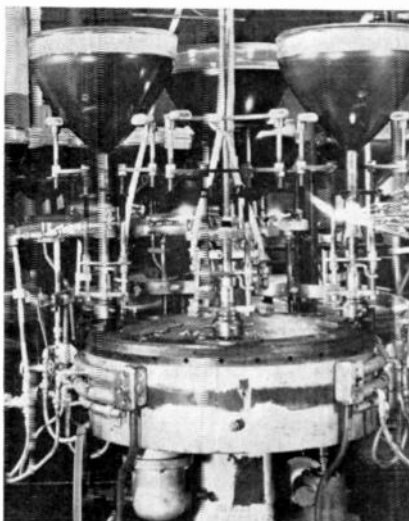

*Based on information supplied by Thomas Electronics, Inc., Passaic, N. J., whose plant facilities are illustrated on this page.

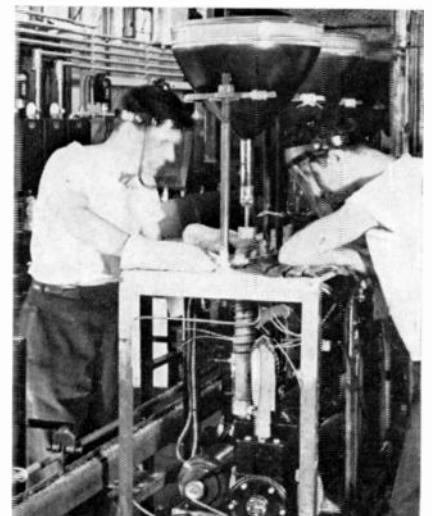

Going on the Air

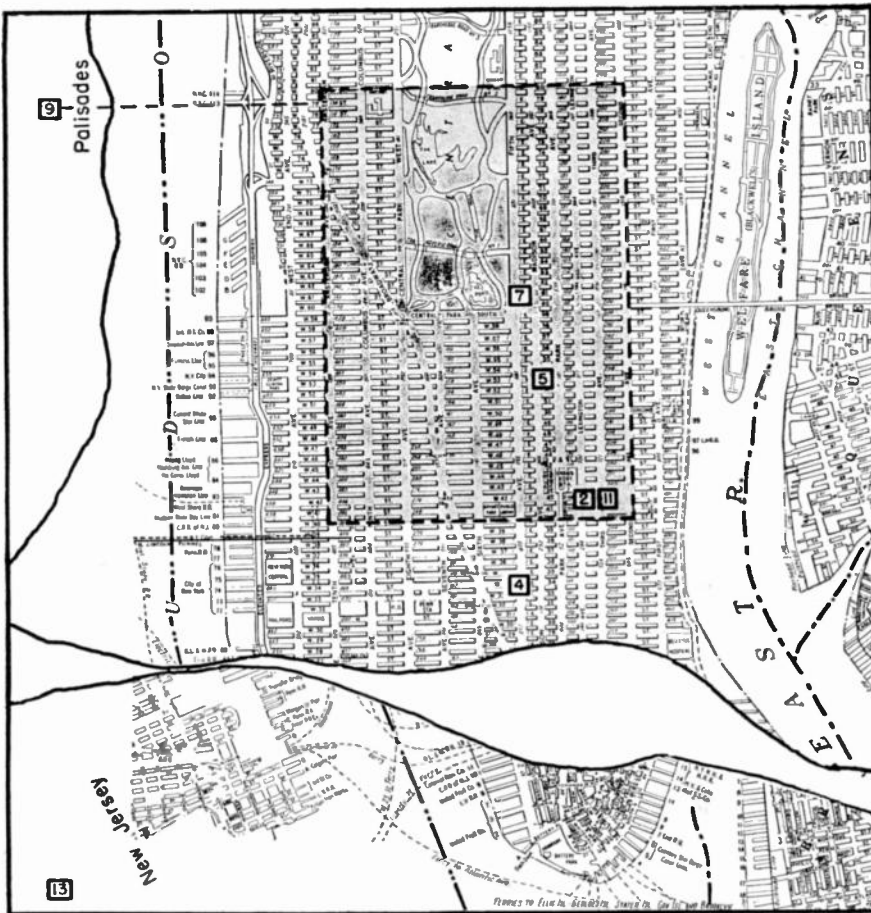

Figure 1
Rectangular receiving area surveyed to determine receiving results from WOR-TV operating on channel 9.

THE MAXIM . . . first come, first serve . . . appears to have found itself a new frontier, this time in TV, involving receiver adjustments in those areas where there have been station additions over a period of years. The condition was disclosed quite boldly in a recently-completed survey which revealed that in urban areas, where reception problems are complex, the best-received signals were on those channels which were on the air at the time of installation.

The survey,¹ conducted in New York City, concerned WOR-TV operating on channel 9, the last channel to be placed in operation. With a tower located on the New Jersey side of the Palisades, and signals radiating in a different direction than the other metropolitan-area channels placed in operation earlier, the sets installed and adjusted in the mid-town area¹ prior to the time when channel 9 was placed in operation were found to favor the other channels.

In compiling the results of the survey, covering channels 2, 5, 7 and 9, it was found that 2 and 5, which were among the first to go on the air, were received better than 7 and 9, the last two channels on the air.

While from a superficial analysis of the survey results the majority of the channel 7 and 9 reception difficulties might be attributed to antenna problems this was actually found to be only partially the trouble. A breakdown of the reception faults showed that quite a few receiving-set conditions contributed to the problem. The report showed, for instance, that intermittent streaks were identified as a reception fault. Actually intermittent streaks are the result

¹To make an impartial survey of the reception in a squared off area WOR-TV retained a polling group (*The Pulse, Inc.*) who contacted 103 commercial establishments which had television receivers in operation.

The interviewer confined the survey to a comparative analysis of four of the seven channels in the area.

of sound in the picture, due to the fact that the front end of the switch type tuner in the receiver has not been adjusted for this specific channel. It is therefore to be assumed that the majority of the TV receivers which were installed prior to the operation of channel 9 which did not have the continuous type of tuner² in its front end may require adjustment if sound streaks or bars appear in the picture. To detect this trouble the streaking should be viewed carefully to see if it follows the sound modulation of the program on the channel. When there is only a tone being transmitted with the pattern, continuous bars will appear across the pattern, but when music is transmitted along with the test pattern the streaking follows the tempo of the music.

Another receiving complaint, entered in the report, declaring that the picture did not stay in place or jumped around, also can be identified as a receiver problem. Here we have a case of insufficient signal on certain types of tel-

With the Last TV Channel

Operation of New Transmitter in Areas Where Several Channels Have Been in Use for Long Periods Can Be Beset by Many Problems, at the Receiving Point, Survey Discloses. Poll for WOR-TV, the Last Station to Go on the Air in New York City, Reveals Variety of Pickup Difficulties Present, Particularly in Those Receivers Installed and Adjusted Prior to Inauguration of Service. Use of Proper Antenna Systems and Remediating of Set Problems Found to Be Solution in Practically All Instances.

by **IRA KAMEN**, Manager, Television Department, Commercial Radio Sound Corp.

vision receivers, which require heavy drive of sync level if the pictures are to be stable. A 3-step correction technique can be followed, in making the best adjustment of rear-panel hold controls on sets which do not have stable *afc* circuits, or their hold controls on the front panel:

(1) The channel selector switch should be set to the weakest station.

(2) The contrast control should be adjusted to the minimum level at which the pattern on this channel can be seen.

(3) Then the hold controls should be set for the most stable adjustment.

It is obvious that if the hold circuits are stable with this minimum drive, at higher contrast settings and stronger signal levels these circuits will be more stable. Unfortunately many of these fine points of adjustment required on some of the earlier TV models, have been overlooked and as a result reception has suffered.

Another listener complaint, cited in the report, which was not due the TV station or the antenna, concerned the problem of tuning in the picture and sound together. Here is an indication that the front end of the tuner needed nothing more than a screwdriver adjustment on the local oscillator to enable sound to be tuned with the picture.

A complaint of static in the sound (normally accompanied by an auxiliary complaint of low audio level) was also reported in the poll. Here we have a channel alignment or antenna problem, with insufficient FM level to operate the noise limiting circuits in the

FM sound section of the TV receiver. The continuous opening and closing of cash registers, starting and stopping of refrigerator motors and ignition discharges from automobiles, cause much of the trouble, the noise riding into the 300-ohm twin lead. Replacement of the open lead with shielded balanced line or coax line and a matching transformer* will help relieve this situation.

Another receiving fault reported, the result of TV receiver front-end misalignment, was inability to get sound on channel.

Need for Joint Program

As stations go on the air, in many areas they will be faced with the same problem which confronted WOR-TV. Cooperation with the local service operation will be found to be quite an effective means of remediating the situation.

A comprehensive program should be adopted by the broadcaster in his ties

Figure 5
Sound bar pattern in picture caused by tone from the transmitter entering the picture circuit.

(Courtesy RCA)



with the Service Men. Since the Service Man cannot afford to make a service call every time a new station goes on the air and furnish equipment and services without charge to the customer, the broadcaster should relay to their audience *exactly* what must be done for better viewing.

Four-Point Message

Listeners can be told that:

(1) The Service Man may have to reorient your antenna.

(2) Install another antenna as an attachment or with its own transmission line.

(3) Adjust the tuner of the TV receiver.

(4) A small sum paid to the Service Man will be more than repaid by the entertainment available over this new channel.

According to J. R. Poppele, vice-president, in charge of engineering, at WOR-TV, an extensive cooperative Service-Men program in the N. Y.-N. J. area is being planned now.

Methods used to solve the WOR-TV problem will be covered in detail in a report which will describe the actual reception conditions and solutions successfully applied not only in the metropolitan area but within a fifty-mile radius.

Antenna Positioning

In Figure 6 is illustrated the receiving-antenna position problem encoun-

*Kamen, Ira, and Winner, Lewis, *TV-FM Antenna Installation*, Fig. 115.

²Inductuner.

Interviewers rating of reception

	Channel 2	Channel 5	Channel 7	Channel 9
Is the picture:				
Good
Not Too Good But Good Enough To Watch
Too Poor To Watch
Can't Get A Picture
Does the picture have any of the following? (Check if yes.)				
1. Double or multiple images.
2. Snowy or washed out pictures.
3. Intermittent streaks, bars or herring-bone patterns.
4. The picture does not stay in place, jumps around.
5. The picture and sound cannot be tuned in together properly.
6. There is a lot of static on the sound.
7. Cannot get sound on the channel.
Name	Address			
Interviewer's Initials.....				

Figure 2

Questionnaire submitted by polling group, in which receiver owners were told: "We are conducting a study on television reception. I would like to check the reception of several stations on your set. Would you mind turning to channel 2, 5, 7, 9? (Start with whatever channel is on set and go in clockwise direction.)"

	WCBS-TV		WABD		WJZ-TV		WOR-TV	
	#	%	#	%	#	%	#	%
Good	71	69.0	70	68.0	49	47.6	29	28.2
Not too good but good enough to watch	22	21.4	23	22.3	31	33.0	19	18.1
Too poor to watch.....	8	7.8	9	8.7	12	11.6	29	28.2
Can't get a picture.....	2	1.9	1	1.0	8	7.8	26	25.2
Total locations surveyed.....	103	100	103	100	103	100	103	100

Figure 3
Reception results on four TV stations.

Figure 4
Faults reported by viewers during reception survey.

	WCBS-TV		WABD		WJZ-TV		WOR-TV	
	#	%	#	%	#	%	#	%
a: Double or multiple images	10	9.7	12	11.6	23	22.3	12	11.6
b: Snowy or washed out pictures	11	13.6	18	17.5	20	19.4	17	16.5
c: Intermittent streaks, bars or herringbone patterns	12	11.6	10	9.7	16	15.5	28	27.2
d: The picture does not stay in place, jumps around.....	8	7.8	13	12.6	16	15.5	14	13.6
e: The picture and sound cannot be tuned in together properly	2	1.9	1	1.0	5	4.9	6	5.8
f: There is a lot of static on the sound	5	4.9	5	4.9	15	14.6	11	10.7
g: Cannot get sound on the channel	1	1.0	1	1.0	2	1.9	15	14.6
Total Mentions	52		60		97		103	
Total locations surveyed.....	103		103		103		103	

tered by WOR-TV. It will be noted that receiving antenna 1 points towards the majority of the low and high stations which are in the opposite direction from WOR-TV. The TV receiver connected to this antenna would probably prompt two or three of the complaints detailed in the report analysis of Figure 4.

Use of Conical

In Figures 7 and 8 appear illustrations of practical solutions to the pick-up problem.

In one method advantage has been taken of the side lobe pickup pattern of the conical antenna (Figure 7) which is normally a disadvantage in areas polluted by reflections.

Straight and folded dipoles used as in-line or combination antennas do not have high gain side lobe pickup; therefore a direct substitution of the conical type antenna may bring in channel 9 at a satisfactory level. In many cases, however, the conical antenna may mar the reception on other channels, in comparison to the signals received on a straight or folded dipole antenna in complex urban areas, where it may accept reflections from the side which were not previously received. Should this be the case the in-line straight dipole is preferred, with a high frequency attachment as shown in Figure 8b.

Broadband In-Line Antennas

In Figure 8, a and b, is an illustration of a broadband in-line antenna being used to pick up the high and low-frequency channels from one direction. A high-frequency attachment has been added to the in-line antenna and pointed at approximately right angles to the in-line antenna. The success of this high-frequency attachment will depend on the installer's strict adherence to the following procedure:

(1) Adjust in-line antenna for best reception on New York City channels 2, 4, 5, 7 and 11, and then record quality of picture on each channel.

(2) Take the transmission line from the in-line antenna and connect it to the high-frequency attachment. Adjust attachment for best reception of channel 9.

(3) Connect the high-frequency attachment to the in-line antenna with

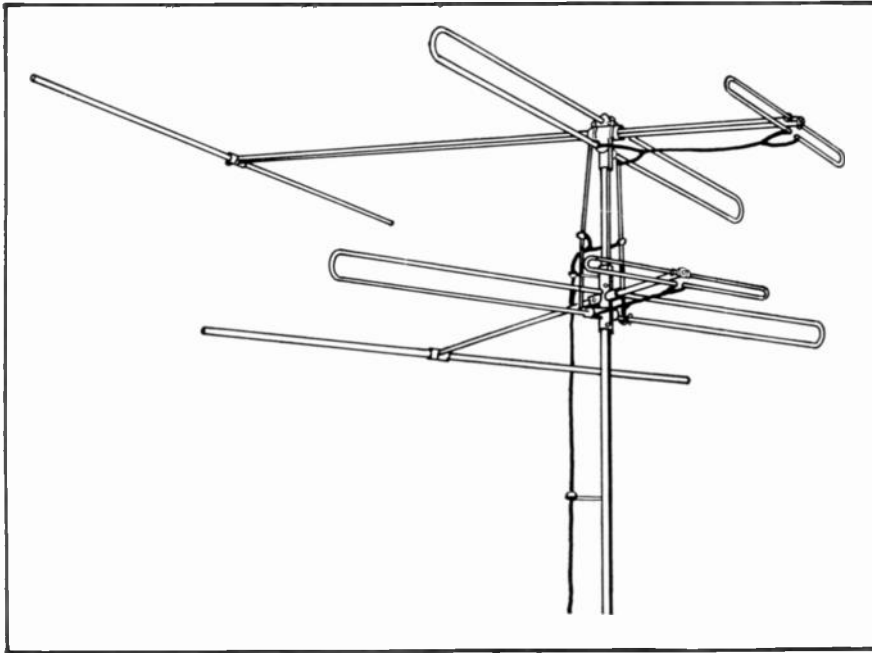

Figure 9
Array setup using split orientation of stacked broadband high-gain antennas.
(Courtesy Amphenol)

approximately 20" of 75-ohm twin lead as shown in *a* of Figure 8. Compare pictures on channels, other than 9, with the information recorded before the high-frequency attachment was connected. Recheck channel 9 reception and readjust as necessary.

HF Element Problems

There are times where the high-frequency element may pick up a reflection on a low-frequency channel and induce it into the antenna circuit so that it mars the reception on a low-frequency channel.

Coax Switches

If the high-frequency attachment, when connected and adjusted does mar the reception on both the high and low-frequency channels as received by the in-line antenna, there then is no alternative except to install a separate coaxial

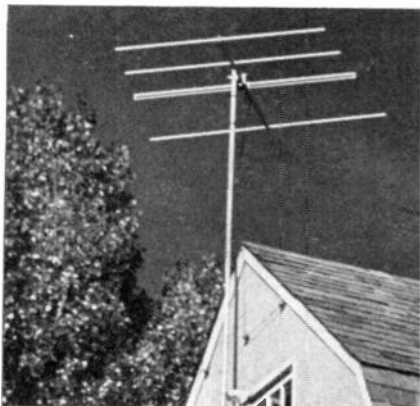

Figure 10 (left)

A typical yagi antenna.
(Courtesy Vee-D-X)

transmission line and transfer switch as shown in *b* of Figure 8.

Split Orientation

While it may be possible to solve the channel 9 pickup problem of receiving antenna 2 in Figure 6 with the solution shown in *a* and *b* of Figure 8, there has been some success with the application of split orientation of stacked broadband high-gain antennas as shown in Figure 9. It was interesting to note that in one application of this principle the channel-13 pickup was improved greatly, since at that distance and bearing, channels 9 and 13 were in line.

The Yagis

In fringe areas experience has shown that single-channel yagis of the type shown in Figure 10 are the best answers to receiving any one specific desired channel.

Figure 8 (right)

Layouts of broadband in-line straight dipole arrays.

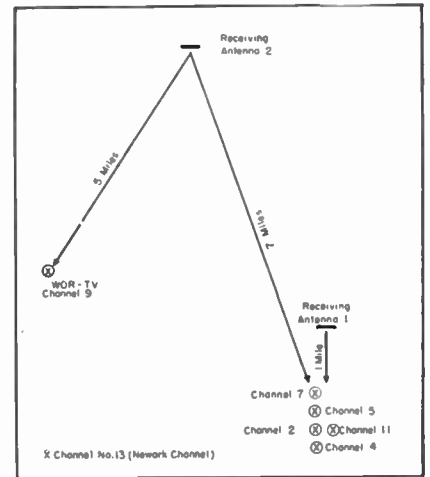

Figure 6
Diagrammatic illustration of the problem faced by WOR-TV in the urban area, where signals from all other stations are from other directions.

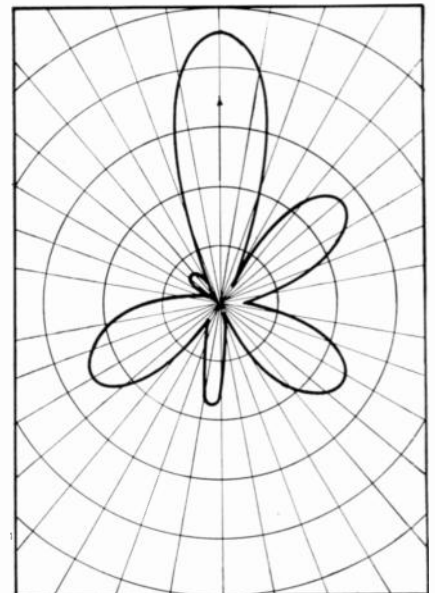
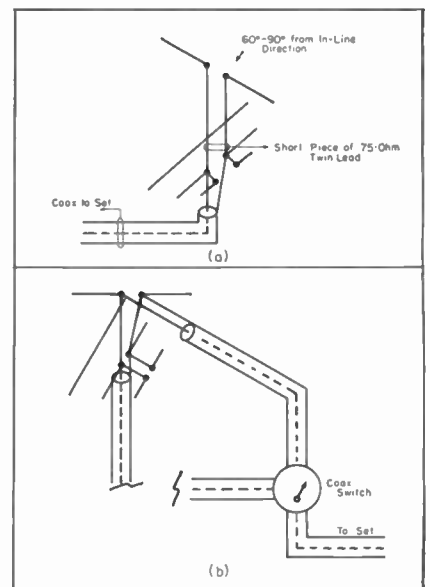

Figure 7
A typical conical pickup pattern on channel 9.



TV CAMERA

IN THE INITIAL installment,* covering design highlights of the image dessector and the iconoscope, it was stated that the photo-sensitive mosaic is a key operational factor. Actually, the photo-sensitive mosaic is the heart of the pickup tube, the mosaic being made by depositing silver globules, coated with a photo-sensitive material, upon the mica sheet. These individual globules are smaller than .001" in diameter and they are insulated from each other, many thousands of these individual globules serving to make up the mosaic. The electron beam which scans the globules has an approximate diameter of .007"; thus a number of globules are scanned at any given instant by the electron beam.

On the reverse side of the mica sheet, upon which the mosaic is formed, is a thin layer of graphite so that each globule is capacitively coupled to the conducting coating or the signal plate.

Operation of Iconoscope Mosaic

Operation of the mosaic in this tube is quite interesting. Light falls upon the globule, which is essentially a photocathode; the globule is capacitively coupled to a load resistor. The plate of this single element may be considered to be the collector ring and thus a complete circuit is established from cathode to plate through the voltage source, the load resistor and back to the capacitor. When an electron beam strikes the photocathode, the scanning beam acts to replace electrons lost by photo emission.

If electrons were emitted due to a photoelectric action, directly proportional to the incident light, the electrons could be replaced by the scanning beam and a signal voltage obtained across the load resistor. However, the action of the *iconoscope* mosaic is not quite this simple. Let us assume that there were no illumination upon the mosaic and the electron gun were scanning one individual globule. This globule would emit secondary electrons whose number were *greater* than the number of electrons in the beam being scanned. The secondary electrons could return directly to the globule or escape and go to either the collector ring or to another globule. The indi-

vidual photocathode is insulated from the signal plate and the collector ring so that its potential will increase, since the number of electrons escaping is greater than the number of electrons flowing to it from the scanning beam. An insulated point which loses electrons, assuming that it started with zero potential, will end up with a positive potential.

The Positive Potential

If the scanning beam were to stay on the single globule for a sufficiently long time, a positive potential would be reached. This is the point where the number of electrons leaving the globule is equal to the number of electrons arriving. This value of potential is approximately 3 volts positive for a single globule.

Voltage Changes

The globule does not remain at this potential, however, because after the scanning beam has passed to another section of the mosaic, electrons from other globules come to the single one under discussion and change its potential to a negative value. Some of the secondary electrons from other globules arrive at and, under normal operating conditions, cause this globule to be approximately one and one-half volts negative in relation to the collector ring which is at ground potential. All of this takes place with no light on the individual globule: it stays at 1½ volts negative. During the next arrival of the scanning beam, this globule re-

leases electrons and becomes three volts positive.

If the mosaic is acted upon by light an additional action takes place. When a globule has light falling upon it, it will emit electrons due to the photo sensitivity of the metal surface. With no scanning beam present, an illuminated globule will emit electrons and also receive a few secondary electrons from other globules. Because of the emission of electrons, due to illumination, this globule does not reach as negative a potential. Thus it does not have to rise so far to reach the +3-volt value. As a result there is a smaller charge released to the collector ring as the scanning beam strikes an illuminated globule; it is this difference in charge between the illuminated globule and the unilluminated one which represents the signal output.

As the electron beam scans a dark mosaic, there will be a constant current flow due to secondary emission from each globule to the collector ring. This current flow will cause a voltage drop, due to the load resistor connected between the signal plate and ground.

The Signal Circuit

The complete signal circuit is the mosaic, signal plate, and collector ring. A variation in this signal current is desired to produce a video output. When the mosaic is illuminated by a scene to be televised, the electron beam scans the scene and produces a variable signal output which is the video signal. The beam current is constant and the current flow from the mosaic to the collector ring is variable depending upon the amount of light which struck each globule of the mosaic. In this manner, a voltage is developed in the load resistor which depends upon the light on each individual globule. As the beam moves from a dark section of the mosaic to a brighter portion the output signal decreases. In this manner it may be seen that the video signal of the *iconoscope* is a reversed or negative polarity signal. A bright spot on the image gives a negative-going signal voltage, and a dark spot on the image presents a positive-going signal voltage. The photo-sensitive mosaic retains its

Figure 1
Keystoning the iconoscope scanning.

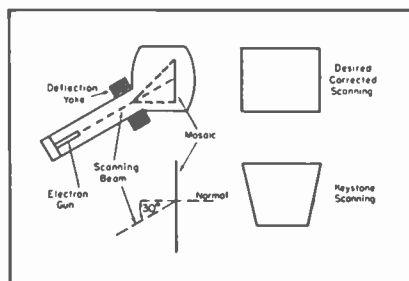

*TELEVISION ENGINEERING, January, 1950.

Tube Design

Part II: Operation of the Iconoscope Mosaic . . . Keystoning . . . Shading Signals . . . Low Resolution Pickup Tube for Experimental Work . . . Improved Type Image Dissector and Image Iconoscope Features.

by ALLAN LYTEL

Temple University Technical Institute

image impression until it is scanned by the electron beam. In this respect the *iconoscope* has a memory, since it retains light-image impressions until they are released by the scanning of the electron beam.

Keystoning

Since the electron beam strikes the mosaic at an angle of 30° with the normal, a distorted scanning pattern results. If a constant amplitude sweep is applied, a greater width of sweep will be obtained at the top of the mosaic than at the bottom, due to the greater distance between the electron gun and the photo-sensitive mosaic. This is known as *keystoning* and is illustrated in Figure 1. To produce the standard rectangular pattern, the amplitude of the applied sweep decreases as the electron beam travels from the bottom to the top of the mosaic. While a scanning beam moves across one line at the top of the mosaic the sweep voltage is made smaller than the sweep used to scan a line at the bottom of the mosaic. This, together with the inherent trapezoid pattern, produces a normal rectangular sweeping pattern. The horizontal deflection voltage is modulated to produce a rectangular pattern and correct for keystoning.

The Shading Signal

The load resistance used between the signal plate and ground is approximately 30,000 ohms and an output signal of the order of 0.003 volt peak-to-peak is developed. In addition to the electromagnetic sweep, together with its keystoning modulation, several other

signals are used with the *iconoscope*. One of these is the *shading signal* which is used to correct for a spurious signal. This undesired output or *dark-spot signal* appears as shading over different portions of the picture. The camera tube has several signals which may be used to overcome this dark-spot signal.

A blanking voltage is also used to cut off the scanning beam during the fly-back portion of the applied sweep. The signal used for blanking in the *iconoscope* is a series of negative voltage pulses applied to the grid of the electron gun.

Use of Back Lighting

During the manufacture of the tube the inner surface of the glass walls apparently become slightly sensitive due to the deposit of minute particles from the mosaic. The introduction of back lighting has been found to reduce the dark-spot signal and also improves the picture contrast. To provide this improvement, two small lamps are mounted behind the signal plate, and illuminated during operation, the exact

amount of lighting varying with the operating conditions of the camera.

Low-Resolution Tubes

For experimental television in laboratories, for teaching television techniques in schools, and for general industrial applications, a smaller version of the *iconoscope* with less than standard resolution, 250 lines, has also been produced. This model, the 5527¹ uses electrostatic deflection and electrostatic focus to overcome the need for expensive and bulky magnetic deflection coils and circuits.

The mosaic functions in the same manner as the conventional *iconoscope* except that the signal plate is transparent. Mounted on the top of the tube, the mosaic has the image to be televised focused upon its transparent signal plate.

Simpler Control Circuits

Since the mica base of the mosaic is also transparent, illumination passes through the signal plate and the mica sheet to cause electron emission from the globules in standard fashion. Since the mosaic is perpendicular to the scanning electron beam, there is no inherent keystoning of the picture; this allows for a simpler control circuit. Other added features include operation without shading signals and the use of inexpensive lenses. Since the mosaic is

Figure 1a
Television camera featuring use of type TK30A image orthicon.

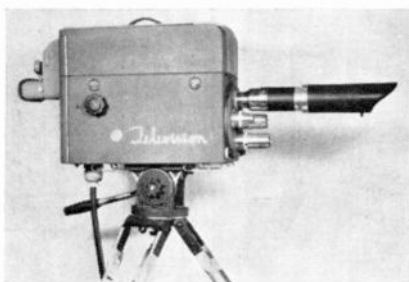

¹RCA.

Camera Tube Design

(Continued from page 23)

physically closer to the external wall of the tube, lenses of short focal length may be used.

In the conventional *iconoscope* the mosaic is mounted at a distance behind the glass face of the tube, thus limiting the focal length of the camera lens used. Deflection electrodes of the smaller version are similar to the type found in electrostatically-deflected picture tubes; the deflection electrodes have a high sensitivity and thus only a small driving voltage is necessary. All of the deflecting electrodes have their own base pin connections which allow use of balanced deflection, giving increased picture definition.

Tubes' Gain Characteristics

Because of its inherent storage action, the *iconoscope* is a more sensitive device than the basic *image dissector*; the storage effect is cumulative and each picture element stores information which it retains until it is scanned by the electron beam. In the *image dissector* there is only provision for the scanning of a single element, while the *iconoscope* releases the energy stored over the entire sequence. A theoretical gain of many thousand times could be obtained with the *iconoscope*; actually, the gain is somewhat less, being of the order of several thousand only. This decrease of theoretical gain occurs

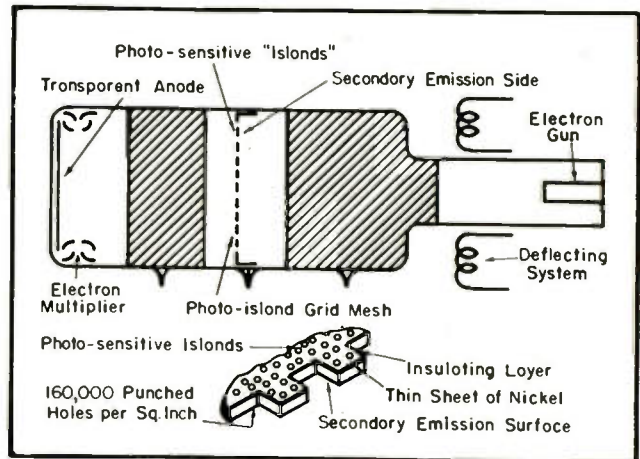
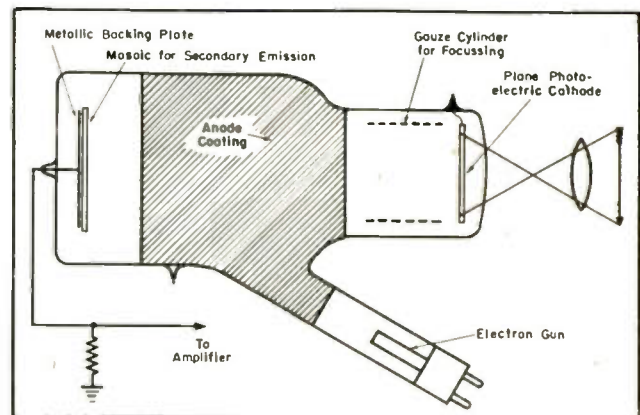

Figure 2

Schematic of the improved Farnsworth camera tube.

Figure 3

The image iconoscope.



"Pardner, this Amphenol
INLINE* Antenna is up to
 stay! Our boss knows his
 business, because these
 people will get the best
 possible pictures and we
 won't have any call-back
 time here."

AMERICAN PHENOLIC CORPORATION
 1830 SO. 54TH AVENUE - CHICAGO 53, ILLINOIS
 *U. S. PATEN. NO. 2,474,483

AMPHENOL

because of the interaction between globules.

There are two fundamental principles which are used in today's television camera tubes; both of these are illustrated in the basic *image dissector* and *iconoscope*. One method is the formation of an electron image, such as with the dissector tube, and the other is the formation of a storage action by a photosensitive mosaic, which is essentially made up of many thousands of individual photoelectric cells. The more advanced tubes use both of these actions together to produce increased sensitivity and improved operation.

The Improved Image Dissector

In Figure 2 appears one version² of the advanced type of pickup tube which features both basic camera-tube ideas. The scene to be televised passes through a transparent anode to a unique photo-sensitive grid arrangement. By means of secondary emission the signal strength is increased many times and further gain is obtained by an electron-multiplier output.

Grid Structure

The grid has approximately 160,000 small holes per inch punched from a nickel plate. On one face this plate has an insulating material covered with a great number of photo-sensitive areas. These photo cathodes or *islands* are insulated from one another just as are the globules of a conventional mosaic. The face of this nickel plate, toward the electron gun, is specially treated to produce secondary emission. An electron gun, together with its magnetic deflection system, is mounted in the neck of the tube. Light is focused through the transparent anode upon the photo-sensitive islands. Each of these individual areas emits electrons in relation to the amount of illumination it receives. Thus, a varying electrical charge results, just as was the case with the *iconoscope* mosaic. The scanning electron beam passes over the face of this grid, opposite to these islands. Secondary electrons are emitted in great numbers by this nickel surface; these electrons function as a virtual cathode. They move through the many holes of the mesh in accordance with

the potential existing on the photo-sensitive side of the grid.

Grid Characteristics

Since the potential existing at any point on the photo-sensitive islands depends upon the illumination of that given point, the number of electrons passing through any given area of the grid mesh depend upon the potential existing at that point. This grid acts as an amplifier grid in that it controls the flow of a great number of electrons whose source is secondary emission.

Tube Sensitivity

After the electrons have passed through the holes in the grid, they travel through the anode and the electron multiplier where they produce the signal current. A tube of this nature is more sensitive by an approximate factor of 10, than the conventional *iconoscope*. By a combination of a mosaic and an electron image, a gain is produced in relation to the basic *image dissector*. Shading signals are also eliminated in this tube. In the CBS color system a tube, quite similar to this improved type tube, is used.

The Image Iconoscope

In Figure 3 appears another improved type of pickup tube, the improved version of the basic *iconoscope*, known as the image *iconoscope*, which uses an electron image and mosaic. The scene to be televised is focused upon a transparent photoelectric cathode, similar in function to the basic *image dissector* cathode. Electrons are

emitted in the form of an electron cloud which travels down the tube impinging upon a mosaic. Electrostatic focusing is used to prevent this electron image from becoming distorted due to the mutual repulsion of electrons.

Secondary Emission Factors

This mosaic, while similar in physical construction to the mosaic of the basic *iconoscope*, is *not* treated for photo sensitivity. The individual globules are rather designed for secondary emission only. The electron image falling upon this mosaic causes electrons to leave due to secondary emission. Many more electrons leave than arrive, between three and ten electrons for one. The electron gun, scanning arrangement, and output signal, are quite like the fundamental *iconoscope*. This tube may be classified, basically, as a combination *image dissector* and *iconoscope*.

Short Focal Length Lenses

The photo-sensitive transparent cathode produces an electronic image which, in turn, causes secondary emission from the mosaic. This tube has an increased sensitivity of approximately ten times over the basic *iconoscope* because of secondary emission. It will be seen that because the cathode is close to the glass face of the tube, short focal length lenses may be used, increasing the amount of light available on the photo cathode.

Both electrostatic and electromagnetic deflection systems have been used with this tube.

[To Be Continued]

Figure 4

Schematic arrangement of the 2P23 image orthicon.

(Courtesy RCA Tube Department)

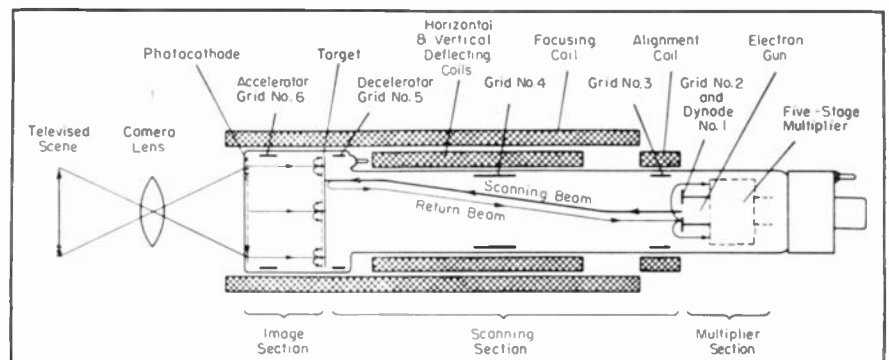

²Farnsworth.

A Line Equalizer

by HERBERT G. EIDSON, Jr., Chief Engineer, WIS and WIS-FM; Technical Director, WIST

IN REMOTE and studio-transmitter program-loop work, frequency-response equalization is extremely important. Unfortunately, though, the complexity of some of the equalizing systems has made application a bit difficult. Exploring the possibilities of simplification, a parallel anti-resonant circuit with a selector to obtain a choice of two peak frequencies, 5 and 10 kc, was evolved. A variable resistor of 200 ohms was included to change the effective Q of the circuit, allowing a smooth transition from 5 to 25 db of equalization at either 5 or 10 kc. If a higher value of variable R had been used, the starting figure of 5 db could have been lowered somewhat, but only at a sacrifice of critical adjustment at the other end of the control.

So that the device could be used also as a special-effects filter, a bat-handle

toggle switch was incorporated for switching in and out of the circuit at will.

Theory of Operation

Development of the loop equalizer was predicated on the theoretical operation of a parallel-tuned circuit when such a circuit is placed across a generator whose output contains all frequencies; only the frequency to which the anti-resonant trap is tuned will pass without attenuation. The reason for this is based on the premise, that if the Q of the tuned circuit is high, or its losses are low, then at F_0 , Z will become an extremely high R . This will be very much greater than the 600-ohm

¹Webster defines equalization as: "One that equalizes; character or condition of being equal; level, even, not varying or changing; exactly the same in measure, quantity, quality, status or position."

line which it has been placed across, and thus will offer no loading effect and so practically no attenuation at this self-resonant point.

When a frequency lower than the resonant frequency of the tuned circuit is employed, the circuit then becomes inductive, the angle increasing as the frequency decreases, until when zero frequency is obtained the inductance becomes zero. Thus we have a short circuit, less its own R losses. When the frequency is caused to rise above F_0 of the trap then the circuit becomes capacitive. The effects of the inductive reactance gradually disappears and the capacitive reactance becomes more predominant, until the point is reached where the frequency is infinite and the capacitor effects a short circuit. Therefore, it can be seen then that due to the inductive loading and the capaci-

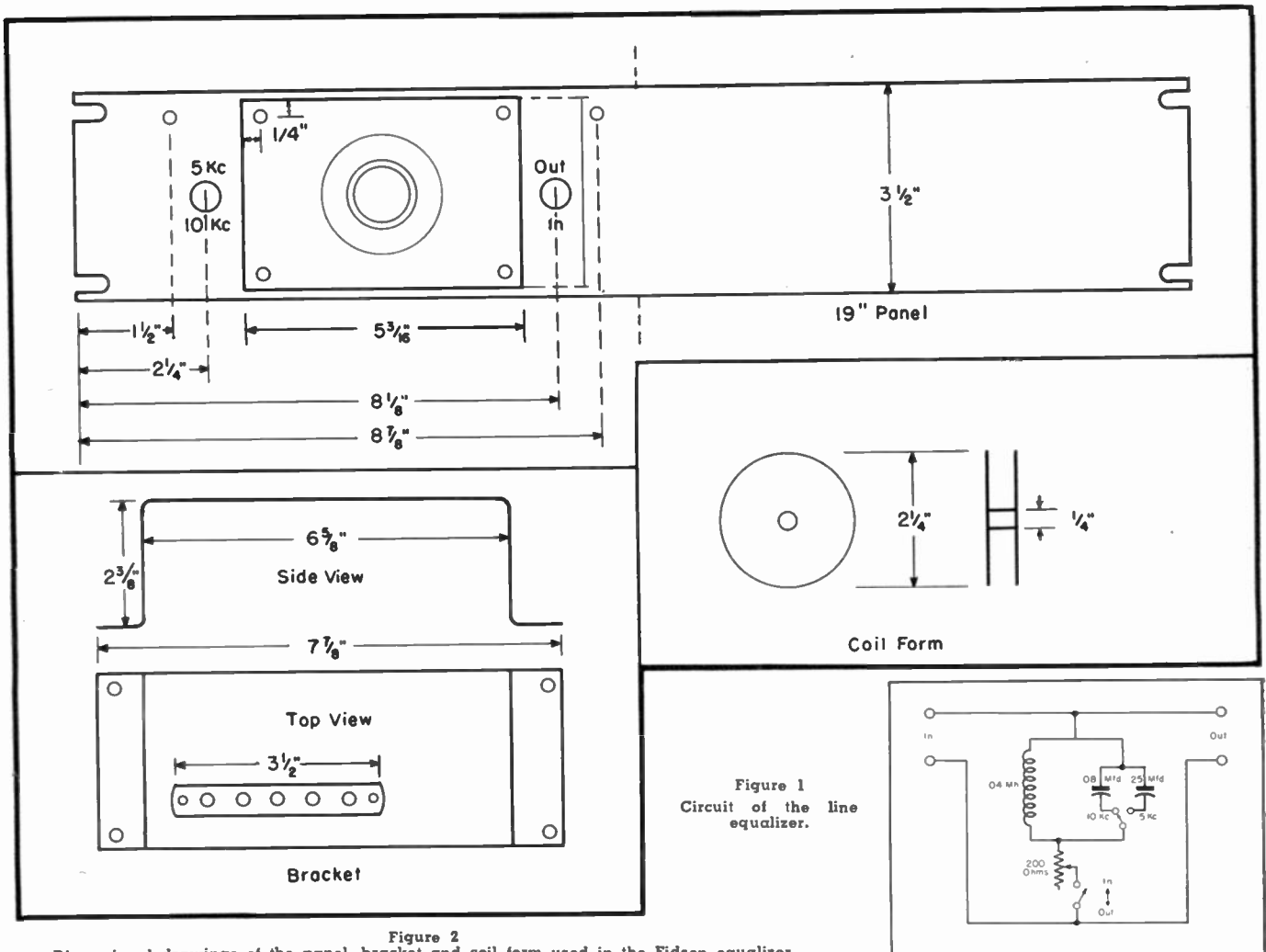

Figure 2 Dimensional drawings of the panel, bracket and coil form used in the Eidson equalizer.

Loop Equalizer, Employing a Parallel Anti-Resonant Circuit Providing Choice of 5 and 10-Kc Peaks, Permits Equalization of Frequency Response of Telephone Lines for Remote Studio, Transmitter and Program Loops. System Can Also Be Used as a Diameter Equalizer for Disc Recorders and as a Special Sound-Effects Filter.

tive loading of the circuit the lower and higher frequencies are attenuated by the parallel-tuned circuit.

Equalization Application

From the practical standpoint of utilizing this unit as a line equalizer, we are interested only in its operational behavior at its resonant frequency and below. To convert the generalized interpretation¹ of equalization to our use, we followed the view that if the capacity of a given line is such that a great many of the higher frequencies are attenuated, then our equalizer must be capable of attenuating the rest of the audio spectrum in which we are interested by a like amount, so that when a program level of a given intensity and uniform response is introduced at one end, the same frequencies would be reproduced at the other end with even amplitude. A program of flat response would thus be provided.

Construction

To mount the equalizer an aluminum panel 3½' wide and 19" long was used. Space was left so that another equalizer of the same type could be added at some later date. To hold the individual components, a bracket formed of aluminum sheet was used. The base of an old 16" transcription disc, bent to form an inverted U, serves this purpose nicely.

Standard paper capacitors were used, one having a value of .25 mfd to obtain an F_0 of 5 kc and two others, placed in parallel, to produce a total of .08 mfd, for the resonant frequency of 10 kc when used with the inductance of .04 mH.

The coil, consisting of 425 turns of No. 22 dsc wire, was wound on a ¼" wooden dowel 7/16" long, through which was inserted a brass bolt holding stiff cardboard round-end sections, 2¼" diameter.

If it is desired to use another type of coil or use a different size of wire, the proper number of turns can be determined by the use of a variable audio oscillator and an ac voltmeter as an indicating instrument.

In positioning the unit careful placement was found necessary to minimize pickup of hum due to the unshielded condition of the inductive portion of

(Continued on page 39)

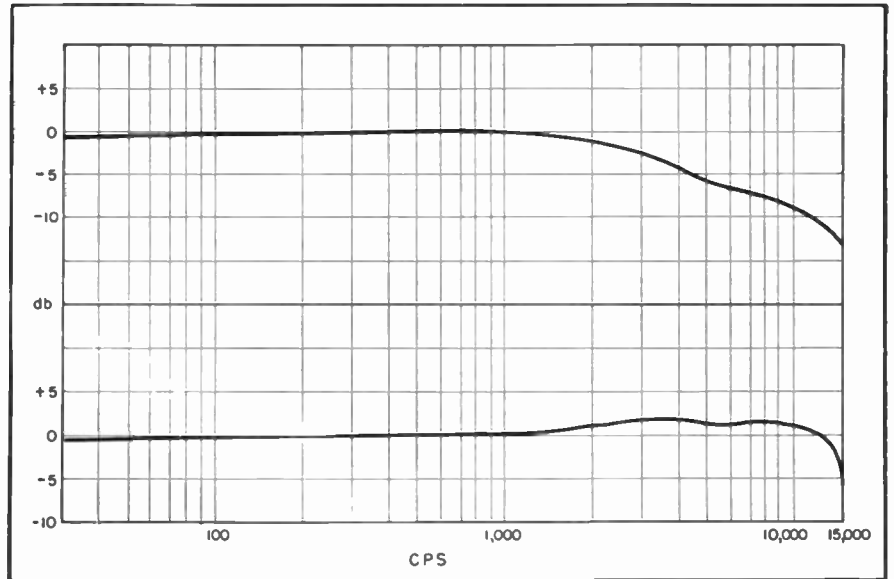
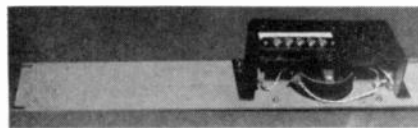

Figure 3
Frequency response plot, the top curve illustrating the response of a four-mile telephone loop used for remotes (half is in lead and half is open wire), and the lower curve showing the response of the same line after equalization with the equalizer set on 10 kc and the control set on approximately 10 db.

Side view of equalizer.



Front view of loop equalizer.

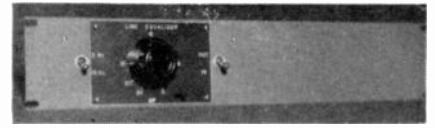
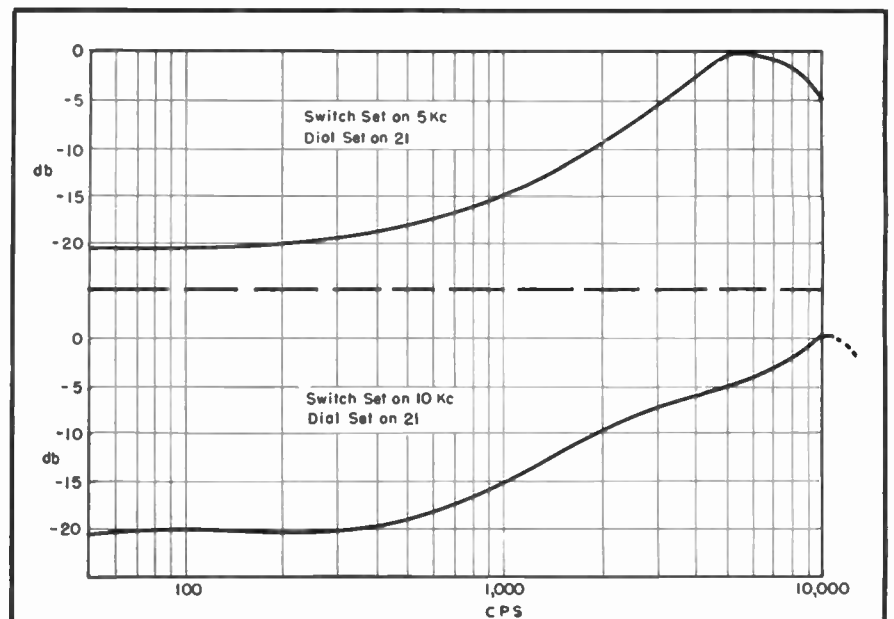

Figure 4
Composite line-equalizer plots; top curve illustrates the results with the switch set on 5 kc (dial set on 21) and the bottom curve illustrates the results with the switch set on 10 kc (dial set on 21).



Amplitude Modulator

AN AMPLITUDE MODULATOR, designed for use with an FM signal generator, as well as with other signal generators for receiver tests where amplitude modulation is desired with negligible incidental FM, has been developed. It modulates the signal generator output after attenuation, so that reaction on the oscillator frequency, which produces FM, is eliminated.

Modulation up to 80% at 60 cycles, is provided internally. External modulating frequencies between 20 cycles and 15 kc can be used. Input and output impedances are 50 ohms.

Radio-frequency range is 10 to 150 mc with a gain of 0.1, and 10.1 to 11.3 mc with a gain of 10.—Type 1023-A; General Radio Co., 275 Massachusetts Ave., Cambridge 39, Mass.

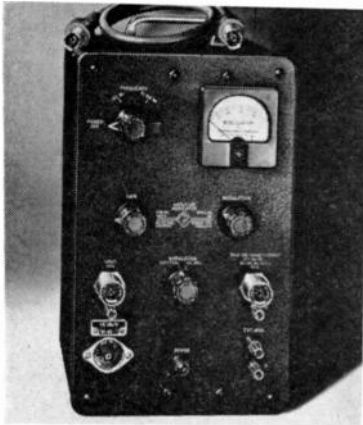

G-R amplitude modulator.

Vacuum Tube Volt-Ohmmeter

A VACUUM TUBE VOLT-OHMMETER, 120 cubic inches in size, designed especially for television servicing has been announced. Has a $4\frac{1}{2}$ " meter.

Instrument's *dc* input resistance is said to be 10 megohms for all ranges. Has five *dc* and five *ac* voltage ranges, five resistance ranges, three *af* voltage ranges, db from -20 to +63 in five ranges, a zero center galvanometer for FM discriminator alignment and an *rf* voltage range with 20 volts maximum and flat frequency measurements between 20 kc and 100 mc.

Equipped with a *dc* voltage probe, an *ac* voltage-ohms probe and a ground lead. Accessory equipment includes a high-frequency probe and a 30,000 volts high-voltage probe.—Type 303; Simpson Electric Co., 5200-18 W. Kinzie St., Chicago 44.



Simpson vt volt-ohmmeter.

High-Voltage CRT Oscilloscope

AN OSCILLOGRAPH, using a 5RP-A high-voltage *crt* operating on 13,500 volts, is now available. High potential makes possible the observation and photographing of high-speed signals recurring either at random or at slow, recurrent intervals.

Recurrent, single, or driven sweep durations are continuously variable from 5 seconds to 10 microseconds. The cathode-ray beam rests at the left side of the screen which is said to result in negligible sweep starting time on driven sweep. On the return cycle the trace is automatically blanked out. A Z-axis input is provided for intensity modulation.

Input signals may be applied through an *ac* amplifier, through a *dc* amplifier, or directly to the deflection plates for both X- and Y- axes. Frequency response of the *dc* amplifiers is said to be uniform within 10% to 200,000 cps, response of the *ac* amplifiers uniform within 10% from 5 to 200,000 cps.

A built-in square-wave voltage calibrator, said to be accurate to within $\pm 5\%$, provides outputs of 0.01, 0.1, 1.0, 10 and 100 volts.—Type 250-AH, Allen B. Du Mont Laboratories, Inc., Instrument Division, 1000 Main Ave., Clifton, N. J.



Du Mont oscilloscope.

TV Marker

A MARKER to provide crystal controlled markers for sound and picture carriers on each of the twelve TV channels, has been produced for alignment of TV receivers and tests on TV *rf* front ends for alignment of intercarrier pick-off circuits. Two markers appear simultaneously, for the channel selected by a front panel switch, at a panel coaxial connector. A 10:1 switched attenuator and a continuously variable attenuator covering an additional 10:1 range controls the *rf* output. Tone modulation may be switched on or off the sound marker. In addition the sound marker may be switched off leaving only the picture marker active. A second coaxial panel connector supplies a 4.5-mc signal. This output is controlled by a second continuously variable output level control.

Separation between sound and picture carriers is said to be 4.5 mc \pm 500 cps. Output level at *rf* is approximately 100,000 microvolts.—Dual Mega-Marker, Sr.; Kay Electric Co., Pine Brook, N. J.

Vacuum-Tube Voltmeter-Ohmmeter-Kilovoltmeter

A VACUUM-TUBE voltmeter-ohmmeter-kilovoltmeter, featuring 6 *dc* and *ac* ranges, etc., is now available.

The *dc* ranges are: 0 to 3-10-30-100-300 and 1000 volts (all ranges are said to have a constant input resistance of 11,000,000 ohms); *ac* ranges . . . 0 to 10-30-100-300 and 1000 volts at 1000 ohms per volt; kilovolt range . . . 0 to 30 kilowatts (input resistance 1100 megohms, using high-voltage probe); ohmmeter ranges . . . 0-1000, 0-10,000, 0-100,000 ohms and 0-1, 0-10, and 0-1000 megohms; and *rf* voltage ranges . . . 0-3-10-30-50 volts (to over 100 mc which may be measured using *rf* probe).

Meter uses a bridge amplifier circuit.—Transvision, Inc., New Rochelle, N. Y.

FM Signal Generator

A FREQUENCY-MODULATED signal generator, has been designed for use with telemetering receiver equipment and in other associated applications. Covers 175+ to 250 mc. Provided with three continuously adjustable deviation ranges: 0-24 kc, 0-80 kc, and 0-240 kc. Amplitude modulation up to 50% may be obtained using an internal audio-oscillator and modulation to 100% with an external audio oscillator.

Internal audio oscillator provides eight fixed frequencies between 50 cycles and 15 kc, any one of which may be selected by a rotary type switch for frequency or amplitude modulation.

Deviation sensitivity of the frequency modulation system is said to be within ± 0.5 db from *dc* to 200 kc. The amplitude modulation system is said to be substantially flat from 30 cycles to well above 100 kc.

A front panel jack permits direct connection of an external modulation voltage source directly to the screen element of the final stage for pulse and square wave amplitude modulation. Under these conditions the rise time of the modulated carrier envelope is said to be less than 0.25 microseconds and the decay time less than 0.8 microseconds.

A monitoring meter is used to standardize the output level of the signal generator to make the mutual inductance (piston type) *rf* attenuator direct reading over the range from 0.1 microvolt to 0.2 volt. The output impedance (with cable attached) is 26.5 ohms.—Type 202-D; Boonton Radio Corp., Boonton, N. J.



Boonton FM signal generator.



FIELD TESTED

Installation Information on

TV and FM

RECEIVING ANTENNAS

TV . . . FM Antenna Installation

by IRA KAMEN,

Manager, Antenaplex and TV Dept., Commercial Radio Sound Corp.

and LEWIS WINNER,

Editorial Director, Bryan Davis Pub. Co., Inc.; Editor, SERVICE and TELEVISION ENGINEERING

The only practical book on the all-important item in TV and FM reception . . . based entirely on actual experiences in the most active TV and FM areas in the country. . . . Over 35,000 words of vital data with over 130 photos and drawings.

TEN CHAPTERS COVERING:

*Installation Tools
Antenna Installation Procedures
Securing 12-Channel Coverage
HF Antenna Installations
TV Interference*

*Fringe Reception
Master Antenna Systems
FM Antennas
Installation Business Practices
Tricks of the Trade*

The first book in which you'll find complete design and installation information on every type of TV and FM receiving antenna. . . . Contains detailed illustration and subject index for rapid reference.

✓✓ "The best book on the market at this time dealing with the problem of television antennas and antenna installation . . . If more Service Men would read this book, it would help them considerably in making better installations and providing better television reception for their customers."—*M. J. Shapp, President, Jerrold Electronics Corp.*

✓✓ "Will recommend it to all the Service Men and technical people I meet."—*Charles Cahn, Field Service Engineer, Bendix Radio.*

✓✓ "Well organized and illustrated, very complete and up-to-date, carefully detailed. It will definitely improve the ability of the man who studies it and therefore is mighty useful to a firm like ours."—*Hamilton Hoge, President, United States Television Mfg. Corp.*

✓✓ "Will certainly fill a long-felt need for some practical information . . . sincerest congratulations."—*George P. Adair, Former Chief Engineer, FCC, and now Consultant in Washington, D. C.*

✓✓ "A thorough-going compendium of the installing art . . . Going to recommend it highly to our Service Control Department and our service organizations."—*Ernest A. Marx, General Manager, Television Receiver Sales Div., Allen B. DuMont Laboratories, Inc.*

✓✓ "Informative and extremely well written."—*R. Morris Pierce, Vice President in charge of Engineering, WJR, WGAR, KMPC.*

AT YOUR JOBBER
OR ORDER DIRECT



Price \$2 Post Paid

**BRYAN DAVIS PUBLISHING CO., INC., Book Dept.
52 Vanderbilt Avenue, New York 17, N. Y.**

Send me a copy of TV . . . FM Antenna Installation, post-paid, for which I am enclosing \$2.00.
(Please print)

NAME

ADDRESS

CITY AND STATE

It's EASY to install "Payroll Savings"

... and 20,000 companies' experience proves it pays!

If you've put off installing the Payroll Savings Plan in your company because you feel it would be "a lot of work," then this advertisement is certainly for you! Because it's really very simple to give your employees the advantages of investing in U. S. Savings Bonds the easy, automatic "Payroll" way.



HERE'S ALL YOU NEED TO DO

Appoint one of your top executives as Savings Bond Officer. Tell him to get in touch with your State Director, Savings Bonds Division, U. S. Treasury Department. Here's what happens . . .

The State Director will provide application cards for your employees to sign—plus as much promotional material and personal help as necessary to get the Plan rolling in your company.

Those employees who want Savings Bonds indicate on the applications: how much to save from their pay; what denomination of Bonds they want; and the inscription information to appear on the Bonds.

Your payroll department arranges to withhold the specified amounts, arranges to get the Bonds, and delivers them to the employees with their pay.

The Bonds may be obtained from almost any local bank or from the Federal Reserve Bank or may be issued by the company itself upon proper certification by the Federal Reserve Bank or Branch in the company's District.

THAT'S ALL THERE IS TO IT!

In case you're skeptical as to how many of your employees would like to have Payroll Savings, canvass your plant—and be prepared for a surprise. (Remember that pay-check withholdings for Bonds are *not* a "deduction"—the employee takes home his Bonds with his pay.) One leading manufacturer, who had professed little faith in the Plan, found his eyes opened when he asked the people in his plant whether they would like to obtain Bonds in this way. Within only six months after he installed the

Plan, half his employees signed up. A prominent aircraft manufacturer, whose company had used the Plan for some time, was not aware of its potentialities until his personal sponsorship increased participation by 500% among his company's employees.

THE BENEFITS ARE BIG— FOR EVERYONE

The individual employees gain security—they know that the Bonds they hold will return \$4 for every \$3 at maturity. The company gains from

the resultant increased stability and efficiency of its workers. The whole nation gains because Bond sales help stabilize our economy by spreading the national debt and by creating a huge backlog of purchasing power to boost business in the years ahead.

Is it *good policy* to deprive your company of Payroll Savings—even one more pay day? Better at least have a talk with your U. S. Savings Bonds State Director, get the answers to your questions, and *know for sure*.

The Treasury Department acknowledges with appreciation the publication of this message by



TELEVISION ENGINEERING

This is an official U. S. Treasury advertisement prepared under the auspices of the Treasury Department and The Advertising Council.

NETWORK FEEDING

From a Small Station

WHEN, a couple of football seasons ago, it was decided to not only pick up the home and away games of the University of Iowa, but feed these reports to a network of twelve stations, we were faced with the small-station problem of weighing quality of production against costs. In reviewing the situation, it was found that a very satisfactory type of transmission could be provided, even though it would be necessary to effect one compromise and that would be in the class of telephone lines used, schedule *D* lines. The judicious use of a modified program equalizer¹ offered the major solution to our problem, offsetting to a very noticeable extent, the low-quality lines we used.

Other equipment was also modified or specially built, some as we went along to provide improved service. An interesting example of one such station-built unit was a standby battery pack with a change-over relay built into a small, rugged overnight case. Several times, during power failures, this battery pack *saved the show*. An external mixing box was also designed to allow for the use of two microphones, and the switching in of a third mike via a 50-ohm *T* pad for crowd noise pickup. Since an open booth was found best for our work, we had more than enough crowd noise, and accordingly the crowd-noise mike has been used rarely.

To simplify microphone interchange, we standardized on 50-ohm mikes and connectors² to fit. During the recently completed football schedule, it was suggested that a sideline mike would be useful for additional color. With enough cord to reach the center of the playing field the mike could be used to pick up the coin toss and pre-game words from the officials. To assure complete control of this pickup the side-lines announcer was provided with a pair of phones so that he could take cues directly from the booth. Since it would have been very difficult to string wires from the booth down to the field we decided to use the telephone circuit and rented a pair and a half from the telephone company. To these three wires we connected a double button carbon mike³ that

Novel Audio Facilities Developed by Low-Power Station to Provide Comparatively Good-Quality Signals Over Schedule D Type Lines for Feeding of Football Home and Away Games to Network of Twelve Stations.

By ELLIOTT FULL, Chief Engineer, KXIC, Iowa City, Iowa

was terminated in the booth at a changeover box. This box provided a switch of the cue down to the field when the booth was on the air. When the field mike was live, we could switch off the cue and connect the field mike into the sportscasters channel. This link was provided via a repeat coil, and a combination gain control and impedance matching pad. Incidentally, the mike battery, which was also located in the box, was not switched in because of the clicks that would have resulted.

Our remote amplifier,⁴ a single-channel type, did not have a *vi*, and thus we provided a portable unit for volume indication. The meter and remote mixer simplified gain riding since some of the booths are small and tables for

the engineer are either very small or nonexistent.

The studio end of the pickup operation involves a comparatively small amount of equipment. Only a program equalizer and two isolation amplifiers were found necessary; one amplifier with a single dual triode and the other with two dual triodes. Both amplifiers, push-pull throughout, were provided with 600-ohm and bridge inputs and 600-ohm outputs. A 6-db pad was provided on a patchboard for feeding long lines. Patchboard jacks with a sufficient number of points were provided so that the bridge and 600-ohm input could be reached with a single patch cord. This feature served to cut down the patchboard puzzle that always turned up during a busy Saturday.

For home-game operation the feeds were arranged so that the stadium line could be fed right into the station console, one iso unit bridging the stadium line and feeding an equalizer which fed another iso unit, a two-tube ampli-

(Continued on page 32)

³The carbon mike provided very satisfactory results since the crowd noise covered up all the hiss and carbon noise. However, we going to try to use a high-output dynamic mike on the field for both cue and speech during our next year's broadcasts, thus simplifying the switching and battery problem. The high output has been found necessary, since the wires, going up to the booth are not shielded, and therefore it's necessary to override hum and noise.

Additional equipment used at KXIC for feed facilities (left to right): single-channel unit (above appears overnight case reconstructed to accommodate standby battery pack); external mixing box; portable volume indicator, and changeover box in which are terminated leads from a double button carbon microphone.

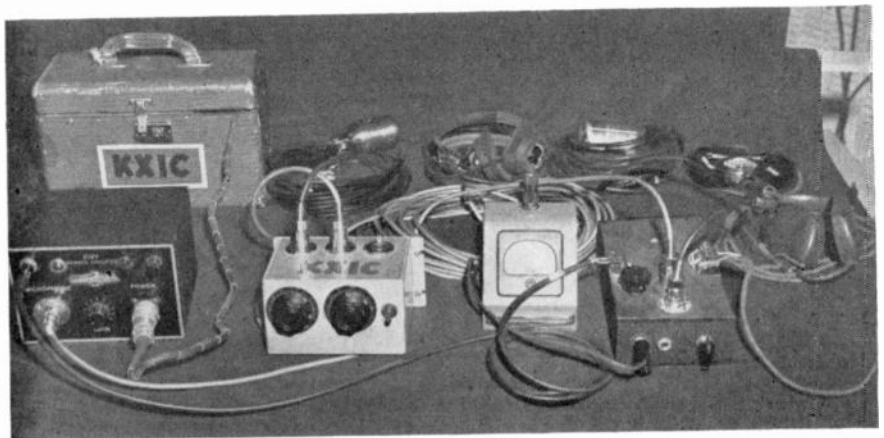

¹Collins. ²Cannon XL-3. ⁴Collins 212-Y.

New Type 2A TAP SWITCHES

HAVE A CONSTANT CONTACT RESISTANCE OF
ONLY 1 or 2 MILLIOHMS!

These high quality switches with up to 24 contacts were specifically developed to meet the need for rugged precision instrument switches that have longer operating life and are economical components in competitively priced electronic instruments and military equipment.

Write for Technical Bulletin No. 28.

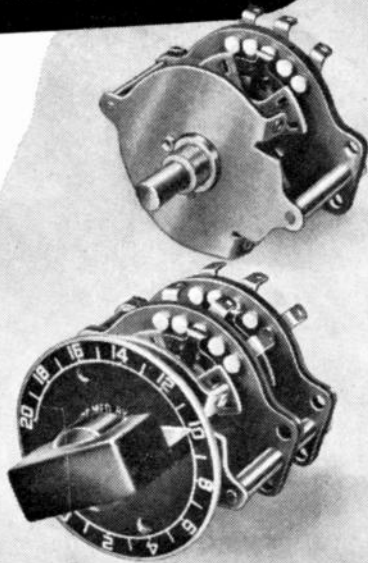

TECH LABORATORIES PALISADES PARK
NEW JERSEY

For **HEAVY DUTY**
WORK! Severest Electrical Services!



P-506-Ct
Plug with Cap



S-506-DB
Socket with
deep Bracket

JONES
PLUGS &
SOCKETS

500 SERIES

*Proven
Quality*

For 5,000 Volts,
25 Amperes per
Contact Alter-
able by circuit
Characteristics.

Socket contacts phosphor bronze, knife-switch type, cadmium plated. Plug contacts hard brass, cadmium plated. 2, 4, 6, 8, 10, and 12 contacts. Plugs and sockets polarized. Long leakage path from terminal, and terminal to ground. Caps and brackets, steel parkerized (rust-proofed). Plug and socket blocks interchangeable in caps and brackets. Terminal connections most accessible. Cap insulated with canvas bakelite.

Write for Jones BULLETIN 500 for full details on line.

Jones **HOWARD B. JONES DIVISION**
CINCINNATI MANUFACTURING CORPORATION
CHICAGO 24, ILLINOIS
SUBSIDIARY OF UNITED-CARB FASTENER CORP.

IRE National Convention
GRAND CENTRAL PALACE
and
HOTEL COMMODORE
New York

**RADIO
ENGINEERING
SHOW**

March
6-9
1950

247
Exhibitors



Come Again— Television Men!

"Spotlight is on the New" in 230 Electronic Exhibits for you to see. Hear 3 technical sessions and 2 Symposiums of 24 papers of all the latest phases of television. Last March 15,710 attended. The Registration (4 days) is \$3.00, for television industry people.

Not open to general public.

The Institute of Radio Engineers
1 E. 79th Street, New York 21, N. Y.

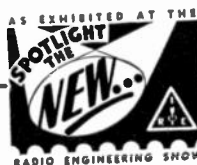

Veteran Wireless Operators Association News

Personals

FROM VWOA OLDTIMER, Sten Perry, has come an extremely interesting bit of reminiscent copy covering his experiences as a brass pounder which began back in '12. In '17 Perry received his ham ticket and in '19 a first class commercial radiotelegraph license as a result of some intensive home study. Between '20 and '26 Perry saw service on a variety of ships plying the Coast and the Atlantic Ocean. During the war he served as Operations Officer for the Coast Guard Reserve and was in charge of sealing and testing transmitters on merchant ships in Boston harbor. Perry now operates a mobile ham setup which he believes to be the only all-band amateur phone and cw station in existence. SSP, a MIT graduate, is now a sales engineer in the Boston District office of Worthington Pump and Machinery Corp. . . . From Al Schuster ye secretary also received an informative recap of early experiences. Schuster reported that his last wireless operating job was aboard the S.S. West Kyska, a USSB ship. This was a one year post, '26 to '27, which was followed by a three-year session with RCA Photophone in the sound recording division. In '29 AS transferred from Photophone to Pathe News with whom he remained until '42. In '42 he joined the U. S. Naval Reserve and served with the Bureau of Aeronautics, Photographic Division, for four years. Although his active operating days ended some years ago, an active interest in radio is still maintained by way of a ham steup. "Commercially I still get a kick out of ship-to-shore activities," he said in his letter, "and keep 500 kc and hf receivers working at home. I was jolted back into the past some months ago when I heard WSL being paged by a spark transmitter, from a Spanish ship."

12-BAY TV ANTENNA

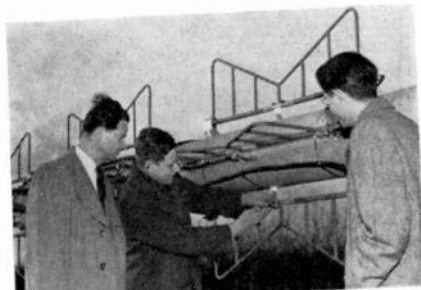

The WHAS-TV (Louisville, Ky.) 12-bay antenna being inspected by (left to right) Orrin Townner, chief engineer of WHAS; M. E. Hiehle, G.E. engineering section, and H. W. Granberry, G.E. TV sales.

TeleVision Engineering, February, 1950

Personals

David A. Hillman, formerly with the RCA Service Co., has been appointed assistant to Ira Kamen, manager of the TV department, at Commercial Radio Sound Corp.

George M. Hartley has been appointed manager of the G. E. glyptal alkyd resin plant in Schenectady, N. Y.

Jerome R. Steen, director of quality control for Sylvania Electric Products Inc., has been elected to grade of Fellow by the IRE board of directors. The award was for his work "in the introduction and development of statistical quality control techniques in electron tube manufacturing."

Kenneth C. Meinken, Jr., has been appointed National Union Radio Corp. mid-western sales manager of tube sales to initial equipment manufacturers.

Headquarters are at 2800 North Milwaukee Ave., Chicago.

Frank Goldstein has been appointed chief engineer of WMOR, Chicago FM station, succeeding David B. Pivan, who resigned to join James E. Everett, Engineers, Evanston, Ill. Walter Childress, Jr., has been appointed assistant chief engineer.

Harold J. Adler has been appointed chief television engineer of The Hallicrafters Company. Adler, who will be in direct charge of all television chassis development, was formerly with Sentinel Radio, Chicago, where he was chief engineer on both radio and television.

C. C. Fisher has been named chief engineer of Utah, Inc.

Fisher has been with Permoflux as a consulting engineer, and Hawley Products, Radio Division, and Magnavox.

Industry Literature

The Standard Transformer Corp., Elston Kedzie and Addison Sts., Chicago 18, Illinois, have released a 20-page booklet, *Stancor Television Components Replacement Guide* (form DD338C), listing replacement transformers for 215 TV receivers and chassis made by forty-three manufacturers. Replacement part numbers are listed together with manufacturers' part numbers for identification.

The Bundy Company, Detroit 14, Mich., have published an 18-page bulletin, describing steel tubing. Detailed are fatigue and corrosion resistance, and methods used to fabricate tubing, involving cutting and machining, joining (double flare), serpentine bends, bending, forming, coating, etc.

A series of photomicrographs are also featured in the bulletin.

Measurements Corporation, Boonton, N. J., have published a 44-page catalog, describing pulse generators, standard signal generators, square wave generators, uhf radio noise and field strength meters, vtvm, megacycle meter, if converter, rf attenuators, megohm meters, and bridges.

FOR ULTRA-PRECISION
CATHODE RAY TUBES...

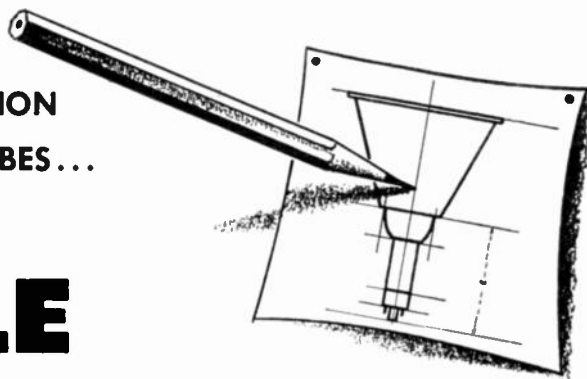

KAHLE CUSTOM-BUILT MACHINERY

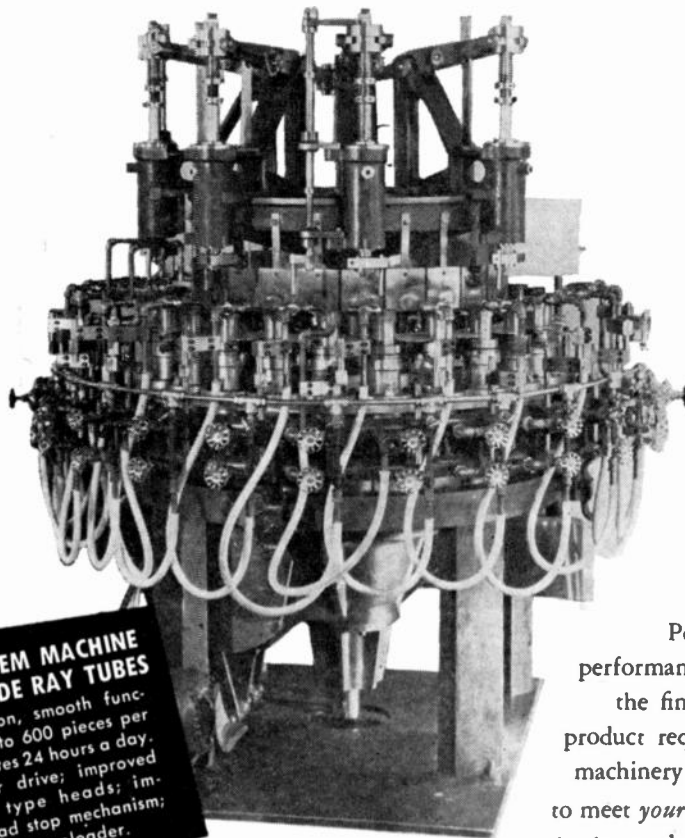

BUTTON STEM MACHINE FOR CATHODE RAY TUBES

High precision, smooth functioning. Up to 600 pieces per hour; operates 24 hours a day. Dual motor drive; improved clean-out type heads; improved head stop mechanism; automatic stem unloader.

Perfect performance in the finished product requires machinery built to meet *your* need in the production

stage. Kahle's years of experience in meeting the *specific* requirements of ultra-precision operations with custom-engineering, has helped many outstanding manufacturers of cathode ray tubes operate efficiently and profitably. This Kahle know-how may solve your unusual problem, too. Kahle specialists are available for consultation, without obligation.

Consult Kahle On Any Requirement • Write For Complete New Catalog

Kahle Specializes in Equipment
and Methods for the Manufacture
of Complete Production Units For

Cathode Ray Tubes • Subminiature Tubes •
Electronic Tubes • Fluorescent Lamps • Neon Tubes
• Photocells • X-Ray Tubes • Glass Products

Kahle ENGINEERING COMPANY
1305 SEVENTH STREET • NORTH BERGEN, NEW JERSEY

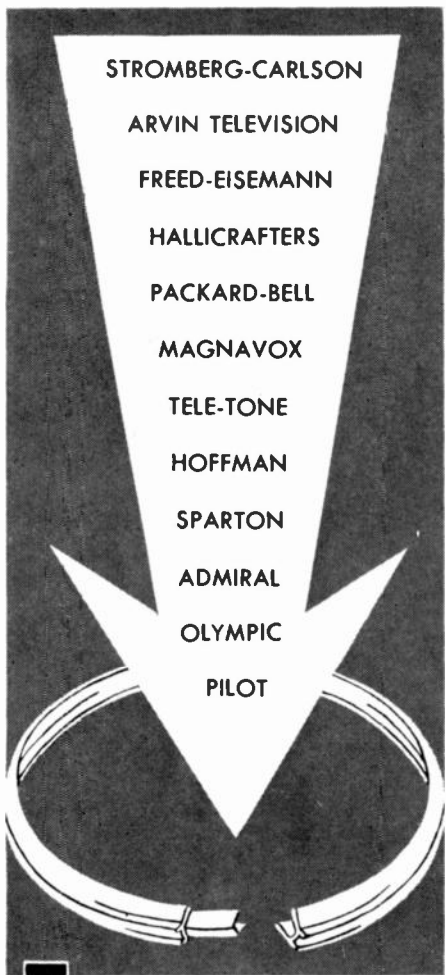

They ALL come to Anchor...

... for perfect, low-cost mounting and full insulation of metal TV tubes, which facilitates rapid Underwriters' approval. Mounting ring* and sleeve* in 8 1/2", 16", and 19" sizes. Safe, secure, economical.

Write or call.

Cross section, ring and sleeve



Complete assembly



ANCHOR PLASTICS CO., Inc.
537 Canal St., New York 13, N. Y.
Telephone Dlgby 9-1242

AT AAAS N. Y. MEETING



Section of a TV exhibition, staged by the AIEE, during the 116th annual meeting of the American Association for the Advancement of Science in New York. Left to right: Robert Gaines, DuMont engineer; Dr. Frank Carver, professor of electrical engineering at the Illinois Institute of Technology; Roy B. Shank, of the Bell Telephone Labs, and chairman of communications division, New York Section of AIEE; I. E. Lattimer, A.T.&T. Long Lines Department engineer, and Scott Helt, DuMont engineer, chairman of the subcommittee on exhibits.

Germanium Diodes

(Continued from page 11)

of background illumination of the picture. Capacity coupling of the video amplifiers removes the *dc* level of the signal that was established at the transmitter. If a diode is installed as a peak rectifier in the grid circuit of the picture tube, as illustrated in Figure 3, it will add a *dc* bias dependent on the peak voltage of the synchronizing pulses and maintain the tips of the pulses at a fixed *dc* level. The operating point of the picture tube is then established by the brightness control.

In the absence of the diode, the video signal would vary about an *ac* axis. However, the diode permits the capacitor, *C*, to charge to a voltage proportional to the synchronizing pulse voltage, adding a *dc* voltage to the video signal to maintain a constant reference level. An analysis of the operation of this circuit discloses that the best performance is obtained with a diode having low forward resistance and high back resistance. Since the forward dynamic resistance of the germanium diode is lower than a tube, some improvement in performance can be realized. On the other hand, only those diodes selected for high back resistance will perform properly. In application, it has been found that a resistor of approximately 1/2 megohm, in parallel with the diode, minimizes the effect of variation of back resistance between diodes, maintaining uniform performance between receivers.

* The Audio TV Circuit

The audio circuit of a television receiver is similar to an FM receiver. Detection of the FM *if* signal is accomplished by a discriminator or a ratio-detector circuit, which employ two diodes and require balanced conditions.

The most common type of discriminator circuit, the Foster-Seeley circuit, is shown in Figure 4. Germanium diodes have been successfully substituted in this circuit for vacuum tubes. The only precaution taken has been to add shunting resistors to the diodes to maintain a fairly uniform balance between the two halves of the circuit with respect to the back resistance.

In the ratio-detector type circuit, it has been found that the balance between the two halves of the system becomes more critical. This is due to the fact that the purpose of the ratio detector is to provide AM suppression as well as FM detection and depends for its operation solely on the balance of the two halves of the circuit. As

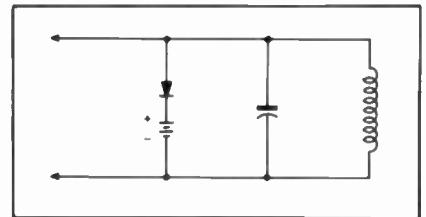

Figure 5
A biased diode limiter stage.

previously mentioned, the back resistance of diodes is not uniform and can change with temperature and voltage level. Such changes also may not be the same in two diodes. Hence, it does become more difficult to use germanium diodes in the ratio detector. Variations of the ratio detector have been devised that minimize the detrimental effects of the finite back resistance of the germanium diodes. Such circuits can approach the operating quality of the conventional vacuum tube circuits.

Biased Diode Limiter

Practically all television receivers use a limiter stage ahead of the discriminator, even when a ratio detector is used. The function of the limiter stage is to clip off any amplitude variations of the sound *if* signal that may be caused by noise or non-uniform *if* amplification over the frequency band. Usually a one or two-stage grid-biased limiter is used, but can be quite expensive. Where the normal amplification of the limiter is not necessary, a biased diode can be used more inexpensively.

The circuit of Figure 5 illustrates this point.

The diode with a bias voltage equal to the normal signal level is placed across a tuned circuit. It will conduct only on peaks that exceed that normal level and will hence short out noise peaks. Harmonic distortion due to such clipping can be minimized by using two diodes to clip both the positive and negative peaks. The bias also can be from an *RC* circuit, so that it is automatically adjusted to the signal level.

Germanium diodes can also be used in the many varied types of sync-separating circuits. Individual circuits would have to be analyzed, however, to determine the best grade of diode to use in these applications.

The use of germanium diodes in television receivers as well as many other electronic devices is relatively new. However, their advantages are numerous and their uses are growing rapidly. In addition, during the past year, the cost has steadily dropped and will continue to decrease as manufacturing techniques improve.

Quality Control

(Continued from page 9)

Defective: "An item containing one or more defects."

Fraction Defective: Ratio of number of defective items to total number of items inspected.

p Chart: A graph of fraction defective observed in consecutive samples of inspected items and the limits between which these fractions may vary if the process is in control.

APPENDIX II

Procedure for Sampling Inspection

In order that a sampling inspection reflect the condition of the line accurately and quickly, it is necessary that:

(1) Samples be drawn at random; that is, no prejudice enter into the selection of the sample.

(2) Sample be drawn from a pool of material just produced, not a day or several days after the production of the material.

To obtain an efficient sampling system, the following procedure must be adopted:

(1) Following the addition of the *ert* belly-band, the chassis should be placed in a stock pile.

(2) Every twenty-five minutes the inspector should pick the last or next to last chassis placed on the pile. This chassis should be inspected and the results of the inspection entered on a form. A chalk mark (number) should be placed beside the pile which is under inspection until the complete sample of five has been inspected.

(3) If the chassis are placed in racks, the inspector must draw his sample of five when a rack of thirty-six chassis has been filled.

(4) In two hours, five chassis should be inspected and the results recorded. At the completion of the inspection of the group of five chassis, the total number of defects appearing are found and this number plotted on a graph.

(5) Each chassis inspected should bear the inspector's stamp.

Instructions Based on Control Chart

A: If a point, representing the number of defects in a sample of five should fall inside the established control limits, no specific action is required. Inspection can be continued as before.

B: If a point should fall outside the control limit, the inspector should be alerted to watch the next thirty points. If in the succeeding thirty points, another point falls outside the control limit, the following procedure must be followed:

(1) The inspector will be responsible for notifying the *riveting line supervisor* immediately.

(2) The inspector is also responsible for informing the *process inspection supervisor* as soon as possible about the out-of-control condition.

(3) After the *line supervisor* has been notified of the existence of an out-of-control condition, it is his responsibility to

IT'S KINGS FOR CONNECTORS

Pictured here are some of the more

widely used R. F. co-axial, U. H. F.

and Pulse connectors. They are all

Precision-made and Pressurized

when required. Over 300 types

available, most of them in stock.

Backed by the name **KINGS**—the leader in the manufacture of co-axial connectors.

Write for illustrated catalogs, Department "T"



Manufacturers of Radar, Whip, and Aircraft antennas
Microphone Plugs and Jacks.

Radar Assemblies, Cable Assemblies, Microwave and
Special Electronic Equipment

take either one of the following courses of action:

(a) He must attempt to remedy the trouble himself.

(b) If he cannot correct the trouble within one hour or if he realizes immediately that he cannot solve the problem, he must summon the *factory engineer* in charge of the *riveting process*.

(4) The *factory engineer* will be responsible for taking any and all necessary steps to see that the *riveting line* is brought under control at the desired level.

(5) It will be the responsibility of the *factory engineer* to request that the *methods engineer* make any fundamental changes in the riveting process if it appears that this action is necessary in order to bring the process into control.

(6) The *methods engineer* is responsible

for cooperating and making any fundamental changes that are required to eliminate the trouble in riveting.

(7) It is the responsibility of the *process inspection supervisor* to institute 100% inspection if, in his judgment, the trouble is beginning to threaten the main line.

(8) The *process inspection supervisor* is responsible for requesting that the rivet process be stopped if the out-of-control condition persists and there is no reason to believe that the trouble will be cleared up very shortly: Very shortly is to be interpreted as being one week from the time that the trouble first becomes evident.

(9) The request for the stopping of the rivet process shall be addressed to the *factory inspection manager*.

[To Be Continued]

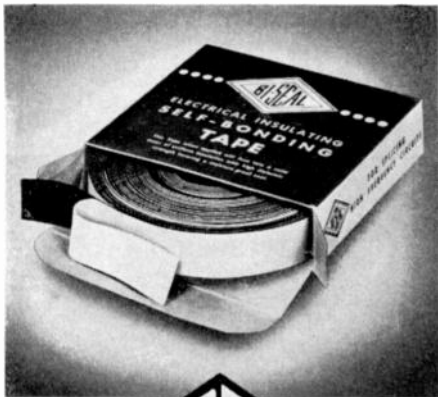

SELF-BONDING TAPE

for Insulating and Hermetic Sealing
Radio • Television • UHF Electronic
Components and Installations

★ Excellent HF Dielectric

S.I.C. 2.13 and P.F. 0.004 @ 10mc. Break-down over 800V/MIL. Stable electrical properties over wide temperature and humidity range.

★ Self-Bonding

Fuses to a solid mass. "Memory Effect" of resins does the trick. No surface adhesives to dry out.

★ Resistant Protection

BI-SEAL is unaffected by moisture, corrosive fumes, ozone, sunlight. It's stable over and compatible with other insulations. It will not corrode metals. Absence of volatile plasticizers contributes to superior aging characteristics.

★ Shapes to Any Contour

Balanced mechanical strength and excellent elasticity allows you to make a wrapped seal perfectly matching the most complex shape contour component.

We feel confident that you will find BI-SEAL to be the answer to many of your UHF insulating, sealing, terminating problems. Write for literature and samples.

Bishop Manufacturing Corporation

Established 1847

420 East 25th Street, New York 10, N. Y.

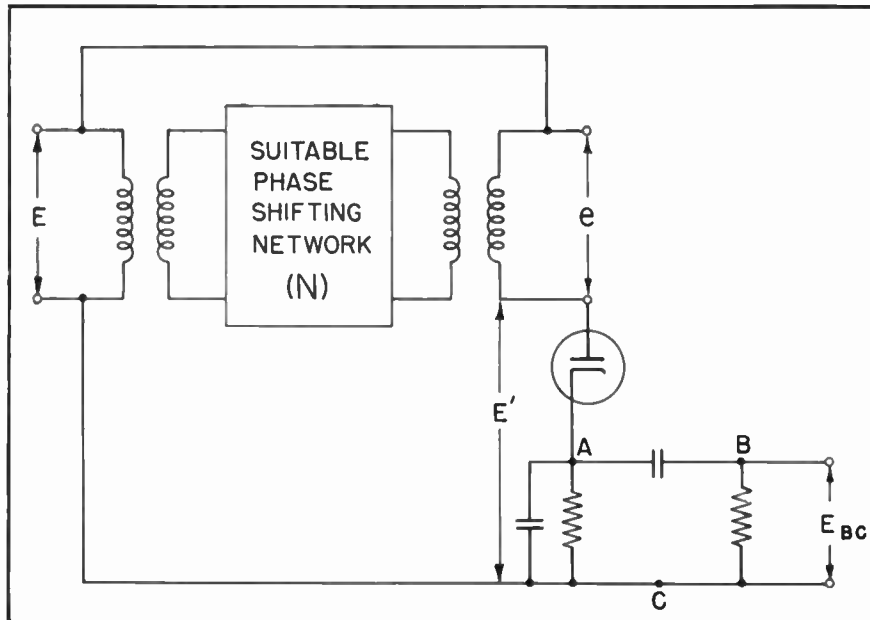

Figure 10 (above)
Generalized FM detector circuit.

Figure 11
Conventional discriminator circuit.

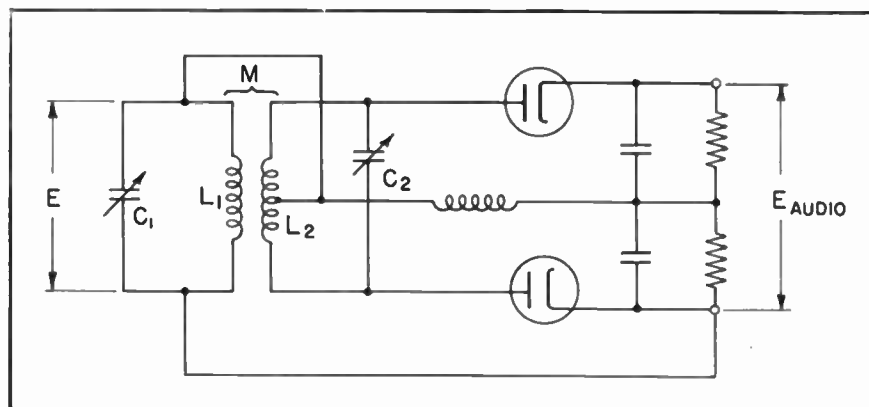
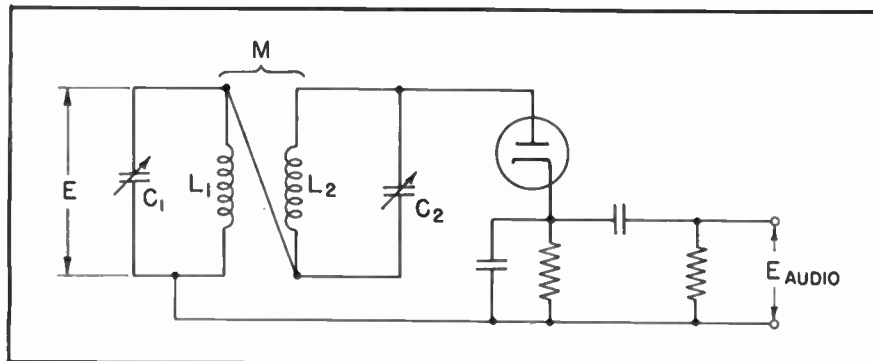

Figure 12

Discriminator of Figure 11 bisected and connected to conventional diode circuit of Figure 8 for use as an FM detector.



FM Detection

(Continued from page 13)

greater rapidity and better linearity of the phase shift through the pass region of certain band-pass types of structure make these types more to be preferred, than either low-pass or high-pass types. Bode has indicated² that linear phase shift through the pass band of a filter structure can be attained by proper design of the network.

In TV receivers today the present practice is to use FM in the sound channel, with an intermediate frequency for the sound channel of from 21.25 mc to 21.75 mc and a frequency deviation of ± 75 kc for maximum modulation. Whichever phase shifting network, (N), is used, it should center on the $\frac{\pi}{2}$ and produce the requisite changes in phase about this point, preserving reasonable linearity over a range of ω_s/ω corresponding to this deviation plus a comfortable margin on either side.

The FM detector most commonly used today is the discriminator illustrated in Figure 11, or a variation of it called the ratio detector. The discriminator is a differential detector in which two voltages are produced, each of which varies with the phase angle of the associated network. One of these voltages increases in magnitude while the other decreases in magnitude as the phase angle changes. The discriminator then differentially combines these two voltages in such a manner that an output voltage is produced, which is proportional to the difference

in the magnitudes of these two voltages.

From the previous discussion it is evident that *differential* operation of the foregoing type is not actually necessary to recover the modulation from an FM wave. In fact, the discriminator may be bisected *per se* and still perform as an FM detector when connected as shown in Figure 12. It then assumes one form of the generalized circuit indicated in Figure 10.

All of the devices described are sensitive to amplitude modulation as well as to frequency modulation and consequently must be preceded by limiters, just as a discriminator is if they are to be responsive to frequency modulation only.

In conclusion then, it may be stated that any device capable of developing an output voltage whose amplitude is proportional to the rate of change of the time varying phase angle will act as an FM detector. A simple solution to the problem is the insertion into the system of a network which will produce

two voltage vectors $(2n + 1) \frac{\pi}{2}$

ans out of phase with each other at the undisturbed carrier frequency, the phase angle between the two vectors varying proportionately with the change in frequency of the FM wave above and below the carrier frequency. The vector sum of these two voltage vectors is then applied to an ordinary rectifying device which converts the variations in frequency into corresponding variations in amplitude. This conversion will be free of distortion as long as the resultant vector voltage is linear with $d\phi/dt$ over the entire frequency swing.

¹Carson, John R., and Fry, Thornton C., *Variable Frequency Electric Circuit Theory with Application to the Theory of Frequency Modulation*, Bell System Technical Journal, Vol. XVI, pp. 513-540; October, 1937.

²Bode, H. W., *A General Theory of Electric Wave Filters*, Journal of Mathematics and Physics, Vol. XIII, pp. 275-362; November, 1934.

Bode, H. W., and Dietzold, R. L., *Ideal Wave Filters*, Bell System Technical Journal, Vol. XIV, pp. 215-252; April, 1935.

Line Equalizer

(Continued from page 27)

the circuit. A small section of a heavy iron water pipe can be used for coil shielding if the hum becomes too bothersome.

The equalizer has been in use at this station for about nine months and has been found very effective.

Welcome to the 1950 I. R. E. CONVENTION

New York—March 6-9

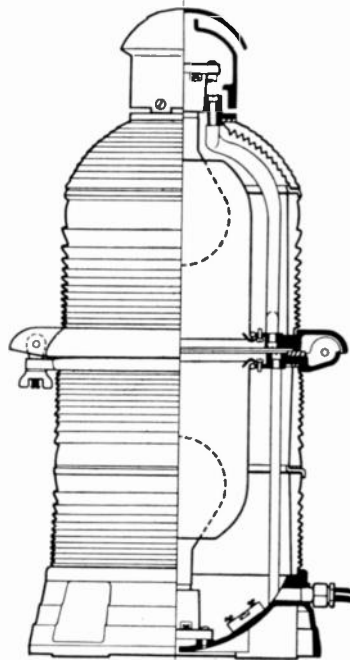

BE SURE TO SEE THE
HUGHEY & PHILLIPS DISPLAY
(Booth 215)

300 MM CODE BEACON:

Patented ventilator dome provides forced circulation for cooler operation and longer lamp life.

OTHER H & P PRODUCTS:

- SINGLE and DOUBLE OBSTRUCTION LIGHTS
- MERCURY CODE FLASHERS
- "PECA" SERIES UNIT PHOTO-ELECTRIC CONTROL
- COMPLETE LIGHT KITS FOR A-2, A-3, A-4 and A-5 TOWERS

HUGHEY & PHILLIPS
TOWER LIGHTING DIVISION

60 East 42nd St.
New York 17, N. Y.

326 N. La Cienega Blvd.
Los Angeles 48, Calif.

AMPERITE

Studio Microphones at P.A. Prices

Ideal for BROADCASTING

- RECORDING
- PUBLIC ADDRESS

"The ultimate in microphone quality," says Evan Rushing, sound engineer of the Hotel New Yorker.

- Shout right into the new Amperite Microphone—or stand 2 feet away—reproduction is always perfect.
- The only type microphone that is not affected by any climatic conditions.
- Guaranteed to withstand more "knocking around" than any other type mike.

Special Offer: Write for Special Introductory Offer, and 4-page illustrated folder.



Models
RBLG—200 ohms
RBHG—Hi-imp.
List \$42.00



"Kontak" Mikes
Model SKH, list \$12.00
Model KKH, list \$18.00

AMPERITE Company, Inc.

561 BROADWAY • NEW YORK 12, N. Y.

In Canada: Atlas Radio Corp., Ltd., 560 King St. W., Toronto

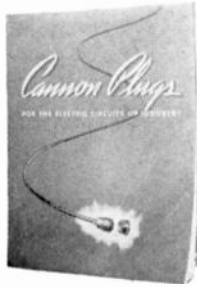

Cannon Plugs

**FOR THE
ELECTRIC CIRCUITS
OF INDUSTRY**

COPIES of this deluxe, 76-page book on the "Quick Disconnect" are still available at no cost to you. It is a digest of ideas on quicker and better assembly, easier servicing, maintenance and greater portability of electric equipment through the use of Cannon Plugs. The book covers such divisions as Communications, Power, Controls, Railroads, Aviation, Textiles, Television, Welding, Mining, Motion Pictures, Technical Institutions, Sound, Public Utilities, Process Industries, Automotive, Commercial Radio, Electro-Motive Power, Petroleum, and Marine.

Cannon Electric also manufactures signal equipment for hospitals, industrial plants, schools, institutions and many other electrical specialties such as conduit fittings, D.C. Solenoids, fire alarm relays, cable terminals, indicator and pilot lights, etc., etc.

Address Cannon Electric Development Co., Division of Cannon Manufacturing Corporation, 3209 Humboldt Street, Los Angeles 31, Calif. Canadian offices and plant: Toronto, Ontario. World export: Frazar & Hansen, San Francisco.



Briefly Speaking . . .

TV COLOR's immediate possibilities, which to some of the legislators in Washington appear to be quite dazzling, but to most of industry quite dull, received quite a frank analysis in a recent RMA report entitled *Is Color Television Ready for the Home?* Presented were blunt answers, to such questions as . . . What are the principal issues which the FCC must decide. . . . What are the important characteristics of the systems now under consideration. . . . Why shouldn't we go ahead with one of the systems now, trusting the scientists to overcome any existing weaknesses as we go along. . . . Will all broadcasts be made in color. . . . What procedure is recommended for developing commercial color television as quickly as possible. . . . What does the situation add up to in terms of when color will become available. . . . Pending a final decision on color what other action on TV should be taken by the FCC. . . . The report merits close study, particularly by those on Capitol Hill. . . . The reorganized National Television Systems Committee under Doc Baker's leadership should be of inestimable value in accelerating TV progress and providing acceptable answers on color TV to the Commission. . . . The importance of propagation was accented recently in Washington when the Bureau of Standards received approval to build a \$4,500,000 propagation laboratory at Boulder, Colorado, which will cover about 210 acres near the University of Colorado. Construction of the lab is expected to be started in the summer of '51. . . . William R. Spittal has returned to the transformer manufacturing field with a plant at Hicksville, L. I. Operating the Highland Engineering Co., Spittal will manufacture transformers, inductors, rectifiers, power supplies, etc. . . . J. D. Heibel has become director of research and development of the electronics division of Erie Resistor Corp. Nello Coda has been named chief electrical engineer of Erie Resistor and will be in charge of the electrical engineering department and the quality control laboratory. . . . New tape recording standards have been proposed by the NAB Recording and Reproducing Standards Committee. Proposals include for the first time a recommended standards hub and flange for use in reels containing magnetic tape. . . . The Sonotone Corp. have been licensed to manufacture and sell the DuMont bent-gun mount to television tube manufacturers. . . . A new type of tube for converting *ac* to *dc*, known as a caesium rectifier, was described recently at the winter AIEE meeting in N. Y. City by Dr. Albert W. Hull, consulting scientist of the G.E. research laboratory. . . . An interesting exhibit portraying TV transmission was featured at the AIEE meeting at the Hotel Statler. . . . A new type of silicone dielectric compound, known as G.E. 81083 has been described in a special report. The compound is said to form a waterproof seal and to be substantially unchanged by temperatures ranging from -70° to 450° F. . . . M. J. Obert and W. A. Needs of the RCA tube department presented a paper recently before the Radio Club of America describing a ferrite-core yolk for deflection use with the wide angle 16-inch picture tubes now coming off the line.

BIRTCHE
STAINLESS STEEL - LOCKING TYPE
**TUBE
CLAMPS**

Stainless Steel

Corrosion Proof



83 VARIATIONS

Where vibration is a problem, Birtcher Locking TUBE CLAMPS offer a foolproof, practical solution. Recommended for all types of tubes and similar plug-in components.

More than three million of these clamps in use.

FREE CATALOG

Send for samples of Birtcher stainless steel tube clamps and our standard catalog listing tube base types, recommended clamp designs, and price list.

THE BIRTCHE CORPORATION
5087 HUNTINGTON DR. LOS ANGELES 32

ADVERTISERS IN THIS ISSUE

TeleVision Engineering

FEBRUARY, 1950

AMERICAN PHENOLIC CORP.	24
Agency: Burton Browne, Advertising	
AMPERITE CO.	39
Agency: H. J. Gold Co.	
ANCHOR PLASTICS CO., INC.	36
Agency: Cont'l Adv. Agency, Inc.	
BIRTCHE CORP.	40
Agency: W. C. Jeffries Co.	
BISHOP GUTTA PERCHA CO.	38
CANNON ELECTRIC DEVELOPMENT CO.	40
Agency: Dana Jones Co.	
GENERAL RADIO CO.	Back Cover
Agency: The Barta Press	
HAYDU BROS.	Inside Front Cover
Agency: Cont'l Adv. Agency, Inc.	
HUGHEY & PHILLIPS.	39
Agency: Welch-Hollander, Advertising	
THE INSTITUTE OF RADIO ENGINEERS.	34
HOWARD B. JONES DIV. CINCH MFG. CORP.	34
Agency: Symonds, MacKenzie & Co.	
KAHLE ENGINEERING CO.	35
Agency: Harold Marshall Adv. Co.	
KINGS ELECTRONICS	37
Agency: Howard Adv. Associates, Inc.	
MOTOROLA, INC.	Inside Back Cover
Agency: Gourfain-Cobb Adv. Agency	
SYLVANIA ELECTRIC PRODUCTS, INC.	3
Agency: Cecil & Presbrey, Inc.	
TECH LABORATORIES	34
Agency: Lewis Adv. Agency	
THOMAS ELECTRONICS, INC.	32
Agency: Cont'l Adv. Agency, Inc.	
U. S. TREASURY DEPT.	4
WILCOX ELECTRIC CO.	1
Agency: Arthur G. Rippey & Co.	

MOTOROLA "RESEARCH" LINE OF F.M. 2-WAY RADIO

Chosen again

and again by city after city for superior adjacent channel performance

TYPICAL REPORT: "In compliance with test requirements, Motorola Inc., installed three 250-watt fixed station transmitters (on 155.73 mc.; 155.79 mc.; 155.85 mc.). The Motorola mobile equipment selected the 155.73 mc. station in all conditions with good results. No reception of the adjacent channel station was noted even when the mobile unit was operated in the immediate vicinity of the other transmitter."



"RESEARCH" LINE OF F.M. 2-WAY RADIO

with revolutionary new developments engineered at Motorola—the World's largest laboratories devoted exclusively to the development of radio communications systems—specialists in this field for over twenty years.

COMPARE Motorola with any other equipment. Write today for complete details.

protection

... of your long-term investment. PROTECTION against obsolescence for many years to come.

Specify Motorola "Research" Line for permanence in FM 2-way radio operation.



REPORT (CONTINUED)

"These tests preclude and safeguard us against future possibility of interference from any other transmitters that may be set up."

"Car to car tests exceeded all reasonable demands for car to car operation in emergency services."

"Collectively the tests have proven that Motorola equipment will amply provide for a modern communications system for our fire and police departments, not only at the present but in the future."

Motorola

UNIT INSTRUMENTS



Types 1205 and 1207

Types 1205 and 1206

PLUG-IN • VERSATILE • INEXPENSIVE

THE new G-R line of unit instruments — each complete in itself, with straightforward circuit, good accuracy and adequate shielding — provide a means for acquiring the basic measuring instruments for any small electronics laboratory with the minimum financial outlay.

These units are especially valuable in the college laboratory. All of the circuit components are permanently mounted in small, rigidly-constructed cabinets with open wiring which can be modified by students into a wide variety of typical circuits, and then restored to their original design with the minimum of time. Adequate metering is supplied. The accuracies are sufficient for a very large number of routine laboratory measurements, including use with various bridge circuits.

The power supply plugs into each unit, automatically furnishing the latter with proper filament and plate voltages. An accessory Jones plug is furnished so that customer-built units may be plugged into the power unit.

Type 1205-A Unit Power Supply This unit supplies output voltages of 6.3 volts at 2.5 amperes and 300 volts dc at 50 ma. The hum level is 0.8 volt at maximum output load. Connections to the associated unit equipment are made through a multipoint connector mounted in the ends of the instrument. An extra connector is supplied for use with other equipment. **Price: \$55.00**

Type 1206-A Unit Amplifier This amplifier uses two triode voltage-amplifier stages and an impedance-coupled output stage. It has a maximum voltage gain of 45 db with a maximum output of 30 watts. The frequency response is essentially flat from 100 cycles to 100 kc. Above 100 cycles the distortion is less than 2% with 1 watt into a 7500-ohm load. **Price: \$65.00**

Type 1207-A Unit Oscillator With separately available, high-Q plug-in coils this oscillator produces a test signal at frequencies from 400 cycles to 80 Mc at ½ watt maximum output. Seven plug-in coils provide continuous frequency coverage from 70 Kc to 80 Mc. Three fixed-frequency coils supply audio frequencies at 400, 1000 and 20,000 cycles. A blank coil is furnished with each instrument. The frequency stability is adequate for most routine laboratory uses except when highly selective tuned circuits are involved. **Price: \$73.00**



Seven plug-in coils cover the range of 70 kc to 80 Mc; three coils provide fixed frequencies of 400, 1000 and 20,000 cycles. Prices: from \$9.00 to \$19.50 each



Each unit is equipped with a multipoint plug (at rear) to pick up filament and plate voltages from the power supply. Small plug at front insures adequate mechanical connection between separate boxes



GENERAL RADIO COMPANY

Cambridge 39, Massachusetts

90 West St., New York 6 920 S. Michigan Ave., Chicago 5 1000 N. Seward St., Los Angeles 38

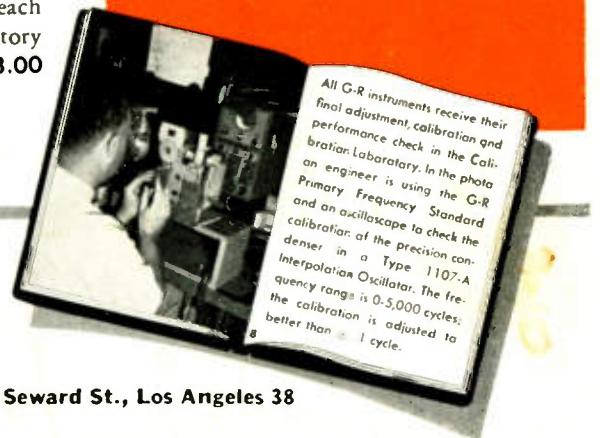

All G-R instruments receive their final adjustment, calibration and performance check in the Calibration Laboratory. In the photo an engineer is using the G-R Primary Frequency Standard and an oscilloscope to check the calibration of the precision condenser in a Type 1107-A Interpolation Oscillator. The frequency range is 0-5,000 cycles; the calibration is adjusted to better than 1 cycle.