

The **TALKING** *Machine*
MACHINE
WORLD

*For the
 makers &
 sellers of
 talking
 machines*

Published Each Month by Edward Lyman Bill, Inc., at 383 Madison Ave., New York, November 15, 1923

Victrola

REG. U. S. PAT. OFF.

The word "Victrola" as well as the picture "His Master's Voice" is an exclusive trademark of the Victor Talking Machine Company. Being registered trademarks they cannot lawfully be applied to other than Victor products.



"HIS MASTER'S VOICE"
 REG. U. S. PAT. OFF.

Victor Talking Machine Company, Camden, N. J.

The Highest Class Talking Machine in the World

THE INSTRUMENT OF QUALITY
Sonora
CLEAR AS A BELL



Chippendale De Luxe
\$575

Sonora Possesses the Three Vital Attributes of Quality Merchandise

YOUR future as well as present phonograph business is wholly dependent upon the degree in which the instrument you handle possesses the three vital attributes of quality merchandise. These consist of *natural* tone quality, beauty of design and a comprehensive range of prices to suit all types of purchasers.

One demonstration will convince you that Sonora possesses those attributes in

greater degree than others. Listening to it play one record will establish its far superior tone quality; a glance at the accompanying illustration will show you that Sonora is unsurpassed in attractive, artistic cabinetry, while the range of prices, from \$60 to \$3000, will clearly indicate the tremendous market available to you.

Send for the Sonora proposition—it will interest you.

The Choice of those who've heard them all

Sonora Phonograph Company, Inc.

279 Broadway, New York

Canadian Distributors: Sonora Phonograph, Ltd., Toronto

The Talking Machine World

Vol. 19. No. 11

New York, November 15, 1923

Price Twenty-five Cents

VOX CORP. ENTERS THE TRADE FIELD

Management of Vox Corporation of America, Manufacturers of Talking Machine Products, in Charge of A. Fodor, Backed by Strong Sales Organization Headed by O. P. Graffen

The talking machine industry will be interested to learn that Vox products, which have become prominent in a very short time abroad, will now be merchandised in the country through the Vox Corporation of America, with headquarters at 25 West Forty-fifth street, New York. The management of the American organization is in charge of A. Fodor. Mr. Fodor has a reputation for his technical ability to develop and standardize inventions and for his extraordinary knowledge and experience as an organizer of new industries. He is assisted by a competent sales staff headed by O. P. Graffen, one of the best-known members of the talking machine trade. Vox products comprise almost everything manufactured in the talking machine trade, and according to present plans the American organization will concentrate its energies upon the sale of records, spring and electric motors, sound boxes, tone arms, dictating machines and electric typewriters, etc.

Full details regarding the company's campaign for merchandising these products in this country will be announced in the near future, and in the meantime plans are being prepared for their rapid and efficient distribution throughout the country. With an international reputation behind them, it is expected that the Vox products will find a ready market in this country, and during the past few months hundreds of applications have been received for dealer franchises from representative houses in the leading trade centers.

NEW METROPOLITAN EDISON DEALERS

Phonograph Corporation of Manhattan Opens New Agencies in Gotham and Vicinity

The Phonograph Corporation of Manhattan, distributor of the New Edison in the metropolitan district, has recently established many new dealers, among which are A. S. Gould, 37 Main street, Flushing, N. Y.; A. Salomane, 467 Main street, Metuchen, N. J.; James McGarry, 486 Broad street, Newark, N. J.; E. J. Schoonmaker, 414 Main street, Bound Brook, N. J., and Max Bruskin, 278 Steinway avenue, Long Island City.

The popularity of the Edison line among the members of the retail trade, as well as the public in the metropolitan territory, has been growing steadily, and, according to reports from dealers throughout the trade who are in a position to know, the approaching holiday season will be one of the biggest on record as far as the Edison line is concerned.

WIDENER SHOPS ADD BRANCH

The Victrola department of G. Schirmer, Inc., 3 East Forty-third street, New York City, has been taken over by the Widener Shops, and in the future it will be operated under the supervision of that concern. The Widener Co. is planning to discontinue the store at 4 West Thirty-seventh street, consolidating the business in one establishment.

An important announcement appears in our London letter, elsewhere in this issue, to the effect that the Brunswick-Balke-Collender Co. recently closed arrangements with the famous house of Chappell & Co., Ltd., 50 Old Bond street, London, to act as distributors for Brunswick phonograph records in Great Britain. This firm is one of the oldest in England.

MUSIC TRADE TO MEET IN NEW YORK

Leading Branches of Industry Headed by Prominent Men—Irwin Kurtz Represents Talking Machine Trade on Arrangements Committee

At a meeting of the directors of the Music Chamber of Commerce, held in New York on November 2, it was decided that the annual convention of that organization and its divisional unit members would be held in New York at the Waldorf-Astoria Hotel. The week of May 18 to 23 was set tentatively as the date. The committee in charge of convention arrangements consists of Robert N. Watkin and W. C. Hamilton, representing the National Association of Music Merchants; C. T. Purdy, representing the New York Music Merchants; Irwin Kurtz, representing the New York talking machine dealers; J. W. Stevens, representing the New York piano manufacturers; A. W. Johnston, representing manufacturers of musical supplies, and W. J. Haussler, representing small goods and musical merchandise trades.

GEO. P. BENT RE-ENTERS TRADE

Widely Known Piano Man Joins Forces With His Son in Operating "The Music Shop"

CHICAGO, ILL., November 10.—R. B. Corcoran and H. J. MacFarland, co-partners with C. M. Bent, conductors of the retail Victor store at 214 South Wabash avenue, known as "The Music Shop," have sold out their interests to George P. Bent, former head of the George P. Bent Piano Co., who retired from business several years ago as a piano manufacturer and has since made his home in Los Angeles. From now on C. M. Bent and his father, George P. Bent, will conduct this business as partners. The father will continue to reside in Los Angeles and the management of the business will be looked after by his son here in Chicago.

KAUFMAN & BAER SECURE SONORA

Prominent Pittsburgh Department Store Closes Important Deal With Sonora Jobber—Complete Line of Instruments Placed on Display

PITTSBURGH, PA., November 8.—The Sonora Distributing Co., of this city, Sonora jobber for this territory, closed an important contract yesterday with the Kaufman & Baer Co., whereby this well-known department store will carry a complete line of Sonora phonographs. This deal was closed by Earl Miller, of the Sonora Distributing Co.'s sales staff, and arrangements have been made for an artistic display of the Sonora product. H. Milton Miller, manager of the company, is enthusiastic over closing this deal, which places the Sonora line in one of the largest department stores between New York and Chicago. George Israel, merchandise manager of the Kaufman & Baer Co., and Thos. J. Coyne, manager of the store's talking machine department, represented the department store in the negotiations which have just been closed.

NEW ORCHESTRAS FOR VOCALION

Coleman's Hotel Ambassador and Club Trocadero Orchestras Signed Up to Record

Among the new Vocalion Red records to be released shortly will be the first recordings of the orchestras controlled by Emil Coleman, namely, the Ambassador Hotel Orchestra and the Club Trocadero Orchestra, which have been added to the long list of prominent dance orchestras now playing for the Vocalion. The announcement of the first numbers by the Coleman orchestras will be made in an early Vocalion bulletin.

MIGUEL FLETA RECORDS FOR VICTOR

Spanish Tenor Scores at Metropolitan Opera House—Three Other Artists Also Join Victor List—First Records Soon to Be Released

F. K. Dolbeer, sales manager of the Victor Talking Machine Co., announced this week that Miguel Fleta, the celebrated Spanish tenor, who scored such a great success at his debut at the Metropolitan Opera House, New York City, last week, will record for the Victor Co. According to the critics of the daily papers, Fleta is one of the greatest tenors who ever came from Spain. He is still young and has a large repertoire, including a number of recent works not yet heard in America. His voice is lyric, but powerful, and of exceptionally fine quality in all registers. The good reports that have come to us from Europe and South America regarding Senor Fleta are evidently well justified.

Other artists who recently consummated arrangements with the Victor Co. to make records are Charles T. Tittmann, Della Baker and Claire Brookhurst.

Mr. Tittmann is a basso with a sonorous voice of unusual range and quality. He is widely known, having to his credit eight consecutive annual appearances at the celebrated Bach festivals in Bethlehem, Pa. He has also appeared in recitals throughout the country as soloist for leading orchestras and in opera.

Miss Della Baker is a native of St. Louis, who recently entered the concert field in New York. She has appeared with some of the leading orchestras and at musical festivals. Her voice is one of rare beauty.

Miss Claire Brookhurst is also an American, having been born in New York City, and her musical education has been acquired in this country. She has appeared in concert with the Russian Symphony Orchestra and made a trans-continental tour in concert. She is now soloist in a prominent church in Harlem. She has an unusual contralto voice with a wide range, and, owing to her linguistic ability, she sings all songs in the original language.

APPOINTED VOCALION RECORD DEALER

Bloomington's to Handle Complete Vocalion Record Line—Deal Closed by Musical Products Distributing Co., New York Jobber

Herbert D. Berkeley, manager of the phonograph department of Bloomington Bros., New York, announced recently that this store had arranged to carry in this department a complete line of Vocalion Red records, manufactured by the Aeolian Co. This important deal was closed by the Musical Products Distributing Co., New York, jobbers for Vocalion Red records in metropolitan territory, and B. D. Colen, president of this company, is highly gratified to add Bloomington's to the growing list of New York Vocalion record dealers.

REALTOR'S MESSAGE ON RECORDS

Special Records Made for Minneapolis Firm Teach Home Ownership

MINNEAPOLIS, MINN., November 7.—For the first time in history real estate precepts have been inscribed on phonograph records and set to music. The idea is the work of Dick Woodruff, manager of the small house department of Confer Bros., who has conceived the plan of utilizing the talking machine as a means toward teaching home ownership. The records, manufactured by an Eastern concern, have popular airs sandwiched in between short talks on the benefits to be derived from home ownership. More than 2,000 of these records have been sent out by mail by Confer Bros.

Value of the Phone as an Aid to Selling

Many Methods of Making the Phone Pay Dividends in Increased Sales Being Used by Live Retailers—Clever Phone-Mail Stunt Pays

In these days of keen competition the dealer who would get his share of business must utilize every possibility of increasing his sales volume. Half-way measures mean lost opportunities. The merchant who advertises and does not take advantage of other methods of securing business, such as canvassing, direct mail and all other forms of selling and publicity, is losing business. He may be what he considers successful, but the fact remains that greater success would attend the utilization of all mediums that lead to sales. A medium which is assuming a more and more important and effective place in the retailers' plans for enlarged sales volume is the telephone. During the last year many brief stories describing the way dealers are making their telephones pay actual dividends have appeared in the columns of *The World*.

Various Ways of Cashing In on the Phone

In some talking machine establishments one member of the sales organization is delegated to spend a certain amount of time telephoning customers regarding certain records which it is assumed will please the patron and this has been found quite effective in stimulating sales. A well-known department store has trained its records saleswomen to study each customer in order to ascertain the musical likes of each. A record is kept by each salesperson as to the particular records purchased in the past and from this a pretty accurate idea of the musical likes of each customer is obtained. Once each week the saleswomen of this establishment spend an hour at the telephone making contact with customers. Through this means also many slow-moving records have been disposed of. These records were non-sellers simply be-

cause in the average store it is the custom to steer clear of the better type of music and concentrate on the more popular recordings, to the detriment of records which really should form the backbone of the record business.

Novel Way of Making the Phone Pay

One of the most novel ways of making the phone produce business is now in use by one of the largest talking machine and music stores in the metropolitan district. The manager of this department has delegated a man to use the phone in calling up various people whose names have been taken from the phone book and directory. Of course, he is thoroughly familiar with the streets of the city and knows approximately the type of people living in the streets selected for his phone operations. The salesman talks to the lady of the house and cleverly secures certain information, i. e., whether a talking machine is owned, what type of music is desired, etc. To homes where there is no talking machine the following form letter is immediately sent:

In reference to our phone conversation, we were surprised to learn that you did not order the records that we were holding for you, awaiting instructions to send them.

In the course of the conversation you mentioned that you did not have a Victrola in your Home.

Why deprive yourself of the unrivaled sweetness and power of Caruso's voice that filled the Metropolitan Opera House to capacity whenever he sang?

Do you not miss the beautiful voice of John McCormack singing "I Hear You Calling Me" and "At Dawning"?

Is it not a treat to hear Fritz Kreisler play "Thais-Meditation," as well as to hear Galli-Curci sing one of your favorites?

All of these Victor Records can be best reproduced on Genuine Victrolas. The new Victrola Console Models we have on display will not only give you the fullest pos-

sible enjoyment from its exact reproduction of tone, but these Consoles serve as a beautiful piece of furniture as well.

The Rudolph Wurlitzer Co., being the largest Musical House in the World, is financially able to sell Victrolas to people who do not care to pay cash, but would rather pay monthly. The monthly payments are trivial, compared with the amount of enjoyment you will receive from a "Genuine Victrola from Wurlitzer."

After you have carefully gone over the catalog we are sending you, we would like to have you pay us a visit and see the actual Victrolas on display. When can you call?

If there are no results another letter is sent out after a lapse of a reasonable length of time. This letter asks whether the first communication has been received and it also emphasizes the fact that the enclosed catalog illustrates the latest models; requests that a personal visit be made to the store so that the line may be examined at first hand and an idea of the tone quality of the instruments may be realized and closes with the following paragraph, which makes action on the part of the customer easy:

"If unable to come in personally and examine the various models side by side, telephone Bryant 8140, Desk 52, or write a line and a salesman will call on you and give you full information, without obligating you in any way."

Phone Helps Small Dealers

The telephone way of selling should prove of especial benefit to retailers who are unable to maintain an outside sales organization. It is inexpensive and a most forceful means of bringing the product forcibly to the attention of prospective customers. People who will invariably refuse to talk to a salesman will answer the phone and will listen to the message of the dealer or salesman provided it be brief and to the point.

Last Call for Nyacco Record Albums For Holiday Trade

THE TALKING MACHINE'S HELPMATE



In order to take care of the holiday demand for Nyacco albums you must place your orders now. The demand for Nyacco albums this Fall has been exceptional. However, our two factories, New York and Chicago, will save you freight and insure prompt delivery if you order now.

Ask for our No. 600 Nyacco album, the highest grade album on the market. Samples sent on request to responsible houses.

TO JOBBERS ONLY:—

Write for samples of our new delivery bags of No. 1 Kraft paper (35 lb.) with strings and buttons at very attractive prices.

The Best Interchangeable Leaf Record Album on the Market



Write for display card—mailed without cost. It will help you sell more Nyacco Albums. Present stock available at low prices. Write now.

New York Album & Card Co., Inc.

NEW YORK
-23-25 Lispenard St.

CHICAGO
415-417 S. Jefferson St.

Pacific Coast Representative: Munson-Rayner Corporation { 643 South Olive Street, Los Angeles, Calif.
86 Third Street, San Francisco, Calif.

Victor supremacy is the supremacy of performance

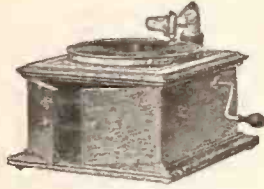

Victrola IV, \$25
Oak



Victrola VIII, \$50
Oak



Victrola No. 111
\$225
Electric, \$265
Mahogany or walnut



Victrola No. 125
\$275
Electric, \$315
Mahogany

The satisfaction, prestige, and profit which are part of the business of every dealer in Victor products, reflect it.



Victrola No. 210
\$100
Mahogany or walnut



Victrola No. 300
\$250
Electric, \$290
Mahogany or walnut



Victrola No. 410
\$300
Electric, \$340
Mahogany



Victrola

REG. U. S. PAT. OFF.

Look under the lid and on the labels for these Victor trade - marks

Victor Talking Machine Company

Camden, New Jersey

COLUMBIA DEMONSTRATION RECORD

Mammoth Publicity Campaign to Feature Special Columbia Demonstration Record—Presents Selections by Famous Artists—Designed to Successfully Stimulate Record Business

Starting on November 17 and continuing throughout the month, the Columbia Phonograph Co. will sponsor a tremendous advertising campaign featuring a ten-inch demonstration record that will be offered to the public at twenty-five cents. This demonstration record has been introduced to give Columbia dealers an opportunity to call to the attention of prospective record purchasers the distinctive merits of Columbia New Process records. Coming at the height of the Fall buying season, this record will undoubtedly act as a material stimulant to record business during the holiday season.

The Columbia demonstration record features on one side an operatic selection by Charles Hackett, famous tenor and exclusive Columbia artist; a violin solo by Toscha Seidel, well-known violinist and exclusive Columbia artist and a symphony orchestra recording. On the reverse side is a popular dance hit by Ted Lewis, one of the country's leading dance orchestra directors and an exclusive Columbia artist.

The demonstration record campaign includes a full-page advertisement in the Saturday Evening Post of November 17, a full page in four colors in the American Weekly of November 25, with a circulation of 4,500,000; full pages on November 25 in rotogravure sections of newspapers throughout the country, with a combined circulation of 8,000,000, and black and white full-page advertisements on November 25 in Sunday editions with a combined circulation of 1,500,000. In order that Columbia dealers may cash in on this tremendous campaign, the company's advertising department has prepared a striking window poster in colors to be posted in the dealer's window. This poster will call the attention of passersby to the demonstration record and link up the advertising campaign with the dealer's store. Proofs of the American Weekly and Saturday Evening Post advertisements will be sent to the Columbia branches for distribution, or, if possible, direct to the dealers.

The special demonstration record will have the new Columbia gold label on the side featuring

Chas. Hackett, Toscha Seidel and the Columbia Symphony Orchestra, and the new fire bronze label will be on the Ted Lewis side. To further distinguish it from the ordinary record, it will have the words "Sample Record, 25c" lettered in white under the name Columbia. Each record will be enclosed in a special envelope of a distinctive color and the envelope will give the complete story of the record and its purpose. The value of a demonstration record as a sales stimulant was proved several years ago and there is no question but that this new demonstration record will be invaluable to Columbia dealers the coming season in developing sales for Columbia New Process records.

WENDELL HALL ON VICTOR LIST

Well-known Composer and Singer to Make Victor Records Exclusively—Popular Among Radio Fans Throughout the Country

In Wendell Hall, a new and exclusive Victor artist, whose first record will appear in the November 23 list, the Victor Talking Machine Co. is presenting to the music-loving public a singer and composer with an unusual history. Mr. Hall started his professional career in 1913, appearing in quartets, men's choruses and in church work. He later played the clarinet, saxophone and trombone, and following this he traveled from coast to coast in vaudeville with his act, "The Singing Xylophonist." During the war he went to France with the A. E. F. as a bugler.

His next step was to write popular songs, including both words and music, and he is credited with such hits as "Underneath the Mellow Moon," "My Carolina Rose" and others. About two years ago Mr. Hall became one of the pioneer radio entertainers and to-day he is known to radio enthusiasts throughout the country, having appeared at more than twenty-five of the largest broadcasting stations. Although a native of Chicago, he spent a number of years in the South, where he became acquainted with Southern customs and expressions, and where he made a study of Southern songs. Mr. Hall's first Victor record will feature two of his own compositions, self-accompanied on the ukulele.

The Carl Co., of Schenectady, N. Y., C. W. Carl, proprietor, suffered heavy loss in a fire early this month. The building in which the business was housed was practically destroyed.

A. F. KIEFER NOW STARR JOBBER

Takes Over Kunde Holdings in Milwaukee, Including Distribution of Starr Phonographs and Gennett Records in That Territory

MILWAUKEE, Wis., November 9.—Alfred F. Kiefer announced this week that he had taken over the holdings of A. G. Kunde, who had been local distributor for Starr phonographs and Gennett records, exclusively. Before taking over this interest Mr. Kiefer was for a while connected with the talking machine department of the Yahr & Lange Drug Co., Sonora distributor, and before that was for ten years ac-



Mrs. and Mr. A. F. Kiefer

countant and auditor for the Hoffman Co., which concern formerly operated a phonograph jobbing business. Besides the exclusive representation of Starr phonographs and Gennett records, Mr. Kiefer also maintains a twenty-four-hour service department for Starr phonographs. In this work he takes care of the local Starr and Gennett dealers and assures them of prompt delivery by calling for and delivering the repaired jobs.

ARTISTIC VICTOR HOLIDAY FOLDERS

Christmas Publicity for Dealer Distribution Features Machines and Records

The Victor Talking Machine Co. is distributing to the trade some exceptionally handsome holiday folders designed for dealer distribution. One of the folders, handsomely illustrated in colors, carries the complete line of Victor console, cabinet and portable instruments. The cover of this folder contains a picture of the interior of the home with a Victor console prominently displayed in the center of the room, while behind it are pictures of the various famous Victor artists. The rear cover shows the outside of a house in a Winter setting, with a band grouped before it. The text is brief and carries a Christmas atmosphere.

Another folder deals entirely with records designed especially for Christmas. This is also done in colors and the text on the front cover urges the appropriateness of Victor records as Christmas gifts.

B. R. FORSTER ENDS LONG TRIP

Byron R. Forster, president of the Brilliantone Steel Needle Co., New York City, returned last week from a trip across the continent in the interest of Brilliantone needles. Mr. Forster visited the principal cities en route and found generally good conditions prevailing everywhere. The outlook for 1924 seemed very promising and substantial orders for Brilliantone needles were placed. Mr. Forster returned through the Southern territory, stopping off at his old home for a short visit. Needless to say, he enjoyed his stay among his old friends, whom he had not seen for some time.

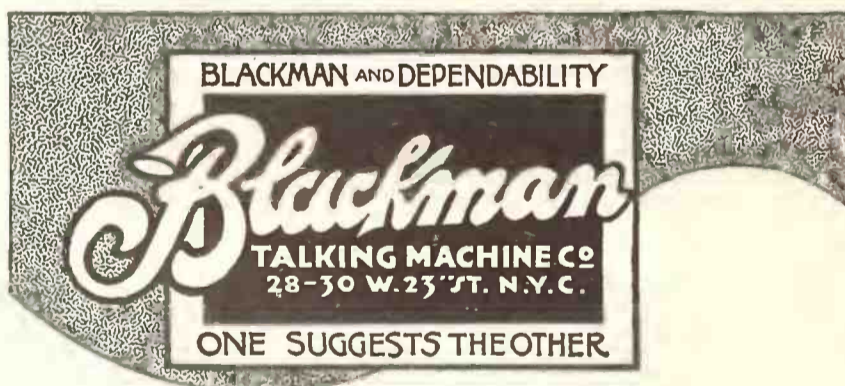

Blackman offers a Dependable service to Dependable dealers.
"Birds of a feather flock together."

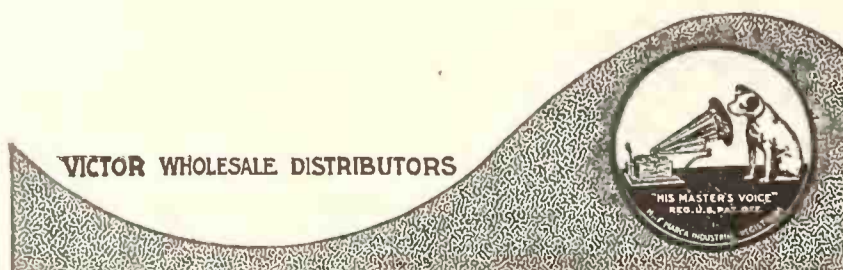

Victor supremacy is the supremacy of performance



Victrola VI, \$35
Mahogany or oak



Victrola IX, \$75
Mahogany or oak

Of performance past and present. Just as the Victor has occupied its position of leadership for a quarter-century, so it continues to lead the way in the talking-machine industry.



Victrola No. 80
\$100
Mahogany or walnut



Victrola No. 105
\$180
Mahogany or walnut



Victrola No. 215
\$150
Mahogany or walnut



Victrola No. 230
\$375
Electric, \$415
Mahogany



Victrola No. 405
\$250
Electric, \$290
Walnut



"HIS MASTER'S VOICE"

Victrola

REG. U. S. PAT. OFF.

Look under the lid and on the labels for these Victor trade-marks

Victor Talking Machine Company

Camden, New Jersey

Are You Preparing for Holiday Business?

Pre-Christmas Weeks Offer Greatest Sales Opportunity of Year
—Gift Dollars Can Be Garnered by Intelligent Sales Promotion

A month from the time this issue of *The World* reaches its readers the holiday rush will be on in real earnest. Whether the talking machine dealer gets his share of the gift money of the public will depend largely upon himself and the efforts he has put forth to attract attention forcibly and favorably to his line of merchandise. The big idea to remember is that in order to make the most of his Christmas-sales opportunity the dealer must use an entirely different plan of presenting talking machines, records and any other musical lines which he handles to the public. In short, the presentation in advertising and other methods of bringing his wares to public attention must be largely on the basis of suitability of his line as a Christmas gift. His entire business organization must be established for the moment with this object foremost at all times: Talking machines and records make suitable gifts. That should be his slogan from now until Christmas is over. It should be the central theme of all sales talks, store arrangement and decoration and window displays. In short, the "gift" idea should permeate the entire establishment. No half way measures will do. Negligence may mean lost business, and dealers in other lines will get a share of the profit which should go to the talking machine merchant.

The Matter of Service

Past experience has shown members of the talking machine trade that service is an important part of their business. Service, that is, courteous attention to each customer and doing everything to make every patron happy and satisfied, is comparatively easy during the

months of the year when there is no particular rush. The situation becomes more complicated during the holiday period, however. It must be remembered that during the few weeks preceding Christmas every store is rushed to a greater or lesser extent. Many people are crowded around the counters, the majority of them impatient to be waited upon as quickly as possible so that they can do further Christmas shopping. Whether the talking machine dealer and his salesmen serve their patrons efficiently, quickly and thoroughly, never losing an opportunity to make the most of each sales possibility, depends to a large extent upon their knowledge and experience. But a great deal depends upon another factor—store arrangement. Stock, both talking machines and records, should be arranged so that they are easily reached by both customers and salesmen. The fewer people who are forced to spend a lot of time with the salesman the better it is for the business. One dealer last year placed several tables in the open space available in the center of his store. Upon these tables were placed a number of records suitable for Christmas. A simple thing, truly, but one which has resulted in an astonishing number of sales of these special records in past years and it will probably result in as good, if not better, business this year. The point of this incident is that the salesmen do not have to spend a lot of time suggesting records. People, while waiting to be served, walk over to the table and naturally read the titles of the various recordings. Perhaps they did not enter the store with the intention of purchasing any of these records, but the idea

hits them as being good and thus another sale is added to the list. Another dealer is installing Audaks, a record demonstration device which facilitates selling, to meet increased demands.

Christmas Gift Opportunities

It is not only in the sale of the larger talking machines and records that the dealer has a wonderful opportunity of cashing in in a big way. There are the children to consider. After all, one of the great forces of Christmas as celebrated in this country is to make the kiddies happy, and the talking machine dealer has it in his power to compete with toys and the usual things which make the heart of a child happy. Besides, he has something which not only furnishes amusement for the tots, but something which has a distinct educational value. A most valuable talking point. This is the portable talking machine and the various clever recordings on the market designed especially for the amusement and education of children. It would not be a bad idea to fix up a part of the store especially for the purpose of catering to the children. And a portion of the window display space also could profitably be used in this manner. Some stores are paying a good deal of attention to the children this year as prospects. And this applies not only to the wee youngsters, but to those of primary and high school age. Talking machines and records as gifts to the children and from the children to their parents or other loved ones! There you have it in a nutshell. Dealers in the Middle West and Far West, especially, have taken cognizance of the child in the merchandising scheme around Christmastime. Several of the Western stores have special rooms for the children. Naturally, when the parents visit the store they take the tots to this room, which is fitted up as a children's play room. A small talking machine and a good display of juvenile records form the main feature of the display. Remember the children!

Early Preparation Necessary

As was mentioned last month in *The World* the great mass of detail which confronts the talking machine dealer in making his plans for holiday business necessitates early planning. The dealer who waits too long, or trusts to providence to take care of his holiday sales preparations, will be one of those who wail the loudest about the paucity of business. There is one thought that cannot be reiterated too often and that is: It is the go-getter who gets the business. This does not mean the chap who expects to win by sheer aggressiveness, but the man or woman, regardless of what business he or she may be in, who thinks, plans and acts. So, we repeat, get the threads of your holiday sales drive together and then launch it and follow it up with all the energy, skill and knowledge your sales organization is capable of.

JENSEN BROS. OPEN BRANCH

TERRE HAUTE, IND., November 3.—Jensen Bros., well-known Brunswick dealers, operating a store at 527 Wabash avenue, have just opened an attractive branch store in the new bank building at Twelve Points, this city. The new store is in charge of Mrs. Sallie G. Shaw, who has had several years' experience in the music business locally and who is widely acquainted among music lovers of this vicinity.

An attractive store, to be known as Frank's Music House, has been opened at 1205 Vine street, Cincinnati, O., by Max Frank, who has been manager of Hoffman's music department for the last three years. Talking machines, records, player-pianos and music rolls are handled.

ADD-A-TONE

THE TONE AMPLIFIER

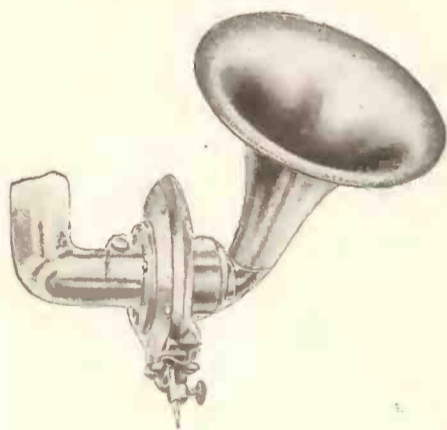

THE ADD-A-TONE is the Supreme Tone Amplifier, and is designed to operate in place of the ordinary sound box of the phonograph. It is a simple, neat appliance, which can be easily and quickly attached to your machine.

Put up in an Attractive Box—Will Make a Beautiful Christmas Gift

Incomparable for Dancing

"If you haven't heard the ADD-A-TONE you haven't heard your machine."

UNIQUE REPRODUCTION CO., Inc.

32 Union Square

NEW YORK

Cable Address: ADDATONE, N. Y.

ANNOUNCING The PEERLESS \$50.00 WINDOW DISPLAY CONTEST

Will give \$50 in gold to the Phonograph dealer who sends us a photograph of the best dressed Peerless Album window between now and Christmas.

CONDITIONS

1. Photographs must be taken between now and Christmas of a street store window. All dealers are eligible.
2. One or more Peerless Albums or show cards must be displayed with the word Peerless in evidence.
3. Award will be made according to strength of selling appeal, artistic arrangement, unique idea conveyed and general impression of Peerless quality.
4. All photographs must be received at this office by noon on December 24. Prize winner will be announced in the January 15 Talking Machine World.
5. Judges are as follows:
Lee Robinson, Talking Machine World
Curt Wessel, Phonograph Weekly
Vivian Burnet, Talking Machine Journal
6. All photographs, properly marked for identification, will be returned to the senders upon written request.

Phil Ravis

Pres.

*IN VIEW of the fact
PEERLESS*

—the album

should constitute the backbone of your Gift Record Selling Plan for Christmas—by all means—dress your window accordingly, have a photograph

taken and submit it to us for entrance in this contest.

NOTE: If you are one of the few dealers who do not carry a stock of Peerless Record Albums, send for our attractive show cards, which you can use to decorate your window and win first prize. These we supply gratis.

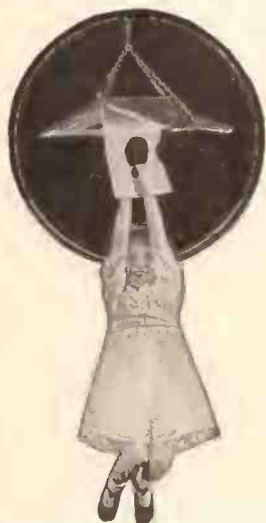

PEERLESS PRODUCTS

DeLuxe Record Albums
All Grades of Record Albums
"Big Ten" Albums
Record-Carrying Cases
Interiors for Victrolas
Interiors for Phonographs

Classification Systems for Albums
Record Album Sets for All Make Machines
Record Stock Envelopes
Record Delivery Bags
Supplement Mailing Envelopes
Photograph Albums

Write us for Quotations on Special Grade No. 6 Album



A postal will bring this sign to you in the next mail—write

PEERLESS ALBUM COMPANY

PHIL. RAVIS, President

WALTER S. GRAY CO.
Pacific Coast Representative
San Francisco and Los Angeles

636-638 BROADWAY
NEW YORK

L. W. HOUGH
146 Mass. Avenue
Boston, Mass.

The TALKING MACHINE WORLD

For the makers & sellers of talking machines

(Registered in the U. S. Patent Office)

PUBLISHED BY EDWARD LYMAN BILL, Inc.

President and Treasurer, C. L. Bill, 383 Madison Ave., New York; Vice-President, J. B. Spillane, 383 Madison Ave., New York; Second Vice-President, Raymond Bill, 383 Madison Ave., New York; Secretary, E. L. Bill; Assistant Treasurer, Wm. A. Low.

J. B. SPILLANE, Editor

RAY BILL, B. B. WILSON, BRAID WHITE, Associate Editors

C. R. TIGHE, Assistant Editor

LEE ROBINSON, Business Manager

L. E. BOWERS, Circulation Manager

Trade Representatives: V. D. WALSH, E. B. MUNCH, ROBERT C. ANOERSON, JR., A. F. CARTER, F. G. SANOBLOM, C. CHACE, EDWARD LYMAN BILL, A. J. NICKLIN

Western Division: Republic Building, 209 So. State Street, Chicago, Ill. Telephone, Wabash 5242. EUGENE F. CAREY, Representative

Boston: JOHN H. WILSON, 324 Washington Street

London, Eng., Office: 2 Gresham Building, Basinghall St. W. LIONEL STUROY, Mgr.

The Talking Machine World has regular correspondents located in all of the principal cities throughout America.

Published the 15th of every month at 383 Madison Ave., New York.

SUBSCRIPTION (including postage): United States, Mexico, \$2.00 per year; Canada, \$3.00; all other countries, \$4.00 Single copies, 25 cents.

ADVERTISEMENTS: \$5.50 per inch, single column, per insertion. On quarterly or yearly contracts a special discount is allowed. Advertising pages, \$150.00.

REMITTANCES should be made payable to Edward Lyman Bill, Inc., by check or Post Office Money Order.

NOTICE TO ADVERTISERS—Advertising copy should reach this office before the first of each month. By following this rule clients will greatly facilitate work at the publication headquarters.

Long Distance Telephones—Numbers 2642-3-4-5-6-7-8 Vanderbilt
Cable Address: "Elbill," New York

NEW YORK, NOVEMBER 15, 1923

REASONS FOR THANKSGIVING IN THE TRADE

THE nearness of Thanksgiving brings to mind that the talking machine industry has a special reason to be thankful, as it approaches, in a triumphant way, the close of 1923. Month after month has witnessed substantial progress in manufacturing, in distribution, in retailing and in greater prestige for the talking machine, based upon the production of musical instruments that represent greater perfection in design, construction and musical excellence.

Since the disturbing deflation period in the years following the World War the industry has displayed such a measure of recuperation and vigor as to be surprising to those who a year or more ago were prone to indulge in indigo-hued phrases as to the future of the industry. Readjustment is now at an end. This accomplishment has been no easy task. Hence, now is the time to preach, and, better still, to practice constructive rather than destructive policies, to the end that there will develop greater faith in the industry and confidence in the men who make it.

We are to-day enjoying a gratifying measure of activity. Every branch of the industry is bringing a fair reward to those who are striving by the application of progressive ideas to score success. From a financial point of view the industry was never so healthy, this despite misleading articles in some daily papers due probably to a misunderstanding of the legal procedure which became necessary in order to complete the reorganization of a great manufacturing organization and to insure its future operation along successful lines. This meant progress, not disaster. Then another concern of national reputation was forced into print without a knowledge of the cause. Court proceedings helped, however, to demonstrate its financial integrity and capable management, as well as the absolute unreason for the action, inasmuch as the legal proceedings instituted were quashed. Therefore, despite the wagging tongues of unthinking persons, nothing has happened to undermine the stability of the talking machine industry. In one case an unfavorable condition, a relic of war days, has been removed; in the other the critics of the administrators of the business have been convinced of its financial health and the lack of necessity for the action taken.

Now, in this connection, it may not be out of place to point out the unwisdom, nay, the danger, of loose remarks that breed suspicion and doubt when the financial affairs of any concern are discussed. Every member of the industry should have sufficient pride in its success to resent implications that subject any enterprise to unmerited comment, particularly where its financial affairs are concerned. When we consider the history and development of the talking machine industry, its wonderful achievements, and the notable men who have played, and are playing, such an honorable part in its upbuilding, it becomes the duty of everyone interested in its welfare to be missionaries in maintaining the dignity and standing of the industry. Idle conjecture and the reiteration of rumors, often malicious, that are apt to retard or destroy confidence in the soundness of the talking machine industry should be condemned and discouraged. They lead to a false idea of the condition of the industry not only in the minds of the public, but in banking and financial circles as well.

MAKE THE DEALER'S STORE A MUSICAL CENTER

IT is interesting to note that the members of the Talking Machine Men, Inc., the organization of talking machine retailers in New York City and neighboring territories, have arranged to supply the needs of individuals in their localities seeking musical organizations and artists for dances, musicales, etc., by acting in co-operation with a newly organized booking office controlling a number of well-known orchestras, as well as individual artists.

The idea is in the elementary stage and its working out will be carefully watched, for the plan has been adopted not because it is calculated to arouse special interest in this or that make of records or those who make them, but because it will attract attention to the store of the neighborhood dealer as a place where musical requirements of all kinds may be met.

It is quite logical that the talking machine dealer should be regarded in his community as something more than the ordinary type of merchant, for the success of his business is based primarily upon the musical desires and musical appreciation of the public. He is, therefore, in an excellent position to keep in close contact with things musical, supporting them generally and in turn reaping the reward of increased interest in his establishment.

In various sections of the country dealers have underwritten the appearance of recording orchestras and artists, or, through their efforts, encouraged the appearance of such artists, but the New York movement goes somewhat further than this in putting the dealer in a position to place the customer in touch with the musical world in general by securing for him talent of various descriptions, ranging from the individual artists and the trio to symphony orchestras and brass bands. Moreover, the plan carries with it direct profit-making possibilities, and the work of its carrying out will be watched with distinct interest not only in the metropolitan district but in other sections of the country.

SUPPORT THE PRICE MAINTENANCE BILLS

THE question of a Federal statute legalizing the fixing and maintenance of retail prices on trade-marked goods is more vital just now than it has been in the past for the reason that liquidations and adjustments of wholesale and retail stocks, a percentage of which has not been overhonest or ethical, has, in a large measure, served to undermine public confidence in commodity values. It is a recognized fact that the trade-marked articles of recognized standing are being used in a constantly increasing number of cases as bait to lure purchasers for so-called bargain goods of decidedly questionable merit.

Various organizations in the music trade have on many occasions endorsed the price maintenance bills that have been presented to Congress, but in spite of these endorsements and of the direct efforts made to bring about the passage of the bills, success still lies in the offing. It might be well for trade organizations to give thought to the Merritt Bill, introduced by Representative Schuyler Merritt of Connecticut, which is designed to permit the manufacturer of an article offered under a trade-mark or special brand to specify or mark on the article the price at which it is to be resold.

The Merritt Bill overcomes some of the objections offered to previous measures, such as the Kelly-Stephens Bill, by providing that the privilege of fixing prices shall not exist where the manu-

facturer is in a position to enjoy a monopoly in his field, and that the fixing of prices cannot be brought about by joint agreement between a number of manufacturers.

The development of the talking machine industry, particularly of the distributing branch of the industry, was due directly to the policy of price maintenance observed rigidly until the courts decided against the particular systems in vogue. Price maintenance not only protects against the price cutter, but likewise acts as a check to the profiteer. A measure such as the Merritt Bill should have a direct and powerful influence in restoring public confidence in the intrinsic values of a manufactured product.

IS A NATIONAL EXHIBITION DESIRABLE?

TO show or not to show, is one of the questions that are interesting the talking machine trade in New York and vicinity just now, particularly the members of The Talking Machine Men, Inc. There are those in the trade who, having had the propositions broached to them, are firm in the belief that the only thing needed to place the industry on a high wave of prosperity for months and even years to come is a so-called national exhibition of talking machines to be held in New York in some large building, such as Madison Square Garden, some time in the immediate future. There are others who, having had something to do with, or some knowledge of shows of similar kind, are inclined to be conservative and study the matter closely before endorsing any such plan.

If the proposed talking machine show, or for that matter a general music show, is to be operated by the promoter of the private venture, well and good; but if the trade or any organized division of the trade, such as The Talking Machine Men, Inc., are to stand sponsor for the venture, financially, as well as morally, then it might be well for them to study the experiences met with in previous shows of the kind.

A general music show is not in any sense a new idea, for there have been a half dozen or more of them held, the last one in Grand Central Palace, New York, during the Winter of 1920, and on a basis that in elaborateness compared most favorably with any other trade exhibition. The director and manager of the music exhibi-

tion was an experienced showman and he got results, but the talking machine men might do well to find out from him just what his experiences were. They, perhaps, would afford an excellent guide in the making of a decision regarding the proposed new venture.

There is no question but that co-operatively the talking machine trade has a wealth of material with which to attract huge crowds and there should be available for any such show, if it is to be successful, the greatest musical organizations and artists in the country, if not in the world. The questions to be studied, however, are, first, the cost of the show; second, whether all the leading interests of the trade will participate and bear a share of that cost, and third, the sort of publicity that will put the idea over, and fourth, and by all odds most important, just what tangible results may be expected immediately or in the future from such a show, from a purely dollars-and-cents angle.

We don't seek to appear pessimistic in the matter, but there is real experience to draw from in forming conclusions. It is a known fact that promoters are careful to refer to the outstanding successes among such shows as the automobile, and more lately the radio show, but a neglect to mention the scores of failures which are to be registered for every success is a matter to be studied carefully before a decision is reached. Before the venture is decided upon there must be evident a strong spirit of co-operation and a readiness to work and work hard.

UNION OF RETAIL FORCES IN LOS ANGELES

FROM Los Angeles comes the announcement that the Radio Dealers' Association in that section has become part and a division of the Music Trade Association of Southern California. It is rather early to prophesy just what this new combination of the radio and music trades in one association is going to accomplish, or what the general effect will be. But the move will appeal to those who have urged the linking of the two interests and to those members of the music trade who regard radio as a more or less dangerous competitor. From the last angle it would seem better to have the competitor in the same camp where he can be watched and co-operated with rather than to have him outside the pale.

MIS_{CO}



A Complete Victor Jobbing Service

*Merchandise — Selling
Advertising — Finance*

Musical Instrument Sales Co.

Victor Wholesalers

673 Eighth Avenue

TELEPHONE 9400 LONGACRE

New York

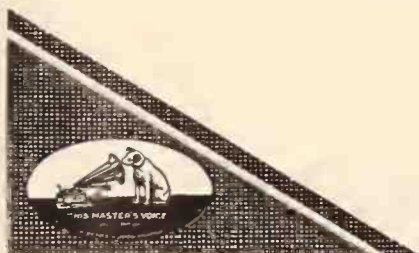

Concerts as a Means of Sales Promotion

Interesting Suggestions for Making Wholesale Demonstrations of Talking Machines and Records Described by Frank H. Williams

Is there any better way of selling a talking machine than by demonstrating it to the prospective purchaser?

The actual hearing of the music rendered by the phonograph is, in the majority of instances, quite sure to arouse interest and oftentimes makes a purchaser of the prospect. Consequently, it looks as though it would be the best sort of business to build business by staging concerts more frequently.

Let us consider what could be done by talking machine stores along this line, enabling them to get more business and make more money.

Noon-time Concerts

During the noon hour in the average city there are a large number of office workers and retail sales people and others who, after eating a light luncheon, wander around the business districts looking for something to attract and hold their attention. Since this is the case, why wouldn't it be good business for the talking machine store to draw some of these people into the establishment by the simple procedure of staging concerts during the noon hour which would be open to everyone and be of such a popular nature that the majority of the noon-hour seekers for amusement and entertainment would be mighty glad to attend them?

While staging these concerts the store might secure the names and addresses of the people present by passing out cards on which they could write the selections they would like to hear rendered at the next noon-time concert given by the store and on which they could also affix their names and addresses. This sort of a stunt would serve a double purpose in that it would show just what sort of music is most popular with this class of people, and in that it would give the store a good list of people who were enough interested in phonograph music to go to the trouble of suggesting special selections that they would like to hear.

All of this could be used by the store to good advantage in personal solicitation among the people signing the cards. And it would, unquestionably, be of help to the store in getting more business.

Noon-time Concerts in Restaurants

Practically every restaurant owner knows that if he has music during meals he will be doing something which will be of real help to him in getting more business. Consequently most restaurant owners would readily give permission to the proprietor of a phonograph store to come to the restaurant during the noon hour and put on a special concert on a machine sent by the music house for the occasion. And the restau-

rant owner, of course, would be perfectly willing for the music store to cash in on the stunt by placing placards prominently about the restaurant stating that the Smith Music House was giving the concert as a means of demonstrating the merit of the Blank phonographs which it handles.

Then while the concert was under way the employes of the music store might pass out cards to the people in the restaurant on which they could indicate which of the selections rendered during the concerts had most powerfully appealed to them. Of course, too, there would be space on the cards for the people to sign their names and addresses.

In this way the store would again secure a live-wire list of people who were interested in music and whose business could be personally solicited and, undoubtedly, from this list the store could work up a large number of sales. Also it wouldn't be such an utterly impossible thing to make sales of phonographs to some of the restaurant owners in whose places of business the concerts had been rendered.

Special Invitation Concerts

Nearly everyone gets a thrill upon going to the phone and having the person at the other end of the line deliver some such message as this:

"This is the Smith Music Store. We are having a special concert in our hall this evening at which we will play some of the latest operatic and classical music on one of our largest phonographs. We know you are interested in this sort of music and would be glad to have you attend the concert. There is no admission fee, of course, and no obligation on your part. Also we will be glad to have you bring some of your friends if you desire to do so. As our seating space is limited we will be very glad to have you tell us now whether or not you will attend and, if so, how many people you will bring with you."

A personal invitation of this sort would be sure to get responses from many of the people who were invited, because of the fact that the folks who were invited in this way would feel quite flattered at the invitation, and so the store would be sure to have a good group of people in attendance.

Then during the course of the concert the store could pass out cards to all of the people present on which they could write their suggestions for other selections they would like to hear played at future concerts and on which they could also write out any suggestions they might have to offer as to ways and means by

which the concerts could be made more interesting and popular. Then there would be space for each person to sign his name and address.

Most of the people who attend a free concert of this sort would under these circumstances feel a certain obligation to the store, despite the statement that "there was no obligation," and so would feel like signing the cards for the purpose of discharging this obligation. The store would, therefore, get a lot of cards from the people present and this would give another splendid list of prospects to work on through personal solicitation.

Sunday School and Church Concerts

Frequently the Sunday school or the church entertainment is dull and uninteresting because of the fact that it is the same old thing done over and over again in the same old way. The officers of the Sunday school or church probably realize that this situation obtains and they would be glad to arouse more interest in the affairs by instituting some changes, but they are at a loss to know just what to do.

So if the talking machine dealer went to some Sunday school or church entertainment committee and offered to send a phonograph and operate it with appropriate selections during the school sessions or during the church entertainment, his offer would, unquestionably, be gladly accepted and the school superintendent, or the chairman of the entertainment committee, would gladly make an announcement to the school or the assemblage telling about the kindness of the dealer in supplying the music free of charge and so on. All of which would be the best sort of advertising for the phonograph store and it would probably lead to some very good sales.

When such concerts are arranged it would be a good plan for the dealer or salesman to spend quite a little time conferring with the officers of the Sunday school or with the members of the entertainment committee for the purpose of seeing just what music they would like to have played at the events. During these conferences the owner or salesman would get quite intimate with these people and would find out whether or not they had phonographs in their own homes and so would be able to lay the foundation for future sales which, otherwise in the normal course of events, would never have been made.

There is no question but that the more people the phonograph store interests through the use of concerts the more prospects it will dig up and the more business it will get.

Your mind is the fountain-head of opportunity; why not use it?

The MODEL "E" PORTABLE PHONOGRAPH

Artistic---Superior Tone Quality---Light Weight---
Compact---Durable.

Not a Seasonal Portable.

By removing four screws, which hold the phonograph in the case, it is instantly converted into a table model.

A VERY DESIRABLE AND EXCLUSIVE FEATURE. PLAYS ALL RECORDS.

Write for Our Proposition

THE GENERAL PHONOGRAPH MFG. CO.
ELYRIA, OHIO.

**** FULL OF LIFE, POTENTIAL ENERGY AND POWER**



A SIZE FOR EVERY
PHONOGRAPH MOTOR

A Complete Line of
Talking Machine Repair
Materials

Everybody's
TALKING MACHINE CO. INC.
PHILADELPHIA, U. S. A.

Makers of
Honest Quaker Main Springs
& Umantone Needles

Record Service That Pays Big Dividends

When the Salesman Is Compelled to Say "We Are Out of That Record" Sales Are Lost Unless the Desired Selection Is Secured

The proposition has been demonstrated time and time again that where competition is keen the dealer who conducts his business along the most efficient lines and extends the best service never lacks patronage. Experience has proved that a merchant's success is measured by these things, provided that he handles standard and worth-while products. And of all the elements that make up a business enterprise service is probably the most important, for by this means patronage can be built up.

These are the principles which have proved eminently successful in building up a large following for the Ideal Music Co., which is located in the center of the financial and commercial district of downtown New York. In addition to the Gotham establishment, this firm operates stores in Newark and Plainfield, N. J., and in Brooklyn, N. Y., and the Victor line is featured exclusively. The New York store is under the direct management of Edmund V. Bragdon, treasurer of the company, who, by the way, is one of the real live wires of the trade.

Catering to Business People

As has been mentioned, the New York store is in the financial and commercial district of the city and the only persons who spend any time there are on business bent. The problem of building up a steady clientele is an entirely different one from that with which the neighborhood talking machine retailer is faced. The office workers and business people who spend their days in the giant business structures which crowd one another in this district are all commuters. Each morning they pour forth from subways, trains and ferries, many of them coming from towns and cities forty and fifty miles distant. They do their day's work and then rush for the same vehicles of transportation to take them home. From this brief description of the conditions which the Ideal Music Co. must face it will readily be seen that entirely different methods must be utilized in bringing the store to the notice of prospective customers than the neighborhood dealer has at his command. Newspaper advertising here is worthless, personal canvassing is out of the

question and direct mail to individuals in offices is impossible, and these are the obstacles which this company has successfully surmounted.

While a merchant so situated cannot use the methods of the dealer in the small town or one who caters to residential districts, the latter will find much of value in some of the practices employed by the Ideal Music Co. For example: Mr. Bragdon has instituted a service program in the merchandising of records which has resulted in the sale of thousands of dollars' worth of records, the majority of which would not have been sold otherwise. He noticed that often there is a shortage of a certain record and that when customers were told that that record was not in stock they often went out without making any purchase, nor did they ever take the trouble to come back later to determine if the record had been secured as promised. To retain this patronage and at the same time extend a service which would result in increased sales the Ideal Music Co. had two cards printed, one on which the customer is asked to place the name and number of the record desired which was not in stock, as well as other information, and the other is a special post card to be mailed to the customer when the record desired has been secured. The first card is reproduced below so as to give some idea of the form followed:

PLACE THE NUMBER OF THE RECORD DESIRED HERE →		
USE A SEPARATE CARD FOR EACH RECORD		
WITHOUT OBLIGATION TO ME, KINDLY NOTIFY ME WHEN YOU CAN SUPPLY THE ABOVE RECORD.		
NAME _____		DATE _____
ADDRESS _____		
IF YOU DO NOT KNOW THE NUMBER OF THE RECORD WRITE NAME HERE		
NOTICE SENT	HOLD UNTIL	RECORD CLAIMED
	OVER	

The reverse side of this card is devoted to a cleverly worded message to customers which in reality is an advertisement of the plan of ordering records which do not happen to be in stock. The reasons for the necessity of the service

are briefly and clearly outlined in the following neatly printed text:

IDEAL SERVICE COUNTS
To our friends:
 As you no doubt know, there has been a great shortage of Victor records. This condition, we believe, will right itself in the near future.
 You are probably looking for some of the "hard-to-get" records. Without obligation to yourself, let us notify you when we can supply them. We will gladly furnish all of these cards you need.
 IDEAL Music Co.

When a customer asks for a record which the company happens to be out of the salesman immediately suggests that he be permitted to secure the record for him or her and one or more of these cards are given to the patron to fill out. One card is used for every record desired.

When the record has been secured the following printed card is mailed to the customer:

Your VICTOR RECORD Is Here

We have just received a supply of

Record No. _____

One of them is being reserved for you, and we will hold it for you for three days.

When In—ask to hear Record.

Ideal Music Co.
 29 JOHN ST. NEW YORK

That this plan has been a tremendous factor in increasing the record business of the Ideal Music Co. there can be no doubt when it is considered that during a recent shortage of certain records over a thousand dollars' worth of "deferred" record orders were filled with the aid of this system. In addition many people who were very infrequent purchasers were turned into steady customers through this concrete evidence of willingness to be of service. This may seem a small thing in itself, but the results speak for themselves and no talking machine dealer can go wrong if apparently small things such as this are developed for the benefit of patrons.

IMPORTANT RADIO CONFERENCES

Leading Manufacturers and Distributors Plan Meeting to Promote a Better Understanding

It was announced recently that leading manufacturers and distributors in the radio industry would meet in a series of conferences in the near future to promote a better understanding among radio manufacturers and broadcasters. These meetings will be sponsored by the National Radio Chamber of Commerce, and a preliminary conference was held a few weeks ago.

At this meeting J. Walter Drake, assistant secretary of the Department of Commerce, gave a very interesting and informative talk, during the course of which he expressed the hope that the radio industry would co-operate with the National Radio Chamber of Commerce in its work of organization. Mr. Drake made it plain that unless the radio industry was in a position to express its desires in Washington with a united front, the opinions and wishes of individuals could not be accorded consideration.

OKEH DEALER ENLARGES STORE

PASSAIC, N. J., November 7.—Max Laiks, at 145 Second street, this city, is now the owner of one of the most attractive stores in Passaic. In addition to his general store, Mr. Laiks recently took over the establishment next door and has turned it into an up-to-date phonograph and record store. Six booths have been erected and Mr. Laiks, who is an exclusive Okeh dealer, is making plans for a banner holiday trade.

To Do or Not to Do

A Good Holiday Business Depends Upon Today's Decision

It is an undisputable fact that the months of November and December mean the biggest business for the Sonora dealer. Those who have ordered enough merchandise for the Holiday Season will find themselves in the right position. The dealer who wants to profit by past experience will understand this message—and act at once!

Sonora

Greater City Phonograph Co., Inc.

Exclusive Distributors for New York, Staten Island
 and the Lower Hudson Valley

234 West 39th Street

New York

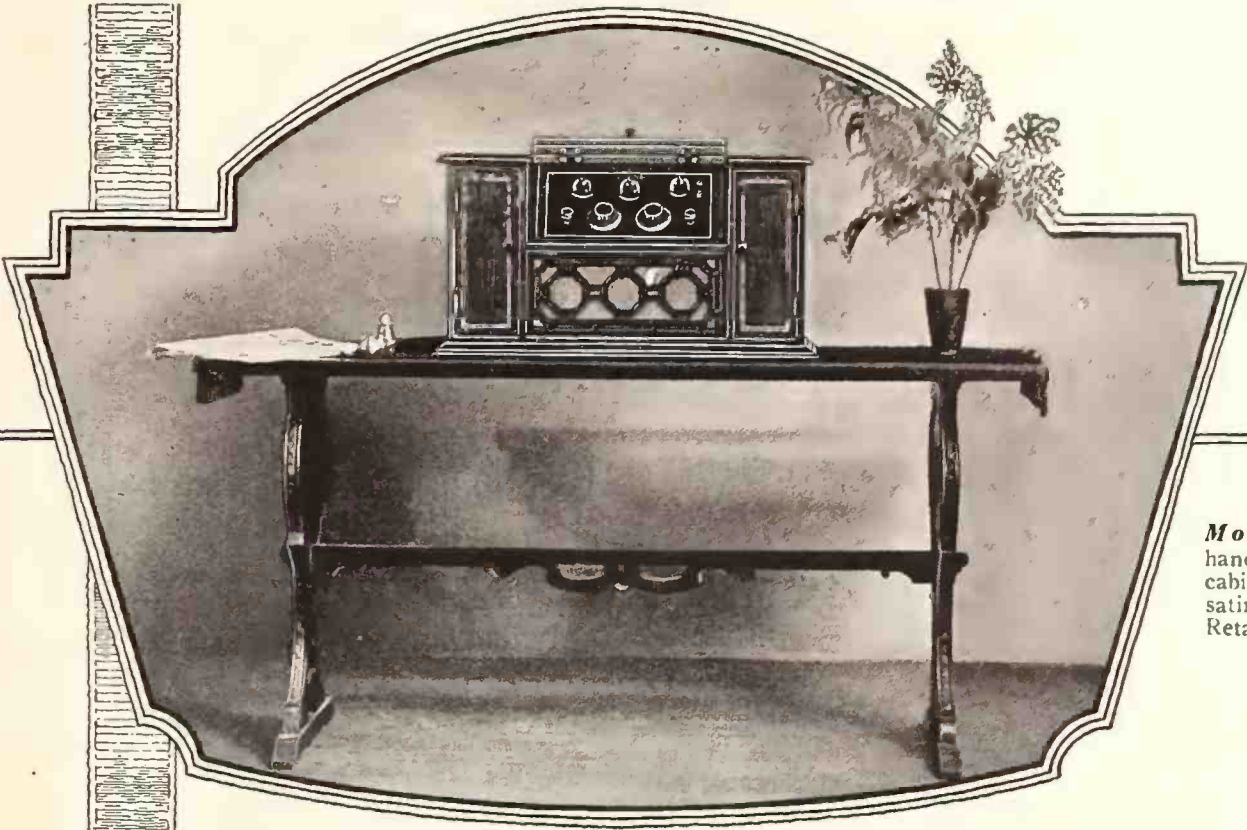

Model X— Beautiful hand-rubbed mahogany cabinet with inlay of satin-wood and ebony. Retail price, complete \$285.00

An Unusual Radio Merchandising Opportunity

New Kennedy Radio Sets, greatly simplified, now available in exquisite furniture models

THERE now exists a real opportunity for *one* music dealer in each community to secure exclusive representation for the new Kennedy radio furniture models.

Two things give these new Kennedy radio models their unusual merchandising possibilities:

First, the radio units in these models have been perfected in the Kennedy Engineering Laboratories so that now anyone without previous knowledge of radio can operate them. This also makes it easy for your piano and phonograph salesmen to successfully sell these Kennedy sets.

Second, the furniture in which these new units are housed is in period architecture, produced by skilled designers—it is so exquisitely proportioned that it lends itself to the most refined surroundings. Dials and external trimmings are gold plated—loud speaker built in. Equipment includes individual phones, tubes and batteries. All fully enclosed.

In a word, the Kennedy organization has lifted radio out of the “technical” class—simplified it and put it on a plane with the most tasteful drawing room furniture.

The Kennedy merchandising policy calls for the appointment of only one music dealer in each community. Protection is complete and with it comes the assurance of prestige and profits that are highly desirable.



Spanish Desk Model— Cabinet finished in either mahogany or American walnut. Interior completely lined with golden bird's-eye maple. Retail price, complete.....\$825.00

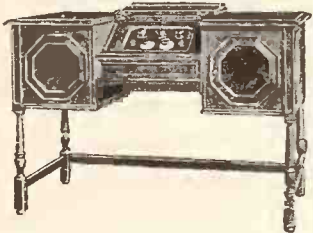

Jacobean Console Model— Built of American Walnut with artistically matched paneling. Exemplifies late Jacobean design. Retail price, complete\$775.00

All Kennedy receiving sets are regenerative— Licensed under Armstrong U. S. Patent No. 1,113,149.

Descriptive literature and dealers' discounts sent on request. Write or wire for exclusive dealer proposition.

THE COLIN B. KENNEDY COMPANY
SAINT LOUIS SAN FRANCISCO

KENNEDY

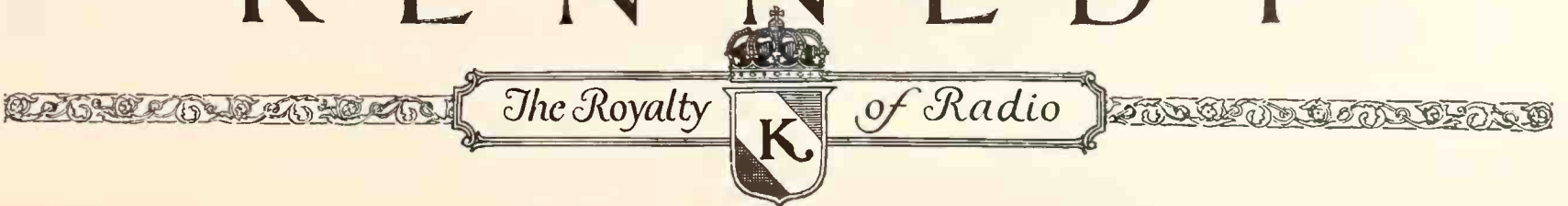

Sell the Idea that

Vigorous health and summer-time pep can be maintained during the winter months by exercising to

DR. KELLOGG'S HEALTH LADDER

on

Columbia

New Process RECORDS

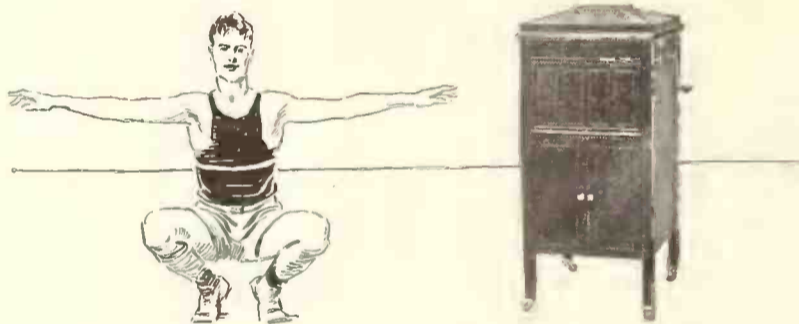

YOU can do your customers no finer service than to sell them the way to build up health and energy during these winter months.

Why? Because health is what people want. During the summer they had it because they were out of doors and exercised in play or at work. Winter-time, however, hinders outdoor activity. Unless there is a substitute the inevitable follows—muscles become soft and flabby, circulation is impaired and resistance is lowered.

Here then is your opportunity. Sell these people Dr. Kellogg's Health Ladder—a system of enjoyable exercises given with inspiring music on Columbia *New Process* Records. The man or woman who buys the Health Ladder and uses it daily will soon possess again the summer-time health and vigor which makes life a pleasure.



In offering Dr. Kellogg's Health Ladder to your trade you have one of the finest series of physical exercises ever arranged. For over forty years these exercises have been an important feature of Dr. Kellogg's system of health treatment at the famous Battle Creek Sanitarium.

Dr. Kellogg's exercises are right for the business man, his wife, son and daughter. Old and young, all are considered, not solely the trained athlete, as might be the case were the director a specialist in physical drill or athletics.

Your customers need the Health Ladder to increase their happiness and efficiency—to add years to their lives. If you have the Health Ladder you can sell it to them. Supply yourself now. The Health Ladder retails for \$10.00 a set. Place your orders at once so as to get this profitable winter business.

COLUMBIA PHONOGRAPH

Exercise is Health

and Exercise with Music is Pleasure

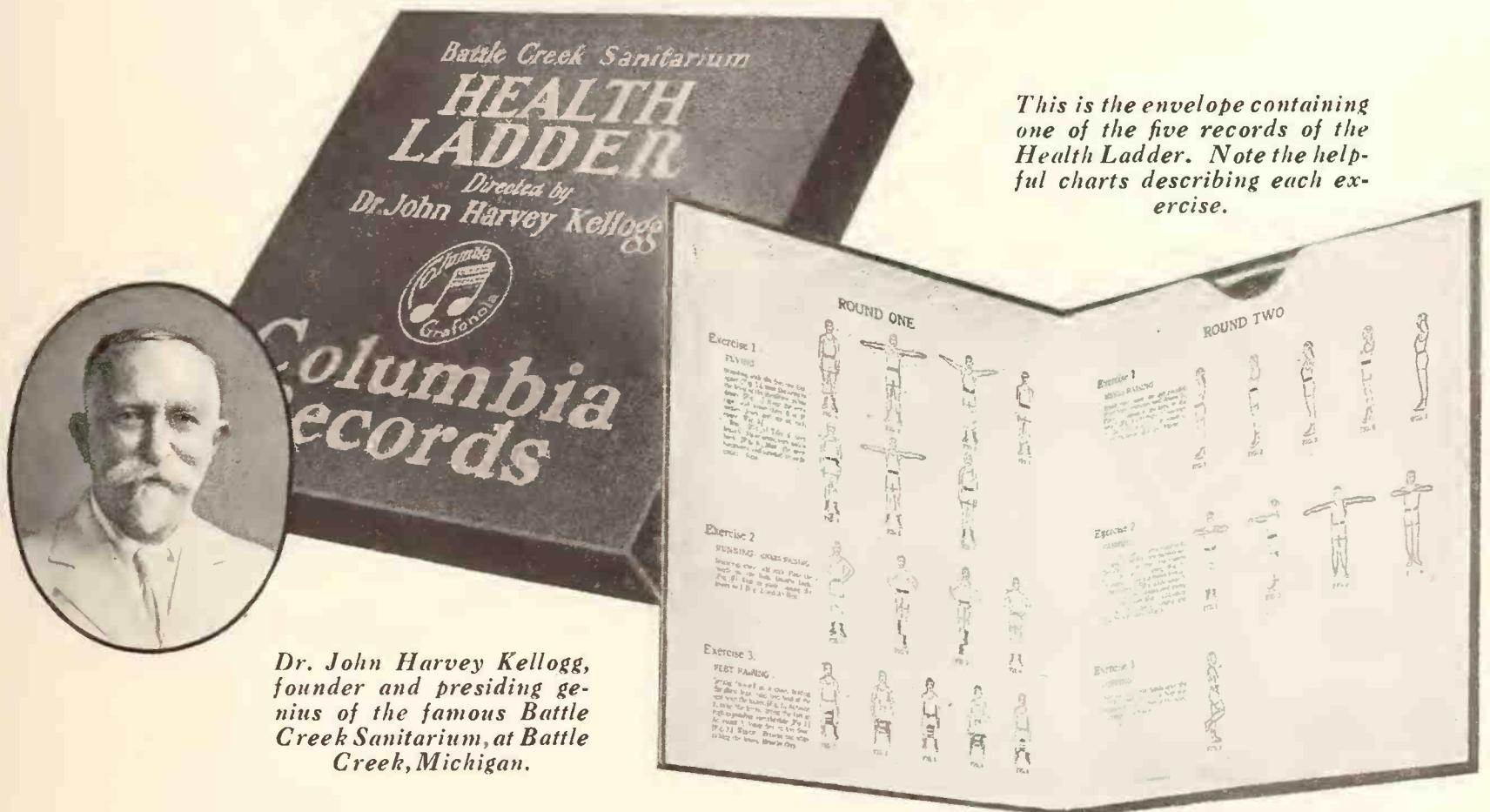

Dr. John Harvey Kellogg, founder and presiding genius of the famous Battle Creek Sanitarium, at Battle Creek, Michigan.

A Description of Dr. Kellogg's Health Ladder

DR. KELLOGG'S Health Ladder is a series of five records, including twenty different exercises, directed by Dr. Kellogg exclusively for Columbia Records. These exercises are divided into groups called "rounds," of which there are eight.

The arrangement of the exercises of the Health Ladder is such as to bring all parts of the body into active play, thus encouraging symmetrical development. So well graduated are the exercises that those unable to go through the entire series at first can advance from one "round" to another as their strength increases.

What the Health Ladder aims to ac-

complish can be summarized as follows:

1. To correct wrong poise in sitting or standing, bad postures at work, such defects in physique as flat chest, round back, projecting abdomen and forward carriage of hips.
2. To improve breathing and circulation by strengthening the heart, chest muscles, diaphragm and abdominal muscles.
3. To restore as nearly as possible to normal position the prolapsed or fallen stomach, liver, kidneys, colon and other abdominal and pelvic organs.
4. By localized muscular work, to remove undue accumulations of fat.
5. By general muscular work to improve the general nutrition, thus increasing vital resistance, endurance and mental and physical efficiency.

COMPANY ✿ ✿ NEW YORK

The ALBUM method EXCELS all other RECORD FILING systems EVER TRIED



SELECTING THEIR FAVORITES

To the Trade:

Our Record Album factory—all or any part of it—is at *your command*. Hundreds of customers can and will gladly testify as to the good quality of our production.

Our large and growing business is due to satisfied customers and repeat orders.

Imprint (firm name or trade mark) stamped on covers if desired when orders are sufficiently large to justify it.

OUR ALBUMS ARE MADE TO CONTAIN VICTOR, COLUMBIA, EDISON, PATHE, VOCALION AND ALL OTHER DISC RECORDS

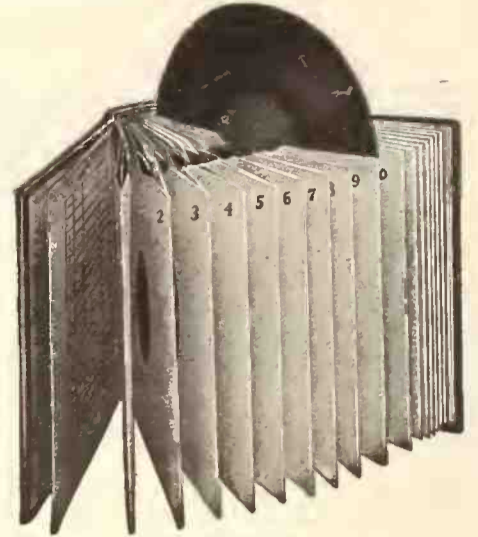

THE PERFECT PLAN

NATIONAL PUBLISHING CO., 239 S. American St., PHILADELPHIA, PA.

New York Office, 54 Franklin Street, Telephone, Franklin 1227, James E. Maguire, Representative

All Set for the Talking Machine Men's Ball

Over Score of the Leading Recording Orchestras Agree to Furnish Music for the Evening of November 21—Present Prospects Are for a Record-breaking Crowd

Plans are now completed for the annual ball of the Talking Machine Men, Inc., to be held at the Hotel Pennsylvania on Wednesday evening, November 21, and which from present prospects promises to eclipse previous affairs of the same order held by that organization. The committee in charge of the arrangements has succeeded in lining up for the ball the great majority of the leading recording orchestras, the list reading like a directory taken from all the catalogs, and the names offered are such as should insure a tremendous attendance on the part of the public.

Among the orchestras that have promised to provide music for the ball are included the following: All Star Trio, Ben Selvin's Orchestra, Bennie Krueger's Orchestra, Ben Bernie's Orchestra, Brooke Johns' Orchestra, Carl Fenton's Orchestra, California Ramblers, The Columbians, The Collegians, Coleman's Montmartre Orchestra, Charles Dornberger's Orchestra, Dixieland Jazz Band, Elkeles' Club Deauville Orchestra, Great White Way Orchestra, Gene Rodemich's Orchestra, Jos. C. Smith's Orchestra, Memphis Five, Paul Whiteman's Orchestra (Himself), Paul Specht's Orchestra, Ray Miller's Orchestra, S.S. Leviathan Orchestra, Ted

Lewis and Band, Tennessee Ten, The Virginians, Vincent Lopez and His Orchestra, Yerkes' S.S. Flotilla Orchestra and Zez Confrey and His Orchestra.

The main problem seems to be at this time that of arranging a schedule that will permit of all the orchestras playing one or two numbers each and still keep within the time limits

Victor Co. Factory Working Under Pressure

Various Departments on Overtime Basis in Effort to Meet Heavy Demands for Victrolas and Records—Substantial Increase in Record Business Is Reported

At the present time the factory of the Victor Talking Machine Co. is one of the busiest manufacturing plants in the East with all departments working full time under pressure and a goodly number of them overtime in an effort to keep up with the demand for both machines and records, and to overcome the annual shortage that is already making itself felt in respect to the former product.

The immense building just completed to house an addition to the company's record pressing plant has not yet been occupied for

set by the hotel. Last year the grand ballroom of the Pennsylvania was packed almost to suffocation by those seeking the opportunity to dance to the music of the recording orchestras, and although a slightly higher price for tickets prevails this year, it is confidently believed that the crowd will be as large.

The ball is held by the Talking Machine Men, Inc., for the purpose of building up the treasury of the organization to enable it to carry on co-operative advertising campaigns for the benefit of its members and to engage in other work calculated to help the trade and the cause of music generally.

that purpose, although it will be soon after the first of the year, the empty space is being utilized to good advantage in helping out temporarily other departments of the business.

According to officials of the company the demand for records has shown a substantial increase over that registered during previous years, due to two causes, among others. First, the new system of weekly releases which makes for a heavier distribution of popular numbers, and, second, the double facing of Red Seal records, a no mean task in itself, which has served to stimulate that division of the record business.

While utilizing their existing facilities to the uttermost, the Victor Co. is busily engaged in perfecting, and, for that matter, carrying out plans for increased production right along the line. These include the new pressing plant in Camden, the building for which is now completed, and the recording and pressing plant in Oakland, Cal., which is now actively under construction and which when completed will serve to take considerable pressure off the main headquarters.

SERIES OF EDISON CHRISTMAS ADS

A series of dealer ads designed for use in holiday campaigns has been prepared by Thomas A. Edison, Inc. These advertisements are up to the usual high standard of the work turned out by the Edison advertising department in its dealer publicity service. The console phonograph as an appropriate Christmas gift is given prominence. The layouts of the ads are appropriate to the season, making an effective display, and dealers can secure mats and electros by communicating with the advertising department of the company.

The Rudd & Rix music store, Green street, Herkimer, N. Y., has been purchased by Robert A. Bothwell, formerly manager. He will continue the business under his own name. A complete line of Victor talking machines, records and sheet music is handled by this concern.



THE EDISON PROPOSITION

is *not* a loading proposition.

INSTEAD,

it is a quick turn-over proposition.

EXAMPLE

after example can be cited to show that, with ordinary effort, a merchant can turn-over his initial investment several times a year. We will gladly tell you how. Just drop us a line.

*Popular Priced Models—From \$100.00 up
Smooth Surface White Label Records*

The Phonograph Corporation of Manhattan

Metropolitan Distributors

Orange

New Jersey

Imported Recordings

Through the International Talking Machine Company, the oldest and largest in Europe

A new phase of phonograph Record Merchandising

WITH the introduction of imported recordings, phonograph record dealers in all parts of the country have grasped a new merchandising possibility.

Other industries have for years taken full advantage of the magic influence of the word "imported." The buying public of America has been taught to regard imported merchandise as particularly desirable. For the products of the Old World, from briar pipes to clothing fabrics, have a quality distinctively their own, which domestic merchandise cannot duplicate.

The General Phonograph Corporation has for the past year been amassing a carefully selected repertoire of imported recordings for the purpose of supplying American record dealers with a line of "imported recordings" which would have no domestic equal.

Already the music lovers of America are becoming familiar with the superb, musical value of those Old World recordings. On the following two pages we have endeavored to briefly summarize the desirable qualities of these recordings and give dealers an insight into this new phase of record merchandising.

It will pay you to read the following pages!

Imported

Odeon Records

IN the past, only those people who traveled in Europe were privileged to hear famous European artists at their best, for it has long been a recognized fact that artists from Europe lack the necessary inspiration of their art when away from their own countries. Although these artists are frequently heard in this country, their performances do not possess the superb brilliancy that characterizes their appearances in their homelands. Now, however, it is possible for everyone in the United States to hear the celebrated European artists at their very best—to possess phonograph records made by these artists right in their own countries, under ideal musical and artistic conditions.



*The following records
selections a*

Rare Records

- | | |
|--------------------------|---|
| 3004
12 in.
\$1.25 | Hungarian Rhapsody No. 2 (Part 1) ...European Sym. Orch.
Hungarian Rhapsody No. 2 (Part 2) ...European Sym. Orch. |
| 3008
12 in.
\$1.25 | Brummel Petrus—IntermezzoDajos Bela Orchestra
The Wedding of Sleeping BeautyDajos Bela Orchestra |
| 3017
12 in.
\$1.25 | Blue Danube WaltzMarek Weber and His Orchestra
Southern Roses WaltzMarek Weber and His Orchestra |
| 3024
12 in.
\$1.25 | Silent Night, Holy Night—First Violin, Second Violin
and OrganMarek Weber Trio
Song of Christmas—Violin, Harp and Organ..Marek Weber Trio |
| 3025
12 in.
\$1.25 | Greetings of JoyMarek Weber and His Orchestra
Sunset On The St. Lawrence.....Marek Weber and His Orch. |
| 3033
12 in.
\$1.25 | Premier Oui—Hesitation WaltzDajos Bela and His Orch.
Le Tango Du Reve—Tango.....Dajos Bela and His Orch. |
| 3035
12 in.
\$1.25 | Batik—Valse BostonDajos Bela and His Orch.
Papillon—Valse BostonDajos Bela and His Orch. |
| 3037
12 in.
\$1.25 | DreamingMarek Weber and His Orchestra
Souvenir De MarieMarek Weber and His Orchestra |
| 3039
12 in.
\$1.25 | Just One NightMarek Weber and His Orchestra
Ecstasy of LoveMarek Weber and His Orchestra |

- | | |
|--------------------------|---|
| 3045
12 in.
\$1.25 | Frasquita—WaltzesMarek Weber and His Orch.
Serenade TarengliMarek Weber and His Orch. |
| 3046
12 in.
\$1.25 | Electric GirlMarek Weber and His Orch.
Mangia, Mangia, Papirusa!Marek Weber and His O |
| 3048
12 in.
\$1.25 | La SerenadeMarek Weber and His O
La Lune Qui Danse (The Dancing Moon)
Marek Weber and His Orch. |
| 3049
12 in.
\$1.25 | Ballade Argentine—TangoMarek Weber and His O
Tango Pervers—TangoMarek Weber and His O |
| 3052
12 in.
\$1.25 | Pas Du CygneDajos Bela and His Orch.
Dreams Of The FlowersDajos Bela and His Orch. |
| 3056
12 in.
\$1.25 | PelicanMarek Weber and His Orch.
SalomeMarek Weber and His Orch. |

Odeon
RECORDS

Records
manuf
United
makers

GENERAL PHONOGRAPH CORPORATION

Recordings

BY special arrangements with the International Talking Machine Co., we alone are able to import through them the matrices of recordings by world-famous operatic stars, internationally known musical organizations, and the foremost musical celebrities of practically every country in Europe. We then press the records in the Okeh factories and release them under the Odeon Label. Each month a notable selection of these splendid recordings is released, and the rapidly increasing demand for them is a clear indication of public approval. They are bringing to the music lovers of America a greater familiarity with, and a finer appreciation for, the true worth and beauties of Europe's music.

Dealers who feature these remarkable recordings gain not only new, steadily-buying customers, but also build invaluable reputations for handling a line of records that is of an unusually high standard and quality.

typical examples of the
 ble from our
importations



- 3061 } ColombinellaMarek Weber and His Orchestra
 12 in. }
 \$1.25 } AmbrosiaMarek Weber and His Orchestra
- 3064 } Loin Du BalDajos Bela and His Orchestra
 12 in. }
 \$1.25 } Whispering FlowersDajos Bela and His Orchestra
- 3066 } Forget Me NotDajos Bela and His Orchestra
 12 in. }
 \$1.25 } PeggyDajos Bela and His Orchestra
- 3067 } AmraMarek Weber and His Orchestra
 12 in. }
 \$1.25 } InvanoMarek Weber and His Orchestra
- 3070 } Prelude In C Sharp MinorMarek Weber and His Orch.
 12 in. }
 \$1.25 } Minuet In G (Op. 14, No. 1)Marek Weber and His Orch.
- 3072 } Schubert Serenade—Violin, Harp and Organ
 12 in. }
 \$1.25 } Serenade Toselli—Violin, Harp and Organ...Marek Weber Trio

SPECIAL ALBUM SETS

Symphony in B Minor

- 5008 } Symphony In B Minor—1st Movement
 12 in. } Symphony In B Minor—1st Movement (Continued)
- 5009 } Symphony In B Minor—1st Movement (Continued)
 12 in. } Symphony In B Minor—2nd Movement
- 5010 } Symphony In B Minor—2nd Movement (Continued)
 12 in. } Symphony In B Minor—2nd Movement (Continued)

Played by Eduard Moerike and the Orchestra of
 The German Opera House, Berlin
 Sold In Sets Only Retail Price, \$5.00

Der Freischutz and Oberon Overtures

- 5022 } Der Freischutz—Overture, Part I
 12 in. } Der Freischutz—Overture, Part II
- 5023 } Der Freischutz—Overture, Part III
 12 in. } Oberon—Overture, Part III
- 5024 } Oberon—Overture, Part I
 12 in. } Oberon—Overture, Part II

Played by Eduard Moerike and the Orchestra of
 The German Opera House, Berlin
 Sold In Sets Only Retail Price, \$5.00

Okeh
RECORDS

OTTO HEINEMAN, President

NEW YORK

When you stop to realize—

(continued from the preceding pages)

That each month the General Phonograph Corporation releases more Dance Records than any other company;

That our Foreign Language Records are made by native artists in their native lands—and, therefore, have a genuine appeal to the millions of foreign-born Americans;

That OKeh Records are the first on the market with the hits;

That some of the country's most famous artists record exclusively for OKeh;

That OKeh Race Records are supreme in the colored field—

You must agree that it will pay you to handle

OKeh Records

The Records of Quality

Know Your Overhead and Prevent Losses

Dealer Handling More Than One Line Must Keep Accurate Check on Each to Get a Correct Idea of His Profits—A Simple System

A fundamental principle of business management is to know accurately the overhead expense so that a close check can be made at all times to determine profits. Undoubtedly every merchant, whether he be in the talking machine business or in any other enterprise, has some method of determining his profits, but there are many merchants who, through faulty systems of cost finding, imagine they are making a profit when the contrary is the case. When a single line is handled it is a simple matter to secure an accurate idea of actual profits, but when two or more lines are carried the problem becomes more complicated. The larger concerns which operate various departments, such as talking machine, record, musical merchandise, radio, etc., have more or less elaborate systems of cost finding, enabling them to know the overhead of each department and also which lines are paying and which are failing to make good. Many small dealers, however, do not operate departments, although they may handle several lines, and also in many cases there is little or no effort made to determine exactly what the profits are from each line of goods handled. Too often the cost finding consists merely of treating the business as a whole, and where this method is practiced there are no accurate data on actual profit or loss in the handling of the various lines.

The profits of one line may be eaten up by another which is consistently losing money. Without accurate information it is impossible to determine where the trouble lies and, consequently, the dealer is unable to take measures to eliminate the loss, either by improving his

merchandising policy or by discontinuing the line which is not proving profitable.

A Case in Point

The case of a certain dealer which came to the attention of the writer a short time ago excellently illustrates this point. This merchant operated a fine, large establishment in a prosperous section of a large city not very far distant from New York. His talking machine and record business was doing well, but one day he conceived the idea of installing a line of cameras and accessories and for this purpose he spent considerable money in purchasing a special showcase and wall cases for a fair-sized stock of photographic necessities. He spent very close to a thousand dollars for stock and fixtures. His main object in selecting cameras was to bring people into his store to get acquainted with him and the fine line of talking machines he handled. According to his own statement he made no effort to determine what it was costing him to run this department. Where this dealer made his first mistake was in selecting a line entirely foreign to the music business. His second mistake was in overlooking the fact that just around the corner was a store which specialized in cameras, printing and developing, which had an established reputation and was getting practically all of the trade in that line in that neighborhood. His third, and perhaps worst, mistake was in not keeping an accurate check on the cost of operation of this new venture. As a matter of fact, when this last failure was brought home to him he realized that he was spending a good bit of money for something which was bringing him

practically no return—this money might better have been spent in some good advertising.

It often has been emphasized that quick stock turnover and a fair margin of profit are the two essentials of success, but if the dealer does not know what it is costing him to sell his goods he has no means of fixing a fair price.

How One Dealer Does It

A large and successful talking machine establishment, which has a number of lines, keeps separate accounts for each, and every month the profit and loss statement is drawn up by the auditor as follows: The gross sales are first determined. From this are deducted, in the case of talking machines, the loss on returns, allowances and discounts, if there are any. Then the cost of goods sold is deducted, giving the gross profits. From the gross profits are deducted the cost of advertising, rent for the space occupied (if one-third of the entire floor space is occupied one-third of the rent is charged), salaries (this includes salesmen, canvassers, collectors, bookkeeping, etc.), freight and cartage, light, heat, phone, etc., giving the net profits. If interest is charged on sales or any other income is derived from other sources this is placed under the head of miscellaneous income and added to the monthly net profits, giving the total net profits of the talking machine section of the business. This is a very simple system and one which can safely be used for every line or department of the store, thus giving the dealer at all times a clear idea of just how he stands. Where several lines are handled the net profit of each department must be added to determine total net profit.



DOUBLE FACED RED SEAL
Galli-Curci
VICTOR RECORDS
Come in and hear this Victor Artist

To Increase Sales
of
New Double-Faced
VICTOR
RED SEAL
RECORDS

Double Faced
RED SEAL RECORDS
by
JASCHA
HEIFETZ
Come in and hear this
VICTOR ARTIST



Now that the Victor Company has double-faced their Red Seal records and at the same time greatly reduced their price, it will, no doubt, create a greater interest from those who formerly confined their purchases to the popular releases.

It is an opportune time for dealers to make a special effort to interest their customers in this higher standard of music rendered by the celebrated artists that record exclusively on the Victor Red Seal discs.

Supplementary to our regular weekly service featuring one popular record each week, we have issued a series of fourteen panels of Red Seal artists (portraits drawn from photographs) four of which we illustrate. If this series of panels is of interest to you, write us for descriptive circular with prices.



Double Faced
RED SEAL RECORDS
by
CHALIAPIN
Come in and hear this
VICTOR ARTIST

ARTISTS FEATURED

<i>Caruso</i>	<i>Chaliapin</i>
<i>Galli-Curci</i>	<i>Gigli</i>
<i>Louise Homer</i>	<i>Jascha Heifetz</i>
<i>Jeritza</i>	<i>Fritz Kreisler</i>
<i>John McCormack</i>	<i>Paderewski</i>
<i>Rachmaninoff</i>	<i>Ruffo</i>
<i>Schuman-Heink</i>	<i>Werrenrath</i>

The Da-Lite Electric Display Co.
116 No. Erie Street Toledo, O.

Double Faced
RED SEAL RECORDS
by
Schuman-Heink
Come in and hear this
VICTOR ARTIST



Reawakening Public Interest in Records

More Intensive Merchandising Methods Necessary to Get Full Benefit of More Frequent Releases of Records, Says L. H. Holt

The practice that has now become general of releasing records at weekly intervals or even oftener presents many new angles for the consideration of both manufacturers and dealers and calls for a general rearrangement of distributing methods in order to take full advantage of the new opportunities and conditions.

The present system of release necessarily means that many former production, selling and promotion plans and strategies must be, and to a large extent have already been, relegated to history. Around the new system of what we may term "ready release" new plans of manufacturing and merchandising have naturally been created. While a good deal of this work has already been done by the manufacturers, and to a certain extent by distributing interests, the process has by no means been completed in that many refinements will come through actual experience.

In the first place, the weekly, or even daily, release of new records, as compared to the system of monthly releases which existed so long, is a natural development of the desire for, and necessity of, capitalizing on the popular hits before they have reached the peak of success and of not delaying until that peak is passed. Experience proves that the first record issued of a new popular number corralled a heavy percentage of the demand for that number, and the natural development was to arrange for the release of all new records as soon as possible. There was a twofold reason for this. First, the force of competition, and, secondly, the idea of securing an increased volume of public patronage.

In conjunction with the new plans to release records at short intervals, most of the manufacturers are producing supplements and other publicity and sales material designed to capitalize on the reawakened public interest with the utmost completeness. These supplements and bulletins compare most favorably with those in effect when monthly releases were the vogue, and they describe each release in an illuminative, newsy and effective style. The most im-

portant thing for the dealer to do, therefore, is to see that these supplements and other publicity matter go into the hands of his customers and prospects with a minimum of delay.

Mailing the Bulletins

There has been much discussion relating to the mailing of record bulletins. This discussion has centered mainly on whether or not to include form letters, whether the letters should be filled in, what kind of envelopes the bulletins should be mailed in, etc.

After checking up the methods pursued by a large number of retail merchants handling various makes of records, the writer has concluded that the best system is to mail the bulletins out without any letter or any other enclosure of any sort. In the first place, this is the cheapest method, and, in the second place, it necessarily concentrates attention on the newsiest part of the dealer's message—namely, the new records themselves. In the third place, the bulletins supplied by the manufacturers are generally of a higher grade in so far as paper, printing, illustrations, typography, etc., are concerned than the literature produced by the local retailer. Consequently, unless a good deal of money is spent on the matter sent out with the bulletin by the dealer—and this additional matter obviously adds distraction—the impression on the recipient will not be uniformly good.

Finally, as regards the envelopes, on account of the fact that the bulletins relating to current releases are so small in comparison with the former monthly bulletins, they can be readily enclosed in the ordinary envelope of the dealer, although special envelopes which permit flat mailing are probably more desirable.

The Factor of Economy

The work incident to the mailings of the type recommended above is as follows: In the first place, the list of customers and prospects should be stenciled so that mailings may be made promptly and at a minimum of expense. In the second place, the list should be constantly edited so that the deadwood may be cut out and new names constantly added. Provision

must also be made for the placing of the dealer's name and address on each bulletin mailed out. This should preferably be done by printing, but where there will be too much delay in time and the cost also is thought too high these should be done by plain embossing. Machines for this purpose can be procured at a cost of but a few dollars and the effect is infinitely superior to that of rubber stamps, which are generally blurred and offset.

Persistence Is Necessary

The foregoing discussion pertains to an individual mailing, but it must be clear that if a prompt clearing of the information about new releases is important for one day or one week, it is just as important for every other day and every other week in the year. A trip through a daily newspaper plant should afford inspiration of the right sort.

In other words, the newsier the news is, the more important are the results to be secured by conveying it to the dealer's customers. Therefore, in view of the present system of release, every dealer should plan to immediately clear each and every release along lines similar to those suggested above. Promptness and consistency should be the watch words of the retail industry.

Coincident with the new plan of record release, there are many other things which require attention, although, as has been stated, the matter of bringing the news to the public by direct mail through bulletins is the first and most important thing for the dealer to do.

Educating the Public to Visit the Store

The next important thing to do is to everlastingly foster a habit on the part of the public to continually visit the store in order to hear and learn more about the new records. Hitherto the practice has been to educate the public to come in only once a month, but now there is occasion for a constant procession of visitors and that habit should be aided and abetted in every possible way. Posters and bulletins in the store, the conversation of the sales organization, the window display and many other avenues should be continuously employed to build the line of visitors into ever larger proportions. Also this new development in record release means that record demonstration booths of a comfortable and acoustically correct character are more important to the dealer's success than ever. It also means that as the number of visitors is increased the facilities for their reception should be steadily increased.

Again, there is the proposition of newspaper advertising. This, of course, in the case of many dealers cannot be done on an extensive scale. At the same time every dealer should make some effort to call the attention of the public to the new records and should be continually inviting the public, through the medium of the newspapers, signboards and other advertising media, to come in and hear the new records.

There are, of course, many other angles to this record selling problem, but the most important ones have been touched on in this article. A more comprehensive analysis will be possible after the table of trade experience has grown more extensive, but meanwhile it is highly important that every retail talking machine dealer fully appreciate the tremendous opportunity that the new system of record release offers to keep his business and his products constantly before the public and in an extremely newsy and, therefore, influential way.

The new system of releasing records undoubtedly requires a type of enterprise which is redundant with the spirit of that old adage about the early bird and the worm. In other words, quick action is the keynote.



HENRY BURR



ALBERT CAMPBELL



JOHN MEYERS

EIGHT POPULAR VICTOR ARTISTS

In Concert and Entertainment
Personal Appearance of
Eight Popular Favorites on
One Big Program

A live attraction for live dealers and jobbers

Bookings now for season 1923-1924
Sample program and particulars upon request

PHILIP W. SIMON, Manager
1674 Broadway New York City



FRANK CROXTON



MONROE SILVER



BILLY MURRAY



RUDY WIEDOEFT



FRANK BANTA

Popular Ensembles including
Campbell & Burr - Sterling Trio - Peerless-Quartet

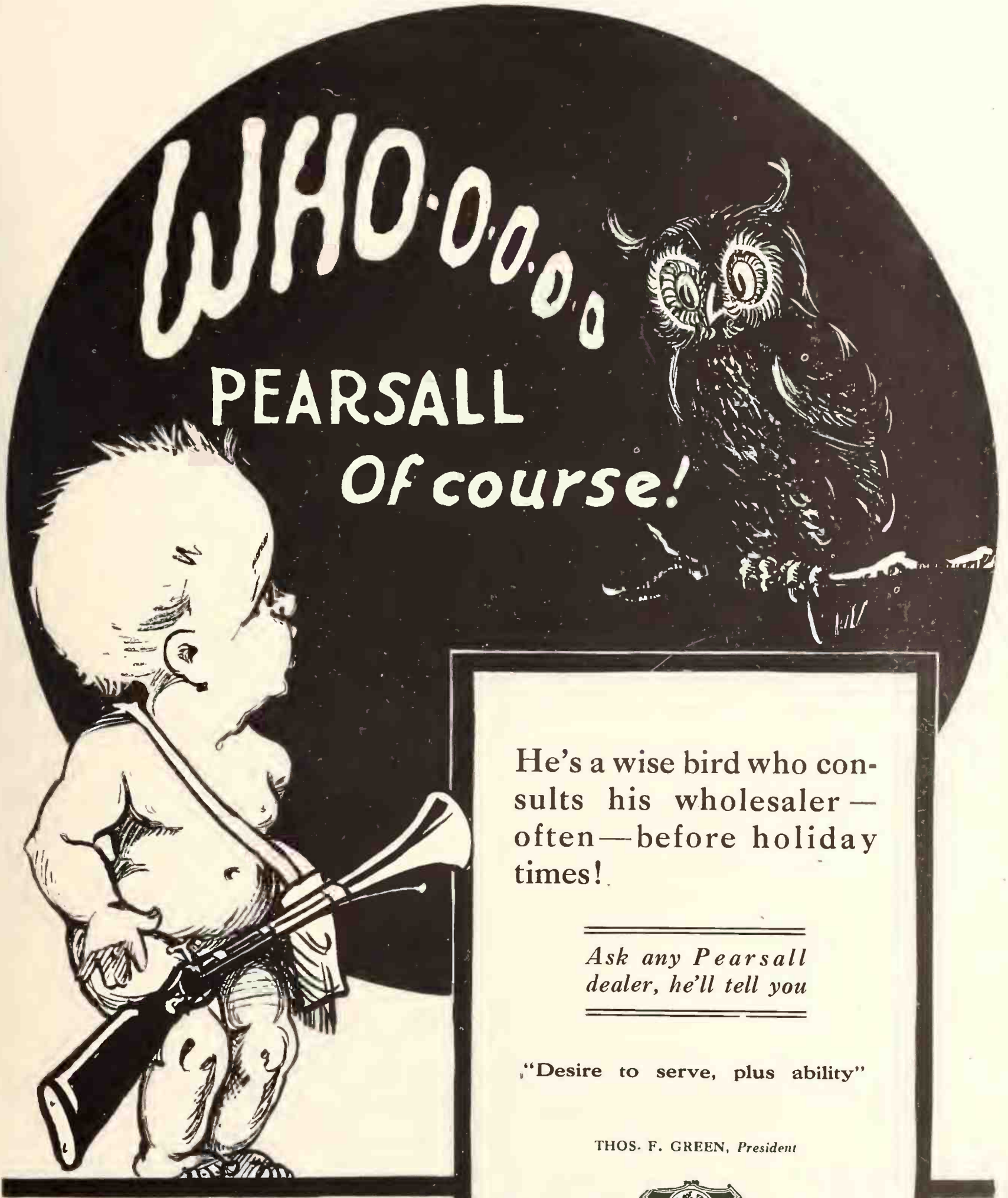

He's a wise bird who con-
sults his wholesaler —
often—before holiday
times!

*Ask any Pearsall
dealer, he'll tell you*

“Desire to serve, plus ability”

THOS. F. GREEN, *President*

10 EAST 39th ST.

NEW YORK CITY

SILAS E. PEARSALL COMPANY

DISTRIBUTORS

Timely Holiday Business Building Stunts

W. B. Stoddard Tells of Some Clever and Successful Publicity Ideas Which Any Talking Machine Dealer Can Use to Advantage

Now is the time when dealers should plan their holiday campaigns in the way of window displays or newspaper advertising, for any stunts they wish to pull off should be made the first of December, immediately following the withdrawal of the Thanksgiving displays. Indeed, the campaign should be under way before the first of December, particularly if the dealer wishes to interest patrons in a Christmas Club. Many who would like to buy a talking machine do not feel that they can afford the outlay at one time, and if convenient payments are stressed, the holiday sales will be greatly increased. A St. Louis firm advertised early in November:

**SAVE YOUR DIMES AND BUY XMAS GIFTS
JOIN THE XMAS CLUB THIS WEEK**

When the holidays arrive you will have money for a worth-while gift. This is the plan: Lay aside \$1 the first week; \$2 the second; \$3 the third; \$2 the fourth, and \$1 the fifth. When the holidays arrive you will have \$9, which will be the first payment on

A HANDSOME PHONOGRAPH
If you do this there will be no choosing a gift in a crowded store, and no frantic wondering as to where the money is to come from for purchasing a gift.

A card with a similar advertisement in large letters was placed in the window, together with three different models of phonographs from which to choose.

How a Columbus Dealer Puts It Over

Another trade-inducing stunt was that of the Christmas Shopping Bell, which was introduced with much success last year by a firm in Columbus, O. During the latter half of November they ran in the papers the outline of a big bell, within which was the announcement:

CHRISTMAS BELL DAY

Hear Ye! Hear Ye!
Official Christmas Bell Day, December First.
The glad tidings bell will ring in two weeks.
(This was changed to "ten days," "a week," etc., as the date drew near.)
On this date commences the Christmas Sales Campaign on Phonographs.
Save now for enjoyment all the year around.
Keep close watch on our windows for the opening day.

Upon the day in question the windows and doors were wreathed with ropes of evergreen and festoons of it were draped the entire length

of the interior. Mingled with this were sprays of holly and mistletoe, presenting a very festive appearance. In the window were set a number of phonographs on a floor covered with cotton wadding sprinkled with diamond dust, while on the cabinets were laid sprays of holly and mistletoe also powdered as if with snow. A card beside each machine announced the special Christmas sale price at which the machines would be sold. But the chief novelty of the sale, which compelled the attention of everyone who passed, was a gong that sounded automatically every half minute. This was placed over the door, and its insistent clang rose above the noises of the street, and informed even the most careless and preoccupied that something unusual was transpiring.

Novel Stunt in Having Literature Read

At this season of the year it is advisable to send out literature on the subject of phonographs supplied by the manufacturers. But sending it out and getting it read are two different things. A dealer in St. Paul hit upon a novel plan for securing attention to his circulars. He had received what he considered a very good proposition for a special sale of talking machines and was anxious that it be placed before responsible parties. Accordingly a number of these circulars were enclosed in envelopes, and mailed to a selected list of prospects. The envelope bore the name of the firm and the signature of the president, while in heavy type was printed "My personal check payable to you is enclosed herein." Naturally, every circular was opened, and therein was found a check for 10 cents, payable to bearer on demand. The short letter explained that the check was in payment for the time spent in glancing at the circular, and went on to suggest that a phonograph, of the kind mentioned in the circular, would make an excellent Christmas gift. "The interesting feature of the stunt," said the manager, "was that a very small percentage of the checks were cashed, most of the recipients seeming to prefer to keep them as a curiosity. The novelty of our method, however, caused them to read our circular, as they fig-

ured it must be worth while if we were willing to pay them actual cash for so doing. As a result of this little letter we had numerous telephone calls and visits, and a considerable number of the instruments we were advertising were sold through them."

Value of a Smiling Service

At this season of the year smiling service counts for much, and a dealer in Portland, Ore., had capitalized this thought to good advantage. Stamped on his stationery and emblazoned on cards is his guarantee:

TO MY PATRONS

My custom and policy is to see that every patron is pleased. It is impossible to serve you all personally, but I have tried to select salesmen who will give you the very best of service at all times. If at any time you should receive discourteous treatment or are dissatisfied with a sale, I would consider it a special favor if you would call at my office and allow me to make amends.

He has capitalized his smile, for many of his ads are adorned with a cut of his countenance—a face lighted up with a pleasant smile that inspires confidence in the man and his methods. One of his most effective modes of advertising is by street-car signs, using his slogan, "Service with a smile," his photo and at the bottom "Sandy's not nervous, so gives you good service." His ads, too, are highly original, and in addition to their humor always have a basis of sound common sense. For example, a one-column, six-inch ad, with plenty of white space, was in the form of a little narrative:

"A sweet young thing of sixteen came into our music store recently and inquired of our particular Adonis 'Have you 'A Heart That Beats for Me,' and he promptly fainted.

"Once in a while, of course, a customer will ask for a record we do not have, but he's got to go some to do it this season, as we have the biggest and classiest line of records in the city. Ask to hear some demonstrated."

OLDENDORF BUYS VICTOR AGENCY

LAWRENCEVILLE, ILL., November 3.—G. I. Nunn has sold his Victrola agency to the Oldendorf Music House, which will handle the Victor line, in addition to the Edison, in this city hereafter. Mr. Nunn has been the sales agent for Victor talking machines in Lawrenceville for the past twenty years, but is selling out in order to have more time to devote to his other interests.

LARAWAY CO. OPENS BRANCH STORE

CORVALLIS, ORE., November 3.—The Laraway Music Co., of Eugene, Ore., recently opened an attractive branch store at 130 South Second street here. In addition to the Victor and Brunswick lines, pianos are handled. Artistic interior decorations and arrangement make this one of the finest establishments of its kind in this section. Paul B. Norris is in charge.

NEWARK BRUNSWICK SHOP CHARTERED

NEWARK, N. J., November 4.—The Brunswick Shop, Inc., of this city, has been granted a charter of incorporation under the laws of New Jersey, with a capital of \$100,000, to deal in phonographs, pianos, etc. Henry Gottfried, of this city, is the incorporator.

FULL LINE of HARDWARE FOR UPRIGHT, CONSOLE AND PORTABLE PHONOGRAPHS. IN NICKEL, GOLD AND SPECIAL FINISHES.

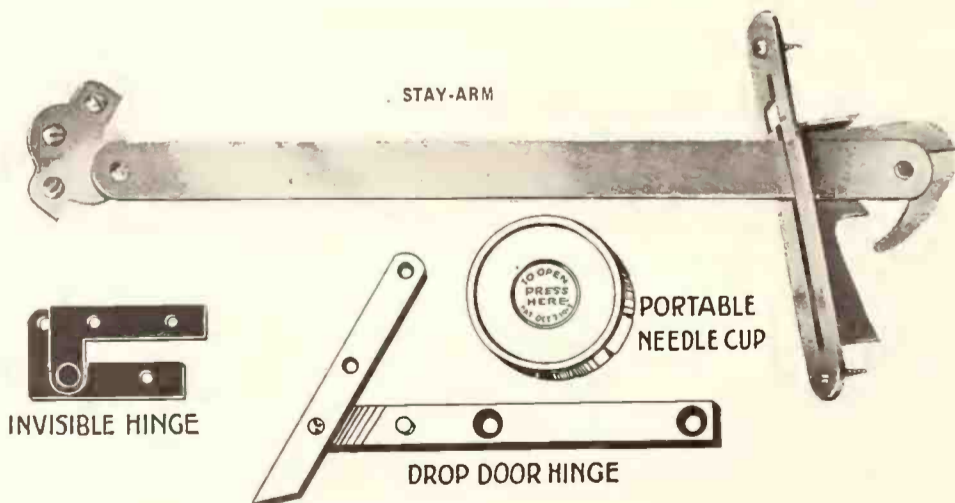

We have been catering to the hardware needs of the talking machine industry for a number of years. Consequently we are in a position to give attention and service of the highest calibre.

H. A. GUDEN CO., Inc.

227 CANAL STREET

NEW YORK, N. Y.

COTTON FLOCKS

.. FOR ..

Record Manufacturing

**THE PECKHAM MFG. CO., 238 South Street
NEWARK, N. J.**



PAL

\$ 35

RETAIL

Made in Genuine
Dupont Fabrikoid
(A fine imitation leather.)

LIBERAL
DISCOUNTS.

A Premier CHRISTMAS Gift!

Its outstanding quality—its remarkable tone—its beauty make it as ideal a phonograph for the home as it is for the outdoors.

This, together with its low retail price, produces a Christmas gift that will bring you a sale well worth while!

For the rest of the year there is no phonograph that is so certain to produce profits as the PAL PORTABLE.

Holiday Orders Are Being Filled Now!

PLAZA MUSIC CO.

18 WEST 20th STREET.

NEW YORK

HALF PAST TEN

'SOP-TIM-BOM'

NOVELTY CHINESE WALTZ SONG

Ed- 'ry time the clock strikes half past ten, All my tho'ts go rush-ing back a -gain

Profiteering Price Cutter Is a Trade Pirate

The Hon. Clyde M. Kelly, Representative From Pennsylvania, Likens Price Cutter to a Spider Waiting for Unwary Fly—Declares Him Trade Demoralizer and Business Killer

"The profiteering price cutter who takes a standard, identified, widely wanted article and reduces the standard price in order to deceive the unwary customer is a trade pirate," says Clyde Kelly, of Kelly-Stephens bill fame. "He is a spider luring the puzzled customer into his web. He is not a public benefactor, he is a public malefactor. His predatory plan is to fool the purchaser by giving him a few cents on one transaction so that he may rob him of dollars on others. He is a price cutter in order to be a profiteer. He gives twenty-five buyers a bargain on known goods so that he may overcharge 500 customers on unknown goods. He piles up profits for his department store or mail-order house by the tactics of the green goods man and advertising faker and the deceived public foots the bill. His success, built on unfair methods, means higher price and lower quality on all goods. In the beginning he robs the consumer by fraud and later devours him by extortion.

"The profiteering price cutter ruins the reputation of high-grade goods and destroys the goodwill of the makers, thus stealing both purse and good name in one operation. He advertises standard goods at a loss and then seeks to persuade the public to accept substitutes on which he makes money. He demoralizes the price and the product. He forces other dealers to follow his lead or refuse to handle the article. He restricts sales and lessens distribution. His unfair practices leave the manufacturer helpless to protect his business, into which he has put his name, his labor and his money.

"The profiteering price cutter drives the small distributor to the wall by the worst form of illegitimate competition. He destroys competition by the very practices the anti-trust laws were intended to prevent. He is the cut-throat competitor who is everywhere and always the forerunner of monopoly. He is a restrainer of trade and a lessener of competition. He robs the neighborhood of their corner stores, which can give best service under fair competition. He shouts for a free market where, in a jungle war, his unscrupulous tactics may give him a stranglehold on business.

"The profiteering price cutter helps to weaken the honesty and morality of American business. He seizes any straw, however flimsy, to free himself from moral and legal obligations to fulfill contracts and obligations. He breaks down

HAWLEY ON EDISON ACHIEVEMENTS

General Manager of Girard Phonograph Co., Philadelphia, Speaks Before Kiwanis Club, of Trenton, N. J., and Gets Fine Reception

"The Life of Thomas A. Edison and His Favorite Invention" was the subject of an address made by P. R. Hawley, general manager of the Girard Phonograph Co., Philadelphia Edison distributor, before the Kiwanis Club, of Trenton, N. J., on October 17, by arrangement with the Hurley-Tobin Co., Edison dealer in that city.

Mr. Hawley was the principal speaker at the regular weekly luncheon on that day at the Stacy-Trent Hotel, and provided the members of the club with some exceedingly interesting facts relating to the development of the phonograph as well as numerous other of Mr. Edison's inventions.

In summing up his address Mr. Hawley described some of the powerful influences which music has over the mind and predicted that the phonograph would some day become more than a means of entertainment. He said that even now experiments are being conducted at the Edison Laboratories for the purpose of cataloging the influences which different kinds of music have over the average mind and for putting the results to practical use.

Joseph Tobin, of the Hurley-Tobin Co., was elated with the impression which Mr. Hawley's address made upon the club and stated that he felt it an inspiration for renewed effort in promoting Edison business in and around Trenton.

The Boot Music Co., of Denver, Col., recently added the Brunswick line of machines and records. The concern also handles the Victor talking machines and records.

the one-price-to-all system, which is an inseparable companion to honesty. He is the author of many degrading tendencies in business. His spirit of disregard of fair play is encouragement to every cheat in business. He helps rot the fabric of American commerce. He breeds the tax dodger and the canceler of honest contracts and the men who cheat but keep within the law. He encourages 'gentlemen's agreements.' He is an enemy to the public good and he must go."

PLANS NEW STORE FOR JAMESTOWN

Danielson's Music House to Reopen at Former Location on North Main Street

JAMESTOWN, N. Y., November 3.—Danielson's Music House, located at 17-19 East Third street, where the Lauter, A. B. Chase, Mehlin, Packard and Cable-Nelson pianos and Victor talking machines are handled, has arranged to open a new store at his old location, 17 North Main street, which was burned down some time ago. A new fireproof building has replaced the burned structure and the music house will occupy the ground floor, which will be fitted up in a modern manner. At the Third street store twelve booths are available for demonstrating records and rolls.

MUSIC HOUSE BUYS SITE

KLAMATH FALLS, ORE., October 30.—A building plot on Main street, near the Elks' Temple, has just been purchased by the Earl Shepherd Music Co., with a view to erecting a new structure here in the near future. The lot will afford thirty-three feet of frontage by 120 feet in depth. The Shepherd family, which has been engaged in the music business exclusively for fifty-seven years, carries the agency for the Knabe, Gulbransen and other pianos. The Victor and Sonora lines are also handled.

"RADIO" AUTO TO ENFORCE LAW

Wireless is being used to detect radio law violators. The U. S. Bureau of Navigation in the third and eighth districts of the radio service has equipped automobiles with wireless. An inspector and an assistant regularly tour their territories in the motor, equipped with a complete receiving set which is used for picking up unauthorized stations.

PHONOGRAPH CASES

RADIO CASES

Reinforced 3-ply Veneer

The Standard Case for Talking Machines and Radio Sets

Let us figure on your requirements

MADE BY PLYWOOD CORPORATION, Goldsboro, N. C. Mills in Va., N. C. and S. C.

SEE WHAT

Anger says

ON PAGE 35

Read what this dealer
“FROM MISSOURI”

has to say about the AUDAK — the
 modern system for demonstrating records

—without booths—

Paul's
Victrolas and Records
 1103 Walnut Street
 Kansas City, Mo.

10/5/ 23

Artophone Corporation,
 203 Kansas City Life Bldg.
 Kansas City, Mo.

Gentlemen:

Replying to your inquiry regarding
 Audak equipments purchased from you will say that
 we are now using nine of these equipments and
 expect to add additional ones in the near future.

Having formerly operated a Music Shop
 in Kansas City, using conventional booths, I was
 at first dubious as to just how customers would
 take to the Audak idea, but I am very glad to say
 that we have had no complaints from customers, and
 several of them have told me that they much prefer
 the quick convenient service afforded by Audaks
 rather than be put in a stuffy, unsanitary booth.

As you know, our salesroom is rather
 small, 12 X 20 feet, and Audaks actually give us
 a nine booth capacity.

There is no question but that in this
 era of high rents Audak equipments solve the
 problem of doing a profitable record business.

Yours very truly,

Paul Record Store - Aug
By M M Paul
Manager

MMP/A

Here are a few of the conspicuously successful firms now using AUDAKS to sell more records at a better profit:

Wanamaker's, New York and Phila.
 Kaufman's, Pittsburgh, Penna.
 Bloomingdale Bros., New York.
 Frederick Loeser & Co., Brooklyn, N. Y.
 Lord & Taylor, New York.
 Jordan Marsh & Co., Boston, Mass.
 Saul Birns, New York.

J. L. Brandeis & Sons, Omaha.
 Gimbel Brothers, New York and Phila.
 Euclid Music Co., Cleveland.
 Forbes & Wallace, Springfield, Mass.
 Aeolian Co., New York.
 Lit Brothers, Philadelphia.

Rothschild & Co., Chicago.
 The Boston Store, Milwaukee, Wis.
 R. H. Macy & Co., New York City.
 Brunswick Shop, Detroit.
 The Emporium, San Francisco.
 And many others.

Audak is recognized as the means toward greater record sales and the reduction of the
 cost of selling them—bringing the increased profit to the dealer, which today he
 must have.

Write or wire for catalog and details

Distributors in all principal cities

AUDAK COMPANY

:: ::

565 Fifth Avenue, NEW YORK

Local Musical Events Open Way to Sales

Talking Machine Dealers Must Actively Co-operate in the Musical Events of Their Communities in Order to Reap Resulting Profits

A limited number of talking machine dealers in various localities have for some time past been making an effective tie-up with musical organizations and artists in their localities through acting in a sense as booking agents. In some cases the dealers have brought to their towns and underwritten the concerts of prominent recording orchestras and artists and have their reward always in the publicity accruing from the concert and most generally from the dollars and cents profits realized through their endeavors.

Up to this time the work of such dealers has been largely along lines of exploitation and designed to center public interest on talking machine artists and stimulate record sales rather than to make the store a recognized center for musical activities. The new departure is to have the dealers constitute themselves booking representatives for various recording organizations and artists, for the convenience of customers and others in their localities who plan to hold recitals, dances, etc., for various purposes, and seek suitable music for the occasion.

Members of The Talking Machine Men, Inc., New York, have arranged to carry on this work in a large way in co-operation with the central booking offices controlling well-known orchestras and artists. In this connection the idea is not so much the direct exploitation of records and artists of any particular company as it is the matter of impressing the public with the fact that the neighborhood talking machine dealer is in a position to provide musical entertainment of every character rather than simply talking machines and records.

The talking machine store in any community which is not linked closely with local music and concert activities is missing what is perhaps its strongest and closest point of contact with the class that are the best type of prospects for the merchandise it sells. This has been proved time and again by the experiences of some of the leading houses in the retail music trade. It is impossible to mention very many names of merchants who have not consistently pursued this policy as one of the funda-

mentals of their selling methods. The experience of years has taught these concerns the helpful results, at comparatively small expenditure, that are obtained from this policy.

Merely mentioned as an incident, but a striking one nevertheless, is the statement that the Dreher Piano Co., of Cleveland, which handles large numbers of talking machines, expects, through linking its establishment closely with one of the local concert courses in that city, to draw approximately 200,000 people to its store between now and the end of the musical season. Is there any other method which could place that number of people already interested in music in contact with the warerooms at a lower investment?

According to present prospects, the musical season just opened will be one of the greatest which the country has ever experienced. This, of course, is something that is annually said, but this year there is a far more accurate basis for the statement than is usually the case. The work which has been consistently done in arousing popular interest in music has at last reached a cumulative stage where its results are direct and apparent. It is not meant by this that they come to the merchant's ware-rooms without effort upon his part; but it is meant that the popular state of mind is such that it responds readily and directly to exploitation work which takes into consideration the present-day psychology and uses that as a guide.

There should not be a city in the country in which local concerts or recitals are held where in the music merchants do not play a prominent part in their promotion and support. They should do more than merely lend their support financially; they should use their own personal efforts and be active, individually or collectively, in this work. It may be frankly said that there is nothing philanthropic in it nor is it simply a contribution to community betterment, no matter how great the results may be in this direction. It is one of those rare instances where self-interest and public interest are in the same channel.

It is trite to say that the basis of all sales of musical instruments is music. But it is a truism that cannot be repeated often enough, and one which can never be driven home forcibly enough to the talking machine or general music merchant and to the salesman who come in contact with his prospective customers. Any sales plan which in the long run disregards this fundamental fact is false in its relation to the problem that confronts the dealer. And this falsity is expensive in that the overhead cost represented therein cannot bring its due proportion of results when disregarding it.

There is another angle to this entire situation which should not be disregarded. Musical activities in any community work directly to the benefit of all music merchants who draw sales from the people within the radius of their influence. Therefore, no music merchant can afford to disregard, or to be deficient in support of these events, no matter what instruments may be used or featured.

If the merchant handling talking machines or musical instruments of any kind fails to link his establishment as closely as possible with the musical people and the musical events of his community he is invariably failing to take advantage of what is probably his one best selling approach. And there is no dealer, no matter how great his volume of business may be, who can afford to be so indifferent.

SHOW WINDOW CONTEST IN GOTHAM

Advertising Exposition Will Offer Prizes to New York Merchants for Artistic Displays

A contest in show window dressing will be held for New York merchants and storekeepers at the Advertising Exposition to be held at the Seventy-first Regiment Armory from November 12 to 17. Each contestant's window display will be photographed and the pictures will go before a jury of award, upon whose report prizes will be distributed at the exposition. The displays will be made throughout the city a week before the opening of the show.

There will also be an advertising critic contest, in which readers will be asked to vote on the attractiveness of 100 advertisements. A prize will be awarded for the most popular choice. Another prize will be awarded for advertising copy, plan, thesis or central idea submitted by New Yorkers to supply any deficiency in the city.

Educational classes will be conducted every morning and afternoon. All young persons interested in advertising will be invited to attend.

NEW RECORD LIST FOR SALESMEN

The Victor Talking Machine Co. has just issued a special record list to facilitate the work of salesmen in selecting and looking up records for customers. The list includes the new Victor records released from September 21 to October 26 inclusive. The records are arranged by titles in alphabetical order.



SEE
WHAT

Minger Says

ON
PAGE 35



BRUNS MADERITE Phono Moving Covers

Cover, Straps Attached



*For all models of Upright and
Console Machines*

Every progressive dealer needs a supply of dependable moving covers. Mr. Average Man dislikes to unpack anything he buys. By using padded delivery covers you protect and deliver a perfect instrument with no necessity for dirt, inconvenience or trouble to your customer.

It is much more simple to slip a cover over an instrument at the store and off at point of delivery and the impression left with your customer is pleasant. MADERITE covers are strong, well padded and satisfactory from every standpoint.

Consult your accessory jobber, phono distributor or write us for literature and prices.

A. BRUNS & SONS

Manufacturers of Canvas Goods

50 Ralph Avenue

BROOKLYN, N. Y.



Radiola Grand and Mahogany Stand with "B" batteries and 4 Radiotron WD-11 dry cell vacuum tubes \$350.00

Radiola Grand

WITH the Radiola Grand, radio takes on new meaning. The simplicity of tuning in—just a knob or two to turn. The big distances it covers—picking up far-away stations with volume enough to fill a room. The perfection of tone with which the loudspeaker—carefully built in like the horn of a fine phonograph—gives forth the music and speech. All this—combined in a cabinet of skillful workmanship and tasteful design—places radio in the home where beauty counts—and performance.

Points to note:

All the batteries—dry cells—are hidden away inside.

You can regulate the volume of sound by a control that governs the loudspeaker.

For long distance, plug in the headphones. Coast to coast reception is no unusual record for Radiola Grand!

Famous for true reception, undistorted. For keen sensitivity. And for beauty.

"There's a Radiola for every purse"

Radio Corporation of America

Sales Department
Suite: 3007
233 Broadway
New York

District Sales Offices
10 So. LaSalle Street Chicago, Illinois
433 California Street San Francisco, California

DEALERS: Write today for the RCA catalogue, full description of the Radiola Grand, and the RCA selling plan.



This symbol of quality is your protection

Radiola

REG. U. S. PAT. OFF.



This symbol of quality is your protection



The NEW Columbia is superior

*Hearing
is believing*

The Motor is the Acme of Precision.
As accurate as a watch because it was made that way by phonograph engineers and scientists who set that standard as their goal. The result? The New Columbia delivers an even and measured flow of power which makes the rhythm, tempo and tone of each record perfect. *Hearing is believing.*

COLUMBIA PHONOGRAPH COMPANY
New York

HUMES MUSIC CO. IN ITS NEW HOME

Well-known Southern Music Company Stages Formal Opening of Building Remodeled at Cost of \$150,000—Thousands of Visitors

COLUMBUS, GA., November 3.—The Humes Music Co. held a formal opening of its handsome new music store at 1122 Broad street last month, when several thousand citizens took the opportunity of inspecting the new quarters of

space. The text told something of the history of the company and of its wonderful progress.

The building into which the Humes Co. has just moved was purchased by the company some time ago and remodeled throughout to meet the particular demands of the business, the cost of the building and improvements being in the neighborhood of \$150,000. The first floor has its front arranged to represent an imposing lobby, which may be viewed from the street through plateglass windows extending to the floor. On this floor are located the small goods, Victor record and music roll departments, and here is also displayed a full line of Victrolas, with the main display on the mezzanine floor.

The second floor is devoted to a magnificent display of pianos and on the third floor is a spacious recital hall.

In addition to hundreds of interested local visitors who flocked to the store the following out-of-town guests were present: Maurice O. Beckham, special Ampico representative of the American Piano Co., New York City; A.

R. Boone and Irving Bimstein, of Birmingham; Mr. and Mrs. C. L. Elyea and daughter, Mr. and Mrs. J. F. Gordy, H. G. Ray and M. E. Lyle, of Atlanta; D. S. Pruitt, of the Victor Co., Camden, N. J.; French Nestor and Earl Dahlberg, of Jacksonville, Fla.

The equipment in this beautiful establishment was installed by the Unit Construction Co., of Philadelphia, Pa., and it represents the most modern thought in interior fittings.

The Humes Music Co. was organized by J. E. Humes, president of the company, in 1908, with quarters at 1127 Broad street. In 1914 it was found necessary for the company to seek larger quarters and it was necessary to move again in 1918. It is believed that the present building will meet the requirements of the company for some years to come.

THE TALKING MACHINE AS EDUCATOR

How Prof. Mohler's Lectures to School Teachers at Columbia College on Cultivation of Musical Taste and Appreciation Help

Louis H. Mohler, a well-known authority in the educational world, has been conducting at the Teachers' College, Columbia University, New York, regular classes of grade teachers and music supervisors on the subject of "How to most successfully cultivate the taste for and appreciation of good music among school children." The subject matter of these lessons, as developed by Mr. Mohler, comprises specially selected records from the Columbia catalog. These selections are taken from the symphony list of records and the Columbia library of educational records. The teachers go out to the schools in the country and practice Mr. Mohler's methods with great success. To make it possible for teachers to follow his method after attending his classes and even without attending, Mr. Mohler has compiled a very thorough outline of his course, listing appropriate records and explaining methods of instruction.

THOMAS A. EDISON HONORED

Thomas A. Edison, the electrical wizard, was the guest of honor at a luncheon held recently in the Hotel Biltmore, New York, in connection with the opening of the Electrical and Industrial Exposition in the Grand Central Palace. In a brief address Mr. Edison predicted that development in the electrical field in the next decade will be as great as in the last ten years.

SOPHIE TUCKER ENLARGES REPERTOIRE

Sophie Tucker, popular vaudeville headliner, is taking another swing on the big-time vaudeville circuit, and after completing a transcontinental tour, will return to New York to make Okeh records, for which she has an exclusive contract. Miss Tucker's new act has met with an enthusiastic reception everywhere, and as a vaudeville headliner she is one of the leaders in the theatrical world.

The stock of talking machines and records of the Grafonola Shop, East Washington street, Suffolk, Va., was damaged by water and smoke during a recent fire in an adjoining store.

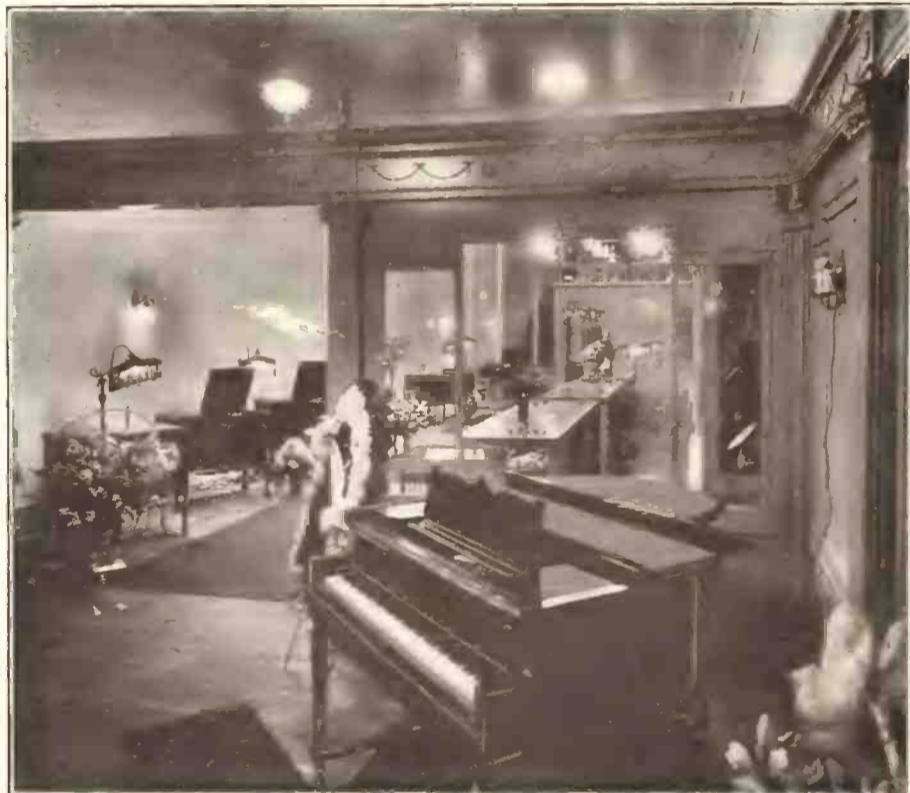

Looking Into Humes' Artistic Display Rooms

the company, and in some cases placing orders for musical goods. The opening was made the occasion of a three-page story in one of the local newspapers in which the advertisements of the Humes Co. and of the various concerns whose products it handles occupied prominent

K-E AUTOMATIC STOPS

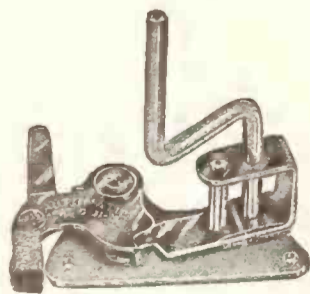

The K-E is still the best Automatic Stop made
Because it:

- Avoids motor strain
- Is not attached to Tone Arm
- Low installation cost
- No extra parts
- Operates all Records.

Send 50c. for sample

Kirkman Engineering Corporation
484-490 BROOME ST. NEW YORK

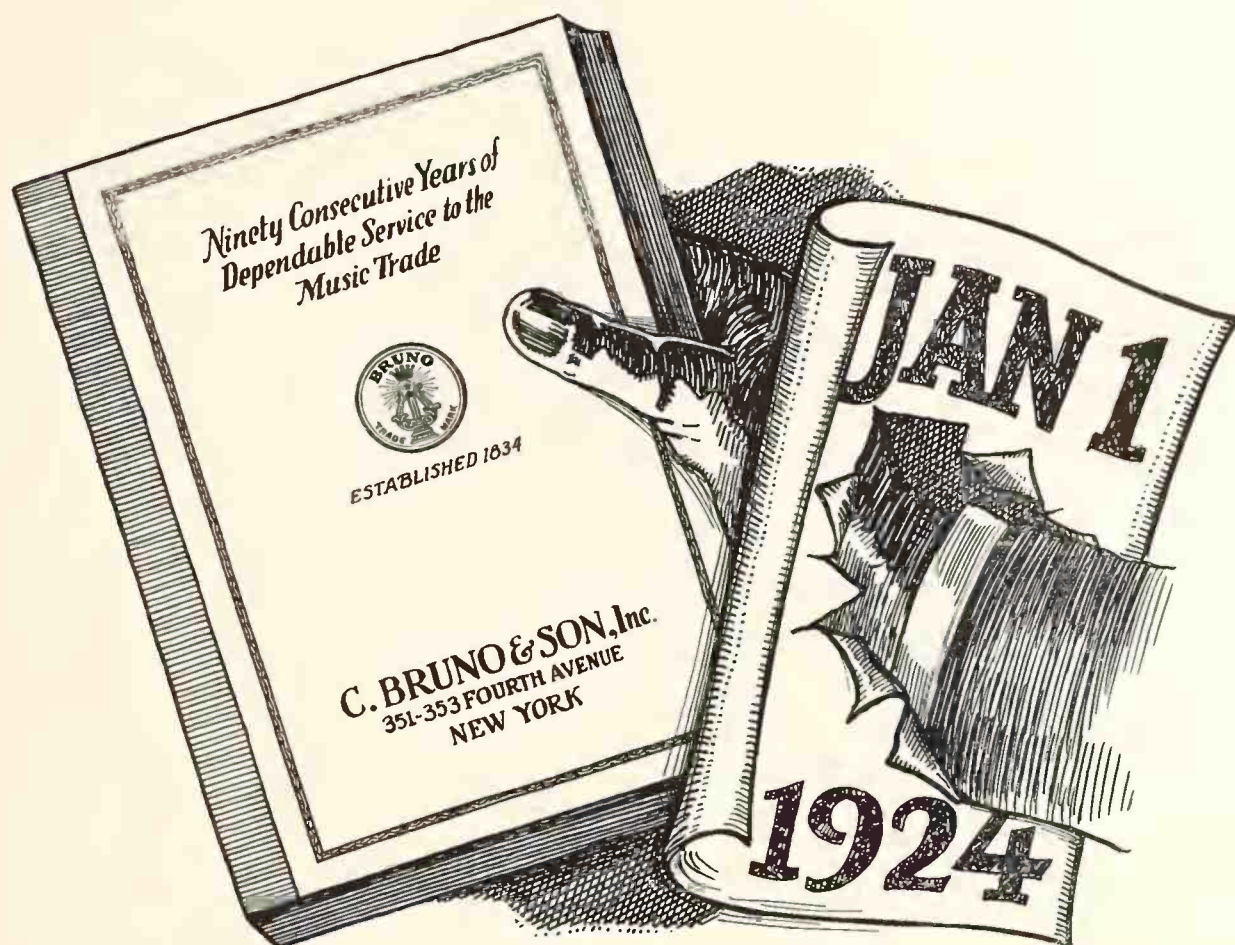

Get a Flying Start on 1924 Business

THE Music Dealer who has the ambition to make his business a bigger and better one should not be without the 1924 Bruno Catalog—the handbook and purchasing guide for the musical merchandise trade.

Only merchandise of proven merit and dependable character finds a place in this complete and elaborate edition.

And so every Music Dealer may have implicit confidence that he is buying goods of a kind and quality that will

maintain for him a high reputation resulting in greater prestige in his community.

The Bruno Catalog holds real and substantial value for the Music Merchant. He should make it his business to have a copy close at hand at all times. To be without it means a sacrifice to him.

You are not doing yourself or your business justice without it. Write for a copy—today is the day.

C. Bruno & Son, Inc.

Wholesalers Exclusively of Dependable Musical Merchandise Since 1834

351-353 Fourth Avenue

New York

Radio Opportunities in the Rural Sections

Survey of the Farming Districts Made for the Radio Corp. of America Indicates That Rural Dwellers Will Represent an Important Part of the Retail Radio Sales Field

That the farmer is ready for radio is evidenced by the results of a thorough survey of the farm field recently made by the Thos. F. Logan Advertising Agency in behalf of the Radio Corp. of America. In its detailed report regarding this survey the agency commented in part as follows:

"Almost from the beginning the ultimate market for radio in the farm field had been fully understood by men of vision in the industry. However, the question had constantly recurred: 'Is the farmer ready; is the art sufficiently advanced, and is the way prepared for the full use of radio by the farmer and his family as a medium of entertainment, education and as a part of the business equipment of the farm?'"

"It was important to answer this question conclusively so as to avoid untimely or premature activity such as would create a bad reaction against radio.

"The fact that the farm survey now in the hands of the Radio Corp. of America gives an affirmative and constructive answer to this question is one of interest and importance to rural merchants as indicating that before long a large volume of radio merchandising will be moving into the hands of the farm family.

"Practically every section of the country is now covered by one or more broadcasting stations. With nearly 600 stations now operating, no farmer need go without his nightly radio entertainment. And who, more than the farmer, has greater need for such entertainment and

the other information that is broadcast? Yet, despite the stories we hear and the pictures we see, radio has meant very little or nothing to the tillers of the soil. Only isolated instances have been cited.

"The ideal receiving sets for farmers are the single-tube set for distances up to fifty miles from the broadcasting station, two-tube receivers for distances up to 100 miles or more. It is well to note in this connection that these ranges are quite arbitrary. The range of a given set is dependent upon many variable factors which can only be determined by actual experience. Thus a receiver rated at fifty miles may under favorable conditions reach out to 1,000 miles or even more. Conversely the same receiver may, during the Summer season, cover but twenty-five miles. These sets are all well within the range of the farmer's purse. The receivers produced to-day by reliable manufacturers are dependable and efficient in every way. They require no engineering knowledge whatever, no tiresome 'fussing around,' in fact, they require no more mechanical ability to operate than the talking machine. The harvester, the threshing machine and even the automobile are infinitely more difficult to operate. And what farmer has not shown himself adept in the manipulation of one or all of these farm machines?"

"The best way to sell to the farmer is to call on him personally at his home and give actual demonstrations. This immediately prevents him from putting off the purchase until he 'goes to

town.' It is also an excellent idea to leave the set for a short while on trial. The farmer's greatest need right now is an introduction to the delights of radio reception. Once he has had an opportunity to listen to music, lectures, sermons, sports, weather reports, market quotations and the hundred and one other interesting subjects that fill the air, he will be very reluctant to give back the set. Often he will buy a better and more powerful set than the one left on trial.

"In selling the farmer, as in selling anyone else, the best sales talk centers around the one word 'entertainment.' Next in importance are 'ease, simplicity and comfort in operation.' The less that is said about amplification, audio-frequency and regeneration the better. The farmer is not frightened by these terms. Worse than that, he is annoyed. The talking machine salesman does not worry his prospect with springs, moment of force, compensator and the like. He sells the delightful idea of sitting back in a rocking chair and listening to the world's greatest artists. He shows the radio dealer how to sell radio sets.

"The Radio Corp. of America has planned a vigorous campaign of introduction in the farm papers for the Fall and Winter of 1923-24. The list includes regular insertions in such papers as: The Country Gentleman, Successful Farming, Farm Journal and Capper's Farmer."

The Infeld Music Store Co., operating talking machine stores in Hamilton and Oxford, O., recently added the Brunswick line of machines and records, which it will feature in addition to the Victor line.

The only horse worth betting on, says Forbes Magazine, is Horsesense. Not a bad tip!

HAVE YOU STOCKED THE "PHONO-VAUDETTE" FOR THE CHRISTMAS TRADE?

The Season's Catchiest Novelty



HAWAIIAN DANCER



TRAMP COMEDIAN



SCOTCH LASSIE

☐ A well-constructed, artistically designed, brightly colored stage, all complete with back drop, wings and proscenium arch, furnishes a realistic setting for the clever performers.

☐ Nothing could be more simple than the operation of the "Phono-Vaudettes." There are no attachments of any kind to mar or deface the finest instrument. Simply stand the "Phono-Vaudettes" on the front of the phonograph and the revolving turntable does the rest.

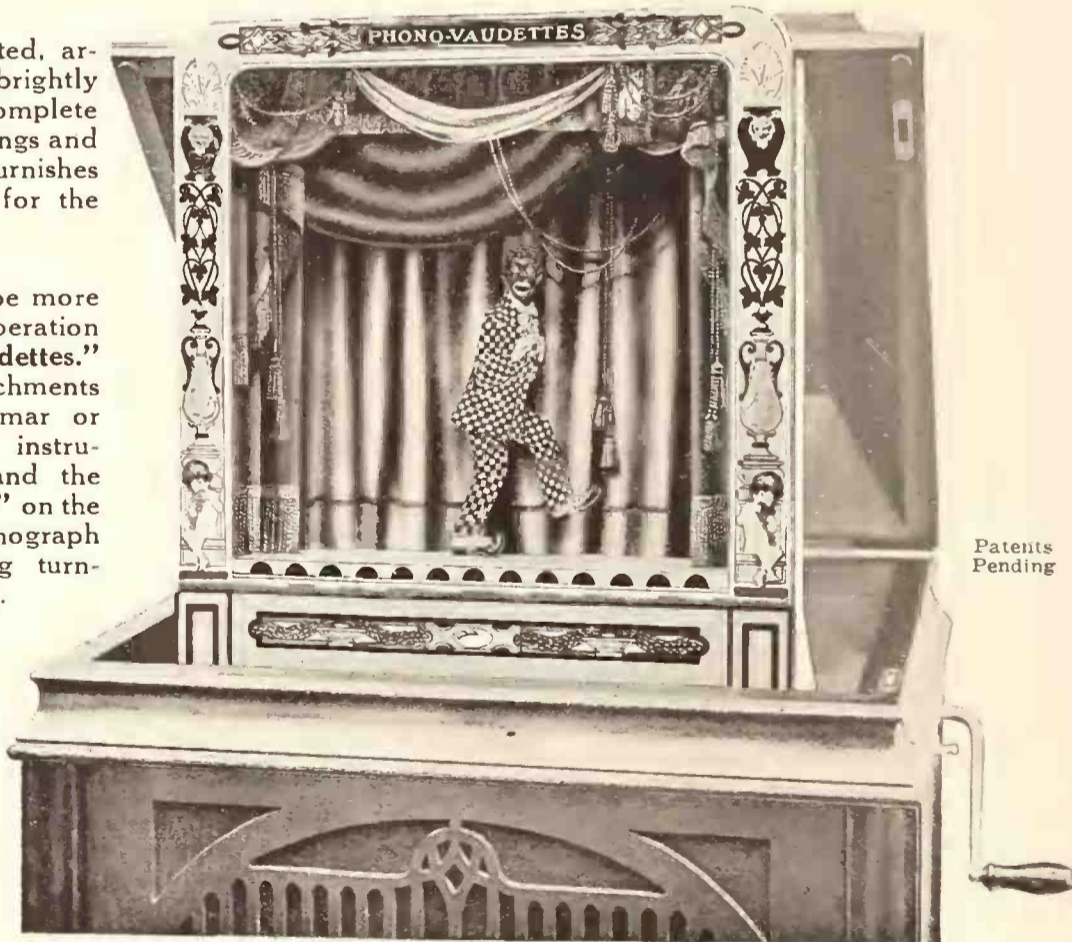

Patents Pending

SHUFFLING SAMBO

IMPORTANT "LAST CALL" NOTICE TO DEALERS

There is just time enough to get particulars of our Holiday money-making offer and an express shipment before the peak of the Christmas trade is reached.

COMMERCIAL ART SHOP
COVINGTON, KY.

Use the Coupon NOW

Hasten particulars about special offer "Phono-Vaudettes."

Name
Address

STARS

of the
EMERSON
CATALOGUE

HOTEL ASTOR
ORCHESTRA
BENNIE DAVIS
EDDIE CANTOR
WALTER SCANLAN
HENRY BURR
SAM ASH
IRVING KAUFMAN
BILLY MURRAY
FRED VAN EPS
ELIZABETH MURRAY
ELLIOTT SHAW
JACK KAUFMAN
PHIL BAKER
VERNON DALHART
GEORGE JESSEL
BILLY JONES
LEWIS JAMES
CHARLES HARRISON
CHARLES HART
FRED HILLERBRAND
ERNEST HARE
ARTHUR FIELDS
ZEZ CONFREY
ROYAL DADMUN
TOM ENNIS
JOHN FINNEGAN
SIBYL SANDERSON
FAGAN
GEO. HAMILTON GREEN
ADA JONES
JOHN KIMMEL
JULES LEVY
MILAN LUSK
ELIZABETH LENOX
REED MILLER
EDDIE NELSON
LANE ROGERS
MAXIMILIAN ROSE
WILLIAM ROBYN
NOBLE SISSLE
RUDY WIEDOEFT
WATSON SISTERS
MANA ZUCCA
JOHN YOUNG
FRED WHEELER
STASSIO BERINI
MAX BLOCH
LAURA COMBS
MONROE SILVER
CAL STEWART
RIA ROSA
HARRY STODDARD AND
HIS ORCHESTRA
ALL STAR TRIO
BERGH'S CONCERT
BAND
CRITERION MALE
QUARTET
FERERA & FRANCHINI
GLANTZ AND HIS
ORCHESTRA
BENNIE KRUEGER'S
ORCHESTRA
LANIN'S ROSELAND
ORCHESTRA
LOUISIANA FIVE
NATZY'S BILTMORE
HOTEL ORCHESTRA
PEERLESS QUARTET
PENNSYLVANIA HOTEL
ORCHESTRA
HARRY RADERMAN'S
ORCHESTRA
SHANNON FOUR
SIX BROWN BROTHERS
JOSEPH SAMUELS MUSIC
MASTERS
SELVIN'S NOVELTY
ORCHESTRA
STERLING TRIO

Emerson Records

Fifty Cents Retail



HOTEL ASTOR ORCHESTRA
Exclusive Emerson Dance Combination

Popular Priced Records a Dominant Factor

Progressive phonograph dealers are installing Popular Priced Record Departments in their stores in order that they may avail themselves of the profits such a department represents, rather than to continue to permit a sale of such large volume to be diverted to other channels.

It Is Time for All Dealers to Face the Issue Squarely

The popular priced record is an established department of the phonograph industry today. Every day a dealer puts off adding such a department to his store he is eliminating about fifty percent of the record profits that normally belong to him. The phonograph dealer with a store of high standing and a clientele of discriminating buyers will select a Popular Priced Record of outstanding quality, with a sales policy back of it that will protect him against undesirable competition, cut prices, and unsatisfactory service.

Emerson Records at Fifty Cents Retail

The new Emerson Record is one of unsurpassed merit, stable in price, sold on a policy in harmony with the best traditions of the phonograph industry. Send for samples of the new Emerson Record, and know its merits musically and artistically. With the samples we will send you a copy of the policy under which the Emerson Record is sold. Of course, the profit is the same as on any other standard record.

Emerson Phonograph Company, Inc.

105-111 West 20th Street
New York City

Mamma Loves Papa

Papa Loves Mamma

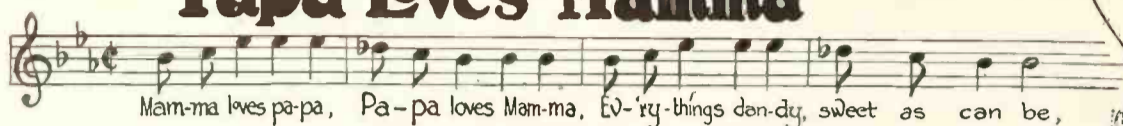

NEW BUSINESS FROM OLD CUSTOMERS

Salesmen Who Neglect Former Patrons Are Ignoring Valuable Opportunity of Getting Line on Friends Who May Be in the Market

Old customers offer an opportunity for new business which the salesman might well take advantage of. In the majority of instances after the sale has been made the salesman who closed the deal forgets all about the customer, turning to new fields for business when he might further cultivate the friendship of the person who has already shown preference for the line which he represents and who, if thoroughly sold on the original purchase, should prove a prolific source of new prospects.

There is nothing original in the thought expressed above, perhaps, but it is timely and, therefore, worthy of consideration. One salesman whose annual business volume is far greater than that of his fellow workers, declares that a large proportion of his new business comes through the recommendation of former customers who have been pleased with their

purchases. In order that the people to whom he makes sales get the most out of their purchases this salesman drops into their homes whenever he happens to be in the vicinity, his ostensible object being to see if the instrument is working properly and giving thorough satisfaction. If he finds that this is not the case he ascertains the reason. In many instances he has found machines are in need of minor adjustments and these he makes on the spot. Also, if there are any other differences or misunderstandings, he sees to it that they are straightened out, thereby impressing on the patron's mind the fact that his firm is extending service of a high order to its customers. Of course, while he is in the home of a customer he injects the question as to whether there are any friends who might be interested in a talking machine. Many times the customer thinks of some friend who might be persuaded to invest in an instrument. The recommendation thus secured affords the salesman easy entrance into the homes of live prospects, and the very fact that the line he sells has been giving satisfaction immediately removes a big doubt in the mind of the prospect as to whether this particular make of machine will give returns commensurate with the money spent and, consequently, an important obstacle to a sale is removed, making the work of the salesman easier and much more effective.

Those salesmen who forget a customer as soon as the name has been placed on the dotted line will do well to ponder these few paragraphs and then give this method of securing prospects and making sales a thorough tryout. Of course, it is not necessary for a salesman to go out of his way to visit customers, but it is worth while to drop in when he is in the immediate neighborhood of a former patron.

TALKS TO WORLD VIA RADIO

On October 17 M. Millerand, president of the French Republic, addressed the world via St. Assise radio station, near Paris. The International News Service carried the message in full, and it was broadcast by stations in the United States and other countries. Vessels on the Atlantic and Pacific received the message via the Radio Corp.'s marine centers. This was the first time in history that a French President addressed the world by radio.

EDISON EXTOLS THE SIMPLE MELODY

Interesting Remarks Follow a Talk With Bandmaster Sousa on Music in America

When Thomas A. Edison and John Philip Sousa were brought together some time ago by Theo. Presser, of Philadelphia, the great bandmaster naturally complimented the famous inventor on his achievements and pointed out that, thanks to his genius, the great instrumentalists, singers and conductors can now be heard in the humblest homes.

Mr. Edison, in reply, deplored the fact that so few really cared to hear the great artists. "The public as a whole is very elementary, very primitive in its tastes. . . . A few people like the most advanced music—very, very few. The Debussy fanatic thinks that because he likes Debussy there must, of course, be thousands and thousands who do. He would be amazed if he knew on what a little musical island he is standing. You could hardly see it on the great musical map of the world. All the world wants music; but it does not want Debussy; nor does it want complicated operatic arias. I know at my own expense. Sometimes out of four thousand records advertised all up and down the land, some made by men and women of very great reputation, the public deliberately selects for its own some simple, heartfelt melody sung by some comparatively unknown singer, and demands this in such quantities that we have a hard time manufacturing enough."

CONGRATULATIONS, MR. STEINFELD

Samuel Steinfield, president and treasurer of the Claremont Waste Mfg. Co., Claremont, N. H., manufacturer of cotton flocks, was married on October 23 to Miss Jane Goldman, daughter of Mr. and Mrs. Harris Goldman, of Brookline, Mass. Mrs. Steinfield is well known in musical circles throughout New England, and has a host of friends in the musical world. Mr. and Mrs. Steinfield are now away on a honeymoon, and will be at home at Claremont, N. H., after December 1.

Elpert's, prominent merchant of Niagara Falls, N. Y., has a fine new store on Main street. Talking machines, jewelry and furniture are handled.

MAIN SPRINGS FOR ALL MOTORS

Best Quality - Quick Service - Low Prices



Each spring packed in a separate, numbered box. Each spring made of best crucible steel, tested and carefully inspected before leaving our factory.

Send us your order to-day.

	Price each	Price in lots of 50	Price in lots of 100
For Victor Motor			
No. MSW 1—1 inch wide, .022x13 feet long, pear shaped hole at both ends.	50c	48c	45c
No. MSW 2—1 1/4 inch wide, .022x17 feet long, pear shaped hole at both ends.	75c	72c	70c
No. MSW10—New Style, 1 inch x .022x13 feet long, crimp end on inside.	50c	47c	45c
No. MSW20—New Style, 1 1/4 inch x .022x17 feet long, crimp end on inside.	75c	72c	70c
For Columbia Motor			
No. MSW21—25/32 inch wide, .025x10 feet long, pear shaped hole.	45c	43c	40c
No. MSW22—29/32 inch wide, .025x11 feet long, pear shaped hole.	45c	43c	40c
No. MSW 3—1 inch wide, .028x10 feet long, pear shaped hole.	50c	48c	45c
For Heineman Motor			
No. MSW21—25/32 inch wide, .025x10 feet long, pear shaped hole.	45c	43c	40c
No. MSW 6—1 inch wide, .025x12 feet long, pear shaped hole.	50c	48c	45c
No. MSW23—1 3/16 inch wide, .026x19 feet long, pear shaped hole.	80c	77c	75c
For Brunswick, Krasberg, Saal, Sonora, Stevenson, Silvertone, Aeolian, Cheney, United, Meiselbaeh or Thomas Motors			
No. MSW 8—1 inch wide, .026x13 feet long, oblong hole.	55c	53c	50c
No. MSW 9—1 inch wide, .026x16 feet long, oblong hole.	65c	63c	60c
No. MSW10—1 inch wide, .026x18 feet long, oblong hole.	75c	73c	70c
No. MSW25—1 inch wide, .027x10 feet long, oblong and pear shaped hole.	45c	43c	40c
We punch both an oblong and pear shaped hole on the end of these springs, so that they may be used for any type of motor.			
Other Standard Makes			
No. MSW17—3/4 inch wide, .025x10 feet long, pear shaped hole.	40c	38c	35c
No. MSW18—7/8 inch wide, .025x10 feet long, pear shaped hole.	45c	43c	40c

These prices are F. O. B. Chicago. Send enough to cover postage if wanted by parcel post or we will ship by express. Combination orders may be made to obtain quantity price.

COLE & DUNAS MUSIC CO.
430 S. Wabash Ave. Chicago, Ill.

Headquarters for Everything in Musical Merchandise. Write for our new bargain bulletin; 1000 different items at special prices.

SYRIAN AND ARABIAN RECORDS

IMPORTED AND DOMESTIC

Of the Best Artists

"Macksoud," "Baidaphone" and "Odeon"

10, 11 and 12 Inches. Double Faced

Liberal Discount to Dealers. Ask for Catalogue

A. J. MACKSOUD

77 WASHINGTON STREET

NEW YORK, N. Y.



The New Pathé record that plays on all phonographs with steel needles—

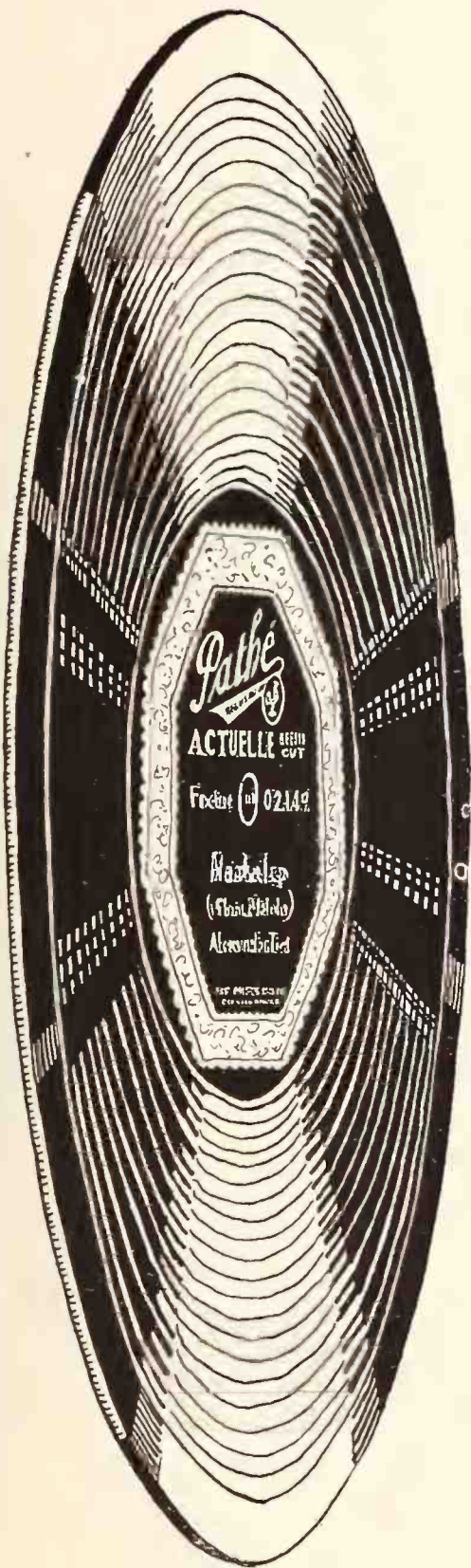

The period between now and the Christmas Holidays represents the **BEST RECORD BUYING SEASON** of the entire year. The following list of Records carries a distinct Christmas appeal. No one class of Records sells as well during this period. *Cash in on this demand by ordering these numbers TODAY.*

55 Cents Each, 2 for \$1.00

(FOR THE CHILDREN)

- | | |
|------------------|--|
| Quantity Ordered | 022191—Christmas Eve In The Toy Shop.....Hunting & Sterling Trio |
| | —'Twas The Night Before Christmas.....Russell Hunting |
| | 020472—How Santa Claus Makes His Toys.....Gerard & Hunting |
| | —How Santa Claus Distributes His ToysGerard & Hunting |
| | 021016—Bedtime Tales, No. 1.....Gerard & Hunting |
| | —Bedtime Tales, No. 2.....Gerard & Hunting |
| | 021017—Bedtime Tales, No. 3.....Gerard & Hunting |
| | —Bedtime Tales, No. 4.....Gerard & Hunting |

(SACRED AND STANDARD)

- | |
|--|
| 021084—Silent Night, Holy Night.....Placide Morency, Tenor |
| —Adeste FidelesPlacide Morency, Tenor |
| 021083—Noel (O Holy Night)Turner Roe, Baritone |
| —The Star Of BethlehemTurner Roe, Baritone |
| 025089—Silent Night, Holy NightMargaret Matzenauer, Contr. |
| —Home, Sweet HomeMargaret Matzenauer, Contr. |
| 022433—Christians Awake, Salute The Happy Morn.....Shannon Four |
| —God Rest Ye, Merrie Gentlemen.....Shannon Four |
| 020454—Lead, Kindly Light (Chimes).....Chris. Chapman |
| —Nearer, My God, To Thee (Chimes)Chris. Chapman |
| 025090—Somewhere A Voice Is Calling.....Tito Schipa, Tenor |
| —Don Pasquale "Cerchero lontana terra".....Tito Schipa, Tenor |

(OPERATIC AND STANDARD)

- | |
|--|
| 025067—Barber Of Seville "Una voce poco fa".....Helen Yorke, Soprano |
| —Lucia di Lammermoor "Mad Scene".....Helen Yorke, Soprano |
| 025096—Love Sends A Little Gift Of Roses (Violin Solo).....Alexander Debruille |
| —Mignon "Gavotte" (Violin Solo).....Alexander Debruille |
| 025086—El Contrabandista (Piano Solo).....Joseph Lhevinne |
| —Ecoisaises (Piano Solo).....Joseph Lhevinne |

**Include these "UP TO THE MINUTE" hits in your order—
They're really January numbers**

- | |
|---|
| 032002—Dreamy Melody.....Apollo Male Trio |
| —Easy MelodyApollo Male Trio |
| 032005—No, No, Nora! (Vocal).....Frank Bessinger |
| —Since I Fell In Love With YouCharles Cinway |
| 021068—Covered Wagon Days (Fox Trot) (Vocal Chorus).....Strand Roof Orchestra |
| —Foolish Child (Fox Trot)Strand Roof Orchestra |

Pathé the World Over

Pathé Phonograph and Radio Corporation
20 Grand Avenue, Brooklyn, N. Y.

Rush by first (.....) Records ordered above. If ordered in not less than five (5) of a number, our price to be 30 cents each. **RUSH.**
Exp.—Frt.—P. P.

NAME.....

ADDRESS.....

STATE.....

Per.....

Musical Sidelines as Stimulators of Trade

How Sidelines Can Be Made a Source of Increased Revenue and Some Important Problems Involved in Efficient Merchandising

Talking machine dealers are turning more and more to musical sidelines to increase their profits and to stimulate sales generally. Small musical instruments, radio, sheet music and music rolls are all receiving their share of attention. For the most part the dealers are working on the principle that anything that brings people into the store, provided it does not require a too large investment and is a ready seller and must be worth handling. Experience is bearing out these theories.

Sidelines Require Attention

The talking machine dealer, however, who installs a sideline and expects sales to drop into his lap is badly mistaken. The same principles of business management apply to the handling of a sideline that affect the general business. That is, the dealer must use the same intelligence and energy in bringing his sideline to the attention of the public that he uses to push the sale of talking machines and records. This means advertising and other forms of publicity, as well as real constructive sales promotion work. It is very true that a sideline, especially a musical product, will enable the talking machine dealer to enlarge his sales scope and thus increase his profits, but this holds good only when the dealer takes the trouble to get behind his product.

Some retailers are turning to sidelines foreign to the music field and generally this policy is not as good as sticking to the music business. This is so for a number of reasons, chief among which are that he is familiar with the merchandising of music; he has his musical prospects lined up and his whole business structure has been built for the specific purpose of

selling musical instruments. He knows from past experience how to approach his prospects and what results he may logically expect, whereas if he installs a line which bears no relation to the musical instrument business, after having established his reputation, he is placed in a position where he finds it necessary to learn to merchandise something with which he is entirely unfamiliar.

How Sidelines Help General Business

Another angle of the sideline proposition is that very often a product closely allied with the main business will have the effect of helping the sales of the main line handled. One of a number of enterprising dealers who have found this so is the Elizabeth Phonograph Shop, Inc., Elizabeth, N. J., which, in addition to a complete line of talking machines and records, handles music rolls, sheet music and musical merchandise. S. Brandes, proprietor of this establishment, in discussing the effect of the sideline on the sales of the main line, declared that in many instances people come into the store to purchase sheet music or music rolls and remain to hear and purchase talking machine records. "No dealer can expect to make a success of the sideline unless he gives the same intelligent thought to merchandising it that he does to his main business, whatever that may be," said Mr. Brandes. "We advertise and make every effort to impress upon the people in this vicinity that we handle sheet music and musical merchandise. Another thing I have found is that customers to whom I have sold talking machines, records or sheet music furnish an excellent prospect list to use when digging for musical merchandise business. These lines

interlock to a certain extent. They all pertain to music and it has been my experience that when there is one type of musical instrument in a home there is an excellent opportunity of making sales of other instruments of a different character. Just as the talking machine customer is a good prospect for musical merchandise, just so is the owner of a band or stringed instrument a good prospect for a talking machine, and this rule also applies to owners of pianos, etc. As I said, however, success depends largely upon the dealer himself."

Getting People Into the Store

Anything that brings people into the store is bound to help general business and that is one of the main objects of handling a sideline. Of course, if the dealer loses money by installing additional lines, he must take some drastic action, either placing the sideline on a profitable basis or, if necessary, discontinue handling it altogether. It is a foolish practice to spend money for fixtures and stock in the hope of bringing a few people into the store if there is no profit in the transaction. It would be much better to spend the money in boosting the sale of talking machines and records. However, there is some real profit in the musical sideline and, as Mr. Brandes so aptly puts it, "Success depends largely upon the dealer himself."

Alterations to the building housing the A. L. Arvidson Piano Co. business in Denver, Col., will soon be completed and the concern is getting ready for an intensive sales drive on pianos and talking machines, after a period of forced inactivity. The renovated warerooms will be the equal of any here in point of attractiveness.



Model G



Interior. Models D, G, H and I



Model I



Model H

Attractive Consoles in Combination American Walnut and Brown Mahogany—Top 35x22 in. Height 34½ inches.

LET US FURNISH YOUR HOLIDAY REQUIREMENTS

Write Today for Cuts and Prices



Model D

THE H. LAUTER COMPANY

West Washington and Harding Streets

INDIANAPOLIS, INDIANA



The New \$100 CONSOLE — A Big Holiday Seller

Deliveries now being made of the new KIMBERLEY "Grand." Its superb cabinet finish, attractive lines and quality construction insure a quick turnover.



There are Six
More
Kimberley
Models
Ready
for
Immediate
Delivery

Limited
Jobber
Territory
Now Open.
—
If you are
interested
write us
today.

New Kimberley "Grand"
List Price \$100
Mahogany only

WHY THE KIMBERLEY LINE IS A SALES LEADER

1. Superior Piano Finish.
2. Exclusive Precision Made Tone-Arm and Latest Type Motor.
3. Unusually Liberal Trade Discounts.

YOU NEED THE KIMBERLEY AGENCY NOW

Write or Wire for Details.

The Kimberley Phonograph Company of New Jersey

Perth Amboy, N. J.

Factory: Perth Amboy, N. J.

Office and Show Rooms: 206 Broadway, New York City

How a Live Dealer Sold Over 1200 Machines

People Visiting Weil Bros. Furniture House Must Pass Through Attractive Talking Machine Department—Cater to Foreigners—Overcome Keen Competition—Investigation Before Delivery

It is always as interesting as it is helpful to know "how the other fellow does it"—how talking machines and records are merchandised at retail in a manner to increase sales to customers, particularly in a locality where the large majority of residents are of small means. Disposing of more than twelve hundred talking machines in less than two years is the record of Weil Bros., who conduct a department for the sale of talking machines in conjunction with their furniture business on Third avenue, New York City.

To get an idea of the problems which this concern has had to meet one must know something about the neighborhood in which the store is located. The entire district is devoted to tenement houses, in which live many foreigners, including German, Swedish, Polish, Italians, etc. Also in that neighborhood are a great many cut-price stores and one of the greatest problems has been to meet this competition and at the same time to conduct business on a legitimate basis.

As has been mentioned, advertising has been the chief means of bringing people into the store, although the fact that the concern handles furniture has been instrumental in bringing many patrons into the warerooms of this concern. The talking machine department is on the main floor, occupying considerably more than half the entire floor space and, consequently, all customers find it necessary to pass long lines of beautiful Victor and Sonora instruments before they reach the elevator which takes them to the furniture department. The talking machine department itself is one of the handsomest and most spacious in the immediate district. There are nine booths, installed by the Unit Construction Co., as well as cases for the display of small musical instruments and talking machine accessories. Ten thousand records are carried in stock at all times.

Although such a large number of machines have been sold in the two years in which this department has existed repossessions are almost unknown, due to the fact that various inducements are given to the customers to make their payments promptly and to pay for the machine as quickly as possible. For example, each customer is advised that if the instrument purchased is paid for in from six to nine months the interest charge will be deducted. Every effort is made to keep the accounts of customers up to date and, wherever possible, weekly payments are stipulated in the contract. In most cases, also, an endeavor is made to have customers come to the store to make their payments, although where this is impossible collectors are sent out at regular intervals.

The surprising lack of repossessions is partly due to the rigid system of investigation which is pursued before the instrument is delivered, according to S. B. Simins, manager of the talking machine department, who, by the way, is a live wire of wide experience in the talking machine field. When a deal has been closed with a customer the contract is turned over to the credit department. When references are given these are quickly checked up and when investigation discloses the fact that the customer has lived in one house or apartment for a number of years and is in good standing with the landlord and dealers in the immediate vicinity the instrument is delivered without further investigation.

GETTING THE RECORD LIST TO BUYER

The advertising department of the Columbia Graphophone Co., New York, announced recently that beginning with the January issue of the Columbia record supplement there would be introduced a radical departure in the mailing of these supplements. Instead of using the usual supplement envelope, the supplement itself will be neatly addressed and stamped on the back cover, thereby enabling the recipient of the supplement to thoroughly appreciate the fine art work that characterizes the supplement cover. Columbia advertising executives believe that an envelope, no matter how attractive, stands an excellent chance of taking the shortest route from the mail box to the waste basket without ever being opened, but the presentation of a supplement addressed directly on its cover is calculated to give it maximum value as an attention getter.

SUGGESTS SPECIAL SALES DRIVE

Following out its plan of timely, practical suggestions to Victor dealers in the stimulation of record business, the Musical Instrument Sales Co., New York, Victor wholesaler, recently forwarded a letter to the trade suggesting that a special sales drive be instituted featuring Victor Record No. 961. This record presented in the November 9 list is by John McCormack, the famous Irish tenor, who sings "Wonderful One" and "Love Sends a Little Gift of Roses." The Musical Instrument Sales Co. offers to send its dealers leaflets, display cards, streamers, etc., in order to make the drive on this record profitable.

NEW ARNOLD-EDWARDS BUILDING

JACKSONVILLE, FLA., October 30.—The new store of the Arnold-Edwards Piano Co., of this city, is rapidly nearing completion and when ready for occupancy will be one of the most elaborate retail music warerooms in the entire South. The building represents a total investment of \$90,000 for construction cost alone.

The structure is three stories in height and will contain not only display rooms but an auditorium and professional studios as well.

The Ellis Reproducer Stands Supreme



The Ellis Reproducer is recognized by the critical musician and the music lover as the most perfect sound box made. Adaptable to all tone arms. Dealers and manufacturers proposition submitted upon request.

Manufactured by

Arthur Brand & Co.
1618 Vine St. Cincinnati, O.

Distributors of Talking Machine Repair Parts and Supplies



The Reflexo Counter Display

Minger says

Gilt Edge Needles Once Introduced Become a Steady Repeater!

Once sold the first time, Gilt Edge Needles produce repeat orders automatically on the basis of their clean-cut superiority. They are easy to sell the "first time" through the attractive attention-compelling metal display stand we furnish free with every assortment of 100 packages.

GILT EDGE The Needle That Plays 10 Records

From the first record to the tenth, each Gilt Edge Needle will bring out every tonal beauty originally put into the record. The Gilt Edge Assortment contains one hundred packages of Gilt Edge Needles (40 loud tone, 20 extra loud, 20 medium, 20 dance tone) retailing at 10c, total \$10. Cost to you, \$5 complete with display stand—100% profit!

REFLEXO

Blue Steel Needles are a marvelous improvement. One needle plays every tone, loud, soft or medium. 100 packages sell for 15c each, total \$15. Cost \$7.50. Test it!

Write for samples. Ask your jobbers.

The Reflexo Counter Display



Reflexo Products Co., Inc.

Sole Agents for W. H. BAGSHAW CO.

Gilt Edge and Reflexo Blue Needles

Factory—Lowell, Mass.

Office, 347 Fifth Ave., New York

FOR CHRISTMAS

Two Ideal Instruments

Flemish Design Period Model

THE classic design and rich coloring of this Flemish Period Model make it an ideal gift phonograph.

Gold-plated hardware and velour turntable add greatly to its appearance.

A divided top allows for the placing of a lamp or vase and the new drop door discloses a silk and wood grille.

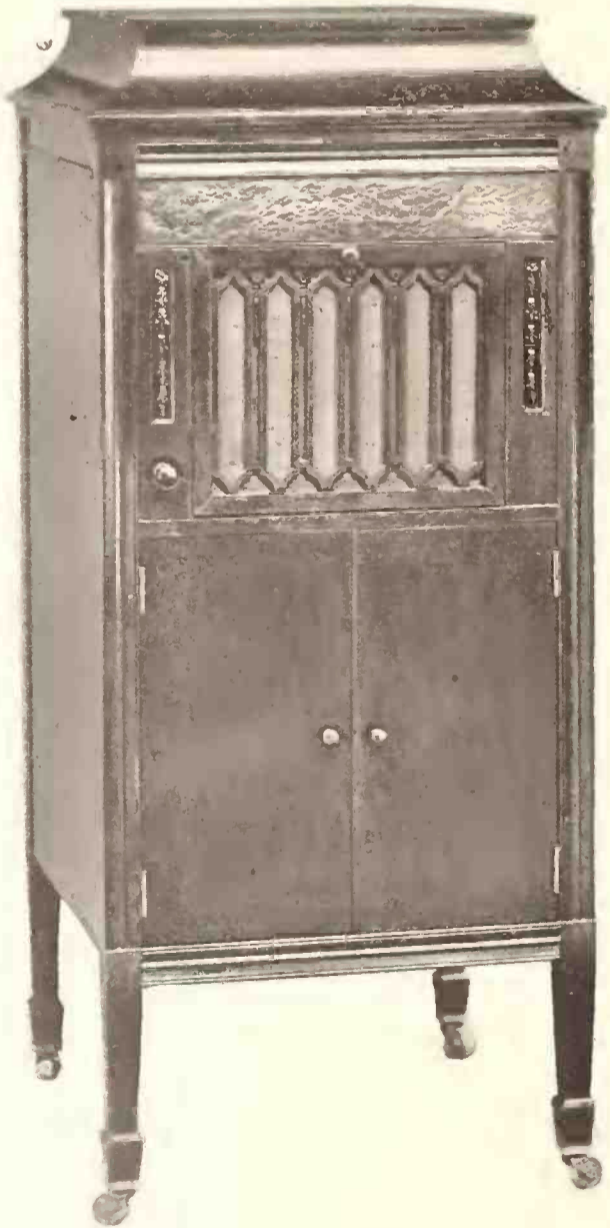

Flemish Design Period Model 1644.
Priced \$185.

Specifications — Height, 35"; Depth, 22"; Length, 35". Graduola—Velour Turntable—Gold-plated hardware.

Conventional Vocalion Style 660.

Price \$160

An unusually graceful design which adapts itself to smaller spaces and room corners.

Specifications—Height, 47"; Width, 21"; Depth, 21". Graduola—Gold-plated hardware, Albums.

Both of these instruments are equipped with the GRADUOLA which gives the pleasure of individual expression and control of tone.

Other Styles from \$125 upwards

The **AEOLIAN COMPANY**
AEOLIAN HALL NEW YORK

VOCALION

RED RECORDS



COLIN O'MORE

*"The Greatest Tenor Ballad
Singer of Our Time"*

That is what critics say of Colin O'More, tenor, with the San Carlo Opera Company.

Perfect tone and diction are delightful qualities in Colin O'More's singing which reproduce perfectly on exclusive

VOCALION

RED RECORDS

10"—\$1.25

- 24016—At Dawning
I Hear a Thrush at Eve
- 24017—Because
A Dream
- 24034—Because of You
Heaven at the End of the Road
- 24018—Believe Me If All Those Endearing
Young Charms
Foggy Dew
- 24030—Dear Little Shamrock
Low Back'd Car
- 24044—Fallen Leaf
Out Where the Blue Begins
- 24019—I Hear You Calling Me
Bonnie Sweet Bessie

10"—\$1.25

- 24029—I Love A Little Cottage
When I Awake
- 24043—A Kiss In The Dark
Wonderful One
- 24008—Little Town in the Ould County
Down
Pretty Kitty Kelly
- 24021—Pale Moon
The World is Waiting for the Sun-
rise
- 24039—The Tumble Down Shack in Ath-
lone
The Little Lilac Garden
- 24032—Three O'Clock in the Morning
For the Sake of Auld Lang Syne

Vocalion Red Records Play on All Phonographs

The AEOLIAN COMPANY
AEOLIAN HALL NEW YORK

Distributors of Vocalion Red Records

- MUSICAL PRODUCTS DISTR. CO.,
37 E. 18th St., New York City.
- WOODSIDE VOCALION CO.,
154 High St., Portland, Me.
- A. C. ERISMAN CO.,
174 Tremont St., Boston, Mass.
- GIBSON-SNOW CO.,
306 W. Willow St., Syracuse, N. Y.
- LINCOLN BUSINESS BUREAU,
1011 Race St., Philadelphia, Pa.
- SONORA DISTR. CO.,
217 Stanwix St., Pittsburgh, Pa.
- VOCALION RECORD CO. OF MD.,
305 N. Howard St., Baltimore, Md.
- O. J. DEMOLL & CO.,
12th and G Sts., N. W. Washington,
D. C.
- LIND & MARKS CO.,
530 Bates St., Detroit, Mich.
- VOCALION CO. OF CHICAGO,
Distributors of Vocalions and
Vocalion Records,
529 S. Wabash Ave., Chicago, Ill.
- VOCALION CO. OF OHIO,
328 W. Superior St., Cleveland, O.
- LOUISVILLE MUSIC CO.,
570 S. 4th St., Louisville, Ky.
- HESSIG-ELLIS DRUG CO.,
Memphis, Tenn.
- GUEST PIANO CO.,
Burlington, Ia.
- D. H. HOLMES CO.,
New Orleans, La.
- STONE PIANO CO.,
Fargo, N. D.
- STONE PIANO CO.,
Distributor of Vocalions and Vo-
calion Red Records
826 Nicollet Ave., Minneapolis,
Minn.
- STREVELL-PATERSON HARD-
WARE CO.,
Salt Lake City, Utah
- MOORE-BIRD CO.,
1720 Wazee St., Denver, Colo.
- MUNSON-RAYNER CORP.,
643 S. Olive St., Los Angeles, Cal.
- MUNSON-RAYNER CORP.,
86 Third St., San Francisco, Cal.

My Home Town In Kansas

Nan Halperin's big song hit
by "LITTLE JESSIE JAMES"

If you could just see my home-town in Kan-sas! We've got a tree and

NEW VOCALION PIANO RECORDINGS

Record by David Pesetzki and Another by Cliff Hess and the Ambassadors in the December List of the Vocalion Red Records

Among the new Vocalion Red records to be released in December will be a piano record played by David Pesetzki. On one side of the record is "Juba" (Dance), from the suite "In the Bottoms," a characteristic number, and on the other side is "Marche Mignonne." These two compositions are standard selections of a lighter vein and are beautifully rendered. This record is the first of a series of piano records to be made in the future by different artists, ranging from the light standards to the more substantial classics.

The December Vocalion Red record bulletin will also contain another piano record that will have a popular appeal. This is record No. 14671, with "Upright and Grand" on one side and "Corn on the Cob" on the reverse side. Both numbers are fox-trots, with Cliff Hess and the Ambassadors playing "Upright and Grand" and Frank Banta and Cliff Hess with the Broadway Syncopaters playing "Corn on the Cob."

Dunkerly & Co., of Passaic, N. J., now own the building formerly owned by the People's Bank Co. An attractive Victor department occupies the first floor.

CONGRATULATIONS ARE IN ORDER

David Goldman, Okeh Auditor, Buys the Cigars Upon Arrival of Helen Sonia—Miss C. Motto Joins Forces of Okeh Betrothals

David Goldman, auditor of the General Phonograph Corp., manufacturer of Okeh and Odeon records, has been having a busy few weeks, for only recently he received congratulations of his co-workers upon the arrival of a baby girl, who has been christened Helen Sonia. Mr. Goldman is now the father of a pair of Queens, and, if the deflection in the ranks of his organization continues, they will both be needed in the very near future.

Within the past four years three of Mr. Goldman's right-hand assistants have entered the happy state of matrimony, and on October 31 Miss Camille Motto, who has been associated with Mr. Goldman for nearly a year, was the guest of honor at a reception given by her co-workers to celebrate her betrothal to Harry Leoni. Mr. Goldman has figured out that twelve members of the accounting department have become engaged during the past few years, one of the most recent being Miss Sally Dodds, whose betrothal to Wm. Buckheit was announced a few weeks ago.

The Tedstrom Furniture Co., of Pine Bluff, Ark., was recently appointed Edison dealer in that territory.

URGES DISPLAY TO BOOST SALES

Max Willinger, President, New York Album & Card Co., Tells Story With a Moral

To just what extent sales have been lost by retailers through the lack of display of goods in stock is, of course, hard to estimate. Max Willinger, president of the New York Album & Card Co., New York City, manufacturer of the "Nyacco" line of albums, tells the interesting story of a man, an owner of a talking machine, who learned for the first time last month that there was such a thing existing as a record album. This man, calling at the headquarters of the New York Album & Card Co., relative to the purchase of photograph albums, happened to pick up a record album and asked Mr. Willinger what it was. When told, the man asked if these record albums could be purchased from a talking machine retailer as the only place he had for storing his records were shelves which often caused the marring and breaking of the records. Mr. Willinger has had for some time a counter display card of the "Nyacco" album, but the display of the album itself, he points out, would undoubtedly improve sales.

MANY REQUEST NEW PLAZA CATALOG

Volume Showing "Certified Repair Parts" Demanded by Dealers Throughout the Country

The sales department of the Plaza Music Co., New York, reports a country-wide demand for the new catalog which the company issued recently, featuring "Certified Repair Parts." This catalog features a complete line of repair parts of every description, specializing on main springs, motors and talking machine supplies. The catalog is arranged in convenient form and the use of clear-cut illustrations showing the



Cover of Plaza Co.'s Repair Parts Book various parts has been an important factor in the success of the publication.

Included in the various parts listed are main springs for practically every type of motor on the market, parts for the standard makes of talking machines, felts, graphite, hardware, mica, turntable covers, etc., in addition to many types of motors, reproducers and tone arms. The last few pages of the catalog call attention to some of the many products that are manufactured or distributed by the Plaza Music Co., including Banner records, Little Tots nursery tunes, the popular Pal portable and Jewel rolls.

We Serve New York!

ENTERPRISING dealers who are reaping the benefits of handling the fast-selling, popular

Okeh Records

The Records of Quality

will soon be involved in the inevitable hurry and scurry of holiday business. To those dealers who are within the Metropolitan district, we earnestly suggest that they fortify themselves against profit-losing delays and incomplete deliveries by availing themselves of the unfailingly prompt and efficient service that we are thoroughly equipped to give.

GENERAL PHONOGRAPH CORPORATION

New York Distributing Division

15 West 18th Street

New York City



Buy
Okeh
Needles

They
Keep
Record Sales
Alive!



for
Beauty
for
Tone
for
Price



Queen Anne
Special
\$150
Costs You
\$66

Two-tone shortage, we said!

(And it has come—but we can still supply you)

Business already in tells the story

(Dealers ordering *now* will get the merchandise)

These Direct STRAND Representatives Are Ready to Serve You:

- R. H. ARNAULT, 95 Madison Avenue, New York City.
- ARTOPHONE CORPORATION, 1213 Pine Street, St. Louis, Mo.
- ARTOPHONE CORPORATION, 317 Kansas City Life Bldg., Kansas City, Mo.
- CONSOLIDATED TALKING MACHINE CO., 227 W. Washington Street, Chicago, Ill.
- OTIS C. DORIAN, 321 King Street, E. Toronto, Ont.
- A. C. ERISMAN, 174 Tremont Street, Boston, Mass.

- W. L. ECKHARDT (General Radio Corp.), Tenth and Cherry Streets, Philadelphia, Pa.
- W. S. GRAY, 1054 Mission Street, San Francisco, Cal.
- W. S. GRAY, 926 Midway Place, Los Angeles, Cal.
- L. D. HEATER, 357 Ankeny Street, Portland, Ore.
- IROQUOIS SALES CORPORATION, 210 Franklin Street, Buffalo, N. Y.
- R. J. JAMIESON, 625 Sweetland Bldg., Cleveland, Ohio.
- M. E. LYLE, 63½ Walton Street, Atlanta, Ga.

- RICKEN, SEEGER & WIRTS, Globe Bldg., Detroit, Mich.
- STERLING ROLL & RECORD CO., 137 West Fourth Street, Cincinnati, Ohio.
- GENERAL RADIO CORP., 1005 Liberty Avenue, Pittsburgh, Pa.
- L. C. LE VOIE, 623 Nicollet Ave., Minneapolis, Minn.
- SHARP MUSIC COMPANY, 823 Fifteenth Street, Denver, Colo.
- W. O. CARDELL, Box 1271, Tulsa, Okla.
- R. W. ORTTE, 310 Magazine Street, New Orleans, La.
- H. J. IVEY, Box 235, Dallas, Texas.

To responsible dealers we offer a profitable franchise in localities not yet being covered. *Write or wire.*
 MANUFACTURERS PHONOGRAPH CO., INC., GEO. W. LYLE, President, 95 Madison Avenue, NEW YORK

Important Radio Merchandising Factors

Experiences of Some Leading Talking Machine Merchants in Retailing Radio—Interesting Digest of Problems Facing Dealers

That talking machine dealers are paying more and more attention to the possibilities awaiting them by tying up their talking machine business with radio in some way is evidenced by the increasing number of dealers who have added radio in some form or another. Other dealers, who have not yet reached the point of installing radio departments, are studying the problems connected with radio and informing themselves on the ramifications of the radio field in connection with retail merchandising in order to be fully informed before they take the plunge. There seems to be a growing feeling that sooner or later radio will be an important part of the talking machine dealer's

business, but many are convinced that the radio, to be made the most of by the talking machine trade, must be sold either as an attractively cased complete set, or in combination with a talking machine, both enclosed in the same cabinet. The consensus of opinion appears to be that handling parts for assembling purposes should be shunned by the talking machine trade. There is general agreement that necessary accessories must be handled, not so much for the profit that there may be in this branch of the business, but mainly as a necessary form of service for the purchaser.

Advocates Careful Selection

Sol Lazarus, one of the most progressive dealers in the metropolitan area of New York, commenting on radio merchandising possibilities for the talking machine dealer, holds the opinion that too much care cannot be exercised in the selection of the line handled. "The talking machine dealer who contemplates adding radio," declared Mr. Lazarus, "must exercise the greatest care in selecting a line that is not in the hands of the gyps. The one great drawback in the radio business to-day is the vast volume of goods which is being sold by unscrupulous dealers who are out to make a quick profit regardless of the effect of their methods on the trade in general. The legitimate dealer can overcome this form of competition to a large extent by selecting the best possible line to handle. This must be a line manufactured by a reputable firm and one which is not being sold at impossible prices. Another important consideration involved in the handling of radio is the method of merchandising. I believe that the best way to sell radio sets is by staging demonstrations in booths as is the case with talking machines. Of course, the trade is thoroughly equipped for this type of merchandising, so that is no hardship."

Installment Sales Best

"Then there is the question of whether or not to sell radio on the installment plan. Experience has convinced me that while the deferred payment plan is the only way in which radio can be sold to the masses a large down payment must be received. I consider in the neighborhood of 25 per cent to be about right. Twenty-five per cent down and the balance to be paid for in between five or six months. This means 20 per cent of the balance after the first payment has been made must be received by the dealer each month. Longer terms involve a credit risk which no dealer can afford to overlook."

Something New in Radio Merchandising

A combination talking machine and radio outfit is the best way to combine the talking machine business with this comparatively new entertainment medium, according to Saul Birns, who operates six talking machine stores in the metropolitan district of New York, and who at the present time is engaged in fitting up a radio salon in his main store on Second avenue, New York. His plans include many original ideas regarding selling and display. The main room is about twenty by forty feet, handsomely decorated. Along the walls of this room are placed between fifteen and eighteen combination talking machine and radio outfits. The cabinets include upright and console models of the talking machine type now in use; some of them are beautiful period models. Part of these cabinets contains the talking machine complete in all details and the remainder is devoted to the radio outfit, which is entirely hidden and is only disclosed by lifting the lid of the cabinet as in the case of a talking machine. All of these instruments are connected, ready for instant use, by means of an indoor aerial, which

consists of a wire along the ceiling of each side of the room. The radio programs are clipped from the papers each evening and all machines are tuned in ready for instant playing, so that when a customer comes in the radio program can be listened to merely by turning on an electric switch. There is no fussing around with the dials trying to "pick up" a station, involving loss of time and the possible loss of a customer through long waiting and inability to get a station. Of course, when there is "nothing in the air" the customer is informed of the fact and an attempt is made to arrange a demonstration later in the day.

Service an Important Requisite

In addition to the various factors involved in merchandising radio mentioned in the preceding paragraphs, service following the sale is of the utmost importance, according to Lambert Friedl, manager of the talking machine department of the New York Wanamaker store. There is always the possibility of something happening to the radio set after it has been installed in the home, according to Mr. Friedl. Connections may become loose, batteries run down, etc., and not everyone is capable of inspecting the outfit and locating the trouble. The dealer who handles radio outfits must be prepared to take care of customers after the sale has been made by making necessary repairs, adjustments, etc., if the good will of the patron is to be maintained and the merchandise is to retain its prestige with the purchaser.

The Wanamaker store, which handles nationally known radio lines, also sells a combination talking machine and radio outfit, and several demonstration booths formerly devoted to talking machine and record demonstrations are now used for displaying and demonstrating the combination outfits. The Wanamaker store is featuring these outfits in some timely advertising and a number of the combinations have already been sold.

Sell Radio Separately

The Landay Bros. retail chain of stores in the metropolitan district are paying considerable attention to radio. M. Price, manager of the Newark, N. J., store of the concern, declares that radio is not tied up with the talking machine department. No effort is made to sell talking machine customers radio, although he declares that he intends to make a bid for business among his talking machine customers some time in the future. The radio department occupies a prominent position in the warerooms and advertising is proving effective in securing new business from people who may also prove live prospects for talking machines and records, musical instruments, etc.

WITHDRAWS FROM PARTNERSHIP

READING, PA., November 5.—Ralph E. Hangen has recently withdrawn from the partnership existing between Edgar P. Hangen, Paul S. Hangen and himself, trading as Hangen's Music House.

The PHONOMOTOR CO.

WM. F. HITCHCOCK, Proprietor

121 West Avenue Rochester, N. Y.

An Electric Equipment for the PHONOGRAPH

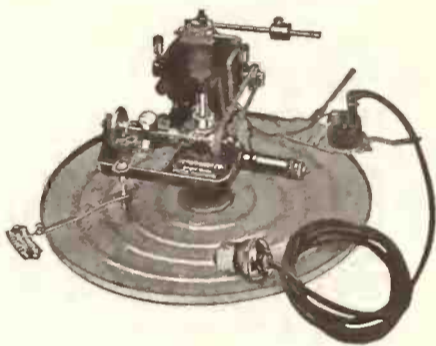

Fully GUARANTEED

Universal—alternating or direct current. Complete, with every part ready to run.

Sample, mounted on motor board, 12x12¾, \$25.00 C.O.D. Money back if not satisfactory.

The PHONOSTOP

An automatic stop for all talking machines, 100% efficient.

STANDARD FOR EIGHT YEARS



Guaranteed.

Sold direct to manufacturers all over the world.

Nickel or Gold,

Your phonograph is worthy of the best stop.

This is the only one.

Your customers appreciate it

Our NEED-A-CLIP

A fibre needle clipper with hardened tool steel blade, retails at 75c, does its work perfectly, indefinitely.

WE ALSO SELL GENERAL PHONOGRAPH HARDWARE

Trade Prices upon application

The PHONOMOTOR

Trade-Mark Reg. U. S. Pat. Office

STYLUS BARS

Stylus Bar & Mfg. Co.

Clague Rd.

North Olmsted . . . OHIO

P. O., ROCKY RIVER, O.

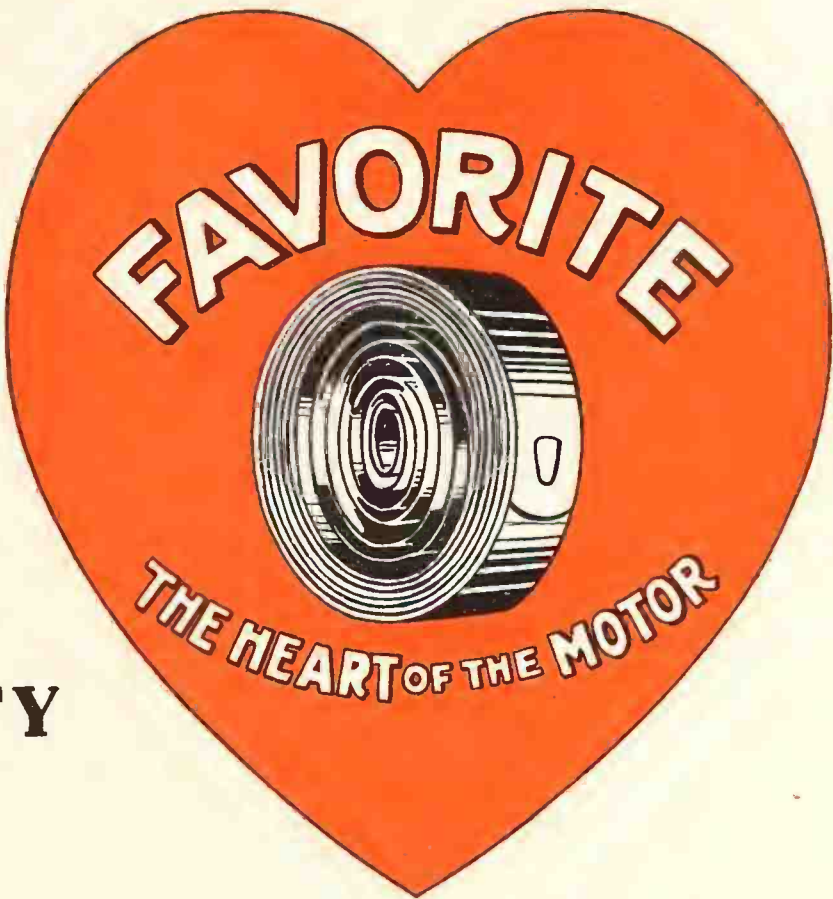

HIGHEST QUALITY

MAIN SPRINGS

MAIN SPRINGS

	Price each
2 in. x 0.22 x 16 ft., Meisselbach No. 18.....	\$1.25
2 in. x 0.25 x 16 ft., for Edison	1.25
1 3/4 in. x 0.22 x 17 ft., reg. for Victor	0.60
1 3/4 in. x 0.22 x 17 ft., Victor bent arbor	0.60
1 3/16 in. x 0.25 x 16 ft., Heineman No. 44.....	0.60
1 1/2 in. for Edison Disc	1.25
1 in. x 0.25 x 12 ft., Heineman No. 33 and 77.....	0.40
1 in. x 0.25 x 12 ft., oblong hole, western motors	0.40
1 in. x 0.25 x 16 ft., oblong hole, for Meisselbach, Sonora and Krasberg	0.60
1 in. x 0.28 x 10 ft., for Columbia, 2, 3, and 4 Spring Motor	0.38
1 in. x 0.22 x 10 ft., for Columbia, Single Spring Motor.....	0.35
1 in. x 0.20 x 13 ft., for Victor	0.40
1 in. x 0.20 x 13 ft., for Victor bent arbor	0.40
3/8 in. x 0.22 x 10 ft., oblong hole, Meisselbach No. 9.....	0.30
3/8 in. x 0.23 x 10 ft., for Blicke motor	0.30
3/4 in. x 0.25 x 19 ft., oval hole	0.28
3/4 in. x 0.22 x 8 ft., German motor	0.25
5/8 in. x 0.22 x 8 ft., for Swiss motor	0.22
5/8 in. x 0.25 x 11 ft., for Edison	0.22
1 in. x 0.25 x 19 ft., for Brunswick	0.65
1 in. x 0.22 x 9 ft., for Meisselbach No. 12, oblong hole....	0.35

MEISSELBACH REPAIR PARTS

	Price each
P9764 Main springs for motors 16, 17, 19.....	\$0.60
P9765 Main springs for motor No. 12	0.35
CP532 Governor	Complete 1.90
P1504 Governor shaft, new style	0.75
P1505 Governor shaft, old style	0.75
AP533 Governor ball	Complete 0.10
CP644 Turntable shaft Nos. 16, 17, 19.....	1.50
CP645 Turntable shaft for No. 14	1.25
AP697 Spring barrel cup for Nos. 16, 17, 19.....	0.50
AP698 Spring barrel cup for No. 12.....	0.50
CP1113 Spring barrel shaft and gear	0.90
P1529 Brake lever, bottom plate	0.10
P604 Brake lever, top plate	0.10
AP528 Winding shaft for Nos. 16, 17, 19.....	0.75
AP529 Winding shaft, straight cut, Nos. 16, 17, 19.....	0.95
AP530 Winding shaft, spiral cut, for 10; 12.....	0.35
AP531 Winding shaft, straight cut, for 10; 12.....	0.35
AP591 Brake lever	0.35
CP536 Intermediate gear for Nos. 16, 17, 19.....	0.90
M Winding cranks, 3 sizes	0.75
140 Speed indicator	0.45

REPAIR PARTS FOR VICTOR MOTOR

	Price each
5012 Winding gear	\$0.60
5013 Turntable gear, straight cut, small teeth.....	0.35
5014 Turntable gear, large teeth, straight cut	0.35
5015 Turntable gear, small teeth, spiral cut	0.35
5016 Turntable gear, big teeth, spiral cut	0.35
5021 Rubber back for exhibition box	0.35
5017 Rubber back for No. 2 sound box	0.35
5018 Governor collar	0.15
5019 Spring barrel shaft	0.60
5020 Stylus bar for No. 2 box	0.35
5022 Stylus bar for exhibition box	0.35
5011 Attachment for vertical cut record	0.25
Governor springs, for Victor	Per 100 1.00
Governor screws, for Victor	Per 100 1.00
Governor balls, new style, for Victor.....	0.08
Needle arm screws for exh. box.....	Per 100 1.50
Needle arm screws for No. 2 box.....	Per 100 1.50

MICA DIAPHRAGMS

1 23/32 in. Victor Ex. Box, 1st grade.....	\$0.15
1 7/8 in., new Victor No. 2, very best	0.18
1 31/32 in., for Sonora	0.20
2 1/16 in., for Meisselbach box	0.22
2 3/8 in., for Pathé new style	0.35
2 3/16 in., for Columbia No. 6.....	2.25
2 9/16 in., for Pathé or Brunswick	0.45

SAPPHIRES

Pathé, very best, loud tone, genuine	\$0.12
Pathé, soft tone, ivory setting.....	0.18
Pathé, soft tone, steel setting.....	0.10
Edison, very best, medium tone	0.18
Edison, very best, loud tone	0.15
Edison, genuine diamond	1.25

STEEL NEEDLES

Brilliantone, all tones	Per 1000 \$0.45
Blue Steel Reflexo, per package	0.07 1/2
Wall Kane Needles, per package	0.06

ATTACHMENTS

In Gold or Nickel-Plated	
Kent, for Victor arm	\$0.25
Kent, for Edison with C box	2.50
Kent, without box for Edison, nickel or gold.....	1.80
Kent, attach. for Victor	0.25
For Columbia, plays vertical records	0.25
Kent special adaptor with sound box, gold-plate or oxidized..	4.95
Favorite Master Adaptor, "Supreme" box N. P.....	4.60
Favorite Master Adaptor, "Supreme" box gold P.....	6.10
Favorite Master Adaptor, "Supreme" box oxidized.....	6.10

MOTORS

Distributors for Heineman and Meisselbach Motors	
Meisselbach, No. 17, 3-spring.....	\$15.00
Meisselbach, No. 19, 4-spring.....	17.00
Krasberg, 2-spring	9.00
Krasberg, 3-spring	10.50
Krasberg, 4-spring	13.50
Heineman, No. 36, 2-spring	7.50
Heineman, No. 33, 2-spring	8.50
Heineman, No. 77, 2-spring	9.50
Heineman, No. 44, 2-spring	12.50

All motors complete with 12 in. Turntables

ILSLEY LUBRICANT

10-lb. Can	\$3.00
5-lb. Can	1.60
1-lb. Can	0.40
4-oz. Can	0.15

COLUMBIA REPAIR PARTS

No.		
427 Columbia main springs, No. 2951	Complete	\$0.38
3451 Columbia spring barrel head.....	Complete	0.75
5008 Spring, barrel winding gear, old style.....		0.75
3834 Spring barrel winding gear, new style.....		0.75
604 Needle cups	Per 100	2.00
606 Needle cup covers.....	Per 100	1.00
5106 First intermediate gears	Complete	0.40
5107 Second intermediate gears	Complete	0.40
12537 Worm gear for single-spring motor		0.30
12336 Bevel pinion single-spring motor		0.35
12333 Bevel pinion, regular style		0.75
12334 Bevel pinion, latest style		0.75
12235 Bevel pinion for old-style double spring.....		0.50
12332 Bevel pinion disk shaft	Complete	1.00
13496 Male winding pinion		0.30
12496 Female winding pinion		0.30
3004 Governor shaft		0.40
11778 Driving shaft	Complete	0.50
13796 Governor balls	Complete	0.08
3570 Governor springs, each 0.02.....	Per 100	1.50
6739 Stylus bar	Complete	0.35
5010 Universal attachment		0.35
13228 Winding crank, 3 sizes, 7, 8 and 9 in. long.....	Each	0.35
Columbia Governor Screws	Per 100	1.00
Columbia Barrel Screws, No. 2621.....	Per 100	1.00
Columbia Sound Box Thumb Screws.....	Per 100	1.50

PARTS—HARDWARE

5000 Crown gear for Blicke motor	\$0.25
5001 Crown gear for Melophone motor	0.25
5002 Crown gear for Heineman No. 0.....	0.25
5003 Tone-arm goose neck for independent arm.....	0.25
5004 Governor pinion for imported motor	0.25
5005 Tone-arm base for independent arm.....	0.25
Automatic nickel-plated lid supports	0.22
Automatic gold-plated lid supports	0.55
Piano hinges, nickel-plated, 1 5/8 in. long.....	0.22
Highly nickel-plated needle cups	Per 100 2.00
Covers for cups	Per 100 1.00
Highly gold-plated cups	Per 100 7.00
Needle cup covers, gold-plated	Per 100 5.00
Turntable felts, 10-in., round or square.....	0.15
Turntable felts, 12-in., round or square.....	0.18
Motor bottom gear for Triton motor.....	0.20

HEINEMAN REPAIR PARTS

CP5226 Governor	Complete	\$1.50
CP9799 Turntable shaft	Complete	1.50
AP9924 Governor balls, 33; 77; 44		0.10
AP9925 Governor balls for No. 36		0.10
P5004 Governor pinion for No. 0.....		0.25
P5003 Governor shaft		0.50
CP9629 Speed indicator	Complete	0.45
P9764 Main spring for No. 33 or 77.....		0.40
P9765 Main spring for No. 36.....		0.28
P9766 Main spring for No. 44.....		0.60
AP9778 Spring barrel cup for No. 33 or 77.....		0.50
AP9779 Spring barrel cup for No. 36.....		0.50
AP9780 Spring barrel cup for No. 44.....		0.75
P9762 Winding shaft for motor No. 33.....		0.60
P9966 Winding shaft for motor No. 36.....		0.40
5304 Winding shaft for No. 44 or 77.....		0.75
5007 Escutcheon	Complete	0.15
AP9409 Turntable brake		0.15
AP10072 Winding crank, 3 sizes		0.75

STONE ARMS

No. K With sound box	\$1.25
No. K Nickel-plated without sound box.....	2.75
No. P Gold-plated, without sound box	4.50
No. M Tone arm, Meisselbach sound box	4.75
No. M Gold-plated Meisselbach sound box	7.50
No. L Made of brass tubing, nickel-plated.....	2.50
No. L Made of brass tubing, gold-plated	4.50

SOUND BOXES

No. B1 Bliss sound box, fit Victor	\$1.25
No. B Balance, fit Victor	0.75
No. F Favorite, fit Victor	1.75
No. I "Supreme" nickel-plated, loud and clear	3.00
No. I "Supreme" gold-plated, loud and clear.....	4.50
No. M Nickel-plated, mellow tone, for Victor	1.75
No. M Gold-plated, mellow tone.....	2.25
No. G Nickel or gold-plated	1.00
No. P Gloria patent, extra loud	3.00
No. H Imported nickel-plated	0.75
No. 6 Columbia, nickel-plated	2.25

Tremendous Stock of Homokord German Records

FAVORITE MFG. CO., 105 E. 12th St., New York City

WANTED AGENTS FOR STATE RIGHTS

**Corner Fourth Ave.
Telephone 1666 Stuyvesant**

WANTED AGENTS FOR STATE RIGHTS



The NEW Columbia is superior

*Hearing
is believing*

The Motor is a Mechanical Triumph.
For years Columbia engineers and scientists worked to achieve a perfect phonograph motor and now it is here in the New Columbia. *Investigating is believing.*

COLUMBIA PHONOGRAPH COMPANY
New York

CENSUS CHANGES ARE SUGGESTED

Music Industries Chamber of Commerce Suggests Changes in Classifications of Music Trade Figures That Will Make for Accuracy

At the request of the Bureau of the Census of the United States Department of Commerce, the Music Industries Chamber of Commerce has aided in the preparation of the schedule for musical instruments manufactured in 1923 and has made some suggestions in regard to classification which have been adopted by the department.

For example, a distinction has been drawn between player actions made for sale to piano manufacturers and those made by the manufacturers for installation in their own instruments, the value of which would appear in the price of the completed player-piano. This distinction has been noted by adding the words "made for sale" to the appropriate classification of player actions.

At the suggestion of the Chamber the item "Records—phonographs" has been taken out of the general musical instrument schedule and assigned to the figures classified under the phonograph industry.

Other changes have also been made in the census schedule which will result in its presenting a more accurate and reliable report of the musical instrument industry. A letter has been received from the Chief Statistician of the Bureau thanking the Chamber for its assistance in perfecting the schedule.

GRIGGS HOUSE IN NEW QUARTERS

KEWANEE, ILL., November 5.—New quarters have just been taken by the Griggs Music House, being now located in the Scandia Building on East Second street, formerly used as the Carpenter & Cavanagh music room. Partitions have been placed in the room and business has already been started at the new location.

DE FOREEST SELLS WARREN, O., STORE

Stewart-Edison Co. Takes Over Business of De Foreest Music Co. in That City

WARREN, O., November 3.—Announcement is made of the sale of the De Foreest Music Co. to the Stewart-Edison Co. of this city. The sale includes the fixtures and the Victor agency. The De Foreest store in this city has been a real musical center and in making the announcement Mr. De Foreest expressed his regret in leaving the city. He is heavily interested in business in Greenville and Sharon, Pa., and his interests there have become so extensive that he decided to close the local store. The Stewart-Edison Co. has been in business here for several years, operating an Edison shop on North Park avenue. Robert Markley, who has been manager of the De Foreest store since it was opened, will soon open it for the exclusive sale of Brunswick machines and records.

OPENS BRANCH STORE IN WALTHAM

WALTHAM, MASS., November 5.—A new branch music store, carrying a complete radio line, has been opened at 712 Main street by the K. M. Cahoon Co. Elliott C. Paul will act as manager of the new branch and the Moody street store will be continued as before. Both stores will carry complete lines of sheet music, pianos, Edison and Victor machines.

NEW CLEVELAND STORE SUCCEEDS

CLEVELAND, O., November 5.—The Harmony Music Shop, recently opened at 20017 West Twenty-fifth street, this city, where Steger & Sons pianos and phonographs, together with Okeh and Odeon records, are handled, has met with quick success. Walter S. Rader is president of the company, Walter Bienenke, vice-president, and J. W. Kegel, secretary.

FOR REDUCTION OF WAR TAXES

Senator Smoot Would Also Repeal Certain Taxes Imposed As War Measure

WASHINGTON, D. C., November 7.—The reduction of some of the war taxes now carried in the Revenue Law and repeal of others is proposed by Senator Smoot, who will this year be chairman of the Senate Finance Committee. Possibilities of reducing the revenue taxes by a half billion dollars were discussed by Senator Smoot with President Coolidge and Secretary of the Treasury Mellon at the White House.

Senator Smoot's proposals include a reduction of surtaxes, making the maximum 33 1/3 per cent instead of 50 per cent as at present; exemption from taxation of all incomes below \$2,000, and probably those below \$3,000; the reduction of taxes on incomes between \$3,000 and \$10,000, and a reduction of \$75,000,000 on certain of the special taxes.

These changes can be made in the Revenue Law, declared Senator Smoot, provided Congress does not get extravagant and there is no attempt to pass a soldiers' bonus bill. Under the present system of conducting the Government operations, the reductions in revenue, which would aggregate approximately a half billion dollars, would not be a source of embarrassment. Before effecting any sweeping changes, however, it will be necessary, it was pointed out, to learn what Congress proposed to authorize in the way of expenditures and, if the present appropriations are exceeded, how the money shall be raised.

LARGER QUARTERS IN VISALIA

VISALIA, CAL., November 3.—The Hockett-Cowan Music Co., Visalia, Cal., has moved to new quarters at the corner of West Main and Locust streets, where more room is available for display of the company's lines.

RETAIL PRICE \$10

An entirely new market will be yours with this perfect reproducing phonograph, retailing at \$10. Besides, you can attack an old market with a new selling appeal.

Explanation of possibilities upon request

The Yale Phonograph has an impressive exterior. A gracefully designed wooden cabinet, finished in mahogany, and a satin gold horn are part of it. Inside is a strong, smooth-running motor. Through a particularly fine reproducer is heard a clear, rich vigorous tone that makes customers wonder how such an instrument can sell for \$10.

Write for trade price, and a sample machine

DAVIS MFG. & SALES CO., 763 State Street - NEW HAVEN, CONN.

YALE PHONOGRAPHS



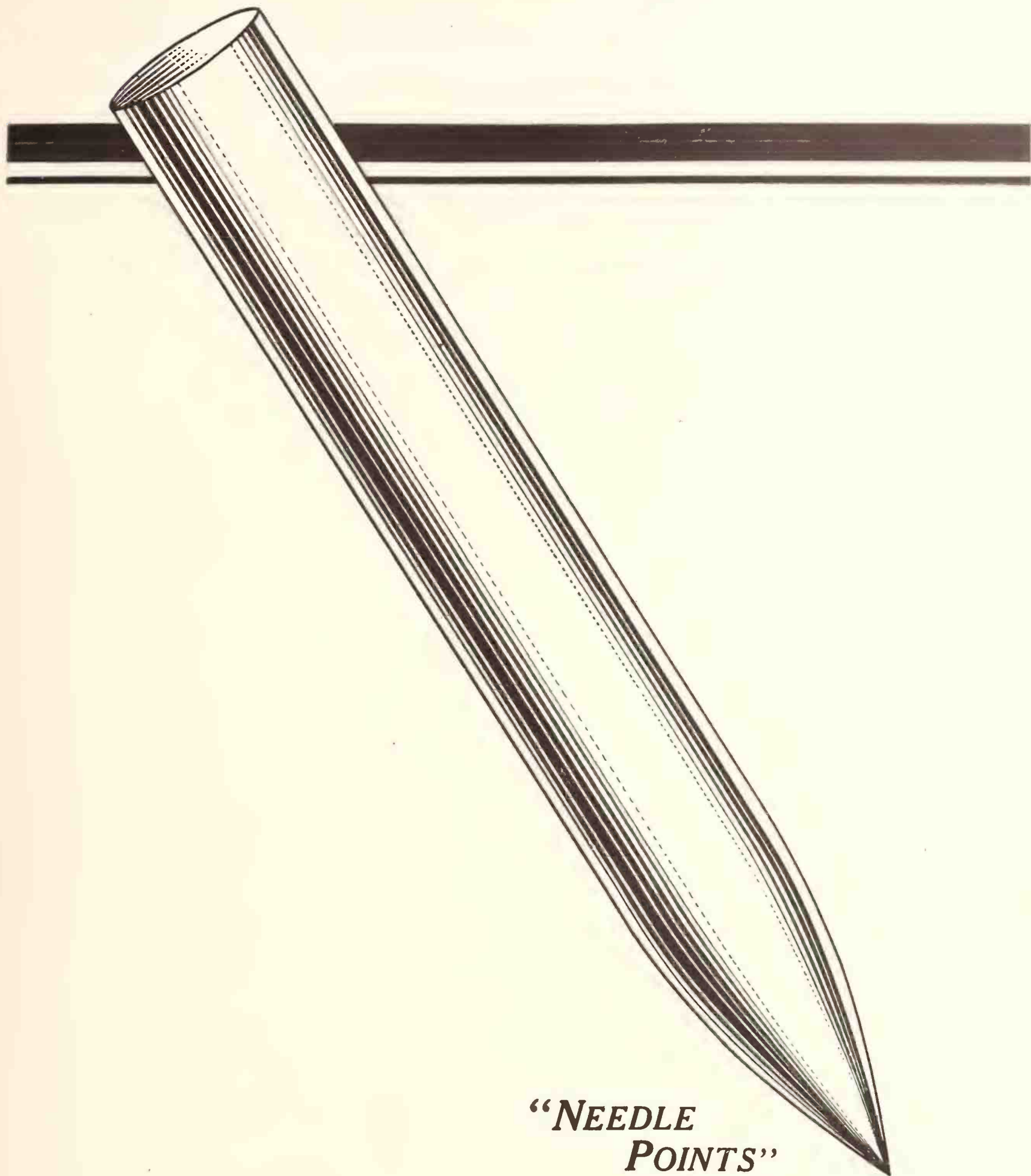

**“NEEDLE
POINTS”**

No. 1 Merely because they are tiny there is a strong inclination to believe that needles “are all alike.” Wrong! In the manufacture of Okeh Needles only the highest grade carbon steel is used. Only men of long experience supervise the hardening and tempering of the uniform points and uniform tone-sizes of

General Phonograph Corporation

OTTO HEINEMAN, President

25 West 45th Street

New York

OKEH

QUALITY

NEEDLES



Artistic Window Displays Strike the Eye

Message Is Emphasized by Centering the Attention of Shoppers on One or Two Objects—Avoid Making the Window a Stockroom

Simplicity is beauty. And insofar as the talking machine business is concerned this does not apply any more forcibly to any branch of the business than it does to the window displays. Whether the dealer has one or more windows at his disposal or whether the space be large or small this rule holds good. One of the most successful advertisers in the country once declared that the public cannot assimilate two ideas at once and, therefore, he made it a standing rule that his publicity, no matter what the type, should be centered around only one idea. This holds true in the talking machine business, whether it be in window displays or any other kind of advertising.

Simplicity is beauty! Does the accompanying illustration of a window display of C. C. Baker, Columbus, O., bear out this declaration? In the opinion of the writer this is one of the finest talking machine window displays that have yet come to his attention. Notice that only one model machine is displayed and the rest of the window is in reality a setting for this instrument. The records in the foreground are a necessity and emphasize not only the main theme of the window (music by means of the talking machine), but the arrangement is such that added beauty is given the entire display. Actually there are only twelve objects in this large window.

The beauty of this display is that with but trifling changes it can be made appropriate for any day or season of the year. Take, for example, this display arranged as a Christmas window. A very few changes will do the trick. The basket of flowers might be replaced by holly or a Christmas tree, the velvet drapery should be red or green in color and the placards in the illustration could be replaced by others setting forth the talking machine and records as Christ-

mas gifts. Then, too, the background affords further opportunity for seasonal decoration.

This one-idea type of window display has the advantage over an exhibit where many different kinds of instruments or products are displayed, and the talking machine dealer can follow out the idea in any display he undertakes. It is

class than it is to put a conglomeration of all the various types of recordings in the window. For instance, records of the various operas, together with window cards giving necessary and interesting information, would provide the means of an attention-compelling window. Then there are the vocal records, violin, piano, quartet, etc.

It is the small neighborhood retailer who most often falls down on his window displays and generally it is the dealer who arranges the display himself or who delegates the task to a salesman. Now, although a salesman may be able to sell talking machines and records it does not follow that he has the requisite ability for effective window dressing. The larger stores, especially the department stores, have in their employ expert window display men, who have an eye for artistic effects and who have been thoroughly trained in the art of display. Of course, the small dealer cannot afford to go to this expense, but he can and should plan to make his windows attractive. The display must deliver a message to the passing throng and the most effective window is the one where the theme is easily grasped.

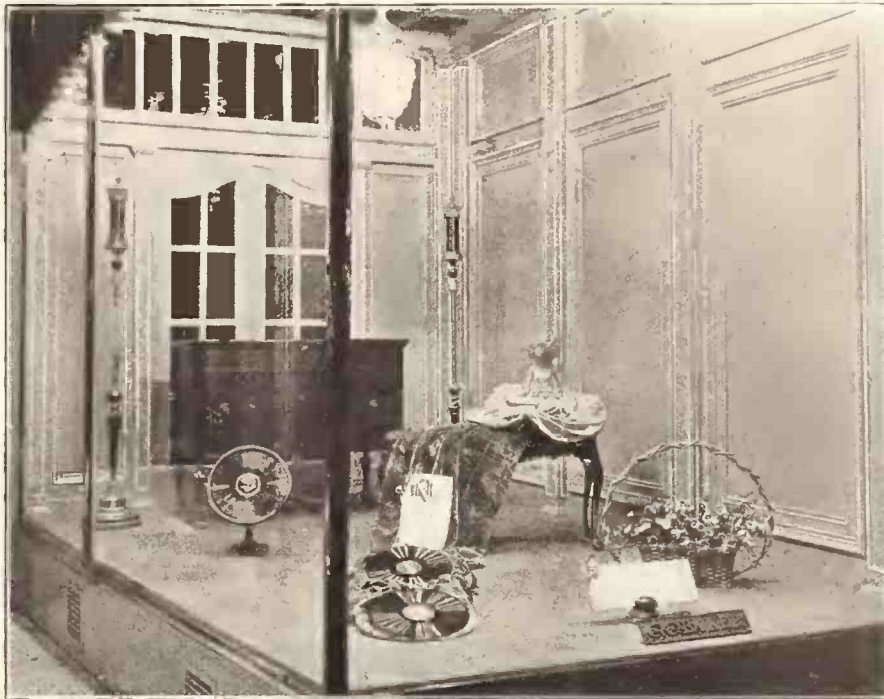

Simple but Attractive Display of C. C. Baker

an easy matter to change the talking machine model each week, thus drawing attention to a different instrument regularly. Changes in the drapery and lighting effects as well as the placards will give the window an entirely different effect. The same plan can be followed in displaying records. It is a much more profitable policy to display records according to

display men, who have an eye for artistic effects and who have been thoroughly trained in the art of display. Of course, the small dealer cannot afford to go to this expense, but he can and should plan to make his windows attractive. The display must deliver a message to the passing throng and the most effective window is the one where the theme is easily grasped.



Sherman, Clay & Co.

*Victor Distributors
on the Pacific Coast*

*Victrolas Victor Records
Victor Accessories*

Main Wholesale Depot:

741 Mission Street, San Francisco, Cal.

Branch Wholesale Depots:

10th and Santee Streets, Los Angeles, Cal.

N. W. Corner 13th and Glison Streets,
Portland, Oregon

Oceanic Bldg., Cor. University and Post Streets,
Seattle, Washington

330 West Sprague Ave., Spokane, Washington

5 DISTRIBUTING DEPOTS for YOUR CONVENIENCE

Send
for
this
Book!

The

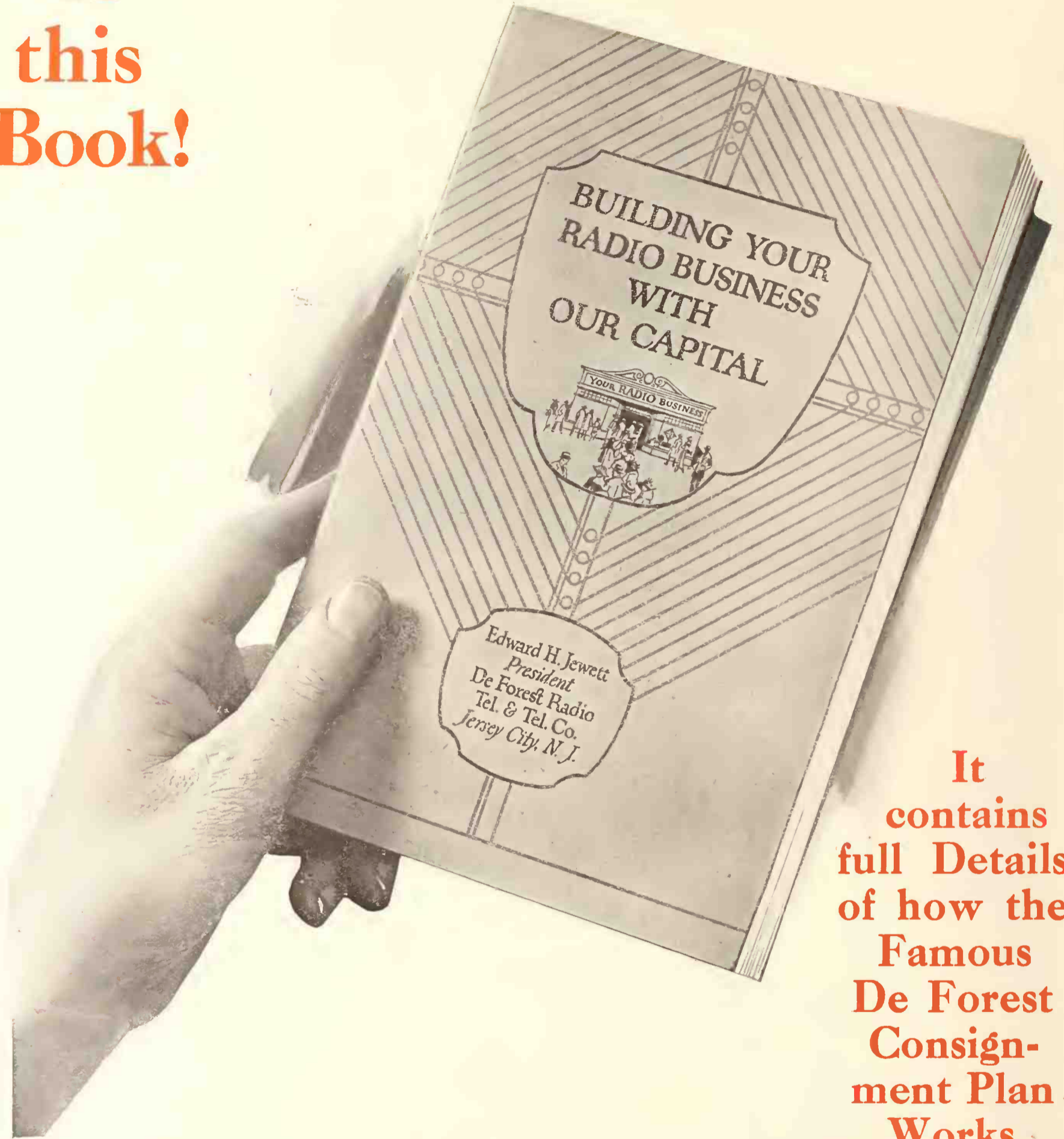

It
contains
full Details
of how the
Famous
De Forest
Consign-
ment Plan
Works

De Forest

Talking Machine Dealer

Listens with Interest to the Word "Consignment"

WHEN you say "Consignment" to a talking machine dealer he sits up and takes notice.

Of all dealers in the world he has suffered most from investing large sums of money in expensive stock—paying high rents for the considerable floor space on which to display this stock—and then seeing it stay on the floor.

The talking machine dealer tried to get into the radio business early. He saw the light. He knew it was going to be a great field.

However, unless he happened by chance to stock De Forest Radiophones, he may have become discouraged with the way radio sets sell.

Now all the doubt is removed from the radio business so far as the talking machine dealer is concerned.

The De Forest Company will put on his floor strictly on a consignment basis whatever stock he thinks he can sell in the course of one month, and it is only necessary for him to make a deposit of one-third of this single month's quota. As the stock sells he deducts his compensation. No other investment is necessary. No doubt is left. Turn the stock over as often as you want in the course of the month. Profits vary from 35 to 40% for each turnover.

This plan has revolutionized the entire radio industry. Send for the new De Forest book "Building Your Radio Business with Our Capital," which gives you full details of how the plan works.

Talking machine dealers all over the United States are writing or wiring in for exclusive De Forest agencies. Territories are going fast. If interested, please let us hear from you at once.

De Forest Radio Tel. & Tel. Co., Dept. T. W. 3 Jersey City N. J.

If located West of Pennsylvania address

De Forest Radio Tel. & Tel. Co., Western Sales Division Dept. T. W. 3 5680—12th Street, Detroit, Mich.



Radiophones



**The NEW
Columbia
is superior**

*Hearing
is believing*

A Beautiful Cabinet. Whether it be an upright or a console model, every New Columbia is a masterpiece of the cabinet-maker's art. Combine this exterior beauty with a tone-reproducing mechanism that is without par, and you have the New Columbia.

**COLUMBIA PHONOGRAPH COMPANY
New York**

Points to New Era in Record Merchandising

Development of Larger Sales of Records to Individuals by Means of "Group Sales Plan" Receiving Attention of Live Dealers, Says Phil Ravis, President, Peerless Album Co.

That the talking machine dealer is on the threshold of a new era in record merchandising is the opinion of Phil Ravis, president of the Peerless Album Co., manufacturer of record albums at 63 Broadway, New York City. He bases his conviction on a series of facts, accumulated on a recent trip visiting some of the largest talking machine and music houses and interviewing the buyers in music departments of the large department stores. In conversation with a World representative this week Mr. Ravis said:

"A quarter century has passed since the introduction of the phonograph and public acceptance has gone through the successive stages of curiosity, investigation and general approval. Up until a year ago the sensational scoop on a popular record was quite a common thing, but to-day there are in addition many music lovers more conservative in their tastes who choose records as they do books.

"The manager of one of the most successful stores in Ohio told me his gross business was greater than ever, on a smaller inventory than was carried in 1920-21, which means that the turnover on standard catalog selections was increased. This was accomplished by a sales drive on the group record plan and home record library idea. Albums were brought to the foreground and played an important part in cultivating the trade of this along consistent and methodical purchasing lines.

"Do not misinterpret what is meant by 'group record sales.' The worst possible thing is to try to sell a customer too many of one class of records at one time. It has never worked favorably and never will. But to get an album into the customer's home, properly labeled as containing a certain class of music, is to instill a permanent idea with the customer that the album should be filled. 'When' and 'how' are matters to be left solely with the customer.

"It is a very bad thing to be overzealous about anything, particularly when you are selling, and the little plan of merely suggesting the class of records to be purchased in future by the label on the album is usually sufficient.

"I noticed particularly a store that priced regular phonographs considerably higher than list and inquired about this. For instance, one tag read \$89 for a \$75 instrument. It was explained as being the logical way to meet the demand for a complete outfit and overcome sales resistance. Instead of saying one machine \$75, six albums \$9, six records \$4.50, needles 50 cents, they simply said 'complete, \$89.' It appeared to me that this was an excellent plan to keep the album and record sales in the same store where the instrument was bought and that more Eastern dealers should try it.

"How the album is assisting the proper merchandising of records is forcefully demonstrated by another store. This particular dealer has read my 'gift advertisement' and found that a

SEEKS TO TRACE RECORD SALES

Victor Co. to Endeavor to Determine Direct Sales Results of Music Memory Contests

In a review of the development of the music memory contest idea in various sections of the country and the active participation in such affairs by the Victor Talking Machine Co. and its dealers, Mrs. Frances E. Clark, director of the educational department of the Victor Co., has arranged with dealers to have them keep a notation of all records sold either to homes or to schools to be used in preparation for music memory contests. The figures will be compiled next Spring and it is hoped then to be able to determine just what influence music memory contests have on record sales generally.

VAGABONDS' FIRST GENNETT RECORD

The Vagabonds have just recorded their first Gennett record which will be released very soon. The selections are "Sweet Butter" and "I'm Sittin' Pretty." This orchestra certainly is "different" and it has a style all its own. It is recording exclusively for Gennett and the first record is being rushed through.



SHELTON ELECTRIC CO., 16 East 42nd Street, New York

THE SHELTON Electric Motor

The "Simplicity" electrifies Victor, Edison and Columbia phonographs by simply taking off winding handle and placing motor against turntable. Automatic switch in motor operated when the turntable is started or stopped. Operating on AC or DC current of 110 volts. Specify type of current when ordering.

sign in his window featuring a 'dance album' (with three records to start) or an 'opera album' (with three records) were greedily pounced upon every now and then by passers-by. While his sales were not sensational in any degree they were steady and came as a direct result of the plan. In other words, he did get business that ordinarily would go to the candy or novelty store.

"There is no question in my mind but that people everywhere are to-day taking more pride in their record collections than ever before. While talking with a dealer in a large store a customer came in and explained that she needed but two more records to complete the whole opera of 'Aida' and she added that her husband had purchased a special cabinet to keep the classified albums in, this cabinet matching their library bookcase.

"It occurred to me then what great advantages would accrue to every dealer who could encourage and develop a wide clientele of customers with the enthusiasm displayed by this woman."

N. C. JOHNSON OPENING WAREROOM

LANCASTER, PA., November 5.—The opening of a new piano wareroom has just been announced by Nelson C. Johnson, for many years associated with his father, Kirk Johnson, in the sale of pianos. The store, which is now under construction, will be located at 110 North Prince street. Mr. Johnson plans to carry a diversified line of pianos, including the Hallet & Davis, Story & Clark, Art-Trio and Angelus reproducing piano. The Columbia phonograph line will also be handled.

HATCH OPENS NEW STORE

KENMORE, O., November 3.—A music store, handling phonographs and pianos, has been opened here recently at 1520 Boulevard by Ralph C. Hatch. The quarters have been completely remodeled and two sound-proof booths for demonstrating records have been installed. Mr. Hatch handles a very complete line of musical instruments and sheet music in addition to his other lines.

SECOND YEAR SUCCESSFUL LEADER

Canada Patent Applied

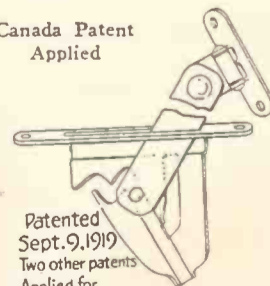

Patented Sept. 9, 1919
Two other patents Applied for.

Samples on request.

two styles—flexible and bent.

The Most Dependable and Inexpensive Lid Support on the Market

The bottom plate is constructed of one piece of metal and it works automatically perfect. No parts to go out of order. The hinges are made in two styles—flexible and bent.

STAR MACHINE & NOVELTY CO.

81 MILL STREET

BLOOMFIELD, N. J.

G. L. LAING CO., Canadian Distributor
41 Richmond St., East Toronto, Ont.

Two Big Holiday Sellers!

Both Health Builder Sets of Walter Camp's "Daily Dozen" and the Camp-Fone provide the dealer with quick selling merchandise with a strong Christmas gift appeal

The CAMP-FONE



at
\$25

Camp-Fone weighs only 15 pounds. Measures 14x11½x6, closed. Retail at \$25; Middle West, \$27.50; Far West, \$30.00. Quick sales and liberal profits for live dealers.

The *Camp-Fone* is a quick easy sale at \$25 because it looks like a lot more money. Handsome mahogany finish, hardwood case, trimmed in nickel, comfortable leather handle. 10 inch turn table, heavy-duty noiseless motor, triple weight governor, speed adjuster, needle cup with safety cover, sturdy 10 inch piano hinge with strong top holder catch. Equipped with album holding 6 records. The first high-class small portable ever produced and an attractive holiday gift.

Walter Camp's "Daily Dozen" Health Builder Record Sets

\$10 List
Price

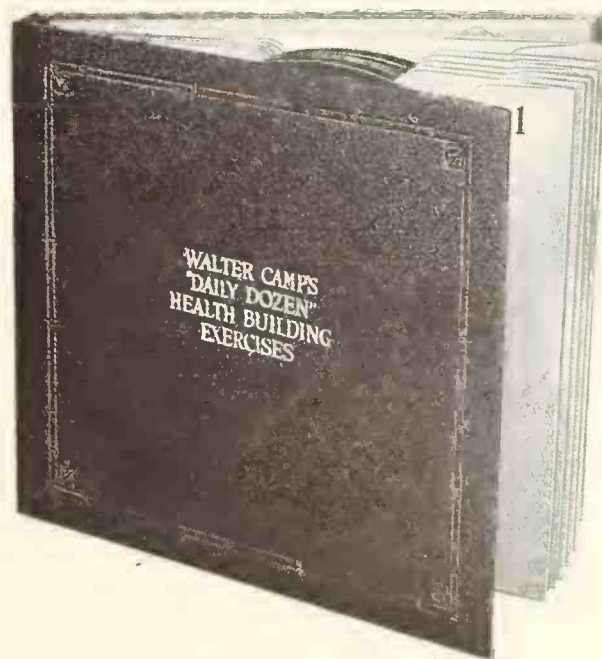

Last Christmas season the sale of these sets was tremendous. Many dealers could not fill all the demands and had to lose some profits. Their specific gift appeal together with their nominal price made quick sales.

If you are not already selling Health Builder sets send to-day for full information. If you are we recommend that you increase your stock *now* for the holiday season.

HEALTH BUILDERS, Inc.

DEPARTMENT W 11

334 FIFTH AVENUE

NEW YORK, N. Y.

STEALING to VIRGINIA

A Dancing Song

"You can't go wrong
With any FEIST song"

Words by **GUS KAHN** Music by **WALTER DONALDSON**

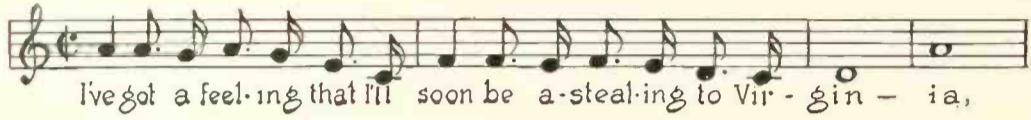

© LEO. FEIST inc N.Y.C.

CONCENTRATION IN CANVASSING PAYS

Scattered Calls Mean Waste of Time and Overlooked Prospects—How a Live Dealer Thoroughly Covers His Territory

Canvassing is still being found a good road to sales by those dealers who go about it in the right way. One of these is J. L. Brett, well-known dealer at Niagara Falls, N. Y., who does a very large business in Edison phonographs and records. Mr. Brett has found that the only way to eliminate waste of time in canvassing and to get worthwhile results is to map out his territory by streets and work each family on one thoroughfare or section before carrying the scene of operations to the next, and although he has only two outside men they certainly bring home the bacon. The plan is this: Each day these men take a street or a section of the city which they cover without missing a home or a family, the object being to secure permission to place a machine and some records in the home for a trial period of three days. Mr. Brett is authority for the statement that one out of every four instruments placed in this manner remains permanently in the home. This is certainly a good ratio of sales—one to every four calls. It is also excellent proof that where a determined effort is made canvassing is an unbeatable way of bringing the sales volume to assume respectable proportions.

Where many canvassing campaigns fall down is in the lack of concentration. In other words, scattering the drive over too large a section of the city or town without definite direction. It is very well to send individual canvassers and salesmen to different sections and streets, but unless these men cover their territory thoroughly the results will fall below par. This is not a theory, but a fact which has been proved many times. If a man calls on three families in a six-family apartment house or three homes out of six on a block the chances are exactly even that the persons he is overlooking may be in the market and can be sold.

The Benedict Piano Co., handling Gulbransen players, Victrolas and records, musical merchandise, etc., has moved to larger quarters in Clarinda, Ia.

ADDING TO SERVICE FACILITIES

Forbes & Wallace, of Springfield, Mass., Make Changes to Handle Growing Trade

SPRINGFIELD, MASS., November 6.—Present activity at the Forbes & Wallace store gives an indication of the excellent business which all music dealers in Springfield report. Manager Larkin, of the musical merchandise department, reports good results so far this year and looks forward to even bigger things in the remaining months. To keep pace with the growth in business Mr. Larkin has found it necessary to expand facilities. Improvements are under way.

Rayburn Clark Smith, of the Unit Construction Co., of Philadelphia, has worked with Forbes & Wallace in the development of the layout for the new departments, which will greatly increase efficiency in handling customers. As the department was all Unico equipped, the rearrangement and additions are being made without any interruption to business.

The Ludwig Co., of this city, has also recently added some Unico service units, increasing its ability to serve its trade.

A UNIQUE COLLECTION LETTER

A collection letter is used by a printer in Fernwood, Pa., which has been wonderfully successful in stimulating collections and which can be applied to any business where the collection problem prevails. The letter follows:

"Dear Sir: "Here is a pin. (A pin is stuck in here.) It's not an ordinary pin—not the kind your wife pins her dress with or anything of that kind—it's really a magic pin.

"We are going to let you use it for a few minutes—and only a few minutes, because it is imperative that we get it back.

"It is going to serve a wonderful purpose. It is going to get a lot of matters cleared up that have been pending for some time.

"The real reason for this pin, and the real use you are to make of it, is to pin your check to the attached statement and return it to us.

"You can see at a glance that this pin will really do a lot of good for both of us. Very sincerely, John J. Weber.

"P. S. Don't forget to return the pin at once—others are waiting to use it."

NEW SET OF OKEH MOVIE SLIDES

Leading Record Artists Featured in Slides Well Received by Okeh Dealers

The advertising department of the General Phonograph Corp., New York, manufacturer of Okeh records, announced recently a new set of Okeh movie slides, which has been received en-



Slide of Vincent Lopez and Orchestra

thusiastically by Okeh dealers throughout the country. The slides in this set feature Vincent Lopez and His Hotel Pennsylvania Orchestra, Markels Orchestra, Sophie Tucker and Gerald Griffin, all of whom are exclusive Okeh artists. Two other slides are general in char-



Slide of Markels Orchestra

acter, inviting the moviegoers to visit the dealer's establishment and emphasizing the dance hits included in the Okeh library. The slides are brilliantly colored, with ample room for imprinting the dealer's name and address, and the Okeh advertising department suggests various ways by which these slides can be used to splendid advantage.

TUSSEY-WILLIAMS CO. OPENS

WESTERVILLE, O., November 5.—The formal opening of the new store of the Tussey-Williams Music Co. was recently held here during the fourth anniversary week of the company. The new address of the concern is the building at 34 North State street, which will afford three floors, two for showroom purposes.



YOU might as well have the best

For Accessories, Repair Parts and Motors---Use

"Specialty Brand Products"

THE SPECIALTY PHONOGRAPH AND ACCESSORIES CO.

Manufacturers

210-212 East 113th Street

New York, N. Y.



CESCO REPEATER

A Suitable Gift from
ANYBODY to EVERYBODY
—And Only a Dollar!

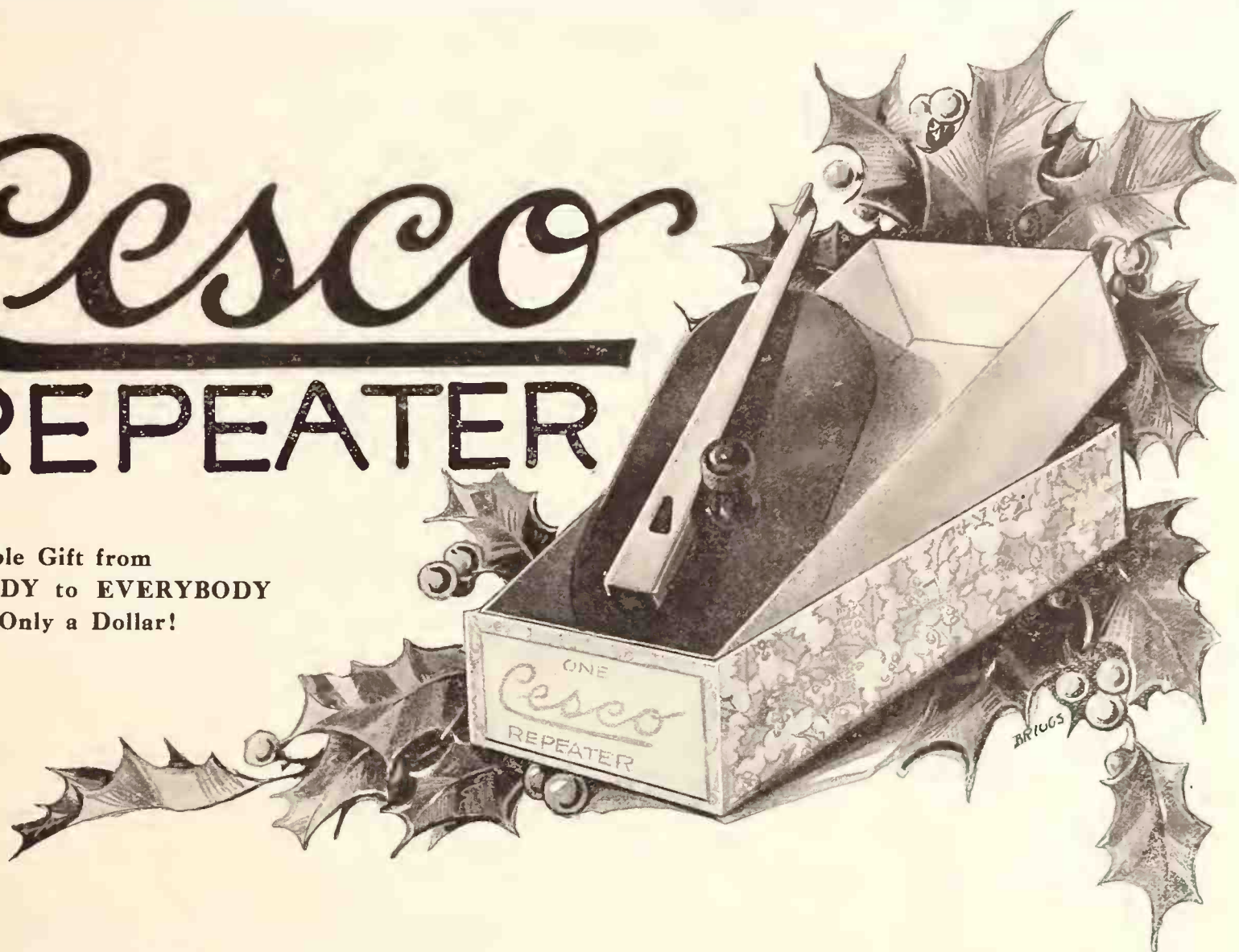

Holiday Time is Dancing Time!

ALL the world owns a phonograph and dances to it—that makes the CESCO Repeater a *universal* gift. The CESCO Repeater is the ideal repeater, quick as a flash in operation, positive in action, simple in design. It is sturdily built of sheet metal without intricate mechanism or complicated parts. *Needs no adjusting whatever*—just sets in the center of the record. Does not touch the playing surface, nor will it injure the needle or reproducer.

The CESCO Repeater is the most salable accessory in the talking machine industry. It will help you skim the cream off the Christmas trade.

The standard finish is gun metal base with nickel plated arm which retails at the popular price of one dollar. Also carried full nickel plated at \$1.50 and gold plated at \$2.00. Put up in cartons of 12 with holly boxes for holiday trade. Distributed through jobbers. Sample to dealers on receipt of jobber's name.

THE RAPID REPEATER CO.
260 Van Alst Ave., Long Island City, N. Y.

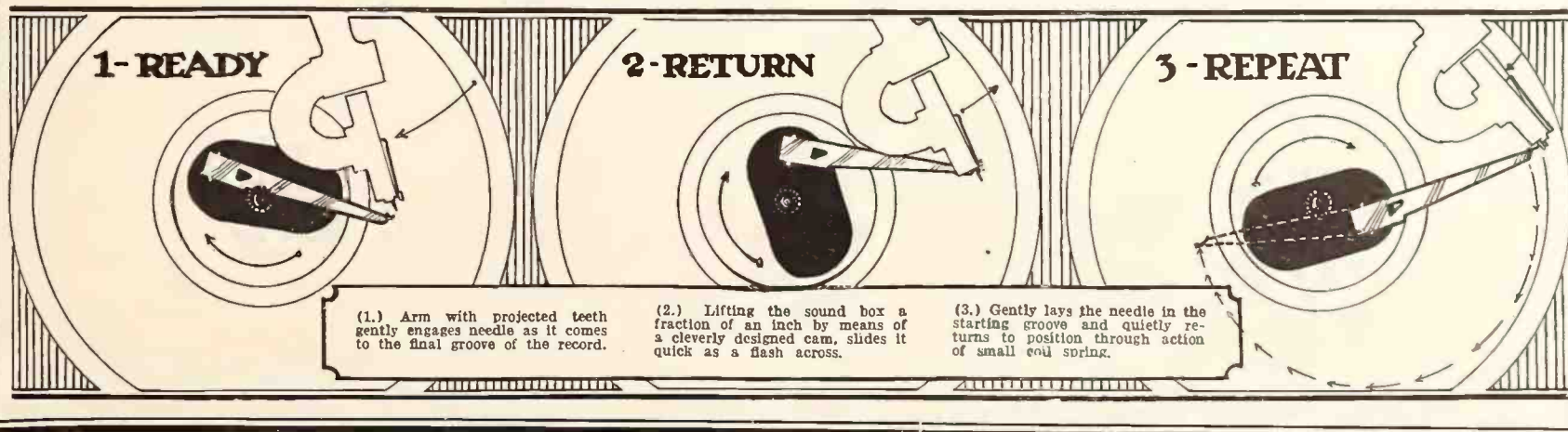



**The NEW
Columbia
is superior**

*Hearing
is believing*

*The New Reproducer banishes
Screech and Blare.* Here is an accomplishment—a sales argument that will convert every former opponent of the phonograph and win every phonograph owner "Not quite satisfied" with his own instrument. *Hearing is believing.*

COLUMBIA PHONOGRAPH COMPANY
New York

Final Awards in Better Homes Music Contest

Event Aroused Wide Interest Throughout the Entire Country—H. G. Van Closter, of Kansas City, Mo., Wins First Prize—Second and Third Prizes to Katherine Hustvedt and J. M. Williams

The awards of prizes in the Home Music Contest held throughout the country during Better Homes Week, June 4-10, under the joint auspices of the Music Industries Chamber of Commerce and the National Council of Better Homes in America, have just been announced, showing a lively interest in the value of music.

The winner of the first prize, a \$500 piano or allowance of that amount on a piano to be selected from the list of twenty-six, is H. G. Van Closter, of Kansas City, Mo. His statement follows: "Music makes better homes because dance music lightens labor and speeds play. The performance of concerted music, whether vocal or instrumental, fosters harmony and co-operation. Music of sentiment eloquently expresses the spirit of each tender relationship of the home and makes very real those intimate emotions which timid hearts seldom dare express in words."

According to the terms of the contest the explanation had to be written in fifty words or less and a list of ten selections of the best music for the home bearing out the definition.

The second prize, a \$200 phonograph or allowance on an instrument to be selected from a list of seven, was awarded to Katherine Hustvedt, of Decorah, Ia. Miss Hustvedt says music makes better homes because: "Music, the most social of all the arts, welds the family and its friends together in an enjoyment which can be shared by the tiniest tot and the oldest grandparent. It is a trouble-chaser, a gloom-dispeller, an electric tonic of high power. It tones you up physically, mentally and aesthetically."

John M. Williams, of East San Diego, Cal., winner of the third prize, has this to say: "Music makes better homes because it (1) cultivates the imagination; (2) appeals to the higher emotions; (3) awakens slumbering desires and ambitions; (4) cements home ties; (5) arouses patriotism; (6) develops the rhythmic sense; (7) encourages the faint-hearted; (8) cultivates such social activities as dancing, singing; (9) awakens the religious side of the listener; (10) is an outlet to the emotions of happiness; (11) sadness; (12) unexpressed aspirations."

The contest was judged upon (1) the reasons given why music makes better homes; (2) the choice of ten selections best suited to support these reasons, and the committee on awards who judged the entries included Mrs. John F. Lyons, president, National Federation of Music Clubs; Mrs. M. E. Oberndorfer, music chairman, General Federation of Women's Clubs; C. M. Tremaine, director, National Bureau for the Advancement of Music; K. S. Clark Bureau of Community Music, Community Service.

The Better Homes in America campaign reached 1,000 cities this year; although the music

contest was organized too late in the campaign to be promoted thoroughly in all of these communities, the quantity of the replies and the general scattering of them throughout the country proves that the contest was a great success.

A complete list of winners follows: First prize, H. G. Van Closter, 510 East Eighth street, Kansas City, Mo.; second prize, Miss Katherine Hustvedt, 401 Grove street, Decorah, Ia.; third prize, John M. Williams, 3683 Reed avenue, E. San Diego, Cal.; fourth prize, Miss Helen Walters, 3560 Grim street, San Diego, Cal.; fifth prize, James Potter Keough, 808 Lexington avenue, New York City; sixth prize, Miss Katherine Nicholson, 226 Yanell avenue, S. E., Grand Rapids, Mich.; seventh prize, W. L. Thickstun, Central College, Conway, Ark.; eighth prize, Malcolm L. Cobb, 353 Central avenue, New Haven, Conn.; ninth prize, George Ashton, 122 East Sixtieth street, New York City; tenth prize, Miss Elizabeth K. Chamberlain, 123 Bellaire avenue, Louisville, Ky.; eleventh prize, Mrs. Laura Schubert, 301 Ninth street, St. Charles, Mo.; twelfth prize, Louis Harrison, 608 Fulton street, Salisbury, N. C.

The following prizes were offered through the co-operation of the Music Industries Chamber of Commerce:

First prize—\$500 piano, or an allowance of \$500 on any piano or player-piano to be selected by the winner from the following list: Acoustigrande, Biddle, Brambach baby grand, Cable-Nelson, A. B. Chase, Chickering, Emerson, J. & C. Fischer, Hardman, Hallet & Davis, Haines Bros., Jacob Bros., James & Holmstrom, Wm. Knabe & Co., Kohler & Campbell, Lindeman & Sons, Mansfield, Mathushek, Milton, Poole, Steger & Sons, Sterling, Story & Clark, Weaver, Wing & Son and York.

Second prize—\$200 phonograph, or an allowance of \$200 on any phonograph to be selected by the next winner from the following list: Brunswick, Edison, Pathé, Starr, Columbia, Victrola, Wing & Son,

Ten prizes—\$25 each, allowance in musical merchandise to be selected from the following list by the next ten winners: Music rolls—Connorized, Q R S, United States; phonograph records, Brunswick, Columbia, Edison, Gennett, Odeon, Okeh, Pathé, Victor; sheet music, music publications, etc.—Boosey & Co., John Church Co., Chas. H. Ditson & Co., Carl Fischer, Fred Fisher, Inc., J. Fischer & Bro., Harold Flammer, Gamble Hinged Music Co., Hinds, Hayden & Eldridge, Shapiro, Bernstein & Co., Inc., G. Schirmer, Inc.; small goods—violin, guitar, mandolin, ukulele, harmonica, saxophone, accordion, cornet, drums, strings, etc.—C. Bruno & Son, Buegeleisen & Jacobson, C. G. Conn, Ltd., Gibson Musical String Co., Fred Gretsch Mfg. Co., M. Hohner, Leedy Mfg. Co., Lyon & Healy, Inc., C. Meisel, Inc.

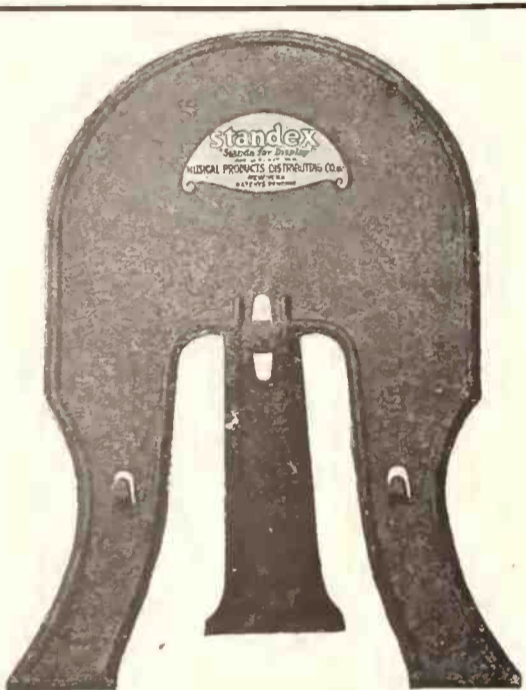

standex
"Stands for Display"
REG. U.S. PAT. OFF.

**For Your Holiday and
Christmas Window
and Store Displays**

as well as for all year 'round use

A New Metal Display Stand for
Universal Use in Music Shops.

**ECONOMICAL
ATTRACTIVE
SUBSTANTIAL**

May be used for displaying 10 in. and
12 in. Records, Monthly Window
Service, Sheet Music, Phonograph
Displays, etc.

6 FOR \$2⁷⁵

Made in one size and finish for
all purposes

Manufactured by

MUSICAL PRODUCTS DISTRIBUTING CO., INC.
37 East 18th Street New York
Attractive Offer to Distributors

Letting the Phonograph Dealer in on Some News

GULBRANSEN NATIONAL ADVERTISING schedules for 1924 include the publication of twelve *four-color* cover advertisements in The Literary Digest. This is the most extensive line-up of color advertising that the piano industry has ever known. A full-page, four-color ad *every month!*

In addition, The Saturday Evening Post and American Magazine will be used—carrying full-page advertising of the Gulbransen Registering Piano; farm papers, too.

That mere announcement of continuous advertising explains to the phonograph dealer the whole story of "active demand." Any merchant who knows what consistent, effective National Advertising will do for a worthy product will quickly understand why the Gulbransen has been singled out for representation by dealers who have for years restricted themselves to the sale of phonographs.

You will be interested in details of the progressive merchandising policies on which Gulbransens are sold:

National Advertising
Co-operative Local Advertising
National Prices Instruction Rolls
Freight Prepaid

Full details gladly given to inquirers in territory where representation is available. Just fill in the handy coupon.



One of the illustrations used in Gulbransen National advertising
The originals of these illustrations are painted in oils
by Philip Lyford

GULBRANSEN-
DICKINSON CO.,
3236 W. Chicago Ave.
Chicago



Gulbransen Trade Mark.

GENTLEMEN: Tell us how the Gulbransen "fits in" with a Talking Machine business.

Name

Address

City

(Pronounced Gul-BRAN-sen)

GULBRANSEN

The Registering Piano

DON'T SAY

"KAN'T"

Say

"KENT"

Successfully used for TEN YEARS as a Sales Clincher by hundreds of EDISON DEALERS

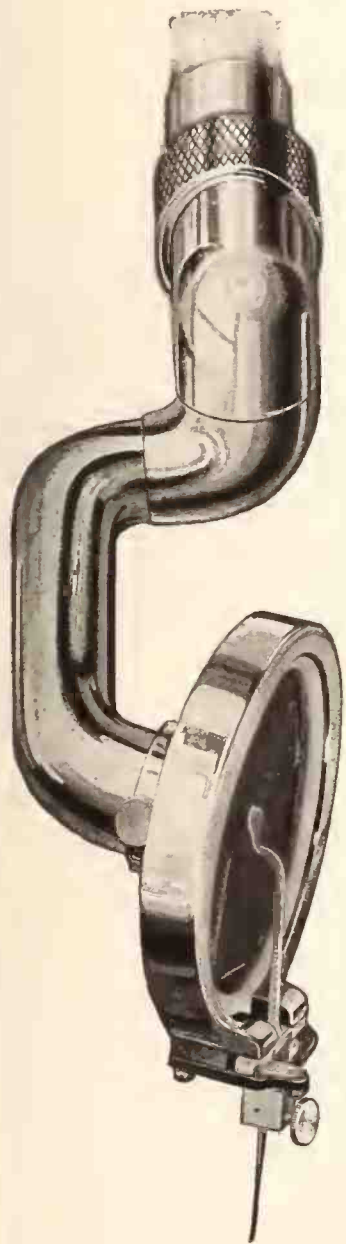

The KENT PRODUCTS excel in:

Value
Quality
Material
Workmanship
Simplicity
Durability
Practicability

The KENT COMPANY is noted for:

Stability
Versatility
Excellent Service
Square Business Methods



Reg. U. S. Pat. Off.

As our KENT No. 1 with soundbox, as illustrated, comprises only a part of our line, write for our catalog. Highest grade TONE ARMS made to order. Your inquiries are solicited.

F. C. KENT COMPANY
IRVINGTON, N. J., U. S. A.

EDISON REPLACES HOTEL ORCHESTRA

Imperial Hotel, Temby, South Wales, Installs Phonograph in Special Resonating Chamber in Ballroom—Some Fine Edison Publicity

LIVERPOOL, ENGLAND, November 3.—A new field for the phonograph is suggested in the sale recently by Jake Graham, one of our most progressive dealers, of an expensive console model Edison phonograph to the Imperial Hotel, Temby, South Wales. The hotel management has constructed a resonating chamber in the ballroom in which the instrument has been placed. This chamber, a little larger than the Edison phonograph, is built of plywood and glass and acts as a resonator. The machine itself stands on a three-ply drum which acts as a soundboard. The results have been beyond expectations, and the Edison is now used regularly in place of a small orchestra. When the instrument is playing a brass wire gauze fits over the resonating chamber in the form of windows.

Jake Graham, through General Manager Burt Reynolds, has been utilizing some unusual publicity to bring the merits of Edison phonographs before the public. One of his best publicity stunts, following an Edison tone-test in Liverpool some time ago, has been the preparation and broadcasting of a four-page folder which bears the title "The Musical Ideal of Thomas A. Edison." This is followed by an outline of the tremendous amount of research work which finally resulted in the perfected Edison instrument. The second page is devoted to the story of the Liverpool tone-test, the first ever held in England. Following this another page is devoted to the enthusiastic comments of the critics and an illustration of a console Edison phonograph. The last page contains an advertisement of Jake Graham (The Edison Specialist), together with the announcement that daily demonstrations are held in the firm's Edison salons and home demonstrations can be arranged. An unusually effective bit of publicity!

The trade outlook is quite good in this section of England, and the general price reduction in all products has had the effect of reviving business to a considerable degree, according to Burt Reynolds, of the firm.

NEW EQUIPMENT FOR SEXTON STORES

WASHINGTON, D. C., November 6.—The K. C. Sexton Co., one of this city's pioneers in the Victor line, has just completed improvements in its store, consisting of the installation of equipment by the Unit Construction Co.

The Sexton family is a real factor in talking machine merchandising in the national capital. In addition to the store operated by K. C. Sexton, his son, Francis, opened a store at 647 H street, Northeast, a few years ago.

Charles Clement, of the sales staff of the Unit Construction Co., handled the details of the installation for both K. C. and Francis Sexton.

PLAN RADIO STATION IN DENVER

DENVER, COL., November 4.—The General Electric Co. is planning to erect a radio station in Denver, Col., which will be one of the three largest stations in the country. Musical and other programs will be broadcasted regularly. Hendrie & Bolthoff, of this city, are the distributors in the Rocky Mountain region for the radio products of the General Electric Co. and the Radio Corp. of America.

CLEVER CIRCULAR BRINGS TRADE

ELIZABETH, N. J., November 6.—McManus Bros., Victor dealers of this city, are using circulars which bear a close resemblance to theatre tickets. On the face of the tickets is the word "Reserved" and the headline "We have reserved for you a genuine Victor-Victrola." The brief text requests the recipient to call, states terms and bears the imprint of the firm.



The NEW Columbia is superior

*Hearing
is believing*

The Sound is Unobstructed. It's all right to filter water—but sound from a phonograph is more or less muffled when strained through latticework or fabric. In the New Columbia the exclusive control leaves and "organ pipe" effect permit the sound to issue forth fully and freely. *Hearing is believing.*

COLUMBIA PHONOGRAPH COMPANY
New York

DIAPHRAGM CO. ANNOUNCES NEW PRICE

Violin Spruce Reproducer Reduced in Price—
New Chicago Representative, Illinois Diaphragm Co., Appointed by H. C. Cooley

CLEVELAND, O., November 7.—H. C. Cooley, who was recently appointed sales manager of the Diaphragm Co. in this city, manufacturer of the Violin Spruce reproducer, recently returned from a trip to Chicago. While in that city Mr.



H. C. Cooley

Cooley made arrangements whereby the company will be represented by T. C. Findley, who will conduct activities as the Illinois Diaphragm Co. Mr. Findley is well known in Chicago talking machine circles, and is entering upon his new activities with keen enthusiasm.

The Diaphragm Co. recently announced a set of new prices for Violin Spruce reproducers and this new price schedule represents a substantial reduction over former prices. Increased

No. 35861. Holly Wreath, natural prepared, everlasting, fireproofed, with bow, holly berries and silver effect; per dozen, \$10.00.



Write today for our Xmas Catalogue No. 35, containing illustrations in colors of Artificial Flowers, Plants, Vines, etc., mailed free for the asking.

FRANK NETSCHERT, Inc.
61 BARCLAY ST. NEW YORK, N. Y.

manufacturing efficiency, together with rapidly growing sales totals, enabled the company to reduce its manufacturing and selling expenses so that a new price list could be announced to the trade. Mr. Cooley has interested several well-known manufacturers in the distinctive features of the Violin Spruce reproducer, and plans are being made whereby this reproducer will be used as standard equipment by these manufacturers.

RIGHT METHODS BUILD BIG TRADE

Records 60 Per Cent Increase in Business This Year as Result of Making Store a Rendezvous for Lovers of the Best in Music

NORTHAMPTON, MASS., November 7.—The record of business development here of the A. M. McCollum Co., which is now known as the Consolidated Dry Goods Co., is an indication of what can be accomplished through the right kind of merchandising methods. This year the business has shown an increase of 60 per cent over the same period last year. Largely responsible for this satisfactory state of affairs in the talking machine department are H. C. Marsh, manager, and Miss Marion Dragon, who is in direct charge of the department. Miss Dragon is an accomplished musician and she has been successful in building up a select clientele of lovers of the best music. The talking machine department is located in the basement of the establishment. It has been attractively fitted up and is the rendezvous of the music lovers of the city. Victor, Edison and Pooley machines are featured by this live dealer.

NEEDLE SALESMAN GYPS DEALERS

Canadian Police Captures Swindler Who Has Been Victimizing Talking Machine Retailers

BUFFALO, N. Y., November 5.—A man giving the name of Fred J. Newberry, and said to have induced a number of talking machine dealers in Welland County, Ontario, into buying large quantities of needles for cash, with the promise of talking machines to be delivered later, has been arrested and is being held in Chatham, Ont. The phonographs were to have been shipped by the Phonograph Needle & Cabinet Co., of Toronto, which it has been learned is non-existent. The man was not arrested at the instance of any of the merchants whom he had swindled, but they are not displeased at the announcement of his arrest.

FAIRALL'S MUSIC HOUSE EXPANDS

NEWARK, O., November 5.—Fairall's Music House, Fourth and Main streets, this city, has almost doubled its floor space. Extensive alterations have just been completed. These were made necessary by reason of the fact that the business has enjoyed steady growth. The talking machine department has come in for its share of expansion.

NEW KIMBERLEY MODEL POPULAR

New Console Well Received by Dealers—P. L. Baerwald Expanding Sales Organization Throughout East—Plant Is Rushed

In a recent chat with The World Paul L. Baerwald, sales manager of the Kimberley Phonograph Co., Perth Amboy, N. J., commented upon the enthusiastic reception that had been accorded the company's latest model, a \$100 console. Mr. Baerwald stated that the dealers throughout the East are ordering this new model in quantities far beyond expectations



New Kimberley Console

and the factory is working to capacity to take care of the requirements of the trade.

During the past few weeks Mr. Baerwald has been visiting the dealers in metropolitan territory, and he states that there is a feeling of optimism which is substantiated by the sales totals reported by the majority of the dealers. The Kimberley sales organization in New York is being expanded gradually, and Mr. Baerwald is making plans whereby the company's representation in the East and throughout the country will be augmented materially by the first of the year. David Isenberg, president of the company, is devoting practically all of his time to production activities at the factory, and under his direction the plant is working at full speed with maximum efficiency.

TAKES OVER TAYLOR MUSIC HOUSE

NORTHAMPTON, MASS., November 7.—One of the progressive music concerns of this city is the Taylor Music House, 98 Pleasant street, which was recently purchased from Mr. Taylor by Bernard M. O'Shea, formerly proprietor of the White Music Shop, and one of the most popular business men in this vicinity. In addition to handling a line of pianos Mr. O'Shea operates a large talking machine department, which is in charge of Miss Ruth M. Sprout, who is an experienced talking machine merchandiser.

**Retails
for \$2.50**

**Packed in
Display
Container**



Front of Container

Container Open as a Display

Back of Container

**Orders Piling in Fast for
JUNIOR OPERETTA RECORDS
Order Now for Christmas Selling**

Dealers are so enthusiastic about this brand new record idea and orders are coming in so fast—order now if you want to be sure to get the supply to meet the big Christmas Demand.

Ideal Christmas Gift for Children

Little Red Riding Hood, the first of the Junior Operetta Series, on three double faced

10-inch unbreakable

records is packed in a wonderfully attractive container (which is its own display fixture) and sells itself on sight. The entire set retails, complete, at \$2.50.

There's a big profit in each sale for you.

***One Big Victor
Dealer Writes:***

"We received the sample of your Junior Operetta of 'Little Red Riding Hood,' which we think is about the finest thing yet in the line of records for children."

**Triple your
Sales Record
with Triple
Record Sales.**

***One Big Brunswick
Dealer Writes:***

"Your set of Junior Operetta received.

"We must admit that it is the finest of its kind."

Order Direct or from the following Distributors:

A. C. Erisman Co.
175 Tremont Street
Boston, Mass.

Shapleigh Hardware
Company
St. Louis, Mo.
Vocalion Co. of Chicago
529 So. Wabash Ave.
Chicago, Ill.

General Radio Corp.
10th and Cherry Streets
Philadelphia, Pa.
and
1005 Liberty Avenue
Pittsburgh, Pa.

Bristol & Barber, Inc.
3 East 14th Street
New York City

VULCAN RECORD CORPORATION
15 East 40th Street
New York City

Good - night - dear - good - night; - There's a light in your eyes shin - ing bright,

GOOD NIGHT

The New Novelty Waltz
With the Bugle Call Effect

© LEO FEIST Inc. NYC

PRINTED IN THE USA

You can't go wrong — with any FEIST' song

REALISTIC RECORD WINDOW DISPLAY

Live Edison Dealer Arranges Window of the Record, "Saw Mill River Road," Which Tells a Real Story and Attracts Much Attention

How records can be featured in window displays in a forceful and realistic manner was

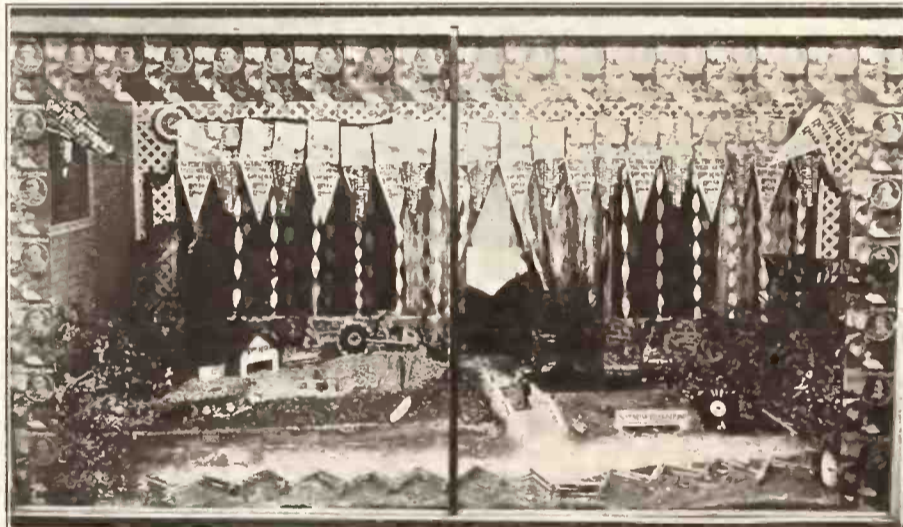

How W. P. Fowler & Co. Featured Popular Edison Record demonstrated recently by W. R. Coats, manager of the W. P. Fowler & Co. store, Edison dealer, Chickasha, Okla., who designed and built a most ingenious window display of the record, "Saw Mill River Road," which, to say the least, is strikingly descriptive. Naturally this display received deserved attention on the part of the public; in fact, it aroused much favorable comment and praise.

As may be seen in the illustration the theme

of the record has been carried out in the display. There is a miniature saw mill, with a saw made from an Edison record which turns like the real thing. Realism is further produced by the oxen hauling a load of logs to the mill, and another feature of the display is the river—real water running across the entire window with real fish in it. Boats on the river, a rustic bridge with a couple crossing, moonlight, and an old-time rail fence with chickens sitting on it completed this effective ensemble.

W. P. Fowler, proprietor of the Chickasha store, has built up a large business through progressive methods such as these. He owns and operates three Edison shops and has substantial investments in other successful Edison establishments in this prosperous territory.

FORMAL OPENINGS IN NEW HAVEN

Wooley & More and Blair & Brodrig Open Attractive Establishments

NEW HAVEN, CONN., November 7.—Two Brunswick dealers in this city held formal openings of their establishments recently, and conspicuous among the decorations were floral offerings from the Eastern division of the Brunswick-Balke-Collender Co. The newly renovated store of Wooley & More, 71 East Main street, has won the enthusiastic praise of music lovers in this city, and the new store of Blair & Brodrig, 103 Orange street, is one of the most up-to-date phonograph establishments in the State. The latter concern has stores in Bristol and Waterbury and is planning to feature the Brunswick exclusively during the coming holiday season. Ned R. Mann, of the Brunswick Co., was present.

George A. Cassidy, proprietor of a music concern in Schenectady, N. Y., has just purchased a two-story building at 24 Jay street, which will be remodeled as a business place.

SONORA SIGN BRINGS BUSINESS

Risik & Ray Find That the Right Kind of Publicity Results in Sales Stimulation

Among the new Sonora dealers in New York territory who are closing an excellent Fall business is the firm of Risik & Ray, located at 103rd street and Third avenue, New York. This account, which was recently opened by the Greater City Phonograph Co., Sonora jobber in metropolitan territory, is splendidly situated to cater to a residential trade, and the large Sonora



Risik & Ray's Establishment in New York sign on the side of the building indicates the effective way in which the Sonora line is being featured by this dealer.

MOORE'S MUSIC SHOP OPENS

PLEASANTVILLE, N. Y., November 6.—Moore's Music Shop, the only exclusive music store in this vicinity, recently staged its formal opening, which was attended by many local music lovers. Lyle K. Moore, formerly connected with the Rudolph Wurlitzer Co., is the proprietor. The Brunswick line is featured.

EXPERIENCED GOOD FALL BUSINESS

ANSONIA, CONN., November 6.—The Duo-Tone Co., Inc., this city, manufacturer of De Luxe needles, has experienced good Fall business. The De Luxe needle is a semi-permanent needle which is claimed to play from 100 to 200 records. As evidence of the quality of the De Luxe needle, an official of the company pointed out the steady re-orders that are being received.

ITALIAN Popular Music

PHONOTYPE RECORDS

Recorded in Italy by the Best-known Italian Artists

AND

ITALIAN STYLE MUSIC ROLLS

MONTHLY RELEASES
WRITE FOR CATALOGUES
Out-of-Town Agents Wanted
Distributed by

ITALIAN BOOK CO.
145 Mulberry St. New York, N. Y.

QUALITY IS NOT AN ACCIDENT

The superior quality of our COTTON FLOCKS for record manufacture is the result of continual study of the manufacturer's requirements—diligent adherence to the use of raw materials which will produce the best flocks and scrupulous attention to every detail of their manufacture. Numerous record manufacturers are profiting by the cleanliness and uniformity of our product through reduction in spoilage of records.

ARE YOU ONE OF THESE MANUFACTURERS?

CLAREMONT WASTE MFG. CO. Claremont, N. H.

LITTLE TOTS' NURSERY TUNES

SONGS, GAMES, STORIES ON RECORDS



THE biggest selling juvenile record the trade has ever seen—because it gives the biggest value the trade has ever known!

Six different selections on three double-faced 7 inch records, with colored picture and verse cards in a beautiful **LOOSE LEAF** album—\$1.00 retail.

Individual records, 7 inch double-faced, with picture cards, are 25c. each.

Liberal discounts.

Order Plenty for the Holidays—NOW!

REGAL RECORD CO. Little Tots' Record Division
20 W. 20th St., New York

Meeting of Brunswick Dealers in New York

Eastern Phonograph Division of Brunswick Co. Host to Nearly 250 Dealers in Hotel Pennsylvania—Interesting Addresses—Discuss Plans—Luncheon and Entertainment

The Eastern phonograph division of the Brunswick-Balke-Collender Co. was the host recently to the Brunswick dealers in metropolitan territory at a meeting and luncheon held at the Hotel Pennsylvania, New York. This was the first gathering of Brunswick dealers in the East and the fact that nearly 250 were present at the meeting indicates the rapid strides in popularity that the Brunswick line has attained in this territory. The meeting was divided into two sessions and P. A. Ware, manager of sales promotion of the Eastern phonograph division, who was the toastmaster, took care of this important work with signal ability.

T. A. Dwyer, secretary and treasurer of the Brunswick-Balke-Collender Co., New York, ex-

chandising plans that added materially to the success of the merchants who tried out these ideas. As he has been identified with the subject of credits for many years, Mr. Teele is thoroughly familiar with every phase of this important branch of the dealers' affairs and the suggestions that he gave to the Brunswick representatives were based on fact and not theory.

One of the principal ballrooms at the Hotel Pennsylvania had been set aside for the use of the Brunswick party and during luncheon the guests were entertained by the Oriole Orchestra, an exclusive Brunswick organization that has attained countrywide popularity. This orchestra is unique in that three of its members are well-known composers, including Dan

capacity. After having served possibly seven or eight years in retail and wholesale I then graduated to a semi-executive position with one of the chief manufacturers. My retail experience I regard as the most valuable of all, as it gave me a more intimate insight into the real workings of the business than any or all of the other branches combined, and it stood me in good stead in my later years of experience, particularly in giving me a keener appreciation of the retailers' problems and all of the ups and downs which they fall heir to. It has never been difficult for me to put myself on their side of the fence and to view things from their angles. Probably the greatest of these was the ability to understand the fluctuation of trade conditions and to be able to overcome them by throwing pressure into certain periods in order to overcome a natural periodic inertness which has characterized this business, as well as all other branches of retail merchandising.

"The gains during the past six or eight months in all of the Eastern sections have been phenomenal, so much so, in fact, that we are already beginning to curb our activities as regards new accounts in order to safeguard our present established dealers. During the past week in excess of \$30,000 in new accounts have been rejected, partly for that reason, as well, of course, for the reason that some of the applicants under consideration are not looked upon as representative in character or temperamentally unsuited to our business. We are to-day exercising every possible care in determining upon new dealerships, as there is no inclination whatsoever to accept new business merely for the sake of a dollar-and-cent gain. Neither will new accounts be accepted which will in any way prove a detriment to our present dealers who are conscientiously endeavoring to work for the upbuilding of Brunswick in their communities."

After referring to the advertising campaign, which, he said, "from this time on is going to be a tremendously big one," Mr. Beach concluded as follows: "At this time of the year, however, we do want to have you anticipate your needs as far in advance as possible as our factories are being taxed to their fullest capacity and will be for some months to come. You will render us invaluable aid in placing your requirements just as quickly as possible, as by this means we will be in a better position to command the necessary share of Brunswick products from our factories. You know as well as I that we have a prosperous period ahead and there is no earthly reason why buying should not be on a very large scale, as our country is enjoying most unusual prosperity. There is ample money in circulation to guarantee this and I hope that you will get behind us in helping us in every possible way to gauge our supplies at least for the coming four or six months."

Following Mr. Beach's talk, interesting addresses were made by Mr. Ware and H. D. Leopold, manager of the recording department of the Eastern phonograph division.

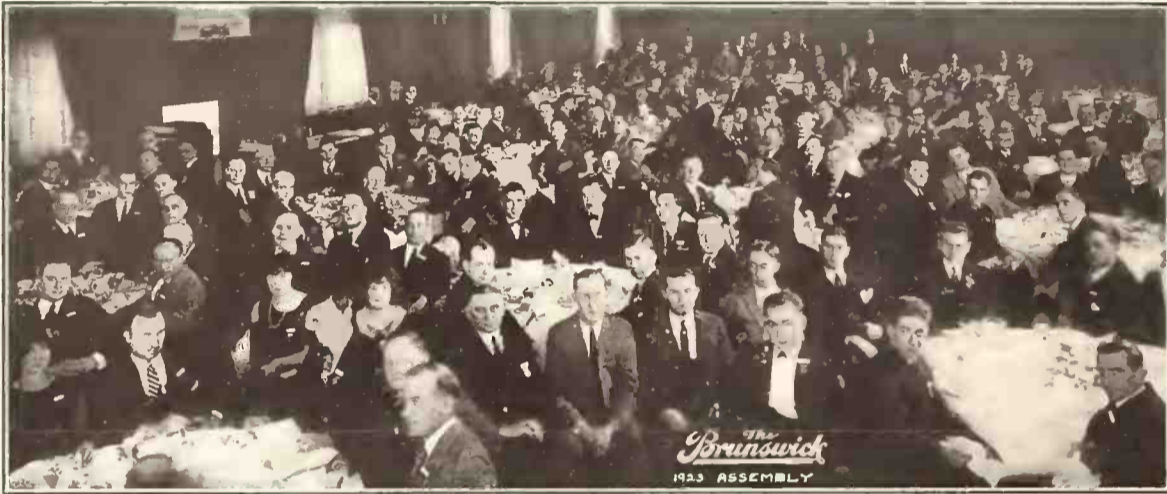

Metropolitan Brunswick Dealers at Hotel Pennsylvania Meeting

tended to the dealers a cordial welcome in behalf of the executive organization and pointed out briefly the accomplishments of the Brunswick Co. in its respective fields of endeavor. Mr. Dwyer congratulated H. A. Beach, sales manager of the Eastern phonograph division, upon the splendid character of the Brunswick representation in this territory and told the dealers just how the Brunswick Co. was trying to co-operate with them.

E. A. Strauss, assistant secretary of the Brunswick Co. and well known in the phonograph industry, told the dealers something about the company's plans in connection with its new building at Seventh avenue and Fifty-second street, which will be ready for occupancy the early part of the year. F. W. Teele, credit manager of the company's New York headquarters, gave an interesting and informative address that was enthusiastically received by the Brunswick dealers. Mr. Teele emphasized that the credit department is in a position to help the dealers along practical and profitable lines if taken into their confidence. He illustrated several instances showing how the credit division had not only assisted dealers in times of emergency, but had been responsible for mer-

Russo, conductor of the organization. The other composers in the orchestra are Teddy Fiorito, who has to his credit the present popular hit, "No, No, Nora," and J. F. Naset, pianist. The other artists on the program included Margaret Young, vaudeville headliner and exclusive Brunswick artist, whose rendition of popular hits thoroughly emphasized the fact that she is entitled to recognition as one of the leaders in the recording field. Miss Isa Kramer, internationally famous as a singer of selections in practically every popular language, gave the Brunswick dealers a most enjoyable recital. Miss Kramer, who is an exclusive Brunswick artist, has won exceptional success in concert both here and abroad.

Subsequent to luncheon and the musical entertainment Mr. Ware introduced Mr. Beach as one of the pioneers of the talking machine industry with an intimate familiarity with every phase of phonograph activities. Mr. Beach gave an exceptionally forceful and interesting address, during the course of which he said: "My first experience dates back to the year 1900, and after spending considerable time in the retail end I became interested in the wholesale branch of the business and in a managerial

WALL-KANE NEEDLES

Each needle guaranteed to play ten records.

CONCERT NEEDLES

Steel needles in tones of extra loud, loud, medium and soft.

JAZZ NEEDLES

The special extra loud needle. The only one of its kind in the world.

Profit-Producing Jobbing Proposition

WALL-KANE NEEDLE MFG. CO., 3922 14th Avenue, BROOKLYN, N. Y.

66 $\frac{2}{3}$ %

**Reduction on MYSTO Multi-Playing
NEEDLES**



50 NEEDLES IN A BOX

60 BOXES TO A CARTON

**EXTRA LOUD
LOUD
and
MEDIUM TONES**

SELLING PRICE

**5c Per Box or
6 Boxes for 25c**

COST 2c Per Box

We purchased the entire stock and right to name and trade mark, eliminating the jobber's profit, cost of collection and cut the manufacturer's profit to the bone, enabling us to offer this same needle for cash, at **\$1.30** per carton, in quantities of 10 cartons or more.

Price in one hundred (100) carton lots **\$1.20** per carton.

We will gladly send parcel post PREPAID one sample carton either extra loud, loud or medium, on receipt of check for \$1.50

Phonograph Jobbers Corporation

Manufacturers and Distributors

Mr. Manufacturer, consult us when you contemplate retiring.

56 Bleecker Street New York, N. Y.
Telephone Spring 7197-8

Mr. Buyer, consult us when you contemplate launching a sales campaign.

SUCCESSFUL RECORDING EXPEDITION

Okeh and Odeon Record Lists Enlarged by Addition of Several Popular New Artists as Result of Chicago Recording Trip

R. S. Peer, of the sales division of the General Phonograph Corp., New York, manufacturer of Okeh and Odeon records, returned to his desk recently after spending two weeks in Chicago, where he was in charge of a special recording expedition that made its headquarters in the building of the Consolidated Talking Machine Co., in that city, Okeh distributor. The members of this party included: Arthur Bergh, Okeh musical director; Chas. F. Hibbard, technical director of the recording laboratory; H. P. Decker, his assistant, and A. F. Thalmeyer, manager of the company's foreign language record division.

One of the features of the recording expedition was the work of Finzell's Arcadia Orchestra, consisting of seventeen well-known musicians, which made a special trip from Detroit

to record for the Okeh library. A special car was used to bring the orchestra from Detroit to Chicago, and banners on the sides of the car informed the public just where the orchestra was going. King Oliver's Jazz Band, which is popular throughout Chicago, also made a number of records during this trip, as well as Guyon's Paradise Orchestra, another prominent dance organization. Bennie Moten's Orchestra, of Kansas City, Mo., made its first Okeh recordings at Chicago, and, in addition, Mr. Thalmeyer sponsored a large number of recordings in foreign languages, including a variety of selections in Italian, Green, German, Bohemian and Lithuanian.

A very handsome and cleverly designed window front is being installed in the Davega double store, located on the north side of 125th street, between Seventh and Lenox avenues, New York City. When completed this front will give an opportunity for a splendid display of the talking machine, musical merchandise, radio and sporting goods lines handled by this house.

**IMICO INDIA RUBY
MICA
DIAPHRAGMS**
ALL SIZES—IMMEDIATE DELIVERY
Samples and quotations on request
INTERNATIONAL MICA CO.
Phone Baring 535 PHILADELPHIA Cable Filasse'

WINDOWS WIN FOR CLARK CO.

Timely and Attractive Window Displays Prove Business Stimulators

GREENSBURG, PA., November 7.—The Clark Music Co., of this city, Sonora dealer, is a firm believer in the value of timely and attractive window displays, and the accompanying photograph showing one of the recent windows prepared by this company will give some idea of



Clark Co.'s Artistic Window Display the originality of these exhibits. This particular window won the enthusiastic approval of passersby, and of interest is the fact that the popular Sonora walking doll formed one of the main parts of this display.

DA-LITE'S VICTOR RED SEAL PANELS

Da-Lite Electric Display Co. Issues Series of Red Seal Panels—Fourteen Colored Panels Feature Records by Leading Artists

TOLEDO, O., November 6.—The Da-Lite Electric Display Co., of this city, manufacturer of display signs for Victor dealers, has just introduced a new series of panels featuring Red Seal records exclusively. This company for several years past has presented each month a series of sign panels that usually feature the latest Victor hits, with one standard number in each set. With the double facing of Red Seal records, however, Harry Cuddeback, head of the company, appreciated the fact that Victor dealers could use to splendid advantage a set of panels devoted to Red Seal records only, and a series of fourteen panels presenting records by some of the greatest artists in the Victor Red Seal Catalog are now ready for the trade.

Mr. Cuddeback has prepared a very attractive circular announcing the new Red Seal panels, although this circular, which is reproduced in black and white, hardly does justice to the multi-colored effects of the original panels. Among the famous and exclusive Victor Red Seal artists who are featured in these panels are the following: Caruso, McCormack, Heifetz, Paderewski, Galli-Curci, Chaliapin, Rachmaninoff, Werrenrath, Ruffo, Schumann-Heink, Homer, Kreisler, Gigli and Jeritza.



SEE WHAT

Minger says

ON PAGE 35



The **PHONOGRAPH'S "RIGHT ARM"**
is the **PHILLIPS TONE ARM**

NO. 5 TONE ARM
AND NO. 5 SOUND BOX

READY SOON

NEW DESIGN No. 1 THROWBACK AT A VERY ATTRACTIVE PRICE

Write for Sample

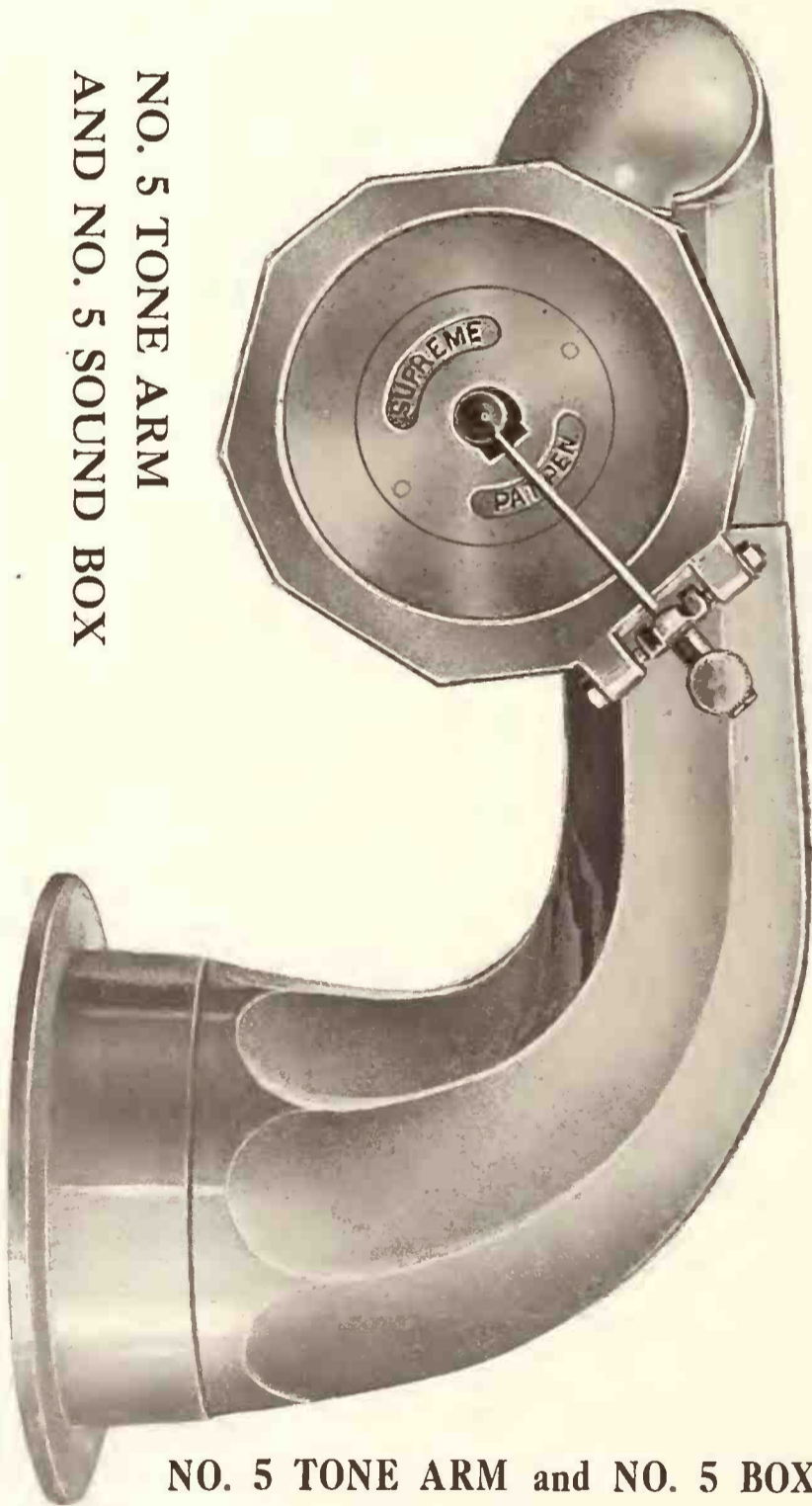

NO. 5 TONE ARM and NO. 5 BOX

WILL HELP SELL YOUR PHONOGRAPH
Pleasing to the Eye!
Pleasing to the Ear!

W.M. PHILLIPS PHONO PARTS CORP.

145 West 45th Street

CABLE ADDRESS: PHONOPARTS

New York City

Price Maintenance to Protect the Public

Representative Schuyler Merritt Says Fixed Resale Prices on Trade-Marked Goods Will Give Quality Guarantee to the Buyer

Editor's Note.—Representative Schuyler Merritt, of Connecticut, who has written the following article for The Talking Machine World, is the author of the Merritt Bill, which will be again introduced in the new Congress, which opens the first week of December. This bill provides for the maintenance of resale prices on products marketed under a trade name or special brand, and is known as H. R. 13494. It was introduced by Mr. Merritt in the last Congress and reads in part as follows:

"That in any contract for the sale of articles of commerce to any dealer, wholesale or retail, by any grower, producer, manufacturer or owner thereof, under trade-mark or special brand, hereinafter referred to as the 'vendor,' who shall for the purpose of preventing discrimination and protecting his good will clearly mark on each salable unit of his product, or otherwise make generally known the price at which such unit shall be resold, it shall be lawful for such vendor, whenever the contract constitutes a transaction of commerce among the several States, or with foreign nations, or in any territory of the United States, or in the District of Columbia, or between any such territory and another territory, or between any such territory or territories and any State or the District of Columbia, or with a foreign nation or nations, or between the District of Columbia and any State or States, or a foreign nation or nations, to prescribe the uniform prices and manners of settlement to all purchasers in like circumstances at which the different qualities and quantities of each article covered by such contract may be resold: Provided, that such vendor shall not have any monopoly or control of the market for articles belonging to the same general class of merchandise as such article or articles of commerce as shall be covered by such contract of sale; and that such vendor shall not be a party to any agreement, combination or understanding with any competitor in the production, manufacture or sale in interstate commerce of any merchandise in the same general class in regard to the price at which the same shall be sold either to dealers, wholesale or retail, or to the public: Provided further, that if the purchaser shall in good faith be unable to sell such goods at the published price, the purchaser shall first offer such goods to the seller at the purchase price before he may sell same at less than the published price."

The bill H. R. 13494, which I introduced in the last Congress and expect to introduce again in the Sixty-eighth Congress, is based on the proposition that if a man has property rights in a copyright, or a trade-mark, or a trade name, these rights should be protected like any other property rights and should not be subject to robbery or depredation without redress.

There have been repeated decisions of the Supreme Court asserting such property rights, but several of the decisions have contained intimations and suggestions, in view of existing anti-trust and anti-conspiratory legislation, which in effect state that while a man has property rights in his trade name or good will and while he may have something to say as to the price at which his branded goods shall be sold and the conditions under which they shall be sold, nevertheless if he takes steps necessary for any real protection of his good will he may be liable to punishment under existing statute law.

Corrective Legislation Necessary

This interpretation of the law seems to make corrective legislation necessary if we are to protect the rights of property which are recognized in the Constitution.

While, therefore, from the legal side, the case for legislation is strong it is equally so from the economic side.

When any article is subject to open competition, and especially in the retail trade where the purchasers are not experts and are neither competent nor can they afford to test the quality of the goods purchased, there is a constant tendency to sacrifice quality to price. Such sacrifice always tends to deception and sometimes, as in the case of foodstuffs and medicines, is dangerous to health. The only cure thus far discovered for these evils is, first, the manufacture of goods to be sold on their quality rather than price; second, the education of the public as to the economic advantage of purchasing articles of good quality; third, convincing the public that the particular articles are of such good quality; fourth, marking the articles with

a trade-mark or trade name so they can be identified as the goods previously brought to the attention of consumers.

These conditions involve large expense and risk on the part of the manufacturer to produce the goods, to educate the public and, finally, and most important, to maintain this quality so that the reputation of the goods may not suffer.

What the Purchasers Want

Bear in mind that articles covered by this bill are not necessities and not monopolies, such as water, light, transportation, etc. These articles are bought simply because the purchasers want them. They want to be certain as to quality and to know that they are purchasing the goods at a fair price and on an equality with other purchasers.

To give the purchaser this opportunity the articles must have a wide distribution through the regular and ordinary distributing channels. To induce the jobbers and retailers to carry the necessary stocks for distribution they must be assured of a reasonable profit for carrying the stock and selling it. They are entitled, when they buy stocks of such specialties, to be assured that some department store or some rival will not purchase similar goods and use them as leaders by advertising cut prices which leave no profit or, perhaps, a loss. The public, in the end, does not profit from such price cutting because it is clear that no class of goods can continue to be sold at a loss and that, if a loss is incurred on one class, it must be more made up on another, or the price of the article in question must finally be advanced beyond the regular price. There is no danger that,

under this legislation, unreasonable prices will be charged the public because under price control the producer cannot afford to ask unreasonable prices as that would stop or limit the sale of his goods and at once stir up destructive competition.

By reading the bill it will be seen that it covers very simply the points above set forth as desirable. There is a distinct proviso that the contracts enacted by the bill shall not apply in case the vendor has a monopoly or control of the market for the articles belonging to the same class of merchandise as shall be covered by the contract. In case the purchaser, acting in good faith, shall be unable to sell his goods at the published price he must first offer such goods to the seller at the purchase price, and if the seller refuses to purchase then he may sell at less than the published price.

Controversies to Be Settled by Law

Finally, this bill avoids any reference to the Federal Trade Commission and gives it no power to interfere or fix prices. I believe that, under this bill, it will be safe and wise to leave all parties concerned to the rights under law without the intervention of the Federal Trade Commission, and I am entirely opposed to extending further the power or control of the Federal Trade Commission or any trade commission over business and business men. President Harding well said: "We want more business in government and less government in business."

A Victrola concert marked the opening of the new store of Ralph E. Dodson, Palo Alto, Cal.

CLARAVOX REPRODUCERS REFLECT CREDIT ON EDISON PRODUCTS

How to Sell More Edison Phonographs

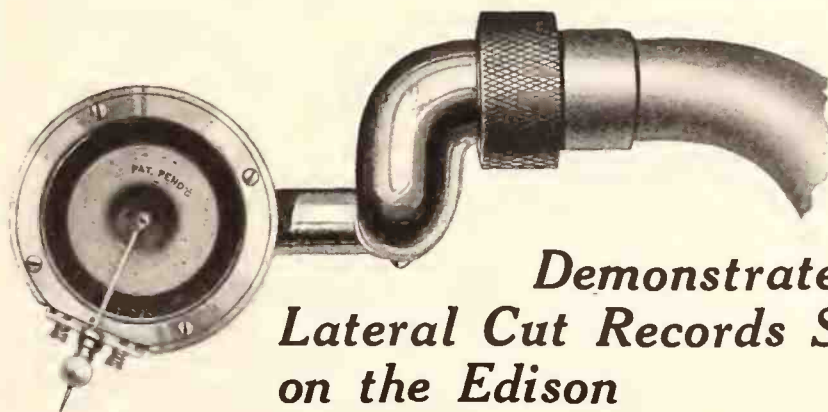

No. 1 Edison Attachment

Why Not Demonstrate That Even Lateral Cut Records Sound Better on the Edison

CLARAVOX

CLEAR VOICE

The No. 1 Edison attachment provides you with your most effective sales argument. Sells phonographs to people you could not otherwise influence because the Claravox diaphragm gives results never before heard from lateral cut records. Its merits are now generally recognized by Edison Dealers in all parts of the country.

Usual discounts to dealers. Retail price complete, Nickel Plated.....\$7.50

Correctly Plays Edison Records on Talking Machines

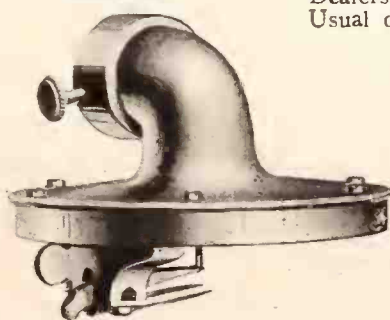

STANDARD Diamond Point

Employs a genuine diamond point, microscopically ground, and Claravox stylus and diaphragm. Usual discounts to dealers. Retail price complete, Nickel Plated \$12.50

SPECIAL Jewel Point

Nearest approach to the permanency of the diamond point. Claravox stylus and diaphragm. Usual discounts to dealers. Retail price complete, Nickel Plated \$7.50

A Post Card will bring any of these products on 10 days' trial

THE CLARAVOX CO. Youngstown, Ohio

CLARAVOX — MAKES PHONOGRAPHS SOUND REAL



Look Below the Surface!



*Sawed-through section
of Sonora Tone Arm*

A tone arm, scientifically constructed of the best material and of correct proportions, is vitally necessary for true amplification. Sonora tone arms represent the ultimate in quality. Read the message below—of interest to all phonograph purchasers.

Sonora Tone Arms Are Correctly Proportioned

Drawn brass has been chosen by Sonora as the only proper metal for the tone arms of "The Highest Class Talking Machine in the World." For brass assures permanent strength and eliminates absorption of air displacements.

The Sonora brass tone arm is only one of many quality construction features hidden below the surface which any Sonora dealer will gladly demonstrate.

Sonora Dealers Have More to Offer

Part for part, unit for unit, dealers handling Sonora have more value to offer their prospects than those handling other lines.

As one illustration, consider the Sonora tone arm. It is made entirely of brass, the one best material for metal tone arms.

The same high quality of material and construction is found in all other parts of Sonora. It is this construction which gives to Sonora its far superior tone, its strikingly attractive and different cabinetry and dependable motor performance.

This exceptional high quality is selling Sonoras in quantity. You, too, can build profitable business with this line. Write for the Sonora proposition.

The choice of those who've heard them all

Sonora Phonograph Co.

INCORPORATED

279 BROADWAY

NEW YORK

Canadian Distributors

SONORA PHONOGRAPH, Ltd.

Toronto

THE INSTRUMENT OF QUALITY
Sonora
 CLEAR AS A BELL



The Highest Class Talking Machine in the World

The distributor named below who covers the territory in which you are located will be glad to answer all inquiries regarding a Sonora agency on receipt of a letter from you

The New England States

Sonora Phonograph Co. of New England,
221 Columbus Ave., Boston, Mass.

State of New York

with the exception of towns on Hudson River below Poughkeepsie and excepting Greater New York.

Gibson-Snow Co.,
Syracuse, N. Y.

States of North Dakota, South Dakota, Minnesota and Iowa, with exception of the river towns

Doerr-Andrews-Doerr,
Minneapolis, Minn.

New York City, with the exception of Brooklyn and Long Island

Counties of Westchester, Putnam and Dutchess; all Hudson River towns and cities on the west bank of the river, south of Highland; all territory south of Poughkeepsie.

Greater City Phonograph Co., Inc.,
234 W. 39th St, New York

Western Pennsylvania and West Virginia

Sonora Dist. Co. of Pittsburgh,
217 Stanwix St., Pittsburgh, Pa.

Missouri, Northern and Eastern Part of Kansas, and 5 counties of N.E. Oklahoma

C. D. Smith Drug Co.,
St. Joseph, Mo.

Ohio and Kentucky

Sonora Phonograph — Ohio Company,
417 Bulkley Bldg., Cleveland, Ohio.

States of Montana, Colorado, New Mexico, Nebraska and Wyoming East of Rock Springs

Moore-Bird & Co.,
1720 Wazee St., Denver, Colo.

All of Brooklyn and Long Island

Long Island Phonograph Co.,
17 Hanover Place, Brooklyn, N. Y.

State of Indiana

Kiefer-Stewart Co.,
Indianapolis, Ind.

Utah, Western Wyoming, Southern Idaho and Eastern Nevada

Strevell-Paterson Hardware Co.,
Salt Lake City, Utah.

State of New Jersey

Sonora Sales Co. of New Jersey,
605 Broad St., Newark, N. J.

Wisconsin and Michigan

Yahr & Lange Drug Co.,
Milwaukee, Wis.

Eastern Pennsylvania, Maryland, Delaware, District of Columbia and Virginia

Sonora Co. of Phila., Inc.,
1214 Arch St., Philadelphia, Pa.

Illinois and river towns in Iowa

Illinois Phonograph Corp.,
616 S. Michigan Ave., Chicago, Ill.

Washington, California, Oregon, Arizona, Western Nevada, Northern Idaho, Hawaiian Islands

THE MAGNAVOX CO.,
115 Jessie St., San Francisco, Cal.

Brooklyn Territory Ready for Holidays

Seasonal Sales Drives Ready for Launching—
"Kiddies' Room" Installed to Boom Sales to
Youngsters—Trade News and Activities

The approaching holiday season is already making itself felt in the Brooklyn and Long Island territory, according to reports of dealers, many of whom are making preparations for intensive sales drives. Despite a lull in business during the past month, there is a general feeling of optimism and the conviction that this will be one of the best holiday business seasons ever experienced. Although sales have not come up to expectations lately, they have been fair and there is really no cause for worry on the part of the trade. Many of the more progressive merchants have succeeded in overcoming any lethargy that existed simply by going after business harder than ever. This was accomplished in most cases by increased advertising and more intensive outside sales work. The holiday rush will find the majority of the retailers prepared, both as regards volume of stock and service facilities.

Loeser's Catering to Kiddies

A new and unique method of pushing the sales of records and talking machines of the type designed for children has recently been inaugurated by the talking machine department of Frederick Loeser & Co., 484 Fulton street, Brooklyn, under the supervision of Mabel Arend, manager of the talking machine department.

The plan consists of devoting an entire room to the little folk. The room is furnished throughout with children's furniture and contains in addition several toy phonographs. There are also many toys placed in view. This room is a most attractive one and is certain to catch the eye of anyone who happens to be passing.

The children's records are placed on a small table and are arranged to facilitate the choosing of these records by either the little ones or the grown-ups. The saleswoman in charge of this room plays the records on a phonograph and the children are allowed to make their own selections just as older folk do, although it often occurs that they know exactly what they want before they come to make a pur-

Feature Something Special

MANY OF OUR DEALERS HAVE FOUND IT TO THEIR ADVANTAGE TO FEATURE VICTOR RECORDS BY GIVING CONCERTS IN THEIR STORES.

THIS IS GOOD NEIGHBORHOOD ADVERTISING. IF ANY OF OUR DEALERS ARE INTERESTED, WE CAN PUT THEM IN TOUCH WITH MUSICIANS WHO ARE FAMILIAR WITH THIS CLASS OF WORK.

AMERICAN TALKING MACHINE CO.

BROOKLYN, N. Y.
VICTOR WHOLESALERS



chase, according to Miss Arend. The saleswoman who has charge of this room is a mother of two children and consequently is able to understand the children's wants better than someone whose experience in that respect is limited. Great interest has been evinced by the young folk in this room as the surroundings are planned so as to make them feel at home and do away with any feeling of awe which children are apt to have in a setting of this character.

Considerable advertising is being used in the local papers which is prepared with the idea of attracting the children through their parents, and, according to Miss Arend, several mothers have stated that their children would not give them a minute's peace until they had been brought in to see the children's room and listen to the music.

The little ones take pride in making their own

purchases and come prepared to pay for the records they may select. Not only have the records and phonographs been sold through this method, but a number of orders have been placed for the various toys on display.

Among the record lines carried in stock are the "Junior Operetta" series, made by the Vulcan Record Co., the "Little Tots' Records," manufactured by the Regal Record Co., and the "Bubble Books," published by Harper & Bros.

C. J. Ianell With Abraham & Straus

C. J. Ianell, formerly of Bloomingdale's and more recently manager of the talking machine department of the H. Batterman Co., Brooklyn, has recently become connected with Abraham & Straus as manager of the talking machine department there, succeeding Joseph Flanagan. Mr. Ianell's experience in the talking machine business extends over a long period and his friends throughout the trade wish him well in his new undertaking.

John H. Bieling in New Home

John H. Bieling, Victor dealer, of Hempstead, L. I., has moved from Main street to new and larger quarters at 283 Front street, Hempstead. This move was made necessary because larger space was required to handle a rapidly increasing business. The new store is advantageously located and modern equipment makes this one of the most up-to-date establishments in the vicinity.

Selling High-priced Instruments

H. Lipschitz, manager of Krakauer Bros., 1653 Pitkin avenue, Brownsville, Brooklyn, has met with considerable success in selling high-priced Sonora models. During the last six weeks this company has sold a \$3,000 Bardini model, as well as two \$750 Italian and English Renaissance models.

J. L. Jones Opens Store

A new store was recently opened by John L. Jones, exclusive Sonora dealer, at 1815 Coney Island avenue, Brooklyn, N. Y. The establishment has been attractively fitted up and plans are under way by the live proprietor for an intensive sales drive.

Formal Opening of Woodhaven Music Shop

The Woodhaven Music Shop, exclusive Victor dealer, held the formal opening of its newly remodeled and enlarged store at 9309 Jamaica avenue, Woodhaven, L. I., during the last week in October. A musical program was furnished by Maine M. Rountree and His Orchestra, which rendered a number of popular selections.

"The favorite instrument of Holiday buyers"

THE INSTRUMENT OF QUALITY
Sonora
CLEAR AS A BELL



*The Highest Class
Talking Machine in the World*

Our complete exhibit of the superb Sonora Period Phonographs is especially important during the Holiday season—bring your prospects.

*Write or call for information about
our 100% Sonora selling service.*

Long Island Phonograph Co., Inc.

Sonora Distributers for Brooklyn and Long Island

17 Hanover Place, Brooklyn, N. Y.

Telephone Main 1217-18

The NEW Columbia is superior

Hearing is believing

Every Model is a Delight to the Eye. Rare craftsmanship and artistic ability are reflected in every model of the New Columbia. Each one is a beautiful piece of furniture—worthy of any home—always a “thing of beauty.” *Seeing is believing.*

COLUMBIA PHONOGRAPH COMPANY
New York



The store contains complete new equipment, consisting of hearing rooms and talking machine, record, piano and other departments.

A “Live” Long Island Dealer

In the accompanying photograph Jerome Ackerley, the popular Victor dealer located in Patchogue, L. I., is presented just before enter-



Jerome Ackerley “On the Job”

ing the home of a prospect to sell one of the new Victrola models. Mr. Ackerley, or “Jerry,” as he is known to his friends in the trade, is one of the live-wire Victor dealers in the metropolitan territory, and his success may be attributed to his thorough knowledge of Victor product, coupled with an exceptionally keen sense of aggressive salesmanship.

New Sonora Accounts

The Long Island Phonograph Co., Sonora distributor for Brooklyn and Long Island, has secured several new accounts, among them being Al Bersin, 1253 Bedford avenue, and the Kern Music Shop, 292 Flatbush avenue, Brooklyn, N. Y.

Wins First Prize at Fair

The Cavanora Music Shop, Riverhead, L. I., one of the most aggressive dealers in Long Island territory, was awarded first prize recently at the Riverhead Fair, which attracts thousands of visitors from all parts of Long Island territory. This successful dealer showed a very attractive booth, featuring Sonora phonographs, Edison diamond disc phonographs, Okeh rec-

ords and Crosley radio receiving sets. This is the second consecutive year that the Cavanora Music Shop has been awarded first prize for its exhibit at this fair.

Clever Stunt Bringing Prospects

Prospects are being secured and interest is being aroused among owners of old talking machines by a clever stunt which is being staged by the talking machine department of the Sterling Piano Corp., of Brooklyn. The concern has arranged a special window display, announcing that a \$250 Victor instrument will be given away to the person owning the oldest Victor talking machine. Considerable advertising in the local newspapers has further augmented the interest of the public. Many people owning old Victrolas have already signified their intention of entering the race. All information as to the age of the instruments already in the contest is being withheld from the public by the Sterling Piano Corp. in order to keep interest at a high pitch. This plan possesses distinct merit as a prospect producer, according to E. T.

LeTure, manager of the talking machine department, judging from the number of people owning old machines who have already entered the race for the fine new console Victor model.

Blout to Open Flushing Store

The large store at 36 Main street, which has been occupied by Irving Riesenburger as a furniture store, has been divided into two stores, and one has been leased by Emanuel Blout, who will open an establishment for the sale of Victrolas, records, pianos and musical instruments. Mr. Blout has stores in Newark, N. J.; Fordham, N. Y.; Bayonne, N. J.; Poughkeepsie, N. Y., and Brooklyn.

Schweiger Bros. Add Sonora

Schweiger Bros., who operate two large talking machine establishments in Brooklyn, have recently added the Sonora line of phonographs and they are planning to feature this line in an intensive manner. This concern is considered one of the liveliest and most successful in this territory. The deal was closed by the Long Island Phonograph Co., Inc., Brooklyn.

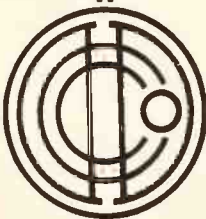

DOEHLER

The World's Largest Producer of
DIE-CASTINGS

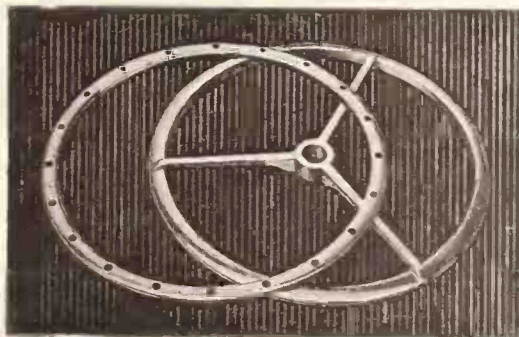

Doehler Die-Cast Aluminum Phonograph Reproducer Rings

Occasionally, a change from machined to die-cast parts would involve preliminary experiment and expense which a logical user of die-castings may hesitate to enter upon.

Doehler engineers are always ready to work with such a prospective customer—to make with him, in his own plant, a survey of his product and processes—to study his individual problem in detail—and to make recommendations based upon an unequalled experience.

And the Doehler Company will share with the prospective buyer the expense involved in this survey and development.

DOEHLER DIE-CASTING CO.
BROOKLYN, N.Y.
TOLEDO, OHIO.



New Releases Monthly

A. CENTONZE MUSIC CO.
PUBLISHERS

Distributors and Jobbers in
RECORDS and PIANO ROLLS
174 Johnson Avenue Brooklyn, N. Y.

Our Latest Rolls Have Met with Great Success

Labruzzo duci Mazurka
Bocca da baci Mazurka

It's not too late

1923 NOVEMBER 1923						
Sun.	Mon.	Tue.	Wed.	Thu.	Fri.	Sat.
				1	2	3
			7	8	9	10
4	5	6	14	15	16	17
11	12	13	21	22	23	24
			28	29	30	

*To get your
full Holiday
Supply of*

*Order
Now
December
May be
Too Late*

BAGSHAW NEEDLES

Despite the rush demand for BAGSHAW Needles which has continued at an ever-increasing pace throughout the early fall, we are still in a position to make full deliveries with reasonable promptness. We can fully take care of your holiday requirements—provided you order NOW. If you delay your order further, we cannot guarantee complete delivery at present prices. We strongly urge prompt action on your part in sending us your complete holiday requirements. You may be sure of prompt action on our part in attempting to fill them.

W. H. BAGSHAW CO.

Factory, Lowell, Mass.

370 SEVENTH AVENUE
AT 31st STREET

NEW YORK
SUITE 1214

Pacific Coast Distributor:
Walter S. Gray Co.
1054 Mission St.
San Francisco, Cal.

Canadian Distributor:
The Musical Mdse. Sales Co.
79 Wellington St., W.
Toronto

Western Distributor:
The Cole & Dunas Music Co.
430 So. Wabash Ave.
Chicago

Foreign Export:
Chipman, Ltd.
8-10 Bridge St.
New York City

A Smashing Success



*Our Supply is
Being Rapidly
Exhausted*

BRILLIANTONE Record Cleaner and Container Combination

500 NEEDLES ~ The steadily mounting demand for this novel and useful combination is rapidly exhausting our present supply. Rush your order to us *now* to be sure of complete holiday delivery. Each waterproof tin box contains 500 needles; the well padded velvet cushion is an ideal record cleaner. Packed in display cartons containing 20 packages. The Special Minimum Quantity Introductory Offer of 10 cartons costing you \$60 and selling for \$100 will be withdrawn shortly.

BRILLIANTONE

STEEL NEEDLE COMPANY OF AMERICA, Incorporated

Selling Agents for W. H. Bagshaw Co., Factories, Lowell, Mass.

370 SEVENTH AVENUE, at 31st Street, Suite 1214, NEW YORK

Pacific Coast Distributor:
Walter S. Gray Co.
1054 Mission St.
San Francisco, Cal.

Western Distributor:
The Cole & Dunas Music Co.
430 So. Wabash Ave.
Chicago

Canadian Distributor:
The Musical Mdse. Sales Co.
79 Wellington St., W.
Toronto

Foreign Export:
Chipman, Ltd.
8-10 Bridge St.
New York City

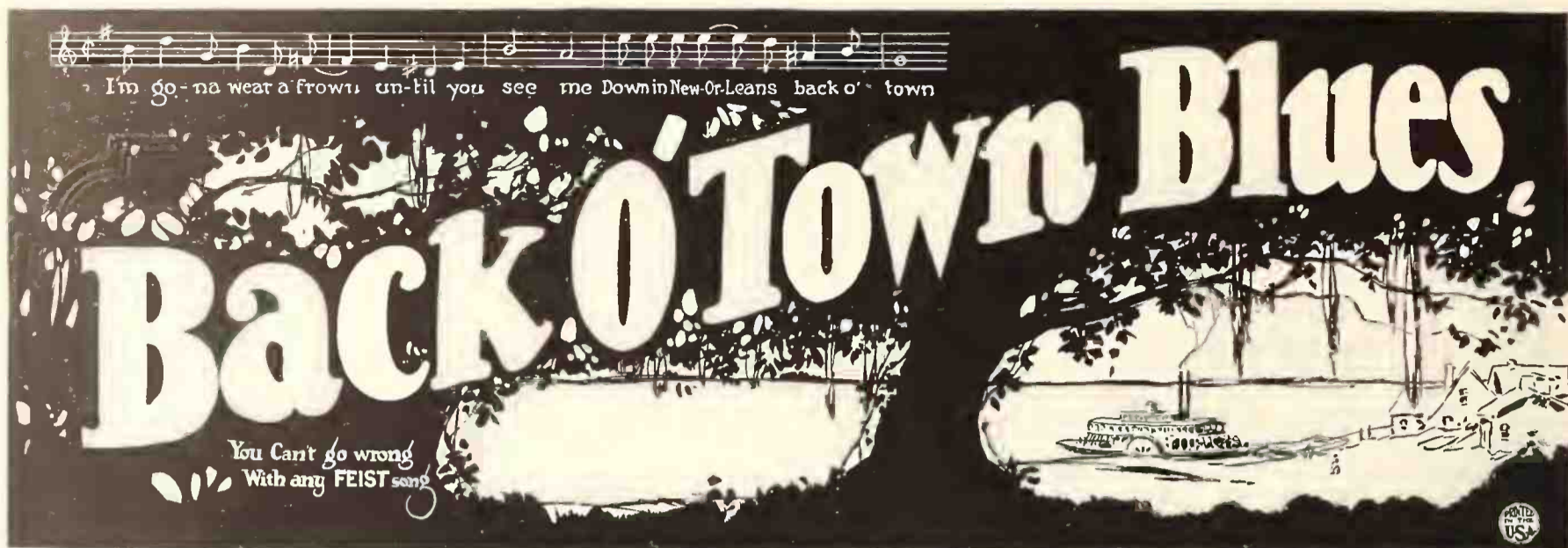

LARGE EMERSON PHONOGRAPH SALES

Quota for Eastern States Booked Up—Emerson Records Also Going Big—Many New Dealers—Some Striking Window and Counter Features—Jewish Records Grow in Favor

An impressive indication of Eastern activity in the talking machine field is contained in a statement by the Emerson Phonograph Co., Inc., manufacturer of Emerson records, which shows that the sales of the new Emerson phonographs in its territory are already sufficient to cover the quota for the Eastern States to January 1. The entire Emerson line of new models has won the approval of Emerson retailers, and the movement to the consumer at this period has been greatly beyond earlier anticipations.

The sale of Emerson records since the reduction in price has shown substantial increases. The various Emerson record jobbers have added considerably to their orders each month and plans for a greatly increased production have been found necessary by the Emerson Co., not only to care for the current monthly business, but also the stimulated demand induced by the proximity of the holidays.

Several new members have been added to the sales staff of the Emerson record organization in order to care for the enlarged business, including W. R. Hall, who, for a number of years, was connected with the Pathé Radio & Phonograph Co., Inc.

The Emerson Phonograph Co., Inc., issues monthly a series of attractive window strips and counter advertising material on individual record numbers. These the retailer finds are sales creators. Of particular importance to dealers handling the foreign catalog of Emerson records have been the attractive posters on the new Jewish records. The Emerson Co. has added some new Jewish stage favorites to its list of artists and under the present plans of the company six timely Jewish selections will be included in each monthly list.

The records of Bessie Weissman, the Jewish character singer, are among the most successful of the foreign selections handled by Emerson dealers. The new clarinet solos by N. Brandwine have also been found to be active sellers. Other Jewish Emerson record artists include Morris Goldstein and Michael Michalesko.

B. Abrams, president of the Emerson Co., recently stated that his organization is looking forward to one of the busiest holiday seasons in the history of the company. Retailers, he said, who have not planned far in advance to care for a heavy volume of holiday business will find themselves unable to get goods.

H. C. GAWLER WITH GENERAL RADIO

Widely Experienced in Radio Merchandising—Was Formerly With Radio Corp. of America

Harry C. Gawler, for the past three years connected with the sales department of the Radio Corp. of America, New York, has severed his connections with this company, and on November 1 joined the forces of the General Radio Co., of Cambridge, Mass., as sales promotion manager. As a radio man, in both the administrative and technical branches of the service, Mr. Gawler is well known to engineers, radio operators and a host of business men identified with the merchandising of radio apparatus. He has been identified with radio circles since 1904 when he joined the Communication Division of the Navy, and ever since that time he has taken a keen interest in radio activities.

In the World War Mr. Gawler carried the rank of captain in the First Signal Battalion of Massachusetts, and the rating of lieutenant in the U. S. N. R. F. While assigned to duty in the Azores during the war, Mr. Gawler won recognition from the Portuguese Government and was decorated with the Order Militaire de Avis for distinguished service during the influenza epidemic on the island.

"PHONO-VAUDETTE" WINS FAVOR

COVINGTON, KY., November 5.—Although it had made preparations for a record-breaking holiday trade, the Commercial Art Shop, of this city, manufacturer of "Phono-Vaudettes" has found it impossible to keep pace with the demands of the trade. The company states that orders have been received from dealers throughout the country and even from abroad, with the result that the factory is working to capacity. The use of the novel characters, such as "Shuffling Sambo," "Scotch Lassie" and others to form a group of vaudeville artists, has apparently made a popular appeal.

FAIR EXHIBIT BRINGS PROSPECTS

Live Dealer in Hazleton, Pa., Secures an Active List of Sonora Prospects and Closes Several Sales as a Direct Result of Fair

HAZLETON, PA., November 7.—Robert Meikrantz, Sonora dealer in this city, recently sponsored a very attractive exhibit at one of the local fairs,

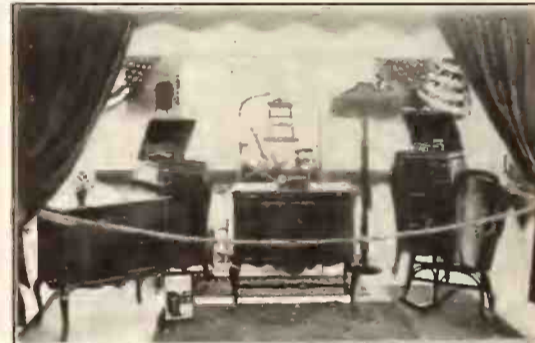
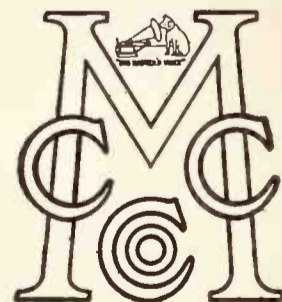

Exhibit Made by Robt. Meikrantz at Fair which not only was responsible for securing an active list of prospects but resulted in the closing of several sales. The booth was artistically decorated, and, as the accompanying illustration will show, the Sonora line was presented to excellent advantage.

NEW ROCHELLE DEALER BANKRUPT

NEW ROCHELLE, N. Y., November 7.—A petition of involuntary bankruptcy was recently filed against Philip Pravder, Inc., dealing in pianos and phonographs.

Victor Wholesalers



The House
of
Mellor
in
Pittsburgh
since
1831

Phonograph Parts and Supplies

MOTORS, TONEARMS, SOUNDBOXES, SPRINGS AND NEEDLES OUR SPECIALTY

Lowest Prices and Best Qualities Always Available for Delivery Anywhere

Send for Bargain List of Repair Parts and Motors

THE VAL'S ACCESSORY HOUSE

1000-1002 Pine Street

St. Louis, Mo.

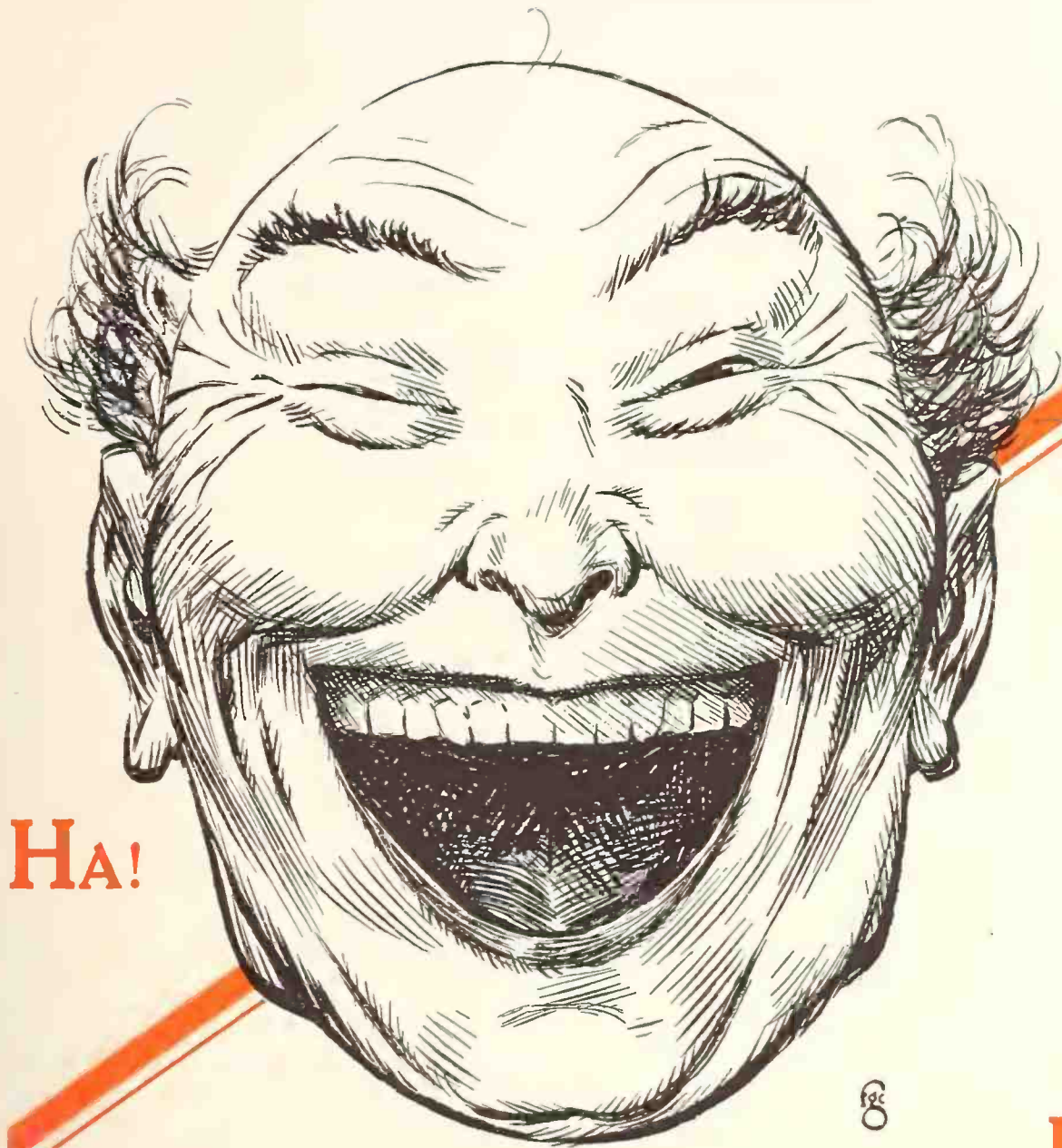

HA!



HA!



HA!

Now for the

Second Spasm!

You remember the first one, of course! That nation-wide convulsive spasm of prolonged laughter caused by hundreds of thousands of Okeh Laughing Records—the largest and fastest selling records in the industry. And yet, with all the tremendous sales that these records have had, the sales-surface has hardly been scratched! There are still millions of people in this country who have never heard these rare bits of riotous comedy—millions who will unquestionably want and enjoy their irresistible, contagious mirth. The Okeh Laughing Records, "The Original"

and No. 2, "The Singing Lesson," are by no means things of the past! Right now they are being steadily sold all over the country. Brand new attention-getting, sales-producing window displays and other well-planned advertising material have been specially prepared to create new enthusiasm for these records among the millions who have yet to hear them. Watch your mail for the "broadside" explaining our new extensive publicity campaign and the part you can play in making it a howling success! We are out to make the demand for these records greater than ever!

Last year the Okeh Laughing Records became the biggest business-getters in the industry. You can help make them the same this year by effectively using our specially-prepared advertising material and putting your best sales effort behind them. The Okeh Laughing Records, incomparable riots of fun and laughter from start to finish, are just what the laugh-loving public is always eager and ready to purchase. We have "the goods"—let's make the "Second Spasm" of The Okeh Laughing Records longer, louder, and livelier than ever before!

The **Okeh LAUGHING RECORDS**

BUY OKEH NEEDLES

GENERAL PHONOGRAPH CORPORATION
25 West 45th Street OTTO HEINEMAN, President New York, N. Y.

The NEW Columbia is superior

*Hearing
is believing*

The Motor has Limitless Life. Think what this means—constant and faultless performance for every owner of a New Columbia. Never was there a better phonograph motor built. It has set a new standard in the phonograph industry. *The years will tell.*

COLUMBIA PHONOGRAPH COMPANY
New York



NEW FEDERAL DISTRIBUTING PLAN

Present Plan Includes Placing Distributing Agencies in Small Cities as Well as More Important Trade Centers of the Country

ALBANY, N. Y., November 8.—The Federal Record Corp., of this city, has announced a wide plan for the national distribution of its product, the Federal record. Under the arrangements inaugurated by the company exclusive Federal dealers are to be appointed in the smaller cities and territorial allotment in the larger trade centers. By this plan it is proposed to add considerably to the present distribution of the company and also to continue retailing this record at a popular price.

The Federal catalog comprises a long list of current, vocal and instrumental selections of the popular variety and a large and comprehensive catalog of standard, classical and sacred music. The recordings often carry the name of nationally known artists and the dance selections are the work of musical combinations that make a feature of that type of program.

Besides the plan of protection to its dealers the Federal Record Corp. lays particular stress on the quality of its product, its durability and its finish. A special point is made of service to the retailer on deliveries, co-operation and definite sales plans.

The Federal Record Corp. some years back was known as the Indestructible Phonographic Record Co. Originally established in 1900, it produced for many years a cylinder record which had large sales in various parts of the country.

The personnel of the organization remains the same as when the company bore the older name. They are, therefore, record specialists of long experience, both from a technical laboratory standpoint and trade and merchandising experience.

TEACHERS LIKE CHILDREN'S RECORDS

Educational Value of Records for Children Being Recognized by Manufacturers

That children's records have other values than for mere entertainment purposes is rapidly being recognized by manufacturers of such goods. This is the result mainly of the encouragement received from teachers and others particularly interested in the development and welfare of children. This is impressively demonstrated by commendatory letters. Among the hundreds of such letters received by the Regal Record Co., Inc., manufacturer of "Little Tots' Nursery Tunes," is the following from Miss Winnie May Hill, kindergarten teacher of Macon, Ga., which speaks for itself:

"The 'Little Tots' Nursery Tunes' are delightful and I am using all I can get of them in my kindergarten. They are so clear and little children can understand the words so well. They are by far the best children's records I

have ever found, and I wish to let you know how much we enjoy them every day, and that we would love to have more of them. The pictures are lovely and appeal to the children."

A Loud Speaker That Compares Favorably with the Highest Phonograph



*Natural
Re-PRODUCTION
Atlas
AMPLITONE
LOUD SPEAKER*

Trade-Mark

Letters from Users Requested

What have you accomplished with your Atlas Amplitone? Tell us about it!

SELL the loud speaker that reproduces music on a par with your finest phonographs. The *Atlas Loud Speaker* completely satisfies the musical critics. Patented "double diaphragm" responds to delicate overtones fully and to heavier tones with perfect restraint. No blasting, distortion. Voice and instrument NATURAL AS LIFE. Adjustable to all sets and to individual receiving conditions.

Stock NOW for CHRISTMAS and a QUICK Turnover

Write for Booklet "O" Contains helpful information

Sole Canadian Distributors

The Marconi Wireless Telegraph Company of Canada, Limited, Montreal, Canada

Multiple Electric Products Co. Inc.

ORANGE ST.

RADIO DIVISION

NEWARK, N. J.

While Spalding plays



The **NEW**
P H O N O

at Carnegie Hall—



A PATTERN of welcoming applause as an energetic, boyish figure steps out upon the stage; two deep, sonorous piano chords; and the pensive, singing melody of the Thais "Meditation" pours from Spalding's violin.

Music lovers had to travel to the artist, until the ideals and the genius of Edison conceived the possibility of actually Re-Creating song, speech and music; until years of research and a fortune of three millions of dollars were spent in order to make that Re-Creation an established fact.

But the New Edison Phonograph now brings the world's richest, rarest musical treasures into the homes of people everywhere—it has become a great cultural influence in the home life of the nation.

And public appreciation has built up a demand that makes the Edison franchise one of the major prizes in the musical field.

(Continued on next page)

EDISON

G R A P H

—your townsfolk hear



The **NEW**
P H O N O

the master violinist

HICKORY LOGS softly flaming on the hearth; deep-sunk in cozy easy-chairs a friendly group, expectant — and from the magic cabinet pours again the haunting melody of Massenet's inimitable "Meditation" — exactly as Spalding may be playing it to-night in New York.

Every vibrant, vital shade of expression, every glorious tone-color are preserved, Re-Created by the New Edison for the delight of thousands of lovers of great music.

You see the instrument; but you *hear* the artist's true performance. The New Edison is the only phonograph that dares direct comparison with the living artist.

Your townfolk want to see, and hear—and buy —the New Edison.

THOMAS A. EDISON, Inc.
ORANGE, NEW JERSEY



EDISON
G R A P H

These Song Hits are the talk of the town.

**"NO, NO,
NORA!"**

THE Foxtrot
Sensation

**"I
LOVE
YOU"**

The Melody
Song hit from
"LITTLE JESSIE JAMES"

**"LOVE
TALES"**

A fine swinging
FOX-TROT TUNE

"You can't go wrong with any FEIST song"

ALBANY

*Christmas Clubs in Process of
Organization—Shortage of Cheap
Models—Brisk Trade—The News*

ALBANY, N. Y., November 7.—The Albany dealers have practically all organized Christmas clubs for the sale of talking machines for delivery the week before Christmas. The plans do not vary much, all providing for initial payments of from \$1 to \$2.50 and a like amount in weekly payments. The plan was first tried last year by a few dealers who realized they had started too late in the season, but the result showed its value and this year nearly every dealer started his club early in October and all report gratifying returns. The problem now before them is to be able to deliver the machines before Christmas, as promised. There is a shortage of the cheaper models, but little difficulty is experienced in obtaining those of higher price. The majority of the Christmas club members have ordered the \$100 models. The holiday trade in machines will be confined nearly to the club plan, but the dealers are planning extensive sales of records for Christmas gifts. The weekly release of Victor records is welcomed by the dealers, who are now able to become more familiar with the new issues and demonstrate them without waiting for the

larger stock of monthly releases. Extensive advertisements are being placed in the local papers by the Victor Talking Machine Co. and the Sonora Phonograph Co., featuring the new releases.

The Baker Music House, Inc., instituted a voting contest for the most popular boy or girl November 1, to close December 1, with a bicycle as a prize. One vote is given free to each contestant and ten votes with every Columbia record sold.

The American Phonograph Co., distributor of Victor records for eastern New York, reports largely increased orders, compared with the Fall business of last year. Mr. Griffin says the new policy of the Victor Co. in price reductions and the introduction of double-faced records and more frequent releases has greatly stimulated sales for the holiday demands and hopes that the factory production will be sufficient to enable him to fill all orders.

The American Phonograph Co., 707-9 Broadway, Edison distributor, has been kept busy supplying its dealers with sufficient stock to meet the growing demand. Edison retailers are evidently taking good care not to be caught short of stock when the real pre-holiday buying gets under way. The Edison is firmly entrenched among the most popular instruments in this section of the State and the outlook for a big year-end business is excellent.

Frederick W. Tietz, Sr., the oldest music dealer in Albany, died October 27, at the age of seventy-two. The Tietz music store has been

in its present location for more than a century, the business having been started by Mr. Tietz's father at 712 Broadway. The first Mr. Tietz came from Germany and began the manufacture of pianos and occasionally Albany dealers come into possession of the old Tietz grand style of instruments. Mr. Tietz was the first music dealer in New York State to sell Edison talking machines, the old models with the big horns. The first records sold by him were the round, tinfoil kind. Mr. Tietz encountered much opposition to the sale of the machines and records from musicians, who said the public taste for music would be spoiled by the crude rendering of the classics, but he lived long enough to note their change of attitude. Mr. Tietz continued to deal in the Edison and other lines of phonographs and records until his health failed, and the business has been in charge of a son, Frederick W. Tietz, Jr., the fifth generation bearing the name. He is also survived by his widow and another son, Adam Tietz, of Saginaw, Mich.

William J. Killea, South End dealer in phonographs and records, has organized the South Pearl Merchants' Association, comprising merchants in all lines in this section. He is the Association's first president. The first act of the Association was to open the stores of the section Saturday evenings. Mr. Killea reports a big sale of records each Saturday evening.

McClure & Dorwaldt are making extensive interior alterations to their store at 64 North Pearl street. A new mezzanine floor has been added, to which the offices were moved, and the record department has been moved to the front of the store. Additional space is provided in the rear for the Victrola department. The decorative scheme was changed from mahogany to ivory.

Ralph W. Jones has joined the sales force of the Strand Temple of Music.

Joseph Kennah, of the sales force of Pommer & Sons Music Store, recently resigned to accept a similar position in the Schenectady store of the Baker Music House, Inc. Mr. Kennah was succeeded by his brother Vincent.

SOPHIE BRASLAU IN RECITAL

Well-known Contralto and Victor Artist Attracts Brilliant Audience in New York

Sophie Braslau, prominent contralto and Victor record artist, gave a very successful recital at Carnegie Hall on Sunday afternoon, October 28, which was attended by a number of prominent musicians, including Rachmaninoff, Godowsky and several members of the Chauve Souris Co., who came over from Philadelphia with Mr. Balieff especially for the concert.

TO INTRODUCE NEW MODEL

The Columbia Mantel Co., Brooklyn, N. Y., announces that a new model will shortly be added to the well-known "Recordion" line of talking machines which it produces. This will be of the console type in English-Renaissance.

EDISON—

The Key to Opportunity!

Do you know that right now—this very day—in your town, the opportunity to develop a highly profitable Edison business is before you?

You should know—and you should act.

Nominate yourself for this opportunity of profit before it is too late. Find out all about this "once-in-a-lifetime" Edison sales opportunity.



Write or telephone today. Don't delay finding out all you would like to know about an Edison franchise.



AMERICAN PHONOGRAPH CO.

707-09 BROADWAY, ALBANY, N. Y.

The Jewel-Tone Reproducer and Tone Arm

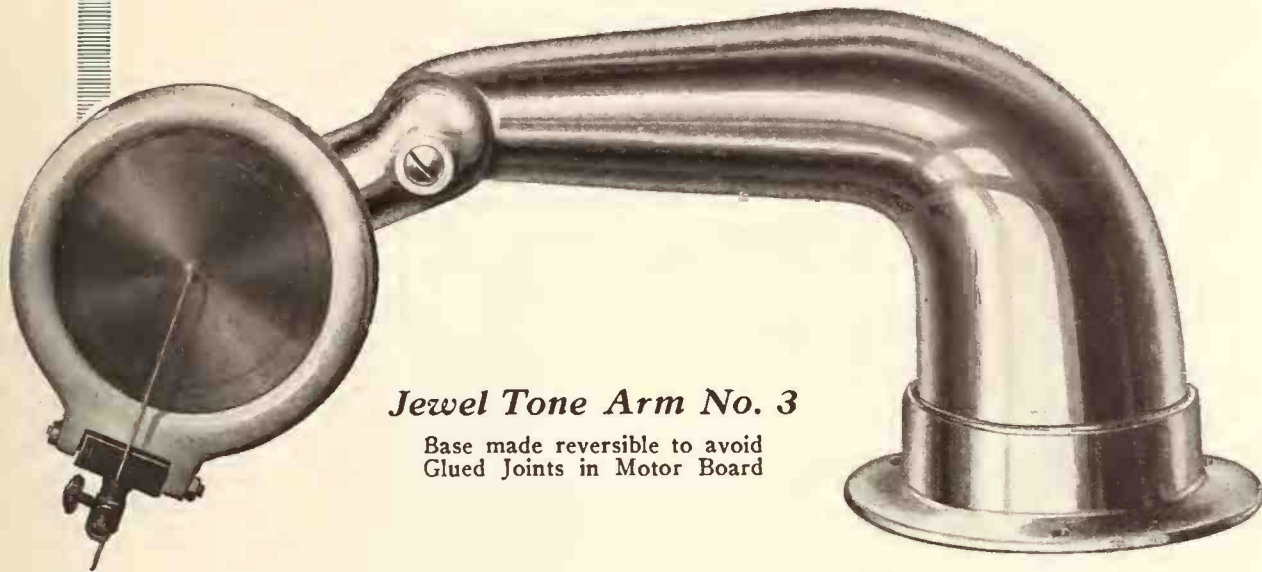

Jewel Tone Arm No. 3

Base made reversible to avoid
Glued Joints in Motor Board

Original and Exclusive Features

Play Edison and Pathe Records in actual Edison position and with a fibre needle.

Made in 8½", 9½", 10½". When thrown back on tone arm in Edison position, the reproducer lies flat, so dome cannot touch it when closed.

Finished in nickel or gold plate.

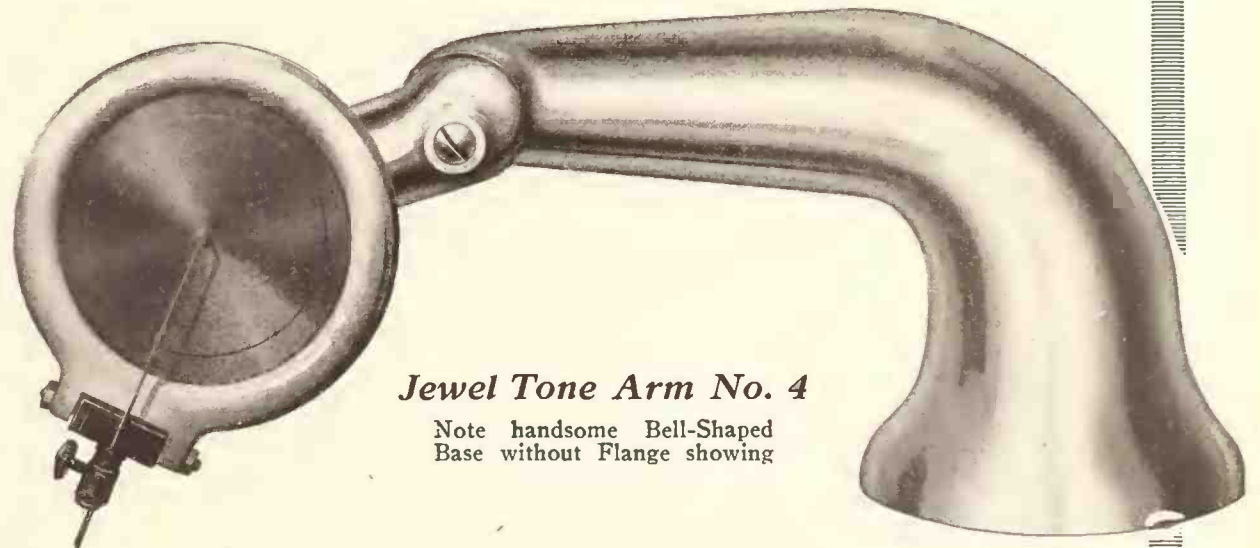

Jewel Tone Arm No. 4

Note handsome Bell-Shaped
Base without Flange showing

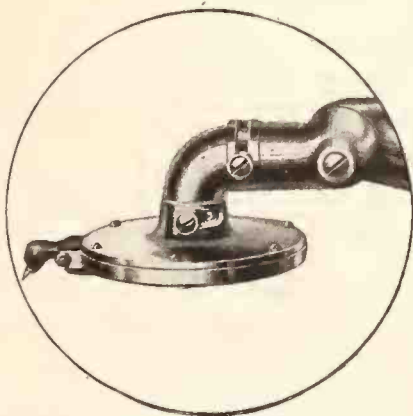

Reproducer in position to play
Edison Records with Saffo
point or fibre needle.

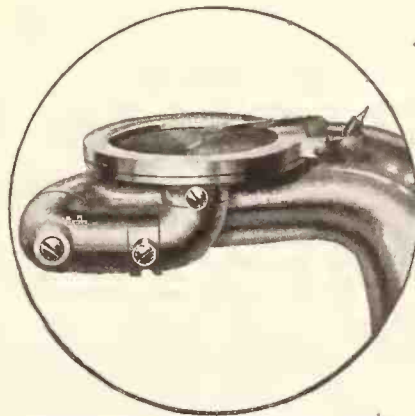

Shows reproducer thrown back
on tone arm in Edison position.
Dome cannot touch it.



Equipped with or without
Mute, Mica or NOM-Y-KA
Diaphragm.



150-160 Whiting Street

CHICAGO, ILLINOIS, U. S. A.

FORMAL OPENING OF LIBERTY STORE

Edison Phonograph Department Is a Feature of Twelve Points, Ind., Establishment

TWELVE POINTS, IND., November 5.—The new Liberty Store, 1247 LaFayette avenue, staged a formal opening here which was attended by many friends and patrons of the concern. A feature of the new establishment is an attractive phonograph department in which are displayed a complete line of Edison instruments and records. A musical entertainment, in which the Edison phonograph played a prominent part, was enjoyed by the guests, who included L. P. Brocke, of the Indiana Phonograph Co., Edison distributor. Mr. and Mrs. Joe Edgerton, the proprietors, have been in business here for seven years.

THOMAS MUSIC CO. OPENS

SCRANTON, PA., November 3.—The Thomas Music Co., which has remodeled its store at 232 North Main avenue, has held its formal opening here.

MAKES SALES TO HOTEL GUESTS

The Ansonia Music Shop, Brunswick dealer, which is located diagonally opposite the Ansonia Hotel in New York, has closed many sales recently to celebrities in various walks of life who make their headquarters in this prominent hostelry. Among the recent sales closed were handsome Brunswick models to Chas. W. Schwab, famous steel magnate, and Babe Ruth and Wally Schang, of the Yankee baseball team, world's champions. In each case a representative assortment of Brunswick records accompanied the sale.

HOLLY BOXES FOR REGAL PRODUCTS

The Regal Record Co., Inc., manufacturer of Regal records and "Little Tots' Nursery Tunes," recently announced to the trade its ability to furnish special holly boxes for Christmas sales. These will be distributed through its jobbers and, undoubtedly, these neatly packed Christmas goods will be the means of increasing holiday sales.

ANNOUNCE HOME RECORDER ON PATHE

All Models of Pathé Phonographs to Be Equipped With Device for Making Records at Home—Pathé Dealers Enthusiastic

Ever since the production of the first phonograph the novelty of listening to one's own voice has maintained its appeal. A number of separate home recording devices for disc machines have appeared on the market from time to time. It has remained, however, for the Pathé Phonograph & Radio Corp., Brooklyn, N. Y., to surprise the trade with a home recording device built as a part of the regular talking machine. Effective immediately, all models of Pathé phonographs will be equipped with a Pathé home recorder, an exclusive feature manufactured by the Pathé Co. This clever

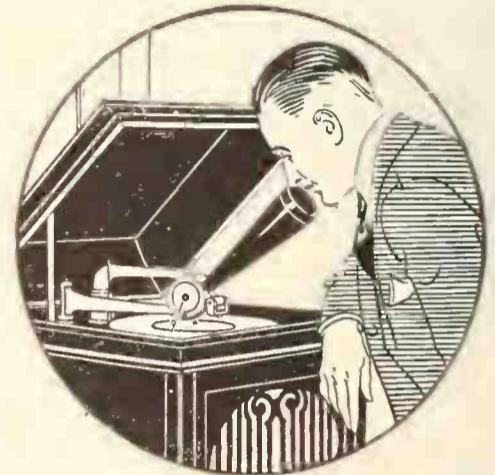

How Pathé Home Recorder Operates

new device makes it possible for all, novice or otherwise, to make their own records in their homes and immediately after, by bringing into use the regular tone arm of the Pathé machine, it is possible to "hear your voice as others hear it." The Pathé home recorder is a separate and distinct device from the reproducing part of the machine and is installed at the left of the turntable and may be swung completely out of the way or detached when not in use. It consists of a swinging arm or bracket, a recording horn and a Pathé diamond-cut stylus. The recordings are made on a special smooth aluminum composition disc which has been named "Pathégram." As this disc is entirely smooth and ungrooved a master guide for the grooves is furnished which controls the grooving at the same time as the recording. From the initial announcement of this important, exclusive feature of Pathé machines enthusiastic congratulations were received from Pathé dealers all over the country. The opinion generally expressed was that this exclusive feature was one much in demand by the buying public and would contribute greatly towards increased machine sales.

Another point of the "Pathégram" presented by the Pathé Phonograph & Radio Corp. in its literature is as a medium of correspondence, claiming that it can be produced cheaper than a typewritten message, and will carry with it the personality of the voice of the sender. The label of the "Pathégram" suggests that the writer dictate his answer on the reverse side.

PLANNING "BANNER RECORD WEEK"

The sales and advertising departments of the Plaza Music Co., manufacturer of Banner records, have announced a "Banner Record Week," November 17 to 24 inclusive. A special campaign will be made during that period on Banner records in co-operation with the Plaza's retailers. Some very original advertising features for dealers' use will be forwarded to the trade and many special window showings of Banner records and the use of window streamers, hangers and other material to attract the consumer have been arranged.

The Abbott-Troyer Music Co. recently held the formal opening of its new store at 117 South Eighth street, St. Joseph, Mo. Souvenirs were given to all visitors.

A Broad Claim

We maintain that our model S.S. motor is the perfect equipment for Portable use and is guaranteed to play in excess of two records. This statement is based on its acceptance and approval by the representative manufacturers of Portable Talking Machines.

We also manufacture two types of double spring motors guaranteed to play three and five records.

Further information supplied on request.

THE SILENT MOTOR CORPORATION

CHARLES A. O'MALLEY, *President*

321-323-325 Dean Street

BROOKLYN, N. Y.

Telephone Sterling 4861

AT DAY
THE TOWN CRIER of TODAY
 THE SATURDAY EVENING POST

IN the quaint old villages and towns of long ago, when each community was a world unto itself, the Town Crier played an important part in the affairs of the day. With news, perhaps weeks old, that occasionally drifted in from outside places.

Today news from all parts is immediately available right at your fireside. No matter how isolated your abode, Radio binds you to civilization. By a turn of the dial, the happenings, entertainments and the amusements of the world are yours to command.

The Crosley Manufacturing Co. has done much toward bringing this new wonder within the reach of all and has made Radio a living, tangible thing—something to use in daily life in business or pleasure.

Popularly termed "the famous receivers give perfect performance." Unsolicited letters are received daily from owners telling of satisfaction and new distance records.

Everyday tests prove to us that Crosley instruments are the most simple and efficient radio receivers ever offered to the public, regardless of cost.

For Sale In Local Dealers Everywhere.

Write for Complete Catalog. This fully describes the Crosley line of Radio Parts and receivers which range in price from a 2 tube set at \$25 to a beautiful Console Model No. 510.

CROSLEY MANUFACTURING COMPANY
 CINCINNATI, OHIO
 1211 ALFRED ST.

CROSLEY
 Better-Cost Less
 Radio Products

CROSLEY
 Model X-J
 \$65

CROSLEY
 MODEL X-J

CROSLEY
 Better-Cost Less
 Radio Products

MAIL THIS COUPON
 CROSLEY MANUFACTURING COMPANY
 1211 Alfred St., Cincinnati, Ohio

Making it Easy to sell Crosley Products

Back of the proven quality of Crosley Radio Receivers and parts is the consistent Crosley advertising which is educating the public to the merits of those instruments and creating an ever-increasing demand for them. Above is reproduced a full-page advertisement that will appear in the December 1st issues of the Saturday Evening Post, Country Gentleman, Popular Mechanics, and all the leading radio publications. It is the first of a new series that is bound to bring big results.

If you handle the Crosley line you are offering to your customers the best-known, most successful line of radio products ever produced.

From the two-tube Crosley Model VI at \$30 to the beautiful Console, Model X-L, at \$140, Crosley receivers have proven the most remarkable sets ever offered to the public, regardless of cost.

The Model X(ten)-J illustrated above is a four-tube set combining one stage of radio frequency, detector and two stages of audio frequency amplification.

Write for Complete Crosley Catalog, sending us the name of your jobber.

An Enlarged Reproduction of the Page Advertisement pictured above will be sent on request.

It makes a very attractive Window Poster.

~~CROSLEY~~ Better-Cost Less Radio Products

List prices on our equipment west of the Rockies 10 per cent higher. In Canada add duty.

Crosley Manufacturing Company

Powel Crosley, Jr., President

1126 ALFRED STREET

CINCINNATI, OHIO



**The NEW
Columbia
is superior**

*Hearing
is believing*

*The Automatic Start and Non-Set
Stop is unfailing.* We have made ten thousand tests by actual count. Regardless of what record is played, this exclusive feature is positive in its performance. The turntable starts revolving when the needle is placed on the record and it *stops* every time after the music is finished without any previous adjustment. *Testing is believing.*

**COLUMBIA PHONOGRAPH COMPANY
New York**

RICHMOND

*Good Business Continues — Fine
Holiday Outlook—Consoles Lead
Demand—Activities of the Month*

RICHMOND, VA., November 5.—Talking machine dealers of this city are agreed that the outlook for late Fall and Christmas trade was never better than it is this year. Practically all of them report that business during October surpassed that of any corresponding month in recent years and they feel confident that sales of both machines and records will continue to maintain a high mark the remainder of the year. Some delay is being experienced in getting goods from the factory, but this is not dampening their spirits to any appreciable extent, for they feel sure that adequate stock will be in hand by the time the holiday rush season opens up strong. One dealer is already well stocked. This firm is Walter D. Moses & Co., Victor dealer, which, in accordance with its annual custom, began stocking up the early part of the Fall season, an upper floor of its establishment being reserved for this purpose. Louis J. Heindl, head of that company, reports business at this time fully twice as good as it was at the same season last year. Considerably more cash sales are being made, while time

payments are showing marked improvement, money being apparently plentiful with all classes. Consoles continue to be the leading sellers.

Edison dealers are preparing for an exceptional holiday business and they do not intend to be caught short of instruments, if the volume of orders being received by the C. B. Haynes Co., Inc., Edison distributor, may be taken as an indication. The C. B. Haynes Co. covers an extensive territory, including Virginia and the Carolinas. The Edison has made steady strides in popularity throughout this section and the demand is rapidly growing.

The weekly issuance of records has greatly stimulated sales in this line since that policy was adopted, customers calling more frequently than they used to do when the records were issued monthly. The retail department of the Corley Co. reports that sales of Victor records have been increased not only by that policy, but by the double-faced records which are to be had for a sum slightly in excess of that paid previously for two separate records. "Blues" records are the favorites with a large class of the trade.

The Colonial Piano Co., Columbia dealer, says that the "Jail House Blues" record, a new one on the market, is proving an especially good seller.

Sales of "The Song of Love," from "Blossom Time," were boosted greatly by the recent appearance of that play at the Academy of

Music, many playgoers who saw the show having since made purchases of these records. Lee Fergusson, Victor dealer, reports that "Last Night on the Back Porch" is having quite a good run, with no prospect of the interest in this record abating. This dealer finds the \$150 console models to be his best seller, and there is a gratifying increase in cash payments.

The Cohen Co., department store of this city, recently added a record department and is handling the Pathé line. It is the first department store here to expand in this direction and, if the venture proves satisfactory, it is thought likely that it will take on the Pathé machines also. Goldberg Bros., Pathé distributors, covering the Virginias and the Carolinas, are still pushing the sales of their concert Actuelles and report that the drive is meeting with gratifying success. One of these models is now being tried out at the Y. M. C. A. in Richmond. Several others have already been sold here in recent weeks. Orders from dealers indicate they are stocking up well for the holiday trade throughout the territory. The Pathé sapphire needle, adjusted to play soft or low, is proving popular with the trade and is helping sales of both models and records, according to dealers.

H. Wallace Carner, Starr distributor, has returned from a business trip through North Carolina and the southern section of Virginia and reports finding business picking up appreciably in that territory. "Black Sheep," a new Gennett record, is going strong, he says. Another record finding a ready sale just now is the "Land of Cotton."

Sterchi Bros., Inc., of Asheville, N. C., have taken on the representation of the Victor lines and are prepared to push them strongly. The firm recently opened a large furniture store there.

W. T. Davis, of Baltimore, factory representative of the Victor, traveling Maryland, District of Columbia and the two Virginias, was a visitor to Richmond recently. He reported business holding up strong throughout his territory.

P. E. Lotz, formerly manager of the Winston-Salem, N. C., branch of the Sprinkle Piano Co., is now in charge of the Richmond branch of that company, having been transferred on October 15. He succeeds A. H. Nokes, who resigned to form a connection with a life insurance agency in Richmond. Mr. Lotz' successor at Winston-Salem is E. R. Woolidge, formerly assistant manager of the Sprinkle store there. The Richmond store is exclusive dealer for the Brunswick talking machine, having been given exclusive jurisdiction in that city within the last several months. Console models priced at \$200 are in greatest demand with the Richmond trade, according to Manager Lotz.

J. L. MORRIS OPENS NEW STORE

MIAMI, FLA., October 29.—A new music shop is to be opened this week in the arcade store block by J. L. Morris, formerly bandmaster at Athens, Ga. Mr. Morris plans to have "everything musical in his shop."

THE C. B. HAYNES, CO. INC.

Disc and Amberola Instruments
DISTRIBUTORS
Recreations and Amberol Records



\$ A L E S P R O F I T S \$

Brisk fall business has begun and the busy winter season is approaching

A few more dealerships must be established to serve this growing demand

Our Salesmen are now in the Carolinas and Virginia calling on interested merchants

A letter from you may result in the most profitable transaction you have ever made

ACT NOW

RICHMOND, VIRGINIA

EDISON SERVICE
THAT SATISFIES

How Hohner Helps You!!

*The Greatest Campaign for Increasing Your
Hohner Harmonica SALES Ever Inaugurated!!*

Magazine Advertising

Hohner Advertising is appearing in 45 national periodicals having a combined monthly circulation of over 50,000,000 copies.

Newspaper Advertising

The Hohner Harmonica is being consistently advertised in leading newspapers throughout the country.

Publicity Stories

Through our efforts the Hohner Harmonicas are being featured in newspaper publicity stories, editorial comment, including photographs and rotogravure pictures.

Radio Advertising

Hohner broadcasting secures additional harmonica publicity. Hundreds of thousands have listened in on these radio concerts.

Movie Advertising

Wesley Barry, the celebrated movie juvenile star, is giving the Hohner Harmonica valuable publicity in thousands of motion picture theatres.

Window Display Charts

Attractive charts in colors for your windows showing how easy it is to play the Hohner Harmonica. These charts create quantity sales of Hohner Harmonicas.

Boy Scout Publicity

Every boy scout in the land is reading about Hohner Harmonicas. Hohner Harmonicas have been selected for the supply department of the great Boy Scout Organization.

Harmonica Contests

With the co-operation of M. Hohner, newspapers, civic and state authorities, and also other organizations have arranged tremendously popular harmonica contests in many cities.

Vaudeville Publicity

Not less than forty-five individuals and teams of national renown are playing Hohner Harmonicas exclusively in vaudeville. 116,800,000 people annually are being thus entertained by the Hohner.

Artists' Testimonials

Great artists like Dr. Hugo Riesenfeld, director of the famous Symphony Orchestras at the Rivoli and Rialto Theatres, New York City, give unreserved praise to the Hohner Harmonica.

Instruction Books

The most comprehensive and easily understood instruction book ever written on Harmonicas has been published by M. Hohner and 300,000 have already been circulated, creating tremendous sales. A new edition of 1,000,000 copies now being distributed.

Demonstrating Artists on Tour

Leading professional performers in the service of the house of M. Hohner are demonstrating the musical possibilities of Hohner Harmonicas on extended tours. The cumulative effect of these varied activities is of incalculable value to all music dealers.

Everything Free to You!

HOHNER HARMONICA—THAT MUSICAL PAL OF MINE

M. HOHNER

114-116 EAST 16th STREET

NEW YORK

Verbosity Often Kills Interest of Buyers

The Salesman Who Talks Too Much Destroys His Chances of Making Sales, Says Braid White—Several Concrete Illustrations

The tales that have been told about salesmen who first talked their customers into buying and then talked them out again are almost as numerous as the variations on the late B. L. T.'s valve handle wheeze. Tales of salesmen who talk too much are, in fact, altogether too numerous to be ignored.

The man who talks too much usually suffers from poor control over his nerves. If he really were master of them he would not be frightened during any part of an interview, and he would have complete control over his words. He would know precisely what he was going to say and precisely when to stop and let the other person have a bit of a say for himself. It is a strange fact, but one confirmed by the experience of every man and woman who has to deal with salesmen, that the point of view of the buyer is usually the last point to which the seller pays the slightest attention. Books are filled with all kinds of good, bad and indifferent instructions to the salesman about how to persuade or even to bully people into a purchase, but hardly anyone ever seems to stop to think that no sale is worth a hang unless the purchaser comes to realize that the thing bought is in reality something actually wanted and needed, but of which the want and the need were not at first recognized. The finest salesmanship is the salesmanship which devotes itself to proving to a prospective purchaser that the thing offered is a thing actually needed and in reality desired.

Men who talk too much are men who do not understand and cannot apply the principles of salesmanship suggested above. There are as many kinds of salesmen as there are kinds of tumble-bugs, and of all the many kinds perhaps the most inept, the most thoroughly futile for all his hard and serious work, is the conversational salesman. Him I should like to divide, metaphorically speaking, into two and consider him under two heads, as the familiar nuisance and as the nervous "buttinski."

The Familiar Nuisance

Let us, then, consider the familiar salesman. He is met often in small towns, if he is a retail man. If he is a wholesaler it is dollars to

doughnuts that he only makes small towns. This sort of gentleman always approaches one closely, assumes an air of fraternal solicitude and calls one "brother." If the community is sufficiently small and sufficiently puritanical he may even call a woman "sister." In any case, he calls a man "brother," invariably, and his method is something like that of the conversational person who some three years ago happened to fall athwart me at a time when there was much talk about the housing shortage.

An Example of "Aggressiveness"

My wife and I were out together one afternoon when we found ourselves by chance upon a side street containing nothing but one row of small and singularly ugly stucco bungalows which had been run up that Summer and were now being offered for sale. [They call houses of that sort bungalows, but when I showed one of them to a brother of mine who has lived most of his life in a bungalow in the foot-hills of the Himalayas along the northeastern frontier of India, he gave one look and fainted.]

However that may be, we were walking along and when we came to this street its amazing ugliness and the extraordinary ingenuity of the builders in causing each "bungalow" to look exactly like a very poorly constructed dry-goods box so appealed to us that we felt we must have a better view. So down the street we went, and about half way along found ourselves in front of a stocky young man with what are called in the books on salesmanship a "piercing glance" and an "aggressive manner." He gave one look at us and transfixed us with a basilisk glare and laid down forthwith the following barrage:

"Good evening, people, you had better get busy and buy a 'home.' Soon there won't be any homes to buy in this whole city the way they are going and with the shortage of labor; I heard the other day there was only two hundred homes left in all the city last week, people, so you had better buy one of these while there are one or two left. Don't hesitate, brother; take the lady inside and show her one of these grand little bungalows. Just the thing for young married people like you. Soon you'll be having

a third, maybe, to share it with you, eh, people? Ha, ha, but, as I was saying, there ain't no homes to be had no more, people, in this city and you'd. . . ." But we fled.

The embodiment of "aggressive salesmanship" who thus held forth never stopped once for breath between his sentences, nor did he address us two unfortunates as "people" fewer than four times in half a minute. He started at us the very moment he saw us coming and he was still talking when we escaped. He never asked once what our object might be; he never troubled to inquire about our possible wants. He simply fired off his barrage of words at us and seemed simply amazed because we only stood and stared at him without a word. We made good our retreat, fortunately—but suppose we had really wanted to look at a house, should we have been more susceptible to the possible beauties and conveniences of the buildings this young man had to sell after a fusillade of verbal fire such as I have all too faithfully transcribed above? Hardly.

That young man had, perhaps, been trained in one of the correspondence schools, whose courses tell the ambitious ploughboy thirsting for glory far from the farm that the thing to do is to "look your man in the eye" and "dominate" him with the forceful argument and convincing appeal you make. Well, I am quite certain that this young chap was trying to "dominate" me. He certainly looked me in the eye, all right. As for my wife, all she could remember afterwards was that he had compared us with a young married couple—which she thought, somewhat doubtfully, was perhaps a sincere compliment.

Of course, I know that those who sell musical instruments do not have this sort of approach laid out for them, in the nature of the case; but the point I want to make is of universal application. It may be expressed in these words of advice:

Whatever you do avoid offensive familiarity. Rather be reserved than effusive. Don't talk too much. Try to find out, first, what your customer is likely to find interesting and then lead him or her gently and unobtrusively along the path from the thing thought of to the better thing not yet thought of, but easily connected with the first.

The Nervous Buttinski

Now the second kind of salesman is the painfully nervous kind. He usually talks too much also, but the trouble with him is not in the flow of his tongue, but in his inability to avoid interrupting the prospect when the latter wants to talk, and in his tendency to butt in at the wrong moment with remarks of his own. This is an evidence of painful nervousness and the result usually of the efforts of an inexperienced man to appear old and experienced. At any moment the work of making a sale is likely to be all spoiled by one imprudent remark, for it is a case always of mental climates and atmospheres, as one might say, which are very easily disturbed. The young salesman should be on guard every minute against the fatal error of interrupting the prospect's thought. Let the prospect talk, be silent and respectful and say nothing until he or she has ceased.

Selling Is Persuasion

Making a sale is an act of persuasion. To persuade is to bring another mind to accord with one's own. That can never be done by monopolizing the conversation. Every human animal likes to hear the sound of his or her own voice. But when a sale is on, the salesman is wise who lets the other animal do the braying as much as he or she wants to. It is time enough to talk when the prospect can think of nothing more to say.

KENDRICK & DAVIS Electric Drive for Phonographs

Price but little higher than standard spring motor

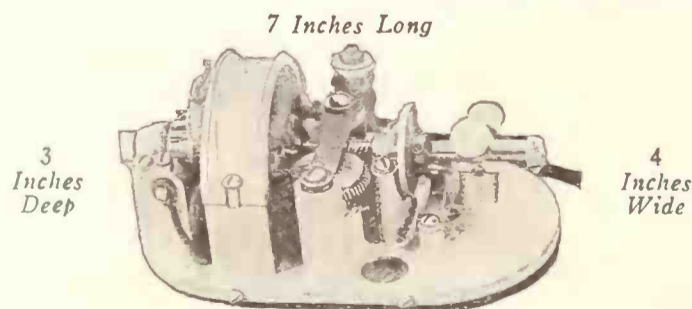

Weight 4 Lbs.

The motor is universal, direct drive, 110-volts, with standard resistance unit which cares for varying voltage; the shaft is one-piece tool steel; the brass worm with one formica gear constitutes the simple working gears. The governor is mechanically controlled. Phosphor bronze bearings. Friction idler in spindle prevents stripping gears.

A very unusual feature of the Kendrick & Davis electric drive is the switch control, operating through spindle, serving as a positive playing-stop, starting-switch and protective-lock. These three talking points alone have immense merchandising value in modern phonograph competition.

Sales Agent

H. A. ROBBINS 142 Berkeley St., Boston, Mass.

NO MATTER WHICH WAY YOU LOOK AT

The New 1924

Wolverine

PHONOGRAPH

"The Standard of Comparison"

IT SHOWS VALUE



Sheraton Console—\$100

Height35 inches
Length34 inches
Depth21 inches



Louis XV Console—\$215

Height35½ inches
Length40 inches
Depth23 inches

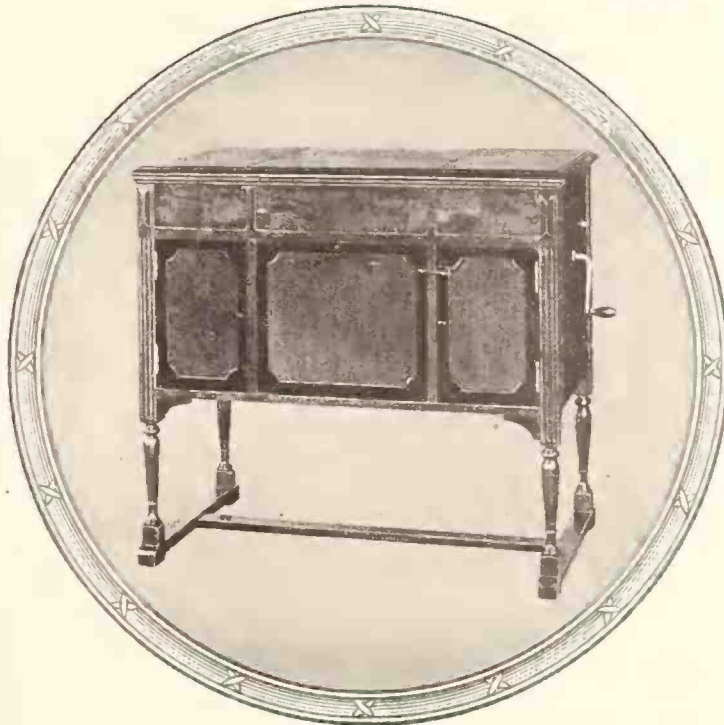

Tudor Console

Height34 inches
Length38 inches
Depth22 inches **\$175**

- Value—in true tone reproduction
- Value—in cabinet construction
- Value—in mechanical detail
- Value—in correct appearance
- Value—in appeal to the customer
- Value—in profits to the dealer
- Value—in satisfaction to both

The Wolverine has arrived. It has been accepted with enthusiasm by dealers all over the country. Customers are proclaiming its merits. Dealers are making extra profits on account of the quick turnover and better discount. Our factory is working overtime. Are you in on this?

Write us now concerning territory and discounts. Many new dealers have taken on the new "WOLVERINE"—it means quicker sales, greater profits and a higher standard of phonograph perfection than you have ever thought possible.



Queen Anne Console

Height35 inches
Length36 inches
Depth21 inches **\$125**



The FIVE-YEAR GUARANTEE—protects dealer and customer and is furnished with each WOLVERINE.



Stuart Console

Height35 inches
Length36 inches
Depth21 inches **\$150**

LIND AND MARKS CO.

MANUFACTURERS

Wholesale Distributors

Aeolian-Vocalion and Vocalion Red Records

CLEVELAND OFFICE, ERIE BLDG., 9th and PROSPECT STREETS

BATES AND CONGRESS STS.

DETROIT, MICH.

Some Thoughts on the Foreign Record Trade

A Live Western Dealer Finds Chinese Live Prospects—Romance of the Talking Machine Business
—Market for Foreign Records Indicated by Steadily Increasing Production of Manufacturers

The fact that there is a market for Chinese records in this country, a market that can be realized upon by energetic dealers, was made the basis of a special article in *Printers' Ink* recently by Roger Davis, who told of the manner in which a Western dealer had demonstrated Chinese records before a group of local laundrymen and had closed several sales of machines and complete libraries of Chinese records.

The story made interesting reading, even though the same or similar plans have been carried out by large merchandisers in the trade for many years. It might be well for writers of business articles to give more attention to retail talking machine trade for there is real material for thought in the manner in which the international language of music is utilized in developing trade among the foreign-born.

The fact that the leading companies exploit successfully elaborate catalogs of records in foreign languages, and have been carrying on that work for years, indicates that there is a real market for such selections, and dealers are aggressive enough to go after them.

Although the playing of a group of Chinese records serves to excite Chinese laundrymen to a point where they are willing to spend real money for the records and a machine to play them on, it must not be taken as an exceptional case, for many an immigrant from Europe has been made to feel more at home in this country through the fact that the talking machine brought to him the melodies of his homeland with words in his native tongue.

There is romance in the talking machine trade, plenty of it for the man who takes the trouble to dig it out. The trouble is that those in the business itself lose sight of the romance in their anxiety to build business and in the earnest attention they give to that pursuit, but from the side lines there is material for some mighty

interesting articles regarding the manner in which the foreign record catalog has been developed and sold.

When the immigrant from the heart of Russia, for instance, buffeted here and there on his journey to the land of the free and then set down in a place where all he hears is the English language, which at the outset means nothing to him, finally hears a talking machine record of some folk-song of his childhood, something he can understand, he is liable to be just a bit enthusiastic. When he buys that record and others of the same character he is not buying simply a talking machine and something to play on it. He is buying happiness and a cure for homesickness.

When the claim is made that talking machine dealers deserve to be considered something more than mere merchants, for they are really workers for the good of mankind, there are cold business men who smile and may mutter softly, "Bull." But the fact remains that when through the selling of their products they bring happiness to the foreigner within our gates, as well as to the native son, they are accomplishing something for the cause of Americanization that the average furniture or clothing dealer is not doing—the reason being obvious.

ELLIS WITH SHERMAN, CLAY & CO.

SAN FRANCISCO, CAL., November 6.—Griff P. Ellis, formerly of the Chicago Talking Machine Co., came here recently, saw Andrew G. McCarthy, treasurer of Sherman, Clay & Co., who is also head of the Victor department, and was promptly secured by Mr. McCarthy for Sherman, Clay & Co.'s Los Angeles Victor department. Mr. Ellis is supposed to be one of the most able men in his line and has had long experience in it.

The Manufacturers of the *Finest* Phonographs and Sound Boxes use and endorse our AAA quality
India Ruby Mica
DIAPHRAGMS

All sizes for immediate delivery

WILLIAM BRAND & CO.
27 East 22nd Street New York City
Telephone, Ashland 7868

TO MAKE GENNETT RACE RECORDS

Miss Josie Miles Among Those Signed Up to Sing "Blues" for the Gennett Catalog

The Starr Piano Co., maker of the Gennett records, has taken steps to enlarge materially its catalog of "race" records of "blues" numbers, and among other things has contracted with Miss Josie Miles, of Summerville, S. C.,



Miss Josie Miles

who has never before recorded, to make a number of "blues" records for that section of the catalog.

Miss Miles, although she never made any records before, is well known among the colored artists, having been a member of the "Shuffle Along" company and other organizations presenting plays and vaudeville acts. It is said for her that her voice is particularly well adapted for recording purposes. Her first records, which are now being pressed, include: "Baby's Got the Blues" and "Kansas City Man Blues." These records will be released shortly.

SHIPS BRUNSWICK TO TOKYO

NEW BRUNSWICK, N. J., November 7.—Joseph A. Cramer, 17 Livingston street, this city, Brunswick dealer, has been closing an excellent Fall business, and it is stated that in proportion to merchandising possibilities his sales totals compare favorably with the figures of the leading dealers throughout the country. A recent sale closed by Mr. Cramer called for the shipment of a Brunswick phonograph to Tokyo, Japan, this instrument being purchased by a student at Rutgers College, which is located in this city.

VICTOR WHOLESALE DISTRIBUTORS



"Self-preservation is the first law of Nature." The best way to discourage unfair competition is not to encourage it directly or indirectly.

BLACKMAN AND DEPENDABILITY

Blackman
TALKING MACHINE CO
28-30 W. 23RD ST. N.Y.C.

ONE SUGGESTS THE OTHER



SEE
WHAT

Myer says

ON

PAGE 35



REGAL 50¢ RECORDS

*Predominate
the field*

The moment a customer hears a REGAL RECORD he recognizes its unusual VALUE! New hits! Interesting, original recordings! Excellent reproduction! The 50c. price!

Like thousands of others he buys with the satisfaction that he is getting BIG value for his money.

That, in a nutshell, explains why REGAL is the biggest selling 50c. record today, just as it has been since its introduction as the pioneer 50c. record in the field.

You are interested in boosting your sales. Write for complete details. Ask for a sample REGAL RECORD—today!

A few REGAL DECEMBER selections. Every record a hit:

Easy Melody
Foolish Child
Sobbin' Blues
If I Can't Get the
Sweetie I Want
An Orange Grove in
California
Every Night I Cry
Myself to Sleep
Covered Wagon Days
Roses of Picardy
Moonlight Kisses
Last Night on the
Back Porch
Tell all the Folks in
Kentucky
Night Time in Italy
Indiana Moon
So This is Love



REGAL RECORD CO.

20 West 20th. St. New York, N.Y.

*Write for a Regal Sample—
it will be sent gratis!*

FOTO SHOP OUTGROWS QUARTERS

Rapid Development of Trade Makes Move Imperative—Does Large Repair Business

MILWAUKEE, WIS., November 6.—The Foto Shop, of this city, John H. Becker, proprietor, which handles machines and records and a complete line of cameras and supplies, will in the latter part of this month be housed in more spacious quarters in a handsome new store at 421 Twelfth street. The move has become necessary due to the rapid expansion of business. The concern operates a large repair department in which all makes of instruments are repaired. This department has been built up until at the present time not only is a large transient repair business enjoyed but the concern also takes care of the machines of many customers, making periodical inspections. This establishment handles Starr phonographs and Gennett and Okeh records, which are growing in popularity. In its new quarters the Foto Shop will be much better situated in a sales way, as the street is a very busy one with good sales possibilities and a large number of passersby. Mr. Becker is one of the most progressive business men in the city and he has had a wide experience in the merchandising of talking machines.

KEEN ON VALUE OF WINDOW DISPLAY

A very effective use of Victor publicity, covering all forms of display cards, record lists and general literature, is that made by Schnabel Bros., talking machine dealers of 244 West 116th street, New York. These Victor posters form the background to a window display with a single Victor style, make a very striking arrangement which cannot fail to attract the

attention of passersby, as it did the writer.

Schnabel Bros. operate a double store, one side devoted to talking machines and the other to radio, small musical instruments and sporting goods. In the second window the Crosley radio sets are being featured to good advantage. On the whole, the Schnabel windows are so well arranged that they are well worth being copied by other dealers in New York.

BRISK PORTABLE DEMAND CONTINUES

Substantial Business Being Done in Small Instruments Disproves Idea That Portable Machines Are "Seasonal" Products

There is a continued active sale of portable talking machines, which, if it does not decrease, will entirely eliminate the former belief that such products are seasonable merchandise. There is no evidence that this continued sale has in any way interfered with the merchandising of table models. Seemingly, small machines of all kinds still have their usual quota of sales, and while the portable machine sales are not in as large a volume as during the Summer months, they are substantial in volume. Some of the portable business undoubtedly is due to the general pre-holiday stimulation of business. At any rate, the demand is in sufficient proportion to make the portable a profitable product from the standpoint of the retailer.

Among those who see a heavy and continued sale of portables is the Plaza Music Co., New York City, manufacturer of the "Pal" portable. Both the sales and advertising departments of this company have arranged plans to care for a heavy volume of business on such instruments during the next two months.

LOCAL VICTOR DEALERS CONVENE

Interesting Session of Metropolitan Victor Dealers' Association Held on October 19—Discuss Merchandising Methods and Other Matters at Well-attended Meeting

The Metropolitan Victor Dealers' Association of New York and vicinity held a get-together luncheon at the Café Boulevard on Friday, October 19, at which there were present many of the leading Victor retailers in this section, together with the representatives of all of the Victor distributors in metropolitan territory. Matthew Levin, president of the Association, officiated as toastmaster and among the speakers were Moe Goldsmith, secretary of the organization, and the representatives of the Victor distributors.

Mr. Levin in his introductory talk emphasized the ideals and aims of the Association and introduced Mr. Goldsmith, who gave the dealers and their guests a practical discussion as to the past, present and future of the Victor business in New York and vicinity. Mr. Goldsmith called attention to certain fundamental problems of retail merchandising which he stated were confronting Victor dealers everywhere, and solutions for these problems were advanced by the Victor jobbers' representatives. Among those who made addresses were W. J. Haussler, C. Bruno & Son, Inc.; Fred P. Oliver, Blackman Talking Machine Co.; J. J. Davin, Musical Instrument Sales Co.; Lloyd L. Spencer and V. W. Moody, Silas E. Pearsall Co., and R. H. Morris, American Talking Machine Co.

Talking machines and records are being put to a new use in the public schools of Huntington, Ill., which are using them in fire drills.



ST800
H 32W28D20½



ST909
H 33W33D21

Four New Models

You can make money quickly by selling "Natural Voice" machines, for their cabinet designs, splendid tone and excellent workmanship produce profits and quick turnover.

These machines represent 10 years' experience and are not guesswork or experiments. The four new models illustrated are the last word in present-day phonograph construction.

Write for prices and catalogs for the complete instruments or the cabinets only. QUICK SERVICE.

Natural Voice
Talking Machine Co.

(Ben Ferrara, Prop.)

ONEIDA, N. Y.



ST915
H 34W36D21



ST900
H 32W28D20½

Windsor Phonograph

Cremona Model

Carvings executed by hand in solid mahogany.

The tone quality of the Windsor is in keeping with its artistic cabinets.
A portfolio showing sixteen beautiful designs of upright and console models
will be sent upon request.



WINDSOR FURNITURE COMPANY

INCORPORATED 1885

1420 CARROLL AVENUE
CHICAGO

America's Oldest Makers of Console Phonographs

U. S. Letters Patent No. 1279743

*Exhibited and
sold to dealers by*

CHICAGO
WINDSOR FURNITURE COMPANY
1414 S. Wabash Avenue

BOSTON
PECK & HILLS FURNITURE CO.
127 Clarendon Street

LOS ANGELES
WINDSOR FURNITURE COMPANY
917 Maple Avenue

KANSAS CITY
KANSAS CITY CASKET & FURNITURE CO.
626 Broadway

PHILADELPHIA
PECK & HILLS FURNITURE CO.
642 N. Broad Street

The NEW Columbia is superior

*Hearing
is believing*

The Reproducer is TRUE to International Pitch. Sell this feature to the student of vocal or instrumental music who has deprived himself of the aid of a phonograph in his work because of its having a different pitch. With a New Columbia the music student can sing or play with the record as it is played. *Hearing is believing.*

COLUMBIA PHONOGRAPH COMPANY
New York



OMAHA

Excellent Outlook for Big Holiday Business—Edison Exhibit at Pure Food Show—News of Month

OMAHA, NEB., November 7.—October business, according to all reports, bears out the promise of the early Fall as to an increased volume of trade. Crops in the surrounding territory have been excellent, and this has stimulated trade along every line, in consequence of which dealers are declaring themselves well pleased with present conditions and predict unusually heavy late Fall and early Winter business.

Interesting Display at Pure Food Show

The Omaha Pure Food Show, which was held in the city auditorium under the auspices of the World-Herald, was very largely attended, and Schultz Bros., Edison jobbers, who have recently added an electrical department to their store at Sixteenth and Howard streets, had a large display of Edison phonographs, among which the "Baby Console" proved very attractive to the visitors at the booth. N. F. Tuttle, formerly with the phonograph department of the Brandeis stores, has recently joined the sales force of Schultz Bros. Mr. Tuttle is a live wire as a salesman and will prove a valuable addition to the force.

Prepare for National Music Week

National Music Week will be observed from May 4 to 10, 1924. The City Concert Club has changed its "Music Week," observed during the annual Thanksgiving week, to the Spring season to conform to the new plan of having a uniform Music Week throughout the country. All music dealers, as well as music teachers, movie managers, ministers and persons interested in music, have been requested to bear this date in mind.

Ben Brodkey, manager and part owner of the

State Furniture Co., which maintains a large and flourishing phonograph department, reports that they have had an exceptionally fine trade in Brunswick talking machines. While the console type is the favorite, this firm has had a splendid trade in cabinet types.

Takes on the Cheney Phonograph Line

The Oakford Music Co. has just announced that, beginning with November 1, it will handle the Cheney talking machine exclusively. In consequence the company is disposing of all the talking machine lines formerly carried.

The Victor and the Teachers

The Nebraska Teachers' Association met in Omaha the week of October 29 to November 2 and Mickel Bros., Victor jobbers, took cognizance of this event by preparing exhibits of educational records and distributing some excellent literature among the teachers relative to their use. Various Victor dealers throughout the city extended an invitation to the visiting teachers to come in and see a demonstration of some of the new educational records. Three thousand teachers were in attendance from all over the State and Mickel Bros. expect this event to speed up the record business for their out-State dealers, as well as for Omaha firms handling the records.

Okeh Records in Great Favor

Popular records are still selling as leaders, according to R. L. Lincoln, manager of the Rialto Shop, Okeh record dealer. However, various dealers in records claim that there has been an increase in the sale of high-grade records during the past month, due, in part, to the demand for numbers sung by Rosa Ponselle and Sigrid Onegin, both of whom appeared in concert in Omaha during October. Music lovers are also trying to secure records made by the Ukrainian Chorus, which made such a favorable impression here last year and which is to appear in this city in concert again during the late Fall.

The phonograph department of the Brandeis Stores, under the management of P. G. Spitz,

has recently had a record sale of Columbia phonographs. Mrs. E. Albertson has recently returned to the record department of this store, after taking an extended vacation.

Miss Lois Ferrin, manager of the talking machine department of the Burgess-Nash stores, states that October has been an excellent month in reference to the volume of business, as compared to the previous month. They are showing some beautiful new Cheney models, and their Brunswick trade has been strong. The special sale of Emerson phonographs which they featured recently was a great success.

EXCEL PLANT WORKING OVERTIME

I. A. Lund a Recent Visitor to New York—Excel Phonograph Plant Working Night and Day in an Effort to Meet Demand

A recent visitor to New York was I. A. Lund, sales manager of the Excel Phonograph Co., Chicago, Ill., who called upon the trade in Eastern points. In a chat with The World he reported a remarkably active condition of business at the factory—in fact, orders in hand are of such volume that it has been necessary to put on a night force in addition to a full day force, and thus the plant is working day and night in an effort to turn out sufficient machines to fill the needs of the trade. At the present time the company is virtually sold out for some months to come. It is hoped, however, that with the present producing schedule it will be possible to catch up with the present volume of orders after Christmas. Mr. Lund reports a most active call for the console types of phonographs made by this company, which, by reason of their finish, equipment and tone resources, have won particular favor.

Mr. Lund, who is one of the best-informed men on phonograph production and the industry generally, had a very pleasant stay in the metropolis. From here he wended his way Westward via Philadelphia.

Edison Is Always First!



The first Phonograph
First with Console Phonographs
First with Broadway "Hits"
First to play all makes of Records

EDISON INVENTED IT—EDISON MANUFACTURES IT

SHULTZ BROTHERS, Inc.

16th and Howard Streets
OMAHA

Edison Distributors for Nebraska
and Western Iowa

A few dealerships open. Write
or wire



Making the Most of Your Opportunity

Should Be the Aim of Every Victor Dealer

The Holiday Season is rapidly approaching and unless you have planned for it you cannot hope to get a maximum return.

Put your effort into the sale of Instruments that are available. There will be a shortage in some types.

Promote the sale of single face Red Seal Records at the reduced prices. There will probably be a shortage in the double face.

Dealers in our territory are invited to consult with us on any problem in their Victor Business.

We are here to serve.

THE LOUIS BUEHN COMPANY

of Philadelphia

Victor Wholesalers

The Trade in PHILADELPHIA and LOCALITY

TRADE OPTIMISM CONTINUES DESPITE SPOTTY BUYING CAUSED BY UNUSUALLY MILD WEATHER

Peculiar Condition in the Trade Is That While Some Sections Are Busy Others Are in Lethargic State—Important Retail Changes—Live Dealer Cashes in on Schools—Month's News Budget

PHILADELPHIA, Pa., November 7.—Anomalous conditions exist in the talking machine business in its entirety, although, when they are considered along the lines of the several divisions of the business, the apparent contradiction disappears. To get from the abstract to the concrete: wholesalers fortunate enough to be in possession of adequate stock of popular models of nationally advertised makes are doing what really can be called a rushing business. In sharp contrast, jobbers stocked up with the lesser-known makes or with other than the popular numbers of the widely known brands report that business is sluggish. Retailers located in the anthracite coal regions or in territory commercially related to it are overwhelmed with orders, and the limit to the amount of business which they can do seems to be placed only by their ability to get goods. On the other hand, retailers in the purely agricultural sections of Pennsylvania and adjacent States whose metropolitan market is Philadelphia find buying of a very spotty character, with no particular tendency in either direction. Likewise in this city the neighborhood dealers in the textile districts are doing a very much restricted business although those in most of the purely residential sections, and particularly those inhabited by the wealthy classes, find trading quite up to normal for this season of the year. In a general way, those who are not doing the business they expected to do are still of the opinion that the quietness is of a transient character and that a not unimportant element in it has been the unseasonably warm weather of the last week. They are confident that the appearance of cold weather will tone up the market and will usher in a very satisfactory holiday business.

Important Changes in Retail Field

Because of the retirement from the talking machine business, which he followed for many years, and in order to devote all his time to the real estate field, Monroe M. Johnson has disposed of the two establishments he formerly conducted under the title of the Monroe M.

Johnson Co. The new owner of the branch at 2530 West Lehigh avenue is E. Louis Stapf, formerly connected with the machine order department of the Victor Co. Mr. Stapf will sell Victor talking machines and records and a general line of musical merchandise. He has made many improvements to the store, enlarging the booths, advancing the display rooms to the front, making the windows attractive with hardwood floors and redecorating the entire establishment.

Wilson Co. Acquires Germantown Ave. Store

The second talking machine store, formerly conducted by the M. M. Johnson Co., has been purchased by the J. R. Wilson Co., which will conduct the business in a newly renovated store in the Johnson Building, 5439 Germantown avenue. Negotiations for the sale and transfer of the merchandise and franchise were conducted by the Penn Phonograph Co., Victor distributor, this city. The Wilson Co. is equipping the new store with standard Wilson equipment and expects the booths, record racks and musical merchandise cases to be fully installed this week. This makes four stores that the Wilson Co. is now operating.

Pomeroy's Music Hall Formally Opened

Music Hall, the name given by Pomeroy, Inc., of Harrisburg, Pa., the largest department store in the interior of Pennsylvania, to its very much enlarged musical department, an outstanding feature of which will be the taking on of the Brunswick line, was most auspiciously opened on November 8 with the all-day appearance of Carl Sutton and his celebrated orchestra, and in the evening a banquet was held in conjunction with the Kiwanis Club, with O. F. Jester, manager of the Brunswick branch in this city, as special guest. The complete line of models made by the company was given the honor place in the exhibit and reception to which several thousand Pomeroy patrons from Harrisburg and all the surrounding towns were invited. S. J. Jenkins is in charge of the amplified musical department.

The Brunswick Co. during the month also installed its machines and records in the establishment of the Roebling Piano Co., one of the oldest houses in the trade in Wilmington, Del., of which W. E. Holland is president. Manager Jester has just returned from a very satisfactory trip through Pennsylvania, with Bethlehem, Easton and Allentown the focal points.

Builds Big School Trade

Fruits of the development in Williamsport schools and in those of the country sections surrounding of a fallow field for talking machines in teaching and the attractions to the youthful mind of talking machine entertainment now are being enjoyed by M. H. Housel, head of the company bearing his name, and the leading Victor dealer of the section. Being thoroughly imbued with a realization of the possibilities of Victor machines and records for teaching to both teacher and pupils, and being possessed of an unlimited enthusiasm, Mr. Housel did pioneer missionary work in persuading the members of the Williamsport Board of Education and the School Commissioners of the county to introduce machines and records in all the classrooms from the kindergarten to the most advanced grades. Moreover, for the rural schools a selection of Victor records along the line of agricultural instruction and entertainment helped the good work along. Use of machines and records is now an established element of the county and city educational establishments.

Enjoy Halloween Party

Halloween festivities, delayed but none the less enjoyable, attracted to the phonograph department of the Estey Co., Seventeenth and Walnut streets, on the second floor of the Estey Building, on November 3, 200 members of the organization, their families and friends. Included in the program were renditions of Victor, Sonora and Cheney records. The stairway leading to the ballroom was converted into a harvest field with cornstalks and pumpkins lining the way up to the upper hall. Owls and pumpkin lanterns suspended from the ceiling and contrasting with the yellow and orange colors of Halloween were used in decorating the room. The evening's entertainment consisted of Estey store talent in solos, quartets, recitations and

(Continued on page 86)



Velvaloid Record Cleaners Are Delivering the Dealer's Message Every Day in Millions of Homes Throughout the World

Their BUSINESS BOOSTING VALUE is fully attested to by the amount of our sales and the repeat orders arriving daily. For A CHRISTMAS SOUVENIR the dealer cannot go wrong BECAUSE in presenting a VELVALOID RECORD CLEANER personally to a customer or a prospect, GOOD WILL is created and that cannot be bought. Your advertisement can be imprinted so beautifully that such a gift is valued, kept and used. Your name registers every time a Record is played. What more can you ask for the amount invested? Pyralin and Plush have advanced. We cannot guarantee our present low price long, but we can fill your orders now. DON'T DELAY. Order thru your jobber for the Holidays when you will want them. If you haven't a sample and prices write us at once. Do this anyway and get our catalog of Business Boosting Novelties.

THIS IS IT
3 1/2-inch Diameter
Patented



COLUMBIA
PHILLIPS MUSIC HOUSE
14 East Third Street
Bethlehem, Pa.

PHILADELPHIA BADGE CO., Manufacturers, 942 Market St., Phila., U. S. A.



There is a lot of lost motion and complications in selling what you haven't got. Although our every effort will be to supply your wants, we suggest, in the interest of good merchandising, that you place your special sales efforts on the models available.

Model No. 215 is your best bet.

The Talking Machine Company

Victor Wholesale Exclusively

1025 Arch Street Philadelphia, Pa.

"LET PHIL FILL 'EM"

THE TRADE IN PHILADELPHIA AND LOCALITY—(Continued from page 85)

dances by individuals and in groups. Prizes were awarded the best costume and the most grotesque, all the merrymakers being masked. A banquet followed the closing of the evening's festivities. Music was furnished by an orchestra, while the prize awards were made by Mrs. P. M. Quimby, head of the phonograph department. Those who arranged the entertainment were Ronald Wyse, talking machine department; Thomas Power, advertising manager; Gerald L. Quimby, radio department, and Alice Plyvel, of the office force. Guests from the New York offices were: President G. W. Gittens, Hy. Eilers, O. C. Stone and A. Dalrymple, of the Estey Co.

John Snyder Again With Heppe

After an absence of five years John Snyder has again joined the wholesale talking machine department of the C. J. Heppe Co. Mr. Snyder will take over his old territory, covering Philadelphia. Wedding bells rang during the week for Miss Mabel Ziegler, daughter of H. S. Ziegler, head of the wholesale talking machine department, who became Mrs. Clarence Hutton.

Pushing Vocalion Christmas Records

Vocalion Christmas records are being featured by the Lincoln Business Bureau, 1011 Race street, in its campaign of special distribution, in order to give the trade an opportunity

to hear the three special leaders of the advance list. They are "The Night Before Christmas," by Lewis James, in two parts, and the combination record containing "The Star of Bethlehem," by Charles Harrison, and the "Voice of Chimes," by the Criterion Quartet. D. H. Rogers, head of the firm, is now placing two salesmen on the road to take care of the holiday demands.

Harold B. Cregar Promoted

Harold B. Cregar, formerly assistant to Manager Earl G. Dare, of the record department of the Penn Phonograph Co., has been advanced to record ordering clerk, taking over the duties of Victor E. Moore, who resigned during the month. Mr. Cregar has been with the firm since 1915. At first he was outside salesman, visiting the Philadelphia trade, and in 1918 took the road. The Penn Co. has distributed among the dealers attractive posters calling attention to the fact that in the Vicor list are four numbers taken from "Chauve Souris," the sensational Russian importation now playing at the Schubert Theatre, including the "Parade of the Wooden Soldiers."

Nathan Worth Reopens Improved Store

The Louis Buehn Co., 835 Arch street, said it with flowers in expressing the firm's congratulations to Nathan Worth and his two sons, who conduct the only Victor agency in their

town and who have just made extensive improvements in their talking machine department. In celebration of the reopening the firm had special concert selections and the new window was artistically arranged, featuring Victrolas. Vice-president Charles W. Miller, of the Buehn Co., made an extensive trip to the trade in the northeastern part of the State, renewing old acquaintances, and has returned again to headquarters.

Girard Co. Staff Visits Thos. A. Edison

Five members of the staff of the Girard Phonograph Co., Edison distributor of this city, together with P. R. Hawley, general manager, met with Thomas A. Edison at his Orange, N. J., laboratories recently to discuss plans for promoting new business throughout the Philadelphia territory.

Mr. Edison spent several hours outlining various original sales plans with which he is now experimenting, and the Philadelphia distributors came away much elated at what they had heard. The remainder of the day was spent inspecting the laboratories and the various processes of manufacture, and was followed by a dinner tendered the visitors by the officials of the Edison Co. Those in the party, in addition to Mr. Hawley, were A. W. Rhinow, assistant to Mr. Hawley; W. C. Stiver, A. W. Merrihew, A. L. Stott and C. E. Greniger.

Guarantee Co. Adds 200 New Dealers

The Guarantee Talking Machine Supply Co., of this city, reports that it has added over 200 new dealers to its list within the past few months, a visible proof of the steady growth of the company. Guarantee springs are now being boxed separately under the "Guarantee" label. Before long it is expected that the "Guarantee" trade mark will be stamped on each individual spring, thus identifying the product. Upon the completion of this change it is planned to put into effect a guarantee system whereby entire satisfaction may be guaranteed in the event of a possible defect and an exchange made.

General Radio Publicity Drive Starts

"The Musical Instrument of Radio" is the manner in which the Music Master Horn is aptly described in the first full-page announcement of the big national publicity campaign now being conducted by the General Radio Corp., of this city. This page appeared in the Saturday Evening Post in October and immediately upon its appearance created considerable favorable comment on the part of both the talking machine and radio trades. From a literary, artistic and typographical standpoint this advertisement ranks among the most attractive produced and was the result of a series of conferences between Walter L. Eckhardt, president of the General Radio Corp., and five members of the staff of the J. H. Cross Co., advertising agent for the General Radio Corp. As it can be safely expected that the succeeding advertise-

On Guard



Penn-Victor Dogs are the best watchmen of Victor Welfare in the Home.

Sold by most Victor Distributors.
Write them or us for prices.

Penn Phonograph Company

913 Arch Street Philadelphia, Pa.

Victor Wholesale Only



\$100
RETAIL
PRICE

It's more than a *phonograph*.

It's a NEW EDISON

GIRARD PHONOGRAPH CO.

A FEW
DEALERSHIPS OPEN
WRITE US

Edison Distributors Exclusively
1819-1859 NORTH 10th STREET
PHILADELPHIA, PA.

PLAYS ALL RECORDS

THE TRADE IN PHILADELPHIA AND LOCALITY—(Continued from page 86)

ments of the campaign will compare favorably with the initial announcement, this publicity undoubtedly will increase the demand for the products of the General Radio Corp.

Business thus far this year has been exceptional. August was the greatest month in the history of the organization, as was previously announced. It is interesting to note that September business increased 50 per cent over August, and October another 50 per cent over September. A financial statement, which was recently prepared, visualizes the present healthy financial condition of the company and augurs well for the future.

H. F. Miller Works for Charity

H. F. Miller, vice-president of the Penn Phonograph Co., Victor distributor, this city, was an indefatigable worker in the money-raising campaign of the Welfare Federation conducted in this city from October 24 to November 5. This campaign constituted the combined efforts of 130 charitable institutions of the city and received the whole-hearted support of local business men. Mr. Miller was selected as a captain of one of the campaign teams.

A. J. Catterson With Everybody's

The volume of business being done by Everybody's Talking Machine Co., this city, in talking machine parts has reached the point where the services of a traffic manager were found to be an absolute necessity. A. J. Catterson, Jr., a professional traffic manager of many year's experience, has been appointed to that important position. The work of an executive of this character is found to be of exceptional assistance to the shipper of merchandise. Through the careful routing of shipments several days are often saved in the receipt of merchandise as well as money saved in the cost of delivery. The appointment of Mr. Catterson to this position at the beginning of the heavy Fall and holiday business will be a service that will be felt and appreciated by all the dealers doing business with Everybody's Talking Machine Co., and is still further evidence of the growth of the Everybody's organization.

N. Snellenburg & Co. Add to Sales Force

Announcement has just been made by Everett W. Keefe, manager of the Edison department of N. Snellenburg & Co., that he has added four new salespeople to his rapidly growing staff. These include: John A. Usher, who was formerly connected with N. Snellenburg & Co. as an Edison salesman and who has just returned to the same capacity after an absence of two years in the West. Mr. Usher entered the music publishing field two years ago and traveled considerably, with the result that he has added greatly to his already wide acquaintanceship among Edison dealers and the trade in general.

Raymond Crawford, formerly with the local Dictaphone branch of the Columbia Co., has also allied himself with the Snellenburg house under

Mr. Keefe's direction. Mr. Crawford has spent many years in the musical field in and around Philadelphia, which should prove a decided asset to him in promoting sales in that city and its suburbs.

Miss Mary Heyburn, who has already had experience in the musical field, has been placed in complete charge of the re-creation department and will devote most of her time to re-creation customers.

Miss Eleanor Brunt, who has been with N. Snellenburg & Co. for a little more than a year, has been appointed assistant to Mr. Keefe in charge of the offices and will direct the mail service to owners which is being conducted on a large scale by the department.

Well Pleased With Trade Outlook

The Louis Buehn Co., Victor distributor, finds that the business of its dealers is improving steadily as the Fall season progresses. The retailers are putting themselves whole-heartedly behind the weekly releases and are, accordingly, substantially increasing their volume of record business. A number of visitors have called at the headquarters of the Louis Buehn Co., on Arch street, during the past month, among them being Elmer B. Hunt, of the Portland branch of Sherman, Clay & Co., and M. Housel, of the M. H. Housel Co., Williamsport, Pa. The Louis Buehn Co. has taken on the Audak agency for

its territory. Inquiries for this demonstrating device have been received from a number of prominent dealers and a large demand for Audaks is expected.

Philadelphia Badge Co. Products in Demand

The record cleaners, combination needle container and record cleaner, and other devices produced by the Philadelphia Badge Co., are now found to be receiving world-wide recognition. Orders are being received from all over the world, until there is not a country on the globe to which these cleaners have not been sent. In several instances, J. Abrahams, president of the company, reports that these foreign houses have simply clipped the advertisement from The Talking Machine World and sent their orders in without the formality of first requesting a sample.

Special Shipping Case for Edison Salesmen

If there are to remain any merchants in the territory covered by the Girard Phonograph Co., Edison distributor in this city, who are not familiar with the Edison phonograph it will not be the fault of that company's staff of field representatives.

Each of the company's four representatives has been provided with a specially built shipping case sufficiently large to hold a \$295 upright model of Chippendale design. These are
(Continued on page 88)

A Big Christmas Proposition

The Treasure Chest

This package set of six Victor records, described on page 195 of the October "Voice of the Victor," furnishes an added opportunity for substantial profits. Send to us for full information.

H. A. WEYMANN & SON, INC.

1108 Chestnut Street Philadelphia, Pa.

VICTOR WHOLESALERS



TRADE MARK

"All that the name implies"

To know that the part you get is the right one, and genuine, is the first and most important step in a satisfactory and enduring repair job on your motor; and to get that part promptly is the next important consideration. From the smallest screw to a completely assembled unit, we give you accurate, speedy service.

Let us co-operate with you in making 1923 your banner year.

GUARANTEE TALKING MACHINE SUPPLY CO.

109 N. TENTH STREET, PHILADELPHIA

JOBBER'S

REPAIR PARTS

GRAPHITOLEO

ALBUMS

BRILLIANTONE

NEEDLES

SAPPHIRES

JOBBER'S

MOTORS

TONE ARMS

SOUND BOXES

ADDATONES

3-IN-1 OIL

ATTACHMENTS

THE TRADE IN PHILADELPHIA AND LOCALITY—(Continued from page 87)

shipped to towns and cities where new representation is desired and recitals are given to all of the merchants likely to become prospective Edison dealers.

Since the plan was inaugurated a few weeks ago several new dealers have already been reported and the Girard Phonograph Co. is highly elated over its success.

Now a Departmental Feature

The phonograph business, formerly the exclusive feature of the Davies Phonograph Co., in both the stores at 534 West York street and 4231 Germantown avenue, is now converted into a department of the expanded furniture store which has been opened at the West York street address, and which may be the development of the Germantown avenue establishment as well. Although the furniture sales will be the main feature of future business, the sales of Sonora and Edison phonographs will remain as a departmental activity. The proprietor, J. Harry Davies, has been in business many years.

Todd's Store Being Re-equipped

The name "Todd" is thoroughly impressed on piano and record buyers of Philadelphia, so much so that an expansion in his sales facilities has become necessary. In addition to some improvements in his first floor facilities the Unit Construction Co., of this city, has just installed a second floor talking machine and piano display room that increases his capacity for service almost 50 per cent and a big jump in sales is expected.

Dealers Tie Up With Paul Specht

Columbia dealers in this city made a great tie-up with Paul Specht and His Orchestra, exclusive Columbia artists, when they appeared recently at Keith's Theatre in this city. The Philadelphia branch employees attended the



Trucks Featuring Paul Specht

opening night performance in a body, and a new Columbia phonograph, together with proper signs, was placed in the lobby of the theatre and remained there the entire week of the performance. The attraction was further broadcasted by large signs, featuring Paul Specht's appearance, which were displayed on Columbia delivery trucks.

Chandler & Neuman, Columbia dealers, Fresno, Cal., secured prospects and made sales through a display at the Fresno County Fair.

PROGRESS OF CHENEY SALES CORP.

Cheney Resonator, Live House Organ of the Cheney Talking Machine Co., Pays Tribute to Its Distributor in Eastern Territory

In the October issue of the Cheney Resonator, the official organ of the Cheney Talking Machine Co., Chicago, the remarkable progress and accomplishments of the Cheney Sales Corp., Eastern distributor of the Cheney line,



G. Dunbar Shewell

are described, and glowing tribute is paid to its president, G. Dunbar Shewell, in an article captioned "Cheney Sales Corp. Does Wonderful Work; G. Dunbar Shewell, His Son and His Able Assistants Are Making the Cheney a Power in Eastern Talking Machine Trade."

It is pointed out that the Cheney Sales Corp., although starting in a modest way, now has offices located in Philadelphia, Boston and New York, with sales organizations that have grown tremendously, as was necessary to cover the broad territory which is its field. G. Dunbar Shewell, president, is in every sense an executive, in touch with every detail of his large organization. He has, therefore, become somewhat of a nomad, traveling between the various offices, which he does regularly each week. Mr. Shewell has sprung from an old Philadelphia family and was in the music business for many years prior to his formation of the Cheney Sales Corp. His knowledge of local Eastern conditions, plus that of the music industry, well fits him for his present position. Another instance of Mr. Shewell's executive ability is that he has surrounded himself in each office with associates of the highest caliber.

Illustrations are shown of G. Dunbar Shewell, president, as well as G. Dunbar Shewell, Jr.,

who is associated with his father and gives most of his time to advertising, general publicity and the organization of sales methods and campaigns throughout the extensive territory of the company.

On the first page are also shown the handsome new display rooms and offices of the Philadelphia branch of the Cheney Sales Corp., which were recently opened in the new Jefferson Building, that city. Both Mr. Shewell, Jr., and senior have their headquarters in these offices,



G. Dunbar Shewell, Jr.

together with D. H. Fulmer, local manager. At the same time there are shown illustrations of the Cheney departments of two of the large Philadelphia department stores, Strawbridge & Clothier and John Wanamaker, both served by the Cheney Sales Corp.

An article on "How Not to Sell—A Tale of Weird Adventure in Three Shocks" is an interesting story written by Mr. Shewell, describing his efforts at buying in another branch of the music business, with a pertinent epilogue. Of interest to the trade at large are findings presented by Mr. Shewell, entitled "Why and How Business Will Be Good This Winter," in which he analyzes the prospects and finds them good. Summing up Mr. Shewell's reasons in short form, he presents the following as the result of his analysis: First, everybody is optimistic; second, the public buying power is as great as it ever was, if not actually greater than ever; third, dealers are roused to see that they must work harder to get business.

One of the most recent music stores to open in Northampton, Mass., is The Record Shop, 181 Main street. The proprietor is J. H. Meisse, who is specializing in records. Hallet & Davis phonographs also are handled.

The Player-Tone

IT'S SIMPLY GREAT

No Better Tone Instrument In the World

TWO

High Grade Lines of Phonographs With a Price That Will Sell

Every instrument on this page is exceptionally good, regardless of price, with the house back of it for years.

We offer you phonographs that are masterful in their perfection of high grade cabinet work, exquisitely finished by skilled workmen, and when you sell one of these perfect tone producing instruments, you prepare the way for another sale.

The more closely you analyze our high grade construction, combined with perfect tone quality, the more fully will you realize its unqualified value.

Write for our booklet and net prices, which are exceptionally low, in large or small quantities of either line.

Player-Tone Talking Machine Co.

Office and Salesrooms

632 Grant
Street

Pittsburgh,
Pa.



New List \$100.00
Model 17
Brown Mahogany or
American Walnut
Round Ivory Horn,
record shelves, gold
equipment.



New List \$125.00
Model 20
Brown Mahogany Only
Music Master Horn
No. 44 Motor, record
album filing device.
All exposed parts gold-
plated.



Model 100
Height, 36"; width, 36";
depth, 24". Adam Brown
Mahogany or American
Walnut.



Model 125
Height, 36"; width, 36";
depth, 24". Adam Brown
Mahogany or American
Walnut.



Model 40
All gold equip-
ment, with 5
record filing al-
bums. \$150.00



\$150.00
Model 901
All Gold Equipment



\$80.00
Model 310
Mahogany and Oak



\$100.00
Model 311
Oak or Mahogany



\$110.00
Model 314
Oak, Mahogany or Walnut



\$125.00
Model 316
Oak or Mahogany

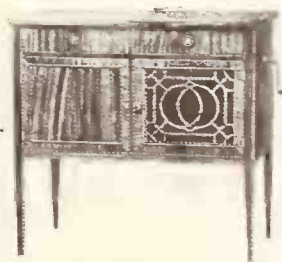

Model 30
All gold equip-
ment, with 5
record filing al-
bums. \$135.00

M I L W A U K E E

Retailers Fear Shortage of Most Popular Instruments—Outlook Promising for Big Holiday Rush—Trade Activities of the Month

MILWAUKEE, Wis., November 7.—There is no fear among Milwaukee talking machine men that business in November and December will not be good or that it will not outstrip by a healthy margin the best holiday season on record. The only fear that exists is among the men selling the more popular and best-advertised lines, for the shortage which was predicted at mid-Summer and repeated ever since that time already has become an actuality, and the jobbing trade here is now confronted by the problem of allocating their supplies among their retailers. It is safe to say that by Christmas Eve there will be few, if any, instruments left on the sales or warehouse floors.

Victor Shortage

"With our factories working night and day they do not seem to be able to give us enough instruments," said Harry Goldsmith, secretary of the Badger Talking Machine Co., Victor jobber in Wisconsin and upper Michigan. "We are sorely behind on scheduled deliveries right now and some of the most popular sellers are not coming in in sufficient numbers to give dealers all they need to cover current orders. Business is just fine, with the possible exception of the shortage of merchandise that is staring us in the face. The country districts are waking up after a rather quiet Summer and city dealers are figuratively selling their heads off. I do not know that Milwaukee is any exception, but trade here is mighty satisfactory."

Enthusiastic Over Sonora Prospects

Fred E. Yahr, president of Yahr & Lange, and Irving S. Leon, sales manager of the musical merchandise division, spoke with much enthusiasm of immediate and prospective business. This big Sonora wholesale house, which also distributes the Okeh and Odeon records, has achieved extraordinary success in the lower Michigan territory, which was added to its jurisdiction two months ago. Business in the old territory of Wisconsin and upper Michigan is exceeding every past mark and the holiday season is confidently looked upon as the biggest in history. "We are going like the proverbial house afire," said Manager Leon, speaking of October business and the volume piled up so far in November. "Our only worry is getting all the goods we must have by December 20, so that our loyal dealer organization will be satisfied. Our retailers are putting across a splendid line of business. Wisconsin enjoys a peculiarly good position which is helping to make good talking machine business better even in the rural districts. The Wisconsin farmer is not grumbling like his fellow in the one-crop wheat States. Corn and oats are the big crops, and they are bringing good prices.

But it is not grain, but dairying that is the backbone of Wisconsin agriculture, and farmers have ample funds to buy more than the bare necessities. In Milwaukee, the city of diversified industries, every able-bodied man who wants to work is busy. Our factories are running along in great shape and there is no unemployment. More dwellings have been built here in the past season than ever before in history, and every new home furnishes a live prospect for a talking machine. These parts are a wonderful field for the Sonora, I am here to say!"

Among several new salesmen added by Yahr & Lange is Harry M. Hahn, who returns to the company as manager of the retail talking machine department, after several years with the Milwaukee Piano Mfg. Co.

Yahr & Lange were among the leading exhibitors at the annual Food, Household and Electrical Exposition held here, in connection with which they staged a local Sonora Week, which is described on another page of this issue.

New Columbia Models Popular

The new Columbia models are attracting a ready response to intensive sales cultivation, while the Columbia record is selling at a rate heretofore unknown. The smaller, as well as the larger, dealers in Milwaukee are full of praise of the status of Columbia in popular esteem. Jack Kapp, record supervisor at the Chicago branch, called on the local trade a few days ago and was very much pleased with conditions.

Brunswick Demand Exceeds Supply

P. H. McCulloch, manager of the talking machine division of the Brunswick-Balke-Collender Co.'s Milwaukee branch headquarters, has been making numerous trips across Lake Michigan to Muskegon to speed up deliveries, for which dealers in the Wisconsin and upper Michigan territory are crying. His visits into the field and the opinions given by dealers who recently have visited the branch house confirm the belief that November and December will turn over the heaviest volume the Brunswick line has ever had in this part of the country. The Brunswick record has become a serious contender for the right to be classed as "the most popular."

J. B. Bradford Branch in New Home

The J. B. Bradford Piano Co., 411 Broadway, moved its South Side store into its permanent new quarters at 608 Mitchell street, on October 20. The store is almost a duplicate, in miniature, of its downtown store. A Victor franchise has been secured for the South Side store. Heretofore the Victor has been handled at the main store only. The Brunswick and Vocalion

thus are given a most amiable but aggressive companion in the Bradford branch.

Celebrates Fortieth Anniversary

Edmund Gram, Inc., is celebrating the fortieth anniversary of the establishment of its business in 1883. Mr. Gram, who has just turned sixty, is one of the imposing figures in the American music trade. He was the first Cheney talking machine dealer in this city and also handles the Brunswick and Columbia. The business has a record for development along steady substantial lines equalled by few similar merchandising enterprises in this country. Clean business has brought about this result.

Record Edison Demand

Edison dealers in Milwaukee are enjoying excellent business and, with the support of more advertising and other promotion, have built up the largest volume this line has ever experienced in Milwaukee.

Kesselman-O'Driscoll Co.'s Display Best

The Kesselman-O'Driscoll Co., dealer in the Victor, Edison and Brunswick, was awarded the premier honors for the beauty of its display at the recent fifth annual Food, Household and Electrical Exposition, held in the mammoth Milwaukee Auditorium. Practically every make of talking machine was represented in the music division, which was combined in Juneau Hall, one of the smaller ground floor rooms just off the main arena. All of these displays were beautiful and the judges reported that it was a most difficult task to make a selection of the best.

A \$750 Sonora offered by the exposition management as second prize in a State-wide contest among amateur orchestras was given the Bach Orchestra, of Madison, Wis.

KENT CO. RUSHED TO MEET DEMAND

The F. C. Kent Company, 67 Grace street, Irvington, N. J., manufacturer of the well-known Kent adaptor and other products, including tone arms and sound boxes, has found it necessary in recent weeks to add considerably to its manufacturing force, the demand of the trade for the Kent adaptor having increased over 40 per cent during the Fall season, according to the records of the sales department. In order to make deliveries on the other Kent products it will be necessary for the factory to work its force overtime between now and the holidays.

JAMES W. BRIGHT IN NEW POST

CINCINNATI, O., November 7.—James W. Bright, formerly connected with the Cincinnati Brunswick branch as a salesman, and later with the Cleveland Brunswick organization, has been made manager of the new Brunswick department of Alms & Doepke, which opened here on November 1. Mr. Bright is a man of exceptional ability and his wide experience in the talking machine business should prove a valuable asset to the new concern.

NATURELLE

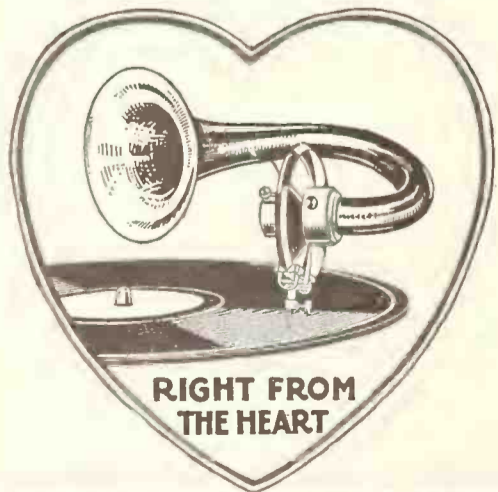

For
Portable
and
Cabinet
Phonographs

The Naturelle Co.
125 East 23rd St.
New York, N. Y.

NATURELLE is the original Reproducer of its kind—a chemically prepared wooden diaphragm—with complete sound box and horn attachment. Buy NATURELLE and you get the natural voice of the singer and instrument, very distinct and musical, without the metallic sound which the mica diaphragm gives out. All infringements will be prosecuted. Beware of imitations.

—specially designed for the Talking Machine Trade

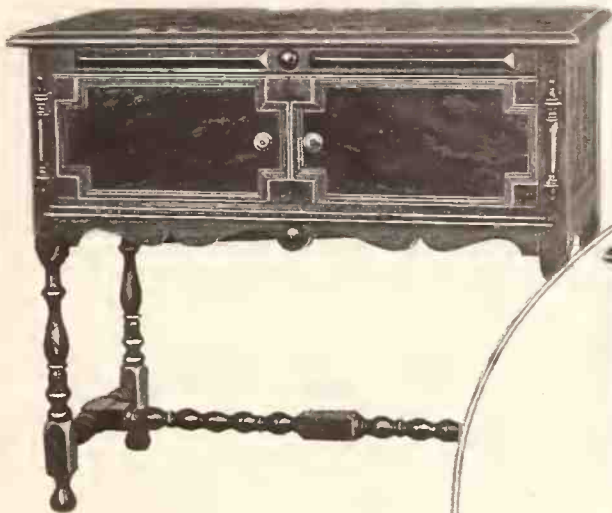

Cutting and Washington Radio Receiver 11C—cabinet design console type. Completely self-contained, a three-tube set that has proved in comparative tests to have higher selectivity and volume than any other instrument in its class.

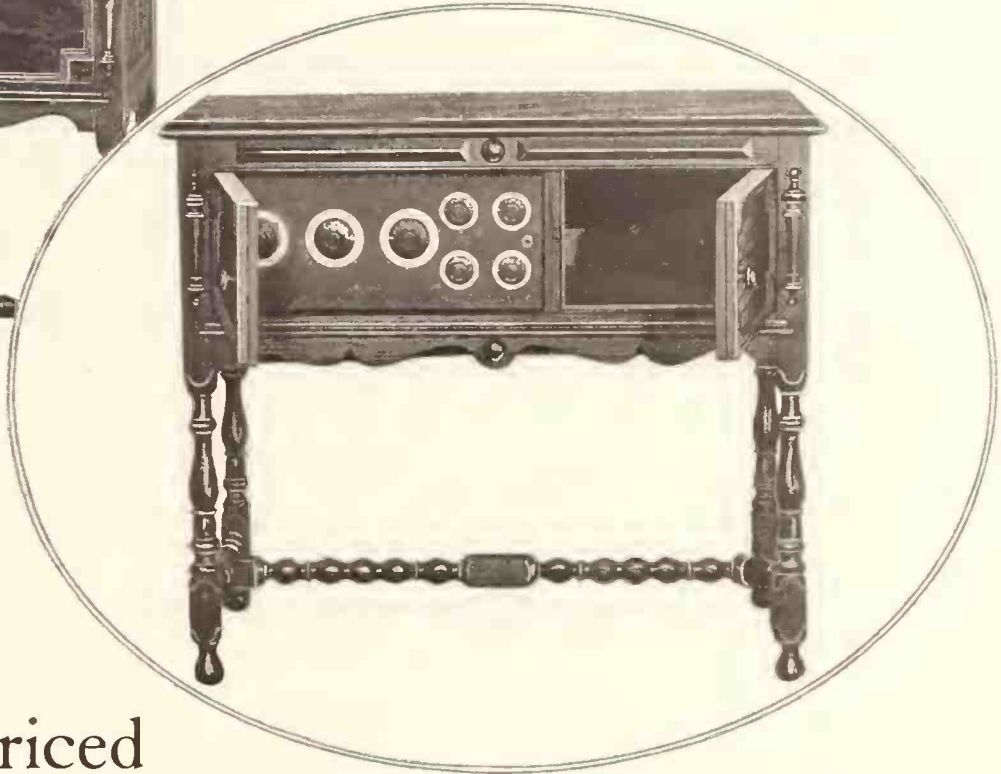

A moderate-priced Cabinet Receiver—Console Type

Here at last is the instrument which enables the talking machine dealer to enter confidently into the radio business, feeling that he is now assured of success.

Designed by Cutting and Washington, two of America's best-known radio engineers, pioneer manufacturers of radio equipment—a concern with strong financial backing that has a reputation for service. This new instrument is the leader

of the C. & W. line, which covers all ranges of price. All sets licensed under the Armstrong Patents—admittedly the best for radio reception.

Dealers securing the C. & W. franchise are given territorial protection and backing by a comprehensive advertising campaign.

Secure the details at once and be in position to profit by the radio business this Fall and Winter.



Cutting and Washington Receiver 12A—"Town and Country" model (portable type). A two-tube set which makes an ideal receiver both for the home and for outing use. For either single circuit or double circuit.

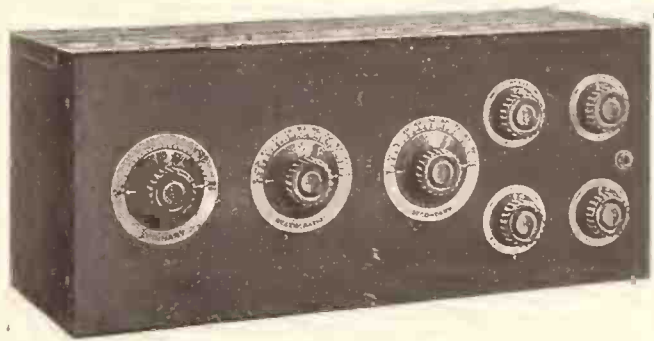

Cutting and Washington Radio Receiver 11A—similar in mechanical design to the receiver used in the cabinet model but of the box type—an instrument that has already had a big sale all over the country.

TALKING MACHINE
DEALERS & DISTRIBUTORS

Write for full details of the Cutting and Washington dealer plan and copy of the book, "The Future of Radio Retailing," sent without obligation to Talking Machine Dealers.

Cutting and Washington Radio Corp.
Operating Station WLAG—"Call of the North"
Minneapolis Minnesota

Cutting and Washington

America's oldest manufacturers of commercial radio

CLEVELAND

Planning Next Year's Convention—Jobbers Aiding Dealers by Timely Sales Helps—L. Meier & Sons' Anniversary—The News

CLEVELAND, O., November 7.—Unity of music trade interests is being demonstrated at this time here in the combination of forces of the Music Merchants' Association of Northern Ohio and the Cleveland Music Trade Association to make the convention of the Music Merchants' Association of Ohio, to be held in Cleveland next September, the biggest event of its kind ever attempted. The two local factions represent the talking machine and piano interests, which are combined largely in the State Association.

At meetings held during the last few weeks a strong committee has been appointed. This is headed by George M. Ott, the G. M. Ott Piano Mfg. Co. With him are Harry P. Valentine, Henry Dreher and William G. Bowie, the Dreher Piano Co.; Edward B. Lyons, the Eclipse Musical Co.; George R. Madison, the Cheney Phonograph Sales Co.; Louis Meier, the L. Meier & Sons Co.; Otto C. Muehlhauser, the Muehlhauser Bros. Piano Co.; C. H. Randolph, Randolph House of Good Music; A. B. Smith, the A. B. Smith Piano Co., Akron, and Rexford C. Hyre, association secretary.

Launch Drive for Funds

At first an elaborate program of musical events was planned, in order to raise funds to defray convention expenses. These were outlined at previous meetings. At the first meeting of the committee, however, it was seen that sufficient funds may be raised right within the local bodies and a campaign has been started to raise that fund. If additional money is needed, and this will be known by the end of November, the program as outlined originally will then be considered.

Jobbers Co-operating

Meanwhile jobbing factors are doing more than their bit to assist the dealer in getting started right for the 1923-1924 season. One unusual effort in this direction has been instituted by the Eclipse Musical Co. Large framed window cards have been prepared for use by all Cleveland Victor dealers. These cards tell that the Philip Spitalny Orchestras in the Hanna and Grebe restaurants and in the Allen Theatre will play at least two Victor record selections during each week. In the restaurants cards will be hung up when these record selections are being played. On the framed window cards a blank space has been left and here the dealer can attach extra small strips with the selections printed thereon. This will mean that much publicity will be given to certain records by one of the leading musical directors of the city, and give the dealer a chance to cash in in a manner he has not had before. Moreover, the

records will be distributed on the Friday preceding the Sunday on which they will be played at the different gathering places, giving the dealer two Saturdays in which to do business.

Edison Tone-tests

The tone-tests that have been a feature of Phonograph Co. activities in the distribution of the Edison will be a feature again this year. Arrangements have been completed by E. S. Hershberger, secretary, for a series in and near Cleveland for Edison dealers. It is planned to have twelve such concerts, starring Miss Elizabeth Spencer, soprano; Miss Lucille Collette, piano, and Harold Lyman, flute. Their appearances in Cleveland will be in Glenville Auditorium, by Dealer F. W. Rose, and on the West Side by Dealer George C. Lang.

Stresses Importance of Timeliness

To help dealers increase their record sales, timeliness is being emphasized by the Cleveland Talking Machine Co., Victor wholesaler. Every day wherein something unusual in music has developed, regardless of its significance, that development is capitalized. A brief statement covering the event and records that are appropriate to the occasion are listed on a post card and sent to dealers. This series has not only stimulated record sales, but is giving the dealer strong talking points that lead to sales of the better class of selections, according to W. D. Sayle, member of the Cleveland Co.

Another Aid to Dealers

Another aid to dealers, one that usually cannot be bought at any price, has been inspired by C. H. Kennedy, local distributing representative of the Bush & Lane Duo Vox. The Sunday editor of a newspaper in a nearby city was so impressed with the musical qualities of this instrument that he decided to make a first-page story, with pictures, for the magazine section.

Carola Accounts Result of Exhibit

In the recent National Exposition, held at Public Hall, one of the exhibitors was the Carola Co., with N. I. Schwartz, general manager, in charge. The exposition attracted merchants from distant points and, according to Mr. Schwartz, numerous new accounts among the retailers were opened. Shipments to these new dealers were made daily during the exposition as soon as orders were received.

Brunswick Get-together

What looks like an annual event for Brunswick dealers may be seen in the second get-together held by the local Brunswick district office at the Hotel Winton. The event marked the return to the Cleveland district of the Oriole Orchestra, for a month's propaganda work in

this vicinity, their first appearance this time being in the Winton Rainbow Room. More than 200 dealers and their associates, coming from all parts of this territory, attended. During the early part of the day they visited local Brunswick headquarters, where they viewed the latest models and incidentally placed orders for a total of 520 machines, according to Leslie I. King, district manager of the phonograph division. Here also they obtained first-hand information on business conditions generally and on the talking machine trade particularly from J. F. Ditzell, sales promotion manager. In the afternoon the visitors went about the city and in the evening they attended the dinner dance at the Winton.

Changes in the staff of the Brunswick in this territory include the appointment of F. H. Burbec, formerly with the C. C. Miller Co., Pittsburgh Victor distributor, for Pittsburgh territory. Maurice Sternlick will handle the Syracuse, N. Y., section.

L. Meier & Sons' Anniversary

Probably the biggest undertaking by an individual dealer will be the presentation, for two performances, of the Eight Famous Victor Artists by the L. Meier & Sons Co., Victor dealer, in the largest West Side theatre in town. This event will hold forth toward the end of November to celebrate the firm's twenty-sixth anniversary, which will be held during the greater part of the month. Prizes, including twenty-six Victrolas, will be given away each day. Balloons will be sent aloft with lucky numbers attached. Music will be a weekly feature during the celebration. The intrepid Louis Meier, head of the firm, is being complimented by dealers from distant points for his astuteness in bringing the Artists' aggregation to Cleveland. The Artists have been heard here before, but it was an association effort that brought them here, not an individual dealer's ability and nerve.

Merchants' Meeting to Be Social Affair

To strengthen the talking machine faction in the Music Merchants' Association of Northern Ohio, the November meeting, on the nineteenth, will be made a social affair, with a dinner dance in the Georgian Room of the Hotel Cleveland. The committee handling this event includes Dan C. Baumbaugh, the May Co.; Edward B. Lyons, the Eclipse Musical Co.; William G. Bowie, the Dreher Piano Co.

Columbia Artists Aid Record Sales

Ted Lewis and his jazz artists were guests of S. S. Larmon, branch manager of the Columbia Phonograph Co., while that aggregation was in town. While here Mr. Lewis made the Remick Music Shoppe his temporary headquarters and signed records which were bought avidly by the crowds that came to see him. Likewise, he signed a two-year contract to make records for the Columbia Co. while in Cleveland.

The new Detroit branch of the Columbia Co. will henceforth be located at 439 East Fort

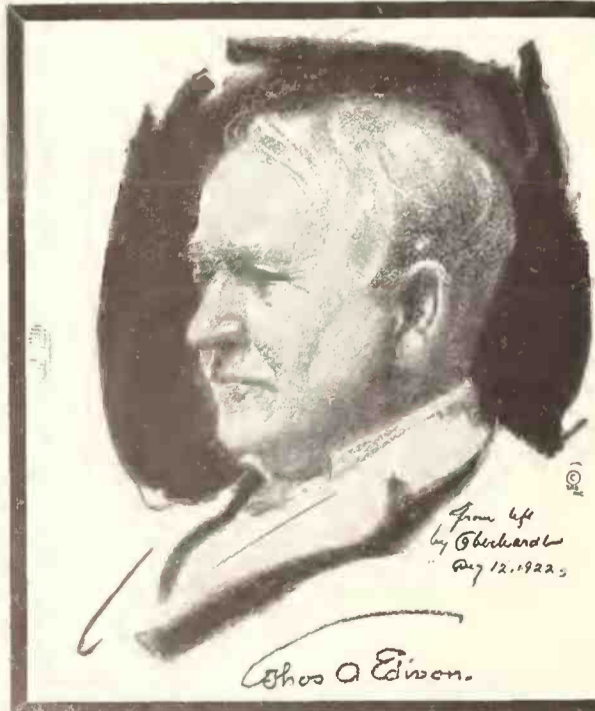

Make Your Store the Musical Center

of your community by adding The New Edison to your business.

The New Edison adds PRESTIGE and PROFITS; both are essential for success.

Edison is First in Quality, Cabinets and Late Hits. (New records are issued weekly.)

We are now oversold for the holiday trade so cannot accept new dealers until after January first. In the meantime write us for our latest dealer proposition.

THE PHONOGRAPH COMPANY

Exclusive Edison Distributors

Cincinnati, Ohio:
314 West Fourth St.

Cleveland, Ohio:
1240 Huron Rd.

street, that city, lease for which was closed recently by Branch Manager Larmon.

During the appearance of Kiraly Erno, Hungarian violinist, in Cleveland, Mr. Larmon was host to Hungarian Columbia dealers, a box party being arranged for the occasion.

Big Sonora Ad Drive

One of the most consistent advertising campaigns in the trade is being conducted by the Sonora Phonograph Ohio Co. under direction of J. T. Pringle, general manager. As new dealers are added to the Sonora list here they are included in this publicity, until now more than twenty such dealers are getting this representation. This is part of the general program here to assist the dealer in his Fall and Winter business campaign. It is a natural follow-up of the Sonora situation, Mr. Pringle points out, since practically the entire quota of machines for this territory has been absorbed by orders previously placed, and new business most likely will have to wait upon this early demand being filled from both Cleveland and Cincinnati warehouses.

Unique Sonora Exhibit

Another Sonora feature is the establishment of an exhibit at the second busiest corner in the country, Euclid and East Ninth, where the Cleveland Trust Co. donates the use of some of its space to Cleveland business interests. This exhibit, sponsored by the Buescher Co., contains the parts of the Sonora instrument, with instructive data explaining their use. This exhibit had to be bid for weeks in advance, so popular is the location with local manufacturers and distributors.

Dealers Feature New Red Seals

Official release of the new double Red Seal Victor records here was marked by a full-page advertisement in local newspapers, duplicating the national Victor advertising, in which both jobbers and dealers took part. The Eclipse Musical Co. and the Cleveland Talking Machine Co., jobbers, and the Bailey Co., May Co., Euclid Music Co., Buescher Co. and Dreher Piano Co. filled out the page.

Popular Prices Stimulate Demand

Popular prices for new models are considered one of the factors that are stimulating the talking machine demand in this section at this time, in the opinion of George R. Madson, president, the Cheney Phonograph Sales Co., back from a tour of his dual territory. This accounts for the new business by dealers running well ahead of the better seasons in recent years, Mr. Madson believes.

Diaphragm Co. Launches Campaign

Expansion of activities for the violin spruce reproducer, handled by the Diaphragm Co., already is under way, according to H. C. Cooley, sales manager. Publicity is being distributed wherein the consumer will be reached direct. Another advertising program in a large list of class journals is being planned, in which attention of the consumer will be directed to this company's products. T. C. Findley has been appointed distributor in the Chicago territory. Prices of the different models of the instrument have been reduced, since greater outlet has increased production and consequently lowered production costs.

Plans Unico-equipped Department

The C. L. Kauffman Furniture Co., of West Twenty-fifth street, is planning for active business in the talking machine department. During the recent visit of George Lyons, of the Unit Construction Co., Philadelphia, Pa., plans were developed for a Unico-equipped department, the installation of which will be made the latter part of the month.

Many Dealers Add New Lines

The period has been productive of more new dealers being added by the jobbing interests here than for any similar recent period. These include: Edison—Madison Music Shoppe and the Antisdale-Mathys Co., Cleveland; Degart & Bittner, Sandusky; C. Schwarzwaelder, Willoughby; Frank Cerne, Cleveland; A. C. Burgess, Oberlin. Victor—Stewart's Music House, Warren, which takes over the interest there



Old and New Phonographs Are Vastly Improved With a VIOLIN SPRUCE REPRODUCER

Models for Columbia, Victor, Cheney, Vocalion, Sonora, Claxtonola, Vitanola, etc.....	Dealers' Samples Nickel \$3.00
EDISON ATTACHMENT	3.60

Dealers' Discounts and Terms upon request

THE DIAPHRAGM CO., 1836 Euclid Avenue, CLEVELAND, OHIO

Order Direct or from Your Nearest Distributor

Louis Jay Gerson
63 Reade Street
New York, N. Y.

T. C. Findley
Illinois Diaphragm Co.
280 N. Wabash Ave.
Chicago, Ill.

of M. V. DeForest & Son; Soriano Music Co., Niles, which takes over the M. V. DeForest & Son interest there; Howenstine Music Co., Louderville. Brunswick—Miltner Piano Co., Cleveland; East Liberty Spear Co., East Liberty, Pa.; Schroeder Piano Co., Pittsburgh and New Castle, Pa.; the Rosenbaum Co., Pittsburgh; M. Nathan, Johnstown, Pa.; C. A. Focht Co., Wellsboro, Pa.; J. W. Houck Co., Buffalo; Lincoln Furniture Co., Buffalo. Sonora—Mintz Piano Co., Cleveland, which is opening a new downtown store. Columbia—Hulshoff Clothing Co., Lockport, N. Y.; Columbia Music Shoppe, Buffalo; Williamsville Pharmacy, Williamsville, N. Y.; Merle High, Convo, O.

Thousands Visit "Talker" Salon

One of the most attractive features conceived by a dealer of this city for some time has been the talking machine salon conducted at the William Taylor Son & Co. A similar show was held a year or so ago, but this one surpassed the first attempt—in the amount of space devoted to it, in the elaborate hangings and

floor coverings used, in the wide variety of makes and types of machines shown and in the music used to demonstrate them. Instruments featured during this showing included the Victor, Sonora, Brunswick and Cheney lines. The event lasted ten days, somewhat longer than the original show, and attracted the attention of thousands of persons, many of whom are likely prospects.

Buescher Ties Up With the Opera

Buescher's Music Store in this city is using the back cover in the official program issued for the Wagnerian Opera Co., which will give eight performances in this city at the Masonic Auditorium, beginning November 20. In its advertisement on the cover, Buescher's features the Odeon recordings of Schubert's "Unfinished Symphony," which were made under the supervision of Eduard Moericke, who will conduct the orchestra for the Wagnerian Opera Co. in the Masonic Auditorium. The advertising calls particular attention to the fact that the Odeon recordings of the "Unfinished Symphony" are furnished complete in one album.



To have pioneered the perfection of tone reproduction in what is today the most popular of musical instruments. required

Genius

To set a standard that would so perpetuate the immortality of the world's greatest musical celebrities, was demonstrative of good

Judgment

To maintain unparalleled leadership as a natural consequence of devotion to an ideal, bespeaks

Generosity

Those are the high lights in the history of the Victor organization moving ever onward with the trend of the times.

To make our service to Victor dealers as preeminent as the Victrola itself, is the privileged purpose of the Eclipse organization.

Console models, of course, are leaders. Keep them on display.

THE ECLIPSE MUSICAL CO

VICTOR WHOLESALERS CLEVELAND OHIO



Every Night I Cry Myself To Sleep Over You

"You can't go wrong
With any FEIST song"



Ev-'ry night I cry my-self to sleep o-ver you, —

A FOX TROT BALLAD—with a punch in both melody and lyric

© LEO. FEIST INC
N.Y.C.

O. P. GRAFFEN'S IMPORTANT POST

Appointed General Sales Manager of Vox Corporation of America, With Headquarters in New York—Widely Known and Esteemed

The many friends in the trade of O. P. Graffen will be glad to learn that this popular talking machine man has just been appointed general sales manager of the Vox Corporation of America, with headquarters at 25 West Forty-fifth street, New York. Mr. Graffen assumed his new duties on November 1, and he is now



O. P. Graffen

busily engaged in making sales and publicity plans for a gigantic campaign in behalf of Vox products. The Vox name, while comparatively new on this side of the Atlantic, is a recognized leader in the phonograph industry abroad, and among the products that will be merchandised through Mr. Graffen's organization are records, spring and electric motors, sound boxes and tone arms.

O. P. Graffen needs no introduction to the talking machine trade throughout the country, as he has been identified with the industry for many years and has attained success and popularity in his various associations. A number of years ago Mr. Graffen was connected with the Victor Talking Machine Co.'s traveling department and subsequently joined the Columbia Phonograph Co. where he was exceptionally successful as a member of the New York sales staff. He won the esteem and friendship of the dealers wherever he called, through his ability to cooperate with them along practical lines.

In recent years Mr. Graffen was identified with the General Phonograph Corp., manufacturer of Okeh and Odeon records, and the Granby Phonograph Corp. In the capacity of general Eastern manager of the latter organization, with headquarters in New York, he built up a very large clientele for Granby

phonographs and won recognition as one of the foremost members of the wholesale talking machine fraternity throughout the Eastern territory.

In securing Mr. Graffen as general sales manager, the Vox Corporation of America is to be congratulated, for he brings to his new work an unusually wide experience in the talking machine field that embraces practically every phase of merchandising and salesmanship. He knows and understands the dealer's problems and can, therefore, assist Vox representatives in develop-

ing their business profitably and permanently.

In speaking with The World, Mr. Graffen was very enthusiastic over the quality of Vox products. He particularly pointed out the Vox records which, although well-known abroad, he predicts, will contain, without doubt, many surprises for the trade here on their clearness and quality. According to Mr. Graffen's present plans his company will merchandise its products through jobbers and dealers, and within the next few weeks the details of his campaign will be ready for announcement.

CO-OPERATES WITH VICTOR DEALERS

Musical Instrument Sales Co. Issues Timely Sales Help—Designed to Aid Record Sales

The Musical Instrument Sales Co., New York, Victor wholesaler, through its service department, has distributed among metropolitan Victor dealers photographs of scenes from "Poppy," one of the musical comedy hits in New York, featuring Madge Kennedy. The Victor record responsible for this unusual service and co-operation is "What Do You Do Sunday, Mary?", a dance number that gives every indication of being a big hit during the next few months.

The company's service department has already announced a practical form of co-operation consisting of a four-page folder, entitled "Analysis of Better Records." This folder is

issued weekly coincident with the release of new Victor records and from each weekly list there are selected five or six records that are particularly noteworthy. These records are analyzed carefully and practical information is given to the dealers and their clerks. Suggestions are made as to the most likely class of prospects and the most interesting features of the record, and a list is given of records by the artists making the particular selections presented. These folders can be used to advantage in the stimulation of record sales and the Musical Instrument Sales Co. has been congratulated upon its activities in preparing this interesting data.

The formal opening of the W. Bentley Stevens Music Shop in Deep River, Conn., was held recently. Souvenirs were given to patrons attending the reception.

PERFECT SATISFACTION

From your Talking Machine can only be realized by using a Perfect Needle.
Why not therefore secure the best and always insist on getting

DE LUXE NEEDLES

Perfect Reproduction of Tone *No Scratchy Surface Noise*

PLAYS 100-200 RECORDS

DUO-TONE COMPANY, INCORPORATED

Sole Manufacturers of De Luxe Needles

ANSONIA, CONN.

Price 3 for 30 Cents

Liberal Trade Discounts

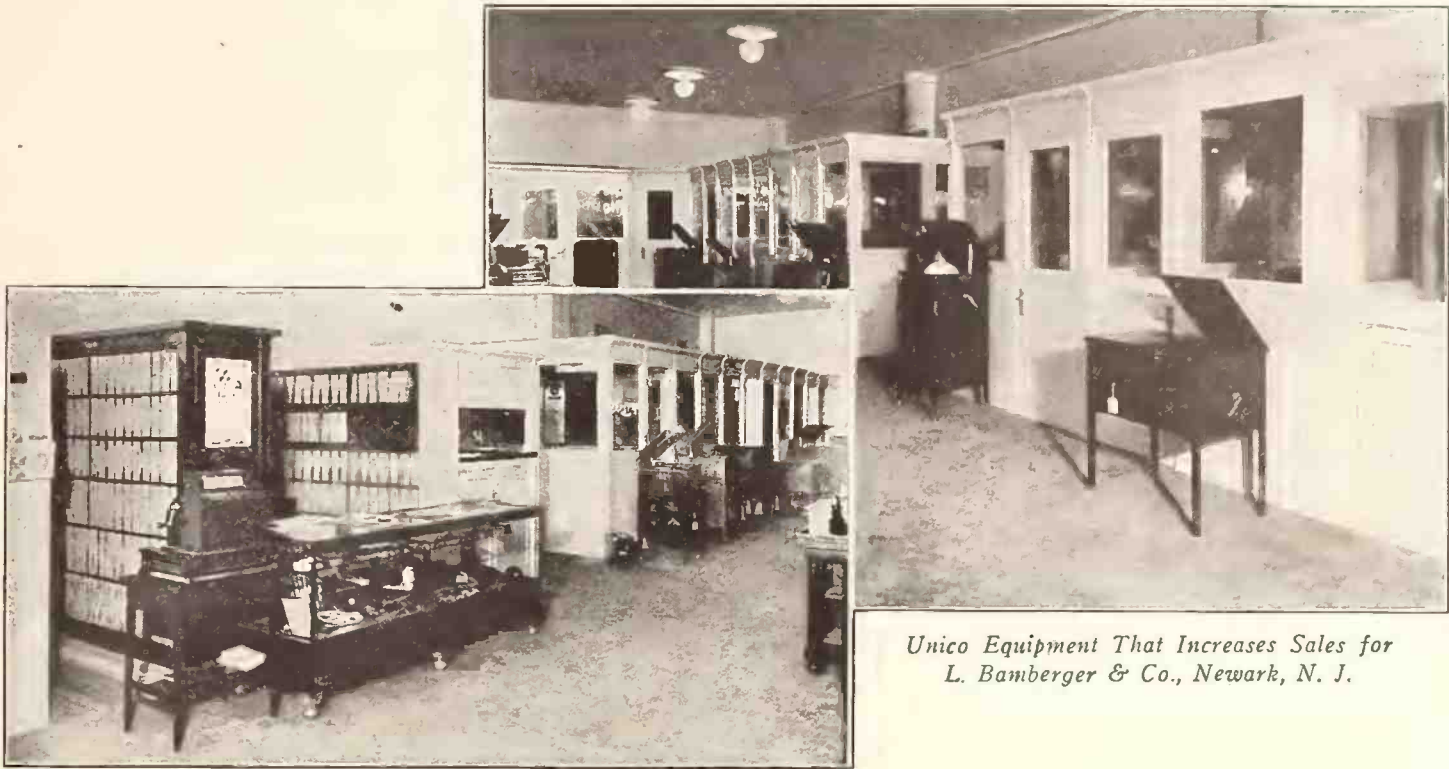

Unico Equipment That Increases Sales for
L. Bamberger & Co., Newark, N. J.

Profit Now—Pay Later!

New terms of exceptional value *now*—store equipment 100% efficient for Fall and Holiday Trade; payments conveniently distributed.

DEFERRED terms are new—but quality and business building ability are old; the same that has brought satisfaction to over 3700 users.

INCREASED sales invariably follow an installation of Unico Equipment—a quality product sells more readily in a quality atmosphere.

FACE facts! Machine and record buyers are more discriminating than they have been in years past. Create in your store an atmosphere in harmony with your business; the sale of an art product.

DON'T lament the fact that "the standard records do not sell"—they *do* sell but they must be *sold* in audition rooms where comfort and surroundings approximate home conditions.

TRUE, some records are *bought* without trial hearing or with a half-hearted demonstration—but you can't *sell* that way.

ADEQUATE Audition Room facilities—efficient store planning sell most records and machines. Unico Equipment gives best facilities—don't delay—consult Unico TODAY.

Immediate shipment from stock. There is still time for you to increase your sales.

UNIT CONSTRUCTION COMPANY

Kern Dodge, Receiver

58th St. and Grays Ave.

PHILADELPHIA, PA.



Tunes that are in the air —



THE REWARD OF ENTERPRISE

J. A. Wuchter Music Co., Allentown, Pa., Has Record of Sixteen Years of Growth—Opens Year-end Drive—Large Radio Stock

ALLENTOWN, PA., November 5.—Sixteen years ago the J. A. Wuchter Music Co., 927 Hamilton street, started in the phonograph business in this city. It has handled the celebrated Columbia line all these years and to-day boasts of one of the finest stores of its kind to be found in any other city of like size.

To properly inaugurate the Fall and Winter season, the store recently held a formal opening, which lasted three days. The interior was properly decorated for an occasion of this kind.

An added feature, grown to large proportions, is the radio department. Scouting the future of the radio business, Mr. Wuchter started in a small way to build up a radio department. He handles such leading makes as DeForrest radio sets, Radio Corp. of America line and Music Master radio amplifiers.

USEFUL NEW PLAZA BULLETIN

Handy Reference Guide for Use of Talking Machine Dealers and Salesmen

The Plaza Music Co., well-known manufacturer and distributor, has just mailed to the trade a six-page bulletin carrying data, prices and illustrations of its complete line of phonograph accessories. The bulletin is issued in two colors and is divided into twenty-four sections, making a ready reference guide.

The sales department of the Plaza Music Co. has issued this little publication, bearing in mind the fact that such merchandise brings added revenue to the dealer's coffers. Many of these products can be sold at the time the initial sale of talking machines is made. At any rate they are marketable to practically every talking machine owner.

The Brunswick Shop, 847 Orange street, Wilmington, Del., H. C. Miller, proprietor, has reopened.

"TREASURE CHEST" AS XMAS GIFTS

C. Bruno & Son, Originators of These Sets, Urge Dealers to Make the Most of Their Pre-Christmas Sales Opportunities

Victor retailers and distributors have placed themselves energetically behind the "Treasure Chest," produced by C. Bruno & Son, Inc., New York City, Victor distributors, until at the present time this set has received wide distribution and many reorders are being received.

In the October Voice of the Victor a full page is devoted to the "Treasure Chest" and the idea of selling records in sets rather than single record sales. It will be remembered from previous announcements that the "Treasure Chest" is an attractively cartoned set of six ten-inch, double-disc records from the Victor catalog, carefully selected to carry out the idea of "musical gems from foreign lands." Supplied with the set is descriptive matter thoroughly explaining the musical theme of each record, making for greater appreciation and enjoyment of the different selections.

As originally stated, the "Treasure Chest" is in no sense of the word a commercial development of C. Bruno & Son, Inc. It was instigated largely by the desire to introduce the sales of sets of records that would intensify the interest of the public in record music. C. Bruno & Son, Inc., are co-operating with both dealer and distributor in the exploitation of this new idea. A series of dealer helps, well destined to help the dealer increase his sales, have been originated. In a recent letter to the trade attention is called to the desirability of the "Treasure Chest" as a holiday gift and its appropriateness in both appearance and popular price. As an additional aid to dealers in the development of sales two letters were prepared and enclosed. These letters, designed to stimulate interest in the "Treasure Chest," are for dealer distribution. There were also enclosed suggestions for window card copy. Four-color window cards, size twenty inches by thirty inches, have been prepared to be supplied to the dealer at absolute cost.

Although the "Treasure Chest" is in every sense of the word a novelty it is, at the same time, decidedly a staple product and, therefore, the intensive work of the present time is the foundation upon which dealers may build up a substantial superstructure for years to come.

CINCINNATI CONCERN IN NEW HOME

CINCINNATI, O., November 5.—Arthur Brand & Co., distributors of Spencerian portables and phonograph repair parts, and manufacturers of the popular Ellis reproducer, are now occupying larger quarters at 1618 Vine street, in this city. The company was formerly located at 1602 Race street, with warerooms on Elm street, but with the rapid expansion of its business it found these quarters inadequate. In its new home the organization will be under one roof with ample facilities for giving the trade which it serves efficient service.

THE TROTTER ELECTRIC MOTOR

Is an Attractive Retail Proposition
for Phonograph Dealers

Easily Installed

Will Run on Any Current

Guaranteed for One Year

The Trotter motor can be sold to any one who owns a spring motor driven phonograph. Any one can install it and when following printed instructions can change his phonograph into an electric machine in ten minutes.

Plymouth Phono Parts Co.

PLYMOUTH

WISCONSIN

DISTRIBUTORS

Plaza Music Co., 18 West 20th Street, New York

Lakeside Supply Co., 73 West Van Buren Street, Chicago



Federal

RECORDS

50¢ Standard Retail Price **50¢**

FEDERAL RECORDS meet the steadily increasing demand for a First Class, Popular Priced Record that will afford reputable Dealers both Profit and Protection.

WHY have FEDERAL RECORDS created this new market and **WHY** have protected Federal dealers found them to be a fine business stimulator? Here are the reasons:

QUALITY—In Tone Values, Durability and Beauty of Finish, FEDERAL Records are unsurpassed at any price. They reflect the skill and experience of twenty years of successful record making.

LATE HITS—All the newest Dance and Vocal Hits, recorded by nationally-known artists, appear first on **Federal** in Monthly and Special Releases. In addition there is a large and varied catalog of Standard, Classical and Sacred Music.

SERVICE—**Federal Service** means prompt deliveries, a definite Sales Plan and hearty co-operation in every way.

PROTECTION—Exclusive territory to live dealers guarantees them a permanent as well as a profitable business.

Write for our Dealer's proposition at once!

FEDERAL RECORD CORPORATION

(Formerly The Indestructible Phonographic Record Co. Established 1900)

ALBANY, N. Y.

Recording Laboratory: 108 East 16th Street, New York City

IN DES MOINES

Record Business Dominates Trade—Harger & Blish Arrange Series of Tone-Tests—Look Forward to Big Holiday Business—The News

DES MOINES, IA., November 8.—Retailers of talking machines in this city and territory have reported October as a rather dull month for machine sales. The record business, on the other hand, has been unusually brisk for this time of the year. Retailers attribute part of the increase in the record business to the "no-approval" policy governing the sale of records in the city. An unusual number of good releases has also augmented the normal business.

Jobbers report business as very good. Dealers are placing their orders for Fall and Winter goods and most of the orders show good increases over last year's Fall buying. Dealers supplied by Des Moines jobbers have found business better than expected during the Summer. Consequently they are placing orders with more confidence than a year ago. Jobbers claim that the dealer who has resumed aggressive sales policies has enjoyed a good volume of business this year.

All connected with the talking machine and record industry are looking forward to an excellent holiday business. The general employment situation over the State is good, and Iowa dealers are basing their estimates for increased business on that fact. Several flourishing Victrola clubs have been started by Victrola dealers of the State. Harger & Blish will offer special Edison numbers for Christmas. The Duning Co. has announced a special offering of Christmas records by Gennett in attractive holiday folders. Gennett's offering, according to the Duning Co., will include selections by several well-known movie stars. One side of the record will be given over to some standard Christmas selection.

Increase in Portable Business

An unusual feature of October's business was the increased volume of portable machine business reported by the Duning Co. It is generally assumed that the portable season for Iowa ends with the vacation days, but, by concentrating sales efforts on schools, the Duning Co. increased its portable business over the record for September. The machines went mostly to smaller schools, where the expense of anything but a portable machine would have been prohibitive.

Gennett Iowa Records Popular

Through the efforts of W. D. Duning, of the Duning Co., Gennett has recorded two new Iowa numbers whose popularity promises to be as great as that of the "Iowa Corn Song." "On, Iowa," is a number of especial interest to alumni of Iowa State University, where it has become very popular. On the reverse side of the record Gennett has recorded "Men of

Iowa," a spirited march by O. E. Van Doren, bandmaster at the university. The two numbers were recorded under the supervision of Mr. Van Doren, who made the trip to the Gennett plant for that purpose. Since the release of the new number, on October 20, the Duning Co. has been flooded with orders.

Tone Tests Arranged by Harger & Blish

Harger & Blish have announced a new series of "tone test" concerts, to be held the two weeks following November 19. Three Edison artists, Elizabeth Spencer, soprano; Lucile Collette, pianist and violinist, and Harold Lyman, flutist and saxophonist, will be heard. Some ten or twelve concerts will be held at various points over the State.

Dealers Establish Trade-in Allowance

At the last regular monthly meeting of the Des Moines Music Merchants' Association a new retail policy was discussed and finally adopted. Feeling that somewhat large trade-in allowances have been demanded from and allowed by dealers, the Association decided to establish a maximum allowance on "off-brand" machines. In the future not over \$30 will be allowed for a used machine, unless the instrument is of standard make. Five or six well-known machines were designated as standard machines by the dealers.

Victor Record Business Good

According to H. B. Sixsmith, of the Mickel Bros. Co., the Victor record business during

SERVICE AWARDS FOR AEOLIANITES

Those in Employ of Company for Ten Years or More Presented With Certificates and Pins at Annual Get-together Dinner Held Recently

One hundred and forty-six members of the Aeolian Co. organization, who had been in the service of that company for ten years or more, were awarded service certificates and appropriate pins at the annual get-together dinner of the Aeolian Employees' Association held at the Hotel Majestic on Monday evening of last week and attended by over 450 men and women. Among the officials of the company who received awards for service were E. S. Votey, vice-president; W. V. Swords, vice-president and general manager; H. B. Schaad, secretary; W. H. Alfring, general sales manager; Herbert T. Proudfit, advertising manager; Charles H. Addams, manager of the wholesale piano department, and Charles A. Laurino, retail sales manager. The real veteran of the group receiving awards was Isaac R. Barbour, of the delivery department, who has a record of forty-two years of continuous service.

ILSLEY'S GRAPHITE PHONO SPRING LUBRICANT

Ilsley's Lubricant makes the Motor make good. Is prepared in the proper consistency, will not run out, dry up or become sticky or rancid. Remains in its original form indefinitely.

Put up in 1, 5, 10, 25 and 50-pound cans for dealers. This lubricant is also put up in 4-ounce cans to retail at 25 cents each under the trade name of

EUREKA NOISELESS TALKING MACHINE LUBRICANT

Write for special proposition to jobbers

ILSLEY-DOUBLEDAY & CO., 229-231 Front St., New York

last month was exceptionally good. Part of the increase in business, he claims, was due to the adoption of the weekly release plan. The double-facing of Red Seal records has also made Victor releases popular among buyers.

Hugo Heyn, of the Mickel Bros. Co., has resigned his position to become a partner in the All Makes Typewriter Co., of Omaha, taking charge of the dictating machine department.

Belle Hendrix Smith, of the Mickel Bro. educational department, delivered a series of talks on the subject of "Music Appreciation" before the County Teachers' Institute at Eldora, Ia., during the latter part of October. The Victor Health Exercises were also demonstrated.

Takes Charge at Chase & West

W. McGlasson has been appointed manager of the Victrola department of Chase & West, this city. He has had long experience in the talking machine business.

Mickel Bros. Co. reports the appointment of Zona Berg & Son, of Superior, Neb., as Victor dealers at that place.

Port's Victor Parlors, of Vinton, Ia., recently arranged with the Presbyterian minister of that place to give a program of sacred selections on the Victrola. The selections were illustrated with stereopticon views as the selections were given.

During the course of the evening short addresses were made by Mr. Swords and Mr. Proudfit, and also by H. S. Jewett, of the wholesale promotion department, who told of the development of the Duo-Art music fantasy "Sonia's Song." The fantasy was then presented with Sergei Barsukov as the featured artist. During the course of the evening other entertainment was provided by Irving Kaufman and Monroe Silver, Vocalion recording artists. Robert M. Richter, president of the Aeolian Employees' Association, presided.

An elaborate minstrel show, consisting of talent drawn exclusively from the Aeolian organization, was presented at Aeolian Hall Monday night, November 5. It was a huge success in every way.

G. R. SUTTON OPENS NEW STORE

LIVINGSTON, TEX., October 30.—A new music store has been recently opened here by George R. Sutton, formerly in the music business at Lufkin. The store will be situated in the Polk County Enterprise office building.

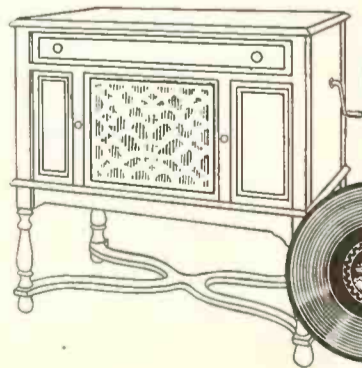

Edison



COMPARISON WITH THE LIVING ARTIST
REVEALS NO DIFFERENCE

HARGER & BLISH DES MOINES



THE VOICE OF THE WORLD



Introducing

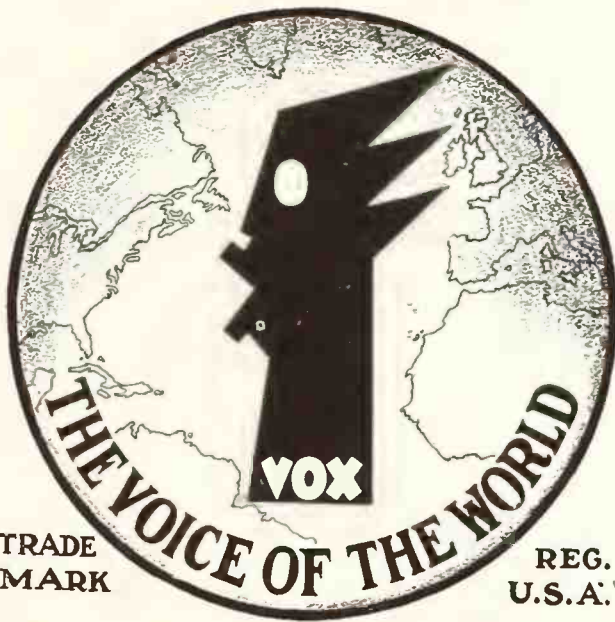

This VOX trade-mark represents a line of talking machine and kindred products that are recognized throughout Europe as the highest achievement in technical perfection.

Among the most prominent of these products are: Records in all Foreign Languages—Phonographs—Electric and Spring Phonograph Motors—Wooden Sound Boxes and Tone Arms—Accessories—Dictating Machines—Electric Typewriters.

These VOX products are now about to be placed upon the American market.

It will pay all *Dealers* and *Jobbers* to investigate VOX products, both from the standpoints of larger profits and the satisfaction derived in using or selling an article that will make good reputations better.

We will shortly make further announcement of more definite plans and list our first releases of the VOX Foreign Records.

In the meantime VOX makes its bow to the talking machine industry of America.

VOX CORPORATION OF AMERICA
25 WEST 45TH STREET
NEW YORK U.S.A.



THE VOICE OF THE WORLD



The Trade in **BOSTON** *and* **NEW ENGLAND**
 JOHN H. WILSON, Manager
 324 WASHINGTON ST., BOSTON, MASS.

DEALERS HEED ADVICE TO STOCK UP FOR HOLIDAY BUSINESS BY EARLY AND HEAVY ORDERING

Care Noticeable in the Selection of Lines—Shortage in Some Quarters Expected—Postpone Music Exposition—Planning for Music Week—Other Important News and Activities

BOSTON, MASS., November 7.—October saw a good business all along the line; most of those in the talking machine trade were pretty well satisfied, but there were those who did not make so good a report of the month as did others. The jobbers say that the advice offered annually to the trade to lay in their stocks early has been heeded pretty generally, though there has been more care exercised than ever before in choosing the lines of goods, for the most part the more expensive types of machines having the early and generous call. There is a feeling in some quarters that after all there is to be a shortage with some manufacturers of goods, and that some dealers are going to feel it keenly at the eleventh hour. The current month ought to be a good one; in fact, traditionally it ought to considerably exceed October which has a fairly satisfactory record.

Postpone Music Exposition

The music exposition originally planned for the last week of November at Mechanics' Building, and which has been mentioned several times in *The World*, has been postponed until Spring. The various concerns which had become interested as exhibitors have pledged themselves to take space if it is decided definitely to hold the exposition in the Spring.

Organizing for Music Week

Meantime the trade in New England has had brought to its attention the nation-wide observance of the week of May 4, "Music Week," which already has received the endorsement of prominent persons locally. Mayor Curley has promised the city's fullest co-operation in the movement, in which schools, churches, theatres and musical organizations will take a leading part. The city council will be asked to set aside an appropriation. At a meeting held at the Boston Art Club a temporary organization was effected and among those attending the meeting were John A. O'Shea, who is identified with the music department of the Boston public schools; Frank C. Brown, a local architect; Chester I. Campbell, who has steered to success a great many large shows and expositions; Courtenay Guild,

head of the Apollo Club, a leading singing society of Boston; Professor John P. Marshall, of Boston University; Frank P. Spear, president of Northeastern College; Mabel Daniels, who has been active in managing private shows and is a composer of merit. Mrs. William Arms Fisher, director of education of the National Federation of Music Clubs, was chosen director of the undertaking, with authority to appoint a chairman, treasurer and secretary.

Preparing Billboard Campaign

Kraft, Bates & Spencer, Inc., of which Harry Spencer is the head, and who are the New England representatives of the Brunswick, are preparing their annual illuminated, painted billboard campaign throughout Boston, and some very catchy material has been made ready for these displays. There are three big artists who are soon to appear in Boston whose records already are being widely called for, these being Bronislaw Huberman, violinist, who plays at Jordan Hall November 8, and who is expected to call at the Boston offices of Manager Spencer; Segrin Onegin, who appears at Symphony Hall on November 25, and Josef Hofmann, who also is to appear at Symphony Hall.

Heavy Brunswick Demand

Harry Spencer states that the Brunswick business was very heavy in October, and the indications are that it will be big right up to the holidays. He expresses the belief that there is to be a shortage of Brunswick goods and there are some types that it is difficult to secure even now. Harry's brother, Lloyd Spencer, has just returned from a two weeks' trip to Maine, where he visited the bigger cities only, and he found business in the Pine Tree State to be of a most satisfactory nature.

Cheney Business Booms

The Cheney Sales Corp., of which Stephen A. Colahan is the head, and whose headquarters are at 376 Boylston street, reports that the Cheney business in the New England territory has exceeded all expectations and the new Cheney console, known as Style 119, has been especially in favor locally, and already the out-

Victor Loyalty Pays

Exclusively



Wholesale

The Eastern Talking Machine Co.
 85 ESSEX STREET
 BOSTON MASS.

put consigned to Manager Colahan has been exhausted. A new dealer, who has been signed up to carry the Cheney, is E. W. Guillimette, of 782 Manchester, N. H., who has a very artistically arranged store, where several of the best models of the Cheney are attracting much attention. Another new dealer to carry this line is Harry W. Seaford, of 17 Forrest avenue, Portland.
 (Continued on page 100)

DITSON SERVICE

Has back of it years of successful experience and an understanding of the dealer's problems that will make the road smoother for him during the busy months to come.

Service From Two Big Centers

OLIVER DITSON CO.
 BOSTON

CHAS. H. DITSON & CO.
 NEW YORK

**DITSON
 VICTOR
 SERVICE**



Love of Good Music Is Not Limited to Any Class, Creed or Race

The NEW EDISON

Through its marvelous REALISM, bringing to actual LIFE the subtle personalities of the artist, perfect technique, the individual tone of voice and instrument, this

phonograph, The NEW EDISON, fully meets every desire of all exacting MUSIC LOVERS. It will bring increased patronage to every Edison Dealer's store.

FULL CABINET MODELS IN CONSOLE AND UPRIGHT DESIGNS, \$100 UP

Certain
Localities
Offer Dealer-
ship Opportuni-
ties. Write us.

THE PARDEE-ELLENBERGER CO., Inc.

Edison Jobbers for New England

26 Oliver Street

Boston, Massachusetts

Edison
is
FIRST
with
HITS

THE TRADE IN BOSTON AND NEW ENGLAND—(Continued from page 99)

land, Me. He has recently taken a store on the street floor and his Cheney business is reported to have been very good from the start.

Changes in General Corp. Territory

The General Phonograph Corp. in its New England territory exceeded its quota for October and Manager N. B. Smith is elated that business in the Okeh and Odeon lines is "making good" in his field. The especial success during October was due in part to the fact that there were a number of new pieces brought out during the month, these including "That's a Lot of Bunk," "Marcheta" and "Last Night on the Back Porch." There has been a slight shifting of territory in the New England field of the company. Charles E. Hodgkins, who heretofore had the Boston territory, beginning November 1, had assigned to him the territory north of Boston, extending from Lynn to Haverhill, and the Boston field will be taken care of by Manager Smith and Assistant Manager P. J. Donovan, who will divide the territory between them. At the present time the quarters of the General Phonograph Corp., at 142 Berkeley street, are sorely pressed for sufficient room because of the large stock of records that the concern has to keep on hand. A Boston caller a few days ago was W. C. Fuhri, general sales manager of the corporation, who expressed himself as immensely pleased with the volume

of business that is being done throughout the New England territory.

A Letter to Sonora Dealers

J. H. Burke, sales manager of the Sonora Phonograph Co. of New England, Inc., apropos the recent experience which the company has passed through, has issued a circular letter to the company's New England dealers, which in part reads as follows:

"We wish to confirm the notification you have already received from the New York office, to the effect that the temporary receivership of the Sonora Phonograph Co., which was granted on the application of two stockholders, has been vacated. The press of the country has already published the statement given out by the chairman of the executive committee and the president of the Sonora Co. to the effect that the company is now experiencing the greatest prosperity in its history, with unfilled orders of over twice what they were a year ago, notwithstanding increased production, and that net earnings have never equaled the present figures. The situation is therefore definitely cleared up in a way that reflects greatly to the credit of the Sonora Co. The entire situation is, of course, regrettable, but when the fact is appreciated that the difficulty was due to the desirability of controlling the stock of a corporation which is as fundamentally healthy as

Sonora, no ill effects shall result from it, but on the contrary greater confidence than ever before will be reposed in Sonora's product and policy by the trade and by the public."

Incidentally, it is of special interest that the New England department has not been called upon to accept the cancellation of a single order, which speaks well for the standing of the Sonora in this territory.

Ideal Music Co. Adds Sonora

A new dealer to take on the Sonora is the Ideal Music Co., which is located on Broadway, Chelsea, which store is in charge of I. Grood, who has had a long experience in the talking machine business. There is to be an official opening of this store on November 10 and several of the Sonora men from the Boston headquarters will go out for the occasion.

Trinity Radio Models Please

H. A. Robbins, of the Trinity Phonograph Co., makes a very encouraging report on the progress that the Trinity radio is making in the New England field, and he says that it is with difficulty that orders can be filled. The instrument is put out in console models only and the cabinet work is especially mentioned by those who examine the instrument carefully.

Double Red Seal Records in Favor

The wholesale Victor business has been very good these last few weeks, according to Manager Kenneth Reed, of M. Steinert & Sons, who also states that the double Red Seal records are finding favor, not only in the trade but with the buying public as well. There has been an especially large demand for the most popular numbers of the great artists.

Brunswick Executives in Town

Two Boston visitors who paid a visit to Harry Spencer's headquarters within the last week were P. I. Deutsch, secretary of the Brunswick Co., and Sinkler Darby, chief recorder at the Brunswick laboratories, who came to town direct from Los Angeles, where he had been to make some experiments in recording a large orchestra.

Parke Willis, Jr., a Local Visitor

A Boston caller lately, who has come in close touch with the Victor trade, was Parke Willis, Jr., of the production department of the Victor, and who made a pretty thorough canvass of the New England territory, calling on dealers in Bridgeport, New Haven, Springfield, Worcester, Portland, Bangor, Nashua and Lowell.

B. M. O'Brien Ends Long Tour

B. M. O'Brien, who is in charge of the Columbia department at Smith Bros.' Store, Washington street, this city, has just completed an automobile trip of 2,600 miles through New England and up into Canada. Mr. O'Brien stopped off at the Canadian phonograph exposition in Toronto, where he says an entire building was devoted to talking machines. He says he picked up a lot of valuable information at

We Serve New England!

DEALERS who are being served by us have no concern regarding the type of service that they will receive during the holiday rush. Theirs is the confidence that comes only from continually receiving the same dependably prompt, accurate, and efficient service during all seasons of the year.

Due to the marked demand that exists for ODEON and Okeh Foreign Language Records we are carrying extra large stocks of records in Italian, Polish, German and other foreign languages. We still continue our maintenance of a special list of all Irish Records.

**General Phonograph Corporation
of New England**

142 Berkeley Street

Boston, Mass.

Okeh Records



Buy
Okeh
Needles
They
Keep
Record Sales
Alive!

sales talks which he attended which will be of great use to him in his business.

Miss Ethel Armitage Promoted

Miss Ethel Armitage, under the tutelage of Mrs. Alice W. Graves, record and stockkeeping expert of the Boston branch of the Columbia Phonograph Co., and also of Roland Luce, has become head of the record department of Lord & Co., Inc., 440 Essex street, Lawrence. Miss Armitage is quite enthusiastic over the manner in which the customers of the house accept the Columbia New Process record hits.

Eastern Co. Giving Mail-order Service

The Eastern Talking Machine Co. has just put out a mail-order book that is a distinct credit to the house. There is a carbon and the buff-colored card, which will be the one sent into the office, carries the printed name of the home office, and a one-cent stamp. There are twelve order blanks in the book, and the last one is red, the receipt of which by the company indicates that it is time to send another book. Although this mail-order book has been out only a few days several returns have been received and with good orders, some from dealers who have not been sending in orders for goods in large quantities of late. The book is being sent out to all the Eastern Co.'s customers throughout New England.

William J. Weyand a Benedict

William J. Weyand, who is of the repair department of the Henderson store at 32 Boylston street, Boston, was married on Sunday evening, October 28, to Miss Mae C. Sweeten, of Dorchester, the ceremony having been performed at St. Ambrose's Church, that section. Mr. Weyand is a friend of Mayor Curley and the couple were the recipients of a beautiful gift from His Honor. Mr. and Mrs. Weyand went on a honeymoon trip by auto through the White Mountains and they are to make their home at 7 Leonard street, Dorchester.

Lester Jones on Empire State Trip

Lester Jones, of the talking machine department of the Hallet & Davis Co., has lately been on an extended trip through New York State, taking in a number of the principal cities, and visiting the Hallet & Davis dealers at each place in the interest of the instrument which this big Boston house puts out.

Pushing New Lines

Sharmat & Son, now located at 28 Court square, have just received a new consignment



TODAY, Not TOMORROW,

is the time to send in your order for Victrolas.

A shortage on certain popular types already exists which we regretfully predict will spread to other models during the busy season.

Your order should NOW be on file with your Wholesaler, assuring you of participation in shipments as they are received from the Factory.

Do It Now

M. STEINERT & SONS

Victor Wholesalers

35-37 Arch Street Boston, Mass.

Consult Us for Proposition on DeForest Radio Merchandise

ANYWHERE IN NEW ENGLAND

of Arionolas and Nationals, the latter coming from the factory of the National Console Phonograph Co., and for both of these lines the concern is finding many customers. The location, close to the City Hall annex, is in a good downtown section of the city.

New Strand Dealers

Arthur C. Erisman is happy in the fact that the Strand line went big during October; in fact, it was the biggest month since he has had this line for the New England territory. Mr. Erisman has been over in Philadelphia, having motored over the road with friends, spending several days en route in New York, Wilmington and Baltimore. New Strand contracts that Mr. Erisman has been able to sign up lately have been the Happy Home Furni-

ture Co., of New Bedford; Nugent Furniture Co., Lawrence, and the new store of the Atherton Furniture Co., Portland, Me. A caller a few days ago at Mr. Erisman's office was Mr. Gibbs, of the Meiklejohn Co.'s Pawtucket store.

A dealers' service table is the latest thing to be installed in Mr. Erisman's quarters at 175 Tremont street. Those dealers who have inspected the idea are quite enthusiastic over it and have planned to install something similar in their own stores.

Arthur Champagne Engaged

An engagement of interest in the trade is that of Arthur Champagne, manager of the Grafo-nola Shoppe at Hudson, and Miss Mary Margaret Kelly, of Watertown. Mr. Champagne is receiving congratulations of many friends, in Columbia circles especially, since this is the talking machine line that he has much to do with.

Allston Shop in Better Location

The Allston Music Shop, which handles the Columbia line, has moved to a new location on the opposite side of Brighton avenue, Allston, a very advantageous location. The removal was found necessary because of growing business and the store is now on the side of the thoroughfare which sees the larger crowd of passers-by.

Equipping Caldwell Co. Store

J. H. Crane, of the Unit Construction Co., has been over this way, having come to equip the talking machine department of the Caldwell Furniture Co. in Malden, and Upham's Piano Rooms, also in that city.

Pleased Over Mr. Fleischman's Success

The good news percolates to Boston that Herman Fleischman, lately of M. Steinert & Sons and who is now in Worcester, is decidedly making good as head of the talking machine department of the Marcellus Roper Co., and his many friends are correspondingly delighted.

Columbia at Fairs

Columbia dealers have been profitably displaying the new Columbia models at the county fairs throughout New England, in which Salesman Ingalls co-operated with a number of the dealers in seeing that the line was properly exploited.

Miss Lillian Mugford Weds

The marriage of Miss Lillian Mugford, secretary to R. O. Ainslie, of the Hallet & Davis Co., a fortnight ago to Albert Curley, at Quincy, (Continued on page 102)

KRAFT-BATES AND SPENCER INC.
NEW ENGLAND DISTRIBUTORS

New Brunswick Records Every Day

No waiting now for Brunswick records—they come NEW EVERY DAY. A constant stream of the novelties in music to bring customers into the store of Brunswick dealers every day, instead of once a month.

Always something in advance to play for the record customer. The public is pleased. The sales of records prove it. Dealers like it. Their profits prove it.

Brunswick records can be played on any phonograph. Brunswick phonographs play all records.

KRAFT, BATES & SPENCER, Inc.
80 KINGSTON STREET, BOSTON, MASS.
New England Distributors

Steel Needles Motrolas Record Brushes Khaki Covers

Getting More AND Giving More

The **CHENEY**

The Master Phonograph

The success which the Cheney has achieved, the character of the merchants who sell it, the appreciation of those who have purchased it, and the fairness of Cheney prices bespeak a line of unusual merit.

Cheney success is undoubtedly due to the ability of a quality product and exclusive Cheney franchise to give more and thereby getting more.

If you are interested in generous and permanent phonograph profits, we urge you to write at once.

We offer the maximum of service to Cheney dealers in the above territory.

Cheney Sales Corporation
(Distributors)

376 Boylston St., Boston 1015 Chestnut St., Philadelphia 1107 Broadway, New York
G. DUNBAR SHEWELL, Pres.

THE TRADE IN BOSTON AND NEW ENGLAND—(Continued from page 101)

was an event that was of special interest a few evenings ago. When Miss Mugford left her desk she carried away with her a chest of silver, the gift of the officers of the company and her fellow employes. She and her husband are to make their home in Detroit, Mich.

New Pooley Dealers in New England

W. B. Glynn, of the W. B. Glynn Distributing Co., Saxton's River, Vt., exclusive distributor for the Pooley phonograph in New England territory, visited Springfield, Mass., recently to meet Howard Hodson, manager of production and sales for the Pooley Co. in order to arrange for a large allotment of Pooley console models. Although his firm had recently received fifteen carloads of these new models, Mr. Glynn considered it advisable to get an increase in the allotment in order to satisfy the demand in New England for this product.

Recent additions to the Pooley dealers are as follows: N. W. Brown Piano Co., Springfield, Mass.; Flint & Brickett Co., Springfield, Mass.; A. B. Clinton Co., Hartford, Conn., and New Haven, Conn.; Feinblum-Peizer Music Co., Hartford, Conn.; Loomis Temple of Music, New Haven, Conn.; Miller's Music Shop, New Haven, Conn.; Piquette Piano Co., Bridgeport, Conn., and Shelton, Conn.; Boston Store, Ansonia, Conn.; Kemp's Music House, Manchester, Conn.; Talking Machine Shop, Norwich, Conn.; Kane Furniture Co., Boston, Mass., and Woonsocket, R. I.; Rhode Island Supply Co., Providence, R. I.; Parkinson Piano House, Providence, R. I.; Meiklejohn Co., Pawtucket, R. I.; B. L. Rich Piano Co., Fitchburg, Mass.; Fitchburg Music Shop, Fitchburg, Mass.; Atherton Furniture Co., Taunton, Mass., Plymouth, Mass., and Waterville, Me.; McWhirr Dry Goods Co., Fall River, Mass.; New Bedford Dry Goods Co., New Bedford, Mass., and C. F. Wing Co., New Bedford, Mass. These recent additions to the Pooley family in New England make it necessary for Mr. Glynn to solve the problem of securing merchandise rather than endeavor to build up sales.

Enormous Vocalion Business

The Vocalion business throughout New England during the past month was simply enormous, according to Arthur Erisman, and it is an interesting and significant fact that with the announcement of the return of the musical comedy, "Little Nellie Kelly," in a few weeks to

the Tremont Theatre, there has been an immediate revival of interest in these records, which were made immediately following the premiere of this piece at this same theatre a year or more ago. Two of the biggest hits in the Vocalion line lately have been "She's Just a

Girl That Men Forget" and "House of David Blues." These records have gone big.

New Edison Models in Demand

October proved an unusually large month with the Pardee-Ellenberger Co., Inc., and Mr. Silliman says that there is sure to be a shortage of Edison outfits, judging by the sales last month and the prospects that his sales force are getting for November. The new models of the Edison have been especially popular with dealers, who, in turn, are finding a quick sale for them; in fact, they are likely to be considerably oversold. It is of interest that the higher-priced models get the most attention.

Takes Over New England Talking Machine Co.

The New England Talking Machine Co., Boston, Mass., is now under the ownership and management of Halford H. Ambler. Mr. Ambler took over the company during the past month and the business is being conducted at the same address, 16 Beach street, without the slightest interruption. This business was originally established in 1914 by the late Charles P. Trundy. Upon his untimely death and since January, 1919, Mrs. Maude H. Chesley, a sister of Mr. Trundy, became trustee for the heirs and has conducted the business up to its recent purchase. The new owner, Halford H. Ambler, has stated his intention of continuing the business along the same high-class lines of quality of product and service to the trade which have distinguished it in the past.

W. A. Harvey Back From Maine Hunt

Winthrop A. Harvey, head of the C. C. Harvey Co., which handles the Brunswick, Edison and Victor lines, was up in the Maine woods during October on a hunting trip, but he was not as successful as in former years, for he brought back no deer.

Broadcasts Junior Operetta

The Arthur C. Erisman Co., of this city, one of the most successful distributors in the talking machine industry, recently arranged to broadcast from the radio station of the Hender-



A Change

I have just taken over this business, which for 9 years has been the manufacture of "Perfection" Attachments and Reproducers.

From now on the quality is improved; the service bettered and the prices adjusted to pay you for your selling effort.

If you have never purchased any "Perfection" Reproducers and Attachments write for samples and prices.

H. H. AMBLER, President

NEW ENGLAND TALKING MACHINE CO.

16-18 BEACH STREET

BOSTON, MASS.

The NEW Columbia is superior

*Hearing
is believing*

The Reproducer Prevents Blast.
Why? Because it has what might be called "shock absorbers" which take up the excess vibration that causes this annoying defect. Try a lyric soprano record on the New Columbia. *Hearing is believing.*

COLUMBIA PHONOGRAPH COMPANY
New York



son Stores the Junior Operetta "Little Red Riding Hood." The broadcasting was a signal success and the Erisman organization, which is a distributor for Junior Operettas, manufactured by the Vulcan Record Corp., New York, is delighted over the direct and indirect results of this unique publicity idea.

Berry's Open Sixth Store

One of the latest store openings in this city is Berry's, a large furniture house, which operates stores in five other Massachusetts cities. The handsome new store at 760 Washington street is one of the most modern establishments in the city. There are five floors and, although furniture is the principal line handled, the talking machine department on the mezzanine floor is second to none in the immediate vicinity. All of the most popular makes of machines and records are handled. Officers of the concern are: Nathan Saltman, president and general manager; Henry W. Berry, secretary; John A. L. Odde, treasurer.

Enthusied Over Leo F. Reisman Records

New England dealers have been most enthusiastic over the special releases of the first Columbia New Process recordings of Leo F. Reisman and His Orchestra, who nightly appears at the Hotel Brunswick, in this city.

T. M. Connell in Mid-West

T. M. Connell is making a trip through the Middle West in the interest of H. A. Robbins, agent for the new Kendrick and Davis electric motor and is booking many orders.

Local Visitors

Harry A. Beach, of the New York office of the Brunswick, was a Boston caller the latter part of October, making an extended visit with Harry Spencer.

Some other Boston visitors lately have been W. H. Avery, of Concord, N. H.; Harry Russell, of the Outlet Co., of Providence; Harris Monroe, of Orange, and Mrs. C. W. Norton, of Farmington, Me.

F. H. Hedinger, sales manager of the Vocalion Sales Corp., was over here from New York the end of October, spending most of his time with Arthur Erisman.

Jack Elliott, of the talking machine department of the Shepard Stores, Providence, drove over the road to this city during October, bringing his mother with him so that she might enjoy a bit of Boston life.

SISTER OF J. H. WILSON DIES

BOSTON, Mass., October 31.—Mrs. Amy W. Wills, sister of John H. Wilson, Boston representative of The World, died at her home, Jamaica Plain, Boston, on Wednesday, October 24. Mrs. Wills was widely known as a prominent worker in St. John's Episcopal Church in that section. Funeral services took place at her home Friday, October 26, the Rev. Thomas C. Campbell, of St. John's Episcopal Church, officiating and Suffragan Bishop Samuel G. Babcock pronouncing the benediction. The interment took place in the family lot in Forest Hills Cemetery. Mrs. Wills is survived by a son and daughter, as well as her brother.

BRINGS RECORD ARTISTS TO CANTON

CANTON, O., November 5.—One of the most extensive campaigns to stimulate interest in the sale of Brunswick machines and records has been effected by George S. Dales, head of a concern operating three retail music stores in this part of the State, who has completed arrangements for the appearance here all this week of Bennie Krueger's Orchestra at the South Main Gardens, the largest dance pavilion in this section. Mr. Krueger will autograph his records both at the dance hall and at the store. A heavy advertising campaign is under way heralding the event.

CELEBRATED FORTIETH ANNIVERSARY

HOLYOKE, MASS., November 5.—One of the veteran music dealers in the New England States is John O'Shea, who operates a complete music store at 462 High street. Mr. O'Shea recently celebrated his fortieth year in the business. His establishment is one of the finest in the city and the lines handled include Cheney and Stradivara phonographs and Emerson records, musical merchandise, pianos, etc.

FIRST PRIZE FOR BEARD CO. WINDOW

PAWTUCKET, R. I., November 5.—The J. J. Beard Furniture Co., exclusive Columbia dealer in this city, won the first prize in the Fall window display contest which was held among the furniture stores of this city. The window featured a living-room suite which, of course, included a Columbia phonograph and the display attracted a large number of people.

NEW RADIOLA GROWS IN FAVOR

Latest Product of Radio Corp. of America Rapidly Growing in Favor

The sales department of the Radio Corp. of America, New York, manufacturer of Radiolas, is delighted with the reception accorded the new

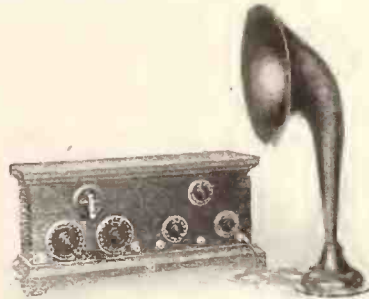

The Radiola V

Radiola V, which is becoming one of the most popular models in the company's line. The new Radiola V, which is furnished with three radiotrons, antenna plug and a type FH loud speaker, offers entertainment of all kinds, and because it is dry-cell operated is universally serviceable. It is designed in a handsome mahogany finished cabinet and complete with the loud speaker is listed at \$142.50.



More than 20,000
Now in Use

EDISON DISC RECORDS

should NOT be played by untried reproducers and haphazard attachments.

The "VICSONIA"

has long been accepted by the Trade for its distinctive interpretation of the Edison Disc records.

Furnish your customers with Vicsonias and increase your record circulation.

Sample Vicsonia, in silver, set with sapphire point, sent on receipt of \$4.50.

VICSONIA MFG. CO.

INCORPORATED

313 East 134th Street
NEW YORK

EDISON TAKES PERSONAL CHARGE

Thos. A. Edison Himself Assumes Sales Management of the Edison Phonograph Industry With A. M. Farrier as His Chief Executive

Much interest was aroused recently by the announcement from the headquarters of Thos. A. Edison, Inc., to the effect that Thomas A. Edison himself had arranged to take over the



A. M. Farrier

general sales management of the Edison phonograph industry and give his personal attention to that division of his organization.

Mr. Edison's chief executive is A. M. Farrier, who will occupy the post left vacant by the resignation of A. H. Curry. Mr. Farrier's merchandising experience is broad and varied. He brings to the Edison Co. a record of accomplishments in the selling and executive fields. He is a graduate of Dartmouth and his selling career began with J. A. & W. Bird & Co., of

Boston, paint and roofing manufacturer, where he was a traveling representative. Later he was a sales engineer with the M. A. Treadwell Co., of New York. Following that Mr. Farrier became vice-president, salesmanager and stockholder of the Eastern Car & Construction Co., New York. Before joining the Edison forces he was treasurer and sales manager of the Thrift Homes Corp., New York.

The development of the Edison phonograph business under Mr. Edison's personal direction will be watched with great interest, for he has always devoted considerable attention to that division of the great Edison activities, in spite of his many other pressing duties.

J. J. DAVIN LOSES RIGHT BOWER

J. J. Davin, of the Musical Instrument Sales Co., New York, Victor wholesaler, is mourning the loss of his right bower, for Miss Olive Madeline Aiken, who has been his secretary for a number of years, resigned recently to make plans for her marriage on November 20 to Alfred S. Harrison, who is associated with the General Electric Co. Miss Aiken officiated as Mr. Davin's secretary while he was a member of the sales staff of the New York Talking Machine Co., occupying the same position when Mr. Davin joined the forces of the Reincke-Ellis Co., subsequently moving her desk to Ormes, Inc., and later to the Musical Instrument Sales Co. She is succeeded by Miss E. L. Mansfield.

CONGRATULATIONS TO JOHN DORN

WEST NEW YORK, N. J., November 7.—John Dorn, the live wire Edison dealer in this city, is receiving the congratulations of his many trade friends on the arrival of a third son. We add ours. According to P. J. Burns, of the Phonograph Corporation of Manhattan, Edison distributor, there is a scarcity of good retail salesmen, and, in his opinion, John has decided to raise his own.

ANNOUNCES NEW EMERSON DEALERS

Wasmuth-Goodrich Co. Establishes Dealers in Leading Trade Centers—New Emerson Consoles Proving Popular Throughout the Trade

PERU, IND., November 7.—The Wasmuth-Goodrich Co., of this city, manufacturer of the Emerson phonograph, states that during the past few months it has established dealers for its products in practically all of the leading trade centers. The new line of consoles has met with popular favor, and among the well-known music stores, department stores and house-furnishing establishments handling the Emerson line are the following: Gimbel Bros., New York; Nathan-Dohrmann Co., San Francisco; Consolidated Music Co., Salt Lake City; Stone Piano Co., Minneapolis; D. H. Holmes Co., New Orleans; Aeolian Co., St. Louis; Mandel Bros., Chicago; Denver Music Co., Burlington, Iowa; Belknap Hardware & Mfg. Co., Louisville, Ky.; Parmelee-Dohrmann, Los Angeles; The Emerson Phonograph Co., New York; Seattle Music Co., Seattle, and G. F. Johnson Piano Co., Portland, Ore.

ST. LOUIS SYMPHONY WITH VICTOR

The Victor Talking Machine Co. has completed arrangements for the making of records by the St. Louis Symphony Orchestra, of St. Louis, Mo. The recording will be done in that city and it is expected that the first records will be made some time this month. This orchestra is very popular in the Middle West.

SAILS FOR MEXICO AND CUBA

R. C. Ackerman, export manager of the General Phonograph Corp., New York, accompanied by Mrs. Ackerman, sailed on November 3 for his semi-annual sales trip to Mexico and Cuba. He will be away about three months, visiting all of the principal cities in these countries and calling on Okeh distributors.

This Tone Arm Now in Big Demand

Increase Your Sales by Using This Outfit

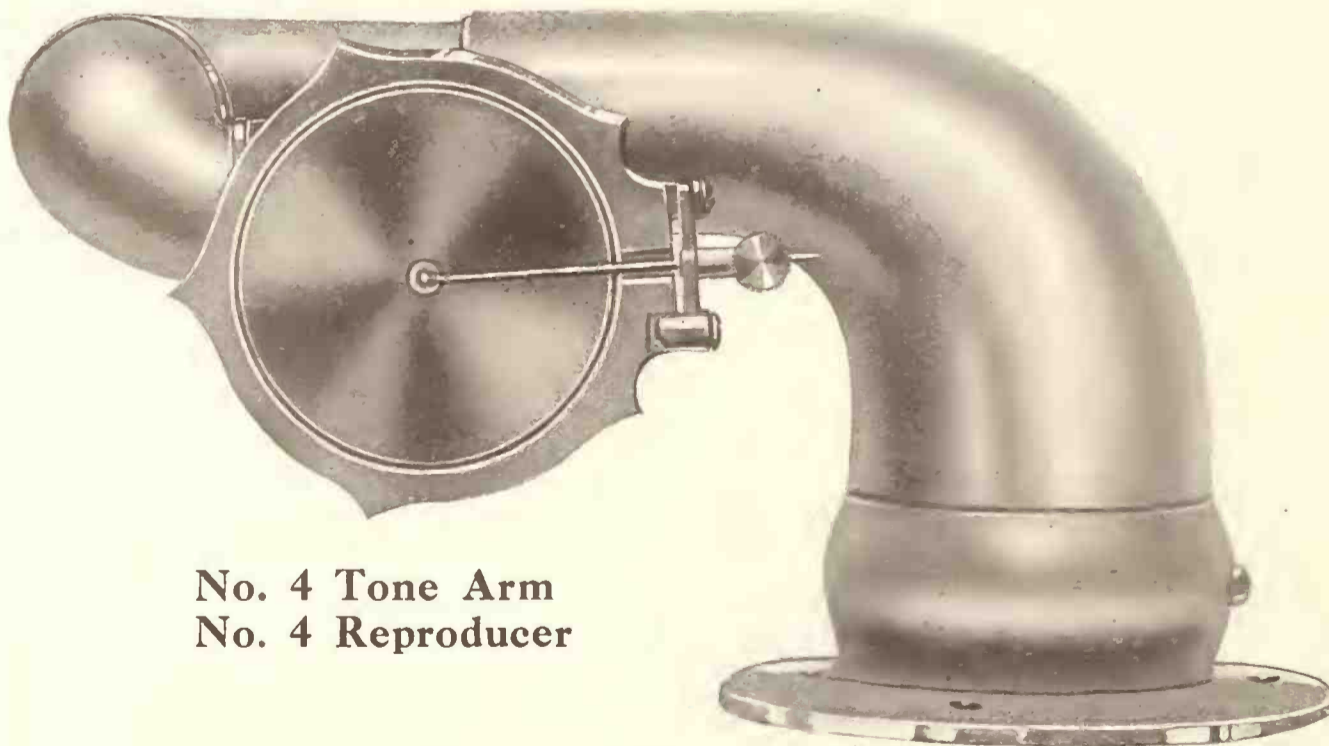

No. 4 Tone Arm
No. 4 Reproducer

The new Mutual outfit has a twofold appeal — it not only pleases the ear through its brilliant true tones, but pleases the eye as well just as soon as the cover is raised.

First appearances count and the impression gained by the artistic appearance of this tone arm is going to help you sell more machines.

Send for Samples and Prices

MUTUAL PHONO PARTS MFG. CORP.
149-151 Lafayette Street New York City

The Russell Gear & Machine Co., Ltd., 1209 King St., West, TORONTO, CAN., Exclusive Distributors for Canada and All Other British Possessions. INDUSTRIAS UNIDAS, S. A., Balderas 110, MEXICO CITY, Exclusive Distributor for Mexico.

The Pooley

PHONOGRAPH



Model 220
\$115
Figured Mahogany or Walnut



Model 225
\$120
Figured Mahogany or Walnut



Model 230
\$135
Figured Mahogany or Walnut



Model 400
\$160
Figured Mahogany or Walnut

A reputation for excellence in manufacturing, which is faithfully carried out down to the smallest detail, has for the past thirty-five years set the Pooley Co.'s standard of quality above all others. In superiority of figured veneers, beauty of design, solidity of construction and in its wonderfully clear appealing tone, THE POOLEY PHONOGRAPH is unequalled in the world of today.

POOLEY PHONOGRAPHS are established throughout the country today as one of the foremost and best selling phonograph lines on the market. This success has been attained through the quality of the product, the practical selling plan behind it and the splendid proposition offered to wide-awake, aggressive dealers. If you are a phonograph merchant who appreciates these important manufacturing and merchandising factors, you will find the Pooley agency the most valuable franchise you can possibly secure. Write to the distributor in your territory for further details or direct to the factory at Philadelphia if there is no distributor in your territory.

An unusually attractive proposition for the aggressive wide-awake dealer.

A quality product made and unqualifiedly guaranteed by one of the country's foremost manufacturers.

POOLEY DISTRIBUTORS

MUSICAL PRODUCTS
DISTRIBUTING CO.
37 East 18th St., N. Y.
Greater New York and a
50-Mile Radius

VOCALION CO. OF
CHICAGO
529 So. Wabash Avenue
Chicago, Ills.
State of Illinois

C. L. MARSHALL CO.
514 Griswold Street
Detroit, Mich.
328 Superior St., W.
Cleveland, Ohio
Michigan and Ohio

W. B. GLYNN
DISTRIBUTING CO.
Saxtons River, Vt.
New England States

COLE & DUNAS
MUSIC CO.
430 So. Wabash Avenue
Chicago, Ills.
State of Wisconsin

C I N C I N N A T I

*Cooler Weather Results in General Stimulation of Business—
Dealers and Jobbers Optimistic—Trade Activities of the Month*

CINCINNATI, O., November 7.—The month of October brought with it stimulated business for the talking machine dealers and jobbers in this territory. While September had proved to be a good month, the past four weeks have shown a comfortable increase which has given encouragement to the trade and which has led the officers of various companies to predict that November and December are likely to break records for volume of business for many concerns. While the weather during October was delightful as far as pleasure was concerned, there were so many days when the weather was warm that retail business in all lines, including talking machines and records, was cut down in volume of sales by a considerable amount. When the cool spells came for several days at a stretch the added sales were noticeable at once and business took on a more brisk aspect.

The jobbers here are confronted with the same problem that they have had to face most of this year; that is, getting sufficient instruments and records to supply the demand from the public. Most of the dealers, however, are of the opinion that there will be no acute shortage of either instruments or records and that before this month is over there will be enough shipments on hand to meet the demand.

Bright Edison Outlook

Manager Oelman, of the Phonograph Co., Edison distributor, reports that business has been good throughout the month of October and that the outlook for the rest of the year is for a further improvement. The Edison instruments have been selling well, according to local retail dealers who handle them.

Big Victor Business

The Ohio Talking Machine Co., Victor jobber in this territory, has been doing a big business during the past month and sales have shown a nice increase over the same period of 1922. C. H. North, secretary of the company, states that both the record and Victrola business have been excellent. The new policy of releasing Victor records weekly is working out splendidly in local stores. A customer will come in now on Friday and Saturday each week and buy sev-

eral new records where before he only came in once a month. By coming in weekly he will spend more money without feeling that he is spending more than he ought to. Sales have increased on records since the weekly release policy was adopted. The double-face Red Seal records also are going over strong, although there have only been a few of these released.

Other Lines Doing Well

Another company which has experienced an unusually good month during October is Widener's Grafonola Shop. Morris Fantel, manager, said that the sales for the past four weeks are far ahead of last year and that the holiday business which he expects to do will run considerably ahead of 1922. The Sterling Roll & Record Co. has also been doing a big business, says Ben L. Brown, manager. There has been much effort put lately on the sales of Strand phonographs, and these instruments are having brisk sales. Four of the retail music stores had window displays of Strands during the past week. Okeh records are also in heavy demand.

Satisfactory Brunswick Report

The Brunswick-Balke-Collender Co.'s district office states that the sales of both Brunswick machines and records during October were entirely satisfactory and that the Cincinnati territory is producing a large sales quota. Dealers have been enthusiastic with the reception their customers have given the Brunswick machines and records and expect its continuance.

Introduces Records Through Musicals

The Chubb-Steinberg Music Shop, 17 East Sixth street, one of the liveliest stores in the city, held its opening musical of the Fall season recently. The store was decorated appropriately for the season and the Chubb-Steinberg De Luxe Orchestra, under the direction of A. Hicks, played the new music of the Victor records. Two concerts, from 11:30 in the morning until 1 in the afternoon, and from 2 to 4, were given with hundreds of people attracted during those hours to the Fall opening. The Chubb-Steinberg De Luxe Orchestra is Cincinnati's newest organization, composed mostly of men from world-famous bands. This orchestra is

EDITH LORAND ON ODEON LIST

Edith Lorand, a young Hungarian violinist who makes her first appearance in the United States through the medium of Odeon recordings on the December list, is well known in Europe as a dance orchestra leader. Miss



Lorand is an exception to the general rule that men constitute the best orchestra leaders, for she has attained considerable success abroad, and has also won praise through her concert work. Her Odeon record is distinctive and individual, typifying the playing of the gypsy violinists of her homeland.

open for engagements throughout the city and nearby territory to play on social and dance occasions and will carry the Chubb-Steinberg name with it always. This is a splendid advertising plan and should mean increased business for the Chubb-Steinberg Music Shop. This company's Christmas Victrola Club, which was formed recently, is increasing rapidly in numbers and is proving to be a very popular innovation for this aggressive concern.

Julius Berger in New Quarters

Julius Berger, Columbia dealer, has just moved into his new quarters at 911 Central avenue, where he has a new modern three-story building, and is installing complete new hearing rooms. A large increase in record sales is reported since he moved into this new store.

Sol. Gershuny, 554 West Sixth street, is enlarging his record department and will handle the Columbia line exclusively.

Stages Physical Culture Window

The Starr Piano Co. has been featuring the Gennett Physical Culture records lately. Much attention was attracted to this company's main display window when it was filled with basketball and football equipment, punching bags, weights, golf clubs and other athletic equipment. All of this was used as a background for the message concerning the physical culture records. Several weeks ago a woman demonstrated the records and their value in the window. In addition, physical educational classes are being conducted under the direction of a competent instructor with the Gennett Physical Culture records used as a manual.

Mrs. Harris Freidman Convalescent

Mrs. Harris Freidman, of this city, is recovering from an operation for appendicitis at the Hotel Sinton. Mrs. Freidman is the wife of Harris Freidman, manager of the Cincinnati Song Shop of Waterson, Berlin & Snyder, and acts as Mr. Freidman's assistant manager in the store. She will be back at the old stand before long boosting Columbia New Process records as vigorously as ever.

Trade Visitors

M. O. Giles, of the General Phonograph Corp., was here during the past week conferring with the Sterling Roll & Record Co., jobber for Cincinnati territory. Mr. Lopin, of Lopin's Music House, Charleston, W. Va.; Finley Davidson, of Middletown, O., and Mr. Lay, of Lay & Fox, Corbin, Ky., were other visitors in the Cincinnati market during the past week.

Miss Stevens, manager of the Victrola department of the Baldwin Piano Co., says that business has improved very much during the past few weeks and that the outlook is good.



Net Profit—Counts!

*Edison Dealers Figure Net Profit
This Way*

1. DOLLARS and CENTS—Even after Uncle Sam has taken his there is a very substantial sum left.
2. GOOD WILL—No line pays as well in good will as the Edison. This is a real asset and can be capitalized.
3. THERE'S A SENSE OF SATISFACTION in knowing you have given your customers the best. This is non-taxable and you cannot lose it.

Investigate the Edison Dealers' Proposition

THE PHONOGRAPH COMPANY

CINCINNATI
314 West 4th Street

CLEVELAND
1240 Huron Road



CONSOLIDATED SERVICE

HUNDREDS of Okeh dealers have had occasions to rigidly test the reliability of Consolidated Service time and time again under all sorts of conditions. They have found it to be as smoothly efficient in meeting their most urgent demands as it is in meeting their ordinary every-day requirements.

Our maintenance, at all times, of a thoroughly complete stock of every record listed in the Okeh catalogues, combined with a smoothly running organization working under tested, up-to-date methods of production, not only insures a complete filling of every order, but insures also the filling of the order with unflinching promptness and efficiency.

A more reliable combination could hardly be found than that of Consolidated Service and

Okeh Records
The Records of Quality

Buy Okeh Needles—They Keep Record Sales Alive!

Consolidated Talking Machine Co.

227 W. Washington Street

CHICAGO, ILL.

Branches:

2957 Gratiot Ave., Detroit, Mich.
1121 Nicollet Ave., Minneapolis, Minn.

Mid-West Point of View

WESTERN DIVISION OF THE WORLD, CHICAGO, ILL., Nov. 9, 1923.

THE mid-West's musical season has been wonderfully stimulated at its very opening time by the visit of the German Wagnerian

Tying
Up With
Music

Opera Company, which is just finishing its triumphant two weeks in Chicago and will be in Milwaukee by the time this issue of The Talking Machine World appears. Detroit, Cleveland and other mid-West cities will within a short time hear this remarkable group of operatic experts. The Chicago Civic Opera is also about to open and the symphony orchestra season is already in full swing. It is an auspicious beginning to what ought to be the finest season of musical activity the Middle West has ever known. It is for mid-Western music business men to take this fact to heart and to realize that musical art and music appreciation are taking a firm root in this great community. We should like to stir up the imaginations of our talking machine men a little bit and beg them to visualize what all this stirring and artistic activity really means. If it be said, as it will be said by the narrow-minded and the small men, that there is nothing "practical" in co-operation with the protagonists of music, and that business and art have nothing to do with each other, the answer is simple and positive. Music business is wholly founded on the existence of musical art. If there were no musicians, no teachers of music, no opera, no symphony orchestras and no concerts, would there be any music business? There would not. All the dance orchestras and all their records cannot alone keep the music business alive. It is upon artistic music that popular music founds itself and the craze for this or that popular music would droop in a very short time if it were not buoyed up by the strength of musical art. Now the talking machine business is a record selling business also, and the musical taste of a community ought to express itself in the sale of records. When we find a musical community where, however, records of first-class music do not readily sell, we must simply conclude that the talking machine merchants are not "on to" their jobs. There is a portion, an ever-growing portion, of the mid-West community which takes a steady interest in things musical. This element can be sought out and turned into buyers of records and owners of talking machines. To neglect it or not to plan intelligently to find and keep its custom is extremely short-sighted and extremely foolish.

THE recent attacks of price-cutting mania, not to mention others which appear to threaten, throw one's thoughts toward the need

Where Is
Price
Maintenance

for some sort of legislation which will curb these raids, for such they are, upon the community's legitimate prosperity. If utter selfishness must run riot, if the legitimate values which have been built up by patient honorable dealing, are to be destroyed whenever it pleases the unscrupulous to do the unholy work of tearing down, then the legitimate business man, especially in a trade like ours, might as well go out of business right now and save the pieces while he may. The whole thing is all wrong. In fact, one may question whether a good deal of the recent raiding of values is not within the purview of the laws against fraudulent advertising which have been enacted in some States. Our situation in Illinois is not favorable in this respect, and it would be well for the legislative committee, constituted at the recent Peoria convention of the Illinois Music Merchants Association, to bring some pressure to bear at Springfield towards making it less easy for price raiders to do their destructive work. If the situation is not handled properly, we shall see most serious results to the prosperity of talking machine men throughout this territory. The hands of the Better Business Bureau of the Music Industries Chamber of Commerce should be strengthened also. Every merchant who belongs to the National Association can have the benefit of the Bureau's work, and even those who are not members will find the Bureau ready to help them whenever and wherever it can. Raids upon established values are ethically despicable, and in some cases very nearly criminal.

THOSE who have watched the recent trend of developments in the policy of the record manufacturers are aware that Chicago has

We
Make
Records

become a recording center. Recording is being done here steadily and the chances are that more rather than less of it will be done as time goes on. The principal reason for the new trend of affairs is to be found in the fact that Chicago has been developing a great deal of musical talent of all sorts, popular and classical, and that the entire mid-West, following Chicago's lead, has been taking a grip on musical ideas which is really wonderful. Now, the record manufacturing companies are finding it entirely worth while to set up recording studios from time to time in this city and thus to draw to themselves the choicest of the local talent, not alone from the city, but also from all the great central territory around Chicago. All this should help local business very much. Local artists are being encouraged and local pride is being stimulated. Local sales of records by local artists, especially of well-known dance orchestras and of singers whose work is nightly applauded in Chicago theatres, will thus be markedly increased. It is to the interest of the local merchants to boost local recording.

TALKING machine merchants in steadily increasing numbers are taking on general musical merchandise. The fact goes to show

Musical
Merchandise
Too

that the musical nature of the talking machine business is by now generally and firmly recognized. A talking machine store is a store where music is sold in circumstances and according to conditions which probably are the best imaginable. Music here is, almost literally, on tap. It is right that talking machine men then should seek to take advantage of the favorable conditions which their stores present to stock sheet music and small musical instruments. It all means more business, more men, women and children coming in, more sales and more profits. There is nothing wrong about the idea, which, in fact, represents simply the legitimate development of the talking machine store into a general music store which, more and more as time goes on, it is bound to become. It must never be forgotten that the most direct road to better talking machine and record business is found to lie in the direction of better community feeling towards music. Whatever helps to create even the desire for a harmonica benefits the talking machine business.

It is altogether too late to talk to dealers about getting in orders early for Christmas, for dealers who have put off the inevitable

Old
But
Good

for so long as the present date are in all probability already doomed to a great deal of disappointment. But it is worth while pointing out, as the end of the year comes within our view, that the progress the talking machine industry has made towards complete and permanent stabilization owes very much to the consistent and persistent propaganda in favor of abolishing the seasonal buying which the trade papers, and especially The World, have given up so much of their space to preach. It is necessary to remember, however, that just in proportion as the dimensions of the industry increase, and its complexity increases parallel-wise, so also does the need grow and deepen for effective organization of its production. Just so far as buying is seasonal, that is to say, restricted to certain periods of feverish activity in placing orders, periods which may be all run into the space of three months in each year, so long will the manufacturing end of the industry be compelled to do less than justice to the retailing end. The manufacture of any article whatever, save the most primitive, is necessarily an undertaking much more hazardous than the selling of the same at retail, no matter on how large a scale. To render it less hazardous, security is the chief essential. By security is meant the assurance that production plans can be laid well ahead, for twelve months ahead at least, and that when laid they can be carried out without involving overproduction. The ideal is practical but dealers must do their share.

From our CHICAGO HEADQUARTERS

REPUBLIC BLDG., 209 SOUTH STATE ST TELEPHONE WABASH 5242

EUGENE F. CAREY, Manager

BRISK DEMAND IN ALL LINES PRESAGES EVEN BUSIER DAYS TO COME BEFORE HOLIDAYS PASS

Dealers and Jobbers in an Optimistic Frame of Mind—Consoles Lead—Chicago Assuming Importance as Record-making Center—Other Important Activities of the Month

CHICAGO, ILL., November 8.—Throughout the retail trade talking machines are moving in a satisfactory manner, with the console models still leading. It is notable, however, that the cabinet types are moving better at this particular time than they have during the past year. This may be due to the fact that there is an apparent shortage in the console instruments

and that dealers are, therefore, pushing the up-rights. It is noteworthy regarding all types of instruments, whether they be of console, upright or portable models, that the workmanship shows much improvement. The finishes are much better in many of them and the same holds true of the materials used.

Many of the retailers report that there was

quite a sharp increase in business beginning the 30th of last month. This was due in all probability to the first snowstorm of the season which happened on that day and possibly caused the buying public to appreciate that the Christmas season is but comparatively a few weeks off. Whether or not this was the actual reaction to the season's first snowfall has not been positively determined, but, anyway, something started business a-rolling and made everyone happy. Records and sheet music are moving in such a manner that all retailers here are thoroughly satisfied with this end of the business. The same applies to those who are handling "small goods," and it might be mentioned here that there is much activity in the musical merchandise field, and the number of dealers handling band, string and small musical instruments is constantly growing.

John McKenna New President of Piano Club

Signal honors were conferred upon John McKenna, manager of the Chicago branch of the Columbia Phonograph Co., when the Chicago Piano Club elected him president for the ensuing year. Not only was that honor conferred upon Mr. McKenna, but Harry Schoenwald, sales manager of the Consolidated Talking Machine Co., came in for his share as well by having the secretaryship of the club bestowed upon him. The election took place in the Red Room of the Hotel LaSalle and was preceded by a banquet and a fine musical entertainment. Among the talent were Guyon's Paradise Orchestra, Gus Edwards (himself), the Jarros Trio, representatives from the Forster Publishing Co., and others.

At the first Monday noonday meeting over which Mr. McKenna presided he aroused the intense enthusiasm of the membership by giving an outline of the plans of the Chicago Piano Club for the ensuing year. The principal object of the club is to create a goodfellowship feeling among all branches of the trade, and now President McKenna proposes to step out and work for the cause of music to a greater extent among outsiders. While it is true that the Piano Club has already done a great deal by way of sponsoring music and musicians, Mr. McKenna's plans call for even greater activity.

One of Mr. McKenna's proposals is to arrange with some of the music schools of Chicago to require a certain amount of actual instruction work throughout settlement districts before the giving of teachers' diplomas to pupils. In furtherance of this scheme, President McKenna also suggested that a yearly concert be held in some prominent auditorium at which such students could demonstrate their work and progress.

Other plans and schemes too numerous to mention were offered by various members of the club and were taken under consideration, but whatever is done during the coming year, the Piano Club of Chicago is assured that with two able men at the helm, such as President McKenna and Secretary Schoenwald, the success of the Piano Club for the ensuing year will be greater than ever before.

A. J. Wolf Gets Important Post

It is announced that A. J. Wolf, who has been associated with the talking machine trade for over twenty years, is now manager of the talking machine department of The Fair. Mr. Wolf, who recently came from Canada, has had wide experience through his long association with Brunswick interests across the border. This department has recently been made larger by moving it from the third to the seventh floor where more space has been taken on and very

(Continued on page 110)



For The New Edison



Showing Reproducer of Jewel Needle Equipment Turned Up to Change Needle; Also Position When Not in Use



Showing Reproducer of Jewel Needle Equipment in Position for Playing Edison Record With Fibre Needle.

Plays all types of records. Operates the same as the "EDISON" with the LEVER.

No adjustments necessary when changing from lateral to vertical cut records. Stop prevents swinging to the right.

Needle scratch almost entirely removed.

Turning back of Reproducer permits of easy access to needle socket and saves records from unnecessary scratching.

Is the ONLY equipment that plays vertical cut records with a Fibre needle in the proper "EDISON" position with the Reproducer turned FACE DOWN to the record, giving it a floating action.

Needle CENTERS on all records.

Straight air-tight construction and absence of movable joints insure perfect reproduction and great volume.

Pivoted ball-joint insures perfect reproduction and freedom of movement both vertically and horizontally.

Weight is the lightest that can produce perfect results, thus saving the record, and permitting a freedom and sweetness of tone considered impossible.

Indestructible NCM-Y-KA diaphragms do not blast, crack, split or warp, and are the greatest development in phonographic sound reproduction in years.

NOT Just Another Equipment BUT

a distinct improvement in Tone Reproduction as well as in Mechanical Construction and Finish.

Send for descriptive circular which contains "HINTS REGARDING THE CARE OF A PHONOGRAPH."

WRITE YOUR EDISON JOBBER. HE HAS IT.

Price the same. Liberal discount to dealers.

GUARANTEED IN EVERY WAY.

MONEY BACK IF NOT SATISFIED.

We handle highest grade Jewel Point Needles.



Showing Reproducer of Jewel Needle Equipment in Position for Playing Lateral Cut Records on Edison Phonograph



Showing Back View of Jewel Needle Equipment in Position for Playing Lateral Cut Records on Edison Phonograph

JEWEL PHONOPARTS COMPANY, 160 W. Whiting St., Chicago

FROM OUR CHICAGO HEADQUARTERS—(Continued from page 109)

attractive display rooms have been made. There has been no manager in the department since W. B. Papineau had to leave on account of illness some time ago, but C. C. Sweng, who is now in charge of the service department, has been acting as manager.

Mr. Wolf reports that he is surprised over the amount of business that is being done in all lines. "We are experiencing a very large Christmas trade," said Mr. Wolf, "and I am afraid that by the time Christmas comes it will be difficult to get enough goods to take care of the demand, especially for the higher priced models. This department handles all standard makes, including Victor, Brunswick, Sonora and Widdi-comb, with a complete line of records and musical merchandise.

Chicago Becoming Recording Center

From the looks of things at this writing Chicago is destined to become one of the important recording centers of America. This city has been quietly at work building up its talent, and the talent in turn has been working its way up to national recognition. The recognition in turn has been noticeable in every direction, and consequently the recording companies have at last taken note of this recognition and have begun to do their stuff.

A few years ago it was rumored that there was a movement on foot by certain recording companies to establish temporary laboratories in this city, and after months of preparation this plan has been carried out in several instances. The number of record manufacturers recording in Chicago has gradually grown until to-day practically all of them are doing part, at least, of their recording work in this city.

The talk on the street at present is that before the end of the year every recording company in the country will have at least a temporary laboratory here to handle local talent. These recordings are stimulating the sales of records and sheet music to a remarkable degree.

It's an old story that every city or town boasts its home talent and the old "city by the lake" is quite logically like every other city or town in that respect.

L. C. Wiswell Enters Retail Field

The many friends in the trade of L. C. Wiswell, formerly manager of the wholesale and retail Victor departments of Lyon & Healy, of this city, will learn with interest that Mr. Wiswell has resigned from the Lyon & Healy organization in order to concentrate his activities on the development of his chain of retail Victor establishments. Mr. Wiswell controls several



L. C. Wiswell

stores in the most important sections of this city, and it is understood that he will add another South Side shop to his chain in the very near future. At present he is also president of the Fuller-Ryde Co., Victor retailers at Indianapolis, Ind., and of the West Music Co. at

A Better Fibre Needle Cutter for Less Money

RETAIL PRICE \$1.00

The ALTO



Manufactured by ALTO MFG. CO.

1801-1803 Cornelia Ave., CHICAGO, ILL.

Joliet, Ill. In addition to all of these Victor activities, Mr. Wiswell is president of the Hall Manufacturing Co., manufacturer of Hall fibre needles and an important factor in the phonograph industry.

As one of the most popular members of the talking machine trade, Mr. Wiswell will be able to give his retail establishments the benefit of twenty-five years' continuous service with Lyon & Healy. He is generally recognized as one of the most capable and efficient sales executives in the talking machine field, and for many years was active in the affairs of the National Association of Talking Machine Jobbers, having served as president of that organization. Before assuming his retail duties Mr. Wiswell was the guest of honor at a dinner given by his old friends and associates in the dining-room of Mme. Galli's Cafe. One of the features of the dinner was the presentation of a handsome pair of cuff links by the girls of Lyon & Healy's Victor department and a fireplace set from his friends who were present.

Sold Entire Output

I. A. Lund, sales manager of the Excel Phonograph Mfg. Co., has just returned to Chicago after a successful trip throughout the Eastern territory. On this trip Mr. Lund was successful in booking up the factory solidly for the balance of the year, and, since his return, has

KIMBALL PHONOGRAPHS

Sales Show Great Activity

DEALERS and individual customers are buying the phonograph that bears the name of the reliable manufacturer—

The Kimball name means satisfaction. Compare the Kimball in construction, in visible beauty or tone and accurate reproduction and there is none to excel.

The excellence and convenience of the Upright type of phonograph should not be overlooked.

In the Kimball of both Console and Upright types there is variety of design and wide range of prices.

Ask about Territory and Agency Terms.

W. W. KIMBALL CO.

Established 1857

Kimball Hall

306 So. Wabash Ave.

CHICAGO

Manufacturers of Phonographs, Pianos, Player Pianos, Pipe Organs; Distributors of Okeh Records



Style J Mahogany



Style M

One of several beautiful console models

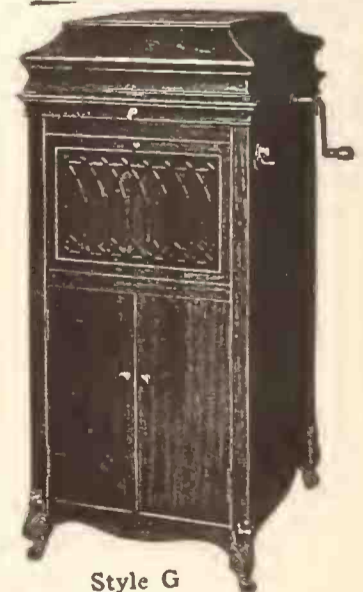

Style G

One of several beautiful upright models

KIMBALL PHONOGRAPHS PLAY ALL RECORDS

FROM OUR CHICAGO HEADQUARTERS—(Continued from page 110)

made the announcement that no more business will be taken on and that only orders are being accepted for 1924 delivery.

Ashley Analyzes Coast Conditions

In a recent exclusive interview with the Chicago representative of The Talking Machine World, Merwin F. Ashley, vice-president of the Krasco Mfg. Co., talked about California. "We," said he, "who live in the Central West, particularly in big cities like Chicago, Detroit, and even those in the East, like New York and Boston, hear much about business activities of the California district, particularly in and about Los Angeles.

"From the stories we have heard we had naturally come to the belief that this locality is enjoying what is known as a boom, with everybody rushing in, spending their money, and rushing out again.

"As we note from past experiences, boom pe-



Merwin F. Ashley

riods are like bubbles which sooner or later explode and leave nothing behind them. When, however, one takes a trip through California, one is obliged to admit that the supposed boom is in reality nothing but an expression of normal activity.

"To the newcomer the Los Angeles district, on the surface, has the earmarks of a boom section, and only after a real study is made of the business conditions there does one find out that he is mistaken.

Positively
Eliminate
Surface
Noise



Cannot
Possibly
Injure
Records

Your Trade Wants These Wonderful Needles

Talking machine owners who appreciate the marvelous musical value of their machines want to bring out the best in records—the way to accomplish this is to play with HALL FIBRE NEEDLES.

Semi-permanent; play 30 to 50 records with each needle.
Profitable—will sell more better-class records.
HALL FIBRE NEEDLES Combine Quality and Service.

Stock them at once and avoid disappointment by not having them during the Holiday period.

Ask your wholesaler for circulars or send direct to us for The Needle the "Tongue of a Talking Machine" and "Records on Approval" for your trade.

HALL MANUFACTURING CO.

Successors to B & H FIBRE MFG. CO.

33-35 West Kinzie Street,

CHICAGO, ILL.

"Just as many Easterners imagine that Chicago is a wild and woolly overgrown village, without any aim in life, large numbers of us here in the Central West have the same ideas concerning the Coast metropolis, but the proof of the pudding is the eating, and mistakes rectify themselves just as quickly as a real insight can be obtained.

"The money going into the California territory is being put there to stay. It is being utilized in the erection of manufacturing plants, in large buildings, in harbors, etc. They are not merely digging holes in the earth, like in the old mining days, and getting nothing for their labors except the hole. On the contrary, California is the coming country, and offers wonderful opportunities for our music industry.

Myer & Weber Now on Michigan Avenue

One of Chicago's oldest retail music stores, that of Myer & Weber, has moved from 120 South Wabash avenue to 174 North Michigan boulevard. This firm was one of the pioneers of Piano Row. The business was formerly con-

finned to pianos exclusively, but several years ago this concern branched out by taking on an exclusive retail representative of the Cheney Talking Machine Co. The present move is due to the fact that the old location was part of the property occupied by the Palmer House, one of Chicago's most famous landmarks, which will be wrecked in the near future in order that a new and larger hotel may be put up in its place.

Myer & Weber have been doing business in the same store on Wabash avenue for over thirty-three years. The business is now conducted by Carl Weber and his son Targot. The new location on Michigan avenue offers bigger possibilities for retail distribution, owing to the fact that it is in the heart of Chicago's new link bridge section, the main thoroughfare connecting Chicago's north and south sides. The advertising value alone of the location is tremendous. The store will be beautifully decorated throughout and will be brightly lighted

(Continued on page 112)

ORO-TONE PORTO-TYPE

For Christmas Sales

This year all records for heavy holiday buying will be shattered. Indications point to enormous Christmas sales. Will you be prepared to make prompt deliveries on ORO-TONE PORTO-TYPES, the phonograph sensation of the year?

SPECIFICATIONS

Height 7½ in., Width 11½ in., Length 16½ in. Weight 20 pounds. Plays two records with one winding. The automatic arm and reproducer on this PORTO-TYPE is shown and described on another page of this issue of Talking Machine World.

The ORO-TONE PORTO-TYPE is especially suited for small apartments and for buyers who want a high-grade yet inexpensive phonograph for the home. The splendid volume and quality of the tone produced by this wonderful PORTO-TYPE is due to full sized ORO-TONE equipment used. Sample will be sent promptly on approval.

List Price \$37.50

Usual discount to responsible dealers. Advertising helps free.



Showing position when playing lateral cut records. Has detachable record file. Case exceptionally durable and finely finished.



Shows position when playing vertical cut records. All adjustments are automatic. The most attractive and practical porto-type phonograph made.

1000-1010 George St. *The Oro-Tone Co.* CHICAGO ILLINOIS
QUALITY FIRST

FROM OUR CHICAGO HEADQUARTERS—(Continued from page 111)

during the evening for the benefit of the thousands of motorists who pass it.

Murray Home From Great Britain

C. R. Murray, general manager of Barnhart Brothers & Spindler, has just returned from a month's vacation, which he spent visiting Great Britain. Owing to press of business at the plant during the Summer months Mr. Murray was unable to take his vacation until this late date. From his present appearance he benefited greatly from his outing.

Mr. Murray is a golf enthusiast and while traveling through Scotland took advantage of the opportunity to play a few games on the famous links of the St. Andrew's Club.

Forster Adds to Staff Artists

Announcement has just been made by Johnnie Fink, manager of the Forster Music Publisher, Inc., this city, that he has just signed up Moe and Elsie Thompson, of St. Paul, Minn., as exclusive Forster staff artists.

Moe Thompson is said to be the most popular song entertainer in that city and is a headliner



Moe and Elsie Thompson

at the Ambassador Cafe. His sister, Elsie, has charge of the organists of the Finkelstein Theatres here, and she, too, is a headliner of much prominence. Both Moe and Elsie Thompson are songwriters who have put over many clever numbers in the past year, among which is "Seal It With a Kiss," which will shortly be published and marketed by the Forster Co.

Mr. Fink and the Thompsons have been



Repair Parts

For All and Every Motor That Was Ever Manufactured



We can supply any part. The largest and most complete assortment of repair parts—in the United States—on hand, for old, obsolete and present-day motors. If your order cannot be filled from stock, we will make it up special.

Special prices on main springs, governor springs, micras, repair parts, motors, tone arms, steel needles, etc., in quantity lots.

Expert repairing on all makes of phonographs and motors.

INCORPORATED UNDER THE LAWS OF ILLINOIS

Consolidated Talking Machine Co.

Manufacturers of
High Grade Talking Machines, Disc Records, Talking Machine Supplies, Etc.

SUCCESSIONS TO
Standard Talking Machine Co.
United Talking Machine Co.
Harmony Talking Machine Co.
O'Neill-James Co.
Aristo Co.

227-229 W. WASHINGTON ST. CHICAGO ILL.
Branches: 2957 Gratiot Ave., Detroit, Mich. 1121 Nicollet Ave., Minneapolis, Minn.

TRADE MARK
"CONSOLA"
CABLE ADDRESS
"CONSOLA"

friends for many years, but it was not until the return of the artists from their successful trip to Chicago, where they recorded exclusively for the General Phonograph Corp., that he signed them up as exclusive staff writers for Forster.

Visiting New York

Gus Fricke, president of the Lakeside Supply Co., has just returned from a visit to New York where he spent about a week in calling on talking machine parts manufacturers. Mr. Fricke has just brought out a new motor built along quite novel lines, which is said to be simpler than almost any other known. He has been showing it to many of his friends in Chicago and when news of its introduction reached the Eastern metropolis it aroused so much interest that several of the foremost manufacturers in the New York territory invited Mr. Fricke to call on them to demonstrate it.

Mr. Fricke's plans for marketing the new motor have not been announced as yet, but several of his friends on the inside who profess to know claim that one of America's largest motor manufacturers has offered to take on the building and marketing of it.

Local Talent Makes Okeh and Odeon Records

From a recording standpoint Chicago saw two of its most active weeks during the latter part of October, while the recording forces of the General Phonograph Corp. were recording here. Those of the Okeh forces who came to Chicago for the purpose of doing the recording, or attending to some of the details pertaining thereto, were A. Bergh, musical director; C. L. Hibbard, recording engineer; Pete Decker, assistant recording engineer; A. Thallmayer, manager of the Okeh Foreign Division, and R. S. Peer.

(Continued on page 114)

The RECORD NEEDLE CUTTER

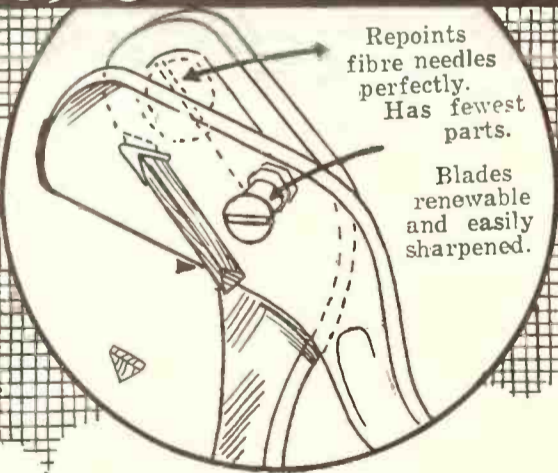

Repoints fibre needles perfectly. Has fewest parts. Blades renewable and easily sharpened.

Retail Price \$1.50

Jobbers and dealers write for discounts.

Best Selling Fibre Needle on the market because—

- Easily operated, cuts like pair of scissors
- Does not crush fibre shell
- No variation in angle
- Cuts with grain of needle to the point
- Makes possible economical use of fibre needles
- No scratched records, giving longer life and sweeter reproduction

Write for sample—Post paid 90 cents

BADGER TALKING MACHINE CO.
191-93 Fourth Street Milwaukee, Wis.

The Badger Talking Machine Co.



The
**FLETCHER UNIVERSAL
 TONE ARM and REPRODUCER**

Gives Proper Playing Weights for All Records. No Adjustment Screws or Springs
 SAMPLES \$8.00 Specify 8½" or 9½" arm

FLETCHER-WICKES CO., 116-122 West Illinois Street, Chicago, Illinois

THE McLAGAN PHONOGRAPH CORPORATION, LIMITED, STRATFORD, ONTARIO, EXCLUSIVE CANADIAN AGENTS

FLETCHER REPRODUCER

Scientifically

Constructed



Gives Perfect
 Reproduction
 of Voice
 or Instrument

ACTUAL SIZE

Volume and
 Perfect Detail

Dealers, Send for
 Prices and Terms



Reproducer
 and Connection
 for
NEW EDISON
 Plays all Records

Carried in Stock for Victor and Columbia

THE FLETCHER "STRAIGHT"

Design Patented November 29th, 1921

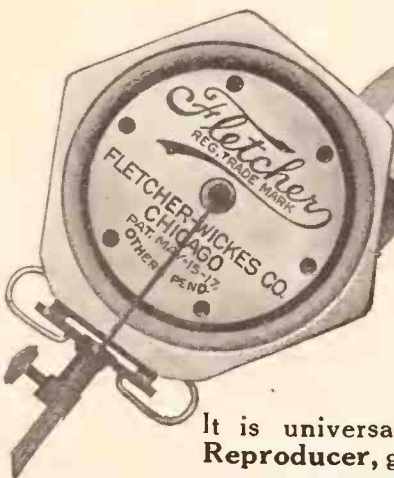

**STRAIGHT INSIDE—Taper Outside
 BALL BEARINGS THROUGHOUT
 NEW DESIGN NEW CONSTRUCTION**

It is universal and equipped with the Regular Fletcher Reproducer, giving the same natural tone quality as heretofore
 Made in two lengths, 8½" and 9½" SEND FOR PRICES AND TERMS



FLETCHER-WICKES COMPANY
 116-122 WEST ILLINOIS STREET CHICAGO

THE McLAGAN PHONOGRAPH CORPORATION, LIMITED, STRATFORD, ONTARIO, EXCLUSIVE CANADIAN AGENTS

FROM OUR CHICAGO HEADQUARTERS—(Continued from page 112)

A temporary recording laboratory was erected on the fourth floor of the Consolidated Talking Machine Building at 227 West Washington street and numbers were recorded by local artists, including many of Chicago's best musical talent, such as orchestras and singers.

Among those who were recorded were Moe Thompson and his sister, Elsie, who came on from St. Paul. Moe Thompson is headliner and manager of the musical entertainment at the Ambassador Cafe, St. Paul, and his sister, Elsie, is one of the leading organists in that city and directs the organ entertainment in the various Finkelstein houses. The discovery of Moe and his sister, Elsie, was due to the work of E. A. Fearn, who has been watching their progress for many months past, and when their popularity had assumed great proportion in that section of the country Mr. Fearn lost no time in signing them up as exclusive Okeh artists.

The actual recording was done by Messrs Hibbard and Decker and it can be said without flattery that the work of these gentlemen was, to say the least, remarkable. Many artists who can boast of unusual talent were practically helpless when placed before the recording instruments, and it was into this breach that Messrs. Hibbard and Decker stepped, bringing them through in ship-shape manner. In the recording processes Mr. Fearn, of the Consolidated Co., showed himself an able director.

Vitanola Co. Activities

In former years manufacturers encouraged dealers to anticipate their wants for the holiday trade, but it has usually been a tough proposition. Many dealers were new in the game and could not appreciate what a factory is up against. However, through constant work the manufacturers have at last managed to get their dealers to co-operate with them to a very high degree and to anticipate their wants far enough in advance to enable the manufacturer to work on a well-planned schedule.

It might be said that in this territory one



THE LIDSEEN FIBRE NEEDLE CUTTER

Is the Only Cutter which will sharpen the needle without necessitating its removal from the tone arm.

It thereby overcomes the only objection to the fibre needle.

Selling Lidseen Fibre Needle Cutters will not only be profitable to you, but will greatly increase your fibre needle sales.

Write today for further details and prices

LIDSEEN PRODUCTS
830-846 South Central Ave., CHICAGO

concern which is most fortunate in obtaining the close co-operation of its dealers is The Vitanola Talking Machine Co. This co-operation in turn has enabled the Vitanola Co. to arrange its production schedules so that instruments are being shipped exactly as promised when the order was received. This working schedule has in turn spread a feeling of satisfaction throughout the entire Vitanola family, and all Vitanola dealers feel sure that they will be able to take care of holiday business satisfactorily. This co-operation has brought the output of the Vitanola plant up to its full capacity and so permits officers of Vitanola to already begin their plans for the year 1924.

Karig Shows Trotter Motor

K. Karig, of the mechanical department of the Plymouth Phonoparts Co., Plymouth, Wis., and Lake laboratories of Elkhart Lake, Wis., spent a few days in Chicago recently calling on manufacturers.

Many of Mr. Karig's calls were educational. He visited the mechanical departments of a number of manufacturers who use the Trotter electric motor put out by his company, and talked to the workers on its construction, maintenance and service. Mr. Karig was much pleased with the outlook for the electric motor and indicated that large numbers of manufacturers expect to use the electric Trotter motors in 1924.

Eliminate Trouble Possibilities

On several occasions The Sterling Devices Mfg. Co. has had its attention called to the fact that when stylus bars of the Sterling enclosed reproducer need repairing it is necessary to send the reproducer back to the factory, because of certain technical features which present obstacles to ordinary repair men.

This was due to the fact that in the old type Sterling reproducer the stylus bar is constructed

(Continued on page 116)



Vitanola 46
List Price, \$175.00
Height, 35 1/4"
Width, 40"
Depth, 24"



Vitanola 49
List Price, \$125.00
Height, 34 1/4"
Width, 36 1/2"
Depth, 22"

VITANOLA
The Phonograph of Marvelous Tone

The Biggest Dollar for Dollar Value on the Market

There must be a reason why our factories are working to capacity.

Quality machines at prices that allow dealers to make their necessary profit.

Write for catalogue "F" and dealers' prices, from which you will understand why Vitanola dealers stick to the line and prosper.

VITANOLA TALKING MACHINE CO.

738 So. Michigan Avenue

CHICAGO, ILLINOIS

"It is easier to sell the Vitanola than to compete with it"

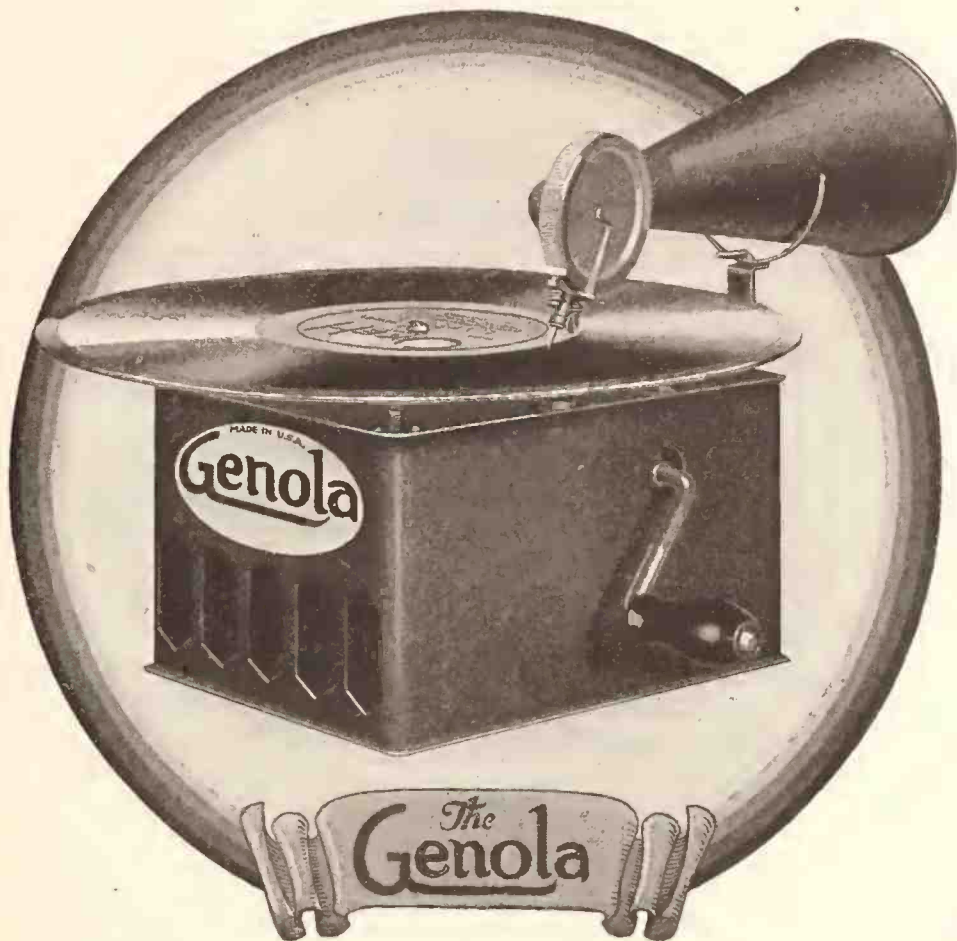

a \$5
Retail
Article

ARE THERE ANY OF
THESE IN YOUR TOWN?

**Put a "Genola" on Your Counter
—Folks Will Come to Marvel**

The volume of good music coming from such a tiny source will arouse buying interest and cause comment.

"Just bought the best little phonograph I ever heard. Genola, it's called. Small enough to fit in your hat, but it isn't a toy. And play? Ten-inch records, too! Say, go over and hear it. For \$5, it's certainly a bargain."

Conversation like the above will sell many more Genolas. Exceptional value is so obvious in this little phonograph that it opens the way for a sale to everybody. There's a quick turnover and a nice profit here, Mr. Dealer, without the usual risk in handling novelties. Order your Genolas now.

Some of the reasons why people wonder and talk!

The contrast between Genola's size and its ability to reproduce awakens immediate interest. The little instrument—only 8¼ x 5½ x 7½ inches—contains a real phonograph motor.

The Genola is American-made throughout—priced low, due to quantity production. Not an importation.

The handsome black japanned case is complete with horn.

The Genola plays all lateral cut, ten inch records.

Here is obviously a lot of phonograph value for \$5.

- Barber Shops
- Shoe Shining Parlors
- Confectionery Shops
- Drug Stores
- Smoke Shops
- Fraternal Organizations
- Boarding Houses
- Police Stations
- Fire Stations
- People in Moderate Circumstances
- Rest Rooms
- Billiard Parlors
- Bargain Seekers
- Parents
- Schools
- Nurseries
- Hospitals

Then you know specifically who will be a few of your many Genola buyers.

Sample for \$3.⁵⁰

f.o.b. Chicago, Detroit or Minneapolis.

Dozen for \$3.35 each,

50 for \$3.25 each,

100 for \$3.10 each,

" " " " "
" " " " "
" " " " "

1,000 for only \$2.85 each, f.o.b. factory

CONSOLIDATED TALKING MACHINE CO.

2957 Gratiot Ave
Detroit, Mich.

227-229 W. WASHINGTON ST.
CHICAGO

1121 Nicollet Ave.
Minneapolis, Minn.

FROM OUR CHICAGO HEADQUARTERS—(Continued from page 114)

of two pieces soldered together. The solder occasionally loosened and blasting would then occur. In the new type of Sterling reproducer, however, this two-piece stylus bar is done away with and a cleverly constructed one-piece bar is used instead.

Another improvement in the Sterling product has been made at the base of the tone arm. Heretofore, this tone arm, which embodied the old-fashioned ball-bearing race-way, has entailed difficult assembling methods, but it has now been replaced by a new type of annular ball-bearing race-way, such as is utilized in the wheels of automobiles. Anyone familiar with automobile wheels knows the two annular ball-bearing race-ways used on both sides of the hub. In the construction of the new Sterling base the same principle is used, and this permits greater freedom of movement of the tone arm.

Another improvement in the Sterling product is seen in the new throw-back. Heretofore

Sterling offered only non-throw-back arms, but is now in position to offer both. The old pivot type base is retained for those who want it.

Brunswick Christmas Campaign

Announcement is made by the sales promotion department of the Brunswick-Balke-Collender Co. of a complete Christmas dealer campaign which offers the dealer a perfect tie-up with the Brunswick national advertising campaign both in newspapers and magazines during the month of December. These advertisements consist of seventeen retail ads with beautiful art work selling copy. The company is supplementing this campaign by offering the dealers several beautiful Christmas record delivery bags in four colors, a two-color folder on the different instruments and two-color record cards, making what the company considers one of the most complete dealer Christmas campaigns ever inaugurated.

Some New Features Planned for 1924

This week the Blood Tonearm Co. made the



Patented Aug. 14, '23
Other Patents Pending

**For Extra Profits
Thank the Triplex:**

Even rival cabinet designers and manufacturers are proclaiming the Triplex Artistic Phonograph as the finest, most efficient and beautiful Talking machine ever conceived.

Beautiful pictorial or decorative subjects are sold or exchanged, either ready made or the parts for owners to make to suit individual taste; as well as Records. Portable only may be sold and at some other time the Cabinet alone. The Triplex Artistic Phonograph meets every need in any house and for any occasion. The Triplex gets customers and holds them. Owners are delighted. Sales talk is short.

Turnovers and total profits greater than on any other talking machine. 1924 Model now ready. List Prices \$110.00 and up.

Triplex Artistic Phono. Co.

Pershing Road and Ridgeland Avenue
BERWYN, ILLINOIS

WHY NOT

Look about you and see the number of very successful concerns marketing original or modifications of original BLOOD ideas—there's a reason:

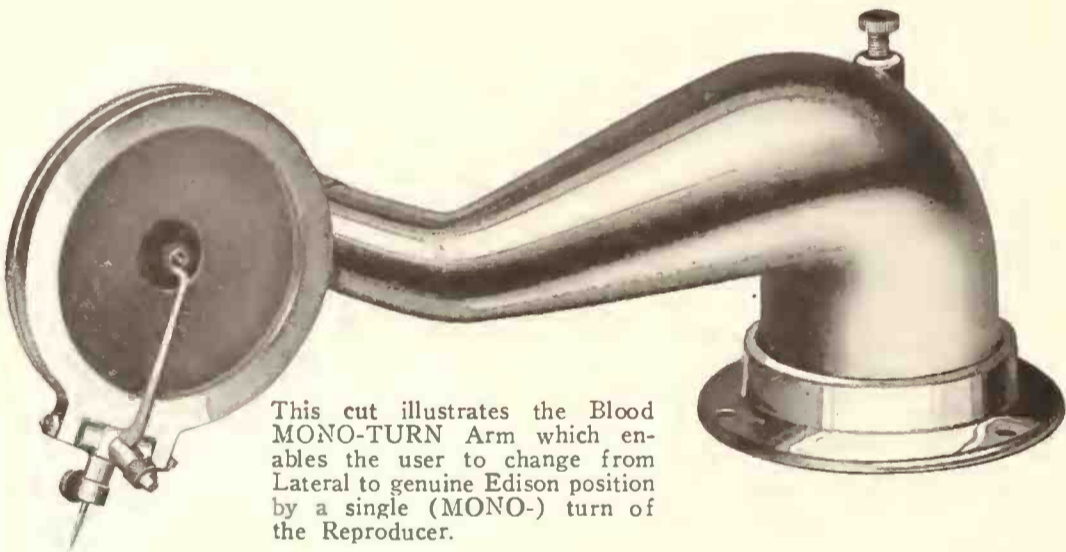

This cut illustrates the Blood MONO-TURN Arm which enables the user to change from Lateral to genuine Edison position by a single (MONO-) turn of the Reproducer.

BLOOD ideas and products are accepted and recognized by the trade as being mechanically perfect—that's why they're big sellers and keep our factory working night and day.

When in need of high grade tone arms and reproducers why not come to the original source of production.

*Save Money—Worry—and
Confusion*

The Blood Tone Arm Company
326 River St. CHICAGO, ILL.

announcement, from its headquarters at 126 River street, that many new features and improvements will be added to its new line to be introduced to the trade early in 1924. The new line consists of many novel improvements in the Blood product, among which may be mentioned the new method for preventing any loose joints or parts. Just what these new improvements are has not been definitely announced, but it is understood that they entirely eliminate the possibility of joints loosening by keeping the moving parts constantly lubricated.

Records by Wendell Hall

The first record made by Wendell Hall, of local fame, has just been released on Gennett records and a big sale is anticipated, especially in the Middle West where Mr. Hall is very well known through his radio activities. The records are very clever and original. The titles of the songs recorded by Mr. Hall are "It Just Keeps on a Rainin'" and "The Red Headed Music Master," introducing "Red Hot." The number is 5271. These numbers were recorded in New York, and Mr. Hall accompanied himself on the ukulele.

Interesting Saxophone Literature

"The saxophone is here!" The above is the opening line seen on a new circular just gotten out by Cole & Dunas. Following this is some effective text matter, telling how the saxophone got here and of its possibilities. This is followed by illustrations of saxophones, with their prices and trade names. The close of the circular text matter is devoted to a number of "harmonies," clever little quips having to do with music and the saxophone. The circular, which was edited by Joe Dunas, of Cole & Dunas, is being placed in the dealers' hands and is a four-page affair. There is a space open for the insertion of the dealer's name.

DeForest Co. Sales Meeting

H. H. Roemer, general sales manager of the DeForest Radio Telephone & Telegraph Co., held a get-together meeting of his sales forces in the LaSalle Hotel, Chicago, recently. All of Mr. Roemer's men who handle the Central Western territories were at the meeting and sales plans were made for a campaign, the like of which has never been seen in this section before, so far as radio is concerned.

Mr. Roemer also outlined plans for the year of 1924 and kept his salesmen up considerably by showing some of the new products which the DeForest Co. contemplates putting on the market, beginning with 1924.

"Heretofore," said Mr. Roemer to a World representative, "one of the big bugbears of radio was the service question, but the trade can now rest assured that this is now eliminated, or at least will be so completely with the introduction of the latest DeForest receiving

FROM OUR CHICAGO HEADQUARTERS—(Continued from page 116)

sets. In other words, DeForest instruments are now being made so that there is practically no service necessary. A great deal of the improvement is in the loop antenna we are using on our sets. All that is necessary to do with the new instruments is to replace a battery or a lamp occasionally."

Professor Cheney Ends His Western Tour

Professor Forest Cheney, of the Cheney Talking Machine Co., returned to this city on October 30 from a two months' tour of the Pacific



Prof. Forest Cheney

Coast region. During his travels he visited some of the most important cities in the Central West and in the States of Oregon, Washington and California. His visits to these localities brought him closely in touch with general business conditions, and the facts he learned on his trip have caused him to believe that certain territories in the Coast section give every promise of becoming recognized as centers of the nation's wealth.

"In certain places throughout the Coast re-

gion," said Professor Cheney, "particularly in the Los Angeles district, there is a tremendous influx of tourists and homeseekers. They have usually been supposed to be only transients, but this is by no means true of them all. Statistics show that many of them become fascinated with the Pacific Coast, invest their money in local real estate and commercial activities and remain permanently.

"For example, the building that is going on there is remarkable. It is true there are a number of flimsy bungalows being erected, but most of the buildings, as a matter of fact, are substantial affairs, costing anywhere from \$5,000 to \$20,000 apiece. Then, again, take a look around at the countless number of oil derricks already erected and in course of construction. This means that wealth has been brought there, as anyone who is familiar with the oil business knows that it takes thousands and thousands of dollars to drill an oil well.

"But to get away from the realty and oil business, let us look on the other side. For example, the farming situation. Both California and Washington are producing a wonderful

wealth of farming produce, especially in fruits, which is calling to those States tremendous amounts of wealth, not only for investment but as returns from the activities of the farmers. In California and Washington the farmers are exceptionally well organized and this is having a telling effect in building up the financial status of these territories. The Japanese catastrophe was the cause of much activity throughout the lumber districts in Washington, which, in turn, is having its reaction on general business. Oregon, however, is not so fortunate, for its farmers are practically unorganized and taxes are said to be very, very high."

While Professor Cheney was making his trip through the Coast States he not only got in close touch with the music dealers, but he was fortunate in meeting important people in practically every walk of life. In all he made twenty-four public addresses, and attended banquets at such clubs as the Rotary, Kiwanis, Fellowship and Advertising Clubs, and Chambers of Commerce. He also made addresses at many high schools before the students. His

(Continued on page 118)



Improve the appearance of your doors by using our No. 1008 semi-concealed hinge

Regular finish is in nickel, but other special finishes may be had upon writing for samples and prices.

This little device is especially sturdy in construction and is made so that the screw holes are set in a position to readily adapt themselves to practically any sized door without fear of losing screw grip solidity. Can be used on any door from five-eighths inch to seven-eighths inch in thickness.

Write for Our Special Prices on Jones-Motrola. Samples \$8.50

LAKESIDE SUPPLY COMPANY

73 W. Van Buren Street CHICAGO, ILL.



Oro-Tone No. 4 Automatic

The Most Scientific Edison Equipment Ever Produced



SHOWING POSITION FOR PLAYING VICTOR AND OTHER LATERAL CUT RECORDS



SHOWS POSITION FOR PLAYING EDISON AND OTHER VERTICAL CUT RECORDS

- the ORO-TONE No. 4 Edison equipment automatically gives the correct weight on the record, the correct needle center and the correct angle of the reproducer.
- there are no weights to shift, no adjustments to make, a simple turn of the hand and your phonograph is ready to play either lateral or vertical cut records perfectly.
- the No. 4 AUTOMATIC will not damage records, due to perfect weight adjustment, the correct needle center and the sensitive operation when playing.

PEOPLE who buy Edisons do so because they know that the Edison does actually recreate the original. That is why they want to equip their Edisons for playing lateral cut records, with the best attachments obtainable. The new ORO-TONE No. 4 is worthy in every way of being associated with the superb Edison for playing lateral cut records. Sample will be sent on 30 days' approval.

Nickel	\$7.00
Gold	9.00
Oxidized (Antique Bronze).....	9.00

Packed in fancy box with our two-year guarantee on each box. Usual discounts to responsible dealers.

The Oro-Tone Co.
QUALITY FIRST

1000-1010 George Street, Chicago, Ill.

Ask your Edison jobber for sample.

Distributed in Canada by R. S. Williams & Sons Co., Toronto, Montreal and Winnipeg.

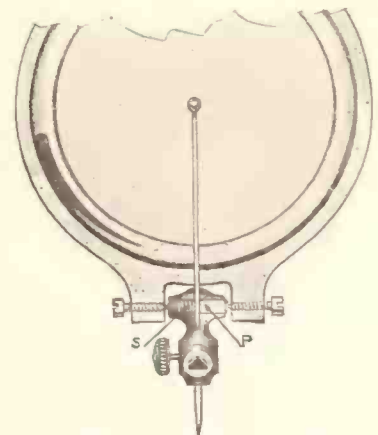

Equipped with this new ORO-TONE AUTOMATIC pivot point reproducer—the most scientific and satisfactory reproducer ever made—will not wear loose—always perfect in operation.

W. W. KIMBALL CO. SERVICE

Okeh Records

Records of Quality

The popular "hits of the moment" as well as the records that continue as "best sellers"; famous singers and instrumentalists.

W. W. KIMBALL CO., Wholesale Distributors.
306 So. Wabash Ave. *Kimball Building* CHICAGO

The dealer anywhere who establishes his connections here has the service that only experience can make available. Kimball all-the-year-around, ready friendly assistance helps to solve selling problems.

FROM OUR CHICAGO HEADQUARTERS—(Continued from page 117)

talks were varied and their subjects ranged from advertising and publicity propaganda to modern inventions, the influence of jazz on business, the purpose of fine arts, music as a science, etc.

Urge Uniform and Conditional Sales Act

On Monday and Tuesday, October 22-23, the third annual convention of the Illinois Music Merchants' Association was held at the Jefferson Hotel, Peoria, Ill. A goodly representation of talking machine men from both the wholesale and retail branches of the trade was present. Although not quite so large in point of attendance as previous gatherings the convention was a big success, both from a business and an entertainment standpoint, and great credit goes to the retiring president, Charles C. Adams, and his fellow officers for the arrangements made to receive the visitors. In spite of the fact that many of the dealers were busily engaged with their own affairs, owing to the Fall business which naturally accumulates at this time of the year, nevertheless many found or took the time to travel to the State's second largest city.

Following registration in the morning the conventioners were taken Monday afternoon on an automobile ride through the city of Peoria. In the evening the president gave a dinner at the Peoria Automobile Club, some seventeen miles out of Peoria, Ill. This was a highly successful affair. After dinner President Adams introduced James P. Lacey, music merchant of Peoria, who acted as toastmaster. Mr. Lacey had arranged the program of entertainment, in which Willard Beller, pianist, and Pearl Bradford, soprano, of Lyon & Healy artists' department, figured. Another representative of Lyon & Healy, E. J. Fishbaugh, superintendent of the Lyon & Healy plant in Chicago, addressed the convention on "The Manufacturer's Viewpoint of His New Products." Billy Collins, also of Lyon & Healy, closed the affair with several very interesting humorous readings.

On Tuesday morning, at the first business session, W. W. Kerr, of the Cable Company, was the principal speaker. He urged the members of the State Association to co-operate with other State organizations in securing the passage of a uniform and conditional sales act. The value of such an act to retail talking machine houses doing an instalment business was forcefully presented by Mr. Kerr, who showed how such an act, if passed, would overcome many of the troubles which Illinois retailers are now confronted with. One of the most resultful acts of the entire convention came from this discussion, viz., the appointment of a committee consisting of Guy Hornish, of Peoria; Fred Hanger, of Lincoln, and M. G. Ogle, of Galesburg. These gentlemen will work with the Credit Men's Association, the Illinois Furniture Dealers' Association and the State Chamber of Commerce in endeavoring to secure the passage of a uniform conditional sales act.

Tuesday noon the music men attended a

The BROADCASTER CORPORATION



Model C-3
Specifications:
39 inches wide, 23 inches deep,
35½ inches high. Gold plated.
Three-spring motor. Plush-velvet
turntable. Piano hand-
polished finish. Finished in Ma-
hogany and Walnut. ¾-5 ply
Veneers

A Bigger Plant
A Greater
Organization

Facilitates a larger
and more Superior
Talking Machine
Production at
LOWER PRICES.

Users of either large or small quantities of talking machines are urged to write for information regarding our line—useful for special sale purposes.

Write for price list and specifications of our other models.



Model No. 3
BROADCASTER
50" High, 20" Wide,
20½" Deep. Guarant-
eed two-spring mo-
tor. Figured birch
5-ply. Finished in
mahogany and wal-
nut. French pol-
ished, finish or dull.
A Rare Buy!



Model C-4
Specifications:
35½ inches wide, 22½ inches
deep, 35 inches high. Central lid
opening. Two-spring motor. Fur-
nished in either nickel or gold.
Piano hand-polish finish in Ma-
hogany or Walnut. ¾-5 ply
Veneers

Broadcaster Corporation

(Successor to the Linerphone T. M. Co.)

New Plant

2414 to 2430 W. Callerton St.
CHICAGO, ILL.

FROM CHICAGO HEADQUARTERS

(Continued from page 118)

luncheon at the Lions Club, where John McKenna, president of the Chicago Piano Club, was introduced as the guest of honor and toastmaster. Then came some highly interesting entertainment features, given by Axel Christensen, also of the Piano Club of Chicago. The principal speaker at this luncheon was the Superintendent of Schools of Peoria, John Fisher.

The Tuesday afternoon session was addressed by W. F. McClellan, secretary of the National Association of Piano Tuners, after which the annual election of officers followed, with the following results: Fred P. Watson, of Mt. Vernon, president; O. F. Anderson, Springfield, vice-president; J. E. Rice, Mt. Olive, second vice-president; R. J. Van Fossen, Beardstown, secretary, and Lloyd Parker, treasurer.

The annual banquet was held on Tuesday night in the Palm Room of the Jefferson Hotel, when the retiring president, Charles Adams, introduced the new president, Fred Watson. Addresses were made by Roy S. Dunn, representing the National Piano Travelers' Association, and M. J. Kennedy, secretary of the National Association of Music Merchants, who emphasized the value of good-fellowship and better co-operation between local associations and the national body.

The guest of honor and chief speaker was T. M. Pletcher, president of the Q R S Music Co., who gave a highly interesting talk on salesmanship in the music trade and the opportunities that lie before the energetic music merchant. In illustration, he emphasized the value of radio and the manner in which it was being featured successfully by numerous members of the music trade.

The phonographs exhibited at the convention included the Sonora line, which was shown by J. F. Corcoran; the Howezie record rack, with O. H. Eliel in charge, and the Davenport Phonograph Accessories Co., E. Q. Hewping in charge of this display.

New Hall Needle Display

The Hall Mfg. Co. has had prepared a very artistic window display card featuring the Hall fibre needle. This carries photographs of the various departments of the Hall plant, and under each is descriptive matter telling of the



Fibre Needle Window Display

processes through which the Hall fibre needle goes in each department.

At the side of the display card will be found samples of fibre in all the various stages through which it goes from the time it enters the factory as raw material until it passes out as a finished product. Text matter is also found here telling about these various stages of the needles' progress. A large number of these window displays have already been sent out and

(Continued on page 120)

The Motor



The Hall Mark of Dependability, Service and Quality

Two Million in Use

and giving satisfaction. A revelation in smoothness and quietness. Each and every part used in the building of a Krasco Motor is produced by the Krasco Manufacturing Company. Krasco is built—not made or assembled.

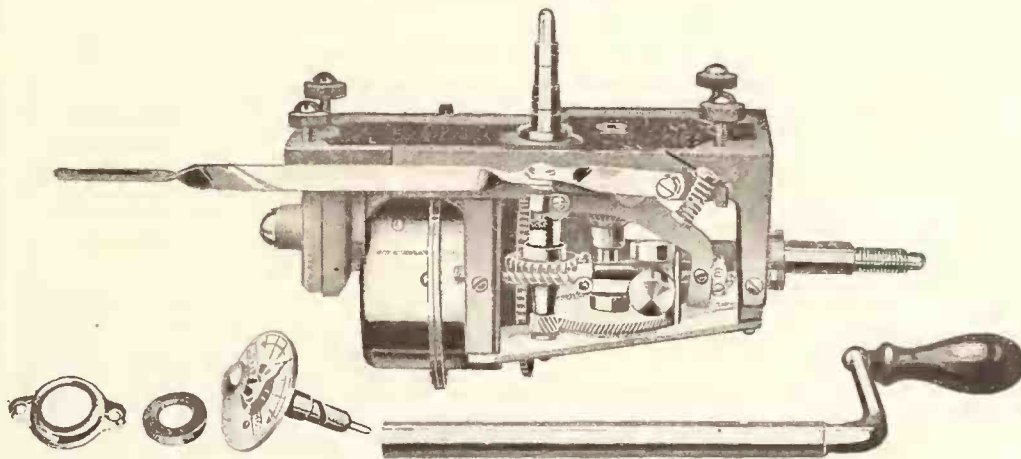

SIX SIZES

From a double spring motor playing four 10-inch records to a Four spring playing ten.

"A Powerful Engine Built to Stand the Gaff"

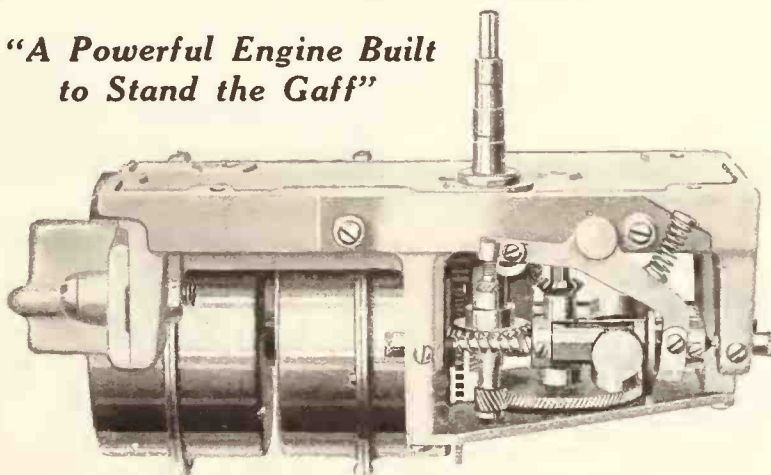

Krasco Motors Are Interchangeable as to Mounting—Borings for One Fit All

Simple in design, compact, sturdy, mechanically right. Built to meet the most exacting demands for long distance playing on one winding.

May we quote you prices and send descriptive literature?

KRASCO MFG. COMPANY

451 East Ohio Street

CHICAGO

FROM OUR CHICAGO HEADQUARTERS—(Continued from page 119)

have proved very effective in stimulating trade for Hall fibre needles.

Art in Phonograph Design

In these columns last month reference was made to a chronological chart compiled by the Windsor Furniture Co. which goes back to primitive days and takes up the growth and progress of art and furniture in a sort of "family tree" style right up to the present day. In the beginning it deals with the most primitive styles of furniture and gradually comes up to the present-day types, and at various times it branches off, showing the influences of certain types upon the so-called period designs.

One branch of this "tree" is particularly interesting in that it deals with the Italian Renaissance period, how it was influenced by the Greek age and how these, in turn, are having their effects upon the present-day architecture and design in furniture.

In these periods much attention was paid to the human figure from a carving and sculptural standpoint. The furniture designers in those days, in keeping up with the demands of the times, made use of the figures and utilized them in the making of legs, for example.

In the furniture of the day we very frequently

find the use of the human figure in designing furniture, particularly in consoles, serving tables and wall tables, as well as an occasional use of them as pilasters in the construction of very expensive pianos.

Some thirty years ago the Windsor Furniture Co. had on exhibit in the furniture building at the World's Fair, Chicago, some very fine samples of carvings of the human figure as applied to high-grade furniture. It will be remembered that some of the World's Fair buildings were destroyed by fire, including the one in which these carvings had been displayed. Happily, however, the Windsor Furniture Co. managed to rescue a large amount of its exhibit and has since that time kept these carvings as souvenirs.

Since the introduction of the console talking machine the Windsor Co. has made use of carvings of the human figure in embodying it in several of its designs of high-grade console talking machines. The resurrection of these carvings and their application to modern console talking machine design have created unusual interest throughout the trade, which has, in turn, caused considerable demand for high-grade Windsor art models. So great has this

demand become of late that the Windsor Co. has been making plans further to increase its production of these instruments and in this connection is utilizing its aforementioned chronological chart for the benefit of dealers.

Gulbransen-Dickinson's Significant Bulletin

The September bulletin of Gulbransen-Dickinson has some of its space devoted to a mass photograph, showing nineteen Gulbransen dealers' billboards. From the standpoint of publicity there is something very significant in this photograph of the group of billboards which should arouse much interest throughout the talking machine trade.

The billboards in question just pertain to the Chicago territory and show the co-operative publicity existing between a number of live Gulbransen dealers and the Gulbransen Co. In all the Gulbransen has forty-two dealers in Chicago, all of whom take advantage of the Gulbransen publicity service, but the above-mentioned nineteen have been picked at random. It is an impressive list and eloquent testimony to the standing of the Gulbransen in this city.

The significant thing of these nineteen posters is that sixteen of them devote some of (Continued on page 122)

Oro-Tone Automatic No. 16

Means More Selling Power for Your Phonograph

No Weights
to Shift

No Adjustments
to Make

AUTOMATICALLY

- gives correct weight on record
- centers needle on record
- permits correct reproducer position



A simple turn of the hand and the ORO-TONE AUTOMATIC No. 16 is ready to play either lateral or vertical records perfectly. All adjustments work automatically.

ADVANTAGES

The No. 16 AUTOMATIC is attractive in appearance and perfect in operation. It gives a powerful, rich, mellow tone that charms the ear of both dealers and customers. It is equipped with the wonderful ORO-TONE automatic pivot point reproducer, the finest scientifically designed reproducer on the market.

Tests have demonstrated the preference of the public for the ORO-TONE AUTOMATIC No. 16. This will mean more sales and more profits for your line. We invite you to test the new ORO-TONE AUTOMATIC No. 16 Tone Arm and Reproducer for yourself. A sample will be sent promptly on 30 days' approval.

SAMPLE SENT ON
30 DAYS' APPROVAL

The Oro-Tone Co.
QUALITY FIRST

1000-1010 George Street, Chicago, Illinois

Manufactured in Canada by W. H. Banfield & Sons, under the trade name ORO-TONE-BANFIELD.

Australian distributors: The United Distributors Co., Melbourne and Sydney.



POSITION FOR HILL AND DALE RECORDS

A turn of the hand and the reproducer is in the correct or Edison position with correct angle and perfect needle center—note dotted line.

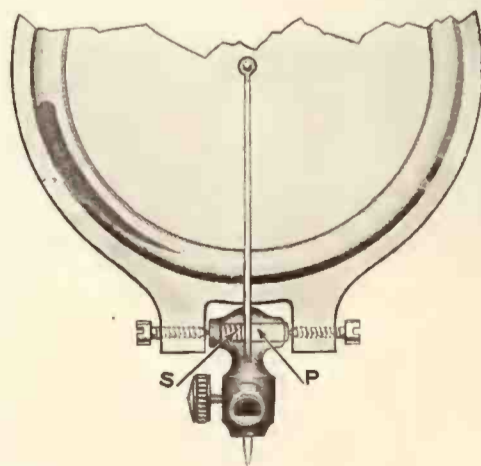

The New ORO-TONE AUTOMATIC 100 per cent perfect pivot point reproducer.

Announcement!



Style 10

Since October 1st our factory has been sold up for the balance of the year.

Our dealers appreciate the quality of our goods as well as our service and have cooperated with us to their fullest extent by anticipating their requirements in advance.



Style 20

Now is an opportune time to do likewise.

We are booking orders for 1924 delivery only.

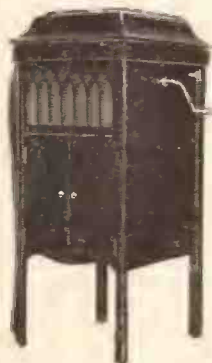

Style 1

Size: 40 inches High, 17 inches Wide, 18½ inches Deep. Finish: Mahogany or Oak. Panels 3-ply Gum. United 2-Spring Motor.

Console models Nos. 20, 30, and 40 are constructed of genuine 5 ply mahogany panels.

Console model No. 10, constructed of gum panels.

Size of all console models 35 inches wide, 33 inches high and 21 inches deep.



Style 2

Size: 46 inches High, 21 inches Wide, 23 inches Deep. Finish: Mahogany or Oak. Panels 3-ply Gum. United 2-Spring Motor.



Style 30



Style 4

Size: 48 inches High, 21 inches Wide, 23 inches Deep. Finish: Mahogany, Oak or Walnut. Panels 5-ply. United 2-Spring Motor.



Style 40

EXCEL PHONOGRAPH MFG. CO.

400-412 West Erie Street

CHICAGO, ILL.

FROM OUR CHICAGO HEADQUARTERS—(Continued from page 120)

their space to advertising nationally known talking machines.

Since talking machine dealers are familiar with the handling of nationally advertised products they are in a position to appreciate the value lying in products of such a nature. The Gulbransen line of pianos, being nationally known and advertised, fits in very well with other nationally advertised musical instruments, and that is why there is such splendid cooperation existent among Gulbransen dealers.

Plans are now being made by the publicity department of the Gulbransen-Dickinson Co. to increase its publicity during the coming year, and it is believed that when all plans have been carried out the proportion of Gulbransen dealers handling talking machines, which at present shows a ratio of sixteen to nineteen, will have been greatly increased.

New Brunswick Artist Announced

Another artist from the "New Hall of Fame" is to make records exclusively for the Brunswick, Elizabeth Rethberg, soprano of the



Elizabeth Rethberg

Metropolitan Opera Co., will record for Brunswick in the future. The photo shows Miss Rethberg at Ravinia Park this Summer, where she sang with great success. This artist, late of the Dresden Opera, has aroused a great deal of interest in announcing her American debut for the coming season with the Metropolitan Opera Co. Her home was in the Schwarzenberg in the Erz mountains and her musical

Announcing The New Sterling Tone Arms and Reproducer

We are now ready to submit our new and complete line of STERLING Tone Arms to the trade.

Everything has been done to increase quality and decrease costs.

We can now supply either straight or throw-back reproducer, pivot or ball-bearing tone arm—a ball-bearing arm that is DIFFERENT.

Manufacturers:—

We will be pleased to submit quotations on your requirements and send samples for your inspection.

Sterling Devices Manufacturing Co.
412 Orleans Street, Chicago, Ill.

talent developed early. At the age of seventeen, after studying the piano and singing, she entered the Dresden Conservatory. Shortly afterwards she appeared on the stage of the Dresden Opera. The critics of Germany, Austria, Hungary and Scandinavia have generously agreed with those of America in her praise.

Opens Krasco Stockroom in New York

E. B. Cadwell, of the Krasco Mfg. Co., spent a number of days in Chicago the first of the month visiting the plant. Although his headquarters are in New York he visits the Chicago factory frequently. On his last visit he and other officers of the company spent considerable time going over plans for the balance of the year and the coming year.

In order to expedite shipments to its Eastern clientele the Krasco Mfg. Co. has opened a stockroom at 120 West Forty-second street,

New York, where a large supply of Krasco motors, Krasco units and Krasco parts will be kept constantly on hand. This new Krasco wareroom will be looked after by D. S. Root, treasurer of Krasco, and E. L. Krans, Mr. Root's assistant.

Cable Company Features "Midnight Rose"

The attractive display shown herewith was seen recently in the Jackson street window of the Cable Company, featuring "Midnight Rose"



Cable Company's Window Display

with the Brunswick. As expressed by the Brunswick Co., the display is another example of the energetic as well as a thorough campaign recently inaugurated in behalf of the Brunswick by the Cable Company.

Anthony Leaves Pathé

After five years' service as office manager and assistant sales manager A. V. Anthony has severed his connections with the Pathé Phonograph & Radio Corp. Mr. Anthony is very well known in the Chicago trade and, since his entrance into the talking machine business, has built up a nice reputation. Because of his original sales methods he has been instrumental in establishing many retail accounts in the Chicago district and throughout the Middle West. Mr. Anthony has not as yet announced his plans for the future.

Strand Sells in Chicago

C. R. Newman, manager of the J. O. Twichell Store, 11015 South Michigan avenue, reports increased sales for the Strand talking machines. Mr. Newman is managing a store located in

(Continued on page 124)

IN BEAUTIFUL XMAS BOXES
FOR HOLIDAY GIFTS



THE GEER REPEATER

Finished in genuine gold plating at the same price, \$1.50, in beautiful holly and poinsettia boxes for Christmas Gifts. Send us your orders early for prompt shipments.

Walbert Manufacturing Company

925-41 Wrightwood Avenue

Chicago, Ill.

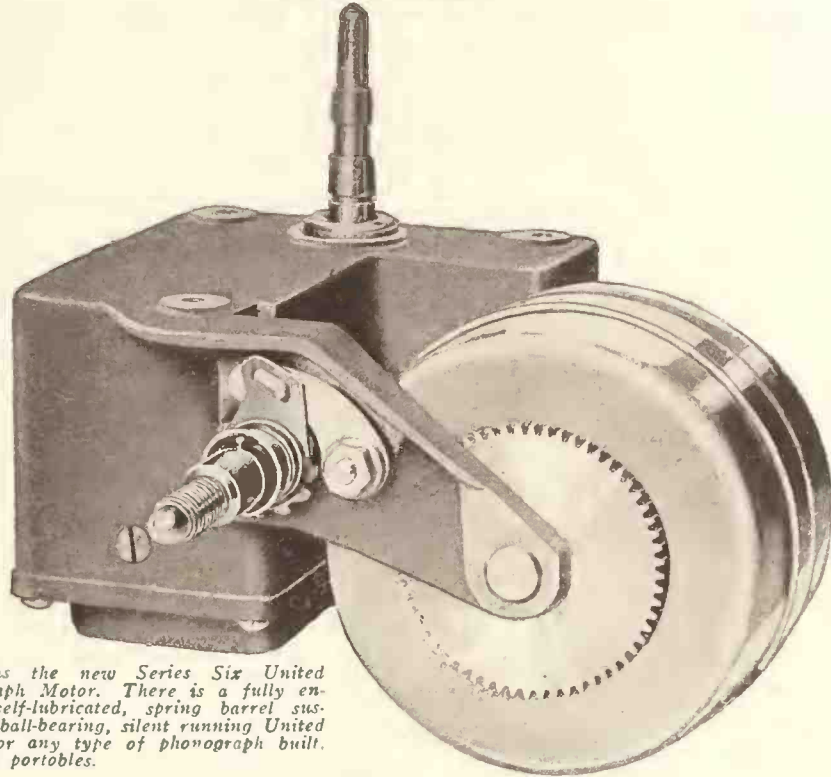
 UNITED

This is the new Series Six United Phonograph Motor. There is a fully enclosed, self-lubricated, spring barrel suspension, ball-bearing, silent running United Motor for any type of phonograph built, including portables.

A thin dime—and two minutes' time

No one has discovered how to make springs that never break—but United has discovered how to make a thin dime and two minutes' time replace a broken spring in a phonograph motor. Instead of at least one hour's time spent in the mussy job of taking apart the motor, installing a new spring and reassembling, with a United motor you merely take out the old spring assembly and insert a new one—an operation which anyone can perform in two minutes or less, using a screw-driver (or a thin dime in emergency). And you don't even soil your fingers!

UNITED

PHONOGRAPH MOTORS

STANDARD ON A SWEEPING MAJORITY OF ALL MAKES OF PHONOGRAPHS

Completely Enclosed!

The only enclosed motors of international reputation are the United. Cast-iron box houses governor, gears, worm and lower end of shaft. Excludes dust, dirt, shavings, slivers, sawdust, needles, etc., forever. Protects vital parts from damage during assembling, shipment, demonstration and use. Insures permanent alignment. Removes necessity of "tuning" motor when installing it.

Self-Lubricated!

Phonograph users are notoriously forgetful about oiling their motors. Or they overdo it. United Motors—another exclusive feature!—do not require oiling more often than once in four or five years. The automatic and continuous wick-oiling United system, made possible by the air-tight housing, keeps all moving parts evenly and adequately lubricated.

Other Superiorities!

Spring barrels are held in positive alignment by the exclusive United suspension—cannot work loose. Smooth, easy functioning of control lever always assured. All plain bearings are perfectly machined and trued in United motors. Ball bearings take care of end-thrust. Finally, each motor is mounted, tested and regulated before shipping—insuring silence.

Send for our book—"The Heart of the Phonograph"

UNITED MANUFACTURING AND DISTRIBUTING COMPANY

9705 Cottage Grove Avenue, Chicago, Illinois

The world's largest independent makers of phonograph motors

FROM OUR CHICAGO HEADQUARTERS—(Continued from page 122)

the center of Chicago's busy Roseland district, and one of the parts in Chicago territory in which no one can deny that the keenest of competition exists. Besides handling talking machines the J. O. Twichell shop handles a well-known line of pianos and players, but the Strand talking machine is handled exclusively. Mr. Newman says that his sales of Strand talking machines for the past month exceed all other months and, from present indications, the balance of the year will bring forth a Strand business far in excess of anything he has up to this time accomplished.

Second Annual Luncheon of Sonora Dealers

S. O. Martin, vice-president and general manager of the Sonora Phonograph Co., Inc., New York, was the principal speaker at the second annual luncheon of the Sonora dealers in Chicago territory held November 7 at the Congress Hotel. The Illinois Phonograph Corp., Sonora jobber in this territory, was the host at this luncheon, and many practical subjects were discussed during the course of the meeting.

During the course of his address Mr. Martin gave an intimate idea of the present status of Sonora activities, emphasizing the fact that the company is enjoying the most prosperous era in its history and that the factory at Saginaw is working day and night to keep pace with the requirements of the jobbers and dealers. Incidentally, Mr. Martin was able to give the Chicago trade first-hand information regarding Saginaw affairs, for he had just visited the mammoth Sonora plant in that city. Among the other speakers during the afternoon were E. D. Coats, sales promotion manager, Sonora Phonograph Co.; A. G. Rodway, president of the Illinois Phonograph Corp.; Leon Golder, general manager, and Harry O'Connor, sales manager. Several of the local dealers also participated in an interesting round-table discussion and a musical program added to the success of the conference.

Piano Club Hears Talk on Radio

Members of the Chicago Piano Club heard last week a very interesting and enlightening talk on the subject of "Radio in the Music Industry" by W. S. Hedges, editor of the radio department of the Chicago Daily News. Mr. Hedges began by stating that the vast majority of programs broadcast are musical. "The radio fans want music," said he, "and for that reason music is given preference over all other items. Radio has thereby brought music into thousands of homes where there never was any music before and is, furthermore, giving the music industry the greatest advertising it has ever had, because the people want a variety of music, and all types of musical programs are broadcast. Radio music might be called impermanent music because it is not played over and over again, and those who like a certain song will have to go out and buy the record or roll for either their talking machine or player-piano.

"Now, I understand that the musical instrument manufacturers are doing a big business this year, which I attribute to radio, or rather the advertising of music by radio. It matters not whether radio is an evolution or a revolution, for, whatever it is, it is here to stay and should be supported instead of flouted. It is logical to assume that radio will not die, for what is good lives. For example, when vaudeville was introduced some were afraid that it would replace the drama, and when motion pictures were introduced others thought that they would replace the acting stage altogether or to a very large extent, whereas neither is interfering with the other.

"Now, there is no reason for the music industry to view radio with disfavor, for radio is not interfering with the music industry, but is, rather, helping it. For example, the song 'Mellow Moon' was a very obscure number before it was broadcast. The composer went to the Drake Hotel and broadcast the number himself. Within one month the sales were 100,000 copies.

"You, gentlemen, should get in on radio because it is musical. I do not mean that you should stock your shelves with parts. Let the electrical dealer take care of this trade. What you should sell is the high-grade finished set. Investigation by a radio manufacturer who sells his product exclusively to music merchants shows that, of all the music men handling radio, 90 per cent have made money, 3 per cent have lost money and the remaining 7 per cent have broken even, which, I think, is a very good showing. One Los Angeles music dealer in the past year sold \$200,000 of complete radio sets and he still is selling phonographs. I do not think the music store is complete unless it has all three—the talking machine, the piano and the radio."

Chicago Incorporation

The Ver Celli Anctil Co., 11405 Michigan avenue, has been incorporated with a capital of \$20,000, to deal in phonographs, pianos, musical records and rolls. Incorporators: Bernard Ver Celli, Isabelle Ver Celli, Jos. S. Anctil.

Correspondents: McKinley and Schmauch, 731-111 West Washington.

Opening of Brunswick Dealer

The large assembly shows the opening of Geo. L. Berkel Co., of Los Angeles, Brunswick dealer. A feature of the opening was the entertaining of Abe Lyman and His California Am-



Crowd at Geo. L. Berkel Co. Opening
bassador Hotel Orchestra, exclusive Brunswick artists. The occasion marked a very beautiful display of the Brunswick line in a very modern music shop.

Columbia Brieflets

Sol. Biasco recently opened the Archer Music Shop, 4237 Archer avenue, Chicago, Ill. Modern fixtures were installed and the new Columbia line will be handled exclusively. The neighborhood is chiefly Lithuanian, Polish and Italian, and a complete stock of Columbia records in these languages will be handled.

E. Kinentt, foreign record representative for the Columbia Co.'s Chicago branch, spent last week in St. Louis territory working with the trade on their Christmas foreign record requirements.

C. R. Salmon has been placed on the Loop and North Side territory for the Chicago branch of the Columbia Co. Mr. Salmon was in the Columbia organization for eight years at St. Louis. After spending two years with the Brunswick Co. in New York he is returning to his first love.

A recent visitor to the Chicago office of the Columbia Co. was W. W. Cooper, dealer in Genoa, Ill., who looked over the new Columbia line and placed an order to meet his Fall requirements.

The Fisk University Jubilee Singers, an exclusive Columbia organization, is touring the Chicago branch territory during the months of October and November. The Columbia catalog contains a large assortment of exclusive records by this organization, and their appearances have always materially boosted record sales for dealers.

PITTSBURGH FIRM CHARTERED

PITTSBURGH, PA., November 8.—The Pittsburgh Phonograph Distributing Co., this city, has been chartered with a capital of \$5,000 by C. C. Robertson, J. H. Boyd, L. D. Brown.

RAINBOW RECORDS

add to many dealers' profits.
Some good territory open
for distributors. Write for
our proposition.

THE RODEHEAVER COMPANY

Record Dept.

218 Wabash Ave. Chicago 814 Walnut Street Philadelphia

UPKEEP

Has it ever occurred to you that there is a certain upkeep charge on talking machines?

Insignificant, perhaps, but nevertheless continuous.

Using a needle each time you play a record, plus the wear and tear of that record by that type of needle, costs money eventually.

Figure the cost of one record plus the large amount of needles and you'll be surprised.

Have you ever told this to your customers, Mr. Dealer?

"Tonofone"

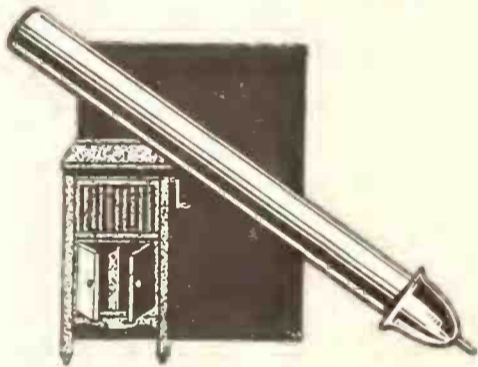

Tonofone Semi-Permanent Needles play on an average fifty records each without wear or tear.



Packed in Colored Display Cartons

One hundred packages to carton.

Red and White cartons contain 25c packages; Blue and White, 10c packages.

RETAIL PRICES

Package 12 needles.....25 cents
Package 4 needles.....10 cents

100% Profit to Dealers

Jobbers' proposition on request.

THE TONOFONE COMPANY
110 So. Wabash Ave., CHICAGO, ILL.

Inventors and Sole Makers

Eastern and Export Representatives:
South Atlantic Export Co.
25 Broad St., New York, N. Y.

Do You Know—Mastercraft “Juvenola”?

**BUILT FOR THE KIDDIES
AS THEIR VERY OWN**

The “Juvenola” is a genuine phonograph—not a toy.

Here’s an opportunity for receptive little minds to easily learn the worth while things in music.

In addition to the typical kiddie compositions—appealing to all boys and girls—the first appreciation of the world’s finest harmonies may be instilled in the younger generation.

Made in the console style—with a real motor—playing two ten-inch records on one winding. Reproduction—sweet, persuasive—superb.

VERY MODERATELY PRICED

All of which means that the go-getting dealer and jobber—with vision—can make big money—during the coming months.

Other “MASTERCRAFT” models in our complete line—are at your service.



Attractively finished in

**BLUE
GRAY
IVORY
MAHOGANY**

THE WOLF MANUFACTURING INDUSTRIES

BUILDERS OF “MASTERCRAFT” PHONOGRAPHS

QUINCY, 3, ILLINOIS

Interest Grows in Chicago Radio Exposition

Practically All the Large Manufacturers Will Be Represented at the Coming Show Which Will Be Held at the Coliseum From November 20 to 25—Elaborate Programs Prepared

CHICAGO, ILL., November 10.—The talking machine trade in Chicago and the surrounding territory is evincing keen interest in the Second Annual Radio Show, which will be held in the Coliseum from November 20 to 25 and at which will be exhibited the products of the leading manufacturers in the radio industry. Practically all of the exhibition space has been sold and when the doors open there will be presented the greatest array of radio products that has ever been shown. Various interesting features have been prepared by the show management and the Chicago broadcasting stations have organized to broadcast the question “What Would You Like Most to Hear Over the Radio?” There will be about 500 prizes offered for the most interesting answers and it is expected that more than 200,000 replies will be received to this query.

Many well-known personages in the radio industry will be among the speakers at the trade meetings and at the show, among these being Major Armstrong, Dr. Lee De Forest, Prof. Hazeltine, N. T. Llewelling and others. There will also be presented feature concerts broadcasted direct from the Coliseum by means of sealed wires to the local broadcasting stations.

James F. Kerr, manager of the Chicago Radio Show, is delighted with the enthusiastic reception accorded his publicity matter by the dealers throughout the Middle West. He states that the show management circularized 8,000 Middle Western dealers, telling them of the show and inviting them to attend. The responses to the invitations, have been gratifying beyond all expectations and Mr. Kerr predicts that Chicago will surely be the radio center of the world during the show.

Among the prominent manufacturers in the

radio industry who have reserved space at the show are the following: De Forest Radio Tel. & Tel. Co., Colin B. Kennedy Co., Federal Tel. & Tel. Co., Cutting & Washington Radio Corp., Crosley Mfg. Co., Precision Equipment Co., American Radio & Research Corp., Nathaniel Baldwin, Inc., Bristol Co., Zenith Radio Corp., Atwater Kent Mfg. Co., United Mfg. & Distributing Co., Moon Radio Corp., Walbert Mfg. Co., A. H. Grebe & Co., F. A. Dandreaux, Inc., and others.

FITZGERALD ORGANIZATION MEETS

Personnel of Prominent Los Angeles Music House Comes Together at Dinner-Meeting—Interesting Talks Feature Event

LOS ANGELES, CAL., November 5.—Interesting addresses on business development and plans for the future featured the dinner-meeting of the Fitzgerald Music Co.’s organization at the Paulais Cafe, this city, last month. Those present numbered 110, ample evidence of the development of this progressive music concern. Addresses were made by J. F. Fitzgerald, head of the concern, and other officers and executives, including Manager Mansfield, of the phonograph division, who spoke of the rapid and steady growth of this department during the past eighteen months. Mr. Mansfield pointed out that the talking machine division has shown a gain of from 50 to 75 per cent each month over the corresponding period a year ago.

The Fitzgerald Music Co. is not only one of the largest music houses on the West Coast, but it is also one of the most successful, due to progressive merchandising methods. Musical instruments of all kinds are handled, including

a complete line of pianos and Brunswick phonographs and records. The talking machine department, by the way, is a feature of this fine establishment, the most modern fixtures and the last word in interior arrangements making it a delight to visitors.

EDISON AS GOLDEN WEDDING GIFT

Carlin Music Co. Sells Instrument as Gift and Receives Cash in Gold

INDIANAPOLIS, IND., November 7.—The Carlin Music Co., Edison dealer, at 143 East Washington street, this city, reports an unusual sale. Mr. and Mrs. Chas. W. Houson, local residents, recently celebrated their golden wed-



Mr. and Mrs. C. W. Houson

ding anniversary and, as a token of love and admiration, which had strengthened with the passing of half a century of time, Mr. Houson presented his wife with a New Edison phonograph and an assortment of Edison records. When the Carlin Music Co. presented the bill Mr. Houson promptly paid it—in gold. Presented herewith are likenesses of the happy couple.

DISCUSS TALKING MACHINE SHOW

Talking Machine Men, Inc., Considered Proposal at Meeting Last Month—Also Discuss Participation in Music Week and Plans for the Annual Ball to Be Held November 21

The advisability of endorsing and participating in the holding of a national phonograph and talking machine exposition in New York some time during the coming year was one of the chief matters discussed at the monthly meeting of The Talking Machine Men, Inc., held at the Café Boulevard on Wednesday, October 17. There were those who felt that the success of such a show was too remote to warrant the association becoming involved in the movement, but the more optimistic ones prevailed with the result that Lambert Friedl was appointed chairman of a committee to consider the matter and report on the project later.

The participation of the members of the association in the next annual music week celebration and particularly the music memory contest in the public schools of the city also came up for considerable discussion, particularly as the members have been very slow to respond to letters from the president inquiring as to their willingness to lend their co-operation by working with the schools in their respective districts, giving them certain quantities of records included in the list, and otherwise lending their aid. It appeared that less than 5 per cent of the members had taken the trouble to write to the president regarding the matter.

Among the outside speakers at the meeting were: J. G. Horne, of the Consolidated Orchestras Booking Co., who outlined a plan whereby dealers could draw attention to their stores and likewise increase their profits by acting as booking offices for orchestras in co-operation with his company; Miss Isabel Lowden, Director of the New York Music Week Association, who asked the support of the talking machine men for the music contests now being carried on in the various school districts by that association, and L. M. Bernstein, of the Wilmark Service System, the function of which organization is to check thefts in retail stores.

Representatives of the A. J. Stasny Music Co. were present at the meeting and demonstrated several of the company's hits, including "Sun-Kist Rose," "Waltz Me to Sleep in Your Arms," and "How Can I Believe You?"

The entertainment committee of the organiza-

tion is working hard to make a success of the annual entertainment and ball of the association to be held at the Hotel Pennsylvania on the evening of November 21, and at which a majority of the leading recording orchestras and a number of prominent artists will appear. H. Emerson Yorke, of M. Witmark & Sons, was appointed a member of the committee.

"LITTLE TOTS" SPECIAL TUNES

Special Christmas Book Added to Regal Record Company's Catalog—"Little Tots' Phonograph" Makes Its Debut in the Trade

The special Christmas book of "Little Tots' Nursery Tunes," manufactured by the Regal Record Co., Inc., has timely additions to this firm's catalog. The sales department of the



Little Tots' Phonograph

company expects these Christmas books to add considerably to the importance of its product and to increase the volume of sales during the holidays.

In conjunction with the Christmas book of "Little Tots' Nursery Tunes," the company has placed on the market a juvenile phonograph for use on the table, floor or anywhere in the nursery. It carries the trade name "Little Tots' Phonograph" and is highly decorated and multi-colored with designs which appeal to the child.

In the metropolitan district of New York a long list of department stores and dealers are making a feature of "Little Tots' Nursery Tunes." Among the department stores which give these records and books special showings are: Lord & Taylor, Abraham & Straus, Bamberger's, Frederick Loeser & Co., Gimbel Bros., Bloomingdale Bros., Hearns, James McCreery & Co. and Hahne & Co.

AUDAK IN COUNTRYWIDE USE

Record Demonstration Device Now in Retail Stores Throughout the Country

Following the introduction of the Audak in recent months by the Munson-Raynor Corp., the Pacific Coast representative, this talking machine record demonstrating product is now in use in retail establishments in practically every State in the Union. The Audak, originally used by dealers in Eastern territory, and subsequently gaining popularity in the Middle West, is now being given attention by the entire trade when considering record sales.

Recently a representative of the Audak Company made a tour through the Eastern and Middle West trade centers and reported many instances where the Audak is being constantly used to increase record sales, save sales energy and conserve floor space. With distributors in the larger cities, and with one or more Audaks in use in various other centers, it is now possible for the merchant to see and hear records demonstrated by this product in stores in his own locality.

The popularity of the Audak name in places where it is not yet in use recently was forcibly demonstrated to an Audak representative who visited a store in the Middle West, and who, in a chat with *The World*, said: "I found that the dealer had purchased a demonstrating device presumably thinking it was the original. While the dealer was not satisfied with its use, he did not at once discover the fraud, laboring under the impression that the original was over-advertised. When shown the difference, and after hearing records demonstrated by the real product, he denounced the sales organization that had perpetrated the fraud, particularly inasmuch as the counterfeit was billed as an 'Audak' on the invoice."

Regarding this latter situation, Maximilian Weil, head of the Audak Company, obtained the invoice in question and other data and has placed it in the hands of his attorney. He states that action will be taken, both from a criminal and civil standpoint.

TRADE NEWS FROM CANTON

CANTON, O., November 6.—Trade Extension Week, held by Alliance merchants last week, was participated in by six Alliance music dealers, three of whom were active in the various promotions. The Vernon Piano Co., J. H. Johnson Sons and the Cassidy Drug Co., Victor dealers, presented special window displays and staged a number of exploitation stunts.

The talking machine department of the William R. Zollinger Co., here, will soon be remodeled and four new booths installed under the supervision of Manager W. E. Pyle.

The S. S. Kresge Co., here, will maintain a complete record department, specializing exclusively in Regal records in its store opened in Canton this week.

Alice Kestel, formerly with the D. W. Lerch Co., is now in charge of the record, rolls and small goods department of the Alford-Fryar Piano Co.

George C. Wille Co. will be in its new location at Fourth street and Market avenue soon after December 1.

Almost twice the present space will be available for the talking machine department at the Hefling Music Co., New Philadelphia, O., when alterations now in progress are completed.

H. C. MILLER ENTERS FIELD

WILMINGTON, DEL., November 7.—The Brunswick Shop, of this city, formerly under the direction of Peter Casper, has recently been reopened by H. C. Miller, with a complete line of Brunswick machines and records. This is Mr. Miller's first venture in the phonograph business and he has the best wishes of a host of friends here.

BLACKMAN AND DEPENDABILITY

Blackman

TALKING MACHINE CO
28-30 W. 23RD ST. N.Y.C.

ONE SUGGESTS THE OTHER

Measure your Distributor's service by his average—we all miss at times. On the average Blackman Service cannot be excelled.



VICTOR WHOLESALE DISTRIBUTORS



List \$225
 The "Bergundy," an Emerson Console
World's Greatest Phonograph Value
 A wonderful example of the Louis XV
 period. Choice of warm Ale Brown
 Mahogany or sumptuous deep toned
 American Walnut. Width 40 inches,
 height 37½ inches, depth 21 inches.

Greater Profits from the New Emerson Console Line

Live merchants are finding the new Emerson line the most valuable Console line ever created.

Because we are building and delivering the most practical and attractive period designs which at list prices of from \$110 to \$225 are unequaled by competition.

Because Emerson exclusive features, such as the "Fount of Pure Tone," are sales makers.

Because our remarkable discounts allow you long profits on "quick turnovers" popular-priced Consoles.

Order promptly to insure prompt delivery

Since we offered the new Emerson Console our distribution has increased beyond expectations. This valuable merchandising opportunity has attracted carload orders from Coast to Coast. To insure full advantages of special service and discounts order now.

List of Models and Prices

- | | |
|--|--|
| List \$110—"Wayne"
Adam design. Brown Mahogany finish. Height 35 inches, width 33 inches, depth 21 inches. | List \$150—"Blenheim"
"Queen Anne" Special. Brown Mahogany or American Walnut finish. Height 35 inches, width 36 inches, depth 21 inches. |
| List \$125—"Lady Churchill"
"Queen Anne" Period. Brown Mahogany finish. Height 35 inches, width 33 inches, depth 21 inches. | List \$175—"Beverly"
"William and Mary" design. Brown Mahogany or American Walnut finish, gold trim. Height 35 inches, width 36 inches, depth 21 inches. |
| List \$135—"Piedmonte"
Italian Renaissance. Brown Mahogany finish or American Walnut finish. Height 35 inches, width 36 inches, depth 21 inches. | List \$200—"Alaric"
"Gothic" design. Brown Mahogany or Walnut finish, gold trim. Height 40 inches, width 27 inches, depth 22 inches. |

WASMUTH-GOODRICH COMPANY Peru, Indiana

Manufacturers of Emerson Phonographs

- | | |
|--|--|
| <i>Eastern States Distributor</i>
Emerson Phonograph Co.
105 West 20th Street
NEW YORK, N. Y. | <i>Central States Sales Representative</i>
L. C. Samuels
22 Quincy Street
CHICAGO, ILL. |
| <i>Southern State Sales Representative</i>
L. W. Freeman
306 Candler Building
ATLANTA, GA. | <i>Western States Sales Representative</i>
Thomas W. Hindley
New Montgomery and Howard Sts.
SAN FRANCISCO, CAL. |

WASMUTH-GOODRICH Co., Peru, Indiana
 Gentlemen: Please send me complete catalog and your special introductory offer.

Name

Address

City..... State

The cross section of the "Music-Master" horn shows how the fibres of spruce lie paralleled. Only in this manner can the rich, warm resonance of the famous Stradivarius violin be obtained.



The Fount of Pure Tone

Featuring the MUSICAL POSSIBILITIES of the TALKING MACHINE

[EDITOR'S NOTE.—This is the thirty-second of a series of articles by William Braid White devoted to the various interesting opportunities which prevail in the domain of education for the retailer of talking machines. The subject is one of great interest and we commend these articles to the consideration of all who are devoting attention to the rearing and developing of the musical possibilities of the talking machine.]

OPERA, RECORDS AND THE PUBLIC

There is not the slightest doubt that the American public is taking a deeper interest than ever in opera. There remains, of course, the prejudice, not by any means unfounded, which holds that grand opera is a society plaything in America, whatever it may be elsewhere. Yet, despite the circumstances in which operatic representations continue to be given at the Metropolitan Opera House in New York, the fact remains that this particular form of musical art is steadily becoming popular. Here is some information on the subject which talking machine dealers will do well to realize.

The Chicago Civic Opera Co. is the name of the organization which took over opera management in Chicago when the family which for some years had been supporting it and paying the deficits decided that it was tired of holding the bag, as they say on the stock exchange. At the head of the new organization is a committee of business men, headed by the president of the principal public utility company. These business men have been trying to straighten out the tangled affairs of the company and to infuse a little business spirit and method into the various spending departments. They have been very successful and have evolved many novel schemes for carrying on. Realizing that, until the public has been entirely "sold" on the idea of opera as a civic institution, deficits must be incurred the managers have secured guarantees from business houses and individuals which assure them that all deficits will be met during the next five years. Meanwhile an intensive selling campaign is going on for the coming season. By billboards, by cards in street cars and elevated trains, by every kind of newspaper and outdoor advertising, the opera is being "sold" to the people. Coupon books are offered at reduced rates and are introduced to the public as "opera mileage books." These entitle the holder to seats for any operas he may from time to time select by presentation of the book at the box office, when the necessary equivalent amount in coupons is detached for each purchase of seats. Opera in Chicago is being "sold" to the people—and is actually in danger of becoming a popular, non-society affair!

Opera Without Stars

Let us point the moral more sharply by means of another concrete instance. The Wagnerian Opera Co. from Berlin came over to the United States last season and gave some performances in the East which were well received. This season they have been coming West. They have had two weeks in Chicago, presenting, in German only, the works of the Wagnerian repertory, with one Mozart opera and two new German works, which are now being heard for the first time in this country. Now, this company is unique in one very im-

portant particular. Not only is it a very good company, not only is it a well-trained company, not only has it a splendid orchestra (mostly American, by the way) and eminent conductors, but, *mirabile dictu*, it has no stars! That is to say, there is no question of star personality, no pushing forward of this or that prima donna or first tenor. Scarcely anyone in Chicago knows the name of a single one of the singers; and nobody cares. The names are there, but they are not starred, not advertised, and there is no press agent to tell weird tales to the newspapers about what Mme. X and Herr Y are doing, have done or will do. The singers have come almost unknown as members of a superb team, but as team members only, not as stars. They work for their operas, not the operas for them. In fact, the names of the eminent musicians who are conducting (Stransky especially) are much better known in America than those of any of the excellent singing artists. Yet the whole two weeks' season in Chicago has been a stupendous success, which has been achieved without any of the tricks or schemes which have become associated with the production of opera in America, and which excellent people suppose to be inherent in the game and cannot possibly be destroyed. Yet these German artists, working without stars, in a theatre much too small and with stage difficulties simply immense, without adequate or skillful press representation, have filled every seat at almost every performance of their two weeks' stay in Chicago. They have given the four dramas of the Ring twice, and each of the other Wagner works at least once, some twice. They have had sometimes two performances a day. They have created a public sensation. Chicago has taken them to her heart. There is more talk about them than there has been about anything musical which has been heard and seen in Chicago in ten years. Moreover, advance news from Milwaukee, Cleveland and Detroit indicates that the same triumphs will be scored in these cities.

Now, what does all this mean? It simply means that the public is waking up. If the statements made above have any significance at all, they have this: the public is waking up. It is beginning to take a genuine interest in opera; not as a society affair, not as interesting newspaper reading, but as music. That is what all this means.

Where We Come In

Now the talking machine business has had a lot to do with the more or less slow process of education which during the last twenty years has been leading the American people out of the desert of misunderstanding into the Promised Land of appreciation. The talking machine business has probably done more than any other agency ever did to make people familiar with the music of the various operas and with the names of the works themselves, of their composers and of the great singers who have interpreted them. Probably the names of the singers are best known, but that cannot be helped. The point is that the educational work is now bearing fruit and it is time to do something to take advantage of the harvest.

Now, in fact, is the time to begin pushing as hard as possible the opera reproducing properties of the talking machine. It matters not, for the purposes of these remarks, what style or make of machine a merchant may have to sell. What does matter is that we are arriving at a moment when the talking machine industry can safely go to the people and tell them that opera and records go together, that opera at home is within everyone's reach and that the way to get ready for next season is to learn

all one can at home this Winter about the operas and their interpreters by listening to the music in the intimacy of the home.

Of course, this has been done already, but the point is that merchants as a class have been chary of coming out and arguing these things with the force and persistency which can now be seen to be called for. The psychological moment has arrived and if we do not have sense enough to take advantage of its arrival we need blame only ourselves.

Some Practical Suggestions

A merchant could take advantage of the existing favorable conditions in some such way as the following:

First, he can look over his stock, make lists of records representing different operas (of whatever makes these records may be, for the make is not in question) and let the people know that he has them. For a beginning it is a very good thing to take the programs of the New York or the Chicago operas for the season, find out what is available in the way of records and advertise these.

Second, he can put on concerts. He can invite by special letter the members of the local musical society (women especially) or the choir of his church, or the pupils of some teacher in whom he is interested, to come around some evening and listen to as many selections as he can give of some special opera. There are some complete operas. "Faust" is one of them and "Pagliacci" another—each of which is very popular and can be obtained complete in records.

Thirdly, he can induce to the best of his power his salespeople to cooperate with him. In so doing he will have to overcome obstacles, but the effort must be made. Once get the salespeople interested in pushing high-class records, and the sales sheet will begin to take on a very different look. Of course, the best way to get the salespeople interested is to deal with them faithfully by giving them occasional chances to listen at leisure to the music one wants them to sell. Merchants might think more often of this extremely simple idea, which is about as effective a way of teaching record salesmanship as can be imagined.

To get salespeople to take an interest, to select the right groups in the community to sell to, and to tell the world that we have these high-class musical treasures, is to-day to do the most practical thing that can be done to feature the musical possibilities of the talking machine, to the vast advantage of the commercial and social prestige and to the considerable financial profit of every merchant who has sense enough to discern the signs of the times.

ALTERATIONS IN HAHNE STORE

The phonograph department of Hahne & Co., Newark, N. J., has been undergoing slight alterations since being consolidated with the piano department under the management of W. O. Black. A group of offices, formerly situated among the nest of demonstration booths, has been removed and the quarters of the combined music department are now by themselves. The booths have also been painted and renovated.

Dealers' Repairs

FINEST SHOP IN THE CITY
Facilities for the repair of every
make of sound box and motor

Special attention to out of town
trade sent to us by mail

IDEAL REPAIR SERVICE
284 East Houston St. New York City

MOTORS

Ready for Delivery

Double Springs; play two 10-inch Records; suitable for Portable Phonographs. Sample, \$3.75. Larger motor playing two to three 12-inch Records; suitable for Phonograph selling for \$100. Sample, \$5.75.

MERMOD & CO., 16 East 23d St.
N. Y.
Telephone Ashland 7395

BANNER 50¢ RECORDS



We merely point to fact!

BANNER has brought similar success to hundreds of other merchants because it gives full 75c worth of record value for 50c. In quality of materials and recording BANNER is equal to the finest 75c product made.

In the point of quick release of hits BANNER has a record for making big release scoops that stands head and shoulders above all competition.

Always—the basic idea back of the BANNER RECORD is to give more than usual value—in every possible way!

It will be to your advantage if you write for the BANNER proposition—NOW!

Here's the experience of one BANNER dealer!

Record sales were not what they should have been, therefore Mr. Blake made one change. He added a department for BANNER 50c Records because he had heard much about this record and many customers had asked him for it.

Here is what happened!

On a \$60 initial investment for 200 BANNER Records he made a gross profit at the end of the year totaling \$1920.

After handling BANNER Records for two months Mr. Blake increased his stock from 200 records to 400 records. Thereafter he turned his stock over every two weeks—he sold 800 records a month—9600 records a year. At a profit of 20c per record—40%—he earned \$1920 in one year.

His average investment during the year was \$120—the cost of 400 records.

BANNER paid him well. It brought him more customers. It doubled his total volume of business. It enabled him to sell more high priced classical records than ever before.

The BANNER proposition will interest you too!

Write NOW!

Plaza Music Co. 18 W. 20th St. New York, N.Y.

BUFFALO

Medium-priced Models Have the Call—Dealers and Jobbers Enjoy Business Gains—The News

BUFFALO, N. Y., November 8.—Early November gives indications of a brisk holiday trade in talking machines in the western New York district, according to leading jobbers and dealers of Buffalo. The greatest demand is for medium-priced models. The only thing to cast a shadow over the bright horizon of a tremendous Winter trade is the lack of instruments in the best-selling models, jobbers declare. October was a fairly good month, although warm weather throughout the month is believed to have cut the volume of sales that was expected earlier in the season. November, however, is starting out well, dealers report, and sales are increasing on a large scale. The increase in business averages from 15 to 50 per cent. Record sales are good in every section of the city.

F. D. Clare, manager of the Troquois Sales Corp., western New York distributor of Strand talking machines and Okeh records, reported a 50 per cent increase in business for the month of October over the corresponding month of last year. The greatest demand in talking machines has been for the higher priced models, he said. "We are quite pleased with the showing of our books for the month of October," Mr. Clare said. "Each month for the past year has shown a gain over the corresponding month of a year ago and October business was 50 per cent greater than last October. Indications are that November will be the best month we have had and I am looking forward to a tremendous Christmas trade. The greatest worry for us at present is the inability of the factory to satisfy the demand for Strands. I believe that before the end of the year the shortage of instruments

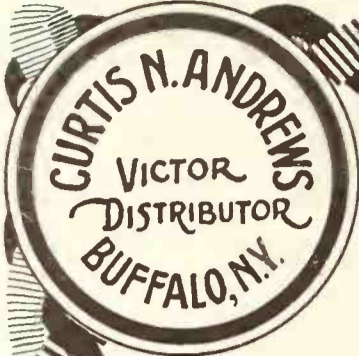

CURTIS N. ANDREWS
VICTOR
DISTRIBUTOR
BUFFALO, N.Y.

SERVICE

Victor Supremacy

Victor weekly releases, coupled with the double facing of Victor Red Seal records, means unlimited sales possibilities for the aggressive Victor retailer. The new Victrolas 400, 405 and 410 are the finest instruments ever presented to the trade, and will be important factors in making 1923 "A VICTOR YEAR."

Victor products will be at a premium this Fall. There is going to be an unprecedented demand for Victrolas and Victor records, and orders placed now will enable you to meet this demand.

We are at your service

CURTIS N. ANDREWS
Victor Distributor
BUFFALO, N. Y.



HIS MASTER'S VOICE
REG. U.S. PAT. OFF.

will really become a very serious condition."

Mr. Clare reports a big demand for dance records and a brisk trade in the foreign classics.

C. May & Sons, furniture dealers on Niagara street, have added a line of Strand talking machines to their stock.

E. C. Seigesmund, sales manager of C. N. Andrews, Victor jobber, reports business flourishing and that dealers are ordering early. "Prospects for November and December are very bright," Mr. Seigesmund said. "The great-

est concern with our house is in the supply. We do not see anything on the horizon that would cause any fear as to the outlook for the coming months of this year and early 1924."

F. E. Russell, sales manager of Neal, Clark & Neal, says there is good business in high-priced machines. Victor Models 410 and 405 are leaders, he declares. Models 215 and 210 are going well also, with a great deal of favor shown for the walnut finishes.

"The new Victor record release is very pleasing to the trade," Mr. Russell said, "and our record business has been increasing at such a rate that we have found it necessary to add three new salesgirls to this department."

Mr. Russell reports that the Neal, Clark & Neal exhibit at the Niagara Frontier Industrial Exposition, in the Broadway Auditorium, greatly stimulated sales and that, although the exhibition was for manufacturers and jobbers, there was a surprisingly large number of sales made to exhibitors. Quite a number of prospective buyers were lined up at the exhibition.

C. O. E. Curtiss, manager of the Brunswick Shoppe, reports a great increase in sales in instruments and records. "Our early Fall business has been very good," Mr. Curtiss said. "Brunswicks are in great demand and we are enjoying an excellent trade."

"Sales have been large," says E. R. Burley, talking machine dealer in West Ferry street, "with the greatest demand for instruments selling from \$100 to \$150. Victor Model 210 is well liked, but scarcity of this model causes delay in delivery, which is one of the most serious problems before us."

"Talking machine business the past month is a great improvement over that of the previous month," remarked F. F. Barber, of the J. N. Adam Co. Music Store. "Record business is also good, with interest in the new double-face Red Seal records increasing."

The Hoffman Piano Co. is celebrating its twenty-first anniversary and is featuring the Brunswick and Columbia talking machines in large advertising. "We are looking forward to an exceptional November and December," said Sales Manager R. E. Smith.

Exhibits have been planned for the Better Homes Exhibit, held under the auspices of two Buffalo newspapers, in Broadway Auditorium, during the week of November 12, by Neal, Clark & Neal, S. J. Butler and Goold Bros., Inc.

Miss Eileen Stanley, Victor artist, was honored by the Victrola Dealers' Association,

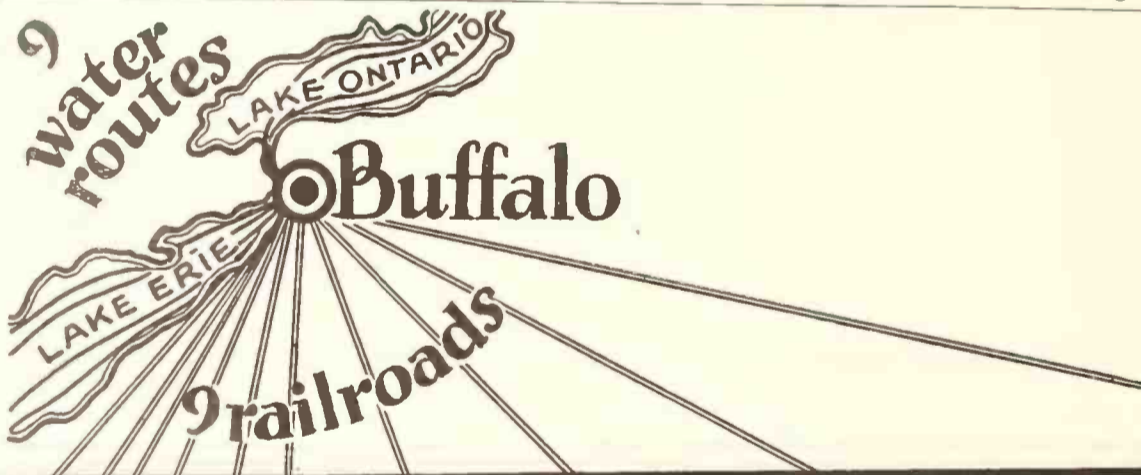

BUFFALO *A NIGHT'S RIDE FROM EVERY IMPORTANT TRADE CENTER IN THE EAST*

The veritable network of shipping facilities which Buffalo offers to Victor dealers—is the answer why the Buffalo Talking Machine Co. service is reaching a larger number of dealers each year.

This is unquestionably a real service which builds long-lasting friendship with a better and more efficient business for all.

Why not try this service? It will pay you.

BUFFALO TALKING MACHINE CO.

Victor Wholesalers
BUFFALO, N. Y.



Worth Its Weight in Gold



Are You Worth \$33 Per Week?

IF you are, and this Directory gives you in 30 seconds information it would take you an hour to secure through other sources—

Then this Directory will pay for itself and give you a dividend of 50% or more, depending on how much more than \$33 per week your time is worth.

But the big point is that the Talking Machine World Trade Directory will not save you time on just one occasion—it will do so many times each month, because—

It is the complete and authoritative “Who’s Who,” “What’s What” and “Where” of the talking machine business.

Only 50 Cents



Edward Lyman Bill, Inc.
383 Madison Ave., N. Y. C.

Kindly send me—all postage prepaid—a copy of the 1923 TALKING MACHINE WORLD TRADE DIRECTORY in payment for which I enclose fifty cents (stamps, check or money order).

Name _____
Address _____
City _____

VAN VEEN & COMPANY

Woodworkers Since 1907—Still Going Strong

Complete equipment for the talking machine, radio, musical merchandise and sporting goods trade.

Hearing rooms, counters and record racks ready for prompt shipment.

There is responsibility and reputation behind our product—*“adding much to the value but nothing to the cost.”*

VAN VEEN & COMPANY, Inc.

Offices and Warerooms:

413-417 East 109th Street

'Phone Lehigh 5324

NEW YORK CITY

when she appeared at a Buffalo theatre recently. A luncheon was given in the Statler Hotel in her honor, at which about fifty guests were present. She repeated her vaudeville act for the Association after the luncheon. The act included a novelty Victor record feature, in which she carries on a conversation with her recorded voice. Her two songs, written by her piano accompanist, Robert H. Buttenuth, "I Can't Believe It" and "I'm a Lonesome Cry-baby," were favorites with her audiences in Buffalo.

The Vincent Lopez Hotel Statler Orchestra opened its season in the Buffalo Hotel Statler on October 22. The orchestra has been playing under the direction of Vincent Lopez in the Hotel Pennsylvania, New York. The concerts given by the orchestra are broadcasted from Station WGR atop the hotel each evening.

Elpert's, phonograph dealers in Niagara Falls, have moved from their old location to the Silberberg block at Main and Niagara streets, Niagara Falls.

One of the features in the remodeled store of the Neal, Clark & Neal Co., which recently added a large piano department, is the installation of several Audak Units, where prospective record buyers can hear records demonstrated without interfering with other musical demonstrations.

E. C. Beshgetoor, music dealer in Jamestown, has moved from Roosevelt square to the Palace Theatre Building, 217 Spring street—a larger and much more convenient location.

The Albion Furniture Mfg. Co. is a new concern in Albion, N. Y., which, it is said, will manufacture talking machine cabinets. The new factory will begin with a paid-in capital of \$40,000.

About one hundred employes of the Rudolph Wurlitzer Co. were entertained by the manager of the local store, Charles Stewart, in Wurlitzer Hall, at a Halloween party. Prizes were awarded for the best costumes.

Joseph Dombroski, one of the most successful talking machine dealers on the East Side, was married recently to Josephine Krysinski. The couple are occupying a handsome home at 326 Humbolt Park.

The Camp-fone has been added to the stock of the Iroquois Sales Corp. and is reported as being a very good seller.

The Pathé Actuelle Co., Pathé dealer of Hartford, Conn., recently moved from 236 Trumbull street to larger quarters at 76 Asylum street, that city. Expansion of the business made the move imperative. The new store has been attractively remodeled.

O G D E N

Prosperity Follows Harvesting of Chief Crops—Early Holiday Sales Reward of Trade Activity

OGDEN, UTAH, November 7.—A brisk trade is reported by dealers of the Ogden district, which embraces northern Utah and parts of Idaho, Nevada and Wyoming. Prosperity has followed the harvesting of the chief crops of the various sections and it has been reflected in increased business of talking machine dealers.

Ezra Jones, of the Jones Phonograph Shop, Brunswick and Sonora dealer, said that during the last half of October his business doubled over the same period in 1922. The sale of records has been exceedingly good, especially in the popular numbers, while the sales of phonographs has been good. Mr. Jones said he is reaping excellent results from his tie-up with Brunswick and Sonora newspaper advertising and direct-by-mail circularizing.

Records made by Abe Lyman's Ambassador



"The demand of the public for the NEW EDISON was never greater.

The models never more artistic
The records never better.

The service in record releases never so prompt.

These with the new low level in prices on instruments and records make

Large Profits Certain

We have a few towns open for dealers.

Write for particulars.

Proudfit Sporting Goods Co.

OGDEN, UTAH

Intermountain Distributors

Utah, Idaho, and Part of Wyo. and Nev.

Hotel Orchestra, of Los Angeles, and Paul Ash's San Francisco Grenada Theatre Orchestra are enjoying a good sale in this district. These orchestras are popular with West Coast visitors. The outlook for November and December is bright, said Mr. Jones, who asserted that already purchases are being made for Christmas deliveries.

Glenn Bros.-Roberts Piano Co. is busily engaged in getting its new home in order for the Winter trade. The removal sale, which is still in progress, has given this company opportunity to dispose of a large stock of machines. New shipments from the jobbers have been placed on the floors to replace the stock depleted by the business enjoyed in October.

Browning Bros., Brunswick dealers, have added the Banner line of records. Through an advertising campaign they created a heavy demand for this new line. Glen Thomas, the manager, said business so far this Fall has been increasing steadily.

G. C. Spratt, district distributor for Brunswick, was a recent caller on local dealers.

The Proudfit Sporting Goods Co., Edison distributor for Utah and Idaho and parts of Wyoming and Nevada, reports a steady gain. One day's shipment totaled seventy-five phonographs, with follow-up shipments of varying amounts. Thomas S. Hutchison, of the Proudfit Co., is in Montana on a selling drive.

C. E. Armstrong, Pathé and Edison dealer, tells of increasing business, and the Williams Music Co., handling the Steger, says conditions are satisfactory.

EARLY RELEASE OF BANNER RECORDS

Enables Dealers to Prepare for Heavy Holiday Business—Publicity Helps Included

The Plaza Music Co., manufacturer of Banner records, will issue its entire December list of releases on November 15. This list includes several Christmas records and an assortment of some of the better-known sacred hymns and anthems, and an unusually lengthy list of current popular successes. The purpose of this advance release of so substantial a character is to make it possible for the retailer to care for a heavy early December and holiday business. Another feature of the advance list will be two violin records by the well-known author, Rudolph Polk. These are double-faced records, carrying "Melody in F," "Spring Song," "Humoresque" and "Ave Maria." Accompanying the releases will be much display and other advertising material for both retailer and consumer use.

EDISON TONE-TEST SERIES UNDER WAY

Thousands Hear Comparison Recitals in Pennsylvania Towns and Cities During Month—Edison Dealers Everywhere Enthusiastic

A series of Edison tone-tests, given in various cities and towns throughout the State of Pennsylvania during the past month, has demonstrated to thousands of people the reproducing qualities of this instrument. These tone-tests were arranged by Thomas A. Edison, Inc., in co-operation with the Edison dealers in towns in which they were given and in practically every instance the hall, theatre, or wherever the recitals were staged, was crowded to capacity, and the success of the various events and the enthusiasm of the dealers under whose auspices they were held were indicated by the large number of telegrams of congratulation received by Arthur L. Walsh, advertising manager of Thomas A. Edison, Inc., who has been active in preparing the campaign. The Edison artists who participated included Elizabeth Spencer, Lucille Collette and Harold Lyman.

The publicity derived from these events is, according to statements of the dealers themselves, of inestimable value and, while the results may not be noticed at once, the effects of the tone-tests are cumulative and the dealers who stage them must ultimately profit.

According to information given out by the advertising department of Thomas A. Edison, Inc., plans are under way for a total number of two hundred tone-tests during the Fall and Winter season. This, undoubtedly, is one of the most comprehensive campaigns of this character ever staged by Thomas A. Edison, Inc.

Among the telegrams of congratulation received by Mr. Walsh from dealers who co-operated in tone-tests were the following: W. J. Grygo, Shenandoah, Pa.; Louis Luxenberg, Barnesboro, Pa.; R. E. Kaplan Furniture Co., McKeesport, Pa.; H. L. Lyman, East Liverpool, O.; L. C. Milheim, Butler, Pa.; J. M. Burns & Sons, Waynesburg, Pa.; G. W. P.

Jones, Washington, Pa.; Wm. H. Bonnage, Pittsburgh, Pa.; G. A. Mytinger, Pittsburgh, Pa.; F. Bowman Sons, Allentown, Pa.; L. Hummel Sons, Pottsville, Pa.; H. Levin, McDonald, Pa.; George A. Schwartz, Lehigh, Pa., and Decoster Bros., Jeannette, Pa.

RAPID REPEATERS AS HOLIDAY GIFTS

The holiday packaging of merchandise in the talking machine trade is taking increased hold as each Christmas season arrives. The talking machine retailer is particularly fortunate in carrying in stock a number of items that serve as novel Christmas gifts. Featuring them at this time adds to profits. One of the latest houses to take advantage of the holiday appeal of its product is the Rapid Repeater Co., of Long Island City, producer of the repeating device of that name.

The Rapid Repeater is now being produced in a very attractive holly box. This spirit of co-operation manifested by the Rapid Repeater Co. is being much appreciated by the dealer, as it furnishes an additional aid to him in securing his share of the good business prevalent during the pre-holiday season. The nominal price of the article also provides a wide scope of prospects.

TALKING FILM INTRODUCED

A dispatch from Copenhagen tells of a talking film on which the Danish engineers Poulsen and Peterson have been working for several years, and which was publicly exhibited recently in that city. It is stated that the voice is pleasantly free from metallic sound. Two films, one providing the pictures and the other the words, were used, being connected electrically. The experts present at the demonstration say that although the apparatus has not been wholly perfected the problem has been solved satisfactorily. Mr. Poulsen will be remembered as the inventor of the telegraphone, a continuous record idea which was displayed publicly in New York at one time.

AKRON, O.

Dealers Stocking Up in Anticipation of Big Holiday Business—Yuletide Decorations for City

AKRON, O., November 5.—Predictions of industrial leaders are that there will be no lack of employment for workers this Winter in Akron despite the apparent slowing up on account of overproduction in the rubber industry the last few months. Music dealers are entering into the year-end trade with renewed confidence. For the first time since the close of the World War dealers are taking the precaution of stocking up for the holiday business and not only are their sales floors filled to capacity, but there are large reserve stocks. Money appears to be easier than it was a month ago, with thousands of dollars soon to be released in Christmas savings funds in banks, and talking machine dealers are in a happy frame of mind.

Talking machine dealers of Akron have been asked to co-operate with other retail merchants to decorate the four principal business streets in the down-town district with wreaths, Christmas trees and other Yuletide decorations. This will be done late in November, and, according to Jack Moore, secretary of the Retail Merchants' Association, it is expected to instill the Christmas spirit in the buying public and will tend to help stimulate sales.

George S. Dales announces that his South Akron store will be doubled in space so as to insure a better display of Victor and Brunswick talking machines. The Music Shoppe, also a Dales store, located on South Main street, which handles the Brunswick machine exclusively, will also be enlarged. The second floor and the storeroom next to it have been taken over.

Earle Poling, head of the Earle Poling Music Co., Mill and South Howard streets, reports a phenomenal record business, pointing out that this has been accomplished by pushing the hits as soon as they are released.

Smith & Mitten, newly established music house in the Masonic Temple Building, announced that they would determine within the next week or ten days the line of talking machines to be carried by the new store. At the present time the store has on its sales floor several Pooley machines.

In the absence of Miss Elsie Baer, who recently underwent an operation for appendicitis and who has headed the talking machine department of the M. O'Neil Co. department store, George E. Sirlouis has been placed in charge of this department until she is able to resume her old position. The Cheney line is featured here.

The Columbia line of talking machines, as well as records, has been taken on by A. E. Jones, who has opened a complete music store on Cuyahoga Falls avenue. Mr. Jones formerly was connected with the George S. Dales Co. and prior to that was with William R. Zollinger & Co., Canton.

NEW BUSH & LANE STORE

HOQUIAM, WASH., November 7.—The Bush & Lane Piano Co., of Seattle, Wash., will shortly open a branch store in this city. The concern will handle a full line of pianos, talking machines and other musical instruments and plans a strong selling campaign.

VICTOR WHOLESALE DISTRIBUTORS



**The
Discriminating
and Fair-Minded
Dealer
Always Appreciates
Blackman Service**

BLACKMAN AND DEPENDABILITY

Blackman
TALKING MACHINE CO.
28-30 W. 23RD ST. N.Y.C.

ONE SUGGESTS THE OTHER

SEE
WHAT
Minger Says
ON
PAGE 35



There's A Double Demand For Bubble Books

Swing It YOUR Way This Christmas!

Children clamor for more Bubble Books after they've been given the first one. And parents follow up this demand because children who own Bubble Books take less of mother's and dad's time.

What happens when two members of a family want an article? They go after it without delay!

You've started the Bubble Book habit in many homes in former Christmas seasons. Keep these books "that sing" before your customers by means of our splendid dealer helps and they'll come to your store to fill their youngsters' Christmas demands for the next Bubble Books.

Then, too, new children are arriving at the Bubble Book age all the time. New families are coming to town. New faces are appearing in your store—and the Christmas season will find them looking for gifts for the children. Start the demand for Bubble Books among them. Sell them their first Bubble Book. They will soon be around again for the next and the next and the next.

Remember, there are fourteen Bubble Books and good profit to be made on each, and it takes very little pressure to sell an article for which there is a double demand.

Gain favor for your store through a Bubble Book Hour. Ask us about this and other dealer helps.



Bubble Book Distributors

Boston, Mass.—A. C. Erisman Company, 175 Tremont St.

Chicago, Ill.—Consolidated Talking Machine Co., 227 W. Washington St. (Also Detroit and Minneapolis), Marshall Field and Company.

Cincinnati, Ohio—Rudolph Wurlitzer Co., 121 E. 4th St.

Denver, Colo.—Columbia Stores Company (also Salt Lake and Spokane).

New York, N. Y.—Cabinet and Accessories Co., 3 West 16th St. Progressive Musical Instrument Corp., 311 6th Ave.

San Francisco, Cal.—Walter S. Gray Company, 1054 Mission St.

BUBBLE BOOKS **"that Sing"**

by RALPH MAYHEW
and BURGES JOHNSON
Illustrated by Rhoda Chase

Retail at \$1.00
with three records

When you sell one you sell a habit
and when you sell a habit you're
building business.

HARPER & BROTHERS, BUBBLE BOOK DIVISION

ESTABLISHED 1817

49 EAST 33rd STREET

NEW YORK

Kiss

SONG of LOVE

*That beautiful Waltz
Melody from*
"BLOSSOM TIME"

WONDERFUL ONE

Paul Whiteman's
Sensational
Waltz Hit

"JOURNEYS END"

McCarthy & Tierney's
BIG HIT from "UP SHE GOES"

"You can't go wrong with any Feist song"

INDIANAPOLIS

Retailers Urging Early Buying for Christmas Delivery—Holiday Campaigns Well Under Way—Trade Optimistic—Month's News

INDIANAPOLIS, IND., November 5.—Promises for a prosperous month of October were well borne out by the sales record for the month, most dealers reporting business, while not sensational, to have been very satisfactory. Most merchants held to regular methods during the month and in a few cases an effort was made to clear all used and trade-in machines from stocks—clearing the decks, as it were, for the Winter and holiday trade. The drive for holiday business has already begun, if we may recognize that there is such a thing where dealers are, as a rule, as active in August as they are in November. It would be more proper, perhaps, to say that dealers are advising their customers to secure their machines for Christmas gifts at this time, and an example of this is the advertising of the Indianapolis Talking Machine Co., in the daily newspapers, offering the regular terms on machines, the machines to be delivered at this time or to be held for holiday delivery. The purpose of such advertising obviously is to bring in at this time those prospects who might be "holding off" until late in December, thus stabilizing the de-

mand to a great extent. The Brunswick Shop also is featuring this sort of newspaper advertising quite extensively.

C. P. Herdmann, manager of the talking machine division of the Baldwin Piano Co. of Indiana, reports that this store enjoyed its share of the October trade, the Brunswick York and Raleigh models being the most popular in console types, with the usual demand for the upright models. Mr. Herdmann also reports quite a few sales of electric machines.

Sonora passed through a good month, the Chas. Mayer & Co. store having placed a good number of the higher-priced models in homes during the last four weeks, and the Widener store and the Banner Furniture Co., the other Sonora dealers in Indianapolis, also report good sales. The Mayer store was one of those which, by special sales offers, cleared their stock of used machines. The Victor and Columbia business of the Widener store, according to W. G. Wilson, was up to the usual standard.

There was no unusual activity on the part of Victor dealers during the month, excepting, perhaps, the enlargement sale of the Taylor

Carpet Co., which included the Victor department of the store. The Pettis Dry Goods Co., L. S. Ayres & Co., as above noted, Fuller & Ryde and other Victor dealers in general report a very satisfactory month.

At the time of this letter the Pearson Piano Co. store is being decorated for the celebration of its fiftieth anniversary. Included in the plans for this celebration, the talking machine department will conduct a vigorous drive on Victor machines to be sold complete with records, albums, needles, etc. F. X. Donovan, manager of the talking machine department, reports October to have been a very good month for machines, but that there was a slight decline in record sales.

Edison sales generally have been good during the month and are showing a slight increase with the coming of cooler weather. Edison dealers throughout the State, according to H. G. Anderson, of the Phonograph Corp. of Indiana, wholesale distributor in this territory, have placed large orders in anticipation of a record holiday and Winter business. Mr. Anderson and F. C. Pullen, manager of the Phonograph Corp., have been spending the greater part of their time during the month with their dealers in Indiana, Kentucky and Illinois. Local Edison sales have been satisfactory, W. G. Meskill, of the Meskill Music Co., reports. The Meskill Co. has taken over the distribution of Jewell products in the territory formerly covered by the Phonograph Corp.

The State Teachers' Convention during the latter part of the month was responsible for a slight stimulus in the sale of musical products. Sousa's Band appeared in Indianapolis one night and this had the effect of stimulating the sale of Sousa recordings. Columbia dealers are making plans to feature Ted Lewis numbers when he appears here later in the month. The appearance of Lewis and his band is generally considered to be one of the most stimulating in point of record sales of that of any Columbia artist.

In connection with the fifty-first anniversary of the founding of the store, the L. S. Ayres & Co. department store offered a number of machines which had been secured for the purpose, at special prices, last week, according to R. M. Follis, manager of the talking machine department of this store.

BRENNAN'S SHOP IN NEW HOME

BROOKLYN, N. Y., November 7.—Brennan's Phonograph Shop, formerly located at 866 Flatbush avenue, is now located in new quarters at 856 Flatbush avenue. George Brennan, proprietor of the concern, recently purchased the building at the latter address. The entire structure was remodeled to fit the needs of the business, record racks, booths, etc., being installed. The Sonora and Brunswick lines are handled, and the increased space permits of the display of the various models with an effect impossible in a smaller store.

SALES RESISTANCE is more easily overcome by confining Sales Effort to a Standard line of merchandise

The Edison Line gives any merchant



Prestige-Profit-Progress

Better get in while the getting-in is good!

Your inquiry will receive prompt attention—without obligation to yourself. Write right now!

Phonograph Corporation of Indiana

325 North Delaware

Indianapolis, Indiana

The CHENEY

THE MASTER PHONOGRAPH

The most perfect music-reproducing instrument

The Abbotsford—Style 117. A Queen Anne period design in Biltmore Mahogany. Gold plated metal parts. Six record albums. \$300



Early English Model—Style 120. American Walnut stained to an English finish. Exposed metal parts plated in Romangold. Six record albums. \$250

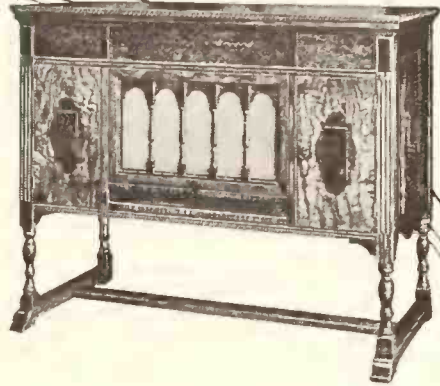

The Westminster—Style 31. An early English period model. Finished in the popular two-tone oak effect. Nickel plated metal parts. Plays all records. \$150



The Oxford—Style 41. English period design. Dark Oak with Walnut applique. Gold plated metal parts. Eight record albums. \$200



Georgian Period Model—Style 5. Biltmore Mahogany or Newby Walnut. Metal parts gold plated. Eight deluxe albums. Plays all records. . . . \$235



The Salisbury—Style 118. After the work of Sheraton and Shearer. In Mahogany and Walnut. Exposed metal parts gold plated. Albums \$200



These prices apply east of the Rockies only

The Greatest Fall Business in our History!

Extraordinary Value of Cheney Line Brings Deluge of Holiday Orders

Dealers are saying: "It's the greatest phonograph line that we can handle." They are backing their statements with orders. Never before has The Cheney been in such widespread demand. Dealers everywhere tell us they find a growing appreciation of The Cheney in the public mind—a conviction that The Cheney is genuinely superior.

From the dealer's standpoint, he finds the line admirably suited to his needs. Note particularly the models illustrated. Cheney console models reflect unmatched

elegancy in design and workmanship—yet they retail as low as \$165. Similarly, Cheney upright models take their place in the home with dignity and elegant simplicity—and such models retail as low as \$100.

Above all, every Cheney model is a *real* Cheney with the tone quality, which only the Cheney acoustic system can develop. Such distinctive superiority makes The Cheney easy to sell. It is unquestionably "the most perfect music-reproducing instrument."

To insure complete stocks for holiday trade it is essential that dealers place their orders at once

THE CHENEY TALKING MACHINE COMPANY · CHICAGO

DISTRIBUTORS

CHENEY PHONOGRAPH SALES CO.
1965 E. 66th St., Cleveland, Ohio
Ohio, W. Va., Western Pa.

CHENEY SALES CORPORATION
376 Boylston St., Boston
New England

MIDDLE PHONOGRAPH CO.
1205 Elm St., Dallas, Tex.
Texas, Southern Okla.

MUNSON-RAYNER CORP., 643 S. Olive St., Los Angeles

CHENEY SALES CORPORATION
1107 Broadway, New York City
Greater New York, Western Conn., New Jersey

CHENEY SALES COMPANY
Brandeis Bldg., Omaha
Iowa, Nebr., Colo., Wyo.

ROLYAT DISTRIBUTING CO.
Provo, Utah
Utah, Southern Idaho

MUNSON-RAYNER CORP., 86 Third St., San Francisco, Calif.

CHENEY SALES CORPORATION
Jefferson Bldg., 1015 Chestnut St., Philadelphia
Eastern Pa., Del., Md., Washington, D. C.

EDW. G. HOCH & CO.
27-29 Fourth St., N., Minneapolis
Minn., N. D., S. D., Northern Wis., Mont.

CHENEY PHONOGRAPH CO.
212 Selling Bldg., Portland
Washington and Oregon

All territory not listed above is handled direct by The Cheney Talking Machine Company, Chicago

THE TWIN CITIES

Stimulation of Business Follows Cold Snap—A Half Million Record Stock—T. G. Kinney With Beckwith Co.—The Month's News

MINNEAPOLIS and ST. PAUL, November 5.—Twin City phonograph men are no more down-hearted than the winning gridiron teams. Business is undoubtedly good, both among wholesalers and retailers. Especially good orders are reported from the iron range country, Wisconsin and western North Dakota.

Beckwith's Enormous Record Stock

George C. Beckwith & Co., Northwest Victor jobber, will have over one-half million records in stock, one of the biggest inventories in the country, when the stock of the W. J. Dyer & Bro. firm, which Beckwith's recently purchased, is assembled in the Beckwith stock-rooms.

"Business is remarkably good from the standpoint of volume," according to Charles K. Bennett, vice-president and general manager of the Beckwith Co. "We have sent out three times as many orders since taking over Dyer's wholesale business. With the immense stock we will be able to give dealers the most satisfactory service they have ever received. We advised dealers to stock up early for holiday selling, as we sensed a shortage in certain models. Models 80 and 210 are scarce. We have been out of them for three weeks and the factory can assure us only a few before Christmas. The range is returning substantial business," according to Mr. Bennett, "so is Wisconsin, but southern Minnesota is spotty."

Kinney in Charge as Credit Man

On account of the extensive increase in the business at the George C. Beckwith Co. and the number of accounts the firm has added a credit manager, Thomas G. Kinney, to its force. One of his duties will be to go out among the dealers and assist them in establishing accounting and collection systems and such other services as they may require.

E. E. Ells With Beckwith

Another addition at Beckwith's is E. E. Ells, who, with the transfer of Dyer's wholesale business to the Minneapolis concern October 15, left Dyer's for Beckwith's. Mr. Ells, who has been for six years assistant to George A. Mairs, manager of the Victrola jobbing interests

of the Dyer & Bro. firm, will look after the dealers' service end of the business.

New Edison Accounts

"Business is pretty good in Wisconsin and western North Dakota," said J. Unger, of the Lawrence H. Lucker Co., Edison distributor. "Conditions in the dairy country are excellent. As to the retail trade in the Twin Cities a little cold snap was what was needed and the last ten days or two weeks have resulted in remarkably good business. We have opened new accounts in Wisconsin, North Dakota and some in Minnesota," Mr. Unger stated. "Dealers are placing their Christmas orders and making use of the special list of holiday records in ordering. They are applying extensively for the special hanger which the Edison Co. has prepared for holiday windows.

Visitors During the Month

Thomas F. Green, president of Pearsall Co., New York, and William T. Haddon, president of the Ohio Talking Machine Co., spent several days visiting George C. Beckwith and Mr. Bennett. They pronounced themselves much impressed with Minneapolis, its lakes, its wide streets and its possibilities. Harry Goldsmith, of the Badger Talking Machine Co., Milwaukee, also visited the Beckwith offices recently.

Condemns Record Approval System

Otto May, assistant traveling manager of the Victor Co., who is visiting the trade in the Twin Cities, says that he believes the "records-on-approval" system is being much abused here. Everywhere he goes, he says, he sees salespeople polishing up records which have been misused by customers who have had the records on trial, buying but few, possibly none, from the collection sent them.

Larger Sonora Territory

Iowa has been added to the territory of the Doerr-Andrews & Doerr Co. in distributing Sonoras. In connection with this addition to its territory John E. Date has been to Des Moines and other points, where he reports excellent business. He returned November 3. Sewall D. Andrews, head of the Sonora distributing departments, says "Business is showing improvement. Dealers are placing consid-

erable orders for their holiday requirements." Mr. and Mrs. Andrews returned October 27 from a short stay in the East.

New Cheney Consoles Favorites

Edward G. Hoch, of the Edward G. Hoch Co., Cheney distributor, who returned October 31 from South Dakota, finds that the two new consoles, 119 and 118, retailing at \$165 and \$200, are the most popular with the trade. Just at present the Cheney office here finds that the demand for consoles and uprights is running about fifty-fifty. The medium-priced uprights are popular, although those desiring a high-priced instrument prefer the consoles. Mr. Hoch says it is now a question of getting the goods and his office is experiencing a marked shortage of models to fill his orders. Among the new accounts Mr. Hoch opened is that of E. W. Owen & Co., in Mankato, and The Boston Store, in Milwaukee.

Good-size ads are being run in the Milwaukee Journal, as well as in the Minneapolis papers and St. Paul Dispatch, calling attention to the Cheney. The Emporium department store, which recently established a Cheney agency, ran a remarkably fine ad in the St. Paul papers in the interests of the instrument.

Lester Heinsheimer, of the Home Furniture Co., Sioux Falls, mentioned to Mr. Hoch that he anticipated a large holiday business in Cheneyes and that, in his opinion, South Dakota was regaining its prosperity. The same feeling was voiced by Charles A. Mayer, of the Home Furniture Co., Watertown, S. D.

August Weyand, exclusive Cheney dealer, located at 23 East Eighth street, St. Paul, reports interesting results from a large display of the instruments at the Food Show in the St. Paul Auditorium late last month.

The Miles Music Co., which has recently taken over the Cheney in Duluth, has been featuring this line in special campaigns.

Interesting News Brieflets

Miss Grace Barr and Miss Conn, of the educational department of the Victor Co., were on the program at the session of the Minnesota Education Association here, commencing October 31. The appearance of the Victor artist, Mabel Garrison, at the Minneapolis Auditorium, November 2, caused a good demand for her records, according to dealers here.

The Vocalion Red records of Ben Bernie and His "College Eleven" Band have been selling excellently since the appearance of this band at the Hennepen Orpheum. Dealers tied up with the appearance of the band here in the form of a large ad.

The estate of the late W. L. Harris, head of the New England Furniture & Carpet Co., who until ten years ago was the Victor distributor here, will reach close to \$2,500,000, it was revealed last week, when Charles L. Harris, his son, was appointed administrator of the estate. In the absence of a will the estate goes in equal shares to the widow, the son and a daughter, Mrs. Ethel Harris Gauntlett, of Sussex, England.

LATEST PATHE FOREIGN RECORDS

Although it is only natural that records in the English language constitute the great proportion of record sales in this country, still foreign language sales are of a surprisingly large volume and provide many retailers with a substantial amount of income. The Pathé Phonograph & Radio Corp., Brooklyn, N. Y., which conducts a special department for foreign records, reports that the business of this department is constantly growing. It is the custom of this company to release these records in monthly supplement form similar to the regular numbers. In the release for January are included five German and six Polish double-disc records carefully selected on their appeal to the purchasers of this class and well calculated to stimulate the business of the retailer of foreign language records who is awake to the opportunities in this field.



The New Edison is recognized as the foremost phonograph of all time. It means prestige to the merchant who sells it.

The new low priced models—upright and console—new increased discounts, quick turnover and timely release of the latest hits offers steady increasing profits.

We have a liberal proposition and open territory for live merchants of the Northwest. Write now. Cash in on the Fall and Holiday demand.

LAURENCE H. LUCKER

Northwest Edison Distributor

Established 1902

17 South Sixth St.

Minneapolis, Minnesota

**Edison
Dealers
Enjoy
Every
Advantage**

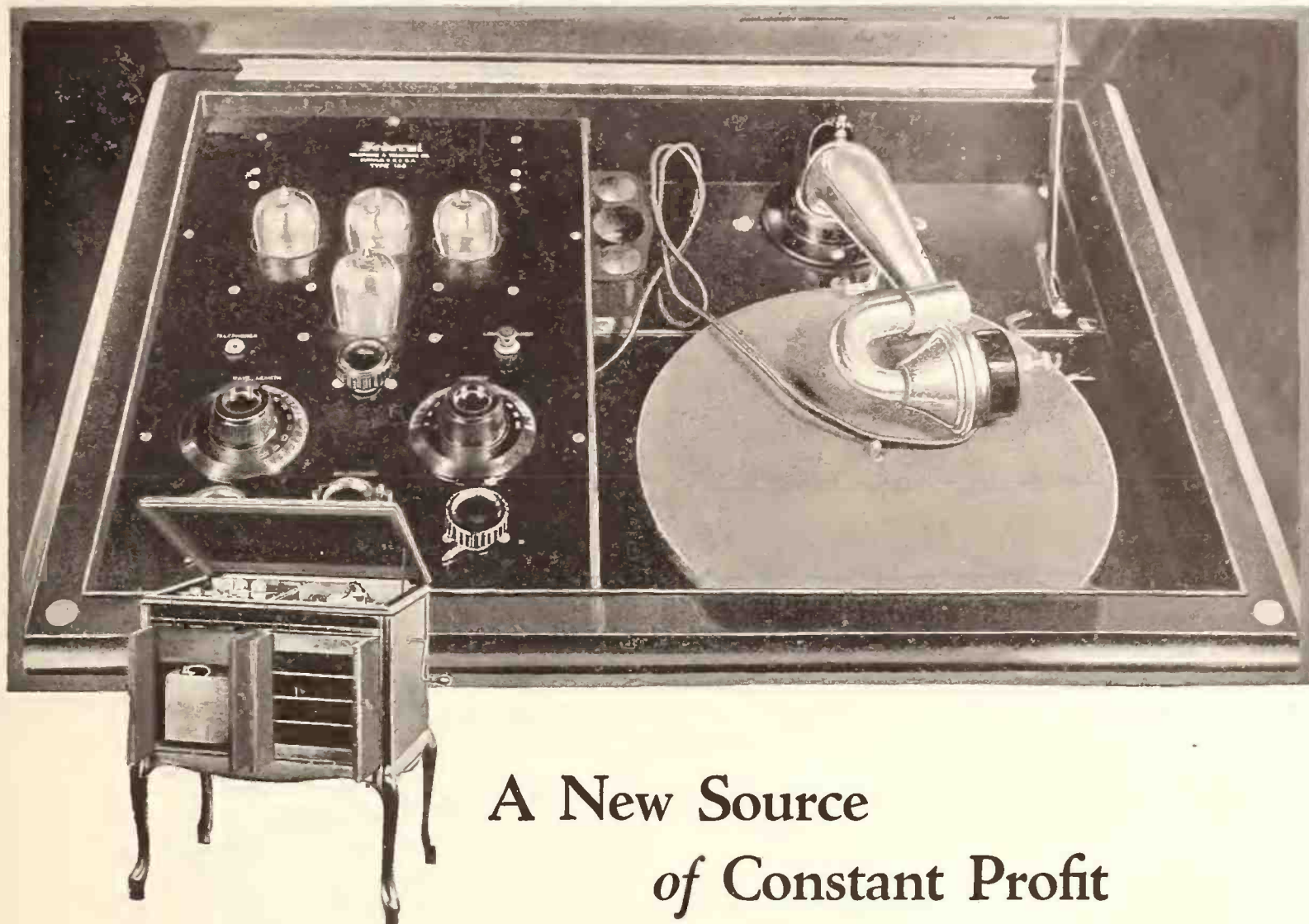

A New Source of Constant Profit

RADIO like any other new device is attractive, easily sold and profitable. It is readily purchased for cash and need not be offered on the partial payment plan.

Phonograph dealers are the natural distributors of Radio because they are headquarters for "entertainment for the home" and, like

phonographs, the Radio Receiving Set is precisely for that purpose.

The Federal Set shown above is designed to fit the console type of phonograph of various makes. It is sold *exclusively* through phonograph dealers. It is fully guaranteed by Federal, the oldest and largest maker of a complete line of Radio parts and sets.

A complete line of Receiving Sets and parts of the highest quality, adapted to the phonograph dealer's requirements, fully guaranteed, are also offered by Federal. Unusual range, simplicity of operation and sturdy, dependable efficiency have built for Federal Sets and parts a nation-wide reputation.

Write today for the Federal proposition for phonograph dealers.

Federal Telephone and Telegraph Co.

BUFFALO, N. Y.

Boston New York Philadelphia Chicago Pittsburgh
San Francisco Bridgeburg, Canada London, England

Federal

Standard **RADIO** Products

"TIE UP WITH A WINNER!"

The NEW EDISON Phonograph

Is Acknowledged "THE DADDY OF THEM ALL"

THE LIVE DEALER

Can take advantage of this public confidence by tying up with an agency for the New Edison Phonograph.

"YOUR MIND IS AT REST WHEN YOU SELL THE BEST"



1114
Olive
Street

Write for the LIBERAL Edison Agency Proposition for Your Town

Southwestern

EDISON DISTRIBUTOR

St. Louis, Mo.

SAINT LOUIS

Holiday Atmosphere Tinges Trade as Dealers Start Christmas Club Drives—Artophone Co. in New Home—Month's News Budget

St. Louis, Mo., November 7.—October was a good month for talking machines and records, with sales accelerating with the opening week of November. Medium-priced consoles, at around \$150, are in greatest demand. There is also a good movement of higher-priced consoles. The Christmas note is creeping into the business. Several firms have started Christmas clubs, featuring the \$1 down and \$1 a week, to run until delivery, and after that regular terms.

Artophone Co. in Its Handsome New Home

The Artophone Corp. and the Shattinger Music Co., which were burned out three months ago, are back in their restored building at 1103 Olive street. The Artophone Co. has resumed on a larger scale than before, occupying all of the building except part of the first floor, which is used by the Shattinger Co. The Artophone concern will, as in the past, handle Artophone and Strand machines and Okeh records. Both firms during the interim following the fire were temporarily at 1213 Pine street.

F. H. Brandt, traveler for the Artophone

Corp., has returned from a trip through southern Illinois and southern Indiana and to the principal cities of Tennessee, where he closed some successful business.

Dealers Tie Up With "Easy Melody"

Record sales have been growing rapidly ever since cool weather set in. The popularity of "Easy Melody," composed by Gene Rodemich and Larry Conley, St. Louis star musicians, which has been increasing in the past few weeks, has come to a head with its appearance on Brunswick record No. 2500, played by Isham Jones at Rodemich's request, and coupled with "Somebody's Wrong," also played by Jones. Extreme co-operation on the part of St. Louis Brunswick dealers and Gene Rodemich's Orchestra has made certain a rousing reception by the public for this great record.

Frank Horning, music department manager at Stix, Baer & Fuller, has sent out 50,000 circulars on "Easy Melody" to the store's mailing list. He also has had fifty large signs prepared for distribution throughout the store, is running special advertisements in the newspaper,

has prepared a unique and extremely attractive window on Washington avenue and, as a crowning feature, engaged Gene Rodemich's Orchestra to play this and other late Brunswick hits in his music salon.

Famous & Barr and Scruggs, Vandervoort & Barney have prepared special advertisements and signs on "Easy Melody," as have the T. D. Music Box, Kieselhorst Piano Co., Hunleth Co., Baldwin Piano Co. and Kirkland Co. All Brunswick neighborhood dealers have large banners in front of their stores, all have special windows and are also advertising it in either neighborhood or daily newspapers.

The Lehman Piano Co. is back in its restored building at 1101 Olive street and is featuring the Brunswick.

W. C. Fuhri, general sales manager of the General Phonograph Corp., New York, was here the first week in November.

Returns From Vacation in the East

Edward Roth, secretary of the Koerber-Brenner Music Co., has returned from a month's Eastern trip, accompanied by Mrs. Roth. They visited Philadelphia, New York and Atlantic City and stopped off at Camden, N. J., for a call on the family of F. S. Horning, manager of the Stix, Baer & Fuller music department here.

Thomas Husselton, Victor representative, has been spending a month in St. Louis conferring with and helping dealers.

Silverstone Music Co. Activities

G. Manne, traveler for the Silverstone Music Co., Edison distributor, is trying the experiment of visiting the Missouri trade in a Ford coupe. He thinks he can save time, in spite of the fact that Missouri roads are not yet all that they should be. T. Larray, of Mexico City, Mex., dropped in at the store of the Silverstone Music Co. the other day and bought a Chippendale Edison and \$45 worth of records and handed over to L. M. Schlude the price plus the express charges for sending it to Mexico. Mr. Larray is an engineer, conducting some tests at Illinois University.

Collins and Harlan, vaudeville artists, pioneer record makers for the Edison, still teaming after twenty-four years, were at the Missouri Theatre the first week in November and as a novelty made a record on the stage. To make it more convincing local talent also was given a chance to make a record at each performance.

C. O. Thompson has been made manager of the phonograph, radio and record department of the Kieselhorst Piano Co. George F. Standke, former manager, will confine himself to the selling of phonographs and radio sets.

J. E. Mayer, formerly with the Rudolph Wur-litzer Co., has taken charge of the outside talking machine work of the Kaemmerer Music Co. at both its North and South St. Louis stores.

Brief But Interesting

H. J. Arbuckle, manager of Widener's, Inc., had a Halloween window which attracted much attention and resulted in considerable business.

THE Artophone CORP.



for beauty—for tone—for price

Because we indorse the STRAND policy: "Quality Merchandise at Low List and Long Discount."

And because over two years of remarkable STRAND success have proved that it can be done!

THE Artophone CORPORATION

1213-15 Pine Street

St. Louis, Mo.

203-4-5 Kansas City Life Bldg., Kansas City, Mo.

Complete stock of all phonograph accessories and supplies

Splash! - Three Hits - All Over Our Blotter!

**RED
HOT!**

A HOT FOX-TROT

**"HOOT
MON"**

A SCOTCH
FOX-TROT

Oh, You Little
**Sun-Uv-
Er-Gun"**

A snappy
Fox-trot Song

"You can't go wrong
with any FEIST song"

© LEO FEIST INC.

He has his annual Christmas Club going nicely.

Miss Grace Cartwright, formerly with Kieselhorst's talking machine department, is now with the sales organization of Stix, Baer & Fuller.

William Casey, formerly with Stix, Baer & Fuller, is back with that firm.

John L. Stevener, manager of the Vocalion department of the Aeolian Co., says October business in machines and records was 25 per cent better than October, 1922.

R. V. Johnson, formerly with the Vocalion department of the Aeolian Co., is now city representative of the Brunswick Co. C. R. Reynolds, traveler for the Brunswick Co., has been having a very successful trip through the Southern territory served by this branch.

F. B. Jenkins, Jr., of the J. M. Jenkins Music Co., Kansas City, Mo., distributor of Victors, stopped in St. Louis on his way back home from a visit to the Victor factories.

The Stix, Baer & Fuller Victrola department is getting ready for the Christmas rush by installing a number of Audiphones in its service counter.

Miss Mildred Butts, of the Wainwright Music Co., Marietta, O., was an interested visitor to a number of Victor stores in St. Louis.

The De-Merville Piano & Music Co., Victor dealer, of South St. Louis, is making a big addition to its store, having bought two adjoining buildings. Partitions have been removed, tripling the floor space and making one large store.

During the Missouri Teachers' Association conference, to be held in St. Louis in December, Mrs. Frances E. Clark, of the educational department of the Victor Co., will appear on the music program.

Mrs. E. E. Baker, Baker Music House, Victor dealer, of St. Louis, recently had a very charming window display, featuring the record "Cut Yourself a Piece of Cake." A knife added to the invitation.

Two thousand people heard Chaliapin in his concert at the Odeon October 23. Victor enthusiasts pronounced him all that his records had proclaimed him to be.

"The Needle" Makes Its Debut

The first house organ to appear in the St. Louis territory is being issued by the T. D. Music Box. Its name is "The Needle," so called because it follows the records closely. "Josephine," who has a "swell job" in the place, writes a letter for each issue and, while the manner of the whole is frivolous, it has seriously good suggestions, such as weeding out the mid-Victorian records from one's collection and other excellent pointers.

Eighteen Victrolas for Telephone Co.

The Stix, Baer & Fuller Co.'s Victrola department, in charge of Frank Horning, has just made a sale of eighteen Victrolas to the Bell Telephone Co. The contract department of the telephone company is refurbishing all of its restrooms through the Stix, Baer & Fuller Co. and new model Victrolas are being sent to the various restrooms.

TRI-STATERS HEAR LLOYD EGENER

Manager of Victor Traveling Department Gives Facts About Changes in Victor Goods—Eight Famous Victor Artists Introduced—Concert and Dinner Enjoyed

St. Louis, Mo., November 7.—The Tri-State Victor dealers met for a few hours' get-together before the concert by the Eight Famous Victor Artists. The Hotel Claridge was the meeting place and at four o'clock dealers assembled to hear Lloyd Egener, manager of the traveling department of the Victor factory, tell some interesting facts about the recent changes in Victor goods. The Famous Eight were introduced. Dinner was served to those assembled and was followed by a round-table discussion, led by Mr. Egener, on various matters of importance to Victor dealers. The crowd then adjourned to the Odeon for the concert, which was given to a sold-out house. Those present were Mr. and Mrs. L. Harter, of Webster Groves, Mo.; Mr. and Mrs. J. E. Rice and two guests from Mt. Olive, Ill.; Charles H. Beetle, of Shelbyville, Ill.; Russell N. Smith, of Carthage, Ill.; Miss Lillian Allen, of Rolla, Mo.; L. F. Parrish and son, of Metropolis, Ill.; Miss Estelle Heuman, of Lebanon, Ill.; Lloyd Egener, of Philadelphia, Pa.; Harry G. Koerber, H. S. Grover, C. B. Gilbert, Tom Cummins and Miss Golda Airy, of Koerber-Brenner Co., and J. N. Meyer, of the advertising department;

Geo. G. Neville, of Hellrung & Grimm, St. Louis; Mr. Peeler and Miss Birdie Young, of the Peeler-Todd Co.; Fred Dykins, of Flora, Ill.; Mr. and Mrs. E. E. Baker, of the Baker Music Co., St. Louis; Miss Laura Mertens and Miss Amelia Lipscomb, of Smith-Reis Piano Co., St. Louis; Fred Lehman, of East St. Louis; Mr. Burton, of Girard, Ill.; Walter Rhein and brother, of Belleville, Ill.; Wm. McKinley, of Mason City, Ill.; A. W. Hosier, Miss Wilson and Mrs. Gladding, of Scruggs-Vandervoort-Barney, St. Louis; Wm. Bauer, Mr. Stevens, T. W. Maetten, Miss Dorothy Howard and Miss Jane Lange, of the Aeolian Co.; Miss Annabelle Weible, of Columbia, Ill.; Jerome Munie, O'Fallon, Ill.; Wm. Todd and daughter and Mrs. Baumker, of the Todd Music Co.; Mrs. Engelman, Miss Laura Williams and E. O. Thompson, of Kieselhorst's; Mr. and Mrs. Frank Horning, Miss Helen Hatfield and Mr. Hutchison, of the Stix, Baer & Fuller D. G. Co.; Fred Gerbig, of Glaser's Music Shop; Mr. Geissler, of Famous-Barr, and Mr. Van Zant, of Chicago Talking Machine Co.

FRIEDA HEMPEL ON AMERICAN TOUR

Frieda Hempel, the distinguished soprano and Edison artist, returned last week from a vacation spent in Switzerland. This distinguished singer opened her American tour in Lynn, Mass., on Sunday night and will be heard in New York at Carnegie Hall on November 27.

THE Artophone CORP.

COMBINING the complete stocks of all OKeh and ODEON Records which are kept on hand at all times with the use of the speediest of modern methods of distribution, we are equipped to give our well-known "Same-Day Service" under all conditions. "Same-Day Service" means that your orders for

OKeh Records
The Records of Quality

are accurately and completely filled and shipped out to you the same day they are received. It is a reliable service that you will find especially valuable during the coming holiday season. Let us demonstrate it *now!*

THE Artophone CORPORATION

1103 Olive Street

St. Louis, Mo.

New Kansas City Branch Office

Kansas City Life Bldg.,

Kansas City, Mo.

Complete stock of all phonograph accessories and supplies



BUY
OKeh
Needles
They
Keep
Record
Sales
Alive!

"A new Gennett!"



The **ELUSIVE CHARM**

—the magnetic personality of the artists' original rendition of music is the distinctive alluring appeal in **Gennett Records**.

Timeliness, wide range and highest quality of recording account for the popularity of Gennett Records.

"First and Best on Gennetts" is the slogan. Gennett Records Released Weekly.

Gennett Records

Manufactured by

THE STARR PIANO COMPANY
RICHMOND, INDIANA

New York—Chicago—Los Angeles—Birmingham—
Detroit—Cincinnati—Cleveland—Indianapolis—
Boston—Jacksonville—London, Canada

The NEW Columbia is superior

*Hearing
is believing*

The Tone is True. On the New Columbia a violin is a violin, a 'cello is a 'cello, a soprano is a soprano, a contralto is a contralto, a tenor is a tenor, and a baritone is a baritone—due to the New Columbia Reproducer. *Hearing is believing.*

COLUMBIA PHONOGRAPH COMPANY
New York



DETROIT

City Becoming Center of Distribution — Activities of Dealers Resulting in Stimulated Trade

DETROIT, MICH., November 6.—This city has become quite a center for distributors of talking machines, which not only indicates the importance of Detroit in the commercial world, but also indicates the prosperity for the talking machine industry. All of these distributors, seen by The World correspondent the past few weeks, reported that business was picking up splendidly, which means that the retailer is either selling more machines or is stocking up in anticipation of a good holiday business. We know it to be a fact, however, that the retailer is enjoying a very good business, so far as Detroit and Michigan are concerned. One good reason is that there has as yet been no slumping off in general industrial activities and all over the State manufacturers are busy.

Grinnell Bros.' Best Month

Grinnell Bros. are probably the best medium through which to find out the State conditions, as they operate forty retail stores, most of them scattered in all sections of Michigan. Charles H. Grinnell, manager of the Victor wholesale department of this concern, who recently returned from a visit to New York and the Victor factory, states that October was the best month his department has had this year in point of sales, both for talking machines and records. And he speaks not only for the stores operated by his company, but for hundreds of other retail establishments which buy their Victor goods from Grinnell Bros.

Retailers Tying Up With Recitals

A great many record artists have been in Detroit the past few weeks for recitals and more

are yet to come, according to schedule. This has offered an opportunity to the retail stores to exploit their records quite heavily, not only through advertising, but particularly through window displays. John McCormack, for example, was here last week. Every Victor dealer, especially downtown, took advantage of his appearance and fixed up very attractive windows pointing out the McCormack records which were available. The Columbia stores also were on the job to take full advantage of the presence in the city three weeks of "The Passing Show" with Ted Lewis' Band and, of course, they featured the Ted Lewis records. And we could go on and recite a half dozen other instances where dealers have been quick to exploit records of visiting artists—which is as it should be, because this sort of thing is certain to stimulate sales of the particular records involved and others as well.

The Charles J. Holton Co., of East Larned street, has taken over the local distribution of Lincoln records. Mr. Holton for many years was a leading cigar jobber.

Great Lind & Marks Co. Activity

Sam Lind, of Lind & Marks Co., distributor of Vocalion records and Wolverine phonographs, says October was by far the greatest month the company has ever had in the matter of sales. Many new accounts have been added in Michigan and Ohio, while Wolverine phonographs have been shipped to retailers in all parts of the United States. We might say, in this connection, that the Wolverine is their own product, being especially made for Lind & Marks. The company recently opened a Cleveland office in charge of Louis Marks, who already has sent in some very fine new business.

Finzel Orchestra Records Popular

The Finzel records in the Okeh list, made by the General Phonograph Corp., are finding much favor in this city because of the fact that the Finzel Orchestra hails from this city and is a nightly feature at one of our leading dance

places. Okeh records are well distributed in Detroit, as well as throughout the State.

Pooley Going Well With Marshall

The C. L. Marshall Co., jobber, with offices in Detroit and Cleveland, is shipping out a lot of Pooley phonographs. This line is a strong feature at the J. L. Hudson Music Store and there are many leading retailers all over Michigan and Ohio now handling this line.

Console Continues to Be in Favor

October was a very big month for the Brunswick Shop, especially on the higher priced consoles. In fact, 90 per cent of the business today at the Brunswick Shop is on the console model, the walnut finishes being particularly in demand. "We are having excellent Fall business, both in talking machines and records," declared Manager Quinn. "We anticipate the biggest Fall business in our history and we don't see how we can be disappointed. Already our sales for the first ten months are far ahead of any previous year."

Edison Shop Satisfied With Progress

R. B. Alling, of the Edison Shop, is extremely well satisfied with the way retail business is forging ahead. This firm has been a consistent user of large space right through the Summer and, while the bulk of its trade is among the elite of the city, yet there are a great many factory workers buying the Edison phonograph and Edison records. Peter S. Sweeney is in charge of the Edison phonograph sales and he declares that "if we once get people into our recital room and can give them the proper demonstration we usually are able to sell them. Proper demonstration is everything to the person who is at all critical."

BRUNSWICK PARLORS IN WARREN, O.

WARREN, O., November 7.—Opening of Markley's Brunswick Parlors on North Park avenue took place recently. The new shop will be exclusive agent for Brunswick phonographs and records.

**If the Best is the Cheapest to Buy,—
Then the Best is the Cheapest to Sell.**

Music lovers everywhere recognize that only the New Edison can give real music; for it is the only phonograph that actually Re-Creates the artist's performance. Its realism is so profound that the music critics have been unable to distinguish the original from the Re-Creation.

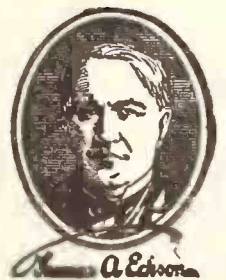

Write us for our latest agency proposition



The Phonograph Company of Detroit

Distributors for Michigan and Northern Ohio

1540 Woodward Avenue

Detroit, Michigan



Heppelwhite Model 20—finished in Red or Antique Mahogany and Walnut. Equipped with automatic stop and patented tone control.



Sheraton Model 8—finished in Red or Antique Mahogany and Walnut. Equipped with albums for records, automatic stop and patented tone control.

The Widdicomb appeals in a two-fold way

A phonograph of rare grace—a phonograph of unsurpassed tonal quality—

Here, in two brief phrases, are summarized the two outstanding reasons why the Widdicomb is known as the phonograph with a two-fold appeal.

Fashioned in artistic period designs embodying the skillful touch of master craftsmen—equipped with reproducing mechanism embodying the latest developments in scientific tone reproduction—the Widdicomb naturally finds favor among lovers of the beautiful in art as well as music.

If you are interested in the sales possibilities among this class of buyers, write us for detailed information regarding the profits made by merchants in this lucrative field.

Widdicomb
PHONOGRAPH
The Aristocrat of Phonographs

THE WIDDICOMB FURNITURE COMPANY, GRAND RAPIDS, MICH.

Fine Furniture Designers Since 1865

IN THE MUSICAL MERCHANDISE FIELD

Hohner Harmonica Campaign Covers Country

William J. Haussler, of M. Hohner, Addresses 2,000 School Children—Monster Publicity Campaign Making Itself Felt in Demands on Retailers—Dealers Tie Up With Harmonica Artists

William J. Haussler, of the well-known harmonica manufacturing house of M. Hohner, New York City, recently addressed the students of the Hawthorne School and the South Side High School on the subject of the harmonica, in connection with the general program of the harmonica contest week held recently in Newark, N. J. As he is without doubt one of the



William J. Haussler

best-informed men in this country on the subject his discourses were both interesting and constructive. At the conclusion of his talk the faculty of the school candidly stated to Mr. Haussler that the Hohner harmonica was a revelation and they expressed their enthusiasm over the interest manifested by the pupils.

Mr. Haussler brought out in his address that the possibilities to be found in the harmonica were almost unlimited. In the Hohner harmonica, he pointed out, was to be found inspiration, wholesome entertainment, a fundamental education in music, musical accuracy and portability. Its extremely low cost, he also

pointed out, brings it within the range of everybody interested in music.

In talking with The World Mr. Haussler stated: "The Hohner harmonica is promoting interest in music on a scale never before attained. I am glad to say that the harmonica, as a musical instrument, is receiving the hearty support of music dealers everywhere. The fact that an entire line may be displayed in the small amount of space occupied by a revolving rack means that the overhead of the dealer is not increased to any degree by adding this line. It has an appeal to all ages and classes. The various harmonica-playing contests that have been conducted in the big cities throughout the country have found enthusiastic entrants from both boys and girls in the lower grades of the public schools to elderly men and women. The professional man and the business man and the laborer have all shown interest in the Hohner harmonica.

"The various advertising campaigns, harmonica contests and innumerable publicity features have also greatly increased interest in the Hohner harmonica and correspondingly created a demand on the dealer. The Hohner harmonica instruction book, together with the attractive window display signs in colors, proclaims that 'It is easy to play a Hohner Harmonica.' A study of this little booklet, which is distributed by the dealer, will enable anyone to quickly learn to play the harmonica. The daily press in the various cities has realized the importance of the harmonica and many interesting articles have appeared, creating additional interest in this instrument. The New York Evening Mail saw fit recently to devote several columns to the harmonica, which were headed: 'Harmonica Comes Into Its Own as Real Musical Instrument.' Talking machine

To Dealers:

When considering the proposition of taking on a full line of musical instruments and accessories why not give "Strings" your earliest approval. WHY? Because of small investment—steady sales—fine profits—then get the best—



"AN ASSORTED GROSS AT LESS THAN GROSS RATE"

DISPLAY CASE

For Window and Counter

Write for Introductory Offer

STANDARD MUSICAL STRING & MFG. CORP.

104 South 4th Street Brooklyn, N. Y.

dealers are cashing in on this publicity and we find that an increasing number of dealers are taking on the Hohner harmonica, as our records show each week. The harmonica has long been popular, but we believe that as a result of the publicity which it is receiving it will attain and hold still greater popularity among all classes for years to come."

The Hohner harmonica will be specially featured (Continued on page 144)

NEW PRICES
NEW MERCHANDISE
NEW SELLING IDEAS

Be the Progressive dealer in your town. Write today for catalog.

WRITE, PHONE OR CALL

Musical Instruments of Every Description

Progressive
MUSICAL INSTRUMENT CORPORATION

319 SIXTH AVENUE NEW YORK

BRUNO

THE OLDEST AND LARGEST MUSICAL MERCHANDISE HOUSE IN AMERICA

Exclusively Wholesale
ESTABLISHED 1834

C. BRUNO & SON, INC.
351-53 FOURTH AVE. NEW YORK CITY

IN THE MUSICAL MERCHANDISE FIELD—(Continued from page 143)

tured in the city of Chicago during the week beginning November 17, when will be celebrated "Chicago Harmonica Week." Various harmonica-playing contest will, of course, be staged, and it is also announced that Borrah Minevitch, well-known professional and Hohner harmonica enthusiast, will appear during that week at the McVickers Theatre. Mr. Haussler intends to be in Chicago during the entire week. Extensive plans for advertising and other methods of dealer co-operation are being made.

Mr. Haussler also told a World representative this week that he had been receiving glowing reports from Borrah Minevitch, who has been conducting a concert tour in the Middle West, playing the Hohner harmonica. He was particularly busy in St. Paul, Minn., where a contest was put on under the auspices of W. J. Dyer & Bro., musical merchandise jobbers and retailers. In addition to the usual Hohner prizes the Dyer firm donated \$15 and \$10 in merchandise orders to the winners. There was a great deal of harmonica advertising by the dealers in the newspapers and the contest, as well as Mr. Minevitch's concert appearances and the undivided co-operation of all the dealers.

The W. J. Dyer & Bro. store in St. Paul devoted an entire window to the display of Hohner harmonicas. Posters announcing the appearance of Minevitch at the Capitol Theatre and many other Hohner advertising posters were used. Hohner assortments and Hohner cut-outs and charts were displayed in large numbers throughout the window. Through the kindness of A. L. Brown, small goods manager of Dyer's, Minevitch played before the Kiwanis, Rotary and Exchange clubs while in St. Paul.

After leaving St. Paul Mr. Minevitch went to Duluth and other cities where he found the dealers eager to tie up with his appearance.

RADIO BOOKLET IN THIRD EDITION

"Grebe Radio in the Well-appointed Home," the interesting illustrated booklet prepared by R. A. Sayres, of the Lyon Advertising Agency, for A. H. Grebe & Co., manufacturers of radio sets, Richmond Hill, N. Y., has now had its third reprinting. This booklet has a specific quality appeal and presents the features of the Grebe radio in a very inviting manner. Accordingly, the demand for this literature by Grebe dealers has been exceptional.

**Your Copy Is Ready!
Trade Price List No. 7 For 1924**

The new edition of that useful little book for Music Merchants, published by the Fred. Gretsch Mfg. Co., has just come from the printer.

If you buy Musical Merchandise you need this book. And we want you to have it.

Nearly 3,000 different Instruments and Accessories are listed here at new, low 1924 prices. Stringed Instruments, Brass, Woodwind and Drums! The right retail and wholesale price on everything that makes up a modern Musical Merchandise stock.

And, more than that, the TRADE PRICE LIST is the visible embodiment of one of the largest Musical Merchandise Stocks in the United States. It brings that stock within easy reach of your store, to help you serve your customers more efficiently—and more profitably!

It simplifies your buying—supplements your inventory—increases your resources for service to your trade.

So write, today, for your copy. It is waiting your request.

The FRED. GRETSCH MFG. COMPANY

Musical Instrument Makers Since 1883

60 BROADWAY

BROOKLYN, N. Y.

BAILEY'S, INC., SPOKANE, EXPANDS

Purchases the Music Shop, That City, and Will Make Extensive Changes for the Better

SPOKANE, WASH., November 5.—W. E. Bailey, president of Bailey's, Inc., with a store at 819 West Sprague street, has purchased the Music Shop, at 722 Riverside avenue, from Ray A. Grombacher, the owner, who has conducted the establishment for the past four years, handling talking machines, records and sheet music.

Only recently the store of Bailey's, Inc., was remodeled and four demonstration rooms for talking machines and records installed, the company having taken on the Brunswick line. The Music Shop will also be remodeled and improved and the line of Victor and Brunswick talking machines and records, together with sheet music, will be continued.

The Sprague street store's policy will not be changed. Bailey's will there feature their exclusive lines of Buescher, Leedy, Orpheum, Vega, Paramount and Deagan band and orchestra instruments, classic music and teachers' supplies. Mr. Bailey's two sons are also officers in the company, Russell T. Bailey being vice-president-treasurer and H. G. Bailey, secretary. Possession of the new store will be taken at once and contemplated changes will be made immediately.

NEW BUESCHER BAND APPEARS

Employees' Organization Plays at Housewarming of the New Factory

ELKHART, IND., November 6.—The Buescher Band Instrument Co., manufacturer of the Buescher



New Buescher Building Being Constructed

line of saxophones and band instruments, held a housewarming last week in its big, new addition to the factory. The affair was attended by every employe and all the officials of the concern.

A feature of the evening was a band concert by the newly organized Buescher Band of forty-five pieces, under the direction of George A. Dierstein. Refreshments were served and dancing was enjoyed and a good time was had by all who attended.

BAKER INSTALLS SMALL GOODS

ALBANY, N. Y., November 7.—The Baker Music House is installing a musical merchandise department in its store on North Pearl street. A complete line of band and orchestra supplies will be stocked and the department will be placed in charge of a competent manager. This firm operates stores also in Utica and Schenectady and in each of these stores successful small goods departments have been maintained for some time.

GOOD PROFITS

BANJOS

MANDOLINS

LUTES

GUITARS

**V
E
G
A**

TRUMPETS

TROMBONES

SAXOPHONES

CLARINETS

New Catalogs—Just Out

THE VEGA COMPANY

155 Columbus Ave.

Boston, Mass.

IN THE MUSICAL MERCHANDISE FIELD—(Continued from page 144)

HOHNER Harmonicas and Accordions

THE WORLD'S BEST

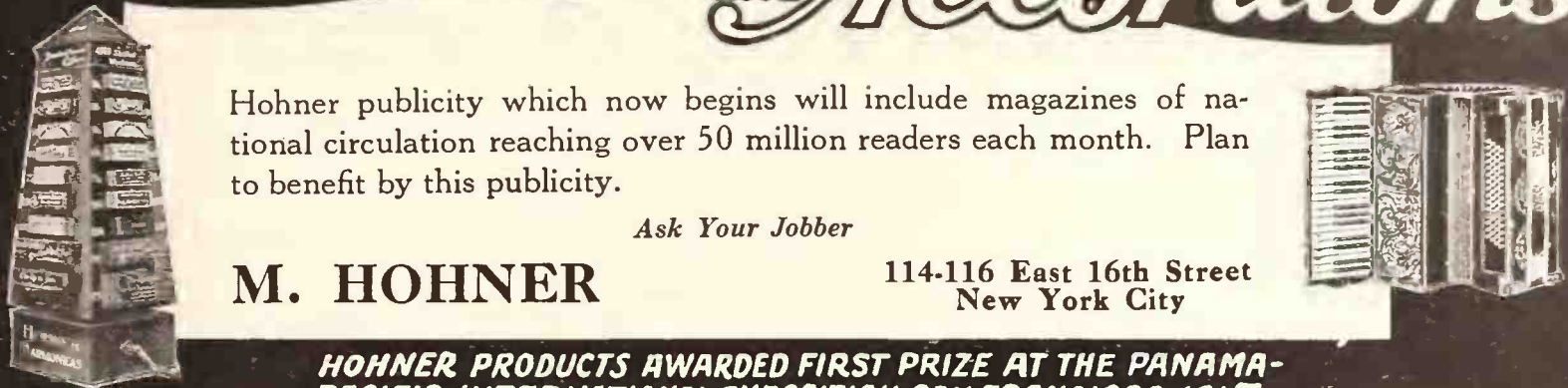

Hohner publicity which now begins will include magazines of national circulation reaching over 50 million readers each month. Plan to benefit by this publicity.

Ask Your Jobber

M. HOHNER 114-116 East 16th Street
New York City

HOHNER PRODUCTS AWARDED FIRST PRIZE AT THE PANAMA-PACIFIC INTERNATIONAL EXPOSITION SAN FRANCISCO 1915

ARTISTIC NEW GRETSCH CATALOG

Three Thousand Musical Instruments and Accessories Listed and Described—Business Active as Early Holiday Season Opens

The approach of a new year has brought about the publication and distribution of a considerable number of catalogs. Various houses have vied with each other in the production of this literature and the result has been the surpassing of all former attainments in this line. One of the latest publications of this character is the new trade price list No. 7, published by the Fred Gretsch Mfg. Co., Brooklyn, N. Y., and covering 1924. This catalog, just off the press, lists nearly 3,000 musical instruments and accessories. As may be well imagined, these instruments cover a wide scope and include string, brass and wood-wind variety.

E. E. Strong, advertising manager of the Fred. Gretsch Mfg. Co., reports that the company has concluded the biggest October in sales volume in the history of the organization, with November opening well. Every number of the entire line is going good. As the Fall and Winter seasons progress the demand for trap drum outfits has proportionately increased, until, at the present time, the sales volume in these numbers is very large. Mr. Strong also reports the continued popularity of Robert wood-wind instruments and the establishment of a number of new agencies for this line.

TO HOLD EDUCATIONAL MEETINGS

Association of Musical Merchandise Manufacturers Launches Series of Educational Meetings During Winter Months

CHICAGO, ILL., November 7.—The recently formed Association of Musical Merchandise Manufacturers, organized to promote better business methods in this field, is making progress. A series of educational programs has been worked out for the Winter months. Each month there will be a special meeting to take up for discussion different phases of the manufacturing of the small goods. Men who are thoroughly familiar with the subject will give short talks and the members will then take part in discussion, asking such questions as are needed for further information. The programs have been arranged with the idea of imparting valuable and instructive knowledge to the members and indicate the advanced work that this organization intends to do.

A. MAHARAM WITH PROGRESSIVE CO.

Prominent Salesman to Develop Interests of This Concern in His Territory

Arthur Maharam, formerly with the New York Conn Co., has joined the selling staff of the Progressive Musical Instrument Corp., 319 Sixth avenue, New York. He is exceptionally well known in the music trade and has just visited many dealers in New Jersey.

Mr. Maharam has successfully established many new dealers for the Holton band instruments and Bacon banjo lines and reports that the Holton saxophone is receiving special attention from dealers. Many orders have already been received for this line. Dealers everywhere have told Mr. Maharam that they expect a big musical instrument trade this Fall and Winter.

TIE-UP WITH BUESCHER ARTISTS

LOS ANGELES, CAL., November 5.—A most effective tie-up in which Buescher band instruments were featured was recently staged by the Southern California Music Co., this city, when Tom Brown, of the Six Brown Bros.; Lew Dockstader, famous minstrel, and Julian Eltinge, celebrated feminine impersonator, appeared here with the Black and White Review of 1924. Accompanied by the forty-piece Clown Saxophone Band, a regular old-time minstrel parade was staged. The line of march ended at the main store of the Southern California Music Co., on Broadway, and thousands witnessed the event. The company staged a special window display and instituted an extensive advertising campaign. In addition the artists posed in the store lobby, the combination resulting in a substantial increase in business.

EUCLID OPENS ITS FIFTH STORE

Cleveland Concern Rapidly Expanding—All Stores Doing a Large Business

CLEVELAND, O., November 8.—The Euclid Music Co. is rapidly becoming one of the greatest musical merchandise selling organizations in the Middle West. Announcement has been made of the opening of another store at 12338 Superior avenue. This is the second store this concern has opened in the past year, making the total of stores in the Euclid chain now five in number, the other stores being located at 207 East Ninth street, 10602 Euclid avenue, 10134 Superior avenue and 11794 Detroit avenue. Every one of these stores is doing a remarkably large volume of musical merchandise business, according to James R. Frew, vice-president of the company, who is in charge of the musical merchandise sales division of this progressive organization.

Mr. Frew is the author of that widely read book entitled "Selling Musical Merchandise." According to Mr. Frew, everyone of the stores shows a large increase over last year in all lines of business. In connection with this pronounced growth of the business, Mr. Frew was delighted to receive the other day a cartoon from P. H. Hayward, an elevator boy at one of the stores, which humorously pictures the progressiveness of Mr. Frew and Grant Smith, general manager of the company.

Exclusive Territory Now Open for
Bacon
Banjos Mandolins
Banjo Ukes

WRITE, PHONE OR CALL

Musical Instruments of Every Description
Progressive
MUSICAL INSTRUMENT CORPORATION

319 SIXTH AVENUE NEW YORK

Greater Profits For You With
Perfactone
REC. U.S. PAT. OFF.
Band Instruments
Banjos
Banjo Mandolins

WRITE, PHONE OR CALL

Musical Instruments of Every Description
Progressive
MUSICAL INSTRUMENT CORPORATION

319 SIXTH AVENUE NEW YORK

IN THE MUSICAL MERCHANDISE FIELD—(Continued from page 145)

THE BEST RECORDS
ARE PLAYED WITH

BUESCHER

Band Instruments and Saxophones

The outstanding record dealers of the country find Buescher Band Instruments and Saxophones the most enticing window display they can use. Buescher window cut-outs of famous Record Bands, Orchestras and Soloists sell Buescher Instruments and sell records, too.

Almost every time you play a record for a customer you are demonstrating the fine qualities of Buescher Instruments. Leading Record Distributors, such as Weymann, Philadelphia; Euclid Music Co., Cleveland; Southern California Music Co., Los Angeles; New York Band Instrument Co., New York, and countless others East and West find it doubly profitable to carry the instruments that make the records they sell.

If you do not carry Buescher Instruments, ask us about stores like yours in towns like yours that find the Buescher Line just what they need to put profit in the ledger. Catalogs and trade figures sent on request.

Buescher Band Instrument Co., G-93 Buescher Block, Elkhart, Indiana



The Virginians Use All Buescher Instruments

SCHOOLS GOOD SMALL GOODS FIELD

Opportunities of Sales to Schools and Students Demonstrated by Live Dealer, Who Has Placed Music on a Par With Athletics

HAZLETON, PA., November 5.—An intensive campaign designed to place band and orchestra instruments in the schools of this city and vicinity during the past year, which has resulted in placing music on a par with athletics among the students, is the work which Landau's Music Store, prominent talking machine and general music dealer of this city, has accomplished in twelve months. This, aside from the important consideration of profits and the prestige and future sales which undoubtedly will result from the drive.

An idea of the success of the campaign may be realized when it is considered that during the year approximately \$12,000 worth of musical instruments was disposed of as a result of the campaign. An order for \$4,000 worth of band and orchestra instruments for one organization in one day and the sale of two \$150 and one \$350 saxophone in one day were some of the satisfactory and startling results of this intensive drive.

During the opening months of the campaign arrangements were made with the supervisor of school music so that talented pupils could secure an instrument for as low as \$5 a month if they presented his recommendation. The supervisor was anxious to develop the talent of the school and as a result of his co-operation and Landau's generous offer almost every school in the district soon had under formation a school band or orchestra, with a central group of seventy-five players to represent the district. Free instruction in the instruments was given to the pupils by the supervisor and his staff and this work is constantly being extended.

Leo Landau, the enterprising manager of this store, in commenting on his success in the drive, declared that there is no harm in putting some novel ideas up to the school boards. In his preliminary arguments to the school directors he declared that there was no reason why membership in the school band or orchestra should

not be made competitive, that is, if a musically inclined student maintains his scholastic standing he be privileged to become a member of the school musical organization, his membership to continue only so long as his scholastic standing remains at par. He pointed out that the organization of a forty-piece school band, open to students who were doing good class work, would promote good scholarship, improve school morale and would be a direct incentive to study. The argument won the day and after some discussion the school directors purchased the \$4,000 worth of instruments mentioned in the first paragraph. Before delivery a window display of these instruments was arranged, attracting widespread interest in the school plan and the musical merchandise.

The ruling that a student shall retain his place in the band only so long as he maintains his class standing has had the effect of bring-

ing considerable business to Landau's. Many of the students who are awaiting places in the band, which will be open as students drop out because of failure to keep up with their classes, are buying musical instruments and learning to play them so that they will be ready when a vacancy occurs. The three saxophones mentioned previously were purchased by students who are in the waiting class.

This is but the opening gun of what is probably the most successful sales drive of this character ever staged by a dealer. The three other Landau stores in Wilkes-Barre, Nanticoke and Pittston will stage similar drives. These also are bound to be successful, according to Manager Landau, in view of the fact that the other drive was inaugurated in the face of a five and a half months' strike in the coal fields, upon which this district depends to a large extent for prosperity.

NEW BRUNO & SON CATALOG

New York Jobber Distributing New Publication to Its Many Dealers

One of the finest catalogs that has ever made its appearance in the musical merchandise trade is the 1924 wholesale catalog being distributed to the trade by C. Bruno & Son, Inc., the old-established musical merchandise wholesale house, 353 Fourth avenue, New York City. It is the ninetieth edition of the annual Bruno catalog, the house having been established in 1834. This catalog replaces all previous ones.

The cover of the book is an important feature. Realizing that the catalog will see hard service with the music dealers, the house of Bruno has determined to have the catalog hold its shape, and the cover is of such heavy stock that it is very nearly stiff cardboard. An extra front and back insert, also of exceptionally heavy stock, reinforces the cover which is attached to the book with a special binding.

The edition runs 192 pages. The pages are fully illustrated, and complete descriptions are given of the complete line of Bruno merchandise. A new feature of the book this year is a special insert in buff and dark brown color featuring the two Hohner business builders for dealers, the Hohner harmonica instruction booklet and the Hohner window display chart. Another orange color insert is devoted to M. Hohner accordions. Other inserts include special natural color reproductions of Bruno violins, Bell Brand and Black Diamond strings, Orpheum banjos, Gibson Gold Medal strings and Grover accessories.

The book is designed for the dealers' use and retail prices are given throughout.

A. W. Landay, head of the Progressive Musical Instrument Corp., New York, is on a mid-West trip.

BUYS ITS NEW YORK BUILDING

A significant real estate transaction was consummated recently by the Rudolph Wurlitzer Co., in New York, when the fifteen-story building at 116-18 West Forty-second street, wherein its main Eastern offices are located, was purchased. The building fronts fifty feet on Forty-second street and extends through to Forty-first street with a frontage there of eighty-five feet.

The Wurlitzer Co. has agreed to purchase the property from the Woodbury G. Landon estate and has obtained a loan of \$1,300,000 on the structure, running for a term of years.

To Sell Musical Merchandise Advantageously You Require
**MUSICAL INSTRUMENT CASES
SMALL GOODS DISPLAY COUNTERS
SHEET MUSIC RACKS**

Complete store interiors carried in stock. Prices on request.

**ZIMMERMAN-BITTER
CONSTRUCTION COMPANY**
325-27 East 94th Street, New York
Phone Lenox 2960

Exclusive
Territory Now Open
for
Holton
Band Instruments

WRITE, PHONE
OR
CALL

Musical Instruments of Every Description

Progressive
MUSICAL INSTRUMENT CORPORATION

319 Sixth Avenue, New York

Along The Rainbow Trail

A Beautiful Fox-trot Melody

You can't go wrong with any FEIST song

I see a quaint old-fashioned gar - den, — A rus-tic gate where ro - ses twine,

© 1923
Leo. Feist, Inc.

MADE IN THE USA

A Unique and Comprehensive Dealer Service

Girard Phonograph Co., Edison Distributor, Announces "The Rostrum—for Edison Salesmen"—Advisory Council of Experts to Solve Merchandising Problems of Retailers and Salesmen

The Girard Phonograph Co., Edison distributor, of Philadelphia, Pa., has just announced what will probably be one of the most comprehensive service plans ever instituted by a phonograph wholesaler, "The Rostrum—for Edison Salesmen," designed to aid retailers in solving their business and merchandising problems by giving them the benefit of the advice and experience of authorities in the talking machine merchandising field.

"The Rostrum—for Edison Salesmen" is in reality an open forum and its purpose is to answer the many questions asked by retail customers and to solve dealers' merchandising problems. Dealers and salesmen are privileged to ask as many questions as they desire and these will be submitted to an advisory council, composed of authorities on various phases of business management and merchandising, who will transmit to the questioners the most modern thoughts on business management and will give the benefit of their specialized knowledge of merchandising in solving problems.

Once each month the questions answered will be published and mailed to dealers. This plan will be followed throughout the Fall and Winter, and in the Spring it is the purpose of the Girard Phonograph Co. to publish a booklet which will contain all the questions asked by dealers and their salesmen, together with the answers. A. W. Rhinow, secretary of the company, will give his attention to this service work and all questions must be sent to the company addressed to him.

Although, as has been mentioned, the plan has only just been announced to dealers and salesmen by means of circulars and other direct-mail literature, questions are already pouring in, and indications are that this service will fill a long-felt want. Every day dealers and salesmen are confronted with new and strange problems and often a wrong move may have serious consequences. With the inauguration of this service Edison dealers and salesmen have at their command experts who will be glad to give their opinions and advice. The advisory council and the wide field it covers consists of the following:

Girard Phonograph Co., Philadelphia, P. R. Hawley, general manager: Owing to its immediate contact with Edison dealers and salesmen, the distributor shall endeavor to advise and instruct in all matters pertaining to the construction of the Edison phonograph and records as well as those of a scientific nature relating to their development.

The Talking Machine World, New York City: The most influential and widely read trade journal in the phonograph industry will tell how other dealers have solved problems similar to those presented by the advisory council.

The Metropolitan Musical Bureau, New York City: The largest musical booking bureau and the one managing the careers of many of the biggest Edison artists knows all there is to know about how a dealer can "cash in" on the local appearance of Edison artists.

Commercial Investment Trust Inc., New York City: The largest banking organization of its kind will advise dealers concerning their financial problems.

Einson-Freeman Co., New York City, window displays: The creators of the Edison window displays and pioneers in the phonograph window advertising field will offer their wide experience in solving window display problems.

Shubert Philadelphia Theatres, Philadelphia, Leonard A. Blumberg, general manager: The representative of Lee and J. J. Shubert, the largest and most widely known theatrical producers in the country, has been chosen to tell

dealers how to make the most of the visiting musical shows in their cities.

Leo Feist Publishing Co., New York City: The largest musical publishing organization in the country will answer inquiries concerning the newest song hits.

William A. Hersey, New York City, sales consultant: Mr. Hersey has earned country-wide recognition in the sales promotion field and he will tell dealers how to write pulling sales letters.

Gunner & Forman, Philadelphia, printing counselors: Inquiries concerning printing, layout, circularizing and kindred subjects will be answered by an organization amply equipped for this purpose.

Charles E. Stapleton, New York City, representing Northwestern Life Insurance Co.: The star salesman will offer his combined salesmanship and former Edison retail experience to assist Edison dealers and salesmen.

Charlie Kerr's Orchestra, Philadelphia, Charlie Kerr, director: The director of this now famous orchestra, whose interpretations of numerous dance hits have been recorded on Edison records, will answer inquiries concerning the editing of records.

**ZIMMERMAN · BITTER
CONSTRUCTION · COMPANY**

S. L. SCHOTT, 64 S. 4th St., Mt. Vernon, N. Y.

Another very good illustration of the modern method of remodeling with Z.-B. equipment, showing all merchandise advantageously, yet carrying out harmony in design.

quality *design*

Record Racks Display Cases
Hearing Rooms Musical Instrument
Service Counters Cases, Etc.
Prices on request

**ZIMMERMAN-BITTER
CONSTRUCTION COMPANY**
325-27 East 94th Street, New York
Phone Lenox 2960

IN PITTSBURGH

Low-priced Talking Machines Hard to Get—Aiding Dealers in Sales Promotion Drives—Trade Changes—Store Improvements—The News

PITTSBURGH, PA., November 7.—With the advent of November, and less than seven weeks before the Christmas season, there is more than ordinary activity in local talking machine circles. An outstanding feature is the dearth of talking machines that retail at \$75 and \$100. These instruments are as scarce as the proverbial "hen's teeth." This condition is well exemplified in the Victor line, as the local dealers are practically sold out of the \$100 instruments, according to men in the trade who are in a position to speak with authority.

The industrial situation in the Pittsburgh district, which covers, for shopping purposes, a radius of about forty miles from the Steel City, was never better. Busy mills, mines and factories are an unfailing indication of prosperity, and with huge payrolls being disbursed regularly every two weeks the thousands of dollars that are distributed in wages will, in part, find their way into the coffers of wide-awake talking machine dealers.

R. J. Coleman Aids Standard Co. Dealers

Robert J. Coleman, who recently joined the executive staff of the Standard Talking Machine Co., Victor talking machine distributor, has been devoting his time to a plan of retail sales promotion for Standard-Victor dealers that is meeting with much favor among those to whom it has been introduced. Mr. Coleman's entire energies are being expended as "idea man" and retail business stimulator for Standard-Victor dealers. Mr. Coleman spends as many days with a retail Victor dealer as the latter may desire, studying the business from the standpoint of useful ideas and plans of which the Standard Talking Machine Co. already has knowledge, enabling the dealer to draw generously on this store of merchandise information. It is being found that a host of devices to produce business can be adopted in one locality after another and that there is no better way of spreading them than by the practical instruction given by Mr. Coleman.

Wallace Russell, general manager of the company, in referring to the work of Mr. Coleman, stated that it is given without any cost or obligation to dealers.

In speaking of business conditions Mr. Russell emphasized the fact that it would be impossible to supply all of the Victor dealers with the \$100 Victrolas, due to the enormous demand for this style of instrument. Mr. Russell also stated that Victor records were selling well and that the outlook for a highly satisfactory holiday trade is exceedingly bright.

Joseph C. Roush, president of the Standard Co., was a recent visitor to Columbus, O.

E. B. Hart, of Sherman, Clay & Co., Portland, Ore., was a visitor to the Standard Talking Machine Co. offices, as were Leslie W. Wiswell, formerly of the Victor department of Lyon & Healy, Chicago, and W. Frank Davison, vice-president of the Victor jobbing house of the Perry B. Whitsit Co., Columbus, O.

Offutt Co. Adds Another Branch

The Offutt Co., of New Castle and Butler, Pa., has purchased the Ely Bros., Inc., store at Jeannette, Pa. The Ely store contains a very up-to-date Victor department, which the new owners will continue.

Max Roth Improving Store

Max Roth, of Leechburg, Pa., one of the progressive Victor dealers of western Pennsylvania, is making extensive alterations and improvements to his shop. Unico equipment is to be installed by the Unit Construction Co.

Max Tannenbaum in New Post

Max Tannenbaum, who is well known to the local talking machine trade as a distributor of the Gold Seal record repeater, is now affiliated with the Hub Store of George W. Robinson, of Steubenville, O., in charge of the talking machine department.

Places Edison in Schools

The Columbia Music Co., Edison dealer, sold to the Belmar School in the Homewood district of Pittsburgh a London Upright Model. Several months previously it sold a similar instrument to the Allen School, Pittsburgh. The latter instrument was put to a very severe test and won over a well-known talking machine that is represented in the Pittsburgh schools. John F. Henk, manager of the Columbia Music Co., is quite elated over the fact that he won out in these two places and that the New Edi-

son has found its way into the local schools an important entering wedge to even more business.

T. E. Shortell With Buehn Co.

Thomas E. Shortell, who is well known in local talking machine circles and who for a number of years was manager of the talking machine department of the S. Hamilton Co., is now associated with the Buehn Phonograph Co., Edison distributor, as a member of the traveling staff.

New Edison Accounts

Among the new Edison dealers who will be served by the Buehn Phonograph Co. are the Milleman Music Co., New Castle, Pa.; D. Shaffer, Hooversville, Pa.; J. V. Wilson, Fairchance, Pa.; S. T. McKinley, Pennsboro, W. Va., and the Rothert Co., of Tyrone, Pa. One of the features of the taking on of the Rothert Co., as an Edison retailer, was the fact that the initial shipment of Edison phonographs, a representative line being sent, was disposed of in a few days and a duplicate order was sent immediately. The Rothert Co. operates other stores in central Pennsylvania, and the signal success with the Edison line was bulletined to the other stores, where other makes of phonographs are carried.

New Sonora Dealers Appointed

H. Milton Miller, manager of the Sonora Distributing Co. of Pittsburgh, stated that the Sonora line was meeting with exceptional success and that Sonora dealers reported that advance orders for holiday deliveries were coming in very rapidly.

One of the new Sonora and Aeolian record dealers who will be served by the Pittsburgh distributing agency is the Parsons-Souders Co., located in Clarksburg, W. Va. The formal opening of the Sonora and Aeolian record department was held on November 3 and was attended by a number of persons in and about Clarksburg. Fred Johnson, the department manager, and a staff of salesfolk welcomed all callers. The Sonora Distributing Co. of Pittsburgh was represented by Earl Miller.

Other Sonora dealers of recent origin are Davis Bros., West End, Pittsburgh; William Boyle, Bakerstown, Pa.; W. P. Risinger, Homer City, Pa.; Foulk-Davis Co., Greenville, Pa.; Victor Nelly, Carnegie, Pa.; J. Lipman, Hazelwood, Pittsburgh; Steele Furniture Co., Homestead, Pa., and John C. Gray, Southside, Pittsburgh; R. H. Thomas, this city.

Expects Big Edison Holiday Sales

A. A. Buehn, treasurer of the Buehn Phonograph Co., Edison distributor, has been able to keep at his desk the past few weeks, even though he underwent a series of operations due to an infected bone in his face. The last operation proved successful and Mr. Buehn is now on the high road to ultimate recovery from a very painful affliction. In speaking of business conditions Mr. Buehn stated that the outlook is very bright for holiday sales of Edison phonographs and records.

General Radio Corp. Busy

Brisk business was reported by Frank Dorian, of the General Radio Corp., whose offices and exhibition rooms are at 1005 Liberty avenue. He stated that sales of the Strand phonograph and the Okeh records were increasing right along. As to the holiday outlook, Mr. Dorian was quite optimistic. He stated that the radio line was one that should appeal to every talking machine dealer as, in time, it would undoubtedly take its place in the music trade as an essential part of the business.

"Victrola Week" a Success

The C. C. Mellor Co. recently staged a "Victrola Week" in its retail department where a full line of the Victor talking machines was on display. H. H. Fleer, manager of the department, stated that sales of high-grade Victor machines were very gratifying.

C. B. Hammond a Visitor

C. B. Hammond, of the Cleveland offices of the Cheney Talking Machine Co., was a visitor to the Pittsburgh Cheney dealers the past week.

(Continued on page 150)

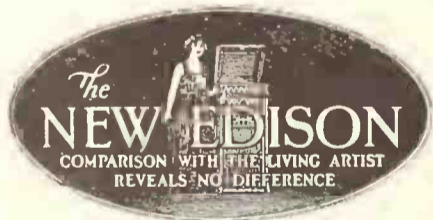

Distinctive cabinet designs—superior tonal quality—attractively priced models—three of the many reasons for the popularity of the New Edison.

Forty years of labor by the world's foremost inventor have given us the perfected musical instrument bearing his name.

BUEHN PHONOGRAPH CO.
EDISON DISTRIBUTORS

421 SEVENTH AVE.

PITTSBURGH

New Edison Records Every Week

ORDER

from this

TREMENDOUS STOCK

Records! Reams and rooms of records! Stack upon stack of the latest song and dance hits! Two enormous stocks to choose from—one in Philadelphia, the other in Pittsburgh. We are now supplying hundreds of OKEH and ODEON Record dealers with holiday stocks.

Okeh Records

"The Records of Quality"

and

Odeon Records

"The Records of International Renown"

Orders shipped from either Philadelphia or Pittsburgh on the *same day they are received!* Dealers who have never tried GENERAL RADIO CORPORATION service will be pleased beyond measure. Holiday orders taken care of with promptness and efficiency. Write, telephone or wire your wants. Depend on us to come through in a hurry!

GENERAL RADIO CORPORATION

WALTER L. ECKHARDT, President

S. W. cor. 10th and Cherry Sts., PHILADELPHIA

1005 Liberty Ave., PITTSBURGH

*Distributors for OKEH Records, ODEON Records, STRAND Phonographs,
GOLD SEAL Record-Repeaters and Radio Corporation of America*

Makers of the Famous MUSIC MASTER Radio Reproducer

TRADE HAPPENINGS IN PITTSBURGH

(Continued from page 148)

Mr. Hammond stated that Cheney sales in the Pittsburgh district are very satisfactory.

Miss Margaret Stuart Resigned

Miss Margaret Stuart, who for a number of years was connected with the Victor department of the S. Hamilton Co., and latterly with the talking machine department of the Rosenbaum Co., resigned on October 31 and is now connected with the Philadelphia Co., a leading public utility organization.

Dealers Add Aeolian Records

New Aeolian record dealers are F. H. Miller, Sharpsville, Pa.; L. E. Manuel, Charleston, W. Va.; Todd & Stevens, Monongahela, Pa.; Frew Furniture Co., New Castle, Pa.; R. H. Thomas, the well-known druggist of Mt. Washington, Pittsburgh, who is making alterations to his place of business and will install a talking machine department with a full line of Sonora phonographs and Aeolian records.

Good Columbia Demand

"An optimistic outlook" was the expression of S. H. Nichols, manager of the local offices of the Columbia Phonograph Co., in referring to the trend of business. Mr. Nichols stated that the sales of Columbia instruments and records were larger than ever and indicated that sales for November and December would, by far, exceed the sales of the same months a year ago.

Dawson Bros.' Sales Gain

Paul S. Mechling, sales manager of the Dawson Bros. Piano Store, Starr phonograph and Gennett record dealers, stated that October sales had shown a marked increase over September, and he intimated that the sales department is confident of record-breaking sales for the holiday season. C. L. Dawson, president of the company, is planning to leave for Florida, about November 15, on his annual outing in the South.

Jacob Schoenberger's Fiftieth Anniversary

Jacob Schoenberger, president of the Lechner & Schoenberger Co., Edison, Victor and Columbia dealer, on October 26 celebrated the fiftieth anniversary of his wedding. Mr. and Mrs. Schoenberger were hosts to their children and grandchildren and other relatives to the number of thirty at a family reunion and dinner. Mr. Schoenberger was the first president of the former Talking Machine Dealers Association of Pittsburgh. His two sons, L. J. Schoenberger and Homer Schoenberger, are associated in business with him.

Player-Tone Co. in New Home

The Player-Tone Talking Machine Co., through the president, I. Goldsmith, reports a very brisk volume of trade, especially in the

console models of the Player-Tone line. Sales for October, it was stated, were very flattering and the outlook for the next few weeks is considered excellent. The Player-Tone Co. is now located in new quarters, 623 Grant street.

Leslie I. King a Visitor

Leslie I. King, district sales manager of the Brunswick-Balke-Collender Co., with headquarters in Cleveland, O., spent several days in Pittsburgh the past week. He reports a very excellent Brunswick business and stated that sales in the Pittsburgh territory were increasing steadily.

News Gleanings

F. H. Burbick, who was formerly connected with the wholesale Victor department of the C. C. Mellor Co., is now manager of the Pittsburgh branch of the Brunswick Co.

Thomas T. Evans, manager of the wholesale Victor department of the C. C. Mellor Co., stated that "business was booming" and that the only complaint he had is "the inability to furnish my dealers with all the Victor merchandise they need."

George H. Rewbridge, manager of the wholesale Victor department of the W. F. Frederick Co., states that all indications pointed to his clients having an exceptionally brisk holiday season.

Horace Hays, of the E. G. Hays Co., Brunswick dealer, held a meeting of his sales force at Monessen recently, which was attended by twenty-four salesmen. A dinner preceded the meeting and Mr. Hays delivered one of his celebrated "inspirational" talks.

R. B. WHEELAN CLOSES MANY DEALS

President of Health Builders, Inc., Returning From Resultful Trip to Pacific Coast

Robert B. Wheelan, president of Health Builders, Inc., New York, is on his way home, after an extended business trip which carried him as far as the Pacific Coast. On his way out Mr. Wheelan made stops at Cincinnati, Detroit, St. Louis, Kansas City, Salt Lake City and many other trade centers. On his return trip he is stopping at the principal cities in the Southern section of the country. Mr. Wheelan undertook the trip in the interest of all three of the products of the company, the Camp-fone portable talking machine, Health Builder sets of Walter Camp's "Daily Dozen" and the Health Builder Weight Reducing sets. Mr. Wheelan visited many of his friends in the trade en route. Although the trip is not as yet completed many new jobbers have been appointed to distribute the various lines of the company.

Bakertone for Phonographs

No surface noise and no sacrifice of volume or tone quality.

No need to alter the phonograph. A simple attachment that can be added by anyone. Helps records sales. Sells at \$3.50.

Ask for discounts.

**Bakertone
Corporation**

408 Pearl Street
BUFFALO, N. Y.



J. A. CRABTREE OFF TO EUROPE

President of the International Mica Co. to Make Extensive Business Tour of the Continent

WEST PHILADELPHIA, PA., November 7.—James A. Crabtree, president of the International Mica Co., of this city, sailed recently on the Olympic for Europe, which he plans to cover in the interests of mica and mica diaphragms for talking machine and radio loud speaker manufacturers. Mr. Crabtree will examine the products now manufactured abroad to learn of any improvements which foreign manufacturers might be making on their apparatus and on which "Imico" consumers will be properly advised. He will also arrange for further importations of mica from India for 1924 to take care of the requirements of the company for "Imico" India ruby mica diaphragms.

The International Mica Co. has been unable thus far to receive any satisfactory communication from its Yokohama office, in charge of Francis Grattan, since the earthquake. The company has communicated with the American Consular offices for information.

SENDS OUT MONTHLY CALENDARS

Heralded by a series of ingenious form letters the Columbia Mantel Co., Brooklyn, N. Y., sent out the first of a series of twelve monthly calendars to those of the trade on its large mailing list. These calendars are of the Indian heroine series and are lithographed in colors. From an advertising standpoint they feature the "Recorder" line of talking machines made by the Columbia Mantel Co.

FEATURING THE MODERNOLETTE FOR THE HOLIDAYS HAS INCREASED SALES FOR OTHER DEALERS

The Modernolette sold as well for the Holidays last year as in the Summer season. It makes a very desirable machine for the home. Get your order in NOW.

MANUFACTURED BY

MODERNOLA COMPANY

Factory and Office

JOHNSTOWN, PA.

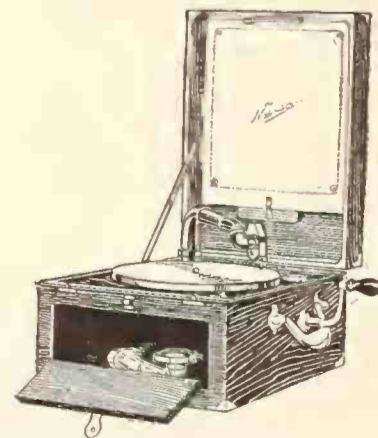

OUTING TALKING MACHINE CO., Inc., Mount Kisco, N. Y.

JOBBERS



- A. C. ERISMAN CO.....174 Tremont St., Boston, Mass.
 - BRISTOL & BARBER CO., INC.....3 East 14th St., New York, N. Y.
 - GENERAL PHONOGRAPH CORP.....15 West 18th St., New York, N. Y.
 - GEORGE C. ULRICH & CO.....56 Estey Bldg., Philadelphia, Pa.
 - BENNETT PIANO CO.....52 W. Market St., Wilkes-Barre, Pa.
 - STARR PHONOGRAPH CO.....634 Grant St., Pittsburgh, Pa.
 - J. K. POLK, INC.....294 Decatur St., Atlanta, Ga.
 - INDEPENDENT JOBBING CO.
112 East Center St. North, Goldsboro, N. C.
 - IROQUOIS SALES CORP.....210 Franklin St., Buffalo, N. Y.
 - VOCALION CO. OF OHIO.....328 Superior St., W., Cleveland, O.
 - C. L. MARSHALL CO.....514 Griswold St., Detroit, Mich.
 - CONSOLIDATED TALKING MACHINE CO.,
227 Washington St., Chicago, Ill.
 - CONSOLIDATED TALKING MACHINE CO.,
1121 Nicollet Ave., Minneapolis, Minn.
 - YAHR & LANGE DRUG CO.....Milwaukee, Wis.
 - THE DUNNING CO.....303 Second St., Des Moines, Iowa
 - RENIER MUSIC HOUSE.....545 Main St., Dubuque, Iowa
 - ARTOPHONE CORP.....1103 Olive St., St. Louis, Mo.
 - ARTOPHONE CORP.....203 Kansas City Life Bldg., Kansas City, Mo.
 - JUNIUS HART PIANO HOUSE123 Carondelet St., New Orleans, La.
 - TEXAS RADIO SALES CO., INC.....2005 Main St., Dallas, Texas
 - CARL FLORINE131 East 4th Ave., Denver, Colo.
 - WALTER S. GRAY & CO.,
1054 Mission St., San Francisco Cal.; Los Angeles, Portland, Seattle
- Export:—CHIPMAN, LTD.
New York, London, Montreal, Wellington, Sydney,
Melbourne, Perth, Havana, Mexico City, Buenos
Aires, Rio De Janeiro, Santiago de Chile.
Cable Address: Chipmonk, New York

Announcing

"One handle handles it" The Outing Junior

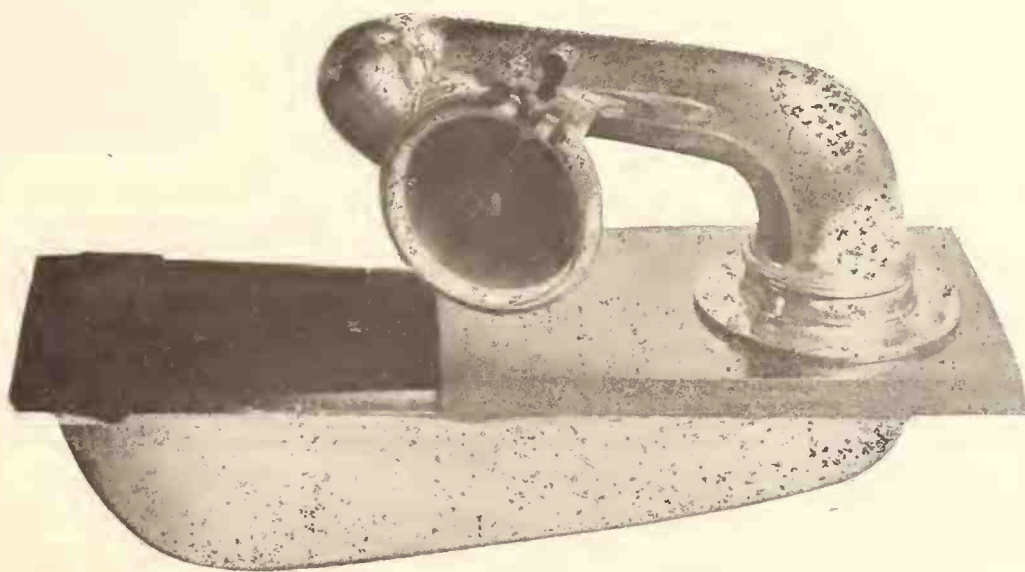

The little bath tub through which the sound waves pass, emerging
CLEAN! CLEAR! and as sweet as they were meant to be.

WRITE YOUR JOBBER FOR SAMPLE

This is an "Outing" product

There are several states still open to jobbers. We invite correspondence

W. D. ANDREWS CO.

DISTRIBUTORS OF
VICTROLAS and VICTOR RECORDS

"Service That Satisfies"

SYRACUSE, N. Y.

IN SYRACUSE

Dealers Make Extensive Christmas Sales Plans—W. D. Andrews Host to Optimists—Canvassing Results in Business—The News

SYRACUSE, N. Y., November 9.—The talking machine trade throughout this territory is in an optimistic mood, due to the fact that business has improved steadily during the past month and all indications point to a record-breaking trade. The dealers themselves have been making comprehensive plans to get their share of the Christmas gift dollars and there is no doubt that this aggressive activity will have a beneficial influence on the public when it does its Christmas shopping. In fact, signs are in the air that many people have made up their minds to shop early and avoid the rush. Concrete evidence of this is given by the inquiries already received by some of the dealers.

Andrews Entertains Optimists

W. D. Andrews, head of the W. D. Andrews Co., Victor wholesaler in this city, was the host recently to several score members of the Optimists' Club of Syracuse at a dance and buffet supper served at the commodious Andrews Co. headquarters on Washington street. Mr. Andrews is an enthusiastic member of the Opti-

mists' Club, an organization of business men which holds a weekly get-together luncheon at one of the local hotels.

Sells 200 Edisons a Year

Frank E. Bolway & Son, Inc., of this city, Edison jobber, received recently an interesting letter from the Greene Specialty Co., of Malone, N. Y., Edison dealer, in which the company stated: "We have four men canvassing at the present time and plan to sell at least 200 Edisons during the year. We have already sold so far this year 135, and prospects for Edison business are looking better each day, as we are getting this territory thoroughly Edisonized."

Unprecedented Sonora Demand

The Gibson-Snow Co., Inc., Sonora distributor of this territory, with headquarters in this city, has been hard put to it to supply the demands of its dealers. In fact, so tremendous has the volume of business become that the company is finding it almost impossible to supply dealers with some of the more popular models. The volume of orders and the quantity

of Sonoras called for are undoubted evidence that Sonora dealers throughout this section of the State expect things to happen during the remainder of the year and they do not intend to be caught without the means of satisfying the desires of their customers. The dealers themselves are further accelerating the steadily growing volume of business by utilizing every means of impressing on the public the merit of this line.

Clark Co.'s Edison Display at State Fair

The Clark Music Co. of this city recently sponsored a very attractive display at the State Fair held in Syracuse. During the week of the



Interested Crowd at Clark Co.'s Booth

fair this enterprising dealer arranged for the services of George Wilton Ballard, who has made several fine recordings for the New Edison catalog. Mr. Ballard sang in direct comparison with the Edison Re-Creations of his voice, and his recitals kept the display crowded at all times. As a result of its exhibit at the State Fair, the Clark Music Co. obtained a large number of prospects, especially for the laboratory model of the New Edison, and Mr. Richardson, who is the manager of the Clark Co.'s phonograph department, believes that some excellent sales will be closed from this list.

Making Improvements in Store

Several improvements are being made in the talking machine department of the Clark Music Co. here, including the remodeling and redecorating of the basement and the installation of four new demonstration booths to take care of the increasing trade. C. E. Richardson, manager of the department, reports a particularly satisfactory volume of trade just now, following a slight let-up early in October.

Letter Increases Record Sales

Schuderer & Castle, 109 North Washington street, Rome, N. Y., have been very successful in increasing the sale of Edison records by means of cleverly written letters calling attention to certain selected recordings. One of these business-pulling letters is as follows:

Dear Friends: We take pleasure in herewith submitting the new form Edison record supplement for your approval. We think you are going to like it better.

It is our desire to give you the best record service possible, and after carefully going over this supplement we would like to call your attention to some of the outstanding numbers, or the ones we consider the cream of the supplement.

GIBSON-SNOW Co. Inc.

THE INSTRUMENT OF QUALITY
Sonora
CLEAR AS A BELL

SYRACUSE, N.Y.

THE PERFORMANCE OF SERVICE

is the test of any organization

The Gibson-Snow Co. as distributors in New York State for the Sonora phonograph and Vocalion records, accomplishes this test of service that does help the dealer merchandise his product in an efficient manner.

We are prepared to help you. Ask us for our co-operation.

Sonora phonograph and Vocalion record distributors for New York State.

GIBSON-SNOW CO., Inc.
Syracuse, N. Y.

If you like classical numbers do not fail to get 82298, "Villanelle," by Anna Case. This is Case at her best—a wonderful number.

Then for those who like a beautiful instrumental number, there is 80764, "Answer" and "A Dream," by Locey's Instrumental Quartet. A record of which you will never tire—a real gem for your collection.

Another one of those catchy piano numbers is 51209, "Knice and Knifty," by Ernest L. Stevens.

Number 51230, "Roll Along Missouri," is a waltz number you will want to hear over and over again. While 51225, "Pretty Peggy," just won't let your feet behave. Other numbers on this supplement that are worthy of special mention are 51231, 51226 and 51212.

We will be glad to play any of these numbers for you at the store or, if you live out of town, our mail-order department is at your service. Just mail us a card with the numbers you want and Uncle Sam will quickly bring them to your door.

W.F.HITCHCOCK PLANS SOUTHERN TRIP

Owner of Phonomotor Co. Will Take Well-deserved Rest—Company's Sales Totals Far Ahead of 1922 and Growing Rapidly

ROCHESTER, N. Y., November 7.—W. F. Hitchcock, proprietor of the Phonomotor Co., of this city, manufacturer of the Phonomotor electric drive, Phonostop and the Need-a-Clip needle cutter, is planning to leave for a Southern trip on November 21, which will be in the nature of a well-deserved vacation. In a chat with The World recently Mr. Hitchcock stated that his company's business had increased substantially during the past few months and that on October 1 more goods had been sold during the nine months of 1923 than during the entire year of 1922.

Incidentally, Mr. Hitchcock referred to the splendid results that he had received from his advertising in The World, stating that he had built up a large foreign trade, including clients in Australia, Japan, China, Denmark and England, with all of this business directly traceable to his World advertising. He has also received orders from the talking machine trade throughout America referring to the advertising that he is using regularly in The World.

HANDSOME STORE IN POUGHKEEPSIE

B. M. Rose Now Occupying Ground Floor of Building Which He Purchased Recently

POUGHKEEPSIE, N. Y., November 7.—B. M. Rose, who for some time past has been conducting a piano and music store in this city, is now settled in new quarters at 39 Cannon street, in a building which he purchased recently. The main floor is divided into a number of separate show-rooms, each fitted up in a most homelike manner, and with only one instrument shown in a room. The Hardman line of pianos and players is handled, as is the Sonora phonograph.

GRIFFIN PIANO CO. PROGRESS

ROCHESTER, N. Y., November 5.—The Griffin Piano Co., which has fine quarters at 57 North Clinton avenue, this city, and which was formerly known as the Griffin-Bailey Piano Co., is building up a very fine business in Story & Clark and Chickering Bros. pianos, Estey organs, Sonora phonographs and other instruments. John F. Griffin, who has been in the piano business for the past twenty-seven years, is president and treasurer, and George B. Riker, for many years with the Story & Clark Co., is vice-president and secretary. The store is located on a most desirable corner in the heart of the business section of the city.

PERKINS MUSIC CO. CHARTERED

A charter of incorporation has just been granted to the Perkins Music Co., of Malden, Mass., which will be capitalized at \$50,000. Musical instruments will be handled.

Joseph M. Quirk, of Batavia, N. Y., who has operated a talking machine store at 4 Court street for a number of years, has moved his business to 5 Jackson street.

The NEW EDISON

in

New Models, New Prices

EDISON FEATURES

Permanent Diamond Point Reproducer.
Plays all Makes of Records Better.
Edison Records Play Longer, Wear Longer.
New Improved Records.

Dealers proposition submitted upon request

Frank E. **BOLWAY** & Son Inc.

SYRACUSE

Jobbers

Est. 1889

FARM BUYING POWER INCREASES

Department of Agriculture States Purchasing Power of Farm Products at Highest Point in Three Years—Good News for Retailers

WASHINGTON, D. C., November 8.—According to the November Review of the Department of Agriculture just issued the purchasing power of farm products has reached the highest point it has achieved during any time for the past three years. The index number of the purchasing power of this group is put at seventy-five, as against seventy-three in August and sixty-four in September, 1922.

Farm prices have shown steady advancement, a condition which should be reflected in the buying of rural communities. The Department of Agriculture's statement will do much to relieve the situation of apprehension created through the low prices for wheat, which, after all, affected but a comparatively small propor-

tion of the nation's farmers and which was largely confined to a comparatively small section of the country.

BAGSHAW OFFICIALS VISIT GOTHAM

C. H. and W. J. Bagshaw, of the W. H. Bagshaw Co., Lowell, Mass., were among the recent visitors in New York City. The Messrs. Bagshaw divided their time between the headquarters of the Brilliantone Steel Needle Co. and Reflexo Products, Inc., both of which are selling agents of the various talking machine needles made by this company. Plans for 1924 were discussed. The plant of the company is reported very busy and the present year will surpass all others in needle production.

Talking machines to match the furniture in the homes of his customers are made by E. L. Corle, who has opened a shop in Hutchinson, Kans., where he makes instruments to order.

REGINA Phonograph Reproducer and Radio Loud Speaker

TWO IN ONE

In about 30 days we will have ready for delivery a new Regina Phonograph Reproducer and Radio Loud Speaker for all makes of phonographs. It is a combination of the two in one without change. Just "plug in" to listen to the radio.

Will retail for \$15.00.

Dealers wanted—write for full particulars.

The Regina Phonograph Co.

Manufacturers

Rahway

New Jersey

Regina Phonos—Regina Hexaphones and Music Boxes

THE SIGN OF
MUSICAL
PRESTIGE

Brunswick
PHONOGRAPHS AND RECORDS

Brunswick enterprise in seeking the best musically, no matter where it is to be had, is only another evidence of the typical aggressive Brunswick policies which have won for it the pre-eminence in the phonograph field.

Today, the Brunswick sign over a music dealer's store is a mark of prestige, a proof of high musical standing in his community.

Just as the great modern artists of the New Hall of Fame turned to Brunswick to perpetuate their art, because they recognized Brunswick's supreme achievements in making records, so has the public turned to Brunswick for the best in phonograph interpretations.

World musical authorities say Brunswick records are far in advance of the times.

New England Distributors:
Kraft, Bates & Spencer, Inc.
80 Kingston Street
Boston, Mass.

Canadian Distributors:
Musical Merchandise Sales Co.
79 Wellington Street, West
Toronto, Ont.

THE BRUNSWICK-BALKE-COLLENDER CO., CHICAGO

Brunswick
PHONOGRAPHS AND RECORDS

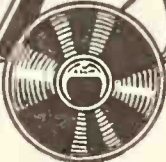

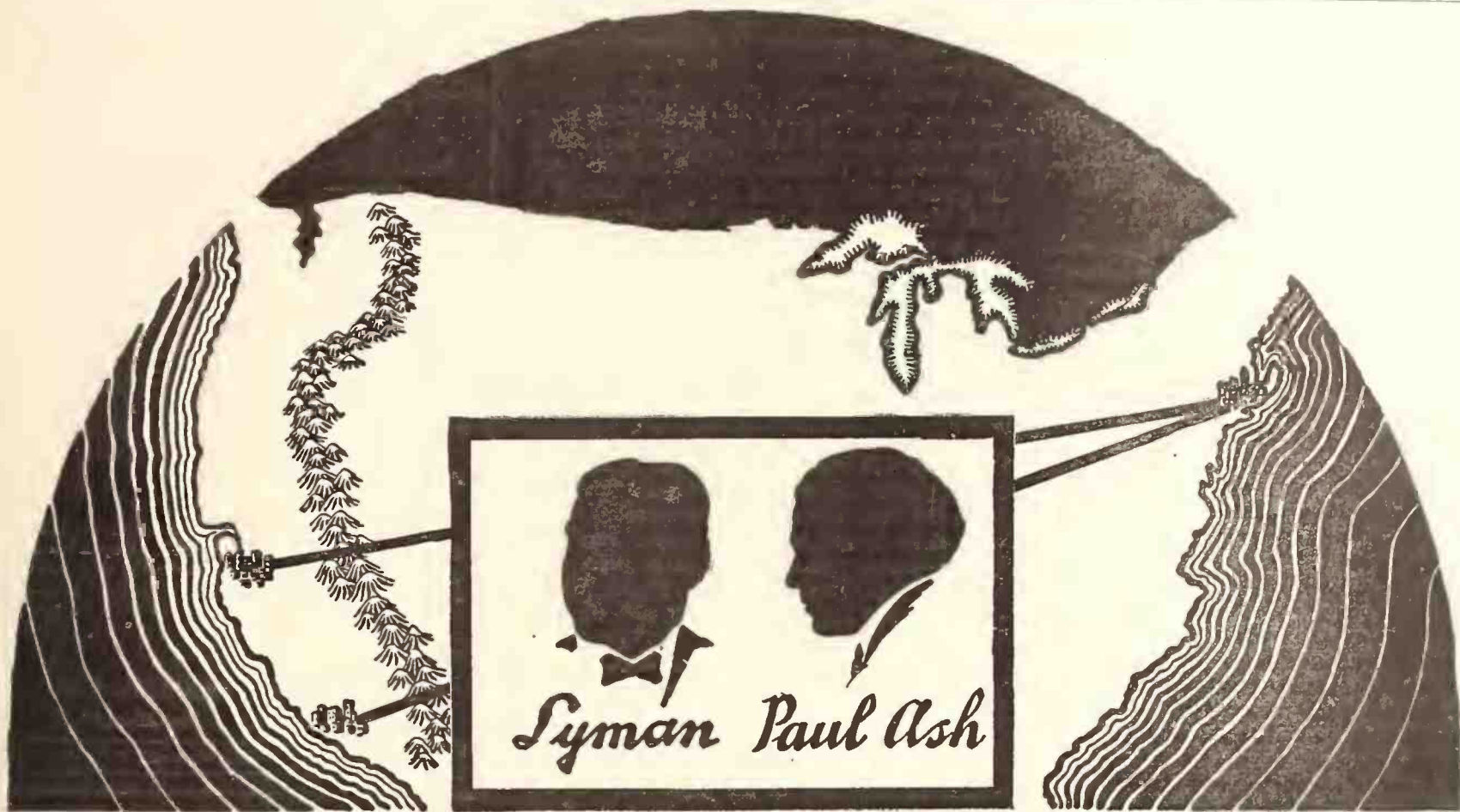

ACROSS THE CONTINENT

to make Brunswick Records on the Coast because Two Western Orchestras are commanding national attention

A notable musical event of national consequence



IT is the new thing in popular music that fosters public demand and builds the dealer's profits—a new song—a new star—a new way of “putting it over.” That is the big news in this announcement—for something distinctively new has come out of the West.

Tourists returning from the coast have been bringing the news of two unusual orchestras out in California. The swelling tide of their enthusiasm prompted immediate Brunswick action—and on a scale unprecedented in the phonograph field. We have carried a special recording laboratory and technical staff direct to the center of this new musical movement—and we have carried back to the East a group of truly phenomenal recordings.

Both orchestras are exclusively Brunswick. One of them is Lyman's Ambassador Hotel Orchestra. The other—the Paul Ash Orchestra—will be announced in detail later.

The first records of this famous series are on the market now—and within a month thousands of American homes will respond to Lyman's California Ambassador Hotel Orchestra, just as the Pacific Coast does now. This announcement is one of the biggest phonograph events of the season. All Brunswick dealers are preparing for a heavy demand to take advantage of this unusual opportunity. We have promised our dealers that these first Lyman Records are unsurpassed. They are new. They are sensational. They are beautiful. Lyman and his orchestra are inimitable—so are his records.



THE BRUNSWICK-BALKE-COLLENDER CO., CHICAGO

Brunswick
PHONOGRAPHS AND RECORDS



TOLEDO

Shortage of Popular Models Felt Here—Expect Big Holiday Business—Month's Trade Activities

TOLEDO, O., November 7.—During the past month talking machine demand has been exceptionally good. The one serious drawback, however, is a shortage of models, and there is little hope that the situation will be improved before the holidays.

Concert artists are playing a big part in stimulating record sales. Already several internationally known artists have appeared before Toledo audiences, and there are still many who will come within the next few months. Most merchants are co-operating in making local concerts a success by assisting in the box office sales and in advertising the event in stores, windows and newspapers.

At the Toledo Talking Machine Co., Victor distributor, the demand for machines exceeds the supply. There are a few available models, but the majority of consoles are out of stock, and after orders on file were filled November 1 the large warerooms were nearly empty. Today few orders can be filled complete. About the only consolation for dealers who have waited too long to buy is for them to purchase machines which are available, and these include several of the high-priced variety.

The Lion Store Music Rooms have coupled efforts with the sixty-sixth anniversary sale, which is being conducted throughout the large enterprise. The store has more than 1,500 live prospects listed. Outside salesmen soliciting for Victrolas, Cheney's and Brunswicks, report much holiday interest.

O. Packard, formerly with Grinnell Bros., has joined the salesforce here. Other additions will be made which are in line with expansion plans under way.

At the La Salle & Koch Co. November trade opened well, and volume for the year is ahead of former years, Forrest O. Edwards reports. Miss Emma Smith is a new member of the record force.

At the J. W. Greene Co. machine and record volume is climbing as the holidays approach, with the total for the past month nearly twice as great as last year.

An innovation started here consists of backing up the salespeople. That is, in order to keep the sales force upon the floor and behind the service counters and out in the booths or free-

from trivial matters, Miss Bonna Hadley has been engaged to assist in overcoming trifles and to take up the slack in the sales rope.

A window featuring the "Covered Wagon" song hit, "Oh Sussanna," has sold a large number of the records. A covered wagon, modeled after those in the film, has turned the trick. So great is the Red Seal record increase, it is said, that selections which formerly averaged five to ten a year now sell to the tune of fifteen a month. A feature which is assisting sales is the setting of a monthly sales quota for salespeople. Above the sum set a commission is paid on all sales, which is limited only by their efforts. Miss Helen Baumgardner is a new member of the department, likewise, Edine Heck.

At Grinnell Bros. records of noted artists on tour who will visit Toledo in the near future are exploited in the store organ "Melody." Then the three attractive Victor display rooms with floor lamps, wicker furniture, rugs and genuine home atmosphere, add to sales possibilities. Miss Deister and Miss Thelma Woodward recently became associated with the Victrola department.

The Goosman Piano Co. is meeting with success in its campaign for school contracts. The principal drawback to closing school machine sales is that generally it is necessary to work out a plan whereby sufficient funds may be raised to take care of the payments. In this the house has been successful, Fred N. Goosman states. Bush & Lane, Starr, Vocalion and Columbia models are dealt in here.

The United Music Store, foreign record specialist, is finding this a profitable field. The foreigner is a liberal buyer, once convinced the dealer understands his likes, speaks his language and will assist in making proper selections, Harry Wasserman reports. He also states that since the announcement of his new foreign record and talking machine shop opening appeared in *The World*, he has received letters from all sections of the country asking for information about the venture. Two outside men, John Pzriminski and Wm. Jones, have lately joined forces with the house.

At the Whitney-Blaine-Wildermuth Co. the gift certificate for Christmas is being urged as a worth-while present. The double facing of Red Seal records has marked the greatest single advance for increasing sales yet promulgated, according to Miss Maud Winchell, in charge of the talking machine department. C. E. Everingham, formerly associated with the Starr Piano Co. and the Cable Company, is now a member of this organization.

The Frazelle Piano Co. is fast completing its

Recordion
TRADE MARK

Phono-
graphs

Reg. U. S. Pat. Off.

5 Upright
3 Console
1924 Models
of Standard
Value Always
Offering the
greatest oppor-
tunity to dealers

Also Radio Cabinets



WANTED—Jobbers and dealers to handle this long-established line. Reputation, quality and service responsible for past success, locally. Sales plans now include entire country. Write to-day for full details and secure exclusive territory rights now being awarded.

COLUMBIA MANTEL CO.

175-177 Powers St. Brooklyn, N. Y.

Real Merit Wins—The "Recordion" has it

expansion program. A downstairs store and basement has been added to the upstairs store. Vocalion and Sonora booths will be installed in the new shop. A formal public opening of the enlarged store will be held in the near future, following the completion of extensive remodeling and improvements.

COMMENDS AUDAK EQUIPMENT

Kansas City Dealer Installs Record Demonstrating Device and Increases Facilities

Paul's Record Store, Inc., 1103 Walnut street, Kansas City, Mo., dealing in Victrolas and Victor records, recently completely remodeled its salesrooms. Included in the new equipment of the store is a series of "Audaks," the well-known record-demonstrating product. M. M. Paul, manager of the store, in a letter to the Audak Co., recently, said:

"We are now using nine of these equipments and expect to add additional ones in the future. Our customers seem to prefer the service afforded by 'Audaks.' When it is considered that our warerooms are small, twelve by twenty feet, the 'Audaks' add greatly to our capacity."

The K & D Electric Phonograph Motor

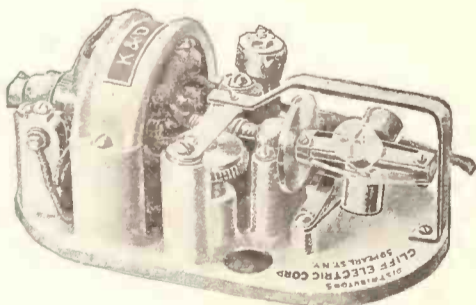

Prices,
Sample Motor or
Booklet on Request

FEATURES

- I. A real automatic stop, containing in one unit a switch and protective lock.
- II. Uniform speed—Is run direct from motor to formica spindle gear. It has no belt to slip. No electrical control to need adjustment. Runs on either alternating or direct current.
- III. Price—No electric phonograph motor has been sold at as low a price. Our production and experience enable us to compete with the spring motor. A real guarantee is back of the K. & D.

You should look into these three features.

DISTRIBUTORS

CLIFF ELECTRIC CORPORATION

59 Pearl Street, New York

GLEANINGS *from the* WORLD *of* MUSIC

Theatrical Prosperity and the Music Dealer

Opening of Theatrical Season Shows Encouraging Activity Especially With Musical Productions—
From Dealer's Standpoint Present Conditions Are Highly Encouraging

Of particular interest to the talking machine dealers and, of course, music publishers, is the fact that the theatrical business has returned to an activity that had not been reached for the past two seasons. Of added importance is the number of musical shows now touring the country and the exceptional lengthy periods for which they make their appearances. Cities that formerly supported a road show one or two days have, in many instances, lengthened the stay of the more successful productions to a week and the larger trade centers, where a week was considered sufficient time to play the city, now find it possible to play at least two weeks. In some instances productions have been booked for return engagements.

The fact that the theatrical business is most prosperous and that a number of road shows, particularly of the musical comedy type, are playing to packed houses while on tour means so many added sales for the retailer. This, together with the fact that the Fall business on strictly popular numbers has been in heavy volume, should mean much in the way of profits for the sheet music and record merchants before the close of the present season.

Production numbers are having unusually large sales and as a number of producers of successful shows are sending out a number of companies carrying the same title these offerings, undoubtedly, will have covered the entire country before next Summer. Thus the sales

of these particular offerings will assume national proportions.

One indication of the success of strictly musical offerings is that of the production of "Blossom Time," based on the life of Franz Schubert. Following its success in New York the producers sent out two road shows last season and again with the opening of Fall touring "Blossom Time" shows were placed on the road. The outstanding number of this show is "Song of Love," the sales of which have been most steady. In this particular instance not only do the sheet music and records sell during the time the show appears in various cities, but invariably there is an active demand for the number for many weeks after it closes.

It might also be pointed out that the musical productions that are having the most success on the road are those that are based upon some legitimate plot and the music of which is an appropriate part of the story. This cannot always be said of the strictly musical revues, although some of them have been contributors of exceptional sellers. The real musical show with a story, however, seems to be less of a gamble for the publisher, if not for the producer.

From the dealer's standpoint the success of musical road shows can be looked upon with favor, inasmuch as they invariably mean additional sales that could hardly otherwise be obtained. With the strictly popular counters

quite active, added sales from another source not only mean greater profits, but often bring people into the store who might otherwise stay away for many weeks.

After all, bringing people into the store is the most important part of retailing. During the past Summer this was most impressively demonstrated when the sales of "Yes! We Have No Bananas" jumped to 1,000,000 copies within a very short period of time. There were other good sellers upon the counters but, undoubtedly, "Bananas" induced some hundreds of thousands of people to enter the music store some weeks before they had intended. These purchasers, undoubtedly, once in the store, made a number of additional purchases than had been their original intention.

With the musical comedy road shows playing to packed houses resulting in a demand for the songs from the productions, and the popular business showing an upward trend, the Winter season gives promise of returning to a similar successful period that made the music stores so active during the season of 1919-20. Of course, much depends upon how dealers take advantage of their opportunities.

HEARST EXPLOITS "BEAUTIFUL ROSE"

Hearst Music Publishers, Ltd., is exploiting its waltz number, "Beautiful Rose," in conjunction with the motion picture exhibition of D. W. Griffith's "The White Rose." The various booking exchanges in charge of the release of this Griffith film are giving unusual co-operation to the publisher of the above "rose" song, and exhibitors and orchestras of motion picture houses are also lending aid by programming it.

Stasny's International Hits

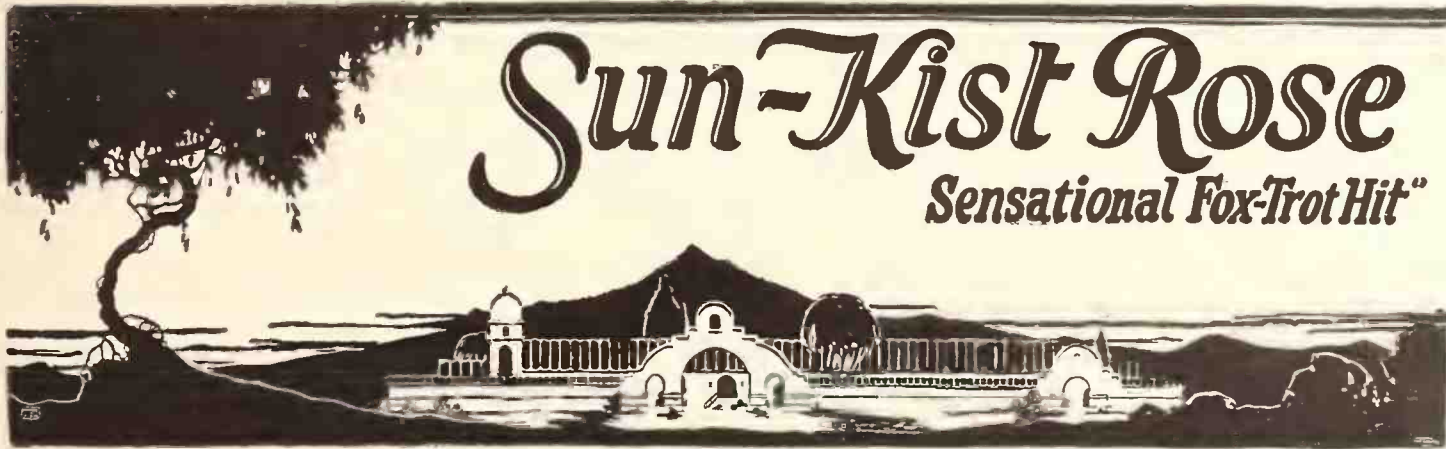

Featured by
Paul Specht
and his
Hotel
Alamac
Orchestra

The Biggest
Selling Waltz
of the
Season
Featured
by
Vincent Lopez
and his Hotel
Pennsylvania
Orchestra

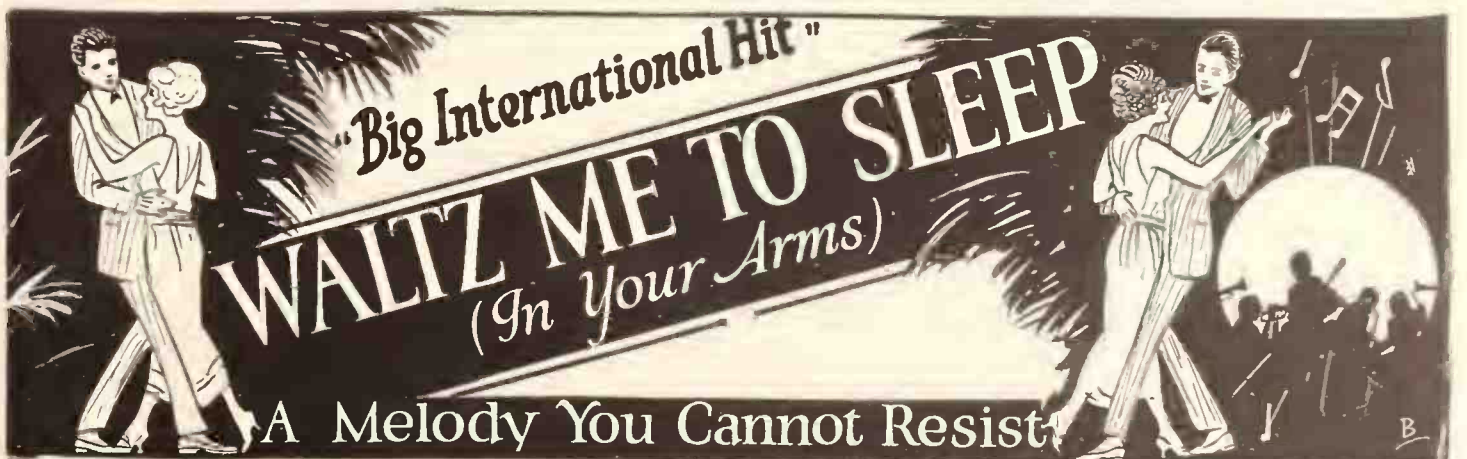

ORDER NOW

A. J. STASNY MUSIC CO., Inc.
56 WEST 45TH STREET, NEW YORK CITY

Released by Leading
Record and Roll Companies

HIT HARRY VON TILZER'S HIT
DEAR-OLD-LADY

A BEAUTIFUL FOX TROT

Sung By Hundreds of Vaudeville Acts.

Played By Thousands of Orchestras.

NEW STASNY CO. REPRESENTATIVES

Frank Gibney Handling Stasny Catalog on Pacific Coast With Billy Newsome Rendering the Same Service in Chicago

Frank Gibney, recently connected with J. H. Remick & Co., Seattle, has arranged to again represent the catalog of the A. J. Stasny Music Co. on the Pacific Coast, making his headquarters in San Francisco. He has a fine tenor voice and will exploit the Stasny feature numbers, "Sun-Kist Rose" and "Waltz Me to Sleep in Your Arms" in the theatres and over the radio. Harry Tobias, New York salesman for Stasny, who is now on the Coast, is sending in good orders for various numbers in the Stasny catalog.

Billy Newsome, formerly connected with Waterson, Berlin & Snyder, and Irving Berlin, Inc., is now representing the A. J. Stasny Co. catalog in Chicago and surrounding territory and is arranging some effective exploitation stunts for the various numbers.

McHUGH NEW SHEET MUSIC MAGNATE

James Francis McHugh Taken Into Jack Mills, Inc., and Voted Substantial Block of Stock—Well Known and Popular in Sheet Music Trade

James Francis McHugh—so listed in the City of Boston's record of births, but better known in the "Furious Forties" as Jimmy McHugh—has not as yet purchased a silk hat, but it is rumored that he has already taken to the smoking of big, black cigars. Three or four times daily, of late, Jimmy walks casually into the cashier's office at Jack Mills, Inc., and takes a long look at the safe.

And all because, at a recent meeting of the board of directors of the Mills concern, it was decided to vote Jim into the firm and present him with a generous block of stock. Jim—big, dapper and gray beyond his years—has just passed his thirtieth birthday, but his face has begun to show signs of the "grind." In his bright lexicon there is no phrase quite so important as "the ballad looks terrific."

Starting ten years ago in the publishing business, "Mister" McHugh successively represented several publishers in Boston, and came to New York in 1919. Shortly after the inception of the Jack Mills project, Jim came along to lend a hand, and, to quote "Dulcy," "The rest is history."

An engaging personality, coupled with that all-important faculty of making and keeping friends, has made Jimmy McHugh distinctly popular in the industry. None questions his position as one of the most capable professional men in the business and his reward has come as a fitting climax to years of effort.

"Send 'em all around to interview me," said Jim, immediately after being informed of the decision of the board of directors. "I'll take Arthur Brisbane, Frank Crane and the whole crowd on to a decision. Put it in big, black type and just say, 'Jack Mills and Jimmy McHugh Are Partners!'"

THE DEMAND IN LOS ANGELES

"No, No, Nora" and "That Old Gang of Mine" Among City's Leading Sellers

LOS ANGELES, CAL., November 5.—The Fall business in the sheet music departments is usually started at the time of the opening of the schools and as this took place early last month business has been exceptionally good, according to reports from the various managers.

The two leading popular songs seemed to be "No, No, Nora" and "That Old Gang of Mine," copies of these two songs have been selling in enormous quantities all along the line.

J. J. Apffel, manager of the sheet music department of the Southern California Music Co., states that business in its new store, 806-808 South Broadway, has been remarkable, necessitating additions to the sales force.

ADDED TO THE BERLIN CATALOG

"Sittin' in a Corner" and "Roamin' to Wyomin'" Latest Songs to Be Exploited by That House

Among the new songs added to the catalog of Irving Berlin, Inc., is "Sittin' in a Corner," lyric by Gus Kahn and music by George W. Meyer. The professional department of the house is already making this song a feature in vaudeville, and the band and orchestra department will also give the number wide exploitation. Two other recent releases from the Berlin catalog are "Roamin' to Wyomin'," words by Sidney Clare and music by Walter Donaldson, the latter having a long list of successes to his credit, and Joe Young and Sam M. Lewis, authors of "Mammy," "Ten-Ten-Tennessee" and other songs, with music by Lou Handman, have contributed "Lovey Came Back." These numbers, together with "Indiana Moon," one of the outstanding waltz successes of the season, will be the active numbers of the Berlin catalog during the coming weeks.

POPULAR BALLAD SUCCESSES

THE WORLD IS WAITING FOR THE SUNRISE
 BY LOCKHART & SEITZ

IF WINTER COMES
 BY ARKELL & TENNENT

SMILE THROUGH YOUR TEARS
 BY BERNARD HAMBLEN

ROSES OF PICARDY
 BY WEATHERLY & WOOD

SONG OF SONGS
 BY VAUCAIRE-LUCAS-MOYA

THE BELLS OF ST. MARY'S
 BY FURBER & ADAMS

SOME DAY YOU WILL MISS ME
 BY GREY & DAREWSKI

THERE'S A SONG IN MY HEART
 BY BERNARD HAMBLEN

CHAPPELL-HARMS, INC.
 185 MADISON AVE, NEW YORK.

Extra Profits for Record and Roll Dealers

"Just A Girl That Men Forget"

THE POWERFUL SERMON-BALLAD SENSATION

This epoch-making "lesson-song" has been released "two-ways" on practically every phonograph record and piano roll, and has been acclaimed by press and pulpit, as well as leading headliners and orchestra leaders "The Most Amazing Song of the Century."

You Are Selling the Records and Rolls—Why Not the Sheet Music? Write For Our Proposition.

JACK MILLS, Inc.

MUSIC PUBLISHERS
 JACK MILLS BUILDING

148-150 WEST 46th STREET
 NEW YORK, N. Y.

EILEEN

IRISH FOXTROT BALLAD

"You can't go wrong with any FEIST song"

Eí - leen, Eí - leen, Ma - cush - - - - la míne,

© 1923 Leo. Feist, Inc.

MADE IN THE USA

PRINCE DANCES TO "SUN-KIST ROSE"

Prince of Wales Among Those Who Have Danced to Music of Stasny Number as Played by Jack Hylton's Grafton Galleries Orchestra

One of the leading fox-trot hits in England for some time past has been "Sun-Kist Rose," the A. J. Stasny Co. publication, which, in addition to being featured by a number of orchestras in and about London, has been recorded for His Master's Voice records by Jack Hylton's noted Grafton Galleries Orchestra. The organization plays dance music for royalty, which patronizes the Galleries regularly to dine and dance. The Prince of Wales and other members of the royal family have danced to the music of "Sun-Kist Rose" while at Grafton's and it was there that Whiteman and His Orchestra appeared for a time while in London, playing alternately with the Hylton organization.

Another Stasny number that has won a place for itself in England as well as in the United States is "Waltz Me to Sleep in Your Arms," which is being featured by a large number of orchestras and was also recorded on records and music rolls.

SALES OF "YOU" ON INCREASE

Substantial Demand for New Irving Berlin, Inc., Number Reported Particularly From the East—Being Featured Prominently in Vaudeville

One of the recent publications of Irving Berlin, Inc., to win quick success is "You," a number with an excellent melody written by Al Wholman, who is presenting the song in the course of his vaudeville tour over the Keith Circuit. Mr. Wholman appeared at Keith's in Detroit and is on his way to New York, where he will appear at several of the Keith houses,

although stopping at Buffalo and Rochester en route home.

It is significant that wherever Mr. Wholman has featured the song his appearance in vaudeville has been followed by quantity orders for "You" from local dealers for immediate delivery, and the demand for the number generally is increasing steadily. A number of music stores, particularly in the East, have arranged effective window displays of "You," and many of the leading orchestras are featuring it.

HEARST NUMBERS IN VAUDEVILLE

Large Number of Acts Successfully Using Numbers From This Publisher's Catalog

The Hearst Music Publishers, Ltd., numbers, "Wonderful Child," "Beautiful Rose," "In the Land of Sweet Sixteen," "Some Day You'll Cry Over Somebody Else" and "Always Looking for a Little Sunshine," are finding favor with singers, the following artists using one or more of them: Norman Stanley; Bobbie Lowe, of "Youth & Melody"; Larry Francis, of Milford & Francis; Gene Leighton's Rainbow Six; Happy Benway & Sonny Dinkins; Farrell & Hatch; Dolly St. John; Jack Reidy, of Reidy & Curry; George Britt; Gazette & Thornydyke; Jack Lipton; Joe McAnallan, of Coburn's Minstrels; Olga La Marr; Mabel Lorraine; Frederick Sisters, with Mack's Four Steppers; Betty Baun & Jack Byrnes; Charlie Holdsworth; Fletcher, Ivy & O'Connor; Barnes and Robison; Mabel Besthops and Margie Catlin.

Si Conn, orchestral leader, of Proctor's One Hundred and Twenty-fifth Street Theatre, New York City, used "Some Day You'll Cry Over Somebody Else" as the musical theme for Rex Beach's famous film play, "The Spoilers," and reports that the song went with the theme of the play as though it had been written especially for the picture.

"MIDNIGHT ROSE WEEK" PLANNED

Beginning November 26 M. Witmark & Sons Begin Big Sales Drive on This Number

The week of November 26 will be set aside as "Midnight Rose Week" by the trade through the announcement and arrangements made by M. Witmark & Sons, the publishers. The plans call for one of the most intensive sales drives ever inaugurated on a popular song and dance success.

The entire sales, professional, band and orchestra departments, as well as the various branch offices and representatives of the Witmark organization, are to take part in the coming campaign. Theatres everywhere will program the number. Dance orchestras everywhere, motion picture houses and cabarets and other places where music holds swing will feature "Midnight Rose."

Plans for many window displays and the featuring of "Midnight Rose" on music counters have been arranged with retailers. The Witmark organization has issued some very effective advertising material for this purpose. It includes special title pages, streamers, hangers, cut-outs and other sales creators.

MARKS CO. GETS "FEELIN' BLUES"

To Publish New Number Featured in Vaudeville by Team of Farrell and Hatch

Among the vaudeville teams who are singing their own songs over the various circuits with great success are Farrell and Hatch, who have won great popularity with vaudeville fans with their act which is filled with melody from start to finish. The latest number featured by the team is "The Feelin' Blues," which has been accepted for publication by the Edward B. Marks Co., and will be published shortly.

You Didn't Care When You Broke My Heart
(So Why Should I Care Now)

"You can't go wrong with any FEIST song"

You did-nt care when you broke my heart, So why

© 1923 Leo. Feist, Inc.

MADE IN THE USA

Extensive Feist Publicity Drive Under Way

Rotogravure Advertising in New York Paper Ties Up With Records by Featuring McCormack, Record Artist, and Feist Hit—Campaign National in Scope—Window Display Contest

Leo Feist, Inc., the well-known popular music publishing firm, inserted a full-page advertisement in the rotogravure section of the New York Tribune on Sunday, November 11. Of particular importance to the talking machine trade is the fact that a good portion of the space used was given over to a large photograph

the latter a song and dance success of no mean proportions from the musical show, "Little Jessie James." An interesting feature of all of these announcements was the fact that mention was made that the numbers advertised could be procured for the piano, phonograph and player-piano. Undoubtedly such advertising,

as "No, No, Nora," "Swingin' Down the Lane," "Cut Yourself a Piece of Cake," "Love Tales," "Blue Hoosier Blues" and "Saw Mill River Road." Mention was also made of the "Good Old Timers," the publication carrying seventy-five popular selections of ancient and modern vintage.

In connection with this latter campaign \$500 in prizes is to be distributed by Leo Feist, Inc., for the best window displays of either the "Feist Dance Folio No. 6" or the "Good Old Timers" publication, or both, or display of material of these two folios, the latter being



Type of Feist Full-page Advertising Tying Up Artists and Records With Song and Dance Hits of John McCormack. There also appeared a reproduction of Victor record No. 961, a recent McCormack release of the Feist song and waltz success, "Wonderful One"; a series of other current Feist numbers were also mentioned.

This is the third of a series of full-page announcements which the Feist organization has used in the Sunday rotogravure section of the New York Tribune during this Fall. The previous announcements have carried publicity on "Saw Mill River Road" and "I Love You,"

supplemented by the other Feist activities, has created many additional sales of the sheet music and the mechanical renditions of the numbers featured.

Advertising plans somewhat more national in scope were also a part of the Feist November publicity. The outstanding feature of these latest plans was the insertion of a full-page announcement in this week's Saturday Evening Post (November 17) advertising the "Feist Dance Folio No. 6," and comprising such songs

furnished gratis by the Feist company. This contest will close December 15.

All in all, this is quite a large campaign, particularly where individual numbers are given the publicity. It is of added importance inasmuch as, undoubtedly, a fair proportion of the advertising redounds to the benefit of the talking machine trade.

The prominence which is given the talking machine record in a great deal of music publishers' advertising at the present time shows

KEEP YOUR CASH REGISTER

RINGING

FEATURE HEARST MUSIC

HEARST PUBLICATIONS

STANDARD POPULAR INSTRUMENTAL

Write for Catalogue

Featuring HEARST Music is like making love to a Widow—You can't overdo it!

ORDER NOW from your Jobber or any of the following Offices

HEARST MUSIC PUBLISHERS OF CANADA LTD.

1658 Broadway, NEW YORK Phoenix Bldg., WINNIPEG 199 Yonge St., TORONTO

and make your own conditions instead of being at the mercy of them.

—100% PROFIT—

THE BIGGEST CASH REGISTER CATALOGUE YOU CAN HANDLE

Rings the bell like a bill collector

BIG PROFITS — QUICK SALES — BIGGER BUSINESS

There is no loss on any HEARST Song. All unsold copies fully returnable

Prices F. O. B. Nearest Office:

100 of one Song14½c

100 Assorted...14½c

Less than 100...15c

FIVE RECORD RECORD-BREAKERS

LOVEY CAME BACK

A Real Hit By JOE YOUNG, SAM LEWIS and LOU HANDMAN

YOU

The New Melody Song Hit

ROAMIN' to WYOMIN'

Successor to "Carolina In the Morning" by the same writers

KOKOMO

A Novelty Comedy Song different from the rest

WHY SHOULD I GIVE MY LOVE TO YOU

Another "You Know You Belong to Somebody Else" By the same writers

Above Songs Featured by Orchestra and Vaudeville Acts from Coast to Coast

IRVING BERLIN, Inc., 1607 Broadway, New York

without question the ever-growing importance of this side of the distribution of popular song numbers. To-day all music publishers' publicity is but additional to the publicity of the

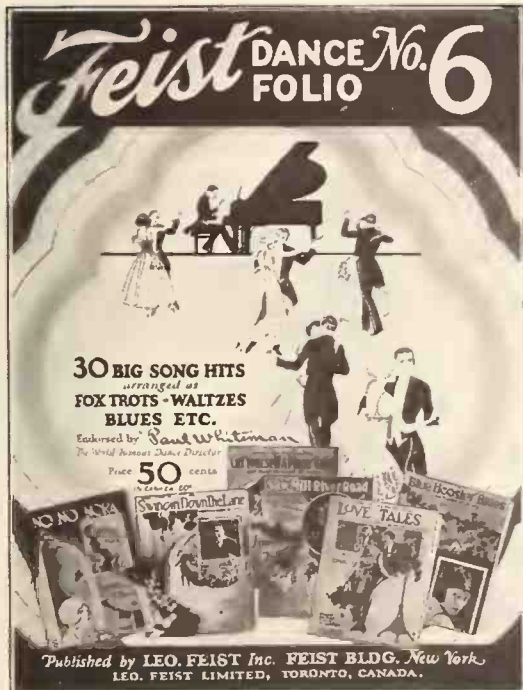

Folio Featured in Feist Campaign talking machine trade itself, for unquestionably a great number of people are influenced to buy these songs in mechanical recorded form as well as in the form of sheet music.

"Just One More Kiss," a Viennese number recently added to the catalog of the Sam Fox Publishing Co., has been released in both instrumental and vocal form. A wide campaign of publicity has been arranged to popularize this European success, and both the sales and professional departments of the company expect it to be one of the season's outstanding features.

Hear Margaret Young, Sophie Tucker and Mamie Smith Sing

"HE MAY BE YOUR GOOD MAN FRIDAY"
(But He's Mine on Saturday Night)

OTHER CURRENT SUCCESSES
"MY DAWG"

"If You Think You're Going to Stay Out All Night on Me; That's Your Hips"

KAY STERN, Inc. 1540 Broadway New York

NEW BERLIN DANCE FOLIO

Publisher to Bring Out Special Edition of Universal Dance Folio With Many Late Hits

Irving Berlin, Inc., announces the early release of a special edition of the Universal Dance Folio for Piano. It contains many of the latest additions to the Berlin catalog and is considered one of the best compilations ever arranged by that house. The numbers include fox-trots, waltzes, one-steps and numbers with jazz effects. Included in this folio are "That Old Gang of Mine," "Indiana Moon," "When You Walked Out Someone Else Walked Right In," "Down Among the Sleepy Hills of Tennessee" and "Love" (My Heart Is Calling You.) In all there are twenty-six numbers published in the usual Berlin sized folio with a particularly attractive title page.

LOUIS BREAU ENDS MID-WEST TRIP

Louis Breau, of the publishing firm of Breau & Tobias, returned to New York late last week following a nine weeks' trade tour through the Middle West. Six weeks of this period he spent in Chicago, where he closed arrangements for a series of theatrical tie-ups on several songs from his catalog, including "At the End of the Swanee," "Voice With a Smile" and "Hot Roasted Peanuts."

DRIVE ON KAY STERN SONGS

Kay Stern, Inc., 1540 Broadway, New York, has inaugurated a campaign on the novelty song "He May Be Your Good Man Friday" (But He's Mine on Saturday Night). A campaign among orchestras has also been arranged on a song entitled "My Dawg."

That "Smilin' Through" continues to smile merrily on its way is evidenced by the fact that when Reinald Werrenrath sang it for encore at his concert in Peoria, Ill., the Transcript of the next morning spoke highly of it.



BUYS BALLAD SUCCESS, "SWEET PAL"

Shapiro, Bernstein & Co., Inc., have purchased from Reinhardt's Music Shop, Memphis, Tenn., the ballad success, "Sweet Pal." The number has shown much activity in recent weeks and the Shapiro, Bernstein & Co. professional department contemplates wide activity on the number in co-operation with a national sales campaign.

Jerry Hoffman, formerly on the Dramatic Mirror, has joined the organization of the E. B. Marks Music Co. as exploitation manager.

The recognized
WALTZ HIT
of the
OLD and NEW WORLD!

SONG VERSION BY
BALLARD MACDONALD

JUST FOR TO-NIGHT
(NUR EINE NACHT)

PUBLISHERS OF THE WORLDS ORCH.
MILLION DOLLAR FOX-TROT 25¢
SONG HIT BAND
"PARADE OF WOODEN SOLDIERS" \$1.00

SPECIAL ORCH. JUST FOR TO-NIGHT 25¢, BAND 50¢
MUSIC RECORDS, ROLLS ON SALE EVERYWHERE

Edmar B. Marks Music Co.
225 WEST 46th ST. NEW YORK

2 ENORMOUS FOX TROT HITS PLAYED-SUNG-DANCED EVERYWHERE

BEBE

PREPARE FOR JUBILEE WEEK

Midnight Rose

NOVEMBER 26th to DECEMBER 3rd

M. WITMARK & SONS - NEW YORK



AN EFFECTIVE RECORD TIE-UP

Remick Song & Gift Shop, Portland, Ore., Features Gennett Record of "Somebody's Wrong"

PORTLAND, ORE., November 6.—"Somebody's Wrong" was recently featured in a clever window display by the Remick Song & Gift Shop, which, in the display, "tied up" the number with

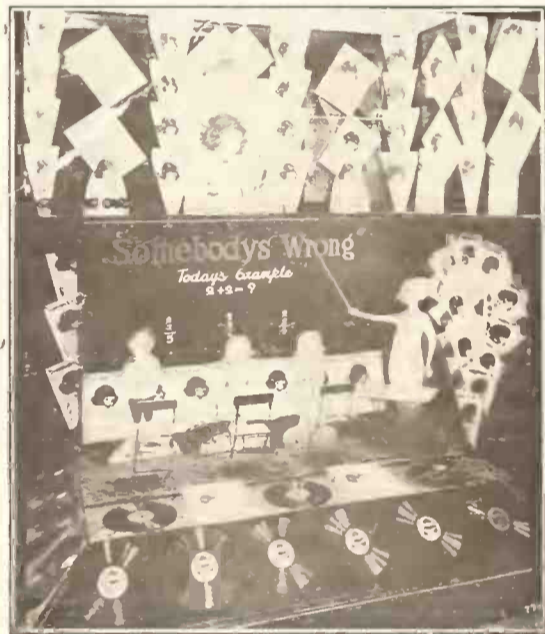

Clever Window Display by Remick Shop the Gennett record by the same name. Both sheet music and record sales were materially stimulated through the display. I. F. Sklare, manager of the local shop, who is responsible for working out the clever idea, also received the cooperation of all prominent local orchestras and theatre organists while the window was "dressed up," which also helped "put over" "Somebody's

Wrong" in the right way. The display featured by the Remick Shop was particularly pleasing to the wholesale department of the Starr Piano Co., of this city, which is the Pacific Northwest distributor of the Gennett records. Charles Soule, wholesale manager, reports excellent sales of "Somebody's Wrong" and, with the co-operation such as Remick has given, he expects even larger returns from this excellent number throughout the present season.

NEW BLUES PUBLISHERS

Rainbow Music Corp. to Specialize in Production of Blues Numbers

The Rainbow Music Corp., 1547 Broadway, New York City, announces the opening of a new publishing company specializing in "blues" songs. Its staff is composed of well-known writers, including the very popular songwriting team, Bob Ricketts and Porter Grainger.

Bob Ricketts is a graduate of Oberlin University with a degree of master musician. He has arranged and composed some most successful "blues" songs. Porter Grainger began his career in Chicago about eight years ago after much training under the late Burrell Van Buren and is the writer of a number of successes. The above team is responsible for such songs as "Triffin' Blues," "Laughin'," "Cryin' Blues" and "If You Want to Keep Your Daddy Home."

The Rainbow Music Corp. has started a campaign on a new catalog comprised of such songs as "Wish I Had You" (And I'm Gonna Get You Blues), "Just Thinkin'," "Love Ain't Blind No More," "Mistreatin' Daddy," "Tired O' Waitin' Blues" and "Do Doodle Oom."

DITSON DEPARTMENT SETTLED

Wholesale Victor Department of Chas. H. Ditson & Co. Now on Third Floor of Building

The wholesale Victor department of Charles H. Ditson & Co., under the management of Paul Carlson, is now comfortably settled on the third floor of the commodious Ditson Building, at 10 East Thirty-fourth street, having been moved down to that floor from the eighth. The department, although occupying the same floor space as formerly, has been rearranged in a manner to give more space to the stockrooms and also provide more commodious showrooms and offices. The move, coming just at the time when business was most active, kept Manager Carlson, his assistant, J. C. May, and the other members of the force working nights and Sundays, but the result is well worth while and there was not the slightest delay in shipments to dealers during the process. This, needless to say, was an achievement of which all concerned should be proud.

F. A. Anderson is a recent addition to the sales staff of the wholesale Victor department of Chas. H. Ditson & Co., covering the metropolitan district.

THE POPULAR SONG IN CARTOON

Cartoon on Oklahoma Situation Revives Memories of the Songs of the Great War

The manner in which the title of a popular song sticks in the mind of the public during the years is well illustrated in the accompany-

Our New State Song

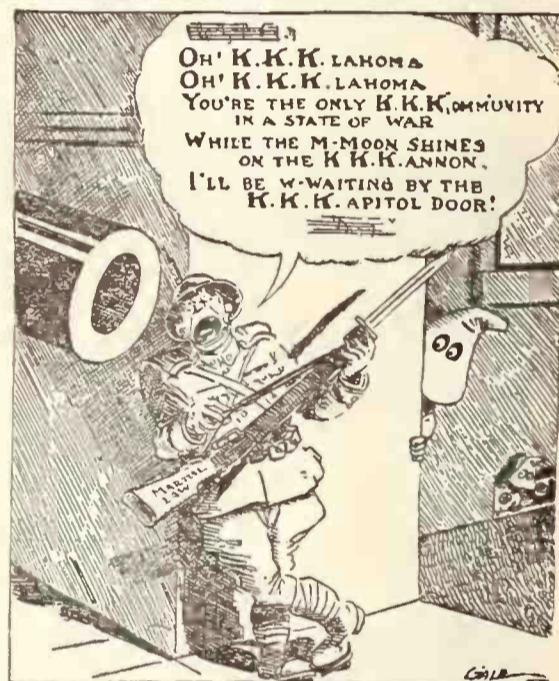

Gale, in the Los Angeles Times.

ing cartoon from the Los Angeles Times, which uses the wartime comic song "K-K-K-Katy," published by Leo Feist, Inc., as a means of suitable reference to the situation that has developed in Oklahoma, where the "two-gun man" of the old West has come again into the lime-light for a spell.

ACT TO SETTLE OLD PATHE AFFAIRS

The first move in the final settlement of the affairs of the old Pathé Frères Phonograph Co. was made in November when a meeting of the creditors was held in the United States District Court of the Eastern District of New York, in Brooklyn. The creditors approved the proposed claim allowances as well as the accounts of the receiver and steps were taken providing for his early discharge.

MARKS CO. PUBLISHES "LIZZIE"

The Edward B. Marks Music Co. has arranged to publish "Lizzie," a new song recently added to its catalog, at once. The number is by Johnny Tucker, who is known as the "Jolly Singing Fireman," a member of the department's quartet, and Leslie Moore.

Carlson Bros., prominent dealers of Moline, Ill., recently held the formal opening of a fine new store at 1405 Fifth avenue. The first floor is devoted to a Victrola department.

VICTOR DISTRIBUTORS

PERRY B. WHITSIT CO.

Record Business

THE Whitsit organization is paying close attention to the dealers' activities in connection with the development of Victor record business. Our facilities and experience are at your disposal—why not take advantage of it?

COLUMBUS - OHIO

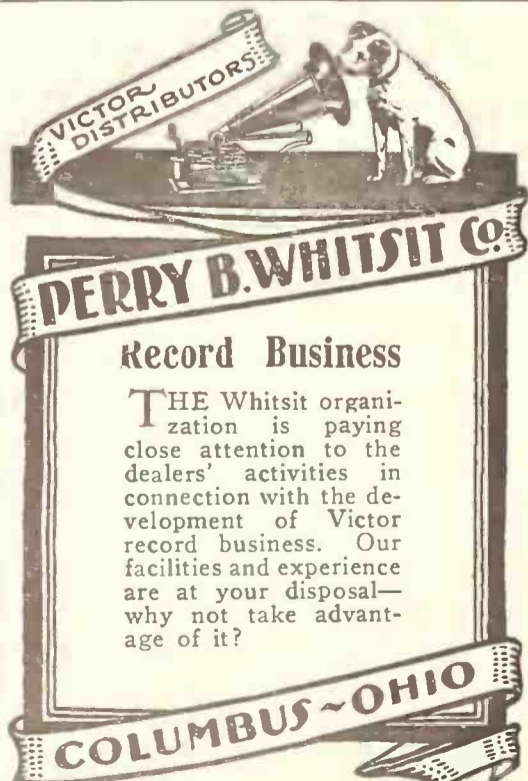

LOS ANGELES

*Radio Trade Association Becomes Division of Music Trades Body
—Death of Joe Carter—Prominent Visitors—The Month's News*

LOS ANGELES, CAL., November 7.—Whether the radio department in the music store will become a twin sister of the talking machine department, or whether it will become as distant and separate as the piano and other divisions, remains to be seen, but at present there is a distinct tendency to link the radio and phonograph departments together and arrange for salesmen to sell both, using the same methods more or less as those which they have become accustomed to with the latter. At any rate the action taken by the Radio Trades Association of Southern California in deciding by unanimous vote to become a part and division of the Music Trades Association of Southern California marks a precedent which will, doubtless, be followed in many other parts of the country. It is perhaps all the more interesting in this particular case in Southern California, when it is taken into consideration that the present Music Trades Association of Southern California was formed some years ago from an original association—the Talking Machine Association of Los Angeles.

The basis upon which this amalgamation took place was the claim of its backers that radio is 90 per cent music and that there was every indication that music stores were demonstrating their ability to sell radio sets with greater facility and more proper procedure than the electric store, although it is believed that the latter will in time separate its radio department entirely from the ordinary electric supplies and conduct it on lines similar to those used by music store departments. The specialty radio store also will, like the specialty phonograph store, adopt plans for instalment sales, sound-proof booth demonstrations, trade-ins, and establish the rules and regulations of the music store. The new division of the Association will have its chairman and committee in the same way as the musical merchandise, sheet music and other divisions of the Association already have their chairmen and committees. They will also have two members on the advisory board of the Association.

New Brunswick Model Popular

The new Brunswick Raleigh model is proving to be a very popular instrument and Brunswick dealers who placed orders for large consignments a few weeks ago are now receiving big shipments, which should see them well supplied for the holiday trade. Howard L. Brown, branch manager of the Brunswick wholesale department, is very enthusiastic over this model.

Griffith Ellis Locates in Los Angeles

Griffith Ellis, former secretary and director of the Chicago Talking Machine Co., recently

arrived in Los Angeles with his family and has decided to take up his permanent residence here. He has now taken a position with Sherman, Clay & Co., Victor distributors, and is attached to the branch in Los Angeles.

Death of Joe Carter

Joseph Carter, well-known talking machine salesman, died after a short illness last month. "Joe" Carter, as he was known to his many friends, was a member of the phonograph sales force of the Southern California Music Co. for a number of years and was well known in talking machine circles here and a favorite with all. He was originally in the business many years ago in Pittsburgh.

Winnipeg Phonograph Man Here

Andrew G. Farquharson, formerly manager of the phonograph department of the J. J. H. McLean Co., Winnipeg, Man., has arrived in Southern California, accompanied by his family. He was manager of the Brunswick, Sonora and Victor departments of a large Winnipeg music house for a number of years and has now decided to locate permanently in this city.

Seattle Manager in Los Angeles

Elmer Hunt, manager of the wholesale Victor department of Sherman, Clay & Co., Seattle, spent a few days in Los Angeles last month. He had just come from a trip to the Victor Co.'s headquarters in Camden, N. J., where he reports work is progressing rapidly, with a double shift working continuously.

Long Beach Store Places Big Order

The Long Beach branch of the Fitzgerald Music Co. recently placed orders for three carloads of the new Raleigh Brunswick phonograph, Manager Hutchinson being confident that this model would create a very large demand. The three carloads arrived on the same day and attracted a good deal of attention en route between the freight yards and warerooms.

Orpheum Stars at Platts

Billy Golden, who has been known for so many years to hundreds of vaudeville fans and whose talking machine records are familiar to thousands, paid daily visits to the Victor record department of the Platt Music Co. while he was filling an engagement at the Orpheum last month. Max Dolin, leader of Max Dolin's Orchestra, was also at the Orpheum last month and his records were featured by the Platt Music Co., resulting in sales of the Victor records which this famous foreign orchestra has made. Miss Johnson, manager of the record department of the Platt Music Co., states that on account of the Orpheum being next to the Platt Music Co. they receive a great number of visits from stars and artists, which are of the

greatest benefit to the members of the record department and often interesting to customers.

New Song Makes Hit

"Perhaps" is a song composed by Harold Shaw, leader of Soloman's Dance Orchestra. It has already been recorded on a Vocalion record and every indication points to its becoming very popular. Mr. Soloman, proprietor of the famous Los Angeles dance hall which bears his name, is featuring it in one of his usual novel ways. A silver loving cup with "Perhaps" and the Vocalion record number inscribed will be presented by some famous motion picture actress to the best dancing couple and 10,000 badges with similar inscriptions.

Brilliantone President Here

Byron R. Foster, president of the Brilliantone Steel Needle Co., was a recent visitor to this city, having motored down here with Walter S. Gray, president of the Walter S. Gray Co.

De Luxe Billboard Attracts

A very handsome de luxe billboard erected by Foster & Kleiser occupies a huge front on the ocean front, Long Beach, at American avenue. It advertises Barker Bros. and the Cheney phonograph and is the only billboard on the ocean front, past which hundreds of thousands of people go annually.

A. C. Harper, president of the Cheney Talking Machine Co., has been spending some time in Southern California, making his headquarters at the Munson-Rayner Corp.

COLUMBIA RECORD RETURN PRIVILEGE

Columbia Co. Announces Interesting Record Return Plan—Received With Enthusiasm

Geo. W. Hopkins, general sales manager of the Columbia Phonograph Co., advised the Columbia trade recently that effective from October 1 a maximum return privilege of 10 per cent of record purchases will be allowed Columbia dealers for the three months ending December 31, 1923. This announcement has been received with keen satisfaction by Columbia dealers throughout the country, as it solves a problem that has been discussed by dealers generally for the past few years.

The Columbia record return plan provides that the return of records from the dealer should be made to the branches responsible for the territory in which the dealer is located and only perfect records will be accepted. The value of the credit will be made on the cash value at the time of return reckoned at list price less dealer discount, but not to exceed 10 per cent of the records purchased in the preceding three months. The credit will be a money credit and will be available for the use of the dealer on his account the following month. The first return from the dealers will be made on receipt of advice from the Columbia Phonograph Co. after January 1, 1924, as to purchases of the previous three months. The 10 per cent return privilege on records will be available at the end of each three months' period.



IROQUOIS SALES CORPORATION

210 FRANKLIN STREET

BUFFALO, N. Y.

Distributors for New York State and Northwestern Pennsylvania for Okeh Records and ODEON Records.

A capable, efficient sales organization that is ready and willing to co-operate with Okeh and Odeon dealers in building up a permanent, profitable demand for these popular record lines.



A TUNE YOU CAN'T FORGET

Linger Awhile

by the writer of LOVE TALES



© 1923 Leo Feist, Inc.

The stars shine above you, — Yet linger awhile

You can't go wrong with any FEIST song

WASHINGTON

*Special Advertising and Christmas Clubs Start Holiday Drives
—Trade Displays at Better Homes Exhibit—News of the Month*

WASHINGTON, D. C., November 7.—Talking machine dealers of this city were very active during the past month in putting on special advertising, inaugurating Christmas buying clubs, etc., in an effort to get the holiday sales started.

A Better Homes Exhibit was held here recently under the auspices of the Washington Herald and Times for the purpose of demonstrating all kinds of home equipment. Music and musical instruments were prominently featured both in the model rooms of the exhibit and in daily lectures. Four model living rooms were each furnished with console type talking machines. Among the exhibitors were the Hecht Co.'s Music Store, Victor, Columbia and Granby dealer; O. J. DeMoll & Co., Victor and Vocalion lines; Homer L. Kitt Co. and Arthur Jordan Piano Co., Victor dealers.

Another big affair of the month was the "Jubilee Sales Week Celebration," put over by the Northeast Business Men's Association, to stimulate sales in this center and to encourage Northeast residents to make their purchases from community merchants. The celebration was given a good send-off by a big automobile parade. The car of the F. O. Sexton Co., 647 H street, Northeast, a Victor dealer, was especially attractively decorated, being painted white and having orange-and-black streamers draped over the hood and sides. On top of the car were a large horn and a big Victor dog in front of it listening to "His Master's Voice." The "voice" in this instance was supplied by a talking machine connected from the inside of the car to the horn on the roof, and popular numbers were played continuously during the parade. On the bumper at the front of the machine was built a little platform with two more Victor dogs on it, paper "reins" leading from these dogs to the dashboard. A pennant

on the radiator cap and big signs on the sides of the car advertised the dealer and the Victor products.

Louis & Co., dealers in Victor and Brunswick machines, at Seventh and G streets, Northwest, have finished the remodeling of the upper stories of the building in which they are located. The arrangement of the ground floor has not been changed materially, the record department, listening booths, roll department and an enlarged sheet music department being located here as before. The second floor, which has been handsomely decorated, is devoted to the small instrument department, listening booths and exhibits of Victor and Brunswick console models. The third floor is given over to exhibits of models of period and console

L. J. GERSON ACTIVE IN RADIO FIELD

Well-known Talking Machine Man to Carry Federal Tel. & Tel. Sets—Will Install Them in Standard Makes of Phonographs

Louis Jay Gerson, distributor of radio and phonograph products, including the Music Master loud speaker, records and accessories, has arranged to carry the products of the Federal Tel. & Tel. Co., one of the leading manufacturers of radio receiving sets. Mr. Gerson is planning to market this company's radio sets in conjunction with all types of talking machines, and the installation work is being done under his personal direction. Incidentally this field is not a new one for Mr. Gerson, as he is a graduate electrical engineer and a former manufacturer of telephones.

One of the principal sets of the Federal Tel. & Tel. line to be marketed by Mr. Gerson will be a six-tube set, self-contained and using only

talking machines. On this floor, too, are located two extremely large, comfortably furnished booths, which take up practically half of the entire floor space. The object in making them so large was to give a prospective customer some idea of how a talking machine would look in the average-sized room. Gus Louis is proprietor of this store.

Edward Wallerstein, traveling man for the Brunswick Co., recently visited the Chas. Schwartz & Son store to discuss Winter sales campaigns with Miss Florence Terwilliger, manager of the phonograph department.

A big get-together dinner at the Raleigh Hotel on November 15, to be followed by a dance, will be held by the three Victor jobbers of this city for all the Victor retail dealers. The jobbers, Cohen & Hughes, Rogers & Fisher and E. F. Droop & Sons Co., have made arrangements to give the dealers a "bang-up" good time and the affair is expected to be one of the biggest of its kind ever held here. F. K. Dolbeer, from the Victor factory, will be one of the speakers and will discuss factory outlook, output, distribution methods, etc.

a loop instead of an antenna. This set will be placed in a console phonograph and will include the Federal Tel. & Tel. apparatus, the Music Master horn unit and the Geraco loop. This outfit is very simple, working on a single knob control, with only one switch to turn on or shut off the apparatus. Mr. Gerson has already received orders for installing these six-tube sets in practically all of the standard makes of talking machines.

VISITS VOCALION DISTRIBUTORS

O. W. Ray Finds Satisfying Conditions in Chicago, Detroit and Cleveland—Outlines Plans of Company to Windy City Dealers

O. W. Ray, general manager of the Vocalion Red Record department of The Aeolian Co., returned recently from a trip through the Middle West in the course of which he visited the Vocalion Red Record distributors in Chicago, Detroit and Cleveland. In Chicago a convention of the sales organization of the Vocalion Co. of Chicago was called while Mr. Ray was in town and he took occasion to outline before the meeting the details of the future sales and publicity campaign to be devoted to the exploitation of Vocalion records.

In each of the several cities visited Mr. Ray found a steady increase in the demand for records, with a large number of new dealers being added to the lists constantly. The double facing of the standard and classical records in the Vocalion catalog and the liberal exchange put into effect to free the dealers' shelves of surplus stocks of single-faced records had an excellent effect upon trade generally, and it is believed will prove a distinct stimulant to the business.



Size 13x13x7½"
Wonderful—Loud—Clear—Tone
Mahogany finish or Leatheroid covering. Weight, 13 lbs.

NEW IMPROVED Fulton "AUTOMATIC" Portable Model No. 25

Sample to Dealers \$12.50 Discount in Quantities
CASH WITH ORDER

This remarkable new portable is equipped with a durable motor, and a new feature patented throw-in-arm. No parts to disconnect when closing up. Simply close the lid, and the tone arm falls in automatically with it; open the lid and the tone arm comes up in position ready to play.

We still have a limited quantity of our Model 35 at the same price, \$12.50.
Phonograph and Accessories, Repair Parts for All Makes.
Puritone and Truetone Needles at 25c per M in lots of 10 M and up.

**Fulton Talking Mach. Co. 253 Third Ave.
New York City**

Long Console Cabinet No. 90

*Designed to accommodate the VICTROLA IX
The most attractive console cabinet on the market*

List Price \$40



Long Console Cabinet No. 90
Four Doors and One Horizontal Drawer



**Long Console Cabinet
No. 90, Open**

The LONG CONSOLE CABINET No. 90, designed to accommodate the VICTROLA IX, is, without question, the finest cabinet ever introduced to the trade. It is finished in mahogany and its attractive lines compare favorably with the most artistic period console talking machines marketed by the leading manufacturers.

Deliveries are now being made.

Order *now* to avoid delays.

Can also be fitted to accommodate Victrola VIII.

We would suggest that you place orders now for Long Console Cabinets Nos. 601, 603, 608 and 610, designed to accommodate Victrolas VI and IV, and for Upright Cabinet No. 606 for the Victrola IV.



The Geo. A. Long Cabinet Company

HANOVER, PA.

KANSAS CITY

Industrial and Agricultural Prosperity Insures Good Business for Retailers—Holiday Activities Under Way—News of the Trade

KANSAS CITY, Mo., November 5.—While dealers and wholesalers of this city are reporting that business is decidedly "spotted," the general condition is admitted to be considerably improved. The monthly statement of the Federal Reserve Bank of this, the Tenth District, dated November 1, states that not only are the banks of the district liquidating their obligations, but that there is a heavy movement of farm products, live stock, petroleum, mineral products and manufactured articles, with a heavy money return. In addition to this, the prices of most of these are higher than a year ago. Labor is generally employed at high wages. The heavy rains, however, have cut down the volume of trade in some sections and interfered with outdoor activities of all kinds.

The general feeling is that the trade connected with the holidays will be good. Dealers are preparing for a large business, not only by stocking up with new and attractive goods, but also by planning large advertising and selling campaigns.

Sales of Edisons Are Large

Manager Blackman, of the Edison Shop, connected with the Blackman Music Co.'s store, says that his sales of Edisons have been better during October than in any previous year. He says that a peculiar thing about the sales has been that they have been largely among the employes of business houses and wholesale concerns. This, he thinks, indicates that the high wages of the former are out of proportion to the profits of the merchants and manufacturers here.

Concentrating on Christmas Activities

The Jones Store Co. is conducting its annual Christmas Club for the sale of talking machines, the advertising on the same appearing the middle of October. Persons may join the club by depositing a dollar and paying in a dollar a week. This plan has been used with success by the Jones Store Co. for several years.

A plan somewhat similar is in use this year by the Leader Department Store of St. Joseph, and other dealers in the territory. The Leader is using the Brunswick Bank plan. A small metal bank, made to resemble an upright ma-

chine, is issued to the prospective customer for \$1.00. Funds are collected in this bank until the time for the Christmas purchase is to be made, and then the bank is returned with the savings, and the original dollar, as well as the rest, is applied on the purchase of the machine.

The Schneider Athletic Goods Co. is another live St. Joseph concern which will push the sale of phonographs hard this season. This firm has just arranged to spend a thousand dollars in nine motion picture theatres of the city in advertising the Brunswick.

Edison Distributor in Optimistic Mood

The Phonograph Co., Edison distributor of this city, is optimistic, as are other distributors, regarding business possibilities during the remainder of the year and the early months of the new year. Preparations of dealers for heavy holiday buying are indicated by the fact that they are ordering heavily. Record business also is

J.W. JENKINS'
SONS MUSIC CO.
KANSAS CITY, MISSOURI

Victor Wholesalers
for
The Heart of America

To Victor Dealers of the Southwest we offer a complete jobbing service, including large stocks, dealers' finance plan and advertising.



"HIS MASTER'S VOICE"
REG. U.S. PAT. OFF.
TRADE MARK REGISTERED

The Leader has just ordered a full carload of Brunswick machines for the holiday trade, and it will be shipped direct from the factory. Among the publicity stunts planned for the Christmas campaign is the placing of an immense electric sign on the building, advertising the Brunswick.

good, and it can truly be said that the trade conditions, at least as far as the Edison is concerned, are very satisfactory.

The Kimball Co. has added much to the attractiveness of its show window by the artistic use of Autumn leaves.

Columbia Activities

The Columbia Co. reports that dealers are expressing great satisfaction with the new models and that the sales reported by the dealers are very encouraging. Dealers are making favorable comments as to "the design of the cabinet, the special filing devices that are exclusively Columbia, also the high-class finish on the new instruments." The new reproducer is also highly commended because of its natural tone.

O. D. Standke, of the Grafonola Shop, reports increased record sales, especially the new Ted Lewis numbers, which have shown an unusually heavy sale for the past few weeks.

Keene R. Dudley has just installed a complete line of Columbia machines and records in his store at Thirty-fifth and Woodland. This is in one of the residential districts of the city and will bring the Columbia products to the homes of that territory.

J. C. Finke, of the Joplin Furniture Co., Joplin, Mo., was a recent visitor to the Columbia Kansas City branch. He reports that business has held up remarkably well during the past few months and he anticipates a large business during the rest of the year, especially as the new style machines are being furnished the dealers.

Miss Florence Hazlett, special representative of the Kansas City branch of the Columbia Co., who was in charge of the exhibit of Waldo & Branham at the county fair at Ellis, Kan., advises that the exhibit was a decided success and believes that such exhibits are among the

How EDISON Meets the Popular Price Demand

Four Winners Ranging in Price from \$100 to \$175 list

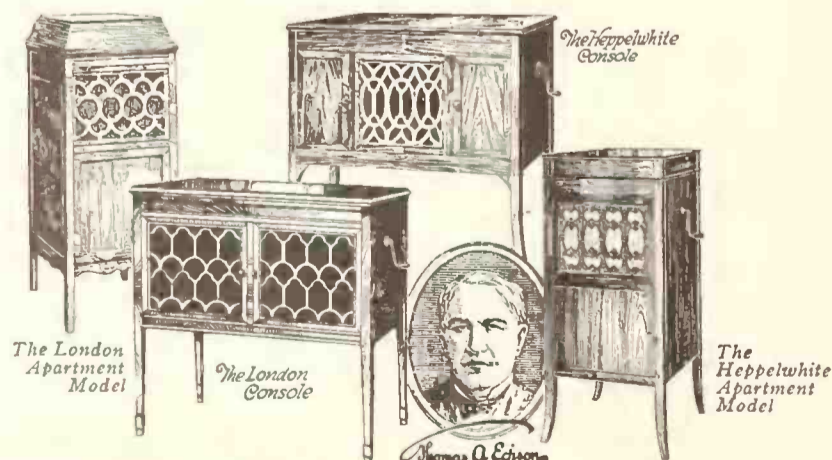

A few good dealer territories open in Missouri, Kansas and Oklahoma

Write

The Phonograph Co.
1215 McGee St.
KANSAS CITY, MO.



The NEW Columbia is superior

*Hearing
is believing*

The Motor is Silent. Listen to the New Columbia Motor—all you will hear is your own breathing and heart-beat. Such silence as this is due to nothing more than the fact that the New Columbia Motor is a mechanical triumph—made expressly for a superior phonograph—the New Columbia. *Hearing is believing.*

COLUMBIA PHONOGRAPH COMPANY
New York



most effective ways of bringing to the residents of the rural districts the virtues of instruments and records.

Victor Dealers Hear Aileen Stanley

J. W. Jenkins Sons Music Co., Victor wholesaler, states that October has been a good month, but it is looking for a steady betterment in business later. At the monthly meeting of the Victor dealers at the Baltimore Hotel in October they were entertained by the Victor artist, Aileen Stanley, who was filling an engagement at the Newman. She sang several songs for the assembly and delivered a talk on how a record is made, giving some very interesting personal experiences.

NEW COLUMBIA TRADE-MARK

Attractive Design Features Word "Columbia" and the "Notes"—New Trade-mark Effective

The Columbia Phonograph Co. has been congratulated upon the simplicity and attractiveness of its new trade-mark, a reproduction of which is shown herewith. The famous notes are still



New Columbia Trade-mark

in evidence, but it will be noticed that there is no reference to any name of the product except the word "Columbia." The new trade-mark will be a prominent feature in the mammoth advertising campaign introduced by the Columbia Phonograph Co. a few weeks ago and it is suggested to Columbia dealers that they scrap all of the old trade-marks, using the new trade-mark in their publicity matter.

TO RESUME "DOEHLER TOPICS"

The Doehler Die-Casting Co., Brooklyn, N. Y., maker of die-castings for the talking machine and other industries, will shortly resume publication of its interesting house organ, "Doehler Topics." Prior to the time that the war dominated all the activities of the Doehler Die-Casting Co., "Doehler Topics" was published regularly each month and was a source of much interesting news regarding the activities of this company. At that time W. R. Ahrberg was editor of the publication. Although Mr. Ahrberg's duties at the present time are so numerous that he will not be able to take over the details of the editorship, it is expected that he will be connected with the publication in its new issuance in a consulting capacity. The new editor will be Charles I. Hodgson, of the Doehler organization, and it is anticipated that the first number will appear in December.

L. L. SPENCER HOST AT LUNCH

Entertains Talking Machine Men at Beginning of Red Cross Drive

Lloyd L. Spencer, of the Silas E. Pearsall Co., New York, was the host at an informal luncheon held Thursday, October 25, at the Café Boulevard. This luncheon took place primarily to call the attention of the metropolitan trade to the forthcoming Red Cross drive, which will start on November 11 and continue throughout the month. The Red Cross organization was represented by one of its field secretaries, who gave those present an intimate idea of the splendid work the Red Cross is doing and asked for the co-operation of the talking machine trade. Mr. Spencer is chairman of the Red Cross committee in the talking machine industry, and everyone present at the luncheon will assist him in securing the quota allotted this industry. Among those present on Thursday were Otto Heineman, president of the General Phonograph Corp.; Frank J. Coupe, Sonora Phono-

graph Co.; E. A. Widman, president Pathé Phonograph & Radio Corp.; R. H. Keith, Long Island Phonograph Co., Brooklyn, N. Y.; T. J. Niles, Columbia Graphophone Co.; Chas. B. Mason, New York Talking Machine Co.; G. T. Williams, American Talking Machine Co., Brooklyn, N. Y.; Paul Carlson, Chas. H. Ditson & Co.; Don Leopold, Brunswick-Balke-Collender Co.; Jerome T. Harris, C. Bruno & Son, Inc.; Maurice Landay, Greater City Phonograph Co.; Oscar W. Ray, Aeolian Co.; B. D. Colen, Musical Products Distributing Co. and Irwin Kurtz, president Talking Machine Men, Inc. At the close of the discussion regarding the plans for the Red Cross campaign, Mr. Kurtz briefly discussed the subject of trade advertising for the coming Fall along the lines prepared this Spring, during the course of the National Music Week, and also inquired as to the attitude of the trade towards a phonograph show to be held some time next year. Both of these subjects were discussed at length, but no definite decision was reached as to the plans to be pursued in connection with these two ideas.

LATEST QUOTATIONS ON COLUMBIA RECORDS

All American selections both Vocal and Instrumental. Packed 25 of a number in Cases of 400 records. Comprising surplus stock listed in the June 1923 Columbia Numerical Catalogue.

15c Net Each

IN 3 CASE LOTS (Total 1200 Records)

TERMS: Net Spot CASH. F.O.B. Bridgeport, Conn.

Do not confound these records with obsolete, stock-worn or returned goods. All records above quoted are new and "first quality" double-faced regular 75c Blue Label Columbia Records.

Special quotations for Ten Thousand lots or over
All quotations subject to change and prior sale

We Have Both Foreign Language and Opera Records, 10-in. and 12-in. Sizes

GRAFONOLAS

And Phonographs of Other Makes

Small stocks of Grafonolas, all NEW and in ORIGINAL CASES still available at BARGAIN PRICES. F. O. B. several points in the United States. Write for quotations on them.

CATALOG OF THE NEW KIMBERLEY CONSOLES AND UPRIGHTS
Sent on Request With Trade Prices

LOUIS JAY GERSON

High Grade Radio and Phonograph Specialties

63 READE STREET

Telephone 4875 Worth

NEW YORK CITY

Cable Code "Gersondale" New York

ATLANTA

Dealers Advertising Christmas Clubs — Business Remains Good — Trade Activities of the Month

ATLANTA, Ga., November 7.—Christmas clubs are the order of the day. In all cities the newspapers carry the dealers' invitation to pay a dollar down and a dollar a week until Christmas, thus making sure of delivery of the desired instrument on Christmas morning. Of course, terms are arranged to take care of the balance, after delivery of the machine, within a proper number of months.

The Cable Piano Co. has already begun to stay open evenings until 8:30 p. m. This live house believes in giving its customers time to do their Christmas shopping early.

A recent visitor was Robert B. Wheelan, president of Health Builders, Inc. Mr. Wheelan is on the last lap of a trip around the entire country in the interests of the famous "Daily Dozen" and Reducing records, and establishing new jobbers on the Camp-fone. The latter, although called a portable, is selling largely at this season of the year as a table model, with the added advantage of being easily carried about when required.

Loveman, Joseph & Loeb, Birmingham's big department store, are moving their talking machine department to the balcony in the main store. New booths and equipment—Unico—are being rushed them from the factory at Philadelphia, as it is planned to take advantage of the large holiday demand for phonographs, so Unico's ability to make prompt shipment and to erect the equipment almost overnight has been taken advantage of.

P. C. Brocknan, of the Polk Corp., Okeh and Outing distributor, left recently for a trip to Florida, where the trade is just at the threshold of its busiest season. The Okeh records and Outing portable are going strong throughout the entire territory.

W. L. Parks is again with the Columbia Co. and is heartily welcomed by the trade here. He has already taken up his new duties with the Atlanta branch.

"The best business I have seen for the past two years," is the way M. E. Lyle sums up the present situation. Mr. Lyle has just returned from a trip through northern Alabama. The



"We Serve the South"

THE test of real, dependable service lies in its ability to function as efficiently in the "pinches" as it does in filling the casual requirements of the dealer.

Polk Service has been tested many times under trying conditions. It still retains the unlimited confidence of those Okeh dealers who are partaking of its merits and advantages. It readily discloses the reasons why it is at present playing so large a part in aiding hundreds of Okeh dealers throughout the South to reap the benefits that come from handling the fast-selling, popular

Okeh Records

The Records of Quality
Inquiries from Dealers Solicited

Wholesale Phonograph Division

JAMES K. POLK, Incorporated

Offices and Show Rooms:
294 Decatur Street ATLANTA, GA.

Buy
Okeh
Needles

They
Keep
Record Sales
Alive!

only thing which is causing the dealers some concern is the problem of securing machines to sell at from \$100 to \$150. Strands are now coming through from the second large plant, which has just begun production, and so far Strand dealers have been able to get what they need.

Phonographs, Inc., Edison distributor for this territory, with headquarters at 41 Cone street, in common with jobbers of other lines of machines and records, is kept on the jump supplying the needs of its dealers. The Edison is apparently a good seller and the outlook for a big holiday demand for these phonographs and records is excellent.

The "Lasses" White Minstrel Show, exclusive Columbia artists, was in Waycross, Ga., during October. "Lasses" himself appeared at the Walker-Hood Furniture Co. and sang a number of popular hits, greatly stimulating record sales.

The Williams-Guttenberger Music Co., Ma-

con, Ga., is advertising Bessie Smith, Columbia artist, very intensively and a substantial quantity of her records are being sold.

The Mason Furniture Co., Huntsville, Ala., is enjoying a good Fall Columbia phonograph and record business. The new Columbias are featured in current advertising. The problem for the future is to obtain a sufficient number to take care of the holiday trade.

R. W. Richardson, Columbia salesman, reports big record sales in Nashville, Tenn., as a result of the appearance there of Gypsy Smith, William McEwan and Clara Smith, exclusive Columbia artists.

The W. L. Hall Furniture Co., Knoxville, Tenn., is very enthusiastic over the New Columbias and is doing very extensive advertising, featuring the new models.

The Tullahoma Drug Co., Tullahoma, Tenn., reports big Columbia New Process record sales this month, as does also the Melody Music Shop, Memphis, Tenn.

The G. A. Grant Furniture Co., Montgomery, Ala., has moved into its new quarters. It has a splendid phonograph department in which the Columbia phonographs and New Process records are featured.

John A. Cunningham, Columbia dealer, of Jacksonville, Fla., is planning a big sales drive.



The Name "EDISON"

FAMOUS the world over the name EDISON in the phonograph industry stands for tonal supremacy and merchandising prestige.

The EDISON Dealer has sales arguments at his disposal that are unlimited in scope and importance. Emphasize the supremacy of the EDISON consistently and aggressively—sales will multiply steadily.

We have a few towns in our zone open for the proper Edison dealer representation

PHONOGRAPHS, INC.

EDISON DISTRIBUTORS

41 Cone Street - - - - Atlanta, Ga.

K. & D. MOTOR MAKING PROGRESS

Electric Motor Ready for Distribution in a Few Days—S. A. Jacobs Visits Factory

"Production on the K. & D. electric phonograph motor has been progressing satisfactorily, and, although as yet the factory has been unable to make any deliveries to us or other distributors, it is only a question of days when the motor will be available to the industry," said S. A. Jacobs, of the Cliff Electric Corp., New York, who returned recently from the Kendrick & Davis factory at Lebanon, N. H. He states that the reason deliveries have not been made before now is that both the factory and the distributors wish to have the motor brought to such a point of perfection that it will be absolutely fool-proof and give efficient service.

Mr. Jacobs believes that it is far better to keep the trade waiting for a perfect product than to have troubles arising from too much haste and production. Within a few days, however, the factory will be in a position to make substantial deliveries and orders taken by the distributors will be filled promptly.

Take

The Big Melody Hit from the
New ZIEGFELD FOLLIES

Those Lips Away
by McCarthy and Tierney

"You can't go wrong
with any FEIST song"

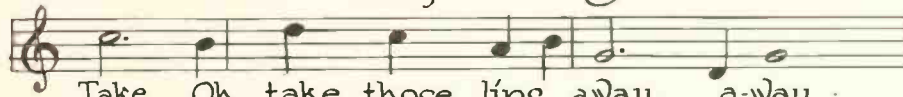

Take, Oh take those lips away, a-way;

© 1923
Leo. Feist, Inc.

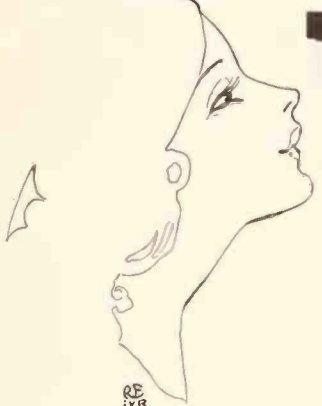

SONORA CO. STRONGER THAN EVER

Dealers and Jobbers Throughout the Country Send Telegrams of Confidence and Co-operation Following Quashing of Receivership

During the last week of October the talking machine trade learned with surprise that a receiver in equity had been appointed for the Sonora Phonograph Co. in the United States District Court in Brooklyn. A few days afterward, however, Judge Garvin, who had appointed the receiver, rescinded his order and the incident was closed. The court happenings were brought about by the activities of two minority stockholders, but the matter worked out to the distinct advantage of the Sonora Co., as evidence was submitted which indicated conclusively that the company is at present enjoying the most prosperous era in its history.

There was absolutely no foundation for the appointment of a receiver and Judge Garvin's dismissal of the court action was made by the consent of all concerned. Subsequent to the decision by Judge Garvin the following interesting statement was issued by S. O. Martin, vice-president and general manager of the Sonora Phonograph Co.: "It is gratifying that Judge Garvin acted so promptly in vacating this receivership. The prosperity of the company was never questioned even by the applicants, who applied to the court without any notice to the company or to any of its creditors. In fact, the company is now experiencing the greatest prosperity in its history. Unfilled orders are over twice what they were a year ago, notwithstanding increased production, and the profit is extremely good. It is also gratifying that the plaintiffs who obtained the receivership realized so promptly that their action was creating a false impression, not only about the standing of the Sonora Phonograph Co., but about the phonograph industry in general." In addition, it is interesting to note that the Sonora Phonograph Co. shows a present cash surplus of \$750,000.

Mr. Martin and his associates were greatly encouraged during the course of the legal happenings to receive telegrams and messages of confidence and co-operation from Sonora jobbers and dealers throughout the country. The dealers were unanimous in expressing their appreciation of the sound and efficient basis upon which the Sonora Co. had been working the past few years and congratulated Mr. Martin and his organization upon the splendid showing Sonora had made during the first ten months of the present year.

SADLER ERECTING NEW BUILDING

AURORA, ILL., November 5.—A new two-story brick structure to cost in the neighborhood of \$20,000 is to be erected by the Sadler Music Co., Inc., on the site of its present store, 54 South Broadway. Work on the new building has already been started.

J. N. BLACKMAN AS A HUNTER

Victor Wholesaler Enjoys Vacation in Maine Woods—Partridge and Rabbit Hunting Huge Success—Deer Included in Game Bag

J. Newcomb Blackman, president of the Blackman Talking Machine Co., New York, Victor wholesaler, and the members of his family are enjoying venison steak at their home in Brightwaters, L. I., as the aftermath of a very successful hunting trip in the Maine woods. Although Mr. Blackman was not the hunter



Blackman Party in Nimrodian Rôle

who captured the deer, he is sharing in the proceeds of the hunt as a reward for the hard work which he contributed to the festivities of camping life.

The members of the Blackman hunting party comprised Mr. and Mrs. Blackman and their son, Albert, together with two personal friends, Mr. and Mrs. H. W. St. John, of Bayshore, L. I. The party encamped at Northeast Carry at the head of Moose Head Lake, Me., where they occupied Camp Applejack, and where they were

very successful in getting good-sized bags of partridge and rabbits, while Mr. St. John had the honor of landing a handsome deer. In the interim Mr. Blackman participated in the killing of numerous porcupines, which were more of a nuisance than an enjoyment.

REGINA EXPORT TRADE GROWING

Line Exhibited at International Furniture and Decorative Art Exposition in Spain

The Regina Phonograph Co., of Rahway, N. J., manufacturer of the well-known line of Regina phonographs, recently received a copy of the "El Dia Grafico" in which appears a reproduction of the Regina exhibit at the International Furniture and Decorative Art Exposition held in Barcelona. This is one of the greatest expositions of the year held on the European continent and, from an artistic standpoint, the product shown must be of the highest standard and pass numerous inspections.

The sales department of the Regina Co. is very much gratified at the honor conferred upon its product and expects it to be the forerunner of much additional export business. The Regina Co. has had an exceptionally heavy South American business in recent years, and its European business has shown a considerable increase during the present season.

TAKES THE GULBRANSEN LINE

BURLINGTON, IA., November 5.—The Gulbransen registering piano line was recently added to the music department of the Gulick-McFarland Co. The deal was closed by L. Q. Selzer, manager of this department, and extensive announcements of the new agency appeared in the local press.

If you are building Phonographs or Radio Cabinets equip with the
SCOMA COMPOSITION HORN

The cost is no more than for wood or metal and the sound is far superior.

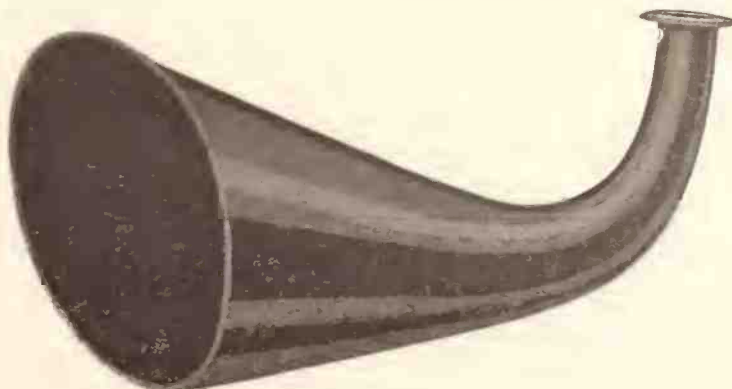

Write for Sample and Particulars.

ECKOPHONE COMPANY, 75 Rockwell Place, Brooklyn, N. Y.

BALTIMORE

Jobbers Behind in Orders as Demand of Public for Machines Improves—Columbia Dealers Hear Future Plans—News of the Month

BALTIMORE, Md., November 9.—Talking machine business last month in this city, generally speaking, was what may be termed "spotty." This situation also applied to some extent to the wholesale trade, but this is due principally to the fact that the majority of jobbers are behind in their orders and are unable to supply the trade with the most popular types of machines in demand. This is particularly true of the Nos. 80, 100 and 210 styles of the Victor machines, on which all the local jobbers reported being over-sold for some time.

Columbia Dealers Hear Future Plans

One of the most enthusiastic meetings of talking machine dealers ever held in Baltimore took place on the first of the month at the Hotel Emerson under the auspices of the Columbia Wholesalers, Inc., when nearly a hundred Columbia dealers from Baltimore, Washington and other nearby points assembled to hear talks on salesmanship and future plans of the Columbia Co., in addition to enjoying a real Maryland chicken dinner.

George W. Hopkins, vice-president and general sales manager of the Columbia Co., was the principal speaker of the evening and he outlined the plans for the future. He told of how the company had been reorganized and equipped so that it was now in a better position than ever before to give the dealers an article that was without exception in a class by itself as far as talking machines were concerned. He explained the new model and motor and the New Process records.

During the course of his remarks Mr. Hopkins announced that under the new policy of the company dealers would no longer have to run

the risk of being overstocked on records for which the demand had stopped as they could return 10 per cent of the amount of records purchased during a three months' period and would not be required to take other records in exchange.

Another announcement that brought the dealers to their feet with long and loud cheers was that the company would release on the nineteenth of this month one of the greatest New Process records ever put out at the record-breaking price of 25 cents each, which will be in the nature of a demonstration record, showing the merits of this product. The record, which will be a ten-inch double-faced record, will have some of the best fox-trots arranged in a medley by Ted Lewis' Orchestra and Schubert's Serenade sung by Charles Hackett, accompanied by the Columbia Symphony Orchestra.

The dealers present were so pleased with this announcement that dozens of orders, ranging from 500 to 1,500 records, were given as soon as Mr. Hopkins had finished his address. Leonard Trout, of Trout's Music Shop, on Eastern avenue, placed the 1,500 record order.

Other speakers were: L. L. Andrews, president, who spoke on salesmanship; W. H. Swartz, secretary and treasurer, who told of the extensive advertising campaign now being conducted in this section of the country, and John W. Swope, one of the directors of the company, who told something about the financial standing of the concern.

As an outcome of this meeting a movement was started for the organization of a local Columbia dealers' association and the first meeting will be held the latter part of this month,

when a permanent organization will be effected.

Victor Jobbers Busy

W. C. Roberts, manager of E. F. Droop & Sons, Inc., Victor jobbers, said that for the first time this year his business last month failed to show a substantial increase over the corresponding month of last year, but at the same time the retail business ran far ahead of October, 1922, and business so far this month, both wholesale and retail, has been exceptionally good. He reports excellent results with the No. 215 Victor machine, which is now selling as well as the other popular types.

Great Activity With Cohen & Hughes

Cohen & Hughes, Inc., is another Victor jobber who reports business as being very good. Advance orders for the holiday trade are larger than for several years past, both here and at the Washington branch, and delivery of orders already booked is now the principal work of the firm. William Biel, vice-president of the company, who has just moved here from New York, has taken up the active management of the business, thereby relieving I. Son Cohen, head of the firm, of some of his duties.

Local Brunswick Activities

Manager C. F. Shaw, of the local Brunswick branch, reports a gradual catching up with orders and believes that with a little luck in shipments he will be able to fill orders in time for the holiday trade. For the first time he is now up on deliveries on the York, but is still behind on the new \$100 upright. The record business is going ahead by leaps and bounds and a new record was established when the agency released seventeen new records in fifteen days with excellent results on all of them. Mr. Shaw reports good results from the national advertising campaign in practically all parts of this territory. New accounts opened during the month include: Lea-Lewis Co., Danville, Va.; E. W. Hubbard, Farmville, Va., and the Gastonia Furniture Co., Gastonia, N. C. Brunswick dealers throughout the territory, according to Mr. Shaw, report the outlook as very



BALTIMORE, MD.



"HIS MASTER'S VOICE"



WASHINGTON, D. C.

STANDING THE TEST!

Anticipating our dealers' needs
the season finds us fully prepared.

Cohen and Hughes, Inc.

Baltimore, Md. VICTOR DISTRIBUTORS Washington, D. C.

encouraging and several of them have requested the local agency to supply them with additional help in the way of salesmen, as proof of good business.

Josef Hofmann, Brunswick artist, appeared at the Lyric Theatre for a recital on the sixteenth of last month and dealers throughout the city took occasion to feature his selections in window displays with very good results. The Ukrainian National Chorus, another Brunswick feature, will appear in Baltimore on the twenty-seventh.

Brunswick dealers visiting the local agency during the month included: Fred Laux, of the Toulaine Music House, Newport News, Va.; W. H. Bennett, of the Brunswick Shop, Washington, D. C.; Harry Beneman, of B. Beneman & Sons, Cumberland, Md.; M. M. Burns, of Cornier, Burns Co., Harrisburg, Va., and T. W. Zercheser and W. Grimm, of the Regal Co., York, Pa.

Shortage of Popular Columbia Models

W. H. Swartz, secretary and treasurer of the Columbia Wholesalers, Inc., reports business for

the past month as very good, due principally to the new Columbia models which, as he puts it, "are going like wildfire with the trade," coupled with the extensive advertising campaign which the company is putting on in this territory. This has brought about a shortage on the popular types of machines, such as the Nos. 200, 150 and 125 consoles and the Nos. 150 and 125 uprights. He also reports a big increase in the sales of portable machines during the past six weeks, which would seem to disprove the idea that this type of machine is a Summer seller.

The Bessie Smith records continue to be one of the biggest sellers in this territory, and her two latest, "Jailhouse Blues" and "Graveyard Blues," are especially popular with the colored trade. Mr. Swartz also reports large increases in the sale of sacred music and the better class of music, which, he said, indicates some reaction from the tremendous sales of popular music for the past three years.

New accounts opened by the Columbia wholesalers the past month include: Lain Jackson, Summerville, Va.; E. D. Sutton Piano Co., Clin-

ton, N. C.; Scotland Neck Furniture Co., Scotland Neck, N. C.; L. C. Cobb, Elm City, N. C.; Service Stores, Inc., Sparrows Point, Baltimore, and Martin Music Co., Richmond, Va.

Home Demonstrations Prove Worth

Edward Keefer, manager of the talking machine department of the Kranz-Smith Piano Co., Cheney dealer, reports good results from a new sales campaign which he inaugurated last month, which includes a demonstration at the home of the prospective purchaser. This concern finds that once an instrument has been placed in a home few will permit removal.

Artists' Appearances Aid Sales

Cohen & Hughes, Inc., report big increases in the sales of Chaliapin records following his appearance at the Lyric last month, when all local dealers arranged feature window displays of his selections. Dealers are also reaping the benefits of the appearance of the Philadelphia Orchestra here last Wednesday, when selections of this Victor organization were again featured.

Hochschild, Kohn & Co. recently celebrated their twenty-sixth anniversary.

NEW JUNIOR OPERETTA JOBBERS

Shapleigh Hardware Co. and Vocalion Co. of Chicago Appointed Jobbers by Vulcan Record Corp.—Factory Is Working to Capacity

F. H. Hedinger, secretary and general manager of the Vulcan Record Corp., New York, manufacturer of Junior Operetta records, announced recently that the company had appointed the Shapleigh Hardware Co., St. Louis, Mo., and the Vocalion Co. of Chicago, 5209 South Wabash avenue, Chicago, as distributors for its products. Both of these companies are well known in the talking machine trade and their sales organizations comprise experienced men who are thoroughly familiar with the merchandising problems of the dealers and their requirements.

In a recent chat with *The World* Mr. Hedinger stated that the jobbers which the company had appointed during the past six weeks had placed sufficient orders to keep the factory working to capacity. The demand for the "Little Red Riding Hood" series has been very gratifying and it is probable that after the first of the year plans will be consummated for increasing factory facilities. In metropolitan territory several of the leading department stores have been featuring Junior Operetta records through the medium of artistic wareroom and beautiful displays and these displays have not only attracted general interest, but have produced tangible sales. Gimbel Bros.' New York store has prepared an artistic exhibit featuring "Little Red Riding Hood" records, and the Vulcan Record Corp. co-operated with this store in furnishing material for this display. Mr. Hedinger has prepared a large quantity of sales and publicity matter that he is placing at the disposal of Junior Operetta dealers.

SPECIAL EDISON CHRISTMAS FOLDER

Issued for Direct Mail Distribution by Dealers—Handsomely Illustrated in Colors—Theme "Christmas Is Music Time"

Special Christmas folders for distribution by dealers through the mails have been prepared by Thomas A. Edison, Inc. These folders are handsomely illustrated in colors, making an unusually striking appeal to the eye. The theme of the text is "Christmas Time Is Music Time," and the folder is designed both in text and layout to impress the suggestion on the minds of the recipients.

These folders should play an important part in the direct-by-mail activities of the Edison retail trade. Publicity of this high character is always beneficial and the slight cost involved in mailing is more than compensated for by the effect produced upon the prospect or customer. Then, too, added force will be given to the dealer's holiday publicity campaign if he makes effective use of the mails in his sales work.

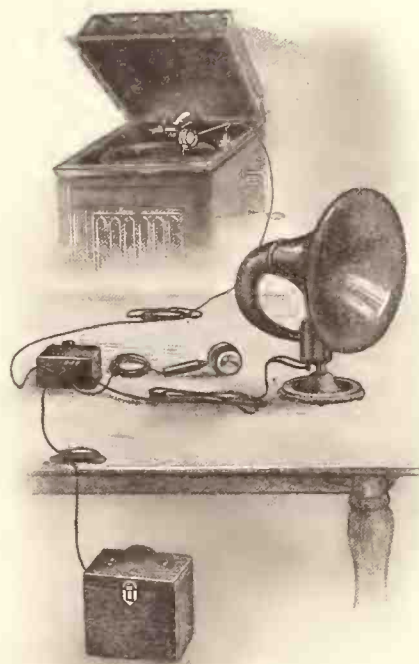

The Successful House Party

requires a phonograph of unusual qualities—clear, snappy tone quality with extra high volume.

THE BRISTOL

TRADE MARK
AUDIOPHONE
REG. U. S. PAT. OFFICE

Phonograph Record Reproducer

is the ideal instrument for small dances. Club gatherings, schools, restaurants, lodges, church societies, etc.

The same Loud Speaker can also be used for radio receiving. This double utility insures against disappointment.

The Audiophone reproduces and amplifies the records with the same undistorted tone, big, mellow and clear, full like the original voice or instrument. It eliminates surface noises.

May we write you in detail or arrange for a demonstration?

THE BRISTOL COMPANY
WATERBURY, CONN.

SAN FRANCISCO

Third Annual Music Week Stimulates Every Branch of the Music Trade—Dealers Plan for Banner Holiday Trade—News of Month

SAN FRANCISCO, CAL., November 5.—Talking machine dealers in the San Francisco Bay Section are in line for a banner holiday business, according to reports from various representative houses in this part of the country. In fact, sales for the past month have been very satisfactory in volume and the outlook is for steady improvement for the remainder of the year.

Music Week Stimulated Trade

Music Week has, no doubt, exerted quite a stimulating effect on the sale of talking machines and records, as well as other types of musical instruments and musical merchandise. This city celebrated her Third Annual Music Week, October 29 to November 3, and the event turned out to be one of the most elaborate and successful affairs of the kind ever attempted in the West, at least. The program was noticeably wider in scope than last year's Music Week, or the year before, and the attendance was more than double. The music dealers gave their hearty support. George R. Hughes, secretary of the Wiley B. Allen Co., served as chairman of the Ways and Means Committee, other members of which included Shirley Walker, of Sherman, Clay & Co., who is also president of the San Francisco Advertising Club, and James J. Black, treasurer of the Wiley B. Allen Co., who devotes special attention to the talking machine end of the business. Besides the daily afternoon and evening programs in the Civic Auditorium, which embraced the best talent to be had in all kinds of music, various special events were staged at the theatres, hotels, cafés and music stores.

Prominent among the latter was the personal appearance of the Duncan Sisters at the Quarg Music Shop, 198 O'Farrell street. In striking costumes they sang some of their popular selections and autographed their records. After an unsurpassed run of their "Topsy and Eva" at one of the local theatres, needless to say, the store was thronged with people to see and hear them at close range, and the autographed records were sold as fast as they could be tied up and handed out. Naturally the event had been well advertised.

The sale of Paul Ash Orchestra records was

likewise stimulated very noticeably by an entertainment in the Wiley B. Allen Co.'s store, arranged by the record department.

Wiley B. Allen Stores Improved

During the past month the Wiley B. Allen Co. has celebrated its fiftieth anniversary in business, and, one might add, is still growing. At present extensive improvements are in progress at the San Jose branch, which will give the talking machine department greatly increased space and importance in the new arrangement. This will be the fifth of the company's eight stores to undergo complete renovations during 1923; or to be more exact, the Fresno, Sacramento and San Diego stores have been completely remodeled and new quarters have been occupied in Oakland.

A recent visitor to the local trade was Arthur Geisler, of the New York Talking Machine Co., accompanied by Mrs. Geisler. While here Mr. Geisler made his headquarters with Sherman, Clay & Co., Western Victor jobbers.

Prof. Cheney a Visitor

Prof. Forest Cheney, originator of the Cheney phonograph, was in San Francisco early in the month, accompanied by W. H. Munson, of the Munson-Rayner Corp., Western distributors of this line. Prof. Cheney spoke before the local Ad Club, Downtown Association, the Buyers' Club of the Emporium and other organizations. The Emporium address was arranged for by Charles Mauzy, manager of the phonograph department of that large department store.

News Gleanings

B. R. Scott, manager of the talking machine department of the Nathan-Dohrmann Co., is receiving the congratulations of his friends on his recent marriage. Returning from his honeymoon in Southern California, Mr. Scott is ready for a very active holiday sale of machines and records. His department handles the Victor, Cheney and Emerson lines and, owing to the rapid growth in business, is now beginning to feel the need of more space.

W. E. Henry, better known as "Pop" Henry, Pacific Coast manager for the General Phonograph Corp., of New York, is limping around as the result of an automobile accident on his

way back from a trip to Los Angeles. Mrs. Henry sustained more serious injuries.

Following the disastrous fire in Berkeley, across the Bay, when over thirty blocks of residences were destroyed, Henry Hauschildt, of the Hauschildt Music Co., immediately announced to the "fire victims" cancellation of all indebtedness to his company on destroyed pianos and talking machines, which action was greatly appreciated by the losers of homes.

Clark Wise & Co. have been celebrating their thirty-fifth anniversary in business.

Live Columbia Dealer

A very optimistic spirit permeates the atmosphere in and around San Francisco, in relation to the new Columbia phonograph line. In the city of South San Francisco, a hustling little suburb, Columbia has just about the liveliest dealer in this territory. J. J. Jennings is an exclusive Columbia dealer. With an eye towards the future he has just completed the erection of a new building on the main street. A beautiful mezzanine floor is being devoted exclusively to the sale of the Columbia line of phonographs. Mr. Jennings has also installed an amplifier, so that no person can fail to hear the latest Columbia records.

Ordering Edison Holiday Stock

Edison Phonographs, Ltd., distributor of the Edison line in the Coast territory, with offices in this city, Los Angeles and Portland, Ore., is having a busy time of it these days in keeping up with the demands of the many dealers which it serves. The number and size of the orders being received indicate that the Edison retail trade is expecting a very busy holiday season, for which preparations are being made.

PLANS FINE NEW DEPARTMENT

Geo. C. Wille Co. to Feature Talking Machines in a Big Way in New Location to Be Occupied Early Next Year

CANTON, O., November 8.—The George C. Wille Co., in its new local Nobil building, Fourth and Market avenue, after January 1 will have a talking machine section second to none in the State, according to announcement recently by George C. Wille, head of the music house.

"I plan to spend more than \$5,000 on appointments and interior decorations and fixtures," said Mr. Wille this week. "I want to make it the finest music store in Canton, to cater to the musical needs in every line," he said.

Installation of eleven full-sized booths, all prettily appointed, will be made on the main floor of the store, and in the rear of the store will be at least nine other booths, making a total of twenty.

In the new store Mr. Wille plans to specialize in the same line of talking machines as he has always featured, the Victor and Edison.

ANNOUNCES THE OUTING JUNIOR

Outing T. M. Co. Places New Instrument on Market—New Jobbers in Southern Territory Appointed—Factory Working Full Speed

The Outing Junior is the name of a new portable that has just been placed on the market by the Outing Talking Machine Co., Mount Kisco, N. Y., manufacturer of the Outing portable, which has secured country-wide distribution during the past year. The new model will retail at \$25 and will be ready for delivery within the next week or ten days.

A. J. Coté, president and general manager of the Outing Talking Machine Co., is enthusiastic regarding the sales possibilities for the Outing Junior, which he states has several unique features, including a new method of tonal reproduction. The Outing factory is working at full speed, and orders have been received from Outing distributors which indicate that this portable is being accepted as an all-year-round seller. Several new jobbers have been appointed recently, including the Independent Jobbing Co., Goldsboro, N. C., and the Junius Hart Piano House, New Orleans, La.

*The territory
we serve*



Comprises the Entire Pacific Coast

If you are a live dealer in this territory—or want to become a live one and would know, in detail, the full possibilities that this great market holds for Edison goods, write one of our three offices.

We carry at all times an exceptionally large stock.

This means prompt service.

Edison Phonographs, Ltd.

Portland

San Francisco

Los Angeles

COLUMBIA RAPIDLY REORGANIZING

Great National Advertising Campaign Well Under Way—Demand for New Models Taxing Factory—Dealers Supporting Company

Plans for the reorganization of the Columbia Graphophone Mfg. Co. are going ahead rapidly and H. L. Willson, who is president of the company and is also one of the receivers, is giving his entire time to the development of the details of the reorganization plan which was submitted to the creditors and stockholders. In an interview with *The World* Mr. Willson stated that the response to the reorganization plan had been gratifying beyond all expectations and that within a very short time full details would be announced regarding the plans for the future. In the meantime, Mr. Willson has been congratulated upon the sales and publicity activities of the company, as the demand for the new Columbia phonographs is taxing the factory to capacity and the great national advertising campaign inaugurated a few weeks ago is producing splendid results. This advertising campaign comprises national magazine publicity, together with full pages in forty-three Sunday newspapers and regular advertising in 750 daily papers.

In an announcement appearing recently in the financial columns of the daily newspapers the holders of participation certificates issued by the New York Trust Co. on April 26, 1922, the holders of certificates of deposit of the Guaranty Trust Co., of New York, issued on February 2, 1922, and the holders of undeposited five-year gold notes were advised that the plan and agreement of reorganization for the Columbia Graphophone Co. had been deposited with the New York Trust Co. for their inspection. The holders of these certificates and notes have evinced keen interest in the details of this plan and agreement of reorganization, and judging from all indications there will be no dissenting voice to the reorganization agreement as officially prepared.

General optimism is the prevailing sentiment with Columbia dealers, who are giving every support to the company, and the recent announcements of the return record privilege, new labels, demonstration record and new trademark have served to strengthen this optimism to a considerable degree.

A petition of bankruptcy has been filed this week against Abner Geffen, proprietor of a music shop at 25 Cook street, Brooklyn, N. Y. His liabilities are listed at \$3,708, with no assets.

TABLE PHONOGRAPHS NOT TOYS!



Model 19 1/2

16" wide, 17" long, 7 1/2" high. Made of veneered wood finished in mahogany color with a polish like a piano. The motor is a strong, single spring with a ten inch turntable. It is durable, even running and will prove satisfactory. Universal tone arm and reproducer. All parts nicked.

These machines have a full clear tone and are worthy of being real phonographs.

Wholesale price \$12 each

Terms: 2%—10 days; Net 30 F.O.B.N.Y. Samples sent C. O. D. to those unrated.

Musical Merchandise Co.

MANUFACTURERS

562-564 Grand Street, Brooklyn, N. Y.

Telephone Stagg 0918

A. W. FRITZSCHE'S NEW ACTIVITIES

Assistant Treasurer of General Phonograph Corp. Developing Needle Business—Results to Date Have Been Very Satisfactory

Allen W. Fritzsche, assistant treasurer of the General Phonograph Corp., New York, and identified with the organization for the past several years, is now concentrating his activities on the development of the company's needle business. Mr. Fritzsche is spending the greater part of his time visiting the trade in the leading distributing centers, and the results of his efforts are reflected in the fact that needle sales during the past few months have shown a substantial increase over preceding months and a good-sized gain over last year.

The General Phonograph Corp. manufactures a complete line of needles, and during recent months detailed plans have been completed for co-operating with the trade and stimulating the demand for Okeh needles. These needles are attractively packed and presented to the dealer in such a form that they can be merchandised to splendid advantage. Mr. Fritzsche has prepared an intensive sales campaign for the coming year that will undoubtedly stimulate the sale of Okeh needles throughout the country.

ADVANCE ORDERS HELP JOBBER

Greater City Phono. Co. Giving Dealers Efficient Service—Railroad Facilities Better Than Heretofore—Dealers Ordering Early

"We have been closing an excellent business the past six weeks," said Maurice Landay, president of the Greater City Phonograph Co., Inc., of New York, Sonora distributor for New York City, Staten Island and the lower Hudson Valley, in a recent chat with *The World*. "Several new accounts have been opened and an increase in activity is noted among our dealers. The results of our recent convention have proved very satisfactory, inasmuch as many of the dealers placed orders at dates considerably in advance of previous years."

As a souvenir of the convention luncheon held in the Pennsylvania Hotel Mr. Landay has sent to all dealers who were present a large photograph of the gathering, which was taken just preceding the luncheon. Mr. Landay commented briefly on the improved railroad situation over the corresponding period of last year. He states that deliveries are being made promptly and that Sonora dealers are, in turn, receiving maximum service.

VICTOR FLOAT WINS PRIZE

Middle Western Dealer Has Built Large Business by Aggressive Methods

CIRCLEVILLE, O., November 7.—Carl F. Seitz, 138 West Main street, this city, believes in taking advantage of every opportunity of bringing his products to the attention of the public. Recently he had a particularly attractive float in the parade in connection with the Annual Pumpkin Show. This float attracted widespread attention and was awarded second prize. Mr. Seitz is one of the veterans of the music business in this section. He has sold musical merchandise of all kinds since 1891, and he has built up a large business in Victor, Brunswick and Sonora phonographs, pianos and small goods.

BOOKS REFLEXO BUSINESS IN WEST

Louis J. Unger, president of Reflexo Products, Inc., New York City, recently returned from an extensive trip throughout the Middle West in the interest of Reflexo blue steel needles and Gilt Edge needles. Mr. Unger found conditions particularly good on his trip and booked considerable new business. The new free display stand has gone over big and many dealers report its value in the increasing of needle sales.

What Is Ideal Merchandise?

People will buy in quantities that article of merchandise which is obviously better value than competing lines. Sales resistance becomes immediately broken, while selling time and costs are lessened, thereby giving the dealer larger profits.

Dealers handling



Semi-Permanent Needles

place them in this category. For their capacity to play 50 and more records, together with the insurance against record scoring that goes with these needles, makes them an obviously better buy. Write for a sample.

Sonora Phonograph Company, Inc.

279 Broadway New York

Canadian Distributors:
Sonora Phonograph, Ltd., Toronto

Sonora Stays Wherever Placed

"We took on the Sonora line for two reasons: First, because we have had a number of requests for the Sonora. And second, on investigation we found that the Sonora is a machine of merit. Since taking on this additional line we find it to be very satisfactory, both as a merchandising and selling proposition. We may add that the demand is increasing, and that wherever placed the Sonora stays." That's what the manager of the phonograph department of one of the largest Eastern Department Stores writes about Sonora (name furnished on request).

You, too, can build for the future with Sonora. Write us for our proposition.

Sonora Phonograph Company, Inc.

279 Broadway New York

Canadian Distributors:
Sonora Phonograph, Ltd., Toronto



HAPPENINGS IN THE DOMINION OF CANADA

DEALERS IN MONTREAL TERRITORY ARE VERY ACTIVE

Berliner Gramophone Co., Ltd., Constructing Plant for Manufacture of "His Master's Voice" Cabinets—Retailers Add New Lines—Expansions and Other News of the Trade

MONTREAL, CAN., November 8.—"His Master's Voice" Victrola cabinets, which have hitherto been imported into this country from the United States, will soon be made in Canada by the Berliner Gramophone Co., Ltd., of this city, which for some years has manufactured the Victor machines and records. They are now fitting out a modern reinforced concrete building which will be used exclusively for the manufacture of these cabinets. This building is five stories high, about 500 feet long, and contains approximately 100,000 square feet of floor space. It was erected, together with a 1,200 h.p. power plant, in 1921. The value of the building and the complete modern equipment being installed is a little over \$1,000,000. The work, the company expects, will be completed about December 1. The plant when operated to capacity will require the employment of about 350 additional workers, but it is not counted on reaching full capacity before 1925. During the coming year, however, the company expects to take on about 200 additional employes.

C. W. Lindsay, Ltd., will hereafter handle the Vocalion records and will, as in the past, feature Sonora and Columbia phonographs. The firm is carrying on an extensive advertising campaign in the interest of Sonora, which is bound to have telling results.

"Lord Renfrew's favorite, 'His Master's Voice' Victor Victrola, again supplied by Layton Bros., Ltd. A royal tribute to the Victrola, the choice of Lord Renfrew on his recent visit to Canada." This is the way Layton Bros., Ltd., announced in the daily press that they had again supplied this make to the heir to the throne. An illustration was also shown of the machine, Style No. 400. It is also worthy of note that Lord Renfrew purchased a similar model to be shipped to England for his own personal use.

Palm-O-Phone, Reg., has opened up talking machine parlors at 2833 St. Catherine street, East, where it is carrying a number of different makes of "talkers" and featuring the sale of Starr-Gennett records. Five demonstration booths are daily in operation.

J. W. Shaw & Co. are now featuring Vocalion records and quite recently made a very nice window display of these goods.

Charles Culross is receiving exchanged pianos in quite goodly numbers in part payment for Sonora and Aeolian-Vocalion phonographs.

Lord Renfrew (H. R. H., the Prince of Wales) during his recent visit to Montreal personally complimented Joseph C. Smith's Orchestra (exclusive Brunswick artists), which plays daily at the Mount Royal Hotel, on its wonderful playing.

Wm. Lee, Ltd., has been running considerable newspaper copy exploiting the Brunswick and emphasizing the fact that Lord Renfrew danced to and enjoyed the following Brunswick records: No. 2447, "Stella" (fox-trot); No. 2402, "Wonderful You" (fox-trot); No. 2352, "When Hearts Are Young" (fox-trot); No. 2393, "Un Tango Dans la Nuit" (tango), and No. 2440, "Sweetheart of Sigma Chi" (waltz).

Isa Kremer, Brunswick artist, paid a return visit to Montreal the past month and met with an enthusiastic reception.

Beniamino Gigli, tenor of the Metropolitan Opera Co. and exclusive Victor artist, sang to a capacity audience in Windsor Hall the latter part of October.

Layton Bros., Ltd., during the late visit to Montreal of the Right Hon. David Lloyd George, supplied him in his suite at the Mount

Royal Hotel with a Model No. 300 Victor-Victrola.

J. Wilfrid Bourgoïn, "His Master's Voice" dealer, 1 St. Catherine street, East, is planning to soon open a branch store. One cannot but help notice the neat arrangement for quick serv-

ice to customers in locating records which are labeled under different headings, for example: "Dance Concert"—Light Vocal, Instrumental, Concert and Operatic, French, etc. Sales of consoles and uprights are about fifty-fifty as leaders in the sales race, while a large repair business is handled.

A. Pratte, Jr., expects in the near future to have a complete line of phonographs, and is at present handling Starr-Gennett records, supplies, etc.

IMPORTANT CHANGES IN THE TORONTO TRADE FIELD

R. J. Dearth Takes Over Old G. L. Laing Co. and Will Distribute Honest Quaker Main Springs—G. W. Hopkins to Speak Before Canadian Advertisers—New Stores Opened—Month's News

TORONTO, ONT., November 8.—An agreement has been reached whereby R. J. Dearth takes possession of the business formerly carried on under the name of G. L. Laing Co., this city. Mr. Dearth assumes all liabilities of the former company. He will act as direct factory distributor for Honest Quaker main springs, Empire tone arms and reproducers, Silent motors, Phonostops and other phonograph accessories.

E. A. McMurtry, Canadian manager of the Columbia Co., recently visited Winnipeg, Man., where he found dealers taking a very keen interest in the new line of Columbia phonographs and the Columbia New Process records.

Geo. W. Hopkins, general sales manager of the Columbia Phonograph Co., New York, is to be one of the leading speakers at the annual convention of Associated Canadian Advertisers to be held at the King Edward Hotel during the early part of November.

S. Aronson, president of the Presto Phono Parts Co., Inc., Brooklyn, N. Y., was a recent trade visitor to Toronto. M. G. Beatty, this city, is sole Canadian distributor for these products.

J. B. Heighton, Uxbridge, Ont., has been granted a Canadian patent covering four claims on "A composition of matter for manufacturing amplifiers."

Thomas Nash, manager of the Sun Record Co., who has so successfully handled the marketing of the Apcx records ever since they were first put on the market by the Compo Co., of Lachine, Que., has just returned from a business trip to Chicago and other United States centers. In Chicago Mr. Nash appointed a distributing house for Ajax records, also manufactured by the Compo Co., Ltd., large shipments of which are already entering the United States.

The Scythes Vocalion Co., Ltd., of this city, Canadian manufacturer and distributor of the Aeolian Vocalion phonographs and records, announces that C. W. Lindsay, Ltd., Montreal, has taken on the Vocalion record line.

During Lord Renfrew's holiday on his western Canadian ranch he visited Calgary, Alta., calling at the store of the Alberta Piano Co., Ltd., to select a number of records, including the latest hits. The selections made were "His

Master's Voice" Victor records. While H. R. H. the Prince of Wales was on the E. P. Ranch he used and enjoyed immensely the Victrola, Style No. 280, supplied by the Alberta Piano Co.

A new piano-phonograph shop has been opened in Windsor, Ont., by William H. Hardy and is known as Hardy's Music Store.

Henry Pratt has recently opened an exclusive phonograph store at 998 St. Clair avenue, West. The Brunswick is among the lines handled.

Manager Sibbitt, of the Ottawa Phonograph Corp., Ottawa, Can., in order to attract attention to his show window recently employed the headliner from one of the local theatres who did his tricks in the window. Coupons were distributed on which the people were asked to state whether he was a man or a machine, and also to give the age of the "inan." Ten records were given to the person giving the correct answers.

Charles Kirke Music Co., Ottawa, is now handling Aeolian-Vocalion records in its handsome new store on Sparks street.

Herb. Byshe, one of the first phonograph retailers in Canada, has discontinued the sale of records.

Jones Bros. have succeeded to the business of M. P. Wright, Rideau street, Ottawa.

LIVE DEALER ORGANIZES ORCHESTRA

MONTPELIER, IDAHO, November 7.—F. M. Williams, Brunswick dealer here, has organized a dance orchestra called the Harmony Five. Mr. Williams states that his orchestra plays so-called Brunswick tunes, because all of their dance numbers are identified with Brunswick records. The orchestra is being booked in many places in southern Idaho and some points in western Wyoming. By identifying his dance program with Brunswick dance records he is developing a big record business.

DANIELSON IN NEW WAREROOMS

JAMESTOWN, N. Y., November 8.—Danielson's Music House participated in the big opening celebration at Roosevelt Square here recently when the new Rogers block was dedicated.

Talking Machine Springs and Repair Parts

NONE BETTER IN QUALITY NONE LOWER IN PRICE

THE RENÉ MANUFACTURING CO.
MONTVALE, NEW JERSEY



THE ORSENIGO PERIOD PHONOGRAPH



BUCKINGHAM

From an assortment of seventeen period models you can choose the ones which are most suitable for your clientele; oak, walnut, fine lacquers made by artisans who take infinite pains with their work.

Cabinets of the finest construction; mechanism which needs no adjectives to emphasize its tonal qualities; and priced lower than any high grade cabinet on the market.

THE ORSENIGO COMPANY, Inc.

*Showrooms: 383 Madison Avenue
New York City, N. Y.*

*Factory: Skillman Ave. and Rawson St.
Long Island City, N. Y.*



Before You Go

You'll never let go of this FOX-TROT song

"You can't go wrong
with any FEIST song"



© 1923
Leo Feist, Inc.



SALT LAKE

Retailers and Wholesalers Enjoying Prosperous Season—Outlook for Holidays Is Excellent

SALT LAKE CITY, UTAH, November 5.—All is well with the talking machine industry in this section. Without a single exception leading men in the business—dealers and wholesalers alike—are congratulating themselves on the prosperity which is attending them and that business will continue good now right up to Christmas is, of course, a foregone conclusion according to well-informed heads of the leading concerns in this territory.

Donald Daynes, treasurer of the Daynes-Beebe Music Co., and Ted Lewis, of the phonograph department, have gone to southern Utah on a deer-hunting trip. President Joseph J. Daynes has been on several brief duck-hunting trips which were productive of good sport.

Several favorite Mormon hymns, recorded recently by the Victor Co. to sell at 75 cents, are in good demand in this territory.

The Utah Phonograph Co. had an attractive booth at the recent State Fair.

There is not as much call now for the "jazzy" stuff as for the better class music, according to Manager Henry Gardner, of the Z. C. M. I. talking machine department. Miss Geneve Swayze, the charming young lady assistant in the Keith-O'Brien Co.'s phonograph department, now discontinued, has joined the Z. C. M. I. phonograph department under Mr. Gardner.

"It's a Lot of Bologny," by Billy Murray. This was featured in the John Elliot Clark Co.'s window recently. There were frankfurter sausages to give the song a realistic touch. Hundreds stopped to see the window.

H. E. Dewsnup, former sales manager of the Consolidated Music Co., has purchased an interest in the O'Loughlin Co., Main street.

Sales Manager Thomas, of the Consolidated Music Co., has been elected to the board of directors of the company. He has been with the firm nine years. Dean Daynes, of the Consolidated, has returned from a hunting trip in southern Utah, which he took in company with county officials.

Miss Beth Erickson, head of the John Elliot Clark Co.'s educational department, took a leading part in the program of the recent State Teachers' convention, held in this city. Miss Erickson appeared on the general program of the convention and also on the program of the music section. She discussed music appreciation, with, of course, special reference to the Victor machines.

The John Elliot Clark Co. is fitting up its second floor as a fine, new salesroom to be devoted entirely to period models of Victrolas.

The Utah Association of Music Industries has decided to hold quarterly meetings hereafter and to make each meeting a convention and social on a small scale. Members thought this would be preferable to holding meetings at more frequent intervals. The executive committee will be responsible for the conduct of the Association's business to a greater extent than heretofore. Secretary Fred Beesley, Sr., said they hoped to get employes of the different establishments out at the quarterly meetings and discuss various phases of the business of interest and value to them in their work.

Miss Gussie Pearson, of the Fisher Music Store, East Third street, South, reports that there is a good demand for second-hand records at this time. The Fisher Co. sells second-hand musical instruments and equipment exclusively. Its store is neat and attractive and no "junk" is carried.

T. E. Ashworth, of the Auerbach Co.'s phonograph department, reports a brisk demand for Columbias. "We can't get them fast enough," he said. The Auerbach Co. will soon move into its new store, where it will have a larger phonograph department.

Branch Manager Spratt, of the Brunswick-Balke-Collender Co., has just returned from a short trip into the Idaho territory, where he called on Brunswick dealers in Pocatello, Blackfoot and Idaho Falls.

The Daynes-Beebe Music Co. displayed a very pretty Brunswick window during State Fair week.

The Bates Stores Co., Brunswick dealer, Provo, Utah, has announced its big phonograph sales campaign. Extensive advertising is a feature of the event.

Messrs. Boyden and Carlson, of Coalville, Utah, and Logan, Utah, respectively, were recent visitors to the local Brunswick offices.

Mr. Perry, of the Brunswick Co., has returned from a short trip into the Wyoming territory. He reports Brunswick sales as very active in Evanston, Kemmerer and Afton, Wyo.

DEALERS IMPROVING THEIR STORES

Leon Tobias, secretary of Van Veen & Co., Inc., reports considerable activity on the part of talking machine retailers in improving their warehouses. Among contracts in progress and recently completed are the following: A complete phonograph department for Bloomingdale Bros.; alterations for Chas. H. Ditson & Co. and C. Bruno & Son, Inc., both Victor distributors of New York City; Home Furniture Co., Trenton; installations for M. F. Malarkey, Pottsville, Pa.; Griffith Piano Co., Newark and Trenton stores; Mt. Pleasant Music Shop, Washington, D. C.; Oscar A. Hoffmann & Bro., Cincinnati, O.; Hudson Music Shop, Hastings, N. Y.; Charles Azzara, Yonkers, N. Y.; Brunswick Shop, Washington, D. C.; William R. Zollinger & Co., Canton, O., and Frederick Loeser & Co., Brooklyn, N. Y.

SONORA SCORES AT TRI-STATE FAIR

Walter C. Reinhardt, of Memphis, Tenn., Wins Fine Publicity for His House and the Sonora Line Through Exhibit at Fair

MEMPHIS, TENN., November 5.—Walter C. Reinhardt, president of Reinhardt, Inc., Sonora dealer in this city, is being complimented upon his aggressiveness in securing maximum publicity for his house and Sonora product during the Tri-State Fair. The company erected a special tent close to the Agricultural Building, and among the Sonora consoles displayed were the Queen Anne, Canterbury, Marquette, Marlborough and Serenade, together with the Grand, Barcarolle, Melodie and the portable. Quite a few Sonora sales were consummated during the course of the fair, and it was estimated that 180,000 people passed the Sonora tent at one time or other.

One of the most interesting features of the entire fair was the "Enchanted Sonora," this display consisting of a Sonora Grand, mounted on four fish bowls in which gold fish sported about in full sight of the visitors, showing the impracticability of any wired connection and yet this instrument told the visitor's name, describing his clothes and answering any question intelligently. The solution of the mystery rests with Mr. Reinhardt, but the "Enchanted Sonora" was the means of packing the tent every hour of the day and evening with thousands of visitors, each of whom received a catalog and the famous walking Sonora doll.

In addition to displaying the Sonora product in a specially designed tent, Mr. Reinhardt also featured the instrument in another display in the Merchants' Building, entertaining the crowds with concerts on the Sonora, using Vocalion Red records. Instruments were also placed at the disposal of other exhibitors to entertain their visitors, and among the companies which took advantage of Mr. Reinhardt's liberal offer were the Coca Cola Co., which broadcasted Vocalion records by means of a Sonora and a Magnavox, the Dixie Mfg. Co., which also used these products, the Sweet Pal Candy Co., and the official restaurant at the fair.

ADDITION TO BRUNSWICK PLANT

KNOXVILLE, TENN., November 7.—An addition to the Lonsdale plant of the Brunswick-Balke Collender Co. has just been announced, and plans have been made to build an assembling plant here within five years, for the manufacture of Brunswick phonographs. The company intends to cover the entire block it has purchased.

The Moller Music Co., of Hagerstown, Md., which this year completes its forty-third year in business, has leased new warehouses in the old Hotel Franklin building, giving it largely increased quarters and better facilities to take care of its growing business.

EQUIPPING NEW LANDAY STORE

Zimmerman-Bitter Co. Secures Sixth Avenue Store Contract—Closes Other Important Contracts—Final Rush Before Holidays

The final rush of remodeling and equipping talking machine stores before the beginning of the late Fall and holiday business is being completed by the Zimmerman-Bitter Construction Co., New York City, according to A. Bitter. Among the recent installations completed by this company is that of the Berger Talking Machine Co., of Ridgefield Park, N. J., consisting of six hearing rooms, record racks, sheet music and musical instrument departments. The entire store has been redecorated in French period design. The store of Max Liaks & Son, of 143 Second street, Passaic, N. J., has added complete equipment for a phonograph department.

Emanuel Blout's store in Flushing, L. I., has been equipped with eight hearing rooms, piano rooms, record racks, musical instruments, sheet music, music roll and small goods departments. A new musical instrument department has also been added to the Blout store in Bayonne, N. J., and a similar department has been added to Landay Bros.' New Haven store. The Good Luck Talking Machine Co., New York City, has added additional booths and musical instrument cases.

The Zimmerman-Bitter Co. is at present engaged in enlarging the showroom of Landay Bros. at 311 Sixth avenue and is also equipping the new Landay store at Sixth avenue and Thirty-fourth street. This installation will comprise thirty-five hearing booths and complete equipment throughout all departments, including musical instrument, sheet music, small goods racks and showcases, etc. The main floor will be finished in walnut and the second floor in French grey. Mr. Bitter states that conditions are particularly promising for a good Fall business and that his company anticipates continued activity in the installation of equipment.

INTRODUCES NEW TYPE LOUD SPEAKER

Radio Specialties Apparatus Co. Places "Excello" Loud Speaker on Market

A new phonograph type loud speaker has recently been placed on the market by the Radio Specialties Apparatus Co., Upper Montclair, N. J., which is being merchandised under the trade name of "Excello." This amplifier is designed with the idea of permitting the owner of a phonograph and radio set to combine the two, using the phonograph horn as the loud speaker. The device is attached to the tone arm of the talking machine and is finished in gold, silver and nickel plate to match the various tone arms. It is adjusted by the turning of a knob, thus making the music, both vocal and instrumental, loud or soft, as is desired. The Excello fits any type of tone arm either by simply attaching it to the tone arm or, in the case of certain old-style tone arms, various removable adapters are used, thus making a complete unit which may be changed at will.

The Radio Specialties Apparatus Co. also manufactures the Excello horn type amplifier, which has all the adjustment features of the phonograph type and is light in weight. This amplifier is made in an artistic design, which makes it appropriate for use in the home. The horn type comes in three finishes—standard black, crystal black and mottled green. H. G. Thompson, president of the Radio Specialties Apparatus Co., states that these two types of instrument have met with approval in the talking machine trade.

CLIFFORD CO. IS CHARTERED

NORWALK, CONN., November 5.—Incorporation papers for a new music house here have just been filed under the name of the Clifford Jewelry & Music Co., Inc. Capital, \$10,000.

NEW COLUMBIA LABELS READY

Distinctive Set of Labels Will Appear on All Columbia Records—Attractive Design With an Effective and Distinctive Display

Commencing with the January supplement as a unit and on all repressings of previously listed records starting at once, the Columbia Phonograph Co. will use a new label that is distinctive and entirely different from the labels used in previous years. A reproduction of the label is shown herewith, but the black and white reproduction hardly does justice to the attractive colorings that characterize the new series of labels.

According to an announcement sent out by Geo. W. Hopkins, general sales manager of the



The Artistic New Columbia Label company, the new labels will be classified as follows: gold label for a special list of symphony artists; silver label for the balance of symphony artists; bronze label to replace the present blue label, or 75-cent record; green label to replace the present green label, representing records in the foreign language catalog made in America, and the blue label for foreign

language records made abroad. While the color for each classification is different than the other colors in the series, the general design for all of the labels is similar, with the word "Columbia" prominently displayed between two unfolded red, white and blue flags and the new Columbia trade-mark at the top.

Columbia dealers who have received samples of the new labels are enthusiastic regarding their artistic design and their advertising value, as there is a minimum of type matter with a most effective layout. It is understood that coincident with the issuance of the new labels a new numbering system will also be announced.

PROGRESS ON NEW VICTOR PLANT

OAKLAND, CAL., November 3.—Construction work on the Western plant of the Victor Talking Machine Co. started here a few days ago, and Architect William Knowles, of Oakland, plans to have the structure completed by January 15 of next year. The new building, located at the foot of Seventy-eighth avenue, will have a frontage of 120 feet and a depth of 200 feet, being entirely of brick construction. The local factory will entail a cost of \$130,000 for its erection and will employ about 200 people when operated.

F. B. JENKINS, JR., VISITS NEW YORK

F. B. Jenkins, Jr., manager of the wholesale Victor division of the J. W. Jenkins' Sons Music Co., was a visitor to New York recently after spending a few days at the Victor factory. Mr. Jenkins spoke enthusiastically regarding business conditions in his territory, stating that the Victor dealers throughout the Middle West are apparently enjoying one of the most prosperous cras in recent years.

Collect the interest on every instalment sale you make. Failure to charge interest means the loss of a considerable sum of money annually.



The Excello Phonograph Type Loud Speaker

Made in both phonograph and horn design.
Adjustable air gap and cushioned diaphragm so as to bring out the full tone and quality of both vocal and instrumental selections.
Fits all tone arms perfectly by means of invisible adapters and height adjuster.

Place your order C. O. D. or check in advance. If, after ten days, you are not satisfied with the Excello, and it is returned in first-class condition, your money will be refunded. Liberal trade discount.



The phonograph type Excello loud speaker, in nickel or gold-plate, to match tone arm finish\$15.00



The horn type loud speaker, light in weight, adjustable, in three finishes, Standard Black, Crystal Black and Mottled Green\$30.00

Radio Specialties Apparatus Co.
357 North Fullerton Avenue
Upper Montclair, N. J.

These Hits—Hit The Bullseye—

"You can't go wrong
with any FEIST song"

**Dusting
The Keys**

A dusty rag
FOX-TROT

**LINDY
LADY**

A SOUTHERN
MELLOW MOON
SONG

**NICKLE
IN THE SLOT**

A Musical Novelty
by ZEZ CONFREY

© LEO FEIST INC.

PORTLAND, ORE.

Trade Conditions Never Better—L. D. Heater to Distribute Okeh Records—Record Artists in Local Concerts—The Month's News

PORTLAND, ORE., November 5.—Trade conditions in this city never were better and the outlook shows nothing but increased prosperity for this section of the country. With general business conditions in such splendid shape the only problem confronting the talking machine dealers and jobbers is the shortage of goods. This is already proving a great issue and with a tremendous holiday business in sight the dealers are experiencing some uneasy moments.

L. D. Heater, Oregon and Washington distributor of the Strand phonograph and the Portophone, has been made the distributor for that territory for Okeh records and anticipates a rapidly growing business. Portland firms to take on the Okeh line are: Vern Wenger Phonograph Co., McCormick Music Co., Inc., and the Seiberling-Lucas Music Co. Out-of-town dealers are: Cobban Music Co., of Astoria, Ore.; Smith & Carlson Drug Co., of Cosmopolis, Wash., and the W. E. Bennett Music Store, Everett, Wash.

New Strand dealers are: Remick Song & Gift Shop of Portland, Gervurtz Furniture Co. and Wm. Gadsby Furniture Store, all of this city.

The musical season was opened here recently by the appearance of prominent artists, including: Mary Garden, Columbia artist, and Claire Dux, Brunswick artist. The local Brunswick branch extensively advertised the local appearance of Miss Dux and all of the local Brunswick dealers did the same. Another artist to make his initial bow to Portland recently was Tito Schipa, Victor artist.

Lorraine Evon, violinist, and the Golden Bird, a canary, who record exclusively for Gennett records, also appeared locally. The Starr Piano Co., distributor of Gennett records, advertised Miss Evon's appearance, and sales of her records were greatly stimulated as a result.

Portland music houses have contributed liberally to the State development fund, which has been held under the auspices of the Portland Chamber of Commerce, thanks to the efforts of the chairman, J. H. Dundore, manager of the Sherman, Clay & Co. store.

Charles Soulé, district manager of the Starr Piano Co., is planning a visit through the Eastern part of his district, which will include stops at Spokane, Wash., and Boise, Idaho.

Elmer Hunt, wholesale manager of the local Sherman, Clay & Co. branch, has been visiting the Victor factory at Camden, N. J., and different jobbers as well as studying general conditions.

Victor dealers who visited the Sherman, Clay & Co. wholesale department during the past month were A. W. Burton, Powers, Ore., a new Victor dealer, and Stanton Powell, of

Grants Pass, Ore., proprietor of the Music & Supply House.

Sherman, Clay & Co. were awarded the first prize for the best musical window display during the Better Homes Week, and were given a handsome silver cup by the Portland News.

George Bohlen, representative of the Kimball Co., of Chicago, visited Portland during the past month, calling on the McCormick Music Co.,

local distributor of the Kimball pianos and phonographs.

J. A. Price, manager of the Wiley B. Allen branch at Centralia, Wash., was a visitor at Portland headquarters during the past month.

New saleswomen added to the record department of the Wiley B. Allen Co. are Gertrude Lee and Kathryn McCarthy.

Miss Emma Reynolds has been appointed manager of the record department of the Bush & Lane Piano Co.

Forest Cheney, of the Cheney Talking Machine Co., called recently on G. F. Johnson, of the G. F. Johnson Piano Co., representative of the Cheney interests in the Pacific Northwestern States, and accompanied him to Seattle and other Washington cities.

Standard Selections Growing in Popularity

General Phonograph Corp. Reports Tremendous Increase in Demand for Odeon Records—Otto Heineman Responsible for Their Phenomenal Success—Important Announcements Ready Soon

With every division of the General Phonograph Corp. working to capacity, Otto Heineman, president of the company, has found it necessary to divide his day so that each of the company's products may receive a certain portion of his individual attention. Okeh records are hitting new marks in sales totals; the new Heineman motors have been accorded an enthusiastic reception by the trade everywhere and Okeh steel needles are winning new friends steadily, but the outstanding feature of the company's activities is the tremendous and unprecedented demand for Odeon records.

The Odeon record division of the General Phonograph Corp. has been Mr. Heineman's special "baby" for the past three years and the remarkable success that these records have achieved is due in a large measure to his efforts and activities in their behalf, together with the co-operation of his associates. In 1920 Mr. Heineman spent several months in Europe and while abroad completed arrangements with the International Talking Machine Co. whereby the General Phonograph Corp. was given the exclusive right to import the matrices of recordings by world-famous operatic stars, internationally known musical organizations and the foremost musical celebrities of practically every country in Europe. The records from these matrices are pressed in the Okeh factories and released under the Odeon label. Each month a notable selection of the recordings is issued and it is gratifying to learn that dealers throughout the country are handling these Odeon records as a feature record line in their establishments.

At the present time a comprehensive catalog of Odeon recordings is in process of completion and when ready for distribution this catalog will emphasize concretely the remarkable progress that the General Phonograph Corp. has made in the introduction of these popular recordings to the trade in this country. Special album sets

have recently been introduced to feature Odeon records and these album sets have served to provide the dealer with a new and more profitable method of record merchandising. Mr. Heineman expects to have several important announcements to make during the next few weeks regarding his company's 1924 plans so far as Odeon records are concerned, and these announcements will undoubtedly prove of interest and benefit to the Odeon trade.

SINGLE RECORD DISPLAYS POPULAR

Special Window Displays Featuring Single Records Arranged by Thomas A. Edison, Inc., Prove Business Getters for Dealers

The policy recently adopted by Thomas A. Edison, Inc., of featuring individual Edison records in window displays, prepared especially for the use of Edison dealers, is meeting with popular approval, and reports coming from dealers who have utilized the displays indicate that concentration on a single product in a window display is a paying proposition.

The first display release by Thomas A. Edison, Inc., was in September, and each month since then new displays have been added. Placards and other publicity material going into the window are prepared by the Edison Company and supplied to dealers on request. The illustrations are especially attractive, and insofar as possible they convey a distinct thought on the particular record upon which the exhibit is based. In addition, neatly printed placards have been prepared on which appear brief messages designed to induce early action, resulting in the purchasing of the record featured.

The Carroll Music Co., 125 Putnam street, Marietta, O., recently reincorporated under the new name of the Cullen & Myers Music Co. Incorporators are M. and D. M. Cullen and B. B. Myers.

Made under Patent No. 995758 which has been vigorously contested and sustained by the Court of Appeals.

Any infringers and those involved in the manufacture, sale or use of same will be liable for prosecution and subsequent damages.

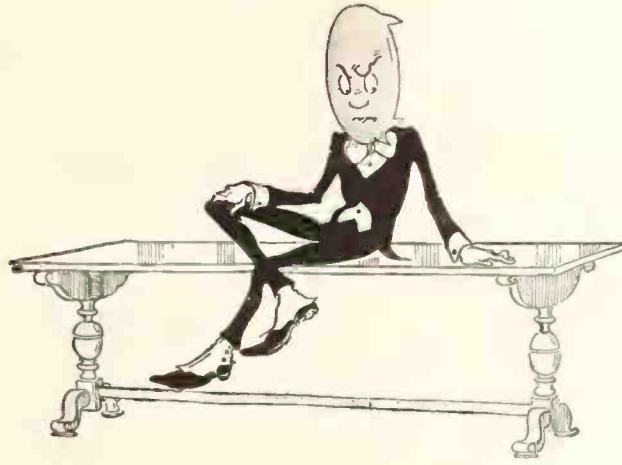

Serviceable furniture footwear has much to do with satisfied customers

ARE you interested in furniture after it leaves your factory? You are keenly anxious to manufacture the sort of furniture that sells easily and stays sold.

DOMES OF SILENCE will help you.

You can't possibly know what sort of conditions each piece of furniture you make must meet in the home to which it finally goes—whether it will be used on wood or tile floors—on rugs or carpets or linoleum. You don't need to worry where it's going to be used when you equip with



Made in Six Sizes

A correct size for every piece of furniture you make

The size best suited to any particular piece is one that will leave at least 3-16 of an inch margin between the edge of the Dome and the outside edge of the furniture leg. The use of the correct size on each piece of furniture is important to you—to your dealer customers and to the buying public. The correct size will give the maximum furniture footwear service.



DOMES OF SILENCE

"Better than Casters"

Because—equipped with **DOMES OF SILENCE** you can send your furniture anywhere knowing that the footwear will give complete satisfaction. Thus insuring Good Will.

They give complete satisfaction on any floor—any floor covering. They glide easily—silently over any surface. They will glide from the abrupt edge of a thick pile rug to the floor without fear of breakage and without strain or injury to the furniture itself.

DOMES OF SILENCE Division

Henry W. Peabody & Co.
17 State Street, New York City

The truest sort of factory economy lies back of **DOMES OF SILENCE**. Inexpensive themselves, they are quickly, easily—economically attached. By making them standard equipment on all your furniture, you straightway cut costs and simplify manufacturing process. Nor have you any apology to make for your finished product. Rather, you have added a selling point—you have given dealer and consumer just what they want in the way of furniture footwear.

MADE IN SIX SIZES SUITABLE FOR ALL KINDS OF FURNITURE



Extra Heavy Size—1 1/2 in.



1/8 in.



3/4 in.



5/8 in.



1/2 in.



3/8 in.

Reg. U. S. Pat. Off. No. 995758 which will be strictly enforced

What we say about Furniture applies also to Phonographs

Al Jolson's Sensational Hit in "BOMBO"

ARCADY

Fox-Trot Melody of rare beauty

You can't go wrong
with any FEIST song

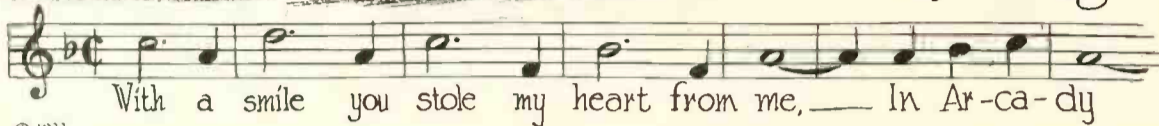

© 1923
Leo Feist, Inc.

COLUMBUS

Christmas Buying Starts—Trade Holding Instruments for Future Delivery—Business Gains Grow

COLUMBUS, O., November 9.—The Christmas season business is already well under way here. Among the firms that have a considerable number of machines stored away for delivery a few days before Christmas are the Elite Music Store, Victrola specialists; F. & R. Lazarus Co., and Heaton's Music Store. The last two concerns are also Victor dealers.

The C. C. Baker firm, Victor and Brunswick dealer, is making plans for Christmas business. This firm, as well as a number of others which have not started their Christmas campaigns, will launch special drives in a few days.

Console style machines have been unusually popular in this city. According to several Victor dealers as many as ten console models are sold to each upright. The machine business has been splendid in the past few months and at Heaton's Music Store during the first week in November an average of two machines were sold daily.

The "hit" in dance records for the past sev-

eral weeks has been "Last Night on the Back Porch," a fox-trot produced by the Paul Whiteman Orchestra, a Victor organization.

Ever since the inauguration of double-faced Red Seal Victor records the C. C. Baker Store has shown an increase in Red Seal sales.

Anticipating a heavy trade in the next few months Heaton's Music Store has engaged Miss Dorothy Wells, a well-known local musician, as a member of its sales force in the record department.

Steinway & Sons, Brunswick dealers, have also experienced a good business in the past several weeks. The \$250 console has been the favorite machine among their customers. Chester S. Carter and N. V. Wadley have recently been added to the sales force.

The first concert of a series arranged by the American Legion took place at Memorial Hall November 7. Mme. Schumann-Heink was the artist and the concert was a great success in every way. Sales of Victor records by this artist were greatly stimulated by her appearance here.

Dealers are co-operating in the promotion of coming concerts. The seat sale for the United States Marine Band is being held at Heaton's Music Store. Tickets for the Sousa concert are being sold at Goldsmith's Complete Music Store.

Due to the fact that the first State Music Memory Contest proved to be a tremendous success a second annual contest will be given next year under the State Department of Education. It will be conducted on practically the same rules and regulations as the one held this year, the final contest to be held in March. This year's contest, however, started just a few weeks after the first day of school, which is an added advantage over last year's contest, which was not launched until some time in February.

Local dealers are already co-operating with the students who have entered the contest. In the near future they expect to put on concerts when the numbers included in all three lists will be played for the benefit of all contestants. In addition to this arrangements are now under way whereby literature dealing with the numbers on the list will be distributed.

Ian S. Seeds, president of the Robert L. Seeds Co., Columbia and Cheney dealer, has just returned from a motor trip to the East.

The firm, at 112 South High street, has been at this location but six weeks and in that short time a definite increase of phonograph sales has been made.

Word comes from the Wainwright Music Co., Victor dealer, Marietta, O., that again this firm is assisting in the management of the community concert series. Miss Lucrezia Bori, Victor artist, gave the first recital of the 1923-24 concert series on October 12 and scored a big success.

Legions of friends and acquaintances of Messrs. Fred, Jr., Simon, Robert and Jeffrey Lazarus are sympathizing with them in their bereavement on account of the recent death of their mother, Mrs. Fred Lazarus, Sr.

CAPITALIZES ON BIG EDISON ORDER

Live Webster City, Ia., Dealer Lets the World Know That He Expects a Busy Season by Displaying Large Edison Shipment

WEBSTER CITY, IA., November 7.—One of the live dealers of this State is F. C. Ruegnitz. Proof of this statement is contained in the photograph of Edison phonographs reproduced herewith. This represents one shipment of instruments, and piled in front of the store they



Receives Big Edison Shipment

almost blot out the warerooms. Mr. Ruegnitz believes in publicity, therefore he had a large sign painted announcing to the world at large that the pile of instruments represents only one shipment, and in order to give passersby a clear idea of just how the Edison appears two of the instruments were uncased and placed one on each side of the sign.

Recording for the Phonograph Trade

The best equipped and efficient—low cost—laboratory in the industry.

Our success in recording for some prominent makes of records assures you a high-class product.

A visit or telephone call will give you the details.

Let us solve your technical problems.

We will be glad to send samples of late recordings.

A. J. BAUM, Manager
ARTHUR BERGH, Musical Director
FRED OCHS, Recorder

INDEPENDENT RECORDING LABORATORY, Inc.

102-104 West 38th Street New York

DIRECT FACTORY PRICE—JUST MENTION THE QUANTITY

MOTORS	CASTINGS	TURNTABLES	Stylus Bars
TONE ARMS	Grey Iron	MOTOR FRAMES	Screw Machine Parts
REPRODUCERS	and Brass for	TONE ARMS	Talking Machine Hardware
		HORNS and THROATS	

Direct Quantity Importations On { JEWEL and STEEL (Bulk or Packed)
PHONOGRAPH NEEDLES
GENUINE RUBY BENGAL MICA

D. R. DOCTOROW

Vanderbilt Ave. Bldg.
51 East 42nd Street, New York
Tel. Vanderbilt 5462
Murray Hill 800

TIMELY SONORA ADVERTISING

Full-page Advertisements in Daily Newspapers Emphasize Prosperity of Talking Machine Industry and Growth of Sonora Business

The position of the Sonora Phonograph Co., Inc., and its products in the talking machine trade are being emphasized for the benefit of the public in a most convincing way in attractive full-page advertisements being run in the daily newspapers of the country.

One of these advertisements appeared in the New York Times on November 11, and in a border showing the great variety of models offered in the Sonora there was set interesting explanatory text, the opening paragraph, for instance, reading: "The phonograph industry was never in a more prosperous condition. Phonographs are being purchased throughout the country in great numbers and the proportion of instruments of better grade was never higher. Dealers everywhere are clamoring for additional merchandise. Manufacturers of high-grade phonographs are already oversold. By increasing its production more than 30 per cent Sonora is striving to meet this demand." Then follows descriptive material relative to the construction, styles and prices of Sonora products.

FEATURES FEDERAL SET NO. 59

Attractive Advertising for New Federal Receiving Set—Has Several Important Features

The Federal Tel. & Tel. Co., manufacturer of Federal radio receiving sets, carried a very attractive half-page advertisement in the November 10 issue of the Saturday Evening Post, featuring the new Federal receiving set No. 59. The advertising showed an excellent photograph of the new set, and called attention to its various merits, among which are an unusual distance range and a high degree of selectivity which enables the user to hear distant

stations through local broadcasting without interference. The advertisement also called attention to the fact that all of the parts in the new 59 are manufactured by the Federal Tel. & Tel. Co. and may be purchased separately.

DR. DE FOREST TO VISIT RADIO SHOW

Famous Inventor One of the Feature Speakers at Chicago—Will Talk Over Air From Chicago and Detroit—Guest of E. H. Jewett

CHICAGO, ILL., November 8.—One of the features of the Chicago Radio Show will be the visit of Dr. Lee DeForest, inventor of the famous radio products bearing his name. It was in this city some twenty years ago that Dr. DeForest conceived the idea of the Audion tube, which represents one of the most important developments in the radio industry and which has attained world-wide renown. On November 22 Dr. DeForest will visit Chicago, accompanied by E. H. Jewett, president of the DeForest Radio Tel. & Tel. Co.; Chas. Gilbert, vice-president and treasurer; W. H. Priess, inventor of the Reflex set, and H. H. Roemer, sales manager of the company. Dr. DeForest is one of the feature speakers at the convention meetings and will also be the guest of honor at a dinner given by the DeForest distributing agents and retail representatives at the South Shore Country Club.

On Thursday evening Dr. DeForest will talk over the air from one of the Chicago broadcasting stations between 9 and 10:30 and, subsequently, will leave for Detroit as the guest of Mr. and Mrs. E. H. Jewett. In all probability Dr. DeForest will talk from the Detroit News broadcasting station, WWJ, on Friday night, and his talk will be of interest to radio fans.

There will be a large DeForest celebration at the Radio Show in this city and H. H. Roemer, who is chairman of the reception committee, has prepared an interesting program for all visitors to the show.

K. R. PERKINS ON BRUNSWICK STAFF

Well-known Wholesale Traveler Joins Brunswick New York Staff—Popular in Trade

Kenneth R. Perkins, one of the most popular wholesale travelers in the metropolitan territory, has been appointed a representative on the New York staff of the Eastern phonograph division of the Brunswick-Balke-Collender Co. He is an addition to the Brunswick staff and his appointment means no change in the present personnel of the organization. Mr. Perkins was for five years a sales representative of the Sonora Phonograph Co. in the metropolitan district. During his first year's connection with that company he was in charge of the dealers' service department, and during the past two years he was associated with the Greater City Phonograph Co., Sonora jobber.

H. H. ROEMER VISITS NEW YORK

H. H. Roemer, sales manager of the DeForest Radio Tel. & Tel. Co., was a visitor to New York this week, spending considerable time at the DeForest factories in Jersey City. Mr. Roemer was accompanied by C. E. Flynn, Western zone manager, with headquarters in Des Moines, Ia., who will probably spend a month in New York, doing special work in connection with the activities of the Eastern sales organization.

VICTOR CHRISTMAS PUBLICITY

Included in the great volume of special Christmas display material which the Victor Co. is preparing for dealers' use is a large hanger containing a special list of holiday records and a window strip in colors bearing the message: "Victrola—a Christmas Gift for Every Member of the Family." This publicity material is designed either for use in window displays or in warerooms and booths.

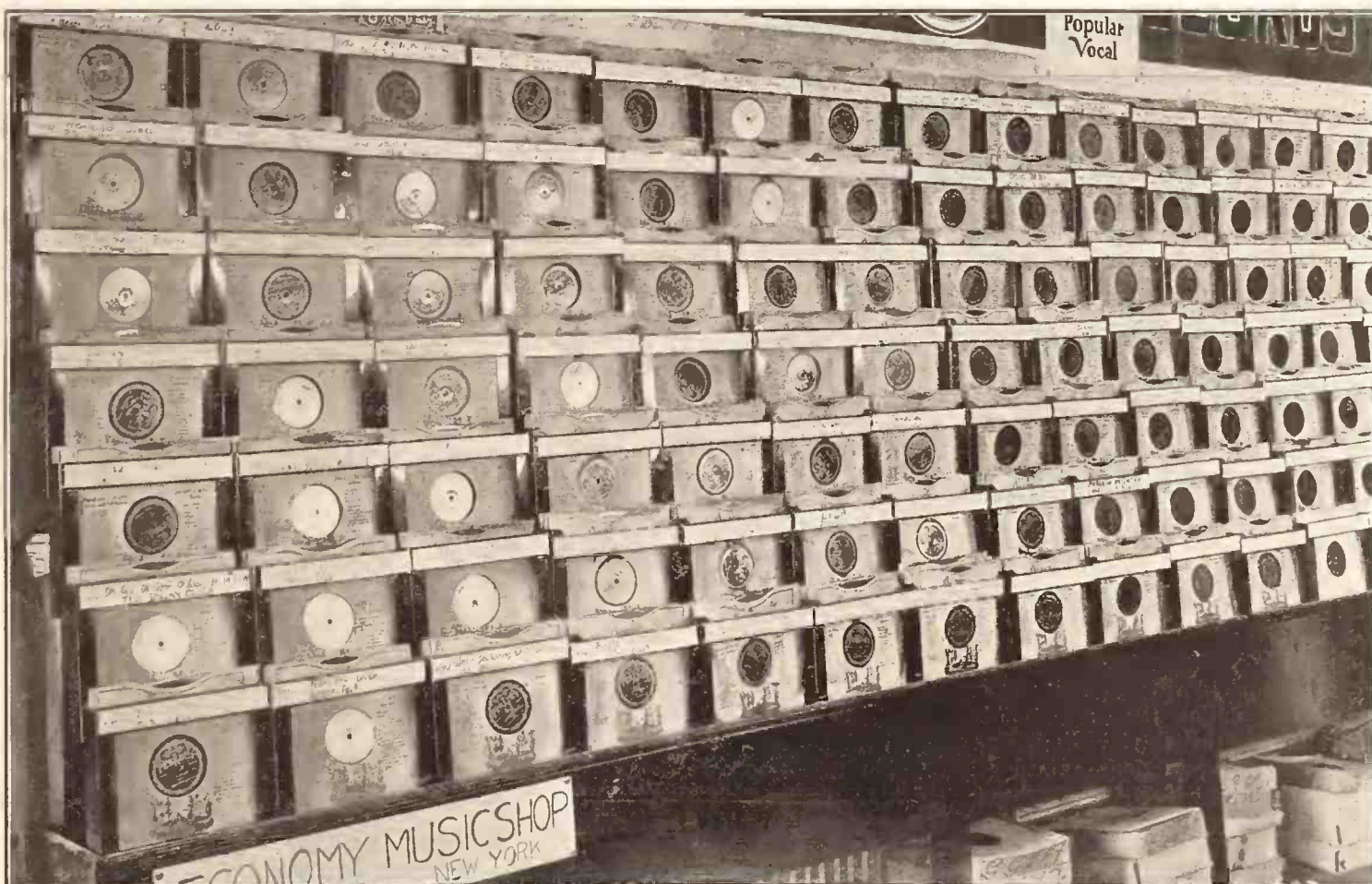

Something New That Will Positively Increase Your Sales 500 Per Cent

No. 590 NEW UNIVERSAL STOCK RECORD RACK, for 10-inch records. Display your stock records along the wall. Each record is visible at a glance. Quickly disposes of all slow-moving records. Features to-day's best-selling numbers. At the top of each pocket is a channel slide to receive record title, which is seen at a glance. Made in 4 and 7 pocket vertical units.

Send for new catalogue No. 1251, showing prices and details

UNIVERSAL FIXTURE CORPORATION

135 West 23rd Street, New York

My Sweetie's Sweeter Than That

"You can't go wrong with any FEIST song"



A Sweeter Than Sugar Fox-Trot



The honey-suckle is sweet, it gives the bees all a treat,

© 1923 Leo. Feist, Inc.

J.M.R.

EXPORTS AND IMPORTS OF "TALKERS"

Export and Import Figures on Talking Machines and Records Show Increasing Tendency as Compared With Last Year

WASHINGTON, D. C., November 8.—In the summary of exports and imports of the commerce of the United States for the months of August and September (the latest period for which it has been compiled), which has just been issued, the following are the figures bearing on talking machines and records:

The dutiable imports of talking machines and parts during August, 1923, amounted in value to \$71,654, as compared with \$42,056 worth which were imported during the same month of 1922. The eight months' total ending August, 1923, showed importation valued at \$513,839, as compared with \$353,088 worth of talking machines and parts during the same period of 1922.

Talking machines to the number of 5,242, valued at \$199,249, were exported in August, 1923, as compared with 2,859 talking machines, valued at \$92,430, sent abroad in the same period of 1922. The eight months' total showed that we exported 40,007 talking machines, valued at \$1,587,209, as against 30,901 talking machines, valued at \$1,093,450, in 1922.

The total exports of records and supplies for August, 1923, were valued at \$99,418, as compared with \$61,454 in August, 1922. The eight months ending August, 1923, show records and accessories exported valued at \$931,491, as compared with \$672,704 in 1922.

The countries to which exports were made in August and the values thereof are as follows: France, \$485; United Kingdom, \$8,703; other Europe, \$14,483; Canada, \$16,651; Central America, \$4,452; Mexico, \$16,171; Cuba, \$3,513; Argentina, \$21,738; other South American countries, \$8,257; China, \$2,099; Japan, \$36,963; Philippine Islands, \$2,683; Australia, \$27,588; Peru, \$3,722; Chile, \$12,559; New Zealand, \$10,049; other countries, \$9,133.

The Figures for September

The dutiable imports of talking machines and parts during September, 1923, amounted in value to \$40,000, as compared with \$24,375 worth which were imported during the same month of 1922. The nine months' total ending September, 1923, showed importations valued at \$553,839, as compared with \$377,463 worth of

talking machines and parts during the same period of 1922.

Talking machines to the number of 5,419, valued at \$231,646, were exported in September, 1923, as compared with 5,532 talking machines, valued at \$199,110, sent abroad in the same period of 1922. The nine months' total showed that we exported 45,426 talking machines, valued at \$1,818,855, as against 36,433 talking machines, valued at \$1,292,560, in 1922.

The total exports of records and supplies for September, 1923, were valued at \$93,074, as compared with \$70,985 in September, 1922. The nine months ending September, 1923, show records and accessories exported valued at \$1,024,565, as compared with \$743,689 in 1922.

The countries to which exports were made in September and the values thereof are as follows: France, \$245; United Kingdom, \$4,110; other Europe, \$5,032; Canada, \$89,503; Central America, \$6,031; Mexico, \$24,528; Cuba, \$4,455; Argentina, \$9,657; other South American countries, \$13,779; China, \$946; Japan, \$4,878; Philippine Islands, \$3,737; Australia, \$29,386; Peru, \$3,800; Chile, \$12,723; New Zealand, \$8,354; other countries, \$10,473.

VICTOR CO. DENIES RECORD CUT

No Basis for Story in Theatrical Weekly That Prices of Victor Jazz Records Would Be Reduced After the First of the New Year

In its issue of November 10 the Billboard, a theatrical publication, carried a sensational story to the effect that "The Victor Talking Machine Co. has decided to make a substantial reduction in the price of its jazz records, effective January 1, 1924," and that the decision had been arrived at at a meeting of the board of directors of the company the week before.

When his attention was called to the story by The World Ralph L. Freeman, director of distribution of the Victor Co., stated in substance: "The article has every appearance of being inspired and, so far as I am aware, there is nothing whatever to offer a basis for the published report."

SELF-SERVICE IDEA POPULAR

Helping Customers to Help Themselves Is Good Business—Universal Fixture Corp.'s New Record Rack Does This

The self-service idea in the talking machine wareroom is noticeably gaining ground. It has been found that the display of merchandise within reach of the customer has contributed decidedly to increased sales. Following this idea the Universal Fixture Corp., which is well known throughout the trade as the manufacturer of numerous display fixtures for the talking machine retailer, has placed a new fixture, consisting of steel wall pocket units providing for the display of records broadside, on the

market. These units are provided in vertical series of four or seven and there is a channel at the top of each record pocket in which can be placed, in large readable type, the name of the record. A number of dealers who have purchased this fixture from the Universal Fixture Corp. have ordered enough units to cover the entire wall of one side of the store.

LANDAY BROS. TO OPEN NEW STORE

The eighth of the Landay Bros. chain of music shops, and the third in the retail shopping district of Manhattan, will be opened shortly in the Marbridge Building, Thirty-fourth street and Broadway, Landay Bros. having leased a store on the Broadway side of that building for a period of fifteen years.

Baily's, Inc., prominent music dealers of Spokane, Wash., recently purchased the Music Shop, 722 Riverside, from Ray A. Grombacher, who opened the store four years ago.

STATEMENT OF THE OWNERSHIP, MANAGEMENT, CIRCULATION, ETC., REQUIRED BY THE ACT OF CONGRESS OF AUGUST 24, 1912, OF THE TALKING MACHINE WORLD, published MONTHLY, at New York, N. Y., for October 1, 1923.

State of New York, County of New York, ss.
Before me, a Notary Public, in and for the State and county aforesaid, personally appeared J. B. Spillane, who, having been duly sworn according to law, deposes and says that he is the Editor of The Talking Machine World, and that the following is, to the best of his knowledge and belief, a true statement of the ownership, management (and if a daily paper, the circulation), etc., of the aforesaid publication for the date shown in the above caption, required by the Act of August 24, 1912, embodied in section 443, Postal Laws and Regulations, printed on the reverse of this form, to wit:
1. That the names and addresses of the publisher, editor, managing editor, and business manager are: Publisher, Edward Lyman Bill, Inc., 383 Madison avenue, New York City; Editor, J. B. Spillane, 383 Madison avenue, New York City; Managing Editor, J. B. Spillane, 383 Madison avenue, New York City; Business Manager, Lee Robinson.
2. That the owner is: (If the publication is owned by an individual his name and address, or if owned by more than one individual the name and address of each, should be given below; if the publication is owned by a corporation the name of the corporation and the names and addresses of the stockholders owning or holding one per cent or more of the total amount of stock should be given.) Edward Lyman Bill, Inc., Caroline L. Bill, Edward Lyman Bill, Raymond Bill, Randolph Brown, Carleton Chace, Lee Robinson, J. B. Spillane, B. B. Wilson, all located at 383 Madison avenue, New York City. Edward Van Harlingen, 209 South State street, Chicago, Ill.
3. That the known bondholders, mortgagees, and other security holders owning or holding 1 per cent or more of total amount of bonds, mortgages, or other securities are: (If there are none, so state.) None.
4. That the two paragraphs next above, giving the names of the owners, stockholders, and security holders, if any, contain not only the list of stockholders and security holders as they appear upon the books of the company but also, in cases where the stockholder or security holder appears upon the books of the company as trustee or in any other fiduciary relation, the name of the person or corporation for whom such trustee is acting, is given; also that the said two paragraphs contain statements embracing affiant's full knowledge and belief as to the circumstances and conditions under which stockholders and security holders who do not appear upon the books of the company as trustees, hold stock and securities in a capacity other than that of a bona fide owner; and this affiant has no reason to believe that any other person, association, or corporation has any interest, direct or indirect, in the said stock, bonds, or other securities than as so stated by him.
5. That the average number of copies of each issue of this publication sold or distributed, through the mails or otherwise, to paid subscribers during the six months preceding the date shown above is (This information is required from daily publications only.)
J. B. SPILLANE.
Sworn to and subscribed before me this 1st day of October, 1923.
M. A. FOWLER,
Notary Public, Kings County, No. 71,
Certificate in N. Y. County No. 108
Register No. 4135.
(My Commission expires March 30, 1924.)

SEE WHAT
Minger Says
ON PAGE 35

Immediate Delivery Guaranteed!!

on All Samples of

Oh! Pep!

SOLID BRASS

DRAWN TONE ARMS

The Oh Pep Phonoparts Co. has at last surmounted all difficulties incident to the bringing out of its SOLID BRASS DRAWN TONE ARM and is now in position to make immediate delivery of samples of all sizes of its product.

Remember

Oh! Pep! Tone Arms and Reproducers incorporate no Die Castings whatsoever.

Oh! Pep! Tone Arms are of one piece Solid Brass Tubing, bent and tapered to shape, and of uniform thickness throughout.

Oh! Pep! Tone Arms will be shipped at once upon receipt of order accompanied by check covering cost of sample.

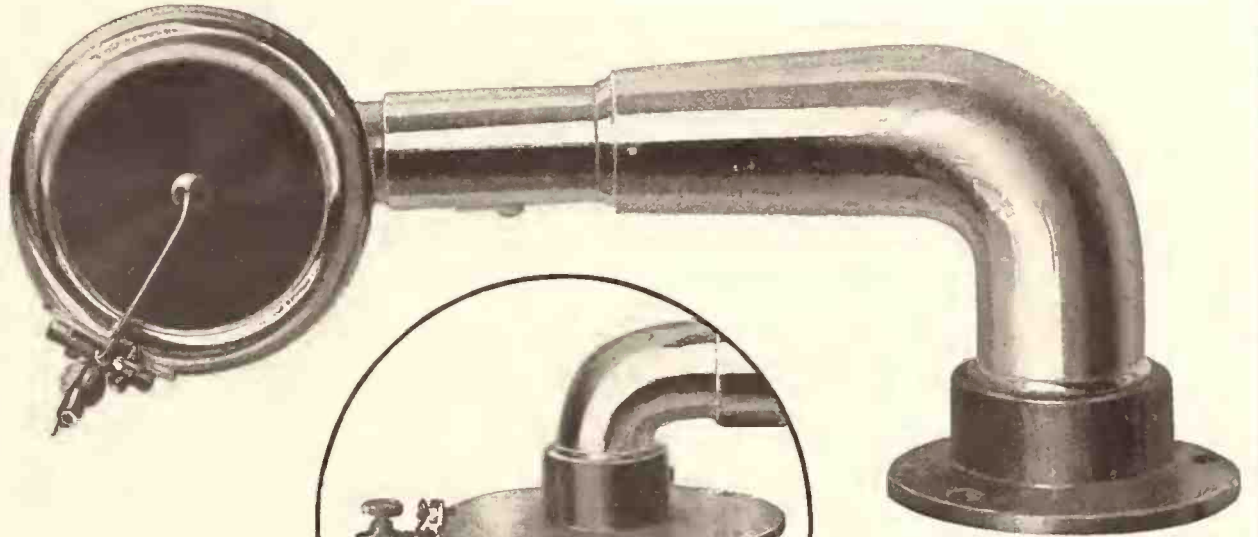

No. 1
Size 7½" — 8½"

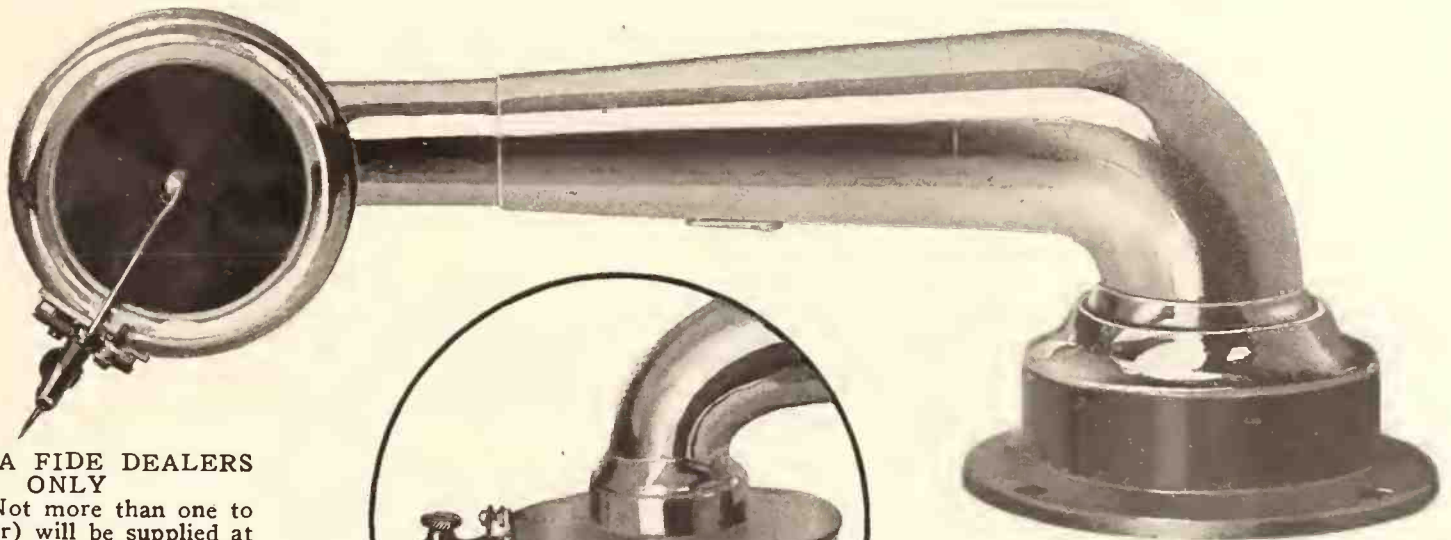

No. 2
Size 8½" — 9½"

TO BONA FIDE DEALERS ONLY
Sample (Not more than one to each dealer) will be supplied at following prices which apply to this transaction only:

- No. 1 ARM
- 7½"\$2.50
- 8½"\$2.75
- No. 2 ARM
- 8½"\$3.50
- 9½"\$3.75

The above prices include an Oh! Pep! Reproducer which is of Pressed Steel. If Solid Pressed Brass Reproducer is desired add 25c extra.



6912 Cottage Grove Ave.

Chicago, Ill.

DALLAS

Aggressive Policies Result in Business—Plan Holiday Drives—Convention Plans—Month's News

DALLAS, TEX., November 7.—There is a general feeling of optimism throughout the Southwestern trade territory. This is based on the steadily increasing business of the past month and indications of an excellent holiday business season. It must be admitted, however, that the good business is in a large measure the result of the activities of the live dealers in this territory. In this city, especially, the retail trade has been developing intensive campaigns which have been responsible for a good demand for both machines and records and sales are growing. Holiday plans are already under way by many merchants, including talking machine dealers.

The Edison is one of the instruments which stands at the pinnacle of popularity in this section. The Texas-Oklahoma Phonograph Co., Edison distributor, with headquarters in this city, is busy supplying the demands of its dealers, an indication that the Edison retail trade is in a prosperous condition. Since the return of A. H. Curry, head of this concern, from the Edison Laboratories, Orange, N. J., things have been humming in the local organization. The ability of Mr. Curry in surrounding himself with men of the keenest executive ability and the spirit of co-operation which exists in this distributing house are manifest by the high type of service accorded dealers and the efficiency with which the business is conducted.

Plans are being made for the annual meeting of the Texas Music Merchants' Association, to be held in Galveston on May 22. According to a recent announcement a two-day session will be held in the Hotel Galvez on that date, and it is expected that about 300 music merchants from this State will attend the meeting. Arrangements are being made for addresses by prominent trade members, including several nationally known speakers from New York and Chicago. After the convention many of the music merchants will go by boat to New York, where the national convention will be held ten days later.

The new Columbia instruments are attracting considerable attention here. This was particu-

larly true at the State Fair of Texas, held in this city, when the new models were exhibited by the Columbia Co.'s local branch. A complete line of the Columbia New Process records was also on display and daily demonstrations at the company's booth drew the crowds, who manifested considerable interest in the improvements embodied in the new models.

The Bush & Gerts Piano Co. of Texas, of this city, staged a most successful exhibit in the building at the State Fair. Jack Roberts, singer, drew large crowds to the booth. He is in charge of the sheet music department and he sang popular songs during the afternoons and evenings. Miss Irene Webber furnished the classical music for the sheet music division of the exhibit. Miss Lola Clark accompanied both singers.

The phonograph division of the exhibit was under the direction of C. D. Mills, with his assistants. Paul E. Burling was in charge of the piano department.

F. F. Dawson, sales manager of the Texas-Oklahoma Phonograph Co., in a letter to the Edison trade in the territory which it serves, is urging dealers to plan intensive record sales campaigns in order to make the most of pre-holiday trade opportunities. The necessity of early ordering of both machines and records is also pointed out as the means for insuring timely deliveries and avoiding shortage when a representative stock will be most needed.

RIGHT HOT OFF THE GRIDDLE!

H. C. Faber Writes The World Editor on Retail Merchandising Practices in a Vigorous, Right-From-Shoulder Style

Monongah, W. Va., October 29, 1923.
Editor, The Talking Machine World,
New York

My Dear Sir:—The much-used and abused phrase, "business is slow," is not caused by sluggish bowels and overwork. No sir. The main and outstanding cause is sluggishness in the space where brains are supposed to dominate. And while they, no doubt, are there, they fail to hit on all cylinders. Such being the common complaint among a great many dealers in talking machines and records, I would suggest a remedy that is a sure and everlasting cure for these "sluggards"; that remedy is found on page 4 of the October issue of the talking machine dealers' only and best every-day friend, i. e., The Talking Machine World, under the

**MICA
DIAPHRAGMS**

Absolutely Guaranteed Perfect
We get the best India Mica directly.
We supply the largest Phonograph Manufacturers.
Ask for our quotations and samples before placing your order.

American Mica Works
47 West St. New York

caption of "Is the Mail Order House Your Competitor?"

Every solitary word in this article is the plain truth with the spaces between found full of truth also. It would be a miracle, indeed, could one go through a day without hearing the worn-out phrase, "Hell, but this is a dull time. Everything's on the bum. The fools (citizens) send out and patronize the darned mail order houses in preference to our own home industry, etc."

I have only one comment to make regarding such chronic kickers, and that is—it is good for you. The home talent or home folks used to know you sold machines and records, but you were so cocksure of their future patronage that you just came to the conclusion that you would cut expenses some and quit advertising in the home papers. Results: the home folks not seeing your business in the papers any more, and daily receiving mail order requests for their patronage, the consequences were, and are, that these out-of-town houses who do not help your town in the tax question, get all the home trade and consequently you get a second-grade article and pay more than a first-grade price for same. Bear in mind, words are a game that can be made to win and at the same time not have a hint of the truth in same. By sending off to these town wreckers, you individually pay all expenses and a good margin of profit besides and eventually you find out that you got soaked, but the nice word-juggling advertisements came to you by mail until you got it into your head that it was the only place where you could buy a talker or records, and all on account of the home dealer being too stingy to invest a few dollars in the home papers.

It's a plain case of saving a few cents and losing a great many dollars. I can point, for instance, to the county papers here at home where everything is quiet and peaceful, and, holy-jumping-bees-wax, look, here it says that so-and-so is going to put on sale at a certain date such and such a brand of goods. Consequently on that date the cars are overcrowded all day and every darn store in the town gets a good share from the suckers that go to get bargains (mind you, bargains). But the satisfied "bargainer" is the advertiser; he sells and sells and you are wondering what hit you.

Such being the case, why not wake up and put this great big giant of a business-getter, advertising, on your payroll and keep him there. Perhaps he would not make a fortune for you in the twinkling of an eye, but as the sun rises and sets daily, just so sure will he convince you that he is on the job, and prove it daily to you by great strides in your business.

I can prove to anyone interested that advertising of the proper sort with nothing but the naked truth all through it will be a sure and a permanent silent business partner for you. Spasmodic advertising is a poor, useless and costly investment. When it appears the public takes it for granted that you have a good thing; when it ceases, then the public knows you are out of the running or else the goods you are carrying are useless and not worth letting the public know about.

There are to-day plenty of stores that advertise almost daily and it gets soaked into one's brain so that if we saw the paper and it did not contain an announcement of so-and-so we



WILLIAM AND MARY



CHIPPENDALE



SHERATON (SANS INLAY)



WILLIAM AND MARY



LONDON CONSOLE

A valuable asset to any merchant is our 1924 dealership for the one **INCOMPARABLE PHONOGRAPH**

THE NEW EDISON

It is not too late to get in on the Holiday Trade—a few open points in Texas-Oklahoma territory. Write us.

TEXAS-OKLAHOMA PHONOGRAPH CO.
2025 Jackson St. Dallas, Texas



BABY CONSOLE



CHIPPENDALE



LOUIS XIV



JACOBEAN



XVIII CENTURY ENGLISH



HEPPELWHITE



SHERATON UPRIGHT



SHERATON (INLAY)



ITALIAN (UMBRIAN)

would get a nervous shock and wonder what the trouble was. Go into any store of respectable size and you cannot help noticing that certain parts of this store have a large crowd in it, while the remaining parts are almost vacant. The cause is the "blessed" advertisements, for these stores can stick in an advertisement to-day that to-morrow they will have on sale dish rags, cheesecloth, Summer socks (for men) in the Winter time; in fact, any tomfoolery, and the consequences are that on the date advertised they sell out their stocks of "deads" entirely and get credit for it besides. Advertising does it, though.

Individually, I am here to truthfully say that I have been acquainted with the music lovers of this town for a long time and would have staked my last dollar that nothing but the highest grade of a famous make of record would ever enter their homes, but I was badly and sorrowfully surprised when I saw package after package of the lowest grade of records come into these "high-grade" music lovers' homes.

Investigation of this happening cracked me a blow square between the eyes when I was truthfully informed that these records were advertised in such and such an out-of-town paper and these parties thought that no local store handled them because they did not see them advertised. A shame it is that the dealer cannot change places with the customer just for a week or two and see from the outside what the insider should see and practice.

A good machine and a good record made by the best advertised factory in the United States is a valuable thing to own when we take into consideration that we are getting what the best artists in the world can give us. They are cheap at any price and make a quick turnover for the dealer who has got the scales washed off his eyes. But there are dealers who have their racks and shelves stocked full of these high-grade goods and do not make much noise either, simply because the public does not know they have them. So please read over (twice won't hurt) this mail order house article and act honestly with yourself. Give the home town a chance to buy at home and increase your sales and thus find out what a dose of continuous advertising will do for both your stock and your pocketbook.

H. C. FABER.

SONORA PORTABLE FOR FIREMEN

EUREKA, CAL., November 7.—James E. Mathews, local Sonora dealer, recently had a fire in his store. Through fast work the Eureka volunteer fire department rushed his entire stock out into the street, taking only eighteen minutes to transport forty-two phonographs and thirteen pianos to safety, thus saving Mr. Mathews from a considerable loss.

To show his gratitude he presented a Sonora portable to the members of the fire department, together with a supply of records. The little instrument has been busy day and night.

REPAIRS

TALKING MACHINE TROUBLES AND
HOW TO REMEDY THEM

Conducted by Andrew H. Dodin

MACHINE WITH LARGE SOUND VOLUME

Guelph, Ont., October 20, 1923.

Editor, Service Department,
Talking Machine World, New York.

I want to assemble a phonograph that can be plainly heard in a hall holding about 500 and trust you will pardon me for making the following inquiries, viz.:

- Wouldn't a long horn be best?
- What should a thirty-inch horn measure at large end?
- Would a long tone arm be best? How long?
- Who makes the most powerful reproducer? What model?
- Do you consider the concealed horn type best for my purpose? Who makes this type?
- Are motors furnished with winding key and turntable as part of their standard equipment?
- Who makes fittings, tone arms and tone arm brackets for old-style horn machines?

Thanking you sincerely in anticipation for your kindness in furnishing me with the information, yours faithfully,

(Signed) S. V. C. Shortis.

Answer: The volume required in a machine for demonstration to an audience of 500 people would depend upon whether the audience was assembled to listen to the machine or for the purpose of dancing. When a large number of people are dancing there is, of course, a greater number of attendant noises which tend to drown out even the music of a small orchestra.

The Victor Auxetophone, operated with compressed air forced through the sound box, is about the only machine I know of which would adequately answer the purpose.

To answer your several questions:

- The horn type would, without doubt, be the best.
- The horn can measure any diameter desired. The basic idea in horn construction is that the longer and more gradual the taper the more possibility there is in throwing the sound waves a further distance.
- Length of tone arm can be eight and one-half to eleven and one-half inches. Longer than this is not necessary.
- The Columbia No. 6 sound box is about the loudest all-around-purpose box made. There are also many other similar makes which have the same diameter diaphragm (23-16 inches), and the pivoted needle bar, which, if carefully assembled, give about the same results.

- See answer to question A.
- Motors are always furnished complete with turntable, winding key, brake, etc.

G. General Phonograph Corp. (Heineman) is about the only firm handling the old-style horn type tone arms and brackets. These parts are obtainable from their jobbers in various cities. The Victor Co. makes a horn type arm, also the Columbia Co. These parts, I don't doubt, could also be obtained through their jobbers and dealers.

DOING EXCELLENT WORK FOR MUSIC

Managers of Philpitt Stores in Tampa and Orlando, Fla., Conduct Special Concerts and Attract Wide and Enthusiastic Attention

The activities of S. Ernest Philpitt, well-known music merchant of Florida, in promoting elaborate musical affairs in Miami, where his headquarters are located, and bringing artists of wide reputation to that city, have evidently had their effect on the managers in charge of Mr. Philpitt's other stores in Florida, judging from results during the past few weeks.

In Tampa, for instance, Senor Giovanni Diaz, a well-known operatic tenor, was featured in recital under the auspices of C. R. Putnam, manager of the Tampa store of S. Philpitt & Son. Supporting Senor Diaz were Mrs. Jessie S. Pamplin, contralto and accompanist, and Gray Terry, pianist. An elaborate program of operatic numbers was rendered for the benefit of a large and enthusiastic audience. The Steinway was the official piano.

Particularly noteworthy was the accomplishment of Ross V. Steele, manager of the Philpitt store in Orlando, Fla., who organized and developed an excellent symphony orchestra made up of local musicians within a short period of seven months and recently gave his first concert. The performance of the orchestra aroused great enthusiasm and it is now firmly established as a definite factor in Orlando's musical life.

NEW BENTON HARBOR GRINNELL STORE

BENTON HARBOR, MICH., November 9.—A permanent location for the branch piano store of Grinnell Bros., of Detroit, has just been secured at 179 Pipestone street. This concern has been compelled to move several times since opening in Benton Harbor, on account of short-time leases. The interior of the store at the new location has just been decorated and improved throughout.

CHANGE IN SPRINKLE CO. MANAGERS

RICHMOND, VA., November 8.—P. E. Lotz, formerly manager of the Sprinkle Piano Co. store in Winston-Salem, N. C., has taken charge of that company's store in that city, succeeding C. H. Nokes, who has entered another field of business. E. R. Woolridge, formerly assistant manager of the Winston-Salem store, has now been placed in full charge as successor to Mr. Lotz.

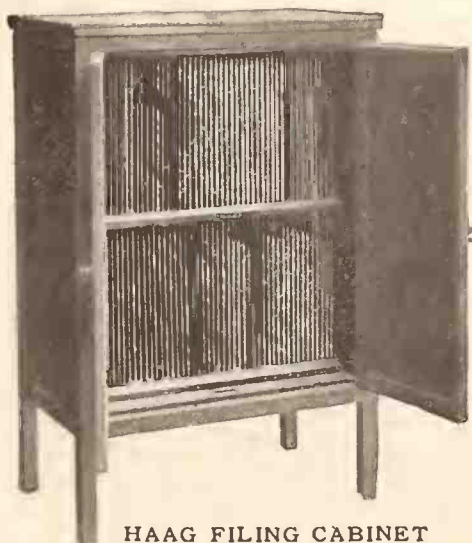

HAAG FILING CABINET
K-100

TO MEET THE DEMAND

—of—

EDISON DEALERS

We Are Now Marketing THE NEW

HAAG RECORD FILING CABINET

Accommodates 100 Edison Records. In Brown and Red Mahogany
TO RETAIL AT FIFTY DOLLARS

The Most Practical and Attractive Cabinet Ever Put on the Market

Orders Filled Only in the Sequence Received

HAAG & BISSEX COMPANY, Inc.
Calvert Building
Baltimore, Md.

JOBBERS:—

Desirable territory is open for financially strong established jobbers to represent the

Pooley Phonograph

proven out by experience to be a high quality desirable product, in a class of its own; our files and present jobbers will verify the statement that the Pooley Phonograph has been a sales success wherever it has been introduced.

POOLEY FURNITURE CO., Inc. 16th Street and Indiana Avenue Philadelphia, Pa.

STAGES SONORA WEEK IN MILWAUKEE

Sonora Dealers Combine in Staging Unusual Window Displays—Yahr & Lange Exhibit at Food, Household and Electrical Exposition

MILWAUKEE, Wis., November 5.—By far the largest and admittedly the most picturesque exhibit at the recent Fifth Annual Food, Household and Electrical Exposition in the Audi-



Seidel Bros.' Striking Display at Auditorium in Milwaukee was the showing made by the Yahr & Lange musical merchandise division, exclusive distributor of the Sonora in Wisconsin and Upper and Lower Michigan, with the co-operation of its eighteen dealers in the city of Milwaukee. The week of the exposition also was observed by Yahr & Lange as "Sonora Week" in Milwaukee, every retail representative in the city having made a special



Kleinert Music Shop Window display and interior trim, linking up the observance with the community exhibit at the Auditorium. The displays reproduced here with give a general idea of the lengths to which

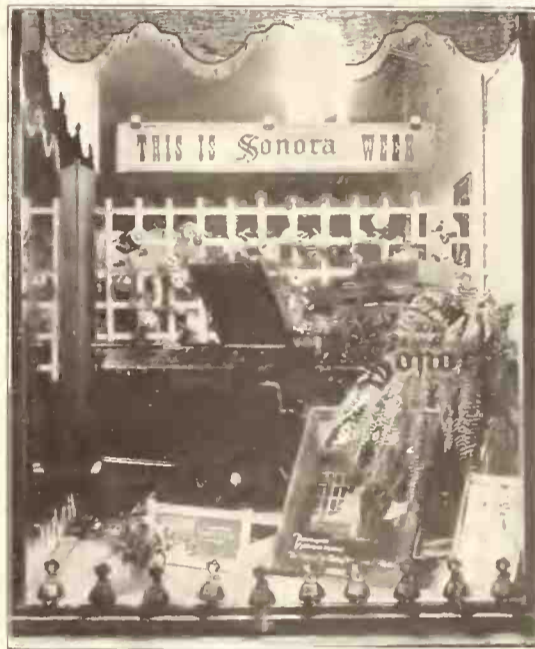

Display of the West Side Music House window display and interior trim, linking up the observance with the community exhibit at the Auditorium. The displays reproduced here with give a general idea of the lengths to which



Window of Wm. A. Kaun Store the dealers went in tying up with artistically arranged window displays.

The exposition display of Yahr & Lange occupied a space 130 feet long, the largest area used by any one exhibitor. Looming up in the

middle of the gorgeous display was a Bardini model of the 'Sonora, which sells for \$3,000. This was the most expensive talking machine on exhibition. Every other type of the Sonora, including the new Argyle model, was shown.

Directly in charge of the exhibit was Irving S. Leon, who, since August 1, has been sales manager of the Yahr & Lange music division, and whose acquisition was followed by the awarding of the exclusive wholesale Sonora franchise in the lucrative Lower Michigan territory to the Yahr-Lange organization. He was assisted by Walter Pugh, city representative in Milwaukee, and George Campbell, field representative in Wisconsin. Each Sonora dealer in this city was privileged to have two salesmen on the floor of the exhibit throughout the week of the exposition. In addition to seventeen actual sales closed on the floor, Manager Leon reports that 597 live prospects were secured out of 115,000 people who were present.

A special entertainment program was given for the exposition on one evening of the week by Yahr & Lange. Miss Marian Yahr, daughter of Fred E. Yahr, president of the company, presented several artistic dance numbers. Mrs. Eileen Shepherd Cavanagh, of Kenosha, Wis., a noted soprano, accompanied by Margaret Harwig, of Kenosha, was another feature.

WILSHIRE MUSIC CO. OPENS

LOS ANGELES, CAL., November 5.—The Wilshire Music Co., Walter C. Lilley, proprietor, recently opened an attractive store at 125 South Western avenue, this city. The booths are in the front of the shop, while in the rear is a large room for display purposes. No expense has been spared in the decorations. Oriental rugs, fine furniture and works of art combine in making a beautiful setting for the display of the instruments.

ASHER OPENS IN MINEOLA, N. Y.

MINEOLA, L. I., November 6.—An up-to-date music shop, handling Brunswick phonographs, records, pianos and sheet music, will be opened on Second and Main streets by Harry Asher, Mr. Asher came to Mineola four or five years ago and has engaged in a successful retail drug business here since that time.

NATIONAL METALS DEPOSITING CORPORATION

FACTORY
34 East Sidney Ave., Mt. Vernon, N.Y.
Telephone: Oakwood 8845

MOUNT VERNON — NEW YORK
MANUFACTURERS OF

LABORATORY
9 East 47th St., New York City
Tel. Vanderbilt 4153



WE DEPOSIT THE
FINEST COPPER
IN THE WORLD

FOR YOUR CONVENIENCE
DELIVER RECORDED WAX
TO OUR LABORATORY



OUR
IMPROVEMENT
ALL STAMPERS
HAVE
**HIGHLY POLISHED
MACHINED BACKS**

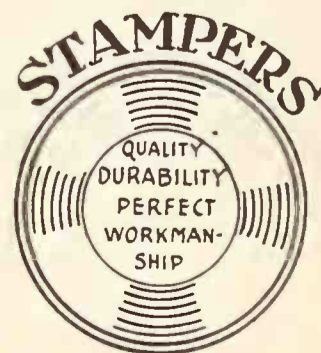

MAKES MANY SALES BY CANVASSING

P. L. Cavanaro, Edison Dealer, Covers Wide Territory and Sells Many Instruments by Canvassing and Home Demonstrations.

RIVERHEAD, L. I., November 7.—The value of canvassing as a means of sales is being demonstrated every day by P. L. Cavanaro, live Edison dealer. This live retailer covers a large territory surrounding the town in which his stock is located, and he has succeeded in placing many Edisons in the homes of Long Island



P. L. Cavanaro

residents through the canvassing route. The photograph reproduced herewith shows an Edison being placed in a prospective customer's home. This particular instrument was sold in the record time of fifteen minutes to a person residing twenty miles from the store, showing that when canvassing is coupled with a thorough knowledge of the line and progressive sales methods it is doubly productive of business. Mr. Cavanaro is seen standing to the right of the instrument, which is about to be delivered.

CLOSING EXCELLENT BUSINESS

Player-Tone T. M. Co. Reports Active Year—Consoles and Uprights in Demand—Factory Working to Capacity to Fill Orders

PITTSBURGH, PA., November 8.—I. Goldsmith, president of the Player-Tone Talking Machine Co., of this city, returned to Pittsburgh recently after spending ten days at the Jamestown furniture market. Referring to this show and to conditions generally, Mr. Goldsmith stated: "This has been one of the most successful seasons we ever had, and, in fact, we left the market a little earlier than usual in order to speed up our factory to take care of the tremendous demand for our new consoles, as well as our uprights. If sales continue this way we will run ahead of all previous years, and, in fact, we are certain there will be a shortage of products before the year is out.

"It is quite probable that we will be obliged to disappoint some of our most valued dealers, but this cannot be avoided, as we did everything possible to convince our trade that it will be necessary to anticipate requirements for this year's activities. During the coming year we are planning to increase our factory capacity by at least 50 per cent, as we have every confidence in the future of the talking machine industry.

"While we are enjoying a splendid business in the East, we are astounded at the number of inquiries received from Far Western and Southern points and incidentally there is an active demand for uprights. Of course, the console business is far beyond previous years and the reports received from our dealers indicate that they are moving the merchandise speedily and profitably."

E. H. Uhl has purchased the interests of the late Frank J. Hart in the Southern California Music Co., Los Angeles. Mr. Uhl is widely known in the industry.

JOINS JAMES K. POLK, INC., STAFF

W. Shephard Miller Added to Okeh Jobbers' Force—Well Qualified for the Post

ATLANTA, GA., November 5.—P. C. Brockman, head of James K. Polk, Inc., of this city, South-eastern distributor of Okeh records, Honest Quaker main springs, repair parts and other



W. Shephard Miller

phonograph accessories, announced recently that W. Shephard Miller had joined the company's sales force. Mr. Miller is the son of W. J. Miller, proprietor of the Miller Piano Co., Augusta, Ga., Okeh representative in that city. Mr. Miller has been associated with his father for the past year, handling in a retail way all the lines which are distributed by James K. Polk, Inc.

THE EMPIRE UNIVERSAL TONE ARMS AND REPRODUCERS

Positively Create Richness and Fullness of Tone Combined with Perfect Reproduction.

Send for sample of our new Tone Arm for Portable Machines and Edison Attachments.

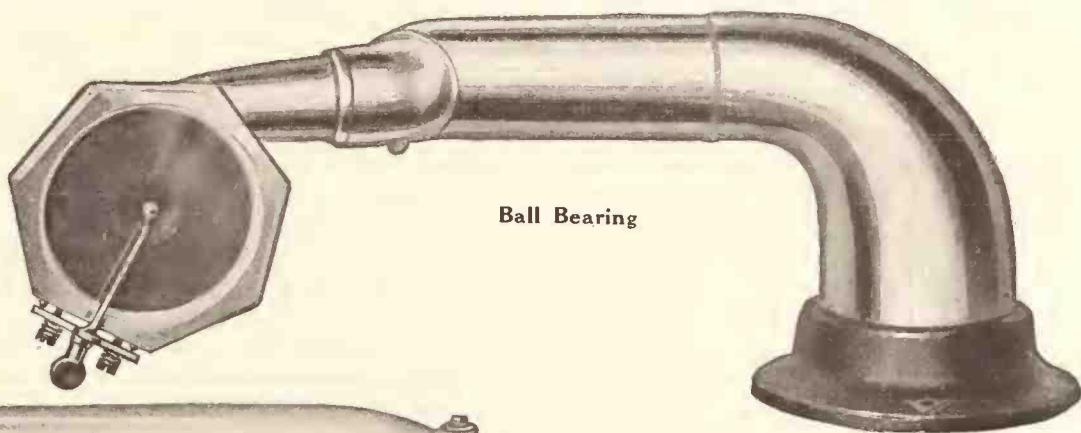

Ball Bearing



Pivot Base

We invite a personal test. There is nothing more convincing. Order a sample arm and test it out. It will win you on merit only. Our prices are low and the quality second to none.

Write or wire us for samples and quotations and give us an outline of your requirements.

Send for sample of our new Tone Arm for Portable Machines and Edison Attachments.

THE EMPIRE PHONO PARTS COMPANY, 1362 East Third Street, Cleveland, O.

Established in 1914

Manufacturers of High-Grade Tone Arms and Reproducers

W. J. McNAMARA, President

Cable Address "Emphono"

When Lights Are Low

An Enchanting Waltz Song
You'll never forget

"You can't go wrong
with any FEIST song"

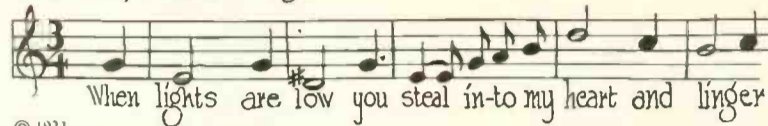

© 1923
Lea Feist, Inc.



CHECKING PARCEL POST PACKAGES

WASHINGTON, D. C., November 6.—Business men throughout the country are urged by the Third Assistant Postmaster-General to keep an accurate record of all insured and C. O. D. parcels received by them or originally mailed by them and returned as undeliverable. Such a record, it is pointed out, would not only be a protection to the patron, but would also assist the post office in settling claims and in ascertaining the reason for return without delivery of an undue number of parcels. A number of cases have arisen where the number of parcels returned as undeliverable was of too high a proportion, but the department is unable to ascertain the reason for such non-delivery in cases where an accurate record is not kept. The post offices throughout the country have been instructed to keep as complete a record as possible and to secure the co-operation of patrons who also should keep a record, thereby permitting the service and the patron to get together for the determination of causes of failure to make deliveries.

MELODY SHOP INCORPORATED

BLUEFIELD, W. VA., November 6.—Changes in the organization of the Melody Shop have been effected recently and papers of incorporation have been filed. The new company will open

an exclusive music shop here about December 1 in the Bradmann Building, opposite the post office. A. A. Treadway will be in active charge of the store.

MAX M. TAYLOR NOW IN CHARGE

KELSO, WASH., November 5.—Max M. Taylor, of Longview, has just arrived here to take charge of the Cowlitz Music Store, which has just opened for business at the corner of Third and Allen streets. The store will handle, in addition to a line of pianos, a selection of sheet music and small goods. The Brunswick line of phonographs and records will be handled exclusively. Before coming to Kelso, Mr. Taylor was in Dalles, Ore., where for five years he was manager of a music house and made a striking success.

GOLDBERG MANAGER OF COLLINS

NEW ORLEANS, LA., November 5.—Samuel R. Goldberg has just been appointed general manager of the Collins Piano Co., 155 Baronne street. For the past two years Mr. Goldberg has been connected with the Harry B. Loeb Piano Co. as secretary and treasurer. He has had many years experience in the music business, working for a considerable period for the Philip Werlein Co. as salesman.

SONORA ART POSTERS POPULAR

The art posters issued this month by the Sonora Phonograph Co. featured the William and Mary Deluxe model and the new Argyle.



Sonora Art Poster

These posters are being used to splendid advantage by Sonora dealers throughout the country, as they depict the Sonora Deluxe models in an environment thoroughly in accord with their attractive lines.

THE TALKING MACHINE WORLD'S CLASSIFIED ADVERTISING

FOR SALE

At sacrifice—Following Unit Construction Co.'s equipment, practically new. French grey, enamel finish:

4 6x9 rooms, design No. 1.

4 record rack units.

1 counter No. 3, glass display case.

Address Klingman Furniture Co., Grand Rapids, Mich.

WANTED

Discontinued models of Columbia Grafonolas C-2 and D-2, any finish and quantity. M. Calderon, 408 N. Main St., Los Angeles, Cal.

FOR SALE

Exclusive music shop, carrying dealerships for Edison and Columbia phonographs, also good line of pianos, situated in city of 60,000, with additional 50,000 to draw from. Long term lease, store well located and fully equipped. Write "Box 265," care The Talking Machine World, 383 Madison Ave., New York, N. Y.

FOR SALE

Exclusive talking machine business in Roanoke, Va. Established twenty years. Has Victor talking machine agency. Owner wishes to retire from business. Address "P. O. Box 492," Roanoke, Va.

DEALERS ATTENTION

Repairs and parts for Mandel and all other motors. Distributors of Wall Kane needles. We carry a full line of all well known motors and tonearms. Send for price list. Mandel Phonoparts Co., 1530 Milwaukee Ave., Chicago, Ill.

FOR SALE

One million foreign records; Columbia; all catalog numbers; all languages. Sold in small quantities or in one lot. Lovey & Alweis, 402 W. 40th St., New York, N. Y.

FOR SALE

Table phonograph cabinets. 36 new table phonograph cabinets, size 18 inches wide, 12 inches high, 20 inches deep; 3/5 veneered, 2/5 red gum mahogany finished in original boxes. Factory price \$12.75 in dozen lots. Will sell at \$7.50 each for cash. Address M. W. Hassey, 2932 Atlantic Ave., Brooklyn, N. Y.

CARVED LEGS

Eight designs in gum, oak and mahogany. Prices reduced. Send for circular. Klise Mfg. Co., Grand Rapids, Mich.

WANTED—SALESMEN

To call on phonograph jobbers and dealers with the Cresco Repeater as side line. Newest and most approved type of repeater on the market. Retail for one dollar. Fastest selling accessory in the industry. Liberal commissions. Write for sample and details. Rapid Repeater Co., 260 Van Alst Ave., Long Island City, N. Y.

POSITION WANTED—Salesman wishes to represent a reliable music house in New England territory. Large following built up by seven years' experience. Address "Box 1352," care The Talking Machine World, 383 Madison Ave., New York, N. Y.

WORLD'S CLASSIFIED ADVERTISING

Any member of the trade may forward to this office a "Situation" advertisement intended for this Department to occupy a space of four lines, agate measure, and it will be inserted free. Replies will also be forwarded without cost. Additional space will be at the rate of 25c. per line. If bold faced type is desired the cost of same will be 25c. per line. Rates for all other classes of advertising on application.

POSITION WANTED—Recording engineer of ability and experience desires to become associated with reliable firm manufacturing records of quality. First-class mechanic and familiar with all branches of the trade. References furnished. Address "Box 1342," care The Talking Machine World, 383 Madison Ave., New York, N. Y.

STATE REPRESENTATIVE WANTED—Men who have exclusive distributing privileges on line of musical accessories and who travel their territory can add to their income by writing to "Box 1343," care The Talking Machine World, 383 Madison Ave., New York, N. Y.

WANTED AGENTS—For exclusive State territorial rights. Full line of highest quality phonograph parts and accessories. Experience necessary. Address "Box 1344," care The Talking Machine World, 383 Madison Ave., New York, N. Y.

WANTED SALESMAN—Sell full line of highest quality phonographs and supplies. Address "Box 1345," care The Talking Machine World, 383 Madison Ave., New York, N. Y.

POSITION WANTED—Sales and general manager. Thorough knowledge of phonograph and music business, wholesale and retail. Have had over ten years of successful experience in this field. Capable of managing office, handling advertising, etc. Want position in Chicago. Formerly connected with nationally advertised line. Address "Box 1348," care The Talking Machine World, 383 Madison Ave., New York, N. Y.

WANTED SALESMEN—Phonograph salesmen who are traveling in different parts of the country will find it to their advantage to carry my quick-selling sideline, which you can sell to the same people you are calling upon. Good commissions and monthly settlements. Apply to "Box 1349," care The Talking Machine World, 383 Madison Ave., New York, N. Y.

SPECIALTY SALESMEN—We have territories open for live men wishing a good side line. A distinctive article for the talking machine and piano trade. Used in every home. A sure and profitable winner. Get territory while you can. The Glo-Rite Co., Inc., "Box 237," Camden, New Jersey.

WANTED — A number of live-wire, thoroughly experienced talking machine salesmen. Will pay \$60 a week and commission, which will approximate \$100 a week earnings to the right applicant. Call to see Saul Birns, 111 Second Ave., New York, N. Y., any morning between 10 and 12 o'clock.

POSITION WANTED—By recording expert with 25 years' experience in all parts of the world; thoroughly practical in all branches of recording and record manufacture; has own complete modern recording apparatus. Write "Box 1346," care The Talking Machine World, 383 Madison Ave., New York, N. Y.

POSITION WANTED—As material expert; thorough knowledge of formulas, machinery and production. Highest references. Apply "Material," The Talking Machine World, 383 Madison Ave., New York, N. Y.

POSITION WANTED—Young man, 11 years' experience as phonograph salesman and repairman. Connection desired with established house, either as salesman, repairman or assembling. Last position, foreman of shop. Address "Box 1351," care The Talking Machine World, 383 Madison Ave., New York, N. Y.

SPOT CASH

Wanted phonograph motors, hardware, legs, etc. Also veneered panels. Must be cheap.

Illinois Phonograph & Supply Co.
237 S. Market St. Chicago, Ill.

SPRINGS

VICTOR

1 1/4"x.022x17", bent each end.....	No. 6543	\$.57
1 1/4"x.022x18" 6" marine ends.....	No. 3014	.58
1 1/4"x.022x17" marine ends.....	No. 3014	.55
1 1/4"x.022x17" bent arbor.....	No. 5362	.57
1 1/4"x.022x13" bent arbor.....	No. 5423	.50
1 1/4"x.022x9" bent arbor.....	No. 5427	.42
1 1/4"x.022x9", bent each end.....	No. 6546	.42
1"x.020x13" 6" marine ends.....	No. 2141	.32
1"x.020x15" marine ends.....	No. 3335	.35
1"x.020x15" bent arbor.....	No. 5394	.38
1"x.020x15", bent at each end.....	No. 6546	.43
3/8"x.020x9" marine ends.....	No. 988	.29

COLUMBIA

1"x.028x10" Universal.....	No. 2951	.33
1"x.028x11" Universal.....	No. 2951	.35
1"x.030x11" hook ends.....		.45
1"x11" for motor No. 1.....	No. 1219	.35

HEINEMAN

1"x.025x12" motors, Nos. 33 & 77.....		.33
1 3/16"x.026x19", also Pathé.....		.75
1 3/16"x.026x17".....	No. 4	.59

MEISSELBACH

3/8"x10" motors, Nos. 9 & 10.....		.29
1"x9" motors, Nos. 11 & 12.....		.29
1"x16" motors, Nos. 16, 17 & 19.....		.49
2"x.022x16", rectangular hole, 18k10.....		1.20

SAAL-SILVERTONE

1"x.027x10", rectangular hole.....	No. 144	.42
1"x.027x13", rectangular hole.....	No. 145	.48
1"x.027x16", rectangular hole.....	No. 146	.58

BRUNSWICK

1"x.025x12", rectangular hole, regular.....	No. 201	.45
1"x.025x18", rectangular hole, regular.....	No. 401	.60

KRASBERG

1"x12" motor 2A, pear-shape and rect. holes		.45
1"x16" Motor 3 & 4, on outer end.....		.55

EDISON DISC

1 1/2"x.028x25" regular size disc motors.....		1.25
1"x.032x11", Standard.....		.55
1 5/16", Home.....		.70
1 5/16"x18" type A 150, old style disc.....		1.28
1" Amberola 30-50-75.....		.56
1 1/16", B 80.....		1.15

SUNDRIES

1"x.025x16" rectangular hole.....		.50
1"x.025x16", pear-shaped hole.....		.50
3/8"x.023x10", marine ends, Hein. Col., etc.....		.29
3/8"x.025x10", marine ends, Hein. Col., etc.....		.27
3/8"x.020x9", marine ends.....		.21
3/8"x.020x9", marine ends.....		.18
Victor Gov. springs, No. 1729.....	per 100	.95
Victor Gov. spig. screws, No. 3304.....	per 100	.92
Victor Gov. balls, n/style, No. 3302.....	each	.07
Victor Gov. spring screw washer.....	per 100	.72
Columbia Gov. springs, No. 3510.....	per 100	.95
Colum. Gov. spig. screws, No. 439.....	per 100	.92
Columbia Gov. spig. screw washers.....	per 100	.72
Columbia Gov. ball, lead, flat and spring.....		.08
Columbia Gov. ball, new style & spring.....		.08
Turntable felts, all wool, green, 10", round.....		.15
Turntable felts, all wool, green, 12", round.....		.18

Terms, 2% cash with order.

TALKING MACHINE SUPPLY CO., PARK RIDGE, N. J.

FOR SALE

A live-going Chicago business paying over \$25,000 yearly profit and two executive salaries of \$7,800 each can be bought for \$100,000 cash. Is a leader in their line, selling goods in every civilized country in the world through high-class distributors. Has 22 patents allowed and pending covering goods made and patent protection on goods in foreign countries. Highest mercantile and bank references. The line has great mail-order possibilities. Ill health from climatic changes in this part of the country reason for selling. Must act quick, as best five months are to come. Address P. O. Box 667, Chicago, Ill.

NOTICE RECORDING ENGINEERS

We are ready to furnish a homogeneous recording wax for professional recordings. Have furnished recording wax to the leading engineers of the profession. 25 years' experience in making wax for the trade.

NO CHIPS NO ACID ATTACK
RIBBON CUT

Standard Wax Co., 228 Bergen Ave., Jersey City, N. J.

WILL BUY FOR CASH

We want to buy for spot cash Columbia Grafonolas; all types. State lowest prices.

Colonial Piano Corporation,
18 West Broad St.,
Richmond, Va.

FOR SALE

Four hundred 46-in. gum wood mahogany finished, straight-legged, upright cabinets. These instruments are equipped with high-grade Columbia two-spring motors and Columbia tone-arms of unused but discontinued models. The sale price of complete talking machine is \$25.00 each, in lots of 100. Chicago Phonograph Realization, 1427 Carroll Ave., Chicago, Ill.

WILL BUY AND SELL

Any Quantity

Pianos, phonographs, records, rolls or any musical merchandise.

Spot Cash

J. K. Morgan,
401 South State St.,
Chicago, Ill.

FOR SALE

100 high-grade portable phonographs, Model No. 25, to close out at \$10.00 each in lots of 10 up; also 1,000 sets of record-filing albums, 6 to a set, at 75 cents per set in lots of 20 sets and up. Address "Box 1347," care The Talking Machine World, 383 Madison Ave., New York, N. Y.

FOR SALE Fine Phonographs at Prices

A manufacturer of fine phonographs, the line being nationally known for its beauty of design and cabinet work, has five discontinued upright models to close out at very attractive prices.

These phonographs are in perfect condition, and are installed with the finest of equipment. Finishes include mahogany, walnut, golden and fumed oak.

This is a real buy. They will not last long. Write today. "Box 1350," care The Talking Machine World, 383 Madison Ave., New York, N. Y.

FROM
OUR

EUROPEAN HEADQUARTERS

2 GRESHAM BLDG., BASINGHALL ST., E.C. LONDON.



W. LIONEL STURDY, MANAGER

INCREASED ACTIVITY NOTED THROUGHOUT TRADE AS BUSIEST SEASON OF THE YEAR APPROACHES

Reduction of Record Prices Has Favorable Influence on Buying—"His Master's Voice" Co.'s Annual Report—Association Advocates Standard Gramophone Parts—Other Important News

LONDON, ENGLAND, November 3.—That more or less indefinable period, so called "the season," is now with us in very truth. In the aggregate, all sections of the trade are busy, although here and there things seem to be in a state of flux, due, for the most part, to local influences of a nature adverse to good business. From a general viewpoint it is a sound reflection that although industries may rise and fall the gramophone and record trade carries on ever in goodly measure all the time.

The element of competition among manufacturers and wholesalers became very keen last year; it is more than ever keen this season, as witness the wholesale reductions in the prices of records to which full reference is made elsewhere in this section. If anything were needed as a stimulus to the development of trade, these record price reductions, together with an increase in the number of cheaper cabinet and table grand instruments, are generally regarded as in the nature of a last straw to break the back of any industrial apathy.

Increased production is the order of the day, not only to satisfy the home market, but to meet the foreign demand. The latter aspect of trade is a good sign of the times. It is very necessary that the mother country should look after her colonies and the increasing facilities

afforded for exploration and development of these markets are being taken full advantage of by live British gramophone houses.

"His Master's Voice" Co.'s Annual Report

The report of the Gramophone Co., Ltd., for the year ended June 30 last is just to hand and discloses an extremely satisfactory state of affairs. The trading profits were more than double those for the previous twelve months, having amounted to £283,769, as compared with £140,307, and exceeded those of all previous years. The directors also state that sales since July 1 last show a good advance over the corresponding period of last year. Despite this fact, however, no alteration is being made in the dividend, 15 per cent again being the rate; but in this connection it has to be remembered that the 850,000 "B" ordinary shares, on which 8s per share has been paid, making £340,000, rank for dividend. These "B" shares were issued in 1920 to the Victor Talking Machine Co., when it was agreed that for the financial years ended June, 1921, 1922 and 1923, the ordinary shares should be entitled to a preferential 15 per cent dividend, and that after a like dividend had been paid on the "B" shares, both classes should rank together. No dividend was paid on the "B" shares for 1920-21 or 1921-22, but now the full 15 per cent is to be distributed,

and from now on the distinction between the two shares disappears. The full distribution of the dividend this year will amount to £163,500, as compared with £112,500. There remains £126,237 to be carried forward, as against £44,054 brought in, so that a larger dividend could have been paid if desirable. The general finance sheets show a strong position, and the report states that the net tangible assets, irrespective of goodwill, trade marks, patents, etc., and after deduction of liabilities and debenture stock, amount to £1,680,336.

With regard to the Continental markets the directors state that "the abnormal conditions on the Continent reported last year, have intensified to the company's disadvantage, and, notwithstanding the largely increased business, trading continues to be unprofitable."

The Columbia Position in Great Britain

Coming on top of the tremendous advertising campaign commenced with issue of the new instruments and records, reported last month, and the subsequent tremendous activities of the British Columbia Graphophone Co., the news that the Federal court had appointed receivers for the American company occasioned more comment in trade and public circles here than otherwise would be the case.

An immediate press interview with Louis Sterling, the managing director of the British company, brought forth statements that cleared the air. Mr. Sterling explained that the British company has absolutely no financial connection with the American. "For two years," he said, "the American company has been on the point of reorganization, and apparently the message



Unique Oval Model. Satin Mahogany finish, paneled all around; height, 8½ ins.; depth, 19 ins.; width, 16 ins. Reliable Swiss single spring, silent helical wind, worm gear motor; plays 10-in. and 12-in. records; 10-in. turntable, plush covered, with special nickel-plated rim. Internal floating amplifying chamber. Fret front and silk screen. Sound-adjusting doors with piano hinges. Nickel-plated tapering tone-arm, with crane back and "gooseneck." Fitted with special plate holding two needle bowls, one with cover. Dial speed regulator and indicator. "BANDMASTER" perfected "Carmen" sound box for steel or fibre needles.

18 Different Models
British made components throughout

The Hub of the Gramophone World!!

(Patent and registration rights applied for)

The tremendous reception accorded BANDMASTERS is the greatest proof of their merit. The tone of BANDMASTERS—The elegant cabinet work—The high quality fitments—all these at once please the most fastidious visitor to your store, and the extremely low price makes it quite unnecessary to sell on credit when your stock is comprised of BANDMASTERS.

The World's largest individual order for gramophones was taken by Bandmasters in open competition with English and German manufacturers. There is a strong reason for it. We can furnish that reason. Overseas trade especially catered for. BANDMASTERS appeal to the keen-eyed business man who knows his business.



Baby Grand. Unique Horseshoe design. Solid Mahogany, Satin Finish, beautifully inlaid; height, 32½ ins.; width, 20½ ins.; depth, 21 ins. Reliable Swiss double spring, silent wind, worm gear motor; plays 3 records one wind; 12-in. turntable, plush covered, with special nickel-plated rim. Voluminous mellow internal floating amplifying chamber, with cast metal elbow connection. Sound-adjusting doors. Heavily nickel-plated tapering tonearm with crane-back and extra long "gooseneck." Needle bowls for new and used needles, one with cover. Dial speed regulator and indicator. "BANDMASTER" perfected "Carmen" sound box for steel or fibre needles.

18 Exclusive designs
British made components throughout

"THE FAME OF 'BANDMASTER' SPREADS DAY BY DAY"

VIDE THE
LONDON PRESS

BANDMASTER LIMITED, BANDMASTER WORKS - - Hendon, London, England

FROM OUR EUROPEAN HEADQUARTERS—(Continued from page 190)

from New York indicates that the first step has been taken. In fact, only last Saturday (October 13) I received a letter stating that an application for a receivership was being made. We have no connection whatever with that company. All the goods we sell are manufactured in Great Britain. We own the trade mark 'Columbia' for the whole of Europe and the British colonies, and, therefore, we operate under the same name, but there is no financial connection."

Reductions in Price of Records

In contrast to the last occasion when the record companies announced reductions, this month has witnessed substantial reductions generally without overloud preliminary blasts from the advertising trumpets. As I foreshadowed in my October report, there had been a feeling in the air for some time regarding possible reductions, and with the beginning of this month came the first announcement from "His Master's Voice" Co., whose slogan is "Back to Pre-War Prices." From October 1 prices of the double-sided Black Label records are reduced from 7s 6d to 6s 6d for the twelve-inch and from 5s 6d to 4s 6d for the ten-inch; Plum Label, from 6s to 4s 6d for the twelve-inch and 4s to 3s for the ten-inch. No change is announced in the "Celebrity" records, which, as the company states, are already below pre-war prices.

Simultaneously with "His Master's Voice," the British Zonophone Co. announced reductions in the price of "Zonophone" records as follows: ten-inch double-sided from 3s to 2s 6d; twelve-inch double-sided from 5s to 4s.

The Columbia Co. also announced from October 1 a reduction in the Dark Blue Label of from 3s 6d to 3s for ten-inch and from 5s 6d to 4s 6d for twelve-inch. The Light Blue Label double-sided series remain at 5s for ten-inch and 7s 6d for twelve-inch, and the "Regal" records also remain at 2s 6d for ten-inch double-sided and 4s for twelve-inch double-sided.

The Edison Bell "Violet Face" records are down. Violet Label double-sided from 3s 6d to 3s for the ten-inch and from 5s 6d to 4s 6d for the twelve-inch. A new (Green) label is announced at 3s 6d for the ten-inch and 5s 6d for the twelve-inch.

Aeolian "Vocalion" records from October 1 are as follows: Blue Label twelve-inch from 7s 6d to 6s 6d; ten-inch from 5s 6d to 4s 6d; Black Label twelve-inch from 6s to 4s 6d; ten-inch from 4s to 3s. Brown Label ten-inch from 3s 6d to 3s; which brings into the cheapest series a number of vocal and instrumental selections formerly only available in the dearer classes.

From October 11 the Pathé Frères Pathéphone, Ltd., "Pathé" series dropped as follows: Size ten-inch, Black, from 3s to 2s 6d; Red, from 4s to 3s. Size twelve-inch, Black, from 4s 6d to 3s 6d; Red, from 6s to 4s 6d; Buff, from 7s 6d to 6s; Blue, from 10s to 7s 6d; White, from 12s 6d to 8s 6d. The "Actuelle" series range: Size ten-inch, Pink, from 3s to 2s 6d; Ivory, from 4s to 3s; Green, from 5s to 4s. Size twelve-inch, Pink, from 4s 6d to 3s 6d; Green, from 7s 6d to 6s.

In order that the change may bear as lightly as possible on everybody concerned, most of the companies are allowing rebates to dealers on their net purchases from June 1 to September 30. The exception is the Pathé Frères Pathéphone, Ltd., which asks for a return of all stocks held, when, if an equivalent covering order is placed, rebates will be allowed.

Advocate Standard Gramophone Parts

A potent factor in determining gramophone trade conditions on this side is the Association of Gramophone and Musical Instrument Manufacturers and Wholesale Dealers. It is affiliated with the Federation of British Music Industries and to that body contributes a higher ratio of subscriptions than any other trade association. A strong committee meets at regular intervals to discuss and consider plans for the general

betterment of the industry. Active measures are now in hand to (1) obtain the definite agreement of all gramophone manufacturers against trading with co-operative societies (who by means of share-profit or dividend tickets are thereby able to offer the public certain price advantages to the detriment of other dealers' trading) unless this method in regard to gramophone goods is discontinued, and (2) to secure, if possible, a general standardization of fittings—in particular, tone arms and sound boxes. Gramophones are designed to fit these parts, whereas a reversal of the order would permit a more general conformity to recognized standard British and Continental fittings in regard to interchangeability of parts and cases.

This is a matter worthy of close study. Its application would tend to simplify costs and speed up production in manufacture of the parts and assembling of the instruments.

A British Gramophone for Canada

William Noon, director of the Duophone Co., this city, sailed October 24 on a visit to Toronto, Canada. The object of his visit is to complete negotiations for the formation of a new Canadian concern—Duophone (Canada), Ltd., under the chairmanship of the Right Honorable, the Earl of Hardwicke, and backed by an influential financial group in Toronto. In due course the new company will announce its plans and trading policy. It starts with every prospect of success from the viewpoint of finance, personnel and product. Mr. Noon embarked upon his trip accompanied by good wishes from many trade friends for the success of the new venture, and I believe that even the Right Hon. Mackenzie King, Prime Minister of Canada, now in London, found time to convey a message of goodwill. It is understood that Mr. Noon may shortly be opening up negotiations for the establishment of a company in the United States of America to exploit the Duophone invention.

This gramophone is very highly thought of (Continued on page 192)



(Patent and registration rights applied for)

Record clip to hold 6 records, secured by ball catch; releasing record by a mere turn.

Complete Frosted finish aluminum motor-board and sound reflector.

Key-clip fixed in a convenient position.



Patent Record holder, with self-adjusting rubber pad acting as needle cup cover when closed, thus preventing needles falling out when carried.

Patent Tonearm with spring elevator lowers upon closing lid, ensuring rigidity when machine is being carried.

Needle cup ready for use immediately lid is opened.

Special graduated tone amplifying chamber.

Well-made cases in oak or leather covered.

Size: Height, 5 1/2 ins.; depth, 11 1/2 ins.; width, 12 1/2 ins.

Reliable Swiss single-spring motor, silent helical wind, 8 1/4 in. turntable, plush covered, with nickel-plated rim; plays 10-in. or 12-in. records. "BANDMASTER" perfected "Faust" sound-box. No adjustment of parts. Ready to play upon opening lid. Weight under 11 lbs. when packed. Carry 6 records.

Model "A" in Solid Oak. Model "B" in Covered Leather Cloth.

British-made components throughout

Portable Perfection!

Known and Supported

by the British trade as the

Most Wonderful Portable Gramophone

← on the Market at any Price!

The tonal delivery is exceptionally bright and in volume equal to any cabinet.

BANDMASTER PORTABLES are now replacing all other portables at home and on the Overseas Markets.

Keen export quotations mailed immediately on request.

It's a "Bandmaster" Sensation—Make it Yours!

BANDMASTER LIMITED, Bandmaster Works, Colindale Avenue, Hendon, London, England

FROM OUR EUROPEAN HEADQUARTERS—(Continued from page 191)

Hornless, Table Grand, Upright and Horizontal Cabinet Grands

Actual Manufacturers Export a specialty

REX GRAMOPHONE COMPANY

59 Chiawell Street, LONDON, E. C., England
Cable Address "Lyrecodisc, London"

in the United Kingdom and has won the approbation of leading musicians, as well as the gramophone trade. Col. Mackenzie Rogan, late conductor of the Band of H. M. Coldstream Guards and one of our leading musical exponents, has associated himself with the Duophone in giving a series of musical lectures throughout the country.

The Duophone, by the way, embodies many unique features of construction, chief of which is the double-channeled tone arm and twin sound boxes. The fidelity of its reproduction is remarkable.

New Official Wireless Regulations

The Broadcasting Committee appointed on April 24, 1923, by Sir Wm. Joynson-Hicks, then Postmaster-General, issued its report at the beginning of October, and arising out of the report new regulations as below have been issued by the present Postmaster-General:

Home constructors of wireless apparatus not in possession of an experimenter's license can obtain authority to use the apparatus at an annual fee of 15s, but must not knowingly use parts manufactured out of Great Britain.

The license for the use of a B. B. C. set remains at 10s.

Bona-fide experimenters can still obtain license for 10s, but must sign a declaration to the effect that they will not use the broadcast programs except for experimental purposes.

Licenses to cover all requirements are now obtainable, precluding the necessity of any owner of a receiving set being outside the law.

The license fee provides a larger contribution to the B. B. C.

B. B. C. broadcasting sets will cost less than formerly because the royalty payable to the B. B. C. by manufacturers will be reduced by 50 per cent, and even more in the case of crystal sets.

Manufacturers are no longer required to pay a deposit of £50 on becoming members of the B. B. C.

Dealers also, under certain conditions, can now become members of the B. B. C.

The chief alteration is the reduction in the royalties payable by the members to the B. B. C. and as set out in the table below:

	Amounts payable	
	Before Sept. 30	After Sept. 30
	£ s d	£ s d
On each crystal set	7 6	1
On each microphonic amplifier without using valves.....	7 6	5

On each crystal set with one valve..	1	7	6	11
On each crystal set with two valves..	2	2	6	18 6
On each one-valve set	1			10
On each two-valve set	1	15		17 6
On each set adapted for more than two valves a further sum for each additional valve holder of.....		10		5
On each telephone earpiece		3		Nil
On each loud-speaker with or without trumpets		3		Nil
On each valve		2		Nil
On 1 F. valve amplifier.....		10		5

Gramophone dealers selling wireless apparatus report from all localities that while the boom of last Autumn is not equaled, a tremendous stimulus to trade has resulted from the more or less stabilized position since the issue of the report and the Postmaster-General's new regulations.

An All-British Wireless Exhibition and Convention will commence at the White City, Shepherd's Bush, on November 8 and remain open until November 21.

Annual Meeting of Gramophone Dealers

The Gramophone Dealers' Association held its annual meeting recently, Ernest Marshall, president, taking the chair. A small but representative gathering of dealers attended. Sydney E. Moon, a well-known Plymouth dealer, was elected president for the ensuing year, and

Gerald C. Forty, of Dale & Forty, Ltd. (London and Provinces), was made vice-president. L. Ingram was appointed secretary in place of Robert R. Brown, who tendered his resignation at the last committee meeting.

The main item on the agenda was the scheme for the exchange of surplus unsalable records, particulars of which I gave in our last issue. After a keen debate the following resolution embodying the Association's proposals was formulated and unanimously adopted: "That dealers be entitled to return up to 10 per cent of their purchases and to receive in return a cash credit for two-thirds of the value of same. Exchanges to take place twice yearly at times to be fixed by the manufacturer." Special propaganda is being adopted by the Association to insure that every dealer will co-operate in urging the acceptance of this offer by the manufacturers.

There are reasonable prospects of this very vexed question being soon settled, the manufacturers being as desirous as the dealers to secure a permanent recognized scheme. The differences outstanding between the manufacturers' and the dealers' associations are now thought to be not nearly so irreconcilable as they were six months ago.

FAMOUS ENGLISH FIRM NOW BRUNSWICK RECORD FACTOR

Chappell & Co., Ltd., Great Britain's Oldest Music House, Becomes Distributor of the Brunswick Record Library for England—A Pioneer in the Development of Music in England

LONDON, ENGLAND, November 5.—One of the most important developments in the phonograph trade here is the announcement that Chappell & Co., Ltd., 50 Bond street, will hereafter handle the full Brunswick record library, not only in London, but throughout England. This representation of the Brunswick product is a highly important one, for in this country the names of both Chappell and music are practically synonymous.

The House of Chappell is Great Britain's oldest music house, having celebrated its one hundredth anniversary as far back as 1911, giving it a continuous existence of 112 years. It is not only pre-eminent among British music dealers, but it is also probably our largest music publisher, having been the original publisher of many of the leading composers of the past century, including such names as Mendelssohn, D'Albert, Balfe, Gounod, Gilbert and Sullivan, all of whose famous Savoy operettas it publishes, and many others as well. It has also maintained a long connection with our best known producer of light opera, George Edwards having published many of the scores of his widely known productions at both the Gaiety and Daly's Theatre.

The House of Chappell was a pioneer in bringing recognition to England's composers, in 1840 giving the world the first collection of genuine English songs and ballads, thus refuting the claims of a contemporary writer to the

effect that England possessed no national school of music. In 1813 it was a Chappell who was responsible for the founding of the first Philharmonic Society in London. In 1822 the firm received its first appointment as Purveyors to the Crown, being made music sellers to George IV at that time.

The house is probably best known for its work in founding the famous London institution of "pop" concerts, which took place in the early fifties. It financed the building of St. James' Hall at a cost of nearly £80,000, to give the London public music at low prices. Some of the famous artists who appeared at these concerts with the seats at from one to five shillings were Mme. Schumann, Mme. Carreno, Rubinstein, von Bulow, Liszt, Saint-Saens, Joachim, Piatti, Wieniawski, Vieuxtemps, Ysaye, de Pachmann, Paderewski and many others. For more than forty years these concerts were held weekly on Saturdays and Mondays and it is probably due to them that we owe the introduction of chamber music here.

The Chappell house is also one of the leading British piano manufacturers, as well as being the retail house that probably does the largest business in musical instruments of all kinds.

It will thus be seen that Chappell & Co., Ltd., is a firm of splendid traditions worthily maintained and that Brunswick records should be chosen by this firm is a tribute, indeed, to their excellence.

EDISON BELL

WINNER
TRADE MARK
GRAMOPHONE RECORDS

CABLE
"PHONOKINO,
LONDON"

ARE THE GREATEST VALUE FOR MONEY PRODUCED IN GREAT BRITAIN

TEN INCH

DOUBLE SIDED

NEEDLE CUT

PLAY ON ALL GRAMOPHONES

Catalogue contains 4000 Titles by the Premier Artistes, Instrumentalists, Orchestras and Bands of the British Empire

DEALERS PREPARED TO DO BUSINESS ARE INVITED TO COMMUNICATE WITH

Proprietors and Manufacturers, **J. E. HOUGH, Ltd., 62 Glengall Road, London, S. E. 15, England**

LATEST PATENTS RELATING TO TALKING MACHINES AND RECORDS

WASHINGTON, D. C., November 8.—Phonograph. Benjamin H. Dietz and Albert E. Hansen, Chicago, Ill. Patent No. 1,463,311.

This invention relates to improvements in phonographs, the object being to provide a novel and improved phonograph having a casing which is a reproduction in miniature of a piano and which simulates a piano as to all its features and parts visible from the outside, said parts being combined and correlated in such manner that all of the functions and adjustments of the device as a phonograph are performed and made possible.

In the drawings:

Figure 1 is a perspective view of a phonograph embodying the invention; Fig. 2 is a top plan view thereof; Fig. 3 is a vertical detail

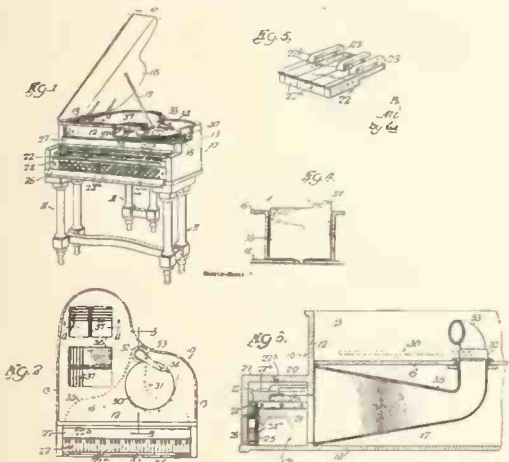

section on an enlarged scale through the phonograph in a plane indicated by the line 3—3 of Fig. 2; Fig. 4 is another vertical detail section through the phonograph in a plane indicated by the line 4—4 of Fig. 2; Fig. 5 is a detail perspective view of a fragment of a dummy keyboard embodied in the case of the phonograph.

Automatic Stop Record. James W. Whalen, Richmond, Ind. Patent No. 1,463,235.

The object of the present invention, broadly speaking, is to provide improvements in phonograph records or discs by which each record-disc will be provided with self-contained means whereby immediately upon the completion of the reproduction of the recorded matter the phonograph mechanism will automatically stop, said means being simple in character, effective

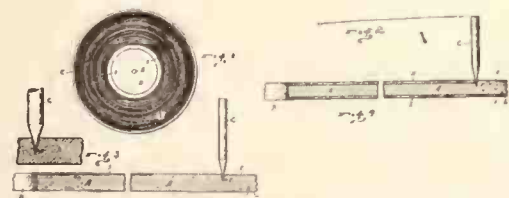

in practice, requiring no thought on the part of the attendant for its installation, attention or control; the same being practically inconspicuous in appearance, will not become inoperative by usage and the production and installation cost of which will be practically nil.

The preferred means for carrying out the principles of the invention in a practical manner are shown in the accompanying drawings, in which Figure 1 is a plan view of one side of a record disc, the same being taken on a reduced scale from actual size, and showing the invention in connection therewith; Fig. 2 is a cross section of a portion of a record disc and of the needle operative therewith, the same being taken on a greatly enlarged scale from actual size and showing the invention; Fig. 3 shows a portion of a record disc and a portion of a needle, and showing the invention, all on a scale still further enlarged from that of Fig. 2. And Fig. 4 is similar to Fig. 2, but showing a slight modification thereover.

Brush for Talking Machines. Joseph E. Borst, Brooklyn, N. Y. Patent No. 1,464,405.

The present invention relates to new and useful improvements in brushes for talking machines and it pertains more particularly to a single brush therefor such as disclosed in prior application for patent filed February 1, 1921, and allowed October 12, 1921.

It is one of the objects of the present invention to provide a brush capable of attachment to the sound box of talking machines in such a manner that the brush will travel in the path of the stylus of said sound box and remove foreign material therefrom.

It is a further object of the invention to construct a frame for supporting the brush of material which has low qualities for sound transmission.

It is a further object of the invention to so construct the frame for holding the brush that the latter will be resiliently carried relatively to the sound box upon which it is mounted.

It is a further object of the invention to so construct the frame that the brush will be carried by a resilient arm projecting therefrom.

It is a still further object of the invention to so construct the frame that the same is yieldingly mounted upon the sound box to which it is attached.

With the above and other objects in view, reference is had to the accompanying drawings, in which—

Figure 1 is a side view of a sound box equipped with a brush constructed in accordance with the present invention; Fig. 2 is a

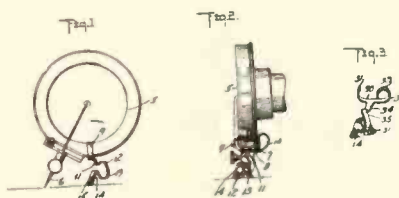

detail sectional view showing the specific manner in which the brush is attached to the sound box, and Fig. 3 is a perspective view of a modified form of brush.

Record Lifter for Talking Machines. Mabel Blackman, New York, assignor of one-half to Lillian K. Hosier and one-half to Estelle McKee, both of New York. Patent No. 1,464,023.

This invention relates to phonograph attachments and particularly to such a device employed for the purpose of assisting in removing the record discs from the turntable.

A particular object is to provide a device of the character described which can be manufactured at low cost, can be conveniently attached to the turntable of a phonograph and will not be conspicuous.

Figure 1 is an elevational view of a part of a phonograph, the turntable thereof being shown in section to illustrate the record-lifting

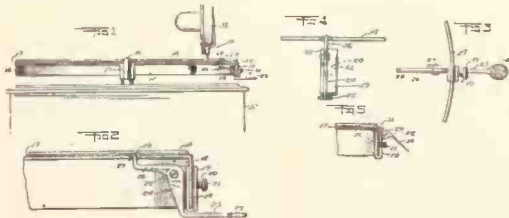

attachment in conjunction therewith. Fig. 2 is an enlarged sectional view of a part of the turntable showing more clearly the record-lifting attachment; Fig. 3 is a top plan view of the device, the top of the turntable being removed to expose the downwardly extending flange thereon; Fig. 4 is a view of the device as seen in Fig. 3, looking from the center of the turntable; Fig. 5 is a view of a modification of the device.

Sound Box. Charles J. Meehling, New York. Patent No. 1,465,239.

This invention relates to reproducing devices or sound boxes for disc sound records, and one of the objects of the invention is to provide a sound box capable of use on all machines and with the two kinds of records now in general use.

It is understood that with the commercial types of machines now in general use it is necessary to mount the sound box with its diaphragm extending in an upright plane, either disposed tangent to the curvature of the grooves on the record disc or disposed across the line of the grooves or in another type of machine with the diaphragm disposed in a substantially horizontal plane, that is parallel to the plane of the record disc.

It is also known that there are in general use two types of record discs. One the hill and dale type, which consists of a series of vertical indentations or impressions formed on the face of the disc, which when traveling against the sound box stylus or needle produce vibration of the stylus in a vertical plane or in the plane of the vertical axis of the stylus or needle and the horizontal or laterally cut grooves, which consists of a series of horizontal indentations or impressions formed on the face of the disc, which when traveling against the sound box stylus or needle produce vibration of the stylus in a direction parallel to the surface of the sound record disc.

This invention contemplates the providing of a single sound box, which may be mounted in certain positions, depending upon the character of the machine to which it is attached and to provide this sound box with a plurality of styluses or needles, so arranged that the proper playing instrument may be brought into operative engagement with the records to most effectively play the particular record on the machine equipped with this form of sound box.

It is a further object of the invention to provide an attachment designed to take the place of the usual binding screw with one form of sound box now known and to provide this attachment with a plurality of styluses arranged to be brought into playing position to play a disc different from the type of discs used usually on a machine designed to play discs of one particular character.

Referring to the accompanying drawings: Figure 1 is a view in elevation of a preferred embodiment of the invention; Fig. 2 is a side

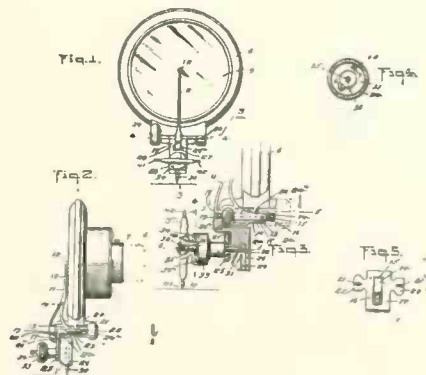

view of the device shown in Fig. 1; Fig. 3 is an enlarged view in side elevation of the sound box casing and showing the lower portion thereof in vertical section, taken on the line 3—3 of Fig. 1; Figs. 4 and 5 are transverse sectional views of details taken on the lines 4—4 and 5—5 of Fig. 3.

Sound Refining Box. William V. Ogren, Columbus, Neb., assignor of one-half to Charley D. French, same place. Patent No. 1,465,170.

The object of the invention is to provide a sound box or resonator for graphophones, (Continued on page 194)

PATENTS RELATING TO TALKING MACHINES AND RECORDS—(Continued from page 193)

phonographs and like instruments whereby the sound as received from the record through the sound arm while being amplified will be refined to eliminate harshness and mechanical noises to the end that a relative purity of reproduction may be secured, and with this object in view the invention consists in a construction and combination of parts of which a preferred embodiment is shown in the accompanying drawings, wherein—

Figure 1 is a vertical sectional view of a portion of a reproducing instrument having a sound box constructed in accordance with the invention; Fig. 2 is a horizontal section of the same

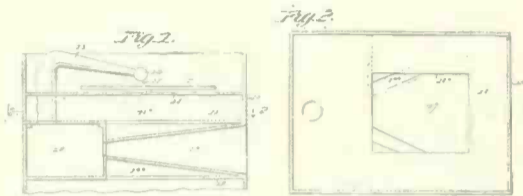

on the plane indicated by the line 2—2 of Fig. 1. Record Lifter. Robert F. Thomson, Watertown, N. Y. Patent No. 1,464,785.

This invention comprehends the provision of a useful handling device and is especially adapted for use in handling phonograph records.

An object of the present invention is the provision of a device by means of which phonograph records may be placed upon or removed from the turntable of a talking machine and thus prevent the transfer of oil, grease or other injurious matter to the record, from the hands of the operator.

Another object of the invention is the provision of a device of the above character which is simple of construction and operation and which will effectually grip and hold a record or similar article without damage to the same.

In the drawings:

Figure 1 is a view partly in section showing a portion of a phonograph with the invention in use, a record being shown in section upon the turntable; Fig. 2 is a similar view showing the record raised, preparatory to its removal;

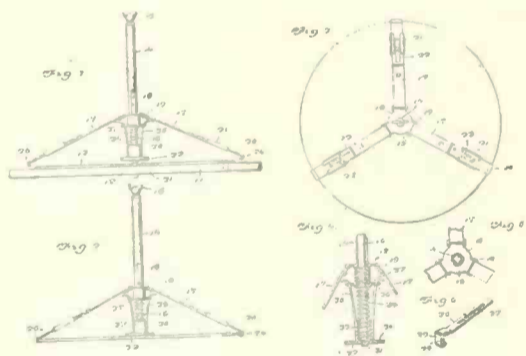

Fig. 3 is a plan view with the parts in the position shown in Fig. 1; Fig. 4 is an enlarged central vertical sectional view of the device removed from the record; Fig. 5 is a horizontal section; Fig. 6 is a detail view of one end of one of the pivoted arms showing a modified form of grip.

Lid Support. Donato Di Carlo, Philadelphia, Pa. Patent No. 1,468,460.

This invention relates to lid supports or holders for phonographs or other cabinets, and the object of the invention is to provide a support adapted to hold a hinged lid or cover open in various positions and to provide simple means

whereby the lid support will automatically engage and simple means for releasing it from engagement.

Figure 1 is a fragmentary vertical sectional view of a cabinet having a hinged lid with the improved support and releasing means. Figs. 2 and 3 are perspective views of parts of the

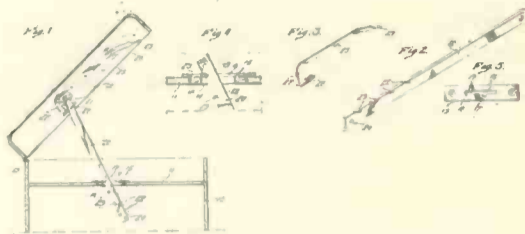

device. Figs. 4 and 5 are enlarged fragmentary sectional and plan views of parts of the support.

Table for Talking Machines. Joseph F. Borst and William Borst, Brooklyn, N. Y. Patent No. 1,466,576.

The present invention pertains more particularly to a new and improved construction of talking machine table.

It has been found by actual experiment that the motor in its operation produces certain friction, vibration and sounds conveyed to the sound box by the various metal parts of the mechanism, and which are responsible to a large extent for poor and improper reproduction on the part of the sound box.

It has also been found that spring members used in talking machines do not rotate the table at a constant speed. This condition, owing to the uneven movement between the record and the stylus, produces objectionable vibration, and sounds and noises which could be eliminated if the table were driven at constant speed.

It is, therefore, one of the primary objects of the invention to insulate the diaphragm from friction, vibration and sounds from the sound box and stylus and various metal parts of the machine. By so doing friction, vibration and sounds are controlled to the greatest extent possible, thereby allowing vibration and harmony to act in its clearest state.

Figure 1 is a sectional view of a talking machine table and sound box. Fig. 2 is a detail top plan view partly in section of a table constructed in accordance with the present invention. Fig. 3 is a detail sectional view taken at the central portion of the table.

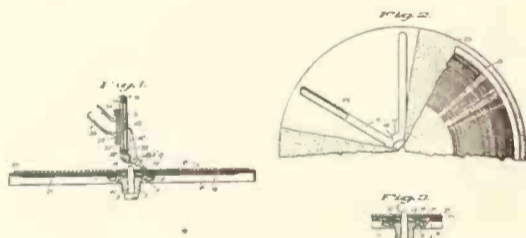

Tone Arm. Alfred K. Miller, Los Angeles, Cal. Patent No. 1,466,140.

This invention relates to devices and apparatus of the general character that is used as, and is generally known as, the tone arm of a phonograph mechanism; so, for the purpose of clearly describing and illustrating the invention, a specific form of the invention which is particularly designed as a tone arm for a phonograph is here considered, but it will be distinctly understood that the invention is not limited to such particular use. In its broader aspects the invention may be considered to be a sound transmitting and modifying apparatus.

Considering thus the invention as applied to tone arms (without any implied limitation of the invention thereto) it may be stated preliminarily that one of the objects is to provide a tone arm construction that will amplify sounds coming from a phonograph reproducer; will amplify and expand the sound without introducing into it foreign vibrations of any objectionable character; will transmit the sound from the reproducer in its original purity; and will, without materially altering the character or quality of the tones produced by the reproducer, somewhat qualify those tones, so as to eliminate

from those tones certain somewhat undesirable features. This elimination of certain undesirable features or qualities of the tone coming from the reproducer applies more particularly to ordinary reproducers than to the reproducer of the character shown in the accompanying drawings. In an ordinary reproducer as used in present phonographs, there is always a tendency for certain tones or sounds to blare out; that is, to be reproduced with such force and volume as to practically drown out the accompanying sounds. This objectionable feature has been to a very large extent eliminated in the reproducer; but the tone arm itself has, as will be explained, the quality of "covering" tones which would otherwise be produced in a blaring fashion.

Figure 1 is a plan of the improved tone arm, showing a reproducer in connection therewith and showing the connection of a tone arm of

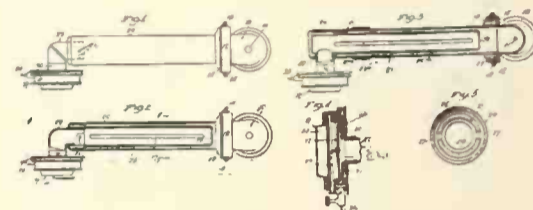

the phonograph. Fig. 2 is a horizontal longitudinal section of the same. Fig. 3 is a similar horizontal longitudinal section showing a slightly modified arrangement. Fig. 4 is a section showing the improved reproducer, which is here shown in connection with the tone arm. Fig. 5 is an enlarged detail section taken as indicated by line 5—5 on Fig. 2.

Multiple Sound Reproducing Apparatus. Wm. H. Bristol, Waterbury, Conn. Patent No. 1,468,455.

The invention relates to improvements in sound reproducing apparatus, and more particularly to apparatus of this character employing a plurality of sound reproducing members, that is to say apparatus in which a plurality of styli track tandem in the record grooves.

It has for its object to carry the various reproducers, which may be of the direct or of the electrical transmitter type, or both, from a common movable arm, as the tone arm of the talking machine proper; and to provide convenient means for independently setting each stylus in the same groove of the record, including a universal joint between the reproducers so that there will be no tendency for the styli to leave the groove, in which they are originally set, during reproduction of the entire record. A further object of the invention consists in maintaining a substantially fixed distance between the styli during operation.

Figure 1 is a plan of a talking machine of well-known type, having the improved mechanism attached thereto. Fig. 2 is a similar view illustrating a further embodiment of the invention. Fig. 3 illustrates a modification whereby the tone arm may be dispensed with entirely if electrical reproduction only is desired. Fig. 4 illustrates a modification in the carrying arm.

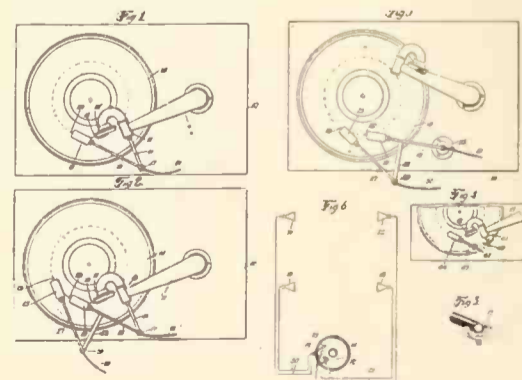

Fig. 5 is a detail perspective view of universal joint which may be employed in connection with the mounting of the electrical reproducers. Fig. 6 is a diagrammatic view illustrating the manner in which sound may be distributed by means of the improved arrangement of reproducers.

REPAIRS

All Makes of Talking Machines Repaired Promptly and Efficiently
REPAIR PARTS FOR ALL MACHINES

ANDREW H. DODIN

28 Sixth Avenue New York
TELEPHONE, SPRING 1194

Advance RECORD BULLETINS for December, 1923

VICTOR TALKING MACHINE CO.

LIST FOR NOVEMBER 9

- 19119 Hush, Somebody's Calling My Name, Bethel Jubilee Quartet 10
(Under Direction of Rev. T. H. Wiseman)
You Must Come in at the Door, Bethel Jubilee Quartet 10
- 19160 Struttin' Jim, Miss Patricola with The Virginians 10
Nobody Else Can Love Me Like My Old Tomato Can, Billy Murray 10
- INSTRUMENTAL RECORD**
- 19133 Vision of Salome—Waltz, Pietro 10
Kiss of Spring—Waltz, Pietro 10
- DANCE RECORDS**
- 19161 Sittin' in a Corner—Fox-trot, Paul Whiteman and His Orchestra 10
Maggie! "Yes, Ma'am"—Fox-trot, The Manhattan Merry-makers 10
- 19162 Little Butterfly—Fox-trot, Paul Whiteman and His Orchestra 10
So This Is Love!—Waltz, The Troubadours 10
- 19163 Nobody But You—Fox-trot, Brooke Johns and His Orchestra 10
Love, My Heart Is Calling You—Fox-trot, The Manhattan Merry-makers 10
- RED SEAL RECORDS**
- 946 Memory's Garden (G. Denni-L. Denni), Frances Alda 10
Coming Home (Eardley-Wilmot-Willeby), Frances Alda 10
- 947 Mazurka (Chopin), Fritz Kreisler 10
Mélodie (Paderewski-Kreisler), Fritz Kreisler 10
- 6420 Requiem—Confutatis maledictis (From the Accursed Call Me Forth) (Verdi)—In Latin, José Mardones 12
Stabat Mater—Pro Peccatis (For His People Unrelenting) (Rossini)—In Latin, José Mardones 12
- 961 Love Sends a Little Gift of Roses, John McCormack 10
Wonderful One, John McCormack 10
- LIST FOR NOVEMBER 16**
- 19168 Mammy's Little Silver Lining, Vernon Dalhart 10
Memories of Virginia, Peerless Quartet 10
- INSTRUMENTAL RECORD**
- 19120 Italians in Algiers—Overture, Part I, Victor Symphony Orchestra 10
Italians in Algiers—Overture, Part II, Victor Symphony Orchestra 10
- DANCE RECORDS**
- 19164 Oh Gee, Oh Gosh, Oh Golly, I'm in Love—Fox-trot, Garber-Davis Orchestra 10
First, Last and Always—Fox-trot, Garber-Davis Orchestra 10
- 19169 An Orange Grove in California—Fox-trot, Paul Whiteman and His Orchestra 10
Dancing Honey-moon—Fox-trot, Paul Whiteman and His Orchestra 10
- 19170 I've Got a Song for Sale—Fox-trot, The Original Memphis Five 10
Tin Roof Blues—Fox-trot, The Original Memphis Five 10
- RED SEAL RECORDS**
- 953 La Serenata (Serenade) (Tosti)—In Italian, Geraldine Farrar 10
Madrigal (Your Tender Kisses) (Van Ormelingen-Chaminade)—In French, Geraldine Farrar 10
- 948 Rigoletto—La donna è mobile (Woman Is Fickle) (Verdi)—In Italian, Miguel Fleta 10
Puritani—A te, o cara, amor talora (To Thee, O Dearest) (Bellini)—Italian, Miguel Fleta 10
- LIST FOR NOVEMBER 23**
- 19141 Oh Saviour, Hear Me (Gluck-Buck), Charles T. Tittmann 10
Be Thou With Me (Hiller), Charles T. Tittmann 10
- 19171 It Ain't Gonna Rain No Mo', Wendell Hall 10
Red Headed Music Maker, Wendell Hall 10
- 19173 Kiss Me With Your Eyes, Della Baker 10
Indiana Moon, Claire Brookhurst-Lewis James 10
- 19176 Out There in the Sunshine With You, Henry Burr 10
You Didn't Care When You Broke My Heart, Elliott Shaw 10
- DANCE RECORDS**
- 19165 Old-Fashioned Love—Fox-trot, Arthur Gibbs and His Gang 10
Charleston—Medley Fox-trot, Arthur Gibbs and His Gang 10
- 19174 Broken-Hearted Melody—Waltz, The Troubadours 10
The Waltz of Long Ago—Medley Waltz, The Troubadours 10

- 19175 Steamboat Sal—Fox-trot, Garber-Davis Orchestra 10
Down South Blues—Fox-trot, The Virginians 10
- RED SEAL RECORDS**
- 955 Voi Dormite, Signora! (Sleep On, Fair Lady!) (Tosti)—In Italian, Giuseppe de Luca 10
Berceuse (Lullaby) (Gretchaninow)—In Italian, Giuseppe de Luca 10
- 6424 Adagio (Mozart-Friedberg), Mischa Elman 12
German Dance (Dittersdorf) (2) Gavotte (Gossec), Mischa Elman 12

COLUMBIA PHONOGRAPH CO.

- A3994 Sittin' In a Corner (Meyer)—Fox-trot, California Ramblers 10
Tell All the Folks In Kentucky (Berlin)—Fox-trot, California Ramblers 10
- A3993 Midnight Rose (Pollack)—Fox-trot, Club Deauville Orch. 10
Not Here—Not There (Breuer)—Fox-trot, Club Deauville Orch. 10
- A3996 Mamma Goes Where Papa Goes (Ager)—Fox-trot, The Georgians 10
Somebody's Wrong (Marshall, Egan and Whiting)—Fox-trot, The Georgians 10
- A3986 You've Simply Got Me Cuckoo (Hirsch and Greer)—Fox-trot, California Ramblers 10
If I Can't Get The Sweetie I Want (Schwartz)—Fox-trot, California Ramblers 10
- A3987 Land of Cotton Blues (Bennett, Jerome and Ahlert)—Fox-trot, The Georgians 10
Mamma Loves Papa (Friend and Baer)—Fox-trot, The Georgians 10
- A3989 I Love You (Intro: "Little Jessie James" from "Little Jessie James") (Archer)—Medley Fox-trot, The Columbians Dance Orch. De Luxe 10
Pretty Peggy (Intro: "My Cretonne Girl" from "Earl Carroll's Vanities of 1923") (Carroll)—Medley Fox-trot, The Columbians Dance Orch. De Luxe 10
- A3992 Chansonette (Friml)—Fox-trot, Paul Specht and His Orch. 10
Easy Melody (Conley-Rodemich)—Fox-trot, Paul Specht and His Orch. 10
- A3988 Poppy (Amapola) (Lacalle)—Tango Fox-trot, Spanish Tango Orch. 10
Step Easy (Pasolindo) (Lacalle)—Fox-trot, Spanish Tango Orch. 10
- A3984 You've Simply Got Me Cuckoo (Hirsch-Greer)—Comedian with Orch. accomp., Al Jolson 10
Oh! Min (Conrad)—Tenor Solo with Orch. accomp., Frank Crumit 10
- A3997 Old Fashioned Love, from "Runnin' Wild" (Mack-Johnson)—Tenor Solo with Orch. accomp., Frank Crumit 10
My Home Town In Kansas, from "Little Jessie James" (Archer)—Tenor Solo with Orch. accomp., Frank Crumit 10
- A3985 Dreamy Melody (Koehler, Magine and Naset)—Male Quartet with Orch. accomp., Shannon Four 10
Out There in the Sunshine With You (Ball)—Tenor Solo with Orch. accomp., Charles Hart 10
- A3983 Sunrise and You (Penn)—Tenor Solo with Orch. accomp., Edwin Dale 10
The Road That Brought You to Me (Hamblen)—Tenor Solo with Orch. accomp., Edwin Dale 10
- A3998 The First Noel (Traditional)—Male Quartet with Orch. accomp., Criterion Quartet 10
It Came Upon the Midnight Clear (Willis)—Male Quartet with Orch. accomp., Criterion Quartet 10
- A3990 Under The Double Eagle (Wagner)—March, Columbia Band 10
Manhattan Beach (Sousa)—March, Columbia Band 10
- 80817 To a Wild Rose (MacDowell)—Violoncello Solo with Walter Golde at the Piano, Pablo Casals 10
- 81055 Kniwiazek (Second Mazurka) (Wieniawski)—Violin Solo with Maurice Eisner at the Piano, Duci De Kerekjarto 10
- 80604 Mefistofele "Dai campi, dai prati" (from the fields, from the grove) (Boito)—Tenor Solo with Orch. accomp., Charles Hackett 10
- A6232 Hungarian Rhapsody No. 6—Part 1 (Liszt)—Piano Solo, Mischa Levitzki 12
Hungarian Rhapsody No. 6—Part 2 (Liszt)—Piano Solo, Mischa Levitzki 12
- A6233 Lucia Di Lammermoor (Mad Scene) "Ardenzi incensi" (these flaming tapers)—Solo with Orch. accomp., Flute Obligato by Ellis McDiarmid—Soprano, Florence Macbeth 12
Barriere Di Siviglia "Una Voce Poco fa" (The

- voice I heard e'en now) (Rossini)—Solo with Orch. accomp., Soprano, Florence Macbeth 12
- A3999 Plaisir D'Amour (The Joys of Love) (Martini)—Solo with Orch. accomp., Soprano, Carmela Ponselle 10
L'Heure Exquise (The Hour of Dreaming) (Hahn)—Solo with Orch. accomp., Soprano, Carmela Ponselle 10

AEOLIAN CO.

(VOCALION RECORDS)

CHRISTMAS—STANDARD

- 14678 The Night Before Christmas—Part I (Moore-Van Vollenhoven)—Orch. Accomp., Lewis James 10
The Night Before Christmas—Part II (Moore-Van Vollenhoven)—Orch. Accomp., Lewis James 10

CHRISTMAS—SACRED

- 14683 The Star of Bethlehem (Weatherly-Adams)—Tenor, Orch. Accomp., Charles Harrison 10
The Voice of the Climes (Deacey-Hahn)—Orch. Accomp., Criterion Quartet 10

STANDARD

- 60013 Blue Bells of Scotland (Grant)—Soprano, Aeolian Orch. Accomp., Evelyn Scotney 10
Home, Sweet Home (Payne-Bishop)—Soprano, Aeolian Orch. Accomp., Evelyn Scotney 10
- 24049 I'll Sing Thee Songs of Araby (Willis-Clay)—Tenor, Aeolian Orch. Accomp., Colin O'More 10
The Song of Songs (Lucas-Moya)—Tenor, Aeolian Orch. Accomp., Colin O'More 10

IRISH—VOCAL

- 14677 A Handful of Earth From My Dear Mother's Grave (Joseph Murphy)—Tenor, Orch. Accomp., Charles Harrison 10
I'm Sitting by the Stile, Mary (Dufferin-Barker)—Tenor, Orch. Accomp., Charles Harrison 10

INSTRUMENTAL

- 60014 Caprice No. XIII (Paganini-Kreisler)—Violin Solo, Piano Accomp. by Helen Hamilton, Sasha Culbertson 10
Chorus of Dervishes (From "Ruins of Athens") (Beethoven-Auer)—Violin Solo, Piano Accompaniment by Helen Hamilton, Sasha Culbertson 10

- 35024 Morning, Noon and Night (Suppe)—Overture, Band of H. M. 1st Life Guards 12
Marche Militaire (Schubert), Band of H. M. 1st Life Guards 12

PIANO—INSTRUMENTAL

- 21001 Juha (Dance) (From the Suite "In the Bottoms") (R. Nathaniel Dett)—Piano Solo, David Pesetzki 10
Marche Mignonne (Dainty March) (Ed. Poldini)—Piano Solo, David Pesetzki 10

INSTRUMENTAL

- 14679 On the Square (Panella)—March, Lt. F. W. Sutherland and His 7th Reg. Band 10
7th Regiment March (Gray Jackets) (Neyer), Lt. F. W. Sutherland and His 7th Reg. Band 10

HAWAIIAN (VOCAL)

- 14680 Just a Breath of Hawaii (Costello-Earl)—Accomp. by Ferera-Franchini, Hawaiian Guitars, Lewis James-Elliott Shaw 10
Hula Hula Rose (Reed-Awan)—Accomp. by Ferera-Franchini, Hawaiian Guitars, Lewis James-Elliott Shaw 10

DANCE

- 14674 That Old Gang of Mine (Henderson-Rose-Dixon)—Fox-trot, The Ambassadors 10
Foolish Child (Bargy-McPhail)—Fox-trot, The Ambassadors 10

- 14686 Rememb'ring (From "Topsy and Eva") (The Duncan Sisters)—Fox-trot, The Ambassadors 10
Old-fashioned Love (Intro. "Charleston," from "Runnin' Wild") (Mack-Johnson)—Fox-trot, The Ambassadors 10

- 14681 I Love You (From "Little Jessie James") (Archer-Thompson)—Fox-trot, The Bar Harbor Society Orch. 10
What Do You Do Sunday, Mary? (From "Poppy") (Jones-Cesar)—Fox-trot, The Ambassadors 10

- 14671 Upright and Grand (Banta)—Fox-trot, Frank Banta and The Ambassadors 10
Corn on the Cob (Cliff Hess)—Fox-trot, Banta-Hess, with Selvin's Orch. 10

- 14675 Sittin' in a Corner (Kahn-Meyer)—Fox-trot, The Broadway Syncopaters 10
Bit by Bit You're Breaking My Heart (Kahn)—(Continued on page 196)

THE QUICKEST and BIGGEST DANCE HIT OF THE YEAR

SOBBIN BLUES

Order from your Jobber or direct

MELROSE BROS.
63RD & Cottage Grove
CHICAGO

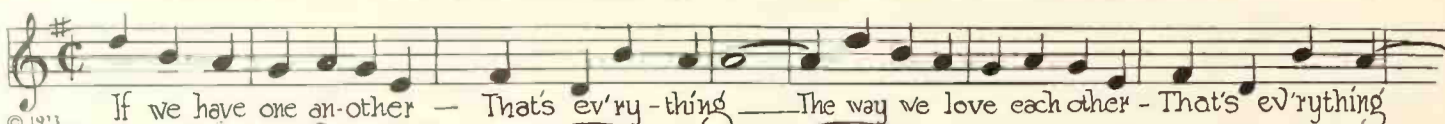

© 1923
Leu Feist, Inc.

THAT'S EVERYTHING

"You can't go wrong with any FEIST song"



Everything That Makes A Wonderful FOX-TROT

ADVANCE RECORD BULLETINS FOR DECEMBER—(Continued from page 195)

- Bloom)—Fox-trot. The Broadway Syncopaters 10
- 14690 So This Is Love (From "Little Miss Blue-beard") (E. Ray Goetz)—Waltz, Selvin's Orch. 10
- The Waltz of Long Ago (From "The Music Box Revue, 1923") (Irving Berlin)—Waltz, Selvin's Orch. 10
- 14661 Odaliscas (Odaliques) (Belisario de Jesus Garcia)—Fox-trot—Cancion.....The Castillians 10
- Perdoname (Forgive Me) (Belisario de Jesus Garcia)—Waltz.....The Castillians 10
- VOCAL**
- 14687 Nobody Else Can Love Me Like My Old Tomato Can (Downs-Baskette)—Comedy Song, Accomp. by Selvin's Orch....Irving Kaufman 10
- Back in the Old Neighborhood (Hager)—Accomp. by Selvin's Orch....Irving Kaufman 10
- 14672 Somebody Else Took You Out of My Arms (But They Can't Take You Out of My Heart) (Conrad-Rose)—Accomp. by Selvin's Orch.Irving Kaufman 10
- You Wanted Someone to Play With (I Wanted Someone to Love) (Fred Fisher)—Ballad, Accomp. by Selvin's Orch....Irving Kaufman 10
- 14676 If I Can't Get the Sweetie I Want (I Pity the Sweetie I Get) (Schwartz)—Accomp. by Selvin's Orch.Isabelle Patricola 10
- Mamma Goes Where Papa Goes (Or Papa Don't Go Out To-night) (Ager-Yellen)—Accomp. by Selvin's Orch....Isabelle Patricola 10
- 14662 Asi cantaha la fuente (Thus Did the Fountain Sing) (Pruneda-Garcia)—Cancion Colombiana, Accomp. by the Castillians, Jose Moriche 10
- Ojos Verdes (Green Eyes) (Wervo-Garcia)—Cancion Colombiana, Accomp. by the CastilliansJose Moriche 10
- NEAPOLITAN**
- 14684 Figlio, nun manna' dollari (Son, do not send dollars) (Chirazzi-D'Annihale)—Character Song....Ria Rosa con Orchestra Napoletana 10
- Tarantella Sott' 'e Rose (Tarantella Under the Roses) (Vento-Albano)—Folk Song, Ria Rosa con Orchestra Napoletana 10
- 35021 Napule E Mamma (Naples and Mother) (Bascetta-Giovanetti), Ria Rosa con Orchestra Napoletana 12
- 'O Sentimento (A Sensitive Sweetheart) (Fior-delisi-Fonzo)—Duet, con Orchestra Napoletana....Ria Rosa-Raffaele Balsamo 12
- JEWISH**
- 14673 Rumeiniso Feferlach (From "The Roumanian Wedding") (Gilrod-Sandler)—Comic Duet, Orch. Accomp., Aaron Lebedeff-Bessie Weisman 10
- Nit Bei Motien (From "The Roumanian Wedding") (Gilrod-Sandler)—Comic Song, Orch. Accomp.Aaron Lebedeff 10
- RACE RECORDS**
- VOCAL**
- 14688 Graveyard Dream Blues (Ida Cox)—Piano Accomp. by Leslie Hutchinson....Hazel Meyers 10
- Low Down Papa (Treat Sweet Mamma Kind) (Spencer Williams)—Piano Accomp. by Leslie HutchinsonHazel Meyers 10
- 14689 Wish I Had You (And I'm Gonna Get You Blues) (Grainger-Ricketts)—Piano Accomp. by Porter Grainger....Viola McCoy 10
- Mistreatin' Daddy (Grainger-Ricketts)—Blues, Piano Accomp. by Porter Grainger, Viola McCoy 10
- 14659 Wicked Dirty Fives (Lemuel Fowler)—Blues, Piano Accomp. by Lemuel Fowler, Edna Hicks 10
- Squawkin' the Blues (Lemuel Fowler)—Blues, Piano Accomp. by Lemuel Fowler, Edna Hicks 10
- 14682 It Won't Be Long Now (Stanley Miller)—Blues, Piano Accomp. by Fletcher Henderson; Saxophone by Coleman Hawkins, Rosa Henderson 10
- Every Woman's Blues (Smith-Miller)—Piano Accomp. by Fletcher Henderson, Saxophone by Coleman Hawkins....Rosa Henderson 10
- RACE-DANCE**
- 14691 Just Hot (McHugh)—Blues Fox-trot, Fletcher Henderson and His Orch. 10
- Down South Blues (Henderson-Waters)—Fox-trot.....Fletcher Henderson and His Orch. 10

EDISON DISC RECORDS

ALREADY RELEASED SPECIALS

- 51218 Rustle of Spring—Piano Solo....May A. Meyers 10
- Murmuring Zephyrs—Transcription—Piano Solo, May A. Meyers 10
- 80765 Trovatore Selection—Part 1.....Peerless Orch. 10
- Trovatore Selection—Part 2.....Peerless Orch. 10
- 82303 Voice of the Mountain Land.....Mario Laurenti 10
- Nita Gitana.....Henri Scott 10
- 82302 Our Paradise.....Anna Case 10
- Jerusalem—Gallia.....Anna Case 10
- 51239 Coral Sands of My Hawaii.....Waikiki Hawaiian Orch. 10
- I Still Believe in You.....Waikiki Hawaiian Orch. 10
- 51256 When You Dance With a Wonderful Girl—

- Fox-trot from "Go-Go".....Stevens' Trio 10
- Dreamy Melody—Medley Waltz (Intro.: "Rocky Mountain Moon").....McNalpak's D. Orch. 10
- 51257 "Deeze," "Doze" and "Dem".....Billy Jones 10
- Mamma Goes Where Papa Goes (Or Papa Don't Go Out To-night).....Elsie Clark 10
- FLASHES**
- 51232 You're Like a Baby—Fox-trot, Meadowbrook Dance Orch. 10
- Cuddle-Uddle Up—Fox-trot, Meadowbrook Dance Orch. 10
- 51233 Cannibola—Fox-trot.....Broadway Dance Orch. 10
- No, No, Nora—Fox-trot.....Broadway Dance Orch. 10
- 51235 That's a Lot of Bunk, Billy Jones and Ernest Hare 10
- That Old Gang of Mine, Billy Jones and Ernest Hare 10
- 51238 I'm Sitting Pretty in a Pretty Little City—Fox-trot.....Atlantic D. Orch. 10
- Home—Fox-trot.....Don Parker's Dance Orch. 10
- 51237 Music of Love (From "Artists and Models"), Broadway Dance Orch. 10
- Covered Wagon Days—Fox-trot, Don Parker's Dance Orch. 10
- 51240 Once in a Lifetime—Fox-trot, Stevens' Dance Quartet 10
- Tinkle Tune—Fox-trot (From "The Dancing Honeymoon").....Stevens' Trio 10
- GENERAL LIST**
- 51244 The Life of a Rose (From "George White's Scandals").....Lewis James 10
- Midnight Rose.....James Morton 10
- 82304 Amore o grillo—Madam Butterfly, Guido Ciccolini and Thomas Chalmers 10
- La Campana di San Giusto.....Guido Ciccolini 10
- 80766 Ah! mon fils (Ah! My Son) (Le Prophete), Maria Duchene 10
- Stride la vampa (Fierce Flames Are Scaring) (Il Trovatore).....Maria Duchene 10
- 51245 Just a Girl That Men Forget—Violin Solo, Rae Eleanor Ball 10
- Rufus on the Old Kent Road—Violin Solo, Rae Eleanor Ball 10
- 80767 Azt mondjak (Scenes de la Czarda No. 8)—Violin Solo.....Mary Zentay 10
- Caprice XIII—Violin Solo.....Mary Zentay 10
- 59:08 Shulamith and Absalom (Duet from Shulamith), Morris Goldstein and Lizza Tuchman 10
- "Shabes Jom tov" ("Raisins and Almonds") (From Shulamith), Lizza Tuchman and Morris Goldstein 10
- 51242 He'll Always Be One of Those Guys, Anna Chandler 10
- She Walked Right Up and Took My Man Away (Blues Song).....Ellen Coleman 10
- 51243 Drigo's Serenade—Waltz (Adaptation from "Les Millions d'Arlequin"), Harry Barth's Mississippians 10
- Indiana Moon—Waltz, Harry Barth's Mississippians 10
- 51241 Steal a Little Kiss While Dancing—Waltz—Piano Solo.....Ernest L. Stevens 10
- When You Are in My Arms—Waltz from "Poppy"—Piano Solo.....Ernest L. Stevens 10
- 51246 The Jelly Roll Blues—Fox-trot, Original Memphis Five 10
- A Bunch of Blues—Fox-trot—Drag Fox-trot, Original Memphis Five 10
- 51249 I Love You—Fox-trot (From "Little Jessie James").....Broadway Dance Orch. 10
- Dirty Hands! Dirty Face!—Fox-trot, Ernest Stevens' Dance Orch. 10
- 51247 Darktown Reveille—Blues Fox-trot, The Jazz-O-Harmonists 10
- Salt Your Sugar—Blues Fox-trot, The Jazz-O-Harmonists 10
- 51250 When Dixie Stars Are Playing Peek-A-Boo, Al Bernard and Frank M. Kamplain 10
- Circus Days (Oh! You Circus Days), Robert White and Chorus 10
- 51248 Just One More Waltz Before We Part for Old Time's Sake.....Lewis James 10
- I Love You (From "Little Jessie James"), Harvey Hindermeyer and Chorus 10
- 51234 The World Is Waiting for the Sunrise—Fox-trot, Stevens' Trio 10
- Like a Rose—Fox-trot.....Stevens' Trio 10

EDISON BLUE AMBEROL RECORDS

- 4765 Silent Night, Elizabeth Spencer-John Young-Vernon Archibald 10
- 4795 After Toiling Cometh Rest, Betsy Lane Shepherd and Chorus 10
- 4796 Finlandia—Tone Poem.....American Symphony Orch. 10
- 4797 Kashmiri Song—Indian Love Lyrics....Maggie Teyte 10
- 4798 La Gitana—Violin Solo.....J. Piastro Borissoff 10
- 4799 His Lullaby.....Merle Alcock 10
- 4800 Swingin' Down the Lane—Fox-trot, Paul Victorin's Orch. 10
- 4801 Oh! Harold—Fox-trot.....Atlantic Dance Orch. 10

OKEH RECORDS

- 4930 A Japanese Sunset (Jessie L. Deppen)—Whistling Solo, Accomp. by String Orch., Sibyl Sanderson Fagan 10
- The Swaying Narcissus (Ring-Hager)—Whistling Solo, Accomp. by String Orch., Sibyl Sanderson Fagan 10

- 4931 Silent Night, Holy Night—Orch., Sandor Joszi and His Orch. 10
- O Du Froehliche (O Sanctissima), Sandor Joszi and His Orch. 10
- 4932 O Tannenbaum (O Faithful Pine)—Orch., Sandor Joszi and His Orch. 10
- A Sprig Arose to Glory (Es ist ein Ros' entsprungen).....Sandor Joszi and His Orch. 10
- OKEH DANCE RECORDS**
- 4917 Carolina Mammy (Billy Jones)—Fox-trot, Markels Orch. 10
- I'm Drifting Back to Dreamland (Jack Sadler)—Waltz.....Blue Diamond Dance Orch. 10
- 4918 Dipper Mouth Blues (Oliver-Armstrong)—Fox-trot.....King Oliver's Jazz Band 10
- Where Did You Stay Last Night? (Armstrong-Hardin)—Fox-trot.....King Oliver's Jazz Band 10
- 4919 Dreamy Melody (Koehler-Magine-Naset)—Waltz.....Markels Orch. 10
- Love Tales (Leonora) (Vincent Rose)—Fox-trot.....Markels Orch. 10
- 4920 Cut Yourself a Piece of Cake (And Make Yourself at Home) (Billy James)—Fox-trot, Singing Chorus by Billy Jones....Rega Dance Orch. 10
- Hi Lee, Hi Lo (Chop Suey a La Fox-ee Trot-ee) (Ira Schuster)—Fox-trot, Singing Chorus by Billy Jones....Rega Dance Orch. 10
- 4921 Gloria (Ring-Hager)—Fox-trot, Piano Solo by Vincent Lopez, Vincent Lopez and His Hotel Penn. Orch. 10
- Ragging the Scale (Claypoole)—Fox-trot, Piano Solo by Vincent Lopez, Vincent Lopez and His Hotel Penn. Orch. 10
- 4922 Tell Me a Story (John Schonberger)—Fox-trot, Markels Orch. 10
- Born and Bred in Brooklyn (From the musical comedy "The Rise of Rosie O'Reilly") (Geo. M. Cohan)—Fox-trot, Incidental Whistling by Sibyl Sanderson Fagan, Blue Diamond Dance Orch. 10
- 4923 Pay Day Blues (Walter C. Ahlheim)—Fox-trot, Harry Raderman's Jazz Band 10
- Wet Yo' Thumb (Harry Akst)—Fox-trot, Harry Raderman's Jazz Band 10
- 4924 Mean Eyes (Too Late Blues) (Bob Miller)—Fox-trot (B. H. Warner, Director), Warner's Seven Aces 10
- Lonesome Lovesick Got-to-have-my-daddy Blues (Ernie Erdman-Chester Cohn-Clarence M. Jones)—Fox-trot (B. H. Warner, Director), Warner's Seven Aces 10
- 4925 Kansas City Man Blues (Clarence Williams-Clarence Johnson)—Fox-trot, Clarence Williams' Blue Five 10
- Wild Cat Blues (Clarence Williams-Thomas Wiley)—Fox-trot, Clarence Williams' Blue Five 10
- 4928 Oh! Gee, Oh! Gosh, Oh! Golly I'm in Love (Ernest Brever-Ole Olson)—Fox-trot, Singing Chorus by Billy Jones-Ernest Hare, Rega Dance Orch. 10
- Oh! Min (Con Conrad)—Fox-trot, The Yellow Jackets 10
- 4933 High Society Rag (King Oliver)—Fox-trot, King Oliver's Jazz Band 10
- Snake Rag (Oliver-Piron)—Fox-trot, King Oliver's Jazz Band 10
- 4934 Havana (John Schonberger)—Fox-trot, The Yellow Jackets 10
- March of the Siamese (Paul Lincke)—Fox-trot.....Markels Orch. 10
- 4936 Love (My Heart Is Calling You) (Joe Cooper)—Fox-trot, Vincent Lopez and His Hotel Penn. Orch. 10
- Rose of Brazil (Ray Klages-Billy Fazioli)—Fox-trot, Vincent Lopez and His Hotel Penn. Orch. 10
- 4938 That Old Gang of Mine (Ray Henderson)—Fox-trot, Vincent Lopez and His Hotel Penn. Orch. 10
- No. No. Nora (Ted Fiorito-Ernie Erdman)—Fox-trot, Vincent Lopez and His Hotel Penn. Orch. 10

OKEH VOCAL RECORDS

- 4926 Kansas City Man Blues (Clarence Williams-Clarence Johnson)—Contralto Solo, Accomp. by Harlem Trio.....Mamie Smith 10
- Lady Luck Blues (William Webber-Clarence Williams)—Contralto Solo, Accomp. by Harlem Trio.....Mamie Smith 10
- 4927 I've Got the Yes! We Have No Banana Blues (Lew Brown-James F. Hanley-Rohert King)—Contralto, with Orch., Eva Taylor with Clarence Williams' Blue Five 10
- Oh! Daddy Blues (Clarence Williams)—Contralto-Baritone Duet, with Orch....Eva Taylor-Clarence Williams with C. Williams' Blue Five 10
- 4929 Ten Thousand Years From Now (J. Keirn Brennan-Ernest R. Ball)—Tenor, with Orch., Lewis James 10
- Just a Girl That Men Forget (Al. Dubin-Fred. Rath-Joe Garren)—Tenor, with Orch., Lewis James 10
- 4935 Good Looking Papa (Clarence Williams)—Contralto Solo, Piano Accomp. by Clarence Williams.....Mamie Smith 10

ADVANCE RECORD BULLETINS FOR DECEMBER—(Continued from page 196)

- You Can't Do What My Last Man Did (J. C. Johnson-Allie Moore)—Contralto Solo, Piano Accomp. Mamie Smith 10
OKEH INSTRUMENTAL RECORD
 4937 Scouting Around (Jimmy Johnson)—Piano Solo Jimmy Johnson 10
 Toddlin' (Jimmy Johnson)—Piano Solo, Jimmy Johnson 10
OKEH RACE RECORDS
 8089 Original Charleston Strut (Thomas Morris)—Contralto, with Orch., Eva Taylor and Clarence Williams' Blue Five 10
 If You Don't I Know Who Will (Chris Smith-Timm Brymn-Clarence Williams)—Contralto, with Orch., Eva Taylor and Clarence Williams' Blue Five 10
 8090 Atlanta Blues (W. C. Handy-Dave Elnan)—Contralto, with Orch., Sara Martin and Clarence Williams' Blue Five 10
 Blind Man Blues (Eddie Green-Billie McLaurin)—Contralto, with Orch., Sara Martin and Clarence Williams' Blue Five 10
 8091 Daddy, You've Done Put That Thing on Me (Eddie Heywood)—Contralto Solo, Piano Accomp. by Eddie Heywood, Martha Copeland 10
 The Penetrating Blues (Eddie Heywood)—Contralto Solo, Piano Accomp. by Eddie Heywood, Martha Copeland 10
 8092 Bedtime Blues (Gray-Liston)—Contralto Solo, Piano Accomp. by Clarence Williams, Virginia Liston 10
 You Thought I Was Blind But Now I See (Williams-Gray-Liston)—Contralto Solo, Piano Accomp. by Clarence Williams, Virginia Liston 10
 8093 Troubled Blues (Sara Martin-Porter Grainger)—Contralto Solo, with Piano Accomp., Sara Martin 10
 I'm Satisfied (Don Heywood-Porter Grainger)—Contralto Solo, with Piano Accomp., Sara Martin 10
 8094 The Mixed-up Blues (Eddie Heywood)—Piano Solo Eddie Heywood 10
 The Black Bottom Blues (Eddie Heywood)—Piano Solo Eddie Heywood 10

ODEON RECORDS

RECORDED IN EUROPE

- 2007 Forest Murmurs—Descriptive; Bird Voices with Instrumental Accomp. 1034
 Nightingale—Descriptive; Bird Voices with Instrumental Accomp. 1034
 3068 Jolly Fellows (Lustige Brueder) (Vollstedt), Dajos Bela and His Orch. 12
 Accelerations (Johann Strauss), Dajos Bela and His Orch. 12
 3069 Stradella Overture, Part 1 (Flotow), European Symphony Orch. 12
 Stradella Overture, Part 2 (Flotow), European Symphony Orch. 12
 3070 Prelude in C Sharp Minor (Rachmaninoff), Marek Weber and His Orch. 12
 Minuet in G (Op. 14, No. 1) (Paderewski), Marek Weber and His Orch. 12
 3071 Liebesfreud (Love's Joy) (Old Vienna Waltz) (Fritz Kreisler)—Violin Solo, Piano Accomp., Edith Lorand 12
 Liebesleid (Love's Sorrow) (Fritz Kreisler)—Violin Solo, Piano Accomp., Edith Lorand 12
 3072 Schubert Serenade—Violin, Harp and Organ, Marek Weber Trio 12
 Serenade Toselli—Violin, Harp and Organ, Marek Weber Trio 12
 5025 Merry Wives of Windsor (O. Nicolai)—Overture, Part 1, Dr. Weissman and the Orch. of the State Opera House, Berlin 12
 Merry Wives of Windsor (O. Nicolai)—Overture, Part 2, Dr. Weissman and the Orch. of the State Opera House, Berlin 12

BRUNSWICK RECORDS

- 50040 Ah! Moon of My Delight (From "In a Persian Garden") (Lehmann)—Tenor, with Orch., Mario Chamlee 10
 When My Ships Come Sailing Home (Stewart-Dorel)—Tenor, with Orch., Mario Chamlee 10
 15058 Silent Night (Christmas Hymn) (Gruber)—Soprano and Male Trio, with Orch., Florence Easton and Male Trio 10
 Holy Night (Cantique de Noël) (Adam)—Soprano and Chorus, with Orch., Florence Easton and Chorus 10
 50041 Symphonie Espagnole—Andante (Fourth Movement) (Lalo)—Violin Solo, Pianoforte by Paul Frenkel, Bronislaw Huberman 10
 Symphonie Espagnole—Rondo (Fifth Movement) (Lalo)—Violin Solo, Pianoforte by Paul Frenkel, Bronislaw Huberman 10
 50042 Ballade in A Flat (Chopin)—Pianoforte Solo, Leopold Godowsky 10
 Nocturne in D Flat (Chopin)—Pianoforte Solo, Leopold Godowsky 10
 13095 All Through the Night (Old Welsh Air) (Boulton)—Tenor and Male Quartet, with Orch., Theo. Karle and Male Quartet 10
 At Dawning (Eberhart-Cadnan)—Tenor, with Orch., Theo. Karle 10
 5193 O Little Town of Bethlehem (Christmas Hymn) (Brooks-Barnby)—Mixed Voices, with Orch., Collegiate Choir 10
 The Infant Jesus (Gesu Bambino) (Martens-Yon)—Mixed Voices, with Orch., Collegiate Choir 10
 2496 Serenade (Toselli-Fradkin)—Violin Solo; Harp by Arthur Jones, Frederic Fradkin 10
 Chansonette (Bass)—Violin Solo, Pianoforte by Frederic Persson, Frederic Fradkin 10
 20014 Pomp and Circumstance March, No. 1 (Elgar)—Concert Band, Walter B. Rogers and His Band 10
 Raymond Overture (Thomas)—Concert Band, Walter B. Rogers and His Band 10
 2492 Dreamy Melody (Koehler-Magine-Naset)—Tenor and Male Trio, with Orch., Allen McQuhae and Male Trio 10
 When Clouds Have Vanished and Skies Are Blue (Clay-Johnson)—Tenor and Male Trio, with Orch., Allen McQuhae and Male Trio 10
 2493 Just a Girl That Men Forget (Dubin-Roth-Garren)—Soprano and Contralto, with Orch., Irene Audrev-Emily Earle 10
 Little Pal of Long Ago (Hirsch-Sacre-Dixon)—Tenor and Baritone, with Orch., Billy Jones-Ernest Hare 10
 2494 Lovey Came Back (Young-Lewis-Handman)—Comedienne, with Orch., Marion Harris 10
 I've Got a Cross-eyed Papa (But He Looks Straight to Me) (Ingraham-Zany-Duval)—Comedienne, with Orch., Marion Harris 10
 2495 The Merry-go-round (Van Dyke)—Yodeler, with Orch., Paul Van Dyke 10

- That Naughty Yodel (Van Dyke)—Yodeler, with Orch., Paul Van Dyke 10
 2485 That Old Gang of Mine (Rose-Dixon-Henderson)—Fox-trot for Dancing, with Vocal Quartet, Jennie Krueger's Orch. 10
 Wonder If She's Lonely, Too (White-Grossman)—Fox-trot for Dancing, Bennie Krueger's Orch. 10
 2486 Rampart Street Blues (Robinson)—Fox-trot for Dancing, The Cotton Pickers 10
 Back o' Town Blues (Bowen-Berbedeaux)—Fox-trot for Dancing, The Cotton Pickers 10
 2487 I Love You (From "Little Jessie James") (Thompson-Archer)—Fox-trot for Dancing; Piano Passages by Phil Ohman and Victor Arden, Carl Fenton's Orch. 10
 What Do You Do Sunday, Mary? (Intro, "Alibi Baby," from "Poppy") (Caesar-Jones)—Fox-trot for Dancing; Piano Passages by Phil Ohman, Carl Fenton's Orch. 10
 2489 Lost Melody (Kahn-Fiorito)—Fox-trot for Dancing, Oriole Orch. 10
 Bit by Bit You're Breaking My Heart (Kahn-Bloom)—Fox-trot for Dancing, Oriole Orch. 10
 2490 Mama Goes Where Papa Goes (Or Papa Don't Go Out To-night) (Yellen-Ager)—Fox-trot for Dancing, The Cotton Pickers 10
 Walk, Jenny, Walk (Creamer-Wooding-Schafer)—Fox-trot for Dancing, The Cotton Pickers 10
 2491 Drifting Back to Dreamland (Charlesworth-Harrison-Sadler)—Waltz for Dancing; Vocal Chorus by Charles Hart and Elliott Shaw, Carl Fenton's Orch. 10
 The Land of Broken Dreams (Scott-Parker-Wilson)—Waltz for Dancing; Vocal Chorus by Mary Ann Lee and Emily Earle, Carl Fenton's Orch. 10

- Carl Fenton's Orch.
 2498 Remem'ring (Duncan Sisters)—Fox-trot for Dancing, Paul Ash and His Granada Orch. 10
 Betty (MacMoret-Ash)—Fox-trot for Dancing, Paul Ash and His Granada Orch. 10
EXTRA SPECIAL
 2499 Last Night on the Back Porch—Fox-trot for Dancing, with Vocal Chorus, Carl Fenton's Orch. 10
 Chick-a-dee—Fox-trot, Carl Fenton's Orch. 10

GENNETT LATERAL RECORDS

- 10080 La Danza (Tarantella Napoletana) (Rossini)—Tenor, Fausto Cavallini 10
 The Last Song (Lultima Canzona) (Tosti)—Orch. Accomp., Fausto Cavallini 10
 10083 All Through the Night (Maynard)—Tenor, Orch. Accomp., Henry Moeller 10
 Silver Threads Among the Gold (Rexford-Danks)—Tenor, Orch. Accomp., Henry Moeller 10
 10084 Men of Iowa (O. E. Van Doren), Gennett Military Band 10
 On Iowa (W. R. Law), Gennett Military Band 10
 5218 Grandpa's Spells (Morton), Ferd (Jelly Roll) Morton 10
 Kansas City Stomp (Morton), Ferd (Jelly Roll) Morton 10
 5220 Mr. Jelly Lord (Morton), New Orleans Rhythm Kings 10
 Clarinet Marmalade (Shields), New Orleans Rhythm Kings 10
 5221 London Blues (Morton), New Orleans Rhythm Kings 10

(Continued on page 198)

"THE ROLL OF HONOR"

We are dedicated to the principle that our very existence hangs upon our ability to serve the player industry to the utmost. U. S. Rolls, more eloquently than words can describe, are the concrete expression of our efforts to make them the most constructive influence in the trade.

Whether or not you sell players—you, too, must direct your roll trade to promote interest in players.

U. S. Rolls Are Not Competitive!

Neither Dealers in Nor Makers of Musical Instruments Are Financially Interested in the Manufacture of U. S. Rolls

UNITED STATES MUSIC COMPANY

2934-2938 West Lake Street, Chicago

122 Fifth Avenue, New York



Sell U. S. Rolls—You'll Sell More Players!

ADVANCE RECORD BULLETINS FOR DECEMBER—(Continued from page 197)

- Mad (Cause You Treat Me This Way) (Mc-Hugh-Heath)New Orleans Rhythm Kings
5224 The Ideal Republic (Address), William Jennings Bryan National Emblem March (Bagley), Gennett Military Band
5227 Somebody Cares—Baritone, Orch. Accomp., Homer Rodeheaver
Where They Never Say "Good Bye"—Baritone, Orch. Accomp., Homer Rodeheaver
5231 Fagin (Mortimer Kaphan).....Dramatic Monologue
Wilkins Micawber (Mortimer Kaphan), Dramatic Monologue
5232 Foolish Child (Nelson-McPhail-Bargy), Bailey's Lucky Seven
No, No, Nora! (Kahn-Fiorito-Erdman), Bailey's Lucky Seven
5233 Deceitful Blues (Perry Bradford).....Julia Jones
Here's Your Opportunity (If Anybody Here Wants a Real Kind Mama) (Brooks), Julia Jones
5234 Tin Roof Blues—Edna Hicks, Piano Accomp., Lemuel Fowler
Oh Daddy Blues (Russell-Herbert)—Edna Hicks, Piano Accomp., Lemuel Fowler
5238 "La Maleva" (A. Buglione), Gonzales y su orquesta
"Princesita" (J. Padilla).....Gonzales y su orquesta
5239 The Last Rose of Summer (Michael Hoffman)—Violin Solo, Piano Accomp., Joe Engleman
Hungarian Dance No. 1 (Brahms-Joachim) (Michael Hoffman)—Violin Solo, Piano Accomp., Joe Engleman
5241 I've Got the Yes! We Have No Bananas Blues (Brown-Hanley-King).....Bailey's Lucky Seven
That Old Gang of Mine (Rose-Dixon-Henderson).....Glantz and His Orch.
5243 Home (Fazioli-Klages).....Bailey's Lucky Seven
That Big Blond Mama (Rose-Monaco), Bailey's Lucky Seven
5245 Where the River Shannon Flows (Russell), Frank Ferera's Hawaiian Entertainers
Come Back to Erin (Claribel), Frank Ferera's Hawaiian Entertainers
5246 Last Night on the Back Porch (Brown-Schraut-stader).....The Mobile Trio
Struttin' Jim (Dixon-Carleton).....The Mobile Trio
5247 Fado 31 (Alves Coelho).....Gonzales y su orquesta
El Emperador de los Pobres (Vals) (A. Bar-ranco).....Gonzales y su orquesta
5248 I Wish I Had Some One to Cry Over Me (Parish-Young-Squires)—Tenor, Orch. Ac-comp., Lewis James
Swinging Down the Lane (Kahn-Jones)—Orch. Accomp., Shannon Four
5249 Oh! Min (Con Conrad).....Bailey's Lucky Seven
Steamboat Sal (Fisher-Raskin-Couser), Bailey's Lucky Seven
5250 Serenata Galante (Colombina), Gonzalez y su orquesta
Su Majestad El Fox-trot (G. Polanco), Orquesta del Bosque
5251 Mama Goes Where Papa Goes (Yellen-Ager), Porter's Blue Devils
Somebody's Wrong (Marshall-Egan-Whiting), Porter's Blue Devils
5252 Satisfied Blues (Fowler)—Edna Hicks, Piano Accomp., Lemuel Fowler
No Name Blues (Hicks-Smith)—Edna Hicks, Piano Accomp., Lemuel Fowler
5253 She's Got That Too (Schmitt-Krumpe-Aichele), Justin Huber's Orch.
Sweet Papa Joe (Link-Britt-Russell-Seibert), Justin Huber's Orch.
5254 Every Night I Cry Myself to Sleep Over You (Johnson-Wood-Bibo), The Biltmore Hotel Orch.
Will You Always Love Me (Traveller-Halstead), The Biltmore Hotel Orch.
5255 Dreamy Melody (Magine-Kochler-Naset), Art Landry and His Call of the North Orch.
Rip Saw Blues (Landry-Hager, DeKay-Megson), Art Landry and His Call of the North Orch.
5256 I Love You (Thompson-Archer), Wood's "Bijou" Orch.
For Old Time Sake (Klickman), Wood's "Bijou" Orch.
5257 In Fair Hawaii (Wirth).....The Specialty Orch.
You Didn't Want Me When I Wanted You (Yellen-Stern).....The Specialty Orch.
5258 Oh! You Little Sun-Uv-Er Gun (Howard-Sol-man).....Bailey's Lucky Seven
Stealing to Virginia (Kahn-Donaldson), Bailey's Lucky Seven
5259 I Know the Lord Has Laid His Hands on Me (Homer Rodeheaver), Homer Rodeheaver and Wiseman Quartet
Great Day (Homer Rodeheaver), Homer Rodeheaver and Wiseman Sextet
5260 Just a Girl That Men Forget (Dubbin-Roth-Garren)—Tenor, Orch. Accomp., Billy Jones
Out There in the Sunshine With You (Brennan-Ball)—Tenor, Orch. Accomp., Lewis James
5261 Baby's Got the Blues (Creamer-Wooding)—Josie Miles, Piano Accomp., Stanley Miller
Kansas City Man Blues (Johnson-William)—Josie Miles, Piano Accomp., Stanley Miller
5263 Black Sheep Blues (Jahn-Bake), The Black Dominoes
Land of Cotton Blues (Bennett-Jerome-Ahlert), The Black Dominoes
5262 Novelli Sposi (Nitti Nise).....Iasilli's Band
L'Espizione Di Torino Mazurka (A. D'Anno), Iasilli's Band
5264 Cuddle-Uddle-Up (Mitchell-Parish), The Biltmore Hotel Orch.
Tell All the Folks in Kentucky (I'm Comin' Home) (Irving Berlin).....Bailey's Lucky Seven
5265 Juanita (Norton).....Stellar Trio
In the Gloaming (Molloy).....Stellar Trio
5269 Cradle Song (Brahms-Cornellissen), Culp String Quartet
Finale D Major Quartet (Haydn), Culp String Quartet
5270 Rory O'More.....Mary Ellen Conlon
Miss Ramsey (Schottische).....Mary Ellen Conlon
5271 It Ain't Gonna Rain No Mo' (Wendell Hall), Wendell Hall
Red Headed Music Maker (Wendell Hall), Wendell Hall
5272 I've Got a Song for Sale (Jack Nelson), Ladd's Black Aces
All Wrong (Martin-Kahn-Jones), Ladd's Black Aces
5273 Thanksgiving Hymn (Mrs. William Jennings Bryan)—Orch. Accomp., Amy Ellerman
There's a Light in the Valley (P. Bliss), Critteron Quartet
- 10678 Waltz of Long Ago—Waltz.....Emerson Dance Orch.
So Tuis Is Love—Waltz.....Epp's Hotel Astor Orch.
10683 An Orange Grove in California—Fox-trot, Emerson Dance Orch.
Little Butterfly—Fox-trot.....Emerson Dance Orch.
10677 Sitting In A Corner—Fox-trot, Emerson Dance Orch.
Twilight Shadows—Waltz.....Emerson Dance Orch.
10676 Music of Love—Medley Fox-trot, Epp's Hotel Astor Orch.
If I Knew You Then As I Know You Now—Fox-trot.....Glantz and His Orch.
10681 I Love You—Tenor Solo, Orch. Accomp., Jack Boyle
Roaming to Wyoming—Baritone and Tenor Duet, Orch. Accomp., Kaufman-Ryan
10684 Easy Melody—Fox-trot.....Emerson Dance Orch.
Moonlight Kisses—Fox-trot.....Emerson Dance Orch.
CHRISTMAS SPECIALS
1087 Adeste Fideles, Come All Ye Faithful—Male Quartet, Shannon Four
Holy Night, Peaceful Night—Male Quartet, Shannon Four
10270 Hark! The Herald Angels Sing—Male Quartet, Stellar Quartet
Joy To the World—Male Quartet.....Stellar Quartet
10459 Kiddies' Patrol (Christmas Eve)—Descriptive, Emerson Concert Band
Kiddies' Dance (Christmas Morning)—Descrip-tive.....Emerson Concert Band
- PATHE PHONOGRAPH & RADIO CORP.**
- POPULAR VOCAL
032002 Dreamy Melody.....Apollo Male Trio
Easy Melody.....Apollo Male Trio
032005 No, No, Nora!.....Frank Bessinger
Since I Fell In Love With You.....Charles Cinway
032001 Why Should I Give My Love to You, Charles Cinway
You Didn't Care When You Broke My Heart (So Why Should I Care Now).....Frank Sterling
032003 Who Will It Be?.....William Rundle
When Clouds Have Vanished and Skies Are Blue.....Frank Sterling
032004 Mama Goes Where Papa Goes (Or Papa Don't Go Out To-night).....Vernon Dalhart
When Dixie Stars Are Playing Peek-A-Boo, Dixie Trio
RACE RECORDS
032006 Baby's Got the Blues.....Tudie Wells
Uncle Sam Blues.....Tudie Wells
032007 Down South Blues.....Hannah Sylvester
I Want My Sweet Daddy Now.....Hannah Sylvester
032008 Deceitful Blues.....Mary Jackson
If Anybody Here Wants a Real Kind Mama (Here's Your Opportunity).....Mary Jackson
DANCE
036001 You Darling You—Fox-trot.....Golden Gate Orch.
Mamma Loves Papa, Papa Loves Mamma—Fox-trot.....Golden Gate Orch.
036002 An Orange Grove in California (from "Third Annual Music Box Revue")—Fox-trot, Golden Gate Orch.
Learn To Do The Strut (from "Third Annual Music Box Revue")—Fox-trot, Don Parker and His Strand Roof Orch.
036003 I've Got a Song For Sale That My Sweetie Turned Down—Fox-trot, Don Parker and His Strand Roof Orch.
Sweet Butter—Fox-trot, Nathan Glantz and His Orch.
036004 Havana—Tango Fox-trot, Max Terr and His Orch.
Passionetta—Fox-trot, Nathan Glantz and His Orch.
036005 Chansonetta—Fox-trot, Max Terr and His Orch.
Mamma's Little Silver Lining—Fox-trot, Nathan Glantz and His Orch.
036006 I'm Sitting Pretty In A Pretty Little City—Fox-trot, Hollywood Dance Orch.
Rock Me To Sleep With My Virginia Melody—Fox-trot, Hollywood Dance Orch.
036007 Mississippi Ripples—Waltz, Casino Dance Orch.
Steal A Little Kiss While Dancing—Waltz, Casino Dance Orch.
036008 Down On The Farm—Fox-trot, Nathan Glantz and His Orch.
The Animal Fair—Fox-trot, Casino Dance Orch.
036009 The Waltz Of Long Ago (from "Third Annual Music Box Revue")—Waltz, Fry's Million Dollar Pier Orch.
Indiana Moon—Waltz, Fry's Million Dollar Pier Orch.
036010 When It's Night-Time In Italy It's Wednes-day Over Here—Fox-trot, Fry's Million Dollar Pier Orch.
Old Fashioned Love (from "Runnin' Wild")—Fox-trot, Fry's Million Dollar Pier Orch.
STANDARD VOCAL
021085 The Trumpeter.....William Rubinoff
I Hear A Thrush At Eve.....William Rubinoff
SACRED
021086 Flee as a Bird.....Earle F. Wilde
A Clean Heart.....Earle F. Wilde
INSTRUMENTAL
021087 United Empire March.....American Republic Band
Naval Reserve March.....American Republic Band
021088 Grace And Beauty—Banjo Solo.....Fred Van Eps
The Oriole—Banjo Solo.....Fred Van Eps
HAWAIIAN
021089 Southern Blues, Louise and Ferera Hawaiian Troupe
My Old Kentucky Home, Louise and Ferera Hawaiian Troupe
OPERATIC
025109 Manon Lescaut "In quelle trine morbide" (Puccini) (In Italian).....Claudia Muzio
Il Trovatore "Tacea la notte" (Verdi) (In Italian).....Claudia Muzio
- REGAL RECORDS**
- DANCE RECORDS
9551 Every Night I Cry Myself to Sleep Over You—Fox-trot.....Roy Collins' Orch.
Foolish Child—Fox-trot, Vocal Chorus by Billy West.....Roy Collins' Orch.
9552 Mama Goes Where Papa Goes—Fox-trot, Missouri Jazz Band
I'm Sitting Pretty in a Pretty Little City—Fox-trot.....Missouri Jazz Band
9553 If I Can't Get the Sweetie I Want—Fox-trot, Six Black Diamonds
Sobbin' Blues—Fox-trot.....Six Black Diamonds
9554 Little Butterfly (From "Music Box Revue, 1923")—Fox-trot.....Continental Dance Orch.
An Orange Grove in California (From "Music Box Revue, 1923")—Fox-trot, Continental Dance Orch.
9555 Sweet Henry, the Pride of Tennessee—Fox-trot, Majestic Dance Orch.
Easy Melody—Fox-trot.....Majestic Dance Orch.
9556 Dreamy Melody—Waltz.....Continental Dance Orch.
In Your Embrace—Waltz.....Continental Dance Orch.
9557 Last Night on the Old Back Porch—Fox-trot, Jos. Franklin's Orch.
- Sittin' in a Corner—Fox-trot, Jos. Franklin's Orch.
9558 Roses of Picardy—Fox-trot, Hollywood Dance Orch.
Covered Wagon Days—Fox-trot, Hollywood Dance Orch.
9559 Saw Mill River Road—Fox-trot, Majestic Dance Orch.
A Kiss in the Dark—Waltz.....Xylo Novelty Orch.
POPULAR VOCAL RECORDS
9560 When It's Night Time in Italy It's Wednesday Over Here—Comedy Solo, Orch. Accomp., Billy West
Tell All the Folks in Kentucky—Tenor Solo, Orch. Accomp., Vernon Dalhart
9561 When Clouds Have Vanished and Skies Are Blue—Tenor Solo, Orch. Accomp., Vernon Dalhart
Pal of My Dreams—Tenor Solo, Orch. Accomp., Billy Burton
9562 Indiana Moon—Duet, Orch. Accomp., Robert Craig-Chas. Dalton
Somebody's Wrong—Baritone Solo, Orch. Ac-comp., Charles Dalton
9563 You Didn't Want Me When I Wanted You—Tenor Solo, Orch. Accomp., Lou Hayes
Somebody Else Took You Right Out of My Arms—Tenor Solo, Orch. Accomp., Arthur Hall
9564 Out There in the Sunshine With You—Tenor Solo, Orch. Accomp., Billy Burton
Kiss Me With Your Eyes—Tenor Solo, Orch. Accomp., Billy Burton
9566 Spring Song (Mendelssohn)—Violin Solo, Piano Accomp., Rudolph Polk
Melody in "F" (Rubinstein)—Violin Solo, Piano Accomp., Rudolph Polk
9565 Ave Maria (Schubert)—Violin Solo, Piano Ac-comp., Rudolph Polk
Humoresque (Dvorak)—Violin Solo, Piano Ac-comp., Rudolph Polk
CHRISTMAS RECORDS
9389 Kiddies' Patrol (Christmas Eve)—Descriptive, Orch. Accomp., Walter Rogers
Kiddies' Dance (Christmas Morning)—Descrip-tive, Orch. Accomp., Walter Rogers
960 Holy Night, Peaceful Night—Male Quartet, Liberty Quartet
Hark! The Herald Angels Sing—Male Quartet, Regal Male Quartet
961 Adeste Fideles (Oh Come, All Ye Faithful)—Male Quartet, Liberty Quartet
Joy to the World—Male Quartet, Regal Male Quartet
- FEDERAL RECORDS**
- DANCE
5331 When It's Night Time in Italy—Fox-trot, Vocal Refrain by Jack Murray, Southern Syncopators
Mamma Goes Where Papa Goes—Fox-trot, Southern Syncopators
5332 Sop-Tim-Bom (Half-past Ten)—Chinese Waltz, Metropolitan Players
Oh, You Little Sun-uver-gun—Fox-trot, Metropolitan Players
5333 Take, Oh Take, Those Lips Away (From "Zieg-feld's Follies")—Fox-trot, Golden Gate Orch.
Home Tow'r Blues—Fox-trot, Golden Gate Orch.
5334 Dreamy Melody—Waltz, Rialto Dance Orch.
Mississippi Ripples—Waltz, Rialto Dance Orch.
5335 Little Butterfly (From "Music Box Revue")—Fox-trot, The Carolinians
An Orange Grove in California (From "Music Box Revue")—Fox-trot, The Carolinians
5343 Old-fashioned Love (Intro, "Open Your Heart," from "Runnin' Wild")—Medley Fox-trot, Miami Beach Orch.
I've Got a Song for Sale—Fox-trot, Miami Beach Orch.
5342 The Waltz of Long Ago (From "Music Box Revue")—Medley Waltz, Lenox Dance Orch.
Bit by Bit You're Breaking My Heart—Fox-trot, Lenox Dance Orch.
VOCAL
5336 When Clouds Have Vanished and Skies Are Blue—Tenor, George Wilton Ballard
Pal of My Dreams—Tenor, George Wilton Ballard
5337 Tell All the Folks in Kentucky I'm Comin' Home—Baritone, Ernest Hare
The Old Folks at Home—Tenor, Vernon Dalhart
5338 Watchin' the Moon Rise—Tenor and Baritone, Charles Hart-Elliott Shaw
Kiss Me With Your Eyes—Tenor, Lewis James
5339 Little Boy—Tenor, Tom Moore
Why Don't My Dreams Come True?—Tenor, Charles Hart
5341 Out There in the Sunshine With You—Bari-tone, Elliott Shaw
Memories of Virginia—Baritone, Arthur Raymond
CHILDREN'S RECORD
5340 Mother Goose Songs No. 1—(1) Three Little Kittens; (2) Dickory, Dickory, Dock! (3) Tom, Tom, The Piper's Son; (4) Simple Simon; (5) Twinkle, Twinkle; (6) Little Boy Blue.....Lewis James
Mother Goose Songs No. 1—(1) Ding, Dong, Dell; (2) Ba, Ba, Black Sheet; (3) London Bridge; (4) Humpty, Dumpty; (5) Song of Six Pence; (6) Little Miss Muffet.....Lewis James
CHRISTMAS RECORDS
3344 Silent Night (Saxophone-Xylophone-Piano), Viennese Trio
Belfry Chimes (Saxophone-Xylophone-Piano), Viennese Trio
5073 Hark The Herald Angels Sing—Male Voices, Stellar Trio
Lead Kindly Light—Baritone and Tenor, Wheeler-Ballard
5088 Christmas Chimes.....Chris Chapman
Cathedral Chimes.....Chris Chapman
5129 Holy Night—Tenor, Charles Harrison
Star of the East—Tenor and Baritone, Ballard-Wheeler
5130 Silent Night—Male Quartet, Shannon Four
Adeste Fideles (Oh Come, All Ye Faithful)—Male Quartet, Shannon Four
5131 Star of Bethlehem—Tenor, Charles Harrison
Nazareth—Basso, Wilfred Glenn
STANDARD
5124 Aloha Oe (Farewell to Thee)—Contralto with Male Chorus, Louise Terrell
Juanita—Male Quartet, Shannon Four
5068 Little Grey Home in the West—Tenor, Charles Harrison
I Hear You Calling Me—Tenor, Charles Harrison
5096 Drink to Me Only With Thine Eyes—Tenor, George Wilton Ballard
Love's Old Sweet Song—Soprano, Nevada Van Der Veer
INSTRUMENTAL
5288 Mighty Lak' A Rose (Nevin) (Violin-Cello-Piano).....Mendelssohn Trio
Simple Confession (Thome) (Violin-Cello-Piano).....Mendelssohn Trio
- EMERSON RECORDS**
- LATEST DANCE AND VOCAL HITS
10682 Last Night On the Back Porch—Fox-trot, Pennsylvania Syncopators
Somebody's Wrong—Fox-trot, Pennsylvania Syncopators
10679 What Do You Do Sunday, Mary?—Fox-trot, Glantz and His Orch.
Foolish Child—Fox-trot, Glantz and His Orch.

- 5284 Salut D'Amour (Elgar)—Violin Solo... Ted Kasloff
- Polonaise (Vieuxtemps)—Violin Solo... Ted Kasloff
- HAWAIIAN
- 5049 Hawaiian Twilight (Hawaiian Guitars),
Malina Malamalama (Hawaiian Guitars),
Ferera-Franchini

BANNER RECORDS

DANCE RECORDS

- 1263 Last Night on the Old Back Porch—Fox-trot,
Hollywood Dance Orch.
- Foolish Child—Fox-trot, Vocal Chorus by Billy
West... Hollywood Dance Orch.
- 1264 Easy Melody—Fox-trot... Missouri Jazz Band
- I'm Sitting Pretty in a Pretty Little City—
Fox-trot... Missouri Jazz Band
- 1265 Every Night I Cry Myself to Sleep Over You
—Fox-trot... Six Black Diamonds
- Sobbin' Blues—Fox-trot... Six Black Diamonds
- 1266 Dreamy Melody—Waltz... Imperial Dance Orch.
- In Your Embrace—Waltz... Imperial Dance Orch.
- 1267 An Orange Grove in California (From "Music
Box Revue, 1923")—Fox-trot,
Imperial Dance Orch.
- Little Butterfly (From "Music Box Revue,
1923")—Fox-trot... Imperial Dance Orch.
- 1268 If I Can't Get the Sweetie I Want—Fox-trot,
Jos. Franklin's Orch.
- Sweet Henry, the Pride of Tennessee—Fox-trot,
Jos. Franklin's Orch.
- 1269 Covered Wagon Days—Fox-trot,
Majestic Dance Orch.
- Roses of Picardy—Fox-trot... Majestic Dance Orch.
- 1270 Mamma Goes Where Papa Goes—Fox-trot,
Roy Collins' Orch.
- Sittin' in a Corner—Fox-trot... Roy Collins' Orch.
- 1271 A Kiss in the Dark—Waltz... Clark's Marimba Orch.
- Saw Mill River Road—Fox-trot,
Hollywood Dance Orch.

POPULAR VOCAL RECORDS

- 1272 Somebody's Wrong—Baritone Solo, Orch. Ac-
comp... Chas. Dalton
- Somebody Else Took You Out of My Arms—
Tenor Solo, Orch. Accomp... Arthur Hall
- 1273 When It's Night Time in Italy It's Wednesday
Over Here—Comedy Solo, Orch. Accomp.,
Billy West
- Tell All the Folks in Kentucky—Tenor Solo,
Orch. Accomp... Vernon Dalhart
- 1274 Out There in the Sunshine With You—Tenor
Solo, Orch. Accomp... Hugh Donovan
- Pal of My Dreams—Tenor Solo, Orch. Accomp.,
Hugh Donovan
- 1275 Indiana Moon—Duet, Orch. Accomp.,
Robert Craig-Chas. Dalton
- You Didn't Want Me When I Wanted You—
Tenor Solo, Orch. Accomp... Lou Hayes
- 1276 When Clouds Have Vanished and Skies Are
Blue—Tenor Solo, Orch. Accomp... Vernon Dalhart
- Kiss Me With Your Eyes—Tenor Solo, Orch.
Accomp... Hugh Donovan
- 2104 Melody in "F" (Rubinstein)—Violin Solo,
Piano Accomp... Rudolph Polk
- Spring Song (Mendelssohn)—Violin Solo, Pi-
ano Accomp... Rudolph Polk
- 2103 Humoresque (Dvorak)—Violin Solo, Piano Ac-
comp... Rudolph Polk
- Ave Maria (Schubert)—Violin Solo, Piano Ac-
comp... Rudolph Polk

STANDARD RECORD

- 2105 Stars and Stripes Forever—March,
Banner Military Band
- Under the Double Eagle—March,
Banner Military Band
- CHRISTMAS RECORDS
- 2063 Kiddies' Patrol (Christmas Eve)—Descriptive,
Orch. Accomp... Walter Rogers
- Kiddies' Dance (Christmas Morning)—Descrip-
tive, Orch. Accomp... Walter Rogers
- 2065 Adeste Fideles (Oh Come, All Ye Faithful)—
Male Quartet... Liberty Male Quartet
- Joy to the World—Male Quartet,
Banner Male Quartet
- 2066 Holy Night, Peaceful Night—Male Quartet,
Liberty Male Quartet
- Hark! The Herald Angels Sing—Male Quartet,
Banner Male Quartet

VICTOR WINDOW DISPLAY MATERIAL

Some excellent material for use in window displays, especially holiday displays, has been prepared for dealers' use by the Victor Co. This consists of cardboards cut in the shape of stars, in the center of which appears a likeness of famous Victor artists. Each of the "stars" has a red border, presenting a pleasing appearance and furnishing window display material which offers excellent opportunities for diversified arrangement.

INCREASING DEMAND FOR "THE YALE"

NEW HAVEN, CONN., November 5.—The Davis Mfg. & Sales Co., of this city, is doing considerable business with the Yale talking machine which it manufactures. This small table machine is very attractively produced and has a surprising tone value. Although the Yale talking machine has an all-year-round demand, the holiday season has still further augmented the business of this company. Dealers handling this product are unanimous in their expressions of approval over its sales possibilities.

**SOUTHERN
VICTOR WHOLESALERS**
The Corley Company
RICHMOND VIRGINIA

**CONSTRUCTIVE ARTICLES IN THIS
ISSUE OF THE WORLD**

Ready Reference for Salesmen, Dealers and Department Heads

<p>Value of the Telephone as an Aid in Selling 4</p> <p>Are You Preparing for the Holiday Business? If So, How? 8</p> <p>Reasons for Thanksgiving in the Talking Machine Trade 10</p> <p>Making the Dealer's Store a Musical Center 10</p> <p>Support for the Price Maintenance Bills 10</p> <p>Is a National Exhibition Desirable? . 11</p> <p>Concerts as a Means of Sales Promotion 12</p> <p>Record Service That Pays Big Dividends 14</p> <p>Know Your Overhead and Prevent Losses 19</p> <p>Reawakening Public Interest in Talking Machine Records 20</p> <p>Several Timely Holiday Sales-building Stunts 22</p> <p>The Profiteering Price-cutter Is a Trade Pirate, Says Clyde M. Kelly 24</p> <p>Local Musical Events Open the Way for Sales of Records and Machines 26</p> <p>The Talking Machine as an Educator Radio Opportunities in the Rural Sections 28</p> <p>The Development of New Business Among Old Customers 32</p> <p>Musical Side Lines as Trade Stimulators 34</p> <p>How a Live Dealer Sold Over 1,200 Machines 35</p> <p>The Value of Display in Boosting Sales 38</p> <p>Important Radio Merchandising Factors Discussed by Dealers 40</p> <p>Artistic Window Displays Always Strike the Eye 43</p> <p>Group Sales Plan Points to New Era in Record Merchandising 46</p>	<p>Concentration in Canvassing Pays... 48</p> <p>Final Awards Made in Better Homes Music Contest 50</p> <p>Price Maintenance to Protect the Public, Written by Representative Schuyler Merritt 59</p> <p>Verbosity Often Kills Interest of Buyers 78</p> <p>Some Valuable Thoughts on Foreign Record Trade 80</p> <p>Dealers in Boston Territory Stock Up for Holiday Business by Early and Heavy Ordering 99-102</p> <p>Vital Trade Topics Discussed in the mid-West Point of View 108</p> <p>Brisk Demand in All Lines in Chicago Territory Presages Even Busier Days to Come Before Holidays Pass 109</p> <p>Keen Interest Displayed in the Chicago Radio Exposition..... 125</p> <p>Featuring the Possibilities of the Talking Machine 128</p> <p>The Hohner Harmonica Campaign Covering Country 143</p> <p>Happenings in the Musical Merchandise Field 143-146</p> <p>Issuance of a Unique and Comprehensive Dealer Service 147</p> <p>Buying Power Increases in Farming Communities 153</p> <p>Theatrical Prosperity and the Talking Machine Dealer..... 157</p> <p>Gleanings From the World of Music 157-162</p> <p>Happenings in the Dominion of Canada 174</p> <p>Latest Patents of Interest to the Talking Machine Trade 193-194</p> <p>Advance List of Talking Machine Records for December..... 195-199</p>
---	---

CORRESPONDENCE FROM LEADING CITIES:

Brooklyn, 62-63—Albany, 72—Richmond, 76—Omaha, 83—Philadelphia, 85-88—Milwaukee, 90—Cleveland, 92-93—Des Moines, 98—Boston, 99-103—Cincinnati, 106—Chicago, 109-125—Canton, 126—Buffalo, 130-131—Ogden, 131—Akron, 132—Indianapolis, 134—Minneapolis and St. Paul, 136—St. Louis, 138-139—Detroit, 141—Pittsburgh, 148-150—Syracuse, 152-153—Toledo, 156—Los Angeles, 163—Washington, 164—Kansas City, 166—Atlanta, 168—Baltimore, 170—San Francisco, 172—Dominion of Canada, 174—Salt Lake City, 176—Portland, 178—Columbus, 180—Dallas, 184—European News From The World's London Office, 190-192.

TEST IT.

OUR VICTOR

Record Service

has a reputation for efficiency.
Suppose you try it.

E. F. DROOP & SONS CO.
1300 G. STREET, WASHINGTON, D. C.
281 N. HOWARD STREET, BALTIMORE, MD

The
Toledo Talking Machine Co.
Toledo, Ohio

*Wholesale Victor
Exclusively*

A C B Z A C O F H K L N P O S U V X V B D E G I J L N P O S U V X Z V C E F H J K W O P R T A C E M O P Q R S T U V W X Y Z

INDEX TO ADVERTISERS

S R P O M K V H F E C V B C E F H J K W O P R T U V W X Y Z S D E F G I J K L M N O P Q R S T U V W X Y Z

A

Aeolian Co. 36, 37
 Alto Mfg. Co. 110
 American Mica Works. 184
 American Phonograph Co. 72
 American Talking Machine Co. 62
 Andrews, Curtis N. 130
 Andrews, W. D., Co. 152
 Artophone Corp. 138, 139
 Audak Co. 25

B

Badger Talking Machine Co. 112
 Bagshaw Co., W. H. 64
 Bakertone Corp. 150
 Bandmaster, Ltd. 190, 191
 Barnhart Bros. & Spindler. Inside back cover
 Berlin, Inc., Irving. 161
 Blackman Talking Machine Co. 6, 80, 126, 132
 Blood Tone Arin Co. 116
 Bolway & Son, Frank E. 153
 Brand & Co., Arthur. 35
 Brand & Co., William. 80
 Brilliantone Steel Needle Co. 65
 Bristol Co. 171
 Broadcaster Corp. 118
 Bruno & Son, Inc., C. 29, 143
 Bruns & Sons, A. 26
 Brunswick-Balke-Collender Co. 154, 155
 Buehn Co., Inc., Louis. 84
 Buehn Phono. Co. 148
 Buescher Band Instrument Co. 146
 Buffalo Talking Machine Co. 130

C

Centonze Music Co., A. 63
 Chappell-Harms, Inc. 158
 Cheney Sales Corp. 102
 Cheney Talking Machine Co. 135
 Claravox Co. 59
 Claremont Waste Mfg. Co. 54
 Classified Want Ads. 188, 189
 Cliff Electric Corp. 156
 Cohen & Hughes 170
 Cole & Dumas Music Co. 32, 105
 Columbia Phonograph Co. 16, 17, 28, 42, 46, 50, 52
 63, 67, 76, 83, 103, 141, 167
 Columbia Mantel Co. 156
 Commercial Art Shop. 30
 Consolidated Talking Machine Co. 107, 112, 115
 Corley Co. 199
 Crosley Mfg. Co. 75
 Cutting & Washington Radio Corp. 91

D

Da-Lite Elec. Display Co. 19
 Davis Mfg. & Sales Co. 42
 De Forest Tel. & Tel. Co. 44, 45
 Diaphragm Co. 93
 Ditson & Co., Chas. H. 99
 Ditson Co., Oliver. 99
 Doctorow, D. R. 180
 Dodin, Andrew H. 194
 Doehler Die Casting Co. 63
 Doerr-Andrews-Doerr 61
 Droop & Sons Co., E. F. 199
 Duo-Tone Co. 94

E

Eastern Talking Machine Co. 99
 Eclipse Musical Co. 93
 Eckophone Co. 169
 Edison, Inc., Thos. A. 68, 69, 70, 71, back cover
 Edison Phonographs, Ltd. 172
 Eight Popular Victor Artists. 20
 Emerson Phonograph Co. 31
 Empire Phono. Parts Co. 187
 Everybody's Talking Machine Co. 13
 Excel Phonograph Mfg. Co. 121

F

Favorite Mfg. Co. 41
 Federal Record Corp. 97
 Federal Tel. & Tel. Co. 137
 Feist, Leo, Inc. 24, 32, 38, 48, 54, 66, 72, 94, 96, 134
 139, 147, 159, 164, 169, 176, 178, 180, 182, 188, 196
 Fletcher-Wickes Co. 113
 Fox-Vliet Drug Co. 61
 Fulton Talking Machine Co. 164

G

General Phonograph Corp.,
 Inserts following pages 18, 42, 66
 General Phonograph Corp. (New York Distributing
 Division) 38
 General Phonograph Corp. of New England. 100
 General Phonograph Mfg. Co. 12
 General Radio Corp. 149
 Gerson, Louis Jay 167

Gibson-Snow Co. 61, 152
 Girard Phono. Co. 87
 Glynn Distr. Co., W. B. 105
 Greater City Phonograph Co. 14, 61
 Gretsch Mfg. Co., Fred. 144
 Guarantee T. M. Supply Co. 88
 Guden & Co., H. A. 22
 Gulbransen-Dickinson Co. Insert facing page 50

H

Haag & Bissex Co., Inc. 185
 Hall Mfg. Co. 111
 Harger & Blish. 98
 Harper & Bros. 133
 Haynes Co., C. B. 76
 Health Builders, Inc. 47
 Hearst Music Pubrs., Ltd. 160
 Hessig-Ellis Drug Co. 61
 Hohner, M. 77, 145
 Hough, J. E., Ltd. 192

I

Ideal Repair Service. 128
 Isley, Doubleday & Co. 98
 Independent Recording Labs. 180
 International Mica Co. 58
 Iroquois Sales Co. 163
 Italian Book Co. 54

J

Jenkins Sons Music Co., J. W. 166
 Jewel Phonoparts Co. 73, 109

K

Kay-Stern, Inc. 161
 Kennedy Co., Colin B. 15
 Kent Co., F. C. 51
 Kiefer-Stewart Co. 61
 Kimball Co., W. W. 110, 118
 Kimberley Phono. Co. Insert facing page 34
 Kirkman Fugg. Corp. 28
 Kraft, Bates & Spencer, Inc. 101
 Krasca Mfg. Co. 119

L

Lakeside Supply Co. 117
 Lauter Co., H. 34
 Lee-Coit-Andriessen Hdw. Co. 61
 Lidsen Products 114
 Lind & Marks Co. 79
 Long Cabinet Co., Geo. A. 165
 Long Island Phonograph Co. 61, 62
 Luckner, Laurence H. 136

M

Macksoud, A. J. 32
 Magnavox Co. 61
 Manufacturers' Phono. Co. 39
 Marks Music Co., Edw. B. 161
 Marshall Co., C. L. 105
 Mellor Co., C. C. 66
 Melrose Bros. Music Co. 195
 Mermod & Co. 128
 Mills Pub. Co., Jack. 158
 Modernola Co. 150
 Moore-Bird & Co. 61
 Multiple Elec. Products Co. 67
 Musical Instrument Sales Co. 11
 Musical Merchandise Co. 173
 Musical Products Distr. Co. 50, 105
 Mutual Phono. Parts Mfg. Co. 104

N

National Metals Depositing Corp. 186
 National Publishing Co. 18
 Natural Voice T. M. Co. 82
 Naturelle Co. 90
 Netschert, Frank 52
 New England Talking Machine Co. 102
 New York Album & Card Co. 4

O

Oh! Pep Phono. Parts Co. 183
 Oro-Tone Co. 111, 117, 120
 Orsenigo Co. 175
 Outing Talking Machine Co. 151

P

Pardee-Ellenberger Co. 100
 Pathé Phonograph & Radio Corp. 33
 Peabody & Co., Henry W. 179
 Pearsall Co., Silas E. 21
 Peckham Mfg. Co. 22
 Peerless Album Co. 9
 Penn Phonograph Co. 86
 Philadelphia Badge Co. 85
 Phillips Phonograph Parts Co., Wm. 58
 Phonographs, Inc. 168

Phonograph Co., Cincinnati 106
 Phonograph Co., Cleveland 92
 Phonograph Co., Detroit 141
 Phonograph Co., Kansas City, Mo. 166
 Phonograph Corp. of Indiana. 134
 Phonograph Corp. of Manhattan. 18
 Phonograph Jobbers Corp. 57
 Phonomotor Co. 40
 Player-Tone Talking Machine Co. 89
 Plaza Music Co. 23, 129
 Plymouth Phono. Parts Co. 96
 Plywood Corp. 24
 Polk Co., Inc., James K. 168
 Pooley Co. 105, 186
 Progressive Musical Instrument Corp. 143, 145, 146
 Proudfit Sporting Goods Co. 131

R

Radio Corp. of America. 27
 Radio Specialties Apparatus Co. 177
 Rainbow Record Co. 124
 Rapid Repeater Co. 49
 Reflexo Products Co. 35
 Regal Record Co. 55, 81
 Regina Phono. Co. 153
 Rene Manufacturing Co. 174
 Rex Gramophone Co. 192
 Robbins, H. A. 78

S

Shelton Elec. Co. 46
 Sherman, Clay & Co. 43
 Shultz Bros. 83
 Silent Motor Corp. 74
 Silverstone Music Co. 138
 Smith Drug Co., C. D. 61
 Sonora Co. of Philadelphia. 61
 Sonora Distributing Co. of Pittsburgh. 61
 Sonora Phonograph Co. of New England. 61
 Sonora Phonograph Co., Inc., Inside front cover, 60, 61, 173
 Sonora Phonograph Co. of Illinois. 61
 Sonora Phonograph—Ohio Co. 61
 Sonora Sales Co. of New Jersey. 61
 Southern Drug Co. 61
 Southern Sonora Co. 61
 Specialty Phono. & Acc. Co. 48
 Standard Musical String Co. 143
 Star Mach. & Nov. Co. 46
 Starr Piano Co. 140
 Stasny Music Co., A. J. 157
 Steinert & Sons Co., M. 101
 Sterling Devices Mfg. Co. 122
 Strevell-Paterson Hardware Co. 61
 Stylus Bar & Mfg. Co. 40

T

Talking Machine Co., Philadelphia. 86
 Talking Machine Supply Co. 188
 Texas-Oklahoma Phono. Co. 184
 Toledo Talking Machine Co. 199
 Tonofone Co. 124
 Triplex Artistic Phono. Co. 116

U

Unique Reproduction Co. 8
 Unit Construction Co. 95
 United Mfg. & Distr. Co. 123
 United States Music Co. 197
 Universal Fixture Co. 181

V

Val's Accessory House. 66
 Van Veen & Co. 131
 Vega Co. 144
 Viesonia Mfg. Co. 103
 Victor Talking Machine Co. Front cover, 5, 7
 Vitanola T. M. Co. 114
 Vocalion Co. of Illinois. 105
 Von Tilzer Co., Harry. 158
 Vox Corp. of America. Insert facing page 98
 Vulcan Record Corp. 53

W

Walbert Mfg. Co. 122
 Wall Kane Needle Mfg. Co. 56
 Walthall Music Co. 61
 Wasmuth-Goodrich Co. 127
 Weymann & Son, H. A. 87
 Whitsit Co., Perry B. 162
 Widdicomb Furniture Co. 142
 Windsor Furn. Co. Insert following page 82
 Witmark & Son, M. 162
 Wolf Mfg. Industries. 125

Y

Yahr & Lange Drug Co. 45

Z

Zimmerman-Bitter Constr. Co. 146, 147

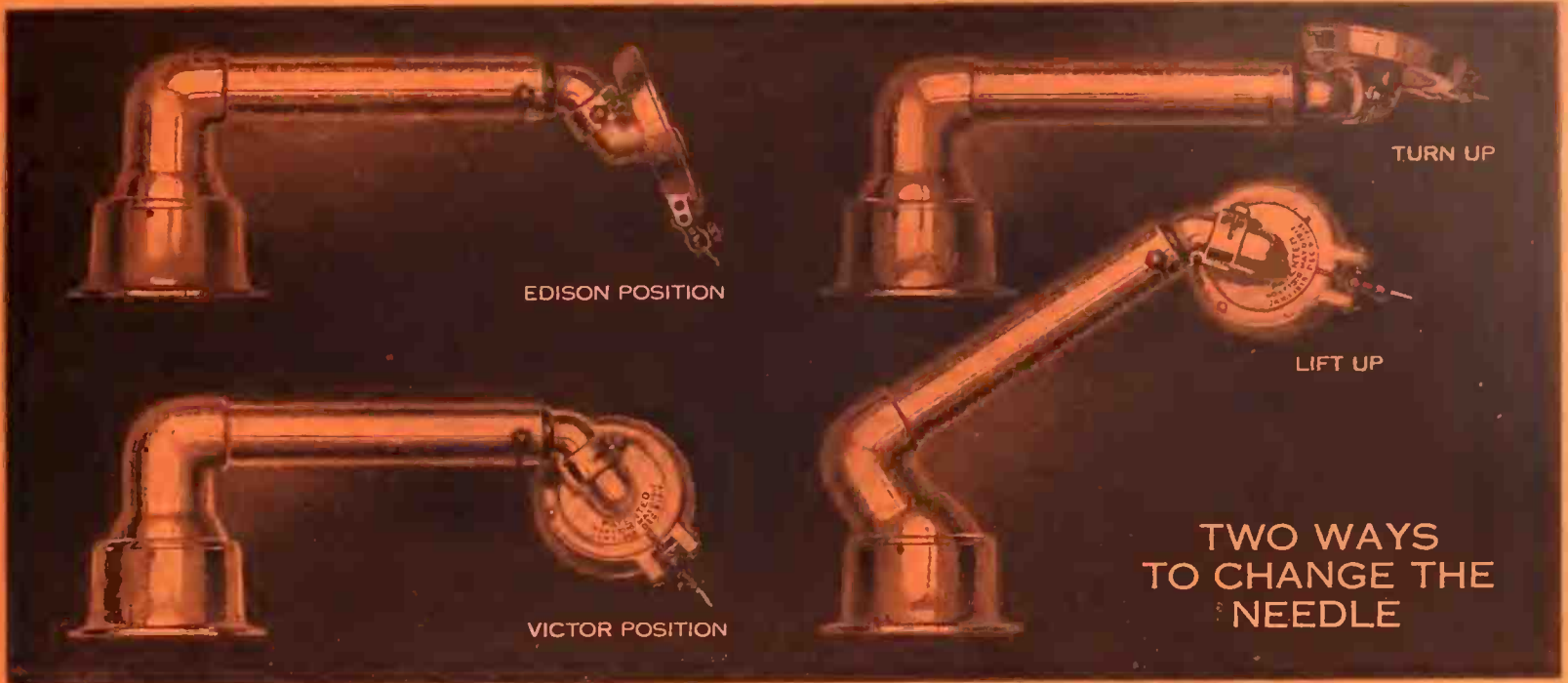

TWO WAYS TO CHANGE THE NEEDLE

The SCOTFORD TONEARM & SUPERIOR REPRODUCER

HOW TO SELL A PHONOGRAPH

To the Dealer or Salesman:

The Scottford Tonearm and Superior Reproducer are used by a number of manufacturers of high grade phonographs. If your store handles any one of these instruments you can increase your sales and profits by thoroughly learning and then informing the customer of the "Twelve Points" of superiority given below. Remember it is no proof of selling ability to take an order for a phonograph, the preference for which has been fixed in the customer's mind by big national advertising campaigns. Such order taking proves the power of advertising—not the sagacity of salesmanship. The saving in advertising cost is made up for by extra quality and extra profit for the store in the Scottford equipped instrument. There is a better future for the business in the lasting satisfaction of the purchaser who takes an instrument of genuine music into his home. Give the customer a comparison of tone on all the different makes. If he is not deaf, he must appreciate the extraordinary difference in tone—the Scottford's genuine musical reproduction, without the metallic sharpness, and without the scratch. Then prove yourself not an ordertaker but a salesmaker by continuing with a detailed explanation of why the Scottford is better as analyzed in the "Twelve Points."

Keep the tonearm unscrewed at the base, so you may lift it off in your hand for thorough examination inside and out—not necessary to screw it down until sold and ready to deliver

TWELVE POINTS

- 1—Its good looks. A neat, trim, tailor-made appearance. Nicely proportioned lines which any artist will approve. Not the swollen appearance of the continuous taper nor angular lines in conflict with the cabinet design.
- 2—The substantial, simple construction—cast parts of solid white brass, long straight tube of yellow brass, hard rubber bushing to prevent metallic vibration at the reproducer connection elbow.
- 3—No obstruction anywhere inside—an absolutely clear passage, with the approved two-inch inside diameter at base, and a solid 45-degree deflecting plane at the turn to direct the sound waves straight downward into the amplifying chamber.
- 4—The simple swinging movement of the tonearm base—how freely it floats when lifted up onto the recording—but how a supporting lug inside the base at back prevents the arm from swinging when off the record and does not allow the needle point to let down so low as to mar the cabinet.
- 5—The handy lift-up or side turn, affording two ways to change the needle.
- 6—Light pressure on the record—the squareness of the turn causing the weight to be supported by the base, whereas a more curving turn would throw too much weight forward to the needle point.
- 7—How perfectly the needle centers the groove—turning the reproducer for playing lateral or vertical cut records leaves the needle on exactly the same point at the same and only correct angle. A minimum of surface noise on records noted for scratch.
- 8—Reproducer frame split clear through—making it a spring, held under tension by the long screw which adjusts the pivotal mounting of the stylus bar.
- 9—Any looseness that might ever develop in the pivoting of the stylus bar may be readily detected and instantly corrected by adjusting the long screw until the needle holder and stylus bar feel tight.
- 10—The inclined position of the reproducer and angle of the stylus bar by which a greater impulse is imparted to the diaphragm, with finer sensitivity to minor vibrations than the ordinary straight upright design.
- 11—Fineness of the mica diaphragm—a perfect crystal edge disc of selected clear India mica costing five times as much as the "seconds" and "thins" used in cheap soundboxes.
- 12—Perfect insulation—a rubber gasket entirely separating the reproducer frame from the backplate, and again a complete break in the contact of metals by the hard rubber bushing in the tonearm. This double insulation insuring against metallic effect in the tone, and preventing the surface scratch being magnified by the metals of the reproducer and tonearm.

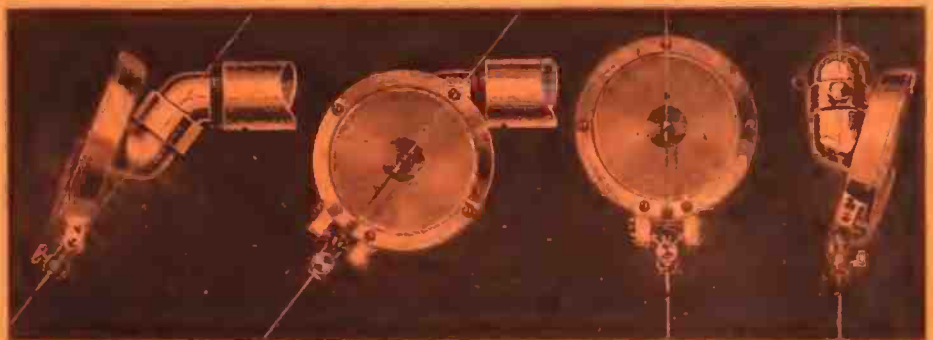

The Reproducer turns on its axis—the needle remaining on exactly the same center and at the same correct angle in both positions

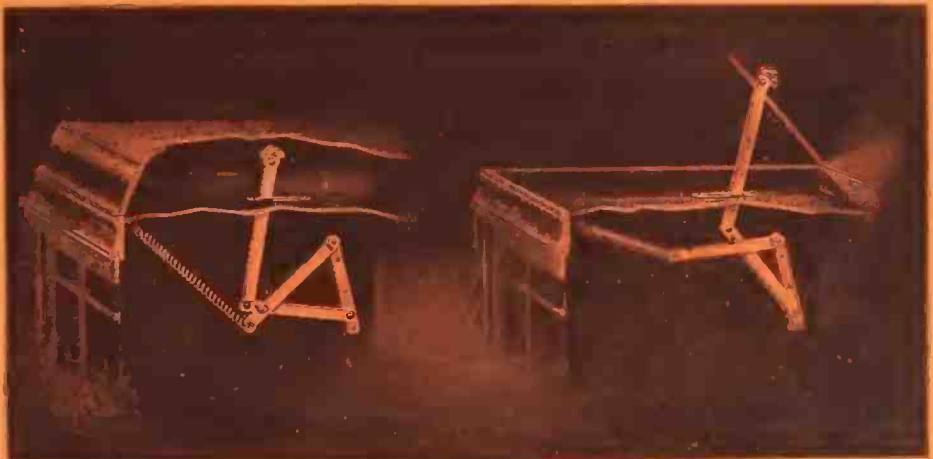

THE SUPERIOR LID SUPPORT

Balances the Lid at any point

The final point of excellence in the equipment of a cabinet that often decides the sale. A touch of one finger lifts or closes the lid, which stops at any point desired. Cannot warp the cover. Noiseless in operation. The simplest support made. Easiest to install.

We are prepared to supply this Tonearm and Reproducer to a number of additional manufacturers of phonographs in certain parts of the United States, and contracts remain open for some foreign countries. Write us for particulars and prices.



We are able to supply this Support in any quantity. Made of steel, high gradenickel or gold plate finish. Samples sent to manufacturers anywhere for trial. Write for low quantity prices. State type and weight of lid.

BARNHART BROTHERS & SPINDLER

SUPERIOR SPECIALTIES FOR PHONOGRAPHS MONROE & THROOP STREETS, CHICAGO

Pages 68, 69, 70 and 71
of this issue of the Talking
Machine World carry a
message of interest to every
music dealer.

**JOBBER OF THE NEW EDISON, EDISON RE-CREATION, THE NEW EDISON DIAMOND AMBEROLA
AND BLUE AMBEROL RECORDS**

CALIFORNIA
Los Angeles—Edison Phonographs,
Ltd.
San Francisco—Edison Phonographs,
Ltd.

COLORADO
Denver—Denver Dry Goods Co.

GEORGIA
Atlanta—Phonographs, Inc.

ILLINOIS
Chicago—The Phonograph Co.
Wm. H. Lyons (Amberola only).

INDIANA
Indianapolis—Phonograph Corpora-
tion of Indiana.

IOWA
Des Moines—Harger & Blish.

LOUISIANA
New Orleans—Diamond Music Co.,
Inc.

MASSACHUSETTS
Boston—Pardee-Ellenberger Co.
Iver Johnson Sporting Goods Co.
(Amberola only).

MICHIGAN
Detroit—Phonograph Co. of Detroit.

MINNESOTA
Minneapolis—Laurence H. Lucker.

MISSOURI
Kansas City—The Phonograph Co.
of Kansas City.
St. Louis—Silverstone Music Co.

MONTANA
Helena—Montana Phonograph Co.

NEBRASKA
Omaha—Shultz Bros.

NEW JERSEY
Orange—The Phonograph Corp. of
Manhattan.

NEW YORK
Albany—American Phonograph Co.
Syracuse—Frank E. Bolway & Son,
Inc., W. D. Andrews Co.
(Amberola only).

OHIO
Cincinnati—The Phonograph Co.
Cleveland—The Phonograph Co.

OREGON
Portland—Edison Phonographs, Ltd.

PENNSYLVANIA
Philadelphia—Girard Phonograph
Co.
Pittsburgh—Buchn Phonograph Co.
Williamsport—W. A. Myers.

RHODE ISLAND
Providence—J. A. Foster Co.
(Amberola only).

TEXAS
Dallas—Texas-Oklahoma Phono-
graph Co.

UTAH
Ogden—Proudfit Sporting Goods Co.

VIRGINIA
Richmond—The C. B. Haynes Co.,
Inc.

CANADA
Montreal—R. S. Williams & Sons
Co., Ltd.

St. John—W. H. Thorne & Co., Ltd.
Toronto—R. S. Williams & Sons
Co., Ltd.

Vancouver—Kent Piano Co., Ltd.
Winnipeg—R. S. Williams & Sons
Co., Ltd.

Babson Bros. (Amberola only).