

The TALKING MACHINE WORLD

For the
makers &
sellers of
talking
machines

Published Each Month by Edward Lyman Bill, Inc., at 373 Fourth Ave., New York, July 15, 1920

*The instrument by which
the value of all musical
instruments is measured*

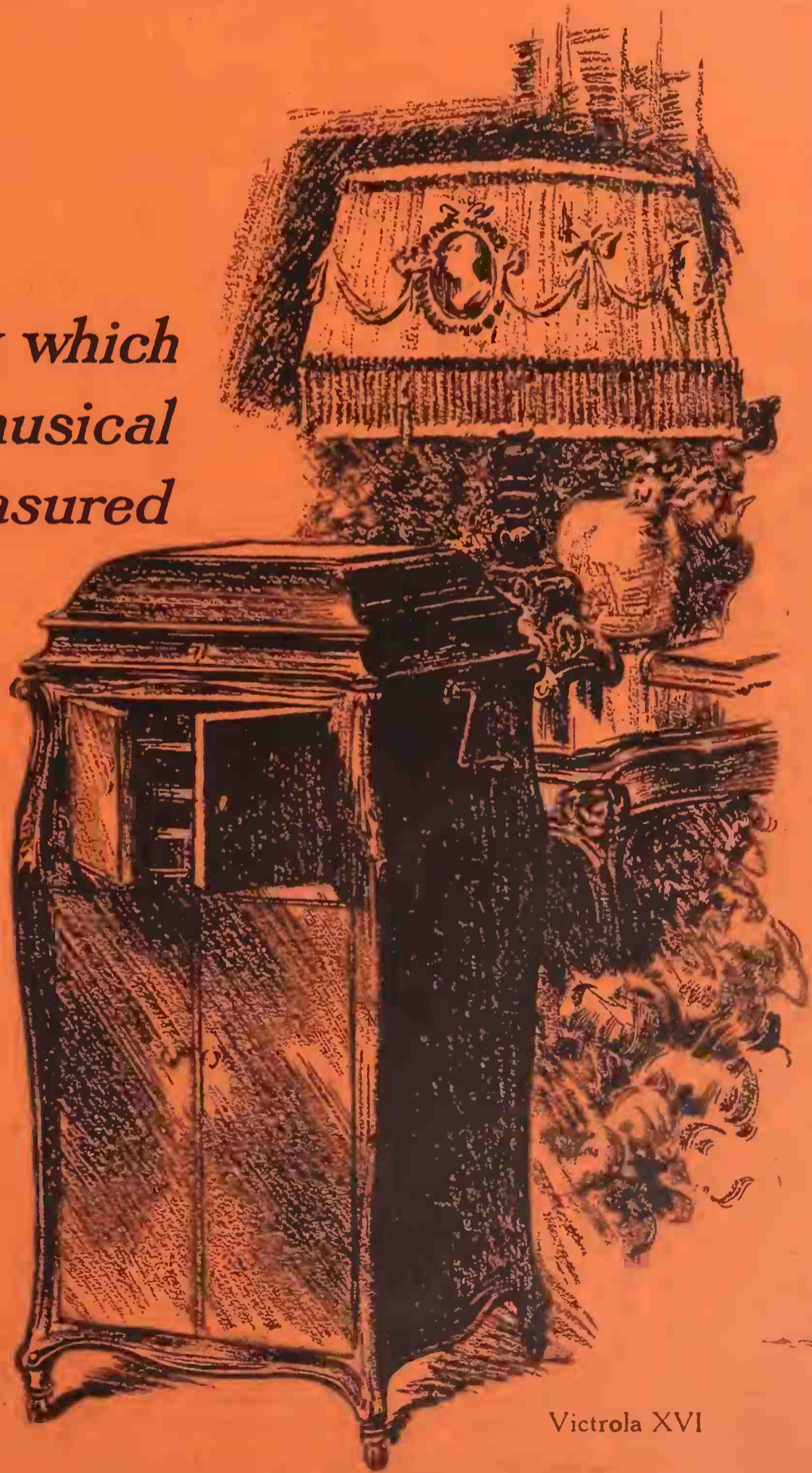

Victrola XVI



This trademark and the trademarked word "Victrola" identify all our products. Look under the lid! Look on the label!

VICTOR TALKING MACHINE CO.
Camden, N. J.

Pride of Possession Creates Demand



GRAND

SONORA sales continue to increase at a phenomenal rate because the purchaser of a Sonora enjoys the pride of possessing the best that can be made. Not "How many?" but "How good!" has always been Sonora's motto.



MINUET

THE INSTRUMENT OF QUALITY
Sonora
 CLEAR AS A BELL



The Highest Class Talking Machine in the World



NOCTURNE

is famous for its wonderful tone, for its superb design and for its many important features obtainable in no other phonograph.

The Sonora is sold as soon as it is seen and heard, and *it sells without offering "easy payments" as the leading attraction.*

If you are interested in handling the Sonora, write us.



INVINCIBLE

Sonora Phonograph Company, Inc.

GEORGE E. BRIGHTSON, President

New York: 279 Broadway

Canadian Distributors: I. Montagnes & Co., Toronto

At the Panama Pacific Exposition Sonora won highest score for tone quality and its supremacy is steadfastly maintained

NOTE: Sonora is licensed and operates under BASIC PATENTS of the phonograph industry

The Talking Machine World

Vol. 16. No. 7

New York, July 15, 1920

Price Twenty-five Cents

ADVERTISING MAKES FOR HONESTY

Remakes the Firm That Uses It, Says Vice-President of George Batten Co.—Advertising Expands the Business Man's Horizon

"Advertising remakes the firm which employs it," declared William J. Boardman, vice-president of the George Batten Co., New York, in an address before the sixteenth annual convention of the Associated Advertising Clubs held recently in Indianapolis, Ind.

"No man," he said, "ever does real advertising without expanding his own horizon. Many a man who was local-minded has been forced by the very progress of his advertising into national mindedness. For national mindedness is merely that quality of mind which embraces an understanding of the habits of life and ways of thinking of many localities. The man who has successful business relations with representative houses in all of the States has the national mind as truly as a Secretary of State or Justice of the Supreme Court.

"Again advertising enforces upon the advertiser the practice of honesty. It is an organism which the instinct of self-preservation automatically urges to cast out the crook exactly as your physical bodies strive to cast out the unwholesome foreign substance.

"Third, advertising forces upon its practitioner, to a greater degree than any other method of commerce, the application of foresight based upon accurate knowledge of the essential facts. If a man buys land, buildings or machinery unwisely he can recoup a part of his losses by selling at a sacrifice, but if he has spent his money on advertising based on false premises he has no recovery.

"Last and most important, advertising forces upon the advertiser a revelation of the enormous influence in human affairs of the unseen and the intangible. He learns to spend his money on ideas as confidently as previously he spent it for bricks and steel. Previously, he may have pat-tered glibly of supply and demand, but his advertising forces upon him in sharp relief a new comparative evaluation of supply—that is the material things—and of demand—that is the human need guided by public information both intangible and both paramount."

SELLING RECORDS BY AUTOMOBILE

Plaut-Cadden Co., of Norwich, Conn., Are Using a Closed Automobile With Record Racks and a Full Stock, Accompanied by Competent Salesmen, to Cover Specially Arranged Routes

Something entirely novel in the line of record demonstration has been conceived by the Plaut-Cadden Co., the widely known Victor dealers of Norwich, Conn. They have arranged for a closed automobile with record racks and a stock of records, and with a staff of competent salesmen will visit all homes in which there is a talking machine and sell the records from the stock carried in this car. Special routes have been laid out for each day and a very thorough canvass of the territory which they control will be made. They will also carry one of the smaller types of Victrolas so as to interest prospects in this instrument, and it can be used, if necessary, to demonstrate records.

The entire idea is as novel as it is excellent, and is one that should be especially valuable to dealers who desire to work up trade among Summer hotels and boarding houses where talking machines are sure to be found. Summer boarders are invariably anxious to purchase records—it breaks the monotony and adds to the enjoyment of their country stay if they can get them conveniently. A visit from an automobile equipped with a stock of records would mean the building up of a very large trade.

MUSIC IN MILWAUKEE SCHOOLS

Superintendent Potter Praises Values of Talking Machine in Educational Work—Just as Important as Reading and Writing, He Says

MILWAUKEE, Wis., July 5.—Some time ago one of the progressive schools of this city purchased a talking machine for the amusement of the children. It was not long before the teachers discovered that this machine was rendering a very real service in all round musical education. Milton C. Potter, superintendent of schools, is heartily in favor of the talking machine in education and on this subject recently said:

"Every school in the city has its talking machine now—look around and see," he said.

"In typewriting classes, in penmanship, where the rhythmic training gives a sure style, they have their everyday, practical use, but it is as a matter of musical education that the talking machine has proved its importance.

"It is easy to teach reading to a child who comes from a literary home, where good books are discussed and enjoyed.

"But our problem is with the child who has not that background, not that previous training, who would not recognize poor music from good unless taught. That problem the talking machine helps to solve.

"Imagine what it means to such a child to be able to get at the finest things in the world's music, to have that musical consciousness really furnished for him, built up for him.

"The talking machine, in my opinion, is one of the greatest forces for culture in the world to-day."

TALKING MACHINE EXPORTS GROW

Exports, Including Records, for Ten Months Ending April, 1920, Total \$6,226,032

WASHINGTON, D. C., July 5.—In the timely summary of exports and imports of the United States for the month of April, 1920 (the latest period for which it has been compiled), which has just been issued, the following figures on talking machines and records are presented:

The dutiable imports of talking machines and parts during April, 1920, amounted in value to \$34,784, as compared with \$30,402 worth which were imported during the same month of 1919. The ten months' total ending April, 1920, showed importations valued at \$641,585, as compared with \$233,128 worth of talking machines and parts during the same period of 1919.

Talking machines to the number of 8,238, valued at \$380,719, were exported in April, 1920, as compared with 3,743 talking machines, valued at \$141,057 sent abroad in the same period of 1919. The ten months' total showed that we exported 64,555 talking machines, valued at \$2,882,295, as against 41,184 talking machines, valued at \$1,244,583, in 1919, and 78,293 talking machines, valued at \$2,168,752, in 1918.

The total exports of records and supplies for April, 1920, were valued at \$403,040, as compared with \$266,730 in April, 1919. For the ten months ending April, 1920, records and accessories were exported valued at \$3,343,737; in 1919, \$2,327,571, and in 1918, \$1,653,390.

LIBRARY TO ISSUE RECORDS

The public library of Dallas, Tex., has inaugurated a new service for its patrons. A large collection of talking machine records has been donated by the Wednesday Morning Choral Club and these records are being issued by the library on cards just as books are issued. As many as three records may be taken out on one card. The collection includes all types of records, both popular, classical and operatic. This move is being watched with interest.

CAMPAIGN SPEECHES IN NORWICH

Local Columbia Dealer Draws Many Patrons to His Store by Advertising Records of Debates and Speeches by Several Prominent Men

During the week just preceding the Republican convention, and also just before the Democratic gathering at San Francisco, W. H. Griffin, a Columbia dealer of Norwich, N. Y., drew crowds to his store by announcing campaign speeches given by well-known statesmen and politicians by means of the campaign records which have been issued by the Nation's Forum and the Columbia Co. The speakers for the Republican party were Senators Lodge and Harding, General Wood and Governor Coolidge of Massachusetts. Later the Democratic speakers were Attorney General Palmer, William G. McAdoo, Dr. Stephen S. Wise and Bainbridge Colby, Secretary of State. These campaign speeches on current topics aroused considerable attention throughout the community.

IMPORTANT BEACON CO. MOVES

J. H. Adamson Appointed Distributor for Large Territory—D. J. Speck Gets New York State and Part of Eastern Pennsylvania

J. H. Adamson, who for many years has been a prominent wholesale furniture dealer in New York, has been appointed a distributor for the Beacon Phonograph Co., Boston, Mass. Mr. Adamson has opened offices in Philadelphia and will handle a considerable part of Pennsylvania, Maryland, Delaware, Washington, D. C., and the lower part of New Jersey.

D. J. Speck, who has been connected with the talking machine trade for a number of years, has been appointed Beacon distributor for New York State and a part of eastern Pennsylvania. Mr. Speck has opened offices in Syracuse and a staff of three men will visit the trade in his territory.

H. Frank Spurr, who has been opening up New York State territory for the Beacon Phonograph Co., has been called to the executive offices in Boston and will spend most of his time in sales promotion work in the New England territory.

George W. Orcutt, New York City representative for the Beacon line, has opened up many desirable accounts and reports an active demand for the Beacon product in New York City.

MELBA RECORD MADE BY WIRELESS

Song Carries 1,000 Miles and Is Recorded by Receiving Apparatus—Concert Plainly Heard by Stations Many Miles Distant

Music authorities and wireless enthusiasts in Europe expressed keen satisfaction at results of the first wireless concert, held at the Chelmsford Marconi station, near London, when Mme. Melba sang into a wireless telephone, her voice being heard full and mellow over a radius of 1,000 miles.

Melba sang "Home, Sweet Home," in English; a song in French and two selections from "La Boheme" in Italian. She also rendered "God Save the King" in both French and English. Her singing was accompanied by a pianoforte.

Reports indicated that wireless stations at Berlin, Madrid, The Hague, Christiania and Warsaw had heard the concert quite clearly. At Paris a talking machine record was made of Melba's voice over the wireless telephone, the recorder being placed close up to the wireless telephone receiver.

After the concert Melba expressed delight at the results. "I greatly enjoyed this most wonderful experience of my life," she said. "It was really a marvelous accomplishment."

Developing the Vast Uncultivated Field of "Better Class" Prospects :: :: By Courtney Harrison

A few days ago I made an interesting experiment. It happened this way. I had just been in for a chat with a furniture dealer friend of mine who handles talking machines. Notice I say "handles" them. Of course he sells a few of them every month, but I happen to know quite a bit about the "insides" of his business and I told him some time ago that I did not think he was getting near the amount of talking machine business he should; that he was allowing his advertising man and sales force to consider them too much as a "side line." In other words, I told him he was letting talking machine business slip past his doors every day. His come-back was: "We can't see where it would pay us to put a lot of money in advertising the talking machine department individually, sending out special sales letters, or having salesmen devote too much time to this line. Anyway, you know what I think? I believe nine out of ten of the better class of people, the people we want to do business with and who would be liable to visit our store to buy an instrument, already own one." I assured him, of course, that he was all wrong—that he still had a vast uncultivated field of "better class" prospects to sell machines to. But he didn't believe me.

And so I made this experiment I started to tell you about. And here's what I did. I started out (it was then about 10 o'clock in the morning) and every business acquaintance or friend I came in contact with that day I asked him if he had a talking machine at his house. Remember, I didn't pick and choose. I met that day what you might call the "average run" of business men, taking them as they come, and to each and every one of them I put the question: "Have you a talking machine up at your place?" And if the answer was "no," I asked why my informant didn't own an instrument.

I got some interesting information. First off, what do you suppose? Fifty per cent of the sixty-three business men I put the question to did not have a talking machine in their homes. To be exact, thirty-three owned instruments and thirty did not.

Of course, it would not be possible to take up the necessary space here to tell what sort of people owned the most machines or why those who did not own them had not bought one, but I can and will set down a few interesting things

in connection with my several brief interviews.

The first man I put the questions to was a chair manufacturer. I took it as a matter of course he would have a machine, as he certainly has money to buy anything he wants. But to my surprise he said he didn't own one. Why? He had no particular answer. The only thing definite I could get out of him was that "My wife and I have thought several times about getting one, but I guess nobody has kept after us hard enough to make us buy one."

My next "victim" was an advertising man (of all people, he didn't own one either). He laughed when I asked why, and said: "Oh, I don't know hardly myself; of course we can afford it, but you know I guess there are so many ads claim-

Many People Do Not Own a Talking Machine Because the Dealer Has Not Urged Them to Purchase

ing so many different things we never have gotten right down to brass tacks and picked out one. Now, I'm an advertising man, as you know, and if you put the question straight up to me to know what would 'get' me—of course I'm not the average case, understand—I would say that some music shop would have to either write a good sales letter, or send out some sort of special invitation that would get my wife and me down to see and test the machine the store set out to sell us. My wife doesn't go out a great deal, and perhaps because she hears enough about advertising from me, she doesn't read ads a great deal. As I naturally would wait for her to take some initiative before I spent the money, some sort of appeal would have to reach her that would give her the right 'jolt.' But, as I said before, we are not average cases."

My third and fourth, also the fifth man I talked to, all owned talkers (mechanical ones, I mean).

The sixth chap was another who "didn't own." His reason was that he and his wife had been living with her folks until a month or two before, and as the old folks owned a machine the young people had not bought one. However, this man admitted that some day "the fever" would get him, and he would go down and buy a machine. Some day, he said, when some store ran his "buying temperature" up to the proper degree.

The seventh man had no instrument either. Said they had a piano but his wife seldom played, was all out of practice. Had been intending all along to get a talking machine, but "just never had done it."

And so it went throughout my interviews. Some of these people, as pointed out, may have been exceptional cases to reach, but the most of them were just average, every-day, better class Americans. The fact that they had never bought a talking machine does not reflect on talking machine advertising or special talking machine sales efforts either. The cumulative publicity that is reaching them in one form or another will some day turn them into talking machine owners. In the meantime, the store that puts on extra steam and tries the hardest to reach them can cop off the sales, perhaps.

But this was not intended to tell you particularly how to sell talking machines. It was more to show you the possibilities for making sales that are at hand.

The experiment I made any one can make, and I believe you, yourself, will be surprised at the number of people who still do not own talking machines. Try it to-day. Make it a point to ask every man you come in contact with whether or not he owns a talking machine. And if he doesn't, ask him why. It will help you to do a bigger, better business through helping you to get the right angle from which to appeal to the folks in your town.

A. I. Namm & Son, Brooklyn, N. Y., have recently announced an increase in their capital stock from \$1,000,000 to \$2,500,000. This store has a large talking machine and record department.

Reasons Why NYACCO Albums Are the BEST

[In Six Chapters]

CHAPTER I

The first consideration in the making of a NYACCO album is having the back made of wood in one piece, reinforced with cloth hinges. This is a positive guarantee that the back will never loosen from the cover of the album. You can assure your customer of this when you sell him the album.

Watch next issue for the second Chapter

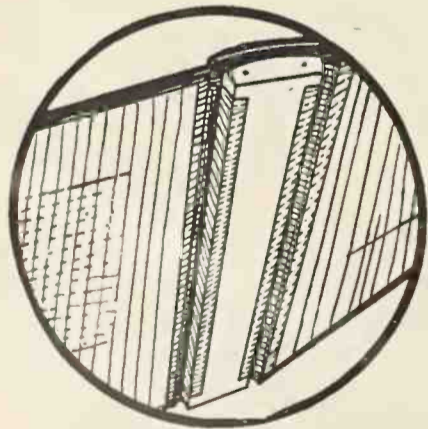

Executive Office
23-25 Lispenard St.
New York, N. Y.

New York Album & Card Co.

Chicago Factory
415-17 S. Jefferson St.
Chicago, Ill.

DISTRIBUTORS:

Boston, Mass.: Boston Talking Machine & Accessories Co.

Cleveland, O.: Cleveland Talking Machine Co.

Philadelphia, Pa.: Penn Talking Machine Co.

Chicago, Ill.: T. J. Cullen
Cole & Dunas Music Co.

Milwaukee, Wis.: Yahr & Lange Drug Co.

Pittsburgh, Pa.: C. C. Mellor Co.
Standard T. M. Co.

New York, N. Y.: Plaza Music Co.

Washington, D.C.: E. F. Droop & Sons Co.

Victor Supremacy

The enormous public demand for the Victrola, the unparalleled success of Victor retailers everywhere, unmistakably tell of Victor supremacy.

"Victrola" is the Registered Trademark of the Victor Talking Machine Company designating the products of this Company only.

Warning: The use of the word Victrola upon or in the promotion or sale of any other Talking Machine or Phonograph products is misleading and illegal.

Important Notice. Victor Records and Victor Machines are scientifically co-ordinated and synchronized in the processes of manufacture, and should be used together to secure a perfect reproduction.

Victor Wholesalers

- | | |
|---|--|
| Albany, N. Y.Gately-Haire Co., Inc. | Milwaukee, Wis. ...Badger Talking Machine Co. |
| Atlanta, Ga.Elyea Co. | Minneapolis, Minn. ..Beckwith, O'Neill Co. |
| Phillips & Crew Piano Co. | Mobile, Ala.Wm. H. Reynolds. |
| Baltimore, Md.Cohen & Hughes. | Newark, N. J.Collings & Co. |
| E. F. Droop & Sons Co. | New Haven, Conn. ..The Horton-Gallo-Creamer |
| H. R. Eisenbrandt Sons, Inc. | Co. |
| Birmingham, Ala. ...Talking Machine Co. | New Orleans, La. ...Philip Werlein, Ltd. |
| Boston, Mass.Oliver Ditson Co. | New York, N. Y. ...Blackman Talking Mach. Co. |
| The Eastern Talking Machine | Emanuel Blout. |
| Co. | C. Bruno & Son, Inc. |
| The M. Steinert & Sons Co. | Charles H. Ditson & Co. |
| Brooklyn, N. Y.American Talking Mach. Co. | Knickerhocker Talking Ma- |
| G. T. Williams. | chine Co., Inc. |
| Buffalo, N. Y.W. D. & C. N. Andrews. | Landay Bros., Inc. |
| Buffalo Talking Machine Co., | Musical Instrument Sales Co. |
| Inc. | New York Talking Mach. Co. |
| Burlington, Vt. ...American Phonograph Co. | Ormes, Inc. |
| Butte, Mont.Orton Bros. | Silas E. Pearsall Co. |
| Chicago, Ill.Lyon & Healy. | Omaha, Nebr.Ross P. Curtice Co. |
| The Rudolph Wurlitzer Co. | Mickel Bros. Co. |
| Chicago Talking Machine Co. | Peoria, Ill.Putnam-Page Co., Inc. |
| Cincinnati, O.The Rudolph Wurlitzer Co. | Philadelphia, Pa. ...Louis Buehn Co., Inc. |
| Ohio Talking Machine Co. | C. J. Heppe & Son. |
| Cleveland, O.The Cleveland Talking Ma- | The George D. Ornstein Co. |
| chine Co. | Penn Phonograph Co., Inc. |
| The Eclipse Musical Co. | The Talking Machine Co. |
| Columbus, O.The Perry B. Whitsit Co. | H. A. Weymann & Son, Inc. |
| Dallas, Tex.Sanger Bros. | Pittsburgh, Pa.W. F. Frederick Piano Co. |
| Denver, Colo.The Knight-Campbell Music | C. C. Mellor Co., Ltd. |
| Co. | Standard Talking Mach. Co. |
| Des Moines, Ia.Mickel Bros. Co. | Portland, Me.Cressey & Allen, Inc. |
| Detroit, Mich.Grinnell Bros. | Portland, Ore.Sherman, Clay & Co. |
| Elmira, N. Y.Elmira Arms Co. | Richmond, Va.The Corley Co., Inc. |
| El Paso, Tex.W. G. Walz Co. | Rochester, N. Y. ...E. J. Chapman. |
| Honolulu, T. H. ...Bergstrom Music Co., Ltd. | Salt Lake City, U. ..The John Elliott Clark Co. |
| Houston, Tex.The Talking Machine Co. of | San Francisco, Cal. ..Sherman, Clay & Co. |
| Texas. | Seattle, Wash.Sherman, Clay & Co. |
| Indianapolis, Ind. ..Stewart Talking Machine Co. | Spokane, Wash. ...Sherman, Clay & Co. |
| Jacksonville, Fla. ..Florida Talking Machine Co. | St. Louis, Mo.Koerber-Brenner Music Co. |
| Kansas City, Mo. ..J. W. Jenkins Sons Music | St. Paul, Minn.W. J. Dyer & Bro. |
| Co. | Syracuse, N. Y.W. D. Andrews Co. |
| Schmelzer Arms Co. | Toledo, O.The Toledo Talking Machine |
| Los Angeles, Cal. ..Sherman, Clay & Co. | Co. |
| Memphis, Tenn.O. K. Houck Piano Co., | Washington, D. C. ..Cohen & Hughes. |
| Wholesale Dept., 115 | E. F. Droop & Sons Co. |
| Union Ave. | Roht. C. Rogers Co. |



Victrola VI, \$35
Mahogany or oak



Victrola IX, \$75
Mahogany or oak

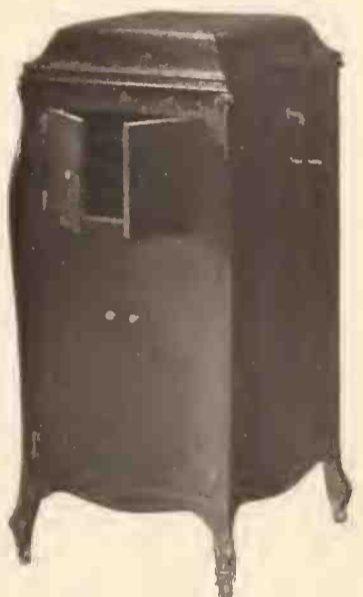

Victrola XI, \$150
Mahogany, oak or walnut



Victrola XVI, \$275
Victrola XVI, electric, \$337.50
Mahogany or oak

Victor Talking Machine Co.

Camden, N. J., U. S. A.



"HIS MASTER'S VOICE"
REG. U.S. PAT. OFF.

ALL RECORD CUSTOMERS ARE ALBUM CUSTOMERS



MAKING THEIR SELECTION

A Place for Every Record and Every Record in its Place

Albums are an **Indispensable Requisite** in the talking machine business and wherever records are sold. Practical and handy. Save time and records. A **profitable adjunct** to the business.

We manufacture disc Record Albums to fit cabinets of all sizes and styles. With the indexes they are a complete system for filing all disc records.

We have unexcelled manufacturing facilities, and considering quality our prices are the lowest. Write us, giving quantity you may desire, and we will quote prices.

OUR ALBUMS ARE MADE TO CONTAIN VICTOR, COLUMBIA, EDISON, PATHÉ, VOCALION AND ALL OTHER DISC RECORDS

NATIONAL PUBLISHING CO., 239 S. American St., PHILADELPHIA, PA.

CHICAGO OFFICE: 508 S. Dearborn Street.

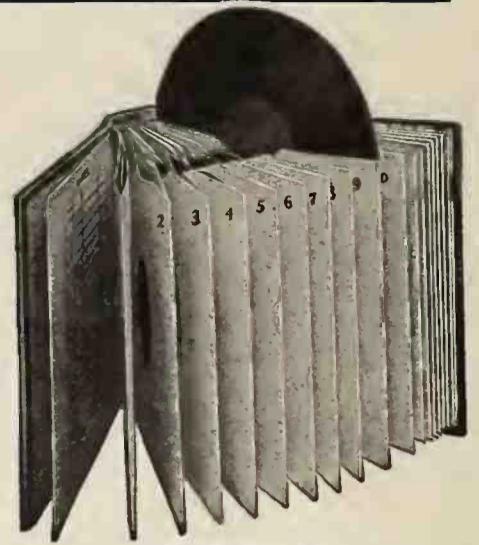

THE PERFECT PLAN

BRINGING MUSIC TO THE SOLDIER

"Vicky" Is the Daughter of the Regiment in the Recreation Rooms of the Various Outposts, Thanks to the Splendid Work of the American Red Cross Bureau of Camp Service

"Feed her some jazz records and we'll have this little old truck unloaded so quick the natives will think a cyclone struck it!"

Half a dozen khaki-clad figures gaily shimmyed from the barracks platform at Zapata to the big truck laden with equipment which had just made the trip from San Ygnacio, Tex., each hugging a Victrola record to his breast, while feet and shoulders kept time to the strains of "Dardanella." It was the first music of any kind the doughboys had heard since leaving Fort McIntosh. There was only one other Victrola in the town and that in a private home, where few of the boys had ever been invited.

When the American Red Cross, Bureau of Camp Service, Southwestern Division, decided to equip the recreation rooms at the various outposts music was set down at the very top of the list. The unrestrained enthusiasm with which the soldiers welcomed this first aid to the collywobbles was abundant evidence that the drive for Victrola records to go to camp had not been a mistake.

"Gee, buddy, doesn't that tune sound like more?"

"Give John McCormack another encore!"

"Now let's have 'Oh, What a Pal Was Mary,' and everybody come in on it!"

With such beguiling accompaniments the big

truck was soon unloaded, for the music-hungry lads had insisted that the Victrola should be the first article to be taken off and it was no sooner off the van than eager hands were putting on records and lusty voices were joining their rumbling basso or clear tenor to its harmonies.

Music is one of the most far-reaching and satisfying enjoyments the American Red Cross Bureau of Camp Service provides. No greater calamity can befall a recreation room than to have "Vicky" lose her voice. At the Marine and Naval Station at Point Isabel, Tex., where the talking machine sustained injuries from some unknown cause the deepest gloom prevailed until two of the electricians volunteered to give first aid treatment. They obtained a wheel about the size of the disc and then connected it with an electric fan, slowed down to low speed. The hilarity which burst forth when the anxiously watching sailors found that the machine would work brought every one at the Point to the recreation room under the impression that the circus must have come to town.

Two Victrolas are in use at the Convalescent House at the hospital area at Camp Pike, and these are kept merrily jazzing all day long, for, as the boys in the service declare:

"'Vicky' is the best little substitute for home and mother a fellow can dig up. She's the daughter of the regiment, all right, all right!"

The man who gets the business to-day is the one who does something different from his competitor and can show a good reason why he is the one that should have the business.

EDISON PRODUCTION AT HIGH MARK

Laboratories Announce Biggest Output Yet Reached for June

It is announced that Re-Creation production at the Edison laboratories has reached the highest point since April, 1919, and June has had by far the largest output in the history of the business. New equipment recently installed promises to facilitate the output of catalog numbers, as well as increase the rate of production of new numbers.

Recognition of Edison Re-Creation by persons of a high degree of musical culture is reflected in the constantly growing demand for classical and operatic selections. It is stated at the Edison laboratories, however, that there will be no dearth of popular ballads and dance numbers, despite the tremendous strain on production facilities.

ART HICKMAN DEFINES JAZZ

Art Hickman, who is identified with the Columbia Co. recording department, insists that his orchestra, now playing on the Ziegfeld roof, is not a jazz band. "Jazz," says Mr. Hickman, "is merely noise, a product of the honky-tonks, and has no place in a refined atmosphere. I have tried to develop an orchestra that charges every pulse with energy without stooping to the skillet beating, sleigh bell ringing contraptions and physical gyrations of a padded cell."

Be a hope spreader and you will be a success getter.



VITANOLA FOURTEEN

Associated Furniture Manufacturers

Distributors of

VITANOLA

The Phonograph of Marvelous Tone

PERSONAL COOPERATION IS THE BASIS OF OUR VERY SUCCESSFUL DEALER SERVICE

1209 Washington Avenue

::

ST. LOUIS, MO.



Victrola IV, \$25
Oak



Victrola VI, \$35
Mahogany or oak



Victrola VIII, \$50
Oak



Victrola IX, \$75
Mahogany or oak



Victrola X, \$125
Mahogany, oak or walnut



Victrola XI, \$150
Mahogany, oak or walnut



Victrola XIV, \$225
Mahogany, oak or walnut



Victrola XVI, \$275
Victrola XVI, electric, \$337.50
Mahogany or oak



Victrola XVII, \$350
Victrola XVII, electric, \$415
Mahogany or oak

Victor Supremacy

The universal recognition of Victor supremacy is one of the greatest assets of every Victor retailer.

With Victrolas in such splendid variety, Victor retailers can satisfy every demand, and the volume of business is limited only by the individual effort of each retailer.

"Victrola" is the Registered Trade mark of the Victor Talking Machine Company designating the products of this Company only.

Warning: The use of the word Victrola upon or in the promotion or sale of any other Talking Machine or Phonograph products is misleading and illegal.

Important Notice. Victor Records and Victor Machines are scientifically co-ordinated and synchronized in the processes of manufacture, and should be used together to secure a perfect reproduction.

Victor Talking Machine Co.

Camden, N. J., U. S. A.

The TALKING MACHINE WORLD

For the makers & sellers of talking machines

PUBLISHED BY EDWARD LYMAN BILL, Inc.

President and Treasurer, C. L. Bill, 373 Fourth Ave., New York; Vice-President, J. B. Spillane, 373 Fourth Ave., New York; Second Vice-President, Raymond Bill, 373 Fourth Ave., New York; Assistant Treasurer, Wm. A. Low.

J. B. SPILLANE, Editor

RAYMOND BILL, B. B. WILSON, Associate Editors

L. M. ROBINSON, Advertising Manager

Trade Representatives: WILSON D. BUSH, C. CHACE, EDWARD LYMAN BILL, V. D. WALSH, E. B. MUNCH, CHAS. A. LEONARD, SCOTT KINGWILL, L. E. BOWERS, A. J. NICKLIN

Western Division: Republic Building, 209 So. State Street, Chicago, Ill. Telephone, Wabash 5774.

Boston: JOHN H. WILSON, 324 Washington Street

London, Eng., Office: 2 Gresham Buildings, Basinghall St. W. LIONEL STURDY, Mgr.

The Talking Machine World has regular correspondents located in all of the principal cities throughout America.

Published the 15th of every month at 373 Fourth Ave., New York.

SUBSCRIPTION (including postage): United States, Mexico, \$2.00 per Year; Canada, \$3.00; all other countries, \$4.00. Single copies, 25 cents.

ADVERTISEMENTS: \$5.50 per inch, single column, per insertion. On quarterly or yearly contracts a special discount is allowed. Advertising pages, \$150.00.

REMITTANCES should be made payable to Edward Lyman Bill, Inc., by check or Post Office Money Order.

NOTICE TO ADVERTISERS—Advertising copy should reach this office before the first of each month. By following this rule clients will greatly facilitate work at the publication headquarters.

Long Distance Telephones—Numbers 5982-5983 Madison Sq.
Cable Address: "Elbill," New York.

NEW YORK, JULY 15, 1920

DEVELOPING BUSINESS IN SUMMER MONTHS

IN many branches of the music trade the summer months have long been considered a period of inactivity—a season of recreation when no special effort is made to develop prospects and expand trade. No progressive, wide-awake dealer who believes in constantly expanding his business takes stock in this view of things. To him the summer months are as prolific of results in a business way as are the winter months. He fails to see the wisdom of resting on his laurels—rather he calls the sales force around him and perfects plans and policies whereby he is enabled to make the summer months yield new business and profits.

This type of man is a breaker of images. He takes no stock in trade superstitions. With him there are no slack months. Every month in the year is a producer, and this is made possible by the inauguration of a summer campaign that will mean an enhancement of the prestige of his house as well as placing a very substantial sum on the right side of the ledger in the way of sales.

There are so many ways in which talking machine business can be developed profitably during the summer that they are almost self-evident. In the sales of records particularly, the summer months should show the largest output. The talking machine plays as effectively and as satisfyingly on the porch or in the parlor of the summer hotel or boarding house as in the city. It must also be remembered that the millions of people who cannot get away from their city homes enjoy the talking machine in the summer evenings as much as in the winter, and those who do not can be educated to the recreative value of the talking machine at all times. This should be the work of the dealer. When there is such an interesting product as the talking machine to talk about there is material at hand for most effective summer work, and it is up to the dealer to get busy.

TIME FOR CLEAR-HEADED BUSINESS JUDGMENT

IT is but natural that talking machine dealers generally, as well as merchants in other so-called stable lines, should look askance at the present wave of price cutting that has existed for a couple of months and which has swept across the country with an effect that is calculated to alarm even the retail merchant who is doing business on a fair margin of profit and seeks to maintain that margin. There are those who with great freedom of speech are declaring

that the period of reaction against high prices is here and that the public is in a mood where it will refuse to buy unless coaxed along with a substantial price reduction. There are others better balanced who view conditions as they actually exist, and emphasize the fact that material and labor costs and the general overhead met in the production of most standard products, including musical instruments, preclude any possibility of retail price cutting until such time as manufacturing costs decrease.

The talking machine dealer who gets panicky and is somewhat inclined to follow the price cutting craze, not by shaving the list price necessarily, but by offering sales terms that amount to the same thing, is simply starting on the road to business trouble. If he looked about him he would find that the wave of price cutting has struck principally what are termed seasonable lines such as clothing, shoes and house furnishings, the supplies of which change periodically. A late spring has much to do with curtailing the buying of such articles, particularly clothing, and the merchant who has announced substantial reductions in prices of these goods is not in any sense a philanthropist. He is simply showing good business judgment by taking a small profit right now rather than pay storage charges for several months, tie up his money for that period, and be compelled to make similar reductions later. Remember, if a talking machine is not sold to-day it can be sold next year and at the same price. The style does not change materially, nor does the machine lose its value in storage. The same can be said of the standard records and the supply of popular priced records in proportion to the demand is generally so meagre as to preclude any danger from that score.

It is time for clear-headed business judgment, when the merchant can sit tight, conserve his resources and insist upon doing business on a basis that will insure him a normal profit. If he makes any change in the system let it be a change in selling methods—a change that will mean going after business just a little harder than before. If the merchant, or salesman, really goes after trade he will have little time to worry about what the drygoods house next door is doing, for the wave of price cutting has not included the standard lines of talking machines and records. In fact, price cutting announcements have quite ostentatiously brought attention to the fact that such products were exempt, and this fact in itself should inspire confidence.

BENEFITS FROM TECHNICAL CONFERENCES

THE suggestion has been made on several occasions, and very recently in *The World*, that the technical experts of the industry evolve some plan for getting together at regular intervals for the purpose of exchanging ideas and enjoying mutual discussion relative to the new developments, or planned developments in the industry.

A number of recording laboratory officials in and about New York have recently adopted the idea and have been holding a most interesting and successful series of conferences relative to recording methods and practices and the problems that are common, rather than individual, in their application. It has been found that although recording experts are in a sense competitors, there are many things connected with recording processes that are not competitive, and by an interchange of ideas individuals may profit by the actual experiences of others and thus avoid delays and expense incident to experiments similar to those already conducted by other members of the trade.

Technical conferences are in no sense new. In many industries the practice of holding such conferences attended by the technical men representing various manufacturers, has been long established, and has proven distinctly successful. In the piano trade, for instance, there have been conferences of technical men held in both New York and Chicago that have served to clear up many disputed points and wrong impressions without interfering in any way with the individual character of the products in which the technical men were interested.

With a score of men working for talking machine and record development, it is but natural that many of them must go over the same ground representing a duplication of effort and expense, and what is more important a waste of time that might better be devoted to genuine progress. Through the medium of conferences, these men can exchange ideas regarding the fundamental principles of

sound reproduction and progress to a definite given point along recognized lines before branching out according to individual theories.

The conference idea is worth considering seriously with a view to its development along broad lines for the advancement of the industry as a whole.

THE DEVELOPMENT OF THE TALKING MACHINE

THE interview with Eldridge R. Johnson, president of the Victor Talking Machine Co., which appeared recently in the Philadelphia Public Ledger, is of particular interest to the talking machine trade as a whole, not alone because it sets forth some little known facts regarding the development of the talking machine, but because in it Mr. Johnson takes occasion to prophesy that it will take twenty-five years more to perfect the talking machine and that in the end it will play as important a rôle in the educational field as the printing press does to-day.

When one considers that the talking machine has been developed to its present satisfactory form within a period of twenty-five years, the possibilities of twenty-five years more of development work appear to be tremendous. Along just what lines the progress will be made remains to be seen, but it is certain that there are many bright minds in the industry who are unceasingly studying and inventing with a view to bringing about improvements that will represent real advancement in talking machine and record construction and operation. Having passed the experimental stage, future developments, unless they are distinctly revolutionary, must of necessity be rather slow, but the fact that the leaders of the industry realize that absolute perfection has not yet been attained holds forth distinct promise and is an earnest of continuous effort toward new achievements.

WHY DEALERS SHOULD STUDY CONDITIONS

WITH the coming again of the buyer's market in the talking machine trade—and a change in the market is distinctly in evidence—the average dealer will be compelled to give more attention than he has been giving to the question of service. With the shortage of goods, too many dealers have apparently been quite content to rest in the assurance that the public was happy enough to get certain desired records and certain desired types of machines without any particular amount of service in connection therewith. With the majority of dealers well supplied with both machines and records, however, a condition that now seems imminent, the question of service will enter more strongly than it has for years past.

With the knowledge that a certain machine, or a certain record may be obtained at any of a half dozen stores, the purchaser is going to patronize the store that makes the strongest appeal. That is human nature, and the retailer should see to it that his particular store offers the most attractions in this matter. The factor in service that most directly appeals to the customer is an exhibition of a more

or less thorough knowledge of his tastes and requirements—a knowledge gained through the medium of the first and succeeding sales, and carefully listed for future reference. More than one dealer enjoys the constant patronage of a man simply because when the customer enters the store he is welcomed immediately by name. Other customers are constant in their patronage because a certain salesman knows enough to offer them first operatic and concert songs rather than the popular records of the day, knowing that such music is most desired. And so it goes.

The dealer likewise cannot afford to hide his light under a bushel. He will have to advertise locally to tell prospective buyers where his store may be found. That he has the agency for a well-known line of machines that in itself is well advertised nationally is not sufficient. The dealer's profit and his success depend upon the manner in which he handles the line. Babe Ruth, the "home run king," is getting large money and much fame in baseball circles not because he uses a Spaulding bat, but because he uses that bat in a way to get results. The dealer's success with the agency of an established line is based on the same principle.

The handling of a widely known, nationally advertised line of machines and records is perhaps the greatest asset a dealer can have in meeting business conditions that are to come, but there are undoubtedly other dealers in the territory that handle the same line as direct competitors, offering the same goods at the same list prices. In meeting this competition the dealer must depend upon the element of service, and it is a matter that is worthy of immediate and earnest attention, if such attention has not already been given to it.

This is just the time and not late in the fall to give this subject earnest consideration. The wise business man lays the foundation for success by building his plans well in advance of their being put into operation.

THE INFLUENCE OF ARTISTIC CABINETS

NOT only is the talking machine credited, and justly, with proving the biggest factor in the development of musical knowledge and appreciation in the United States, but it has likewise been credited with being instrumental in stimulating a desire for better home furnishings, for furniture that is artistic rather than simply ornate. Perhaps it is the influence of the music of the talking machine that moves the possessor thereof to desire things about him that are better and more artistic, but it is more logical to assume that credit belongs where the furniture men themselves place it, to the simple, pleasing, but thoroughly artistic, lines in the better grade of talking machine cabinets. If the talking machine has succeeded in placing artistic cabinet designs within the reach of the average home owner and by that means made him prouder of his home and desirous of seeing it furnished properly, then it has accomplished a purpose quite as important as that of entertaining and perhaps educating its owner.

Wholesale

Victor

Service

BUFFALO TALKING MACHINE CO., INC.

BUFFALO, N. Y.

REG. U.S. PAT. OFF.

INDIA SHELLAC AND MICA TRADE

Government Shellac Control Removed and Large Decrease in Shipments to U. S. Noted—Mica Exports to America Likewise Declined

The annual review of the trade of India for the fiscal year ending March 31, 1919, has just been issued and reported to the Bureau of Foreign and Domestic Commerce at Washington by Consul General James A. Smith, Calcutta. The year covered by the review has been a most unusual one in point of volume of trade, says the report, which dwells on the conditions in the shellac and mica markets as follows:

"The scheme introduced in January, 1917, under which all shippers of shellac guaranteed to Government suitable shellac in quantities representing 20 per cent of their shipments on private account at a fixed f. o. b. price of \$13.63 per maund (82 2/7 pounds), was in force during the greater part of the year under review. Control was removed altogether on December 4, 1918. The total quantity exported decreased from 289,700 hundredweight in the previous year to 222,900 hundredweight. The value of the exports was \$9,084,133. The declared value per hundredweight in the previous year was \$40.23, as against \$40.88 in 1918-19. The shipments to the United States decreased, while there were larger exports to the United Kingdom, Japan, France and the Philippines. Of the total exports the United States took 44 per cent, the United Kingdom 29 per cent, Japan 8 per cent, and the Philippines 5 per cent.

"There was a decrease in the quantity of mica exported together with an increase in the value, due largely to the strength of the demand for superior grades. The shipments amounted to 2,800 tons, a decrease of 15 per cent as compared with the preceding year, but still 14 per cent above the pre-war average. The value of these exports increased by 4 per cent to \$2,915,034. The entire quantity was exported to the United Kingdom. The exports to destinations other than the United Kingdom were prohibited."

VICTOR DOG INVITES CUSTOMERS

Oregon Dealer Uses Victor Pup as a Business Getter and Secures Good Results—Shop Has Many Features Which Increase Service

SALEM, ORE., July 5.—The H. L. Stiff Furniture Co. of this city has one of the best business getters that we know of. A large Victor dog sits outside the store with a basket full of catalogs in his mouth, with the sign "The Victor Dog Says Take One." Every day new people come into the store with the catalogs asking to hear records. The increase in business has been noticeable.

The talking machine department was opened March 1 with a full line of Victor, Columbia, Brunswick and Pathé machines and records. This department is managed by Olga B. Moreland and has a number of original features. The six record booths are finished in white and old rose. Instead of chairs, an upholstered bench holding three people is in each booth. Underneath these seats the surplus records are kept. The record racks are back of the booths and also have original features. Between the doors from the booths into the racks are swinging shelves that can be hooked up to hold the records before putting into the racks.

Another original feature is the method in which the stock cards are kept. Any salesman in the store can find any kind of record he wishes to demonstrate without having to look in the catalog or memorize the number. This is not a color system, which also has to be memorized; but an alphabet system, which takes in all the Red Seal records.

A signal system is also used on these stock cards which shows the surplus of that particular record, also how many were ordered, when received and selling history. A small blackboard is used to suggest records to the salesman.

There is nothing else which will fix a floating life and prevent it from being tossed hither and thither like forming a habit of prompt decision.

COMBINES BUSINESS AND PLEASURE

Miss Hobson, of Stewart Co.'s Educational Department, Spending Vacation on Pacific Coast, But Will Help Mrs. Clark's Program

INDIANAPOLIS, IND., July 5.—Miss Caroline Hobson, head of the Educational Department of the Stewart Talking Machine Co., is enjoying a two months' vacation in California at the close of a most active season. Although she planned her vacation as a complete rest from educational affairs, she has accepted a place on the educational program to be given in San Francisco July 19, under the direction of Mrs. Frances E. Clark, head of the Educational Department of the Victor Co. Miss Hobson's part of this program deals with folk dancing and constructive talks to dealers.

When she returns to Indiana in August her educational work will be given entirely to aid in the improvement of educational departments in the various Victor stores throughout this territory. She will take a leading part in the movement to supply six or eight finished teachers to every county institute in Indiana, spreading the gospel of educational music and the value of using the Victrola in rural schools. In a letter to the county superintendents she has invited their co-operation in planning a definite music course involving the intelligent use of the Victrola.

INSTALL SEVERAL NEW BOOTHS

The Plaut-Cadden Co., of Norwich, Conn., have, owing to the increasing demand for Victor machines and records, been compelled to add to their floor space. Plans have just been perfected for the erection of five modern demonstration booths, which gives them an equipment of eleven rooms for displaying Victor talking machines and records. This establishment is putting a number of ideas into force that will do much to expand their business during the Summer and Fall months.



Style A

Dulcitone

Dulcitone Walnut, Rich Mahogany,
Red or Brown

Dulcitone

Tone Appearance Superiority

The wonderful tone of the Dulcitone is not an accident, but the result of right development of known principles governing tone production. The especially constructed tone chamber, embodying proper dimensions, shape and quality of material, is the medium by which tone once properly started in the reproducer is amplified and brought out full, clear and rich.

Dulcitone appearance is one of the prime factors in its popularity. Veneered in beautifully matched genuine Walnut and Mahogany veneers, it appeals instantly to the eye and commands admiration. DULCITONE WALNUT IS THE MOST BEAUTIFULLY FIGURED AND PERFECTLY MATCHED VENEER IN THE ENTIRE PHONOGRAPH INDUSTRY.

The combination of wonderful tone and incomparable beauty of finish places the Dulcitone at the head of the list of all Phonographs and explains its unquestioned popularity with both dealer and customer.

Write for prices and further interesting information.

PROMPT SHIPMENTS.

Dulcitone Phonograph Company

Chicago Office, 404 Republic Bldg.

SOUTH HAVEN, MICHIGAN

Victor magazine advertising creates sales for Victor retailers right through the year

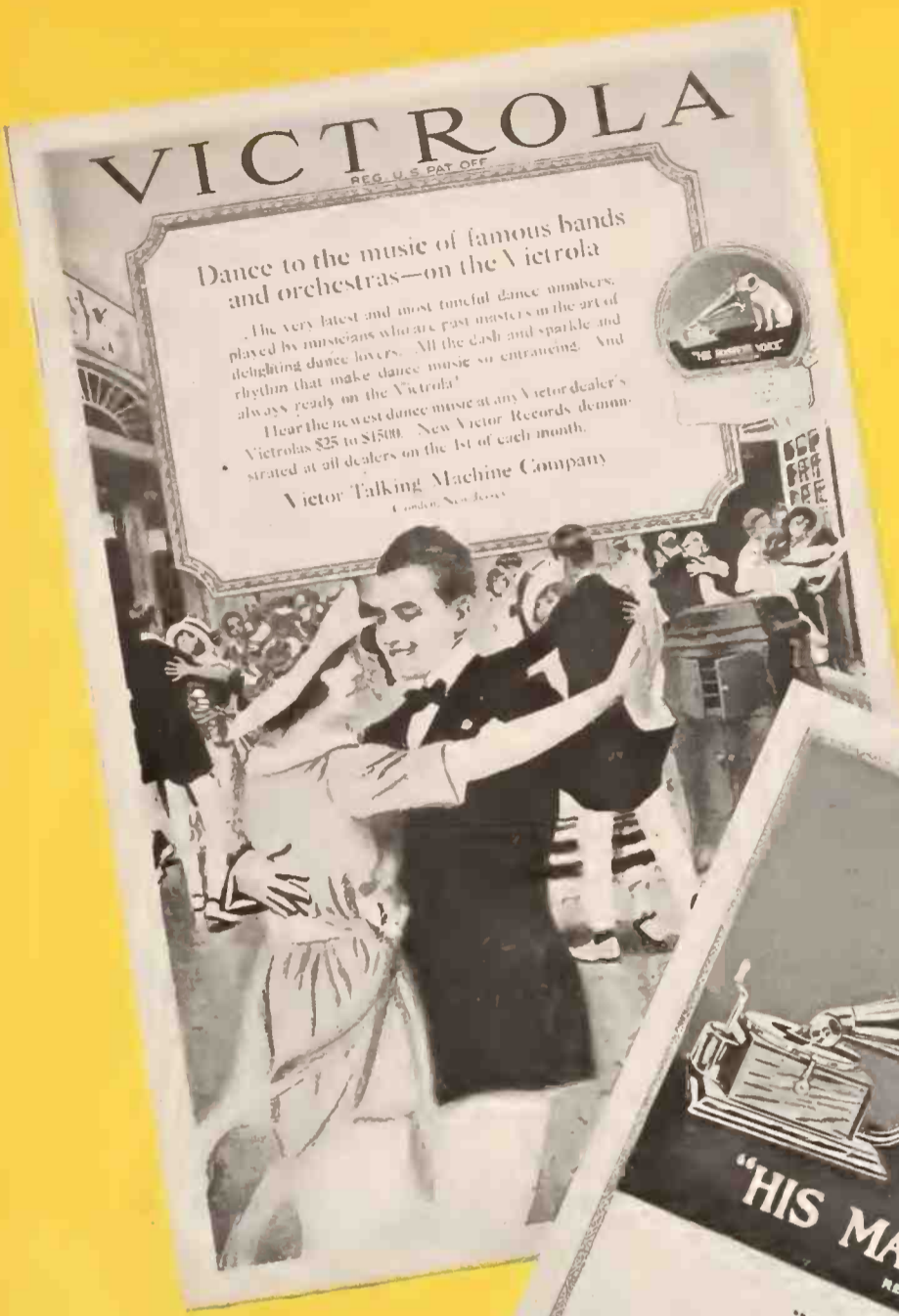

Every Victor advertisement is a salesman for every Victor retailer. These current magazine advertisements are a part of *your* sales force right now. They tell the public of the merits of Victor products and keep on impressing them with the all-around supremacy of the Victor.

With the Victrola and Victor Records you hear the greatest artists just as they wish to be heard

Your interpretation of a piece of music may be in itself a highly artistic achievement, but not if superimposed on the interpretation of a master. It then would be neither one thing nor the other.

The Victrola is equipped with doors so that the volume of tone may be regulated to suit varying conditions. They are not intended to be used in imposing amateur "interpretations" upon those of the world's greatest artists, for that would be to lose the very thing you seek—the finest known interpretations of music.

A Victor Record of Caruso is Caruso himself—provided always that some less qualified person shall not tamper with what the artist himself has done.

Victrolas \$25 to \$1500. Victor dealers everywhere. New Victor Records on sale at all dealers on the 1st of each month.



VICTROLA
REG. U. S. PAT. OFF.

is a trademark word which designates products manufactured by the



Victor Talking Machine Co.
Camden, New Jersey

The greatest m in the ent

The mighty structures of steel and concrete which constitute the immense Victor factories at Camden, N. J., are a living, ever-growing monument to the pioneers who blazed the way in the talking-machine industry, who developed the talking-machine from a mere toy into the greatest musical instrument the world has ever known.

Their lifework is talking-machines, and all the experience and knowledge gained in nearly a quarter-century devoted entirely to the talking-machine art is summed up in Victor products.

The Victor Company not only completely revolutionized talking-machine construction by the invention of the cabinet-style instrument—the Victrola—but every worthwhile accomplishment in the higher development of the talking-machine art is the result of Victor skill and progressiveness, and its artistic achievements have been one unbroken series of successes.

While thus leading the way in the talking-machine field, the Victor factories have grown from a small one-room workshop into the greatest musical industry in all the

VICTOR TALKING MAC

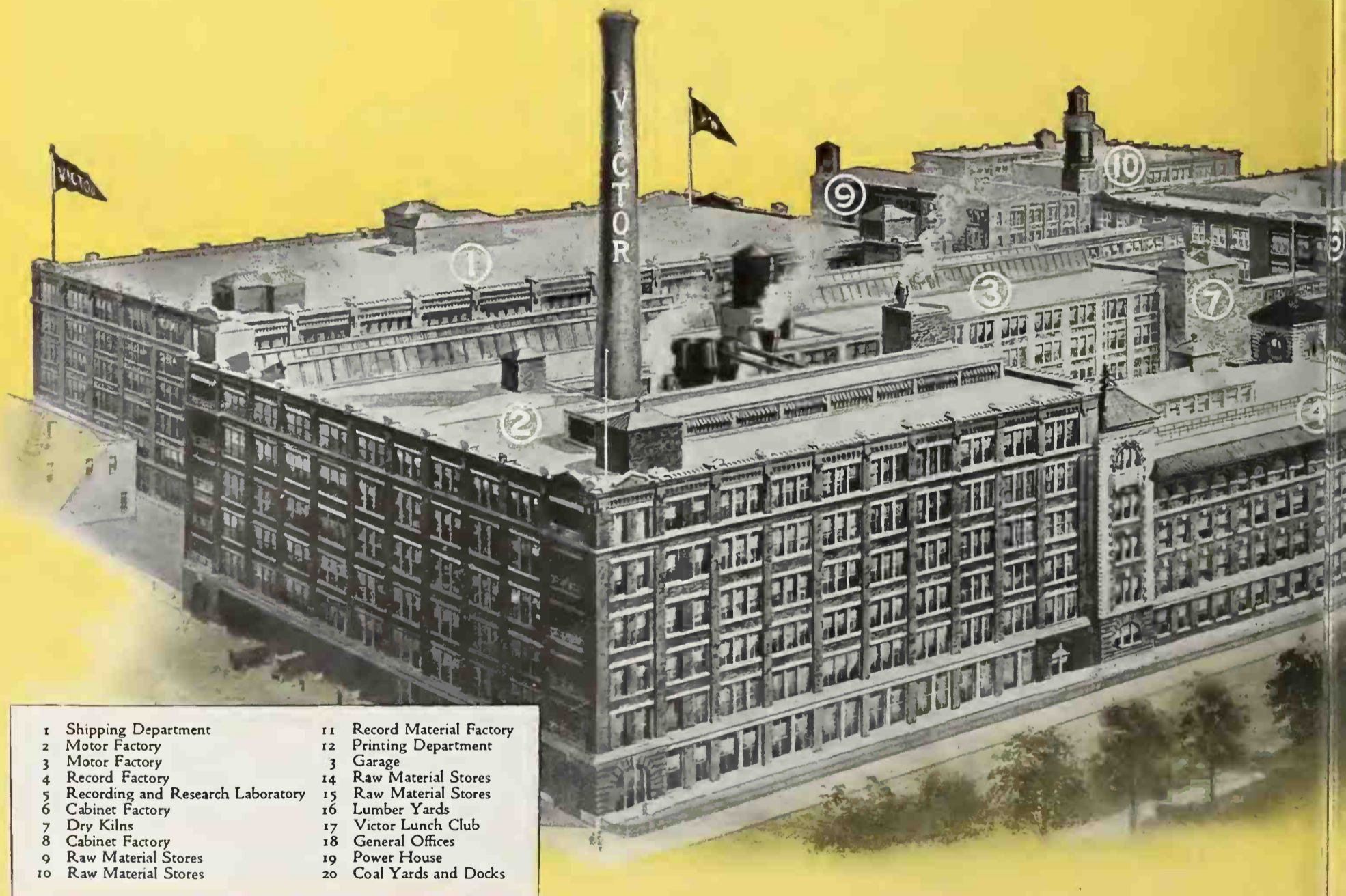

- | | |
|-------------------------------------|----------------------------|
| 1 Shipping Department | 11 Record Material Factory |
| 2 Motor Factory | 12 Printing Department |
| 3 Motor Factory | 3 Garage |
| 4 Record Factory | 14 Raw Material Stores |
| 5 Recording and Research Laboratory | 15 Raw Material Stores |
| 6 Cabinet Factory | 16 Lumber Yards |
| 7 Dry Kilns | 17 Victor Lunch Club |
| 8 Cabinet Factory | 18 General Offices |
| 9 Raw Material Stores | 19 Power House |
| 10 Raw Material Stores | 20 Coal Yards and Docks |

Victor center spreads are
the big broadsides of the
Victor magazine campaign

The Victor center spreads in the Saturday
the largest single advertising units in the
month in the year. They are an important
covers the entire country and gives added

musical industry entire world

world. They stand absolutely unique in the talking-machine industry. The Victor plant is the largest, the most modern, the best equipped plant in which complete talking-machines are built. Its immense buildings were specially planned and erected solely for the production of talking-machines, and represent an investment of many millions of dollars.

To the music-loving public these facts mean more than a mere statement of size. They mean musical quality. They mean that the Victrola stands alone as the supremely satisfying musical instrument. They mean that the Victrola is made by the most completely trained specialists in the most completely equipped talking-machine plant in the world.

It is due to this experienced, highly efficient organization, and to the perfection of its products, that the Victrola has achieved its world-wide supremacy, that it is universally recognized as the one standard talking-machine.

There are Victor dealers everywhere and they will gladly play any music you wish to hear. Victrolas in great variety of styles from \$25 to \$1500.

MACHINE COMPANY Camden N.J.



Evening Post and Literary Digest are among the magazine field, and the Victor uses them every part of the Victor advertising campaign which prestige to Victor retailers everywhere.

**Victor center spreads
command attention and
benefit every Victor retailer**

Victor newspaper advertising helps the business of Victor retailers everywhere



What artists will appear?
Who is in the cast?

How many of these artists have you ever heard?

ALDA	FARRAR	MCCORMACK
BESANZONI	GALLI-CURCI	MELBA
BORI	GARRISON	MURPHY
BRASLAU	GILLY	PADEREWSKI
CALVE	GLUCK	RUFFO
CARUSO	HARROLD	SAMMARCO
CLEMENT	HEIFETZ	SCHUMANN-HEINK
CORTOT	HOMER	SCOTT
CULP	JOHNSON	SEMBRICH
DE GOGORZA	JOURNET	TETRAZZINI
DE LUCA	KINDLER	WERRENRATH
DESTINN	KREISLER	WITHERSPOON
EAMES	KUBELIK	ZANELLI
ELMAN	MARTINELLI	ZIMBALIST

And every one of them is a Victor artist. Their fame is as wide as the world. Their names are known wherever music is known, and with a Victrola their art becomes as familiar as their names.

Any Victor dealer will gladly play any music you wish to hear. Victrolas \$25 to \$1500. New Victor records demonstrated at all dealers on the 1st of each month.

VICTROLA
U.S. PAT. OFF.



The trademark and the trademark name "His Master's Voice" are registered trademarks of Victor Talking Machine Co., Camden, N. J.

Victor Talking Machine Company
Camden New Jersey

Just the Victrola you want for summer

These portable styles of the Victrola enable you to have the best music whenever you want it, and *wherever* you want it. You can easily take them

on the porch
on the lawn
on your boat
to your bungalow
on your camping trip
or—anywhere!



Victrola IV, \$25
Columbia

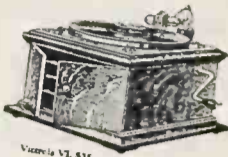

Victrola VI, \$35
Columbia



Victrola VIII, \$50
Columbia



Victrola IX, \$75
Columbia

Any of these Victrolas will play any of the more than 5000 in the Victor Record. Hear them today at your dealer's.

VICTROLA
U.S. PAT. OFF.

Victor Talking Machine Co.
New Jersey



The trademark and the trademark name "His Master's Voice" are registered trademarks of Victor Talking Machine Co., Camden, N. J.

Select the instrument for your home just as you select the opera or theatre or concert you will attend. You will go to hear the greatest artists. Just as you will select the Victrola. This is not only because the best instrumentalists make Victor Records, because the Victrola, and the Victrola alone, plays exactly as they themselves approved their own wish it to be heard. Victor dealers everywhere. New Victor Records on sale at all dealers 1st of each month.



VICTROLA
U.S. PAT. OFF.
Victor Talking Machine Co., Camden, N. J.

Supplementing the extensive Victor magazine advertising, the Victor newspaper campaign brings business still nearer to the stores of Victor retailers. Victor advertising of every kind all works together for the benefit of every Victor retailer.

Rare Records, Like Rare Coins or Books, Have an Increasing Army of Purchasers

It is nothing unusual for The World to receive inquiries from talking machine enthusiasts regarding records of special selections or records by certain artists such as are not generally obtainable. It quite often happens that these records had been little known or in little demand while on the market and were included in the cut-out list of the manufacturers some years ago. It is likewise no unusual thing for the inquirer to offer a substantial bonus for some much-desired selection, even though it may have been already used.

This is a phase of the record question that is worthy of some thought. It is not likely that rare records will ever reach the point of value of rare stamps and coins, for the simple fact that there is always the chance that should the demand warrant it records might be put back into the catalog, inasmuch as the masters have been, and are, preserved by the manufacturers. This fact, however, does not prevent the layman from offering a substantial price for a rare record when he wants it. The chance of it again being put on the market several years hence does not appeal to him.

This demand for old records is not in any sense confined to popular numbers of brief popularity. In fact, popular numbers are seldom sought. There have been inquiries for records, however, of the lesser-known selections made by such artists as Caruso, principally by admirers of one artist or another, who when the records were on the market happened by chance to overlook them and found out too late that the number had been cut out.

One enthusiast in Chicago refused to set a limit on the amount he is willing to pay for a

record by a well-known artist now deceased. This enthusiast had a sample of every record known to have been made by that artist and accidentally broke one of his favorites in the set. So far as is known, he has not as yet been able to get a duplicate record, but this failure has not been due to lack of effort.

The talking machine dealer and salesman, of course, cannot always guard against the unfilled

time to be included in the cut-out list and that it would be advisable to purchase them as a matter of self-protection before it is too late.

One dealer, as a matter of fact, persuaded the customer to buy several duplicate records listed as cut-outs, because the customer was partial to those several selections and did not want to run the risk of being unable to replace the records should they become broken or worn out. Of course, this is an extreme case, but it does not seem beyond the realms of possibility that some live dealer in a big center who is possessed of the gambling instinct will make it a point to hold out samples of records included in cut-out lists, with a view of being able to supply such records perhaps at a premium when they are no longer available in the general stocks. It will mean a fair investment of money, but if the venture is advertised to the trade itself and perhaps to the public such a dealer should soon become recognized as a factor in that particular field just as certain dealers are relied upon to provide, or secure, rare books. It is, of course, looking somewhat into the future, but the idea seems to be worth while.

Demand for Special Selections by Artists and Enthusiasts a New Phase of Talking Machine Industry

demand of some enthusiast, but the retailer can take the precaution of keeping such enthusiasts as are numbered among his customers informed regarding the numbers included in the latest cut-out lists, so that the desired purchase may be made before it is too late. It would seem a matter of wisdom where a customer shows a strong inclination towards the records made by one or another artist to bring to his attention the lesser-known records made by that artist, with the suggestion that they are liable at any

INCORPORATED IN BROOKLYN

The Arell Phonograph Co. has been incorporated in Brooklyn, N. Y., to do a business in talking machines and phonographs, with a capital of \$10,000. The incorporators are J. D. and D. Freeman and J. R. King.

No matter how small your window, no matter how small your stock, you cannot afford to put in an indifferent display.

GUARANTEED

Model No. 2150 D.D.
2 Units Illustrated.

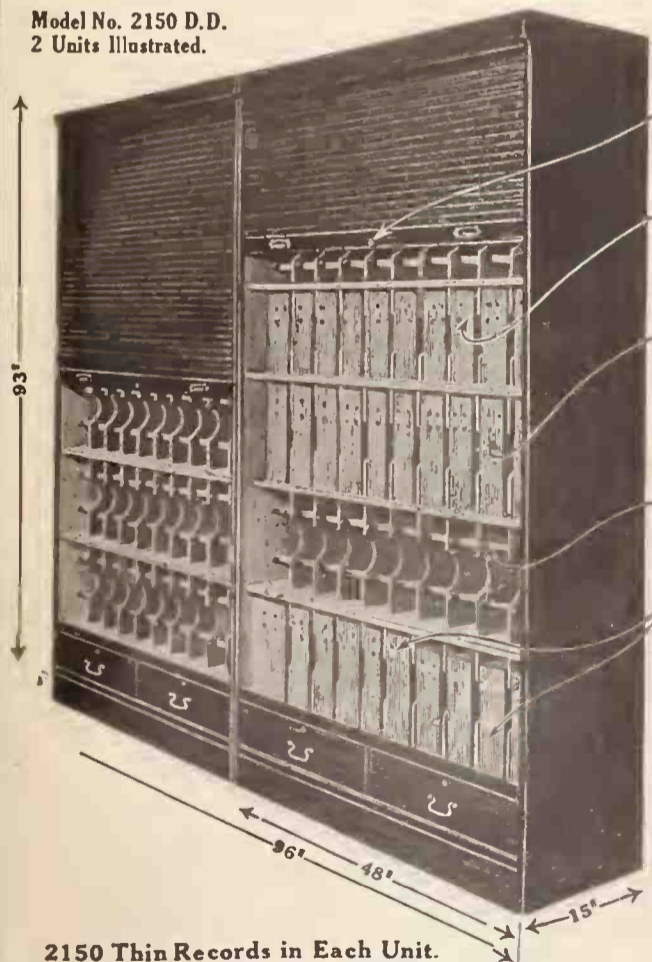

Locking Roll Top Prevents Dust and Theft, also supplied with Spanish Leather Curtains.

350 10" or 10 1/2" Records on each shelf. Filed in Sales System Covers and with Index Guides.

350 10" or 10 1/2" Records on this shelf, also 3 shelves above.

Soft Flat Supporting Springs Prevent Warping (Patented). Holds 350 10" or 12" records.

10 and 12" Records Filed on same shelf. Held Flush at the front by Patented Adjuster.

Sectional Models Fit Any Size Stock and Help You Grow.



File Your Records so you can find them and it's easy to sell them

This System pays for itself by increasing Sales through better service and Automatic ordering of "Sold Out" Records.

Secure These From Your Jobber:

COLUMBIA DISTRIBUTORS

Columbia Co., All Branches.
Tampa Hardware Co.

EDISON DISTRIBUTORS

Harger & Blish.
C. B. Haynes Co., Inc.
Laurence H. Lucker.
Montana Phonograph Co.
Phonographs, Inc.
The Phono Co. of Chicago.
The Phono. Co. of Cincinnati.
The Phono Co. of Detroit.
The Phono. Co. of Kansas City.
The Phono Co. of Milwaukee.

VICTOR DISTRIBUTORS

W. D. & C. N. Andrews
Badger Talking Machine Co.
Blackman Talking Machine Co.
C. Bruno & Son, Inc.
Louis Buehn Co., Inc.
The Cleveland Talking Machine Co.
The John Elliott Clark Co.
Cohen & Hughes.
W. J. Dyer & Bro.
Elmira Arms Co.
Eclipse Musical Co.
Elyea Talking Machine Co.
J. W. Jenkins' Sons Music Co.
Mickel Bros. Co., Des Moines.
Mickel Bros. Co., Omaha.
Putnam-Page Co.
Stewart Talking Machine Co.
The Toledo Talking Machine Co.
Talking Machine Co., Birmingham.
The Perry B. Whitsit Co.

OTHER DISTRIBUTORS

Buffalo Wholesale Hardware Co.
Interstate Phonograph Co.
C. M. McClurg & Co.
Cabinet & Accessories Co.
Sonora Dist. Co. of Texas.
Yahr & Lange Co.
Crafts-Starr Phono. Co.
W. H. Caldwell.
M. Sellers & Co.
L. E. Lines Music Co.
Ellis Jones Drug Co.
H. A. Copeland Sales Co.
Collier Bros.

SALESMEN

W. O. Harris.
W. J. Kelchum

2150 Thin Records in Each Unit.
4300 Records in These 2 Units Illustrated.
2150 Edisons in These 2 Units.

Ogden Sectional Cabinet Co., Inc.
LYNCHBURG, VA.

The Ogden Sales System Is Equivalent to an Extra Clerk and Increases Sales.

Columbia

Practical Selling

Service That Rings Your Cash Register

Columbia dealers are rapidly realizing that after we've delivered the goods in Columbia Grafonolas and Records, we keep right on delivering the goods with the most efficient Dealer Service that great sales experts can devise.

Columbia dealers have seen their business grow at an astonishing rate. They know that the possibilities of increase for loyal Columbia dealers are practically limitless. Their experience of past Columbia service has filled them with faith in Columbia's future.

First of all, our nation-wide advertising campaign keeps our product before the public and creates continuous demand. Secondly, our "built-to-dealer's-order" sales service is *exclusive* for Columbia dealers.

Sales are the first consideration of this scientific *exclusive* sales service. Experience is at the root of every plan it recommends. Every Columbia sales

plan is prepared by a corps of practical selling experts with actual retail experience of all kinds.

These plans are proved in actual practice before we offer them to our dealers. The best brains in the phonograph business study every selling problem for months in order to make this selling service scientifically, mechanically, and artistically right.

All the risk of manufacture of every Columbia sales device is ours; the reduced cost due to quantity manufacture is yours, however small your requirements. Columbia Dealer Service will help every department in your store.

Place your summer sales requirements for Columbia Dealer Service Helps with your regular Columbia distributor immediately. He'll supply you with the kind of service that will wear out your cash register bell.

COLUMBIA GRAPHOPHONE COMPANY, New York

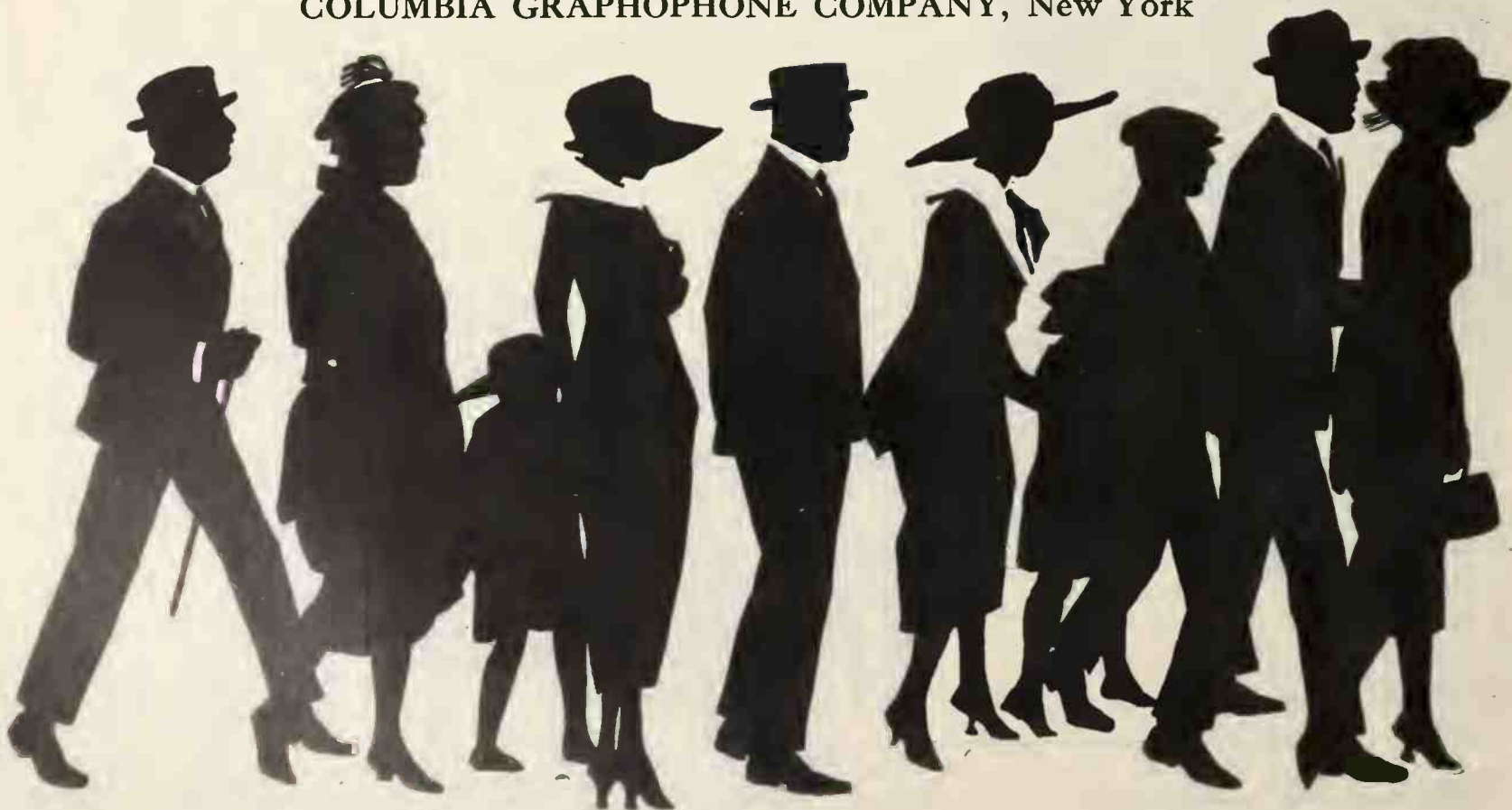

Dealer Service

Sells the Goods

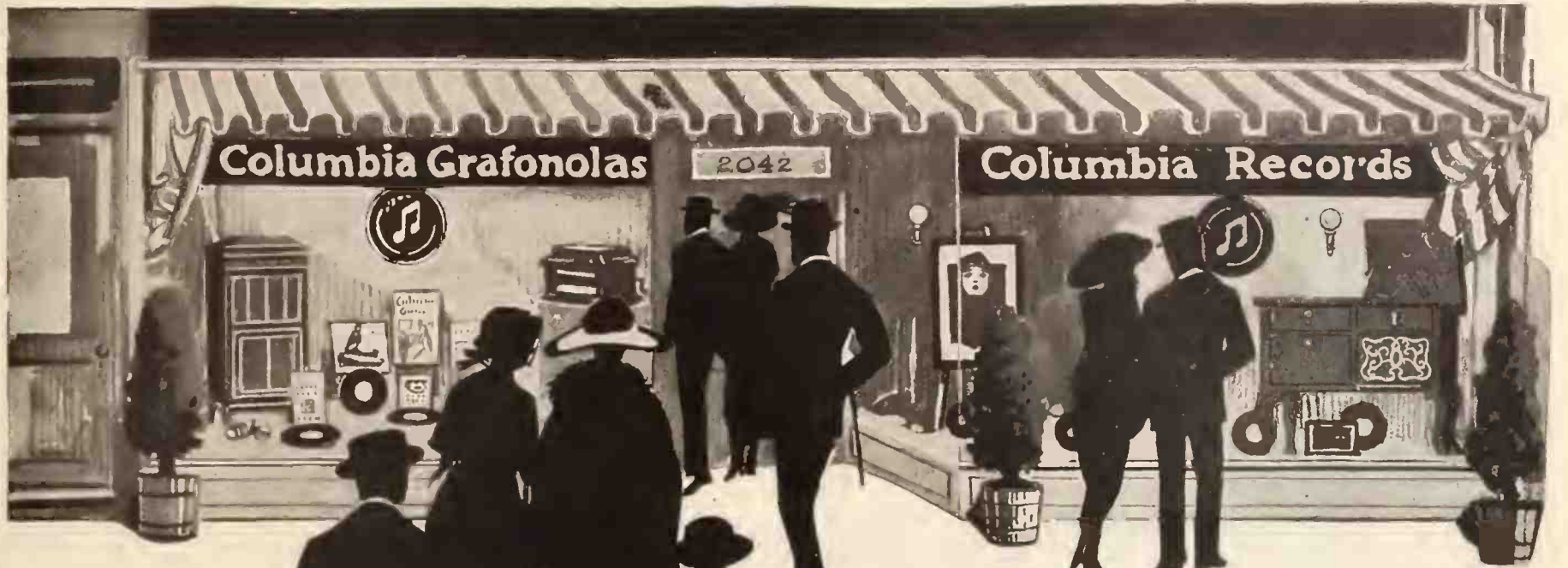

The Big Exclusive Columbia Feature

Columbia dealers have something to offer no other phonograph dealers can get. The *only Non Set Automatic Stop* is now a part of the new Columbia Grafonola. Built right into the motor. Invisible. Automatic. Operates on any record, long or short. Nothing to move or set or measure. Just start the Grafonola, and it plays and stops itself.

No other phonograph has it. No other phonograph can get it. Basic patents protect the Columbia *Non Set Automatic Stop*. It is the last touch of comfort and convenience added to the greatest of all musical instruments, the Columbia Grafonola.

COLUMBIA GRAPHOPHONE COMPANY
NEW YORK

Canadian Factory: Toronto

Lundstrom

CONVERTO

PATENTED DEC. 11, 1917

Talking Machine CABINET



One of the advantages of the Converto is that the Portable Victor that fits into it *remains* portable. People who want a machine which they can easily move to other parts of the house, out on the porch, into the garden or summer house, and about vacation camps and bungalows, may still have a neat cabinet and record file for it in its more usual place.

The C. J. Lundstrom Mfg. Co.

LITTLE FALLS, N. Y.

Lundstrom "Converto" Cabinets are broadly covered by patents. Infringements will be promptly prosecuted.

Converto Wholesale Distributors

Atlanta, Ga.....Elyea Talking Machine Co.
Phillips & Crew Piano Co.
Baltimore, Md....Cohen & Hughes, Inc.
E. F. Droop & Sons Co.
Birmingham, Ala.Talking Machine Co.
Boston, Mass.....Eastern Talking Machine Co.
Buffalo, N. Y.....W. D. & C. N. Andrews
Burlington, Vt....American Phonograph Co.
Chicago, Ill.....Lyon & Healy
Cincinnati, Ohio..Rudolph Wurlitzer Co.
Cleveland, Ohio...Cleveland Talking Mach. Co.
Columbus, Ohio..The Perry B. Whitsit Co.
Dallas, Texas....Sanger Bros.
Denver, Colo.....The Knight-Campbell Music Co.

Des Moines, Ia...Mickel Bros. Co.
Elmira, N. Y.....Elmira Arms Co.
El Paso, Texas...W. G. Walz Co.
Houston, Texas...The Talk. Mach. Co. of Texas
Jacksonville, Fla..Florida Talking Machine Co.
Kansas City, Mo...J. W. Jenkins' Sons Music Co.
Schmelzer Arms Co.
Memphis, Tenn...O. K. Houck Piano Co.
Milwaukee, Wis..Badger Talking Machine Co.
Mobile, Ala.....Wm. H. Reynolds
Newark, N. J.....Collings & Company
New Orleans, La..Philip Werlein, Ltd.
New York City...Emanuel Blout
Cabinet & Accessories Co., Inc.
Kulckerbocker Talking Machine Co.
Omaha, Nebr....Mickel Bros. Co.

Peoria, Ill.....Putnam-Page Co.
Philadelphia, Pa...C. J. Heppe & Son
The Geo. D. Orustein Co.
Penn Phonograph Co.
H. A. Weymann & Son, Inc.
Pittsburgh, Pa...W. F. Frederick Piano Co.
Standard Talking Machine Co.
Portland, Me....Cressey & Allen, Inc.
Richmond, Va....The Corley Co., Inc.
St. Paul, Minn...W. J. Dyer & Bro.
San Francisco, Cal.Walter S. Gray Co.
Sioux Falls, S. D.Talking Machine Exchange
Syracuse, N. Y...W. D. Andrews Co.
Toledo, Ohio.....Toledo Talking Machine Co.
Washington, D. C.Cohen & Hughes, Inc.
E. F. Droop & Sons Co.

Art Studio a New Field of Exploitation for the Talking Machine

:: :: By Frank B. Parsons

The talking machine has entered into so many phases of modern life that it is seldom that an unexploited field presents itself. Once in a while, however, there is presented a new opportunity for the dealer to enlarge the scope of his activities. In the field of photography there have been many improvements and new means are constantly sought by which the efficiency of the professional studio work may be increased.

One means which has been generally overlooked up to the present time is the talking machine and by its use a certain photographer has built up a big portrait business in a short time. Music has come into its own these days as a soother of tired nerves. Under its influence the mind seems to forget its troubles and the world looks brighter. This successful photographer realized this after reading an article in one of the trade papers and at once put the plan into effect.

In his studio he installed a talking machine behind a screen and arranged the instrument so that the music was subdued and soft and seemed to come from a distance. He believed that an atmosphere of music which would be ever present and impress itself upon the mind of the sitter would accomplish the desired result.

The machine was placed behind one of the many screens which are to be found in every photographer's studio. Near the instrument he had a special record rack containing a number of selections ranging from the classical to the popular and jazz. Both instrumental and vocal music were included in the selection, for he realized that in dealing with the individual he must meet many different conditions and tastes. When his subjects came into the studio he at once tried to put them at their ease by his conversation, and if he decided that music would be acceptable he would have his assistant place a record on the machine. In case his customers were fond of music he would turn the discussion to musical matters while the music played, or, as often happened in the case of older people when they heard the old familiar strains of the songs of long ago, he would remain quiet until the last notes had been played. He found after several months of experiment that by the time he had played one or

two selections the feeling of unnaturalness began to pass away and all felt more at home. Then the sittings were begun and the results obtained more than repaid the extra time taken in preparation. With the strained feeling eliminated the pictures were true likenesses and often somewhat flattering, which is what most of us desire in a portrait. Consequently his pictures became very popular, his business grew rapidly and he soon was on the road to a substantial income.

This particular photographer would have made a wonderful salesman in the record department of any talking machine store, for in the course of his work in his studio he came to un-

work of taking the picture was thus made easy.

His unusual success with photographs of children brought in a steadily increasing patronage and he was obliged to enlarge his shop.

He employed and trained assistants carefully, teaching them his own method. He secured larger quarters, dividing the room into several sections so that a subject could be photographed in each section at the same time without any interference due to conflicting musical selections.

By arrangement with his local dealer he always received the new records on the first of the month or on whatever date they were released. Consequently his studio came to be known as the place where the latest thing in music was always to be heard. His establishment was really one of the best advertisements for the local dealer that the latter could possibly have. Realizing this, the dealer saw to it that the photographer was supplied with everything that could be had in the line of improvements. A satisfactory arrangement was made which was mutually advantageous.

Photographers can well profit from the example of this man who cashed in on one of the greatest business-building ideas ever tried out. The plan requires very little initial investment and could be put into operation with the aid of the local talking machine dealer. The possibilities are so attractive that it is strange more photographers have not put it into practice. The dealer himself would do well to suggest the plan to his local photographers for his record sales certainly would increase from the free advertising received in the studios. Another advantage would be that the plan would materially cut the number of demonstrations required at the talking machine store, for once the record was heard in the studio it would be unnecessary to have it played over again. All in all, the use of the talking machine in the photographer's studio should be pushed by both parties to the advantage of each.

The "price" of what you sell is what you ought to get. Price is what you're entitled to; price is always right. If you fail to get that much then it's you that's wrong—not price.

When looking for that flowery bed of ease remember that every rose has its thorns.

How the Photograph Studio Can Be Made Valuable to Dealers by Proper Co-operation Is Worth Noting

derstand the power of music and the musical tastes of the day. He found that older people liked the songs of long ago best of all. He delighted the young people with the latest dance numbers and the song hits from the reigning musical shows. With little children especially he found the talking machine invaluable. Children are the hardest subjects for the photographer because they seldom can be induced to sit still and if they do sit quiet for very long at a time they either have a scared look or else look so solemn that when the proofs are shown to the parents the latter either fail to recognize their progeny or else rush to disclaim ownership. However, our friend the photographer-musician found that band selections appealed to children and made them laugh. The talking book and talking doll records for the little tots never failed to amuse and once in a good humor the



HERE IT IS
The
**FLETCHER UNIVERSAL
TONE ARM and REPRODUCER**

Gives Proper Playing Weights for all Records. No Adjustment Screws or Springs.

SAMPLES \$8.00

Specify 8½" or 9½" arm

FLETCHER-WICKES CO., 6 East Lake Street, Chicago, Illinois

THE GEORGE McLAGAN FURNITURE CO., STRATFORD, ONTARIO, EXCLUSIVE CANADIAN AGENTS

THE FUTURE DEVELOPMENT OF THE TALKING MACHINE

Eldridge R. Johnson, President of the Victor Co., Tells of the Greater Field of Usefulness Yet to Be Developed for the Talking Machine—The Progress of the Victor Co.

Almost an entire page in the Philadelphia Public Ledger was devoted recently to setting forth the character and service of Eldridge R. Johnson, president of the Victor Talking Machine Co., as presented in a sketch and interview by William A. McGarry. The writer told in a brief way of the development of the tremendous talking machine business bearing the Victor gonfalon from its starting point in an obscure machine shop in Camden a quarter of a century ago, and of what Mr. Johnson has accomplished not only in the talking machine field, but in other fields where his work has not received so much prominence.

Of direct interest to the talking machine industry as a whole, however, are the comments offered by Mr. Johnson on the future development of the talking machine as he sees it, for he takes occasion to say:

"It will take twenty-five years more to perfect the talking machine," says Mr. Johnson. "What the future holds can only be imagined by those who are learned in this new art. It will play as important a part in future educational matters as the printing press in the past.

"Have you noticed the difference in reading one of Shakespeare's plays yourself and having it read by a world-renowned elocutionist? Perhaps because I am a slow reader myself I have always taken note of this. And it has occurred to me, as undoubtedly it has occurred to others, that the presentation of literary masterpieces on the talking machine, reproducing every tone and inflection of the artist, offers one of the widest fields for the development of the art. The value of such reproduction can hardly be overstated. We are working on the problem, and we think we have found the solution.

"The day is coming when you will be able to sit in an easy chair at home and hear the greatest prose and poetry masterpieces of all time, just as you listen to-day to operatic selections. Improvements come hard nowadays. The field is no longer a virgin one. Great chunks of free gold are no longer lying around to be picked up by lucky hunters. Comparatively speaking, prospecting must be done with a diamond drill, and upon the location of a good vein great shafts must be sunk and an expensive plant built before pay dirt can be taken out. It is now also necessary to dig according to the latest scientific methods and keep on digging with the best equipment that money can buy. What the public is eager to purchase to-day cannot be given away to-morrow."

In telling of the early days of the talking machine, Mr. Johnson explained that a quarter of a century ago inventors were numerous and made their haunts in small machine shops. They were generally impractical and visionary and

possessed of unbounded enthusiasm. He says of his experiences in the machine shop:

"It was interesting work, and there was profit in it if you could collect your bill; but in many cases the machine shop proprietor took a portion of his profit, at least, in experience. During the model-making days of the business one of the very early types of talking machines was brought to the shop for alterations. The little instrument was badly designed. It sounded much like a partially educated parrot with a sore throat and a cold in the head, but the little wheezy instrument caught my attention and held it fast and hard.

"I became interested in it as I had never been interested in anything before. It was exactly



E. R. Johnson

what I was looking for. It was a great opportunity, and it came to me as it can never come to any other man in the talking machine business again. The talking machine was a new art with a boundless future waiting only to be developed. Contact with so many inventors had inoculated me with their disease, and the talking machine fever broke out all over me.

"Mr. Berliner had given the world the greatest basic improvement in talking machines since the day of Mr. Edison's original discovery, and I happened to be the man who happened to be there at the right time to give this great discovery the needed improvements and refinements, and to manufacture it in such forms and designs as to become most popular with the buying public. My years of hard experience in model working and repair work had well qualified me to cope with intricate designs and processes.

MICA DIAPHRAGMS

Absolutely Guaranteed Perfect
We get the best India Mica directly.
We supply the largest Phonograph Manufacturers.

Ask for our quotations and samples before placing your order.

American Mica Works
47 West St. New York

"I immediately undertook a course of experimenting with talking machines and made discovery after discovery until a talking machine of the disc gramophone type, capable not only of reproducing sound in its own mechanical fashion and in a tone of its own but of reproducing the tone true to the original sound, stood in my laboratory.

"The Victor Company was a very small affair when it was first formed in 1901," he says, "but it has grown and will continue to grow as long as its products continue to grow better and better. The Victor Company, with its organization of competent experts, is able to accomplish more in a day now than I was able to accomplish in twelve months twenty years ago. Its great object and ambition is to improve its product. Just as soon as a certain improvement is secured the experts in the organization are set to the task of making something new that is better than the last improvement. The Victor Company is now in possession of many patents and secret processes, but our greatest secret process is this: We seek to improve everything we do every day."

SEND INVITATION TO THE TRADE

Engraved invitations have been mailed to the trade by the Remington Phonograph Corp., cordially inviting the trade to visit its new warehouses and executive offices at 1662 Broadway. An invitation is also extended to dealers to make use of these offices as headquarters while in the city.

M. C. SIMONS BECOMES DISTRIBUTOR

M. C. Simons has been appointed sole distributor of the Lark Talking Machine Corp., of Camden, N. J., with offices at 1-3 Delancey street, New York City. Mr. Simons has already secured a number of representative agencies for this talking machine and finds the outlook bright.

We are largely the sum of our habits. If we go to our duties every morning, determined to put our best efforts into our work, we will surely accomplish much more as the days and months roll by than we would otherwise.

The "Don" Variable Tone Needle

The "all-in-one" phonograph needle which enables you to play all lateral cut records in any degree of tone desired

—Loud Tone

—Medium Tone

—Soft Tone

Without removing the needle from the sound box. The needle point is adjustable. When set as indicated above the various gradations of tone are possible.

The "Don" Variable Tone Phonograph Needle is scientifically constructed throughout.

The "Don" Plays 1000 Records Perfectly

And the one-thousandth playing will be as clear as when used on the first record. The needlepoint, when worn out can be replaced without trouble or annoyance.

Retail Price Complete, \$1.00

Refiller Points 25 cents each

JOBBERS AND DEALERS WRITE FOR QUOTATIONS

Sole Distributors



FRANK J. HART
SOUTHERN CALIFORNIA
MUSIC COMPANY
332-334 SOUTH BROADWAY, LOS ANGELES.

—For Soft Tone extend point thus:—
—For Medium Tone extend point thus:—
—For Loud Tone extend point thus:—



The Smallest Thing You Sell Is the Most Important

THE most beautiful instrument in your shop—the most expensive records—are lifeless and useless without the needle that draws out their hidden tones.

Until you have pointed it out to them your customers have never realized how important that little bit of steel is. Without it the talking machine is dumb. With a poor needle its voice is strained and hoarse, but with a perfect needle—a needle that is always uniform in length, uniform in its finish and uniform in its tempered ball point—the talking machine gives out always a uniform fullness and richness of tone.

More than any other one thing poor needles have caused customers, who once were enthusiastic about their talking machines, to become indifferent, and on this matter as on many other technical points the customer

must look to his dealer for guidance. You know the importance of an absolutely perfect uniform needle. You can impress your customer with your care for his interest by showing him that the needles that you recommend—made by the largest needle factory in the world—are selected by you because of their unvarying uniformity.

If you like you can prove it to him. You can open up a package of Uniform, ball-point needles and spread them out on the counter. Every one of them will be of the same length, the same thickness, with the same non-rust finish, and with the Uniformly rounded point. To your customer that means service. In these days of keen competition the customer is going to buy his supplies from the man that he trusts, and the man that gives him real service.



Tear out the attached coupon for samples of the only Ball-pointed Steel Needle in the world

Condon & Company, Inc.
SOLE AGENTS
200 FIFTH AVE., NEW YORK CITY

Condon & Co. Inc.
200 Fifth Ave.
New York City

Please send me by mail, without obligation, free samples of the Torrington Uniform Needles.

Name

Street

City or Town

State



Don't let your Grafonolas and record cabinets get cloudy or finger-marked. Shine 'em up—keep them shined. Look 'em over—"a stitch in time saved mine" said one dealer who uses our Dealer's Grafonola Re-Finishing Outfit. Bright, clean goods sell quicker.

Columbia Graphophone Co.
NEW YORK

TRADING ON ESTABLISHED NAME

Misleading Advertising in Indianapolis Suppressed Through Efforts of Stewart Talking Machine Co. and Better Business Bureau

INDIANAPOLIS, IND., July 3.—Through the efforts of George E. Stewart, of the Stewart Talking Machine Co., and G. F. Olwin, of the Indianapolis Better Business Bureau, forward steps have been taken towards eliminating misleading and fraudulent statements in the advertising of phonographs and talking machines in this city.

There appeared recently in the classified departments of two Indianapolis newspapers this advertisement: "Beautiful mahogany Victrola. \$150 size; like new, and records, cheap; cash or bonds. 3137 Ruckle."

Investigation disclosed that a man lives at this address having the agency for the Avalon talking machine. His wife was asked to show the mahogany Victrola advertised for the sale as a "\$250 size, used about three months, for \$100, party leaving city," and was shown a machine of another make. When attention was called to the fact that the machine was not a "Victrola" the lady stated, "It is not a 'Victor Victrola,' but a much better make." She was then asked to show the \$150 size Victrola advertised, and exhibited a machine of another make priced at \$150.

The identity of the investigator and the purpose of the visit was then disclosed and the lady was very profuse in her apology, pleading that she thought all talking machines were "Victrolas" and that the "Victor Victrola" was identified by the name "Victor." She was told that this was a very poor excuse in light of the fact that her husband was agent for another make machine and that any repetition of this false advertising would be prosecuted. Promises were secured that future advertising by these people would be without offense.

The Indianapolis newspapers were all advised

of the result of the investigation and have assured the Stewart Talking Machine Co. and the Better Business Bureau of their full co-operation.

The story of this investigation is just one story of the dozens of investigations conducted every month at the instance of the Stewart Talking Machine Co. It is gratifying to observe that the need for these investigations is decreasing, due to the wholehearted efforts of the newspapers and the Better Business Bureau.

TWO POPULAR PATHE RECORDS

Rosalie Miller one of America's favorite sopranos, who records for Pathé Frères, has just made a charming record of "My Love Is a Muleteer" (Francisco di Nogero). This song has been received with acclamation wherever she has sung. The same firm reports an increasing demand for the same composer's "A Sevilla Love Song," as recorded by Paul Althouse whose lovely tenor voice finds expression in a love song of unusual qualities. Those who know Paul Althouse best are aware that he avoids love songs. "This one is different," he says, and those who have had the privilege of listening to this record will agree with Mr. Althouse, for it is a record worth having.

TO OCCUPY NEW BUILDING

Bain Bros. & Friedberg, Inc., 235 Utica avenue, Brooklyn, N. Y., will soon occupy a handsomely equipped building right directly across from their present location, with Irving A. Fenison as manager. The Victor line will be specially featured by means of a large electric sign in front of the building. Other branches of this concern are at 1525 and 1658 Pitkin avenue, Brooklyn.

There is just a little difference between firmness and obstinacy. When it's you, it's firmness; when it's the other fellow, it's obstinacy.

ALYSWORTH-WILSON WEDDING

Daughter of General Manager of Thomas A. Edison, Inc., Marries Walter S. Alysworth

Miss Helen Julia Wilson, daughter of Mr. and Mrs. Carl H. Wilson, vice-president and general manager of Thomas A. Edison, Inc., was married in East Orange, N. J., last month to Walter Sanger Alysworth, who is also connected with the Edison laboratories. The groom's father, the late Jonas Walter Alysworth, was associated with Thomas A. Edison for many years in the capacity of chief chemist and was also an inventor of considerable note. The wedding was followed by a brilliant reception at the Essex County Country Club, at which were present a number of officials of the Edison laboratories.

COLUMBIA DEALER SERVICE

The Columbia Dealer Service system was fully outlined and discussed by Cortland B. Shaw in the June issue of Printers' Ink Monthly. In the article the basic principles of the service were explained, these being that the dealer is open to any proposition that will enable him to sell more goods, and he is willing to pay for any service which he is convinced will be an asset to his business.

AVOID THOSE VAIN REGRETS

Show me the business man who gives no thoughts to his business, who neglects his trade or technical journal, and remains in ignorance of the important things going on in his line, and I'll show you a man who trusts somebody to do these things for him, or who will have some vain regrets when he wakes up.

A real salesman is one part talk and nine parts judgment. He uses the nine parts of judgment to tell him when to use the one part of talk.

Our Complete Stocks of

Emerson Records

assure prompt service and quick deliveries

Western Iowa and Nebraska Dealers
Write TODAY for this Agency

CARPENTER PAPER COMPANY
OMAHA Distributors NEBRASKA

Emerson
Records

THE BRUNSWICK-BALKE-COLLENDER CO.
623-633 SO. WABASH AVENUE
CHICAGO

EXECUTIVE
OFFICES

June 29, 1920.

To Brunswick Dealers
and the trade:

Every keen analyst of business strategy knows that he can bank on the judgment of the public in any final appraisal of any product. Quality never is overlooked nor unrewarded.

Products may thrive and products may die, but the reason lies within the policies of the makers, not in the complaint that the public is unappreciative.

Witness the remarkable success of the Brunswick Phonograph. This, gentlemen, is proof sufficient for any business man. It reaffirms an ancient business principle, to wit: The people want what they want and won't have what they don't want.

One can force anything on the public for a little while, but not for long. This isn't Barnum's day. Times change. Minds change. People change. Phonographs change.

The Brunswick Phonograph has won its cherished place in the hearts of the people, first because it is a FINER phonograph, and secondarily, because of the integrity of Brunswick Dealers.

People are learning to refuse a lesser phonograph nowadays. They have learned to compare. They have become keener judges. They know the dealers who are giving them the utmost for their money.

In every community Brunswick Dealers have won the respect of people who judge phonographs the new way. And that has created a vast momentum of word-of-mouth advertising-- the rarest and most priceless element in selling

In our great national advertising campaign we set people thinking, we induce them to come and visit a Brunswick Dealer. We appeal to their curiosity. We make them choose wisely.

They are therefore the best sort of prospects. Such a clientele means a stabilized business for a Brunswick Dealer, one that gives satisfaction daily, and one that grows healthfully through the years.

.....

For later appointment, in a few localities there will be openings for Brunswick Dealers -- maybe in your community. If you are interested in a Brunswick Franchise, the most fruitful business proposition imaginable, write to us at once for particulars.

We will tell you further of Brunswick success and what it can mean to you if you are a man with a vision.

Yours truly,

The Brunswick-Balke-Colender Co.
S. Hendrick

GEN'L SALES MGR.
PHONO. DIV.

Brunswick

PHONOGRAPHS AND RECORDS

ANNOUN EXTRAC

THE Brunswick-Balke-Collender Company, makers of The Brunswick Phonographs and Records, have the distinction to announce that through arrangement with Mr. James Slevin they have concluded negotiations for the return to America of the Vatican Choir and Soloists, so that they may perpetuate the highly artistic attributes of this unique and famous organization by a most interesting series of records typical of its liturgical renditions.

Branch Houses
in Principal Cities of United States,
Mexico and Canada

THE BRUNSWICK-BALKE

General Offices: 623-63

Brunswick
PHONOGRAPHS AND RECORDS

CEMENT RDINARY

THE Vatican Choir, which until its limited American tour last year, had not left the Eternal City, has never before recorded for any phonograph company. The Brunswick has secured the exclusive recording rights in the interests of countless thousands of music lovers who expressed a genuine regard and a keen appreciation of the superb artistic qualities of that aggregation of talent.

COLLENDER COMPANY

5. Wabash Avenue, Chicago

Canadian Distributors:
Musical Merchandise Sales Company,
819 Yonge Street, Toronto

Brunswick

PHONOGRAPHS AND RECORDS

*Display them prominently and proudly—
they will win respect and sales*

IN every town in the land there are people to whom the Brunswick story has had a tremendous appeal.

Our constant advertising of Brunswick Phonographs and Brunswick Records is being read by people everywhere—in *your* town and for miles around.

But people want to know *where* to come. We urge them to visit a Brunswick Dealer—but the Brunswick Dealer must come forward and identify himself with the entire community.

You cannot attain the full value of Brunswick Advertising until you stand out prominently in the community as The Brunswick Dealer.

Once the public locates you definitely, you will find a constantly increasing trade.

So we point out again the value of local advertising and a “tie-up” with our national campaign. Our extensive Dealers Service makes this easy. We co-operate to the limit.

Thus the value of a Brunswick Franchise becomes accumulative. It builds you a permanent business.

Public demand on the one hand and intelligent salesmanship on the other, are irresistible factors in success.

THE BRUNSWICK-BALKE-COLLENDER COMPANY

General Offices: 623-633 S. Wabash Avenue, Chicago

Branch Houses in Principal Cities of United States, Mexico and Canada

Canadian Distributors: Musical Merchandise Sales Company, 819 Yonge Street, Toronto

REFINISHING DAMAGED CABINETS

Some Excellent Advice to Dealer and Repairman on the Handling of Cabinets That Have Become Damaged While in Transit

It is a rare occurrence for the average talking machine dealer to receive any large shipment of machines without finding one or more of the instruments in need of some slight touching up. Sometimes it is only a light scratch or bruise. Then again there may be more serious damage to look after before the machine can be put on the floor for sale.

In the "Voice of the Victor" there were recently offered some excellent suggestions on the subject of refinishing cabinets, suggestions that may be adapted in the refinishing of any style cabinet. The article reads:

"When a Victrola leaves the factory it is in perfect condition, and knowing the rough handling it is liable to receive our shippers take the greatest care in packing it, but still it is impossible to guarantee that every instrument will reach its destination in the same perfect condition. By following the instructions given here you will be able to put damaged cabinets in perfect condition again.

"After carefully unpacking the Victrola, wipe it off with a piece of fine cheesecloth to remove all dirt and marks of packing. Then with a clean piece of cheesecloth rub the cabinet with a small portion of cleaner. Never use ready-made liquid polishes which are so extensively advertised as wonder workers. They will make the surface sticky, spotted and clouded, and destroy the finish.

"By mixing three parts benzine to one part paraffin rubbing oil you will have the best possible cleaner and polisher for a Victrola cabinet. Rub briskly, always lengthwise of the grain, cleaning off all surplus polish. Brush out all the corners with a brush, preferably a soft, round 3° bristle varnish brush.

"If paper has become stuck to the cabinet it can easily be removed with a cloth and water. The cabinet should then be carefully dried and the surface rubbed with a 3° pumice stone, a soft felt and paraffin oil. Care should always be taken to rub lengthwise of the grain.

"Never sponge a cabinet and then expose it to the sun in the show window. The glass intensifies the heat, which may blister the varnish, or fade the color and ruin the whole finish. When this happens the whole finish must be removed by an expert mechanic, carefully re-finished and carefully French polished.

"Bruises or scratches should be rubbed out with a piece of soft felt, a 3-F pumice stone and paraffin rubbing oil. Go only so far as the body varnish will permit and rub only lengthwise.

"If the bruise or scratch is too deep to rub out, it will have to be burned in with shellac cement, the spot leveled up with fine sandpaper and touched up to the required color. It will then be necessary to French polish it with a solution of shellac, alcohol and raw linseed oil, using a piece of cotton covered with a piece of fine linen cloth. This requires skill and experi-

ence and should never under any circumstances, be attempted on a large flat surface by a novice.

"Rubbed spots and white corners on a red mahogany cabinet can be touched up with spirit stain made from Bismarck brown dissolved in alcohol, to which a little shellac is added. For English brown-finished cabinets add a little nigrosine to the above-mentioned solution. Special finishes and oak require the color adapted to the finish.

"If after treating the cabinet in any or all of these ways scratches and marks still show it will be necessary to employ a skilled polisher to French polish the whole cabinet to the desired finish, which must then be dulled off with a soft brush dipped in 3-F pumice stone and cleaned as before mentioned.

"If the finish has turned gray or become spotted by being exposed to dampness or some other unusual condition, the whole finish will have to be removed by an experienced wood finisher and refinished as above mentioned."

H. H. DOEHLER'S SPLENDID WORK

Headed Salvation Army Home Service Drive in Brooklyn—First Anniversary of Topics

The deep interest shown by H. H. Doehler, president of the Doehler Die Casting Co., of Brooklyn, N. Y., in civic and altruistic campaigns is once more manifested in the recent announcement that Mr. Doehler accepted the chairmanship of the Salvation Army Home Service Appeal in Brooklyn. Mr. Doehler's unselfish work in the somewhat recent Liberty Loan drives is well remembered and he has put the same enthusiasm into the Salvation Army Fund drive, of which he was the head in Brooklyn. Mr. Doehler outlined the situation and made a specific appeal to Doehler employes in the June issue of Doehler Topics.

The June issue of Doehler Topics marks the first anniversary of the appearance of this newspaper for Doehler employes. Doehler Topics has been published throughout the year without missing an issue and during that period has not only grown remarkably in size, but has become firmly established among thousands of employes at the Doehler plant. In the June issue an item in the phonograph department reports that a recent record was established in that department, when 7,974 tone arms, each one perfect, were turned out in one day.

ESTEY STORES HAVE CRAFTS LINE

RICHMOND, VA., July 8.—A. J. Crafts, president of the A. J. Crafts Piano Co., recently returned from his trip to New York, and has made the important announcement that the Estey Piano Co. will hereafter carry the Crafts phonographs in all their various warerooms. Mr. Crafts also closed very satisfactory arrangements for his export business while in New York recently.

The general offices of the A. J. Crafts Piano Co. have been moved to the factory building at Twentieth and Franklin streets, and the retail store of the company, at 218-220 North Second street, will be placed under the direction of a branch manager.

**Your Customers
Want to Know
About
"GLISS"**

The other day I had the opportunity of visiting one of the largest piano factories in the country.

In passing from one department to another I was most impressed by the painstaking care in the polishing department. More time is spent in giving a lasting finish than in any other one operation.

Out of long experience manufacturers of pianos and talking machines realize that the appearance and very often the sale of an instrument depends upon the highly finished case.

Your customers are just as anxious to keep their talking machine or piano looking as spick and span as the day it came from your store, and it is equally to your interest to have the instrument you sold them always looking its very best.

"GLISS" is a polish whose "lustre lasts." It is the only polish on the market scientifically blended to bring out the maximum lustre in a piano or talking machine case. It is used by many of the foremost manufacturers. It is sold to you on the right terms, with an unqualified guarantee of money back if not satisfactory.

You can recommend "GLISS" without reservation to your customers, but first I would suggest that you try it out in your own store. You will be surprised at the ease with which it is applied, and the lasting character of the brilliant finish that it adds to your instruments.

Simply sign and mail the attached coupon, and I will be glad to send you, without obligation, a free sample.

[Handwritten Signature]
President

COUPON

CONDON & CO., INC.,
200 Fifth Ave.,
New York City.

Please send me a free sample of "Gliss," the polish whose "lustre lasts."

Name
Street
City State



AUTOMATIC STOPS

The simplest and most efficient Automatic Stop on the market. They give excellent service, are easily installed and are absolutely guaranteed.

Send 50 cents for Sample Stop

Kirkman Engineering Corporation
484-490 Broome St., New York

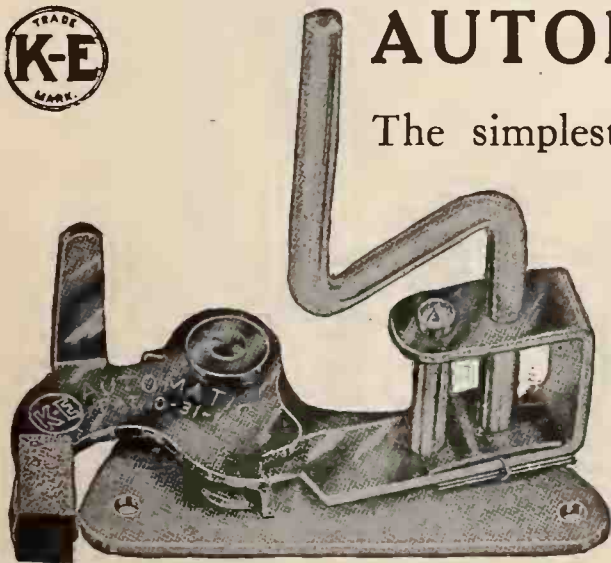



THE
VICTOR!
America's Favorite

THE Supremacy of Victor, "America's Favorite," has already been established.

WE believe the dealer handling Victor Exclusively will have no regrets, as specialization brings the best results.

ORMES, Inc.

Wholesale Exclusively

Ormes Inc.

26 East 125th St., New York

Briggs

EXPORTING OF TALKING MACHINES

Some Facts Regarding Foreign Demand for American Talking Machines and the Problems It Presents to the Domestic Manufacturer

The demand for American phonographs abroad is so persistent, according to J. B. Wilmeth, assistant manager, export department, Victor Talking Machine Co., Camden, N. J., in an interview published in the New York Evening Post, that more and more production is the industry's chief concern.

"It is not to be assumed from this, however," went on Mr. Wilmeth, "that all is plain sailing and easy going. We have our troubles, our obstacles to overcome just as other industries do. Some foreign governments, even of non-manufacturing countries, have been inclined to look upon the talking machine and records from a luxury standpoint, at the expense of a proper regard for the educational and spiritual worth of good music, thus seriously handicapping the business through excessive import duties and other taxation. These difficulties are, however, in the main, gradually becoming less pronounced as a broader appreciation is being accorded.

"Complicated customs regulations are the common lot of all American exporters in dealing with many countries. But improvements in this direction are also gradually being made, and an intimate understanding of their minutiae and strict conformity reveals them as more an imaginary than a real obstacle.

"So far as shipping and burdensome handling charges are concerned, reform, like charity, may well begin at home. In some instances it costs more to clear goods from an American port than ocean freight to a distant country amounts to.

"The world at large has never before been so eager for standard American products. It is not so much a selling proposition as one of satisfying the conscious wants of the various peoples with the genuine article, which, after all, is the essence of good salesmanship."

NEW BEACON DISTRIBUTORS

J. N. England, of Atlanta, and Chas. B. Branner, of Richmond, Appointed Distributors for Important Territory in Southern States

The Beacon Phonograph Co., of Boston, Mass., announced recently that distributing arrangements have been made with J. N. England, who for a number of years has been Southern representative of the Kroeger and Straube pianos, with headquarters in Atlanta, Ga. He will distribute the Beacon line in the States of Georgia, Alabama, Florida, Tennessee and Louisiana.

Similar arrangements have been made with Charles B. Branner, who for twenty years has represented the Chase-Hackley Piano Co. throughout the South. His quarters are in Richmond, Va., and the territory he will cover comprises Virginia, North and South Carolina.

MACK HOWE APPOINTED MANAGER

Mack Howe, one of the popular young business men of Nashville, Tenn., has taken charge of the Pathé department of the Sharp-Howse Furniture Co. in that city. He has had considerable experience in the piano and talking machine field and is well fitted to take charge of the department in the Sharp-Howse store.

SAM SCHAEER A BENEDICT

Sam Schaer, of the sales staff of the Amalgamated Phonograph Accessories Corp., and the Independent Talking Machine Co., New York, was married on June 15 to Miss Solomon, of Buffalo, N. Y. His honeymoon was spent on visits to several trade centers where he combined both business and pleasure.

The Delaware Talking Machine Co., Wilmington, Del., has been incorporated with a capital of \$100,000 by Franklin Mettler, M. E. and L. F. Mettler.

IOWA VICTOR DEALERS TO MEET

Annual Convention of State Association to Be Held in Des Moines on August 2—Victor Golf Tournament Under Way—New Exclusive Columbia Store to Open in Des Moines

DES MOINES, IA., July 5.—The date of the fourth annual convention of the Iowa Victor Dealers' Association has been changed from Tuesday, August 3, to Monday, August 2. This has been necessary in order to make satisfactory arrangements with different features of the program. An attendance of over 200 is already assured.

John Gregg Paine of the legal department of the Victor Co., will address the members of the Iowa Victor Dealers' Association at their convention.

The annual Victor golf tournament was held in Des Moines last month. A number of matches have already been played with the leading players, H. B. Sixsmith and E. H. Haglund of Mickel Bros., Oliver Pearson of the Victor traveling department and Dave Walsh of the Victor Educational department.

Oliver Pearson, Iowa representative of the Victor Co., has just finished his work in Des Moines and will call on the Victor trade in the eastern section of the State during June and July. Mr. Pearson's previous work has been in the eastern part of the State, where he has made a host of friends.

David Walsh, the educational representative of the Victor Co., is conducting a series of "Musical Appreciation" talks at the Summer school at Carroll, Ia.

H. Wilson will shortly open an exclusive Columbia store at Sixth and Locust streets, this city. The installation will consist of two booths on the first floor and two in the basement, a large record rack and a service counter. The offices will be on a balcony in the rear.

The impressions created through good window displays are of a lasting quality.

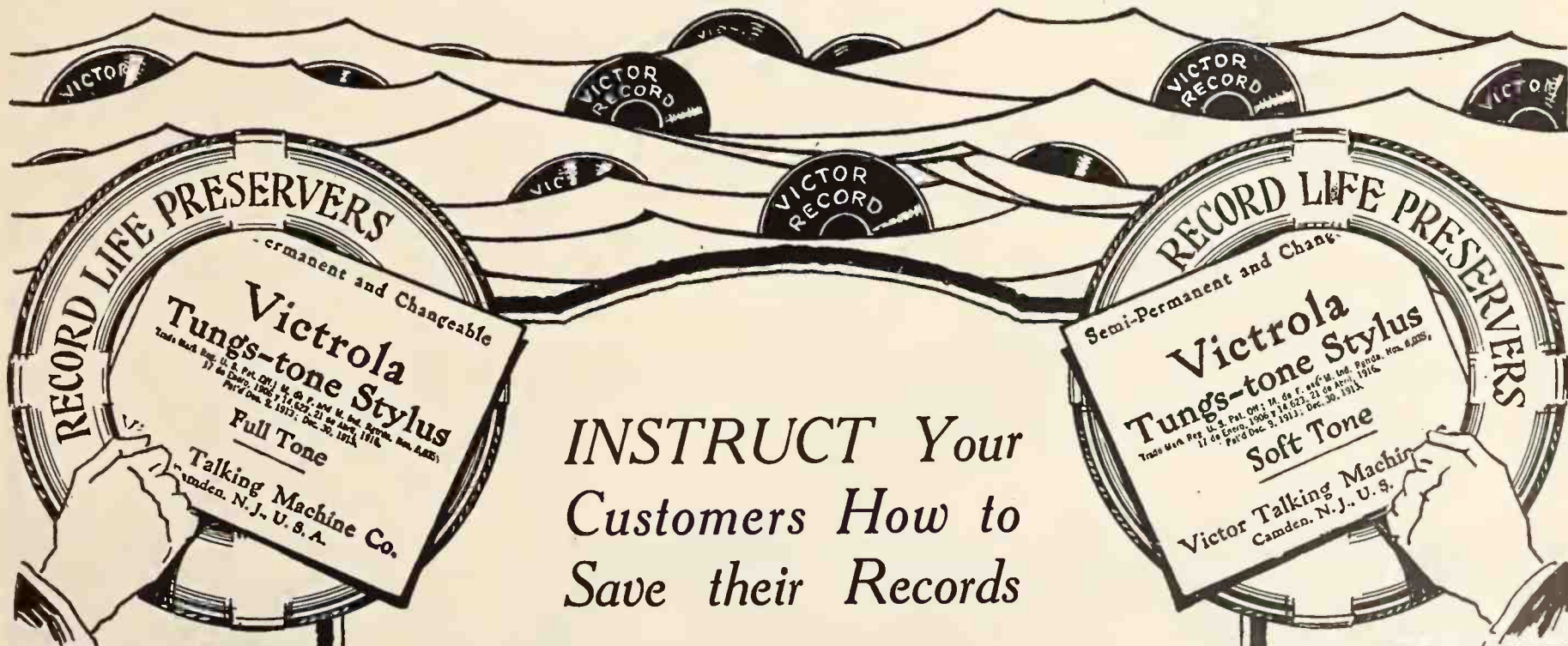

INSTRUCT Your Customers How to Save their Records

Advocate the use of the

Victrola Tungst-tone Stylus

It gives the best possible reproduction with the least wear on the record. It is an *exclusive* Victor product, and in its sale VICTOR DEALERS have the opportunity of supplying the public exclusively with this wonderful needle.

COLLINGS & COMPANY

Plum Building, Clinton and Beaver Streets, Newark, N. J.
VICTOR DISTRIBUTORS for Northern New Jersey and North Eastern Pennsylvania

Stewart

PHONOGRAPH

To be without this sensational phonograph is like saying "We don't want to make money"



Plays All Makes of Records

Any size, any style, any price.

Improved and refined at many points. Now finished in rich mahogany enamel with fine nickel trimmings. Universal reproducer. The finest motor of its type yet achieved—tested to play two 10-inch records with one winding. Its wonderful volume and quality of tone will amaze you.

IT'S the biggest selling proposition in the phonograph world—one of the fastest and most profitable specialties ever devised! Its amazingly low price—its wonderful tone quality—its rich appearance—its portability—all combine to make it an unparalleled sensation!

The whole world has welcomed the return of the famous Stewart Phonograph. From almost every civilized country orders are pouring in. Jobbers and merchants all realize that the Stewart is a phonograph for everyone—a universal entertainer—that brings the good cheer of music whenever and wherever desired.

STEWART PHONOGRAPH CORPORATION, Inc.

Lincoln Building

BUFFALO, N. Y.

MERCHANTS in every line of business are making big money selling the popular-priced Stewart phonograph. Demand will soon overtax our vast production. Now is the season when sales hit a high peak. Wire for our proposition. Distributors are now being allotted territory. Get in touch with us at once!

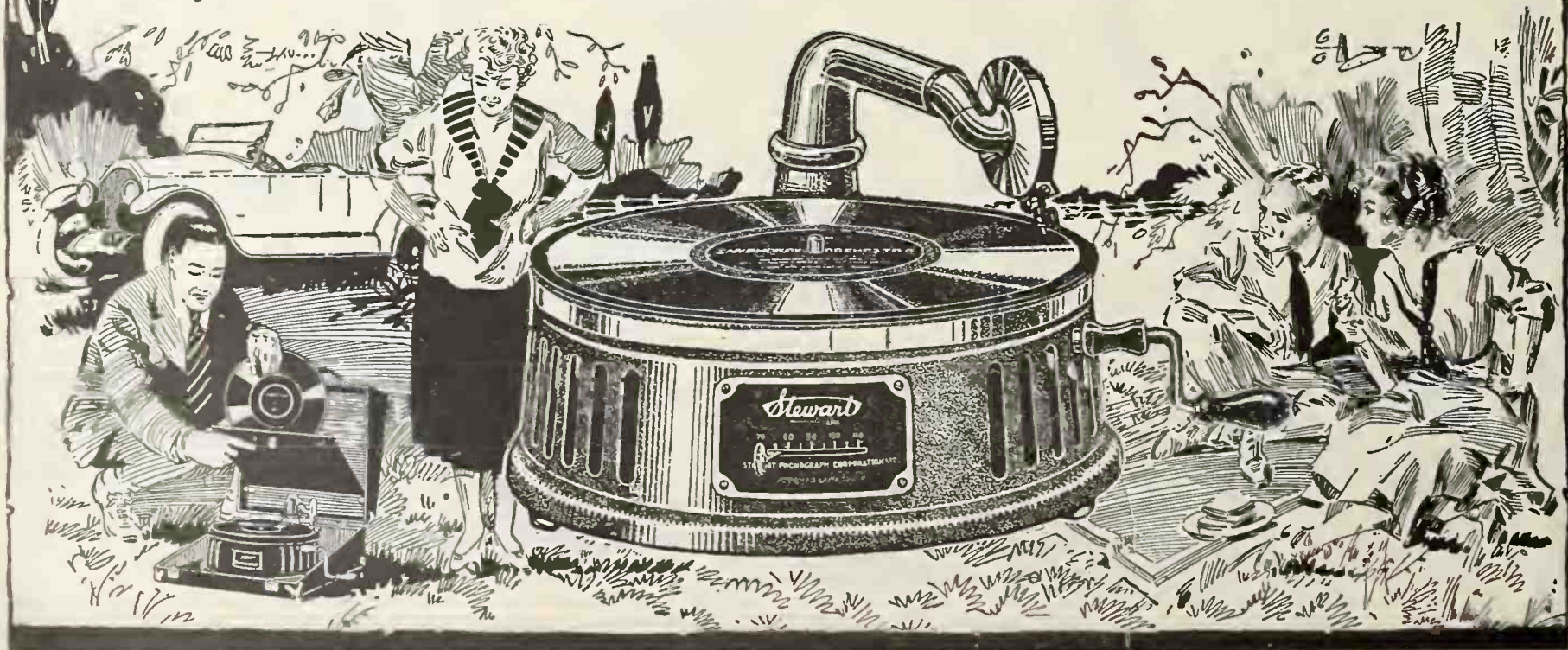

Creating Summer or "Outing" Atmosphere in Talking Machine Advertising :: By W. B. Stoddard

A lover of music—not a professional, but one reared in the atmosphere of the best musicians, and accustomed to hearing each season the finest artists, both vocal and instrumental—who spent a year in Alaska, teaching the Indians in a small town far distant from the mainland, where sometimes for several weeks she saw no white face, wrote to her friends back home:

"More than anything else I miss the thrill of the violin and the magic of the spell woven by Gluck. When the longing becomes irresistible I get out the little old music box—Heavens only knows how it found its way up here—and start it going. As it screeches and rasps its way to the bitter end I try to imagine I hear the wonderful voices that used to delight me—but it is terribly hard on the imagination. O, for my beautiful Victrola, or a compact, high-grade little machine that I could tuck under my arm—one that would really give me some real music, even if it is canned!"

Doesn't a letter like that open up vistas of sales to the modern, up-to-date dealer in talking machines? There are hundreds, perhaps thousands of such people scattered all over the country—on the lonely prairies, in the deep forests, on the high mountains—people to whom music of the right sort would be a greater blessing even than books.

This was the idea of the Chapin Music Store, Medicine Hat, Canada, whose display set forth eloquently the value of music in the wilderness. The interior of a rude cabin was depicted, with a rag rug on the floor, and the log walls hung with skins. There was a cot in one corner, a rude table holding a lamp and several magazines, a great fireplace filled with logs (back of the logs were several bulbs, and red paper stuffed between them gave the simulation of fire), and above the mantel, on a pair of antlers, rested a rifle. Seated in a big chair, in rough outing clothes, a pipe between his teeth, was a young man listening to a talking machine which stood on a box near the cot. A large card attached was lettered:

THERE IS NOTHING SO VALUED AS GOOD COMPANY

It comforts a person; it makes him forget life's little worries, and keeps him cheerful. The talking machine is the most perfect of instruments. Buy one now for that camping trip, or sojourn in the wilderness, far from the sound of human voice. YOU WILL NEVER FEEL LONESOME WITH A TALKING MACHINE FOR A PAL

This display was backed up with some snappy advertising. The major part of one of the ads consisted of a cut made from a photograph of the window trim. The picture was captioned: "Scenes like this are common wherever one of our portable talking machines are included in the luggage. Note the look of absolute content upon the face of the young man in the chair. Truly 'You will never feel lonesome with a talking machine for a pal.'"

The Eastern Outfitting Co., Seattle, Wash., was another concern that made a play for the outing trade. In the early Fall it sent to its regular trade and to a selected list of business and professional people whom it was desired to gain for customers a neat little letter adorned with a cut of a portable phonograph. The announcement was captioned:

TAKE A PHONOGRAPH TO THE PICNIC and double the enjoyment of the whole party. You can dance to the latest music or listen to the newest song hits and old favorites as well. Your picnic can't be anything BUT a success if you take along a

BLANK A Portable Model Like This (Cut) will cost you only \$20.00, and paid on the Eastern Plan of "as little as you like," you'll never know you're paying for it. Come in and hear some of the new music on this very instrument.

THE EASTERN OUTFITTING CO.

The Hopper-Kelly Co., Seattle, Wash., went a step further in pushing its line of talking machines, for in addition to window signs and newspaper ads suggesting the purchase of a portable machine for the Summer vacation, and offering same on the weekly payment plan, it clinched many a deal with this additional offer: "We allow full value on exchange. Should you buy any of the portable models for Summer, and want a larger one in the Fall we will allow full price on the exchange."

Meier & Frank, Portland, Ore., recently advertised talking machines for outings very effectively. A canvas drop in the background showed a blue sky and sparkling waters, while set in front of it were a number of young fir trees. It was floored with moss and twigs and at one end was a tent. In front of the tent was a camp stool on which reposed a portable machine. There was a simulated fire of logs at the other end and scattered through the display were many of the accessories of camp life. What attracted the widest attention, however, were the living models used to demonstrate the machine. There were two of them, a young man and young woman, both clad in hiking or camping togs. Two demonstrations of an hour each were given—one in the afternoon and the other in the evening. The couple came out of the tent, with guitar and mandolin and played several selections. Then the young man placed a record on the machine, and they grouped themselves in picturesque attitudes to listen. After this both sang, with the "talker" as an accompanist; and the performance was concluded with several dances, both solo and duet, with the talking machine to furnish the music. At night

gay Japanese lanterns were strung across the window, and it was lighted by blue bulbs, giving an excellent simulation of moonlight. A tall dead tree at one side was hung with records, each with a card giving the name and price, while a bulletin board down front gave the name of the selection—solo, march, or dancestep—that was being played at the time. At the other side was a long, narrow panel with the caption: "Easy Terms on Our Portable Talking Machines," followed by: "Come in and listen to the clear tones, and find out how easily you may become the possessor of a standard portable machine. Just the thing to take along in your canoe on a camping trip, or to beguile the evening on a hunting or fishing expedition."

TO INSTALL 43 UNICO ROOMS

Gimbel Bros. Talking Machine Department Will Have One of the Largest Record Equipments in Country—Installation Now Under Way

An indication of the big business expected in the talking machine trade in New York City is to be found in the extensive equipment to be installed in the talking machine department of Gimbel Bros. department store during the Summer months by the Unit Construction Co., of Philadelphia, Pa. Forty-three Unico demonstrating rooms have been ordered, finished in mahogany. In the record department there will be installed one of the largest record filing equipments in the country. It is planned to carry the entire stock of records on the floor, entirely surrounded with record counters, in this way making all records accessible.

VICTOR SUPREMACY



"HIS MASTER'S VOICE"

REG. U. S. PAT. OFF.

M. DE F. MARCA INDUSTRIAL REGISTRADA

**VICTROLAS
VICTOR RECORDS
VICTOR TUNGS-TONE NEEDLES**

Co-ordinated to produce the most perfect sound reproduction. By educating your customers regarding this fact you will have an everlasting flow of customers into your store.

Knickerbocker Talking Machine Co.

VICTOR WHOLESALERS

138-142 West 124th Street

New York City

THE QUESTION OF TAX RETURNS ON INSTALMENT SALES

Music Industries Chamber of Commerce Sends Out Bulletin of Information to Members of the Trade Following Complaints of Demands for Double Payment of Taxes

The Music Industries Chamber of Commerce has received complaints from members of the trade that the Internal Revenue Department has apparently endeavored to impose payment of a tax twice on dealers who have previously made tax returns on a cash basis and have now changed to an income basis, under which latter form of return the sale of an instrument on instalment is not included except in so far as instalments are actually paid.

In case a change is made from cash basis to income basis care should be taken that all sale payments previously reported are excluded in the following year's return. In case representatives of the Internal Revenue Department advise to the contrary, or taxes are imposed on the amount of sales previously reported, members of the trade are advised to communicate immediately with the Chamber and the matter will receive the prompt attention of Mr. Pound, its general counsel.

The complete statement of the Chamber on this important matter follows:

"The War Revenue Tax Act of 1918 has now been in force long enough to develop its technical income and accounting features. Many of our members are experiencing perplexity in reporting and accounting on their instalment plan sales. Two general methods are in the purview of the Internal Revenue Department. One, and, of course, the simplest, is to treat the entire deferred payment transaction as cash. The obvious objection to this is that the vendor is advancing the tax upon the unpaid instalments.

"Then when it is necessary to repossess property due to the failure of the purchaser to make payments or otherwise, the corporation may deduct as a loss so much of the profit reported on the original transaction as was represented in the unpaid instalments and the repossessed property should be taken into stock at its then

value. The first transaction was closed with the charging off of the loss so that the repossession of the property is in effect a purchase of the property at its then value and gain or loss on the next sale will be determined as in the first sale; that is, on the basis of the difference between the repossessed value at which it was taken back into stock and the new selling price of the article.

"The other method, more economical in cash payment of taxes, but necessitating more bookkeeping and therefore objectionable to some merchants, is quite fully set forth in Article 42 of Regulations 45 of the Internal Revenue Department. The rule there is that in the instalment plan the income to be returned by the vendor will be that proportion of each instalment payment which the gross profit to be bears to the gross contract price. In this case, if the vendee defaults and the vendor repossesses, the

entire amount received on instalments less the profit already reported will be income of the vendor in the year of repossession and the property repossessed must be included in the inventory at its original cost to himself less proper allowance for use and damage.

"It has come to our attention that many of our merchants are changing their system of bookkeeping and changing over from the first to the second method in handling this tax. Any change in bookkeeping at this time is scrutinized by the Internal Revenue Department and care should be exercised. In the second method as ordinarily used the annual report includes payments received in the taxable year on account of sales effected in earlier years as well as those effected in the taxable year. Where returns had previously been made on the cash basis this would result in a duplication of tax payment if care is not exercised. Regulations apparently to the contrary notwithstanding, the Department should not impose payment of a tax twice. Therefore sales payments previously returned should be excluded in the following year's return."

THE "ARIETTA" MAKES ITS DEBUT

The Rountree Corp., of Richmond, Places New Talking Machine on Market—Being Made in Four Styles—Many Agents Being Appointed

RICHMOND, VA., July 9.—The Rountree Corporation, well known throughout the talking machine trade as distributor of Emerson records, has placed on the market a new talking machine named the "Arietta." Although only recently generally announced to the trade, this instrument has been in existence for some time past and has achieved much popularity in the warehouses of the various dealers who are carrying the line. The production at the factory in this city has now reached the point where prompt shipments on all models are possible and agencies are being established in Virginia, West Virginia, North and South Carolina, where the

Rountree Corp. has a well-established selling force, covering the record end of its business.

The Arietta line will consist of four models, one table model and three floor models. In an attractive six-page folder which the company has issued the models are illustrated and a full description is given. Many high claims are made for this new talking machine and much care has been given to the selection of its equipment. The Arietta is the newest addition to the talking machines which are being manufactured in the South, and the location of the plant in this city provides excellent facilities in the prompt shipment of orders.

Every knock is a boost—let the other fellow do the knocking, and, if he can use it, hand him a big hammer. The bigger the hammer, the sooner he'll tire, and the more business he'll knock in your direction.



Back on the Job

Just returned from A. C. where I thoroughly enjoyed myself—lots of fun but lots of "good stuff" at the Victor meetings.

Feel fine, with plenty of Victor pep, energy, and optimism. Every Victor dealer should feel the same way, for we are getting ready for the biggest Victor year in history.



SILAS E. PEARSALL COMPANY

DISTRIBUTORS

WHOLESALE ONLY

Victrolas and Victor Records

10 East 39th Street, New York

VITANOLA

The Phonograph of Marvelous Tone



VITANOLA
FOURTEEN

Quality—

Vitanola quality is unquestioned.

It is born of ample facilities—"know how" and wide experience—for instance, the first practical, all-disc record machine was produced by Vitanola.

Stand the Vitanola side by side with any machine on the market—it sells itself either from the standpoint of appearance or performance.

And Vitanola buyers are satisfied customers.

Publicity—

Look in the big newspapers—the **Saturday Evening Post**.

You'll find Vitanola advertised—regularly—with large size copy.

And the big campaign back of this instrument is worth the money it costs because it helps our dealers cash in on what they say is the finest instrument ever produced.

Write for the book, "How to Make a Phonograph Department Pay." It's Free.

VITANOLA EXHIBIT SECTION 20—SIXTH FLOOR 1319 BUILDING CHICAGO, TO JULY 30TH.

VITANOLA TALKING MACHINE COMPANY, 508 West 35th Street, CHICAGO, U. S. A.

Metropolitan Sales Representatives: M. M. ROEMER SALES CORP., 1123 Broadway, New York, N. Y.

The Advantages of Operating a Store With Novel Display Features

By Warfield Webb

One way to increase sales for talking machine records, player rolls, players and even pianos is to have the interior of the store attractive and home-like. The latter term is coming to have a greater meaning to the retailer, and if he can demonstrate this in a way that will help to make his store attractive he has done something at least to encourage trade to seek his place of business. The main plan in mind to-day is that of appealing to the prospective customer to come to your store because of the atmosphere that can be found there.

Novel effects are being tried out that help this sales plan and in Cincinnati there is a new one now in operation. George P. Gross, the well-known piano and talking machine dealer, who handles a very extensive line of Victor, Edison, and Columbia machines, has very recently opened his fourth store in that city. It is located on Vine street, in a section that is populous and where many people daily pass the door. There are attractive show windows that act as an invitation to the passerby and inside the store other features make this a reality.

There is a long counter where are placed, easy to select from, a large assortment of late records. These can be looked over by the customer and a selection made without delay. It is a self-service plan, and after a selection has been made one can enter the Swiss Cottage, a few feet farther back, where the demonstration rooms are found. The exterior of these rooms resembles a Swiss cottage. There are two windows on either side of a doorway, where bracket electric lights are seen. The exterior is of stucco, and the red tile roof makes the effect

most homelike as the customer approaches the same.

The doorway leads to a hall, on either side of which are the booths for machine or record demonstration. The interior of these booths is most delightful and the walls and general effect make them like rooms in a private home. There is a tall standing electric lamp, chairs, talking machine and table. The light is soft and the effect soothing. One can enter here and seat



The Swiss Cottage Feature

himself and at once feel at home. The music always sounds sweeter where the surroundings are so satisfying. Can one wonder that sales could be made with this environment?

Back of the record booths there is a demonstration room for players and still further back a room for player roll demonstration. The plan of arrangement here is ideal. The big feature is the Swiss Cottage, and then the idea of the record self-service is also a help, inasmuch as the customer has an opportunity to make her

own selection of the records without much aid from the salesperson.

If the dealer can give quick and effective service, can offer by way of inducement a reason for the customer seeking him, there is a combination of sales helps that are sure to be found most effective in making his store a popular one and in making his sales show an increase at all times. This is being given a practical test here that is sure to be found most helpful and adds to the arguments why sales will increase where the foundation elements are not overlooked.

PACIFIC PHONOGRAPH CO. BUYS

Acquires Additional Warehouse Which Will Be Used for Storage Purposes

PORTLAND, ORE., July 6.—The Pacific Phonograph Co. has purchased the "Old Crow" warehouse, which is situated at 1036 East Broadway and adjoining the present plant of the company, together with a piece of ground 60x100 feet, from Frank Masson. The consideration was \$12,000. The warehouse will be used for storage purposes by the company. The Pacific Phonograph Co.'s business is increasing very rapidly and according to E. M. Barlow, vice-president and manager, the new storage space will allow space for added equipment to the plant. It is the purpose of the company to eventually use the additional ground purchased for building purposes when the increase in business demands an additional unit.

Sunshine is the reward of those who don't kick about the clouds.

STODART

PHONOGRAPH

The sign of a quality phonograph

A high grade instrument appealing to high grade prospects
Exemplifies its superiority—in Case Design, Tone and Equipment

Five handsome and distinctive models in mahogany.

Stephenson Precision-made motor with velour turn-table.
Universal Tone Arm.

Its remarkable reproducing device creates extraordinary tonal volume and tonal beauty. Tone modifying rod.

The Stodart Phonograph is distinguished for the identical quality which has made the Stodart Piano famous for a century.

A constantly growing demand is reported by our enthusiastic chain of nationally distributed Dealers.

Find out how and why this Leader can make money for you.

Write right now.

STODART PHONOGRAPH CO., Inc.

"PHONOGRAPHS WITH A PEDIGREE"

GEORGE H. BEVERLY, General Manager

119 West 42nd Street

NEW YORK



STYLE
AA



STYLE
D

Okeh Records

4 STARTLING SPECIALS 4

ON SALE AS SOON AS RECEIVED

4118 { IN SWEET SEPTEMBER—Fox-trot,
10-in. Ray Miller's Black and White Melody Boys
\$1.00 MY SAHARA ROSE—Fox-trot,
Harry Raderman's Jazz Orchestra

4119 { ROSE OF SPAIN—Fox-trot,
10-in. Ray Miller's Black and White Melody Boys
\$1.00 KISMET—Fox-trot...Green Brothers' Novelty Band

4120 { TELL ME PRETTY MAIDEN (From Musical
10-in. Comedy, "Florodora")—Fox-trot,
\$1.00 Rega Dance Orchestra
POLLY—One-step,
Jos. Knecht's Waldorf Astoria Dance Orchestra

4121 { LE WANNA—Fox-trot,
10-in. Green Brothers' Novelty Band
\$1.00 JEAN—Fox-trot,
Harry Raderman's Jazz Orchestra

RAY MILLER'S
**BLACK and
WHITE**

**MELODY
BOYS**

RAY MILLER has developed the Black and White Melody Boys to a perfection of superiority.

They are nationally elected the Kings of Syncopated Harmony. When they play a dance tune the rhythm and pure melody are not sacrificed by their spirited verve.



They are producers of superior jazz marvels.

Ray Miller comes from San Francisco; between the East and West he has blazed a trail of glowing popularity.

His incomparable reputation will win YOU instantaneous sales of OKEH'S SENSATIONAL SPECIALS.

GENERAL PHONOGRAPH CORPORATION

OTTO HEINEMAN, *President*

25 West 45th Street, New York City, N. Y.

Factories: Newark, N. J. Elyria, Ohio Putnam, Conn. Springfield, Mass. Kitchener, Ont.
Branch Offices: Chicago, Ill. San Francisco, Cal. Toronto, Can. London, Eng.



Don't hide your light under a bushel. You don't have to if you put up the Columbia Awning. True, it's an awning plus—it has an attractive color—it carries the Columbia Trade Mark and it protects the goods in your display window. Nobody can miss it.

**Columbia Graphophone Co.
NEW YORK**



MARION HARRIS WITH COLUMBIA

Popular Comedienne to Make Columbia Records—Will Be Introduced During Special Week From August 28 to September 3

The Columbia Graphophone Co. announced this week that arrangements have been completed whereby Miss Marion Harris becomes an exclusive Columbia artist. To properly celebrate



Marion Harris

this important announcement, there will be a special Marion Harris week from August 28 to September 3, featuring her first Columbia records, which will be ready for the trade August 10.

Miss Marion Harris is well-known to talking machine dealers and to the general public from Coast to Coast. Since the advent of the "Blues" type of song she has risen to pre-eminent height as a singer of this character song. In fact, she

is known as "The girl with the voice which chases the 'blues' away by singing them."

Miss Harris is a Kentucky girl and a descendant of Benjamin Harrison. For over six months she has charmed thousands of music-loving vaudeville fans and the announcement of the Columbia Graphophone Co. that she is now an exclusive Columbia artist will be welcome news to Columbia dealers everywhere.

In order to co-operate with Columbia representatives in adequately announcing Miss Harris' engagement as an exclusive Columbia artist the Columbia Graphophone Co. has prepared an intensive advertising campaign. This will include window streamers for the dealers' windows, units in the September window display, hearing-room hangers, advertising for the dealers' local newspapers and a full page in the August 28 issue of the Saturday Evening Post.

VALUABLE WORK ON CREDITS

"The Technics of Credit" is the title of an interesting twenty-four-page booklet written by E. O. Rockwood, credit manager of the Columbia Graphophone Co., New York. Mr. Rockwood is one of the recognized authorities on credits in the talking machine industry and the booklet that he has prepared for the use of the Columbia organization has won the enthusiastic approval of every member of the sales and executive staffs.

In this publication Mr. Rockwood gives interesting facts and figures as to the most logical methods of determining the credit possibilities of the talking machine dealers. From his many years' experience in the industry Mr. Rockwood has developed an intimate knowledge of every phase of the credit situation and his booklet is therefore practical and valuable.

If you can't figure out why you should do more work than you get paid for, do it anyhow just to prove to yourself that you can do work which will warrant more pay.

MACHINE PLAYS HOUR AT A TIME

Boston Inventor Has New Device Embodying Radical Departure in Playing Methods

By making records as interchangeable sections fitting on a common mandrel, George W. Bowers, a mechanical and consulting engineer of Boston, has introduced a new phase in record music, according to the Scientific American. Whereas the average talking machine does not handle records larger than twelve inches in diameter, with a playing time of four minutes, Mr. Bowers has a machine which plays for an hour without a break.

The new invention makes use of an exceptionally large mandrel on which records, in the form of large cylinders of narrow width, are placed side by side. The needle or stylus passes over one record and right on to the next without a break, according to the inventor. In this manner the machine can be made to play for one hour, if desired; or, again, it can be adjusted to stop automatically at any pre-determined time or spot.

The tone-arm arrangement of this machine is as ingenious as it is interesting. It permits the reproducer to cover the entire length of the mandrel without a hitch. The reproducer is arranged to play the hill-and-dale-cut records, which system, in this case, is far simpler to accommodate than would be the lateral-cut system, which predominates in the usual disc records.

FRED BURBICK NOW IN CANTON

Fred H. Burbick, for several years connected with the talking machine department of the Lewis Bros. Co., East Liverpool, O., has joined the sales force of the talking machine department of the D. W. Learch Co., in Canton.

It is not enough to be industrious; so are the ants. What are you industrious about?

FOUNDED 1835

ARMSTRONG'S



Distributors

There are certain desirable localities still open for wide-awake Pathé dealers in the South.

Our *Superior Service*, co-operation and jobbing experience enable us to give all dealers the right start. A good start is half the game. Write today for full information.

ARMSTRONG FURNITURE CO.
59 and 61 North Main Street
Memphis, Tenn.



STEGER

The finest reproducing
phonograph in the world

BUILT along artistic, harmonious lines, a distinct creation of the wood-crafter's highest art, the Steger makes an eloquent appeal to every lover of the beautiful.

It is an exquisite adornment of the home—and more. It is the soul of music.

The masterful artistry of living genius finds in the Steger its most faithful medium of expression. Every beauty of score, every delicate shading of sound is as exact in its rich quality as if emanating direct from artist or instrument. It plays all records *correctly*—no parts to change.

This marvelous fidelity to original tone value is chiefly attributable to the patented Steger tone arm and tone chamber, triumphs of human ingenuity and skill.

Active dealers have found that the interest and appreciation of critically inclined buyers eventually center on the Steger.

You can make it a big asset of your business because of the quick turn-over—and because we can ship at once upon receipt of order.

Write for Steger phonograph style brochure today

STEGER Phonograph Wholesalers

Iver Johnson Sporting Goods Co., 155 Washington Street, Boston, Mass.	Smith & Nixon Co., 306 West Walnut St., Louisville, Ky.
Steger & Sons Piano Mfg. Co., 867 Broad St., Newark, N. J.	Hall Music Company, 246 Pine Street, Abilene, Texas.
Jones Brothers Co., 317 Main St., Jacksonville, Fla.	Warfield-Pratt-Howell Co., 1st and Court Sts., Des Moines, Iowa.
Jones Brothers Co., 137 Whitehall Street, Atlanta, Georgia.	Campbell Phonograph Sales Co., 60 East South Temple Street, Salt Lake City, Utah.

STEGER & SONS PIANO MFG. COMPANY
Steger Building, Chicago, Ill.



Model 506 - \$280.00



Model 505 - \$210.00



Model 502 - \$140.00



Model 504 - \$190.00



Model 503 - \$155.00



Model 501 - \$110.00



Model 509 - \$225.00



Model 500
\$90.00



Model 510 - \$275.00

THE PERSONAL TOUCH BETWEEN CLERK AND CUSTOMER

How One Western Department Cultivates the Personal Element to Its Great Business Advantage
—Listing the Peculiarities of the Customer for Future Reference

The average talking machine dealer realizes fully the value of the personal element in promoting business, and takes due cognizance of the fact that regular customers like to be waited on by sales people with whom they are acquainted and who have some idea of their likes and dislikes in the matter of records. It is the usual thing, of course, for the regular customer to ask for a certain sales person when entering the store, with the feeling that that person best understands what is wanted.

A Western talking machine department manager feeling that certain customers should be credited to certain members of the sales staff, enlarged upon the personal touch idea by providing a separate card index for each member of the sales staff in which index was listed the name and address of the customer, information regarding their likes and dislikes, peculiarities, etc., numbers of records asked for but not in stock, together with the numbers of records that had already been bought. This is all information that every sales person should have at hand, and it was felt by the department manager that it was better to have such information on a permanent card record than simply to trust to memory.

With a separate file each member of the sales staff naturally takes a personal interest in keeping the information on the card accurate and up-to-date, and is inclined to list items that would never appear on cards in a general customers' file. The sales people are instructed to receive the customer in the usual manner and ascertain what particular record is desired. As soon as the record has been secured, and while it is being demonstrated for the customer in one of the hearing rooms, the clerk goes immediately to his, or her, private file and at a glance refreshes the memory regarding the sort of records favored by the customer and what records he was unable to obtain on his last visit. With this information at hand the clerk is able to make suggestions of a sort that are acceptable to the customer, and indicate a distinctly personal interest on the part of the sales person as representative of the store.

Each sales person is provided with a business card, and a card is always slipped in the corner of the package or handed to the customer, with the suggestion that the same sales person be asked for on the next visit. Customers appear to appreciate this personal attention, and hardly one comes back the second time without making definite inquiries for some member

of the staff. The employes, too, seem to appreciate the opportunity of asserting their individuality to a certain extent. Where the sales person called for by name is not present, a substitute by quick reference to the absentee's personal file can gather the necessary information regarding the customer's characteristics to smooth the way in handling the sale.

It is human nature to appreciate doing business with people whom one knows, whether it be the waiter in the restaurant where one eats, or the clerk in the store where one shops. The acquaintanceship is believed to insure a certain amount of special attention that would not be forthcoming to a stranger, and the theory has an excellent foundation in fact. In promoting the personal touch between the sales person and the customer, the Western department has simply been working along well established lines.

TRADE ACTIVITY IN RALEIGH

RALEIGH, N. C., July 9.—The branch wareroom of the A. J. Crafts Piano Co., of Richmond, Va., in this city, has increased its sales force and added several new delivery trucks to take care of its phenomenally increasing business in both pianos and Crafts phonographs. The distributing business throughout North Carolina has grown to such an extent that it has been found necessary to secure a large warehouse in this city for storage purposes. Crafts phonographs will be shipped in carload lots from Richmond, Va., to Raleigh, where they will be promptly re-shipped to the Crafts dealers. It is expected that this change will eliminate delay in filling orders and will offer the individual dealer not only more prompt deliveries, but a considerable saving in freight charges.

PHONOGRAPH CO. ENTERTAINS

Edison dealers located in the vicinity of Cincinnati met informally in that city last month at the invitation of The Phonograph Co., Edison jobbers, to discuss existing conditions in the phonograph industry. P. H. Oelman, manager of The Phonograph Co., acted as chairman, and William Maxwell, vice-president of Thomas A. Edison, Inc., who stopped at Cincinnati on his return from Atlanta, Ga., represented the Edison laboratories.

A discourteous clerk should remain in your employ only long enough to write his pay check.

WELBURN RESIGNS FROM HOUCK CO.

Severs Connection as Director and Branch Manager of the O. K. Houck Piano Co.—Has Not Announced Definite Plans for the Future

NASHVILLE, TENN., July 1.—Allan Welburn, member of the board of directors of the O. K. Houck Piano Co. and manager of the Houck Nashville store, has tendered his resignation, which took effect to-day, both as manager and director of the concern.

Mr. Welburn has been connected with the Houck interests for fifteen years, with the ex-



Allan Welburn

ception of three years, during which time he was associated with the Musical Instrument Sales Co. of New York. While with the M. I. S. Co. he was active and instrumental in opening a number of piano and Victor departments in New York and other cities. In June, 1916, he returned to the O. K. Houck Piano Co. as manager of the Nashville store and was made a member of the board of directors of the company, in which capacity he has served since that time.

In tendering his resignation to the Houck Co. he has expressed his best wishes for the future of the company and his regrets at leaving his associates of many years. Mr. Welburn's future plans have not been completed, but we understand they will be announced to the trade at an early date.

Will Play 100 to 200 Records Without Changing

Is What We Claim and Expect of

The De Luxe Stylus

THE BEST SEMI-PERMANENT NEEDLE MADE

3 for 30 cents

Let the "De Luxe" Speak for itself and Send for Free Samples, Discounts, etc.



Medium Tone



Full Tone

DUO TONE COMPANY, Inc.

Sole Manufacturers of De Luxe Needles

ANSONIA, CONN.



1921 isn't so far away. That's why we stress the 1921 Columbia Calendar. It's an elaboration on the 1920 issue and an attractive proposition to the dealer. Ask us about it now—the edition is limited.

Columbia Graphophone Co. NEW YORK

FAMOUS ARTISTS IN WOONSOCKET

Record Makers Delight Large Audiences With Elaborate and Interesting Program

WOONSOCKET, R. I., July 5.—The appearance here last month of the Eight Famous Record Artists under the auspices of La Roe's Music Store, Victor dealers, was a notable event in musical circles. These well known artists, Albert Campbell, Henry Burr, John Meyers, Frank Croxton, Monroe Silver, Fred Van Eps, Billy Murray and Frank Banta, rendered an extensive program at the Park Theatre. La Roe's Music Store received many compliments for the way the affair was handled and the record sales of the numbers recorded by these artists was very large. A special program was printed and distributed to the guests. This program contained on the back cover a list of records by each of the artists and stated that these could be obtained at La Roe's, which is an exclusive Victor store.

FACTORY OUTPUT INCREASES

Beacon Phonograph Co. Making Large Shipments to Trade Throughout Country

BOSTON, MASS., July 6.—During the past two months the production at the factory of the Beacon Phonograph Co. has increased rapidly. A. R. MacDonald, president of the company, who was formerly connected with one of the largest production engineering organizations in the country, has spent most of his time at the factory, where changes have been made which have resulted in a tremendous increase of production. Additional new machinery has been installed, and other factory space has practically been obtained which will enable the company to fulfill its promises to Beacon dealers and make prompt shipments on all orders received.

At the present time large shipments are being made to the dealers throughout the East and Middle West. All the territory East of the Mississippi is now closed for distributing represen-

tation, and all goods are shipped from the ten distributing points located in this territory. It is planned by Fall to open up the Far West and also develop the export trade which the Beacon Co. has heretofore been unable to handle because of the requirements of domestic dealers.

PATHE DEALER HOLDS CONCERT

Mt. MORRIS, N. Y., July 5.—A. H. Jenks & Son, progressive Pathé phonograph dealers of this locality, arranged a very attractive concert recently which was well attended and proved a decided success. Alonzo Jenks, manager of the phonograph department, was formerly a professional musician, and his "Jenks Ensemble" is now giving a series of concerts in the western part of the State. He is director of the Genesee Valley Band of thirty-five players and also of the Livingston county orchestra. The program recently rendered at Mt. Morris consisted of nine numbers, including gems from eminent composers of Pathé records.

Sell what the people want to hear

THE writer of this ad recently asked a saleswoman in a New York phonograph shop what class of music sold better than anything else.

The girl's eyes got big and round as she replied in a stage whisper, "HITS!"

It was the same all along the line. "People want lively stuff — HITS," said one salesman. Another replied, "We sell mostly popular music—it's what everybody wants."

Just then a woman came in and asked for "Jingo" and "Washington Square."

It is easy to see why Emerson Records

are so popular with dealers in the Metropolitan territory.

Eight out of every ten customers ask for song hits and dance hits. No wonder Emerson dealers are wearing the smile that won't come off. Here are two Emersons that are going big right now:

10192 So Long, Oolong, How Long You Gonna Be Gone? Fox Trot Green Brothers Novelty Band

Yokohama Japanese Fox Trot Knickerbocker Specialty Orchestra

10194 Jean Fox Trot All Star Trio

Wild Flower Waltz All Star Trio

Emerson Record Sales Company, Inc. EXCLUSIVE METROPOLITAN DISTRIBUTORS 6 West 48th Street, New York City



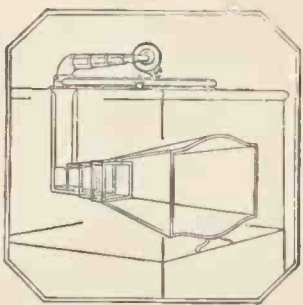

The playing of The Cheney reveals an unsuspected wealth of harmony because of new principles of design. All music finds full and true expression in its mellow tones.

Visitors to the Furniture Market at Grand Rapids will find more than usual interest in the showing at The Cheney display rooms, 423 Monroe Avenue, N. W.

In addition to our regular upright and console models, especially designed art cabinets will be displayed. These creations offer a combined beauty of tone and cabinet work which will win the admiration and approval of dealers and public throughout the display, from June 28th to July 24th.

A cordial invitation is extended all who attend the Market to call upon us for a demonstration.

CHENEY TALKING MACHINE COMPANY CHICAGO

The
CHENEY



You can't take it easy if you carry "Take it Easy" fox-trot by Art Hickman's Orchestra. And if you hear their "Come Back to Georgia" you'll want to buy your ticket for Dixie. This record will be heard this summer wherever there is dancing. A-2938.

Columbia Graphophone Co.
NEW YORK

MAURICE EDITS EMERSON RECORDS

World-famous Ballroom Dancer to Put Stamp of Approval on Emerson Records for Dancing

The Emerson Phonograph Co. announced recently that arrangements have been completed, whereby Maurice, the world's most famous ballroom dancer, will place his personal stamp of approval on the rhythm of all Emerson dance



Maurice and Hughes

records, thereby insuring Emerson dealers and their clientele perfect rhythm for Emerson fox-trots, one-steps and waltzes.

This announcement is particularly interesting in view of the fact that Maurice is internationally famous, having attained phenomenal success in Paris, London and New York. His fame has steadily increased and to-day he is acknowledged everywhere as the foremost exponent of modern ballroom dancing.

At the present time Maurice is appearing in London with Miss Leonora Hughes. They have scored a triumph with their act and in all probability will appear shortly in New York. Emerson dealers who have been advised of the contract closed with Maurice are planning to feature it extensively in their respective territories, realizing the fact that Maurice is very popular among all devotees of modern dancing.

WHAT IS A PEPTIMIST?

A peptimist is a man who sticks more than he straggles, tackles more than he talks, compiles more than he complains, works more than he worries, deserves more than he desires, and is rewarded in ways never guessed by a mere dollar counter.—The Peptimist.

ARE YOU PLANNING AHEAD?

Customers you now have will not always be with you. Some will move out of the community—some will die, while others will go to your competitors in spite of all you can do to hold them. What are you doing to recruit others to fill their places?

IMMORTALIZING THE ARTIST

Why Maud Powell, the Great Violiniste, Will Live Forever Through Her Victor Records

One of the pleasing signs of the times is the new conception among musicians of the value of the talking machine. It has demonstrated its worth as one of the greatest factors in developing musical taste and appreciation in history. In this connection, the following, which we clip from The Voice of the Victor, is as significant as it is interesting:

"Hardly yet do people realize the value of the Victrola in giving permanence to the interpretative artist. The composer at least has a written record of his musical dreams from which they can be rebuilt after his death; but when the singer dies, then also dies the song upon his lips unless the Victrola has managed 'to recapture the first fine careless rapture.' The fact that she made so many Victor records is one of the few consolations that help to lighten the loss to the world of music of Maud Powell. As an artist

she was intensely personal; all her moods, all the varied moods of the human heart, found expression through her violin. Every performance an artist gives is something of a creative act; something illumined by the vital spark of life itself. That is certainly true of Maud Powell's Victor records. In having them we not only retain something of her, but we have her in her most exalted moods."

HEIFETZ SCORES IN LONDON

Famous Victor Artist Not Only Duplicates but Enhances New York Success in London

Jascha Heifetz, the celebrated violinist, who has scored such a tremendous success in the United States, and who is made more familiar to the general public through his very excellent Victor records, has made a remarkable hit in London, England—in fact he has become quite a fad there and his various records are having sales of unparalleled magnitude among all classes.



Genuinely Interested in the
Dealer Who is Genuinely
Interested in Victor

Elyea Talking Machine Co.
Atlanta, Georgia

Exclusively Victor

Strictly Wholesale

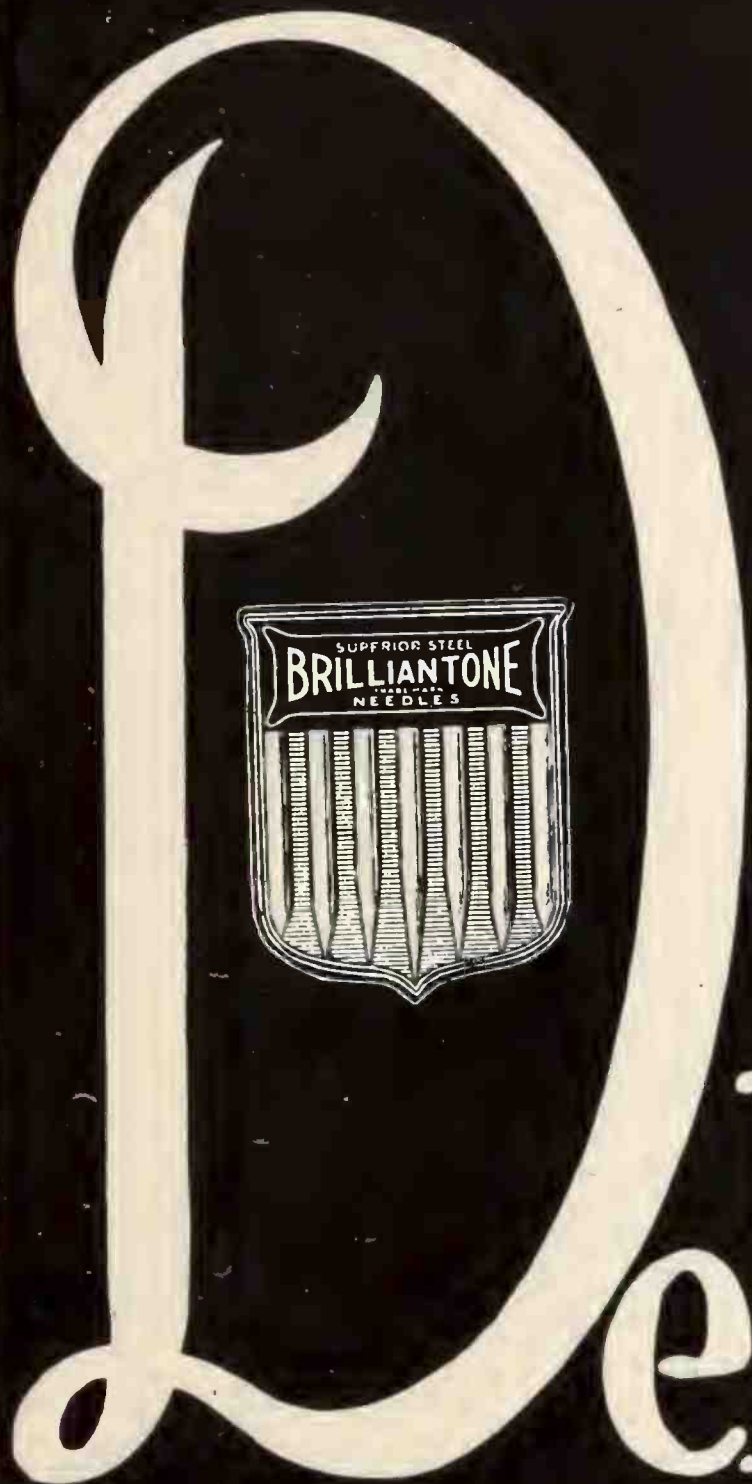

Many of our dealers have profited the past twelve months by timing their purchases according to our advice. We now suggest that it will be to your material interest to book your Fall requirements for

**BRILLIANTONE
STEEL NEEDLES**

now, and thereby not only get the benefit of present low prices, but also to assure yourself

**IMMEDIATE
Deliveries**

Write for samples and prices to your nearest distributor.
If he cannot supply you, write direct to us.

**BRILLIANTONE
STEEL NEEDLE CO. of America,
Incorporated**

**347 FIFTH AVENUE,
NEW YORK**

AT 34th STREET

SUITE 1003

CLOSE NEW PORTOPHONE ACCOUNTS

M. I. Mayer, President of the Tri-Sales Co., Returns From Canadian Trip—Business Active—To Introduce Line of Turn-table Toys

M. I. Mayer, president of the Tri-Sales Co., St. Louis, Mo., was a visitor to New York last week, after making an extensive trip through Canada. This company is a distributor for the Portophone machine and has developed a phenomenal demand for this instrument in its territory.

In a chat with The World Mr. Mayer stated that the Portophone was very well received in Canada and that important agency connections were established. The distinctive merits of the machine, together with its musical quality, won the approval of the Canadian dealers and an aggressive campaign in behalf of the instrument is now being launched in the leading trade centers in Canada.

Upon his arrival in New York Mr. Mayer received enthusiastic letters from G. H. Phelps,

treasurer and general manager of the Tri-Sales Co., who stated that the sale of the Portophone in the Middle West is steadily increasing. The company has an efficient sales staff visiting the trade throughout the West and agency connections have been established everywhere.

While in New York Mr. Mayer stated that the Tri-Sales Co. was practically ready to announce an addition to its line of products, constituting a set of turn-table toys, embodying many features. Plans have been made whereby the company will absorb the entire output of a large manufacturer in St. Louis, and judging from the comments of the New York trade, these toys will be accorded a hearty welcome by the dealers.

The Liberty Phono Motors Corp., Brooklyn, N. Y., has been incorporated under the laws of New York State to do a business in foundry and factory supplies. The new corporation starts business with a capital of \$12,000. The incorporators are C. F. Hahn, J. J. Braun and J. J. Braun, Jr, 1321 Gates avenue, Brooklyn.

YEAGER TAKES UP NEW DUTIES

Former Victor Man Joins Hunt's Leading Music House in White Plains as Director

WHITE PLAINS, N. Y., July 3.—Lawrence R. Yeager, who recently purchased the stock holdings of Deputy County Treasurer Leonard E. Teed in Hunt's Leading Music House, Inc., has been elected to the board of directors of the company and made secretary and treasurer. He has officially taken up his active duties as a member of the corporation. He will bring his family here some time this month.

Mr. Yeager was for several years on the traveling staff of the Victor Talking Machine Co., of Camden, N. J. In making his rounds of Victor dealers he became favorably impressed with the possibility of entering the music and Victrola business in White Plains.

GRAFONOLA POLISH INTRODUCED

Announcement Contained in Circular Sent Out by Dealer Service Department

The Dealer Service department of the Columbia Graphophone Co. has just issued a circular announcing a new Grafonola accessory, which will be known as Grafonola polish. The litera-



Grafonola Polish Counter Display

ture emphasizes the fact that a satisfactory polish is extremely important, as it furnishes a distinct service of real benefit to the dealers' customers.

The new Grafonola polish, which was tested and approved by the Columbia Co. before being offered to the dealers, is scientifically prepared to maintain the genuine lustre of finely finished surfaces. Each bottle bears the famous Columbia trade-mark, and Columbia dealers can undoubtedly feature this accessory to advantage.

Be a man with ideas—an information bureau—and keep your information always on tap.

Why Break Records?
Just File Them!

That is if you have the wonderful Record filing system which is a feature of

The Marvelous MAGNOLA



Watching the Music Come Out

This is only one feature of many that will command your interest and attention. Let us send you handsome illustrated catalog and information as to our plans for helping you to make money with MAGNOLA.

MAGNOLA TALKING MACHINE COMPANY

OTTO SCHULZ, President

General Offices 711 MILWAUKEE AVENUE CHICAGO
Southern Wholesale Branch 1530 CANDLER BLDG. ATLANTA, GA.

The New Model "E" Garford Phonograph

The Greatest Value on the Market

IMMEDIATE DELIVERIES IN ANY QUANTITY

High
in
Quality
Low
in
Price



High
in
Quality
Low
in
Price

New Model "E" Garford Phonograph

The New Model "E" Garford Phonograph has every desirable feature of the high price phonograph

- 1 Plays all makes of records without an attachment.
- 2 Superior Tone Quality.
- 3 Standard Motor of Recognized Merit.
- 4 Artistic Appearance.
- 5 Guaranteed to Give Excellent Service.

Order Now for Immediate Delivery

SELLS LIKE "WILD-FIRE" THE YEAR ROUND

We have an Attractive Dealer Proposition

The General Phonograph Mfg. Co.

(FORMERLY NAMED THE GARFORD MFG. CO.)

ELYRIA, OHIO

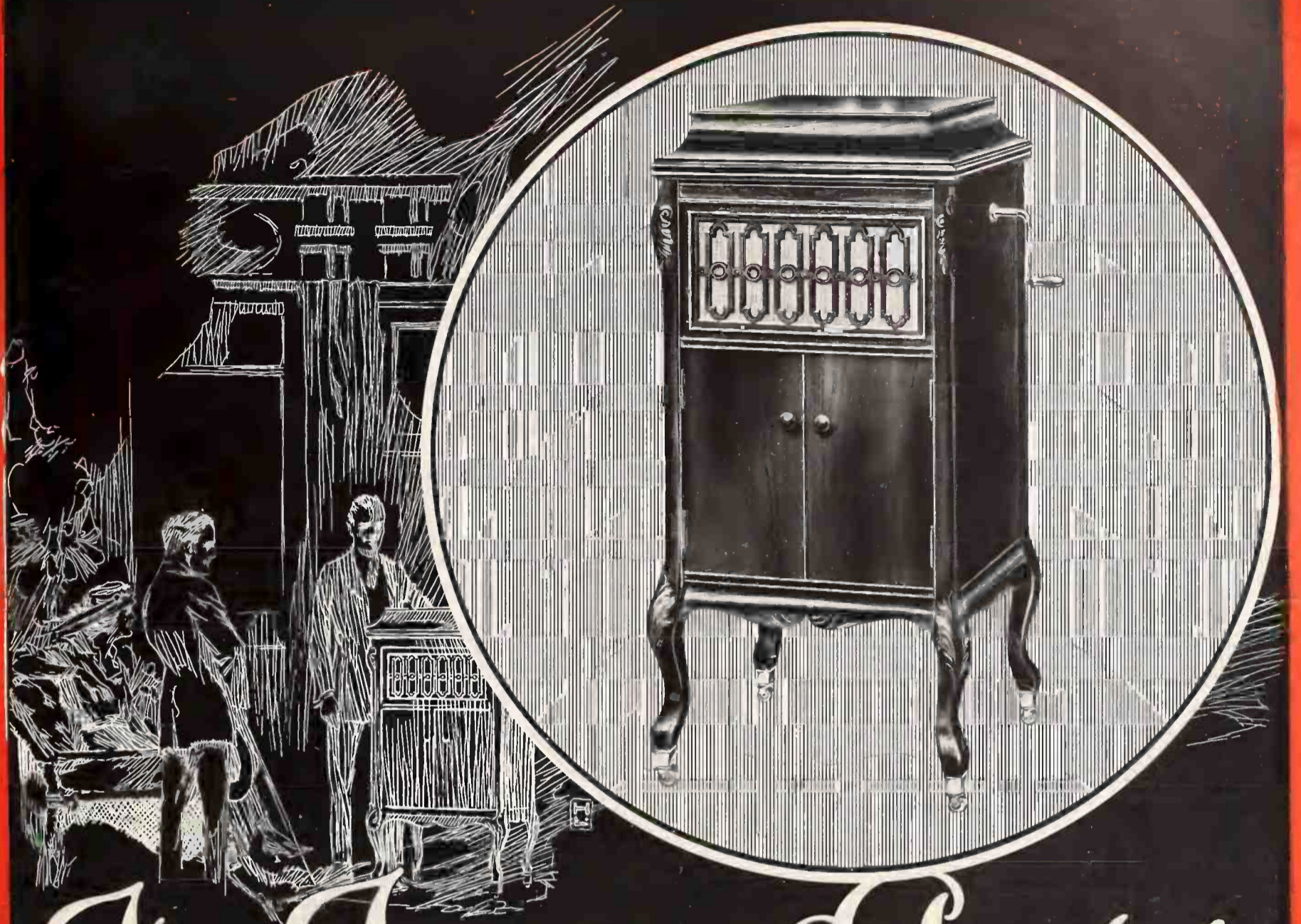

The Tone of Pathe

IS ITS BEST SALESMAN

IN TONE as in every other essential to the phonograph—*Pathe is supreme.* Pathe Phonographs and records give an absolute duplication of the artist's original interpretation.

Pathe TONE is the difference between metal and life.

Pathe TONE is the difference between the strident harshness of steel needles and the gliding smoothness of a rounded, jewel-polished sapphire!

To the experienced or inexperienced prospective customer but little dealer demonstration is necessary to prove the superior qualities of the Pathe over other phonographs or talking machines.

The Pathe is almost a self selling proposition for the dealer!

Pathe Records played on the Pathe Phonograph compose a combination unsurpassed.

Pathe
REG. U.S. PAT. OFF.



Costs no more
than the ordinary
PHONOGRAPH



PATHE RECORDS SPIN PROFITS

THEY are the weavers who are "making a turn" for the benefit of the Phonograph Dealer. Every turn table on every Phonograph is the place for you to put Pathe Records at a profit—we say Pathe Records, we mean Pathe Records—

BECAUSE:

Every day the demand for Pathe Records increases. Every day more people recognize the exquisite tone quality of Pathe Records.

Every day more people discover that Pathe is first with the hits that make Broadway famous.

Every day people find out that they get the widest possible choice in Pathe Records—everything in music—operatic, orchestral, band and vocal—from the classical favorites and the "songs that never grow old" to the raggy, jazzy popular melodies of the day.

Because of Pathe National Advertising which is effectively telling the public about Pathe Records day by day, week by week, month by month. And every time 24 hours go by, ten times that many people right in your neighborhood have discovered that Pathe Records give them the music they want—and surpassing tone.

Pathe
REG. U.S. PAT. OFF. 



THE IMMIGRANT AND HIS MUSIC

Pathé Foreign Records

EVERY population center in this country has its foreign language colony. The American catalogue means nothing to those people—yet. They want their own music from their own country—and they can afford to pay for it.

They can get it—and get more of it—from the Pathe catalogue than from any other source, because the Pathe repertoire is the largest in the world. It puts the Pathe dealer here in a class by himself—beyond any possible serious competition in the foreign language and music field.

The Pathe message reaches these people regularly and all the time in their own newspapers. We are using every foreign language paper of standing in the country. We have blazed the trail for you to this business—it is up to you to make sure of it.

It's doubly worth while: first because of the immediate dollars and cents that are in it: and also because it will lay the foundation for the American record business that will follow as these people become Americanized.



Pathé
REG. U.S. PAT. OFF.

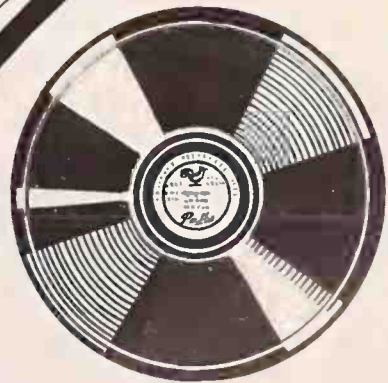



PATHÉ DISTRIBUTORS

ARMSTRONG FURNITURE CO.
59 N. Main St., MEMPHIS, TENN.

BRISTOL & BARBER
3 East 11th St., NEW YORK

BUFFALO WHOLESALE HARDWARE CO.
317 Washington St., BUFFALO, N. Y.

BURNHAM, STOEPEL & CO.
19 E. Larned Street, DETROIT, MICH.

CHURCHILL DRUG CO., BURLINGTON, IA.

CHURCHILL DRUG CO., CEDAR RAPIDS, IA.

CHURCHILL DRUG CO., PEORIA, ILL.

COMMONWEALTH PHONOGRAPH CO.
19 and 21 Lyman St., SPRINGFIELD, MASS.

THE FISCHER COMPANY
943 Chestnut Ave., CLEVELAND, O.

THE FISCHER COMPANY
41-46 Vine Street, CINCINNATI, O.

FULLER-MORRISON CO.
510 W. Randolph St., CHICAGO, ILL.

JOHN A. FUTCH CO.
35 Auburn Ave., ATLANTA, GA.

JOHN A. FUTCH CO.
1500 S. Boulevard, CHARLOTTE, N. C.

JOHN A. FUTCH CO.
630 Washington St., JACKSONVILLE, FLA.

GRAY & DUDLEY CO., NASHVILLE, TENN.

HALLET & DAVIS PIANO CO.
146 Boylston St., BOSTON, MASS.

HARBOUR-LONGMIRE PHONOGRAPH CO.
1001 Elm St., DALLAS, TEXAS

HARBOUR-LONGMIRE PHONOGRAPH CO.
311 W. Main St., OKLAHOMA CITY, OKLA.

INTERSTATE PHONOGRAPH CO.
1026 Chestnut St., PHILADELPHIA, PA.

W. W. KIMBALL CO.
Jackson and Wabash Aves., CHICAGO, ILL.

F. P. MAY HARDWARE CO.
469 C Street, WASHINGTON, D. C.

MOONEY, MUELLER & WARD COMPANY
101 S. Meridian St., INDIANAPOLIS, IND.

MORLEY MURPHY HARDWARE COMPANY
GREEN BAY, WIS.

PATHE CITY SALES
18 East 42nd Street, NEW YORK CITY, N. Y.

PITTSBURGH TALKING MACHINE CO.
963 Liberty Ave., PITTSBURGH, PA.

RICE-STIX DRY GOODS CO., ST. LOUIS, MO.

RICE-STIX DRY GOODS CO.
NEW ORLEANS, LA.

ROCHESTER PHONOGRAPH CO., Inc.
11 Clinton Ave., North, ROCHESTER, N. Y.

SALT LAKE HARDWARE CO.
SALT LAKE CITY, UTAH

M. SELLER & CO.
Fifth and Pine Streets, PORTLAND, OREGON

M. SELLER & CO., SPOKANE, WASHINGTON

G. SOMMERS & CO.
Park Square, ST. PAUL, MINN.

WM. VOLKER & CO., DENVER, COLORADO

WM. VOLKER & CO., HOUSTON, TEXAS

WM. VOLKER & CO.
Main, 2d and 3d Sts., KANSAS CITY, MO.

WEAVER PIANO COMPANY, YORK, PA.

WESTERN PHONOGRAPH CO.
820 S. Broadway, LOS ANGELES, CAL.

WESTERN PHONOGRAPH CO.
985 Market St., SAN FRANCISCO, CAL.

WRIGHT & WILHELMY CO.
Tenth and Jackson Sts., OMAHA, NEB.

PATHÉ FRÈRES PHONOGRAPH CO.

EUGENE A. WIDMANN, President

10-56 GRAND AVENUE BROOKLYN, N. Y., U. S. A.

London, England

The Pathé Frères Phonograph Co. of Canada, Ltd., Toronto





No. 100 Sound Box
with No. 100 Tonearm
Tension Spring with
Exterior Adjustment

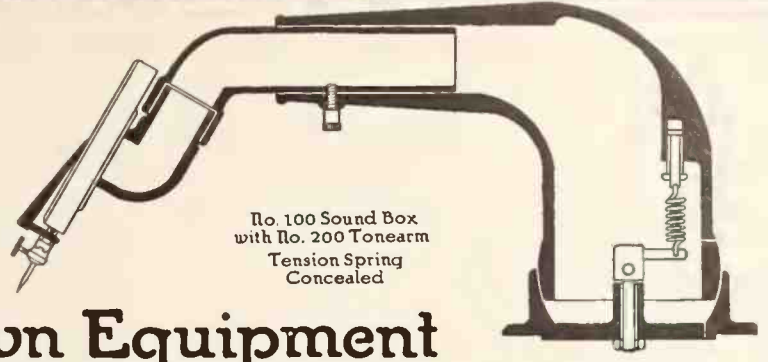

No. 100 Sound Box
with No. 200 Tonearm
Tension Spring
Concealed

Assemble Your Own Equipment

WE OWN the Dies for producing the Die Cast parts of the above Sound Box and Tonearm designs, and furnish Die Castings to large users at no expense for Dies

SPECIAL Connections can be produced for adapting any make of Sound Box to these Tonearms. Prices on application. Samples sent prepaid upon deposit of \$1.50

Die Casting
Department

Barnhart Brothers & Spindler

Monroe & Throop Streets
CHICAGO

TIMELY SUGGESTIONS FOR SELLING CUT-OUT RECORDS

Selling Discussion at Recent Meeting of the Pittsburgh Talking Machine Dealers' Association Prolific of Some Interesting Schemes for Disposing of Cut-out Records

During a record selling discussion at a meeting of the Pittsburgh Talking Machine Dealers' Association last month, a number of very excellent schemes were suggested for selling cut-out records which dealers in that city and vicinity had tried out and found successful. These schemes have been collated and sent out by the Standard Talking Machine Co. of Pittsburgh to dealers for their use. They are not visionary suggestions, but rather practices of different members of the Association who have found them available and which should be equally successful in developing sales in talking machine stores generally. These suggestions follow:

* * *

By placing white or colored tape on the outside edge of the green stock record envelope of all cut-out records in stock, a salesman can pick out such records at a glance when in search of records to push.

* * *

Nearly all dealers find that self-service racks create record sales. When cut-outs are mixed with quicker selling numbers on the self-service displays, customers will often select cut-out records they would not listen to if recommended by a salesman.

* * *

If albums are filled with records you wish to push, with a brief typewritten description pasted on each pocket and placed in booths and on counters, customers will browse through them while waiting and make purchases from them.

* * *

Classify your cut-outs in every way possible. In making up lists for booths, window, for a circular, or for salesmen, divide your selections under such heads as dances, violin numbers,

band selections, male quartets, humorous, and the like. Display the records themselves in groups of similar classifications. A dance fan cannot resist thumbing through a record display labeled "Delightful Dances."

* * *

When a customer hurries in and turns to hurry out when you say "No we haven't that," stop him and say, "Let me have your address and I'll notify you when we get that record." Within a few days he will be pleased by a polite note stating that the record has not arrived but that you have the following similar numbers, which you will be very glad, etc., etc. You are thus adding to your live mailing list and demonstrating your good service. The S. Hamilton Co. sent out 106 such cards and received returns.

* * *

Many customers bring in lists of selections they wish to hear. Intersperse such of these as

OGDEN SALES SYSTEM GUIDE

Featured in Spanish Edition of "The Voice of the Victor"—J. B. Ogden Visits New York

LYNCHBURG, VA., July 2.—Much space was accorded a description of the Ogden Sectional Cabinet Co., of this city, in a recent number of the Spanish edition of "The Voice of the Victor," which is published for and circulates throughout the Latin American countries. The various models of record files for the dealer were illustrated as well as the Ogden Sales System Guide, which is a combination numbered index made to fit these cabinets which serves as a sales record and locates immediately all record files, and eliminates the use

of stock envelopes. The entire system with its many advantages is printed in Spanish.

A postal card, announcing to patrons that you have just received a limited supply of Werrenrath's "Neapolitan Love Song," which will never again be available when these few records are gone, has produced surprising returns for some dealers.

* * *

It will pay you well to make an arrangement with a good card writer and have frequent lists, well lettered, for your window, booths and store. Change them often. Classify your selections. Keep them new and fresh. The sales will amply justify the small expense.

* * *

The Standard Talking Machine Co. also enclosed in its letter a list of its cut-out stock, urging that the recipient check his cut-out stock against this list at once and return copy as an order. In this way it was believed that mutual benefit would accrue.

J. B. Ogden, president of the company, was a visitor in New York recently on his return from a trip which he made to Connecticut. Mr. Ogden reports that his factory is very busy and increasing numbers of dealers are adding his record filing equipment in anticipation of the big business ahead.

COOK BROS. CLOSE MUSIC STORE

The music business formerly conducted in Holland, Mich., by Cook Bros. was discontinued on July 1. This house has been in business in Michigan for more than twenty years and has a large clientele.

THE PHONOSTOP—No Machine Is Complete Without It

- ☐ This stop is now tested and adjusted in actual use at our factory before shipping, and is *guaranteed to do the work. It stops on the line.*
- ☐ More PHONOSTOPS in use than all other makes put together.
- ☐ Adjustability is one of our features, and it is an exclusive one.

Made Right Stays Right Acts Right

Order early—we will ship

Immediate Delivery up to 10,000.

THE PHONOMOTOR CO. - 121 WEST AVENUE ROCHESTER, N. Y.

CHICAGO REPRESENTATIVE: Henry Engel, McClurg Building

500,000
IS OUR 1920
OUTPUT
FIGURE

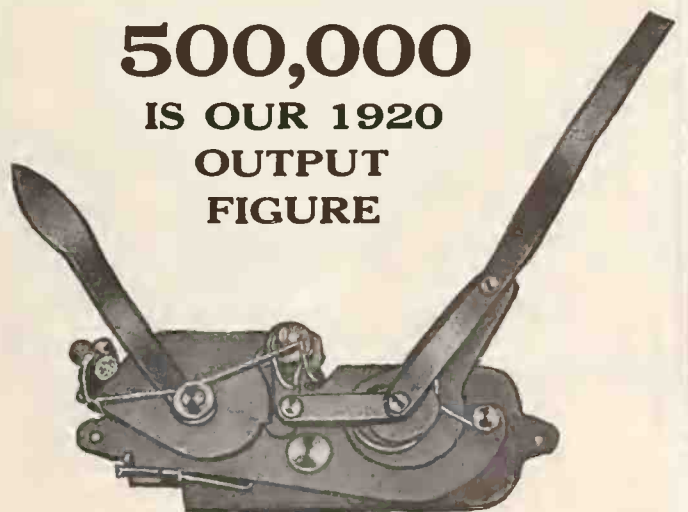

VATICAN CHOIRS TO RECORD FOR BRUNSWICK RECORDS

Contract Put Through by Brunswick Officials and James Slevin Sails for Europe to Bring Famous Organization Back—First Time in History that Such Music Is to Be Recorded

One of the most important additions to the realm of record music will soon be released from the Brunswick recording laboratories, when the remarkable music of the Vatican Choirs of Rome recorded for the music lovers of the world will be announced. This famous organization which visited this country last year and won instant and enthusiastic approval among music critics throughout the land, will record exclusively for Brunswick records. The contract was closed by Percy L. Deutsch, one of the directors of the Brunswick-Balke-Collender Co., and William A. Brophy, general manager of the recording laboratories at a conference with James Slevin, the well-known impresario, who sailed on July 19 for Europe to bring back the famous Vatican Choirs with him.

Mr. Slevin takes with him to Rome the official requests of the leading Roman Catholic prelates in the United States, urging the Vatican Choirs to return to this country and record their music and make a tour of the entire country. Last year, at the close of their tour, Monsignor Casimir Casimiri, leader of the choir, expressed a willingness to return to the United States at some future time. Pope Benedict XV gave his permission and the arrangements were concluded by Mr. Slevin through the International Concert Bureau, directed by Milton Diamond.

The acquisition of the Vatican Choirs contract by the Brunswick Co. marks an important step in the extensive program laid out by Mr. Brophy and his department for their high-class record catalog. In discussing the move with The World, Mr. Brophy said that he was highly gratified that the negotiations had been successfully carried through and he expected to have some remarkable recordings ready soon after the choirs arrive. The new recording rooms of the laboratories are now nearly finished and within a few weeks will be ready for the strenuous demands which will be put upon them.

Just before he sailed on the "Patricia" Mr. Slevin was asked for his opinion on the possibilities of the talking machine in spreading

abroad the gospel of music, especially of such music as is furnished by the choirs from the Vatican and the Roman Basilicas. He replied: "To afford the greatest possible opportunity to stimulate that interest universally it is felt that the talking machine offers opportunities unequalled in any other direction and it was particularly gratifying to Rome that this great enterprise is to be undertaken by an American concern. It is conceded that to undertake to record the voices of so large a personnel is an innovation without precedent. At the same time confidence in Yankee ingenuity prevailed.

"As relates to the concert tour incidental to this undertaking it will be remembered that last year's tour was cut short by the recall of the singers to Rome to conduct the ritual of important holidays, with the result that many communities that were eager to hear the Vatican singers and which had made elaborate arrangements to that end were deprived of the privilege. There is a disposition in Rome to consider the disappointment of those centers and to go to great lengths to permit of the fulfillment of deferred engagements in order that the Papal choirs may be heard in person. My visit will be largely in the interests of that aim—to crystallize the generous sentiment that prompts the Roman Basilicas to contemplate the absence of their most cherished ritualistic feature in order that these neglected American communities may not be longer slighted. I have reason to hope that arrangements can be reached to embrace every city so situated."

OPEN NEW YORK HEADQUARTERS

Remington Phonograph Corp. Establishes Ware-rooms and Offices on Broadway

The Remington Phonograph Corp. has opened new warerooms and executive offices at 1662-1666 Broadway, New York, where adequate quarters have been provided for a display of the company's products and the reception of the visiting trade, who are invited to make the new offices

NYOIL
FOR YOUR PHONOGRAPH

Made in Our Watch Oil DEPARTMENT

which for half a century has made 80% of all the watch, clock and chronometer oil used in America.

The Best Oil For Any Talking Machine

In refining, Nyoil is given the same care as our famous watch oil receives. All gums and impurities are removed, leaving it

Colorless, Odorless and Stainless.

Housekeepers say they would not be without Nyoil because it is best for phonographs and sewing machines—for polishing furniture and woodwork and is odorless and will not stain. It is free from acid and will not gum, chill or become rancid. Sportsmen find it best for guns because it prevents rust.

NYOIL is put up in 1-oz., 3¼-oz. and 8-oz. Bottles and in Quart and Gallon Cans.

For Sale by all Talking Machine Supplies Dealers
WILLIAM F. NYE, New Bedford, Mass., U.S.A.

their headquarters while in the city. James S. Holmes, vice-president and general manager of the company, is in charge of these very attractive quarters.

DOEHLER CO. SECURES INJUNCTION

An injunction has been granted the Doehler Die Casting Co., of Brooklyn, N. Y., against August G. Gutmueller, a former employe, and the Accurate Brass Casting Co., which he organized after leaving the Doehler Co. In the complaint made by the Doehler Die Casting Co. it is alleged that Gutmueller, after working his way from chauffeur to head of the brass casting department, left the company's employ, taking with him certain secret processes of manufacturing. Since then, it is stated, the Doehler Die Casting Co. has found castings marketed and bearing the very earmarks of Doehler castings. A motion for the continuation of the injunction is to be made.

REED DISPLAY FIXTURES

Make every inch of your store, booth or window space produce more business. There is a Reed Display for your every need.

Illustrated herein are but a few of the large variety of Displayors we carry in stock at all times. Write for circular showing our complete line.

Discount for 30 days for styles now in stock 40% F. O. B. Pittsburgh.

"UNIVERSAL FIXTURES"

No. in Stock	Style	No. in Stock	Style	No. in Stock	Style	No. in Stock	Style
37	550	16	513	3	563	34	514
12	528	4	513-L	51	556	28	500-A
16	557	17	503	38	558	3	527-S
15	518	14	502	6	519	35	504
36	507	29	506	38	508	3	559
18	500	19	505	31	501	11	551
						27	552

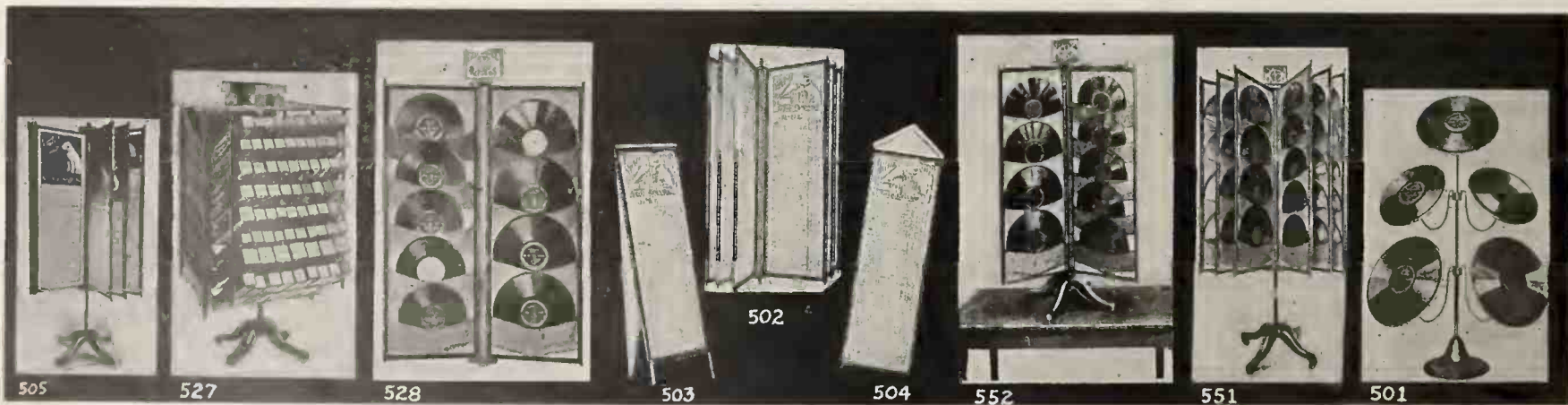

5748-50 Ellsworth Avenue

THE REED COMPANY INC.

Pittsburgh, Penna.

Something New, Something Different,

which may
account for
its already
very big
success



*Only
Four Months
Old-yet the
fastest selling
polish on the
market*



Send Coupon for Samples and Prices
of Reflexo Needles and Polish

REFLEXO PRODUCTS CO., Inc.

347 Fifth Avenue

Suite 1003

At 34th Street

New York City

REFLEXO
PRODUCTS
CO., Inc.

347 Fifth Avenue
New York City

Send us samples
and prices of
Reflexo Needles and
Reflexo Polish

Canadian Distributors:
The Musical Mdse. Sales Co., Toronto

Foreign Export :
Chipman, Ltd., 8-10 Bridge St.
New York City

Clip This Coupon and Mail To-day

Dealer's Name.....

Address.....

Your Local Distributor's Name.....

Address.....

Stratford
The Shakespeare of Phonographs

NOTED FOR:

Tone
Quality
Distinction
Service



Stratford
Queen Anne

MODELS:

Adam
Louis XVI
Sheraton
Queen Anne

Stratford
The Shakespeare of Phonographs

World's Finest Reproducing Instrument

AS Shakespeare, born at Stratford-on-Avon, Warwickshire, England, was the world's greatest poet, so is the Stratford the world's greatest phonograph, says one of America's great Bachelors of Music.

Tone of the Stratford has richness, depth, purity and beauty that has brought the musical world to a new appreciation of the phonograph.

Stratford Phonographs give a perfect reproduction of either Lateral or Hillandale cut records without any change of parts.

In design, motor, method of amplification, workmanship, choice of woods, finish and tonal quality the Stratford is announced by critics, musicians and dealers as the world's finest reproducing instrument.

Quality representation solicited. Artistic catalogues, window display cards and newspaper mats furnished to Stratford dealers

The Stratford Phonograph Co., Inc.

Factories
Ashland, Ohio
General Offices

THE MISTAKE MADE IN PLAYING UP THE "TRIAL ORDER"

Ray Giles Offers Some Interesting Information Regarding the Working Out of the "Trial Order" Plan in a Recent Issue of Printers' Ink—A Trade Illustration That Is Worth Noting

Many manufacturers in various lines of industry have become convinced that the building up of new business on the "trial order" basis is a game that is seldom worth the candle, and have taken a strong step to discourage the practice on the part of their salesmen, while at the same time making an energetic drive for exclusive representation.

The main objection to the practice is that it enables the buyer to get rid of the salesman by giving him a trial order and then declaring that the goods are not up to standard, or do not meet his requirements. Being placed in the store on a trial basis, the buyer, or manager, is not inclined to devote any great attention to featuring the product in competition with other goods of the same sort for which he has paid, and which he must sell to make the proper showing for his department.

In an article in a recent issue of Printers' Ink, Ray Giles offers some interesting information regarding the working out of the trial order plan and cites an instance of particular interest to the talking machine man, an instance that should make a distinct impression. He says, in part:

"Out of experiences with salesmen and selling methods there stand some striking examples of mistakes made in playing up the 'trial order,' and perhaps, as the branch manager declared, the average trial order is about as respectable as a 'trial marriage.'

"Over and over the attitude of the dealer or buyer has proved wrong toward the trial order. The word 'trial' fastens itself in his mind more strongly than any single virtue which the salesman has claimed for the goods. The dealer is not really sold on the merits of the merchandise—it is made plain to him that he is simply 'trying them out.' Didn't the salesman admit as much? The result is that the user is looking for defects quite as expectantly as he looks for virtues, and he finds that it is quite as easy to discover the former as the latter. In other words, he gets what he looks for.

"A dealer in musical instruments placed side by side on his floors three makes of phonographs. One day the salesman for one of the phonograph houses dropped in, and had brought home to him for the first time the evils that sometimes attend the trial order. As he recalls it, the confession made by the dealer was something like this:

"From now on I am going to sell only your machine. I have come to the conclusion that there is too much matching up of models and

tone and features all through this shop, and that it doesn't do either me or my sales force any good. I think the trouble all started with you fellows, who sold me your machines just hard enough to get me to put in a partial stock of them. When I got the three on the floor I was naturally fairly warm on all of them, but not completely sold on any one. I can't put my attitude in a chart or analyze it down to a fine point, but I know that it hurt my business, and this same attitude I passed on to the boys on

OPTIMISTIC REGARDING BUSINESS

A. L. Crane, of the Western Jobbing & Trading Co., Los Angeles, Tells of General Conditions and Prospects in Visit to New York

A recent visitor to the executive offices of the Emerson Phonograph Co., New York, was A. L. Crane, of the Western Jobbing & Trading Co., Los Angeles, Cal., distributors of Emerson records, who spent some time with Joseph I. Carroll, manager of sales of the company, and Harvey Morrison, his assistant.

Discussing general conditions, Mr. Crane was optimistic regarding present business and the outlook for the future. He was particularly anxious to see the new Emerson phonograph, admitting frankly that he expected to see something very fine. After a thorough investigation of the new instrument, he expressed his keen enthusiasm regarding every musical and sales feature. Mr. Crane stated that when he returned to California he would start an energetic campaign in behalf of the Emerson Phonograph Co., for he was "sold" to the last degree on the line, and would convey this enthusiasm to J. W. Booth, manager of his company.

In the course of his conversation, Mr. Crane commented on the loyalty of his organization towards the Emerson product, referring to the splendid sales totals already achieved in his territory, and the extensive plans in preparation.

A considerable part of his time in New York was spent by Mr. Crane in a detailed examination of Emerson cabinet work and the "Music Master" horn. Mr. Crane is a specialist on furniture and cabinet construction, and is just completing an eight months' investigation which carried him to practically every furniture and cabinet plant in the United States. His hearty approval, therefore, of the Emerson phonograph, particularly its cabinet work, constituted a tribute of unusual importance.

the floor by my even praise for all three instruments. Then they passed it on to the customer, and the result has often been that the customer got warmed up on all three makes and then left without buying, saying that he wanted to think it over before deciding which he preferred.

"I am still of the opinion that each of the three has its good features, but lately I have thought it out to a point where I believe that yours has something of a bulge on the others, and from now on we are going to sell your phonographs instead of comparing them with a couple of other makes. Sales forces and floor space come too high these days for me to be able to afford to use my store and sales people for exhibition purposes."

CHANGES IN COLUMBIA SALES STAFF

Important Announcement Regarding Changes in Sales Staff of the Organization

Geo. W. Hopkins, general sales manager of the Columbia Graphophone Co., New York, sent out to the Columbia sales organization this week an important announcement in connection with changes in the sales staff.

Effective July 1, N. F. Milnor, manager of the San Francisco branch, resigns on account of ill health.

N. J. Wilcox, formerly manager of the Philadelphia branch, has been appointed manager of the San Francisco branch, effective July 1.

Pearson C. Cummin has been appointed manager of the Philadelphia branch. Mr. Cummin has had extensive experience in the sales field, having been connected with the National Cash Register Co., and more recently with the Smith, Kline & French Co., Philadelphia.

Robert E. Rae, of the Columbia executive offices, has been appointed manager of the new Columbia branch at Omaha, Neb. This new branch will be one of the most up-to-date wholesale establishments in the West, and under Mr. Rae's direction, will undoubtedly achieve pleasing success.

H. L. Pratt succeeds Mr. Rae in the executive offices. Mr. Pratt is well qualified for his new post, having been associated recently with the Roger W. Babson Co.

NEW DETROIT PATHE DISTRIBUTORS

Burnham, Stoepel & Co., with headquarters at 19 East Larned street, Detroit, Mich., have succeeded Williams, Davis, Brooks & Hinchman's Sons as Pathé distributors in that city. The change took place on June 22. C. H. Chambers will have charge of the Pathé work of the new distributors.



BOOST!



THE ECLIPSE MUSICAL CO.

Victor Wholesaler

Cleveland, Ohio

Edison Message No. 73

In our opinion it will be many years before the general price level is as low as the present prices of Edison Phonographs.

The increase since 1914 has been less than 15 per cent—and this includes the War Tax.

“Edison Stood the Gaff”

THOMAS A. EDISON, Inc.
ORANGE, N. J.

Enthusiasm One of the Greatest Factors in Successful Salesmanship :: :: By Charles L. Smith

There is perhaps no single factor of greater value in closing talking machine sales these days than enthusiasm. This refers to the usual sale where a machine is chosen for the home where it will be a permanent part of the furnishings and is chosen on its merits as a musical instrument. In the selling of the small portable type of machine which is used in most cases just for the Summer at camp or seashore the finer points of salesmanship are not observed quite so closely because the customer does not demand it.

It is, of course, assumed that the salesman knows the fine points of the particular instrument he is selling, for his enthusiasm must in large measure be based on his belief in the superiority of his instrument over all others. He must also know all the good points of his competitors' machines and he must be able to prove that his machine is superior on these very points, not by knocking the rival machine but by showing through his knowledge just where his own product has the advantage.

Knocking the other fellow's goods has long been condemned in every line of selling but it still persists in some circles because there are salesmen who, not looking into the future, think that the present moment is all that counts and that anything they can say against the other talking machine will redound to their own advantage. These salesmen fail to remember that all the time they are knocking the other fellow they are keeping the customer's mind fixed on the other fellow's product while the one which is to be sold is kept in the background.

Forget the other machine for a moment. Act as if your talking machine was the only one in existence. Then turn on your enthusiasm. Any talking machine is a wonderful thing when you stop to consider just what it is and does. It is a musical marvel, especially at the present time when the union of science and art has brought about so many refinements and improvements. Look back a few years and compare the machine of that day with the present instrument. Surely the picture is enough to arouse enthusiasm in any music lover.

This thought alone will create enthusiasm in the prospect if dwelt upon in the proper way. The salesman should be full of this, his subject. He should be fairly bubbling over with enthusiasm. Enthusiasm is contagious. There is nothing which will spread more quickly from one person to another. Battles have been won by enthusiasm. And in the prospect the enthusiasm can be aroused by picturing the joys that a real talking machine will bring into the home. Once you have convinced him of these facts he will always associate these advantages with your own instrument. You have made a permanent convert and a permanent advertisement and booster for your line.

There is a certain salesman in a large New York talking machine store who has won great success and whose biggest asset is enthusiasm. He is, first of all, a real talking machine man, for he has served his apprenticeship and knows the intimate details of construction from every angle. He has studied selling in many cities and has learned from the experiences of many. While many salesmen would be content with having reached that stage of the game, believing that anyone with such accurate technical knowledge would be the most successful salesman in

the world, this New York salesman looks further. He does not rely entirely upon his knowledge of construction. His one best bet is enthusiasm. When he unlimbers his heavy artillery he fairly sweeps his customers off their feet by his enthusiasm. He convinces them of his sincerity, of his belief in the talking machine he is selling. He does it in such a way that he cannot possibly offend the customer and his argument is all the stronger because he arouses the enthusiasm which makes the prospect convince himself. His sincerity is so evident that the customer cannot fail to believe in it. This sincerity is, after all, the basis of enthusiasm.

Any talking machine salesman can acquire this enthusiasm in selling if he studies the game hard enough. He will not learn by warming a chair in the warerooms, but he must study the talk-

ing machine problem. He must profit by the experience of others who have gone before him. Once he has started he should find it such an interesting study that he will want to follow it to the end. If the salesman fails to find any absorbing interest in his work he should get out of the game and try his hand at some other line of effort. He can never succeed at anything in which he has not whole-hearted interest. He must work to arouse enthusiasm in his own self. After that the task of communicating it to others will be easy.

Duncanson Bros., of Lynchburg, O., have opened a branch store in Hillsboro in the Bell Opera House block. A general line of musical goods, including talking machines, will be carried by this establishment.



The same organization that builds Bush & Lane Pianos and Cecilian Player-Pianos makes Bush & Lane Phonographs.

The same men and the same resources that have made the name of Bush & Lane dominant in the field of pianos and players, are back of Bush & Lane Phonographs.

Phonograph dealers can find no better guarantee than this, either on the phonograph itself, or on the organization back of it. Decades of success have proved that buyers may safely trust any instrument that bears the name of Bush & Lane.

Dealers who associate themselves with this famous name, gain not only in prestige, but in the support they secure from a great manufacturing organization that works sincerely for the best interests of its distributors.

Bush & Lane Piano Co., Holland, Mich.

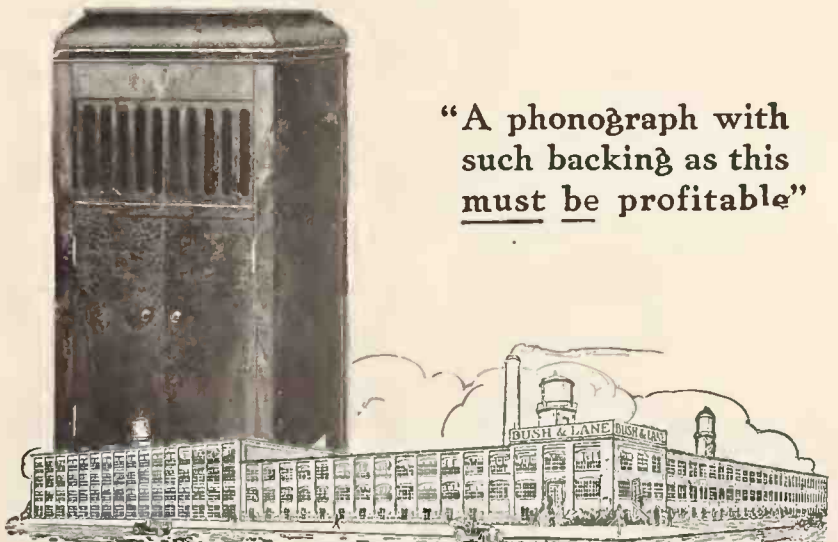

"A phonograph with such backing as this must be profitable"

SEND FOR ILLUSTRATED PRICE LIST AND FREE SAMPLE
"GLOBE" TRANSFER NAME PLATES
 DEALERS EVERYWHERE APPLY THEM ON PHONOGRAPHS, PIANOS, ETC.
GLOBE DECALCOMANIE CO.
 JERSEY CITY, N. J.

BUFFALO DEALERS HOLD OUTING

Automobile Club Grounds Thrown Open to 100 Dealers and Their Families—Skirmishes With Town Constable and Victor Pups Liven Up Day—Ball Game Brings Call for Safety Pins

BUFFALO, N. Y., July 2.—The Talking Machine Dealers' Association of Buffalo held its annual outing on Wednesday, June 16, at the Automobile Club grounds, which is about eighteen miles from this city. About 100 people, consisting of dealers and jobbers and their families, attended.

The arrangements committee, consisting of T. A. Goold, of Goold Bros.; C. Bellanca, of A. Bellanca & Son, and B. E. Neal, of Neal, Clark & Neal, planned an admirable program. The weather, however, was not favorable as it rained all the forenoon but having a wet committee, naturally a wet day was expected.

The trip out to the club was made in automobiles shortly after the noon hour. On the way out V. W. Moody, of the Buffalo Talking

Do You Throw Money Away?

It is not a popular pastime—but still it is unconsciously done by many who just don't know that *Repair Parts* can be bought for less

**RENE MADE SPRINGS AND PARTS LAST LONGER
COST LESS**

RENE MFG. CO.

Montvale, N. J.

Machine Co., endeavored to see how fast he could drive through one of the small villages. The town constable told him, but it cost him \$15 for the information. This little incident, however, did not seem to impair Mr. Moody's high spirits. A small Victor dog mounted on the radiator of C. E. Siegesmund's car also caused considerable trouble as several dogs

challenged him on the way out. Victor supremacy, however, reigned.

The afternoon was given over to games and sports of all kinds, which were in charge of E. Burley and A. Biesinger, of Burley & Biesinger. The feature of the day was a ball game made up of two teams picked at random and captained by Ed. Van Dyne, of Goold Bros., and William Melzer, of the I. Melzer Co., both heavyweights of the 300-pound class. After twelve innings, "Bill" Melzer's team won by a score of 12 to 9. The captain of the opposing team laid his defeat to an accident to his trousers which required him to carry around large safety pins. During the game, C. N. Andrews, who was official score keeper, received many presents in the form of baseballs and clubs from his many admirers.

Other games, consisting of running races for both men and women, tug-o'-war, putting the shot, were also played, and suitable prizes were awarded for the first and second places. V. W. Moody continued his automobile speed in most of the races and succeeded in winning more prizes than the other contestants who participated in the meet.

Toward evening the party adjourned to the dining room of the club, where a lobster and beefsteak dinner was served. During the dinner Miss Dorothy Aylward, of Neal, Clark & Neal, favored the party with an appropriate ballad song rendered in a most beautiful manner.

After dinner dancing was greatly enjoyed until a late hour. All pronounced the outing one of the most successful ever held and expressed their appreciation to the committee for their splendid work.

WEEKLY RECORD RECITALS POPULAR

Weekly record recitals given in the talking machine department of the Crescent Department Store in Spokane, Wash., have increased the record and talking machine sales to a marked degree, according to the report of Mrs. L. H. O'Dea, manager. These concerts are held at the same hour on Thursday of each week and it is noticed that many people form the habit of dropping into the comfortable talking machine section to hear a few selections and later purchase them.

Miller & Levy, Petersburg, Va., have taken the agency for the New Comfort talking machine. Several instruments are on display and an active drive will be made during the Summer months.

Line Up with a Leader—Link Up to LAUZON!



A product of one of the oldest and finest furniture factories in Grand Rapids.

Backed by a plant that for many years has made the art furniture requirement of great home furnishing houses and large department stores from coast to coast.

Containing the highest standards of motive power, tone reproduction and accessory equipment.

LAUZON cabinet construction, plus the STANDARD motor, plus the FLETCHER tonearm, plus ample resources, plus square dealing, equals success.

Line up with a leader—link up to LAUZON!

SEVEN UPRIGHT AND TWO CONSOLE MODELS

IMMEDIATE SHIPMENTS

Attractive Proposition for Jobbers and Dealers FOR AVAILABLE TERRITORIES

ADDRESS

MICHIGAN PHONOGRAPH COMPANY

Office Address: National City Bank Building

Factory Address: Monroe Ave. and Sixth St.

GRAND RAPIDS, MICHIGAN.

ACME-DIE

CASTINGS

ALUMINUM-ZINC-TIN & LEAD ALL TYPES

Acme Die-Casting Corp.
Boston Rochester Brooklyn, N.Y. Detroit Chicago



GENERAL PHONOGRAPH CORPORATION

OTTO HEINEMAN, *President*

25 West 45th Street - - New York

FACTORIES:— NEWARK, N. J. ELYRIA, O.
PUTNAM, CONN. SPRINGFIELD, MASS. KITCHENER, ONT.



CHICAGO

TORONTO

SAN FRANCISCO

LONDON, ENG.

The Sensation of the Trade!

OKEH MOTOR with the OKEH PLUSH TURNTABLE

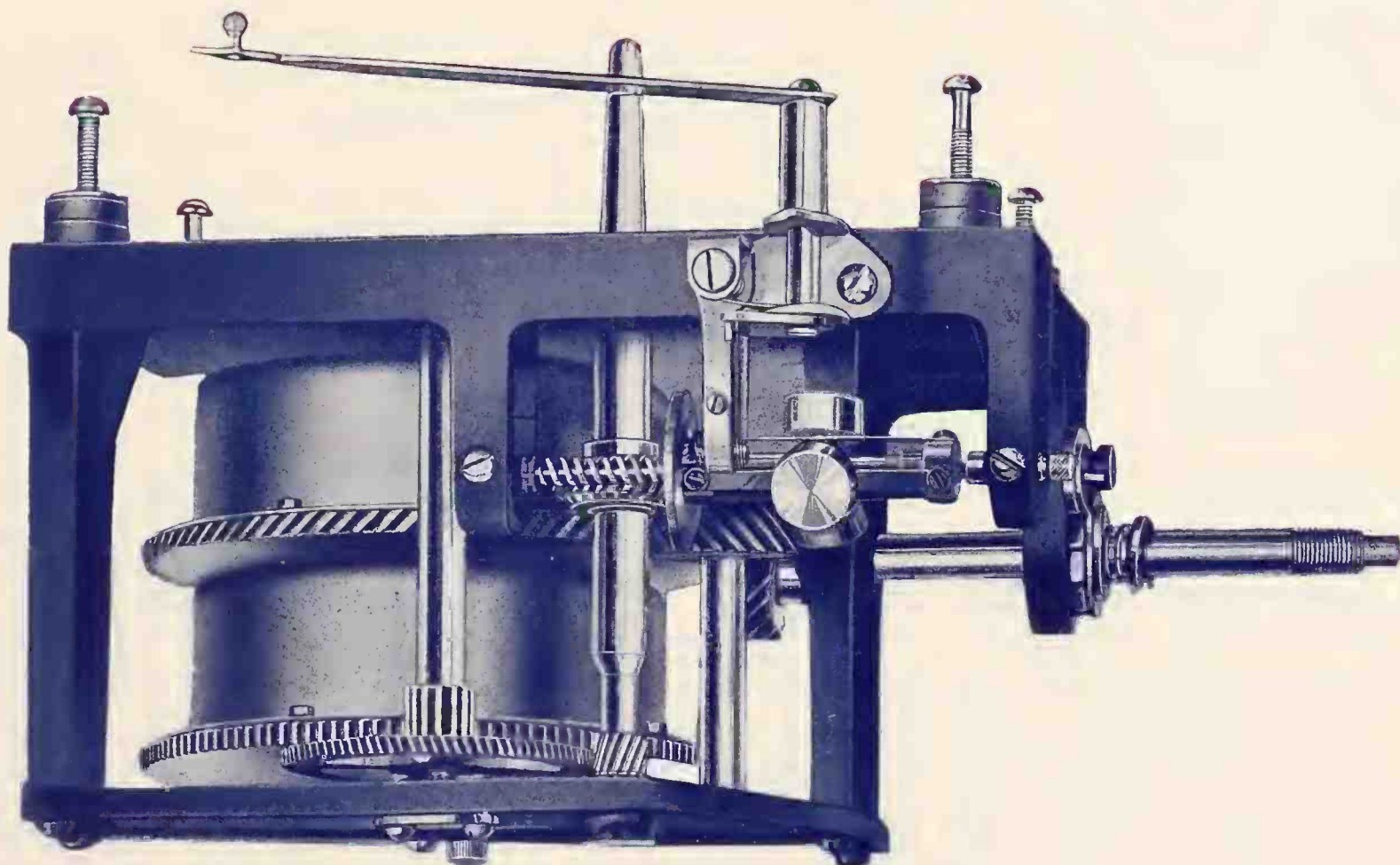

OKEH MOTOR No. 44

THE PERFECT PHONOGRAPH MOTOR

Silent Winding ∴ Silent Running

Ready for Delivery

Order Now



GENERAL PHONOGRAPH CORPORATION

OTTO HEINEMAN, *President*

25 West 45th Street - - New York

FACTORIES:— NEWARK, N. J. ELYRIA, O.
PUTNAM, CONN. SPRINGFIELD, MASS. KITCHENER, ONT.



CHICAGO

TORONTO

SAN FRANCISCO

LONDON, ENG.

“Lassie” and “Alabama Moon,” both medley waltzes by Prince’s Orchestra, get everybody on their toes. It may be the swing, the rhythm or just the way the orchestra plays them. Your sales will tell. A-6153.

**Columbia Graphophone Co.
NEW YORK**



BEAUTIFUL SONORA CALENDAR

The accompanying illustration showing the 1921 calendar hardly does justice to this beautiful calendar, which is made up exclusively for Sonora dealers in de luxe style, embossed white front sheet and baby blue back sheet, tied with a blue tassel.

The calendars are imprinted with dealers' ad-



New Sonora Calendar

vertisements and furnished with envelopes. During recent years, Sonora dealers have used calendar advertising to excellent advantage, and there is every reason to believe that the 1921 calendar will meet with an enthusiastic reception.

The early bird catches the worm; but what good that does the worm has never been clearly explained.

**REPAIRING
AND
REPAIR PARTS**
*for all makes of
Talking Machines*

BOND'S GRAPHOPHONE SHOP
38 Arcade :: Nashville, Tenn.

JOBBER COMMENDS EDISON POLICY

Phonographs, Ltd., Pacific Coast Edison Jobber, Sends Letter to Coast Dealers

Following the announcement made by the Edison Laboratories that the Edison Co. has been doing business in phonographs and records under a narrower margin of profit than some other concerns, themselves absorbing about half of the increased cost of production, Edison Phonographs, Ltd., the Pacific Coast jobbing agency handling the New Edison in the Pacific region and the so-called inland empire States, sent out a letter to their dealers, informing them of the Edison price policy. This letter outlined the reasons why Thomas A. Edison, Inc., have decided not to increase their prices and prepare for "the long pull" in the future when their line will not be affected by radical price reductions.

Lose no time—be always employed in something useful; avoid all unnecessary actions

MAKING DELIVERY BY “FLIVVER”

MEMPHIS, TENN., July 6.—The customers of Zumsteg Bros. are so anxious to get Sonora machines that the dealers have to work fast. As



How Zumsteg Bros. Deliver the illustration shows, they simply hoist a Sonora on a "flivver" and rush it off to the buyer's home in a couple of minutes. This not only saves delay, but makes packing unnecessary.

“LIBROLA”

A Library Table PHONOGRAPH

Two thirds of top is stationary, no need to move anything when playing phonograph.
Fully equipped to play all disc records. Your satisfaction guaranteed.
Large percentage of re-orders indicates satisfied dealers.
Write for prices and exclusive territory.



No. 250T. Patent applied for
48" long, 28" wide, 31" high. Finished all around
Oak, Mahogany or Walnut

SEABURG MANUFACTURING COMPANY
JAMESTOWN, NEW YORK



MR. JOBBER

We want you to investigate the Independent line as a *leading jobbing proposition*

We have one jobber in the South who sells 1,000 Independents per month.

We have a jobber in New England who sells 850 Independents per month.

We have a department store in the middle West which sells 500 Independents per month.

We have several large dealers whose monthly business with us is in excess of 200 machines per month.

We own and operate 3 large factories which are building quality machines, which it will pay you to investigate.

Our manufacturing facilities have been greatly enlarged, and we want a few more live responsible jobbers who have a following and who want high class talking machines at prices which are lower (quality considered) than anything on the market.

Our discounts are liberal, our co-operation of the very highest order. Our representative will call on responsible people who request same in response to this ad.

INDEPENDENT TALKING MACHINE CO., Inc.

12 East 42nd Street, New York City

COLUMBIA CO. PREPARES ROAD SIGN FOR DEALERS' USE

Farm Paper Advertising Campaign Given Added Support by Preparation of Novel Sign to Be Posted by Rural Dealers in Their Communities—Prepared by Dealer Service Department

The Dealer Service department of the Columbia Graphophone Co. announces a "Tack-around" Road Sign for dealers, in support of the Columbia Co.'s farm paper advertising campaign. The signs have been prepared in a quantity sufficient to allow each of their many dealers a widespread publicity on the highways and byways leading from the outlying districts to their shops. Signs being available at this particular period of the year allow the dealer

tion of the wording 'Columbia Grafonolas and Records' and a mention of the non-set automatic stop. Only the dealer's name appears in a four or five line imprint in the body of the sign."

The Columbia road sign is of particular value to the city dealer inasmuch as suburbanites, traveling the road daily to their work in the city, become acquainted with the shop where they may purchase Columbia records and

is made of 29 gauge metal and lithographed in four brilliant colors which are baked on and varnished for preservation. The back of the sign, in order to give a maximum service by preventing rusting, is given a heavy coat of paint. Properly punched holes make tacking a simple matter which likewise eliminates the danger of injury by hammering. Important suggestions for use accompany data.

AMERICAN TRADE BREAKS RECORD

Huge Balance of \$17,000,000,000 Rolled Up Against the World Since Beginning of War—Largely With Countries of Europe

Since the beginning of the world war in 1914 the United States has rolled up a trade balance of approximately \$17,000,000,000 against the world. This exceeds by several billions the total balance in favor of the United States from 1875 to 1914.

Department of Commerce figures just issued show that the trade balance made in favor of the United States in the fiscal year ending in 1914, one month before the war began, was only \$470,000,000. During the first year of the war it was \$1,094,419,600, and in the next year, ending June 30, 1916, it was \$2,135,599,375. During the succeeding year the total was \$3,530,693,209.

Meantime the United States had entered the struggle and in the year ending June 30, 1918—the first full fiscal year of America's participation—the balance was only \$2,974,055,973. In the next year ending last June 30, however, it was \$4,136,562,618.

During the first eleven months of this fiscal year the balance was only \$2,788,451,602, but exports were larger in those eleven months than in any other full fiscal year in the nation's history, totaling \$7,474,193,349, as against the previous twelve months' record of \$7,232,282,686.

At the same time that America's export trade began to advance by leaps and bounds the import trade also showed an enormous increase, totaling \$2,917,883,510 in the year ending June 30, 1916, and advancing steadily each year to a new high record of \$4,685,741,747 during the eleven months of the present fiscal year. The previous high record was \$3,095,720,068 last year.

Most of the favorable trade balance of the United States has been against the allied and neutral countries of Europe. Many of the South American and North American countries and some of those in the Far East have a balance against the United States.



The Columbia "Tackaround" Road Sign Featuring the Grafonola and the Local Dealer

ample time in which to get them around and to benefit by the direct advertising to the heavy traffic on the country roads during the Summer season.

In a chat with The World regarding this new sign, a member of the Dealer Service department said:

"The road sign is a type of advertising, distinct and apart from other outdoor forms such as the billboard. Its value from the standpoint of circulation is unlimited; in comparison with other media it is one of the least expensive. There are seldom any costs for distribution or space rates. While the average newspaper would never consider a contract for an equal amount of space in even one issue, the road sign is practically permanent and occupies valuable advertising space that is free to the dealer.

"Tacked up on old barns, sheds and fences, the road sign becomes, by familiarity, a landmark and an indicator of distances to all who pass; it catches the eye and registers an impression on the transients of the road, whether they ride in automobile, buggy or are traveling afoot. The landscape holds but little interest for the average farmer, for its details are customary and therefore monotonous, but the road sign offers diversion for the eye and food for thought.

"The farmer who may read the Columbia advertisement in his trade paper one evening and on his way to town the next day has his attention attracted to the Columbia road sign is definitely directed to the Grafonola Shop. The Columbia road sign, in every case, is the dealer's sign; its letters are designed flat instead of the usual embossed type, in such a way as to make the dealer's name and address an actual part of the design. There are no suggestions that the placing of the dealer's name on the sign is an after-thought or a later addition, and so that the dealer is assured of receiving full value for the sign, all text is eliminated, with the excep-

Grafonolas. The aggressive far-seeing city dealer therefore has equal opportunities to capitalize on the widespread use of the road sign as well as the country dealer. Again, there are those suburban districts from which people are daily attracted to the city for shopping and while in town have the time and leisure to step into the Grafonola Shop and listen to the latest records.

The Columbia road sign measures 14"x20",

Victor Dealers Everywhere

Regardless of your location or prestige, the most valuable asset you have in your business is the Victor Trade Mark, "His Master's Voice," on the goods you sell identifying them as genuine and thus assuring your customers that you offer nothing but the best obtainable.



**TALKING MACHINE CO.
BIRMINGHAM**

RAPIDLY INCREASING COST OF PHONOGRAPH PRODUCTION

Some Interesting Figures Presented by "Sonora Bell" Which Give a Very Excellent Idea of the Increased Cost of Making Talking Machines To-day in Contrast to Years Ago

In an interesting article published in a recent issue of the "Sonora Bell" pertinent facts and figures are presented showing that the present prices of talking machines are not high considering the tremendous increase in the cost of labor and material. One section of this most timely and illuminating contribution reads as follows:

"A buyer of one of the finer Sonora models owns something which is of real and lasting value. The prices quoted on Sonoras are fair and reasonable. In distinction from such articles as clothing, foodstuffs, etc., which are precisely the same as they were seven years ago, the phonograph of 1920 is an immense improvement over the phonograph offered before the war.

"It is evident that the price of the 1920 phonograph cannot be fairly compared with the price of the pre-war phonograph because the buyer to-day is securing an infinitely higher grade instrument.

"However, neglecting this important consideration, an investigation shows that the increase in prices in Sonoras has been extremely modest in comparison with the increase in prices of such other articles as diamonds, clothing, shoes, sugar, linens, cottons, furniture, and a long list of other commodities which are not singled out, particularly to be pointed at as examples by the Federal Reserve Bank.

"An investigation of the prices paid for materials in 1915 and those paid in 1920 is illuminating as showing why phonograph prices have advanced. Study this table.

Lumber—	1915	1920
Sound Wormy Chestnut.....	\$22.50 M	\$85.00 M ft.
Birch, No. 1 common.....	28.00 M	125.00 M ft.
Mahogany, 1st and 2nd.....	150.00 M	360.00 M ft.
Gum, No. 1 common.....	29.00 M	150.00 M ft.
Oak, No. 1 common.....	35.00 M	125.00 M ft.

Veneer—	1915	1920
Poplar	3.50	14.00 M ft. up
Mahogany	¾ to ½c ft.	.055 ft. up
Qrt. Oak	16.00 M	60.00 M ft. up
Cir. Walnut06 ft.	.18 ft. up
Shellac95 gal.	cannot get
Stains, dry60 lb.	1.75 lb.
Varnishes	1.35 gal	2.15 gal.

"It will be seen that lumber has advanced from over 250 per cent. to 500 per cent.; shellac is simply out of the market; stains are triple and varnishes have almost doubled.

Cabinet Makers' Rates During 1915 and 1920:

	Hours Per Week	Minimum	Maximum
March 1, 1915	60	.19 hour	.22 hour
March 1, 1920	50	.55 hour	.68 hour

"Wages, it is apparent, have increased over 300 per cent and the working week has shortened from sixty hours per week to fifty hours

EDISON ELECTED TO ROTARY CLUB

Organization in Orange, N. J., Makes Inventor Honorary Member at Monthly Dinner

Honorary membership in the Rotary Club of the Oranges was accepted by William H. Meadowcroft on behalf of Thomas A. Edison at the monthly dinner of that organization held in West Orange, N. J. Mr. Edison commended the work of the club in the following letter, which was read by the secretary:

"Your invitation to me to accept honorary membership in the Rotary Club of the Oranges is greatly appreciated and it gives me much pleasure to express my acceptance.

"I must ask you, however, to excuse me from attending your next meeting. My hearing has grown so poor and my time is so taken up with a vast array of work that I have given up the idea of attending any social functions.

per week, a decrease of one-sixth in working time.

"With all these remarkable increases in the cost of labor and materials, the prices of Sonoras have been held down to extremely reasonable levels.

"Only through production on an extremely large scale has it been possible for Sonora to keep the price of the completed phonograph from mounting as did the individual items of materials which entered into the production of the instrument and as did the labor costs.

"In conclusion, there is given a comparison of the average prices received March 1, 1914, and March 1, 1920, by producers in the United States of eight important agricultural products. These are figures given out by the bureau of crop estimates of the Department of Agriculture and show the following increases: Cotton, 200 per cent; wheat, 173 per cent; corn, 116 per cent; potatoes, 244 per cent; hay, 91 per cent; eggs, 96 per cent; butter, 115 per cent; wool, 231 per cent."

"I appreciate the good features of the Rotarian idea and the club has my most cordial good wishes."

Mr. Edison continues to devote as much of his time at work as anyone at his vast laboratories in Orange and still sets the pace for his associates.

NEW SHOP OPENS IN NEW HAVEN

Wittstein's Music House has opened in New Haven, Conn., as a Columbia shop. The opening was held some time ago and the store was thronged with visitors during the day. A very attractive window display showing several Columbia Grafonolas in a setting of palms and flowers was a feature of the day.

Yours may be just one in a hundred advertisements in to-morrow's paper—then make it stand out.



The New
Portable
C I R O L A



Ideal for the Vacationist

Although the Cirola is a good all year round selling proposition, the extreme ease with which it may be carried makes it especially attractive to the Vacationist.

Dealers would do well to take care of this trade with the Cirola. It measures 12½" x 11½" x 6½", is attractive in appearance. It is without sound chamber, has remarkable tonal volume and many exclusive features. Covers may be had if desired.

Territory is open for distributors.

Write today.

Cirola Phonograph Corporation

Factory
1227 Germantown Avenue
Philadelphia Pa.

General Offices
Colonial Trust Co. Bldg
Philadelphia Pa.

The Heywood-Wakefield

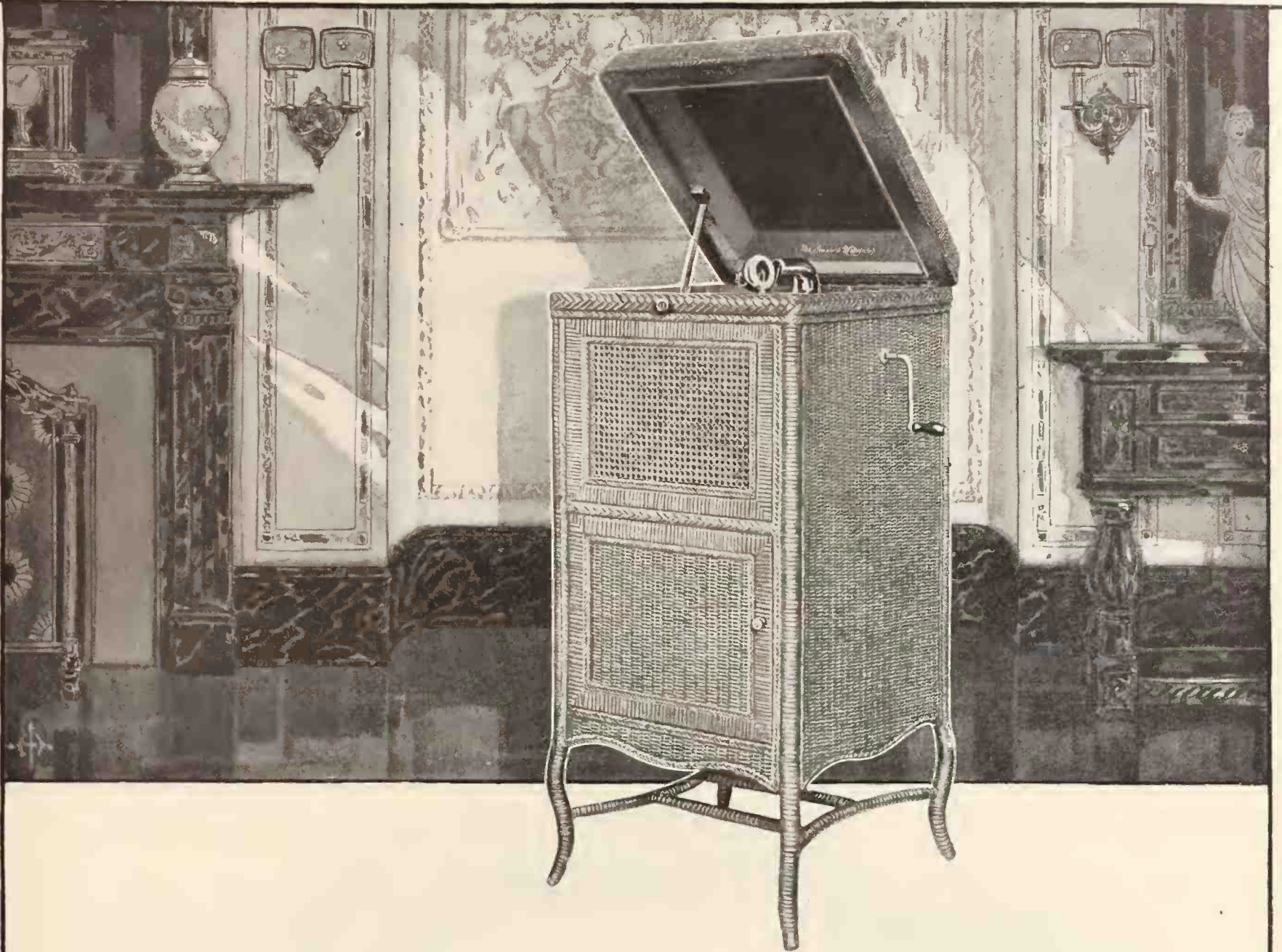

A phonograph with a variety of sale appeals

THE unusual appearance and purity of tone of the Heywood-Wakefield have attracted the favorable attention of thousands. People everywhere want to see and hear it, and learn all about it.

The dealer who stocks and displays this instrument is capitalizing a sound selling proposition. Its advantages are clear-cut facts.

A reed cabinet which eliminates vibratory noises; a cushioned reproducer constructed on the principles of the human organs of sound—faultless in reproduction, and unmarred by metallic taint. And for those who prefer it, the dealer will find the electric motor a good point. It never

heats, is always uniform in speed and absolutely silent in operation.

Of special interest are the artistically designed cabinets of reed, which may be finished in any one of three hundred different color schemes. Their rare decorative qualities are a strong selling factor, for they harmonize with all styles of furniture.

This phonograph is a new creation—an instrument that fills every requirement. Its variety of appeals make it an exceptionally profitable phonograph for the dealer to handle. The Heywood-Wakefield is made under the Perfek'tone patents. Write today for details of models, prices and specifications. Address the nearest office of

HEYWOOD BROTHERS AND WAKEFIELD COMPANY

New York Philadelphia Boston Baltimore Buffalo Chicago Portland, Ore. San Francisco Los Angeles
Factories: Gardner, Mass.; Chicago; Wakefield, Mass.

When you visit Atlantic City see all models of the Heywood-Wakefield at the Perfek'tone Store, 517 Boardwalk

SUPREME

TONE ARMS & SOUND BOXES

*We take Pride in
this Achievement!*

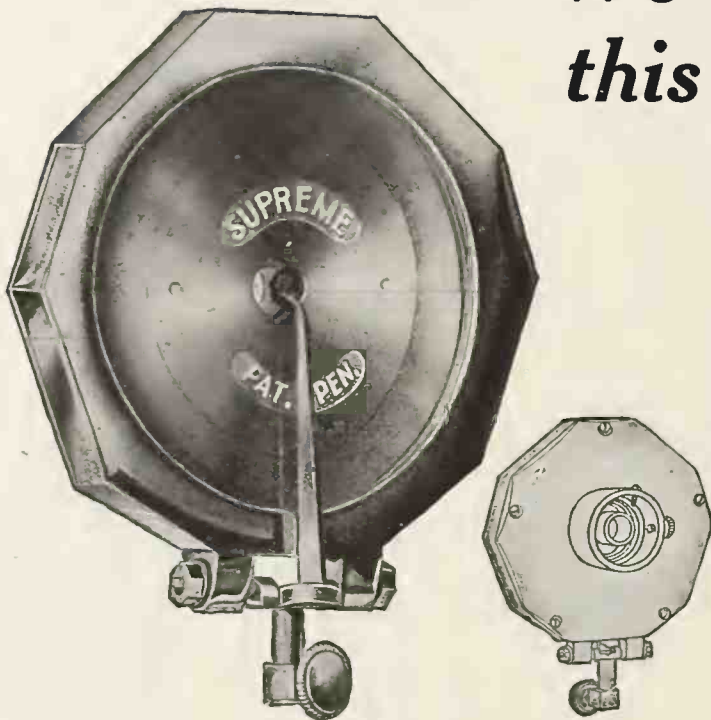

IN experimenting on this new type of sound box, we realized from the very start that the tone produced was unusually clear and resonant. Perfected after considerable research, the new Hub Sound Box is a revelation for volume and purity of tone.

Sample in nickel \$3.00

Send today for a New Hub Sound Box and put it to a test.



Size 8½ inches
center to center
Samples \$4.00

Just a word about the Supreme Tone Arm

We know of no better recommendation of quality than the fact that we have sold more Supreme Tone Arms without a come-back than any other tone arm manufacturer in America.

WILLIAM PHILLIPS SERVICE

Manufacturers of Supreme Tone Arms and Sound Boxes

145 West 45th Street : New York

Chicago Representative : H. ENGEL, McClurg Bldg., 218 S. Wabash Ave.

PLAYS MUSIC WITHOUT RECORDS

Visitors at Advertising Convention in Indianapolis Entertained by Orchestra Concealed Within Huge Model of Talking Machine

INDIANAPOLIS, IND., July 6.—Can music come from an imitation talking machine which has no motor and no records? Ask any of the young women who are employed in the offices at the Statehouse.

An interesting exhibit among the displays of the Associated Advertising Clubs of the World held in the spacious rotunda of the Statehouse last month was a big reproduction of a popular type of talking machine, about twelve feet high.

A crowd of visiting advertisers stood about the "phony" machine, when suddenly music burst from the hollow instrument. An air of mystery was created as snappy one-steps and "blues" were reeled off. The puzzle was solved only when one of the members of a three-piece orchestra, concealed in the interior of the framework, could hold out no longer and lighted a cigarette.

Then followed a musical program that made a big hit with the girls of the Statehouse offices, for with most of their bosses absent from the city, due to a certain gathering in Chicago, there was little work to do. The tile floor of the Statehouse corridors is pretty fair and some of the delegates to the advertising convention knew all the wild steps.

FERGUSON CO. LEASES ANNEX

C. W. Ferguson, of the Ferguson Co., Kewanee, Ill., has leased the Albrecht Building in that city and will occupy that location as an annex to the main store at 217 Third street. The present quarters of the company are not large enough for the adequate handling of the growing music business and the change was deemed imperative. The new building is being remodeled, and it is hoped that it will be ready for occupancy by the end of the month.

NEW PATHE JOBBERS IN DETROIT

Burnham, Stoepel & Co. Appointed Distributors for This Important Territory—C. H. Chambers in Charge of Phonograph Department

Announcement has been made from the headquarters of the Pathé Frères Phonograph Co. in Brooklyn, N. Y., that Burnham, Stoepel & Co., of 19 East Larned street, Detroit, Mich., have been appointed Pathé distributors. This concern succeeds Williams, Davis, Brooks & Hinchman's Sons, who no longer handle the Pathé line. C. H. Chambers, thoroughly acquainted both with Pathé distributing and the Michigan trade, is in charge of the phonograph department of Burnham, Stoepel & Co.

SURE CURE FOR SUMMER DULLNESS

Victor Co. Urges Dealers to Make Special Drive for Business During Summer

"There is one sure cure for hot weather dullness," says the Victor Co. in its letter to the trade enclosing its advance August order list, "and that is to make a special drive for business, and center the drive on the August Victor records. The new records provide the right kind of ammunition, and Saturday, July 31, opens up the way to a flying start. The merchant who keeps constantly plugging throughout the hot months need entertain no useless regrets when he closes out his books at the end of the year. Study your requirements carefully before ordering, and then read in the advance list the interesting word pictures of the musical content of each new record."

TEXAN DEALER RETIRES

T. E. Davis has purchased the interests of his partner, J. F. Freeman, in the music business of Freeman & Davis, Brady, Tex. Mr. Freeman decided to retire from business on account of ill health and has left for his home in Waco.

PRICE MAINTENANCE ON TRIAL

Beech-Nut Packing Co. Case to Go Before U. S. Supreme Court—Powers of Federal Trade Commission to Regulate Prices to Be Tried

In the well-known price maintenance case of the Federal Trade Commission vs. the Beech-Nut Packing Co. a writ of certiorari has been issued by the United States Supreme Court.

It will be recalled that this case attained prominence some time ago, not only because it involved the legality of a certain method of resale price maintenance, but also because the Federal Trade Commission, which regarded the Beech-Nut price maintenance plan as unfair competition and therefore illegal, suffered a reversal of its restraining order by the United States Circuit Court of Appeals.

In trade circles generally this decision of the Circuit Court, taken in connection with the prior Supreme Court ruling in the Colgate case, was regarded as a distinctive victory on the part of those interested in maintaining the power of resale price control over trade-marked specialties in the hands of the manufacturer. At the same time, it was recognized that the decision was in sharp conflict with certain avowed policies of the Trade Commission and would necessitate changes in its practice and principles so far-reaching as to occasion probably no little embarrassment to that body.

PORTSMOUTH MUSIC SHOP OPENS

PORTSMOUTH, VA., July 6.—The Portsmouth Music Shop, Inc., opened for business last week at 715 High street, with a complete line of Columbia Grafonolas and records. J. Henry Resch is president of the shop. Every effort has been made, in the arrangement of the shop, to provide accommodations for those desiring to hear the latest Columbia records, and to display the stock of the shop to the best advantage. Careful thought has been given to the furnishings which are harmonious and attractive throughout.

Just What You Have Been Waiting For

The GATELY Carrying Case

for VICTROLA VI's

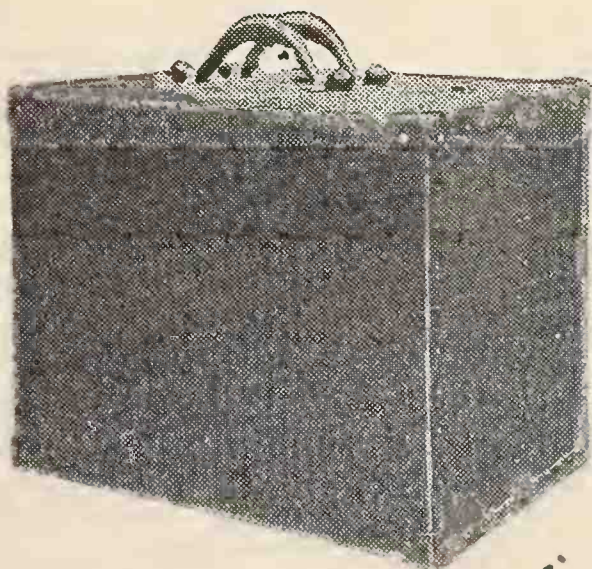

This handsome carrying case will help increase your VICTROLA VI sales.

The Gately Carrying Case is constructed of wood, covered with black waterproof fibre and substantially made so that it can be carried by one man or as baggage.

Each case is arranged to hold thirty 10-in. or 12-in. records, and has a separate place for a sound box, winding key and needles.

Price, \$8.50 Wholesale

Write for Descriptive Circulars

GATELY-HAIRE CO., Inc.

Albany, N. Y.



"All The Boys Love Mary," and if you don't believe it, let Van & Schenck sing this dry-time song for you. For a real Blues-Killer follow Harry Fox's "Way Down Barcelona Way." Both of these songs ring the cash register bell. Get ready! A-2942.

**Columbia Graphophone Co.
NEW YORK**

SALESMEN WHO ADHERE TO HONESTY IN STATEMENT WIN

Some Reflections on Selling Methods That Should Be Universally Adopted—Written for The World by J. H. Winner, Who Knows His Field of Operations

To most people the phonograph is a most mysterious and complicated piece of merchandise, so there is only one policy for a salesman to pursue, and that is one of absolute honesty in the statement of facts. A small lie may later bring you trouble. Far better to have lost the sale. The customer will soon become familiar with the workings of the phonograph, and the small lie, having made an impression, comes back to the salesman and the house later. Honesty, and a plain, sincere statement of facts will pay bigger dividends in the long run.

The salesman must take it for granted that the prospective customer is familiar with the good points of the machines of your competitors, so build your suggestions around the points in which the customer seems the most interested. Drive your point home by an expression of enthusiastic suggestion, ringing

true with honesty of purpose, and you cannot help but make a lasting impression for your merchandise. A salesman cannot afford to jump at conclusions. Size up the situation first. Feel that you are right and act accordingly. Even if a prospect does decide to "look around," you stand 99 per cent more of a chance of having them come back if you stated the truthful facts about your merchandise.

The dealer in the smaller city comes in personal contact with many of his customers, and his reputation enters largely into selling. The small city dealer has an opportunity to know the customer's financial standing, the size of the family, and the home surroundings, but the dealer in the large city must act on his judgment by quick thinking and build his plan of action from the few words he may get from the prospective customer.

Conditions brought about during the war have created many different makes of phonographs. I have found as many as eight dealers, representing ten different makes of phonographs in towns of one thousand population. The manufacturers of the cheap machines have established agencies at any place where one or two phonographs could be sold. I have found barbers, butchers, milliners and garages selling phonographs. This has brought into the phonograph field a large number of people who try to sell by knocking their competitors' merchandise and personality. Now, no good salesman will try to fight a competitor at his own game, when it comes to knocking his merchandise and personality, so the salesman who sticks to the policy of honesty in statement of facts, and hangs on to the sound ethical fundamentals of salesmanship is the one who will win.

THREE INDICTED IN THEFT CASE

Grand Jury Moves Against Brooklyn Dealers Charged With Stealing Machines in Camden

Aaron Frelich, a talking machine dealer of 59 Graham avenue, Brooklyn, N. Y., was indicted recently by the Grand Jury in that city for criminally receiving stolen property in connection with the theft of \$15,000 worth of talking machines from a firm in Camden about a month ago. Frelich is charged with having seven of the forty-three stolen machines in his store. With him were indicted Louis Abrams of 1175 Broadway, from whom Frelich is alleged to have purchased the talking machines, and Benjamin Ginsberg of 543 Myrtle avenue. District Attorney Lewis asked that each be held in \$5,000 bail for trial. This amount was fixed for Abrams and Ginsberg, while Frelich was held in \$3,500 bail.

THE VALUE OF TEAM WORK

A little relaxation not only refreshes a man but it relieves him from what might be termed a fixed viewpoint and when he again takes up his problems he may see them in a different light and find their solution easier. Another thing the ball game should remind us of is the importance of team work, and the fact that individual stalling without team work support will not get a man very far. Rest and recreation are just as essential to good health and progress as earnest application to the business itself. Get the proper mixture and you will get good results.

Factory rules and bulletins should have applied in their making the theory that the simpler they are the better.

COTTON FLOCKS

.. FOR ..

Record Manufacturing

THE PECKHAM MFG. CO., 238 South Street
NEWARK, N. J.

Ward's Khaki Moving Covers



Grade "D" Cover with No. 3 Straps.

THE C. E. WARD CO.

(Well-Known Lodge Regalia House)

101 William St., New London, Ohio

Also Manufacturers of Rubberized Covers
and Dust Covers for the Wareroom

Distributors

BRISTOL & BARBER, INC.
111 E. 14th St., New York City

YAHN & LANGE DRUG CO.
207-215 E. Water St., Milwaukee, Wis.

COHEN & HUGHES, INC.
Washington, D. C.

BECKWITH-O'NEILL CO.
Minneapolis, Minn.

STREVELL-PATERSON HARDWARE CO.
Salt Lake City, Utah

C. L. MARSHALL CO., INC.
Beckman Bldg., Cleveland, O.
Butler Bldg., Detroit, Mich.

THE REED CO.
237 Fifth Avenue, Pittsburgh, Pa.

C. J. VAN HOUTON & ZOON
140 S. Dearborn St., Chicago, Ill.

SONORA DISTRIBUTING CO. OF TEXAS
Dallas, Texas

CHAS. H. YATES
311 Laughlin Bldg., Los Angeles, Cal.

W. D. & C. N. ANDREWS
Buffalo, N. Y.

SACHS & CO.
425 So. Wabash Ave. Chicago

SHERMAN, CLAY & CO.
741 Mission St., San Francisco, Cal.

JOHN A. FUTCH CO.
35 Auburn Ave., Atlanta, Georgia
1500 South Boulevard, Charlotte, N. C.
630 Washington St., Jacksonville, Fla.

ORTON BROTHERS MUSIC HOUSE
Butte, Mont.

GRAY & DUDLEY CO.
Nashville, Tenn.

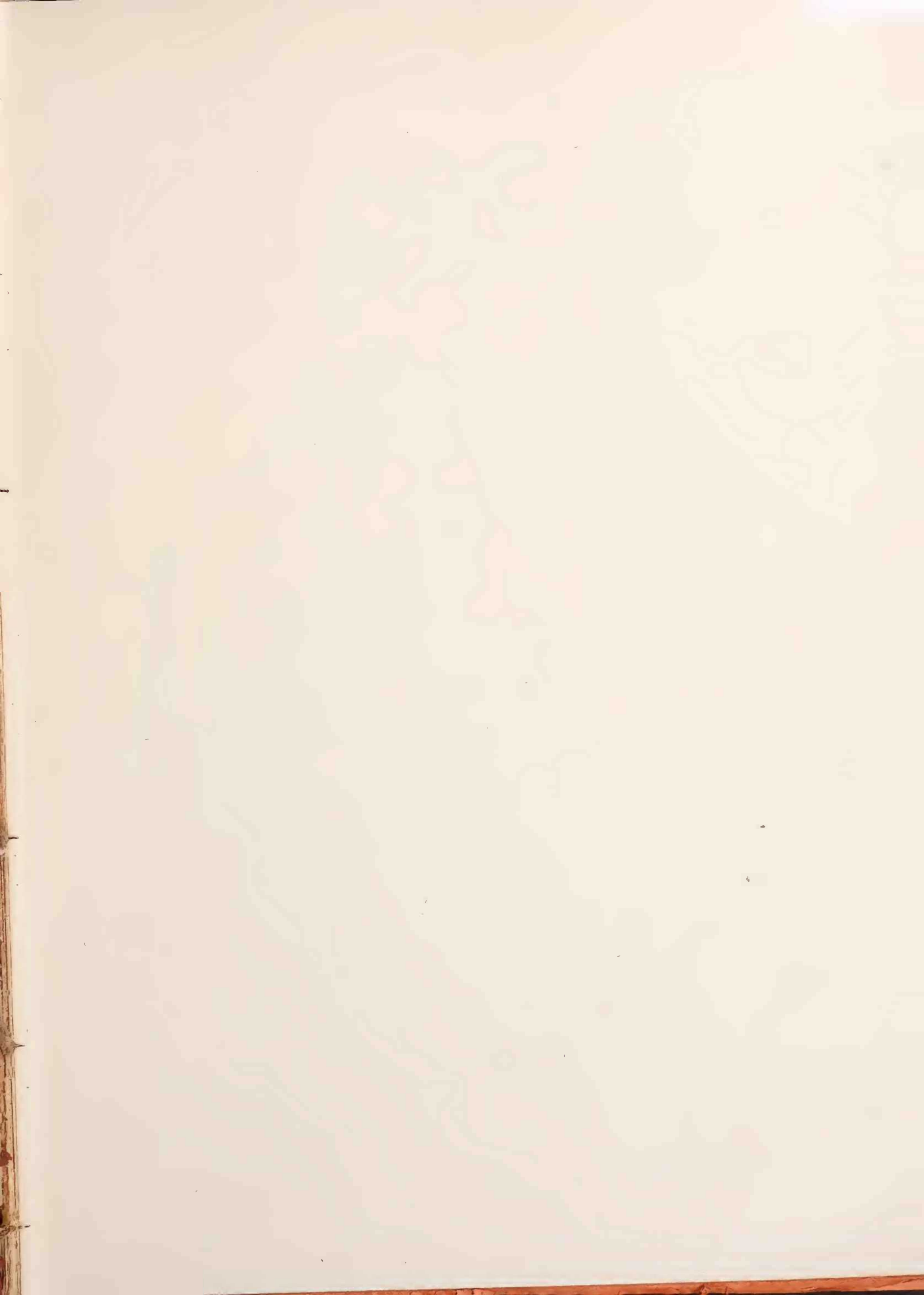

The BEACON



An intensive news-
paper advertising
campaign this Fall
will back every
Beacon Dealer

The BEACON

The future of any phonograph concern lies in the appreciation of its product by the ultimate purchaser.

The dealer who is now buying a mediocre product for a quick sale with excessive profits for himself is not looking ahead.

The Beacon is created for the progressive merchant who has foresight enough to realize that he must handle a product which advertises itself through its owner. In this way only can he be assured of permanent profits and a growing future business.

The Beacon is distinctly a quality product.

The design is exclusive and covered by basic patents.

The tone is musical, pure and *scratchless*.

The motor is silent and durable.

Write to us at once.

If you qualify for an agency, you will be granted a franchise and may have shipment of goods deferred until Fall if desired.

Distributors everywhere East of the Mississippi River.

Beacon Phonograph Co., Inc.
19 Milk Street Boston, Mass.



Beacon service
and co-operation
make Beacon
dealers Beacon
enthusiasts

MAKE THE STRATFORD PHONOGRAPH

The Stratford Phonograph Co. Organized With Capital of \$1,000,000, With a Strong Directorate—Large New Factory Arranged For

ASHLAND, O., July 7.—There has been recently incorporated in this city the Stratford Phonograph Co., which has already begun the manu-



Frank K. Amreihn, President

facture of a line of talking machines to be known as the "Stratford—The Shakespeare of Phonographs." It is expected that a complete line of Stratford phonographs will be available for the trade at the end of the month. This new enterprise is capitalized for \$1,000,000, consisting



Charles H. Yahrting, Vice-president

of \$400,000 of eight per cent preferred stock, and \$600,000 common stock, par value \$10 each.

Frank K. Amreihn, who has spent a number of years in the piano and talking machine industries, and who was recently manager of the F. A. Starck Piano Co. in Detroit, is president and general manager of the Stratford Phonograph Co. Charles H. Yahrting, president of the Yahrting-Raynor Piano Co. of Youngstown, O., and also president of the Ohio Music Men's Association, is vice-president. A. B. Cornell, president of the A. B. Cornell Co., New York, and a well-known consulting engineer, is secretary. S. E. Gongwer, county treasurer of Ashland county, O., is treasurer.

A large new factory located on the main line of the Erie R. R., is now being erected, and E. C. Curtis, formerly production manager for several well-known talking machine manufacturing companies, is in charge of the production.

Dealers in various parts of the country are now receiving their first shipments of Stratford talking machines, and the company expects to institute a nation-wide advertising campaign in conjunction with extensive dealer helps.

PRAISES WORK OF DETROIT BUREAU

Manager of J. L. Hudson Co. Lays Improvement in Advertising to Local Bureau

Oscar Webber, general manager of the J. L. Hudson Co. of Detroit, is authority for the statement that the tone of advertising in that city is much improved when compared to that of two or three years ago. He ascribes this to the work of the Detroit Bureau.

Similar results are reported from other cities. In Baltimore the total cases investigated during the last year were 15 per cent less than the year preceding, while the percentage of decrease in complaints found to be justified was 34 per cent. The conclusion may well be drawn that when advertisers know that the Bureau is there to check their copy, they are so careful in preparing it that there is one-third less chance that any reasonable objection may be found to it. Another interesting phase of the Baltimore report is that the decrease is spread through all lines of business, instead of being limited to a few.

STRIKING USES OF VENEERS

In studying all late offerings in furniture and talking machines the domineering note in the use of veneer is one of neatness rather than striking effect. There is evidence of more thoughtful matching of veneer, more careful laying and a general refinement in the use of figured wood. It indicates that the artistic sense is strengthening, as it should, and that the furniture of the day will come nearer being worth the price than in bygone days, when both the material and furniture were much lower in price.

The **HOWE**

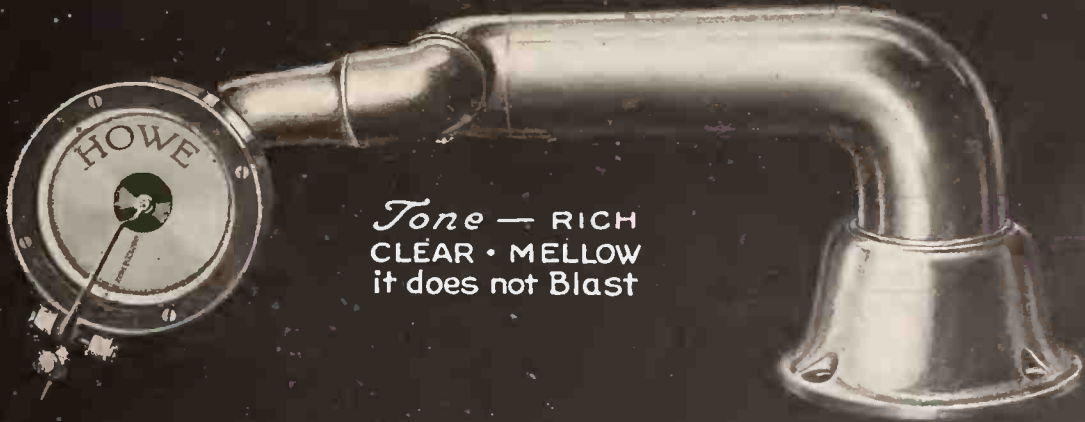

Tone — RICH
CLEAR • MELLOW
it does not Blast

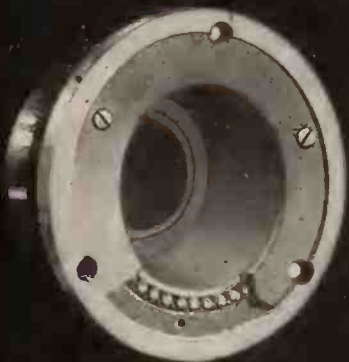

BALL BEARING
No obstruction
in the base

C.W. Howe & Company
21 East Van Buren St. Chicago Ill.

Quality Instruments Assure Permanent Success

That's why the dealers' choice is

THE PERFECT TONE OPEROLLO FOR EVERY HOME

Reg. Trade Mark for Operollo Phonographs

Prominent features which made "Operollo" famous and popular:

EXCLUSIVE DESIGNED CABINETS—SUPERB FINISH

CONSTRUCTION EQUIPMENT BASED
ON LATEST SCIENTIFIC PRINCIPLES

QUALITY AND DISTINCTION THROUGHOUT

No "Paper Guarantee," but 100% Perfection and Service which Satisfies

These are no shallow words, we mean exactly what we say and are ready to back our statement. We invite dealers to make a test case of the merits of our instruments and compare our quotations. We shall continue to lead as before in the American Market with "*Quality Instruments for Less Money*," as we concentrate only on popular-priced Machines which *sell on the strength of incomparable Values*.

Demand for Operollos increasing tremendously

In order to give the trade better service, we are now turning the business in numerous states over to Operollo Distributors. In a later number of the World we shall announce the appointed State Distributors.

New Models added during 1920

EIGHT CABINET MODELS, RETAIL PRICES, \$110 to \$275

Attractive Discounts—Prompt Service assured

Write for 1920 Catalogue and Dealers' Discounts

Operollo Phonograph Company

54 West Lafayette Blvd.

Detroit, Mich.

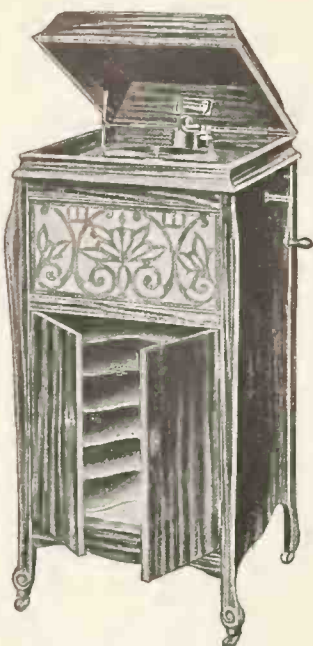

MODEL 115

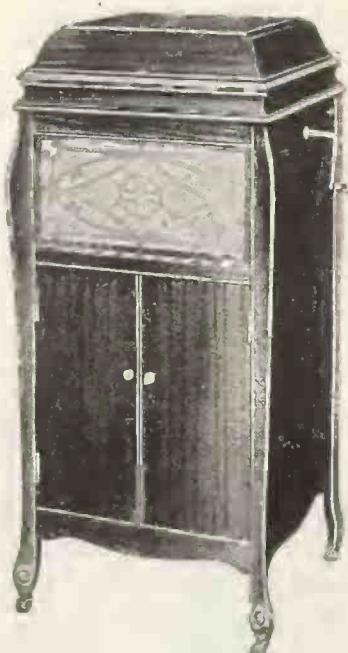

MODEL 135

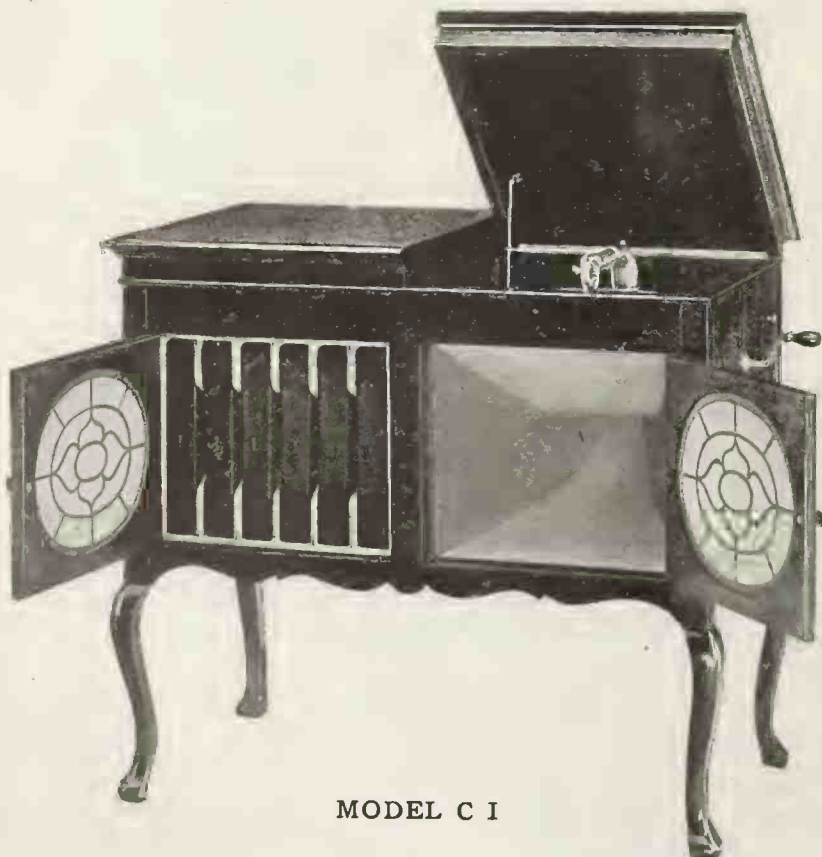

MODEL C I



MODEL 175



MODEL 275

Display a carton of Grafonola Polish in your store. Watch it sell. Make a bottle of this polish part of the Grafonola outfit at the time of sale. It will be a real service to your customer and a profit to you. Then there are the repeats.

**Columbia Graphophone Co.
NEW YORK**



SOME NEW HAVEN HAPPENINGS

Columbia Branch in This City a Live Trade Center—News of Interest

NEW HAVEN, CONN., July 6.—H. E. Gardiner, manager of the Columbia Graphophone Co.'s branch in this city, spent a few days recently visiting dealers in the Western part of his territory, and his reports on general conditions are very optimistic.

Frederick C. Collins, manager of the Dealer Service department of this branch, visited the Columbia executive offices a few days ago, getting some ideas on dealer service and advertising. Mr. Collins met the heads of all of the departments at the executive offices, and was supplied with some very interesting data on Summer advertising, together with details regarding campaigns introduced by dealers who are canvassing the farm trade with motor trucks.

The New Haven Columbia baseball team has just been formed and consists of employes of the local branch. It is under the guidance of Mr. Collins, who is well known in local athletic circles, and T. McKiernan, who is captain.

O. F. Benz, of the Columbia executive offices, visited Hartford and New Haven recently, calling upon some of the dealers in each city, and also addressed a branch sales meeting in the evening. Mr. Benz outlined various sales plans, and told of the efforts being put forth by the factories to keep pace with the tremendous demand for Columbia products.

Visitors at the New Haven Columbia branch the past week were as follows: Nathan Belly, of the South Norwalk Music Shop; M. Quadretti, Shelton, Conn.; David Bedrick, Hartford, Conn.; F. Abbott, Derby, Conn.; S. Finkelstein, Bridgeport, Conn.; Homer Klock, Stamford, Conn.; Roy Ward, New Haven; E. Wittstein, New Haven, and Frank David, Bridgeport, Conn.

Miss Florence Collins, a member of the Columbia Graphophone Co.'s office staff, has tendered her resignation so that she may embark on the sea of matrimony.

TO OPEN BRANCH AT MASSILLON

Canton Music House to Feature Brunswick at New Branch Establishment

CANTON, O., July 6.—The George C. Wille Co., an old established Canton firm, will open a new branch store this week at 200 West Main street, Massillon, O., just eight miles west of Canton. The new store has all modern appointments and a complete line of talking machines, pianos and musical merchandise will be carried. The leader among phonographs will be the Brunswick. The Canton store is located at 410 Market avenue North. Mr. Wille is the first Canton music dealer to extend his business to Massillon.

THESE CRAZY JAZZ TIMES

Strike and the world strikes with you, work and you work alone; our souls are ablaze with a Bolshevik craze, the wildest that ever was known. Groan and there'll be a chorus, smile and you make no hit; for we've grown long hair and we preach despair and show you a daily fit. Spend and the gang will cheer you, save and you have no friend; for we throw our bucks to birds and ducks and borrow from all who'll lend. Knock and you'll be a winner, boost and you'll be a frost; for the old sane ways of the pre-war days are now from the program lost. Strike and the world strikes with you, work and you work alone; for we'd rather yell and raise blue hell than strive for an honest bone. Rant and you are a leader, toil and you are a nut; 'twas a bitter day when we pulled away from the old-time workday rut. Wait and there'll be a blow-up, watch and you'll see a slump, and the fads and crimes of these crazy times will go to the nation's dump.—New York Sun.

In the early days of opera no women's voices were employed. The part for women in the drama was taken by men with alto voices. Times have surely changed!

MARKET GROWS BY ADVERTISING

Every Misleading Advertisement Weakens the Power of Good Ads, Says Roger Babson

Roger W. Babson, the well-known statistical expert, analyzes the results of misleading and fraudulent advertising in an interesting way.

"Every time a man or woman is cheated by a bogus advertisement," he says, "the pulling power of advertising is weakened. Advertisers ask themselves: 'Why don't I get more replies, more customers, more orders?' One reason is because the fakers have taught the public to suspect the truth of advertising. That is why the honest advertiser has to put forth so much more effort to get business.

"Again, every time a community is robbed of its money in exchange for worthless goods the purchasing power of that community is partially destroyed. The faker has killed the market and soured the trade. It is a practical principle of economics that in any community there is a food fund, a clothing fund, an investment fund and so on. The amount spent on each line per family averages about so much comparatively in a year. Therefore, if the family fund is squandered on worthless merchandise in some lines, it is an economic impossibility for other merchants, manufacturers and bankers to get the patronage to which they are rightfully entitled.

"Honest advertising develops the market. Dishonest advertising exploits it and turns good customers into poor ones. The movement for honest advertising is to conserve the public purse for the benefit of legitimate business."

GEORGIA EDISON MEN MEET SEPT. 1

ATLANTA, GA., July 6.—The Edison Dealers' Association, composed of the dealers in the southeastern States, has accepted the invitation of Herbert R. Brown, of Brunswick, Ga., to hold the next meeting in that city on September 1. The invitation was extended to the association at its last meeting held in this city.

VITANOLA DISTRIBUTING AGENCY OF TEXAS

THE TEXAS DISTRIBUTORS OF

THE VITANOLA

"The Phonograph of Marvelous Tone"

If you are in Texas territory, write for information regarding an agency for this progressive line.

907 COMMERCE ST.

'Phone X-5511

DALLAS, TEXAS

And again Sonora leads!

KEEPING a close watch on the trend of the public's taste, the makers of Sonora discerned three important facts:

- (1) The call for our high quality period styles is increasing.
- (2) There are many requests for our attractive high-grade period styles at moderate prices.
- (3) The buyers who want the finest period phonographs that can be made are ready to pay for value received.

To satisfy the demand we have ready wonderful new models of

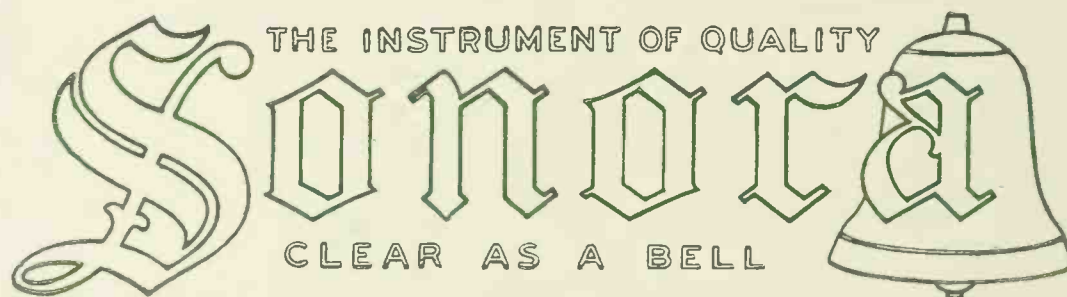

THE new line of *Sonora* period styles retails at \$325.

These are meeting with a most enthusiastic reception.

There are also available now the most wonderful phonographs produced by any manufacturer—the *Sonora de luxe* period models which are priced

up to \$2,500 and which, because of their superb tone, exquisite artistic cabinetry and flawless construction, are unequaled and are worth all that is asked for them.

Both in period and upright styles *Sonora* maintains its supremacy and is in tremendous demand because of its unrivaled value.



IF you are interested in handling Sonora, The Highest Class Talking Machine in the World, write today to the jobber covering your territory.

AMERICAN HARDWARE & EQUIPMENT CO.,

Charlotte, N. C.
North Carolina and South Carolina

GIBSON-SNOW CO.,

Syracuse, N. Y.
State of New York with the exception of towns on Hudson River below Poughkeepsie and excepting Greater New York.

W. B. GLYNN DISTRIBUTING CO.,

Saxtons River, Vt.
States of Maine, New Hampshire, Vermont and part of Massachusetts

GRIFFITH PIANO CO.,

605 Broad St., Newark, N. J.
Northern New Jersey

HESSIG-ELLIS DRUG CO.,

Memphis, Tenn.
Arkansas, Louisiana, Tennessee, Mississippi

HILLMAN PHONOGRAPH CO.,

Wheeling, W. Va.
Virginia and West Virginia

KIEFER-STEWART CO.,

Indianapolis, Ind.
Entire State of Indiana

LEE-COIT-ANDREESSEN HARDWARE CO.,

Omaha, Nebraska
State of Nebraska

THE MAGNAVOX CO.,

616 Mission St., San Francisco, Cal.
Washington, California, Oregon, Arizona, Nevada, Hawaiian Islands, Northern Idaho.

M S & E.

221 Columbus Ave., Boston, Mass.
Connecticut, Rhode Island and Eastern Massachusetts

SONORA DISTRIBUTING COMPANY OF TEXAS

Dallas, Texas
Western part of Texas

SONORA PHONOGRAPH COMPANY, INC.,

279 Broadway, New York
Distributors for Greater New York

SOUTHERN DRUG CO.,

Houston, Texas
Southeastern part of Texas

SOUTHERN SONORA CO.,

310-314 Marietta St., Atlanta, Ga.
Alabama, Georgia and Florida

SOUTHWESTERN DRUG CO.,

Wichita, Kans.
Southern part of Kansas, Oklahoma (except 5 N. E. counties), and Texas Panhandle

C. L. MARSHALL CO., INC.,

82 Griswold St., Detroit, Mich.
409 Superior St., Cleveland, Ohio
Michigan and Ohio

MINNEAPOLIS DRUG CO.,

Minneapolis, Minn.
States of Montana, North Dakota, South Dakota, Minnesota

I. MONTAGNES & CO.,

Ryrie Bldg., Toronto, Canada
Canada

MOORE-BIRD & CO.,

1751 California St., Denver, Colorado
States of Colorado, New Mexico and Wyoming east of Rock Springs.

ROBINSON-PETTET CO., INC.,

522 West Main St., Louisville, Ky.
State of Kentucky

C. D. SMITH DRUG CO.,

St. Joseph, Mo.
Missouri, Northern and Eastern part of Kansas and 5 counties of N. E. Oklahoma

SMITH, KLINE & FRENCH CO.,

Philadelphia, Pa.
States of Pennsylvania, Maryland, Delaware, District of Columbia, and New Jersey south of and including Trenton

STREVELL-PATERSON HARDWARE CO.,

Salt Lake City, Utah
Utah, Western Wyoming and Southern Idaho

C. J. VAN HOUTEN & ZOON,

Marquette Bldg., Chicago, Ill.
Illinois and Iowa

YAHR & LANGE DRUG CO.,

Milwaukee, Wis.
Wisconsin, Upper Michigan

END OF MUSIC MEMORY CONTEST IN NEW YORK SCHOOLS

Widespread Interest Shown in Second Annual Contest With Silver Loving Cup Donated by Chas. M. Schwab as Grand Prize—Several Hundred Thousand Children Participate

The silver loving cup donated by Charles M. Schwab as the grand prize for the winning team in the second annual Music Memory Contest of the Department of Education of New York City was won by Public School 127 of Brooklyn with a score of 199.9 points out of a possible 200. Public School 108 of Brooklyn was second with 199.8 points and Public School 93 of Manhattan third, with 197. The contest was held in the auditorium of the Washington Irving High School, in Irving Place, the middle of last month. Despite the excessive heat a large audience was present. George H. Gartlan, director of music of the New York schools, presided.

The cup presented to the winning team last year was donated by Otto H. Kahn. The fact that men of the calibre of Mr. Schwab and Mr. Kahn should show sufficient interest in music memory contests as to give valuable prizes is regarded as significant of the trend of the times.

The contest held last month was the culmination of a series of eliminating contests in the schools throughout the city. First a contest was held in each school to determine by elimination who should represent the various schools in the district contests. In the district contests the winning teams to appear in the final contest were determined.

In the final contest in the Washington Irving High School eleven of the numbers selected to test the memory of the pupils were played by Mr. Gartlan on a Stieff piano, six on the auditorium organ and three on a Victrola.

While the records turned in by the children were being examined instrumental and song music was furnished by Jerome Swinford, baritone, and Gabriel Engel, violinist; Miss Lois Ewell, soprano, of the Haywood Institute of Universal Song, accompanied by Miss May Fine, and Alexander Fichandler, pianist, principal of Public School 165 of Brooklyn. The contest was

arranged and conducted by Frederic M. Davidson.

The winning team, as announced by James J. McCabe, district superintendent of Brooklyn schools, was composed of four girls and one boy. The boy was George Rocklein and the girls were Rosa Cohen, Marguerite Crane, Esther Ratner and Evelyn Davren. Of particular interest was the disclosure that Rosa Cohen is totally blind. Miss Josephine M. Burnett is principal of Public School 127 and Miss Florence Piretti, special music teacher.

In his introductory remarks Mr. Gartlan said that the number of pupils who participated in the contest this year had not yet been determined. Last year, he said, the number of participants reached the enormous total of 254,000. He paid tribute to all who had aided in the tremendous task of bringing the contest to a successful conclusion, and commended the National Bureau for the Advancement of Music for the work it is doing in instigating such contests in all parts of the country and furnishing information of assistance to the persons conducting them.

Mr. Gartlan referred specifically to the cup donated by Mr. Schwab and the banners given by the National Bureau for the winning teams in the district contests in the Boroughs of Manhattan, Brooklyn, Queens and Richmond.

C. M. Tremaine, director of the National Bureau for the Advancement of Music, who with other representatives from his office was an interested spectator of the contest, said that the Bureau has received a remarkable number of letters from schools throughout the United States in reference to music memory contests. One of the most interesting features to him, he said, is that these contests are becoming permanent institutions. For instance, the New Orleans public schools have just held their third

annual contest with 100 perfect scores out of 300 participants.

So widespread has become the adoption of this form of musical development, Mr. Tremaine said, that the Bureau has in preparation a booklet designed as an aid to newspapers in arousing public interest in such contests and carrying them along from stage to stage to a successful end. This is in addition to two other pamphlets already issued on the subject, which are now in wide circulation.

C. L. WAINWRIGHT MADE MANAGER

Takes Charge of Edison Department of Memphis House—Knows Southern Territory Well

MEMPHIS, TENN., June 28.—The Bry-Block Mercantile Co., prominent music dealers of this city, has announced the appointment of C. L. Wainwright as manager of the phonograph department. Mr. Wainwright has had a wide experience in selling the New Edison and has gained a broad acquaintance with Edison patrons in this territory. He was for many years with the Armstrong Furniture Co. here and later was promoter and manager of the Edison Phonograph Shop.

HE SPENT A PLEASANT EVENING

Caruso was recently invited to a reception at the home of a wealthy society woman. Knowing that he would be called upon some time in the evening to sing, the great tenor decided to take steps to protect himself. He walked over to the grand piano and when no one was looking locked the lid and put the key in his pocket. Later, after a diligent search, in which the famous Victor star was an industrious helper, they gave up the hope of hearing him and he spent an enjoyable evening. When he was saying good-bye to the hostess he handed her back the key with his compliments.

"Pull" takes all the "push" out of many a good man.

Three Big Factories—and "Knowing How"



Made of 5 ply Panel Stock

6 Models at Popular Prices

Prima-Donna
"The Phonograph Inspired"

BUILT in our three large, efficient plants from lumber to finished product by master craftsmen who know the high standard a successful phonograph must measure up to; and marketed by a sales organization of wide experience in the phonograph field, that aids the jobber and the retailer, thru our advertising and sales helps, to bring the Prima-Donna to the ultimate user.

Mr. Retailer we have a jobber in your territory who can supply you over night with these big value phonographs at a liberal discount.

Also manufacturing other well known brands.



Guaranteed One Year

6 Models at Popular Prices

GENERAL SALES CORPORATION
1520 BUFFUM STREET MILWAUKEE, WIS.

OWNING & OPERATING
GENERAL MFG. CORPORATION RECORDEON PHONOGRAPH CO.
HEANEY-SCHWAB BILLIARD MFG. CO.
Makers of Fine Billiard Tables Since 1882

Still
Have
Some
Territory
Open

Write
For
Our
Liberal
Proposition

**TONOFONE—The Needle Triumphant—
The Needle that Everybody's Talking About**

TONOFONE has won its long battle for better phonograph music. It has reached the pinnacle of its own renown and, by force of its own distinctive merit, it has raised the modern talking machine to the highest plane of musical excellence.

**The Needle with the Flexible Point of Uniform Diameter
that brings out every Tone like a Grand Piano**

TONOFONE should be on sale in every shop in the world. The dealer who does not handle this "needle that's different" denies to his customers what is theirs by right and so turns from his door the ever-growing throng of those who demand the best.

**Remember *TONOFONE*—the Needle that's different—
The Needle with the Flexible Point**

If you are not already using and selling this needle that everybody's talking about, it is high time that you ask us for full particulars and the address of our nearest distributor.



R. C. WADE CO.

110 South Wabash Avenue

CHICAGO, ILL., U. S. A.

Inventors and Sole Makers

CALL FOR INTERNATIONAL RECORDS

R. F. Bolton, of the Columbia International Record Department, Tells of Conditions in Various Important Centers of Country

R. F. Bolton, sales manager of the international record department of the Columbia Graphophone Co., returned recently from an Eastern trip which included a visit to Columbia branches in Philadelphia, Baltimore, Boston, Portland, Me., Pittsburgh and Buffalo. On this trip, Mr. Bolton conferred with the branch managers and the sales organizations regarding the development and expansion of foreign language record business.

In a chat with *The World*, Mr. Bolton stated that the sale of international records is steadily increasing, and that the dealers are optimistic in their predictions for the future. Arrangements were made recently with the Columbia factories whereby the international record department will get a much larger output of "B" series records than heretofore, which will enable the branches to co-operate with the dealers more

efficiently than they have done in the past. Prospects for Summer business are very satisfactory, and one of the reasons for this general optimism is the fact that thousands of immigrants are arriving here each week, and the current statistics indicate that immigration is steadily outdistancing emigration. Moreover, as Mr. Bolton points out, these immigrants are 100 per cent buyers of foreign language records, whereas the great majority of emigrants were considerably less interested in this class of music.

EVAN WILLIAMS POINTS A MORAL

The late Evan Williams, entertained by a wealthy European shoe manufacturer, was asked to give some numbers. He sang several selections for the guests and was much applauded. The next day he visited the store of his host, put on a pair of the best shoes in the place and started to walk out. The shoe man wanted to know if Mr. Williams wished him to send a bill. "No," said Williams, "I am a professional singer and make my living that way. You make your living making shoes." They were quits.

SOME CLEVER MOVIE PUBLICITY

How Olive Thomas, the Famous Selznick Movie Star, Pays Tribute to the Sonora

Olive Thomas, the famous Selznick movie star, is an ardent admirer of the Sonora phonograph and one of her most treasured Christmas presents was a Louis XVI Sonora. That this talented young actress does not forget about the Sonora in her travels is shown in one of her recent films, "The Flapper." In this film a boarding school miss who passes through New York on her way to her home down South decides to see a little of New York's "high



Olive Thomas

life" and takes a bus down Fifth avenue. As the bus passes Forty-second street the big Sonora sign with the Sonora slogan, "The Highest Class Talking Machine in the World," is clearly seen. This Sonora advertising will be seen by hundreds of thousands of theatre patrons.

The number of well-known actresses who are owners of Sonoras is growing steadily from month to month. Among those who have Sonoras in their homes are Lillian Russell, Julia Sanderson, Blanche Ring and Norma Talmadge.

FORM AMERICAN MUSEUM OF MUSIC

Building Will Be Erected to Preserve Works of Art and Representative Instruments

Supreme Court Justice Tierney approved recently the incorporation of the American Museum and Temple of Music, Inc., which purposes to "erect and maintain a building suitable to contain and preserve objects of art, interest and instruction relating to the history, science, art, influence, utility and production of music." The organization expects to become affiliated with the National Federation of Music Clubs.

Mrs. Frank A. Sieberling has been elected president and the directors chosen are Charles Sumner Ward, Sarah Cleveland Clapp, Edna Marione, Mrs. David Allen Campbell, Supreme Court Justice Guy and Albert E. Ruff.

LOYALTY

Victor Dealers:

Loyalty is a word oftentimes lightly used, and readily forgotten when its observance means personal discomfort or financial loss.

WHY

WHY push other goods at the expense of the line that has made it possible for you to be in the Talking Machine business?

ACT

Become Victor Exclusively, and know that your act of today will bring its reward tomorrow.

Think It Over.



The
**Toledo Talking Machine
Company**

Victor Wholesalers : Toledo, Ohio

ROTTEN STONE

We are the only miners and manufacturers in this country of Rotten Stone for use in Phonograph Record making. Our product is now in use by practically every record manufacturer in this country. We are also headquarters for all other minerals for record making and everything we handle is made especially for this purpose and absolutely guaranteed. Expert advice given upon any formula.

KEYSTONE MINERALS CO.
41 Union Square, New York City



REG. U. S. PAT. OFF.

*The Standard by Which All
Phonograph Motors are Judged and Valued*

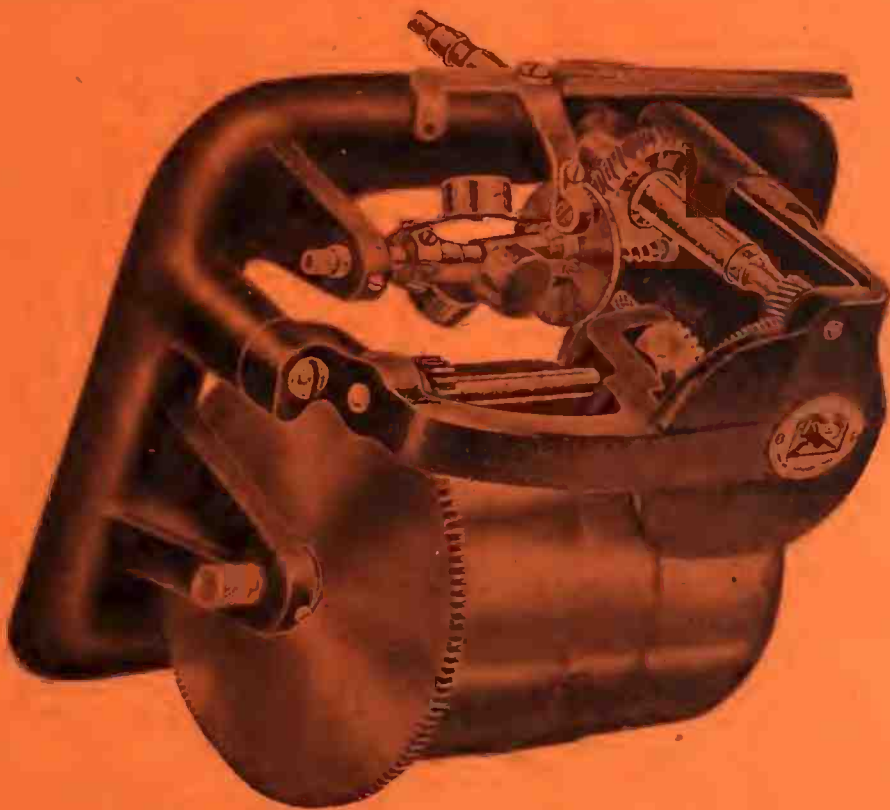

A Scientific Reason for Every Detail

In every detail of the Sphinx—in the principles on which it is based; in the nature, quality and weight of the materials employed; in the design and construction of the three independent self-contained units of which it is composed; in the alignment, balance and inter-relation of the parts—the problem of permanent and dependable uniformity of service has been worked out by a corps of able and experienced motor engineers. The Sphinx was not offered to the trade until that problem had been finally and positively solved.

Hence, for every detail in the Sphinx there is a sound, scientific reason and a practical and essential reason. Send for catalog.

SPHINX GRAMOPHONE MOTORS, Inc.

512 Fifth Avenue

..

..

..

..

New York

ELBEL BROS. BUY VICTOR STOCK

Acquire Entire Holdings of C. W. Copp Music Shop and Will Enlarge Victor Service

SOUTH BEND, IND., July 6.—The entire Victrola stock of machines and records formerly held by C. W. Copp, proprietor of the C. W. Copp Music Shop of this city, has been purchased by Elbel Brothers, an establishment which has been known here as a music center for thirty-five years. For the past twenty years this house has handled the Victor line on a large scale and this latest purchase was made in the interests of consolidating the Victor interests in order to afford the most complete Victor service possible.

PAPER SCARCITY AND ALBUMS

Some Timely Topics Discussed by Max Willinger, President of the New York Album & Card Co.—New York and Chicago Plants Busy—The Advantages of Location

Max Willinger, president of the New York Album & Card Co., returned to New York recently after some weeks spent at the Chicago factory of the company. He reported great activity at the Chicago plant and remarked that this as well as the New York factory had materially increased their production. Mr. Willinger, in discussing the album situation, said in part: "The tremendous demand for albums continues from all quarters without abatement. Our business thus far this year has exceeded all former records by a wide margin. There is every indication that this good business will continue for an indefinite period ahead. The only cloud in an otherwise clear sky is the paper situation. I believe that the trade as a whole are aware that there is a great scarcity of paper, but the greatest realization of this condition comes in actually trying to secure this commodity in the market. We have always used a certain high quality of paper in Nyacco albums and we are expending our entire energies in securing the necessary paper stock in order to fill the large orders we have on hand. It is gratifying to be able to state that we have thus far been able to overcome the difficulty, and the same high quality paper stock is being continued in Nyacco albums. Of course, the price of any commodity is governed by the law of supply and demand and the paper scarcity has greatly increased its market price thus far, and there is every indication that prices will advance still further. The advantage of having two factories, one in the East and one in the West, has been demonstrated recently during the railroad crisis. With these two factories, widely separated geographically, our deliveries were not nearly so seriously handicapped as they might have been had we been dependent upon a single factory located in any one city."

Every man has two educations—that which is given him, and that which he gives himself. Of the two kinds, the latter is by far the most valuable. Indeed, all that is most worthy in a man, he must work out and conquer for himself. It is that that constitutes our real and best nourishment. What we are merely taught seldom nourishes the mind like that which we teach ourselves.—Richter.

NEEDLES
WE MANUFACTURE
Diamond needles for Edison
Sapphire needles for Edison
Sapphire needles for Pathe
in stock ready for delivery
MERMOD & CO., 874 Broadway, N. Y.

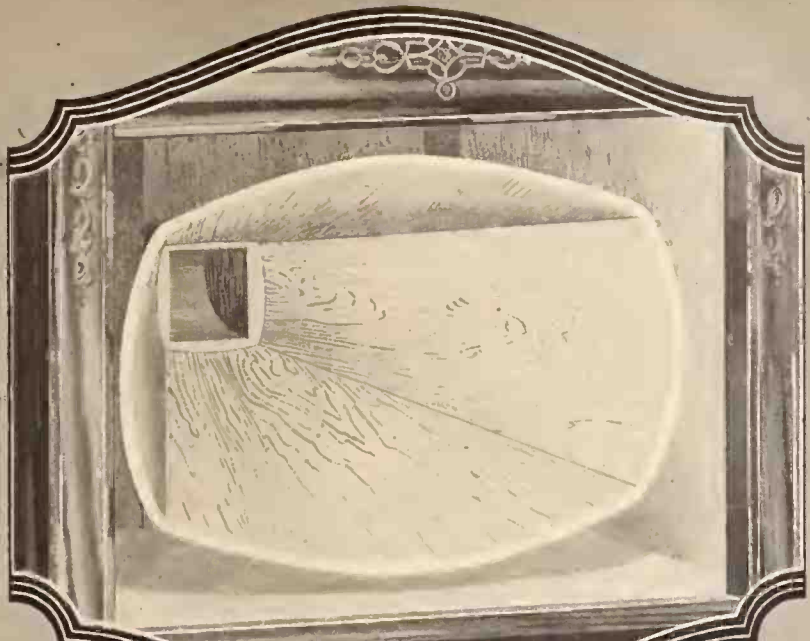

HARPONOLA

Harponola's Hidden Beauty

Harponola dealers are in position to make an unusual appeal both to the ear and the eye of music lovers.

This "phonograph with the golden voice" produces the mellowest and richest of music.

It is as beautiful to hear as it is to see.

And there is even more beauty concealed within the cabinet than exposed to the casual gaze.

Music lovers thrill with approval when the grille is removed, and the rare beauty of the golden horn is brought to view.

This horn, scientifically built of mellow spruce—nature's most vibrant of woods—is the real heart of Harponola's beauty. It is the reason for the clear, pure music that differentiates Harponola from other makes. It is the reason for the easy sales being built up by Harponola dealers.

THE HARPONOLA CO.

101 MERCELINA PARK
CELINA, OHIO

EDMUND BRANDTS, President

A limited amount of jobbing territory now open. Get our combination proposition on Harponolas and OkeH Records.

The
PHONOGRAPH
with the
GOLDEN VOICE

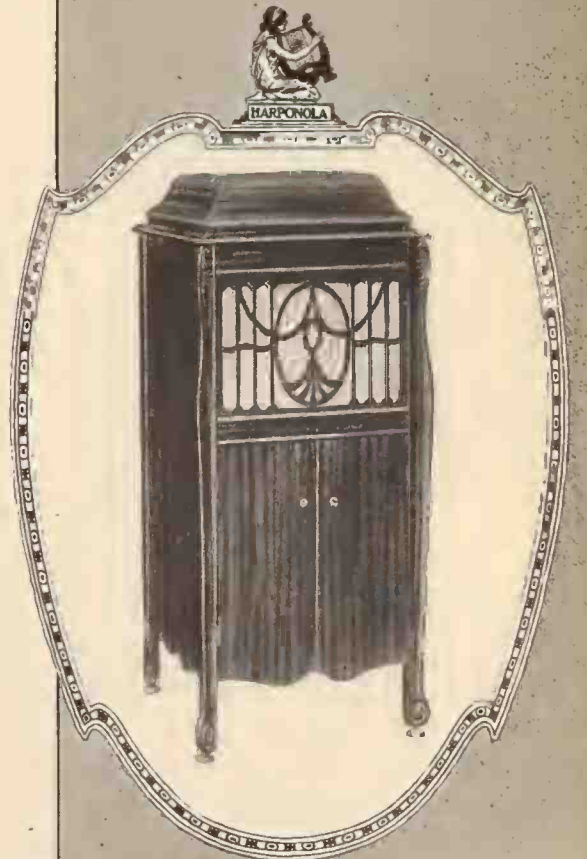

A UDELL CABINET

is a legitimate part of every sale of a table machine—it doubles the value to the customer and the profit to the dealer—

And the
UDELL

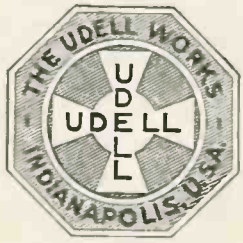

TRADE-MARK

Guarantees
Satisfaction



(Horizontal Shelves)
For New Victrola IX-A

No. 1405

Height, 36½ in. Width, 19 in. Depth, 22½ in. Holds 10 Victor albums. Mahogany Front or Quartered Oak Front. Average weight, crated, 90 pounds.

[If vertical interior is desired, order No. 405.]

[If felt interior is wanted, ask for No. 405F.]

Catalog on Request

The Udell Works
1205 W. Twenty-eighth St.
Indianapolis :: :: Ind.

TO RECORD FOR PATHE FRERES

Helen Yorke, Coloratura Soprano, Latest Addition to Increasing List of Pathé Artists

Helen Yorke, coloratura soprano, is the latest acquisition to the large list of nationally known artists whose recordings appear exclusively on



Helen Yorke

Pathé records. Miss Yorke is favored in musical circles and her various appearances in recitals at Carnegie Hall have earned well-merited commendation from critics. Musical authorities have acclaimed the quality of her voice. It is expected that the first recordings by Miss Yorke will appear in an early Pathé supplement. Miss Yorke in private life is Mrs. Misha Appelbaum. The good works of her husband as founder and head of the Humanitarian Cult are well known throughout the country.

EDISON RECITAL DIRECTOR WEDS

Arthur L. Walsh Marries Miss Agnes E. Mulvey, a Resident of Newark

Arthur L. Walsh, director of the tone-test recital department at the Edison laboratories, was married in Newark, N. J., last month to Miss Agnes E. Mulvey, daughter of Mr. and Mrs. Martin Mulvey, of that city. The wedding was the outcome of a romance which began five years ago while Mr. Walsh was touring the country as a concert violinist. Following a trip to Colorado Springs, where they are spending their honeymoon, the couple will return at the end of June to reside in East Orange.

Mr. Walsh has been connected with the Edison laboratories for over five years, during which time he has visited every State in the Union as a conductor of tone-test recitals. Last August he was made director of that department and much of its success since that time is attributed to his careful guidance.

JOINS COLUMBIA BUFFALO BRANCH

R. J. Milholland has been appointed a member of the sales staff of the Buffalo branch of the Columbia Graphophone Co. He spent some time recently at the Columbia executive offices in New York and visited the factories at Bridgeport acquiring an intimate knowledge of Columbia merchandising and manufacturing plans.

EXTRA DIVIDEND DECLARED

The Columbia Graphophone Manufacturing Co. has declared an extra dividend of one-twentieth of a share, payable in common stock, in addition to the regular quarterly dividend of 25 cents a share, and \$1.75 a share on the preferred. All these advances were payable July 1 to stockholders of record of June 18.

Disc Record Manufacturers ATTENTION

If you are not satisfied with your product—

If some part of the manufacture needs perfection—

Let me help you.

I was the pioneer to introduce the present disc record into Europe in 1901. Successful factories were erected in England, France, Spain, Germany, Austria, and Brazil under my management. I know the record business from A to Z, and can straighten out your difficulties.

The present system of permanent masters was perfected in my laboratories in 1904 and has never been improved upon.

The double-sided record was my patent and brought out in 1903.

If you want the best to be had in recording machines; if you want the latest development in pressing records from shells; if you want increased record production in power-driven presses—I can help you.

*Complete installations
taken charge of*

F. M. PRESCOTT
RIVERDALE, N. J.

Phone No. 2 Pompton Lakes N. J. Telegrams Prescott, Pompton Lakes N. J.

The SUPERIOR LID SUPPORT

A Spring Balance That Does Not Warp the Lid

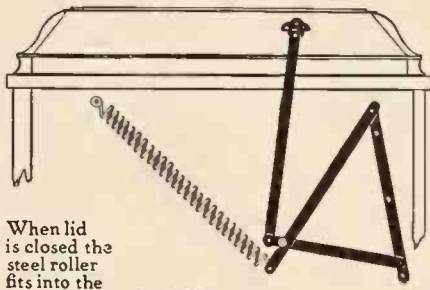

When lid is closed the steel roller fits into the notch of track-arm, preventing spring from exerting any pull on the lid while down.

Patented 1920

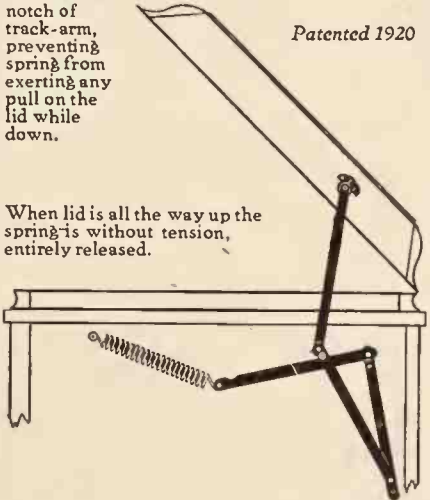

When lid is all the way up the spring is without tension, entirely released.

A mere touch of the finger lifts or closes the lid, which stops at any point desired. The simplest support made. Easiest to install. Positive and noiseless in operation.

Sample—Nickel 75c, Gold \$1.50

Prepaid anywhere upon receipt of price. Submitted on approval, subject to return within a reasonable time, in which event the full price will be refunded.

Quantity Prices Quoted on Application

Barnhart Brothers & Spindler
Monroe & Throop Sts.
CHICAGO

PATHE DEALERS and JOBBERS



The SCOTFORD Model I REPRODUCER

Will be a great aid in developing the sale of Pathe Records. Made to fit the Victor gooseneck exactly—it is as quickly attached as the Victor Reproducer is quickly removable. An Attachment also made for applying it to the Columbia Tonearm. Order a sample and realize the profit for you in the richness of its tone—surpassing all in purity, sweetness and power.

NET PRICES OF SAMPLES PREPAID

Nickel Plated Scotford Model I Reproducer - \$5.50
Gold Plated Scotford Model I Reproducer - 6.50
Nickel Plated Scotford Attachment for Columbia .35
Gold Plated Scotford Attachment for Columbia .50

Submitted on Approval, subject to return, in which event the full price paid will be promptly refunded.

Liberal Reduction on Quantity Orders
Profitable Arrangement for Jobbers

Barnhart Brothers & Spindler
Superior Specialties for Phonographs
Monroe and Throop Streets, CHICAGO

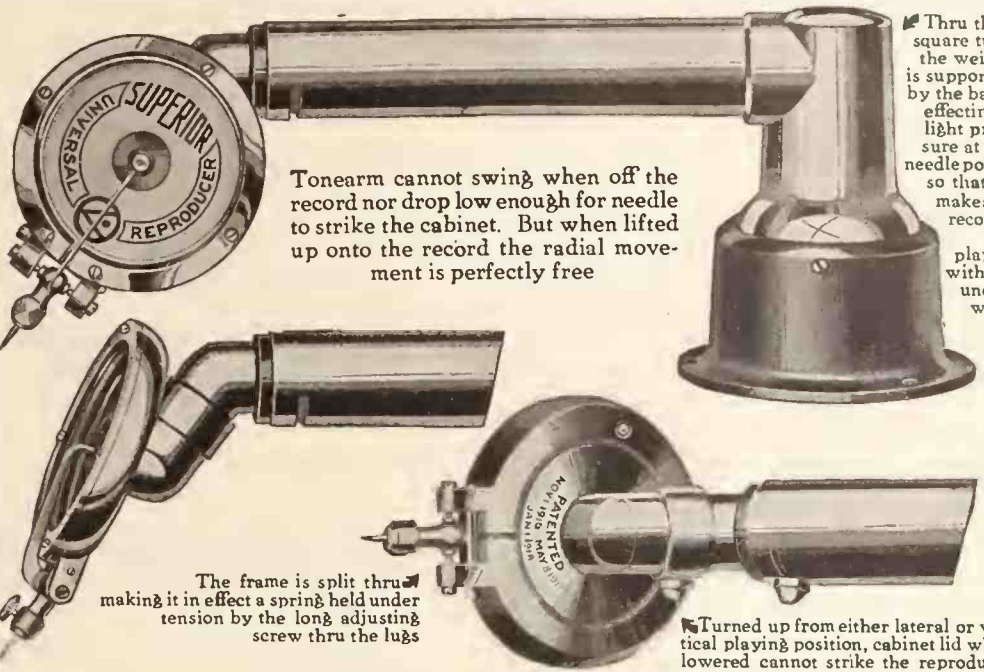

Tonearm cannot swing when off the record nor drop low enough for needle to strike the cabinet. But when lifted up onto the record the radial movement is perfectly free

Thru the square turn the weight is supported by the base, effecting a light pressure at the needle point, so that all makes of records are played without undue wear

The frame is split thru making it in effect a spring held under tension by the long adjusting screw thru the lugs

Turned up from either lateral or vertical playing position, cabinet lid when lowered cannot strike the reproducer

Why the Owner of the Ordinary Phonograph Soon Tires of It

THERE are lately a few phonograph reproducers which avoid the usual phonographic sharp metallic tone by going to the other extreme and producing a flat, unmusical sound. But the vast majority are disagreeably sharp in playing the high notes. This sharpness becomes an irritant to the ear, so that owners of such phonographs soon tire of playing them, lose interest, and stop buying records.

Nobody ever tires of genuine music. The human soul craves the comforting solace and ennobling inspiration that only music can give. It must be our aim to satisfy this great need—not the passing jag of jazz. The phonograph must become an instrument of genuine music if it is to endure.

There is one reproducer that measures up to the job of reproducing *musically* all the varying qualities of instrumental and vocal tones. It is never sharp, nor in avoiding this does it ever descend to the other extreme of flatness, but is always on the pitch, exactly reproducing the original rendition in all its purity, sweetness and power. This long sought goal is attained in the Superior Reproducer through its split frame, making the entire soundbox in effect a spring held under tension by a long adjusting screw through the two pivot lugs at bottom.

DISTINCTIVE FEATURES OF THE SUPERIOR REPRODUCER

The frame of the reproducer is split through, making the frame in effect a spring, held under tension by an adjusting screw through the pivot lugs at bottom. The back plate is entirely separate, insulated from the frame by a rubber gasket, and does not interfere with tensioning the frame.

It is the spring frame of this reproducer that accomplishes the important achievement of absolutely overcoming without any loss of volume or musical quality the usual phonographic sharp metallic tone on high notes. It is plain that tones picked up from the record by the needle and diaphragm mounted in a spring body will be more musical than will result when the body is of solid and hard metal, or of toneless and absorbent material.

Note particularly that the entire soundbox is in effect a spring. The split which accomplishes this results in the most important of the several Scotford patents. Soundboxes, which attempt to overcome the sharpness of tone by employing springs, rubber, fibre or other cushioning for the needle bar pivotal mounting, or use a composition diaphragm of sound-absorbing nature, result only in making the diaphragm less sensitive and prevent it from reproducing the finer shadings and overtones in the record.

The springlike frame also absorbs the extraneous vibrations so that the surface noise is practically eliminated. A manufacturer of a well-known machine who is an enthusiastic user of the Superior reproducer advertises as his slogan "the tone without the scratch."

Strong basic patents have been granted Mr. Scotford on the universal feature of his reproducer and our company holds the exclusive franchise to manufacture for general sale under these patents. Mr. Scotford in his contract with us agrees to co-operate in developing improvements, and covenants to give us before others the opportunity to review all new ideas or inventions he may originate in this line, with priority rights to manufacture and sell any such that are approved.

The universal feature is unique in that the needle aligns with the pivotal axis on which the reproducer turns from one position to the other. This holds the needle on exactly the same center at the same correct angle in both lateral and vertical (hill-and-dale) positions. The plane of the diaphragm being inclined with respect to the pivotal axis, instead of the ordinary straight needle bar of normal leverage, it is practicable to use the more desirable bar of angular shape effecting longer leverage, making the diaphragm more responsive to the needle action.

The needle bar is pivoted on sharp pointed steel screws, and is easily kept in perfect adjustment, free from side play, by the long adjusting screw through the lugs above the pivots. Any contraction of the metal parts that takes place cannot pinch the needle bar in its pivotal mounting, and thus interfere with its free vibration, owing to the spring construction of the frame. Any expansion that takes place, or wear of the pivot points, causing looseness and side play, can be instantly corrected by tightening the long adjusting screw.

Sample SCOTFORD Tonearm and Superior Reproducer with Mica Diaphragm	Nickel \$9.25	Gold \$11.25
Extra Reproducer with SCOTFORD Black Diaphragm	5.00	6.00

Prepaid anywhere, on receipt of price. Submitted on approval, subject to return within a reasonable time; in which event the full price will be refunded

Quantity Prices on Application

BARNHART BROTHERS & SPINDLER

Makers of SUPERIOR Specialties for Phonographs



Monroe and Throop Streets
CHICAGO, ILLINOIS



Responsibility

According to statistics only a very small percentage of those entering business succeed. The others would not or could not master the responsibilities.

Responsibility is something we may avoid or refuse to take, but we eventually pay the price in any event.

The VICTOR Company accepts the responsibility of maintaining VICTOR SUPREMACY.

The VICTOR distributor's responsibility does not end with past performance, but is a continual obligation. He is responsible not only to the VICTOR factory, but to the VICTOR dealers he serves.

Responsibility shouldered and mastered by the majority of VICTOR distributors and dealers, will correct many evils and best insure VICTOR SUPREMACY.

To be listed as a VICTOR distributor or dealer is a valuable asset, but not without its responsibilities.

It is our desire to not only master our responsibility as a VICTOR distributor, but to help our VICTOR dealers meet theirs. If we fail ourselves or through our dealers, we are not fulfilling our mission and we are contributing to a result in which we alone do not suffer.

VICTOR dealers, we believe, should and will support those distributors whom they consider responsible and therefore dependable. Likewise, they should expect support if they meet their responsibilities as VICTOR dealers.

The responsibility of VICTOR distributors and dealers during 1920, to intelligently distribute and market a greatly increased VICTOR product, will be an obligation to be treated seriously.

Be responsible, Mr. VICTOR Dealer.—be loyal, be efficient, and you will be successful. Do not worry or be side-tracked from your purpose through bad example or unfair competition.

Responsibility mastered, opens the path to further opportunity, and will ensure success in the VICTOR business, or any business.

J. NEWCOMB BLACKMAN.

Blackman
 TALKING MACHINE Co.
 81 READE ST. NEW YORK N.Y.
 VICTOR DISTRIBUTORS - WHOLESALE ONLY

SELLING TALKING MACHINES IN THE FOREIGN MARKETS

Recording of Local Folk Songs and Operettas an Important Feature of Any Campaign for Foreign Trade, Declares Edmond Sause of the Columbia Graphophone Co.

Operations of the larger talking machine companies in the export markets of the world partake of a two-fold character, in that not only do they effect the sale of their instruments and records, but one of their chief sources both of revenue and of popularity in foreign countries is the recording in those lands of the individual and characteristic music of each and from the actual singing and playing of native artists and vocal and instrumental ensembles on the ground.

Some idea of what these activities represent in outlay of labor, time and money and as wholly preliminary to and apart from the later routine work of serving the export trade as such, was set forth for a representative of the New York Evening Post, by Edmond Sause, manager of the export department of the Columbia Graphophone Co., this city, in discussing the peculiarity of this phase of the company's export business. He said:

"Not only the standard music of whole nations and whole races—that is to say, music of a traditional character such as folk songs and folk dances, national hymns, favorite selections from their musical literature, such as operas, operettas and, in the case of Spain, Portugal and the Latin-American countries, zarzuelas and concert and band pieces—must be recorded, but obviously it is a question of commercial policy to keep abreast of their newest and latest offerings in songs and instrumental music.

"This necessitates sending to the scene of such recording to be done by us not only a high-salaried and thoroughly trained musical director, one familiar with the peculiarly exacting requirements of voice and instrument recording, but a mechanic no less experienced and qualified in his calling and very often an accompanying staff of musical and laboratory aides. Then they have to take along with them a considerable paraphernalia, including 'wax masters,' or large, matzoth-like crude discs of wax composition, most carefully packed in cotton-lined boxes, to be used in recording each composition. These are much larger in circumference than the average finished disc and very thick. Each of these, more carefully packed after recording than before, has to be returned to the factory in the United States, where steel dies or matrices are produced from the engraved wax and from which the commercial phonograph records are made.

"All this naturally represents expense, but the

most expensive item lies in the fact that after oftentimes interminable journeys over sea and land, when the 'scene of action' is reached, it not infrequently happens that a protracted period of tedious preparation and 'coaching' of the singers or instrumentalists to be recorded is found to be necessary, as also acoustically suitable recording chambers or quarters. When we realize that some of our greatest and best schooled opera singers and concert artists require the most careful and painstaking instruction before they can properly gauge their voice or instruments for the 'speaker' or 'receiving horn,' it follows that musicians in remote places, sometimes in primitive regions, however capable they may be as performers, are pretty sure to require the greatest effort and care in coaching before they can be recorded. Then, when the record has been obtained, it has to be packed and handled and conveyed with infinite caution. The slightest contact of the recorded surfaces of these original wax master records would destroy them completely, as the engravings are sometimes less than 3/1,000 of an inch deep.

"Like the sewing machine, typewriter and cash register, the talking machine can be said to be an American product. Its possibilities in foreign trade were appreciated practically from the beginning. While the industry was still struggling in home markets, progress was being made in developing foreign trade.

"Few American industries can show as large a percentage of foreign trade to its total turnover as the talking machine industry during the last twenty years."

JACOBSEN'S AMERICAN CAREER

Although Sascha Jacobsen, the talented Columbia artist, is generally thought of as a native Russian, he was born at Finland twenty years ago. He commenced study of the violin at 8 years of age and at 11 came to America, where he completed his study under the guidance of Franz Kneisel, made his debut in New York and is probably the only great violinist who has scaled the tops of fame and reputation solely on an American career.

There is nothing in the world that commands such a high price as effective ideas, and this obtains in all fields of effort.

The Portophone

A High Grade

Portable Phonograph that is
High Grade



"The Portophone" plays any disc record with perfect tone

Container in Lid Holds Twenty-four Selections



Examine the motor and listen to the tone. You will be convinced that it is the kind of a Phonograph all Reputable dealers should sell.

The TRI-SALES CO.

Victoria Bldg.

St. Louis, Mo.



Sonora

Semi-Permanent Phonograph

NEEDLES

Well known, well advertised, Sonora Semi-Permanent Needles are favorites with owners of ALL MAKES of phonographs.

These needles are in demand, they sell for 25c a package, they bring you a larger profit per sale than any other make of needles and their beautiful playing qualities make them unequalled in value from the buyer's point of view.

If you haven't yet ordered these needles, do so now. If your stock is incomplete, re-order.

25c per package of 5 40c in Canada

Sonora Phonograph Company, Inc.

GEORGE E. BRIGHTSON, President

NEW YORK: 279 Broadway

Canadian Distributors:
I. Montagnes & Co.
Toronto

Caution! Beware of similarly constructed needles of inferior quality.



30 at Random



30 at Random

Three hundred Unico Equipments have been ordered and installed since January first



More than 40 per cent. of these installations were repeat orders.

THE thirty installations shown on the opposite page were taken at random from our files and are typical of what the Unico System does towards creating atmosphere to stimulate sales.

Our customers are located in virtually every State and principal City in the country. The Unico System is adapted to your individual use by our Planning Department, in order to insure the most desirable medium for the proper display of goods and the establishment of an inviting atmosphere.

The flexibility of the equipment allows for rearrangement and relocation. More than 40 per cent. of the installations shown were repeat orders, where Unico Equipment had developed requirements for increased facilities. Experience with hundreds of installations has shown a resulting business growth, which can be readily cared for by the use of our equipment.

If you have not installed the Unico System with its sales compelling force, *now* is an excellent time to do so, in order to take care of the coming fall and holiday activities.

Ask your friends and competitors about Unico Equipment; they are probably using it now.

Key to Photographs on Opposite Page:

- | | | | |
|---------------------------------------|----------------------|------------------------------------|----------------------|
| 1. GREGORY'S MUSIC HOUSE, | Saginaw, Mich. | 15. GIMBEL BROTHERS, | New York City, N. Y. |
| 2. MAISON BLANCHE COMPANY, | New Orleans, La. | 16. F. J. WEIGAND, | Barberton, Ohio |
| 3. KNICKERBOCKER TALKING MACHINE CO., | New York City, N. Y. | 17. M. STEINERT & SONS CO., | Boston, Mass. |
| 4. YAHRLING & RAYNOR PIANO CO., | Youngstown, Ohio | 18. M. O'NEILL, | Akron, Ohio |
| 5. WILSON MUSIC COMPANY, | Oshkosh, Wis. | 19. G. A. BARLOW SONS CO., | Trenton, N. J. |
| 6. B. B. TODD, | Philadelphia, Pa. | 20. BLOCK & KUHL COMPANY, | Peoria, Ill. |
| 7. F. L. STEERS & CO., | New York City, N. Y. | 21. KRAFT, BATES & SPENCER, | Boston, Mass. |
| 8. C. C. MELLOR COMPANY, LTD., | Pittsburgh, Pa. | 22. HERBERT THIELE, | Brooklyn, N. Y. |
| 9. ECLIPSE MUSICAL COMPANY, | Cleveland, Ohio | 23. TREMONT TALKING MACHINE CO., | Boston, Mass. |
| 10. COHEN & HUGHES COMPANY, | Washington, D. C. | 24. GEWEHR PIANO COMPANY, | Wilmington, Del. |
| 11. NEW YORK TALKING MACHINE COMPANY, | New York City, N. Y. | 25. KESSELMAN O'DRISCOLL CO., | Milwaukee, Wis. |
| 12. CRESSEY & ALLEN, | Portland, Me. | 26. NEAL, CLARK & NEAL CO., | Buffalo, N. Y. |
| 13. RUDOLPH WURLITZER CO., | Columbus, Ohio | 27. THE BUESCHER COMPANY, | Cleveland, Ohio |
| 14. CLARK WISE & COMPANY, | San Francisco, Cal. | 28. McCOY'S, INCORPORATED, | Hartford, Conn. |
| | | 29. LANDAY BROTHERS, INC., | New York City, N. Y. |
| | | 30. W. F. FREDERICK PIANO COMPANY, | Pittsburgh, Pa. |

UNIT CONSTRUCTION COMPANY

Rayburn Clark Smith.....President
58th Street & Grays Ave
PHILADELPHIA

Unico
Construction
is Patented

NEW YORK
299 Madison Ave.
Corner 41st St.

CHICAGO
Willoughby
Building

Unico
Designs
are Patented

H.K. Lorentzen

Manufacturer of

Exclusive Cabinet Hardware and Accessories

60 Grand Street

New York City

NEW CARRYING CASE POPULAR

Knickerbocker "Ready to Play" for Victrola IV in Demand—Dealers Installing Jones-Motrolas Electric Winding Device

Quantity production of the new Knickerbocker "Ready to Play" carrying case for Vic-



Knickerbocker Carrying Case for Victrola IV's will shortly be under way. The first models of this new case made of both wood and fiber have earned enthusiastic comment where shown. One of the novel features of this new case, which is said not to be contained in any other carrying case made, is that

the machine may be played without removing it from the case. The case is very attractive in appearance, and it is expected that it will prove an all-year-round seller and not be limited to any one season.

The Knickerbocker Talking Machine Co., New York City, Victor wholesalers and producers of this carrying case, have had remarkable success with the Jones-Motrola electric winding device, which they also distribute. A number of the large Victor dealers in New York City, upon the suggestion of the Knickerbocker Talking Machine Co., are installing Jones-Motrolas on the machines in their demonstrating booths in addition to retailing this device. The Jones-Motrola in the demonstrating booth has proved a valuable time and labor saver to the salesman in the demonstration of both records and machines.

"RIGHT ON THE JOB"

The same day that the advertising department of the Sonora Phonograph Co. received word from its jobber covering that territory that Rowell's Pharmacy, of Benkelman, Neb., had been appointed a Sonora dealer the following letter was received:

"Please rush some newspaper cuts of the Sonora machines. We want to hook up with your national advertising. This national advertising has put several people in our store this week and we feel we can help a lot with some local ads. (Signed) "Rowell's Pharmacy."

The interesting part of this communication is the fact that the population of Benkelman is

only about 600 and the town is surrounded by farming and grazing regions, with a total population slightly under 5,000.

This live-wire merchant, however, realized the fact that the extensive advertising used by the Sonora Phonograph Co. could be utilized as the basis for an intensive co-operative campaign and started immediately to feature the Sonora.

JEWETT PHONOGRAPH CO. OFFICERS

Complete Line of Instruments, Including Cabinet and Console Models, to Be Introduced

DETROIT, MICH., July 6.—George M. Seymour, vice-president of the newly organized Jewett Phonograph Co. of this city, recently announced that there will soon be ready for the trade a complete line of instruments, including standard cabinet models and console styles. Excellent progress is being made towards heavy production, and merchandising plans will be ready shortly.

The president of the Jewett Phonograph Co. is Edward H. Jewett, of Jewett, Bigelow & Brooks, coal producers. Harry M. Jewett, president of the Paige-Detroit Motor Car Co., one of the leading automobile manufacturing concerns in the country, is vice-president of the company; Frederick L. Jewett, vice-president of the Paige interests, is treasurer of the Jewett Phonograph Co., and John D. MacKay, of Stellwagen, MacKay & Wade, well-known lawyers, is secretary. Mr. Seymour is in charge of sales, and an aggressive campaign in behalf of the new line will be launched in the near future.

The "LARK" TALKING MACHINE CORPORATION

CAMDEN, N. J.

*Announce to the trade
the appointment of*

M. C. SIMONS

As sole distributor of their products

Model V, in Mahogany, now retailing at \$200, is undoubtedly the most accurate and perfect musical instrument in the talking machine line.

Available territory is now open for progressive dealers to secure the exclusive sales rights in their locality for this new talking machine of exceptional qualities.

Write today for your territory and full information to

M. C. SIMONS
1-3 Delancey Street New York City



Lateral
Cut

Okéh Records



Lateral
Cut

Tenth Supplement

PLACE YOUR ORDER NOW

- 4108 { DADDY, YOU'VE BEEN A MOTHER TO
10-in. ME—Tenor, with orch.....Lewis James
\$1.00 WHO'LL TAKE THE PLACE OF MARY?—
Vocal Trio, with orch.....Crescent Trio
- 4109 { MANYANA—Fox-trot,
10-in. Green Brothers' Novelty Band
\$1.00 WHOSE BABY ARE YOU?—One-step,
All Star Trio
- 4110 { DANCE-O-MANIA—Fox-trot,
10-in. Joseph Knecht's Waldorf Astoria Dance Orch.
\$1.00 WOND'RING—Fox-trot.....All Star Trio
- 4111 { AGES AND AGES—Tenor, with orch....Sam Ash
10-in. EVERYBODY'S BUDDY—Tenor, with orch.,
\$1.00 Billy Jones
- 4112 { MARION (YOU'LL SOON BE MARRYIN'
10-in. ME)—Soprano-Tenor Duet, with orch.,
\$1.00 Rachel Grant-Billy Murray
- I'M ALWAYS FALLING IN LOVE WITH
THE OTHER FELLOW'S GIRL—Con-
tralto-Baritone Duet, with orch.,
Helen Clark-Joseph Phillips

- 4113 { THAT THING CALLED LOVE—Contralto,
10-in. with orch.Mamie Smith
\$1.00 YOU CAN'T KEEP A GOOD MAN DOWN—
Contralto, with orch.....Mamie Smith
- 4114 { MISSY (Intro.: "Rainbow of My Dreams")—
10-in. Fox-trot.....Rudy Wiedoeff's Palace Trio
\$1.00 ALABAMA MOON—Waltz,
Green Brothers' Novelty Band
- 4115 { ZOMA—Fox-trot,
10-in. Joseph Knecht's Waldorf Astoria Dance Orch.
\$1.00 I LIKE TO DO IT—Fox-trot,
Green Brothers' Novelty Band
- 4116 { WAILANA WALTZ ("Drowsy Waters")—Ha-
10-in. waiian Guitar Duet.....Ferera-Franchini
\$1.00 BEAUTIFUL HAWAII—Hawaiian Guitar
Duet Ferera-Franchini
- 4117 { BEAUTIFUL ISLE OF SOMEWHERE—
10-in. Mezzo Soprano-Baritone Duet, with orch.,
\$1.00 Jean Neelson-James Jordon
- HOLY GHOST WITH LOVE DIVINE—
Tenor, with orch.....Reed Miller

SEASON'S BIGGEST HIT!

- 4146 { THE LOVE NEST (from Musical Comedy "Mary")—Fox-trot
10 Inch Lanin's Roseland Orchestra
\$1.00 The intrinsic freshness of this Fox-trot and the instantaneous popularity of Geo. M. Cohan's late production, "Mary," have won for THE LOVE NEST a first place as a POPULAR Favorite.
Okéh was quick to recognize its VALUE FOR YOU, and have made a special recording that you may have an EARLY release of that which is to be "a-most-in-demand record."
ENTICING (Seduisante)—Waltz
Joseph Knecht's Waldorf Astoria Dance Orchestra

SPECIAL RELEASE—BEGIN DELIVERY JULY 20th

GENERAL PHONOGRAPH CORPORATION

OTTO HEINEMAN, *President*

25 West 45th Street - - New York City, N. Y.

Factories:

NEWARK, N. J.
ELYRIA, OHIO
PUTNAM, CONN.
SPRINGFIELD, MASS
KITCHENER, ONT

Branch Offices:

CHICAGO, ILL.
SAN FRANCISCO, CAL.
TORONTO, CAN.
LONDON ENG.



Summer will soon be in full swing. There are 74 Special Summer Dance Records—jazz band jazes, saxophone waltzes and rollicking fox-trots with popular one-steps. Every one is a dancing ace. Get them, but you can't keep them.

**Columbia Graphophone Co.
NEW YORK**



THE STORY THAT NEVER GROWS OLD

Love and War Seek Music's Aid to Bring Romance to Happy Ending—Love at First Sight Over the Record Counter Brings Congratulations and Orange Blossoms

The story of a war romance in which a soldier, a pretty girl and a Victrola were the leading characters is being told by James J. Davin, of the New York Talking Machine Co. The girl is Miss Grace C. Gallagher, of 152 Eighteenth street, Flushing, L. I., and the hero is Edward E. Lyden, of Youngstown, O. This is how it all came about:

Miss Gallagher, who is now in charge of the Victrola department of Irving Reisenburger's store at 27 Main, was employed four years ago by Mrs. M. B. Kaplan, who conducted a store on Fulton street, Jamaica, where the sale of Victrolas was the principal feature. Mr. Lyden had enlisted during the early part of the war, in Youngstown, and had been assigned to the 803rd Air Squadron, and sent to Camp Mills, Long Island, with some other troops. While in camp, which was at Mineola, Lyden frequently went into Jamaica, and when the boys of his company decided to purchase a Victrola he said that he knew a store in Jamaica where they sold them, and he would ascertain how much they were.

While it seems hardly necessary to tell the rest, the story would be incomplete from a writer's standpoint, were it not said that he went into Mrs. Kaplan's store, met Miss Gallagher and—but what's the use. Well, anyhow, she started to show him the Victrolas, and you know how it is when a pretty girl commences to play modern melodies on a Victrola. She

played most of the latest tunes, but it is a question whether the soldier heard them or not, because he was busily engaged in looking at the young lady.

Strange as it may seem, Lyden bought a new record whenever he went into Jamaica, and he bought them all at Mrs. Kaplan's store, and sometimes he got to Jamaica twice a day and as many times in the evening.

Finally, when his company received orders to go to France he fixed everything up before he left. So the last tune he heard in Mrs. Kaplan's store was "Till We Meet Again." He was in France eighteen months. Now he is back, and—it's going to take place in September. The bride-to-be is wearing a handsome diamond and also a prettier smile than she ever wore before, and that's smiling some.

Miss Gallagher is a daughter of Mr. and Mrs. Charles Gallagher, and her hubby-to-be lives with his parents at Youngstown. He is coming to Flushing in the early Fall, alone, but he won't go home alone—Oh, no. It will be a church wedding and all Miss Gallagher's friends are congratulating her.

The young couple will make their home in Youngstown, where Mr. Lyden is engaged in business, and where they will have a little Victrola all their own.

THE "PORTOPHONE" IN MONTREAL

MONTREAL, CAN., July 2.—Louis J. Bourgette, whose offices are located at 93 City Councillor's street, this city, is representing the "Portophone" in the interests of the Esco Music & Accessories Co., in addition to the other lines of talking machine accessories which he carries.

SENDS RECORDS BY PARCEL POST

Columbia Co. at Bridgeport Has Own Post Office Branch in Factory—Several Tons of Records Sent by Mail Every Day

BRIDGEPORT, CONN., July 6.—There is hardly a factory or manufacturing establishment in this city which is not using the parcel post to place its products on the market in the face of the great difficulties in making shipments by freight or express. The Columbia Graphophone Co., for example, is making large shipments of records by parcel post, often sending out as many as two or three tons a day in this way. Two regular postal distributors are now on duty at the plant sorting the packages and placing them in the mail sacks. So great has been the demand on the postal facilities that additional equipment is being arranged for.

The cream-tinted walls are a pretty background for the shade lights and mahogany furniture, and make a perfect setting for the strains of all music from opera to jazz.

Mr. Sims, the manager, has been connected with some of the largest music houses in the South, and his experience in these lines will be of material benefit to purchasers.

MINISTER ASKS FOR VICTROLA

OTTAWA, ONT., July 6.—At a recent session of the Presbyterian General Assembly held in this city, Rev. Mr. Johnson, Assinaboia, Sask., stated that if a congregation could not support a minister that congregation should get a Victrola with records of sacred music and sermons and let the minister go somewhere where he would be paid a fair remuneration.

Foreign Music Rolls

for Your Foreign Record Customers

ITALIAN MUSIC ROLLS

MUSICA ITALIANA
Sonata da pianisti Italiani

JEWISH MUSIC ROLLS

אידישע מוזיק
געשפיעלט ביי אידישע פיאניסטען

POLISH MUSIC ROLLS

POLSKA MUZYKA
Przez Polskich Pianistów

AUTHENTIC IN EVERY DETAIL

From the Original Scores and with all the characteristics of their respective nationalities

MUSIC AS IT SHOULD BE PLAYED

OPEN CUT ROLLS ON BEST PAPER

THE MONOROLL

Four Sizes: 75 cents to \$1.25 Retail

Jewish, Italian and Polish Rolls now ready. In preparation: Hungarian, Bohemian and Lithuanian Rolls

Made by **THE ROSE VALLEY CO., 55th St. and Hunter Ave., Philadelphia**

Gennett

RECORDS

"The difference is in the tone"



The Individuality of Music

as conceived and interpreted by the artist, is offered in the new Gennett Records. They endow your phonograph with a *new* and entrancing charm. Try these new Gennett Records.

JULY LIST

- | | |
|---|---|
| 9033—Daddy, You've Been a Mother to Me (Fisher) Tenor Solo with Orchestra Accompaniment.
George Wilton Ballard | 9035—Blues, My Naughty Sweetie Gives to Me (Fox Trot) (Swanston-Carron-Morgan).
Harry Raderman's Orchestra |
| Cuddling Arms (Jerome-Lewis Young) Tenor and Bariton Duet with Orchestra Accompaniment.
Chas. Hart and Elliott Shaw—\$1.00 | Son of Omar (Edwards) (Novelty Fox Trot).
Harry Raderman's Orchestra—\$1.00 |
| 9034—I'm Always Falling in Love (With the Other Fellow's Girl) (Meyer-Caesar) Tenor Solo with Orchestra Accompaniment.
George Wilton Ballard | 9036—Karzan (Dulmage) (Fox Trot) Saxophone Solo with Orchestra Accompaniment.
Duane Sawyer and his Novelty Orchestra |
| Hand in Hand Again (Whiting Egan) Tenor and Bariton Duet with Orchestra Accompaniment.
Chas. Hart and Elliott Shaw—\$1.00 | Miss Me (Holland) (Fox Trot) Cordes' Orchestra.
Billy De Rex sings the chorus—\$1.00 |
| | 9042—On Miami Shore (Jacobi) (Waltz)
Cumberland Lane Orchestra |
| | Wild Flower Waltz (Marten Earl).
Diarilof's Orchestra—\$1.00 |

Any Starr Dealer will be glad to demonstrate the new standard of Gennett Record Perfection. They, as well as the Starr Phonographs are a revelation. Hearing is believing.

THE STARR PIANO COMPANY, RICHMOND, INDIANA
NEW YORK CHICAGO LOS ANGELES BIRMINGHAM DETROIT CINCINNATI CLEVELAND INDIANAPOLIS LONDON, CANADA



Starr
PHONOGRAPH

STARR PHONOGRAPHS
and
GENNETT RECORDS

Are distributed
throughout the Eastern States

By
J. SAMUELS & BRO. Inc.
Providence, R. I.
For New England

THE WITLIN MUSICAL INSTRUMENT CO.
8th and Chestnut Streets, Philadelphia
*For Eastern Pennsylvania, Delaware, Maryland, Dis-
trict of Columbia and South Western New Jersey.*

THE WALTERS & BARRY CORP.
256 Main Street, Buffalo, N. Y.
For Western New York

THE STARR PIANO CO.
9 and 11 East 37th Street, New York City
*For Eastern and Southern New York and North
Eastern New Jersey*

*Application for local selling rights from
dealers within the territories outlined
should be addressed to the distributor
covering that local territory. All
other applications should be addressed to*

THE STARR PIANO COMPANY
RICHMOND, INDIANA
NEW YORK CHICAGO LOS ANGELES
BIRMINGHAM DETROIT CINCINNATI CLEVELAND
INDIANAPOLIS LONDON, CANADA

F. McAllister / 20

THINK IT OVER

Mr. Victor Dealer:

Summer is here, but for only a short time and THEN WILL COME THE BUSIEST SEASON VICTOR DEALERS HAVE EVER KNOWN.

ARE YOU PREPARED to do a bigger and better business and DO IT RIGHT, to the SATISFACTION OF YOURSELF AND YOUR CUSTOMERS?

Now is the time to take stock of your condition and make plans to IMPROVE it, unless you feel that there can be no improvement.

See that you are THOROUGHLY EQUIPPED to do an up to date business. METHODS OF SEVERAL YEARS AGO WILL NOT DO TODAY. You must be up to date or you cannot expect to be one of the LEADERS IN YOUR LINE.

Plan your Fall advertising campaign now for the season and get it off your mind before the rush arrives.

YOU ARE SELLING A FIRST-CLASS PRODUCT, therefore see that your EQUIPMENT IS WORTHY OF REPRESENTING THAT PRODUCT.

You do not have to make excuses for your merchandise, therefore do not be obliged to make any for your selling methods or your establishment.

Live dealers are looking into the future and it is THE DEALER WHO GIVES THE BEST REPRESENTATION OF THE VICTOR PRODUCTS WHO WILL BENEFIT MOST IN THE END.

GET INTO THE GAME WITH ALL YOU HAVE IN YOU.

Remember—There is business in Summer as well as in the Winter for the live dealer. Do not say, "IT CANNOT BE DONE" but "GO OUT AND GET IT."

We are always glad to consult with our dealers in regard to any improvements they may contemplate and give them the benefit of our long experience.

Our service department is at your disposal. It may suggest something that you have not thought of.

Yours for service,

AMERICAN TALKING MACHINE CO.

AMERICAN TALKING MACHINE CO.
356 Livingston Street - - BROOKLYN, N. Y.

DEALERS IN INDIANAPOLIS ARE GOING AFTER BUSINESS

Any Temporary Slowing Up Is Being Counterbalanced by the Active Campaign Now Conducted by Leading Merchants Who Are Selling More Talking Machines and Records Than Ever Before

INDIANAPOLIS, IND., July 6.—With the Summer weather having a tendency, along with other factors, to slow up business, the live local dealers are stimulating business by "going out after them."

E. R. Eskew, manager of the Pathé Shop, has out a corps of women solicitors. Whenever these women locate a prospect a salesman follows up and closes the deal. If a prospect wishes it, a machine is placed in the home for demonstration and the salesman makes it a point to get out to the house early in the evening, when the man of the house is at home.

Other dealers are using similar campaigns on the outside. The results of these campaigns are two-fold—they keep up the morale of the sales force during the hot weather and they keep the people thinking and talking about talking machines, bringing in a certain percentage of business that could not be had otherwise in the Summer months.

Morris Rosner, manager of the Pearson Piano Co. talking machine department, noticed a decided improvement in business during the last ten days. Two of his sales force, Miss Ruth and Miss Hankins, have gone to Portland, Ore., to attend the Shriners' convention.

George Standke, manager of the Brunswick Shop, said that the trend of business continues to be toward the higher-priced instruments and that the demand for lower-priced and smaller instruments is negligible. Harry Bibb, of the Chicago office of the Brunswick-Balke-Collender Co., visited the local store last week.

W. O. Hopkins, formerly of Evansville, Ind., has succeeded A. H. Snyder as manager of the Edison Shop. Mr. Hopkins is contemplating the purchase of the shop.

Carl Anderson, manager of the Indianapolis Talking Machine Co., obtained much favorable publicity for his shop and the Victrola in connection with the showing here of the movie "Why Change Your Wife?" Mr. Anderson supplied a Victor machine and records, which were used effectively in connection with the picture. Business has been brisk in the portable models, Mr. Anderson said. The month of June brought wedding bells to the shop twice—Roy Cooper, of the sales force being married last week, and Miss Ruth Tamblym being married this week. Al Bates, of the Ohio Talking Machine Co. of Cincinnati, visited Mr. Anderson and other Victor dealers recently. Miss Lois Killen has joined the record sales force of Mr. Anderson.

The remodeling of Wideners' Grafonola Shop has been completed with the exception of a few finishing touches. W. G. Wilson, manager, is proud of the shop and he has reason to be. J. L. Peters is spending his vacation at Lake Tippecanoe. Miss Dorothy Jones, in charge of the record department, has returned after a two months' leave.

"What Indianapolis Missed in 1820" was the title of a clever window display featured by H. E. Whitman, of the Circle Talking Machine Shop, during the Centennial celebration. His window was covered with a canvas log cabin and by looking through the "window" of the cabin one could see an electric Victrola.

Ernest Arthur, manager of the Sonora department of Charles Mayer & Co., said the newspaper advertising campaign being carried on was getting results.

Taylor's is featuring the Victor machines and records with a large illuminated billboard in the heart of the downtown business district.

C. O. Mueller, manager of the talking machine department of Mooney-Mueller-Ward Co., Pathé distributor, said that the dealers in this territory

who have seen the new Model T Actuelle Classique are enthusiastic over it and predict a big sale. The Schneider Music Co., of Vincennes, Ind., has taken on the Pathé agency there.

George Stewart, of the Stewart Talking Machine Co., said that the reports from his salesmen indicate a great activity among Victor dealers in making preparations for increased business. Many dealers are remodeling their stores and enlarging them, Mr. Stewart said.

W. S. Barringer, who has been in charge of buying for the Stewart Co. for the last eleven years, has resigned his position to go into business for himself in Kokomo, Ind. Mr. Barringer will open a high-grade Victrola store. As photography has been his life-long hobby, Mr. Barringer also expects to carry a line of photographic supplies.

The New York Store, of this city, which han-

dles the Victor line, has enlarged and remodeled its Victrola department. It now has a forty-foot record counter.

Walter E. Kipp, of the Kipp Phonograph Co., expects that at least 100 dealers from this territory will attend the Edison convention in Chicago July 12.

Among the new Columbia dealers in this territory, as announced by the Indianapolis branch, are Scott & Hart, of Clinton, Ind.; S. C. Prevo & Sons, of Greencastle, Ind.; Odon Music Store, of Odon, Ind., and R. W. Wade, of Ladoga, Ind.

PIERSON CO. BEING ORGANIZED

A correspondent in Rockford, Ill., informs us that efforts are being made in that city to organize a company for the manufacture of talking machine cabinets. The new organization, when it is formally launched, will be known as the Pierson Phonograph Parts Co.

Remember that there is one teacher who is always satisfied with his salary, and he is experience.

A RECORD CABINET MATCHING VICTROLA NINE A



309 1/2

309 1/2.—Mahogany, golden oak, fumed oak, weathered oak, nickel plated trimmings, lock and key, shelves interior, casters. Height, 33 inches. Top, 18 3/4 x 21 1/4 inches. Matches New Victrola IX A. Patented rimmed moulding with removable back piece, so machine can easily slide in, giving a perfect "Cabinet-match" appearance. Average weight, crated, 70 pounds.

MANUFACTURED BY

SCHLOSS BROS.

637-645 West 55th Street

New York

Cabinets of all descriptions and finishes

Catalogue No. 20 Ready for Distribution

Have You One?

"WHAT ARE YOU SHORT?"

Get in touch with us. We have everything in the phonograph line—Needles, Tone Arms, Motors, Cabinets, all kinds of accessories and repair parts. We specialize on Main Springs, Bettertone Phonographs. Let us do your repairs.

PLEASING SOUND PHONOGRAPH CO.,
204-206 East 113th St., New York.

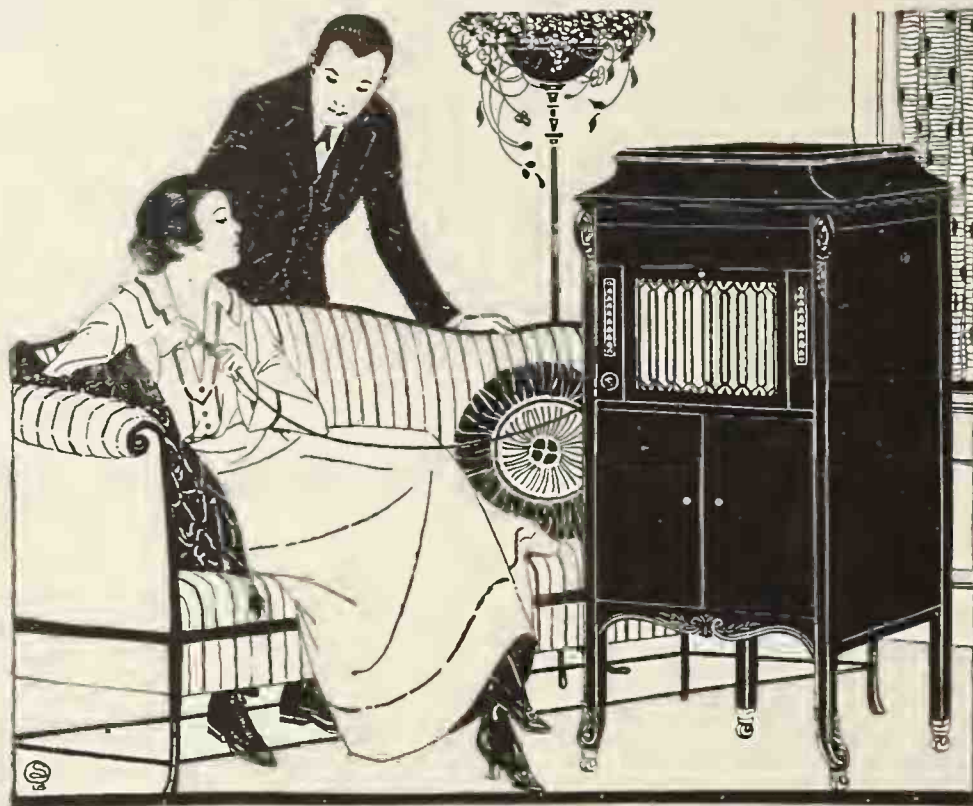

The AEOLIAN-VOCALION

The Phonograph that has made the Talking Machine a Real Musical Instrument. Manufactured by the Aeolian Company—Foremost Manufacturers of Musical Instruments in the World

REPRESENTATION A VALUABLE ASSET
FOR THE DEALER

VOCALION representation will, in the near future, be at a premium. The superiority of the Vocalion itself in musical quality, durability, appearance and "selling" features like the Graduola, etc., the superiority of the Vocalion Records and the magnificent national advertising being carried on in the *Saturday Evening Post* and other mediums is having a steady, strong, cumulative effect.

Progressive merchants who would appreciate the opportunity to handle a product which will be not only exceedingly profitable, but will add measurably to the prestige of any establishment, are invited to communicate with

SOUTHERN DISTRIBUTORS

O. J. DeMOLL

O. J. DeMOLL & COMPANY
WASHINGTON, D. C.

EMMONS S. SMITH

AEOLIAN-VOCALIONS

MELODEE PIANO PLAYER ROLLS

VOCALION RECORDS

ADVOCATES USE OF MOTOR TRUCKS

Geo. W. Hopkins Addresses Columbia Dealers at Indianapolis Meeting of Branch Managers—Ben Brown Tells of Visit to Bridgeport

INDIANAPOLIS, IND., July 6.—The Indianapolis branch of the Columbia Graphophone Co. held a meeting of its dealers at the Lincoln Hotel here recently. George W. Hopkins, of the Columbia Co., addressed the dealers on the use of motor trucks in selling the country trade.

"Just consider what your sales would be if you sold every person in your territory just \$1 worth of Columbia product each year," said Mr. Hopkins. "It seems absurd to mention such a figure and yet an actual check on your business will show you that in most cases your average is not equal to this amount. But by bringing your store to the people, with the use of the truck, you have the problem solved." H. L. Tuers sold the idea of Dealer Service to every dealer present. He explained in detail the policy of the company in its efforts to serve the dealer.

Robert Porter, new field sales manager of the company, was introduced to the dealers, and he talked to them on the importance of proper location for their stores, the class of trade they cater to, and the idea of having a definite quota each week as their working basis throughout the year.

Charles B. Lang, assistant branch manager, assured the dealers that the aim of the company men was to show a daily improvement in the service to the dealers. Mrs. Nellie I. Sharpe, educational representative working out of this branch, outlined the activities of the educational department.

Ben Brown, manager of the local branch, requested Manager McKenna, of the St. Louis, Mo., branch to tell about the trip made to the New York and Bridgeport factories with the St. Louis branch dealers. Mr. Brown hopes to have his dealers make the same trip shortly.

SHAW SUPPLY STORE REMODELED

Tacoma Victor, Edison and Columbia House Now Installed in Handsome Building—Large Electric Signs Advertise Location From Afar

TACOMA, WASH., July 3.—Alterations which have been in progress in the building of the Shaw Supply Co., Inc., for the past two months have been completed. This company, which handles the Victor, Edison and Columbia, has completely remodeled the building and has greatly increased the facilities for the display of talking machines and records. The talking machine and record department is now located on the first floor and has been handsomely finished in ivory enamel.

The general offices have been moved to the third floor of the building, where the accountants have what are said to be the best working conditions of any similar office in the city, on account of the abundance of daylight and fresh air. The new private offices of Paul T. Shaw and Henry G. Shaw are also on the third floor and have been handsomely fitted out in golden oak and mahogany. The entire store front of the building has been cleaned and four large electric signs have been added.

OPENS NEW STORE IN ENSLEY, ALA.

Ellis Jewelry Co. Music Store Becomes New Music Center for Victor and Columbia

BIRMINGHAM, ALA., July 6.—The formal opening of the Ellis Jewelry Co. Music Store in Ensley, which took place last month, marked another advancement in the tide of that city's progress.

This store occupies the place formerly occupied by the jewelry store, and has been converted into a modern home for the fifty-seven varieties of music that are now being offered to the public. With sound-proof booths in which to hear the latest Victor and Columbia records, one can let the rest of the world go by and not be disturbed.

BUYS INTEREST IN CAPITAL CO.

Jay T. Kanney, Formerly of La Porte, Ind., Will Have Charge of Olympia Store

OLYMPIA, WASH., July 6.—Announcement has been made of the sale of half interest in the Capital Music Co. by L. R. McIntosh to Jay T. Kanney, recently of LaPorte, Ind. Mr. Kanney has had ten years' experience in the talking machine business and will have charge of the inside work at the store. He is a son-in-law of J. D. Kuhns, manager of the Sloan shipyards for the Emergency Fleet Corp. Mr. McIntosh retains half interest in the business and will devote his attention to the outside sales. The Capital Music Co. is one of the best known concerns in its line in Thurston county and specializes on talking machines. Its stock of records is said to be one of the most complete in this section of the State, comprising more than 3,000 records.

A. C. HUFF'S BEAUTIFUL STORE

A. C. Huff, of Allentown, Pa., is converting his place into one of the most beautiful establishments in the Lehigh Valley handling talking machines. He just completed alterations in a large double property adjoining his present location. He has fitted up one of the most attractive piano and talking machine establishments to be found in that section. He has installed twelve attractive demonstrating rooms and four player-piano rooms. His recent opening was largely attended by the people of the city.

TO BUILD FACTORY ADDITION

The Rentz Talking Machine Co., Wells, Minn., is planning to build an addition to its factory in that city. Several shipments of material have already arrived and work will begin as soon as possible.



VICTOR SUPREMACY

VICTOR Retailers can look forward to a Banner 1920 Fall Season, for behind their product stands the acknowledged supremacy and leadership of the **VICTROLA** and **VICTOR RECORDS**

Are You Prepared to Handle this Trade?

G. T. WILLIAMS CO., Inc.
 217 Duffield Street
 Brooklyn
 N. Y.

EQUIPMENT

Blood Universal Tone Arm
Heineman No. 36 motor
12-inch 12 record album

Specially designed needle containers

Plywood construction

Extra heavy nickel plated hardware

Piano finish

List price \$52.50

with Little Wonder "WI" Motor
\$45



Patent Pending

The instrument for every home as well as for every occasion requiring a portable phonograph.

Dealers interested in high grade, standard machines can secure immediate shipments. Insure Christmas deliveries by ordering now.



Size 8 x 13 x 15 inches
Weight 16 pounds
A Portable in 30 seconds
Carries 12, 12-inch records in album

PIKNIK PORTABLE PHONOGRAPH, Inc. :: :: :: Lakewood, N. J.

SEES HEAVY FALL RECORD TRADE

Manager of Independent Record Department Which Features Okeh Records Finds Business on the Increase—Deliveries Maintained

S. F. Nusbaum, manager of the record department of the Independent Talking Machine



S. F. Nusbaum

Co., New York City, stated that he expected the Fall record business to be much heavier than that of last season.

Mr. Nusbaum has been connected with the talking machine industry for the past ten years. Prior to his joining the Independent forces he was a member of the staff of the General Phonograph Corp. His department carries exclusively the Okeh record, a product of which he is a great admirer. It has shown an increase of Okeh record orders each month, and these increases have been most substantial. He makes a feature of giving service to his dealers, and a point of always being ready to deliver at least 90 per cent of any orders received.

In speaking of conditions during the past few months, Mr. Nusbaum said: "Despite the shipping situation, embargoes, etc., we have been able, with very little delay, to keep our trade supplied with Okeh records. It is true that conditions at times were somewhat trying, but most of such problems have been met without any exasperating delay."

Mr. Nusbaum further stated that he found that the Okeh monthly hanger, denoting the record releases, are looked forward to by the trade eagerly, and from all indications they find this material a sales creator.

STANDARDIZE SIGNBOARD CAMPAIGN

Collings & Co., well-known Victor jobbers in Newark, N. J., recently sent to their dealers a plan for inaugurating a standardized signboard advertising campaign. The campaign will advertise Victor products and will of course also feature the dealer's name. Spaces have already been arranged for and concerted action from Victor dealers is planned.

LARGE NEW SCHLOSS BROS. FACTORY

New York Cabinet Manufacturers Moving Into New Quarters—Normal Production Expected by September—Facilities Greatly Increased

Schloss Bros., well-known cabinet manufacturers at 645 West Fifty-fifth street, will shortly move into their new factory at 797-805 East 135th street, corner of Oak, New York City. Their new home is a specially designed and equipped building for the manufacture of talking machine, player roll and other cabinets, as well as piano benches. It is three stories high, and contains approximately 50,000 square feet of floor space.

This firm is moving into its new quarters by degrees, thus keeping the production at the two plants at about normal. It is hoped to have all of the machinery and other equipment moved into the new building by August 15, and normal production will be reached by September 1. The floor space, machinery and other equipment, as well as the working force has been greatly increased, and in the early Fall months of this year the Schloss factory will be turning out double the production of that of their former home.

The new Schloss building is modern in every respect, and is what is described as a daylight plant. It has many conveniences for the workers, and the whole has been planned for efficiency. G. T. McCarthy, a well-known architect and builder, who is also responsible for the new home of the Gotham National Bank, is the designer and builder of the new factory.

SOUTHERN DISTRIBUTORS

Pathé PHONOGRAPHS and RECORDS



GRAY & DUDLEY CO.

Write Today for Agency Proposition

NASHVILLE - - - TENNESSEE

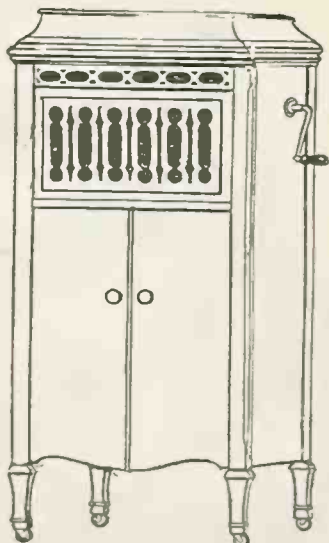



YORK MODEL



MILAN MODEL



RHEIMS MODEL

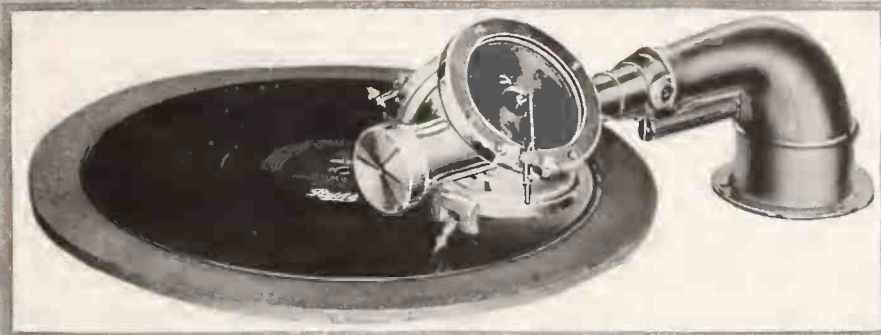

Your customers will instantly appreciate the advantages of the

Cathedral Phonograph

Good judgment prompts wise dealers to heed the constantly increasing demand for a phonograph that will properly reproduce all makes of records.

Without employing make-shift attachments the *Cathedral* gives the greatest number of playings from every record—conforming to the exact requirements of each type of record.

Cathedral Exclusive Features Insure Rapid Turn-Over

The Cathedral phonograph is replete with selling appeal. Its points of superiority are so instantly apparent that it creates a sensation wherever shown.

The Cathedral Reproducer is the first device designed to play all types of records according to each record's exact requirements.

A simple turn of the hand automatically presents the proper point at the correct weight with perfect synchronism for each type of record.

The Cathedral Amplifier is built of heavily ribbed spruce, scientifically shaped to eliminate sympathetic vibrations and reflect the amplified tone waves with perfect distinctness.

Distinctive Designs. Each of the Six *Cathedral* Models is a fine example of modern furniture designing. The grill designs and trimmings are adapted from the windows of famous Old-World Cathedrals. Every feature of the *Cathedral* Line expresses quality and distinction.

Cathedral Phonograph Co.

General Offices—Omaha, Neb.

Factories: Marion, O. Chicago, Ill. Grand Rapids, Mich.

Al Jolson's "Some Beautiful Morning (I'll Find You in My Arms)" is the Home-Run King of Songs. It's a seller from the start. Get ready by ordering big. A-2940.

**Columbia Graphophone Co.
NEW YORK**



COULD NOT BELIEVE THEIR EARS

Edison Tone-test Recital in Iola, Kan., Shows Good Qualities of Edison Reproduction

Vernon Dalhart, who is one of the widely known Edison artists, was sitting beside the New Edison on the stage during the recital held in Iola, Kan. The instrument was playing Van Eps' "Dixie Melody." The reproduction was so exact that many of the audience thought Mr. Dalhart was playing the banjo and stood up or craned their necks in order to get a better view. The newspaper account of the affair was as follows:

"The phonograph proved its ability to reproduce violin, piano and banjo music, as well as the human voice. The crowd was very much amused in connection with the banjo type of instrument to see the puzzlement of the spectators who had overflowed into the choir loft. These were unable to see the stage and were obviously at a loss to tell whether a real banjo was being played or not and every time they

craned forward trying to see, the rest of the crowd laughed in a way that increased their curiosity until several of them finally stood up and openly walked far enough around to be able to see what was going on."

WOOLEN MILLS SOLD FOR FACTORY

Davenport Cabinet Works Secures Site for New Factory—Will Mean Big Expansion

DAVENPORT, IA., July 6.—The old Davenport Woolen Mills property at 1227 East River street, considered one of the best of the remaining factory sites in east Davenport, has been purchased by the Davenport Cabinet Works, a new corporation engaged in the manufacture of talking machines. A contract of sale was signed to-day and the new owners will take possession of the building as soon as it has been remodeled for factory purposes. The consideration is said to be \$30,000.

The Davenport Cabinet Works is now located in a small factory building at Second and War-

ren streets. Its officers are L. E. Martin, president; John Kjellberf, vice-president, and D. E. Hallberg, secretary-treasurer. They announce that between forty and fifty men will be added to the working force.

A. W. LANDAY JOINS DENVER HOUSE

Becomes Manager of Victor Department of Knight-Campbell Music Co.

DENVER, COL., July 2.—A. W. Landay, of Landay Bros., Victor dealers of New York, has come to this city and is now in charge of the Victor department of the Knight-Campbell Music Co. Mr. Landay was forced to leave New York on account of ill health and disposed of his interests there some time ago. He has had long experience in the Victor business and is well qualified to look after the details of his new connection. He succeeds Tower O. Askerlund, who recently resigned to become associated with the Q R S Music Co.'s Denver warehouse and Western supply department.

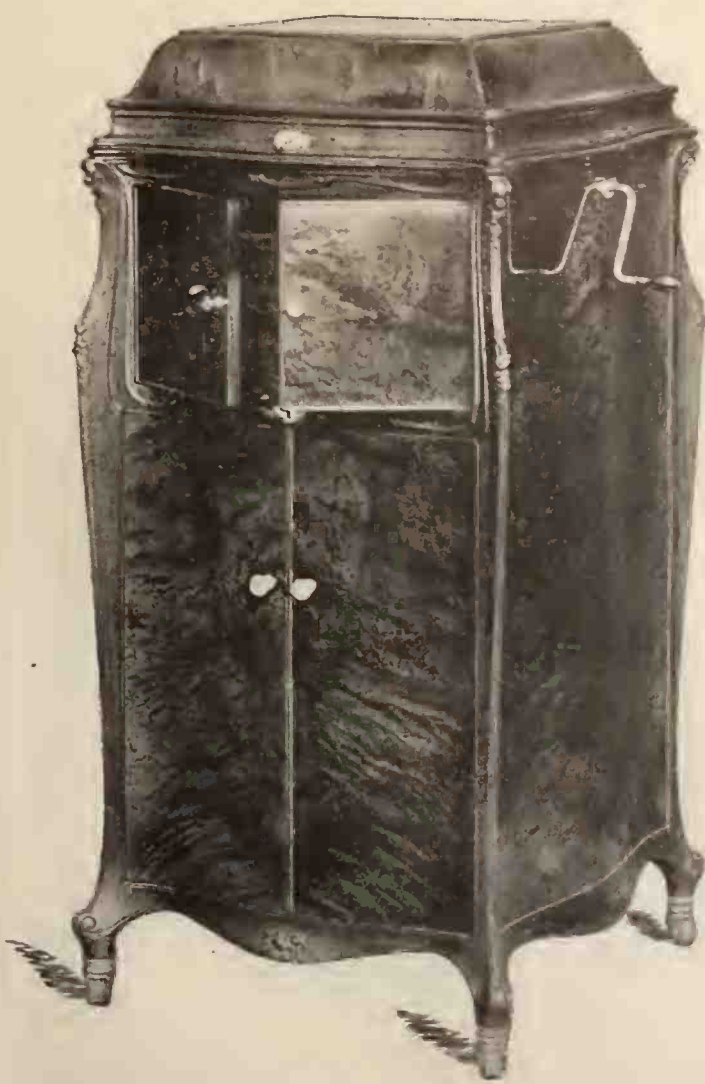

A WALNUT TALKING MACHINE CABINET

The finest phonograph is appropriately encased in

AMERICAN WALNUT

"The Cabinet-wood Superlative."

Superb and refined beauty — rich shading which even improves with age — wonderful reliability as a cabinet-wood — all these together put AMERICAN WALNUT in the very front rank of woods

For Phonograph Cabinets

More and more purchasers every day are giving to AMERICAN WALNUT their very first (and very insistent) preference. It pays to supply what is demanded.

We illustrate herewith an AMERICAN WALNUT TALKING MACHINE CABINET of elegant design. Could you imagine a more beautifully figured veneer than that which it exhibits?

Send for our valuable data for manufacturers — or data for dealers. Also the worth-while Walnut Book.

AMERICAN WALNUT MANUFACTURERS' ASSOCIATION
Room 1022 616 So. Michigan Boulevard Chicago.

Phonograph Dealers of New York and Pennsylvania

Sell the Brooks—the Automatic Repeating Phonograph that has every good feature found in all other machines, and many additional points of value possessed by no others.

The Brooks plays and repeats automatically *any* make of record *any* desired number of times, then stops automatically with the tone arm suspended in the air. The strong silent motor plays 6 to 8 ten-inch records with one winding. When it comes to TONE,—this remarkable instrument yields superiority to no other phonograph.

Dealers in New York State and immediate vicinity are advised to communicate with us very quickly if they are interested in a big sale of phonographs this season.

The Walters & Barry Corporation

256 Main Street

BUFFALO, N. Y.

We are the LARGEST Distributors of Brooks Automatic Repeating Phonographs in the United States.



The First Really Complete Phonograph

WILFERT BROTHERS TELL OF PLANS

Well-known Inventors Interested in the Musical Recording & Reproducing Co., With Plants in Augusta and Portland, Me.

BOSTON, MASS., July 6.—After having spent four years at least in perfecting the model that was to represent their idea of the most nearly perfect talking machine on the market the Wilfert Brothers, George F. and C. J. Fred, have practically closed out their business of fine cabinet makers and designers of high-class furniture at 27 Cambria street and gone to Maine. That is the latest chapter in the interesting story of a new talking machine, to be known as the Fidelis, which was referred to in a recent issue of *The World*.

The company controlling this instrument is a Maine corporation, to be known as the Musical Recording & Reproducing Co., and at Augusta, Me., are to be the head offices; to be more specific, 54 State street. It is to Augusta, where the factory for the manufacture of the machines is to be carried on, that George Wilfert, who is the vice-president of the company, will go, while the brother Fred will go to Portland, where it is planned to manufacture a line of records and where the recording laboratories are to be, also.

The latter gentleman will, however, make frequent visits to the Augusta factories.

The output of the company will be handled by the Fidelis Sales & Distributing Co. and it will have headquarters in New York, Chicago, Boston and Philadelphia. For the present there will be three models manufactured, but later there may be a fourth. One of these models, in the shape of a baby grand recently was exhibited before a group of invited guests at the Copley-Plaza in this city and created a most favorable impression, expert musicians being especially interested in the combination tone chambers. This baby grand model was sent a few days ago to Portland, where a demonstration was given.

The Musical Recording & Reproducing Co. has been capitalized for \$2,000,000 and its officers are Moxley Hill, president; George F. Wilfert, vice-president, who is also the inventor of the tone chamber; Embrey O'Bean, treasurer; John M. Goodwin, general manager, and C. J. Fred Wilfert, assistant general manager. Mr. Green, of New York, who has lately associated himself with the company, will be an important factor in the distributing concern, already mentioned, with headquarters in New York.

The Wilfert Brothers are also working on a universal reproducer which will handle all cuts of records. Patents have been applied for.

TO RECEIVE MICA FROM ABROAD

The Phonograph Appliance Co., which recently moved into its new home at 174 Wooster street, New York, has greatly enlarged its output of "Crystal Edge" mica diaphragms. The company recently closed arrangements whereby they will receive the highest quality of foreign mica over a long period, deliveries of which are already being made. This, together with their own mines, puts them in a position where they can make additional contracts for Fall business.

BUYS FITCH & LAMB ACCOUNT

Joseph Freed, Pittston, Pa., has purchased the account of Fitch & Lamb. The entire building will be remodeled and a full line of Victor machines and records will be carried. Six Unico booths will be added and an active drive for business made.

FIRE CAUSES SLIGHT DAMAGE

The talking machine and music store of Peter N. Paul, 2322 Kensington avenue, Philadelphia, was recently damaged by fire which started in the front of the store. Some of the instruments on display were damaged but the loss was small.

Schmelzer Arms Co.

Kansas City, Missouri

Exclusively Wholesale
Victrolas and Victor Records

Ample capacity and facilities insure you against delay and disappointments.



About 275,000 square feet of floor space devoted to manufacture of STANDARD Motors and other phonograph products.

STANDARD Open Phonograph Motor A QUALITY Product

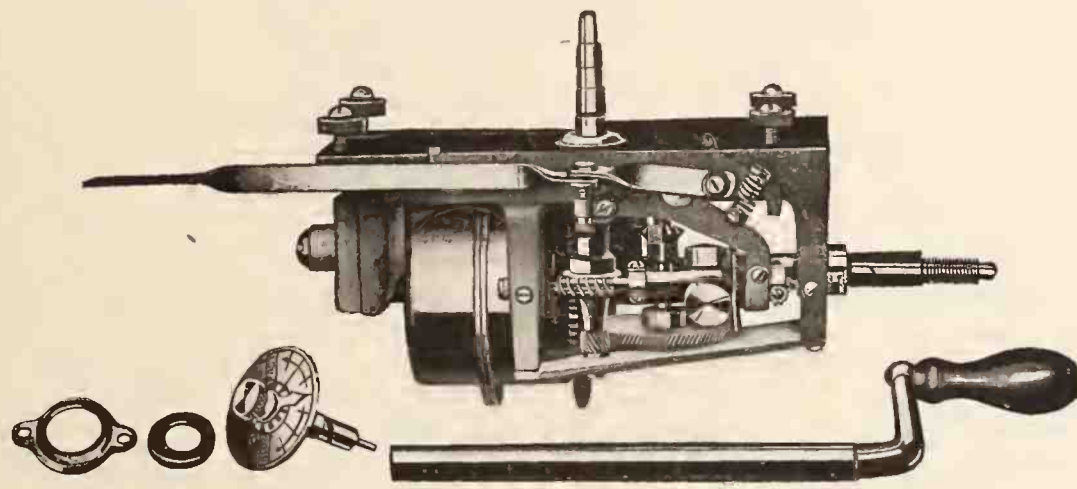

Silent

Powerful

Durable

A phonograph can be no better than its Motor. Install STANDARD Motors in your instruments and thus place them in the QUALITY class.

Standard Phonograph Motors, Inc.

Successors to

Krasberg Engineering & Manufacturing Corporation

451-469 East Ohio Street

CHICAGO

STANDARD

The following is the opinion of our experienced counsel on the subject of

UNFAIR TRADE PRACTICE

THE enforcement of the Sherman Anti-Trust Act, which became a law on July 2, 1890, revealed a variety of methods and practices which trusts and other large concerns adopted to destroy competition and interfere generally with the free course of trade.

These methods and practices were in the main not illegal, but they enabled large and powerful interests to obtain control over certain lines of commerce, to the detriment of the public, resulting in situations which constituted the corporation or the individual adopting such practices, an offender under the provisions of the Sherman Anti-Trust Act.

After the Supreme Court had rendered its decisions in the Standard Oil and Tobacco Company cases in 1911, business found itself in a state of uncertainty. There was a continual menace of legal prosecution. It was generally recognized that there was a certain natural growth to business which should not be interfered with. But it was also realized that there should be some legislation which would expressly define these unfair trade practices and prohibit them. This it was felt would arrest unfair methods of competition in commerce in their incipiency, and yet not interfere with the orderly development and expansion of business. As a result, certain legislation was enacted, among which was the Clayton Act, which became a law on October 25, 1914. The report of the Senate Committee on Judiciary on this bill shows its legislative purpose. It was there pointed out that the object of the Act was to prohibit and make unlawful certain trade practices which as a whole, singly and in themselves, were not covered by the Sherman Law and

other anti-trust acts. The Clayton Act, by making these practices illegal, was "an attempt to arrest the creation of trusts, conspiracies and monopolies in their incipiency and before consummation."

Among other of these unfair trade practices, and which the Clayton Act directly prohibits, are conditional or tying contracts. Dealers in phonographs, as well as other commodities, know that it was formerly the common practice of large concerns to "tie up" their customers so that dealings in products of and with competitors were rendered practically impossible. The usual form of clause in these contracts was as follows:

"The dealers shall not sell or permit to be sold on the premises any other (product), and will not deal or trade in any except those supplied by the manufacturer."

By Section 3 of the Clayton Act, this practice is made unlawful, and the insertion of a "tying condition" in a contract is prohibited in interstate commerce whether the articles are patented or unpatented and whether the delivery is made by sale or lease.

Since the enactment of this statute, various means have been sought to circumvent and defeat its provisions, particularly Section 3 referring to tying contracts. Instead of

written agreements containing these tying clauses, manufacturers have sought to have a dealer "understand" that the manufacturer would decline to sell any further merchandise to the dealer if the latter dealt in the products manufactured and sold by a competitor. An isolated instance of this sort would not be a violation of the law, but it is quite improbable that a manufacturer would pursue such a course with only one dealer. If, however, the same thing were done with a number of dealers, these "understandings" would tend to show that there was an attempt, not only to evade the provisions of the law, but that such "understandings" were sought for the purpose of lessening competition and were intended as a means to create a monopoly in the particular line of commerce. These are the very practices which the Clayton Act seeks to prohibit.

It is important for dealers to know also that the Clayton Act provides for a remedy for one who has been injured by anything forbidden in this statute, by giving to the person injured in his business or property, by reason of anything forbidden in the Anti-Trust laws, the right to sue therefor in any district court of the United States in the district in which the defendant resides or is found or has an agent. The recovery in any such proceeding may be threefold the damages sustained, the costs of the suit, etc.

By resisting any attempt to make them parties to unfair trade practices and unethical business methods, dealers and other persons similarly situated, will serve to make the Clayton Law a power and a weapon for their own protection, as this Act was passed not only to throttle at the source the creation of trusts and large concerns and the practice of unconscionable business methods, but for the protection of the dealer.

Sonora Phonograph Company, Inc.

GEORGE E. BRIGHTSON, President

NEW YORK

279 Broadway

NEW TYPHONE RECORD ENABLES BLIND TO SEE BY EAR

Invention of Viennese Physician Substitutes Sound for Touch and Is Read by Means of Talking Machine Record—Bible May Be Recorded for Thirty Cents—Whole Book on Six-inch Record

The talking machine record has been adapted so that it becomes an aid to the blind, substituting sound for touch, according to the invention of Dr. Max Herz, a Viennese specialist in heart diseases, who arrived in this country a few weeks ago at the request of M. C. Migel, chairman of the New York State Commission for the Blind, together with many other organizations who were interested in his work.

The invention is based on a sound alphabet devised by Dr. Herz from the Morse code, eliminating the dash and using the dot in various combinations. A talking machine record is made of a story in the sound language. The record is placed on an instrument resembling a talking machine equipped with a sound box and the blind person, after becoming familiar with the alphabet is able to read by ear rather than through the fingers as in braille, the method in use at present.

The alphabet is based on the single dot, two dots and four dots used in various combinations. The record is made in the following manner: Using an instrument like a typewriter the person engaged in the work will punch holes in a narrow tape, each group of perforations being a letter in the dot alphabet. The tape is then run through an electrical machine and the perforations are transferred in sound to a master record. Duplicate records are made in any quantity.

Dr. Herz, who is a member of the faculty of the University of Vienna, calls his system typhonia, or reading by sound, and the instrument the typophone. He declares that his system has many advantages over the Braille system of raised dots which is exceedingly difficult to learn. Another advantage is in saving of space, for a book of 200 pages may be transferred to a six-inch record, according to Dr. Herz.

Here the question naturally arises as to why use a sound alphabet to be reproduced by the typophone rather than to reproduce in the first instance the spoken words directly from an ordinary record. Dr. Herz's answer is that it would take 400 records to reproduce what can be reproduced on one six-inch record by means of the typophone. Then the spoken word on the ordinary talking machine is difficult to comprehend. The great expense involved in reproducing a book of 200 pages on 400 records is obvious, to say nothing of the space that one such "book" would occupy.

The Bible in Braille takes several volumes. Six thin typophone records costing from 12 to 30 cents would bring within the purview of the blind person the contents of the great book when the cost of the work in Braille might be tremendous.

The reproducing instrument has the appearance of a small talking machine and is kept in a wooden case like a traveler's typewriter. The weight is two or three pounds. Like the talking machine, there is a large circular disc about nine inches in diameter. Above this disc is another disc, about the size of a six-inch record. This disc receives the typophone record. Connecting the two is a reduction gear. The "reader" places the record in position and fastens the needle to the sound boxes as in the ordinary talking machine. In order to begin reading the book he turns the large disc and the words of the story are then tapped out in the improvised code. The reduction gear causes the record to rotate at a rate one thirty-sixth as slow as the lower disc is turned. The operator may "read" as slowly or as rapidly as he desires merely by twirling the lower disc to suit his ability to comprehend the sounds.

Recognizing that a "reader" may grow tired after perusing a few chapters, Dr. Herz has contrived an ingenious "bookmark" that enables him to begin "reading" where he left off. A small clutch inside the wooden case clamps the bar holding the needle in the place where the "book" is "closed."

It is the dream of Dr. Herz that there may eventually arise in the United States an International Institute for the Blind, with sections for all the nations. By the system of typhonia he is of the opinion that the world of literature, science and culture may be opened to the afflicted. Records, he says, can be made in all languages. As most of the blind are poor, he insists that his invention must be given free of cost or at cost.

MAUDLIN OPENS IN FORTUNA. CAL.

J. W. Maudlin, of Fortuna, Cal., who is well known in that section as a hustling sewing machine salesman, has decided to branch out in the business line and has opened a talking machine store in that city, where he will carry the Victor, Pathé and Kimball lines.

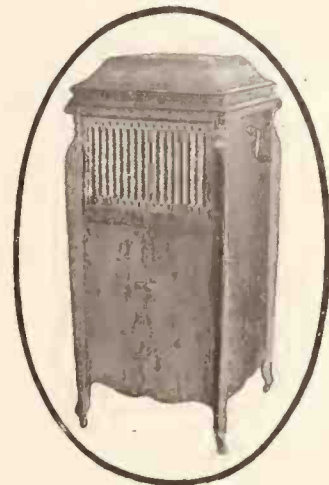

BLANDIN

Development of the Blandin Phonograph was based on one all-important object—the elimination of blarish, runching sounds or "phonographic" noise.

This has been accomplished and the result is—perfect re-production. You are asked to be the sole judge.

We cordially invite your inquiry for details.

Racine Phonograph Co., Inc.
RACINE, WISCONSIN.



STANDARD SUMMER FANS READY

What is more appreciated these sultry days than a free fan? The dealer who hands his weary customer one of these cooling favors will be long remembered. The Standard Talking Machine Co. of Pittsburgh has prepared its 1920 Victor record fan, which is designed after the form of a record, with space provided for the local dealer's imprint on one side. The decorations of the fan are illustrations of Summer scenes, each one showing the necessity for a Victor machine and records for Summer entertainment.

Far too many men behave themselves merely because they are afraid of the police and the devil.

Intermountain

Victrola

Service



Our new and completely equipped wholesale plant places us in a position to give careful, first class service.

Progressive Victor Dealers are making new plans to broaden their activities, and we will welcome the opportunity to help make *your* store the musical center of your community.

THE JOHN ELLIOTT CLARK CO.
Victor Wholesalers
SALT LAKE CITY, UTAH

REGINA CO. ISSUES DEALER HELPS

Hints on Selling and Advertising Sent Out as Addition to Service Department—Will Inaugurate Publicity Campaign Next Fall

The Regina Co., manufacturers of the Regina phonograph, and for over twenty-five years a producer of musical instruments, with executive office in the Marbridge Building, New York, and factory at Rahway, N. J., has recently been forwarding to the trade a book containing general ideas and "hints and helps" in sales and advertising, prepared specially for dealers. This is in conjunction with the service department, which is in a position to deliver to Regina dealers, copy, cuts and other material for local newspaper and mail order campaigns.

The book covers the advertising field thoroughly, and is replete with timely suggestions and constructive material, which should prove of much value to dealers using it in a co-operative way. The suggested ads are most artistic in tone, at the same time the sales copy is most

pointed. In addition to the material mentioned above, the Regina Company is also in a position to furnish advertising slides for the motion picture houses. These without doubt in some territories should prove business getters.

The Regina Co. in its own behalf will inaugurate a big campaign during the coming Fall. Publicity will be given this line in many channels.

USES THORNS FOR TALKER NEEDLES

The thorn has come into its own! The blight of the fragrant rose which has caused so many unkind words by its insistent needle point has been elevated to a real sphere of activity. E. V. Galloway, Chicago manager of Henry Holtzmann & Sons Co., says that he has a relative who is not only a kinsman but a mechanical genius as well. In his backyard is a thorn apple tree. He conceived the idea of trying these thorns, which are very hard and firm, on his talking machine. He claims to have met with great success. Not new, but it is interesting.

GREATER SAPPHIRE NEEDLE OUTPUT

John A. Botta, Who Acquired Extensive Knowledge of Jewels in Switzerland, Came to U. S. in 1910 to Specialize in Sapphire Needles

John A. Botta, a well-known manufacturer of sapphire needles, whose plant is located in Suffern, N. Y., was a recent visitor at the offices of The World. He remarked that he recently



John A. Botta

enlarged his output of sapphire needles, and states that he is now in a position to meet the needs of the trade to a greater extent than in the past.

Mr. Botta has had twenty-three years' practical experience in the manufacture of jewel needles. Born in Italy, he spent several years in the jewel factories of Switzerland, followed by a number of years in England. He has been in this country since 1910 and prior to his opening a plant of his own, he was connected with several organizations, making a specialty of talking machine jewel needles. He has on his staff seven practical jewel experts. Mr. Botta was the recipient of a grand prize and gold medal at the Acqui, Italy, Industrial Hygiene and Alimentary Exhibition in 1907, where he exhibited phonograph, watch and electric jewels.

Who answers the bell at your business front door? What impression does he or she make upon your customers or prospects?

"Does It Play All Records?"

Certainly MAGNOLA does; and without any extra attachments, too. This is only one feature, albeit a most important one, in the thoroughly up-to-date equipment of the MARVELOUS MAGNOLA.

MAGNOLA "Built by Tone Specialists"



Watching the Music Come Out

May we send you our handsome illustrated catalog chock full of information concerning the wonderful construction system of Magnola and the beauties of its musical results, its artistic appearance and its moderate price?

Send your name and let us tell you more!

MAGNOLA TALKING MACHINE COMPANY

OTTO SCHULZ, President

General Offices
711 MILWAUKEE AVENUE
CHICAGO

Southern Wholesale Branch
1530 CANDLER BLDG.
ATLANTA, GA.

Diaphragm Prices are too High Supplies are doubtful Deliveries uncertain Quality unreliable

These problems have to be met by purchasing agents everywhere. Sources of supply that are reliable, constant, and at fair prices, have been hard to find.

For many years The Phonograph Appliance Company has been one of the largest producers of high class mica diaphragms; but even we, with our large resources of imported mica, our own mines, our modern factory, and the earnest work of a thoroughly experienced staff, have found it impossible to supply all the demand of the trade for CRYSTAL EDGE MICA DIAPHRAGMS.

We have had to limit the size of our customers' orders at times, but we have never failed to make promised deliveries, nor have we tolerated any falling off in quality.

To meet the ever-growing demand for the highest quality of goods at reasonable prices, we have been compelled for the third time to move to larger quarters. We have more than doubled our equipment, and in addition are now receiving mica from all parts of the world. We have stocks in our warehouses and afloat fully adequate for our summer and fall business, and are now ready to extend our well-known quality service.

More Customers—Larger Orders More Perfect Service—Highest Quality

Let us solve your mica problems for you. Don't wait until the rush is on. Write us now—tell us your needs and we will take pleasure in giving you the full benefit of our experience and resources. Be your needs large or small we can supply you promptly and at FAIR PRICES.

All our diaphragms are sold on a guarantee of perfect satisfaction. We have served and satisfied the same customers for years on this basis. Let us serve you.

THE PHONOGRAPH APPLIANCE CO.

174 Wooster Street

New York

Sell **GRETSCH** Musical Instruments and Make **YOUR** Store The Musical Headquarters of Your Community

The biggest thing in our life is the business of making friends.

That means that we have to put superlative quality into our merchandise, of course.

A small line of GRETSCH Musical Merchandise will increase the volume of your sales without adding to the cost of doing business.

The test of a retailer's business is turnover. GRETSCH local sales co-operation assures rapid turnover.

There are many out-of-the-ordinary advantages in representing the GRETSCH line. Your source of supply will come from the largest musical instrument manufactory in the United States. You will be supplied with STANDARDIZED musical goods—the supply of which is constantly available.

The GRETSCH organization will print your own catalogue of STANDARD Musical Merchandise FREE for distribution in your community.

National and local advertising, store helps, window trims, catalogues and other co-operation will help you to develop a larger and larger local trade.

Let us make up an assortment of GRETSCH Musical Merchandise such as Violins, Mandolins, Banjos, Ukuleles and the like. Complete assortments can be had at \$500, \$1,000 or \$2,000. On request we will submit a complete list suggesting an assortment to suit any sum you may wish to invest.

The FRED. GRETSCH MANUFACTURING CO. cordially invites your correspondence on the business prospects of a Musical Merchandise Department.

Investigation does not place you under any obligation. Suppose you write for details of our complete assortment plan and HOW—We co-operate to help you build up a larger local trade.

In writing please address your letter to the Sales Promotion Dept.

THE FRED GRETSCH MFG. CO.

Musical Instrument Makers Since 1883

50-80 Broadway, Borough of Brooklyn, NEW YORK CITY



Violaphone Talk- ing Machine Needles

Each needle will play ten records. They retail at 15 cents per box of fifty needles. Priced to the trade at \$3.90 per package of 60 boxes. The sixty boxes retail for \$9. In hundred package lots, we will allow you an

extra discount of 5%. Terms are 2% 10 days, or net 30 days. VIOLAPHONE needles are packed in attractive counter display boxes. We furnish imprinted circulars on request. We guarantee the quality to be equal to the finest needle now on the market.

Suppose you send us a trial order for one package containing 60 boxes to retail at 15c. each. Your money back—without any question—if your customers are not pleased with the VIOLAPHONE needle.

THE VIOLAPHONE *The Master Phonograph With The Violin Tone*

Five Models retailing from \$100. to \$250. Our plan gives you an opportunity to sell the instruments within 90 days before we ask for payment.

We simply request the privilege of placing ten VIOLAPHONE PHONOGRAPHS in your store on a three months basis. To help you sell these instruments, we have an extensive advertising campaign under way. We invite careful comparison as to the quality of every part of the VIOLAPHONE. In every particular this instrument is equal to talking machines now selling at \$30 to \$50 more at retail. Our trade discounts are 50% off. Write for more details and our plan of local sales co-operation.

THE FRED GRETSCH MFG. CO., 50-80 Broadway, Brooklyn, N. Y.

EDUCATING THE DEALER TO STUDY HIS NEEDS

Constructive Dealer Literature Put Out by Columbia Peptimist Most Admirable—Forcing Dealers to Concentrate on Vitally Essential Questions of Moment to Their Business

One of the most constructive bits of dealer literature gotten out in some time is the May number of the Columbia Peptimist, which is devoted to an analysis of the dealer's business and offers a complete list of questions which every talking machine dealer can ask himself concerning his own store. The traveling representative of any large company always finds it his greatest task, when on the road visiting his dealers, to systematize the time which he can devote to each individual to the best advantage. As the Peptimist suggests, suppose you see twenty dealers on a trip and each dealer has fifty questions and one dealer has fifty-one, you have 1,001 problems to solve before you can even begin to take up your suggestions as to how he can improve his business. The only solution for this evil is to educate the dealer to have all his questions ready when you arrive so that the discussion may begin at once.

The Peptimist presents a sort of personal questionnaire which it suggests should be sent to every dealer and used by them to check up their business. A study of these questions by any talking machine dealer would be worth while, for they form the basis of good business practice in the talking machine industry. A classified outline of these questions follows:

Location.—Are you located in the best business section of your city or town? Is your shop in as quiet a location as possible? Are you on the side of the street where traffic passes? Are your neighbors such as to attract the buying public?

The Shop.—Does your shop say "Music?" Is your shop clean enough, light enough to make sitting through a demonstration a pleasure? Is your window a continually new, fascinating invitation to "come in"? Are your hearing rooms stuffy or fresh? Is your shop up to the level of surrounding salesrooms or better?

The Booth Felt Company, Inc.

Mechanical Felt Products

Turntable Felts

Motor Felt Washers

Motor Brake Felts

Needle Rest Felts

Cabinet Strip Felt

We carry a large stock of well assorted merchandise which insures prompt deliveries.

If interested in Velour or Velveteen Discs we can supply them.

FACTORIES

BROOKLYN, N. Y.

CHICAGO, ILL.

463-473 Nineteenth Street

732 Sherman Street

Stock.—Have you at all times at least one complete set of all Columbia records? Do you take stock regularly so you know where you are at all times? Are you making use of all Dealer Service stock equipment? Is one clerk trained and responsible for keeping stock classified, in order and to see orders for "out" records are sent in before they are out? Are records all demonstrated from clean, new envelopes? Are you continually studying where you can enlarge and improve your stock so the public will feel whatever they want they can get in your shop?

Literature.—Do you study Columbia literature? Do you keep literature clean and fresh? Do you distribute literature carefully?

Grafonolas.—Is your display stock of Grafonolas at all times clean and well equipped? Do you always start your demonstrations on the higher priced instruments? Do you know at least six definite selling points on Grafonolas which can be used one at a time until you strike the right one for each individual buyer?

Records.—Do you know "by heart" at least twenty, varied, individual Columbia records which always sell? Do you study up one or two new records weekly so as to increase your working and selling knowledge of the line? Do you always consider the "record asked for" by a prospect as already sold and sell him another? Do you have sales meetings monthly with your salesmen and go over the list, record by record, picking out and noting sales points of each?

Mailing List.—Is your mailing list brought up-to-date at least once a year by a return postal check-up? Do you cover your entire list at least once a month? Do you regularly intensively work sections of your list with various offerings, special announcements, etc.? Have you your copy of the Columbia Record for May, 1919, with the complete mailing list subject analyzed? Do you compare your mailing list with your sales records and follow up along the lines of least resistance?

BEGINS CO-OPERATIVE CAMPAIGN

Makers of Dulciphone Products Plan Active Drive in Interests of Dealers—B. Abrams to Tour Middle West Territory

The Grand Talking Machine Co., Brooklyn, N. Y., manufacturer of the Dulciphone line of talking machines, has just announced a novel co-operative advertising campaign as an assistance to its dealers, the advertisements to be inserted in the local papers in dealer territory.

While the Dulciphone is not a new product, this season's models carry special features which add to their value. The firm has increased its production and for the purpose of getting the direct interest of the consumer, the present advertising campaign is planned.

B. Abrams, head of the company, will leave late this month on an extensive trip throughout the Middle West territory for the purpose of getting the campaign under way in some of the larger trade centers. Closely following the Middle West campaign, a big publicity drive has been arranged for the Southern territory.

In addition to manufacturing the three models of the Dulciphone, the firm is also distributors of the Dulciphone steel needle.

BANG!

NOW READY

Pathe Dealers

Every authorized Pathe Jobber in the United States now has Hustylus in stock.

HUSTYLUS
PATHE

There is no reason for you being any longer without a good supply of this essential accessory for playing Pathe records on standard lateral cut machines.

Herbert & Huesgen Co.
Sole Sales Agents
18 East 42nd Street
New York

NEW YORK

CHICAGO, ILL.

QUINCY, ILL.

JAMESTOWN, N. Y.

OTSEGO, MICH

SONATA

TRADE MARK

THE PHONOGRAPH OF PERFECTION

PLAYS ALL MAKES OF RECORDS WITH ACCURACY AND CLEARNESS

KESNER AND JERLAW
 PRODUCERS OF EXCLUSIVE PHONOGRAPHS
 FOR THE JOBBERS AND LARGE DISTRIBUTORS

SCIENTIFICALLY CONSTRUCTED
 PIANO FINISHED
 WHOLESOME NATURAL TONE
 LOUDEST OF VOLUME
 LATEST AND BEST MODIFIER
 OUR OWN PATENTED HORN
 IMPROVED PERFECT SOUND BOX
 BALL-BEARING TONE ARM
 LATEST TYPE OF GUARANTEED
 MOTOR
 NEW BEVEL EDGE TURNTABLES
SIX BEAUTIFUL MODELS
 OF ARTISTIC DESIGN



MODEL A

Every Phonograph is
GUARANTEED FOR ONE YEAR
 Against All Manufacturer's
 Imperfections

Write For All
 Information and Particulars
 To Either Address

M. L. KESNER
 47 West 34th St.
 NEW YORK
 Telephone
 Greeley 6251

N. JERLAW
 316 So. Clark St.
 CHICAGO
 Telephone
 Wabash 2646

GRAND RAPIDS EXHIBIT
 4th Floor Klingman Bldg.
NOW SHOWING



MODEL B

MODEL C

MODEL D

MODEL E

MODEL G

The Trade in **BOSTON** *and* **NEW ENGLAND**
 JOHN H. WILSON, Manager
 324 WASHINGTON ST., BOSTON, MASS.

BOSTON, MASS., July 5.—Summer conventions of talking machine companies are playing their part in attracting to the various places the representatives of local houses and each and every one of the men return to the city imbued with new ideas as to the product, how best to market it and what to stress in the art of salesmanship. With the increasing arrival of goods there seems to be little difficulty in disposing of them and the 1920 Summer business promises to make a very good showing with all the companies represented in the New England territory.

Interest among the talking machine men is more or less focused just now on the two days' convention of musical interests that is to be held in this city on September 16 and 17. The plans are being worked out by the New England Music Trade Association, in whose membership are many piano men who also handle talking machines. The social side of the sessions will not be overlooked and on the first night there will be a concert at the Pops in Symphony Hall and on the second day a harbor trip is among the events considered. Of the 400 possible attendants a good proportion of them will be men interested in the talking machine business.

Fred E. Mann Discusses Conditions

Fred E. Mann, manager of the Boston branch of the Columbia Graphophone Co., who returned the first of the month from an extended trip in the West, addressed a well-attended Columbia dealers' meeting in the Swiss Room at the Copley-Plaza on the evening of June 16. His talk was concerned with the New England stock situation, which recently has been very favorable. This territory, he said, has lately been fortunate at the expense of branches in the West and South, owing to railroad embargoes

New England Dealers!

The new "Empire" catalogue is now ready for you. Liberal discount and terms. Write us for territory.

New England Piano & Phonograph Co.

Exclusive New England Distributors

405 BOYLSTON STREET : BOSTON, MASS.

Wholesale Distributors:

**New England Pianos
 New England Player Pianos
 Wm. J. Ennis Players**

**Empire Talking Machine
 "The World's Best Phonograph"**

against shipments of machines and records to the more distant localities, the consequence being that shipments which undoubtedly would go farther afield have been diverted to Boston for New England distribution.

It was Mr. Mann's advice to the dealers to take up at this time all the goods they could get, thus insuring themselves against any possible shortage later, for should the embargoes against the West and South be raised very soon shipments into the local territory probably would show a drop. It was certain, he said, that there will be no depreciation in the value of Columbia stock for the Fall and Winter trade.

Mr. Mann also discussed the Columbia's July

advertising campaign, which is to be built around the dance records on the catalog, and in this connection stated that he has had convincing proof that dancing is to be a very popular pastime this Summer. One of the leading bits of evidence along this line, he said, was the difficulty which Summer hotels throughout New England have been having to obtain the services of dance orchestras, the latter being relatively few to meet the demand.

The meeting was attended by dealers from Springfield, New Bedford, Fall River, Salem, Taunton, Ware, Brockton, Mass., and Derry, N. H., and Randolph, Vt. The program included several selections by Margaret Romaine, of the Metropolitan Opera Co., a Columbia artist, accompanied by James Ecker, of Boston. Miss Romaine proved a very popular entertainer, not only because of the excellence of her singing, but for her genial and gracious personality.

Columbia Staff Changes

Mr. Mann this month announced a number of temporary changes in the Boston branch personnel, resulting from the serious illness recently of J. F. Luscomb, Columbia traveling associate in southern Massachusetts and Rhode Island. D. A. Ingall, traveling associate in Vermont, has been transferred to Mr. Luscomb's territory for the time being and his territory is being covered by E. H. McCarthy, dealers' service manager at the Boston branch headquarters.

On Monday, June 21, Mr. Mann left Boston to attend the International Convention of Rotary Clubs at Atlantic City, to which he was a delegate. He was accompanied by Mrs. Mann and planned to be away for the entire week.

During the middle of the month R. F. Bolton, sales manager of the international record department of the Columbia at the New York executive offices, was a visitor at the Boston headquarters. He visited Portland, Me., also.

Merry Party for Jobbers' Convention

A pleasant party that motored over to the Victor jobbers' convention consisted of Robert Steinert and Wholesale Manager Kenneth Read from the Arch street offices of the Steinert house, Herbert Shoemaker of the Eastern and Charley Snow of Cressey & Allen of Portland, Me. They planned to spend a day in New York and when they left Boston they were pleasantly anticipating the entertainment they were to receive at the hands of President R. C. Smith of the Unit Construction Co. at his country estate at Villa Nova, Pa.

Strong Force Covering New England

The Musical Products Co., which is located at 142 Berkeley street, is now permanently settled on the fourth floor, just above the one into which it moved a few weeks ago, as its present

(Continued on page 85)

*"New England Service for
 New England Dealers"*

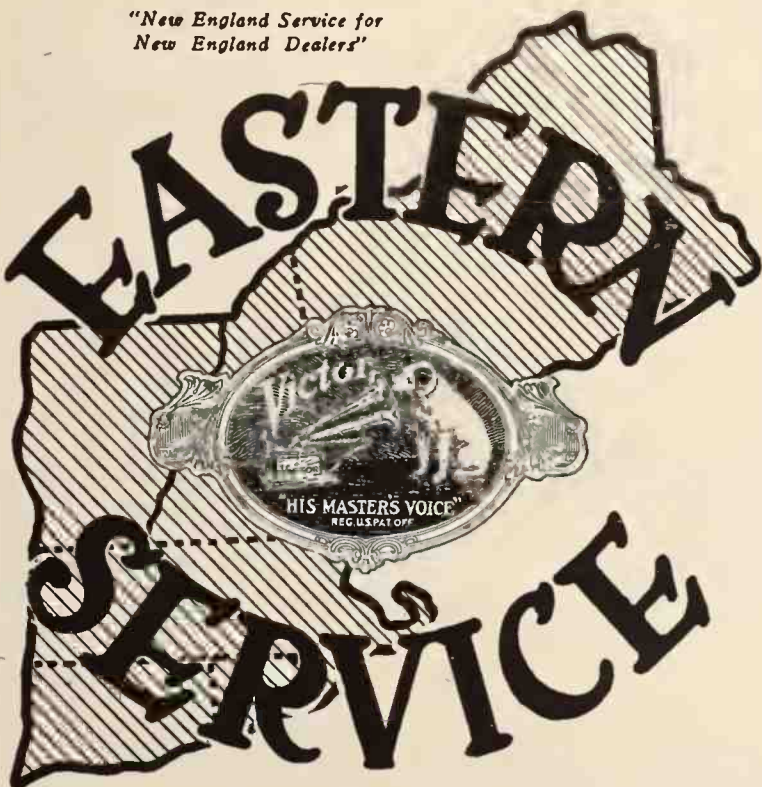

OUR slogan is again exemplified by our successfully placing Victor goods into the hands of our dealers in the face of embargoes, stevedore strikes and seemingly insurmountable difficulties.

Ask the dealer!

This time our barge "Olive" turned the trick

The Eastern Talking Machine Co.

VICTOR WHOLESALERS

85 Essex Street

BOSTON

Oldest and Largest
Manufacturers of
Talking Machine
NEEDLES
in the World



W. H. BAGSHAW CO.
LOWELL, MASS.

ESTABLISHED 1870

INCORPORATED 1917

W. H. BAGSHAW
COMPANY
LOWELL, MASS.



Stock up on Pathé Staples Now

NOW is the time for Pathé dealers to stock up on staple machines and records. During the next ninety days, when retail business is naturally lighter than at any other season of the year, is the time to accumulate some surplus stock in preparation for the heavy business of fall and winter.

Merchandise of this character will be very difficult to obtain, this fall. By laying in what staple stock you can secure this summer, you will insure a steady, even flow of business when it will be next to impossible to secure the goods you need.

Pathé dealers are urged to write us, at once, looking towards procuring some reserve stock NOW to assist in carrying them through the drought of merchandise and downpour of freight embargoes and congestion which the coming season is sure to develop.

Hallet & Davis Piano Co.

146 BOYLSTON STREET, BOSTON

General Distributors for United States of
Pathé Phonographs and Pathé Records.

New York Office:
Hallet & Davis Bldg., 18 East 42d Street



THE TRADE IN BOSTON AND NEW ENGLAND—(Continued from page 83)

quarters were not then ready. The rooms are numbered 407, 8 and 9. Manager Sheddell says the Sonata goods are coming along well and that already there are many machines in the storehouse around in Appleton street, only a few blocks distant. He now has six men in the New England field. They are J. A. Normyle, an experienced man in the business, who has Worcester, Lowell, Lawrence and intervening territory; Frederick Finn, six years with the Eastern Co., who will cover western Massachusetts, with headquarters at Springfield; Merritt E. Dockey, who has been connected with Bailey's Music Stores, well known in Vermont, who will have that State and New Hampshire territory; Leon M. Higgins, Metropolitan Boston; William S. Townsend, the Providence territory, and E. Bennet Fox, the State of Maine, with headquarters at Portland.

It is Manager Sheddell's plan late in the Sum-

mer to give demonstrations in all the large cities, these demonstrations which are to be in one of the hotels and to continue a week, will be especially for dealers, and Manager Sheddell believes that they will be the quickest and most convincing way to prove the merits of the Sonata proposition.

Important Beacon Connections

One of the results of Richard Nelson's recent trip to the South is that distributing arrangements have been made with J. H. England, who will look after the Beacon's interests in the States of Georgia, Alabama, Florida, Tennessee and Louisiana. Arrangements of a somewhat similar nature have been made with Charles B. Branner. With headquarters in Richmond, Va., he will be the distributing medium for this machine for Virginia, North and South Carolina. J. H. Adamson, who has been a wholesale furniture dealer in New York for a num-

ber of years, will open offices in Philadelphia, from which he will handle a good part of Pennsylvania, Maryland, Delaware, Washington and the lower part of New Jersey. D. J. Speck, with offices in Syracuse, N. Y., has been appointed Beacon distributor for New York State and a part of eastern Pennsylvania.

Mr. Nelson says that Beacon production has been coming along very fast and that good shipments are now being made to dealers through the East and Middle West. He says that all of the territory east of the Mississippi is now closed and goods shipped through the ten distributing points are located in this territory. It is the purpose of the company to open up the Far West in the Fall. A. R. MacDonald, the president of the company, is now spending much of his time at the factory, where certain changes have been made which will result in a

(Continued on page 87)



Vitanola
Phonographs

Lyric Records
Mysto Needles

S. W. SHARMAT & SON

Wholesale Distributors

5 Bromfield Street, Boston, Mass.

Twinkle, Twinkle, Little Star (With Apologies to Anonymous)

Twinkle, twinkle, little star,
How I wonder what you are
Cheese-box, Ice Chest, Boat or Tent,
Surely not an instrument.
Music never got one's goat
Such as comes from out the throat
Of your "exclusive" patent horn.
Do you think that natural tones
Can be made on megaphones?
No, the only proper ways
Are as the Vitanola plays.



Lyric Lateral Records

Dealers Supplied at Short Notice

S. W. SHARMAT & SON

Wholesale Distributors

5 Bromfield Street, Boston, Mass.

Steinert Service Serves

WHOLESALE



HEADQUARTERS

M. Steinert & Sons Co.

35 Arch Street :: :: :: Boston

noticeable increase in production. H. Frank Spurr, who has been opening up the New York State territory, will hereafter spend most of his time in sales promotion work in the New England field, making his headquarters here in Boston.

Brunswick Expansion

Wholesale Manager Fred E. Walter is planning to introduce the Brunswick into some new territory and in preparation for the big Fall demand for goods he may decide to sign up with several well-known dealers who have been anxious for some time to ally themselves with the Brunswick proposition. Goods for the most part have been coming along fairly well, but one car that had been sent out from Chicago some time ago was lost somewhere in Pennsylvania for a time and that interfered with both the wholesale and retail output. The latest issue of Brunswick records is taking well with the trade, and there are certain numbers that it is difficult to supply enough of to the trade.

C. A. Hewett with Cheney Forces

C. A. Hewett, who for some time was manager of the talking machine department of the Jordan, Marsh Co., is now associated with the Cheney and will shortly open Boston offices, from which he will operate through the New England territory. Burton Colver, sales manager for the Eastern territory for the Cheney, was lately in Boston conferring with Mr. Hewett.

To Handle Sonora Exclusively

Manager Joseph E. Burke, of the Musical Supply & Equipment Co., reports that his company has disposed of its Emerson franchise and hereafter it will confine itself to the Sonora proposition. The group of men to whom the Emerson franchise has been sold (they are not local persons it is understood) have leased a factory out at Framingham, where Emerson records will be pressed.

Mr. Burke has taken into the Musical Supply

HORTON-GALLO-CREAMER CO

NEW HAVEN CONNECTICUT



VICTOR SERVICE SPECIALISTS

Are you making the most of your opportunities as a VICTOR Retailer?

Perhaps we can help you solve a knotty problem.

Call on us at any time.

& Equipment Co. his brother, Thomas E. Burke, who is to be assistant sales manager. The first-named Mr. Burke has established his family at Allerton, Hull, for the Summer and much of the time Mr. Burke motors back and forth.

Important New Pathé Representatives
The Quality Furniture Co. at Brattleboro,

Vt., and the Jackson Furniture Co. at Providence, R. I., are among the latest concerns to take on the Pathé line, having lately been signed up by Manager R. O. Ainslie. The demand for the Pathé in this territory is growing rapidly and extensive advertising in the daily papers, together with attractive window dis-

(Continued on page 88)

KRAFT-BATES AND SPENCER INC.

NEW ENGLAND DISTRIBUTORS



ON BED-ROCK

The Brunswick proposition wins dealers because of its permanence

Business men who analyze the times realize that the House of Brunswick has built upon a lasting foundation. That is the greatest inspiration for confidence. Brunswick has a history of 75 years of successes. Its destiny is guided by some of the ablest executives in American industry. Its financial resources are unlimited.

There is a vast momentum behind Brunswick Phonographs and Brunswick Records. These great musical advancements have won the public.

As one studies the advantages of a Brunswick franchise, its value grows. And men who analyze the situation see the constantly increasing momentum that insures an even greater future. It's a wise business man who associates himself with a winner. Many of the wealthiest men in your community have progressed that way.

You can't understand the complete value of a Brunswick franchise until you take all facts into consideration. We invite Brunswick dealers and others to analyze the success of Brunswick and apply it to their own opportunities.

Then pure dollar and cents reasoning will prove the extreme high market value of a Brunswick dealership franchise.

KRAFT-BATES & SPENCER, Inc., 156 Boylston Street, BOSTON, MASS.

NEW ENGLAND DISTRIBUTORS

TONOFONE, VICTROLENE, MOTROLAS, RECORD FLASHER
Steel Needles Jewel Points Albums Record Brushes Khaki Covers



THE TRADE IN BOSTON AND NEW ENGLAND—(Continued from page 87)

MICA DIAPHRAGMS

Watson Brothers, Inc.
170 PURCHASE ST.
BOSTON MASS.

plays, are playing an important part in pushing these goods. S. D. Colahan, manager of the retail department, is building up his end of the business fast. E. B. Holmes, whom he has succeeded, plans to go into business for himself, it is understood.

Arthur Chamberlain's Summer Plans

Arthur Chamberlain, manager of the talking machine department of the Iver Johnson Co., has been able to get several week-end trips to his country home at New Found Lake, N. H., to which he motors up. He plans to take a more extended vacation some time in August.

Opens New Talking Machine Department

C. G. Faux, of the New England Piano & Phonograph Co., reports that the McGrath Department Store at Lawrence has opened up a talking machine department and the Empire and New England will be carried. Louis Cohen has been in Portland, Me., several times lately trying to find a suitable location in which to open up a department of the New England. R. C. Rose is spending much of his time in New Hampshire territory, where he finds a good call for the Empire and New England machines.

To Handle Musical Merchandise

The Hanover Music Store, located at 205 Hanover street, which is an exclusively Italian establishment, of which M. Rocci is manager, will hereafter carry general musical merchandise. It is having a good demand for the Empire and New England talking machines.

Attended Edison Convention

Francis White, manager of the talking machine department of the C. C. Harvey Co., and Carl Root, his assistant, are going over to the Edison convention in New York, July 8 and 9. They will be accompanied by Merrill Jones, manager of the talking machine department of

PERFECTION BALL-BEARING TONE ARMS

PERFECTION FLEXI-TONE REPRODUCERS

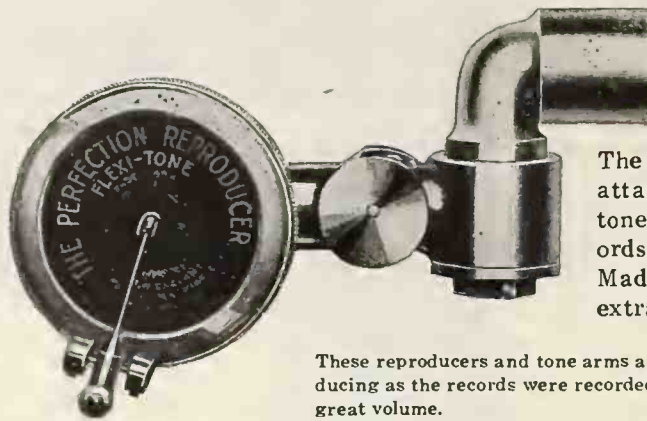

**Manufacturers—
Jobbers—
Dealers—**

The Perfection Flexitone reproducer No. 7 attached to the Perfection ball-bearing tone arm No. 4 plays all lateral cut records on all types of Edison Disc Machines. Made in nickel and 24 carat gold finish, extra fine quality disc.

These reproducers and tone arms are the very finest made, mechanically—reproducing as the records were recorded in the recording room—clarity of sound with great volume.

WRITE FOR DESCRIPTIVE CATALOG AND PRICES

Manufactured by

New England Talking Machine Co.

16-18 BEACH STREET

BOSTON, MASS.

DISTRIBUTORS:

CALIFORNIA

San Francisco—Walter S. Gray Co.

COLORADO

Denver—Denver Dry Goods Co.

IOWA

Des Moines—Harger & Blish

MASSACHUSETTS

Boston—Pardee-Ellenberger Co.

NEBRASKA

Omaha—Shultz Bros.

NEW YORK

New York—The Phonograph Corp. of Manhattan

PENNSYLVANIA

Pittsburgh—Buehn Phono. Co.
Philadelphia—Girard Phono. Co.

UTAH

Ogden—Proudfit Sporting Goods Co.

VIRGINIA

Richmond—C. B. Haynes Co., Inc.

the Harvey company's Brockton store, and Lawrence Barry, manager at the company's Lynn store.

Fitzgerald Expands Force

Billy Fitzgerald, who is forging ahead as a Victor retail distributor at his new quarters in the Studio Building in Tremont street, has now associated with him James A. White, an expert repair man, formerly with the Eastern Co., and Harry M. Renaud, who will be an outside

traveling man. Mr. Fitzgerald lately received from Bath, Me., a handsome autographed photograph of De Gogorza, the famous baritone who has been singing for the Victor for a number of years.

A. C. Barg, wholesale manager of the Vocalion's Boston headquarters, is back from a visit over at the New York offices.

Attended Commencements

George Lincoln Parker, the Edison distributor in the Colonial Building, went down to Providence the latter part of June for the Brown commencement exercises. Mr. Parker, being an alumnus of Brown, has not missed a commencement of his alma mater since he was graduated.

R. O. Ainslie was another college man who had eagerly looked forward to enjoying his college commencement. Mr. Ainslie is a Williams man and so he took several days off from his

(Continued on page 90)

Lansing Khaki Moving Cover

For Delivering TALKING MACHINES

Same quality as originally made. Heavy Felt Padding for Grade A; Specially prepared Clean Cotton Batt Padding for Grade B.

LANSING COVERS wear well and are cheapest in the long run. Use them for every delivery. They mean insurance against finger prints, scratches and bruises; save repair men's time, clerk service, and aid the delivery men.

Write for prices and descriptive catalogue

LANSING SALES COMPANY

Successors to E. H. LANSING
Manufacturers

Eliot and Warren Streets, BOSTON

San Francisco Representative: WALTER S. GRAY
942 Market Street

PHOENIX TRADING COMPANY

1265-69 Broadway, New York

H. A. Copeland Sales Co., Charlotte, N. C.



No. 3 Carrying Strap Shown in Cut



Disc Record, Player Roll and Sheet Music Cabinets. The Best in the Market
See Display Ad in This Issue

Peerless Record Album

Standard of Quality to preserve the Records
See Display Ad in This Issue

Send your orders for both these lines to
L. W. HOUGH, 20 Sudbury St., Boston, Mass.
New England Representative

Send for Descriptive Circular
Curry DEMONSTRATION BOOTHS AND RECORD CASES
IN STOCK OR TO ORDER
"SOUND PROOF"
FRANK B. CURRY
72-74 Dedham St. Boston, Mass.



Perfect Radiation in Ditson VICTOR Service

FROM THE HUB OF NEW ENGLAND to every down East city and town Ditson Victor Service moves smoothly and regularly. It forms a connecting link from the Victor factory that is complete and direct. It follows the machines and records through the dealer's store and into the home of the customer with an interest and helpfulness that is practical.

Service of the Ditson kind is now and will be most valuable to the dealer in the solving of stock and selling problems that are cropping up.

The house of Ditson does not hoard its experience, but passes it on for the benefit of its clientele. This is a fact worth remembering.

*Right Service is Highly
Important Just Now*

Oliver Ditson Company
BOSTON

Chas. H. Ditson & Company
NEW YORK

THE TRADE IN BOSTON AND NEW ENGLAND—(Continued from page 88)

duties at the Hallet & Davis warerooms, where he is the Pathé manager, and hid himself to Williamstown, where he had a time (almost) as good as a year ago.

Miss Clark Succeeds Herbert Lunt

Herbert Lunt, who has been in charge of the record department of the Vocalion, mentioned a short time ago as planning a trip to England, his home country, has already reached the other side. It is not impossible that he will remain over there provided he can connect with the Vocalion's London house.

Miss Minerva Clark has taken Mr. Lunt's place in the record department of the Vocalion. She has been with this house for some time.

A. M. Hume's Enjoyable Outing

A. M. Hume, head of the A. M. Hume Music Co., which is an exclusive Victor store, took a week away from business early in June and enjoyed a trip along the St. Lawrence and the Saguenay rivers in Canada. Mr. Hume was accompanied by Mrs. Hume and both greatly enjoyed what is really a beautiful trip, as anyone can testify who has ever taken it.

SHIPPING VICTORS BY WATER

How Prominent Victor Jobbers of Boston Secured a Shipment of Talking Machines From the Victor Talking Machine Co. at Camden

BOSTON, MASS., July 5.—So great was the success of the experiment of bringing over a consignment of Victor goods direct from the Camden factory to this city by water that the Eastern Talking Machine Co. may decide to undertake a similar trip again. Many dealers have been interviewed as to their sentiments in the proposition, and there is a general unanimity of feeling that in view of the prevalent freight situation it would be a good thing to repeat it, especially as there was so little delay in getting the barge "Olive" into Boston.

The slight inconvenience that was experienced in

transit was almost nil and the barge reached the Quincy Market Cold Storage warehouse wharf almost according to schedule. G. Hovey Dodge on



Happy Over the Victor Arrivals

From left to right—James Frye, Victor Representative for New England; Geo. Leim, Traffic Manager for Victor Co.; G. Hovey Dodge, Sales Manager for Eastern Co., and H. L. Sommerer of the Victor Purchasing Department.

his way down the harbor to his summer home late one afternoon, was the first to discover the barge in tow of the tug and he immediately sent the



Loading Victor Goods for Boston on Barge "Olive" at Camden Dock

joyous news of its arrival to all the interested parties, including Henry Winkelman of the Oliver

REMEMBER
"IF IT'S A PHONOGRAPH
ACCESSORY OR REPAIR
PART, WE HAVE IT."

Complete stock of
Needles, Motors, Tone Arms, Main
Springs, Attachments, Repair Parts
and other Accessories.

Prompt Deliveries Fair Prices
Send for our latest monthly Price List

Phonograph Supply Co.
of New England
COURT SQUARE BOSTON, MASS.

Ditson Co. and Kenneth Reed and Robert Steinert of the Steinert house. The next morning all was made ready to receive the goods and it was not long after the barge was hitched alongside the wharf before the unloading was begun. Thanks to an admirable system worked out by Herbert

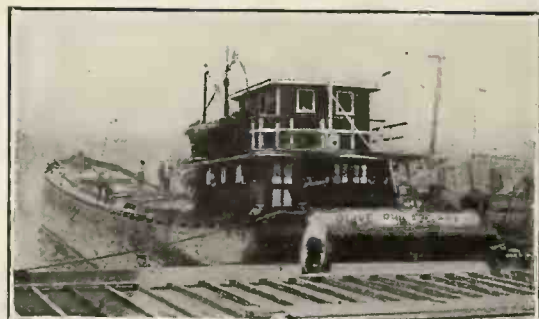

Barge Olive Leaving Camden Bound for Boston
Shoemaker and Hovey Dodge the goods were shipped immediately to the dealers who had guaranteed to take consignments so that the barge was minus its Victor freight in a pretty short space of time.

Cressey
and
Allen

Portland
Maine

Victor
Distributors

VICTOR DEALERS
IN
NEW ENGLAND

Territory will find
Cressey & Allen
Victor service ex-
ceptionally satis-
factory.

We cover New
England thorough-
ly, and aim to give
Victor Dealers
maximum service
and co-operation.



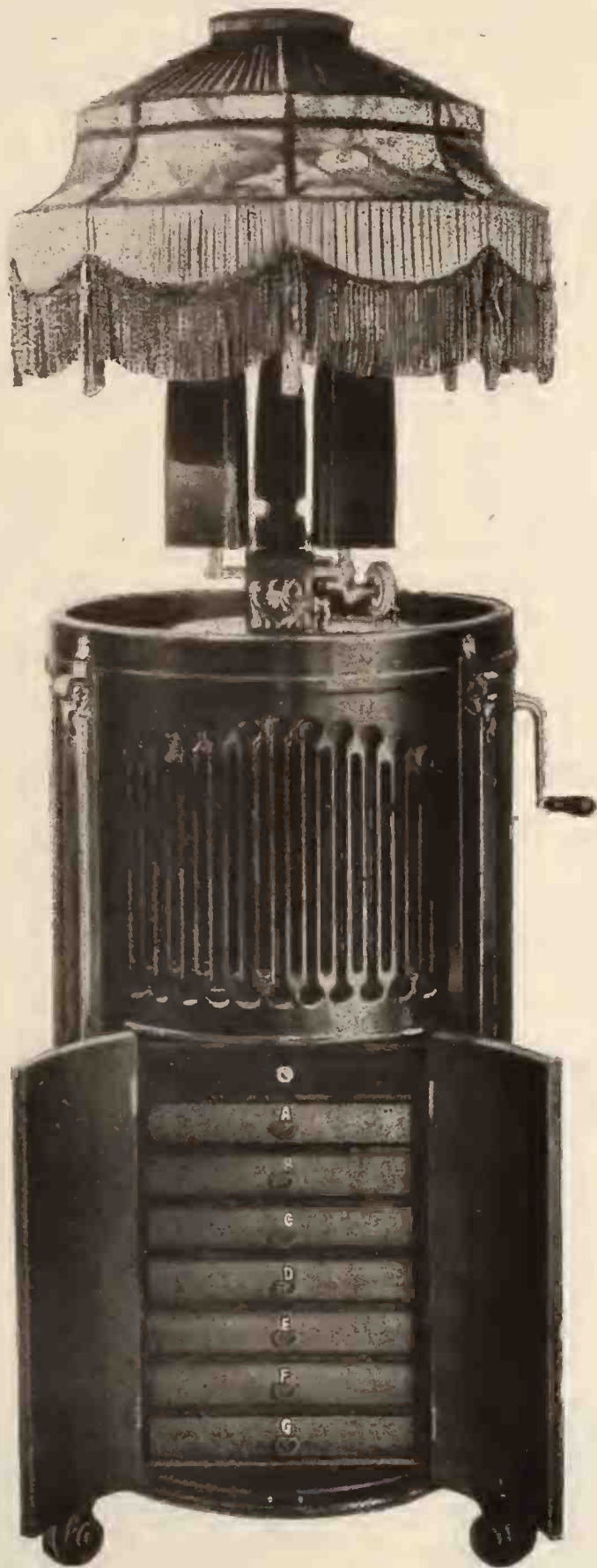

Jobbers!

MODERNOLA production has been greatly increased. It makes possible an extension of our distribution plans. We are now in a position to place wholesale distributing agencies with concerns whose position in the trade justifies.

We will be pleased to hear from those previously interested in a Modernola jobbing proposition, as well as from others in a position to handle this individualized instrument.

The Modernola offers a wonderful opportunity for the right organization in every territory. Its appeal has proven irresistible—everywhere

Write Us—Today—Right Now

THE MODERNOLA COMPANY

JOHNSTOWN, PA.

Eastern Representative, Geo. Seiffert

45 West 34th St., Monolith Bldg., New York

Greeley 2978-2291

*A strictly high-grade
Phonograph—made
in Richmond, Va.*



PHONOGRAPH

*Special Advantages in Deliver-
ies and Service to Dealers
in Virginia, West Virginia,
North Carolina and South
Carolina*

Announcing—the *Arietta Phonograph!*

THE opening trade announcement of the Arietta Phonograph finds a large proportion of the factory output for the next year already allotted to our dealers.

Many prominent dealers operating in the territory to which the Arietta's sale will be confined applied for agencies following an inspection of advance sample machines. It soon became apparent that the idea of a high-grade Phonograph made in Richmond, Va., with sales limited to nearby territory and facilities for prompt and regular deliveries was "just what the trade was waiting for."

Every preliminary step found such enthusiastic interest and support that we were forced to delay this opening announcement for months until we could make up all models

in quantities to take care of initial orders and prepare for the flow of general orders sure to follow for fall delivery.

We are now ready to hear from interested dealers who desire full particulars about a strictly high-grade Phonograph that will compare most favorably—point for point—with the best machines now on the market.

If you are located in our territory—Virginia, West Virginia, North Carolina and South Carolina—you will doubtless be interested in looking into the Arietta Phonograph. We advise immediate action as our first object shall be to take care of our dealers and we shall not assign new agencies beyond the point where dealer demand and factory output check one another.

Trade discounts will be very favorable.

Wholesale Distributors of Emerson Records

We are Exclusive Distributors of Emerson Records for Virginia, West Virginia, North Carolina and South Carolina

Rountree Corporation : Richmond, Va.

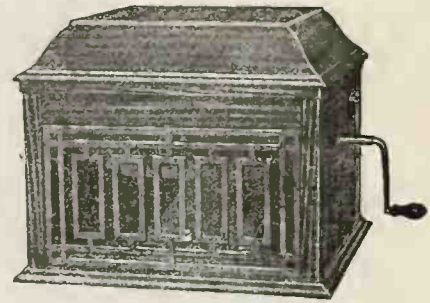

Arietta—Model 1

Order one or more Arietta Phonographs on Approval for Inspection



Arietta
Model II



Arietta
Model III



Arietta
Model IV

The Trade in PHILADELPHIA and LOCALITY

PHILADELPHIA, PA., July 6.—The general condition of the talking machine industry in the Quaker City during the past month has been most satisfactory, and shows considerable gain as compared with the same period of last year, which by the way made an excellent record in the volume of business transacted. Machines have been coming through faster especially for the past two or three weeks, due no doubt to the transportation embargo, which has caused a certain congestion of machines among manufacturers in the East, who have been shipping to the jobbers who can be reached by auto truck. The regular embargo generally has militated against the shipment of machines from local jobbing houses to far-away points in the State which it was not possible to reach by auto trucks. This of course has been to the advantage of the local retailers who have been receiving more than their usual allotment.

P. G. Cummin in Charge at Columbia Co.

The most interesting recent piece of news in Philadelphia is the change in the management of the local Columbia Graphophone Co. In order to explain the change to the trade Robert Porter, field sales manager, under date of June 30, sent out the following letter:

"Effective July 1, 1920, Pearson G. Cummin, formerly with Smith, Kline & French, Philadelphia, has been appointed branch manager of the Philadelphia branch of the Columbia Graphophone Co., succeeding N. J. Wilcox, who has been transferred to San Francisco as branch manager. May we take this opportunity to thank you for your loyal co-operation and to assure you that the object of the Philadelphia branch under Mr. Cummin's administration will be to render a prompt, courteous and friendly service to all Columbia dealers. Mr. Cummin

will visit you shortly, at which time we would suggest that you discuss Columbia and Columbia policies with him, in order that he can appreciate the individual problem of each Columbia dealer."

Dealer Service Men to Meet

On July 8, 9 and 10 there is going to be a meeting of the Dealer Service men of the Columbia at the local offices of the firm at Sixth and Filbert streets. H. L. Tuers, manager of the Dealer Service department, executive offices, New York, will be here to take charge and a number of executives will come over from New York to address the meeting. It is practically a merchandise conference of the Dealer Service managers.

Picnic of Columbia Forces a Success

On Wednesday, June 16, the Columbia manager and employes had their second annual picnic at Neshaminy Falls, and it was a howling success. It was given by the courtesy of the management who gave all employes a day off and Manager Wilcox provided the "eats" and the prizes. The committee in charge of the affair was headed by C. R. Dunlop. Mr. Callahan was the starter of the events, while Mr. Jennings, assistant manager, and Mr. Conoway were the judges.

At 8 o'clock in the morning of the day of the picnic the entire party, including Manager Wilcox, left the Columbia headquarters and arrived at the picnic grounds about 9:30, going by automobile. The track and field events were started at once. They were as follows. A one hundred yard dash for men, which was won by Reisenwitz; a marshmallow eating contest for ladies, which was won by Miss E. MacGowan; a backward 50-yard dash for men, won by J. J. Dougherty; an egg race for ladies,

won by Miss E. Eisentrauger; an egg race for men, won by Joe Marron; a water race for ladies, won by Miss E. Taggart; a pushmobile race for men, won by Messrs. Jester and Duffy; a toeing-the-line for ladies, won by Mrs. Printz; a rescue race for men won by Messrs. Jester and Gordon and a boat race, one lady and one man, won by Mr. Gordon and Miss Quig.

The special event of the day was a three-legged race between the management and the sales force. The teams consisted of: (1) Messrs. Wilcox and Jennings; (2) Messrs. Thallmayer and Westervelt; (3) Messrs. Jester and Gregory; (4) Messrs. Woodford and Schreiner, and (5) Messrs. Sheppard and Connelly.

The winners were Messrs. Woodford and Schreiner, though Manager Wilcox and Assistant Manager Jennings only missed first place by a whisker. The prizes were a leather belt and a silver buckle. These were duly presented to the champion tripeds.

An exciting ball game was played between the sales force and the office force on one side and the stock room force on the other. The score was 6 to 4 in favor of the sales and office force. Their battery was Doherty, pitcher and "Dick," catcher; while the stock room team battery was pitcher, Reisenwitz, and catcher, Pollock.

Recent Visitors to the City

Manager Fred E. Mann and Mrs. Mann, from the Columbia Co.'s Boston branch, stopped in Philadelphia at the end of last week on their way home from the meetings of the Rotary Club which were held in Atlantic City. Field Sales Manager Robert Porter will be in Philadelphia for the month of July working with the new Columbia manager, R. G. Cummin.

(Continued on page 96)

A trombone with a sense of humor

A TROMBONE with a funny bone. A xylophone with a college education. Kettle drums that know what Cleopatra looked like—and are trying to tell.

These are the little "finishing touches" that give personality to an Emerson Record, and make it something more than a mere mechanically correct rendition.

Emerson song hits and dance hits have the "something more" that makes them stick in people's minds.

Emerson dealers turn their stock quickly because Emerson hits are usually a couple of jumps ahead of competing records in getting before the public. And people have a weakness for the new hits while they ARE new.

Here are two of the "Hits" announced in The Saturday Evening Post of July 24th.

10192
So Long, Oolong, How Long You Gonna Be Gone?
Fox-Trot . . . Green Brothers' Novelty Band
Yokohama
Japanese Fox-Trot . . . Knickerbocker Specialty Orchestra

10194
Jean
Fox-Trot All Star Trio
Wild Flower
Waltz All Star Trio

We are looking for additional dealers to handle the Emerson line in Eastern Pennsylvania, Southern Jersey, Delaware, and Washington, D. C. Write for details.



Emerson Philadelphia Co.

Parkway Building

BROAD and CHERRY Streets

PHILADELPHIA, PA.

Distributors of EMERSON RECORDS

THE LOUIS

On the THRESHOLD of Victor Production

And to show our confidence in the continued supremacy of the Victor product, we announce the purchase and improvement of a modern business building, with 17,500 square feet of floor space, to be used solely for Victor merchandise.

Thus we anticipate increased production, and know that the Buehn policy of fair dealing, accurate methods, and the Victor Product Exclusively and Wholesale Only, leads to the success of both you and ourselves.

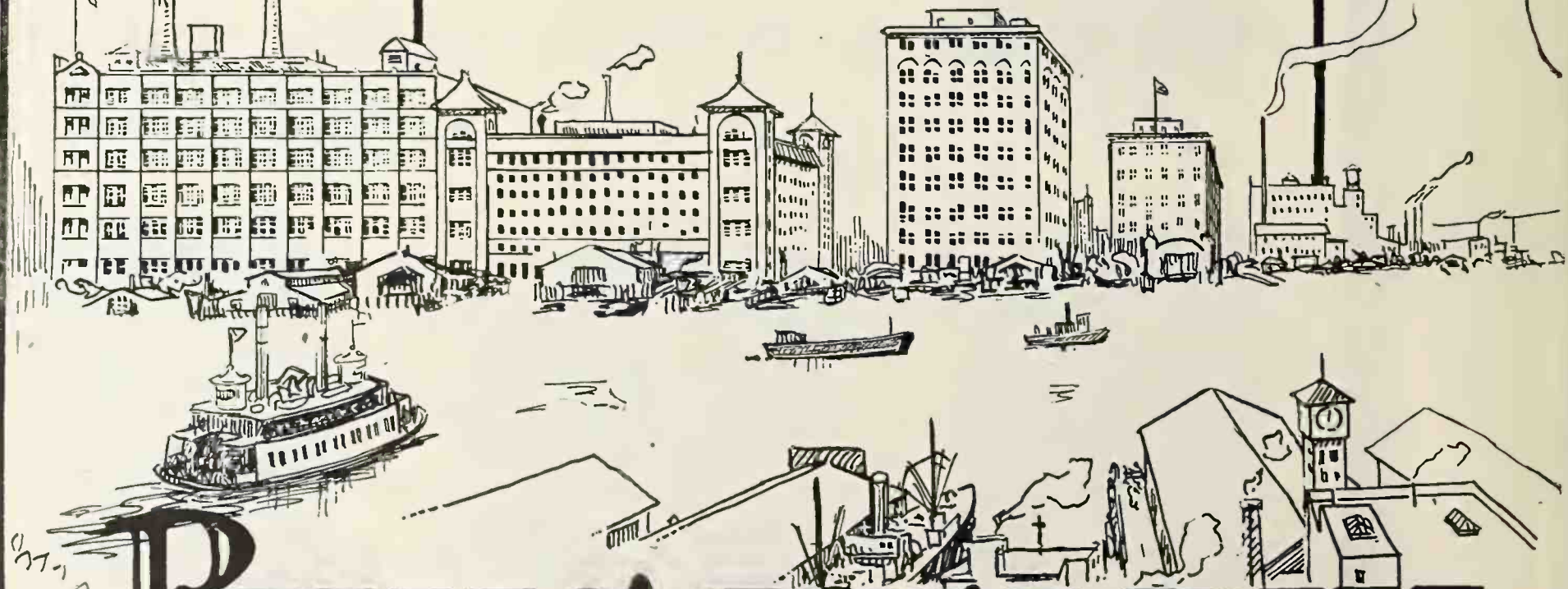

PHILADELPHIA

Handwritten initials and numbers in the bottom right corner, including '35', '37', and '70'.

BUEHN Co

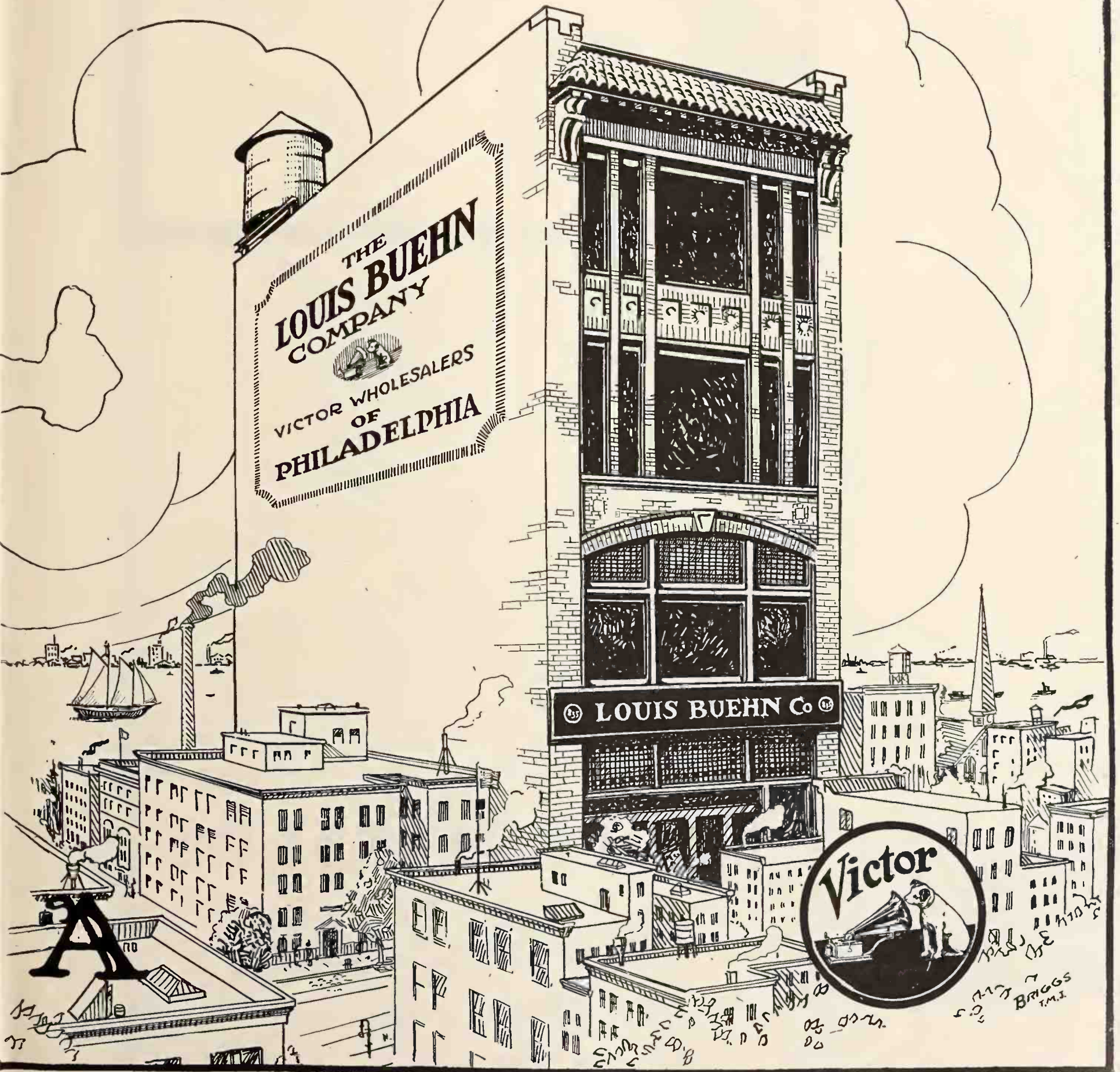

THE TRADE IN PHILADELPHIA AND LOCALITY—(Continued from page 93)

mins. R. H. Woodford, who covers the Reading territory for the Columbia, has been home ill for the past two weeks. F. W. Zerker, president of the Regal Umbrella Co. of York, Pa., was a visitor here on Monday afternoon, on his way home from the Rotary Club meetings.

Business with the Columbia Co. in June was very gratifying. Assistant Manager Jennings says that the prospects for July look promising. "June has shown a substantial increase over the same month of last year," he says. Mrs. K. C. Wallace, private secretary to Mr. Jennings, leaves this week for a two weeks' vacation which she will spend at Wildwood.

Miss Mae Henderson of the Victrola department of Strawbridge & Clothier, is also away on her vacation at the present time.

Takes on the Sonora and Dusonto

The Cunningham Piano Co. has recently added to its talking machine department the Sonora and the Dusonto talking machines, which will be featured more than ever the coming season by the energetic sales force of the company's talking machine department.

To Move to Larger Quarters

The United Music Stores will shortly move to their new home at 619 Cherry street, where they will devote an entire floor to the exploiting of the Lyric talking machine records.

To Leave on Vacation

Herbert E. Blake, head of the firm of Blake & Burkart, will leave this week for a two weeks' vacation which he will spend among friends in his former homes near Rochester and Buffalo, N. Y. Mrs. McIlwain, head bookkeeper of the firm, will leave for her vacation at the end of this week.

Brunswick Activities

Manager Chew, the local representative of the Brunswick Co., reports that his business has been very good through June. Shipments are getting better, but the embargo at present is tying the company up on outside shipments. Mr. Chew states that within the next two weeks he will be able to announce several important new handlers of the Brunswick. An unusually large number of the Brunswick De Luxe machines are now being received and a fine display of these instruments is being made in their warerooms.

New Pathe Dealers

Among the recently new dealers in this territory to handle the Pathé are: Ogden Howard, of Wilmington, Del., and the Mundy Furniture Co., of the same city.

Attended Jobbers' Convention at Atlantic City

H. M. Miller and T. W. Barnhill, proprietors of the Penn Phonograph Co., accompanied by their wives, as well as a number of members of their sales force, are at Atlantic City this week attending the Convention of the Victor Talking Machine Jobbers. At the office it was reported that business in June was fair, so far as the jobbing business is concerned, but the dealers were able to dispose of all the machines and records they could get out. Owing to the

Established 1864
Manufacturers and
Wholesale Distributors
WEYMANN
1108 Chestnut Street
Philadelphia, Pa.

THE BEST RESULTS

are obtained by Victor dealers concentrating their entire efforts on Victor Merchandise in the talking machine field.

For extra profits to the dealer, we heartily recommend the two entirely non-conflicting lines which we are also distributors of.

A player roll and a musical instrument department are both money-makers and yet the dealer remains an exclusive Victor retailer.

Send for catalogue

VICTROLAS and VICTOR RECORDS

Q · R · S

PLAYER ROLLS

WEYMANN "Keystone State"
String Instruments and Accessories

shortage, dealers are now preparing to stock up on all available records and machines anticipating a very prosperous Fall business, which goes to show the confidence the trade has in the industry generally.

L. P. Brown, of the Penn sales force, will go away on his vacation on Saturday of this week.

Keeping Business Active in Summer

Walter E. Eckhardt, the Pathe Shop man, and one of the best-equipped men in the trade, commenting on the present condition of business, has this to say: "I blame the merchant if he finds his business dull. I am convinced in my own mind, and from my observations, that in spite of seasons, business is what the merchants make it. At a time when there is evidence of a quiet business, that is the proper time to put forth unusual efforts and compel business to continue, if you please, in a normal state, because the after-war conditions that we have just passed through were of an abnormal character.

"It is the old story, if you are willing to accept conditions as they occur, business naturally will not respond because there is no definite support. But there are so many different ways to stimulate and promote sales, any one of which, if adopted, means success, that I cannot help but feel that, as stated above, the mer-

chant or department manager is the guardian of his own destiny and success.

"While the sales potentiality in any given territory or city may not be as great during the Summer period as other parts of the year, the average quota of sales in this period may be usually maintained by redoubling efforts and expanding through the various channels at the merchant's command. It is, in my opinion, lamentable that so many firms and corporations are apparently satisfied to accept 10, 15 or 20 per cent of the potential sales possibilities of their sales institutions, and in this regard I have in mind a number of our large merchants whom it has been my good fortune to talk with during the past few months, who are surprised to learn, in comparison, that the sales of their phonograph department are not over 10 per cent in some cases of what they really are and could be.

"During a recent survey of a large establishment with the managing director, in one of the New England cities, it occurred to me that a considerable space of the house was utilized by the furniture department and upon inquiry I was advised that this department required 10 per cent of the total space of the house, although the sales of the furniture department amounted to only 3½ per cent, which figure

(Continued on page 98)



MODEL 17

NO LOST SALES

Guaranteed Immediate Deliveries
Service that Assures Sales & Profit

Write for Catalog

Vitanola Distributors Co.

1025 ARCH STREET

PHILADELPHIA

The "PENN" has been on the talking machine map 22 years and has always stood for a square deal.

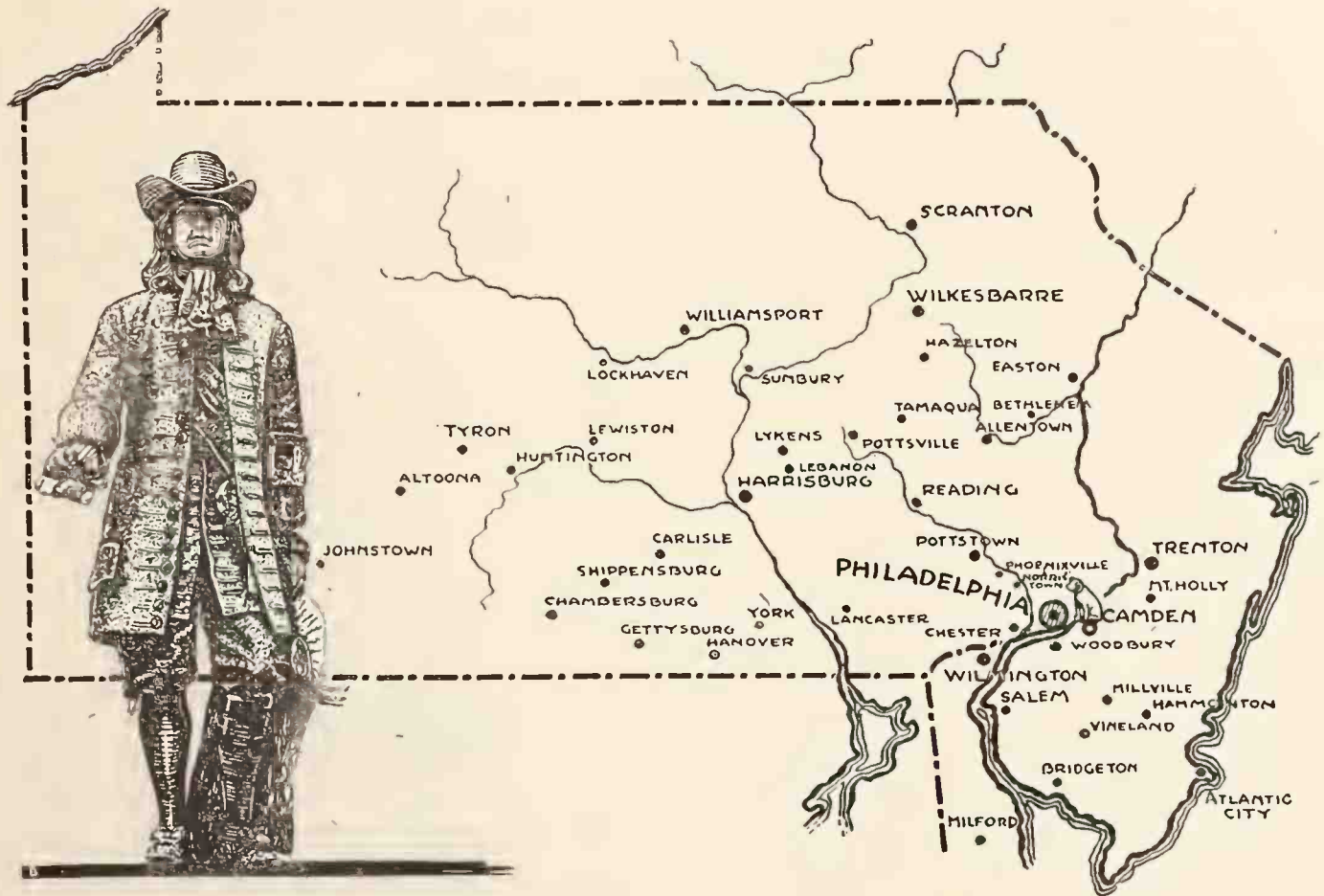

VICTOR SUPREMACY is firmly established and an era of still greater VICTOR prosperity is here.

Dealers in revising their policies to fit new conditions, have at their service the experience of the oldest Victor distributor in Philadelphia.

PENN PHONOGRAPH COMPANY PHILADELPHIA

ESTABLISHED 1898

EXCLUSIVELY WHOLESALE

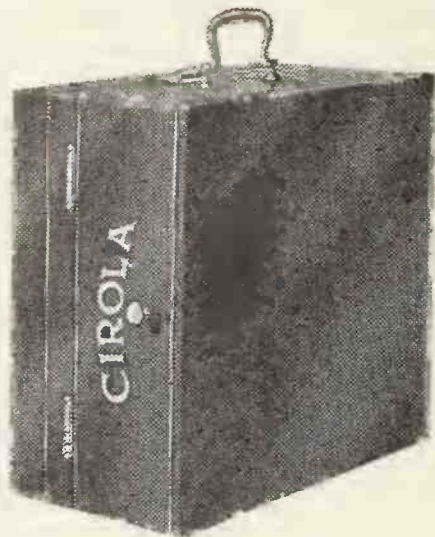

Size: 12½ x 11½ x 6

"Take Your Music With You"

"CIROLA," the only PORTABLE Phonograph without sound chamber; has twin spring motor; highly nicked metal parts; is finished like a Piano; built like a Battleship; folds like a suitcase; weighs 16 lbs.; plays all records better because the good fresh air is its sound amplifier; and we will give \$10,000.00 for any Cabinet Phonograph at \$100.00 that will produce a larger volume of tone. Write for our proposition quickly. Enterprising dealers everywhere are rapidly stocking these Spring and Summer Whirlwinds. Covers may be had if desired.

CIROLA DISTRIBUTING CO., Inc.

Distributors of the
CIROLA PHONOGRAPH

PROMPT
DELIVERIES



203-04 Colonial Trust Bldg.
Phone Spruce 6340
PHILADELPHIA, PA.
U. S. A.

THE TRADE IN PHILADELPHIA AND LOCALITY—(Continued from page 96)

was not a just return for the space occupied; whereas, by condensing the said department one-third of its space at least, it would afford sufficient room for the furniture department and return to the firm for the same space at least 7 per cent in the handling of phonographs.

"By this I mean to infer that many of our larger institutions are devoting considerably more space than necessary to a certain department, which could be condensed without any material effect on its sales, and afford all the space required for the maintaining of a creditable music section, which, if properly and carefully administered, would readily yield more than 3 to 5 per cent of the total business of any of our largest institutions.

"In the advancement of sales promotion for many years past I have never found a dull moment, irrespective of season, and have always found that the return fully justified every effort advanced, although it seems a little difficult at times, but the result is commensurate with the effort."

Buehn Business Shows Healthy Trend

Louis Buehn & Co. have been enjoying a much better business in June of this year than last. "The majority of our Victor dealers have exceeded," they say, "the business of a year ago owing to the fact that they were able to get double the amount of records and machines of June a year ago. As far as this organization is concerned our business is continuing in a good, steady, reliable way. Our dealers are still making calls upon us for Victrolas, and for records, and we are trying to satisfy these calls by equalizing our shipments to the best of our ability. As for the needs of our dealers in the Fall, we hope that the coming month will bring us sufficient shipments that we can, as near as possible, fill all demands upon us."

Among the recent Buehn visitors was Robert Shipley, representing the firm of Storm & Ship-

ley, the well-known dealers of Frederick, Md.
Quaker City News Brieflets

S. Friedenberg, head of the Philadelphia Talking Machine Co., had very satisfactory business in June. Early in July he expects to open his new branch at the southeast corner of Seventh and Morris streets.

Joseph Freed, of Pittston, Pa., has purchased the account of Fitch & Lamb, and is remodeling the entire building. He will carry a full Victor line in connection with his jewelry business. Six Unico booths have been installed.

Victor Moore, of the Penn Phonograph sales force, will shortly go on his vacation to Island Heights, N. J.

Robert Troop, of the J. H. Troop Music Co., of Harrisburg, stopped on his way from Harrisburg to Ocean City, where he has taken his family for the Summer.

Herbert E. Blake, as well as three members of his sales force, will be in attendance at the convention in July of Edison dealers in New York.

Luke Moore, in charge of the Edison talking machine department at the store of N. Stetson & Co., has been able to resume his duties after an absence of three weeks due to illness.

Paul Winner Again in Civilian Harness

Paul Winner, of F. A. Winner & Son, of Altoona, Pa., extensive Victor dealers in that city, and who has seen much government service abroad, recently returned home and has assumed his old position.

New Building for Porch Brothers

Porch Brothers, of Johnstown, Pa., have purchased a new building at a cost of about \$150,000 and are planning a very handsome and up-to-date Victrola department.

Dorney Co. Moves Its Department

The Dorney Furniture Co., of Allentown, Pa., exclusive Brunswick dealers in that city, has, owing to the great demand for Brunswick ma-

chines and records, moved its department from the third to the first floor and has placed an order with the Unit Construction Co. for a number of new booths and record racks.

Making Extensive Alterations

Hayes Harmon, of Chambersburg, Pa., and George J. Palmer, of West Chester, Pa., are making extensive alterations in their stores.

New Emerson Dealers Appointed

The Emerson Philadelphia Co. has just received its first shipment of the new Emerson phonographs. They are beauties in every sense of the word, and Mr. Fox believes he is going to have a very large business on these machines from the orders already in hand. Three new Emerson dealers have just been appointed in this territory: P. Dunham & Co., of Trenton, N. J.; the Diehl Furniture Co., of Palmerton, Pa.; and the West Hazleton Supply Co., of West Hazleton, Pa. The latter firm has just had an opening. Mr. Fox is arranging to make a complete trip covering his entire territory. No definite decision has as yet been made on the new home of the Emerson Philadelphia Co.

Urges Early Buying of Stock for Winter

John A. Scott, the high-light of the Solotone Mfg. Co., reports that business has been very good, and he is very optimistic as to the future. This is shown in the fact that the company is working all its factories to the limit and is getting out as big a stock as possible. It is also engaging as much store room as is available. Anticipating the bad transportation problems that are likely to be encountered this Fall. Mr. Scott says the company is urging its dealers to lay in its Winter stock as soon as possible. He does not believe, at least for the next two years, that there is going to be any material reduction in the cost of machines, in labor or in materials used in construction.

**Operaphone
RECORDS**

PHILADELPHIA DISTRIBUTORS
SUPPLEE - BIDDLE HARDWARE CO.
PHILADELPHIA, PA.

LYRIC RECORDS

The Lyric records are lateral cut and will play on any machine. New issues August 1st, 1920. Write for catalogs and discounts

UNITED MUSIC STORES

1124 Walnut St., Philadelphia, Pa.

Exclusive Philadelphia Jobbers of

**LYRIC RECORDS
CONNORIZED MUSIC ROLLS
PIANOSTYLE MUSIC ROLLS**

MOTORS—TONE ARMS

We Can Furnish Any
HEINEMAN or MEISSELBACH
Motor or Tone-Arm or part at factory prices.
Send for catalog, enclosing trade card

EVERYBODY'S TALKING MACH. CO.

Authorized Distributors

Heineman & Meisselbach Motors

38 N. 8th Street, Philadelphia, Pa.



GENERAL PHONOGRAPH CORPORATION

OTTO HEINEMAN, *President*

25 West 45th Street - - - New York

FACTORIES:— NEWARK, N. J. ELYRIA, O.
PUTNAM, CONN. SPRINGFIELD, MASS. KITCHENER, ONT.



CHICAGO

TORONTO

SAN FRANCISCO

LONDON, ENG.

DEAN NEEDLES

We manufacture the famous Dean Needles—Quality—Puritone, Cleartone, Truetone are known all over the world.

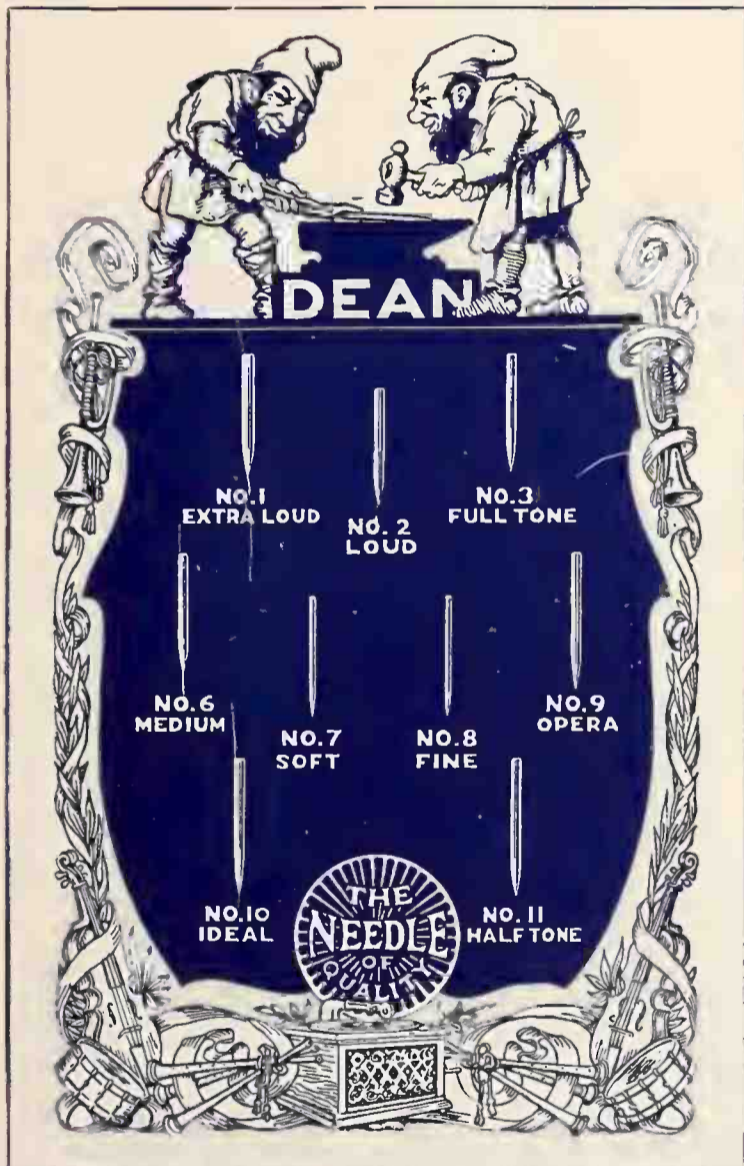

We can make you an attractive needle proposition. Have you ever tested our gold or silver plated Needles?

Write for Information.

GENERAL PHONOGRAPH CORPORATION

OTTO HEINEMAN, *President*

25 West 45th Street - - - New York

FACTORIES:—
PUTNAM, CONN.

NEWARK, N. J.
SPRINGFIELD, MASS.

ELYRIA, O.
KITCHENER, ONT.

CHICAGO

TORONTO

SAN FRANCISCO

LONDON, ENG.



ATLANTA TRADE CONDITIONS GOOD

Dealers All Declare Business Is Steady and Shipments Are Coming Through—Columbia and Brunswick Lines Taken On—New Store Opened by Phillips & Crew Co. in Savannah

ATLANTA, GA., July 6.—Conditions in the trade in this city during June have been satisfactory. Several changes and additions in stores have been made and the talking machine business is constantly broadening and enlarging.

The Zaban Furniture Co., former Columbia dealer, has qualified as a Brunswick dealer and has installed the complete line of Brunswick phonographs and records. E. E. Thornton, formerly Columbia traveler in Tennessee and Alabama and for many years identified locally with some of the largest talking machine stores, is the manager of this department and reports a large business and enthusiastic reception for the Brunswick line.

The Myers-Miller Furniture Co. has taken on the Columbia line and installed an up-to-date phonograph department. Miss Lila

Gordon, formerly in the Columbia department of the Haverty Furniture Co., this city, is in charge.

The Phillips & Crew Piano Co., the oldest Victor dealer in Georgia, of whom it was recently announced in these columns that they had opened a store in Savannah, Ga., continues to do an excellent business in both the Atlanta and Savannah stores. Victor product seems to be coming through in larger volume than for a long time and this concern with others is sharing in the benefits afforded by a better supply.

The Columbia, Victor, Edison, Sonora, Pathé and Brunswick distributors or branches all report a large and constantly increasing volume of business.

The Haverty Furniture Co. has recently concentrated all its energies on the Columbia Grafonola and Columbia records, has remodeled and enlarged the record and hearing rooms and is using larger advertising space on this old and popular line than has ever been taken in the local papers before. Their business in Birmingham, Ala.; Savannah, Ga.; Columbia and Charleston, S. C., and in certain Texas cities,

ILSLEY'S GRAPHITE PHONO SPRING LUBRICANT

Ilsey's Lubricant makes the Motor make good
Is prepared in the proper consistency, will not run out, dry up, or become sticky or rancid. Remains in its original form indefinitely.
Put up in 1, 5, 10, 25 and 50-pound cans for dealers.

This lubricant is also put up in 4-ounce cans to retail at 25 cents each under the trade name of

EUREKA NOISELESS TALKING MACHINE LUBRICANT

Write for special proposition to jobbers.

ILSLEY-DOUBLEDAY & CO., 229-231 Front St., New York

also Memphis, Tenn., is reported as flourishing and growing. A recent issue of the Memphis Sunday Commercial-Appeal carried a full-page advertisement on the Columbia line.

PATHE DEALERS MEET IN OMAHA

Large Gathering Convene as Guests of Wright & Wilhelmy—Interesting Addresses Made—May Decide to Form Permanent Association

OMAHA, NEB., July 10.—A large attendance of Pathé dealers in this State was reported at the first annual Pathé Dealers' Convention held at the headquarters of Wright & Wilhelmy Co., Pathé distributors, of this city, on July 9-10. An address of welcome was given by J. David Larson, commissioner of the Omaha Chamber of Commerce. Inspiring addresses were made by James Watters, secretary, and H. N. McMenimen, managing director of the Pathé Frères Phonograph Co., who journeyed from Pathé headquarters in Brooklyn to attend this "get-together" meeting. Entertainment was furnished by two celebrated Pathé artists, Marion Cox and Lewis James. At the close of the session opportunity was given to all dealers to give the expression of their views on the various daily problems that arise. As additional entertainment the Wright & Wilhelmy Co. planned a Matinee orpheum party for the ladies and all delegates journeyed to Krug practically at night. As the outcome of this convention it is expected that the Pathé Dealers' Association will shortly be formed in this section of the country.

NEW QUARTERS FOR SHARMAT & SON

R. B. Henry Joins Organization to Sell Vitrolas and Lyric Records

BOSTON, MASS., July 6.—S. W. Sharmat & Son, at 5 Bromfield street, have been so successful in marketing the Vitrola and the Lyric records that they have been obliged to secure larger quarters and the last of June they moved to quarters four times as large as those now occupied on the floor below in the same building. R. B. Henry, formerly sales engineer of another talking machine concern, has associated himself with the Sharmat interests.

HELD FOR FALSE REPRESENTATION

Raymond L. O'Neil and his wife, Liana Rose O'Neil, who, according to Federal officials, were until recently selling talking machines and records on Broadway, near Forty-second street, as the Associated Music Publishers of New York, were held in \$3,750 bail each in the Federal Court on June 28 on an indictment charging use of the mails to defraud buyers. Assistant United States Attorney Simmons says they falsely represented they were authorized agents for standard types of talking machines.

FAULTLESS

PIVOT BEARING

CASTERS

Casters that roll easily across the floor—and smoothly. No clatter—no unsteadiness.

Simple construction—no complicated parts to get out of order, nothing to retard easy movement. Strong—plenty of metal in required places to resist strains.

Silent—neat appearing—a real necessity to YOUR talking machine, these FAULTLESS CASTERS.



Full Size—C.65

Made with leather, fibre, felt, steel and lignum vitae wheels. A word from you puts all our caster experience at your service and brings you a copy of Faultless Catalog "G".

**FAULTLESS
CASTER COMPANY
EVANSVILLE, INDIANA**

"Move the FAULTLESS Way"

Eastern Sales Office:
Geo. Mittleman, 200 Fifth Avenue, N. Y.

DECALCOMANIA

Name Plates for Talking Machines, Pianos, etc.

High Class Workmanship

Write us for further information

National Decalcomania Co.
220-230 N. 60th St., Philadelphia, Pa.

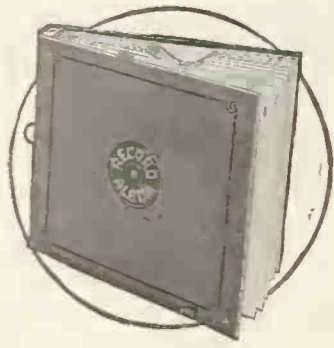

The Home of **PEERLESS ALBUMS**

22,000 square feet devoted solely to the
manufacture of PEERLESS ALBUMS

Standard
Grade



Peerless
Metal Back

THIS plant represents the most modern and completely equipped Album Factory on the continent.

The product of the organization—Peerless Albums—is in keeping with the high standard set by the foremost talking machine company in the world.

From this plant 90% of the Victor distributors in the United States secure their supply of record albums. If you are of the remaining 10% we would like to quote you.

PEERLESS ALBUM COMPANY

PHIL RAVIS, President

43-49 Bleecker Street

NEW YORK CITY

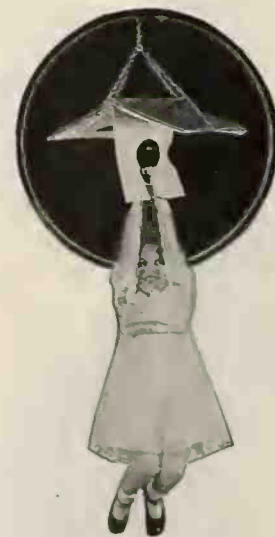

National Association of Talking Machine Jobbers Holds Convention

Fourteenth Annual Gathering of Victor Jobbers Held at Hotel Traymore, Atlantic City, June 28-29 Best Attended Meeting in History of Organization—President Eldridge R. Johnson Electrifies Banqueters With Masterful Address—Spirit of Optimism and Confidence Rules—L. C. Wiswell Elected President

ATLANTIC CITY, N. J., July 1.—The annual convention of the National Association of Talking Machine Jobbers, held at the Hotel Traymore on Monday and Tuesday of this week, was without question the largest and most successful gathering of that organization ever held and the strictly constructive results of the various business conferences were well worthy of the interest taken in the meetings.

The presence at the convention for the first time of Eldridge R. Johnson, president of the Victor Co., and the opportunity it gave the jobbers to get in close touch with this prominent figure of the talking machine trade, as well as with many other Victor officials and department heads who attended, was a feature that was greatly appreciated and the delegates went away with a new conception of the mighty brain that directs the destinies of the Victor organization.

Throughout the convention there was a distinct tendency to build for the future and let the past take care of itself. The reports and discussions in practically every instance had to do with ways and means for merchandising Victor products most efficiently during the coming year and were constructive in the fullest sense.

The messages brought from the Victor factory by officials and department heads, indicative of the steady progress that is being made in developing the facilities and increasing the output of Victor goods, proved particularly encouraging to the jobbers who attended the meetings. It gave many of them a new conception of what was being accomplished for their benefit at the factory.

The convention attracted practically 100 per cent of the entire Association membership, a number of the delegates arriving a week or more in advance of the session in order to attend the big international Rotary Convention and the meetings of the several music trade bodies held last Friday and Saturday, or simply to enjoy a little longer vacation at the seashore.

Incidentally, it may be mentioned that the jobbers did not confine their attention wholly to purely trade matters, but displayed a real interest in national questions calculated to affect business generally. The action taken on the two important referenda governing labor conditions, as submitted by the Chamber of Commerce of the United States, of which body the Association is a member, indicated plainly its wide interest in questions of moment.

President Mickel's Report

President Mickel in his report said: "This is the fourteenth convention of the National Association and for the first time in the history of this organization every jobber of Victor products in the United States is a member. This should be very gratifying to us and a fact on which we can be congratulated.

"During the past year two executive committee meetings have been held, the first one November 18-19, 1919, at which meeting matters that had been referred to the committee at the previous annual meeting in July were taken up.

"Our second executive meeting was an open meeting, one with which you are all familiar and which, perhaps, was the most successful and enthusiastic meeting ever held by this committee. This was along educational lines

and of very practical benefit to everyone in it. The first day's session was held in Chicago March 22 and the second session in New York on the 24th of March. At the close of these meetings an executive committee meeting was held at Philadelphia.

"I strongly recommend that an open executive meeting be held each year, one in the West and one in the East.

"We are facing the most important period of our history as an organization. With fewer distributors, with larger increased production and stronger competition we must determine among ourselves that we will make the National Association of Talking Machine Jobbers the strongest sales organization, individually and collectively, that is in this country for the marketing of any line of talking machines.

"We have the brains, industry, energy, experience and initiative necessary and we must bring them to bear on our problems. I again



Geo. E. Mickel

reiterate that we need closer and more friendly co-operation among ourselves.

"Some of our members may have larger vision than others—then let the others see it. Some may be better advertisers; if so, give us the tip—some better merchandisers, and if so put us wise. We must assume the responsibility of leadership in our different communities in the talking machine line.

"Every member of this organization is held responsible for the success and stability of his own business, but it is not enough for us to think only of the present. The man among us to-day who does not look to the future with every confidence in himself and the Victor line is not only standing still, but is falling behind. We must get the vision of the possibilities in our line. Let us be always alert to every opportunity to advance Victor representation. Let us strengthen our own organization wherever pos-

Officers of the National Association of Talking Machine Jobbers for 1920-1921

President, Lester C. Wiswell
 Vice-president, Louis Buehn
 Secretary, A. A. Trostler
 Treasurer, W. H. Reynolds

sible, for it was never so necessary as it is to-day for us to have active and efficient organizations. We should keep before us continually the purpose of inspiring the dealers with a larger con-

ception and a keener appreciation of Victor goods. Let us have but one yardstick on our action, 'Is this best for Victor representation?'

Report of the Secretary

The next report was that of the secretary, A. A. Trostler, who covered the activities of his department during the past year in a careful and complete manner. The report in full follows:

"Your secretary takes pleasure in giving you a résumé of the work done in this office during the past year. There has been nothing of importance to take up with our members the past year. The little that has been necessary you received written reports on. You obtained in person all information and activities of your executive committee when you attended either the Chicago or New York open executive meetings this last Spring, and while on this subject I want to say that 98 per cent of our membership was represented at the combined meetings.

"During the past twelve months we lost the membership of Collister & Sayle, Cleveland, O., which was absorbed by the Cleveland Talking Machine Co. We lost the membership of A. Hospe & Co., of Omaha, Neb., which was absorbed by Ross P. Curtice Co., at Lincoln, and who have moved their jobbing plant from Lincoln to Omaha, Neb. This reduces our membership two members, but we added the American Phonograph Co., Burlington, Vt., and the Ohio Talking Machine Co., Cincinnati, O., making our membership to-day seventy-three parent houses for full membership and seven branch houses for branch memberships. Total membership, eighty.

"It is indeed gratifying to report to you that we have no delinquent members in our Association. All dues have been paid to August, 1920.

"At this particular time I want to ask the members of this Association to stand for a minute with bowed heads in respect for our lost members, M. G. Price, of Newark, N. J., and O. K. Houck, of Memphis, Tenn. It was indeed a grievous duty for your secretary to convey to the families of these members our profound sorrow in their bereavement.

"You have all been advised of the new appointments at the Victor Talking Machine Co., Sales Manager J. S. Macdonald and Assistant Sales Manager Edward J. Dingley, to whom this office sent our congratulations and our earnest support at all times.

"I have kept in close touch with the factory so that should anything of importance come up I would then be in position to advise our members. I have found this: That the Victor Co. are not leaving a stone unturned to bring their plants to capacity production, and while on this subject I desire to call your attention to a statement made at the convention in 1919 in which we were told the necessity of doing extra sales work because of the increased production that the Victor Co. would have last Fall. In turn, I want to say that we are nearer to this tremendous production to-day than we were twelve months ago. I mean by this that we will have Victor goods this Fall, not all that you or your dealers can sell, but more than we ever had before, and it is up to us to put forth our right foot in the right direction along educational and sales lines because we must be awake to the situation of a larger output from now on, so

(Continued on page 102)

NATIONAL ASSOCIATION OF TALKING MACHINE JOBBERS HOLDS CONVENTION—(Continued from page 101)



Attendants at the General Convention of the National Association of Talking Machine

this thing of simply marking Victor goods with your dealer's name and shipping, is nearly a thing of the past, because the Victor Co. are going to give us Victor goods.

"Your executive committee has held three meetings as follows: November, 1919; March, 1920, and June, 1920.

"Your Association has been asked by the Chamber of Commerce of the United States to vote on two referendums, No. 29, which was answered in the affirmative, and No. 30, which was answered in the negative.

"Now that your secretary's duties are at a close, I wish to take this opportunity to thank each and every one of you for the wonderful support you have extended to me during my administration as secretary of this Association, and I want to assure you that I consider it a great honor to have been elected to this office. I have kept your president advised on all subjects pertinent to our Association and he in turn has kept me advised on matters pertaining to my office."

Excellent Financial Report

The treasurer's report, presented by W. H. Reynolds, covered the financial affairs of the Association and showed that the organization was in a healthy financial condition.

Legislative Committee's Report

J. Newcomb Blackman, as chairman of the legislative committee, gave an important and interesting report covering the many legal affairs of the Association during the past year. The report was as follows:

"As is usual, there has been considerable development along legislative and judicial lines affecting our industry since our convention a year ago. At that time the subject of greatest importance was the then recent decision by the United States Supreme Court in the well-known Colgate case. By this decision the right to refuse to sell was sustained and the Association's counsel, Gilbert H. Montague, rendered a very valuable opinion in which he interpreted its meaning for our purposes.

"Perhaps I may safely say that we have been winning in the courts and have paved the way steadily for legislation that will either give or restore to us rights which we claim the manu-

ly define our right, obligations and restrictions the law of common sense and good business judgment used by each of us individually, backed with the courage of conviction, will be the only safe course for us to pursue.

"We are fortunate in having on the legal staff



J. Newcomb Blackman

of the Victor Talking Machine Co. to-day the very best counsel obtainable. Under the guidance of such men as ex-Supreme Court Justice, Hon. Chas. E. Hughes, and ex-Assistant Attorney General, Hon. James M. Beck, we should

nothing will be overlooked that will insure the eventual passing of the Stephens bill, or some similar legislation which will make less neces-



A New England Group

sary decisions of the court favorable to our cause.

"We should not be discouraged, for it takes time and hard effort to accomplish anything worth while. The outlook is very bright and I am sure your executive committee will be fully competent to carry on our activities and will realize the importance of stimulating rather than diminishing our activities along legislative and legal lines.

"Concluding, I wish to assure the general membership and particularly your officers and

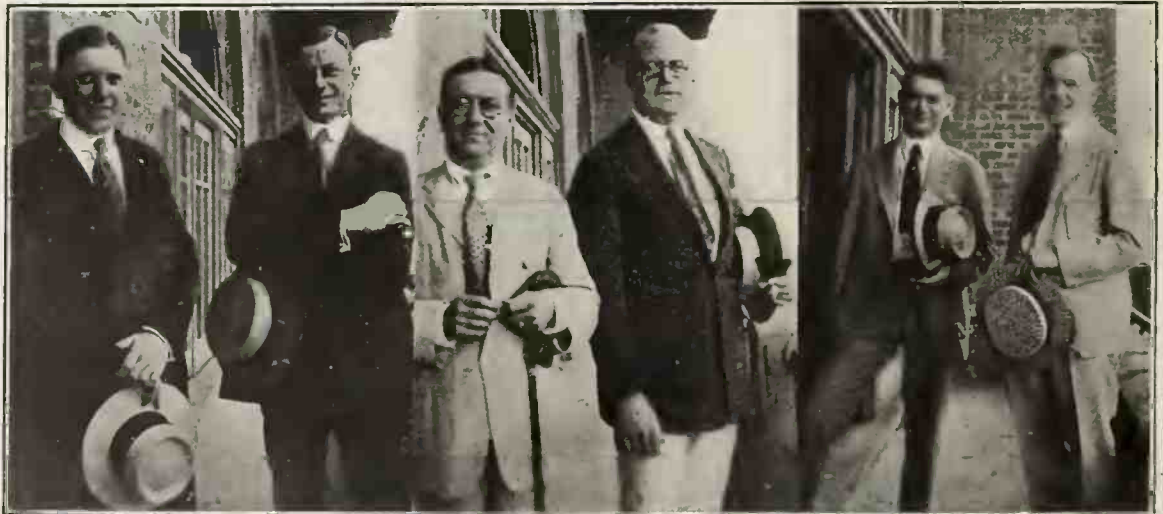

Left to right: W. M. Evans, F. W. Schwoebel Thos. F. Green, Lloyd Spencer, Sam Fox and W. G. Garlan

feel secure. Then we have our own able and well-known counsel, Gilbert H. Montague.

"As practically our entire membership was represented and heard Mr. Montague talk at our meetings in New York and Chicago in March, I hope it will be unnecessary for me to emphasize the value of his counsel and advice to our membership.

"My regret will be shared by all, I am sure, at his inability to be present, as expected, to address us in convention. However, his report, entrusted to me to read, should have the most careful consideration and not only be absorbed but retained in our minds and govern us in our daily business.

"My position as a member of the executive committee of the American Fair Trade League enables me to say that under the advice of the League's counsel, Hon. Jos. E. Davies, former chairman of the Federal Trade Commission,

executive committee of my full appreciation of the hearty support I have received as chairman of the legislative committee.

"The responsibility of every member and the way we meet it will not only affect our own



Chas. Womeldorff, Toledo Talking Machine Co.; R. H. Morris, American Talking Machine Co.; C. L. Price, Ormes, Inc.; E. C. Gallo, Horton-Gallo-Creamer Co.



Robert Steinert, Herbert Shoemaker, Mr. and Mrs. Kenneth Reed

facturer, wholesaler and dealer in honest merchandise and methods is entitled to. However, until such time as pending decisions more clear-

NATIONAL ASSOCIATION OF TALKING MACHINE JOBBERS HOLDS CONVENTION—(Continued from page 102)



Jobbers, Held at the Hotel Traymore, Atlantic City, N. J., June 28 to 29, 1920

standing and good will, but reflect credit or otherwise to our entire organization, as well as

gled for so many painful years. Our organization has lost a staunch member and supporter and meet it is we set it down that the world is poorer by his loss. The National Association of Talking Machine Jobbers in annual convention assembled at Atlantic City, N. J., places itself on record as tendering to his stricken family and business associates of a lifetime its sincere and heartfelt sympathy in their bereave-

Endorse Important Labor Referenda
During the course of the afternoon the Association went on record as endorsing unanimous-



Dan A. Creed, Joseph C. Roush, Arthur A. Trostler and Thomas Towell

the dealers with whom we should be a guiding force by example.

"In this respect, my message in the form of a full-page announcement appearing in the next issues of the trade papers will further emphasize my convictions."

Reports of Other Committees

The arrangements committee, consisting of L. C. Wiswell, chairman; H. Goldsmith, H. Miller, C. K. Bennett and C. L. Price, reported on the work done to make the various functions of the convention go off smoothly and was warmly complimented on its good work.

The press committee in its report expressed its appreciation of the work of the trade papers in



H. T. Barnhill H. F. Miller
The Men Who Put the Penn Dog on the Map

ment and direct that this minute to his memory be spread upon its records and a copy suitably prepared sent to the mourning family of our loved and lamented comrade. After life's fitful fever he sleeps well."

A further resolution in memory of M. G. Price was adopted and read as follows: "In the death of M. G. Price, an old and tried member of this body, the National Association of Talking Machine Jobbers has lost a valued friend and associate and deeply mourns his loss. We extend to his loved ones and his business associates

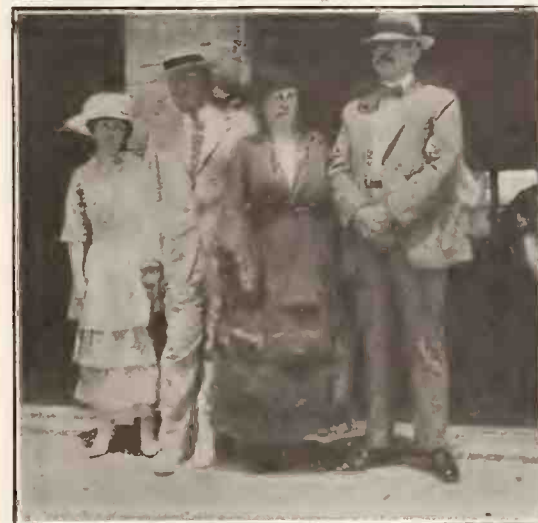

Mr. and Mrs. W. C. DeForest and Mr. and Mrs. C. M. Andrews

ly Referendum No. 31 sent out by the Chamber of Commerce of the United States of America, on the report of the Committee on Industrial Relations regarding employment relations, favoring, among other things, the open shop, the subjection of both employers' and employes' associations to legal authority and making other important recommendations relative to the relationship of employers and employes, including means for the adjustment of employment re-



Left to Right: O. L. Neal, Buffalo Talking Machine Co.; Emil Blout; H. T. Barnhill, Penn Phonograph Co.; Lester Burchfield, Sanger Bros.

giving publicity to the doings of the Association during the year.

Memorial Resolutions Adopted

The committee on resolutions, composed of French Nestor, George Stewart and J. F. Bowers, presented a resolution on the death of Oliver Kershner Houck of Memphis, Tenn., which was unanimously adopted. The resolution was as follows:

"Oliver Kershner Houck, good friend, good son, good citizen, is no more. He passed away on May 30 last at his home in the city of Memphis, Tenn., in the season he loved most, the season of sunshine, music and flowers, the one which gave him relief from the cruel malady which afflicted him and against which he strug-



Roy Marshall and Geo. H. Bliss

our deep and heartfelt sympathy in their bereavement and direct that this minute of appreciation and respect for his memory be spread upon our records and a copy sent to his mourning family."



L. C. Wiswell and Miss Wiswell

lations and a settlement of industrial disputes.

The Referendum condemns organizations of Government employes, national, State and municipal, as opposed to community welfare, and states: "In public service activities the public interest and well-being must be the paramount and controlling consideration. The power of regulation and protection exercised by the State over the corporation should properly extend to the employes in so far as they be necessary to assure the adequate, continuous and unimpaired operation of public utility service."

The Association also endorsed Referendum No. 32 on the report of the special committee on public utilities concerning the regulation of employment relations to public service corporations and reading:

1. That strikes by employes of all public service corporations, performing public services, essential to the lives, health, security, comfort
(Continued on page 105)

To the Users of Varnish Dry Kilns—Please Take Notice:

THE introduction of the Grosvenor Process of drying varnish and other siccativ coatings by subjecting them to heat and moisture in certain balanced relations has revolutionized this phase of the industry during the last ten years.

The owners of the basic patent (Grosvenor Patent—No. 1,186,477) were the pioneers in the application of this process and in the development of apparatus to make these applications practicable.

Notwithstanding the well-established prior right and ownership of the basic patent, infringing apparatus making use of this Process is still being offered to the trade.

The undersigned has always sought to palliate these evils by amicable and fair adjustment and its record is substantial proof of its reluctance to subject purchasers of infringing apparatus to embarrassment and financial loss.

Where, however, it is impossible to estop the manufacture and sale of infringing apparatus which may be used in carrying out this Process by direct recourse to the manufacturers and sellers thereof, the only course left is for us to bring suit for recovery of damages against the users of the infringing apparatus.

We therefore most respectfully warn the trade against purchasing and using varnish drying equipment not licensed under the Grosvenor Patent—the user thereof is liable not only for the comparatively small value of the equipment, but also for the profits accruing from the use thereof, for the recovery of which we shall vigorously prosecute all offenders against our business and that of our licensees.

Full information regarding the Grosvenor Patent and arrangements for licensing will be furnished upon request.

THE equipment manufactured by Drying Systems, Inc., and A. S. Nichols Company, sole licensees under the Grosvenor Patent, is the result of highly specialized knowledge, careful experimentation and years of development.

Eliminate entirely the hazards which always accompany the use of makeshift, improvised drying equipment.

Install our equipment—speed production and guarantee quality and appearance of finish through absolute control of heat and moisture within the drying room, no matter what these conditions may be outside.

WENBORNE-KARPEN DRYER CO.

(Patent Department)

1212 Tribune Building

Chicago, Illinois

Sole Licensees under the Grosvenor Process Patent:

DRYING SYSTEMS, Inc.

A. S. NICHOLS CO.

(Western Territory)

(Eastern Territory)

11 So. Desplains St., Chicago, Ill.

Aeolian Hall, New York, N. Y.

NATIONAL ASSOCIATION OF TALKING MACHINE JOBBERS HOLDS CONVENTION—(Continued from page 103)

and well-being of the people, should by law be prohibited, and

2. That suitable tribunals should be created by law to adjudicate the differences between the employes of public service corporations and their employers, and that the decisions of such tribunals should be final and binding upon both parties.

The New Officers Elected

A feature of the Monday afternoon session was the election of new officers and members



A. A. Trostler, Secretary

of the executive committee of the Association to serve for the coming year, the result being as follows:

President—Lester C. Wiswell, Lyon & Healy, Chicago, Ill.

Vice-president—Louis Buehn, the Louis Buehn Co., Philadelphia, Pa.

Secretary—Arthur A. Trostler, Schmelzer Arms Co., Kansas City, Mo.

Treasurer—W. H. Reynolds, Reynolds Music House, Mobile, Ala.

The following were elected members of the executive committee: Frank Davison, Perry B. Whitsit Co., Columbus, O.; J. Newcomb Blackman, Blackman Talking Machine Co., New York; Joseph C. Roush, Standard Talking Machine Co., Pittsburgh, Pa.; Louis Buehn, Louis Buehn Co., Philadelphia; L. C. Wiswell, Lyon & Healy, Chicago; Arthur A. Trostler, Schmelzer Arms Co., Kansas City; Thomas F. Green, Silas E. Pearsall Co., New York; E. C. Rauth, Koerber-Brenner Co., St. Louis, Mo.; George E. Mickel, Mickel Bros. Co., Omaha, Neb.; Dan A. Creed, Chicago Talking Machine Co., Chicago; Charles K. Bennett, Eclipse Musical Co., Cleveland; W. H. Reynolds, Reynolds Music House, Mobile, Ala.; Henry A. Winkelman, Oliver Ditson Co., Boston, Mass.; Lester Burchfield, Sanger Bros., Dallas, Tex.; Fred H. Putnam, Putnam-Page Co., Peoria, Ill.

Reception to Victor Co. Officials

Monday evening was given over to an affair unique in association history, namely, a reception and dinner dance tendered to the officers

and directors of the Victor Talking Machine Co. by the Jobbers' Association, in the Submarine Grill of the Traymore, which proved very successful and delightful in every particular. The entire Submarine Grill had been reserved for the



Louis Buehn, Vice-president

party and after an elaborate supper the Traymore orchestra furnished music for dancing. The Victor Co. officials who attended the reception, in company with their families, were: E. R. Johnson, president; C. K. Haddon, vice-president; B. G. Royal, vice-president; W. J.



L. C. Wiswell, President

Staats, treasurer; A. W. Atkinson, director power, building and construction; R. L. Freeman, director of distribution; C. G. Child, director of recording; E. E. Shumaker, general purchasing agent; L. F. Geissler; E. K. MacEwan, secretary; Walter H. Hunt, assistant secretary; E. H. Haines, assistant secretary; F. B. Middleton, Jr., assistant treasurer, and G. W. Jaggers, assistant treasurer, and a number of others.

Important Business at Sessions on Tuesday

The session held Tuesday morning was devoted entirely to addresses by Gilbert H. Mon-

tague, counsel for the Association, and Richard B. Aldcroftt, president of the Music Industries Chamber of Commerce. Mr. Montague, unfortunately, was unable to be present in person, but his address was read by J. Newcomb Blackman, chairman of the Legislative Committee. Mr. Montague, as is his wont, reviewed the developments in the legal and legislative fields as they affect the talking machine trade and particularly the members of the Jobbers' Association since the last session of that organization. He offered a clear presentation of the facts as they existed that served to clear up a number of questions of a legal nature.

Aldcroftt Tells of Chamber of Commerce

In his address Mr. Aldcroftt took occasion to call attention to the change of attitude between piano and talking machine dealers and the closer relationship that has sprung up between the several divisions of the music industry and which has been developed most strongly through the medium of the Music Industries Chamber of Commerce, of which the National Association of Talking Machine Jobbers and the Victor Talking Machine Co. are members. He particularly emphasized the objects of the Cham-

(Continued on page 106)



Wm. H. Reynolds, Treasurer

CAN WE DELIVER?

We showed the man from Missouri — where do you live? — Ask your stock man how many needle-cups and covers you need for the next six months — then tell us

Nickel — Brass

CONTINUOUS HINGES
NEEDLE RESTS



Gold — Silver

AUTOMATIC SUPPORTS
AUTOMATIC STOPS

WEBER-KNAPP CO.

OUR CATALOGUES
WERE PRINTED FOR YOU

Jamestown, N. Y.

NATIONAL ASSOCIATION OF TALKING MACHINE JOBBERS HOLDS CONVENTION—(Continued from page 105)

ber as set forth in the constitution, which declares that one of its functions is "to foster and promote the development of music and the interests of those engaged in any business, etc., pertaining to music; to reform abuses relative thereto; to secure freedom to its members from unjust and unlawful actions; to settle differences between its members."

Mr. Aldcroft told of the big number of organizations now affiliated with the Chamber and representative of every division of the music industry and declared that the promotion of music and of the industry was a matter of common interest to all concerned. He emphasized the fact that of the twenty-one members of the board of directors of the Chamber four are directly associated with the talking machine trade.

In closing his address Mr. Aldcroft dwelt upon the functions of the National Bureau for the Advancement of Music, what had already

been accomplished by that Bureau and what was planned for the future and bespoke the support of the talking machine men for the music advancement campaign.

Tuesday Afternoon Session

The Tuesday afternoon session was given over to various officials and department heads of the Victor Talking Machine Co. Among those present were: Ralph L. Freeman, director of distribution; J. S. Macdonald, sales manager, and Ernest John, advertising manager. Mr. Freeman had for his subject "Conditions, Present and Future," and told in detail of the manner in which the Victor Co. had met the changed trade conditions as they developed and had planned carefully and logically for the future. He told of what had already been accomplished and delivered a message that aroused much enthusiasm among the jobbers.

Mr. Macdonald, who took up the duties of sales manager only recently, told of some of the

plans of his department and advised the jobbers regarding what they could do to promote sales co-operation in the distribution of Victor products.

Ernest John had for his subject "Period Victrolas" and offered some valuable suggestions relative to the most effective means for the selling and advertising of these products. He particularly emphasized the great care used in designing the period cabinets and the absolute authenticity of every detail.

Several of the Victor department heads who were unable to be present took the opportunity of preparing papers which were read before the jobbers. Among those who sent papers were B. G. Royal, director of production, who told how the Victor factory was progressing steadily in meeting the demands made upon it, and aroused particular enthusiasm when he told of the new equipment that had been installed and was being installed in the Victor factory, and

The Motrola way is the only way to wind your phonograph

Hence the reason why the following phonograph jobbers are acting as Motrola Distributors

VICTOR DISTRIBUTORS

- Cohen & Hughes, Washington, D. C.
- Florida-Talking Machine Co., Jacksonville, Fla.
- Lyon & Healy, Chicago, Ill.
- Cohen & Hughes, Baltimore, Md.
- E. F. Droop & Sons Co., Baltimore, Md.
- Eastern Talking Machine Co., Boston, Mass.
- Beckwith O'Neill Co., Minneapolis, Minn.
- J. W. Jenkins' Sons Music Co., Kansas City, Mo.
- Schmelzer Arms Co., Kansas City, Mo.
- W. D. & C. N. Andrews, Buffalo, N. Y.
- Perry B. Whitsit Co., Columbus, Ohio.
- Penn Phonograph Co., Philadelphia, Pa.
- Badger Talking Machine Co., Milwaukee, Wis.
- Stewart Talking Machine Co., Indianapolis, Ind.
- Reynolds Music House, Mobile, Ala.
- Talking Machine Co., Birmingham, Ala.
- H. A. Weymann & Son, Philadelphia, Pa.
- Geo. D. Ornstein Co., Philadelphia, Pa.
- Cleveland Talking Machine Co., Cleveland, Ohio.
- Rudolph Wurlitzer Co., Chicago, Ill.
- W. J. Dyer & Bro., St. Paul, Minn.
- J. Samuels & Bro., Inc., Providence, R. I.
- Clark & Jones Piano Co., Birmingham, Ala.
- Knight-Campbell Music Co., Denver, Colo.
- Horton-Gallo Creamer Co., New Haven, Conn.
- E. F. Droop & Sons Co., Washington, D. C.
- Rudolph Wurlitzer Co., Cincinnati, Ohio.
- W. J. Dyer & Bros., St. Paul, Minn.
- Collings & Co., Newark, N. J.
- Buffalo Talking Machine Co., Buffalo, N. Y.
- Knickerbocker Talking Machine Co., New York City.
- W. D. Andrews Co., Syracuse, N. Y.
- Toledo Talking Machine Co., Toledo, Ohio.
- W. F. Frederick Piano Co., Pittsburgh, Pa.
- J. Samuels & Bros., Providence, R. I.
- O. K. Houck Piano Co., Memphis, Tenn.
- W. G. Walz Co., El Paso, Texas.

EDISON DISTRIBUTORS

- Denver Dry Goods Co., Denver, Colo.
- Pardee Ellenberger Co., New Haven, Conn.
- Phonographs, Inc., Atlanta, Ga.
- Diamond Music Co., New Orleans, La.
- Pardee Ellenberger Co., Boston, Mass.
- Harger & Blish, Des Moines, Iowa.
- American Phonograph Co., Gloversville, N. Y.
- Phonograph Co., Milwaukee, Wis.
- American Phonograph Co., Albany, N. Y.
- Phonograph Corporation, Chicago, Ill.

- Lawrence H. Lucker, Minneapolis, Minn.
- Silvertone Music Co., St. Louis, Mo.
- Phonograph Co., Cincinnati, Ohio.
- Phonograph Co., Cleveland, Ohio.
- Girard Phonograph Co., Philadelphia, Pa.
- Buehn Phonograph Co., Pittsburgh, Pa.
- Proudt Sporting Goods Co., Ogden, Utah.
- Kipp Phonograph Co., Indianapolis, Ind.
- Harger & Blish, Des Moines, Iowa.
- American Phonograph Co., Gloversville, N. Y.
- Phonograph Co. of Milwaukee, Milwaukee, Wis.

PATHE DISTRIBUTORS

- John A. Futch Co., Jacksonville, Fla.
- Fuller Morrison Co., Chicago, Ill.
- Hallet & Davis Piano Co., Chicago, Ill.
- W. W. Kimball Co., Chicago, Ill.
- National Piano Co., Baltimore, Md.
- Hallet & Davis Piano Co., Boston, Mass.
- Wm. Volker Co., Kansas City, Mo.
- Wright & Wilhelmy Co., Omaha, Nebr.
- Pathé Freres Phonograph Co., New York City.
- Fischer Co., Cleveland, Ohio.
- Philadelphia Pathéphone Co., Philadelphia, Pa.
- Pittsburgh Pathéphone Co., Pittsburgh, Pa.
- Buffalo Wholesale Hardware Co., Buffalo, N. Y.
- Harhour Longmire Phonograph Co., Oklahoma City, Okla.
- Salt Lake Hardware Co., Salt Lake City, Utah.
- R. B. Broyles Furniture Co., Birmingham, Ala.
- Western Phonograph Co., San Francisco, Cal.
- Interstate Phonograph Co., Philadelphia, Pa.
- Gray & Dudley Hardware Co., Nashville, Tenn.
- G. Sommers & Co., St. Paul, Minn.
- Pathéphone Shop, Rochester, N. Y.

STARR PIANO COMPANY—All Branches and Distributors

BRUNSWICK DISTRIBUTORS

- Kraft, Bates & Spencer, Inc., Boston, Mass.
- Butler Bros., Chicago, Ill.
- Brunswick Balke Collender Co., Seattle, Wash.
- Wallace Brown, Inc., Detroit, Mich.
- Brunswick-Balke-Collender Co., Los Angeles, Cal.
- Wallace Brown, Inc., Detroit, Mich.

SONORA DISTRIBUTORS

- Western Jobbing & Trading Co., Los Angeles, Cal.
- Minneapolis Drug Co., Minneapolis, Minn.
- Smith, Kline & French Co., Philadelphia, Pa.
- Yahr & Lange Drug Co., Milwaukee, Wis.
- Hessig Ellis Drug Co., Memphis, Tenn.
- Strevell-Paterson Hardware Co., Salt Lake City, Utah.
- Southern Sonora Co., Atlanta, Ga.
- Southern Drug Co., Houston, Texas.
- C. J. Van Houten & Zoon, Chicago, Ill.
- Alexander Drug Co., Oklahoma City, Okla.
- Sonora Distributing Co., Dallas, Texas.

MISCELLANEOUS

- A. C. Becker Co., Chicago, Ill.
- Empire Talking Machine Co., Chicago, Ill.
- F. C. Henderson Co., Boston, Mass.
- National Phonograph Co., Pittsburgh, Pa.
- Hoeffler Piano Co., Milwaukee, Wis.
- American Phonograph Co., Burlington, Va.
- E. R. Godfrey & Sons Co., Milwaukee, Wis.
- Gilbert Bros. Mfg. Co., Wichita, Kansas.
- Associated Furniture Manufacturers, St. Louis, Mo.
- Wiley B. Allen Co., San Francisco, Cal., and branches.
- Cabinet & Accessories Co., New York City.
- Plaza Music Co., New York City.
- Emerald Co., Birmingham, Ala.
- O. J. De Moll & Co., Washington, D. C.
- Wade Talking Machine Co., Chicago, Ill.
- Wilson-Broadway Music Co., Chicago, Ill.
- New Orleans Furniture Co., New Orleans, La.
- Sanford, Chamberlain & Albers Co., Knoxville, Tenn.
- Commonwealth Edison Co., Chicago, Ill.
- Cheney Talking Machine Co., Chicago, Ill.
- A. G. Kunde Music Co., Milwaukee, Wis.
- H. T. Gratz, Louisville, Ky.
- Adora Phonograph Co., Detroit, Mich.
- Federal Talking Machine Co., Pittsburgh, Pa.
- Haverty Furniture Co., Charleston, S. C.
- Electric Supply Co., Memphis, Tenn.
- Waltham Piano Co., Milwaukee, Wis.
- Tiffany Phonograph Sales Co., Cleveland, O.
- Grand Talking Machine Co., Brooklyn, N. Y.

BROOKS MFG. CO., Saginaw, Mich.

COLUMBIA WHOLESALEERS Everywhere

CANADIAN DISTRIBUTOR—His Master's Voice, Ltd., Toronto, Canada

29 W. 35th St., New York

JONES-MOTROLA, Inc.

315 So. Broadway Los Angeles

57 E. Jackson Blvd., Chicago

Jobbers—Write us—We have a wonderful proposition to offer you

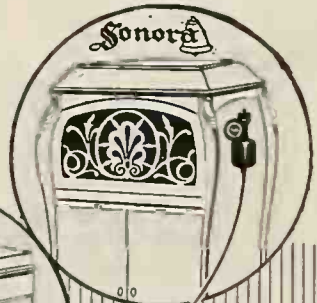
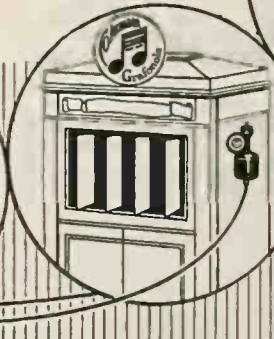
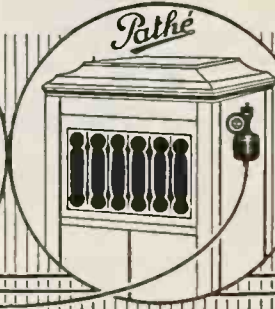
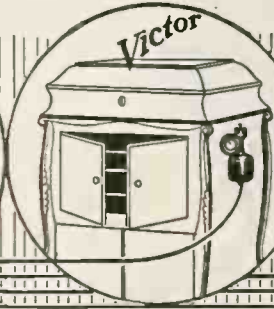
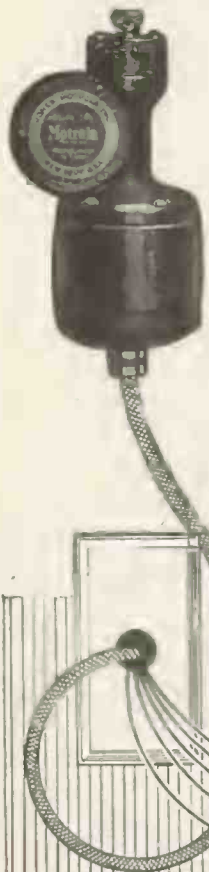

NATIONAL ASSOCIATION OF TALKING MACHINE JOBBERS HOLDS CONVENTION—(Continued from page 106)

particularly of the new record-pressing plant that will soon be in active operation. C. K. Haddon, vice-president of the company, offered a most interesting address on "Legal Aspects," in the course of which he covered a number of distinctly important matters.

Those Present at Convention

Those present at the convention were: R. H. Morris, W. H. Barker, Chas. Offerman, American Talking Machine Co., Brooklyn; Mr. and Mrs. C. N. Andrews, W. D. & C. N. Andrews, Buffalo. Mr. and Mrs. R. L. Andrews, W. D. Andrews, of Syracuse; H. A. Goldsmith, George F. Ruez, Jos. G. Slottow, Badger Talking Machine Co., Milwaukee; F. M. Hoyt, Beckwith-O'Neill Co., Minneapolis; W. D. Adams, Berg-

Miss and Mr. Henry Stadlmair, Mrs. F. T. Benjamin, C. Bruno & Son, New York; Mr. and Mrs. Louis Buehn, Louis Buehn Co.; Philadelphia; Mr. and Mrs. W. H. Nolan, Mr. and Mrs. E. P.

City; G. W. Bates, representing Sherman, Clay & Co., and the various branches on the Coast; J. C. Roush, French Nestor, Wallace Russell, Standard Talking Machine Co., Pittsburgh;

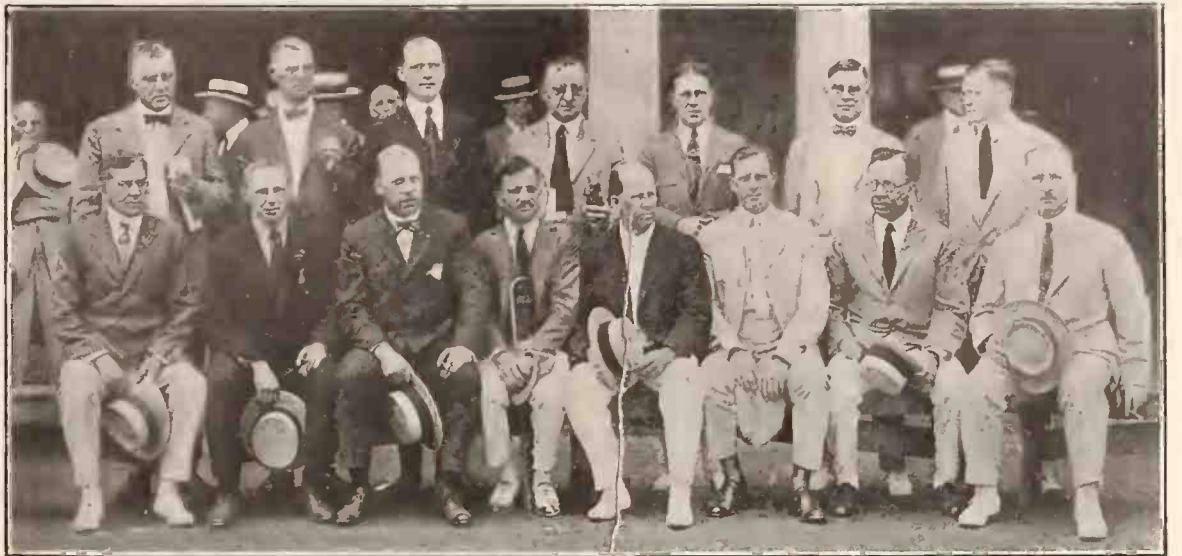

Executive Committee of the National Association of Talking Machine Jobbers



He Simply Mentioned That He Had a Cramp and the Response Was Immediate

strom Music Co., Honolulu; Mr. and Mrs. J. Newcomb Blackman, Albert Blackman, Fred P. Oliver, Blackman Talking Machine Co., New York; Mr. and Mrs. Emanuel Blout, C. B. Riddle, Elizabeth Blout, New York; Chas. F. Bruno,

Bliss, Mrs. F. D. Reineck, Miss L. C. Buehn; Miss Adeline Buehn, Louis Buehn Co., Philadelphia.

O. L. Neal, H. B. Clarke, V. W. Moody, Buffalo Talking Machine Co.; E. J. Chapman, Rochester, N. Y.; Dan A. Creed, Chicago Talking Machine Co.; Fred A. Bain, John Elliott Clark Co., Salt Lake City; Mr. and Mrs. Howard J. Shartle, Cleveland Talking Machine Co.; Mr. and Mrs. I. Son Cohen, Miss Evelyn Cohen, E. J. Walz, E. M. Griffiths, Cohen & Hughes, Inc., Baltimore; Mr. and Mrs. F. S. Harris, Cohen & Hughes, Inc., Washington; Mr. and Mrs. L. W. Collings, Mr. and Mrs. J. L. Spillane, Mr. and Mrs. H. A. Lamour, Collings & Co., Newark, N. J.; J. G. Corley, F. W. Corley, Miss Biscoe, Miss Metzgar, Corley Co., Inc., Richmond, Va.

A. A. Trostler, Schmelzer Arms Co., Kansas

Robert S. Steinert, Mr. and Mrs. Kenneth Reed, M. Steinert & Sons Co., Boston; Mr. and Mrs. George Stewart, Stewart Talking Machine Co., Indianapolis; Mr. and Mrs. T. E. Swann, Talking Machine Co. of Texas, Houston, Tex.; Mr. and Mrs. A. R. Boone, Talking Machine Co. of Birmingham; Mr. and Mrs. Eugene Stern, Harry A. Ellis, Morton Stern, Talking Machine Co. of Philadelphia; Chas. H. Womeldorff, W. L. Kellogg, C. A. Ericsson, J. J. Ryan, Toledo Talking Machine Co.; Geo. Neville, W. G. Walz Co., El Paso, Tex.; Parham Werlein, J. D. Moore, Philip Werlein Co., Ltd., New Orleans; Mr. and Mrs. Weymann, Mr. and Mrs. Albert Weymann, Mr. and Mrs. H. P. Weymann, H. A. Weymann & Sons, Philadelphia; Mr. and Mrs. Perry B. Whitsit, Mr. and Mrs. A. B. Hershey,

(Continued on page 108)

WANTED—200 Talking machine owners of Washington to join our "Motrola" Club. Apply Ansell, Bishop & Turner, Inc., 1221 F St. N. W.

YOU Should Be One of the Fortunate 200!

Here is an opportunity to do away with the most disagreeable part of playing your talking machine—constantly winding it up every few minutes. The Motrola is a small electric motor easily attached to the outside of any talking machine in place of the winding crank, without marring the woodwork or altering the mechanism. We offer a—

SPECIAL CLUB SALE
of the
MOTROLA
Attached to Any Talking Machine For
\$5.00 CASH AND \$5.00 MONTHLY
(Payments for 7 Months)

In order to distribute throughout Washington this wonderful labor and time saving invention, we are introducing it through the medium of a special club limited to a membership of 200. Be one of that favored two hundred by calling tomorrow for demonstration. You will be more than interested.

Ansell, Bishop & Turner, Inc.
1221 F Street N. W.
The Most Modern and Magnificently Equipped VICTOR PARLORS in Washington
"DO YOUR VICTOR SHOPPING HERE."
OPEN EVENINGS

Progressive Dealers! Follow This Example

—of Ansell, Bishop & Turner, Inc., of Washington, D. C., who have cashed in on our National Advertising Campaign.

Tying up with our ads appearing in current issues of Literary Digest, Life, and other popular magazines, they have formed MOTROLA Clubs, thru which MOTROLAS are sold at \$5.00 cash and \$5.00 monthly, for seven months.

We are daily creating a greater consumer-demand for you:—it's up to you to meet it thru this club plan, which places the MOTROLA price within easy reach of all of your customers.

Now is your opportunity to increase your sales of phonographs and records thru taking advantage of the growing enthusiasm of customers who, having become "MOTROLA-WISE," fully appreciate the possibilities of mechanical music.

Write to us for detailed information regarding the promotion of MOTROLA CLUBS in your locality.

JONES-MOTROLA, Inc.
29 W. 35th St. 57 E. Jackson Blvd. 315 S. B'way
New York Chicago Los Angeles



NATIONAL ASSOCIATION OF TALKING MACHINE JOBBERS HOLDS CONVENTION—(Continued from page 107)

W. F. Davisson, Perry B. Whitsit Co., Columbus, O.; G. T. Williams, S. W. Williams, Brooklyn, N. Y.; Mr. and Mrs. E. H. Uhl, L. E. Noble, Rudolph Wurlitzer Co., Chicago; Mr. and Mrs. T. F. Sigman, Rudolph Wurlitzer Co., Cincinnati.

Mr. and Mrs. W. T. Haddon, Ohio Talking Machine Co., Cincinnati; Mr. and Mrs. A. Davega, Mr. and Mrs. I. Davega, Mr. and Mrs. Byron R. Forster, Joseph Schwetz, Knickerbocker Talking Machine Co., New York; C. G. Campbell, Routt Bryant, Knight-Campbell Music Co., Denver; Mr. and Mrs. E. C. Rauth, C. B. Gilbert, H. Spencer Grover, Miss Alice Grover, Miss Viola Grover, Koerber-Brenner Co., St. Louis; Mr. and Mrs. Max Landay, Mr. and Mrs. James G. Landay, Louis Hirsch, F. B.



Mrs. Marshall, Mrs. Benjamin, Henry Stadlmair Dunn, Landay Bros., New York; J. F. Bowers, L. C. Wiswell, Miss Elizabeth Wiswell, Lyon & Healy, Chicago; Mr. and Mrs. John G. Fischer, W. C. Dierks, T. T. Evans, C. C. Mellor Co., Pittsburgh; H. B. Sixsmith, Mr. and Mrs. Geo. E. Mickel, Miss G. Mickel, Mickel Bros. Co., Des Moines; C. Alfred Wagner, C. R. Wagner, Musical Instrument Sales Co., New York; A. D. Geissler, Hugh C. Ernst, New York Talking Machine Co.; Clarence L. Price, Ormes, Inc., New York; William Sandeman, Geo. B. Ornstein Co., Philadelphia; Mr. and Mrs. Thomas F. Green, Lloyd Spencer, Silas E. Pearsall Co., New York; Mr. and Mrs. T. W. Barnhill, Mr. and Mrs. Henry F. Miller, Miss Barnhill, Penn Phonograph Co., Philadelphia; Fred H. Putnam, Roy Page, Mr. and Mrs. P. A. Ware, Putnam-Page Co., Peoria; Mr. and Mrs. W. H. Reynolds, Reynolds Music House, Mobile; Mr. and Mrs.

R. C. Rogers, R. C. Rogers Co., Inc., Washington; Ernest Urchs, Phillips & Crew Piano Co., Atlanta; Lester Burchfield, Sanger Bros., Dallas; C. B. Snow, Cressey & Allen, Inc., Portland, Me.; Ross P. Curtice, Ross P. Curtice Co., Lincoln, Neb.; Paul E. W. Carlson, Chas. H. Ditson Co., New York; Henry Winkelman, Oliver Ditson Co., Boston.

W. C. Roberts, E. F. Droop & Sons Co., Baltimore; W. R. Lyman, E. H. Droop, Carl A. Droop, Chas. L. Houser, E. F. Droop & Sons Co., Washington; Geo. A. Mairs, W. J. Dyer & Bro., St. Paul; Geo. A. Dodge, Mr. and Mrs. G. Hobey Dodge, Herbert Shoemaker, Eastern Talking Machine Co., Boston; T. H. Towell, T. J. Towell, F. B. Lyons, Dave Miller, Mr. and Mrs. Chas. K. Bennett, Eclipse Musical Co., Cleveland; Mr. and Mrs. W. A. Eisenbrandt,

Miss Elsie Eisenbrandt, Miss Alice Eisenbrandt, C. H. Eisenbrandt & Sons, Baltimore; J. W. Butts, Elmira Arms Co., Elmira, N. Y.; W. N. Edwards, F. W. Schwoebel, Florida Talking Machine Co., Jacksonville, Fla.; Mr. and Mrs. W. F. Frederick, Mr. and Mrs. Geo. Rewbridge, W. F. Frederick Piano Co., Pittsburgh; Mr. and Mrs. John L. Gately, Gately-Haire Co., Albany; A. A. and C. H. Grinnell, G. F. Martin, Grinnell Bros., Detroit; W. J. Elwell, Frederick J. Heppe, H. S. Zigler, C. J. Heppe & Son, Philadelphia; E. C. Gallo, Horton-Gallo-Creamer Co., New Haven, Conn.; L. U. Pitts, N. A. Sutherland, O. K. Houck Piano Co., Memphis, Tenn.; M. E. Schoenly, J. W. Jenkins' Sons Music Co., Kansas City; B. F. Bibighaus, Elyea Talking Machine Co., Atlanta, Ga., and a number of others not officially enrolled.

The Banquet of the Jobbers' Association

The big social function of the convention was the annual Association banquet in the Rose Room of the Traymore on Tuesday night. It was the largest banquet in the history of the organization, with close to 500 people present.

The affair started off with a rush, and while the diners were discussing a menu of particular excellence, prepared under the direction of the Arrangements Committee, of which L. C. Wiswell is chairman, they were entertained by the eight famous record artists, including Billy Murray, Albert Campbell, Henry Burr, John Meyer, Frank Croxton, Monroe Silver, Frank Banta and Fred Van Eps, who have made jobbers' banquets joyous affairs on previous occasions. An important added feature was the singing of Miss Margaret Young, a new Victor artist.

Retiring President's Message

James F. Bowers, the permanent toastmaster of the Association, gave freely of his natural wit in introducing the several speakers, the first of whom was George E. Mickel, retiring president. In his address Mr. Mickel thanked the members of the Association for the co-operation extended by them during his term. He laid special emphasis on the fact that the National Association of Talking Machine Jobbers is the greatest and most powerful sales organization in the talking machine industry and that Victor wholesalers are recognized as leaders in the industry in every territory.

The big surprise of the evening was the ap-

pearance of Eldridge R. Johnson, president of the Victor Co., in the role of speaker, it being the first banquet of the Association ever at-



James F. Bowers, Toastmaster

tended by Mr. Johnson. His address, which follows, was in a sense sensational.

E. R. Johnson's Address

In his introductory remarks Mr. Johnson spoke extemporaneously, referring particularly to what he termed the recent realization of a long-standing ambition, namely, the acquisition by the Victor Co. of a stock interest in the Gramophone Co., Ltd., of England. He stated that, as a result of this accomplishment, it was assured that goods of Victor origin and Victor quality would be marketed through Victor methods in all civilized countries. This, he thought, came as near to the "ownership of the earth" in the spirit of Kipling's "If," later quoted, as he cared to contemplate.

Mr. Johnson's formal address was as follows:

"During the last five years the Victor Co. has experienced a series of most trying circumstances. It almost seemed as though the good fortune which had before smiled so consistently upon us had deserted us, but we knew an organization worthy of the favor of fortune must be prepared to stand all the trials that fortune imposes. The loyalty of Victor distributors through that trying period was a remarkable display of confidence and was indeed a kindly light 'midst the darkness and confusion that so often seemed to threaten the very life of the company.

"It was not an easy matter to save the vital structure of the organization built up through twenty-five long years when the demands of war called for its most important men regardless of their special value due to their special training. Nor was it easy to finance the business and

**CUT YOUR
COST IN
HALF**

**USE
PAPER**

H. G. NEU & CO.

**PAPER TWINE
ENVELOPES**

108 Worth Street

New York

Franklin 2049

NATIONAL ASSOCIATION OF TALKING MACHINE JOBBERS HOLDS CONVENTION—(Continued from page 108)

maintain a sound credit when the turnover was so suddenly reduced by war regulations to a small fraction of normal.

Absorbing Increased Costs

"The Victor organization during this period successfully handled an increase in the cost of labor of 166 per cent and an increase in the cost of materials at least as great with only about 34 per cent increase in its prices." Previous profits were not excessive either; the Victor Co. was never a profiteer. It was not easy to turn the plant from the manufacture of goods for which it had been specially built to the manufacture of the radically different product of war munitions. It was a slow and difficult task to bring the scattered organization back and to restore production to the normal output of the usual products. Personally, I was out of the worst of it, being incapacitated by illness, but I knew the Victor organization was equal to the great emergency. At the end, they could, one and all, appreciate the following wonderful lines of Kipling, doubtless familiar to you, but well worthy of repetition:

"If you can keep your head when all about you
Are losing theirs and blaming it on you,
If you can trust yourself when all men doubt you,
But make allowance for their doubting too;
If you can wait and not grow tired by waiting
Or, being lied about, don't deal in lies;
Or, being hated, don't give way to hating,
And yet don't look too good or talk too wise.
"If you can dream and not make dreams your master,
If you can think and not make thoughts your aim,
If you can meet with triumph and disaster,
And treat those two impostors just the same;
If you can bear to hear the truth you've spoken
Twisted by knaves to make a trap of fools,
Or see the work you have given your life to, broken,
And stoop and build it up with worn-out tools;
"If you can fill the unforgiving minute
With sixty seconds worth of distance run—
Yours is the Earth and everything that's in it
And—what is more—you'll be a man, my son."

How Victor Output Is Climbing

"To-day the Victor Co. is far in the lead of its normal output, and is still climbing. Perhaps the responsibilities of the Victor organization can best be illustrated by a few statistics: We own and operate 1,663,552 square feet of factory floor space in one united plant at Camden and have under construction 218,023 square feet more, with land available to double this entire plant; we have 16½ acres of lumber piled from twenty to fifty feet high on every available foot the most valuable lumber pile in the world—and a 50 per cent extension under way; we have also 10,000 employes and could use 5,000 more. This force is being increased as rapidly as skilled workers can be employed and trained; we pay out, when our people all feel like working, about \$300,000 in weekly wages, besides the monthly salary roll, and expect to pay 50 per cent more as soon as people can be found to take the money; we are using 36,850,000 feet of high-grade lumber per year and will use 50 per cent more soon; we burn 55,000 tons of coal per year, and are making preparations to burn 80,000 tons. I could cover many pages with such statistics, but this is enough to show you that we are still going strong.

"I feel that I have said enough of the Victor Co.'s troubles; they are largely of the past, and I know you will expect me to say something of the future—a most difficult task in these uncertain times. The control of the Victor Co. is not going to pass into other hands—during my lifetime. It is not going to be amalgamated with or absorbed by a trust or any other combination. The Victor Co. is increasing its output as rapidly as circumstances will permit, but Victor goods will always be manufactured in Victor factories. I believe the Victor plant to be the largest and most efficient plant in the world devoted exclusively to the manufacture of talking machine goods. We built this plant because experience had proven that we could not have parts, especially cabinets of the Victor standard of quality, made in any substantial quantity by outside parties.

General Business Facing Grave Crisis

"If we look the situation squarely in the face,

we must see that general business is facing a grave crisis. There would be nothing in the situation to cause undue alarm, if our Government was alert to the danger and capable of meeting the circumstances, which are really no more critical than might be expected after a war of such huge proportions. The fact is that the fate of modern civilization is now resting largely



Eldridge R. Johnson

on the United States, and if we fail to meet the responsibility the world will mark time for a century.

"It is also apparent that a boundless opportunity for good has been created. The very foundations of society and industry have been shaken throughout the world, especially in Europe where the true spirit of progress was so long bound by social conservatism to such an extent that the great mass of the people were dangerously dissatisfied. Now everything is changing. The great increase in wages and

prices, though excessive in many cases, will, in the end if intelligently controlled, achieve a far better distribution of wealth, and conditions for countless millions will be improved.

Responsibility of the United States

"The United States stands face to face with the greatest responsibility that any government has ever faced since that period in history known as the Decline of the Roman Empire, at which time about the same situation developed. The Roman government failed because of the inefficiency of the men entrusted with great responsibilities. The cost of that government was made excessive by incapable and dishonest politicians. The cost of its military operations and defenses made the maintenance of an army and navy unpopular. Rome was ruled by a ring of grasping and unpatriotic politicians. Ancient Rome suffered from the same trouble that is now threatening all the great nations—the inefficiency of men in high places.

"Almost every idea that is being so skillfully and dangerously put forth to-day by the various groups of inefficient, radical politicians, who have so successfully fooled the public for the last twenty years, was used by those old Roman politicians to further their foolish and dangerous policies; the same class of dangerous and radical legislation was indulged in; the same silly cry against wealth was raised; the same excessive taxation was forced upon the industrious and thrifty classes; the same waste by inefficient government bureaus was permitted; the same kind of radical talk and radical theory was used to fool the public.

"Contrary to the accepted theory, the Romans did not become weak and effeminate. They were a strong, brave race of people and Roman civilization, although it lay dormant for centuries, has survived. It is the civilization of to-day. They were always victorious in their wars when their armies were well equipped and trained, but frequently they were found unpre-

(Continued on page 111)

**The
Fundamental
Factor of a
Successful
Service
is
Personal
Co-operation**



C. BRUNO & SON
INCORPORATED
Victor Distributors to the Dealer Only

351-353 Fourth Avenue **NEW YORK**

WE DO NOT RETAIL

Announcing

The

MAGNAVOX

Music and Voice Telemegafone

Increases the volume of any
Phonograph many times

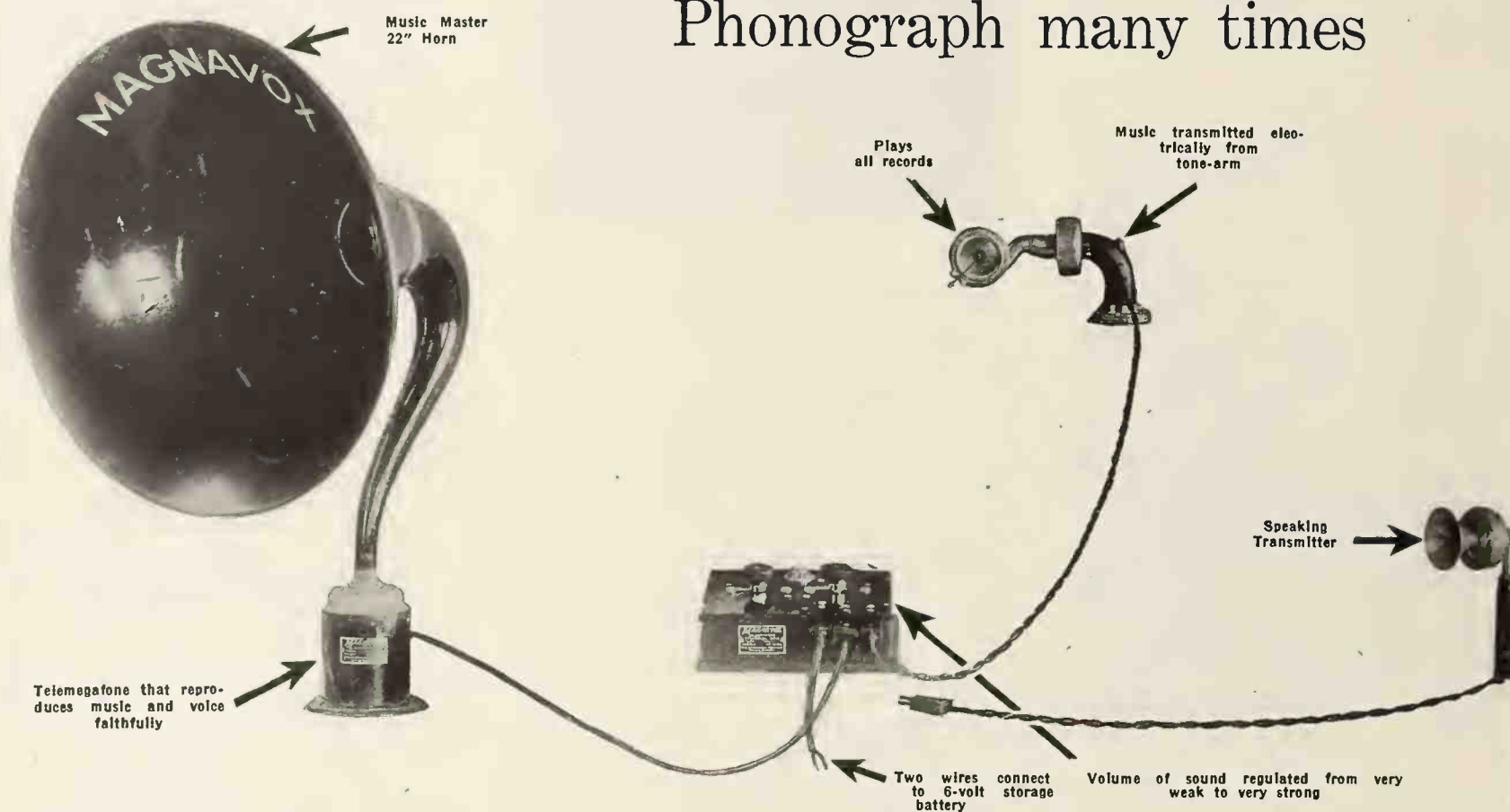

FOR Schools, Colleges and Clubs, Summer Resorts, Camps and Parks, Public Speaking and Announcing, Steamships and Theaters, Dancing, Entertainment or Novelty and numerous other places.

DEALERS The Telemegafone will be distributed direct from the factory and dealers interested should not delay in applying for Agency Proposition.

TERRITORY Available in nearly all parts of United States.

Bulletin 22520 Will Tell You More.

Write today to

The Magnavox Company

2701-2759 East 14th Street

:

Oakland, California

NATIONAL ASSOCIATION OF TALKING MACHINE JOBBERS HOLDS CONVENTION—(Continued from page 109)

pared. Radical socialism and 'peace at any price' theories are not new; these ancient people also tried to save themselves by peace treaties and foolish laws.

"It was the German race who eventually, through a long series of wars in which they were generally defeated, indirectly caused the fall of Rome. Six years ago, after preparing for years, their aggressive government again made one of their war moves. It was the same old game but played on a greater scale and now, as ever before, the German race, though defeated, is a dangerous and difficult problem.

"The German military power deliberately conspired and prepared to destroy the British Empire. A great emperor in Germany could have averted the war, but the emperor was not great. He was a very incompetent man in a very high place. He intended to destroy the British Empire and then the world would have been Prussianized. Nothing could have checked him. England still survives, thanks to the United States, but it was fortunate for the United States that England survived until America could get ready to help her.

"The German military power is crushed. The direct purpose of the war is accomplished, but the war is not yet ended. Fighting which would have been classed among the great wars five years ago is still going on. A state of war that is far more than a theory still exists.

Much of Europe Helpless

"Germany, Russia, Central Europe, and Western Asia are to a great extent helpless and prostrate. The United States and the Allies must help them to put their affairs in order and to resume their usefulness. The world can never be prosperous and content without them. They are an indispensable part of civilization. We cannot long continue prosperous unless we help those who have lost their all in the war. A large part of the people of Europe who are suffering are our friends. We and our Allies are victorious, but that is not all—we now have a new duty and one which cannot safely be ignored; we must make permanent the fruits of victory.

"The people of the United States, through their President, promised the Central European Nations an humane and practical peace if they would break away from militaristic government. The revolutions which ended the war were in response to that promise, and that promise has not yet been fulfilled. Some of these peoples are now crying to America 'You have fooled us' and that cry is sounding all through central and northern Europe. Members of the old Imperial military governments are beginning to say to their people 'We told you so' and a great many similar things we never hear anything about in the United States. This is having its effect. The old Prussian militaristic spirit is beginning to revive. The recent German elections show that very plainly.

"For the first time in the history of their race the German people have revolted against their rulers, have overthrown their Imperial Government and taken their own affairs into their own hands. While it is quite right that they should pay for the material damage they inflicted on the invaded countries it is foolish and dangerous to try to saddle them with the burden of a debt that will make them nothing but tax slaves for the next century.

"If the hand of national fellowship by a just, practical peace had been held out as was promised, they would now be in the process of becoming a new nation with high democratic ideals, and would, I believe, be content to pay their debts, attend to their business and become a useful member of the Society of Nations. But, unless prompt steps are taken to this end the demoralization of that people will be complete. They will become hopelessly embittered and a terrible menace to civilization will be perpetuated in Central Europe. The League of Nations may be advisable eventually, but the world needs a practical peace immediately.

"I present this statement of conditions as I see them to show you why I think no business man or group of business men can know what is in prospect.

Future of Business the Problem

"The Victor Co. has plenty of business. The crop conditions are fairly satisfactory, the purchasing power of the average citizen is greater than before the war, far greater, but this is not sufficient. The future welfare of business is a present problem. There should be an armistice declared on all questions vital to the interests of the country during this period of recon-

struction. Labor leaders should check all agitation save in the most extreme cases. Labor's claims must be adjusted liberally and fairly, but the financial situation, too, calls for careful adjustment; there is a limit past which it is not safe to go.

rights are of more importance than the rights of the other one hundred million people in this country. This is a dangerous and impractical doctrine. There are still many people whose wages should be raised, but the ones who are making the most trouble are the ones who are fairly well paid already. Our Government, however, has failed in many things that it has undertaken in the way of constructive accomplishments, and is largely responsible for the complicated labor situation.

Effect of Government Regulation

"The effect of our Federal laws is felt in every



Smiling Groups of Talking Machine Men Were Always to be Found About the Traymore or on the Boardwalk and the Sartorial Effect was Perfect

struction. Labor leaders should check all agitation save in the most extreme cases. Labor's claims must be adjusted liberally and fairly, but the financial situation, too, calls for careful adjustment; there is a limit past which it is not safe to go.

"Business men have made many sacrifices, but every interest should be content to suffer some temporary inconvenience for the general good. Labor unions have been led to believe that their

line of commercial enterprise. The American Merchant Marine at one time carried its full share of the commerce of the world, but United States has been out of it for the last sixty years, and the situation at present seems to be hopeless. One important reason is that our shipping laws, many of them well intended, are imperfect. The proposed legislation applying to marine commerce, while displaying a desire on

(Continued on page 112)

Perfect Uniformity and Uniform Perfection in

Turntable Felts

You get just that in Turntable Felts made by the American Felt Company. That's why they are the choice of leading manufacturers in the Talking Machine trade.

Send us your specifications for felts for any mechanical purpose. They will have the attention of technical experts with laboratory facilities at their disposal

American Felt Company

TRADE MARK



100 Summer Street
BOSTON

114 East 13th Street
NEW YORK

325 So. Market Street
CHICAGO

NATIONAL ASSOCIATION OF TALKING MACHINE JOBBERS HOLDS CONVENTION—(Continued from Page 111)

the part of Congress to do something, is certainly very imperfect. The railroads have, I believe, been under Government regulation in a general way for the past twenty years. During this time we have lived in a fool's paradise in the belief that we had the cheapest transportation in the world, but it now appears that our past low freight rates were achieved at too high a cost and that we shall have to pay dearly in the future for this error of the past.

"We trusted the Government to regulate business, but the results have been very unsatisfactory. For many years business men have been criticised and persecuted by the Government in spite of which the American business man has made good during this time, while the Federal Government has made bad. American business men have constructed the greatest group of business enterprises ever known in the history of business in spite of bad government. Commodities are made at less cost and of better quality, under higher wages and shorter hours, than by any other country.

"We trusted the Government to keep us at peace and to prepare for war and woke up to find the Government asleep. Then we had to break our backs and our pocketbooks, and our hearts, doing in frenzied haste what we should have been fully prepared for. There had been plenty of time. The war started in 1914, and we did not enter it until 1917.

"We trusted the Government to finance the war. We bought bonds knowing they would fall far below par. Our War Bonds are now a dangerous embarrassment to us. They represent inexcusably bad financiering. They failed as a popular investment. They have absorbed entirely too much of the credit provided by the Federal Reserve Banks; and the natural expansion of business will be seriously checked.

"We trusted our Government to tax us fairly and intelligently, but it has passed all records in uneconomic and vicious taxation. No nation on earth can long endure such confiscatory taxes.

False Ideas of Economy

"The group of radical politicians who have controlled the affairs of this country for the past twenty years, and who have been responsible for these false ideas of political economy, do not constitute the majority in Congress. Their ideas do not even have the virtue of originality. As a rule, they are very clever men who believe they can hold themselves in office by appealing to the selfish instincts of unthinking people. Their ranks have been materially strengthened of late by the most dangerous political parasite of all—the labor union politician. He is not a friend of labor. He uses labor unions as a means to an end. His plan is first to secure Government control of everything and then to control the Government—very simple!

"It would be useless for business men, as a class, to enter into direct political competition with those men. Politics is not the business man's game; he would be hopelessly outclassed. Very few business men are fitted by temperament and experience to hold public office, and the only defense that business men of America, and any other country for that matter, have today is a direct appeal to the public by spreading a propaganda of education in the matters they know about, financial, industrial, and business matters in general.

Regarding Business Regulation

"I do not disapprove of the theory of business regulation. I believe that the Interstate Commerce Commission could be made an efficient organization to stabilize transportation matters, and I believe the Federal Trade Commission is the proper organization to guide business, but the Department of Justice should co-operate with them. Furthermore, they must be supported by sound public opinion. In the light of experience in the last few years it is very apparent that the Sherman Law and the Clayton Act are very imperfect. No Government agency can successfully regulate business in this country under such imperfect laws, no matter how

well disposed it may be, and no progress can be made in the matter of Government regulation, either of railroads or other big business enterprises, until these laws have been redrafted to conform to the needs of the time. Even the United States Supreme Court, which holds the greatest responsibility of any body in the land, appears to be confused by these bad laws. As bad as these laws are, however, business men must abide by them at any sacrifice so long as they remain on the statute books. The Department of Justice apparently means to enforce them, and it can although many of the decisions under the Sherman Law and Clayton Act are promoting unfair competition and restraint of trade in direct opposition to their purpose.

Taxes Must Be Revised

"There is a great cry against high taxes and these taxes will have to be very intelligently revised: if made too low the cost will be greater than the present cost of high taxes. This is a great country and it needs a great sum of money to run it. There are many beneficial things that only the Government can do. The problem is to develop a fair and practical tax law and then spend the money economically after it has been collected.

"This is not a difficult problem. It is a very simple one. The difficulty lies in creating a sound public opinion that will support sound methods. There are plenty of good men in Congress but they do not get people's support; public opinion does not back them up.

"This country is really ruled, as it should be, by public opinion, but public opinion has been misled. There is every sign, however, that the people are suspecting that something is wrong and I believe they are in a listening mood. If every business man in the country will study the situation until he fully understands it himself much may be accomplished. A complaint to be effective must be intelligent.

"Many well-intending people seem to be under the impression that in order to secure better government some radical change is necessary. I do not subscribe to this theory. Our present form of government is 90 per cent good and the remedy lies not in radical changes, but in efficient administration and simplification of the laws.

"All governments are an experiment and they will be for ages to come. To some extent there will always be a feeling of unrest, for such is progressive thought.

"We must have a better and more efficient

government system and I believe the tide has turned. The business men of America can do much to help, but they will have to work along intelligent lines in the matter of creating wholesome public opinion rather than enter the race for political office. They will have to think right, talk right and act right.

"While I do not believe a man with nothing but a business training would make a good president I do believe it is necessary to organize the Federal Government more on business lines. This could be accomplished very quickly. The Cabinet should be reorganized into a sort of executive committee representing not only the different branches of the Government, but also the different social and industrial interests. The strictly governmental departments are already fairly well represented. Agriculture and labor are also represented and there should be added men experienced in finance and investments, banking, railroading and manufacturing. Then something could be accomplished. This executive committee should have some power. It should not be wholly subservient to the president. The vice-president should be an effective member of the organization and it should be able to transact business when the president is ill or absent. This country is too big for one man to run. It requires a group of wise men who are fairly representative of the various interests of the country."

New President Introduced

L. C. Wiswell, the new Association president, was next introduced and took occasion to emphasize the great value of team work among the members of the Association and everyone in the Victor business during the coming year. He paid particular tribute to the foresight of the Victor Co. in meeting conditions that have developed and urged that the jobbers do their part in preparing for the future.

Dr. Petty Speaks on Brotherhood

The last speaker was the Rev. Dr. C. Wallace Petty, of New York, who in an address that was both witty and weighty emphasized the necessity of a proper understanding and practice of brotherhood in business relationships to solve in some measure the problem of unrest that now exists.

Dance Closes the Evening

At the conclusion of the speaking the record artists continued their interesting program, after which there was dancing ad lib. to the accompaniment of excellent music by the Traymore orchestra.

THE FINEST OF

CORE STOCKS

For Phonographs and Record Cabinets

Are supplied by the

GERMAIN BROS. CO.

MAKERS OF THE FAMOUS "GERMAIN PIANO BACKS"

SAGINAW MICHIGAN

CONDITIONS ARE SUCH THAT WE
ADVISE IMMEDIATE CORRESPONDENCE

Victor Co. Concert Immense Success

Caruso, Rachmaninoff and Hans Kindler, Together With Victor Orchestra, Under Direction of Josef Pasternack, Appear in Elaborate Program at Complimentary Concert Tendered by the Victor Co. to the Jobbers' Association at Hotel Ambassador on Evening of June 30th—Supper and Dance Follow

ATLANTIC CITY, N. J., July 2.—The final social event of the Jobbers' Convention, and by long odds the most noteworthy, was the complimentary concert by Victor artists to the Jobbers' Association given at the Ambassador Hotel Wednesday night, June 30, under the auspices of the Victor Talking Machine Co. The Victor Co. has been responsible for so many elabo-

rate entertainments that it was hardly believable that past efforts could be surpassed, but the affair at the Ambassador unquestionably set a new high mark.

There were two big surprises at the concert, both kept carefully under cover until the last moment. These surprises were the appearance of Enrico Caruso, who came to Atlantic City from Havana, where he has been appearing in opera, and the appearance of Sergei Rachmaninoff, the famous Russian pianist. The third artist was Hans Kindler, the noted Dutch

cellist. The Victor orchestra, under the direction of Josef A. Pasternack, provided a number of orchestral selections and also the accompaniment for the several artists.

The program provided for the occasion was a distinctly elaborate one and included autographed photos of the three featured artists and of Pasternack, together with the reproduction of two cartoons by Caruso, one of himself and the other of Pasternack.

The Artists and the Program

The concert was in direct charge of C. G. Child, Director of Recording for the Victor Co., who introduced each artist personally in a few well-chosen words. At the opening of the program he presented to the audience Josef A. Pasternack, conductor of the Victor Orchestra, saying:

"Four years ago it became necessary for the Victor Co. to seek a new director for our orchestra. The problem of finding the right man was very difficult, as our musical work required a man of great experience and unusual skill, because of the varied nature of our recording.



Supper Tendered by Victor Co. at the Ambassador June 30, 1920



Sergei Rachmaninoff

conducting the Summer season of the Boston Symphony Orchestra.



Josef Pasternack



Enrico Caruso

"I found there a conductor of unquestionable ability, a serious musician, a man of wonderful

(Continued on page 114)

NATIONAL ASSOCIATION OF TALKING MACHINE JOBBERS HOLDS CONVENTION—(Continued from page 113)

experience—but would he fit into the organization? Then I heard a Strauss waltz played as I had never heard it played under any other baton save that of Edward Strauss himself, and, like Steve Brodie, we took a chance and that chance was more than a 1,000 to 1 shot.

"He has not only fitted into the organization, but also has won the respect and co-operation of officers and staff alike and the wonderful improvement in our orchestral and accompaniment recording is due to the fact that everything which comes to his hand, whether it be a



Hans Kindler, 'Cellist

symphony, operatic aria or jazz, is music to be done in the best way possible. Nothing escapes him. Nothing is slighted, and while you have all heard him before, I want to introduce him to you to-night by his laboratory pet name, 'Eagle Ear Joe Pasternack.'

After Mr. Pasternack had led the orchestra through the mazes of the overture from "Tannhauser," Mr. Child introduced Hans Kindler, the noted 'cellist, who played two selections by Popper. In presenting Mr. Kindler Mr. Child said:

"Frequently we have been asked why it is that records by the same artist appear in the Victor catalog in different classes. Our reply has always been: 'Listen to the records in the first class in which they appeared and compare them with the records in the class they are now in and you will find the answer.'

"Comparatively a few years ago a young gentleman from Holland came to this country and was at once engaged as soloist and first violoncellist of the Philadelphia Symphony Orchestra and almost immediately a contract was made with him by the Victor Talking Machine Co. for some records in a popular-priced class. His art increased with such rapidity that it was but a very short time before we realized that he had earned for himself a much higher rating. His reputation has increased so that he could not permanently continue even with so famous an organization as the Philadelphia Orchestra and this year he will appear in concert as one of the great instrumental soloists of the present day and at the same time has taken his rightful place in the Victor celebrity catalog as a Red Seal artist. It is with great pleasure I present to you Hans Kindler."

Caruso Arouses Enthusiasm

The enthusiasm of the audience was aroused to high pitch when Mr. Child again advanced to the center of the stage and said: "At previous meetings I have referred to the early ambition of the Victor Co. to make the Victrola the greatest musical instrument in the world. In a word, to take the talking machine out of Coney Island. The foundation and cornerstone of this great ambition was laid in 1902, when the first Victor Red Seal record was made by a young Italian tenor who had taken London by storm and whose success was so great and yet so legitimate that the whole world wondered. You, our

guests, know far better than I can tell you what this artist's name and influence has meant to us—how greatly it has aided in building the reputation which we now hold so firmly.

"Through eighteen years it has been my privilege to attend the opening performances at the



C. G. Child

Metropolitan Opera; through eighteen years it has been my privilege to be present at the first performance of each new role that he has created and year after year I have watched and wondered at the ever-increasing beauty of his voice and the constant seriousness with which he devotes himself to his art.

"It has been a very great privilege to have known the artist, but a far greater privilege to have known the man. Through these long years of closest intimacy I have never heard him speak a word in unkind criticism of a fellow artist; I have seen him aid and encourage younger singers with the most gentle kindness; his acts of generosity, instances of his help to those in trouble are numberless; he takes his obligations to the public with the serious consideration of a man of great business integrity.

"His records have always been greeted with the keenest interest; they have been a constant help and stimulus to you, to your sales people and to the public and through these eighteen years of association he has kept every obligation to you and to us with unflinching loyalty. To the talking machine jobbers his name needs no introduction, but it is a very great honor to present to you in person Comm. Enrico Caruso.

"In introducing Mr. Caruso for his second appearance on our program I want to present

not the artist alone, but also our friend, Caruso."

Mr. Caruso then sang the aria "Una Furtiva Lagrima," from "Elisir d' Amore," and was accorded a distinct ovation. Another number by the orchestra, the Liszt "Hungarian Rhapsody," followed. Next Mr. Child introduced to the audience one of the latest additions to the famous Victor list of record artists, no less a personage than Sergei Rachmaninoff, the noted pianist. In his introduction of Mr. Rachmaninoff Mr. Child said:

"In 1910 a great artist came to the United States from Russia. His reputation as a composer, conductor and pianist had preceded him. His concert appearances at that time were nothing less than a series of triumphs. He did not come again until 1918. During his absence his beautiful music had been performed by the great symphony orchestras, his compositions for piano had been played by artists all over the world and he was even more famous than before. His return was heralded as an event by the music lovers of this country.

"But to us there was a touch of sadness at this time, for even though his manager approached us in regard to an engagement we were compelled to decline because the Victor Co. was



R. L. Freeman Snapped

then working for the United States Government and doing its duty in another field. So this great artist was persuaded to accept an offer from another company. It may be old-fashioned, but one of the ethics of the Victor Co. most firmly

Confidence

Empires were built by real confidence. Discriminating manufacturers demand distinctively designed Hardware because they have confidence in sound value.

Phonograph Accessories

For Immediate Delivery—Needle Cups. 3,000 Double Spring Motors, capable of playing three 12-inch records.

Also—Lid Supports, Automatic Stops, Tone Rods, Knobs, Escutcheons, Sockets, etc.

Furniture Trimmings

A complete offering in all the Period and Commercial Furniture lines.

Refrigerator Hardware

All sized Locks and Hinges.

Complete information on request

Grand Rapids Brass Company
Grand Rapids, Michigan New York: 7 E. 42nd St.

adhered to is never to approach an artist whom we know is under contract to another company and it was a matter of regret to think that this great name and art was lost to us.

"Early this Spring Mr. Kreisler and Mr. McCormack made a record of one of this artist's compositions and when the record was completed and played for their approval I had the pleasure of being introduced to the author."

Mr. Child then led up to the placing of the artist under a Victor contract and said: "The addition of his name to the long list of Victor celebrities is a great honor, and no name added in recent years has meant more to Victor supremacy than the artist it is my great privilege

now to present to you, Sergei Rachmaninoff."

Rachmaninoff then played in a masterly style, on a Steinway grand, Mendelssohn's "Rondo Capriccioso" and Chopin's "Valse Scherzo." Then came another selection by the orchestra and Caruso's final number, "Vesti La Giubba," from "Pagliacci." The program wound up with the playing by the orchestra of Tchaikowsky's "March Slave," that is, so far as the fixed program went, but the enthusiasm of the audience was unbounded and each of the artists, as well as the orchestra, furnished many encores.

Mr. Child also took occasion to introduce to the jobbers the associate director, Mr. Bourbon, a well-known cellist, who directed the Kindler

number. Those who arranged the concert, as well as the artists who participated, were accorded a tremendous ovation by their guests at the conclusion of their program.

Following the concert the jobbers were the guests of the Victor Co. at an elaborate supper at the Ambassador during which they were entertained by a number of the popular record artists, including Ralph Bingham, Rudy Wiedoeft, Billy Murray, the All Star Trio, the Peerless Quartet, Joseph Smith and his orchestra and others. Following the supper there was dancing in the Renaissance Room of the Ambassador to the accompaniment of Smith's orchestra the Palace Trio and the All Star Trio.

Stray Splinters From the Boardwalk

A convention of the Jobbers' Association without a little rain would probably prove a distinct shock to the majority of the delegates and this year the weather ran true to form. After a week of perfect weather for the conventions of the Rotarians and various music trade bodies the talking machine men were treated to a thunder storm on Tuesday which almost made



Otto Goldsmith, L. A. Schwarz, Phil Ravis some of them wish for the protection of feather beds. More than one suit of flannels lost its shape during the storm.

The terpsichorean devotees had ample opportunity to exhibit their skill and ability during the course of the convention, for there was dancing on Monday, Tuesday and Wednesday. Among the experts in the Association may be numbered Lloyd Spencer of the Silas E. Peav-sall Co., Arthur A. Trostler of the Schmelzer



W. F. Frederick, G. H. Rewbridge Arms Co., Herbert Shoemaker of the Eastern Talking Machine Co., and Kenneth Reed of the M. Steinert & Sons Co.

A certain party of Eastern jobbers left New York on Saturday morning for Philadelphia with every expectation of reaching Atlantic City on Sunday morning at the latest. Many of their friends were alarmed when they failed to arrive on time, but they finally reached the Traymore at 4 a. m. Monday morning. We under-

stand that their automobile became "hors de combat," but it is possible that Rayburn Clark

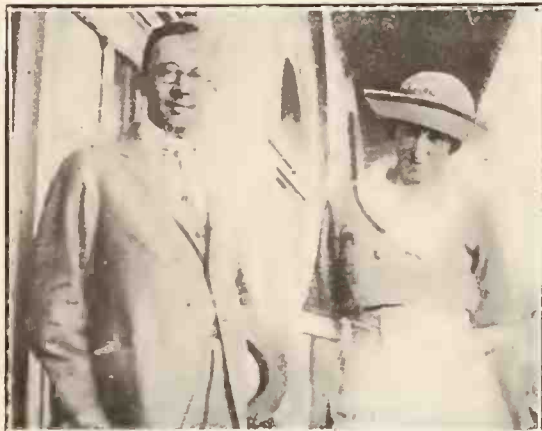

Mr. and Mrs. E. C. Rauth Smith of the Unit Construction Co. can give further details as to the delay.

An Eastern jobber, noted for his sporting proclivities, whether in stocks, with cards or with "galloping dominoes," recently played a horse named Daylight Saving, on one of those surc-thing tips. When asked about the result of the race his sole comment was, "Daylight



President L. C. Wiswell and Vice-President Louis Buehn Saving forgot to change his watch and ran on standard time."

The high cost of living has even affected hydroplane flights. Some years ago the charge



G. B. Wiswell, Joliet, Ill.; Albert Blackman, J. N. Blackman, Geo. Mickel

was \$15 for fifteen minutes in the air. Now the charge for a "standard flight" of about ten minutes is \$25, and even at that rate there are plenty of passengers.

A party of four jobbers visited one of the leading Boardwalk amusement places and consumed three rounds of so-called high balls. When the "bad news" was received it read \$18



Mr. and Mrs. Henry Thos. T. Evans, C. C. Miller Mellor Co.; Harold Lamor, Collings & Co.

for drinks and \$4 for "cover charge." Four temporary converts to prohibition were enlisted right then.

Rolling chairs were in demand constantly when the business sessions were not programmed, and C. B. Snow, of Cressey & Allen, was one of the many chair enthusiasts who appreciated the beauties of the Atlantic City boardwalk.

The Association banquet on Tuesday was a decided success, but it is doubtful if H. A. Gold-



French Nestor, F. P. Oliver, Wallace Russell smith, of the Badger Talking Machine Co., and Clarence Price, of Ormes, thoroughly appreciated the dinner. In fact, they were probably too tired to appreciate anything in particular, for in their capable hands were placed the details of the entire affair. They prepared the floor plan, the seating arrangements and distributed the tickets, and needless to say this was "some job," for over 500 were present at the dinner.

Competition was eliminated entirely in the (Continued on page 117)



The *VICTOR* trade-mark of the little fox terrier sitting attentively in front of the talking machine stands for supreme quality in talking machines and records.

The firm name of *W. D. & C. N. ANDREWS* stands for the very best co-operation and service that a *VICTOR* jobber can offer the trade.

W. D. & C. N. ANDREWS
BUFFALO, NEW YORK

NATIONAL ASSOCIATION OF TALKING MACHINE JOBBERS HOLDS CONVENTION—(Continued from page 115)

thoughts of the visiting jobbers from the large cities, as for example, G. T. (Billy) Williams, of the G. T. Williams Co., and R. H. Morris, of the American Talking Machine Co., traveled the corridors together, while they discussed the activities of the Brooklyn trade.

By a unanimous vote, Thomas F. (Tom) Green, of the Silas E. Pearsall Co., was voted the Beau Brummel of the convention. Regardless of the



L. C. Mountcastle
P. W. Simon



J. C. Roush
L. C. Wiswell

blistering heat and the crowded banquet rooms, he always managed to give the impression that he had just visited his tailor. If popularity prizes were given out, Tom Green would be a sure winner.

One of the most popular groups at the convention consisted of Henry Stadlmair, president of C. Bruno & Son, Inc., Mrs. Benjamin and Miss Stadlmair. The latter was a prominent factor in all of the social activities, and frequently numbered two or three partners to a single dance.

Perry B. Whitsit, of Columbus; W. H. Reynolds, of Mobile, Ala., and R. H. Morris, of Brooklyn, N. Y., were numbered among the jobbers who came to Atlantic City to attend the Rotary convention. There were also several dealers in attendance, including George Wiswell, of Joliet, Ill., brother of L. C. Wiswell, new president of the Jobbers' Association.

The conventioner at this time needs only a thirst, a bankroll and a merely formal intro-



Henry Burr and Princess Watahwaso, V. W. Moody and Margaret Young, Mr. and Mrs. I. Davega

duction to forget that there is any such thing as an Eighteenth Amendment or a Volstead Act. It was noticed, too, that many arrivals handled their bags personally and with care.

Chas. K. Bennett brought his family with him from Cleveland, the family, in addition to Mrs. Bennett, consisting of Miss and Master Bennett, two lively youngsters who saw all there was to see about the hotel and its environs and enjoyed things immensely.

L. C. Wiswell, the new president, arrived early in order to introduce his oldest daughter, a charming young lady, to Atlantic City convention festivities.

"The Supply Trio" was the apt designation accorded to Phil Ravis, of the Peerless Album Co., Otto Goldsmith, of the Cabinet & Accessories Co., and G. L. Mortenson, of the Repeater Stop Co. They exchanged anecdotes incidental to the growth and development of their respective products.

B. R. Forster, of the Brilliantone Steel Needle Co., and well known to the jobbers from Coast to Coast, conversed diligently with the visitors on the probable output of Brilliantone needles during the coming year. A welcomed souvenir presented by Mr. Forster consisted of a combination blotter and ruler.

As usual, the Traymore service was superb, and Manager Montgomery well deserved the congratulations which he received from the jobbers and their families.

The Traymore was crowded to the limit, but there were several rooms which seemed to be Meccas for the visiting jobber. One of these rooms was No. 739, which was the scene of many conferences of an informal and social nature. Perhaps there was a reason—liquid.

There was a feeling of optimism and confidence among the visiting jobbers that augured well for a banner season this Fall. From North, East, South and West, reports were circulated which indicated that Victor jobbers and dealers are absolutely "sold" on the idea of prosperity during 1920.

One of the best known jobbers from the sunny South is quite willing to discourse eloquently on the value of "three tens full," as compared to "three nines full." The jobber



Left to Right—W. T. Haddon, Fred Putnam and H. S. Grover

holding the latter hand won second money, but that was hardly satisfactory.

When outdoor sports were on the program, Fred P. Oliver, of the Blackman Talking Machine Co., was a foremost figure. In addition to winning one of the golf cups, Mr. Oliver was

a member of all bathing parties that were staged between sessions. He also consented to have his photograph snapped by The World's photographer, in company with Fred T. Putnam of the Putnam-Page Co., and several other visitors to the beach.

Among the lobbyists, H. C. Ernst, of the New York Talking Machine Co., was a familiar fig-



T. E. Swann and B. R. Forster

ure. In his white flannels and calm assurance, Mr. Ernst settled many discussions as to the possibilities of a Republican President being elected this Fall.

It is understood on good authority that one of the popular Victor artists at the convention was obliged to watch the "galloping dominoes" for twenty successive rolls before he finally discovered that there were any other numbers outside of two, three and twelve. However, "it is an ill wind that blows nobody good," which will be affirmed by a well-known citizen of Pennsylvania.

One talking machine man, who had fortified himself against an arid evening by placing a glass container in his inside coat pocket, slipped on the stairs leading to the grill and fell quite heavily. He was assisted to his feet and seemed none the worse for his experience when he suddenly felt a warm fluid trickling down his body. "My Lord, I hope it's blood," was his worried comment.

When Caruso arrived at Atlantic City to sing at the entertainment tendered the jobbers by the Victor Co., he was a center of interest for the daily newspaper correspondents, who wanted

(Continued on page 118)

Victor Dealers—

will find in our new wholesale store every facility for the marketing of

VICTROLAS and RECORDS

Our New Location at Penn Avenue and 12th Street brings our wholesale department to within one block of the Pennsylvania Station.

Be Sure to visit the Model Victor Sales Room on the first floor.



Mellor's
PITTSBURGH, PA.

THE CONVENTION OF T. M. JOBBERS

(Continued from page 117)

his views about the great jewel robbery and the bomb outrage at the Havana Opera House.

Howard Shartle, Mrs. Shartle and W. T. Haddon, who are now listed among the "inland" citizens, seemed to take special delight in



W. T. Haddon, Ohio T. M. Co., and Mr. and Mrs. Howard Shartle, Cleveland T. M. Co.

firting with the briny, and carried back into the West some beautiful shadings in sunburn and tan.

Mr. and Mrs. W. A. Condon easily ranked among the most popular and handsomest couples that stepped along the Boardwalk during convention days. Unfortunately the snapshot The World took was ineffective owing to unfavorable light conditions.

After watching a quartet of jobbers play "kelly pool" for an hour or so at a dime a corner, one is convinced that it is a fortunate thing that it does not require pool sharks to wholesale talking machines.

George E. Mickel, of Mickel Bros., Omaha, Nebr., entertained Miss Elizabeth and Mr. L. C. Wiswell at dinner Thursday evening, July 1st, at the Shelburne. During the dinner President E. R. and Mrs. Johnson visited the Mickel table and chatted for several minutes. After the dinner, the party was a guest of Mr. Mickel to a rollicking good time down the boardwalk. Mrs. George E. Mickel, Miss Gladys Mickel and Edward Lyman Bill were also present.

Everyone voted the Victor banquet and entertainment on Wednesday night to be the greatest musical and social event in trade history.

PERIOD TONE ARM

Mr. Talking Machine Manufacturer:

Before you place your order for tone arms and sound boxes, write to us for the new **PERIOD UNIVERSAL TONE ARM.**

PERIOD TONE ARM CORPORATION

55-61 West 17th Street

New York City

Tel. Chelsea 4744-4745

W. J. Staats, treasurer of the Victor Co., and Mrs. Staats motored over to the convention. No brighter or broader smiles than theirs were



W. J. Staats, Treas. Victor Co., and Mrs. Staats to be found in and around the well-known Traymore lobby.

THE JOBBERS' GOLF TOURNAMENT

Exciting and Close Contest Enjoyed by Nearly Two Score Trade Golfers—C. A. Grinnell Wins the First Prize, the Johnson Trophy

ATLANTIC CITY, N. J., July 2.—The much heralded golf tournament of the National Association of Talking Machine Jobbers at the Atlantic City Country Club Wednesday proved a distinctly exciting contest with the final results in doubt almost up to the last minute. In fact there was much "private session" activity among the committee judges on handicaps before it was found possible to announce the winners definitely. C. A. Grinnell won the first prize, the Eldridge R. Johnson trophy, with a gross score of 98, a handicap of 23, and a net score of 75. Fred P. Oliver won the second prize, the J. Newcomb Blackman cup, with a gross of 101, handicap of 25, and net score of 76. C. Alfred Wagner and Dan Creed tied for third place and the A. D. Geis-

ler trophy, both having a score of 82 net. Mr. Wagner made 97 gross, less a handicap of 15, while Mr. Creed had 103 gross, less a handicap of 21. T. H. Towell won fourth place, and the Russell Steinert trophy, his gross score being 101, less a handicap of 18, or 83 net. Garrett Schenck finished fifth and won the Wur-litzer trophy with a gross of 109, a handicap of 25 and a net score of 84.

The first part of the match was played under most favorable weather conditions, the contestants finding the course in excellent shape. Just before the end of the tournament, however, there was some heavy rain which served to spoil part of the contest to a certain degree. The committee made every effort to match the players as evenly as possible, the handicaps ranging downward from a maximum of 25. Among those who participated in the tournament were Emanuel Blout, Louis Buehn, Clarence Campbell, L. W. Collings, Dan Creed, Ross P. Curtice, John G. Corley, W. C. Dierks, E. J. Dingley, R. L. Freeman, A. D. Geissler, H. S. Goldsmith, Max Landay, James Landay, F. B. Middleton, Jr., C. W. Miller, H. A. Murray, George E. Mickel, French Nestor, R. B. Reinick, B. G. Royal, G. F. Ruez, G. R. Schenck, Lloyd L. Spencer, R. S. Sterritt, W. J. Staats, T. H. Towell, C. A. Wagner, W. G. Walz, G. W. Bates, C. A. Grinnell, A. A. Grinnell, Roy Page and R. Wolf.

MILHOLLAND WITH COLUMBIA CO.

R. J. Milholland has been appointed a member of the sales staff of the Buffalo branch of the Columbia Graphophone Co. Mr. Milholland spent some time recently at the Columbia executive offices in New York and visited the factories at Bridgeport, acquiring an intimate knowledge of Columbia merchandising and manufacturing plans.

You are now well into the Summer season. How many of those resolutions to put your house in order have you carried out? If those few hot days took all the starch out of you, take a brace and you will not regret it next Fall and Winter when you will have very little time to do anything else but sell.

New! New! APEX Fibre Needle Cutter

Cuts with the grain to the point.
Makes the use of fibre needles as cheap as steel.
No variation in angle or size of cut.
Does not crush the shell.

Small Size—Simple Construction
For sale through jobbers and dealers.

Retail Price \$1.50

Manufactured by

W. H. WADE 14 N. Michigan Avenue
CHICAGO

New! New!

Patents Pending.

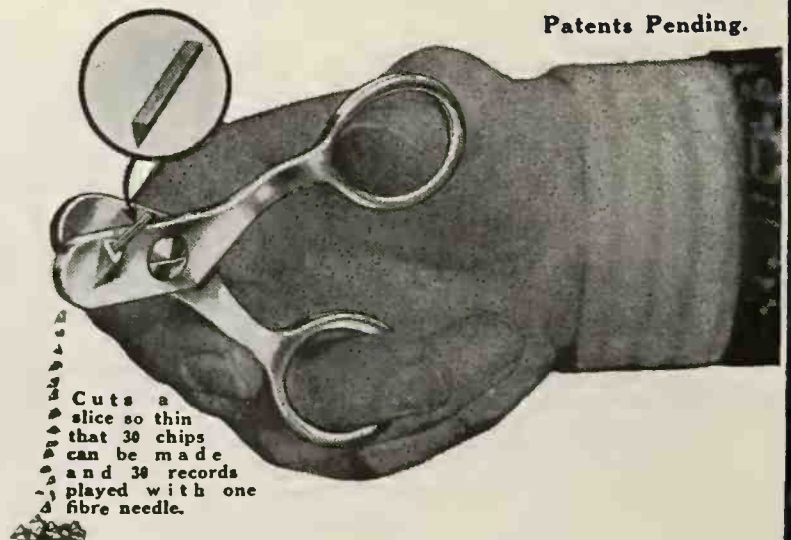

Cuts a slice so thin that 30 chips can be made and 30 records played with one fibre needle.

If
your die-cast parts
do not perform
perfectly
you are not using
Doehler
Die-Castings

The millions of Doehler Die-Cast Tone Arms and other phonograph parts in use are giving satisfaction.

The superiority of Doehler Die-Cast Tone Arms and other phonograph parts is produced by rigid adherence to the following manufacturing methods.

1. By the proper designing of the part.
2. By using only the best of raw materials in the alloys.
3. By producing a casting that is closely grained.
4. By temperature control of die as well as alloy.
5. By maintaining uniform conditions during the casting process.
6. By minimizing casting defects.
7. By extreme care while in process of cleaning.

By carrying out all these minute manufacturing details it has been found that Doehler Die-Cast phonograph parts faithfully respond to the finest vibrations of the reproducer and immeasurably add to the richness and fullness of the tone.

You can pin your faith to Doehler Die-Castings

THE WORLD'S LARGEST MANUFACTURERS OF DIE CASTINGS
DOEHLER DIE-CASTING CO.
WESTERN OFFICE AND EASTERN PLANT: BROOKLYN, N.Y. CENTRAL PLANT: TOLEDO, OHIO. WESTERN PLANT: CHICAGO, ILL.
SALES OFFICES IN ALL PRINCIPAL CITIES



He Will Find It Out—Tell Him!

Your customers, purchasing talking machines, are given painstaking advice regarding their proper regulation care and general upkeep. Once sold, they are counted among your permanent assets or liabilities, according as the machines continue to give satisfaction or the opposite. Each is a potent mouth-to-mouth advertiser of your success or failure.—

YET—

How many times do you neglect to inform the customer regarding the most vital element in retaining his confidence in your ability as a merchant?—the needle question.

The use of the proper stylus is passed over lightly, as of little importance. The purchaser is left to bury his original enthusiasm beneath an accumulation of ruined records—or to discover for himself the truth regarding the B & H Fibre reproduction.

If he continues a purchaser of records he will eventually come to the B & H Fibre Needle, and to the merchant who recommends it.

He will find it out—Tell him, and establish yourself in his confidence!

B & H FIBRE MFG. CO.

33-35 W. Kinzie Street, Chicago, Ill.

HOLMES WITH REMINGTON CORP.

Former Piano Man Enters Talking Machine Trade—Assumed New Duties on July 1

Everett H. Holmes announces his acceptance of the position as sales manager for the Remington Phonograph Corp., 1662 Broadway, New York City, of which corporation his father, James S. Holmes, is vice-president and general manager.

The young man is well known in the piano trade, having for the past six years occupied the position of Eastern sales manager of the



Everett H. Holmes

Hobart M. Cable Co., LaPorte, Ind. Mr. Holmes, who entered upon his new duties July 1, has also been elected a director of the Remington Phonograph Corp.

While Mr. Holmes will make his general headquarters at the New York offices of the Remington Phonograph Corp., yet his friends among the music dealers of the country may expect his frequent personal visits.

Mr. Holmes carries with him to his new position the sincere best wishes from a host of friends in the music trade industry.

ENGINEERS AT AEOLIAN CO. PLANT

Meriden Branch of American Society of Mechanical Engineers Holds Annual Meeting at Aeolian Co. Factory in That City

MERIDEN, CONN., July 1.—The annual meeting of the Meriden branch of the Connecticut section, American Society of Mechanical Engineers, was held last Thursday afternoon and evening at the factory of the Aeolian Co. in this city, in order that the members of the society might make a direct inspection and study of the modern piano and Pianola manufacturing plant. In the afternoon the engineers were taken on a tour of inspection throughout the factory, and at 6:30 were entertained at supper served in the drafting room. During the supper music was furnished by the Aeolian Co.'s orchestra.

After supper the annual business session was held with the election of officers as one of the features. C. K. Decherd was elected chairman, and Frank L. Rowntree, secretary and treasurer. Following the business meeting a professional session was held at which H. L. Thompson, superintendent of the record department of the Aeolian Co., read a paper on "Manufacture of Talking Machine Records," and E. W. Carruth, production manager of the Aeolian Co., read a paper on "The Manufacture and Use of Talking Machine Spring Motors."

Without exception the engineers, to the number of forty-five, were deeply interested in the various processes and the engineering problems connected with talking machine, record and Pianola manufacturing.

MARCEIS WITH SPEAR & CO.

Jean J. Marceis, formerly with the talking machine and piano departments of Gimbel Bros., New York, is now in Pittsburgh as manager of the Spear & Co. department.

JACK NORWORTH AGAIN ON STAGE

Prominent Pathé Artist to Assume Role in "My Lady Friends" Played by Clifton Crawford

It has been announced that Jack Norworth, popular singing comedian and exclusive Pathé artist, is to go back on the legitimate stage. The Jack Norworth records in the Pathé list have



Jack Norworth

always proved very popular, and judging from the distribution of the records it would seem that this Pathé star has a large following in every city, town and hamlet in this country. Mr. Norworth will play the part in "My Lady Friends" created by Clifton Crawford, who met a terrible death the night he arrived in London. Mr. Norworth will appear in his new role at Atlantic City July 31.

You can't always tell what's in a bottle by reading the label. The old saying applies these days all right.

THE GREATEST TALKING MACHINE VALUE OF TO-DAY

A Phonograph of unusual distinction—a finished product—combining in one superb instrument every good feature found in all others, plus many additional exclusive points of value.

Model 311
Height 46"
Width 21"
Depth 23½"

Built of finest materials by master craftsmen who know what a high standard of perfection a successful phonograph must measure up to. Every detail of construction, finish and mechanical appliance is closely supervised by men who know only what is "best."

Superbly cased, a glorious musical instrument, it becomes the standby of the reliable merchant, and creates an ever growing demand because—it is even better than we say it is.

"When Sold They Stay Sold"

ONE OF THE MOST INTERESTING FACTS

The Player Tone Phonographs are so moderately priced—quality considered—that they assure the dealer real profits. Six models in all finishes. Write for our booklet and special dealer's discount. You will be interested.

Desirable territory open for live representatives. Write today.

The
Player Tone Talking Machine Co.
Executive Offices, 967 Liberty Avenue
PITTSBURGH PA.

Model 316
Height 51½"
Width 24"
Depth 25"

Edison Message No. 74

There is talk of deflation in the air, but no talk of deflation in Edison Phonograph prices. There was no inflation.

“Edison Stood the Gaff”

THOMAS A. EDISON, Inc.
ORANGE, N. J.

NEW EDISON APPOINTMENTS MADE

Four Prominent Edison Men Affected by Change at Orange Laboratories

Much importance is attached to a number of

manager of the record service department; the latter having been made manager of the disc recreation manufacturing division.

F. S. Brown, who succeeds Mr. Michie, is succeeded as office manager by A. M. Hird, heretofore assistant to the manager of the musical phonograph division. Each of the above has been connected with the Edison Laboratories for a number of years and needs no introduction to the Edison trade.

the following timely statement recently issued to Iowa business men by the Better Business Bureau (vigilance committee) of Des Moines, which is a part of the advertising club movement, and the advertising association particularly commends the thought to all who use advertising as a means for promoting sales:

"A number of advertisements have been called to our attention, in which the word 'profiteer' is used—generally to the effect that the advertiser is helping the dear public to beat the game and to overthrow the said profiteers.

"We have handled several instances of this kind, in which we were able to convince the offending advertiser that such copy cast a reflection upon all other business men in the city, and that he would find difficulty in maintaining an attitude of being the only pure white light in a grey and cheerless world.

"These incidental services of the bureau are often of greater value to business as a whole than catching an out-and-out crook. We believe in constructive advertising and that the use of such statements cannot prove otherwise than detrimental."

ADS WHICH SELL

Bulletin From Associated Advertising Clubs of the World Describes the Qualities Which Characterize Advertisements of Real Trade Value

Advertisements which fail, for any reason, to foster the thought of buying are poor advertisements, declares a bulletin from the Associated Advertising Clubs of the World, dealing especially with the use of the word "profiteer" by thoughtless merchants who hope to increase their own sales by indicating that there is something decidedly wrong or dishonest about the methods of some other business man.

"Advertising is a form of salesmanship, and the knack of selling calls for getting the buyer into the buying mood. It should make him think about buying, instead of thinking of not buying," says the bulletin. This bulletin quotes

EASTERN CO. OFFICES REARRANGED

Essex Street Warerooms Now Have Offices Partitioned Off by Glass

BOSTON, MASS., July 6.—The Eastern Co. has made a most advantageous rearrangement in the offices of the Essex street warerooms and now instead of all being separated only by railings each office is partitioned off by glass. While one can see through the series of booths occupants of each are assured of that privacy so necessary in the proper conduct of business in large establishments. G. Hovey Dodge and his wife motored over to the Atlantic City Jobbers' Convention, starting several days in advance of the convention. George Dodge also motored over.



F. C. PULLIN



R. L. MICHIE



A. M. HIRD



F. S. BROWN

Members of Edison Staff Given New Posts

new appointments just announced at the Edison Laboratories at Orange, N. J.

R. L. Michie, heretofore manager of the order and service department, succeeds F. C. Pullin as

knack of selling calls for getting the buyer into the buying mood. It should make him think about buying, instead of thinking of not buying," says the bulletin. This bulletin quotes

You can do it—with the Kent

Can do what? Sell more machines, if you handle the Edison, or sell more records by catering to Edison owners, as the case may be. Your money invested in the KENT MASTER ADAPTER will yield you prompt and material profits, both directly and indirectly.

WHY? Because—

The
KENT
Master
Adapter
plays all
RECORDS
on the
EDISON



Registered in U. S. Pat. Office



PLAYING
LATERAL
CUT
RECORD



PLAYING
HILL and
DALE CUT
RECORD

MANUFACTURERS OF

Tone Arms, Sound Boxes and Attachments for Edison, Columbia and Victor Machines. We also have on hand large supplies of Steel, Sapphire and Diamond Points.

KENT PRODUCTS "Win their way by their play."

F. C. KENT COMPANY

IRVINGTON

N. J., U. S. A.

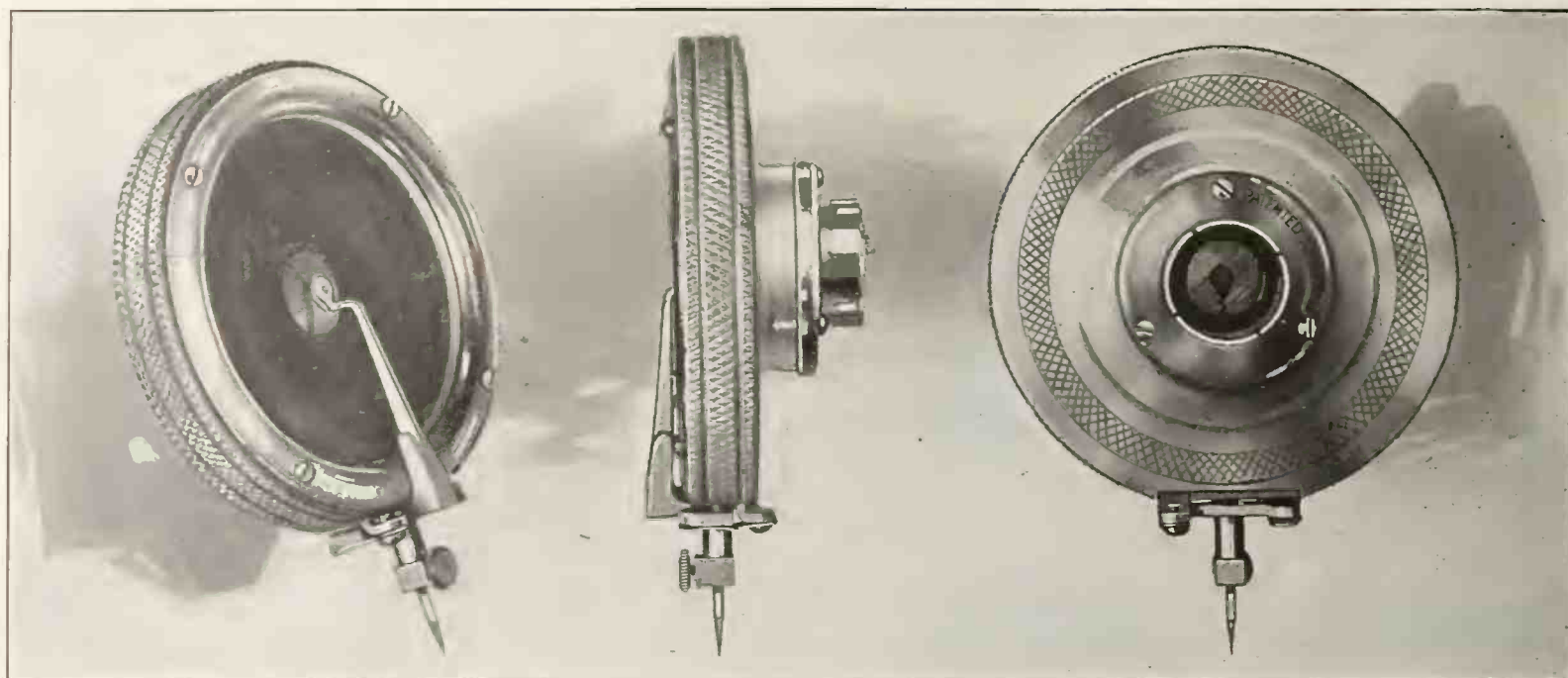

This New ALUMINUM Sound Box Has Proven To Be a Sensational Success!

INQUIRIES and orders have been pouring in to us. Phonograph manufacturers and dealers who desire to secure a wonderfully pure, clear, pleasing tone are enthusiastic over the quality features of the new aluminum sound box which we announced recently.

The reason for the superiority of this sound box lies in the fact that it is made from advanced mechanical designs based on painstaking and successful research and experiment.

This is a proposition to be considered by both *manufacturers and dealers* who wish to have the best possible tone in the phonographs they sell. The quality of materials and workmanship in this sound box makes long life and complete satisfaction a certainty.

This sound box greatly increases the value of the phonograph on which it is placed. We are prepared to furnish this sound box bearing *your* label and trade mark. *Though every detail of this product is of the very highest grade, our prices are remarkably low.*

Today write for one of these handsome new aluminum sound boxes. Test it thoroughly. Hear the improvement in the tone. Then note our quotations and order the number of sound boxes you require. Orders are being filled promptly.

Presto Phono Parts Corporation

124-132 PEARL STREET

BROOKLYN, N. Y.

PACIFIC COAST TRADE REPORTED ON A NORMAL BASIS

Machines and Records of Standard Makes Being Received in Greater Numbers and the Demand Continues Good—Interest in Edison Convention—Outing of San Francisco Dealers

SAN FRANCISCO, CAL., July 1.—General business conditions on the Coast are not as lively as they were, which conditions are said to be the result of the tendency of the banks to curtail credits, but as far as the talking machine trade is concerned the volume of sales is about normal for this season of the year. Standard goods are coming in with greater promptness and the demand for records of lighter character is heavy. The past month has been notable for many special sales in all lines of business. In talking machine goods there have been no very radical reductions in price.

Interested in Coming Edison Convention

The San Francisco trade is greatly interested in the Edison convention, which will be held here on July 19 and 20. The novel plan of holding three monster district gatherings instead of one national meeting appeals to the dealers as being a very sensible and practical idea. The program announced for the San Francisco gathering is surely peppy enough for the most progressive members of the trade. The meetings will be held in the Columbia Theatre and at this place also will be presented four plays on trade themes written by William Maxwell, vice-president of the Thomas A. Edison Co., Inc. Allison N. Clark, of the San Francisco office, has received assurance of a large delegation of Edison dealers from the western territory and he is most enthusiastic in his preparations for welcoming the visitors. Apart from the business and educational features of the San Francisco meet, there will be many entertaining features which should add to San Francisco's reputation for hospitality.

"The Little Traveling Salesman"

L. Gruen, Pacific Coast manager for the General Phonograph Corp., has a large stock of supplies on hand for distribution on the Coast and he does not expect any special difficulty from now on in getting sufficient Okeh records. The new factory at Newark is getting into full swing and the output of the company is accordingly greatly increased.

Mr. Gruen invented a device a few months ago which he calls "Our Little Traveling Salesman." This is a special trunk of small size which is built to hold a small phonograph with the new Okeh motor and two sets of tone arms. This outfit is sent to customers who wish to experiment with the goods in view of manufacturing talking machines. The trunk contains all that is essential for a thorough demonstration and serves as a substitute for a regular repre-

sentative of the company when it is not convenient to send one in person. The little silent traveler has already made a number of successful trips by express and been the means of securing considerable business.

Outing of Talking Machine Men

The members of the talking machine trade of San Francisco enjoyed a delightful outing at Wildwood, near Saratoga, in the Santa Cruz Mountains, on Sunday, June 27. Over a hundred attended the picnic, making the trip in motor buses. A beefsteak luncheon was the chief attraction in the way of eats and there was outdoor dancing to phonograph jazz music. Billy Morton, manager of the retail talking machine department of Sherman, Clay & Co., engineered the picnic and he has been warmly congratulated by reason of his success in making the affair enjoyable in every way. The revelers returned home by moonlight, singing most of the way.

N. F. Milner Retires

N. F. Milner, manager of the San Francisco office of the Columbia Graphophone Co., will retire from business this week and start on a tour of the world which he expects will take him about a year. Mr. Milner has been with the San Francisco branch for two years and previously was with the company for six years as general sales manager of the dictaphone department. No successor has yet been appointed. To show their love and appreciation of the retiring chief, the office force in San Francisco presented him with a handsome walrus traveling bag.

Art Hickman's New Post

Art Hickman, whose records have made a great hit during the last year, has been appointed Western director of musical productions for the Columbia Co. Mr. Hickman now has his orchestra in New York and it is expected that while East he will make some new records.

Found Trade Most Optimistic

A. C. Love, assistant manager of the local office of the Columbia Co., has just returned from a motor trip to Southern California. He found the trade very optimistic and says that most of the dealers have enjoyed a larger business thus far this year than they did for the same period a year ago. The banks down the San Joaquin are still very liberal in advancing money on commercial paper and there is apparently no basis there for predicting a financial stringency.

To Handle Victors Exclusively

The California Phonograph Co. and the Em-

Well Rated Dealers
Can Discount Their

**PHONOGRAPH INSTALLMENT
CONTRACTS**

WITH US

Thereby Turning Their Accounts
INTO WORKING CAPITAL



DAVID REWES BLDG.
SAN FRANCISCO

porium talking machine department will deal exclusively in Victor goods after July first. Other well known local concerns are expected to adopt a like policy very shortly. Victor goods are coming in steadily now and ample supplies are promised for all dealers in the near future.

A Budget of Brieflets

R. B. Young, who is manager in San Diego for the Wiley B. Allen Co., has just been paying a visit to headquarters in San Francisco.

Clark Wise attended the big Shriner concatenation in Portland, Ore., last week, and this week he is welcoming Shriner pilgrims in San Francisco.

Walter King, who conducts the new talking machine shop in the Heine Piano Co. building on Stockton street, has several irons in the fire. He is the director of the Olympic Club orchestra and has now made arrangements to go into the music publishing business with Forrest Brocket, owner of the Melodie Shop on Haight street. Mr. King has composed a number of songs which have been well received. The new company will be called the K. & B. Publishing Co.

Walter S. Gray, the "Needle King," has gone on a business trip to Southern California after spending a short vacation in the Yosemite Valley.

J. F. Mahoney, manager of the Brunswick wholesale branch of San Francisco, has returned from a State tour in the interests of his line.

Fred Sherman, of Sherman, Clay & Co., being pressed for time, this month visited several branch establishments of the company in the South by aeroplane, thereby saving a week of land traveling.

The Needle Once Used—Always Enjoyed

BEST SEMI-PERMANENT **STYLUS**

Plays 300 Records *No Scratch, No Hiss*

You owe it to yourself and to your customers to sell "THE MOST SATISFACTORY NEEDLE ON THE MARKET."

After once using the "BEST semi-permanent STYLUS" your customers will never use any other.

The attractive discounts, coupled with the superiority of our Needles, make the handling of the "BEST STYLUS" an asset in your business.

Samples and full particulars upon request

THE ANSONIA NEEDLE CO.

ANSONIA, CONN.



The Spirit of a Product

MICHAEL ANGELO, the great sculptor, demanded that one of his statues speak to him; Dickens wept over the character Scrooge; Andrew Carnegie once said that every piece of steel had a message for him.

The artist sees the statue grow until it appears as if it must have spirit; the author lives with his characters until to him they are living, breathing people; the manufacturer works to perfect his product until to him it is more than just a form of iron and steel.

We have no place in our hearts for the one who says that there is no art in business; for the one who claims that business is entirely a cold, commercial transaction, dominated solely by the spirit of profit. We have no place in our hearts for such a one because we know full well that there is room for the manufacturer who would build his product to an ideal, who would labor over it until it seems to him that it must be a living, breathing thing.

When we feel that this business must be conducted on any other basis, when we feel that the spirit of gain must be substituted for all that is worth while in life, we shall close these doors and turn our faces toward the Land of the Setting Sun.

STEPHENSON
INCORPORATED
One West Thirty-fourth Street
New York City

MAKERS OF THE STEPHENSON PRECISION MADE PHONOGRAPH MOTOR

BRUNSWICK DEALERS AT BANQUET

Southern California Representatives of Brunswick Phonograph Entertained by Brunswick-Balke-Collender Co. in Los Angeles

Los Angeles, June 28.—Brunswick dealers of Southern California were entertained by the local distributors on Monday, June 21, at a banquet given in their honor. Howard L. Brown, sales manager of the phonograph department of the Los Angeles branch of the Brunswick-Balke-Collender Co., planned a most attractive program for this "Harmony Meeting" and, in addition to a very pleasing dinner, there was music with some tenor solos by Edward Humphrey, manager of Hamburger's music department, and interesting addresses by Messrs. Tucker, La Motte and A. F. Tanner. Mr. Tanner, who had just returned from a trip to Chicago and a visit to the Brunswick factories, spoke of the things which he had seen there. He said that the wonderful machinery and equipment was inspiring to a degree but that the harmony which existed among Brunswick employes had impressed him more than anything else. The treatment which these workers received from the Brunswick Co. was bound to instill loyalty, and loyalty plus good material and equipment meant first-class goods. E. P. Tucker, general manager of the Wiley B. Allen Co., Los Angeles, spoke of the talking machine industry and its elevation in the realm of music. A. D. LaMotte, general manager of the Thearle Music Co., San Diego, impressed his audience with the paramount importance of advertising and selling quality rather than terms. J. O. Smith, general manager Lyon-McKinney-Smith Co., Los Angeles, talked of the impression which the talking machine business had made on himself and his firm. A. G. Farquharson, secretary of the Music Trades Association, summed up briefly.

The following Brunswick dealers and their sales forces were present: Merickel & Gillett of Whittier; Thearle Music Co., of San Diego; Wiley B. Allen Co., of San Diego; Louis Danz of Anaheim; Riverside Music Co.; Matson Bros., Redlands; A. F. Tanner Co., Monrovia and Covina; Long Music Co., Pasadena; Henry Lezy Co., Santa Barbara; R. M. Matson, Long Beach; A. J. McAllister, Santa Monica; Padghem & Son, Santa Ana; Wiley B. Allen Co., Los Angeles; A. Hamburger & Sons and Lyon-McKinney-Smith, Los Angeles.

Experience, unless you sell it to others for more than it cost you, is a dead loss.



DEATH OF MRS. E. D. WILSON

Mother of Associate Editor of The World Passes Away at Her Home in This City—A Cultured Gentlewoman of the Old School

The death is announced of Mrs. Elizabeth D. Wilson, mother of B. Brittain Wilson, Associate Editor of The Talking Machine World, which occurred at her home, 74 West 102nd street, New York, on Sunday, June 27, after a protracted illness. Mr. Wilson was at Atlantic City at the time of his mother's death, attending the various convention activities, and hastened homeward when the sad news reached him. Mrs. Wilson was born in the South and was of the Brittain family who have long been prominent in that section. She was a cultured woman who possessed many charming traits of character, a loyal friend and a good neighbor. She was noted for her broad sympathies, always seeking to aid

and to encourage those around her. All who knew Mrs. Wilson intimately loved and admired her, and her passing is to them, as to her family, a source of extreme sorrow. The funeral services took place at the home of the deceased on Tuesday, June 29, and were largely attended. The interment was in Oakland Cemetery at Yonkers. Mrs. Wilson is survived by her husband and an only son, B. Brittain Wilson.

NEW PATHE DEPARTMENT MANAGER

Miss Gertrude Krantz Now in Charge of Doll & Sons' Talking Machine Section

Miss Gertrude Krantz has joined the sales force of the retail store of Jacob Doll & Sons, Inc., Forty-second street, New York, succeeding Sam Herrmann, who left with his orchestra for Lake Hopatcong some time ago. Miss Krantz will have charge of the Pathé department of the store. She was formerly with F. A. Jenkins in Honesdale, Pa., where she has had several years' experience in selling machines and records.

BUREAU EDITORIAL WELL RECEIVED

Newspapers Commend First Article of New Editorial Service Instituted by National Bureau for the Advancement of Music

The growing influence which the National Bureau for the Advancement of Music is exerting in the newspapers of the United States is being felt on all sides and the results of the first editorial sent out to the press have been distinctly gratifying. This editorial was sent out to a selected list of newspapers as the first step in a regular monthly editorial service in the interests of the cause of music. Several of these newspapers have sent letters to the bureau commending the editorial. The Florida Metropolis of Jacksonville, Fla., placed the bureau's editorial as the leading article on the editorial page. The editor of this paper declared that he was willing to co-operate in every way for the advancement of music in his community. He further said that since the inauguration of a music page in the Metropolis the interest in things musical has greatly increased in Jacksonville.

Other papers which commended the work of the bureau and the value of the first editorial were the Washington Times and the Lancaster (Pa.) Intelligencer. The editorial in question was based on the tribute paid to music by Bernard Shaw in a recent address.

THE CABINET & ACCESSORIES COMPANY
 145 E. 34th STREET · NEW YORK

THE CIROLA
 Get this Portable for the Summer Rush



List Price, \$47.50
 Special Introductory Discount to Dealers
 Write or Phone for Representative to call

'IN THE HEART OF NEW YORK'

GET ALL YOUR ACCESSORIES FROM ONE SOURCE

- Standard Phonographs
- Lundstrom Converto Cabinets
- Record Albums
- Record Delivery Envelopes
- Motrolas
- Record-Lites
- Fibre Needle Cutters
- Cirola Phonographs
- Phonograph Cabinets
- Table Cabinets, All Kinds
- Talking Machine Toys
- Brilliantone Needles
- Velvetone Needles
- Red, White & Blue Needles
- Polishes and Oils
- Ready File Cabinets
- Repeaters and Rotometers
- Wall-Kane Needles
- Record Cleaners
- Dust and Moving Covers

All from One Source

OTTO GOLDSMITH
 President

Your Sales in the Future

WILL BE BASED UPON MORE THAN MERE DEMAND

Good Salesmanship?
Yes.

Good Buying? **YES!**

Sales will be made by good presentation of GOOD MACHINES. NOW is the time to LAY YOUR PLANS.

*Look at the
Simplicity of the
Brooks Automatic*



Brooks

Automatic Repeating Phonograph

is the only machine that will play any record any number of times and then stop automatically with the tone-arm suspended in the air.

How is this done?

Place the needle on the record at its finishing edge. Set the pointer for one or two or five or eight playings, whatever you—or the dancers—want.

The motor starts, the record plays, and replays and stops automatically with tone-arm and needle suspended in the air!

No records are scratched! No one has to get up and rush to shut the machine off! The convenience is wonderful and appealing to every buyer—especially a woman. Its mechanical perfection grips the interest of men.

Can You Sell Such a Machine?

Its tone and its finish are both as superior. This machine is available to high-grade dealers who propose to stay in business handling high-grade goods.

INQUIRE ABOUT YOUR TERRITORY FROM

THE BROOKS M'F'G. CO.
SAGINAW MICHIGAN

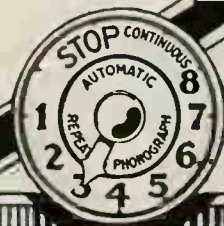

PITTSBURGH TRADE WAITING FOR BETTER SHIPMENTS

Freight Transportation Tangle Proves Embarrassing—F. J. Drake Heads Mellor's Retail Department—Fine Educational Work in Steel Mills—New Manager for Spear & Co.

PITTSBURGH, PA., July 6.—Trade conditions in the talking machine line during June were reported to have shown a marked increase over the same month a year ago. The present movement in talking machines is rather brisk, according to statements made by the various managers of the principal distributing houses here and the managers of the leading talking machine shops. The railroad freight situation has been a handicap to the talking machine trade inasmuch as shipments of records and talking machines have been much delayed. The chances now favor a speedy adjustment of the railroad situation in view of the plan to announce the new wage scale for the railroad workers about July 20. This will have a tendency to get a more prompt movement of trains and in turn benefit the talking machine trade.

Announcement has been made of the promotion of Fred J. Drake, of the C. C. Mellor retail Victrola department, to the managership of the retail department. Mr. Drake, who is a well-known Victor salesman, having for some time been connected with the sales force of the Victor Talking Machine Co., has been in Pittsburgh for some months and proved his ability as a Victor promoter. The retail Victrola department of the Mellor Co. has been given new life since the entry of Mr. Drake into its affairs, aided by a corps of efficient sales persons. It is now planned by the Mellor Co. to have John Fischer assume the sole managership of the wholesale Victrola department, which is located in the new Mellor warehouse, at the corner of Penn avenue and Twelfth street. Mr. Fischer, who is now spending his annual vacation on a fishing trip on the Potomac River, near Oakland, Md., has mapped out plans for an extensive campaign in his department this Fall and those who know Mr. Fischer and his capabilities, reinforced by his staff of roadmen, anticipate that he will "bring home the bacon."

Miss Lillian A. Wood, of the educational department of the Mellor Co. Victrola department, who spent nearly all of the month of June in visiting the welfare branches of the Carnegie Steel Co., at Munhall and Homestead, where she gave exhibitions of folk dancing, etc., left this week for her home at Bradford, Pa., to spend her vacation. Miss Wood stated that the Fall educational work would be most extensive and on a scale much more stupendous than heretofore carried on.

Jules Tallow, manager of the talking machine department of the Kaufmann & Baer store, is well pleased with business conditions and closed a very satisfactory volume of business for June. The department over which Mr. Tallow presides handles the Victrola, the Aeolian-Vocalion and the Columbia Grafonola.

H. E. Young, manager of the Victrola department of McCreery & Co., stated to The World

representative that the Victrola and Victor record sales for June showed a decided increase over the same month a year back. Mr. Young also emphasized the fact that July was starting out well with sales of high-priced Victrolas. He is confident that the Fall trade in Victrolas in his department will be one of the best in the history of the department. Mr. Young has supervision over a well-arranged and well-equipped Victrola department, which is located on the eleventh floor of the McCreery department store building.

H. Milton Miller, of the Philadelphia Show Case Co., who distributes the Sonora phonograph in the Pittsburgh territory, is very optimistic concerning business conditions and pointed out that there was a pronounced demand for high-grade instruments. He said: "Our sales of Sonora machines and Okeh records are showing up real well, considering the handicap under which we have been placed due to the railroad situation. We feel that there is every reason for preparing for a brisk market, judging from the demands that are made upon us for merchandise." Mr. Miller has a large amount of territory under his direction, with a number of live dealers. Mr. Miller's hobby is to have many small dealers in preference to one large dealer. He is of the opinion that he can obtain better results in dealing with a score or more of small merchants than with one leading dealer. He says that, while it is a great deal more troublesome, it is a plan that works out satisfactorily.

Miss Mary Sigler, who is connected with C. M. Sigler, Inc., Victrola dealers of Harrisburg, Pa., has returned from Camden, N. J., where she took a two weeks' course in the Victor School of Salesmanship.

The Sheekey Drug Co., of East Pittsburgh; Rapport-Fetterman, of Connellsville, Pa.; M. Pearl, of Masontown, Pa., and F. Schutz, of Turtle Creek, Pa., are the latest additions in western Pennsylvania to the list of Sonora dealers.

Some thirty or more Edison dealers in the Pittsburgh Zone plan to attend the Edison Caravan session in New York City. A. A. Buehn, treasurer of the Buehn Phonograph Co., Edison distributors, has sent out to all the Edison dealers in his territory letters calling attention to the Edison caravan. Assistant Manager H. M. Swartz, of the Buehn Co., will head the delegation from Pittsburgh.

Among the new Amberola dealers in the Buehn Co. territory are Fred Pepper, of Evans City, Pa.; C. R. Henry & Son, of New Lexington, Pa., and M. C. Czigan, of Auburn, W. Va.

R. W. Bolton, of the International record department of the Columbia Co., and S. W. Lukas, of the Warren street, New York City, offices of the same company, were visitors to the Pittsburgh offices of the company.

Charles L. Hamilton, secretary-treasurer of the S. Hamilton Co., one of the oldest piano houses in the State, and who also has a large and extensive talking machine department, with Victrolas and Columbia Grafonolas on sale, returned from Princeton, N. J., where he attended the twenty-fifth annual reunion of the class of 1895. A feature of the reunion was the novel exhibit made of the various articles made or sold by the former students. Mr. Hamilton had as his exhibit a Columbia Grafonola and a Chickering-Ampico grand piano. In addition to this Mr. Hamilton distributed to his classmates a Columbia record which bore on one side a recording of the class song and on the other an address by the president of the class.

W. A. Hipp, of Connellsville, Pa., is the latest addition to the list of Pathé dealers who will be supplied by the Pittsburgh Talking Machine Co., Pathé distributors. H. J. Brennan, manager of the company, stated that sales for June showed a very excellent movement of merchandise.

Jean J. Marceis, formerly of Gimbel's piano department, New York City, is the new manager of the piano and talking machine departments of Spear & Co. In the talking machine department the Victrola, the Sonora, the Aeolian-Vocalion, the Vitrola and the Silvertone are on sale. Miss M. Kusterman has charge of the record sales, with Misses Mae Harnette Crider and Edith Vensel as her assistants.

The celebrated Kimball phonograph has been placed on sale in the Pittsburgh territory by Newton B. Heims, the distributor. Mr. Heims has a full line of the Kimball instruments on exhibition in his salesrooms and offices in the Jenkins Arcade Building. Mr. Heims is also the Pittsburgh distributor of the Brooks automatic repeating phonograph. Both instruments, he stated, are having brisk sales in his territory.

Columbia dealers who called at the offices of the company, in charge of S. H. Nichols, were A. A. Clark, Connellsville, Pa.; M. Slaven, of Morgantown, W. Va.; F. Lincoff, Weirton, W. Va.; J. M. Wilson, Sharon, Pa., and Mr. and Mrs. H. Polagrin, of Farrell, Pa.

George R. Madson, of the Cheney Phonograph Sales Co., of Cleveland, O., distributors of the Cheney phonograph in western Pennsylvania, Ohio and West Virginia, was a business visitor to Pittsburgh. Gray & Martin and the Dauler-Close Co. are the retail Cheney dealers in Pittsburgh. Mr. Martin, of the former firm, closed a deal for a \$250 type Cheney phonograph that was heard by the purchaser just a half-hour before closing time. Mr. Martin says that frequently some of his best sales have been made just before the close of what is generally termed a very dull day.

I. Goldsmith, president of the Player-Tone Talking Machine Co., accompanied by Sales Manager Hollander, is spending several weeks at the noted Furniture Show at Grand Rapids, Mich. They have on display there several types of the Player-Tone. One that is much admired is a Console type. Mr. Goldsmith anticipates a record-breaking business this Fall.

Northwest Phonograph Jobbers, Inc.



PORTLAND

122 SOUTH MONROE STREET
SPOKANE, WASHINGTON

SEATTLE



Thoroughly Covering Washington, Northern Oregon, Northern Idaho and Western Montana as Factory Distributors for

Emerson Records, Brooks and Paramount Phonographs

and a complete line of Phonograph Accessories, including
BRILLIANTONE AND WALL KANE NEEDLES, RECORD ALBUMS, RECORD BRUSHES, ETC.—

As a \$100,000 corporation officered by men thoroughly familiar with the musical instrument business as a result of many years' experience, we can assure dealers in our territory at all times

ESPECIALLY DEPENDABLE SERVICE and EXCEPTIONALLY COMPLETE STOCKS

INQUIRIES SOLICITED FROM DEALERS ONLY

**ANNOUNCEMENT TO THE TRADE
INTERNATIONAL MICA COMPANY**

PHILADELPHIA, PA.

HAS AT PRESENT AN

**EXECUTIVE REPRESENTATIVE VISITING EUROPE
IN THE INTERESTS OF THE INDUSTRY**

whose services are at the disposal of "IMICO" consumers gratis for the purpose of investigation and comparing any particular market and to ascertain any information possible that might be desired by the talking machine trade in general for their individual benefit and for the good of the industry

"IMICO" and "SERVICE" are SYNONYMOUS—DON'T be BACKWARD in COMING FORWARD

All applications for the above will have prompt and careful attention by addressing:

DIAPHRAGM SALES DEPARTMENT (Foreign)

REMEMBER THE "RUSH"

BE PREPARED THIS TIME

A BUDGET OF PATHE NEWS

600 Workers Taken On at Brooklyn Plant—Large Warehouse in Chicago Gives Greater Facilities—Annual Welfare Outing to Be Held September 4 Instead of June

The Pathé Frères Phonograph Co. now occupies four floors in the new building of the group which constitutes the Pathé plant in Brooklyn, N. Y. Accordingly, six hundred more employes have been added to the already large Pathé family.

Additional facilities in Pathé distribution have been secured in the acquisition of a large warehouse in Chicago, with floor space of over 200,000 square feet. This warehouse is destined to provide increased facilities for the distribution of merchandise to Pathé distributors in the Middle West.

The official launching of the "Actuelle" will occur in August. Great publicity has been planned which will include extensive advertising in the leading publications throughout the country.

M. Jacque Pathé, who is in charge of the London offices and plant of the Pathé Frères Phonograph Co., is expected to arrive in this country in July for one month's stay.

Eugene A. Widmann, president of the company, has just returned from a tour through the Middle West, during which time he addressed a large Pathé Jobbers' Convention at St. Paul, Minn., on July 1.

The annual outing and games of the Welfare Association, of which practically every Pathé employe is a member, will be held on Saturday, September 4, this year, instead of during the month of June, which has been the usual cus-

tom. The entire Pathé family will leave the plant in Brooklyn at 10 o'clock for Duer's Whitestone Landing, where time will be equally divided between sports, dancing and "eats."

In the current edition of Pathé Records, published by the Pathé Frères Phonograph Co. for its associates, a unique idea is carried out in a double-page spread showing the photographs of

a large number of the future generation of Pathé employes.

The new Pathé twenty-four-sheet poster, in colors, which measures approximately nine feet high by twenty-one feet long, is being used extensively by Pathé dealers, as may be seen through the large number of requests for these posters being received at Pathé headquarters. The poster is very striking in appearance and is the work of Cugot, the eminent French artist.

L'ARTISTE OFFICIALS IN BOSTON

Boston, Mass., July 6.—Wholesale Manager Monroe, of L'Artiste, returned to Boston a few days ago, after a productive trip through portions of New England, and he was able to interest a number of dealers in this machine.

E. S. White, of the Smith, Kline & French Co., L'Artiste distributing managers for the Philadelphia territory, was in town a short time ago conferring with C. C. Moir, the New England distributor, relative to the Fall business for this machine.

**Natural Voice Phonograph Co.
ONEIDA, N. Y.**



Style 175



Style 125

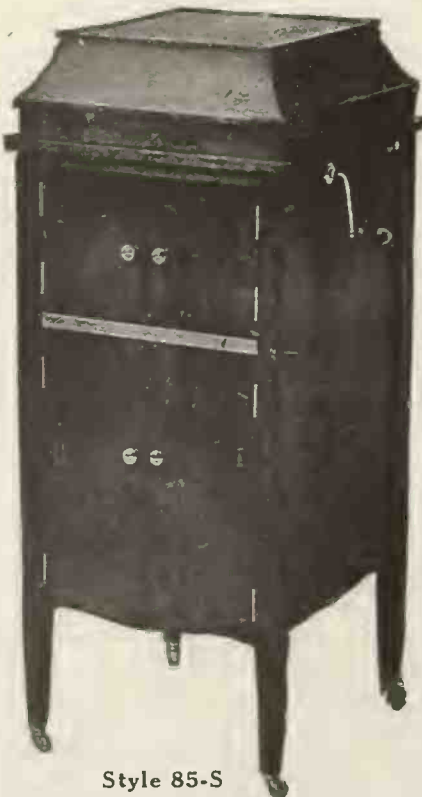

Style 85-S

Natural Voice is a splendid line of Talking Machines which will appeal instantly to your patrons. In fact, Natural Voice is as perfect as money can make it, and is worthy of its name and guarantee.

Natural Voice is the most remarkable musical instrument now before the public. For a full line of machines and price list, inquire.

**Natural Voice Phonograph Co.
ONEIDA, N. Y.**

Distributors of this Line
Wanted in every State.

What More Can You Ask

All the features that go to make a talking machine *Profitably Salable* you will find as regular equipment of *Magnola*: "Built by Tone Specialists."



Watching the Music Come Out

Complete description of all these features is to be found in our *handsome illustrated catalog*, which we should like to send you. May we? Ask us to tell you our plans for your benefit!

MAGNOLA TALKING MACHINE COMPANY

OTTO SCHULZ, President

General Offices 711 MILWAUKEE AVENUE CHICAGO
Southern Wholesale Branch 1530 CANDLER BLDG. ATLANTA, GA.

IF IT'S FOR THE PHONOGRAPH WE HAVE IT SEASONABLE SUGGESTIONS

Banjuke No. 50

Played exactly like the Ukulele. Has the distinctive banjo twang. Has 7-in. maple shell.

Extra Fine Tone

Banjo Head

Three-piece Neck



Retail Price \$15.00

Price to Dealer \$6.50

Highest Grade Made

UKULELES

No. 100. Very popular style. Plain neck, genuine mah. Retail \$6.00. Dealer \$3.00.

No. 125.—Same as No. 150 except not inlaid on edge. Retail \$10.00. Dealer \$4.25.

BANJUKES

No. 40.—Mah. shell, 7 in. 20 in long. Single piece neck. Retail \$10.00. Dealer, \$4.25.

No. 60.—Finest inlaid Banjuke, size same as No. 40. Retail \$30.00. Dealer \$10.00.

Ukulele No. 150

This Ukulele is made of genuine Mahogany, hand rubbed. Sound hole ornamented with inlaid colored woods.

Three-piece Neck



Retail Price \$15.00

Price to Dealer \$6.50

Highest Grade Made

DEAN STEEL NEEDLES

FINEST AMERICAN MADE

Extra Loud - Loud - Medium - Soft 50 cts. PER THOUSAND 10 THOUSAND LOTS

FIBRE NEEDLES

The Only Original Fibre Needle

B. & H. Needles are used the world over by those particular in their care of records. A perfect reproduction with no surface noise.

Packages— 50 Retail.....\$0.25
Packages—100 Retail..... .50
Dealer's Price, Per Thousand..... 3.00

The New Apex Fibre Needle Cutter

"SIMPLE"

Nothing to get out of order; no springs to break; no blades to fall out; easy to operate; cannot come apart. It is not possible to properly cut a fibre needle unless the cutter is in perfect order

"EFFICIENT"

Each time the needle is inserted the result in the same. Not the slightest variation in the position of the needle, the angle of the cut or the size of the cut.

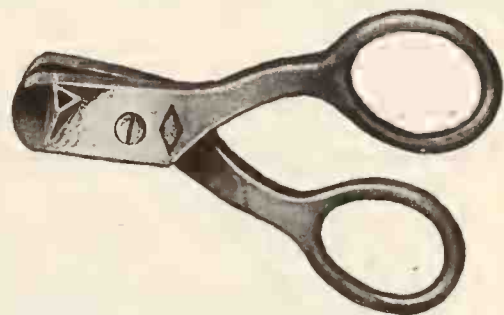

"ECONOMICAL"

The NEW Fibre Needle Cutter will take at least thirty cuts off a needle, which is double the possibilities of any other cutter on the market and makes the use of Fibre Needles more economical than steel needles.

Retail \$1.50, 40 and 10% Discount.
Dealer's Net Price, Per Doz., \$9.72



This display container handsomely finished in the same color scheme as the boxes, holds 100 packages of a kind, loud, extra loud or medium. Costs the Dealer \$7.50 per container, retails for \$15



This handsome metal enameled display stand holds 60 packages, 2 doz. extra loud, 1 doz. medium and 2 doz. loud, each package containing 50 WALL-KANE needles. Complete stand costs the Dealer \$4.60, retails for \$9

DISTRIBUTORS

Okch Records



WADE "SUPERIOR" SERVICE WILL INTEREST YOU—GET OUR PROPOSITION—IT IS A REAL MONEY-MAKER.



COAST TO COAST SERVICE

ORDER FROM

Wade Talking Machine Co

WHOLESALE DISTRIBUTORS.

DO IT TODAY

12-22 NORTH MICHIGAN AVENUE : CHICAGO, ILLINOIS

THE STORY OF WALLACE BROWN

Successful Detroit Brunswick Dealer Is Theme of Story in Business Magazine—Has Methods All His Own Which Have Proven Their Merit

The progressive business methods of Wallace Brown, the active Brunswick dealer of Detroit, Mich., have attracted the attention of the trade and in the July issue of "Business," published by the Burroughs Adding Machine Co., there is a comprehensive article outlining in full Mr. Brown's way of doing business. The article is written by William C. Sproull and traces the story from the days when Wallace Brown made his move into East Grand River avenue and began to sell the Brunswick machine by radically new methods, to the present time when he is recognized as one of the most successful salesmen in the game.

Brown believes in selling his product at his own store. He does not do any bell ringing to enlarge his trade, but has found that by real salesmanship in his own warerooms he can accomplish the desired results. He advertises consistently and well. In his advertisements he talks to the public as he talks to them in the store. He talks facts. He finds out what he wants to know about the customer and then does all the rest of the talking himself. He meets the prospect on his own ground and shows him just where the Brunswick will prove superior to the machine now in his home. He relieves the customer's mind of all uncertainty as to just what the proposition involves. To quote from Mr. Sproull:

"For example, he knows that a woman dislikes to figure interest. If she pays \$25 down and \$15 a month she does not understand why she has to pay \$6.87 at a future date to cover something people call interest. For this reason he adds a flat charge of \$5 or \$10 to the original price, and deducts the amount from cash sales.

"The record problem is another example.

Everyone asks the question, 'How many records do you 'throw in?' The dealer cannot afford to give records away, yet he knows the customer expects it. Mr. Brown includes \$5 extra in his price to cover the charge for a half-dozen records. In other words, he states his proposition to be that for \$165 he will sell you this machine, give you six records and allow you a year to pay it. That is the agreement. There is no uncertain quantity such as interest or cost of records."

A VICTOR DOG THAT GROWLS

Emerson Piano Co., Decatur, Ill., Find New Way for Attracting Attention of Public

DECATUR, ILL., July 3.—A Victor dog which growls good-naturedly attracts much attention from passersby to the Emerson Piano Co. store. He has been a familiar object in Decatur for some time but his tendency to growl about it came recently when a Claxton horn was fitted to a board and pushed into his head, and a dry battery and a button inside the store did the rest.

At the same store, the ingenious Manager McDermott, to relieve the monotony of the streamer, "The June Victor Records Are Here," used for each month's Victor record announcements, arranged packages of Victor needles (steel and Tungs-Tone) to spell out the same message on the floor of his window.

HAS 450 RECORDS IN HIS LIBRARY

Wondering just how many records she might have been selling to him, Miss Langley, of Bullpitt Bros., Taylorsville, Ill., asked a customer to list them for her. He had 450 records and was still buying. A recent sale to him were the records of the instruments of the orchestra, that he might identify certain instruments whose sound he did not know, for he is not a musician.

COMPANY TAKES OVER ARTOPHONE

Artophone Corporation Formed in St. Louis With Capital Stock of \$100,000—Another New Concern Just Organized Called Olympic Co.

St. Louis, Mo., July 3.—The Artophone Corp. of this city has been chartered with a capital stock of \$100,000 and has bought the stock and fixtures and trade name of the Artophone Co., talking machine manufacturers and distributors, now of 1113 Olive street, but which have leased the building at 1103 Olive street. The officers of the new company are Edwin Schiele, president, who has been a stockholder in the Artophone Co. for the past nine months; Herbert Schiele, his son, vice-president and treasurer, and J. Kramer, secretary. The latter is Edwin Schiele's son-in-law. They have taken over the lease of the five-story building at 1103 Olive street, recently secured by the Artophone company, and will occupy it in a short time. They expect to add pianos and player-pianos. For the present it is the intention to devote their attention to the retail and mail order trade on the Artophone, but may later engage in the wholesale business extensively.

R. H. Cone, Sr., and Albert T. Gardner, formerly sales manager of the Artophone company, have organized the Olympic Co. and announce that they will enter the wholesale talking machine trade in an extensive way. They will place the Olympic talking machine on the market at once. They have ample factory facilities, they state, and will be in a position to furnish the trade, in the Olympic, with an excellent product and assure prompt shipment and an all-round balanced service. The new concern has opened offices and attractive salesrooms at 800 Columbia Building, Eighth and Locust streets, this city.

But of all wasted power, the greatest waste is inside the human skull, that "temple of ivory" in which everything is possible.

**"Easier to sell
than any other
phonograph in the world"**

That's the way salesmen talk about

The **Aeolian-VOCALION**

The new and greater phonograph

VOCALION RECORDS Two distinct styles of records. A lateral cut and a hill and dale. You can therefore sell EVERY phonograph owner in your community.

Ask for our Dealers' Proposition
We are Western Distributors, prepared to give you the goods you want **WHEN YOU WANT THEM.**



13 to 19 East 1st, South - - - - - Salt Lake, Utah

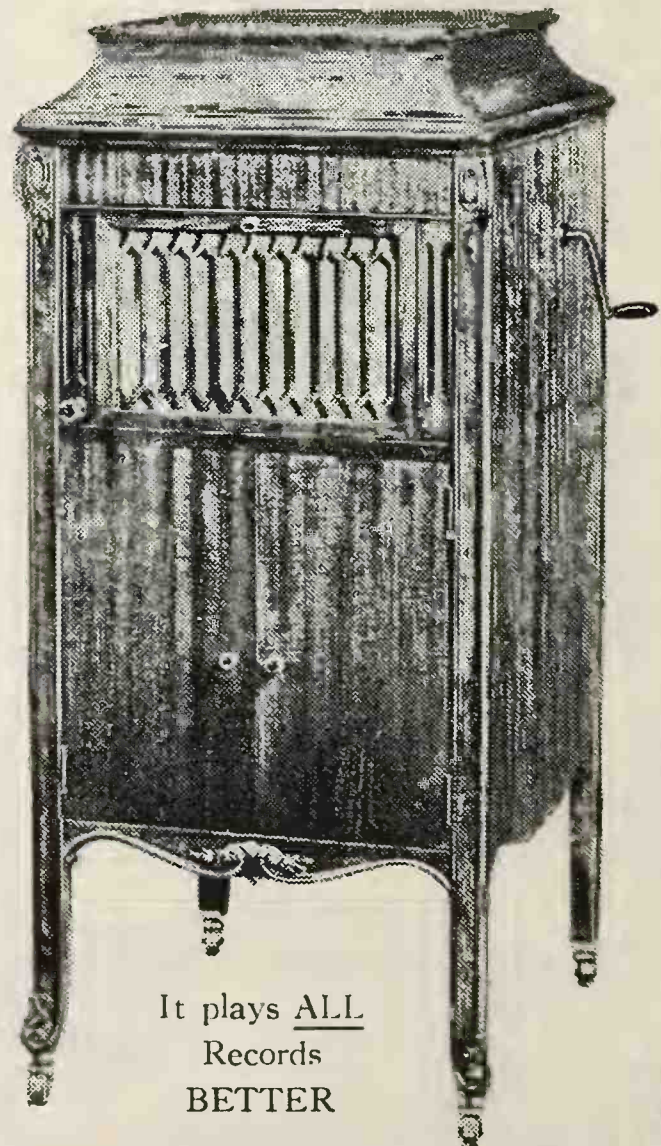

It plays **ALL**
Records
BETTER



A Rare Combination of Fine Qualities

The Empire combines in one instrument the fine qualities that distinguish all other high class phonographs.

It gives you that perfect balance of desirable features—that satisfying *completeness*—which *wins* and *holds* public favor.

The Empire is *not* an “assembled” phonograph. Its component parts, from reproducer to cabinet, were *designed and made for the Empire*.

Each Empire model represents *value in excess of its price*.

Empire Records “Simply Irresistible”

Empire records—made under an exclusive patent—are the very latest development in record making. Compare them with the best of other brands and judge for yourself. No “freak” numbers, no “slow sellers” but the popular favorites, new and old, that *keep the cash register busy*.

Order a trial assortment of Empire records and see how quickly they will be snapped up.

The sixth Release of Empire records is now ready.

Get the Empire Agency Special Proposition

Write for attractive agency proposition and full details of our extensive program of newspaper advertising and dealer cooperation. Empire Phonographs and Empire Records are a powerful sales combination. It will interest you. Write today.

Empire Talking Machine Company

JOHN H. STEINMETZ, President

429 So. Wabash Ave.

::

Chicago, Ill.

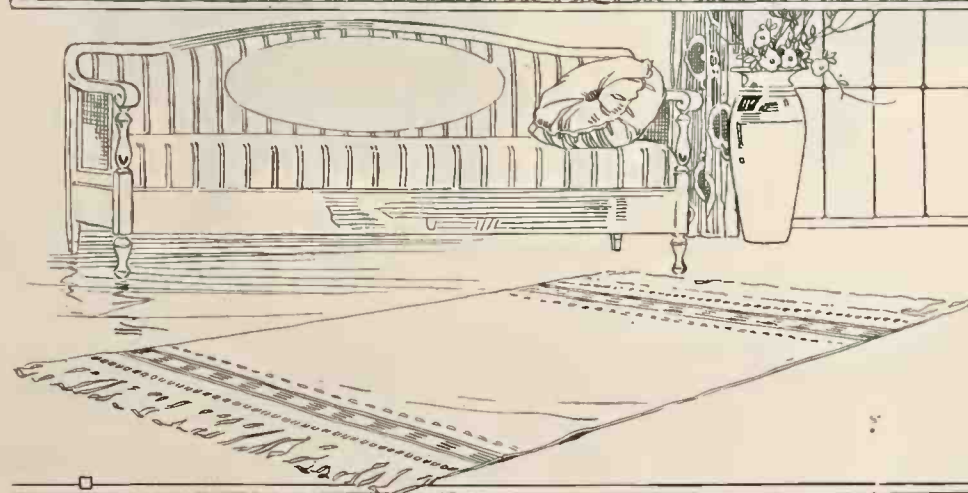

"BILLY" MURRAY NOW "EXCLUSIVE"

Signs Contract With Victor Co. Whereby This Company Controls His Recordings from July 1, 1920—One of the Great Favorites

CAMDEN, N. J., July 3.—C. G. Child, director of recording for the Victor Talking Machine Co., has officially confirmed the rumors that have been abroad recently to the effect that "Billy"



Billy Murray

Murray had been signed up as an exclusive Victor artist, from July 1, 1920.

Billy Murray certainly ranks as a great national favorite and the sales of his records have undoubtedly been as large or larger than those of any popular artist recording at the present time. His name is known to talking machine owners from coast to coast, thousands of whom have placed standing orders with their dealer for every Billy Murray record that is produced. His voice is recognized as particularly adaptable to recording purposes and his enunciation has won the enthusiastic commendation of musical critics. He is "an old timer" but is to-day

MUSICAL INSTRUMENT

CASES RECORD COVERS CASES

Write for **Catalogue**

"A SAMPLE WILL CONVINCING YOU"

going stronger than ever. Originally he was a Victor artist, but for the last two years has been singing for a number of record companies. The news of this famous tenor's becoming an exclusive Victor artist will please Victor dealers.

GEORGE PARKER LEAVES FOR COAST

BOSTON, MASS., July 3.—George Lincoln Parker is leaving on July 5 for the Pacific Coast and is therefore unable to attend the Edison convention. He will spend a part of his time at Berkeley, Cal., where the headquarters of the American Photo Player Co. is located, and then will go to Van Nuys, where the Robert Morton Organ Co. has its plant. The trip is partly for business and partly for pleasure. Mr. Parker will go West over the Canadian Pacific system and return via the Santa Fe route, so that he may visit the Grand Cañon.

COLUMBIA STORE IN DES MOINES

W. A. Wilson has opened a new Columbia Grafonola store in Des Moines, Ia. The building which he has just occupied has been entirely remodeled and four demonstration booths have been built.

You don't swallow food whole. Why should you swallow names and words whole. Read with an encyclopaedia and a dictionary near at hand. You may think yourself well educated, but there is always more to learn.

EDISON JOBBERS VISIT ORANGE

Albert Buehn and Robert L. Proudfit Remain in City for Caravan Convention—Latter to Travel to Coast With Delegates

Visiting jobbers to the Edison laboratories during the past week were Albert A. Buehn, treasurer of the Buehn Phonograph Co., Pittsburgh, and Robert L. Proudfit, president of the Proudfit Sporting Goods Co., Ogden, Utah.

Despite the railroad tie-ups, the results of which continue to make themselves felt throughout the western Pennsylvania district, business in general, according to Mr. Buehn, is looking forward to a substantial increase in July. Mr. Buehn states further that the Edison dealers in his territory, who are carrying out the 1920 sales promotion plans originated by the Edison laboratories, are enjoying a largely increased volume of business, illustrating that there is little or nothing in general conditions to prevent live dealers, who go after business in the right way, from reaping a generous share of the prevailing prosperity.

Mr. Proudfit expected to remain in the East to take part in the New York sessions of the Edison caravan convention. He plans to accompany the caravan on its entire tour across the continent, the last stop being San Francisco, where he expects to meet most of the Edison dealers from his territory. He is most enthusiastic over the program prepared for the conventions by the Edison Co.

GARFORD "BABY" PHONOGRAPHS

*A Popular Line of Toy Phonographs
"Nothing More—Nothing Less"*

**THE "BABY" MODEL
RETAILS AT \$6**



Description of "Baby" Model
Plays Little Wonder or 7-inch records
Metal Cabinet finished in high grade Ebony Enamel with nickel trimmings.
Length 8 3/4 inches Height 7 1/2 inches
Width 5 1/2 inches Weight 3 1/2 lbs.
Provided with one spring worm gear motor. 5 1/4-inch turntable. High grade sound box, with wonderfully clear reproduction. Speed regulator.

**MODEL X
RETAILS AT \$10**



CLOSED

Description of Model "X"
Plays Little Wonder records and also 7-inch records. Cabinet finished in Mahogany
Height 17 1/4 inches Width 8 5/8 inches
Depth 9 5/8 inches
Provided with one spring worm gear motor. 5 1/4-inch turntable. High grade sound box, with wonderfully clear reproduction. Speed regulator.



OPEN

A LIBERAL PROPOSITION FOR PROGRESSIVE DEALERS

GENERAL PHONOGRAPH MFG. CO. Elyria, Ohio

FORMERLY NAMED THE GARFORD MFG. CO.



Here's a favorite model of our
Console creations in

The Windsor
Phonograph.

a work of art in design and work-
manship worthy to be classed with
the rest of the furniture line we have
been making for the best trade
since 1885.

Brochure of views sent on request.

*Originator of the Console and
Period Designs in Phonographs*

WINDSOR FURNITURE CO.
Chicago, Ill.

THE MID-WEST

WESTERN DIVISION OF THE WORLD, CHICAGO, JULY 10, 1920.

WHEN we were composing the brilliancies and the coruscations which illuminated these pages last month, the air of this metropolis was heated to the point of evaporation by the oratory of the human phonographs of the Republican party, oratory which strangely and feverishly contrasted with the silence of the seven (or was it nine) gentlemen whose manipulations—described by their enemies, of course, as machinations—brought about the nomination of the gentleman who has now become the Presidential candidate. Well, now, all that is over and the folks out at San Francisco are just getting through with their troubles. But we simply don't know what rest means out here. The Best People On Earth have descended upon us, as the Assyrian came down, although whether they or we will turn out to be the wolves is a matter which history will have to take care of. All that the Western Division of The World knows is that it is very hard indeed amidst all this excitement even to find the point-of-view of the Mid-West, not to say, give it any adequate expression. How, one asks, is it to be done? How on earth—or in The World, as one might say—is one to be witty and wise, charming and informative, with the B. P. O. E. yelling their heads off all over State Street and the rumblings of the Third Party's Convention machinery already beginning to fill the circumambient on the Lake Front and elsewhere? This is no sort of a job for hot weather and we so declare it. But of all slaves the newspaper slave is the most slavish. The printer's devil is running after him at all hours; and so long as the wireless, the telegraph, the telephone or the airplane mail conduct their business between Chicago and Manhattan, the Western Division know that the wrath of their editors followeth them day and night. With which preliminaries, dear brethren, we address ourselves to the task of representing the feelings and beliefs of the great middle empire, so far as these relate to the talking machine industry, for the benefit of The World in general.

OF COURSE we are feeling the freight tie-up. How could it be otherwise? But a good many of us are wondering whether it is not just a bit too simple an explanation, when we say "car shortage" and let it go at that. The fact is that some authorities who ought to know tell us that there is no car shortage at all and that we are suffering from a vicious system of distribution and from nothing else. The other day we were looking at some car service figures which showed that during the middle week of June as many as two hundred and thirty-five thousand cars were reported tied up or delayed in transit. Of these no less than eighty-five thousand were reported as awaiting switching facilities at junction points. It is as plain as the proverbial nose on the proverbial face that this state of affairs means lack of labor, not lack of cars. It is equally plain, if the Federal Trade Commission is to be believed, that faulty distribution of motive power and rolling stock is also largely to blame. Mr. Colver, of the Commission, is quoted as saying recently that there will never be a return to normality in freight conditions until the motive power and rolling stock of all the railways are pooled in such a way that they can be distributed, at the behest of a single controlling body, just as may be needed from time to time. Apart from political considerations, this is surely something worth careful thought. In a few weeks the great crop movement will be in full swing. As a natural consequence, the present congestion will be intensified and we may consider ourselves fortunate if there does not arise a cry for priority decisions. All of which of course will be at our expense. Now it seems to us out here in the Mid-West that it is pretty nearly time to stop messing around about these things and to begin to look at them as a whole. The railway question is not, and cannot be, a local question. Unless and until it is considered as a whole, in all its bearings, considered nationally and not sectionally, we shall not get very far with any schemes for improvement. It is as sure as anything can be that the music industries in

Polly
Ticks
Prevail!

general will have reason to complain ere long if they do not put their thought into these matters. We are dealing with a national problem which has to be solved. If it is not solved someone is going to suffer severely.

THE furniture expositions are with us again and there is much excitement around the Boul Mich at Thirteenth and Fourteenth Streets. Incidentally, if one wishes to create trouble amongst furniture men, one only has to forget to mention one of the exposition buildings and concentrate one's attention on the other. It does not matter which one. The man one is talking to always has his goods in the building one is forgetting. Wherefore, we pause to remark that in the above statements we include the "1411" building and the "1319" building; both. Now some of our divisional news sleuths have been sleuthing up around the Xpo buildings and they report that the talking machine exhibits are few in number; fewer than in any previous year. At the same time, they tell us that the quality of the exhibits in general is higher than ever. Whether as to finish, quality of woods used, interior workmanship and construction or mechanical devices, there is every reason to feel happy over the goods which are being shown by our phonograph and talking machine makers. Much the same may be said about the exhibits at Grand Rapids, according to the reports made by The World's Western Division man who attended the opening of the big July Show in that city. This is all, of course, as it should be. Regrettably as the statement may appear, there is no use in concealing the fact that a good deal too much shoddy was patched up and thrown out on the market during the earlier days of the industry. There was a time indeed when manufacturers were engaged in a continual struggle between their sense of honor and their sense of expediency. The demand for goods of any kind was so great that the pressure to get out quickly almost any old thing was hard to resist. Among the blessings of the present time, we might as well include the existing opportunity to take time and thought over the construction and finish of the manufactured product.

THERE was another noticeable feature about the Furniture Expositions. No one could help noticing the very large number of Period styles, so-called. In fact, it seemed as if every manufacturer who aimed at doing something attractive had made a creditable attempt to design cabinets in one or more authentic reproductions of the famous Periods. The styles of Chippendale, Heppelwhite, Adam, Queen Anne, Sheraton, the Louis, the James, the Charles, William-Mary and the Georges were to be seen in abundance. Moreover, there was another side to the matter. It was not merely an attempt to reproduce the superficial decorations and mannerisms of the great designers, whilst leaving the general outlines untouched. On the contrary, there was the strongest effort to assimilate the entire structure to the requirements of each Period. Chests, high and low curio cabinets, escritaires and every sort of piece well known to the great masters of domestic design have been studied, with results often as delightful as surprising. Now this again makes us feel happy. The Mid-West has been the home of the later development of the talking machine to such an extent that we feel a sort of quasi-parental pride in any artistic achievements which may be attributed to it. Our makers, in a word, are coming out of the exuberance of childhood and are settling themselves down into maturity. This is well. It is very well indeed. And there is another, more immediate, side to the whole matter. It is being noticed by the keener merchants that the "period" machines are making a great hit with women buyers. Now, women, in fact, have quite as much to do with buying talking machines as men have. Their tastes and their prejudices must be considered. Those who do not consider them will surely suffer. Period styles appeal to women. Partly this is because they possess the air of distinction which all women of taste admire. Partly it is

Our Own
Little
Xpo!

Nationwide:
Not
Local

The Style
and the
Period

POINT OF VIEW

because they are "different." Mainly it is because they are beautiful. One looks to see the talking machine designs leaning further and further towards reproduction of classic furniture.

THE rumors and gossip, the excursions and alarms, which periodically pester the mind of the busy and harassed trade paper editor,

Just
Ropes of
Sand

leave very little time for thought as to their origin or value. This is, after all, not as unfortunate as some might think, for of them all it is usually correct to say that they come like water and like wind

they go; if one may slightly paraphrase the translator of Omar Khayyam. To take a quatrain from that same lovely garden of Persian roses:

"Myself when young did eagerly frequent
Doctor and Saint; and heard great argument
About it and About: But evermore

Came out through that same door wherein I went."

which, whether or not it represents a historical, certainly represents a psychological truth. We are always frequenting the doctors, those who are supposed to know: and we are always hearing great argument, about it and about. Likewise, we find, distressingly often, that the door through which we are let out is identical with the portal which we so confidently and hopefully entered. Rumors, gossip, rumors: talk, talk, whisper, whisper: it is all very stupid and very tiring. We are to-day a great and busy industry in a great and busy nation. We have, unhappily, our share of black sheep, even of sheep whose color is positively ebony. But the flock in general is a very nice flock and it is subserving a very useful purpose, on the whole. Not all the men one meets are angels indeed: but most of them are a good deal nearer the angelic than the diabolic. Our industry has its ups and downs; but it is safe and secure, if so it be that those who run it use a modicum of good sense. There is so much more of good than of bad in the industry that of its security and future progress no wise man can for a moment doubt. But it is quite certain that it was a wise Greek who, to his concept of Evil, gave the name Diabolus or the slanderer. Rumor, gossip and malicious talk are at the bottom of all the evil there is or can be. Wise men keep their ears stopped and refuse to listen. After all, gossip is only hot air: and hot air is about the lightest compound there is. Our industry is just beginning to sit up and take a healthy interest in life. Let us at least not strangle it in its cradle through our own stupidity. There is room in this great land of ours for the utmost possible expansion of an honest talking machine industry during the whole of the next decade: and after that there will doubtless come a new development which will start us all over afresh. One finds it hard to get up worries over the future of the talking machine industry.

WE HAVE cited from time to time some evidence of misunderstanding concerning the method of settlement for goods received known as the Trade Acceptance. The criticisms which have been made are not all espoused by us, but we give them for what they may be worth. In effect, it is claimed that dealers have found themselves in a difficult position when they have given acceptance for goods against

But What
Do We
Accept?

Bill of Lading and afterwards have found the goods not up to standard. In such cases, it is said, the dealers have sometimes declined to pay the paper when it has fallen due; and in consequence there has been trouble for the manufacturer. Well, this may or may not be; but one thing is quite certain. The whole theory of the acceptance is based on mutual confidence. It requires as its foundation the notion of reliable goods bought and paid for on faith and coming up to expectations when received. It is quite certain that on any other basis the whole procedure becomes in the highest degree uncertain; and is, in fact, a positive danger. But, of course, it follows, or ought to follow, that the men who are asking merchants to do business on the basis of acceptances should be beyond criticism. The very moment you allow the suspicion to exist that there is, or is

likely to be, something wrong with the product which a manufacturer is turning out you destroy the confidence and trust which are the common basis of commercial honor; and you render the acceptance an unwieldy and even dangerous tool for business purposes. Here, too, the attitude of the banker must be considered. The banker has to take this paper on the basis of a belief that true value lies behind it. If there is any suspicion as to this value the banker cannot retain this confidence; and consequently his attitude towards those who do business on this basis must be unfavorable. We decidedly want to retain the trade acceptance as the basic tool for the expanding work of our industry. But: it must be based on quality goods. That is the secret. The system is good; in fact, it is very good: but it presupposes quality goods. Let us not forget that.

"You must wake and order early, order early, Dealer, Dear!"—Tennyson Revised.

OF COURSE you must; if you expect to have any goods to sell this Winter. It's "old stuff," of course; but old stuff has to be retailed,

Old Stuff,
but
Timely

early and often, when it is both correct and unhappily neglected, not to say treated with scorn and contumely. Sometimes one can get new ways of looking at old stuff; and we think we have one at

least. This industry of ours cannot keep going as it should if it is to be run on a seasonal basis. For one thing, such a system is wasteful and stupid. For another thing, it keeps costs up and production down. For still another thing, it renders impossible prompt delivery and good service. Now, one cannot pretend that the people will buy as many talking machines during the vacation months as they will in November and December: but the fact is that until dealers learn to keep their floors filled with machines and records all the year round they will never make a serious effort to do Summer business. If dealers knew that they could not get goods in Winter unless they ordered in Summer there would be no excuse to postpone orders till the last moment. Well, now, the truth is that the industry cannot keep going in a healthy state if it is to be half shut down during three months of the year. That is wasteful and stupid. The time to order for future requirements is Now. The goods won't come the day after. Nobody need worry about that. The railroads will see to it that they take their time in arriving. But: the man who orders now will be in shape when the other fellow is howling his head off and calling down imprecations on every manufacturer.

P'st, c'mere! Great Secret! F. D. Hall is going to take a vacation. For the first time in eighteen years or thereabouts, he is going to

Listen:
Big
News!

cut out business and have a good time. Which is very nice. Everybody who knows the B & H Fibre needle will wish the boss thereof all the good times in the world and will agree that he has earned any

holiday he chooses to take. He will be in California with Mrs. Hall for a couple of months or so and we hope that when he gets back he will feel fit as a fiddle. We do not know exactly how fit that may be; but however much it is, we want him to feel just that way. There are very many of us, some thousands of us in fact, who feel personally indebted to the B & H Fibre needle; and all our good wishes will go with the creator of this first aid to poor reproduction.

OUR friends, the Starr Piano Co., who make the Starr talking machine, are trying out something new down in their retail store on

Le Sage,
Monsieur
Rousseau

Wabash Avenue, which is in Chicago. Our very good friend Rousseau, who manages things for them there, has taken on as one of his sales force a young lady who combines talents for salesmanship with even greater talents for the vocal art. Talk about equipment for selling talking machines! Think of the advantage which

comes from being able to let the customer hear the song from a human voice along with the record, at all times and in all places! To Miss Jelsa we extend felicitations,



NEW YORK
Talking Machine Co.
○ 119 West 40th St.
Victor Wholesaler's Exclusively

CHICAGO
Talking Machine Co.
○ 12 N. Michigan Av.

From our **CHICAGO HEADQUARTERS**
 REPUBLIC BLDG., 209 SOUTH STATE ST TELEPHONE WABASH 5774

EDWARD VAN HARLINGEN

WILLIAM BRAID WHITE

EUGENE F. CAREY

ARTHUR E. NEALY

A. SNYDER

CHICAGO, ILL., July 9.—The outstanding feature of the Western trade at present is its comparative quietness in both the wholesale and retail branches. This condition is due entirely to the arrival of the warm months when, unfortunately due largely to habit, business is traditionally slow. Dealers do not seem to realize the opportunity of developing Summer business. Anyway our faces are to the future and we must prepare for the excellent Fall business that is bound to come. Just as someone once said: "In time of peace prepare for war," so the slogan of the far-sighted talking machine dealers during the coming thirty days should be "In time of slack demand prepare for large."

It is undoubtedly true that some talking machine dealers have well-stocked warerooms at the present time, but there are many who have failed to contract for anywhere near as many instruments as they are absolutely certain to sell in the Fall.

It is safe to assert that next Fall and during the Winter holidays the trade will equal, if not exceed, the phenomenal business of the past year. This being true, the experiences undergone by talking machine retailers during the past two big seasons will be repeated in 1920. But the reason this time will be different. Heretofore the shortage has been almost entirely due to the lack of machines. This year it seems evident that a similar shortage is inevitable, but this time because of the inadequate transportation facilities. The car shortage affects us in the Middle West as pointedly as it affects any other part of the country. Right now the writer has in mind certain manufacturers who have been unable for several weeks to get carloads of instruments and supplies shipped into this city.

The Freight Situation Is Serious

That the freight shortage is urgent is shown by the fact that the Chicago Piano and Organ Association, which includes in its membership the important piano men of the city, together with some representatives of the talking machine industry, has taken definite action in asking all of its members to aid in securing a quicker turnover of freight cars. Co-operation immediate and definite is necessary to alleviate the very serious shortage in cars. The Association, through a special committee, consisting

of the head executives of the Kimball Co., the M. Schulz Co. and Lyon & Healy, has mailed out letters to all members urging them to combine in an effort to expedite the handling of freight. As a further aid to overcoming this condition the Association seriously urges dealers now to estimate their Fall requirements as nearly as possible and to order sufficiently in advance to assure the use of the railroads during the present less congested period. This letter, which has been sent out to hundreds of piano merchants throughout the Middle West, concisely expresses the whole problem confronting the trade and is printed as follows in full:

"An exceedingly serious car shortage throughout the country is obvious and there are no indications of any material improvement within the year. Only a few cars were made during the period of the war and very few since. As cars are required to move material from which cars are made relief from that quarter must be slow. With the impending crop movement upon us, the movement of coal this Summer and Winter, together with a tremendous tonnage of raw materials and finished products, you can readily understand that under the most favorable conditions we cannot expect any improvement affecting general transportation by rail for many months. It is recommended, therefore, that we make the best use possible of present facilities.

"If one thousand car users will load or unload one car one day earlier one thousand cars per day will be released for service. After a very thorough investigation of the situation your committee vigorously recommends a sincere and concerted effort on the part of the musical instrument manufacturers and dealers to relieve the present and pending car shortage, and also that this organization be committed to a policy of co-operation with and support of those who are trying to deal with this serious situation.

"In view of the foregoing, it is the manifest duty of all members of our trade, whether manufacturers, jobbers or retailers, to anticipate their transportation needs as far as possible and stock up during June, July and August, so as to make the least demands upon transportation facilities later in the year when agricultural products, fuel and other commodities necessary to sustain life must be moved.

"We recommend that orders be placed now

for shipment as early as the goods can be moved for all requirements for the balance of the year. It is better to lose interest on the investment for a short period than to be without necessary supplies for the Fall trade. An earnest, tangible effort on the part of our trade to assist transportation authorities, as above outlined, will go far toward preventing priority orders or any action tending to deprive us entirely of transportation facilities."

Prospective Increase in Freight Rates

In an interview with a number of officers of the above Association, the writer heard that there is in prospect a raise in railroad freight rates of from 25 to 35 per cent. It is said this raise will take place in September, which only presents another excellent reason why dealers should order at the present time.

Business and Pleasure

The talking machine department of Mandel Bros. have devised a scheme for increasing the sales of Vocalions as follows. The talking machine salons are on the ninth floor, where also are the lunch rooms. The employes of the talking machine department spend the noon hour each day in the lunch room and have lately been given an incentive for creating Vocalion customers by a special commission of five dollars to every employe who brings in a customer-friend from the dining room. The idea not only has brought in new customers but has acquainted hundreds of Mandel employes with the fact that an Aeolian concert may be enjoyed during the noon hour without leaving the store.

New Federal Agency

S. H. Siegel, of the Federal Phonograph Corp., reports that a new agency has been established by his concern for the jobbing of Federal talking machines in the Pennsylvania territory. The agency is located in Philadelphia, Pa. The Federal organization is speeding up production at their new plant in expectancy of a large Fall business.

Washday Music

In a letter to the Daily News Charles Nielson, head of a laundry company on the Northwest Side, here, comments on a news item from Bath, England, which recounted how a talking machine had been installed in a laundry there to provide music while the employes worked.

(Continued on page 141)

"ORIGINALITY"

says Webster "..... is the state of being 'first in order'; not copied, but offering something from which copies are made."

The Wade Fibre Needle Cutter was the first on the market; therefore it was the ORIGINAL.

What more need be said? Webster's definition makes it clear.

Just add the words "Dependable" and "Quality Unsurpassed" and the tale is told.

WADE & WADE

3807 Lake Park Avenue

CHICAGO, ILL.



FOUNDED 1864

We think the VICTROLA justifies the most beautiful advertising of the day. Our aim is always to get the best obtainable.

LYON & HEALY

VICTROLA DISTRIBUTORS

CHICAGO

The Lyon & Healy Victrola newspaper advertising service sets a new standard for quality. These attractive illustrations are available for the use of the one best Victrola Dealer in each city.

FROM OUR CHICAGO HEADQUARTERS—(Continued from page 139)

"To some people this would appear to be a novelty, but I believe that an investigation will show the use of phonographs, pianos or player-pianos in a great many institutions in this city," writes Mr. Neilsen. "For instance, the laundry company of which I am president has a player-piano which is played morning, noon and night and at recess periods in the morning and afternoon, also. We have found it a valuable asset and would miss it very much now if we did not have it. We believe it cheers everybody up and makes us happy and helps us to forget our troubles, if we have any. The old saying that 'music hath charms' is certainly true, and its accuracy is demonstrated by the presence of such equipment in commercial institutions."

Get Emerson Machines

F. W. Clement, of the Emerson Phonograph Co., has received the initial shipment of the new Emerson talking machine. A special room has been prepared for housing the sample, which will be used as a dealer demonstration room. Mr. Clement looks for a considerable demand next Fall for Emerson talking machines and states that the Eastern factories are producing at full speed in order to meet the expected call for the instruments.

Supply Men Optimistic

One of the best barometers of the industry is found in the talking machine supply houses. Chicago's three principal supply houses report the Summer business as quite normal, which is to say rather low during the warm months. The supply men seem to be placing orders with their manufacturers to the fullest extent on the assumption that there will be a large Fall business.

Wm. Wade, of the Wade Talking Machine Co., feels that the present condition of the market is purely temporary and incidental to the season of the year. There is no surplus of musical instruments or merchandise of any kind in retail warerooms, he says, for which reason he looks for a return of a business as great as, if not in excess of, last Fall's business.

Wm. Fricke, speaking for the Lakeside Supply Co., states that sales are well up to the average of the season. The Lakeside Supply Co. is taking advantage of the warm months of lessened demand to embellish their stocks.

Cole & Dunas report a very satisfactory demand for such instruments as ukuleles, banjos, table model talking machines, and so forth; in fact, they find themselves in a difficult position in the matter of meeting their customer's orders for Summer musical merchandise.

Lyon & Healy Victor Dealers' Concert

One of the interesting events in the Lyon & Healy talking machine department last month



Listening to Victor Artists at Lyon & Healy's was the concert given in the recital hall by Miss Margaret Young and Princess Watahwaso, both popular Victor artists. Many of the Lyon & Healy Victor dealers were present and had an opportunity of meeting these artists, whose records are creating more and more interest.

Makes New Needle Cutter

Joseph Brandstetter, designing engineer of long experience in the talking machine industry and formerly connected with Sears, Roebuck & Co. as a designer of special devices and special machinery, is the inventor of the Alto fiber needle cutter, manufactured by the Alto Mfg. Co., of this city. Mr. Brandstetter claims for his cutter the advantages of quantity production—that it is manufactured from specially treated

and tempered tool steel in order to lengthen the life of the cutting point. It goes through fifty operations and a number of special machines have been designed by Mr. Brandstetter to achieve more efficient manufacturing processes.

A Tip to Record Salesmen

"Freddy" Firestone, manager of the Smith Piano Co., states that he has a remarkable list of records prepared for a certain type of customers which he says frequently visits the store. "It was many years ago, when a man entered a store in which I worked," said Mr. Firestone, "and asked if I knew of a talking machine record that could out-talk a woman. I thought a moment and replied that I had. I sold him a certain record which was remarkable for its voluminous tone and later on made up a small list of such records. I always have this list ready and whenever a sort of henpecked individual enters the store I know just what he wants: a record to out-talk his wife."

Rothschild's Takes Brunswick

The Brunswick line of talking machines and records have been taken on by Rothschild's department store, of this city. This concern previously handled the Victor and Columbia lines exclusively and have always had one of the most progressive of the department store talking machine departments in the city.

Recitals Go Big

W. C. Ekhart, sales manager of the Phonograph Co., reports great success for the Edison recital department, organized some months ago under his supervision. The recital department develops plans for promoting Edison concerts throughout the city. The Edison Co. headquarters offer \$5 rebate for every recital given by the dealer who has spent at least \$10 during sixty days prior to the actual holding of the concert. Mr. Ekhart's recital organization is working with dealers on this factory plan. It has been most successful. Engagements have been booked all over the city in churches, lodges,

(Continued on page 143)

Your Account With Us

Lateral
Cut

**Okeh
Records**

Lateral
Cut

**Will Be an Insurance Policy Against
EMPTY RECORD SHELVES LOSS OF CUSTOMERS
LOSS OF PROFITS**

**Record Dealers Reach the Acme of Wisdom
WHEN THEY STOCK UP WITH POPULAR HITS ON**



No Waiting for Delayed Shipments When You Order From Us

MAGNOLA TALKING MACHINE COMPANY

711 Milwaukee Avenue

OTTO SCHULZ, President

CHICAGO, ILL.

ANNOUNCEMENT

Phonograph Motors Corporation Contracts with "H. G. Saal Co.," to Make and Sell "Johnson" Electric Motors

The Phonograph Motors Corporation has completed arrangements with the H. G. Saal Company of Chicago, one of the largest Spring Motor Manufacturers for Phonographs, whereby the Saal Company is to manufacture and sell the well known Johnson Electric Motor.

All of the important bearings, worms and special wearing parts will be made in the Saal factory under contract. This arrangement has already worked to a distinct advantage to the Motor.

The Saal Company, as well as most Phonograph Manufacturers and Dealers, has realized for some time the gradual but pressing demand for electrically driven Phonographs.

It is the conclusion of the Saal Company to live with the Electric Idea, not as a present substitute for the Spring Motor, but an evolution in Phonograph Motor Construction and one which must be reckoned with in the near future.

The Saal Company believes that its present contract with the Phonograph Motors Corporation and the association of the "Johnson Idea" with the Saal Factories will enable it to offer soon The New "Johnson" Motor in quantities, as a guaranteed, practicable and dependable Electric Drive for Phonographs.

H. G. SAAL COMPANY

SEND INQUIRIES TO
H. G. SAAL COMPANY
1800 Montrose Avenue
Chicago, Illinois

A Better Cutter For Less Money

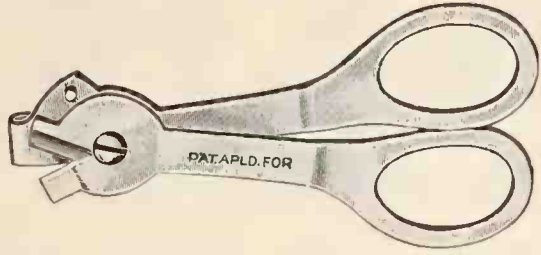

The **ALTO**
Retail Price \$1.00

THE Alto Fibre Needle Cutter is distinctly a quality product. The unique design, together with our highly specialized manufacturing methods, makes it possible to sell the Alto Cutter at this remarkably low price. Its construction from carefully tempered tool steel makes it the most durable cutter on the market. By handling the Alto you will maintain your reputation of selling the best at the lowest price. Order a dozen today.

Your Customers Will Appreciate The Value

ALTO MANUFACTURING COMPANY

3801 ROKEBY STREET

::

::

CHICAGO, ILLINOIS

FROM OUR CHICAGO HEADQUARTERS—(Continued from page 141)

clubs, moving picture houses and so forth. An average of seventy-five recitals a week have been pulled off, 40,000 people having been reached with the message of the Edison at present. It is the intention to cover the entire city before finishing with the work. "The artists," says Mr. Ekhart, "are not Edison artists, but are selected from local talent."

Columbia Dealer Entertains

C. B. Cordner, proprietor of the Symphony Music Co., 1020 Wilson avenue, entertained his Columbia friends on Tuesday, June 29, at his North Side store. There was a program of music, games and dancing, greatly enjoyed by those present. The balcony of the store was cleared off, the floor waxed and dancing was enjoyed to the music of Columbia records by Ted Lewis. A. J. Bell, of the record sales department of the local Columbia branch, entertained the visitors with a very excellent imitation of the famous "Frisco." Numerous games were played and prizes awarded to the winners.

Constructive Cheney Expansion

The Cheney Talking Machine Co. has just launched a campaign which will tend to expand the activities as well as the business carried on by this company in far greater proportions than at present. According to W. E. Burr, sales manager of the Cheney Co., all of the expansion plans which were formulated recently are now well under way. Several additions have been made to the direct sales organization, not only in the Central West, but in the New York office territory as well, and several new jobbing connections have been established.

Mr. Burr, who, by the way, is a pro-optimist, says: "In the whole Cheney organization there is no pessimism as to the stability or the future of the talking machine market, although there are numerous and perplexing problems confronting the trade in general now, which are causing much thought among manufacturers and retailers."

"The biggest problem we will have to contend with," continued Mr. Burr, "is the coming traffic strain on shipping facilities, due to the crop movement in the late Summer and the coal movement in early Fall. We are trying to overcome this by stocking our various district warehouses now and to the dealer who is trying to find an answer to the problem we are suggesting that he lay in his supply before the transportation facilities of the country are excessively burdened."

"Undoubtedly each manufacturer has in view the anticipated freight rate increase, which will necessarily be due to the proposed readjustment of the railroad employes' salaries, and this in turn will have some effect on raw materials and finished goods. A big market this Fall is anticipated by dealers everywhere and it is going to again create that shortage of materials, particularly when coupled up with the expected shipping conditions. All talking machine merchants with vision, leaving entirely aside the sound merchandising principle involved, are looking forward to handling at least two or three established and nationally advertised lines of merchandise. This is our analysis of the present market and we are therefore going ahead

with our proposed plans, simply because we have that same optimism."

London Man Here

R. Gordon Willis, representing the British Polyphon Co., was in Chicago on the 14th of June, and while in the city called on various members in the talking machine industry, as well as on the Western division of The Talking Machine World. Mr. Willis is a mighty bright young man.

Remodel Smith Piano Co.

The talking machine department of the Smith Piano Co. has undergone extensive changes. A number of additional booths have been added and increased facilities for the handling of customers provided. The Smith Piano Co. has also installed a player roll department on the first floor. This is for them a new departure.

Open New Store

L. R. Cook and W. R. Bender have formed a partnership and opened a music store at 260 North Crawford avenue, where they will handle talking machines, records, pianos and players. These gentlemen have both had previous experience in the music business. Mr. Cook having been connected with the Cable-Nelson Piano Co., makers of the Dulcitone talking machine.

An Artist Sales Lady

Miss Katherine Jelska, soprano and saleslady of talent and accomplishment, has joined the retail sales force of the Starr Piano Co. at its store on Wabash avenue. Miss Jelska is a protegee of E. F. Lapham, of Grosvenor-Lapham Co., who early recognized her abilities. Manager

(Continued on page 145)

TRANSFER NAME-PLATES

We make the Transfer Name-Plates and Trade-Marks for the largest talking machine manufacturers in this country and for dealers in every state.

YOUR NAME, Mr. Dealer, on every machine brings the owner back to you or records and his friends to you for a machine.

Samples, Suggestions and Sketches Furnished Free

THE MEYERCORD COMPANY, CHICAGO

Largest Manufacturers of **DECALCOMANIA** Transfer Name-Plates

4 WINNERS

For Fall Business, Supreme In

TONE — FINISH — DESIGN

Federal Phonographs

are built up to a standard of art. The cabinets are unexcelled for beauty, the Federal design tone arm is unique, and the distinction of the name FEDERAL stands back of all our console and upright phonographs.

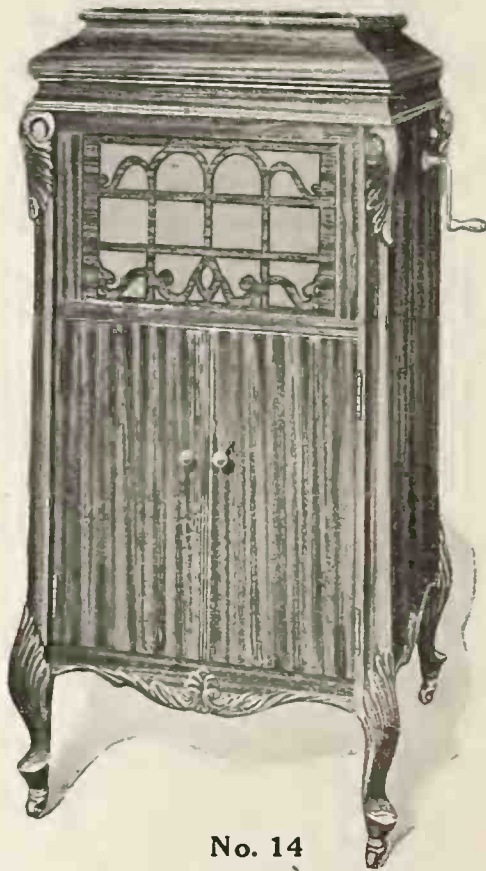

No. 14

Style—Queen Anne.
Wood—Selected figured mahogany with all hand-carved mahogany trimmings.
Dimensions—Height, 51 inches. Width, 23½ inches. Depth, 24 inches.
Finish—Red, brown and satin.
Motor—Heineman No. 44 or Meisselbach No. 17, with plush turntable.
Tone Arm—Federal Own Design.
Record Accommodations—Sufficient room for 6 twelve-inch albums.
Trimmings—Best quality gold or nickel plated.
Price—Nickel Plated, \$250.00. Gold Plated, \$275.00.

Federal Phonographs

are made in our own factory, which has been famous for over 25 years in the production of high grade furniture. The material used is of the very best selected wood, and the equipment throughout is designed to please the most discriminating buyers.



No. 18

Style—Sheraton inlaid on doors and legs.
Wood—Selected figured mahogany.
Dimensions—Height, 36 inches. Width, 39½ inches. Depth, 23½ inches.
Finish—Red, brown and satin.
Motor—Heineman No. 44 or Meisselbach No. 17, with plush turntable.
Tone Arm—Federal Own Design.
Record Accommodations—Sufficient room for 6 twelve-inch albums.
Trimmings—Best quality gold or nickel plated.
Price—Nickel Plated, \$350.00. Gold Plated, \$375.00.

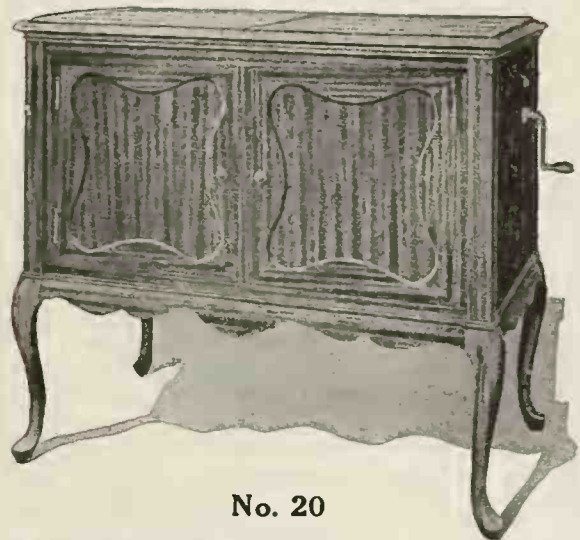

No. 20

Style—Queen Anne.
Wood—Selected figured mahogany.
Dimensions—Height, 36 inches. Width, 39½ inches. Depth, 23½ inches.
Finish—Red, brown and satin.
Motor—Heineman No. 44 or Meisselbach No. 17, with plush turntable.
Tone Arm—Federal Own Design.
Record Accommodations—Sufficient room for 6 twelve-inch albums.
Trimmings—Best quality gold or nickel plated.
Price—Nickel Plated, \$325.00. Gold Plated, \$350.00. Walnut, \$10 extra.



No. 16

Style—Adam.
Wood—Selected figured mahogany. All solid mahogany hand carvings.
Dimensions—Height, 36 inches. Width, 39½ inches. Depth, 23½ inches.
Finish—Red, brown and satin.
Motor—Heineman No. 44 or Meisselbach No. 17, with plush turntable.
Tone Arm—Federal Own Design.
Record Accommodations—Sufficient room for 6 twelve-inch albums.
Trimmings—Best quality gold or nickel plated.
Price—Nickel Plated, \$325.00. Gold Plated, \$350.00. Walnut, \$10 extra.

Federal Phonograph Corp.

1458-1464 W. Kinzie St.
CHICAGO, ILL.

Michigan and Pennsylvania
Representatives:

Federal Sales and Supplies Corporation

34 FARMER STREET
DETROIT, MICH

FROM OUR CHICAGO HEADQUARTERS—(Continued from page 143)

Rousseau vows that her talents as a saleslady are as great as her ability as a singer, and that isn't all—she uses the one to help the sales of the other, giving demonstrations of voice and talking machine and voice and player-piano when making sales.

The place of the chief floor salesman of the Starr establishment made vacant by the resignation of Ward W. Stratton has been filled by W. H. Newton, who has been in the Starr employ since the opening of the store a couple of months ago. Mr. Newton has had enough experience in the retailing of talking machines. He was formerly employed by the Cable Company and with Adam Schaaf.

Another addition to the Starr wholesale force is H. S. Conover, who is in charge of the city sales of the Starr talking machine. Mr. Conover is a gentleman of considerable experience in the music business, being first with the Chicago Talking Machine Co. for four years and later with the Rudolph Wurlitzer Co. for eight years. He represented the latter concern in the States of Indiana and Michigan, with his headquarters in Detroit.

F. D. Hall to Coast

F. D. Hall, accompanied by Mrs. Hall, will leave Chicago around the middle of July for a well-earned vacation in California. Mr. and Mrs. Hall will be gone for about two months. The former has not been feeling extra well during the past twelve months and has planned to take a complete rest and relieve himself of all burdens incidental to the needle business which he has built up through many years of work.

H. J. Fiddelke, formerly of Lyon & Healy, takes the position of manager of the B & H Fibre Mfg. Co. during Mr. Hall's absence. Mr. Fiddelke, at the time he left Lyon & Healy, was acting as assistant manager of the talking machine department, under L. C. Wiswell. He has a most remarkable record with this concern for more than twenty years. He started as office boy and went through all the various stages of

J. E. ROBINSON ESTABLISHED 1879 M. J. DECKER
 TEL. HARRISON 420

ROBINSON THE PLATER

*Platers to the trade —
 Gold our Specialty*

500 W. VAN BUREN STREET
 CHICAGO

advancement up to the city credit department, where he acted as credit manager for ten years and then, three years ago, became Mr. Wiswell's assistant. All his activities have been in connection with talking machine sales and he is therefore excellently qualified to take the helm at the B & H plant during Mr. Hall's absence.

Improvements at Lyon & Healy

Lyon & Healy have considerably enlarged

their retail talking machine department. The new department remains on the same floor, but is extended much further back toward the rear of the building, now giving this concern what is probably the largest retail record department in the country. The Lyon & Healy record department has long been known as one of the largest in the United States, doing an immense

(Continued on page 147)

NEW IMPROVED PLAYRITE TONE ARM

The No. 2 Playrite Tone Arm and Sound Box represents a great improvement over our No. 1.W. Tone Arm, which was one of the most widely used arms on the market.

The No. 2 Tone Arm assures more volume, better tone and less breakage than any other arm now available.

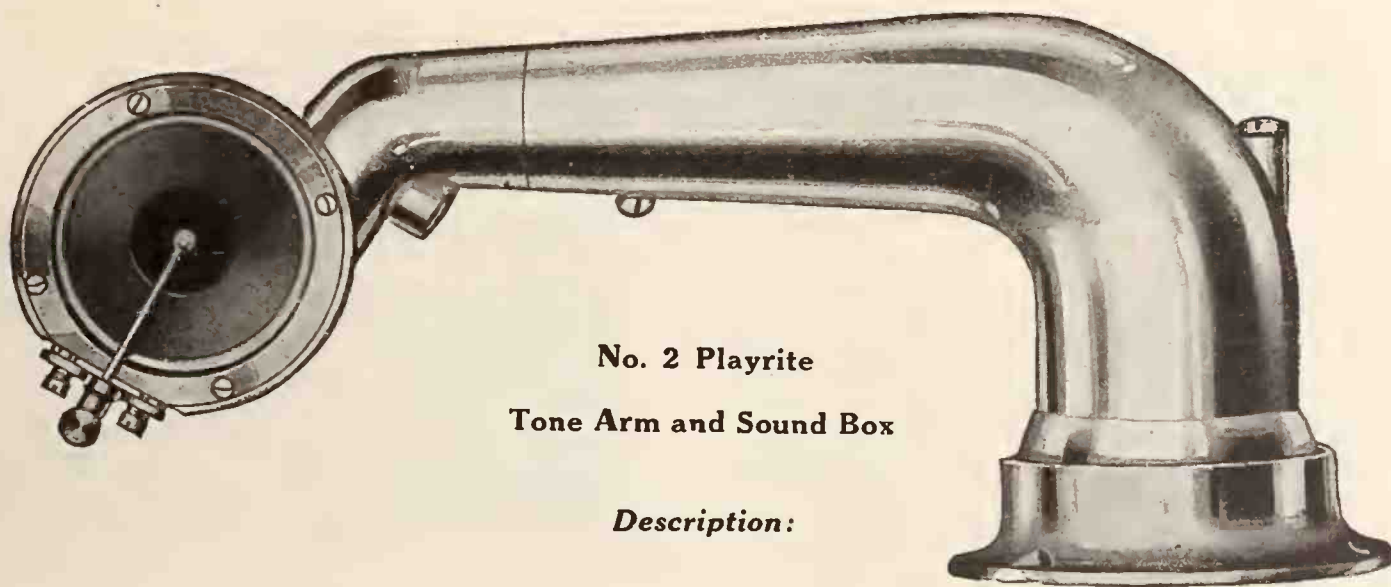

**No. 2 Playrite
 Tone Arm and Sound Box**

Description:

This arm is heavily nickel plated and measures from center of flange to needle point 8⁵/₈" ; height 4¹/₄". There are absolutely no loose joints. It has a ball bearing universal device, and centers when in position for playing either lateral or hill and dale records. There are also a number of other features including weight adjustment.

Write for samples and quantity prices at once. Sample Price \$5.00

AMERICAN PHONOPARTS COMPANY

35th Street and Normal Ave.

ESTABLISHED 1914

CHICAGO, ILL.

Hiawatha
PHONOGRAPHS

Listen to this simple story
to this song of Hiawatha
LONGFELLOW



Hiawatha

Production

Service

Delivery

*Hiawatha
Production*

Will guarantee you splendid service, and immediate delivery in all models. The

increase in our business has been so great during the year that we could not accept any new business until our production had reached this stage.

*Quality is Our
Watchword*

Jobbers and dealers can prepare for the fall trade now. Know before you buy. The quality of all Hiawatha models is beyond question.



Hiawatha Phonograph Company

209 SO. STATE ST.

CHICAGO, ILL.

A Watch Without a Case— no matter how good—could not be kept in running order very long. Could it?

Dust and grit would constantly scratch and grind the gears, shafts and bearings. Oiling would only make it easier for dirt to stick and gum it up.

Put it in a case. Dust and grit are shut out. Gears, shafts and bearings remain smooth and polished. A little oil—applied once or twice a year—lubricates every frictional surface by capillary attraction.

All phonograph motors were made like a watch without a case until we built

The Original Enclosed Motor “IRONCLAD” Silent as a Shadow

With every vital gear enclosed, with all its bearings in one solid casting, properly lubricated, it stays adjusted and remains quiet—giving constant silent service.



CHERINGTON MFG. CO.

Main Office and Factory:
WAUKEGAN, ILLINOIS

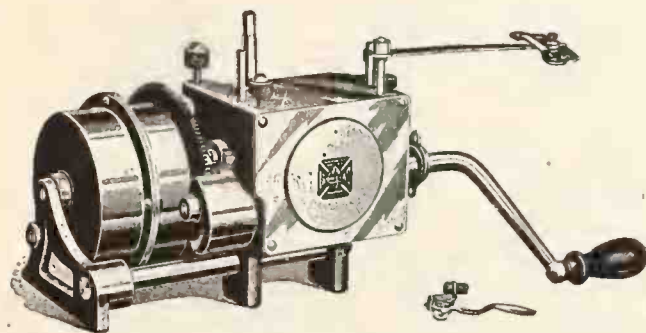

MADE IN SIX SIZES

- B-2—2 1-in. springs; plays 4 records
- C-2—2 1¼-in. springs; plays 5 records
- B-3—3 1-in. springs; plays 6 records
- C-3—3 1¼-in. springs; plays 8 records
- C-4—4 1¼-in. springs; plays 12 records
- C-6—6 1¼-in. springs; plays 16 records

ONE QUALITY

FROM OUR CHICAGO HEADQUARTERS—(Continued from page 145)

volume of business, and the necessity of still larger space speaks most eloquently of L. C. Wiswell's successful administration of the talking machine department. Perhaps the most remarkable feature of the Lyon & Healy department is the genial atmosphere and quick courteous service rendered. One cannot but be impressed with this when getting off the elevator on the second floor. A young lady greets the visitors and immediately shows him or her to a waiting saleslady or a vacant record booth. The watchword of the Lyon & Healy talking machine department has always been "service to their customers" and the recent improvements are undoubtedly brought about with this idea in view. Here is a bit of copy inserted in the Chicago newspapers by Lyon & Healy, which expresses characteristically their attitude toward customers.

"There is always the other side to the street.

"When we feel we are getting too set in our notions we like to remember that, after all, a good many things are a matter of taste.

"In China, for instance, the men wear gowns and the women wear trousers. And a Chinaman, you know, never shakes hands with a friend, but shakes hands with himself. We like fresh eggs, but the Chinaman has a partiality

for an egg that has been buried for about seven years. He blacks his boots white, strings his money on a stick and reads his books backward. When he takes a cup of tea he puts the saucer on top of the cup and not under it.

"Really there is something to be said for the other side of the street! We are all traveling the same journey, trying to make the world a little better for our stay.

"So in the matter of rules and regulations of this store there is always a willingness to receive suggestions. If our system doesn't seem right we are glad to discuss the matter.

"We wish to avoid, most of all, the mental attitude of Eliphaz, Bildad and Bophar. Job, you may remember, protested to his three friends in these words: 'No doubt but ye are the people and wisdom shall die with you.'"

Attends Sonora Convention

Walter J. Hanilin and L. Golder, of J. C. Van Houten & Zoon, left Chicago around the first of the month to attend a Sonora jobbers' convention in New York on July 12. From this point Mr. Golder starts his vacation and will be away for two weeks before his return to Chicago.

Attends Ad Convention

Charles E. Byrne, advertising manager of Steger & Sons' Piano Mfg. Co., accompanied by Mrs. Byrne, traveled through Bedford Springs, Pa., during the middle part of June, where the former attended the convention of the Association of National Advertisers. Mr. Byrne at this convention delivered a talk on the "Relation of the Business Paper to National Advertising."

Singer Makes Big Hit

Margaret Romaine, prima donna of the Metropolitan Grand Opera Co., made a decided hit while in Chicago at the North Shore Festival. Miss Romaine, it will be remembered, while here appeared also before the assembled Columbia deafers at the Congress hotel, where she sang for the dealers.

Three Good Window Displays

The Lyon & Healy corner store window has been dressed with a very pretty and attractive Summer display. A life-sized yacht of the Class C type has been floated on a pool of water and the scene made life-like by means of an electric fan, which blows wind upon the sail, making it swing to and fro.

The Talking Machine Shop invites passersby upon the street to "take a trip to fairyland for your vacation." A group of gnomes, bowling with talking machine records, with a fair queen presiding over the scene, create a very pretty effect.

The Cable Company, just before the Fourth of July, prepared an attractive patriotic window, in which records of patriotic numbers were prominently displayed against a painted background, which arrested the attention of the passerby.

On Auto Trip

F. S. Spofford and H. H. Hays, Sonora dealers in the Republic Building, spent a week touring through Indiana during the latter part of June and the first few days of July. They visited George Ade's home and stopped off for a couple of days at French Lick, Ind.

Cincinnati Visitor

E. M. Abbott, progressive music merchant of

(Continued on page 148)

REPAIRS

—ON—

All Makes of Phonographs Promptly and Efficiently—24-hour Service

Jobbers in all Repair Parts
Motors, Tonearms, Needles and Records

Central Music Sales Co.

173 Sixth Street

Milwaukee Wisconsin

Repair Service

For all makes of
Talking Machines and
MOTORS

Rosenberg Phonograph Co.

1252 So. Jefferson Street

Telephone Canal 4325 Chicago, Ill.

FROM OUR CHICAGO HEADQUARTERS
(Continued from page 147)

Cincinnati, was in Chicago, calling upon the local trade during the latter part of June. While here Mr. Abbott gave out the information that he is about to open another store at Sixth and Walnut streets, that city, where he will handle talking machines and player rolls exclusively.

An Attractive Window

L. Golder, of Van Houten & Zoon, Sonora jobbers, representatives of the Middle West, received the accompanying photograph from one of their dealers, namely, the Kennedy Music Co., Dixon, Ill. The window consists of the display of talking books and is filled with pictures of animals, birds and so forth, with a real live parrot to lend color to the whole. In the



Unique Talking Book Window

center, surrounded by sand, is a replica of a pool of water, made with a piece of glass. As a display it has obtained good results and attracted favorable comment of the public. These window ideas may be of use to other dealers.

Guarantee Roll Prices

The United States Music Co. is sending out to its dealers announcements to the effect that the U. S. player roll prices are guaranteed not to decline. Says President Arthur A. Friestedt in the notice: "Their market value is assured and the complete confidence of dealers and consumers is thereby established. Player roll prices are less now than ever before, despite labor and material advances of from 100 to 350 per cent. Regular rolls used to list from 75c to \$1.75, with average mechanical royalties of less than 1c per roll, while current retail prices range from 60c to \$1.25, with mechanical royalties averaging 10c, due to word roll rights, at 6c and 12c per roll, the latter price prevailing."

Windsor Man Killed

A tragedy which shocked Chicago occurred on Sunday, June 6, at the offices of the Windsor Furniture Co., manufacturers of talking machines, at 1420 Carroll avenue. Charles C. Dietrich, forty-seven years old, former secretary of the Windsor Furniture Co., was working at night and was seen by a night watchman while manipulating the combination of the furniture

company's safe. The watchman, thinking Dietrich a burglar, phoned for the police. The latter appeared at the factory and ordered the secretary to give himself up. Dietrich, thinking the detectives were burglars, put out the light, slammed shut the door and started to run. The detectives fired and killed Dietrich. He is survived by an aged father and mother and a

brother, Kline, who is a veteran of the world war and widely esteemed.

New Wilson Man

The phonograph department of Thomas E. Wilson & Co. is now headed by A. C. Moreland, lately with Elting & Co. Mr. Moreland is an experienced talking machine man and a
(Continued on page 150)

Blood
TONE ARM & REPRODUCER

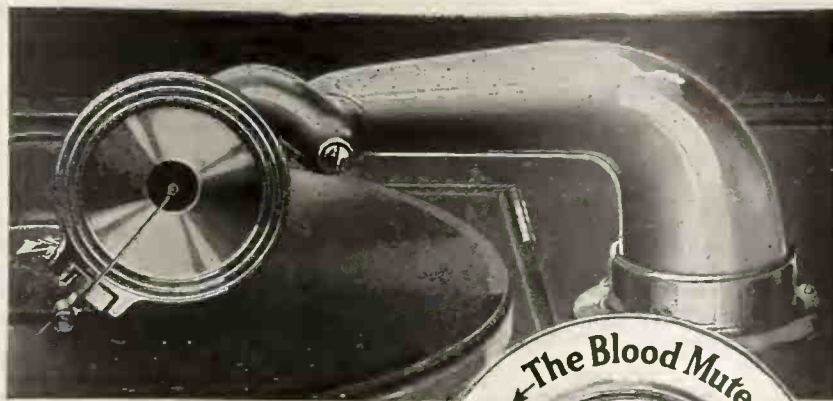

Here's Your Chance

To build up a big business in phonographs by featuring the **BLOOD TONE ARM AND REPRODUCER** with Mute Attachment—every demonstration means a sale.

An exclusive sales feature that produces marvelous results

The "BLOOD," which is noted for its natural and lifelike reproducing qualities, is still further improved by the addition of this new and proven invention, so that we now offer you

Improved Tonal Quality plus Perfect Tone Control

What's the good word?

JEWEL PHONOPARTS COMPANY

668-670 W. WASHINGTON BLVD. CHICAGO

All Steel and Iron

Will absolutely square cases and will not wear out.

Labor Saving and Indestructible

Gives Speed and Accuracy

WE ILLUSTRATE THE

"HANDY" REVOLVING CASE CLAMP

WE ALSO MAKE IT STATIONARY

Nothing better made for Clamping and Squaring Talking Machine Cabinets

Write for Catalogue of Clamping Machines for "Domes" and for all purposes.

VENEER PRESSES AND CLAMPS

HANDY MFG. CO.

27 E. Madison St., Chicago, Ill.

AMBEROLAS

will sell themselves if given a fair chance.

We ship anywhere in the U. S.

J. I. LYONS

17 WEST LAKE STREET
CHICAGO

SILENT
SAAL
 PHONOGRAPH MOTORS

Saal Motors Represent Seven Years
 of Accumulated Knowledge.

In Them You Get—"Experience"—
 Not Experiment.

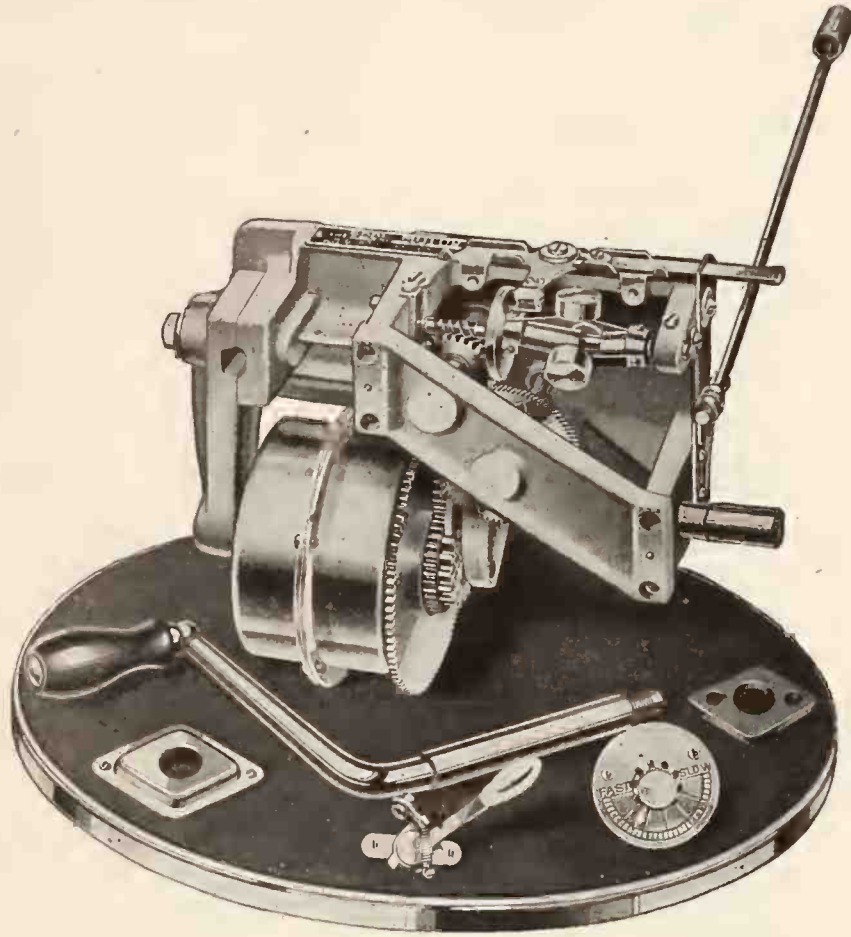

Motors

Insure a Service of Satisfaction

NO EXPERIMENTS TO OFFER—But a Motor which has stood the test of time—
 Proven its superior Qualities over practically all others in the hands of big users and most
 critical purchasers.

The "Saal Motor" not only sells Phonographs, but it keeps them sold.

Supply your customers with the Motor which spells "SATISFACTION" and New
 Orders.

Employ the greatest of all advertising mediums—"A Satisfied Customer"—that living ex-
 ample of "Your Money's Worth."

Send for illustrative and descriptive catalog.

H.G. Saal Company
 1800 Montrose Ave. Chicago, Ill.

THERE IS NO SLACK SEASON FOR **Repeater-Stop** DEALERS

"Here is a little food for thought"

A dealer writes us he sold 7 Repeater-Stops in one day—4 in the forenoon and 3 in the evening, making a total profit of \$21.00—at \$3.00 for sales expense—this is a clear extra profit besides the sale of other things throughout the day made with the least difficulty and the chances for these 7 to bring back 7 more reorders through their exhibition are more than probable.

Dealers who build for permanency handle the Repeater-Stop, an instrument without competition.

THE THOUSANDS NOW IN USE

- ☞ To produce—High Quality Perfect device.
- ☞ To sell them at a price commensurate.
- ☞ To market them through Jobbers exclusively.
- ☞ To protect the trade and allow a good reasonable margin of profit.

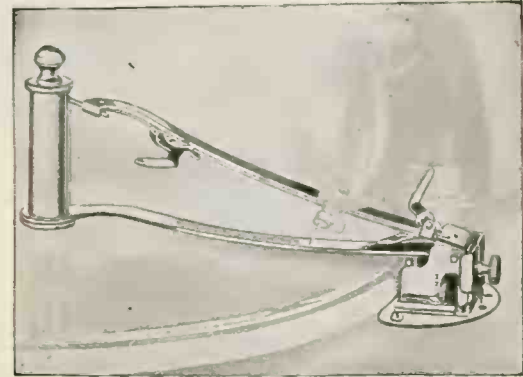

THE RECORD REPEATER WITH THE AUTOMATIC STOP

That briefly is our policy, and back of it a wide experience—insures its success

REPEATER STOP CO.

115 South Dearborn Street - Chicago

FROM OUR CHICAGO HEADQUARTERS—(Continued from page 148)

capable executive. His enthusiasm and efforts in the interests of the Wilson talking machine will undoubtedly result in their increased popularity.

Standard Corp. Busy

Walter Magill, advertising manager for the Standard Phonograph Motors, Inc., reports a slight alleviation of the labor situation, which has aided somewhat in increasing the Standard production during the past thirty days. The Lake Shore Drive plant is one busy little place and continues to operate at full speed.

New Records Go Well

J. H. Steinmetz, president of the Empire Talk-

ing Machine Co., is most enthusiastic over the new Empire records and the way in which they are being called for by dealers. The new records are listed in standard and popular numbers and an effort has been made to include only those which will find a quick turnover in the retail stores.

New Sixty-third Street Store

On Saturday, June 19, Lyon & Healy opened a new retail music store at 1018 East Sixty-third street. The opening was marked by a program of festivities and entertainment provided by Lyon & Healy for residents of the neighborhood. C. T. Landherr has been appointed man-

ager of the branch establishment, under the supervision of L. C. Wiswell, manager of the Lyon & Healy talking machine department. Approximately everything handled by the downtown store will be handled by the Sixty-third street branch. The well-known Lyon & Healy slogan, "Everything Known in Music," will hold true at the new store.

"Sunday" to Be Recorded

The late song success published by Forster, "I Love You, Sunday," with words by Charles Byrne, of the Steger & Sons Piano Mfg. Co., and the music by Charley Straight, of the Imperial

(Continued on page 152)

MELODIA Phonograph Company

The
MELODIA
furnished in five
styles and sizes rang-
ing in price from
\$75⁰⁰ to \$325⁰⁰

WRITE FOR
ATTRACTIVE DEALERS'
OFFER

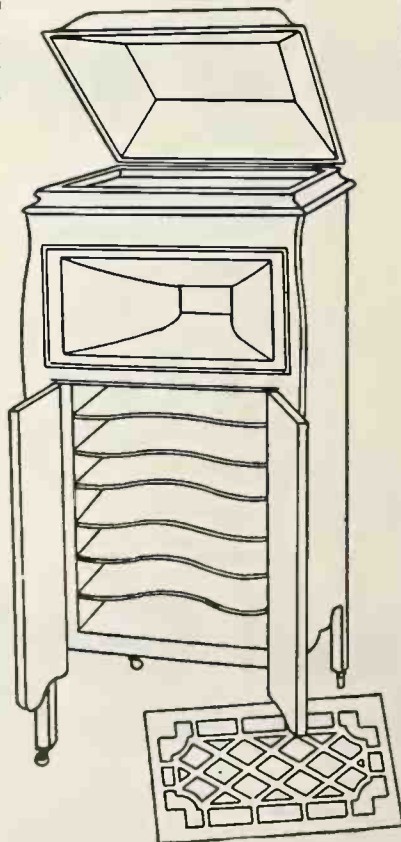

**400 N. Sangamon St.
Chicago Ill.**

Melodia now occupies the stage. Every machine is built of heavy five-ply stock. Furnished in standard finishes. The Melodia is unsurpassed in tone on account of its "Patent Applied For" tone chamber and its equipment of the best motor and tone arm. Played and indorsed by "Marinuzzi," director of Chicago Grand Opera Co. Live dealers wanted.

The Melodia Phonograph Co.
400 N. Sangamon Street
CHICAGO, ILL.
PHONE, HAYMARKET 3833

The AEOLIAN-VOCALION IN PERIOD DESIGNS



THE AEOLIAN-VOCALION

"In its evolution upward the American public is fast attaining that desirable condition where each family feels it has the right to have beautiful things in the home."

—THE BUSH MAGAZINE

There is a nation-wide demand for the finest in period furniture which logically includes phonographs.

Many buyers of period furniture know what is good and what is not.

Vocalion Period Models may be offered to the most discriminating with the utmost assurance.

Business prestige is increased by the Vocalion. Period and conventional models both reflect design and craftsmanship of the highest order. Vocalion Records (lateral cut) are the supreme achievement of the art of recording. Their quality is apparent on any standard phonograph.

THE AEOLIAN COMPANY

529 South Wabash Avenue
Chicago, Illinois

YES, THIS IS

The Oro-Tone

QUALITY FIRST

THE PERFECT EDISON ATTACHMENT
WE CAN PROVE IT—IF YOU WILL SAY—
“Send sample on approval” or ask your jobber

Retail Price, Nickel Plated, \$8.50 Highest Grade Gold Plating \$12.50

The New ORO-TONE Safety Point Steel Needle Now Ready
Sample Thousand 60 Cents

Mfrs. of highest grade tone arms, reproducers, attachments for phonographs for playing all records. Diamond and jewel point needles, motors, supplies, etc.

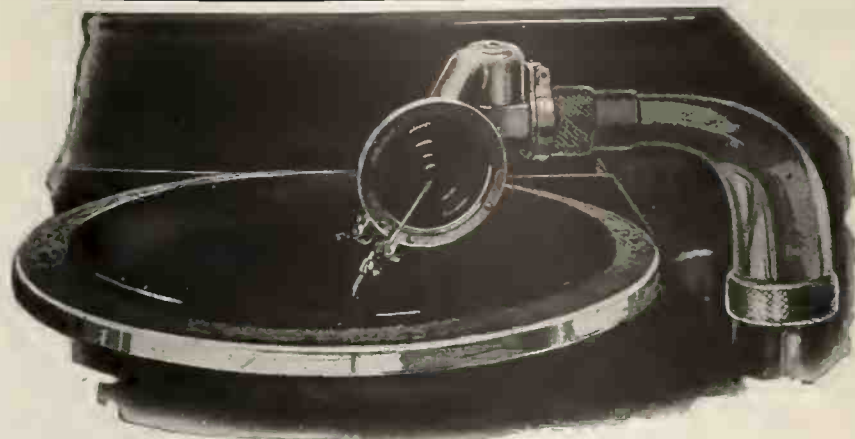

ILLUSTRATION SHOWS THE ORO-TONE ATTACHED

The Oro-Tone Co.
QUALITY FIRST

Successors to COMBINATION ATTACHMENT CO.

1808-10 IRVING PARK BOULEVARD, CHICAGO, ILL.

FROM OUR CHICAGO HEADQUARTERS—(Continued from page 150)

Player-Roll Co., seems to be meeting with considerable success; in fact, it has proved so popular that a number of record and player roll concerns are now contemplating the recording of it on talking machine records and player rolls. “I Love You, Sunday” possesses a simple, winning melody and attractive “singable” words, which will undoubtedly make it a popular song of the day.

Vitanolas in Panama

The modern progressiveness of the Latin-American dealer is shown in the accompanying illustration of a Vitanola dealer in the Republic of Panama. The electrical sign in the main entrance of the store shows the merchant to be “on the job,” perhaps more so than he is ordinarily credited with by manufacturers here in the States.

Six Best Sellers

The six best Victor sellers are: “Oh! By Jingo” and “Nobody but You”; “Alexandria” and “Oriental Stars”; “Who’ll Take the Place of Mary” and “Marion”; “Greatest Miracle of All”; “The Woman of Cadiz”; “I Think I Will Get Wet in the Summer.”

The Columbia best sellers are: “My Sahara Rose” and “Sudan”; “Oh! By Jingo” and “So Long, Oolong”; “I’ll See You in Cuba” and “When the Moon Shines on the Moonshine”; “Patches” and “Without You”; “Your Eyes Have Told Me So” and “Deep in My Heart”;



How the Vitanola Is Advertised in Panama

“My Isle of Golden Dreams” and “On Miami Shore.”

The six best Edison sellers are: “Dardanella” and “Make That Trombone Laugh”; “Aloha Land” and “Wait Until the Roses Bloom”; “La Zingarella” and “Singing to You”; “At a Georgia Camp Meeting” and “Liberty Bell March”; “Symnoves Song” and “Will o’ the Wisp”; “Serenade” and “Drink to Me Only With Thine Eyes.”

The six best Pathé sellers are: “The Hen and the Cow” and “Way Down Barcelona Way”; “Rings” and “In Shadowland”; “Karavan” and “La Guapa Muchacha”; “Your Eyes Have Told Me So” and “Weeping Willow Lane”; “The Little Whistler” and “By the Babbling Brook”; “Tarzan” and “My Sahara Rose.”

The six best Vocalion records are “Manyana” and “Marion”; “The Moon Shines on the Moonshine” and “I’m the Good Man That Was So Hard to Find”; “Syncopated Dreams” and “Dance-O-Mania”; “Alabama Moon” and “Whose Baby Are You”; “Florodora Sextet” and “Florodora Selections”; “Lucia” Mad Scene.

The six best Brunswick sellers are: “Swance” and “You’re My Gal”; “Venetian Moon” and “Mystery”; “La Vecda” and “So Long, Oolong”; “Sahara Rose” and “Jean”; “Whose Baby Are You” and “Someone”; “Bound in Morocco” and “On Miami Shore.”

The six best Emerson sellers are: “Oh! By Jingo,” vocal and instrumental; “Rose of Washington Square” and “Torcadore”; “Bo-La-Bo”

ARTO MUSIC ROLLS

WITH \$1 SUPREME WORDS QUALITY

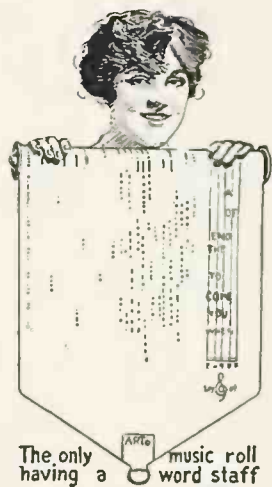

You will give your customers *best quality, most attractive boxes, the newest music, patented word staff; Artistic hand playing, and best of all good service* by selling these quality Rolls.

Judged from any standpoint you may wish, ARTO Music Rolls are Supreme! Increase both your business and profits by ordering of us today.

Catalogues of Jewish, Polish, Italian, Spanish songs with or without words.

Consolidated Talking Machine Company
227-229 W. Washington Street : Chicago, Illinois

Here is the attractive PLAYERPHONE ad that ran in the SATURDAY EVENING POST, JUNE 19th. It will make over 10,000,000 readers good prospects for YOU.



Model "G"

The Day The
Playerphone
The QUALITY TALKING MACHINE

Enters Your Home
A New Era of Happiness Starts

¶ The charm of this beautiful instrument is felt by all. As pleasing to look at as it is delightful to hear, the PLAYERPHONE makes your home a more cherished, attractive spot.

¶ And with the PLAYERPHONE your choice of musical selections is unlimited—it plays every make of disc record without change of equipment, giving the fullest tone value to each record. This is possible because of the distinctive features of our own tone arm, reproducer and weight adjuster, exclusive to the PLAYERPHONE, which makes the operation so simple and accounts for the unusual sweetness of its rich tone.

¶ The beautiful PLAYERPHONE is our very own product, from the delicate tracery of the fine hand carving of the beautiful cabinets to the accurately constructed reproducer, done in our own great factory by master artisans of long experience.

¶ Before buying, see and hear the PLAYERPHONE—the talking machine with the human tone. Nine styles and sizes, ranging from \$110 to \$500. Each PLAYERPHONE is guaranteed to give entire satisfaction.

¶ RETAILERS—NOTE THIS: Write or wire for terms today to the nearest one of these well known jobbers. They carry our full line and back the PLAYERPHONE with their own name.

- Van Vleet Mansfield Drug Co., Memphis, Tenn.
- Houston Drug Co., Houston, Texas.
- Chapman Drug Company, Knoxville, Tenn.
- Clawson & Wilson, Buffalo, N. Y.
- The Day Drug Co., Akron, Ohio
- The Des Moines Drug Company, Des Moines, Ia.
- L. S. DuBois Son & Company, Paducah, Ky.
- W. J. Gilmore Drug Company, Pittsburg, Pa.
- Healy Brothers, 13th & Hoyt Sts., Portland, Ore.
- Hornick, More & Porterfield, Sioux City, Iowa.
- Kauffman-Lattimer Co., Columbus, Ohio.
- Reld-Lawson, Inc., Birmingham, Ala.
- Chas. Leitch & Co., Evansville, Ind.
- The Murray Drug Company, Columbia, S. C.
- Oklahoma Book Company, Oklahoma City, Okla.
- Orchard & Wilhelm Company, Omaha, Nebr.
- Twin City Talking Machine Co., Ulrichsville, O.
- F. M. Umphred & Son, Oakland, California.
- Western Jobbing & Trading Co., 724 S. Broadway, Los Angeles, Calif.
- H. W. Williams & Co., Fort Worth, Texas.
- Don's Music Store, Hastings, New Zealand.

¶ A few splendid jobbing territories still open. Add your name to this list in next month's advertisement. Write today to

PLAYERPHONE TALKING MACHINE COMPANY

4223-41 W. Lake St., Chicago
D. W. MCKENZIE, W. D. CALDWELL,
President Treasurer



White House Model

FROM OUR CHICAGO HEADQUARTERS
(Continued from page 152)

and "Sweet and Low"; "On Miami Shore" and "Swanee"; "La Veda" and "Anvil Trot"; "Slow and Easy" and "Lone Star."

The six best Okeh sellers for the month are: "Venetian Moon" and "Oh! By Jingo"; "You're a Million Miles From Nowhere" and "When the Harvest Moon Is Shining"; "Song of Omar" and "Rose of Washington Square"; "Alexandria" and "Make That Trombone Laugh"; "So Long, Oolong" and "Ching-a-Ling's Jazz Bazaar"; "La Veda" and "There She Goes."

The six best Empire sellers are: "Can't Yo' Hear Me Callin', Caroline" and "Kentucky Babe"; "When Irish Eyes Are Smiling" and "Mother Machree"; "My Wild Irish Rose" and "Annie Laurie"; "Nightingale Song" and "Bonnie Doon" "Old Folks at Home" and "Old Black Joe"; "Love's Old, Sweet Song" and "Woodland Echoes."

More Empire Service

The new Empire service department has brought out an attractive and highly practicable record window display stand for the use of their dealers. The stand is staunchly designed of wood, with a wooden backing for the record, to



An Artistic Window Display Stand lessen the danger of warping the record when in the window. This is the first product of the new Empire service department and is in line with its plans for increased dealer service. Business with the Empire Co. is unusually brisk particularly in the record field. This department is showing tremendous activity.

Magnifies Sound 50 Times
ACME SOUND AMPLIFIER

Enables the repairman to locate the precise point of origin of unnecessary noise in the motor without loss of time or useless disorganization of the mechanism which results from guessing or the sense of hearing alone.

MAKES EVERY MOVING PART IMMEDIATELY ACCESSIBLE

"Guesswork Won't Do"

The ACME allows a test with the drag of the needle throughout the length of the record.

ACME

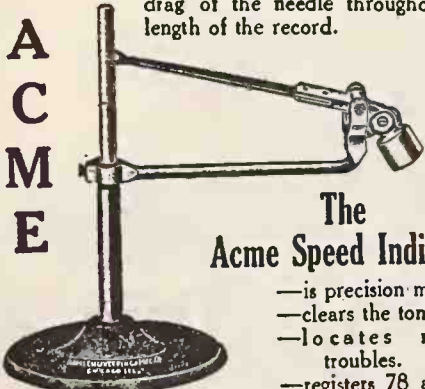

The Acme Speed Indicator

- is precision made.
- clears the tone arm.
- locates motor troubles.
- registers 78 and 80 revolutions.

"The repairman's stethoscope."
Made by
Acme Engineering & Mfg. Co.
1622 Fulton Street CHICAGO

LAKESIDE MONOGRAPH PRODUCTS

WE CARRY A FULL LINE OF MOTORS, TONE ARMS, ACCESSORIES AND HARDWARE.

Send for Our New Catalog **JUST OFF THE PRESS**

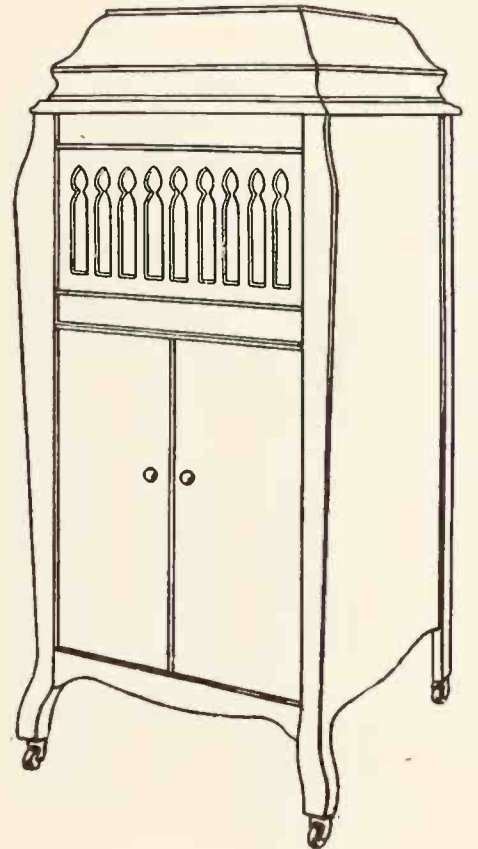

CAN YOU BEAT IT!

LAKESIDE ELECTROPHONE

An Electric Driven Phonograph

DEALERS WRITE FOR **RETAIL DISCOUNTS** **\$135.00**

Furnished in All Standard Finishes
45" High, 18 3/8" Wide, 21" Deep

Many Inquiries and Orders Already Received on "Electrophones"

Our new automatic stop now ready for distribution

For the convenience of our Pacific Coast Customers we have established a Western Division, with Headquarters at Williams Bldg., San Francisco, Cal.

Lakeside Supply Co.

Telephone Harrison 3840

416 S. Dearborn Street Chicago, Ill.

THE SAAL CO. TO MAKE THE JOHNSON MOTOR

H. G. Saal Co., Chicago, Contracts to Manufacture and Sell the Johnson Electric Motor—Hailed as Move to Increase Production

CHICAGO, ILL., July 10.—A business transaction of much interest to the talking machine industry has been brought about, whereby the Phonograph Motors Corp., formerly the Johnson Motor Co., manufacturer of high grade electric talking machine motors, made arrangements with the H. G. Saal Co., of Chicago, for the latter company to manufacture and sell the Johnson electric motor. All the important bearings, worms and special wearing parts will be made at the Saal factory under contract.

The Saal factories are so organized that each working unit maintains the highest order of efficiency, and this arrangement is already working to a distinct advantage in the production of the Johnson motor.

The H. G. Saal Co. was founded in 1900 by Henry G. Saal and was first known and achieved its reputation as a manufacturer of micrometer gauges, dies and precision instruments, of which absolute accuracy is the prime essential. This experience, when later applied to talking machine motors proved invaluable and has been one of the large contributing factors to the popularity of Saal motors.

It is understood that the Saal factories have been oversold for the past two years, and no attempt was made towards any abnormal increase in the production, because the Saal Co., working along conservative lines, saw that all of its old customers were adequately supplied, and therefore very little new business was added. The output of the Saal factory is said to be approximately 1,500 per day.

One of the most recent additions to the Saal property holdings is a very large daylight die casting plant, which is equipped with the most modern up-to-date machinery, and is well manned with expert die casters. The sides and roof of this building are entirely of opaque glass. The height of the casting room measures over thirty feet from the peak of the roof to the floor in which the machines are. The fumes made by the die casting machines are drawn out of the building by a large seventy-two centrifugal fan, which changes the air every three minutes. Another modern and well equipped building that has been added to its chain of factories and which by the way furnishes an additional 20,000 square feet to the old factory area is the nickel and gold plating plant. However, this entire space is not used up by the plating plant, as there is a part given over to the punch press department. A special building, or annex, has been apportioned off, and rebuilt with a special foundation to accommodate the new "Jumbo" punch press. The weight of this press alone is over 66,000 pounds

VARNISH DRYROOMS

A REAL DRYING EQUIPMENT

MAKE EVERY DAY A PERFECT DRYING DAY

DRYING SYSTEMS, INC., 11-17 So. DESPLAINES ST. CHICAGO.

and it has a pressure capacity of over 2,400,000 pounds. The principle use of this machine will be for the stamping of Saal turn-tables. In addition to this monster press in the aforesaid building, there has been installed twenty-five Brown & Sharpe and other automatic machines. This will enable the company to make in its own factory every screw, nut, gear, bolt and spring entering into the construction of not only the Saal motor, but the Johnson electric as well.

BRUNSWICKS IN THE ORIENT

Brunswick Wholesaler in Orient Reports Big Demand—Some Sales Peculiarities

CHICAGO, ILL., July 6.—Robert L. Ward, of the Euro-Chino Trading Co., who represents the Brunswick-Balke-Collender Co. in the Orient, with headquarters at Shanghai, China, reports an ever increasing demand for talking machines in the Orient.

The above company has established branches in the following cities: Shanghai, Yokohama, Seoul, Tien Tsin, Peking, Hankow, Canton, Singapore, Rangoon, Bombay, Calcutta, Tokio, Nagasaki, etc.

The Euro-Chino Trading Co. has six hundred Chinese salesmen, carrying its wares to cities in China. The Chinese salesman is a most enviable sort of person. He has a definite following of customers, and no one else can sell the people he goes to. The Chinese do not

always believe in being content with only one talking machine. Mr. Ward writes of an instance where he sold a Chinaman eleven. He asked the purchaser why he wanted eleven talking machines in his home. The latter replied, "leven rooms, need 'leven phonographs." Neither is the Chinese customer satisfied with cheap instruments. Mr. Ward states that there have been a number of sales up in the thousand dollar class. All of which indicates that the talking machine business is highly successful in the Far East.

REPEATER STOP CO. FILES SUIT

Chicago Concern Asks for Injunction and Damages Against Wurlitzer Co. of Cleveland

On June 28 the Repeater Stop Co. entered suit against the Rudolph Wurlitzer Co., of Cleveland, in the United States District Court of that city. The Repeater Stop Co. asks an injunction and an accounting for damages on allegation that the Rudolph Wurlitzer Co. has sold the Repeatograph made by the Repeatograph Co. in infringement of the Repeater Stop patents No. 1,060,955, No. 1,062,369, No. 1,273,823 and No. 1,317,259.

TOURING THE MIDDLE WEST

D. Tauber, president of the Progressive Phonographic Supply Co., New York City, is making a trip through the Middle West in the interest of Wall Kane needles, which he represents.

The Oro-Tone
QUALITY FIRST
No. 1-VR

For Playing all Records on the Victor Talking Machine Using the Victor Reproducer

Attached in two seconds. Fits all Victor goose necks. Makes the Victor a universal machine for playing all records with the Victor reproducer.

Ask your jobber or we will send

Sample on Approval

Retail Price, Nickel \$2.00
Retail Price, Gold \$3.00



Cut shows Victor Reproducer attached

THE ORO-TONE CO.

1808-1810 Irving Park Blvd., Chicago, Ill.

Equip Your Phonographs With Perfect Automatic Brakes

Samples \$1.00 Each
Cash with order
State make of tone arm used



Also made with long brake shoe for 1 inch offset

Patented Aug. 28, '17

Simple construction and easily attached. Made in four styles to fit any make of tone arm.

Write for attractive quantity price

PERFECT AUTOMATIC BRAKE CO.
Room 400, 425 S. Wabash Ave., Chicago

That "WIDDICOMB ATMOSPHERE"

THE dealer in fine goods comes to feel toward them almost as he feels toward his personal possessions. There is an "atmosphere" about the fine things of commerce which only those who deal in them can fully appreciate.

It is this atmosphere which distinguishes the high-class dealer from his lower-class competitors, and which draws to the former the high-class cash-paying trade.

*To Be a Widdicomb Dealer
Is to Enjoy
to the Very Fullest
the Advantage of the Unique
Widdicomb Reputation
Based on Fifty Years of
Character and Repute*



The Widdicomb
A FINISHED
PRODUCT

To dealers who want only the BEST, and can sustain the necessary business-like requirements of such representation, we have something interesting to say.

PHONOGRAPH DIVISION

THE WIDDICOMB FURNITURE COMPANY
GRAND RAPIDS, MICHIGAN



Here's the novelty record of the month, "Love and Money" and "Popular Neapolitan Melodies" by the Russian Balalaika Orchestra. String a mandolin at a lower pitch—several of them—and then you get the deep harmony heard in an orchestra of these instruments. E-4642.

Columbia Graphophone Co. NEW YORK

IMFELD MUSIC CO. INCORPORATES

New Organization Formed in Hamilton, O., to Take Over Business of Late Ferd Imfeld—Will Enlarge Store to Handle the Victor Line

HAMILTON, O., July 6.—The Imfeld Music Store Co. has been incorporated at Columbus with a capital stock of \$36,000 by Clement F. Imfeld, Elizabeth Games, Agnes Imfeld, E. Z. Cochran and Harry J. Koehler, Jr. The purpose of the company is to take over the business of the late Ferd Imfeld. This business was established in Hamilton in a rather small way twenty years ago, but through the energy and ability of Mr. Imfeld was developed into one of the most prosperous and important business houses of the city.

It is the purpose of the company to meet the growing needs of its business by greatly enlarging the present store on South Third street. The basement of the building now occupied is to be improved so that much of the business of the company can be carried on there. Under the new arrangement the entire first floor will be given over to the handling of Victrolas and Victor records, while other branches of the business will be distributed as judiciously as possible. While the company now has but three record rooms, under the new arrangement it will have ten record rooms, which will permit of a much greater and a better showing of the instruments and records which the company handles.

REAL CAMPING SCENE IN DENVER

Knight-Campbell Music Co. Has Attractive Window Display Featuring the Victrola IV

DENVER, COL., July 6.—A real mountain camp scene in the window of the Knight-Campbell Music Co. has been attracting much attention here recently. This window display, which was designed and set by Mrs. Ellen Glass, the regular window dresser, was complete in every detail and showed a camp scene which would give

many a hardened camper a few useful hints. At one side is a small tent with the flap drawn back disclosing the interior with all the fittings that a well appointed camp tent should have. Outside are the fire and the coffee pot, grub box, fishing rod and basket and a Victrola IV ready for service. The Victor dog is comfortably seated listening to his master's voice, unmindful of the sly little animal making a raid on the grub box. In the pine tree at the left is a small bear and on a line in back of the tent a pair of woolen socks are drying in the sun. From this it can be seen that details are not forgotten.

PURCHASES NEW BUILDING

Talking Machine Co. of Texas Buys Spacious Structure in Houston to Be Devoted to Wholesaling of Victor Machines and Records

HOUSTON, TEX., July 5.—The Talking Machine Co. of Texas, Victor wholesalers, located in this city has just purchased a new two-story build-



Wholesale Home of Talking Mach. Co., Houston ing located in the heart of Houston and within a block of all the railroad freight stations and across the street from the express depot. T. E. Swan, president of the company, in chatting with The World said the new building will soon be occupied, and will be exclusively devoted to Victor wholesaling. The purchase price was \$90,000 and floors measure 100 feet by 110 feet. Mr. Swan, in addition to his Victor business and the chain of retail furniture stores he owns and operates in many Texas cities, has recently arranged to aggressively wholesale Q R S music rolls in Texas, Louisiana, Oklahoma, Arkansas.

B. F. WHITE WITH CLEVELAND CO.

CLEVELAND, O., July 2.—B. F. White joined the Cleveland Talking Machine Co., Victor wholesalers operating in Ohio territory, on July 1. He will serve as right-hand assistant to Howard Shartle, the head of the company. Mr. White's experience in the talking machine industry covers a period of over seven years, during which he was active in the complaint, repair, record exchange and machine order departments of the Victor Talking Machine Co. at Camden. He served for two years in the infantry during the great war and participated in much active overseas fighting.



B. F. White

Mr. White has made many friends in the Ohio territory and members of the trade wish him the best of success with the Cleveland Talking Machine Co.

DEMAND FOR LUCKY 13 LINE

D. Bartelstone, head of the Lucky 13 Phonograph Co., New York, recently stated that the demands his firm has been receiving for diamond, sapphire and steel needles had not diminished in recent weeks. The call for jewel needles has been especially heavy, and it is expected to be almost continuous throughout the balance of the year.

The Lucky 13 Phonograph Co. has arranged a new system of sending out quotations on their various lines. These are sent out in the form of a series of circulars each month.

FOUR SPECIALS ON **Oké** Records

Order Now—Immediate Delivery—The Most Popular Hits of the Day

- 4118 { IN SWEET SEPTEMBER—Fox-Trot, Ray Miller's Black & White Melody Boys
- 4119 { MY SAHARA ROSE—Fox-Trot..... Harry Raderman's Jazz Orchestra
- 4119 { ROSE OF SPAIN—Fox-Trot.... Ray Miller's Black & White Melody Boys
- 4120 { KISMET—Fox-Trot..... Green Brothers' Novelty Band
- 4120 { TELL ME, PRETTY MAIDEN—Fox-Trot..... Rega Dance Orchestra
- 4121 { POLLY—One-Step..... Joseph Knecht's Waldorf-Astoria Dance Orchestra
- 4121 { LE WANNA—Fox-Trot..... Green Brothers' Novelty Band
- 4121 { JEAN—Fox-Trot..... Harry Raderman's Jazz Orchestra

Phone Barclay 2493

ZIEGLER, BAKER & JOHNSON

Service In or Out of Town

100 Chambers Street, New York City

CHARMAPHONE

"DISTINGUISHED BY ITS TONE"

QUALITY
AT
POPULAR PRICES

Well made, attractive styles, with quality Mahogany Finish—equipped with smooth running Heineman double spring motors.

Our Dealer arrangement is a proposition you should investigate—NOW.

Make Charmaphone Phonographs your leaders and cash in on the quick profits from these sales features.



CHARMAPHONE MODEL No. 4
"THE *Universal* PHONOGRAPH"

Height 42 inches
Width 18 inches
Depth 23 inches

RETAIL PRICE \$75.00



CHARMAPHONE MODEL No. 3

Height 12 inches
Width 18 inches
Depth 20 inches

RETAIL PRICE \$45.00

LIBERAL DISCOUNT TO DEALERS

→ Write For Our New Catalog Illustrating Our 1920 Line ←

CHARMAPHONE COMPANY

39 West 32nd Street, New York City

Factory: Pulaski, N. Y.

Samples of Our Long-Playing Two-in-One Records

Profiteering Blues
SUNG BY BILLY MURRAY
Tiddle-dee-Winks
SUNG BY BILLY MURRAY
Was There Ever a Pal Like You?
SUNG BY MEL EASTMAN
Nobody Knows
SUNG BY MEL EASTMAN
All four songs complete on the back and front of one record, No. H2007, \$1.00.

Silver Threads Among the Gold
SUNG BY HENRY BURR
In the Gloaming
SUNG BY HENRY BURR
Carry Me Back to Old Virginny
SUNG BY STETSON HUMPHREY
Darling Nellie Gray
SUNG BY STETSON HUMPHREY
All four songs complete on the back and front of one record, No. H2008, \$1.00.

Up the Street March
MILITARY BAND
Cruiser Harvard March
MILITARY BAND
Second Regiment March
MILITARY BAND
Boston Commandery March
MILITARY BAND
All four marches complete on the back and front of one record, No. H4003, \$1.00.

Washington Post March
MILITARY BAND
Liberty Bell March
MILITARY BAND
Manhattan Beach March
MILITARY BAND
King Cotton March
MILITARY BAND
All four marches complete on the back and front of one record, No. H4004, \$1.00.

Grey Gull Records, Two-in-One Style, play from 4½ to 5½ minutes, and usually have four complete pieces on each record. Yet they cost no more than the ordinary record. If there's any surer way to increase your record business than by giving a twice bigger money's worth than has ever been given before, we have yet to learn of it. The business you build in Grey Gull Records, Two-in-One Style, is *all your own*. There is no other record anything like it to be obtained elsewhere.

We will gladly send you samples, at 70 cents each, parcel post prepaid. Use coupon below.



INCORPORATED

295 HUNTINGTON AVE., BOSTON

FILL OUT THIS COUPON AND MAIL

GREY GULL RECORDS, 295 Huntington Ave., Boston, Mass.

Please send prepaid, to address below, an easy-selling assortment of.....Grey Gull Records, at 70 cents each, for which remittance is enclosed. Privilege of returning these records within ten days, at your expense, and obtaining a refund of the remittance is reserved. Also send your two leaflets, "Distributor Proposition" and "Dealer Proposition," and catalog of your records.

Name _____

Address _____

Featuring the MUSICAL POSSIBILITIES of the TALKING MACHINE

[Editor's Note:—This is the first of a new series of articles by William Braid White, to be devoted to the fundamental problems of sound recording and reproduction, the writer believing that he can open up a new avenue for research and general trade interest. We commend these articles to the consideration of those who are interested in featuring and developing the musical possibilities of the talking machine.]

ASPECTS OF SOUND RECORDING

I—The Echo Difficulty

I think it will be generally acknowledged that the art of recording sound has been brought to very considerable perfection. The progress which has been made has not perhaps been traceable step by step; but one needs only to take a fairly long view to see how much has been accomplished. Consider, for instance, the records of piano-playing which were accepted ten years ago as representing the highest achievements in the art. To-day these records are regarded, and justly so, as obsolete. Similar statements could undoubtedly be made concerning the records of other stringed instruments, whether in solo playing or in large groups.

The human voice, on account of its flexibility and the singer's relatively great freedom of manipulation during the process of recording, is of all musical sources the most satisfactory for the purposes of the recorder. It is nevertheless certain that further progress can and should be made here too and that the art of recording can be pushed still further in this, as in every other, direction.

The great manufacturers of talking-machine records have always displayed a most meritorious readiness to investigate, and if possible make use of, all new ideas looking towards progress in the art of recording sound. They have not been contented to continue along the lines of least resistance, but have steadily branched out in all directions. They will therefore look with sympathy upon an effort to clear up disputed and obscure questions, on the correct solution of which depends, furthermore, the achievement of substantial perfection.

All makers of records, and all who have had practical experience with the actual process of recording, are aware that one of the principal difficulties they have to encounter is connected with what is called "echo." The phenomena of echoes are well known to all. Everybody has heard, or heard of, some famous echo which repeats a cry or a series of words many times over. Echoes are, however, much more frequent than this. Indeed, every room, every enclosed space of any kind, as well as innumerable places all over the great outside, are capable of giving, and do give, rise to echoes of greater or less intensity.

Physically, an echo is the result of an unusually acute and well defined reflection. When a compound sound wave, proceeding from some complex sonorous body, such as a musical instrument in action, impinges upon some surface which throws it back and reverses its direction without breaking it up into its component parts, we have an echo. The sound retains its form more or less perfectly, whilst its direction is reversed. As it were, when we throw a sound at certain surfaces, we find that the latter have power to throw the sound back virtually unchanged. These are examples of perfect reflection.

In point of fact, no enclosed space exists which is completely neutral in respect of the complete reflection which produces an echo. If therefore echoes are to be avoided, means must be taken to prevent reflection. Now reflection of sound waves depends upon physical conditions, mainly upon the angular outline of the enclosed space.

Experiments have been made at various times to determine methods for preventing echoes in large buildings. In general, the results have been

negative, revealing what we ought not to do rather than exactly what we must do, to prevent the reflection of sound in such definite form as to produce echoes. Dr. Sabine of Harvard has shown that when the corners of auditoria are filled out with felt paddings, and salient angles are turned into re-entrant curvilinear angles, a great deal may be accomplished in the way of preventing the definite reversal of direction of sound-waves. Dr. Dayton Miller of Cleveland has experimented in the same direction. In general, it is certain that the formation of echoes can best be prevented by observing the following precautions:

- a. Using non-conducting materials for walls, ceilings and floors.
- b. Avoiding outlines which emphasize angles and pockets in corners.

Now all this is of the first importance for the practical manipulation of sound-records. Everyone who has ever listened critically to piano records knows that, in spite of all the wonderful improvements which have been made, there still persists quite a deal of reverberation, the effect of which is to blur the sustained tones and generally to impart an effect more or less banjoish to the reproduced sounds.

It is my conviction that a good deal of this defective condition could be remedied by more careful attention to the design and construction of the rooms in which the recording is done. It is also more than probable that special attention to the design and construction of the pianos used in accompanying or for solo work would assist likewise. Of this second point it will also be advisable to speak later.

My point, then, is that the principal remaining imperfection in respect to the art of sound recording is to be found in the persistence of reverberations and echoes, which find their way into the record during the process of recording. This happens because the design and construction, both of the musical instruments and of the rooms in which the work is done, lend themselves to distortions, diffusions and mass-reflections of sound. It is plain that if the causes can be eliminated, the effects will be eliminated likewise.

Here has been brought up a question of very considerable importance and one moreover

which has not received in the past the attention due to it. With the permission of the readers of The Talking Machine World I shall wish to carry on some investigations through these columns which will, I think, provide some new and practical ideas looking towards the elimination of the principal among the few imperfections which still persist in the art of recording sound.

I have no patent remedies, but it is quite certain that there are no insuperable difficulties. The main thing is to obtain a thorough recognition of the actual physical facts. Once these are recognized, the provision of remedies becomes a matter of relative certainty.

(To be continued)

EDISON TONE-TEST IN PORTLAND

Marie Morrissey Delights Large Audience in Recital at White Temple, Under Management of Reed-French Co.—Harold Lyman Assists

PORTLAND, ORE., July 6.—The Reed-French Co. presented Miss Marie Morrissey, the celebrated contralto singer and Edison artist, in an Edison tone-test concert at the White Temple on June 18. The large audience which filled the auditorium was surprised and delighted at the perfection attained by the New Edison in re-creating the beautiful voice of Miss Morrissey.

The stage setting was particularly attractive and harmonious. A handsome New Edison phonograph, a grand piano and a number of plants and cut flowers, especially roses, made an attractive picture and the beauty of the ensemble was enhanced by the appearance of Miss Morrissey, who was assisted by Harold Lyman, flutist, who gave an interesting lecture in connection with the concert.

It was not always possible to tell when Miss Morrissey was singing and when the New Edison was re-creating. When Mr. Lyman played his flute solos, which were followed by the re-creations, the audience was very much impressed. After Miss Morrissey's contributions to the concert a record of Anna Case's was placed on the phonograph, "Charmant Oisean," a most wonderful reproduction. The New Edison made a big hit and gained many admirers.

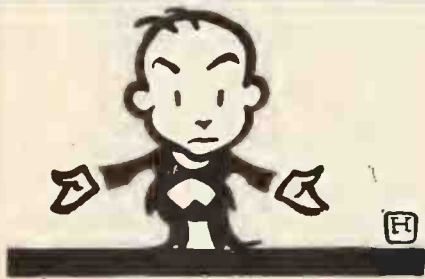

Harding Is Nominated!

That sure was good news for Ohio Republicans. Here's some more good news for certain Ohioans.

Every Ohio Victor Dealer

who would welcome a few moments' diversion once a month can receive a series of delightful short stories by prominent authors merely by placing his name on our mailing list. There are twelve of these little books for you—absolutely without cost or any other obligation except your promise to listen to our story about Lu-Franc Envelopes—a monthly proposition, too. We use the books to advertise our envelopes; you should use the envelopes to advertise **your business.**

To Victor Dealers In Every State

This offer is extended, but act today, the edition is limited. Fill in this coupon and attach to your letterhead.

Please send me that series of short stories by prominent authors, it being understood I am put to no expense whatsoever.

MY NAME IS..... MY FIRM IS.....

OUR ADDRESS.....

I shall be pleased to learn the details of your Lu-Franc Monthly envelope service.

LU-FRANC SALES SERVICE

1201 DIME BANK BUILDING

DETROIT, MICHIGAN

The Emerson

ANNOUNCING

The New Emerson Phonograph

WITH THE BUILT-IN, SOLID-SPRUCE ROUND EMERSON MUSIC MASTER HORN

A NEW phonograph built according to a scientific principle never before utilized in phonograph construction.

Almost too good to be true, isn't it?

Yet here it is—the new Emerson Phonograph—with the *Emerson Music Master Horn*.

Authorities on acoustics have proven that sound—*tone*—travels in spiral, circular, *round* waves. That is why the Emerson Music Master Horn is *round*—perfectly *round*.

In the Emerson Music Master Horn sound waves—*tone* waves—are encouraged to make the most of themselves—to come out pure, full, clear, *round*. They enjoy full play every inch of the way.

Why?

Because the Emerson Music Master Horn is *round*. It has no obstructing angles for *tone* waves to strike against—no corners for them to echo in.

This principle is roughly illustrated by the megaphone. Did you ever see a *square* megaphone? Of course not.

The music which flows from the Emerson Music Master Horn is full, clear, pure, *round*—because the horn is perfectly proportioned—perfectly *round*—made of solid, *rounded* spruce, the one wood of all others most resonant and vibrant.

Hear the new Emerson Phonograph. Enjoy the marvelously full, *round* music which flows from the full, *round* Emerson Music Master Horn. Every note in every selection is full and *round*, because there are no corners for the music to echo in—no angles for it to strike against.

The Emerson Phonograph will be introduced to the country at large in the August 21st issue of the *Saturday Evening Post*. Meanwhile send for copy of the new Emerson loose-leaf catalog, showing the various Emerson models. It describes the Emerson Music Master Horn and explains why its full, *round* tone can come only from this full, *round* sound chamber or horn.

Emerson Phonograph Company, Inc.

NEW YORK
206 Fifth Avenue

CHICAGO
7 East Jackson Blvd.

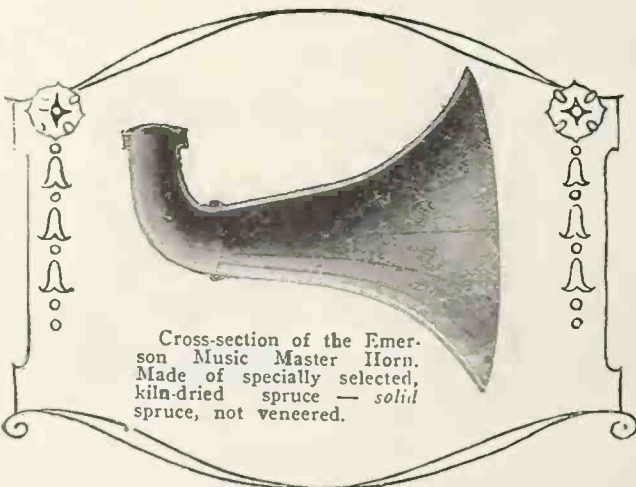

Cross-section of the Emerson Music Master Horn. Made of specially selected, kiln-dried spruce—solid spruce, not veneered.



Phonograph

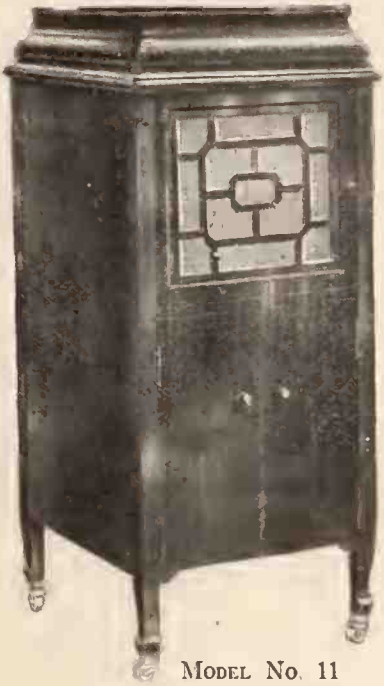

MODEL No. 11



HEPPLEWHITE
MODEL No. 35



MODEL No. 14



SHERATON
MODEL No. 30



QUEEN ANNE
MODEL No. 40



MODEL No. 20



MODEL No. 7



MODEL No. 17

APPOINTED WESTERN MANAGER

William H. Reed, Jr., Takes Charge of Western Offices of Van Veen & Co. in Chicago

An important addition to the already strong organization of Van Veen & Co., Inc., New York City, manufacturers of Van Veen "Bed Set Hearing Rooms" and record filing equipment, is to be found in the announcement that William H. Reed, Jr., has been appointed Western manager in charge of the Western offices of the company. Mr. Reed is well known throughout the trade and particularly in the territory in which he will devote his energies for Van Veen & Co.



W. H. Reed, Jr.

Mr. Reed was formerly president of the Reed Co., of Pittsburgh, the success of which largely was built up through his efforts. Van Veen & Co. have opened new offices at 7 West Madison street, Chicago, where Mr. Reed will make his headquarters. L. Tobias and William H. Reed, Jr., were in Atlantic City during the period of the convention of Victor distributors.

UNIQUE SALES CAMPAIGN

Jemtone Co. Will Give Cash Bonuses to Dealers Based on Sales

OMAHA, NEB., July 8.—The Jemtone Co., of this city, manufacturer of the Jemtone tone improving device for talking machines, has developed an unusual sales campaign, which is attracting the interest of the trade.

According to its plans, the company will distribute \$25,000 in bonuses among 144 retailers of phonograph accessories. The campaign is worked out in such a way that the dealer in a small town has just as much opportunity of earning the first bonus of \$1,000 as the dealer in a city of a million population. Competition is encouraged in this plan, for the keener the competition the greater the dealer's opportunity of earning one of the bonuses.

The 144 bonuses will be distributed in cash: \$1,000 each to the first seven dealers; \$500 each to the next seven dealers; \$250 each to the next five dealers, and \$100 each to 140 dealers.

The company has issued its preliminary announcement regarding this unique plan, and dealers are evincing the keenest interest in the details of the bonus distributing arrangements.

PLACES VERY LARGE ORDER

Emerson Record Sales Co. Orders 20,000 Phonographs—Making Plans for Active Fall Trade

In a chat this week with *The World*, Jos. I. Carroll, manager of sales of the Emerson Phonograph Co., New York, stated that the company's local jobber, the Emerson Record Sales Co., had placed an order for Emerson phonographs totaling 20,000 machines. This progressive jobber states that dealers in metropolitan territory are evincing the keenest interest in the new Emerson phonograph, and that every machine in this tremendous order has been sold before delivery.

The Emerson Record Sales Co. of New York has been paying particular attention to the rendition of practical service and co-operation to Emerson dealers in this territory, and the phenomenal success achieved by this jobber with Emerson records will undoubtedly be enhanced with the introduction of the Emerson phonographs. The local sales organization is keenly enthusiastic regarding this phonograph, and this enthusiasm cannot fail to be reflected in the sales in the metropolitan district.

During the past few weeks the Emerson Phonograph Co. has received large orders from its distributors in all parts of the country calling



At The Height Of Popularity

Dealers selling the Portophone are cleaning up. Why not be one of them? Mail your order at once. Prompt deliveries

There is no question but that the Portophone is the highest quality machine of its kind on the market. Double spring motor. Universal tone arm. Guaranteed. Carrying compartment for 12 Records.

Also a full line of accessories. Prices on request

Esco Music and Accessories Company

OSCAR ZEPERNICK

137 LAWRENCE ST., BROOKLYN, N. Y.

JOSEPH A. KERR

for the immediate delivery of Emerson phonographs. These orders indicate that Emerson dealers are preparing an aggressive campaign in

behalf of this new instrument, and are planning to feature its musical and constructional qualities along high-grade effective lines.

NOT ONE VITAPHONE MOTOR IS FOUND IN THE

thousands of phonographs now lying in storage warehouses because the public is wise to poor talking machines.

All *Vitaphone Motored Phonographs* sell as quickly as built.

Seven years' experience has taught our engineers how to build the Vitaphone right. "Moral": Use the Vitaphone.

Export Distributors

CRAMER EXPORT-IMPORT CORP.

143 Liberty Street

New York City, N. Y.

NATIONAL *Vitaphone* CORPORATION
C. B. Repp, Pres. PLAINFIELD, N. J.

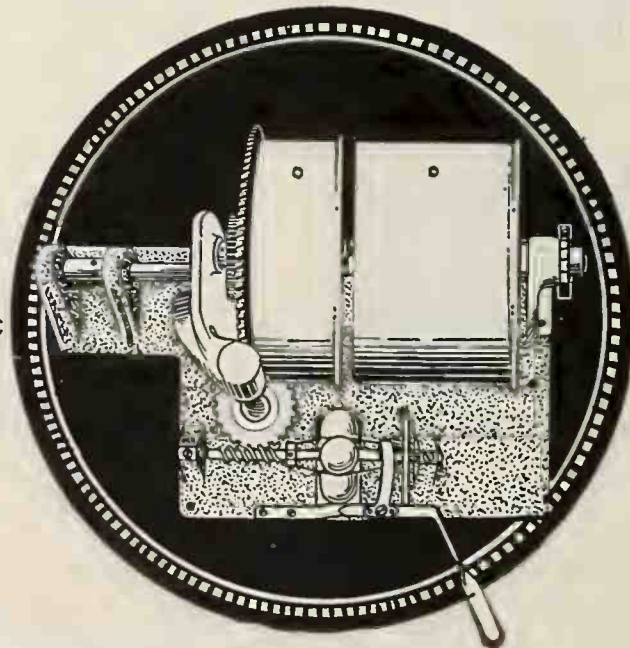

NEW ORLEANS IS BUSY DESPITE INTERRUPTIONS

Getting the Best of Transportation Difficulties
—Many New Dealers Appointed—Caruso Scores in Concert—Desire to Help Shippers—Victrolas Donated in Music Memory Contest—J. D. Moore at Convention—News of Month

NEW ORLEANS, LA., July 7.—With a street car and electric power and light tie-up threatening the city because of a menacing strike, the talking machine business continues as though nothing but warm weather was present to hinder it. All houses report very good business. There are the usual vacations of employees. Transportation difficulties seem to be of less consequence and all retailers and distributors are getting more records and machines than at any time in the last six months. Some are even able to accumulate a little surplus, but they are not bragging, because one or two delayed shipments would wipe it out.

The Edison branch reports it is getting shipments within eleven days and formerly it had to wait as long as sixty days frequently.

Miss C. Bienvenu, of Collins Piano Co.'s talking machine department, left July 3 for the Victor salesmanship class at Camden, N. J.

New dealers in the Edison line who signed contracts last month are: Lumberton Drug Co., Lumberton, Miss., and the Walker-Clover Drug Co., Biloxi, Miss. L. T. Donnelley and A. Schreiber, manager and assistant manager of the Edison branch, expect to be in Chicago to attend the Edison caravan convention July 12 and 13.

A. B. Creal, manager of the Columbia branch, left New Orleans June 28 for New York to attend a conference at the main office. He was accompanied by E. L. Estes and W. W. Twigg, salesmen, who went on to Bridgeport, Conn., to visit the Columbia factories. Robert Moran, of the Baton Rouge, La., Music Co., and L. C. Wicks, of the Hammond Way Furniture Co., Hammond, La., were visitors at the Columbia branch during the month.

New Columbia dealers in the New Orleans territory are: Folse & Wade, Oak Ridge, La.; Grantham Bros., Gatsville, Miss.; Palace Store, Ruston, La.; Jennings Furniture Co., Jennings, La.; Cannon Drug Co., Magee, Miss.; L. H. Conard Furniture Co., Demopolis, Ala., and Fish Drug Co., Monticello, Ark. They will receive their premier orders the first of the month.

The Maison Blanche department store reports it is selling more period designs of Brunswicks, Columbias and Victrolas than usual.

The Louisiana Railroad Commission has sent queries to many shippers asking them if the express service in the State has been satisfactory and if not, in what way it has been displeasing. This questioning was done with the idea of making the express companies provide more equipment and labor to handle shipments.

Three Victrolas and a number of records

Phonographs and Show Window Record Stands

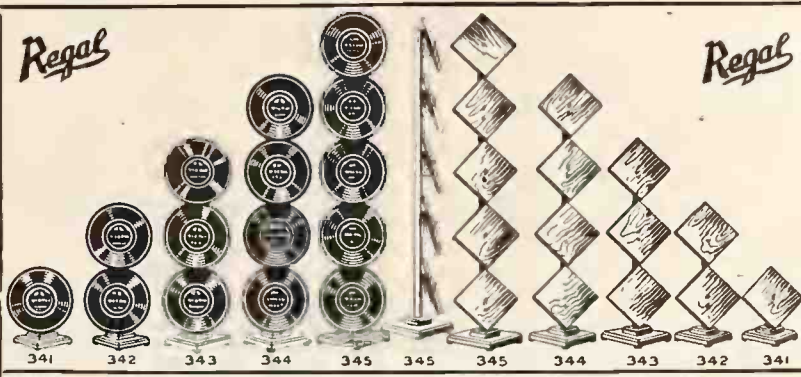

These Show Window Record Stands will increase your sales on records and help you make attractive window displays. Send for Dealers' Price.

THE OSCAR ONKEN CO., 6651 4th Street, Cincinnati, O.

were donated by Philip Werlein, Ltd., Victor distributor in the New Orleans territory, and Dugan Piano Co. and Collins Piano Co. to the winners last month of a public school music memory contest, under the direction of Miss Mary Conway, supervisor of music in the schools.

Caruso, the famous Victor and operatic star, gave a concert to a packed house in New Orleans June 26 and it was unquestionably the great event of the musical season. He was in great voice. The call for Victor records at all the stores before the concert indicated that the public desired to "check up" on the great tenor, and after the concert the purchases were in greater quantity.

B. G. Powell, manager of the talking machine

NEWS FROM THE NATIONAL CAPITAL

Harry C. Grove Celebrates 25th Anniversary of Entrance Into the Trade—New Vocalion Agencies Recorded—Improvements in Stores

WASHINGTON, D. C., July 6.—A great majority of the talking machine dealers in the National Capital expressed themselves as being well satisfied with business conditions in general. Machines and records are coming through from the factories in increasing quantities, and although Washington's population drops off materially in the summer for obvious reasons, the demand is keeping up surprisingly well.

Harry C. Grove celebrated the twenty-fifth anniversary of his entrance into the phonograph business last week. Mr. Grove left the employ of the Washington city post office to work with the Columbia Phonograph Co., located at that time, in Pennsylvania avenue between Ninth and Tenth streets. This quarter of a century spent in dealing with phonograph records has placed him in a position where his opinion carries considerable weight. So, when Mr. Grove says that the best selling records he carries are "Rail-road Blues," a jazz record, and "Baby Mine" and "Mammy Song" sung by Lucy Gates, they must be interesting.

and player roll department of Maison-Blanche, recently underwent a serious operation.

A school Victrola has been furnished Loyal University Summer school by Werlein's.

Edgar Newman, of Maison-Blanche, the member of the firm who takes quite an interest in the talking machine department, left June 24 for three months' rest in White Mountains, N. H.

Mr. Castleman, of the Victor Co., was a recent visitor in New Orleans.

J. D. Moore, manager of the wholesale Victor department of Philip Werlein, Ltd., attended the Victor jobbers' convention in Atlantic City. He was to return via Toledo, O., his former home. Parham Werlein, president of the firm, spent one or two days at the convention, also, but returned sooner than Mr. Moore.

Charles A. Watson, general sales manager of the wholesale department of the Vocalion branch of De Moll & Co., has just returned from a trip to the South. Agencies for the Vocalion have been placed with W. P. Moore, Bishopville, S. C.; the Callaway Department Store, La Grange, Ga.; F. E. Morgan, Richland, Ga.; and with Dr. D. P. Bushong, of Washington, D. C.

Mr. Watson will attend the convention of Aeolian-Vocalion traveling salesmen to be held in New York City the week of July 12.

Ansell, Bishop & Turner, Inc., are being complimented upon the rearrangement of their store, which has just been completed. The front room, previously occupied as a salesroom for Victrolas, now contains the counters for the sale of records. The cashier has been placed nearer the door. Victrolas are now displayed on the mezzanine floor.

They have placed electric fans in each of their twenty-five phonograph booths. All of the instruments in the booths are now equipped with the Motrola, which obviates the necessity of constant winding of the motors.

McHugh & Lawson, agents for the Pathé phonograph, report that business in records has shown vast improvement during the past two weeks.

FOR VICTOR SERVICE

PHILIP WERLEIN, Ltd.

OF NEW ORLEANS

THE LEADING SOUTHERN WHOLESALERS

**TWIN CITY ASSOCIATION
NOW BEING DEVELOPED**

Meeting in Minneapolis Results in Formation of Tentative Association—To Attend Edison Convention — Beckwith-O'Neill Co.'s New Quarters—Opening of Benson's New Store

MINNEAPOLIS and ST. PAUL, MINN., July 7.—Preliminary action toward the formation of a Twin City association of retail talking machine dealers was taken at a gathering of Columbia dealers held June 29 at the Northwestern headquarters of the Columbia Graphophone Co., 18 North Third street, Minneapolis. There were some twenty-five dealers present and they were called together to discuss the advisability of adopting a rule providing for the collection of interests on deferred payments on goods sold on instalment plans. It soon developed that any rule might soon become ineffective unless supported by some authority and the only available authority, it was apparent, could only be vested in an association of the dealers themselves. All present promptly agreed to become members of an association and to abide by its rules. A committee, consisting of Robert O. Foster and P. Benson, Minneapolis; Stewart McLeod, of the Emporium and W. J. Simpson, Peyer Music Co., St. Paul, were delegated to enlist all the talking machine dealers in the movement. The present understanding is that membership will be limited to dealers in talking machines and phonographs.

Nearly a hundred Northwestern dealers will attend the great Edison convention in Chicago July 12-13. They will assemble in Minneapolis and will leave July 11 in special Pullmans on the famous Pioneer Limited. The Minnesota Phonograph Co. will take with it as special guest the saleslady making the best record for thirty days ending July 9.

Edison business in the Northwest is reported as highly satisfactory by Laurence H. Lucker, the jobber and general distributor. Wholesale orders are good, retail sales are good, collections are good and the prospects are good, and that's about all the goodies a commercial house reasonably can demand.

Within thirty days the wonderful Victor headquarters in Minneapolis of the Beckwith-O'Neill Co., 16-18 South Sixth street, will be shipshape and it will be a sight worth seeing to talking machine men. The decorative effects and color tints are dainty and delicate enough for a ladies' boudoir and the vista of the office

with surrounding booths is about as different from the general impression of a jobbing house as could well be devised. Victor dealers in the Northwest are leading a more complacent life than was vouchsafed them in 1919 and while normal conditions hardly prevail they have not nearly so many things to annoy and disconcert them as formerly.

One of the interesting events of the past week was the formal opening of the P. Benson Music Co.'s enlarged store. Several hundred patrons and friends visited the place and showered the beaming proprietor with compliments for his fine establishment. John J. Roden, Victor manager for the Dayton Co., on his return from the Victor school gave it unstinted praise, because of the highly useful and practical nature of the course of instruction. F. M. Hoyt, of the Beckwith-O'Neill Co., who accompanied Mr. Roden, remained in the East to take part in the Atlantic City convention.

Gladys Hutchins, Victor manager for Davis

& Rubin, has returned from a rather prolonged visit with her family in Oregon.

Victor business with the Powers Mercantile Co. is excellent. Manager Culp states that every month of 1920 shows a steady increase over the totals for the corresponding months of 1919.

There's not a kick in the entire Northwestern establishment of the Columbia Co., declares Manager W. L. Sprague. The travelers are sending in goodly orders and fine crop reports. The stock of instruments and records is the largest in the history of the house and there is every indication of a continuance of fine business from now until after the holidays.

Considerable advertising is being done in the Twin City dailies by the Vitanola Talking Machine Co. from the executive offices in Chicago. There are eight Vitanola dealers in Minneapolis and three in St. Paul.

George A. Mairs, head of the Victrola department, W. J. Dyer & Bro., after attending the convention in Atlantic City, has scheduled to have a long, earnest and heartfelt talk with the moguls of the Victor Co. anent large and frequent shipments of Victrolas and records. W. J. Dyer & Bro. could do a monster Victor business if they could get all the goods needed.

H. J. SMITH LABORATORIES

Jewel Manufacturer

EXECUTIVE OFFICES,
FINISHING and
RECORDING
LABORATORY JEWELS

Plant No. 1
833 Broad Street
Telephone 2896 Market
NEWARK, N. J.

SAWING
GRINDING
ROUGHING
ROLLING and
EXPERIMENTAL
LABORATORY

Plant No. 2
54 1/2 Franklin St.
NEWARK, N. J.

Manufacturer of

Phonograph Diamond and Sapphire Reproducing Points—Recording Laboratory Jewels—Rough Diamond—Diamond Powder—Experimental Work. Jewels manufactured for all talking machine records. Consulting Specialist on all experiments relating to any new recording grooves. Recording problems satisfactorily worked out.

YAZOO RIVER RED GUM

Specials for prompt shipment:

- 5 carloads 2" 1st and 2nds Plain Red Gum.
- 5 carloads 2" No. 1 Common Plain Red Gum.
- 5 carloads 2" 1st and 2nd Qrtd. Red Gum.
- 5 carloads 2" No. 1 Common Qrtd. Red Gum.
- 10 carloads 2 1/2" No. 1 Common and Better plain and Qrtd. Red Gum.
- 8 carloads 3" No. 1 Common and Better plain & Qrtd. Red Gum
- 8 carloads 1 1/4" No. 1 Common Plain Red Gum.
- 2 carloads 3/4" 1st and 2nd Qrtd. Red Gum.
- 5 carloads 1 1/4" No. 1 Common Qrtd. Red Gum.
- 3 carloads 1 1/2" No. 1 Common Sap Gum.
- 7 carloads 1" No. 1 Common Qrtd. Red Oak.
- 5 carloads 1" No. 1 Common Qrtd. White Oak.

Our Red Gum is of soft texture and rich, dark color. Specially manufactured and seasoned.

Send us your inquiries for all kinds of cabinet woods.

THOMAS & PROETZ LUMBER CO.

3400 Hall St., St. Louis, Mo.



**SAPPHIRES
IMPORTED**

BALLS	POINTS
20 c. each	20 c. each
16 c. in dozen lots	18 c. in dozen lots
13 c. in hundred lots	15 c. in hundred lots
12 c. in thousand lots	13 1/2 c. in thousand lots

942 MARKET STREET
SAN FRANCISCO, CAL.

*Life starts with the
beating of the heart*

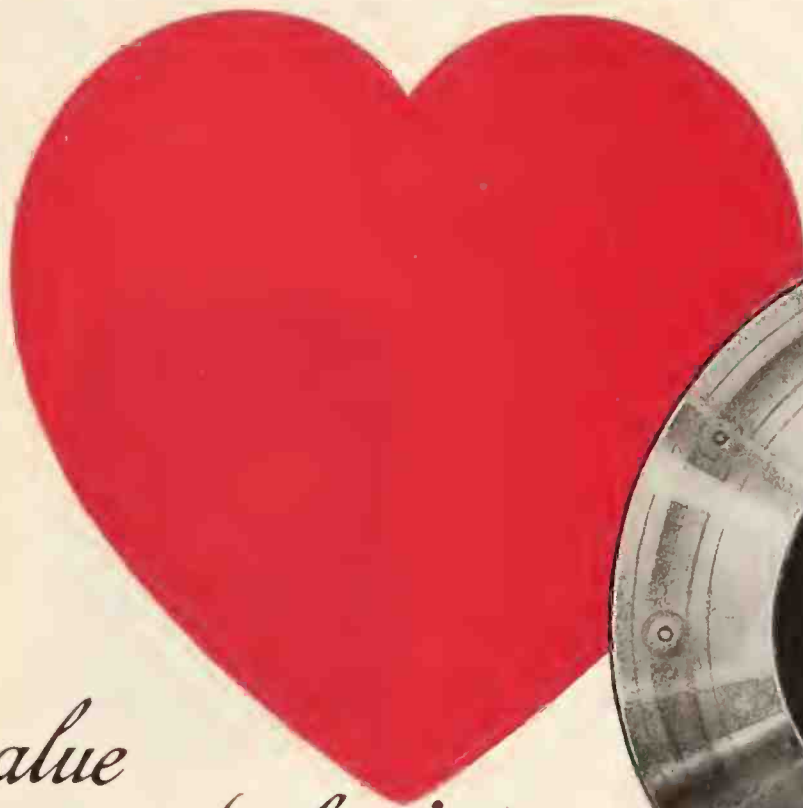

*The
musical value
of a phonograph begins
with the REPRODUCER—
the heart of the machine*

*The
Remington Reproducer*

*THE HEART OF THE
Remington Phonograph*

REMINGTON PHONOGRAPH CORPORATION

Philo. E. Remington
President

1662-64-66 BROADWAY
NEW YORK, U. S. A.

James S. Holmes
Vice-Pres. & Gen. Mgr.

THE GRADUOLA FEATURE OF
THE AEOLIAN-VOCALION
 PERMITS
PERSONAL INTERPRETATION

and gratifies the Creative Musical Instinct which every normal human being possesses to some extent

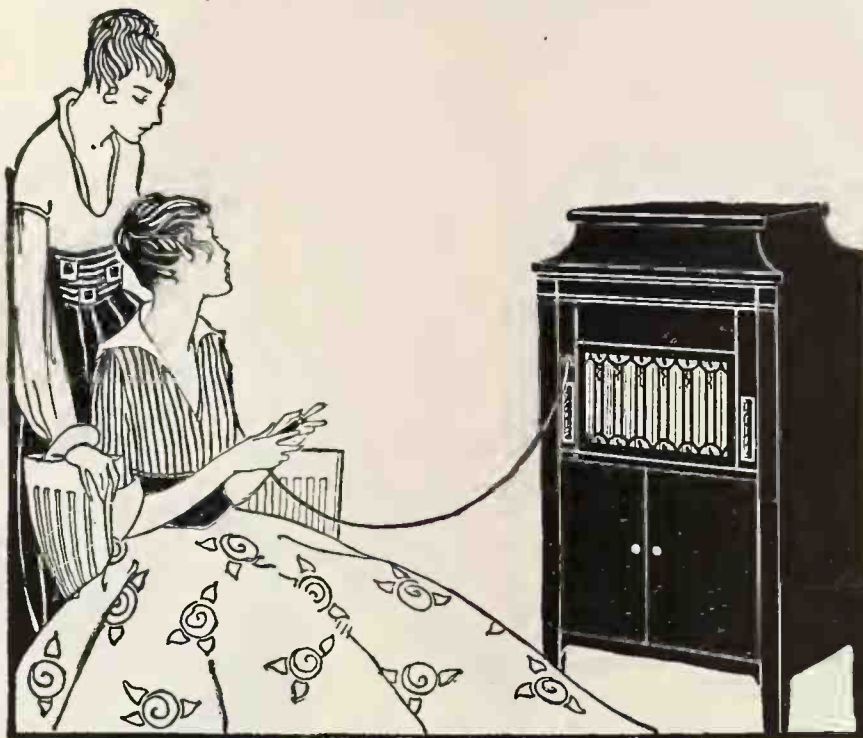

Playing an AEOLIAN-VOCALION with the Graduola

THE GRADUOLA is one of several features which combine to make the Aeolian-Vocalion a distinctive phonograph and which are selling points that a live dealer must recognize.

THE NEW (lateral cut) Vocalion Records are the result of the Aeolian Company's unparalleled corps of scientific and musical engineers.

**THE AEOLIAN-VOCALION AND
 VOCALION RECORDS**

Present today the finest in phonograph manufacture. There is no question of the excellence of these instruments or of the fidelity with which Vocalion Records repeat the singing and playing of the Artists

FOR FURTHER INFORMATION WRITE

STONE PIANO COMPANY

MINNEAPOLIS, MINNESOTA
 STONE BUILDING

FARGO, NORTH DAKOTA
 STONE BUILDING

DISTRIBUTORS FOR

MINNESOTA

NORTH AND SOUTH DAKOTA

MONTANA

WESTERN WISCONSIN AND UPPER MICHIGAN

JOBBER OF THE CELEBRATED MEL-O-DEE ROLLS

VERY LITTLE DROPPING OFF OF BUSINESS IN BUFFALO

General Public in That City Still Remains Free With Money—Goold Bros. Open New Store in Niagara Falls—Many Dealers Remodeling and Improving Quarters—General News

BUFFALO, N. Y., July 5.—Prosperity—an over-worked term during the past few years—is a feature of Buffalo's talking machine trade this Summer. In fact the same condition may be noted in many other lines. Despite the warning given by the Government and the banks that the people should save for "the lean days that are sure to come" the working people continue to spend money with a lavish hand, with no apparent fear of the future. In fact people in nearly all walks of life are following the same course. The Buffalo public simply refuses to become tight-fisted, so that talking machine sales in this city are very satisfactory. Within the past few weeks local workmen have recovered from their vernal restlessness and are showing a great tendency to stay on the job. This steadiness in industrial circles has produced a corresponding evenness in the volume of sales at the city's talking machine shops. Generous contributions to this trade have been given by quite an army of newlyweds. There were so many members of this class here in June that they were described by a local newspaper as "a solid phalanx of bridal couples bound for Hap-pyland."

A large electric sign, bearing the Columbia emblem, has been placed in front of the Koenig Piano Co.'s store. Albert F. Koenig, Jr., twelve years old, is an energetic worker in the record department on Saturdays. He has a taste for good music and has a number of fine sales to his credit.

Buffalo's population has just passed the half million mark, having shown an increase of 19.6 per cent in the past ten years. The talking machine trade has kept pace with this expansion. The list of talking machine dealers has increased considerably since the last census was taken in 1910. The merchants who have stuck to their posts have forged ahead satisfactorily.

Goold Bros. recently opened a new piano and talking machine store at Niagara Falls under the management of Gordon Cattley, in the employ of Robert L. Loud for twelve years. The record section of Goold Bros.' store at Main and Utica streets, Buffalo, is in charge of Arthur Rice, who served Uncle Sam in France. Edward Williams, salesman, is planning a two months' vacation. William Goold, father of Goold Bros., expects to return in August from his journey to England.

Frank Schuler and B. Frank Harrington, manager of the Schuler store, recently returned from a successful fishing trip to a point several miles north of Toronto, Ont.

Miss Margaret Hatten, in charge of the record section of the Hoffman Piano Co., is booming business there. Charles F. Hoffman, president, and R. E. Smith, salesman for the firm, are active members of the Claremont Tennis Club.

Improvements are about completed at William Turner's new store at Main and Utica streets.

Mr. Turner has added the Starr talking machines and Gennett records to his stock.

John Schuler, who handles the Sonora, Columbia and Brooks lines, has the following salesmen boosting his sales: Messrs. Marsh, Woods, Nevils, Johnson and Ballou. The latter was recently with the Columbia Co. of Boston. Mr. Marsh, who covers the country, reports unusually good times there.

Charles Hereth, who features the New Edison, has returned from a pleasure and business trip to Toledo, O. Mr. Hereth is living at his Summer home near Bowmansville, where he grows potatoes as a pastime.

Stephen T. Lockwood, federal attorney, has appointed E. J. Hengerer of the William Hengerer Co., Victor dealers, as a member of Buffalo's business men's advisory committee. The members are helping Uncle Sam in an anti-profiteering campaign.

"The freight conditions are very bad," according to a representative of the talking machine trade. Information on the same subject was recently given out at a regular meeting of the transportation committee of the Buffalo Chamber of Commerce. It was stated that an embargo more sweeping than the one placed April 9, when the switchmen tied up the freight terminals, has been put in force by the New York Central.

In spite of these handicaps W. D. and C. N. Andrews recently received a shipment of goods from the Victor factory on record time. The freight car containing this merchandise left Camden, N. J. on a Monday night and arrived in Buffalo at about 5 o'clock on the following Wednesday afternoon. To bring about this service the Buffalo firm had a representative in the East to get the car started and to see that it wasn't delayed for an indefinite period on the way to this city.

F. E. Russell, manager of J. N. Adam & Co.'s talking machine department, reports that the record recitals at that store will be resumed in the fall. He is receiving many inquiries regarding these popular programs. "The Victor and Columbia companies supply us with the best of record service," he said. "Our sales have shown a 100 per cent increase in the past year."

R. C. Hudson, president and general manager of J. N. Adam & Co. for the past seven years, has resigned that position for a very much needed rest. His successor is Alfred J. Jennings.

A complete line of foreign records, the product of the Columbia Co., is featured at the Winegar Co.'s branch store at 935 Broadway.

Mr. and Mrs. C. N. Andrews attended the recent convention of Victor jobbers at Atlantic City.

L. K. Scott, manager of the William Hengerer Co.'s Victrola department, has thoroughly recovered from a recent illness, which confined him to his home for six weeks.

WARNING

WALL KANE STEEL NEEDLES are the standard trade-marked needles of the phonograph industry. Like any article that is a proven success, WALL KANE STEEL NEEDLES are being imitated.

The genuine WALL KANE NEEDLES are manufactured by intricate, chemical processes, and we guarantee them to possess the quality of playing ten records perfectly, the last one as well as the first.

Every WALL KANE NEEDLE is a great improvement of the highest grade steel needles of American manufacture, absolutely uniform in temper, length and taper. You may line up any number of any of the three grades of WALL KANE NEEDLES and you will find the above statement to be correct.

The point of the needle is greatly improved in the WALL KANE. Ordinary steel needles, owing to their fibrous structure, flatten out readily and bring more and more of the grain of the steel in contact with the record grooves. The point of the WALL KANE NEEDLES is treated by various chemical processes, several coatings being placed on it, thereby creating a layer of soft material that will not wear off until at least 3,000 revolutions are made and thus does not permit the grain of the steel to come into contact with the record grooves.

This material placed on the point, is softer than steel and such that it will greatly benefit the record, minimize the scraping sound, prolong the life of the record and play it better.

Any instrument or record will show off best when WALL KANE NEEDLES are used.



BEWARE OF IMITATIONS

This handsome metal enamel display stand holds 60 packages, 2 doz. extra loud, 1 doz. medium, and 2 doz. loud; each package containing 50 WALL KANE NEEDLES, retailing for 15c. Price of Stand to dealers, \$4.60; \$4.90 Far West. Single packages, 7½c; 8c in the Far West.

Attractive display containers, each holding 100 packages of a kind of WALL KANE Needles, cost the dealer \$7.50; \$8.00 in the Far West.

SOME JOBBING TERRITORY STILL OPEN

Progressive Phonographic Supply Co., Inc.

145 West 45th Street, New York

AMERICAN

The American line will bring you success. Nine models made in the popular finishes.

Also Cabinets in quantities.

Write for Catalog.

American Phonograph Co.

17 No. Ionia Ave., Grand Rapids, Mich.



No. 8



No. 11

CINCINNATI STOCKING TO MEET FALL DEMANDS

Interesting Review of Trade Conditions—May Form Association—Phonograph Co.'s New Business Home—Progress of Ohio Talking Machine Co.—Vocalion Expansion—Stock Conditions Being Relieved—News of Month

CINCINNATI, O., July 3.—For the time being there is a lull in the market of the Middle West. This, in a way, is appreciated by the talking machine manufacturers and dealers since it gives both a chance to stock up in anticipation of the business later in the Fall.

That the trade believes this condition will prevail is shown by the attitude of the various houses which are grabbing all material possible and placing it in storage. In some instances the systems of the houses have been rearranged so as to care for a warehouse plan, the merchants evidently having little faith in a genuine restoration of normal shipping conditions for a year or more.

An instance of this is the remodeling work just completed by Wm. R. Graul, Government Square, now handling the Crystola, who has installed four demonstrating booths. It cost a little money, Mr. Graul said, but it will place his business away from the worries of shortage of stock.

A. M. Abbott, of the Abbott Piano Co., Seventh and Elm streets, wants to get in touch with every phonograph merchant in Hamilton county and across the river, with a view of forming an association which is to be allied with the Music Industries of Cincinnati. Mr. Abbott is some dealer in phonographs himself so the merchant of long standing will not be meeting with a novice when he files his membership application. He was recently elected president of the local organization, the object of which is to promote business harmony and permit competitors to have an opportunity of meeting each other occasionally and thereby learning that "they are not such bad fellows after all." "This movement," Mr. Abbott said, "will enable the individual, through an organization, to protect his business interests. No one chap can make as loud a protest as the association." Therefore, brethren, get busy and make yourself known to Mr. Abbott.

Manager Oelman, of The Phonograph Co., dealing in the Edison, spent the Fourth of July in superintending the arrangement of his new business home, on two floors of 214 West Fourth street. That Mr. Oelman expected to make the change three and four months ago is neither here nor there at this time. Labor had some ideas on the subject, not because of the owner or the tenant but wage questions in general. Anyhow, Mr. Oelman's office commenced to make the new move on Thursday and before the month is well advanced he expects to make his following happier than it has been in months by reason of better deliveries. He

PRESERVE PHONOGRAPH RECORDS

WITH A



"TONAR"

TRADE MARK

RECORD BRUSH

Our special treatment not only removes the dust but lubricates the record so as to bring out the most delicate tone qualities

It Not Only Cleans the Records But Preserves the Tone

RETAIL PRICE, FIFTY CENTS

PARKS & PARKS, Inc.

TROY, N. Y.

New York Office, C. E. Peabody & Co., 186 Greenwich St.

expects to take at least two special car loads of merchants to the Edison convention, to take place in Chicago, July 12 and 13.

Manager T. Sigman, of the Victor department of the Rudolph Wurlitzer Co., accompanied by Mrs. Sigman, attended the Victor convention this past week at Atlantic City.

The Ohio Talking Machine Co., now running in fairly good shape, is not quite able to meet the demands of the trade for Victor supplies so the corporation has adopted, for the time being, a policy of equal distribution which is expected to meet with approval from the merchants until shipping conditions are better. A. H. Bates, vice-president, stayed on the job, seeing to the prompt distribution of the July supplement, while W. T. Haddon, president, represented the company at the convention of Victor jobbers.

The Starr Piano Co.'s Cincinnati branch is shy on medium priced materials, due to the Richmond (Ind.) factory being unable to meet the demands of the trade.

Dan Stevens is happy over the manner in which the Vocalion is being placed on the map of the Middle West through the Cincinnati office. Mr. Stevens said:

"Seeing the importance of stocking up now for the Fall business the dealers are beginning to place their Fall orders. The present demands from the dealers have made it necessary to place two additional wholesale Vo-

calion travelers in the territory. There has been quite a number of new dealers added in the territory, one of the most important being the W. C. Moore Co., Columbus. This concern is going into the talking machine business in the proper manner and should do a very good business in the Vocalion way. There is a number of large deals pending at present which are expected to be closed very shortly. The advance in record prices does not seem to materially decrease demands for the records as the dealers are writing in every day with words of praise for the lateral cut record.

"Stock conditions are being relieved somewhat and we are looking for shipments to come through promptly in the near future."

The Baldwin Co., Cincinnati, is still "up in the air" so far as a phonograph line is concerned for the new store adjoining the warehouse on West Fourth street. The addition is virtually complete, but the phonograph is yet to be selected, according to Lucien Wulsin.

W. S. MEFFORD A VISITOR

W. S. Mefford, prominent Pathé dealer of Toledo, Ohio, accompanied by Mrs. Mefford, spent some time in New York during the past month. Mr. and Mrs. Mefford visited Pathé headquarters and reported that their business in Toledo was "wonderful," with a very bright outlook ahead. This enterprising dealer has a record of selling ninety-four Pathés in three days.

Deliveries from Stock of High-Grade Low-Priced Table Machines

THE GREATEST VALUES ON THE MARKET



WONDER No. 15

WONDER No. 15—All metal machine, splendid tone quality, cast iron cabinet and cast iron frame motor. *Universal* tone-arm playing *all* records.

WONDER No. 23—Highly polished mahogany finished cabinet, all cast iron frame, *worm gear* motor. High-grade *Universal* tone-arm.

Priced from \$4.20 up

Write for catalog and dealer's proposition



WONDER No. 23

WONDER TALKING MACHINE CO., Inc., 109 East 12th St., New York

Portrola THE PERFECT PORTABLE PHONOGRAPH

FOR HOME USE FOR OUTINGS

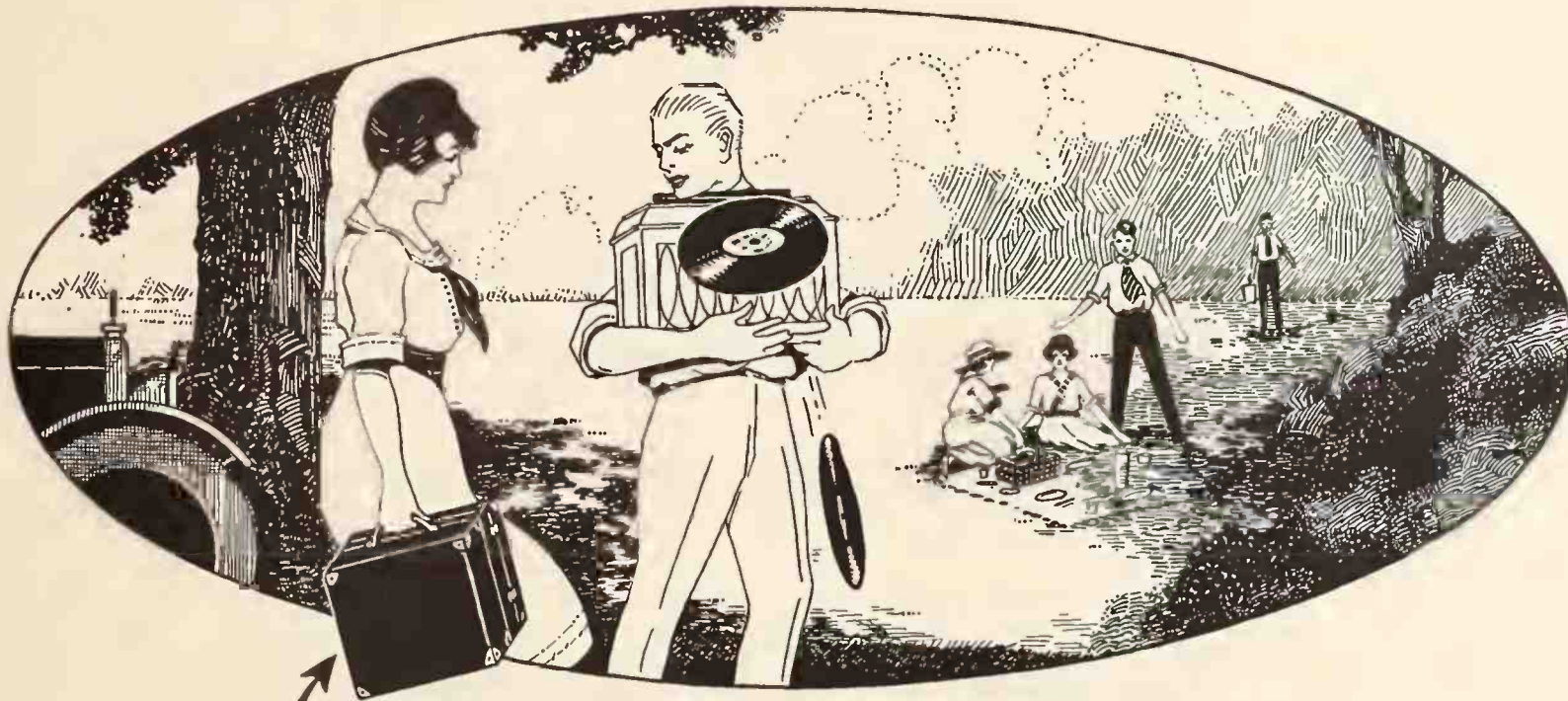

A PORTROLA
"My Records Are Inside"

Plays All Records With Clear Full Tone

Every Machine Guaranteed

Built like an elegant traveling case with LEATHER CORNERS, ROUND LEATHER HANDLE, SILK GRILLE, enclosed cast METAL HORN, UNIVERSAL TONE ARM, and NEEDLE REST; CLIP for holding Tone Arm when carried; RECORD COMPARTMENT and NEEDLE-BARREL for carrying needles.

YOUR CUSTOMERS WILL BE PROUD TO OWN THIS BEAUTIFUL INSTRUMENT



DISTRIBUTORS:

- Chicago, Ill.....Wade Talking Machine Co., 14-20 N. Michigan Ave.
- Dallas, Tex.....Sonora Distributing Co. of Texas
- Kansas City, Mo.....Tri-State Sales Co., 218 East 10th St.
Richards & Conover Hardware Co., 5th and Wyandotte St.
- Long Beach, Cal.....Barnum's Phonograph Co., 117 E. Seaside Blvd.
- Milwaukee, Wis.....A. G. Kunde, 516 Grand Ave.
- New York City.....Brown, McManus & Co., 51 E. 42nd St.
Cabinet & Accessories Co., 145 E. 34th St.
- Portland, Ore.....The M. J. Wax Co., 203-206 Fenton Bldg.
- St. Louis, Mo.....Associated Furniture Manufacturers, 1209 Washington Ave.
St. Louis Phonograph Sales Co., 620 Chestnut St.
Fairy Phonograph Lamp Co. of Missouri, 5th Floor, Arcade Bldg.

Every Enterprising Dealer Will Fill In Blank Below and Mail to Nearest Distributor At Once

[TEAR OFF HERE]

..... 1920

.....
(Write name of nearest distributor.)

.....
(Address.)

Gentlemen:

Please ship at once by express f. o. b. factory Portrola-I (double spring motor) list price, \$45.00; Portrola II (single spring motor) list price, \$35.00. It being understood that I am to receive the usual dealer's discount.

Edison Amberola Message No. 8

As a man is known by his works, so is an article of merchandise judged by its ability to create and hold public demand.

The Diamond Amberola is such an article.

More than 40 years ago, Thomas A. Edison invented permanent recording of sound. His medium was the cylinder type of Phonograph. This type gave birth to the Phonograph industry.

To-day, the cylinder Phonograph—the Diamond Amberola—is still the acknowledged leader in the medium-priced Phonograph field.

THOMAS A. EDISON, Inc.

AMBEROLA DEPARTMENT

ORANGE, N. J.

SOUTHERN CALIFORNIA TRADE STILL FEELS PROSPERITY

Lively Meeting of Music Trades Association in Los Angeles—City Now Largest on Coast—200 Per Cent Business Increase for June Reported—New Dealers Enter the Field

LOS ANGELES, CAL., July 2.—In spite of emphatic forecasts to the contrary, the business for the month of June, 1920, has been universally good throughout Southern California and in some cases among wholesalers and retailers has actually surpassed the previous months of this year. Stocks have been well replenished especially as far as instruments or machines are concerned and although the record situation is still far from the desired 100 per cent—or for that matter 70 per cent—records have been arriving in much larger quantities and numbers received have included many of the old favorites which, conspicuous by their absence for so long, had been almost given up in despair.

Music Trades Association Meets

The regular monthly meeting of the Music Trades Association of Southern California was held on the second Tuesday of the month at Barker Bros. General Manager Boothe of the music department of this firm arranged for the meeting to be held in the Senate Chamber of Barker Bros., where, as it is well known, industrial democratic systems prevail. There was a large attendance and many important matters were discussed. There was also a motion made with regard to closing of stores at 1 P. M. on Saturdays throughout July and August. Since the meeting was held, the leading music stores of Los Angeles have decided to adopt this plan.

Remarkable Increase for June

The phonograph department of the Platt Music Co. showed an increase of nearly 200 per cent over the corresponding period of 1919. Department Manager Walter Evans states that this is, of course, partly due to the remodeling of the department which took place some months ago, but he attached great importance to the tremendous efforts which the sales force have put forth during the last few weeks, actu-

ated by loyalty to President B. Platt as much as by the common desire to "Go over the top." The Blue Bird phonograph has been especially featured together with Emerson records. The former is a home product and the latter will soon have a branch factory in Los Angeles.

West Seventh Street Extending

Like so many cities, throughout the world we might say, Los Angeles is spreading west. That is to say, particularly via West Seventh street. High class stores continue to establish themselves further and further to the west. Richardson's, Inc., with a huge Victor dog at the doorway, bearing the legend hanging from its collar, "My only home on West Seventh," is enjoying good and increasing business. Mrs. W. Hollenbeck, who is well known in talking machine circles, is now in charge of the record department.

Huge Increase in Population

The United States census returns show that Los Angeles is now the largest city in the United States west of St. Louis. The official figures are 575,840, an increase of 80 per cent since 1910. Los Angeles has for a long time believed that a census of her talking machines and records in homes and on the floors of the music stores would place her also far in the lead and she is now more convinced than ever.

New Store on North Main Street

The American Music Co. has opened new quarters at 359 North Main street. The new store, which is more than twice the size of the old one at 367, is very attractively fitted up and decorated. The ten record demonstration rooms are finished in old ivory and are sound proof in construction. Columbia, Edison and Victor are carried.

The Lamphon Co. has recently opened a store at 721 West Seventh street, where they are sell-

ing a new and attractive combination phonograph lamp. The general agents are the Hill Co.

Remodeled Phonograph Department

The Barnes Music Co. recently remodeled its store at 231 South Broadway. The talking machine department presents an unusually attractive appearance and consists of a number of beautifully furnished sound-proof rooms with long record racks in the rear connecting with each booth.

Attractive Dance in Pasadena

A very swell affair was given by the Hancock Music Co. at the Maryland Hotel and the young people of Pasadena enjoyed the dance given in their honor on this occasion very greatly. A splendid dance orchestra rendered charming music throughout the evening.

Detroit Man Here

G. F. Martin, of Grinnell Bros., Detroit, Victor dealers and distributors, spent a few days recently in Los Angeles, in order to visit his mother, who resides in Los Angeles.

Columbia Branch Congratulated

Local Manager Stidham of the Columbia Co. has received a letter of congratulation from General Manager Hopkins on the June business. An increase of 100 per cent was made over June, 1919, and also over May, 1920.

Aeolian-Vocalion Manager in Los Angeles

Pacific Coast Manager Hull of the Aeolian-Vocalion was a recent visitor in Los Angeles. He has appointed John R. Pickering to assist E. R. Darvill in the Los Angeles territory.

New Record Manager at Bartlett's

W. E. Smith has been appointed manager of the record department under Department Manager V. B. Chatton by General Manager Scarles.

INDEPENDENT CO. INCORPORATES

The Independent Talking Machine Co., New York, has incorporated with a capital of \$1,000,000. The incorporators are R. Kanarek, S. Hechler and C. M. Brouse, 240 Riverside Drive, New York City.

EMPIRE UNIVERSAL TONE ARM and REPRODUCER

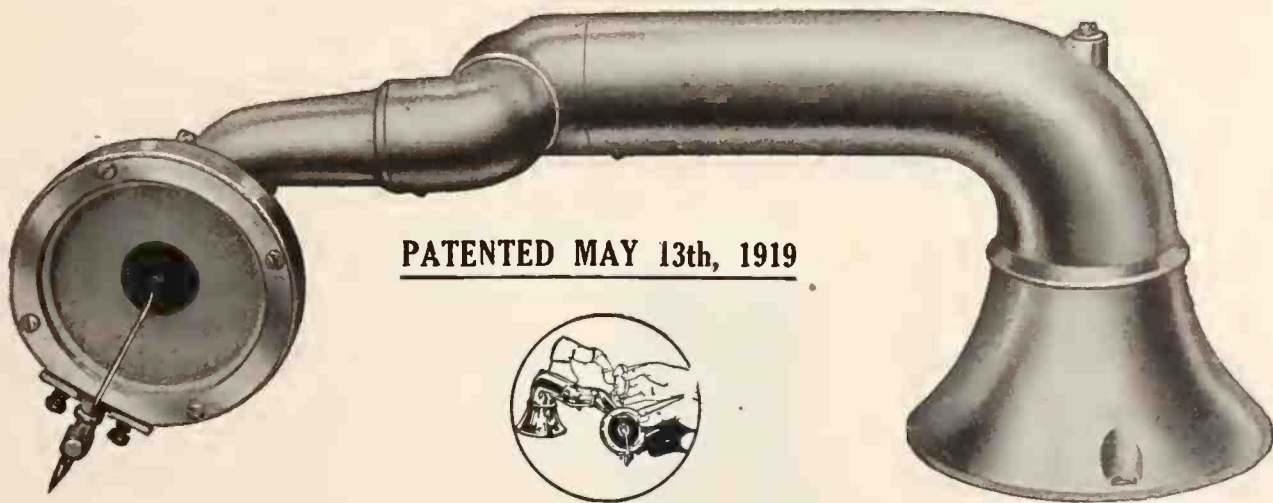

PATENTED MAY 13th, 1919

In designing the phonograph that you manufacture do you realize that the use of high grade sound reproducing-mechanism is a very important item?

Have you ever given the importance of the throw back feature your consideration?

The Empire Tone Arm and Reproducer excels in every important feature—

1st, on appearance alone it will appeal to your dealer customer and will enable him to interest the best kind of trade.

2nd, on performance it will reproduce all makes of disc records at their best and will bring out all the overtones that are usually lost.

3rd, mechanically the Empire Tone Arm is more nearly perfect than any other tone arm.

WRITE FOR OUR PRICES AND GIVE US AN OUTLINE OF YOUR REQUIREMENTS FOR 1920

THE EMPIRE PHONO PARTS COMPANY

ADDRESS ALL INQUIRIES TO CHICAGO OFFICE
Sales Office: 423 S. Wabash Avenue, CHICAGO, ILL.
Factory: 1100 W. 9th Street, Cleveland, Ohio

REVIEW OF CONDITIONS IN MILWAUKEE TRADE

Demand for Records Is Extraordinary—Why Trade Is Not Affected by Price-Cutting Wave—Trade Convention September 1—Kesselman-O'Driscoll Co.'s New Home—Other News

MILWAUKEE, Wis., July 10.—"We are selling everything we can get, but we are not getting everything we could sell if we had it," might well be set down as the composite expression of retail talking machine dealers in Milwaukee and vicinity in answer to inquiries concerning the condition of business. Although the demand for instruments is not quite so feverish as it was earlier in the year, business in records is far more active than at any time since Jan. 1, and with supplies not appreciably increased so far, most dealers are kept in hot water, so to speak, to fill all requirements promptly.

The extraordinary demand for records is a reflection of the remarkably good business in instruments in recent months. These instruments require new "fuel" constantly, which creates unquestionably the most urgent demand for records that has ever been known. On the first day of each month, when the new lists are announced in the press, there is a rush of buyers that quickly depletes stocks and has piled up a relatively enormous volume of unfilled orders.

More Milwaukee people are spending the summer at the numerous inland lakes in Southeastern Wisconsin than ever before, due both to the good financial position of the average family, and the situation in respect to dwelling rentals in the city. The modern summer residence, no matter how lowly or how elaborate, is not regarded as complete until its equipment includes a talking machine. Many of these are being taken from the city residence to the country cottage, but in many other cases new instruments, ranging from the least expensive outing type to the more expensive parlor type, are being purchased.

The supply of instruments is generally short of requirements, according to representative dealers. Reports, however, are somewhat conflicting, some merchants being acutely short of machines while others have better stocks than in several months. On a general average, supplies of instruments are below immediate needs. Usually at mid-summer the dealer trade is giving serious consideration to the accumulation of stocks to fortify themselves against the Fall and holiday rush, but conditions this year are not much better than a year ago in this respect. Unless production should take a spurt, which is deemed hardly probable, the local trade will enter the coming new season with practically no stocks with which to meet demands from October to Christmas.

The nation-wide wave of cut-price merchandising among department stores and dealers in wearing apparel, which is still on, has not affected talking machine business to any appreciable extent, although some dealers have noted a tendency among prospective buyers to do more shopping and be more exacting about prices than for many months past. Price is steadily becoming more and more of a factor in purchasing, due to the greater regard with which the average family respects its resources.

To the everlasting credit of the vast majority of local dealers, it should be recorded that with very few exceptions none joined the department stores and apparel shops in the general offering of discounts. Stocks of talking machines and supplies have not been at the point of surplus at any time in the last two years, while few dealers were so involved with loans that they found it necessary to convert stocks into cash hurriedly. Musical instruments being an all-year staple, and not a seasonable product, the lateness of the season this year did not affect discount merchandising as in dry goods and clothing lines. On the basis of supply and demand, it would be folly for talking machine dealers to cut prices, and it has not been done.

The local trade looks forward to a brisk holi-

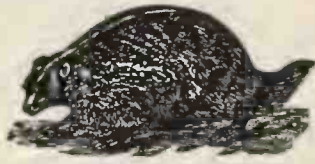

PERSONAL SERVICE

The members of our Company are always available and will gladly see you personally or write you at any time we can possibly serve you.

Why not communicate at once with us?

EXCLUSIVELY WHOLESAL

BADGER TALKING-MACHINE CO. 135 Second Street
MILWAUKEE, WIS.
VICTOR DISTRIBUTORS

day business and judging by the reports from wholesalers and jobbers, retailers are putting in requisitions for all the goods they can possibly get during the remainder of the Summer and next Fall. There has been not the least hesitancy among dealers to continue buying, and all jobbers say that their allotments until the end of the year are practically absorbed as early as the beginning of July.

The Wisconsin Association of Music Industries has decided to hold another big State convention in Milwaukee during the week of the annual State Fair. The date is Wednesday, Sept. 1. The first convention held a year ago was so successful in every respect that State Fair week again was chosen this year. The fair comes two weeks earlier than in 1919, which is regarded as a distinct advantage, for the gathering will be held before the Fall rush sets in and the dealers will find it less difficult to get away from their stores. Richard H. Zinke, president of the R. H. Zinke Music Co., is president of the association and since re-engaging in the retail music business in April is pushing association work with renewed vigor.

The local trade is deeply interested in the first formal step taken late in June toward making music an elective study in the high schools of Milwaukee. This has been a pet project of the local and State dealers' associations for a long time. Obviously, the trade has not put itself in the limelight in this movement, but it has accomplished splendid work in getting the musical societies, teachers, students and others interested in the art to a common point. A petition containing 5,049 signatures was presented to the Board of School Directors at its monthly meeting in June, and is up for action this month.

Charles J. Orth, who retails the Puritan in this city, as well as being wholesale distributor in Wisconsin and Upper Michigan, traces a great many Puritan sales in this city to satisfaction of customers with pianos sold in the course of

nearly a quarter of a century of business here.

Adolph Polstein, who engaged in manufacturing at Marshfield, Wis., a year ago, has organized the business under the name of the Elgentone Phonograph Co. Up to this time the production has been absorbed largely in the central part of Wisconsin, but Mr. Polstein now plans to extend his trade territory.

As in the case of Memorial Day, music stores and other shops in Milwaukee were closed on Monday, July 5, in observance of Independence Day, which fell on Sunday. The extra vacation was much appreciated by the employees.

The Kesselman-O'Driscoll Co., a leading Victor and Edison house in this city, is now comfortably settled in its new three-story building with a forty-foot frontage, at 517-519 Grand avenue. The actual removal from the Plankinton Arcade was effected June 1, but it required nearly a month before all of the improvements could be completed. The formal opening was held during the first week of July. Inside and outside, the store is one of the handsomest and also one of the largest music shops in the Northwest. It is the development of a small Victor shop opened by Louis M. Kesselman and M. J. O'Driscoll on Fond du Lac avenue less than seven years ago. To-day the concern is a \$250,000 corporation operating a general music store but continuing to feature talking machines. The main floor is devoted largely to demonstration and display rooms and record counters.

Hugh M. Holmes, sales manager of the J. B. Bradford Piano Co., Victor and Sonora dealer, and Merle E. Rousselot, secretary-treasurer of the Lyric Music Co., Pathé and Kimball dealer, were members of the Arab Patrol of Tripoli Temple, Nobles of the Mystic Shrine, which won high honors at the forty-sixth annual convention of the order, held at Portland, Ore., June 22, 23 and 24. Mr. Holmes returned by way of San Francisco and Los Angeles, while Mr. Rousselot visited in Portland and Seattle.



FOR every \$5000 Automobile sold there are 500 popular priced cars. Are you confining your efforts to the \$5000 class in the Phonograph business, overlooking entirely the low-priced field? Many are doing this, for the phonograph manufacturers have neglected the low-priced models. The demand for them is tremendous. The "CROSLEY," retailing for \$75, fits right in with any line. Read the specifications and look at the illustration.

The "CROSLEY" Phonograph is a neat and attractive mahogany-finished piece of furniture that will grace and decorate the handsomest home.

It stands 38½" high closed; is 19" deep and 18" wide. Shipping weight, about 80 lbs.

Distributors and Dealers: Write to-day for our proposition. The discounts will surprise you

Crosley Phonograph Co.
1 Vandalia Ave. Cincinnati, Ohio



Copyright, 1920, Talking Machine World Service. The money we pay for a single original drawing is far more than you pay for the entire Service!

We send you 17 or more cuts and ads, large and small, every month—also form letters, window display plans, etc.

STOP!

YOU are in danger of losing the most valuable opportunity in the talking machine trade! The Talking Machine World Service for Retail Dealers is sold to **one dealer only** in each territory. Several hundred territories are already sold. Yours may have been sold to a competitor, it may be sold tomorrow, it may be sold next week.

You will at least want to investigate this remarkable merchandising and sales service. Investigation costs you nothing but a 2 cent stamp. Mail the coupon! Get our sample ads, cuts, form letters, window display plans, merchandising ideas, and explanation of the special ads, letters and ideas we prepare to your order. **MAIL THAT COUPON!**

LOOK!

We have hundreds of comments like these:

"To say that we are pleased is putting it mildly, and we wish to extend you our thanks for helping us out with the additional service sent us."

"Since we are using your Service, customers have been coming in the store and want to know who our new advertising man is."

"The circular letter is a wonder."

Etc., etc., etc.



© T.M.W.S. 1920

LISTEN!

This coupon does not obligate you in any way. You've nothing to lose, everything to gain! **Mail It.**

THE TALKING MACHINE WORLD SERVICE,
373 Fourth Avenue, New York City.

Let me look over your proposition, which you say is making a big profit for other retail merchants. Send samples and price per month for exclusive use in my territory.

Population of my city is.....

I handle these instruments.....

FIRM NAME

By

ADDRESS

Copyright, 1920, Talking Machine World Service

(W-12, 7/15/20)



MOST EFFICIENT SERVICE

The Ohio Talking Machine Co.
Cincinnati Ohio

Lanin's first Columbia Dance Records. "Oh! By Jingo" one-step played by Lanin's Roseland Orchestra. Truly a great dance record. Also "The Rose of Chile" a tango fox-trot by Lanin's Roseland Orchestra, played as only Lanin can direct to bring out jazz and sparkle. Order big. A-2943.



**Columbia Graphophone Co.
NEW YORK**

VICTOR EDUCATIONAL CONFERENCE

Annual Convention of Educational Forces of Victor Co. to Be Held in San Francisco During Week of July 19—Some Noted Speakers

The annual conference of the Educational Department of the Victor Co. is to be held in San Francisco during the week of July 19, under the auspices of Sherman, Clay & Co., Victor distributors. Conferences in previous years have been held at the factory in Camden, but distance has often prevented the attendance of far Western dealers and distributors, so in order to equalize the advantage of these conferences, the Victor Co. has placed this year's session on the Pacific Coast.

The California dealers in particular are welcoming this conference, since the California State authorities will conduct a State-wide educational drive in the Fall. Doctor Margaret S. McNaught, State Commissioner of Elementary Schools, has announced that it is the hope of the authorities to have installed a Victrola in every school in California, no matter how remote the district.

The San Francisco conference will be under the direction of Mrs. Frances E. Clark, assisted by Miss Hallie Owen, Miss Emily Rice, Miss Margaret Streeter and S. Dana Townsend, of the Educational Department.

An elaborate program has been arranged and the services of the following have also been enlisted: Walter G. Garlan, traveling department, Victor Co.; Arthur Chamberlain, editor, Sierra News; Arthur Garbett, formerly editorial department Victor Co.; Miss Caroline Hobson, Stewart Talking Machine Co., Indianapolis, Ind.; Dr. John Landsbury, University of Oregon, and Glenn Woods, supervisor of music, Oakland, Cal.

The wise dealer is now planning out his campaign for Fall trade.

HARDING RECORDS FIRST SPEECH

Republican Nominee for President Chooses Record as Medium Through Which to Spread His First Speech of the Campaign

WASHINGTON, D. C., July 6.—Senator Warren G. Harding, Republican nominee for President, opened his political campaign here last week by having his first address recorded on a talking

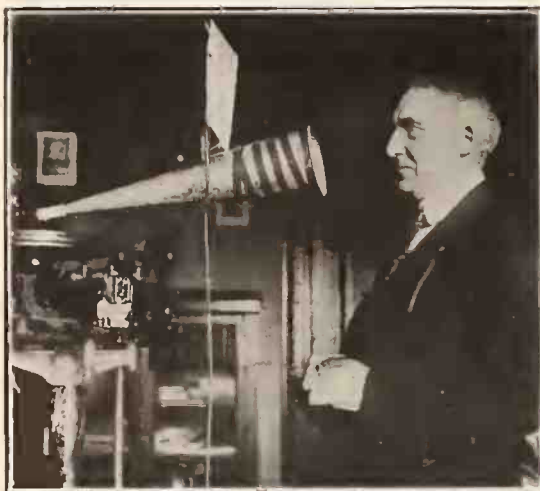

Senator Harding Recording Campaign Speech machine record. As he spoke into the recording horn of the instrument, unheard by anyone except the operator, he outlined his views on Americanization which were heard in all parts of the country on July 4 when the records were distributed by the local Republican committees and local talking machine dealers.

His speech was an impassioned plea for Americanism as opposed to internationalism. He traced the steps by which the American democracy was built up and declared that the present constitution was the real basis of all Americanism. In regard to mingling in the affairs of Europe he said:

"We do not mean to hold aloof, we choose no isolation, we shun no duty. I like to rejoice in

an American conscience and in a big conception of our obligations to liberty, justice and civilization. Aye, and more, I like to think of Columbia's helping hand to new republics which are seeking the blessings portrayed in our example. But I have a confidence in our America that requires no council of foreign powers to point the way of American duty.

"We wish to counsel, co-operate and contribute, but we arrogate to ourselves the keeping of the American continent and every concept of our moral obligation. It is fine to idealize, but it is very practical to make sure our own house is in perfect order before we attempt the miracle of Old World stabilization."

Governor Calvin Coolidge, of Massachusetts, the nominee for Vice-President, also spoke into the recording horn, the topic of his address being "Law and Order." He declared that the industrial goal is equal honor for equal endeavor.

RESERVE BANKS DECIDE CREDIT'S

Federal Reserve Board Will Not Arbitrarily Say What Constitutes Essential Paper

WASHINGTON, D. C., July 6.—The Federal Reserve Board has never undertaken to say what constitutes essential paper, according to a statement just made by W. P. G. Harding, governor of the Board, in a letter made public by the National Canners' Association yesterday. This was in answer to a request for a definition of the position of the Reserve Board toward the character of the paper which the Federal Reserve banks may discount. In view of the general tightness of money at the present time it was claimed that discrimination was being shown by the banks. Gov. Harding declared that it was the opinion of the Board that banks in granting credits should take into consideration the essentialness of the industry and the season of the year. It was taken that the attitude of the Board is that the banks must decide just what these essential industries are.



Progressive Dealers in Southeast get in touch with us immediately for exclusive territory for this money-making machine—the instrument that when "put" stays "put."

H. H. SAPP & CO., Distributors, Macon, Ga.



STOCKS IN GOOD SHAPE IN ST. LOUIS STORES

Trade Has Very Little Complaint to Make Regarding Existing Situation, Although Business Has Dropped Slightly—Columbia Dealers Form Club—More Space for Val's Store—Trade Happenings in General Show Progress

St. Louis, Mo., July 3.—There have been worse months than the past month in the talking machine business in St. Louis but there have also been better months, for the clearly discernible but not alarming decline that set in the month before continued last month. Talking machines, which had continued to sell well long after the selling of pianos became difficult, came at last to be implicated in the general reaction and the degree of its implication has increased during the past month. Records have not suffered as much from the situation as the machines, but sales of these have not been as brisk as formerly. The opening of the Municipal opera season has stimulated the record sales to some extent. There has also been a fair demand for small machines and records for outing purposes. Stocks are in better shape than at any time during the past year. Shipments were badly interfered with for a time owing to the railroad men's strike, but that condition has improved. The prospects are that jobbers and retailers will enter upon the Fall business with adequate stocks of both machines and records.

Val Kusnitz, proprietor of Val's Phonograph Accessory House, has leased additional space adjoining his retail store at Tenth and Pine streets, for his wholesale business, where he carries a complete stock of repair parts, main springs, needles, repeatographs and various accessories for his rapidly growing wholesale trade. He has just added a large stock of sapphire points.

J. J. Buehlman, for eight years office manager of the Aeolian Co.'s St. Louis branch, has joined the Tri-Sales Co. of this city as sales manager, enabling Messrs. Phelps and Mayer, the heads of the business, to spend more time on the road. G. H. Phelps has returned from a trip to the Pacific Coast, where he secured excellent business on the Portophone and also the new "Comedies," the attractive turntable novelty which the company has recently placed on the market. M. J. Mayer has returned from a trip through Canada and to the East and also reports good contracts on both specialties.

When Columbia dealers of St. Louis were on their trip East last month they formed a club with the purpose of having something or other of a social nature each month. The charter members were A. Rummler, E. Geitz, F. Schanzle, D. Gregson, A. Roesch, C. R. Salmon and J. McKenna. Their first something or other was a dinner at Bevo Mill. Other dealers were invited and about thirty dealers and their wives attended. It was a pay-your-own-way affair, as all the something or others are to be. After the eatings they talked shop and exchanged ideas and the dealers had a chance to tell the Columbia organization men their side of the merchandising story. The next one will be a picnic. The details have not been arranged.

H. P. Victor, of the Columbia auditing department, and J. V. Schuyler, of the International Record Department, have been in St. Louis recently. Mr. Victor has been doing a little auditing and Mr. Schuyler has been going over International records with the dealers.

C. R. Salmon, city salesman of the Columbia Co., is putting over a billboard campaign. The idea is to have a billboard company put up painted boards in various localities, the dealer of each locality to pay for his own boards and get all the benefits of them. The paint is to be changed every six months.

Manager Jackson, of the Brunswick Co., announces that it has been settled that the Baldwin Co. is to handle the Brunswick line of talking machines in St. Louis. Some stock has already been delivered to the Baldwin store, although the talking machines are not to be



Operaphone

AUGUST, 1920

POPULAR VOCAL

21171	{	In My Garden of Yesterday (Ash-Ring-Hager). Tenor, Orch. Accomp..Sam Ash
\$1.00	{	Le Wanna (Bernard). Baritone, Orch. Accomp.....Ernest Hare
21172	{	Some Pretty Day (Lewis-Young-Ahlert). Contralto and Tenor Duet, Orch.
\$1.00	{	Accomp.....Helen Burke and Charles Knapp
	{	Shadows (Brennan-Rule). Orch. Accomp.....Peerless Quartet
21173	{	Profiteering Blues (Wilson-Bibe). Tenor, Orch. Accomp.....Billy Murray
\$1.00	{	I Want a Jazzy Kiss (Ring-Hager). Comedians, Orch. Accomp..Collins and Harlan
21174	{	Rose of Washington Square (MacDonald-Hanley. Baritone, Orch. Accomp.,
\$1.00	{	Sidney Phillips
	{	There's a Typical Tipperary (Gerber-Silver). Orch. Accomp.,
	{	Melodious Four Male Quartet
21175	{	I'd Like to Know Why I Fell In Love With You (Timberg). Tenor, Orch.
\$1.00	{	Accomp.Lewis James
	{	Who'll Take the Place of Mary? (Dubin-Gaskill-Mayo). Male Trio,
	{	Orch. Accomp.Orpheus Trio

DANCE

31150	{	Rose of the Orient (Johnston-Arthur). Fox-trot.....Nonpareil Novelty Band
\$1.00	{	Dance-O-Mania (Gilbert-Cooper). Fox-trotNonpareil Novelty Band
31151	{	Abadele (Toddard-Franklin). Fox-trotSam Rosner's Dance Orchestra
\$1.00	{	Vanity (Schanes). Waltz.....Sam Rosner's Dance Orchestra
31152	{	Jade Lady (Webb). One-stepNovelty Dance Orchestra
\$1.00	{	Do You Know? (McNamara-Fitzgibbon). Fox-trot..Sam Rosner's Dance Orchestra
31153	{	Wigwam (Samuels). Fox-trot.....Sam Rosner's Dance Orchestra
\$1.00	{	Manyana (Fier). Fox-trot Sam Rosner's Dance Orchestra

INSTRUMENTAL

51137	{	Hawaiian Twilight (Sherwood-Vandersloot).....Hawaiian Instrumental Duet
\$1.00	{	Some of the Time I'm Lonely (Hatch).....Fred Roland Saxophone Solo

OPERATIC

81101	{	Carmen (Bizet). "Micaela's Air," in French. Soprano, Orch. Accomp.,
\$1.00	{	Helene Buepre
	{	Lakme' (Delibes). "Bell Song." in French. Soprano, Orch. Accomp.,
	{	Helene Buepre

SACRED

71107	{	Flee as a Bird (Dana-Root). Baritone, Orch. Accomp.....Victor Churchill
\$1.00	{	Jesus I Come (Sleeper-Stebbins). Tenor and Baritone Duet, Orch. Accomp.,
	{	Lewis James and Harold Wiley

RECORDS

OPERAPHONE CO. INC., LONG ISLAND CITY, N. Y.

24 NEW TITLES EVERY MONTH

Operaphone Records Play on All Talking
Machines Without Attachments

OPERAPHONE DISTRIBUTORS:

New York City
Philadelphia, Pa.
Pittsburgh, Pa.
Chicago, Ill.
Selma, Alabama
Knoxville, Tenn.

BROWN-McMANUS & CO.,
SUPPLEE-BIDDLE HARDWARE CO.
REED CO., Inc.
OPERAPHONE SALES CO.,
SOUTHERN SUPERTONE CO.,
C. M. McCLUNG

51 East 42nd St.
237 5th Ave.
190 No. State St.

Write for Your Nearest Distributor

OPERAPHONE CO., Inc., Long Island City, N. Y.

pushed until the company gets into its enlarged store and has an equipment of booths. Following the removal of the Artophone Co. from 1113 Olive street, next door to the present Baldwin store, the Baldwin Co. will occupy the vacated building as well as the present one. The first floor is to be made over into one large storeroom with talking machine booths along both walls. The company has heretofore done very little with talking machines, but when the alterations are completed it will push that branch of the business.

Assistant Manager Bennett, of the Brunswick Co., has noticed that there is an increasing demand from the country for art models. All through the South, he says, dealers are reporting inquiries and are expressing a desire to be supplied with these models. In most cases they are uncertain what model is best adapted to their needs and arrangements are being made to provide them with various models for a thirty days' display to enable them to find themselves and determine what they need. In St. Louis the art models are being pushed successfully by the Scruggs, Vandervoort & Barney talking machine department, in charge of Miss Merritt, and the Trorlicht, Duncker & Renard Carpet Co., where Manager Smith, of the Brunswick department, has only recently completed the installation of booths.

Better facilities for display and demonstration of talking machines form the theme of alterations which are going forward at various music stores. In addition to the alterations planned by the Baldwin Co., Manager Fay, of the Connorized Music Co., has just completed remodeling of the additional building occupied by him at Thirteenth and Olive streets, for a display of Starr machines. The Kieselhorst Piano Co. and the Wurlitzer Co. are making extensive alterations, with more space for talking machines as the prime consideration. The Famous & Barr Co. department is being made over and the Stix, Baer & Fuller department is to have adequate space for the first time when the carpenters and decorators finish the work they have begun.

O. M. Kiess, General Field Supervisor of the Pathé Freres Phonograph Co., was in St. Louis recently on a trip to visit the Pathé jobbers everywhere. From here he went to Memphis and New Orleans and was then to go West by the southern route and back by the northern route. He found things flourishing in the Pathé way at the Rice-Stix Dry Goods Co., which jobs the Pathé for most of the Mississippi Valley. Manager Hiner had opened about 150 new accounts since the first of the year. The company is jobbing both from its St. Louis headquarters and its New Orleans branch. Mr. Kiess reported that the Pathé company was in good shape on machines and improving on records, with the assurance of much greater improvement with the completion of the addition to the plant, which will give a 125,000 a day capacity.

The Tri-State Victor Dealers' Association will have a meeting August 6 at the Century Boat

Club. There will be a business session from 11 A. M. to 12:30 P. M., followed by a buffet luncheon. From 2 to 6 there will be lectures and discussions of methods. At 7:30 there will be a banquet with Mr. Paine, of the Victor organization, as the principal speaker. Then there will be a dance. The arrangements are in the hands of the Executive Board, composed of Val Reis, T. W. Maetten, E. C. Rauth, Charles Lippman and Fred Lehman.

The Koerber-Brenner Co. have just received a shipment of the new edition of the official Victor catalog for schools, known as the "Graded List of Victor Records for Children in Home and School." This book contains much information valuable to record buyers outside the educational circle. For instance quite a detailed description is given to such favorites as "Rondino," "Souvenir," "Minuet in G" and hundreds of others—facts unobtainable elsewhere.

LAWTON SUCCEEDS DENISON

Takes Charge of Columbia Co. in Buffalo—Other Important Changes—New Dealers Appointed—Arranging to Secure New Building

BUFFALO, N. Y., July 3.—The latest addition to the Columbia force in Buffalo is W. H. Lawton, who has succeeded F. A. Denison as branch manager. Mr. Lawton was formerly with the Columbia Co. in Cleveland. He has promoted G. W. Peace, former sales manager, to assistant branch manager. D. A. Little has been appointed general salesmanager of the Columbia's Rochester territory. R. J. Milholland is the new Columbia representative in the Syracuse territory.

"The sale of Columbia dance and other records for June showed an increase of 400 per cent in the Buffalo territory over that of the same month last year," said Mr. Lawton. "Many new accounts, recently added to the list of dealers handled by the Buffalo branch will be published shortly. J. N. Adam & Co. have put in the complete Columbia line, including the

period models. The Laurens Enos Co., the King Furniture Co. and the Koenig Piano Co. had elaborate Columbia window displays tying up with the Miss Columbia feature for the Fourth of July."

Mr. Lawton is arranging to secure, as soon as possible, a new branch location for the Columbia Co. in Buffalo, with approximately 26,000 square feet of floor space. This new branch, when completed, will be equipped with a model retail Columbia Grafonola shop for demonstration purposes only. All the latest wholesale equipment the Columbia Co. is using will also be installed in the new branch.

GROWING FAST IN TERRE HAUTE

The Scott & Hart Stove and Furniture Co., which handles the Edison, Columbia, Pathé, Mandel, Puritan and several other lines of talking machines and phonographs in Terre Haute, Ind., has found its talking machine business growing very rapidly. Only a short time ago the total business did not run over six or eight machines a month, while to-day it is over 200.

"The Campbell"

DIGNITY

In appearance is an element for your consideration and while this illustration can give you a faint conception of the harmonious possibilities of the Campbell product

ONLY PERSONAL CONTACT

can portray the

TONE WONDER

transformations effected by the Vibration Rod feature in the

CAMPBELL

The Phonograph of The Century

Send for Samples
with Prices and
Discounts

Campbell Industries
Executive Offices: 36 S. State St.
Chicago, Ill.





THE AEOLIAN-VOCALION *and* VOCALION RECORDS

MADE BY THE WORLD'S FOREMOST MANUFACTURERS OF MUSICAL INSTRUMENTS

THE AEOLIAN-VOCALION plays all makes of records as they **should** be played.

VOCALION RECORDS (lateral cut) are the finest achievement of the art of recording. Their supreme quality is apparent on all standard phonographs.

With this combination you can take the lead and successfully meet all competition.

*Now is the time to prepare
for Fall business*

*Some good territory is still
open for dealers*

THE AEOLIAN COMPANY

CINCINNATI, OHIO

Distributors for

SOUTHEASTERN INDIANA

SOUTHWESTERN OHIO

KENTUCKY and TENNESSEE

EXCELLENT FINANCIAL REPORT

Emerson Phonograph Co. Submits Very Satisfactory Report for Fiscal Year—H. T. Leeming Gives Interesting Resumé of Company's Accomplishments the Past Twelve Months

The Emerson Phonograph Co., New York, has just issued a financial report for the fiscal year ending April 30, 1920, which indicates that this company completed a very successful year. The details of this report are as follows:

ASSETS	
Cash	\$ 210,880.01
Investments	50,825.00
Notes and Accounts Receivable.....	500,179.43
Inventories (consisting of Masters, Matrices, Stock and Equipment).....	516,956.38
Unexpired Insurance and Advance Payments..	21,777.99
Treasury Stock at Par (\$5.00).....	2,605.00
Total Assets	\$1,303,223.81
Patent Rights, etc.....	882,490.19
Good Will	1.00
	\$2,185,715.00
LIABILITIES	
Notes and Accounts Payable.....	\$ 695,588.26
Sundries	45.00
Subscription Account	1,645.00
Accrued Taxes, Interest and Payroll.....	54,157.01
Total Liabilities	\$ 751,435.27
Capital Stock	1,009,400.00
Surplus	424,879.73
	\$2,185,715.00

When issuing this report to the stockholders, H. T. Leeming, vice-president and general manager of the Emerson Phonograph Co., commented as follows: "During the year we have accomplished the evolution from the smaller size phonograph records to the standard ten-inch and twelve-inch sizes. This accomplishment is one that we all have good reason to be proud of, and our president, Victor H. Emerson, and his engineering and technical staff are to be congratulated for the improvement in technique, recording and general reproductive qualities of the Emerson Gold Seal Record. All this, during the year just past, has made

possible the perfection of a system of twenty-five exclusive distributors in the main wholesale centers throughout the country, who have absorbed our entire production of records, and who in addition, by reason of our publicity campaigns, and the ever-increasing popularity of Emerson records, have made it necessary for us to make extensive increases in the manufacturing end of our business.

"New plants of large capacity are now nearing completion in Long Island City, N. Y.; Framingham, Mass., and Ambler, Pa. The building of another plant is just being started in the South, and we are negotiating for still another on the Pacific Coast.

"All of this progress has been made in spite of the extreme difficulty that we, as well as other manufacturers, have experienced with labor, transportation embargoes and the highest cost for raw material that the industry has ever known. We are pleased to report to you that while our raw material costs are now at their highest point, there has been a marked decline in the cost of these materials, and we have commitments which will be delivered within the next few months which will enable us to manufacture Emerson Gold Seal Records on a much more favorable basis. In addition, the ever-increasing production volume of Emerson Gold Seal Records will enable us to make still further reductions in cost by reason of the small overhead per record resulting from a greater volume. The last two months of the current fiscal year show an increase in record shipments at the rate of \$6,000,000 per year.

"For a long time, the officers and directors of this company have given serious consideration to the question of placing on the market a complete line of Emerson phonographs, and to strengthen our competitive situation we decided, some few months ago, not to wait any longer, but to launch the line during the coming Summer. The introduction of the new Emerson phonograph means for our trade the definite assurance of an even greater increase in the sale of Emerson records. This superb new

instrument has many new exclusive features. Samples of the line will be shipped to distributors during the current month, and regular quantity shipments will commence within a few weeks thereafter. For the present year there will be eight models in various woods and finishes, namely: one table model, listing at probably \$70, four standing or self-contained models, listing at from \$135 to \$225, and three period console tables in the popular styles, at still higher prices.

"Our trade has been carefully canvassed and we feel confident that there will be developed a far greater demand for the Emerson line of phonographs than we will be able to meet for many months to come.

"The name 'Emerson' is becoming known nationally in such a way that this company and its products are rapidly forging their way to the front rank with the leaders in the industry."

INCREASES SALES STAFF

Player Tone Talking Machine Co. Appoints C. A. Jacobs, Western Sales Representative

PITTSBURGH, Pa., July 7.—The Player Tone Talking Machine Co., of this city, manufacturers of Player Tone talking machines, has announced the appointment of C. A. Jacobs as sales representative in the Western district. Mr. Jacobs has been associated with the talking machine industry for the past five years, residing in Cleveland, O., where he will make his headquarters. His territory will include the Ohio, Indiana and Kentucky districts.

I. Goldsmith, president of the Player Tone Talking Machine Co., added Mr. Jacobs to the company's sales organization in order that the dealers in this important territory may receive the benefit of his many years' experience in the trade. These dealers will be given efficient service and co-operation in the development of Player Tone business, as Mr. Jacobs is planning to spend practically all of his time in the important trade centers in his district.

ACME

Stands for Highest Quality and Prompt Service

WE MANUFACTURE

ACME MICA DIAPHRAGMS

WE SUPPLY AFRICAN AND INDIA RUBY EXCLUSIVELY

Any Size and Any Thickness and Quantity

LET US HAVE YOUR INQUIRY

ACME MICA COMPANY, Incorporated

Importers and Manufacturers

56 BLEECKER ST.,

Phone, Spring 7197 and 7198

NEW YORK



One little, two little, three little bottles— when Bert Williams gets through, you'll say there's a kick in every bottle—that is in every syllable. Here's real comedy packed away in "Ten Little Bottles." A-2941.

Columbia Graphophone Co. NEW YORK

OTTO HEINEMAN SAILS FOR EUROPE

President of General Phonograph Corp. Will Visit Leading European Countries—Gives Discussion on Current Trade Problems

Otto Heineman, president of the General Phonograph Corp., New York, sailed Saturday, July 3, for a trip abroad, which will include a



Otto Heineman

visit to England, France and Switzerland. According to his present plans, Mr. Heineman will be away about a month, and will return to New York accompanied by Mrs. Heineman, who sailed for Europe a few weeks ago.

Before leaving for Europe, Mr. Heineman spent a few days at the Chicago branch of the company in conference with S. A. Ribolla, general manager of the company's Illinois corporation. After a careful investigation of general conditions in the West, Mr. Heineman returned

to New York convinced that the outlook for the coming year is satisfactory in every respect. He states that while business at the present time is comparatively quiet, there is an under-current of confidence and optimism which will undoubtedly be reflected in sales this Fall.

Mr. Heineman was also greatly encouraged at the reports received from the company's factory executives in different parts of the country. At the present time the company's manufacturing facilities are in excellent shape, and the new Newark works are going ahead even more quickly than was anticipated. This new factory has already started to press Okeh records, and in a very short while will be an important factor in the manufacture of this popular line of records.

This new Newark factory of the General Phonograph Corp. represents one of the finest plants in the talking machine industry. It is equipped with the most modern types of machinery for the production of the company's motors, and the building devoted to record pressing is up-to-date in every detail. Working conditions are ideal, and Otto Heineman, together with the other executives of the company, have received the hearty congratulations of the talking machine manufacturers throughout the country upon the completion of a plant which is typical of this company's progress and success.

DECIDE ON STOCK ARRANGEMENT

At a special meeting of the stockholders of the General Phonograph Corp., held at the company's executive offices on June 25, it was voted to carry on the company's business with a capital of \$4,000,000. There are 30,000 shares of preferred stock at \$100 a share and also 200,000 shares of common stock having no par value.

Record sales show no sign of falling off this Summer, anyhow. It is difficult to supply the demand.

BIG VICTOR SIGN IN INDIANAPOLIS

Taylor Carpet Co. Erects Large Outdoor Sign in Prominent Location in That City

INDIANAPOLIS, IND., July 1.—Realizing the many advantages of outdoor advertising, the Taylor Carpet Co., one of the seven Victor dealers in Indianapolis, has had a large outdoor display board erected at the corner of Washington and



Taylor Co.'s Striking Sign

Illinois streets, in one of the city's leading centers. The shape and size of the new board are the same as those of the score of other Victor boards erected along the principal streets of the city at the suggestion of the Stewart Talking Machine Co., the prominent Victor wholesalers.

Large electric lights are arranged along the top of the board in such a way that the crowds who pass by cannot resist admiring the beauty of the Victrola XVII so artistically painted in colors in the center of the board. At the left of the machine appears the famous Victor caution, "Look Under the Lid. The Genuine Victrola is Labeled." In place of the names of the seven Indianapolis dealers carried on the other Victor boards, the name of Taylor's is flashed to the public.

VOCALION ARTIST IN NEW SHOW

Sam Asche, who sings for Vocalion records, will play the leading male role in the new musical comedy, "Honey Dew," the music of which was written by the famous violinist, Efreim Zimbalist.

SOLOTONE

We are now in a position to serve a few more dealers in Ohio, Illinois and Virginia. We are prepared to render substantial help to new dealers in local advertising campaigns, and through the use of trade acceptances, will aid deserving dealers in making their purchases.

The models illustrated are made with 5 ply 3/4" panels and solid Mahogany trim throughout. They will appeal to the dealer accustomed to the better class of goods.

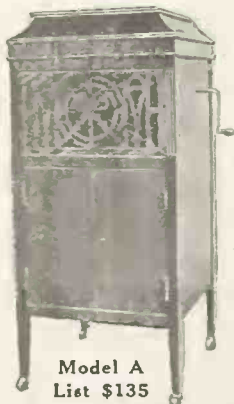

Model A List \$135

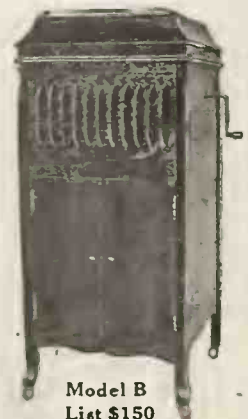

Model B List \$150

Executive Offices: 1727 Chestnut Street Philadelphia, Pa.

Factories: Washington, N. J. Lititz, Pa.

SOLOTONE MANUFACTURING CO., PHILADELPHIA, PA.

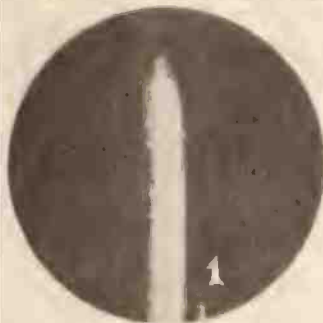

Ten-M-Needle point, after playing many records. The point always fits the groove exactly with no metal to form shoulders.

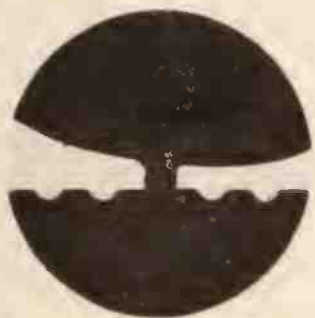

Ten-M-Needle point in record groove, showing that the point fills groove completely but CANNOT form shoulders.



Tapered steel needle after playing four records. Shows how shoulders ride on surface of record. Same needle shown in picture below.

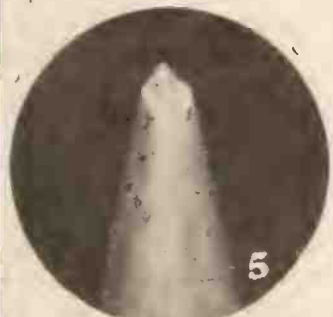

Tapered steel needle, advertised to play 10 times. Photographed after playing 4 records. Poor reproduction and very hard on records.

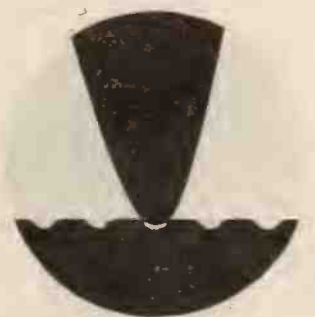

Loud tone tapered steel needle, very blunt. Will not fit groove until most of the record has been played and will then have shoulders worn.

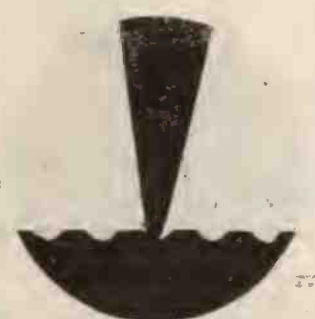

Soft tone tapered steel needle. Does not fill the groove and cannot give perfect reproduction. Wears records very rapidly.

Ten-M-Needle

PLAYS 10,000 RECORDS

Price \$250

FACTS about needle points can only be obtained by the use of the Microscope. *Actual Size*

We show these un-retouched microphotographs, magnified twenty-six diameters, so that you may know the TRUTH about needle points.

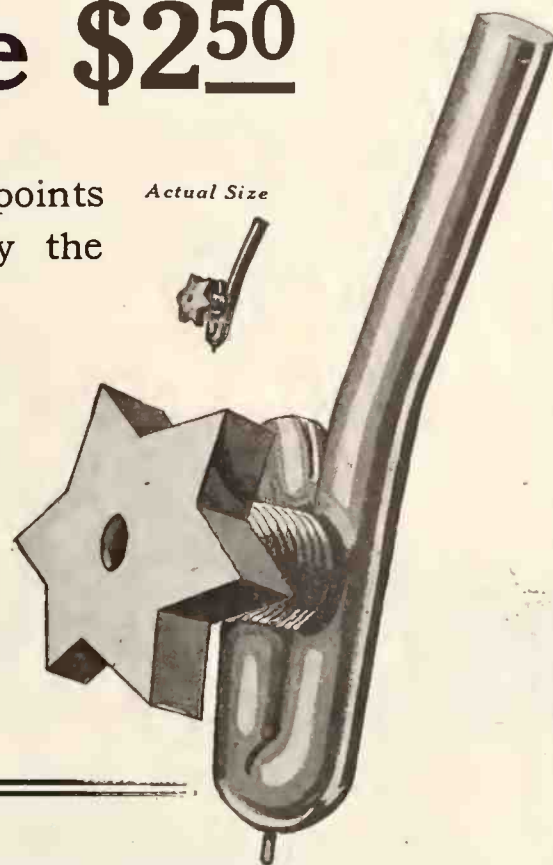

Your customers want GOOD MUSIC and look to YOU for GOOD SERVICE. GOOD SERVICE RETAINS customers and increases your PROFITS.

TEN-M-NEEDLE will give your customers BETTER MUSIC.

Will you give them this BETTER SERVICE NOW?

ORDER TEN-M-NEEDLES TODAY. We will send circulars with microphotographs and attractive wall cards with your order.

Dealers' Discount 40%.

No accounts opened for less than one dozen.

Single needles \$1.50 cash with order or C. O. D.

Every TEN-M-NEEDLE is guaranteed not to blast and to be free from defects in workmanship and material.

Address all communications to

BAKER-SMITH COMPANY

Rialto Building

SAN FRANCISCO

THEY LIVED HAPPILY EVER AFTER

Sailor Wins Bride After Three-day Courtship and Sails With Her for Australia—Romance Began Over Record Counter in Portland Store

PORTLAND, ORE., July 6.—A romance in real life has added a little zest to the regular routine of selling talking machines and records in that department of the Meier & Frank Co. Day after day pretty Juanita Leslie attended to the wants of customers, gaining many friends by her amiability and charming manner. Love and romance were far from the thoughts of the practical young lady, who was deeply interested in her work and rapidly becoming a good business woman. Then one day there breezed into the department a sailor man, a good looking sailor, a captain of a merchant vessel-bound for Australia. He loved music and wanted a good big supply of new records to enliven the long journey to the Antipodes. Miss Leslie demonstrated record after record, he bought them all. He

FRITZ LÜTHY-RÄZ & Co.
SWISS-MANUFACTURERS
 U. S. BRANCH, 299 BROADWAY, NEW YORK

NEEDLES DIAMOND FOR EDISON
 SAPPHIRE " EDISON
 SAPPHIRE " PATHE



came again in the afternoon and bought more records. He talked—he was a very interesting talker—and Miss Leslie listened. He came again the second day, bought more records, was even more entertaining than before. To make a short story very short indeed, at the end of the third day he wooed and won the pretty little Portland girl, married her and sailed away with her

on his good ship to his home in Sydney, Australia, where his father and mother will welcome their son and his charming American bride, who is now the wife of Captain Jay, a man who had no time to waste, knew exactly what he wanted, both in records and a wife.

EMERSON SEEN IN "HITCHY KOO"

Artistic Scene in Raymond Hitchcock's New Show Will Feature Emerson Phonographs and Records—Unusual Stage Setting

An unusual stage scene of significance and value to Emerson dealers will be introduced this season in the first road company of Raymond Hitchcock's new "Hitchy Koo" show. In this show there will be presented a scene featuring an Emerson Shop, in which the chief comedian of the show, Stan Stanley, occupies the center of the stage. Mr. Stanley uses a dialogue wherein he inquires for many songs, and twenty-five Broadway beauties emerge from a life-size Emerson phonograph and sing the refrains of the different songs, all of which are presented on Emerson records.

As Raymond Hitchcock's "Hitchy Koo" is one of the most popular revues of the year, Emerson dealers will have a splendid opportunity to utilize timely publicity in connection with the appearance of the revue in their respective localities. The scene will be handsomely staged and the featuring of Emerson phonographs and Emerson records will enable the dealers to work in co-operation with this idea.

August and September are still ahead and these months hold great possibilities for the dealer who is in the habit of getting what he goes after.

ASTORIA MAHOGANY
LUMBER & VENEERS



Up the Loghaul to the Largest Mahogany Sawmill

Hour after hour the giant mahogany logs from Africa and Central America ride up this great loghaul to the largest mahogany sawmill on the Atlantic and Gulf Seaboard—the last leg of their journey through the largest complete mahogany lumber and veneer organization in the United States.

Astoria Mahogany Company, Inc.
 347 Madison Avenue, New York

Successors to
 Huddleston-Marsh Mahogany Co.
 Astoria Veneer Mills and Dock Co.
 F. W. Kirch, Inc.

Mills and Yards, Long Island City, N. Y.

BRANCHES:
 44 North Market Ave., Grand Rapids, Mich.
 2256 Lumber Street, Chicago, Ill.

"The Music Without the Blur!"

This ideal of talking machine manufacture is attained more nearly than by any other, in the construction of the

MARVELOUS MAGNOLA
 "Built by Tone Specialists"

"Magnola's Tone Deflector eliminates the scratch"



Watching the Music Come Out

We want to show you how to make money with MAGNOLA; and how MAGNOLA is the best buy on the Talking Machine Market to-day.

Send us your name and let us send you some real Talker Tips.

MAGNOLA TALKING MACHINE COMPANY

OTTO SCHULZ, President

General Offices 711 MILWAUKEE AVENUE CHICAGO
 Southern Wholesale Branch 1530 CANDLER BLDG. ATLANTA, GA.

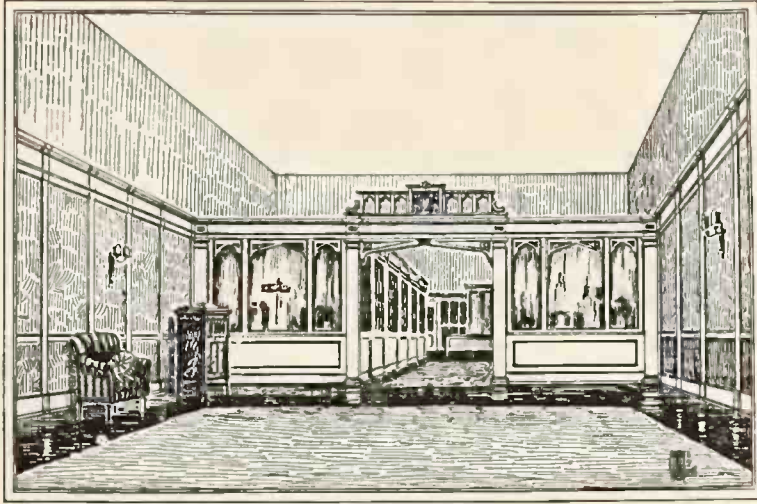

--A TUDOR DESIGN--

VAN VEEN & COMPANY INC.

SERVICE EQUIPMENT

THE HOUSE OF NO DISAPPOINTMENTS

LET us help you plan that new store or rearrange your present one. Let our experts work out your ideas. Our experience will prove beneficial. The service is gratis. Yours for the asking.

"VAN VEEN" Music Store Equipment represents the acme of Interior Woodworking. We are equally proud with the owner of every "VAN VEEN" Installation. The equipment must be right or we would not put our name on it.

No matter whether you contemplate one additional Hearing Room or a Battery of them, or additional Record Racks, or a combination Wrapping Counter and Display Case; write us for prices. Perhaps they cost less than you expect. Bear in mind too, that all "VAN VEEN" equipment is of Sectional Construction. It is easily erected or taken down and rearranged at any time.

"SERVICE AND QUICK SHIPMENT" IS OUR MOTTO

• HEARING ROOMS • RECORD RACKS • COUNTERS •

SALES OFFICE
1711 CHESTNUT STREET
PHILADELPHIA

EXECUTIVE OFFICE
47-49 WEST 34th STREET
NEW YORK CITY

BRANCH OFFICE
ROOM 706-7 WEST MADISON STREET
CHICAGO



Style 87, shown with top moulding which covers open base of Victrola IX. Note the fine "floor type" effect produced.



Style 87, shown with doors open. Note the attractive shelf arrangement.



Style 87, shown with "flat top" and without top moulding, with "old style" Columbia machine. Note the "floor type" effect produced.

LONG
QUALITY
HANOVER, PA., U.S.A.

LONG CABINETS

Quality Leaders in the

CABINET FIELD

In every industry there is a recognized leader, and through years of experience in cabinet manufacturing the Geo. A. Long Cabinet Co. has won unquestioned leadership in the cabinet industry.

The dealer who features LONG Cabinets *knows* that he is offering his trade the finest cabinets that are produced. Every LONG Cabinet embodies perfection of workmanship and design, and the highest grade materials.

The LONG Cabinet Line is complete. Write for a copy of our catalogue.

**The Geo. A. Long
Cabinet Company**
HANOVER, PA.

THE TALKING MACHINE WORLD SERVICE

Robert Gordon's Page

A DEPARTMENT DEVOTED TO PROMOTING RETAIL SALES



Solving the "Hard-to-Solve" Problems

WHAT to do with cut-out records is always a problem. One very clever and successful scheme has been devised by Grinnell Bros., of Detroit, Mich. They have had printed a hanger of the same size as the regular monthly hanger supplied by the Victor Co., which it resembles in general typography, etc. The hanger is very neat in appearance, and at the top is a design followed by the lettering "Records Now In Stock." Below this is a list of popular selections, with number and price, of records of which the retailer has a good stock. Then follows another caption "Red Seal Records." Under this caption is a list of Red Seal records. Under both the popular and Red Seal record class opportunity is provided to list selections which have been cut out or which, from the dealers' standpoint, constitute slow-moving stock. As fast as the supply of a given record on the list is sold out a line is drawn through it.

These hangers are displayed in the booths and on the record counters, and it has been found that the customers ask for the records listed and buy them.

ALIVE subject in the talking machine trade just now is the question of the exclusive dealer versus the dealer who handles several lines. As an example of the letters we receive on this subject, I quote the following:

"Dear Mr. Gordon: I would like to know whether in your opinion the phonograph dealer is most successful who handles one line exclusively, or whether the fellow who stocks two or more makes is the one who shows up the big net profits. I have been trying to decide this matter in my own mind of late—thinking that perhaps we should have a second line here, which would sell at a little lower price.

"It is no doubt true that marked instances of successes can be found among both exclusive dealers and those who handle several lines. But do you think my questions can be answered with a degree of certainty which would warrant a generalization either way?

"If we are passing up good business by confining ourselves to one line I want to know it. But if, on the other hand, by specializing on one line and centering all our sales efforts on that make of phonograph, we can do just as well, I would rather keep to one line. Frankly, I am at present inclined to add a second line.

"What do you think? Your opinion will be valuable.

"Very truly yours, X. Y. Z."

"Dear Sir: In your letter of recent date you ask whether I believe that the talking machine dealer is most successful who handles one line exclusively, or the fellow who stocks two or more makes.

"This query is quite comparable to another one we are frequently asked. I refer to 'Is the Edison zone system of wholesale distribution, the Columbia branch office system of wholesale distribution, or the Victor independent wholesaler with unlimited territory type of distribution the best?' The answer in this case, even as in the case which you have brought up, lies not so much in the method pursued as in the brain and capital effort put behind each plan, as well as, of course, in the quality of the product itself. Great success is possible over any one of these routes.

"At the present time certain of the larger talking machine manufacturers are 'favoring' those dealers who represent their line exclusively. This 'favoring' with its attendant inducements deserves special consideration. You will have to judge the value of these inducements for yourself, but in the retail business I assure you it is quite possible to succeed with an exclusive store, as well as with the store handling several lines. In the third paragraph of your own letter you indicate you fully realize this. All I can add, therefore, is that the success of your business does not necessarily depend on the selection of a plan to pursue.

"The fundamental elements in the success of retail talking machine institutions, aside from the quality and reputation of the instruments handled and the manufacturers' merchandising assistance, are (1) the ability of the manager; (2) the character of the service rendered to the public; (3) the class of good will that is built up; and (4) the skill with which the advertising and inside organization work is accomplished.

"Skeletons are necessary, but skeletons of their own accord never walk very far. The plan is the skeleton. It's up to you to clothe that skeleton and give it life. Whatever plan you choose, remember that intelligent action on your part will bring the biggest return.

"ROBERT GORDON."

THE cost of doing business is always a vital question with every retail merchant. I have had many inquiries on this subject and therefore the following letter with its answer will be of general interest:

"Gentlemen: Replying to your letter, wish to state that I did not get all information desired from your letter or from Mr. Gordon's page, which you enclosed.

"The information that I desire is what would the selling expense of the Grafonola department be figured against the gross sales for a year of a good prosperous business.

"We would also like to know what is considered the best method of working the salesmen of such a department; on a commission or salary basis, the advantages and disadvantages of both. And, if commission basis, what would be a fair commission for both parties.

"J. H."

"Dear Sir: A retail talking machine store doing an annual turnover of \$100,000 will have a gross income of approximately \$40,000. The net book profits on this \$40,000 should amount to \$25,000, providing the business is managed in a highly efficient manner. The cash profits, of course, will run somewhat smaller, due to money being tied up in instalment accounts, purchase of new floor stock, store equipment, etc.

"We believe the commission plan for salesmen is vastly preferable, because it enables the retail merchant to pay in accordance with the business produced, and allows the salesman to earn in accordance with the success he attains. It is mutually fair and, providing you can secure the services of capable salesmen, is certain to prove mutually advantageous from a financial standpoint. The chief objection to the salary plan is that the best type of salesmen will never work on it, because the best type always wants to feel that they are going to get a direct return for every direct result they achieve. The salary plan, moreover, in the selling end of the business, has a tendency to encourage a slacking off of effort from time to time, whereas the commission plan keeps a man on his toes day in and day out.

"The generally accepted rate of commission for outside salesmen is 10 per cent, although for a man to be able to earn a good income on this it is necessary that he have a fairly rich list of prospects. Sometimes it is difficult to get a man to start on commission, because he feels that he must have enough guaranteed to him to pay for the necessities of life until he has had sufficient time to hit his selling stride. In such cases, it sometimes becomes necessary to advance more than commissions earned for a temporary period, but this period should be very limited on account of the danger of getting too many men who will stay with you only during the "banking" period. The right kind of salesman won't take too long to start sales rolling in, and he will be able to pay off any temporary advancement in short order. The wrong type never will.

"A very important part of getting a good sales organization on the commission plan lies in making the original arrangement with the individual men. It is very important to run over the subject very carefully with each new man you add to your force, in order that he may become fully cognizant of the reason why the commission plan offers the greatest opportunity to him in the long run, and also is the most mutually fair. If a man with whom you are making new arrangements gathers from the interview that you are interested in seeing him treated fairly and that, at the same time, you fully believe he does not want to treat you in any but the fairest manner, an element of confidence will enter that is certain to prove an asset to the morale of your sales organization later.

"Keep on writing us any time you want our opinion about anything connected with the talking machine business, and rest assured we will do our best to give you our utmost consideration.

"ROBERT GORDON."

EDITOR'S NOTE—Mr. Gordon, who writes this monthly page, is also director of "The Talking Machine World Service." Mr. Gordon will publish on this page any good ideas submitted by you for the benefit of the trade, and also answer any questions you ask him concerning merchandising problems. Use this department as much as you like. It is intended to serve you.

Its Musical Quality builds larger sales



There are only the same old words, "exquisite" and "wonderful," to describe the tonal qualities of the Dalion; but with the Dalion these overworked words retain their full meaning. The Dalion dealer never worries about a wandering prospect being sold some other phonograph, because of that phonograph's superiority as a musical instrument. The Dalion has a soft, mellow tone-grace all its own.

Its Many Refinements build larger sales



No freakish lines mar the harmonious, well-balanced beauty of Dalion cabinets. Skilled design, honest workmanship, and flawless finishes produce cabinets of irresistible appeal.

The Dalion plays all records and is equipped with every attachment that can add to the purchaser's satisfaction.

Its Exclusive Feature builds larger sales

With the average instrument, the biggest problem the salesman faces, is *one big exclusive feature to put the sale across*—to convince the undecided prospect.

No other instrument is equipped with the "Auto File"—the compact, large-capacity record filing device, whose "automatic brain" solves every inconvenience of record handling—and prevents the misfiling of records by refusing to give up a second record until the used record is put back in its proper compartment.

Every Dalion dealer knows what this feature means to him.

Its Sweeping Guarantee builds larger sales

Accompanying every Dalion is the broadest, most sweeping guarantee ever placed back of a phonograph. Not only is the instrument warranted unreservedly, but the owner is further protected from repair cost for one year on all main spring breakage.

Show this guarantee to a prospect—the manufacturer's sincerity in backing the Dalion quality increases the instrument's desirability.

Its National Advertising builds larger sales

We are not waiting for phonograph buyers to learn these things for themselves. More than five million of the best class of American families are being taught the Dalion's superiority in a broad, strongly individual, advertising campaign. Its force starts the new dealer with interested prospects the day he displays the Dalion.

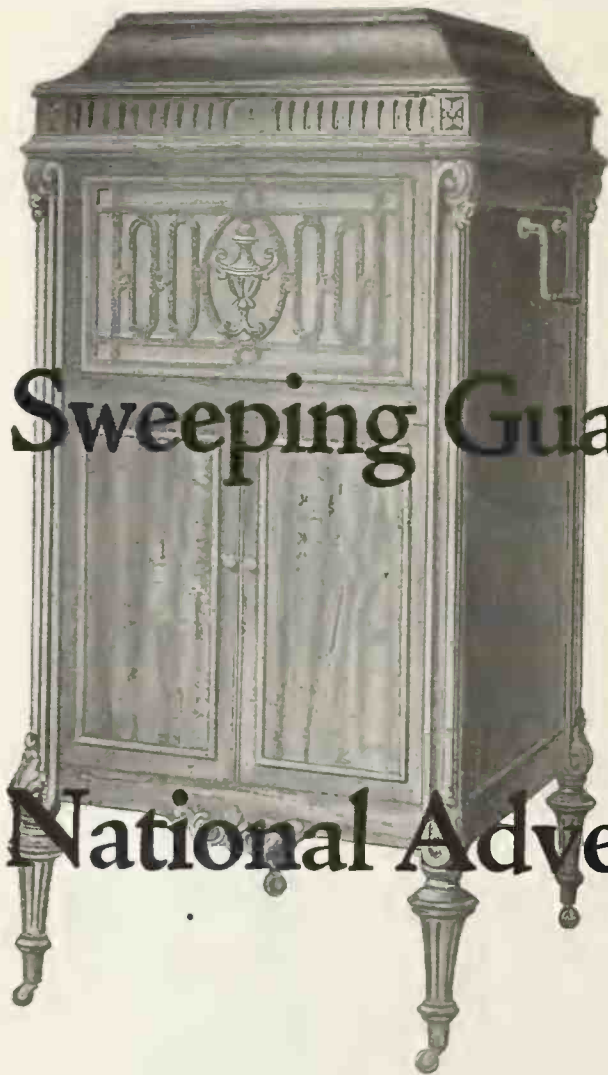

*The Phonograph
Instrumentized*

We're awaiting your inquiry. When it arrives we'll come through with our whole proposition—lay all our cards on the table—show you exactly what benefits are yours as a Dalion dealer. Then the decision is yours. There is neither cost nor obligation in getting full particulars. Write today.

Milwaukee Talking Machine Mfg. Co.

Milwaukee

HAPPENINGS IN THE DOMINION OF CANADA

CANADIAN TAX ON MUSICAL INSTRUMENTS REVISED

Additional 10 Per Cent Excise Tax Taken Off After Strenuous Protests by Members of Industry—Tax Now the Same as Since 1918—Seven and One-half Import Tax Also Removed

OTTAWA, CAN., July 6.—The talking machine industry in Canada has won its fight against the additional 10 per cent excise tax which was proposed in the speech of Sir Henry Drayton, Minister of Finance, in his address before Parliament in May. Immediately following the declaration that this additional tax was to be levied on the manufacturers' price the talking machine industry marshaled its forces and presented in concise form the reasons why this tax would prove unjust. Officials of the Canadian Manufacturers' Association joined a deputation which visited the Commissioner of Taxation to present these arguments. After more than a month's delay the result was announced that the additional 10 per cent had been rescinded and the tax remains as it has been since 1918.

The news that this tax had been removed was

hailed with delight by members of the trade, for it had a quieting effect on conditions which have been hampering business in talking machines and records for some time. There will be no rebate, however, on taxes collected at the higher rate between May 19 and June 17.

The sales tax, a 1 per cent on turnover, remains unchanged except where the manufacturer sells direct to the retailer, then the rate is 2 per cent. All manufacturers and wholesalers must collect 1 or 2 per cent, as the case may be, on each invoice for talking machines, records, supplies, and all their sales, as a separate item on the invoice and remit to the Government.

The 7½ per cent war duty has been removed on all talking machines, records, etc., imported from the United States.

TORONTO DEALERS TO ORGANIZE

H. Ruthven McDonald Named as Temporary President Pending Election of Officers—Sentiment Favors Interest on Instalment Sales and Sending Records Out on Approval

TORONTO, ONT., July 7.—Retailers of talking machines and records in Toronto have decided to form an association. At an open informal meeting held recently at the King Edward Hotel the desirability of an organization that would bring the dealers together occasionally for the discussion of trade matters and methods of creating greater public demand for machines and records was decided upon. A short discussion resulted in a motion to organize and this was carried unanimously.

The meeting was the outcome of the proposition being mooted at the annual meeting of the Toronto Retail Piano Dealers' Association in April, the members of which are all actively interested in the talking machine and record business. They had found that various grievances had been successfully eliminated by co-operative effort and consensus of opinion was that an association for the talking machine retailers would be a desirable movement.

On presentation the nominating committee's slate was adopted unanimously so that the officers until an election takes place are: President, H. Ruthven McDonald; vice-president, J. D. Ford, of the R. S. Williams & Sons Co., Ltd.; secretary-treasurer, H. E. Rorke, of Mason & Riseh, Ltd.; executive committee, S. F. Bauleh, Herhard Heintzman, Ltd.; C. R. Coleman, Thos. Claxon, Ltd.; A. N. Clements, Toronto Music Co., Ltd.; M. E. Standfield, Standfield-Macpherson Co.

On Mr. Bauleh assuming the chair during the temporary retirement of Mr. Ruse from the room, an interesting discussion was provoked by the former asking "What is your opinion in regard to charging interest on all contracts and what should that rate be?" There seemed to be no doubt on the part of those who spoke to the question about the necessity of charging interest on time sales, but one dealer pointed out that because a competitor only a few doors away featured no-interest he was compelled very reluctantly to adopt the same method after losing a number of sales because of his policy of charging interest.

The next question relating to records on approval proved to be an even greater concern. "Are you favorable to sending out records on approval, either with machine sales or to regular customers?"

"When a machine is sold," said one speaker, "it is necessary to satisfy the customer with

records that he is going to keep and I am personally in favor of sending from twelve to eighteen records on approval, those not selected to be returned in twenty-four hours." This speaker contended that on regular record business, not linked up with new machine sales, more business can be done where the customer can be supplied with records that have not been out of the store. A records-on-approval policy, he declared, meant selling second-hand records.

The sentiment expressed by the speaker above referred to seemed to be general except as to the period of time records should be allowed out with a machine. Some thought the period should be forty-eight hours, which would provide for sales made on Saturdays.

J. E. WHITE DIES IN ST. ALBANS

Widely Known Talking Machine and Piano Man Dies at His Home in St. Albans—Had Been in Poor Health for Long Time

TORONTO, ONT., July 6.—Both the talking machine and piano trades were shocked to learn of the death of John E. White, of the Musical Merchandise Sales Co. of this city, who passed away at his old home, St. Albans, recently. Mr. White had not been in robust health for some time. Last Fall he was ill for two months or more, during which he underwent an operation. This Spring, in an attempt to save the life of his little seven months' old daughter, he gave some of his own blood for transfusion to the child. Apparently he was not strong enough to stand this extra strain on his constitution. Just a few days after pneumonia set in and a wire reached Toronto telling of his death.

The late John E. White was born in St. Albans, Vt., forty-one years ago. His business life was spent in Burlington, Vt., and New York City, until six years ago when he came to Ottawa with the Hurtean-Williams Co. A year later he went with that firm in Montreal. In

October, 1916, he came to Oshawa as sales manager of the Williams Piano Co., Ltd., which position he held until February, 1918, when he removed to Toronto to join with Messrs. W. B. Puckett and Fred A. Trestrail in the Musical Merchandise Sales Co., to distribute Brunswick phonographs in Canada.

Mr. White was popular to an unusual degree. Always bright and jolly, he made friends easily. Both Mr. Puckett and Mr. Trestrail paid a high tribute to his personality and referred feelingly to the great loss his passing was to their organization and to the trade. The deceased left a wife and two children.

Members of the Brunswick organization who attended the funeral in St. Albans were: Messrs. Puckett, Trestrail and Weicker, Toronto, and O'Donnell of the Montreal branch.

K. A. ROSS MADE SALES MANAGER

Was Formerly Western Manager for Musical Instrument Sales Co. of Toronto

TORONTO, ONT., July 5.—Kenneth A. Ross, of Edmonton, Western manager for Musical Merchandise Sales Co., Canadian distributors of Brunswick phonographs, who has just arrived in this city, now becomes sales manager of the firm, a promotion that his customers will be glad to learn of. Mr. Ross, who is a "Kingston Old Boy," has lived in the West for the past nine years and is well known in music and trade circles. He is an enthusiastic exponent of the Brunswick line and looks forward with considerable pleasure to doing business in the entire country. He expects to remove his family East and establish his home in Toronto. The Musical Merchandise Sales Co. announces the acquisition of the agency for Reflexo products.

COLUMBIA FORCES MEET IN WINNIPEG

First Convention of Kind Held in the Dominion a Great Success—Many Constructive Talks

WINNIPEG, MAN., July 7.—The Columbia Graphophone Co., not content with an advertising campaign in the United States and Canada which involves an outlay of six million dollars a year, has adopted the plan of educating its agents by means of conventions. The first of this kind in Canada was held at the Fort Garry Hotel, this city, recently. The chairman was Robert Shaw, manager of the Columbia Graphonola department of Cassidy's Limited, wholesale distributors in the Canadian West.

The principal speaker was A. E. Landon, general manager of the Columbia Co. in Canada. Other speakers, especially brought from New York for the occasion, were O. F. Benz, assistant to general sales manager and superintendent of record output for the American head office of the company; H. L. Tuers, manager of the Dealer Service department; W. A. Willson, manager of the educational department, and

(Continued on page 189)

Talking Machine Supplies and Repair Parts

SPRINGS, SOUND BOX PARTS, NEEDLES

THE RENÉ MANUFACTURING CO.
MONTVALE, NEW JERSEY

Crafts Superiority



MODEL "A"

Mahogany or Oak
17" wide; 19" deep; 42" high

This is an exceedingly artistic model, built to meet a popular demand. Nickel-Plated Hardware is used throughout, and the shelf for Albums is made of five-ply veneer.

The sale of the CRAFTS Phonograph does not depend upon so-called "talking points."

The CRAFTS Phonograph possesses all the essentials to meet the popular demand and satisfy the true musician.

The CRAFTS Phonograph sells on merit solely, and it is built to endure. Guaranteed for a lifetime!

The growth of the demand for the CRAFTS Phonograph has been little short of phenomenal, considering that no extravagant expenditures were made in launching it upon the market.

The CRAFTS Phonograph at once found a place for itself among the recognized standard makes, and the gratifying repeat orders in constantly increasing volume attest the recognition of CRAFTS Superiority by the trade.

America's foremost Music Houses now offer the CRAFTS Phonograph to discriminating buyers because of its high standard of excellence as a musical instrument.

Descriptive folder and an outline of CRAFTS Dealer's Service sent upon request.

A sample order will show you the wisdom of making the CRAFTS Phonograph your leader. It is better to offer the CRAFTS in competition than to meet it that way!



MODEL "AA"—OPEN

Mahogany or Oak
14½" high; 16½" wide; 20¼" deep

Like the more expensive Models, "AA" will play all makes of Disc Records.



MODEL "B"—CLOSED

Mahogany, Walnut or Oak
18" wide; 20" deep; 43¾" high



MODEL "C"—CLOSED

Mahogany, Walnut or Oak
22¾" wide; 24½" deep; 46¾" high

A. J. CRAFTS PIANO CO.

Manufacturers

RICHMOND

VIRGINIA

TRADE HAPPENINGS IN CANADA
(Continued from page 187)

Robert Shaw, of Winnipeg. The delegates to the convention were a hundred strong, Columbia dealers from all parts of the prairie provinces.

There were various addresses and as one expert after another held forth, the men from the shops in city and country were surprised and delighted with the suggestions that were made.

At the recherche luncheon served in the beautiful Rose Room of the Fort Garry, the program of music discoursed by the orchestra was printed on the menu cards and beneath each number were such entries as "Columbia Record A-2908, R-4018, A-2885, etc." When the convention adjourned late in the afternoon, after a day of speeches, practical demonstrations, lantern lecture, and Grafonola music, the delegates indicated their satisfaction by warm words of appreciation. The success of this experiment will lend to its adoption as a regular feature in various sections of Canada.

At the close of the last address of the convention, a "Columbia Clinic" was put on in which experts demonstrated to the dealers the merits of the new Columbia non-set stop Grafonola. The enthusiastic appreciation of the hospitality of the officers of the Columbia Co. and of the valuable addresses delivered signified the pronounced success of the first convention of its kind ever held in Canada.

TORONTO FAVORS "RECORD WEEK"

Association Receives Proposition Favorably at Meeting—Investigates House Sales

TORONTO, ONT., July 4.—At a recent meeting of the Retail Phonograph Dealers' Association of this city, the idea of all the retailers in the city co-operating in a "record week" was advanced by J. D. Ford, who thought that concerted movement of this kind would result in a big impetus to record sales. The idea was favorably received.

House peddlers of talking machines also received considerable attention by different speakers, one of whom stated that he personally called at eleven private homes at each of which a talking machine was advertised for sale. Of the eleven instruments seen ten were the product of one manufacturer. The Association proposes to "go after" this class of trader.

TRADE CONDITIONS IN MONTREAL

Usual Summer Dullness Now Prevails—H. S. Berliner Returns From England

MONTREAL, CAN., July 6.—The usual Summer dullness, apparent at this particular season of the year, is being observed by all dealers. The majority of the trade is pushing hard for Summer business in the way of camp outfits and machines for Summer homes, etc.

Layton Bros., Edison and Columbia dealers, recently held their second annual picnic to Otterburn Park where a program of games was held and dancing indulged in.

H. S. Berliner, vice-president the Berliner Gramophone Co. Limited, has arrived home from a two months' visit to England, where he was accompanied by Mrs. Berliner and their little daughter.

The Starr Phonograph Co., of Quebec, has opened up at 1600 St. Lawrence boulevard where Starr phonographs and Gennett records are being featured for distribution in the Province of Quebec.

Charles Culrose reports a demand for Motrolas in excess of supply. He has taken on the representation of the Portophone and expects a number of machines in any day.

C. W. Lindsay, Ltd., has added a new feature to its service—that of renting phonographs. Two models of Columbia Grafonolas are being rented—a cabinet model, type "X," or a portable type "D." If the client decides within six months to purchase the instrument rented, the money paid as rental is applicable on the purchase price.

FOREIGN MUSIC ROLLS THE LATEST

Rolls of Jewish, Polish and Italian Music Played by Native Musicians Expected to Have Strong Appeal for the Foreign Element

A surprisingly large number of talking machine dealers discovered years ago that a most substantial and profit producing business could be developed in the handling of foreign records intelligently in sections where the foreign population was of substantial proportions. As a matter of fact certain dealers have for a long time done the bulk of their business with the foreign element and in foreign language records.

The appeal to the foreign speaking population having already proven of distinct value in record sales, it is logical to assume that the presentation of authentic music in music roll form should have an almost equal attraction. Following out this idea the Rose Valley Co., of Philadelphia, Pa., has just placed on the market the Monoroll catalog containing Polish, Italian and Jewish selections, many of them made from the original scores and all played by musicians of the same nationality, thus insuring accuracy in interpretation. The Jewish rolls particularly are of a character that has made a strong impression upon the members of that race who have heard them. In the near future it is planned to add rolls of the music of a number of other nationalities as soon as arrangements can be made, thereby increasing the scope of the Rose Valley roll library.

It is the belief of the manufacturers that talking machine dealers who have been featuring foreign records have at hand unexcelled means for placing the foreign music rolls to advantage, inasmuch as a goodly number of the talking machine owners are likewise owners of player-pianos. Having brought the customers into the store for foreign records it should be a simple matter to interest them in music rolls of the same type which should mean additional business.

Okeh Records **The Very Latest HITS** **Okeh Records**

Always out on Okeh Records

We Stand for Dependability and Speedy Delivery Immediately Upon Receipt of Orders

Hear the **FOUR** Most Popular **SPECIALS** and Send Us a Quick Order

4118	{	IN SWEET SEPTEMBER—Fox-trot,	Ray Miller's Black & White Melody Boys
10-in.		MY SAHARA ROSE—Fox-trot.....	Harry Raderman's Jazz Orchestra
\$1.00			
4119	{	ROSE OF SPAIN—Fox-trot,	Ray Miller's Black & White Melody Boys
10-in.		KISMET—Fox-trot.....	Green Brothers' Novelty Band
\$1.00			
4120	{	TELL ME PRETTY MAIDEN—Fox-trot.....	Rega Dance Orchestra
10-in.		POLLY—One-step... Joseph Knecht's Waldorf Astoria Dance Orchestra	
\$1.00			
4121	{	LE WANNA—Fox-trot.....	Green Brothers' Novelty Band
10-in.		JEAN—Fox-trot.....	Harry Raderman's Jazz Orchestra
\$1.00			

STOFFER & STACKHOUSE CO.
BOURBON, INDIANA
DISTRIBUTORS OF OKEH RECORDS

\$25,000 IN BONUSES to Jemtone Dealers

We have developed a most unique and distinctive sales plan for the distribution of Jemtone Phonograph Attachments. Part of it is to divide bonuses amounting to \$25,000.00 among our dealers.

This is a new departure in the selling of merchandise and is certain to meet with popular approval. It provides for a division of profits among those who sell our products and pays to those the largest returns who show the biggest results.

Clip the coupon, fill in, and attach to your letterhead. Complete information will be sent to you by return mail. Doing this will bring to you a most unique sales plan—one that will not only pay you liberal profits on the sales you realize, but one that will make it possible for you to earn one of the many cash bonuses, running up as high as \$1,000.00.

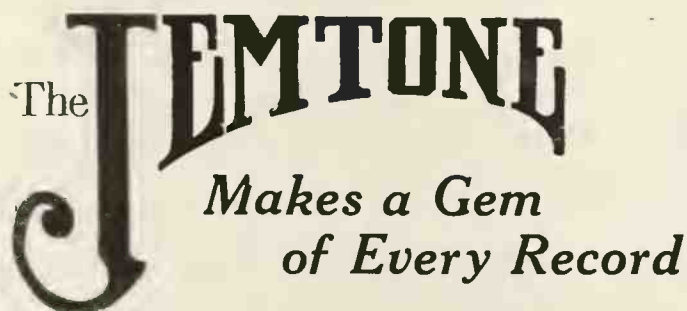

The Jemtone is an auxiliary attachment that fits into the needle holder of the sound box of changeable needle machines.

The Jemtone removes metallic sounds, reduces scratching and surface noises where they are no longer objectionable, eliminates overtones and blasts, greatly naturalizes tones—and softens, clarifies and mellows tones.

The Jemtone is a proven success. Those who use it endorse it enthusiastically and pronounce it an indispensable addition to their phonograph.

The Jemtone is small in size and as easily and quickly attached as an ordinary needle. The retail price of \$1.50 places it within the reach of everyone. The liberal margin it pays dealers makes it a profitable accessory to handle.

Write for full information on the Jemtone, and learn more about our plan of paying bonuses to dealers. This plan is certain to interest you. We have a distinctive product and just as distinctive a plan to introduce it.

Obey the impulse—write to-day!

THE JEMTONE COMPANY, Inc.
OMAHA, NEB.

The Jemtone Co., Inc.,
Omaha, Nebraska.

Mail us complete information regarding your plan of paying bonuses to dealers for selling Jemtone, and give us more detailed information about the Jemtone. Writing does not obligate us in any way.

by
Executive Capacity.

TRADE ACTIVE IN PORTLAND DESPITE SHRINE FESTIVAL

Dealers Well Satisfied With Situation—Edison Transcontinental Tour—Watts With Western Jobbing & Trading Co.—Many Dealers in City During Shrine Week—New Lines for Wax Co.

PORTLAND, ORE., July 6.—While the talking machine business was not very active during the Shrine convention in Portland, dealers are well satisfied with the situation, as immediately after the convention and Rose Festival, which followed it during the latter part of the week, business became very brisk. Music was the outstanding feature of the convention, seventy-six bands, about 3,000 musicians, being here with the Shriners.

While there was plenty of band music in Portland week before last, the Reed-French Co. instituted a little concert of their own at Twelfth and Washington streets. An elevated platform in front of their store was appropriately decorated and a talking machine placed on it, which played all day long.

A transcontinental lecture tour extending from coast to coast, including Canada, has been arranged for the Summer by the Edison Co., to present the recording features of the New Edison. Phonograph dealers from the entire country will be invited to attend these lectures. Miss Helen Davis, a young mezzo soprano and pupil of F. X. Arens, the voice specialist of New York, will illustrate the lectures.

A. A. Campbell, of the Seattle branch of the Bush & Lane Piano Co., after a visit to his son, H. T. Campbell, manager of the Portland branch of the Bush & Lane Co., has returned to Seattle. H. T. Campbell became a full-fledged Shriner just before the convention and is a member of Al Kader Temple. Bush & Lane's window was one of the finest in Portland during the convention. A desert scene was shown and the Arab sitting in front of his tent, contemplating a passing caravan of camels and drivers, was very realistic. The Sphinx, the Pyramids, the oasis with its palms, surrounding the spring of water, formed an artistic as well as an appropriate window picture.

D. T. Watts, formerly of the Perry Music Co., has just returned from Los Angeles, where he has accepted the position of district manager of the Western Jobbing & Trading Co. This company is the distributor of the New Emerson phonographs and records and intends to erect immediately a \$1,000,000 factory in Los Angeles and will employ between 600 and 800 girls. It will be in full operation by November 1 and will give Western dealers the advantage of quick service, as goods can be delivered from three to four weeks earlier than they can be delivered by Eastern factories. Mr. Watts will have the territory covering Washington, Oregon and Alaska. He has just opened an office in Seattle and in sixty or ninety days will open an office in Portland.

O. C. Schindler, in charge of the wholesale department of the Perry Music Co., has just returned from a successful business trip down the Willamette Valley, which he found in even more than its usual prosperous condition. He opened new agencies at Harrisburg, Forest Grove, Newberg, Albany and Oregon City. A Cremona talking machine was sold by the company to Pacific College at Forest Grove. Mr. Schindler says they are selling a great many Emerson records.

The Excel, the Modernola and the Portola are now carried by the M. J. Wax Co., which is getting ready to incorporate. Grey Gull records are also being carried by this company. During the Shrine convention week A. R. Cyrus, of Astoria, Ore., and F. A. Rankin, of Eugene, Ore., called at the Wax offices and ordered a supply of goods.

E. B. Hunt, manager of the wholesale Victor department of Sherman, Clay & Co., has returned from a visit among the dealers in Eastern Oregon and Idaho. He found the dealers very anxious to get Victor stock and all are expecting a prosperous Fall trade. A great many Victor dealers visited Portland during Shrine week. Among them were C. B. Sampson, of Boise, Idaho; W. W. More and George Will, of Salem,

Ore.; L. L. Thomas, of Marshfield; Stanton Rowell, of Grants Pass; W. L. Hembree, of McMinnville; F. G. Mitchell, of Hillsboro; Mr. Cohoun, of Boston, Mass., and John Gercovich of San Francisco.

"The Stradivarians," a club composed of the officers and employes of the Pacific Phonograph Co., were hosts at a picnic at Crystal Lake Park on Saturday for all employes of the concern.

W. H. Dirrett, of Albany, Ore., has put in an order for a complete line of machines carried by the M. J. Wax Co. Mr. Dirrett has a store in Albany, Ore., and another in Corvallis, Ore.

W. B. Maxwell reports a good month in the talking machine department of the Powers Furniture Co. A complete list of Brunswick records is now on hand for the first time since they were put on the market. During the Shrine convention there were many Shriners who visited the department and bought records, and a big

list of names has been added to their regular mailing list.

Mrs. Olga Binder, who was in the talking machine department and afterwards cashier of the Wiley B. Allen Co., is now with Lipman, Wolfe & Co. in their talking machine department.

Mrs. Stonebrink, who resigned her position in the record department of Lipman, Wolfe & Co., is now with the Bush & Lane Piano Co., in the talking machine department.

V. G. Lunt is a strong advocate of the Pacific point, a record needle of which he is the inventor. He is having good success in selling it.

PARK SLOPE TALKING MACHINE SHOP

Among the most recent entries into the talking machine field in Brooklyn, N. Y., is the Park Slope Talking Machine Shop, which has a capital of \$40,000. Incorporators are M. and A. and B. Goldblatt.

Sedgwick & Casey have attractive "talker" quarters in Hartford, Conn.

Latest Hits in Records!



Ask for our latest bulletin showing complete list of all releases up to date.

The *Lyric* has made constant progress in technical improvement and can be favorably compared today in quality only with the old standard makes of records.

Sample orders will lead to immediate re-orders.

We have made extensive enlargements of our accessories department and our jobbing facilities are situated to furnish *immediate delivery* and *complete service*.

Special Offer!

To every rated merchant we will ship an assortment of three dozen (36) Lyric Records of the popular hit class.

Lyric Records retail at 85 cents.

Big-profit discounts.

OPEROLLO PHONOGRAPH CO.

54 W. Lafayette Blvd.

Detroit, Mich.

IN SWEET SEPTEMBER
MY SAHARA ROSE

**OKeh
Records**

ROSE OF SPAIN
KISMET

"THE WINNING COMBINATION"
(The Most Valuable Obtainable Agencies)

HIGH CLASS CLEAN CUT
PROFITABLE SUCCESSFUL

The MASTER-TONE PHONOGRAPHS

OPPORTUNITY is knocking at *YOUR*
door NOW!

Let us prove it to you

Iroquois Sales Corporation
10-14 North Division Street, Buffalo, N. Y.

TELL ME, PRETTY MAIDEN
POLLY

**OKeh
Records**

LE WANNA
JEAN

THE FUTURE OF THE PORTABLE

C. E. Dodson Prepares Interesting Article Presenting Practical Sales Plans—Important Information for the Dealers

C. E. Dodson, general manager of the Portable Phonograph Co., Kansas City, Mo., recently prepared an interesting brochure for the members of his organization entitled "The Future of the Portable Phonograph." In this article, Mr. Dodson points the way to a new field for dealers in the development of talking machine and record business, and says:

"A wide field for the sale of phonographs and records is pointed out to dealers and this field has hardly yet been scratched. The advertising matter pertaining to the Portrola portable phonograph calls attention to the sale of Portrolas to young people employed and other lovers of music, who cannot for many good reasons use a cabinet machine. Heretofore the

thousands who represent this class of people have bought small, cheap machines to satisfy, in a measure, their longing for good music. On account of their mode of living a phonograph is a temporary proposition with them and naturally they do not invest much money in this machine. The result is their phonograph is more or less unsatisfactory. They are often compelled to change their abodes suddenly and when it comes to moving the machine they conclude 'the thing isn't worth it.'

"Take, for instance, people who have fine cabinet machines in their homes. When they go on an outing and as soon as they get settled one of the first things mentioned is 'now if we just had the phonograph, wouldn't it be great?' Those persons who are accustomed to good music of their phonograph naturally miss it more than others and they are not satisfied with purchasing a cheap phonograph for this special occasion. It would be out of the question to take their large machines with them

and they dislike to crate or have some special kind of case made for some smaller model so it may be transported.

"Going back to the young folks—the majority of them are more familiar with the new dance records, though they do not own a phonograph, than most of those who have fine cabinet machines. These young folks spend at least part of their time in their rooms or boarding houses and 'what could be sweeter' than a real portable phonograph they could

We have proven that you can
sell the—

Adora

The Clearer Phonograph

The ADORA phonograph has attractive sales possibilities for you as a phonograph retailer. We have proven this fact conclusively during the past year in our Detroit stores.

Slightly over a year ago we introduced it to the Detroit public. Since then we have sold more than 5,000 ADORA phonographs to as many satisfied buyers in the city of Detroit.

You can sell proportionately as many ADORA phonographs in your city, because it is an unusually good phonograph at an unusually low price for such a quality instrument.

The public has shown an immediate and constantly increasing appreciation for the ADORA. Its owners are its greatest advertisers. We find that innumerable ADORAS are sold solely on the recommendations of people who already have purchased this instrument.

The tone of the ADORA is mellow, full, true and so clear that it has earned the title "The Clearer Phonograph" in exacting tone tests against many other and much higher priced phonographs. The various models are handsomely designed, exquisitely finished and come in a wide variety of upright and period designs.

Every ADORA phonograph you sell is guaranteed to give perfect satisfaction over a long period of years.

We have a very attractive proposition to offer reliable phonograph dealers throughout the United States and Canada. Full information, prices, discounts, terms and all details, upon request.



45" HIGH
MODEL No. 6, \$75

Adora Phonograph Co.

242 East Jefferson Avenue, Detroit, Mich.

Wholesale Distributors: Adora Phonographs, Lyric Records, U. S. Rolls and Supplies



Carroll E. Dodson

take with them on their outings or to their friend's house and could close it up and set it out of the way when not in use in their rooms. This class of trade has never been properly appealed to before. The dealers would find it very profitable to do so. I personally know they would take to it quickly if the real portable machine were shown to them and it would certainly stimulate the dealer's record sales to a large per cent.

"I feel safe in predicting a change in the phonograph industry concerning the future of the portable phonograph and in a few years doubtless there will be only two kinds of machines found extensively on the market. Namely, the cabinet machine for the parlor or music room and the portable machine for all other purposes. I refer, however, to the portable phonograph as one built as a carrying case with a handle and place for records; not so heavy as to be a burden to carry; nor requires no extra crating or case to take it along."

NEW HOME FOR HACKENSACK HOUSE

The Bergen Talking Machine Co., which handles the Victor line in Hackensack, N. J., has moved into new quarters on Main street, that city. A large electric sign with 116 bulbs has been placed in front of the store which is now one of the very attractive establishments in that town.

THE TOUCH OF PERFECTION FOR PHONOGRAPHS



TIME is the soul of music. In phonographic reproductions of the art of great singers and musicians it is absolutely essential. The slightest variation in time will take away from the full measure of enjoyment.

At last an electric motor that will positively give the correct turn-table speed regardless of voltage changes in the current. No phonograph can be perfect without

The Tru-Time Motor

It is Guaranteed to operate any phonograph at a constant speed. It is silent in operation, will not heat up, and requires no oiling, adjustment or attention for at least two years. It is installed inside the phonograph—no unsightly mechanism outside the instrument.

Add the final touch of perfection—include the Tru-Time Motor as standard equipment to your machine.

“It is to the Phonograph What the Conductor is to the Opera”

EFFICIENCY ELECTRIC CORPORATION

124 White Street
New York

Factory
Lowell, Mass.



The Puritan

AN OPPORTUNITY FOR DEALERS—The PURITAN Phonograph literally "speaks for itself." There is a richness and purity in the reproduction, quite different from other instruments, that invariably pleases the listener. The most critical music-lovers declare that such smoothness, clearness and volume of tone have never been produced by ordinary phonographs.

THE REPRODUCER—A new type of sound-box and tone arm give absolutely free horizontal and vertical movement, enabling the needle to receive ALL THE IMPULSES from the corrugations of the record. The faintest recorded sounds are faithfully transmitted to the ear. The mechanism is very sensitive to record vibrations, and is the result of long experiment.

The great clearness of tone in the PURITAN is produced by the

Eight beautiful models now ready for immediate shipment.

The Puritan Phonograph plays all makes of Disc Records, with all the distinctness and volume of which the record is capable.

LONG WOOD HORN—This is an exclusive, patented feature, and CANNOT BE USED BY ANY OTHER MANUFACTURER.

The PURITAN HORN is a rectangular channel representing an organ-pipe, extending from the tone arm to the bottom of cabinet. It has only one bend (see illustration).

THIS IS THE MOST EFFECTIVE AMPLIFIER EVER PRODUCED

The PURITAN HORN magnifies and mellows the vibrations from the diaphragm. At the same time it absorbs all hissing and grinding sounds, delivering the MUSIC ONLY in a wonderfully realistic way.

The entire instrument, including motor, sound-box and cabinet, is made in our own factory, and we guarantee every part.

Puritan Lateral-cut Records are brilliant and contain the latest popular numbers.

Write for Catalog and dealership proposition.

United Phonographs Corporation

Factory and General Offices: Sheboygan, Wisconsin

SIX MONTHS BUSINESS SHOWS BIG GAIN IN DETROIT

Despite Numerous Handicaps Dealers Report Sales Averages as High, With the Strongest Demand for the Better Grade Instruments—Summer Record Business Starts With a Snap

DETROIT, MICH., July 6.—A review of talking machine business the first six months of this year reveals the fact that sales have been considerably ahead of the same period last year, despite the fact that the scarcity of houses and the freight and express congestion and embargoes have raised havoc with trade conditions. Dealers say that never in the entire history of the industry have conditions been so bad as in the past six months. It's been a case of one series of troubles after another. It is to be hoped that these troubles will not be repeated in the next six months to come, although the horizon is rather cloudy, and dealers say they would not be surprised at anything.

The demand continues for talking machines priced at \$150 and up, and dealers were unable during April and May to handle the business, although in June conditions eased up owing to the lifting of the freight and express embargoes from the East, which helped the situation considerably. Those machines which did come in were immediately delivered to homes where orders had been on file for months. For the better class of homes the period or table designs are unquestionably what the people there want. This is best proven by statements from dealers who handle period designs.

Record business is always good in Detroit during the Summer months, owing to the vast number of Summer resorters all over the State who use them at their cottages and on their boats. Dealers are taking advantage of this situation by keeping up a steady gait of newspaper advertising during the hot weather announcing the new popular records as they come out.

Although the Victor Co. is to-day the only firm selling popular hits at 85 cents, dealers say they have not had any complaints from customers who buy other makes of records at \$1, referring particularly to the Columbia and Emerson. In fact, dealers say that \$1 should eventually prove a more popular price because it makes a standard price for popular records and makes less trouble in arranging change, etc. Victor dealers tell us that they hope their company will also raise to \$1. In fact, human nature is a funny thing. People have asked why it is that the Victor records remain at 85 cents while others charge \$1.

The Jewett Phonograph Co., with offices in the Penobscot Building, will make their machines in Allegan, where they have purchased a factory which has been considerably enlarged and which is now being properly equipped for production on a large scale.

The Adora Phonograph Co., of which Felix Sadowski is the principal stockholder, now boasts of ten retail stores in Detroit, with more coming by Fall. These stores are located downtown and on most of the main thoroughfares of the city which lead into the residential sections.

The Keenan & Jahn Co., Aeolian-Vocalion dealer, now has the talking machine department on the second floor, installing new record booths.

The J. L. Hudson Music Store, which by the way, is closing at 5 o'clock daily and at noon Saturdays, during July and August, is handling four lines of phonographs, the Victor, Cheney, Sonora and Widdicomb.

The miniature phonograph shop in the building of the Columbia Co. wholesale quarters on State street, is attracting a great deal of attention and interest among retailers, who have been frequent visitors to the building. Manager Sam Lind reports that merchandise has been coming in very good of late and that he has been able to take excellent care of his customers.

Grinnell Bros. were well represented at the convention of Victor jobbers held last week in Atlantic City.

The Burroughs Adding Machine Co., in a recent issue of its house organ, wrote at length about the great business which Wallace Brown, of the Wallace Brown Brunswick Shop, had developed through consistent advertising. It was a great compliment to Mr. Brown's ability.

Quite a number of talking machine manufacturers and jobbers were at Grand Rapids for the semi-annual furniture show during the month of June. In fact, some manufacturers have permanent exhibits in the Furniture City, which is visited annually by thousands of retail furniture dealers.

A dealer's business can never be any larger than his business methods.

The **SONATA** Phonograph

MODEL G
ONE OF MANY GOOD STYLES

The line that represents the greatest value in the industry



Eight Famous Victor Artists
In Concert and Entertainment
Personal Appearance of
Eight Popular Victor Favorites on One Program

A live attraction for live dealers and jobbers
Bookings now for season 1920-1921
Sample program and particulars upon request

P. W. SIMON, Manager
1604 Broadway New York City



FRANK CROXTON



MONROE SILVER



BILLY MURRAY

FRED VAN EPS

FRANK BANTA

Famous Ensembles including
Campbell & Burr - Sterling Trio - Peerless Quartet

Okeh

Every list of New Okeh Records containing the best selling hits of the day.

Musically and commercially the recognized leader in the record field.

Kennedy-Green Co.
1865 Prospect Ave.
Cleveland, O.



Crimi



Peterson



Raisa



Easton



Rimini

THE NEW VOCALION RECORD

Lateral Cut, Playable on All Standard Machines

THE development of the phonograph has been one of the most interesting and far-reaching events in musical history.

The phonograph and the phonograph record are practically one—that is, neither is of value without the other. An improvement in either directly affects both. While this is true, however, the most obvious improvements in recent years have been connected with the instrument. A notable illustration of this is furnished by the *Aeolian-Vocalion*, which is recognized both here and abroad as representing a definite and decided advance in phonograph construction.

It is significant that from the source that produced this new phonograph should emanate a Phonograph Record of improved type.

The importance of the New Vocalion lateral-cut Record may hardly be overestimated. To



Nellie

Kouns



Dambois

D'Alvarez

Sundelius

Scotney

O'More

the public it means that the most perfect record ever put upon the market is now available for use with all standard phonographs. To the music-trade it means one more vital sales feature added to the many included in the representation of the Aeolian-Vocalion. The new Vocalion Record is a super-record. In true musical quality, in durability, in content and timeliness of issue it is not equalled in the whole phonograph field.

Up-to-date merchants who are not in the phonograph business, and those who are, but are not handling the Aeolian-Vocalion, will see in this new record one more cogent reason for securing Vocalion representation before territory is all assigned.

THE AEOLIAN COMPANY

NEW YORK · LONDON · PARIS · MELBOURNE · SYDNEY · MADRID

DISTRIBUTORS

- | | |
|---|---|
| Nordheimer Piano & Music Co., Ltd.
Toronto, Canada | Emerald Co. . . Birmingham, Alabama |
| The Aeolian Co. Chicago, Ill. | Guest Piano Co. . . . Burlington, Iowa |
| The Aeolian Co. . . . Cincinnati, Ohio | D. H. Holmes Co., Ltd., New Orleans, La. |
| The Aeolian Co. St. Louis, Mo. | O. J. DeMoll & Co., Washington, D. C. |
| The Aeolian Co. . . San Francisco, Cal. | Stone Piano Co.
Fargo, N. D., and Minneapolis, Minn. |
| Consolidated Music Co.
Salt Lake City, Utah | R. W. Tyler Co. Wheeling, W. Va. |
| B. Dreher's Sons Co. . Cleveland, Ohio | Vocalion Co. Boston, Mass. |
| | D. L. Whittle Music Co., Dallas, Texas |



Sara

Kouns

WILL BE "STARRED" IN NEW SHOW

Walter Scanlan, Exclusive Emerson Artist, Will Be Star of "Hearts of Erin"—Has Gained Success as a Popular and Well-known Tenor

Walter Scanlan, famous popular tenor and an exclusive Emerson artist, will be starred the coming season in a new show named "Hearts of Erin." This well-known artist has been placed under an exclusive contract with the Shubert organization, and will appear in various plays during the next few years.

The Emerson Phonograph Co. received the hearty congratulations from its dealers upon the consummation of its arrangements some time since whereby Walter Scanlan became an exclusive Emerson artist, and the Emerson records made by this artist have been featured extensively by the dealers from coast to coast. Mr. Scanlan has made a specialty of popular Irish ballads, and his splendid voice has been found particularly adaptable to recording purposes. In a recent article in the New York Times the following tribute was paid to Mr. Scanlan: "A rival to Messrs. Olcott and O'Hara is to be launched next season in the person of Walter Scanlan, who has sung here in 'Eileen,' 'Somebody's Sweetheart' and 'Always You.' He will be starred next year in 'Hearts of Erin,' by Charles Bradley."

ADD TWO NEW LINES

Cabinet & Accessories Co. Now Handle the Bubble Books and Sanozone for Booths—Irving Saks a Recent Addition to Staff

The Cabinet & Accessories Co. has added two additional accessories to its large list that are already proving very popular throughout the trade. They are the Bubble Books, published by Harper & Brothers, and the Sanozone. Otto Goldsmith, president of the company, reports that the dealers are having much success with the Bubble Books. The general magazine ad-

vertising, planned by this company for the Fall and Winter, will undoubtedly generate a heavy demand for these books on the part of the public and a big season is expected. The Sanozone is a disseminator and deodorizer for the talking machine booth. It is made of plaster of paris and is decidedly decorative in design and appearance. It has proven its worth in the demonstration booth. A variety of perfumes are available and at the same time that the Sanozone deodorizes the impure air it disseminates the perfume with which it is filled.

Irving Saks, formerly of the Plaza Music Co., has joined the staff of the Cabinet & Accessories Co., New York City. He will cover the New Jersey and Pennsylvania territory for this company.

EXHIBIT SONATA AT GRAND RAPIDS

Kesner & Jerlaw Have Interesting Display at Grand Rapids Furniture Show

Kesner & Jerlaw, well-known manufacturers of the Sonata line of talking machines, with factories in Quincy, Ill., Chicago, Jamestown, New York and other centers, whose executive offices are in New York and Chicago, had an exhibit of their products at the furniture show held in Grand Rapids, Mich., recently.

Space for the exhibit was reserved in the Klingman Building, that city, and much interest was shown in the equipment, which included motors, tone arms and sound boxes of a high quality.

Attending the exhibit were M. Kesner & N. Jerlaw and others of their organization. Visitors included many of the leading Kesner & Jerlaw jobbers as well as a long list of furniture dealers handling or contemplating handling talking machines.

The J. W. Brown Piano Co., of Canton, O., has recently secured the agency for the Puritan phonograph and also the Puritan records, and will feature them extensively.

Stewart's

-jobbery
for the -
Victor
Talking
Machine
Company

Indianapolis

BRIGGS WITH WALTERS & BARRY

George Briggs, formerly of the sales force of Emerson, Inc., New York City, and who has for several years been connected with the wholesale end of the talking machine business, has recently joined the sales force of the Walters & Barry Corp., Buffalo, N. Y. Mr. Briggs will cover the Eastern half of New York State representing all the lines the firm handles, namely, the Briggs automatic repeating phonograph, the Starr phonograph and Gennett records.

TRIANGLE AUTOMATIC STOP

OPERATES 100% PERFECT

*SIMPLE
EFFECTIVE
ACCURATE*

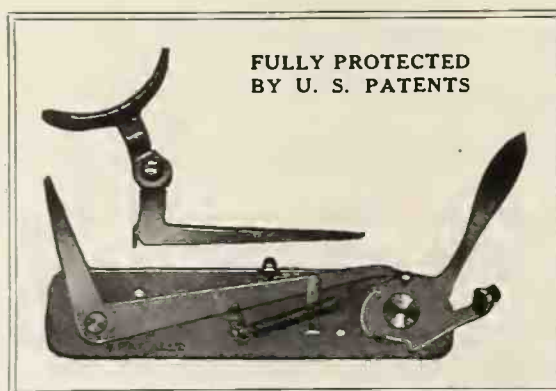

*INVISIBLE
INEXPENSIVE
EVERLASTING*

A perfect Automatic Stop will add many customers to your list. This is accomplished by adding very little to the cost of your machine.

The Triangle Stop is simply yet substantially constructed—it *will* stop at the desired point *every time*.

Write for samples

TRIANGLE PHONO PARTS CO.

722 ATLANTIC AVENUE

BROOKLYN, N. Y.

For Victor Dealers Only



DOMES OF SILENCE

Simple in construction, made of case-hardened steel, will save talking machine cabinet legs from strain, save floors from scratches, save rugs from tearing, and make the cabinet still more sightly. It is for these reasons that Victor use these slides on their model Victrola X.

HENRY PEABODY & CO.

17 State Street

Domes of Silence Division

New York

Specify DOMES OF SILENCE

INTERESTING FACTS REGARDING PERIOD VICTROLAS

As Presented in a Special Paper Read Before the Annual Convention of the National Association of Talking Machine Jobbers by Ernest John, Advertising Manager of the Victor Co.—Significance of the Various Ornamental Features Dilated on Most Interestingly—The Evolution of the Design Explained and the Purpose Behind It—An Illuminative Contribution

[The World is privileged to reproduce herewith the paper on the subject of "Period Victrolas" read before the convention of the National Association of Talking Machine Jobbers, at Atlantic City, on June 29, by Ernest John, advertising manager of the Victor Talking Machine Co.—EDITOR.]

"Period furniture is probably classified in the mind of the average man along with Japanese prints, vintage wines, or any of the other things for which he doesn't expect to have any considerable use, but people with leisure, taste and money to spend on home designing find themselves compelled to take period furniture into account just as the music student finds that he can't get very far in music without bumping up against Beethoven, Bach and Mozart.

"In a hazy sort of way we probably all feel that furniture has been one of our possessions from time immemorial. It has been—but only to a very limited extent.

"Step outside the pale of civilization even today and you will find that the wigwam of the Indian and the hut of the savage contain very little that can be described as furniture, and in the days when our hairy ancestors went a-courting with a club there was still less. In fact, the use of tools and the acquisition of property—chattels—go far toward marking the deadline between man and beast.

"The Roman, the Greek, the Gaul, and the Briton got along with precious little furniture. Heavy tables, benches, a throne, a chair or two—a chest for clothing, a cupboard for food or for utensils of one kind and another—furniture design and construction began and ended there or thereabouts.

"Norman, Plantagenet and Tudor successively occupied the throne of England—in the days of chain mail and the cloth yard arrow—and through all that time all over Europe man's chief business was war. His home was his so long as he could defend it, and craftsmanship of necessity was devoted chiefly to the production of weapons.

"Medieval times look wonderfully attractive—from a safe distance—and the development of our domestic equipment is an intensely interesting study on which one might spend an unlimited amount of time. But reduced to the minimum the precise facts in the case are these:

"The passing of the centuries brought greater personal safety, and when the immediate fear of violence had departed men and women had more time and opportunity to give to their surroundings—time to think and to plan for more of comfort and of beauty.

"So long as violence had been the order of the day domestic equipment had been built to suit. Donnybrook Fair and Chippendale furniture belong to two quite different conditions of mind, and so long as any sword may leap from

its scabbard at a word or a look, pewter mugs will be more serviceable than Venetian glass.

"Life having become somewhat less hectic and the need for finer, gentler and more beautiful forms having been felt, there shortly arose men who could satisfy that need. Craftsmen, too, had grown more kindly with the coming of kindlier times and instead of heavy oaken benches they began to express themselves in less cumbersome workmanship, and it was thus that what we now call period furniture came to be.

"A good bit of their work, no doubt, was not good enough to last, but the Eighteenth Century produced a considerable number of master craftsmen who did for domestic architecture what the master composers did for music—they established certain fundamental forms.

"And, by the way, it is rather interesting to note that for the most part when we speak or think of period furniture it is the handicraft of the Eighteenth Century that we have in mind. Truly enough, earlier centuries had contributed interesting and valuable designs, but perhaps because our mode of life and our mental attitude have so changed we seldom go back further than the Renaissance for our examples and references.

"We are less familiar with the names of individual French craftsmen because, just as in England the work of individuals is sometimes spoken of more generically as William and Mary, Queen Anne or Georgian, the French evolutions were identified broadly under the name of the ruling monarch, Louis XV (Louis Quinze), Louis XVI (Louis Seize) and so forth.

"It would be quite impossible to present any comprehensive picture of period furniture design and its developments in the space of time allotted to me, and I believe it will be much more to the point if, instead of discussing the relative merits of Sheraton versus Louis Quinze, we deal with certain salient facts regarding period Victrolas manufactured by the Victor Talking Machine Co. and marketed by you gentlemen who distribute our products.

"I believe it will be of service, however, to present here a brief outline of the different characteristics which have been embodied in the types the Victor Co. is now manufacturing.

"Advertising men, I assure you, are quite like other human beings—though there seems to be some uncertainty on this point—and if they can become experts in advertising they won't have the time or energy to become experts in anything else, and so in order that the information so conveyed to you should be authoritative I appealed to Mr. Kieffer, superintendent of our cabinet factory, to assist me on this point."

Mr. John here read interesting detailed descriptions of the decorative features of several of the period style Victrolas, including the Adam Victrola, No. 50; Sheraton, No. 50; Sheraton, No. 51; Chippendale, William and Mary; Louis XVI; Queen Anne, Gothic, etc., as prepared by Mr. Kieffer, who, in his introductory, said:

"In the production of period work, the designer and builder are called upon to faithfully produce the work of a master craftsman.

"The instructions of the Victor Co. to me, in the manufacture of our period cabinets, have been very emphatic on this point, and, in addition, very explicit, to produce a cabinet that would be both a credit to the Victor standard of excellence and a faithful conception of the master craftsman's art as produced in the periods which the cabinet is called upon to represent."

"So much for the concrete facts," continued Mr. John. "Now as to the philosophy of the case, for it is important that we should all realize how the tremendous sincerity of purpose which has characterized the whole Victor development has been applied to the building of Victrolas in period styles.

"As a matter of fact, our case has been so clearly stated by Mr. Johnson that whatever more may be said will be merely an amplification. His statement of the case was: 'There were no Victrolas in Chippendale's time, but what we have done is to build Victrolas as we conceive Chippendale or Sheraton would have built them.'

"One thing we may all be very sure of and that is that they would have built them primarily as the musical instruments they are and not as cupboards, chests or tables—which they are not.

"Why does a Victrola take the particular form which has now become so very familiar to so many people? The Victrola that is built with no other consideration than that of producing the best instrument within the bounds of commercial possibility? Is it accident? Assuredly not! Ah, design then! Not quite—it is due rather to evolution. Why does the violin take its characteristic form? For the same reason—as the result of very similar evolutionary processes.

"In either case the maker was in search of—what? An instrument of music, with—in the case of the Victrola—the added difficulty of producing not one kind of music but all kinds. Both are built to perform a specific function, and their relative value, that is, the relative value of one violin to another, one talking machine to another, lies in the quality of its performance.

"Consequently then we are compelled to believe that the general dimensions—the form of any Victrola has a very definite and indeed integral relationship to its own particular needs, to the particular function it was designed to perform.

"Would you expect a violin which had been
(Continued on page 203)



The VICSONIA

DOUBLES THE VALUE OF THE MACHINE

It is the Recognized Reproducer for Playing Edison disc records on Victor and Columbia Machines with Perfect Tonal Results

"VICSONIA" REPRODUCER
(Model "A")

ANOTHER SUCCESS!

MODEL "B" VICSONIA—Plays both Pathe and Edison disc records.—Order sample NOW. Retail Price \$7.50

A sample reproducer Model "A" or "B" will be sent on receipt of \$4.50

VICSONIA MFG. CO., Inc., 313 E. 134th St., New York, N. Y.



THE HOUSE THAT
MADE DETROIT
FAMOUS AS A
VICTOR
WHOLESALE
CENTER

GRINNELL BROS.

“THE LEADERS
of MICHIGAN'S
MUSIC INDUSTRY
for over a
HALF-CENTURY”

DETROIT 4th CITY

IS your income keeping pace with the growth of the community in which you do business? Detroit has increased 123.4% and now harbors with its completely surrounded municipalities over 1,000,000 people. Most leading centers of Michigan, according to the new census, enjoyed a similar growth. Opportunity lies before Victor retailers located in this rich territory. Grinnell Bros. wholesale are redoubling their efforts in rendering 100% constructive co-operation to Victor retailers. We *specialize* on this most wonderful field.



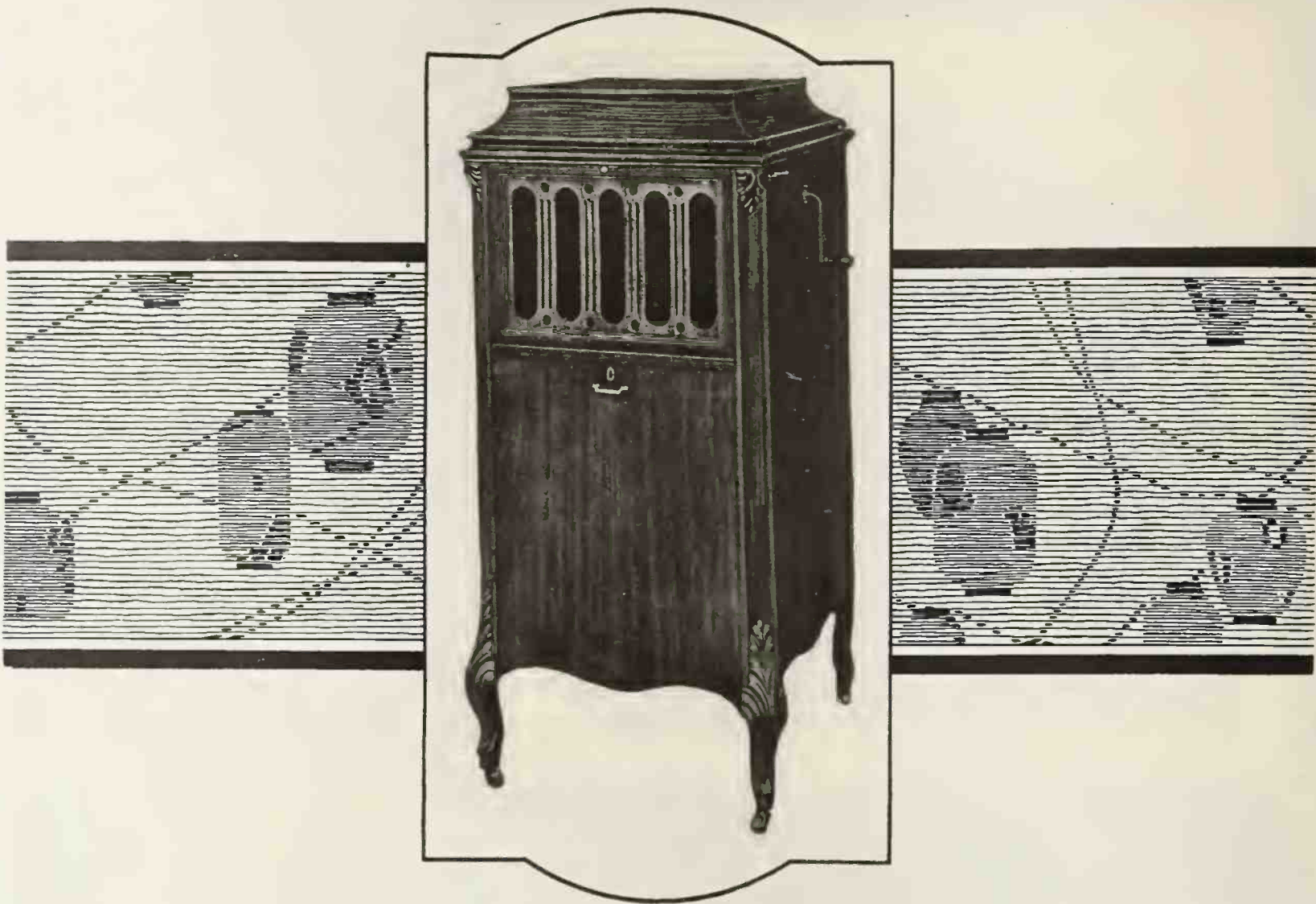

Six Months After

*the Sale Is Made, Just How Does That Sale Stand
on Your Books? Is It a Double-Asset
or Merely an Asset?*

If your customer is still satisfied the transaction is *more* than an asset. Whether it was sold for cash or on payments makes no difference—the sale becomes a *double-asset* for the customer is friendly to you. You have won his *good-will*.

If, on the other hand, the customer has become dissatisfied, the sale, if it was for cash is a liability, for you have *lost* his good-will. If payments are still due, it is doubly a liability for you have lost his good-will and in addition *he has your money*.

Do not let a buyer go out of your place with a potential liability. Send him away with "good-will" merchandise.

Send him away with a machine that has care and conscience *built right in*. Sell him the DELPHEON!

The Delpheon is allotted in exclusive territories. Apply to

THE **Delpheon** CO.
BAY CITY MICHIGAN

New York Office, 25 Church Street
Rosen Phono. Sales Co., 27-28 Court Street, Boston, Mass.
Delpheon Shop, Peachtree Arcade, Atlanta, Ga.
Walter Verhalen Co., 703 Busch Building, Dallas, Texas
Verbeck Musical Sales Co., Buffalo, N. Y.

FACTS ANENT PERIOD VICTROLAS
(Continued from page 200)

vitaly changed in appearance to be still the same instrument, still perform its designed functions with the same excellence? Does anyone suppose the form of it is an arbitrary thing or the result of a whim? No—you feel morally certain that the violin in its own characteristic form was developed—not to please the eye, not to cater to the dweller in cramped quarters, not as a matter of fact to cater to anyone—but for the single purpose of producing the best quality of tone available and the greatest accuracy of pitch.

"If we needed more sound amplifying surface or surfaces of an entirely different shape, we should assuredly use them. If a better result could be secured by using less, then that is what we should do, and there would in either case be a resulting change in the dimensions. Why? Because it would look better—because it would fit better between the fireplace and the door? Not at all—but primarily or indeed wholly because it would do better work.

"It is not only a matter of principle, though that of itself should suffice, but there is another vital stumbling block.

"The 'Master of all Good Workmen' has told us that a man may not serve two masters, and the centuries have shown us that man's handiwork may not serve two quite different purposes with equal merit. That to straddle is to compromise, and a compromise because it is a compromise must necessarily be something less than the best. I have seen guns which consisted of one shotgun barrel and one rifle barrel mounted on the same stock, but I never yet saw one which was satisfactory as a rifle or satisfactory as a shotgun.

"Give the compromise idea the benefit of the doubt. Consider it in what I suppose is one of its most acceptable forms—it is still something less than the best. Take, for instance, a combination pool and billiard table. Would anyone choose such a table for a tournament—of either billiards or pool? It is perfectly true that on such a table one may play pool or one may play billiards—that is, pretty good pool or pretty good billiards—and neither with the greatest possible degree of satisfaction. I have used the best example of a compromise product I could think of. You can imagine what might be done by anyone whose disposition was to ridicule, and since they all serve quite different purposes there is so far as I am able to discover no more justification for making a Victrola in the form of a medieval buffet than there

is for making a violin in the form of a hatrack. "Gentlemen, the Victrola is not a commercial hope—it is the development of a quarter century, and every step on the way has been taken with whole-hearted sincerity, an honesty of thought and action that is the one sure foundation for all human effort. We know that a given diameter of diaphragm requires a given amount of amplifying space, elastic in part of its journey, rigid in others—that a given progression of taper in a tone-arm or in a floating horn gives precisely this, that or the other form of reaction. We know that in order to reflect, to give back the tones given to it, there must be a motor which shall give not merely a circular motion but a circular motion with a predetermined application of power. We know, in short, that the best possible reproduction cannot be secured haphazard but that it is the result of a most delicate co-ordination of many factors to which co-ordination all other considerations must be sacrificed and in which there is assuredly no room for extraneous purposes. Given these things and the need—or perhaps it would be better to say the desirability of space for the storing of records—the Victrola must necessarily have certain dimensions, and having certain dimensions it must necessarily take a certain form. Those dimensions, that form, were determined—by what? By the functions it was to perform, and that, if you will permit me to say so, is the one first principle in all art and in all craftsmanship that is worthy of the name.

"Because of these facts, because of these considerations, we believe you will agree with us that you may put your individual energies into the distribution of Victrolas in period style just as thoroughly, just as vigorously, as you do into any other Victor products, in the positive assurance that, tried by any artistic or commercial standard, the goods themselves, in the conception and in execution—are right!"

SPECIAL CAMPAIGN RELEASES

McAdoo Plays Tuba Solo of "The Long, Long Trail" and De Valera Sings "Come Back to Erin"—Complete List for Politicians

With the news that the Presidential nominees and their supporters are to use talking machine records in sprcading their campaign speeches throughout the country, the following list of choice selections has been specially prepared as a guide to political bosses and drivers of the various machines by H. I. Phillips in the New York Globe:

- "I'm Always Chasing Rainbows"—(Solo)...Woodrow Wilson (Reverse side) "Heart of the World".....Ditto
"Comin' Thru the Rye"—(Solo).....Teddy Edwards
"I'm Forever Blowing Bubbles"—(Duet), Procter and Wood (Reverse Side) "That Ivory Glide".....Ditto
"Silver Threads Among the Gold"—(Solo)...W. J. Bryan (Reverse Side) "When the Sands of the Desert Grow Cold"Ditto
"My Little Gray Home in the West"—(Piccolo), Hiram Johnson (Reverse side) "Those Convention Blues"—(Bass Horn)Ditto
"Beautiful Ohio"—(Duet).....National Chairmen (Reverse side) "When the Roll Is Called Up Yonder" Ditto
"Somewhere a Voice Is Calling"—(Solo).....Al Smith (Reverse side) "Abide With Me"—(Solo)...Chas. Murphy
"I Dreamt I Dwelt in Marble Halls"—(Solo), Herb. Hoover (Reverse) "That Family Sugar Bowl"—(Waltz), Ditto



FULTON (Model 35)

Mahogany, 16x16x10 in., double spring motor, universal tone arm. Back casting and metal horn. Discount according to quantities.

True-tone, Cleartone, Brilliantone and Puretone Needles in metal boxes or packages at 50 cents per M. Discount in large quantities. Truetone Needles come 200 to a metal box.

Double and triple spring Motors, Tone-arm, Auto Stops, Repeater Stops, etc. Phono parts and accessories, as Motors, Tone-arms, Sound Boxes, Cabinets and Cabinet hardware. Repair parts for all makes.

Records—Standard make, lateral cut, at \$50.00 per 100.

Cash with order

FULTON TALKING MACHINE CO. 253-255 Third Ave., New York City Between 20th and 21st Streets

BEE CROFT Delivery Envelopes Art Series New Designs NEW LIST OF RECORDS Every 60 Days A Selected List of Victor Records We Will Be Pleased to Play Any of Them for You

Very attractive proposition to Jobbers Write for trial shipment CLEMENT BEECROFT 5546 North 5th Street PHILADELPHIA

"The Long, Long Trail"—(Tuba).....W. G. McAdoo (Reverse) "Liberty Loan Blues"—(Song).....Ditto "Come Back to Erin"—(Solo).....De Valera Anvil Chorus from "Trovatore," Symphony by Disappointed Office Seekers

Whatever a man can imagine he can do. He brings lightning down from the sky; he sends buildings of stone up into the clouds where the lightning travels.

"MAGNET" DECALCOMANIE NAMEPLATES FOR TALKING MACHINE CABINETS ETC. Pamphlets with fac-simile illustrations and prices mailed on request. SMITH-SCHIFFLIN CO. 149 Church Street New York City

CLEVELAND PUSHES SUMMER SALES

Dealers Co-operate to Boom Small Models of Talking Machines—Fischer Co. Finds Pathé Club Brings Results—Columbia Co. Scores Hit With Records by Harding and Coolidge

CLEVELAND, O., July 7.—In a move to stimulate Summer sales of Pathé phonographs and records the Fischer Co., Pathé distributor of this city, has inaugurated a comprehensive advertising campaign in conjunction with a club plan, which is an elaboration of the system originated by Willard S. Mefford & Co. in Toledo. In this advertising campaign the Mefford Co. appealed to its prospects by outlining a club plan, offering to take contracts for not more than two hundred clients with one dollar down payment, provided the contract was made before a certain date. Each member of the club was also to purchase twelve records. No contract was to run over twelve months. Ninety-four contracts were made by this plan. Assistant Sales Manager A. R. Saunders, of the Fischer Co., has said that he will adopt this plan here and from this, together with the co-operation of the national advertising of the Pathé Co., he expects to turn in a large sales total.

When the nomination of Senator Harding and Governor Coolidge was announced J. L. Du Breuil, general manager of the Columbia Graphophone branch here, was alive to his opportunities and at once got a large supply of the records made by the candidates. Columbia dealers all over the city took up the idea with clever window displays and a big drive was made which netted excellent results.

The newly remodeled department of the May Co. will be ready in the Fall and will rank as one of the most elaborate and comprehensive talking machine departments in this section of the country. Some twenty booths will be installed, according to Manager Dan E. Baum- baugh, who is hard at work selling the portable Victrolas for Summer use.

Brunswick activity in this section will be greatly increased when the alterations and improvements to the Cleveland branch of the Brunswick-Balke-Collender Co. are completed. Not only will there be better facilities provided for visiting dealers, but with the added stock of machines and records it will be possible to take on several new accounts.

In order to push the sales of the smaller types of Victrolas fifty-five local dealers have united in a co-operative advertising campaign. Full-page ads every two weeks tell the story and the local jobbers, the Cleveland Talking Machine Co., the Eclipse Musical Co. and others are giving considerable impetus to the drive.

SOSS

INVISIBLE HINGES



Soss Invisible Hinges

preserve beauty. The fine cabinet work which is required in many instances to preserve the disguise of talking machine cabinets requires that hinges be as inconspicuous as possible. Soss Hinges are *invisible*.

Write for Catalogue T.

SOSS MANUFACTURING COMPANY
Grand Avenue and Bergen Street, Brooklyn, N. Y.



The wholesale department of the Phonograph Co., Edison dealer, has been doubled in size, space being afforded in an extension of the main building.

Record business as a whole is very active in all lines. During the past few weeks several new accounts have been opened outside of this city for Okeh records, according to Walter E. Gunn, assistant general manager of the Kennedy-Green Co.

Recent visitors at the new headquarters of the Cleveland Columbia Graphophone Co. have been Gus Mayer, district manager of the Unit Construction Co. of Philadelphia; Harry Weber, of the Standard Music Co., Akron; E. J. Krapp, Witt Music Co., Lorain; E. J. Sauer, Lorain; Geo. A. Clarke, Lorain; C. F. Moore, Willard, O.

TO HANDLE STARR LINE

The Walters & Barry Corp., of Buffalo, N. Y., wholesale jobber, has recently taken on the Starr line, including the Starr phonograph and Gennett records. This concern, which will have the extensive territory of the State of New York with

the exception of the metropolitan and Hudson River districts, believes that there is an unusual opportunity for quality merchandise of the Starr type in the northern and western half of the State, and the first general scan of the territory has shown most exceptional possibilities.

INTRODUCES THE "PIKNIK"

The Piknik Portable Phonograph, Inc., was recently incorporated under the laws of New Jersey with a capital stock of \$50,000 for the purpose of manufacturing a new portable phonograph. The company's plant is located at Lakewood, N. J., and plans are being made for an active sales campaign.

The Piknik is essentially a small home machine, but is adaptable for any purpose requiring a portable type of instrument. Needles are carried in specially designed containers, and a dozen records, either ten-inch or twelve-inch, may be carried in an album in a separate compartment, which is an integral part of the machine. Auguste N. Mautulet is president of the new organization.

STERLING REPRODUCER

Victor and Edison Dealers:

Hear the Sterling—
Examine its
Construction—
Note how it plays
both lateral and
hill and dale records

—and YOU WILL
WANT TO SELL IT

Attachments for either
Victor or Edison machines

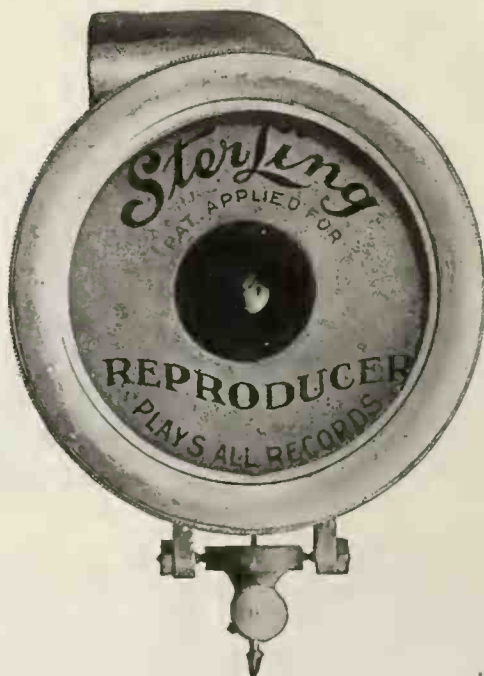

Plays all Records

To adjust for the playing of different records means just a quick, easy turn of the reproducer. No extra elbows. You ought to see and HEAR the Sterling. You will be surprised at its convenience, its beauty and wonderful improvement of tone.

Send for circular and prices

Standard Phonograph Motors, Inc.

Successors to

Krasberg Engineering &
Manufacturing Corporation

451-467 E. Ohio St.

Chicago Illinois U.S.A.

NO PHONOGRAPH COMPLETE WITHOUT IT!

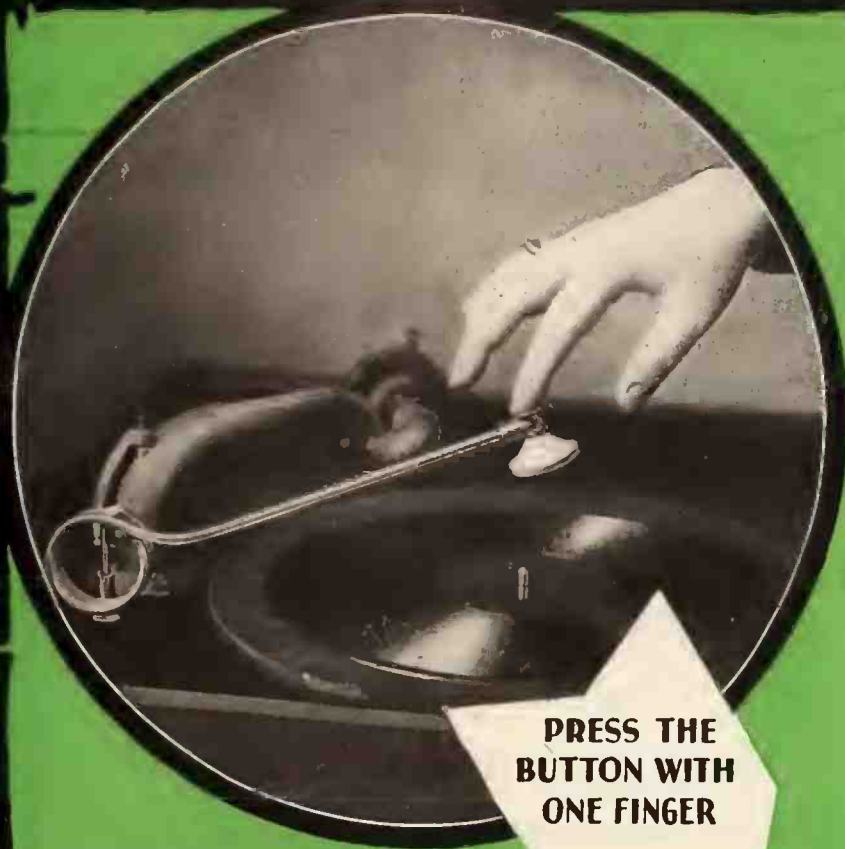

PRESS THE
BUTTON WITH
ONE FINGER

MORE ESSENTIAL TO A PHONOGRAPH
THAN A SELF-STARTER TO AN AUTOMOBILE

THE DEALERS' MOST
PHENOMENAL SUCCESS

THE SIMPLEST, MOST
NECESSARY DEVICE IN
PHONOGRAPH HISTORY

SHOULD YOUR JOBBER
NOT SUPPLY YOU, WE WILL

VACUUM RECORD LIFTER

OF THE FIRST LIQUID FIRE APPARATUS USED

BY THE ALLIED ARMIES

INVENTED BY JOSEPH MENCHEN, INVENTOR

SUCTION
LIFTS THE
RECORD INTO
YOUR HAND

WHAT IT IS —

A SUCTION DEVICE - ADJUSTS ON ANY MACHINE WITHOUT THE USE OF TOOLS - AVOIDS SCRATCHING THE RECORD OR KNOCKING AGAINST THE TONE ARM - NOTHING TO GET OUT OF ORDER - CANNOT WEAR OUT

WHAT IT DOES —

LIFTS THE RECORD SAFELY - SAVES BRUISED FINGERNAILS - BY SIMPLY PRESSING A BUTTON THE PRESENT UGLY DAMAGING METHOD OF REMOVING THE RECORD IS ELIMINATED - A 1919 MASTER PATENT

PRICES NICKEL PLATED \$ 2.50 COMPLETE
GOLD " 3.50 "

VACUUM RECORD LIFTER, LTD.

701 SEVENTH AVE., NEW YORK

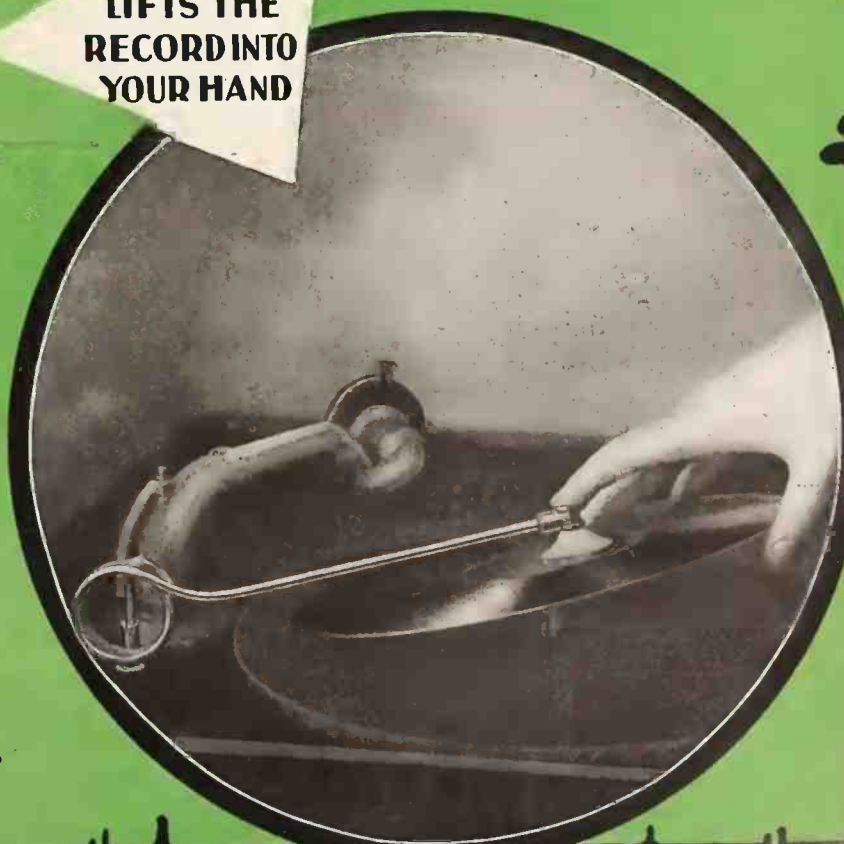

NO RECORD SAFE WITHOUT IT!

IMPORTANT NOTICE

TO THE AMERICAN TRADE

The Sterno Manufacturing Company

19 CITY ROAD

LONDON, E. C. ENGLAND

Manufacturers of the world known COMPACTOPHONE—the most complete portable gramophone extant—beg to announce the conclusion of arrangements for the EXCLUSIVE SELLING RIGHTS IN THE UNITED STATES OF THE

High Grade Motors Manufactured By **Mermod Freres** St. Croix Switzerland

WONDERFUL MECHANISM

These motors represent the acme of workmanship and quality. Each part is made to the finest gauge limits and assembled to run with the precision of a watch—silent and true. Messrs. Mermod Freres is an old established Swiss manufacturer. Back of their motors are years of hard practical experience. The experimental stage was left behind a decade or more ago. Reliability and quality are therefore assured.

DIFFERENT MODELS

Mermod Freres motors comprise several types—single and double spring worm and pinion-gear drive, the very latest and scientific method of construction.

CONSULT US

Before placing your orders elsewhere consult us as to prices and terms of trading. We are out for quick shipments and prompt delivery direct from the factory to the buyer.

SPECIAL TERMS TO JOBBERS

Within the near future it is proposed to establish
A CENTRAL DISTRIBUTING DEPOT IN NEW YORK
Meanwhile trade inquiries should be directed to

THE STERNO MANUFACTURING CO.

19 CITY ROAD

LONDON, E. C., ENGLAND

Caravan Convention of Edison Dealers an Immense Success

Program, Including Five Playlets by Wm. Maxwell, Addresses by Noted Personages, Business Discussions and Tone Tests, Presented in Succession in New York, Chicago and San Francisco—Convention Ends With Big Banquet—Hosts of Dealers in All Sections in Attendance

The Edison Dealers' Convention this year was in the form of a distinct novelty, the convention being divided into three parts, held respectively in New York, Chicago and San Francisco, with a view to saving time and money to the majority of the company's dealers.

By this arrangement a large number of dealers located in the Middle West and on the Pacific Coast, who heretofore could not spare the time to come to New York to attend the former conventions, were given the opportunity to participate in the biggest and most unique trade convention ever held, by having the convention brought to them. And participate they did.

Originality was an outstanding feature of every part of the program, which fulfilled in every way its purpose to demonstrate that the

business. All day they came, and the second day, too, until it began to appear as though the well-worn phrase, "Standing room only," would be the only answer to greet the late-comers desiring seats. Virtually all Broadway took notice of the event, which was new even to that famous thoroughfare.

T. J. Leonard Opens Convention

Promptly at the designated hour, Thomas J. Leonard, general sales manager of the Edison Laboratories, stepped out on the stage and made the address of welcome. At the end of his address the house curtain rose, exposing the special Edison Caravan Convention drop curtain, whereupon he introduced the chairman of the convention, F. F. Christine, Edison dealer at Stroudsburg, Pa.

Wm. Maxwell's Address

Immediately following the formal opening, William Maxwell addressed the dealers on behalf of the Edison Laboratories in a talk entitled, "Judge Them By Their Deeds," in which he said:

"A long, long trail—it has been all of that. You and we have met many adversities and endured many disappointments. The weight of these has rested heavily upon all of us—perhaps upon no one more heavily than upon myself. However, as I look back over the past six years, a somewhat consoling thought comes to my mind. This is the thought: If everything had been smooth sailing from the beginning we would not be here to-day. We would still be hedged about by the traditions of the talking machine business. There would be no Edison spirit, such as is manifested here this morning, and Edison salesmanship would not be what it is to-day—a thing utterly apart from talking machine salesmanship.

"The hand of Providence, guiding the genius of Edison, has placed in our custody an instrumentality which, if properly employed by us, will make music, next to religion, the greatest and best influence in the world. In the hard school of adversity we have been purged of the methods and have cast off the limitations of the talking machine business. We have been made fit for the part that we are to play in the destiny of the greatest human art—music.

"I regard my appearance here to-day as a sort of farewell appearance. For several years I have come before you dealers with apologies for the past and promises for the future. The need for this is passing into oblivion and when the tour of the Caravan Convention is ended I shall drop forever the role of official apologist. I hope to attend a great many Edison Conventions in the future, but this is the last convention at which I shall offer the slightest word of excuse for non-performance on the part of our manufacturing laboratories.

"A year ago you had three chief causes for concern:

"First—The supply of cabinets.

"Second—The surface of the Re-creations.

"Third—Increased production of Re-creations.

"We promised to make good on cabinets. We have done so.

"We promised to give you a smooth Re-creation. We have done so.

"The third question looms large in your minds to-day. We have arrived at a point where it is possible to place a business man in charge

of the Re-creation manufacturing laboratories. We have reached a stage where it is possible to divorce experimental work from manufacturing operations. The manufacturing technique has been stabilized to an extent that makes it safe to design automatic machinery to facilitate production. In other words, we are all set. The proposition has been turned over to Fred C. Pullin, who was recently appointed manager of the Re-creation manufacturing laboratories. Mr. Pullin regards his appointment as the one big opportunity of his career and he expects to achieve a success that will be almost startling in its scope and character. As all of you know, mould production is the neck of the jug in the manufacture of Edison Re-creations. Mr. Pullin is devoting most of his attention to the proper distribution of mould production and, like a good



T. J. Leonard

phonograph is not a luxury, but a definite need in American home life. Numerous phases of Edison phonograph salesmanship were illustrated in a striking way through the medium of five brilliant business plays, written by William Maxwell, in charge of the phonograph industry at the Edison Laboratories, whose former productions of a similar character have created wide attention throughout the entire advertising field. Another highly interesting feature was that of having a number of celebrities, including an eminent psychologist and an American composer of international fame, address the dealers on subjects vital to their interests. In addition to this, the program included a tone-test by a widely known Edison artist and the presentation of a living picture of the September magazine advertisement, through the courtesy also of an Edison artist highly popular with the dealers. A series of open forums, in which the majority of dealers participated and without which no Edison Dealers' Convention would be complete, likewise came in for its share of interest.

Long before the opening hour on July 8, dealers began to arrive in twos and threes from all points of the compass. By 10 o'clock, the hour set to begin, the Knickerbocker Theatre, that famous Broadway playhouse, was well filled with expectant dealers, primed for immediate



William Maxwell

general, is accumulating reserves. This plan is temporarily limiting production, but in a very short time, when his reserves are completed, he will have his production stabilized so that future supplements and reissued blocks of catalog numbers can be put through exactly on schedule. For example, all of the moulds for the November supplement will be completed before a single print is made. Then all of them will be put on at the same time and the end of the run can be calculated almost to an hour.

"You will perhaps wonder why this has not been done in the past. Some of you undoubtedly have had sickness in your homes, which required the presence of trained nurses, and you will recall, no doubt, that the diet cooking in the kitchen was very disturbing to the regular culinary operations of the household. The experimental work, which for several years has of necessity been done in the manufacturing laboratories had about the same disturbing effect on manufacturing operations as a trained nurse's activities produces in the family kitchen.

"The experimental men have done a good work. We owe a great deal to them, but we are glad to see them leave, just as any family is glad when the trained nurse's services are no longer needed.

"Disc Re-Creation manufacture is up to Mr. Pullin and his assistants. He is unfettered and
(Continued on page 208)

CARAVAN CONVENTION OF EDISON DEALERS AN IMMENSE SUCCESS—(Continued from page 207)

untrammled. All of the money that he needs will be placed at his disposal. The results will speak for themselves. I have unlimited confidence in Mr. Pullin and I believe that my confidence is shared by all of you.

"Stabilized production means the prompter issuance of timely selections and this is an accomplishment which we have very definitely in mind. I think adequate provisions have been made to insure that in the future so-called hits will be issued in timely season.

"Stabilized production also means that we can deal with new talent more intelligently and satisfactorily than has been true in the past. We have recently contracted with and shall shortly announce the engagement of a woman whom we consider is destined to earn recognition as the world's greatest dramatic soprano. Other important negotiations are pending and from time to time there will be news of interest and moment. We particularly welcome the opportunity to compare our Re-Creation of an artist's performance with talking machine reproductions thereof and we hope for noteworthy developments along that line.

"All of you know that the general business conditions which prevail to-day were anticipated by us many months ago. All of our plans during the past twelve months have had these conditions definitely in mind and they can be turned to your advantage if you will only take the proper steps. Your banker can give you the necessary line of credit and will do so, if you will make an Edison booster of him. I hope that every one of you here to-day who has not already sold an Edison phonograph to his banker will go home with the determination to do so. Convert your banker into an Edison enthusiast at the earliest possible moment.

"You are all aware that Edison prices have increased less than 15 per cent since 1914 and that a portion of this increase is war tax. Other manufacturers, in the same period of time, have made increases ranging from 50 per cent to 100 per cent—and I say to you, as a matter susceptible of absolute and indisputable proof, that our margin of profit in 1914 was narrower than that of any other established manufacturer. Mr. Edison passed up millions in profits he might have made and stood the gaff in order to insure the future of this business. Many dealers are now beginning to cash in on this far-sighted policy. Every one of you should do so. The



Dr. W. V. Bingham

public will be increasingly slow to buy, unless it is satisfied that prices are right. You all know that Edison prices are right, and it is up to you to let the public know what you know. We may have to increase our prices this Fall, but we shall make every effort to avoid doing so.

"Before concluding I want to say a word about the fourteen sales propositions. They were prepared because we believe there would be a slowing up of general business in 1920. These propositions, properly carried out by you and the laboratories, will overcome any tendency on the

part of your public to curtail its buying. This has already been demonstrated in localities which have been acutely affected by the transportation tie-ups. A 100 per cent increase in your business this year is not too much to expect. The business is waiting for you, if you will go and get it.

"This convention will sound a new note in Edison merchandising. It marks the beginning of a new epoch in the music trade. All of us have learned how to sell music, as music, but the great big outstanding thing about music is what music will do for you, and, when we have learned to sell that—in other words, 'The Thing Beyond the Thing Beyond'—we shall have made



Thos. A. Edison

the Edison phonograph business as solid as the flour business, or the meat business, or any other business that deals in the necessities of life.

"We have traveled a long, long trail together. At times the road has been difficult, but we have surmounted the difficulties, and to-day we are where we can look down into the enchanted valley and see spread before us in beautiful prospect the realization of all of our dreams. What we see is not a mirage. It is a reality—a reality which means profits and prestige for all of you, but, above and beyond that, the satisfaction of knowing that you are engaged in a great and constructive work."

Sales Aid Service Discussed and Demonstrated

Sales Aid Service, the first of the sales promotion plans to be discussed, was introduced in a striking way by the presentation of "It," a comedy in one act, and the first of the plays on the program. The scene took place in the living room of a cottage and showed how a live Edison dealer gives Sales Aid Service to the Edison phonograph owners in his community. After overcoming, one by one, the numberless objections put up by the lady of the house, the salesman-inspector finally succeeds in transforming a not too enthusiastic owner into a live Edison booster. Then followed the open forum, led by J. J. Menton, of Paterson, N. J., and a discussion of canvassing, another closely related subject, led by H. Lester Marvil, of Waycross, Ga.

Dr. Bingham's Interesting Talk

"The Thing Beyond the Thing Beyond," or "What Music Will Do For You," the most talked of subject in the Edison business, and referred to by Mr. Maxwell in his address as the big outstanding thing about music which all interested in the Edison phonograph business must sooner or later learn to sell, was the subject of the next address shown on the program and was made by Dr. W. V. Bingham, director of the Division of Applied Psychology at the Carnegie Institute of Technology at Pittsburgh. At the International Musical Congress in Paris, in 1914, just before the war broke out, Dr. Bingham read a paper summarizing the results of all the research that has been carried out by means of the phonograph, in studying exotic music, the songs of savages and primitive peo-

ples in all parts of the world, and his fondness for music leads him to be particularly concerned about the effects of music on human nature.

The Second Edison Play

"I Saw Your Ad," according to the program "A near allegory—at any rate, not a play," followed, and depicted the right and wrong way to give the realism test, one of the psychological factors in selling the New Edison. The open forum on this subject was led by S. A. Phillips, of Morgantown, W. Va.

"After the Nut Is Off"

"After the Nut Is Off," another comedy, opened the subject of compensation of salesmen, the discussion of which was led by H. W. Brooks, of Springville, N. Y.

THE SECOND DAY'S PROGRAM

On the second day, the enthusiasm was even greater than on the first. Perhaps this was because the kind of enthusiasm nurtured by Edison dealers is of a particularly contagious sort, or perhaps it was because so many big things were promised for the second day.

Message From Thos. A. Edison

The sessions opened with military promptness and began with a message from Thomas A. Edison, entitled "Ten Years From Now," and delivered by his son, Charles Edison.

"Ten years on the calendar, or in the life of a man, is a considerable period of time, but, when we build for the future, a decade is a small measure.

"There are several major arts, and, of these, music, in my opinion, is the greatest. The masterpieces of music appeal to practically everyone, because the appeal is in a language that is understood by everyone. Literature, painting and sculpture, even in the Golden Ages of those arts, had a restricted circle of appreciation, for the reason that many of the higher manifestations of literature, painting and sculpture require education as a prerequisite of appreciation. Not so with music. If a man tells you he has written a masterpiece of music which is not understood, or appreciated, by the public, he states what is a manifest absurdity. The real masterpieces of music live on, from gen-



Chas. Edison

eration to generation, because in theme and form they are concordant with those finer emotions which we call the best impulses of the human heart.

"From the earliest days of which we have any history, or traditions, music has been recognized as capable of exerting a great influence for good upon the human mind. However, the

CARAVAN CONVENTION OF EDISON DEALERS AN IMMENSE SUCCESS—(Continued from page 208)

influence of music has heretofore been restricted, because the number of competent musicians is comparatively small, and music, unlike books, could not be multiplied at will and distributed throughout the world at a cost within the reach of everyone.

"The phonograph did much to change this condition, but the ordinary phonograph, as we have known it, had rather definite limitations and fell somewhat short of conferring upon its owner all of the pleasure and benefits that can be derived from good music. The greatest shortcoming of the phonograph was its lack of realism, and, as you know, it is this shortcoming which I have sought to overcome. The re-

phonograph in every American home. What I want to see in every American home is music, so realistic and so perfect in its rendition as to be an unending source of benefit and pleasure. To this object I am prepared to devote every energy and all of the resources at my command. We do not contemplate radical changes which will disturb and embarrass you, but we intend to progress in such a way as to keep constantly alive the public's interest in music, and in our phonograph, as the most comprehensive means of enjoying the benefits of music.

"The business management of our phonograph industry will shape our business policies in a way that is calculated to meet every con-

by many to be the most beautiful woman on the American stage, took part in each of the plays, as did J. Sydney Macy, who was remembered by dealers as having created the part of "Zebulon Old Father" in last year's convention. Gene Lockhart, who played the comedy parts, was uproariously funny, and his singing between the scenes of the plays was particularly well received. All of the plays were under the direction of D. B. Babcock and J. S. Macy. The scenery was from the studio of John H. Young.

A Live Advertising Talk

"The Hook in Advertising," the next subject on the program and a dominant feature of this year's national Edison advertising campaign, was



1



2

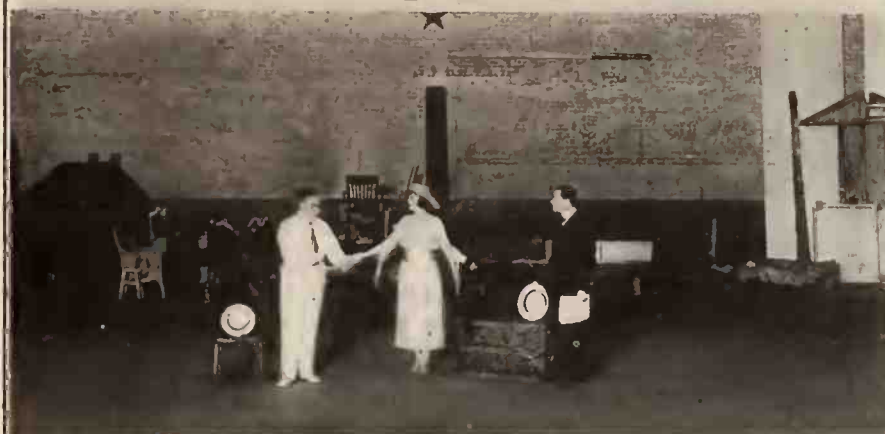

3



4



5

Scenes from the Five Plays Presented During Edison Dealers' Convention

- 1. "It"; 2. "I Saw Your Ad";
- 3. "After the Nut is Off";
- 4. "Detected"; 5. "I'll Say She Did".

sult is a degree of realism in our present phonograph which is baffling to even the most expert ears.

"We now have a phonograph which suits me very well and a method of manufacturing our records, or re-creations, that gives us a very satisfactory product. In fact, our present product accomplishes the first phase of my ambition to bring the full benefits of music within the reach of everyone, no matter where he may live.

"The circumstance that we have such an instrument places upon you dealers and upon us a certain ethical responsibility to the public. In discharging this responsibility we are likely to be well paid for our efforts, but I desire to impress upon your minds that the natural development of this business will tend to make you exponents of a great art, as well as distributors of merchandise.

"I have been quoted as desiring to see a

condition that will arise, and to stimulate a steady growth of your Edison phonograph business.

"Ten years from now I believe that our phonograph will be recognized throughout the world as the greatest factor in music, and that the benefits of music, as re-created by our phonograph, will be so universally recognized that this industry will be admitted to an undisputed place among those most essential to the mental and moral well-being of the human race.

"I feel that you can safely rely on the Edison phonograph business as a permanent and enduring business and I give you my assurance that we shall spare neither money nor effort in that behalf."

The Cast of the Plays

The cast for the plays, chosen for its ability to characterize the kind of individuals common to the life of the average Edison dealer, did its part in an excellent manner. Miss Vera Leonard, recently in "Aphrodite," who is considered

discussed by John Lee Mahin, representing the Federal Advertising Agency, which is now handling the Edison national advertising copy. Mr. Mahin is the man who coined the word "Certainteed," persuaded the N. K. Fairbanks Co. to change Fairy Soap from an oblong to an oval cake, and had a negro waiter in a Chicago restaurant photographed to make the well-known Cream of Wheat trade-mark. His talk was particularly interesting to the dealers.

Thomas Chalmers in a Tone-Test

Thomas Chalmers, considered the most popular American grand opera baritone, then created a furore by appearing in an Edison tone-test, similar to those which have been witnessed by more than two millions of people since their inauguration a few years ago. Mr. Chalmers enjoys the distinction of having sung more roles at the Metropolitan in recent seasons than any other baritone. His popularity as an Edison

(Continued on page 210)

THE EDISON CARAVAN CONVENTION

(Continued from page 209)

artist brought added interest to the occasion and the performance was received with considerable enthusiasm, expressed in the generous applause which followed and which delayed the progress of the convention for many minutes.

A Talk on "American Music"

"American Music," by an American composer whose work has won him international fame," is the way the next number appeared on the program. Henry Kimball Hadley, who perhaps has done more than anyone else to gain world-wide recognition for the modern school of American symphonic music and opera, and who has composed more than two hundred pieces of music of every classification, was particularly



Prof. Henry Kimball Hadley

qualified to address and interest the dealers on the subject chosen.

"I'll Say She Did"

Another of William Maxwell's plays entitled "I'll Say She Did" then followed and opened the subject of window displays, after which the open forum was opened by Harry Somers, of Philadelphia, who talked on "The Worth of Windows." D. B. Babcock, who is associated with the Edison Laboratories, also spoke on the subject of "Window Displays."

Living Picture of September Advertisement

After this came a presentation of a living picture of the September magazine advertisement, through the courtesy of the great xylophonist, Signor "Friscoe," also highly popular as an Edison artist. Since the inauguration of the 1920 sales promotion plans by the Edison Labora-

tories, of which the advertising campaign is by far the most popular, Edison national advertising has excited considerable comment throughout the entire field and probably has attracted the attention of more people than any other



Thos. Chalmers, Baritone

phonograph advertising. The advertisement to appear next September will feature Signor "Friscoe," whose popularity and distinction were well described in the remarks made by the chairman in introducing him.

The Diamond Amberola

The Diamond Amberola also came in for its

share of the glory. With the orchestra playing "You'd Be Surprised," J. W. Scott, Amberola supervisor, and for many years associated with the Edison Laboratories, stepped out on the stage and talked to the dealers on his favorite subject. While he has no ill-feeling toward the disc, Mr. Scott regards the Amberola as the one best bet and his enthusiasm grows greater year after year. He is known personally to Edison dealers in every State of the Union and throughout Canada and probably no one in the Edison organization is better fitted to discuss the little brother of the New Edison disc.

As a result of Mr. Scott's remarks, dealers immediately caught the contagion of his unbounded enthusiasm and many expressed the opinion that this year will establish a record in the history of the Diamond Amberola business that will exceed all expectations.

Edison re-creation concerts, another one of the Edison sales propositions, was also a topic of discussion, led by Harry Meyer, of Pittsfield, Mass.

The last of the plays was a farce comedy in one act entitled "Detected," the scene of which took place in an Edison dealer's demonstration room and which introduced the subject of the turn-table discussion of which was led by A. D. Elster, of Meriden, Conn.

Conventions in the West

At the Blackstone Theatre in Chicago, where the New York convention was duplicated on July 12 and 13, the same interest and enthusiasm prevailed. The attendance in both of these cities exceeded all expectations and included many dealers who had not registered in advance, but who had decided at the last minute that they could not afford to miss the event.

The program was alike throughout, except for the fact that a different dealer chairman presided at each of the conventions and that the discussions by dealers were led by different dealers.

At Chicago the chairman was James P. Lacey, Peoria, Ill., and the discussion on Sales Aid Service was led by William Scott, of Chicago, while that on Canvassing was led by Clarence Ream, of Fairmount, Minn. Berthold J. Newburger, of Joplin, Mo., led the open forum on the Realism Test, and the Compensation of Salesmen was discussed by J. Adam Reinmund, of Muscatine, Ia.

The subjects on the second day, namely, The Worth of Windows, Re-Creation Concerts and the Turntable were led at the Chicago meeting by A. F. Odell, of Quincy, Ill., William Ritt, of St. Peter, Minn., and Lowell Neff, of Logansport, Ind.

Following the Chicago meeting, the convention will be held at the Columbia Theatre, San Francisco, Monday and Tuesday, July 19 and 20. In San Francisco the chairman will be James T. Fitzgerald, of Los Angeles. The discussion on Sales Aid Service will be led by Mark A. Sawrie, of Selma, Cal.; on Canvassing by R. J. Coates, of Jerome, Idaho; on the

Show Windows vs. Sales Windows

THE conversion of your dealers' windows from *show* windows into *sales* windows is grounded in practical merchandising, sound advertising and a perfect adaptation of definite art principles.

To sell goods is the preconceived object and the *test* of an Einson Litho window display.

To the creation of selling windows and other Lithograph material the Einson Litho brings an organization of thoroughly schooled merchandising men and experienced advertising men who express themselves through the medium of a completely equipped art studio and a modern lithograph plant.

National advertisers who desire to capitalize their dealer opportunities will find food for thought in our "Portfolio of Selling Windows"—sent upon request of an executive.

EINSON LITHO INCORPORATED

NEW YORK
71 WEST 23rd ST.

CHICAGO
332 S. MICHIGAN AVE.

CARAVAN CONVENTION OF EDISON DEALERS AN IMMENSE SUCCESS—(Continued from page 210)

Realism Test by H. N. Jamison, of San Francisco, and on the Compensation of Salesmen by F. K. Joslyn, of Riverdale, Cal. The several discussions in the second day session were

led by H. E. Roberts, of Wenatchee, Wash.; S. S. Hockett, of Fresno, Cal., and W. J. Carson, of San Francisco. The various talks were greatly enjoyed by all in attendance.

pany, Cecil Cunningham, who was superb in her imitations; Walter Kelly, the far-famed judge from a Virginia court; Keegar & Edwards in song and dance, the Farber sisters in their comedy songs; Robins, the walking music store; Eddie Cantor, with his spicy Ziegfeld songs; Leonia LeMar, the bewildering psychic and mind-reader, and the Causinos in Spanish dance. The dinner lasted late, as has been previously
(Continued on page 212)

The Banquet on Friday Night

On the evening of July 9, as a fitting climax to the entirely successful Edison Caravan Con-

Jazz Band, Mang & Snyder, the celebrated tumblers; Pat Rooney and Marion Bent and com-



Those in Attendance at the Caravan Convention of Edison Dealers in New York, July 7 to 9

vention held in New York City, the Edison jobbers of the Eastern section of the United States tendered a sumptuous banquet in honor of and to the Edison dealers who had attended the two-day session at the Knickerbocker Theatre. The banquet was set in the Grand Ball Room of the Hotel Commodore, which was filled to capacity and decorated along patriotic lines. At one end was a well-constructed stage, in front of which sat, or rather for the most part played, Earl Fuller's Orchestra.

The hosts of the evening, to be more specific, were the Edison jobbers of Albany, Atlanta, Boston, Montreal, New Haven, New York, Pittsburgh, Philadelphia, Richmond, St. John's, Syracuse, Toronto and Williamsport.

Preceding the banquet the dealer-guests, the jobbers and the representatives from the Edison Laboratories joined in a reception held in the grand foyer. Then the doors to the banquet hall opened and from that time on everybody tried to simultaneously look, listen and eat.

The dinner itself was a marvel of the epicurean art. It lasted from eight till one in the morning, during which time there was a steady entertainment provided by what the program too modestly described as "some of the highest-class vaudeville performers on the stage to-day." This dinner show talent was secured through the private entertainment bureau of the B. F. Keith Theatres and staged under the personal direction of Frances R. King. Every act was of the kind that is used to electrify Broadway. Among the artists were the Mason & Dixon

THE NEW EDISON
THE PHONOGRAPH WITH A SOUL

from

SYRACUSE, N. Y.

By

FRANK E. BOLWAY & SON, Inc.
Exclusive Edison Distributors

CARAVAN CONVENTION OF EDISON DEALERS AN IMMENSE SUCCESS—(Continued from page 211)

stated, but with talent like this garnishing the festive board it is easily manifest why everyone was on the tip of his toes through this notable dinner.

But that was not all. When the dinner, with its dinner show, reached the finale an impromptu concert was given by a number of Edison Recreation artists who attended the banquet. William Maxwell took the floor to introduce them, but before proceeding with the concert proper called for a three-cheer vote of thanks for Mr. Christine for his excellent work as convention chairman and for Ernest Cutting, director of Earl Fuller's Orchestra. Both were given with a right good and sonorous will, and right here we want to add that Mr. Christine fully qualified as a super-good convention leader and Ernest Cutting batted throughout the convention somewhere up in the Babe Ruth class.

The first Edison artist to sing was Marie Rappold, of the Metropolitan Opera Co. She was followed in turn by Helen Clark, Al Bernard and Ernest Hare, Cecile Arden, of the Metropolitan Opera Co.; Gladys Rice, Helen Davis, Signor Friscoe, on the xylophone; Betsy Lane Sheppard, Thomas Chalmers, of the Metropolitan Opera Co., and Marie Tiffany. Each one of the Edison artists sang beautifully and the informal character of their concert went far toward promoting a feeling of personal friendship between the artists and the men who are out on the firing line offering their Re-creations to the American public.

William Maxwell closed the concert by calling for a rising vote of thanks to the Edison jobbers for their wonderful hospitality, after which the "call of the dance" held sway until quite late in the morning.

Banquets in the West

Similar banquets were rendered by the Edison jobbers of the Middle States, when the caravan reached Chicago in the Medinah Temple, and by the West Coast Edison jobbers in San Francisco at the St. Francis Hotel.

How Edison Promotes Research Work

For nearly a year, Thomas A. Edison has been promoting research work, for the purpose of analyzing the mental and emotional reactions of human beings to music. Dr. W. V. Bingham, director of the Division of Applied Psychology at the Carnegie Institute of Technology, has been in charge of the work, assisted by Dr. C. H. Farnsworth, of Columbia University, and other internationally known authorities. The entire expense of the research work is being defrayed



Mme. Marie Rappold

by Mr. Edison and the results are to be dedicated to the public.

While it is not probable that the results of Dr. Bingham's work will be revealed to the

Over the Sands With the Caravan

The Edison Caravan Camels Hump a Few.

The dealers and others attending the Edison Convention without exception followed the advice offered in the program which read: "Don't take any wooden money—or alcohol. Despite what is said by one of the characters in the skit, 'After the Nut Is Off,' there is no perfectly safe booze for sale in New York."

And yet, at that, during the repartee between Signor Friscoe, the mighty xylophonist, and members of the audience, when Friscoe said it couldn't be had in New York, some Convention-ite rejoined that he would get it if Friscoe would pay.

public for some little time, it is understood that very definite principles of mental reaction to music are revealing themselves and that the real value of music to humanity will be much better understood in the future than has been the case in the past.

Another of Mr. Edison's ambitions is to develop widespread interest in music on the part of the American people, and he recognizes that, to accomplish this, typically American standards of judgment must be created. The Edison Laboratories consider themselves exceedingly fortunate, therefore, in being able to induce Henry Kimball Hadley to address the dealers at the conventions on this vital subject.

Mr. Hadley's career qualifies him adequately to speak on this subject. At the age of twenty he composed his first orchestral piece, the overture "Hector and Andromache," performed in New York under Walter Damrosch. Since then Mr. Hadley has composed over two hundred pieces of music of every classification—many of which he himself conducted with the world's greatest orchestras.

His work is modern in freshness and buoyant individuality. The gift of melody is his in greater degree than it is of any other American composer.

Another thing the Friscoe act brings to mind is that beautiful rendition by a certain young lady of the Humoresque. "Humty-ump-tee"—remember?

Earl Fuller's orchestra certainly was on the



The Edison Caravan Train Under Way

job in superlative form during the caravan.

As a sales manager and chief executive of the phonograph division, William Maxwell is a great playwright. As a playwright he makes a darn good salesmanager and chief exec. All of which means he rings the bell at both.

The recently appointed advertising manager, R. B. Gregg, thought he was going to get a joy ride all the way to California without having to make a speech, but John Turner brought him into a nicely handled discussion on envelopes.

F. F. Christine as chairman of the New York Caravan, certainly looked like a million plus in his form-fitting buff alapaca—or was it a Palm Beach.

Frank E. Bolway and his "on-your-toes" associates from Syracuse were certainly real enthusiasts. Not surprising, for the "Salt City" is "some" town.

When last seen in New York the Caravan was boarding the Twentieth Century for Chicago. The Edison Caravan travels on a pretty speedy camel, n'est-ce pas?

Mrs. Hadley certainly sang beautifully, when her talented husband, Prof. Hadley, played a few of his original compositions at the close of his address on American music.

The press owes a vote of thanks to Mr. Wheeler for his hearty co-operation.

Quality Sapphire Needles

FOR PATHE

FOR EDISON



Grand Prize and Gold Medal

AMERICAN MANUFACTURED

SAPPHIRES

Highest Grade—Finest Workmanship

Book Your Orders Now for the Fall Season

JOHN A. BOTTA Suffern, New York

The Best Phonograph Wins

and the best phonograph is the one equipped with the best motor.

Insure your future business by installing the

Universal Master Motor No. 20

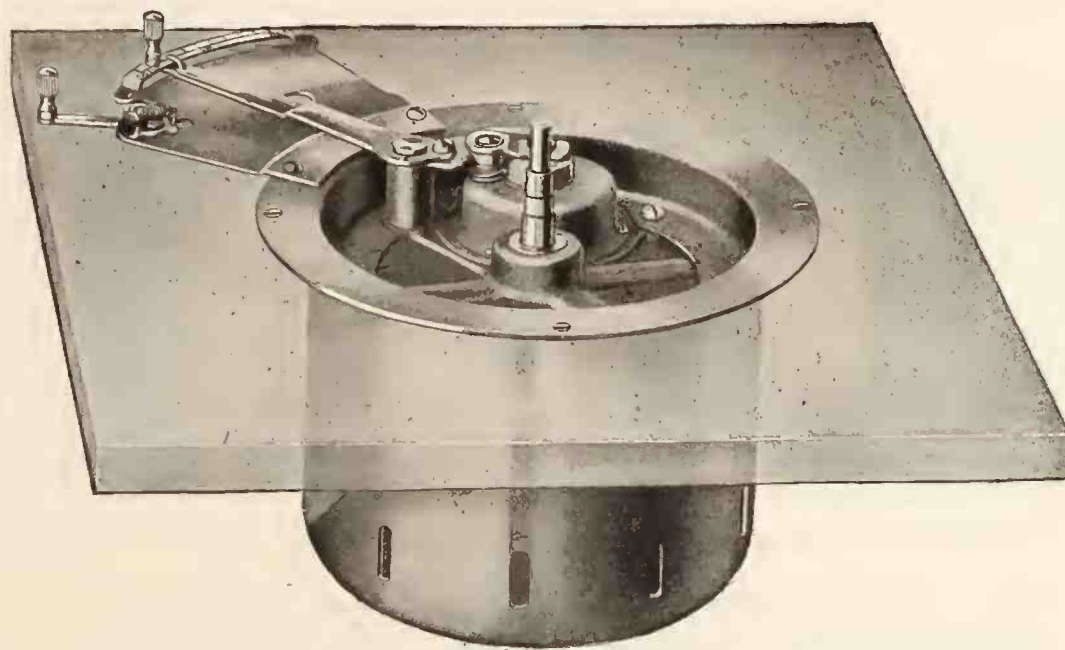

Let the Universal Master Motor No. 20 sell your Phonographs. Its unique and dependable features are talking points that will solve your selling problem.

*We are still able to take on a few more customers
so write or wire immediately if interested*

Universal Stamping & Mfg. Co.

1917-1925 S. Western Ave., Chicago

UNIVERSAL

ELYEA COMPANY HAS NEW LOCATION

Idea Shop Is Attractive Feature of New Home of Atlanta Concern—W. R. Lewis Now Traveling Representative in Southern Territory

ATLANTA, GA., July 7.—The Elyea Talking Machine Co. is now permanently located in the new

shown in the accompanying photograph. A close inspection of the photograph will show a small model Victrola painted in white, decorated with small animals appealing to children. This talking machine was gotten up especially for use in furthering the sales of children's records. It is one of the many original ideas which Mr.



Service Department and Idea Shop of the Elyea Co., Atlanta, Ga.

quarters next door to the Elyea Co., from which it is an outgrowth. The interior not only in-



B. F. Bibighaus, Mgr. W. R. Lewis, Trav. Rep. cludes spacious executive offices, but also a service department and idea shop, which is



Bibighaus is successfully putting into practice. Since B. F. Bibighaus became manager of the company he has instituted this idea shop, which he believes is only a small part of the service which a Victor jobber can render Victor dealers. The recent appointment of W. R. Lewis as traveling representative of the Elyea Co. proves even more conclusively that the new policy of the company is that of co-operation with their clients. W. R. Lewis has been connected with the Victor Co. and has had much practical experience in furnishing sales ideas in sales promotion important to Victor dealers.

The man who advertises for three months and quits is a great admirer of staying power in a horse.—Class Magazine.

TO PRESS RECORDS IN BROOKLYN

Densite Products Mfg. Co. Now Equipping a New Factory in That City

The Densite Products Mfg. Co., New York, has secured a two-story factory building in Brooklyn and is installing a record pressing plant, which it is believed will be ready for operation about August 1. The company's capitalization was increased recently to permit expansion in the record field. H. E. Marcus is president of the company, L. Carr is treasurer, and S. Carr, secretary and general manager. S. Carr is a graduate engineer and has specialized in industrial and consulting engineering work.

TO DISTRIBUTE NEW NEEDLE

Andrew H. Dodin Secures Eastern Agency for the Fletcher All-Tones Needle.

Andrew H. Dodin, well-known talking machine repairman and dealer, at 28 Sixth avenue, New York, has just secured the distributing rights for New York and vicinity for a new semi-permanent talking machine needle known as the Fletcher All-Tones Needle, the invention of Theodore Fletcher, of San Antonio, Tex. The needle is so made that by changing its position in the needle holder it can be made to play loudly or softly as the occasion demands, and it can be made also to produce practically any intermediate volume of tone.

Mr. Fletcher, inventor of the needle, together with M. B. Nix, also of San Antonio, are at present in New York for the purpose of demonstrating the model of a new type talking machine and a new recording process which when perfected will make it possible to produce records that will play for twenty minutes or more and carry practically the whole score of an opera.

The lull in retail buying should serve to bring out some real salesmanship.

**TALKING MACHINES OF THE HIGHEST STANDARD
HAVE TURNTABLES EQUIPPED WITH**



GRAND PRIZE
GOLD MEDAL

A.W.B.
Boulevard
VELVETS

ST. LOUIS
EXHIBITION

VELVETS, VELVETEENS, PLUSHES

Add to the Quality and Attractiveness of Your
Machines and Use A. W. B. Boulevard Velvets

Write for Samples and Prices

A. WIMPFHEIMER & BRO., Inc.

ESTABLISHED 1845

450-460 FOURTH AVENUE

NEW YORK

CHAMBER OF COMMERCE ORGANIZES AN EXPORT BUREAU

Gathering of Directors of the Music Industries Chamber of Commerce at Atlantic City Productive of Excellent Results—Export Bureau to Be Established and Monthly Bulletin Issued

ATLANTIC CITY, N. J., July 4.—One of the outstanding features of the well-attended meeting of the directors of the Music Industries Chamber of Commerce, held at the Hotel Traymore recently, was the decision to add a new Export Bureau to the Chamber's department, the new Bureau to be in charge of an experienced export man and equipped with proper facilities for carrying on the work for the entire industry.

The directors also voted to publish monthly an official bulletin of the Chamber. This monthly publication will be sent to all of the members of the various member associations of the Chamber and individual members, comprising a total mailing list of about 3,500. It is distinctly a house organ of the Chamber and will not carry



© Underwood & Underwood
Richard B. Aldcroftt, President

any advertising. It will contain the monthly reports of the activities of the various bureaus of the Chamber and information concerning the purposes of the Chamber and other material of interest to the members.

The next convention of the Chamber and its annual meeting will be held in May at the Congress Hotel in Chicago, the exact date to be settled by the president, after consultation with the officials of the various member associations, who will hold their convention at the same time.

The former standing committees of the Chamber have been abolished and the president was instructed to reappoint the salaries and finance committee with additional committees, so that it will be representative of all branches of the industry and also to appoint the following committees: Legal and legislative committee, better business committee, committee on the advancement of music, export committee and trade information service committee.

These committees will be advisory committees for the various bureaus of the Chamber and will be available for consultation by the bureau in question and will make investigations, reports and recommendations to the directors for action upon matters of policy and activity.

The general manager was instructed to take measures preparatory to the incorporation of the Chamber, which at present is an unincorporated association. The final details connected with the incorporation will be passed upon at the next meeting of the board. In connection with the incorporation there will also be a revision of the constitution and by-laws of the Chamber, made necessary by growth and enlargement of its activities.

The committee considered and voted favorably on referendum 31 of the Chamber of Commerce of the United States of America, being the report of the Special Committee on Public Utilities concerning regulations of employment relations to public service corporations.

The directors voted to contribute to the erection of a building in Washington for the Chamber of Commerce of the United States, which will serve as headquarters for the nation's business in Washington. This is in accordance with the policy of the Music Industries Chamber of Commerce to co-operate with the National Chamber upon important business questions of a national character affecting this industry.

GETS IMPORTANT REPRESENTATION

L. A. Schwarz, manufacturers' representative, New York City, has recently been appointed representative of the Penn Victor dogs for his territory. During the Victor convention week he served as representative of the Penn Phonograph Co., of Philadelphia, in promoting their famous plaster paris miniature of the Victor dog.

INCREASE DELIVERY FACILITIES

DES MOINES, IA., July 6.—Mickel Bros. Co., of this city, Victor distributors, have added another motor truck to their delivery facilities, in order to co-operate with the dealers in this territory. H. A. Sixsmith, sales manager of the company



at Des Moines, returned recently from the Victor jobbers' convention at Atlantic City. He is enthusiastic regarding the outlook for the Fall season, and predicts that the Victor dealers in this territory will close the greatest business in their history.

Repeating Phonograph

We have developed an entirely new instrument which marks a new era in the Talking Machine industry.

The outstanding feature is the equipment of each of these new phonographs with our patented

BUILT IN

*Automatic Stop,
Automatic Starter,
Automatic Repeater.*

Repeats entire record or any part of it as you choose.

This wonderful new feature is not an attachment; it is an integral part of the complete talking machine.

Operated With The Motor. The only parts which show are two small buttons and the rest for the needle.

Simple Control. One of the buttons operates the repeating device. The other, at a touch, gives either continuous playing or stop, as desired.

Stop-Lock. The automatic stop locks as soon as the needle is pressing on the rest. When pressure is relieved turntable at once revolves.

Accuracy. The repeating device is so accurate that it replaces needle in the exact starting groove, placing the needle on record lighter than is possible by hand.

TO ASSURE PROMPT DELIVERY ONLY ONE MODEL IS BEING MANUFACTURED—ALL PERTINENT INFORMATION GLADLY FURNISHED TO THOSE WHO WRITE FOR JOBBER'S or DEALER'S PROPOSITION TO

The Singerphone Company
MILWAUKEE, WISCONSIN

VOCALION TRAVELERS' CONVENTION HELD IN NEW YORK

Managers and Travelers from Aeolian Co. Branches and From Jobbing Houses Attend Interesting Series of Business Conferences—Program Covers Five Days

There was held at the headquarters of the Aeolian Co., New York, this week the first general convention of the Vocalion travelers, for which a most interesting and elaborate five-day program had been prepared, with business and pleasure mixed in just the right proportion. The convention was attended by managers and travelers of Aeolian Co. branches in various cities of the country, together with managers and other representatives of Vocalion jobbers.

Those who attended the convention were formally welcomed by W. H. Alfring, manager of the wholesale department of the Aeolian Co., in the Green Room at noon on Monday, after which the party adjourned to the Republican Club, where, after an excellent luncheon, they listened to an address on "Artistic Ideals" by H. B. Schaad, of the Vocalion recording laboratories, and a distinctly practical talk on "Recording" by Mr. Johnson.

The first business session in the Green Room in the afternoon opened with a talk on "The Physics of Sound," by E. W. Scherr, Jr., illustrated by the Phonodisk. This was followed by a talk on cabinet design and construction by W. A. Bowen, of Grand Rapids, and another talk on "Record Analysis," by T. P. Ratcliff. After each of the talks there was a general discussion of the subject.

On Tuesday morning the visitors were conducted on a tour of inspection of the recording laboratory and after luncheon at the Republican Club Charles H. Tracy awarded the prizes for the competitive sales talks. H. B. Levy, of Chicago, delivered an interesting address in the afternoon on "Why Should a Dealer Handle and Push the Vocalion," and A. A. Fair, likewise of Chicago, gave an excellent talk on merchandising. H. W. Hornberger, of St. Louis, delivered a talk on "Study Your Customers' Tastes in Music and Know Your Stock," and T. H. Fletcher, retail manager for the metropolitan district, talked on "Retail Sales." Each subject was left open for discussion. In the afternoon, also, the delegates were greeted by W. V. Swords, general manager of the Aeolian Co.

On Wednesday and Thursday the travelers visited the Long Island City factory. On Wednesday there was mechanical demonstration and practical work on Vocalion motors, under John Kaiser, and on Thursday a practical demonstration of cabinet refinishing, under George Eberhard. Thursday evening the entire party were the guests of the Aeolian Co. at the Selwyn Theatre to witness "Ed Wynn's Carnival."

The convention closed with a Friday session, when the delegates were addressed by George

H. Bliss, manager of the wholesale Melodee roll department, and by George Sheffield, of the recording department. There were also several other addresses, including one on "National and Local Advertising," by V. E. D. Fuller, head of the new trade promotion department of the Aeolian Co., and another on "Printed Matter," by R. E. Wilkinson.

The convention in every way was a distinct success and the travelers went back to their respective territories with a new conception of Vocalion manufacturing, selling and advertising methods and possibilities.

Among those who attended the sessions were: From the Nordheimer Piano & Music Co., Toronto, Ont., H. H. Main, Charles Culrose and John Sprott; from the Aeolian Co., Cincinnati, D. S. Stephens and E. J. Koper; Vocalion Co., Boston, E. M. Wheatley, A. C. Barg and H. G. Stoehr; Aeolian Co., St. Louis, W. P. Chrisler, R. V. Johnson, H. C. Hornberger, S. C. Currah and F. H. Brandt; Aeolian Co., Chicago, H. B. Levy, W. A. Everly, A. A. Fair, John T. Shipplett, G. V. Travers, A. M. Devereau and G. D. Phillips; Dayton, D. E. Ahlers, E. F. Kent; Rochester, A. H. Warren; Savannah, P. E. Riley; D. L. Whittle Music Co.; Dallas, Tex., Herbert Gupton, O. J. DeMoll & Co.; Washington, O. J. DeMoll and Charles A. Watson, and from the New York offices, W. H. Alfring, V. E. B. Fuller, L. B. DeVeau, Charles H. Tracy, George H. Bliss, Oscar Ray, W. D. Fay, George Sheffield, Thomas H. Fletcher, H. B. Schaad, F. L. Young, John B. O'Brien, Henry Pinner, R. E. Wilkinson, L. A. Holley, T. P. Ratcliff, J. B. Sabath, A. T. Doty, R. W. Pain and F. D. Langford.

VICTROLA IN FOX NEWS FILM

Knight-Campbell Co., of Denver, Introduces Victrola in Scenes of Bathing Beauties

DENVER, COL., July 6.—The Knight-Campbell Music Co., of this city, scored a big success in advertising the Victrola through the medium of the motion picture film. The Fox News Service was taking pictures of some of the bathing belles on the beaches near the city and during the filming of the pictures the Knight-Campbell Music Co. placed a Victrola on the lawns of one of the estates and the bathers came up and danced to the strains of "The Yellow Dog Blues." Miss Alice Schneider, champion woman swimmer and high-diving expert of Colorado, was shown in a close-up changing a record on the machine. The Victrola carried a large sign with the name of the Knight-Campbell Co. on it and in this way the store was well advertised. The film was shown at the local theatres and provided advertising which could not be bought at any price.

MAKE RECORDS FOR NATION'S FORUM

On page 175 of this issue of The World there appears an article relative to the speeches recorded by Senator Harding and Governor Coolidge, the Republican candidates for President and Vice-President respectively. These important records were made for the Nation's Forum, which specializes on the manufacture of records by men who are prominent in public affairs. These records will be distributed exclusively by the Columbia Graphophone Co., which distributes all records manufactured by the Nation's Forum.

PLEASED WITH BUSINESS RECORD

B. R. Forster, president of the Brilliantone Steel Needle Co., reports that the first six months of 1920 established a record in the volume of business transacted in the history of this company. "Business is good," said Mr. Forster, "and the only hindrance at the present time is the scarcity of envelope containers and the shipping conditions."

STARR Phonographs and GENNETT Records

Complete Stock and REAL Service

Crafts-Starr

PHONOGRAPH CO.

Factory Distributors
2-4-6 SOUTH EIGHTH ST., RICHMOND, VA.
Write for Dealers' Proposition

NEW STYLE OF CABINET

Berkeley Cabinet Now Ready for the Trade—Embodies Many Distinctive Features

The Berkeley Phonograph Cabinet Co., New York, has just introduced to the trade a new cabinet which involves many distinctive features. This cabinet is designed to accommodate the portable model Victrola VI.

One of the most important features of this new cabinet is the fact that the Victrola may



The Berkeley Co.'s New Cabinet

be placed in it without any adjusting or mechanical work of any kind whatsoever. It is not necessary to unwind the winding key and the machine is left intact. When the cabinet is played with the lid open, the panelled sides act as a sounding board and reflects the tone.

The company has also introduced a traveling trunk for Victrolas IV and VI, and this trunk is perfected in such a way that the instrument can be played in the trunk without being removed. Factory arrangements have been completed, and the company has established offices at 120 West Forty-third street, New York.

LARGER QUARTERS FOR FOX CO.

Prominent Bridgeport Concern Remodels Establishment and Plans Handsome Quarters

BRIDGEPORT, CONN., July 7.—The Alfred Fox Piano Co., this city, has just consummated a deal whereby in the very near future the quarters it occupies will be increased in the neighborhood of 600 per cent. The new space is all in the present building. In chatting with Harry C. Norrish, the manager. The World learned that the window frontage on the ground floor will be remodelled along superlatively attractive lines. The ground floor will be largely devoted to talking machines and records and the upper floors to nicely fitted piano sales rooms. The Fox organization also operates retail music stores in South Norwalk and Stamford. In Bridgeport the Victrola and Edison are handled.

MAIN-SPRINGS

For any Phonograph Motor
Best Tempered Steel

1	in. x 10 ft. for Columbia.....	Each	\$0.50
1	in. x 13 ft. for Victor.....	Each	0.50
1 1/4	in. x 18 ft. for Victor.....	Each	0.75
1	in. x 12 ft. for Heineman.....	Each	0.60
3/8	in. x 10 ft. for Col. Pathé-Heineman	Each	0.50
1 3/8	in. x 16 ft. for Heineman	Each	1.20
1	x 16 ft. for Saal or Silvertone....	Each	0.90
1	in. x 10 ft. for Saal or Silvertone..	Each	0.60
1	in. x 16 ft. for Sonora or Brunswick	Each	0.90
3/4	in. x 10 ft. for all small type machines	Each	0.45
1 1/2	in. full size for Edison Disc.....	Each	2.10

SAPPHIRES—Genuine

Pathé very best loud tone genuine, each 15c;
100 lots, \$11.50.
Edison very best loud tone, 15c each or \$12.00 in
100 lots.

MOTORS

Special price on Krasberg motors.
Order right from this ad.
Send for price list of other repair parts.

The Val's Accessory House
1000-1002 Pine St. St. Louis, Mo.

HOLD INFORMAL CONVENTION

Dealer Service Department of the Columbia Branches Met in Philadelphia Last Week and Transacted Real Constructive Business

An informal convention of representatives of the Dealer Service departments in the branches of the Columbia Graphophone Co. was held last week at the company's Philadelphia branch. All of the representatives of this department from the branches East of the Mississippi were present at this convention, and an interesting program that was filled with important and practical topics was scheduled during the three days' session.

H. L. Tuers, manager of the Dealer Service department, was in charge of the meetings, ca-

pably assisted by the members of his executive organization. Philadelphia was selected as the meeting place because of the fact that a Model Shop had just been installed in this branch and ideal facilities were afforded for the meetings.

The Dealer Service department of the Columbia Graphophone Co. has attained phenomenal success during the past few years under Mr. Tuers' direction, and the plans for the coming year include many important campaigns that will be of the utmost value to Columbia dealers everywhere. These campaigns are based on cooperation and service to Columbia merchants, and judging from the success of the various plans introduced by Mr. Tuers recently, the dealers will be keenly interested in the announcements that will be issued by this department for the coming year.

PATHE SUMMER SALES CAMPAIGN

Many Valuable Suggestions Contained in June Issue of Pathé News—National Advertising Campaign to Be Greatly Enlarged

The June issue of Pathé News was eight pages in size and contained a wealth of valuable suggestions for the Pathé dealer. An inspiring article by President Widmann furnished the key-

and dealers from all sections of the country indicate that 1920 will contain not a dull season. Summer sales campaigns are being inaugurated from coast to coast by the Pathé dealer with the objective of making 1920 a banner record-breaking year.

The national advertising campaign on Pathé phonographs and records has been considerably enlarged and now covers the newspapers in practically every large city in the United States and all the leading magazines, with a full page in the Saturday Evening Post twice a month. In New York City the Rotogravure sections of six of the metropolitan dailies are used. The total circulation reached by Pathé advertisements in the magazines is estimated at 12,000,000, while through the newspapers the Pathé ads reach over 8,300,000.

The Pathé Actuelles in period models are in demand in all sections of the country and are being sold to many handsome residences, where it is often desirable to have the phonograph harmonize entirely with the period in which the room is furnished. The Pathé Actuelle shown in the accompanying photograph now adorns the palatial home of a prominent Brooklyn citizen. Much study has been given by the craftsmen at the Pathé factory, not only



Pathé Actuelle in Artistic Surroundings

note of optimism for the months ahead. As usual, Pathé News includes a large number of advertising suggestions for use in the local newspapers, the matrices for which Pathé Frères Phonograph Co. furnish to dealers without cost. Letters reprinted from distributors

to the details of workmanship but also to having the cabinet follow exactly the period it represents.

William Turner, of Buffalo, N. Y., has secured the Starr agency for that city.

VICTOR DEALERS

Turn **PASSERS-BY** into **FOLKS WHO BUY**

You can't sell merchandise to the people that pass your window.

They've got to come into your store.

The **USOSKIN MONTHLY VICTOR DISPLAY SERVICE** is bringing people into the stores of Victor dealers throughout the country.

Write for details and photographs—**NOW.**

USOSKIN LITHO, Inc.
230 WEST 17th ST., NEW YORK CITY

MONTALVO OPENS NEW QUARTERS

Handsome Temple of Music Formally Dedicated by Live Dealer in New Brunswick, N. J.

NEW BRUNSWICK, N. J., July 3.—There was formally opened last night on Albany street a new Temple of Music of a character that cannot be surpassed in many cities of the country regardless of size. The new temple is incorporated in the establishment of Ramon Montalvo, who in the course of a number of years has developed the largest talking machine business in this section of the country.

The new building is devoted entirely to the cause of music, and in addition to handsomely equipped, elaborately furnished and well-stocked showrooms, together with generous batteries of demonstrating rooms for Victor and Edison machines and records, includes a recital hall capable of seating several hundred people and which it is believed will become a musical center.

The new recital hall was put to good use during the opening celebration. A number of well-known singers and instrumental soloists from New York and other cities were brought to New Brunswick to take part in the elaborate program prepared by Mr. Montalvo, and following the formal entertainment there was plenty of dancing to the accompaniment of some lively music.

The new Temple of Music is a tribute not only to the business success of Mr. Montalvo, but to the musical importance of New Brunswick, and representatives of the talking machine manufacturers with which Mr. Montalvo does business attended the opening in person to extend their congratulations.

TALKERS FOR SUMMER ENJOYMENT

Houseboats and yachts as well as smaller boats and canoes have found a talking machine a useful and pleasurable thing to have on a cruise or even while lying at anchor in the harbor.

THE SUPREME

A SUPER-PHONOGRAPH possessing unusual excellencies of tone, design, cabinet work and finish, and special features that are more than talking points.

For Instance:—Simply pressing one button lights up the machine throughout. One dainty electric lamp illuminates the turn-table. Another throws a flood of light through the tone chamber, bringing out the beauties of the art glass grill and falling on the record drawer. Another lights up the record compartment, showing the numbers on the compartment, the list on the door and the titles on the records. The special plush-lined drawer receives the records as they are taken off the turn-table or shoves away ready for instant use two or three pet records.

This machine makes a wonderfully attractive sales-making window display produced in several original styles

It's a high-grade machine but a quick seller :: :: :: **THE PRICE?**

STONE MANUFACTURING COMPANY

FACTORY:
2623 OLIVE STREET

ST. LOUIS, MO.

SALES OFFICES:
GAMBLE BLDG., 7th & Chestnut Sts





Picture side of record

“HITCH YOUR
WAGON
TO THE
STARS”

and make new customers out
of the 20,000,000 movie fans

TALKING PHOTOS

“SPEAK FOR THEMSELVES”

A Combination of
Phonograph Record of the voice of the star
Artistic photograph of the star
Autograph of the star

Will play on any machine on which a steel needle is used.

A most effective presentation of the great screen favorites whose enthusiastic friends are numbered by the hundreds of thousands.

One of the most attractive novelties ever introduced into the phonograph field.
An irresistible seller.

The first purchase starts the “fan” on a collection; the rest is easy.

Records by the following artists now ready:

- | | |
|-------------------------|---------------------|
| Mildred Harris Chaplin, | Lew Cody, |
| Viola Dana | J. Warren Kerrigan, |
| Mary Miles Minter, | Bert Lytell |
| Mae Murray, | Tom Meighan, |
| Gloria Swanson, | David Powell, |
| Anita Stewart, | William Russell, |
| Clara Kimball Young, | H. B. Warner. |

New issues monthly. 100 leading artists
under exclusive contract. Retail price, 35c,
three for a dollar. Samples on request.



Playing side

TALKING PHOTO CORPORATION,

334 Fifth Avenue,

Robert B. (“Patt”) Wheelan, Pres.

New York

Manufactured under exclusive license granted by Talking Book Corp.

GLEANINGS *from the* WORLD *of* MUSIC

MUSIC PUBLISHERS CO-OPERATE WITH COMMUNITY SINGS

The General Advancement of Music Materially Helped by the Sympathetic Attitude of the Publishers—Why Talking Machine Men Should Join Forces in This Good Work

During the past few years music publishers have given their most earnest co-operation to community sings. Many of the publishers issue special material for the use of bodies interested in such work. Some have even published booklets for the purpose.

There has, of course, always been a question as to the value of such work on the part of the publishers, when the sales of sheet music itself were considered, but there never has been a question of the results such publicity gives to the sales of mechanical reproduction of numbers featured in such sources.

More recently, however, the feeling of most of the publishers has been that such sings tend to give popularity to works, and create sales for sheet music, in addition to the records and player rolls of the number, where some care is taken in the manner by which such works are exploited.

All agree that such numbers as "There's a Long, Long Trail," "Smile, Smile, Smile," "Keep the Home Fires Burning" and songs of that type can hardly ever be injured from a sales standpoint by the work of community sings.

In seasons to come more and more co-operation will be given by the music publishers to the work of such bodies. The probabilities are that it will be better planned than heretofore, and an arrangement will be made whereby selected numbers will be given a measure of popularity which will redound to the sales of the song in every form in which it is issued—sheet music, record and player roll. Therefore it would appear that the local talking machine dealers should give the utmost encouragement to community sings and watch carefully the work of such bodies and give special displays, etc., to the timely numbers receiving such exploitation.

The National Bureau for the Advancement of Music at the present time, in addition to its other work, is giving much attention to factory sings or what is known as "music in industry." It is now stated that hundreds of organizations, through the encouragement and influence of the Bureau, are having sings each week, some of

them are even having them twice a week and others once a day. This is creating a greater interest in music, is constructive propaganda and is a sales creator. Especially is this so when the numbers used are of the more popular variety.

Commencing with July 6 of this year, Hunter College, New York, inaugurated music classes for those interested in community sings. It is proposed by the work to turn out song leaders, and if these classes are a success, which they no doubt will be, much good material for the purpose should result. Song exploitation from community sings, factory sings, etc., will be increased and will under this new arrangement create sales for the records of all popular numbers coming into such use and no doubt the standard numbers as well.

Men Who Make Popular Songs

No. 14—Albert Von Tilzer

The success which the musical comedy, "Honey Girl," has attained in New York marks a new era in the writing history of Albert Von Tilzer, who, of course, needs no introduction to the trade.

The show is the musicalized version of the drama, "Checkers," and it is to the music to



Albert Von Tilzer

a great extent that its success is due. There are at least five big numbers in the production that are having good sales, and, as it is the intention of the producers to have several road shows the coming season, the demand for the songs will probably increase.

The results Albert Von Tilzer obtained in

this his first musical comedy have encouraged him to further efforts in this direction, and it is now understood he will be the writer of the music of at least two productions to be shown in the coming Fall. The biggest numbers in "Honey Girl" are "Close to Your Heart," "I Love to Fox-trot," "You're Just the Boy for Me," "I'm Losing My Heart to Someone." While it is true that Albert Von Tilzer has always been associated with popular numbers in the past, he has by no means confined himself to that type entirely, as he is also responsible for a goodly list of high-class compositions, including "Waters of Venice Waltzes," "Forever Is a Long, Long Time," "Say It With Flowers." His more popular numbers include the following: "Lonesome" (Edna May's song in the "School Girl"), "Put Your Arms Around Me, Honey" (Madame Sherry's song), "Nora Malone" (Blanche Ring's song), "Take Me Out to the Ball Game," "Smarty," "Honey Boy," "Give Me the Moonlight, Give Me the Girl, and Leave the Rest to Me," "Oh, How She Could Yacki Hacki Wicki Wacki Woo," "Alcoholic Blues," "My Little Girl," "Oh, by Jingo."

A VIRGINIA INCORPORATION

The Jamestown Musical Distributors have been incorporated in Jamestown, Va., with a capital of \$10,000. The incorporators are A. D. Patchen, V. F. C. and M. A. Anderson.

"Ain't nature grand?" sighed the poor young thing.

"Yes, pat a man on the back and you make his head swell," replied the other who was only poor.

Alabama Moon
Latest
Waltz Song
Sensation
By GEORGE HAMILTON GREEN
Sam Fox Pub. Co. Cleveland

REGINA
Phonograph

Plays all disc records with an unusual clearness, richness and beauty in tone.

Attractive Proposition for active Dealers

The REGINA Co.
47 W. 34th St.,
New York
209 S. State St.,
Chicago

Hinds, Hayden & Eldredge, Inc.
11 UNION SQUARE, NEW YORK CITY

Announce Two Remarkable Ballads

"IN THE AFTER GLOW"
By FRANK H. GREY

and

"WHEN YOUR SHIP COMES IN"
By LILY STRICKLAND

Programmed by America's Foremost Concert Artists
Watch for Them on the Record Lists

ANNUAL AEOLIAN CO. BALL GAME

Contest Between Vocalion and Piano Department Teams Made Occasion for Outing—Piano Men Triumph in the Final Score

Members of the Aeolian Hall staff in large numbers turned out on June 26 to witness the interesting baseball game between the members of the piano and Vocalion departments of the Hall held on the grounds of the Hackley School at Tarrytown, where this contest has been staged each year. The game was a lively one and ended with a score of 11 to 7 in favor of the piano department, due largely to a two-bagger by Laurino in the second inning which brought in two men and resulted in a six run lead for the piano department in that stanza. The battery for the Vocalion team was Field, pitcher, and Brown, catcher, and for the piano team, Holroid and Weigert.

Following the baseball game the metropolitan sales force of the Aeolian Co. held their annual dinner at Florence Inn, Tarrytown, which proved one of the most successful ever held. The dinner was strictly informal but there was a suppressed air of mystery pervading the room until Charles Laurino took occasion to present to Thomas H. Fletcher, retail manager of the Aeolian Co., a handsome loving cup as a mark of the esteem in which he is held by members of the staff.

Following Mr. Laurino, Mr. Bogart, who enjoys a wide reputation among Aeolianites for his ability to offer the proper toast at the proper time, read several toasts to President Tremaine, General Manager Swords and other officials of the Aeolian Co., and to the teams who had played in the afternoon.

Eddie Reulbach, former star pitcher of the Chicago Cubs, was one of the guests at the dinner and was deserving of the honor, having umpired the ball game with the assistance of Lawrence C. Kederichs. A group of entertainers served to keep a well prepared program lively until a late hour.

DIRECT FACTORY PRICE—JUST MENTION THE QUANTITY

MOTORS	CASTINGS	} TURNTABLES MOTOR FRAMES TONE ARMS HORNS and THROATS	} Stylus Bars Screw Machine Parts Talking Machine Hardware
TONE ARMS	Grey Iron		
REPRODUCERS	and Brass for		

Direct Quantity Importations On { JEWEL and STEEL (Bulk or Packed)
PHONOGRAPH NEEDLES
GENUINE RUBY BENGAL MICA

EASTERN REPRESENTATIVE
CHERRINGTON MFG. CO.
IRONCLAD MOTORS

D. R. DOCTOROW

Vanderbilt Ave. Bldg.
51 East 42nd St., New York
Tel. Vanderbilt 5462

SONORA JOBBERS IN SESSION

Notable Men From All Parts of the Country Gather as World Goes to Press

The Sonora Phonograph Co., New York, is playing the role of host this week to Sonora jobbers from all parts of the country, who assembled in New York on Monday for a series of "get-together" meetings. These meetings are being held at the Waldorf-Astoria and every Sonora jobber is present.

Geo. E. Brightson, president of the Sonora Phonograph Co., personally prepared the program for the jobbers, and an interesting series of important topics are scheduled. The social side of the meetings is being given careful attention by Mr. Brightson, assisted by Jos. Wolff, treasurer of the company, and Frank K. Coupe, director of sales, and judging from the enthusiasm of the Sonora jobbers, there is every reason to believe that these meetings will be a signal success.

management of W. A. Dice, formerly with the Home Music Co., of Lancaster, Pa. Both houses plan extensive campaigns.

CRIPPEN CO. IN TROUBLE

Petition in Bankruptcy Filed Against New York Concern Last Week—Liabilities Said to Be About \$75,000 and Assets \$15,000

A petition in bankruptcy was filed last week against the Crippen Co., Inc., jobber and retail dealer in pianos and talking machines at 437 Fifth avenue by three creditors, Thomas A. Cabasino, Lyman Potter and the Amsterdam Sales & Publicity Corp. It is stated that the liabilities are about \$75,000 and the assets \$15,000. An assignment has also been made to Kevie Jaffe.

The Crippen Co. was incorporated in 1914, and has been engaged particularly in the distribution of player-pianos and special lines of talking machines.

NEW COLUMBIA DEALERS IN YORK

Two new Columbia agencies have been opened in York, Pa. These are: P. Wiest's Sons, where the Grafonola department is in charge of Walter H. Owens, and for some years with the Weaver Piano Co.; Charles H. Baer & Co., under the

INCORPORATED IN DELAWARE

The Ansonia Phonograph & Record Co. has been incorporated under the laws of Delaware with a capital of \$2,500,000. The incorporators are A. E. Nacheimer, C. T. Fitzgerald and P. Zak, Chicago, Ill.



Showing No. 95-A

A Queen Anne Creation. Designed expressly for use with the Chalet Model Edison Instrument equipped with the famous Eject-O-File Record Filling System. Produced in natural figured Red Gum and rouge Red. Dimensions: 20" wide, 22" deep, 32" high.

We will again begin shipments of the famous **EJECT-O-FILE CABINET**

No. 95 and 95-A

in September from our entirely new factory, rebuilt complete from foundation to roof since our fire April 29, 1920. Mr. Dealer get in touch with your jobber at once.

Manufactured by

THE EJECT-O-FILE CO., Inc.

FACTORY AND GENERAL OFFICES
HIGH POINT, :: NORTH CAROLINA



Showing No. 95

A straight line effect conforming with the Chalet Model Edison Instrument for which it is designed and produced. Equipped with the Eject-O-File Record Filling System. Dimensions and Finish same as No. 95-A.

Cleartone

PHONOGRAPH

SPEAKS FOR ITSELF

MICA DIAPHRAGMS

We are now cutting our own Mica Diaphragms and can take orders in any quantity. We can furnish you first quality clear Ruby India Mica. Sizes $1\frac{23}{32}$ " to $2\frac{9}{16}$ ". Also occasionally some second quality.

SUNDRY DEPARTMENT

MOTORS

Swiss A. B.—Double-spring, 10-inch turntable, plays 2 10-inch records, \$3.75.

Swiss F. V. B. — Double-spring, \$6.85.

No. 2—Double-spring, 10-inch turntable, plays 3 10-inch records, \$4.00; with 12-inch turntable, \$4.25.

No. 9—Double-spring, 12-inch turntable, plays 3 10-inch records; cast-iron frame, \$7.85.

No. 11—Double-spring, 12-inch turntable, plays 7 10-inch records; cast-iron frame, bevel gear wind, \$9.75.

STONE ARMS AND REPRODUCERS

Play All Records

No. 1—\$1.95 per set.
No. 4—\$4.50 per set.

No. 6—\$4.25 per set.
No. 7—\$3.75 per set.
No. 9—\$2.95 per set.

MAIN SPRINGS

No. 00— $\frac{5}{8}$ in., 9 ft., 29c.
No. 01— $\frac{7}{8}$ in., 7 ft., 29c.
No. 02— $\frac{3}{4}$ in., 7 ft., 29c.
No. 1— $\frac{3}{4}$ in., 9 ft., 39c.
No. 1A— $\frac{3}{4}$ in., 10 ft., 49c.
No. 2— $1\frac{1}{8}$ in., 10 ft., 39c.
No. 3— $\frac{7}{8}$ in., 11 ft., 49c.
No. 4—1 in., 10 ft., 49c.
No. 5—1 in., 11 ft., heavy, 69c.
No. 6— $1\frac{1}{4}$ in., 11 ft., 99c.
No. 7—1 in., 25 gauge, 15 ft., 89c.

We also carry other size main springs to fit Victor, Columbia and all other motors.

Special prices on springs in quantity.

RECORDS.—10-inch double disc records, 42c each; 12-inch, 60c each.

GOVERNOR SPRINGS—To fit VICTOR, COLUMBIA and all other motors. Special prices on large quantities to Motor Manufacturers.

We also manufacture special machine parts, such as worm gears, stampings, or any screw machine parts for motor; reproducer and part manufacturers.

Special quotations given to quantity buyers in Canada and other export points.

Write for our 84-page catalog, the only one of its kind in America, illustrating 33 different styles of talking machines and over 500 different phonographic parts.



No. 135—Price \$135



Model 105—Price \$105

SAPPHIRE, DIAMOND AND STEEL NEEDLES

STEEL NEEDLES

10,000 Lots.....39c per M
100,000 Lots.....35c per M
1,000,000 Lots.....30c per M
5,000,000 Lots.....29c per M

SAPPHIRE BALLS

Dozen Lots 14c
Hundred Lots 12c
Thousand Lots 11c
5-Thousand Lots 10c

SAPPHIRE POINTS

Dozen Lots 15c
Hundred Lots 13c
Thousand Lots 12c
5-Thousand Lots 11c

GENUINE DIAMONDS

Sample \$1.75
Dozen Lots 1.50
Hundred Lots 1.40
Thousand Lots 1.25
5-Thousand Lots 1.15



Model 175—Price \$175

The CLEARSTONE has become very popular because of its quality, splendid value and the advertising sales campaign that now stands back of it. DEALERS! Watch us grow—write for our agency and grow with us. Keep our 84-page catalog of phonographs and all accessories handy—Sent free on request.

LUCKY 13 PHONOGRAPH COMPANY

46 East Twelfth Street, New York, N. Y.

PROGRESS OF THE CATHEDRAL CO.

This Company Has Been Steadily Branching Out and Has Now Two Spacious Plants—Something of the Men Behind the Enterprise

OMAHA, NEB., July 5.—Few of the newer talking machine companies have "gone into production" with a more complete and practical organization in all branches of their enterprise than the Cathedral Phonograph Co. of this city. Not only the officers, but all the men in charge of the different departments, are substantial stockholders and members of the board of directors and were asked to join in the organization of the company because of their particular fitness for the positions they occupy.

The company, as recently stated in *The World*, has purchased the plant of the Houghton



Merton L. Corey, President

Mfg. Co., at Marion, Ohio, with which they had already contracted for cabinets. This plant gives them a capacity of 30,000 square feet of floor space, and its already excellent equipment has been greatly added to since the company took hold. The property covers four and a half acres of ground, giving plenty of opportunity for additions to buildings as the business grows. The railroad facilities are excellent and the

company itself holds 700 feet of trackage. The plant has a capacity of about 150 cabinets a day, and it is already indicated, by the orders at hand, that it will easily reach its maximum output the first year.

The company has also established two plants for the construction and assembling of the patented tone arm and reproducer, a distinctive fea-



C. A. Briggs, Vice-Pres.-Sales Mgr.



Harry Hildreth, Jr., Secretary-Treasurer

ture of the Cathedral phonographs. One of these is at 16-18 Fulton street, Grand Rapids, and the other at 16-18 South Desplaines street, Chicago. In describing the reproducer, the company says:

"The Cathedral triple-diaphragm reproducer is designed to play all makes of disc records, employing the correct weight at point of contact, riding at the exact angle and perfectly synchronized to the record groove. It is 'fool proof' in its adjustment—the length of arm and weight being automatically adjusted. The hill-and-dale types of record are being reproduced with a genuine diamond and sapphire ball equipment, the lateral cut with the steel needle, semi-permanent point or fiber needle.

"Likely injury to the reproducer diaphragms is practically impossible, in view of the fact that the various playing positions are accomplished by a specially constructed guide that eliminates the necessity of taking hold of the reproducer case.

"A counterbalance valve is provided to relieve excess weight; is constant in its action and serves, the company claims, to prolong the life of the record to many times that of a reproducer dragging over the record at a dead weight. This feature not only increases the life of the record, but adds to the smoothness of tone only obtainable when the reproducer is riding in the groove of the record at perfect equilibrium.

This is especially noticeable on records that are slightly warped."

The name Cathedral was chosen for the company's product not only because of its association with the highest class of music, but also because of the character of the very beautiful case designs. The line at present consists of six models, each of which is named after one of the



R. W. Morrison, Production Mgr.



Ernest F. Bader, Advertising Mgr.

famous European cathedrals, the windows of which furnish the suggestion for the design of the grille.

Merton L. Corey, president of the company, one of the prominent men of Omaha, is general attorney and registrar of the Federal Land Bank, of this city, one of the largest institutions of its kind in the country.

C. A. Briggs, vice-president and sales manager, the man who organized the company, is well known in the Western trade and has been connected with the industry in one capacity or another for nearly seventeen years.

Harry Hildreth, Jr., secretary and treasurer, was formerly connected with manufacturing concerns in Chicago and for six years was assistant city treasurer of Chicago. He has other important business interests in Omaha, but is devoting his entire time to the Cathedral Co.

R. W. Morrison, the production manager, is particularly fitted for the position by virtue of his education and business experience. He is a graduate of the School of Engineering, Kansas University, and has been associated for years with the phonograph trade.

Ernest F. Bader, the advertising manager, also a director of the company, has sold talking machines almost since he got out of school and afterwards was advertising manager for one concern for eight years. He is now at work on an excellent series of dealers' aids, which are of an extremely artistic nature, and he has some plans for co-operating with dealers in the presentation of the Cathedral to the trade.

It may be said of the other directors that Frank Gartner, of Wayne, Neb., a well-known furniture designer, is responsible for the Cathedral phonograph designs. George Mayer is a well-known business man of Nebraska City. J. R. Roberts is in the music business at Seward, Neb. D. M. Hildebrand, of Seward, is chairman of the advisory board of the Cathedral Co. and is treasurer of the First Trust Co., of Seward, and president of the H. Bowles Elevator Construction Co. J. T. Bertwell is president of the Fairmount Creamery Co., of Fairmount.

J. B. Wideman, superintendent of mechanical construction, with headquarters at the Chicago plant, was for five years superintendent of the Woodstock Typewriter Co. and was also superintendent of the mechanical department of the Goddard Tool Co.

C. B. Van Eck, superintendent of the wood-working division, was for years superintendent of the Leopold Desk Co., Burlington, Iowa, and is considered a cabinet expert of high degree.

H. E. Monroe has been connected as assistant superintendent of the Marion plant, and T. G. Sievers, acts in the same capacity in Grand Rapids.

Mr. Briggs has a strong sales organization, composed of men who received their training in the business under his direction. The general offices of the company occupy fine ground quarters at 203 South Nineteenth street.

CABINETS WITH OR WITHOUT EQUIPMENT



WE CAN SHIP IMMEDIATELY LARGE or SMALL QUANTITIES

These High Grade Cabinets, made in Mahogany, Walnut and Oak, built up to the standard for which our product is noted

For Descriptive Matter Address

FUEHR & STEMMER PIANO CO., 2701 So. Wells St., Chicago

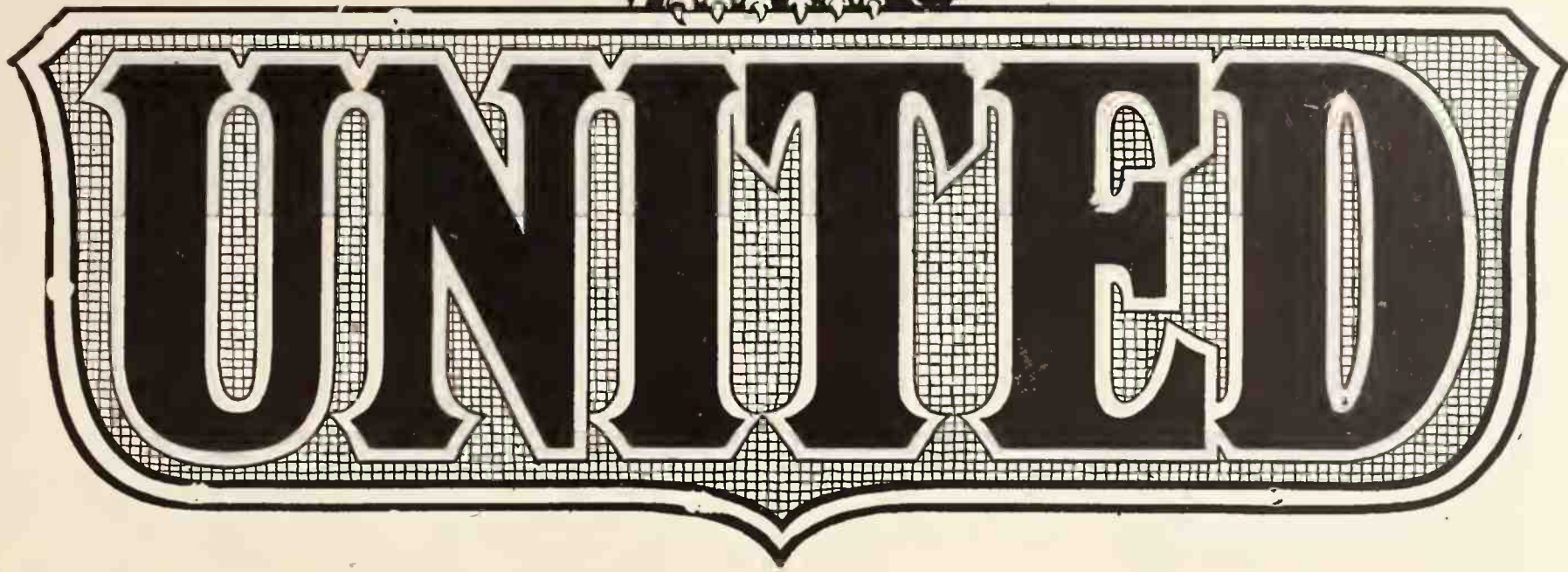

Phonograph Motors

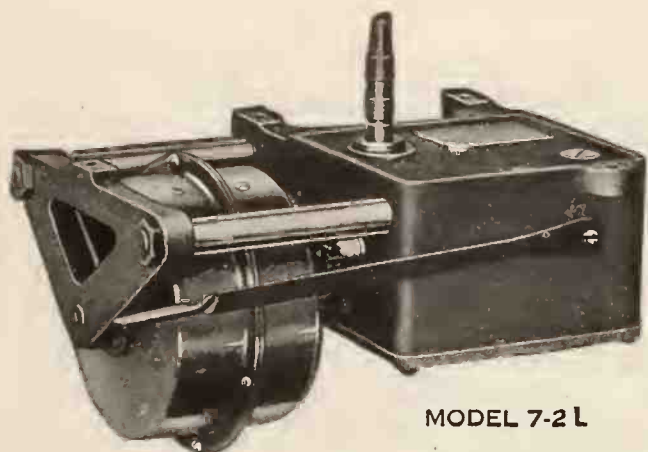

MODEL 7-2 L

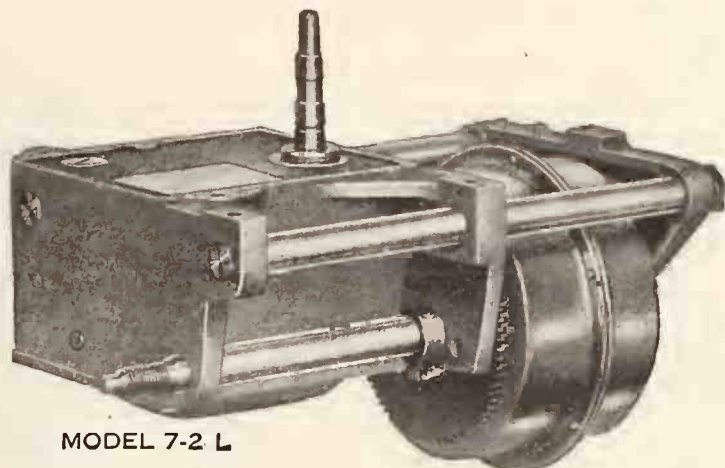

MODEL 7-2 L

Silent—Self-Lubricating—Enclosed

FOUR REAL REASONS FOR UNITED SUPERIORITY

DESIGN

The basis of all motor trouble is faulty design. Workmanship, however good, cannot offset it.

It is one thing to make a motor which by special "tuning" and adjustment will run fairly well until it is shipped, and quite another story to produce motors which will assemble into cabinets without any bother and run "sweetly" for a term of years.

Our Engineers did not follow the beaten path, except where old practice was sound. We knew by experience the shortcomings of the phonograph motor and solved the problems back of each trouble, and that those troubles are overcome you will realize when you test and analyze the United Motor.

LUBRICATION

One of our Engineers was for years designer and in charge of production for the largest makers of automatic lubricating equipment in this country. Naturally, he understands practical lubrication and how to accomplish it.

A continuously silent and vibrationless motor is absolutely impossible without automatic lubrication of all the chief bearings and gears. This we achieve by means of the

enclosed casting and a capillary oiling system, original, simple and effective.

The motor needs no attention for at least a year, when a tablespoonful of oil may be necessary. The enclosed casting makes this oiling system possible and keeps out dust and dirt and protects the mechanism in handling.

RESOURCES AND EQUIPMENT

Excepting only springs and castings, felts, etc., we make every part of the motor in our own works, where we can and do vigilantly control accuracy and quality. Our tool equipment is modern and the best money can buy.

Ample financed, material requirements covered, we have no impediments to real quality production.

CONCENTRATION

We make just one thing—The United Motor. We concentrate on it, and it is a highly specialized business. Our present capacity is approximately 2,000 Motors daily, and we have been making big quantities for years. We supply some of the largest talking machine companies in this and other countries.

Supplied in 2, 3 and 4 Spring Models.
Felt and Velour Table Coverings, Nickel and Gold Finish
Write us for full information, details of design, models, prices, etc.

UNITED MANUFACTURING & DISTRIBUTING Co.
LAKE SHORE DRIVE AND OHIO ST. CHICAGO, ILL.

VOCALION IN PATRIOTIC FUNCTION

Furnishes Appropriate Music at Flag-raising Ceremony at Old Block House in Central Park, New York, at Sunrise on July the 4th

The Aeolian-Vocalion again proved to be one of the most pleasing features of New York's most unique Independence Day function. Since 1783, at sunrise of the morning of the



T. F. Gannon, Mrs. Moorehouse and Vocalion Fourth of July, there have gathered at the old Block House in Central Park, near 110th street, a number of true Americans. Headed this year by Mrs. Moorehouse, a granddaughter of an officer on General Washington's staff, they came to pay a fitting tribute to those men through whose patriotism this country of ours was founded. No greater tribute could be paid to any company than that its instrument be chosen to take part on this solemn occasion. The Aeolian-Vocalion was chosen several years ago as the most suitable instrument for this important event, so that the playing of the Aeolian-Vocalion has become an annual feature. This year's speakers were Mrs. Moorehouse, who read the Declaration of Independence; Thomas F. Gannon, Department Commander of the United Spanish War Veterans, and William J. Lee, Superintendent of Playgrounds of the City of New York. The Color Guard was a detachment of Spanish War Veterans. During the exercises the Aeolian-Vocalion played the "Star Spangled Banner," the "Stars and Stripes" march, "Semper Fidelis" and a medley of patriotic airs.

The Home Music Co., Lancaster, Pa., has moved into its new home on West King street. Manager Klugherz secured a large stock of Columbia Grafonolas for the formal opening celebration.

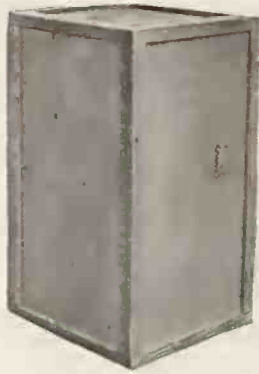

PHONOGRAPH CASES Reinforced 3-ply Veneer

The Standard Case for Talking Machine and Records

Let us figure on your requirements

MADE BY

PLYWOOD CORPORATION, Goldsboro, N. C. Mills in Va., N. C. and S. C. Chicago Office: 111 Monroe St.

REPORT ACTIVE RECORD TRADE

Ziegler, Baker & Johnson, New York, distributors of Okeh records, report a constantly increasing sale of this popular line of records. In fact these jobbers are handicapped solely by a shortage of stock, as the demand for the records is far beyond the supply.

The new Okeh supplements have met with a hearty reception from the dealers in local territory, who have not only expressed their approval of the musical quality of the records, but have also commented upon the timeliness and popularity of the selections that are listed. Ziegler, Baker & Johnson are making plans for a banner Fall trade, especially as they have received assurances from the General Phonograph Corp. that the shipments of Okeh records will be materially augmented during the next few months.

REMODELING AEOLIAN CO. OFFICES

Executive Offices of Company to Be Moved to Front Section of the Second Floor

The front section of the second floor at Aeolian Hall, used at various times for impromptu Duo-Art and Vocalion recitals, is now in the hands of the carpenters and decorators and is being remodeled to provide new quarters for the executive offices of the company now located on the fourth floor. When the executive offices are moved the wholesale and general offices now located on the fifth floor will be transferred to the old executive offices on the fourth floor, thereby providing more room on the fifth floor for the trade promotion department and other activities of this progressive institution.

A CONVENTION OF PATHE DEALERS IN ST. PAUL, MINN.

ST. PAUL, MINN., July 4.—At a convention of Pathé dealers held in this city on June 30 and July 1 at the St. Paul Hotel, Eugene A. Widmann, president of the Pathé Frères Phonograph Co., was presented with a live rooster. It was expected that the fowl would confuse

headed the party from Brooklyn headquarters, which consisted of H. N. McMenimen, managing director of the company; James Watters, secretary, and two famous Pathé stars, Louis James, tenor, and Marion Evelyn Cox, contralto. Addresses were made by the foregoing officers of



Banquet of Pathé Dealers at the St. Paul Hotel in St. Paul, Minn.

and embarrass the worthy president, but he accepted the bird, made a great fuss about it, and promptly expressed it to Pathé headquarters in Brooklyn. The rooster was a pedigreed Rhode Island Red and carried himself proudly, as should the trade-mark of this well-known line of machines and records.

The convention was well attended and was inspirational in character. President Widmann

the company and the artists rendered a number of selections which are familiar to Pathé enthusiasts from coast to coast. The address of welcome was made by George Sommers in behalf of G. Sommers & Co., Pathé distributors of this city. This was the occasion for the rooster episode. Following a dinner which was served, the entire party, 150 in number, attended a performance at the Orpheum Theatre nearby.

ORDER NOW

IMMEDIATE DELIVERY

OF THE LATEST HITS ON

Okeh Records

Coupled with Efficient Service which we extend to Okeh Dealers

SEND FOR OUR LATEST OKEH CATALOGUE

WE HAVE THEM—ALL THE OKEH HITS

WHOLESALE DISTRIBUTORS:

PHILADELPHIA SHOW CASE COMPANY

127 North 13th Street

PITTSBURGH BRANCH: 2002 Jenkins Arcade Bldg.

Philadelphia, Pa.



Pacific Coast Phonograph Dealers

will find much to interest them in the new

Wholesale Supply House of

The

AEOLIAN-VOCALION

in San Francisco

MAKE 455 Mission Street your San Francisco headquarters. Hear the superb tone-quality of the Aeolian—investigate the Graduola, by which you can really “play” the Aeolian Vocalion—also the universal tone-arm which permits the playing of all lateral cut and hill and dale records—all distinctive features of this superior instrument.

We Help You Sell Vocalions

Effective national advertising appears monthly. Dealers are liberally supplied with brochures, folders, sample advertisements, electrotypes, window displays and other sales helps. Write or visit our San Francisco branch and note the splendid facilities at

455 Mission Street, San Francisco

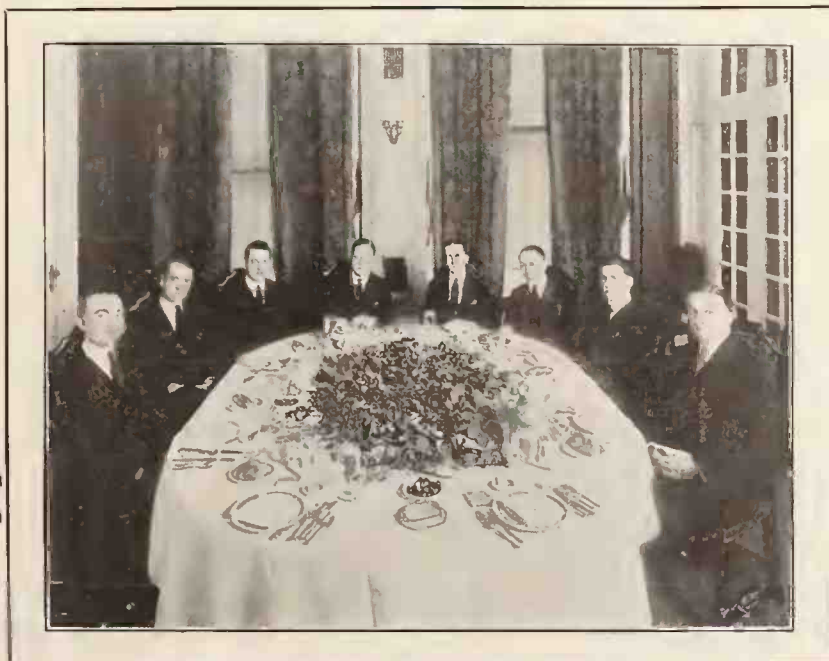

WORLD'S CLASSIFIED ADVERTISING

Any member of the trade may forward to this office a "Situation" advertisement intended for this Department to occupy a space of four lines, agate measure, and it will be inserted free. Replies will also be forwarded without cost. Additional space will be at the rate of 25c. per line. If bold faced type is desired the cost of same will be 25c. per line. Rates for all other classes of advertising on application.

Having recently withdrawn my connections as member of wholesale phonograph and supply concern, in sales capacity, will entertain a good proposition. Address "Box 816," care The Talking Machine World, 373 Fourth Ave., New York City.

RECORD EXPERT, years of practical experience. Can show results. Competent to equip laboratory in every detail. Knowledge of up-to-date pressing equipment. "Box 824," care The Talking Machine World, 373 Fourth Ave., New York City.

WANTED—A good high-notch talking machine salesman who can get out and "rustle" the business for a general line of phonographs. Address Turner Music Co., 117 W. Douglas Ave., Wichita, Kan.

WE WANT a representative in every State in the United States, with the exception of a few States, which are now covered by competent men. We want only men who can show a successful record. What we have to offer is a high-grade line of talking machines which are advertised extensively and which have numerous improvements over the standard brands, and sold successfully on its merits and guarantee. All applications will be treated strictly confidential. State territory desired, experience, references, and whether you are able to employ sub-salesmen. We want good men only, and for such we have a mighty interesting proposition. Address A. M. Druckman, 140 West 23rd St., New York City.

GENERAL MANAGER at present of branch office largest phonograph concern in the world, open for similar position. Applicant is one of the few existing executive sales organizers who possesses minute knowledge of the phonograph equipment industry and manufacturing end. Do not reply unless you can pay a big salary and participation of profits. Address "Box 817," care The Talking Machine World, 373 Fourth Ave., New York City.

MR. DEALER, I will build your business. Three years' talking machine experience, understand the handling of Victor, Columbia, Sonora, Brunswick. Salesgetter, systematizer, co-operator. Employed as assistant to buyer of large Eastern department. What I want is a managership. Address "Box 818," care The Talking Machine World, 373 Fourth Ave., New York.

SUPERINTENDENT WANTED.—For new phonograph factory in the Middle West. Must be thoroughly familiar with every phase of phonograph manufacture and possess the faculty of getting production under present labor conditions. Write fully and frankly as to experience, present position, financial arrangements and any information that will help us in the selection of the right man. Address "M. A., 25," care The Talking Machine World, 209 South State St., Chicago, Ill.

WANTED—Salesman for pianos and Victrolas to work in city and country. Splendid opening; \$150 per month and better for a hustler. State age and experience. "B. M.," care The Talking Machine World, 373 Fourth Ave., New York City.

SALESMEN wanted in each State to handle our line of popular-priced talking machines as a side line on a liberal commission basis. See our advertisement. Charmaphone Co., 39 West 32nd St., New York City.

WANTED—An experienced phonograph assembler, qualified to lay out cabinets and installing motors. Good wages and steady work. State salary and experience in first letter. Player Tone Talking Machine Co., 967 Liberty Ave., Pittsburgh, Pa.

UNUSUAL OPPORTUNITY — Central Western manufacturer of old established, strictly high grade, well-known line of phonographs has openings in Southern and North-western territory for capable, thoroughly experienced salesmen with wide acquaintance and established trade. The men preferred are forty or under, energetic, of good address, and now employed by leading factories. They have a clean, successful past which will bear closest investigation. Splendid opportunities with a live institution await their applications. Full line of references, age, previous experience and late photo must be in first letter. Address "Box 796," care The Talking Machine World, 373 Fourth Ave., New York City.

FOR RENT

One story brick building. About 35,000 square feet completely equipped with wood working machinery and motors. Now in operation.

North Side Sash & Door Co.
1111 S. Washtenaw Ave.,
Chicago, Ill.

LABORATORY

I have made arrangements to secure the use of a fully equipped recording laboratory for a limited period. This laboratory and my services are offered for master record making or development work of any kind in the phonograph field. F. W. Matthews, 16 West 39th St., New York.

FOUNDRY FOR SALE

PONTIAC, MICH.

within twenty-five miles of Detroit on good concrete road—good rail facilities. Fully equipped for aluminum, brass and bronze casting work and could readily be converted to grey iron. Fifteen thousand square feet of floor space. One-story concrete block construction built about two years ago. Four acres of land. Plant is centrally located and labor conditions are good. Will sell with or without equipment. For particulars and price, write:

DRAWER 47, SYRACUSE, N. Y.

FOR SALE

1,200 standard lateral cut records in different languages at 30c. 75 tone arms for large machines at \$3.25. Standard best known cabinet machines at 30% off. Standard lateral cut operatic records 40% off. Double spring motors at \$4.00. Write for details. Progressive Bargain House, 88 Rivington St., New York City.

Monthly Price List of Main Springs

2 in. x 0.22 x 16 ft., Meisselbach No. 18..	Each \$1.25
1½ in. x 0.27 x 21 ft., for Edison Disc...	Each 1.50
1¼ in. x 0.22 x 17 ft., reg. Victor	Each 0.75
1¼ in. x 0.22 x 17 ft., Victor new style..	Each 0.75
1 3/16 in. x 0.25 x 16 ft., Heineman No. 44.....	0.90
1 in. x 0.25 x 16 ft., sq. or round hole..	Each 0.75
1 in. x 0.25 x 12 ft., Heineman No. 33 & 77....	0.50
1 in. x 0.23 x 10 ft., for Columbia.....	Each 0.50
1 in. x 0.20 x 13 ft., Victor	Each 0.50
1 in. x 0.20 x 13 ft., Victor new style..	Each 0.50
¾ in. x 0.23 x 10 ft., for Blick motor....	Each 0.38
¾ in. x 0.23 x 10 ft., oval hole	Each 0.35
¾ in. x 0.22 x 8 ft., for Swiss motor....	Each 0.27
¾ in. x 0.25 x 11 ft., for Edison	Each 0.27

MICA DIAPHRAGMS

1 23/32 in. Victor Ex. Box, first grade..	Each 0.15
1 7/8 in., new Victor No. 2 very best....	Each 0.18
1 31/32 in., for Sonora	Each 0.20
2 3/16 in., for Columbia No. 6.....	Each 0.25
2 9/16 in., for Pathé or Brunswick..	Each 0.45

SAPPHIRES

Pathé, very best loud tone, genuine....	Each 0.15
Pathé soft tone.....	Each 0.18
Edison, very best, medium tone.....	Each 0.15
Edison, very best, loud tone.....	Each 0.18
Edison, genuine diamond	Each 1.90

STEEL NEEDLES

AMERICAN MADE extra loud, loud, medium and soft needles.....	Per 1,000 0.50
--	----------------

ATTACHMENTS

In Gold or Nickel-plated	
Kent attachments for Victor arm.....	Each 0.25
Kent attachments for Edison with C box	Each 2.50
Kent attachments without box for Edison	Each 1.60
Victor, Universal old style.....	Each 1.15

MOTORS

Distributors for Helmenan and Meisselbach Motors. Best Prices. Immediate Deliveries.

TONE ARMS

No. K with sound box	Each \$3.25
No. E with sound box, very loud.....	Each 6.00
No. M with sound box, very loud.....	Each 4.90

SOUND BOXES

No. B 1 Bliss Sound Box, fit Victor..	Each \$1.75
No. B Balance, fit Victor	Each 0.75
No. C Balance, fit Victor	Each 1.00
No. F Favorite, fit Victor	Each 1.90
No. F Favorite, fit Columbia	Each 1.90
No. P Favorite, fit Victor	Each 2.00
No. G Glory, fit Victor	Each 3.25

LID SUPPORTS

Automatic, nickel-plated.....	Each 0.30
-------------------------------	-----------

NEEDLE CUPS

Highly nickel plated	Per 100 1.50
Covers for cups	Per 100 0.75
Highly gold plated	Per 100 7.00
Cover gold plated	Per 100 5.00

REPAIR PARTS

Columbia driving shaft, No. 11778.....	Each 0.50
Columbia bevel pinion, No. 12333.....	Each 0.90
Columbia bevel pinion, latest style..	Each 0.90
Columbia bevel pinion, No. 3189.....	Each 0.35
Columbia worm gear No. 6409.....	Each 0.30
Columbia Stylus bar	Each 0.50
Columbia driving gear ratchet No. 2152	Each 0.20
Columbia cranks	Each 0.45
Columbia governor weights	Each 0.08
Columbia governor shaft, No. 3004....	Each 0.40
Columbia gov'r bearing, No. 11923....	Each 0.25
Columbia governor springs	Per 100 1.00
Columbia governor screws	Each 0.01
Columbia barrel screws, No. 2621....	Per 100 1.00
Columbia so'dbox thumb screws....	Per 100 1.50
Victor cranks, short or long	Each 0.45
Victor Stylus bar (needle arm).....	Each 0.35
Victor governor springs	Per 100 1.00
Victor governor screws	Each 0.01
Victor governor balls, new style.....	Each 0.10
Turn-table felts, 10 in., round.....	Each 0.15
Turn-table felts, 12 in., round.....	Each 0.20
Motor bottom gear for Triton motor....	Each 0.20

FAVORITE MFG. CO.

1506 DeKalb Ave., Brooklyn, N. Y.

BARGAIN LIST FOR JULY

BRILLIANTONE NEEDLES ANY TONE

25 thousand lots..... .52 per M
 50 thousand lots..... .50 per M
 100 thousand lots..... .48 per M
 500 thousand lots..... .46 per M
 1 million lots..... .45 per M

REPEAT-O-GRAPHS

Retail Price \$7.50 Regular Dealers Price \$5.00
 1 to 50..... \$3.50 each
 50 to 100..... \$3.40 each

MYSTO GOLD NEEDLES LOUD OR MEDIUM

Carton of 60 Pkgs. Regular Dealers Price \$3.90
 1 to 6..... \$3.30 per carton
 7 to 12..... \$3.10 per carton
 13 to 25..... \$2.95 per carton
 26 to 50..... \$2.75 per carton

TRUETONE NEEDLES LOUD TONE ONLY

Special Price in 100 M Lots47 per M

The Phonograph Supply Co.
 OF N. E.

COURT SQUARE BOSTON, MASS.

MANUFACTURERS OPPORTUNITY

I have just finished a complete set of assembled and detailed drawings, tracings and blueprints for a phonograph power plant; high grade; two or four tandem springs, each 1 3-16 inches wide and 19 feet long; grease-tight spring barrels; stamped and pressed steel frame; no bolts, screws, cast iron or machined parts enter into frame construction; spiral drive, no spur gears except for winding; gear ratio, 1 revolution of the spring shaft to 56 revolutions of the turntable shaft and 840 of the governor shaft; end thrust is against hardened steel balls; triple weight governor and indexed speed adjustment; manufacturing costs about half that of producing any other high grade motor. What producing and marketing proposition have you to offer? Address "Designer 54," c/o The Talking Machine World, 373 Fourth Ave., New York City.

PATENTS FOR SALE

Will sell outright or on royalty basis. My latest talking machine patents as follow: U. S. Pat. rights No. 1291556 — 1291027 — 1199192 — 1341751. Canada rights No. 201430 — 201429. Box "823," care The Talking Machine World, 373 Fourth Ave., New York City.

WANTED!

Victor records. Spot cash, any numbers.
 D. L. PHILLIPS
 405 Boylston St., Boston, Mass.

RECORD STOCK WANTED

Record manufacturer can use large quantity of record stock monthly. Will supply shellac, if necessary. Stock must be of high quality. Will pay cash. Address "Box 819," care The Talking Machine World, 373 Fourth Ave., New York City.

WILL BUY AND SELL FOR CASH

Any make of disc or cylinder records and talking machines, new or shopworn. Dealers, tell us what you have to sell or want to buy. Mr. Benj. Weil, 20 So. 2nd St., Philadelphia, Pa.

FOR SALE

Have about 4,000 feet mahogany, oak and gum wood, and 4-inch molding cut into posts and frames for cabinets. Will sell lot cheap. For particulars write or phone Phonographs, 511 Mulberry Street, Newark, N. J. Phone Waverly 625.

SALESMEN WANTED!

for the

REPEATOGRAPH

TRADE MARK REGISTERED

The Repeatograph automatically repeats phonograph records—the most salable accessory in the talking machine field. Salesmen calling on Dealers can add to their income by carrying the Repeatograph as a side line. Liberal commission. Write today for full information. Address office nearest you.

THE REPEATOGRAPH CO.

New York: 311 Hudson St.,

Chicago: 664 West Randolph St.

TO VICTOR DEALERS AND JOBBERS

Mail us your list of Surplus Domestic and German Records.

E. A. SCHWEIGER, Inc.,
 Exclusive Victor Dealers

1525 Broadway, Brooklyn, N. Y.

Reference:

New York Talking Machine Co.

FOR SALE

Manufacturing concern producing one of the best electric phonograph motors on the market today. Product well known among the trade; plenty of business on hand. This proposition is absolutely clean, and offers wonderful possibilities. Closest investigation invited to those who have the necessary capital. Amount required—six thousand dollars. Box 821, care The Talking Machine World, 373 Fourth Ave., New York City.

FOR SALE

5,000,000 needles, all loud tone, packed 100 in envelope. Close out 28 cents per thousand. Immediate delivery. Address "Box 820," care The Talking Machine World, 373 Fourth Ave., New York.

MASTER WAX

Master wax supplied for regular lateral recording, vertical recording or special work. Quality absolutely guaranteed. I will undertake to meet any reasonable requirement in the way of special waxes. F. W. Matthews, 16 West 39th St., New York City.

WILL SELL

Talking machines and cabinets to the trade; any style made to order. Best possible grade at lowest prices.

DELAWARE TALKING MACHINE CO.,
 Incorporated
 Elsmere Delaware

FOR SALE

Eight sections of Record Racks, capacity 3,000 per section; mahogany finish, 10 feet long, 5 feet high, two shelves for 10-inch and two for 12-inch records. These racks available September 1st. Gimbel Bros., New York, care of Mr. Duggan, General Manager.

MUSIC BUSINESS FOR SALE

A good business in a hustling manufacturing city of about 12,000. Population increased about 50% in last ten years. Only exclusive music store handling complete line and good talking machine agency. Will sell for invoice value of stock fixtures and equipment. Cash or negotiable paper. Will help to decrease stock if too large. Ill health reason for selling. Winslow-Butler Music Co., 733 Grand Ave., Waukesha, Wis.

A BARGAIN

Pathé needles—12 cents each, loud or soft tones. Guaranteed in every respect by one of Chicago's largest manufacturers. Minimum orders accepted, 100 needles. Cash with order or C. O. D. Box 822, care The Talking Machine World, 373 Fourth Ave., New York City.

WANTED

Victor and Columbia records. Job lots any quantity. Spot cash paid for them. Address

DENINGER CYCLE CO.,
 Rochester, N. Y.

WOULD like position with reliable concern building or desiring to build high-grade phonographs. Am 36 years old with several years' experience in the manufacture of phonographs. I also have several good improvements which I would gladly turn over to right party with my services. Address "Box 810," care The Talking Machine World, 373 4th Ave., N. Y. C.

W. S. BARRINGER GOES TO KOKOMO

Experienced Victor Man Starts in Business for Himself—Sold Victors for Nineteen Years

INDIANAPOLIS, IND., July 7.—William S. Barringer is entering the Victor retail field at Kokomo, Ind., after nineteen years' experience in the wholesale and retail business with the Victor Co.

Mr. Barringer began his Victor career in 1901 with Grinnell Bros., Victor wholesalers and retailers at Detroit, Mich. On January 1, 1910, he took up his duties with the Stewart Talking Machine Co., Victor jobbers, of this city, and during the last ten years has earned a reputation for ability and good humor that has made him one of the best-liked workmen in the local field.

He enters the work in Kokomo entirely upon his own responsibility, investing the savings accumulated during his years in the wholesale business. The opening of his shop at 304 Main street will be about August 1 and the firm name will be "Barringer's."

Ansell, Bishop & Turner, prominent Victor dealers in Washington, D. C., have discontinued the plan of keeping open for the Summer months. This plan will be resumed in the Fall.



EUROPEAN HEADQUARTERS

2 GRESHAM BLDG., BASINGHALL ST., E.C. LONDON

W. LIONEL STURDY, MANAGER

Depression Makes Itself Felt in the British Talking Machine Trade—Demand for a More Aggressive Policy—The Problem of Credit Facilities—The British Music Trades' Convention—Quality of Gramophone Records Discussed—Victor Talking Machine Co. Secures Big Interest in the Gramophone Co., Ltd.—To Wage War on Misleading Advertising—Canadian Machines Exhibited—What the New Record Lists Offer—Expansion of the Sterno Co.—General Trade News in Brief

LONDON, E. C., ENG., June 26.—That trade conditions in England are none too bright at the present time is unfortunately true. Some of the reasons were outlined in my previous report. Expression was then given to the belief that the sales depression in gramophone circles would prove of short duration. This is not the case. Every section of the trade is affected in one department or other. Advertising and sales ideas involving expenditure have been curtailed, especially by the smaller concerns, who make little or no effort to stimulate a return to satisfactory trading conditions. As an example, it may be mentioned that several firms who, ordinarily, spend a good deal upon publicity have entirely suspended all effort in this direction. Its effect upon the dealer and other buyers is particularly bad, in that it only confirms many of them in their usual do-nothing policy when "periods" to some extent determine the demand for gramophones and records. In the opinion of leading men of the trade, a live, vigorous policy on the part of British firms is all the more necessary to-day if we are to hold the field against imported manufactured articles, which

are reaching this market in ever-increasing quantities. It is realized that the high cost of materials and labor here to a large extent neutralizes the tariff import duty of 33 1/3 per cent. Where the exchange is in our favor, as instance German imports, the position is even more disadvantageous, particularly to those British firms whose businesses have suffered by the war restrictions, or have been established since. It is a fact that in many cases domestic difficulties have not entirely been overcome, by reason of disorganized markets, shortage of materials, labor troubles, lack of credits, etc. Further complication naturally arises through the encouragement and advent of cheap imported articles at this time when the financial struggle for existence is particularly keen. Sooner or later selling prices must be reduced, and with that in mind it is up to British manufacturers to maintain a vigorous trading policy which takes into account a reasonable anticipation of the public need and the public pocket.

Credit Facilities at a Discount

Credit facilities always are at a discount, but the high bank rate now prevailing is a matter of serious concern to the business community. The excess profits duty of 60 per cent and the threatened—though likely to be abandoned—capital levy is said to be causing a restriction of business development and unsettling conditions all over the country. Except in cases of a very favorable character, the banks are refusing credits by overdrafts, and at 7 per cent credit is not easily given or taken except under dire necessity. Of the latter, instances in the musical instrument trade have come under notice. Collections are generally very slow. In payment for

goods long credit is being taken as between seller and buyer. With thousands of pounds tied up in stock and partly manufactured goods, and quite large sums outstanding on credit accounts, the manufacturers in question find it difficult to conduct normal trade, quite aside from any plans of expansion. The shortage of and great demand for raw material have created unusual competitive conditions, and knowing that they can pick and choose the prevalent custom of merchants is to favor only such orders for raw material as are prepaid, or cash on delivery. In such cases, the manufacturer has in the past been able to secure a reasonable overdraft at the bank. But to such an extent is this now discouraged that many otherwise solvent businesses are in sore straits for a little ready money to tide over a temporary difficulty.

Another aspect of the finance question relates to the resumption of presenting and discounting bills. With plentiful supplies of, for instance, gramophone goods, comes very keen competition. Whereas in times of shortage sellers were able to demand and secure cash on delivery, it is now a question of giving credit on period bills. To carry on, the seller wants to discount these bills, and where it can be done it is only at a substantial discount percentage. These bills are forced upon suppliers of gramophone cabinets and accessories, often to their business disadvantage, just as the buyer or assembler of the completed article is under necessity to accept overlong credit conditions or pass the business. It is up to dealers to settle their accounts promptly monthly and thus ease the situation all around. There is ample scope here for members of the Gramophone Association to confer and



"His Master's Voice"

Copyright

This intensely human picture stands for all that is best in music

—it is the "His Master's Voice" trade-mark, and it brings to you, no matter where you are, the very best music of every kind, sung and played by the world's greatest artists—the greatest singers, pianists, violinists, orchestras and bands—all enshrined in the unequalled "His Master's Voice" records

'His Master's Voice'

—the trade-mark that is recognized throughout the world as the

HALL-MARK OF QUALITY

DENMARK: Skandinavisk Grammophon-Akti-
eselskab, Frihavne, Copenhagen.

FRANCE: Cie. Française du Gramophone, 115
Boulevard Richard Lenoir, Place de la Répu-
blique, Paris.

SPAIN: Compañia del Gramofono, 56-58 Balmes,
Barcelona.

SWEDEN: Skandinaviska Grammophon-Akti-
bolaget, Drottning Gatan No. 47, Stockholm.

RUSSIA: The Gramophone Co., Ltd., 45, Nevsky
Prospect, Petrograd (Petersburg); No. 1
Solyanka, Solyanol Dvor, Moscow; 9, Golovinsky
Prospect, Tiflis; Nowy-Swiat 30, Warsaw; 11
Michallovskaya Ulitsa, Baku.

INDIA: The Gramophone Co., Ltd., 139, Bal-
lughatta Road, Calcutta; 7, Bell Lane, Fort
Bombay.

Great Britain:

The Gramophone Company, Ltd.

HAYES - MIDDLESEX - ENGLAND

AUSTRALIA: S. Hoffnung & Co., Ltd., Sole
Concessionaries of The Gramophone Company,
Limited, 163, Pitt Street, Sydney.

NEW ZEALAND: Gramophonum, Ltd., 118-120
Victoria Street, Wellington.

SOUTH AFRICA: Darter & Sons, Post Box 174,
Capetown; Mackay Bros., Post Box 251, Johannes-
burg; Mackay Bros. & McMahon, Post Box 419,
Durban; Ivan H. Haarbarger, Post Box 105,
Bloemfontein; Frans Moeller, Post Box 108, East
London; B. J. Ewins & Co., Post Box 86, Queens-
town; Handel House, Kimberley; Lawrence &
Cope, Post Box 132, Bulawayo; The Argus Co.,
Salisbury.

EAST AFRICA: Bayley & Co., Lourenco
Marques.

HOLLAND: American Import Co., 22a, Amsterd
Veerkade, The Hague.

ITALY: A. Bossi & Co., Via Orefici 2, Milan.

EGYPT (Also for the Sudan, Greece and the
Ottoman Empire): K. Fr. Vogel, Post Box 414,
Alexandria.

FROM OUR LONDON HEADQUARTERS—(Continued from page 225)

Percy A. Scholes, editor of the Music Student and musical critic of the Observer, in the course of a speech, said that Sir Hugh Allan had made the suggestion that when there is reproduced on a record a fine orchestral selection there might be on the other side of the record an explanation of the theme so that the ordinary man would be better able to understand what he was listening to. Mr. Scholes said he passed the suggestion on for what it was worth.

A banquet, a dance, several concerts and excursions to the surrounding places of interest provided a social side to the convention that well rewarded members for the strenuous discussions. Alexander Dow, in bringing the Federation of the British Music Industries into such prominence as a central organization well deserves and indeed receives the wholehearted support of all keen members of the British music trade.

A Sensational Purchase by the Victor Co.

The financial correspondent of the Chronicle reports as follows: "Some interest was taken in gramophones (the 'His Master's Voice') on rumors that the Victor Talking Machine Co., an American concern, is taking up 850,000 shares at 25/ each, to be known as 'B' shares, entitled to 15 per cent dividends after a similar rate has been paid on the existing capital. Gramophones closed rather better at 35/." The following day, June 4, it was reported that "Some opposition to the Gramophone deal with American interests . . . seems to be developing, and the shares lost ground yesterday."

On June 9, at a meeting of the shareholders of the Gramophone Co., Ltd., a resolution to increase the capital to £1,700,000 was agreed to. This is brought about by the Victor purchase. The present ordinary shares are, however, entitled for the current and next three years to a preferential dividend of 15 per cent. After out-

lining the necessity for the enlargement of the capital at this time, Trevor Williams, chairman, stated that the Victor Co., with its net capital assets of over £6,500,000, had been closely associated commercially and otherwise with the Gramophone Co., Ltd., for something like twenty-five years. He described the result of the deal as an equal partnership and repudiated any suggestion that it would mean for them virtual control by the American interests.

The position is that the Victor Co. hold £850,000 of the £1 ordinary shares, leaving this side £750,000 ordinary and £100,000 preference shares.

The result of this additional capital will doubtless mean great expansion of the "His Master's Voice" this side. We know that developments in the shape of new buildings and plant are under way, and that the company are out to represent an even greater force in the industry than ever.

Misleading Advertisements

The Gramophone Association has circularized its members for co-operation towards suppression of that injurious class of private house trading arising from misleading advertisements. In many papers small advertisements offering "beautiful inlaid mahogany cabinet gramophones at £9 (or £10) equal to 30 guinea instruments" snare the public into purchasing what are very trumpery machines. I do not say they are not worth the money, but the wording of these announcements is wholly misleading to those without knowledge.

A case of this kind was recently before the courts when allegations were made against a dealer that purchasers of inlaid gramophones were jobbed off with inferior instruments. One of the complainants told the court that he answered an advertisement, and was shown a gramophone in a flat at Gloucester House, Hyde

Park. He agreed to buy at £12. The machine delivered was not the one shown him. The legs were tied up, the doors would not close and he could not wind it up.

Great Demand for Jascha Heifetz Records

It was a great day for England when this wonderful violin virtuoso reached London from the States. We had read much of the homage paid to him by your countrymen, and an advance set of his technique as recorded exclusively for the "His Master's Voice" Co. only served to whet our appetite for the complete satisfaction which comes from personal presence. His two London recitals aroused on each occasion a pitch of enthusiasm unique in the annals of British music gatherings. Even his conferees succumbed to this rare genius. The "His Master's Voice" record issues have been much praised by musical critics as masterpieces of record art. A striking window bill, leaflets, and other advertising literature, with generous press publicity have contributed to secure large retail sales of the Heifetz numbers.

London Exhibit of Canadian Gramophones

In no other British dominion or colony has there been displayed such manufacturing activity on the gramophonic side as, perhaps, in Canada. The efforts of its commercial men have expanded in the direction of export trade with the Mother Country. For instance, two or three exhibits of Canadian musical instruments were shown at the Canadian Industries Exhibition in London, June 3 to 17.

Cabinet gramophones of high class finish and design would seem to be a specialized trade in Canada, for it is of this type principally that the exhibits consist. A fine display is made by the Windsor Phonograph & Record Co., Ltd. George S. Pequenat, in charge, tells me that he has received many inquiries for territorial agencies and that the British trade has accorded a good reception to the Windsor line.

Another interesting exhibit is that of the Mc-

GRAMOPHONES

Complete—Fittings—Sundries—Repair
Parts—Needles

Special Lines and Quotations for Export Trade

THE BRITISH POLYPHON CO.

Glasgow, Scotland
27 Jamaica St.

1, 2 and 3 NEWMAN STREET
LONDON, W. 1, ENGLAND



YE "POPULAR" RECORDS

Double-Sided
Superb Needle Cut
"Lateral"

LONDON'S LEADING VALUE!!!

'OUR POINTS' } Have Attracted Keen Overseas Houses
SET OUT BELOW

from SCANDINAVIA to PATAGONIA
AND THE PRINCIPAL
EAST and WEST MARKETS of the WORLD

IMPORTANT We can give customers their own design Labels for LARGE Parcels.

REMEMBER You Can Have CLOSE QUOTATIONS

For 5,000 Lots and up "Your Selection" or a Sample 1,000, made up with "One Example" of Every Catalogued Pairing.

Address: SOUND RECORDING CO., Ltd. CABLES "Grammavox"
EXPORT DEPT., 18-19 Swallow Street London
Piccadilly, London, England "QUOTATIONS CABLED FREE"

POINTS

- ➔ Repertoire Approx 2,000 Titles—Covering
- ➔ Superb Selection, Bands and Orchestras
- ➔ Lightning Shipments
- ➔ Packing by Experts
- ➔ Rock Quotations "Always"
- ➔ F. O. B. London
- ➔ We attend to all Insurances "if Requested" to Buyers A/c
- ➔ Our Shipping Services, this Side FREE

Lagan Furniture Co., Ltd., Stratford, Ontario. Their sales manager, S. J. Cook, is looking after things this side. He tells me that his company is not out for big business yet awhile, owing to pressure of orders for the Canadian market. He is desirous of introducing samples of the superb McLagan gramophone art, and is prepared to treat for a sole agency. The distinctive and artistic style of this firm's cabinet gramophones has attracted considerable interest.

The period of the Canadian Industries Exhibition unfortunately clashes with that of the music trade convention at Scarborough, but there will be a day or so toward the end for the conventionites to put in an appearance at the C. I. E.

A New Gramophone—The Separaphone

A demonstration of the above was given recently at the Oxford Theatre. It is the invention of the brothers Gay. The essence of the instrument is a new kind of sound box. An outer case entirely encloses the diaphragm and stylus, and by this method very natural effects are obtained. Claims are made for other improvements, about which I shall have something to say later on. I am informed by Mr. Gay that many leading men of the musical world have expressed special interest in his invention.

The Winner Wet or Dry Publicity Couplet

For some time the Winner Record Co. has been running a publicity stunt on the London trams, in the form of a couplet—Wet or Dry Winner Records you should try. Any suggestion that this was inspired by Pussyfoot Johnson would doubtless be repudiated, though to be sure, the connection is rather suspected. As yet, the British public remains solidly against the prohibition idea, and aggressively so when it comes to Winner records, which distill such excellent fare of pleasing variety in the world of music. Notwithstanding all this, it appears that before his departure Mr. Johnson left us some mementos of his campaign in the shape

FROM OUR LONDON HEADQUARTERS—(Continued from page 226)

of Winners. These "wet or dry" discs will not figure on the company's ordinary program, having been made to private order, but are intended for use (with the loud-playing Stentorphone) by the pussyfoot prohibitionists. It is a coincidence that among recent Winner issues is a record called "Mister Pussyfoot," by that young comedian, Ernie Mayne.

"We are offering the public just what it wants," said Percy Willis, in the course of an interview with your correspondent, "and it is our policy to be on time with prompt deliveries of the up-to-date songs and musical numbers from the London plays. That is why we are not so much affected by the present sales depression, though, of course, at this time of year, one must not expect to be so overwhelmed with orders as in the Winter months."

It is an interesting fact, by the way, that the Versatile Three so tickled the Prince of Wales at an entertainment prior to his colonial tour, that he ordered a set of their Winner records to take away with him.

Perophone Popularity

In Phonoland business is said to be rather on the quiet side, but one of the firms least affected is the House of Perophone, Ltd., (Lockwood's Branch) City Road. Here I found an absence of the usual busy season's bustle, it is true, but the general air of business concentration bespoke the fact that a goodly volume of trade was under way. This firm are jobbers of the famous Zonophone goods, and have for long undertaken the manufacture of a quality range of instruments of all types, known as Perophones. The company's policy aims at the better class trade by the provision of models of artistic and exclusive design and workmanship, with, in the main, British equipment throughout. Though sold at competitive prices, Perophone machines make no appeal to that class of

trade which is best served by cheap value lines. Oversea buyers conducting a good class trade will therefore find in these products just the degree of merit they require in gramophones and their parts. Messrs. Perophone, Ltd., are now in a position to handle oversea contracts, and will be pleased to open up trading relations with any business reader of this journal not already on their books.

Interesting News in Brief

Another important price reduction is announced by the "His Master's Voice" Co. Dealers have received notice that on and after July 1 the Titta Ruffo records are reduced as follows: Ten-inch solo and concerted, from 8s. to 5s. 6 d.; twelve-inch do, from 12s. 6 d. to 7s. 6d.; twelve inch (No. 2-054049), from 20 s. to 10 s. 6d. Another step in the company's determination to bring the cream of talent within the price reach of a wider public!

From July 26 to August 9, inclusive, dealers and others are reminded that the "His Master's Voice" factories will be closed for the Summer vacation. During this period orders cannot be executed.

The Leipzig Messe catalog of exhibits, etc., published in two volumes, totalled over 1,750 pages. It comprised references to many industries, and shows, at least, that the Teutons are again very much on the move.

As previously noted in these columns, the shellac market is in rather a fluctuating state. An average pre-war price was 70/ per cwt. Early this year the figure of 900/ was quoted. After going down to about half this amount, the price is again upward, it being 620/ per cwt. at the time of writing.

Apropos the recently increased postal charges for the United Kingdom and letters to America, it should be noted that the postcard and printed
(Continued on page 228)

The Sound Box That Has Beaten the Band



An All British Production of the Highest Grade; Marketed at Popular Prices

4—Models Only—4

Export Quotations for Quantities at Extraordinarily Low Prices.

LARGEST OUTPUT IN UNITED KINGDOM

Vernon Lockwood
Manufacturing Co., Ltd.

76-78 CITY ROAD
LONDON, E. C. I.

HOME TRADE OUTPUT BOOKED UP FOR SEASON 1919-1920. WILL MAIL SAMPLE SET 4 MODELS B.C.E.F.(one only) TO ANY RECOGNIZED JOBBER ON RECEIPT DRAFT, \$5 (DOLLARS)

FROM OUR LONDON HEADQUARTERS

(Continued from page 227)

matter rate remains the same, though a revision is expected later.

The recent strike of over 200 men employes at the Columbia record factory, London, has collapsed by the employes resuming their duties on the company's terms.

S. W. McGregor, H. M. trade commissioner in Australia, has arrived in England for the purpose of conferring with British manufacturers concerning trading conditions and prospects in the Commonwealth. My advice is that those interested in the development of trade with this important country can interview Mr. McGregor by appointment at the Department of Overseas Trade, 35 Old Queen street, Westminster.

A "big bargain sale," as it is called, has been launched by an enterprising City Road jobber of gramophone goods. Its duration is twenty-eight days. Tempting advantages are offered dealers to stock up for next season!

A report dealing with the great expansion of American trade abroad, and particularly in the case of India, mentions that for the eleven months ending February last India's total imports from all sources amounted in value to 1,838,152,834 rupees, an increase as compared with same period last year of over 300,000,000 rupees!

Foreign made goods are imported and sold in the United Kingdom without any indication of the country of origin. The Gramophone and other trade associations have taken steps to place their views before the committee now considering the provisions of the merchandise marks act.

Successful experiments have been made in recording sound wirelessly over a distance of forty miles. It is the outcome of the wireless phone, about which we have recently heard much. A demonstration at Marconi House, London, gave some remarkable results. The wireless phone equipment attached to a Dictaphone recorder, registered on the wax cylinder a message spoken at Chelmsford, forty miles away.

Viscount Galway has made for the "His Master's Voice" an interesting record of Hunting Calls. It has been on the list some considerable time, according to the recent discovery of a newspaper reporter! Funny how some of the writers in daily papers "dig" up old news.

Gramophone needle sapphires require special treatment for their work, and are not likely to be ousted by the synthetic article being made in Clarkewell. But it is interesting. A report in the Chronicle states that these synthetic sapphires are made white and yellow for com-



"PERFECT POINTS"

BRITAIN'S BEST Gramophone Needle

(Guaranteed made from High Carbon Steel)

IS MADE BY

W. R. STEEL, of REDDITCH,

Head Office and Works—QUEEN ST.

Scientifically pointed, Hardened and Tempered on the latest up-to-date machinery and plant by skilled craftsmen only.

RESULT:

A FIRST QUALITY NEEDLE far ahead of anything of pre-war quality

INQUIRIES SOLICITED

Special Quotations for Quantities

Manufacturer of all Kinds of Sewing Needles

mercial purposes by fusing down aluminum powder. Dealers aver that they can sell the real article almost as cheap.

The Sterno Co. Expand

Interesting advice of business development reaches me from The Sterno Manufacturing Co., this city. For a considerable time past it has been very obvious by the congestion at the company's City Road premises that something was necessary to ease and permit of increased facilities of output. As a fact, lack of accommodation has for long restricted trading activity. London is a big place, but it is mighty short of suitable factories, owing to cessation of building during the war. But the Sterno people have at last been successful in securing a useful factory of three-floor capacity in the S. E. district, and this is now being equipped with up-to-date machinery for the manufacture of gramophones. Here will be transferred all departments with the exception of office and showroom, which remain at City Road. The company's future plans embrace an augmented output of complete machines of all types—cabinet, table-grand, hornless, portable and exterior horn models, of a good standard of quality, and based upon selling prices that will bear favorable comparison competitively. The Sterno Co. are manufacturers of the well-known portable Compactophone instrument, and sole agents of the Mermod Frères series of motors. These considerations, with the new factory facilities, represent a combination of good promise for next season's trade.

Progress of this nature shows a confident outlook in the future stability of British gramophone effort. Congratulations!

The Motor of Quality

Reports from the London headquarters of the General Phonograph Corp. indicate that, period and conditions considered, sales are keeping up quite satisfactorily. A. Balcombe informs me that trade is not quite so brisk as in former months, though good progress has been registered in comparison with even time a year ago. The retail demand for machines shows an easing off because the public is not buying to the same extent as during the Winter months. Again, with the advent of German goods, which the rate of exchange permits of selling at slightly less than the usual market prices, there is a noticeable tendency on the part of instrument assemblers to revert to the pre-war practice of making up very cheap machines. This is much to be regretted. The foundation, the life-blood of a gramophone, is first-class mechanism, and it should be the aim of everyone concerned to insist upon reliable motive power. In this regard, the motor of quality occupies a recognized place. The company intend to maintain a trading policy which, in its educational aspect, will help all to a wider realization that "Good music depends upon a perfect motor."

By the way, the company has just issued a very attractive folder itemizing full descriptions and illustrations of their various models, and this has been circulated with good results.

Horn, Hornless and Table-Grand GRAMOPHONES

FOR EXPORT

Please State Your Requirements

REX GRAMOPHONE CO. 2 Elizabeth Place
Rivington Street, LONDON, E.C. 2, England
Cable Address "Lyrecodisc, London"

AUSTRALIA.

Herbert G. Polyblank,
SYDNEY,
N.S.W.

BELGIUM.

P. Carton,
Rue Karel Ooms, 11,
ANVERS.

ITALY.

G. Menaboni,
Via S. Sebastiano 2,
LIYORNO.

SPAIN.

Ernesto Verdu,
ALICANTE.

ENGLAND.

A. Walte & Co., Ltd.,
15-17 Figtree Lane,
SHEFFIELD.

Songster Machine Talking Needles

Manufactured by J. STEAD & CO. LTD.
MANOR WORKS. SHEFFIELD ENGLAND.



LATEST PATENTS RELATING TO TALKING MACHINES AND RECORDS

WASHINGTON, D. C., July 8.—Phonograph. Arthur E. Teal, Walker Township, Mich. Patent No. 1,336,492.

The present invention relates to phonographs; and an object thereof is to provide an instrument improved in various features of construction; a further object is to provide a phonograph having improved resonant qualities; a further object is to provide a phonograph having an outer wall sufficiently strong and rigid but nevertheless vibratile under the action of sound waves; a further object is to provide in a phonograph an improved sound amplifier; a further object is to provide in such an amplifier a plurality of branches so disposed interrelatively that the sound waves issuing therefrom intersect and blend; a further object is to provide a phonograph wherein the vibratile outer wall of the phonograph forms a wall of the amplifier; a further object is to provide an amplifier having a middle and side branches; a further object is to provide an improved valve for governing the volume of sound issuing from the

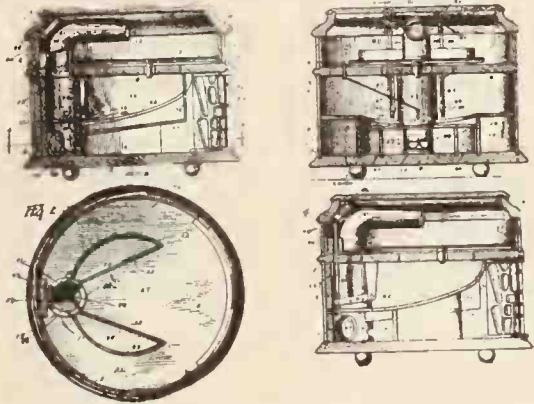

amplifier; a further object is to provide an improved counterbalancing device for the hinged cover of the cabinet.

Fig. 1 is a central vertical section of a phonograph; Fig. 2 is a sectional view of the same taken on a horizontal plane corresponding to line A—A of Fig. 1; Fig. 3 is a central section of the same taken on a vertical plane corresponding to line B—B of Fig. 1, and Fig. 4 is a section of the same taken on vertical planes corresponding to line C—C of Fig. 3.

Sound Box. Forest Cheney, Chicago, Ill., assignor to Cheney Talking Machine Co., same place. Patent No. 1,339,809.

This invention relates to talking machines and particularly to a novel sound box therefor. The principal object is to provide a new and improved apparatus for recording or reproducing sound in connection with talking machines and the like.

Other objects are to provide a sound recorder or reproducer that will operate to preserve the quality of the sound; to provide a sound box for talking machines which will clarify the sound reproduced thereby; to amplify sound by providing a plurality of air cham-

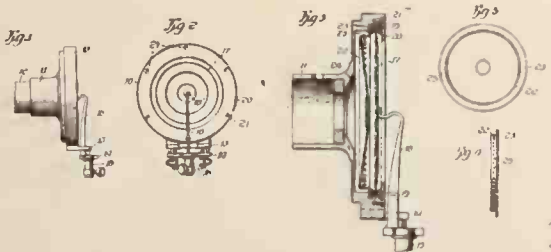

bers, each of which increases in volume in the direction of the flow of the sound.

bers, each of which increases in volume in the direction of the flow of the sound.

Fig. 1 is a side elevation of a sound box made in accordance with this invention. Fig. 2 is a plan view of the same looking from the right hand side of Fig. 1. Fig. 3 is an enlarged vertical sectional view through the center of the sound box made in accordance with the invention. Fig. 4 is an edgewise view of the preferred form of apertured partition, and Fig. 5 is an elevation thereof.

Phonograph and Analogous Apparatus. Elwood Grissinger, Buffalo, N. Y. Patent No. 1,339,649.

This present invention is shown as embodied in a phonographic sound box which is primarily adapted for mechanically reproducing sound from a record, but may be employed for the reverse process of recording sound upon a wax or other impressionable surface. The general purposes and objects of the present invention are similar to those explained in prior applications Ser. Nos. 236,735, 239,512 and 239,513; and the novel features of the present device may be employed in connection with the recording apparatus and methods of application Ser. No. 236,735.

One important object of the present invention is to insure faithful transmission through a lever or other similar machine element, of physical movements corresponding to speech vibrations or other vibrations having similar frequencies or similar complexities.

In the drawings: Fig. 1 is an elevation or face view of a phonographic reproduction embodying one form of the invention; Fig. 2 is an end view of Fig. 1 from below; Fig. 3 is a section on the line 3—3, Fig. 1; Figs. 4 and 5 are sections on the line 4—4 showing an initial position and one of the adjusted positions of the parts; Figs. 6, 7 and 8 are respectively face, end and sectional views corresponding to Figs.

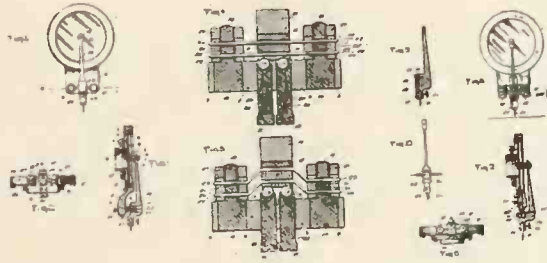

1, 2 and 3, but showing a modified arrangement of the pivotal mounting; Figs. 9 and 10 are respectively longitudinal section and face views of a form of lever arranged for use with a single wire.

Phonograph and Analogous Apparatus. Elwood Grissinger, Buffalo, N. Y. Patent No. 1,339,648.

This present invention is shown as embodied in a phonographic sound box which is primarily adapted for mechanically reproducing sound from a record, but it may be embodied in a phonographic recorder or other apparatus where rigid, frictionless, noiseless pivoting is necessary or desirable in order to insure faithful, undistorted mechanical receiving or transmission of high frequency or complex wave energy.

The present invention relates more particularly to the use of the spaced stretched wires, and it involves in addition thereto a means for further predetermining and fixing the location of the pivotal axis of the lever. Broadly stated, the said means consists of a third element adapted to apply a thrust perpendicularly to the plane of the wires, and along a line parallel with and midway between them. The means employed for this purpose may be varied, but in this application is disclosed how a pair of aligned steel balls may be used for such purpose.

By providing suitable adjusting screws, the pivotal means may be very powerfully forced against the lever, thus affording a convenient and very effective means for transversely displacing the wires and thereby stretching them to any desired degree of tension.

By the above expedient, the aligned balls become the physical bearing surfaces for the pivotal movement of the lever. These bearing surfaces are forced into contact with relatively enormous pressure by the symmetrically applied stresses of the spaced wires. This prevents all possibility of jumping or noise producing movements at the point of contact of the lever with its bearing. The bearing parts are preferably of very hard steel and are formed with smooth, preferably polished surfaces.

Fig. 1 is a face view of a phonographic sound box showing the spaced stretched wire suspension; Fig. 2 is a section on the line 2—2, Fig.

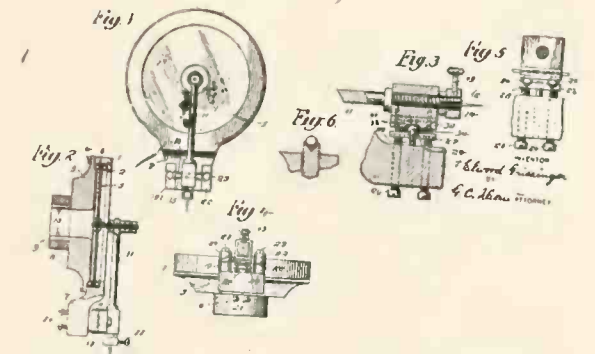

1, the lever and pivotal mounting being shown in side elevation; Fig. 3 is an enlarged vertical section on the line 3—3, Fig. 1; Fig. 4 is an elevation endwise of the lever; Fig. 5 is a detail view showing the pivotal mounting as in Fig. 4, but on a larger scale; and Fig. 6 is a detail section showing a modified form of adjustable ball support.

Phonograph and Analogous Apparatus. Elwood Grissinger, Buffalo, N. Y. Patent No. 1,339,558.

The present invention is shown as embodied in a phonographic sound box which is primarily adapted for mechanically reproducing sound from a record, but it may be embodied in a phonographic recorder or other apparatus where rigid, frictionless, noiseless pivoting is necessary or desirable in order to insure faithful, undistorted mechanical receiving or transmission of high frequency or complex wave energy.

The present invention may include the above features, but it relates more particularly to the use of the spaced stretched wires and it involves in addition thereto, a means for further predetermining and fixing the location of the pivotal axis of the lever. Broadly stated, the said means consists of a third element adapted to apply a thrust perpendicularly to the plane of the wires, and along a line parallel with and midway between them. The means employed for this purpose may be a knife edge or a cylinder of small diameter or a pair of aligned steel balls.

By providing suitable adjusting screws, the pivotal edge or surface may be powerfully forced against the lever, thus affording a convenient and very effective means for transversely displacing the wires and thereby stretching them to any desired degree of tension.

By the above expedient, the knife edge or aligned balls become the physical bearing surfaces for the pivotal movement of the lever. These bearing surfaces are forced into contact with relatively enormous pressure by the symmetrically applied stresses of the spaced wires. This prevents all possibility of jumping or noise

(Continued on page 230)

producing movements at the point of contact of the lever with its bearing. The bearing parts are preferably of very hard steel and are formed with smooth, preferably polished surfaces.

Fig. 1 is a face view of a phonographic sound box showing the spaced stretched wire suspension; Fig. 2 is a section on the line 2—2,

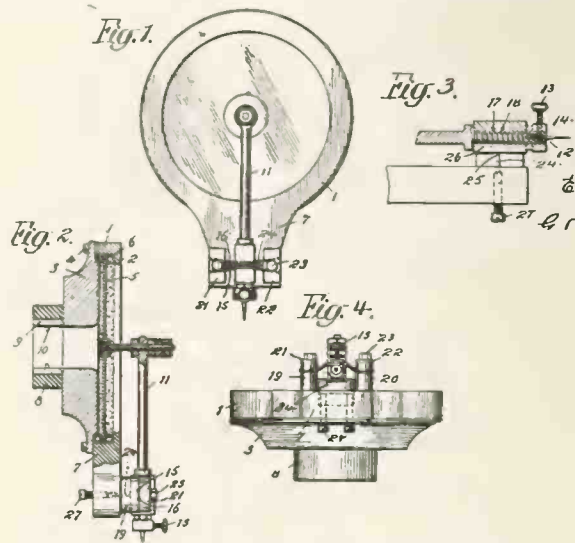
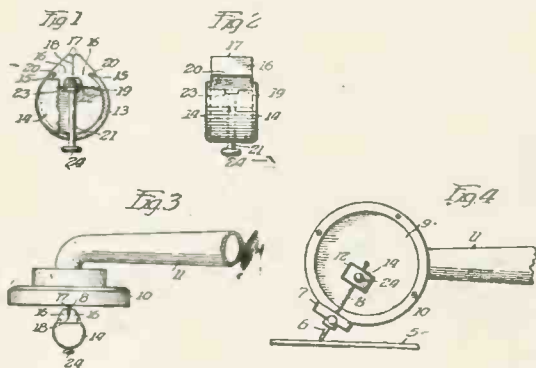

Fig. 1, the lever and pivotal mounting being shown in side elevation; Fig. 3 is an enlarged vertical section on the line 3—3, Fig. 1; Fig. 4 is an elevation endwise of the lever.

Phonograph Tone Modifier. Meyer Maltz, Chicago, Ill., assignor of one-half to B. M. Arnesen and one-half to W. C. Utes, both of Chicago, Ill. Patent No. 1,339,404.

This invention relates to means for modifying tones produced by phonographs and similar machines, and has for an object the elimination of the scratching and metallic sounds frequently produced by phonographs, and a particular object is to modify the tones so as to make them more mellow and pleasing to the ear.

Of the accompanying drawings Fig. 1 is an elevation of the device which is used in modifying the tone of the instrument, certain portions of the device being broken away to show the interior thereof. Fig. 2 is another elevation of the same device. Fig. 3 shows the man-



ner of attaching the modifying device to the ordinary mechanism of the phonograph. Fig. 4 is another view of the device attached to the said mechanism.

Record-Repeating Device for Sound-Reproducing Machines. Rasmus P. Christensen, Buffalo, N. Y. Patent No. 1,340,525.

This invention relates to improvements in record-repeating devices for sound reproducing machines.

This invention is an improvement on an application for patent filed on the 15th day of March, 1917, Serial No. 154,944, and embodies

the same principles therein shown and described; it, however, has for its object to improve and simplify the construction of the parts to render the device easier to operate and to reduce the cost of the same.

In the drawings Fig. 1 is a perspective view of the upper end of a sound reproducing machine of popular style, to which the improved repeating device is attached, part of the cover only being shown. Fig. 2 is a plan view of the machine with the cover removed. Fig. 3 is a transverse section through one-half of the upper portion of the sound reproducing machine with the cover removed, the repeating device being shown in normal position. Fig. 4 is a similar view with the repeating device in a position in which it serves to automatically return the tone or reproducer arm with its sound box or reproducer to the starting point of the record, or to any other desired point from which the record is to be repeated. Fig. 5 is a horizontal section on an enlarged scale taken on line 5—5, Fig. 3. Fig. 6 is a perspective view of one of the stop devices adjustable on the skid or guide arm of the device, said skid or guide arm being shown in dotted lines to better illustrate the application of said stop device to said arm. Fig. 7 is a detached perspective view of the other stop device adjustable on the skid or guide arm of the device, said skid

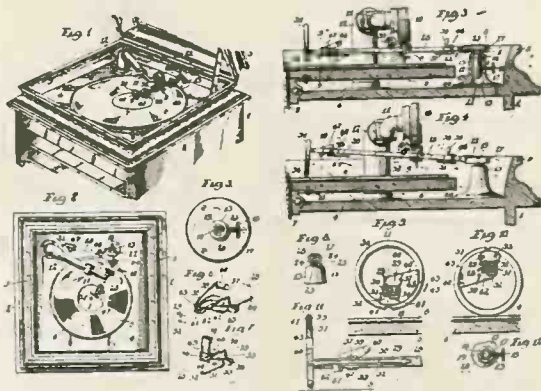

or guide arm being shown in dotted lines to better illustrate the application of said stop device to said arm. Fig. 8 is a transverse section on an enlarged scale taken on line 8—8, Fig. 3. Fig. 9 is a transverse section on an enlarged scale taken on line 9—9, Fig. 3. Fig. 10 is a transverse section on an enlarged scale taken on line 10—10, Fig. 4. Fig. 11 is a longitudinal section taken on line 11—11, Fig. 9. Fig. 12 is a horizontal section taken on line 12—12, Fig. 3.

Sound Box. Eugene T. Turney, New York, assignor of one-half to Ernest C. Wilcox, Meriden, Conn. Patent No. 1,340,854.

This invention relates to improvements in sound boxes, so-called, for use in phonographs and talking machines. The chief object of the invention is to provide a new and useful construction designed to improve the quality of

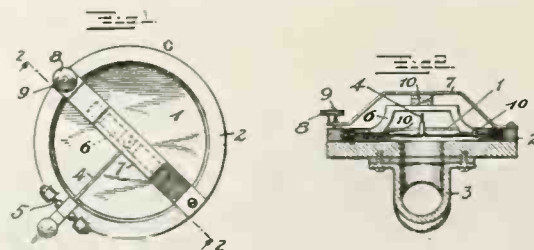

tone reproduced. In the accompanying drawing Fig. 1 is a side elevation. Fig. 2 is a section on the line 2—2 of Fig. 1 looking in the direction of the arrows.

Record-Repeating Device for Sound-Reproducing Instruments. Rasmus P. Christensen, Buffalo, N. Y. Patent No. 1,340,524.

This invention relates to improvements in record-repeating devices for sound-reproducing machines.

The object of the invention is to provide an improved repeating device having adjustable stops whereby any portion or the whole of the record may be repeated.

Another object of the invention is the production of a device of the kind mentioned which will positively return the sounding box of the

reproducer to the starting point of the record while gently lowering the needle into contact with the record, thus assuring full protection to the record and guarding against injury to the needle.

Another object of the invention is the provision of a repeating device which can be easily attached to any disk-playing sound reproducing machine and which may be swung into inoperative position so that the record may be played in the usual manner without repeating.

Fig. 1 is a perspective view of the upper end of a sound reproducing machine to which the improved repeating device is attached. Fig. 2 is a transverse section through one-half of the upper portion of the sound reproducing machine, with the cover removed, the repeating device being shown in normal position. Fig. 3 is a similar view of the repeating device in a

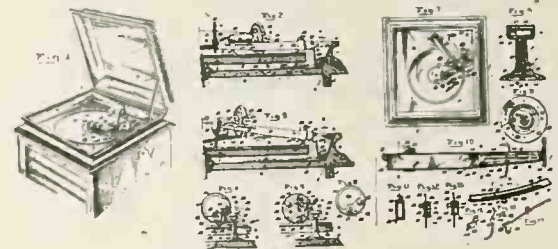

position in which it automatically returns the reproducer to the starting point of the record, or to any other desired point from which the record is to be repeated. Fig. 4 is a section taken on line a—a, Fig. 2, looking in the direction of the arrow crossing said line. Fig. 5 is a section taken on line b—b, Fig. 3, looking in the direction of the arrow crossing said line. Fig. 6 is an elevation of the eccentric whereby the skid or guide member of the device is actuated to place the same in inclined position. Fig. 7 is a plan view of a sound reproducing machine with the cover removed. Fig. 8 is an enlarged vertical section through the skid or guide support. Fig. 9 is an inverted view of the same. Fig. 10 is a longitudinal section through the skid or guide member. Fig. 11 is a cross section taken on line c—c, Fig. 10. Fig. 12 is a cross section taken on line d—d, Fig. 10. Fig. 13 is a cross section taken on line e—e, Fig. 10. Fig. 14 is a longitudinal section taken on line f—f, Fig. 10, the eccentric and its shaft being omitted. Figs. 15 to 17 are perspective views showing in detail parts of the actuating devices forming part of said skid.

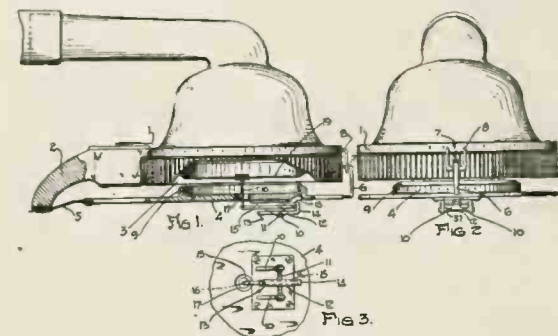

Floating Weight Sound Box. Erwin Cassca, Gloversville, N. Y. Patent No. 1,340,436.

This invention relates to sound boxes for phonographs and has particular reference to a floating weight and the connection of the stylus lever thereto, the said lever being connected with the diaphragm through an intermediate lever and flexible connector, whereby to absorb local vibrations and to reproduce through the diaphragm the recorded vibrations, and to increase the accuracy and tone of the reproduction.

Fig. 1 is a side elevation, partly in section, showing the invention as applied to a sound box. Fig. 2 is an end elevation, and Fig. 3 is a plan view of the stylus and supports.

LESLEY'S PATCHING VARNISH

Dries in 10 seconds, flows without showing the lap. With it damaged varnish can be repaired invisibly. Price now 1 pint, \$1; 1 quart \$1.90. Complete repair outfit, \$3.50. F. O. B. Indianapolis, Ind.

LESLEY'S CHEMICAL COMPANY
Indianapolis, Indiana

REPAIRS

All Makes of Talking Machines
Repaired Promptly and Efficiently

ANDREW H. DODIN

28 Sixth Avenue

New York

TELEPHONE, SPRING 1194

Advance RECORD BULLETINS for August, 1920

VICTOR TALKING MACHINE CO.

Table of vocal records including 'Gems from "Apple Blossoms"', 'Irene', 'The Love Nest', 'Blue Diamonds', 'Tiddle-Dee-Winks', 'I Love the Land of Old Black Joe', 'All Star', 'Love Nest', 'A Young Man's Fancy', 'RED SEAL RECORDS', 'Each Shining Hour', 'Homer (Domu)', 'Zaza', 'Heaven Is My Home', 'Introduction and Tarantelle', 'MME. HOMER AND DAUGHTER', 'When Night Descends', 'Prelude in G Minor', 'Blue Danube Waltz', 'Otello', 'Old Folks at Home'.

COLUMBIA GRAPHOPHONE CO.

Table of Columbia Graphophone records including 'Some Beautiful Morning (I'll Find You in My Arms)', 'I've Got the Profitteering Blues (Bibo)', 'Ten Little Bottles (Monaco)', 'Unlucky Blues (Lewis and Robinson)', 'All the Boys Love Mary (Van and Schenck)', 'Way Down Barcelona Way (Jentes)', 'Oh! By Jingo (Von Tilzer)', 'Rose of Chile (Bowers)', 'Take It Easy (White)', 'Come Back to Georgia (Hickman and Black)', 'Lassie, Intro "Echo" from "Lassie" (Felix)', 'Alabama Moon, Intro. "My Paradise" (Green Zamecnik)', 'Love and Money-Waltz', 'SPECIAL SUMMER DANCE RECORDS', 'Peggy-Fox-trot', 'Tell Me Why-Fox-trot', 'Only-Fox-trot', 'I Ain't Gonna Give Nobody None o' This Jellyroll', 'Hello! Hello!', 'O! What a Pal Was Mary', 'Weeping Willow Blues', 'Sweet Siamese-Fox-trot', 'Aloma-Oriental Fox-trot', 'Patches-Fox-trot', 'I Want a Daddy Who Will Rock Me to Sleep', 'I Might Be Your Once-in-a-While', 'Rainbow of My Dreams', 'Burmese Belles', 'That's Got 'Em', 'A Good Man Is Hard to Find', 'Down Home Rag', 'I Ain't Got Nobody Much', 'Thousands of Years Ago', 'I Wonder Whether', 'I'm Forever Blowing Bubbles', 'That Tumble Down Shack in Athlone', 'Wond'ring'.

Table of Edison Amberol records including 'You Can't Get Lovin' Where There Ain't Any Love', 'A2906 Oriental Stars', 'A6064 I'm Always Chasing Rainbows', 'A6132 Pretty Little Rainbow', 'A6089 Memories of the Past Waltzes', 'A2895 Venetian Moon', 'A2879 Ah! There-Flirtation', 'A2720 Mary Ann', 'Bevo Blues', 'A2880 Dancing Honeymoon', 'A2876 Buddha-Dardanella', 'A5929 Charming', 'A2844 "O" (Oh)', 'A2851 Dardanella', 'A2858 Cairo', 'A2874 Apple Blossoms Waltz', 'A6081 My Belgian Rose', 'A2813 The Hesitating Blues', 'A6137 Oh What a Pal Was Mary', 'A2864 Just Like the Rose', 'A2686 Out of the East', 'A2707 Ja-Da!', 'Rainy Day Blues', 'A2811 My Baby's Arms', 'On the Streets of Cairo', 'A2719 No One But You', 'SPECIAL AUGUST MID-MONTH LIST', 'A2939 Left All Alone Again Blues', 'A2944 The St. Louis Blues', 'A2946 In Sweet September', 'A2948 Marion (You'll Soon Be Marryin' Me)', 'A2945 Somehow', 'A2949 Dance-o-Mania', 'A6157 Tripoli', 'ROYAL PURPLE RECORDS', '29056 Want of You', '29057 Love's Sorrow', 'REGULAR LIST', '4037 Red Tulip', '4038 When I'm Alone', '4039 Pickaninny Blues', '4040 When You're Gone', '4041 Oh By Jingo!', '4042 Dardanella', '4043 Afghanistan', '4044 Bluin' the Blues', '4045 All Over This World', '4046 Semper Fidelis March'.

Table of Edison Re-Creations records including '4047 Everybody's Buddy', '4048 Oh! How I Laugh When I Think How I Cried About You', '4049 Bow-Wow (Wadsworth)', '4050 Oh, Joe (Please Don't Go)', '4051 Will It Ever Be the Same Again', '4052 Hawaiian Smiles', '4053 While Others Arc Building Castles in the Air', '4054 Dinnie Donohue, the District Leader', '4055 As You Were (Gaskill)', '4056 La Veeda', '4057 Sweeter As the Years Go By', '4058 Alabama Moon', '4059 Alexandria (Aphrodite)'. Includes artist names like Lewis James, Rachael Grant, Billy Murray, etc.

EDISON RE-CREATIONS

Table of Edison Re-Creations records including '82188 Scherzo-Tarentelle', '82189 Träumerei', '82190 Elégie (Massenet)', '82191 Carry Me Back to Old Virginny', '80512 Columbia, the Gem of the Ocean', '80523 Old Hungarian Melody', '80528 Gentle Annie', '80529 Home Again', '80530 In an Old-Fashioned Town', '80531 Ambassador Polka', '50623 Hawaiian Breezes', '50652 Hail to the Spirit of Liberty', '50653 Devil's Dream Medley', '50654 Darky's Oration on Woman', '50655 My Friends, Morris and Max'. Includes artist names like Albert Spalding, Frieda Hempel, etc.

AEOLIAN CO.

Table of Aeolian records including '55006 Zaza-O mio piccolo tavolo', '55007 Miserere', '24008 Little Town in County Down', '14072 Oh Susanna', '24009 Joselyn-Berceuse', '14073 Everybody's Buddy', 'When He Gave Me You', '14074 Lone Star', '14074 You Can't Go Wrong With a Girl from Dixieland', '14075 Clouds (David)', '14076 There's a Typical Tipperery Over Here'. Includes artist names like Giulio Chimi, Maurice Dambois, etc.

(Continued on page 232)



THIS SALESMAN
WILL
DISPLAY SUGGEST REMIND SELL
FOR YOU

Dulciphone Needles

"The Highest Quality Needle in America"

MADE SCIENTIFICALLY OF THE HIGHEST GRADE CARBON STEEL. GUARANTEED TO PLAY THE LONGEST RECORD WITHOUT VARIATION AND WITH PUREST REPRODUCTION.

DEALERS' PRICE **6 1/2c.** Per 100 to the Package | Your Initial Order for 200 Packages Brings the Handsome Display Case **Free**
Jobbers and Sales Agents write for our proposition to you

GRAND TALKING MACHINE CO., Inc.

Manufacturers of Dulciphone Phonographs
Dulciphone Needles
Distributors of QRS Player Rolls
Emerson Records
268-270 Flatbush Ave. Extension
BROOKLYN, N. Y.

ADVANCE RECORD BULLETINS FOR AUGUST—(Continued from page 231)

- DANCE SELECTIONS**
14077 A Young Man's Fancy (Music Box), from "What's in a Name?" (Ager)—Fox-trot, Harry A. Yerkes' Dance Orch.
On Miami Shore—Waltz (Jacobi), Harry A. Yerkes' Marimba Band
14078 Wigwam—Fox-trot (Samuels), Murray's Melody Men
Polly—One-step (Richmond), Murray's Melody Men

PATHE FRERES PHONOGRAPH CO.

POPULAR SUPPLEMENT NO. 35
POPULAR VOCAL

- 22381 In Old Madeira (Wehner-Sanders-Carlo), Tenor duetCampbell and Burr
When a Peach in Georgia Weds a Rose from Alaham (Hager-Goodwin), Peerless Male Quartette
22355 I'd Like to Know Why I Fell in Love With You (Timberg), Tenor.....Lewis James
One Loving Caress (Wenrich), Tenor and haritone duet.....Charles Hart and Elliott Shaw
20458 Ten Little Bottles (McDonnell-Monaco), Baritone, piano accomp.....Jack Norworth
I'm On Strike (Feldman), Baritone, piano accomp.,Jack Norworth
22392 I'd Like to Take You Away (From "Betty Be Good") (Smith-Riesensfeld), Contralto and tenor duet.....Marion Cox and Billy Jones
Le Wanna (Bernard), Baritone.....Ernest Hare
22393 I'm the Good Man That Was So Hard to Find (Green-Piantadosi), Baritone.....Ernest Hare
Alihi Blues (Swanstrom-Morgan), Soprano, piano accomp.....Aileen Stanley
22394 Mammy's Little Sugar Plum (Davis-Erdman), Tenor,Nohle Sissle
Gee, I Wish I Had Some One to Rock Me in the Cradle of Love (Sissle-Blake), Tenor,Nohle Sissle
22395 There's a Typical Tipperary Over There (Gerher-Silver), Male quartet.....The Harmonizers
I'll Be With You in Apple Blossom Time (Fleeson-Von Tilzer), Tenor.....Malvin Strong

DANCE

- 22383 Jade Lady (Wehb), One-step, Wehb's Novelty Entertainers
Gems (Broaker), Fox-trot, Wehb's Novelty Entertainers
20459 Missy, Introducing "Rainbow of My Dreams" (Rohe-Stanton), Medley Fox-trot, Rudy Wiedoeft's Palace Trio
Lone Star (Wiedoeft), Fox-trot, Rudy Wiedoeft's Palace Trio
22380 Dance-O-Mania (Gilbert-Cooper), Fox-trot, Green Brothers' Novelty Band
Kismet (Henlere), Fox-trot, Green Brothers' Novelty Band
22396 Do You Know? (McNamara-Fitzgibbon), Fox-trot, (Under personal direction of Joseph Knecht), Waldorf-Astoria Dance Orchestra
Romance (David), Waltz, (Under personal direction of Joseph Knecht), Waldorf-Astoria Dance Orchestra
22397 Korinthia (Kneight), One-step, (Under personal direction of Joseph Knecht), Waldorf-Astoria Dance Orchestra
When Shadows Fall I Hear You Calling, California (Kalmar-Ruby-Jones), Fox-trot, (Under personal direction of Joseph Knecht), Waldorf-Astoria Dance Orchestra

- 40202 Marion (You'll Soon Be Marryin' Me) Introducing "Mayhe" (Ingram-McConnell-Davis), Medley Fox-trot, United States Hotel Orchestra, Saratoga, N. Y.
Some Pretty Day, Introducing "I'd Love to Fall Asleep and Wake Up in My Mammy's Arms" (Ahlert), Medley Fox-trot, United States Hotel Orchestra, Saratoga, N. Y.
INSTRUMENTAL
22373 Underneath the Moon (Brancan-Plunkett), Saxophone solo.....Duane Sawyer
Some of the Time I'm Lonely (Hatch), Saxophone solo.....Duane Sawyer
HAWAIIAN
22391 Hawaiian Twilight (Sherwood-Vandersloot), Hawaiian guitars, Ferera and Franchini
Drifting (Lamb-Polla), Hawaiian guitars, Ferera and Franchini

Regular August Pathé List

POPULAR VOCAL "HITS"

- 22374 Marion (You'll Soon Be Marryin' Me) (Kienzle-Smith-Ingham-McConnell),Orpheus Trio
Good-Bye Sunshine, Hello Moon! (Buck-Eckstein), TenorSam Ash
22376 Tired of Me (Clark-Donaldson), Tenor, Lewis James
Ages and Ages (Kendis-Brockman), Tenor duet, Lewis James and Charles Hart
22377 Rose of Washington Square (MacDonald-Hanley), Baritone,Sidney Phillips
Tiddle-Dee Winks (At All the Men) (Kilgour-

- Handman), Tenor.....Billy Murray
22378 Who'll Take the Place of Mary? (Duhin-Gaskill-Mayo),Orpheus Trio
After You Get What You Want You Don't Want It (Berlin), Tenor.....Billy Jones
22382 The Moon Shines on the Moonshine (DeWitt-Bowers), Baritone.....Ernest Hare
I Want a Jazzy Kiss (Ring-Hager), Collins and Harlan, Comedians
20456 When He Gave Me You (Mother of Mine) (Murphy-White), Tenor.....Henry Burr
That Old Irish Mother of Mine (Jerome-Von Tilzer),Sterling Male Trio
22388 Some Pretty Day (Lewis-Young-Ahlert), Contralto and tenor duet, Marion Cox and Billy Jones
Sunny Southern Smiles (Gilbert-MacBoyle-Cooper),The Harmonizers
22375 Unlucky Blues (Lewis-Rohinson), Tenor, Al Bernard
Oh, Joe! (Please Don't Go) (Walker-Briers), Tenor,Al Bernard
40200 American Fantaisie (Herbert) Artur Bodanzky, Director,New Symphony Orchestra
Invitation to the Dance (Weher), Artur Bodanzky, Director,New Symphony Orchestra
22353 Believe Me If All Those Endearing Young Charms (Moore), Violin, flute and piano, Longo Trio (F. Longo, N. Laucella, S. Guidi)
The Meeting of the Waters (Old Melody), Longo Trio (F. Longo, N. Laucella, S. Guidi)
22387 The Sidewalks of New York (Lawlor-Blake), (H. J. Clarke-Steel Guitar), Royal Waikiki Hawaiian Orchestra
On the Banks of the Wahash, Far Away (Dresser), (H. J. Clarke-Steel Guitar), Royal Waikiki Hawaiian Orchestra
NEW DANCE RECORDS
22354 Just a Little Touch of Paris (Kernell), One-step,Van Eps-Banta Trio
Bell Hop Blues (from "Look Who's Here") (Piantadosi), Fox-trot, Van Eps-Banta Trio
22371 Rose of the Orient (Johnson-Arthur), Fox-trot, Green Brothers' Novelty Band
Dancing Honeymoon (Janssen), Fox-trot, Green Brothers' Novelty Band
22384 Jean (Brooks), Fox-trot, Ernest Hussar's Orchestra
Ahandonado (Pasadas), Waltz, Ernest Hussar's Orchestra
22342 I Know Why (Davis-Morgan), Fox-trot, Nicholas Orlando's Orchestra
So This Is Paris (Motzan-Akst), One-step, Nicholas Orlando's Orchestra
22390 A Young Man's Fancy (from "What's in a Name") (Anderson-Yellen-Ager), Fox-trot, Casino Dance Orchestra
In Sweet September (Monaco), Fox-trot, Green Brothers' Novelty Band
20457 Wigwam (Samuels), Fox-trot, Joseph Samuels' Orchestra
Mississippi Shore (Sizemore-Van Alstyne), Waltz, Joseph Samuels' Orchestra
54047 Somewhere a Voice Is Calling (Newton-Tate), Tenor, in English,Tito Schipa
54046 Good-Bye (Tosti), Soprano, in English, Yvonne Gall
25042 By the Waters of Minnetonka (Cavanass-Lieurance), Baritone.....Percy Hemus
Last Night (Kjerulf), Baritone.....Percy Hemus

PARAMOUNT RECORDS

DANCE RECORDS

- 20001 Dardanella, Fox-trot, Selvin's Novelty Orchestra
That Naughty Waltz, Selvin's Novelty Orchestra
20002 Isle of My Golden Dreams, Waltz, Selvin's Novelty Orchestra
Peggy, For dancing, Selvin's Novelty Orchestra
Irene, Medley Fox-trot, Selvin's Novelty Orch.
20007 Venetian Moon, For dancing, Selvin's Novelty Orchestra
20008 Charms, Fox-trot, Newport Society Orchestra
Jean, Medley Fox-trot, Selvin's Novelty Orch.
20009 I'll See You in Cuba, For dancing, All Star Trio
When My Bahy Smiles at Me, For dancing, All Star Trio
20010 Oh, By Jingo, Vocal, Al Bernard
Saxophone Blues, Vocal, Al Bernard, Saxophone solo,Rudy Wiedoeft
20011 Pickaninny Blues, Vocal,Henry Burr
Let the Rest of the World Go By, Qula Helene Evans
20012 Word'ring, Fox-trot,All Star Trio
Rose of Washington Square, Medley Fox-trot, Newport Society Orchestra
20013 La Veeda, Fox-trot, Newport Society Orchestra
Left All Alone Again Blues, Medley Fox-trot, Newport Society Orchestra
33061 I Might Be Your Once in a While, American Marimba Band
On Miami Shore,American Marimba Band

GENNETT LATERAL RECORDS

SELECTIONS

- 9038 La Veeda (Alden), Fox-trot, Saxophone solo, Orch. accomp., Duane Sawyer and His Novelty Orchestra
The Crocodile (Motzan-Akst), Fox-trot, Bennie Krueger's Melody Syncopators
9039 Railroad Blues (Roberts), One-step, Raderman's Novelty Orchestra
Bow-Wow (Wadsworth), One-step, Saxi Holtsworth Harmony Hounds
9043 Oriental Stars (Monaco), One-step, Rose Garden's Orchestra, A. Uhrmetz conducting
Left All Alone Blues (from "The Night Boat") (Kerns), Fox-trot,Cordes' Orchestra
9036 Who'll Take the Place of Mary (Cunningham-Gaspice-Mayo), Vocal trio, Orch. accomp., Orpheus Trio
One Loving Caress (Wenrich), Tenor and haritone duet, Orch. accomp.,Hart and Shaw
9044 All the Boys Love Mary (Van-Schenck-Sterling), Tenor solo, Orch. accomp.,Billy De Rex
One Little Girl (Klickman-Frost), Tenor solo, Orch. accomp.,Arthur Hall

EMERSON PHONOGRAPH CO.

BIG DANCE HITS

- 10203 The Love Nest, From Musical Production "Mary" (Louis A. Hirsch), Fox-trot, Rudy Wiedoeft's Palace Trio
Close to My Heart, Medley, Intro.: "I Love to Fox-trot" from the Musical Production "Honey Girl" (Von Tilzer-Fleeson), Fox-trot, Rudy Wiedoeft's Palace Trio
10192 So Long Oolong, How Long You Gonna Be Gone? (Kalmar-Ruby), Fox-trot, Green Brothers' Novelty Band
Yokahoma (Gerald Peck), Japanese Fox-trot, Knickerhocker Specialty Orchestra
10193 Hiawatha's Melody of Love (Bryan-Meyer), Waltz,Green Brothers' Novelty Band
Whose Baby Are You? From Musical Production "The Night Boat" (Jerome Kern), One-step,The All Star Trio
10191 My Sahara Rose (Clarke-Donaldson), Fox-trot, Sanford's Famous Dance Orchestra
Old Man Jazz (Gene Quaw), Fox-trot, George Hamilton Green's Novelty Orchestra
10194 Jean (Shelton Brooks), Fox-trot,All Star Trio
Wild Flower (Mary Earl), Waltz,All Star Trio
10196 Cairo (Freed-Weeks), One-step, Plantation Jazz Orchestra
Kismet (Herschel Henlere—Guido Diero), Fox-trot,Continental Military Band
10205 Fatina (Curtis-Van Alstyne), One-step, Six Brown Brothers
12th Street Rag (C. E. Wheeler), Fox-trot, Six Brown Brothers
10197 I Know Why (Davis-Morgan), Fox-trot, The Palace Trio
Do You Know, Medley, Intro.: "Hold Me" (McNamara-Fitzgibbon-Hickman-Black), Fox-trot, The Palace Trio
10195 Rainbow of My Dreams, Medley, Intro.: "Norse Maid" (Freed-Wallace), Fox-trot, Saxophone Sextette,Six Brown Brothers
Jazz Band Blues (James White), Fox-trot, Saxophone Sextette,Six Brown Brothers
10204 Do Another Break (George Hamilton Green), Fox-trot,Green Brothers' Novelty Band
Saxema (Rudy Wiedoeft), One-step, Saxophone Solo Accomp.,Rudy Wiedoeft
10206 Fee Fi Fo Fum (Motzan-Olman), One-step, Van Eps Banta Trio
Palm Beach (C. Luckyth Roherts), Fox-trot, Van Eps Banta Trio

LATEST SONG HITS

- 10198 Marion You'll Soon Be Marryin' Me (Kienzle-Smith-Ingham-McConnell), Tenor Solo, Orch. Accomp.,Irving Kaufman
Whistle a Song (Howard-Kornhlim-Myers), Novelty Song, Orch. Accomp.,Billy Murray
10199 I'd Love to Fall Asleep and Wake Up in My Mammy's Arms (Lewis-Young-Ahlert), Baritone Solo, Orch. Accomp.,Eddie Nelson
Everybody's Buddy (Grossman-Frisch), Baritone Solo, Orch. Accomp.,Arthur Fields
10200 The Argentines, the Portuguese and the Greeks (Swanstrom-Morgan), Comedy Song, Orch. Accomp.,Eddie Cantor
Noah's Wife Lived a Wonderful Life (Yellen-Lewis-Erdman-Olman), Comedy Song, Orch. Accomp.,Eddie Cantor
10202 That Old Irish Mother of Mine (Jerome-Von Tilzer), Tenor Solo, Orch. Accomp., Walter Scanlan
Shamrock Leaves (Rohe-Arthur), Tenor Solo, Orch. Accomp.,Walter Scanlan
10201 In the Shade of the Sheltering Palm, from Musical Production "Florodora" (Leslie Stuart), Tenor Solo, Orch. Accomp.,Sam Ash

Some Leading Jobbers of Talking Machines in America

RECORD BULLETINS FOR AUG., 1920 (Continued from page 232)

- It Seems Like Ages and Ages (And You've Only Been Gone a Day) (Kendis Brockman). Tenor Solo, Orch. Accomp. Sam Ash
- STANDARD AND NOVELTY SELECTIONS**
- 10207 Wailana Waltz. Harry J. Clarke's Royal Waikiki Orchestra
Kawaihau Medley. Waltz, Toots Paka Hawaiian Company
- 10208 Kentucky Babe (Adam Geibel). Male Quartet, Banjo Accomp. Shannon Four
Drink to Me Only with Thine Eyes (Ben Johnson). Tenor Solo, Orch. Accomp. Reed Miller
- 10209 Ragtime at Pun'kin Centre. Monologue. Cal Stewart
The Last Day of School at Pun'kin Centre. Monologue Cal Stewart

EMPIRE TALKING MACHINE CO.

- SIXTH RELEASE
POPULAR SONG HITS**
- 6001 Tell Me Pretty Maiden. Sextette from "Florodora" Empire Light Opera Co.
Marion (You'll Soon Be Marryin' Me). Orch. accomp. Crescent Trio
- 6002 Who'll Take the Place of Mary?. Tenor solo, orch. accomp. Charles Hart
Iliawatha's Melody of Love. Male Duet, orch. accomp. Charles Hart and Elliott Shaw
- 6003 In the Shade of the Sheltering Palm. From "Florodora" Elliott Shaw
My Isle of Golden Dreams. Orch. accomp., Sterling Trio
- 6004 Bless My Swanee River Home. Orch. accomp., Peerless Quartet
Floating Down to Cotton Town. Orch. accomp., Shannon Four
- 6005 Oh! By Jingo. Tenor solo, orch. accomp., Billy Murray
Profiteering Blues. Tenor solo, orch. accomp., Billy Murray
- 6006 Just Like the Rose. Orch. accomp., Sterling Trio
Venetian Moon. Tenor solo, orch. accomp., Henry Burr
- SACRED SELECTIONS**
- 2003 He Leadeth Me. Male Duet, orch. accomp., Reed Miller and Royal Dadmun
I Need Thee Every Hour. Male Duet, orch. accomp., Reed Miller and Royal Dadmun
- CONCERT SELECTIONS**
- 4004 Souvenir. Violin solo, piano accomp., Vera Barstow
Bird Voices. Whistling solo, orch. accomp., Sibyl Sanderson Fagan
- 4005 Sweet Genevieve. Violin, cello and piano. Taylor Trio
Valse Erica. Saxophone solo, Rudy Wiedoeft
- DANCE SELECTIONS**
- 5004 La Veeda. Fox-trot, Empire Jazz Orchestra
Oh My Lady (Listen to My Serenade). One-step, Billy Murray's Melody Men
- 5005 Railroad Blues. Fox-trot, Empire Jazz Orchestra
Whose Baby Are You? One-step, Billy Murray's Melody Men
- 5006 Beautiful Ohio. Waltz, Rector's Dance Orchestra
I'm Forever Blowing Bubbles. Waltz, Choruses Sung, Empire Jazz Band

OPERAPHONE CO., INC.

- POPULAR VOCAL**
- 21171 In My Garden of Yesterday (Ash-Ring-Hager). Tenor, Orch. accomp., Sam Ash
Le Wanna (Bernard). Baritone, Orch. accomp., Ernest Hare
- 21172 Some Pretty Day (Lewis-Young-Ahlert). Contralto and tenor duet, Orch. accomp., Helen Burke and Charles Knapp
Shadows (Brennan-Bule). Orch. accomp., Peerless Quartet
- 21173 Profiteering Blues (Wilson-Bibe). Tenor, Orch. accomp., Billy Murray
I Want a Jazzy Kiss (Ring-Hager). Comedians, Orch. accomp., Collins and Harlan
- 21174 Rose of Washington Square (MacDonald-Hanley). Baritone, Orch. accomp., Sidney Phillips
There's a Typical Tipperary (Gerber-Silver). Orch. accomp., Melodious Four Male Quartet
- 21175 I'd Like to Know Why I Fell in Love With You (Timberg). Tenor, Orch. accomp., Lewis James
Who'll Take the Place of Mary? (Dubin-Gaskill-Mayo). Male Trio, Orch. accomp., Orpheus Trio
- DANCE**
- 31150 Rose of the Orient (Johnston-Arthur). Fox-trot, Nonpareil Novelty Band
Dance-O-Mania (Gilbert-Cooper). Fox-trot, Nonpareil Novelty Band
- 31151 Abadele (Toddard-Franklin). Fox-trot, Sam Rosner's Dance Orch.
Vanity Waltz (Schanes). Sam Rosner's Dance Orch.
- 31152 Jade Lady (Webb). One-step, Novelty Dance Orch.
Do You Know? (McNamara-Fitzgibbon). Fox-trot, Sam Rosner's Dance Orch.
- 31153 Wigwam (Samuels). Fox-trot, Sam Rosner's Dance Orch.
Manyana (Fier). Fox-trot, Sam Rosner's Dance Orch.
- INSTRUMENTAL**
- 51137 Hawaiian Twilight (Sherwood-Vandersloot). Hawaiian Instrumental Duet
Some of the Time I'm Lonely (Hatch). Saxophone solo, Fred Roland
- 81101 Carmen (Bizet) "Micaela's Air." Soprano, in French, Orch. accomp., Helen Buepre
Lakme ("Bell Song") (Delibes). Soprano, in French, Orch. accomp., Helen Buepre
- SACRED**
- 71107 Flee As a Bird (Dana-Root). Baritone, Orch. accomp., Victor Churchill
Jesus, I Come (Sleeper-Stebbins). Tenor and baritone duet, Orch. accomp., Lewis James and Harold Wiley

The Dorney Furniture Co., Allentown, Pa., exclusive Brunswick dealer, has moved its talking machine department from the third to the first floor and has placed a substantial order with the Unit Construction Co.

TEST IT. 

OUR VICTOR

Record Service

has a reputation for efficiency.
Suppose you try it.

E. F. DROOP & SONS CO.
1300 G. STREET, WASHINGTON, D. C.
231 N. HOWARD STREET, BALTIMORE, MD





Where Dealers May Secure

COLUMBIA

Product

Ready, Full Stocks, and Prompt Deliveries from Convenient Shipping Centers all over the United States

Distributors

Atlanta, Ga., Columbia Graphophone Co., 63 N. Pryor St.
Baltimore, Md., Columbia Graphophone Co., 16 South Howard St.
Boston, Columbia Graphophone Co., 1000 Washington St.
Buffalo, N. Y., Columbia Graphophone Co., 737 Main St.
Chicago, Ill., Columbia Graphophone Co., 325 W. Jackson Blvd.
Cincinnati, O., Columbia Graphophone Co., 317-321 East 8th Street.
Cleveland, O., Columbia Graphophone Co., 1812 East 30th St.
Dallas, Tex., Columbia Graphophone Co., 1011 Elm St.
Denver, Colo., Columbia Stores Co., 1608 Glenarm Ave.
Detroit, Mich., Columbia Graphophone Co., 115 State St.
Indianapolis, Ind., Columbia Graphophone Co., 209 W. Washington St.
Kansas City, Mo., Columbia Graphophone Co., 1017 McGee St.
Los Angeles, Cal., Columbia Graphophone Co., 809 S. Los Angeles St.
Minneapolis, Minn., Columbia Graphophone Co., 18 N. 3rd St.
New Haven, Conn., Columbia Graphophone Co., 206 Meadow St.
New Orleans, La., Columbia Graphophone Co., 517-525 Canal St.
New York City, Columbia Graphophone Co., 55 Warren St.
Omaha, Neb., Schmoller & Mueller Piano Co., 1311 Parnum St.
Philadelphia, Pa., Columbia Graphophone Co., 40 N. 6th St.
Pittsburgh, Columbia Graphophone Co., 632-640 Duquesne Way.
Portland, Me., Columbia Graphophone Co., 43 Exchange St.
Salt Lake City, Utah, Columbia Stores Co., 221 South West Temple.
San Francisco, Cal., Columbia Graphophone Co., 130-150 Sutter St.
Seattle, Wash., Columbia Graphophone Co., 911 Western Ave.
Spokane, Wash., Columbia Stores Co., 161 South Post St.
St. Louis, Mo., Columbia Graphophone Co., 1127 Pine St.
Tampa, Fla., Tampa Hardware Co.

Headquarters for Canada:
Columbia Graphophone Co., 54-56 Wellington St., West, Toronto Ont.

Executive Office
COLUMBIA GRAPHOPHONE CO.
Woolworth Building New York

W. J. DYER & BRO.
DYER B'LD'G, ST. PAUL, MINN.
NORTHWESTERN DISTRIBUTORS OF THE

VICTOR
Machines, Records and Supplies

Shipped Promptly to all Points in the Northwest

Mickel Bros. Co.

Omaha, Nebraska
Des Moines, Iowa

Victor Distributors

Sherman, Clay & Co.

San Francisco, Los Angeles, Portland, Seattle, Spokane
PACIFIC COAST DISTRIBUTORS OF VICTOR PRODUCTS

The PERRY B. WHITSIT CO.
Distributors of
Victrolas and Victor Records
COLUMBUS, OHIO

William Volker & Co., Kansas City, Mo.; Houston Tex., and Denver, Col.

Pathé 

DISTRIBUTORS
Complete Pathephone and Pathe Record Stocks.
The best proposition for the progressive dealer.

Wholesale Exclusively
EASTERN TALKING MACHINE CO.
85 Essex Street, Boston
VICTOR DISTRIBUTORS

A C B Z A C D F H K L N P Q R S U A X V B D F G H Y N P Q S U V X Z V C E F H J K W O P R T A C E M O N
 G E F Y
 H J K W
 M J O N
 P Q R S
 T
 SR PQ M KV H FE C VB C EF H JK W OD R TU N YL B DE G IK M JO Q ST VM Y VB D
INDEX TO ADVERTISERS

A

Acme Die Casting Corp. 42
 Acme Engineering & Mfg. Co. 153
 Acme Mica Co. 179
 Adora Phono. Co. 192
 Aeolian Co. 196, 197
 Aeolian Co., Chicago. 151
 Aeolian Co., Cincinnati. 178
 Aeolian Co., San Francisco. 221
 Alto Mfg. Co. 143
 American Felt Co. 111
 American Mica Works 16
 American Phono. Co. 167
 American Phono. Parts Co. 145
 American Talking Machine Co. 70
 American Walnut Mfrs. Assn. 75
 Andrews, W. D. & C. N. 116
 Ansonia Needle Co. 125
 Armstrong Furn. Co. 27
 Associated Furniture Mfrs. 6
 Astoria Mahogany Co. 182

B

B & H Fihre Co. 120
 Badger Talking Machine Co. 172
 Bagshaw Co., W. II. 84
 Baker-Smith Co. 181
 Barnhardt Bros. & Spindler. 35, 51
 Beacon Phono. Co. Insert following page 60
 Beecroft, Clement 203
 Blackman Talking Machine Co. 62
 Bolway & Son, Frank. 211
 Bond's Graphophone Shop 43
 Booth Felt Co., Inc. 82
 Botta, John A. 212
 Brilliantone Steel Needle Co. 33
 British Polyphon Co. 224
 Brooks Mfg. Co. 128
 Bruno & Son, Inc., C. 119
 Brunswick-Balke-Collender Co. Insert following page 94, 95
 Buehn Co., Louis. 9
 Buffalo T. M. Co. 9
 Bush & Lane & Piano Co. 41

C

Cabinet & Accessories Sales Co. 127
 Carpenter Paper Co. 18
 Cathedral Phono. Corp. Insert following page 74
 Central Music Sales Co. 147
 Charnaphone Co. 157
 Cheney Talking Machine Co. 31
 Cherington Mfg. Co. 147
 Chicago Talking Machine Co. 138
 Cirola Distr. Co. 98
 Cirola Phono. Co. 46
 Clark Co., John Elliott. 79
 Classified Want Ads. 222, 223
 Collings & Co. 21
 Columbia Graphophone Co. 12, 13, 18, 27, 30, 32, 43, 50, 53, 67, 75, 156, 175, 180
 Condon & Co., Inc. 17, 19
 Consolidated Music Co. 132
 Consolidated Talking Machine Co. 152
 Crafts Piano Co., A. J. 188
 Crafts-Starr Phono. Co. 216
 Cressey & Allen. 90
 Crosley Phono. Co. 172
 Curry, Frank B. 88

D

Delpheon Co. 202
 DeMoll & Co., O. J. 72
 Ditson Co., Olivcr. 89
 Doctorow, D. R. 218b
 Dodin, Andrew H. 230
 Doehler Die-Casting Co. 119
 Droop & Sons Co., E. F. 233
 Drying Systems, Inc. 154
 Dulcitone Phonograph Co. 10
 Duo-Tone Co. 29
 Dyer & Bro., W. J. 233

E

Eastern Talking Machine Co. 83, 233
 Eclipse Musical Co. 39
 Edison, Inc., Thos. Back Cover, 40, 122, 170
 Efficiency Electric Co. 193
 Eight Famous Victor Artists. 195
 Einson Litho., Inc. 210
 Eject-O-File Co. 218b
 Elyea T. M. Co. 32
 Emerson Philadelphia Co. 93
 Emerson Phonograph Co. 160, 161
 Emerson Record Sales Co. 30
 Empire Phono. Parts Co. 171
 Empire Talking Machine Co. 133
 Esco Music & Accessories Co. 162
 Everybody's Talking Machine Co. 98

F

Faultless Caster Co. 99
 Favorite Mfg. Co. 223
 Federal Phono. Corp. 144
 Fletcher-Wickes Co. 15
 Fox Pub. Co., Sam. 218a
 Fuehr & Stemmer Piano Co. 218d
 Fulton Talking Machine Co. 203

G

Gately-Haire Co., Inc. 49
 General Phonograph Corp., Inserts following pages 26, 42, 66, 98
 General Phonograph, Mfg. Co. 34, 134
 General Sales Corp. 56
 Germain Bros. Co. 112
 Gihson-Snow Co. 55
 Globe Decalcomanie Co. 41
 Glynn, W. B., Distributing Co. 55
 Gramophone Co., Ltd. 224
 Grand Rapids Brass Co. 114
 Grand T. M. Co., Inc. 232
 Gray Co., Walter S. 164
 Gray & Dudley Co. 74
 Gretscli Mfg. Co., Fred. 81

Grey Gull Records 158
 Griffith Piano Co. 55
 Grinnell Bros. 201

H

Hallet & Davis Piano Co. 85
 Handy Mfg. Co. 148
 Harponola Co. 59
 Herbert & Huesgen Co. 82
 Hessig-Ellis Drug Co. 55
 Heywood Bros. & Wakefield Co. 47
 Hiawatha Phono. Co. 146
 Hillman & Son Phonograph Co. 55
 Hinds, Hayden & Eldredge, Inc. 218a
 Horton-Gallo-Creamer Co. 87
 Hough, J. E., Ltd. 225
 Hough, L. W. 88
 Howe & Co., C. W. 51
 Hunt, J. D., Mfg. Co. 134

I

Hisley, Douhleday & Co. 99
 Independent T. M. Co. 44
 International Mica Co. 130
 Iroquois Sales Co. 192

J

J mtone Co. 190
 Jewel Phonoparts Co. 148
 Jones-Motrola, Inc. 106, 107

K

Kennedy-Green Co. 195
 Kent Co., F. C. 123
 Kesner & Jerlaw. Insert following page 82
 Keystone Minerals Co. 58
 Kiefer-Stewart Co. 55
 Kirkman Engineering Corp. 19
 Knickerhocker T. M. Co. 23
 Kraft, Bates & Spencer, Inc. 87

L

Lakeside Supply Co., Inc. 153
 Lansing Co. 88
 Lee-Coit-Andreesen Hdwe. Co. 55
 Lesley's 230
 Lockwood, Vernon 227
 Long Cabinet Co., Geo. 184
 Lorentzen, H. K. 66
 Lucky 13 Phonograph Co. 218c
 Lu-Franc Sales Service. 159
 Lundstrom Mfg. Co., C. J. 14
 Luthy-Raz & Co., Fritz. 182
 Lyon & Healy. 140
 Lyons, J. I. 148

M

Magnavox Co. 55, 110
 Magnola Talking Machine Co. 34, 80, 130, 141, 182
 Manhattan Phono. Parts Co. 48
 Marshall Co., Inc., C. L. 55
 Mellor's 117
 Melodia Phonograph Co. 150
 Mercantile Finance Co. 125
 Mermod & Co. 59
 Meyercoed Co. 143
 Michigan Phono. Co. 42
 Mickel Bros. Co. 233
 Milwaukee T. M. Mfg. Co. 186
 Minneapolis Drug Co. 55
 Modernola Co. 91
 Montagnes, I., & Co. 55
 M. S. & E. 55
 Mutual T. M. Co. 48

N

National Decalcomania Co. 99
 National Publishing Co. 6
 National Vitaphone Corp. 162
 Natural Voice Phonograph Co. 130
 Neu & Co., H. G. 108
 New England Piano & Phono. Co. 83
 New England Talking Machine Co. 88
 New York Alum & Card Co. 4
 New York Talking Machine Co. 138
 Northwest Phonograph Johners, Inc. 129
 Nye, William F. 36

O

Ogden Sectional Cabinet Co., Inc. 1
 Ohio Sales Co. 55
 Ohio T. M. Co., The. 174
 Onken Co., Oscar. 163
 Operaphone Co. 176
 Operollo Co. 52, 191
 Ormes, Inc. 20
 Oro-Tone Co. 152, 154

P

Paramount Talking Machine Co. Inside Back Cover
 Parks & Parks. 168
 Pathé Freres Phonograph Co. Insert following page 34
 Peahody, Henry W. & Co. 199
 Pearsall Co., Silas E. 24
 Peckham Mfg. Co. 50
 Peerless Alum Co. 100
 Penn Phonograph Co. 97
 Perfect Automatic Brake Co. 154
 Period Tone Arm Co. 118
 Perophone Co., Ltd. 225
 Philadelphia Show Case Co. 220
 Phillips, Wm. 48
 Phonograph Appliance Co. 80
 Phonograph Supply Co. of New England. 90
 Phonomotor Co. 35
 Pkknik Portable Phonograph, Inc. 74
 Player Phone T. M. Co. 153
 Player Tone T. M. Co. 121
 Pleasing Sound Phono. Co. 71

Plywood Corp. 220
 Portable Phono. Co. 169
 Prescott, F. M. 60
 Presto Phono. Parts Corp. 124
 Progressive Phonographic Supply Co. 167

R

Racine Phono. Co. 79
 Reed Co. 36
 Reflexo Products Co. 37
 Regina Co. 218a
 Remington Phono. Corp. 165
 Rene Manufacturing Co. 42, 187
 Repeater Stop Co. 150
 Rex Gramophone Co. 228
 Reynolds, Wm. H. 127
 Robinson, The Plater. 145
 Robinson Pettit Co., Inc. 55
 Rosenberg Phono. Co. -147
 Rose Valley Music Co. 67
 Rountree Corp. 92

S

Saal Co., H. G. 142, 149
 Sapp Co., H. H. 175
 Schloss Bros. 71
 Schmelzer Arms Co. 76
 Seaburg Mfg. Co. 43
 Sharmat & Son, S. W. 85
 Sherman, Clay & Co. 233
 Simons, M. C. 66
 Singsphone Co. 215
 Smith Drug Co., C. D. 55
 Smith, Kline & French Co. 55
 Smith Laboratories, H. J. 164
 Smith-Schiffin Co. 203
 Solotone Mfg. Co. 180
 Sonora Distr. Co. of Texas. 55
 Sonora Phonograph Sales Co., Inc., Inside Front Cover, 54, 55, 63, 78
 Soss Mfg. Co. 204
 Sound Recording Co., Ltd. 227
 Southern Cal. Music Co. 16
 Southern Drug Co. 55
 Southern Sonora 55
 Southwestern Drug Co. 55
 Sphinx Gramophone Motors. Insert following page 58
 Standard Phonograph Motors, Inc. 77, 204
 Standard Talking Machine Co. 233
 Starr Piano Co. 68, 69
 Stead & Co., J. 226, 228
 Steel, W. R. 228
 Steger & Sons Piano Mfg. Co. 28
 Steinert & Sons Co., M. 86
 Stephenson, Inc. 126
 Sterno Manufacturing Co. 206
 Stewart Phonograph Corp. 22
 Stewart T. M. Co. 198
 Stodart Phonograph Co. 26
 Stoffer & Stackhouse. 189
 Stone Mfg. Co. 217
 Stone Piano Co. 166
 Stratford Phono. Co. 38
 Strevell-Paterson Hardware Co. 55
 Supple-Biddle Hdwe. Co. 98
 Supreme Phono Parts Co. 48

T

Talking Machine Co. 45
 Talking Machine World Dealer Service. 173
 Talking Photo. Corp. 218
 Thomas & Proetz Lumber Co. 164
 Toledo Talking Machine Co. 58
 Triangle Phono. Parts Co. 198
 Tri-Sales Co. 63

U

Udell Works 60
 Unit Construction Co. 64, 65
 United Mfrs. & Dist. Co. 219
 United Music Stores. 98
 United Phonograph Corp. 194
 Universal Stamping & Mfg. Co. 213

V

Vacuum Record Lifter, Ltd. 205
 Val Accessory House. 216
 Van Houten, C. J., & Zoon. 55
 Van Veen & Co. 183
 Vicsonia Mfg. Co., Inc. 200
 Victory Talking Machine Co. Front Cover, 5 7, Insert following page 10
 Vitonola Distributing Agency of Texas. 53
 Vitonola Distributors Co. 96
 Vitonola Talking Machine Co. 25
 Volker & Co. 233

W

Wade Co., R. C. 57
 Wade & Wade. 139
 Wade, W. H. 118
 Wade Talking Machine Co. 131
 Walters & Barry. 76
 Walthall Music Co. 55
 Ward Co., C. E. 50
 Watson Bros. & Co. 88
 Wehr-Knapp Co. 105
 Wenborn-Karpen Dryer Co. 104
 Werlein, Ltd., Philip. 163
 Weymann & Son, H. A. 96
 Whitsit Co., Perry B. 233
 Widdicomb Furniture Co. 155
 Williams Co., G. T. 73
 Wimpfheimer, & Bro., A. 214
 Windsor Furniture Co. 135
 Wolf, Clifford A. 210
 Wonder T. M. Co. 168

Y

Yahr & Lange Drug Co. 155

Z

Ziegler, Baker & Johnson. 156



Style XX
Retail at \$165
Mahogany, Golden Oak
or Fumed Oak



Style XXX
Retail at \$250
Mahogany, Golden Oak
or Fumed Oak

Six models, all exquisitely built

More Sales to Every Customer With the Complete Paramount Line

You want new customers of course—and the Paramount Line will help you get them. But why not capitalize to the fullest extent on the trade you already have—your present customers?

Handle the complete Paramount Line of Co-ordinated Products—machines, records, needles and

accessories, all under one trade-mark. Once your customers are familiar with the Paramount Trade-mark they will have confidence in the entire line.

Build on Paramount with a large organization behind you, always willing to give you personal cooperation in solving your individual selling problems.

Releases for August

20001	{ Dardanella—Fox-trot.....	Selvin's Novelty Orchestra
\$1.00	{ That Naughty Waltz.....	Selvin's Novelty Orchestra
20002	{ Isle of My Golden Dreams—Waltz.....	Selvin's Novelty Orchestra
\$1.00	{ Peggy—For Dancing.....	Selvin's Novelty Orchestra
20007	{ Irene (Medley)—Fox-trot.....	Selvin's Novelty Orchestra
\$1.00	{ Venetian Moon—For Dancing.....	Selvin's Novelty Orchestra
20008	{ Charms—Fox-trot.....	Newport Society Orchestra
\$1.00	{ Jean (Medley)—Fox-trot.....	Selvin's Novelty Orchestra
20009	{ I'll See You in Cuba—For Dancing.....	All Star Trio
\$1.00	{ When My Baby Smiles at Me—For Dancing.....	All Star Trio
20010	{ Oh, By Jingo—Vocal.....	Al Bernard
\$1.00	{ Saxophone Blues—Vocal, Al Bernard—Saxophone Solo.....	Rudy Woldoett
20011	{ Pickaninny Blues—Vocal.....	Henry Burr
\$1.00	{ Let the Rest of the World Go By.....	Quia Helene Evans
20012	{ Wond'ring—Fox-trot.....	All Star Trio
\$1.00	{ Rose of Washington Square (Medley)—Fox-trot.....	Newport Society Orchestra
20013	{ La Veeda—Fox-trot.....	Newport Society Orchestra
\$1.00	{ Left All Alone Again Blues (Medley)—Fox-trot.....	Newport Society Orchestra
33061	{ I Might Be Your Once in a While.....	American Marimba Band
\$1.00	{ On Miami Shore.....	American Marimba Band

RECENT PARAMOUNT FAVORITES

33056	{ A Dream—Cello with Piano Accompaniment.....	Albert Taylor
\$1.00	{ A Simple Confession—Cello with Orchestra Accompaniment.....	Albert Taylor
33023	{ Oh, Sole Mio—Hawallan Guitar.....	Louise and Ferera
\$1.00	{ Honolulu March—Hawallan Guitars.....	Louise and Ferera
33049	{ Will o' Wisp—For Dancing.....	Selvin's Orchestra
\$1.00	{ Nobody Knows—For Dancing.....	Selvin's Novelty Orchestra

Paramount Talking Machine Company
Port Washington, Wis.

REG. U.S. PAT. OFF.

Paramount

Talking Machines & Records

Distributors:

SHIPLEY-MASSINGHAM CO.,
Pittsburgh, Pa.
For Western Penn. and West Virginia.

E. R. GODFREY & SONS CO.,
Milwaukee, Wis.
For Iowa, Illinois, Michigan, Indiana and Wisconsin.

WILSON FURNITURE CO.,
Louisville, Ky.
For Kentucky, Tennessee and Alabama.

JOERNS BROS. MFG. CO.,
St. Paul, Minn.
For Minn., So. Dak., No. Dak. and Eastern Montana.

COX & SIMPKINS,
(Southern Paramount Co.)
Atlanta, Ga.
For Georgia, No. Carolina and So. Carolina

PEDEN IRON & STEEL CO.,
Houston, Texas.
For Texas.

THE OHIO PARAMOUNT CO.,
6101 Euclid Ave.,
Cleveland, O.
For Ohio.

NORTH WEST PHONOGRAPH
JOBBER, INC.,
915 Riverside Ave.,
Spokane, Wash.
For Wash., No. Oregon, No. Idaho and West Montana.

RICHMOND HARDWARE CO.,
Richmond, Va.
For Virginia.

PECK & HILLS FURN. CO.,
San Francisco and Los Angeles, Cal.
For California.

PECK & HILLS FURN. CO.,
141 Madison Ave., New York City.
For East New York, East Penn., New Jersey.

O'MEARA GREEN MOTOR CO.,
Denver, Colo.
For Colorado.

WITTE HARDWARE CO.,
St. Louis, Mo.
For Missouri.

BRANDON & TURNER,
Little Rock, Ark.
For Arkansas.



All records are recorded in our own specially equipped laboratories.

Edison Message No. 75

Where There Was No Inflation— There Can Be No Deflation

While prices of most merchandise were skyrocketing, the prices of Edison phonographs since 1914 increased only 15 per cent, including War Tax.

“Edison Stood the Gaff”

THOMAS A. EDISON, Inc.
Orange, New Jersey

‘JOBBER’S OF THE NEW EDISON, EDISON RE-CREATIONS, THE NEW EDISON DIAMOND AMBEROLA AND BLUE AMBEROL RECORDS

CALIFORNIA
Los Angeles—Edison Phonographs, Ltd.
San Francisco—Edison Phonographs, Ltd.

COLORADO
Denver—Denver Dry Goods Co.

CONNECTICUT
New Haven — Pardee-Ellenberger Co., Inc.

GEORGIA
Atlanta—Phonographs, Inc.

ILLINOIS
Chicago — The Phonograph Co. James I. Lyons (Amberola only).

INDIANA
Indianapolis—Kipp Phonograph Co.

IOWA
Des Moines—Harger & Blish.
Sioux City—Harger & Blish.

LOUISIANA
New Orleans—Diamond Music Co., Inc.

MASSACHUSETTS.
Boston—Pardee-Ellenberger Co.
Iver Johnson Sporting Goods Co. (Amberola only).

MICHIGAN
Detroit—Phonograph Co. of Detroit

MINNESOTA
Minneapolis—Laurence H. Lucker

MISSOURI
Kansas City—The Phonograph Co. of Kansas City.
St. Louis—Silverstone Music Co.

MONTANA
Helena—Montana Phonograph Co.

NEBRASKA
Omaha—Shultz Bros.

NEW YORK
Albany—American Phonograph Co.
New York—The Phonograph Corp. of Manhattan.
Syracuse—Frank E. Bolway & Son, Inc. W. D. Andrews Co. (Amberola only).

OHIO
Cincinnati—The Phonograph Co.
Cleveland—The Phonograph Co.

OREGON
Portland—Edison Phonographs, Ltd.

PENNSYLVANIA
Philadelphia—Girard Phonograph Co.
Pittsburgh—Buchn Phonograph Co.
Williamsport—W. A. Myers.

RHODE ISLAND
Providence—J. A. Foster Co. (Amberola only).

TEXAS
Dallas—Texas-Oklahoma Phonograph Co.

UTAH
Ogden—Proudfit Sporting Goods Co.

VIRGINIA
Richmond—The C. B. Haynes Co., Inc.

WISCONSIN
Milwaukee—The Phonograph Co. of Milwaukee.

CANADA
Montreal—R. S. Williams & Sons Co., Ltd.
St. John—W. H. Thorne & Co., Ltd.
Toronto—R. S. Williams & Sons Co., Ltd.
Vancouver—Kent Piano Co., Ltd.
Winnipeg—R. S. Williams & Sons Co., Ltd.
Babson Bros. (Amberola only).
Calgary—R. S. Williams & Sons Co., Ltd.