

RADIO & TELEVISION

FORMERLY
S SHORT WAVE & TELEVISION

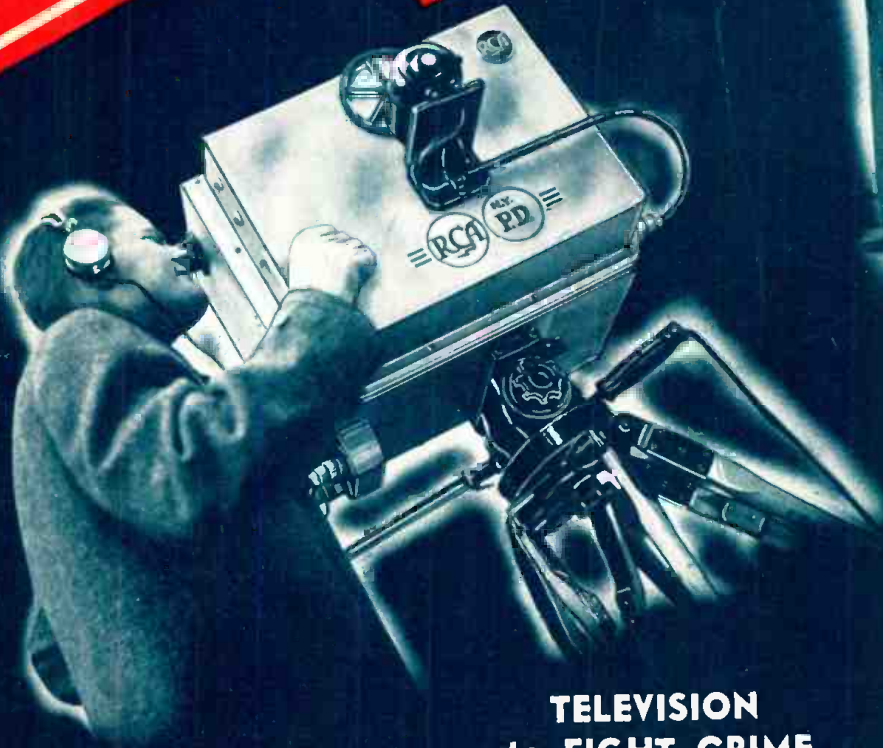

**TELEVISION
to FIGHT CRIME**
SEE PAGE 69

In This Issue —

- Opportunities in Television**
—Dr. Alfred N. Goldsmith
- How NBC Television Evolved**
—O. B. Hanson
- New CBS Television Station**
—Dr. Peter Goldmark
- Introducing "Home" Television**
Television Set Built in 24 Hours
- Ultra Short Wave Superhet**
- World-Wide Radio Digest**
- Best S-W Station List**

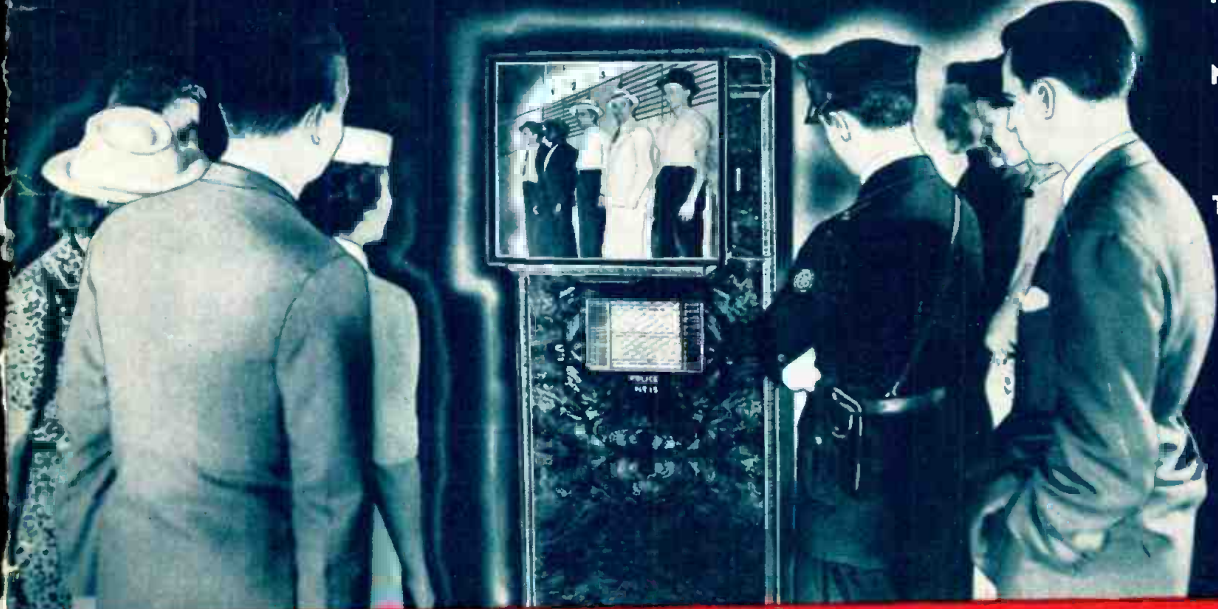

25¢
IN U.S. AND
CANADA

**HUGO
GERNSBACK**
EDITOR

**RADIO EXPERIMENTING
AMATEUR RADIO**

**JUNE
1939**

The Radio Corporation of America Tells
What TELEVISION will
mean to you!



The NBC-RCA Television
 Antenna on the Empire
 State Building, New York.

On April 30th RCA television was introduced in the New York metropolitan area. Television programs, broadcast from the lofty NBC mast at the top of the Empire State Building, cover an area approximately fifty miles in all directions from that building. Programs from NBC television studios are sent out initially for an hour at a time, twice a week. In addition, there will be pick-ups of news events, sporting events, interviews with visiting celebrities and other programs of wide interest.

How Television will be received!

To provide for the reception of television programs, RCA Laboratories have developed several receiving sets which are now ready for sale. These instruments, built by RCA Victor, include three models for reception of television pictures and sound, as well as regular radio programs. There is also an attachment for present radio sets. This latter provides for seeing television pictures, while the sound is heard through the radio itself. The pictures seen on these various models will differ only in size.

Television—A new opportunity for dealers and service men

RCA believes that as television grows it will offer dealers and service men an ever expanding opportunity for profits. Those, who are in a position to cash in on its present development, will find that television goes hand in hand with the radio business of today.

In Radio and Television—It's RCA All the Way



Radio Corporation of America
 RADIO CITY, NEW YORK

RCA MFG. CO., INC. • RADIOMARINE CORP. • OPA MÉRICA • NATIONAL BROADCASTING CO. • R. C. A. COMMUNICATIONS, INC. • RCA INSTITUTES, INC.



J. E. SMITH
President
National Radio
Institute
Established 25
years. He has di-
rected the train-
ing of more men
for the Radio In-
dustry than any-
one else.

I WILL TRAIN YOU TO START A SPARE TIME OR FULL TIME RADIO SERVICE BUSINESS WITHOUT CAPITAL

**HERE ARE A FEW EXAMPLES
OF THE KIND OF MONEY
I TRAIN MY MEN TO MAKE**

**\$200 TO \$300 A MONTH
IN OWN BUSINESS**

"For the last 18 months I have been in business for myself, making between \$200 and \$300 a month. I have N.R.I. to thank for my start in this field."—**ARLIE J. FROEHLER**, 221 W. Texas Ave., Goose Creek, Texas.



\$10 TO \$25 A WEEK IN SPARE TIME

"I am making from \$10 to \$25 a week in spare time while still holding my regular job as a machinist. I owe my success to N. R. I."—**WM. F. RUPP**, 235 W. Front St., West Conshohocken, Pa.



**CHIEF OPERATOR BROADCASTING
STATION**

"When I completed 20 lessons, I obtained my Radio Broadcast Operator's License and immediately joined Station WMLC, where I am now Chief Operator."—**HOLLIS F. HAYES**, 87 Madison St., Lancaster, Mich.



**EARNINGS TRIPLED BY
N.R.I. TRAINING**

"I have been doing nicely. Thanks to N.R.I. Training. My present earnings are about three times what they were before I took the course. I consider N.R.I. Training the best in the world."—**BERTHARD COSTA**, 972 Manhattan Ave., Brooklyn, N. Y.



OVER \$1,000 BEFORE GRADUATING

"Before completing half the N.R.I. Course I was servicing sets, and I made \$1,000 to \$1,200 before graduating. I am doing Radio service work for myself now."—**ASHLEY G. ALDRIDGE**, 1228 Shenherd St., Petersburg, Va.



**Get My LESSON on Radio
Servicing Tips FREE**

I want to prove my Training gives practical, money-making information, that it is easy to understand—what you need to master Radio. My sample lesson text, "Radio Receiver Troubles—Their Cause and Remedy," covers a long list of Radio receiver troubles in A.C., D.C., battery, universal, auto, T. R. F., superheterodyne, all-wave, and other types of sets. And a cross reference system gives you the probable cause and a quick way to locate and remedy these set troubles. A special section is devoted to receiver check-up, alignment, balancing, neutralizing, testing. You can get this lesson Free by mailing the coupon.



**The Tested WAY
to BETTER PAY**

The world-wide use of Radio has made many opportunities for you to have a spare time or full time Radio service business of your own. Four out of every five homes in the United States have Radio sets which regularly need repairs, new tubes, etc. Servicemen can earn good commissions too, selling new sets to owners of old models. Even if you have no knowledge of Radio or electricity, I will train you at home in your spare time to sell, install, fix, all types of Radio sets; to start your own Radio business and build it up on money you make in your spare time while learning. Mail coupon for my 64-page book. It's Free—it shows what I have done for others—what I am ready to do for you.

**Many Make \$5, \$10, \$15 a Week Extra
in Spare Time While Learning**

The day you enroll I start sending Extra Money Job Sheets; show you how to do Radio repair jobs. Throughout your training I send plans and directions that made good spare time money—\$200 to \$500—for hundreds, while learning. I send you special Radio equipment to conduct experiments and build circuits. This 50-50 method of training makes learning at home interesting, fascinating, practical.

**Why Many Radio Experts Make
\$30, \$50, \$75 a Week**

Radio is young—yet it's one of our large industries. More than 28,000,000 homes have one or more Radios. There are more Radios than telephones. Every year millions of Radios get out of date and are replaced. Millions more need new tubes, repairs. Over \$50,000,000 are spent every year for Radio repairs alone. Over 5,000,000 auto Radios are in use; more are being sold every day, offering more profit-making opportunities for Radio experts. And RADIO IS STILL YOUNG, GROWING, expanding into new fields. The few hundred \$30, \$50, \$75 a week jobs of 20 years ago have grown to thousands. Yes, Radio offers opportunities—now and for the future!

**Get Ready Now for Your Own Radio Business
and for Jobs Like These**

Radio broadcasting stations employ engineers, operators, station managers and pay well for trained men. Fixing Radio sets in spare time pays many \$200 to \$500 a year—full time jobs with Radio jobbers, manufacturers and dealers as much as \$30, \$50, \$75 a week. Many Radio Experts open full or part time Radio sales and repair businesses. Radio manufacturers and jobbers employ testers, inspectors, foremen, engineers, servicemen, in good-pay jobs with opportunities for

advancement. Automobile, police, aviation, commercial Radio, loud speaker systems are newer fields offering good opportunities now and for the future. Television promises to open many good jobs soon. Men I trained have good jobs in these branches of Radio. Read how they got their jobs. Mail coupon.

**I ALSO GIVE YOU
THIS PROFESSIONAL
SERVICING
INSTRUMENT**

Here is the instrument every Radio expert needs and wants an All Wave, All-Purpose, Set Servicing Instrument. It contains everything necessary to measure A.C. and D.C. voltages and current; to test tubes, resistance; adjust and align any set, old or new. It satisfies your needs for professional servicing after you graduate (can help you make extra money fixing sets while training).



You Are Trained For Television Also

With N. R. I. you take up Television principles right along with Radio principles—the correct method—since Television receivers combine both sight and sound. You also get more than ten text books devoted entirely to Television.

Find Out What Radio Offers You

Act Today. Mail the coupon now for Sample Lesson and 64-page book. They're free to any fellow over 16 years old. They point out Radio's spare time and full time opportunities and those coming in Television; tell about my training in Radio and Television; show you letters from men I trained, telling what they are doing and earning. Find out what Radio offers YOU! MAIL COUPON in an envelope, or paste on a post-card—NOW!

**J. E. SMITH, President
National Radio Institute
Dept. 9FB3
Washington, D. C.**

**THIS
FREE BOOK
HAS HELPED
HUNDREDS OF
MEN MAKE
MORE
MONEY**



**GOOD FOR BOTH 64 PAGE BOOK FREE
SAMPLE LESSON FREE**

J. E. SMITH, President, National Radio Institute, Dept. 9FB3, Washington, D. C.

Without obligating me, send your Lesson "Radio Receiver Troubles—Their Cause and Remedy," and free book about spare time and full time Radio opportunities now. I can train for them at home in my spare time—about the N.R.I. Set Servicing Instrument. I am particularly interested in the branch of Radio checked below.

- Radio Service Business of My Own
- Spare Time Radio Repair Work
- Retail Sales of Radio Sets and Equipment
- Service Expert for Retail Stores
- Broadcasting Station Operator
- Aviation Radio Operator
- Loud Speaker Systems, Installations and Service
- Auto Radio Installation and Service
- Television Station Operator
- Service Expert with Radio Factory
- Commercial Radio Station Operator
- All-around Servicing Expert

(If you have not decided which branch you prefer—mail coupon now, for information to help you decide.)

NAME AGE

ADDRESS 14X1

RADIO & TELEVISION

The Popular Radio Magazine

June — 1939
Vol. X No. 2

HUGO GERNSBACK, Editor
H. WINFIELD SECOR, Manag. Editor
ROBERT EICHBERG, Assoc. Editor

How to Build a Television Receiver

See Page 82

In This Issue

GENERAL FEATURES

Television in Police Work—Gerald S. Morris, New York Police Department	69
How NBC Television Evolved—O. B. Hanson, Chief Engineer, National Broadcasting Co.	70
CBS Television Atop 80-Story Building—Dr. Peter C. Goldmark, Chief Television Engineer, Columbia Broadcasting System	71
Introducing HOME Television Receivers	72
World-Wide Radio Digest	74
International Radio Review	76
Opportunities in Television—Dr. Alfred N. Goldsmith	79
Radio Test-Quiz—Robert Eichberg	80

CONSTRUCTION

Building a Television Receiver in 24 Hours—Robert Eichberg	82
Television Antenna Construction	87
De Luxe "Beam Power 3" Transmitter—Howard G. McEntee, W2FHP	94
A High-Efficiency 6L6 Exciter—Harry D. Hooton, W8KPX	96
2½, 5 and 10 Meter Superhet—Herman Yellin, W2AJL	100
5 & 10 Meter Converter—Gordon Fraser	102

CONDENSED FEATURES

Giant Television	74
Alexanderson Panel Antenna	75
New KDKA Transmitter	75
Multiple Television System	76
Electron Multiplier	76
Television Projection System	76
Super-Regenerative Circuits	77
Remote Push-Button Tuner	77
Metal Horns to Receive Ultra Short Waves	78
Field Strength Meter	78

Giant Television	74
CBS Film Scanner	74
Television Lands Planes	75
Multiple Television	76
Television Projection System	76
Large Screen Television	77
Opportunities in Television	79
Television Course Lesson	81
Building a Television Receiver	82
Television Antenna Construction	87
Shall I Tackle Television?—Leon L. Adelman	99
Television Sound Converter	102

INSTRUCTION

Radio Test-Quiz	80
Electronics Television Course—Henry Townsend	81
The Radio Beginner—The Superheterodyne—Martin Clifford, W2CDV	85
Question Box	98

MISCELLANEOUS

Radio Kinks	84
World Short Wave Station "Directory"	86
Let's Listen In with Joe Miller	87
Silver Trophy Award for Best "Ham" Station Photo	89
"On the HAM Bands"—Elmer R. Fuller	91
What Do YOU Think?	93
Question Box	98
New HAM Licenses	102
Newest Radio Apparatus	113
I Cover the Pacific Coast!	116

TELEVISION

Television in Police Work	69
The Story of NBC Television	70
CBS Television on 80-Story Building	71
Introducing HOME Television Sets	72

Cover composition by H. Gernsback and Thomas D. Pentz.

Photos of Camera and Receiver—Courtesy N.B.C.; Police "Line-up"—Acme.

RADIO & TELEVISION—Published monthly on the tenth of the month. Entered as second-class matter Feb. 15, 1938, at the post office at Springfield, Mass., under the act of March 3, 1879. Trademarks and copyrights by permission of H. Gernsback. Text and illustrations are copyright and may not be reproduced without permission. Subscription price \$2.50 a year in the United States and possessions and Canada, \$3.00 in foreign countries. Make all subscription checks payable to Popular Book Corporation.

Published by Popular Book Corporation. Publication Office—29 Worthington St., Springfield, Mass. Editorial and Executive Offices—99 Hudson St., New York, N.Y. HUGO GERNSBACK, President; H. W. SECOR, Vice-President; EMIL GROSSMAN, Director of Advertising. European Agents: Atlas Publishing and Distributing Co., Ltd., 18 Bride Lane, Fleet St., London, England; Brentano's—London and Paris. Australian Agents: McGill's Agency, 179 Elizabeth St., Melbourne.

Copyright 1939 by H. Gernsback

July "TELEVISION" Issue

I-Tube Television Sound Converter—
for use with any receiver, Herman
Yellin, W2AJL

"Beam Power 3" Transmitter—Conclu-
sion, Howard G. McEntee, W2FHP

Getting Started in Amateur Radio,
C. W. Palmer, E.E., Ex-W2BV

Building a Television Receiver, Part 2,
Robert Eichberg

Antennas for the HAM—Herman Yellin,
W2AJL

70-Watt Modulator for the HAM Trans-
mitter—Harry D. Hooton, W8KPX

Television Received 22 Miles from Don
Lee Station.

Certified Circuits



When you see this seal on
a set it is a guarantee that
it has been tested and
certified in our laboratories,
as well as privately in different parts of
the country. Only constructional—ex-
perimental sets are certified.

You need not hesitate to spend
money on parts because the set and
circuit are bona fide.

This is the only magazine that ren-
ders such a service.

NBC-RCA Television "Goes into Action"!



1—Scene from television play staged in NBC's New York studio. 2—Television receiver assembly line at Camden, N. J. 3—Television receiving antenna. 4—Testing receivers at factory. 5—Rear of RCA television receiver.

Photos—RCA-Victor

● TELEVISION made its bow to a group of newspaper editors and writers on April 20th when the RCA Building at the New York World's Fair was officially dedicated. The images as well as the accompanying sound of the ceremony at the World's Fair grounds, 8 miles distant, were picked up on a battery of 12-inch C-R tube receivers in the RCA Building, New York City. The images were far clearer than any that the editors had seen previously, and there was no distortion at the edges. A high-fidelity sound channel gave very faithful reproduction of the voice. The camera at the World's Fair grounds was manipulated so as to give a view of the perisphere and trylon, and the great depth of focus obtainable with the improved camera was truly re-

markable. This feature also proved very valuable when a boxing exhibition was later staged for the entertainment of the guests. One of the interesting points noted in observing the image on the new RCA receivers was the high fidelity of small detail, and even when the image of a person appeared very small on the screen, he could still be recognized. The close-ups were exceptionally clear and sharp and no eyestrain was noticeable. Likewise, flickering of the image was absent, and the new images are really like home movie reproduction, with the added flip that live "spot-news," such as the ceremonies at the World's Fair, can be flashed before your eyes right while it is "hot."—H. W. S.

LIST OF TELEVISION BROADCAST STATIONS

as of February 1, 1939

FEDERAL COMMUNICATIONS COMMISSION
WASHINGTON, D. C.

Licenses and Location

Licenses and Location	Call Letters	Frequency (mc.) or Group	Visual Power	Aural Power
National Broadcasting Co., Inc. New York, N. Y. (Mon., Tues., Thur.—11 a.m.-4 p.m.; Wed. & Fri.—4 p.m.-9 p.m.)	W2XBS	42 to 56 mc. 60 to 86 mc.	12 kw	15 kw
National Broadcasting Co., Inc. Portable (Camden, N. J., and New York, N. Y.)	W2XBT	92 and 175 to 180 mc.	400 w	100 w
Columbia Broadcasting System, Inc. New York, N. Y.	W2XAN	42 to 56 mc. 60 to 86 mc.	50 w C.P. 7½ kw	7½ kw 500 w
Radio Pictures, Inc. Long Island City, N. Y.	W2XDR	42 to 56 mc. 60 to 86 mc.	1 kw	150 w
Don Lee Broadcasting System Los Angeles, California	W6XAO	42 to 56 mc. 60 to 86 mc.	1 kw	150 w
Farnsworth Television Incorporated of Pennsylvania Springfield, Penna.	W3XPF	42 to 56 mc. 60 to 86 mc.	250 w	1 kw
Philco Radio and Television Corp. Philadelphia, Penna. (Irregular)	W3XE	42 to 56 mc. 60 to 86 mc.	10 kw	10 kw
Philco Radio & Television Corp. Philadelphia, Penna.	W3XP	204 to 210 mc.	15 w	
Allen B. Du Mont Laboratories, Inc. Passaic, New Jersey (Irregular: 12 mid.-3 a.m.; 8-10 a.m.)	W2XVT	42 to 56 mc.	50 w	50 w

(Continued on page 111)

Please say you saw it in RADIO & TELEVISION

TRAIN FOR ELECTRICITY 12 WEEKS TRAINING THIS QUICK EASIER WAY ACTUAL SHOP WORK—NOT BOOKS

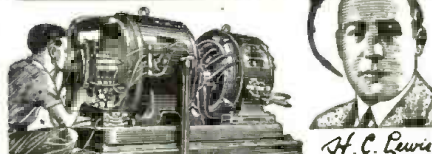

H. C. Lewis

WANT TO EARN MORE MONEY?

Have you ever dreamed of holding down a steady, good pay job? Have you ever dreamed of doing the work you really like in a job that holds promise of a real future in the years ahead? Well, we all know that you can't get the good things in life by just dreaming about them. Hundreds of fellows are today holding down mighty fine jobs with prospects of a bright future. They are filling these jobs because they had the foresight to equip themselves with the right kind of training. Most of these men were only average fellows a short time ago, but the proper training helped to lift them out of the low pay ranks of unskilled workers. The same opportunity is now offered to you.

RADIO 4 WEEKS Course Included

Right now I am including at no extra tuition cost, an extra 4-week course of training in Radio after you have completed your 12 weeks electrical training.

The great fascinating field of ELECTRICITY offers a real future to many men and young men who are willing to prepare for a place in this giant industry.

LEARN BY DOING



FIRST—You are told and shown how

THEN—You do the job yourself.

Here at my school in Chicago, the world's Electrical Center, you can get 12 weeks Shop

Training in ELECTRICITY, that can help give you your start towards a better job.

You will be trained on actual equipment and machinery and because of our method of training, you don't need previous experience or a lot of education. Many of my successful graduates never even completed Grammar School.

Right now I'm including valuable instruction in Diesel, Electric Refrigeration and Air Conditioning at no extra cost. Our practical shop methods make it easier to learn—First the instructors tell you how a thing should be done—then they show you how it should be done—then you do the actual work yourself.

I'LL FINANCE YOUR TRAINING

You can get this training first—then pay for it later in easy monthly payments, starting 60 days after your 12 weeks training period is over—then you have 12 months to complete your payments.

GET THE FACTS

Send the coupon today for all details. When I get it I'll send you my big free book containing dozens of pictures of students at work in my shops. I'll also tell you about my "Pay After Graduation" plan, how many earn while learning and how we help our students after graduation. Fill in, clip coupon, mail today for your start toward a brighter future.

COYNE ELECTRICAL SCHOOL
500 S. Paulina St., Dept. 69-81, Chicago, Ill.

H. C. LEWIS, Pres., COYNE ELECTRICAL SCHOOL
500 S. Paulina St. Dept. 69-81 Chicago, Ill.

Dear Mr. Lewis: Without obligation send me your big, free catalog with facts about Coyne Training and details of your "Pay-Tuition-After-Graduation" Plan and your 4 weeks extra Radio Course.

Name..... Age.....
Address.....
City..... State.....



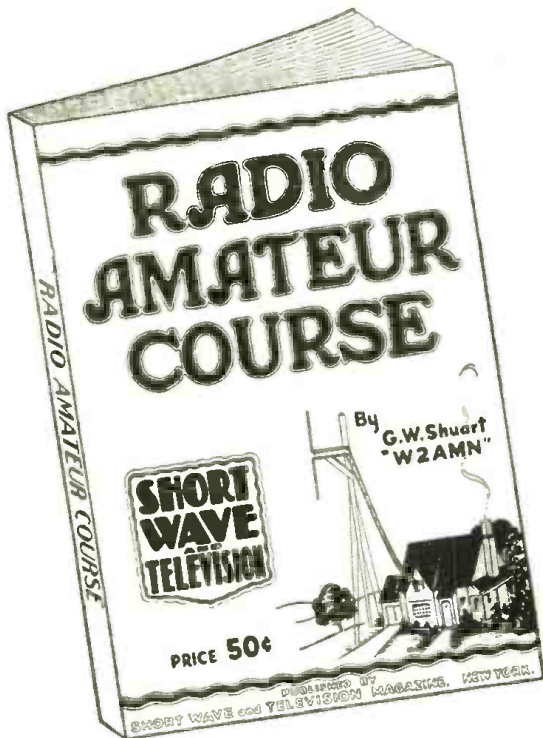

Your Money Back—

IF THE RADIO AMATEUR COURSE DOES NOT REPRESENT THE GREATEST BOOK VALUE EVER OFFERED TO THE RADIO "FANS" FOR 50c

TO convince you that there isn't a better book buy today, the publishers of the **RADIO AMATEUR COURSE** make the sensational offer of a money-back guarantee on such a low-priced book. Stop in at any of the many dealers listed at the right and examine this volume. See for yourself if the **RADIO AMATEUR COURSE** isn't just the book you've always wanted.

Printed on the finest quality paper—well illustrated attractive 4-color cover—complete with radio information you must have. It contains a step-by-step program for obtaining a short-wave radio education.

*Written by George W. Shuart, W2AMN,
foremost short-wave authority*

148 PAGES

6¼ x 9½ INCHES

**OVER 150 RADIO DIAGRAMS
and TECHNICAL PHOTOGRAPHS**

RADIO AND TELEVISION
99 Hudson Street, New York, N. Y.

All Prominent **RADIO DEALERS** Ready to Show You This Big Book!

- ARIZONA**
Sam's Cigar Store, 127 N. First Ave., Phoenix.
- CALIFORNIA**
Scott Wholesale Radio Co., 344 E. Fourth Street, Long Beach.
Offenbach Electric Co. Ltd., 1452 Market Street, San Francisco.
Zack Radio Supply Co., 1426 Market Street, San Francisco.
- COLORADO**
Auto Equipment Co., 44th at Lawrence, Denver.
- CONNECTICUT**
Radio Inspection Service Co., 227 Asylum Street, Hartford.
Stern Wholesale Parts, Inc., 210 Chapel St., Hartford.
- GEORGIA**
Wholesale Radio Service Co., Inc., 430 W. Peachtree St., N. W., Atlanta.
- ILLINOIS**
Allied Radio Corporation, 653 West Jackson Blvd., Chicago.
Newark Electric Company, 226 W. Madison Street, Chicago.
Wholesale Radio Service Co., Inc., 901 W. Jackson Blvd., Chicago.
- INDIANA**
Van Sickle Radio, Inc., 54 West Ohio Street, Indianapolis.
- MASSACHUSETTS**
Greater Boston Distributors, 40 Waltham St., Boston.
H. Jadpe Co., 46 Cornhill, Boston.
Wholesale Radio Service Co., Inc., 110 Federal Street, Boston.
Springfield Radio Co., 337 Dwight Street, Springfield.
H. Jadpe Co., 37 Mechanic Street, Worcester.
- MICHIGAN**
Rissi Brothers, Inc., 5027 Hamilton Ave., Detroit.
- MISSOURI**
Modern Radio Company, 409 No. Third Street, Hannibal.
Burstin-Applebee Co., 1012-14 McGee Street, Kansas City.
Van Sickle Radio Co., 1113 Pine Street, St. Louis.
- NEBRASKA**
Radio Accessories Company, 2566 Farnam Street, Omaha.
- NEW JERSEY**
Arco Radio Co., 227 Central Avenue, Newark.
Wholesale Radio Service Co., Inc., 219 Central Avenue, Newark.
- NEW YORK**
Wholesale Radio Service Co., Inc., 542 E. Fordham Rd., Bronx.
Wholesale Radio Service Co., Inc., 50-08 166th Street, Jamaica, L. I.
Elihu The Radio Man, Inc., 64 Dey Street, New York City.
Eagle Radio Co., 84 Cortlandt Street, New York City.
Federated Purchaser, Inc., 25 Park Place, New York City.
Harrison Radio Co., 12 West Broadway, New York City.
Sun Radio Co., 212 Fulton Street, New York City.
Terminal Radio Corp., 80 Cortlandt Street, New York City.
Thor Radio Corp., 60 Dey St., New York City.
Try-Mo Radio Co., Inc., 85 Cortlandt Street, New York City.
Wholesale Radio Service Co., Inc., 100 Sixth Avenue, New York City.
Radio Parts & Equipment Co., 244 Clinton Avenue No., Rochester.
M. Schwartz & Son, 710-712 Broadway, Schenectady.
- NEW HAMPSHIRE**
Radio Service Laboratory, 1187 Elm Street, Manchester.
- OHIO**
News Exchange, 51 So. Main Street, Akron.
Canton Radio & Supply Co., 1140 Tuscarawas Street, W. Canton.
United Radio, Inc., 1105 Vine Street, Cincinnati.
The Hughes-Peters Electric Corp., 178-180 N. Third Street, Columbus.
Standard Radio Parts Co., 135 East Second Street, Dayton.
- OREGON**
Portland Radio Supply Co., 1300 W. Burnside Street, Portland.
- PENNSYLVANIA**
Radio Distributing Co., 1124-26 Market Street, Harrisburg.
M. & H. Sporting Goods Co., 512 Market Street, Philadelphia.
Cameradio Co., 963 Liberty Ave., Pittsburgh.
- RHODE ISLAND**
W. H. Edwards Co., 32 Broadway, Providence, R. I.
- TEXAS**
Amarillo Electric Co., 111 East 8th Avenue, Amarillo.
- UTAH**
O'Loughlin's Wholesale Radio Supply, 315 South Main Street, Salt Lake City.
Radio Supply, Inc., 46 Exchange Place, Salt Lake City.
- WASHINGTON**
Spokane Radio Co., Inc., 611 First Avenue, Spokane.
- WISCONSIN**
Radio Parts Co., Inc., 536-538 W. State Street, Milwaukee.
- AUSTRALIA**
McGill's Agency, 183-184 Elizabeth Street, Melbourne.
- CANADA**
The T. Eaton Co. Ltd., Winnipeg, Manitoba.
Canadian Electrical Supply Co., Limited, 285 Craig Street W., Montreal, Que.
Metropolitan News Agency, 1248 Peel Street, Montreal, Que.
- CUBA**
The Diamond News Co., Palacio Asturiano, Por San Jose, Habana.
- ENGLAND**
Gorrings American News Agency, 9a, Green Street, Leicester Square, London, W.C.2.
- HOLLAND**
Radio Peeters, Van Woorstraat, Amsterdam, Z.
- INDIA**
Empire Book Mart, Box 631, Bombay.
- MEXICO**
American Book Store, S. A., Avenida Madero 25, Mexico City.
Central De Publicaciones, Avenida Juarez, 4, Apartado 2430, Mexico, D. F.
- NEW ZEALAND**
Te Aro Book Depot, Ltd., 64 Courtenay Place, Wellington.
- SOUTH AFRICA**
Technical Book Co., 5, Strand Street, Cape Town.

*If this book is not at your dealer's, send your order directly to us. We will credit your dealer with the sale of this book. To order your copy of **RADIO AMATEUR COURSE**, fill in coupon below and mail.*

RADIO AND TELEVISION, 99 Hudson St., New York, N. Y.

Gentlemen: I enclose herewith my remittance of Fifty Cents (50c) for which please send me **POSTPAID**, my copy of the **RADIO AMATEUR COURSE**. (Remit by check or money order; register letter if you send cash or unused U. S. Postage Stamps.)

Name

Address

City State R&T-6-39

HUGO GERNSBACK, EDITOR

H. WINFIELD SECOR, MANAGING EDITOR

TELEVISION

in

Police Work

Gerald S. Morris,

Superintendent of Telegraph Bureau, New York City Police Department



Gerald S. Morris,
Supt. of the Telegraph Bureau,
N. Y. City Police
Department.

● POLICE in the United States and in other countries have been considering the possibility of using television in their work, ever since the inception of the art.

I understand that in Germany, not so long ago, the police found an overcoat lying beside the body of a murdered man. The coat was televised to the public in the hope that someone might come forward to identify it, thus linking the killer with his crime. In this way, the police hoped to save at least twelve hours, for it was possible to bring the image of the coat before the public immediately, whereas if they had waited for newspapers to be published, there would necessarily have been a considerable delay. It might have helped in the apprehension of the person wanted.

The police of London's famed Scotland Yard have likewise been investigating television's possibilities. One idea which has been submitted to them calls for the installation of their own transmitter in police headquarters. This equipment was to be used to transmit pictures of wanted men, stolen articles, printed notices and the like to local police stations. It was suggested that if permanent records were desired at the stations, these could be had very simply, merely by photographing the image at the end of the cathode-ray tube.

Consideration has been given to the new medium from many angles without reaching any definite decision as yet. There is a possibility of its value in New York City in several applications.

As a matter of police routine, when a person is robbed and sees the criminal, he is invited to appear at the line-up at Police Headquarters to see whether he can pick out the man from among the criminals who are placed on view before the police officers. Not infrequently, citizens fail to appear at the line-up more than once or twice because it is held in lower Manhattan—some distance from the Bronx, Brooklyn and other

boroughs which comprise the greater city.

The Department could, as a means of bringing the line-up into at least one local precinct house in each borough, televise it—possibly to all local precinct houses. In this way, the victim of a robber would have to travel only a few blocks instead of as many miles in order to inspect the various suspects appearing in the line-up. Briefly, the line-up would be televised and images of suspects might be sent over either a coaxial cable or a special frequency to the various precinct houses.

By use of an interstate television network, it would be possible for the police in various cities to show images of newly arrested suspects to the police officers in other cities. Thus, for example, if a criminal whose description was known to New York Police escaped to Pennsylvania and was picked up by the police in Harrisburg, his description transmitted over the interstate television network similar to the eight (8) State Teletype System now in use might result in his identification by the New York City Police or the victim of a crime. The New York City Police then could televise or transmit by facsimile his likeness and record from their files. The suspect could even be questioned while being televised, or by telephone, with the out-of-town police listening to the conversation.

The writer has participated in a demonstration of this kind at which time he spoke to another member of the department located in a building about one mile away; while looking at his image in a television booth the reactions of the person who was being questioned could be clearly seen.

More recently the writer participated in a similar demonstration in which two members of the Department sat across the table

and assimilated the questioning of a suspect that could have been witnessed by a victim of a crime in some other city. The voice of the suspect and his features, front face, side face, comparative height, etc., could all be checked. The suspect would be immediately released upon failure of the victim to identify him. This would save time of members of this Department and others; also would save money and allow more time to check other information at hand.

Certainly not in the next few years, but in the future, it may be possible that American police will broadcast television images of stolen articles to persons who might innocently purchase them from the thieves, thus laying themselves open to charges of receiving stolen merchandise. By way of explanation, if a valuable piece of jewelry were stolen, an existing photograph of it might be placed before the television transmitter and sent to the attention of pawnshop operators and dealers in second-hand jewelry.

If a person were kidnapped, his image from a photograph might be sent to patrolmen in television-equipped radio cars located throughout the city. In this way, every patrolman stationed where a car carrying the victim might be leaving the area, would know precisely whom to look for, and might thus be enabled to save the life of the victim and to insure his safe return to his family without payment of ransom.

If a homicide is committed and the victim stripped of all marks of identification, the body is sometimes identified through a search of the missing person's files and sometimes by printing a picture of the head of the victim on police circulars. This also applies to persons dying from natural causes in hotels, etc. An increased audience of police officials and friends of the missing person could be had if the body were

(Continued on page 107)

*Twenty-eighth of a series of
"Guest" Editorials*

How NBC Television Evolved

O. B. Hanson

Vice-President and Chief Engineer, National Broadcasting Company

● FROM an engineer's point of view, the beginning of television broadcasting brings more trial than triumph. It means that we put our equipment in the best possible state of perfection, figuratively turn on power, and then wait for things to happen. I am certain that no sooner will we have telecast our first few shows than all the improvements we have so laboriously incorporated in the NBC studio equipment at Radio City and our transmitter in the Empire State tower will seem obsolete to us. New ideas for still further improvements will swarm up like mosquitoes from a tropical swamp. There will, however, be our broadcast schedule to meet—at least two evening shows a week, some special shows from the World's Fair and other points, and transmissions of motion pictures for dealer demonstrations of home receiving sets.

As I say, we have done our best. Our new antenna system. I believe, may revolutionize engineering practice in this particular field. The transmitter itself has been completely dismantled

and reassembled to incorporate new circuits and to replace temporary circuits with permanent installations. The live talent studio at Radio City has been fitted with a new lighting system, a third camera chain and new controls.

The new antenna, whose torpedo-like radiators and other streamlined shapes suggest the science of aerodynamics rather than radio, overcomes what has hitherto been one of the major technical bottlenecks in television. The problem has been to devise an antenna system which would pass a very wide band of frequencies

Engineers had to design radically new sideband filter, antenna, studios — And did! Image is on 45.25 mc.; Sound on 49.75 mc.

without peaking the energy in any segment of the band. This new system, designed by engineers of the Radio Corporation of America, is unique in its ability to communicate signals to the ether over a band (Continued on page 111)

Picture below shows television play being broadcast at NBC studio in New York City. The image signals are carried over a coaxial cable about one-half mile to the transmitter. Antenna is 1300 ft. high.

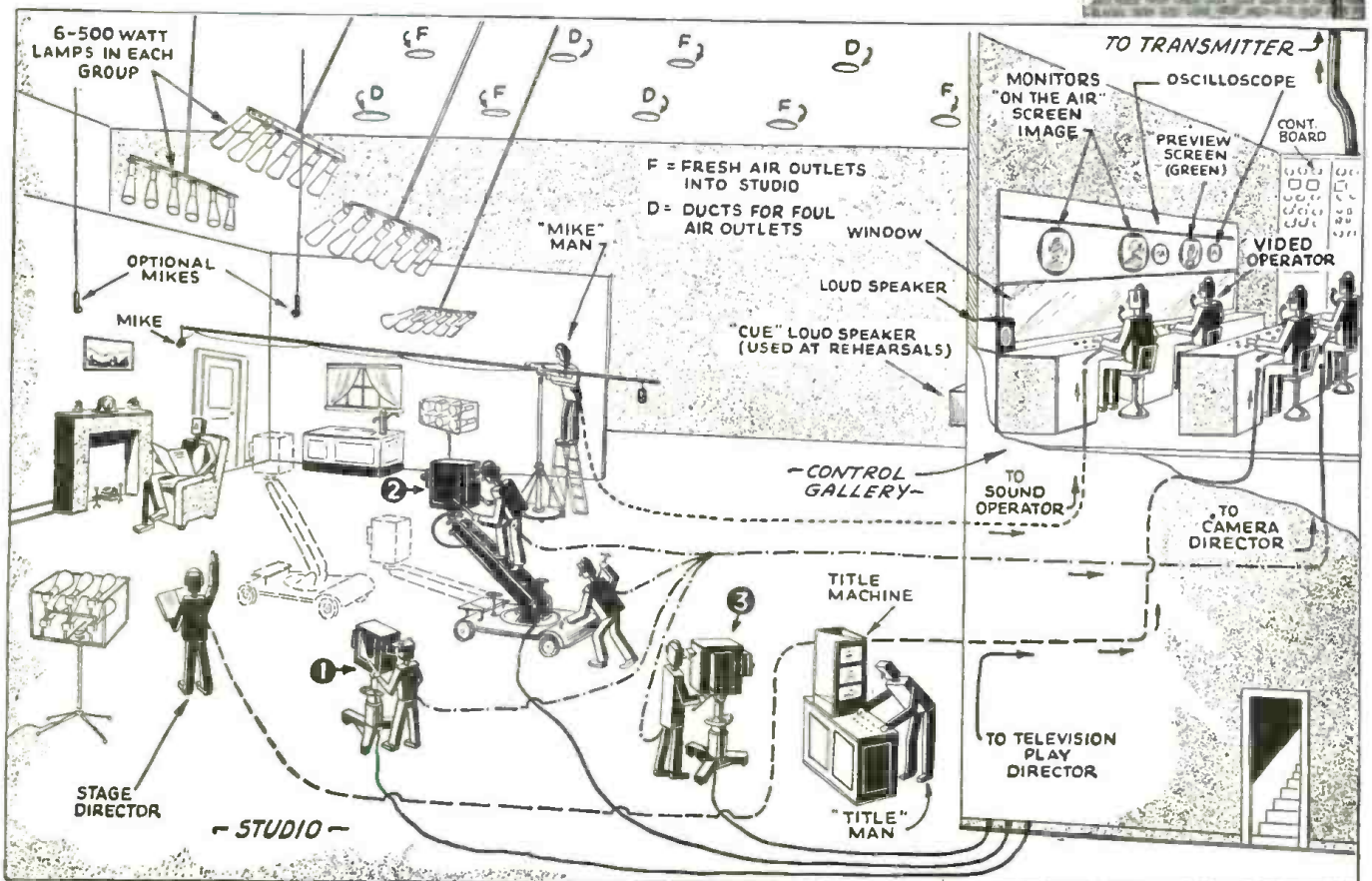

CBS TELEVISION Atop 80-Story Building

Dr. Peter C. Goldmark

Chief Television Engineer, Columbia Broadcasting System.

● MORE than half a year of continuous study was necessary before the planning was completed on the CBS television transmitter. Each problem had to be considered in an absolutely new way since there was no precedent or any adequate experience to go by.

The very simple necessity of finding a suitable place in which to locate the W2XAX transmitter was a problem. The antenna had to be not less than a thousand feet above the ground in order to be able

New York City and areas within 50 miles radius will soon be served by the CBS Television transmitter. W2XAX will broadcast the image on 51.25 mc. and sound on 55.75 mc.

to cover a radius of forty miles. Then there had to be sufficient space at that height to put the transmitter equipment, which weighs more than 100,000 pounds.

We began looking around back in 1936
(Continued on page 106)

Right—Dr. Peter C. Goldmark, CBS Chief Television Engineer, and Gilbert Seldes, Director of CBS Television Programs, examining video transmitter tubes.

Below—Major Edward Bowes, and Dr. Goldmark, inspect power panel of television transmitter. Panel is part of 50 tons of special equipment "shoehorned" into compact space in tower's 74th floor.



CBS Television Transmitter on 74th floor of Chrysler Bldg., N. Y. City. Philip Goetz, engineer, is pointing toward the open control desk panel.

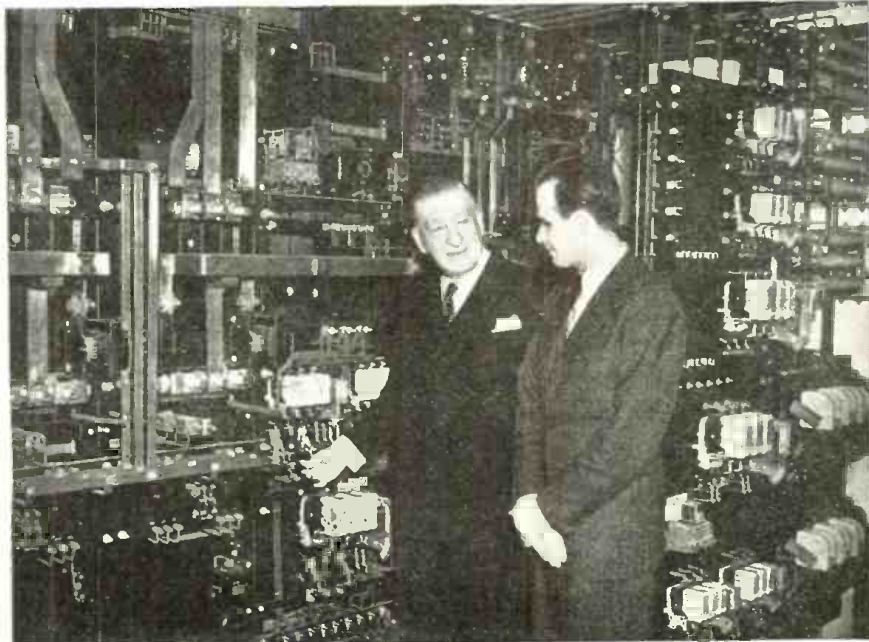

QUESTIONS ON TELEVISION

Answered By DR. GOLDMARK

- Q. What is the range of the CBS television station?
- A. The theoretical range is 40 miles, but with an elevated receiving antenna the range may be as large as 50-60 miles radius.
- Q. What are the wavelengths to be used for sound and image?
- A. 51.25 megacycles will be used for image and 55.75 for sound.
- Q. What is the best type of aerial the viewer may construct on his receiver?
- A. Horizontal dipole as high above his roof as possible, preferably within line of sight of the transmitter, the broad-side of the antenna facing the transmitter.
- Q. Will ultra-short waves be used for national television coverage?
- A. It is hard to foresee at the moment. It looks as though ultra-short waves will be more feasible at the present state of the art.
- Q. What is the height of the transmitter?
- A. 960 feet.
- Q. Is horizontal polarization used? If so, why?
- A. Horizontal polarization is used. It is preferred because, when using it, less interference has been experienced.
- Q. What is the power of CBS television transmitter tubes?
- A. 15 kilowatts peak for video and 30 kilowatts peak for audio.
- Q. How is the studio linked with the transmitter?
- A. By coaxial cable.
- Q. How is glare avoided in studio lighting?
- A. By distributing many low-power lights over as large an area as practical.
- Q. What kind of television cameras will be used?
- A. A number of cameras for direct pickup and for film transmission.



Introducing Home TELEVISION

← RCA

At the end of April, 1939, television made its long heralded advent in the United States. Many leading manufacturers announced sets, kits and parts for distribution to the public. These sets include everything from small table models producing a picture approximately 3 x 4 inches to large consoles affording images approximately 8 x 10 inches—or slightly larger than a type page of this magazine.

Radio Corporation of America is producing several models, two of which are shown here. The table model (TT-5) is a 16-tube plus Kinescope job which provides a 3 3/8" by 4 3/8" picture on a 5-inch C-R tube. The sound is provided by connecting the sound channel output of this little set to any A.C. operated radio receiver. Also shown is the same company's model TRK-9 which produces a 5 1/2" by 7 3/4" image on a 9-inch tube. This console includes a 12-tube 3-band all-wave radio chassis with a switch for phonograph attachment. Both sight and sound on the television channel are produced on this set.

Also in the line are models TRK-5, a 24-tube console including an 8-tube all-wave radio chassis and providing a 3 3/8" by 4 3/8" image; and model TRK-12 which affords a 7 3/8" by 9 3/4" image on a vertically mounted tube. The image is viewed by means of a mirror mounted on the underside of the cabinet lid, which is raised for viewing. This set has 36 tubes, and electric tuning is provided for nine broadcast stations.

General Electric Company, too, is out with a line of four television receivers. The smallest set is the HM-171, a table-type image receiver with sound converter. Like the RCA TT-5, it employs a 5-inch tube. This model is illustrated, as is model HM-225, a console sight-and-sound-set employing 22 tubes, including an 8-inch picture tube. Model HM-185 also has sight and sound, employing 18 tubes including a 5-inch image tube. HM-226 and HM-275 both include all-wave sound receivers as well as television sight and sound. The former employs 29 tubes and the latter 30 tubes, including a 12" C-R tube.

Westinghouse Electric Supply Company, likewise has four sets in its television line. One of them, a table model and sound converter, is similar to the G-E and RCA table models previously described in that it uses a 5-inch tube and obtains its sound through an associated radio receiver. Models WRT-701, WRT-702 and WRT-703 are not shown.

Meissner engineer with Television Kit.

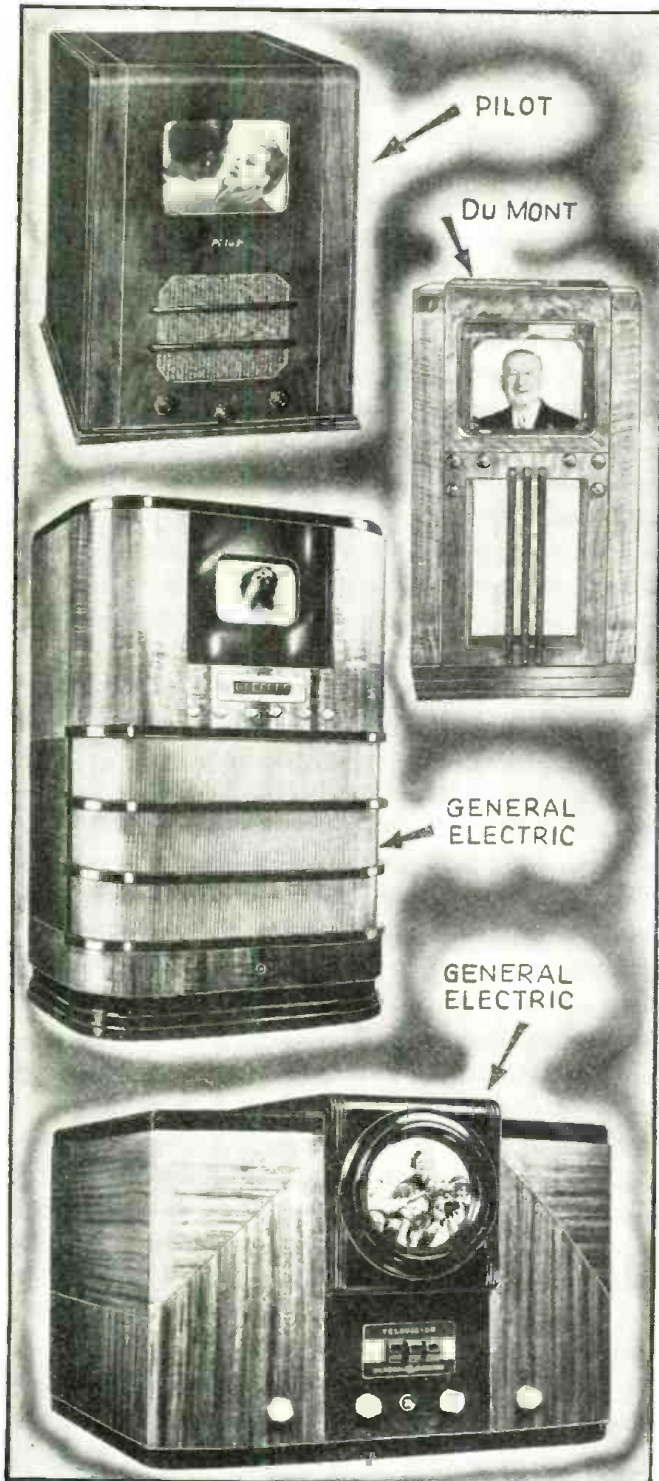

RECEIVERS

to Mr. & Mrs. America

RCA➤

Pilot Radio Corporation presents its model T-90, a 20-tube *sight and sound* receiver. One of the features of this set is a full automatic Raster (background brilliance) control. The images are seen on a 9-inch tube.

Stewart-Warner Corporation has likewise entered the television field and is presenting a receiver which reproduces a television image 9 $\frac{3}{8}$ " by 7 $\frac{1}{4}$ " on its 12-inch tube. The set, illustrated here-with, employs a mirror on the underside of its cabinet lid for viewing the vertically mounted tube. The set shown includes standard *broadcast reception* as well as *television sight and sound*.

The *American Television Corporation* has, in addition to its television table and console models, the "Kinet", which corresponds to the remote speaker in radio. This unit consists of a cathode-ray tube, together with its power supply and controls, mounted in a small portable cabinet. Other models in the line are the VA-5 illustrated, which provides an image on a 5-inch cathode-ray tube and includes a 3-band receiver for *standard broadcasts* (200 to 550 meters), short wave and television.

Philco Radio & Television Company is preparing a line of television sets, but space does not permit their description in this issue. Further details regarding this well-known manufacturer's equipment will appear subsequently.

Allen B. Du Mont Laboratories is also out with a line of fine television receivers, including table and console models. Du Mont is using the largest tube of all, at the present time—one 14 inches in diameter, providing a picture of adequate size to be viewed by a large number of people simultaneously.

Also on the market are television *kits*, two of which are illustrated. The *F. A. D. Andrea Radio Corporation*, in addition to its kits (one of which is described in further detail elsewhere in this issue), is featuring table model television receivers using a 5-inch C-R tube.

The other illustration shows an engineer assembling the cover on the *Meissner* kit. Like the Andrea kit, this employs 17 tubes, including the cathode-ray tube, and provides *sight and sound* on television programs.

F. A. D. Andrea and his 5-inch Receiver

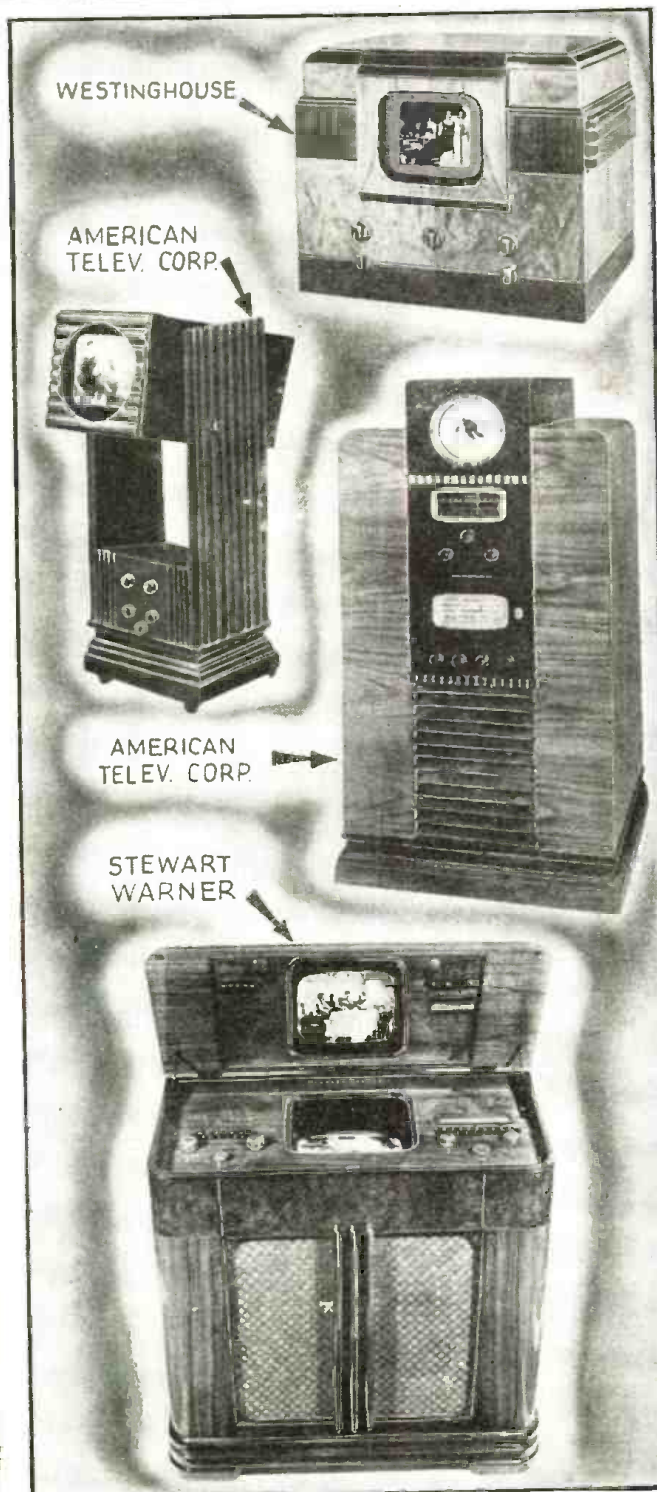

WORLD WIDE RADIO DIGEST

6400 COLORED LIGHTS, which wink "on" and "off" as visitors to the Westinghouse exhibit at the New York World's Fair speak into a microphone, will be part of the amateur radio display. Other features include a visualization of the operating principles of radio transmission and reception.

In the accompanying illustration, Kathryn and Janet Lee Hutchinson, members of the famous "Flying Hutchinson Family," watch E. David Litke describe the action portrayed in the unit which he built. All three are members of the A.R.R.L.

The unit being shown is a representation of a tuned circuit with inductance and capacity.

Other boards will illustrate antenna circuits, amplifier action and similar radio principles.

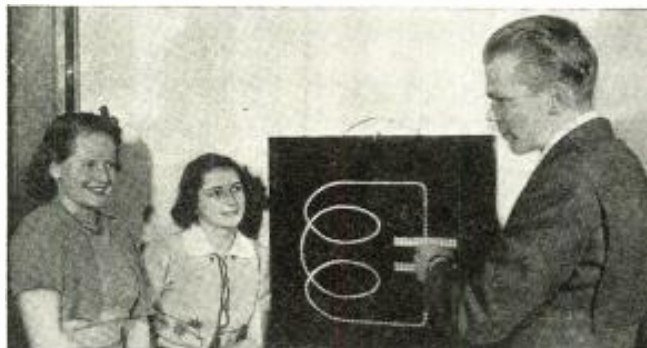

POLICE RADIO equipment has been designed for both dogs and men, as the illustration below shows. Recently the Federal Communications Commission revised its regulations to facilitate the use of portable transmitters by men on foot. According to the F.C.C., this equipment would be particularly useful for officers who work in the open country, impassable to cars and not provided with telephone lines. If operated on the same frequency as police control stations, no special licenses will be required.

In Sydney, Australia, this has been carried a step further. Police there have small portable receivers strapped on the backs of police dogs which can be given instructions, even when miles from their masters.



GIANT TELEVISION images are produced by the RCA equipment shown below. In this apparatus, a high brilliance cathode-ray tube, in conjunction with a lens system, projects the image on a screen which is approximately 4½ x 6 ft. By increasing the brilliance of the tube, and altering the optical system or moving the projector further from the screen, still larger images may be produced.

The British are already equipping motion picture theatres with screens 12 x 15 ft. upon which television images are projected. Two British companies — Sco-phony and Baird Ltd. — plan an invasion of the American field. That they will find competition from American manufacturers is indicated by the apparatus shown here.

Theater owners look upon this new advance with mingled emotions; some feel that it will stimulate business, others fear its competition.



A TRULY PORTABLE P. A. system has been devised for the use of the police in the Argentine, according to *Radio Tecnica*, a South American publication.

The apparatus consists of a dynamic loud speaking unit with a horn mounted in front of it and a microphone above it. It is connected to a power-pack in a case which the officer slings over his shoulder. An additional back pack accommodates the battery power supply. The horn of the unit is made of transparent material to afford minimum obstruction to the user's vision.

ROBOT RADIO to direct traffic is the latest development announced by the Greater New York Safety Council. The units are to be mounted on telephone poles or police stanchions, and to feed their energy into wires stretched along the roadside. The signal will be of low power but sufficient to affect the radio receivers in passing automobiles. In this way, it will be possible to direct drivers of cars actually in traffic. It is planned to use magnetic tape recordings in the transmitters. A "wipe-off" system permits message changes.

CBS'S FILM SCANNER

for television makes use of continuously moving film, causing an electronic scanning beam (which moves upward at exactly the same speed) to produce a stationary electronic image, while a slotted rotating disc acts as a shutter. As a result, the film which was originally photographed at 24 frames per second produces 60 separate stationary frames per second, evenly illuminated and adequately contrasty. This apparatus is now ready for operation.

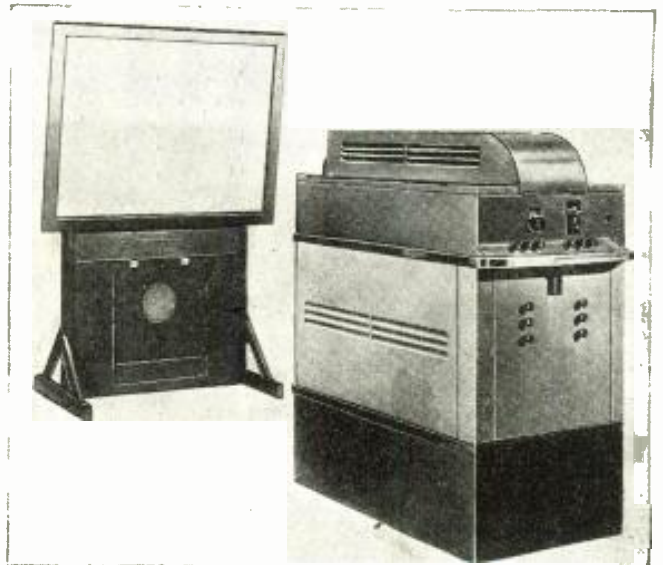



NEW TRANSMITTER for KDKA is under construction near Allison Park, Pa. It should be done by early 1940, when the station will be moved to its new location—within 8½ miles of downtown Pittsburgh. The “shack” will be erected on top of a hill about 1200 feet high and will use a 718-foot steel tower antenna—the world’s highest welded structure. This is the antenna now being used at the Saxonburg location. It will be dismantled for moving to the new transmitter site.

A NEW LAW passed by the Senate of the State of New York makes it unlawful to record *for gain* any broadcast programs without written permission from the broadcaster, or to sell or rent such records. Recording companies are fighting it.

ART TITLES for television are produced by the weird-looking gadget in the accompanying illustration. Seated in front of the apparatus which his co-workers are adjusting is Bill Eddy, in charge of the NBC television sight effects. The machine shown provides dissolves, iris-ins, iris-outs, “faus,” super-impositions, and all the other tricks of the titer’s art which are familiar to movie goers.



A RECORD worth shooting at is the one set by a fan at Burton-on-Trent in England, and reported in *World-Radio*. Between 1933 and the beginning of 1939, he heard 12,410 amateurs in 137 countries. 75 of these countries were phone contacts. The United States (his largest list) provided 6,324 contacts. Don’t our hams get out!

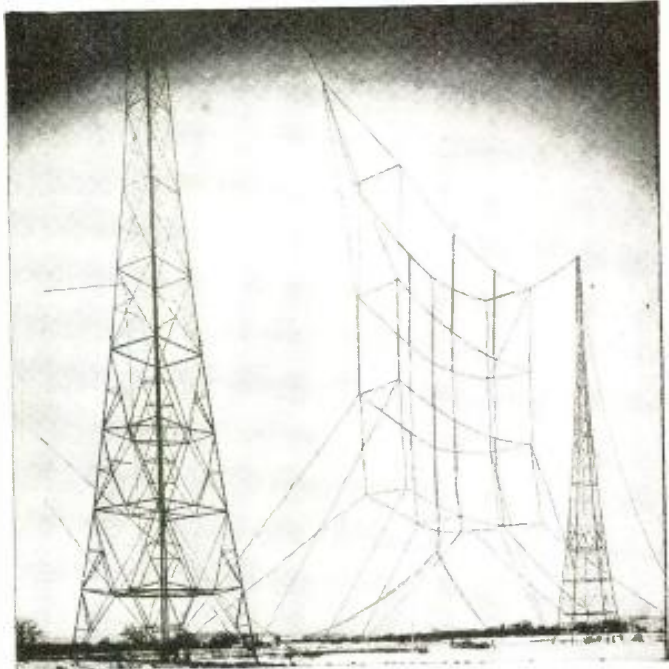

THE NEW ALEXANDERSON panel antenna is expected to double signal strength of G-E short-wave station W2XAD’s transmissions to South America. The secret is that decreased vertical depth will keep the signal path nearer the earth. It is

believed that by thus concentrating the energy, fading will be greatly diminished. The two 300-foot towers, shown above, are erected at South Schenectady. The new equipment has 24 sections—twice as many as were used in directing the Byrd expedition in Little America. These transmissions were horizontally narrowed but spread vertically, thereby losing considerable energy.

Transmissions to the eastern part of South America will be directed at Rio de Janeiro on 9550 kc. or 31.41 meters.

LANDING AIRPLANES in a fog by television is the aim of work being done at the E.M.I. factories, and described in *Practical and Amateur Wireless* (London). In the accompanying illustration, the airplane (4) is in position A, while approaching the airdrome. Its signal is picked up by the directional antenna (3) at the center of the landing field. Beneath this aerial is a room containing a television pick-up transmitter (7).

The pick-up is focused on a miniature model of the landing field and the surrounding district, as shown in the insert. This model may be pivoted to any angle in respect to the axis (10) of the pick-up, and this angle is made to correspond to the position of the directional aerial picking up the plane’s signals. Thus, the pilot can see in what direction he is approaching the field. By using a second aerial (5), and base line (6) known, the plane’s position may be determined.

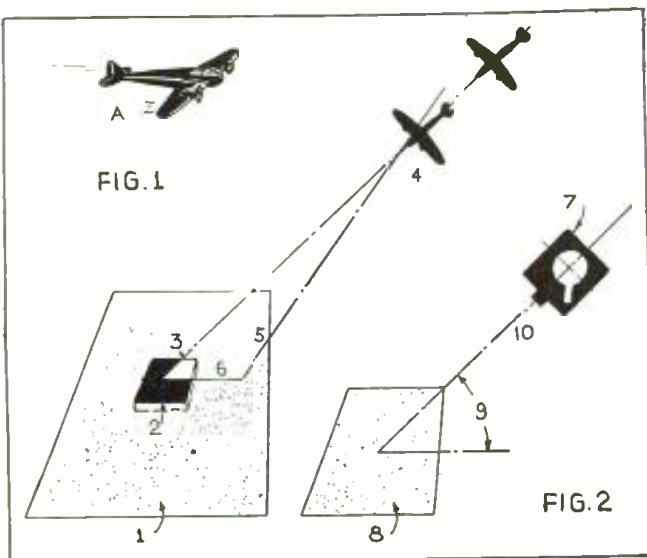

A 12-INCH SCREEN Kinescope has the underside of the top of its funnel coated with a fluorescent material which, when struck by the cathode ray beam projected from the tube’s neck, creates a spot of light. The beam, modulated by signals received from the transmitter, is made to scan the fluorescent surface in a pattern of 441 lines, 30 times a second, thus creating a reproduction of the televised image. This RCA cathode ray tube is one of the largest for television use now being produced commercially, though Du Mont Labs. have a 14-inch model.



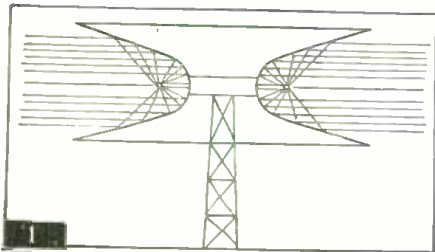

Ultra Short Wave Antenna

1 A NEW type of ultra short wave antenna has been patented by C. Lorenz A.G., of Berlin, and is reported in *FTM*. Parabolic reflectors are used to afford highly directional properties of the radiated wave, as shown in Fig. 1. This will be used for beaming transmissions.

The invention, patented by Fernseh Akt of Germany, is reported in *Wireless World* of Britain.

Projection Systems

4 TWO interesting projection systems are reported in *Television and Short-Wave World*. The first, recently patented

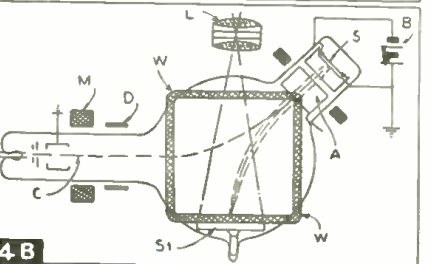
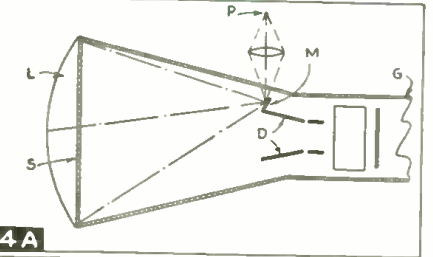
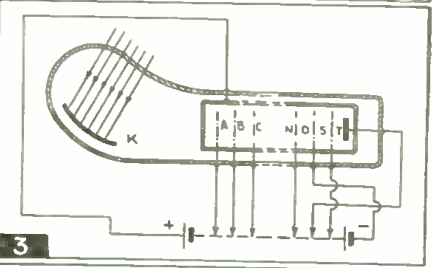
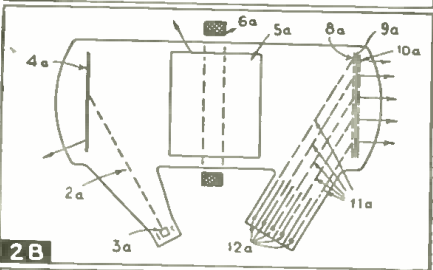
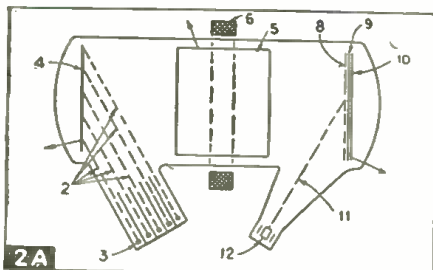

Multiple Television System

2 A NEW television development, reported in *Radio-Amateur*, of Germany, makes use of simultaneous transmission of a number of picture elements, giving a variation of time element in transmitting signals over the same carrier.

The diagram at 2A shows a pick-up tube using five individual electron beams from as many cathodes (3). Each beam is modulated by its own deflector plates (2) as it travels to a secondary emission plate (4). The winding (6) around the collecting electrode (5) causes an image of the five lines to be created electronically on the mosaic plate (8, 9, 10), from which the final beam (11) passes to the anode (12).

The receiving tube, seen at 2B, operates in a similar manner, but reversed. The image on the screen (8a, 9a, 10a) is projected in the direction shown by the arrows at the right.

Electron Multiplier

3 WHEN light falls upon the cathode (K) of the electron multiplier, as shown in Fig. 3, it releases primary electrons which then pass through a succession of perforated secondary-emission electrodes A, B, C . . . N, O, all of which carry progressively increasing positive potentials with, say, 200 volts difference between each. Following the output stage (O) are two retarding electrodes, S and T, each carrying a lower potential than O. This biasing causes extra secondary electrons emitted from S and T, to be collected by O.

by Fernseh Akt, is shown in Fig. 4A. In this tube, the electron stream is used to alter the transparency of a special screen, S, which replaces the usual fluorescent screen. At the outer side of this screen is a projector lens, L. Light from an external lamp, P, is projected through an optical system to a small mirror, M, affixed to one of the deflecting plates, D. This mirror reflects the light to S and thence to the viewing screen. The screen, S, consists of a thin hollow casing containing smoke (!) or other fine particles, which are deposited on the glass according to the varying intensity of the scanning stream, thus changing its transparency.

4B illustrates a system patented by Marconi, Ltd. and L. M. Myers. In this tube, the receiving image is reproduced by *incandescence* instead of *fluorescent* light. The electron stream from the cathode, C, is controlled by the focusing coil, M, and the deflecting plates, D, in the usual manner. Magnetic coil, W, deflects it when it enters the bulb of the tube and causes it to strike special screen, S, which is caesium coated and heated by means of a battery, B, to a sensitive temperature. The electrons cause the emission of secondary electrons, thus producing an "emission image" at S. The anode, A, attracts these electrons which are focused by the winding, W, onto an incandescent screen, S1, which is finely coated with lampblack and pulverized tungsten, causing the points of impact to become white hot. The picture is projected by means of an external lens, L, to a viewing screen, where it may be seen by lookers-in.

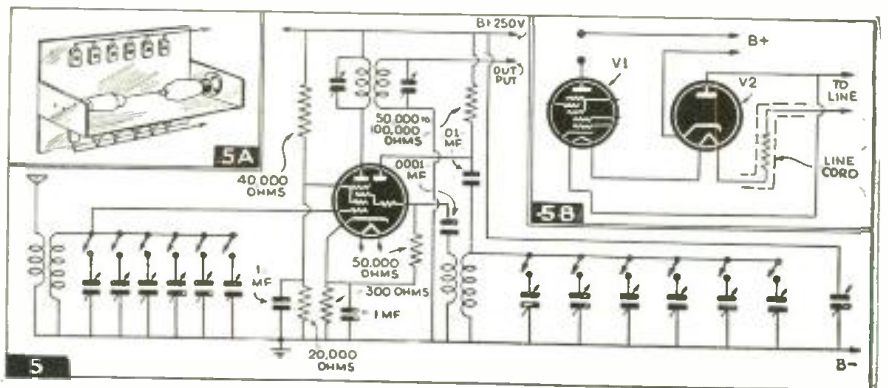

Simple Push-Button Tuner

5 A 2-TUBE remote-control push-button tuner is shown in Fig. 5. This unit, described in *Practical and Amateur Wireless*, makes use of six or eight gang push-buttons.

A simple layout is shown in insert A and the heater wiring diagram in insert B. The

"Y" Type Antenna

8 A "Y" TYPE matched-impedance aerial is described by H. J. Hunt, G5HH, in *The T & R Bulletin* of England. Some bamboo poles 8 ft. long were obtained and a "cradle" constructed by tying three together with an overlap of two feet, thus getting 20 feet in all. The matched

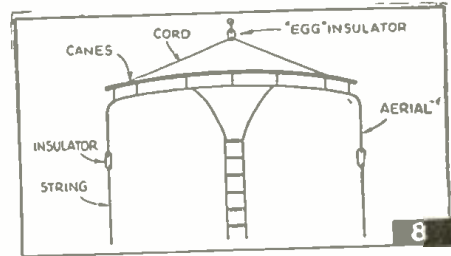

i.f. transformer employed is any standard type for the frequency desired and the tuning coils are for broadcast or any other band which is to be covered. The output of this unit is coupled directly to the antenna post of the regular broadcast receiver through a shielded cable not over 20 feet long.

impedance top was then slung along this support, using insulated hooks, allowing 6 to 7 feet to hang down at each end. The normal top was then replaced by rope and hoisted into place, as shown in Fig. 8.

In an east to west position, G3HH was able to work ZD2H. Strings were tied to the ends of the aerial to rotate it.

Automatic Transmitter

6 AN automatic transmitter, which oscillates in a series of dots as long as the power is connected, is illustrated in Fig. 6.

The 1 mf. is inserted as shown, and after the unit is turned on, is shunted out by means of the switch connected across it.

This unit is good for a hidden transmitter on field days, also for directional work, etc. It was described in *The Australasian Radio World*.

Super-regenerative Circuits

7 FIG. 7A illustrates an Armstrong super-regenerative circuit, while 7B shows the modifications which are employed when a Flewelling circuit is used. A still further refinement is illustrated in Fig. 7C. The unit marked G is a low voltage neon tube.

Fig. 7D illustrates the amplification curves for the various voltages in the local oscillator circuits, while 7E is a complete superhet utilizing the super-regenerative principle. The unit is designed to operate on 5 meters.

Super-regeneration has come into renewed favor for ultra-short wave work.

Large Screen Television

9 LARGE screen television has always been the goal of design engineers. The main problem has been to secure sufficient illumination without having to increase voltages to an impractical degree.

One system is that used by Scophony, a British company, which lights up not only a single picture element at a time but a complete horizontal line, thus increasing the brilliance of the image several hundred times. Fig. 9A illustrates this system, as reported in *Wireless World*.

Other systems use various other means, some of which have been described in previous paragraphs. However, the problem can best be realized by an inspection of Fig. 9B. This shows the standard British system of 405 lines, 20 of which are used for synchronizing. The aspect ratio of the British picture is 4:5, while the American is 3:4.

Cause of Fading

10 THE cause of fading is illustrated in Fig. 10A, taken from *World-Radio*. It shows how two waves traveling in different paths from the same transmitter are re-
(Turn page, please)

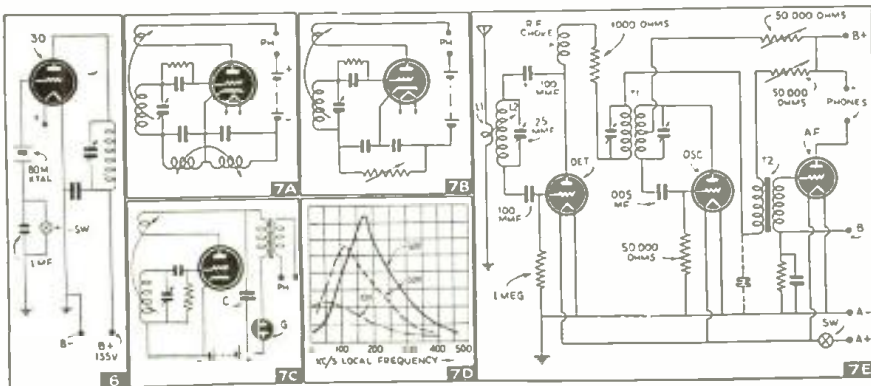
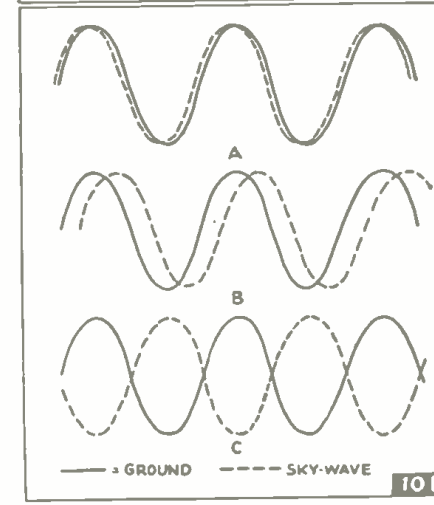
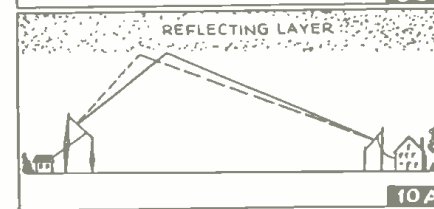
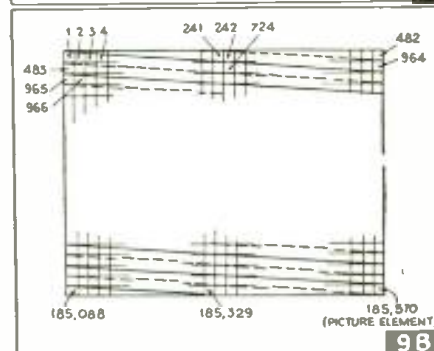
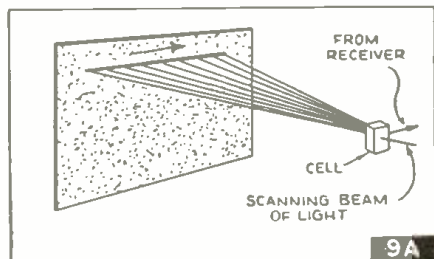

INTERNATIONAL RADIO REVIEW

(Continued from preceding page)

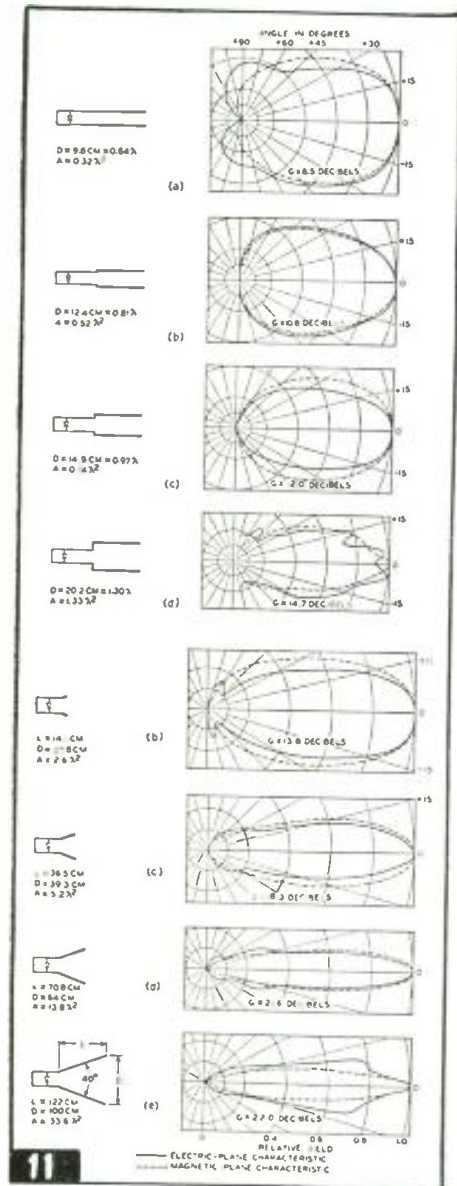

flected and thus get out of phase as they reach the receiver.

Fig. 10B shows the effects of fading. Curve A in the illustration indicates waves "in step" which provide very strong signals. Curve B shows what occurs when one wave begins to lead the other—there is a decline in signal strength. When the waves are completely out of phase, as illustrated in Curve C, signal strength falls to zero and no signal is received.

In Fig. 10A, the wave shown in dots might be in step with the ground wave, while that shown in the solid line might be out of phase, thus causing a degree of fading.

Metal Horns to Receive Ultra Short Waves

11 THE use of metal horns for the reception of ultra short waves has received considerable attention in the press of America. Recently, Dr. George C. Southworth and A. P. King, both of the Bell Telephone Laboratories, told how by using simple metallic horns it is possible to obtain power improvement of some hundred times that of an ordinary simple half-wave antenna. Some of the forms of horns used, together with their directional properties, are given in Fig. 11.

Field Strength Meter

12 A DIAGRAM for a simply constructed field strength meter appears in Fig. 12, as published in *The Australasian Radio World*. The parts used in this outfit are: an 8 x 5 x 1" chassis; a feed-through insulator; a 50 mmf. variable condenser; six 50 mmf. air-trimmers; a 6-point switch; a 4-prong socket; a 15 ohm wire-wound resistor; a type 32 tube; a .002 mf. mica condenser; an on/off switch; a 1 ma. meter; a 4½ volt "C" battery; a 22½ volt "B" battery, and a 1½ volt "A" battery. The coils are wound with No. 20 enameled wire on ¾" forms. There is one inch of winding to each coil. Tuning to 5, 10, 20, 40, 80 and 160 meters is accomplished by means of the air-trimmers.

W. McGowan, VK2MZ, designed the apparatus.

Positive Bias on Diode Detectors

13 THE circuit of a negative feed-back plate curve detector is shown in Fig. 13A. This is a circuit arrived at by *Wireless World's* editorial staff after having experimented considerably with positive bias diode detectors. They believe this circuit superior to those tested because it has all their characteristics without the disadvantage of positive diode damping. This is our *infinite impedance* detector.

Its action is identical with that of a positively biased diode. The grid of this diode controls the electron stream and draws no

current, and there is some slight regenerative effect due to the capacitive cathode load. The apparatus used to run off the laboratory tests of the positively biased diodes at the Marconi School of Wireless Communication is shown in Fig. 13B. You will note that a positively biased diode is used in the first stage.

NBC's Television Schedule

REGULAR evening programs will be presented over the NBC New York television station from 8:00 to 9:00 p.m. on Wednesdays and Fridays. Outdoor pick-ups will be made on Wednesday, Thursday or Friday afternoons. There will also be approximately twenty-three hours of film programs per week—Monday to Friday. They will consist of ten-minute transmissions at fifteen-minute intervals. On Mondays, Tuesdays and Thursdays, film transmissions will be on from 11:00 a.m. until 4:00 p.m.; on Wednesdays and Fridays, they will be on from 4:00 p.m. to 8:00 p.m., after which the regular evening programs will take their place. The picture frequency is 45.25 mc., the sound frequency, 49.75 mc.

"Two Months in the United States"

ROBERT JARDINE (G6ZX), a British "ham," made a tour of the United States and formed many impressions of the American amateur field. He summed them up in *The Television & Radio Bulletin* as follows:

1—Tremendous enthusiasm and great hospitality by U. S. Hams.

2—Great QRN, due to the low cost and general use of household appliances.

3—Availability of standardized components, such as steel racks, panels and chassis, at moderate prices reduces experimenting among American Hams.

4—Government approval of 1000 watt transmitters makes U. S. Hams less careful about maintaining high efficiency than are British Hams who are limited to lower power.

5—Commercial interest in Ham radio, particularly in the development of new Ham tubes.

6—Danger of high voltages used in American Ham equipment.

7—Dead spots where DX sigs are seldom if ever received. This is attributed largely to the great number of power lines in the U. S.

F.C.C. to Report on Television

THE Federal Communications Commission's television committee is expected to make its report on television in the latter part of May. One group believes television should be according to the standards of the RMA, while the other holds that new standards are needed.

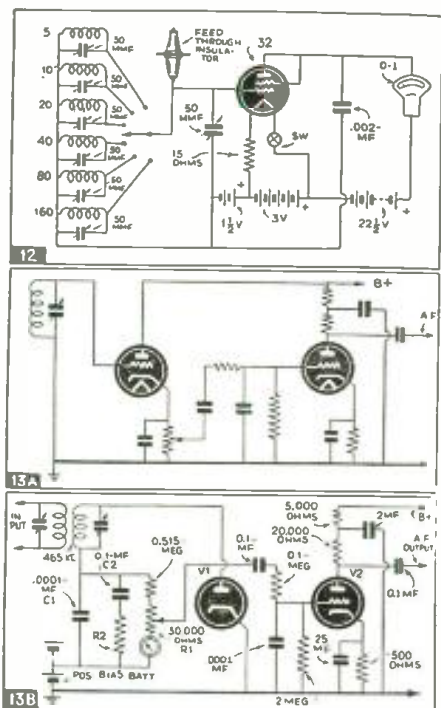

OPPORTUNITIES in TELEVISION

Dr. Alfred N. Goldsmith



The Author,
noted engineer
and consultant.

A variety of ways in which you can profit by the advent of television are outlined by one of America's outstanding authorities.

● **COINCIDENTAL** with the announcement that television was to be released to the public, Americans in two of our largest classes—the unemployed and the low-salaried—became highly interested in whether or not the new industry will provide adequate livelihood for them.

In order to answer this question, several assumptions must be made. First—that the various engineering problems will be solved in the normal course of events; second—that there will be a rapid increase of technical ability so that unforeseen problems will likewise be solved; third—that a means will be found for adequately financing television programs of high entertainment value. Such programs must be sufficiently attractive to afford an excuse for the relatively high initial cost of television receiving equipment. Developments must also be such that companies providing television transmissions will be able to receive remuneration either from sales of broadcasts or through some other adequate means.

As America has always solved its problems technically and financially, it is assumed that this problem will likewise be solved and that television will be not only an interesting novelty, but a means of home entertainment comparable at least to the radio broadcasting of the mid-1920's.

Assuming that this can be done, there will be various opportunities for men and women of average intelligence to enter the television field and profit therefrom.

Manufacturing



men thoroughly trained in radio work but with a special knowledge of television essentials added.

TELEVISION is still in its comparatively early stages, **DESIGN ENGINEERS** capable of doing research and development work on transmitters and receivers will be needed. These will doubtless be

As tubes play an important part in television technique, **TUBE ENGINEERS** will likewise be needed to design the special vacuum tubes and cathode-ray tubes employed in television transmitters and receivers. Many of these men will no doubt be specially trained physicists, but a large number will doubtless be those who have received much of their technical education from correspondence or resident schools, and in actual practice.

The factories will also require **FOREMEN, SUPERVISORS, PRODUCTION ENGINEERS, MANUFACTURING ENGINEERS, TIME-STUDY MEN, TESTERS,** and the like. These will doubtless be drawn from among present factory workers and service men, particularly those who have trained in or studied television or allied lines.

Transmitters



ENGINEERING PROBLEMS will not cease when the transmitter has been designed and manufactured. After it has been received at the station, it must be erected and maintained. **FIELD SURVEY ENGINEERS** will find suitable locations and will design and supervise construction of antenna systems. When their work is done, **CONSTRUCTION MEN** will install the equipment, after which a complete **MAINTENANCE STAFF** must be employed to see that it operates at consistently high efficiency.

Of course, the studio side cannot be neglected. There will not only be the **SOUND ENGINEERS** and **PRODUCTION STAFF** required by present broadcast stations, but there will be complete additional staffs to handle the image end of the broadcasts. These staffs will include **LIGHTING TECHNICIANS**, who may at least in part be drawn from the theatrical or motion picture fields; also needed will be **VIDEO PICK-UP MEN**, who correspond to the expert camera men of the motion picture industry. In addition, there will be **VIDEO CONTROL MEN**, who will handle the image signals, much as the control men

in present stations monitor broadcast programs. These men will require good judgment and quick responses in order to perform their tasks satisfactorily.

As it is now contemplated that much television material may be drawn from motion picture films, there will also have to be expert **FILM PROJECTIONISTS** to run off the reels for the iconoscope to scan.

The duties of those engaged in video work, while comparable to those existing in motion picture studios, will be far more arduous, for in the motion picture studio, errors can often be corrected by means of *retakes*, while in a television studio the *first* pick-up must be the *only* one. The public must be given perfect pictures at the very first try.

In addition to these studio camera men, there will doubtless be large staffs of **OUTSIDE MEN** to pick up not only such spot news as fires, riots and the like, but also to cover important sporting events, such as ball games, polo matches, etc. While many such men will be drawn from the newsreel companies, which require similar abilities, it is easy to believe that schools for training technicians especially for this work will be put into operation when the need for more men arises.

Program Material



at all likely that present radio writers can swing immediately into the television field, for they have been trained in an entirely different technique—that of producing an effect without visual aids. It is probable that short-story writers and motion picture writers will be given special courses in the technique of television which, of course, is vastly different from both.

(Continued on page 117)

ALTHOUGH IT is likely that motion picture films and scenarios may be adapted to television, it is almost certain that special television **SCENARISTS, REWRITE MEN** and **EDITORS** will be required. It is not

1. If someone told you to get a wobbulator, you would come back with
- a vernier dial with lots of backlash.
 - a slightly inebriated gentleman.
 - a device used for varying the frequency of a transmitter to secure secrecy of communication.
 - a device used with a cathode-ray oscilloscope to vary frequency in synchronism with the horizontal sweep.

- it is shielded by a tank-like metal container.
- the waves generated in the circuit are much like those in a tank of water.

7. Ohmic resistance applies specifically to
- direct current resistance.
 - electronic current resistance.
 - resistance for high frequency currents.
 - resistance to any form of current.

12. From your reading of technical books on radio, you have learned that a space charge is
- the rent you pay for your radio shop.
 - the magnetic lines of force around a coil through which A.C. is flowing.
 - the effect of free electrons in a vacuum tube which are not attracted to the plate.
 - the effect of radio waves as they pass from the transmitting to the receiving aerial.

For each question answered fully, count 10 points; half right, 5 points; etc. A perfect score is 180; a good score is 120; below 60 is poor.

This month's Test-Quiz is based on the Sprayberry Dictionary of Radio, and all correct information contained herein was taken from that volume.

— Robert Eichberg's —

Radio Test-Quiz

2. Monel metal, sometimes used for condenser plates and chassis, is an alloy of
- copper, nickel and iron.
 - copper, nickel and silver.
 - nickel, brass and platinum.
 - zinc and lead.

3. If you wished to convert meters into feet, you would
- multiply the number of meters by 36.
 - divide the number of meters by 36.
 - multiply the number of meters by 3.28.
 - divide the number of meters by 3.28.
 - multiply the number of meters by .334.
 - divide the number of meters by .334.

4. Pi (π) is a symbol often used in the mathematics of radio. You know that it is the equivalent of approximately 3.1416. Try out your mathematics on these.

- $(2\pi)^2 =$
- $\sqrt{\pi} =$
- $\frac{1}{2\pi^2} =$
- $\frac{10}{\pi} =$

5. Many Greek letters are used as symbols in radio. See if you can match up the following:

- | | |
|-------------------------|---|
| a. delta (δ) | A. wave length in meters |
| b. eta (η) | B. hysteresis coefficient |
| c. lambda (λ) | C. time constant, or phase displacement |
| d. tau (τ) | D. variations, or small changes |

DELTA $\delta = ?$ LAMBDA $\lambda = ?$
 ETA $\eta = ?$ TAU $\tau = ?$

ARE RADIO SYMBOLS GREEK TO YOU?

6. In a radio transmitter, an oscillatory plate circuit is known as a tank circuit because

- Garbo once used one when she said, "I tank I go home."
- it serves as a reservoir of energy.

8. If somebody said, "In listening to the Kadoop's program last night, I heard a lot of wows," you would know that "wows" means:

- very funny jokes.
- highly skilled performers.
- hit phonograph records.
- phonograph records reproduced at imperfectly controlled speed.

9. If infra-red rays are waves, invisible to the eye, of a wavelength longer than visible red, an infradyne is a variation of a superheterodyne in which

- only long wavelength stations can be received.
- a special low frequency oscillator is employed.
- the intermediate frequency is the sum of the local and signal frequencies instead of the difference.
- or perhaps Infradyne is merely a trade-name for a certain manufacturer's superhet?

10. If you were given the job of building a free-point tester, you would make a device

- to test for free oscillations.
- to enable one meter to be switched to various points in a circuit.
- to locate free electrons.
- to measure free magnetism.



11. If a low whisper is audible at five feet at an intensity level of 10 db., tell what you believe is the average db. level of the following sounds:

- vacuum cleaner.
- Niagara Falls.
- airplane propeller.
- riveting hammer.
- automobile horn.
- motor truck.

13. Many abbreviations that are used in radio are not very familiar, but see if you can tell what each of the following signifies.

- | | |
|-------------|-------------|
| a. M/M | d. J. |
| b. P. D. C. | e. A. W. G. |
| c. H. P. F. | f. Ed. |

14. The term "broadcasting" really means

- any transmission of radio energy from a transmitting station.
- transmission of radio energy from one station to another specific station.
- transmission directed at no particular station.
- transmission of entertainment programs.

15. Caesium is an alkali metal used in photo electric cells. It is particularly sensitive to

- blue light.
- red light.
- green light.
- yellow light.

16. As a radio man, you should know that Lenz's Law

- deals with magnetism.
- deals with lenses.
- deals with capacity.
- has nothing to do with radio, being applicable only to bridge games.

17. Resistances in parallel can be computed most easily by

- use of a slide rule.
- use of an adding machine.
- use of a chart.
- long division.



18. Define the following symbols in the International Morse Code:

- | | |
|--------------|------------|
| a. . _ . _ | d. _ _ _ . |
| b. _ _ _ _ | e. . . _ _ |
| c. _ _ . _ _ | f. . . _ . |

(Continued on page 115)

Electronic Television Course

Sweep Oscillators and the "Sync-from-Video" Separator.

Lesson 1

Henry Townsend

● **SWEEP CIRCUITS:** In this discussion on sweep circuits, it might be well to mention that in the television receiver two sweep circuits are required—one to move the spot of light (produced on the screen by the beam of electrons) in a *vertical* direction and another to move it in a *horizontal* direction. The simplest form of an oscillator to accomplish this is shown in Fig. 1. It consists of a source of d.c. voltage, a resistance, a condenser and some form of a gaseous tube, such as an ordinary neon glow lamp. Current from the d.c. supply flows through the resistor and charges the condenser to a sufficiently high voltage to ionize the gas in the neon tube. As soon as this occurs, the condenser is discharged by this tube at a very rapid rate until a point is reached when the voltage is low enough to de-ionize the gas; the cycle then repeats itself. The repetition rate of the charge and discharge of the condenser can be governed by varying its capacity or the value of the resistor. The smaller the condenser, the faster will be the frequency of its charging rate. The higher the resistance for a given size condenser, the lower the frequency. This is the fundamental principle of all relaxation or gaseous tube oscillators.

The second type of sweep circuit is seen in Figs. 2A and 2B. These are modifications of the above and use gaseous type tubes where the action of the ionization is controlled by a grid. When the gas ionizes in this type of tube, the grid loses control until the voltage falls sufficiently low for the de-ionization of the gas, whereupon the grid again takes control and the cycle repeats. This type of sweep circuit is commonly used in cathode-ray oscilloscopes, the frequency of which is varied from a few cycles to several thousand cycles per second. The saw-tooth wave-form generated by this type of oscillator is not linear in time. Fig. 2B illustrates the use of a saturated pentode which acts as a constant current device in that the d.c. plate supply is caused to flow through this tube and thence to the plate of the oscillator at a constant rate, which tends to charge the condenser at a linear rate. Tubes of this type usually employ Argon gas because the de-ionization period is very short. The types 884 and 885 are typical examples. This circuit has the advantage in that a synchronizing signal applied to the grid will keep the oscillator in step (or synchronism) and trigger off at the proper time.

The third type of sweep circuit, commonly employed in television receivers of foreign make, is the *multivibrator* type saw-tooth generator, illustrated schematically in Fig. 3. It differs from those already mentioned in that *high vacuum* tubes are employed. Tubes, such as the 6J8G or 6C8G which incorporate two triodes in a single envelope, may be used. The circuit is nothing more than a resistance-coupled amplifier, where the energy from the plate circuit of the second tube is fed back through a condenser to the grid of the first tube. This feed-back action causes the circuit to oscillate. The frequency generated in the *multivibrator* type of saw-tooth generator is governed by the resistance and capacity in the cathode of tube No. 2. By making either or both variable the frequency can be varied over wide limits, and properly designed it is capable of generating extremely high frequencies.

Saw-Tooth Wave Must Be Linear

It will be noticed that none of the saw-tooth wave-shapes produced by any oscillator is *linear with time*. This is due to the fact that the charge or discharge of a condenser (upon which these oscillators depend) is non-linear, and consequently some

(Continued on page 122)

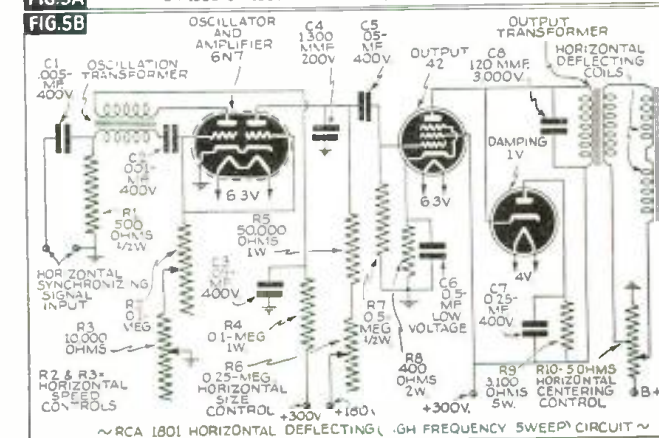
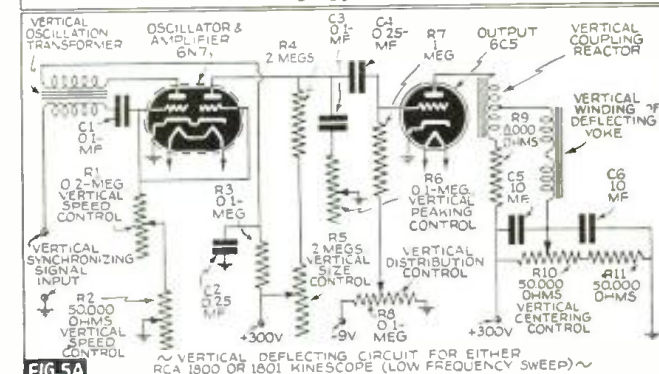
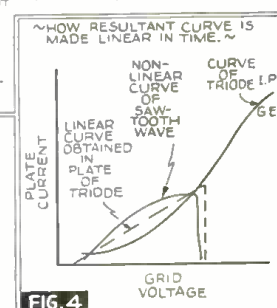
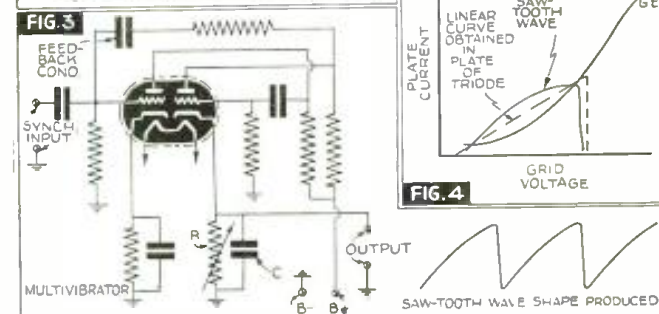
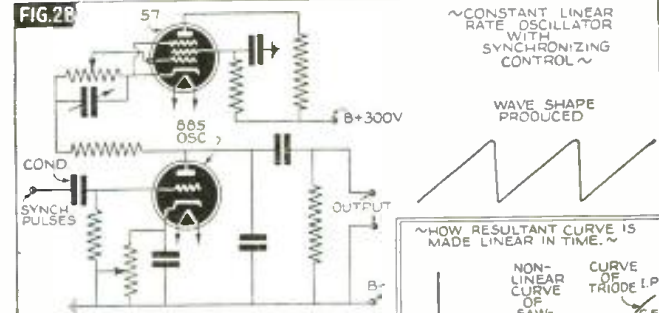
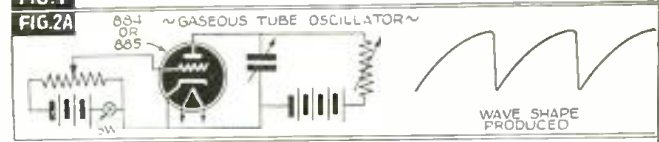
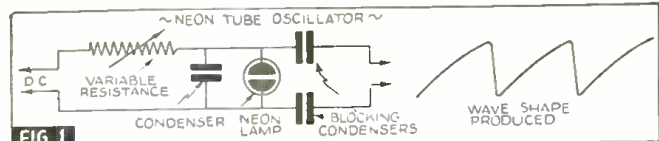

TELEVISION

Writer Tells How He Assembled



This is the way the kit will look when finished—with a picture on the screen 'n' everything.

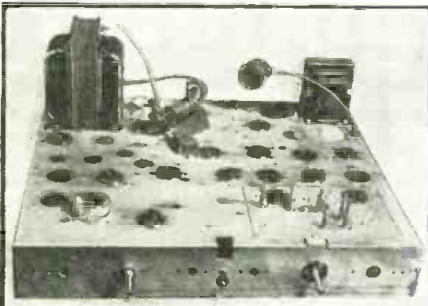

Two transformers and the r.f. unit (right hand lower corner) were mounted in stage one.

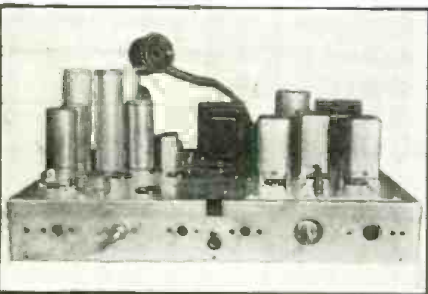

When the Second Stage was completed, the i.f. transformers, filter condensers, audio chokes and C-R tube socket had been added.

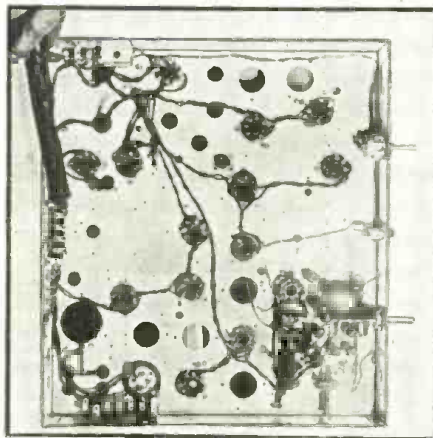

After the wiring of the First Stage had been completed, the underside of the chassis looked like this.

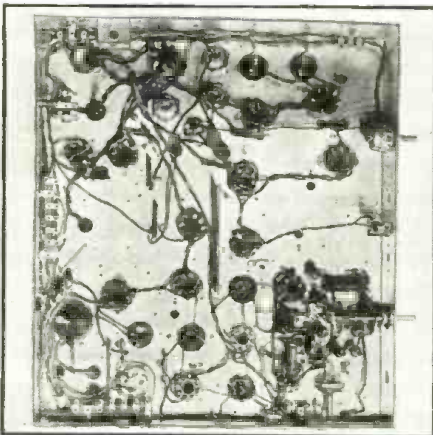

With the Second Stage wiring completed, the unit began to take on a more finished appearance. Note the addition of terminal strips.

● IT is about fifteen years ago that the writer taught a class in construction work—and he has hardly so much as touched a soldering iron since. Even though he has been busy swinging the blue pencil over articles about multi-band superhets, transmitters, and the like, it has been years since he assembled so much as a three-circuit regenerator. So, you see, he started building a 16-tube plus iniconoscope television receiver virtually as a novice. It was, in fact, with some trepidation that he began the task.

None the less, he gathered his courage in both hands and availed himself of an Andrea KTE-5 television "sight and sound" construction kit. When it came, he opened the box, feeling much as Bluebeard's wife must have when she unlocked the fateful door. Inside the box, he found a highly impressive array of components. (All kidding aside, fellows, I'll bet there were 150 parts.) On top of the components was a fistful of instruction sheets. These included one preliminary sheet; 5 large sheets, one of which will be shown next month, each dealing with a separate stage of the assembly; and a final sheet describing how to align the receiver.

The first thing the writer did was to begin unpacking. He couldn't wait for a look at the chassis pan, panel, loud speaker, and R.F. unit. The R.F. unit, seen in the upper right-hand corner of the underside views of the chassis, has a midget condenser on it. The temptation to spin the shaft being uncontrollable, he read a little red tag which said to leave the dry tubular condensers alone, and then proceeded to gladden his heart by spinning the shaft of the midget condenser. When he read a little bit further, he found out that this was one of the things

Below—When the Third Stage was finished, all that still had to be added on top was the bracket for the C-R tube, and panel braces.

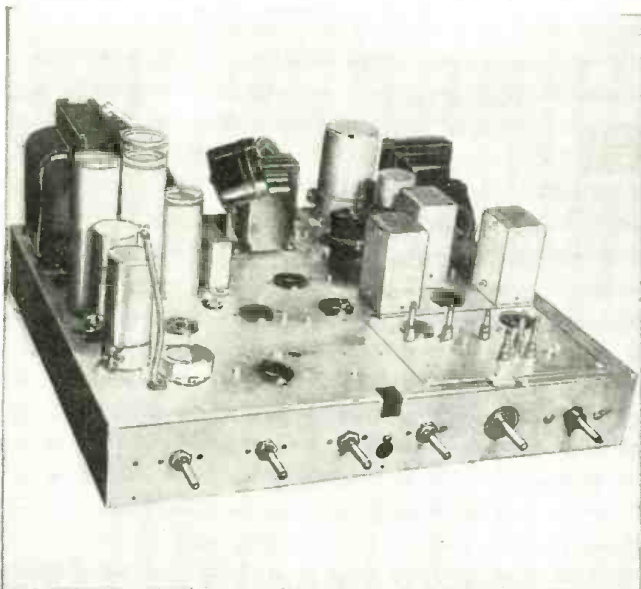

Below—Except for the resistors and condensers, the sub-chassis wiring had been completed when the Third Stage was finished.

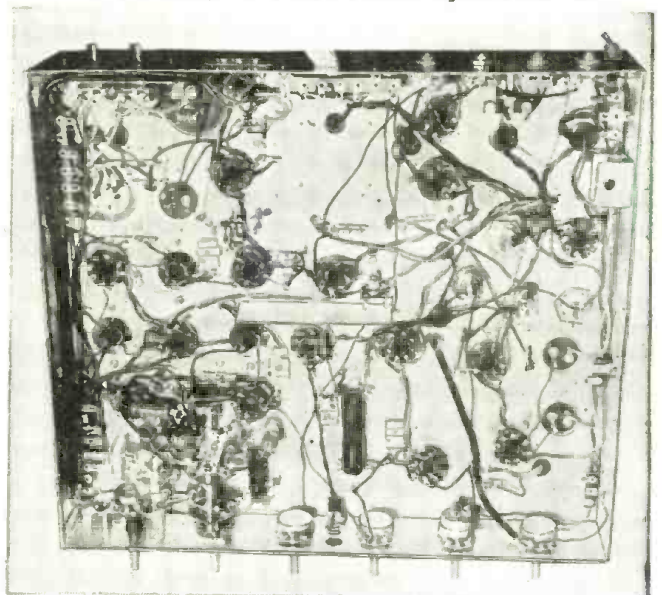

IN 24 HOURS

a 16-Tube "Sight-and-Sound" Kit

Robert Eichberg

he certainly should not have done, as it was preset at the factory with precision instruments. After examining the parts, the writer lay down on a short couch with a long drink and read the instructions on how to assemble Stage No. 1. They were very simple. Typical excerpts are:

Note: Twist the two following wires together. Do not run them separately.

Connect terminal 7 on socket A to 7 on socket B (yellow wire).

Connect terminal 2 on socket A to 2 on socket B (ground wire).

Fasten lug A to the chassis, using a 1/4" self-tapping screw.

Encouraged by this simplicity (they are

the best instructions we ever saw), the writer got out a soldering iron and Mr. Andrea's solder and started to work. The only other tools needed were a pair of pliers, a pair of cutters and a screwdriver. Stage 1 was completely assembled in 2 hours and 55 minutes including finding the parts and checking all wiring. But here is a tip for the next fellow who tries it. The instructions tell you to mount the *safety switch* and then to connect the *line cord* to it. If you reverse this procedure and connect the line cord first, it is much easier, for there is not much room for an iron under the safety switch.

As soon as the stage was entirely wired, it was checked over. That took about 20 minutes. With the heater wiring all taken care of, the writer started on the second

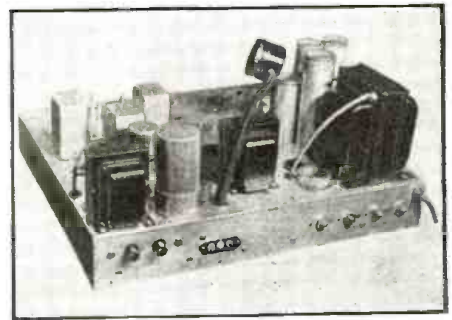

Rear view of the chassis at the end of the Third Stage. Shafts are horizontal and vertical centering controls, horizontal hold, picture width, vertical hold, and picture height.

stage, which is principally concerned with the large filter condensers and the audio chokes. This proceeded just as smoothly as the preceding stage, but there were a couple of points to watch. The list of parts which you are to pick out for Stage No. 2 includes a four-lug terminal strip with the mounting between the first and second lugs. The diagram does not show this part. It shows

(Continued on page 123)

Picture diagram below shows First, Second and Third Stages of a section of the sub-chassis wiring. Even a novice can do the job by carefully following the explicitly detailed instructions.

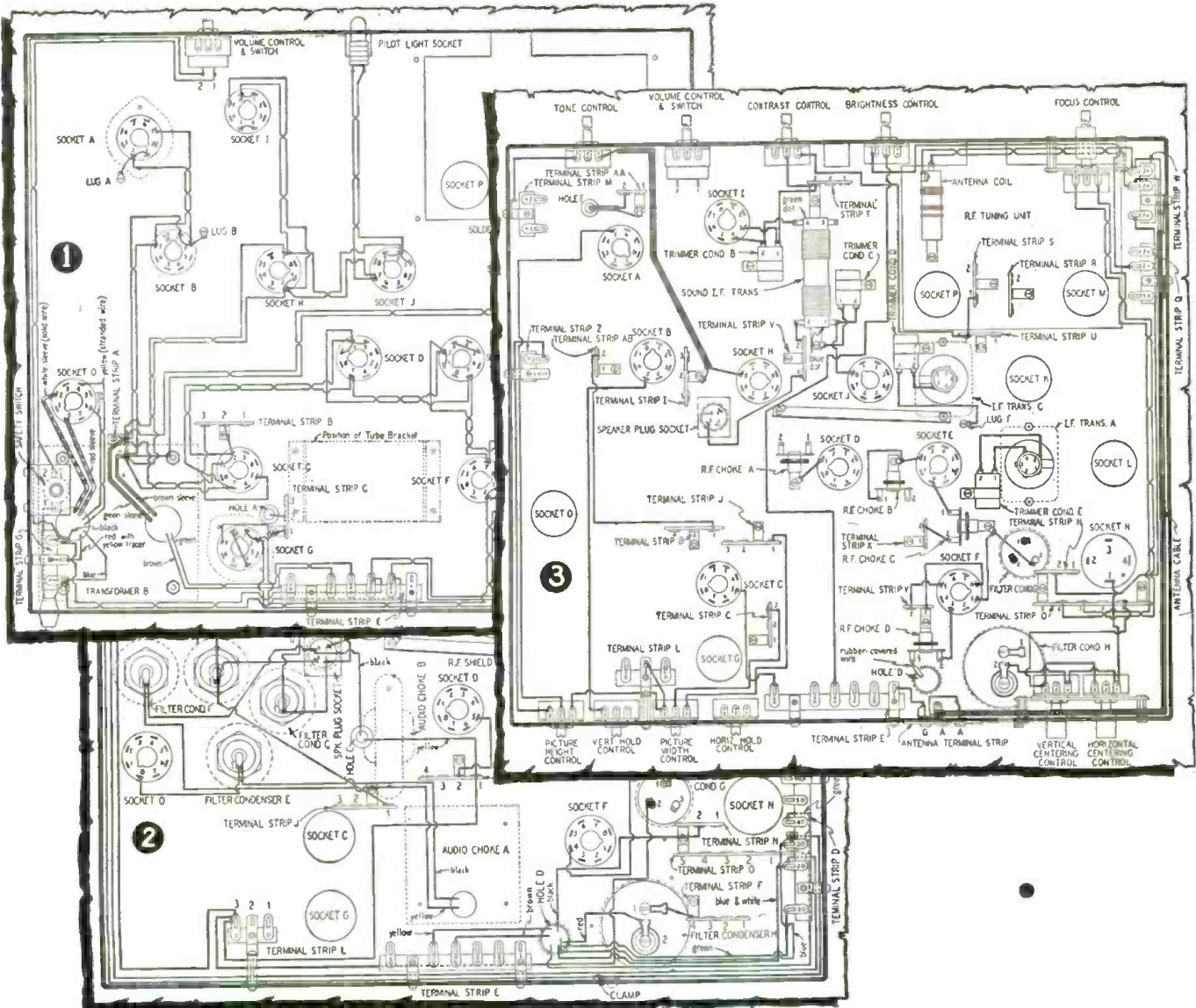

Radio Kinks

Each month the Editor will award a 2 years' subscription for the best kink submitted. All other kinks published will be awarded eight months' subscriptions to RADIO & TELEVISION. Read these kinks; they will be of real use to you, besides indicating what is wanted. Send a typewritten or ink description with sketch of your favorite to the Kink Editor

First Prize Winner Home-Made Dynamic Mike

The accompanying diagram shows how I made a dynamic mike from an old d'Arsonval type voltmeter magnet. I used heavy bond paper for the diaphragm and also wound my

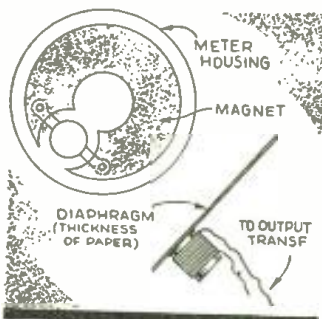

moving coil on a paper form, gluing the coil form to the diaphragm. I tested this as a permanent magnet dynamic speaker and it worked perfectly.

Now I have just tried it out as a dynamic mike. So far, I get enough output power to hear it on earphones connected across the secondary of a coupling transformer. — *Matthew Karabaic, Jr.*

Handy Mike Stand

One of the cheapest, handiest mike stands is made from heavy wire, such as an old coat hanger.

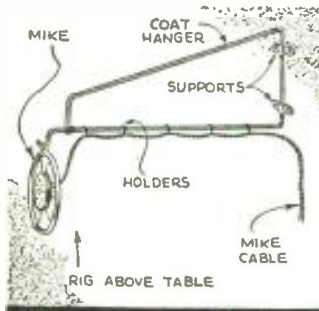

It supports the microphone from the wall, and permits it to be folded back flat when not in use or to be swung forward into operating position at the touch of a finger. A series of hooks on the lower side of the support carries the microphone cable. The stand may be fastened to the wall with screw eyes or small clamps. — *Eldon L. Meredith.*

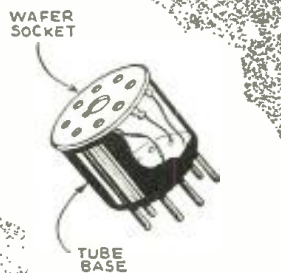

Simple Adapter

It is often necessary to adapt tubes of one type to sockets of another type and the average experimenter does not always have the requisite adapters on hand. This problem is solved by constructing a simple adapter from a wafer socket and a tube base.

The wires are first soldered to the prongs of the socket and are then inserted in the correct prongs of the tube base (this depends upon the type of adapter being made) so that they extend out of the bottom of the prongs. These wires can then be pulled tight and the prongs of the wafer socket pulled down and inserted into the base to form a tight fit. The wires can then be soldered to the prongs and the excess cut off. — *F. Butler Roberts.*

Cleaning Cracked Cabinets

Metal cabinets painted with wrinkled black enamel sometimes begin to look very drab, from too much handling or from the spilling of fluids which leave stains. If this has happened, simply rub on a coat of a good grade of shoe polish and your cabinet will look like new. — *Ed. Kunes.*

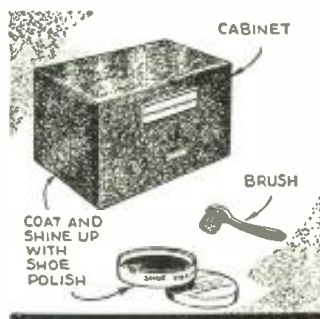

Low Cost Feeder Spreaders

In order to provide spreaders for my antenna feeder, or for a doublet lead-in, I use porcelain tubes 4" or more in length. For each spreader I use one tube and two corks which fit tightly. These are the type of cork which have a shoulder, as shown in the sketch. I slit the cork down the center to the shoulder, place

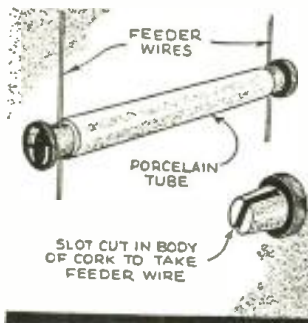

the feeder wire in the slit, put glue on the body of the cork and force it into the tube, making sure that the wires are parallel before the glue dries.

Spreaders should be spaced about every three feet in the feeder or lead-in. There is enough friction from the corks to hold them in place. The porcelain tubes are of the type used in house wiring, and cost about five for a dime at the ten-cent store. — *Lco Blattner, Jr.*

Plate Circuit Relay

Many tubes can be saved by using a high resistance relay in series with the plate supply of a transmitter, for amateurs often forget to turn on their bias supplies when using separate power supplies. If a relay, as shown in the diagram herewith, is connected across the bias supply, the plate voltage cannot be applied until the bias is connected.

A high resistance relay should be used to avoid drawing too much current. If the bias supply becomes defective, it automatically turns off the plate voltage. The contacts of the relay may be connected either to the primary of the plate power transformer or in series with the plate of the tube. — *Louis Benvenuto, W9NSH.*

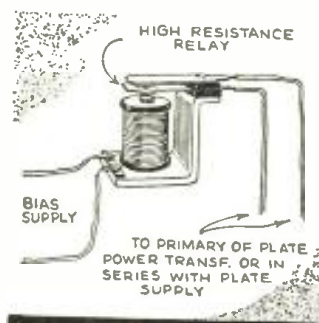

Better Regeneration Control

When a potentiometer is used for regeneration control on a regenerative receiver, the setting is apt to be too critical for convenience. I have solved this problem by adding an auxiliary control, as shown in the drawing herewith. The auxiliary control should have a resistance of about 1/20th that of the original. Thus, a movement of 20 turns on the auxiliary control will equal the movement of the arm from one turn to the next on the regular control. In this way, much smoother and finer adjustment is provided. — *Jonas Savage.*

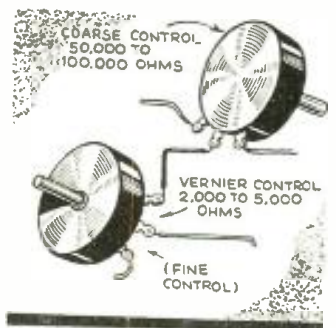

Improvised Wire Shielding

Often when I have wanted to shield a wire, I have been unable to find the necessary copper braid. Now I make my own shielding material by taking a stiff piece of wire of the same diameter as the wire I wish to shield, and putting it in a breast drill. Around this I wind evenly and closely No. 20 or No. 22 wire. I remove this from the piece of stiff wire and slip it over the wire to be shielded, just as I would use ordinary shielding. — *Al. Kocurek.*

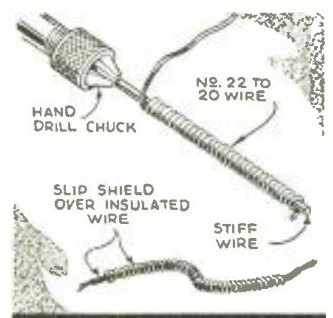

Improvised Insulators

Strong and dependable insulators for aerial wires and mast guy wires are readily made from an old auto casing. Cut slices about one inch wide from the casing, and punch holes in each just inside the bead. Two of these slices are looped together and the wires then run through the holes. — *Bill Smith.*

The RADIO BEGINNER

Lesson 7—The Superheterodyne

Martin Clifford, W2CDV

What is the local oscillator's function in a superhet? What is the I. F. amplifier used for? Why is a second detector used? To what frequency is the I. F. amplifier usually tuned? All these—and more—questions are answered below.

● THERE has been a steady trend during the past few years toward the use of superheterodyne receivers in amateur radio, to such an extent that even newcomers should know something of the principles of their operation.

Most of us are already familiar with the high pitched whistle that sometimes occurs during broadcast reception, due to the proximity of two radio waves. This whistle, known as a *heterodyne* whistle, is actually the combining of the currents of two different frequencies to form a current of still another frequency. This can be better understood by considering the visual representation of heterodyning shown in Fig. 1. One of the basic laws of electro-magnetism is that when two currents combine in a circuit, the resultant current is equal to their algebraic sum.

Stated in simple language this merely means that if we have a current of one unit of strength in a positive direction, and we combine it with a similar current, also of one unit of strength in a positive direction, then the resultant current is *two* units in a positive direction. (See Fig. 2C.) We can also have currents *neutralize* or cancel each other. Thus, if we had a current of three units *positive* and three units *negative*, the resultant current would be zero! In the first instance, the currents assisted each other, but in the second case, although the amplitude of the currents was the same, they were *opposite in sign* with consequent cancellation. When two currents are allowed to combine with each other in this manner, they are said to *beat* against each other, and the new current that is formed is known as the *beat frequency*.

How Superhet Uses "Beat Freq." Effect

The production of a beat frequency forms the fundamental principle of *superheterodyne* operation. Every signal tuned in by the receiver, regardless of the frequency of that signal, is converted into a signal of one frequency—usually about 465 kilocycles. The incoming signal might be 7150 kilocycles or it might be 3500 kilocycles—in either case the receiver would convert it into a signal of 465 kilocycles. In order to accomplish this, it is necessary for the receiver to *generate* a signal or current that can *beat* against the incoming signal. Figure 2 shows the various steps that take place in the operation of a superheterodyne

receiver. The signal voltage applied to the antenna is selected by the tuned radio frequency amplifier. The tuned signal then passes to the *first detector or mixer* circuit—the same circuit to which the locally generated oscillations are being applied. After the incoming frequency and the local oscillations have combined, the *resultant* signal, known as the *intermediate frequency*, passes into an intermediate frequency amplifier, a tuned amplifier which greatly aids the selectivity of the receiver. From the intermediate frequency amplifier, usually abbreviated *I.F.*, the high frequency inaudible currents pass to a *second detector* for conversion into an *audible* frequency. (Otherwise we could not hear them.) The currents may then be amplified further by an *audio frequency* amplifier and then used to actuate a loudspeaker.

Generally speaking, this is the method

Diagrams at right show the fundamental action taking place in simple superheterodyne receivers. The superimposition of the locally generated frequency on the incoming signal frequency is graphically shown, together with the resultant or beat frequency. Simple oscillator circuit for superhet is also shown.

employed in all superheterodyne receivers. It should be remembered that although based on identical fundamental principles, superheterodynes may be designed in a number of different ways. Not all such receivers have high frequency amplifier stages inserted for amplification of the signal *before* conversion to the intermediate frequency. A large number of modern receivers make use of a single tube for generating local oscillations and acting at the same time as a first detector, etc. We have left A.V.C. and other features out of this discussion to make it clearer.

"Step-by-Step" Action in a Superhet

In order to understand more completely what is happening in the several parts of a superheterodyne receiver, we should consider the currents in each unit. (See Fig. 3.) In curve A we have an incoming signal after it has been selected by the tuning circuits. The local oscillations produced by the receiver are shown at C. After these local oscillations have been superimposed

(Continued on page 115)

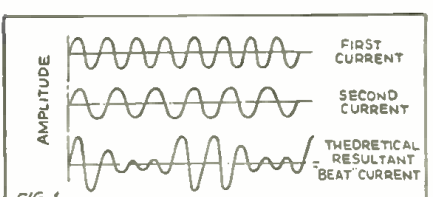

FIG. 1

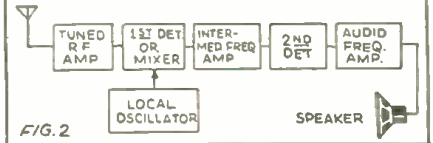

FIG. 2

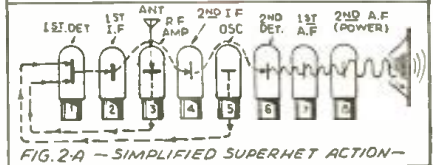

FIG. 2-A—SIMPLIFIED SUPERHET ACTION—

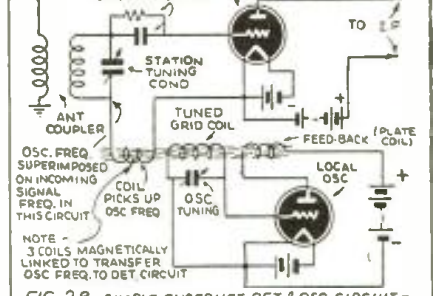

FIG. 2-B—SIMPLE SUPERHET DET & OSC. CIRCUIT—

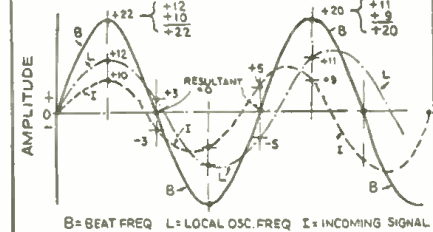

FIG. 2-C—HOW ALGEBRAIC + & - AMPLITUDES OF INC SIG & OSC. FREQ. GIVE RES BEAT FREQ

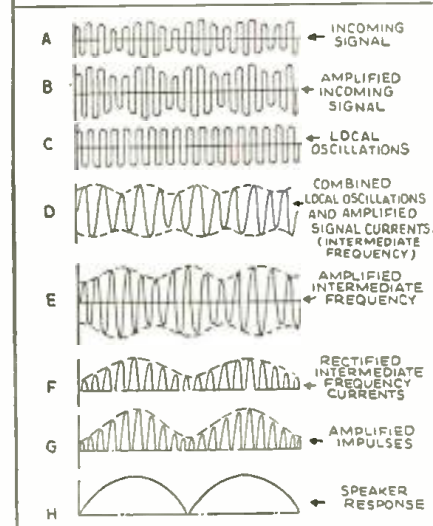

FIG. 3

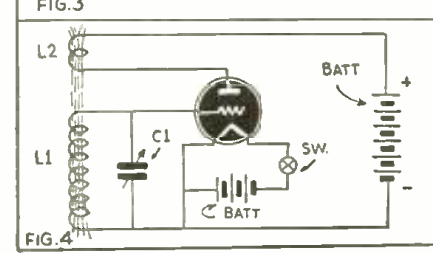

FIG. 4

World Short Wave Stations

Revised Monthly

Complete List of SW
Broadcast Stations

Reports on station changes are appreciated.

Mc.	Call	Station	Mc.	Call	Station	Mc.	Call	Station
33.600	W3XEF	BALTIMORE, MD., 8.93 m. Operates Daytime. No schedule known. Poss. connected with W3XEY.	21.540	W8XK	PITTSBURGH, PA., 13.93 m., Addr. Grant Bldg. Relays KDKA 6.45-9 am.	17.280	FZEB	DJIBOUTI, FRENCH SOMALILAND, 17.36 m. Test XMSN 1st Thurs. each month 8-8.30 am. Next B.C.S. May 4 & June 1.
31.600	WIXKA	BOSTON, MASS., 9.494 m., Addr. Westinghouse Co. Daily 6 am.-1 am., Sun. 8 am.-1 am. Relays WBZ.	21.530	GSJ	DAVENTRY, ENG., 13.93 m., Addr. (See 21.550 mc.) 5.45-8.50-9-10.30 am.	15.550	CO9XX	TUINICU, ORIENTE, CUBA, 19.29 m., Addr. Frank Jones, Central Tuinicu, Tuinicu, Santa Clara. Broadcasts irregularly evenings.
31.600	WIXKB	SPRINGFIELD, MASS., 9.494 m., Addr. Westinghouse Co. Daily 5 am.-12 m., Sun. 7 am.-12 m. Relays WBZ.	21.520	W3XAU	PHILA., PA., 13.94 m., Addr. Col. Broad. Syst., 485 Madison Ave., N. Y. C. Daily 12.30-1.30 pm., Sat. & Sun. 12-1.30 pm.	15.510	XOZ	CHENG TU, CHINA, 19.34 m. Daily 9.45-10.30 am.
31.600	W3XEY	BALTIMORE, MD., 9.494 m., Relays WFBR 4 pm.-12 m.	21.500	W2XAD	SCHENECTADY, N. Y., 13.95 m., General Electric Co., 7-10 am.	15.370	HAS3	BUDAPEST, HUNGARY, 19.52 m., Addr. Radiolabor, Gyalı Ut 22. Sun. 9-10 am.
31.600	W2XDV	NEW YORK CITY, 9.494 m., Addr. Col. Broad. System, 485 Madison Ave. Daily 5-10 pm.; Sat. and Sun. 12.30-5, 6-9 pm.	21.480	PCJ	HUIZEN, HOLLAND, 13.96 m. Addr. N. V. Philips, Hilversum. Irregular.	15.360	DZG	ZEESEN, GERMANY, 19.53 m., Addr. Reichspostenstralamt. Tests irregularly.
31.600	W9XHW	MINNEAPOLIS, MINN., 9.494 m. Relays WCCO 9 am.-12.30 am.	21.470	GSH	DAVENTRY, ENG., 13.97 m. (See 21.550 mc.) 5:45-8:50, 9 am.-noon. To Africa.	15.360	-	BERNE, SWITZERLAND. 19.53 m. Irreg. 6.45-7.45 pm.
31.600	W3XKA	PHILADELPHIA, PA., 9.494 m., Addr. NBC. Relays KYW 8 am.-9 pm.	21.460	WIXAL	BOSTON, MASS., 13.98 m. Addr. University Club. Tues., Thurs., Sat., 10-11 am.	19 Met. Broadcast Band		
31.600	W5XAU	OKLAHOMA CITY, 9.494 m., Sun. 12 n-1 pm., 6-7 pm. Irregular other times.	21.450	DJS	BERLIN, GERMANY, 13.99 m., Addr., Broadcasting House. 12.05-7.50 am.			
31.600	W9XUY	OMAHA, NEBR. No sked. known.	19.020	HS6PJ	BANGKOK, SIAM, 15.77 m. Mondays 8-10 am. See 15.23 mc.	15.340	DJR	BERLIN, GERMANY, 19.56 m., Addr. Br'dcast'g House, 4.50-10.50 pm. to C.A.
31.600	W4XCA	MEMPHIS, TENN., 9.494 m. Addr. Memphis Commercial Appeal. Relays WMC. 10 am.-6 pm.	18.480	HBH	GENEVA, SWITZERLAND, 16.23 m., Addr. Radio Nations. Sun., 10.45-11.30 am.	15.330	W2XAD	SCHENECTADY, N. Y., 19.56 m., Addr. General Electric Co. Relays WGY, 10.15 am.-5 pm.
31.600	W8XAI	ROCHESTER, N. Y., 9.494 m., Addr. Stromberg Carlson Co. Relays WHAM 7.30-12.05 am.	16 Met. Broadcast Band			15.330	W6XBE	SAN FRANCISCO, CALIF., 19.56 m. Addr. General Electric Co., 6.30-10 pm.
31.600	W8XWJ	DETROIT, MICH., 9.494 m., Addr. Evening News Ass'n. Relays WWJ 5 am.-11.30 pm. Sun. 7 am.-11 pm.				17.850	TPB3	PARIS, FRANCE, 16.8 m. Addr. (See 15.245 mc.) 5.30-10 am.
31.600	W9XPD	ST. LOUIS, MO., 9.494 m., Addr. Pulitzer Pub. Co. Relays KSD.	17.845	DJG	BERLIN, GERMANY, 16.81 m., 12.05-7.50, 8-9, 9:15-11 am.	15.310	GSP	DAVENTRY, ENG., 19.6 m., Addr. (See 17.79 mc.) 4.20-6, 6.20-8.30 pm., 12.25-1.15 pm.
31.600	W5XD	DALLAS, TEXAS. 11.30 am.-1.30 pm. Ex. Sat.-Sun.	17.840	HVJ	VATICAN CITY, 16.82 m. Heard 12 n. on Wednesday.	15.300	YDB	SOERABAJA, JAVA, N. E. I. 19.61 m., Addr. NIROM. 10 pm.-2 am.
26.550	W2XGU	NEW YORK CITY, 11.3 m. Relays WMCA.	17.840	-	MOYDRUM, ATHLONE, EIRE, 16.82 m. Addr. Radio Eireann. 8.30-10 am. 12.30-4.30 pm. irreg.	15.300	XEBM	MAZATLAN, SIN., MEX., 19.61 m., Addr. Box 78, "El Pregonero del Pacifico." Irregularly 9-10 am., 1-2, 8-10 pm.
26.550	W2XQO	NEW YORK CITY, N. Y. 11.3 m. Noon-9 pm.	17.830	W2XE	NEW YORK CITY, 16.81 m. (Addr. CBS, 485 Madison Ave., N. Y. C. Daily 6.30-9 am., 12 n.-5 pm. Sat., Sun. 7-11 am., 11.30 am.-5 pm.)	15.300	2RO6	ROME, ITALY. 19.61 m., Addr. (See 2RO, 11.81 mc.) 10 am.-12.04 pm., 3-5.30, 6-9 pm.
26.500	W9XTA	HARRISBURG, ILL., 11.32 m. 2-4 pm.	17.820	2ROB	ROME, ITALY. 16.84 m., Addr. (See 2RO, 11.81 mc.) 4.30-8.45 am.	15.290	VUD3	DELHI, INDIA, 19.62 m. Addr. All India Radio, 9.30-11.30 pm., 1.30-3.30 am., 7.30 am.-12.30 pm.
26.450	W9XA	KANSAS CITY, MO., 11.33 m., Addr. Commercial Radio Eqpt. Co. 10 am.-1 pm., 3-7 pm.	17.810	GSV	DAVENTRY, ENGLAND, 16.84 m., 5.45-11 am. to Far East.	15.290	LRU	BUENOS AIRES, ARG., 19.62 m., Addr. El Mundo. Relays LRI, 7-9 am.
26.400	W9XAZ	MILWAUKEE, WIS., 11.36 m., Addr. The Journal Co. Relays WTMJ from 1 pm. to midnight.	17.800	OIH	LAHTI, FINLAND, 16.85 meters, 4-9 am.	15.280	DJQ	BERLIN, GERMANY, 19.63 m., Addr. Broadcasting House. 12.05-11 am., 4.50-10.50 pm.
26.300	W2XJI	NEW YORK, N. Y., 11.4 m., Addr. Bamberger Broad. Service, 1440 Broadway. Relays WOR 11 am.-5 pm.	17.800	XGOX	CHUNGKING CHINA, 16.85 m., 9.30-11.30 pm. Mar. 21-Sept. 21.	15.270	H13X	CIUDAD TRUJILLO, D. R., 19.65 m. Relays H1X Sun. 7.40-9.40 am. Tues. and Fri. 8.10-10.10 pm.
26.150	W9XUP	ST. PAUL, MINN. 11.47 m. Rel. KSTP 8 am.-1 am.	17.790	SGS	DAVENTRY, ENG., 16.86 m., Addr. B.B.C., London. 5.45 am.-12 n., 12.20-4 pm.	15.270	W3XAU	PHILA., PA., 19.65 m. (Addr. See 21.52 mc.) 2-6 pm.
26.100	W9XJL	SUPERIOR, WIS., 11.49 m. Relays WEBC daily. 10 am.-8 pm.	17.785	JZL	TOKYO, JAPAN, 16.86 m., 4.30-5.30 pm. to S.A., 8-8.30 pm. to Eastern U. S.	15.270	W2XE	NEW YORK CITY, 19.65 m., Addr. (See 21.570 mc.) 5.30-7.30 pm.
26.050	W9XTC	MINNEAPOLIS, MINN., 11.51 m. Relays WCTN 9 am.-9 pm.	17.780	W3XL	BOUND BROOK, N. J., 16.87 m., Addr. Natl. Broad. Co., 8 am.-4 pm. to Europe, 4-9 pm. to So. Amer.	15.260	GS1	DAVENTRY, ENG., 19.66 m., Addr. (See 17.79 mc.) 1.30-3.45 am. to Oceania.
26.050	W9XH	SOUTH BEND, IND. 11.51 m. Addr. South Bend Tribune. Relays WSBT-WFAM 2.30-6.30 pm., exc. Sat. and Sun.	17.770	PHI2	HUIZEN, HOLLAND, 16.88 m., Addr. (See PHI, 11.730 mc.) Daily 7:40-9:10 am. Mon & Thurs. 7:40-9 am. Sun. 6:25-9:45 am.	15.250	WIXAL	BOSTON, MASS., 19.67 m., Addr. University Club. 2:30-3, or 4 pm., ex. Sat. and Sun.
25.950	W6XKG	LOS ANGELES, CAL., 11.56 m., Addr. B. S. McGlashan, Wash. Blvd. at Oak St. Relays KGFJ 24 hours daily. DX tips Mon., Wed. and Fri. 2:15 pm.	17.760	DJE	BERLIN, GERMANY, 16.89 m., Addr. Broadcasting House, 12.05-11 am., 4.50-9 pm. Also Sun. 11-10 am.-12.25 pm.	15.245	TPA2	PARIS, FRANCE, 19.68 m., Addr. 98 Bis. Blvd. Haussmann. "Paris Mondial" 5-10 am.
25.950	WBXNU	CINCINNATI, OHIO. 7 am.-1 am.	17.755	ZBW5	HONGKONG, CHINA, 16.9 m., Addr. P.O. Box 200. Dly. 11.30 pm.-1.15 am., 5-10 am., Sat. 9 pm.-1.30 am., Sun. 5-9.30 am. Operates irreg.	15.230	HS6PJ	BANGKOK, SIAM, 19.7 m. Irregularly Mon. 8-10 am.
21.640	GRZ	DAVENTRY, ENG., 13.86 m. Addr. B.B.C., London. Unused at present.	17.310	W2XGB	HICKSVILLE, L. I., N. Y., 17.33 m., Addr. Press Wireless, Box 296. Tests 9.30-11.30 am. except Sat. and Sun.	15.230	OLR5A	PRAGUE, BOHEMIA. 19.7 m. Addr. (See OLR4A, 11.84) Daily 4.55-8.15 am.
21.630	W3XAL	BOUND BROOK, N. J., 13.8 m. Addr. N.B.C., N. Y. C. 8 am.-5 pm.	End of Broadcast Band			15.220	PCJ2	HUIZEN, HOLLAND, 19.71 m., Addr. N. V. Philips' Radio Hilversum. 3-4.30 am. Tues., 9-30-11.30 am. Weds. Daily 7.25-8.25 am.
21.565	DJJ	BERLIN, GERMANY, 13.92 m., Addr. Broadcasting House. Irreg.						
21.550	GST	DAVENTRY, ENG., 13.92 m., Addr. (B.B.C., London) Irregular at present.						

(Continued on page 88)

All Schedules Eastern Standard Time

Let's Listen In With

Joe Miller

"DX" Editor

● HERE 'tis the last week in April, and we've yet to see a break for the better in conditions, which have been unusually poor for this generally excellent month for DX. The early part of the month was promising, but conditions instead became progressively worse, perhaps due to the unusual spring weather here in the East. Several days "opened" up, but far below our expectations, when remembering '38's great April reception.

Still, much FB DX was heard, mostly by out-of-town DXers. So it seems we were somewhat unfortunate in being here in New York.

We often wondered what those amateurs did who received large numbers of reports, and rarely, if ever, sent out their QSL card in return. Some rather unpleasant conjectures have been offered concerning their disposal of the usual reply coupon enclosed with most listeners' reports. We were shocked (takes a lot these days) to hear from one of our friends, as to the gist of a QSO he overheard between two amateurs discussing listeners' reports. One was definitely heard to say that he was going to use the IRC's he received in many reports to purchase some needed station equipment!!

This amateur has been reported by thousands of SWL's and is very well known—we might say notorious—for his refusal to acknowledge reports.

Thankful we are, indeed, that this case is not in any way representative of the amateurs as a whole, yet there are a good many hams who now refuse to honor a post-paid request for a listener's card.

We can offer only one remedy for this situation, and that is to ask every amateur who is well heard on phone, and is unwilling to answer reports which carry IRC's with them, to notify us of this fact, and we can have their calls listed as a warning to SWL's not to report to them.

We will also ask the amateur magazines to publish a similar request, hoping the results may help alleviate what seems to be a growing canker in the relation between amateurs and SWL's, many of the latter being future amateurs themselves. We'll let this matter rest for the time being, and will be interested to hear from amateurs in other countries concerning this problem.

And—oh, yes! DX:

BURMA

XYZ, 6.007 mc., Rangoon, which was logged in January, has QSL'd with his plain but valued card, and is signed by W. J. Byrne, the same OM who signed our VVS veries.

As may be noted, there is also XZZ, on 3.488 mc., but that would be a rare catch indeed in the U. S., being evidently intended for purely local reception. The sked (schedule) is the same for both: 6:30-10 a.m., 9-11 p.m., Sats. 9:30-11 p.m., though, of course, we could only use the a.m. sked, and then not till next fall, as QRN (noise-level) eliminates reception on the 6 mc. band for the summer. QRA is on card.

CHINA

XGOX, 11.90 mc. and 17.80 mc. at Chungking, China, is now in operation for the summer months. Actually, however, the schedule is from March 21-Sept. 21 for the use of these frequencies. 17.80 mc. operates 9-11 p.m. and 11.90 mc. is on from 7-8, 9-11:50 a.m., first hour being best for East Coast, second period for West. The winter freqs., with the call XGOY, will go into effect on Sept. 21. XGOY on 15.185 mc. and 9.50 mc. are these. Address reports to Chinese Radio Administration, Chungking.

XMHA, 11.94 mc., Shanghai, with a schedule of 5-11 a.m., is very well received. QRA in last issue. Operated by Japanese.

The Chinese Govt. is anxious to know how their stations are heard here, so do your bit, and earn a veri.

IRAQ

HNF, 9.70 mc., Bagdad, the capital of Iran, is a new station in this hard-to-get country, and on a frequency which will be very helpful in logging this nice catch. English is used in sign-off announcement at 3 p.m., after which the National

Anthem is played. Schedule is from 9 a.m.-3 p.m., from latest advices, and QRA same as that of YI5KG, given a few issues back. Occasionally HNF signs-off before or after 3 p.m.

CANTON ISLAND

KF6DHW, 8.10 mc., operating from this island in the Phoenix Group, in mid-Pacific, while making govt. observations, is to be well heard almost every morning at 3:30 a.m., while on schedule with other amateurs. This would give all a new country, and this amateur may not be long there, so now's the time to add KF6DHW to your log. He also operates on 20 meter phone, on 14380, where he is reported on from 7-7:30 a.m. and 10:30-10:55 p.m. Other Pacific Islands to be heard on 20 are KC6CKM, Wake Island, and KG6HCO, Jarvis Island, also KF6ODC, Enderbury Island. KG6HCO may also be heard on 8.10 mc., possibly the others, too.

SOUTHERN RHODESIA

ZEA, 5.99 mc., Salisbury, which operates simultaneously with ZEB, on 6.147 mc., which latter is already QSL'd here, was heard several Sundays ago after 4 a.m. during their Sunday 3:30-5 a.m. schedule. Signal was fairly well heard and a good log obtained. This station will not be heard again till late next Fall.

JAPAN

JVW4, 17.823 mc., Tokyo, was heard relaying a program intended for re-broadcast here over broadcast stations, as Japan's salute to the Fair. This was heard at 1:45 p.m., good signal. JVH, 14.60, and JVE, 15.66 mc., heard at midnight; JVD, 15.86 mc., heard at 4 p.m., 1 a.m.; JIB,

(Continued on page 120)

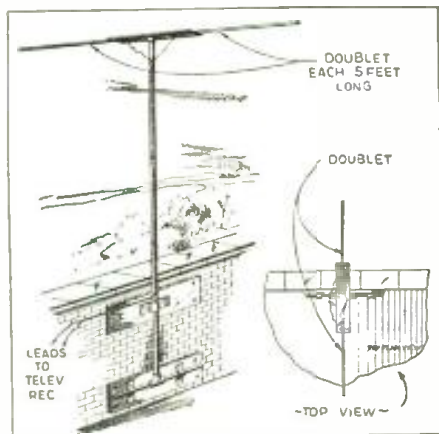

Doublet "Receiving" antenna for Home Television Receivers.

● AS television makes its bow to the American public, probably the most popular type of television receiving aerial will be the *doublet*, each leg of which should measure slightly less than one-quarter the wave length. In the new instruction book supplied with Du Mont television receivers, the following interesting data is given:

The two metal rods comprising the dipole aerial should each be approximately five feet long and placed in a direct line with each other, as one of the accompanying sketches shows. Extreme accuracy in the length of these rods is generally not necessary, and if the television receiver is located very close to the transmitting station, it may be found advisable to cut down the length

Television Aerials Construction Data

of each rod or to use telescopic rods.

The most popular lead-in from the dipole to the television receiver will be a twisted pair, as it is inexpensive and generally satisfactory in locations where the signal is strong.

The length of this lead is usually not of extreme importance. It is better to get the dipole located in the clear, and as far from electrical interference as possible, than to limit its location by using a theoretical, exact length feeder. The twisted pair should be soldered to the legs on the dipole, as a good connection is essential and necessary since several changes in the position of the antenna may be required for best results.

The other form of lead-in is the coaxial line, such as the Amphenol No. 72. This form of feeder should be used in installations where the length of the lead-in is too long for satisfactory work with the twisted pair and again where the installation is at an extreme distance and every bit of energy picked up must be delivered to the receiver.

If the dipole is mounted horizontally, it is said to be horizontally polarized, and if vertical it is vertically polarized. Since the physical location materially affects the aerial, no specific form can be advised and we can merely suggest that you start by using horizontal polarization and change, if necessary, to produce the best results.

Whenever possible, the dipole should be erected so that it is in the line of sight with the transmitter. This does not mean that no signals can be secured where a direct view of the transmitter cannot be obtained. Surprising results are often secured on these high frequencies and no precise rules can be assigned. If the location is on a street having heavy traffic, there may be considerable noise level due to automobile

(Continued on page 121)

How Reflector can be added to receiving doublet to strengthen signal.

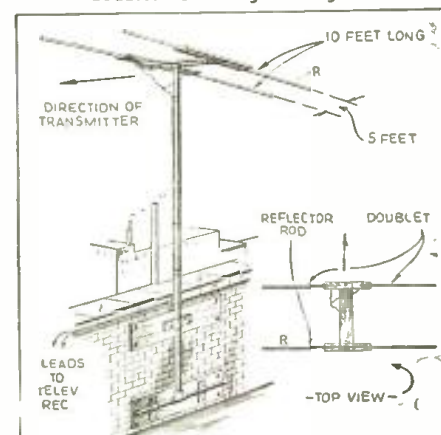

Mc.	Call	Location, Time, and Schedule	Mc.	Call	Location, Time, and Schedule	Mc.	Call	Location, Time, and Schedule
15.215	RV96	MOSCOW, U.S.S.R., 19.72 m. Mon., Tues., Fri., Sat. 2.30-3.30 pm. Daily 3-4 am. Mon., Wed., Thurs. 7-9.15 pm.	13.635	SPW	WARSAW, POLAND, 22 m. Daily 6-8 pm. Sat. & Sun. 6-9 pm.	11.826	XEBR	HERMOSILLA, SON., MEX., 25.37 m., Addr. Box 68. Relays XEBH. 9.30-11 am., 1-4 pm., 9 pm.-12 m.
15.210	W8XK	PITTSBURGH, PA., 19.72 m., Addr. (See 21.540 mc.) 9 am.-2 pm.	12.862	W9XDH	ELGIN, ILL., 23.32 m. Press Wireless, Tests 2-5 pm.	11.820	GSN	DAVENTRY, ENG., 25.38 m., Addr. (See 11.75 mc.) Irregular.
15.200	DJB	BERLIN, GERMANY, 19.74 m., Addr. (See 15.280 mc.) 12.05-11 am., 4.50-10.50 pm. Also Sun. 11.10 am.-12.25 pm.	12.486	HIIN	TRUJILLO CITY, DOM. REP., 24.03 m. 6.40-10.40 am., 5.10-10.10 pm.	11.810	2RO4	ROME, ITALY, 25.4 m., Addr. E.I.A.R., Via Montello 5. Daily 4.30-8.45 am., 10 am.-2.30 pm., 6-9 pm.
15.195	TAQ	ANKARA, TURKEY, 19.74 m., 5.30-7 am., 9.30-11 am.	12.235	TFJ	REYKJAVIK, ICELAND, 24.52 m. Works Europe mornings. Broadcasts Sun. 1.40-2.30 pm.	11.805	OZG	SKAMLEBAK, DENMARK, 25.41 m. Addr. Statsradionfonien. Irreg.
15.190	OIE	LAHTI, FINLAND. 19.75 m. Addr. (See OFD, 9.5 mc.) 1.05-4 am, 9 am.-5 pm.	12.230	COCE	HAVANA, CUBA, 24.53 m.-8 am.-midnite, Sun., noon-mid.	11.801	DJZ	BERLIN, GERMANY, 25.42 m. 4.50-10.50 pm. to N. A.
15.190	XGOX	CHUNGKING, CHINA, 19.75 m. Addr. Central Broad. Admin. Central Exec. Comm. of Kuomintang. Irreg. 9-11 pm.	12.200	---	TRUJILLO, PERU, 25. m., "Rancho Grande." Address Hacienda Chiclin. Irregular.	11.800	COGF	MATANZAS, CUBA, 25.42 m., Addr. Gen. Betancourt 51. Relays CMGF. 2-3, 4-5, 6 pm.-Mid.
15.190	ZBWA	HONGKONG, CHINA, 19.75 m., Addr. P. O. Box 200. Irregular. 11.30 pm. to 1.15 am., 3-10 am.	12.000	RNE	MOSCOW, U.S.S.R., 25 m. 6-6.30, 10-10.30 am., 1-1.30, 3-5.30, 8.30-10 pm., Sun. 6-10 am., 1-6, 9-10 pm.	11.800	ZJZ	TOKYO, JAPAN, 25.42 m., Addr. Broadcasting Co. of Japan, Overseas Division. 8-10.30 am., 4.30-5.30 pm.
15.180	GSO	DAVENTRY, ENG., 19.76 m., Addr. (See 17.79 mc.) 4.20-6 pm., 12 m.-2.25 am., 9-11 am.	11.970	CB1180	SANTIAGO, CHILE, 25.06 m. 7-11 pm.	11.795	DJO	BERLIN, GERMANY, 25.42 m. 4.50-10.50 pm. to N. A.
15.170	TGWA	GUATEMALA CITY, GUAT., 19.77 m., Addr. Minist're de Fomento. Daily 12.45-1.45 pm.; Sun. 12.45-5.15 pm.	11.970	H12X	CIUDAD TRUJILLO, D. R., 25.07 m., Addr. La Voz de Hispaniola. Relays H1X Tue. and Fri. 8.10-10.10 pm. Sun. 7.40-9.40 am.	11.790	W1XAL	BOSTON, MASS., 25.45 m., Addr. (See 15.250 mc.) Daily 3.15-6.30 pm., Sat. 1.30-6 pm., Sun. 1-6.30 pm.
15.166	LKV	OSLO, NORWAY, 19.78 m. 6.40-10 am.	25 Met. Broadcast Band			11.780	HP5G	PANAMA CITY, PAN., 25.47 m., Addr. Box 1121. 6-10 pm.
15.160	JZK	TOKYO, JAPAN, 19.79 m. 12.30-1.30 am. to Canada & Hawaii, and Pacific U.S. 7-7.30 am. to Eastern U.S. 8-9.30 am. to China.	11.940	T12XD	SAN JOSE, COSTA RICA, 25.13 m. La Voz del Pilot. Apartado 1729. 7.30 am.-noon, 4-10 pm.	11.780	OFE	LAHTI, FINLAND. 25.47 m. Addr. (See OFD, 9.5 mc.) 1.05-3 am., 5-6.20, 10 am.-12.30 pm.
15.160	XEWW	MEXICO CITY, MEXICO, 19.79 m., 12 n.-12 m., irregular.	11.940	XMHA	SHANGHAI, CHINA, 25.13 m. 5-11 am.	11.770	DJD	BERLIN, GERMANY, 25.49 m., Addr. (See 15.280 mc.) 11.30 am.-4.25 pm., 4.50-10.50 pm.
15.155	SM5SX	STOCKHOLM, SWEDEN, 19.79 m., Daily 11 am.-5 pm., Sun. 9 am.-5 pm.	11.910	CD1190	VALDIVIA, CHILE, 25.19 m., P. O. Box 642. Relays CB69 10 am.-1 pm., 3-6, 7-10 pm.	11.760	XETA	MONTEREY, MEX. 25.51 m., Addr. Box 203. Relays XET, n.-3.30 pm. and evenings.
15.150	YDC	BANDOENG, JAVA, 19.8 m., Addr. N. I. R. O. M. 6-7.30 pm., 10.30 pm.-2 am., Sat. 7.30 pm.-2 am., daily 4.30-10.30 am.	11.910	---	HANOI, FRENCH INDO-CHINA. 25.19 m. "Radio Hanoi", Addr. Radio Club de l'Indochine. 3.45-4.15 am., 7-9.30 am., 150 watts.	11.760	OLR4B	PRAGUE, BOHEMIA, 25.51 m., Addr. (See 11.840 mc.) Daily exc. Sun. 8.25-10.05 am.
15.140	GSF	DAVENTRY, ENG., 19.82 m., Addr. (See 17.79 mc.) 12 m.-2.25 am., 5.45 am.-12 n. 4.20-6 pm.	11.900	XEWI	MEXICO CITY, MEXICO, 25.21 m., Addr. P. O. Box 2874. Mon., Wed., Fri. 3-4 pm., 9 pm.-12 m. Tues. and Thur. 7.30 pm.-12 m., Sat. 9 pm.-12 m., Sun. 12.30-2 pm.	11.750	GSD	DAVENTRY, ENG., 25.53 m., Addr. B.B.C., London, 12 m.-2.25 am., 10.45 am.-noon, 12.25-6 pm., 6.20-8.30 pm., 9.20-11.30 pm.
15.130	TP86	PARIS, FRANCE, 19.83 m., Addr. "Paris Mondial," 98 Bis Blvd. Haussmann, 1-4 am., 6-8.15 pm.	11.900	XGOY	CHUNGKING, CHINA, 25.21 m., 5.30-10.30, 11-11.30 am., 4-6.30 pm. Mar. 21-Sept. 21.	11.740	SP25	WARSAW, POLAND, 25.55 m., 6-9 pm.
15.130	W1XAR	BOSTON, MASS., 19.83 m., Addr. World-Wide B'cast'g Foundation, University Club. Sun. 11 am.-12.30 pm.	11.895	2RO13	ROME, ITALY, 25.23 m. Irregular 6-9 pm.	11.740	HVJ	VATICAN CITY, 25.55 m. Tues. 8.30-9 am.
15.120	SP19	WARSAW, POLAND, 19.84 m., 6-9 pm.	11.885	TPA3	PARIS, FRANCE, 25.24 m., 10.15 am.-5 pm.	11.740	CR6RC	LOANDA, ANGOLA, Tues., Thurs., Sat. 2-3.30 pm.
15.120	HVJ	VATICAN CITY, 19.83 m., 10.30-10.45 am., Tues., Sun. 1-1.30 pm.	11.885	TPB7	PARIS, FRANCE, 25.24 m. (See 15.245 mc.) 6-8.15, 8.30-11 pm., 12.15-2 am. Irregular.	11.735	COCX	HAVANA, CUBA, 25.57 m. P. O. Box 32. Daily 8 am.-1 am. Sun. 8 am.-1 am. Relays CMX.
15.120	CSW4	LISBON, PORTUGAL, 7-9 am. irreg.	11.880	VLR3	MELBOURNE, AUST., 25.25 m., 3.30-7.15 pm., 9 pm.-3 am. week-days. Sun. mid.-3 am.	11.735	LKQ	OSLO, NORWAY, 25.57 m. 2-6.40, 10 am.-3 pm.
15.110	DJL	BERLIN, GERMANY, 19.85 m., Addr. (See 15.280 mc.) 12.05-2, 8-9 am., 10.40 am.-4.25 pm.	11.870	W8XK	PITTSBURGH, PA., 25.26 m., Addr. (See 21.540 mc.) 2-11 pm.	11.730	PHI	HUIZEN, HOLLAND, 25.57 m., Addr. N. V. Philips' Radio.
15.100	CB1510	VALPARAISO, CHILE, 19.87 m. Testing near 7.30 am.	11.870	VUM2	MADRAS, INDIA. M.W.F. 3.30-4 am. Irregular.	11.730	W1XAR	BOSTON, MASS., 25.58 m., Addr. World-Wide B'cast'g Foundation, University Club. Daily exc. Sat. and Sun. 9.15-11.30 pm.
15.100	2RO12	ROME, ITALY, 19.87 m. Testing irreg.	11.865	---	BERNE, SWITZERLAND, 25.28 m. Irreg. 8-9 pm. to No. Amer.	11.720	CJRX	WINNIPEG, CANADA, 25.6 m., Addr. James Richardson & Sons, Ltd. Daily 6 pm.-12 m., Sat. 6 pm.-Sun. 4 am.
15.083	RK1	MOSCOW, U.S.S.R., 19.89 m. Works Tashkent near 7 am. Broadcasts Sun. 12.15-2.30 pm. Daily 7-9.15 pm.	11.860	GSE	DAVENTRY, ENG., 25.30 m., Addr. (See 11.75 mc.) 5.45 am.-12 n., 12.25-3, 6.20-8.30 pm. (Sun. 6-8.30 pm.)	11.720	ZP14	VILLARICA, PARAGUAY, 25.60 m. 5.30-7.55 pm. irreg.
End of Broadcast Band			11.855	DJP	BERLIN, GERMANY, 25.31 m., Addr. (See 15.280 mc.) Irregular.	11.718	CR7BH	LAURENCO MARQUES, PORTUGUESE E. AFRICA, 25.6 m. Daily 12.05-1, 4.30-6.30, 9.30-11 am., 12.05-4 pm., Sun. 5-7 am., 10 am.-2 pm.
14.960	---	MOSCOW U.S.S.R., 20.25 m., 1st of month, 6 pm. Dutch program.	11.850	C81185	SANTIAGO, CHILE, 25.32 m. Sat. 6-11 pm. and irreg.	11.715	TPA4	PARIS, FRANCE, 25.61 m., (See 15.245 mc.) 7-9.15, 9.30-mid. to No. America.
14.930	PSE	RIO DE JANEIRO, BRAZIL, 20.09 m. Broadcasts 6-7 pm.	11.850	OAX2A	TRUJILLO, PERU, 25.32 m. Testing on this freq. (See 12.200).	11.710	YSM	SAN SALVADOR, EL SALVADOR, 25.63 m., Addr. (See 7.894 mc.) 1-2.30 pm.
14.920	KQH	KAHUKU, HAWAII, 20.11 m. Sats. 1-1.30 am., 11-11.30 pm. Fri. 9-10 pm.	11.840	KZRM	MANILA, P. I., 25.35 m. Addr. Erlanger & Gallinger, Box 283. 9 pm.-10 am. Irregular.	11.710	---	SAIGON, FRENCH INDO-CHINA. 25.62 m., Addr. Boy-Landry, 17 Place A Foray. 7.30-9.15 am.
14.795	IQA	ROME, ITALY, 20.28 m. 4.30-5 am. In Arabic.	11.840	CSW	LISBON, PORT., 25.35 m. Nat'l Broad. Station. 11.30 am.-1.30 pm. Irregular.	11.705	JLG3	TOKYO, JAPAN, 25.63 m. 2.30-4 pm.
14.600	JVH	NAZAKI, JAPAN, 20.55 m. Works Europe 4-8 am. Rel. JOAK 10-10.30 pm.	11.840	OLR4A	PRAGUE, BOHEMIA, 25.34 m., Addr. Czech Shortwave Sta., Praha XII, Fochova 16. Daily 12.45-6.30, 7.55-11.20 pm. Sun. Also 8.25-10.05 am.	11.705	SBP	MOTALA, SWEDEN, 25.63 m., 1.20-2.05, 6-9 am., 11 am.-1 pm., Sat. 1.20-2 am., 6 am.-1.30 pm., Sun. 3 am.-1.30 pm. Wed. and Sat. 8-9 pm.
14.535	HBJ	GENEVA, SWITZERLAND, 20.64 m., Addr. Radio Nations, Broadcasts Sun. 10.45-11.30 am., Mon. 4-4.15 am.	11.830	W9XAA	CHICAGO, ILL., 25.36 m., Addr. Chicago Federation of Labor. Irregular 7 am.-6 pm.	11.700	HP5A	PANAMA CITY, PAN., 25.64 m. Addr. Radio Teatro, Apartado 954. 10 am.-1 pm., 5-10 pm. Sun. 6-10 pm. 7-8.30 am.
14.440	---	RADIO MALAGA, SPAIN, 20.78 m. Relays Salamanca 5.45-7.30 pm. Sometimes 2-4 pm.	11.830	W2XE	NEW YORK CITY, 25.36 m., Addr. Col. Broad. System, 485 Madison Av., N.Y.C. 8-10.30 pm.	End of Broadcast Band		
14.420	HCIJ8	QUITO, ECUADOR, 20.80 m. 7-8.15, 11.30 am.-2.30, 4.45 pm.-10.15 pm. Exc. Mon.	(Continued on page 90)					
14.166	PIIJ	DORDRECHT, HOLLAND, 21.15 m., Addr. (See 7.088 mc.) Sat. 12 n.-12.30 pm.						
13.997	EA9AH	TETUAN, SPANISH MOROCCO, 21.43 m. Apartado 124, 5.15-6.15 pm., 6.30-7.30 pm., 9-10 pm. Relays Salamanca from 5.40 pm.						

All Schedules Eastern Standard Time

12th SILVER TROPHY Award

For Best HAM Station Photo of the Month

Awarded to *George J. Trostle, W9FYC*
Sibley, Iowa

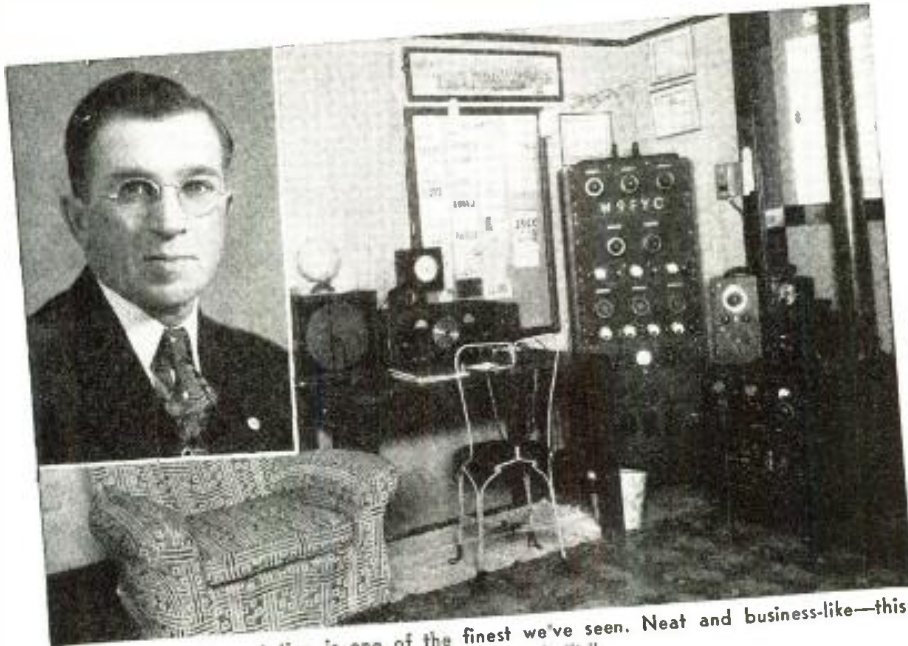

George Trostle's Ham station is one of the finest we've seen. Neat and business-like—this transmitter is "home-built."

● W9FYC was first licensed in August 1928, and operated on this temporary license until May 1932, when a Class "B" license was obtained while attending the Radio Amateur Convention at Ames, Iowa. Later this was replaced with Class "A", and although this ticket will permit the use of unrestricted phone, the only phone used has been with a 56 mc. transceiver, which does not show in the photo.

Although W9FYC is located within a few miles of the highest point in Iowa, radio reception has never been good on the higher frequencies. DX being the chief interest at the present time, the station is operated, for the most part, on the 14 mc. band, the frequency being 14,340 KC.

The receiver is a Hallicrafter's SX16 Super Skyrider and is connected to the transmitting antenna (a 66-ft. zepp.) through a Ward Leonard R.F. relay. Plans are under way to replace this antenna with an Amplex Rotary Beam for use on the 14 mc. band, and to erect an end fed Hertz for use on the lower frequency bands.

The small cabinet above the receiver contains the direction indicator which the operator constructed from the parts obtained from wrecking a couple of old clocks and the addition of the A.C. 110 volt relay.

The cabinet to the right of the receiver contains the jacks for the key, the click filter, and the switches which control the transmitter. These switches are wired in such a way as to make it impossible to turn

on the plate current before the filaments are on. The master switch is on the wall to the right of the transmitter.

The frequency meter-monitor and the wave meter are shown in back of the small transmitter. This transmitter together with the receiver placed on top of it constitutes the portable equipment. The receiver is battery operated. The transmitter is A.C. operated and uses one 47 as crystal oscillator and one type ten as final. There are about 30 watts input; this rig is used mostly on the 80 meter band.

The main rig is homemade and is built in a wooden rack, the panels being of masonite painted with a solution made by dissolving old phonograph records in denatured alcohol and applying it with an airbrush.

Three separate power supplies are used. The lower rack contains the high voltage supply for the final. The transformer, with tapped primary, is rated to deliver 1000 and 1250 volts at 500 ma. when used with choke input. However, if a load of not over 300 ma. is used, the voltage is somewhat higher.

The second rack from the bottom contains the two supplies for the oscillator, doubler-buffer and the buffer. One of these supplies 800 volts and the other 550. The 400 volts used on the crystal osc. are obtained from a tap on the bleeder of the 550 volt supply.

The third rack from the bottom contains the 6L6G crystal oscillator, the 6L6G buffer-



This beautiful silver trophy stands 11 $\frac{3}{4}$ " high and one is awarded monthly by RADIO & TELEVISION magazine for the best photo of a Ham station. The silver statue stands on a handsome bakelite base on which is a silver plate. The name of the winner will be engraved on this plate before the trophy is sent to him.

doubler and the T-20 buffer. The output of the T-20 is link coupled to the grids of the push-pull T-55s in the final. The final occupies the fourth rack and the output is coupled to the antenna by a short link. The input to the final seldom exceeds 280 watts. The tap on the primary of the high voltage transformer is connected through a switch on the panel of the lower rack and permits the use of QRP (reduction of power).

The large photo which hangs above the card rack was taken at the radio convention in Des Moines in 1933. The certificates on the wall are W.A.C., A.R.R.L. and a cancelled O.R.S. Nevada is the only state needed for a W.A.S. The world globe is

(Continued on page 112)

Mc.	Call	
11.676	IQY	ROME, ITALY, 25.7 m. 5.20-5.40 am. ex. Sun., Daily 12.07-12.56, 1.50-2.30 pm.
11.535	SPD	WARSAW, POLAND, 26.01 m., Addr. 5 Mazowiecka St. 6-9 pm.
11.402	HBO	GENEVA, SWITZERLAND, 26.31 m., Addr. Radio Nations. Sun. 7-7.45 pm., Mon. 1-1.15 am., 7-8.30 pm.
11.380	XTS	CHUNGKING, CHINA, 26.36 m. 1-1.30, 8-8.35 am., 6.45-7.30 pm.
11.040	CSW5	LISBON, PORTUGAL, 27.17 m., Addr. Nat. Broad. Sta. Noon-5.30 pm. Sun. 11 am.-5.30 pm.
11.000	PLP	BANDOENG, JAVA, 27.27 m. Relays YDB, 6-7.30 pm., 10.30 pm.-2 am., 4.30-10.30 or 11 am. Sat. until 11.30 am.
10.950	—	TANANARIVE, MADAGASCAR, 27.40 m., Addr. (See 9.38 mc.) 12.30-45, 10-11 am., 2.30-4 am., Irregular.
10.670	CEC	SANTIAGO, CHILE, 28.12 m. Irregular.
10.660	JVN	NAZAKI, JAPAN, 28.14 m. Broadcasts daily 1.50-7.40 am. Works Europe irregularly at other times.
10.600	ZIK2	BELIZE, BRIT. HONDURAS, 28.30 m., Tue., Thurs., Sat. 1.30-2, 8.30-9 pm.
10.535	JIB	TAIHOKU, TAIWAN, 28.48 m. Works Japan around 6.25 am. Broadcasts, relaying JFAK 9-9.55 am., 1-2.30 am. Sun. to 10.15 am.
10.400	YSP	SAN SALVADOR, EL SALVADOR, 28.85 m., 1-3, 6.30-11 pm.
10.360	EAJ43	TENERIFE, CANARY ISL., 28.96 m., 3-4.30, 5-7, 7.45-8.45, 9-10 pm.
10.350	LSX	BUENOS AIRES, ARG., 28.98 m., Addr. Transradio International. Tests irregularly.
10.330	ORK	RUYSSELEDE, BELGIUM, 29.04 m. Broadcasts 12.30-2 pm. Works OPM 1-3 am., 3-5 pm.
10.260	PMN	BANDOENG, JAVA, 29.24 m. Relays YDB 6-7.30 pm., 10.30 pm.-2 am., 4.30-10.30 or 11 am., Sat. to 11.30 am.
10.220	P8H	RIO DE JANEIRO, BRAZIL, 29.35 m., Addr. Box 709. Broadcasts 6-7 pm., Irreg.
10.100	—	DEUTSCHE FREIHEITS SENDER, 29.70 m., loc. in Germany, under cover. 4-5 pm.
10.050	TIEMT	SAN JOSE, COSTA RICA, 29.85 m., 4.30-8 pm.
10.050	DZC	ZEESEN, GERMANY, 29.16 m., Addr. (See 15.360 mc.) Irregular.
10.042	DZB	ZEESEN, GERMANY, 29.87 m., Addr. Reichspostenstralamt. Irregular.
9.995	CO8C	HAYANA, CUBA, 30.02 m., Addr. P. O. Box 132. Relays CMBC 6.55 am.-1 am.
9.920	JDY	DAIREN, MANCHUKUO, 30.24 m. Relays JQAK daily 7-8 am. Works Tokyo occasionally in early am.
9.892	CPI	SUCRE, BOLIVIA, 30.33 m., 11 am.-n., 7-9 pm.
9.855	EAQ	MADRID, SPAIN, 30.45 m., Addr. P. O. Box 951, 7.30-8, 8.40-9 pm. 3.45-4.05, 4.45-5.05 am., also.
9.830	IRF	ROME, ITALY, 30.52 m. Works Egypt afternoons. Relays 2RO. 12-12.25 pm. Thurs. Daily 12.40-1, 1.37-3.35, 6-9 pm.
9.805	COCM	HAYANA, CUBA, 30.60 m. Addr. Transradio Columbia, P. O. Box 33. 8-1 am. Relays CMCM.
9.770	HH3W	PORT-AU-PRINCE, HAITI, 30.71 m., Addr. P. O. Box A117. 1-2, 7-9.15 pm.
9.760	—	SAIGON, INDO-CHINA, 30.72 m., Addr. 17, Place A. Foray. "Radio Boy-Landry," Heard 6-9.15 am.
9.753	ZRO	DURBAN, SOUTH AFRICA, 30.75 m., Addr. S. A. Broadcasting Corp., P. O. Box 4559, Johannesburg. Daily exc. Sat. 11.45 pm.-12.50 am. Daily exc. Sun. 3.30-7.30, 9 am.-12.30 pm., Sun. 5.30-7, 9 am.-12.30 pm., also 4-5 am. on 3rd Sun. of month.
9.735	CSW7	LISBON, PORTUGAL, 30.82 m., Addr. Nat. Broad. Sta. n.-2 pm., 6-9 pm. for No. Amer.
9.730	CB970	VALPARAISO, CHILE, 30.83 m., 6.30-11.30 pm., or mid.
9.708	COCQ	HAYANA, CUBA, 30.90 m. Addr. 25 No. 445, Vedado, Havana, 7-1 am. Sun. 6.55 am.-1 am.

31 Met. Broadcast Band

Mc.	Call	
9.705	—	FORT DE FRANCE, MARTINIQUE, 30.92 m., Addr. P. O. Box 136. 6-8.10 pm.
9.690	TI4NRH	HEREDIA, COSTA RICA, 30.94 m., Addr. Amado C. Marin, Apartado 40. Sun. 7-8 am., Tues., Thurs., Sat. 9-10 pm.
9.690	LRAI	BUENOS AIRES, ARG., 30.94 m., 6-9 pm. Mon-Thur., 4-9 pm. Fri., 7-9 pm. Sat.
9.690	—	TANANARIVE, MADAGASCAR, 30.96 m., 10-11 am.
9.649	ZHP	SINGAPORE, MALAYA, 30.96 m. Sun. 5.40-9.40 am., Wed. 12.40-1.40 am., Mon.-Fri. 4.40-9.40 am., Sat. 12.25-1.40 am., 4.40-9.40 am., 10.40 pm.-1.10 am. (Sun.)
9.685	TGWA	GUATEMALA CITY, GUAT., 30.96 m. Daily 10-11.30 pm.; Sun. 7-10.45 pm.
9.675	DJX	BERLIN, GERMANY, 31.01 m., Addr. (DJD, 11.77 mc.) 10.40 am.-4.25 pm.
9.670	W3XAL	BOUND BROOK, N. J., 31.03 m. Addr. NBC, N. Y. C. 5 pm.-12 m.
9.665	2RO9	ROME, ITALY, 31.04 m. 12.40-1, 1.37-5.30 pm. Irreg. 6-9 pm.
9.660	LRX	BUENOS AIRES, ARG., 31.06 m., Addr. El Mundo, Relays LRI. 6-6.45 am.-9.15 am.-10 pm.
9.660	HVJ	VATICAN CITY, 31.06 m. Sun. 5-5.30 am.
9.650	W2XE	NEW YORK CITY, 31.09 m. (See 21.570 mc. for addr.)
9.650	CS2WA	LISBON, PORTUGAL, 31.09 m., Addr. Radio Colonial. Tues., Thurs. and Sat. 4-7 pm.
9.65	IABA	ADDIS ABABA, ETHIOPIA, 31.09 m., 3.55-4.05, 4.15-4.45, 11 am.-noon, 1-3 pm. Sun. 3.30-3.55 am.
9.645	JLT2	TOKYO, JAPAN, 31.10 m., 2.30-4 pm.
9.640	CXAB	COLONIA, URUGUAY, 31.12 m., Addr. Belgrano 1841, Buenos Aires, Argentina. Relays LR3, Buenos Aires 5 am.-10.45 pm. Sat. to 1 am.
9.636	JFO	TAIHOKU, TAIWAN, 31.13 m. Relays JFAK irreg. 4-10.30 am.
9.635	2RO3	ROME, ITALY, 31.13 m., Addr. (See 11.810 mc.) 12.07-3 pm., 5.30-9 pm., also Mon. 3.50-4.05 pm., Fri. and Sat. 4.4-20 pm.
9.630	HJ7ABD	BUCHARANGA, COL., 31.14 m., 5.45-6.30, 11.30 am.-1 pm., 6-11 pm.
9.620	CXA6	MONTEVIDEO, URUGUAY, 31.19 m., Rel. CX 6 to 9 pm.
9.618	HJ1ABP	CARTAGENA, COL., 31.20 m., Addr. P. O. Box 37. Daily 9 am.-1.30 pm., 7-10.15 pm., Sun. 4.30-9 pm.
9.610	LLG	OSLO, NORWAY, 31.22 m.-3-6, 8-9, 11 pm. mid.
9.606	ZRL	KLIPHEUVAL, SOUTH AFRICA, 31.23 m., Addr. P. O. Box 4559 Johannesburg. Daily, exc. Sat. 11.45 pm.-12.50 am. Daily exc. Sun. 3.20-7.20, 9-11.45 am., Sun. 3.30-4.30 or 4-5, 5.30-7, 9-11.45 am.
9.600	RAN	MOSCOW, U.S.S.R., 31.25 m. Daily exc. Sun. 6-10 pm. Sun. 6-7, 9.15-10 pm.
9.600	CB960	SANTIAGO, CHILE, 31.25 m., 8-11.30 pm.
9.600	GRY	DAVENTRY, ENG., 31.25 m., Addr. See GSC, 9.58 mc., 12.25-6 pm.
9.59	HP5J	PANAMA CITY, PANAMA, 31.28 m., Addr. Apartado 867. 12 n. to 1.30 pm., 6-10.30 pm.
9.595	—	MOYDRUM, ATHLONE, EIRE, 31.27 m., Radio Eireann, 12.30-4.30 pm. Irreg.
9.595	HBL	GENEVA, SWITZERLAND, 31.27 m., Addr. Radio Nations. Irregular.
9.590	VUD2	DELHI, INDIA, 31.28 m. Addr. All India Radio, 1.30-3.30 am., 7.30 am.-12.30 pm., 8.30-10.30 pm.
9.590	PCJ	HUIZEN, HOLLAND, 31.28 m., Addr. (See 15.220 mc.) Sun. 2-3, 7-9.25 pm. Tues. 1.45-3.40, 7.15-8.45, 9-10.30 pm., Wed. 7.15-8.30 pm., Fri. 8-9 pm.
9.590	VK6ME	PERTH, W. AUSTRALIA, 31.28 m., Addr. Amalgamated Wireless of Australasia, Ltd. 6-8 am. exc. Sun.

Mc.	Call	
9.590	VK2ME	SYDNEY, AUSTRALIA, 31.28 m., Addr. Amalgamated Wireless of Australasia, Ltd., 47 York St., Sun. 1-3 am.; 5-9, 9.30-11.30 am.
9.590	W3XAU	PHILADELPHIA, PA., 31.28 m. (Addr. See 21.52 mc.) Mon. and Thurs. 7.30-11.30 pm. Sat. 7.30-10.45 pm.
9.580	GSC	DAVENTRY, ENGLAND, 31.32 m., Addr. B. B. C., Portland Pl., London, W. 1., 12.25-4, 4.20-6, 9.20-11.30 pm.
9.580	VLR	MELBOURNE, AUSTRALIA, 31.32 m., Addr. Box 1686, G. P. O. Daily 3.30-8.30 am. (Sat. till 9 am.) Sun. 12.01-7.30 am. Also daily exc. Sat. 9.25 pm.-2 or 2.15 am. Sat. 5-10.30 pm.
9.570	KZRM	MANILA, P. I., 31.35 m., Addr. Erlanger & Galinger, Box 283. Wkds. 4.30-6 pm. m. tof. 5-9 am., Sat. 5-10 am., Sun. 4-10 am.
9.570	WIXX	BOSTON, MASS., 31.35 m., Addr. Westinghouse Electric & Mfg. Co. 6 am.-12 m. Sun. 7 am.-12 m.
9.566	OAX4T	LIMA, PERU, 31.38 m., 7-8, 11.30 am.-1.30, 4-6.15 pm.
9.560	XGAP	PEKING, CHINA, 31.38 m., 4-9 am.
9.560	DJA	BERLIN, GERMANY, 31.38 m., Addr. Broadcasting House. 6.30-10.50 pm.
9.550	HVJ	VATICAN CITY, 31.41 m., Sun. 5-5.30 am., Wed. 2.30-3 pm.
9.550	TPBII	PARIS, FRANCE, 31.41 m. Addr. (See 15.245 mc.) 11.15 am.-7 pm., 9.30 pm.-mid. Irreg.
9.550	W2XAD	SCHENECTADY, N. Y., 31.41 m., General Electric Co., 5.15-8.15 pm. to So. Amer.
9.550	OLR3A	PRAGUE, BOHEMIA, 31.41 m. (See 11.840 mc.) Irreg. 4.40-5.10 pm.
9.550	XEFT	VERA CRUZ, MEX., 31.41 m. 10.30 am.-4.30 pm., 10.30 pm.-12.30 pm.
9.550	YDB	SOERABAJA, JAVA, 31.41 m., Addr. N.I.R.O.M. Daily exc. Sat. 6-7.30 pm., 4.30-10.30 am. Sat. 4.30-11.30 am.
9.550	VUB2	BOMBAY, INDIA, 31.41 m., Addr. All India Radio. 9.30-10.30 pm., 1-3.30 am. 5-6 am. also.
9.540	DJN	BERLIN, GERMANY, 31.45 m., Addr. (See 9.560 mc.) 12.05-11 am. 4.50-10.50 pm. to So. Amer.
9.540	HJ5ABD	CALI, COLOMBIA, 31.45 m., Addr. La Voz de Valle, 12 n.-1.30 pm., 5.10-9.40 pm.
9.538	VPD2	SUVA, FIJI ISLANDS, 31.46 m., Addr. Amalgamated Wireless of Australasia, Ltd. 5.30-7 am. exc. Sun.
9.535	—	SCHWARZENBURG, SWITZERLAND, 31.46 m., 1-2 pm. 6.45-7.45, 8-9 pm.
9.530	W6XBE	SAN FRANCISCO, CAL., 31.41 m., Addr. Gen. Elec. Co., 7-10 am.
9.530	W2XAF	SCHENECTADY, N. Y., 31.48 m., Addr. General Electric Co. 3-11 pm.
9.530	VUC2	CALCUTTA, INDIA, 31.48 m. Addr. All India Radio. 2.06-4.06 am. 10 pm.-2 am.
9.526	XEDQ	GUADALAJARA, GAL., MEXICO, 31.49 m., n.-4.30 pm., 8-11.30 pm.
9.526	ZBW3	HONGKONG, CHINA, 31.49 m., Addr. P. O. Box 200. 5-10 am., 11.30 pm.-1.15 am. Sun. 5-9.30 am.
9.525	LKC	JELOY, NORWAY, 31.49 m., 4.30-10.30 am., Sun. 2.30-10.30 am.
9.523	ZRG	ROBERTS HEIGHTS, S. AFRICA, 31.5 m., Addr. (See ZRK, 9.606 mc.) Daily exc. Sun. 5-7.30 am.; Sun. 5.30-7 am.
9.520	OZF	SKAMLEBOAEK, DENMARK, 31.51 m., Addr. Statsradiofonien, Heibergsgade 7, Copenhagen, 8-9.30, 9.30-11 pm. to No. Amer.
9.520	YSH	SAN SALVADOR, EL SALVADOR, 31.51 m., Addr. (See 7.894 mc.) Irregular 6-10 pm.
9.520	RV96	MOSCOW, U.S.S.R. 31.51 m., 1-3, 4-7 pm. and irr.
9.510	G8B	DAVENTRY, ENGLAND, 31.55 m., Addr. (See 9.580 mc.—GSC) 12 m.-2.28 am., 12.28-4, 4.20-6, 6.20-8.30, 9.20-11.30 pm.
9.510	HJU	BUENAVENTURA, COLOMBIA, 31.55 m., Addr. National Railways, Mon., Wed. and Fri. 8-11 pm.

(Continued on page 92)

All Schedules Eastern Standard Time

The Short Wave League



On the Ham Bands

(with the "Listening Post" Observers)

Edited by Elmer R. Fuller

HONORARY MEMBERS

Dr. Lee de Forest
D. E. Replogle
John L. Reinartz
Manfred von Ardenne
E. T. Somerset
Hollis Baird
Hugo Gernsback, Executive Secretary

• AT present the Europeans are being heard in Eastern United States about 5 to 8:30 p.m. and at about 8 a.m. The South Africans are being heard from 10 p.m. to 2 a.m., while those in Northern Africa are being heard about the same times as the Europeans. It is a safe bet to look for the Australians during the early morning hours, after the American hams have quit for the night. Other Oceanic calls are being heard from 1 to 9 a.m.

W6NYD, who for several weeks has been heard from the K6 call area, has been assigned a new call, K6NYD.

Several requests have been received for the correct QRA of FP8AA and ZN9AM.

The call of VP3AA has recently been changed to VP3LF. VP3CO is a newcomer, having first been on the air on March 25th. He is Les Talbot, Box 241, Georgetown, British Guiana.

From a letter received by Herbert S. Handler of Baldwin, Long Island, it is learned that G2MS is not being heard in the U.S.A. As has been reported by so many listeners, A. R. Pepin, the operator of G2MS, says that this is a portable call and is used only for testing locally. The station belongs to the "Wireless Society" of Marlborough College, and does not carry on QSO's with the outside world. Evidently some one else is using the call assigned to this station.

Reports for last month were received from the following:

Arizona	Lester Fuller
Arkansas	Bill Henderson
Alabama	Jack Wells
Colorado	Dan T. Wallen
Connecticut	Howard G. Kemp
California	Richard A. Rush
England	Ken Spencer
Iowa	Dick Maunheimer
Iowa	Burns E. Hegler
Kansas	Bob Taglauer
Kentucky	Maurice P. Wynne
Louisiana	Vernon Gabriel
Michigan	Edward Lendzioszek
Massachusetts	Elwyn Barker
Maine	William Dean Noves
Nebraska	William W. Oglesby, Jr.
North Carolina	Charles H. Fuller
New York	John Fitzpatrick
New Jersey	Elwood C. Trueman
Oregon	Stanley Clarke
Ontario	Clarence Hartzell
Pennsylvania	Tom Jordan
South Carolina	Ray Halliday
South Dakota	Robert Hutchinson
South Africa	Oscar Westman
Texas	Morris Wasserzug
Washington	Edward C. Slaughter
	Ernest W. Lang

When making out your reports, please arrange the stations in alphabetical order. This makes it much easier to copy, and unless it is done, it will be impossible for us to use your report.

The U. S. hams got out in great shape, dozens of 'em being reported by our observers in South Africa and England.

The Asiatics fell off considerably since our last reports, and only a few scattered stations were heard. They were:—

Call	Freq.	R	S	Where Heard
XU8B	14.26	5	6	Wash.
VU2VA	14.3	5	2-9	England
VS7VA	14.2	5	6-8	England
J2M1	14.08	5	6-8	Tex., Ark., Ariz., Wash.
J2NO	14.23	5	6-8	Ore., Wash.
J2IK	14.24	5-5		Ore.
J2MC	14.26	5	9	Ariz.
J2NG	14.12	3	4	Wash.
J2NT	14.26	3	6	Wash.
J3CX	14.14	4	5	Wash.
J3FZ	14.27	4	6	Wash.
J5CC	14.255	4-5	7	Ariz., Wash.
J5CW	14.095	3	4	Wash.
J7CB	14.05	4-5	7	Ariz., Wash.
J8CI	14.125	4	7	Wash.
FN1C	14.08	5	6	England

AFRICA:

CN8BD	14.05	5	6-9	Tex., Mich.
CN8AU	14.005	5	6-7	Tex., Canada, Mich.
CN8AV	14.15	4	7	N. J.
CN8AF	14.045	5	6	Canada
CN8AM	14.07	4	7	Canada
CN8MV	14.05	5	7	Canada

Call	Freq.	R	S	Where Heard
CN8MA	14.02	5	8	Mich.
	28.07	5	6	Canada
CR7AD	14.	5	9	South Africa
CT2AB	14.085	5	6	Canada
CT2BE	14.305	5	7	Canada
EA9AH	14.009	3	5	Mich.
	13.997	5	7-8	Tex., Penna., Ala., Canada
EK1AF	14.1	4-5	7	Ala., Canada, Mich.
EK1AI	14.008	5	6	Mich.
EK1AS	14.103	5	9	Mich.
OO5ZZ	14.	5	9	South Africa
SU1GT	28.5	5	7-8	Penna.
SU1CR	14.05	5	7	Canada
SU1MW	14.13	4-5	7-8	Conn., Ala., Canada, Mich.
VQ2TC	14.	5	9	South Africa
VQ2HC	14.07	5	7	Tex.
VQ4ECT	14.02	5	6	Canada
VQ8AE	14.	5	8	South Africa
Z6IA	28.4	5	6	Ark.
Z81OD	14.04	5	7	England
ZS2AZ	14.065	5	7	Tex., England, Mich.
ZS2AV	13.96	5	6	Ore., England
ZS2NL	14.025	5	8	Ark.
ZS2X	14.05	4-5	5-6	Colo., Canada, Mich.
ZS2AQ	14.275	5	6	Ala.
ZS2N	14.025	4	7	Ariz.
ZS2AL	14.055	4	7	Mich.

Call	Freq.	R	S	Where Heard
CE3BM	14.03	5	5	Colo.
CE3AI	14.175	4	7	N. J.
CE3AT	14.015	3	5	Conn.
CE3AQ	14.01	4	7	Ariz.
CE3BX	14.115	5	7	Ariz.
CE3BK	14.085	5	7	Wash.
CE4AC	14.07	5	6-7	Colo., Wash.
CE4AI	14.1	5	6	Wash.
CP1AA	14.	5	8	South Africa
CX2CO	14.1	5	5-7	Ore., England
CX2AK	14.09	3	5	Wash.
CX2AD	14.26	5	8	Wash.
CX3BL	14.24	5	6	Ore., Wash.
CX3AL	14.07	5	8-9	England
HC1PZ	14.23	5	6-8	Ore., Mich., Colo., Wash., Canada
	28.17	4-5	5-7	Calif., Canada
HC1FG	14.255	4-5	5-9	Colo., N. J., Canada
HC1JB	14.43	5	9	Penna.
HC1FT	14.01	5	9	Ariz.
HC2CO	14.035	4	6	Mich.
HC2HP	14.05	5	8	Canada
HC2C	14.105	4-5	8-9	N. J., Conn., Canada
HK1AB	14.31	5	7	Canada
HK3CL	14.12	5	6	Ore., Wash., Colo., Mich., N. J., Ariz.
HK3CO	14.23	5	5-7	Ore., Colo., N. J., Wash.
	28.45	5	8	Canada
HK3CG	14.1	4-5	7-9	Ore., Wash., Ark., Colo., Mich., N. J., Canada
	28.1	5	9	Canada
HK3CW	14.26	5	7-8	Colo., Wash., Canada
HK3CC	14.255	5	3-7	N. Y., Canada
HK3JA	14.08	5	8	Ariz.
HK3CJ	14.265	5	7	Ariz.
HK4CG	14.165	5	9	N. J.
HK4DF	14.07	4	7	N. J.
HK4BH	14.13	4	7	Conn.
HK5AR	14.065	5	7	Canada
LU1DA	14.09	5	5-8	Colo., Penna., Mich.
	28.18	5	8-9	South Africa, Nebr., Calif., Canada
LU1HI	14.035	4-5	6-9	Ariz., Wash.
LU2CA	14.02	5	6	Wash.
LU1QA	14.11	5	7-9	Ark., Penna., Ariz.
LU3HA	28.5	5	8	Ark.
LU4CZ	14.045	4-5	7-8	N. J., Nebr., Wash., England
LU4AH	14.075	5	7	Colo.
LU5CZ	14.05	5	7	Ore., Wash., Mich.
LU5PZ	14.1	5	6	Ark.
LU5AN	14.04	5	6-8	Colo., N. J., Wash., Conn., Ariz.
	28.15	5	6	Ark., Calif., Canada
LU5AH	14.15	5	7	Penna.
LU5CK	14.11	5	6	England
LU7AG	14.03	5	9	England
LU7BK	14.09	5	9	South Africa, Ariz., Wash.
	28.18	5	7	Calif., Canada
LU7GU	14.	5	9	South Africa
LU8EC	14.03	5	6	Wash.
LU9BV	14.135	4	5	Conn.
	28.3	4	4	Calif.
LU9WA	14.03	5	6	Ark.
QA4R	14.	5	9	South Africa
QA4AI	14.065	4-5	5-6	Ore., Colo., Wash.
QA4C	14.27	5	5	Wash.
PY1GI	14.	5	8	South Africa
PY1EA	14.15	5	8	England
PY1GU	14.13	5	6	England
PY1GR	14.08	5	8	England
PY2BH	14.	5	9	South Africa
PY2AC	14.24	5	5-8	Ore., Colo., Penna., Conn., Wash.
	28.15	5	7-9	Calif., Canada
PY2AK	28.2	5	5	Calif.
PY2KC	14.11	5	7	England
PY2JC	14.1	5	8-9	South Africa, Eng-land
PY2MC	14.07	3	5	England
PY2IT	14.	5	8	England
PY2GC	14.095	5	8	Mich.
PY2LN	14.28	5	6	Mich.
PY4CT	14.2	5	7-9	South Africa, Eng-land
PY4BI	14.08	5	4-5	England
PY5BI	14.06	5	8-9	England
PY5AO	14.11	5	4-7	N. Y., Wash.
PY6AG	14.18	5	8	England
PY6AI	14.	5	9	South Africa
PY7AI	14.235	4-5	3-9	South Africa, N. Y., Canada

The JULY Issue will be a
SPECIAL TELEVISION NUMBER

Call	Freq.	R	S	Where Heard
ZS4H	14.05	4-5	5-7	Tex., Mich., Colo., Canada, Calif., N. J., Conn., Penna.
ZS4H	28.08	5	4-9	Calif., Canada
ZS4T	14.025	5	6	Canada
ZS5CZ	14.01	5	6	Tex.
ZS5Q	14.13	5	6	Penna.
ZS5BZ	1	5	6-7	Tex., Canada, Mich.
ZS5AW	14.1	5	6-7	Tex., Canada
	28.175	5	6-8	S. C., Canada
ZS5CL	14.115	4-5	5-7	Colo., Penna., Ala.
ZS5T	14.05	4	8	N. C.
ZS5C	28.0	5	7	Canada
ZS5C	28.0	5	7	Penna.
ZS5Z	14.0	4	6	Calif.
ZS5C	14.09	5	5	Calif.
ZS6F	14.1	5	7	Tex.
ZS6ES	14.11	5	8	Tex.
ZS6EB	14.08	5	8	Tex.
ZS6DL	14.08	5	6	Tex.
ZS6DW	14.07	5	6-7	Tex., Ore., Mich., Penna., Ariz., Can-ada
	28.21	4-5	6-9	Penna., Canada
ZS6DV	14.	5	6	Ore.
ZS6AJ	14.1	5	5-6	Ore., Colo.
ZS6AD	14.	5	5	Ore.
ZS6CN	14.05	5	7	Penna., Ariz.
ZS6ZX	14.107	3	6	Conn.
ZS6W	14.115	3	5	Conn.
ZS6CT	28.17	5	6	Canada
ZS6DK	14.08	4	5	Canada
ZS6DY	14.11	5	7	Canada
ZS6W	28.25	5	8	Canada

Call	Freq.	R	S	Where Heard
SOUT. AMERICA:				
CE1AH	11.04	4-5	5-7	Colo., Wash.
	28.2	5	6	Canada
CE1AR	28.0	4	3	Calif.
CE1AO	14.148	5	9	Mich.
CE1AA	14.03	4	6	Mich.
CE2BX	14.12	5	6-9	Ore., Nebr., Wash.
	28.275	4-5	7-9	Ark., N. J., Calif., Canada
CE3BH	14.03	5	5	Colo.

(Continued on page 118)

Mc.	Call	Mc.	Call	Mc.	Call
9.510	—	8.645	W2XGB HICKSVILLE, N. Y., 34.64 m., Addr. Press Wireless, Mon. to Fri. News at 9 am. and 5 pm.	6.720	PMH BANDOENG, JAVA, 44.64 m. Re- lays N.I.R.O.M. programs. 4.30-11 or 11.30 am. Also Sat. 9.30 pm.- 1.30 am.
9.510	HS8PJ BANGKOK, SIAM, 31.55 m. Thurs- day. 8-10 am.	8.652	HJ4DAU MEDELLIN, COLOMBIA, 34.67 m., Wkds. 7-10 pm.	6.690	TIEP SAN JOSE, COSTA RICA, 44.82 m., Addr. Apartado 257, La Voz del Tropico. Daily 7-11 pm.
9.510	—	8.580	YNPR MANAGUA, NICARAGUA, 34.92 m. Radiodifusora Pilot. 12.45-2.15, 6.45-10.15 pm.	6.675	HBQ GENEVA, SWITZERLAND, 44.94 m. Addr. Radio-Nations. Sun. 1.45- 2.45 pm.
9.503	XEWX HANOI, FRENCH INDO-CHINA. 31.55 m. "Radio Hanoi". Addr. Radio Club de L'Indochine. 12 m.-2 am., 6-10 am. 15 watts.	8.572	—	6.672	—
9.501	PRF5 MEXICO CITY, MEX., 31.57 m. Addr. Apart. 2516. Relays XEW. 7:45 am.-12.30 am.	8.090	YDX MEDAN, SUMATRA, N. E. I., 37.08 m. Daily exc. Sat., 10.30 pm.- 2 am. Sat. 7.30 pm.-1.30 am. Irreg. to 9 am.	6.672	YVQ — 44.94 m., relays Salamanca, Spain, 7-9.45 pm.
9.500	XGOY CHUNGKING, CHINA, 31.58 m. Irreg. 7-8, 9-11.50 am., 4-5.30 pm.	7.894	YSD SAN SALVADOR, EL SALVADOR, 37.99 m., Addr. Dir. Genl. Tel. & Tel. 7-10.30 pm.	6.660	HI5G MARACAY, VENEZUELA, 44.95 m. Irregular.
9.500	VK3ME MELBOURNE, AUSTRALIA, 31.58 m., Addr. Amalgamated Wireless of Australasia, 167 Queen St. Daily except Sun. 4-7 am.	7.870	HCIRB QUITO, ECUADOR, 38.1 m. La Voz de Quito. 8.30-11.30 pm.	6.635	HC2RL TRUJILLO CITY, D. R., 45.05 m., to 8.40 pm.
9.500	OFD LAHTI, FINLAND, 31.58 m., Addr. Finnish Brst. Co., Helsinki. 12.15- 5 pm.	7.854	HC2J5B GUAYAQUIL, ECUADOR, 38.2 m. 11 am.-2, 4-11 pm.	6.630	HIT CIUDAD TRUJILLO, D. R., 45.25 m., Addr. "La Voz de la RCA Victor." Apartado 1105. Daily exc. Sun. 12.10-1.40 pm., 5.40-8.40 pm.; also Sat. 10.40 pm.-12.40 am.
9.497	KZIB MANILA, PHIL. ISL., 31.61 m., 7-9.05 am.	7.797	HBP GENEVA, SWITZERLAND, 38.48 m., Addr. Radio-Nations.	6.625	PRADO RIOBAMBA, ECUADOR, 45.28 m. Thurs. 9-11.45 pm.
9.488	EAR MADRID, SPAIN, 31.6 m., Addr. (See 9.860 mc.) Irreg.	7.614	CR6AA LOBITO, ANGOLA, 39.39 m., Mon., Wed., Sats. 2.45-4.30 pm. Also 7.177.	6.610	YNLG MANAGUA, NICARAGUA, 45.39 m. Emisora Ruben Dario. 1.30- 2.30, 6-10.15 pm.
End of Broadcast Band					
9.465	TAP ANKARA, TURKEY, 31.70 m., 11.30 am.-5 pm. Irreg.	7.520	KKH KAHUKU, HAWAII, Fri. 9-10 pm., Sat. 1-1.30 am., 9.30-10 pm.	6.600	HI6H TRUJILLO CITY, D. R., 45.45 m., 7.40-8.40 pm.
9.445	HCODA GUAYAQUIL, ECUADOR, 31.77 m., 8.15-10.15 pm., exc. Sun.	7.490	EAJ43 TENERIFE, CANARY ISL., 40.05 m., 8-9.30 pm. and Irreg.	6.565	HI5P PUERTO PLATA, D. R., 45.70 m., 5.40-7.40, 9.40-11.40 pm.
9.437	COCH HAVANA, CUBA, 31.8 m., Addr. 2 B St., Vedado. 8 am.-9.30 pm. Sun. 8 am.-12 m.	7.450	T12R5 SAN JOSE, COSTA RICA, 40.27 m. "Radioemisora Athena". 7-11 pm.	6.558	HI4D CIUDAD TRUJILLO, D. R., 45.74 m. Addr. Apartado 623. 12.30-2, 6-8 or 9 pm. Except Suns.
9.390	OAX5C ICA, PERU, 31.95 m., Radio Uni- versal, 7-11.30 pm.	7.440	FG8AH POINT-A-PITRE GUADELOUPE, F.W.I., 40.32 m., 6-7 pm.; also 9-10.30 pm. Irreg. P. O. Box 125.	6.550	XBC VERA CRUZ, MEX., 45.8 m. 8.15-9 am.
9.370	XOY CHENG TU, CHINA, 32.02 m., 9.45-10.30 am.	7.410	HGJ84 QUITO, ECUADOR, 40.46 m., 7- 9.30 pm. irregularly.	6.550	TIRCC SAN JOSE, COSTA RICA, 45.8 m., Addr. Radioemisora Catolica Costarricense. Sun. 11 am.-2 pm., 6-7, 8-9 pm. Daily 12 n.-2 pm., 6-7 pm., Thurs. 6-11 pm.
9.355	HC1ETC QUITO, ECUADOR, 32.05 m., Addr. Teatro Bolivar, Thurs. un- til 9.30 pm. 8-11 pm. Sats.	7.380	XECR MEXICO CITY, MEX., 40.65 m., Addr. Foreign Office. Sun. 6-7 pm.	6.545	YV6RB BOLIVAR, VENEZUELA, 45.84 m., Addr. "Ecos de Orinoco." 6-10.30 pm.
9.350	COCB HAVANA, CUBA, 32.08 m., Addr. Box 2294. Relays CMCD 10 a.m.- 11.30 pm. Sun. 10 am.-9 pm.	7.310	YIG PORT MORESBY, PAPUA, 41.01 m., May 13-27, 3-5 am.	6.520	YV4RB VALENCIA, VENEZUELA, 45.98 m. 11 am.-2 pm., 5-10 pm.
9.345	HBL GENEVA, SWITZERLAND, 32.11 m., Addr. Radio Nations. Sun. 7-7.45, 8-8.45 pm. Mon. 6.50-8.15 pm.	7.280	TPB12 PARIS, FRANCE, 41.27 m., 10.15 am.-5 pm., 8.30-11 pm.	6.516	YNIGG MANAGUA, NICARAGUA, 46.02 m., Addr. "La Voz de las Lagos." 1-2.20, 8-10 pm. Except Sundays.
9.340	OAX4J LIMA, PERU, 32.12 m., Addr. Box 1166, "Radio Universal." 12 n.- 3 pm., 5 pm.-1 am.	7.220	HKE BOGOTA, COL., S. A., 41.55 m. Tues. and Sat. 8-9 pm. Mon. and Thurs. 6.30-7 pm.	6.490	TGWB GUATEMALA CITY, GUAT., 46.2 m. La Voz de Guatemala. Daily 7.45-9 am. 12.45-3.45 pm., 7.30 pm.-12.15 am. Sun. 10.30 am.-5.15 pm., 7 pm.-12 m.
9.295	HI2G CIUDAD TRUJILLO, D. R., 32.28 m. 6.40-8.40 am., 11.40 am.-2.10 pm., 3.40-4.40 pm.	7.200	Y15KG BAGHDAD, IRAQ, 41.67 m., 8.30 am.-4 pm.	6.480	HIIL SANTIAGO DE LOS CABALLEROS, D. R., 46.28 m., Addr. Box 356. 9.40-11.40 am., 7.40-9.40 pm.
9.280	LYR KAUNAS, LITHUANIA, 32.33 m., 11 am.-1.25 pm. and Irreg.	7.200	YNAM MANAGUA, NICARAGUA, 41.67 m. Irregular at 9 pm.	6.470	YNLAT GRANADA, NICARAGUA, 46.36 m., Addr. Leonidas Tenorio, "La Voz del Mombacho." Irregular.
9.200	COBX HAVANA, CUBA, 32.59 m. Addr. San Miguel 194, Altos. Relays CMBX 8 am.-11.30 pm.	7.177	CR6AA LOBITA, ANGOLA, PORT. WEST AFRICA. 41.75 m., Mon., Wed., and Sats. 2.45-4.30 pm. Also see 7.614 mc.	6.465	YV3RD BARQUISIMETO, VENEZUELA, 46.37 m. Radio Barquisimeto, ir- regular.
9.188	HC2AB ECUADOR, 32.65 m., nightly to 10 pm.	7.128	YN3DG LEON, NICARAGUA, 42.09 m., 2-2.30, 8.30-9.30 pm. ex. Surs.	6.455	HI4V SAN FRANCISCO DE MACORIS, D. R., 46.44 m., 11.40 am.-1.40 pm., 5.10-9.40 pm.
9.170	HCIGQ QUITO, ECUADOR, 32.72 m., Mon., Wed., Sat. 9-9.55 pm.	7.100	FO8AA PAPEETE, TAHITI, 42.25 m., Addr. Radio Club Oceanien. Tues. and Fri. 11 pm.-12.30 am.	6.420	HIIS SANTIAGO, D. R., 46.73 m., 5.40- 7.35 pm. Ex. Surs.
9.135	HC2CW GUAYAQUIL, ECUADOR, 32.84 m., 11 am.-1, 7-11 pm.	7.088	PIIJ DORDRECHT, HOLLAND, 42.3 m., Addr. Dr. M. Hellingman, Techni- cal College. Sat. 11.10-11.50 am.	6.400	TGQA QUEZALTENANGO, GUATEMALA, 46.88 m., Mon.-Fri. 9-11 pm. Sat. 10 pm.-1 am. Sun. 1-3 pm.
9.125	HAT4 BUDAPEST, HUNGARY, 32.88 m., Addr. "Radiolabor." Gyali-ut, 22. Daily 7-8 pm., Sat., 6-7 pm.	7.010	XGSA KWEIYANG, CHINA, 42.80 m., 5.30, or 6-11 am.	6.388	HI9B SANTIAGO, D. R., 46.8 m., Mon. & Fri. 8.10-8.40 pm.
9.100	COCA HAVANA, CUBA, 32.95 m., Addr. Galiano No. 102. Relays CMCA Noon-12.15 am. Irreg. to 3 am.	6.990	XEME MERIDA, YUCATAN, 42.89 m., Addr. Calle 59, No. 517, "La Voz de Yucatan desde Merida." Ir- regular.	6.384	ZIZ BASSETERRE, ST. KITTS, W. IN- DIES, 46.99 m., 4-4.45 pm., Wed. 7-7.30 pm.
9.091	PJCI CURACAO, D. W. INDIES, 33 m., 6.36-8.36 pm., Sun. 10.36 am.- 12.36 pm.	6.977	XBA TACUBAYA, D. F., MEX., 43 m. 9.30 am.-1 pm., 7-8.30 pm.	6.357	HRPI SAN PEDRO SULA, HONDURAS, 47.20 m., 6-7.30 am., 2-4 pm. & Irreg. to 10 pm.
9.030	COBZ HAVANA, CUBA, 33.32 m., Radio Salas Addr. P. O. Box 866, 7.45 am.-1.15 am. Sun. 7.45 am.-12 m. Relays CMBZ.	6.960	ZZB WELLINGTON, N. Z., 43.10 m., Mid. 7 am.	6.340	HIIX CIUDAD TRUJILLO, D. R., 47.32 m., Sun. 7.40-10.40 am., daily 12.10- 1.10 pm., Tues. and Fri. 8.10-10.10 pm.
8.965	COKG SANTIAGO, CUBA, 33.44 m. Addr. Box 137, 9-10 am., 11.30 am.-1.30 pm., 3-4.30, 5-6, 10-11 pm., 12 m.-2 am.	6.880	XOJD HANKOW, CHINA, 43.60 m., 6-8.30 am.	6.335	OAXIA ICA, PERU, 47.33 m., Addr. La Voz de Chiclayo, Casilla No. 9. 8- 11 p. m.
8.841	HCJB QUITO, ECUADOR, 33.5 m., 7-8.30 am., 11.45 am.-2.30 pm., 5-10 pm., except Mon. Sun. 12 n.- 1.30 pm., 5.30-10 pm.	6.805	HI7P CIUDAD TRUJILLO, DOM. REP., 44.06 m., Addr. Emisoria Diaria de Comercio. Daily exc. Sat. and Sun. 12.40-1.40, 6.40-8.40 pm. Sat. 12.40-1.40 pm. Sun. 10.40 am.- 11.40 am.	6.324	COCW HAVANA, CUBA, 47.4 m., Addr. La Voz del Radio Philco, P. O. Box 130. 6.55 am.-12 m. Sun. 9.55 am.-10 pm.
8.830	COCQ HAVANA, CUBA, 33.98 m., 6.55 am.-1 am.	6.775	HIH SAN PEDRO DE MACORIS, DOM. REP., 44.26 m. 12.10-1.40 pm., 7:30-9 pm. Sun. 3-4 am., 4.15-6 pm., 4-4.70 pm.	6.310	HIZ CIUDAD TRUJILLO, D. R., 47.52 m. Daily except Sat. and Sun. 11.10 am.-2.25 pm., 5.10-8.40 pm. Sat. 5.10-11.10 pm. Sun. 11.40 am.-1.40 pm.
8.700	HKV BOGOTA, COLOMBIA, 34.46 m., Tues. and Fri. 7-7.20 pm.	6.750	JVT NAZAKI, JAPAN, 44.44 m., Addr. Kokusai-Denwa Kaisha, Ltd., Tokyo. Irregular.	6.300	YV4RD MARACAY, VENEZUELA, 47.62 m. 6.30-9.30 pm. exc. Sun.
8.665	COJK CAMAGUEY, CUBA, 34.64 m., Addr. Finlay No. 3 Altos. 5.30- 6.30, 8-11 pm., daily except Sat. and Sun.	6.730	HI3C LA ROMANA, DOM. REP., 44.58 m., Addr. "La Voz de la Feria." 12.30-2 pm., 5-6 pm.		

(Continued on page 125)

All Schedules Eastern Standard Time

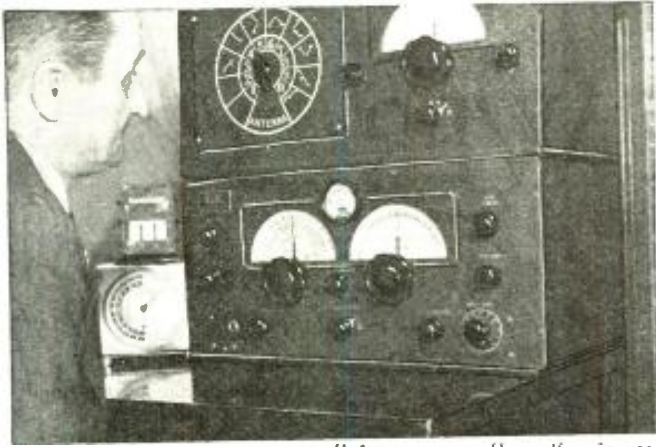

Notice the tricky antenna switch (left upper panel) on the rig used by Eric A. Bristow, of Chicago, who has heard all continents four times, although he has caught only 44 countries.

A HAM Answers "SWL Punk's" Letter

Editor,

I was greatly interested in a letter entitled, "Who Said, 'SWL PUNKS?'", which was written by Austin Wardman and published in February RADIO & TELEVISION. In his letter Mr. Wardman made the complaint that many hams refused to answer his SWL cards. I have, of course, heard the same complaint voiced from many others, so I thought I might perhaps help clear up the situation a bit. It is true that many of the hams do not answer SWL's and I think I can give a fair reason why. In four years of operating CW exclusively I received less than ten SWL cards from the U.S.A., while I received more than that number from foreign countries. Later I operated fone on the 20, 75, and 160 meter bands. Believe it or not, I now have, by actual count, almost three SWL cards for every five QSL cards in my fone files! What does that indicate other than the fact that our United States SWL's are not particularly interested in the code, which they must learn in order to pass the examination to get their license? Allow me to suggest to you SWL fellas that if you will spend more time on the CW bands and less on the fone you will probably find that your percentage of replies will take a definite *up-swing*. At the same time you will rapidly speed up your aptitude for the code and probably discover that you have mastered the 13 w.p.m. (words per minute) before you even have a chance to get any SWL cards printed. How about it, fellas? Wouldn't you rather have QSL cards printed than SWL's?

To date I have never failed to answer every SWL card I have received, be it on fone or CW, but I would much rather answer one from a fellow who heard me on CW, because it indicates to me that he is putting out an effort to learn the code—and succeeding, too.

After all, fellas, we don't need your SWL cards to get a report on our stations. We can very easily work someone and he will tell us what we want to know. Some of us like to get your cards and answer them. Others do not—you can't blame them for not answering your cards when it is all some of them can do to keep up with their confirmation of actual *contacts* (with other hams).

At the same time most of us hams are in the same boat with you. If you think all of our QSL cards are answered you are badly mistaken! I have worked seventeen foreign countries from which I have never been able to get a card, although I have sent them mine. Some of those countries

What Do You Think?

I have worked many times, with still no card from them. Many other hams are worse off than I am

in that respect. You must realize that we had actual contacts with those fellows and we still don't expect anywhere near one hundred per cent replies.

Well, fellas, I hope this will make you feel a little less blue about not getting all your cards answered and perhaps make you feel a little less harsh toward the hams who didn't answer them.

JACK GANT, W5EGR,
1328 N. W. 22 St.,
Oklahoma City, Okla.

"R. & T." Useful in Logging Stations!

Editor,

Although I am not a subscriber to your fine magazine, I have been buying it from the newsstands for the past two years and I can sincerely say I have not been able to



Irene M. and Richard V. Brian, of Minneapolis, have veris from 108 countries on phone, and 141 on phone and CW. The layout includes a 5-tube Doerle and a 9-tube superhet built by W9LEB. Dick copies CW and Irene logs phone; Hams are their hobby. They have QSL's from 756 foreign hams and 1348 SWL cards.

find a better one among the many magazines that are sold today. I think that the magazine holds its popularity because it offers something of interest to everyone, whether he be a ham, experimenter, service man, or SWL, and I hope that it will continue to be the fine book that it is.

I have been an ardent SWL for two years and during that time I have verified 55 countries and all continents six times. I listen on all the "ham" bands and also on the SW bands. Some of my best QSL's are: F18AC, VS7GJ, VS7RF, VK7RZ, PK1VY, ZL4AQ, J2KG, CN1AF, CN8MU, VUD3, JDY, JZJ, PMH, KZRM, EAJ43, and VK3XB and VK2JF on 40 meter CW; also many others.

Joe Miller's column is indispensable in the logging of DX short-wave stations, and the same holds true for "On the Ham Bands," edited by Mr. Fuller.

I would appreciate some information on how I can join the various DX organizations from any SWL who is connected with them.

RICHARD BRUNSMAN,
3026 Eden Ave.,
Cincinnati, Ohio.

Ireland Likes Us!

Editor,

I have managed to pick up quite a few issues of SHORT WAVE & TELEVISION. They certainly are very FB and have our "mags" over here licked for short-wave "news and views". Of course, I do not get them till at least three months after issue, but even then the information contained is up-to-date.

I am a member of the British Short-Wave League and would very much like to correspond with a reader over in America, preferably one about my own age—18 years.

Wishing your magazine every success,
FRED C. BLAIR (B.S.W.L. 1049),
9 Rosebery Gardens, Cregagh,
Belfast, Northern Ireland.

Umbrella Antenna Best Yet!

Editor,

In the December, 1938 issue of RADIO & TELEVISION, page 477, under the heading of "Radio Kinks", there appeared an item "Umbrella Antenna", signed Mario La Cognato, which intrigued me immensely to the point of erecting one on the roof of the 4-story private house where I occupy the top floor.

It was a temporary affair, but I was
(Continued on page 105)

British SWL J. A. Stancliffe has covered most of the world with his Trophy 3-tube job, which has a range of 6.2 to 550 meters. It is shown atop an old battery-operated Marconi ship receiver. He also uses a 6-tube superhet.



De Luxe

"BEAM POWER 3"

Howard G. McEntee, W2FHP

Transmitter

PART 2

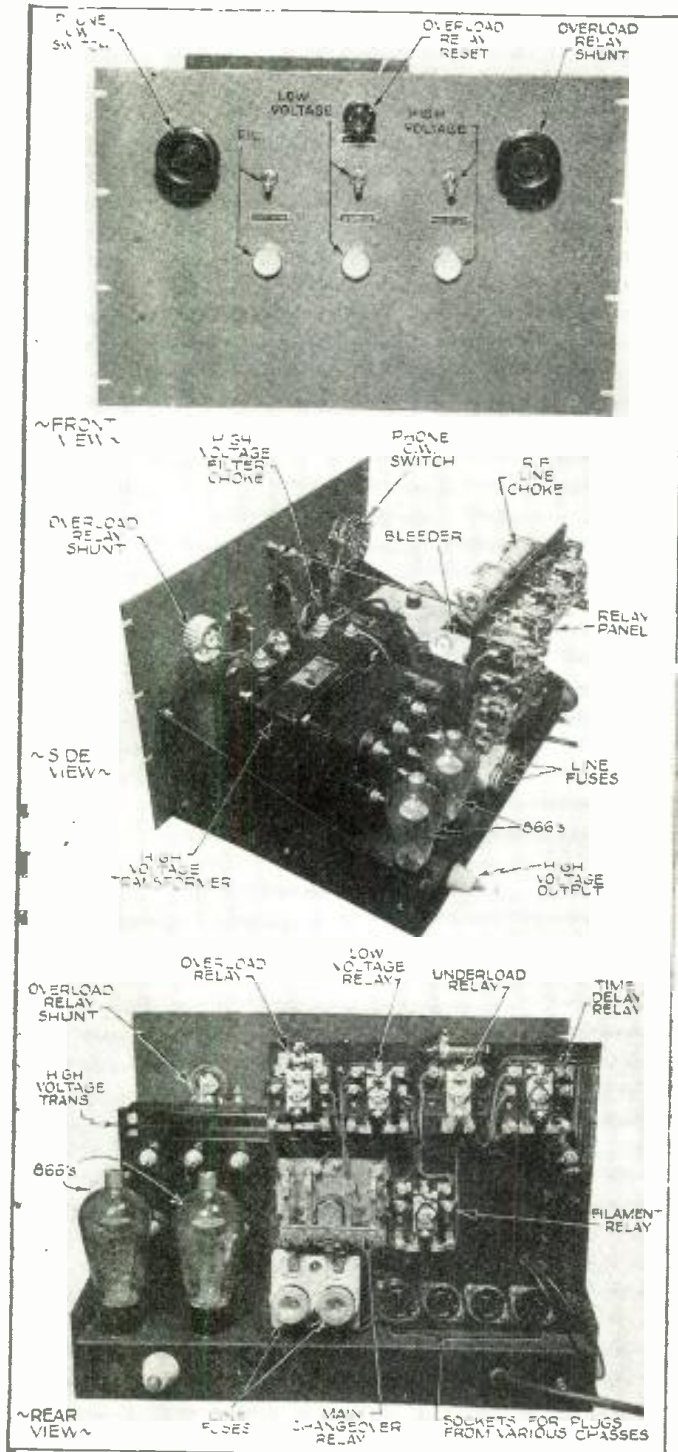

Top photo—Front view of high-voltage power supply unit for transmitter. Center photo—Perspective view from rear. Lower photo—Direct rear view of power-supply unit. Note neat arrangement of control relays. (R.F. unit was described last month.)

● THIS month we shall take up the high voltage power-supply for the r.f. amplifier and the control equipment.

A glance at the schematic will show that the power equipment is very simple, although it occupies most of the space on the 13" x 18" chassis. The complicated part of this section lies in the control circuits.

A few words may be in order as to just what the controls are for. In the first place, the transmitter is designed to be fully controlled from a distance. As the remote cable carries only a very low current for relay supply, it may be of any reasonable length with no loss of voltage at the transmitter. Furthermore, there is no high-voltage except 110 V. a.c. in the cable so that any type of low-power switches may be used at the remote point. While no directions are given for construction of the remote control box, the complete circuit is shown. Most builders have their special preferences as to this equipment. It may be seen that three single-pole switches are all that are required, although a key jack and pilot lamps are added conveniences.

A quick glance at the sequence of operations will doubtless be helpful. When SW1 is closed, the yellow pilot lamp immediately goes on and relay No. 1 operates. Supposing for the moment that we are to operate on CW, relay No. 1 turns on the 866 filaments, and lights all filaments on the r.f. chassis. It also lights the filaments of the modulator power-supply, which are 866 Jrs. At the same time power is supplied to the time delay relay No. 2, which operates automatically after a 30 second interval. This relay makes a very audible click when it goes in, and as soon as this is heard, SW3 may be operated to place the whole transmitter on the air. SW3 operates relay No. 3, and at the same time the red pilot lamp glows. A separate circuit on relay No. 3 runs to two posts which may be used to silence the receiver while transmitting. Another set of posts supplies 110 V. to operate the antenna changeover relay on the antenna tuning section previously described. Of course, no signal is emitted until the key is depressed. The key circuit, as described last month, operates on about 8 V. a.c. so that an open key may be used with no fear of receiving a "jolt."

Should it be desired to tune up the exciter, SW2 is operated instead of SW3. This operates relay No. 4 and places the entire exciter in operation, subject, of course, to control by the key. Also only the green pilot lamp on the transmitter operates, while with SW3 operated, both green and red lights are on, in addition to the yellow.

Relay No. 5 is the overload control and is shunted by R1 situated on the front panel so that any range of overload action may be secured. It is desirable to have R5 operate on about 250 to 300 ma. The reset lever of R5 is worked by means of a long rod (seen in the center photo, left) which terminates in a small knob on the front panel.

When phone operation is required, the four-gang panel switch, SW4, is operated. This immediately turns on the filaments of the modulator tubes and all those in the speech amplifier. Also one section shorts the keying relay, so that when SW3 is operated, the entire transmitter goes into operation, with the carrier on the air.

The high-voltage to the modulator is controlled by relay No. 6; this is set to operate at about 125 ma. by means of a variable resistor built into it. R6 will then operate only when the final amplifier is drawing at least 125 ma. current. This is positive protection for the modulation transformer as well as the other equipment, since it is disastrous to operate a Class B amplifier with no r.f. load. Should the r.f. amplifier be tuned out of resonance or overloaded for any other reason, relay No. 5 operates, and instantly opens R6 so that both high voltage power

supplies are off—a valuable safety feature.

Incidentally, it should be noted that the filaments of the modulator power-supply (866 Jrs.) are turned on as soon as SW1 is closed and are always lighted regardless of the position of SW4 (phone or CW). This is also a safety feature; relay No. 3 may be operated as soon as No. 1 closes, but neither of the high voltage power-supplies can be turned on until relay No. 2 has passed the 30 second *time-delay* interval.

The safe and convenient operation of equipment is assured by the use of the relay control as herein described, and the reader is urged to consider seriously before eliminating any of the relays as it is apt to prove false economy in the end.

A line filter, consisting of the double choke RFC and associated condensers, prevents feed-back of R.F. to the line, an important point where certain types of BCL trouble are experienced. A double line fuse is also provided as a last measure of safety.

There is not very much that can be said of actual construction that is not shown in the illustrations. The relay panel is of 1/4" thick hard Masonite, coated on both sides with flat black enamel. The panel measures 10 1/2" x 9 1/2" high and is held in place by two iron brackets.

After all holes are drilled and the complete relay panel, front panel and side brackets mounted to the chassis, the low voltage wiring may be done. It is advisable to use several different colors of wire to facilitate checking, as there is quite a bunch of wires behind the relay panel!

When wiring is finished, check it all through point to point with an ohmmeter, then apply 110 V. and use a lamp to check whether line voltage is supplied to all points required. High voltage wiring is done after all the other is finished and checked, and auto ignition cable should be used for this purpose. The low voltage wiring should be neatly cabled with waxed linen cord, which may be obtained from your shoe repair shop.

The next article will complete the transmitter with a description of the *speech amplifier* and the *modulator* with its *power-supply*.

LIST OF PARTS

PAR-METAL

- 1—Panel 19" x 12 1/4"—No. G3606
- 1—Chassis 13" x 17" x 2" deep—No. 15212
- 1—Set brackets—No. SB713

THORDARSON

- 1—Choke, 23 henries at 280 ma., No. T64C08
- 1—Power transformer, 1750 V., No. T19P61
- 1—Filament transformer, 2.5 V., at 10 A., No. T64F33

NATIONAL

- 1—Small flexible coupling
- 1—1/4" shaft bushing
- 1—1" feed through insulator

I. R. C.

- 1—50 ohm rheostat—type PR50
- 1—200 W., 100,000 ohm resistor, type HOA

CORNELL-DUBILIER

- 2—.01 mf., 400 V. paper condensers
- 1—4 mf., 2500 V. filter condenser

This article gives details of the high-voltage power supply for the R.F. Amplifier and the control unit. The concluding article on the "Beam Power 3", describing the speech amplifier and the modulator with its power supply, will appear next month.

Next Month

Second—and final—

SPECIAL TELEVISION ISSUE

will feature articles by leading authorities, descriptions of television parts, television antennas, television tubes, and other important essentials of this newest branch of radio.

WARD-LEONARD

- 1—Time delay relay, No. 507-501
- 1—Overload relay, No. 507-512
- 1—Underload relay, No. 507-514
- 1—Break-in relay, No. 507-534
- 2—Remote control relays, No. 507-511

TAYLOR

- 2—866 tubes, V1, V2

AMPHENOL

- 1—8-contact socket
- 1—7-contact large socket
- 1—5-contact socket
- 1—4-contact socket
- 2—4-contact steatite sockets
- 1—8-prong plug
- 1—5-prong plug
- 1—4-prong plug
- 1—7-prong large plug (for remote control box)

GORDON

- 2—2 1/4-inch control wheels
- 1—1-inch control wheel
- 6—Name plates
- 12—1/2" grommets

DRAKE

- 3—Large pilot lamps, type 75, with 110 V. bulbs

MALLORY

- 1—4 pole, 2 position, rotary switch

OHMITE

- 1—Double line choke

Miscellaneous

- 3—Large toggle switches
- 1—Double fuse block

Wiring diagram for high voltage power-supply and control circuits.

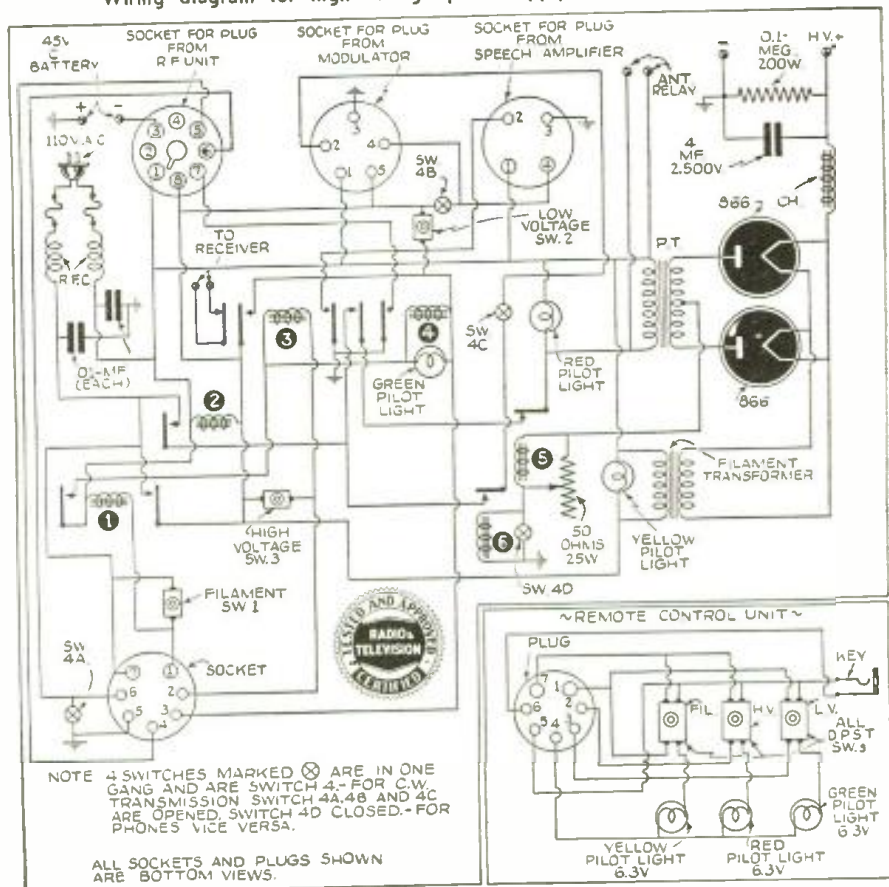



The complete 6L6 exciter unit.

● IN spite of the fact that a great number of excellent easy-to-drive, high-output transmitting tubes are now available, probably the two greatest handicaps of the average "ham" transmitter are low-efficiency frequency multiplication and lack of adequate excitation. It is extremely disconcerting, to say the least, to design a transmitter for certain frequency bands only to find that there is not enough excitation to the final stage. This is due to the fact, in most cases, that the doubler stages do not have sufficient R.F. output. Unfortunately, the higher in frequency we go the more

This high R.F. output exciter can be used as a low-powered C.W. or phone transmitter. Coil data given for 10 to 80 meter bands. 6C5G crystal oscillator, direct-coupled to 807 buffer-doubler, drives a pair of 6L6's in the "final." Over 50 watts power output on 10 meters.

our excitation falls off unless we use either the new high-frequency crystals or a long string of complicated and money-wasting doublers.

Tube Line-up of Exciter

The exciter-transmitter unit to be described here is designed especially for high R.F. output when doubling in the final amplifier. As shown in Fig. 1, the circuit consists of a 6C5-G crystal oscillator direct-coupled to an 807 buffer-doubler, driving a pair of

A High-Efficiency 6L6 Exciter

Harry D. Hooton
W8KPX

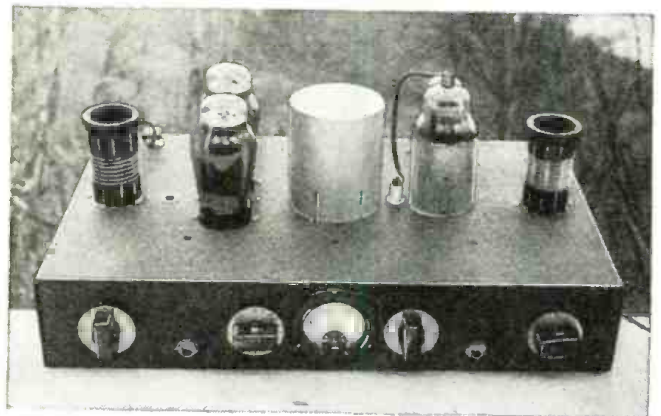

This little exciter unit will appeal to the average Ham, as its construction cost is very moderate.

6L6-Gs in the final. The "push-push," series-tuned output stage was suggested to the author by "Charlie" Nuebling, W2EKC, who has been using it on the 5 and 10 meter bands for some time. Using the arrangement as shown, with an 80 meter crystal in the 6C5-G circuit, the author measured *more than 50 watts of R.F. output* on the 10 meter amateur band! This is plenty to "kick the pants off" some of the new high-power transmitting tubes which have been released during the past two or three years. Or, if desired, the final may be keyed or modulated for a good, low-cost C.W. or phone rig. The 807 is used chiefly because it does not have to be neutralized when operating the buffer directly on the crystal frequency; when operating on the crystal frequency, the heater circuit of one 6L6-G should be opened by means of a switch as shown in Fig. 1. Used in this manner, the "dead" tube forms a perfect neutralizing condenser for the other 6L6-G.

(Continued on page 119)

It's easy to build this 6L6 exciter by following this simple diagram.

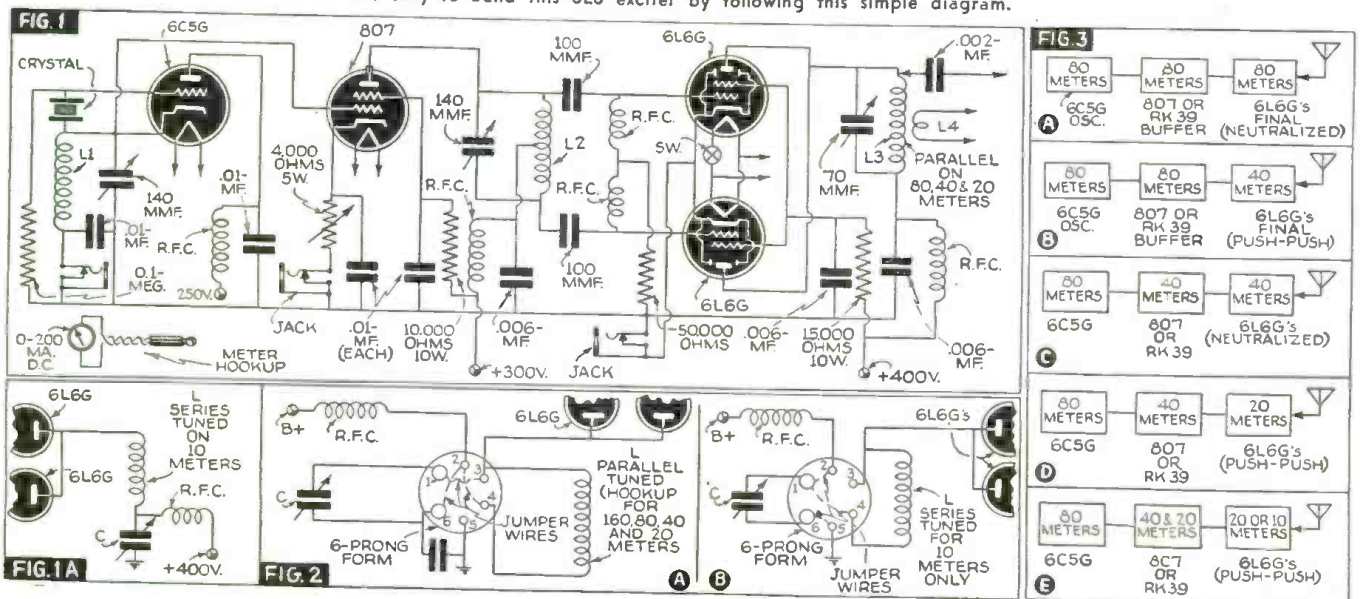

SUPERIOR PRESENTS 5 INSTRUMENTS from its NEW 1939 1100 series!!!!!! Never before has Superior offered so much for so little! Always the Best Buy in the Instrument Field. Superior in this new 1100 series gives you even more value! We have incorporated many refinements, many new features . . . all proven to be sound and practical. We urge you to read the descriptions below carefully; see how these instruments fit your needs. Buy direct from manufacturer and save 50%. **Superior Instruments Are Guaranteed for One Year**

**Superior Announces
—for the First Time!!**

**THE NEW
X-RAYOMETER**

Features:

- * GIANT 9" D'ARSONVAL TYPE METER
- * Built-in power supply enables resistance measurements up to **30 MEGOHMS** (Without external batteries or power supply)
- * 1/2 Ohm easily read on low ohm scale
- * D.C. volts up to 2500 volts
- * A.C. volts up to 1000 volts
- * D.C. currents up to 25 amperes
- * 2 Capacity Ranges: Micahs, papers, electrolytics read up to 50 Mfd. 2% ACCURACY.
- * PERCENTAGE OF LEAKAGE of electrolytics read DIRECTLY on scale.
- * Insulation, Inter-elements and all other leakages directly read up to 30 meg-ohms.
- * 4 Output Ranges up to 1000 volts.
- * 2 Inductance Ranges up to 703 Henries.
- * 3 Decibel Ranges
- * Cathode Ray high voltage power supplies easily measured.

SPECIFICATIONS:

Resistance Measurements in three ranges: 0-1000 ohms, 0-100,000 ohms, 0-30 megohms. Less than 1 ohm easily read on meter scale. D.C. Voltage measurements in five ranges: 0-50/0-250/0-500/0-1000/0-2500 Volts. Television and other high voltage power supply circuits easily measured. A.C. Voltage measurements in four ranges: 0-50/0-250/0-500/0-1000 Volts. D.C. current measurements in five ranges: 0-50/0-250/1 Amp/10 Amps/25 Amps. High current ranges suitable for automotive and industrial work. Capacity directly read on meter scale in two ranges: .005-1 Mfd./2 Mid.-50 Mfd. Percentage leakage of electrolytic condensers directly read on meter scale. Actual condition of condenser quickly determined. Insulation, inter-element and A.V.C. leakages directly read on meter scale up to 30 megohms. Output measurements in four ranges: 0-50/0-250/0-500/0-1000 Volts. Built-in blocking condensers enables rapid alignment of radio equipment. Inductance measurements in two ranges: 1-7 Henries/7-703 Henries. Decibel measurements in three ranges: -10 - +29/-10 - +43/-10 - +49. Audio frequency measurements in both radio and P. A. amplifier. X-Rayometer utilizes an etched aluminum panel and comes housed in a new army grey crystalline, heavy-gauge cabinet. Complete with test leads and instructions. Size 13 3/4" x 10" x 6". Shipping weight 20 pounds. Our net price. **\$17.95**

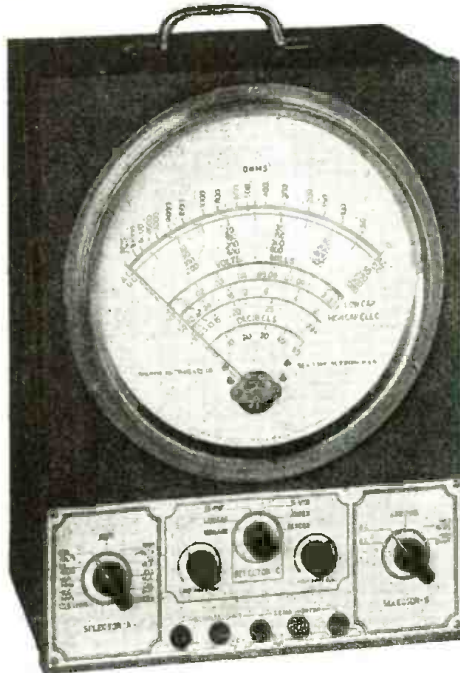

**THE NEW MODEL 1130-S
SIGNAL GENERATOR
WITH AUDIO FREQUENCIES**

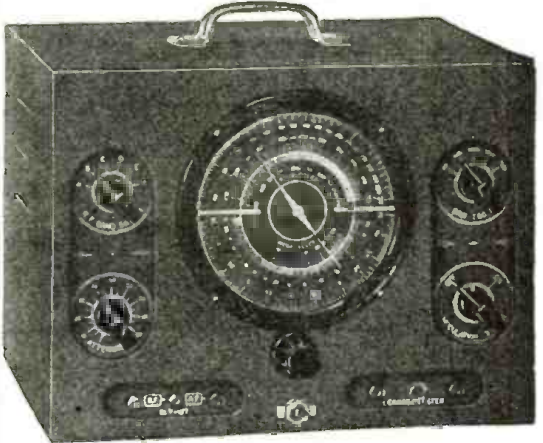

SPECIFICATIONS:

1. Combination R.F. and Audio Signal Generator. R.F. 100 kc. to 100 Mc., A.F.—103-7,500 cycles. All Direct reading, all by front panel switching.
 2. R.F. and A.F. output independently obtainable alone or with A.F. (any frequency) modulating R.F.
 3. Accuracy is within 1% on I.F. and Broadcast bands; 2% on higher frequencies.
 4. Audio frequencies in 5 bands: 100, 400, 1000, 5000, and 7500 cycles.
 5. Giant airplane full vision, direct-reading dial.
 6. Condenser and other leakages tested to 100 megohms.
 7. All services on 90-130 volts A.C. or D.C. (any frequency).
- Model 1130-S comes complete with tubes, test leads, carrying handle, instructions. Size 12" x 9" x 6 1/2". Shipping weight 15 pounds. Our net price. **\$11.85**

**THE NEW MODEL 1150-S
SUPER-ALLMETER**

Featuring the New Sloping Panel

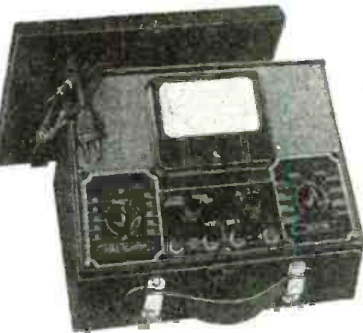

A genuine achievement! For accurate and rapid measurements. Note the following features: A.C. and D.C. Volts, A.C. and D.C. currents, Resistance, Capacity, Inductance, Decibels, Watts.

SPECIFICATIONS:

D.C. Voltage: 0-15, 0-150, 0-750 volts D.C.
A.C. Voltage: 0-15, 0-150, 0-750 volts A.C.
D.C. Current: 0-1, 0-15, 0-150, 0-750 ma. D.C.
A.C. Current: 0-15, 0-150, 0-750 ma. A.C.
2 Resistance Ranges: 0-500 ohms
500-5 megohms
High and Low Capacity Scales: .0005 to 1 mfd. and .05 to 200 mfd.
3 Decibel Ranges: -10 to +19, -10 to +38, -10 to +53.
Inductance: 1 to 700 Henries
Watts
Based on 6 mw. at 0 D.B. In 500 ohms, .006000 to 600
Utilizes new 4 1/2" square 0-1 d'Arsonval type meter with precision resistors housed in our newly devised sloping case for rapid and accurate servicing.
Model 1150-S supplied complete with test leads, tabular charts and instructions. Size 10" x 7 1/2" x 4 1/4", shipping weight 9 pounds. Our net price. **\$11.85**
Portable cover, 75c additional.

**THE NEW MODEL 1180-S
SET TESTER**

*A Complete Laboratory
All in One Unit!*

*Featuring Our New Type Sloping Panel for
Precise and Rapid Servicing*

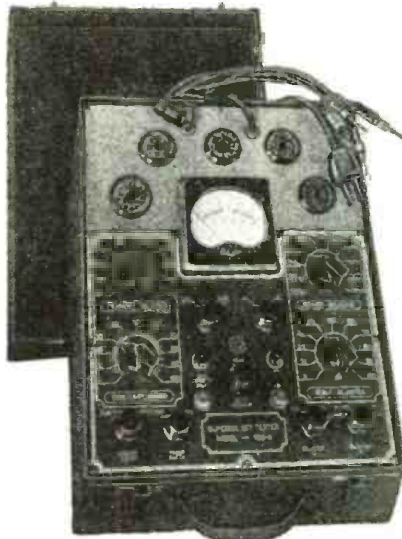

A complete testing laboratory all in one unit! Combines Superior models 1140-S and 1150-S. For specifications read the description of both these models herewith. Comes housed in sturdy, black case with sloping panel for rapid and simple measurements. Complete with test leads, tabular charts, instructions and tabular data for every known receiving type tube, including many transmitting types. Size 11 1/2" x 9 1/4" x 5 1/2"; shipping weight 18 pounds. Our net price. **\$17.85**
Portable Cover, add 95c.

**THE NEW MODEL 1140-S
TUBE TESTER**

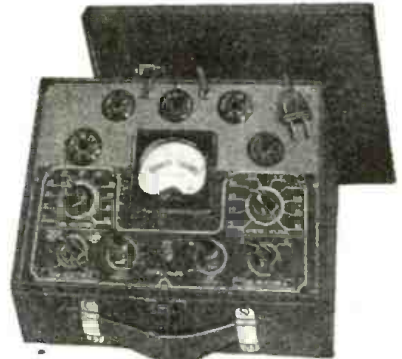

A really modern tube tester conforming to all standards of good engineering practice. Utilizes a 3" d'Arsonval type meter with calibrated scale. Furnished in a sturdy black case with sloping panel for easy operation. Removable cover and carrying handle for either portable or counter use.

SPECIFICATIONS:

1. Tests all 4, 5, 6, 7, 7L, octal and loctal base tubes, including diodes.
 2. Tests by the well-established emission method for tube quality, directly read on the GOOD? BAD scale of the meter.
 3. Affords separate neon test for leakage and shorts between elements.
 4. All services performed by the use of only five controls at maximum, and many tests do not require working all the controls.
 5. Supplied with instructions and reference table so that the filament voltages and emission measuring controls may be properly set for the enumerated long list of tubes, which includes all tubes commonly encountered in servicing.
 6. Works on 90-120 volts A.C. 60 cycle.
- Model 1140-S comes complete with instructions and tabular data for every known receiving type of tube as well as many transmitting types. Shipping weight 10 pounds, size 10" x 7 1/4" x 4 1/2". Our net price. **\$10.85**
Portable Cover, 75c additional.

SUPERIOR INSTRUMENTS CO. 136 Liberty St., RT-6
NEW YORK, N. Y.

Question Box

Facsimile Printer Data

? Recently I purchased one of the new Crosley radio facsimile printers and wish to connect it to my present 8 tube all-wave receiver. Can you show by diagram how I may connect this into the output of the receiver mentioned above?—Sam Laforte, Jersey City, N. J.

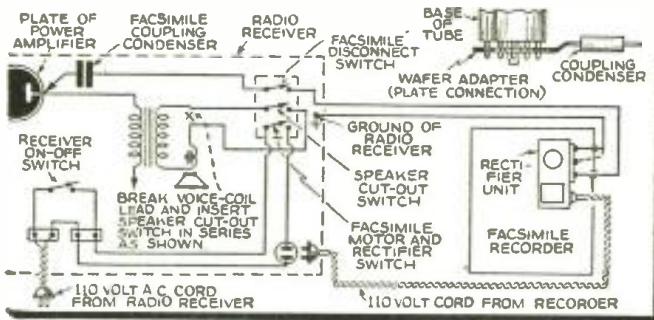

Circuit of Facsimile Receiver Connections—No. 1182

A. The recorder or printer that you have may be connected to the plate circuit of the power output tube through the use of a suitable plate connection "wafer" as shown in the accompanying diagram. If two or more tubes are used in push-pull combination in the power stage, connect to whichever one is in the most convenient location. A .25 mf. paper coupling condenser with a rating of from 400 to 600 volts should be used as indicated. The interconnecting wire may be a twisted pair or a low-capacity shielded cable. The shield (or second wire if a twisted pair is used) should be connected to the ground binding post or other grounded part of the receiver chassis. The single-pole, single-throw toggle switch is for disconnecting the printer when not in use.

Voltage Doubler Circuit

? I wish to build a voltage doubler circuit and intend to build this into an A.C. receiver. Please publish a diagram of such a unit, giving the values of the parts needed. It is for use on 115 volt 60 cycle power line.—Paul Messinger, Buffalo, N. Y.

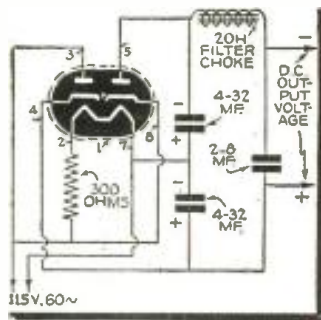

Voltage Doubler—No. 1183

A. Here is the diagram for one using a 25Z6 tube. It shows a voltage doubler circuit such as is used in some receivers operating directly from the A.C. line without the use of a power transformer. The D.C. output voltage will be somewhat less than twice the value which would be obtained with a half-wave rectifier. Its value depends on the capacity of the 4-32 mf. condensers and on the D.C. output current.

Television Kit Construction

? I have seen the Andrea Television Kit advertised in your magazine and am thinking of building one. Can you give me any idea of how long it will take me to construct the receiver from this kit?—John Mellisino, Baldwin, L. I.

A. That will depend upon your skill at following diagrams and constructing radio apparatus. One draftsman assembled the kit in 15 hours; one of the Associate Editors of this magazine assembled the kit in slightly under 24 hours; and the radio editor of a New York newspaper required about 28 hours.

You can figure that it will take you anywhere from 15 to 30 hours, depending on your skill. This time includes selecting parts, mounting parts, and all wiring, checking, rechecking and aligning.

Radio Control for Planes

? I am planning to build a radio-controlled gasoline model airplane and would appreciate information on where to obtain the plans, parts and complete data for building the radio control?—Anthony Goebel, CCC; Hot Springs, Virginia.

A. Complete information together with diagrams showing how such a radio control can be made to operate in either boats or planes was described in the issue of SHORT WAVE AND TELEVISION for August, 1938. We suggest you write our circulation department requesting them to send you a copy of this issue for 25c.

Antenna for Television and Facsimile

? I intend either to purchase or construct an antenna for the reception of facsimile and television signals on the ultra-high frequencies and would welcome any data or information that you may give. If such antennas are on the market can you recommend one that is suitable for these frequencies? Leon Alfred, Portland, Oregon.

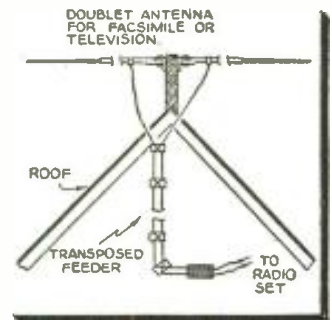

U.S.W. Doublet—No. 1184

A. For best reproduction of facsimile and television it is advisable to install a special antenna that is expressly designed for the ultra-high frequencies. Man-made static, such as produced from spark plugs of passing automobiles, is far more prevalent in the higher frequencies than on the regular broadcast wave lengths. An antenna such as that shown herewith (manufactured by the Crosley Co.) is said to reduce such interference to a minimum, permits higher elevation, provides for balancing the antenna to the receiver and also permits directional control for best results. Such antennas are made by L. S. Brach Co. and RCA Mfg. Co., among others.

The antenna is shown in the correct position (horizontal) for reception of American television waves, which are horizontally polarized.

Multi-band Oscillator

? I intend building a multi-band oscillator and am requesting a diagram of such a unit. I plan to use this on the 80 meter band with an 80 meter crystal. Is it possible to secure about 25 watts from such a unit?—L. B. Morse, Ottawa, Canada.

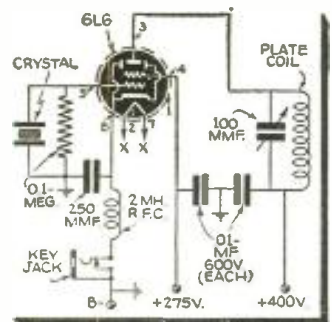

Multi-Band Oscillator—No. 1185

A. Here is a diagram of a multi-band oscillator using the 6L6 tube. It will deliver outputs from 15 to 25 watts on the 80 meter band, depending upon the screen and plate voltages. This oscillator circuit functions most effectively with 80 or 160 meter crystals. As the same crystal will operate on both bands, the only circuit change will be in the tuning of the plate condenser to resonate the circuit at the desired output frequency. From this it can be seen that this oscillator eliminates one doubler stage.

A fee of 25c (stamps, coin or money order) is charged for letters that are answered by mail. This fee includes only hand-drawn schematics. We cannot furnish full-size working drawings or picture layouts. Letters not accompanied by 25c will be answered on this page. Questions involving considerable research will be quoted upon request. Names and addresses should be clearly printed on each letter.

Shall I Tackle Television?

Leon L. Adelman

● WITH television now definitely approaching many experimenters find their interest awakening but are somewhat dismayed at the thought of the amount of study in store for them if they are to obtain a thorough understanding and working knowledge of this new field. Many have spent years in building up their present knowledge of radio and radio receiver design. To start all over again on an apparently even more complicated subject is a discouraging prospect, to say the least, and for this reason many radio men, both hobbyist and professional, are already licked by the new art without a struggle.

Actually, one who has a good working knowledge of ordinary radio receivers has a tremendous "head start" in the television field. If his knowledge combines that of radio receiver design with an understanding of the design and operation of the cathode-ray oscilloscope he is still better off, because after all a video (or television "sight") receiver is essentially nothing more than a radio receiver working into a glorified oscilloscope. If the experimenter will take this attitude in contemplating the new art, he will find it much less dismaying.

Let's take a typical television receiver circuit, such as now being featured in a kit recently placed on the market. Because it has no particular bearing on the problem, we will omit the sound channel, as this is nothing more nor less than an ultra-short wave broadcast receiver.

This video receiver employs a total of sixteen tubes, one of which is the cathode-ray tube. Nine of these tubes are directly comparable with any 9-tube radio set except for some slight variations in some of the constants. They constitute one R.F. stage, converter, three I.F. stages, second detector, two resistance coupled video amplifier stages and the power supply rectifier.

This leaves seven tubes, two of which are the cathode-ray tube and its power-supply rectifier. Four more correspond to the horizontal and vertical sweep oscillators and amplifiers of a sensitive oscilloscope. Thus fifteen tubes are accounted for without straying from functions familiar to every experienced radio experimenter. Only one tube performs an unusual function. This is the synchronizing-signal separator. Its purpose is to extract from the signal the impulses which permit the cathode-ray tube in the receiver to be held in perfect synchronism with that at the transmitter, and to separate the vertical sweep synchronizing impulses from the horizontal impulses. Even this operation, although it is a new type of function, is readily understandable because in its application are involved principles which are old and well known. One of these is the use of a biased diode, which is operated only when the signal peaks rise above a certain value (the value of the bias). This principle has been utilized in some noise limiter circuits. The other is the use of resistance and capacity to separate signals of different frequencies. This is used in all radio sets—in the tone control systems, in filtering radio-frequency currents out of the output of detector circuits, etc.

Perhaps the most important difference between the television receiver and the radio receiver lies in the fact that in the radio receiver, even if it is the high-fidelity type, the design of R.F., I.F. and audio circuits need only be such as to provide an overall frequency response fairly flat up to 8000 cycles or so. In television, however, all circuits must be designed for reasonably flat response up to about 2,500,000 cycles. To accomplish this, it is the practice to load all tuned circuits with resistance, both in the R.F. and I.F. amplifiers. In the video amplifier, unusual precautions must likewise be taken to avoid attenuation of the higher frequencies. Plate resistance values are reduced to only a few thousand ohms in resistance-coupled stages, series inductances are utilized, and relatively high capacity values are employed for by-passing purposes, these large capacities often being shunted by relatively tiny mica condensers to take care of the higher frequencies.

Television transmitters all operate in the ultra-high frequency portion of the spectrum. This fact in itself calls for some incidental variation from conventional tuner design. It is imperative, for instance that all leads, even including those of by-pass condensers, be held to an absolute minimum. By-pass grounding to a single point for each stage, with this point right at the tube socket, is the practice. Even with these precautions, the conventional tubes, such as the 6K7, are practically useless at these frequencies and this is the reason for the newly developed series of tubes, such as the 1851, 1852, 1231, etc.

In the I.F. amplifier much the same precautions must be taken as in the R.F. stages of present short wave receivers, because the intermediate-frequency for television receivers is in the vicinity of 12

(Continued on page 121)

INSIDE STORY

of the

HQ-120-X

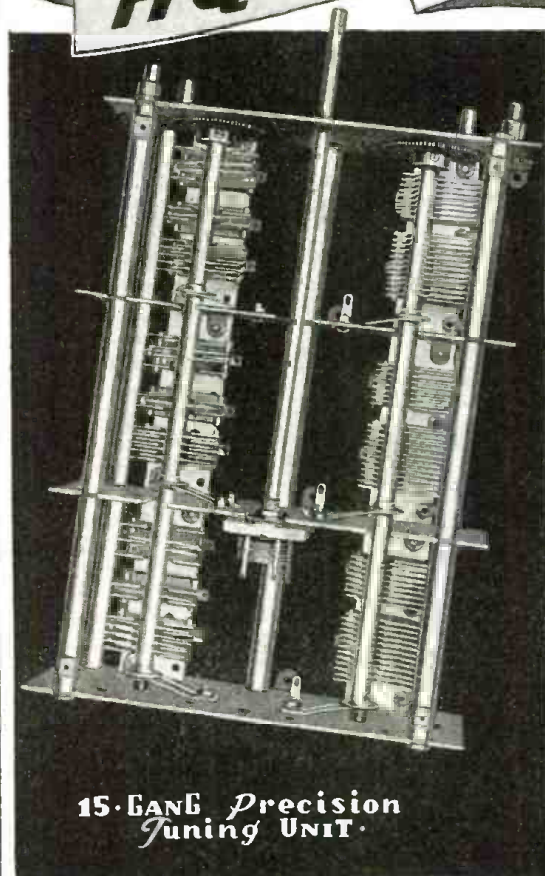
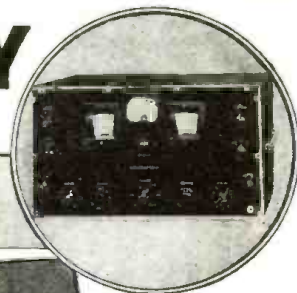

15-BAND Precision Tuning UNIT

"HQ-120-X" is sold at all authorized Hammarlund dealers on easy time payment plan. List \$215—amateur net \$129 complete with crystal filter, tubes and 10" P.M. Dynamic speaker.

Canadian Address: 41 W. Ave., No. Hamilton, Ont.



HAMMARLUND

THE TUNING UNIT of a highly selective and sensitive short wave receiver is really one of the most important parts. As an example, the I.F. amplifier in the "HQ-120-X" is sensitive to 1 kc. without the crystal and less than 100 cycles with the crystal. This means that the condenser must be tuned to 1 part in 30,000 in the first instance, and 1 part in 300,000 in the second when operating at 30 mc. This calls for a condenser absolutely free of all bearing play; only pure rotational motion is permissible. The principle of design is the same as used in watch making. Single polished steel ball bearings are used at each end of the rotor shaft. Six sets of dual in-laid silver to silver contacts and small area widely spaced plates insure electrical stability. This tuning unit costs over 20 times as much as the usual remodeled broadcast condenser. Try an "HQ-120-X" and note the difference!

MAIL COUPON TODAY!

HAMMARLUND MFG. CO.,
Inc. RT-6
424 W. 33 St., N. Y. City
Send me 16 page booklet

Name

Address

City State

FEATURES

- SIMPLICITY
- PERFECT CONTROL
- SEMI-AUTOMATIC
- EASE OF OPERATION

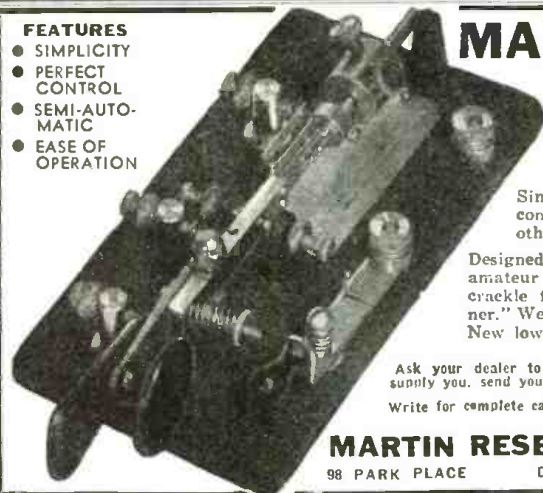

MARTIN FLASH

The greatest VALUE ever offered

STURDY CONSTRUCTION

Single lever. Two pairs of coin silver contact points... one for dots, the other for dashes.

Designed especially to meet the demands of amateur operators. Beautiful black crackle finish. This key is a "winner." Weight, 2 pounds. Base, 6x3x3/4. New low list, each **\$6.95**

Ask your dealer to show you the FLASH Key. If he cannot supply you, send your order direct to us.

Write for complete catalog illustrating and describing all models.

MARTIN RESEARCH & MFG. CORP.

98 PARK PLACE

Dent. RT-6

NEW YORK CITY

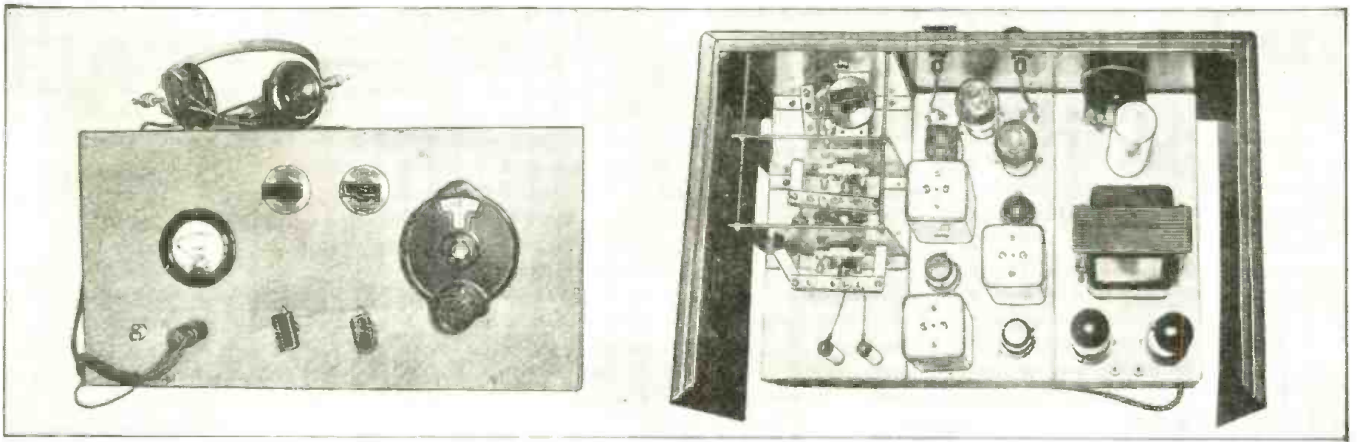

Left, front view of the super, showing controls. Right, top view of the outfit, illustrating layout.

2½, 5 and 10 Meter Super-het

The S-W Converter described last month grows up!

● THE 2½, 5 & 10 meter converter described in the May issue, page 34, was designed with an eye to enlarging it into a complete superhet receiver. A complete ultra-high frequency receiver is much to be desired since it obviates the necessity for a number of interconnecting wires be-

tween the converter and regular receiver. To those enthusiasts appreciative of the above, the complete ultra-high frequency receiver incorporating last month's converter unit is offered. For those who have already built the converter and are desirous of transforming it into the complete

receiver, it will only be necessary to remove the coupling coil and condenser in the plate circuit of the 956 tube.

Since the converter unit, which will be used as the *front end* of the completed receiver was thoroughly described in the preceding article, no further description will

In the diagram below, the circuit of the previously described converter is included, for clarity.

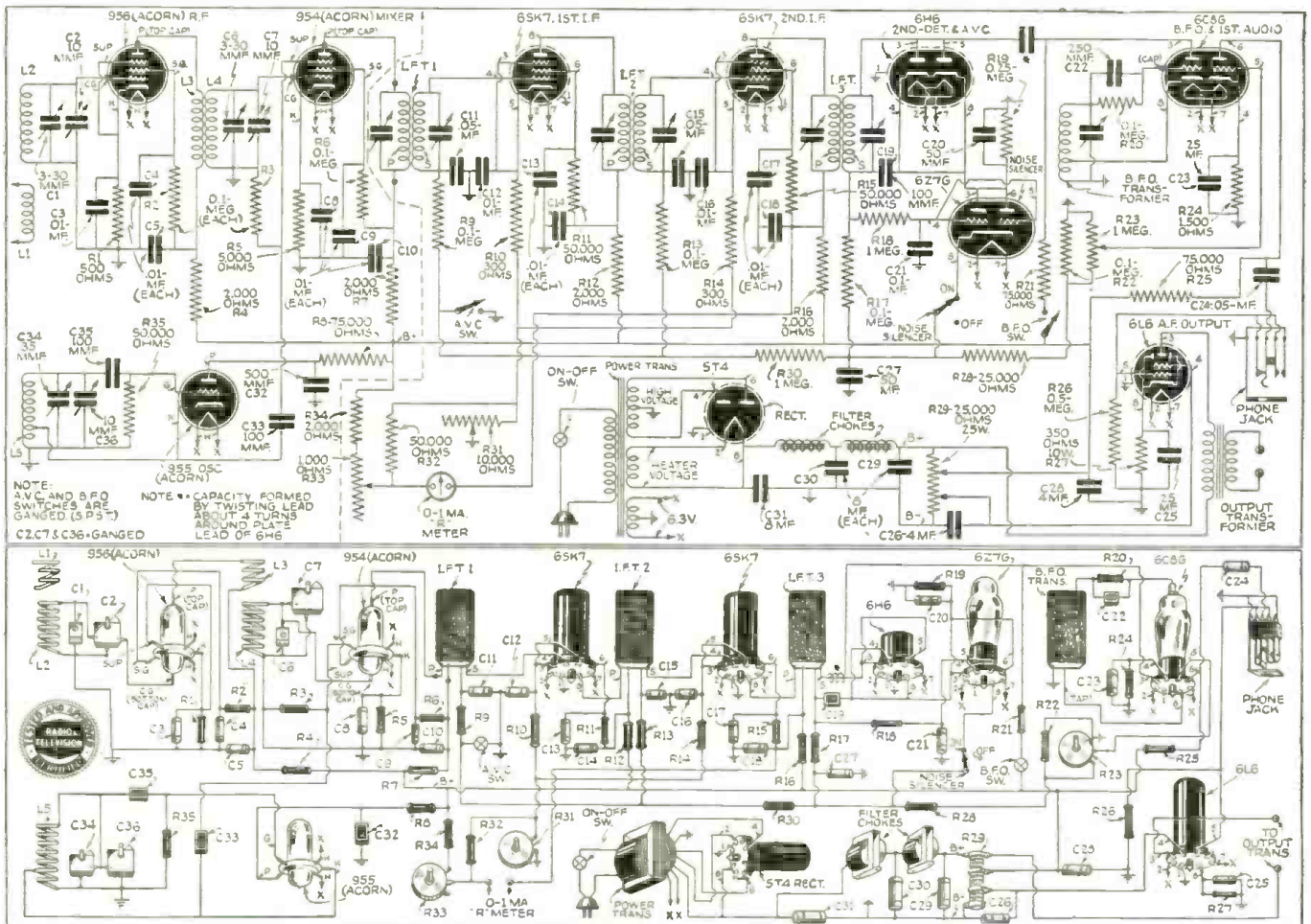

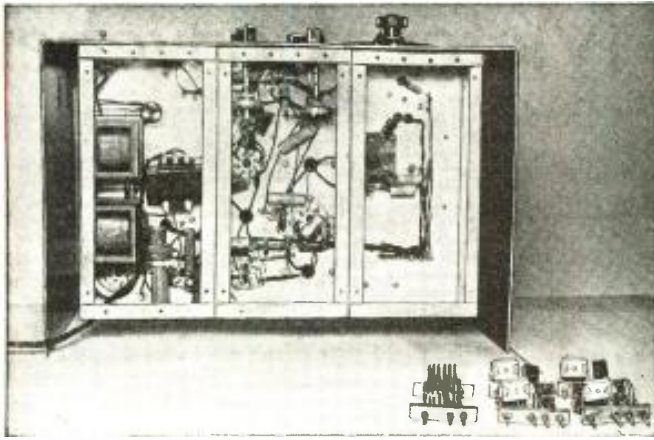

Note how the chassis walls form inter-unit shielding.



Herman Yellin, W2AJL

In this article, you learn how to add the stages which make a full-fledged 10-tube receiver from the S-W converter described last month

be necessary. Suffice it to say that it consists of three acorn tubes; a 956 tuned r.f. stage, a 954 first detector and a 955 oscillator.

This *front end* is coupled into a two stage i.f. amplifier employing 6SK7 tubes with a 6H6 second detector, a 6Z7G noise silencer, a 6C8G combination first audio stage and beat oscillator and a 6L6 power audio stage—all powered by a 5T4 rectifier.

As it was impossible to get a chassis of the desired size, two 5" x 10" chassis were bolted together and the resultant chassis in turn bolted to the high frequency chassis. One of these chassis was used to mount the power supply and audio power stage while the other chassis contains the i.f. tubes. Thus each chassis is devoted to a different function; Chassis I—high frequency; Chassis II—intermediate frequency; Chassis III—power supply and audio power.

Rubber grommets were used to protect the power supply wires passing between the different chassis. Liberal use was also made of the new National *through-point* bushings. Made of low loss Victron, they contain a central conductor which can be easily removed and any ordinary wire passed through the resultant opening. These bushings have extremely low losses at high frequencies. In fact, on the high frequency chassis, all the 1/4" rubber grommets, which were used at first, were replaced with these Victron bushings.

How 954 Is Coupled to First 6SK7

Reference to the diagram will show that the two coils L6 and L7 have been removed from the high frequency chassis. In their place we connected a 3500 kc. i.f. transformer to couple the 954 to the first 6SK7. The 6SK7 tube is one of a new series of single-ended tubes recently released by the tube manufacturers. By "single ended" tube is meant a tube which has all its terminals at one end of the tube. There is no grid cap at the top—like the other connections, it is brought out at the base. Except for its single-ended construction and its somewhat

higher gain, the 6SK7 is similar to the 6K7. In mounting the tube sockets for these tubes, orient the sockets so that the grid and plate leads to the i.f. transformers will be as short and direct as possible. Note that the grid and plate leads are brought out at diametrically opposite points on the tube base, allowing for quite adequate shielding between them by the tube pins. Mount the screen grid by-pass condenser so that it lies across the socket and between the grid and plate contacts, thereby affording additional shielding. This will result in condenser leads only about 1/8" long. All grounds for each stage should be brought to a single point, which can be one of the ground tabs forming part of the socket mounting flange.

I.F. Transformers

The i.f. transformers used by the author were of the type designed for 6K7 tubes and therefore had the grid lead coming from the top of the transformer can. This calls for a slight operation by removing the i.f. coil from the can and bringing the grid lead out the bottom instead of the top. Do this to both the first and second i.f. transformers. The third transformer, feeding the 6H6 second detector, need not be operated on, since its leads all come out the bottom.

R.F. gain is controlled by a 10,000 ohm potentiometer in series with the cathodes of both 6SK7 tubes. No difficulty was experienced with overloading of the first detector, so the 956 r.f. tube is operated at maximum gain at all times. If the constructor desires to control the gain of this stage also, he can place the r.f. gain control in series with the cathode of the 956 as well as the 6SK7 tubes.

Although not necessary on five meters, A.V.C. was incorporated for its advantages on ten meters and also in order to afford operation of the "R" meter. More about the "R" meter later.

Second Detector

The half-wave second detector employs a 6H6 with its two diodes connected in parallel. (Continued on page 108)

DEALERS! SERVICEMEN! AMATEURS!
SOUNDMEN! BUILDERS!

Send for
THE BOOK WITH
RADIO'S GREATEST VALUES! IT'S FREE!

Latest P.A. at New Low Prices!
Now, the greatest P.A. values ever offered! Systems for every purpose—8 to 65 watts—standard and de luxe models—permanent, portable, and mobile. Newest features, Monitor Speaker, Remote Control, etc. Illustrated, America's finest Mobile System. See, also, new P.A. accessories, transcription players, latest recording equipment, discs, etc., in ALLIED's new Spring Catalog! Get Time Payment details and story of the strongest P.A. Guarantee ever made!

and
NEW SETS!
New KNIGHT Radios, with Push-Buttons, built-in "Air-Magnet" aeriads—at new low prices! 60 models—Portable, AC, AC-DC, 1 1/2, 6, and 32 volt, etc., as low as \$3.95!—and radio's biggest line of record players, phonographs, phono-radios!

NEW KITS!
Messner 1, 2, 3 tube, "Pee-Wee's", Television, Phono and Mike, many others! Write for Free Parts Lists! **Builder's Handbook—10c**
For beginners—tells how to read diagrams, build sets. Only 10c.

NEW "SEND-CEIVER"
A sensational new Guthman-Silver "Ham" kit. Consists of 6-band 2-tube receiver with 6-band crystal-controlled transmitter all in one unit. Ideal for portable work, beginners, vacation work, etc. Amazingly low-priced!

TESTERS—PARTS!
All leading lines—new equipment with provision for new Loctal Tubes, etc.—Tube Checkers, Set Testers, Analyzers, Oscilloscopes, Meters—and over 14,000 parts at lowest prices! Everything in radio in one big book!

Fastest Service, Highest Quality, Lowest Prices always! Write for ALLIED's new Spring Catalog!

Free!
SEND COUPON

ALLIED Radio Corporation, Dept. 3-F-9, 833 W. Jackson Blvd., Chicago, Ill.

Send me your new FREE Spring Catalog.
 Enclosed find 10c (plus 3c postage) for Builder's Handbook.
 Send full details on "Send-Ceiver".

Name
Address
City State



5 & 10 Meter Converter

Gordon Fraser

This converter is suitable for picking up "Television Sound" channel, Facsimile, Police and Ham bands, Hi-Fi Broadcast, etc.

Frank Lester at his new 5 and 10 meter converter.

the newly developing u.h.f. ranges.

For the benefit of constructors, the photographs

and circuits of the unit are presented herewith, and this description will likewise give non-constructors some idea of what it is and how it works.

Three tubes are employed in one tuned r.f. stage, converter stage and power supply, the latter making the converter entirely self contained and independent of the receiver with which it is to be used. The r.f. tube is one of the new types developed especially for television and other u.h.f. applications, the 1853. An idea of its unusual capabilities is gained from the fact that its amplification factor is rated three and a half times greater than that of the 6K7 tube which has heretofore been universally employed in r.f. amplifier stages; its transconductance is 5000 as compared with 1650 for the 6K7.

Greatest efficiency is obtained from these new tubes when both grid and plate circuits are tuned, as is done in this converter. In spite of the relatively tremendous amount of gain the tube provides, it is entirely

stable when its circuits are properly designed with careful attention to by-passing, proper grounding and shielding. As will be seen in the photographs, the 1853 and its tuned plate circuit are enclosed in the front right-hand section of the shield partition arrangement, isolated alike from its input circuit (right rear) and the circuits of the 6K8GT. In addition to this, extreme care was used in the converter design, to bring all returns to a common ground point.

The 6K8GT is a glass tube with a metal base, or collar, which is generally considered

(Continued on page 109)

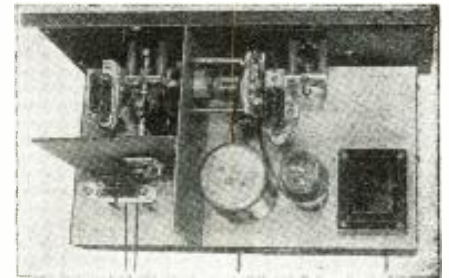

Top view of U.H.F. Converter

● WITH the ultra-high frequency ranges blossoming forth with a variety of services, including, among others, television sound, high-fidelity broadcast, police, commercial and amateur bands, many listeners and experimenters are giving thought to suitable equipment to cover the range from about ten meters down to five meters or thereabouts.

A good converter, connected ahead of a reasonably good receiver, provides all the original advantages shown by the receiver on the lower frequencies, plus effective coverage of the additional ranges provided for in the converter.

Such a converter, described in this article, was designed by Frank Lester (W2AMJ), chief engineer of Wholesale Radio Service Company, and one of the country's leading amateurs. Primarily intended for use on the 5-meter and 10-meter ham bands, the same features which make it outstandingly effective in this critical service recommend it likewise for the other services found in

New HAM Licenses

COMPILED FROM THE LATEST RECORDS OF THE FEDERAL COMMUNICATIONS COMMISSION

THERE are now approximately 50,000 licensed radio amateurs in this country. And dozens of new amateurs are being licensed every month.

Heretofore no publication has listed the names and addresses of the new licensees as issued. RADIO & TELEVISION Magazine now provides this unique service, and publishes a list of newcomers in every issue. Check the names carefully so that you will be able to get in touch, not only with amateurs in your neighborhood and vicinity, but also with those distant amateurs whom you wish to contact either by mail or by radio.

This list contains 388 names of newly licensed amateurs. YLs' names appear in blackface type.

K6REW Kenneth K. Kaizawa, 922 21st Ave., Honolulu, T. H.
 K6RFU Jay W. Conquest, 1678 Kilauea, Hilo, T. H.
 WIACW Lester E. Hughes, 11 Turner, Presque Isle, Maine.
 WIDTS William J. Gibbs, 45 Bradbury, Old Town, Maine.
 WIEHO W. Everette Swift, 15 Arletta Ave., Worcester, Mass.
 WIEKI Waldo J. Barrett, 17 Bigbee St., Plainville, Mass.
 WIFQX George D. Rice, 18 Sargon St., Springfield, Mass.
 WIGFD Everett T. Bailou, 43 Noel, Springfield, Mass.
 WIGFP Robert R. Leach, Jr., 6 Curtis Place, West Haven, Conn.
 WIGKK George L. De Grenier, 358 Union St., N. Adams, Mass.
 WIHON Francis F. Behm, 47 Knowles Ave., Middletown, Conn.
 WIIMX Rubin M. Francer, 69 Lucerne St., Dorchester, Mass.
 WIIVY Elmer D. Litke, 240 East Road, Bristol, Conn.
 WILXW Melvin Snow Hastings, 14 Linden, Marblehead, Mass.
 WILXX Eugene P. Carini, 362 Vernon, Manchester, Conn.

WILXY Felix J. Touches, 1149th Co., CCC Camp 11028, Melrose, Mass.
 WILXZ Robert Henry Saunders, 36 Eastern Ave., Beverly, Mass.
 WILYA Andrew Thomas Penney, 59 Pleasant, Woodstock, Vt.
 WILWW Thomas L. Lapp, 113 Tolland, East Hartford, Conn.
 WILWX Roland G. Marquis, 2 Gowes Lane, Halowell, Me.
 WILWY Gilbert J. Masse, 209 Clark Rd., Brookline, Mass.
 WILWZ Porter V. Noe, 63 Sisson, East Hartford, Conn.
 WILXA Albert J. Cochran, 192nd Co., CCC Camp, Princeton, Me.
 WILXB Milton L. Farnham, 11 Lewis St., E. Hartford, Conn.
 WILXH Robert W. Smith, 46 Jensen, Manchester, Conn.
 WILXI Joseph C. Whitmyer, 1 Rogers Place, Salem, Mass.
 WILXJ Walter Frank Bartlett, 15 Guernsey, Marblehead, Mass.
 WILXO Charles Dorian, 2 Oakland, Natick, Mass.
 WILXP Joseph Maurice Casey, 664A Bth, South Boston, Mass.

WILXQ Clovis Nelson Elie Fontaine, 384 High St., Newburyport, Mass.
 WILXR William Raymond Purrier, 129 Overlook Rd., Arlington, Mass.
 WILXS Thomas Joseph Sherlock, 423 Dudley St., Roxbury, Mass.
 WILYB Charles E. Day, 56 Butman St., Beverly, Mass.
 WILYC Phillip M. Freeby, Brookline, Me.
 WILYD Kenneth W. La Font, Maine St., Walcott, Vt.
 WILYE George P. Earnshaw, 19 Gallup St., Providence, R. I.
 WILYF Abraham M. Gels, 45 Hibbert St., Arlington, Mass.
 WILYG Frederick B. Banan, Jr., 65 Washington St., Peabody, Mass.
 WILYH Guy A. Bixby, 107 Malden, Everett, Mass.
 WILYI George W. Newell, 7 Delano, Dorchester, Mass.
 W2CJU Harry K. Landau, 79 Prospect Ave., Red Bank, N. J.
 W2CTQ Richard H. Davis, 50 Hunting Dr., Dumont, N. J.
 W2DMJ Frank A. Di Bartolo, 310 7th St., Carlstadt, N. J.
 W2ESN Stanley Antell, 80 Van Cortlandt Park South, New York, N. Y.
 W2FGD Frank B. Fessel, 31 Elm St., Huntington, N. Y.
 W2GGS Walter F. Harold, 83 St. Mark's Place, St. George, N. Y.
 W2ISG Joseph N. Acampora, Jr., 96 Union Ave., Mamaroneck, N. Y.
 W2MAG Albin S. Lemansk, 13 Watson St., Paterson, N. J.
 W2MAH Carl G. Levonius, 25 Pine, Oceanside, N. Y.
 W2MAI Ivor J. Nelson, 14 Madison Ave., River Edge, N. J.
 W2MAJ Elmer J. Knapp, 1642 Dill Ave., Linden, N. J.
 W2MAK George W. Dumont, 26 W. 130th St., New York, N. Y.
 W2MAL William Spannuth, 135-15 134th St., S. Ozone Park, L. I., N. Y.
 W2MAQ George R. Westervelt, 3 E. Alpin St., Newark, N. J.
 W2MAR Robert Francis Biloan, 54 W. 106th St., New York, N. Y.
 W2MAS Joseph Endlich, 1903 Ocean Ave., Brooklyn, N. Y.
 W2MAT Howard T. Soldwedel, 271 E. 237th St., New York, N. Y.
 W2MAU Riley N. Stone, 116 W. 72nd St., New York, N. Y.

W2MAV Frank D. Hutchins, Jr., 622 Blvd., E. Weehawken, N. J.
W2MAX Milan J. Krasnican, 11 Madison Ave., Irvington, N. J.
W2MAY Vincent P. Mele, 427 Magnolia St., New Brunswick, N. J.
W2MAZ Walter John Rodriguez, Newtown Lane, East Hampton, L. I., N. Y.
W2MBA Leo Richard Schwartz, 215 E. 202nd St., New York, N. Y.
W2MBB John F. Costello, 712 S. Centre Ave., Bellmore, L. I., N. Y.
W2MBS Walter J. Stiles, 19 Beechwood Drive, Packanack Lake, N. J.
W3ALP William L. Martin, 1711 Oakdale Rd., Richmond, Va.
W3BK2 Burke Edwards, 6303 Florida St., Chevy Chase, Md.
W3FJQ Albert E. Heiser, U. S. NCR, Unit 4, Sec. Z, U. S. Post Office Bldg., Lynchburg, Va.
W3IBQ James M. Anthony, 508 N. Highland Ave., Baltimore, Md.
W3IBP Gordon Leo Aldrich, 2765 Baker St., Baltimore, Md.
W3IBR Sidney E. Horowitz, 419 Porter, Phila., Pa.
W3IBU Edward P. Ellison, 455 Ripka St., Phila., Pa.
W3IBX Whitney Sheffield Gardner, 2510 Talbot Rd., Baltimore, Md.
W3IBY Charles B. Brusich, Unit 6, Sec. 5, NCR, Public School, Flarders, N. J.
W3IBZ Dorsey W. Bull, 14th & Market Sts., Wilmington, Del.
W3ICA Charles J. Schaff, 2426 N. Maryland Ave., Baltimore, Md.
W3ICC Joseph P. Griffin, 1433 S. 29th, Phila., Pa.
W3ICD Alexander Lee Bellen, RFD No. 3, New Brunswick, N. J.
W3ICE Alfred S. Cresse, Cold Springs, Cape May, N. J.
W3ICG Ferdinand L. Newhoffer, Jr., 6735 N. 8th St., Phila., Pa.
W3ICH Harry Miller, Jr., 3046 Frandford Ave., Phila., Pa.
W4AOY Eugene B. Jones, 902 Southwest Ave., Johnson City, Tenn.
W4BFH Edwin M. Hirsdale, 532 San Lorenzo, Coral Gables, Fla.
W4CTU Walter Y. Thomas, Jr., 638 N. Royal St., Jaciso, Tenn.
W4DOU Ross M. Signon, Jr., 630 Maupin Ave., Salisbury, N. C.
W4FYZ William C. Moore, Jr., 2157 Court, Memphis, Tenn.
W4FZA William E. York, 990 N. Storewall, Memphis, Tenn.
W4FZC Louis Jacot Martin, 902 Parr Blvd., Sheffield, Ala.
W4FZE Nelson H. Rodgers, 602 Duncan Ave., Macon, Ga.
W4FZJ Jason F. Flynt, 2321 Garden Dr., Columbus, Ga.
W4FZK Marvin L. Farris, 14 Holcomb, Montgomery, Ala.
W4FZM Sidney J. Crawford, 3473 Coleman Ave., Memphis, Tenn.
W4FZN Charles W. Cleveland, 41 River Falls St., Andalusia, Ala.
W5ACW Joseph S. Chance, 712 Sante Fe, Alva, Okla.
W5ANF Henry G. Garmen, 416 Elm St., Erid, Okla.
W5AVJ Ellis M. Frost, Jr., B15 Fairmont, Amarillo, Texas.
W5AWD Bartlett Edwards, 330 S. W. 24th, Oklahoma City, Okla.
W5BCU Roger J. Conant, 2908 Lafayette, Houston, Texas.
W5BQN Howard L. Crader, 162B 5th Ave., Fort Worth, Texas.
W5CDK George L. Rawlinson, 513 School, Houma, La.
W5DRZ William R. Atkinson, 220 N. 18th St., N. Little Rock, Ark.
W5DWS Maxwell Carruthers Pierce, 3509 Westminster, Dallas, Texas.
W5EMP Joseph D. Carter, 14 Mile W., 4 Mile S. of Walters, Okla.
W5FKU John F. Anderson, 2177 Foch St., Beaumont, Texas.
W5FWH Marshall N. Clark, 1625 Washington Blvd., Beaumont, Texas.
W5GGJ George R. Dickinson, 2546 E. 5th Pl., Tulsa, Okla.
W5GZU Bedford F. Gammon, 1103 W. 9th, Stillwater, Okla.
W5HCQ William R. Flocks, 2324 S. 24th, Fort Smith, Ark.
W5HWV Thurman E. Wilson, 2125 Roosevelt Ave., San Antonio, Texas.
W5HWW Paul W. Klinko, Camp F/37/N. Carlsbad, N. M.
W5HWX Roy A. O'Bannon, CCC Co. 843, 5C5-2-N, Lordsburg, New Mex.
W5HWY Paul Weakly, 3001 Alabama Ave., Shreveport, La.
W5HXB Fred W. Johnson, 1104 S. Hichita, Wewoka, Okla.
W5HZC Ronald S. Frampton, 206 N. Maine, Blackwell, Okla.
W5HXD Carleton L. Buell, 3506 Louisiana Ave., Parkway, New Orleans, La.
W5HXE Albert J. Currier, Dawson, Okla.
W5HXF Lloyd George Dorsett, 435 College Ave., Norman, Okla.
W5HXH Othello H. Ford, 7th St., Granite, Okla.
W5HXI Bert T. Weidner, SW 1/4, Sec. 34-17-4, near Crescent, Okla.

W5HXJ Fred F. Zelinger, 4105 Dewey St., Oklahoma City, Okla.
W5HXK Clyde Steward, 2017 E. Cyprus St., Enid, Okla.
W5HXL Robert Howard Ashby, 1208 N.W. 33rd, Oklahoma City, Okla.
W5HXM Herman H. Hickerson, 1018 Barnes, Alva, Okla.
W5HXR William E. Hubbard, 1500 East Park, Oklahoma City, Okla.
W5HXS Robert J. Hornbeck, 702 East Lincoln, Blackwell, Okla.
W5HXT Walter M. Hill, R. T. Z., Jones, Okla.
W5HXU Harold L. Jester, 1506 South 9th, Lawton, Okla.
W5HXV Paul Vincent King, S. E. 9th St., Oklahoma City, Okla.
W5HXX T. R. Bromley, 2845 Park, Oklahoma City, Okla.
W5HXZ Edwin L. Farmer, 800 S. 13th, Fort Smith, Ark.
W5HYA Carl Fletcher, Coahoma, Texas.
W5HYB Michael F. Strutzel, 948 County Ave., Texarkana, Ark.
W5HYC Hubert Eugene Stokes, 2518 Acacia St., New Orleans, La.
W5HYD Thomas H. Housefluck, Jr., 741 Mena, Nederland, Texas.
W5HYE John Michael Althoff, 1402 S. Travis St., Sherman, Texas.
W5HYF Jean Doss, R. F. D. No. 2, Happy, Texas.
W5HYG Charlie T. Wood, Hilton Hotel, El Paso, Texas.
W5HYH Thomas L. Mantooth, 502 Paul Ave., Lufkin, Texas.
W5HYI Tom R. Harvill, Newellton, La.
W5HYJ Carol Kenneth Elkins, Highway S., Blossom, Texas.
W5HYK Robert M. Wallace, 2910 Alabama, Dallas, Texas.
W5HYL Joe N. Boyd, 116 N. 6th St., Texas City, Texas.
W5HYN Wm. Thomas Little, 1003 Washington Ave., Greenville, Miss.
W5HYO Marian Ruffner, R. No. 6, Pine Bluff, Ark.
W5HYP Mir-or Tiller, 916 East Center St., Searcy, Ark.
W5HYQ Johnny H. Fann, 3 mi. E. of Harrisburg, Ark.
W5HYR Paul Doyle, Sycamore Subdivision, Ferriday, La.
W5HYU Wayland E. McCarthy, 316 White, Norman, Okla.
W6AXI Lovern Leiter, 1327 Morris, Modesto, Calif.
W6EBO Theodore J. Palik, 679 Crescent, San Bernardino, Calif.
W6IRA Garrett S. Van Sickle, 1705 Fletcher, S. Pasadena, Calif.
W6JBB Joseph C. Schutte Jr., 735 Locust, San Jose, Calif.
W6JHM John Kemp Pheley, 2117 Ferger, Fresno, Calif.
W6KAO Alvin H. Lewison, 1148 N. Brand Blvd., Glendale, Calif.
W6LGW Oscar William Peterson, Alamo, Calif.
W6NCJ Warren C. Davis, 2806 Griffin Ave., Los Angeles, Calif.
W6PFK James E. Eichenberg, 132 E. 15th St., Oakland, Calif.
W6PHX Harry L. Elliott, 1613 47th Ave., San Francisco, Calif.
W6REL William M. McGeorge, Portola St., Paterson, N. J.
W6REM William G. Miller, 404 N. Calaveras, Fresno, Calif.
W6REO Claude R. Edwards, Bushman Acres, Winslow, Ariz.
W6RES Orlin A. Covert, Taylor Hotel Courts, Tremerton, Utah.
W6RET William W. Deane, 1168 N. New Hampshire, Los Angeles, Calif.
W6REV John C. Pomeroy, 1929 Atlantic Ave., Long Beach, Calif.
W6REY Jack B. Christen, 645 W. 43rd St., Los Angeles, Calif.
W6REZ Ludwig Kiramidjian, West Ave., Fresno, Calif.
W6RFA Phillip De Grazio, 467 N. Rowan Ave., Los Angeles, Calif.
W6RFB William P. Harriman, 1119 14th St., San Pedro, Calif.
W6RFC Haido S. Fredrickson, U. S. Airway Station, Tobar, Nev.
W6RFD Chester L. Dubois, U. S. Airway Station, Tobar, Nev.
W6RFE Richard Romer Hulse, 1012 E. Osborn Rd., Phoenix, Ariz.
W6RFF Jettie B. Hill, Jr., 621 W. Wabash Ave., Eureka, Calif.
W6RFG Doyle Philip Henderson, 617 25th St., San Bernardino, Calif.
W6RFH James W. Clemens, 1503 Harvard Ave., Salt Lake City, Utah.
W6RFI Joseph W. Trindle, 1301 E. California St., Pasadena, Calif.
W6RFJ Harold Lee Rice, 1650 11th St., Phoenix, Ariz.
W6RFK Rawlings H. Roughton, 1808 Arthur St., Fresno, Calif.
W6RFL Fred M. Levin, 1609 Noe St., San Francisco, Calif.
W6RFM Van D. Lillifors, 1403 Monroe, Red Bluff, Calif.
W6RFN Jack O. Burnes, 2542 E. Willow St., Stockton, Calif.

EXTRA PROTECTION!

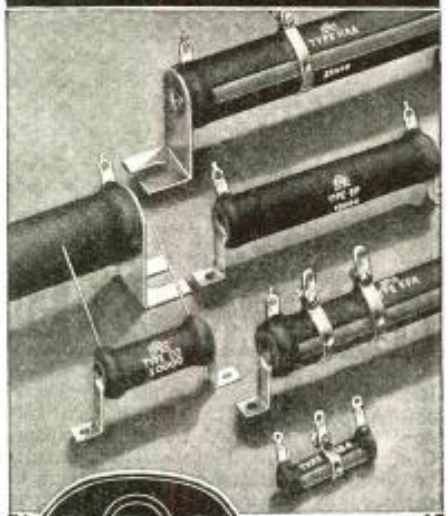

POWER WIRE WOUND RESISTORS (Cement Coated)

That special cement coating on IRC Power Wire Wound Resistors is just as rough and tough as it looks. It is the most durable coating yet developed. It is practically impervious to moisture and heat. It doesn't peel, chip or crack. It offers EXTRA PROTECTION against the most common causes of resistor failure. It gives you true airplane—submarine resistance dependability—at not one cent of extra cost. Its amazing superiority can be demonstrated by any test you care to name. Ask your jobber. Insist on IRC Power Wire Wounds—the only resistors having this exclusive feature.

A 10-WATT SERVICE HINT



Hundreds of servicemen and amateurs save time and money by using these little 10-watt IRC Power Wire Wounds universally for all low wattage resistor requirements. The 10-watt adjustable (Type ABA) is especially handy. Any desired range up to the maximum of the resistor can be tapped off by moving the adjustable band. A few popular ranges equip you for literally hundreds of jobs.

INTERNATIONAL RESISTANCE CO.

401 N. Broad Street, Philadelphia, Pa.

DO MAJOR EXPERIMENTING
WITH THE NEW RADIO

FACSIMILE PRINTING



BUILD IT
YOURSELF

**CROSLEY
READO KIT \$49.50**

Radio in its infancy did not promise as much as FACSIMILE RADIO PRINTING does today. Licensed under the Federal Communications Commission, leading broadcasting stations are broadcasting experimentally late every night on the broadcast bands and in some instances during the day on high frequencies. Now is the time to get in on the ground floor either for future profit or present pleasure. It is a new art already developed to a fascinating degree through daily experimental broadcasts of WOR, WLW and others. It bids fair to be the most important of all radio developments—a not too distant future should see radio facsimile printers in every home, unrolling a constant strip of pictures, news, vital statistics and reports in a steady stream. Grow with the art. Build your own facsimile printer with the Crosley Reado Kit. Get in on the development. Radio Amateurs will soon be exchanging their pictures by TRADE PICTURES WITH OTHER HAMS. The READO radio printers kit is complete with all parts precision machined. Full details of construction are furnished. If a Crosley dealer handling this kit is not convenient write

BE FIRST IN
THE FIELD

THE CROSLEY CORPORATION
READO DEPARTMENT POWEL CROSLEY, Jr., Pres.
113 ARLINGTON STREET CINCINNATI, OHIO

Please send me literature about the Crosley READO, all facsimile broadcasting activities and list of stations now doing experimental broadcasting. Also, the name of my nearest Crosley dealer to carry the Reado Kit.

USE
THIS
COUPON

NAME.....
ADDRESS.....

ALL PURPOSE JACKS



A Jack Of
UNUSUALLY FINE
Quality For All
Radio and Electrical
Applications

● Nickel silver springs assuring positive contact indefinitely ● Circuit-opening points of solid silver ● Heavy laminated bakelite insulation ● In four types: (1) Open circuit, (2) Closed circuit, (3) Double closed circuit, and (4) 3 circuit Microphone.

Priced only 21c to 36c at your BUD jobber.
For free catalog No. RT-69 write

BUD RADIO, INC.

5205 Cedar Avenue Cleveland, Ohio

- W6RFO Elmer E. Hodge, 105 Pelton Ave., Modesto, Calif.
W6RFP John J. Barale, 123 E. 15, Oakland, Calif.
W6RFR Bert Dunn, 494 Drury Lane, Banning, Calif.
W6RFT Arrol Medley, 1919 Hancock St., Los Angeles, Calif.
W6RFV Louis E. Cady, Jr., 1016 Gay, Susanville, Calif.
W6RFW Paul Rainey, Jr., U. S. Airways Station, Tobar, Nev.
W7AC Richard S. Crane, 1008 Fulton, The Dallas, Ore.
W7BSX Bruce V. Duncan, 2465 55th Ave., S. W., Seattle, Wash.
W7CDW Jack Handley, Jr., 910 Delaware St., Butte, Mont.
W7DWC William J. Dingle, 324 Pacific Ave., Bremerton, Wash.
W7EDK Wilfred E. Stacey, 1 mile N. E. City Limits, Vancouver, Wash.
W7EYE Frank G. Barnes, Jr., 3rd and Douglas, Longview, Wash.
W7FJ William H. Germann, 461 2nd Ave. S., Kirkland, Wash.
W7FPT James W. Bostwick, 1 1/2 mi. N. of Milton, Ore.
W7FWM Stacy K. Anderson, 264 East F. St., Casper, Wyo.
W7FXU Gilbert A. Chevigny, 2515 Moulton St., Butte, Mont.
W7HJP Harold F. Gribbin, NE 1/4 Sec. 8T16S, Malheur County, Ore.
W7HKU Charles A. Cameron, 2223 S. E. 32nd, Portland, Ore.
W7HKW Kenneth Boyd, 2415 Rucker, Everett, Wash.
W7HXX William J. Niland, 215 W. Spruce, Rawlins, Wyo.
W7HKY William E. Pope, 1081 Ellen, Marshfield, Ore.
W7HLA Harold M. Roberts, Newcastle, Wyo.
W7HLB Dale P. Smith, 1655 Charlotte, Eugene, Ore.
W7HLC Alan R. Hunt, E 4202 Buckeye, Spokane, Wash.
W7HLD Everett G. Johnson, 432 South Lincoln, Pocatello, Idaho.
W7HLE Bernard C. Wingert, 328 N. Church Ave., Bozeman, Mont.
W7HLF Dwight J. Albright, 2 Adams Lane, 1/4 mile N. of Medford, Ore.
W7HLG Martin W. Bjur, 107 College St., Milton, Ore.
W7HLI Warren L. Leyde, 603 Madison, So. Cle Elum, Wash.
W7HLJ Sigfred Charles Jensen, 259 Commercial, Astoria, Ore.
W7HLK William C. Fuchs, 2116 5th, Bremerton, Wash.
W7HLL William R. Lanplear, 5426 40th Ave., S. W., Seattle, Wash.
W7HLM Allen H. Graham, Westport, Wash.
W7HLN George H. Ebertin, 1726 N. Williamette Blvd., Portland, Ore.
W7HLO James W. Dufey, 4217 28th Ave. S. W., Seattle, Wash.
W7HLP William W. Freiday, 414 W. 16th Ave., Spokane, Wash.
W7HLQ Donal L. Benz, 1915 S. E. 29th, Portland, Ore.
W7HLS Charles E. Diehl, Topperish, Wash.
W7NJ Rex Martin Hess, 4417 W. Othello St., Seattle, Wash.
W8CBB Donal G. LeFevre, 12 Clinton, Potsdam, N. Y.
W8CZM Gordon H. Cusack, 253 E. 6th, Oswego, N. Y.
W8CZY George M. Kinsey, 4430 Jedan Rd., Amlin, Ohio.
W8DLO Ronald Harry Bradley, 2972 Sanborn St., Pittsburgh, Pa.
W8GRP Harvey K. Dodge, 349 S. Division Ave., Grand Rapids, Mich.
W8IOK Hayden G. Davis, 3423 De Soto Ave., Cleveland Heights, Ohio.
W8KKR Theo. P. Hipkins, Mt. Upton, New York.
W8LHW John C. Burke, 14413 Coit Rd., Cleveland, Ohio.
W8MGS Selwyn E. Garber, 3019 Wellington Dr., Dayton, Ohio.
W8NWU Joseph L. Czerniak, 776 Oak, Muskegon, Mich.
W8NXP Harley F. Harris, R.F.D. 3, Grand Ledge, Mich.
W8RRF Charles Henry Braun, 65 Ohio St., Rochester, N. Y.
W8RSV Gregory C. Gressel, 313 N. 7th St., Hamilton, Ohio.
W8SZC Howard R. Ebergole, 326 Maple Ave., Plymouth, Mich.
W8TCL John D. Larkin, III, 124 Lexington Ave., Buffalo, N. Y.
W8TCW Anna R. McGoldrick, 1055 Blair Ave., Scranton, Pa.
W8TCX Glen A. Nelson, 265 James Ave. S. E., Grand Rapids, Mich.
W8TCZ Melby C. Millirans, Orangeville, Mich.
W8TDB Charles A. Tappan, 517 Fulton St., Waverly, N. Y.
W8TDE Roland W. Bell, Jr., 300 Shiffler Ave., Williamsport, Pa.
W8TDH Louis E. Fullerton, 1312 Porter, Dearborn, Mich.
W8TDI Vernon W. Hull, 227 Dayton Ave., Xenia, Ohio.
W8TDJ Charles Borum Seibert, 519 Jefferson St., Morgantown, W. Va.
W8TDL John W. Goppelt, 175 Garden Lane, Saginaw, Mich.
W8TDM Francis F. Hittle, R. F. I, Ansonia, Ohio.
W8TDN Donal Clinton Holzapf, 608 Wayne Ave., Greenville, Ohio.
W8TDO Harker T. Kirby, 15716 Linwood, Detroit, Mich.
W8TDP Robert C. Ewing, R. R. No. 2, Camden, Ohio.
W8TDQ Clarence E. Frizell, 1923 Monroe Ave., Huntington, W. Va.
W8TDR James H. Paragin, 1335 "B," Hamilton, Ohio.
W8TDS Morgan E. Treese, 4522 Charleston Rd., Huntington, W. Va.
W8TDT Robert H. Stewart, R. F. D. No. 2, 1 mile West of Ripley, N. Y.
W8TDU Albert W. Anderson, R. F. D. No. 1, Xenia, Ohio.
W8TDV Melvin H. Langford, 1584 Elmhurst, Detroit, Mich.
W8TDW Harold Rogers Kennedy, Cincinnati, Ohio.
W8TDX Bernard W. Sheldon, 415 Arthur Ave., Endicott, N. Y.
W8TDY Earl Ryder, 3304 Lakeview Ave., Dayton, Ohio.
W8TDZ Howard E. Ralstin, 2005 Crown Ave., Norwood, Ohio.
W8TEB Virgil John Junker, 3305 Montgomery, Dayton, Ohio.
W8TEC Harold E. Koth, 460 Lloyd Place, Cincinnati, Ohio.
W8TED Paul H. Juengel, Jr., 225 N. Jackson, Bay City, Mich.
W8TEE Clayton J. Heller, Elk Rapids, Mich.
W8TEF John R. Swink, 917 W. Auglaize, Wapakoneta, Ohio.
W8TEI John L. Mathews, 226 Harrison, Covington, Ohio.
W8TEJ Luther M. Oliver, 647 Arlington Ave., Lockland, Ohio.
W9AMS Joe B. Allee, 4016 Warwick Blvd., Kansas City, Mo.
W9BSU Leo L. Gibbs, 2157 W. Superior St., Chicago, Ill.
W9DVA Virgil M. Dieter, Cor. Ohio and Warehouse Sts., Muscoda, Wisc.
W9FNJ Donal L. McManis, 1908 Timea, Keokuk, Iowa.
W9FNN William C. Lenmus, 717 N. Grant, Springfield, Mo.
W9FNW Hubert W. Meredith, 1803 Carrol, Keokuk, Iowa.
W9FNZ Robert D. Misner, R. F. D. No. 1, Waynesville, Ill.
W9FPE Clifford P. Lawrence, 3820 1st Ave. N. W., Cedar Rapids, Iowa.
W9FFG Layton D. Munson, R. F. D., Sedgewick, Colo.
W9FFS Leo Newhous, Lake St., Grayslake, Ill.
W9FQE Willis L. Nielsen, 32 N. West St., Waukegan, Ill.
W9FQV Vivian Sprague, 1001 West Mill St., Carbondale, Ill.
W9FRI Wilbur M. Stillwell, 1209 Minn. Ave., Kansas City, Kansas.
W9FRL Joseph T. Summers, 614 37th St., Cairo, Ill.
W9FRV Freddie C. Weishaar, 1214 Edwards, Beardstown, Ill.
W9FRX Ferton F. Taylor, Jr., Rural Route No. 4, Princeton, Ky.
W9FSI Harry L. Teegarden, 2424-5 18th St., St. Joseph, Mo.
W9FSX Faris Brown Davison, 929 Simmons Ave., Huron, S. Dak.
W9FTE Gerald O. Alfred, Ave. F., Scottsbluff, Nebr.
W9FTF Samuel E. Parker 11th and Oak St., Hamilton, Ill.
W9FTI Gerald D. Partney, Van Buren, Mo.
W9FTL Lester Ribling, 405 E. 4th, Beardstown, Ill.
W9FTZ Everett E. Roe, 1204 Bay, Beardstown, Ill.
W9FUD Harold W. Rowland, Marion Rd., Princeton, Ky.
W9FUF Steven Peter Scharpf, 1818 E. 3rd St., Wichita, Kans.
W9FUO Elmer W. Schmittek, 3328 38th Ave., S., Minneapolis, Minn.
W9FUP Grayson C. Self, 404 4th, Praise, Ky.
W9FUU William Simon, St. Andrew's Place, Edwardsville, Ill.
W9FVF Earl W. Smith, 41st and Central Ave., Paducah, Ky.
W9FUS James K. Van Dover, Meramac Sta. Rd., Valley Park, Mo.
W9FWE Daniel P. Vanderhorst, Home Site, So. end of Woodson, Ill.
W9FXP Rupert T. Kokes, 1035 Jay St., Art. A-1, Lincoln, Nebr.
W9FYV George R. Bragdon, 520 Prairie Ave., Wheaton, Ill.
W9FZD William R. Yount, 800 W. Main St., Lexington, Ky.
W9FZS Louis J. Urbanski, 3021 Allen St., Chicago, Ill.
W9FZY Clifford C. Tatge, 1205 1st, Norfolk, Nebr.
W9FZZ Aldrich E. Sebestick, 836 S. Lincoln Ave., Springfield, Mass.
W9GAJ Milton J. Sloggett, 2022 E. River, Two Rivers, Wisc.
W9GAL Bruce G. Edwards, 2801 17th Ave. S., Minneapolis, Minn.
W9GAZ David F. Stodden, 4232 Orleans Ave., Sioux City, Iowa.
W9GBD Frank J. Stodden, 4232 Orleans Ave., Sioux City, Iowa.

W9FBE Paul G. Gray, 904 S. Race, Urbana, Ill.
 W9GBK Harry Otis Barrett, 1/2 mile N. of Endicott, Nebr.
 W9GBM Ancil Z. Arseneau, Sheldon, Ill.
 W9GCC Roger E. Martin, Baraga, Michigan.
 W9GCE Robert H. Pearson, 1129 Diamond Ave., South Bend, Ind.
 W9GCW Paul Eugene Range, 528 St. Charles St., Rapid City, S. D.
 W9GDG Leroy F. Reckling, 811 W. 6th, Davenport, Iowa.
 W9GDK Leslie H. Richards, 830 Waukegan Rd., Lake Forest, Ill.
 W9GDP Neil R. Ritzow, 2640 N. 40th St., Milwaukee, Wis.
 W9GDV Earl R. Ross, 306 Lincoln Ave., Waukegan, Ill.
 W9GDZ Bernard C. Bath, Earlville, Ill.
 W9GEW Manfred C. Johnson, 2210 1/2 1st Ave., Hibbing, Minn.
 W9GFP Earl B. Stone, 225 2nd St. N., Breckenridge, Minn.
 W9GFR Francis Peter Befera, 206 16th Ave., Hibbing, Minn.
 W9GFT B. Harold Stewart, R. F. D. No. 2, Arkansas City, Kan.
 W9GFM Clarence L. Davis, Winside, Nebr.
 W9GJK James J. Hyskey, 935 Willow, Green Bay, Wis.
 W9GJV Stanley Van Deraa, 162 W. 158th St., South Holland, Ill.
 W9GKA Thomas M. Campbell, 1164 E. Riverside, Evansville, Ind.
 W9GMK Robert L. Hoffer, Hayes Center, Nebr.
 W9GMV Stacy Jack Campbell, 607 Harrison, Covington, Ind.
 W9GNA Eino A. Koski, Palmer, Mich.
 W9GNR Darwin L. Dale, 565 Holly, St. Paul, Minn.
 W9GTX Eugene W. Forbes, Highway 66, West Rolla, Mo.
 W9GUU John S. Fitzgerald, 1701 California, Peoria, Ill.
 W9GUP Louis J. Freenkel, Jr., 8114 Ingleside Ave., Chicago, Ill.
 W9GVA Howard S. Wayman, 3819 N. Ridgeway, Ave., Chicago, Ill.
 W9GVB Sidney Y. White, 304 Central Park Ave., Wilmette, Ill.
 W9GUJ Frederick P. Hofferth, 1309 W. Main, Crawfordsville, Ind.
 W9GVK Forbes R. Koehler, 7031 Osceola Ave., Chicago, Ill.
 W9GVO Thomas Owen Hall, 386 Minnesota St., St. Paul, Minn.
 W9GVV Henry J. Blocker, 812 Brown, Valparaiso, Ind.
 W9GWB Ernest M. Cassell, Jr., 3535 Carrollton, Indianapolis, Ind.
 W9GWD Albert O. Fye, 1406 Heisey St., Burlington, Iowa.
 W9GWL Russell M. Price, Griffin, Ind.
 W9GWP William Edwin Ramsey, Buckner, Ill.
 W9GWW Charles F. Reddick, 3132 Converse Ave., East St. Louis, Ill.
 W9GXB Mitchell S. Wiseman, 5342 Canal Blvd., Indianapolis, Ind.
 W9GXF Raymond Robert Nolan, 2146 Singleton St., Indianapolis, Ind.
 W9GXG Bandel T. Linn, 401 S. Water, Crawfordsville, Ind.
 W9GYD Clarence N. McGinnis, 3rd and Howard, Clarksville, Mo.
 W9GYF Samuel Cohen, 203 5th Ave., Alexandria, Minn.
 W9GYN E. Glen Conrad, Naper, Nebr.
 W9GYU Linsy James Rolfe, 2315 Montgomery Ave., Ashland, Ky.
 W9GZF Howard E. Roudebush, 12 E. 29th, Covington, Ky.
 W9HAF Claude W. Schmitz, Lot 364, Blk 9, Grant, Nebr.
 W9HAM William R. Jones, in Carroll County, near Monticello, Ind.
 W9HAP Edwin O. Gilson, 1601 Broadway, Kansas City, Mo.
 W9HAR Wayne D. Field, 11127 Langley, Chicago, Ill.
 W9HAZ Lloyd S. Freeman, Jr., 1601 Broadway, Kansas City, Mo.
 W9HBR Oscar A. Lynner, Rawson, N. Dak.
 W9HBU James L. Merling, 273 Beech Road, Southgate, Ky.
 W9HBZ Edwin H. Ehler, Route No. 4, Champaign, Ill.
 W9HCA James D. Cooper, 1819 Nebraska, Sioux City, Iowa.
 W9HCL Eugene Salyer, Jr., 1111 Bennington, Kansas City, Mo.
 W9HCN Lindell W. Politte, Vineland, Miss.
 W9HDD John F. Valker, 702 2nd Ave., S. E., Minot, N. Dak.
 W9HDK Harl C. Word, R. F. D. No. 1, Willard, Missouri.
 W9HDO Loy J. DeLapp, 3rd and Main, Garrettsville, S. Dak.
 W9HEC Edwin T. Dewey, 208 S. 9th St., Independence, Kan.
 W9HEF Russell M. Andrew, 2107 East 4th, North Platte, Nebr.
 W9HEG Robert L. Byers, Whitewood, S. Dak.
 W9HEH William G. Brown, 130 Cotter Ave., Somerset, Ky.
 W9HEK Harold J. Beckman, 210 N. Marquette, Madison, Wisc.

Cornell-Dubilier Capacitors for Television Applications

FOR RADIO

FOR VIDEO

MICA .00001 to 1 Mfd.

MICA 300 to 100,000 volts

PAPER .0001 to 10 Mfd.

PAPER 200 to 1,000 volts

DYKANOL .05 to 100 Mfd.

DYKANOL 600 to 150,000 volts

WET AND DRY ELECTROLYTICS 2 to 5000 Mfd.

WET AND DRY ELECTROLYTICS 25 to 600 volts



FOR AUDIO

Mica, Paper, Dykanol, Wet and Dry Electrolytics in any capacity and voltage combinations

Standardized sizes, shapes, designs to meet every Radio and Electrical Requirement. Catalog 165-A available on request.

World's Largest Manufacturers of Capacitors



CORNELL-DUBILIER ELECTRIC CORPORATION
1027 Hamilton Blvd., So. Plainfield, N. J.
Cable Address: "CORDU"



Silver Super
CONTROLLED DUAL REGENERATION
...and **WHAT results!**

The new 5 thru 612 meter, 6 band, 8 tube "Silver-Super" communication receiver is the only receiver or kit employing **DUAL REGENERATION**. The veriest tyro knows that plenty of DX laurels are won by 1, 2 and 3 tube single regenerative sets—that regeneration is the **EFFICIENT** means of getting super-sensitivity and super-selectivity.

The new "Silver-Super" uses not single, but dual regeneration in new and completely controlled manners which render it non-radiating yet give amazing selectivity both image and direct—continuously variable from broad high-fidelity to single signal c.w. sharpness. Sensitivity matches in its ability to pull thru stations not even audible on ordinary sets. Inherent circuit noise is so low, signal-to-noise ratio so tremendous, that the "Silver-Super" sounds dead as a tomb until in poor signals both local and extreme DX. Its new built-in noise silencer practically completely eliminates noise and static—enables clear reception of stations ordinary sets can't even get.

All this can at last be yours in the GUTHMAN U-17 "Silver-Super" kit, completely assembled all ready for easy wiring with every wire cut to length and identified for you—only \$49.50. That it's the most amazing receiver development of recent years is proven by tremendous interest and large sales.

See it at your jobbers today.

SEND TO DEPT. RT6 TODAY FOR DETAILS

Edwin I. Guthman & CO., INC.
400 S. PEGION ST., CHICAGO, U.S.A.
CABLE ADDRESS: GUTHMAN-CHICAGO

What Do You Think?

(Continued from page 93)

astounded at the results achieved with it on my RME-69. I have a number of antennae, both inside and out—one is 200 feet long, 70 feet high in the clear, with doublet lead-in—but this Umbrella gadget beats 'em all, bringing in stations I've never heard before, with loud speaker volume, and not nearly so much QRM or QRN.
L. B. PEARSON, 407 Park Pl., Bklyn, N. Y.

June Radio-Craft

Building a Radio Set Into a World's Fair Theme

Servicing Television Receiver Faults—Part I

\$4,000 Public Address Contest

Radio at the World's Fairs

Servicing Coin-Operated Electric Phonographs—Part I

How to Make a 5-Tube Battery Portable

That Fits Your Hand!

The current, June issue of RADIO-CRAFT on all newsstands May 1.

Your Inquiries Invited.

When you need amateur equipment it is to your advantage to write to me. You get personal attention; 6% terms financed by myself so you buy with less cost and more convenience; fair trade-in value for your equipment; ten day trial of all receivers; and my cooperation in every way to see that you are 100% satisfied. For any equipment, the latest information and technical help, write to W9ARA.

Compare My Terms with Others

Model and Receiver	Cash Price	Down Payment	12 Monthly Payments
RME-70	\$138.60	\$27.72	\$9.79
HQ-120X & NC101X	129.00	25.80	9.11
NC100A	120.00	24.00	8.48
NC80X & NC81X	99.00	19.80	6.99
Bretting 49 & S16	99.00	19.80	6.99
Howard 438	49.95	9.99	3.53
NC-44 & S-20	49.50	9.90	3.49
The New SX-23	115.50	23.10	8.15
Sky Buddy	29.50	5.90	2.08

Also HRO, Bretting 9, Howards, Sargents, all others

Similar terms on Hallicrafters, National, Harvey, RCA, RME, Temco transmitters and Thordarson, National, U.T.C., Utah, Kits.

All orders and inquiries attended to by Bob Henry, W9ARA; active amateur for 14 years; graduate M.I.T.E.E.; owner of Henry Radio Shop selling amateur supplies for ten years.

Bob Henry
W9ARA

BUTLER, MISSOURI

BRUSH HIGH LEVELER SERIES MICROPHONES



Range in price from \$22.50 to \$32.50

NEW BRUSH HEADPHONES

Write for your Brush catalog today.

THE BRUSH DEVELOPMENT CO.

3326 PERKINS AVE. CLEVELAND, OHIO

FLASH!

SEND FOR OUR CATALOG containing CIRCUIT DIAGRAMS, and complete information on over 25 different types of short wave receivers and transmitters from \$2.50 to \$32.50.

This catalog is chock full of schematic and picture diagrams, hook ups and short wave information. A book in itself. Well worth the dime, which will be refunded with your first order.

OSCAR B. KUSTERMAN

297 De Kalb Avenue, Brooklyn, N. Y.

CBS Television Atop 80-Story Building

Dr. Peter C. Goldmark

(Continued from page 71)

and finally decided on the 73rd, 74th, and 75th floors of the Chrysler Building, at 42nd Street and Lexington Avenue, in New York City.

The 74th floor was chosen for the placement of the transmitter itself. The floor above, the 75th, is used for air conditioning equipment, and the floor below, the 73rd, is used for the tube water-cooling equipment. On the 73rd floor is also built a fire-proof vault for such units as power supply reactors, plate transformers, audio modulation transformers, etc.

When actual construction was begun, problems were introduced at every turn, because of such physical difficulties as the fact that the 74th floor was only fifty feet square. It had to take care of both the video and the audio transmitter, the power supply transformer vaults, the shielded room for the input equipment, the power distribution panels, control desk, and so forth—and it was in this restricted space that we discovered the Chrysler Building fire tower and stairway.

The same thing was true on the 73rd floor where all the available space seemed to be filled already with water tanks, pumps, elevator machinery, and other equipment necessary to the building itself.

When it came to experimenting on the antenna system, we had the manufacturer build a full scale model of the part of the Chrysler Tower around which the antenna would be located. The model was built of wood and covered with wire mesh. We erected it in the middle of a large field, and tried out many types of antennas, finally working out an antenna system with two video and two audio antennas on each side of the building, placed one above the other.

Another problem which faced us was that of providing safeguards to prevent people working on the transmitter from coming into dangerous contact with the necessary high voltages.

This problem was solved by equipping the two main doors, leading to the equipment behind the transmitter panel, with interlock switches so that when the doors are opened the power of the transmitter is instantaneously shut off. In fact, every door leading to dangerously high voltage areas is equipped with the interlock switches

which automatically cut off the power when the doors are opened.

Besides this, there are several shorting plugs placed near the door behind the transmitter panel. When a man goes through that door, he takes a plug with him. This, of course, disconnects the entire transmitting supply circuit, which is completed again only when he returns from the transmitter panel and replaces the plug.

There are twenty control lamps on the control desk. These show whether the interlock switches are open or closed. Forty more control lights show whether the various units are supplied with power and are working correctly.

Besides all this, the entire 74th floor is covered with thick rubber tile to insulate it from the concrete underneath.

The next problem, once the transmitter was taken care of, was that of finding adequate studio space. Here again there was almost no precedent to go by. A great deal of space, we knew, would be necessary—partly for the elaborate equipment we use and partly to accommodate the necessary cameras, their ranges, and sufficient space for the actors. Also, we had to provide for possible expansion and any unforeseen emergencies that might arise.

We finally took space on the third floor of the Grand Central Terminal Building on East 42nd Street to build a studio 270 feet long, 60 feet wide and 45 feet high.

A space about 1400 feet square is used for the master control room. The rest of the space will be experimented with until we find the exact dimensions and properties required of such a studio. In the meantime, we adapt it to the size we need with portable screens.

The studio is connected with the transmitter by a coaxial cable that extends from the transmitter in the Chrysler Building to the control room in the Grand Central Terminal Building.

The studio control room, which is four feet above the studio, serves two purposes. It contains all electrical equipment needed for studio operations, and is also a production control room for the adjacent studio.

Part of the control room will be used for scanning motion picture film. For this process, film will be projected through a

Line-up for CBS Telecine (motion picture) television.

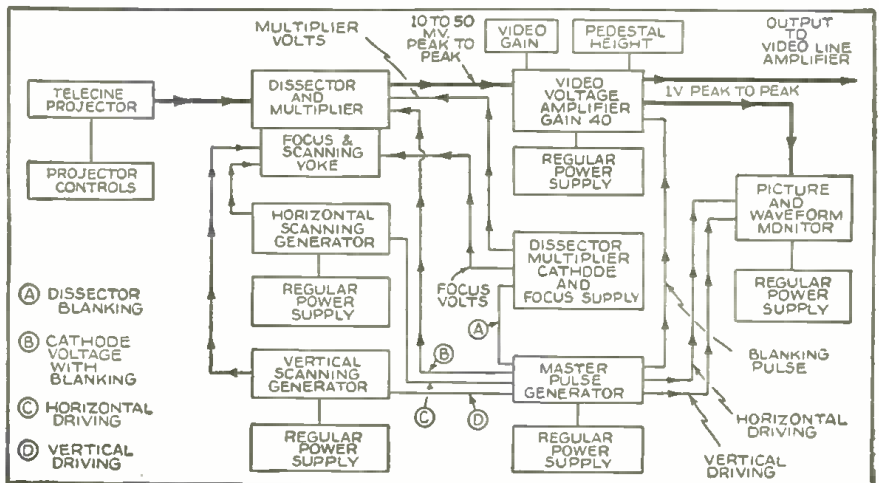

small window into the film camera located in the main control room.

There are several *talk-back* circuits between the studio, the control room, and the telecine room. One of these is provided for each of the three cameras. In this way, the producer in the control room may talk to the cameramen individually or to the studio at large.

The camera outlets in the studio are mounted underneath the control room window where microphone and light outlets also are located. Normally, each camera has about 65 feet of cable, but there is an additional 80 feet which can be drawn into service if the camera must be moved that far.

To light the studio, we can use about 200 kw. of d.c. and about 50 kw. of a.c. We expect to use incandescent lamps on d.c. for both key and spot-lighting, and special gas discharge lamps on a.c., connected in three phase in order to eliminate 60 cycle interference.

Many more problems will present themselves, no doubt. We can only wait until they turn up in order to solve them, since everything about television is like venturing into an unknown land. We must make our own way with answers of our own devising.

Television in Police Work

Gerald S. Morris

(Continued from page 69)

televised, but this, of course, would only be of service after many tens of thousands of television receivers were in general use.

At times, identification is made through garments found on the body, teeth, tattoo marks, operation scars, etc. This entails a great deal of work on the part of the police, who must send a photograph of the article or a description of its marking to a long list of manufacturers, jobbers and retail stores, doctors, dentists, etc.

The task could be simplified to some extent if the object were placed before a television pick-up and its image radiated. Attention of persons who might logically aid in identification could be directed to these television transmissions by means of the daily papers or bulletins broadcast over the radio. For example, if the object was a pair of shoes, persons in the shoe business might be requested to report at their local precinct station at a given hour or at a receiver set up in the manufacturers' office to observe the shoes or other articles which were found at the scene of the crime.

Facsimile, too, might well have its place in police work, for through its use one department would be able to send a permanent printed record of material similar to the foregoing, fingerprints, questionable documents, signatures on checks, etc., to various other departments. In cases where high speed is an essential and where the actual person or object is available, television would probably prove superior, but if only photographs were at hand but where it was essential to make a permanent record, though not at such high speed, facsimile equipment might be used to advantage.

Of course, all these uses of television and facsimile in police work are still in the future, and no concrete plans for either of these two instrumentalities can be announced as yet, as television has not yet reached the stage of development where it can be employed as has been suggested in the foregoing.

Complete RADIO TRAINING for \$1.95

Regular \$39.00 RADIO TECHNICAL INSTITUTE Course



AN UNUSUAL OFFER

A limited quantity of R.T.I. \$39.00 radio servicing courses have been reprinted and are offered to you at only \$1.95. These are the latest courses, complete in every detail with all supplementary material, and exactly the same as the original text.

You know radio is the present-day opportunity field. Hundreds of men with no special talents have studied Radio Servicing for a short time and are now making twice and three times as much money. R.T.I. unique radio training brings rich rewards; you can get ready quickly, inexpensively, easily, and in your spare time for a good job in radio.

ACCEPTED BY INDUSTRY

Forty large radio manufacturers have helped to prepare the R.T.I. course. Just think what this backing by the radio industry means to you. R.T.I. practical training will give you facts and real data you will need on the job. Hundreds of diagrams and illustrations will help you. You will pass quickly from lesson to lesson and in a surprisingly short time will be ready to do real radio servicing.

COMPLETE IN ALL DETAILS

No special previous education or experience is needed. R.T.I. course will give you all the training you need. The lessons are clear, interesting, easy to master and use. Fellows who knew nothing about radio before taking the R.T.I. course are now the leading servicemen in their communities. This is your chance to obtain this excellent course for only \$1.95. From the very start you are introduced to practical servicing equipment and practices. You are told how to open your own shop or radio store. Lesson 15, "The Radio Servicing Business," will give you many practical ideas and hints. The course is so planned that you will be able to earn spare-time money before you have reached your tenth lesson. The special \$1.95 price of the complete course can be earned in a single evening's work.

YOUR GUARANTEE

You are completely protected. We guarantee these courses to be exactly as the original \$39.00 Radio Technical Institute course. Money back guarantee. Reference: Liberty National Bank, Chicago.

THREE COURSES IN ONE

R.T.I. course is really three complete essential courses combined. You get training in (1) Practical and Applied Radio; (2) Fundamentals of Radio Principles; and (3) Advanced Specialized Training. This is the training that will place you above the average radio servicemen—and you get this training for only \$1.95.

There are over 32,000,000 radio sets in use. Over 4,500,000 auto radios alone. You should cash in on this gigantic money market. The R.T.I. easy practical course will pave the way to your success in radio work.

TELLS HOW TO USE INSTRUMENTS

The training is complete. Everything from simple facts to complex alignment problems. Many servicemen have found that R.T.I. training is excellent for brush up and study of modern servicing methods. This is the best buy in a radio education. Take advantage of the bargain price today.



LATEST DATA

Yes, in the R.T.I. course you will find a complete explanation of A.V.C. how to use an oscilloscope, sound feed-back, resonance phenomenon . . . every possible fact you must know to be the best servicemen. You get real radio training. One of the BEST radio courses is yours for only \$1.95.

LIMITED QUANTITY

Hurry Your order to us today. There is but a small quantity of the courses left at the special price. You are completely protected with our guarantee. Send total remittance with order, or we will ship C.O.D. Postal money orders, checks, currency, unused stamps accepted. Answer today.

SUPREME PUBLICATIONS, Agents
3729 W. 13th Street, Chicago, Ill.

Please send the complete R.T.I. radio course at the special \$1.95 price.

- I am enclosing \$1.95, send prepaid.
- Send C.O.D. I will pay mailman \$1.95, plus a few cents postage.

NAME

ADDRESS

SHORT WAVE COIL DATA BOOK
COMPLETE COIL DATA AND CIRCUITS FOR ALL TYPES OF RECEIVERS AND TRANSMITTERS
Price 25 Cents
RADIO PUBLICATIONS
37 Hudson Street
New York, N. Y.

The 1 and ONLY

SHORT WAVE COIL DATA BOOK

Every experimenter knows that the difference between a good and a poor radio set is usually found in the construction of short-wave coils. Coil winding information is vitally important and in the new coil book all "dope" appears. There are illustrations which give instructions on how to wind coils, dimensions, sizes of wire, curves and how to plot them. Every experimenter needs this book—it also contains complete data on all types of receiving coils, together with many suitable circuits using these coils. Also complete data on various types of transmitting coils with many transmitting circuits such as exciters and amplifiers using the various coils described.

Contents Briefly Outlined

- S-W Tuning Inductance Charts • Coil Data for T. R. F. Receivers • One Tube Oscillodyne • Two Tube Bandspreeder • The Mono-Coil • 2-Tube Old Reliable • 2-Tube Globe Trotter • 2 Winding Coils—10-600 Meters • Double 3-Tube "Signal Gripper" Electrified • 3-Tube Bandspreeder for the Ham • General Coverage Coils on Ribbed Forms • Coil Data for Superhet or S-W Converter • Ultra S-W Coils • Switch Coils for S-W Superhets • Experimental Coils • S-W Antenna Tuner • Most Popular S-W Tuning Circuits • Self-Supporting Transmitting Circuits Employing Coils Described • All Band Antenna Tuner for Transmitting • Plug-in Coils for Exciters • Frequency-Wavelength Conversion Chart.

PRICE 25c PREPAID

For a copy of this handy book, send 25c in U.S. Coin or stamps to

RADIO PUBLICATIONS
97 HUDSON STREET NEW YORK, N. Y.

SOLAR gives you MORE for your money
MINICAP
Catalog upon request
SOLAR MFG. CORP., 599 Broadway, New York

Choose the CANNON-BALL HEADSET You Like Best

Rugged construction. Inside or outside terminals. Sensitive. Clear tone. Headset dependable quality. Headquarters guarantee satisfaction. Write for folder T-7.

C. F. CANNON COMPANY
SPRINGWATER, N. Y.

H. G. CISIN'S FAMOUS KITS

1939 Senior Metal Tube SPACE EXPLORER

All-Wave All Electric Beam Power 5 Tube Communications Receiver



SEVEN NON-SKIP OVERLAPPING BANDS—8 1/4 to 2000 meters. Professional Band Spread, Beam Power, Communications Set.

POWERFUL, SENSITIVE, SELECTIVE— Ultra-Modern Features include: Beam Power Output, Built-in Full Toned Electro-Dynamic Speaker, Patented Clean A.C. D.C. Circuit, Low Loss Diode Supply

Band Spread on all bands, Self-Contained Power Supply Precision Filtered to eliminate hum, Full Vision Dial, Antenna Control, Headphone Jack, Dual Regeneration Control, Beam Power tube furnishes over 2 regulated power to dynamic speaker giving Full Loud Speaker Volume, Studio Tone Quality, Sturdy drilled metal chassis. Verified foreign reception reported by many owners. Gives professional results, but plans are so clear anyone, even a novice, can build this set successfully.

Uses 100% Metal Tubes rather than low-priced "g" type tubes in carefully engineered circuit as follows: one metal tube 6J7, one metal tube 6C5, one metal tube 25L6, one metal tube 25Z6, one metal tube K-55-A; as tuned screen grid pentode regenerative detector, powerful 1st audio amplifier, 2nd audio two-way Beam Power Output, Half-wave rectifier and automatic ballast stage.

\$5.95

Complete Senior Space Explorer Kit of all chassis parts, Power Supply and clear, simplified wiring diagram (unwired, less tubes, coils and speaker)

Five Matched Metal Tubes \$3.75; Four S.W. Coils 8 1/4 to 200 meters \$1; Two Beam Coils 200 to 625 m \$1; Long Wave Coil 550 to 2000 meters \$1; Full toned Dynamic Speaker \$1.95; Attractive two-toned wood cabinet \$1.50; Wired and tested \$2.25 extra. Shipping weight 7 lbs. Send stamp for Circular. 25% deposit on all C.O.D. orders.

SPECIAL—Senior Space Explorer, Complete Assembled, Wired, Factory Tested Chassis, with all coils 8 1/4 to 625 meters, set of matched metal tubes, built-in dynamic speaker, ready to use \$15.35

Circulars available on following Kits: Model 3AE Three Tube All Electric All-Wave \$3.20; Model 3B Three Tube Battery All-Wave including Tubes and Earphone \$3.45; Air Scout Jr. Broadcast 1 Tube Battery Kit including Tube \$1; Two Tube All Electric Transmitter including Tubes \$1.

H. G. CISIN, CHIEF ENGINEER
Affiliated Engineering Institute, Dept. S-56
98 Park Place, New York, N. Y.

EXTRA MONEY FOR YOU

Cash In!

MAIL ORDER PLANS
TESTED MONEY MAKERS
BUSINESS SECRETS
SUCCESS SCHEMES

66 PAGES

25 CENTS

A MARVEL BOOK
40,000 WORDS
In TEXT!
you get ALL the real money-makers — dozens of profitable tested mail order plans, confidential business secrets, dozens of practical tested formulas, successful tested schemes—actual experiences of men who have started on a shoestring—with less than \$10 capital. Money-Back Guarantee.

"CASH IN" contains only tested ideas covering every type of full- or spare-time enterprise—it's a "masterpiece" in business ventures.
25 CENTS per copy. Sent POSTPAID anywhere upon receipt of 25 cents U.S. stamps or coin.

NATIONAL PLANS INSTITUTE
246-T FIFTH AVENUE NEW YORK, N. Y.

AMERICAN MICROPHONE CO., Inc.
LOS ANGELES, CALIF.

D6T DYNAMIC Microphone

A Sturdy, Multi-use, Quality Microphone with Higher Output and advantageous Directivity Characteristics.

Output level -46, usable range 30-7000 cps.

D6T, High Imp., \$27.50; D6, Low Imp., \$25.00
Including Cable

General catalogue describes other attractive models. Request copy.

2 1/2, 5 and 10 Meter Superhet.

(Continued from page 101)

allel. Coupled to this detector is a 6Z7G used as an automatic noise limiter. A slight modification of the new Dickert noise limiter, it automatically squelches noise voltages that are more than twice the level of the desired signal. Experiment has shown that if the noise voltages are kept at less than twice the level of the received carrier, the noises will not only be unobjectionable but hardly noticed. The simplicity of the circuit belies its effectiveness and is well worth the additional tube necessary for its use. In wiring this circuit, keep all the resistors and condensers as close to the tube as possible. All leads should be as short as possible. The switch used to turn the limiter on or off is mounted on a bracket near the tube with the shaft extending through the front of the chassis. These precautions will result in really beautiful operation of the limiter, which is effective on c.w. as well as on phone signals.

Beat Oscillator: For a beat oscillator, the author employed a dual triode 6C8G. Since

operating a large speaker on even the weakest of signals, the 6L6 audio power tube is used. The screen grid voltage should be adjusted to about 125 volts. The output transformer should have a primary impedance of 14,000 ohms and a secondary impedance to match the speaker being used.

The completed receiver was mounted in a standard 8 3/4" x 17 1/4" cabinet. Both the r.f. and audio gain controls are mounted on the top of the chassis and flexible shafts used to couple them to the knobs on the front panel. The various photos clearly show the position of the different components.

For lining up the i.f. transformers, it is preferable to have a service oscillator. With the test oscillator adjusted to 3400 kc. and connected to the grid of the 954, successively adjust the three i.f. transformers, starting with the one between the 954 and the first 6SK7 tube, and adjust each trimmer for maximum signal output. The high frequency circuits should of course have been

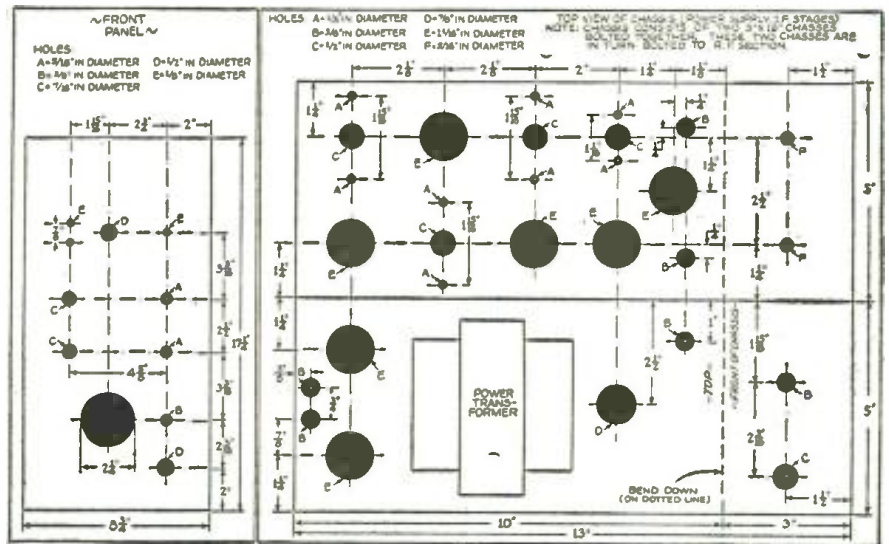

Chassis Details.

it contains two entirely separate triodes in one glass envelope, this tube is particularly well suited for use as a first stage of audio as well as a beat oscillator. The 3500 kc. BFO transformer has a grid leak and condenser already wired-in. The section of the 6C8G which has the grid at the top of the tube is used for the BFO. Although not shown in the photo, it might be advisable to place a shield around the 6C8G tube, especially if a cabinet is not used.

In order to couple the BFO to the second detector, a lead from the BFO plate is twisted about four times around the lead to the 6H6 plate. This will provide the correct amount of coupling. Switching on the BFO and switching off the AVC is done simultaneously with a double pole rotary switch mounted on a bracket so that the switch is near the 6C8G and 6H6 tubes. The switch shaft projects through the front of the chassis, about 2 1/2" away from the noise limiter switch. Since the AVC and BFO should never be on at the same time, it is entirely practical and logical to use a single switch to control both circuits.

Loud Speaker Reception

The output of the audio section of the 6C8G provides not only sufficient output for headphone operation, but can operate a small speaker on the louder signals. For

lined up as described last month.

Incidentally, the i.f. trimmers are of the adjustable coupling type. As supplied by the manufacturer, they are adjusted for optimum selectivity. By re-adjusting the coupling between the two windings in the transformer, either greater or lesser coupling can be secured, resulting in broadening or sharpening the selectivity. If much listening is to be done on 2 1/2 meters, it might be advisable to increase the coupling, since many of the transmitters in that band are not very stable and a broad i.f. will facilitate reception of these signals. However, where 5 and 10 meters are to be used most, the author would recommend leaving the transformers at their optimum coupling adjustment, or even decreasing the coupling and thereby sharpening the selectivity curve.

The "R" meter depends for its action on the AVC. It must always be used with the AVC on and the BFO turned off, while the r.f. gain control is at maximum. Initial adjustments are made as follows. The 1000 ohm "R" meter adjuster is varied until the "R" meter reads zero current. This should, of course, be done with the r.f. gain control at its maximum gain position and the AVC turned on. The antenna should be disconnected or no signal received. When a signal is received, the meter will show the relative strength of that signal. Always return the

R.F. gain control to its calibrating position of maximum R.F. gain when reading the "R" meter.

Parts List

NATIONAL COMPANY

- 7—8-prong CIR sockets
- 1—No. 8 grid grip clip
- 1—Type C-NC100 gray cabinet, less chassis
- 1—Each HRO dial 0-10, audio dial 0-10; R.F. gain dial 0-10
- 2—Small bar knobs
- 2—TX-11 flexible couplings
- 2—Type SB shaft bushings
- Through point victron bushings

INTERNATIONAL RESISTANCE CO.

- 1—Each 1500, 25,000, 250,000, 500,000 ohms; 1/2 watt type BT 1/2
- 2—Each 300, 75,000 ohms; 1 megohm; 1/2 watt type BT 1/2
- 3—Each 2,000, 50,000 ohms; 1/2 watt type BT 1/2
- 4—100,000 ohms; 1/2 watt type BT 1/2
- 1—350 ohms; 10 watt type AB
- 1—25,000 ohms; 25 watt, type DIIA with 2 adjustable bands
- 1—1,000 ohm control, type 11-108
- 1—10,000 ohm control, type 14-116
- 1—1 megohm control, type 13-137

ALADDIN RADIO INDUSTRIES

- 2—3500 kc. I.F. transformers, type A-3500
- 1—3500 kc. I.F. transformer, type A-3502
- 1—3500 kc. BFO transformer, type C-3550

BRUSH DEVELOPMENT CO.

- 1—No. 200 type A crystal headphones

RCA MANUFACTURING CO.

- 2—6SK7; 1 each 6H6, 6L6, 5T4, 6C8G, 6Z7G

SOLAR MANUFACTURING CO.

- 2—4 mf. 450 v. minicap electrolytic condensers, type M414
- 2—25 mf. 25 volt electrolytics, type MO25
- 1—8 x 8 x 8 mf. 500 volt, type D1877
- 2—50 mmf. mica condensers, type MO1410
- 1—.0001 mf. mica condenser, type MO1416
- 1—.1 mf. paper condenser, type SO238
- 4—.05 mf. paper condensers, type SO228
- 6—.01 mf. paper condensers, type SO219

THORDARSON ELEC. MANUFACTURING CO.

- 1—Power transformer, type T-13R13
- 2—Filter chokes, type T47C07
- 1—Universal output transformer, type T-17S57

TRIPLETT ELEC. INSTRUMENT CO.

- 1—0-1 ma. "R" meter, type 221

PAR-METAL PRODUCTS CO.

- 2—5" x 10" x 3" cadmium plated chassis, type C-4508

R. P. MALLORY & CO.

- 2—2-circuit, 2-contact rotary switches, type 3222J
- 2—Insulated tip jacks, type No. 520
- 1—2-circuit phone jack, type 704A

5 & 10 Meter Converter

(Continued from page 102)

the most effective converter tube yet produced for the u.h.f.'s. Among its advantages in this circuit are higher conversion gain, low input and output capacities, and complete independence of its mixer and oscillator sections. The result of this latter is that the tuning of the two circuits is accomplished without interaction of any kind.

The coils are of the plug-in variety, hand-wound and mounted on standard National coil plugs. Winding data appears at the end of this article. The oscillator coil (L4) for each range has its trimmer and padder condensers mounted directly on the coil. These condensers, of 3 to 30 mmfd. each, are utilized to adjust the band-spreading and, by thus including the condensers in the coil assembly, different degrees of band-spreading are provided for each range.

The oscillator is separately tuned by its own dial. It was considered impractical to gang this circuit with the other two for several reasons. In the first place wide band-spreading is not necessary in the r.f. circuits but is essential in the oscillator circuit, so with the oscillator tuned by itself the spread can be adjusted to any degree desired with-

out the necessity for realigning all three circuits for similar spread. Second, if it is desired to shift the intermediate frequency (the frequency to which the receiver is tuned) it is only necessary to tune the oscillator correspondingly higher or lower, with no alteration in the r.f. tuning.

The output transformer (T1) has a tuning range of about 2500 to 6000 kc. and provides a practical means for coupling the converter to any receiver, with the receiver tuned anywhere in this range. The frequency recommended by the designer is 5.7 megacycles. At this high i.f. the converter tube functions more efficiently, images are effectively eliminated on all tuning ranges and "birdies" resulting from harmonics of the receiver oscillator beating with the converter oscillator are avoided. In cases where the receiver will not tune as high as this, a lower frequency, anywhere down to about 2500 kc. may be employed.

The stand-by switch is one of the d.p.s.t. type, one side breaking the B+ circuit of the converter, the other terminating in screw connectors at the rear of the chassis. The coil which covers the 5-meter band can,

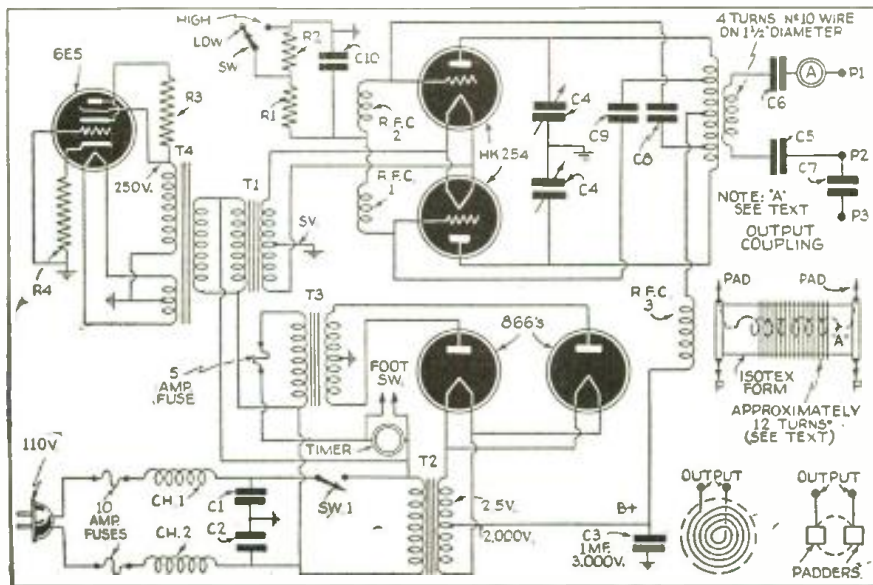

Your Test Problems Solved WITH A.T.A. INSTRUMENTS

710-VOLT-OHM-MILLIAMMETER

- Beats all competition for value, cost, appearance and accuracy. 3" D'Arsonval meter.
- Notice the available tests.
- 0-2.5/10/25/50/100/250/500/1000 and 2500 Volts d.c.
- 0-10/100/1000 D.C. Milliampers
- 0-2500/25000/250000 Ohms.
- Completely out-classes all instruments of similar design. Neat case and etched panel provide a professional finish.



Net Complete Only **\$5.85**

MODEL 720 AC-DC UNIT

Similar to above but also includes the following ranges—

- 15/150/1500 Volts AC.
 - 0/15/150/1500 Output Ranges.
- Net Complete Only **\$7.85**

1200E "Instantometer" Push Button Tester



- Simple, Speedy and Accurate testing with the "instantometer."
 - Study these Available tests—
 - 0 to 2500 volts in five steps; 0 to 1500 A.C. volts in three steps; 0 to 1000 D.C. Ma in four steps; 0 to .25 megohm in three steps; -10 to plus 53 db. in three steps; 0/10/25 D.C. amperes; Wattmeter; from .006 to 600; 1-700 henries inductance and Qualitative paper condenser tests. In addition to Electrolytic leakage Tests.
- Complete with prods batteries and instructions **\$12.95**
Cover extra .75

740 Giant Laboratory Tester

- Tests: 0/15/150/750 volts D.C., 0/1/15/150/750 Ma, D.C.; 0/15/150/150/750 Volts A.C.; 0/15/150/750Ma.A.C.; 001/1/200 mids; 0/500 and 500/5 megs; -10 to plus 19/38/53 db; 0/15/150/1500 output range; 1/700 henries; 006/600 watts. Uses 9" round D'Arsonval Jewelled meter, 0-1 ma. movement at 1000 ohms per volt sensitivity.



Complete Net Price **\$18.95**

Portable Cover extra \$1.00
SERVICEMEN! Why not write for our general catalog?

APPROVED TECHNICAL APPARATUS CO.
57 1/2 Dey St. — New York City

It will pay you...

to write to me whenever you want to buy an Amateur Receiver, Television Receiver, Transmitter, or any other equipment. More and more men, since 1925, have been buying their supplies from me and that's a sure sign that I give a fair and square deal, every time!

My personal attention to your wishes, fair trade-in allowances, reasonable terms for your convenience, prompt safe delivery, and above all—a sincere desire to give you full co-operation—is your assurance of complete and lasting satisfaction.

Be sure to write to me.

73

Bill Harrison, W2AVA

**Authorized Factory Distributor
of all
AMATEUR RECEIVERS**

"Ye Trading Post"

(my Used Dep't) has many good reconditioned and guaranteed trade-in Receivers and Transmitters at attractive prices. Good values! Send stamp for list.

So many of my Amateur customers are also
CAMERA FANS

that I have put in a large stock of cameras, enlargers, film, accessories, and supplies. I call this my

CAMERA DIVISION

and I welcome your inquiries and orders.

HARRISON RADIO CO.
12 West Broadway, New York City

Radio Men Find This Book Handy

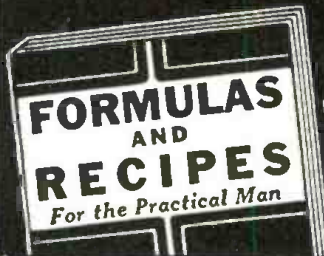

Here is the Contents of the Book

1. Adhesives: Glues, Cements, Gums, Mucilages, Lubricants. 2. Cleansing: Stain Removers, Paint Removers, Bleaches, Cleaning Fluids. 3. Metal Craft: Coloring, Oxidizing, Plating, Repairing, Welding, Polishes, Alloys, Solders, Amalgams. 4. Paints: Colors, Stains, Varnishes, Enamels, Luminous Paint, Washable Paint; Paint-Removing, Waterproofing, Fireproofing. 5. Glass-Working: Cutting, Drilling, Boring, Bending, Blowing, Etching, Engraving, Frosting, Silvering, etc. 6. Wood-craft: Fillers, Fireproofing, Acid-proofing, Waterproofing, Furniture Polishes, Finishes, etc. 7. Inks: Recipes, Eradicators, Ink Stain Removers, Special Inks, Colored, Indelible, Sympathetic, Invisible, Hectograph. 8. Photography: Developers, Emulsions, Filters, Sensitizing, Toning, Printing, Photographic Paper, Blueprint Paper. 9. Antidotes for Poisons, Remedies for Burns and Scalds, Disinfectants, First-Aid in Accidents, Emergency Remedies, Home Remedies. 10. Preparation, Manipulation, Handling, Mixing, Measuring, Weighing, Filtering, Straining Solutions; List of Technical Substances; Emulsifying; Use of Hydrometer; Use of Thermometer; Tables of Weights and Measures, Decimal Systems, Useful Tables.

TECHNIFAX, Division RT-639
560 W. Washington Blvd., Chicago, Illinois

TECHNIFAX, Division RT-639
560 W. Washington Blvd., Chicago, Illinois

Gentlemen: Enclosed please find 50¢ (check, money order, coin or unused U.S. stamps accepted) for which send me **POSTAGE PREPAID**, One Copy of **FORMULAS AND RECIPES** for the Practical Man.

Name
Address
City State

for instance, be adjusted to just cover the 56-60 mc. amateur band if desired. In the model, this band is spread from 5 to 90 on the dial.

Signals can be tuned in even when the out coupling transformer is considerably off tune and with a signal tuned in, it is only necessary to adjust the screw at the top of the transformer can for maximum output. This adjustment will remain correct as long as the receiver is left tuned to the same frequency.

COIL DATA

The schematic diagram shows how the coils should be made up and mounted on the plug-in bases. Make sure when wiring the jack assembly for the plug-in coils that the various leads coincide with the coil wiring.

5 METER COILS:

Antenna coil—4 turns of push-back wire, approximately $\frac{3}{8}$ " inside diameter, wound in same direction as grid coil and interwound on same, near grid end.

R.F. grid coil—7 turns of No. 14 bus bar, $\frac{1}{2}$ " inside diameter round. Spaced to fit terminals of plug.

Combined R.F. plate and mixer coil—7 turns of No. 14 bus bar, wound on $\frac{1}{2}$ " diameter. Spaced to fit terminals designated.

Oscillator coil—7 turns of No. 14 bus bar wound on $\frac{1}{2}$ " diameter, with center tap. Spaced to fit plug terminals, center of coil. The two 3-to-30 mica trimmers should also be mounted on plug.

40-46 MC. COILS:

(Same wire, etc., as 5 meter coils)

Antenna coil—5 turns

R.F. grid coil—11 turns

R.F. plate coil—11 turns

Oscillator coil—10 turns tapped at 5th.

10 METER COILS:

Antenna coil—6 turns push-back wire, approximately $\frac{3}{8}$ " in diameter, interwound at center of R.F. grid coil.

R.F. grid coil—14 turns of No. 14 enameled wire, wound on $\frac{3}{8}$ " diameter and spaced to fit prongs.

Combined R.F. plate and mixer coil—14 turns of No. 14 enameled wire, wound on a $\frac{3}{8}$ " diameter and spaced to fit prongs.

Oscillator coil—12 turns of No. 14 enameled wire, wound on a $\frac{3}{8}$ " diameter and spaced to fit prongs, with the two 3-to-30 mmfd. mica trimmers mounted on plug-in assembly. Tapped 5 turns from grid end.

Parts List

NATIONAL

- 2—Type B dials, 100-0-100
- 2—Dial illuminators
- 3—XB16 coil sockets
- 3—XB16 coil plugs

HAMMARLUND

- 1—Octal Iso socket
- 2—3-30 mmfd. mica trimmers

CARDWELL

- 1—10 mmf. trim-air with rear-shaft extension
- 1—10 mmf. trim-air with solid shafts
- 1—15 mmf. trim-air

AMPHENOL

- 1—4P socket for chassis mounting
- 1—8P Octal socket (ceramic)

AEROVOX

- 3—Mica condensers, .01 mf.
- 3—Mica condensers, .005 mf.
- 3—Mica condensers, .0001 mf., small size
- 1—Mica condenser, .00005 mf., small size

SOLAR

- 1—8.8 mf., 450 V. electrolytic
- 1—Trutest .1 mf., 400 volt, paper
- 1—Trutest power transformer
- 1—Trutest choke
- 1—Bakelite 2-lug mounting strip
- 2—Bakelite 1-lug mounting strips

IRC

- 8— $\frac{1}{2}$ watt BT resistors:
 - 1 250 ohm; 1 3000 ohm; 1 30,000 ohm;
 - 1 50,000 ohm; 1 60,000 ohm; 1 3000 ohm;
 - 1 1-meg.; 1 125,000 ohm
- 1— $\frac{1}{2}$ watt type BW $\frac{1}{2}$, 10 ohms

LAFAYETTE

- 1—5-10 converter chassis, including 2 baffle shields and 1 socket bracket, all copper-plated
- 1—Output coil assembly, tuning range 2.5 mc. to 6 mc.

PYRO PANTAGRAPH



Size of Box:
12 $\frac{1}{2}$ x 8 $\frac{1}{2}$
inches

\$2.75

VOGUE

Shipping weight, 3 lbs.

THIS electrical outfit is especially designed for burning designs permanently on materials such as Leather, Wood, Cork, Bakelite, etc. Plug the Pyro-electric pencil in any 110 volt AC or DC outlet and it is ready to be used. Plug and cord furnished.

By the use of the Pantagraph included in the outfit, any design may be reproduced either in original, reduced or enlarged form.

Outfit consists of: one Pyro-electric Pencil; one Pantagraph; three hardwood plaques; one bottle of Varnish; one Brush; one tracing tip and four-page instruction sheet.

Size of box: 12 $\frac{1}{2}$ x 8 $\frac{1}{2}$ inches.

Outfit will be forwarded by Express Collect if not sufficient postage included with your order.

WELLWORTH TRADING CO.

558 W. Washington Blvd. Dept. RT-639 Chicago, Ill.

OUR STOCK OF U.S. ARMY SIGNAL CORPS LAMPS IS RAPIDLY DEPLETING. EVEN AT \$3.95, COMPLETE WITH FITTINGS AND PACKED IN A WOODEN CARRYING CASE. THE SAVING IS NEARLY 90% FROM THE GOVERNMENT COST.



U. S. ARMY SIGNAL CORPS LAMPS

The lamp of 100 uses

Scout Signalling
Night Bowling Alleys
Trailer Lamp
Night Motor Boat Races
Auto, Truck and Trailer Camps
Tractor Light
Camp Light
Barnyard Lighting
Night Fishing
Radio Shacks
Bungalows
Picnics, etc.



Scouts Signalling

Large size—12 $\frac{1}{4}$ " wide, 5 $\frac{3}{4}$ " deep, 15" high includ. inc. socket, fitted with 10" silver plated reflector (no glass, nothing to break). Packed in portable wooden carrying case, with hinged cover, hump and handles. Every case contains weatherproof extension cord and Plug, 2 extra bulbs, telegraph signalling key and 16 page U.S. Army Instruction Manual. Shipping weight 18 lbs. Price \$23.00 (Cost the Government's about F.O.B. N. Y. \$3.95)

Same size lamp without wooden case or extra fittings \$2.00
Small lamps, 6" \$1.00
Send for catalog containing full descriptions of this and many other interesting items.

GOLD SHIELD PRODUCTS

Dept. RT-6-9 350 Greenwich St. New York

SEE PAGES 114 AND 118,
FOR SPECIAL SUBSCRIPTION OFFERS!

List of Television Broadcast Stations

(Continued from page 67)

Licenses and Location	Call Letters	Frequency (mc.) or Group	Visual Power	Aural Power
General Television Corporation Boston, Mass.	W1XG	42 to 56 mc. 60 to 86 mc. 124 to 130 mc.	500 w	
RCA Manufacturing Co., Inc. Portable (Camden, N. J.)	W3XAD		500 w	500 w
RCA Manufacturing Co., Inc. Camden, N. J.	W3XEP	42 to 56 mc. 60 to 86 mc.	30 kw	30 kw
RCA Manufacturing Co., Inc. Portable-Mobile Camden, N. J.	W1OXX	42 to 56 mc. 60 to 80 mc.	50 w	50 w
General Electric Company Bridgeport, Conn.	W1XA	60 to 86 mc.	10 kw	3 kw
General Electric Company Albany, N. Y.	W2XB	60 to 86 mc.	10 kw	3 kw
General Electric Company Schenectady, N. Y.	W2XD	156 to 162 mc.	40 w	
General Electric Company Schenectady, N. Y.	W2XH	42 to 56 mc.	40 w	
First National Television, Inc. Kansas City, Mo.	W9XAL	42 to 56 mc. 60 to 86 mc. 42 to 56 mc.	300 w	150 w
University of Iowa Iowa City, Iowa	W9XZV	42 to 56 mc. 60 to 86 mc.	1 kw	1 kw
Zenith Radio Corporation Chicago, Ill. (Irregular)				
Kansas State College of Agriculture and Applied Science Manhattan, Kansas	W9XAK	2 to 2.1 mc.	125 w	125 w
(60-line images now; expect change to high definition in autumn)				
Purdue University West Lafayette, Ind.	W9XG	2 to 2.1 mc.	1½ kw	
University of Iowa Iowa City, Iowa	W9XK	2 to 2.1 mc.	100 w	

How NBC Television Evolved

(Continued from page 70)

width of 30 megacycles with discrimination. This leaves an ample margin, since present standards do not call for video signals broader than about 4,000,000 cycles. There are, I understand, few antenna systems in the world today capable of satisfactorily passing a signal of even this band width.

The radiation components consist of two doublets for the video signal and four doublets for associated sound. The units nearest the top of the antenna are for sound signals. The system is built around a unique type of doublet, which doubles back on itself. The four together form a complete loop. Four torpedo-like shapes comprise the two doublets for transmission of the video signal. Interference between sight and sound signals has been eliminated by a calculated arrangement of the two antennas and by using the equivalent of a closed loop for the sound channel and open radiators for the video signal. Both antennas are energized through concentric feeders in a common vertical shaft.

In preliminary test transmissions over the NBC transmitter, the antenna has lived up to advance expectations. The pictures I received at my home in Westport, Connecticut (a distance of 46 miles), were fully 50% better than those we broadcast last year. The antenna will also restore the normal service area to the NBC station. During last year's test we used a dipole arrangement on the north side of the Empire State Building, which limited service to locations north of the building.

The other notable addition to the transmitter is a *sideband filter*, a device which recalls the artistic endeavors of Rube Goldberg in his more extravagant moments. The filter, which suppresses that part of the lower sideband not used by the receiver, is a strange arrangement of tubular conductors and water-cooled resistors which effectively block the passage of frequencies below a certain point. In this case 44.5 megacycles. The video carrier is 45.25 megacycles. This new device will enable us to transmit a full four-megacycle video signal within the limits of a six-megacycle channel, while yet preserving the 250-kilocycle guard band the proper separation between video and sound carriers to prevent mutual

interference. So long as we transmitted both sidebands of the video signal we were practically limited to a maximum of about 2.5 megacycles. By partial suppression of the lower sideband, however, we are now able to widen the upper sideband to four megacycles and yet remain well within the six-megacycle channel. The additional upper frequencies mean much in added picture detail.

There have been two other changes at Empire State, one of them still not complete. The modulator unit of the video transmitter has been improved in the interest of better frequency characteristic and greater power output. The incomplete project is the construction of a new control room on the 85th floor of the building. This room, adjoining the control room now in use, will serve us for at least several years.

The principal changes made at Radio City were in the lighting system of the live talent studio and the arrangement of the associated control room. The new system of studio lighting, it is believed, is the most flexible and efficient yet designed for television. Preliminary setting of lights in position for a performance, an operation which formerly required several hours, now occupies only a few minutes. The ceiling units, furnishing what is known as "foundation" or "key" light, may be changed at will during a performance without interfering with the movement of the studio's three Iconoscope cameras. Modeling light, giving depth to the televised subject, has its source in an ingenious lighting "dolly" manoeuvred about the studio by a single technician.

One has only to be present in the studio during the televising of a show to understand the need for such a lighting system. Motion picture practice ordinarily calls for many "takes," between which lights are adjusted for the following shot. Television, with its demands for continuous performance, makes it imperative that the lighting system be flexible enough to allow for constant adjustment during the "shooting."

In rearranging the control room, directly off the *live talent* studio, we were guided by the demands for smoother and more efficient operation. The program director now sits on a raised platform at the middle of the room in a position that commands an

THIS BOOK FREE!

COVER TO COVER
it's a money saver!
AND IT COVERS
everything in radio!

▼ Send for your **FREE** copy today! Ham, serv-
▼ iceman or dealer—you'll find this great 1939
▼ catalog made to order for you. It's brand new,
▼ a marvel of completeness and right up to the
▼ minute! Everything in radio, including the
▼ talked about Built-It Yourself Kits, a big sec-
▼ tion on streamlined P.A. systems, test equip-
▼ ment . . . prices that save you real money! No
▼ mere scattering of bargains in this book. Cover
▼ to cover, it's one long parade of money-saving
▼ values. Put it to the test! Get a **FREE** copy.
▼ Simply tear off coupon and mail today!

LAFAYETTE RADIO CORP.
AND WHOLESALE RADIO SERVICE CO. INC.

NEW YORK, N. Y. CHICAGO, ILL. ATLANTA, GA.
100 SIXTH AVENUE N. 401 W. JACKSON BLVD. 345 PEACHTREE ST.
BOSTON, MASS. BRONX, N. Y. NEWARK, N. J. JAMAICA, L.I.C.

Rush New **FREE** Radio Catalog No. 76.

NAME..... PLEASE PRINT

ADDRESS.....

CITY..... STATE.....

LAFAYETTE RADIO CORP.
Dept. 4F9—100 Sixth Ave., New York, N. Y.

PASTE COUPON ON PENNY POSTCARD

KORROL

ALL METAL UTILITY CABINETS

NOW READY FOR DELIVERY

Indispensable for keeping under lock and key all **VALUABLE** parts including your QSL or SWL cards. Top drawer has 10 compartments for small parts. In the 6 and 8 drawer cabinets, the two lower ones are made into one unit to hold tubes, crystals, meters, pick-ups, camera lenses, films, micrometers, slide rules, etc. In the smaller compartments you can keep resistors, condensers, bolts, nuts, washers, etc., from being "borrowed".

	Height	Depth	Width	List
6 drawers	9"	8½"	6"	3.50
8 drawers	11½"	8½"	6"	4.50

Bar with lock and key50
Finished in wrinkle, olive green.
Amateur's Discount, 40%. Write for complete catalog.
Ask your dealer to show you a sample. If he has none, send your order direct.

KORROL RADIO PRODUCTS CO.
350 Greenwich St., Dept. 639, New York City

CREI Spare-time Training Leads You to a Better Job

CREI Home-Study Training Prepares You for a Bright Career in Practical Radio Engineering!

Don't "sit-down" on the job! Get busy and prepare yourself for the bigger jobs in store for technically trained men. CREI offers home-study training in Radio Engineering and Television. A post card brings you our 48-page book of interesting facts about your future in Radio—and how we can help you prepare for it.

CAPITOL RADIO ENGINEERING INSTITUTE
Dept. ST-6, 3224-16th St., N.W. WASHINGTON, D. C.

SEND FOR **FREE CATALOG**



RADIO INSTRUCTION

Don't miss the fun in CW! LEARN CODE *the* CANDLER WAY!

Start right in now to learn code properly—write today for CANDLER'S FREE Book of Facts! It will tell you how you can achieve real code proficiency, develop your code speed, and get twice the fun out of CW.



It's easy to learn code the CANDLER way—and you learn it right. You get the proper fundamentals and develop sound consciousness, the real secret of fast code. After a few weeks of Candler training, you no longer read "dits" and "dahs," you read whole words and even sentences, without conscious effort, copying several words behind without strain!

Candler has trained thousands of fast operators including champions like T. R. McElroy, world's record holder. Make your first step toward real code skill today. Write for the FREE "Book of Facts."

FREE! "Book of Facts"

CANDLER SYSTEM CO.

Box 331, Dept. S-6, Asheville, No. Carolina, U.S.A.
British Address: Room 56, Craven House,
121 Kingsway, London, W. C. 2

RADIO ENGINEERING

Complete Radio Engineering Course in 96 weeks. Bachelor of Science Degree. Radio (television, talking pictures and the vast electronic field) offers unusual opportunities for trained radio engineers. Courses also in Civil, Electrical, Mechanical, Chemical, Aeronautical Engineering; Business Administration and Accounting. Tuition, living costs low. World famous for technical two-year courses. Special preparatory department for those who lack required high school work. Students from all parts of the world. Enter June, September, January, March. Write for catalog.

2469 COLLEGE AVE. ANGOLA, IND.

TRI-STATE COLLEGE

YOUR FUTURE IN

These growing industries need trained men for sales, service, operation. Your chance for employment and advancement depends on thorough training. National Schools offer you time-tested training. Complete, modern facilities and equipment in the largest trade school in the West. Est. 1905.

NATIONAL SCHOOLS

4000 S. Figueroa Street, Los Angeles

NATIONAL SCHOOLS, Dept. 6-RT, Los Angeles
Please send free Radio and Television Booklet.

NAME _____ AGE _____
ADDRESS _____
CITY _____ STATE _____

EASY TO LEARN CODE

It is easy and pleasant work to learn the modern way—with an INSTRUCTOGRAPH CODE TEACHER. Ideal for the beginner or advanced student. Always ready—No QRM—beta having some one send to you. Many tapes available ranging from alphabet for beginners to typical messages on all speeds. range 5 to 40 WPM.

FOR SALE OR RENT
Standard with 10 tapes and book of instructions \$20.25
Junior with 5 tapes and book of instructions (not rented) \$12.00
RENTAL Standard with 10 tapes and book of instructions \$3.00 first month, \$2.25 each additional month.
Write for details today

INSTRUCTOGRAPH COMPANY

Dept. SW, 912 Lakeside Place, Chicago, Ill.
Representatives for Canada:
Radio College of Canada, 863 Bay St., Toronto

easy view, at eye level, of the three monitoring Kinescopes. Two of these screens, which are nearly identical with the Kinescope of the home receiver, show the image actually on the air and, from a second camera, a "preview" of the shot to be broadcast next. On the third screen is the image being shaded and otherwise controlled by the video engineer. Switching from camera to camera is effected by the camera supervisor at the program director's side. Sound and picture controls are centered on two desks immediately in front of the program director's position.

The apparatus in the control room racks, of course, has been completely overhauled and makeshift circuits replaced by permanent installations. Everything at Radio City, in fact, from the Iconoscope deflection yoke to line amplifier has been rebuilt to incorporate the changes indicated by nearly three years of operating experience in television broadcasting.

Naturally, the beginning of regular television broadcasting brings up new problems of personnel. Up to this time we have maintained but one staff, the experimental group which not only operated our equipment but also maintained it and rebuilt it during shutdown periods. Now, however, we have a regular schedule to meet. It is desirable, therefore, to set up an operating crew. Accordingly we have added seventeen men to the technical staff, many of whom will be assigned to operating, as distinct from engineering, tasks.

Silver Trophy Award

(Continued from page 89)

used chiefly to keep a record of the DX countries contacted, which is accomplished by pressing in a small colored tack for each new country.

GEORGE J. TROSTLE,
W9FYC 612 5th Ave., Sibley, Iowa.

Note These Important Rules

The photos must be sharp and clear and preferably not less than 5" x 7".

When you submit the photograph of your Ham station, send along a brief description not longer than 300 words, describing the general line-up of the apparatus employed, the size, type and number of tubes, the type of circuit used, name of commercial transmitter—if not home-made, watts rating of the station, whether for c.w. or phone or both, etc., also name of receiver.

State briefly the number of continents worked, the total number of stations logged or contacted, and any other features regarding the station which you think will be of general interest to the reader. Mention the type of aerial system used, especially any unique or new features about it, and which type of aerial you use for transmitting and receiving; also what type of break-in relay system, if any, is used.

Important—Don't forget to send along a good photograph of yourself, if your likeness does not already appear in the picture!

Note that you do not have to be a reader of RADIO & TELEVISION in order to enter the contest. Pack all photographs carefully and the description had best be mailed in the same package with the photos. The Editors will not be responsible for photos lost in transit.

Do not send small, foggy-looking photos because they cannot be reproduced properly in the magazine. If the picture you have or may take of your station is not thoroughly sharp and clear and at least 5" x 7", it would be best to have a commercial photographer take a picture of your station. If you cannot do this, you most probably have a friend who owns a good camera and who can arrange to take the photograph.

Address all photos and station descriptions to Editor, Ham Station Trophy Contest, c/o Radio & Television, 99 Hudson Street, New York, N. Y.

4 Stations Now in Fac-Sim-Chain

When the regularly operating Mutual Fac-simile Network went on the air in mid-April, a portion of the full 90-minute transmission emanated from WJHK, Cleveland, which then became the first addition to the original tri-station fac-simile hookup. WGN, Chicago; WOR, Newark, and WLW, Cincinnati, comprised the original network.

RADIO INSTRUCTION

READ SEND **CODE** Like an Expert

Learn Quickly at Home—Get Real Speed

It's easy, fascinating, to become a good operator with the NEW ALL ELECTRIC MASTER TELEPLEX CODE TEACHER to help you. Only instrument ever produced which records your sending in visible dots and dashes—then sends back to you at any speed you desire. Also sends practice work, recorded by an expert. That is why so many schools teaching code prefer Master Teleplex, why thousands agree this method is surest and quickest.

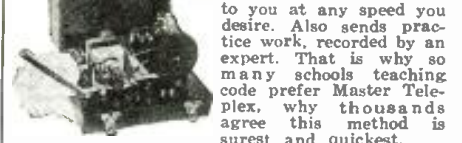

FREE BOOK We furnish Complete Course, lend you Master Teleplex, give you personal instruction with a MONEY-BACK GUARANTEE. Low cost. Send today for booklet \$6, no obligation.

TELEPLEX COMPANY
67-69 Park Place, New York
in Canada write:
CANADIAN ELECTRONIC INST., TORONTO, ONT.

RADIO ENGINEERING

RCA Institutes offer an intensive course of high standard embracing all phases of Radio and Television. Practical training with modern equipment at New York and Chicago schools. Also specialized courses and Home Study Courses under "No obligation" plan. Catalog Dept. SW-39.

RCA INSTITUTES, Inc.
A Radio Corporation of America Service
75 Varick St., New York. 1154 Merchandise Mart, Chicago

BE A RADIO SERVICE EXPERT

Modern receivers require men with modern training for service work

LEARN AT HOME
Our home instruction method and service equipment offer starts you earning money almost at once. Up to \$3 an hour easy in a short time. Write for free book.
Radio Training Ass'n of America
Dept. RT-96
4525 Ravenswood Ave., Chicago

AMATEUR RADIO LICENSES

Day and evening classes in code and theory
Home Study Courses

Hundreds of students now on the air. Results guaranteed. Reasonable, efficient and thorough.

AMERICAN RADIO INSTITUTE
1123 BROADWAY NEW YORK, N. Y.

LEARN RADIO TELEVISION

500 LICENSED graduates placed in past 7 years in shipping, broadcasting, aviation, police, etc.; we also teach radio servicing and repairing; new beginners' class now forming; 60-page catalog free; oldest, largest and best equipped.

MASS. RADIO SCHOOL
18 BOYLSTON ST., BOSTON Est. 1899

RADIO COURSES

New Fall Classes Start in September
RADIO OPERATING—BROADCASTING

- RADIO SERVICING — a practical course
- RADIO AMATEUR CODE ● TELEVISION
- ELECTRONICS—1 yr. day course 2 yrs. eve.

Day and Evening Classes. Booklet Upon Request.
New York Y.M.C.A. Schools
4 W. 64th Street New York City

RADIO ENGINEERING

broadcasting, aviation and police radio, servicing, marine radio telegraphy and telephony, Morse telegraphy and railway accounting taught thoroughly. 48 weeks' Engineering course equivalent to 3 years of college radio work. All expenses low. Catalog free. School established 1874.
Dodge's Institute, Turner St., Valparaiso, Ind.

NEWEST RADIO APPARATUS

New Exciter Tuning Unit

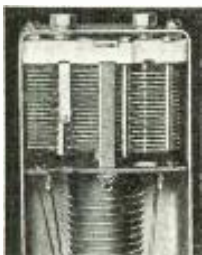

● A NEW exciter tuning unit for use in amateur all-band transmitter exciters, has been announced by the Hammarlund Mfg. Co., Inc. Looking much like i.f. transformers, each unit contains two double-spaced midjet condensers and a coil. The condensers are mounted on an Isolantite base, and the coils are wound with heavy wire on threaded bakelite tubing. A link

coil is provided to permit the use of these units in either capacitive or link-coupled circuits. Designed to operate with 6L6 tubes, the units are available for the 80, 40, 20 and 10 meter amateur bands, completely wired and ready for installation.

Facsimile Kit

● THE amateur who likes to build his own radio receivers can now add another interesting radio development to his accomplishments. He can secure the parts and build his own facsimile radio printer. Because of the great interest aroused by this latest development in radio, The Crosley Corp. has prepared a kit containing all the parts necessary to build a Reado facsimile printer which the amateur can operate in connection with his own radio receiver.

Facsimile radio printing is in its infancy today just as radio itself was twenty years ago, and with the possibility of radio printing coming into widespread use in homes and in other places as yet untouched, the radio amateur has a highly interesting field in which to carry on his experiments.

The Crosley Reado radio printer is a development of the Finch facsimile method and is being used in many places throughout the country.



Permeability Tuner and Kit

● ONE of the most novel devices to make its advent in recent months is the Aladdin Radio Industries Q Control Permeability Tuner. This permits the construction of a broadcast receiver without the use of any variable condensers whatsoever. A highly ingenious arrangement permits all tuning to be achieved by varying the cores of the two tuning coils. A very clever mechanism raises and lowers the cores into the pair of coils as the tuning dial is varied. The instrument is handsome in appearance and may be had in a kit, complete with the necessary i.f. transformers. The completed receiver, shown in the detailed instruction book accompanying the kit, utilizes a 6A8, a 6K7, a 6Q7, a 6F6 and a 24. A set of this type should be highly efficient as it makes use of inductive tuning.



Multi-Range Wave Trap

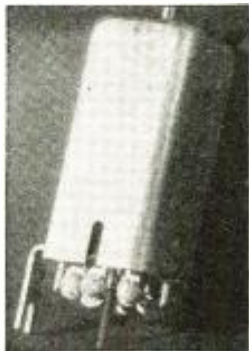

● FOR those whose receivers are troubled with unwanted interference, the Multi-Range Wave Trap is provided by RCA. This new unit is tuned by means of a magnetic core and may be connected either as a "series-tuned" or "parallel-tuned" wave trap. Taps are provided on the cumulative-wound Litz wire coil for matching impedance. Its sharp selectivity curve prevents suppression

on adjacent channels, and the unit has substantially no effect on short-wave or other bands. Therefore it causes no signal loss other than on the station to which it is tuned. It is useful in cutting out interference of code stations, powerful locals, etc.

IRC Introduces Wire-Wound Controls

● LOW power wire wound controls and rheostats are being introduced to both the jobbing and manufacturing trade by the International Resistance Company. These new IRC controls are made in all needed ranges up to 10,000 ohms, and power dissipation is 2 watts. They are equipped with the well-known "Silent Spiral Connector" to provide positive, continuous contact between the rotor arm and end terminal. The units are available with or without switch and with a complete assortment of shaft variations. Descriptive catalog will gladly be sent by the manufacturer upon request.



Police Calls on Car Radio

● A NEW short wave radio for auto radio, to receive police radio signals, has one metal pentagrid converter to provide r.f. amplification of shortwave signal and an intermediate frequency signal of 600 kc., fed to the auto radio receiver, which further amplifies the signal through the entire radio circuit. Wavebands are available from 1600 to 2500 kc.

The ABC Radio Labs. converter can be attached to any standard auto radio, and regular reception is not affected when the converter is not in use.



Novel Microphone

● THE new model D6T dynamic microphone, just introduced by the American Microphone Co., has several desirable features. When placed in a horizontal position, its output is high; when tilted at an angle, its characteristics change and it becomes highly directional. The output impedance of this microphone (model D6T) is 38,000 ohms (to grid). It may also be had with outputs of 200 and 500 ohms for connecting to a line, and a similar model, the D6, has an output impedance of 50 ohms. The microphone has a good response from about 40 to 8,000 cycles, and is suitable for general public address use, as well as for amateur broadcasting, recording, and in special indoor and outdoor applications.



RADIO INSTRUCTION

RADIO Simplified!

with Ghirardi's Home-Training Course COMPLETE IN 1 BIG BOOK



Every Phase of Radio, Electricity, Television, Sound and Cathode-Ray Tubes is made crystal-clear by A. Ghirardi in this fascinating self-instruction course. Here at last is your practical Training for Radio all in 1 big, handy, inexpensive book—compact and complete. That's why it's the most popular radio text in the world!

QUICK and EASY

Let Ghirardi prove to you how simple it is to master the fundamentals of radio quickly. So easy to understand it reads like "A.B.C.!"

36 Volumes in 1—972 pp.—508 Illus.

1. Radio Broadcasting System
2. Sound, Speech, Music
3. Electron Theory; Elec. Current
4. Elec. Units; Ohm's Law; Resistance
5. Elec. Circuits; Batteries
6. Magnetism
7. Electromagnetism
8. Electromagnetic Induction
9. Inductance
10. Capacitance; Condensers
11. A. C. Circuits
12. Filters
13. Measuring Instruments
14. Radio Waves
15. Broadcasting
16. Receiving
17. Vacuum Tube Principles
18. Vacuum Tube Characteristics
19. Vacuum Tube Construction
20. Vacuum Tube Detector and Amplifier Action
21. Radio Frequency Amplification
22. "Superhets"
23. R.F. Amplifiers; Tuning Coils
24. Audio Amplifiers
25. Speakers
26. Battery-Operated Receivers
27. Power-Supply Units
28. Elec. Receivers
29. Automobile and Aircraft Radio
30. Photo Pickups; Sound Systems
31. Short-Wave
32. Photoelectric Cells; Cathode-Ray Tubes
33. Television
34. Antennas and Grounds
35. Testing; Servicing
36. Sound Films

USE IT 5 DAYS—OUR RISK!

Our money-back guarantee protects you 100%. So there's no need to postpone your radio training another day! Clip and mail the coupon—right now!

MAIL COUPON TODAY

RADIO & TECHNICAL PUBLISHING CO.,
45 Astor Place, New York, Dept. R&T-69

Here is my \$4. Please send RADIO PHYSICS COURSE postpaid, with money-back guarantee.

NAME

ADDRESS

CITY State

Send free descriptive literature.

YOU CAN BECOME A MONEY-MAKING RADIO EXPERT

WITH THE New SPRAYBERRY

Personalized HOME TRAINING in RADIO and TELEVISION

You Learn Easily in Your Spare Hours By Doing Many Experiments with Up-To-Date Equipment

Here's a really fine, up-to-the-minute Radio and Television Training that's specially designed to give you quick results.

TRAINING PREPARES YOU FOR GOOD RADIO JOBS ... AT EXCELLENT PAY. My training starts right at the beginning of Radio ... unfolds each subject in a simplified, logical, understandable style. You easily learn Television, Electronics, Facsimile Radio, Radio Set Repair and Installation Work, etc.

NO PREVIOUS EXPERIENCE NEEDED. It makes no difference what your education has been. I can fit you for a good-paying Radio job. Your success is my full responsibility.

YOU GET PROFESSIONAL TEST EQUIPMENT PLUS EXPERIMENTAL OUTFITS. Includes 146 Radio Parts (to build complete Receiver), Tools, All-Wave, All-Purpose Analyzer, and Experimental Outfits for conducting actual experiments with your own hands.

I Supply 146 RADIO PARTS, RADIO TOOLS, ALL-PURPOSE ANALYZER

EARN WHILE YOU LEARN. My BUSINESS BUILDERS show you how to put your Equipment to practical use in handling actual money-making Radio Service Jobs shortly after you begin training.

SERVICEMEN. I offer Advanced Training for those already in Radio. Get complete details in my FREE 32-page Book. The Sprayberry Course is Sold Under a Money-back Agreement.

RUSH COUPON FOR BIG FREE BOOK. SPRAYBERRY ACADEMY OF RADIO. F. L. Sprayberry, Pres. 245-F University Place, N.W., Washington, D. C.

Please send me FREE copy of "HOW TO MAKE MONEY IN RADIO."

Name Age

Address

City State

Tick off this coupon, mail in envelope or paste on penny postcard. Servicemen—Check here

WESTINGHOUSE UNIVERSAL MOTOR

\$2.55 110 Volts AC and DC
Shipping Weight 3 lbs.

Specifications: 1/30 H.P. operates on either A.C. or D.C., 110 volts, 5000 R.P.M. Rheostat can be used to vary speed. Height 3 1/4", Length 3 3/4", Width 1 1/4", Shaft 1/4", one inch long. Can be used to drive Sewing Machines, Models, Buffing Laths, Polishing Head, Drills, Grindstones, etc., etc.



MOTOR only \$2.55
MOTOR with Arbor and 1/4" Chuck \$3.55

Add 25c for special packing and mailing anywhere in U. S. A.

Westinghouse Power Generator

Manufactured for U. S. Signal Corps
200 Watt. 110 V. AC



A. C. ELECTRICAL POWER

from a Windmill, from available Waterpower, from your Automobile, from Four Motorcycles, from your Bicycle, Foot-pedals or Handcrank (for transportable Radio Transmitters, Strong Floodlights, Advertising Signs); do you want to operate AC Radio sets from 32 V. DC farm light systems; operate two generators in series to get 200 V. AC; obtain two phase and three phase AC, etc., etc.

There Are Over 25 Applications
Some of which are:

A.C. Dynamo lighting from eight to ten 20 Watt 110 Volt lamps. Short Wave Transmitter supplying 110 Volts AC for operating "Ham" transmitter. Operating 110 V. AC 60 Cycle Radio Receiver in DC districts. Motor Generator. Public Address Systems. Electric Sirens on motor boats, yachts, etc. Camp Lighting. Short Wave artificial "fore" apparatus. Television. Pelton Waterwheel for lighting or other purposes. Airplane: for lighting strong searchlights or electric signs. Laboratory work, etc., etc. 1/2 to 1/2 H.P. needed to run generator.

BLUE-PRINT 22 x 28 in. and Four-Page 8 1/2 x 12 in. INSTRUCTION SHEETS FREE with Generator.

Generator, as described, including four replacement carbon brushes. Blue-print and instructions **\$7.90**

Send \$2.00 deposit, balance C.O.D. Shipping weight 18 lbs.

(Replacement carbon brushes bought separate \$1.50 per set of four. Set of instructions bought separate \$1.00.)

MONEY-BACK GUARANTEE

WELLWORTH TRADING COMPANY
560 West Washington Blvd., Dept. RT-639, Chicago, Ill.

THE COIL YOU WANT!

is listed in latest DX coil catalog, also many circuits, diagrams. Engineers, service men, set builders like DX coils because they are precision made. Ask your jobber for DX coils, or send us his name with 15c in stamps and receive de luxe catalog. Write today.

DX RADIO PRODUCTS CO.,
1575-B Milwaukee Ave., Chicago



EVERYTHING IN RADIO!
A COMPLETE SOURCE FOR YOUR RADIO NEEDS
Our immense stock of radio sets, parts and supplies enables you to purchase your entire needs on one order. You will find all your Nationally Known Favorites in this big book which is FREE for the asking. Practically every order is shipped the same day it is received.
WRITE FOR BIG NEW CATALOG

BURSTEIN-APPLEBEE CO.
1012-14 McGee St., Kansas City, Mo.

SIX OUTSTANDING SHORT WAVE BOOKS. SEE PAGE 126.

New Cardboard Dry Electrolytics

● A UNIVERSAL metal tab for quicker, easier mounting on any type of application is a new feature of the popular Sprague Type PTM 450 Volt line of small cardboard dry electrolytic condensers. These tabs may be rotated to any position, adjusted to any desired height or bent to any angle.

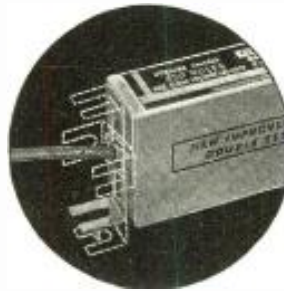

Thus the condensers can quickly be mounted in any position and, wherever necessary, be accommodated to mounting holes already in the chassis. The tabs are now available on all PTM single and dual capacity condensers at no increase in price.

New Tubes



Radio Corporation of America has announced a line of eleven new tubes primarily intended for AC-DC service. The heaters require only .15 ampere, and can be operated with minimum power dissipation in the heater circuit. In addition, there are five new octal glass tubes with electrical characteristics similar to those of the corresponding metal types but having the new tubular glass bulbs. These are the 6A8-GT, 6K7-GT, 6Q7-GT, 25L6-GT and 25Z6-GT.

Characteristics of some of the new RCA tubes follow.

1620 Triple-Grid Detector Amplifier: heater voltage 6.3 A.C. or D.C.; current .3 amp.; grid to plate capacitance .005 mmf. max.; plate voltage 100 to 250; screen voltage 100; grid voltage -3; amplification factor 1185 to over 1500; transconductance 1185 to 1225; plate current 2 to 2.1 ma. These figures are for pentode connections, as a Class A1 Amplifier. If connected as a triode, the screen and suppressor are tied to the plate. A maximum of 250 plate volts is applied with -8 on the grid. In this case, the amplification factor is 20; and the transconductance 2200 micromhos with a plate current of 7.8 ma.

1621 Power Amplifier Pentode: heater 6.3 volts A.C. or D.C.; current .7 amp., max. For use as a triode in a push-pull Class A1 amplifier: plate voltage 327.5; plate current 55 to 59 ma.; power output 2 watts. For use as a pentode in a similar circuit: plate voltage 300; grid voltage -30; plate current 38 to 69 ma.; output 5 watts.

1622 Beam Power Amplifier: heater voltage 6.3 A.C. or D.C.; current .9 amp. max. Used as push-pull Class A1 amplifier: plate voltage 300; grid voltage -20; plate current 86 to 125 ma.; power output 10 watts.

The following are characteristics of other new RCA tubes which are of the single-ended metal type.

12SA7 Pentagrid Converter: heater voltage 12.6 A.C. or D.C.; current .15 amp.; plate voltage 250 max.; Grids No. 2 and No. 4, voltage 100 max. with self-excitation in a Hartley circuit with approximately 2 volts feedback in the cathode circuit. Control grid (No. 3) voltage 0; shell and grid No. 5 voltage 0; conversion transconductance 450; plate current 3.4 ma. The figures are approximately the same for separate excitation except that, in this case, the control grid voltage is -2.

12SC7 Twin Triode Amplifier: heater characteristics, same; plate voltage 250 max.; grid voltage -2; amplification factor 70; transconductance 1325 micromhos; plate current 2 ma. These figures are for each triode unit. The tube is used as a phase inverter.

(Continued on page 124)

FREE - REAL ELECTROPLATING OUTFIT



Now You Can **ELECTROPLATE** Easily with a **BRUSH!**

SOMETHING new for amateurs, fans, set builders—something which gives you the opportunity with which to experiment. Here's an **ELECTROPLATING KIT** amazingly simple to operate—you just Electroplate with a Brush! Requires only one single dry cell.

NOT A TOY

You can electroplate for profit, hundreds of things in the household—sashtrays, fixtures, water faucets, worn brackets, door knobs, musical instruments, jewelry and silverware and other articles. It's an indispensable piece of equipment to you for plating articles in hotels, apartments, office buildings, medical and dental offices, factories, schools, laboratories, etc. Exactly the same outfit (but larger) is used professionally by electricians, radio service men, automobile repair shops, etc. And for radio work, you can electroplate tarnished receiver parts, chassis, contacts, worn radio parts and accessories.

Put this **REAL ELECTROPLATING KIT** to use immediately—make it the most useful article in your lab or work bench. And, you can get it absolutely **FREE** (except for slight mailing cost).

Send your subscription today to **RADIO AND TELEVISION** for One Year (12 issues) and receive absolutely **FREE** one of these **REAL ELECTROPLATING KITS**—New subscribers are accepted or you may extend your present subscription another twelve months under this offer. Mail your remittance of \$2.50 (Plus 10c for shipping charges on kit) to the publishers of **RADIO AND TELEVISION**. (Canada and foreign \$2.85.) You will promptly receive your **FREE REAL ELECTROPLATING OUTFIT** by return mail. Use the coupon below to order your subscription.

RADIO AND TELEVISION

99 Hudson Street New York, N. Y.

RADIO AND TELEVISION

99 HUDSON STREET, NEW YORK, N. Y.

Gentlemen: Enclosed you will find my remittance of \$2.50 for which enter my subscription to **RADIO AND TELEVISION** for One Year (12 issues). Send me promptly my **FREE REAL ELECTROPLATING OUTFIT**. (Canada and foreign \$2.85.) In U.S. add 10c additional to cover shipping charges on kit.

() NEW SUBSCRIBER

() EXTEND PRESENT SUBSCRIPTION

Name

Address

City

State

(Send remittance by check, money order or unused U. S. postage stamps. Register letter if you send cash or stamps.)

RT-6-39

The Radio Beginner

(Continued from page 85)

on the incoming signal, a resultant current is produced, shown at D. At this point the currents are usually further amplified as shown by curve E. After amplification the currents are fed into a *second detector*, the rectified currents being shown at F. Next, audio amplification may be used, as shown in curve G. Curve H shows the effect of these audio impulses on a loud-speaker.

Difference Between T.R.F. and Superhet.

So far we have seen an important difference between the *tuned radio frequency* type of receiver described in the last lesson, and the superheterodyne. In the superheterodyne, radio frequency amplification is carried out on a *fixed* frequency that is independent of the incoming signal. In the TRF receiver on the other hand, all the radio frequency circuits are tuned to the desired signal. Now we can understand one of the points of superiority of superheterodynes over TRF receivers. In the superheterodyne the intermediate frequency amplifier may be set to a single fixed frequency, and once properly adjusted requires no further attention. Since all signals, regardless of their frequency, are converted to the *same* intermediate frequency in a superhet., a maximum efficiency is obtained, while in a TRF receiver the radio frequency amplifier has to respond to a wide variety of frequencies, with loss of efficiency, since the tuned circuits cannot respond equally well to all frequencies.

The Superhet. Oscillator

The apparatus used to generate the local oscillations in a superheterodyne may be considered the heart of the receiver. There are numerous methods of generating such oscillations, but at this point let us consider only a fundamental circuit. One of the most popular methods is known as *feedback*, a circuit arrangement whereby a portion of the energy is fed back from one circuit to another in such a manner as to effect continuous oscillation. (See Fig. 4.) The diagram shown actually comprises two circuits. The first circuit is known as the *grid circuit* and comprises coil L-1, condenser C-1, and the grid inside the tube. The grid circuit is sometimes called the *input circuit*. The *plate-or output circuit* consists of coil L-2, the plate battery, filament switch, and plate inside the tube. Now let us see how such a circuit will function.

When the filament switch is closed, the battery across the filament sends a current through the filament causing it to throw off electrons. The electrons are attracted to the plate. Because of this, a current begins to flow from the plate, through coil L-2, back to the filament. As soon as a current begins to flow in coil L-2, a magnetic field will begin to build up around the coil. This magnetic field, through magnetic induction, will cause a voltage to be developed across coil L-1. This voltage across L-1 makes the grid more positive and hence accelerates the flow of electrons from filament to plate above normal value. In the meantime, however, the voltage across L-1 has become discharged. The grid becomes less positive, the flow of electrons from filament to plate is reduced. This causes the magnetic field around L-2 to collapse. This collapsing magnetic field induces another voltage across L-1, but this time the induced voltage is *opposite in sign* to the voltage originally induced. This new induced voltage, negative in sign, makes the grid nega-

tive. The negative grid retards the flow of electrons to a value below normal. This causes the current flowing in L-2 to have a minimum value, with the result that the grid is gradually allowed to become less negative. As soon as the grid becomes less negative, more electrons begin flowing, a magnetic field is built up around L-2, a positive voltage is induced across L-1, and the whole cycle begins again. If we were to draw a picture of the current as it went through its maximum and minimum values, it would look very much like the curve already shown at B in Fig. 2. The circuit is termed *feedback* because energy is fed back from the *plate or output circuit* to the *grid or input circuit*. Feedback continues until a point is reached in which the maximum current operating conditions allow is flowing in the circuit. The amplitude of oscillations is determined by the filament emission and the plate voltage.

Since the intermediate frequency, or the difference between the incoming signal and the locally generated oscillations must be constant, provision must be made for varying the frequency of the local oscillations. This is usually done by having the grid coil of a fixed value, but tuned by a variable condenser. As the receiver is tuned to signals of various frequencies, the oscillator is tuned at the *same time* so that the *difference* in frequency is always the same.

The local oscillator can be so designed that it operates on a frequency *higher* than the incoming signal, or that it operates on a frequency *lower* than the incoming signal. If the intermediate frequency amplifier is tuned to 300 kilocycles, and the incoming signal is 7000 kilocycles, then the local oscillator can be either 6700 or 7300 kilocycles. General practice is to make the oscillator tune to the *higher* frequency. In order to make sure that the difference between the incoming signal and the local oscillator frequency is constant, the oscillator circuit and the detector circuit are tuned by condensers mounted on the same shaft and rotated by a single dial.

As has been mentioned, the intermediate frequency circuit is usually tuned to approximately 465 kc.

Answers to QUIZ on page 80

1. d
2. a
3. c
4. a, 39.4784; b, 1.7724; c, .0506; d, 3.1142
5. aD, bB, cA, dC
6. b
7. a
8. d
9. c
10. b
11. a, 48; b, 87; c, 120; d, 97; e, 100-110; f, 74
12. c
13. a, microvolts per meter; b, pulsating direct current, pure direct current; c, high pass filter; d, mathematical symbol for "imaginary". Numerically equivalent to $\sqrt{-1}$; e, American wire gauge; f, screen voltage supply
14. c
15. d
16. a
17. c
18. a, ä; b, ch (German or Spanish); c, ñ; d, ö; e, ü; f, é

SPRAGUE ATOMS

"Mightiest Midgets of All"

NO OTHER MIDGET BRINGS YOU SO MANY FEATURES



More honest-to-goodness features — smaller sizes — at the lowest possible cost! That is the story of ATOMS, the amazing Sprague midget dry electrolytic condenser development.

ATOMS are the smallest midgets on the market. They build up to higher surges than any similar units. They have lower leakage and power factor. They're unconditionally guaranteed against blow-ups. They're made in more capacities, more voltages plus a complete line up of dual capacity units with common negative leads. Self-supporting. You mount 'em like paper tubulars. You use 'em for any replacement where you want real efficiency, smallest size, lowest possible cost.

HANDY KITS

Sold singly or in handy kits of 6 or 12 condensers. Write for complete Sprague Condenser Catalog.

SPRAGUE
450 VOLTS

SPRAGUE
PRODUCTS CO.
North Adams, Mass.

A COMPLETE LINE OF STANDARD

RADIO EQUIPMENT

FOR

SERVICEMEN — AMATEURS
DEALERS — EXPERIMENTERS

BETTER SERVICE FROM
OUR LARGE STOCKS
At Standard Discounts

CAMERADIO

963 LIBERTY AVE. • 30 TWELFTH ST.,
PITTSBURGH, PA. • WHEELING, W. VA.
Established 1919

Do you need BINDING POSTS?



The XL PUSH POST with its Spring Action assures Constant Contact and quick connection. Manufactured in All Aluminum Type M at 10c each. Aluminum Body, Bakelite Top Type B1 at 15c each. Type B1 completely insulated with Bakelite Insulating Shell type C1 at 20c each and proven by 200 hr Salt Spray Test AS NON-CORROSIVE our Types CP or NP at 28c each.

Manufacturers and Dealers liberal Discounts

X. L. RADIO LABORATORIES
420 West Chicago Ave., Chicago, Ill.

SIMPLIFIED STABILITY ON 5 METERS

BLILEY HF2 10 METER CRYSTAL
BLILEY ELECTRIC CO., ERIE, PA.

8 GREAT RADIO BOOKS CENT

RADIO FANS EVERYWHERE—These fine ten cent text books give you an excellent foundation for the study of radio. They are clearly written, profusely illustrated and contain over 15,000 words in each book. You'll be amazed at the wealth of information these books have. Handy for review or reference. **Your money back if you are not pleased!**



NO. 1—HOW TO MAKE FOUR DOERLE SHORT WAVE SETS

Literally thousands of radio fans have built the famous DOERLE Short Wave Radio Receivers. So insistent has been the demand for these receivers, as well as construction details, that this book has been specially published. Thousands of copies of this book have been bought by short-wave fans. Contains EVERYTHING that has ever been printed on these famous receivers. These are the famous sets that appeared in the following issues of SHORT WAVE CRAFT: "A 2-Tube Receiver that Reaches the 12,800 Mile Mark," by Walter C. Doerle; "A 3-Tube 'Signal Gripper,'" by Walter C. Doerle; "Doerle '2-Tube,' Adapted to A.C. Operation," by Walter C. Doerle; "The Doerle 3-Tube 'Signal-Gripper' Electrified," and "The Doerle Goes 'Band-Spread'."



NO. 2—HOW TO MAKE THE MOST POPULAR ALL-WAVE 1- and 2-TUBE RECEIVERS

This book contains a number of excellent sets, some of which have appeared in past issues of RADIO-CRAFT. These sets have been carefully engineered. They are not experiments. To mention only a few of the sets the following will give you an idea. • The Megadyne 1-Tube Pentode Loudspeaker Set, by Hugo Gernsback. • Electrifying The Megadyne. • Loud-Speaker Set, by W. P. Chesney. • How To Make a Simple 1-Tube All-Wave Electric Set, by E. W. Harris. • How To Build A Four-In-Two All-Wave Electric Set, by J. T. Bernaley, and others. Not only are all of these sets described in this book, but it contains all of the illustrations, hookups, etc.—each book is up-to-date.



NO. 3—ALTERNATING CURRENT FOR BEGINNERS

This book gives the beginner a foothold in electricity and Radio. Electric circuits are explained. Ohm's Law, one of the fundamental laws of radio, is explained; the generation of alternating current; sine waves; the units—volts, amperes, and watts are explained. Condensers, transformers, A.C. instruments, motors and generators. Here are some practical experiments to perform at home. Simple tests for differentiating between alternating and direct current; how to light a lamp by induction; making a simple electric horn; demagnetizing a watch; testing motor armatures; charging storage batteries from A.C. outlet; testing condensers with A.C.; making A.C. electro magnets; frying eggs on a cake of ice; making simple A.C. motors; many others.



NO. 4—ALL ABOUT AERIALS

This book explains the theory underlying the various types of aerials: the inverted "L," the Doublet, the Doublet-Doulet, etc. It explains noise-free reception, how low-impedance transmission lines work; why transposed lead-ins are used. It gives in detail the construction of aerials suitable for long-wave broadcast receivers, for short-wave receivers and for all-wave receivers. Various types of aerials for the amateur transmitting station are explained. It eliminates, once and for all confusion about the type of aerial to choose for best broadcast and short-wave reception. For the thousands of radio fans who wish to know just what type of antenna they should use and why, this book has been published. Experts in radio have found valuable information in this book.



NO. 5—BEGINNERS' RADIO DICTIONARY

Are you puzzled by radio language? Can you define Frequency? Kilocycles? Tetra-ode? Screen grid? Barf? Anode? Triode? Pole? Ionization? Joule's law? Harmonic? Gravity Cell? If you cannot define these very common radio words and dozens of other, more technical, terms used in all radio magazines and instruction books, you need this book in your library. It's as modern as tomorrow—right up to the minute. It tells you in simple language just what the words that puzzle you really mean. You cannot fully understand the articles you read unless you know what radio terms mean. This is the book that explains the meanings to you. Can you afford to be without it, even one day longer?



NO. 6—HOW TO HAVE FUN WITH RADIO

Stunts for parties, practical jokes, scientific experiments and other amusements which can be done with your radio set are explained in this fascinating volume. It tells how to make a newspaper talk—how to produce silent music for dances—how to make visible music—how to make a "silent radio" unit, usable by the deafened—how to make toys which dance to radio music—sixteen clever and amusing stunts in all. Any of these can be done by the novice, and most of them require no more equipment than can be found in the average home. Endless hours of added entertainment will be yours if you follow the instructions given in this lavishly illustrated book. Get a copy today by using the coupon below—mail it today.



NO. 7—HOW TO READ RADIO DIAGRAMS

All of the symbols commonly used in radio diagrams are presented in this book, together with pictures of the apparatus they represent and explanations giving an easy method to memorize them. This book, by Robert Elchberg, the well-known radio writer and member of the editorial staff of RADIO-CRAFT magazine, also contains two dozen picture wiring diagrams of simple radio sets that you can build. Every diagram is completely explained in language which is easily understood by the radio beginner. More advanced radio men will be interested in learning the derivation of diagrams, and the many other interesting facts which this book contains. It is also helpful in solving many of the problems of servicemen.



NO. 8—RADIO FOR BEGINNERS

Hugo Gernsback, the internationally famous radio pioneer, author and editor, writes in his famous magazines, RADIO and TELEVISION and RADIO-CRAFT are read by millions, scores another triumph with this new book. Any beginner who reads it will get a thorough ground work in radio theory, clearly explained in simple language, and through the use of many illustrations. Analogies are used to make the mysteries of radio as clear as "2+2 is 4." It also contains diagrams and instructions for building simple radio sets suitable for the novice. If you want to know how transmitters and receivers work, how radio waves traverse space, and other interesting facts about this modern means of communication, this is the book for you!

BOOKS ARE ALL UNIFORM

Every book in the GERNSBACK EDUCATIONAL LIBRARY has 32 pages—with illustrations varying from 30 to 66 in number. Each title volume contains over 15,000 words. Positively radio's greatest book buys! If you do not think these books worth the price asked, return them in 24 hours and your money will be instantly refunded.

RADIO PUBLICATIONS • 101 HUDSON STREET • NEW YORK, N. Y.

RADIO PUBLICATIONS, Dept. RT-639
101 HUDSON STREET, NEW YORK, N. Y.
Gentlemen: Please send immediately, POSTPAID, the book numbers circled below. I am enclosing cents—each book being 10c.

1 2 3 4 5 6 7 8

Send FREE listing of 48 new 10c publications.

Name

Address

City

State

Remit by check or money order—register letter if you send cash or unused U. S. postage stamps.

MAIL COUPON TODAY!

I Cover the Pacific Coast!

By Lyle M. Nelson

● SUMMER is here and with it have come a great many changes in short wave reception on the Pacific Coast. Many of the popular broadcasters have shifted to higher frequencies and those that haven't are not audible.

Japan's popular overseas program for the Pacific Coast is now being heard over JZK on 15.16 mc. from 9:30 to 10:30 each night. The Japanese broadcasts from 10:40 to 11:30 p.m. and 1 to 5 a.m. are very well received here over JWV3 on 11.73 megacycles. Several listeners have reported hearing JWV3 and JVN (10.66 mc.) on the air Saturday evenings with the novel baseball broadcasts from the park in Tokio. For the past few years these broadcasts have been regular Saturday night features of the Japanese stations. Listeners tuning to JVN or JWV3 are able to follow the games being played in Tokio Sunday afternoon.

The 25-meter band has been exceptionally active during the late evening hours with stations in London, Tokio, Havana, Paris and Melbourne coming through with excellent volume. COCX on 11.74 mc. in Havana continues to be audible until sign-off at 10 p.m. while GSD (11.75 mc.), JWV3 (11.73 mc.), VLR (11.87 mc.) and TPA3 (11.89 mc.) are best near 11 p.m.

John Cavanagh of Oregon City reports ZHP of Singapore on 9.69 megacycles on Wednesdays from 9:40 to 10:40 p.m. There have been many conflicting reports on ZHP. Some claim it is off the air and others report reception. However, most schedules still list the time as from 1:40 to 6:40 a.m. daily.

Two new unidentified Oriental stations have been reported on 6.13 mc. and 7.30 mc. in the early morning hours. The station on 7.30 mc. has been reported near 4 a.m. with news bulletins in Japanese. Interference from several nearby code stations sometimes blots out reception. The transmitter on 6.13 mc. is heard near 5 a.m. Typical Oriental music and short announcements feature the program. According to George Goehring of Oakland the call letters of the station on 6.13 mc. are CTCY.

According to our good friend, Charles Yoshii, English announcer for the Japanese short wave stations, JZL on 17.78 mc. is now on the air from 5 to 5:30 p.m. daily. In addition to the regular overseas program for the Pacific Coast mentioned earlier in this article, JZK on 15.16 mc. is heard from 4 to 4:30 and 5 to 6:30 a.m., Mr. Yoshii writes.

Signals from CR7BH on 11.72 mc. in Laurencio Marques, Portuguese East Africa, are now reaching the coast with fair strength during the late evenings. CR7BH can usually be picked up from 9:05 to 10 p.m. The station is also weakly audible from 6:30 to 7:30 a.m.

Also reported during the past month of DX has been "Radio Tananarive" in Madagascar. This station is on 6.06 and 9.38 mcs. and is heard only under favorable conditions. Best reception is from 7 to 8 a.m. Several listeners have also reported hearing "Radio Tananarive" on 10.95 mc. from 9:30 to 9:45 p.m. with a weak signal.

One of the most reliable Far Eastern short wave stations has been Manila's KZRG on 9.50 mc. KZRG is exceptionally well received from 1 to 6 a.m. and from 11:15 to 11:45 p.m. Other Manila stations reported by listeners have been KZIB, KZGF and KZRM. KZGF is heard phoning on 5.46 mc. daily at 6 a.m. according to Jack Taylor of Seattle. Mr. Taylor also reports KZIB on 9.49 mc. from 4 to 6 a.m. daily. Latest schedules list KZRM on 9.57 mc. from 2 to 6 a.m. daily, except Saturday and Sunday. On Saturday the station is on the air from 2 to 7 a.m. and on Sunday from 1 to 7 a.m.

OFE in Lahti, Finland, is booming through with fine volume on 11.78 mc. from 11 p.m. to 1 a.m. daily. Kendall Walker of Yamhill, Oregon, writes. Mr. Walker also reports hearing OIE on 15.19 mc. from 10 p.m. to 1 a.m. and sometimes very weakly near 6 a.m.

ZRD of Durban, South Africa, has shifted frequency from 9.76 to 9.73 mc. where it is heard with fair volume from 8:45 to 9:50 p.m. daily except Saturday. Occasionally ZRD is heard near 6 a.m. with a weak signal, reports Jack McClinton of Portland.

ROUND 'N' ABOUT—From listeners' reports. HP5G, Panama City, reported on 11.78 mc. from 5 to 9 p.m. . . . Paris station TPB11 on 7.28 mc. is heard with good strength from 4 to 9 p.m. with same program as TPA3 on 11.885 mc. English news is given at 8 p.m. . . . KOH on 14.92 mc. relays Hawaiian programs from 6 to 6:30 p.m. Saturday and from 9 to 9:30 p.m. Sunday. . . . HBO, League of Nations' station in Geneva, is irregular on 11.40 mc. Mondays from 10 to 10:15 p.m. . . . FO8AA, Tahiti, is no longer QSL'ing reports. . . . 2RO3, 2RO4, 2RO6 and IRF are now on North American beam. 2RO3 and 2RO4 are strongest Europeans heard here at present.

In closing we wish to thank those ardent Pacific Coast DX'ers who have contributed to this column. Reports or comments from any West Coast short wave listener will be greatly appreciated.

Opportunities in Television

Dr. Alfred N. Goldsmith

(Continued from page 79)

Casting Television



HILE A GOODLY portion of the television broadcasts will doubtless be devoted to vocal and instrumental music of the recital type, probably far more time will be given over to the presentation of musical shows and

sketches. These will require CASTING DIRECTORS, PRODUCTION DIRECTORS, PROPERTY MEN and, of course, PLAYERS. The latter will very possibly be recruited from the screen and legitimate stage, and more particularly, the various "Little Theatres." Such recruits will have to be given instruction in television technique, for it differs greatly from the standard acting procedures of either the stage or screen.

There should also be need for VAUDEVILLE ACTORS, INTERVIEWERS, COMMENTATORS and the like—all save the first being drawn from radio station personnel. In addition, there should be considerable demand for SCENIC DESIGNERS, SCENE BUILDERS, SIGN PAINTERS, COSTUME EXPERTS, WARDROBE MEN and WOMEN, PROPERTY MEN, HISTORICAL RESEARCH EXPERTS to check up the inaccuracies of facts which may appear in scripts, etc. This demand should exist from the very start of television broadcasting and should increase rapidly as the years pass and the art develops.

Incidental Activities

The Government will undoubtedly need additional radio supervisors in the various radio districts of the United States to check up on television transmissions. The staff of the Federal Communications Commission will undoubtedly be augmented with experts in the fields of both engineering and the law, especially as it applies to television.

A means of linkage either through the use of co-axial cable or similar wire system, or by using radio relay stations, may have to be devised. Should cables be used, they will have to be constructed, installed and maintained.

Not to go too deeply into the subject, the installation of a line will call either for high-line riggers or ditch diggers (if the cable is to be run underground). The staff employed will be much like that used to construct, install and maintain long telephone lines, more especially the co-axials between New York and Philadelphia.

If relay stations are used, they must be constructed by engineers and serviced by maintenance men.

Summary

In closing, let me urge the person who is contemplating earning his livelihood from television not to rush, but to wait until he can make up his mind which branch of the field to enter. If you are one of these, analyze your abilities, cultivate those abilities by training, and then persevere in bringing them to as high a point of perfection as possible. Success in television, as in any other field, will come through sustained effort rather than through a first flash of enthusiasm.

NEW CATALOGS

New Allied Radio Catalog



THE new Spring-Summer Catalog of Allied Radio Corporation of Chicago has just been released. It is an attractively-bound 164-page book devoted to everything in radio.

An interesting feature of the attractive new catalog is its presentation of each field of radio in individual sections. Attractive rotogravure sections

are devoted to the new Knight Radio Receivers and to public address equipment. Other sections cover service equipment, general parts, Ham gear, builders' kits and supplies, radio accessories, etc. Sections are clearly keyed and completely indexed for quick and easy reference.

The Amateur section features new developments in Beam Antenna equipment and displays prominently the exclusive new Allied "Junior" Amateur Station, a combination transmitter-receiver kit at low cost. The Radio Builders' section features dozens of new kits and more than fifty new circuit diagrams and builders' projects.

Over 14,000 radio parts are listed in the general section covering every conceivable radio need.

Booklet On Recording Essentials

THE Engineering Department of Allied Radio Corporation, Chicago, has prepared a non-technical treatise on the *Essentials of Recording* which is now being distributed. The purpose of the bulletin is to furnish authoritative, non-technical information and advice on the problems and technique of recording, on the most suitable type of equipment and what it costs. The booklet explains the theory of modern recording in easy, readable language. Discussions on cutting needles, recording discs and their characteristics, etc., are included.

A supplementary section covers the requirements of those who have their own amplifiers and who desire to adapt existing equipment for successful recording, with data on the use of volume level indicators, proper matching, etc.

Capacitors for Motors

An entire line of capacitors for A.C. phase-splitting motor applications is described and listed in detail in Cornell-Dubilier Electric Corporation's catalog No. 162-A, consisting of four pages, 8 1/2" x 11". These capacitors are all of the Dykanol types for starting and continuous running duty. They are listed according to the names of the manufacturers of the motors, and the list includes all major makes from Apex Elec. Mfg. Co. to Westinghouse. The units are supplied with external insulating case or sleeve, and extra insulating cases, terminal caps and mounting brackets are available.

Transformer Supplement

A new supplement to Thordarson's Replacement Transformer Encyclopedia is coded as No. 243-D. It contains eight pages, 11" x 8 1/2", and gives complete information regarding the correct replacement power transformer, filter choke, audio transformer or output transformer for all 1938-1939 radio receivers as listed in Vol. IX of Rider's Radio Manual. All prominent manufacturers are covered, all the way from Air King to Zephyr Radio Co.

"Patent Policies"

A new book, *Patent Policies of Radio Corporation of America*, has just been written by Otto S. Schairer, Vice-President in Charge of the Patent Department. It contains 80 pages, plus appendix, size 9" x 6", and is illustrated.

The book was written in view of the current studies of the patent system of the United States and its relationship to industry and the public interest.

Among the points covered by Mr. Schairer are: Inventions Originating with RCA; Patent Rights Acquired by License Exchange Agreements; Patent Rights Acquired by Purchase; Licenses to Competitors; Patent Litigation and Merits of the Patent System and of Suggestive Legislation.



For those transmitting "rigs" handling plenty of "sock" at elevated frequencies, you'll need this porcelain-case mica capacitor. Minimum metal in h.f. field. Units rated in max. current-carrying capacity at 15 mc., 7.5 mc., 3750 kc., and 1875 kc. In capacities of .00005 to .1 mfd. 2000 to 12500 v. D.C. test. Ask your jobber to show you these units. Ask for latest catalog—or write us direct.



"JIFFY" Magazine Binders

Sturdily built and covered with black fabricoid. Has two stamped metal ends with 12 spring wire separators. Magazines can be inserted and removed in a jiffy. No fuses—no lost time—no labor.

- No. 1, 12 1/2" x 9 1/2", with 2-inch back for R & P, Radio-Craft, Radio News, etc. — \$1.00
- No. 2, 10 1/2" x 7 1/2", with 3-inch back for IRT, Radio, Popular Mechanics, etc. — \$1.00
- No. 3, 8 1/2" x 6 1/2", with 3-inch back for Reader's Digest, etc. — \$1.00

De Luxe Models, Above sizes — \$1.50
P.P. Prepaid in U.S. and Canada
Send for catalog containing full descriptions of many other interesting items.

GOLD SHIELD PRODUCTS
Dept. RT-6-9 350 Greenwich St. New York

SAVE MONEY!

ON RADIO SETS AND PARTS

Send for our FREE GIANT Spring Catalog illustrating and describing over 1,000 money saving items.

UNITED RADIO COMPANY

DEPT. S.W. NEWARK, N. J.

CHASSIS RACKS AND PANELS

The Par-Metal Line is the most complete and up to date in the industry. Included are units which enable you to build almost anything from S. W. Receiver to a professional Transmitter or Public Address System.

FREE Catalog just off the press available at your jobber or write direct to

PAR-METAL Products Corp.
3521-41st St., Dept. RT-6, Long Island City, N. Y.

Call	Freq.	R S	Where Heard
VP3CO	14.1	4-5-7-8	Ark., N. J., Wash., Canada
VP3CL	14.1	4-5-3-6	Ark., N. Y.
VP3AA	14.095	4-5-6-7	Conn., England
VP4TH	28.45	5	England, Canada
VP4TK	14.1	5 7	South Africa
VP4TH	14.1	5 9	South Africa, England
YV1AA	14.085	5 4	Colo.
YV1AQ	14.005	5 7-9	Colo., N. J., Mich., Conn., Canada
YV4AE	14.06	5 3-7	Colo., Conn., Canada, N. Y., Mich., Wash.
YV4AA	14.1	5 8	N. J.
YV4ABG	14.035	3 5	Conn., England
YV4AL	14.1	5 5-7	England, Canada
YV5ABF	14.06	5 6	Colo., England, Canada
YV5ABY	14.1	4 7	N. J.
YV5ABG	14.115	4-5-6-8	Conn., Wash.
YV5AO	14.02	5 8	Conn.
YV5ADF	14.155	4 7	Ariz.
YV5CZ	14.085	5 8	Ariz.
YV5ADY	14.1	4 5	Wash.
YV5ABC	14.12	5 7	Canada
YV5ABQ	14.1	5 8	Canada
YV5ACG	14.09	5 7	Canada

CT's were reported by observers in South Africa, Texas, Alabama, New Jersey, North Carolina, Michigan, Connecticut, Pennsylvania and Canada.

EA7BA	14.035	5 7	Canada
EI2L	14.07	4-5-5-9	Tex., Mich., N. J., Canada, Penna., Conn., N. Y.
EI2T	14.26	5 7	Canada
EI3J	14.05	5 7	Canada
EI4L	14.06	5 6	Canada
EI8J	14.115	5 6	Canada
ES5D	14.06	4-5-7	Tex., N. C., Canada
F3CP	14.1	4 7	N. C.
F3DC	14.1	5 6	Canada
F3KH	14.035	5 7	Canada
F3OO	14.09	5 7	Canada

F8's were reported heard in Texas, New Jersey, Connecticut, Pennsylvania, Canada, South Carolina, Alabama, California and Michigan.

G2's, G3's, G4's, G5's, G6's and G8's were reported as being heard in South Africa, Texas, New Jersey, Pennsylvania, Canada, Arkansas, Connecticut, Alabama, Michigan, New York, Washington, North Carolina, Oregon and South Carolina.

G12CC	14.275	5 7	Canada
G18PA	14.125	5 8	Canada

S. W. League

(Continued from page 91)

Call	Freq.	R S	Where Heard
G18UN	14.02	5 7	Canada
GM6RG	14.275	4-5-6-8	Tex., Ore., Canada, N. J., Mich., Penna., Conn.
	28.45	5 8-9	N. J., Ariz., Canada
			Other GM's and GW's were heard in Texas, New Jersey, Pennsylvania, Washington, Texas, Michigan and Alabama.
HB9J	14.09	4 5	Canada
I1TKM	14.065	3-5-6-9	Tex., N. J., Penna., Canada
	28.14	5 6	Canada
I1IT	14.065	5 6	Canada
I1KN	14.055	5 6	Canada
LA1F	14.32	4-5-6-8	Penna., Ala., Canada
LY1S	14.03	5-5-8	Ark., Wash., Canada
LY1J	14.1	5 5	Wash.
ON4VZ	14.15	3 6	Mass.
ON4VK	14.065	5 8	Tex.
ON4AK	14.11	5-7-9	Penna., Ala., Canada
	28.205	5 7	Penna.
ON4PB	28.43	4 6	Penna.
ON4NO	28.12	5 8	Penna.
ON4HS	14.05	5 6	Ala.
ON4FV	14.095	5 7	Canada
ON4MS	14.06	5 7	Canada
OZ9R	7.295	3 5	Mass.
PA0MZ	14.155	4-5-7-9	Mass., Penna., Mich., Conn., Canada
	28.2	5 7	Penna.
PA0UN	14.09	5-7-8	Tex., Ala., Canada
	28.041	5-7-9	Penna., Mich.
PA0AD	14.13	5 8	Penna., Canada
	28.025	5 7	Penna.
PA0AA	14.105	4 6	Penna.
PA0EH	14.13	5 7	Penna., Canada
PA0DR	14.035	5 6	Canada
PA0MP	14.09	4 6	Mich.
SMSI	14.28	5 7	Tex.
	28.375	5 9	Penna.
SM6WE	14.295	5 6	Canada
S1KKE	14.015	4-5-7-8	Ala., Canada
U1BW	14.075	5 9	Ark.
Y1LIT	14.01	5 8	Mich.
YR5AA	14.02	5 5	Canada

Dakota, Michigan, Washington, Arizona, New Jersey, New York, Alabama, Nebraska, Texas, Pennsylvania, Arkansas, California and England.

Call	Freq.	R S	Where Heard
KF6DHW	14.385	5 8	Penna.
PK1RI	14.02	5 5-7	Tex., South Africa, Oregon, Wash., Canada
PK1LI	13.95	5 6	Ore.
PK1JM	14.0	4 4	Ala.
PK1VM	28.28	4 4	England
PK2AY	14.05	5 7	Ark., Canada
PK2WL	28.26	5 5	England
PK3WI	14.05	5 6-7	Tex., Ore., Canada
PK3WA	14.05	5 6	Ark.
PK4KS	14.32	4-5-5-8	Tex., Ore., Penna., Wash., Canada
PK6XX	14.02	4-5-7-9	Tex., Ark., Mich., Ala., N. C.

Far too many VK's were heard last month to list here, about a hundred being reported.

VR2SA	7.155	5 9	Mass.
ZL1MR	28.1	4-5 5	Ore., Calif., Ariz.
ZL1HY	28.2	5 8-9	Ark., Calif., Ariz.
ZL1HI	28.15	4 6	Ariz.
ZL1LC	28.15	5 6-7	Ark., Calif., Ariz., Canada
ZL2BE	14.225	5 7	Canada
ZL2FY	28.395	3-5-5-7	Penna., Calif.
ZL2FV	28.1	5 7	Calif.
ZL3IP	28.4	5 7	Ark.
ZL3BV	28.17	4 8	Calif.
ZL3IF	28.475	5 7	Calif.
ZL3AY	28.13	4 6	Calif.
ZL3KZ	28.14	5 9	Calif., Ariz.
ZL3JY	28.46	5 7	Calif.
ZL3DJ	28.23	5 7	Calif.

Guatemala Dedicates Program to RADIO & TELEVISION

ON Saturday, May 6th, Radiodifusora Nacional De Guatemala "La Voz de Guatemala" dedicated a 2½-hour concert of marimba music, announced in Spanish and English, to RADIO & TELEVISION magazine. The programs were radiated from four transmitters—TGW, 1520 kc.; TGWA, 9865 kc. (31 meters); TGWB, 6490 kc. (46.2 meters); and TGWC, 2320 kc. The special DX concerts, of which the RADIO & TELEVISION program was one, are broadcast on the first and third Saturdays of each month, from 12:00 midnight to 2:30 a.m. (CST), and are under the direction of L. Schlesinger Carrera.

OCEANIA:

Too many K6's and KA's were reported to list them all here, so the places where they are being heard will be given. Their reception was reported from South Africa, Oregon, Colorado, South

TELEVISION'S Stride Today Makes It Essential for You to Read—“ABC of TELEVISION”—

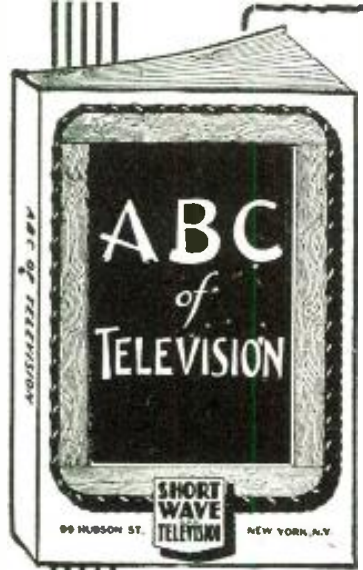

WITH important progress being made in Television every day—and with developments satisfactory to Television engineers that consistent programs will be broadcast shortly, it is important that principles be understood quite thoroughly.

The publishers of RADIO AND TELEVISION give you the opportunity to add "ABC OF TELEVISION" or two other books to your technical library. They make the offer even more attractive by giving these books to you absolutely FREE. A subscription to RADIO AND TELEVISION for seven months at the cost of One Dollar gives you a choice of either of the three books shown in this advertisement. For Two Dollars you receive RADIO AND TELEVISION for fourteen months and you receive any two books of your choice absolutely FREE. To get all three books FREE, enter your subscription for twenty-one months for only Three Dollars. ANOTHER SAVING FOR YOU—THE PUBLISHERS PAY POSTAGE ON THE BOOK OR BOOKS YOU CHOOSE.

Partial Contents of ABC of Television

- CHAPTER 1—The simplest television receiver; how the eye sees; its likeness to television equipment.
- CHAPTER 2—Theory of scanning; the Nipkow disc and its relation to television; the photo-electric cell; neon lamps; brief description of several modern mechanical systems.
- CHAPTER 3—Need for a large number of picture elements; need for broad channel width in transmission of high-fidelity television signals.
- CHAPTER 4—The use of the cathode ray tube in television receivers; necessary associated equipment used in cathode-ray systems.
- CHAPTER 5—How a television station looks and how the various parts are operated.
- CHAPTER 6—The Iconoscope as used for television transmission in the RCA system.
- CHAPTER 7—The Farnsworth system of television transmission.
- CHAPTER 8—The future of television; probable cost of receivers; some expressions of opinion by prominent men; list of present television transmitters.

64 PAGES—100 ILLUSTRATIONS
Stiff, Flexible Covers, 5¼x8¾ INCHES

Get One or All of These Books FREE!!

RADIO AND TELEVISION, 99 Hudson Street, New York, N. Y. R&T-6-39

Gentlemen: Enclosed you will find my remittance of \$....., for which enter my subscription to RADIO AND TELEVISION as checked below; also send me, postpaid, the book or books which I have marked below.

ABC OF TELEVISION
 S.W. RADIO QUIZ BOOK AND KINKS
 SHORT WAVE GUIDE

7 months—\$1.00—choice of any one of three (3) books. (Canadian and foreign—\$1.30)
 14 months—\$2.00—choice of any two (2) of the three (3) books. (Canadian and foreign—\$2.60)
 21 months—\$3.00—all three books. (Canadian and foreign—\$3.90)

If you are a subscriber now, we will extend your present subscription.
 New subscriber Old subscriber

Name..... Address.....
City..... State.....

Send your remittance by check or money order. If you send cash or unused U.S. postage stamps, please be sure to register your letter for your own protection.



Covers hundreds of short-wave questions and answers; illustrates popular short-wave kinks; gives explicit instructions for building simple short-wave receivers; instruction on the best type of antenna installation; diagram and construction details for building transmitters.

S. W. RADIO QUIZ BOOK

This book covers questions and answers on transmitters, short-wave receivers, ultra short-wave receivers; practical hook-ups for experimenters; how to "hook-up" converters, noise silencers, power supplies, modulators, beat oscillators, antennas, pre-selectors and 5-meter receivers.



A High-Efficiency 6L6 Exciter

(Continued from page 96)

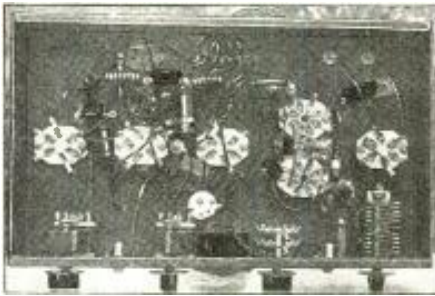

Bottom view of the 6L6 exciter unit.

Parts List for Exciter

HAMMARLUND

- Two tuning condensers, 140 mmf. each
- One dual-section tuning condenser, double spaced, 70 mmf.
- One set of 6-prong coils (see coil table)
- Four midjet r.f. chokes, 2.1 mh. each
- Three isolantite sockets, 8-prong
- One isolantite socket, 5-prong
- Three isolantite sockets, 6-prong (for coils)
- One shield for 807 tube
- One shield for 807 plate coil

SPRAGUE (Condensers)

- Four tubular paper condensers, 0.01 mf., 600 volts
- Two mica condensers, 0.0001 mf.
- Three mica condensers, 0.006 mf.
- One mica condenser, 0.002 mf.

I.R.C. (Resistors)

- One fixed resistor, 100,000 ohms, 1 watt
- One fixed resistor, 50,000 ohms, 2 watts
- One wire-wound resistor, 10,000 ohms, 10 watts
- One wire-wound resistor, 15,000 ohms, 10 watts
- One adjustable, wire-wound resistor, 4,000 ohms, 25 watts

RCA (Tubes)

- One type 6CS-G tube
- One type 807 tube
- Two type 6L6-G tubes

TRIPLETT

- One 0-200 d.c. milliammeter, 2 inch, round type

BUD

- One 10 x 17 x 3 inch crackle-finished steel chassis

BLILEY

- One crystal (40 or 80 meter type)

CENTRALAB

- One double-pole three-position rotary switch

MISCELLANEOUS

- Dials, jacks, plugs, etc.

Coil Table

Coil	Rand	Turns	Spacing	Wire	Diameter
L1*	80 m.	26	1 1/2"	22 E.	1 1/2"
L1**	40 m.	14	1 1/2"	20 E.	1 1/2"
L2	80 m.	28	1 1/2"	20 E.	1 1/2"
L2	40 m.	16	1 1/2"	20 E.	1 1/2"
L2	20 m.	5	1 1/2"	18 E.	1 1/2"
L3	80 m.	35	1 1/2"	26 E.	1 1/2"
L3	40 m.	18	1 1/2"	22 E.	1 1/2"
L3	20 m.	5	1 1/2"	22 E.	1 1/2"
L3†	10 m.	5	1 1/2"	20 E.	1 1/2"

- *With 80 meter crystal.
- **With 40 meter crystal.
- †With tuning condenser (70 mmf.) in series.

How to Adjust Exciter

For operation on 20 meters, using an 80 meter crystal, the following tune-up procedure is employed: Place an 80 meter cathode coil (see coil table) in the oscillator socket and a 40 meter coil in the 807 plate circuit. A 20 meter coil is placed in the 6L6-G output circuit. Turn on the heaters, allowing the tubes sufficient time to warm

up before applying the plate voltage. Place an open plug in each of the 807 and 6L6-G cathode jacks. Close the B minus switch and quickly rotate the 6C5-G tuning condenser for the dip in plate current, as indicated by the 0-200 milliammeter. The plug is now removed from the 807 cathode and the buffer plate circuit is tuned to resonance.

The next step is to tune up the final stage and adjust the coupling to the antenna. Remove the plug from the 6L6-G cathode circuit, insert the milliammeter and quickly rotate the final plate tuning condenser to resonance. The plate current should drop back to 20 or 30 milliamperes or less at resonance, with the antenna disconnected, and will probably go up to 150 milliamperes or higher when the plate circuit is out of resonance. When making adjustments in any part of the transmitter, do so as quickly as possible; the 807 and 6L6-G tubes are easily ruined by allowing them to draw excessive plate currents for even a very short time!

Contact the antenna to the feed-through insulators and retune the final plate circuit for the dip. Adjust the antenna coupling and retune the plate circuit. Continue this procedure until the 6L6-Gs are running at the desired power input with the plate circuit tuned to resonance. A good method of checking the resonance adjustments is to touch a neon bulb to each plate coil and the antenna in turn; resonance will be indicated by maximum brilliance of the neon lamp.

For operation at the crystal frequency, place an 80 meter coil in each of the 807 and 6L6-G plate circuits. Adjust the oscillator and buffer as outlined above. Open the heater circuit of one 6L6-G by means of the switch, as indicated in Fig. 1, and tune the final plate to resonance. No neutralizing whatever is necessary as the "dead" 6L6-G neutralizes the final amplifier. In case the final does not neutralize when operating on the crystal frequency, the heater leads should be reversed at the socket of the "dead" tube.

Several frequency-multiplying combinations are shown in Fig. 3.

Like any other class C amplifier, the push-push doubler may be modulated for phone operation, if desired. When used in this manner, it is important that the two 6L6-Gs are accurately matched, both as to the electrical characteristics and as to the inter-electrode capacities.

Television Opportunities

The problem of earning a living with television is discussed thoroughly in *Television, An Occupational Brief*, prepared and published by the Western Personnel Service. The book, which contains 16 pages, 8 1/2" x 5 1/2", begins with a discussion of the probable future of television, then takes up the question of research engineering, manufacturing; station development and operation and program production. There follows a discussion on the factors which will influence television development, and a brief survey of the companies now engaged in television.

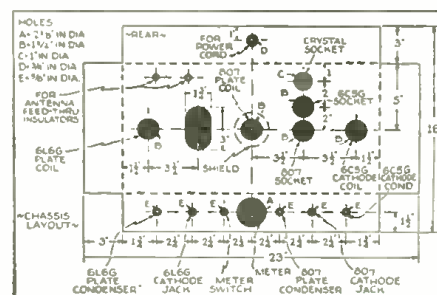

Chassis Details.

Please say you saw it in RADIO & TELEVISION

HERE IT IS... HAMS

A New AC AND DC Pocket Volt-Ohm-Milliammeter

with Ranges to 5000 Volts Self-Contained.

Size 3 1/16" x 5 3/8" x 2 1/8"

MODEL 666-H

Will handle all Amateur Requirements

\$14.50 Net Price

TRIPLET

Model 666 — uses same case as 666-11... Heads to 1000 volts at 1000 ohms per volt.

Net Price **\$14.00**

See the new Triplet 1939-40 line at the June National Radio Parts Trade Show—Booths 403-405.

WRITE FOR CATALOG!

THE TRIPLET ELECTRICAL INSTRUMENT CO.
Section 286 Harmon Ave., Bluffton, Ohio

JUST OUT!

A NEW GERNSBACK PUBLICATION
The Constructive Photo Magazine



ON ALL NEWSSTANDS

FOR serious-minded amateur photographers, here's a photo magazine, FOTO-CRAFT, vastly different from any you've read. It tells you how and why to do things—it's a constructive publication which shows what can be done with the equipment you have, and how to make handy, photographic accessories. FOTO-CRAFT, with its broad editorial features, covers such important branches of photography as—New Scientific Researches; Developing; Printing; Enlarging; Duplicating; Cropping; Photo-micrography; Color Photography; Amateur Movies; and How to Make It Items.

Articles in the Current Issue:

Still Life in Modern Mode—The Art of Projection Printing—Photo Rules Were Made to Be Broken—The Truth About Filters—The Photo Matrix—Photo Hints and Kinks—Photomicrography with Small Cameras—New! Contra-Color Photograph—Develop Your Own—10" and 10" Photo Equipment—Pinhole Camera—Cameraless Photos with Invisible Rays—Stereoscopic Photos with a Hand Camera—Using Your Camera as an Enlarger—Photographs in Spot—Photo Quiz—International Photo Digest—What's New—Questions and Answers—AND Several Prize Contests and a Color Filter. Absolutely Free.

BIG OPPORTUNITY! Get a FOTO-CRAFT Press Card today—with it you can get permission to take photos which might be difficult to obtain. PRESS CARDS are sent FREE to subscribers of FOTO-CRAFT. Enter your subscription for Seven Months for \$1.00—and get your PRESS CARD immediately.

FOTO-CRAFT

99-T HUDSON STREET NEW YORK, N. Y.

PRICED FOR CLEARANCE

Rockbottom Prices on Overstocked New and Rebuilt Merchandise

When prices are low we buy! They're low now—**LOWER THAN THEY EVER WILL BE**—hence this sale. Most of the merchandise is new—never used; some of it reconditioned. 100% satisfaction on each transaction or your money refunded.

ORDER FROM THIS PAGE. Use the convenient coupon below. Be sure to include sufficient extra remittance for parcel post charges, else the order will be shipped express, charges collect. Any excess will be refunded. C.O.D. shipments require a 20% deposit. If full remittance accompanies order deduct 2% discount. Send money order—certified check—new U. S. stamps. No C.O.D. to foreign countries.

ORDER TODAY QUANTITIES LIMITED QUICK SHIPMENTS ASSURED

VARIABLE SPEED UNIVERSAL MOTOR

FOR 110 VOLTS, A.C. OR D.C.

Made for Dictaphone machines by American Gramophone Co. Used, but in excellent condition. Special lever control permits variable speeds up to 3000 r.p.m. 1/4" shaft extends from both sides of motor. Measures 7 1/2" x 3 1/4" diam. overall. Shp. Wt. 6 3/4 lbs.



ITEM No. 11
Your Price **\$2.55**

SPERRY GYROSCOPE LIQUID COMPASS

Made for U.S. Signal Corps; sensitive and accurate. Quick readings easily made from top; accurate readings of graduations through focusing magnifying lens on side of instrument. Complete with level sights and russet leather carrying case. Excellent for boats, boy scouts, campers, hikers, etc. A few turns of wire around its case makes it usable as a galvanometer. Shp. Wt. 3 lbs.



ITEM No. 12
Your Price **\$1.85**

ADJUSTABLE ANGLE VISE

This tool regularly sells for about \$15. A handy tool for use when drilling, filing, marking, grinding, milling, cutting and fitting at tough angles where jigs would ordinarily be used but are not available. Its 2 1/2" jaws open 3" wide and tilt to a 90° angle. Has sturdy end slots for bolting to machine table. Strong screw with steel handle, accurately machined. Jaws are grooved for holding round objects. Measures 7 1/2" long. Shp. Wt. 12 lbs.

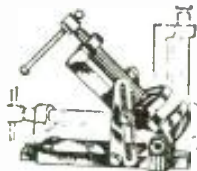

ITEM No. 43
Your Price **\$5.61**

POWER JIG SAW

A trouble-proof powerful tool with self-contained power unit. Cuts 7200 strokes per minute, leaving smooth edges. An ideal machine for wood-crafters, model makers, handy-men, etc. Has 10" square table and gray iron frame mounted on rubber to absorb vibration. Arm blade depth 13 1/2". Designed for 110-120 V. AC use. Measures 9 1/2" x 19 1/2". Adjustable guide and stroke. Sold complete with 8 ft. approved cord and plug, ready to use. Shp. Wt. 12 lbs.



ITEM No. 45
Your Price **\$9.96**

COMPLETE ELECTRIC SPRAYER OUTFIT

Consists of a sturdy compressor 110 V. 1/4 HP, 1750 RPM Motor, 10 ft. hose, efficient spraying gun and all necessary mounting accessories. Costs only 2 cents per hour to operate. Delivers considerable air pressure. Positively will not pump oil. Few working parts to wear. Sprays practically anything. Shp. Wt. 40 lbs.



ITEM No. 46
Kit less motor, but with gun
Your Price **\$6.36**

ITEM No. 47
The complete kit including 1/4 HP motor
Your Price **\$14.53**



NEW FUEL PUMPS

Brown & Sharpe pumps. Brand new; never been used. Can be used for gasoline, oil, kerosene, and other fuels. Not good for water. Takes standard 1/4" input and output pipes. Has 1/4" drive shaft. Measures 4 x 3 1/4 x 3 1/4" diam.

overall. Shp Wt. 8 1/2 lbs.
ITEM No. 24 Your Price **\$4.45**

8" BENCH SAW

For use in work-shops, shipping rooms, repair shops, etc. Experimenters will find it a tremendous time and labor saver. 12 x 14 in. table with 45° tilt. 60° calibrated protractor and adjustable rip fence. Saw blade is adjustable up or down and has automatic drop guard. Weighs 37 lbs. Sold without blade and motor. Shp. Wt. 42 lbs.

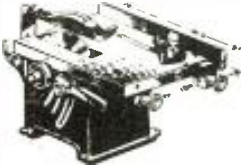

ITEM No. 42
Your Price **\$11.65**



1/75 HP AC MOTOR

Develops 1/75 HP at 3000 RPM. The entire motor is only 3 1/2 inches in diameter. 7/32" shaft. Inductor type motor with shaded pole for self starting. Speed can be varied with suitable rheostat. Complete with cord, plug and base, but less pulley. For use on 110 V. 60 cycle AC line. Shp. Wt. 8 lbs.

ITEM No. 44
Your Price **\$1.75**

20,000 RPM HAND GRINDER

Save 50% on a tough little hand grinder that is extremely useful to radio servicemen, experimenters, jewelers, dental mechanics, etc. Develops 20,000 RPM. Fits solidly in the palm of the hand. Operates on 110 V. AC or DC, 25 or 60 cycles. Its features are: high torque, oilless bearings, sturdy thrust, cool running, handy switch, collet chuck, for 1/8" and 3/32" wheels, finger support for precision work. Shp. Wt. 6 lbs.



ITEM No. 48
Your Price **\$7.62**

VENTILATION FAN

Handy for eliminating kitchen odors. Installs on either window or fue on chimney. Can also be used as radiator fan for room circulation. Induction motor. Operates on 110 volts, 60 cycles A.C. only.

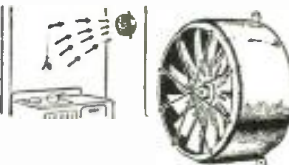

ITEM No. 49
Your Price **\$4.50**

WE HAVE NO CATALOG. ORDER DIRECT FROM THIS PAGE.

HUDSON SPECIALTIES - 40-T West B'way - N.Y.C.

IT'S EASY TO ORDER—CLIP COUPON—MAIL NOW

HUDSON SPECIALTIES CO., 40-T West Broadway, New York, N. Y. RT-639

I have circled below the numbers of the items I'm ordering. My full remittance of \$..... (include shipping charges) is enclosed.
OR my deposit of \$..... is enclosed (20% required), ship order C.O.D. for balance. (New U.S. stamps, check or money order accepted.)

Circle Item No. wanted: 11 12 24 42 43 44 45 46 47 48 49

Name Address

City State

Send remittance by check, stamps or money order; register letter if you send cash or stamps.

Let's Listen In with Joe Miller

(Continued from page 87)

10.53 mc., Formosa, often at 5 a.m., and MTCY, evidently in Manchoukuo, now on 6.12 mc., all reported by OM G. C. Gallagher, W6.

JZL 17.785 mc., is now well heard on an evening transmission from 8-8:30 p.m. for Eastern U. S. JZK, ditto, on 15.16 mc., at 7-7:30 a.m., and for West Coast, JZK operates 12 m.-12:30 a.m. All who wish latest Japanese station news regularly should write the Broadcasting Corp. of Japan, Tokyo, and they'll get regular programs.

OTHER DX

SINGAPORE, S. S.—ZPH, 6.69 mc., QSL'd with a handsome card.

CHINA—We did not mention reception of XPSA, 7.01 mc., Kweiyang, after 8 a.m. recently, but had amateur QRM.

ANGOLA—CR6AA, 7.614 mc., Lobito, has just been verified here, making it a clean sweep of their 3 freqs. Now used, but irregularly, is 7.177 mc., while 7.614 mc. is the main regular transmitter. The 9.666 mc. frequency seems to have been dropped. CR6RC, 11.74 mc., Luanda, operated by the Radio Club of Angola, is reported on a schedule of 2-3:30 p.m., Tuesdays, Thursdays and Saturdays.

ETHIOPIA—IABA, 9.65 mc., at Addis Ababa, is being reported on a schedule of 11 a.m.-noon and 1-3 p.m., signing off with anthems, sometimes carrying past the 3 p.m. sign-off. (S.W.M.)

ROUMANIA—"Radio Rumania, Bucharisti," approximately 9.19 mc., is heard for several hours up to 5 p.m., and often news in English is given at 4:50 p.m. Men and women announcers are used.



Due to curtailment of available space, we can mention DX on the amateur bands only briefly. Let's know by your card how much you're interested in amateur DX.

As we mentioned, conditions are unexplainably poor for April, though there are some good days, but nowhere near our expectations.

20 is pretty dead, and 10 is folding up for its summer vacations.

We'll just list the better DX:

ASIA

KA1FH, 14130; KAILB, 14140; KA1CS, 14140; KA1ME, 14270, heard in Philippines; J5CW, J8CI, 14355, both reported by Bob Suter, W2, with J8 in Korea. FB!

PK4KS, 14320, in Sumatra, was the leading PK to be heard, with a very fine signal every morning. Also PK3AJ, 14270; PK3WI, 14040, in Java.

XU8AM, 14080, and XU8HB, 14000, 14265, from China. VS2AL, Malay, and XZ2DX, Burma, 14040, also reported by Bob Suter, W2.

OTHER DX

SU1CR, 14030; SU1MW, 14130; SU1WM, 14080, all heard from Egypt.

FA3JY, 14100, from Algeria.
VQ4ECJ, 14020, Kenya Colony.
CN8AH, 14030; CN8AM, 14050; CN8AU, 14000; CN8BA, 14085; CN8MA, 14100; CN8MI, 14030; CN8MB, 14100; CN8NU, 14305, all from French Morocco.

EK1AF, 14020, 14110, new call of CN1AF, Tangiers.

CT2AB, 14090; CT2BC, 14090, from Azores, at 3 p.m., during contest.
LX1SI, 14060, Luxembourg, was poorly heard during his I.I.A. special broadcast on March 26 at 2-30 a.m., but we've already received his card acknowledging our report! It's a new country here!

U1BW, 14115, Leningrad, U.S.S.R., heard here at 5:40 p.m., quite well, may be a pirate, as no other Europeans were heard at time of reception. Also TF3C, 14090, Iceland.

ES51D, 14140, Estonia, at 3:45 p.m., on 7 mc.

E88AF, 7.25 mc., at 5 p.m.

Also, EA9AI, Spanish Morocco, QSL'd with nice card.

On 10 meters, ZL's and VK's have been heard on certain week-ends, and in earlier part of day. Europeans and Africans. Latter best 10 a.m.-1 p.m. ZL's best, 6:30-7 p.m., but dying out.

Those heard here include: ZL2BE, 28.42; ZL2BI, 28.40; ZL3IF, 28.50; ZL3AY, 28.18; ZL4FW, 28.50; ZL4RK, 28.22, all in New Zealand. From Australia: VK2GU, 28.18; VK3CF, 28.05; VK4JP, 28.06 mc.

Still a few ZS heard near noon-1 p.m. LY1J, 28.11, Lithuania; SP1MR, 28.17, Poland; SM5WU, SM7YA, 28.14, SM7UC, 28.18, from Sweden; SU1MW, 28.45, Egypt.

Shall I Tackle Television?

(Continued from page 99)

megacycles. Here again, however, the tuned I.F. transformer circuits are heavily loaded with shunt resistors and as a result the gain per stage is relatively low, requiring up to four stages for adequate amplification.

Obviously, in dealing with these unconventionally high frequencies and wide band-widths, it is necessary to use decoupling filters extensively and to by-pass freely. The types and quality of the condensers employed play an extremely important part in the success of any such receiver. In the r.f. amplifier mica condensers are used extensively for by-passing, not because paper condensers are electrically unsuited but because the mica condensers are smaller and therefore the total length of the by-pass circuits can be kept shorter and the inductance therefore held to a minimum.

In the video amplifier circuits, the matter of by-passing is carried to an extent never found in ordinary (sound) radio set design. Plate and screen by-pass condensers are 8 or 16 mfd. electrolytics, and in almost every instance these are in turn by-passed by either .05 mfd. paper, or .01 mfd. mica condensers, utilizing the greater effectiveness of the latter types at the higher frequencies and at the same time providing short leads for this high-frequency by-passing. This latter point may seem unimportant in this portion of the receiver but in this connection it must be remembered that the band-width of this amplifier is 2500 kc. wide, extending from the lower audio frequencies all the way up to the equivalent of short waves. The same precautions must therefore be taken in the matter of by-passing, short leads and avoidance of stray capacities that are necessary in the r.f. end of radio receivers designed to tune down to around 100 meters.

It is in the cathode-ray tube circuits and its power supply that the condenser requirements are the most extraordinary, more nearly approaching the requirements of a transmitter than those of a receiver. The reason for this is that cathode-ray tubes now utilized in television work require transformer voltages of 1500 to 3000 or more.

Condensers have been singled out for special mention, not because the writer is an executive of Cornell-Dubilier, but because these components are of high importance in television circuits.

Television Aerial Construction

(Continued from page 87)

ignition systems. In this case, locate the dipole to the rear of the building and away from the source of the noise as far as possible. In the case of electrical machinery over which you have no control, the same method can be employed along with the utilization of the directional effects of the aerial which will be covered later.

It is a good plan to proceed as follows with the installation.

1. Erect the dipole antenna in the clear. Start by using horizontal polarization (mount the rods horizontally) and turn them until their plane is at right angles with the location of the transmitter.

2. Adjust the receiver to produce a picture.

3. Return to the antenna and make final adjustments for best signal strength and removal of "ghosts," etc.

Where the picture appears to be duplicated and slightly displaced, the additional picture is referred to as a *ghost*. This effect is usually due to the reflection of the signals and can be cured by slanting or rotating the dipole, or by the use of a reflector or reflectors. If, after all possible positions have been tried, the ghost still exists, it will be necessary to change the location of the antenna and try again.

In the simple dipole, directional effects are not very pronounced, but it does have a rather sharp no-signal radius and it is possible in some instances to materially reduce interference by placing the offending source in this area. If the installation of the receiver is being made at quite a distance from the transmitter or if the signal level is very low due to local conditions,



HEY FELLOWS! 6 BACK NUMBERS OF SHORT WAVE AND TELEVISION SENT ANYWHERE IN U.S. FOR 70¢

For a limited time only, and as long as they last, we will send you six back numbers of **SHORT WAVE & TELEVISION** assorted, your choice, for 70 cents.

The usual price for six copies would be \$1.50, and most publishers charge a higher price for back numbers over one year old.

We can supply *only* the following back numbers: Dec., 1930; Feb., April, June, Sept., Oct., 1931; July, Oct., 1932; Jan., April, Oct., Nov., 1933; Jan., Feb., Mar., May, June, July, Aug., Sept., 1934; 1935—All issues except January, February and March; 1936, 1937, 1938—all issues; 1939—all issues to date.

If you do not specify copies, we will send assorted numbers to fill your order. Note, we cannot exchange the copies for ones that have been sent to you.

Every copy of **SHORT WAVE & TELEVISION**

contains information which you should have. Here is a chance to get those copies.

As only a small supply of back numbers on hand, this offer will be withdrawn as soon as they have been sold.

We accept U. S. stamps, U. S. coin, or money order. Rush your order today.

RADIO & TELEVISION 6-39
99-101 Hudson Street, New York, N. Y.

Gentlemen: I enclose herewith 70¢, for which you are to send me six back number copies of **SHORT WAVE & TELEVISION** as follows:.....

Name

Address

City State

Just Published . . . a NEW RADIO AND ELECTRONIC DICTIONARY Containing 3,800 Definitions

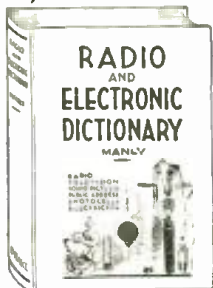

THIS RADIO AND ELECTRONIC DICTIONARY, written by **RODOLPH MANLY**, explains the meaning of 3,800 words used in radio, electronics and other closely allied fields. It includes new terms used in radio transmission, sound pictures, television, public address, aviation radio, navigation and industrial control, photo-electricity, photocoil application, telephotography, etc. This dictionary permits learning every new expression whether you hear it or read it. Alphabetically arranged for quick reference. 550 illustrations augment definitions in the text.

The book is recommended for students, instructors, engineers, service men, experimenters, salesmen and everyone in any way associated with radio. ONLY IN U. S. A. POSTPAID

BOOK OF ITS KIND—HANDY—EASY TO USE—AND TIMELY.
The **RADIO AND ELECTRONIC DICTIONARY** is new, authentic and printed on a single volume of 300 pages, size 8 x 9 inches. The book weighs two pounds, and bound in durable cloth. **SHIPPED ANYWHERE \$2.50**

Mail remittance by check or money order to **RADIO PUBLICATIONS**
99 HUDSON STREET NEW YORK, N. Y.

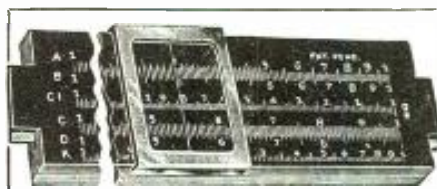

We offer an eight inch, white wood, accurate slide rule with A, B, C, D, CI and K Scales, a 20-page Book of Instructions, How to Use a Slide Rule, a 36-page Book of 300 Examples and Answers, a two-toned Facsimile of the Declaration of Independence, suitable for framing, and an 8-page catalog illustrating and describing indoor games and many unusual items, all five prepaid anywhere in the United States and Canada for **50c**

Send for catalog containing full descriptions of these and many other interesting items.

GOLD SHIELD PRODUCTS
Dept. RT-6-9 350 Greenwich St. New York

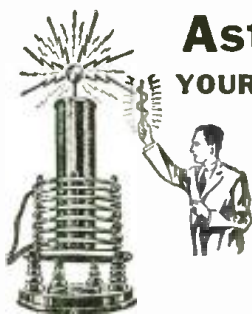

Astonish YOUR FRIENDS!

Pass 500,000 Vts. Thru the Body! Light Lamps, etc.

DATAPRINTS SHOW YOU HOW!

20c Each in Order for 10 **TESLA-ODUDIN HI-FREQ. COILS**

- 36" Sp'k Tesla-Oudin Coil 40c (Data and Drawings only) (1 K.W. Exc. Trf. Data, included FREE!)
- 8" Sp'k Tesla-Oudin Coil 40c (1/4 K.W. Exc. Trf. Data included FREE!)
- 3" Sp'k Oudin; 110 Vt. "Kick Coil" type 40c
- 3" Sp'k Tesla Works on Ford Sp'k Coil 40c
- 1" Sp'k Violetta Hi-Freq. Coil 40c

FREE with order for \$1.00 or more—20 Tricks with Hi-Freq. Coils" (40c separate)

Television Hook-ups—"Sight & Sound" . . 40c

20 **ELECTRIC PARTY AND LODGE TRICKS!** Loads of Fun!

How to Shock 'em! 40c
Order with other prints; see special price below and save.

Solenoid & Magnet Data—Get Our List!

20 Telephone Hook-ups—Build Your Own . . 40c **RADIO CONTROL FOR MODEL BOATS, PLANES, ETC.**

(Circuit data 40c)

S-W DIATHERMY (Artificial Fever)

Dataprint giving Constructional data for Small, Medium and Large size App. (All 3) . . . 40c



Induction PIPE & ORE LOCATOR

Construction Data 40c

You NEED these DATAPRINTS !! 40c Each.

- 20 A.C. Problems and their Solutions.
- 1/2 Meter Transm. & Rec. Rewinding Armatures.
- 20 Telephone Hook-ups.
- 5 Meter Superhet.
- 100 Mechanical Movements.
- 20 Motor Hook-ups.
- 20 Simple Bell Circuits.
- Welding Trans. 2 K.W.
- Einthoven String Galv.
- Wheatstone Bridge.
- Model Ships—get list.

Special Prices: 4 prints \$1.00; 10 for \$2.00; 40c each, single orders.

The DATAPRINT Co.
Lock Box 322A RAMSEY, N. J.

it is well to consider the use of a *reflector*. This is done by placing a rod, about ten feet long, parallel with the dipole and about five feet in back of it; see sketch. The directional effect of the dipole remains the same, namely at right angles to the plane. Signals coming from the front will be greatly increased. In using reflectors, it is well to bear in mind, however, that any signal approaching from the rear (where the reflector is located) will be greatly attenuated. One of the illustrations shows the reflector added to the simple dipole.

COMMERCIAL NOTICES 10¢ A WORD

Under this heading only advertisements of a commercial nature are accepted. Remittance of 10¢ per word should accompany all orders. Copy should reach us not later than the 10th of the month for the second following month's issue.

AGENTS WANTED

300% PROFIT SELLING GOLD Leaf Letters for Store Windows; Free samples. Metallic Co., 446 North Clark, Chicago.

CORRESPONDENCE COURSES

CORRESPONDENCE COURSES and educational books, slightly used. Sold, Rented, Exchanged. All subjects. Satisfaction guaranteed. Cash paid for used courses. Complete details and bargain catalog Free. Send name. Nelson Company, P-210 Manhattan Building, Chicago.

INSTRUCTION

RADIO ENGINEERING BROADCASTING, aviation and police radio, servicing, marine and Morse telegraphy taught thoroughly. All expenses low. Catalog Free. Dodge's Institute, Colt St., Valparaiso, Ind.

RADIO CODE COURSE ON THREE self-teaching records. \$1.00 net. Instruction book sent free upon receipt of 5¢ stamp. Riston Records, Pittman, N. J.

ALGEBRA PROBLEMS SIMPLIFIED \$1.30; Low Voltage Transformer Construction \$0.60; Data on 500 to 20,000 Volt Step-up Transformer Construction \$1.35 (Prepaid). H. Ackerson, Box 322-D, Ramsey, N. J.

MISCELLANEOUS

7 MILLIAMMETER, HEAVY RUBBER insulation, high voltage lacquered cable, suitable for transmitter. 2¢ per foot. Gold Shield Products, 350 Greenwich St., New York City.

PATENT ATTORNEYS

INVENTORS — PROTECT YOUR rights before disclosing your invention to anyone. Form "Evidence of Conception"; "Schedule of Government and Attorneys' Fees" and instructions sent free. Lancaster, Allwine & Rommel, 436 Bowen Building, Washington, D. C.

QSL—CARDS—SWL

100 NEAT SWL CARDS PRINTED with your name and address sent post-paid for \$1. Bunch of samples and RST Chart for five cents in stamps. WJBF, 16 Stockbridge Ave., Lowell, Mass.

SWL-QSL CARDS, 200 FOR \$1.00. Quality printing. Send stamp for Free samples. Miller Printing Co., 399 Thirteenth Avenue, Columbus, Ohio.

ORIGINAL QSL SWL CARDS 200, \$1.50. Samples. WJLWK, 16 Sanger St., Medford, Mass.

RADIO

ANY RADIO CIRCUIT DIAGRAM 25¢. Order mentioning manufacturer's name, model. Catalog Free. Supreme Publications, 3727 West 13th, Chicago.

SHORT WAVE RECEIVERS

THE WORLD FAMOUS SUPER Clipper. Thousands sold at \$22.75. Now offered at the phenomenally low price of \$23.75 each. Seven tubes, built-in signal booster, 3-550 meters. Band-switching, of course, with three stages of audio frequency amplification. The Super Clipper is our most powerful and sensitive receiver. Due to over-production, we are disposing of a limited number at this unheard of price. Act Now! First come, first served. Fully guaranteed for one year. Radio Constructors Labs., 136 Liberty St., New York City.

YOUR OPPORTUNITY TO SAVE. Famous Doerle factory reconditioned receivers, fully guaranteed, 3 tube electric \$3.90, 7C \$8.90, BSS \$11.10, D38 \$19.00, Oscar R. Kusterman, 297 DeKalb Ave., Brooklyn, N. Y.

PLANS 18 RECORD-BREAKING Crystal Sets, SW record 4250 miles, with "Radiobuilder"—25¢ year. Laboratories, 7700-A East 14th, Oakland, California.

SDNG POEMS WANTED

WANTED ORIGINAL POEMS, songs for immediate consideration. Send poems to Columbian Music Publishers, Ltd., Dept. K19, Toronto, Can.

FOR SALE (NON COMMERCIAL) 3¢ A WORD

Under this heading we accept advertisements only when goods are offered for sale without profit. Remittance of 3¢ per word should accompany all orders. Copy should reach us not later than the 10th of the month for the second following month's issue.

RECONDITIONED RECEIVERS. Have several good, reconditioned communication receivers. Send stamp for list. W2AVA, 12 West Broadway, New York.

PRINTING PRESS, 3X5 KELSEY with many extras. Cost approximately \$40. Can print QSL's or anything. Best cash price takes it. C. Vanderline, Station WJBO, Baton Rouge, Louisiana.

ULTRA STRATOSPHERE 10 TRANS-Receiver 2 1/2 to 4000 meters. Have coils 2 1/2 to 600 meters, also Gross short wave 3 tube battery receiver using 3 volt tubes and 4 plug-in coils. Sell both at bargain, \$28.00. Like new. Jensen, 211 East 200 St., Bronx, N. Y.

POSTPAID: SUPREME 545 DIAG-nometer \$50. Hickok QSL2 oscillator \$20. Rider Manuals Volumes IV, V, VI, VII, VIII \$20. Ray Terry, SS Alabama, Texas Co., Ft. Arthur, Tex.

SKY CHAMPION 8 TUBE RE-ceiver, perfect electrical mechanical condition \$30.00. Alvin Abrams, 20 Laurel Hill Terrace, N.Y.C.

P. A. SYSTEM, 6 TUBES, PUSH-pull, case, mike, 50 feet cable, AC-DC, slightly used, \$40— or swap for AC-DC receiver, N80X, N44 or what have you? Dermouta, 134 W. 62nd, New York.

WILL SELL NATIONAL GEO-graphic 1916 to 1937, American Rifleman 1926 to 1937, books or business. Also Popular Science, Popular Mechanics, Mentor and others. Have 22 rifle, Deep sights, 410 and 15 gauge shotguns, etc. A. Welker, 4th No. Harvey, Oak Park, Ill.

NO. 74 GILBERT FRETWORK SET, complete, \$3.00. H. Patchen, 23 Grand St., Sidney, N. Y.

RK21. PHONO-OSCILLATOR, \$3.00. Stempel, 751 Ogden St., Bridgeport, Conn.

GOOD UNIVEX PROJECTOR WITH 50 ft. cord, \$9.75. Cost \$7.00. Piano accordion, beginners model, \$7.50. Cost \$16. Eastman camera size 120, 50c. Howard H. Brown, Edkerton, Wis.

SKILL COMPLETE HAM OUTFIT 40 watt transmitter with power supply and meters, 5 tube receiver, both absolutely complete and in excellent condition. Highest cash offer in two weeks takes them. F. W. Freutel, 840 S. Kenston Ave., Los Angeles, Calif.

S11 SUPER-SKYRIDER \$49.00, Breting 14 \$39.00, Howard 450 \$49.00, Sargent 8-34 \$19.00, Howard 430 \$19.00, FCBT \$10.00, Sky Buddy \$15.00. WBARA, Butler, Missouri.

FIVE TUBE, 5 METER RECEIVER complete \$9.50; fifteen watt, 160 meter transmitter and power supply less crystal, condenser \$13.50, cash or C.O.D. Ross, 208 Charles Ave., New Kensington, Pa.

BARTER AND EXCHANGE—FREE!

NO ADVERTISEMENT TO EXCEED 35 WORDS, INCLUDING NAME AND ADDRESS

Space in this department is not sold. It is intended solely for the benefit of our readers, who wish to buy or exchange radios, parts, phonographs, cameras, bicycles, sporting goods, books, magazines, etc. As we receive no money for these announcements, we cannot accept responsibility for any statements made by the readers. Use these columns freely. Only one advertisement can be. Copy should reach us not later than the 10th of the month for the second following month's issue.

accepted from any reader in any one issue. All dealings MUST be above board. Remember you are using the U. S. mail in all these transactions and therefore you are bound to give exact price with letter. Offer accurately and without exaggeration. Treat your fellow men the way you wish to be treated. We welcome suggestions that will help to make this department interesting and helpful to our readers.

HAVE SW-3 WITH THREE SETS coils. Want good camera. About a 3.5 or 4.5 lens. Bill Sampson, Jr., 2208 Floyd Avenue, Richmond, Va.

HAVE NEW RADIO BUG, 160 AND 80 meter xials ground, also 160, 80, 40 and 20 meter blanks, parts for low power transmitter. Stamp for list. Wanted: typewriter, 2000 V transformer. WTGPP, 1308F, The Dalles, Oregon.

SWAP—SILVER MARSHALL 6 tube receiver, mike, earphones, rifles, typewriter, electric shaver, stereoscope, photo goods, many books. Send your list for mine. M. Epstein, 29-53 Ruckle, Indianapolis, Ind.

HAVE 8 MODEL CRAFTSMAN AND Home Craft, 4 Pod. Mech., CCU insignias, 5 MFD condenser, for practice key or 6K7, or what? Interested in buying reasonable code osc. Ray Davis, Co. 773 CC, Drakeville, Iowa.

WILL PAY CASH FOR METERS, test equipment, and circuits. Frank M. Masters Jr., River Road RD No. 2, Harrisburg, Penna.

HAVE RADIO PARTS, MIKES, RADIO, science and outdoor magazines, books, spark coil, xmitting key and buzzers, etc. Want photography equipment. B. R. Rhett, 2208 Byrd St., Raleigh, N. C.

WANT CRYSTAL MIKE, SET ANAL-lyzer, low power tubes or what? Have Candler course, Nat. transmitting conds., Super power Carostats, Jewell 0-10 R. F. Thermocouple meter and others. Write E. Kammerling, 616 N. Central, Chicago.

WANTED: U. S. PENNIES DATED before 1845 Trade 110 test tubes, 13 star replica C. S. large flag, 85 foreign coins, old Radio Call-books, Cooke auto and radio home work sheets. Rollin Dieter, Blue River, Wis.

SWAP SUPER CLIPPER COM-plete. Want book or magazines covering radio theory. Russell B. Garrett, 218 S. Allen St., State College, Pa.

SWAP GROSS CW-25 TRANSMIT-ter, parts, magazines, etc for crystal mike, velocity, low loss variable condensers, xmit tubes, electrical books and course, transmitter power supply, hi voltage. Nevel Kelly, 294 Congress St., East McKeesport, Penna.

TO TRADE—RIFLES WATCHES, field glass for treasure locator or vel-ean. W. F. McMurphy, 510-14th St., San Diego, Calif.

TRADE 3 TUBE SET AND TRUM-Pet for 0-1 milliammeter or radio books. Toshi Okuma, Itt. 6, Box 1404, Phoenix, Arizona

HAVE FILED 7C RECEIVER ALSO 6J5-6C5-251A-2526 metal tube 2 1/2 meter transceiver, magazines, radio, fiction, etc. Would like Teleflex, In-structograph code machine, typewriter, etc. Shelton Radio Club, 202 South 2nd St., Brooklyn, N. Y.

CORRESPONDENCE WANTED, ALL foreign countries. Will swap stamps. All letters answered promptly 100%. Jay E. Merkel, 29 Murray St., Bangor, Pa., U. S. A.

WANTED: MINT UNITED STATES stamps. Commemoratives in blocks of four preferred. All letters answered. Give exact price with letter. Have cash, radio parts, shop machines and musical instruments. Huddleston, 918 South 25th Street, Temple, Texas.

SWAP: DOUBLE BARREL 12 gauge shotgun (good cond.), electric Phonograph pickup, tubes, or few radio parts. Want Sky Buddy or similar short wave set or transceiver. Please send list. Bill Gilliam, 611 15 Street, Taft, California.

TRADE SMALL BOY'S BICYCLE 12.75 x 2.50 tires, coaster brake. Want Briggs & Stratton, small gasoline engine; rifles; camera; fast lens; out-board motor or what? Richard Schalla, 1555 Ballard St., Lansink, Mich. (Continued on opposite page)

Electronic Television Course

(Continued from page 81)

means must be employed to make this saw-tooth wave-shape linear in time, before it is applied to the cathode-ray tube. One such device is an overbiased triode. Since the portion of the grid voltage, plate current curve of a triode is opposite in effect to the non-linearity of the saw-tooth wave-shape, the resultant current in the plate circuit will be linear in time. (See Fig. 4.) This fact should also be remembered in the discussion of the last type of saw-tooth generator, shown in Fig. 5.

The RCA Laboratories have developed a saw-tooth generator known as the blocking type which functions in the following manner: One section of a dual-triode operates as the oscillator. The oscillations are made to occur due to the feed-back of energy from the plate circuit to the grid through the transformer. Grid current flowing through resistors R1 and R2 develops a voltage sufficiently high, causing the plate current to drop to zero and the oscillations to cease. The charge from the grid leaks off through these resistors to a low enough

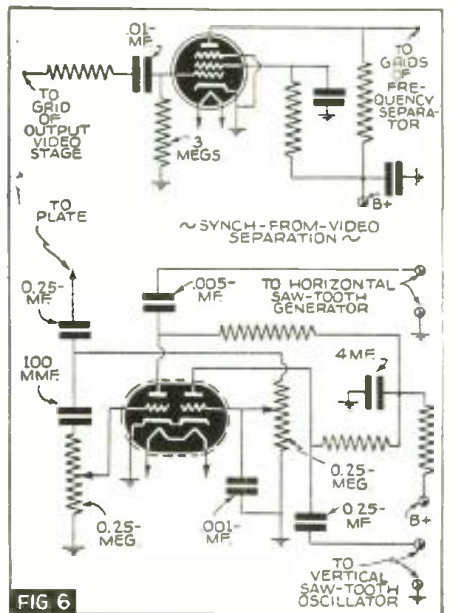

FIG 6 Sync-from-Video Separation Circuit

value so that the circuit can resume oscillating again. The second section of this triode demodulates the oscillations and emphasizes the oscillations relative to themselves through the shunting condenser between plate and ground. The triode following is used, as previously stated, to correct for the non-linearity of the saw-tooth wave produced by the oscillator. This type of circuit or modification of it will be widely used in television receivers manufactured in this country. Both the multivibrator and the blocking type oscillator perform admirably in television receivers constructed by the writer.

The Sync-from-Video Separator

Since the transmitted picture signal contains both synchronizing pulses (60 cycles and 13,200 cycles) and the picture signal, some means must be employed at the receiver to separate these pulses from the signal and finally to separate the 60 cycles from the 13,200 cycles, and apply them to the grids of their respective saw-tooth oscillators. As has been stated, the synchronizing pulses represent the highest

World S-W Stations

(Continued from page 92)

- Mc. Call
- 6.296 OAX40 LIMA, PERU, 47.63 m., Addr. Apartado 1242. Daily 7-10.30 pm.
- 6.280 HIG TRUJILLO CITY, D. R., 47.77 m., 7:10-9.40 am., 11.40 am.-2.10 pm., 3.40-9.40 pm.
- 6.270 YVBRP CARACAS, VENEZUELA, 47.79 m., Addr. "La Voz de la Philco." Daily to 10.30 pm.
- 6.286 YVBRJ CARACAS, VENEZUELA, 47.18 m. 5.30-8 pm.
- 6.243 HIN CIUDAD TRUJILLO, D. R., 48 m., Addr. "La Voz del Partido Dominicano." 12 n.-2 pm., 6-10 pm.
- 6.236 HRD LA CEIBA, HONDURAS, 48.12 m., Addr. "La Voz de Atlantida." 8-11 pm.; Sat. 8 pm.-1 am.; Sun. 4-6 pm.
- 6.225 YVIR0 VALERA, VENEZUELA, 48.16 m. 6-9.30 pm.
- 6.210 — SAIGON, INDO-CHINA, 48.28 m., Addr. Radio Boy-Landry, 17 Place A. Foray. 4.30 to 5.30-9.15 am.
- 6.206 YVBRJ CORO, VENEZUELA, 48.32 m., Addr. Roger Leyba, care A. Urbina y Cia. Irregular.
- 6.200 HIRQ CIUDAD TRUJILLO, D. R., 48.36 m. Irregular.
- 6.190 JLK TOKYO, JAPAN, 8-9.30 am.
- 6.190 HVJ VATICAN CITY, 48.47 m. Mon., Wed., Thur., Sat. 2-3.30 pm., Tues., Fri. 2-3 pm. Thur. also 3-3.30 pm.
- 6.190 T02 GUATEMALA CITY, GUAT., 48.4 m., Addr. Dir. Genl. of Electr. Commun. Relays TGI Mon.-Fri. 6-11 pm., Sat. 6 pm.-3 am. Sun. 7-11 am., 3-8 pm.
- 6.186 HIIA SANTIAGO, D. R., 48.5 m., Addr. P. O. Box 423. 7 am.-5 pm.

49 Met. Broadcast Band

- 6.170 WZXE NEW YORK CITY, 48.62 m., Addr. Col. B'cast System, 485 Madison Ave. 11 pm.-12 m.
- 6.166 YV5RD CARACAS, VENEZUELA, 48.71 m. 11 am.-2 pm., 4-10.40 pm.
- 6.153 H15N MOCA CITY, D. R., 48.75 m. 6.40-9.10 pm.
- 6.150 HJ4DAE MEDELLIN, COLOMBIA, 48.78 m., 9.30 am.-1 pm., 5-11.30 pm.
- 6.150 VPB COLOMBO, CEYLON, 48.78 m. 7-11 am.
- 6.150 CJRO WINNIPEG, MAN., CANADA, 48.78 m., Addr. (See 11.720 mc.) Daily 6 pm.-12 m. Sun. 5-10 pm.
- 6.150 ZPI4 VILLARRICA, PARAGUAY, 48.78 m. 4-6 pm.
- 6.148 ZTD DURBAN, SOUTH AFRICA, 48.8 m., Addr. (See RO, 9.753 mc.) Daily 12.40-3.45 pm., Sat. till 4 pm., Sun. till 3.20 pm.
- 6.147 ZEB BULAWAYO, RHODESIA, S. AFRICA, 48.8 m. Mon., Wed., and Fri. 1.15-3.15 pm.; Tues. 11 am.-12 n.; Thurs. 10 am.-12 n. Sun. 3.30-5 am.
- 6.146 HJ4ABG MEDELLIN, COL., 48.79 m. 11 am.-12 n., 6-10.30 pm.
- 6.140 W8XK PITTSBURGH, PA., 48.83 m., Addr. Westinghouse Electric & Mfg. Co. Relays KDKA 11 pm.-12 m.
- 6.140 SP48 WARSAW, POLAND, 3-5.30 pm.
- 6.137 CR7AA LAURENCO MARQUES, PORT. S. AFRICA, 48.87 m. Daily 12.05-1, 4.30-6.30, 9.30-11 am., 12.05-4 pm., Sun. 5-7 am., 10 am.-2 pm.
- 6.133 XEXA MEXICO CITY, MEX., 48.93 m., Addr. Dept. of Education. Daily 8-11 am., 2.30-4 pm., 7.30 pm.-12.45 am. Sun. 1-30 pm.-12.45 am.
- 6.130 VPI80 GEORGETOWN, BRIT. GUIANA, 48.94 m. 9-10 am., 2.15-6.30 pm., Sun. 5.30-11.30 am., 3-5 pm.
- 6.130 T16M SAN JOSE, COSTA RICA, 48.94 m. "El Mundo." Apartado 1049, 11 am.-11 pm., Sun. 10 am.-6 pm.
- 6.130 CHNX HALIFAX, N. S. CAN., 48.94 m., Addr. P. O. Box 998. 7 am.-11.15 pm. Sat. 8 am.-11.30 pm. Sun., Noon-11.15 pm. Relays CHNS.
- 6.130 LKJ JELOY, NORWAY, 48.94 m. Noon-6 pm.

(Continued on page 127)

BARTER and EXCHANGE FREE ADS (continued)

- WANTED: A GOOD PORTABLE typewriter, will give a complete Modern Business course and a complete taxidermy course valued at \$25. Please write: Henry Berwald, R.2., Madison, Ohio.
- OFFER 1938 SILVERTONE 12 TUBE communications A.C. set with crystal and speaker and 2 tube preselector and serial tuner, for moving picture machine, automatic record changer, television or anything. Mrs. Herbert Davis, Oconomowoc Lake, Oconomowoc, Wis.
- BOOKWORMS. LET'S EXCHANGE books, also have items to swap for books. Send your list for mine. F. Wittich, 7202 Juniper Valley Rd., Mason, N. H.
- HAVE 50 "QST", 12 "RADIO", 1 "ARRL" Handbook, 1 "Radio" Handbook. Will swap for J. Clemens, 4516 N. Oakley St., Chicago, Ill.
- TRADE 3-250 AND 4-100 WATT transmitting tubes. Want portable typewriter, ham receiver, meters in instruments, radio parts, or? Stanley B. Whitman, Yankton, So. Dak.
- I WANT A BUG AN ANTENNA meter (Hioite or Triplet), 500-1000, 0-450-500 transformer at 2500 millis. 1200-0-1200 transformer at 150 millis. filter chokes for these transformers, and Weston or Triplet 150 milliammeter. LeRoy Krutz, Dorchester, Neb.
- WANTED: SUPER SKYRIDER OR other communications receiver. Give full particulars. Price must be reasonable. Also books and magazines in French, Spanish, Dutch, especially radio. Have many R&T and radio parts. Geo. Bixler, Sta. F. Milwaukee, Wis.
- WANT OFFICIAL RADIO SERVICE Manuals or Rider's Manuals, correspondence course, radio books and magazines, analyzer, tube tester, multi-meter, meters, signal generator. Cash. Send for swap list. Kay, 319 Main St., Niagara Falls, N. Y.
- HAVE PONY PREMIO NO. 5 PORTrait camera with double ext. bellows, revolving back, Bausch and Lomb lens. Trade for camera, watches, watch repair eq., or? M. Burnett, 733 2nd Ave., N.E. Camas, Wash.
- HAVE 5 TUBE AC-DC RACO Universal Clipper. Trade for Sky Champion or new Sky Buddy covering ten meters. Will pay difference. Will correspond with Nassau County SWLs. Martin Lewis, 54 Highland Ave., Fort Washington, N. Y.
- SWAP—HAMMARLAND COIL KITS SWK-4 and SWK-5, Superior Almet model AMI, Triplet tube tester 1210, Triplet oscillator 1230 and a light weight A.C. arc welder, 110 volts. R. J. Gardner, 2689 L St., San Diego, Calif.
- WANTED—1800 VOLT D.C. 300 MA. transformer, meters, filament transformers, 5mitter and testing equipment. Will trade Weston Photronic cell, new. Pese cell, M-34 RCA car radio, RK-23 tube, brand new. Garricus, 891 E. Meadville, Penna.
- CORRESPONDENT WANTED. ANY part of the world, interested in radio, languages, and Christianity. Edmund Youngs, 43 Parkgate Road, Watford, Herts, England.
- WANTED: MUSIC BOX (NOT A phonograph). Does not have to be an antique. Would rather have a new one. Will give for it magazines, books, magic, records, etc. Joseph Monahan, Old Frankfurt 14ke, Lexington, Ky.
- HAVE TWO CAMERAS, FIELD glasses, stamp collection, some Popular Science magazines. Would like to have a short wave radio like the Sky Buddy or parts. Alfred Numl, 220 East Spruce St., Chisholm, Minn.
- HAVE "A" AND "B" ELIMINA TOR, BC radio, electric razor, Auto-knitter, Want washer gas engine, electric motor, 8 m. film, Any kind. Swap lists, send yours. Howlett, Potsdam, N. Y.
- SWAP 2 TUBE S.W. RADIO AND power pack for clarinet, sax, trumpet, camera, or what have you. Will answer all letters. Frank Martini, 916 E. North St., Staunton, Ill.
- TRADE NEW FAIRBANKS-MORSE 4 tube 2-6 volt battery superhet. Want 2 volt "National SW-3" in good condition or a shortwave receiver equal to it. Alexander Podstepny, 217 Fine St., Phila., Penna.
- SWAP—RCA 849 COM. TUBE, W.E. 203A, W.E. crystal holder, or tube checker, Supreme volt ohm meter. Rider's Manuals or any kind test equipment in A-1 shape. David Oehlson, 69 W. 23 St., Chattanooga, Tenn.
- TRADE PAIR EXCELLENT RCA 800 tubes, several meters and three good Kodaks. Want rifles or 16mm movie camera. Will pay some. What have you? No Junk. WTRCU, Jerome, Idaho.
- WANTED: CANDLER JUNIOR CODE Course and/or a beginner's radio course for which I will pay cash. Larry Roessler, 1121 Greenwood Ave., Victoria, B.C., Canada.
- WANTED: YELLOW GOLD WRIST or pocket watch, American made; Scott's stamp catalog. Have home-charger, Patent phono-adopter, 0-25 Jewell Milliammeter, misc. radio parts and magazines. F. W. Rose, 475 East 124 St., Cleveland, Ohio.
- 2A3 AMPLIFIER, CARTER GENE MOTOR, Briggs Station engine, 200 watt A.C. Generator, Thorlonsons: T-68R26, T-58A70, T-65-94. Want Polyphase duplex rule, scope, horns. units, audio osc., 0-200 milliammeter. Db. meter, recorder, 12DC 110A1 Inverter. Edgar Rye, Blooming Prairie, Minn.
- WILL SWAP TUBES, 2 42s, 2 47s, A new 45 and a usable 80 for a good 2A5; a 57 and a 30, Ross Smith, 321 S. Highland St., DuBois, Penna.
- FOR TRADE ONE DC GENERATOR volts 500 and 12 amps 6.25, trade for volt ohmmeter and condenser tester. Lewis Mihm, 1450 Market St., San Diego, Calif.

SWL EXCHANGE

- SWL'S EVERYWHERE. WILL swap SWL cards, an especially interested in cigarette cards. Will buy or exchange. A. Nash, 13 Parkfield St., Leonards o/s, Sussex, England.
- SWL'S—I WILL EXCHANGE SWL cards with anyone in U.S.A. and foreign countries. What say, gang? 1 QSL 100%. QRA: Bob Greenwood, 40 Chapel Street, Shirley, Mass.
- I WOULD LIKE TO SWAP SWL cards with all foreign and U.S. listeners. 1 QSL 100%. QRA: Wm. E. Lawson, 343 E. 8th Ave., Conshohocken, Pa., U.S.A.
- ATTENTION AMATEURS AND SWL'S everywhere. I send my QSL to anyone who includes sufficient postage. Best of 73's. WILRV, Michael Calabrese, Jr., 16 Sanier St., Medford, Mass.
- DX SWL'S AND ALL HAMS. I would like to exchange my card for yours. Every card received here will be answered 100%. What say gang? QRA: Dave Bloch, 175-38 88 Ave., Jamaica, N. Y.
- WOULD LIKE TO EXCHANGE SWL cards with any ham in U.S.A. or foreign countries. Will QSL 100%. QRA: Claude Lebrau R.P.D. No. 1, New Market, N. H., U.S.A.
- SWL—LET'S SWAP CARDS. 1 QSL 100% Foreign or U.S.A. QRA: "Windy" Maurice Wynne, 210 Hector Ave., Metairie Branch, New Orleans, La., U.S.A.
- SWL'S, HAMS, UR CIUS WANT ed here from any part of the globe and the U.S. All cards answered by return mail. QRA: George V. Harvey, 305 S. High St., Blackstone, Virginia.
- ATTENTION DX FOREIGN SWL'S. Would like to exchange cards with you. Will QSL 100%. J. W. Cooper, Box 701, Spencer, N. C., U.S.A.
- WILL SWAP SWL CARDS. LET'S hear from you. Allen J. Schwartz, P.O. Box 69, Albany, N. Y.
- CALLING QZ TO ANY QM'S YL's would you like to have a SWL card? Will QSL to anyone, anywhere, 73 to all. Blanchett Bushbury, 11 N. Hillton St., Baltimore, Md.
- SWL'S IN ALL COUNTRIES. Want to swap cards with u. YL's also. Let's hear from the U.S.A. and England. QSL 100%. QRA: Jack Davis, 27 Vernon St., Halifax, N. S. Canada.
- ATTENTION SWL'S IN ALL countries. Wud like to swap my SWL card for ur's. 1 QSL 100%. Eugene Jones, 4012 1/2 Gallia Ave., New Boston, Ohio.
- ATTENTION SWL'S U.S. AND foreign. I will answer all SWL cards rec'd 100%. QRA: William L. Craiger, 4211 Sterling Ave., Portsmouth, Ohio.
- ATTENTION HAMS AND SWL'S of America and foreign countries. I QSL with my F.B. card the same day I receive yours. QRA: Nicola Cannata, 1003 S. Halsted St., Chicago, U.S.A.
- WILL SWAP 100% SWL CARDS, shaft photos or used stamps with other SWL's and hams all over the world. Chick Miles, 37, Coppice Ave., Ikeston, Derbyshire, England.
- WILL SWAP SWL'S CARDS OR correspondence with anyone in any part of the world. QRA: Tom Edgar, 9, Talfour Road, Peckham, London S.E.15, England.
- ATTENTION. I WILL ANSWER all SWL's and postal cards from anyone anywhere. Harold Joseph, 607 W. 11th St., Coffeyville, Kan., U.S.A.
- SWL'S IN ALL FOREIGN COUNTRIES, outside of U.S.A. I will swap my super FB SWL cards with you. 1 QSL 100% with foreign listeners. QRA is Wm. W. Stump, 1704 Wood St., Wilkingsburg, Pa., U.S.A.
- CALLING SWL'S AND HAMS WHO want a nice SWL card in exchange for theirs? 1 QSL 100% same day I receive your card. Albert Dodd, Gen. Del., Summerville, Ga., U.S.A.
- CALLING ANY SWL POST IN U.S. or abroad. Have FB card that I wud like to exchange with U. 1 QSL 100% everywhere in the world. Norm. E. Whitton, 76 Green St., Greenwood, Mass., U.S.A.
- SWL'S IN U.S.A. AND FOREIGN countries. I will send one of my SWL cards to those who send me one of theirs. Correspondence. 1 QSL 100%. Willet Fisher, 200 W. Washington Ave., Pearl River, N. Y., U.S.A.
- SWL CARDS WILL BE APPRECIATED from all countries. Answer all. Robert Hedstrom, 3610 Wright Ave., Racine, Wisconsin.
- SWL'S ALL OVER THE WORLD. Will swap cards with you 100%. Also have many radio parts to trade. QRA: Donald D. Warnock, Converse, Indiana, U.S.A.
- ATTENTION! ALL OM'S ES YL'S. Let's swap your SWL cards for one of mine. QSL 100% here. Bud Treiber, % The Listening Post, Glenmont, New York.
- G. SWL. WILL EXCHANGE S.W.L. cards with any SWL anywhere. 1 QSL 100%. QRA: Wm. Farbotton, 28 Curzon Rd., Bradford Moor, Bradford, Yorks, England.
- I WOULD LIKE TO SWAP MY new SWL cards with SWL's; YL's and Hams from both foreign and U.S.A. 1 QSL 100%. Austin Wardman, 832 Linden Avenue, East Pittsburg, Penna., U.S.A.
- I WILL EXCHANGE MY SWL card with anyone, anywhere. 1 QSL promptly and pass ur QRA too. Robert Chase, 231 Henry St., New York, N. Y., U.S.A.
- "AFRICA CALLING". SW LISTENERS and Hams of the world. Will swap SWL and QSL cards, also shack photos and postcards. 1 QSL 100%. 73's. QRA: SAIBSIL M., Lou Grad, 34 Millbourne Rd., Bertrams, Johannesburg, S. Africa.
- SWL; HAMS, WILL QSL 100%, anyone out of Wg. dir. hearing me. Europe wanted. 7037-7248-7300 K.C. W6147, 1822 Alexandria, Hollywood, Calif.
- ATTENTION SWL'S. WILL SWAP my SWL card for yours. 1 QSL 100%. Also want to join U.S. and foreign S.W. clubs. QRA: Bud Carson, 1613 W. Second St., Dayton, Ohio.
- LIKE TO EXCHANGE SWL CARDS with all OM's and YL's in entire world. Get a card from the seat of the World's Fair. 1 QSL 100%. John Hallin, 40 East 66th St., New York, N. Y.
- ENGLAND CALLING! WOULD LIKE to exchange Postcards, etc., and correspond all over the world with any SWL's. All letters will be promptly answered. R. G. Uplh, 24, Burns Street, Nottingham, England.
- ATTENTION SWL'S THE WORLD over. Send me your card. I will send you mine immediately. 1 QSL 100%. QRA—CHT Hols, 67-24 Ingram St., Forest Hills, New York, U.S.A.
- QZ SWL AND HAMS IN U.S. and foreign countries. O.M., Y.L. and NYL's. Will exchange SWL for SWL and QSL cards. 73ers. QRA: Eber F. Diehl, Jr., 309 So. 17th Street, Camp Hill, Pa., U.S.A.
- ATTENTION YL'S. I WILL QSL 100% with you. 73's es 88's. QRA—Marty Weitz, 89 Lawrence St., Oswego, N. Y.
- I WILL QSL OR SWL WITH ANYBODY in any part of the world. Send ur card. Charles E. Wooster, 32 S. Maine, Peabody, Ohio.
- ATTENTION: HAMS AND SWL'S all over the world. Let's exchange QSL or SWL cards. 1 QSL 100%. 73's es best DX. Ivan McGrette, Jr., P.O. Box 726, Williams, Arizona, U.S.A.
- I WILL QSL 100% TO ANY O.M. or Y.L. in any part of the world. Also swap postal cards and "shak" fotos. Also foreign stamps. QRA: John W. Davis, Church Eastone, Oxfordshire, England.
- WILL SWAP SWL CARDS WITH anyone. Also swap shack fotos. Like to correspond with anyone interested in becoming an amateur. Marvin Seals, 940 15th St., Augusta, Georgia, U.S.A.
- WANTED: S.W.L. CORRESPONDENTS, exchange ideas and hints, also postcards, stamps, etc., if you wish. 1 QSL 100%. QRA: R. Clifford Hansell, 118 Bridge Road, Oulton Broad, Suffolk, England.
- WILL EXCHANGE CARDS OR correspond with SWL's from U.S.A. and foreign countries 100 per cent. Roy Blakeburn, 138 Vulcan Avenue, Sydney, Nova Scotia, Canada.
- QZ! QZ! PHILADELPHIA CALLING—QSL's es SWL's wanted from Mexico, Central Amer., South Amer., Europe es the Far East. 100% QSL. hr. QRA: C. R. Ducey, 514 North 7th St., Philadelphia, Pa., U.S.A.

... THESE OUTSTANDING SHORT WAVE BOOKS ARE Now Available AT YOUR DEALER!

YOU buy parts: tubes, kits, accessories from your local radio dealer—that's what countless thousands of short-wave fans do. Now through a nation-wide distribution service our numerous books are available at your favorite radio dealer—right where you buy other radio equipment. It's more convenient, saves time and you can inspect the books before you buy. Ask your dealer to show you all the books advertised on this page—they're always in stock.



101 SHORT WAVE HOOK-UPS

Compiled by the Editors of RADIO & TELEVISION

Here is a worthwhile book that every short wave listener, every short wave fan, and every short wave amateur has wanted for a long time. It gives you the 101 best short wave hook-ups that have appeared heretofore.

100 Illustrations 50c
72 Pages

HOW TO BUILD AND OPERATE SHORT WAVE RECEIVERS

This is the best and most up-to-date book on the subject. It is edited and prepared by the editors of RADIO & TELEVISION and contains a wealth of material on the building and operation, not only of typical short wave receivers, but short wave converters as well.

150 Illustrations 50c
72 Pages



HOW TO GET BEST SHORT WAVE RECEPTION

M. HARVEY GERNSBACK tells you everything you have ever wanted to know about short wave reception. The author, a professional radio listener and radio fan for many years, gives you his long experience in radio reception and all that goes with it.

40 Illustrations 50c
72 Pages

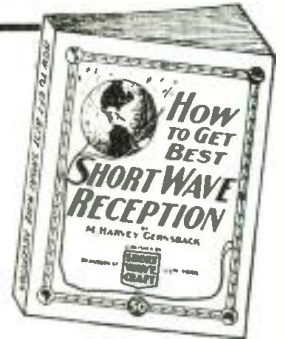

HOW TO BECOME AN AMATEUR RADIO OPERATOR

By Lieut. Myron F. Edly, whose experience in the amateur field has made him pre-eminent in this line.

If you intend to become a licensed code operator, if you wish to take up phone work eventually—this is the book you must get.

150 Illustrations 50c
72 Pages

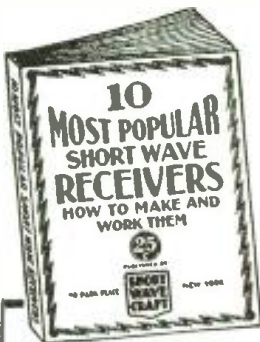

TEN MOST POPULAR SHORT WAVE RECEIVERS

HOW TO MAKE AND WORK THEM

The editors of RADIO & TELEVISION have selected ten outstanding short wave receivers and these are described in the new volume. Each receiver is fully illustrated with a complete layout, pictorial representation, photographs of the set complete, hook-up and all worthwhile specifications.

75 Illustrations 25c
40 Pages

THE SHORT WAVE BEGINNER'S BOOK

Here is a book that solves your short wave problems—leading you in easy stages from the simplest fundamentals to the present state of the art as it is known today. It is the only low-priced reference book on short waves for the beginner.

75 Illustrations 25c
40 Pages

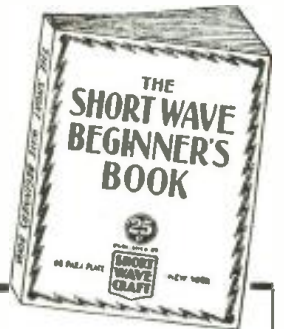

LOOK FOR YOUR NEAREST DEALER

For convenience the publishers list below dealers in all parts of the world where our books are available. On your next shopping trip be certain to examine these volumes. You're sure to want them for your technical library.

- ALABAMA**
Walther Bros., Montgomery
- ARIZONA**
Sam's Cigar Store, Phoenix
- CALIFORNIA**
Electric Supply Co., Oakland
Radio Supply Company, Los Angeles
Radio Television Supply Co., Los Angeles
Pacific Radio Exchange, Inc., Los Angeles
Western Auto Supply, Los Angeles
Zack Radio Supply Co., Los Angeles
Yroman's Book Store, Pasadena
Western Radio & Elec. Co., San Diego
Offenbach Electric Co., San Francisco
Technical Book Co., San Francisco
Zack Radio Supply Co., San Francisco
Radio Specialties Co., San Jose
- COLORADO**
Auto Equipment Co., Denver
Interstate Radio Supply, Denver
- CONNECTICUT**
The Edward P. Judd Co., New Haven
- DELAWARE**
Bronx
Wilmington Elec. Spec. Co., Inc., Wilmington
- FLORIDA**
Radio Accessories Co., Orlando
- GEORGIA**
Wholesale Radio Service Co., Inc., Atlanta
- ILLINOIS**
Allied Radio Corporation, Chicago
Walter C. Braun, Inc., Chicago
Chicago Radio Apparatus Co., Chicago
A. C. McChug & Co., Chicago
Midwest Radio Mart, Chicago
Newark Electric Co., Chicago
Sears, Roebuck & Co., Chicago
Max Stein & Co., Chicago
Montgomery Ward & Co., Chicago
Wholesale Radio Service Co., Inc., Chicago

- INDIANA**
Van Sickle Radio, Indianapolis
- MASSACHUSETTS**
DeWolfe & Fiske Co., Boston
The Personal Book Shop, Boston
Wholesale Radio Service Co., Inc., Boston
Library Book House, Springfield
Tremont Elec. Supply Co., Boston
- MICHIGAN**
Risi Brothers, Detroit
- MINNESOTA**
St. Paul Book & Stat. Co., St. Paul
- MISSOURI**
Burststein-Applebee Co., Kansas City
Radio Labs., Kansas City
Walter Ashe Radio Co., St. Louis
Van Sickle Radio Co., St. Louis
- NEW JERSEY**
Radio Apparatus Co., Newark
United Radio Co., Newark
Wholesale Radio Service Co., Inc., Newark
- NEW YORK**
Fort Orange Radio Dist. Co., Albany
Wholesale Radio Service Co., Inc., Albany
Wholesale Radio Service Co., Inc., City
Harrison Radio Co., New York City
Jomalc, L. I.
American News Co., New York City
Baker & Taylor Co., New York City
Blum, the Radio Man, New York City
David Bogen & Co., New York City
Federated Purchaser, Inc., New York City
Radio Circular Co., New York City
G. E. Stechert & Co., New York City
The Steiger Co., New York City
Sun Radio Co., New York City
Thor Radio Corp., New York City
Try-Mo Radio Co., New York City
Van Biemdyck Book Stores, New York City
Wholesale Radio Service Co., Inc., New York City
H. W. Wilson Co., New York City
Radio Parts & Equipment Co., Rochester
M. Schwartz & Son, Schenectady

- OHIO**
College Book Exchange, Toledo
- OREGON**
J. K. Gill Co., Portland
- PENNSYLVANIA**
Radio Electric Service Co., Philadelphia
Cameradio Co., Pittsburgh
- WASHINGTON**
Seattle Radio Supply Co., Seattle
Wedel Co., Inc., Seattle
Spokane Radio Co., Spokane
- WISCONSIN**
Radio Parts Co., Milwaukee
Wedel Co., Inc., Seattle
- ARGENTINA**
Radio Revista, Buenos Aires
- AUSTRALIA**
McGill's Authorized Agency, Melbourne
- BELGIUM**
Emil Arens, Brussels
- CANADA**
T. Eaton & Co., Winnipeg, Man.
Electrical Supplies, Ltd., Winnipeg, Man.
Wholesale Radio Supply, Winnipeg, Man.
Canadian Electrical Supply Co., Ltd., Toronto, Ont.
Radio Trade Supply Co., Ltd., Toronto, Ont.
Canadian Electrical Supply Co., Ltd., Montreal, P. Q.
- BRAZIL**
Agencia Soave, Sao Paulo
- CHINA**
China News Co., Shanghai
International Booksellers, Ltd., Shanghai
- CUBA**
Diamond News Co., Havana
- ENGLAND**
Gorringe's Amer. News Agency, London
- FRANCE**
Toute La Radio, Paris
- GERMANY**
Rehr G.M.B.H. SW15, Berlin NW No. 7

- HOLLAND**
Radio Peeters, Amsterdam, Z.
- INDIA**
Empire Book Mart, Bombay
- MEXICO**
American Book Store, Mexico, D. F.
Central De Publicaciones, S. A., Mexico, D. F.
Jaques Salvo, Mexico, D. F.
- NEW ZEALAND**
Johns, Ltd., Auckland
James Johnston, Ltd., Dunedin
Te Aro Book Depot, Ltd., Wellington
- SOUTH AFRICA**
Technical Book Co., Cape Town
Central News Agency, Johannesburg
International House, Johannesburg
South African Radio Publications, Johannesburg

IF YOUR DEALER DOES NOT CARRY THESE BOOKS, ORDER DIRECT FROM US. FILL OUT COUPON BELOW, SHIPMENT WILL BE MADE IMMEDIATELY.

POPULAR BOOK CORP. R&T-6-39
99 Hudson Street, New York City.

Gentlemen: I enclose herewith my remittance for for which please send me the following books:

.....

Name

Address

City

State

(Send remittance in form of check or money order. If letter contains cash or unused U. S. postage stamps, register it.)

POPULAR BOOK CORPORATION • Publishers • 99 HUDSON STREET • NEW YORK, N. Y.

World S-W Stations

(Continued from page 125)

Mc.	Call	Station Name	Address	Time
6.128	CXA4	MONTEVIDEO, URUGUAY	48.98 m., Addr. Radio Electrico de Montevideo, Mercedes 823.	8 am.-Noon, 2-10 pm.
6.122	HJ3A8X	BOGOTA, COL.	49. m., Addr. La Voz de Col., Apartado 26-65.	12 n.-2 pm., 5.30-11 pm.; Sun. 6-11 pm.
6.122	HP5H	PANAMA CITY, PAN.	49 m., Addr. Box 1045.	10 am.-1 pm., 5-11 pm.
6.122	FK8AA	NOUMEA, NEW CALEDONIA	49.00 m., Radio Noumea, Addr. Charles Gaveau, 44 Rue de l'Alma., Wed. & Sats.	2.30-3.30 am.
6.117	XEUZ	MEXICO CITY, MEX.	49.03 m., Addr. 5 de Mayo 21. Relays XEFO 9 am.-1 pm., 7 pm.-2 am.	
6.116	—	SAIGON, FR. INDO-CHINA	49.05 m., 6.30-7 am., 11-11.30 pm.	
6.115	OLR2C	PRAGUE, BOHEMIA	49.05 m. (See 11.40 mc.)	
6.110	XEGW	MEXICO CITY, MEX.	49.1 m., Addr. La Voz de Aquila Azteca desde Mex., Apartado 8403. Relays XEJW 11 pm.-1 am.	
6.108	HJ6ABB	MANIZALES, COL.	49.14 m., Addr. P. O. Box 175. Mon.-Fri. 12.15-1 pm.; Tue. and Fri. 7.30-10 pm.; Sun. 2.30-5 pm.	
6.100	YUA	BELGRADE, JUGOSLAVIA	49.18 m. 1-3, 6.30-8.30 am., Noon-6.30 pm.	
6.100	W9XF	CHICAGO, ILL.	49.18 m., 4-6.50 pm. (Sat. to 5.30 pm.) 1-2 am.	
6.100	W3XL	BOUND BROOK, N. J.	49.18 m., Addr. Natl. Broad. Co. 9 pm.-12 m.	
6.097	ZRK	KLIPHEUVEL, S. AFRICA	49.2 m., Addr. S. African Broad. Co., Johannesburg. Daily 12 n.-4 pm., Sun. 12 n.-3.20 pm.	
6.097	ZRJ	JOHANNESBURG, S. AFRICA	49.2 m. Addr. S. African Broad. Co. Daily exc. Sat. 11.45 pm.-12.50 am.; Daily exc. Sun. 3.15-7.30, 9-11.30 am. (Sat. 8.30-11.30 am.) Sun. 3.30-4.30 or 4-5 am., 5.30-7, 9-11.30 am.	
6.095	JZH	TOKYO, JAPAN	49.22 m., Addr. (See 11.800 mc., JZJ.) Irregular.	
6.090	ZNS	NASSAU, BAHAMAS	49.26 m., testing evens.	
6.090	CRCX	TORONTO, CAN.	49.26 m., Addr. Can. Broadcasting Corp. Daily 6.45 am.-4 pm., Sun. 9.30 am.-11 pm.	
6.090	ZBW2	HONGKONG, CHINA	49.26 m., Addr. P. O. Box 200. Irregular.	
6.083	VQ7LO	NAIROBI, KENYA, AFRICA	49.31 m., Addr. Cable and Wireless, Ltd. Mon., Fri. 5.30-6 am., 11.15 am.-2.15 pm., also Tues. and Thurs. 8.15-9.15 am.; Sat. 11.15 am.-3.15 pm.; Sun. 10.45 am.-1.45 pm.	
6.081	YVIRD	MARACAIBO, VEN.	49.32 m. 6-11 pm.	
6.080	W9XAA	CHICAGO, ILL.	49.34 m., Addr. Chicago Fed. of Labor. Relays WCFL irregular.	
6.080	CRY9	MACAO, MACAO	49.34 m., Mons. 8.30-10 am.	
6.080	HP5F	COLON, PAN.	49.34 m., Addr. Carlton Hotel. 7-9 pm.	
6.079	DJM	BERLIN, GERMANY	49.34 m., Addr., Broadcasting House. Irregular.	
6.077	OAX4Z	LIMA, PERU	49.35 m. Radio National 7 pm.-1.30 am. Except Sun.	
6.075	VP3MR	GEORGETOWN, BRI. GUIANA	49.35 m. Sun. 7.45-10.15 am.; Daily 4.45-8.45 pm.	
6.070	CFRX	TORONTO, CAN.	49.42 m. Relays CFRB 6.30 am.-11 pm., Sun. 9 am.-11 pm.	
6.070	VE9CS	VANCOUVER, B. C., CAN.	49.42 m. Sun. 1.45-9 pm., 10.30 pm.-1 am.; Tues. 6-7.30 pm., 11.30 pm.-1.30 am. Daily 6-7.30 pm.	
6.069	—	TANANARIVE, MADAGASCAR	49.42 m., Addr. (See 9.53 mc.) 12.30-12.45, 3.30-4.30, 10-11 am., Sun 2.30-4.30 am.	
6.045	SBO	MOTALA, SWEDEN	49.46 m. Relays Stockholm 4.15-5 pm.	
6.040	—	TANANARIVE, MADAGASCAR	49.5 m., 12.30-12.45, 3.30-4.30, 10-11 am.	

(Continued on following page)

FREE CATALOGS and INFORMATION

By carefully reading the advertising columns, you will find many offers to furnish literature containing valuable technical information that will help you in your work. Use this list freely.

Firm	Business	Offer	No.	Cost	Adv. Page
Aerovox Corporation	Parts Mfr.	Catalog		Free	117
Allied Engineering Inst.	Kit Mfr.	Circulars		Free	108
Allied Radio Corp.	Mail Order	Spring Radio Catalog		Free	101
		Builder's Handbook		10c	
		"Send-'Ceiver" Details		Free	
American Microphone Co., Inc.	Parts Mfr.	General Catalog		Free	108
American Radio Institute	Radio School	Booklet		Free	112
Andrea Radio Corp.	Television Kit Mfr.	Literature		Free	B.C.
Approved Tech. Apparatus	Test Equipment	General Catalog		Free	109
Bliley Electric Co.	Parts Mfr.	Engineering Bulletin	E-6	10c	115
		Circular	A-6	Free	
Brush Development Co.	Parts Mfr.	Catalog	R16J	Free	106
Bud Radio, Inc.	Parts Mfr.	Catalog		Free	104
		Station Log & Data Bk.		10c	
Burstein-Applebee Co.	Mail Order	Catalog		Free	114
Cameradio Co.	Mail Order	1939 Catalog		Free	115
Candler System Co.	Code Course	Book of Facts		Free	112
Cannon, C. F., Co.	Parts Mfr.	Folder	T-7	Free	107
Capitol Radio Engineering Institute	Radio School	48-page Book		Free	111
Cornell-Dubilier Elec. Corp.	Parts Mfr.	Catalog	165-A	Free	105
Coyne Electrical School	Trade School	Electrical Catalog		Free	67
		Radio Catalog		Free	
Crosley Corporation, The	Set Mfr.	Literature		Free	104
Dodge's Institute	Radio School	Catalog		Free	112
DX Radio Products Co.	Parts Mfr.	DeLuxe Catalog		15c	114
Gold Shield Products	Mail Order	Catalog		Free	110, 117, 121
Guthman, Edwin I., & Co.	Set & Parts Mfr.	Information		Free	105
Hammarlund Mfg. Co.	Set & Parts Mfr.	1939 Catalog		Free	99
		16 page Booklet		Free	
Harrison Radio Co.	Mail Order	Information		Free	110
Henry, Bob	Mail Order	Information		Free	106
Instructograph Company	Code Machine	Information		Free	112
International Resistance Co.	Parts Mfr.	Literature		Free	103
Korrol Radio Products Co.	Parts Mfr.	Catalog		Free	111
Kusterman, Oscar B.	Set & Kit Mfr.	Catalog		10c	106
Lafayette Radio Corp.	Set Mfr.	Radio Catalog	76	Free	111
Martin Research & Mfg. Corp.	Radio Keys	Catalog		Free	99
Mass. Radio School	Radio School	60-page Catalog		Free	112
National Company, Inc.	Set & Parts Mfr.	Catalog		Free	1.B.C.
National Radio Institute	Radio School	64-page Book		Free	65
National Schools	Radio School	Radio & Television Bklt.		Free	112
New York YMCA Schools	Trade School	Booklet		Free	112
Par-Metal Products Corp.	Parts Mfr.	Catalog		Free	117
Radio & Technical Publ. Co.	Radio Textbooks	Circulars on each Book		Free	113
Radio Corp. of America	Radio & Television	Literature		Free	1.F.C.
Radio Train. Assn. of Amer.	Radio School	Book		Free	112
RCA Institutes, Inc.	Radio School	Catalog		Free	112
Solar Mfg. Corp.	Parts Mfr.	General Parts Catalog	9S	Free	107
		Transmitting Catalog	2X	Free	
		Condenser Testers Cat.	CBCC-1	Free	
Sprague Products Co.	Parts Mfr.	Condenser Catalog		Free	115
Sprayberry Acad. of Radio	Radio School	52-page Book		Free	113
Superior Instruments Co.	Test Equipment	Catalog		Free	97
Supreme Publications	Publisher	Information		Free	107
Teleplex Co.	Code Machine	Booklet	S-6	Free	112
Triplet Electrical Inst. Co.	Parts Mfr.	Catalog		Free	119
Tri-State College	Radio School	Catalog		Free	112
United Radio Company	Mail Order	Spring Catalog		Free	117
Wholesale Radio Service Co.	Mail Order	Radio Catalog	76	Free	111
X. L. Radio Laboratories	Parts Mfr.	Information		Free	115

Index to Advertisers

A	
Aerovox Corporation	117
Allied Engineering Institute	108
Allied Radio Corporation	101
American Microphone Co., Inc.	108
American Radio Institute	112
Andrea Radio Corp.	Back Cover
Approved Technical Apparatus Co.	109
B	
Barter & Exchange Free Ads.	122-125
Bliley Electric Co.	115
Brush Development Co., The	106
Bud Radio, Inc.	104
Burstein-Applebee Co.	114
C	
Cameradio Co.	115
Candler System Co.	112
Cannon, C. F., Company	107
Capitol Radio Engineering Institute	111
Commercial Notices	122
Cornell-Dubilier Electric Corp.	105
Coyne Electrical School	67
Crosley Corporation, The	104
D	
Dataprint Company	121
Dodge's Institute	112
DX Radio Products Co.	114
F	
For Sale Ads.	122
Foto-Craft	119
G	
Gold Shield Products	110, 117, 121
Guthman, Edwin L. & Co., Inc.	105
H	
Hanniarlund Manufacturing Co., Inc.	99
Harrison Radio Co.	110
Henry, Bob	106
Hudson Specialties Company	120
I	
Instructograph Company	112
International Resistance Co.	103
K	
Korrol Radio Products Co.	111
Kusterman, Oscar B.	106
L	
Lafayette Radio Corp.	111
M	
Martin Research & Manufacturing Corp.	99
Mass. Radio School	112
N	
National Company, Inc.	Inside Back Cover
National Plans Institute	108
National Radio Institute	65
National Schools	112
New York YMCA Schools	112
P	
Par-Metal Products Corp.	117
R	
Radio Amateur Course	68
Radio & Technical Publ. Co.	113
Radio Corporation of America	Inside Front Cover
Radio Publications	107, 116, 121
Radio Training Assn. of America	112
RCA Institutes, Inc.	112
S	
Solar Mfg. Corp.	107
Sprague Products Co.	115
Sprayberry Academy of Radio	113
Superior Instruments Co.	97
Supreme Publications	107
T	
Technifax	110
Teleplex Co.	112
Triplett Electrical Instrument Co.	119
Tri-State College	112
U	
United Radio Company	117
W	
Wellworth Trading Company	110, 114
Wholesale Radio Service Co., Inc.	111
X	
X. L. Radio Laboratories	115

(While every precaution is taken to insure accuracy, we cannot guarantee against the possibility of an occasional change or omission in the preparation of this index.)

Mc. Call			Mc. Call
6.060 YDD	BANDOENG, JAVA, 49.5 m., 5.30 am. on.	5.977 CS2WD	LISBON, PORTUGAL, 50.15 m., Addr. Rua Capelo 5. 3.30-6 pm.
6.060 W8XAL	CINCINNATI, OHIO, 49.5 m., Addr. Crosley Radio Corp. Relays WLW Tues., Fri., Sun. 5.45 am.-12 n., 11 pm.-2 am.; Wed. 5.45 am.-12 n., 9 pm.-2 am.; Mon., Thurs., Sat. 5.45 am.-2 am.	5.975 OAX4P	HUANCAYO, PERU, 50.16 m. La Voz del Centro del Peru. 9-11 pm.
6.060 W3XAU	PHILADELPHIA, PA., 49.5 m. Relays W2XE Wed., Fri., Sun. 7.30-11 pm., 11.30 pm.-1 am., Mon. and Thur. 12 m.-1 am. Tues. 7.30-11 pm., 12 m.-1 am. Sat. 11 pm.-2 am.	5.970 YV5RC	CARACAS, VEN., 50.26 m., Addr. Radio Caracas. Sun. 7 am.-10 pm. Daily 7-8 am., 1-1.45 pm., 4-9.30 or 10 pm.
6.057 ZHJ	PENANG, FED. MALAY STATES, 49.53 m. 6.40-8.40 am., except Sun., also Sat. 11 pm.-1 am.	5.968 HVJ	VATICAN CITY, 50.27 m. Off the air at present.
6.054 HJ6ABA	PEREIRA, COL., 49.56 m. 9.30 am.-12 n., 6.30-10 pm.	5.950 HH2S	PORT-AU-PRINCE, HAITI, 50.37 m., Addr. P. O. Box A103. 7-9.45 pm.
6.050 GSA	DAVENTRY, ENGLAND, 49.59 m., 12.25-4, 4.20-6 pm.	5.940 OAX2A	TRUJILLO, PERU, 50.51 m., Tue., Thu., Sat., Sun. 7-10 pm.
6.050 HJ1ABG	BARRANQUILLA, COL., 49.65 m., Addr. Emisora Atlantico. 11 am.-11 pm.; Sun. 11 am.-8 pm.	5.935 YV1RL	MARACAIBO, VEN., 50.52 m., Addr. Radio Popular, Jose A. Higuera M., P. O. Box 247. Daily 11.43 am.-1.43 pm., 5.13-10.13 pm.; Sun. 9.13 am.-3.13 pm.
6.045 XETW	TAMPICO, MEXICO, 49.6 m. Irregular 7-11 pm.	5.920 YV4RH	VALENCIA, VEN., 50.68 m. 5-9.30 pm.
6.040 W4XB	MIAMI BEACH, FLA., 49.65 m. 1-3 pm., 9 pm.-12 m. Relays WIOD.	5.900 ZNB	MAFEKING, BRI. BECHUANALAND S. AFRICA, 50.84 m., Addr. The Govt. Engineer, P. O. Box 106. 6-7 am. 1-2.30 pm. Ex. Suns.
6.040 W1XAL	BOSTON, MASS., 49.65 m., Addr. University Club. 7-9 pm. exc. Sat. & Sun.	5.900 TILS	SAN JOSE, COSTA RICA, 50.85 m. 6-10 pm.
6.033 HP5B	PANAMA CITY, PAN., 49.75 m., Addr. P. O. Box 910. 10.30 am.-2, 6-10 pm.	5.898 YV3RA	BARQUISIMETO, VEN., 50.86 m., Addr. La Voz de Lara, 12 n.-1 pm., 6-10 pm.
6.030 CFYP	CALGARY, ALTA, CAN., 49.75 m. Thur. 9 am.-1 am.; Sun. 12 n.-12 m.	5.885 HI9B	SANTIAGO, D. R., 50.95 m. Irregular 6-11 pm.
6.030 RV96	MOSCOW, U.S.S.R., 49.75 m. 1-3, 4-7 pm.	5.875 HRN	TEGUCIGALPA, HONDURAS, 51.06 m. 1.15-2.16, 8.30-10 pm.; Sun. 3.30-5.30, 8.30-9.30 pm.
6.030 OLR2B	PRAGUE, BOHEMIA, 49.75 m. (See 11.875 mc.) Off the air at present.	5.855 HI1J	SAN PEDRO DE MACORIS, D. R., 51.25 m., Addr. Box 204. 11.40 am.-1.40 pm., 6.10-8.40 pm.
6.023 XEUW	VERA CRUZ, MEX., 49.82 m., Addr. Av., Independencia 98. 10 pm.-1 am.	5.845 YV1RB	MARACAIBO, VEN., 51.3 m., Addr. Apartado 214. 8.45-9.45 am., 11.15 am.-12.15 pm., 4.45-9.45 pm.; Sun. 11.45 am.-12.45 pm.
6.020 DJC	BERLIN, GERMANY, 49.83 m., Addr. (See 6.079 mc.) 11.30 am.-4.30 pm.	5.825 TI6PH	SAN JOSE, COSTA RICA, 51.5 m., Addr. Alma Tica, Apartado 800. 11 am.-1 pm., 6-10 pm. Relays TIX 9-10 pm.
6.020 HJ3CAX	BOGOTA, COL., 5.30-11 pm., Sun. 6-11 pm.	5.813 TI6PH2	SAN JOSE, COSTA RICA, 51.59 m., Addr. Senor Gonzalo Pinto, H.
6.017 HI3U	SANTIAGO DE LOS CABALLEROS D. R., 49.85 m. 7.30-9 am., 12 n.-2 pm., 5-7 pm., 8-9.30 pm.; Sun. 12.30-2, 5-6 pm.	5.790 T6S	GUATEMALA CITY, GUAT., 51.75 m. Casa Presidencial, Senor J. M. Caballeroz. Irregular.
6.015 PRA8	PERNAMBUCO, BRAZIL, 49.84 m., Radio Club of Pernambuco. 4.9 pm.	5.740 YV2RA	SAN CRISTOBAL, VENEZUELA, 52.23 m., Addr. La Voz de Tachira. 11.30 am.-12 n., 5.30-9 pm., Sun. till 10 pm.
6.010 OLR2A	PRAGUE, BOHEMIA, 49.92 m. Addr. (See OLR, 11.84 mc.) Irreg.	5.735 HC1PM	QUITO, ECUADOR, 52.28 m. Irregular 10 pm.-12 m.
6.010 COCO	HAVANA, CUBA, 49.92 m., Addr. P. O. Box 98. Daily 7.55 am.-12 m., Sun. until 11 pm.	5.460 YNOP	MANAGUA, NICARAGUA, 52.40 m., 8.30-9.30 pm. Sun. 2-3 pm.
6.010 VK9MI	S. S. KANIMBLA, 49.92 m. (Travels between Australia and New Zealand). Sun., Wed., Thurs. 6.30-7.30 am.	5.145 OK1MPT	PRAGUE, BOHEMIA, 58.31 m., Addr. (See OLR, 11.84 mc.) Irregular.
6.010 CJCX	SYDNEY, NOVA SCOTIA, 49.92 m. Relays CJCB 7 am., 1.30, 4-8.30 pm.	5.145 PMY	BANDOENG, JAVA, 58.31 m. 5.30-11 am.
6.007 XYZ	RANGOON, BURMA, 49.94 m., 6.30-10 am., 9-11 pm., Sat. 9.30-11 pm.	4.960 VUD2	DELHI, INDIA, 60.48 m., Addr. All India Radio. 7.30 am.-12.35 pm.
6.007 ZRH	ROBERTS HEIGHTS, S. AFRICA, 49.94 m., Addr. (See ZRK, 9.606 mc.) Daily exc. Sun. 9.30 am.-3.30 pm.; Sun. 9 am.-12 n., 12.15-3.15 pm. Daily exc. Sat. 11.45 pm.-12.50 am.	4.920 VUM2	MADRAS, INDIA, 60.98 m. Addr. All India Radio, 6.30 am.-12.10 pm.
6.008 HP5K	COLON, PAN., 49.96 m., Addr. Box 33, La Voz de la Victor. 7-9 am., 10.30 am.-1 pm., 5-11 pm.	4.900 HJ3ABH	BOGOTA, COL., 61.19 m., Addr. Apartado 565. 12 n.-2 pm., 6-11 pm.; Sun. 12 n.-2 pm., 4-11 pm.
6.008 CFCX	MONTREAL, CAN., 49.96 m., Can. Marconi Co. Relays CFCF 6.45 am.-12 m.; Sun. 8 am.-10.15 pm.	4.880 VUB2	BOMBAY, INDIA, 61.8 m. Addr. All India Radio, 7.30 am.-12.30 pm.
6.006 VE9DN	DRUMMONDVILLE, QUE., CAN., 49.96 m., Addr. Canadian Marconi Co.	4.880 HJ4ABP	MEDELLIN, COL., 61.44 m. 8-11 pm.
6.002 CXA2	MONTEVIDEO, URUGUAY, 49.98 m. Addr. Rio Negro 1631. Relays LS2, Radio Prieto, Buenos Aires. 5.30-10.30 pm.	4.842 HJ3ABD	BOGOTA, COL., 61.95 m., Addr. La Nueva Granada, Box 509. 12 n.-2 pm., 7-11 pm., Sun. 5-9 pm.
6.000 XEBT	MEXICO CITY, MEX., 50 m., Addr. P. O. Box 79.44. 10 am.-1.45 am.	4.840 VUC2	CALCUTTA, INDIA, 61.98 m. Addr. All India Radio, 6.30 am.-12 n.
5.990 ZEA	SALISBURY, RHODESIA, S. AFRICA, 50.08 m. (See 6.147 mc., ZEB.) Also Sun. 3.30-5 am.	4.800 HJ1ABE	CARTAGENA, COL., 62.46 m., La Voz de los Laboratorios Fuentes. Addr. Box 31. Daily 8.30 am.-11 pm., Sun. 10 am.-9 pm.
=====End of Broadcast Band=====			
4.780 HJ1ABB	BARRANQUILLA, COL., 62.72 m. La Voz de Barranquilla, Addr. P. O. Box 715. 11.30 am.-1 pm., 4.30-10.30 pm. Ex. Suns.	4.772 HJ1ABJ	SANTA MARTA, COL., 62.85 m. 11.30 am.-2 pm., 5.30-10.30 pm. except Wed.
4.740 HJ6ABC	IBAGUE, COL., 63.25 m. 7 pm.-12 m.		

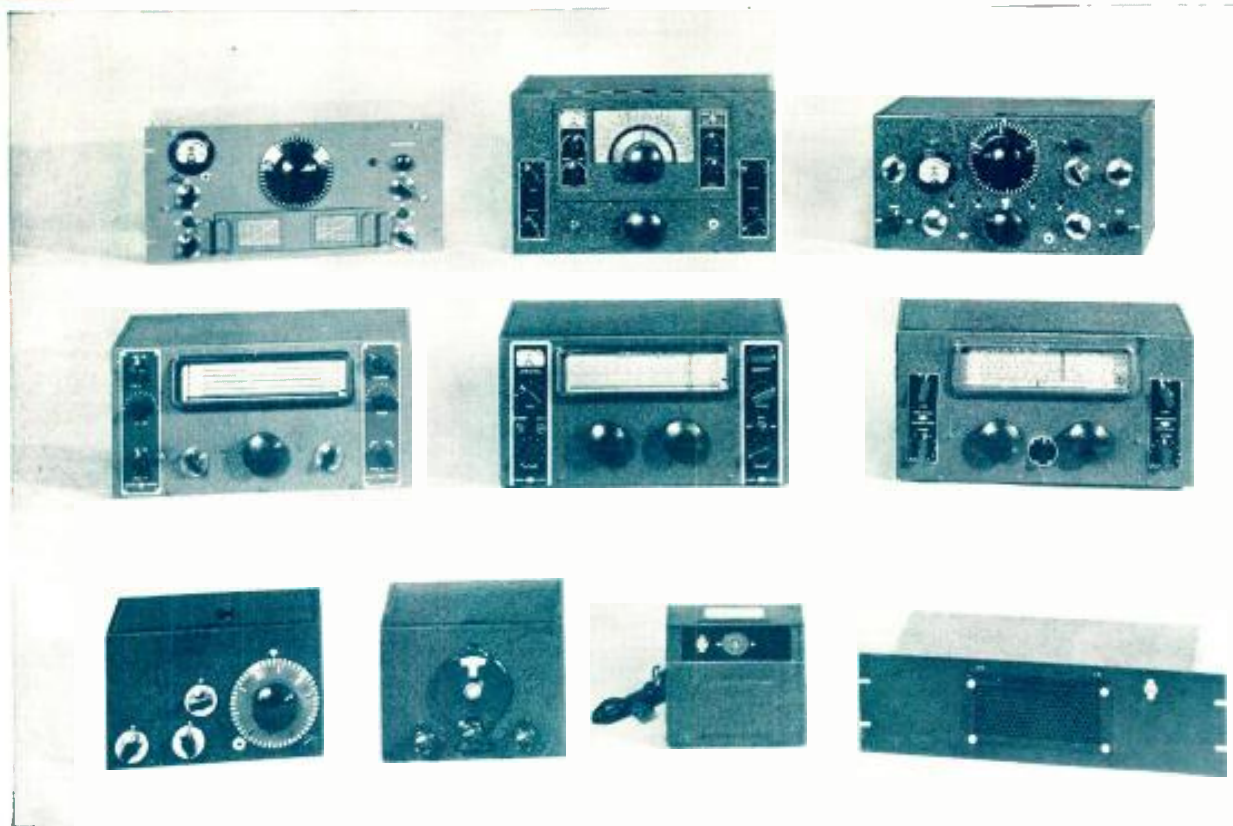

A FINE RECEIVER FOR EVERY PURPOSE

HRO A professional receiver, designed for maximum performance. Features include two high-gain preselector stages giving exceptional signal to noise ratio, crystal filter, micrometer dial S meter, AVC, Beat Oscillator. Approximate List Price \$350*. (Top row, left.)

NC-100A & NC-101X Fine Communication Receivers with splendid tone. These 11 tube superheterodynes are self-contained except for the speaker. The NC-100A series (Top row, center) is ideal for broadcast reception as well as communication work. The NC-101X (Top row, right) covers only the amateur bands. Features include one stage of preselection, as well as complete communication equipment. Approximate List Price \$200*.

NC-80 & NC-81 Excellent Communication Receivers at a moderate price. This inexpensive 10 tube receiver uses a 1560 KC IF amplifier, giving excellent image suppression. Features include crystal filter and communication equipment. The NC-80 is for general coverage. The NC-81 covers only the amateur bands. (Middle row, left.) Approximate List Price \$165*.

NC-44 For capable performance at a very low price. A seven tube superheterodyne with continuous coverage from 550 KC to 30 MC. A CW Oscillator is provided. (Middle row, right.) Approximate List Price \$83*.

NC-510 A specialized superheterodyne covering 28 to 64 MC. The NC-510 (Middle row, center) is strictly a communication receiver, embodying all the features commonly needed in such work, but is specialized to give maximum performance in the range from 28 to 64 MC. Acorn tubes are used. Approximate List Price \$250.

ONE-TEN A specialized receiver for the range from 1 to 10 meters. (Bottom row, left.) The ONE-TEN Receiver is intended primarily for the Experimenter. It is a thoroughly satisfactory receiver for the ultra-high frequencies. Four tubes are used: RF, Super-regenerative Detector, 1st Audio, and Output Audio.

SW-3 A dependable regenerative receiver. (Bottom row, second from left.) The SW-3's seven year reputation for performance and dependability gives it preference for many classes of work. It uses three tubes in a highly developed circuit that provides maximum sensitivity and flexibility.

POWER SUPPLIES National Power Supplies are specially designed for powering high frequency receivers, and include efficient filters for RF disturbances as well as hum frequencies. They are made in a variety of types.

★ The List Prices given above are approximate only, and are intended only to show the price range in which each receiver falls. Complete specifications and prices will be given on request.



NATIONAL COMPANY, INC., MALDEN, MASS.

Build your own Sight and Sound Receiver for



F. A. D. ANDREA—Pioneer in Radio and Television

Andrea led the way with radio kits in 1923. Thousands will remember his famous Neutrodyne kits. Behind the Andrea Television Kit are long years of experience that assure successful assembly and "Sharp-Focus" television reception from the finished receiver.

TELEVISION

SET BUILDERS, STUDENTS, EXPERIMENTERS and SERVICE MEN

The Andrea Television Kit gives you factory-built performance at rock-bottom cost—plus the fun and satisfaction of building your own. Already, set builders are reporting enthusiastically about results from their assembled KT-E-5 kits:

In the N. Y. Sun, April 15th, E. L. Bragdon, Radio Editor, said: "In the writer's

opinion, gained through the actual assembly of the (Andrea) kit, the plan of instructions devised by the manufacturer sets a new high point in that field of radio.—The individual steps in the formation of this television have been so clearly outlined that the only excuse for failure is carelessness on the part of the builder."

FROM TELEVISION HEADQUARTERS:

ANDREA RADIO CORP. is the only television manufacturer whose factory and laboratories are located right in New York City. Thus ANDREA engineers have not been limited to laboratory receiving tests from miniature, experimental transmitters. No, indeed! Every step in the perfection of ANDREA "Sharp-Focus" sets and kits has been checked on actual reception from the New York transmitters which are setting the standards of television technique in the U. S. A.

FINISHED, COMMERCIAL DESIGN: ANDREA is the only manufacturer of television receivers who is making a standard, commercial set available in construction kit form for experimenters, students,

and service men. Because the ANDREA KT-E-5 kit is actually comprised of the parts of the factory-built model 1-F-5 receiver, the kit, when assembled in accordance with the instructions provided, will give you sight and sound reception equal to the factory-built set.

SUCCESS ASSURED: You need only a soldering iron, screwdriver, and pliers. No testing instruments are necessary, for the R.F. circuits are assembled, wired and precision pre-tuned to the 44-50 and 50-56 mc. channels. You'll be delighted to see how every last detail has been planned to assure your success.

BE THE FIRST IN YOUR NEIGHBORHOOD TO OWN AN ANDREA TELEVISION RECEIVER!

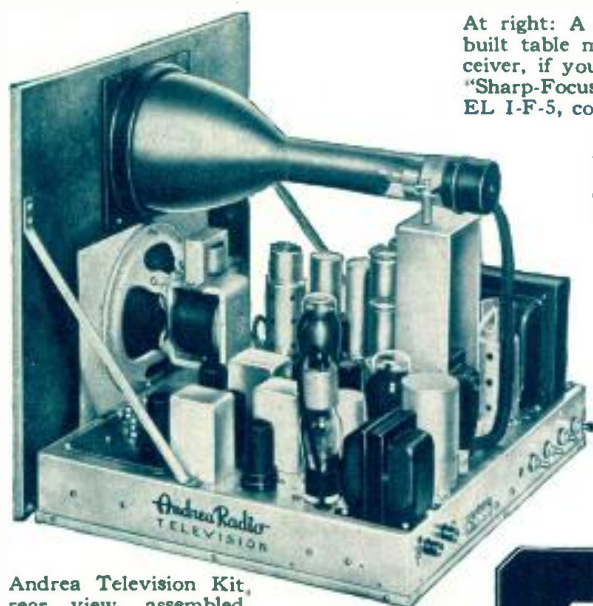

Andrea Television Kit, rear view, assembled.

\$79⁹⁵ less tubes

At right: A complete, factory-built table model television receiver, if you prefer it. Andrea "Sharp-Focus" receiver MOD-EL 1-F-5, complete with tubes.

\$189⁵⁰

Andrea Teleceptor Antenna specially designed for television reception **\$9⁵⁰**

- Complete Wiring Diagrams and Step-by-Step Instructions supplied free with every Andrea KT-E-5 Kit. Or send \$1 for diagrams and instructions alone—authoritative, detailed, profusely illustrated.

- **DISTRIBUTORS:** A limited number of territories are still open. Write for full information.



IMMEDIATE DELIVERY:

Leading dealers are now displaying and demonstrating Andrea sets and kits. Write for the Andrea Television literature and name of your nearest dealer.

Andrea Radio

"SHARP-FOCUS" TELEVISION

ANDREA RADIO CORP. • 48-35 48th Ave., Woodside, L. I., N. Y. • Telephone: Stillwell 4-4754