

RADIO & TELEVISION

FORMERLY
SHORT WAVE & TELEVISION

**THE VODER
CREATES HUMAN SPEECH!**

SEE PAGE 651



In This Issue —

Latest Television News

World-Wide Radio Digest

Radio Test Quiz

Frequency Meter for the "Ham"

4-Tube Switch-Coil Receiver

List of New "Hams"

**HUGO
GERNSBACK**
EDITOR

**RADIO EXPERIMENTING
AMATEUR RADIO**

25¢
IN U.S. AND
CANADA

**MAR.
1939**



Model 438

Only

\$49.95

less crystal

**4 BANDS - 8 TUBES
BUILT-IN SPEAKER**

HOWARD DOES IT AGAIN!

**Models to Suit the Individual Tastes of the
Most Exacting Amateur and Professional**



450A

MODEL 450-A

12 Tubes - 6 Bands - Frequency Coverage .54 to 65 MC . . . Ceramic Coil Forms . . . Dual I. F. Channels . . . Two S. L. F. Ceramic Insulated Tuning Condensers . . . 47 inches of electric bandspread . . . crystal filter . . . Calibrated 'R' Meter . . . Accurately calibrated direct reading dial. Price, with Tubes, less Speaker, less crystal **\$87.50 Net**

MODEL 430

6 Tubes - 4 Bands - Frequency Coverage .54 to 40 MC . . . Ceramic Coil forms . . . B. F. O. with pitch control . . . Iron Core I. F. transformers . . . Electric band spread . . . Built-in Dynamic Spcaker . . . Head-phone jack . . . Accurate direct reading straight line dial . . . Price, Complete with tubes and speaker

\$29.95 Net



430

MODEL 440

9 Tubes - 5 Bands - Continuous coverage 54 MC to 40 MC . . . Ceramic Coil forms, S. L. F. Ceramic Insulated Tuning Condensers, Elec-

tric Bandsread, R. F. on all bands, Iron Core I. F. transformer, B. F. O. with pitch control, calibrated 'R' Meter, Crystal Filter. Price with tubes less Speaker, less Crystal . . . **\$66.50**

WITH the advent of the world famous 430 many have asked for a larger receiver—here it is. Model 438 embodies professional features never before associated with equipment in this price class . . . real "DX" with R-9 reception; Ceramic Coil Forms . . . R.F. Stage on all Bands . . . Separate Coils for each Band . . . Xtal Filter . . . Complete Coverage 540 KC—43 mc . . . Electric Band Spread with vernier control . . . 2-stage Iron Core I.F. . . . Accurately Calibrated Slide Rule Dial . . . 8 Tubes . . . Provisions for a 6-volt Power Supply . . . Band in use Indicator . . . B.F.O. with Pitch Control . . . 2 Watts Power Output . . . Built-in 6" Dynamic Speaker . . . Head Phone Jack . . . Doublet or Marconi Antennae Connections . . . Provision for External Speaker . . . Provisions for Howard tube type 'R' Meter.

HOWARD RADIO COMPANY
1731-35 West Belmont Ave., Chicago, Ill.

_____ Please send me more information on
_____ Model 438 _____ Model 430
_____ Model 450-A _____ Model 440
CABLE ADDRESS: "Howardco" _____ T

Name _____
Address _____
City _____ State _____

America's Oldest Radio Manufacturer



J. E. SMITH, President
NATIONAL RADIO INSTITUTE
 Established 25 years

He has directed the training of more men for the Radio Industry than anyone else.



Broadcasting Stations

Employ managers, engineers, operators, installation and maintenance men for fascinating jobs and pay up to \$4,000 a year.



Repairing Radio Sets

Spare time set repair work pays many \$5, \$10, \$15 a week extra while learning. Full time servicing pays as much as \$30, \$50, \$75 a week.

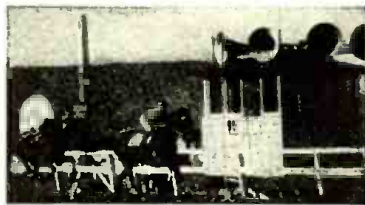

Loud Speaker Systems

Building, installing, servicing and operating public address systems is another growing field for men well trained in Radio.

Lesson on Radio Servicing Tips FREE

I'll prove my Training gives practical, money-making information. Is easy to understand—just what you need to master Radio. My sample lesson text, "Radio Receiver Troubles—Their Cause and Remedy" covers a long list of Radio receiver troubles in A.C., D.C., battery, universal, auto, T.R.F., superheterodyne, all-wave, and other types of sets. A cross reference gives you the probable cause and a quick way to locate and remedy these set troubles. A special section is devoted to receiver check-up, alignment, balancing, neutralizing and testing. You can get this lesson Free. No obligation.



MAIL COUPON NOW

The Tested Way to BETTER PAY

I will send you a Lesson Free
to show how I train you
at home in spare time
for Good Jobs in Radio

Clip the coupon and mail it. I will prove I can train you at home in your spare time to be a RADIO EXPERT. I will send you my first lesson FREE. Examine it, read it, see how easy it is to understand—how practical I make learning Radio at home. Men without Radio or electrical knowledge become Radio Experts, earn more money than ever as a result of my Training.

Get Ready Now for Jobs Like These

Radio broadcasting stations employ engineers, operators, station managers and pay well for trained men. Fixing Radio sets in spare time pays many \$200 to \$500 a year—full time jobs with Radio jobbers, manufacturers and dealers as much as \$30, \$50, \$75 a week. Many Radio Experts open full or part time Radio sales and repair businesses. Radio manufacturers and jobbers employ testers, inspectors, foremen, engineers, servicemen, in good-pay jobs with opportunities for advancement. Automobile, police, aviation, commercial Radio, loud speaker systems are newer fields offering good opportunities now and for the future. Television promises to open many good jobs soon. Men I trained have good jobs in these branches of Radio. Read how they got their jobs. Mail coupon.

Why Many Radio Experts Make \$30, \$50, \$75 a Week

Radio is young—yet it's one of our large industries. More than 28,000,000 homes have one or more Radios. There are more Radios than telephones. Every year millions of Radios get out of date and are replaced. Millions more need new tubes, repairs. Over \$50,000,000 are spent every year for Radio repairs alone. Over 5,000,000 auto Radios are in use; more are being sold every day, offering more profit-making opportunities for Radio experts. And RADIO IS STILL YOUNG, GROWING, expanding into new fields. The few hundred \$30, \$50, \$75 a week jobs of 20 years ago have grown to thousands. Yes, Radio offers opportunities—now and for the future!

Many Make \$5, \$10, \$15 a Week Extra in Spare Time While Learning

The day you enroll, in addition to our regular Course, I start sending Extra Money Job Sheets, show you how to do Radio repair jobs. Throughout your training I send plans and directions that made good spare time money—\$200 to \$500—for hundreds, while learning. I send you special Radio equipment—to conduct experiments, build circuits. This 30-50 method of training makes learning at home easy, fascinating, practical.



I Also Give You This Professional Servicing Instrument

Here is the instrument every Radio expert needs and wants—an All-Wave, All-Purpose, Set Servicing Instrument. It contains everything necessary to measure A.C. and D.C. voltages and current; to test tubes, resistances; adjust and align any set, old or new. It satisfies your needs for professional servicing after you graduate—can help you make extra money fixing sets while training.

You Are Trained for Television Also

With N.R.I. you take up Television principles right along with Radio principles—the correct method—since Television receivers combine both sight and sound. You also get more than ten text-books devoted entirely to Television.

Get Sample Lesson and 64 Page Book Mail Coupon

Act Today. Mail the coupon now for sample lesson and 64-page book. They're free to any fellow over 16 years old. They point out Radio's spare time and full time opportunities and those coming in Television; tell about my training in Radio and Television; show you letters from men I trained, telling what they are doing and earning. Find out what Radio offers YOU! MAIL COUPON in an envelope, or paste on a postcard—NOW!

J. E. Smith, President
 Dept. 9CB3
 National Radio Institute
 Washington, D. C.

HERE'S PROOF



\$10 a Week in Spare Time

"My work has consisted of Radio set servicing, with some Public Address Systems work—all in my spare time. My earnings in Radio amount to about \$10 a week."—WILLIAM MEYER, 705 Ridge Road, Hobart, Ind.



Earnings Tripled by N. R. I. Training

"I have been doing nicely, thanks to N.R.I. Training. My present earnings are about three times what they were before I took the Course. I consider N.R.I. Training the finest in the world."—BERNARD COSTA, 932 Manhattan Ave., Brooklyn, N. Y.

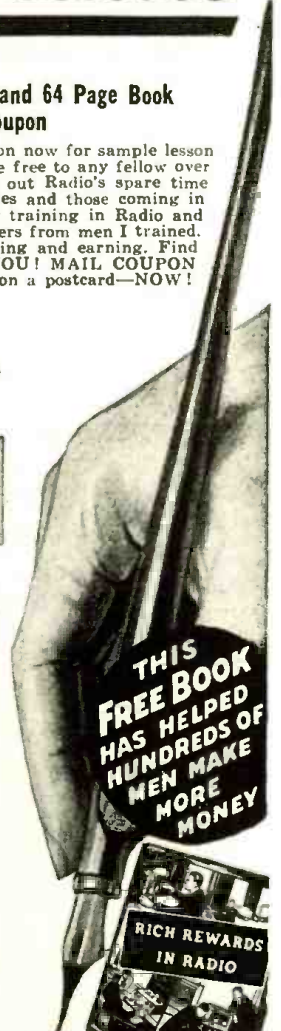

Good for **FREE SAMPLE LESSON and BOOK on RADIO'S OPPORTUNITIES**

J. E. SMITH, President
 National Radio Institute, Dept. 9CB3
 Washington, D. C.

Dear Mr. Smith: Without obligation send me free the Sample Lesson and your 64-Page Book "Rich Rewards in Radio," telling about spare time and full time Radio opportunities, and how I can train for them at home in spare time. (Please write plainly)

Name Age

Address

City State

14X-1

RADIO & TELEVISION

The Popular Radio Magazine

MARCH — 1939
Vol. IX No. 11

HUGO GERNSBACK, Editor
H. WINFIELD SECOR, Manag. Editor
ROBERT EICHBERG, Assoc. Editor

FLASH!

Electronics Television Course

See page 656

In This Issue

GENERAL FEATURES

Editorial—Sun's Effect on the Propagation of Short Waves—Emile Girardeau.....	645
Television Prepares for Debut.....	646
Static-Free Radio Invented by Armstrong.....	647
World-Wide Radio Digest.....	648
Radio Test-Quiz—Robert Eichberg.....	650
How "Voder" Creates Human Speech.....	651
International Radio Review.....	652
The Martian Flash, H. Gernsback.....	657

CONSTRUCTION

Building the "Ham" Beginner's Transmitter— C. W. Palmer, E.E.....	659
Radio Kinks.....	661
A Radio Ore-Locator—Charles E. Chapel.....	669
An Inexpensive Mike.....	669
The "Switched-Coil 4" Superhet—Raymond P. Adams.....	670
One-Meter Receiver—N. G. Haas and C. A. Erbacher.....	672
A Frequency Meter for the "Ham"— Herman Yellin, W2AJL.....	674

CONDENSED FEATURES

Eiffel Tower Television Station.....	648
New B.B.C. Broadcast Building.....	648
N.B.C. Short Wave Antennas.....	649
A.C. Resistance, Capacity and Mu Bridge.....	652
Loud Speaker Design.....	653
New Tubes for Projection Tele- vision.....	678

New Television Projection Tubes.....	678
Curing Television Ills.....	655
Electronics Television Course— Henry Townsend.....	656
New Tubes for Television.....	678

INSTRUCTION

Radio Test-Quiz.....	650
Television Course.....	656
Getting Started in Amateur Radio— C. W. Palmer, E.E.....	659
The Radio Beginner—Lesson No. 5— Martin Clifford, W2CDV.....	660
Question Box.....	676

MISCELLANEOUS

Radio Aids Skiers.....	649
New Facsimile Station.....	652
Loud Speaker Design.....	653
Measuring Cosmic Rays.....	655
Fips Returns—"The Martian Flash"— H. Gernsback.....	657
What Do YOU Think?.....	658
New Ham Course— C. W. Palmer, E.E.....	659
Waves & Harmonics.....	660
Radio Kinks.....	661
World Short Wave Stations.....	662
Let's Listen In With Joe Miller.....	663
Silver Trophy Award for Best HAM Station Photo.....	665
Short Wave League—"On the Ham Bands"—E. R. Fuller.....	667
Question Box.....	676
New Tubes for Television.....	678
Roster of Newly Licensed HAMS.....	680
New Radio Apparatus.....	691

TELEVISION

Television Prepares for Debut.....	646
Eiffel Tower Television Station.....	648
Trailer Displays Television.....	648
Television Transmitter.....	649
Television Goes to War.....	649

Cover composition by H. Gernsback and Thomas D. Pentz.

Photo of Deanna Durbin, Courtesy C.B.S.—See special article, page 651.

RADIO & TELEVISION—Published monthly on the tenth of the month. Entered as second-class matter Feb. 15, 1938, at the post office at Springfield, Mass., under the act of March 3, 1879. Trademarks and copyrights by permission of H. Gernsback. Text and illustrations are copyright and may not be reproduced without permission. Subscription price \$2.50 a year in the United States and possessions and Canada, \$3.00 in foreign countries. Make all subscription checks payable to Popular Book Corporation.

Published by Popular Book Corporation. Publication Office—29 Worthington St., Springfield, Mass. Editorial and Executive Offices—99 Hudson St., New York, N.Y. HUGO GERNSBACK, President; H. W. SECOR, Vice-President; EMIL GROSSMAN, Director of Advertising. European Agents: Atlas Publishing and Distributing Co., Ltd., 18 Bride Lane, Fleet St., London, England; Brentano's—London and Paris. Australian Agents: McGill's Agency, 179 Elizabeth St., Melbourne.

Copyright 1939 by H. Gernsback

Next Month

- An All-Around Multi-Meter for Amateurs—Herman Yellin, W2AJL
- Latest Television Data
- A Switched-Coil 8-Tube Receiver
- How to Connect and Use the HAM Beginner's Transmitter—C. W. Palmer, E.E.
- Electronic Television Course—Part 2—Henry Townsend
- World-Wide Digest of Radio & Television Articles
- Antenna Systems for HAMS—Herman Yellin, W2AJL — The Half-Wave Hertz type
- For "Hams" and "Fans"—A 6-tube 1.4 volt Superhet—Harry D. Hooton, W8KPX

Certified Circuits



When you see this seal on a set it is a guarantee that it has been tested and certified in our laboratories, as well as privately in different parts of the country. Only constructional—experimental sets are certified.

You need not hesitate to spend money on parts because the set and circuit are bona fide.

This is the only magazine that renders such a service.



EASIER WAY TO SUCCESS *in* RADIO

LEARN THE GREATEST INDUSTRY OF THE AGE — TRAIN NOW FOR A REAL FUTURE

I'll Finance Your Training!

Here is YOUR opportunity. Every day brings news of new developments in this fascinating, big-pay field, with new jobs and a greater future for trained men than ever before. If you are ambitious to get ahead, MAIL THE COUPON BELOW and I'll tell you about my "Pay After Graduation" plan, which has enabled thousands to get Coyne Training with very little money. Get training first, then take 12 months to complete small monthly tuition payments starting FIVE MONTHS after you begin your training. NOT a Home study course.

Opportunities for a Good Job, or a Business of Your Own

Are you dissatisfied with your job? Are you out of a job because you lack specialized training for a live industry? Is your future uncertain? Then let me show you an amazing, easy way to get your start in Radio, where thousands of TRAINED MEN earn good pay. Where hundreds of Coyne Graduates are drawing Good Pay every week. Coyne has been training ambitious fellows for their success since 1899. Whether you are 16 or 40 years old, Radio and Television thru Coyne training offers you your start for a real future—and you can start training any time.

H. C. Lewis



"Learn By Doing" in 90 Days In Big Coyne Shops

The great Coyne Shops are famous the world over for their unusual Learn-by-Doing method of practical, individual instruction. There is no book study, no reciting—you learn quickly and thoroughly by doing actual jobs under the personal guidance of trained instructors, on a great outlay of Radio and Sound equipment assembled strictly for training purposes. That is why, in 12 short weeks, we are able to take fellows without previous experience or a lot of book learning, and train them for their start to a real future.

PART-TIME EMPLOYMENT TO HELP YOU "EARN WHILE LEARNING"

If you need part-time work to help pay your living expenses we will give you the help of our employment department to assist you to get a part time job, as we have thousands of others. We give you a 12 weeks practical training in the great active shops of Coyne . . . on one of the greatest outlays of Radio apparatus ever assembled . . . real radios, sound amplifiers, modern service instruments, analyzers, oscilloscopes, television units, microphones, recorders and complete radio transmitters . . . full sized . . . in full operation every day!

HOME OF COYNE SHOPS



THIS IS our fireproof modern home wherein is installed thousands of dollars worth of RADIO EQUIPMENT. Every comfort and convenience has been arranged to make you happy and contented during your training.

RADIO SERVICING
PUBLIC ADDRESS & SOUND MAN
AUTO RADIO INSTALLATION & SERVICE
RADIO FACTORY INSPECTOR & TESTER
STUDIO TECHNICIAN
RADIO OPERATOR
TELEVISION LABORATORY MAN
REFRIGERATION SERVICE MAN
AUTO IGNITION & BATTERY MAN

and many other money making opportunities in the Radio field. Learn by actual work on real radios, sound amplifiers, modern service instruments, analyzers, oscilloscopes, television units, microphones, recorders and radio transmitters, in actual operation right in the Coyne shops.

REFRIGERATION

Send the coupon today and I'll tell you about the Refrigeration instruction I am now including at no extra cost.

PROOF That Coyne Training Gets QUICK Results

"Accepted a position with _____ Co. . . . I am well satisfied with the job . . . thanks for your past interest and help in securing my present position."—John Hotis, N. Y.

"I was transferred . . . to the new _____ store . . . in Pullman, Wash., as head of the Service Department. Of course I received another substantial increase in wages. I certainly appreciate all the help you gave me."—E. Eden, Wash. "I was just a common clerk in a hardware store before coming to Coyne. Everything is different since I graduated from Coyne—shorter hours, earnings increased 95%."—Arne Wiklem, Minn. And I could quote from hundreds of similar letters from successful Coyne-trained men. WHAT THEY HAVE DONE, YOU SHOULD BE ABLE TO DO!

GET THE FACTS . . . NOW

Coyne is your great chance to get into this big-pay field. This school is 40 years old . . . Coyne training is tested. And it costs you nothing to find out about this amazingly easy practical way to learn Radio. Simply mail the coupon below and I'll send you the big, free Coyne book, with photographs . . . facts . . . opportunities. There's no obligation . . . so act at once.

Send Today for this FREE Book!



H. C. LEWIS, President
Coyne Electrical School,
Radio Division
500 S. Paulina St., Dept. 39-2K, Chicago, Ill.

Without obligating me, send full details of your "PAY-TUITION-AFTER-GRADUATION" Plan and Big Free Illustrated Catalog.

NAME.....

ADDRESS.....

CITY.....STATE.....

Mail in envelope or paste on postcard.

COYNE H. C. LEWIS, President Founded 1899
ELECTRICAL SCHOOL
RADIO DIVISION
500 South Paulina Street Dept. 39-2K Chicago, Ill.

Please say you saw it in RADIO & TELEVISION

643

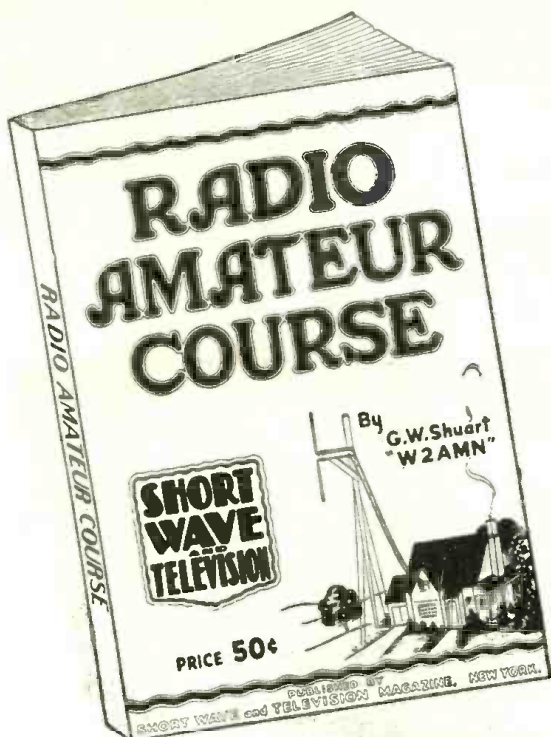

Your Money Back—

IF THE RADIO AMATEUR COURSE DOES NOT REPRESENT THE GREATEST BOOK VALUE EVER OFFERED TO THE RADIO "FANS" FOR 50¢

TO convince you that there isn't a better book buy today, the publishers of the **RADIO AMATEUR COURSE** make the sensational offer of a money-back guarantee on such a low-priced book. Stop in at any of the many dealers listed at the right and examine this volume. See for yourself if the **RADIO AMATEUR COURSE** isn't just the book you've always wanted.

Printed on the finest quality paper—well illustrated attractive 4-color cover—complete with radio information you must have. It contains a step-by-step program for obtaining a short-wave radio education.

*Written by George W. Shuart, W2AMN,
foremost short-wave authority*

148 PAGES

6¼ x 9½ INCHES

**OVER 150 RADIO DIAGRAMS
and TECHNICAL PHOTOGRAPHS**

RADIO AND TELEVISION
99 Hudson Street, New York, N. Y.

**All Prominent RADIO DEALERS
Ready to Show You This Big Book!**

- ARIZONA**
Sam's Cigar Store,
127 N. First Ave., Phoenix.
- CALIFORNIA**
Scott Wholesale Radio Co.,
344 E. Fourth Street, Long Beach.
Offenbach Electric Co., Ltd.,
1452 Market Street, San Francisco.
Zack Radio Supply Co.,
1426 Market Street, San Francisco.
- COLORADO**
Auto Equipment Co.,
14th at Lawrence, Denver.
- CONNECTICUT**
Radio Inspection Service Co.,
227 Asylum Street, Hartford.
Stern Wholesale Parts, Inc.,
210 Chapel St., Hartford.
- GEORGIA**
Wholesale Radio Service Co., Inc.,
130 W. Peachtree St., N. W., Atlanta.
- ILLINOIS**
Allied Radio Corporation,
83 West Jackson Blvd., Chicago.
Newark Electric Company,
228 W. Madison Street, Chicago.
Wholesale Radio Service Co., Inc.,
901 W. Jackson Blvd., Chicago.
- INDIANA**
Van Sickle Radio, Inc.,
34 West Ohio Street, Indianapolis.
- MASSACHUSETTS**
Greater Boston Distributors,
40 Waltham St., Boston.
H. Jappe Co., 46 Cornhill, Boston.
Wholesale Radio Service Co., Inc.,
110 Federal Street, Boston.
Springfield Radio Co.,
397 Dwight Street, Springfield.
H. Jappe Co.,
37 Mechanic Street, Worcester.
- MICHIGAN**
Rissl Brothers, Inc.,
5027 Hamilton Ave., Detroit.
- MISSOURI**
Modern Radio Company,
409 No. Third Street, Hannibal.
Burstein-Appelbee Co.,
1012-14 McGee Street, Kansas City.
Van Sickle Radio Co.,
1113 Pine Street, St. Louis.
- NEBRASKA**
Radio Accessories Company,
2566 Farnam Street, Omaha.
- NEW JERSEY**
Arco Radio Co.,
227 Central Avenue, Newark.
Wholesale Radio Service Co., Inc.,
219 Central Avenue, Newark.
- NEW YORK**
Wholesale Radio Service Co., Inc.,
542 E. Fordham Rd., Bronx.
Wholesale Radio Service Co., Inc.,
90-08 166th Street, Jamaica, L. I.
Clan, The Radio Man, Inc.,
64 Dey Street, New York City.
Eagle Radio Co.,
84 Cortlandt Street, New York City.
Federated Purchaser, Inc.,
25 Park Place, New York City.
Harrison Radio Co.,
12 West Broadway, New York City.
Sun Radio Co.,
212 Fulton Street, New York City.
Terminal Radio Corp.,
80 Cortlandt Street, New York City.
Thor Radio Corp.,
60 Dey St., New York City.
Try-Mo Radio Co., Inc.,
85 Cortlandt Street, New York City.
Wholesale Radio Service Co., Inc.,
100 Sixth Avenue, New York City.
Radio Parts & Equipment Co.,
244 Clinton Avenue No., Rochester.
M. Schwartz & Son,
710-712 Broadway, Schenectady.
- NEW HAMPSHIRE**
Radio Service Laboratory,
1187 Elm Street, Manchester.
- OHIO**
News Exchange,
51 So. Main Street, Akron.
Canton Radio & Supply Co.,
1140 Fuscarawas Street, W. Canton.
United Radio, Inc.,
1103 Vine Street, Cincinnati.
The Hughes-Peters Electric Corp.,
178-180 N. Third Street, Columbus.
Standard Radio Parts Co.,
135 East Second Street, Dayton.
- OREGON**
Portland Radio Supply Co.,
1300 W. Burnside Street, Portland.
- PENNSYLVANIA**
Radio Distributing Co.,
1124-26 Market Street, Harrisburg.
M. & H. Sporting Goods Co.,
512 Market Street, Philadelphia.
Cameradio Co.,
963 Liberty Ave., Pittsburgh.
- RHODE ISLAND**
W. H. Edwards Co.,
32 Broadway, Providence, R. I.
- TEXAS**
Amarillo Electric Co.,
111 East 8th Avenue, Amarillo.
- UTAH**
O'Loughlin's Wholesale Radio Supply,
315 South Main Street, Salt Lake City.
Radio Supply, Inc.,
46 Exchange Place, Salt Lake City.
- WASHINGTON**
Spokane Radio Co., Inc.,
611 First Avenue, Spokane.
- WISCONSIN**
Radio Parts Co., Inc.,
536-538 W. State Street, Milwaukee.
- AUSTRALIA**
McGill's Agency,
183-184 Elizabeth Street, Melbourne.
- CANADA**
The T. Eaton Co., Ltd.,
Winnipeg, Manitoba.
Canadian Electrical Supply Co., Limited,
285 Craig Street W., Montreal, Que.
Metropolitan News Agency,
1248 Peel Street, Montreal, Que.
- CUBA**
The Diamond News Co.,
Palacio Asturiano, Por San Jose,
Habana.
- ENGLAND**
Gorrings American News Agency,
9a, Green Street, Leicester Square,
London, W.C.2.
- HOLLAND**
Radio Peeters, Van Woustraat, Amsterdam, Z.
- INDIA**
Empire Book Mart,
Box 631, Bombay.
- MEXICO**
American Book Store, S. A.,
Avenida Madero 25, Mexico City.
Central De Publicaciones,
Avenida Jusrez, 4, Apartado 2430,
Mexico, D. F.
- NEW ZEALAND**
Te Aro Book Depot, Ltd.,
64 Courtenay Place, Wellington.
- SOUTH AFRICA**
Technical Book Co.,
147 Lonsmarket Street, Cape Town.

If this book is not at your dealer's, send your order directly to us. We will credit your dealer with the sale of this book. To order your copy of RADIO AMATEUR COURSE, fill in coupon below and mail.

RADIO AND TELEVISION, 99 Hudson St., New York, N. Y.
Gentlemen: I enclose herewith my remittance of Fifty Cents (50c) for which please send me **POSTPAID**, my copy of the **RADIO AMATEUR COURSE**. (Remit by check or money order; register letter if you send cash or unused U. S. Postage Stamps.)

Name

Address

CityStateR&T-339

HUGO GERNSBACK, EDITOR

H. WINFIELD SECOR, MANAGING EDITOR

The SUN'S Effect on the Propagation of SHORT WAVES

Emile Girardeau

*General Director,
de la Compagnie Générale de Télégraphie Sans Fil,
Paris, France.*



Emile
Girardeau

● THE study of the propagation of short waves has definitely proven that there exists a certain relation between the varying conditions in the activities of these waves and the changes in the Sun's radiations.

The constant observation of these phenomena, during the last ten years, in the most important centers of radio transmission and reception in France, has made possible the compilation of technical data of unquestionable value from which it is now possible to draw certain conclusions.

It is known that the Sun exerts a normal and regular influence upon the propagation of short waves; another well-known fact is that the length of the wave used for communication between two given points needs to be shorter during the day than at night, and also shorter in Summer than in Winter at the same time of the day.

For example, in 1937 a day wave of 15 meters for trans-Atlantic communication was efficient in Summer, while a wavelength of 22 meters had to be used in Winter. At night, a 30 meter wave was used in Summer and a 40 meter wave in Winter.

Another example: the 22 meter wave successfully linking Paris to New York, five hours a day in January, 1935, was used for progressively longer periods, being efficient ten hours a day in March, and used continually throughout a twenty-four hour day in June.

The efficiency of this wavelength decreased from June to December, from twenty-four hours a day in June to only five hours a day in December.

The influence of the Sun's altitude upon the propagation of short waves along various lines of Radio communications has been determined accurately.

It has been observed that, over a path uniting two points situated on widely different longitudes, such as Paris and Tokio, where the respective altitudes of the Sun vary greatly at the same instant, the efficiency of a given wavelength is reduced much more than over our almost North-and-South connections, such as Paris to Buenos Aires.

Another difficulty observed is that it is almost impossible to find a short wave capable of maintaining satisfactory communications between Paris and Tokio on certain Winter days, between the hours of three and six o'clock in the morning. In this case long wave transmitters, utilizing high-frequency alternators, are operated to assure permanent connections.

There are also the variations in atmospheric conductivity, changing from year to year, which have been observed to follow the variations in the Sun's activity.

In Figure 1 is shown a graph of the annual solar activities according to the sunspot numbers used by astronomical observatories. The curves

are plotted to indicate the average number of hours when wavelengths of 14 to 18 meters were used successfully.

One will notice that the variations in the Sun's activity are nearly identical with variations in wave efficiency. However, for wavelengths of 37 to 50 meters the variations are opposite and almost inversely proportional.

* * *

From the practical viewpoint of commercially exploiting radio communications, the record of these continuous observations is of great value, since it enables us to foretell the most practical wavelength to use, on a particular day, at a certain hour.

Nearly eleven years have passed since these records of short wave propagations were written, and eleven years is the approximate duration of a cycle in the variations of the Sun's activities, which is graphically shown in Figure 2.

Referring to these observations, it is now possible to foretell which will be the best wave to use at a given hour of a certain day, of any month of any year.

Uncertainties and inconveniences can be thus eliminated by avoiding the use of a wavelength unsuitable for communications affected by the varying conditions so far outlined.

There are also other consequences of Solar phenomena, the study of which is of great interest because of the occasional troubles in propagation known as *fading*.

Fading, or the attenuation of a signal being received, may be intermittent, or more or less slow, or at times quite sudden. Nevertheless, the comparison of these effects with the records of astronomical observatories on disturbances in the earth's magnetic field (which invariably follow changes in the Sun's activity) indicate the Sun as the original source of these disturbances.

The power and the influence of the Sun over all things on earth is again reasserted by science, after having been forgotten during the centuries that followed the fall of the ancient gods, such as Amen of the Egyptians.

We can again say, like Phaedra: "Sun, divine Sun from thou I came," or like the Pharaoh's prayer say: "Thou Sun who created the world according to Thy desire."

Solar phenomena are revealed either by *spots* of varied appearance, or by immense flames pouring out of the brilliant disc.

The *spots* form dark areas of various shades and changing dimensions. Taking as an example a recent occurrence from the 30th of September to the 10th of October, 1937, one could observe on the

(Continued on page 682)

*Twenty-fifth of a Series of
"Guest" Editorials.*

Television Prepares for Debut

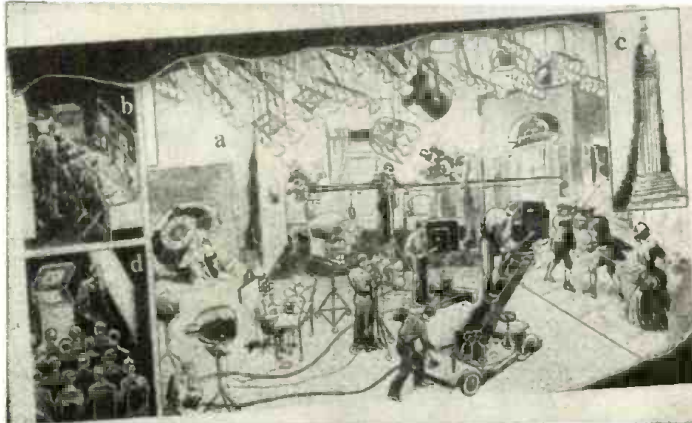

Above—"A" represents a studio set up for three scenes: Left—a beach scene; center—a drawing room; and, at right, a scene where action is taking place for a period play. "b" shows the control room; "c," the antenna atop the Empire State Building; "d," a number of persons watching a program as picked up by a television receiver. Photos courtesy N.B.C.

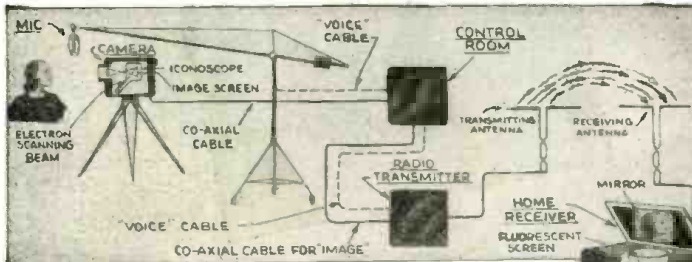

Block diagram of television transmission and reception. Image of girl at extreme left is picked up by iconoscope; her voice caught by mike. Resulting electrical impulses of sight and sound pass through control room and thence to transmitter and antenna. Waves are picked up by receiving antenna.

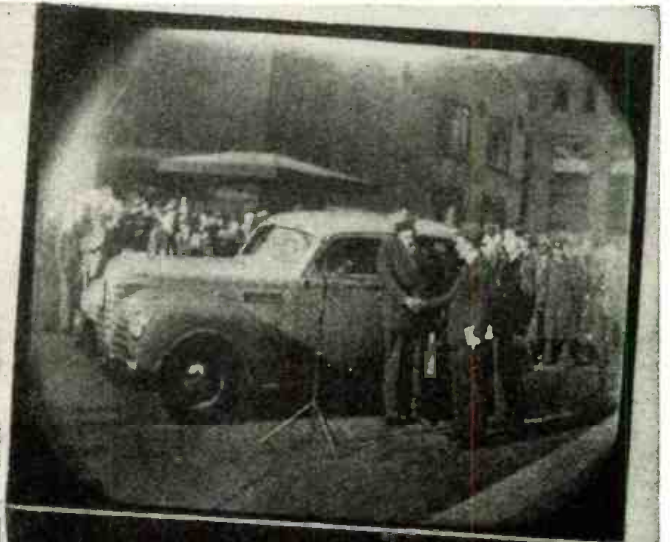

The two pictures above show how an actual scene compares with the television image it produces. Lower picture is an ordinary photo of one of the new model cars being inspected by interested crowd. Above it is actual photo of the image of this occurrence, as received via television. The top picture was taken of the screen at the end of the cathode-ray tube. Notice that while most of the detail is held, the finer detail (such as that of the radiator grille on the car, and the eye shadows of the man in the right foreground) is lost.

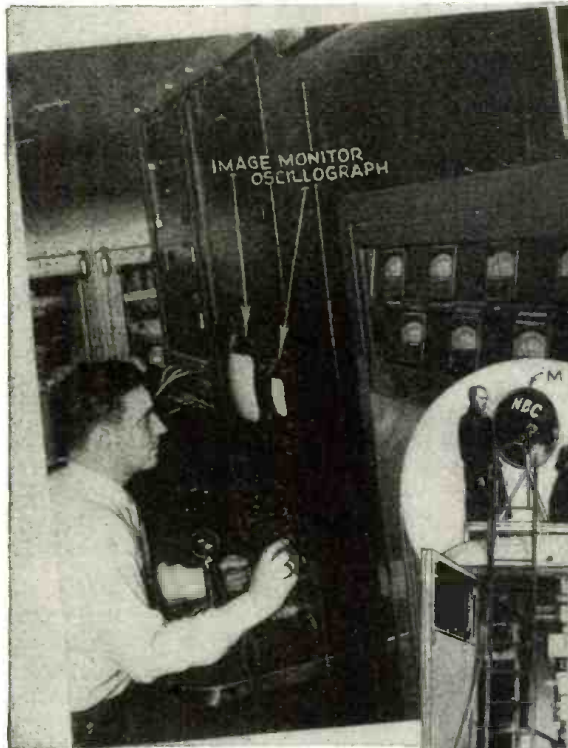

Inside the control room of the mobile unit. Above, an engineer watches the image on the large cathode-ray tube and wave-form on the small one. At the right is seen a set-up atop the truck to pick up sight and sound.

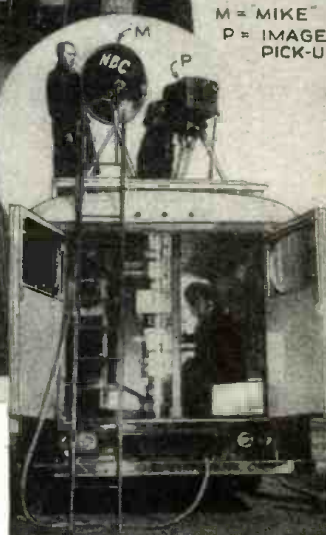

M = "MIKE"
P = IMAGE PICK-UP



The television camera makes a pick-up of the skaters at the rink in the Sunken Gardens at Radio City. Notice the man in the foreground wearing a light gray felt hat. He is the announcer. You can see the microphone cable running back over his right shoulder.

STATIC-FREE RADIO

Invented by
Armstrong

New frequency-modulated wave points the way to a new era in broadcasting. Among other features it provides high-fidelity and multiplex operation.

● MAJOR EDWIN H. ARMSTRONG, Professor of Electrical Engineering at Columbia University, has devised a new method of radio transmission known as *frequency modulation*.

In the present form of wave used for broadcasting, the carrier wave is amplitude modulated; that is, the strength of the wave varies as the voice modulates it. With frequency modulation, the frequency of the wave is changed for each variation in the voice, the amplitude remaining constant. Due to the wide band used for this new system and the special receiver employed for its reception, very high-fidelity reception, free from static and other noises, results.

Not only is *static-free* transmission achieved by this newest invention, but tube noises and other interfering disturbances are eliminated.

Professor Armstrong has built a powerful transmitting station for his new frequency-modulated system at Alpine, N. J., near New York City. This station (W2XMN) has been picked up as far distant as 300 miles at a special receiving station erected atop Mt. Washington in New Hampshire. (Mt. Washington is 6000 feet high.)

At present the Alpine station is operating on a wavelength of 7.5 meters, and while some experimenters and Hams have heard

Static-less radio programs will be broadcast next Spring from this 400-foot tower, when station W2XMN begins operating on the new Armstrong type of ultra short radio wave, which wipes out tube noises, fading and interference. W2XMN, located atop the Palisades near George Washington Bridge (N.Y.), will be the first high-powered frequency-modulated radio station in the world. The tower, with its 150-foot cross-arms, can be plainly seen from Riverside Drive, N. Y. City.

the wave broadcast by this station by listening in with super-regenerative receivers tuned to the edge of the band, considerable distortion occurs; to realize the full benefit of the new type of frequency-modulated wave and the high fidelity afforded, a special receiver has to be used.

The General Electric Company is building some of these receivers and a short time ago a demonstration was carried out between Alpine, N. J., and the G.E. laboratories in Bridgeport, Conn.

In the future, when this frequency-modulated system is extended, receivers will be made available to the public which will incorporate a receiver for the reception of the regular broadcast waves now in use, and a short-wave receiver capable of tuning in the special frequency-modulated waves.

Other experimental transmitting stations using the Armstrong

Noise-free radio programs will be broadcast next Spring through the amplifier shown, when station W2XMN begins operating on the new Armstrong type of radio wave. The station is located atop the Palisades near New York City, and will have a service area of 100 miles. A table has been made into a control desk, as shown in the foreground.

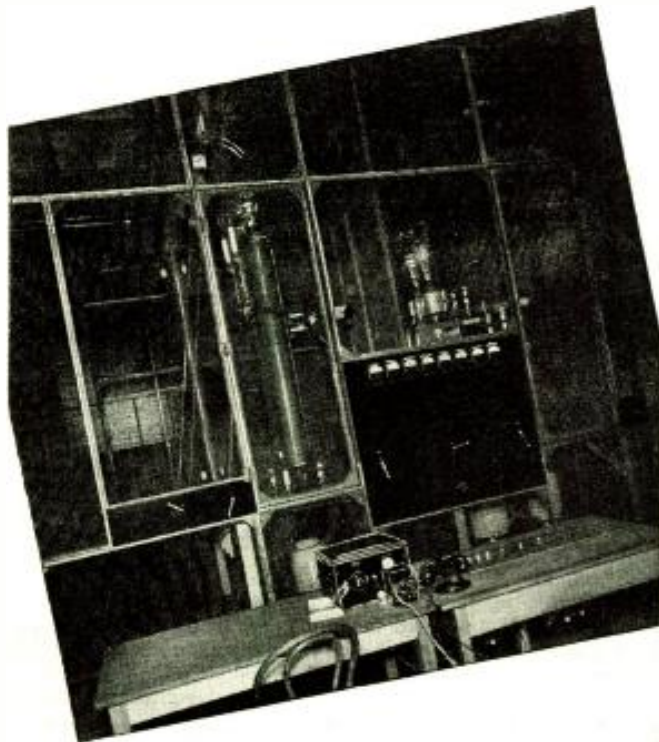

frequency-modulated system have been erected at Yonkers, N. Y., Albany, N. Y., and Storrs, Conn.

The width of the wave channel radiated by the Alpine station is twenty times the width of the ten kc. wave sent out by the modern broadcast station. In other words, the width of the Armstrong frequency-modulated wave is 200 kc. In the wavelengths between one and ten meters, there is room for 1350 stations using the 200 kc. wide "f.-m." wave. In other words, there is opened up a brand new frequency spectrum for broadcast stations, in fact, more stations than we probably have immediate need for.

The new Armstrong static-free transmission system should prove very useful in the future for relaying television programs between cities, as it will undoubtedly prove far cheaper than would the use of coaxial cables between cities.

Range of Station

The average range (radius) of one of these new "f.-m." stations will be about 100 miles, and if in the future our broadcasting system should be converted to this method of radiating waves, we would need many more stations than we have at present to serve the same communities with broadcast programs, owing to the smaller range of the ultra-short wave "f.-m." stations. With the higher power now being used by many

(Continued on page 697)



WORLD WIDE



View of the Future "Broadcasting House"

THE London Broadcasting House will look like this in 1940. The entire plant is being remodeled and will be extended to more than twice its present size. Excavation and the erection of retaining walls around the site should be completed about the middle of this year. The building is expected to be finished by the end of 1940. There will be five underground studios to eliminate all outside noise (bombs?). The main studio will be 80 feet x 54 feet x 30 feet tall; there are also to be three dramatic studios, a sound effects room and a number of rehearsal rooms. Above the ground level will be a number of floors of offices. The control room will be on the 7th floor and a restaurant on the 8th or top floor.



Eiffel Tower Television Station

AN interesting article on the construction of the television station installed in the Eiffel Tower, Paris, France, appears in a recent issue of *Radio Revista*. As the picture above shows, the video equipment, terminal studio equipment, and transmitter apparatus are linked to each other and to the Eiffel Tower radiator by means of a buried co-axial cable. Thirty kilowatts are used to put the signal on the air and to insure its covering the Parisian area with adequate strength.

Orkney Amateur

MR. J. C. Graham, traffic control officer of the British Air Ministry at Kirkwall Airport on the Orkney Islands, has erected an amateur transmitting station at that point, according to *Practical and Amateur Wireless*. If you should hear GM3TR, you will be tuned in on Mr. Graham.

Trailer Displays Television

NOW Midland Television, Inc., of Kansas City, Mo., has equipped a Covered Wagon display coach with portable television demonstration equipment. Special racks were mounted in the trailer to hold the power supplies, amplifiers and a 9-inch cathode-ray monitor tube. Both



the pickup and the monitor are permanently mounted in the trailer. In addition to this equipment, two television receivers are carried, to be taken out and set up in the auditorium or other place where the demonstration is to be made. The definition achieved by this system is 90 lines.

Audiences Cause Distortion

THAT the clothing (or lack of it) in a studio may wreak havoc with the acoustics was discovered at a recent Toscanini broadcast. When it was noticed that tone values, especially in the higher

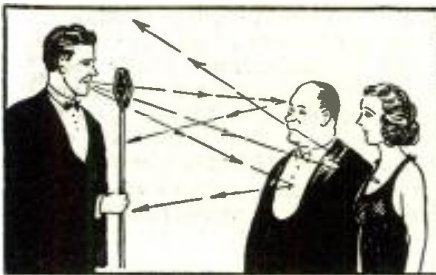

frequencies, were registering with unusual sharpness, an investigation was started. The cause of the trouble was found to lie in the fact that a large number of men in the audience were wearing stiff dress shirts, and many of the feminine visitors to the studio had large expanses of backs and

bosoms uncovered and thus reflecting.

Soft cloth absorbs sound far better than stiff materials, such as a boiled shirt or a sharp shoulder blade. Therefore, the woe!

Well—Could You?

THE *Malayan Radio Times* included in its last issue a questionnaire measuring 8½" x 22", asking listeners a number of questions under the heading of "Could YOU Improve the Singapore Programs?" Some of the questions include "What type of programs do you prefer?"; "Do you prefer 'live' or recorded programs?"; etc. Questions Nos. 8 and 10, which particularly appealed to the world-wide radio review editor, are printed verbatim: "Do you enjoy Chinese Music? If so, which do you prefer: Teochew, Cantonese, Hokien-Amoy, Mandarin, Teochew Gua-Kang, Peiping, Sze Shuan"; "Which of the following Malay programs do you most enjoy? Put numbers against the items to show the order of your preference: Kronchongs, Lagu Malayu, Lagu Extras, Lagu Nasib & Sair, Dramas."

RADIO DIGEST

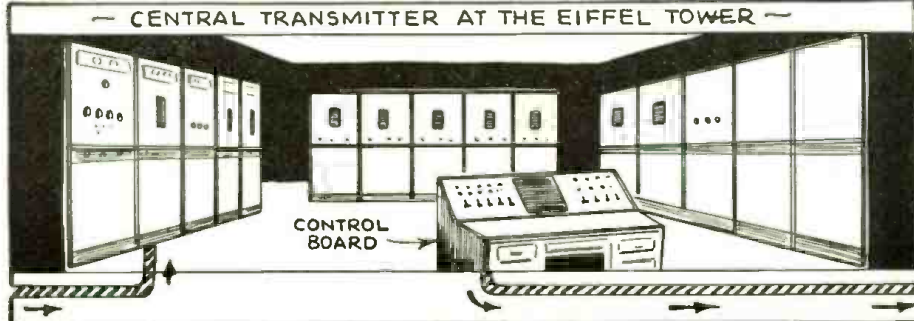

— CENTRAL TRANSMITTER AT THE EIFFEL TOWER —

Radio Aids Skiers

A NEW radio telephone circuit has been set up to enable the hostess at Sunshine Lodge, which is 8,000 feet above sea level, to send a daily message to skiers in various parts of the Canadian Rockies. The photograph shows Miss



Ina May Hummon, hostess at the Lodge, seated at the microphone at the transmitter, which is near Banff.

Television Transmitter

BAIRD of Boston is on the air with a 441-line television signal sent at 30 double interlaced frames per second. While the station has no regular schedule



at the present time, it averaged almost one hour a day during the past year. Programs consist of both direct pickup and motion picture film. The station, W1XG, is sending out the video signals on 46.5 megacycles at 500 watts. There is no audio portion of the program broadcast at the present time.

New N.B.C. Short Wave Antennas

A NEW type of directive short-wave antenna has been installed for N.B.C. short-wave stations, W3XL and W3XAL, which will beam signals from 25,000 watt transmitters directly on Latin America, with effective strength equivalent to 600,000 watts! The frequencies used will be 21.63 and 9.67 mc. The antennas are of the broadside type, consisting of two 150-foot towers 350 feet apart. There are five panels in the radiator and five in the reflector. The beams are directed at Buenos Aires and Rio de Janeiro. The design of the aeriels is such that the center of the beam can be changed through an angle of 20 degrees to cover various other areas of the South American continent. By means of a method of phasing the antenna elements, the beam may be swung through this angle simply by pushing a button located on the transmitter control panel. The antennas will be fed through co-axial cables with an outer diameter of 3½ inches. The space between the center conductor and the outer tube is to be filled with nitrogen gas under pressure to keep out moisture.

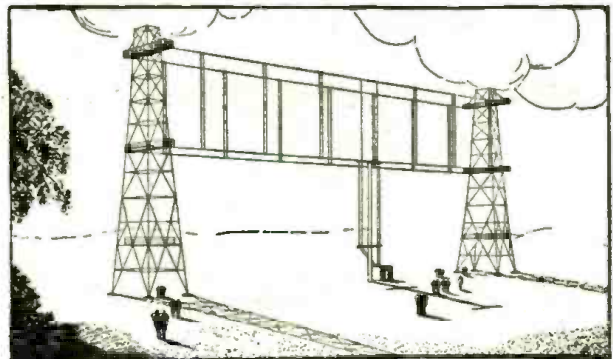

Television Goes to War

OUR America, always in the foreground in invention, is developing television equipment for defensive warfare. Television pick-ups will be sent aloft in planes or balloons, transmitting images of enemy terrain to American staff headquarters and to gun emplacements which may be located several miles back.

View of the Past

DO you recognize the weird object on the table? In case you can't, it is a loose-coupler radio set of the vintage of 1910. J. S. Dobbins, an amateur of that



vintage, is seen enthralled by the "magnificent" programs which were on the air in those days. Mr. Dobbins' call was WNU and his station was located in New Orleans, La.

In those days "fans" listened in for waves several thousand meters long. Loading coils as big as the operator were common, the sections being switched in as required.

Channel, Channel, Who's Got the Channel?

WHEN the Germans took over the Czech Moravska-Ostrava transmitter installed at Soinov (a part of the Sudeten lands ceded to Germany by Czechoslovakia), the Nazis inherited a problem in addition to some equipment. The studio is at Moravska-Ostrava and the Czechs are eager to use it but they can't find a frequency to operate on, the Germans claiming that the 1.204 mc. channel is part of the transmitter. Just to make things simpler, most of the programs now being sent over this outfit are relayed from Breslau.



1. Every year brings the story of some great invention—which no one actually ever sees. Of the following, which is (or are) as yet unproven?

- a. The death-ray, which will kill at distances of several miles.
- b. The destruction ray, which will stop the motors of airplanes and automobiles at a distance.
- c. The television kit, which converts any broadcast receiver for sight-and-sound.
- d. A means of transmission so broad that it can be received without tuning.

2. Under the International Telegraph Regulations, as revised by the Cairo conference in 1938, a period is sent as

- a. didit didit didit
- b. didah didah didah
- c. didahdidahdidah
- d. dadah dadah dadah

3. And under the same rulings, the comma sign is now

- a. didahdidahdidah
- b. dahdahdidahdidah
- c. dididahdidit
- d. dahdit dahdit dahdit

4. The greatest advance in radio in 1938 was said to be

- a. "Wireless" remote control automatic tuning for receivers.
- b. Preparations for the release of television.
- c. The beam power oscilloscope.
- d. The use of ultra-short waves for trans-Atlantic communications.

5. In the "Schmidts at Home" dramatic broadcasts from the Deutscher Kurzwellensender, the American character, Billy Smith, is

- a. the love interest
- b. an admirer of business man Germany
- c. a nice nitwit
- d. a hardboiled
- e. an anti-Nazi
- f. a shrewd Yankee farmer

6. If you are fortunate enough to have a facsimile receiver in your home,

- a. it will typewrite printed matter received via radio.
- b. it will reproduce both type and pictorial matter received via radio.
- c. it will make a permanent readable record of broadcast talks and music.
- d. it will show moving images of broadcast scenes and programs.



7. "You're crazy! That magazine isn't published any more!" exclaimed the news-dealer, when the customer asked him for a copy of

- a. Radioland
- b. All-Wave Radio
- c. Radio Stars
- d. Tower Radio
- e. Wireless Age
- f. Popular Radio

8. The various station selector circuits in a set using push-button tuning are aligned

- a. by means of a movable iron core in each of a number of coils.

RADIO TEST-QUIZ

Meet Your Professor ROBERT EICHBERG

● THIS month a new method of scoring is used in the R. & T. Radio Test Quiz. For each question you answer fully, credit yourself with 10 points; for each you get half right, take five points; etc. A perfect score is 100; a very good score is 136; a good score is 110; fair is 90—and if your score is below 60, you'd better read a lot of books. Harry Winfield Secor, Managing Editor of this publication, won 142 points in 10½ minutes.

b. by means of trimmer condensers in parallel with various coils.

c. through the use of an RF signal generator.

d. by unwinding a number of turns from each of various coils.

9. In Spain, both the Nationalists and the Loyalists refer to short waves as

- a. chicos ricos
- b. poco dinero
- c. bobinas rojas
- d. ondas cortas
- e. gallinas gordas
- f. ojos azules

10. Radio has been credited with much valuable work in advancing the development of

- a. burglar alarms
- b. motion pictures
- c. aviation
- d. hearing aids
- e. automobile design
- f. weather forecasting

11. Can you match the following broadcasters with the types of characters they portray? Well, try your hand at it, anyway.

- a. Jack Benny
- b. Gertrude Berg
- c. Jane Ace
- d. Frank Morgan
- e. Ned Sparks
- f. Kenny Baker
- A. Grouchy
- B. Silly
- C. Penurious
- D. Timid
- E. Boastful
- F. Philosophical

12. Marconi first sent his famous three dots flashing across the Atlantic ocean approximately

- a. 30 years ago
- b. 40 years ago
- c. 50 years ago
- d. 60 years ago
- e. 70 years ago
- f. 80 years ago



13. Perhaps you don't remember, but "talking tape" is or was

- a. steel ribbon on which sounds have been magnetically recorded.
- b. a form of indoor antenna, made of flat tinsel.
- c. talking movie film.
- d. similar to talking movie film, but carrying sound only—without pictures.

14. In broadcasting parlance, "live shows" are broadcasts which

- a. include risqué jokes.
- b. do not originate from phonograph records.
- c. include hot dance music.
- d. are to continue for a series, as compared with those which are only "one-time shots."

15. Newspapers have a very strong feeling about radio because

- a. radio set manufacturers spend lots of money advertising in the papers.
- b. radio stations sometimes compete with the papers by broadcasting news.

c. advertisers spend money for sponsored programs which might otherwise be spent on newspaper advertising.

d. publishing the programs of radio stations attracts more readers to the papers.

16. Ultra-short radio waves are said to travel much like

- a. sound waves
- b. ocean waves
- c. permanent waves
- d. light waves
- e. crime waves
- f. Longmayshiwaves

17. Frequency modulation transmissions

- a. travel farther than other types.
- b. pick up less static than others.
- c. afford higher fidelity than others.
- d. merely evade older patents.

18. If you were running a radio receiver and the line cord got hot, you would know that

- a. there was a burned out primary on the power transformer.
- b. that it was an AC/DC receiver, working as intended.
- c. that there was a short-circuit in the set.
- d. that it was merely due to overloading because of excessively strong signals.

(Cont. on page 698)



How the VODER Creates Human Speech!

Cover Feature

● AN electrical device, based on radio principles, under control of an operator at a keyboard, actually talks — emitting words and sentences! Known as the Voder, it was developed by Bell Telephone Laboratories as a scientific novelty to make an interesting educational exhibit for the company's displays at the San Francisco

combination. It takes a good deal of practice and some time to learn—not as much time as it takes the human to learn the mechanisms he is born with, but still quite a while. And it talks with what might be called a slight electrical accent. Nevertheless, a skilled operator can make it say what she wants.

The designers of the Voder provided it with electrical equipment corresponding to the two kinds of speech sounds. One kind of sound is made by forcing the breath through the mouth, past tongue, teeth and lips. Turbu-



Above: Seated at the keyboard, this young lady can carry on a conversation by pressing keys. A foot pedal changes inflections. The "voice" comes through the loud speaker.

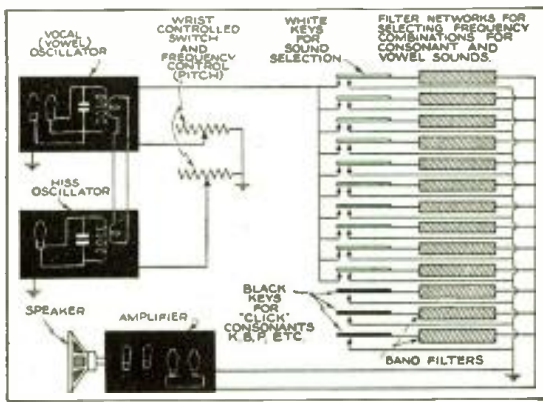

Above: Simplified diagram of the "Voder," showing how radio circuits create the human voice.

Exposition and at the New York World's Fair. It is built, except for its keys, entirely of apparatus used in everyday telephone service.

The Voder is the first machine in the world to create speech. Individual vowels and consonants have been made by a variety of instruments, but they have never before been linked into connected speech. Seated at a keyboard something like that of the old-fashioned parlor organ, an operator can carry on a conversation simply by pressing keys, singly or in

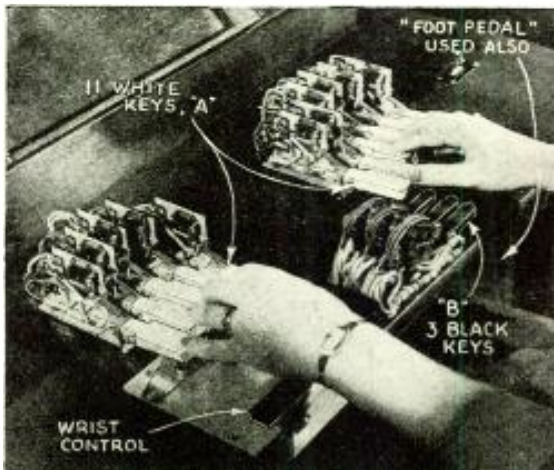

Left: A close-up. Ten of the white keys control speech sounds; the 11th is a volume control. Black keys make "stop" consonants.

lence in the air-stream sets up a hissing sound which contains a

Voder there is an electrical hiss, and with (Continued on page 701)

great many audio frequencies. Some of these are reinforced by resonances in the mouth cavity; that is the way in which are made all the sounds of speech when one whistles, and such sounds as s, th and f. In the

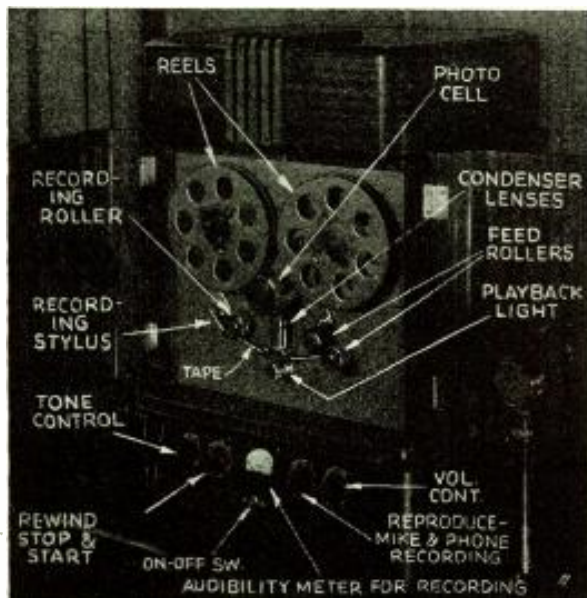

Records on Paper Tape from Mike or Phone

● A NEW type of voice recorder, invented by Merle Duston, veteran radio engineer, affords instantaneous playback of sound - on - tape, without need of processing.

In the new apparatus, cellophane or glassine tape is then placed on reels in the machine, as shown in the accompanying illustration. When words are spoken into the microphone, current passes through the tape from the stylus, re-

coding by discoloring the tape as it goes through.

To reproduce the sound, the tape is re-wound and fed through again in the same direction. The discolorations in the tape intercept a light beam which travels from a small bulb on the panel of the receiver through a condensing lens system and to a photo cell, the output of which is amplified and reproduced in the usual way.

When 6-inch rolls of tape are used, the apparatus will record for approximately 20 minutes without a change; if 7½-inch rolls are used, one hour's recording can be had. A single track is used on the tape so that lengths may be cut out and filed, much as a letter would be. The inventor envisions use of the apparatus in business offices.



New Facsimile Station

1 FACSIMILE stations are breaking out all over the United States. One of the most recent of these is that installed by Station WBEN of the *Buffalo Evening News*. At one o'clock every morning, this station (shown in Fig. 1) transmits an hour's program, producing a miniature 3-page newspaper. The transmissions are on 900 kc. with 1000 watts of power. Picture shows the transmitter.

gram of which is shown in Fig. 3, is extremely simple to construct. The coils are wound on one-inch forms of No. 22 d.c.c. wire. Coil A consists of 50 turns; coil B, 30 turns; and coil C, 60 turns. These are the short-wave coils. The long-wave coils are D, 250 turns; E, 150 turns; F, 300 turns. The variable condenser has a capacity of .0005 mf., and the fixed condenser, .002 mf.

The designer of the apparatus suggests

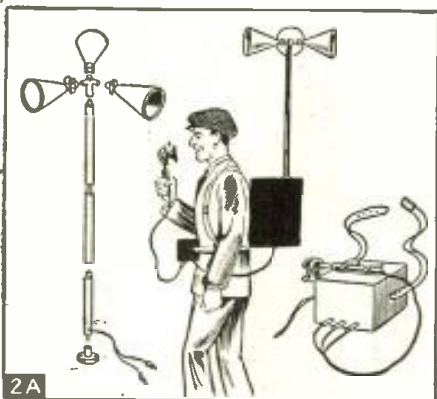

Public Address Pack

2 A PORTABLE public address system that, together with microphone and loud speakers, may be carried on the back of one operator, is described in *Radio Revista*.

Fig. 2A shows the pack as it appears in use. The microphone may be carried inside the case or strapped to the top, while the loud speakers are supported on a collapsible aluminum or bamboo pole.

Fig. 2B gives the detail of the panel, and the switching system which permits a microphone and pick-up to be used and to be faded in and out by means of a volume control.

Fig. 2C illustrates the balance of the wiring diagram to which the numbered terminals in 2B connect. Power for the complete apparatus is supplied by dry cell batteries. The miniature type may be used, as the plate current drawn is relatively low and can be still further reduced by using C bias on the push-pull stage, although this will result in some loss of volume or quality. Standard transformers are used throughout, and values of all fixed condensers are given. Meter may be omitted.

A.C. Resistance, Capacity Mu Bridge

that a single phone of no more than 500 ohms be used. If aerial is more than 60 feet long, insert a .005 mf. condenser in series.

4 L. FRATER (2AZR), writing in *Great Britain's Radio and Television Bulletin*, describes a simple and easily constructed a.c. bridge for measuring resistance, capacity and mutual conductance.

The apparatus diagrammed in Fig. 4A may be broken down into three basic circuits. These are shown in Figs. 4B, 4C and 4D. The fundamental circuit used in the bridge which measures resistance is shown in Fig. 4B. The circuit for measurement of capacities is seen in Fig. 4C, while that used to test mutual conductance is given in Fig. 4D. In Fig. 4B, the network consists of the potentiometer R, the two legs of which are R1 and R2, a known resistance, R3, and the resistance to be measured, RX. Alternating current of a low voltage at about 1000 cycles is applied across the potentiometer, and the point S, where no sound is heard in the phones connected as shown, is determined by experiment. As the bridge is then balanced, the formula is

$$\frac{R_1}{R_2} = \frac{R_3}{R_x} \text{ or } \frac{R_1}{R_3} = \frac{R_2}{R_x}$$

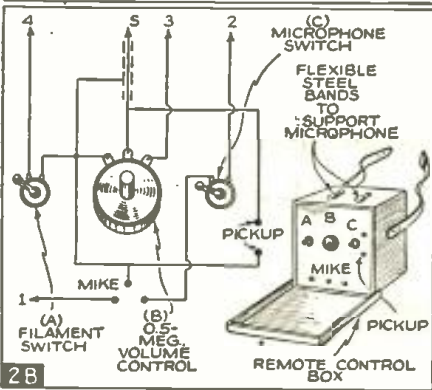

All-Wave Crystal Receiver

3 A CRYSTAL receiver employing band-switching has been described in *Radio Revista*. This receiver, a circuit dia-

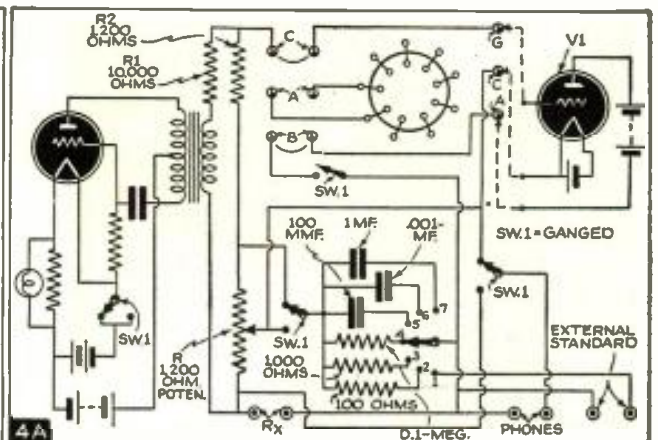
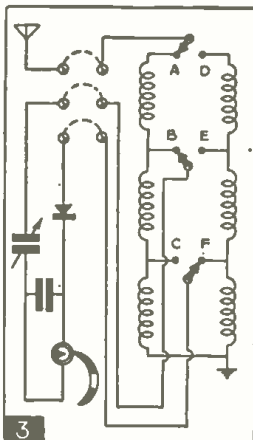
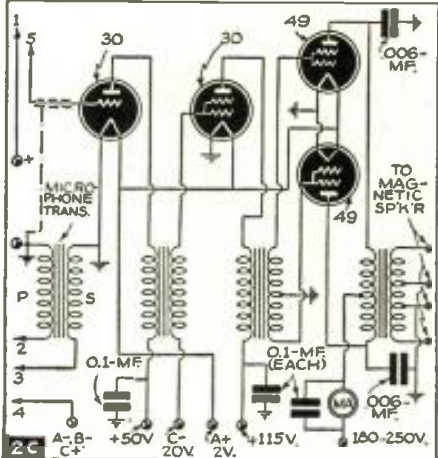

where the equation is simplified,

$$R_x = R_1 \times \frac{R_2}{R_3}$$

The ratio of R1 to R2 may be easily determined by using a calibrated potentiometer.

To test a capacity, a known condenser, C1, is inserted in place of R3 and the condenser under test, CX, is put in the

Mobile Unit Generates Own Power

5 THE mobile unit of Station KDJB (seen in Fig. 5) has traveled some 3500 miles, broadcasting 60-odd programs on 2790 kc. to KGLO where it was re-transmitted on 1210 kc. Five hundred feet of cable are used for line or mike, and when necessary to cover longer distances, a portable unit, W9XRS on 31.1 mc., broadcasts to the truck, which rebroadcasts. The unit's Kato power plant is inset.



position of RX. Fig. 4C illustrates this. The same procedure is followed in making this measurement as in measuring resistance. The adjustment is somewhat more critical because no point of absolute silence may be found, in which case the operator must determine the point of minimum sound.

Inductances may be measured in much the same way, substituting the known and unknown inductances at the points R3 and RX or C1 and CX. Terminals are provided for the installation of a standard inductance, although this apparatus is not installed in the equipment in order to economize on space.

The mutual conductance tests are made with the portion of the circuit shown in Fig. 4D. A point on the potentiometer R is found where no sound is heard, whereupon the formula

$$\text{Mutual Conductance } G_m = \frac{R_2}{R_1 \times R_3}$$

is used. In this case, the resistance R3 must be low in comparison with the anode impedance of the tube under test.

When making resistance and capacity tests, all batteries used in Gm measurements must be completely disconnected from the circuit. The oscillator may be a 2-volt power tube.

Loud Speaker Design

6 A LOUD SPEAKER which includes a "tweeter" for the highs and a large diaphragm for the lower frequencies, is described in the German publication *Rundfunk* and pictured herewith in Fig. 6A.

A Russian publication *Radio* devotes a large section of its latest issue to *baffle* design. Fig. 6B indicates a speaker employing no baffle. Notice the short path which the sound waves may follow from the front to the back of the diaphragm.

A far longer path is found when the speaker employs even a small baffle, as shown in Fig. 6C. 6D shows an application where the speaker must be mounted near the edge of a cabinet. The comparatively short baffle area which would be possible above it is compensated for by extending the baffle toward the rear, thus lengthening the path. A resonating chamber is added to this in Fig. 6E. This is shown in greater detail, and with the addition of a horn, in 6F.

6G shows another method of providing directive properties to a speaker. In this design, the speaker is bi-directional, having two radiating surfaces. The sound is projected both through the smaller horn at the front of the speaker and the larger one at the speaker's rear. A standard American system employing a horn, is shown in Fig. 6H.

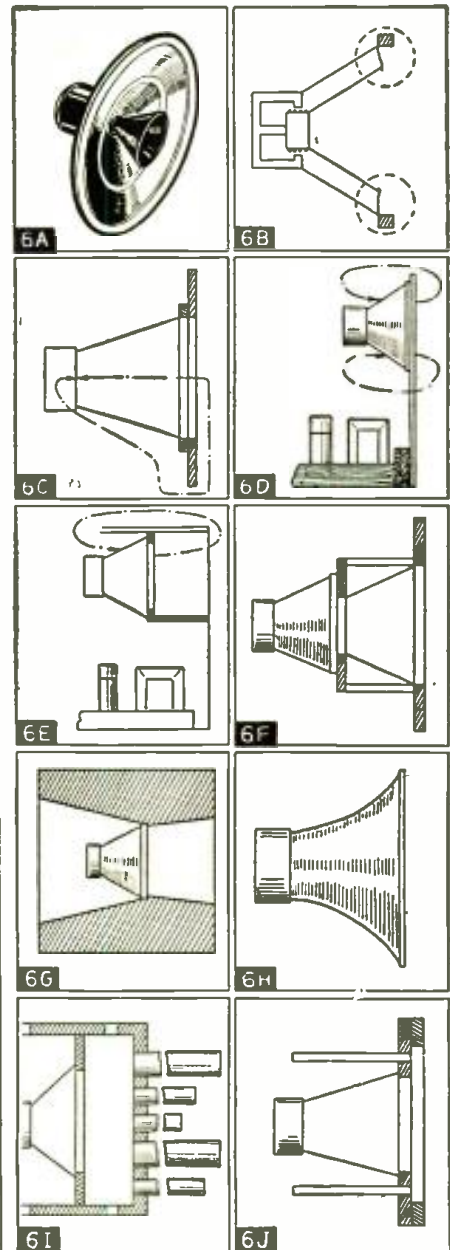
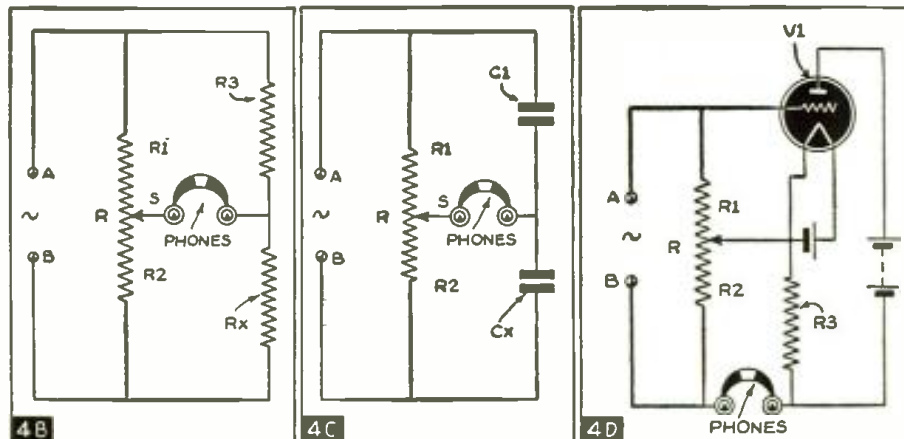

INTERNATIONAL

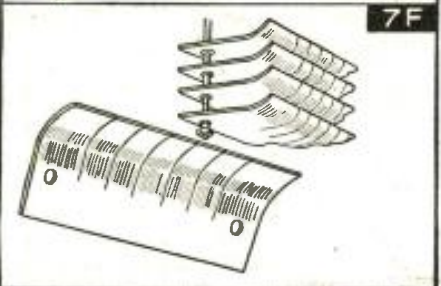
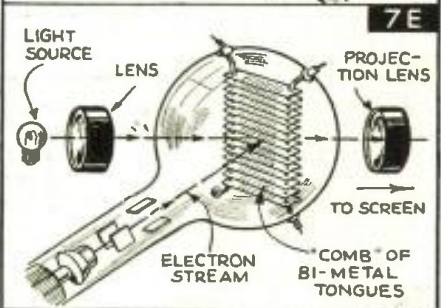
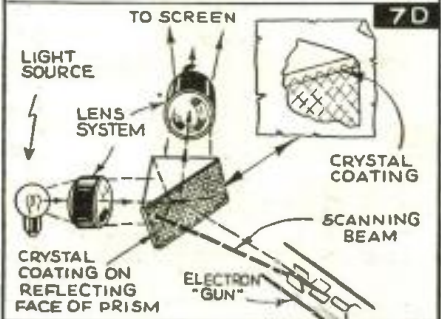
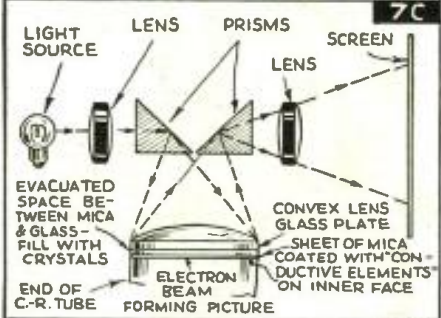
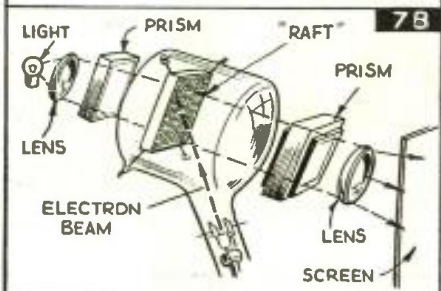
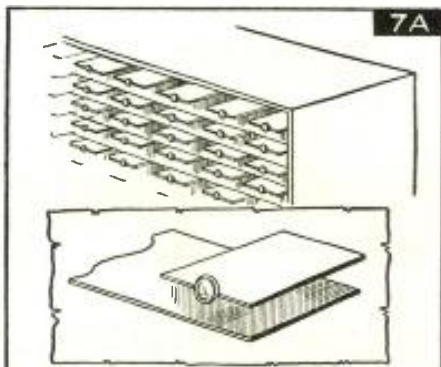

6I shows a further modification of speaker control. In this particular design, the sound is brought out through tubes designed to resonate at given frequencies. The bass notes are "boosted" by the larger tubes and the trebles by the smaller tubes.

More nearly approximating an American method of some years ago is the design shown in Fig. 6J, in which the feed-back of the speaker is controlled by the use of tuned tubes at the speaker's rear.

New Electron Tubes Designed for Projection Television

7 SOME radically new ideas for the projection of large screen television images by electronic means is found in the latest issue of *Television and Short-Wave World*, a British publication. In one scheme, illustrated in Figs. 7A and 7B, an electro-optical matrix would consist of a number of parallel strips of an optical medium, such as glass, Rochelle salts and the like, which become birefringent (doubly refractive) under electric stress. These strips would be arranged in the form of a rectangular plate, in alternate interstices of which would be inserted thin strips of metal foil to form an edge-on grille. In the other interstices would be arranged small electrodes, each having a small button lying flush with the surface.

The mozaic would be mounted within an evacuated bulb provided with an electron gun and deflector plates in order to produce scanning by an electron beam. The beam of polarized light would be passed through the mozaic and through a second polarizing prism from which it would be projected to the screen. As the beam struck each of the buttons, it would change the electrical potential with respect to the strips on either side of it, thus causing stress on the optical medium between and in this manner modulating the light. This idea, suggested by the Baird Company, was tried some years ago without much success.

Marconi's Wireless Telegraph Company, Ltd., and L. M. Myers suggest the idea illustrated in Fig. 7C. In theory, a layer of asymmetrical crystals would disperse the light unless they were struck by an electron beam to "line them up" so that they would

pass light to the mirror's surface. This system, however, is still in the theoretical stage.

The not entirely dissimilar system, shown in Fig. 7D, utilizes a cathode-ray tube with an optically polished end-wall, to which is attached the totally reflecting face of a prism. On the inside of the tube's end plates are carbon particles which are given a positive charge. The electron beam causes the carbon particles to move away from the end wall of the tube, thus changing the reflective factor.

Another idea is to use a very thin metal plate in place of the usual fluorescent screen and to cause the picture element areas of the metal to become incandescent by means of the heat generated by the electron bombardment.

Still another proposed method, shown in Fig. 7E, uses a number of bi-metallic elements which in their cool position block the beam from the light source and then, when heated, bend to permit the beam to pass. Fig. 7F shows detail of the bi-metallic strips. This method, originating in Germany, has not as yet been successful, due probably to thermal lag, though its proponents claim that the use of thin metal with large surface area will speed up the response.

Simple Exciter Unit

8 A SIMPLE one-tube exciter unit (Fig. 8) is described by W. H. Allen (G2UJ) in the *T. & R. Bulletin* of Britain. According to the author, the apparatus has been in use successfully for about two years by GW6YQ.

When an output is required at crystal frequency, C1 is tuned to a point where L1 is out of resonance with the crystal in use.

The output may be adjusted to the required frequency by means of a 4-point switch. S2 selects the plate coils L2 or L3, each of which tunes to two amateur bands. L3 is the 1.7 and 3.5 mc. coil. L2 takes effect with switch SW2 in the other position, when 7 mc. is found at about the center of the condenser.

In order to secure doubling, L1, C1 should be tuned to crystal frequency and the anode circuit to twice that frequency.

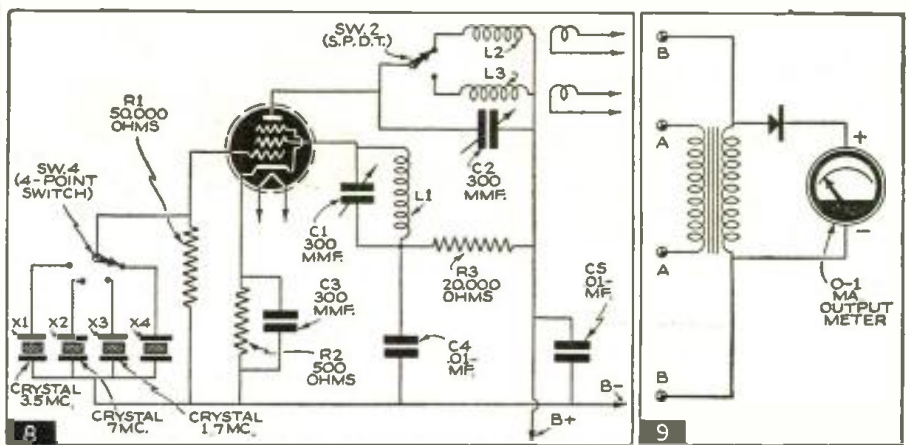

RADIO REVIEW

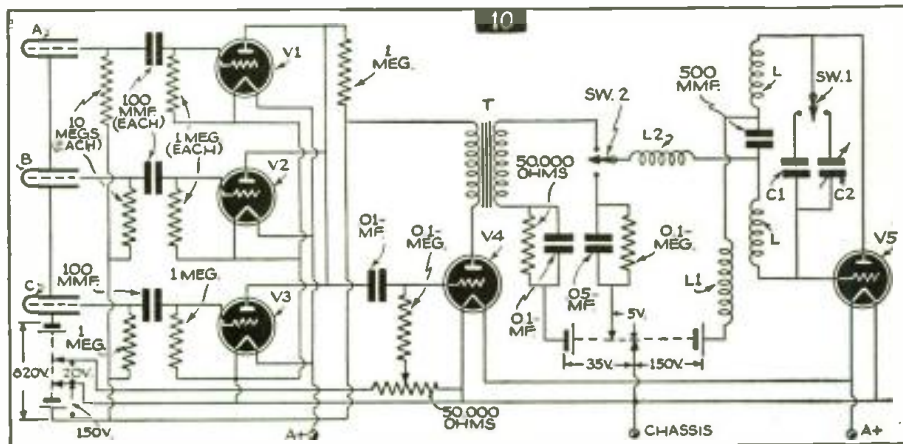

Simple Output Meter

9 A HIGHLY simplified output meter which uses a crystal to rectify the current for an 0-1 milliammeter, is described in *Practical and Amateur Wireless* of England.

The circuit shown in Fig. 9 makes use only of a one-to-one ratio output transformer, a carborundum crystal detector, and an 0-1 milliammeter. It is, of course, necessary that d.c. be kept out of the meter, and for this purpose the transformer is used.

If the set under test does not already incorporate an output transformer the terminals AA in Fig. 9 are connected to the output of the set. If, on the other hand, the set has a built-in output transformer, the terminals BB are connected across the secondary of the transformer already in the receiver.

The particular type of milliammeter used in the outfit shown had 100 ohms internal resistance.

While this is the apparatus as described in the British magazine, the editors of *RADIO & TELEVISION* believe that it would be wise to put a variable resistance of 0-1000 ohms in series with crystal and meter.

Measuring Cosmic Rays

10 MUCH mystery has always surrounded the type of apparatus used for measuring cosmic ray discharges. Now *Wireless World*, a British publication, reveals the workings of the transmitters which are sent up in balloons to count cosmic ray emanations, and signal automatically the altitude at which the observations are made.

The 40 mc. apparatus shown in Fig. 10 was used in the Wordie Expedition to West Greenland and worked satisfactorily at altitudes up to 12 miles.

The ray counter consists of two electrodes in vacuum tubes containing small quantities of certain gases. The electrodes are a straight wire and a metal cylinder surrounding it, a potential of about 800 volts positive being kept on the wire. The circuit is completed through 10-megohm resistors, as shown in the diagram. Charges passing through the counters ionize the gas and cause current to flow.

Triplex Facsimile Speed

11 A NEW type of scanner, upon which U. S. patents have just been granted to W. G. H. Finch, triples the speed at which a facsimile image may be scanned and reproduced.

Fig. 11 illustrates the new device, which employs an endless chain upon which are mounted three styli at regular intervals. The chain travels continuously in one direction and at the same time the platen, carrying the paper upon which the image is to be reproduced, slowly rotates. As one stylus passes off the paper at the right, a second commences its line at the left and as this one travels off at the right, the third is caused to begin the next line. When this stylus has passed across the paper, No. 1 is again ready to start.

The new design simplifies the mechanism greatly, as a reciprocal motion is no longer needed, a continuous motion taking its place.

Rails provided in front of the platen guide the styli accurately along their path.

Curing Television's Ills

12 ONE of the most frequent troubles with the television image is due to non-linear scanning in either the vertical or horizontal sweep. Figs. 12A, 12B and 12C show the familiar cruciform pattern sent out by many television stations for test. In Fig. 12A you will notice that the distance X is greater than the distance Y. This is caused by a non-linear sweep voltage from the line time base. In other words, the saw-tooth oscillation has the wrong form. The discharge of the condenser used in the circuit takes place too late. It may be caused by incorrect voltage or by a change in the value due to overload or deterioration, and is usually cured by reducing the value of the cathode resistance or increasing the value of the charge resistance.

In Fig. 12B, the pattern has its height-to-width ratio out of proportion. The amplitude of the oscillation in the gas relay tube is at fault.

Fig. 12C shows the pattern again, this time as it should be received, although the distance X is slightly greater than X1

(Continued on page 698)

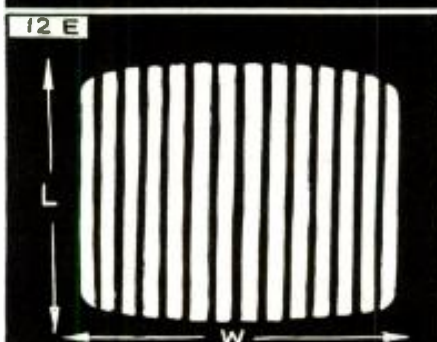
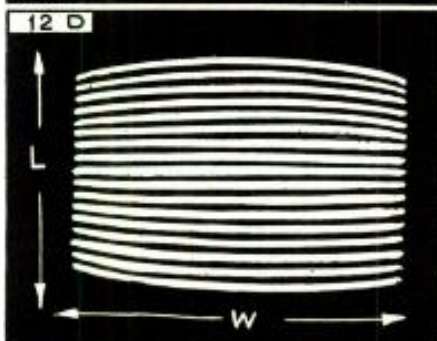
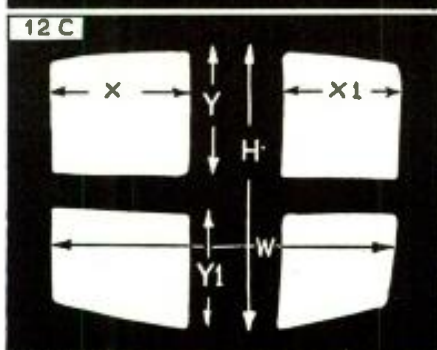
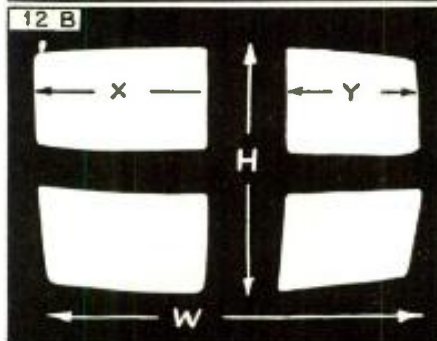
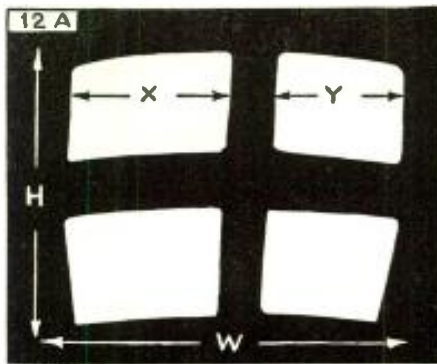
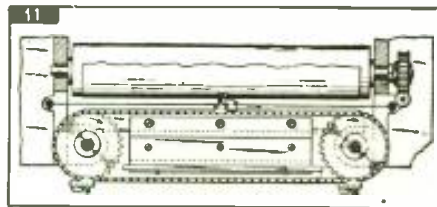

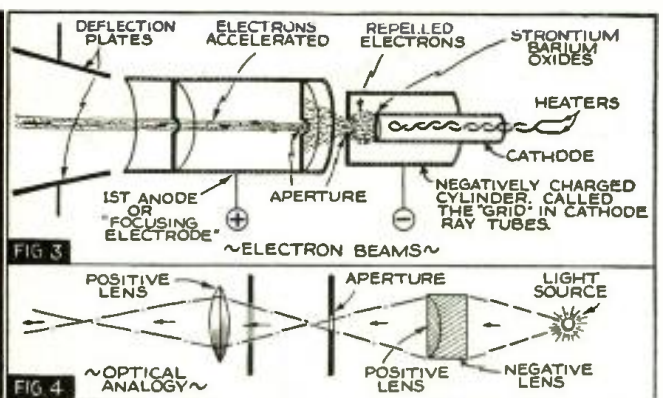
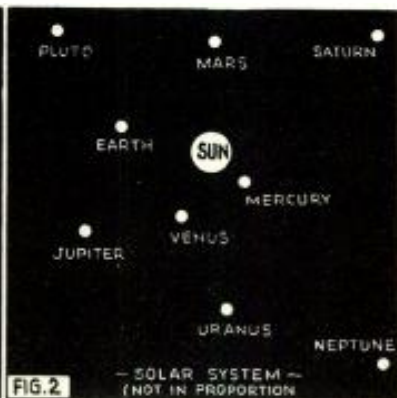
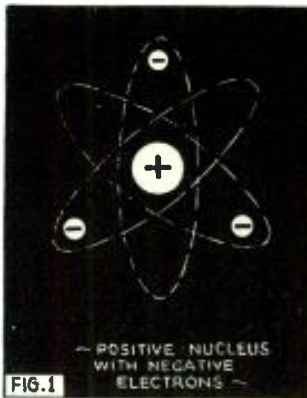

ELECTRONIC TELEVISION COURSE

Henry Townsend

Lesson I—Fundamentals

This series of lessons on television has been prepared by a practical television expert and will cover such vital subjects as photo electrics, cathode-ray tubes and how they work, sweep circuits, receiving systems for image and sound, etc.

● ACCORDING to the accepted classical theories, an *electron* may be defined as a *negative particle* of electricity. An atom consists of a positive *nucleus* with one or more electrons revolving in their respective orbits around this positive nucleus. (See Fig. 1.) The Solar System may be compared to an atom, the sun being the positive center with the planets in their respective orbits revolving around it representing the electrons.

These electrons, as has been stated before, behave exactly as do the planets in the solar system, describing their orbits around the positive nucleus without variations, when the atom is at rest. However, if energy is applied to this atom it begins to move in a given direction and with a speed commensurate with the energy applied. In its travel in a given direction, one or more electrons may strike an adjacent electron of a second atom and dislodge it from its orbit, thus *ionizing* this second atom. A physical manifestation of this phenomena may be observed when we apply energy to a vacuum tube filled with a rare gas, such as neon, and apply a potential to the electrodes. This potential is the necessary energy to cause these atoms of neon gas to travel at speeds sufficient to cause collisions of electrons, making the gas glow with its familiar red luminescence.

How Electrons Are Emitted

All substances will emit electrons when energy is applied, to a greater or lesser degree, the degree depending upon the substance. The elements that emit copious quantities of electrons as used in modern

day vacuum tubes and with which we are familiar are tungsten, thoriated tungsten and oxides of strontium and barium on metal. Each of these substances has its particular use in the field of electronics, but because of the lower energy necessary to emit a certain quantity of electrons, the strontium or barium oxide coated filaments or cathodes are used in the majority as electron emitting surfaces. Due to the low operating temperatures (from 1100 to 1170 degrees Kelvin), these oxide coated cathodes are particularly suited to various applications in electronic tubes suitable for television, because at this temperature they emit very little visible light.

Electron Optics

When a number of electrons are emitted, their paths are indefinite but as these electrons are negative particles of electricity, their paths can be made to follow a given direction by attraction to a positively charged electrode: or we can form beams of these electrons by surrounding the electron-emitting cathode by a negatively charged electrode, thus repelling these electrons to form a narrow beam and then attracting this beam by the positively charged electrode mentioned previously. By suitably arranging negatively and positively charged electrodes of proper shapes and sizes we can make these electron beams behave similarly to visible light. This art is often referred to as *electron optics*.

Certain chemical substances, when exposed to a bombardment of an electronic stream begin to *fluoresce* (emit visible light). This phenomenon is taken advan-

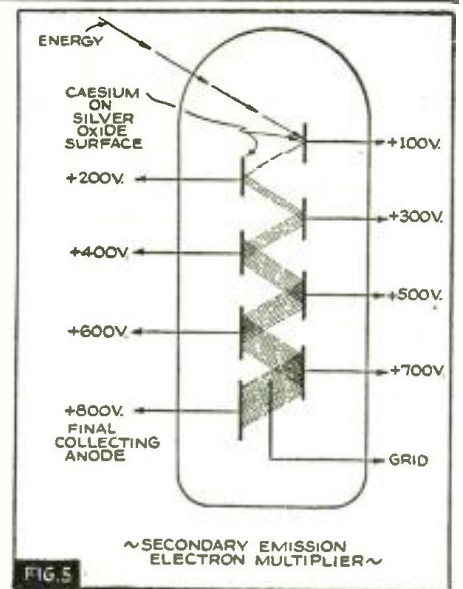

1—Fig. 1 shows positive nucleus with negative electrons; 2—Analogy, the Solar system; 3—How electrons are beamed; 4—Analogy for 3; 5—Illustrating the fundamental action taking place by secondary emission in the Zworykin electron multiplier.

tage of in cathode-ray tubes for the interpretation of electrical energy back into light, so that our eyes may perceive and our brains interpret this phenomena into images. Many chemical substances exhibit this property. The most commonly used are zinc sulphide, zinc silicate-manganese, and cadmium tungstate. These substances fluoresce in visible light, ranging from blue for zinc sulphide to the red end of the spectrum for a combination of zinc-cadmium-silver compounds. These chemicals, in certain proportions, are used in present day television receiving tubes which fluoresce with an almost pure white light.

Electron Multipliers

Another phenomenon of the electronic art, that has brought television to its high present-day status, is known as *secondary electronic multiplication*. All of the alkali metals emit copious quantities of electrons when extremely small amounts of energy are applied to them. In a device called *The Electron Multiplier*, a number of electrodes are coated with these alkali metals, usually caesium. An electron emitted from the first electrode is caused to strike the second electrode with sufficient force to dislodge five or more electrons from its surface and these five or more electrons are in turn attracted by a positive charge

(Continued on page 698)

The Martian Flash

An Inter-Stellar Magazine for all Radio Enthusiasts.

Published:—When Interplanetary Conditions Permit.

Interplanetary Pub. Co., (Very) Ltd.

Fips—Editor

Subscription Price for All Planets—Priceless.

The Editor accepts no contributions of any kind, neither cash nor literary. This entire publication is read at your own risk. The Editor is not responsible for either the contents or your own reactions.

Martian Office—

698743209 K K K 9 Street,
Martolus, Mars.



Fips, the Office Boy, who tells us the latest happenings on Mars.

March, 1939

EDITORIAL

● FIRST of all, thanks, boys, men, and all others, for

the lovely roses and cobblestones which you were good enough to shower upon me. To say that I am overwhelmed is to put it lightly; flabbergasted would be a much better term—although the Martians would not understand it. Indeed, you cannot flabbergast a Martian, much less surprise him. A civilization with fifty million years of experience behind it cannot very well be expected to be surprised even at the most extra—super—ultra—colossal. While I have been here only a few years, I am getting so now, that I am quite immune to surprises myself. So I hope you will bear with me when I relay to you, from month to month, conditions on Mars as they exist nowadays.

Of course, I know some of you are still incredulous of all the wonders of Mars. As I unfold all the technical wonders every month, you will soon appreciate and understand that they are not half as far-fetched as you may imagine.

Just imagine, what even such a reputed wise-guy, as King Solomon with his A number one wisdom, would think if he were suddenly to come to life again on your good old earth now? And remember that only a few paltry thousand

years have intervened between Solomon and you. Then consider that the Martians have been civilized and up to date in all technical wonders for over fifty million years!

I will leave you with that thought till next time.

THE AUTO-TRIBUNAL

By Ulysses Mohammed Fips

* * Martian Star Reporter * *

LAST month (of course, I refer to Earthian months—the Martian month being sixty of your Earth days) I spoke about the Auto-Science-Mech-Ultra-Tribunal. The Editors of your magazine reported several thousand letters of you readers who wanted to know what this fearful thing is all about.

The answer is simple. Always remember that Martian Civilization is fifty million years ahead of your own. In such a civilization you naturally do not expect cops, detectives, judges, juries, and similar Earthian kindergarten stuff. The Martians haven't had any policemen for twenty million years, and such a thing as juries and judges and courts can be found only in the oldest-recorded early history of the planet Mars.

On Mars everything is geared in such a manner that no Martian can do anything out of the ordinary without its being known immediately. Thought recorders, naturally, are old-time stuff here. Originally, they were used to register all thoughts radio-mechanically,



In a few minutes I was apprehended by an automatic guard

whereby the recorded thoughts came out on a moving tape. This tape in turn was fed through a second machine which either worked like a typewriter or could set up type automatically. Thus, when an Editor wanted to put his thoughts



There was a terrible commotion. . . . Tubes blew out, sparks played all about and general pandemonium broke loose.

down, he no longer did so by writing or dictating. He simply *thought* them and when he was finished thinking, he had the whole piece either typed out or printed on a sheet.

After a while, sensitive registering apparatus were designed whereby any extraordinary emotion of a Martian could be recorded, even at a great distance. From this development, it did not take very long, by utilizing other necessary refinements, to reach the stage whereby, if any extraordinary emotion took place in any one of the inhabitants, it was immediately recorded at a central recording office. The idea was not to spy on the thinking processes of the population, but rather as a sort of police duty. Suppose one Martian murdered another fellow being. The accompanying emotion would set loose a veritable tornado of radiation to be instantly recorded at the Radio-Emo Centre. By simple triangulation, the person was instantly spotted, and within ten seconds, the police had the culprit. This was of course, millions of years ago. Nowadays infinite refinements have been made and instead of a man being arrested for any wrong-doing, a sort of hypnotizing-paralyzing beam is directed on him. The culprit then becomes nothing but an automaton with no free will. Nowadays when we no longer have any policemen or judges, everything works automatically. This is how it works:

Let us say someone has committed a theft. The emotion let loose is instantly recorded at Headquarters. Headquarters then sends out its hypnotizing-paralyzing beam, and the culprit is directed to appear at the Auto-tribunal of his district. There are many of such Auto-tribunals throughout the planet. As the subject no longer has any free will of his own, but still can react to everything that is going

(Continued on page 695)

What Do You Think?

He Wants "Trophy" for "SWL" Shacks!

Editor, I have just recently become a reader of RADIO & TELEVISION and I find it is a very constructive publication, just chock full of valuable and interesting information. Of course, being an SWL, I am most interested in Joe Miller's column, and find it both accurate and up-to-the-minute. I am also interested in the Silver Trophy Award for the best amateur station photo of the month. It would be greatly appreciated by the SWL's if they were given a chance, say every other month, to compete with the amateurs for the trophy. I am sure there are many fine looking "SWL Shacks" that would look good in print. What do you say to that?

I have been DXing for a good many years, but I have collected QSL's for only three years. My VAC or HAC is: Africa, 28; Asia, 35; Europe, 42; South America, 40; Oceania, 16, and North America, uncounted. My verified individual countries are 74; I have verified all continents on 20, electrically recorded all continents on 20,

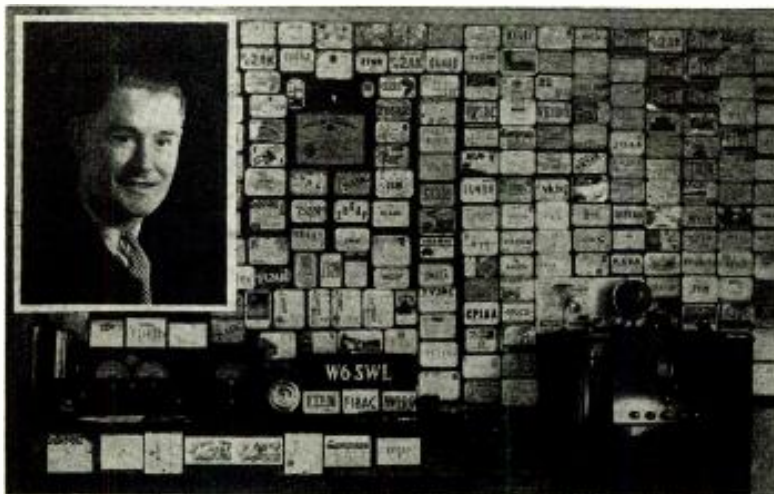

This month's Prize Winner—1 yr.'s subscription to "R. & T.", goes to James E. Moore, Jr., San Francisco, Calif. His receivers are RME-69, DB-20 Pre-selector; 11-tube Philco. Verified 74 countries.

as well as the other short-wave bands. Recorded list is as follows: VK4VD, VK3ME, VR6AY, HH2X, SM5SD, KA1ZL, J2MI, ZU6P, YV1AP, ZBW3, JZJ, RV15, GSB, ZRK, ZRH, TGWA, KKH, DJB, DJQ, CEC, PRF5, Radio Mondial. The recordings of ZRK-ZRH were so well liked by the SABC they were played back to me on three transmissions,

New cards received here since this photo was taken are: ES5D, G8QX, G5BW, G5LJ, G6NF, G6WX, G5BJ, G2TR, G3DO, CT1QG, SPD, SM5SD, HB9J, HB9CL, IRF, OE1CM, VR6AY, VK2VV, VK5FL, VK3WA, VK2OG, J7CR, XU8RB, KA4LH, KA1FH, J2KG, XZ2EZ, VS6AG, VS4CS, YDB, YDC, PK3GD, PK1JR, ZS5AW, ZS2AF, ZS1AX, ZT6Y, ZRD, ZRJ, ZRK (6 meg.), ZRH (6 meg.), HH2S, Radio Martinique.

In my three years of reporting for QSL's, I have had excellent luck with the exception of the Australians, who I believe it is almost impossible to please. It seems there are only a few who will QSL.

They have received IRC, American Dimes, Australian Stamps, and I have even gone so far as to send them actual "recordings" of their signals. After three years I have been able to obtain only 16 cards from Australia and the nearby islands.

JAMES E. MOORE, JR., 3551—18 St.,
Business Manager, I.D.A., San Francisco,
Golden Gate Chapter, California.

He Thinks "R. & T." OK as Is

Editor,

What's the matter with these fellows who are throwing "bricks" at recent RADIO & TELEVISION issues? One fellow doesn't like the cover, another does not want television articles. I do not agree with these readers. I think that the latest issues of RADIO & TELEVISION have been more interesting, and contained more news than ever before.

Dr. R. Essinger, as far as I can see, does not seem interested in learning anything about television; he seems more interested in general radio subjects. Yes, I am broadly interested in radio too, but I would like to read and study progress in television. Then Dr. Essinger also says he wants more radio circuits to be published in R. & T. Each month I find the newest and most modern radio circuits. How about conducting a vote on whether to have television articles?

Joe Miller's column is very FB and is up to the minute each month. The new VAC certificate is very handsome and I am going after mine soon. Please mention in your "mag" that I would like to correspond with listeners in Ontario, Cuba, Argentina and Mexico. All in all R. & T. is the perfect radio and television magazine. This is all for now, but what about this television topic? How about it fellows?

MEREDITH M. STROH, Kitchener, Ont.,
172 Queen St., N., Canada.

Spiral Scanning

Editor,

Upon close study of the methods of television now in practice, namely mechanical and cathode ray types, both have faults that must be corrected before either is successful,

The scanning in both systems has followed the time worn path to form a rectangular picture. Both methods have tried interlacing the scanning lines to eliminate distortion and shadow.

I am of the opinion that right here we should try something else in scanning. What would be wrong with a round picture? Why doesn't someone try experimenting with a spiral scan, by some simple rotational cam or other method? Spiral scanning would do away with returning the beam to one side each time to scan the next line, etc. This method applied by some ingenious method to the cathode ray would eliminate the negative return for each succeeding line.

Before the cathode ray tube was ever used as it is now in the Iconoscope, Dissector and other tubes of this type I mentioned to many of my acquaintances that the disc method was out of the picture, as some means must be found to scan the image as it appeared on the glass negative in a photographer's camera which is exactly what the cathode ray tube now does. However, I do not believe this the ultimate procedure, as probably some system combining the two (mechanical and electronic) methods will eventually answer the purpose.

You might outline spiral scanning in your magazine so that some more fortunate than I can take it up and do something with it. I am sure someone will find a way. Probably a simple mechanical means will be best since the intensity of light in mechanical systems seems greater and its adaptability to color enlargement and stereoptical methods at least practical, with less coverage of the wave band.

DARREL F. WOLFE,
1821 Thompson St.,
Harrisburg, Pa.,

Constructive Criticism

Editor,

I haven't commented on RADIO & TELEVISION for quite some time, so here goes.

Where could a man find a better magazine consisting of non-boring technical articles, inside information concerning radio stations, a complete station list and etc.? Again I ask—WHERE?!!? I think the new make-up is very ultra modern—FB—no disappointments whatsoever in the new changes here at this shack.

May I suggest that you put an asterisk after the author's name and a footnote at the bottom of page, giving his mailing address, so that should a reader wish to correspond with him he may do so? There have been plenty of times I would have given a lot to write to certain authors in order to obtain a little more information.

But after all—you still have a "FB" magazine and I shall continue to buy and save them. I wish you continued success.

JOE HESTER,
1430 South College,
Tulsa, Oklahoma.

(Thanks for the suggestions, Joe, and we're working on some of the ideas. Glad you like the new make-up.—Editor.)

A "Reference Library"

Editor:

We SWL's ought to stick together as far as these Hams are concerned. I am open to any argument from the Hams and will answer all letters promptly, whether from South Africa or the Bronx. I would like to correspond with any SWL in this small world.

I have been in this short-wave game for about two years and still learn of new stations, every day. I use your magazine as
(Continued on page 684)

Getting Started in AMATEUR RADIO

C. W. Palmer, E.E., Ex.-W2BV

Second of a new series

How To Build a Beginner's Transmitter

● HAVE you started in earnest to learn to "copy" code signals in preparation for getting your Operator's license? If so, you are probably anxious to get started making your first transmitter, so that you will be ready on that eventful day when the "tickets" arrive from the radio inspector's office to "get on the air" immediately.

The importance of sticking seriously to the job of learning the code cannot be stressed too much. This is the stumbling block of many embryo Hams, but if you are *really serious*, there is no reason why it should stop you from enjoying the thrills of "contacts" with other amateurs all over the world. Stick to the job!

As we promised last month, we will start right in with the construction of a phone and C.W. (code) transmitter, complete with power supply and all ready to go on the air except for a suitable antenna and antenna tuning and coupling arrangement. When this is completed we will build a modulator to permit it to be used for phone work. You will notice that the parts on the power supply are all at one end of the chassis—this is to leave room for the power supply of the *modulator*.

The circuit shows that the rig is quartz crystal controlled and with the coils described later and two quartz crystals it can be used on three bands—the 3.5 megacycle band for either phone or C.W., the 7 megacycle band for C.W. and the 14 megacycle band for either phone or code.

The type 59 tube is a "tri-tet" (triode-tetrode) oscillator and the 46 is a power amplifier. On the 7 and 14 megacycle bands, the oscillator is used as an "electron-coupled" device, simply by shorting out the coil L1. It can be seen that with plug-in coils and the flexibility offered by the circuit arrangement, it is an easy matter to change from one band to another.

The model shown in the photos is mounted on two bakelite panels—one for the transmitter and the other for the power supply. It is not necessary to use the bakelite panels—dry wood which has been shellacked to keep out moisture is just as good and is a lot cheaper.

It is advisable to use the best of parts where coils and condensers are concerned, as these parts will greatly affect the operation of the unit. All the sockets are isolantite wafer types—two 4-prong sockets being required for the oscillator grid and plate coils, two 5-prong sockets for the 59 tube and the quartz crystals and a 7-prong one for the 46 amplifier tube.

On 3.5 megacycles and 7 megacycles, the oscillator is used as a straight pentode, the coil L1 being shorted out of the circuit by means of a short length of wire, or by bending one of the end plates of C1 so that at maximum position the plates touch.

On the 14 megacycle band, quite a different mode of operation is required. Here the oscillator is a "tri-tet" unit, the cathode coil L1 being tuned to 7 megacycles or higher and the plate coil L2 being tuned to 14 megacycles. Thus, the oscillator serves the double purpose of generating the oscillations and doubling their frequency. This eliminates the need for more than 2 quartz crystals and also increases the stability of operation on the 14 megacycle band.

Mount the parts in the positions shown in the photographs, as this will prevent undesired couplings and will keep leads short. Keep all grid and plate leads as short and direct as possible and twist the filament leads to prevent a modulation hum being picked up.

No exact details for wiring the units will be given, as the wiring is quite simple and the positions of the parts can be readily seen in the photographs.

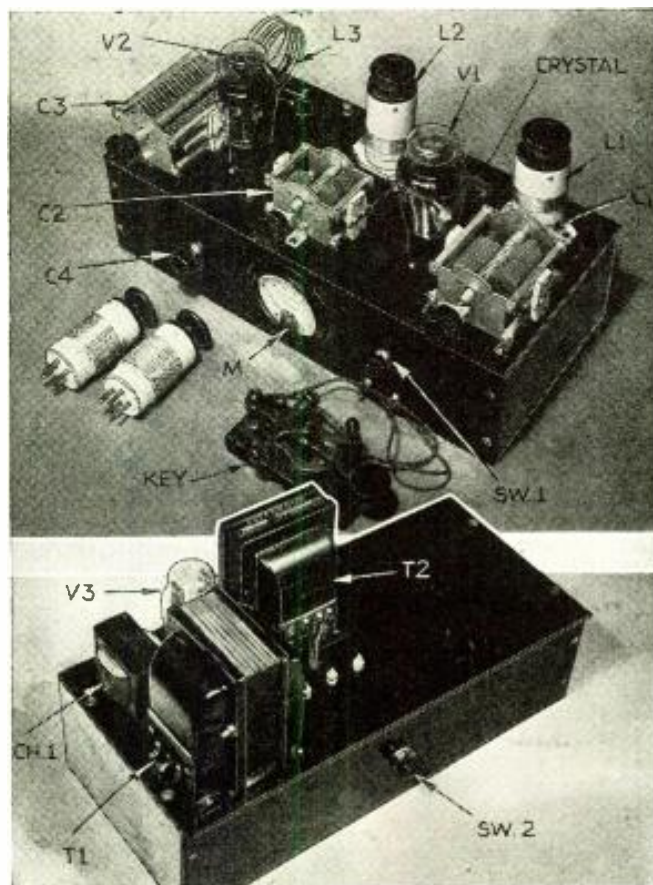

Top Photo—The Beginner's Transmitter here described. Lower photo—Power supply unit.

Coil Winding

The coils are an important part of the transmitter construction and care should be used to make them as neat and strong as possible. For the oscillator grid and plate coils, isolantite plug-in forms are used which make the winding job a relatively simple matter. For the amplifier tank coil (output coil) a different mode of construction is employed. Number 12 wire is used for these two coils and they are made self-supporting by cementing strips of celluloid across the turns at three or four points around the circumference. The wire is wound on a form slightly smaller than that desired for the finished coil—about $2\frac{1}{4}$ inches in our case, to make $2\frac{1}{2}$ inch diameter coils. The desired number of turns are wound on and then narrow strips of celluloid are slid under the wire. Next, the turns are spaced to the desired amount with string, to make the over-all coil the desired length and to keep the turns from short-circuiting.

Next Duco cement is run between the turns onto the celluloid strips. After about an hour, the string spacers are removed and a second layer of cement is run between the turns on to the strips. After about a day, this hardens and makes the coil quite firm.

(Continued on page 681)

Waves and Harmonics

The Radio Beginner—Lesson 5

Martin Clifford, W2CDV

● IF we were to take a piece of thin steel wire, stretch it between two points, and then pluck it, we would hear a noise of a certain pitch that we would call a sound wave. This sound wave would be due to the vibration back and forth of the wire. If we were to shorten the wire, or make it tighter, the wire would vibrate over a smaller distance, giving us an increase in pitch, due, of course, to the fact that there would be more vibrations per second. Speaking in terms of radio we would say that we have increased the number of cycles of sound waves in a given unit of time. Thus, when tightening our steel wire, we could increase the frequency, or speed of vibration, from a thousand cycles per second to ten thousand cycles per second, and we would notice the sound getting higher and higher.

Sound, Light and Radio Waves Similar.

Let us assume that we can make the wire vibrate as rapidly as we wish. The pitch would increase more and more, and then we would no longer *hear* the sound waves, but we would begin to *feel* them. By placing our hand on the wire we would get the sensation of warmth, or heat waves. Increasing the frequency, the wire would get warmer until we could *see* a dull red color—a light wave. Thus we see that the only difference between sound waves and light waves is one of frequency of vibration, and this difference extends itself also to radio waves. The type of wave that we would get, whether radio wave, sound wave, or heat wave, would depend upon the frequency of the vibrations. With more rapid vibrations we would go from heat waves to light waves, then to ultra violet light, to X-rays, and then to gamma rays. There is no sharp dividing line between the waves of various frequencies, since the division of these waves into radio waves, light waves, sound waves, etc., is merely a matter of convenience. All the waves actually belong to one unbroken series, although they may not all be perceived or observed in the same manner, since the identifying characteristics of the waves vary as the frequency is changed. In connection with radio waves we hear the term *cycle* or *kilocycles* (thousands of cycles) and the term *wavelength*. Figure 1 shows the relationship between wavelength and frequency.

What Are Harmonics?

Referring once again to our analogy of the steel wire, we know that we can make it vibrate and produce a wave that we can identify by sound. The sound wave thus produced is not a pure wave—that is, it does not consist of just one wave, but several waves. The wave having the lowest or principal frequency is called the *fundamental* wave. The other waves may be double, triple, or even four times the

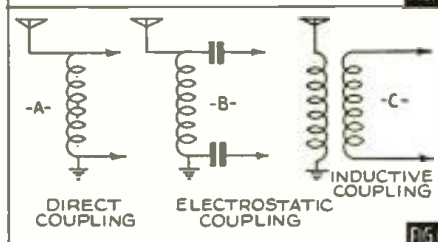
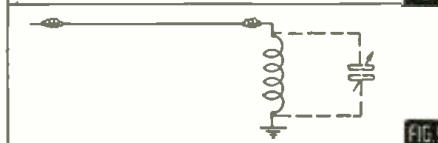
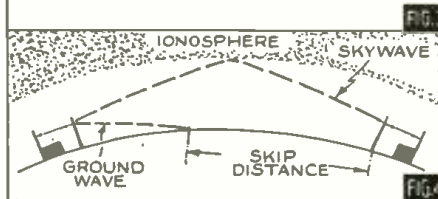
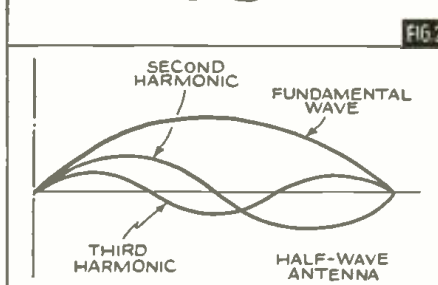
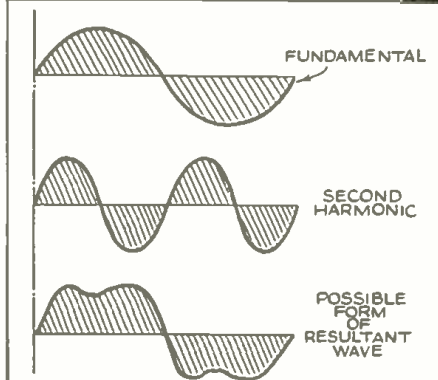
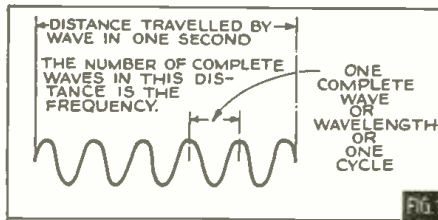

fundamental frequency, and are called *harmonics*. We might very well ask why we do not hear sounds of several different pitches at the same time, when we vibrate the wire, since we produce waves of a number of different frequencies. The answer is that the fundamental frequency and its harmonics combine to form a single wave, as shown in Figure 2. Harmonics are of importance in radio since they have a very valuable application in the field of transmitter and transmitting antenna design. It is by means of harmonics that an antenna, whether used for receiving or transmitting, is able to resonate at more than one frequency. Use of harmonics has a practical application where antenna space limitations exist. For example, an antenna to resonate at a wavelength of 40 meters should be about 132 feet (i.e., 40 meters) long, in which case it would be known as a *full wave* antenna. The same antenna could be used for operation even if reduced to 66 feet, or half the length, in which case it would operate as a *half-wave* antenna. The term is used to indicate that the antenna is resonant at one half the fundamental frequency. Note in Figure 3 that the second harmonic exists as a full wave, since it is double the frequency and that the third harmonic is a wave and a half, or three half-waves long.

Ground Waves and Sky Waves

Radio waves follow the curvature of the earth, in which case they are called *ground waves*, and travel outward into space, this latter component being called the *sky wave*. The sky wave would be useless for radio transmission were it not for the fact that about fifty miles above the earth's surface there is an ionized layer, called the Kennelly-Heaviside layer, that bends the radio waves back to earth. This layer, called also the *ionosphere*, is a region in which the air molecules have been ionized by radiation from the sun and presumably by radiation coming from outside our own particular solar system.

Ionization simply means that the molecules or particles of matter that constitute air have received an electric charge. This does not imply that the molecules of air retain their electric charge permanently, but that they are constantly being re-ionized. At night, absence of radiation from the sun causes a sharp decrease in the amount of ionization, with the result that a variation in transmission and reception is usually experienced. The point at which the wave is returned to earth depends on the wavelength of transmission. For example, waves in the broadcast band (of several hundred meters) are generally directed back to the area around the transmitter. However, as we get down to short waves, the sky wave will not return to the

(Continued on page 701)

1—Illustrating wavelength. 2—Fundamental, second harmonic and resultant wave. 3—2nd and 3rd harmonics relation to fundamental. 4—Sky and ground waves, also "skip distance." 5—Loading aerial circuit with inductance. 6—Various forms of coupling.

First Prize Winner

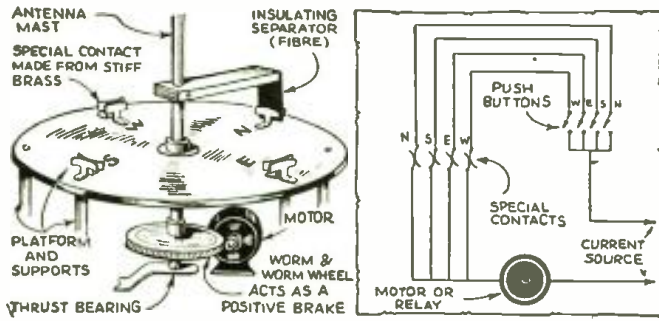

Motor-Driven Rotating Antenna

This is a means for electrically controlling the direction of a beam or loop antenna which is mounted at a point remote from the control panels. Parts needed are: 8 specially made contacts, 4 switch buttons, a motor with a worm drive, and the usual mast which is mounted on a thrust bearing, as the accompanying sketch shows.

The worm drive acts as a brake, eliminating back-lash and making the antenna stop positively in the correct position. The only detail which must be given special care is to make sure that the contacts are perfectly aligned and that the arm which breaks the contacts is accurately positioned.

As a reference to the illustration shows, each circuit is completed by pressing the corresponding button (West, East, South or North), and is broken only when the insulating separator gets between the two contacts as the antenna is rotated. All the other circuits may be completed, despite the fact that one pair of contacts is open. The antenna automatically stops in the desired position. Pressing the same button twice will not change the antenna's position but pressing any of the other buttons will cause it to rotate until it reaches the new position which is wanted.

Pilot lights may be arranged to show the position of the antenna but these are omitted for the sake of simplicity in the drawings.—William L. Teter.

180-Degree Dial Scales for 10c.

Small protractors, such as are sold in the ten-cent store, make excellent scales for radio dials. A protractor is mounted on the panel with the shaft of the control at its center point. A bar knob slipped onto the shaft enables the user to read the control setting on the scale of the protractor.—Louis Massagetti.

Cutting Condensers 1

When broadcast condensers must have their capacity decreased for short wave use, it is always hard to tell when enough plates have been removed to make them of 140 mmf. capacity for use with standard short wave coils. In the accompanying sketch, you will see how the condenser under test is connected to a pair of binding posts across a short wave tuning condenser which is in series with a switch. The

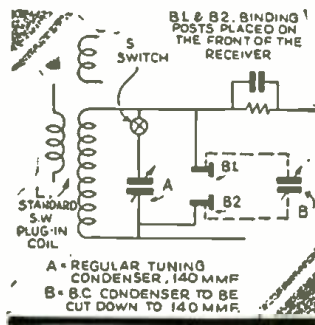

process is to tune in the station with the regular short wave condenser, then to open the switch so that the broadcast condenser is in the circuit until the station is again heard with the plates of both condensers about equally meshed. Tuning is accomplished first with one condenser and then the other, until the condenser being rebuilt covers the same frequency range as the standard. If the plates are removed by being bent back and forth until they break off, instead of by unscrewing the condensers and nuts, the job can be quickly and easily performed.—Eldon Meredith.

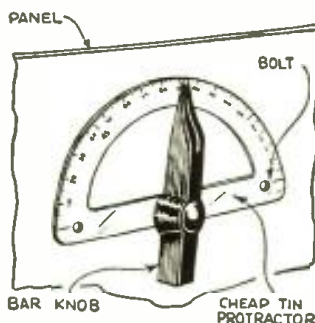

Radio Kinks

Each month the Editor will award a 2 year subscription for the best kink submitted. All other kinks published will be awarded eight months' subscriptions to RADIO & TELEVISION. Look over these kinks; they will give you some idea of what is wanted. Send a typewritten or ink description with sketch of your favorite to the Kink Editor.

Ganging Trimmers

If one of the old Remler condensers is in the odd parts box

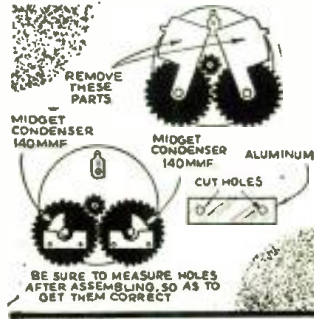

it may be rebuilt into a vernier gang control for two midget condensers. The sleeves on which the Remler plates are mounted are sawed off, leaving about 1" remaining. Then the posts on which these sleeves turn are cut to about 1/2" in length. The shafts of the midget condensers themselves are slipped into the sleeves. The midget condensers are mounted to a piece of sheet aluminum, much as they would normally be mounted on a panel. Finally, the sleeves are soldered to the rotor shafts of the midget condensers.—W. F. Rouse.

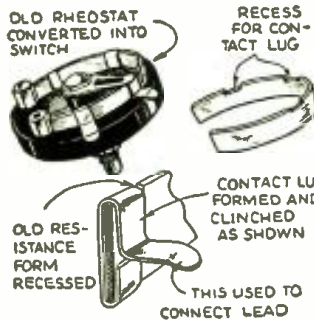

Multi-pole Switch

A simple multi-pole switch can be made from an old rheostat at no cost whatsoever. The resistance element is removed from the rheostat and brass strips are positioned over the insulating material which formerly formed a core for the resistance wire. If this insulating material is notched to take the strips of brass, the arm will fall into position and thus enable the operator to feel when each contact is being made.—Einar Nelson.

Double Regeneration Control

Regeneration is usually controlled by connecting a potentiometer to the plate of the detector, or by using a variable condenser between the tickler and ground. Better results, however, are obtained by coupling both condenser and potentiometer in the detector circuit. Regeneration is very smooth and easy to control, and is especially suitable for s.w. receivers because of the system's wide applicability to the different coils. The condenser is first adjusted to produce regeneration, and then the potentiometer, as usual.—Han Pao Hsuan.

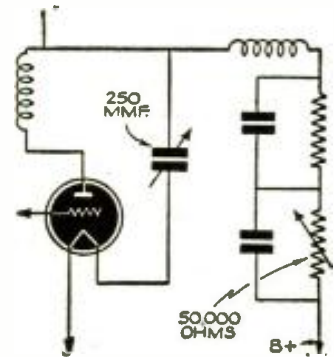

Transformer for Phones

When connecting phones in the detector output stage of a resistance-coupled receiver, there is danger of burning them out when they are simply broken into the circuit. This is particularly true when crystal phones are used. However, by substituting the primary of a one-to-one ratio transformer for the coupled resistor in the detector plate circuit and connecting the phones across the secondary, this is prevented.—D. Grossenbacher.

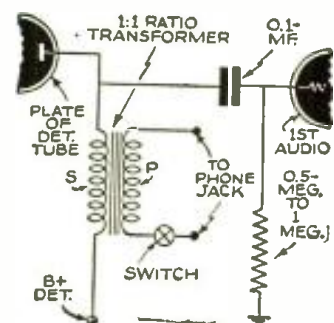

World Short Wave Stations

Revised Monthly

Complete List of SW
Broadcast Stations

Reports on station changes are appreciated.

Mc.	Call	Station	Mc.	Call	Station	Mc.	Call	Station
31.600	WIXKA	BOSTON, MASS., 9.494 m., Addr. Westinghouse Co. Daily 6 am.-1 am., Sun. 8 am.-1 am. Relays WBZ.	21.450	DJS	BERLIN, GERMANY, 13.99 m., Addr., Broadcasting House. 12.05-5.30 am.	15.310	GSP	DAVENTRY, ENG., 19.6 m., Addr. (See 17.79 mc.) 3-5.15 am., 1.45-4 pm.
31.600	WIXKB	SPRINGFIELD, MASS., 9.494 m., Addr. Westinghouse Co. Daily 6 am.-1 am., Sun. 8 am.-1 am. Relays WBZ.	19.020	HS6PJ	BANGKOK, SIAM, 15.77 m. Mondays 8-10 am. See 15.23 mc.	15.300	YDB	SOERABAJA, JAVA, N. E. I. 19.61 m. Addr. NIROM, 7.30 pm.-2 am.
31.600	W3XEY	BALTIMORE, MD., 9.494 m., Relays WFBR 4 pm.-12 m.	18.480	HBH	GENEVA, SWITZERLAND, 16.23 m., Addr. Radio Nations. Sun., 10.45-11.30 am.	15.300	XEBM	MAZATLAN, SIN., MEX., 19.61 m., Addr. Box 78, "El Pregonero del Pacifico." Irregularly 9-10 am., 1-2, 8-10 pm.
31.600	W2XDY	NEW YORK CITY, 9.494 m., Addr. Col. Broad. System, 485 Madison Ave. Daily 6-11 pm.; Sat. and Sun. 1.30-6, 7-10 pm.	16 Met. Broadcast Band			15.300	ZRO5	ROME, ITALY, 19.61 m., Addr. (See 2RO, 11.81 mc.) 11:15 am.-12:15, 2-4 pm.
31.600	W9XHW	MINNEAPOLIS, MINN., 9.494 m. Relays WCCO 9 am.-12 m.	17.845	HVJ	VATICAN CITY, 16.81 m. Heard 12 n. on Wednesday.	15.290	LRU	BUENOS AIRES, ARG., 19.62 m., Addr. El Mundo. Relays LRI, 7-9 am.
31.600	W3XKA	PHILADELPHIA, PA., 9.494 m., Addr. NBC. Relays KYW 9 am.-10 pm.	17.840	DJG	BERLIN, GERMANY, 16.82 m., 10.35 am.-1 pm.	15.280	DJQ	BERLIN, GERMANY, 19.63 m., Addr. Broadcasting House. 12.05-11 am., 4.50-10.50 pm. Also Sun. 11.10 am.-12.25 pm.
31.600	W5XAU	OKLAHOMA CITY, 9.494 m., Sun. 12 n.-1 pm., 6-7 pm. Irregular other times.	17.820	-	ROME, ITALY, 16.84 m., Addr. (See 2RO, 11.81 mc.) Relays ZRO to 6 pm. irregularly.	15.270	H13X	CIUDAD TRUJILLO, D. R., 19.65 m. Relays H1X Sun. 7.40-10.40 am. Tues. and Fri. 8.10-10.10 pm.
31.600	W4XCA	MEMPHIS, TENN., 9.494 m. Addr. Memphis Commercial Appeal. Relays WMC.	17.810	GSV	DAVENTRY, ENGLAND, 16.84 m., 5.45-8.50 am., 12.20-4 pm.	15.270	W3XAU	PHILA., PA., 19.65 m. (Addr. See 21.52 mc.) 3-7 pm.
31.600	W8XAI	ROCHESTER, N. Y., 9.494 m., Addr. Stromberg Carlson Co. Relays WHAM 7.30-12.05 am.	17.810	TPB3	PARIS, FRANCE, 16.84 m. Addr. (See 15.245 mc.) 9.30-11 am.	15.270	W2XE	NEW YORK CITY, 19.65 m., Addr. (See 21.570 mc.) 1-3 pm. Sat. & Sun. 1.30-2.30 pm.
31.600	W8XWJ	DETROIT, MICH., 9.494 m., Addr. Evening News Ass'n. Relays WWJ 6-12.30 am., Sun. 8 am.-12 m.	17.800	TGWA	GUATEMALA CITY, GUAT., 16.84 m., Addr. Ministre De Fomento. Irregular.	15.260	GS1	DAVENTRY, ENG., 19.66 m., Addr. (See 17.79 mc.) 3-5.15 am., 12.20-1.30 pm.
31.600	W9XPD	ST. LOUIS, MO., 9.494 m., Addr. Pulitzer Pub. Co. Relays KSD.	17.790	GS6	DAVENTRY, ENG., 16.86 m., Addr. B.B.C., London. 5.45 am.-10.15 am., 12.20-4 pm.	15.250	W1XAL	BOSTON, MASS., 19.67 m., Addr. University Club. Tues., Thurs. 4.30-6.30 pm.
26.550	W2XGU	NEW YORK CITY, 11.3 m. Relays WMCA.	17.785	JZL	TOKYO, JAPAN, 16.87 m. 8-8.30 pm.	15.245	TPA2	PARIS, FRANCE, 19.68 m., Addr. 98 Bis. Blvd. Haussmann. "Paris Mondial" 6-11 am.
26.450	W9XA	KANSAS CITY, MO., 11.33 m., Addr. Commercial Radio Eqpt. Co. Testing	17.780	W3XL	BOUND BROOK, N. J., 16.87 m., Addr. Natl. Broad. Co., 9 am.-5 pm. to Europe, 5-11 pm. to So. Amer.	15.230	HS6PJ	BANGKOK, SIAM, 19.7 m. Irregularly Mon. 8-10 am.
26.400	W9XAZ	MILWAUKEE, WIS., 11.36 m., Addr. The Journal Co. Relays WTMJ from 1 pm.	17.770	PHI2	HUIZEN, HOLLAND, 16.88 m., Addr. (See PHI, 11.730 mc.) Daily 7.25-8.25 am. Tues. and Thurs., 7.25-8.40 am., Sun. 6.25-9.40 am.	15.230	OLR5A	PRAGUE, CZECHOSLOVAKIA, 19.7 m. Addr. (See OLR4A, 11.84) Mon.-Fri. 7.50-10.55 pm. Sat., and Sun. 5-5.15 pm., Sun. 5.55-8.55 pm., Tues. 4.40-5.15 pm.
26.300	W2XJ1	NEW YORK, N. Y., 11.4 m., Addr. Bamberger Broad. Service, 1440 Broadway. Relays WOR 12 n.-6 pm.	17.760	DJE	BERLIN, GERMANY, 16.89 m., Addr. Broadcasting House. 12.05-5.50, 6-7.50 am.	15.220	PCJ2	HUIZEN, HOLLAND, 19.71 m., Addr. N. V. Philips' Radio Hilversum. Tues. 2-3.30 am., Wed. 9.30-11.30 am. Daily 7.25-8.25 am.
26.100	W9XJL	SUPERIOR, WIS., 11.49 m. Relays WEBC daily.	17.755	ZBW5	HONGKONG, CHINA, 16.9 m., Addr. P.O. Box 200. Dly. 11.30 pm.-1.15 am., 5-10 am., Sun. 9 pm. (Sat.) 1-1.30 am., 5-9.30 am. Operates irreg.	15.210	W8XK	PITTSBURGH, PA., 19.72 m., Addr. (See 21.540 mc.) 9 am.-1 pm.
26.050	W9XTC	MINNEAPOLIS, MINN., 11.51 m. Relays WCTN 9 am.-1 pm., 7 pm.-12 m.	End of Broadcast Band			15.200	DJB	BERLIN, GERMANY, 19.74 m., Addr. (See 15.280 mc.) 8-9 am., 4.50-10.50 pm. Also Sun. 11.10 am.-12.25 pm.
26.050	W9XH	SOUTH BEND, IND., 11.51 m. Addr. South Bend Tribune. Relays WSBT-WFAM 2.30-6.30 pm., exc. Sat. and Sun.	17.310	W2XGB	HICKSVILLE, L. I., N. Y., 17.33 m., Addr. Press Wireless, Box 296. Tests 9.30-11.30 am. except Sat. and Sun.	15.195	TAQ	ANKARA, TURKEY, 19.74 m., 5.30-7 am., 9.30-11 am., Relays ZRO irregularly Afts.
25.950	W6XKG	LOS ANGELES, CAL., 11.56 m., Addr. B. S. McGlashan, Wash. Blvd. at Oak St. Relays KGFJ 24 hours daily.	17.280	FZEB	DJIBOUTI, FRENCH SOMALILAND, 17.36 m. Test XMSN 1st Thurs. each month 8-8.30 am. Next B.C. Feb. 2.	15.190	-	ROME, ITALY, 19.75 m. Relays ZRO till 6 pm., irreg.
25.950	W9XUP	ST. PAUL, MINNESOTA, 11.56 m. Relays KSTP evenings.	15.550	CO9XX	TUINICU, ORIENTE, CUBA, 19.29 m., Addr. Frank Jones, Central Tuinicu, Tuinicu, Santa Clara. Broadcasts irregularly evenings.	15.190	OFO	LAHTI, FINLAND, 19.75 m. Addr. (See OFO, 9.5 mc.) 1-3 am., 9 am.-n., 12.15-5 pm. Irreg.
21.630	W3XAL	BOUND BROOK, N. J., 13.8 m. Addr. N.B.C., N. Y. C. 9 am.-4 pm.	15.510	XOZ	CHENG TU, CHINA, 19.34 m. Daily 9.45-10.30 am.	15.190	ZBW4	HONGKONG, CHINA, 19.75 m., Addr. P. O. Box 200. Irregular. 11.30 pm. to 1.15 am., 3-10 am.
21.570	W2XE	NEW YORK CITY, 13.91 m. (Addr. CBS, 485 Madison Ave., N. Y. C. Daily 7.30-10 am. Sat., Sun. 8 am.-1 pm.	15.370	HAS3	BUDAPEST, HUNGARY, 19.52 m., Addr. Radiolabor, Gyali Ut 22. Sun. 9-10 am.	15.180	GSO	DAVENTRY, ENG., 19.76 m., Addr. (See 17.79 mc.) 4.15-6, 6.20-8.30 p.m., 3-5.15 am.
21.565	DJJ	BERLIN, GERMANY, 13.92 m., Addr. Broadcasting House, 6-7.50 am.	15.360	DZG	ZEESEN, GERMANY, 19.53 m., Addr. Reichspostzentralamt. Tests irregularly.	15.175	RW96	MOSCOW, U.S.S.R., 19.76 m. Mon., Tues., Fri., Sat. 2.30-3.30 pm. Daily 3-4 am. Mon., Wed., Thurs. 7-9.15 pm.
21.550	GS1	DAVENTRY, ENG., 13.92 m., Addr. (B.B.C., London) Irregular at present.	15.360	-	BERNE, SWITZERLAND, 19.53 m. Irreg. 6.45-7.45 pm.	15.170	TGWA	GUATEMALA CITY, GUAT., 19.77 m., Addr. (See 17.8 mc.) Daily 12.15-1.45 pm.; Sun. 12.45-5.15 pm.
21.540	W8XK	PITTSBURGH, PA., 13.93 m., Addr. Grant Bldg. Relays KDKA 6.45-9 am. Also Sunday. 6 pm.	19 Met. Broadcast Band			15.165	OZH	SKAMLEBAK, DENMARK, 19.78 m., Sun. 8 am.-1.30 pm.
21.530	GSJ	DAVENTRY, ENG., 13.93 m., Addr. (See 21.550 mc.) 5.45-8.50 am.	15.340	DJR	BERLIN, GERMANY, 19.56 m., Addr. B'rd'cast'g House, 12.05-11 am.	15.160	XEW7	MEXICO CITY, MEXICO, 19.79 m., 12 n.-12 m., irregular.
21.520	W3XAU	PHILA., PA., 13.94 m., Addr. Col. Broad. Syst., 485 Madison Ave., N. Y. C. 1-2.30 pm.	15.330	W2XAD	SCHENECTADY, N. Y., 19.56 m., Addr. General Electric Co. Relays WGY, 12.15-7 pm.	15.160	JZK	TOKYO, JAPAN, 19.79 m. 12.30-1.30 am., 2.30-4, 4.30-5.30, 8-8.30 pm.
21.500	W2XAD	SCHENECTADY, N. Y., 13.95 m., General Electric Co., 8 am.-12 n.	15.320	OLR5B	PRAGUE, CZECHOSLOVAKIA, 19.58 m. Addr. (See 11.840 mc.) Sun., Wed., Sat. 5-5.10 pm.; Mon., Tues., Thurs., Fri. 6.55-9.55 pm.	15.160	YUD3	DELHI, INDIA, 19.79 m., Addr. All India Radio. 1.30-3.30 am., 9.30-11.30 pm.
21.470	GSH	DAVENTRY, ENG., 13.97 m. (See 21.550 mc.) 5.45 am.-12 n.						(Continued on page 664)

All Schedules Eastern Standard Time

TO RADIO W2-XJM H. YONEDA 652/2 I-CHOME DAITA
 MR. JOSEPH H. MILLER SETAGAYA-KU TOKIO JAPAN
 YOUR REPORT
 THIS CONFIRMS OUR QSL OF 3RD APRIL 1938 AT 0858 G.M.
 UR 20M. MG PHONESIGS RST F-6. AT. CONDX

J2NG—A plain but
 valued veri of a 20
 meter Japanese am-
 teur phone.

WAC JARL J 2 N G ARRL WAC

XMTR: XTAL CONT. WTS INPUT FINAL
 MOD: CLASS B 'S, RCVR:
 ANT:
 TKS FER FB QSL OM! HPE TO CUAGN! PSE TNX QSL!
 73'S ES DX!



J2NG—In person.
 "OM" Harry shows
 his DX layout, which
 "push out" those
 FB phone sigs all
 over the world.

Let's Listen In with

Joe Miller

● CERTAINLY there is no other time of year when background noise is so lacking in evidence, and with many distant signals coming in as never before, combined with a lack of noise, well—what more could anyone ask? Commercial fones, SWBcers, and our ever-reliable amateurs are a pleasure to log, especially the latter ever-growing class of transmitters, whose stations are being heard in this country from all parts of the world, even New Zealand hams on 80 meter fone have been logged on the West Coast! This season was always the DX season, even in the old days of '24-'25, when the famous trans-Atlantic BCB tests were successfully concluded, and with what fond memories do we hark back to those days.

When this issue is published, Spring will not be far off and that is the season when the experienced SW DXer knows he will "clean up" on amateur DX, especially, if not mainly, on 20 meters. So, fellow DXers, look for our DX "dope" in the next issue, which will show you how to get the most from your tuning time during March and April on the ham bands.

Incidentally, and quite an incident, we sez, we have been assured that the new Hallicrafters Dual Diversity will be delivered to us for a two months' DX test, beginning March 1, so you can be sure we look forward to a lively time in DXing this Spring! Thanks to Mr. Durst of Hallicrafters, Inc., for this FB courtesy, and we will consider it a privilege to be able to report to you the expected superlative performance of this receiver.

Now for DX:

IRAQ

YIJG, 7.20 mc., at Baghdad, mentioned here last month as a difficult DX catch for U. S. tuners, was "dug out" from the 40 meter amateur band QRM one recent afternoon, just before their 3 p.m. sign-off, and luckily, sufficient program was heard to permit writing for a confirmation. Erroneously, we stated Iraq as former Persia, when Persia is now known as Iran, a rather similar name! Iraq was formerly called Mesopotamia.

YIJG may still be heard up to as late as mid-April, providing the noise-level and QRM conditions in the 40 meter band permit. Full details in last issue.

FRENCH INDO-CHINA

Radio Hanoi II, 11.90 mc., located at Hanoi, with a power of 100 watts, has already QSL'd Murray Buitkant's report with a letter and gave our W2 friend DXer some FB data, via a native radio magazine published by the Radio Club D'Indo-Chine, which they sent to Murray.

There are 3 transmitters operating in Hanoi at present: Radio Hanoi I, 9.51 mc., with 15 watts; Radio Hanoi II, 11.90 mc., with 100 watts; and Radio-Volonté, on 7.10 mc., no power listed. Schedules are as follows: Radio Hanoi I, daily 11 p.m.-2:30 a.m. and 6-9:30 a.m., Sundays, when it starts at 7:30 p.m. to 10:30 p.m. Sat. night, and from 11 p.m. Sat. to 9:30 a.m. Sun. a.m.

Radio Hanoi II, daily 12 mid.-2:30 a.m. and 6-9:30 a.m. and Sundays, when it also starts Sat. night 8:30-10:30 p.m., then midnight-5 a.m., then 6-9:30 a.m.

Radio Volonté operates every day from midnight to 2 a.m., not very promising.

QRA's for these stations follow: R.H.I. 82 Rue Jules Ferry, Hanoi, R.H. II, 32 Rue de la Pepiniere, Hanoi, Radio Volonté: 15 Bd. Hollandes, Hanoi.

Radio Hanoi II may be heard fairly well on good days, for East Coast, on their last transmission after 6 a.m. when they came in rather well last month. The famous French amateur, Rene Lebon, FIBAC, whose nice QSL appeared here recently, is the constructor of both Radio Hanoi transmitters and deserves a big hand for his fine encouragement of short wave radio in the Far East. Thanks to Murray Buitkant for his FB help.

Bob Sawada, W6, reports a veri of Boy-Landry, 9.76 mc., adding that QRA given here was OK. FB. Bob!

CHINA

XPSA is the correct call of that Chinese station located at Kweiyang, mentioned last month, and frequency is given as 7.14 mc., though heard on 7.00 mc., according to a dispatch relayed here from Han Pao Hsuan, of China, tnx, OM!

The schedule given by Mr. Hsuan for XPSA is as follows: 9-10 p.m., 2:30-3:30 a.m., 9:50-11:50 a.m., which, however, does not check with previous listed schedules. As every schedule we get lists XPSA differently, we believe the I.D.A. schedule here last month is most likely to be correct.

G. C. Gallagher, W6, hears XPSA on 6.98-7.00 mc. around 9 a.m. This station desires reports on reception, addressed to Kweiyang, Kweichow Province, China.

XGRV, 11.40 mc., approximate, at the war-time capital, Chungking, is being heard 1:15 and 8-8:35 a.m. daily, when news is given, at 1 a.m. in Japanese and Chinese, and at 8 a.m. in French and English. Jack Wells, W4, has received a letter from Hollington K. Tong, Chairman of China Information Committee, Hankow, with this data, also mentioning that XTJ has been moved into the interior to avoid the bombing of the enemy. Don Williams, W6, reports XGSA.

INDIA

The Indian BC transmitters on or near 5.00 mc., have astonished the SW world by their amazing signal strength daily, being heard throughout the U. S. with always easily logged signals, during mornings.

One may hear all of these 10 kw. transmitters within a short span on the dial, from 4.88 to 4.995 mc., and, when this news is read, it will still be possible, we hope, to be able to get a log on these real DX catches, on such an unusual low frequency.

VUC2, 4.88; VUB2, 4.905; VUM2, 4.95; and VUD2, 4.995 mc., are logged in that order, from 7 a.m. on through the a.m.'s. The last letter of each call indicates the city, as VUC2, Calcutta. Other cities are Bombay, Madras and Delhi. Address reports to Station Director, All India Radio, and then whatever station and city heard. India.

VWY2, 17.48 mc. Poona, was recently logged at 7:30 a.m., with a FB signal, foning Rugby, England. Inverted speech used on both stations.

ASIATIC REVIEW

TAIWAN—(Formosa) JIB, 10.53 mc., Taihoku, reported by G. C. Gallagher, W6, at 2 and 10 a.m., also here at 3:20 a.m.

PHILIPPINE ISL.—KZIB, 9.503 mc., is a new Manila station, daily from 6-9:05 a.m. (I.D.A.) Has chimes similar to NBC.

FED. MALAY STATES—ZGE, 6.24 mc., Kuala Lumpur, reported off the air, has been taken over by the Govt., and is relaying the programs of ZHP, at Singapore.

U.S.S.R.—RV15, Khabarovsk, reported last month on 6.045 mc., has again returned to their ol' reliable 4.275 mc. spot on the dial.

OTHER DX

TAHITI—FO8AA, 7.10 mc., Papeete, in the South Seas, is beginning to be well heard on their usual
(Continued on page 697)

ZL3KZ — This outstanding cord in orange-yellow, with red letters, confirms 10 meter phone reception.



Mc. Call		Mc. Call		Mc. Call	
15.155	SM5SX	STOCKHOLM, SWEDEN, 19.79 m., Daily 11 am.-5 pm., Sun. 9 am.-5 pm.	11.886	TPB7	PARIS, FRANCE, 25.24 m. (See 15.245 mc.) 9.30 pm.-mid., 12.15-2 am. Irregular.
15.150	YDC	BANDONG, JAVA, 19.8 m., Addr. N. I. R. O. M. 6-7.30 pm., 10.30 pm.-2 am., Sat. 7.30 pm.-2 am., daily 4.30-10.30 am.	11.880	VLR3	MELBOURNE, AUSTR., 25.25 m., 3.30-7.15 pm., 9 pm.-3 am. week-days.
15.140	GSF	DAVENTRY, ENGL., 19.82 m., Addr. (See 17.79 mc.) 3-5.15 am., 5.45 am.-12 n.	11.870	WBXX	PITTSBURGH, PA., 25.26 m., Addr. (See 21.540 mc.) 1-11 pm.
15.130	TPB6	PARIS, FRANCE, 19.83 m., Addr. "Paris Mondial," 98 Bis Blvd. Haussmann, 7-9.15 pm.	11.865	—	BERNE, SWITZERLAND, 25.28 m. Irreg. 8-9 pm. to No. Amer.
15.130	WIXAL	BOSTON, MASS., 19.83 m., Addr. World-Wide B'cast'g Foundation, University Club, 10-11 am., Mon.-Fri. Sun. 10 am.-1 pm.	11.860	GSE	DAVENTRY, ENGL., 25.29 m., Addr. (See 17.75 mc.) 3-5.15, 5.45 am.-10.30 am.
15.120	SPI9	WARSAW, POLAND, 19.84 m., 6-9 pm.	11.855	DJP	BERLIN, GERMANY, 25.31 m., Addr. (See 15.280 mc.) Irregular. 7.15-10.50 pm. for No. Amer.
15.120	HVJ	VATICAN CITY, 19.83 m., 10.30-10.45 am., Tues. only. Suns. 1-1.30 pm.	11.840	KZRM	MANILA, P. I., 25.35 m. Addr. Erlanger & Gallinger, Box 283. 9 pm.-10 am. Irregular.
15.110	DJL	BERLIN, GERMANY, 19.85 m., Addr. (See 15.280 mc.) 12.05-2.8-9 am., 10.35 am.-4.25 pm., Sun., also 6-8 am.	11.840	CSW	LISBON, PORT., 25.35 m. Nat'l Broad. Station, 11.30 am.-1.30 pm. Irregular.
15.080	RKI	MOSCOW, U.S.S.R., 19.87 m., Works Tashkent near 7 am. Broadcasts Sun. 12.15-2.30 pm. Daily 7-9.15 pm.	11.840	OLR4A	PRAGUE, CZECHOSLOVAKIA, 25.34 m., Addr. Czech Shortwave Sta., Praha XII, Fochova 16. Daily 1.55-4.30 pm. Mon. to Fri. 7.55-10.55 pm., Sun. 5.55-8.55 pm.
End of Broadcast Band					
14.960	—	MOSCOW U.S.S.R., 20.25 m., 1st of month, 6 pm. Dutch program.	11.830	W9XAA	CHICAGO, ILL., 25.36 m., Addr. Chicago Federation of Labor, Irregular 7 am.-6 pm.
14.940	PSE	RIO DE JANEIRO, BRAZIL, 20.08 m., Broadcasts Wed. 3.45-4.15 pm.	11.830	W2XE	NEW YORK CITY, 25.36 m., Addr. Col. Broad. System, 485 Madison Av., N.Y.C. Mon.-Fri. 3.30-6.30-10 pm. Sat., Sun. 3-6, 6.30-11 pm.
14.600	JVH	NAZAKI, JAPAN, 20.55 m. Broadcasts irregularly 5-11.30 pm. Works Europe 4-8 am.	11.826	XEBR	HERMOSILLA, SON., MEX., 25.37 m., Addr. Box 68, Relays XEBH. 9.30-11 am., 1-4 pm., 9 pm.-12 m.
14.535	HBJ	GENEVA, SWITZERLAND, 20.64 m., Addr. Radio Nations. Broadcasts Sun. 1.45-2.30 pm., Mon. 1.30-1.45 pm.	11.820	GSN	DAVENTRY, ENGL., 25.38 m., Addr. (See 11.75 mc.) Irregular.
14.440	—	RADIO MALAGA, SPAIN, 20.78 m., Relays Salamanca 5.40-8.40 am. Sometimes 2-4 pm.	11.810	2RO4	ROME, ITALY, 25.4 m., Addr. E.I.A.R., Via Montello 5. Daily 4.40-8.45 am., 10 am.-12 n.
14.430	HCJB	QUITO, ECUADOR, 20.79 m. Sun. 9-9.30 pm. and irreg.	11.805	COGF	MATANZAS, CUBA, 25.41 m., Addr. Gen. Betancourt 51, Relays CMGF. 2-3, 4-5, 6-11 pm.
14.166	PIIJ	DORDRECHT, HOLLAND, 21.15 m., Addr. (See 7.088 mc.) Sat. 12 n.-12.30 pm.	11.805	OZG	SKAMLEBOAEK, DENMARK, 25.41 m. Addr. Statsradiofonien. Irreg.
14.004	EA9AH	TETUAN, SPANISH MOROCCO, 21.4 m. Apartado 124, News at 4.30 and 7.15 pm. Relays Salamanca from 5.40 pm.	11.801	DJZ	BERLIN, GERMANY, 25.42 m. 4.50-10.50 pm.
13.635	SPW	WARSAW, POLAND, 22 m. Daily 6-8 pm, Sat. & Sun. 6-9 pm.	11.800	JZJ	TOKYO, JAPAN, 25.42 m., Addr. Broadcasting Co. of Japan, Overseas Division. 7-7.30, 8-9.30 am., 2.30-4, 4.30-5.30, 8-8.30 pm., 12.30-1.30 am.
12.862	W9XDH	ELGIN, ILL., 23.32 m. Press Wire-less, Tests 2-5 pm.	11.795	DJO	BERLIN, GERMANY, 25.42 m. 4.50-11.30 am.-4.25 pm., 4.50-10.50 pm. Irregular.
12.460	HC2JB	QUITO, ECUADOR, 24.08 m. Daily exc. Mon. 8-10.30 pm.	11.790	WIXAL	BOSTON, MASS., 25.45 m., Addr. (See 15.250 mc.) Daily 4.55-6.30 pm., Tues., Thur., 4.40-6.30 pm., Sat. 1.45-6 pm., Sun. 5-6.30 pm.
12.235	TFJ	REYKJAVIK, ICELAND, 24.52 m. Works Europe mornings. Broadcasts Sun. 1.40-2.30 pm.	11.780	HP5G	PANAMA CITY, PAN., 25.47 m., Addr. Box 1121, 8-11 pm.
12.200	—	TRUJILLO, PERU, 24.58 m., "Rancho Grande." Address Hacienda Chiclin. Irregular.	11.780	OFE	LAHTI, FINLAND, 25.47 m. Addr. (See OFE, 9.5 mc.) 1.05-3 am., 5-6.20, 10 am.-12.30 pm.
12.060	RNE	MOSCOW, U.S.S.R., 24.88 m. Daily 6-7 am., 12 n.-2 pm., 3-6, 10.15-11 pm., also Tues., Thurs. 8.30-9 pm., also Sun. 6-10.30 am., 12 n.-5 pm., 6-6.30, 8.30-9, 10.15-11 pm.	11.770	DJD	BERLIN, GERMANY, 25.49 m., Addr. (See 15.280 mc.) 11.30 am.-4.25 pm., 4.50-11 pm.
11.970	H12X	CIUDAD TRUJILLO, D. R., 25.07 m., Addr. La Voz de Hispaniola. Relays HIX Tue. and Fri. 8.10-10.10 pm.	11.760	TGWA	GUATEMALA CITY, GUAT., 25.51 m. (See 17.8 mc.) Irregular 10-11.30 pm. Sun. 6-11.30 pm., irregular.
25 Met. Broadcast Band					
11.928	T12XD	SAN JOSE, COSTA RICA, 25.15 m. La Voz del Pilot. Apartado 1729. 10 am.-n., 4-10 pm.	11.760	XETA	MONTEREY, MEX. 25.51 m., Addr. Box 203, Relays XET, n.-3.30 pm. and evenings.
11.910	CDI190	VALDIVIA, CHILE, 25.2 m. P. O. Box 642. Relays CB69 10 am.-1 pm., 7-10 pm.	11.760	OLR4B	PRAGUE, CZECHOSLOVAKIA, 25.51 m., Addr. (See 11.840 mc.) Irregular.
11.900	—	HANOI, FRENCH INDO-CHINA, 25.21 m. "Radio Hanoi" Addr. Radio Club de l'Indochine. 12 m.-2 am., 6-10 am., 150 watts.	11.750	6SD	DAVENTRY, ENGL., 25.53 m., Addr. B.B.C., London, 3-5.15 am., 9 am.-noon, 12.30-6 pm., 6.20-8.30 pm., 9.20-11.20 pm.
11.900	XEWI	MEXICO CITY, MEXICO, 25.21 m., Addr. P. O. Box 2874. Mon., Wed., Fri. 3-4 pm., 9 pm.-12 m. Tues. and Thur. 7.30 pm.-12 m. Sat. 9 pm.-12 m., Sun. 12.30-2 pm.	11.740	SP25	WARSAW, POLAND, 25.55 m., 6-9 pm.
11.085	TPA3	PARIS, FRANCE, 25.24 m., Addr. (See 15.245 mc.) 2-5 am., 11.15 am.-6 pm., 7-9.15 pm.	11.740	COCX	HAVANA, CUBA, 25.55 m. P. O. Box 32, Daily 8 am.-1 am. Sun. 8 am.-12 m. Relays CMX.
			11.740	HVJ	VATICAN CITY, 25.55 m. Testing irregular.
			11.730	PHI	HUIZEN, HOLLAND, 25.57 m., Addr. N. V. Philips' Radio, Daily 6.15-6.45 pm. Sat. 7.15-7.45 pm.
			11.730	WIXAL	BOSTON, MASS., 25.57 m., Addr. World-Wide B'cast'g Foundation, University Club. Daily exc. Sat. and Sun. 9-11 pm.

(Continued on page 666)

The Short Wave League



On the Ham Bands

(with the "Listening Post" Observers)

Edited by Elmer R. Fuller

HONORARY MEMBERS

Dr. Lee de Forest
D. E. Replogle
John L. Reinartz
Manfred von Ardenne
E. T. Somerset
Hollis Baird
Hugo Gernsback, Executive Secretary

● CONDITIONS during the month of December have been very bad, and the reports received certainly show it. However, they are on the mend. A few new observers were appointed during the past month, as follows:

Robert Parker Utah
Edward Lenzioszek Massachusetts
Maurice P. Wynne Louisiana
Charles Le Ralle France

L. F. Gallagher, formerly Observer for New York, has asked to notify, via this department, his SWL friends that his new QRA (address) is P. O. Box 419, Osborn, Ohio. He has been transferred to Patterson Field, and is now Aircraft Radio Mechanic.

Reports for the past month were received from the following observers:

Carling, Len M. Illinois
Clarke, Stanley Canada
Fitzpatrick, John New Jersey
Fuller, Charles H. Special Observer for the editor (N. Y.)
Fuller, Lester Arizona
Halliday, Ray South Carolina
Hegler, Burns E. Kansas
Henderson, Bill Arkansas
Jordan, Tom Pennsylvania
Kemp, Howard G. Connecticut
Lang, Ernest W. Washington
Lenzioszek, Edward Massachusetts
Noyes, William Dean Nebraska
Parker, Robert Utah
Slaughter, Edward C. Texas
Taglauer, Robert Kentucky
Wallen, Dan T. Colorado
Sibbin, J. C. New Zealand
Akhtar, Masud India
Wells, Jack Alabama
Wood, James R. Minnesota

And now for the reports on the various continents. As usual, we will start off with Asia, and only a few are reported. This seems to be the rarest of the continents heard.

Call	Freq. mc.	R	S	Observer
VU2COO	14.	4	7	Wood
VU2CQ	14.12	3	6	Wells
F18AC	14.26	5	6	Akhtar
J2KG	14.	3	4	Akhtar

From Africa, several were reported, but not nearly as many as in the previous month.

ZS1AX	14.075	5	8	Noyes
ZS1BV	14.085	5	7	Noyes
ZS1CF	14.05	3	4	Akhtar
ZS1DB	14.	3	3	Akhtar
ZS2AN	14.06	5	5	Akhtar
ZS2G	14.30	5	5	Akhtar
ZS2X	14.043	5	8	Noyes
ZS2N	14.020	4	9	Fitzpatrick
ZS2AF	14.025	4	7	Fitzpatrick, Akhtar
ZS4H	14.170	5	7-9	Jordan, Noyes, Fitzpatrick, Slaughter, Clarke
ZS5CL	14.280	5	8	Akhtar, Taglauer, Henderson
ZS5CO	14.140	5	7	Taglauer, Akhtar, Noyes
ZS5J	14.030	5	9	Fitzpatrick
ZS5CA	14.165	4	7	Fitzpatrick
ZS5C	14.015	3	8	Fitzpatrick
ZS5T	14.015	5	8	Noyes
ZS5BZ	14.040			
ZS6BR	14.15	5	6	Akhtar
	14.027	4	5	Wood, Slaughter, Noyes
ZS6EJ	14.135	5	3-7	Hegler, Akhtar, C. Fuller, Taglauer
ZS6DY	14.210	4	7	L. Fuller, Slaughter, Akhtar
ZS6A	14.120	4	6	L. Fuller, Slaughter, Fitzpatrick
ZS6BE	14.095	4	6	L. Fuller
ZS6EF	14.080	5	7	Taglauer
ZS6BY	14.060	5	8	Taglauer, Noyes
ZS6BW	14.040	5	9	Taglauer
ZS6N	14.040	5	7	Taglauer
ZS6AJ	14.	5	6	Slaughter
ZS6AU	14.	5	6	Slaughter
ZS6DW	14.060	3-5	4-8	Carling, Wells, Fitzpatrick, Slaughter, Clarke, Henderson

Call	Freq. mc.	R	S	Observer
ZS6BD	14.070	5	8	Fitzpatrick
ZS6S	14.120	5	8	Fitzpatrick, Noyes
ZS6DR	14.10	3	6	Akhtar
ZS6ED	14.	5	6	Akhtar
CN1AF	14.110	4-5	5-7	Noyes, Wood, Fitzpatrick, Clarke, Wells
CN8AW	14.010	5	7	Fitzpatrick
CN8BA	28.425	3	5	Halliday
CN8AU	14.050	5	6	Clarke
ZE1JJ	14.11	5	6	Akhtar
ZE1JM	14.26	3	3	Akhtar
ZE1JT	14.	5	6	Akhtar
ZE1JX	14.013	5	7	Noyes
VQ2HC	14.29	5	8	Akhtar
VQ4KT	14.080	5	8	Clarke
VQ4ECJ	14.005	3	5	Fitzpatrick
FB8AH	14.340	5	8	Jordan
SU5NK	14.11	3	4	Yours truly

Because of the poor conditions during the past month, and the consequent dearth of DX, we will include South America in our department for this month.

LU1QA	14.	4	5	Wood
LU1DA	14.090	5	5-8	Carling, Akhtar, C. Fuller, Hegler, Wallen
	28.215	5	8	Fitzpatrick
LU2BJ	14.060	4	7	Hegler
LU4BK	14.095	5	8	Noyes
LU4BC	14.230	4	6	Fitzpatrick, Akhtar

Call	Freq. mc.	R	S	Observer
PY8AG	14.310	5	8	Clarke
YV1AN	14.090	5	8	Carling
YV1AQ	14.030	5	4	Lang
YV4AM	14.175	4	7	Fitzpatrick
YV4AN	14.110	5	6	Wallen
YV4AE	14.075	4-5	7-9	Carling, Lang, Hegler, Wood, Wallen, Fitzpatrick
YV4AX	14.130	5	4	L. Fuller
YV5ABQ	14.075	4	6	Kemp, Wallen
YV5AG	14.215	5	9	Fitzpatrick
YV5ABY	14.225	5	8	Fitzpatrick
YV5ACA	14.135	5	7	Fitzpatrick
CX1AA	14.080	5	8	L. Fuller
CX2AK	14.	5	7	Wood
OA4AS	14.075	5	6	Henderson
HC1FG	14.150	5	8	Carling
HC1JW	14.080	5	5-8	Fitzpatrick, Wells
CE2BX	14.120	4	5	Wallen
CE2BR	14.095	5	7	Henderson
CE3BH	14.205	5	8	L. Fuller
CE3AT	14.075	5	8	L. Fuller
CE3BA	14.240	3	5	Wallen
CE3CH	14.110	5	8	Carling
CE3BK	14.040	4	7	Carling
CE4A1	14.085	5	9	L. Fuller, Jordan
W9AM	14.15	5	8	Wells

Europe came through again last month, but not so strongly as it did in the month before. Several, however, were heard with good signal strength. A glance at the following will prove this.

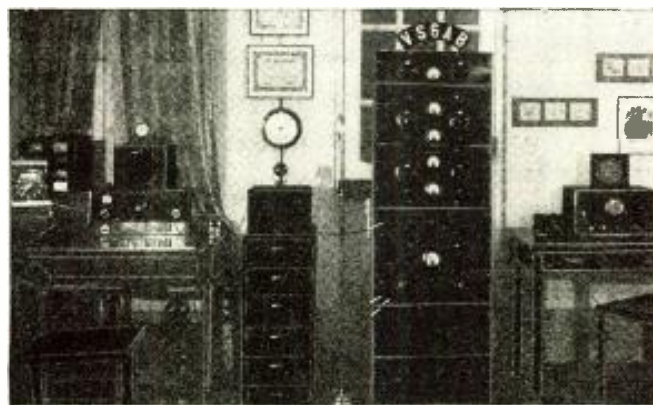

Ham station VS6AB, Hongkong, China. Operated by J. W. M. Brown, c/o Import & Export Office, Kowloon, Hongkong. Photo courtesy of Joe Miller. See veri card in January issue.

LU4ABG	14.250	5	9	Fitzpatrick
LU4CZ	14.060	5	7-8	Henderson, Carling
LU4DJ	14.100	4	7	Henderson
LU5CZ	14.075	5	7	Lang, Noyes
LU7BK	14.120	4	7	Wallen
HK1AH	14.075	5	9	Fitzpatrick
HK1AG	14.015	5	7	Clarke
HK1AA	14.020	5	8	Hegler
HK3CL	14.080	5	9	Jordan
HK3JA	14.08	5	8	Wells
HK3CI	14.160	5	7	Fitzpatrick
HK3LO	14.260	5	7-8	Hegler
HK3CG	14.282	5	5	C. Fuller
HK3CO	14.25	5	7	Wells
HK4DF	14.02	4	4	Yours truly
HK5EE	14.375	5	8-9	Fitzpatrick, Carling, Jordan
PY1HO	14.140	5	4	Lang
PY1FR	14.	5	8	Slaughter, Fitzpatrick, Lang
PY2HA	14.180	5	7	L. Fuller
PY2CK	14.130	5	8	Taglauer, Akhtar
PY2AK	14.100	5	7	Lang, Akhtar, Henderson, Slaughter
PY2DA	14.080	4	5	Lang, Akhtar
PY2IT	14.14	4	5	Akhtar
PY2MI	14.11	5	5	Akhtar
PY2AP	14.160	5	6	Jordan
PY4EJ	14.08	5	6	Akhtar
PY5AH	14.130	4	6	Lang
PY5AU	14.170	5	6	Jordan
PY7AI	14.29	5	6	Wells
PY7GA	14.	5	6	Slaughter

CT1AY	14.100	4	9	Fitzpatrick
CT1ZA	14.115	4	8	Fitzpatrick
CT1BP	14.075	3	5	Kemp
CT1PK	14.09	5	4	C. Fuller, Fitzpatrick
G2VG	28.580	5	7	Halliday, Henderson, Noyes, Hegler, Taglauer
G2MF	28.065	5	9	Taglauer, Fitzpatrick
G2IS	28.200	5	8	Taglauer
G2MS	28.105	5	7	Taglauer
G2MV	28.300	3	6	Fitzpatrick
G2XN	14.115	5	8	Fitzpatrick
G2AC	27.995	4	7	Noyes
G3FA	28.160	5	7	Fitzpatrick, Akhtar
G5ML	14.205	5	7-9	Fitzpatrick, Carling
G5JO	14.050	5	6	Clarke
G5LC	28.400	4-5	6-7	Halliday, Jordan
G5BY	28.158	5	8	Noyes
G5GJ	14.08	5	5	Akhtar
G6WZ	14.09	5	5	Akhtar
G6GX	28.387	5	9	Noyes
G6GW	28.135	5	7	Noyes
G6QX	28.350	3	5	Halliday
G6GF	28.375	3	7	Halliday
G6LL	28.400	3	6	Halliday
G6WS	28.370	3	4	Halliday
G6NF	14.025	5	7	Clarke
G6LA	14.300	3	7	Fitzpatrick
G6LK	28.105	4	8	Fitzpatrick, Noyes
G6LW	28.245	5	7	Fitzpatrick
G6WT	28.110	5	9	Fitzpatrick

(Continued on page 703)

Mc. Call
7.854 HC2J58 GUAYAQUIL, ECUADOR, 38.2 m. Evenings to 11 pm.
7.797 HBP GENEVA, SWITZERLAND, 38.48 m., Addr. Radio-Nations.
7.614 CR6AA LOBITO, ANGOLA, 39.39 m., Mon., Wed., Sats. 2.45-4.30 pm. Also 7.177.
7.510 JVP NAZAKI, JAPAN, 39.95 m., 8-9.30 am.
7.450 TI2R3 SAN JOSE, COSTA RICA, 40.27 m., "Radioemisora Athena". 9.30-11 pm., exc. Sun.
7.410 HCJ84 QUITO, ECUADOR, 40.46 m., 7-9.30 pm. irregularly.
7.410 YDA TANDJONGPRIOK, JAVA, 40.46 m., Addr. N.I.R.O.M., Batavia, 10.30 pm.-2 am.; Sat. 7.30 pm.-2 am.
7.380 XECR MEXICO CITY, MEX., 40.65 m., Addr. Foreign Office. Sun. 7-8 pm.
7.220 HKE BOGOTA, COL., S. A., 41.55 m. Tues. and Sat. 8-9 pm. Mon. and Thurs. 6.30-7 pm.
7.200 YNAM MANAGUA, NICARAGUA, 41.67 m. Irregular at 9 pm.
7.177 CR6AA LOBITA, ANGOLA, PORT. WEST AFRICA, 41.75 m., Mon., Wed., and Sats. 2.45-4.30 pm. Also see 7.614 mc.
7.100 FO8AA PAPEETE, TAHITI, 42.25 m., Addr. Radio Club Oceanien. Tues. and Fri. 11 pm.-12.30 am.
7.088 PI1J DORDRECHT, HOLLAND, 42.3 m., Addr. Dr. M. Hellingman, Technical College. Sat. 11.10-11.50 am.
7.050 FG8AA POINT-A-PITRE, GUADELOUPE, F.W.I., 42.55 m., 6-7 pm., also 9-10.30 pm. Irregular. P.O. Box 125.
6.990 XEME MERIDA, YUCATAN, 42.89 m., Addr. Calle 59, No. 517, "La Voz de Yucatan desde Merida." Irregular.
6.977 X8A TACUBAYA, D. F., MEX., 43 m. 9.30 am.-1 pm., 7-8.30 pm.
6.805 HI7P CIUDAD TRUJILLO, DOM. REP., 44.06 m., Addr. Emisoría Diaria de Comercio. Daily exc. Sat. and Sun. 12.40-1.40, 6.40-8.40 pm. Sat. 12.40-1.40 pm. Sun. 10.40 am.-11.40 am.
6.790 PZH PARAMIRABO, SURINAM, 44.16 m., Addr. P. O. Box 18, Daily 6.06-8.36 am., Sun. 9.36-11.36 am. Daily 5.36-8.36 pm.
6.775 HIH SAN PEDRO DE MACORIS, DOM. REP., 44.26 m. 12.10-1.40 pm., 7:30-9 pm. Sun. 3-4 am., 4.15-6 pm., 4.40-7.40 pm.
6.750 JVT NAZAKI, JAPAN, 44.44 m., Addr. Kokusai-Denwa Kaisha, Ltd., Tokyo. Irregular.
6.730 HI3C LA ROMANA, DOM. REP., 44.58 m., Addr. "La Voz de la Feria." 12.30-2 pm., 5-6 pm.
6.720 PMH BANDOENG, JAVA, 44.64 m. Relays N.I.R.O.M. programs. 4.30-11 or 11.30 am. Also Sat. 9.30 pm.-1.30 am.
6.690 TIEP SAN JOSE, COSTA RICA, 44.82 m., Addr. Apartado 257, La Voz del Tropico. Daily 7-11 pm.
6.675 HBQ GENEVA, SWITZERLAND, 44.94 m., Addr. Radio-Nations. Off the air at present.
6.672 — — 44:94 m., relays Salamanca, Spain, 7-9.45 pm.
6.672 YVQ MARACAY, VENEZUELA, 44.95 m. Irregular.
6.635 HC2RL GUAYAQUIL, ECUADOR, S. A., 45.18 m., Addr. P. O. Box 759, Sun. 5.45-7.45 pm., Tues. 9.15-11.15 pm.
6.630 MIT CIUDAD TRUJILLO, D. R., 45.25 m., Addr. "La Voz de la RCA Victor." Apartado 1105, Daily exc. Sun. 12.10-1.40 pm., 5.40-8.40 pm.; also Sat. 10.40 pm.-12.40 am.
6.625 PRADO RIOBAMBA, ECUADOR, 45.28 m. Thurs. 9-11.45 pm.
6.610 YNLG MANAGUA, NICARAGUA, 45.39 m., Emisora Ruben Darío. 1.30-2.30, 6-10.15 pm.
6.558 HI4D CIUDAD TRUJILLO, D. R., 45.74 m. Except Sun. 11.55 am.-1.40 pm.
6.550 XBC VERA CRUZ, MEX., 45.8 m. 8.15-9 am.

Mc. Call
6.550 TIRCC SAN JOSE, COSTA RICA, 45.8 m., Addr. Radioemisora Católica Costarricense. Sun. 11 am.-2 pm., 6-7, 8-9 pm. Daily 12 n.-2 pm., 6-7 pm., Thurs. 6-11 pm.
6.545 YV6RB BOLIVAR, VENEZUELA, 45.84 m., Addr. "Ecos de Orinoco." 6-10.30 pm.
6.520 YV4RB VALENCIA, VENEZUELA, 45.98 m. 11 am.-2 pm., 5-10 pm.
6.516 YNIGG MANAGUA, NICARAGUA, 46.02 m., Addr. "La Voz de las Lagos." 1-2.20, 8-10 pm. Except Sundays.
6.500 HIL CIUDAD TRUJILLO, D. R., 46.13 m., Addr. Apartado 623. 12.10-1.40 pm., 5.40-7.40 pm.
6.480 HIIL SANTIAGO DE LOS CABALLEROS, D. R., 46.28 m., Addr. Box 356. 9.40-11.40 am., 7.40-9.40 pm.
6.470 YNLAT GRANADA, NICARAGUA, 46.36 m., Addr. Leonidas Tenorio, "La Voz del Mombacho." Irregular.
6.465 YV3RD BARQUISIMETO, VENEZUELA, 46.37 m. Radio Barquisimeto, irregular.
6.450 HI4V SAN FRANCISCO DE MACORIS, D. R., 46.48 m. 11.40 am.-1.40 pm., 5.10-9.40 pm.
6.400 TGQA QUEZALTENANGO, GUATEMALA, 46.88 m., Mon.-Fri. 9-11 pm. Sat. 10 pm.-1 am. Sun. 1-3 pm.
6.384 ZIZ BASSETERRE, ST. KITTS, W. INDIES, 46.99 m. 4-4.45 pm. Wed. 7-7.30 am.
6.340 HIIX CIUDAD TRUJILLO, D. R., 47.32 m., Sun. 7.40-10.40 am., daily 12.10-1.10 pm., Tues. and Fri. 8.10-10.10 pm.
6.335 OAXIA ICA, PERU, 47.33 m., Addr. La Voz de Chiclayo, Casilla No. 9. 8-11 pm.
6.324 COCW HAYANA, CUBA, 47.4 m., Addr. La Voz del Radio Philco, P. O. Box 130. 6.55 am.-12 m., Sun. 9.55 am.-10 pm.
6.310 HIZ CIUDAD TRUJILLO, D. R., 47.52 m. Daily except Sat. and Sun. 11.10 am.-2.25 pm., 5.10-8.40 pm. Sat. 5.10-11.10 pm., Sun. 11.40 am.-1.40 pm.
6.300 YV4RD MARACAY, VENEZUELA, 47.62 m. 6.30-9.30 pm. exc. Sun.
6.295 OAX4G LIMA, PERU, 47.63 m., Addr. Apartado 1242. Daily 7-10.30 pm.
6.280 HIG TRUJILLO CITY, D. R., 47.77 m. 7.10-9.40 am., 11.40 am.-2.10 pm., 3.40-9.40 pm.
6.270 YV8RP CARACAS, VENEZUELA, 47.79 m., Addr. "La Voz de la Philco." Daily to 10.30 pm.
6.255 YV5RJ CARACAS, VENEZUELA, 47.18 m. 5.30-8 pm.
6.243 HIN CIUDAD TRUJILLO, D. R., 48 m., Addr. "La Voz del Partido Dominicano." 12 n.-2 pm., 6-10 pm.
6.235 HRD LA CEIBA, HONDURAS, 48.12 m., Addr. "La Voz de Atlántida." 8-11 pm.; Sat. 8 pm.-1 am.; Sun. 4-6 pm.
6.225 YVIRG VALERA, VENEZUELA, 48.15 m. 6-9.30 pm.
6.210 — SAIGON, INDO-CHINA, 48.28 m., Addr. Radio Boy-Landry, 17 Place A. Foray. 4.30 or 5.30-9.15 am.
6.205 YV5RI CORO, VENEZUELA, 48.32 m., Addr. Roger Leyba, care A. Urbino y Cia. Irregular.
6.200 HI8Q CIUDAD TRUJILLO, D. R., 48.36 m. Irregular.
6.190 TG2 GUATEMALA CITY, GUAT., 48.4 m., Addr. Dir. Genl. of Electr. Commun. Relays TGI Mon.-Fri. 8-11 pm., Sat. 6 pm.-1 am. Sun. 7-11 am., 3-8 pm.
6.185 HIIA SANTIAGO, D. R., 48.5 m., Addr. P. O. Box 423. 7 am.-5 pm.
6.170 W2XE NEW YORK CITY, 48.62 m., Addr. Col. B'cast System, 485 Madison Ave. Mon., Fri. 12 m.-1 am. Sat. & Sun. 11.30 pm., 1 am.

Mc. Call
6.150 CJRO WINNIPEG, MAN., CANADA, 48.78 m., Addr. (See 11.720 mc.) Daily 6 pm.-12 m., Sun. 5-10 pm.
6.150 ZPI4 VILLARRICA, PARAGUAY, 48.78 m. 4-6 pm.
6.147 ZEB BULAWAYO, RHODESIA, S. AFRICA, 48.8 m. Mon., Wed., and Fri. 1.15-3.15 pm.; Tues. 11 am.-12 n.; Thurs. 10 am.-12 n. Sun. 3.30-5 am.
6.145 HJ4ABG MEDELLIN, COL., 48.79 m. 11 am.-12 n., 6-10.30 pm.
6.140 W8XK PITTSBURGH, PA., 48.83 m., Addr. Westinghouse Electric & Mfg. Co. Relays KDKA 11 pm.-12 m.
6.137 CR7AA LAURENCO MARQUES, PORT. E. AFRICA, 48.87 m. Daily 12.05-1, 4.30-6.30, 9.30-11 am., 12.05-4 pm., Sun. 5-7 am., 10 am.-2 pm.
6.133 XEXA MEXICO CITY, MEX., 48.93 m., Addr. Dept. of Education, Daily 8-11 am., 2.30-4 pm., 7.30 pm.-12.45 am. Sun. 1.30 pm.-12.45 am.
6.130 YP3BG GEORGETOWN, BRIT. GUIANA, 48.94 m. 9-10 am., 2.15-6.30 pm., Sun. 5.30-11.30 am., 3-5 pm.
6.130 TIEM SAN JOSE, COSTA RICA, 48.94 m. "El Mundo". Apartado 1049, 11 am.-11 pm., Sun. 10 am.-6 pm.
6.130 CHNX HALIFAX, N. S., CAN., 48.94 m., Addr. P. O. Box 998, Mon.-Fri. 7 am.-11.15 pm., Sat. 11 am.-11 pm., Sun. 12 n.-11.15 pm. Relays CHNS.
6.130 LKL JELOY, NORWAY, 48.94 m. 11 am.-6 pm.
6.125 CX44 MONTEVIDEO, URUGUAY, 48.98 m., Addr. Radio Elctrico de Montevideo, Mercedes 823. 8 am.-Noon. 2-10 pm.
6.122 HJ3ABX BOGOTA, COL., 49 m., Addr. La Voz de Col., Apartado 26-65. 12 n.-2 pm., 5.30-11 pm.; Sun. 6-11 pm.
6.122 HP5H PANAMA CITY, PAN., 49 m., Addr. Box 1045. 10 am.-1 pm., 5-11 pm.
6.122 FK8AA NOUMEA, NEW CALEDONIA, 49.00 m., Radio Noumea, Addr. Charles Gaveau, 44 Rue de l'Alma., Wed. & Sats. 2.30-3.30 am.
6.117 XEUX MEXICO CITY, MEX., 49.03 m., Addr. 5 de Mayo 21. Relays XEFO 9 am.-1 pm., 7 pm.-2 am.
6.115 OLR2C PRAGUE, CZECHOSLOVAKIA, 49.05 m. (See 11.40 mc.)
6.110 GSL DAVENTRY, ENGLAND, 49.1 m., 6.20-8.30, 9.20-11.20 pm.
6.110 XEGW MEXICO CITY, MEX., 49.1 m., Addr. La Voz de Aguila Azteca desde Mex., Apartado 8403. Relays XEJW 11 pm.-1 am.
6.108 HJ6ABB MANIZALES, COL., 49.14 m., Addr. P. O. Box 175. Mon.-Fri. 12.15-1 pm.; Tue. and Fri. 7.30-10 pm.; Sun. 2.30-5 pm.
6.100 YUA BELGRADE, JUGOSLAVIA, 49.18 m. 1-3, 6.30-8.30 am., Noon-6.30 pm.
6.100 W3XAL BOUND BROOK, N. J., 49.18 m., Addr. Natl. Broad. Co.
6.097 ZRK KLIPHEUVEL, S. AFRICA, 49.2 m., Addr. S. African Broad. Co., Johannesburg. Daily 12 n.-4 pm., Sun. 12 n.-3.20 pm.
6.097 ZRJ JOHANNESBURG, S. AFRICA, 49.2 m., Addr. S. African Broad. Co. Daily exc. Sat. 11.45 pm.-12.50 am.; Daily exc. Sun. 3.15-7.30, 9-11.30 am. (Sat. 8.30-11.30 am.) Sun. 3.30-4.30 or 4-5 am., 5.30-7, 9-11.30 am.
6.095 JZH TOKYO, JAPAN, 49.22 m., Addr. (See 11.800 mc., JZJ.) Irregular.
6.090 CRCX TORONTO, CAN., 49.26 m., Addr. Can. Broadcasting Corp. Daily 7.45 am.-5 pm., Sun. 10.30 am.-12 n.
6.090 ZBWZ HONGKONG, CHINA, 49.26 m., Addr. P. O. Box 200. Irregular.
6.083 VQ7LO NAIROBI, KENYA, AFRICA, 49.31 m., Addr. Cable and Wireless, Ltd. Mon., Fri. 5.30-6 am., 11.15 am.-2.15 pm., also Tues. and Thurs. 8.15-9.15 am.; Sat. 11.15 am.-3.15 pm.; Sun. 10.45 am.-1.45 pm.
6.081 YVIRD MARACAIBO, VEN., 49.32 m. 6-11 pm.
6.080 W9XAA CHICAGO, ILL., 49.34 m., Addr. Chicago Fed. of Labor. Relays WCFL irregular.

(Continued on page 699)

49 Met. Broadcast Band

6.156 YV5RD CARACAS, VENEZUELA, 48.71 m. 11 am.-2 pm., 4-10.40 pm.
6.153 HI5N MOCA CITY, D. R., 48.75 m. 6.40-9.10 pm.
6.150 VPB COLOMBO, CEYLON, 48.78 m., 7-11 am.

All Schedules Eastern Standard Time



Left — Finished 3-tube ore-locator in use.

Right — Diagram of 3-tube treasure-locator

A Radio Ore-Locator

Operates with 3 Tubes

Charles E. Chapel

1st Lieut., U.S. Marine Corps, Retired

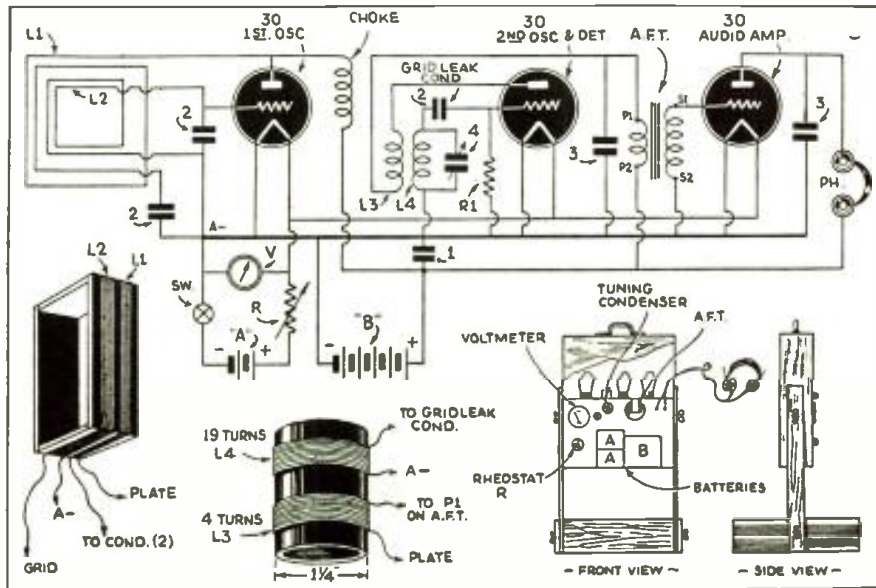

operator can tell when he is passing over buried treasure or minerals, and plot a simple chart that will reveal the spot to start digging.

The materials needed for building the Fisher T-Scope are few in number and comparatively inexpensive. No special equipment is needed. All parts are standard and can be purchased from any dealer in radio and electrical supplies.

The Loop Antenna is 16 by 14 inches, and has two windings, as shown in the diagram. "L-1" has 7 turns of No. 32 D.C.C. wire, and "L-2" has 9 turns of No. 32 D.C.C. wire. Both are wound in the same direction, with 1/2 inch space between the windings.

The holder for the Loop Antenna is made of any lightweight wood, 2 1/2 inches wide and 1/4 inch thick, these being the dimensions of each of the four sides of the Loop Frame.

The Loop Frame, as can be seen in the photograph of the complete set, is rectangular, with each corner braced by a cleat, the sides being joined at the corners with brass screws.

Two oak uprights, 1 1/2 inches wide, 3/4 inch thick, and 18 inches long, are fastened on opposite sides of the Loop Frame, with brass screws. These uprights support the instrument case when the Loop Frame is
(Continued on page 679)

An Inexpensive Mike



Above—Finished "mike." Right—Sectional view of mike stand and suggested hook-up.

● HAVING need for an inexpensive mike, primarily for application in a ham rig, then later for P.A. purposes and certain types of remote broadcasts, we developed a combination of inexpensive parts that makes a very presentable appearance and does the job admirably. The level of this improvised mike is several db's higher than the ordinary crystal mike, although the quality will not permit high fidelity music reproduction. However, it was found to be ideal for communication work and voice reproduction, especially for the ham rig in view of the surprisingly low cost for the quality attained.

The mike proper is a crystal headphone unit, mounted in a half of a sponge rubber ball, purchased at the five and dime store. The case is that of a small bicycle headlamp, with bracket, that sold retail for 80 cents. The glass is removed and ordinary copper screening or tea strainer screen soldered into the cap. The screening is
(Continued on page 688)

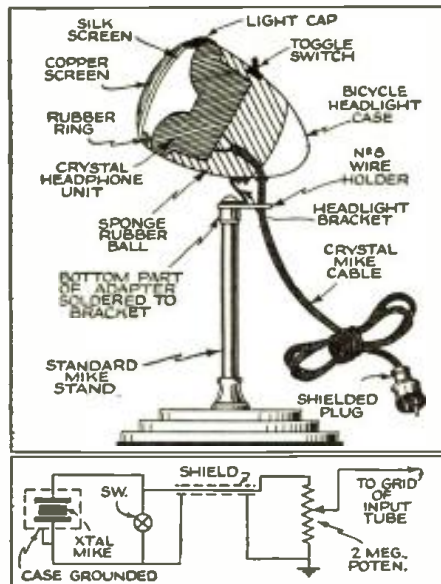

The "Switched-Coil 4"—

Raymond P. Adams

for Mobile, Marine

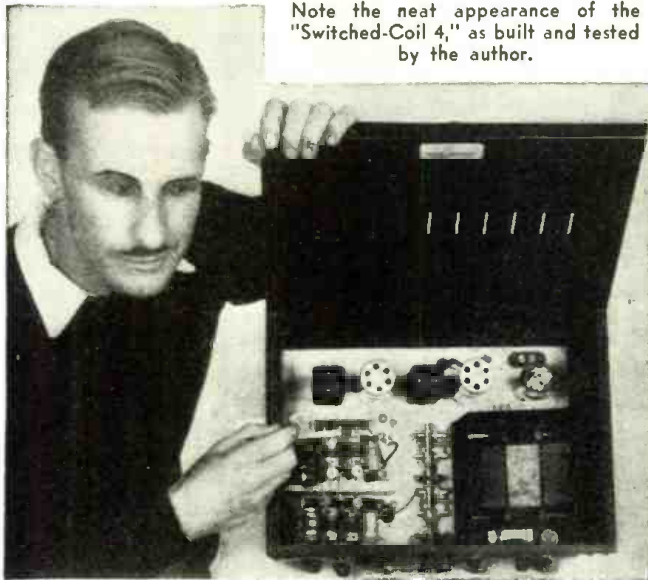

Note the neat appearance of the "Switched-Coil 4," as built and tested by the author.

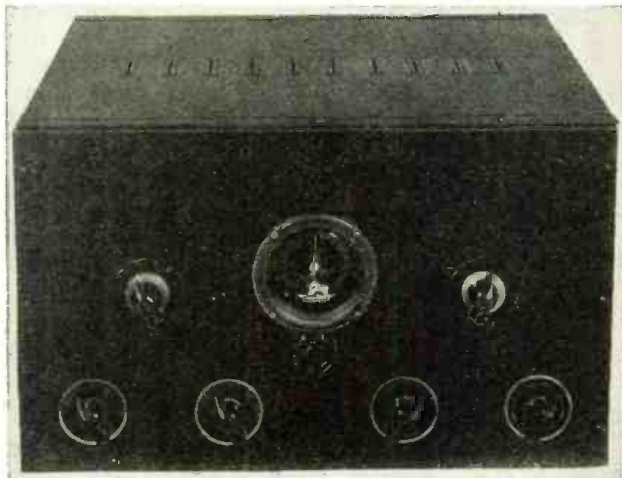

Another view of the 4-tube receiver which should make many friends.

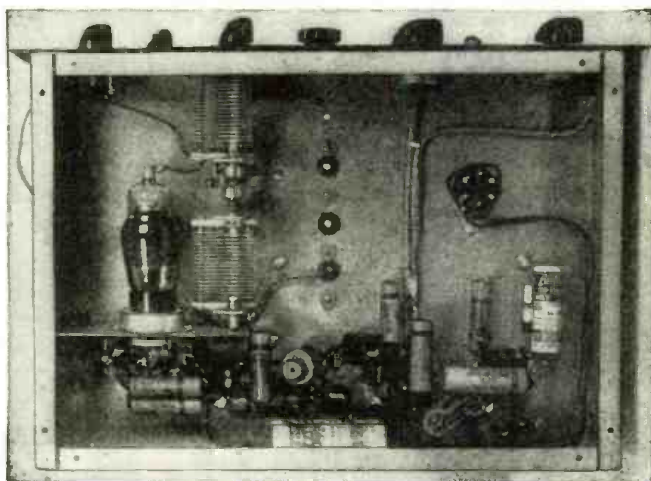

Bottom view of the "Switched-Coil 4."

● THIS new mobile-form (and emergency) super is compact, all-wave, sensitive and economical to operate. Only four tubes are employed; a 6J8G high efficiency mixer; a 6K7G I.F. amplifier; a 6C8G combination grid-leak second detector and first audio amplifier; and a 6V6G A.F. output amplifier. A Genemotor power unit, self-filtered, is featured, mixer and HFO stage coils are *switch selected*, and both the *tank* and the *bandspread* condensers are ganged to facilitate tuning.

No R.F. stage is used. High efficiency coils, mounted right on the selector switch, the 6J8G tube, and careful layout and front-end circuit design all make for unusually good input sensitivity, however.

Coverage is from 530 kc. to 32.4 mc. (9.25 to 565 meters). Four sets of coils are used for these general or band-set ranges: Band 1—530-1575 kc.; Band 2—1.5-4.6 mc.; Band 3, 4.18-12.5 mc.; Band 4—11.2-32.4 mc.

General coverage is provided by the 2-gang 260 mmf. per section tank condenser, and a very practical bandspread is effected by the 20 mmf. per section 2-gang spreader condenser. In the laboratory model the bandspread gang is mounted above chassis and is controlled by the main dial, and the bandset components are arranged below for knob adjustment. This positioning may be reversed by the individual builder who is primarily interested in receiving standard broadcast or 160 meter Ham transmissions.

A jack is provided for headphone reception, and the second detector circuit may be made regenerative to increase the I.F. selectivity, or made to oscillate to facilitate copying c.w. Audio frequency output is entirely ample for loudspeaker reproduction.

Circuit Notes: The mixer and HFO tuned circuits are both related to the self-excited 6J8G, which provides for good conversion even down through the 10-meter band. This tube is simply a 6L7 and a triode in one envelope—the triode's grid tied within the envelope to the mixer section's injector.

Bandspread and band-set condensers are connected in parallel. All coils are Aignaire trimmed, all oscillator circuits padded. A manual trimmer across the tuned mixer circuit is an optional refinement—particularly useful when the receiver is used under various conditions in the field and varying antenna loading effects must be quickly compensated for.

The front-end circuit is familiar to all readers acquainted with similar and common-run 6L7-6C5 Mixer-HFO layouts.

A single I.F. stage affords excellent selectivity and gain (at 456 kc.) in itself, due to its use of Ferrocart iron core transformers in both input and output positions. Additional effective I.F. efficiency is, however, made possible by the use of the second detector regeneration, which peaks the circuit to almost a single-signal condition. The scheme for obtaining this regeneration—and oscillation for c.w. reception, if we like—is an old and practical one involving the incorporation of a broadcast coil in the detector's cathode circuit and of a rheostat control bridged across this coil for feedback adjustment. The I.F. output transformer's peak-tone setting is, of course, affected in a minor degree by any variation of the control resistance, but so long as the initial peaking is made with the rheostat *wide open* for maximum regeneration (just below the point of circuit oscillation), the effect is acceptable, as detuning will then only be introduced as the sensitivity is backed off.

A single tube serves as both second detector and first audio amplifier. This tube, a 6C8G, is much better to use than a 6N7 or 6A6, as it has a separate cathode for each triode section and so eliminates the possibility of annoying inter-circuit coupling—something which even a well by-passed common cathode may effect.

The tube's A.F. section drives the 6V6G to speaker output and provides directly for *headphone* output. Note that the coupling condenser has 25 mf. value, necessary when crystal headphones are employed. (It should be stressed that crystal phones must not, under *any* circumstances, be connected directly into any D.C. circuit, such as the plate circuit of a tube. The phones *must* be isolated properly or they will be irreparably ruined.)

Increased A.F. gain may be brought about through the use of an audio transformer replacing the coupling network. The circuit,

A Practical Superhet



or Farm Application

as given, will be satisfactory under most operating conditions—but if such a transformer is desired it can be added. Not only will the gain be increased, but better isolation between the 6C8G output plate and the 6V6G input grid circuits will be had.

The Genemotor power supply is a complete, self-filtered job. However, to improve performance and reduce supply interference a .25 mf. condenser has been connected from B plus to chassis and a 1 mf. capacitor between chassis and A "hot."

All No. 2 tube filament terminals are connected to chassis, all No. 7 terminals paralleled for common A "hot." The genemotor unit connects to chassis at one point only!

No speaker transformer is wired into the immediate circuit, as the receiver is designed for use with a P.M. reproducer equipped with such a component and designed to work out of the single Class A 6V6G, whose load resistance specification is 5,000 ohms.

Layout: Front panel layout centers the tuning dial for bandspread control (or bank control, if broadcast reception is of greater interest to the builder), with band-switch knob to the left and 3-point "On-Off" knob (the extra point for standby—B circuit open only) to the right. Other knobs, from left to right, are for antenna load compensation, bandset (or bandspread, as the case may be), selectivity-sensitivity-

A useful 6-volt receiver using but four tubes—a mixer, an I.F. amplifier, a combination second detector and first audio stage, and a power output amplifier. A genemotor power unit supplies the plate voltage, and the coils for the various bands are switch-selected. Wavelength coverage is 9.25 to 565 meters.

BFO adjustment, and volume control.

The home-built coil assembly is mounted above the chassis. Immediately behind it is the input I.F. transformer, and across the rear length of the base are the other easily identified major transformer and tube components. The 6J8G mixer is mounted below the chassis horizontally, though it may go "upstairs" in conventional position if the builder so desires. The various condensers and resistors are positioned in circuit groupings close to associated sockets. Leads between front-panel controls and related circuit points, being rather long, run through low-capacity shield tubing—and both B plus and A "hot" leads are similarly shielded for as much of their length as possible and particularly near the receptacle for the genemotor can, though such shielding is not indicated in the under-chassis photograph.

The genemotor, installed in a small shield can provided with a chassis-type male plug in its base, plugs into the receptacle shown at center right to make B plus and A "hot"

connection to circuit points and A minus—B minus connection to chassis right at the socket. The "On-Off-Standby" switch protrudes through the shield wall and receiver front panel for knob control. A receptacle, on the back of the box, is provided for connection to the energizing 6 volt storage battery.

Construction Details

1. Drill the Par-Metal cabinet and chassis to exact layout specifications. Though a smaller assembly might seem possible, stick to recommended dimensions. Do not crowd the various components together, risking inadequate circuit isolation.

2. Build the switch assembly partitions. These should be large enough to amply shield the mixer from the HFO coils and to elevate the whole R.F. assembly far enough above the chassis so that when shields and selector switch are assembled together, its shaft will line up properly with the front panel switch hole. No exact size specification need be given here;

(Continued on page 685)

Wiring diagram of the four tube receiver.

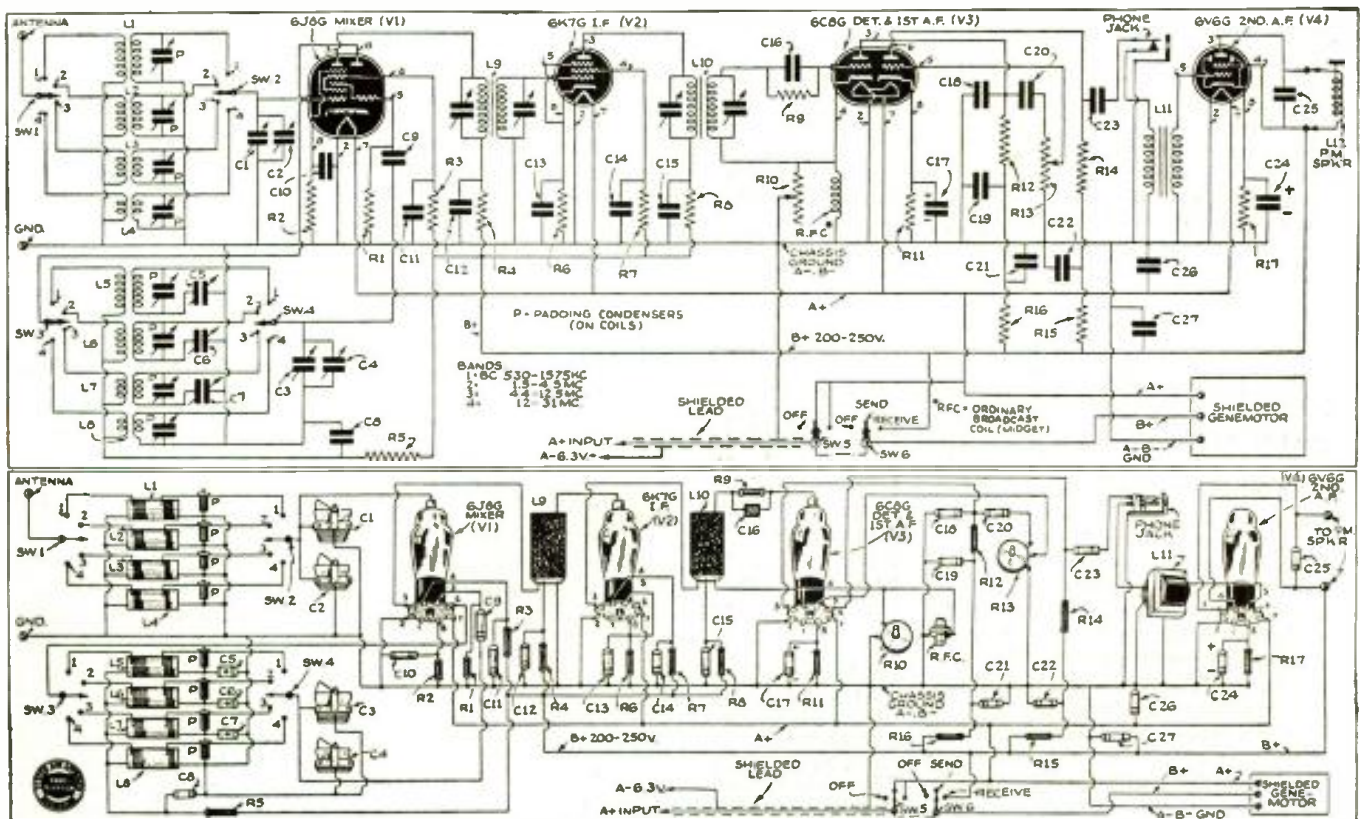

1-Meter WAVES with Ordinary Tubes

Nelson G. Haas and Carl A. Erbacher

Part 2—Conclusion

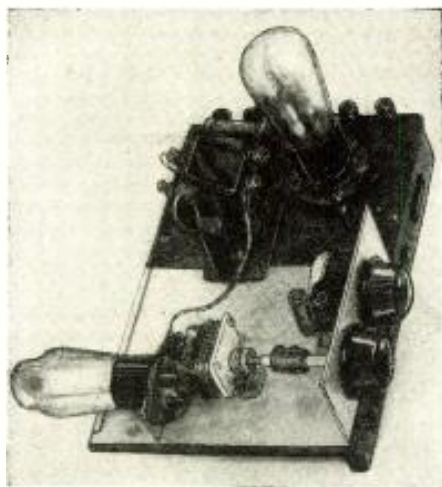

Here is the self-quenching one-meter receiver built by the authors; it uses ordinary tubes.

● TRANSFERRING the output of the one-meter transmitters previously described* to a radiating system or antenna employs the same basic theory used on the higher and more familiar wavelengths; the one *but* here is the need of placing the antenna system free and clear of surrounding objects. Fortunately, the dimensions of the antenna are so relatively small that no difficulty should normally be encountered.

The first antennas experimented with were simple vertical wires, either half- or quarter-waves long, clipped directly to the plate rods of the oscillators, either near the plate end for a half-wave antenna or near the plate-feed (cold) end for a quarter-wave radiator. Not much trouble was experienced in getting radiation from either of these two antennas, other than the necessity for cutting them very close to the proper length for maximum efficiency.

The quarter-wave antenna is clipped directly to the plate rod at a point an inch or so from the plate-feed end. Gradually slide it up toward the plate end of the rod, a fraction of an inch at a time, until maximum load is shown on the oscillator plate meter and maximum radiation, as determined by a field-strength meter placed a few feet away, is also had. A small flashlight bulb inserted in the antenna at the point where it clips onto the plate rod will light to indicate a considerable amount of antenna current.

If the half-wave antenna is used, it should be clipped onto the plate rod a few inches away from the plate end. It may be found that in coupling this type of antenna to the transmitter, the tube will stop oscillating unless the antenna is coupled to the plate end of the rod by means of a small variable condenser (a few microfarads is sufficient). A flashlight bulb inserted in the center of the half-wave antenna will show antenna current by lighting, and will very materially aid in making adjustments.

* Part 1, on Transmitters, appeared in the January issue.

More specific measurements as to the length of these antennas might be found useful. Supposing the Lecher Wires determine that the oscillator is on exactly one meter, a half-wave would necessarily have to be one-half such a length, or $\frac{1}{2}$ meter—almost 19.7 inches (one meter equals 39.37 inches). At all times it is necessary to know the wavelength of the oscillator so as to cut the antenna for it to resonance.

An antenna clipped directly onto the transmitter is not as convenient as one fed from a distance. After much experimentation, and looking around to see what other experimenters were using for feeder systems, the *single-wire untuned transmission-line* was chosen. Not only does it offer a quick and practically foolproof method of exciting the antenna, but its use permits varying the load on the oscillator by the simple expedient of shifting the point at which the feeder is clipped to the plate circuit. Loading up, of course, is accomplished by moving the feeder closer to the plate of the oscillator.

The optimum point on the half-wave antenna to clip the feeder to is best determined by trial and error; it is approximately 14% of a half-wave off the center of the antenna. For a one meter half-wave antenna this would be about $2\frac{3}{4}$ inches from the center.

Directing Waves

Having gotten such a half-wave antenna properly excited by the single-wire feed described, the next step is to set up an array that will make the antenna *directional*. The first thought, and one that proved practical, was to set up a reflector. Such a rod, longer than the half-wave antenna by 2%, was spaced ($\frac{1}{4}$) one-quarter wave behind it and immediately the radiation pattern changed. The field strength meter described in the pre-

Hook-up of the one-meter receiver, as successfully built and tested by the authors. Tubes, such as the 56, 76 or 37 are satisfactory.

vious article (it is a milliammeter placed in series with a fixed carborundum detector and tuned to one meter) soon indicated that behind the antenna the signal strength took a severe dip. The radiation pattern was strongly accentuated in a *forward direction*. This was checked by removing the reflector and placing it on another side of the antenna, only to have the same results.

Not completely satisfied, for we had envisioned a more focused radiation, Mr. Haas

In the previous article the design and construction of two transmitters using readily available tubes as the 56, 27, 76, 37, were covered, together with the method of using a simple Lecher Wire type wavemeter for determining the wavelength at which the transmitters were operating. This article describes the antenna systems for radiating the output of these transmitters and the construction of receivers for these wavelengths.

suggested using a director as well as a reflector. After much experimentation with one it was found that a rod cut to about 87% of the half-wave, and spaced $\frac{3}{8}$ of a wave in front of the antenna, produced a decided *beam* effect.

Playing with antennas proved so intriguing that for several weeks all other experimentation was put aside while the possibilities of squirting one meter signals was thoroughly explored. It was found that, within reason, a reflector or director could be spaced any odd quarter-wave away
(Continued on opposite page)

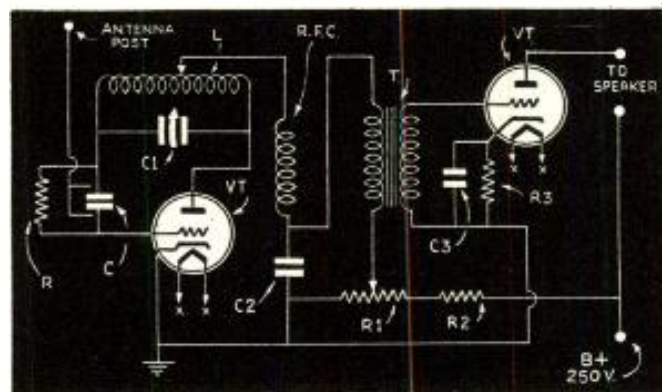

METER



Amplifier "Built in"

Since the higher harmonics from the oscillator get pretty weak, it is desirable to have an amplifier which will amplify them, thereby facilitating their identification in the receiver. The 6L7 accomplishes this very nicely and at the same time mixes in the output of the 10 kc. multivibrator. The plate circuit of the 6L7 is tuned to the approximate frequency of the desired harmonic. If the harmonic is louder than desirable, the tuning condenser is merely detuned. Five coils mounted on a 2-pole rotary switch of the same type as that used in the oscillator cover the range of from 530 kc. to 100 mc. The four lower frequency coils are stock Meissner coils available with small 10 mmf. trimmers attached. Merely set these at their maximum capacity. The broadcast coil which has an L-5 section of 258 turns should be reduced to less than 50 turns. For the highest frequency band the coils are wound with No. 12 bus-bar.

Multivibrator

Essentially a multivibrator consists of a two-stage resistance-coupled amplifier with the output connected to the input; the resultant feed-back leads to oscillations, determined by the circuit constants. When a small amount of voltage is fed into the input from some standard frequency source, such as the 100 kc. oscillator, the frequency of operation of the multivibrator becomes stabilized at a harmonic (in this case the 10th, or 10 kc.) of the controlling voltage and will generate this signal even with minor changes in circuit constants. Thus, with the addition of the 10 kc. multivibrator, signals can be had not only at each 100 kc. throughout the radio spectrum, but also at each 10 kc. with a degree of accuracy limited practically only by the care used in setting the 100 kc. oscillator. The 627G, a dual triode, combines the two-stage amplifier in one envelope. The 20,000-ohm control in the grid of the input section is used to change the frequency of oscillation. With the control set at about its center position, the multivibrator will "lock in step" at the 10th harmonic of the 100 kc. oscillator. Variation of the control to its extreme positions will result in generation of signals from the 8th to the 12th harmonics.

Only 1 Switch Used to Change Frequency

Only one switch is used to control the different stages of the frequency meter. This is a small Mallory 3-pole, 4-position rotary switch, labeled SW-3 (a, b, c) in the diagram. In the first position the unit

(Continued on page 689)

Get this book

SAVE on everything in RADIO!

SEND COUPON FOR ALLIED'S FREE CATALOG

NOW!

SAVE MONEY! MAKE MONEY! WITH KNIGHT SOUND SYSTEMS

ALLIED'S great 1939 Catalog shows everything in Radio, including Radio's greatest line of P.A. Systems. More features, more watts for your money; systems from 8 to 65 watts—in standard and de luxe models—permanent, portable, and mobile. Investigate these revolutionary new Sound Systems now—send for ALLIED'S 1939 Catalog. Also, Electric Guitar Amplifier, Booster Power Stage, and the most complete line of recording equipment in the industry!

30 WATT DE LUXE MOBILE SYSTEM

Ideal for sound trucks, orchestras, lecturers, etc. Operates from either 6 volt battery or 110 volts AC. Delivers full 30 watts output with excellent tonal fidelity. 2 mike input channels, dual phono input, separate volume controls, power stage tap, etc. Priced amazingly low—write for details!

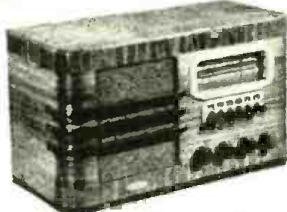

62 NEW SETS

Sensational new KNIGHT values! 62 new models, some as low as \$6.95. New "Tiny Knights," 1.4 volt battery sets. 6 volt radios, sets for AC and AC-DC. Models from 4 to 16 tubes—all backed by Radio's strongest guarantee! Also, complete lines of phono-radios, phonographs, record players, etc.



New! KITS...HAM GEAR...TESTERS

Radio's largest selection—Beginners' Kits, Photo Cell Kit, Electric Fence—100 diagrams and projects. Free Parts Lists.

Giant Ham section—newest Hamcrafters, National, Hammarlund, Howard, Thordarson, Utah, G.T.C. Sargeant equipment.

All leading lines of tube checkers, set testers, analyzers, Oscilloscopes, Rider, Supreme, Triplett, Readrite, etc.

IT'S A FACT!—ALLIED maintains separate Amateur, P.A., Educational and Sales Promotional Staffs to help make your work easier and more profitable. Write!

ALLIED Radio CORPORATION

Send for FREE Catalog!

ALLIED Radio Corp., Dept. 3-C-9, 833 W. Jackson Blvd., Chicago, Ill.
 Send me your 1939 Radio Catalog.
 Enclosed find 10c (plus 3c postage) for Radio Builders Book.

Name
 Address

See Pages 686, 692 and 702 for Interesting Subscription Offers!

GOOD RESULTS DEMAND Good Instruments!



Model 666 Pocket Volt-Ohm-Milliammeter

For all A.C. and D.C. voltage, direct current and resistance analyses. A complete instrument for all servicing and other needs. Complete with alligator clips, battery and test leads. DEALER PRICE \$15.00

The Triplett Electrical Instrument Co.
 283 Harmon Ave., Bluffton, Ohio

Now!

BALLAST REPLACEMENT

made AMAZINGLY SIMPLE!

Only 4 standard types of Amperite AC-DC Regulators will replace 90% (over 100 types) of AC-DC Ballast Tubes now in use!

WRITE FOR CHART AR.

New Low Price \$1.00 List

AMPERITE Co. 561 BROADWAY, N. Y.

AMPERITE AUTOMATIC REGULATORS

Question Box

Remote Control Relay Circuit

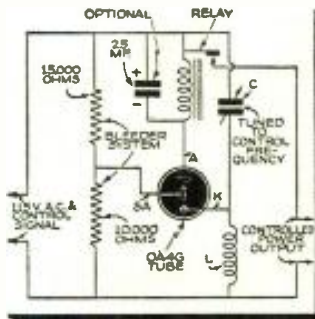

Relay hook-up for remote control. No. 1170

A. The accompanying circuit shows a remote control relay using the 0A4G tube in A.C. service. Note that full line voltage is applied between the anode and cathode, and that a bleeder system is used to maintain a voltage on the starter-anode just below that required for breakdown. The capacity and inductance, C and L, is a high-Q tuned circuit for R.F. signals. When an R.F. signal is transmitted on the power line, a resonant signal appears across the inductance and capacity. The voltage across condenser C increases the negative potential peaks on the cathode and increases the potentials between the cathode and starter-anode. A discharge between the cathode and starter-anode is started by these peaks. This discharge produces free ions which enable the discharge to transfer to the anode when sufficient starter-anode current flows. After this transfer occurs, current flows through the relay.

Precautions should be taken in the application of this type tube so that at high line voltages the A.C. applied to the starter-anode will not be great enough to reach the breakdown point. Precautions should also be taken so that at low line voltages the carrier voltage will be high enough to make up for the lowest line voltage. Therefore a minimum R.F. starter-anode voltage of 55 volts should be provided.

Simple Phone Monitor

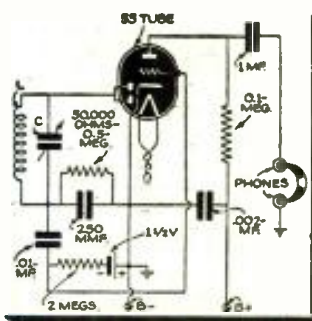

Phone Monitor. No. 1171

more sensitive when tuned to the transmitter frequency.

Here is a satisfactory type of phone monitor using a 55 type tube as a diode detector and audio amplifier. The circuit LC is tuned to the transmitter frequency and a headset is connected to the output posts in series with the condenser and ground.

High Frequency Receiver

? I contemplate building a high frequency receiver, to cover the bands from 10 to 40 meters. In this receiver I would like to make use of band-spread, a beat oscillator, crystal filter, an audio output meter and a built in monitor. In fact I would like to see published in the "Question Box," a diagram containing all these features and using about eight or nine of the most modern type tubes. Could you publish such a diagram?—Paul Cherosky, St. Louis, Mo.

A. A diagram of a high frequency receiver containing the features as mentioned above appeared in the October issue of R. & T.

Wireless Remote Tuner

? I wish to construct a remote tuner, such as the Kadette "Tunemaster," for use with my radio receiver. Will you kindly print a diagram and any suggestions you can offer?—Asa Carney.

A. The Tunemaster diagram you request is published herewith. The coil used to radiate the signal, T3, consists of 35 turns of No. 28 D.C.C. wire wound on a 3 1/4-inch form. It can be tuned with a 30-300 mmf. condenser. Turn the volume of the remote unit on full, and tune the radio receiver until the hiss from the remote unit is heard through the loud speaker with the receiver's volume fully advanced. This will probably be near the high frequency (low wavelength) end of the receiver's scale. If the hiss is not heard, adjust the trimmer across T3 until the hiss is picked up on the receiver. Once this has been done, stations tuned-in on the remote unit will be heard through the receiver—the volume control of which, incidentally, should be kept well advanced, volume being controlled from the remote unit.

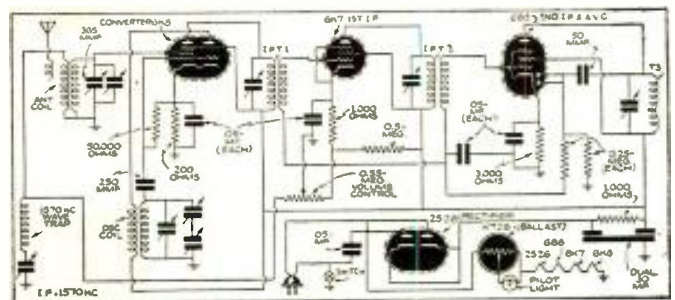

Remote "wireless" tuner for any receiver. No. 1172

Regenerative Battery Receiver

? Will you kindly publish a diagram of a battery-operated regenerative set using one stage of tuned and one stage of untuned R.F., regenerative detector, and one stage of audio amplification? All in all, I should like to use four tubes.—Horace Martin, Richmond, Va.

A. Herewith is a diagram using a 1E5G as an untuned R.F. stage and a 1E5G as tuned R.F. followed by another 1E5G as a regenerative detector feeding into a 1G5G audio. If care is used to make L-1, L-2 identical to L-3, L-4, the two tuning condensers can be ganged. Alternatively, small 10 mmf. trimmer condensers can be shunted across the secondaries of the coils.

Band	L-1 L-2 L-3 L-4				Turn at	L-2 L-4	Close Wound
	30	55	30	55			
1750 Kc.	30	55	30	55	3rd	No. 28 DCC	} Spaced to occupy 1"
3500 Kc.	20	28	20	28	1st	No. 18 Enam.	
7000 Kc.	9	11	9	11	1/2	No. 18 Enam.	} Coil form 1 1/2" diam.
14000 Kc.	5	5	5	5	1/4	No. 18 Enam.	

All L-1—L-2 No. 36 DSC Spacing between coil 1/4"

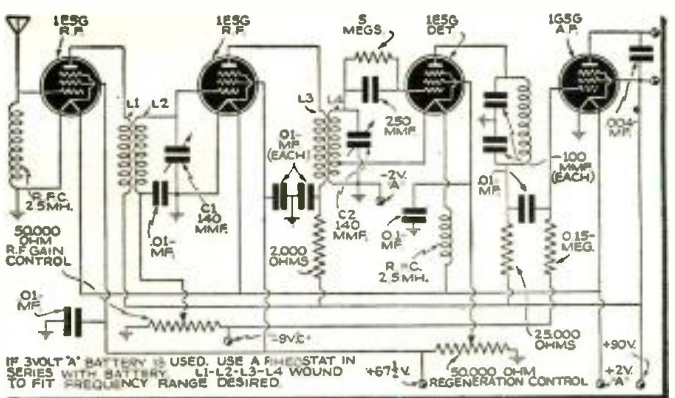

Regenerative Battery Receiver. No. 1173

A fee of 25c (stamps, coin or money order) is charged for letters that are answered by mail. This fee includes only hand-drawn schematics. We cannot furnish full-size working drawings or picture layouts.

1-Meter WAVES with Ordinary Tubes

(Continued from page 673)

several pipes or wiring ran was a definite obstacle that the signals did not penetrate. Similarly, reinforced concrete walls, or those built on metal lath, would act as effective shielding.

On the other hand, the size of the antenna makes possible the setting up of the antenna array within such walls, provided the output is aimed out of a convenient window. Another characteristic that was revealed when checking performance was the unexpected reflection from such objects as a metal floor or table lamp or other household furnishings, having a serious effect on the radiation pattern.

A rod, cut slightly longer than a half-wave antenna, could be carried behind the field-strength meter, which would then show an altogether different reading. On the same principle, a rod experimentally placed in the vicinity of the receiver would, according to its position, increase or decrease the tuned-in signal. No two installations of either receiving or transmitting antenna worked alike, though a careful study soon showed the reason for the difference found.

One of the receivers was made portable by the addition of batteries used with a 37 type tube, and a circle of the house in which the transmitter was installed, was made. Here, too, the pattern was radically different than expected, due, without a doubt, to the variety of reflectors and shields naturally found on the immediate terrain. However, with the antenna array fairly well elevated, as in the second story window, and with no intervening objects to interrupt the light of sight, no difficulty should be had by the most casual experimenter in receiving a signal several miles away!

Apparently complete coverage of a given area is governed solely by the elevation of the transmitting antenna. At Alpine, N. J., commercial interests have erected a 450-foot steel framework atop the Palisades to support antennas for experimentation with Armstrong "frequency modulation" on about two meters, and it is reported, unofficially, that these signals have been picked up in most of the New York metropolitan area.

In working on one meter, many characteristics will be discovered that, at first glance, appear to be either freakish or just plain contrary to accepted practices. It will be seen, however, that once these characteristics are traced to their source, one meter transmissions follow a definite, and not too different pattern, as do transmissions on the lower frequencies.

These ultra-high frequencies are the last unexplored frontier of radio and it is only a question of time before they, too, are put to work, possibly to carry high-fidelity music and, of course, television! The man who now becomes acquainted with them will, in the near future, be one stride ahead of his fellow experimenter who ignores their possibilities.

List of Parts

- L—5 turns ¼-in. dia. No. 22 wire, ½-inch long, soldered directly to condenser terminals
- RFC—30 turns No. 28 wire, ½-inch diameter
- C—50 mmf. fixed mica midget condenser, with small strip ¼ x ¾ inch aluminum bent around it for coupling condenser for antenna
- C1—Split stator condenser, as described in text
- C2—By-pass condenser, .002 mf.
- C3—By-pass condenser, 1 mf.
- R—5 megohms
- R1—50,000 ohm potentiometer
- R2—50,000 ohm fixed 1 watt resistor
- R3—2,000 ohm, 1 watt resistor
- T—Any 3 to 1 (or thereabouts) audio transformer
- VT—Tubes of the 56, 76 or 37 type are satisfactory

for March, 1939

9.7-555 METERS

High Performance ON ALL BANDS

HAMMARLUND'S NEW "HQ-120" is ideal for the amateur and short wave listener. Never before has so much been offered in a moderately priced receiver. This new high frequency receiver is designed for peak performance on all bands. Because of the special manner in which the high frequency circuits have been treated, the gain is uniform throughout the entire tuning range. This high uniform gain is always usable even in the most crowded bands because of the variable selectivity crystal filter. This filter is applicable to reception of voice and music as well as code. Weak stations can be tuned in clearly without interference by selecting the proper band width. Accurately calibrated dials and 310 degrees band-spread greatly simplify tuning.

SPECIAL FEATURES

- ★ Condenser assembly has 15 sections—9 for band-spread and 6 for main tuning. Permits uniform gain.
- ★ Accurate "S" meter calibrated in "S" units from 1 to 9 and up to 40 db. above "S-9." Accurate on all bands.
- ★ Noise limiter for auto ignition QRM and similar disturbances. Extreme aid on 10 and 20 meters.

WRITE DEPT. RT-3 FOR 16-PAGE BOOKLET

HAMMARLUND MFG. CO., INC.
424-438 WEST 33rd ST., NEW YORK
CANADIAN OFFICE: 41 WEST AVE., NO., HAMILTON, ONT.

Greatest Book Value Ever Offered for 50c. See Page 644.

NEW 1939 CATALOG

• 248 PAGES •

SHOWING ALL LATEST
NATIONALLY ADVERTISED
RADIO PARTS
AND EQUIPMENT
FOR EXPERIMENTERS
AND AMATEUR RADIO OPERATORS

Our 1939 Catalog Mailed Free on Request

CAMERADIO

563 LIBERTY AVE. 30 TWELFTH ST.,
PITTSBURGH, PA. WHEELING, W. VA.
Established 1919

SOLAR

MINICAP

gives you MORE for your money

Catalog upon request

SOLAR MFG. CORP., 599 Broadway, New York

Please say you saw it in RADIO & TELEVISION

New Tubes for Television

Black and white images can be reproduced in amateur television receiving stations, thanks to the new cathode-ray tubes now made available in 3, 5, 9 and 12 inch sizes.

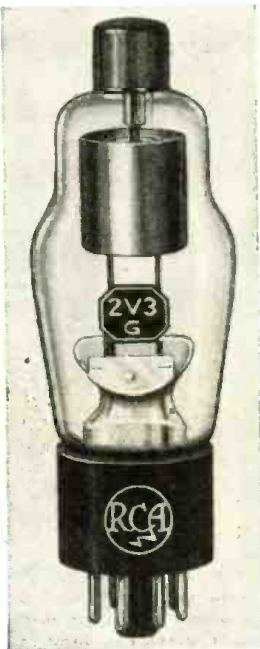

New high-voltage half-wave rectifier for use in television power supply units—type 2V3-G. The peak inverse voltage of this tube is 16,500.



One of the new RCA short-stem television cathode-ray tubes. This is the 9" diameter model, No. 1804-P4.

● **RADIO CORPORATION** of America has announced a new series of television tubes similar to the older style C-R tube, but a refinement of design makes it possible to build the tube shorter while affording the same screen diameter.

Type 1803-P4 is a 12-inch electromagnetic-deflection type with white phosphorus screen. This high vacuum tube, intended for television reception, will pro-

duce a black and white picture about $7\frac{1}{2}'' \times 10''$. It operates with a maximum Anode No. 2 voltage of 7000 volts and a grid No. 1 signal-swing voltage of approximately 25 volts for optimum image contrast. The bulb has been shaped to give minimum internal reflection and to provide maximum strength.

Type 1804-P4 is a 9" tube similar to the one previously described, but is smaller and provides a black and white picture measuring $5\frac{1}{2}'' \times 7\frac{1}{2}''$.

With both of these tubes, 1900 volts may be used on the No. 1 Anode or focusing electrode, and 250 volts on the accelerating electrode, Grid No. 2.

There is also the 1802-P4, a 5" electrostatic-deflection type tube, with white

phosphorus screen, which requires a No. 2 Anode voltage of 2000 volts maximum.

The RCA 906-P4 is a 3" electrostatic deflection type with white phosphorus screen. It takes a maximum voltage of 1500 on the high voltage electrode, and is designed not only for experimental television work but for oscillograph use as well.

RCA has also announced a new high-voltage, half-wave rectifier, Type 2V3-G, which is a tungsten-filament tube for use in suitable rectifying devices to supply the high
(Continued on page 688)

Hook-up for new RCA television cathode-ray tubes: 3" diameter screen—No. 906-P4.

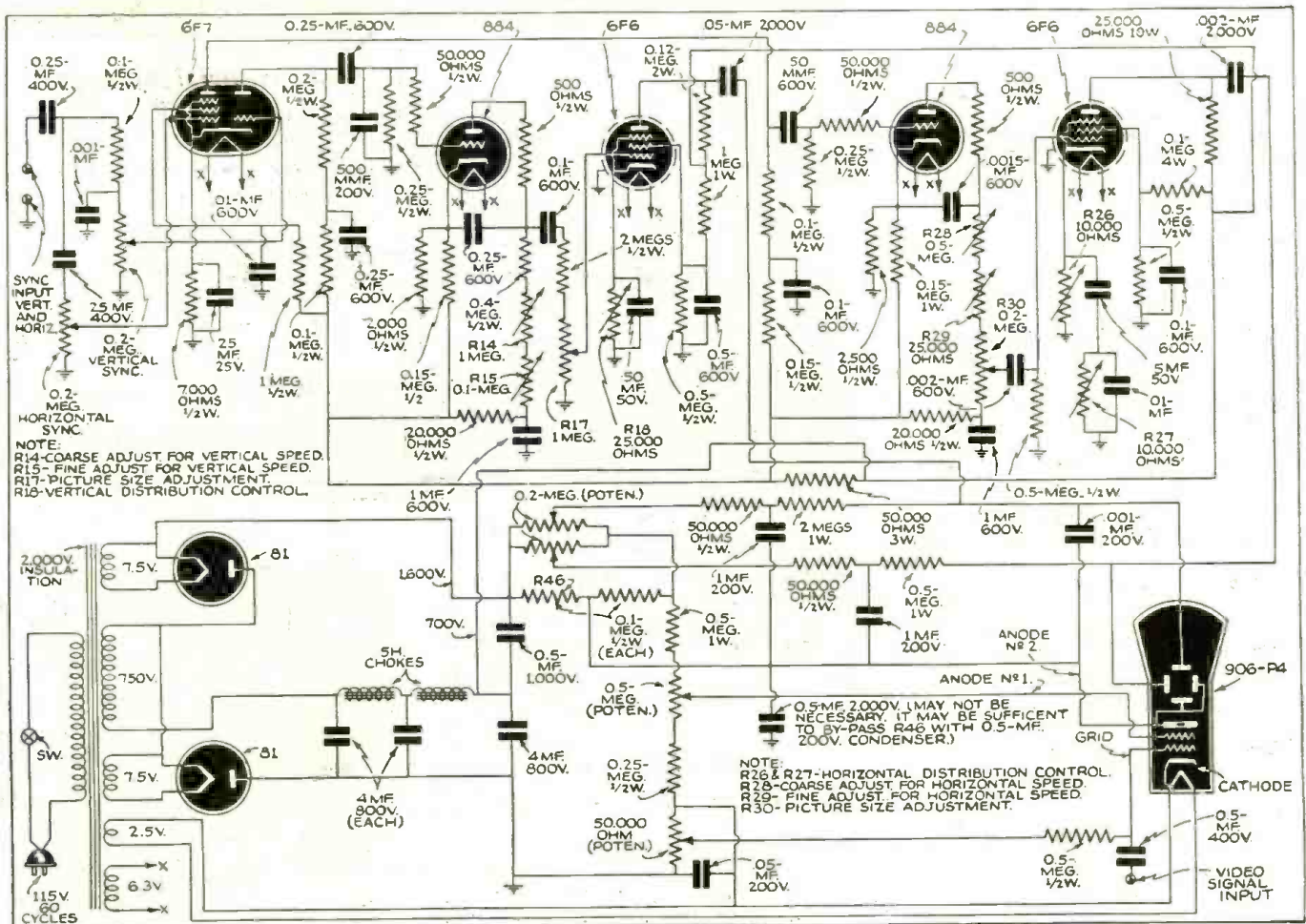

A Radio Ore-Locator

(Continued from page 669)

lowered to the ground, but their real function is to keep a fixed distance between the Antenna and the instrument case. Where these uprights are joined to the instrument case, they are held in place with brass bolts and wingnuts, and are not anchored permanently to the case as they are to the Loop Frame, the reason for this being that the operator can loosen the wingnuts and rotate the case until he obtains the most efficient tuning for the device, in which case he tightens the wingnuts and notes this position.

The instrument case itself can be made with oak pieces, two being 16" x 3" x 3/8", and two being 14" x 3" x 3/8", joined together with brass screws, and reinforced with cleats at the corners. Inside this rectangular frame, 4 inches from the top, is mounted a chassis strip to hold the tubes, while the batteries are held in place at the bottom with wooden cleats. The front and back of this frame are faced with wall-board or light wooden pieces, one being permanently screwed to the frame with the other hinged and hooked so that it can be swung out for inspection and adjustment of the parts. In practice, these dimensions need not be followed exactly—they are only a guide, the principle being to construct a case which will hold all the parts without crowding. The carrying handle, though, must be made of leather or brass, since iron and steel should be kept to a minimum.

To operate, turn on the switch, and adjust the rheostat so that the voltmeter reads "2 volts." Then raise the instrument so that the loop-antenna (the base) is several inches above the ground. Turn the tuning knob until a good audible whistle is heard in the headphones. If the instrument is now carried over a metal object, the whistle will vary considerably in pitch.

You can adjust the tuning knob so that the pitch increases—that is, gets higher over the metal—or you may adjust it so that the pitch decreases. You will find, however, that the most practical adjustment is that in which the pitch decreases over metal.

The rheostat should never be adjusted so that the voltmeter reads more than 2 volts, but as the batteries lose their strength you will find that the rheostat must be turned higher.

To test your set, before going into the field in search of buried treasure, bury a small metal plate a few feet under the surface of the ground. This need not be iron or steel, since the set operates just as well over non-magnetic metals, such as brass and copper. Walk over ground at some distance from the buried plate, and then over the spot where the metal has been placed, and note the variation of pitch in the headphone sounds. With this established, you are now ready to actually hunt treasure or minerals.

The cross-sectional area of metal lying in a horizontal plane is more important than the size or weight. For this reason, a few dollars buried flat in the ground will give a stronger signal than a large number buried on their edges. This T-Scope, as Dr. Fisher calls it, is not designed to trace buried pipes, but it has been used successfully in searching for buried treasure. With a little care in building, and a lot of patience in operating, you, too, should have good luck with this instrument.

This apparatus is patented and the inventor gives permission for you to build this instrument for your own use, but not for re-sale or hire.

(First American Serial Rights)

for March, 1939

GOOD PERFORMANCE!

with Brush products

**BRUSH
PIEZO
ELECTRIC
DEVICES**



Headphones Model BJ. Communications type headphones built to meet the most exacting specifications. Light weight aluminum case, with diaphragm and crystal element hermetically sealed within. Phones enclosed in molded rubber earpieces for comfort and good ear seal. With 5 ft. rubber covered cord, List \$12.00.

Vibromike Model VM-1. For stringed musical instruments, here is an excellent contact mike—sensitive, small, and light in weight. Frequency response from 30 to 6,000 c.p.s., and its sensitivity makes it useable with the smallest amplifier. Dimensions are only 1 1/8" x 3/4" x 5/16". With mounting clamp and 25 ft. cable, List \$17.50.



teur stations and general P.A., applications, this diaphragm type mike is inexpensive and gives excellent results. Output level minus 46 db. and response from 100 to 5,000 c.p.s., plus or minus 5 db. Includes Vari-Swiv mounting, permitting manipulation, bringing out the mike's directional characteristics. With 25 ft. cable, List \$23.50. Socket optional.

Write for new Brush catalog.

THE BRUSH DEVELOPMENT CO.

3326 PERKINS AVENUE

CLEVELAND, OHIO

Material List

- RCA**
3—Type-30 tubes
- TRIMM**
1—2000-ohm headphone set
- TRIPLETT**
1—0-3 D.C. Voltmeter, V.
- CORNELL-DUBILIER**
Condensers:
No. 1. .1 mf.
No. 2. .0001 mf. tubular fixed condensers
No. 3. .002 mf. tubular fixed condenser
No. 4. .0001 mf. variable condenser
- BURGESS**
2—1 1/2-volt Burgess No. F4FH batteries. (Connected in series.) ("A" Batteries.)
1—45-volt "B" battery, No. 5308
- MISCELLANEOUS**
1—"On" and "Off" switch
Resistor (R-1)—1 megohm, 1/4 watt resistor
Transformer—Any make of reliable audio transformer, ratio 3:1
R.F. Choke—25 turns, No. 33 D.C.C. wire, wound on 1/2 inch diameter coil form
1—30-ohm variable rheostat, R

Here's Your Button

The illustration shows the beautiful design of the Official Short Wave League button, which is available to everyone who becomes a member of the League. The button measures 3/4 inch in diameter and is inlaid in enamel—3 colors—red, white and blue. The requirements for joining the League are explained in a booklet, copies of which will be mailed upon request.



Please note that you can order your button at once—Short Wave League supplies it at cost, the price, including the mailing, being 35 cents. A solid gold button is furnished for \$2.00 prepaid. Address all communications to SHORT WAVE LEAGUE, 99-101 Hudson St., New York.

Your Inquiries Invited

When you need amateur equipment it is to your advantage to write to me. You get personal attention; terms financed by myself so you buy with less cost and more convenience; liberal trade-in value for your equipment; ten day trial of all receivers; and my cooperation in every way to see that you are 100% satisfied. No wonder my customers are boosters. You will be too. For the newest equipment, the latest information and technical help, write to W9ARA.

Compare My Terms with Others

Model of Receiver	Cash Price	Down Payment	12 Mo. Payments
HQ-120	\$117.00	\$23.40	\$8.26
The NEW RME-70	\$138.60	\$27.72	\$9.79
Howard 430	29.95	5.99	2.12
NC80X and NC81X	99.00	19.80	6.99
Improved NC101X	129.00	25.80	9.11
The NEW NC100A	120.00	24.00	8.48
Latest RME-69	152.88	30.57	10.80
Sky Champion & NC44	49.50	9.90	3.49
Breting 49 & S16	99.00	19.80	6.99

Similar terms on Howard, Super Pro, HRO, PR-15, Breting 9, Sargents, others. And on Hallicrafter, National, Harvey, RME, Temco, RCA transmitters and National, Thordarson, UTC, Utah kits.

Bob Henry
W9ARA

BUTLER,

MISSOURI

Please say you saw it in RADIO & TELEVISION

H. G. CISIN'S FAMOUS KITS

1939 Senior Metal Tube SPACE EXPLORER

All-Wave All Electric Beam Power 5 Tube Communications Receiver



SEVEN NON-SKIP BANDS—8 1/4 to 2000 meters Professional Band Spread Beam Power, Communications Set.

POWERFUL, SENSITIVE, SELECTIVE—Ultra Modern Features include: Beam Power Output, Built-in Full Toned Electro-Dynamic Speaker, Patented Chain A.C.-D.C. Circuit, Low-loss Air Dielectric Precision Filtered to eliminate H.F. Full Vision Dial, Antenna Control, Headphone Jack, Dual Regeneration Control, Beam Power tube furnishes over 9 watts undistorted power to dynamic speaker and sensitive Full Loud Speaker Volume, Studio Tone Quality, sturdy drilled metal chassis. Verified foreign reception reported by many owners. Gives professional results but plans are clear anyone, even a novice, can build this set successfully.

Uses 100% Metal Tubes rather than low-priced "gr" type tubes in carefully engineered circuit as follows: one metal tube 6A7, one metal tube 6C5, one metal tube 25L6, one metal tube 25Z6, one metal tube K-350A; an tuned screen grid pentode regenerative detector, powerful 1st audio amplifier, 2nd audio two-watt Beam Power Output, Half-wave rectifier and automatic ballast stage.

Complete Senior Space Explorer Kit of all chassis parts, Power Supply and clear, simplified wiring diagram (unwired, less tubes, coils and speaker) \$5.95. Five Matched Metal Tubes \$3.75; Four S.W. Coils \$14 to 200 meters \$1; Two Broadcast Coils 200 to 625 m. \$1; Long Wave Coil 550 to 2000 meters \$1; Full Toned Dynamic Speaker \$1.95; Attractive wood cabinet \$1.50; Wired and tested \$2.25 extra. Shipping weight 7 lbs. Send stamp for Circular. 25% deposit on all C.O.D. orders.

\$5.95

SPECIAL—Senior Space Explorer, Complete Assembled, wired, factory tested, Chassis, with all coils \$14 to 2000 meters, set of matched metal tubes, built-in dynamic speaker. **\$15.35** ready to use

'39 JR. SPACE EXPLORER 4-TUBE RECEIVER



SEVEN BANDS—10 to 2000 meters, Junior Band Spread Professional Communications Set.

MODERN, SENSITIVE AND SELECTIVE! Amplifier Volume, Reception from as many as 50 foreign stations in a single evening reported and verified by many owners.

Uses one 6C6, one 79, one 2A7 (Twin-Tube) and one metal K-105-A, as a tuned screen grid regenerative detector, powerful two-stage pentode audio amplifier, half-wave rectifier and automatic ballast stage. Self-contained power supply operates on 105-120 volts, any frequency A.C. or D.C. Insulation. Built-in Chromatic Speaker, phone jack, antenna control, full vision dial, band spread variable, Earphone broadcast control, sturdy drilled metal chassis. Clear explanatory diagram simplifies wiring. Ideal for the novice.

COMPLETE JUNIOR SPACE EXPLORER KIT of all chassis parts, Power Supply and Diagram (unwired, less tubes, coils and speaker) **\$4.95**

Four Matched Tubes \$2.45, Four Short Wave Coils 10 to 200 m. \$1, Two Broadcast Coils 200 to 600 meters \$1, Long Wave Coil 550 to 2000 meters \$1, Tru-Fidelity Chromatic Magnetic Speaker \$1.45, Full Toned P.M. Dynamic Speaker \$1.95, Attractive Two-toned Wood Cabinet \$1.50. Wired and factory tested \$2 extra. Shipping weight 6 lbs. No circulars available on this model.

SPECIAL—Junior Space Explorer, Complete Assembled, wired, factory tested, Chassis, with all coils 10 to 2000 meters, set of matched tubes, built-in Tru-Fidelity Chromatic P.M. Dynamic Speaker, ready to use **\$13.95**

H. G. CISIN'S All-Wave Air Scout Jr. THREE-TUBE All Electric All Wave Model 3AE Receiver

A powerful sensitive all-wave set. Holds wonderful records for foreign reception, also brings in Police calls, amateur, code. Transatlantic phone and broadcast entertainment. Excellent volume. Works from any A.C. or D.C. house current. Easiest set to build. Employa newest metal ballast tube as one of the tubes. Speaker mounts on attractive panel. Range 9 1/2 to 610 meters or to 1500 meters with special long wave coil. Complete kit includes: Earphone, Antenna, Trimmer, Dial, Sockets, Knobs, Wire, Resistors, Condensers and all other required parts including instructions and diagrams. **\$3.20** With Phone (Less Gram. ONLY)



MODEL 3AE Pat. No. 2,086,256

Following Auxiliary Parts are available: 9 1/2 to 20 meter coil (foreign) \$1.15 to 45 meter coil (foreign) \$1.15; 40 to 80 meter coil (foreign) \$1.15; 500 to 1000 meter coil \$1.15; Coupler, Antenna Kit, 50c; Wood Screw Kit 10c; Tubes for Model 3AE each \$1c; Long Wave Unit and coil \$1; Double Earphone \$1.50; Handmade Ac. Attachment 75c; Air Scout Jr. Model 3AE wired extra \$1.00.

NOTE: If you already have earphones, two extra foreign coils may be substituted in this model. **H. G. CISIN, CHIEF ENGINEER** Allied Engineering Institute, Dept. S-53 98 Park Plaza, New York, N. Y.

New HAM Licenses

COMPILED FROM THE LATEST RECORDS OF THE FEDERAL COMMUNICATIONS COMMISSION

THERE are now approximately 50,000 licensed radio amateurs in this country. And hundreds of new amateurs are being licensed every month.

Heretofore no publication has listed the names and addresses of the new licensees as issued. RADIO & TELEVISION Magazine now provides this unique service, and publishes a list of newcomers in every issue. Check the names carefully so that you will be able to get in touch, not only with those amateurs in your neighborhood and vicinity, but also with those distant amateurs whom you wish to contact either by mail or by radio.

This list contains 100 names of newly licensed amateurs. YL's names appear in blackface type.

- | | | | |
|--------|--|-------|---|
| KB4FTU | Otto Wilhelm Gomez, 13 Commandant Gade, Charlotte Amolie, St. Thomas, V.I. | W5HQB | Norman Kendale, 132 N. Santa Fe, Bartlesville, Okla. |
| WICEV | Lyman Hitchcock, 289 Walnut, Winsted, Conn. | W5HQC | Warren M. Griffith, 203 Lexington, Jackson, Miss. |
| WIHUL | Harry Leighton, Leighton Ave., Limestone, Me. | W5HQD | Alfred A. Corcanges, Iota 9&10, Block 3, Flaxton, N. Dak. |
| WIWLT | Carmine Ciarletto, Silvermine Ave., Norwalk, Conn. | W6DKU | Edwin Harper, 441 E. 1st Ave., Mesa, Ariz. |
| WILSG | James F. Hennessey, 103 Dover Point Rd., Dover, N. H. | W6GDI | Albert L. Hullin, 633 E. Inyo, Tulare, Calif. |
| W2AY | Melvin I. Grummet, 65 Mill, Middletown, N. Y. | W6MAI | Masayoshi Harada, 1777 Euclid Ave., Berkeley, Calif. |
| W2FYL | Robert A. Martiny, 4125 44th St., Sunnyside, L. I., N. Y. | W6QCC | Harold Keto, 4216 Illinois Ave., San Diego, Calif. |
| W2LTP | Alfred Greenberg, 401 Rahway Ave., Elizabeth, N. J. | W6QQE | Joseph Fetzer, 303-E 5th South, Salt Lake City, Utah. |
| W2LTQ | Louis B. Pascal, 772 Forest Ave., New York, N. Y. | W6QQF | Arthur J. Holton, 1446 Jones St., San Francisco, Calif. |
| W2LTR | Thomas J. Phelan, 96-23 45th St., Corona, N. Y. | W6QQG | Albert Ezor, 1434 So. Crescent Heights Blvd., Los Angeles, Calif. |
| W2LTS | Aldro Lingard, Trustee, Fort Monmouth Radio Club, Building 271, Fort Monmouth, N. J. | W6QQH | Bob Cranston, 1929 5th Ave., Oakland, Calif. |
| W2LTT | Harold Epanid, 675 W. 160th St., New York, N. Y. | W6QQI | Justen L. Olsen, 87 W. 1st North, Ephraim, Utah. |
| W2LTU | Jay J. Chichon, 160 Vermilyea Ave., New York, N. Y. | W6QQK | Royal G. Madsen, 1210 Crandall Ave., Salt Lake City, Utah. |
| W2LTV | Eliot Lee Johnson, 160-22 84 Rd., Jamaica, N. Y. | W6QQS | Wm. G. Gerlach, 2939 Best Ave., Oakland, Calif. |
| W2LTX | Leland J. Califano, 1033 Forest Rd., Schenectady, N. Y. | W6QQU | Leslie L. Funston, 237 Grand Ave., South San Francisco, Calif. |
| W2LTY | Robert F. Cassidy, 1035 Woodcrest Ave., New York, N. Y. | W6QQW | Morgan W. Hays, 719 Goshen Ave., Visalia, Calif. |
| W2LTZ | Theodore Grasman, 1506 University, New York, N. Y. | W6QQZ | John F. Schmieskors, 820 Gleen, Fresno, Calif. |
| W2LUA | Fred Wm. Poppe, 615 Eagle Ave., New York, N. Y. | W7ACU | Frederick N. Frost, 4548 47th Ave., N.E. Seattle, Wash. |
| W2LUE | Ann Hallinan, 41 3rd Ave., Hawthorne, N. J. | W7HFM | Clarence E. Saunders, E. 2808 33rd Ave., Spokane, Wash. |
| W3HWS | Rudolph C. Koerner, Jr., 201 S. 35th St., Camden, N. J. | W7HFN | Glenn A. Cox, 646 Hemlock Ave., Marshfield, Ore. |
| W3HWT | Anthony J. Sivo, 54-56 Butler St., Trenton, N. J. | W7HFO | Earl F. Reilly, 1702 Rucker St., Everett, Wash. |
| W3HWU | Leroy M. Lewis, Jr., Curwen Rd., Rosemont, Pa. | W7HFP | Malcolm J. McFarlane, 1907 Hoyt Ave., Everett, Wash. |
| W3HWV | William Benner, 4722 Tampa St., Philadelphia, Pa. | W7HFR | Dennis R. Fenko, Dillingham, Alaska. |
| W3HWW | Douglas M. Parr, 1511 Braddish Ave., Baltimore, Md. | W7HFS | Dallas H. Lien, 617 N. 16th St., Boise, Idaho. |
| W3HXC | Saul Greenstein, 6522 N. Bouvier St., Philadelphia, Pa. | W7HFT | Fred C. Alexander, 5046 So. K St., Tacoma, Wash. |
| W4AKC | Joseph Abernethy, 404 W. Sixth, Gastonia, N. C. | W7HFU | Howard V. Berg, 7558 Earl Ave., N.W. Seattle, Wash. |
| W4AMF | Cleveland Andrews, 1140 Belvidere Ave., Gastonia, N. C. | W7HFW | Robert Wm. Sherman, 6808 30th N.E. Seattle, Wash. |
| W4CCO | Emmett B. Lewis, Jr., 213 S. Marietta St., Gastonia, N. C. | W7HFX | Harry E. Turner, Group 15, Belton, Montana. |
| W4FR | Rollin M. Martin, R.F.D. No. 1, Lodge, S. C. | W7HFY | Raymond D. Kester, 1546 32nd, Milwaukee, Ore. |
| W4FTS | Andrew C. Faire, 29 Baptist Hill, Greensboro, Ala. | W8MPP | Lorraine Swann, 274 E. Hancock St., Detroit, Mich. |
| W4FTV | Charles E. O'Groyn, 416 High St., Montgomery, Ala. | W8SRR | Richard M. Sweet, 11829 Franklin Blvd., Lakewood, Ohio. |
| W4FTX | John M. Hammond, 2325 Cussetta Rd., Columbus, Ga. | W8SRY | Robert T. Smeer, 15998 Nelacrest Ave., East Cleveland, Ohio. |
| W4FTZ | Henry L. Cotton, 327 4th Ave., Jacksonville Beach, Fla. | W8SRZ | Alfred Schafer, 228 Fair St., Berea, Ohio. |
| W4FUA | Samuel S. McInchin, Jr., R.F.D. No. 2, Sharon Lane, Charlotte, N. C. | W8SSA | Jack Rockwell, 513 7th Ave., Williamsport, Pa. |
| W4FUT | James J. Griffith, Jr., 1215 Watauga St., Kingsport, Tenn. | W8SSC | John Driscoll, 173 Florida, Buffalo, N. Y. |
| W4SH | Jacob A. Maxwell, 212 W. Morgan St., Raleigh, N. C. | W8SSD | Jack M. Gabert, 2134 Henry, Sheboygan, Wis. |
| W5CKF | John Henry Connell, Jal, N. Mex. | W8SSF | Arlryn C. Knapp, 414 Emmons Blvd., Wyandotte, Mich. |
| W5EMZ | George S. Johnson, 317 S. Dartmouth, Albuquerque, N. Mex. | W8SSI | Louis C. Barber, Jr., 203 Tinker Ave., Painesville, Ohio. |
| W5HPN | Le Roy J. Langlois, 927 America St., Baton Rouge, La. | W8SSJ | Bruce G. Born, 14809 Darwin Ave., Cleveland, Ohio. |
| W5HPP | Francisco Ortiz, 421 Pierce Ave., San Antonio, Tex. | W8SSK | Bogan Burke, 351 Rockview Ave., Youngstown, Ohio. |
| W5HPR | Jack Cecil, 715 W. Chambers St., Cleburne, Tex. | W8SSL | Wm. J. Clark, 705 Fairmont Ave., Youngstown, Ohio. |
| W5HPV | Fred M. De Vorse, Valdez, N. Mex. | W8SSO | Howard H. Rausch, 315 Mackinaw, Sheboygan, Mich. |
| W5HPW | Wm. R. Baker, Crowville, La. | W8SSV | Frank E. Bien, 9210 Plymouth, Garfield Heights, Ohio. |
| W5HPX | Thomas Atkinson, 530 West 17th St., Houston, Tex. | W9DUR | Ransom V. De Faut, 3423 17th, Racine, Wis. |
| | | W9IFK | Harold E. Coleman, 7 W. 9th St., McCook, Nebr. |

the motion of this cloudy medium are influenced by the Sun's radiations.

It is estimated that the stratosphere layer carrying a maximum ionization charge is approximately at an average height of 144 miles above the earth's surface. The high degree of ionization may be accounted for when one realizes the extremely low atmospheric pressure at such a high altitude.

The various problems involved led several authors to suppose the existence of several layers within the ionized stratosphere. I prefer to consider the hypothesis of a cloudy medium, in motion, of changing composition, and changing in altitude the same as the atmospheric medium does. Of course, in the case of the stratosphere regions, ionization is the main consideration, while the visible clouds are but accumulations of condensed humidity.

The state of the reflecting stratosphere region is influenced periodically by the Sun's radiations; this explains the periodical correlations between the Sun's activity and the propagation of short waves.

It is equally plausible to think that, between the earth's surface and the stratosphere region, at an altitude of 144 miles, the intervening space is far from being in a state of gradually decreasing ionization, as one approaches the earth.

There undoubtedly exist intermediate regions showing various degrees of ionization, much lower than the maximum of the higher region. The hypothesis of these secondary layers of ionization provide an explanation for the various changes in the propagation of wavelengths below 35 meters.

Referring to occasional troubles, such as sudden fading occurring about 36 hours after solar eruptions, one may conclude

that each eruption produces a violent electronic emission, reaching the earth at the observed time of 36 hours later.

These electrons, entering the earth's magnetic field are naturally deflected toward the poles, where they cause an intense bombardment, the first result of this being an extremely deep ionization of the stratosphere. It is then not surprising that the short waves reflected above the polar regions are much more affected than waves traveling along and reflected in regions remote from the poles.

It is known that the Aurora Borealis is equally explained by the Sun's electronic emissions concentrating at the poles and producing the intense ionization, greatly modifying the stratospheric medium as well as the atmosphere itself, in such a manner that the propagation of all radiations, whether luminous or electro-magnetic, is seriously affected.

We cannot say much more now about the development of this hypothetical and perhaps too enthusiastic theory of the Sun's influence over everything happening on earth; it is an important subject which will, no doubt, receive considerable study and development in the near future. Several daring suppositions have been advanced to the effect that the Sun's electronic emissions actually influence not only the health but the mentality of men and other living creatures.

We can no longer laugh at such suppositions; we may now seriously dream of them, although it is difficult to employ reasoning profitably upon this subject, inasmuch as suitably long series of controlled observations do not yet exist.

A Receiver for the "Ultra Highs"

J. Gordon Taylor, W2JCR

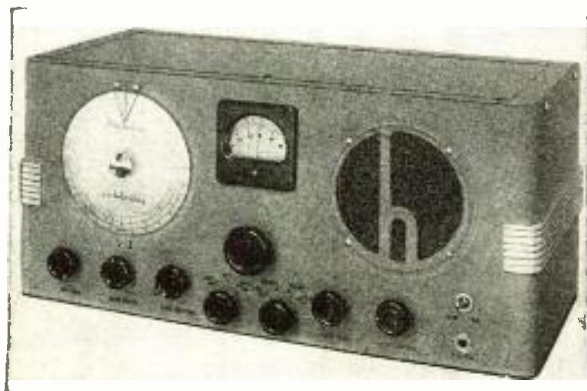

Note the neat arrangement of the controls on the new Hallicrafter "Skyrider 5-10" receiver.

logging purposes has its own calibrated dial.

The circuit employs nine tubes and includes one R.F. stage, mixer, H.F. oscillator, two I.F. stages (the second I.F. tube also serving as the beat-frequency oscillator), second detector-first audio and A.V.C. all in one tube, 6H6 automatic noise-limiter, audio power stage, and rectifier.

One of the most important departures from previous practice is the use of an 1852 tube in the tuned R.F. stage. This is one of the new ultra-high frequency tubes which really provides respectable gain as contrasted with little more than unity gain, or even a loss sustained at these frequencies with conventional tubes such as the 6K7, etc. The mechanical and electrical layout of the R.F. circuits is unique in that the total separation between the coil, band-switch and tuning condenser of each R.F. circuit does not exceed one inch, the coils being mounted right at the switch; both of these immediately below the tuning condenser. Each of the three tuned stages is enclosed within

(Continued on following page)

● IT is generally recognized that the design requirements for 10 meters and downward differ quite radically in some respects from those of standard receivers used on the lower frequencies but there seems to be considerable doubt as to just what these differences are. A brief discussion of a brand-new ultra-high frequency receiver which has just been made available to the public may therefore be of interest to many, particularly to Hams operating in the 5- and 10-meter bands.

This new receiver, the Hallicrafters "Skyrider 5-10," provides a range of 25 to 66 megacycles (12 to 4.5 meters), divided into two bands of 25-44 and 38-66 mc. with band-switching. The main dial is fully calibrated in megacycles. Band-spreading is ample to make tuning non-critical and for

MY FREE BOOK SHOWS HOW
YOU CAN BECOME A MONEY-MAKING RADIO EXPERT!
with my New
SPRAYBERRY
Personalized
HOME TRAINING
in
RADIO
AND TELEVISION
EASY TO START...
EARN WHILE YOU LEARN

I Train You Quickly
in Your Spare Hours
... Right at Home

You Do Practical Experiments with Real Equipment

I offer you a new and altogether different type of practical training for a money-making career in Radio and Television. I teach you in a simplified, logical, understandable style all about Television, Electronics, Facsimile Radio, Radio Set Repair and Installation. I GIVE YOU PERSONAL COACHING ALL THE WAY.

TRAINING PREPARES YOU FOR GOOD RADIO JOBS ... at Excellent Pay

No matter if you desire to BE YOUR OWN BOSS in your own business or hold down a good job in Radio, my training will give you the useful information and knowledge to win success. DON'T JUST WISH FOR MORE MONEY—START TRAINING FOR IT RIGHT NOW.

Read What This Student Says:

EARNED \$250 SINCE STARTING COURSE
"I have only completed one-third of the Sprayberry Course and I find it very interesting, which makes it easy to learn."
"By devoting several hours of my spare time daily to studying and servicing, I have made about \$250 gross since starting the Course." Earl W. Hostetter, R. No. 4, Lebanon, Pa.



YOU GET PROFESSIONAL TEST EQUIPMENT PLUS EXPERIMENTAL OUTFITS

146 RADIO PARTS



RADIO TOOLS



ALL PURPOSE ANALYZER

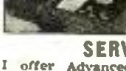

Includes 146 RADIO PARTS for building a complete 5 tube Radio Receiver, RADIO TOOLS, ALL-WAVE, ALL-PURPOSE ANALYZER. Besides its invaluable use in experimental work, my equipment will enable you to make spare time profits while you're learning and can serve you in your own Service business later on. I give you DATA SHEETS on how to build popular Radio circuits. Also you receive BUSINESS BUILDLERS which show you how to get and do spare time, neighborhood Radio Service work.

NO PREVIOUS EXPERIENCE NEEDED

My Training starts right at the beginning of Radio ... covers all essential subjects. It makes no difference what your education has been. I can fit you for an excellent paying job in Radio. Your success is my full responsibility. I know how to get Radio service so that you will understand it ... and remember it.

SERVICEMEN

I offer Advanced Training for those already in Radio. Get complete details in my FREE 52-page Book.

REMEMBER—THE SPRAYBERRY COURSE IS SOLD UNDER A MONEY-BACK AGREEMENT



RUSH THIS COUPON FREE for BIG FREE BOOK

DON'T DELAY! ACT NOW!

SPRAYBERRY ACADEMY OF RADIO
F. L. Sprayberry, Pres.,
245-C University Place, N.W., Washington, D. C.
Please send me FREE copy of "HOW TO MAKE MONEY IN RADIO."

Name Age
Address
City State
Tear off this coupon, mail in envelope or paste on penny postcard. Servicemen—Check here



- FEATURES**
- SIMPLICITY
 - PERFECT CONTROL
 - SEMI-AUTO-MATIC
 - EASE OF OPERATION

MARTIN FLASH

The greatest **VALUE** ever offered

STURDY CONSTRUCTION

Single lever. Two pairs of coin silver contact points . . . one for dots, the other for dashes.

Designed especially to meet the demands of amateur operators. Beautiful black crackle finish. This key is a "winner." Weight, 2 pounds. Base, 6x3x3/8". **\$6.95**
New low list, each

Discount to Amateurs 40%

Ask your dealer to show you the FLASH Key. If he cannot supply you, send your order direct to us.

Write for complete catalog illustrating and describing all models.

MARTIN RESEARCH & MFG. CORP.

98 PARK PLACE Dept. RT-3 NEW YORK CITY

TURNER
Sound Equipment Catalogue
TURNER COMPANY
CHICAGO, ILL.

How TURNER Microphones

- Add Broadcast Quality
- Modernize your Rig
- . . . at Low Cost

TURNER offers 24 different microphones, streamlined for professional appearance and engineered to assure broadcast quality reports, to enable you to improve your equipment at amazingly low cost. Used by thousands of hams and PA men the world over.

There's a TURNER mike for every purpose—indoors or out. With the TURNER Dynamics and Crystals, you reduce feedback, breakage and blasting troubles. Own a microphone that wins you praise and doubles your enjoyment. See the TURNER mikes and equipment. Write today for TURNER'S Free Microphone bulletin No. 40-D.

—Tear Out and Mail Today—

TURNER CO., Cedar Rapids, Iowa

Please send me your Free Microphone Bulletin No. 40-D.

Name

Address

City

State

Just Published . . . a NEW RADIO AND ELECTRONIC DICTIONARY Containing 3,800 Definitions

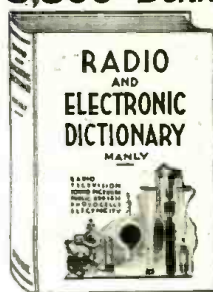

THIS RADIO AND ELECTRONIC DICTIONARY, written by Harold P. Manly, explains the meaning of 3,800 words used in radio, electronics and other closely allied fields. It includes new terms used in radio transmission, sound pictures, television public address, aviation radio, navigation and industrial control, photo-electricity, photocell application, telephotography, etc. This dictionary permits learning every new expression whether you hear it or read it. Alphabetically arranged for quick reference, 550 illustrations augment definitions in the text.

The book is recommended for students, instructors, engineers, service men, experimenters, salesmen and everyone in any way associated with radio. **ONLY**

BOOK OF ITS KIND—HANDY—EASY TO USE—AND TIMELY.
The RADIO AND ELECTRONIC DICTIONARY is new, authentic and printed in a single volume of 300 pages, size 8 x 9 inches. The book weighs two pounds, and bound in durable cloth. **SHIPPED ANYWHERE \$2.50**
IN U. S. A. POSTPAID Price

Mail remittance by check or money order to **RADIO PUBLICATIONS**
99 HUDSON STREET NEW YORK, N. Y.

Do you need BINDING POSTS?



The XL PUSH POST with its Spring Action assures Constant Contact and quick connection. Manufactured in All Aluminum Type M at 10c each. Aluminum Body, Bakelite Top Type B1 at 15c each. Type B1 completely insulated with Bakelite Insulating Shell type CI at 20c each and proven by 240 hr Salt Spray Test. **AS NON CORROSIVE** our Types CP or NP at 28c each.

Manufacturers and Dealers liberal Discounts

X. L. RADIO LABORATORIES

420 West Chicago Ave., Chicago, Ill.

A Receiver for the "Ultra Highs"

(Continued from preceding page)

its own individual shielded compartment.

The intermediate frequency is 1600 kc., selected because it results in greatly improved image selectivity and widely separates any repeat points that may still remain. Broad and sharp selectivity is provided by means of variable I.F. interstage coupling, the selection being made by means of a switch on the front panel.

The completely automatic noise-limiter is especially important at these frequencies,

where ignition noise is ordinarily most troublesome. This system cuts off all noise peaks above the signal level.

That this receiver has the same degree of flexibility as receivers for the lower range is indicated by a listing of the controls. Reading from left to right along the front panel they are: manual R.F. gain, band-switch, tone control and A.C. line, A.V.C.-B.F. o.s.c., broad-sharp I.F. band width, audio gain, B.F.O. pitch control, stand-by switch and headphone jack. The single tuning control is in the center.

An extra refinement and a distinct novelty is the provision for operation either from the 110-volt a.c. line, or from a 6-volt storage battery for portable-mobile work. With special plug removed, the internal power supply is disconnected and by inserting another plug to which the storage battery and an external vibrator supply such as the Mallory VP-554 are connected, the receiver is ready for mobile operation.

In tests conducted at the home station and at those of other New York Hams equipped with outstandingly good 5- and 10-meter equipment, not one could beat out the DX ability of this little receiver on five and ten meters. The only installation to which it ran second was the rig at W2AMJ which consists of a Hallicrafters SX17, plus a 5-meter converter of 2AMJ's own design, in which two of the new ultra-high frequency tubes are used, making a total of 15 tubes in all. Every station picked up on the 15-tube equipment, including 1st, 2nd and 3rd district stations, was likewise heard with the "5-10," but greater volume was obtainable on the big rig.

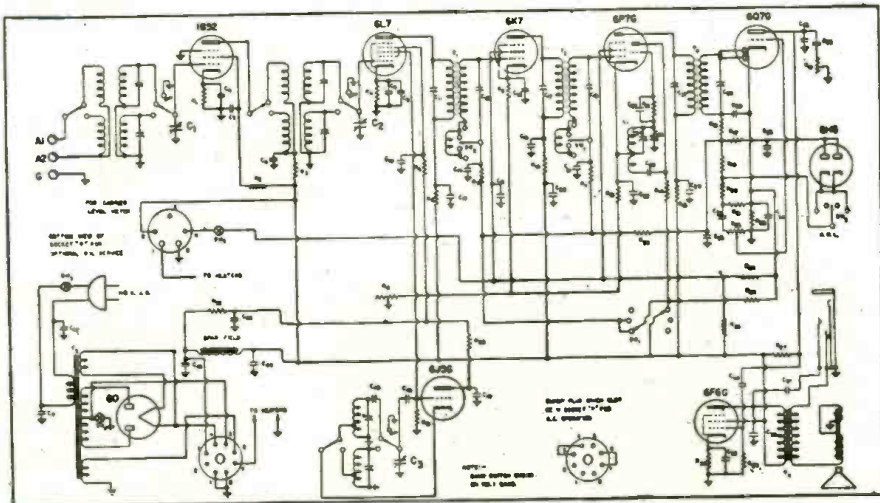

Hook-up of "5-10" Skyriider

What Do You Think?

(Continued from page 658)

a sort of "reference library." I own a Sky Challenger which I wouldn't part with for any radio. Again may I offer my hearty congratulations on the R9+ S-W magazine, "R.&T."

RICHARD NOEL,
Gow School,
South Wales, N. Y.

A "Cover" Idea!

Editor,

I am writing mainly to congratulate you on the F.B. short-wave magazine of which I am an ardent reader. Joe Miller takes the cake, as far as DX is concerned. Here's more luck to you, Joe!

May I criticize one point, though—your

cover? I think that pictures of S-W Listening Posts would be ideal. Each month print a picture of some notable S-W Post with its owner.

(Unsigned.)

Send that PHOTO! It May Win

One Year's Subscription to
RADIO & TELEVISION
FREE

for Best "Listening Post" Photo

Closing date March 15 for May issue, etc. The editors will act as judges and their opinions will be final. In the event of a tie a subscription will be given to each contestant so tying.

The "Switched Coil-4"—A Practical Superhet

(Continued from page 671)

simply use good judgment, fixing mounting feet on at least the back partition, providing in some convenient fashion for mounting the oscillator circuit paddlers, and drilling both plates so that they may replace wafer sections of the switch.

3. Disassemble the specified six wafer switch, then reassemble it, replacing the third and sixth (from the front or shaft end) wafers with the shield partitions. Mount the front-end coils right on wafer pairs, positioned as the photo indicates, with trimmer screws up for convenient adjustment. Connect the high (grid, plate, antenna, etc.) lead selector lugs to associated wafer shorting section terminals so that as the switching progresses from the No. 1 or broadcast position toward and through the higher frequency ranges, the unused coils will be shorted out. Wire in the variable paddlers for Band 1, 2 and 3 oscillator coils and the fixed padder for Band 4, then test the completed coil assembly for proper continuity, etc.

4. Mount the r.f. assembly, the i.f. transformers, tube sockets, headphone jack and speaker terminal unit on the chassis. Mount the two 2-gang condensers (ganging the individual capacitors conventionally with standard insulated couplings) with the bandset above the chassis for broadcast and 160-meter band work or below chassis if the receiver is to be used primarily for short-wave pickup and the bandset items need not be other than direct drive or knob controlled. Carefully cut off the frame extension of the dial assembly, so that with the control assembled on the above-chassis condenser shaft the unit slides tightly over the chassis. Tighten the hub's shaft screw when the inner edge of the dial glass is in

approximately vertical line with the front chassis drop.

5. Mount the tanks below chassis (or ganged 20 mmf. units, as the case may be), also the additional antenna-load compensating trimmer if one is used. Mount the potentiometers, then assemble chassis and cabinet-panel together, using the securing nuts for all front drop controls as a means of such assembly, and placing washers (about 1/16 inch thick) between chassis and panel at each control-shaft point so that there will be sufficient clearance to permit the chassis-panel construction to fit properly into the cabinet.

6. Complete the general assembly, mounting the broadcast or regeneration coil as indicated at the 6C8G socket, and placing tie points here and there where necessary for rigid by-pass condenser and resistor support. Wire up the receiver, following the circuit diagram carefully and using shielded (low capacity) leads between front panel potentiometers and associated circuit items. The B plus and A "hot" leads may well be similarly shielded for as much of their length as possible.

7. The second detector plate circuit must be grounded at the intermediate frequency transformer. Use a mica condenser of from .002 to .005 mmf. value—logically the smallest value which will permit circuit feedback and oscillation.

8. At this point check the operation of the set, using any available a.c. power supply which delivers 6.3 volts for the tube filaments and a well-filtered 200 to 250 volts of B. The power cable may be terminated in a plug designed for connection to the chassis receptacle for genemotor plug-in (i.e., the socket at center right immediately below the genemotor can). Align the i.f. circuits to 456 kc. peak with the regeneration control adjusted for maximum circuit gain (setting just below that for circuit oscillation). Then align the front-end coils at these trimming and padding frequencies:

Band 1—Align at 1400 kc.—Pad at 600 kc.
Band 2—Align at 4.0 mc.—Pad at 1.7 mc.
Band 3—Align at 10.0 mc.—Pad at 4.5 mc.
Band 4—Align at 29 mc.—Pad fixed.

9. With the layout properly adjusted and aligned under a.c. powering, proceed to the construction of the genemotor assembly. The genemotor itself is bolted down securely in the specified shield can for it—the can provided with a base mounted plug for receiver chassis connection, a rear wall receptacle (male) for storage battery line connection, and a front-wall mounted three-way switch (for "On-Off-Standby") supporting any necessary filtering items additional to those incorporated in the genemotor item proper, and positioned so that with the shield-can plug in, the switch shaft will line up with (and protrude through) the front-panel switch hole. The switch shaft, with genemotor assembly mounted on the main chassis, should clear this hole and the can should elsewhere be free of chassis and cabinet contact except at one point only—and that point logically near the A minus-B minus terminal of the chassis receptacle. (The grounding is then effected only with plug-in; genemotor can to chassis.) Use of the specified molded receptacle and plug units, by the way, will elevate the can above-chassis so that this single point grounding may be conveniently effected.

10. Connect the genemotor assembly to an energizing 6-volt storage cell, using

(Continued on page 687)

GREATEST BARGAIN

in 10 years



as little as

Remington
NOISELESS
Portable
NOW AS LITTLE AS
10c a day

10¢
A
DAY

Imagine a typewriter that speaks in a whisper! You can write in a library, a sick room, a Pullman berth, without disturbing others. And superb performance that literally makes words flow from the machine. The Remington Noiseless Portable is equipped with all attachments that make for complete writing equipment—it manifolds and cuts stencils perfectly. Furnished in black with chromium fittings.

SPECIFICATIONS

Standard keyboard. Takes paper 9.5 inches wide. Standard size, 12 yard ribbon. Makes up to 7 legible carbons. Back spacer. Paper fingers. Roller type. Black key cards with white letters. Double shift key and shift lock. Right and left carriage release. Right and left cylinder knobs. Large cushion rubber feet. Single or double space adjustment. A brand new NOISELESS typewriter, right off the assembly line.

10-DAY FREE TRIAL

For the first time in history you can own a genuine Remington Noiseless Portable for as little as 10c a day or \$3.00 a month. Think of it! The finest Remington Portable ever built at the lowest terms we have ever offered. And you don't risk a penny! We will send this brand new Remington Noiseless Portable for a TEN DAYS' FREE TRIAL! If you are not satisfied, send it back. We pay all shipping charges.

FREE - TYPING COURSE

With your Remington Noiseless Portable—absolutely free—a 19-page course in typing teaching you the Touch System, always used by experts. With the help of this course you will find typing the most enjoyable way you ever wrote.



SPECIAL - CARRYING CASE

Carrying Case, handsomely covered in DuPont fabric is included with your purchase. The case makes it easy to take your machine anywhere. You can use it on trains, or on your knees at home. Don't delay. Mail the coupon.



MAIL NOW
Remington Rand Inc. Dept. 300-3
465 Washington St., Buffalo, N. Y.

Tell me, without obligation, how to get a Free Trial of a new Remington Noiseless Portable, including Carrying Case and Free Typing Course for as little as 10c a day Send Catalog.

Name
Address
City State

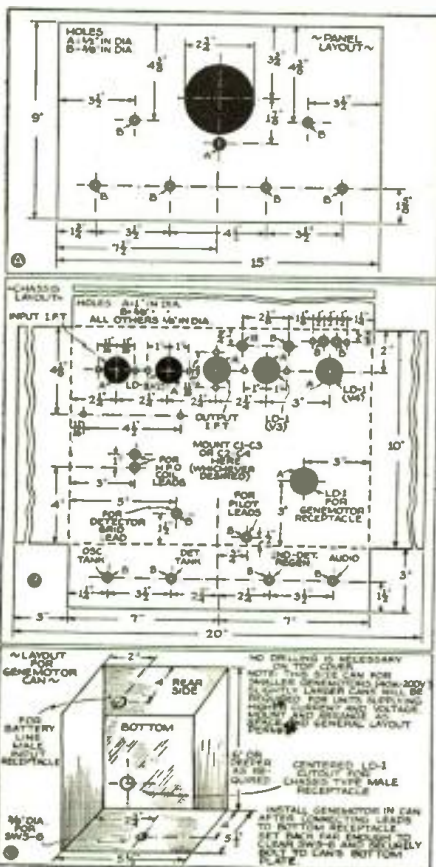

Front panel and chassis details.

Get Any ONE or ALL
of These Books Absolutely

FREE!

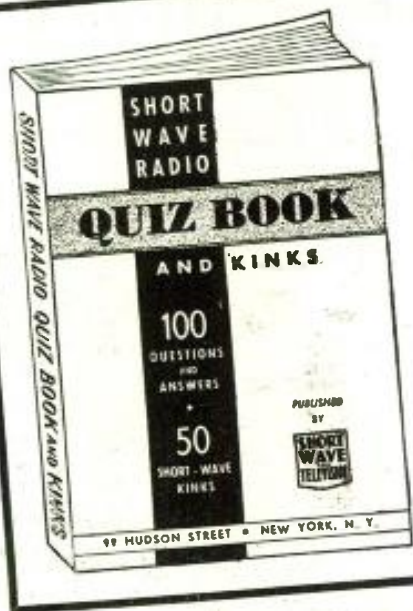

HERE is a brand new book—with an unusually interesting content. The text prepared by the Editorial Staff of RADIO AND TELEVISION, contains a variety of material which only experts could select and incorporate in such an excellent volume. "SHORT WAVE RADIO QUIZ BOOK AND KINKS" cannot be bought—it is sent to you absolutely FREE with your subscription to RADIO AND TELEVISION at the Special Rate of Seven Months for One Dollar. (Old subscribers may get this book by extending their subscription.) The book contains 64 pages with a heavy flexible colored cover. It measures 5½ x 8½ inches, and includes hundreds of photographs and diagrams. The contents are outlined below.

Contents of the "QUIZ BOOK"

Questions and Answers Covering S-W transmitters.
Questions and Answers Covering S-W Receivers.
Ultra-Short-Wave Transmitters and Receivers.
S-W "Kinks"—Short-cuts and Practical Wrinkles, Coil Winding Data.
How to Add an Audio Amplifier to a Small S-W Receiver.

How to Connect an R.F. Stage Ahead of Your Present Receiver.

Dozens of Novel New Hook-Ups for the S-W Experimenter.

Clear diagrams showing how to connect the latest type tubes in place of your old tubes, so as to obtain greater DX.

HOW TO "HOOK UP"—

S-W Converters
Noise Silencers
Power supplies
Modulators
Beat Oscillators
Antennas
Pre-selectors
5-meter receivers

RADIO AND TELEVISION • 99 HUDSON STREET • NEW YORK, N. Y.

**TWO OTHER FREE BOOKS FOR YOU!
SHORT WAVE GUIDE**

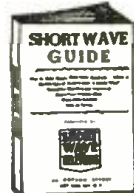

Covers hundreds of Short-Wave questions and answers; illustrates popular Short-Wave kinks; gives instructions for building simple Short-Wave receivers; instruction on the best type of antenna to use; diagram and construction details for building a simple "ham" transmitter; practical hints on Short-Wave tuning.

ABC OF TELEVISION

Contains latest material on Television developments. It covers theory of scanning; simple television receiver, how the eye sees; the photo-electric cell; neon lamps; need for broad channel width in transmission of high-fidelity television signals; cathode ray tube and television receivers; Farnsworth system of television transmission, and other features.



R&T-3-39

Gentlemen: Enclosed you will find my remittance of \$..... for which enter my subscription to RADIO AND TELEVISION as checked below; also send me, postpaid, the book or books which I have marked at the right.

S-W. RADIO QUIZ BOOK AND KINKS
 ABC OF TELEVISION
 SHORT WAVE GUIDE

7 months—\$1.00—choice of any one of three (3) books. (Canadian and foreign—\$1.30)
 14 months—\$2.00—choice of any two (2) of the three (3) books. (Canadian and foreign—\$2.60)
 21 months—\$3.00—all three books. (Canadian and foreign—\$3.90)

If you are a subscriber now, we will extend your present subscription. Old subscriber
 New subscriber

Name..... Address.....
City..... State.....

Send your remittance by check or money order. If you send cash or unused U.S. postage stamps, please be sure to register your letter for your own protection.

New Frequency Meter-Monitor

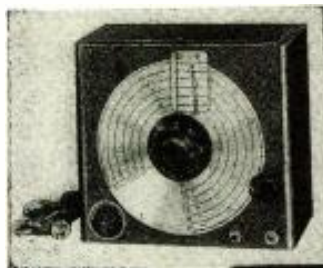

Fig. 1. Front view of instrument at left. Below, Fig. 2, rear view with cover removed.



Fig. 3. Diagram of the New Frequency Meter-Monitor.

● NOW that the Federal Communications Commission has ruled that stations must be accurately monitored, some means of checking frequency must be provided.

One such means, here illustrated, is the new Guthman U10 Frequency Meter-Monitor. This piece of apparatus can be checked to a very high order of accuracy upon nineteen broadcast band stations required by law to maintain frequency to plus or minus 50 cycles. Of course, it can also be checked with WWV, the standard frequency station. Such calibration is accurate to 6 parts in 850,000, according to the manufacturer's claim.

Fig. 1 illustrates the 7¾" accurately calibrated dial which is read against an anti-parallax indicator for the 160, 80, 40, 20, 10 and 5 meter amateur bands. Calibration covers 324 degrees out of a full 360 degree circle 7¾" diameter, with low frequency bands at inside and high frequency bands progressively toward the outside edge. This gives a maximum effective scale length of 21¾" for the outer scale, which is devoted to a vernier scale of 500 divisions, readable to one-half division.

This dial may be rotated either directly or through a 12-to-1 vernier reduction knob. At lower right is the on-off switch and head-phone jack, with input coupling through the small jack at the upper right. The knob and dial at lower left are the zero-setter, or calibration setter. By first setting the main dial to any standard frequency station signal and then adjusting the zero-setter knob to zero beat, oscillation is automatically made accurate for the entire dial scale to closer than it can be read, the manufacturer claims.

Fig. 2 shows a means designed to attain stability. The frequency determining electron-coupled oscillator circuit comprises a very wide-spread, steatite-insulated, ball-bearing tuning condenser, high-Q 15/41 Litz inductance wound on low temperature-coefficient steatite form, and padding or "swamping" capacity of low-drift construction, completely ceramic-sealed. These units are housed in a tightly closed metal box, the back

of which has been removed for visibility. A "dead air" mass around the frequency determining circuit, which resists temperature changes, is provided by this box, itself enclosed inside the outer cabinet. Stability is further assured by using the preferably continuously running tube heaters as heating elements to maintain temperature within a narrow and stable range, well above room temperature.

The fundamental range of the oscillator is 850 to 1030 kc. in order that it may be checked directly against the signals of broadcast stations tuned in on the receiver—or even directly upon the frequency meter in the case of "locals," for it is itself a receiver. Harmonics of this range cover 1700 to 2060 kc., thus including both new and old 160 meter amateur bands. Through the use of a 43 power pentode as oscillator, it can be run in the frequency-stable range well below maximum rating, and at the same time put out strong harmonics down into the 5 meter band.

External coupling is to the plate of the 43 electron-coupled oscillator, in itself forming no part of the oscillator circuit, and additionally isolated by a small 3-30 mmf. adjustable coupling condenser. To be of maximum use both for measurement of transmitter frequency and for received signal frequency as well, a high-gain pentode functions as a beat-note detector-amplifier, coupled to the isolated oscillator plate circuit. This detector-amplifier is the pentode section of a 25A7G dual tube, its diode being the power-supply rectifier. A.C.-D.C. operation is provided, not for economy so much as to obtain the best possible supply voltage regulation. Omitting the usual power transformer, which always introduces some regulation problems, operation is direct from the power line, with only the "B" supply filter and rectifier tube as elements to affect regulation, which further increases flexibility besides improving regulation.

The manufacturer states that drift over 24-hour test periods has been unmeasurable—apparently less than 1 cycle in 1,000,000.

The "Switched Coil-4"— A Practical Superhet

(Continued from page 685)

heavy leads, particularly if they must be overly long. (Voltage drop in the leads will materially affect genemotor output.) Check for *hash* with the receiver in operation. If it is bad with higher frequency front-end coils in circuit, check the shielding for A "hot" and B plus leads, increase that shielding as much as possible, check for single point genemotor chassis-contact, and if reception doesn't clear up install R.F. chokes in the B plus and A "hot" leads—chokes, by the way, designed for the frequencies over which the *hash* is really serious and with any A "hot" item of sufficient capacity to handle the genemotor drain on the battery.

Applications

This job makes a perfect receiver for the farm, summer camp, week-end cabin, and whether the user is an amateur, short-wave enthusiast or simply broadcast listener.

Secondly, it is entirely in line with general marine-service requirements, as it covers the important ship-to-ship, ship-to-shore and U. S. Coast Guard radiotelephone frequencies. It is well shielded, and its parts are amply protected against the severe atmospheric extremes which are encountered.

Third, it is just the thing for the truck or trailer or for general mobile application.

Finally, it is a logical design for emergency service—when a.c. power fails or when installations must be set up either at home or in temporary camps during flood and similar conditions.

NOTE: If this super is to be used in a car and if the vehicle is to be driven in areas affected by municipal ordinances or state laws limiting auto set frequency coverage, some changes in front-end design will be necessary to prevent receiver tuning to and through the taboo wavelengths. The individual builder *must* observe whatever regulations are in effect in his driving area—and *should* find out from local authorities just what the restrictions are before purchasing the coils for his front-end assembly.

Parts List

PAR-METAL

- 1—Type HC-9151 steel cabinet (9x15x11 inches)
- 1—Type C-4524 chassis (10x14x3 inches)
- 1—Type UC-565 or larger shield cabinet

I.R.C.

- Half-watt resistors: R2—400 ohms; R1—50,000; R3—50,000; R4—2,000 or 1,000; R5—30,000; R6—300; R7—100,000; R8—1,000; R9—10 megohms; R11—2,000; R12—50,000; R14—50,000; R15—20,000; R16—20,000; 2 watt: R17—400 ohms
- Variable: R10—1,000 ohms; R13—500,000 ohms

AEROVOX

- Type 484 400 volt tubular—C12; C15; C21; C22; all 0.1 mf.
- Type 484—.05 mf.—C8; C20
- Type 284—.1 mf.—C10, C11, C13, C14
- Type 484—.25 mf.—C23
- Type 484—.006 mf.—C25
- Type PR25—.25 mf.—C24, C17
- Type 284—.25 mf. or larger—C26, C27
- Type 1467 mica—C16—.001 mf.; C9—.0001 mf.; C18—.002 mf.

HAMMARLUND

- C1—C3—both type MC-260
- C2—C4—both type MC20
- Antenna circuit trimmer, if required—type HF-15
- 2—APC couplings

CARTER (Gen-E-Motor)

- 1—Dynamotor for 6-volt operation; filtered for A.F. 40 ma., 200 V. or 50 ma., 200 V.

for March, 1939

Complete RADIO TRAINING for \$1.95

Regular \$39.00 RADIO TECHNICAL INSTITUTE Course



AN UNUSUAL OFFER

A limited quantity of R.T.I. \$39.00 radio servicing courses have been re-printed and are offered to you at only \$1.95. These are the latest 1937 courses, complete in every detail with all supplementary material, and exactly the same as the originals.

Radio is the present-day opportunity field. Hundreds of men with no special talents have studied Radio Servicing for a short time and are now making twice and three times as much money. R.T.I. unique radio training brings rich rewards; you can get ready quickly, inexpensively, easily, and in your spare time for a good job in radio.

ACCEPTED BY INDUSTRY

Forty large radio manufacturers have helped to prepare the R.T.I. course. Just think what this backing by the radio industry means to you. R.T.I. practical training will give you facts and real data you will need on the job. Hundreds of diagrams and illustrations will help you. You will pass quickly from lesson to lesson and in a surprisingly short time will be ready to do real radio servicing.

COMPLETE IN ALL DETAILS

No special previous education or experience is needed. R.T.I. course will give you all the training you need. The lessons are clear, interesting, easy to master and use. Fellows who knew nothing about radio before taking the R.T.I. course are now the leading servicemen in their communities. This is your chance to obtain this excellent course for only \$1.95. From the very start you are introduced to practical servicing equipment and practices. You are told how to open your own shop or radio store. Lesson 15, "The Radio Servicing Business," will give you many practical ideas and hints. The course is so planned that you will be able to earn spare-time money before you have reached your tenth lesson. The special \$1.95 price of the complete course can be earned in a single evening's work.

YOUR GUARANTEE

You are completely protected. We guarantee these courses to be exactly as the original \$39.00 Radio Technical Institute course. Money back guarantee. References: Liberty National Bank, Chicago.

THREE COURSES IN ONE

R.T.I. course is really three complete essential courses combined. You get training in (1) Practical and Applied Radio; (2) Fundamentals of Radio Principles; and (3) Advanced Specialized Training. This is the training that will place you above the average radio servicemen—and you get this training for only \$1.95.

There are over 32,000,000 radio sets in use. Over 4,500,000 auto radios alone. You should cash in on this gigantic money market. The R.T.I. easy practical course will pave the way to your success in Radio work.

TELLS HOW TO USE INSTRUMENTS

The training is complete. Everything from simple facts to complex alignment problems. Many servicemen have found that R.T.I. training is excellent for brush up and study of modern servicing methods. This is the best buy in a radio education. Take advantage of the bargain price today.



LATEST DATA

Yet, in the R.T.I. course you will find a complete explanation of A.V.C., how to use an oscilloscope, sound feed-back, resonance phenomenon . . . every possible fact you must know to be the best servicemen. You get a real radio training. One of the BEST radio courses is yours for only \$1.95.

LIMITED QUANTITY

Hurry your order to us today. There is but a small quantity of the courses left at the special price. You are completely protected with our guarantee. Send total remittance with order, or we will ship C.O.D. Postal money orders, checks, currency, unused stamps accepted. Answer today.

SUPREME PUBLICATIONS, Agents 3729 W. 13th Street, Chicago, Ill.

Please send the complete R.T.I. radio course at the special \$1.95 price.

- I am enclosing \$1.95, send prepaid.
- Send C.O.D. I will pay mailman \$1.95, plus a few cents postage.

NAME
ADDRESS

CROWE

- 1—type 124 dial
- 1—type 28 dial plate
- 1—type 27 dial plate
- 4—type 588 or 286 knobs

MEISSNER

- 1—24-8255 rotary switch—SW5-6
- 1—type 24-9204 six-gang coil shorting rotary switch
- 1—coil assembly rear shield partition, if available
- 1—coil assembly middle shield partition if available
- Set of individual coils to include: 1—14-7921; 1—14-7942; 1—14-7990; 1—14-1018; 1—14-7922; 1—14-7938; 1—14-7954; 1—14-1020
- Padding condensers: one each of types 22-7961; 22-7733; 22-7731; 22-4137
- 1—16-5740 input I.F. trans (456 kc.) and one 16-5742 output
- 1—small broadcast coil, nro type 14-4034 for regen.

YAXLEY

- 1—double circuit phone jack

AMPHENOL

- 1—RSS8 steatite octal socket; three S8 moulded octal sockets; one PM 4 male receptacle; one PM 5 male receptacle; one S3 chassis receptacle or socket

NOTES:

1. Individual R.F. coil trimmers come wired to the coils.
2. C5, C6, C7 are the Osc. circuit padders.
3. Suggested tubes are RAYTHEON, one each of the following: 6J8G; 6K7G; 6C8G; 6V6G.
4. By substituting a type 6G6G output tube for the 6V6G, more economical operation will result. A 50 ma. Genemotor may be employed which will easily fit into the PAR-METAL shield box specified. A.F. output will be down to approximately 1.1 watts—entirely sufficient for mobile operation.

L1 through L8 are the R.F. coils. Optional is L11—a shielded JEFFERSON 1-4 ratio interstage audio transformer, single plate to single grid.

Minimum range extension with the U.H.F. coils in connection (31 mc.) is not guaranteed. Every care must be used to keep leads short and direct in the "front end" if this possible extension is to be reached, with the paralleled tuning condenser arrangement recommended.

ALL METAL UTILITY CABINETS

Indispensable for keeping under lock and key all VALUABLE parts including your QSL or SWL cards. Top drawer has 10 compartments for small parts. In the 6 and 8 drawer cabinets, the two lower ones are made into one unit to hold tubes, crystals, meters, pick-ups, camera lenses, films, microscopes, slide rules, etc. In the smaller compartments you can keep resistors, condensers, bolts, nuts, washers, etc., from being "borrowed".



Drawers	Height	Depth	Width	List
6 drawers	9"	8 1/2"	6"	3.50
8 drawers	11"	8 1/2"	6"	4.50

Bar with lock and key \$0

Finished in wrinkle, olive green. Amateur's Discount, 40%. Write for complete catalog. Ask your dealer to show you a sample. If he has none, send your order direct.

KORROL RADIO PRODUCTS CO.
350 Greenwich St., Dept. 339, New York City

Headset Headquarters GUARANTEE CANNON-BALL



Scientifically Built
Heavy bar magnets greatly increase their efficiency.

Phones to give absolute satisfaction. Unusually sensitive. Noted for fidelity and clarity of tone. Folder T-3 illustrates complete Cannon-Ball line. Write

C. F. CANNON COMPANY
SPRINGWATER, N. Y.

Please say you saw it in RADIO & TELEVISION

RADIO INSTRUCTION

LEARN CODE the RIGHT way!

Don't waste time trying to learn code by yourself! You can acquire real operating skill, easier, quicker and sounder, by the Candler method. When you start with Candler you are started RIGHT, with the correct fundamentals, and make more progress in a few weeks time than you will with months of undirected practice. You learn sound consciousness, with the Candler method, reading letters instead of dots and dashes and soon you read whole words without strain or effort just as you read print, and acquire the ability to copy behind like the skilled operators on the commercial lines. Write for the FREE Book of Facts! Read how Candler trained thousands of successful commercial and skilled amateur operators. Send for your copy today!



CANDLER SYSTEM CO.

Dept. S-3, Box 331, Asheville, No. Carolina
British Address: Room 56, Craven House
Kingsway, London W.C.2.

YOUR FUTURE IN RADIO TELEVISION

These growing industries need trained men for sales, service, operation. Your chance for employment and advancement depends on thorough training. National Schools offer you time-tested training. Complete, modern facilities and equipment in the largest trade school in the West. Est. 1905.

Send for free booklet that shows how you can prepare for these opportunities.



NATIONAL SCHOOLS

4000 S. Figueroa Street, Los Angeles

NATIONAL SCHOOLS, Dept. S-RT, Los Angeles

Please send free Radio and Television Booklet.

NAME _____ AGE _____
ADDRESS _____
CITY _____ STATE _____

LEARN CODE RIGHT

Always ready—no weather interference—books having someone send to you. Speed keys 5 to 40 W.P.M. Radio or Morse. STANDARD with 10 tapes and book of instructions... \$2.00. JUNIOR with 5 tapes and book of instructions (not rented)... \$12.00. Complete oscillator equipment less battery... \$6.50. RENTAL Standard with 10 tapes and books of instructions \$3.00 first month, \$2.25 each additional month, with transformer and tube socket 25c per month more, with key and head phones 30c per month extra, \$10 deposit or business references required. Write for details today.



INSTRUCTOGRAPH COMPANY

Dept. SW-3, 912 Lakeside Place, Chicago, Ill.
Representatives for Canada:
Radio College of Canada, 863 Bay St., Toronto

AMATEUR RADIO LICENSES

Day and evening classes in code and theory
Home Study Courses

Hundreds of students now on the air. Results guaranteed. Reasonable, efficient and thorough.

AMERICAN RADIO INSTITUTE
1123 BROADWAY NEW YORK, N. Y.

RADIO ENGINEERING

broadcasting, aviation and police radio, servicing, marine radio telegraphy and telephony, Morse telegraphy and railway accounting taught thoroughly. 48 weeks' Engineering course equivalent to 3 years of college radio work. All expenses low. Catalog free. School established 1874. Dodge's Institute, Turner St., Valparaiso, Ind.

New Tubes for Television

(Continued from page 678)

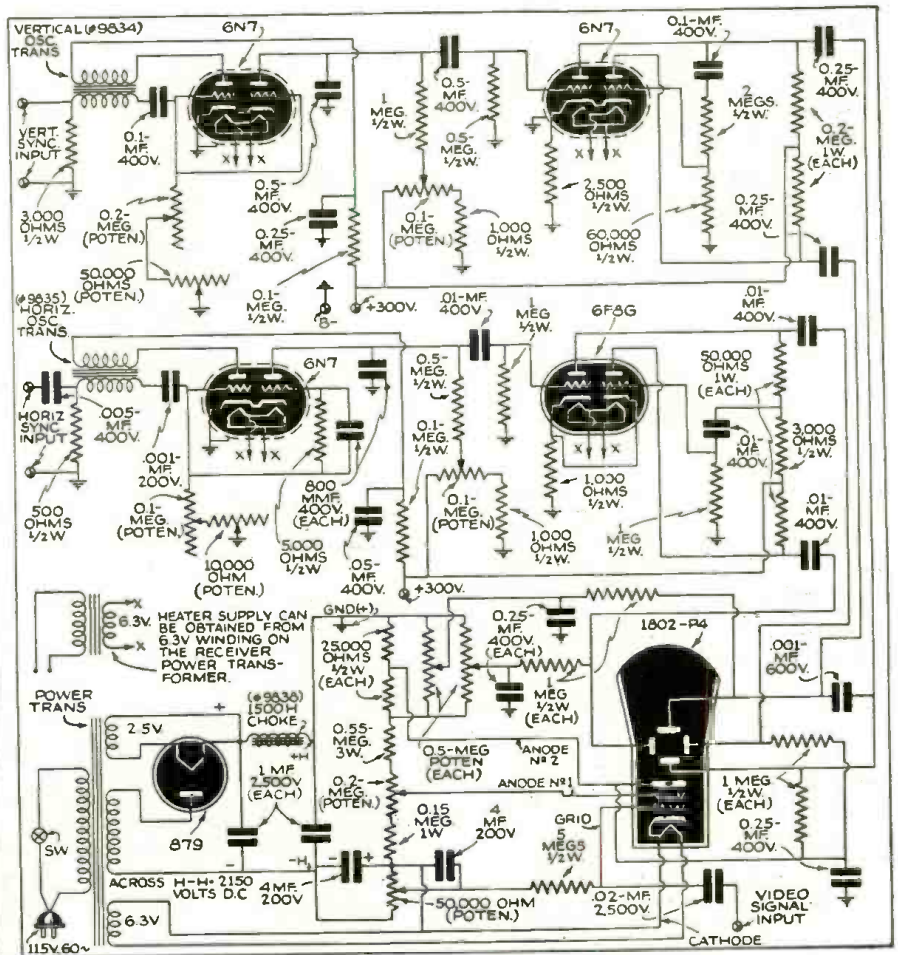

Hook-up for new RCA 5" dia. Television C-R tube (black and white image) No. 1802-P4, Electrostatic Deflection Type.

D.C. voltages necessary for kinescopes and cathode-ray tubes. The peak inverse voltage of the 2V3-G is 16,500 maximum, while the peak plate current is 12 ma. maximum.

New Acorn Tubes

A new series of Acorn tubes—types 957, 958 and 959—are also announced. These have low-current filaments of the coated type and are designed for amateur and experimental use in ultra-high frequencies.

All operate on 1.25 filament voltage and a maximum plate voltage of 135.

The 957 is a triode, for use as detector, amplifier or oscillator. It has a moderately high amplification factor. The 958 is a triode, especially designed for use as oscillator or R.F. amplifier in a transmitter; it may also be used as an audio power output tube for phone or sensitive speaker. The 959 is a sharp cut-off pentode, to be used as R.F. amplifier, detector or moderate gain resistance-coupled A.F. amplifier.

An Inexpensive Mike

(Continued from page 669)

bulged slightly outward. The cable used was the regular standard crystal cable consisting of a single inner conductor with the shield used as the grounded conductor. The three-prong shielded Amphenol plug was used, as it fitted all of the station's equipment, and provided an ideal shielded installation. The mike unit itself is entirely shielded due to the case and screening. The mike stand is a cheap commercial stand costing around a dollar, but a stand can be built with the standard thread at the top very easily and inexpensively.

The general color scheme was crackle

black and chrome, the headlamp being painted over.

The connection between the case and stand presented a rather knotty problem, but was finally solved with the use of a mike adapter cut off and soldered to the half of the bracket bolted to the bike light case and bent back. The cable leaving the case was secured to this with a light homemade clamp constructed of about No. 8 wire, soldered.

The sectional view drawing will be found self-explanatory and helpful in construction.

The complete mike cost less than six dollars.—Philip Whitney, Engineer, WJEL.

NEW RADIO APPARATUS

R.F. Amplifier Kit

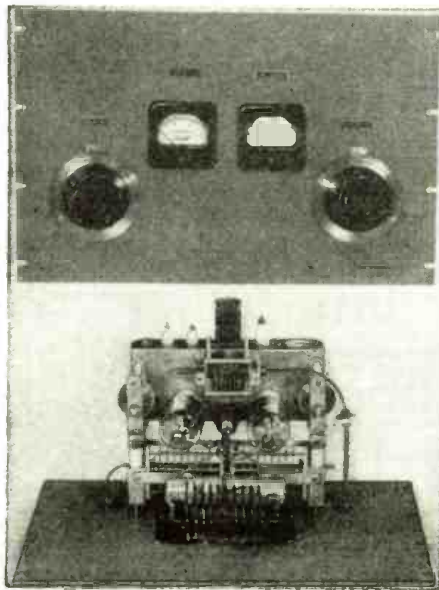

New R.F. Amplifier Kit

● **HERE'S** a new 500 watt Radio-Frequency Amplifier in kit form, announced by Bud Radio, Inc., which is to be the first of a series of knock-down units intended for amateur construction. It is designed primarily for operation on 5, 10, 20 and 40 meters.

There are no closed loops of any sort in either the tuning condenser or in the layout itself. This has been accomplished through utilizing a semi-skeleton type of construction.

The structure of this BPA-500 amplifier is such that it will accommodate any of the various low and medium power triodes in push-pull, and while it is conservatively rated at a maximum of 1750 volts and 500 watts plate input, it is equally efficient at inputs as low as 75 watts. This feature enables an amateur, wishing to start moderately, to utilize a pair of low-priced triodes at a low plate voltage; then, at any future date, a power increase is effected by merely substituting more rugged tubes and raising the plate voltage, no mechanical alterations being necessary.

The difficulties of good mechanical layout and machining are eliminated due to predetermined design. Each kit is supplied complete with wire, drilled and formed sheet metal, rack panel, hardware, etc., but less tubes and meters.

New Portable Receiver



● **THIS** RCA four-tube, single-band, battery-operated superheterodyne covers from 550 to 1560 kilocycles. Its tubes are: a 1A7G, first detector and oscillator; a 1N5G, intermediate frequency amplifier (455 kc.); a 1H5G, second detector, A.V.C. and A.F. stage; and a 1C5G, power output. The set requires 1½ volts of "A" battery and two 45-volt "B" batteries. It consumes but .24 ampere "A" and 9 milliamperes "B," providing an undistorted output of .1 watt or a maximum output of .21 watt. The cabinet is 14" long by 7¾" high by 8¾" deep, and the set, complete with batteries, weighs 16 pounds. The antenna is a built-in loop but external antenna and ground posts are provided, when a permanent installation is made and greater sensitivity is required.

Wireless Record Player

● **A** PHONO-GRAPH record player which operates through any radio set without any connection whatsoever between the two, has just been introduced by the Wholesale Radio Service Company. The new unit is plugged into any 110 volt a.c. outlet and produces a modulated carrier at a frequency of about 1200 kc. The instrument is provided with a jack into which a microphone may be plugged for announcing "home broadcasts"; a crystal pick-up and a turn-table which will accommodate all records up to 12 inches; and its own volume control.



New Hi-Capacity Low-Voltage Condensers

● **NEW** hi-capacity, low voltage dry electrolytic condensers in round aluminum cans for use with "A" eliminators, moving picture sound equipment and other similar circuits have been introduced by the Sprague Products Company. Seven units ranging from 500 mf. at 12 volts to 2,000 mf. at 25 volts are now available. These new condensers are known as Type HLV.



New Speed Key

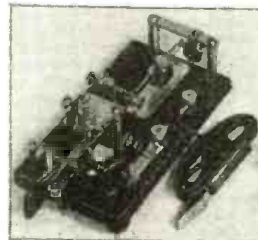

● **HERE** is a new professional type speed key. This "hug" will send out a string of dot signals at a mere flip of a single lever horizontally. This is made possible by means of an accurately designed adjustable pendulum attached to the free end of the lever. The key is fitted

with two pairs of large silver contact points, one for dots and the other for dashes. The key is equipped with a cord and jack plug and it is available in a black crackle finish; or at a slight additional charge, in a nickel plated finish. The Martin Flash Key is manufactured by the Martin Research & Manufacturing Corp.

All Metal Cabinet Parts for Valuable Parts

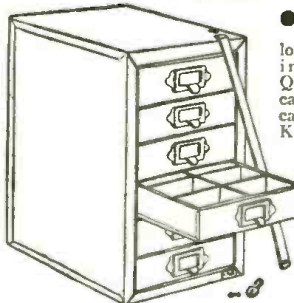

● **A** N indispensable item for locking up parts, including your QSL or SWL cards is this neat cabinet made by Korrol Radio Products Co. The small size unit measures 9" x 8¾" x 6" and has six drawers, the top drawer having ten compartments for small parts and the two

lower drawers being made into one unit to hold tubes, crystals, meters, pick-ups, camera lenses, films, micrometers, slide rules, etc. Resistors, condensers, bolts, nuts, washers, etc., can be kept in the smaller compartments. It has an olive green wrinkle finish.

YOU NEED THIS FREE BOOK

It's a money saver.

Sound specialist, serviceman, experimenter, ham — whatever you are, this book is your "baby"! A radio catalog so packed with values, it takes 188 newsy pages to describe 'em! Here, for quick easy reference, arranged so you can compare brands, is every possible radio part and tool. Plus a P.A. section presenting LAFAYETTE'S big complete line for '39. Everything priced low in this great guide to thrifty buying. Send for your FREE copy of Catalog 73 today. Just mail the coupon.

WHOLESALE RADIO SERVICE CO. Inc.
 NEW YORK, N.Y. • CHICAGO, ILL. • ATLANTA, GA.
 100 S. 5TH AVENUE • 901 W. JACKSON BLVD. • 203 PRINCETON STREET
 BOSTON, MASS. • BRONX, N.Y. • NEWARK, N.J. • JAMAICA, L.I.

WHOLESALE RADIO SERVICE CO., Inc.
 Dept. 4C9-100 Sixth Ave., New York, N. Y.
 Rush FREE RADIO Catalog No. 73

Name _____ PLEASE PRINT
 Address _____
 City _____ State _____

PASTE COUPON ON PENNY POST CARD

NEW CATALOG FREE!!



Send TO-DAY for our BIG 1939 Catalog describing the complete Par-Metal

line of Racks, Panels, and Chassis. See the many combinations possible with these modern units. Servicemen — Builders — Amateurs — you NEED this catalog! Write at once to

PAR-METAL PRODUCTS CORP.
 3529 41st Street, Long Island City, N. Y.

SHORT WAVE CONVERTERS FOR CAR RADIOS



Can be attached to any car radio

MODEL 600 covers 49-31-25-20-19 and 16 meter bands. Designed for American and Foreign short wave broadcast. Distance range 5000 to 10,000 miles. List Price \$24.95

MODEL 700 long wave covers 135 to 410 kc. Receives gov. weather reports, etc. List Price \$24.95

POLICE UNITS
MODEL 100 with fixed condensers, covers 1600 to 2600 kilocycles. List Price \$11.95

MODEL 800 Super Sensitive police converter with fixed condenser. Covers 1500 to 2600 kc. Two metal tubes, exceptional distance range. List Price \$15.95

MODEL 200 with variable condenser, covers 1500 to 6000 kilocycles. List Price \$17.95

MODEL 500 with variable condenser and illuminated dial. Very sensitive, has two metal tubes. Exceptional distance range. List Price \$21.95

Jobs and Dealers wanted

ABC RADIO LABORATORIES 3334 N. New Jersey St., Dept. RT-3, Indianapolis, Ind., U.S.A.

WESTINGHOUSE UNIVERSAL MOTOR

\$2.55 110 Volts
AC and DC
Shipping
Weight
3 lbs.

Specifications: 1/30
H.P. operates on either
A.C. or D.C., 110 volts.
5000 R.P.M. Rheostat
can be used to vary speed.
Height 3 1/4", Length 3 3/4",
Width 1 3/4", Shaft 1/4", one
inch long. Can be used to
drive Sewing Machines, Mod-
els, Buffing Lathes, Polishing
Head, Drills, Grindstones,
etc., etc.



MOTOR only **\$2.55**
MOTOR with Arbor and 1/4" Chuck **\$3.55**

Add 25c for special packing and mailing
anywhere in U. S. A.

Westinghouse Power Generator

Manufactured for U. S. Signal Corps
200 Watt. 110 V. AC

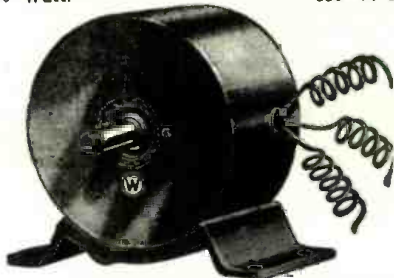

A. C. ELECTRICAL POWER

from a Windmill, from available Waterpower, from your
Automobile, from your Motorcycle, from your Bicycle, Foot-
pedals or Handcrank (for transportable Radio Transmitters,
Strong Floodlights, Advertising Signs); do you want to
operate AC Radio sets from 32 V. DC farm light sys-
tems; operate two generators in series to get 200 V.
AC; obtain two phase and three phase AC, etc., etc.

There Are Over 25 Applications
Some of which are:

A.C. Dynamo lighting from eight to ten 20 Watt 110
Volt lamps. Short Wave Transmitter supplying 110 Volts
AC for operating "Ham" transmitter. Operating 110 V.
AC 60 Cycle Radio Receiver in DC districts. Motor Gen-
erator. Public Address Systems. Electric Sirens on motor
boats, yachts, etc. Camp Lighting. Short Wave artificial
"fever" apparatus. Television. Pelton Waterwheel for
lighting or other purposes. Airplane: for lighting strong
searchlights or electric signs. Laboratory work, etc., etc.
1/4 to 1/2 H.P. needed to run generator.

BLUE-PRINT 22 x 28 in. and Four-Page
8 1/2 x 12 in. INSTRUCTION SHEETS
FREE with Generator.

Generator, as described, including four re-
placement carbon brushes. Blue-print and
Instructions **\$7.90**

Send \$2.00 deposit, balance C.O.D.

Shipping weight 48 lbs.

(Replacement carbon brushes bought separate \$1.50 per
set of four. Set of instructions bought separate \$1.00.)

MONEY-BACK GUARANTEE

WELLWORTH TRADING COMPANY

580 West Washington Blvd., Dept. RT-339, Chicago, Ill.



SALESMEN WANTED:

Radio Hams to represent us
in the sale of shortwave
diathermy units to phys-
icians. Good territories open
in Detroit, Minnesota, N. J.,
N. C., Ga., Fla., Ky., W.
Va., Tex., and the South-
west. Liberal commission.

Established 60 yrs. McINTOSH ELEC. CORP., 227 N.
California Ave., Chicago.

5 METER CRYSTAL CONTROL

Bliley HF2-10 METER CRYSTAL

Your Bliley
dealer will tell
you how to build
a simple, highly ef-
ficient 5 meter crystal
controlled transmitter.
Bliley Electric Co.,
Erie, Pa.

"Wireless Remote" Phono Pick-Up

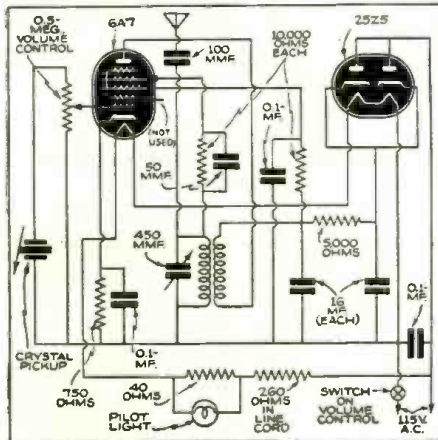

Appearance and Hook-Up of "Wireless" Record
Player.

● THE advent of wireless remote control tuning
for radio receivers has aroused a new interest
in low-power transmitters used to link various
adjuncts to the radio set. It permits a radio to
be located in one portion of the room and to play,
through its loud-speaker, recordings which are on
the turntable in another part of the house and not
connected to the radio by any physical means.

The Allied Radio Corporation is producing the
two-tube "Magic Wireless" record player shown.

The antenna may be a metal plate inside the
record player cabinet, or may be a short length
of wire extending from the cabinet. If such wire
is placed close to and parallel with the lead-in
of the radio receiver, best results will be obtained.
It will perform, however, up to twenty feet away
from the set and may be operated from any
110 volt a.c. or d.c. power line.

New Stand-Off Insulators

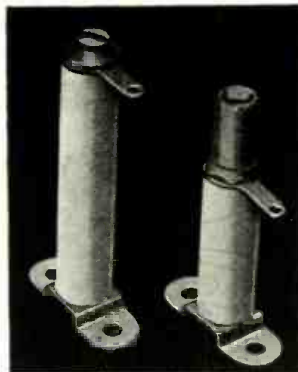

● A COMPLETE line of stand-off insulators
made of pure Isolantite has been announced
by the Hammarlund Manufacturing Company.
This material, according to the manufacturer, is
less liable to breakage, chipping and stripped
threads than the ordinary porcelains. The tips,
provided in both plain and jack type, are heavy
machined brass, cadmium plated. The base is
constructed for two-hole mounting but is removable
for single-hole mounting for which cork washers
are furnished. The insulators are available in a
variety of sizes from 3/8" to 3 1/4" in length, and
1/2" or 3/4" in diameter.

FREE - REAL ELECTROPLATING OUTFIT



Now
You Can **ELECTROPLATE**
Easily with a **BRUSH!**

SOMETHING new for amateurs, fans, set build-
ers—something which gives you the oppor-
tunity with which to experiment. Here's an
ELECTROPLATING KIT amazingly simple to
operate—you just Electroplate with a Brush! Re-
quires only one single dry cell.

NOT A TOY

You can electroplate for profit, hundreds of things in the
household—ashtrays, fixtures, water faucets, worn brack-
ets, door knobs, musical instruments, jewelry and silver-
ware and other articles. It's an indispensable piece of
equipment to you for plating articles in hotels, apart-
ments, office buildings, medical and dental offices, fac-
tories, schools, laboratories, etc. Exactly the same outfit
(but larger) is used professionally by electricians, radio
service men, automobile repair shops, etc. And for radio
work, you can electroplate tarnished receiver parts, chassis,
contacts, worn radio parts and accessories.

Put this REAL ELECTROPLATING KIT to use im-
mediately—make it the most useful article in your lab
or work bench. And, you can set it absolutely FREE
(except for slight mailing cost).

Send your subscription today to RADIO AND TELEVI-
SION for One Year (12 issues) and receive absolute-
ly FREE one of these REAL ELECTROPLATING KITS
—New subscribers are accepted or you may extend your
present subscription another twelve months under this
offer. Mail your remittance of \$2.50 (Plus 10c for ship-
ping charges on kit) to the publishers of RADIO AND
TELEVISION. (Canada and foreign \$2.85.) You will
promptly receive your FREE REAL ELECTROPLATING
OUTFIT by return mail. Use the coupon below to order
your subscription.

RADIO AND TELEVISION

99 Hudson Street

New York, N. Y.

RADIO AND TELEVISION

99 HUDSON STREET, NEW YORK, N. Y.

Gentlemen: Enclosed you will find my remittance of \$2.50
for which enter my subscription to RADIO AND TELEVI-
SION for One Year (12 issues). Send me promptly my
FREE REAL ELECTROPLATING OUTFIT. (Canada and
foreign \$2.85.) In U.S. add 10c additional to cover
shipping charges on kit.

() NEW SUBSCRIBER

() EXTEND PRESENT SUBSCRIPTION

Name

Address

City State

(Send remittance by check, money order or unused U. S.
Postage stamps. Register letter if you send cash or
stamps.)

RT-3-39

NEW CATALOGS

New Condenser Catalog

● THE complete line of condensers offered by Sprague Products is described in a new 16-page catalog. Among the units featured are: the Atom midget dry electrolytics in both single and dual combinations; type HLV high capacity, low voltage aluminum can dry electrolytics; types DR and RP dielectric paper replacements for dry electrolytics; numerous new auto radio units; silvered mica condensers; type CR oil impregnated rectangular transmitting condensers with universal mounting brackets; type PC inverted screw can round condensers for P.A. and transmitter work, television and high gain amplifiers; universal replacement condensers and universal motor starting condensers. The new catalog also lists several hundred of the company's exact duplicate replacements for radio receivers and for motor starting.

Burstein-Applebee Catalog

● THE new Burstein-Applebee Company catalog is a large 162-page issue devoted almost entirely to radio parts, sets, accessories and test equipment. There is an exceptionally wide choice of test units, for more than a dozen pages are devoted to this type of apparatus. The catalog also lists tubes, pick-ups, turn-tables, electric razors, electric flatiron heating units, tools, etc.



Net prices are given on all apparatus; and on the more expensive units, installment prices are also quoted.

Crystal Devices Catalog

● "BRUSH Crystal Products" is the title of a new catalog listing crystal microphones, headphones, pick-ups, and accessories, offered by the Brush Development Company. Among the many novel units shown is a combination unit microphone and desk stand. The stand is of the goose-neck type and may be bent into almost any position. Both diaphragm and sound cell microphones are listed in the catalog which also features a high fidelity mike with a response flat from 30 to 10,000 cycles, plus or minus 2 db. at an output level of minus 67 db.

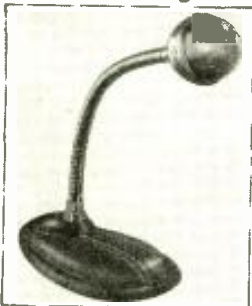

Tube Characteristic Chart

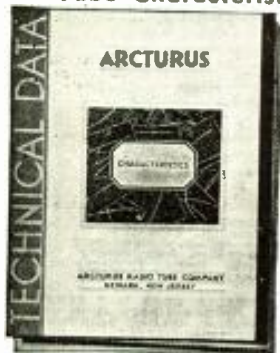

● A NEW tube characteristic chart, first issued by the Arcturus Tube Company, gives complete ballast tube data, in addition to covering 179 different types of Arcturus tubes. The chart shows what tube type numbers are used in various radio sets and indicates what odd types the company's

standard ballast tubes will replace. Formulas are included so that the serviceman may quickly ascertain just what standard RMA type number tube should be used in any set regardless of the original ballast units which may carry only private part numbers. The chart may be wall mounted or kept in a standard data file. Ask for No. 110A.

Meissner's New Catalog

● MEISSNER MFG. CO. has issued a new confidential net price catalog in which are inserted several late additional sheets, including one on 1-, 2- and 3-tube kits, and another on special export kits. Also featured are adapter kits, antenna and r.f. coils, beat frequency oscillator adapter kits, a wide selection of I.F. transformers and oscillator coils, remote control adapters, and eight kits for complete radio receivers. A number of other kits and their components are also described in this book, which has 44 large pages.

Cornell-Dubilier Catalog



● A NEW catalog, consolidating the capacitor listings and descriptions appearing in catalog No. 161, has been released by the Cornell-Dubilier Electric Corporation of South Plainfield, N. J. This catalog, their No. 165A, consists of 12 pages and is complete with concise information on their entire line. It is an ideal quick reference for required capacitors, for servicemen and engineers. Copy

of this catalog sent free on request.

Mail Order Catalog

● THE 1939 Montgomery Ward radio catalog lists a wide variety of public address systems ranging from small 5-tube, 12-watt types to mammoth systems employing 16 tubes and providing output up to 100 watts and suitable for large auditoriums. Also included in the book are turn-tables and pickups, microphones and accessories, loud speakers, hearing aids, test instruments, tools and radio set components. A special line of amateur and S.W.L. receivers is also featured, as are a number of parts and units for use in transmitters. The catalog is printed in rotogravure and has 56 large pages.

New Sears Catalog

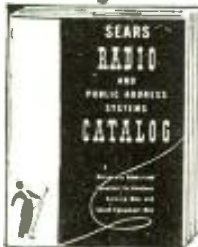

● A 44-PAGE equipment catalog especially for radio "hams," servicemen and sound equipment men was recently issued by Sears, Roebuck and Co.

Because he is an old time "ham" operator, Parker Wiggin, head of their radio department, personally supervised the production of the book. As a result the quality requirements of amateur radio operators have formed the basis of the line presented.

Hammarlund Catalog

● HAMMARLUND'S 1939 catalog lists the "MC" midget condensers, the "MCD" split-stator condensers and the "X" type double-spaced condensers, as well as the "R" type band-spread condensers. There is also a large section on transmitting condensers and another on various types of "micro" condensers. Plug-in coil forms for receiving and transmitting purposes are also featured in various designs, as are Isolantite sockets for standard and Acorn tubes. Other items included in the book are coil and tube shields, flexible couplings, chokes for a number of purposes, intermediate transformers, and trimming and padding condensers. There is also a complete description and price list of the new "super-pro" receivers in models that will tune from 7 1/2 to 240 meters or from 60 to 550 meters.

Taylor Tube Catalog

● 1939 CATALOG and Manual, 44 pages with index, illustrated. Published by Taylor Tubes, Inc., Chicago, Ill. The new Taylor Tube catalog contains 44 pages of information, including not only the company's various type of tubes but also several highly interesting circuit diagrams. One of the pieces of apparatus described in words, pictures and schematics is a De Luxe all-band transmitter which uses 275 watts plate modulated input. Another unit on which all data is given is a quick band-change 125 watt input transmitter, while another is a 450 watt phone and c.w. job. A 150 watt transmitter and an economical 100 watt grid modulated phone rig, complete with constructional details, are also covered.

As to tubes, many popular types are described, together with their complete characteristics and prices. There is also much general information on testing and selecting tubes and choosing the right tube for specific functions. Ask for No. 111A.

Sound Amplifier Guide

● BULLETIN No. 346-D just published by Thordarson Electric Mfg. Co., presents practical and theoretical information on amplifiers ranging from 8 to 120 watts output. Features of this 32-page book are a high quality phono-radio amplifier with volume expansion and tone controls, and a combination 6-volt—115-volt portable amplifier capable of delivering high undistorted output. Each circuit is complete with diagrams, parts lists, constructional data. Ask for No. 112A.

CARBON FIXED RESISTORS



CONSOLIDATED Fixed Carbon Resistors are the result of years of research and experimentation to produce a resistor of suitable operating characteristics for the radio trade. They are of solid molded construction, permanently bonded into one compact unit. Resistance variation is maintained at a 5% average—and is guaranteed within 10% plus or minus. They are quiet in operation—completely moisture-proof and non-inductive, having no capacity effect—and maintain their resistance values over an extremely

wide temperature range. Packed in attractive three-color cartons and sold only through recognized parts jobbers.

See Them at Your Parts Jobber's Today!

CONSOLIDATED
WIRE AND ASSOCIATED
CORPORATIONS
528 S. PEORIA ST. CHICAGO, ILL.

U. S. ARMY SIGNAL CORPS LAMPS



The lamp of 100 uses

- Scout Signaling
- Night Bowling Alleys
- Trailer Lamp
- Night Motor Boat Races
- Auto, Truck and Trailer Camps
- Tractor Light
- Camp Light
- Barnyard Lighting
- Night Fishing
- Radio Shacks
- Bungalows
- Picnics, etc.



Large size—12 1/2" wide, 5 3/4" deep, 1 5/8" high including socket, fitted with 10" silver plated reflector (no glass, nothing to break). Packed in portable wooden carrying case, with hinged cover, flap and handles. Every case contains weatherproof extension cord and plug, 2 extra bulbs, telescope alignment key and 16 page instruction Manual. Shipping weight 18 lbs. Price (Cost the Government's about \$25.00) **\$2.50** F.O.B. N. Y.

Send for catalog containing full descriptions of this and many other interesting items.

GOLD SHIELD PRODUCTS
Dept. RT-3-9 350 Greenwich St. New York

EVERYTHING IN RADIO!

A COMPLETE SOURCE FOR YOUR RADIO NEEDS
Our immense stock of radio sets, parts and supplies enables you to purchase your entire needs on one order. You will find all your National-Kenwood Favorites in this big book which is FREE for the asking. Practically every order is shipped the same day it is received.
WRITE FOR BIG NEW CATALOG

BURSTEIN-APPLEBEE CO.
1012-14 McGee St., Kansas City, Mo.

... THESE OUTSTANDING SHORT WAVE BOOKS ARE Now Available AT YOUR DEALER!

YOU buy parts, tubes, kits, accessories from your local radio dealer—that's what countless thousands of short-wave fans do. Now through a nation-wide distribution service our numerous books are available at your favorite radio dealer—right where you buy other radio equipment. It's more convenient, saves time and you can inspect the books before you buy. Ask your dealer to show you all the books advertised on this page—they're always in stock.



101 SHORT WAVE HOOK-UPS

Compiled by the Editors of
RADIO & TELEVISION

Here is a worthwhile book that every short wave listener, every short wave fan, and every short wave amateur has wanted for a long time. It gives you the 101 best short wave hook-ups which have appeared heretofore.
100 Illustrations
72 Pages

50c

HOW TO BUILD AND OPERATE SHORT WAVE RECEIVERS

This is the best and most up-to-date book on the subject. It is edited and prepared by the editors of **RADIO & TELEVISION** and contains a wealth of material on the building and operation, not only of typical short wave receivers, but short wave converters as well.
150 Illustrations
72 Pages

50c



TEN MOST POPULAR SHORT WAVE RECEIVERS

HOW TO MAKE AND WORK THEM
The editors of **RADIO & TELEVISION** have selected ten outstanding short wave receivers and these are described in the new volume. Each receiver is fully illustrated with a complete layout, pictorial representation, photographs of the set complete hook-up and all worthwhile specifications.

75 Illustrations
40 Pages

25c



HOW TO GET BEST SHORT WAVE RECEPTION

M. HARVEY GERNSBACK tells you everything you have ever wanted to know about short wave reception. The author, a professional radio listener and radio fan for many years, gives you his long experience in radio reception and all that goes with it.
40 Illustrations
72 Pages

50c

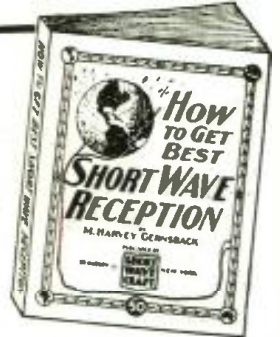

HOW TO BECOME AN AMATEUR RADIO OPERATOR

By Lieut. Myron F. Eddy, whose experience in the amateur field has made him pre-eminent in this line.

If you intend to become a licensed code operator, if you wish to take up phone work eventually—this is the book you must get.

150 Illustrations
72 Pages

50c

THE SHORT WAVE BEGINNER'S BOOK

Here is a book that solves your short wave problems—leading you in easy stages from the simplest fundamentals to the present stage of the art as it is known today. It is the only low-priced reference book on short waves for the beginner.

75 Illustrations
40 Pages

25c

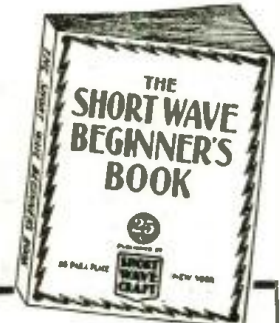

LOOK FOR YOUR NEAREST DEALER

For convenience the publishers list below dealers in all parts of the world where our books are available. On your next shopping trip be certain to examine these volumes. You're sure to want them for your technical library.

ALABAMA
Walther Bros., Montgomery

ARIZONA
Sam's Cigar Store, Phoenix

CALIFORNIA
Electric Supply Co., Oakland
Radio Supply Company, Los Angeles
Radio Television Supply Co., Los Angeles
Pacific Radio Exchange, Inc., Los Angeles

Western Auto Supply, Los Angeles
Zack Radio Supply Co., Los Angeles
Yonah's Book Store, Pasadena
Western Radio & Elec. Co., San Diego
Offenbach Electric Co., San Francisco
Technical Book Co., San Francisco
Zack Radio Supply Co., San Francisco
Radio Specialties Co., San Jose

COLORADO
Auto Equipment Co., Denver
Interstate Radio Supply, Denver

CONNECTICUT
The Edward P. Judd Co., New Haven

DELAWARE
Wilmington Elec. Spec. Co., Inc., Wilmington

FLORIDA
Radio Accessories Co., Orlando

GEORGIA
Wholesale Radio Service Co., Inc., Atlanta

ILLINOIS
Allied Radio Corporation, Chicago
Walter C. Braun, Inc., Chicago
Chicago Radio Apparatus Co., Chicago
A. C. McClurg & Co., Chicago
Midwest Radio Mart, Chicago
Newark Electric Co., Chicago
Sears, Roebuck & Co., Chicago
Max Stein & Co., Chicago
Montgomery Ward & Co., Chicago
Wholesale Radio Service Co., Inc., Chicago

INDIANA
Van Sickle Radio, Indianapolis

MASSACHUSETTS
DeWolfe & Fiske Co., Boston
The Personal Book Shop, Boston
Wholesale Radio Service Co., Inc., Boston

MICHIGAN
Rissi Brothers, Detroit

MINNESOTA
St. Paul Book & Stat. Co., St. Paul

MISSOURI
Burstin-Applebee Co., Kansas City
Radio Labs., Kansas City
Walter Ashe Radio Co., St. Louis
Van Sickle Radio Co., St. Louis

NEW JERSEY
Radio Apparatus Co., Newark
United Radio Co., Newark
Wholesale Radio Service Co., Inc., Newark

NEW YORK
Fort Orange Radio Dist. Co., Albany
Wholesale Radio Service Co., Inc., Albany
Wholesale Radio Service Co., Inc., City

Harrison Radio Co., New York City
Jamaica, L. I.
American News Co., New York City
Baker & Taylor Co., New York City
Bian, the Radio Man, New York City
David Bogen & Co., New York City
Federated Purchaser, Inc., New York City
Radio Circular Co., New York City
G. E. Stechert & Co., New York City
The Steiger Co., New York City
Sun Radio Co., New York City
Thor Radio Corp., New York City
Try-Mo Radio Co., New York City
Van Riemadsky Book Stores, New York City
Wholesale Radio Service Co., Inc., New York City
H. W. Wilson Co., New York City
Radio Parts & Equipment Co., Rochester
M. Schwartz & Son, Schenectady

OHIO
College Book Exchange, Toledo

OREGON
J. K. Gill Co., Portland

PENNSYLVANIA
Radio Electric Service Co., Philadelphia
Cameradio Co., Pittsburgh

WASHINGTON
Seattle Radio Supply Co., Seattle
Wedel Co., Inc., Seattle
Spokane Radio Co., Spokane

WISCONSIN
Radio Parts Co., Milwaukee

ARGENTINA
Radio Revista, Buenos Aires

AUSTRALIA
McGill's Authorized Agency, Melbourne

BELGIUM
Emil Arens, Brussels

CANADA
T. Eaton & Co., Winnipeg, Man.
Electrical Supplies, Ltd., Winnipeg, Man.

Wholesale Radio Supply, Winnipeg, Man.

CANADA
Canadian Electrical Supply Co., Ltd., Toronto, Ont.

Radio Trade Supply Co., Ltd., Toronto, Ont.

Canadian Electrical Supply Co., Ltd., Montreal, P. Q.

BRAZIL
Agencia Soave, Sao Paulo

CHINA
China News Co., Shanghai
International Booksealers, Ltd., Shanghai

CUBA
Diamond News Co., Havana

ENGLAND
Gorringe's Amer. News Agency, London

FRANCE
Toute La Radio, Paris

GERMANY
Rehr G.M.B.H. SW15, Berlin NW No. 7

HOLLAND
Radio Peeters, Amsterdam, Z.

INDIA
Empire Book Mart, Bombay

MEXICO
American Book Store, Mexico, D. F.
Central De Publicaciones, S. A., Mexico, D. F.
Jacques Salvo, Mexico, D. F.

NEW ZEALAND
Johns, Ltd., Auckland
James Johnston, Ltd., Dunedin
Te Aro Book Depot, Ltd., Wellington

SOUTH AFRICA
Technical Book Co., Cape Town
Central News Agency, Johannesburg
International House, Johannesburg
South African Radio Publications, Johannesburg

IF YOUR DEALER DOES NOT CARRY THESE BOOKS, ORDER DIRECT FROM U.S. FILL OUT COUPON BELOW. SHIPMENT WILL BE MADE IMMEDIATELY.

POPULAR BOOK CORP. R&T-3-39
99 Hudson Street, New York City.

Gentlemen: I enclose herewith my remittance for . . . for which please send me the following books:

.....

.....

.....

Name

Address

City

State

(Send remittance in form of check or money order. If letter contains cash or unused U. S. postage stamps, register it.)

POPULAR BOOK CORPORATION • Publishers • 99 HUDSON STREET • NEW YORK, N. Y.

The Martian Flash

(Continued from page 657)

on around him, he only knows one thing now, and that is to get to the Auto-Tribunal as fast as possible. If he is near the Tribunal he will walk; if not, he will use the speediest conveyance to bring him there.

Now, the Tribunal itself, is a very strange affair, usually a great circular room. The most astonishing thing about the Automatic-Tribunal is that there is no living Martian in it except the culprit or culprits, in case there might be more than one, which seldom happens. The minute the culprit enters the Tribunal he is directed into a special chair mounted on wheels. He is then automatically guided past several hundred registering and recording apparatus. Questions are asked him at each stop which he is forced to answer. He cannot lie, of course, as apparatus similar to your old lie-detectors would immediately show up any deception. *What the authorities are interested in most is how he got that way.*

It should be obvious that, as every citizen on the planet knows in advance that he cannot commit even the slightest crime without instant apprehension, the authorities are always concerned with so-called *throw-backs*, who commit crimes simply because something went wrong with their mentality—the first stage of a break-down or something akin to what you would call insanity. For this reason, the Auto-tribunal's main duty is to examine the culprit's mind and after the reason has been found out, other machines, therapeutic and otherwise, which he will pass in due time, try to correct his deficiency.

Martian law is very stringent; so if it is found that there was no mental break-down, and that the reason for the crime may be, let us say, ennui or boredom—which is a terrible thing to commit a crime for in Martian eyes—then of course the victim is punished. If it is not his own fault, as for instance, approaching insanity or such, there will be no punishment but the chair on which the defendant is riding will be shunted into a laboratory where the patient is treated until restored. But let us say the offense was willful. Then there will be punishment, and as your old saying goes—"punishment to fit the crime." For slight cases, this may be nothing but disagreeable shocking, or the inhaling of disagreeable radio-atomic odors, which will make the victim retch for hours at a time. This in itself is a terrible punishment for most Martians.

There are a number of other *psychological punishments* even more severe which you could not possibly understand, as you do not comprehend Martian mentality. Thus for instance, the culprit may have to look at certain symbols engraved on a plate, staring at them fixedly for fifteen minutes. To you, this means nothing and would be considered a joke and no punishment at all. To a Martian, this is heart-rending and soul-racking. There are other punishments of which most are psychological in nature which you could not understand and frankly, I do not myself understand as yet. Finally, the extreme penalty, is death. Atomincing, as it is called here, whereby the condemned is led into a sort of electronic tube and placed between two electrodes which then blow the victim into atoms.

For a number of psychological reasons, the Martians do not wish to become contaminated with a fellow Martian who has thus been atominced, so the remains stay right in the electronic tube which is fired electro-magnetically out of the gravitational region of the planet. When the tube reaches about two hundred thousand miles above the surface of Mars, it explodes and the re-

maining atoms of the unlucky Martian are scattered through interstellar space.

I was living on the planet for about two months when I innocently enough touched a certain object—the likeness of a famous deceased Martian ruler—with my bare hands. This is a terrible offense on Mars. It is usually punished most severely. In my case this was of course, only pure curiosity, and no emotion stirred inside me. Nevertheless, an attendant saw me and the emotion set up in his mind immediately released the usual Martian Automatic Police. The Martian had no trouble in explaining that the emotion was not due to his doing anything wrong, but rather in seeing *me* commit a crime. In a few minutes I was apprehended by an Automatic guard of which they have a few for emergency cases, and in no time I was whisked to the Auto-tribunal. Not being a Martian, the hypnotizing-paralyzing ray did not work on me very well and I still had some of my faculties left, although I was pretty numb. Still, not numb enough to know that if something went wrong I would probably be atominced and blown into smithereens. *You see, Martian justice can never possibly go wrong.* That is, Martian justice for Martians. But I, not being a Martian, was in a terrible predicament, because it was quite possible that there might be, for the first time in millions of years, a miscarriage of justice on account of this.

Amongst some of the things which I had in my pocket, was an old fashioned Earthian menthol nasal inhaler and a piece of garlic, which I had carried with me by pure accident from the Earth. I quickly opened the inhaler and blew into it. Then I started to chew the garlic, figuring that perhaps the combination, totally unknown on Mars, would do something to the fearful, sensitive machinery. And that is exactly what happened. When I came to, one of the machines (which I found out later, recorded certain bodily odors and perspiration, to get an index on one's emotion), just blew up and *short-circuited!* Then there was a terrific commotion and the whole Auto-tribunal seemed to go "hay-wire" instantly. Tubes blew out, sparks played all about, lights flashed and general pandemonium broke loose! You have never seen such terrific displays of a technical fracas in all your born days. And all on account of a simple piece of garlic for which the Auto-tribunal was not prepared. In the ensuing confusion I made my way out of the Tribunal and had no trouble to find my Martian sponsor to whom I unfolded the foregoing events.

The sequel to the story is that I was instantly acclaimed a great hero, being the only living person who had in twenty million years upset the orderly working of the Auto-tribunal! This incident however, decided the Martians, that mere Earthlings could not be trusted alone on the planet, and now I am always accompanied by an automatic guard who calls back to Headquarters what is going on from instant to instant. It is therefore not very likely that I shall again upset an Auto-tribunal as long as I am here.

We Want Constructional Articles On Television Receivers and Facsimile Receivers

Write the Editors and give outline of article, with sketch of circuit. All articles accepted and published will be paid for.

Please say you saw it in RADIO & TELEVISION

I believe...

that a fair and square deal, every time, is the only way to keep up a successful business. That must be right, because since 1925 more and more men have been buying their radio equipment from me.

You, too, will find it to your advantage to deal with me whenever you want to buy a new receiver, transmitter, or any other equipment.

My personal attention to your wishes, fair trade-in allowances, reasonable terms for your convenience, prompt safe delivery, and above all—a sincere desire to give you full co-operation—is your assurance of complete and lasting satisfaction.

Be sure to write to me.

73

Bill Harrison, W2AVA

TIME PAYMENTS?

Check these easy terms—

Receiver	Cash Price	Down Payment	Monthly Payments 5 OR 12
NC-101-X			
HQ-120-X	\$129.00	\$19.96	\$14.21 \$9.66
NC-100A	120.00	18.48	13.22 9.00
8-16, Bretling 49, NC-			
81-X, NC-80-X	99.00	15.34	10.90 7.41
HQ-120	117.00	18.30	12.86 8.75
SX-16, speaker	123.00	19.60	13.47 9.16
SX-17, speaker	149.50	22.60	16.53 11.25
RME-69	152.88	24.10	16.78 11.41
RME-70	138.00	21.10	15.31 10.41

I can change these terms to suit your convenience.

Also terms on all Hallicrafters, Hammarlund, National, RME, Howard, Sargent, Bretling, Patterson, Temco, RCA, Thordarson, Utah, etc. Receivers, Transmitters and Kits.

OUR USED DEPT

has many good reconditioned and guaranteed trade-in Receivers and Transmitters at attractive prices. Good values! Send stamp for list.

HARRISON RADIO CO.
112 West Broadway, New York City

Radio Men Find This Book Handy

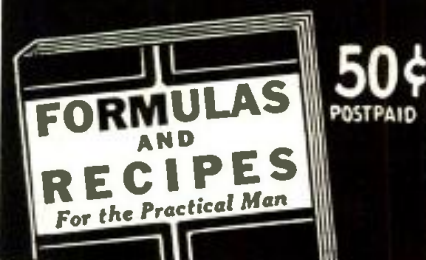

Here Is the Contents of the Book

1. Adhesives: Glues, Cements, Gums, Mucellases, Lubricants.
2. Cleansing: Stain Removers, Paint Removers, Bleaches, Cleaning Fluids.
3. Metal Craft: Coloring, Oxidizing, Plating, Replating, Welding, Polishes, Alloys, Solders, Amalgams.
4. Paints: Colors, Stains, Varnishes, Enamels, Luminous Paint, Washable Paint, Paint-Removing, Waterproofing, Fireproofing.
5. Glass-Working: Cutting, Drilling, Boring, Bending, Blowing, Etching, Engraving, Frosting, Silvering, etc.
6. Wood-craft: Fillers, Fireproofing, Acid-proofing, Waterproofing, Furniture Polishes, Finishes, etc.
7. Inks: Recipes, Erasers, Ink Stain Removers, Special Inks, Colored, Indelible, Sympathetic, Invisible, Hectograph.
8. Photography: Developers, Emulsions, Fixers, Sensitizing, Toning, Printing, Photographic Paper, Blueprint Paper.
9. Antidotes for Poisons, Remedies for Burns and Scalds, Disinfectants.
10. First-Aid in Accidents, Emergency Remedies, Home Remedies.
11. Preparation, Manipulation, Handling, Mixing, Measuring, Weighing, Filtering, Straining Solutions; List of Technical Substances; Emulsifying; Use of Hydrometer, Use of Thermometer; Tables of Weights and Measures, Decimal Systems, Useful Tables.

TECHNIFAX, Division RC-339
560 W. Washington Blvd., Chicago, Illinois

TECHNIFAX, Division RC-339
560 W. Washington Blvd., Chicago, Illinois

Gentlemen: Enclosed please find 50¢ (check, money order, coin or unused U.S. stamps accepted) for which send me POSTAGE PREPAID, One Copy of FORMULAS AND RECIPES For the Practical Man.

Name _____
Address _____
City _____ State _____

FOUR NEW 10¢ RADIO BOOKS

RADIO FANS EVERYWHERE—these little ten cent text books give you an excellent foundation for the study of radio. They are clearly written, profusely illustrated and contain over 15,000 words in each book. You'll be amazed at the wealth of information these volumes have. They are handy for review or reference books.

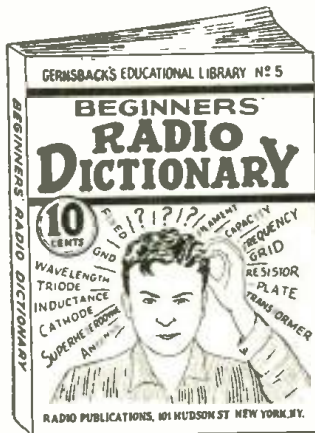

**FAMOUS
GERNSBACK
EDUCATIONAL
LIBRARY
ADDS FOUR
NEW BOOKS!**

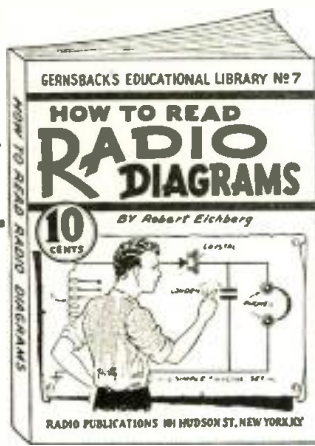

NO. 5—BEGINNERS' RADIO DICTIONARY

Are you puzzled by radio language? Can you define frequency? Kilocycle? Tetrode? Screen grid? Baffle? If you cannot define these very common radio words and dozens of other, more technical, terms used in all radio magazines and instruction books, you need this book in your library. It's as modern as tomorrow—right up to the minute. It tells you in simple language just what the words that puzzle you really mean. You cannot fully understand the articles you read unless you know what radio terms mean. This is the book that explains the meanings to you. Can you afford to be without it, even one day longer?

NO. 7—HOW TO READ RADIO DIAGRAMS

All of the symbols commonly used in radio diagrams are presented in this book, together with pictures of the apparatus they represent and explanations giving an easy method to memorize them. This book, by Robert Eichberg, the well-known radio writer and member of the editorial staff of RADIO-CRAFT magazine, also contains two dozen picture wiring diagrams and two dozen schematic diagrams of simple radio sets that you can build. Every diagram is completely explained in language which is easily understood by the radio beginner. More advanced radio men will be interested in learning the derivation of diagrams, and the many other interesting facts which this book contains.

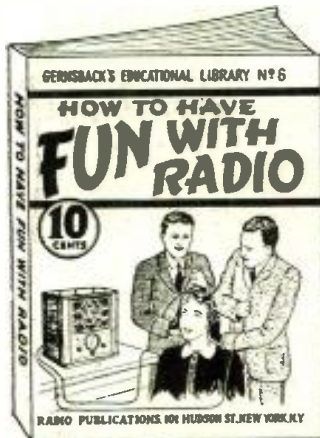

NO. 6—HOW TO HAVE FUN WITH RADIO

Stunts for parties, practical jokes, scientific experiments and other amusements which can be done with your radio set are explained in this fascinating volume. It tells how to make a newspaper talk—how to produce silent music for dances—how to make visible music—how to make a "silent radio" unit, usable by the deafened—how to make toys which dance to radio music—sixteen clever and amusing stunts in all. Any of these can be done by the novice, and most of them require no more equipment than can be found in the average home. Endless hours of added entertainment will be yours if you follow the instructions given in this lavishly illustrated book.

Other Titles In This Series!

- Four other volumes in this ten-cent radio book series—each on a popular subject—are available. The titles are:
- No. 1—HOW TO BUILD 4 DOERLE SHORT-WAVE SETS
 - No. 2—HOW TO MAKE THE MOST POPULAR ALL-WAVE 1- AND 2-TUBE RECEIVERS
 - No. 3—ALTERNATING CURRENT FOR BEGINNERS
 - No. 4—ALL ABOUT AERIALS

BOOKS ARE ALL UNIFORM

Every book in the GERNSBACK EDUCATIONAL LIBRARY has 32 pages—with illustrations varying from 30 to 66 in number. Each title volume contains over 15,000 words. Positively radio's greatest book buys! If you do not think these books worth the price asked, return them in 24 hours and your money will be instantly refunded.

RADIO PUBLICATIONS
101 HUDSON STREET NEW YORK, N. Y.

WIN \$10

by suggesting a title for a new Gernsback book! Each of these books gives full details.

PRIZE WINNERS

- ALFRED CETTIE
Seattle, Wash.
Title: ALL ABOUT AERIALS, Book 4
- RUDY RUZICKA
St. Louis, Mo.
Title: BEGINNERS' RADIO DICTIONARY, Book 5
- KENNETH WARNER
Burbank, Ohio
Title: HOW TO READ RADIO DIAGRAMS, Book 7
- CLYDE SORRELL
Rockyford, Colo.
Title: RADIO FOR BEGINNERS, Book 8

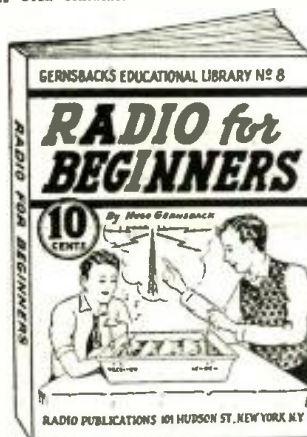

NO. 8—RADIO FOR BEGINNERS

Hugo Gernsback, the internationally famous radio pioneer, author and editor, whose magazines, RADIO & TELEVISION and RADIO-CRAFT are read by millions, scores another triumph with this new book. Any beginner who reads it will get a thorough ground work in radio theory, clearly explained in simple language, and through the use of many illustrations. Analogies are used to make the mysteries of radio as clear as "2+2 is 4". It also contains diagrams and instructions for building simple radio sets, suitable for the novice. If you want to know how transmitters and receivers work, how radio waves traverse space, and dozens of other interesting facts about this most modern means of communication, this is the book for you!

MAIL COUPON TODAY!!

RADIO PUBLICATIONS, Dept. R&T-3-39
101 HUDSON STREET, NEW YORK, N. Y.

Gentlemen: Please send immediately, POSTPAID, the book numbers circled below. I am enclosing....cents—each book being 10c.

1 2 3 4 5 6 7 8

Send FREE listing of 48 new 10c publications.

Name

Address

City

State

Remit by check or money order—register letter if you send cash or unused U. S. postage stamps.

Getting Started in Amateur Radio

(Continued from page 681)

coupling of the transmitter to an aerial. However, as we do not yet have a license, this will not be needed for some little time. Construction of the modulator and aerial coupling units will follow in succeeding parts of this series.

Parts List

HAMMARLUND

- 1—Type MTC-150-B tuning condenser, 150 mmf. double-spaced, C3
- 1—Type MTC-100-C condenser, 100 mmf., C2
- 1—Type MTC-250-C condenser, 250 mmf., C1
- 4—4-prong isolantite plug-in coil forms
- 3—4-prong isolantite sockets
- 2—5-prong isolantite sockets
- 1—7-prong isolantite socket
- 1—Type MC-20-SX variable condenser, C4
- 2—Type CH-X R.F. chokes, RFC1 and RFC2

BLILEY

- 1—Type B5 7 mc. crystal
- 1—Type LD2 3.5 mc. crystal

TRIPLETT

- 1—Type 323 0-150 M.A. meter

SPRAGUE

- 1—.001 mf. mica condenser, C5
- 3—.002 mf. mica condensers, C6, C7, C8
- 2—Type EC-8 8-mf. electrolytic condensers, C9, C10

I.R.C.

- 1—50,000 ohm, 2 watt resistance, R1
- 1—15,000 ohm, 2 watt resistance, R2
- 1—15,000 ohm, type DHA wire-wound resistor with variable tap, R3

RCA RADIOTRON

- 1—Type 59 tube, V1
- 1—Type 46 tube, V2
- 1—Type 82 tube, V3

YAXLEY

- 1—Type 762 2-pole, 2-throw switch, SW1
- 1—Type 10 1-pole, 1-throw switch, SW2

JEFFERSON

- 1—Power transformer, type 465-151, T1
- 1—Filament transformer, type 464-191, T2
- 1—Filter choke, type 466-410, CH1

CORNISH WIRE

- 1—¼-lb. spool No. 22 D.C.C. wire
- 1—¼-lb. spool No. 18 bare tinned wire
- 1—½-lb. spool No. 12 bare tinned wire
- 1—Roll No. 18 hook-up wire

MISCELLANEOUS

- 2—Wooden or bakelite panels, 7 x 15 x 3/16" th.
- 2—Wooden or bakelite panels, 4 x 15 x 3/16" th.
- 4—Wooden panels, 4 x 6½ x ½" th.

BOOK REVIEW

RADIO TROUBLE-SHOOTER'S HANDBOOK, by Alfred A. Ghirardi, B.S., E.E. Stiff covers, size 9" x 11¼", 518 pages including index, illustrated. Published by Radio & Technical Publishing Co., New York City.

The first 275 pages of this book are allotted to a description of actual symptoms and remedies for common troubles for more than 3313 models of 177 different makes of radio receivers.

The center section is devoted to a line of intermediate peak frequencies of more than 15,000 models of superheterodynes. Other sections deal with a cross-index of model numbers of American RCA and RCA-Victors with those of corresponding American G.E., Westinghouse and Graybar sets and with those of corresponding Canadian sets of the same makes. This is followed by a "trouble-shooting" chart for radio receiver troubles, an auto-radio installation and car ignition system data chart, wiring diagrams of 107 different models of 27 makes of cars and much other material, including RMA standard color codes, a directory of radio manufacturers, and useful radio and servicing formulas.

The book will be a valuable addition to the library of any man who is engaged in the installation or servicing of radio receivers.



Astonish YOUR FRIENDS!

Pass
500,000 Vts.
Thru the
Body!
Light
Lamps, etc.

DATAPRINTS SHOW YOU HOW!

20c Each in Order for 10

TESLA-ODIN HI-FREQ. COILS

(Data and Drawings only)

- 36" Sp'k Tesla-Oudin Coil.....40c
(1 K.W. Exc. Trf. Data included FREE!)
- 8" Sp'k Tesla-Oudin Coil.....40c
(1/4 K.W. Exc. Trf. Data included FREE!)
- Sp'k Oudin, 110 Vt. "Klek Coil" type.....40c
- Sp'k Tesla Works on Ford Sp'k Coil.....40c
- 1" Sp'k Violetta Hi-Freq. Coil.....40c

FREE with order for \$1.00 or more—20 Tricks with Hi-Freq. Coils" (40c separate)

Television Hook-ups "Sight & Sound" . . 40c

20 ELECTRIC PARTY
AND LODGE TRICKS!
Loads of Fun!



How to Shock 'em!.....40c
Order with other prints; see special price below and save.

Solenoid & Magnet Data—Get Our List!

20 Telephone Hook-ups—Build Your Own . . 40c



RADIO CONTROL
FOR MODEL BOATS,
PLANES, ETC.

(Circuit data40c

S-W DIATHERMY
(Artificial Fever)



Dataprint giving Constructional data for Small, Medium and Large size App. (All 3).....40c



Induction PIPE &
ORE LOCATOR

Construction Data40c

You NEED these DATAPRINTS !!
40c Each.

- Electric Pipe Thawer.
- 100 Mechanical Movements.
- 20 Motor Hook-ups.
- 20 Simple Bell Circuits.
- Welding Transformer.
- 2 K.W.
- Rewinding Armatures.
- Eindhoven String Galvanometer.
- Resistance Measuring Bridge.

Special Prices: 4 prints \$1.00; 10 for \$2.00; 40c each, single orders.

The **DATAPRINT** Co.

Look Box 322A

RAMSEY, N. J.

BOOK REVIEW

THE RADIO AMATEUR'S HANDBOOK, by the Headquarters Staff of the A.R.R.L. 560 pages, illustrated, size 9 3/4" x 6 1/2", paper bound. Published by the American Radio Relay League, West Hartford, Conn.

The 1939 edition of *The Radio Amateur's Handbook* contains over 300,000 words, as well as some 815 illustrations, 50 charts and tables, and 87 equations and formulas. The material has been thoroughly revised and more than thirty pieces of new equipment were designed, built and tested to furnish data for the text.

The equipment described is based on time-tried circuits and layouts, and features the dependable rather than the merely novel. Vacuum tube tables have been considerably expanded and data on more than 400 types of tubes is given. Among the additional material are tables for control and regulator tubes, and for cathode ray tubes. Treatment of fundamental antenna systems and other important phases of radio have been given a fresh approach and greatly enlarged.

The major chapters deal with receivers, transmitters and radio telephony; they contain the bulk of the new equipment.

This edition is dedicated to the late Ross A. Hull, distinguished amateur, who was accidentally killed while experimenting with his apparatus.

Let's Listen In with Joe Miller

(Continued from page 663)

winter peak, upon the regular Tues. and Fri. 11 p.m.-12:30 a.m. schedule. Reported by G. C. Gallagher, W6, also by Ye Ed. A catch well worth digging in the 40 meter ham band for, and FO8AA should peak in February.

BELGIAN CONGO—Radio Leopoldville, 6.14 mc., with a Sunday schedule of 5:35-7 a.m., reported by Nick Stahevitch, W6, at 6:50 a.m. FB! OPM, 10.14 mc., also at Leopoldville, has been heard recently at 3:20 and 4 a.m. here, but not with the strength they had several years ago.

ANGOLA—CR6AA, at Lobito, and reported once as on 13.00 mc., is operating on both 7.177 and 7.614 mc. during their regular schedule. The 7.177 mc. signal is, surprisingly, the easier one to log, though inside the 40 meter amateur band!

NEW ZEALAND—ZMBJ, aboard the S.S. *Avatea*, and counting, when QSL'd, as New Zealand, has just sent a card to Murray Buitkant stating they will no longer confirm reports on their inverted speech transmissions. As that is their main fare, it will henceforth be rather difficult to elicit a card for a report, unless one is fortunate in tuning in ZMBJ when they happen to be using clear speech.

Mr. N. Stahevitch, W6, has reported a test transmission of a new Irish station on 6.19 mc., located at Moydrum, at 3:30 a.m. Nice DX to be first to hear, from West Coast. OM!

TRIPOLI—ICK, 9.46 mc., heard very FB at 4:15 p.m., during a holiday afternoon, with a man and woman speaking Italian, clear speech. Tripoli is in reality only a town in Libya, an Italian colony.

Static-Free Radio

(Continued from page 647)

of our regular broadcast stations, the transmission has been very much improved in a great many sections of the country and thus the static-free qualities of the new system are not so important as perhaps some of the other features, such as multiplex transmission possibilities and the high-fidelity feature.

It is interesting to note that the new "f.-m." wave can be made to do many unusual tricks, such as transmitting voice and facsimile signals simultaneously. Thus on one wave you can receive a musical program and a facsimile reproduction at the same time, a suitable facsimile reproducing machine being used, of course.

The new receivers, it has been announced, combining units for reception of the regular broadcast channels, as well as the new "f.-m." waves, will cost no more than the present average receiver when they are produced on a quantity basis.

The present-day shortwave receivers, or all-wave receivers provided with a short-wave section, cannot tune in the "f.-m." wave; but a special receiver has to be used.

As aforementioned, experimenters and Hams have intercepted the "f.-m." waves, however, with super-regenerative sets. Station W2XMN will relay the programs of John V. L. Hogan's high-fidelity station, WQXR. Mr. Hogan, according to reports, has filed a petition with the F.C.C. for permission to build an "f.-m." station in New York City.

Owners of the present type radio receivers, whether for regular broadcast waves or for short waves, need not worry that our present regular broadcast stations will swing over to the new "f.-m." system overnight, as it will take a long time to do this, even provided that our broadcast systems should decide to adopt the Armstrong system. So if you have been contemplating the purchase of a new receiver of standard type, you can rest assured that you will have your full service out of it before any radical change in our present broadcast station system will have taken place.

A PROFESSIONAL SLIDE RULE PRACTICAL, EDUCATIONAL, TIME SAVER

Features: Nickel Silver framed indicator with integral friction spring. Scales calibrated directly on well-seasoned wood. Retains accuracy regardless of temperature or humidity changes. Instructions and illustrations of primary operations clearly printed on reverse side of rule for ready reference or teaching. Each rule with a durable pocket carrying case for convenience and protection.

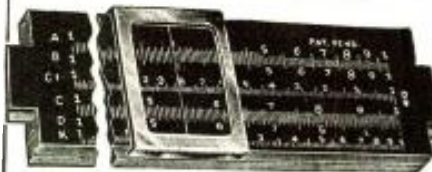

We offer an eight inch, white wood, accurate slide rule with A, B, C, D, C1 and K Scales, a 20-page Book of Instructions, How to Use a Slide Rule, a Book of Examples and Answers, a two-toned "Facsimile of the Declaration of Independence," suitable for framing, and an 8-page catalog illustrating all five prepaid anywhere in the United States and Canada for 50c

STURDY BINDERS

for any size magazines. Covered with black corrugated fabricoid. Has two stamped metal ends with 12 Spring Wire separators. Magazines can be inserted and removed in a jiffy. 12" x 9 3/4" fits R.&T. Radio News, etc. . . . 60c 10 1/2" x 7 1/2" with 3" back, fits QST, Radio, Popular Mechanics, Popular Science, etc. . . . 70c Prices on binders, P.P. prepaid.



STOPPANI COMPASS

A Precision Instrument made in Belgium. Purchased by the U. S. Government at more than \$30.00 each. Ideal for Radio Experimenters Laboratory, also may be used as a Galvanometer for detecting electric currents in radio circuits. Ruby jeweled, solid bronze, 4 inches square, fitted in a hardwood case. Also used by hunters and surveyors. Our price prepaid \$4.50 each



Send for catalog containing full descriptions of these and many other interesting items.

GOLD SHIELD PRODUCTS

Dept. RT-3-9 350 Greenwich St. New York

FREE!

Our new Catalog describing over thirty-two books in the "How to Make More Money" field has just come off the press. This catalog describes each book in detail. It enables you to select one or more books which will meet your requirements in an attempt to improve yourself financially.

Many of the books in the NATIONAL PLANS INSTITUTE catalog tell you how to start a spare- or full-time business of your own.

Write today for your FREE copy of the "NPI" Book Catalog—address a one-cent postcard to Dept. RT-339—and mail it today.

NATIONAL PLANS INSTITUTE
246-T FIFTH AVENUE, NEW YORK, N. Y.

COMMERCIAL NOTICES 10¢ A WORD

Under this heading only advertisements of a commercial nature are accepted. Remittance of 10¢ per word should accompany all orders. Copy should reach us not later than the 10th of the month for the second following month's issue.

AGENTS WANTED

300% PROFIT SELLING GOLD Leaf Letters for Store Windows; Free samples. Metallic Co., 446 North Clark Chicago.

CORRESPONDENCE COURSES

CORRESPONDENCE COURSES and educational books, slightly used. Sold. Rented. Exchanged. All subjects. Satisfaction guaranteed. Cash paid for used courses. Complete details and bargain catalog free. Send name. Nelson Company, 3490 Manhattan Building, Chicago.

INSTRUCTION

RADIO ENGINEERING. BROADCASTING, aviation and police radio, servicing, marines and Morse telegraphy taught thoroughly. All expenses low. Catalog free. Dodge's Institute, Colt St., Valparaiso, Ind.

MISCELLANEOUS

IMPERIAL ELECTRIC RAZOR, absolutely guaranteed, \$1.59 postpaid. Kenneth W. Bailey, 815 West Wayne, Ft. Wayne, Indiana.

MOUNTED STEER HORNS SIX feet spread and good blowing horns for sale. Lee Bertillon, Minocia, Texas.

7 MILLIAMMETER, HEAVY RUBBER insulation, high voltage lacquered cable, suitable for transmitter, 2c per foot. Gold Shield Products, 350 Greenwich St., New York City.

PATENT ATTORNEYS

INVENTORS—PROTECT YOUR right before disclosing your invention to anyone. Form "Evidence of Conception"; "Schedule of Government and Attorneys' Fees" and instructions sent free. Lancaster, Allwine & Rommel, 436 Bowen Building, Washington, D. C.

QSL—CARDS—SWL

100 NEAT SWL CARDS PRINTED with your name and address sent postpaid for \$1. Bunch of samples and RST Chart for five cents in stamps. WIBEF, 16 Stockbridge Ave., Lowell, Mass.

RADIOS

PLANS 18 TESTED CRYSTAL sets, SW record 4250 miles, with "Radiobuilder"—year, 25c. Laboratories, 7700-A East 14th, Oakland, California.

SHORT WAVE RECEIVERS

USED DOERLE'S, D-38, BS-5, 7C, reconditioned by factory, 40% off. See January, 1938 Short Wave & Television for description. Kusterman, 68 Barclay St., New York.

SPECIAL EQUIPMENT

AMATEUR AND COMMERCIAL radio and electronic equipment built to order. High quality, reasonable prices. Correspondence invited. Markill Engineering Co., Annapolis, Md.

SONG POEMS WANTED

WANTED ORIGINAL POEMS, songs for immediate consideration. Send poems to Columbia Music Publishers, Ltd., Dept. K49, Toronto, Can.

TELEVISION

TELEVISION EXPERIMENTAL KIT \$9.50. Arthur Pohl, 4829 Merritt, Detroit, Mich.

TEST EQUIPMENT

YOUR OLD TEST EQUIPMENT is worth money. Write now, telling us what you have and we will send our cash offer. We can supply any Rider Manual circuit for 25c per page. Reo Radio Co., 178 Greenwich St., New York.

WIND ELECTRIC PLANTS

BUILD WIND LIGHT PLANT. Complete plans and valuable catalog 10c. Welders, Electric Fencers, LeJay Manufacturing, 417 LeJay Building, Minneapolis, Minnesota.

Electronic Television Course

(Continued from page 656)

to the third electrode where each electron dislodges five or more electrons from the third electrode. This process may be carried through as many as twelve to fourteen successive stages. Thus, it can be seen that from a single electron emitted from the surface of the first electrode, when carried through twelve successive stages, we have a tremendous amount of electrons on the final collecting electrode. By the use of this principle an amplification of many million times may be obtained in a single tube. We shall see how this phenomenon is taken advantage of in the transmission of television images in subsequent chapters of this course.

Curing Television's Ills

(Continued from page 655)

and Y somewhat greater than Y1. It is difficult to secure accuracy much greater than this, except in the laboratory.

Figs. 12D and 12E show the effect of applying oscillating voltage either to the c-r tube or to the grid of a video tube. Frequencies of 400 to 1000 cycles per second are satisfactory for the vertical test and 150,000 to 200,000 cycles for the horizontal.

Adjustments should be made in the sweep controls of the set to assure even spacing between bars. The test pattern is of great value in determining the linearity of the scanner when no test transmissions are on the air.

"Cairo Conference" Changes

● A NUMBER of new regulations adopted at the Cairo Conference last year have already gone into effect in the United States.

The ARRL will ignore—at least for the time being—one of the major changes; that of punctuation symbols. These were originated in the telegraph conference, held at the same time, and were consented to by the radio conference.

The old QSA code, however, has been abandoned for indicating signal strength and readability, combined. The new QSA code refers to strength only, being: QSA 1—Barely perceptible; QSA 2—Weak; QSA 3—Fairly good; QSA 4—Good; QSA 5—Very good.

Readability is indicated by a QRK code, in which: QRK 1—Unreadable; QRK 2—Readable occasionally; QRK 3—Readable with difficulty; QRK 4—Readable; QRK 5—Perfectly readable.

The familiar abbreviation TNX or TKU for thanks or thank you has been replaced by the still shorter TU—a great time-saver if you're habitually grateful.

Two new classifications of emissions are now in use. Type AO emission is basic uninterrupted carrier; A1, c.w. telegraphy; A2, modulated telegraphy; A3, telephony; A4, facsimile; A5, television.

FOR SALE (NON COMMERCIAL) 3¢ A WORD

Under this heading we accept advertisements only when goods are offered for sale without profit. Remittance of 3¢ per word should accompany all orders. Copy should reach us not later than the 10th of the month for the second following month's issue.

FOR SALE, GOOD GENE-MOTOR, write William Fitzgerald, 72 Franklin Blvd., Pontiac, Mich.

35 WATT XMITTER WITH POWER supply, tubes, coils \$20. W9QZV, Wentworth, Wis.

SELL—433 VARIETIES U. S. postage stamps mounted professionally in album. Do not confuse with cheap foreign collections. \$35 cash, 425 power Wollensak microscope—\$8.50. Cost \$20.

Boy Mechanic Book set—\$3.00. Cost \$8.00. F. P. Pratt, Jr., Salisbury, N.C.

FOR SALE: BRAND NEW DESK type 50 watt phone 80 watt code 5-10-20 meter transmitter, fully guaranteed, at reasonable price. Illustrated description furnished. Alvin Abrams (W2DIT), 30 Laurel Hill Terrace, New York City.

SKY BUDDY \$14.00. RSR CLIPPER \$9.00. S9 Super-Nickrider \$29.00. W9ARA, Butler, Missouri.

METAL LOCATOR, RADIO INSTRUMENT, very sensitive, locates buried metals. Like new in original packing case, price \$40. Russell Free, Box 3, Hot Springs, New Mexico.

USED TELEPLEX CODE MACHINE, early model with carrying case, strong spring motor crank handle, 8 code tapes, good condition, for sale or offered? Will send photos. Joseph Zuk, 513 W. Susquehanna Ave., Philadelphia, Penna.

BARTER AND EXCHANGE—FREE!

NO ADVERTISEMENT TO EXCEED 35 WORDS, INCLUDING NAME AND ADDRESS

Space in this department is not sold. It is intended solely for the benefit of our readers, who wish to buy or exchange radios, parts, phonographs, cameras, bicycles, sporting goods, books, magazines, etc. As we receive no money for these announcements, we cannot accept responsibility for any statements made by the readers. Use these columns freely. Only one advertisement can be placed. Copy should reach us not later than the 10th of the month for the second following month's issue.

Accepted from any reader in any one issue. All dealings MUST be above board. Remember you are using the U. S. Mail in all these transactions and therefore you are bound by the U. S. Postal Laws. Describe anything you offer accurately and without exaggeration. Treat your fellow men the way you wish to be treated. We welcome suggestions that will help to make this department interesting and helpful to our readers.

BEST OFFER IN USED U. S. commemorative or migratory duck stamps gets my I.C.S. Radio Operators' Handbook. Ward E. Williams, 1414 10th Ave., Lake Charles, La.

HAVE AMPERITE MIKE, TYPE writer, projector, radio, field glasses, electric shaver, electric train and equipment. Many others. Let's swap lists. M. Epstein, 2953 Buckle, Indianapolis, Ind.

TRADE 5 INCH MAGNETIC speaker, micrometer vernier 23 plate variable condenser 00053 mfd., Imp gasoline hand torch, small artistic bakelite cabinet. Want phones, telescope, or binders for "R&T" magazine. Alexander Podstepny, 217 Pine St., Phila., Penna.

10 METER PHONE TRANSMITTER Al condition 20 watts, 5 tubes for swap complete. I want good short wave receiver. Hartman, 5713—5th Ave., Brooklyn, N. Y.

TRADE: COMPLETE "CHARLES Atlas" dynamic tension health course, set ten sex books like new, for N.B.I. course or similar radio course. Also take Ghrardi's Radio Physics Course. Earl Olson, 206—5th Ave., S.W., Washington, S. Dak.

HAVE: SILVER KEY WOUND watch, perfect running shape, Bruno guitar, banjo-uke. Want code machine such as Teleplex, Instructograph, CV transmitter, S.W. set, or what have you? Stanley J. Kubik, Pine St., Gt. Barrington, Mass.

HAVE LATEST MODEL AC SW-3 with 2 sets of coils, power pack, etc., xmitter with coil, steel power pack, etc., a Readrite analyzer. Want Sky Champion. Write John Womack, Dimmitt, Texas.

SWAP 303 SAVAGE RIFLE GOOD cond., fishing tackle new, ski boots worn once 94. 3/4 I.P. Everette motor and Gen. Motors 7 tube arcell receiver for ham equipment and meters. Kenneth C. Douglas, Orleans, La.

TRADE 0-300 DC VOLT-METER, two tube regenerative electron coupled set, five meter set, good power supply, coils, carbonophones, modern tubes, other parts, for good S.W. receiver as S.W.3 or transmitting equipment. Walter Turchin, 953 Jackson Ave., New York, N. Y.

HAVE 5,000 FOREIGN AND U.S. stamps in albums. Also many duplicates. In exchange for your radio equipment such as transceiver, transmitter. Also have first day covers. John Kacandes, 47 Osborne Pl., Irvington, N. Y.

HAVE GOOD FIVE METER transceiver enclosed in portable leatherette case including batteries and tubes. Will trade for what have you. All mail answered. William R. Fitzgerald, 72 Franklin Blvd., Pontiac, Mich.

GROSS CP-CB-CW/55 160 M. X.B and AT coils, new 29-key concertina, 20 Duce American Flyer electric train set, 67 consecutive Weekly Philatelic Gossips. What have you? Byron Britt, Alliance, Nebraska.

TRADE—2A FOLDING CAMERA, Electrical Eng. course cost \$30.00, 4 tube RCA Victor BC radio. Want good S.W. factory made radio such as Hillierafter, etc. Also have other parts. W. Fuller, 709 Fenton, Lansing, Mich.

HAVE MUSICAL INSTRUMENTS, cameras and watches to trade for a Doerle or other short wave receiver. A.C. G. H. Gerhold, 112—13 Atlantic Ave., Richmond Hill, L. I., N. Y.

WANTED: 60 LENS LENS DISC and motor. Write to Jack Miller, 41 Wideman Street, Rochester, N. Y.

WILL TRADE RADIO PARTS suitable for hams or SWL's for fishing tackle. W2DMT, 538 E. 6th St., N.Y.C.

NOTICE—ANYONE HAVING ANY of the following—watch repairing tools, watchmaker's lathe, staking tools, course in radio, watchmaking course, DX-4 receiver—drop a card to Miner, Oakdale, Iowa.

TRADE NO. 10 CHEM-CRAFT chemistry set in very good condition and 2—456 kc. Hammarlund air-tuned I.F.'s. Want 8mm projector, phono motors, power transformers, 8mm Kodak titler. W2FZE, 152 Fifth St., Elizabeth, N. J.

72 EDITIONS "HISTORY OF OUR Country," original price 25c each, good condition, average amount of pages in each 30-35, also 7" x 10 1/2". Will swap for what have you? Margaret Schiecher, 930 Hamilton Blvd., Peoria, Ill.

HAVE A THREE TUBE all-wave receiver. Would like to trade for ham equipment. Also have Mailyory "B" eliminator and good Carter Genemotor. Make trade offer. Bilton Bender, Sauquoit, Calif.

VOLUMES 1 AND 2 RIDERS Service Manuals, also Radio Telegraphy and Telephony by Duncan and Drew, value \$20, for camera, guns, skis, electric motors, what have you? T. Booth, Mt. Shasta, Calif.

WANT RADIO PARTS, 8MM movies, art photos, magazines. Have 5 meter A.C. transceiver, microphone, telescope, miniature camera, commemorative stamps. W. M. McDonald, 371 Pearl St., Cambridge, Mass.

(Continued on opposite page)

Answers to QUIZ on page 650

1. a, b, and c. d is spark transmission.
2. c
3. b
4. b
5. a, b, and c.
6. b
7. a, b, c, d, e, and f.
8. a, b, and c.
9. d
10. a, b, c, d, and f.
11. aC, bF, cB, dE, eA, fD.
12. He didn't send them—he received them; they were sent by an assistant.
13. b
14. b
15. Mainly c, but also b, to a lesser extent.
16. d
17. b
18. b—or if an AC set, c.

World S-W Stations

(Continued from page 668)

BARTER and EXCHANGE FREE ADS (continued)

- Mc. Call
- 6.079 DJM BERLIN, GERMANY, 49.34 m.,
Addr., Broadcasting House. 4.50-
11 pm.
- 6.077 OAX4Z LIMA, PERU, 49.35 m. Radio Na-
tional 7 pm.-1.30 am. Except
Sun.
- 6.075 YP3MR GEORGETOWN, BRI. GUIANA,
49.35 m. Sun. 7.45-10.15 am.;
Daily 4.45-8.45 pm.
- 6.070 CFRX TORONTO, CAN., 49.42 m. Relays
CFRB 7.30 am.-12 m., Sun.
10 am.-12 m.
- 6.070 VE9CS VANCOUVER, B. C., CAN., 49.42
m. Sun. 1.45-9 pm., 10.30 pm.-
1 am.; Tues. 6:30-7 pm., 11.30
pm.-1.30 am. Daily 6-7.30 pm.
- 6.069 — TANANARIVE, MADAGASCAR,
49.42 m., Addr. (See 9.53 mc.).
12.30-12.45, 3.30-4.30, 10-11
Sun. 2.30-4.30 am.
- 6.065 SBO MOTALA, SWEDEN, 49.46 m. Re-
lays Stockholm 4.15-5 pm.
- 6.060 — TANANARIVE, MADAGASCAR,
49.5 m., 12.30-12.45, 3.30-4.30, 10-
11 am.
- 6.060 W8XAL CINCINNATI, OHIO, 49.5 m.,
Addr. Crosley Radio Corp. Re-
lays WLW Tues., Fri., Sun. 5.45
am.-12 n., 11 pm.-2 am.; Wed.
5.45 am.-12 n., 9 pm.-2 am.;
Mon., Thurs., Sat. 5.45 am.-2 am.
- 6.060 W3XAU PHILADELPHIA, PA., 49.5 m. Re-
lays WCAU Tues., Fri., Sun.
1 pm.-Mid. Wed. 1-10 pm.
- 6.057 ZHJ PENANG, FED. MALAY STATES,
49.51 m. 6.40-8.40 am., except
Sun., also Sat. 11 pm.-1 am.
- 6.054 HJ6ABA PEREIRA, COL., 49.52 m. 9.30 am.-
12 n., 6.30-10 pm.
- 6.050 GSA DAVENTRY, ENGLAND, 49.59 m.,
10.45 am.-12 n., 12.20-4, 4.15-6 pm.
- 6.050 HJIABG BARRANQUILLA, COL., 49.65 m.,
Addr. Emisora Atlantico, 11 am.-
11 pm.; Sun. 11 am.-8 pm.
- 6.050 HPSF COLON, PAN., 49.59 m., Addr.
Carlton Hotel. Irregular.
- 6.045 RV15 Khabarovsk, U.S.S.R., 49.63 m.
2-11 am.
- 6.045 XETW TAMPICO, MEXICO, 49.6 m. Ir-
regular 7-11 pm.
- 6.040 W4XB MIAMI BEACH, FLA., 49.65 m.
1-3 pm., 9 pm.-12 m. Relays
WIOD.
- 6.040 WIXAL BOSTON, MASS., 49.65 m., Addr.
University Club. Irregular.
- 6.033 HPSB PANAMA CITY, PAN., 49.75 m.,
Addr. P. O. Box 910. 10.30 am.-
2, 6-10 pm.
- 6.030 VE9CA CALGARY, ALTA, CAN., 49.75 m.
Thurs. 9 am.-1 am.; Sun. 12 n.-
12 am.
- 6.030 RV59 MOSCOW, U.S.S.R., 49.75 m. 5-6,
10-11 pm. Irregular.
- 6.030 OLR2B PRAGUE, CZECHOSLOVAKIA,
49.75 m. (See 11.875 mc.) Off the
air at present.
- 6.023 XEUW VERA CRUZ, MEX., 49.82 m., Addr.
Av., Independencia 98. 10 pm.-
1 am.
- 6.020 DJC BERLIN, GERMANY, 49.83 m.,
Addr. (See 6.079 mc.) 1-4.30 pm.
- 6.017 H13U SANTIAGO DE LOS CABALLEROS
D. R., 49.85 m. 7.30-9 am., 12 n.-
2 pm., 5-7 pm., 8.30-9 pm.; Sun.
12.30-2, 4-5 pm.
- 6.015 PRA8 PERNAMBUCO, BRAZIL, 49.84 m.,
Radio Club of Pernambuco, 4.9
pm.
- 6.010 OLR2A PRAGUE, CZECHOSLOVAKIA,
49.92 m., Addr. (See OLR, 11.84
mc.) Wed., Thurs., 4.40-5.10 pm.
- 6.010 COCO HAVANA, CUBA, 49.92 m., Addr.
P. O. Box 98, Daily 7.55 am.-
12 m., Sun. until 11 pm.
- 6.010 VK9MI S. S. KANIMBLA, 49.92 m. (Travels
between Australia and New Zea-
land). Sun., Wed., Thurs. 6.55-
7.30 am.
- 6.010 CJCX SYDNEY, NOVA SCOTIA, 49.92 m.
Relays CJC7 7 am.-1 pm., 4-8 pm.
1.30 pm. 8.30 pm.
- 6.007 ZRM ROBERTS HEIGHTS, S. AFRICA,
49.94 m., Addr. (See ZRK, 9.606
mc.) Daily exc. Sun. 10 am.-3.30
pm.; Sun. 9 am.-12 n., 12.15-
3.15 pm. Daily exc. Sat. 11.45
pm.-12.50 am.
- 6.007 ZRJ JOHANNESBURG, S. AFRICA,
49.94 m., Addr. S. African Broad-
cast. Co., 3.30-4 pm. exc. Sun.

(Continued on following page)

WILL SWAP A.R.R.L. LICENSE manual, eighth edition. Human engineering guitar chord book. Excellent practical violin book. "The Principles Underlying Radio Communication" by U. S. Army Signal Corps. Bill Schroeder, 803 Wisconsin, Peoria, Ill.

SWAP 5-TUBE SHORT WAVE radio, good condition, and Eastman Jiffy Kodak for Arkus enlarger, 35mm developing tank, other developing equipment. All letters answered. Edward Wooten, 14 Maiden Lane, Raleigh, N. C.

FOR TRADE, QUITE A LOT OF radio parts and other things. Will trade for curio of any kind, or horns of any kind. W. H. MEDLEY, Star R, Box N, Rushville, Illinois.

WANTED A SW RCVR IN GOOD condition. Trade for it a good 35mm still projector and/or Boy's Life. Complete Jan. '32-Dec. '38. W. D. Archer, 6202-29th Ave., N. E. Seattle, Wash.

WANT SMALL OCTAGON CONCERTINA, English or Boston female bull-dog, rifles, Indian pottery, relics, coins, vases, statuary. Have guitar, mandolin, banjo-ukule, ukulele, banjo, taxidermy courses, steel-gratings, list. Stanley Fstel, 5025 Ordan Ave., Chicago, Illinois.

WILL PAY PREFERENCE BETWEEN my Ultra-Skyrider, model SX10 and Hammarlund Super-Pro, or National HRO. Nothing older than 1939; model wanted. My receiver is in A-1 condition. J. H. Hood, 37 Club Drive, Greenville, S. C.

HAVE OVER TWO YEARS ISSUES Short Wave & Television. Will swap for equal value in SWL cards or? Also have part of N.R.I. course. Swap for? Warren Dame, Old Connecticut Path, Coahuitate, Mass.

WANTED: ALL BACK ISSUES OF Short Wave Craft between June, 1939, and May, 1932. Will pay cash or trade. State price and condition of magazines. J. DeSousa, Jr., 81 Greendale Ave., Needham Heights, Mass.

HAVE 2 TUBE SHORT WAVE RECEIVER battery set, carphones and tubes included for what have you? Would like Doerle set. Donald Van Dusen, Gibbertville, N. Y.

HAVE WANTED, I NEED VERMONT or W.A.S. Want to make a shed with Vermont or Delaware hang on 40 meters. How about it, some of you fellers? W.G.P.P., The Dalles, Oregon.

HAVE STROMBERG CARLSON magnetic pickup outfit, all electric, complete speaker, GE motor arms, etc. Want new machine or transmitter, or what have you? James Rush, 14 Madison Ave., Pleasantville, N. Y.

HAVE AUTOMATIC CODE MACHINE with tapes, code course. Also meters, microphones, ham parts, pickup. All Star receiver, etc. Swap for Sprayberry's late Radio Course, fast camera, testing equipment or? S. J. Niewicz, 79 Church St., Broad Brook, Conn.

WANTED: LATE CANDLER "Junior" code course or Instructor Guide. Have N. W. Taxidermy course, G. E. electric clock, also 22 repeating rifle in good working condition. Donald Willis, 213 Madison Street, Platteville, Wisconsin.

HAVE OLD U.S. COINS, C.S.A. bills, scarce. Fla. notes, many Southern bills, old books, magazines, butterflies. Wanted a good car radio, early U.S. covers, stamps for a reply. L. Signor, Dover, Fla.

3 TUBE GROSS HAM RECEIVER, electrical hand spread, six coils, 20-550 meters. "B" plate power supply, also filament supply transformer. Want big key, Candler course, typewriter or? Gerald Collins, Pinecrest Sanatorium, Powers, Mich.

TRADE RADIO PARTS, B ELIMINATOR, detective magazines, books, tools, bookmatch covers, stamps, skull, cash for short wave set, radio courses, antique glassware, paper weights or what have you? Russell, Box 314, Hawley, Minnesota.

HAVE TRUMPET, COST \$58.50, in very good condition. Will trade for test equipment or anything in radio. Don Morse, 25 1/2 E. Main St., Freeport, Illinois.

HAVE MODEL AF UNIVEX CAMERA like new. Will swap for receiver or amplifier parts. All letters will be answered. Address all letters to Richard Juddins, 7432 Chappel Ave., Chicago, Ill.

HAVE KW HIGH POWER PLATE transformer, over 2,000 volt ct. at 600 1000 MA. Will swap for 20 meter xtals, stat. mike, typewriter, meters, other xmitter parts or what have you? W8QZV, Wentworth, Wis.

WANTED: TYPEWRITER, BINOCULARS, book by Writtsbury, Zane Grey, Ralston Press, Harvard Classics. Offer mimeographing, courses in art (Federal Schools), salesmanship, mental power, journalism, health, body building. R. T. Birgin, 116 Church Rd., Rockledge, Pa.

TRADE HALLICRAFTERS SX 17 receiver complete with speaker. Purchased by factory guarantee and in first class condition. What have you for offer? Marvin W. Shellhauer, P. O. Box 104, Tamaqua, Penna.

TRADE - QST 1929-1934 COMPLETE 60 copies, also Fall 1938 Radio Amateur Call Book. Want used or mint U. S. stamps. What have you? Eric C. Desanens, WYOL, 406 West Ash St., San Diego, Calif.

SWAP COLLECTION OF 410 FOREIGN stamps in album, 25 different kinds, 75 tubes, volume controls, radio books and radio parts for what have you? R. W. Dieter, R2, Box 109, Blue River, Wis.

SWAP: EMERSON 110V, D.C. motor 1/16 h.p. 1750 rev., Benjamin Will trade for Essex tube broadcast radio. Will trade for radio parts, equipment or what have you? Wallace Bralley, Kellogg, Iowa.

SWAP 330 DIFK U.S. IN NICE album for a D.C. 0-1 millimeter. Also have radio parts, magazines. K. E. McLean, R.R.3, Arcanum, Ohio.

HAVE BOOKS, MAGAZINES, stamp and coin publications, pennants, old radio parts, stamp albums and/or 14mm projector. Andrew Hines, 35 Krakow St., Garfield, N. J.

HAVE "B" ELIMINATORS, "A" eliminator, radio parts, "Flying Ace", "Short Wave Craft", '32-'36, model airplane kits (15), ship kit. Want AC SW-3 with power supply, guitar, or Clarence Schwengel, 123 N. Bedford Madison, Wis.

WANTED, A GOOD 16MM MOTION picture camera and films for 5 tube Doerle set, complete. Best offer takes it. Charles Wilson, 228 Church St., Phoenixville, Pa.

TRADE 5 TUBE T.R.F. SW RECEIVER, black crystal finish cabinet 18" x 12" x 9", built-in 6" dynamic, bandspread, etc. Want Candler course Chicago.

WANTED - PORTABLE LOUD- speaker set, preferably a superheterodyne. Must be light and self-contained. State price, weight and details. Write for my list of trade items. Harry Bohm, R-1, Hinsdale, Ill.

POSTCARD COLLECTOR - 1,000 postcards (view only) for an Elfen G6 for 1 tube, or Amateurs Favorite DX3, or Unives projector. Write K. Burtisch, 1332 E. Taylor, Kokomo, Ind.

TRADE PAIR OF NATIONAL FH7-FBX 40 meter bandspread for 80 meter bandspread coils. Must be A1 condition. W8PVE, 1516 Sherman St., Alameda, Calif.

WILL SWAP NEW HARVARD Classics, 51 vol., 1-4 tube model 57 radio radio for radio parts or short-cups. Chicago, 5915 So. Damen, Chicago, Ill.

WILL TRADE RADIO EQUIPMENT for U.S. stamps. Have radio books, records, and radio parts to trade. Want a good record selector changer. Carl A. Kowalski, WILLS, 601 Perrin Ave., Lafayette, Ind.

WANTED: RECORD CHANGER OR stat. mike. Have all kinds parts, carbon for tube, record player, etc. Also have SW3 receiver with coils. Bill Sampson, Jr., 2208 Floyd, Richmond, Va.

SWAP 40 U.S. COMMEMS. FOR 50 tax tokens, facsimile confederate bill for 10 tax tokens or 10 U.S. Commems., 25 postmarks for 10 tax tokens. Swap SWL cards. Henry Kerecuk, 2649 N. Menard Avenue, Chicago, Illinois.

WILL EXCHANGE 50 FOREIGN stamps for each commem. Oklahoma tax taken for each commem. Newspaper for 10 commem. Five postmarks for each commem. Orville Arnold, Box 311, Henryetta, Oklahoma.

SWAP-\$13 AUTO HOT WATER heater, for two 2 mfd 3000 u filter coils or dual tank cond. 3000 u insulation or what have you? Frank Smith, W8JZM, 1267 Logan Ave., Tyrone, Pa.

HAVE GOOD VIOLIN AND BOW and Mossberg-six shot 22 with telescope. Want S.W. receiver, transmitter with power, typewriter or what have you? Will pay cash for above mentioned. K. Scott, Box 209, Hendersonville, N. C.

BEST OFFER TAKES STAMP collection, radio parts and tubes, taxidermy course, Oklahoma "Jewel-Box" 8-tube electric radio with speaker and tubes. All letters answered. A. Komperla, 4808 S. Seelye A., Chicago, Ill.

WILL TRADE PRINTING FOR anything radio or photographic; magazines, etc. 100% answers. Steve Salata, 137 16th St., Wheeling, W. Va.

WANTED: RECORD CHANGER, power pack, meters and other things. I have DeForest complete radio course, 1 mike trans. (new) wax records, 5 meter transmitter, or what have you? and S.B. mike. Everything answered. Bill Godden, Emmetsburg, Iowa.

HAVE CHEMISTRY EQUIPMENT (glassware, etc.), Chemcraft set number 7%, and United States stamp collection in album. Want 22 single shot rifle, other rifles, State make, model condition, etc. Glen Elliott, 513 Wenonah, Oak Park, Illinois.

WANTED: ELECTRIC TRAINS, any make—regarding conditions accepted. Describe locomotive number, etc. Will pay cash or trade. I have Fred-Eisenmann G-T. bat. radio, crystal sets, piano rollers, earphones. John E. Evans, 1016 Easthigh, Oskaloosa, Iowa.

HAVE 2-VOLT TUBES: 1-19, 2-30's, 1-32, 2-33's, 2-34's, Itaytheons and Tung-sol's. Value \$6.00. Used 1 or 2 hrs. Want good microphone or multi-meter, or what have you. Oran Robertson, W6QCZ, Box 643, Holtville, California.

SWAP 17 3/8" SPEAKER, FOREIGN stamps, postmarks, Baby Brownie camera, sharp tuner dial, Auto safety lighter, 2-tube short wave set with amplifier and speaker, banjo-uke. Send offer. R. Lewis, Griffithville, Ark.

HAVE 2-TUBE RADIO, 80 AND 200-500 m. coils, no power supply. Cook electrical course, 16 mm. movie projector, erector set, 1922-1923 Pop. Mechanics. Want \$10-\$12, slide rule. Douglas Phelps, Sidney, New York.

TRADE OVER 100 RADIO MAGS., manuals, coils, phones. Want Candler Jr., code course, Ultra Sky Rover, AC-DC. List free. John Moskal, 5 Gardner Ave., South Attleboro, Mass.

HAVE FEDERAL PHOTO ENLARGER, never used; Mossberg, 22 caliber rifle in good condition and parts. Want short wave receiver, radio parts or what have you. All letters answered. Harold Tucker, QRS 342, West Point, N. Y.

SWAP WESTINGHOUSE DYNAMO motor output 1000 v. 400 m.a., input 12 v., with 6 v. input, 500 v. 200 ma. Mounting bracket. Want Auto "B" supply with 90 v. tap. J. Zubas, Irvington, N. Y.

I HAVE FOR SWAP 2 GRAFLUX cameras, 2 view cameras, 357 and 34x52, also 3A Eastman Kodak. Want a good 12-gauge hammerless shotgun or Fred R. Wolcott, 273 Medford Road, Syracuse, N. Y.

SWAP A 32V MOTOR-GENERATOR meters a book "Radio Operating Questions and Answers" by Nilson and Horning, issues of Q-S, S.W. F., and Popular Science Mag., and stamps. What have you? W8RAW, Tou Simyth, Beloit, Kansas.

EXCHANGE TWO WESTERN electric 250 watt tubes, Kolster power amplifier, Thordarson transformers, 250 watt Clarostat, etc. Want signal generator and tube tester. R. Larimer, W8BBS, 408 East 11th St., North Platte, Neb.

SWAP STROMBERG-CARLSON short wave converter 4 tubes. Convert any radio A.C. in short wave, 3 bands. Write to R. Garcia, 300 W. 17th St., New York.

WANTED: CANDLER JUNIOR code course; small all wave receiver. Have 800 books, fiction and non-fiction from which equal value can be selected. Also complete file of "Life." Howard W. Sieger, 110 Nobles Lane, Pittsburgh, 10, Pa.

HAVE AN 8-IN. UTAH DYNAMIC speaker. Want Call Book or? Ovide Lee, 220 Adams St., Alpena, Mich.

HAVE CARTOONING COURSE, motor efficiency guide, scout handbook, B-eliminator, several pairs of magnetic phones, and American Boy and Popular Science Magazines. What have you for? H. C. Patchen, 23 Grand St., Sidney, N. Y.

HAVE 500 GREASE GUN WASHERS (leather), 125 radiator and gas tank cap washers (leather). Trade for radio, photographic, musical equipment. If you grease cars you need these. Value \$26.25. Harry L. Tucker, 1838 G St., N.W., Washington, D. C.

WANTED - SKY BUDDY OR other similar set. Have 6V to 275V vibrator power supply, receiving tubes, head phones, 8" dynamic speaker, meters, etc. A. L. Purdy, 2508 Elm St., El Paso, Texas.

GOLD AND SILVER 1, S. COINS, stamps, covers, postcards, radios, books, etc. for your offers, hobby goods, foreign paper money, auto radiator, name plates, zeks, films, printing supplies. Rudolph Zak, 2509 East 99th, Cleveland, Ohio.

WANTED: TO BUY—COMPLETE 20 meter phone transmitter with about 200 watts input. Pay cash. Charles Rosen, 6271 Clemens, St. Louis, Mo.

HAVE B FLAT LOW PITCH clarinet in good condition to exchange for good communication receiver such as Howard or Hallierafter. Lester Carleton, Box 452, Canton, Ala.

WANTED - USED INSTRUCTIONAL tapes, Continental code. Write Ivan Walker, 944 West Main St., Platteville, Wisconsin.

(Continued on following page)

BARTER and EXCHANGE FREE ADS (continued)

World S-W Stations

(Continued from preceding page)

TRADE: COMPACT TRANSMITTER: Uses plug-in coils, xtal stage—59. Final stage 212-A. Chassis 7 by 13". Less power supply. Want micro scope or what have you? WSTALE. 2901 N. Kilbourn Ave., Chicago, Illinois.

HAVE ATWATER KENT 60 minus cabinet, 3 tube A.C.-S.W., 3 tube Kadette, loads other stuff. Want Sky Buddy or similar R.X. Prefer some one near Chicago. Robert Perlich, 3635 So. Wood St., Chicago, Ill.

WILL TRADE UTAH JUNIOR X-mitter (new); Triplet 1200-A V-O-M tester (new); Meisner best frequency oscillator (new). Want S.W. receiver, instructor or Teleplex with tapes. Write for offer. G. H. Burkhardt, Box 202, Woodfield, Ohio.

WANTED: OLD "HAM" CALL Book and map of U.S.A. Will pay their postage for sending it. My QRA is LAUREN SCHNAK, 1608 Campbell Ave., Des Plaines, Ill.

HAVE A NATIONAL 4 TUBE Thrill Box SW-4 to swap for a 30-30 or 32 special. (Battery Set). Will answer all letters. Thor Holm, Cooperstown, N. Dakota.

WILL SWAP 1/8 HORSEPOWER motor, jig saw, 8 tube Monarch radio, long and short wave, fair shape, for tube tester and A.C. D.C. volt-ohm-milliammeter. Ward Smith, 7428 Idlewild St., Pittsburgh, Penna.

WANTED — FIVE METER receiver and sending set, also small spark coil. Will swap white and colored mics, also breeding cages and mouse circus. J. Burns, R.1, Langborne, Pa.

TRADE FIRST FLIGHT FIRST day, dedication covers over 1 year, for unused U.S. postage blocks. Foreign stamps for U.S. War medals for what? Richard H. Munro, 384 Palisade Ave., Union City, N. J.

WANT: SUPER CLIPPER OR Doerle D38. Will give 2 tube A.C.-D.C. receiver, double button American mike, Knight A.C. transceiver, 3" speaker, plug-in coils, plus cash. Herbert Makela, 1129 16th Ave., E. Hibbing, Minnesota.

HAVE THREE TUBE ALL-WAVE receiver, also 25 watt crystal controlled transmitter. Would like to trade for transmitting equipment. E. E. Bateman, R.1, Box 56, Saurus, Calif.

HAVE RADIO PARTS. SHORT wave converter, stands, books, want 14 of Hamstrand G.W. K-17 and 270 meter plug-in coils or? Bud Carson, 1618 W. Second St., Dayton, Ohio.

HAVE 5 TUBE A.C. SHORT WAVE receiver, dynamic speakers, power transformers. Western Electric cradle phone, Baldwin headphones, radio machines. Want binoculars, photographic equipment for receiver. M. Simon, Box 441, Gary, Indiana.

TRADE A W.E. 625-A MIKE, A 160 meter crystal, and a National Union type 210 tube, all for a good mounted Bliley or similar crystal for about 7275 kea. Write: W2KRF, Mount Vernon, N. Y.

EXCHANGE 5 TUBE SILVER- tone set, without panel or top, very good shape. Will swap for type writer or what have you? Will be glad to answer any requests. Russell B. Gurney, Jr., Salem Depot, N. H.

WILL TRADE 1 41 PLATE CARD- well transmitting condenser for an electric phono pick-up, either crystal or magnetic or? Please write. Harold Brace, Jr., Bridge Ave., Berwyn, Pa.

WANTED — PORTABLE TYPE- writer and short wave receiver. Anyone having either of these please write. Have 15 jeweled Swiss wristwatch in fine condition and some cash to trade. All correspondence answered. R. H. Mincer, Oakdale, Iowa.

WILL SWAP GUITAR IN ALL shape for small transmitter, receiver, radio parts and books. All offers answered 100%. Will exchange SWL cards with anyone, anywhere. QSL 100%. Lucien Guitard, Sturgeon Falls, Ont., Canada.

HAVE TRANSCEIVER USING 6T5G and 12AT and American microphone model 871 single button, also have radio physics book by Ghirardi, have power supply tapped 250V, 6V, 4V, 1 1/2 V. What have you? John Krawczyk, 1457 So. 9th St., Camden, N. J.

SWAP MEN'S JEWEL SWISS wristwatch, perfect condition. 1/4 H.P. G.P. motor; model 53A Springfield. 22 rifle for what have you? Joseph N. Moshel, 4002 6th Avenue, Brooklyn, N. Y.

WILL SWAP TUBES, RADIO parts, power supply. Sky Buddy radio and Agfa clipper camera for short wave converter, small transmitter or what? Send for list. Paul Kent, 1116 E. High St., Rockville, Indiana.

TRADE RTI CORRESPONDENCE course, Kato converter 110 DC to 110 AC 10 Va. converter E-250 DC, portable type writer, receiver, parts, diagrams for winding 110 volt 700 watt generator. Want transmitter or parts. R. H. Hillers, Plainville, Kansas.

TRADE—TUNGAR BULBS, USED. 2 and 6 amps sizes. Also 1 Sheldon type G rectifier. For air rifle or used tubes, S. Bedzowski, 11 Horatio St., Newark, N. J.

WILL TRADE CAMERA, AGFA Ilex, with anastigmat F.7.5 lens shutter speed 1/100 second, with case. Cost \$12.50. Want volt-ohmmeter or tube tester or what have you. Eugene Wright, P.O. Box 1794, Vernon, Texas.

WANT TO BUY OLD MOTOR- cycle, for about \$15. Have radio parts and receiver to trade. Edward Peckham, 202 1/2 N. Minnesota, Wichita, Kansas.

RADIO PHYSICS COURSE AND Radio Operating Questions and Answers to swap for high voltage plate transformer and filter parts. Also hundred used receiving tubes to swap for ham stuff. W5QUX, Rio Hondo, Texas.

HAVE 6", 8" AND 10" PARADY 8 volt gonsa like new; Beth Thomas time switches; relays; overload switches for low DC; Hawkins Electric Guides; want Univex movie equip.; 8 mm film or? Wendell, Pretty Prairie, Kansas.

TRADE METERS, RADIO PARTS, or cash for any drummer's supplies you have. Want complete set of drums and cymbals. Will buy single pieces as well as sets. Milton Lippin, 214 E. 54th St., Brooklyn, N. Y.

USED HAWAIIAN GUITAR AND case, cost \$25.00, complete and free lessons. Cost \$29.00 when new. Want model gas engine and plane kit or what? Walter Dunn, 1822 Roys Ave., Elkhart, Ind.

HAVE 2 TENNIS RACQUETS, 12- in. Peerless dynamic, Benito and Pop Meek magazines; Hollywood night club match covers. Want Rider Manuals, tube tester or record changer. John Littjohann, 1736 Gundry, Long Beach, Calif.

I HAVE J. E. SMITH RADIO course, microscopes and many other articles. What have you? Am interested in everything. B. Mummert, 310 W. Douglas, Freeport, Illinois.

WANTED — RIDER'S MANUALS, 1 to 7, analyzer, signal generator, condenser tester, oscilloscope and other test equip. W. D. Brooks, Penn Ave., East Liverpool, Ohio.

WANTED: PARTS FOR 100 W transmitter. Have electric clipper razor, 5 tube D.C. Atwater Kent. Re-aligning radio parts, \$145.00 refrigerator course, refrigerator tools, 16 mm camera and projector. Nesbit A. Boyles, Hartford City, Ind.

TRADE AUTOMOBILE AND MO- torcycle license plates with collectors in other states and countries. Will buy if cheap. Swap shortwave set and big Western alt for old car, or? Anthony Skutumpah, Newport, N. J.

WANTED: A "BUG" KEY IN good condition. Have radio parts to trade or will buy if the price is right. Also interested in transmitting parts. Snick's Ham Shack, Box 244, Perry, Iowa.

HAVE GAS WASH MACH. MO- tor, meters, 6L6s, T20 and other parts. Wanted used Natl. SW3 or? and ham gear. What have you? Henry Macaro, China Road, Winslow, Maine.

TRADE BEAUTIFULLY HAND- woven knitting bags, hand hooked rugs, other items or cash for interesting old bottles, flasks, barber bottles, old colored prints, lithographs, engravings. Gary Thompson, Lakeview Terrace, Asheville, North Carolina, U.S.A.

HAVE 6 TUBE BATTERY RADIO, shortwave kit, 3 tube, rigid. Aiding beginning radio parts, books on radio, courses. Want any radios, 1 to 3 tubes, battery powered, and Guinea pigs. Hillary A. Munk, North Somers, Connecticut.

HAVE UNDERWOOD TYPE- writer, Elgin bicycle motor, 3 eye microscope 500 power. Want Contax. Leica, candid, tenor saxophone Buacher. Kings preferred, or what have you? J. Sefonti, Jr., 9920 37th Ave., Corona, N. Y.

WILL SWAP COMBINATION TAT- tooling machine, tattoo outfits, complete tattooing course, etc., for small short wave radios, headphones, Instru-Graph, radio parts, code oscillator. E. E. Dye, 321 East State St., Kennett Square, Pa.

ASSORTED STAMPS, FOREIGN and U.S. Value \$25.00. Want headphones automatic key, transmitter parts. What have you? Mike Monaghan, 218 S. 2nd St., West Branch, Mich.

SWAP UNITED STATES STAMP collection, many mint commemoratives, metal blocks, etc. Want balloon tire bicycle in good condition and Arctus candid camera in good condition. L. Bernstein, 1071 Elder Ave., Bronx, N. Y.

NEW THORDARSON OSCILLO- scope. W.E. power transformer. Stewart-Warner converter, electric machine, pickup, A.C. 12" Jensen speaker, other items. Want test meters. Riders Manuals or cameras. Edgar D. Growden, 813 Gephart Drive, Cumberland, Md.

FOR TRADE — REMINGTON standard typewriter, electric razor, battery radio, new set (10) fiction books, (8 by Jack London) in exchange for what? E. G. Bartlett, Atlanta, Mo.

HAVE 1916 MODEL T FORD roadster, very good condition, run less than 6000 miles. Want phone xmitter or what have you? William J. Moore, Stanley, N. Y.

SWL EXCHANGE
WOULD LIKE TO SWAP SWL fotos, post card views, and correspondence with anyone. All letters answered 100%. QRA—Edward Iendzioszek, 107th Co. C.C.C., Pittsfield, Mass., U.S.A.

SEND ME YOUR QSL'S, SWL'S, your city or country and shack Photos under cover from any foreign country via Air Mail. My return letter to you same way. W. J. Orszak, 488 So. Koomis St., Chicago, Ill., U.S.A.

WOULD LIKE TO EXCHANGE my QSL for SWL cards. All answered 100%. W6KQS, Melvin E. Walton, 1314 Park Ave., Ingewood, Calif.

HELLO SWL'S OF ASIA, AU- stralia, Central and South America, Canada, Africa, W6 and W7 district, Atlantic & Pacific Islands. Exchange cards. I SWL promptly 100%. Derek Gray, Culvera Close, Winchester, Hampshire, England.

ATTENTION SWL'S, WILL SWAP cards and keep correspondence with you. Jag an Svensk. Eric Hultgren, 77 Seaview Terrace, Bridgeport, Conn., U.S.A.

ATTENTION FOREIGN HAMS and SWL's. Let's swap cards. I will send mine in receipt of yours. What say OM? Lew Molteni, 519-21 St., Union City, New Jersey, U.S.A.

ATTENTION YL'S ES OM'S, Wud like to exchange SWLs with anyone interested and correspond with any SWL. preferably SWL members. I QSL 100%. 73's, 88's, Harry E. Meier, 7 Booserelt Ave., Cranford, N. J.

WOULD LIKE TO EXCHANGE SWL crds with all foreign listeners. Also from Nevada, Idaho, North Dak., New Mex., Wyoming, Delaware and Arkansas. I QSL 100%. QRA, John L. Ballin, 40 East 68th St., New York, N. Y.

SWL'S—SHORT WAVE LISTEN- ers all over the world. I QSL 100%. Swap photos of American suits for foreign makes. QRA—G. E. Kilpatrick, W10-SWL-W3, Conshohocken, Pa., U.S.A.

ATTENTION HAMS: MOST BEAU- tiful SWL and QSL cards for exchange. I SWL have you? Samples given. Postage appreciated. S. W. Post, % Ray and Don Kallbourn, R.D. No. 3, Geneva, Pa.

SWL'S IN AMERICA, EUROPE, Asia, Africa, Australia and elsewhere. If you want a nice QSL send me yours. I QSL 100%. Also have a few fotos, Earle L. Hoars, VE1AL, 83 Preston St., Halifax, N. S., Can.

ATTENTION OM'S ES YL'S, I will send my new SWL card for yours. I QSL 100%. U. S., foreign, or anywhere. 73s. QRA Paul Ankerman, 404 Lima St., Wapakoneta, Ohio, U.S.A.

CORRESPONDENCE WANTED from foreign countries. I will swap SWL cards, postcards and foto. I'll QSL 100%. I will answer all letters. QRA Howard Schrieffer, 614 Soudia St., New Orleans, Louisiana, U.S.A.

ATTENTION SWL'S, WILL SWAP my SWL card for yours. I QSL 100% the day I get your card. 73's es best DX. Milton Benson, 1 No. Main St., So. Hadley Falls, Mass., U.S.A.

ATTENTION SWL FANS ALL OVER the world. Send me your SWL card for my collection and I will send you mine. Trx. Lewis Neuman, P.O. Box 8365, Pittsburgh (18) Pa.

WOULD LIKE TO EXCHANGE SWL cards with any ham in U.S.A. or foreign countries. Will QSL 100% all cards. John Kuhn, 226 S. Mt. Olivet Lane, Baltimore, Md., U.S.A.

CALLING CQ ATTENTION ALL OM's es YL's. Let's swap SWL cards all around the world. I QSL 100%. John W. Clark, 28-24 QSL Flyers, Flushing, N.Y.C., N. Y.

ATTENTION SWL'S, I'M NEW crd. 100% QSL here. Vince and Marie Stasen, 5347 Priscilla St., Philadelphia, Pa., U.S.A.

WILL SWAP SWL CARDS WITH SWL listeners foreign countries and United States. Send me one of yours and I'll send you one of mine. Frank Von Putz, 89-12 75 Road, Elmhurst, L. I., N. Y., U.S.A.

WANTED—TO JOIN U.S. AND foreign short wave clubs. Will QSL 100%. QRA—Paul Bahr, 1205 W. 10th St., Marion, Indiana, U.S.A.

SWL'S ANYWHERE, YOUR SWL will be appreciated. I QSL 100%. QRA: Bill Streeter, 1542 W. 6th St., Brooklyn, N. Y., U.S.A.

Mc. Call		
6.005 HPSK	COLON, PAN., 49.96 m., Addr. Box 33, La Voz de la Victor. 7-9 am., 10.30 am.-1 pm., 5-11 pm.	
6.005 CFCX	MONTREAL, CAN., 49.96 m., Can. Marconi Co. Relays CFCF 6.45 am.-12 m.; Sun. 8 am.-10.15 pm.	
6.005 VE9DN	DRUMMONDVILLE, QUE., CAN., 49.96 m., Addr. Canadian Marconi Co.	
6.002 CXA2	MONTEVIDEO, URUGUAY, 49.98 m., Addr. Rio Negro 1631, Relays L52, Radio Prieto, Buenos Aires, 7.30-10.30 pm.	
6.000 Z6A	SALISBURY, RHODESIA, S. AFRICA, 50 m. (See 6.147 mc., ZEB.) Also Sun. 3.30-5 am.	
6.000 X8BT	MEXICO CITY, MEX., 50 m., Addr. P. O. Box 79.44, 8 am.-1 am.	
End of Broadcast Band		
5.977 CS2WD	LISBON, PORTUGAL, 50.15 m., Addr. Rue Capelo 5, 3.30-6 pm.	
5.975 OAX4P	HUANCAYO, PERU, 50.16 m. La Voz del Centro del Peru, 8 pm. on.	
5.970 YV5RC	CARACAS, VEN., 50.26 m., Addr. Radio Caracas, Sun. 7 am.-10 pm. Daily 7-8 am., 1-1.45 pm., 4-9.30 or 10 pm.	
5.968 HVJ	VATICAN CITY, 50.27 m. Off the air at present.	
5.960 HH2S	PORT-AU-PRINCE, HAITI, 50.37 m., Addr. P. O. Box A103, 7-9.45 pm.	
5.938 YV1RL	MARACAIBO, VEN., 50.52 m., Addr. Radio Popular, Jose A. Higuera M., P. O. Box 247, Daily 11.43 am.-1.43 pm., 5.13-10.13 pm.; Sun. 9.13 am.-3.13 pm.	
5.920 YV4RH	VALENCIA, VEN., 50.68 m. 5-9.30 pm.	
5.900 ZNB	MAFEKING BRI, BECHUANALAND S. AFRICA, 50.84 m. Addr. The Govt. Engineer, P. O. Box 106, 6-7 am. 1-2.30 pm. Ex. 50.85 m.	
5.900 TILS	SAN JOSE, COSTA RICA, 50.85 m., 6-10 pm.	
5.898 YV3RA	BARQUISIMETO, VEN., 50.86 m., Addr. La Voz de Lera, 12 n-1 pm., 6-10 pm.	
5.888 HI9B	SANTIAGO, D. R., 50.95 m. Irregular 6-11 pm.	
5.878 HRN	TEGUCIGALPA, HONDURAS, 51.06 m. 1.15-2.16, 8.30-10 pm.; Sun. 3.30-5.30, 8.30-9.30 pm.	
5.868 HI1J	SAN PEDRO DE MACORIS, D. R., 51.25 m., Addr. Box 204, 12 n-2 pm., 6.30-9 pm.	
5.846 YV1RB	MARACAIBO, VEN., 51.3 m., Addr. Apartado 214, 8.45-9.45 am., 11.15 am.-12.15 pm., 4.45-9.45 pm.; Sun. 11.45 am.-12.45 pm.	
5.838 TI0PH	SAN JOSE, COSTA RICA, 51.5 m., Addr. Alma Tics, Apartado 800, 11 am.-1 pm., 6-10 pm. Relays TIX 9-10 pm.	
5.818 TI0PH2	SAN JOSE, COSTA RICA, 51.59 m., Addr. Senor Gonzalo Pinto, H.	
5.790 T6S	GUATEMALA CITY, GUAT., 51.75 m. Casa Preidencial, Senor J. M. Caballeroz. Irregular.	
5.750 YNOP	MANAGUA, NICARAGUA, 52.11 m. 8-9.30 pm.	
5.740 YV2RA	SAN CRISTOBAL, VENEZUELA, 52.23 m., Addr. La Voz de Tachire, 11.30 am.-12 n., 5.30-9 pm., Sun. till 10 pm.	
5.735 HC1PM	QUITO, ECUADOR, 52.28 m. Irregular 10 pm.-12 m.	
5.145 OK1MPT	PRAGUE, CZECHOSLOVAKIA, 58.31 m., Addr. (See OLR, 11.84 mc.) Fri. 4.45-5.10 pm.; Sat. 5.15-5.40 pm.	
5.145 PMY	BANDOENG, JAVA, 58.31 m. 5.30-11 am.	
4.995 VUD2	DELHI, INDIA, 60.06 m., Addr. All India Radio, 7.30 am.-12.30 pm.	
4.950 YUM2	MADRAS, INDIA, 60.61 m. Addr. All India Radio, 7 am.-12 n.	
4.905 VUB2	BOMBAY, INDIA, 61.16 m. Addr. All India Radio, 7 am.-12.30 pm.	
4.900 HJ3ABH	BOGOTA, COL., 61.19 m., Addr. Apartado 565, 12 n-2 pm., 6-11 pm.; Sun. 12 n-2 pm., 4-11 pm.	

(Continued on page 703)

The Radio Beginner

(Continued from page 660)

area around the transmitter, as shown in Figure 4. Since the ground wave rapidly diminishes in strength, it can be seen that on short waves there will be an area in which no signals from the particular transmitter will be observed. This phenomenon is known as *skip distance* and accounts for the long range communication on short waves. Skip distance seems to increase as the waves become shorter, the limit of skip being the diameter of the earth. Under certain ionospheric conditions and wavelengths, the sky wave may even miss the earth.

Natural Wavelength of an Antenna

If we were to erect an antenna in open space, we would have a device for responding to a radio wave. The wavelength of the receiving antenna would depend upon the length of antenna wire. The *natural wavelength* of the antenna would be its wavelength without the addition of any other equipment. If, for example, the antenna had a natural wavelength of 100 meters, it would be practically insensitive to all other wavelengths, except harmonics of the 100 meter wave. We could, of course, change the natural wavelength by making the antenna longer or shorter, but fortunately we have a much better method. If we were to insert a coil as shown in Figure 5, we would actually be adding wire to the length of the antenna. We could then vary the antenna by adding or subtracting turns from the coil, and in this way *tune* in to different wavelengths. The present method of tuning is to connect a variable condenser across the coil, as shown in Figure 5.

The radio wave manifests itself in the antenna as a very minute current of electricity. The insertion of the coil between the antenna and the ground will compel the current to flow through the coil, since the ground is at a lower potential than the antenna. We recall that an alternating current flowing through a coil will create a rising and collapsing magnetic field. In a previous lesson we learned that such a magnetic field could be transferred through space to another coil, creating a flow of electric current in that coil. We then have all the conditions necessary for taking the current in the antenna and putting it into our radio receiver.

Coupling Antenna to Receiver

There are a number of methods of connecting receivers to antennas, the simplest being *direct* coupling, illustrated in Figure 6A. In direct coupling the electrical energy is fed directly to the receiver. Figure 6B shows another form of coupling known as *electrostatic* coupling, in which the electrical energy of the antenna is transferred to the receiver by the charging and the discharging of the condensers. In *inductive* coupling, Figure 6C, we use two independent coils, one in the antenna circuit, and the other in the closed circuit of the receiver. In this case, the energy is transferred from the antenna circuit to the receiver by means of electro-magnetic induction. In actual practice both coils are wound on the same form, the antenna coil being known as the *primary* and the receiver coil being termed the *secondary*. Maximum transfer of energy is secured when both coils are tuned to the same frequency, or are in resonance.

For Latest TELEVISION News—
Read "R. & T." every month.

BARTER and EXCHANGE FREE ADS (continued)

SWL'S IN U.S.A., FOREIGN COUNTRIES. I will send one of my new SWL cards to those who send me one of theirs. I QSL 100%. QRA is Jimmy Wrath, 1147 White St., Des Plaines, Ill.

JEANS SWL'S ANYWHERE. Would appreciate your card for my collection—will send out exchange SWL card same day. QSL 100%. S. H. Ginn, 18 York Court, Guilford, Baltimore, Md.

ATTENTION SWL'S, I WILL answer all SWL cards received from anyone everywhere. QRA — Gerald Swanberg, 16 Seaver St., Brockton, Mass.

ENGLAND CALLING SWL'S AND Jams in all countries! Send me ur QSL and I will send mine. I QSL 100%. QRA: A. B. Robertson, "Thorncliffe," 5, York Rd., Southport, Eng.

SWL'S IN SOUTH AMERICA, especially also all foreign countries outside of U.S.A. and Canada. I want to swap SWL cards with you. I QSL 100% with foreign listeners. George Cryder, R.D. No. 3, Delaware, Ohio, U.S.A.

WILL EXCHANGE CARDS WITH SWL'S 100% from all over. George Skoba, 1837 South California Ave., Chicago, Illinois, U.S.A.

WILL EXCHANGE SWL CARDS with anyone. U.S.A., Can., Engl., Australia and N.Z. include postage. Stamp collectors send stamps. QRA: Ric Spirajke, 2258 West 24, Chicago, Illinois, U.S.A.

I WOULD LIKE TO EXCHANGE view cards of your city with anyone in return for view cards of Omaha. I QSL 100%. Edw. Wilson, 2702 Burt St., Apt. 9, Omaha, Nebraska.

SWL'S OF THE WORLD! My super SWL card would look PB on the wall in your shack. QRA: Caribbean Listening Post, Cienfuegos, Puerto Rico, West Indies.

How the VODER Creates Human Speech!

(Continued from page 651)

some of the keys the operator can control its quality so as to make those sounds. Other keys make the "stop consonants" like d, k, and p.

Another kind of sound enters into human speech, most importantly in the vowels, like a, e and o. It comes from the vocal cords, and is very complex and somewhat musical. In the Voder, therefore, there is an electrical source of sound corresponding to the vocal cords; and there is a pedal for changing its pitch and for giving to speech a rising or falling inflection as desired. When the operator wants the sounds made by the vocal cords, instead of whispered sounds or consonants, an arm rest switch is depressed. Then the particular parts of this vocalized sound which are wanted are selected by playing the proper keys.

The source for this sound is the so-called "relaxation oscillator" which gives a saw-toothed wave (like that used in television sweep oscillators) in contrast to the smoothly rounded wave of a pure musical note. This saw-toothed wave has a fundamental note which gives the whole sound a definite pitch. Broad changes in this pitch mark the difference between male and female voices; gliding change of pitch over a smaller range constitutes inflection. The Voder may be posed as a man or a woman by turning a knob; it may state a fact, ask a question or emphasize a word, according to the motion of its pedal.

When one talks one shapes his mouth cavity so that some particular parts of the complex sound come through clearly, while other parts are suppressed and unheard. This makes the difference between the vowel sounds. For the same purpose the Voder is provided with ten keys. Each of these operates a variable attenuator to control the current in a definite frequency range. Source of current for each attenuator is an electrical filter which picks from the saw-tooth wave one particular group of its overtones. Normally each attenuator is an open-circuit, so that no sound comes through. The vowel sounds require the selection of only one, two, three or four ranges of overtones; the other ranges contribute nothing to the sound. In human speech, some sound is found in every range, but the Voder seems to speak most understandably when the unimportant overtones are suppressed.

The sounds are generated by oscillators rich in harmonics. The harmonic and tonic combinations required for the various vowel and consonant sounds, ten for the "soft" sounds and three for the "click" sounds, are obtained by selection of the frequency components of the oscillator outputs by means of filter networks. The pitch of the "voice" is varied by a control operated by the operator's wrist. This is a frequency control of the tones from the oscillators (female and male voices).

Combinations of sounds are obtained by touching various keys, thus feeding the desired sounds (tonic and harmonic frequencies) selected by the filter networks in the input of the common amplifier. Sudden breaks (clicks and sharp sounds) such as found in t, k, p, etc., are controlled by three black keys on the control board.

The "secret" of the operation is in the filter networks which take harmonic combinations from the "multivibrator" and high-frequency (hiss) oscillators, to produce the sounds which make up the words.

The operator must be carefully trained in the selection of key combinations to make intelligent "sounds."

Considering all the keys, there are twenty-three different sounds available to the Voder operator. By combination of keys she can mix these sounds and by the fingering she can control the shading. All speech sounds can be produced, but the number any operator can make use of depends on her finger dexterity; even granted the ability, only long practice will bring skill. The young ladies who will operate the Voder at San Francisco and New York were selected from more than three hundred telephone operators; and through long practice they have acquired a sufficient vocabulary to converse on ordinary subjects.

Sounds in the Voder's repertoire are not confined to those of the human voice. Bleating of sheep, lowing of cattle, grunting of pigs, and even the rat-a-tat of the woodpecker can be produced with perfect realism.

Singing will undoubtedly be an early accomplishment of the Voder; this would require a few more keys and pitch controls, with a little more intricate operating technique.

New Dynamic Microphone

● A NEW dynamic microphone is being distributed by the Turner Company, known as the model 99. It is ruggedly built for use indoors and out, under a wide variety of climatic and temperature changes. An acoustic valve is provided to take care of changes in pressure due to climate or altitude and, according to the manufacturer's claims, it is even free from the effects of salt air. The output of this microphone is -59 db. and the response is flat within + or -4 db. from 60 to 9000 cycles. An adjustment is provided so that the microphone may be made semi-directional or non-directional. It is finished in gun-metal.



The company has also issued a catalog describing a number of microphone models, stands and accessories.

FREE-FIFTEEN TO 4 PUBLICATIONS

featuring construction of the most popular
short-wave receivers and transmitters
with a One-Year's Subscription to Radio & Television

THESE publications are large printed sheets which average in size about 11" x 17", the majority of them printed on both sides. All have photographic reproductions of the complete project, as well as detail illustrations. In addition, there are complete wiring diagrams and various technical details to assist the experimenter and builder in constructing the set.

Full parts lists are always given, and the printed text runs anywhere from 500 to 3,000 words, depending on the complexity of the radio receiver.

ALL RECEIVERS AND TRANSMITTERS ARE STRICTLY UP-TO-DATE; THERE ARE NO ANTIQUES OR OUT-OF-DATE PUBLICATIONS IN THIS

LIST. These projects are particularly valuable to the experimenter and constructor who builds "his own". Indeed, the 50 publications shown on this page represent the cream of recent radio construction by the master radio builders of America. Designs of this kind usually are sold for 25c to \$1.00 apiece, and frequently you do not get half the technical information we give you.

When mailing us your subscription, use the special coupon on this page. Select Your 15 projects by their serial numbers. We accept money orders, cash, checks or new U.S. stamps (no foreign stamps or currency accepted). If you send cash or stamps register your letter against possible loss.

THESE 15 PROJECTS, IF BOUGHT SINGLY, WOULD HAVE COST YOU \$1.50. YOU CAN NOW GET THEM ABSOLUTELY FREE!

HOW TO BUILD THE SWITCH BAND 2 RECEIVER. A low-cost receiver for 6 volt battery or A.C. operation which enables the short-wave fan to hear stations in all parts of the world. No. 1

HOW TO MAKE A 2-TUBE RECEIVER FOR THE BEGINNER. This receiver consists of detector and two audio stages. A double purpose tube is used to secure the 2 audio stages. Tubes are for 1 1/2 volt battery operation. No. 2

HOW TO MAKE THE PORTABLE SUPERHET 4. An ace all-wave superhet for battery operation. This receiver features band-spread and has a built-in beat oscillator. No. 3

HOW TO BUILD A 4-BAND 3-TUBE SUPERHET. A 3-tube receiver giving 4-tube results. Rack and panel type construction is employed. It has a regenerative second detector. No. 4

HOW TO MAKE A FIXED-BAND 8-TUBE SUPERHET. This short-wave "fan" receiver tunes over a wide band of frequencies without coil switching or changing. It's a real performer. It operates directly from 110 V. A.C. and has band-spread. No. 5

HOW TO BUILD A 5-TUBE SUPERHET FOR FAN AND HAM. A sure-fire receiver for all short-wave enthusiasts. It uses plug-in coils and iron core I.F. transformers which assure plenty of gain. No. 6

HOW TO MAKE A TWIN-PENTODE RECEIVER. This receiver, especially designed for the beginner, employs but one dual purpose tube which gives results equivalent to a 2-tube receiver. It is for 2-volt battery operation with headphones. No. 7

HOW TO BUILD AN EFFECTIVE SHORT WAVE PRESELECTOR. A signal-booster that will greatly improve reception on any short-wave super. It employs two 6K7 tubes in parallel in a highly efficient circuit in which both input and output are tuned. No. 8

HOW TO BUILD A REGENERATIVE 2-TUBE. This unusual receiver has the tickler coil in the screen grid circuit of the detector. The receiver tunes from 9-270 meters; band-spread is included; metal or glass tubes may be employed. No. 9

HOW TO MAKE THE S.W.&T. COMMUNICATIONS RECEIVER. An unusually fine receiver for the critical Ham and Fan, incorporating many exceptional features. Regeneration is employed in the first detector stage which makes use of an acorn tube. The receiver also incorporates a noise-control circuit, variable selectivity control and a tuning meter. No. 10

HOW TO MAKE A BAND-SWITCHING 2-VOLT RECEIVER. This fine receiver for battery operation employs a band-switching arrangement, enabling the builder to tune from 16-550 meters by flipping a switch. No. 11

HOW TO BUILD THE MULTI-BAND 2 RECEIVER. A receiver for the short-wave beginner. It has a remarkable tuning range of 2 1/2-270 meters with band-spread on all bands. Plug-in coils are used and complete data for an A.C. power supply is given. No. 12

HOW TO MAKE THE VS-5 METAL TUBE SUPERHET. This complete all-wave receiver boasts, among other things, variable selectivity, metal tubes, AVC and band-spread. The tuning range is from 17-550 meters. No. 13

HOW TO BUILD A BEGINNERS 2-TUBE SUPER. A simplified superhet using 2 volt battery tubes which is just the thing for the beginner. It employs plug-in coils which cover a tuning range from 15-200 meters. No. 14

HOW TO MAKE A T.R.F.-3 FAN RECEIVER. This is an all-around receiver employing 2 volt tubes. A T.R.F. stage ahead of the regenerative detector insures good selectivity and sensitivity. Band-spread is provided by a two-speed dial. No. 15

HOW TO BUILD THE FORTY-NINER-A RECEIVER FOR LEAN PURSES. This novel receiver features a space-charge detector and requires only 12 volts of B battery. It uses 2-49 tubes which may be operated from any 2 volt A battery. No. 16

HOW TO MAKE A REAL 5-METER SUPERHET. This carefully designed receiver for ultra-short wave reception employs a straightforward circuit. Careful placement and high quality parts insure fine results. No. 17

HOW TO BUILD THE 2-VOLT SUPER DX-4. This superhet, though small in size is big in performance. Using battery type tubes, it features continuous band-spread, and automatic volume control, which may be cut in or out as desired. No. 18

HOW TO MAKE THE ULTRA-HIGH FREQUENCY WIZARD-6. This is a first-class 5-meter super-regenerative receiver, using acorn tubes in the R.F. and detector stages. The other tubes are of the metal type. The use of the acorn tubes insures exceptionally fine results. No. 19

HOW TO BUILD A HIGH-GAIN METAL-TUBE RECEIVER. This little receiver is a real performer, tuning from 10-200 meters. Continuous band-spread is provided. No. 20

HOW TO BUILD THE WORLD-WIDE 10-METER CONVERTER. Many enthusiastic reports have been received from the builders of this unit, which may be attached to your present receiver for picking up 10 meter signals from all parts of the world. Only 2-tubes are used. No. 21

HOW TO BUILD A DE LUXE 3-TUBE. This is the receiver for the Ham or Fan who wants a really high class receiver of simple design. It employs an unusual band-spread dial. The circuit, employing metal tubes, has a stage of T.R.F. followed by a regenerative detector and a stage of audio. No. 22

HOW TO BUILD THE OCTODE METAL TUBE-3. This receiver is capable of excellent performance on the short waves. It requires only one plug-in coil for each band as a stage of untuned R.F. preceding the detector. It also has an A.F. stage for boosting the volume to comfortable headphone level. No. 23

HOW TO MAKE THE 3-IN-1 REFLEX SET. A 2-tube giving 4-tube performance is this receiver which does its work with a minimum of tubes. A 6B7 is used as a combined R.F. amplifier, detector, and first audio stage; a 6C3 is used as second audio stage. No. 24

HOW TO BUILD THE 100 WATT QRM DOGGER-A COMPACT 5-METER TRANSMITTER. This M.O.P.A. rig puts out a hefty signal and by use of a calibrated vernier oscillator control will overcome the QRM problem on 5 meters. No. 25

HOW TO BUILD A DE LUXE 5-METER MOBILE STATION. A really fine M.O.P.A. mobile transmitter which will work real DX on portable location. It employs five metal tubes. No. 26

HOW TO BUILD THE H-G-M MEDIUM POWER TRANSMITTER. A crystal control set with an output of 90 watts. Band-switching is employed for operation on the 80, 40, 20 and 10 meter Ham bands. It gave excellent results under test. No. 27

HOW TO MAKE THE 806 ALL-BAND TRANSMITTER. An unusual transmitter delivering 400 watts output from an 806 final amplifier. A crystal pentode oscillator is used, followed by a driver stage. Real DX has been worked on 10, 20, 40 and 80 meters with this smooth working job. No. 28

HOW TO BUILD A 125-WATT MODULATOR USING 35T's. This is an ideal unit for the amateur and will modulate any transmitter with a power input up to about 400 watts. A total of 10 tubes are used including the power supply unit. No. 29

HOW TO BUILD THE C-O-M 150 WATT TRANSMITTER. An unusual crystal oscillator, multiplier with but one tuned circuit. It uses a pair of RK37's in parallel with a HK39 driver. The crystal oscillator circuit uses a 6L6. No. 30

A LONG-LINES TRANSMITTER FOR 1-METER TRANSMISSION, AND COMPANION RECEIVER. A really special job for the seriously minded experimenter. This outfit permits short distance contacts in this interesting band. No. 31

HOW TO BUILD A 200 WATT XMITTER WITH PEN-TET EXCITER. This transmitter will really go to town. The use of the Pen-Tet crystal oscillator and frequency multiplier circuit eliminates many headaches from cracked crystals. No. 32

HOW TO BUILD A 10 AND 20 METER TRANSMITTER. A 200 watt transmitter which worked world-wide DX on test. Although compact, it is highly efficient in the 10 and 20 meter bands. Five tubes are used. No. 33

HOW TO MAKE THE WIZARD 1-TUBE 50-WATT TRANSMITTER. An amateur, crystal-controlled c.v. transmitter using the RK20 screen grid Pentode. In tests, it compares with 250-watters. No. 34

HOW TO MAKE THE "OSCILLODYNE" 1 TUBE WONDER SET. One of the most sensitive short-wave sets designed, employing a really new circuit for the first time. Battery operated. No. 35

HOW TO MAKE THE "GO-TWEX" (ONE TUBE PERFORMS AS TWO) RECEIVER. One of the most sensitive 1-tube sets ever designed and very popular. No. 36

HOW TO MAKE THE IMPROVED 3-TUBE OORLE SET FOR BATTERY OPERATION. One of the finest of the Doeris series, by the famous short-wave inventor. No. 37

HOW TO MAKE THE "GO-GET-EM 2" RECEIVER FOR THE BEGINNER. This unusual 2-tube circuit gives 3-tube results. Battery operated. Excellent for beginners. No. 38

HOW TO MAKE THE 1-TUBE ALL-ELECTRIC OSCILLODYNE. This is the famous electrified short-wave receiver, easy to build for little money. Operates on A.C. and D.C. No. 39

HOW TO MAKE THE 2 TO 5 METER TWO-TUBE LOUDSPEAKER SET. This receiver may be used with batteries or with an A.C. Power Pack. Packs a big wallop. No. 40

HOW TO MAKE THE 3-TUBE BATTERY SHORT-WAVE RECEIVER. This receiver was a prize winner in SHORT WAVE CRAFT. An unusual short-wave receiver, easy to build. No. 41

THE BRIEF-CASE SHORT-WAVE RECEIVER AND HOW TO BUILD IT. So small that the entire set, batteries, head set, aerial and everything, goes into a brief-case. Stations from Europe are often received. By Hugo Gernsback and Clifford E. Denton. No. 42

HOW TO BUILD THE POCKET SHORT-WAVE RECEIVER. One of the smallest, pocket-size, battery receivers ever designed by Hugo Gernsback and Clifford E. Denton. A marvelous set that brings in European stations. No. 43

HOW TO BUILD THE GIGAR-BOX 1-TUBE "CATCH ALL" RECEIVER. An effective short-wave battery set which fits into a small clear box, insuring high portability yet great efficiency. No. 44

HOW TO BUILD THE "DUAL-WAVE" SHORT-WAVE BATTERY RECEIVER. With this set, you can hear both ends of radiohone talk, on one set of phones. In other words, you can listen to a ship at sea and the land station communicating with it, simultaneously, by means of this double receiver. No. 45

HOW TO BUILD THE 1-TUBE "53" TWINPLEX RECEIVER. The twinplex, although it has only one tube, works as if it had two. Marvelous in efficiency. Uses either batteries or A.C. power pack for B supply. No. 46

HOW TO BUILD THE PORTABLE MINIDYNE SHORT-WAVE BATTERY SET. Uses no aerial, no ground. The total weight is 3 1/2 lbs. and measures 5x5x6 inches. Self-contained batteries, tube, condensers, and loop. Highly sensitive circuit. No. 47

HOW TO BUILD THE HAM-BAND "PEE-WEE" 2-TUBE. A dandy receiver with high efficiency and band-spread tuning. Works a loudspeaker, yet the entire receiver is no larger than your hand. Works with either batteries or an A.C. power pack. No. 48

HOW TO BUILD THE DUO-AMPLIDYNE. The ideal 1-tube set for the beginner. One of the finest 1-tube sets; it really gives 2-tube performance. Made for battery operation. With only ten-foot antenna. No. 49

HOW TO BUILD THE "MONO-COIL 2". No more "plug in" coils. This set eliminates bothersome coils and is made to cover short-wave bands. Works with either batteries or A.C. power pack. No. 50

RADIO & TELEVISION, 99 Hudson Street, New York, N. Y.

Gentlemen: Enclosed you will find my remittance of \$2.50 for which enter my subscription to RADIO AND TELEVISION for One Year (12 issues). Send me promptly, possibly FREE and POSTPAID, the 15 publications I have circled at the right. (CANADA AND FOREIGN \$3.15.)

NEW SUBSCRIBER EXTEND PRESENT SUBSCRIPTION

Name _____

Address _____

City _____ State _____ R&T-3-39

Send remittance by check or money order. Register letter if you send cash or unused U. S. Postage Stamps.

1	2	3	4	5
6	7	8	9	10
11	12	13	14	15
16	17	18	19	20
21	22	23	24	25
26	27	28	29	30
31	32	33	34	35
36	37	38	39	40
41	42	43	44	45
46	47	48	49	50

RADIO & TELEVISION
99 HUDSON STREET
NEW YORK, N. Y.

World S-W Stations

(Continued from page 700)

Mc.	Call	Address
4.880	VUC2	CALCUTTA, INDIA, 61.48 m. Addr. All India Radio. 6.36 am.-12.06 pm.
4.880	HJ4ABP	MEDELLIN, COL., 61.44 m. 8-11 pm.
4.876	ZRD	DURBAN, SOUTH AFRICA, 61.5 m., Addr. (See ZRK, 9.606 mc.) Daily 12 m.-3.45 pm., Sat. till 4 pm., Sun. till 3.20 pm.
4.842	HJ3ABD	BOGOTA, COL., 61.95 m., Addr. La Nueva Granada, Box 509. 12 n.-2 pm., 7-11 pm., Sun. 5.9 pm.
4.800	HJIABE	CARTAGENA, COL., 62.46 m., La Voz de los Laboratorios Fuentes. Addr. Box 31. Daily 8.30 am.-11 pm., Sun. 10 am.-9 pm.
4.780	HJIABB	BARRANQUILLA, COL., 62.72 m. La Voz de Barranquilla, Addr. P. O. Box 715. 11.30 am.-1 pm., 4.30-10 pm.
4.772	HJIABJ	SANTA MARTA, COL., 62.86 m. 11.30 am.-2 pm., 5.30-10.30 pm., except Wed.
4.740	HJ1ABC	IBAGUE, COL., 63.28 m. 7 pm.-12 m.

BOOK REVIEW

THE EVOLUTION OF PHYSICS, Albert Einstein & Leopold Infeld. Size 7 1/2" x 8 1/2", 319 pages, illustrated. Published by Simon & Schuster, New York City.

This is a book which traces the evolution of ideas in physics from the earliest mechanistic concepts to relativity and the quanta theories. It is written in simple language for the layman, being a collaboration between the world-famed physicist and one of his co-workers in research. It tells, in layman's language, the story of mankind's attempt to reason out its relationship to the world at large. The authors have likewise avoided all highly technical language and mathematical formulae. They bring out their points clearly by using comparisons with known facts of everyday experience, explaining the significance of all major contributions to science since the work of Newton. The book is divided into four major sections, each of which contains numerous chapters. The sections are: The Rise of the Mechanical View; The Decline of the Mechanical View; Field, Relativity; and Quanta. There are numerous diagrams which greatly aid the reader in comprehending the explanations, and a detailed index makes it easy to look up any items which are of particular interest.

S. W. League

(Continued from page 667)

Call	Freq. mc.	R	S	Observer
G6BW	28.245	4	9	Fitzpatrick
G6BY	28.120	5	7	Fitzpatrick
G6WV	28.170	5	6	Taglauer
G8SA	28.140	5	9	Taglauer, Noyes
G8SH	28.375	4	9	Fitzpatrick
G8GM	28.315	4	6	Fitzpatrick
G8KX	14.110	5	9	Fitzpatrick
G8BO	28.300	3	5	Halliday
G8MA	28.265	4	7	Noyes
G8MX	28.410	5	8	Noyes
G8UB	14.	3	4	Akhtar
G8NY	14.06	4	5	Akhtar
GM6WD	14.220	4	8	Fitzpatrick
GM6SR	14.025	5	9	Lendzioszek
GM6RG	28.450	5	8-9	Clarke, Halliday, Jordan, Noyes, Hegler, Taglauer, Henderson, Fitzpatrick
GM8WN	14.175	4	8	Fitzpatrick
GM8MN	14.110	5	7	Clarke
GI2CC	14.	5	7	Wood
GI8UW	14.08	3	5	Kemp
GW5KJ	28.220	5	9	Taglauer, Fitzpatrick
EI9J	28.250	5	7	Clarke, Noyes
PA6EO	28.285	4	8	Fitzpatrick
PA0MZ	14.100	4	6	Fitzpatrick, Akhtar
LA1G	14.145	4	6	Fitzpatrick
ON4ZK	28.230	5	8	Taglauer, Fitzpatrick
ON4PA	28.160	5	9	Taglauer, Fitzpatrick
ON4DI	14.085	4	8	Fitzpatrick
ON4VM	14.210	5	8	Fitzpatrick
ON4VK	28.440	5	9	Noyes
ON4ZA	28.385	4	6	Noyes
ON4DZ	14.10	5	6	Akhtar
H8AN	14.14	5	7	Akhtar
F3OO	14.090	5	7	Clarke
F3AL	14.040	5	6	Clarke
F8LX	14.000	5	6	Clarke
F8RV	14.080	5	7	Clarke
F8RR	28.145	5	9	Fitzpatrick, Noyes
F8MX	28.135	5	7	Fitzpatrick
F8NX	14.100	5	7	Clarke
F8NR	14.09	4	6	Kemp
I1KN	14.395	3	7	Lendzioszek
LX1AI	14.00	4	7	Lendzioszek

FREE CATALOGS and INFORMATION

By carefully reading the advertising columns, you will find many offers to furnish literature containing valuable technical information that will help you in your work. Use this list freely.

Firm	Business	Offer	No.	Cost	Adv. Page
ABC Radio Laboratories	Set Mfr.	Information		Free	691
Allied Engineering Inst.	Kit Mfr.	Circulars		Free	680
Allied Radio Corp.	Mail Order	1939 Catalog		Free	675
American Radio Institute	Radio School	Radio Builders Handbook		10c	
Amperite Co.	Parts Mfr.	Booklet		Free	688
		Chart	AR	Free	675
		Illustrated Bulletins		Free	
Bliley Electric Co.	Parts Mfr.	Engineering Bulletin	E-6	10c	692
		Circular	A-6	Free	
Brush Development Co.	Parts Mfr.	Catalog		Free	679
Bud Radio, Inc.	Parts Mfr.	Catalog	RT39	Free	682
		Station Log & Data Bk.		10c	
Burstein-Applebee Co.	Mail Order	Catalog		Free	693
Cameradio Co.	Mail Order	1939 Catalog		Free	677
Candler System Co.	Code Course	Book of Facts		Free	688
Cannon, C. F., Co.	Parts Mfr.	Folder	T-3	Free	687
Consolidated Wire & Associated Corp's.	Parts Mfr.	Information		Free	693
Cornell-Dubilier Elec. Corp.	Parts Mfr.	Literature		Free	704
Coyne Electrical School	Trade School	Electrical Catalog		Free	643
		Radio Catalog		Free	
Dodge's Institute	Radio School	Catalog		Free	688
Gold Shield Products	Mail Order	Catalog		Free	693,697
Hammarlund Mfg. Co.	Set & Parts Mfr.	1939 Catalog		Free	677
		16 page Booklet		Free	
Harrison Radio Co.	Mail Order	Information		Free	695
Henry, Bob	Mail Order	List		Free	679
Howard Radio Company	Set Mfr.	Technical Information		Free	I.F.C.
Instructograph Company	Code Machine	Information		Free	688
International Corres. Schools	Corres. School	Booklet		Free	704
Korrol Radio Products Co.	Parts Mfr.	Catalog		Free	687
Martin Research & Mfg. Corp.	Radio Keys	Catalog		Free	684
Mass. Radio School	Radio School	52-page Catalog		Free	689
McIntosh Elec. Corp.	S. W. Diathermy	Information		Free	692
National Company, Inc.	Set & Parts Mfr.	Catalog		Free	I.B.C.
National Radio Institute	Radio School	64-page Book		Free	641
National Schools	Radio School	Radio & Television Bklt.		Free	688
New York YMCA Schools	Trade School	Booklet		Free	689
Par-Metal Products Corp.	Parts Mfr.	Catalog		Free	691
Radio & Technical Publ. Co.	Radio Textbooks	Circulars on each Book		Free	689
Radio Corp. of America	Radio	Literature		Free	B. C.
Radio Train. Assn. of Amer.	Radio School	Book		Free	689
RCA Institutes, Inc.	Radio School	Catalog		Free	689
RCA Mfg. Co., Inc.	Set & Parts Mfr.	Literature		Free	681
Remington Rand, Inc.	Typewriter Mfr.	Catalog		Free	685
Solar Mfg. Corp.	Parts Mfr.	General Parts Catalog	9S	Free	677
		Transmitting Catalog	2X	Free	
		Condenser Testers Cat.	CBCC-1	Free	
Sprayberry Acad. of Radio	Radio School	52-page Book		Free	683
Supreme Publications	Publisher	Information		Free	687
Triplex Co.	Code Machine	Catalog	S-3	Free	689
Triplett Electrical Inst. Co.	Parts Mfr.	Catalog		Free	675
Turner Co., The	Parts Mfr.	Microphone Bulletin	40-D	Free	684
Universal Microph. Co., Ltd.	Parts Mfr.	Information		Free	704
Van Nostrand, D., Co.	Book Publisher	Catalog		Free	673
Ward, Montgomery, & Co.	Mail Order	1939 Radio Catalog		Free	682
Wholesale Radio Service Co.	Mail Order	1939 Radio Catalog	73	Free	691
X. L. Radio Laboratories	Parts Mfr.	Information		Free	684

The Finish of the "ERAEKLE"

WITH C-D Quietones

YES—man made crackles are no more when you use the new C-D Quietone Radio Interference Filters.

This new C-D development, engineered to effect the elimination of man made interference, is just what the Doctor ordered for the radio amateur, experimenter and radio set owner.

Ask your local C-D jobber to show you Quietones. They have behind them the integrity of the 29 year old C-D name—the excellence which characterizes all Cornell-Dubilier products.

Available in attractive colors to match room interiors. Remember—there's a Quietone designed to meet every application. Send for free detailed literature today.

CORNELL-DUBILIER ELECTRIC CORPORATION
 7027 Hamilton Blvd., So. Plainfield, N. J.
 Cable Address: "CORDU"

UNIVERSAL
 Heavy Duty Single Button Microphone
 Superlative performance. Low cost. Rugged, dependable. For voice pickup, p.a., amateurs, etc. Standard impedance, 200 ohms. Output level -50 db.

UNIVERSAL MICROPHONE CO., LTD.
 424 Warren Lane, Inglewood, Calif.

THERE'S A
REAL FUTURE
 IN RADIO!

In the future of radio, there's a future for you—if you're prepared for it! That means SOUND, ESSENTIAL TRAINING—the kind of thorough training that the I. C. S. Radio Courses offer. Be a trained man—an I. C. S. man—a man with a REAL FUTURE! Mail the coupon.

INTERNATIONAL CORRESPONDENCE SCHOOLS

Box 2879-F, Scranton, Penna.
 Explain fully about your course in the subject marked X.

- Radio Sound Technicians
 Experimental Television
 Aviation Section of Radio Operating

Name _____ Age _____
 Address _____

(Continued from preceding page)

Aussies have fallen off badly since our last reports, and most of those heard last month were reported by Masud Akhtar, Observer for India.

Call	Freq. mc.	R	S	Observer
VK2ACL	14.14	5	5	Akhtar
VK2GM	14.115	5	6	Lang
VK2UC	14.1	5	7	Wells
VK2ADT	14.	4	7	Wood
VK3SG	14.	5	5	Akhtar
VK3ES	14.08	3	4	Akhtar
VK3KK	14.14	3	3	Akhtar
VK3SB	14.	4	5	Akhtar
VK3BM	14.06	5	5	Akhtar
VK4JP	14.140	4	7	L. Fuller
VK4KH	14.135	4	5-7	L. Fuller, Wallen, Wells
VK4JU	14.14	5	5	Akhtar
VK5TR	14.25	4	4	Akhtar
VK5CS	14.26	5	7	Akhtar
VK6MW	14.13	5	6-8	Hegler
VK6HR	14.13	4	5	Akhtar
VK6HT	14.05	5	8	Akhtar
VK7AB	14.00	4	6	Akhtar
VK7LZ	14.29	3	5	Akhtar

Most prominent last month among the Oceania stations were the K6's. The signal strength from this section of the world is very high, accounting for the large number being received.

K6QQM	29.000	5	8	Hegler
K6BNR	14.160	5	7-8	Lang, Jordan, Henderson, Wallen, Fitzpatrick, Parker, Hegler, L. Fuller, Slaughter
K6PMC	28.630	5	8	Hegler
K6MZO	14.170	5	9	L. Fuller
K6KKC	14.180	5	9	L. Fuller
K6ILW	14.200	5	9	L. Fuller
K6OQE	14.220	5	7-8	L. Fuller, Fitzpatrick, Lang
K6GAF	14.215	5	8	L. Fuller
K6LEJ	14.225	4	7	L. Fuller, Wallen
K6NZO	14.160	5	7	Wallen
K6OGN	14.120	5	6	Wallen
K6NZX	28.005	4	7	Fitzpatrick
K6OJI	14.155	4	8	Parker
K6OTH	14.190	4	9	Parker
K6PLZ	14.180	4	8	Parker
K6CMC	14.160	5	6-9	Parker, Lang
K6BLZ	14.160	4	7	Lang
K6FKN	14.220	5	6	Lang
VR6AY**	14.345	4-5	7-8	Hegler, Carling, Lendzioszek
ZL1GZ	28.200	4	6-8	L. Fuller
ZL3KZ	14.100	4	6	Henderson
W6NYD***	14.255	4	3	Parker, C. Fuller, Wallen, Fitzpatrick
KA1CS	14.148	4-5	5-9	Wood, Hegler, Akhtar
KA1ME	14.260	5	7	Lang
KA1JM	14.05	3	3	Akhtar
KA1JP	14.25	3-4	5-6	Akhtar
KA2OV	14.270	4-5	7	Lang
KA7EF	14.—	5	6	Akhtar
PK1MJ	14.—	5	4-5	Wood

From our observers in other lands, we have the following North American stations reported:—

K4FKC	14.16	5	5	Akhtar			
K4FAY	14.17	3	4	Akhtar			
K5AF	14.15	5	6	Akhtar			
VP6FO	14.10	4	5	Akhtar			
Call	R	S	Obsrv.	Call	R	S	Obsrv.
W1CND	5	5	Akhtar	W4DSY	3	3	Akhtar
W1CRW	5	5	Akhtar	W4BAZ	4	5	Akhtar
W1FGO	3	3	Akhtar	W5DLP	4	7	Sibbin
W1GLH	5	6	Akhtar	W5FIY	3	4	Akhtar
W2ACB	5	5	Akhtar	W5BUK	4	5	Akhtar
W2AZ	5	7	Akhtar	W5EHM	5	6	Akhtar
W2CRI	3	3	Akhtar	W6GYH	3	3	Akhtar
W2BYP	5	6	Akhtar	W6NCW	5	7	Sibbin
W2IKV	5	9	Akhtar	W6NBD	5	8	Sibbin
W2IXY	4	4	Akhtar	W6OI	4	7	Sibbin
W3GQD	5	7	Akhtar	W6LYY	4	7	Sibbin
W3PT	3	3	Akhtar	W8GLY	5	6	Akhtar
W3DO	3	4	Akhtar	W8MUR	3	3	Akhtar
W3EOZ	5	6	Akhtar	W8NJT	3	5	Akhtar
W3AFG	5	7	Sibbin	W8CNO	4	7	Sibbin
W3BSM	4	7	Sibbin	W9LFX	3	3	Akhtar
W4BNR	5	8	Akhtar	W9CJP	5	6	Akhtar
W4AIT	3	3	Akhtar	W9QI	4	4	Akhtar

*W9AM is a portable on board the S.S. California, bound for the Antarctic. Operator contacts W9EYW in afternoons. Power of the transmitter is only 15 watts. Position of the ship on January 1st was off the northern coast of Brazil.

**It has been learned that, a short time ago, VR6AY was off the air, but it is believed that they have now returned, although they have not been heard here for over a month. However, the reports for December indicate that they are being heard in some parts of the country.

***W6NYD is, at the present writing, working portable in the K6 call area. The QRA is: 1001 18th Avenue, Honolulu, Hawaii.

Well, this closes up our department for another month. Don't forget to send along a picture of your listening post. Best 73's and lots of dx.

Special Features for HAMS and FANS in next issue.

Index to Advertisers

A	ABC Radio Laboratories.....	691
	Allied Engineering Institute.....	680
	Allied Radio Corporation.....	675
	American Radio Institute.....	688
	Amperite Co.....	675
B	Barter & Exchange: Free Ads.....	698—701
	Bliley Electric Co.....	692
	Brush Development Co., The.....	679
	Bud Radio, Inc.....	682
	Burstein-Applebee Co.....	693
C	Cameradio Co.....	677
	Candler System Co.....	688
	Cannon, C. F., Company.....	687
	Commercial Notices.....	698
	Consolidated Wire and Associated Corporations.....	693
	Cornell-Dubilier Electric Corp.....	704
	Coyne Electrical School.....	643
D	Dataprint Company.....	697
	Dodge's Institute.....	688
F	For Sale Ads.....	698
G	Gold Shield Products.....	693, 697
H	Hammarlund Manufacturing Co., Inc.....	677
	Harrison Radio Co.....	695
	Henry, Bob.....	679
	Howard Radio Company.....	Inside Front Cover
	Hudson Specialties Company.....	690
I	Instructograph Company.....	688
	International Correspondence Schools.....	704
K	Korrol Radio Products Co.....	687
M	McIntosh Elec. Corp.....	692
	Martin Research & Manufacturing Corp.....	684
	Mass. Radio School.....	689
N	National Company, Inc.....	Inside Back Cover
	National Plans Institute.....	697
	National Radio Institute.....	641
	National Schools.....	688
	New York YMCA Schools.....	689
P	Par-Metal Products Corp.....	691
R	Radio Amateur Course.....	644
	Radio & Technical Publ. Co.....	689
	Radio Corporation of America.....	Back Cover
	Radio Publications.....	684, 696
	Radio Training Assn. of America.....	689
	RCA Institutes, Inc.....	689
	RCA Manufacturing Co., Inc.....	681
	Remington Rand, Inc.....	685
S	Solar Mfg. Corp.....	677
	Sprayberry Academy of Radio.....	683
	Supreme Publications.....	687
T	Technifax.....	695
	Teleplex Co.....	689
	Triplett Electrical Instrument Co.....	675
	Turner Co., The.....	684
U	Universal Microphone Co., Ltd.....	704
V	Van Nostrand, D., Co.....	673
W	Ward, Montgomery, & Co.....	682
	Wellworth Trading Company.....	692
	Wholesale Radio Service Co., Inc.....	691
X	X. L. Radio Laboratories.....	684

(While every precaution is taken to insure accuracy, we cannot guarantee against the possibility of an occasional change or omission in the preparation of this index.)



NC-44

If you judge receivers on the basis of performance per dollar of cost, you will find the National NC-44 an outstanding value. This seven-tube superhet covers from 550 KC to 30 MC in four ranges. The full-vision dial is carefully calibrated in frequency. A straight-line-frequency main condenser is used in conjunction with a separate band spread condenser, and both have inertia-type tuning. A CW oscillator is provided. The performance of the NC-44 is remarkably fine, even at ten meters where so many receivers are unsatisfactory. The Net Price is only \$49.50, including tubes, speaker and built-in power supply.



NATIONAL COMPANY, INC., MALDEN, MASS.

345,000 People Go to Work ...When Radio Throws the Switch



The RCA Victor Family has many long-time members. Above is Group Supervisor Bessie Purnell, who has been with Victor for 32 of its 40 years.



8,000 American radio operators on ships and ashore handle hundreds of thousands of radio messages that help business and guard lives and property. Leaders in these activities are R. C. A. Communications, Inc., and Radiomarine Corporation of America, members of the family of RCA.



NBC engineer Arthur V. Giammatteo throws a switch at Radio City that means entertainment for millions . . . employment for thousands.

TO MOST AMERICANS today radio is entertainment, news, and education . . . the greatest show on earth. But to 345,000 workers and their families . . . a total of some 1,380,000 men, women and children . . . radio is even more than a show, it is a living. Where only a few years ago radio jobs were non-existent, now 700 odd radio stations and 500 and more factories create tens of thousands of jobs.

Radio a Boon to Thousands in Wholesale and Retail Businesses

About 25,000 are connected with wholesale establishments handling

radio merchandise. Retail radio merchants account for 56,000 and salesmen, service men, and others engaged in radio sales and service number 150,000.

For retailers and wholesalers as well as for the 19,000 members of its own organization, the Radio Corporation of America works aggressively to bring ever increasing prosperity by constantly improving the services radio gives the public. America has come to recognize the advantages in going "RCA ALL THE WAY." As a result . . . there is an ever richer field of opportunity for merchants who go RCA All The Way, too.

Listen to the "Magic Key of RCA" every Sunday, 2 to 3 P. M., E. S. T., on the NBC Blue Network.



RADIO CORPORATION OF AMERICA

RADIO CITY, N. Y.

RCA MANUFACTURING CO., INC.

RCA INSTITUTES, INC.

R. C. A. COMMUNICATIONS, INC.

RADIOMARINE CORPORATION OF AMERICA

NATIONAL BROADCASTING COMPANY