

HUGO GERNSBACK  
Editor

# SHORT WAVE CRAFT

June 1935.

WORLD'S  
LARGEST  
SHORT WAVE  
CIRCULATION

New MAGNI-DIAL  
Simplifies S.W. Tuning  
See Page 76

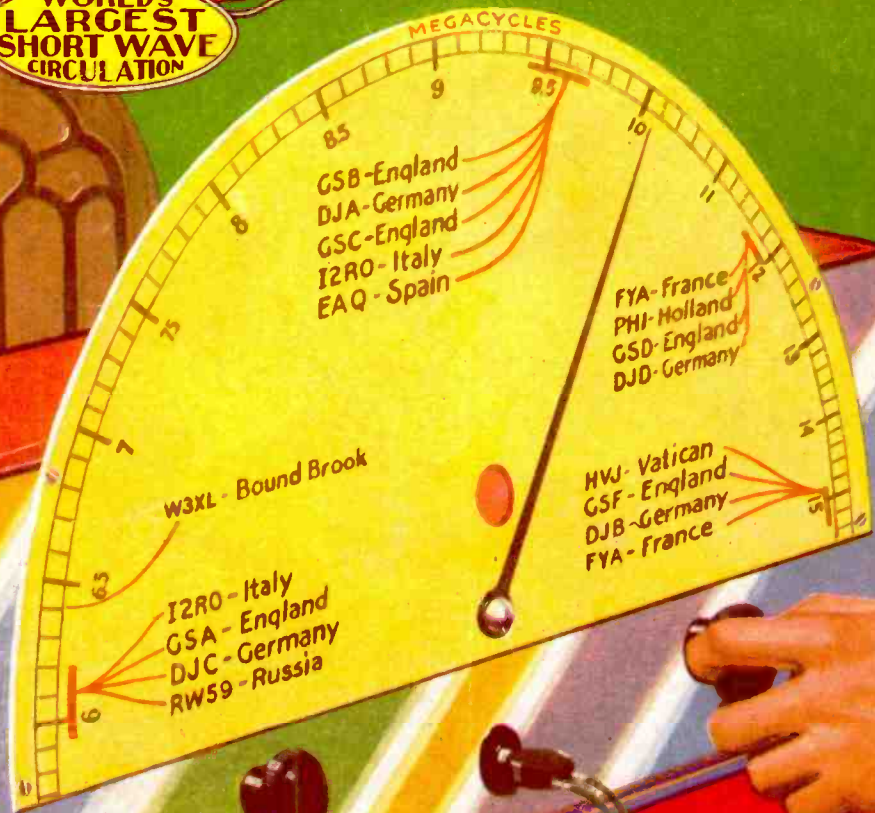

25¢  
IN CANADA  
30¢



*Here's the new - Big*

# 1935 OFFICIAL SHORT WAVE RADIO MANUAL



When we brought out our 1934 OFFICIAL SHORT WAVE RADIO MANUAL, of which many thousands of copies were bought by short wave enthusiasts, we promised you that a new volume would be published every year.

In keeping with this promise, we now take great pleasure in announcing the 1935 OFFICIAL SHORT WAVE RADIO MANUAL. There has been tremendous progress and a great boom in short waves in the past year, and the art has made such rapid progress that no single book, up to now, has been able to keep up with this progress. The 1935 OFFICIAL SHORT WAVE RADIO MANUAL fills this need, and it fills it completely. All the progress made in short waves, whether it is in set building, whether it is in radio servicing, whether it is in new models, whether it is in new short wave specialties, all are faithfully reported and chronicled in this great 1935 volume.

Like its predecessor, it is a BIG book, in which you will find literally EVERYTHING in short waves—nothing has been left out. Not only is it a complete manual, but it is a great encyclopedia of short wave facts, information, bookups, photographs, tables, maps, etc., etc. The wealth of material is so great that it would take several pages to list all the valuable data that has been included in this volume.

Similar to last year's volume, the new book has been edited by Hugo Gernsback, Editor of SHORT WAVE CRAFT and H. W. Secor, Managing Editor, and if you are and have been a reader of SHORT WAVE CRAFT, and particularly if you have seen the 1934 Manual, you will just what you can expect from this, the greatest short wave manual ever put out by Mr. Gernsback.

## 29 ★ Features:

- ★ 1—Short-Wave Beginners' Section—Dozens of new simplified circuits for 1-2 and 3 tube receivers, including famous "Boerle" and "Guthrie" sets, etc.
- ★ 2—Battery Short-Wave Receivers—3 & 2 tube heterodyne, designed especially for battery operation.
- ★ 3—"15-Meter" Department—All the latest "loop"—including newest transmitters, "Long Line" oscillators, improved "high sensitivity" receivers, etc. 5 major transmitters, book-ups, etc.
- ★ 4—Short-Wave "Artificial Feet" Apparatus—All types of ultra short waves, and other allied applications.
- ★ 5—Short-Wave Experimenters' Section—Filled with Short-Wave Kinks, Short-cuts, etc., of interest to every experimenter.
- ★ 6—Ultra Short Waves—Newest circuits, apparatus, and results obtained in this field.
- ★ 7—Commercial "Short-Wave" and "All-Wave" Receivers—Full Servicing Data for "Set-Overs" and "Service men."
- ★ 8—Recording "Foreign" and "Domestic" Short-Wave programs. All systems in use.
- ★ 9—How to build "Power Supply" Units for Short-Wave Receivers.
- ★ 10—Latest Short-Wave Converters—With servicing data on Commercial Models.
- ★ 11—The Short-Wave Antennas—including latitudes, shielded cable, double-insulated, etc. In systems included cable, double-insulated, etc.
- ★ 12—Short-Wave Superheterodynes—From 3 to 11 tubes—Latest descriptions and diagrams including commercial all-wave superhets.
- ★ 13—Phone Transmitters for Amateur Stations—How to build them.
- ★ 14—"Skip" Distance—Heaviside layer, etc.—explained; physics of Short Waves.
- ★ 15—Super-Regenerative Short-Wave Receivers—Latest circuits, etc.
- ★ 16—Recording "Foreign" and "Domestic" Short-Wave programs. All systems in use.
- ★ 17—"High Fidelity"—How to obtain it in Short-Wave Receivers.
- ★ 18—The best Short-Wave Questions and answers of the year.
- ★ 19—The best Short-Wave "Kinks" of the year.
- ★ 20—Foreign Short-Wave Review—Novel circuits, apparatus, etc.
- ★ 21—Tubes for Short-Wave purposes—including tubes and Receivers.
- ★ 22—Short-Wave Transmitters—All about the new Long Line Oscillators as well as other types of transmitters, crystal control, etc.
- ★ 23—Multi-Purpose Tubes—How to use them on tubes=6; etc.
- ★ 24—"Audio Amplifiers" for Short-Wave Receivers, Circuits, etc.
- ★ 25—"Band-Spread"—How to spread the stations over the dial for easier tuning.
- ★ 26—"Plug-less" "Mono-Coil" Receivers—How to build efficient switch-type coils to eliminate plug-in coils; "Clip-Coil" Receivers, etc.
- ★ 27—Boosters, Pre-amplifiers and Beat Oscillators—How they work, with constructional diagrams, etc.
- ★ 28—Portable Short-Wave Receivers and Transmitters—Transmitter Power supply from 2000 Cells, etc.
- ★ 29—Every short-wave diagram, every short-wave set, whether it is a battery set, whether it is an all-wave set, EVERYTHING, in other words, that will be found in this special commercial set, will be found in this special commercial set. Hundreds of valuable diagrams, with tube layouts, resistor values, color codes of wiring cables, etc., and general information wherever this information can possibly be obtained.

**CLIP AND MAIL THIS MONEY SAVING COUPON TODAY**

6-35

SHORT WAVE CRAFT  
99 Hudson Street,  
New York, N. Y.

Gentlemen: I enclose herewith my remittance of \$2.00 for which please send me one copy of the 1935 OFFICIAL SHORT WAVE RADIO MANUAL. My remittance of \$2.00 will be paid as soon as it is published. (Send remittance in check or money order. Register letter if it contains cash or currency.)

Name \_\_\_\_\_  
Address \_\_\_\_\_  
City \_\_\_\_\_ State \_\_\_\_\_

**OVER 240 BIG PAGES • OVER 1000 Illustrations  
Size 9 x 12 Inches — Flexible Looseleaf Leatherette Binder**

### SPECIAL PRE-PUBLICATION OFFER

As has been customary with us in the past, we give our readers the opportunity to order the book before it comes off press and save money. The price of the new 1935 OFFICIAL SHORT WAVE RADIO MANUAL will be \$2.50 as soon as it comes off the press. No reduction in price will be made later. To you, who order this book before publication, the price is \$2.00.

As soon as the OFFICIAL SHORT WAVE RADIO MANUAL is published, the pre-publication price will be immediately withdrawn. It is, therefore, to your advantage to order your copy today.



# How a "Tip" got Tom a Good Job

**Panel 1:** GEE, THERE'S DJC IN BERLIN. THAT'S THE TENTH FOREIGN STATION TONIGHT. RADIO IS SURELY FUN.

**Panel 2:** HELLO, TOM, HOW'S EVERYTHING? OH, NOT SO GOOD BILL, BUT I'M STILL HAVING FUN PLAYING WITH RADIO. HAD DJ LAST NIGHT ON A LITTLE SET I BUILT. IS RADIO STILL YOUR HOBBY TOO?

**Panel 3:** NO, TOM, I'VE BEEN TOO BUSY MAKING GOOD MONEY OUT OF RADIO TO SPEND TIME "PLAYING" WITH IT. GOSH, BILL, YOU'RE SURE LUCKY. I NOTICED YOUR SWELL CLOTHES AND SHAPPY CAR. I THOUGHT YOU HAD INHERITED A MILLION. TELL ME ABOUT IT.

**Panel 4:** I AM LUCKY, TOM, BUT YOU HAD THE SAME CHANCE. REMEMBER ABOUT A YEAR AGO I SHOWED YOU A BOOK FROM NATIONAL RADIO INSTITUTE THAT TOLD ABOUT THE OPPORTUNITIES AND BIG FUTURE IN RADIO, AND HOW OTHERS HAD SUCCEEDED THROUGH THEIR HOME TRAINING? REMEMBER, I TRIED TO GET YOU TO ENROLL FOR THEIR COURSE WHEN I DID.

**Panel 5:** WELL, IT WAS THE SMARTEST MOVE I EVER MADE. I'M DOING SWELL. MARY AND I ARE TO BE MARRIED NEXT MONTH, TOM. WHY DON'T YOU SNAP OUT OF IT? DON'T STAY IN THAT DREARY LOW PAY JOB ALL YOUR LIFE. RADIO IS MORE THAN A PLAYTHING. IT'S A B.G. BUSINESS. IT'S YOUR OPPORTUNITY. TAKE MY TIP. IT ISN'T TOO LATE. RADIO IS STILL YOUNG AND GROWING.

**Panel 6:** IF BILL SUCCEEDED, I CAN TOO! THEN I CAN MAKE REAL MONEY SERVICING RADIO SETS OR GET A JOB IN A BROADCASTING STATION OR INSTALL AND SERVICE LOUD SPEAKER SYSTEMS OR MAKE GOOD MONEY IN ANY ONE OF THE MANY OTHER NEW AND GROWING BRANCHES OF RADIO. THERE'S NO END OF GOOD JOBS FOR A TRAINED RADIO MAN! YES, SIR, I'M GOING TO SEND FOR THAT FREE BOOK AND GET THE DOPE RIGHT NOW!

**Panel 7:** YOU CERTAINLY KNOW RADIO. MINE NEVER SOUNDED BETTER. N.R.I. TRAINING CERTAINLY PAYS. I JUST STARTED A FEW MONTHS AGO AND I'M MAKING GOOD MONEY ALREADY. THIS SPARE TIME WORK IS SWELL FUN, AND SOON I'LL BE ALL SET FOR A GOOD FULL TIME JOB.

**Panel 8:** THANKS!

OH, TOM IT'S WONDERFUL—TO THINK HOW FAST YOU'VE GONE AHEAD SINCE YOU WENT INTO RADIO. WE NEVER COULD HAVE GOTTEN MARRIED ON WHAT YOU WERE GETTING BEFORE.

OUR WORRIES ARE OVER. I'M MAKING GOOD MONEY NOW, AND THERE'S A BIG FUTURE AHEAD FOR US IN THIS LIVE WIRE RADIO FIELD.

..... I will help you start a spare time or full time **Radio service business Without Capital**

**Many Radio Experts Make \$40, \$60, \$75 a Week**

The world-wide use of Radio sets has made hundreds of opportunities for good spare time or full time Radio businesses. Many of the seventeen million Radio sets are only 25% to 40% efficient. I will show you how to cash in on this condition. I will show you how to install and service all types of receiving sets in spare time. I'll show you how to make enough money while learning Radio to start your own service business. Clip the coupon. Get my free book, "Rich Rewards in Radio." Read how hundreds of N. R. I. men have made good money in spare time or full time businesses.



**HERE'S PROOF THAT N.R.I. MEN MAKE GOOD MONEY**

**"Made \$6,000 in 2 Years"**

"Soon after the depression started, I found myself without a job, but I was well protected with N. R. I. training. I swung right to full time Radio servicing and I have made over \$6,000 in a little over two years."—Wm. Spartano, Sparty Radio Service, 93 Broadway, Newark, N. J.



**"\$500 a Year in Spare Time"**

"Although doing spare time Radio work only, I have averaged about \$500 a year extra in addition to my regular income. Full time Radio work would net me many times that amount."—Edw. H. Fawcett, Slough Rd., Ladner, B. C., Canada.



**FREE LESSON**

**ON RADIO SET SERVICING AND REBUILDING**

Let me PROVE my Course is clear, easy to understand, fascinating to study. Send coupon for free lesson, "Direct Stage by Stage Elimination Method of Trouble Shooting." This interesting lesson gives many ways to correct common Radio troubles. I am willing to send it to prove you too can master Radio with my training—just as thousands of others have done. Many men without even a grammar school education, and no Radio or technical experience, have become Radio experts and now earn two or three times their former pay. MAIL COUPON NOW.

**J. E. SMITH, President**  
Nat'l Radio Institute, Dept. 5FB3  
Washington, D. C.

**MAIL THIS for FREE 64 page book**

**Many Make \$5, \$10, \$15 a Week Extra in Spare Time While Learning**  
The day you enroll I start sending you Extra Money Job Sheets which quickly show you how to do Radio repair jobs common in most every neighborhood. I give you plans and ideas that have made good spare time money—\$200 to \$1000 a year for hundreds of fellows. My Course is famous as "the Course that pays for itself."

**Get Ready Now for a Business of Your Own and for Jobs Like These**  
In just about 15 years, Radio's growth has created over 300,000 jobs. Thousands more jobs will be opened by new Radio developments. Broadcasting stations use engineers, operators, station managers and pay up to \$5,000 a year. Manufacturers employ testers, inspectors, foremen, engineers, servicemen, buyers, for jobs paying up to \$7,500 a year. Dealers and jobbers, employ servicemen, salesmen, buyers, managers, and pay up to \$100 a week. My Free Book tells about these and other opportunities.

**Television, Short Wave, Loud Speaker Systems Included**  
There is opportunity for you in Radio. Its future is certain. Television, short wave, loud speaker systems, ship Radio, police Radio, automobile Radio, aviation Radio in every branch, developments and improvements are taking place. Here is a real future for thousands of men who really know radio—men with N. R. I. training. Get the training that opens the door to good pay and success in this growing industry.

**Find Out What Radio Offers You**  
I am so sure N. R. I. can train you satisfactorily that I agree in writing to refund every penny of your tuition if you are not satisfied with my Lesson and Instruction Service upon completion. Get my 64-page book of facts. It's free to any ambitious fellow over 15 years of age. It tells you about Radio's opportunities; about my Course; what others are doing and making. Find out what Radio offers you. No obligation. ACT NOW! Mail coupon in an envelope, or paste it on a 1c postcard.

Dear Mr. Smith: Without obligation send me the sample lesson and your free book about spare time and full time Radio opportunities. (Please print plainly.) I can train for them at home in spare time.

**J. E. SMITH, President, National Radio Institute, Department 5FB3, Washington, D. C.**

NAME.....  
ADDRESS.....  
CITY.....  
STATE.....  
"39"

Please mention SHORT WAVE CRAFT when writing advertisers

## IN THIS ISSUE: PROMINENT SHORT-WAVE AUTHORS

Goodall • McCann • Olsson • McEntee • Scott • Schrage • Shuart

**HUGO GERNSBACK**  
Editor



**H. WINFIELD SECOR**  
Managing Editor

**GEORGE W. SHUART, W2AMN**  
Associate Editor

### Contents for June, 1935

Editorial—"All-Wave Sets," by Hugo Gernsback.....	69
Short Waves at the Hauptmann Trial.....	70
Short-Wave Snapshots.....	71
Short-Wave Scouts—Trophy Contest.....	72
The Ionosphere—Where Short Waves are Reflected, by W. M. Goodall, Radio Research, Bell Telephone Lab- oratories.....	73
"Go-Get-'em 2" For the Beginner, by George W. Shu- art, W2AMN.....	74
Magni-Dial Simplifies S-W Tuning, by H. E. McCann....	76
SHORT WAVE SCOUT "NEWS".....	77
World-Wide Short-Wave Review, edited by C. W. Palmer.....	78
A Good 6-Tube Super-Het Receiver, by Stanley Olsson..	80
Short Waves and Long Raves—Our Readers' Forum....	82
De Luxe 5-Meter Transmitter—Receiver, by Howard G. McEntee, W2FHP.....	84
Simplest HAM Transmitter Uses 802 Tubes, by George W. Shuart, W2AMN.....	86
A New 22-Tube All-Wave Receiver, by E. H. Scott.....	87
New Short-Wave Apparatus—The Browning 35, A 7- Tube Super-Het "Kit".....	88
New Multiple Antenna for All-Wave Sets.....	89
17-in-1 "Multi-Kit" Set, by W. Green.....	90
New Acorn-Pentode 954 Tube is Here!.....	91
The V-Doublet—A Practical S-W Antenna, by H. A. Crossland.....	91
How to Eliminate Radio Interference, by Wilhelm E. Schrage.....	92
SHORT-WAVE STATIONS OF THE WORLD, Edited by M. Harvey Gernsback.....	93
\$5.00 For the Best Short-Wave "Kink".....	97
Short Wave QUESTION BOX.....	98
Transmitting Antennas.....	100
Book Review.....	119
Short Wave League.....	106

### Features in the July Issue

- Beginners' All-Electric Short-Wave Receiver—In which 4  
Tubes=5.
- New 2-Channel S-W Set Receives 2 Stations Simultane-  
ously.
- The Simplest Phone Xmitter, by Stanley Johnson, W9LBY.
- Automatic Volume Control—How to Apply it to Short-Wave  
Receivers, by Clifford E. Denton.
- The Browning 35—Constructional Data
- The "Switch-Coil 2," by Ernest Kahlert.
- A Mobile U.S.W. Station, by Maurice E. Kennedy, W6KQ-  
W6BGC.



### Certified Circuits

● **SHORT WAVE CRAFT** goes to a large expense in verifying new circuits. When you see this seal it is your guarantee that such sets have been tested in our laboratories, as well as privately, in different parts of the country. Only "Constructional-Experimental" circuits are certified by us.

When you see our certified seal on any set described, you need not hesitate to spend money for parts, because you are assured in advance that the set and circuit are bona fide and that this magazine stands behind them.

**SHORT WAVE CRAFT** is the only magazine that certifies circuits and sets.

### OUR COVER

● The cover illustration this month shows the Magni-Dial— an ingenious idea involving the use of an extra large dial, which anyone can easily adapt to their own short-wave receiver. It will help to make the tuning in of short-wave stations much easier. For full details see page 76.

COPYRIGHT, 1935, BY H. GERNSBACK

Published by **POPULAR BOOK CORPORATION**

**HUGO GERNSBACK**, President - - - - **H. W. SECOR**, Vice-President  
**EMIL GROSSMAN** - - - - - Director of Advertising  
Chicago Adv. Office - - - - - **L. F. McCLURE**, 919 No. Michigan Ave.  
Publication Office - - - - - 404 N. Wesley Avenue, Mount Morris, Ill.  
Editorial and General Offices - - - - 99-101 Hudson St., New York, N. Y.  
European Agent: Gorrings's American News Agency, 9A Green St.,  
Leicester Square, London W. C. 2  
Australian Agents: **McGILL'S AGENCY**, 179 Elizabeth St., Melbourne

**SHORT-WAVE CRAFT**—Monthly. Entered as second class matter May 7, 1930, at the post office at Mount Morris, Illinois, under the act of March 3, 1879. Trademarks and copyrights by permission of H. Gernsback, 99-101 Hudson St., N. Y. C. Text and illustrations of this magazine are copyrighted and must not be reproduced without permission. **SHORT WAVE CRAFT** is published on the 1st of every month. Twelve numbers per year. Subscription price is \$2.50 a year in the United States and possessions. Canada and foreign countries, \$3.00 a year. Single copies 25c. Address all contributions for publication to Editor, **SHORT WAVE CRAFT**, 99-101 Hudson St., New York, N. Y. Publishers are not responsible for lost manuscripts. Contributions cannot be returned unless authors remit full postage. **SHORT WAVE CRAFT** is for sale at all principal newsstands in the United States and Canada. European agents: Brentano's, London and Paris. Printed in U. S. A. Make all subscription checks payable to Popular Book Corporation.



# ... SHORT WAVE ESSENTIALS FOR MEMBERS OF THE SHORT WAVE LEAGUE ...

## A FEW WORDS AS TO THE PURPOSE OF THE LEAGUE

The SHORT WAVE LEAGUE was founded in 1930. Honorary Directors are as follows: Dr. Lee de Forest, John L. Reinartz, D. E. Replogle, Hollis Baird, E. T. Somerset, Baron Manfred von Ardenne, Hugo Gernsback, Executive Secretary.

The SHORT WAVE LEAGUE is a scientific membership organization for the promotion of the short wave art. There are no dues, no fees, no initiations, in connection with the LEAGUE. No one makes any money from it; no one derives any salary. The only income which the LEAGUE has is from its short wave essentials. A pamphlet setting forth the LEAGUE'S numerous aspirations and purposes will be sent to anyone on receipt of a 3c stamp to cover postage.

## FREE MEMBERSHIP CERTIFICATE

As soon as you are enrolled as a member, a beautiful certificate with the LEAGUE'S seal will be sent to you, providing 10c in stamps or coin is sent for mailing charges.

Members are entitled to preferential discounts when buying radio merchandise from numerous firms who have agreed to allow lower prices to all SHORT WAVE LEAGUE members.

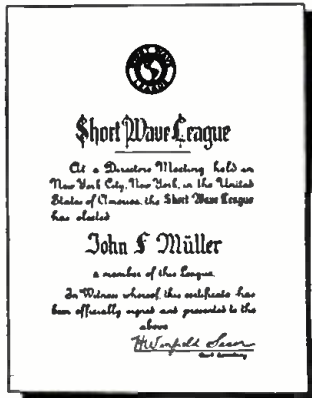

Illustration of engraved free membership certificate

## SHORT WAVE ESSENTIALS LISTED HERE SOLD ONLY TO SHORT WAVE LEAGUE MEMBERS

They cannot be bought by anyone unless he has already enrolled as one of the members of the SHORT WAVE LEAGUE or signs the blank on this page (which automatically enrolls him as a member, always provided that he is a short wave experimenter, a short wave fan, radio engineer, radio student, etc.).

Inasmuch as the LEAGUE is international, it makes no difference whether you are a citizen of the United States or any other country. The LEAGUE is open to all.

## Application for Membership SHORT WAVE LEAGUE

SHORT WAVE LEAGUE 6-35  
99-101 Hudson Street, New York, N. Y.

I, the undersigned, herewith desire to apply for membership in the SHORT WAVE LEAGUE. In joining the LEAGUE I understand that I am not assessed for membership and that there are no dues and no fees of any kind. I pledge myself to abide by all the rules and regulations of the SHORT WAVE LEAGUE, which rules you are to send to me on receipt of this application.

I consider myself belonging to the following class (put an X in correct space): Short Wave Experimenter  Short Wave Fan  Radio Engineer  Student  I own the following radio equipment:

Transmitters .....

Call Letters .....

Receiving .....

Name .....

Address .....

City and State .....

Country .....

I enclose 10c for postage and handling for my Membership Certificate.

## SHORT WAVE LEAGUE LETTERHEADS

A beautiful letterhead has been designed for members' correspondence. It is the official letterhead for all members. The letterhead is invaluable when it becomes necessary to deal with the radio industry, mail order houses, radio manufacturers, and the like; as many houses have offered to give members who write on the LEAGUE'S letterhead a preferential discount. The letterhead is also absolutely essential when writing for verification to radio stations either here or abroad. It automatically gives you a professional standing.

A—SHORT WAVE LEAGUE letterheads, per 100 ..... **50c**

## OFFICIAL SHORT WAVE LISTENER MAGAZINE

The finest magazine of its kind ever published—totally different in get-up and contents from any other. Contains the largest listing of short wave stations in the world, up-to-the-minute, including "Police," "Television" and short-wave stations, as well as a special list of the star short-wave stations with their frequencies and call letters. Also contains photos and descriptions of short-wave broadcasting stations in various parts of the world with photos of short wave studio artists—How to locate "weak" distance stations, and other hints for the "short-wave listener"—Question and Answer Department for the "listener"—Silver Cup Trophy for best photo of readers' listening "posts," etc.

B—Official Short Wave Listener Magazine.....Prepaid **25c**

## RADIO MAP OF THE WORLD AND STATION FINDER

The finest device of its kind published. The world's map on heavy board is divided into 23 sections, while the rotary disc shows you immediately the exact time in any foreign country. Invaluable in logging foreign stations. Also gives call letters assigned to all nations. Size 11"x22".

C—Radio Map of the World and Station Finder.....Prepaid **25c**

## GLOBE OF THE WORLD AND MAGNETIC COMPASS

This highly important essential is an ornament for every den or study. It is a globe, 6 in. in diameter, printed in fifteen colors, glazed in such a way that it can be washed. This globe helps you to intelligently log your foreign stations. Frame is of metal. Entire device substantially made, and will give an attractive appearance to every station, emphasizing the long-distance work of the operator.

D—Globe of the World.....Prepaid **\$1.25**

## SHORT WAVE LEAGUE LAPEL BUTTON

This beautiful button is made in hard enamel in four colors, red, white, blue and gold. It measures three quarters of an inch in diameter. By wearing this button, other members will recognize you and it will give you a professional air. Made in bronze, gold filled, not plated. Must be seen to be appreciated.

E—SHORT WAVE LEAGUE lapel button.....Prepaid **35c**

EE—SHORT WAVE LEAGUE lapel button, like the one described above but in solid gold.....Prepaid **\$2.00**

## SHORT WAVE LEAGUE SEALS

These seals or stickers are executed in three colors and measure 1 1/4 in. in diameter, and are gummed on one side. They are used by members to affix to stationery, letterheads, envelopes, postal cards and the like. The seal signifies that you are a member of the SHORT WAVE LEAGUE. Sold in 25 lots or multiples only.

G—SHORT WAVE LEAGUE seals.....per 25, Prepaid **15c**

## SHORT WAVE MAP OF THE WORLD

This beautiful map, measuring 18x26 in. and printed in 18 colors is indispensable when hung in sight or placed "under the glass" on the table or wall of the short wave enthusiast. It contains a wealth of information such as distances to all parts of the world, political nature of the country in which a broadcast station is located, etc., and from the manner in which the map is blocked off gives the time in different parts of the world at a glance.

F—SHORT WAVE Map of the World.....Prepaid **25c**

PLEASE NOTE THAT ABOVE ESSENTIALS ARE SOLD ONLY TO MEMBERS OF THE LEAGUE—NOT TO NON-MEMBERS WITH EXCEPTION OF ITEM B.

Send all orders for short wave essentials to SHORT WAVE LEAGUE, 99-101 Hudson Street, New York City.

If you do not wish to mutilate the magazine, you may copy either or both coupons on a sheet of paper.

**SHORT WAVE LEAGUE 99-101 Hudson St., New York, N. Y.**



G—15c for 25

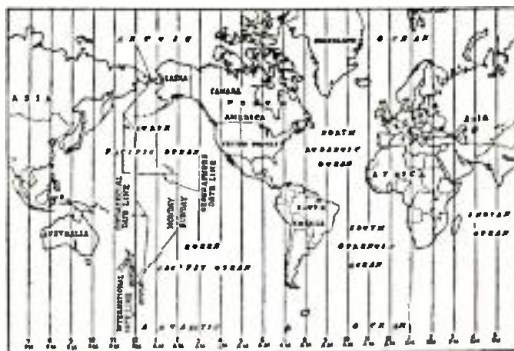

F—25c each

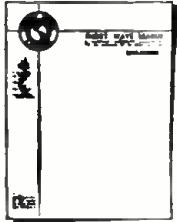

A—50c per 100



B—25c per copy



C—25c each



D—\$1.25 each



E—35c each

SHORT WAVE LEAGUE, 99-101 Hudson Street, New York, N. Y.

Gentlemen:

I am already an enrolled member in the SHORT WAVE LEAGUE

I am a new member and attach my application to this coupon

Please send me the following short wave essentials as listed in this advertisement:

.....  
 .....  
 .....

for which I enclose \$ ..... herewith.  
 (The LEAGUE accepts money order, cash or new U. S. Stamps in any denomination. Register cash and stamps.)

Name .....  
 Address .....  
 City and State .....  
 Country .....

6-35

Please mention SHORT WAVE CRAFT when writing advertisers

MAIL COUPON TODAY!

RADIO PUBLICATIONS, Dept. SWC-6
103 Hudson Street, New York, N. Y.
Gentlemen: Enclosed you will find my remittance of One Dollar (\$1.00) for which send me One Copy of "SHORT WAVES" by Leutz and Gable. I understand this book may be returned to you within three days if I am not completely satisfied, and my money refunded. This offer good in U. S. A. only.

NAME .....

ADDRESS .....

CITY ..... STATE .....

(Include 15c extra to cover mailing charges)

Save \$1.98

Just As Long As the Supply of this Book Lasts

The One and Only ENCYCLOPEDIA on SHORT WAVES

By C. R. Leutz and R. B. Gable

384 PAGES—Over 345 ILLUSTRATIONS

Astonished at the low price we offer this book? You should be! It represents THE GREATEST RADIO BOOK YOU EVER HEARD OF or read about. You SAVE \$2.00 on a volume that regularly sells for \$3.00. The book, "SHORT WAVES" by Leutz and Gable, costs you NOW ONLY ONE DOLLAR.

The publishers of this book went out of business, and we purchased the remaining few thousand copies at a low price—WE ARE PASSING THIS LOW COST ON TO YOU.

"SHORT WAVES" is written by Leutz and Gable, two foremost radio authorities. You will remember Charles R. Leutz as one of the pioneers in radio, also designer and manufacturer of the famous LEUTZ Transoceanic Receivers. Mr. Robert Gable owned and operated one of the finest low power broadcasting stations in the country. He is well known as an experimenter and research worker in scientific fields.

Considering the value of this book for data alone, its cost should really be more than originally asked. But when you see the illustrations in the book you will marvel at how this book could be sold for ONE DOLLAR.

The book is printed on a very expensive super-calendared paper. It contains 384 pages with over 345 photographic illustrations and diagrams. Any printer will tell you that the printing of this book is a job of the craftsmen in the industry.

So confident are we that you will be satisfied with your copy of "SHORT WAVES," that it is sold on a money-back guarantee. If within three days you find that this book is not worth more than the dollar you paid, then return the book to us—your purchase price will be immediately refunded.

"SHORT WAVES" is the most important and comprehensive volume of short-waves ever published. This book has EVERYTHING on short-waves—it literally contains a complete education on short-waves.

The supply of these books is not expected to last long. Once they are gone no additional copies will be available. ORDER NOW—be sure to tell your friends about this remarkable book value. Send the coupon today for your copy of "SHORT WAVES" by Leutz and Gable.

Partial Contents of "SHORT WAVES"

HISTORICAL REVIEW

Maxwell—Hertz—Marconi—Lodge—Pickard—Vacuum Tube Invention—Early Power Tubes—First Long Distance Radio Telephony—Water Cooled Tubes—Improved Filament Construction—Pioneer Amateur Results—Loops—Multiple Tuned Antennae—Wave Antennae—Short-Wave Directional Antennae—Progress in Radio Telephony—Start of Broadcasting—Changes in Broadcast Receiver Designs—Dynamic Speakers—Remote Broadcasting—Ship-to-shore Radio Telephony—Side Band Transmission—and other important historical developments.

SHORT WAVE PROPAGATION

Long Distance Properties—Natural Shielding Effect—Observations on Broadcast Band—Initial Amateur Experiment—Simple Radiation Light Analogy—The Ionized Region—Kennelley—Heavily Side Layer—Critical Wave Lengths—Ground Waves—Actual Results.

COMMERCIAL RADIO TELEPHONY AND TELEGRAPHY

International Telephone and Telegraph Systems—Area Covered—Power Requirements—Standard Transmitter—Associated Equipment—Superheterodyne Receivers—Receiving Circuits—New York to London Circuits—Wavelengths Selected—Details of Ciber Systems.

SHIP TO SHORE RADIO TELEPHONY

Early Experiments—Point-to-Point Measurements—Deal Beach Transmitter—First Public Service—Consideration of Suitable Frequencies—Electrical Interference on Ship Board—Directive Antennae Advantages—Coastal Receiving and Transmitting Station—Automatic Volume Control—Technical Operators—Future Developments.

DIRECTIONAL ANTENNAE

Transmitting Antenna at Madrid—Methods of Sup-

port—Consideration in Design—Constructional Details—Continuation to Short Wave Work—Foreign Developments.

port—Consideration in Design—Constructional Details—Continuation to Short Wave Work—Foreign Developments.

TELEVISION

General Considerations—Transmitter Band Width—Need of Standardization—Colored Television—Early Television Inventions—Jenkins Developments—Transmitter Designs—Importance of Special Receiver Designs—Scanning Equipment—Importance of Synchronization—Television Lamps—General Electric Developments—Introduction on a Large Scale—Cathode Ray Tube Developments.

AIRCRAFT RADIO EQUIPMENT

Bureau of Standard Developments—Radio Frequency Laboratory—Aircraft Receivers—Power Supplies—Ignition Interference—Remote Tuning Controls—Aircraft Antennae—Guiding Aircraft—Radio Range Beacons—Airport Equipment—Directional Transmitters—Navigation.

SHORT-WAVE BROADCAST RECEIVERS

Early Designs—Regenerative Circuits—Advantages of Superheterodyne Circuits—Schematic Diagrams—Superheterodyne Adapters.

ULTRA SHORT WAVES (Medical and Surgical Applications)

Artificial Fevers—Relation of Heat to Disease—Short Wave Oscillators—Gall Fly Experiments—Apparatus Used—Magnatron—Theoretical Considerations—Oscillating Circuit—Frequency and Power Limitations—Electric Surgery—Electric Knife—Apparatus Used—Experiments and Research.

AMATEUR SHORT-WAVE EQUIPMENT

Amateur Communication Equipment—Radio Telegraph—Radio Telephony—Typical Apparatus—Oscillators—Frequency Doublers—Linear Amplifiers—Modulator Unit—Miscellaneous Subjects.

Don't forget that this comprehensive volume is sold on a MONEY-BACK GUARANTEE. If you are not satisfied with it, return it within three days for refund. Use the coupon at the top for ordering your copy of "SHORT WAVES" by Leutz and Gable.

RADIO PUBLICATIONS

103 Hudson Street

New York, N. Y.

Write early for coils or improved C7. write, this you 30-35

PREVIOUSLY SOLD AT

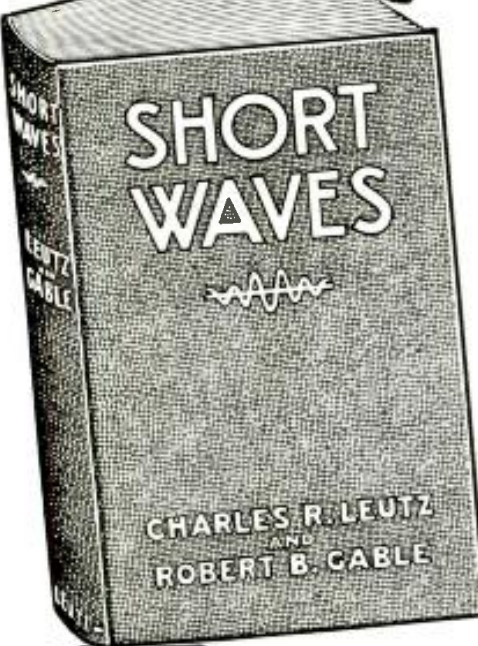

NOW \$1.00

SOLD ON A MONEY-BACK GUARANTEE IF NOT SATISFIED





# All-Wave Sets

An Editorial By HUGO GERNSBACK

● DURING the past two years, the *all-wave* set has come to the front and has made great strides.

Previous to 1933, the public at large had practically no knowledge of an all-wave set, that is, a radio set which could receive both short waves from 15 meters up to 200 meters, and broadcast waves from 200 meters to 545 meters. This has all been changed, and very few commercial sets that come out now are made without the all-wave feature.

At one time, and not so very long ago, the all-wave set was looked upon with distinct suspicion by short-wave enthusiasts, because they felt that any set with a switching arrangement would not be as efficient as a plug-in set, and for that reason the all-wave set was in disfavor with the short-wave fraternity.

Recent engineering progress has changed all this, and there is very little, if any, difference in efficiency today between the plug-in sets and the switching type set.

Constant improvements are made by the radio industry and in a very short time the all-wave sets will no doubt not only be as efficient as the short-wave fan's plug-in set, but they will probably surpass the latter. There are still a number of improvements to be made in the all-wave sets as the larger part of the radio industry has not, as yet, caught up with the demands that the real short-wave enthusiast makes upon a short-wave set. Chiefly, these are the following:

The tuning scale on the majority of all-wave sets, with few exceptions, are entirely too small. What is wanted is a larger scale, where tenths of divisions can be read easily without a magnifying glass.

Second, the overwhelming percentage of all-wave sets still have no band-spread arrangement, which is the one thing that is required on the congested areas such as the 31 meter and 49 meter bands, where the listener is particularly helpless due to the congestion. Band-spread is no longer a luxury but a dire necessity.

Then, there is the matter of getting the most out of the aerial system. The short-wave fan usually does this by means of a variable condenser inserted into the antenna lead in order to get the maximum resonance. This feature is missing in nearly all all-wave sets, but will no doubt be remedied very soon.

Then, there is the illumination of the dial which, in many sets, is still inadequate. If there is one thing that the short-wave listener must have it is excellent illumination on the dial, otherwise it becomes almost impossible to accurately tune in and "log" stations.

Automatic volume control is another point where the radio engineer will probably work wonders in the next few years. It is here where the greatest weakness of most all-wave sets lies. It should be understood that the average listener is not a short-wave expert and does not know much about the vagaries of short waves. He is apt to immediately condemn the set while listening to a foreign station when it fades in and out. In the broadcast band he no longer is bothered with this condition. In the first place, the power of broadcast stations has been stepped up to such an extent

that the matter of fading of stations, particularly when the set has a fair automatic volume control, is no longer of great consequence. But when the average layman first listens to a foreign station when receiving conditions are not excellent, he becomes very much annoyed at the tremendous fading which, at one moment brings in the foreign station at excellent volume only to fade out almost completely within the next few moments.

Many people who do not know much about the technicalities of radio will immediately jump to the conclusion that the fault lies in the set and that listening to short waves is a nuisance. In this the listener is correct and the fault really does lie in the set. You may rest assured that the set ten years hence will not show this fading phenomenon because the sets will not only be far more sensitive but the automatic volume control feature will have been solved completely, even on weak signals. We have not, as yet, the correct automatic volume control tubes, which no doubt we shall have during the next few years. There remains quite a good deal of engineering to be done on this point alone, but I am quite certain that it will be solved very soon.

I am frequently asked the question, now that we have all-wave sets, what incentive is there for experimenters and constructors in building their own short-wave sets? Many individuals jump at the conclusion that set building is definitely over because it is now possible for the short-wave fan to buy a good all-wave set at a low price.

This conclusion is not sound. In the first place, as has been shown through the entire history of the radio art, commercial sets are always from two to three years behind the art. This is not the fault of the manufacturer because it takes time and effort, as well as capital, to develop new sets. There is also such a thing as style, and the tendency of other manufacturers.

The important point, however, is that new things are continuously being developed. Every year new tubes, more sensitive, more efficient, are being placed upon the market. Such tubes are immediately available to the builder and to the experimenter. Thus, SHORT WAVE CRAFT magazine, has for many years built special sets, far in advance of the regular manufactured product. This can easily be checked up by perusing back numbers of the magazine.

It is one of the heritages of the short-wave enthusiast that he always demands the best and latest development first. The minute a new circuit or a new development or a combination of both is published, he will wish to be the first one to build such a set. This situation will prevail for many years to come, if not forever. And this is what makes the radio art the exciting sport that it is.

*The pioneering and adventuring spirit is still rampant in the breast of every young man who has the radio fever, and this is apt to continue indefinitely. When it is impossible for the young man to become an explorer in person, at least he can become, with modest means, an explorer of space, for there is nothing quite so exciting as building a brand new set with brand new means which the radio art places at the radio enthusiast's disposal.*

**SHORT WAVE CRAFT IS PUBLISHED ON THE 1st OF EVERY MONTH**

This is the June 1935 Issue—Vol. VI, No. 2. The Next Issue Comes Out June 1

# Short Waves At the Hauptmann Trial

Short waves played a most important role in the famous million-dollar Hauptmann trial. Two tiny short-wave transmitters were secretly carried by reporters into the courtroom and were used to signal the jury's verdict to other reporters outside the locked courtroom. Short-waves will undoubtedly play many similar important roles in the future.

● SHORT waves played a very important rôle, in fact one of the most important of all, at the famous million-dollar Hauptmann trial, where they were called into action by the most important news-gathering organization in the country—the famous Associated Press. It is a long story, but briefly, here is what happened. If you listened to the radio reports which gave the jury's verdict on that eventful night when they walked into the courtroom, you will remember that the first verdict given over the broadcast stations was to the effect that Hauptmann had been found guilty, with a recommendation for mercy, which meant *life imprisonment*. A few minutes later a second broadcast came over the networks to the effect that he had been found guilty of murder in the first degree, which meant the *electric chair*.

The reason? Oh, just a little mixup on some short-wave code signals, and it happened in this manner. The Associated Press reporter who carried a tiny transmitter with battery and all concealed in an ordinary leather brief-case, sat at the press table and if the jury's verdict was "Guilty—Recommendation Mercy—Life Imprisonment" the A.P. code signal for this verdict was four dots. An A.P. telegrapher sat at his key in the cupola above the courtroom and suddenly was startled by hearing a signal of four dots in his headphones.

But the four signals which he heard, sad to relate, did not emanate from his buddy's transmitter in the little portfolio lying so innocently on the table in the court-room.

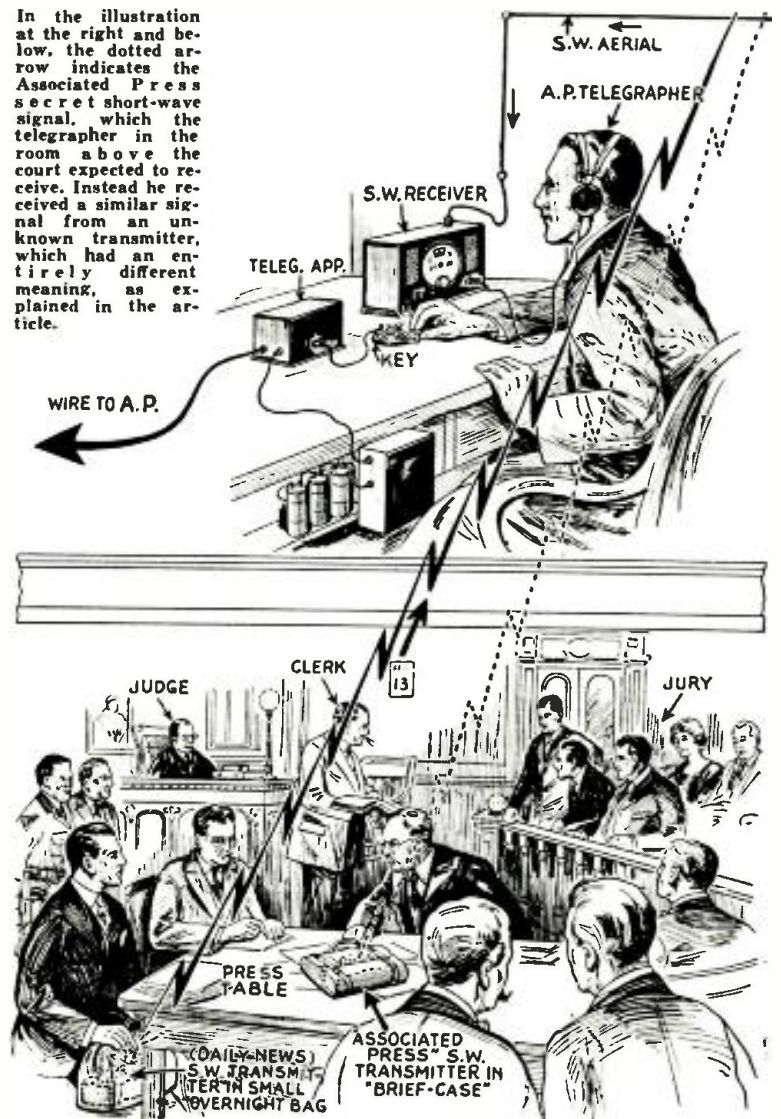

Unknown to the general public and in fact to any of the court officials in the famous Hauptmann trial, was the fact that two tiny short-wave transmitters were carried into the courtroom to signal the jury's verdict to the outside newspaper world. By a peculiar mixup in the signals the wrong verdict was signaled to the press and radio bureaus as explained in the accompanying article, but this was rectified a few moments later as radio listeners will recall.

Unknown to either of the two A.P. news-gatherers was the fact that the *New York Daily News* also had a reporter in the courtroom with a second short-wave transmitter, this one being hidden in a small overnight bag. Just to make things interesting the *Daily News* man's code signal to his coworker on the outside of the locked courtroom was four dots to indicate that the jury had entered the courtroom! So behold, here is what happened! The *Daily News* reporter sent the four dot signal, the A.P. telegrapher in the cupola above the courtroom heard them and presto—out to a waiting world flashed the news via his trustworthy telegraph key that *life imprisonment* was Hauptmann's fate!  
(Continued on page 103)



One of the short-wave transmitters carried by a reporter into the courtroom at Flemington was concealed in a small leather brief-case—Take a look at this photo! SHORT WAVE CRAFT described how to build a short-wave set in a brief-case in the June 1932 issue—three years ago! With a slight change in the connections, this receiver is easily converted into a transmitter for code signals, such as those used at the Hauptmann trial.



# Short Wave Snapshots

Interesting Applications of Short Waves Including Sets Aboard Planes, Bobsleds and Ham Communications

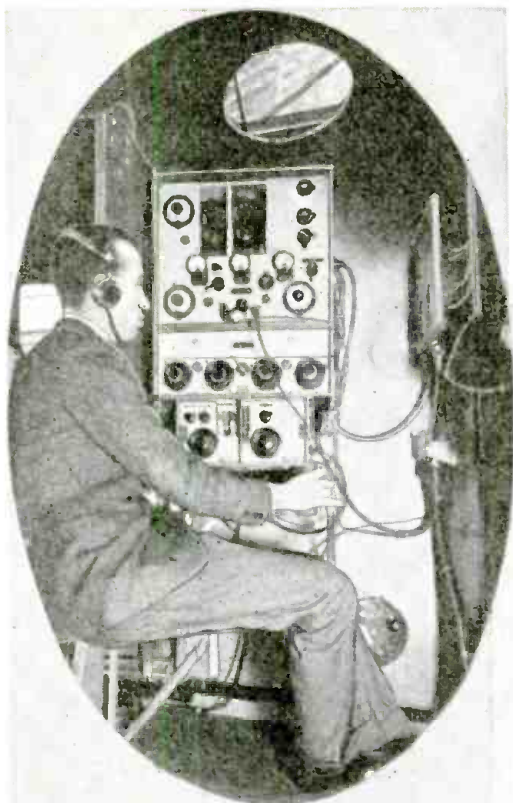

Above—Short Waves recently carried a running description of the sensations experienced in the mile and one-half run of this bobsled at Lake Placid, N.Y. At times the bobsled reached a speed of 70 miles an hour. The young man shown in the "close-up" is Eugene S. Darlington, youthful General Electric Co., engineer, and he is carrying a portable 7-meter radio transmitter on his back, which is complete with batteries and all the "trimmings"; the microphone is shown suspended on his chest. The short-wave voice signals from the transmitter aboard the speeding bobsled were picked up and transferred to another transmitter in the vicinity, which relayed them on to Lake Placid Village, where the voice was picked up by an all-wave receiver and fed into a telephone line to Schenectady, where it was re-broadcast by station WGY and its short-wave "pal," W2XAD.

The top left photo shows a new plane built for the Viceroy of India, which is fitted with the latest Marconi short-wave receiver and transmitter.

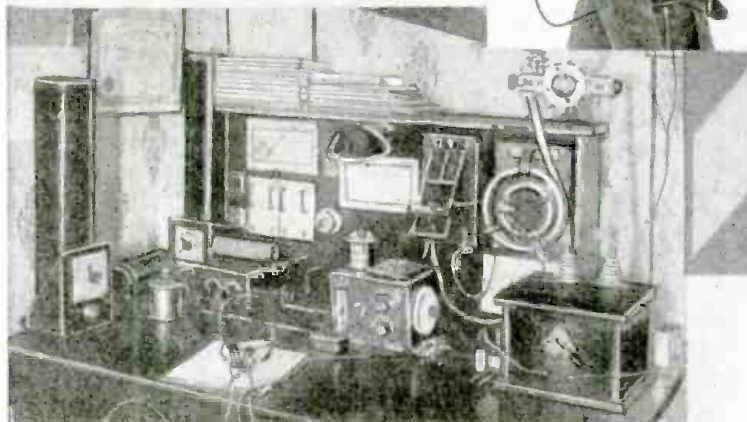

Shades of Heinrich Hertz! Yep—a Ham station of 1916 vintage! Transmitter, receiver, an' everything. On the wall is a membership certificate of the "Radio League of America," established by Hugo Gernsback, editor of this magazine. This station operated on 200 meters, real short for that period, and the receiver was a "1-tuber," observable in the center of the photo. Note the rotary spark gap at the right and the oscillation transformer made of copper ribbon, just below the gap! Roswell J. Parker.



↑ A Japanese Ham operating an amateur transmitter and receiving station in Japan under the license call J1DM. The picture shows 18-year-old Seichiro Handa, a student; apparently he has not heard of the depression (a very common subject of conversation in the occident) judging by the size of the meters on his control board above the table. More power to him!



← At the left—fourteen-year-old radio amateur, George Alan Bryan of Derby, England, who is reputed to be one of the youngest European Ham station operators. His call letter is G2AFV.



# SHORT WAVE SCOUTS

## 15TH TROPHY WINNER

Robert Graham, 314 W. Eldridge Ave., Flint, Michigan

55 Stations; 43 Foreigns

● THE editors are pleased to announce the award of the fifteenth trophy cup to Robert Graham of Flint, Mich., for his excellent list of short-wave stations submitted with verifications. Mr. Graham's list contained 43 foreign stations and 12 United States stations. Our new rules only required 50 percent foreign stations in the list and Mr. Graham has therefore plenty of "foreigners" to spare. Mr. Graham rolled up this very fine list of short-wave stations on his Hammarlund Comet Pro, using an 85-foot flat-top antenna and a connection to a water pipe for a ground. Mr. Graham states in his letter accompanying the list of stations, that he has been a reader of SHORT WAVE CRAFT practically since the first issue. The list of stations submitted by Mr. Graham was accompanied by the required notarized statement that he had personally listened to all of the stations in the list during the thirty-day period between Dec. 13, 1934, and Jan. 12, 1935, and in accordance with the rules, that all verification cards entered with the list were received in reply to reports sent to the respective stations during this specified thirty-day period.

**IMPORTANT:** Do not fail to remember that all the entries must now be entered according to the new rules which are herewith reprinted for the benefit of those who intend submitting lists of stations. Read the new rules carefully!

Briefly they are: The Trophy will go to the person submitting the "greatest number of verifications!" No unverified stations are required! Also, at least 50 per cent of the verifications submitted must be for stations located OUTSIDE of the country in which the entrant resides. Only letters or cards specifically verifying reception of a given station will be considered.

### MR. GRAHAM'S LIST: FOREIGN STATIONS

HP5B 6030 Kc. Daily, 8—10:30 p.m.; Estacion Radiodifusora Miramar, Panama City, Rep. of Panama. "Radio Miramar"  
COC 6010 Kc. Daily, 9:30—11:30 a.m., 4—7 p.m.; Sat., 11:30 p.m.—12:30 a.m.; Havana, Cuba.  
YV5RMO 5850 Kc. Daily, 5:15—9 p.m.; Maracaibo, Venezuela. "Ecos del Caribe"  
COH 9428 Kc. Daily, 5—6, 8—9 p.m.; Havana, Cuba.  
HIX 5980 Kc. Tues., Fri., Sun., 8—10 p.m.; Santo Domingo, D.R.  
ORK 10330 Kc. Daily, 2:45—4:15 p.m.; Radio Ruyselede, Ruyselede, West Flanders, Belgium.  
DJA 9560 Kc. Daily, 8—11:30 a.m., 5:15—9:15 p.m.; Berlin, Germany.  
DJN 9540 Kc. Daily, 3:45—7:15, 8—11:30 a.m., 5:15—10:45 p.m.; Berlin, Germany.  
DJC 6020 Kc. Daily, 12—4:30, 5:30—10:30 p.m.; Berlin, Germany.  
Radio-Coloniale 15243 Kc. Daily, 7—11 a.m. or 1 p.m.; Paris, France. "Ici Paree Radio-Coloniale"  
Radio-Coloniale 11875 Kc. Daily, 11:15 a.m.—2:15 p.m., 3—6 p.m.; Paris, France. "Ici Paree Radio-Coloniale"



## FIFTEENTH "TROPHY CUP" WINNER

Presented to  
SHORT WAVE SCOUT  
ROBERT GRAHAM,  
FLINT, MICH.

For his contribution toward the advancement of the art of Radio

by



Magazine

● ON this page is illustrated the handsome trophy which was designed by one of New York's leading silversmiths. It is made of metal throughout, except the base, which is made of handsome black Bakelite. The metal itself is quadruple silver-plated, in the usual manner of all trophies today.

It is a most imposing piece of work, and stands from tip to base 22½". The diameter of the base is 7¾". The diameter of the globe is 5¼". The work throughout is first-class, and no money has been spared in its execution. It will enhance any home, and will be admired by everyone who sees it.

The trophy will be awarded every month, and the winner will be announced in the following issue of SHORT WAVE CRAFT. The winner's name will be hand engraved on the trophy.

The purpose of this contest is to advance the art of radio by "logging" as many short-wave phone stations, amateurs excluded, in a period not exceeding 30 days, as possible by any one contestant. The trophy will be awarded to that SHORT WAVE SCOUT who has logged the greatest number of short-wave stations during any 30-day period.

### HONORABLE MENTION AWARDS

(None this month.)

Radio-Coloniale 11720 Kc. Daily, 7—10 p.m., 11 p.m.—1 a.m.; Paris, France. "Ici Paree Radio-Coloniale"  
YV3RC 6150 Kc. Daily, 4:30—10 p.m.; "Radiodifusora Venezuela," Caracas, Venezuela.  
PRADO 6620 Kc. Thur., 9—11:30 p.m.; Radiodifusora de "El PRADO," Riobamba, Ecuador.  
PRF5 9501 Kc. Daily exc. Sun., 5:30—6:15 p.m.; Comp. Radio Internacional de Brazil, Rio de Janeiro, Brazil.  
GRU 12290 Kc. Irregular; Rugby, England.  
GBS 12150 Kc. Irregular; Rugby, England.  
GCB 9280 Kc. Irregular; Rugby, England.  
YV2RC 6112 Kc. Sun., 1:30—10:30 p.m.; Daily exc. Sun., 11 a.m.—1:30 p.m.; Mon., Thur., Sat., 4:45—10 p.m.; Tues., Wed., Fri., 4:45—9:30 p.m.; "Broadcasting Caracas" Caracas, Venezuela.  
HJ1ABB 6447 Kc. 11:45—1 p.m., 5:30—10 p.m.; "La Voz de Barranquilla," Barranquilla, Col.  
PRADO 15410 Kc. Sun. afternoon; Riobamba, Ecuador.  
CT1AA 9600 Kc. Tues., Thur., Sat., 4:30—7 p.m.; "Radio Coloniale," Three Cuckoo Calls, Lisbon, Portugal.  
HC2RL 6666 Kc. Sun., 5:45—7:45 p.m.; Tues., 9:15—11:15 p.m.; Guayaquil, Ecuador.  
PCJ 15220 Kc. Irregular—Relays PHI Sun.; "Philips Radio," Eindhoven, Holland.  
HJ1ABG 6042.5 12—1 p.m., 6—10 p.m. daily; Sun., 1—6 p.m.; Barranquilla, Colombia.

RV59 6000 Kc. Daily, 3—6 p.m.; Moscow.  
RNE 12000 Kc. Sat., 10—11 p.m., 6—7, 10—11 a.m.; Moscow, U.S.S.R.  
CEC 15865 Kc. Irregular; Santiago, Chile.  
CEC 19680 Kc. Irregular; Santiago, Chile.  
VK3LR 9580 Kc. 3—8 a.m., daily; Lyndhurst, Victoria, Australia.  
TGF 14485 Kc. Irregular; Guatemala City, Guatemala.  
LSN 9890 Kc. Irregular; Hurlingham, Argentina.  
LSL 7901 Kc. Irregular; Hurlingham, Argentina.  
LSQ 14845 Kc. Irregular; Hurlingham, Argentina.  
DJE 17760 Kc. 8—11:30 a.m., daily; Berlin, Germany.  
I2RO 6085 Kc. 6—7:30 p.m., Mon., Wed., and Fri.; Rome, Italy.  
CJRX 11720 Kc. 8—12 p.m. Sun., 3—10 p.m.; Winnipeg, Manitoba.  
CJRO 6150 Kc. Same as CJRX; Winnipeg, Manitoba.  
CGA3 13285 Kc. Irregular; Drummondville, Quebec.  
CGA4 9330 Kc. Irregular; Drummondville, Quebec.  
CGA8 4905 Kc. Irregular; Drummondville, Quebec.  
VE9DN 6005 Kc. Sat., 11:30 p.m.—12:30 a.m.; Montreal, Quebec.  
VE9GW 6090 Kc. Mon., Tues., Wed., 3-12 p.m.; Thurs., Fri., Sat., 7 a.m.—12 midnight, Sun., 1—9 p.m.; Bowmanville, Ontario.

### UNITED STATES OF AMERICA

WNC 15055 Kc. Irregular; Hialeah, Fla.  
KWO 15415 Kc. Irregular; Dixon, Calif.  
KWU 15355 Kc. Irregular; Dixon, Calif.  
W2XAF 9530 Kc. Daily, 6:30—11 p.m.; Schenectady, N.Y.  
W2XAD 15330 Kc. Daily, 2:30—3:30 p.m.; Schenectady, N.Y.

(Continued on page 120)





# The Ionosphere— Where Short Waves Are Reflected

By W. M. Goodall\*

At one time it was thought that there were two general ionized regions, an upper and a lower. As a result of recent researches it is now known that the ionosphere is composed of at least five, and possibly more, reflecting regions, the heights of which are not constant and may even shift relative to each other.

● WHEN you pick up your telephone and talk with a friend in Europe, South America, or Hawaii, the radio waves commonly employed to carry your voice do not cling to the earth in their journey, but reach their destination after being reflected from some point high in the atmosphere. For short-wave transmission, it has been known for some time that as the receiver is moved away from the transmitter, the received signal becomes weaker and at a comparatively short distance—from 50 to 100 miles—disappears entirely into the background of noise. As the distance is further increased, however, the signal will reappear, and become strong. This phenomenon is known as the “skip” effect. Its observation led to the inference that short-wave signals are returned

to the earth at great distances from the transmitter by being reflected from some of the upper layers of the atmosphere. Without such a reflecting region, long-distance radio communication by short waves would be impossible. It is obviously desirable to have as sound a knowledge as possible, both of the physical nature of this region and of the method by which radio waves are propagated through it. With this in view, experiments have been carried on for some time by J. P. Schafer and the writer at the Deal Laboratory.

Early in 1882, Balfour Stewart had suggested the existence of a conducting layer high in the atmosphere to explain variations in the magnetic field of the earth. In 1902, Kennelly and Heaviside had independently also used the assumption of a conducting layer to provide a mechanism capable of reflecting radio waves. In spite of these early suggestions, however, it was not until the last decade that experiments had been carried out which were sufficiently direct to satisfy the few who held to the bitter end that a conducting layer is an unnecessary assumption. Today, however, no one questions its existence. The evidence admits of no other interpretation.

Present-day knowledge of conductivity in gases suggests that this conducting layer is an ionized region of the atmosphere. Ultra-violet light from the sun is, under favorable conditions, a powerful ionizing agency, and might well produce these ionized regions. From measurements made by the Laboratories during a recent solar eclipse, moreover, it appears that the sun is largely responsible for ionization in at least two of the reflecting regions of the upper atmosphere.

The atmosphere surrounding the earth may be divided into two or more

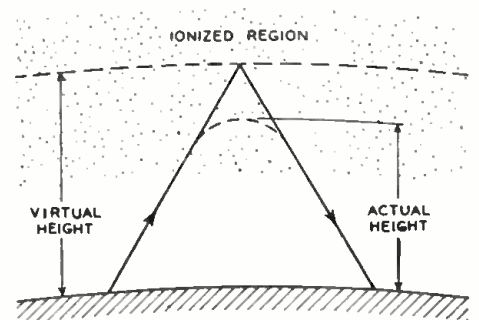

Fig. 1—Radio waves are not reflected as light from the surface of a mirror, but in effect curve around at a decreased velocity.

layers. The lower of these, extending upward to about eleven kilometers above the earth, is known as the troposphere. In this region clouds form and temperature decreases in proportion to altitude. In the region above this level, called the stratosphere, the temperature does not vary with altitude and cloud formations of the type found in the troposphere never appear. It is in a still higher region that radio waves are reflected, and it has been suggested that this latter region be called the ionosphere, a name that was derived from its most important attribute—ionization.

A convenient method of studying the ionosphere is to measure the time required for a radio signal to travel to the reflecting layer and back to the earth. Knowing the velocity of the waves, one can easily compute the distance to the point of reflection from

(Continued on page 116)

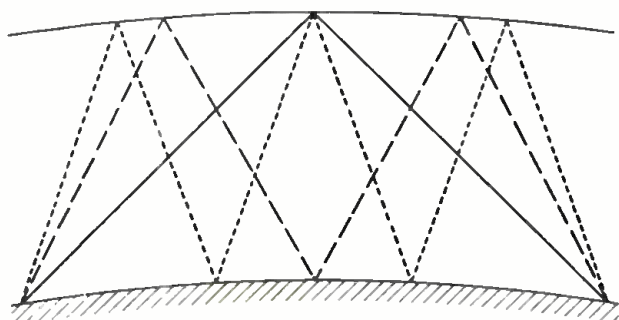
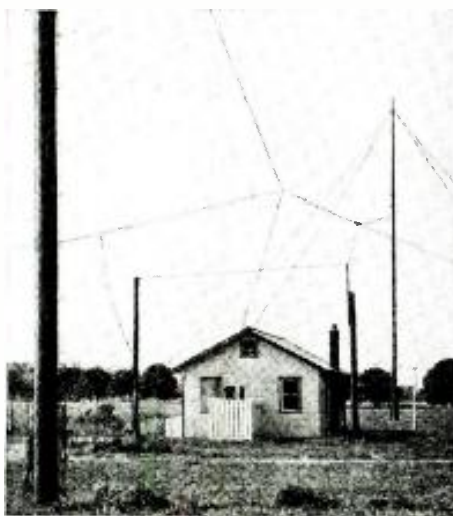

Fig. 2—Photo at left: Ionosphere measurements are made in a small building with transmitting and receiving antennas stretched above it.

Fig. 3—A pattern on a cathode ray tube furnishes the necessary data for calculating virtual heights.

Fig. 7—(Left) Possible multiple paths for radio transmission.



# GO-GET-'em 2" for the

By George W. Shuart  
W 2 A M N

Here is a very nifty 2-tube short-wave receiver which gives a 3-tube performance and operates in conjunction with batteries. The author also clearly explains a good many technical terms and considerations for the benefit of the beginner.

● OUR reader's correspondence has indicated that there are a great number of newcomers to the already great number of short-wave fans and it is for this group that this simple battery-operated receiver is intended. Those just starting in the realm of short waves of course are not so familiar with the various terms used and for this reason we will endeavor to clarify a few of the most confusing along with the description of this 2-tube set. The reason we selected a battery receiver is because the majority of beginners seem to "cut their teeth" on battery-operated sets; probably because they are the most simple to construct.

This set uses a type 19 tube, which serves as a detector and one stage of audio amplification. This tube can serve this dual purpose because it consists of two separate 3-element tubes in a single glass envelope. The second tube used is a power pentode having five elements. The entire receiver is mounted on a metal chassis and we strongly advise the builder to use the metal chassis because it allows neater and more efficient construction than could be had if a wood base board were used.

Referring to the diagrams, we have shown both physical and schematic; the most critical part of the entire set lies in the tuned circuit and its associated components. They are, the coil and tuning condenser, which are marked L1, L2 and C1, the grid condenser and grid-leak, C2 and R1. These parts of the circuit together with the detector tube are the heart of the whole receiver, because upon them depends the sensitivity of the set.

The values shown in the diagram give the best results. These values could be expressed in two different ways. For instance C1 is shown as 140 mmf. It could also have been expressed as .00014 mf. By looking at the figures we immediately see that we have made a decimal of the 140 by moving the decimal point six places to the left and then dropping the one m. Changing .00014 mf. to mmf. is just the reverse—move the decimal six places to the right and add an m. (140 mmf.). For simplicity the decimal is dropped entirely as it is of no consequence when to the extreme right of a number.

The resistor R1 is 2 megohms or two million ohms. To change ohms to megohms we perform the same operation as we did when changing from mmf. to mf. In other words R2, 50,000 ohms in the diagram, could have been expressed .05 meg. simply by moving the decimal point six places to the left. Changing from megohms to ohms the decimal point is moved six places to the right. We hope this will help the inexperienced reader in identifying condensers and resistors either when reading diagrams or when trying to select parts from catalogs which do not happen to use the same terminology he is accustomed to.

Another very important point in set construction is the proper coil connection. A great percentage of failures can be attributed to the coil. In all sets where the tickler is in the plate circuit of the tube, the windings should both be wound in the same direction. The plate will then connect to the lead of the tickler which is farthest away from the grid coil and the grid condenser and grid-leak will be connected to the terminal of the coil which is farthest from the tickler; in other words the two *outer* leads always go to the plate and grid of the tube. The tickler will then always be at the ground side of the grid coil, where it is supposed to be.

The antenna trimmer or coupling condenser also plays an important part and trouble caused by it is hard for the beginner to find. If the capacity of the condenser is large it will block the detector tube on the shorter waves and prevent oscillation. Many fans have obtained fine results on the 100 to 200 meter coil and nothing on the low wave coils, simply because this antenna condenser has a large minimum capacity. The usual run of 35 mmf. condensers have a very low minimum capacity and will serve nicely. If your set fails to oscillate on the low waves, disconnect the antenna from the set and if oscillation is obtained you can bet the condenser capacity is not *low* enough. That is so if the values in the circuit are as specified in the particular diagram that you are following.

If the set does not oscillate with the antenna disconnected then the trouble lies either in improper coil design or the detector tube is not supplied with the proper voltages or the tube itself may be defective and cause lack of oscillations on the lower waves, although it may work fine on the higher waves.

### The Audio Amplifier

In the audio frequency portion of the set we have one triode of the 19 as the first stage and a 33 pentode as the second stage. These two stages of high-gain audio will op-

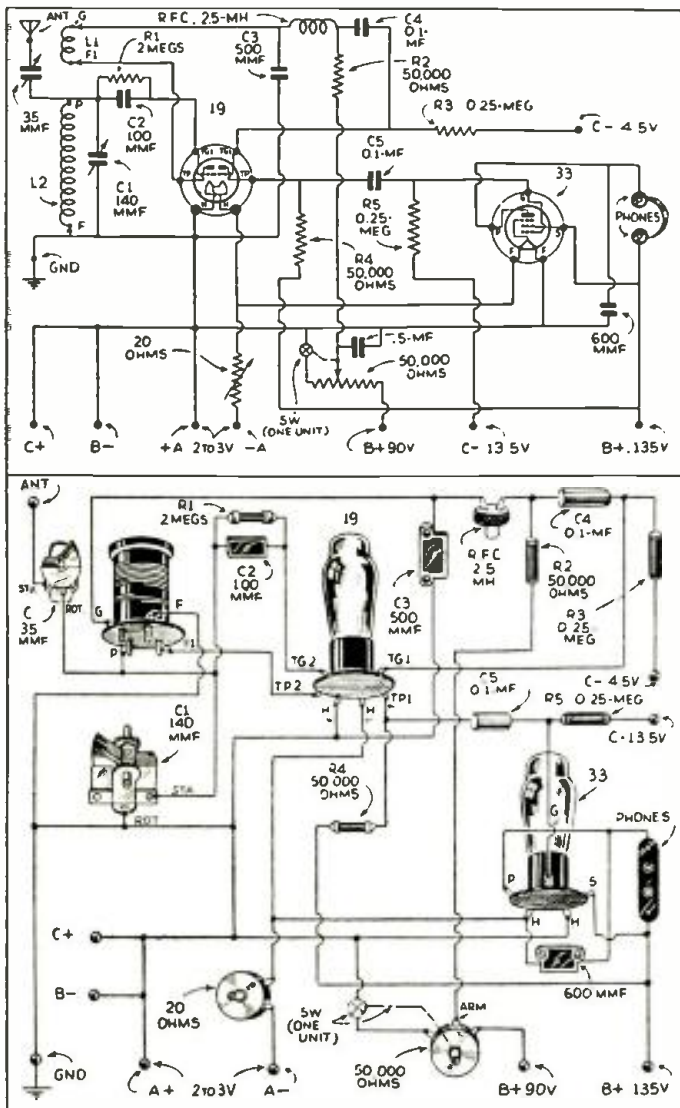

Physical and schematic diagrams of this excellent 2-tube "battery-operated" receiver.



# BEGINNER GIVES 3-Tube Results



erate a magnetic speaker on the average station, although the receiver is best suited to earphone operation. Coupling between the audio stages and the detector is accomplished by the two condensers C4 and C5, resistances and condensers being used in place of the usual transformer. A very important consideration in the audio amplifier is the grid bias (C bias) which produces better tone quality and lowers the plate current of the tubes and thus results in a considerable saving in battery power. Three 4.5 volt C batteries should be used; the full voltage should be applied to the grid of the 33 and the grid return of the first stage should be connected at the 4.5 volt tap nearest the *plus* side of the group. In order to reduce the high pitch hissing noise of the pentode we use a .006 mf. condenser and connect it from the plate to B minus. This also will eliminate any tendency of the amplifier to howl.

### A Few Words About Leads

In building short-wave receivers there are two very important things to remember—these are short leads in the RF portion and securely soldered connections throughout the entire set.

By short leads in the RF portion we mean all leads from the antenna post to the grid and plate of the detector. This takes in the plug-in coil, the tuning condenser, the grid condenser and the grid-leak. Place the different parts so that these leads will be naturally short. The length of the leads in the other part of the circuit is not so important although they should not be made any longer than necessary. Other than the length of the leads the next important consideration in set construction is the manner in which the leads are soldered. Use a hot iron and be sure that the joint is not moved until the solder is cooled, otherwise

the joint will be ineffective.

The battery power needed to run this receiver consists of three 45 volt B batteries and two 1.5 volt dry cells or their equivalent. The 20-ohm rheostat is used to adjust the filament voltage to the required two volts. If one has no voltmeter for measuring the voltage, then the rheostat should be turned on no farther than the point which gives proper results.

### Parts List for Beginner's Set

- 1—140 mmf. variable condenser, Hammarlund (Bud).
- 1—100 mmf. condenser, Aero-vox.
- 1—pr. phones. Cannon-Ball.

The "Go-Get-'em 2" in operation—So simple to tune anyone can roll in the "foreigns" without half trying. It is also extremely quiet as it is battery-operated.



- 1—500 mmf. condenser, Aerovox.
- 2—.1 mf. condensers, Sprague (high frequency type).
- 1—.5 mf. condensers, Sprague.
- 1—600 mmf. mica condenser, Aerovox.
- 1—35 mmf. variable condenser, Hammarlund (Bud).
- 2—¼ meg. resistors, Lynch.
- 1—2 meg. resistor, Lynch.
- 1—20-ohm rheostat, Electrad.
- 1—Set of plug-in coils Na-Ald, (Hammarlund).
- 1—4-prong isolantite socket, National.
- 1—6-prong isolantite socket, National.

(Continued on page 114)

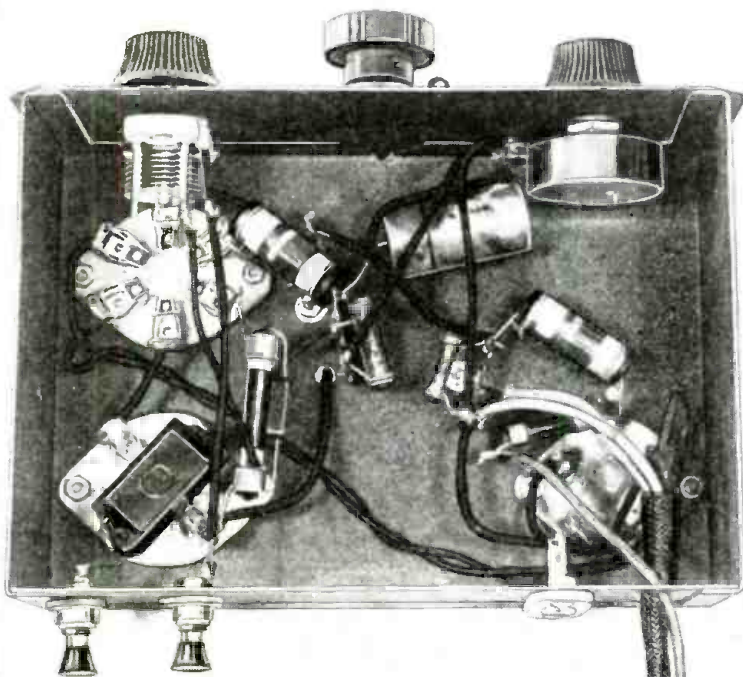

Top and bottom views of the excellent beginner's receiver, showing placement of the various parts.

# MAGNI-DIAL Simplifies S-W Tuning

By H. E. McCann

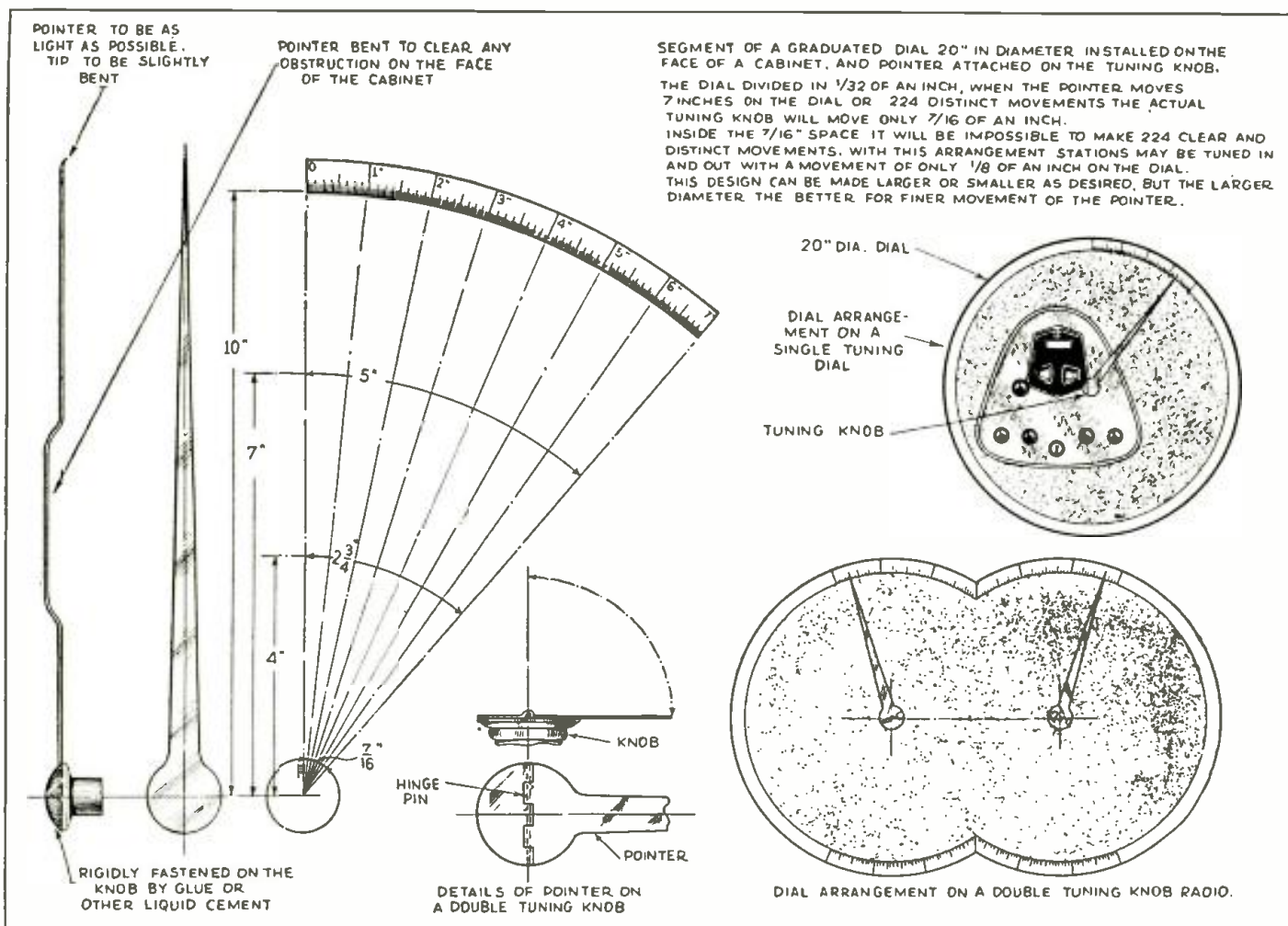

The drawing above shows a very interesting and practical way in which to greatly simplify the problem of short-wave tuning. A greatly lengthened indicator is employed with a highly magnified scale, the needle serving either as an indicator or as the actual tuning device.

● THE illustration herewith shows a practical idea which the writer has worked out and employed very successfully in tuning in stations halfway round the world, with the greatest of ease. One of my principal experiences with this greatly magnified dial for short-wave tuning has been in connection with the McMurdo Silver Masterpiece 2 All-Wave receiver. With one of these large dials fitted to this set I have been able to easily tune in Berlin, Moscow, Paris, Buenos Aires, Madrid or London (on the 20-inch diameter dial; at the writer's location, Cavite, Philippine Islands.) I can tune in any one of these stations and lose them again when I move the dial indicator  $\frac{1}{16}$  of an inch, either to the right or left of the exact point where the station comes in clearly.

As shown on the drawing for example, a section of the 20-inch diameter circle about 7 inches long can ordinarily be used. Now, if you divide this 7-inch segment into  $\frac{1}{32}$ 's of an inch, this means that you can very easily and accurately move the tuning knob 224 times, each movement covering the space of  $\frac{1}{32}$  inch, but on the knob alone these 224 movements in a space of  $\frac{7}{16}$  of an inch would be

## Magni-Dial Easy to Build

The greatly magnified dial portrayed on our front cover should prove a godsend to short-wave fans. This idea may be applied in the manner shown on the cover or the long indicating needle may be used as the actual tuning control itself.

practically impossible, without the use of this or a similar design to allow the knob to be moved 224 times an equal distance in any one direction inside the space of  $\frac{7}{16}$  of an inch.

Receivers equipped with double tuning knobs may have a long pointer like that illustrated fastened on each knob, and used with half a ring or circle of the scale for each knob. In this case it will be found best to hinge

the pointer at its center so as to complete a turn; the pointer or indicator is then started again, thus going twice around the half dial as shown in the drawing.

As the drawing makes perfectly clear, this design can be used in many different ways and on practically all radio receivers regardless of the fact that it uses one or two tuning knobs or controls.

The principal advantage of this idea is that it need not cost practically anything and only requires a little ingenuity on the part of the set owner who wishes to adopt it. As the reader will at once realize upon a little reflection, there are many different ways in which this magnified dial idea can be figured out and the form of the dial and its angular spread will in many cases be dictated by the design of the particular receiver you happen to own or operate. In some cases the dial may have the graduations spread out over a half circle. Another angle of this invention is that you may simply use the new long indicating needle 10 inches in length for example, merely as an indicator and not as the actual tuning control to be set by grasping the end

(Continued on page 103)



# Short Wave SCOUT NEWS

## E. M. Heiser, Brecksville, Ohio, Reports

● ALTHOUGH some evenings were very noisy, the past period (Feb. 20 to Mar. 20) was very fine on the 49-meter band. South American stations, especially, came in well. The European stations on this band were not heard very often, but were very loud when they did come in.

The 25- and 31-meter bands have been getting better, while the 19-meter band has been weak, although KKP comes in very loud any time of the year.

YV6RV is operating on about 46.01 meters now and comes in very loud. The call of this station is hard to get, as sometimes it sounds like YV6RV and at other times like YV5RV.

Some stations were heard, which had not been heard for some time; as follows: KEJ on 33.29 meters; LSN on 30.30 meters; DJN on 31.45 meters; OAX4D on 51.8 meters; KKQ on 25.08 meters; and KIO on 25.68 meters.

A verification has been received from H1A on 6185 kc. or 48.89 meters. They operated from 12:20 to 2:20 p.m. and from 8:20 to 10:20 p.m. daily. Also from HVJ who operate as follows: 10:30 a.m. to 10:45 a.m. on 15,121 kc. or 19.84 meters; 2:00 p.m. to 2:15 p.m. on 5,969 kc. or 50.26 meters. On Monday they speak Italian; Tuesday, English; Wednesday, Spanish; Thursday, French; Friday, German, and Saturday, Dutch. Identification signals are, the tick-tock of the studio clock; bells of Saint Peter strike the hour and the opening and closing words are, "Laudetur Jesus Christus."—Edward M. Heiser, Rt. 2, Box 124, Brecksville, Ohio.

## Turning the Dials at Angelo Centanino's S.W.C. Listening Post at Freeport, Pa.

● YV6RV in Valencia, Venezuela, has changed their wavelength to 46.01 meters.

2RO Rome, Italy, has changed the wavelength for the afternoons and South America broadcasts to 31.13 meters, and lately CT1AA has been on 31.28 meters, the same wavelength as that used by W3XAU.

W9XAA on 49.34 meters has been broadcasting a German program, mornings 9:45 to 10:45 a.m., E.S.T. Don't mistake this with one of the new German transmitters.

Some morning at 10:25 a.m. set your dial at 19.84 meters and you should hear bells ringing. This is station HVJ, Vatican, Rome, Italy, which is operating daily from 10:30 to 10:45 a.m. They give a talk in Italian on Mondays, English on Tuesdays, Spanish on Wednesdays, French on Thursday, German on Fridays, and Dutch on Saturdays.

Germany operates three transmitters nightly, and on the morning of Mar. 7, they were operating three stations; DJA, DJN, and DJB, for North America at 10:00 a.m.

DJD on 25.49 meters broadcasting for Africa is coming in good from 3:30 to 4:30 p.m., E.S.T.; the news in English is given at 4:15.

HP5J, 31.28 meters, is coming in fine; they call themselves the "Voice of Panama."

H1A in Santiago de Caballeros, Dominican Republic, comes in fine nightly. They have been moving around a bit lately and at the present writing are on 48.50 meters.

PCJ on 19.71 meters has been testing and asking for reports. They send a very nice card showing a birdseye view of Phillip's Radio Laboratories in Huizen, Holland.

PRF5 on 31.56 meters, Rio de Janeiro, Brazil, also sends a nice card giving three views of the station; they are rated at 60 kw. power.—Angelo Centanino, Box 516, Freeport, Pa.

## Listening Post Report for March from John Sorensen, Bronx, N. Y.

● STATIONS heard and logged this month are: GSA — GSB — GSC — GSD — GSE — GSF — GCW — DJA — DJC — DJD — DJE — DJN — ORK — EAQ — HBL — HBP — CT1AA — CT1GO — 48.4 meters and 24.2 meters—FYA, 19-25.2-25.6 meters; HVJ 19.9 meters; Rome, on 31.13-49.3 meters; RW15, 70.6 meters; HAT, 55.5 and HAS3, 19.5 meters; PCJ, 19.9; PHI, 25.6 meters; RNE, 25; RKI, 19.8 meters. HJ3ABH, 50.1 meters.

HJ1ABB — HJ4ABE — HJ1ABD, 41.2 meters; HJ4ABA — MEDELIN, 25.7; HJ4ABB — HJ4ABD — HJ3ABE — HJ4ABL, 49.1 meters; HJ1ABC, 49.65 meters; HC2RL — HP5B — H14D, 46 meters; H1H, 44 meters; H1A, 48.6 meters; YV6RV — YV3RC — YV2RC — YV4RC, 47 meters; YV5RMO — HJN, 49.4 meters; COC — COH — CO9GC, Santiago, Cuba, 48.8 meters; YN10P, Managua, Nicaragua, 47 meters; PRF5, PRADO, 45 meters; OAX4B, 48.1 meters; OAX4D, 51.8 meters; TIEP — TIGPH, 51.7 meters; XEBT — HC2ET, 65.2 meters; CO5RY, 42.05 meters; CJRO — CJRX — VE9GW — VE9DN, 49.9

## Latest "Hot" Tips for Short-Wave Listeners from our "OFFICIAL LISTENING POSTS"

meters; VKI, 48 meters, U.S. Army Airport; W2XE, 19-25-49 meters; W8XK, 19-25-49 meters; W3XAL, 16-49 meters; W9XF, 49 meters; W8XAL, 49 meters; W9XAA, 49 meters; W8XAL, 49 meters; KEE, 38.8 meters; WO9, 48 meters; SG7, 45 meters; W1XAL — W1XK — W3XAU 31 and 49 meters; YDA, 49.1 meters; VK2ME — VK3ME — VK3LR.

Also many unidentified stations heard mostly in South American; atmospheric have been very bad this month, also local disturbance (harmonics) has been less this month than usual.

New antenna has been erected here, 480 feet long, 30 feet high, No. 22 stranded copper wire pointed toward E.S.E. German amateur was heard on 45 meters, several Cubans on 20 and 40 meters, several Canadians on 75-20 meters, many South Americans on 40-41 meters.

Verifications received this month are: YV2RC, Caracas; CT1GO, 48.4 and 24.2 meters. DJE, 16.8 meters. DFE, 30.5 meters.

Stations WWDI — WVEC — WWHJ — WWDW 3410 kc., 50 watts, Dept. Commerce, Philadelphia, Pa. Lighthouse Service: GAS, 24.5 meters; W9XBS, 2.5 kw., 64.25 meters, Chicago, Ill.

Many reports have been sent to South American stations but not many replies received.

## Frank Hogler's Report, Brooklyn, N. Y.

● RECEIVED a "veri" from RNE, Radio Centre, Moscow; they give the following schedule for their stations: Broadcasts take place on Monday, Wednesday, and Friday, at 12:00 midnight, Moscow, time: 4-6 p.m. E.S.T. on a wavelength of 1,764 and 50 meters, simultaneously.

On Sundays on 25 meters, from 6-8:45, 10-11 a.m. and 3-6 p.m. On Wednesdays 5-6 a.m. E.S.T. They also sent program for the month in advance and listeners are

especially asked to mark on this program the items which they like best and those which they like least and to return programs thus marked to the Radio Centre, Moscow, U.S.S.R., at the end of the month.

VE9AS on 6,425 kc., Fredericton, N.B., Canada, is heard evenings relaying CRC.

HRP1 on 42.7 meters is heard testing around 10 p.m., E.S.T. This station is located in San Pedro Sula, Honduras.

CSL on 6,140 kc. "Emissora Nacional," Lisbon, Portugal, is heard from 3:30 p.m., E.S.T. till CJRO, in Winnipeg, Canada, goes on the air and blots him out.

A "veri" from JVT and M, Tokyo, Japan, give the following schedule for their stations: Transmitter—

JVT—6,750 kc.—20 kw. Vertical Doublet Antenna.

JVP—7,510 kc.—20 kw. Vertical Doublet Antenna.

JVN—10,660 kc.—20 kw. Vertical Doublet Antenna.

JVM—10,740 kc.—20 kw. Vertical Doublet Antenna.

Daily service hour for relaying JOAK—7 p.m.-5:40 p.m. (next day) E.S.T. Address above station as follows: Kokusai-Denwa Ksaiha, Ltd.; Osaka Bldg., Kojimackiku, Tokyo, Japan.—Frank Hogler, 222 Wyckoff Ave., Brooklyn, N.Y.

## Report from H. W. Hansen, Omaha, Neb.

● THE static level was high and only the old "stand-bys" were heard here fairly good. During the last week due to several dust storms and high winds at times the large eastern U.S. stations could hardly be heard.

The 19-meter band remains fairly good in the early morning. FYA and DJB come in good at times on this band. No foreign stations heard here on 25 meters except I2RO which comes in very good. The 31-meter band has been the worst of all. EAQ coming in good as always, otherwise the only other foreigners heard here on this band were VK2ME, VK3ME, and COH. On 45 meters, HJ1ABB, TIEP, PRADO, and HC2RL were heard fairly well. On 49 meters XEBT, YV5RMO, YV2RC and YV3RC and XEBT are coming in fair as are the eastern stations.

I believe after the air has cleared up that reception in this section of the country will be much better. It seems hard to build an antenna here that will work well on all bands, I would like to hear from some of the other short-wave listeners on their ideas of a good antenna.—Harold W. Hansen, Rt. 5, Box 169, Omaha, Neb.

## Official Listening Post of Geo. D. Sallade, Sinking Spring, Pa.

● WITH spring just around the corner, many changes can be expected. To the DX fan, these changes are already in evidence, since the shorter wave lengths employed by European broadcasters are now audible long after dark. Especially is this true of the Pontoise station on 11.71 megs. This station is badly heterodyned by a new Colombian station, HJ4ABA, located in Medellin. This new disseminator is heard QSA4-5, with R8-9 volume, until 7:00 p.m. From then on, heterodyne whistles prove disconcerting to either station.

Among the new stations heard at this post are: GSL on 6,100 kc, whose schedule at present is Saturday, Sunday, Tuesday and Thursday nights from 10-11 p.m.; HJ4ABL, who transmits on the same frequency, is heard on Saturday nights from 11:00-11:45 p.m. YV6RV, located in Valencia, Venezuela, has changed its frequency to 6520 kc. HJ3ABH, 5,970 kc., is heard irregularly at 10:00 p.m. The Bo-

(Continued on page 109)

# WORLD-WIDE SHORT-

## Ultra-Shorts in Germany

● *DER QUALITATSMARKT*, a German magazine, which, by the way, is published in three languages—German, English and French—the left column on a page being printed in German, the center column in English, and the right column in French

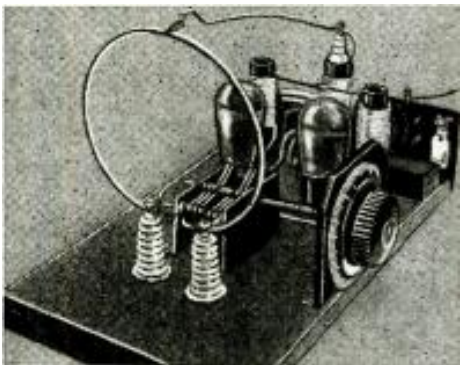

This is a picture of the German ultra-short-wave apparatus.

—recently contained several interesting circuits for ultra-short-wave transmitters and receivers.

The first circuit here is a push-pull transmitter, designed for operation on the 5-meter wave band. This unit has two triodes connected to opposite ends of a single turn coil which completes the plate circuit. Tuning is accomplished by two small variable condensers at the ends of the tuning inductance. The grid circuits of the two tubes are aperiodic and are isolated by the use of R. F. chokes.

The appearance of this transmitter is shown in the photo. The approximate size of the tuning inductance can be seen from the relative size of this coil against the tubes.

The circuit of a transceiver of German design is shown here, also. It consists of two tubes of the receiving variety which are connected, one as modulator and the other as oscillator. The oscillator also acts as a one-tube receiver, so that two-way communication by "phone" is possible, simply by throwing a switch from one side to the other. The values of the parts used in this unit are indicated in the schematic diagram.

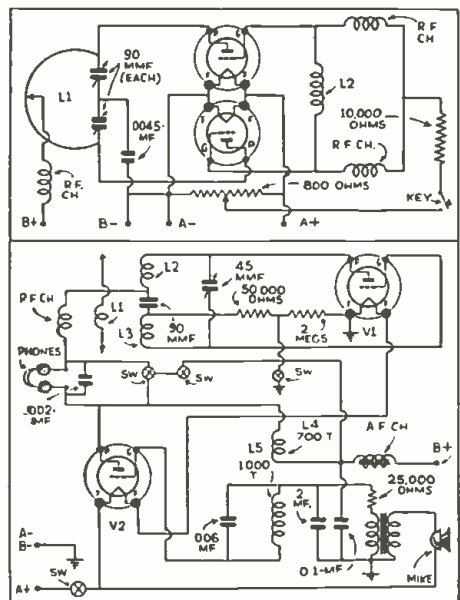

Circuit diagram for U.S.W. receiver and transmitter.

● The Editors have endeavored to review the more important foreign magazines covering short-wave developments, for the benefit of the thousands of readers of this magazine who do not have the opportunity of seeing these magazines first-hand. The circuits shown are for the most part self-explanatory to the radio student, and wherever possible the constants or values of various condensers, coils, etc., are given. Please do not write to us asking for further data, picture-diagrams or lists of parts for these foreign circuits, as we do not have any further specific information other than that given. If the reader will remember that wherever a tuned circuit is shown, for instance, he may use any short-wave coil and the appropriate corresponding tuning condenser, data for which are given dozens of times in each issue of this magazine, he will have no difficulty in reconstructing these foreign circuits to try them out.

## Short-Wave Power Supply

● THE use of electric light lines for supplying the "B" power to short-wave receivers requires special considerations if the background noise is to be kept low enough to permit DX reception. Short-wave sets are much more susceptible to such noises, especially in the R.F. and detector circuits, than broadcast receivers.

To permit the noise level and hum to be reduced sufficiently, *Practical and Amateur Wireless*, an English magazine, recently published the circuit of a filter to be added to a "B" power unit, or the "B" section of the power supply of an A.C. set.

The filter consists of a group of chokes, condensers and resistors connected to the maximum output terminals of the unit. A 30 henry filter choke is connected in series with the "B plus," and another in the line to the detector plate supply. Four filter condensers of about 2 mf. are connected as shown, to by-pass the output of the chokes. A resistance of 20,000 ohms is connected at R1 and a 50,000-ohm potentiometer is shunted from detector "B" to the negative terminal.

This filter unit can be added to an A.C. receiver, by opening the "B" leads to the tubes and inserting the filter. In sets which use separate "B" supply units, the task is even easier, as the filter is simply added in the leads from the "B" unit to the receiver. In addition to reducing the hum and line

noises, this filter will help to keep the plate voltages steady, which is an aid to receiving weak and far distant stations.

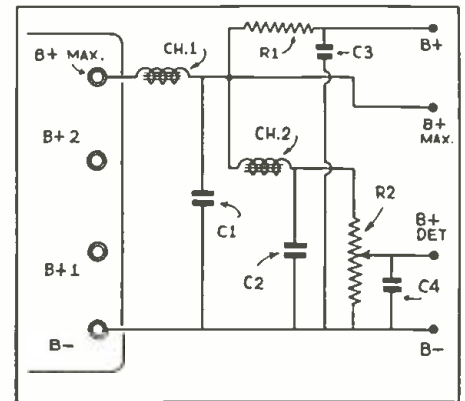

Power supply filter for short-wave set.

## A French Short-Wave Converter

● THE circuit here is a representative arrangement used in France (from *Radio Magazine T. S. F.*) for the reception of short-wave signals. There, converters are much more popular than in this country.

This converter uses an *Octode* tube which is similar to our pentagrid converters (2A7 and 6A7) except for the addition of another element to increase the maximum frequency at which the oscillator will work.

This converter has a single coil, directly connected to the aerial for station selection. The oscillator section of the *Octode* is equipped with the usual two-coil coupled with a tuned grid. A two-gang condenser accomplishes the tuning of both the aerial and the oscillator. The plate of the pentode section of the tube feeds through a condenser to the aerial of the regular broadcast set. An R.F. choke in the "B" lead prevents the output of the converter from being short-circuited through the plate voltage supply.

A series of switches on the three coils connect either one waveband or the other, or the aerial can be connected directly to the broadcast receiver and the converter cut out completely.

The coils, A to F, are designed to cover the required wavebands.

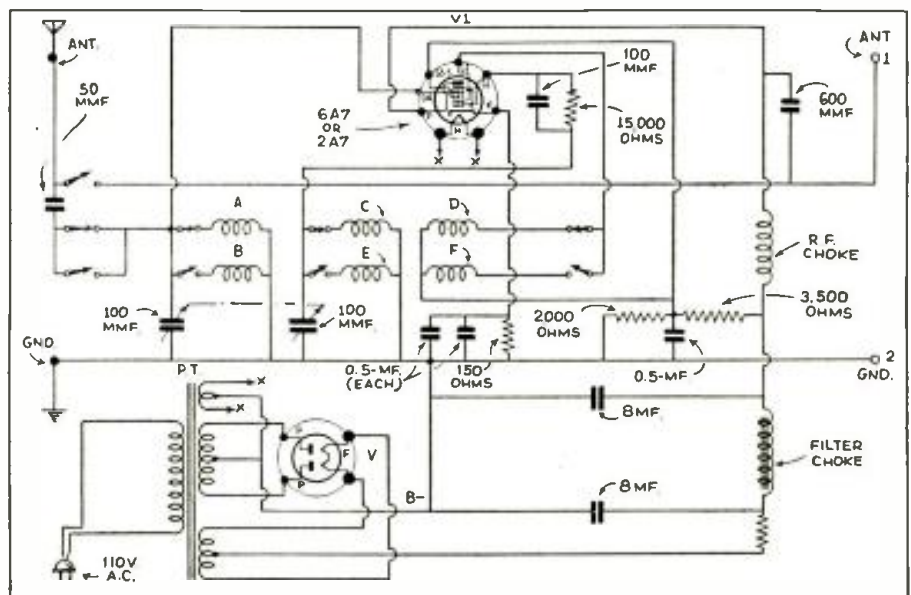

Circuit diagram of the French short-wave converter using 2 tubes.



# WAVE REVIEW.

Edited by  
**C. W. PALMER**

## An English Amateur Transmitter

● A RECENT issue of *Wireless World* contained a description of a beginner's amateur transmitter which might be of interest to American readers.

The transmitter, which uses four tubes, is arranged for both C.W. and phone, and is tuned to the 40-meter band, as the author decided this was the most suitable wave-band for a beginner to tackle.

The transmitter itself consists of a master oscillator, driving a power amplifier tube. The modulating equipment consists of a "class-B" arrangement, having a driver fed from the microphone and transformer, which actuates a full-wave class B tube. This modulator is fed into the power amplifier tube.

The appearance of the complete unit is shown in the photo, here, while all essential values are given on the schematic diagram. The aerial coil consists of 16 turns of bare copper wire, 14 gauge, wound on a ribbed form 2 inches in diameter and spaced 5 turns to the inch. The master

oscillator coil consists of 22 turns of bare copper wire, No. 14 gauge, wound on a form 1 1/4 inches in diameter and spaced 7 turns to the inch. The latter coil is provided with taps at every other turn for the three contact clips, which are situated so as to give the greatest output.

This transmitter will give the reader an idea of what is being done in amateur radio in England—and the circuit may be of assistance to "amateurs to be." You must have a license to operate it.

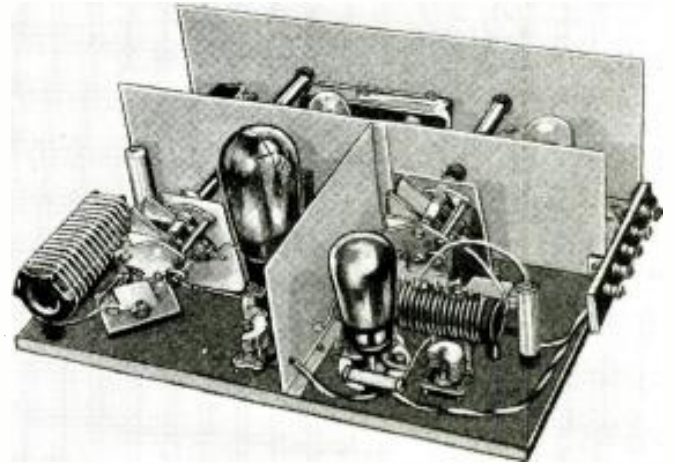

Compact English short-wave transmitter. Diagram below at left.

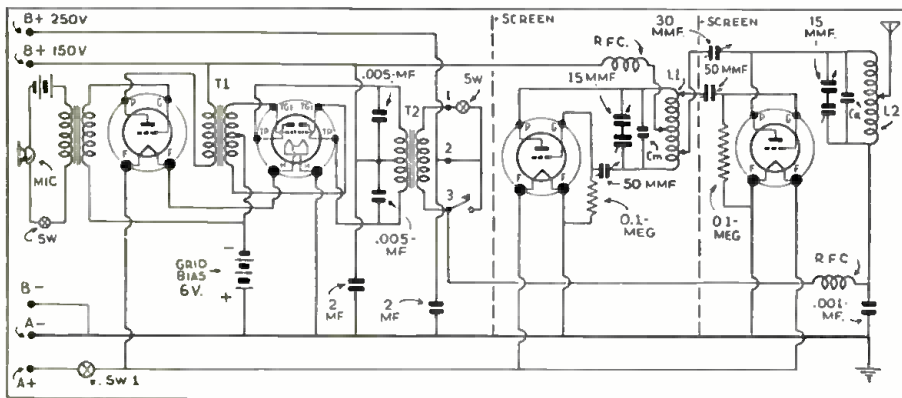

## Improved S.W. Frequency-Changer

● IN employing pentagrid converter tubes or heptodes as they are called in Europe, for short-wave superheterodyne sets, two difficulties are encountered—first, it is impossible to apply AVC bias to the converter tube, because the potential induced on the control grid from the oscillator section above a certain critical frequency exceeds the grid bias and causes grid current to flow. This grid current flow develops a high negative potential which is applied to all the AVC controlled tubes, thus reducing considerably the sensitivity of the entire set.

The second effect is that the frequency of the oscillations generated in the triode section are controlled by the tuning of the

## Some German Ultra-Short Wave Experiments

● AN account of an experimental set-up for transmitting on ultra-short waves was recently described in *Bastelbriefe der Drahtlosen*—a German radio magazine.

The device, as described, appears in the photo here. The tube is mounted on an insulating panel and the grid and plate prongs are secured directly to a double lecher wire system for radiation purposes. A condenser is shunted from grid to plate across the two lecher wires and grid and plate potentials are fed through R.F. chokes consisting of open coils of wire as shown in the photo.

The filament leads are also conducted to the tube through twisted leads, thus forming R.F. chokes in each of the leads from the filament, grid and plate supplies.

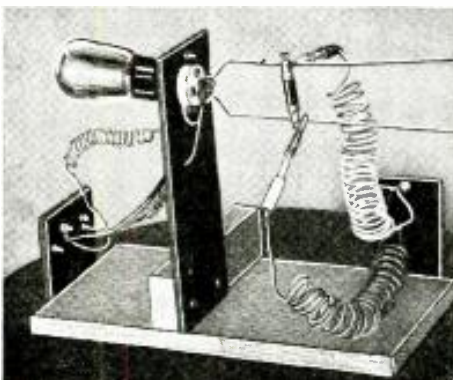

Simple ultra-short-wave oscillator.

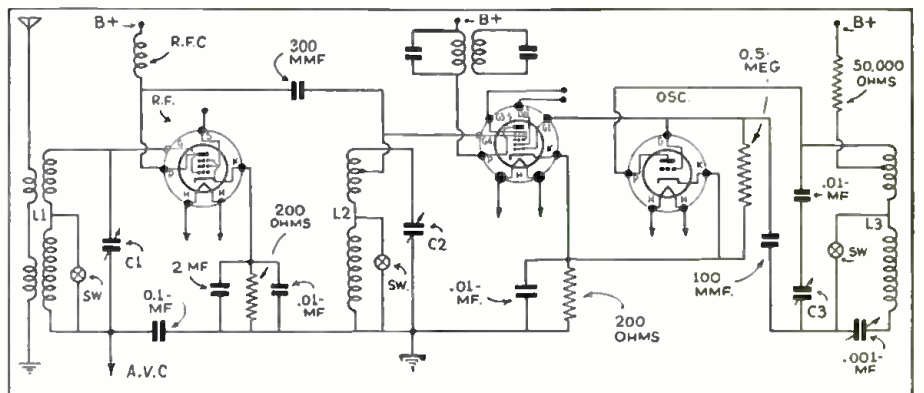
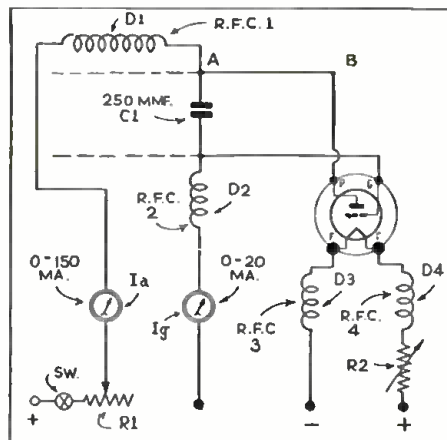

Diagram of improved frequency changer.



grid circuit and if a grid-circuit trimmer is used it will give what is apparently an indication of a very sharp tuning of this circuit, though what is really happening is that the grid-circuit trimmer is in reality tuning in other stations or the original one out, because it varies the oscillator frequency.

The first defect is overcome by using a very high-intermediate frequency, but the second defect cannot be eliminated so easily. The final solution given in an article in *Wireless World* is the use of a triode oscillator with a converter tube, and an R.F. tube and additional tuned circuit. This completely frees the oscillator from the control of the grid circuit of the pentode section—down to at least 10 meters. The grid circuit trimmer only changes the oscillator frequency by a few hundred cycles, which is a negligible amount.

# A Good 6-Tube Super-

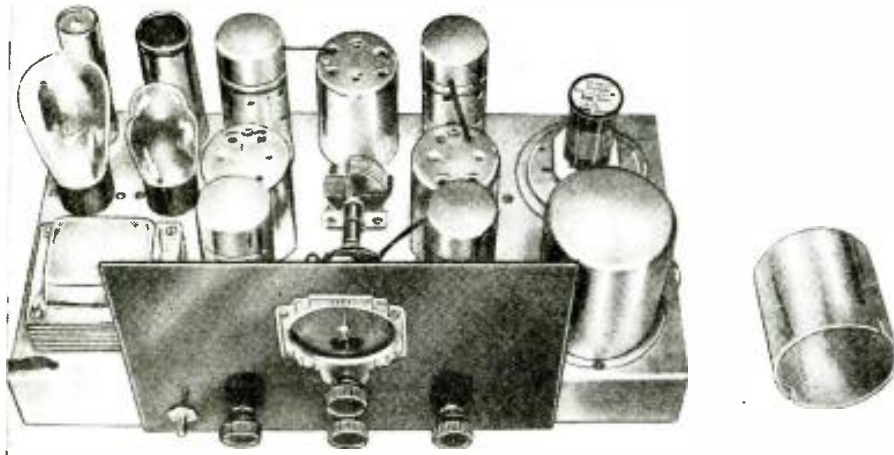

Front view of Mr. Olsson's 6-tube receiver, which has power-supply built in.

● THIS receiver is the final result of approximately one year of spare-time experimenting. After having built any number of regenerative, and tuned radio-frequency receivers, the super was decided upon as the only one that could solve the problem.

Where there are more than 3 or 4 local broadcasters to contend with, as

well as the police broadcasts, the regenerative with one tuned stage is practically useless. When the police come on they occupy the whole dial and the local broadcasters overpower and blanket what short wave signals are picked up. The tuned radio frequency is an improvement, but falls far short of a carefully designed superhet.

Many an experimenter has wanted to build a super but has considered it too complicated and difficult to construct. The receiver to be described is as simple as any tuned radio frequency or regenerative; in fact, it is more simple. I would rather build a half-dozen supers than one regenerative with a built-in power supply. The regenerative almost drives you crazy—trying to eliminate tunable hums.

The circuit used in this receiver is a standard superheterodyne hook-up, without any fancy tricks or gadgets that would complicate it without improving it. In describing the set let us begin with the chassis:

Aluminum was used for the chassis because it is easy to work and the complete job can be done with the usual tools found on the experimenter's bench. The chassis measures 10"x16"x2"—the 2" flange being on the front and back. As the aluminum used was a heavier gauge than usual, two sides gave ample strength for the unit. If the chassis is boiled in a solution of lye water for 10 minutes a very pleasing dull finish is obtained which will effectively cover scratches. The following layout of the various parts was found to be the best and most suitable. The layout and design is best described as "progressive," that is, the incoming signal starts at one end of the chassis, and the final output at the other end. This is very efficient from the electrical standpoint and produces a symmetrical and pleasing design.

A 2A7 is used as oscillator and first detector because of its efficiency and because it is easy to wire up with the least amount of parts. The antenna coil and oscillator coil are located on the extreme right of the chassis. Coil shields are used to minimize and undesired interaction that might be present due to the magnetic field created by the coils. This mixing part of the radio, as it is sometimes called, should be wired very carefully as an unnecessary noise created here will be amplified in the succeeding stages.

The two stages of intermediate frequency amplification are used to obtain the necessary selectivity and sensitivity. "58's" are used in these two stages because of their high amplification and sharp cutoff characteristics. The intermediate frequency of 465 kc. is used to insure a minimum of repeat points or image response. A sensitivity or gain control is placed in the cathodes of these two tubes and controls the incoming signal.

A 57 is used as second detector and does the job in very nice style. The

## List of Parts

- 1 Chassis (Aluminum) 8"x16"x2" (Blan.).
- 1 Panel (Bakelite) 7"x10"x3/16" (I.C.A.).
- 1 Power transformer (Kenyon).
- 1 2-Gang Var. condenser .00014 mf. (Hammarlund).
- 1 Var. condenser (Star) .00014 mf.
- 4 6-prong wafer sockets (Na-Ald).
- 2 4-prong isolantite sockets (Hammarlund).
- 1 7-prong isolantite socket.
- 1 4-prong wafer socket (Na-Ald).
- 3 465 kc. intermediate trans. (Hammarlund).
- 2 Sets of coils (Bud) 4 prong.
- 2 Coil shields (National).
- 1 Voltage divider—15,000 ohms (Electrad).
- 2 Electrolytic cond. 8 mf. each (Sprague).
- 1 Dial (Crowe). 1 R.F. Choke. 85 MH.
- 1 10,000-ohm resistor (V.R.R.) (Electrad).
- 1 500,000-ohm resistor (with switch) (Electrad).
- 1 25 mf. Electrolytic condenser (25 volt) (Sprague) (Aerovox).
- 5 .1 mf. fixed condenser (400 volt) (Aerovox).
- 2 .01 mf. fixed condenser (400 volt) (Aerovox).
- 1 1 mf. fixed condenser (400 volt) (Aerovox).
- 2 .00025 mf. fixed condenser (Aerovox).
- 2 25,000-ohm resistor (Lynch).
- 2 300-ohm resistor (Lynch).
- 1 200,000-ohm resistor (Lynch).
- 1 500-ohm resistor (Lynch).
- 1 Single-Pole, double-throw switch (I.C.A.).
- 2 Tip jacks (phones) (I.C.A.).
- 1 Roll hook-up wire.
- 4 Knobs.
- 4 Tube shields (Hammarlund).
- 1 Dial light and bracket.
- 1 A.C. cord and plug.
- 1 Speaker; 2800-ohm (field).
- 1 Tube 80 (RCA Radiotron).
- 2 Tubes 58 (RCA Radiotron).
- 1 Tube 57 (RCA Radiotron).
- 1 Tube 2A7 (RCA Radiotron).
- 1 Tube 2A5 (RCA Radiotron).

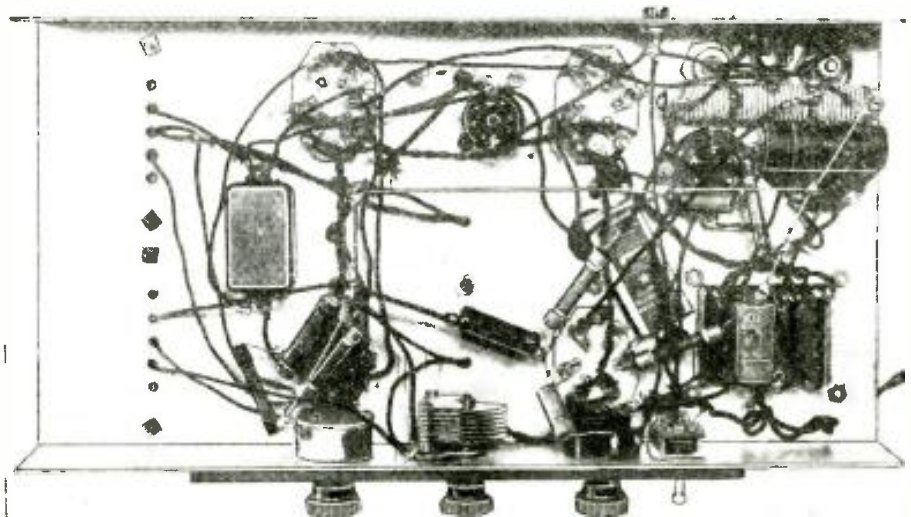

Bottom view, showing the wiring of the straight 6-tube super-het.



# Het Receiver By Stanley Olsson



57 is very sensitive and will handle a great deal of volume without overloading.

A 2A5 tube is resistance-coupled to the 57 and provides more than enough audio amplification. A volume control is placed in the grid circuit of this tube and provides a very smooth and gradual control.

An 80-type rectifier is used in a conventional power supply and should not present any difficulties. A dynamic speaker with an output transformer matched to a 2A5 tube is used. The field coil of the speaker is used as a choke in the power supply. The small bypass condenser connected across the primary of the power transformer should not be omitted as it eliminates tunable hums.

The aluminum chassis makes a poor ground and should never be used as such. A length of bus bar wire runs down the center of the chassis from the minus end of the power transformer, and the various resistors and

## THIS MONTH'S \$20.00 PRIZE WINNER

Many of our short-wave fans who are contemplating construction of a simple superheterodyne receiver will find this one just what they want. It is straightforward in design and uses the latest type tubes. Foreign stations can be pulled in with full speaker volume and it is very easy to tune. Six tubes are used in all and no separate power supply is needed to run this set; it is completely A.C. operated.

condensers are grounded to this wire. This should not be omitted as it contributes a great deal to the stability of the receiver.

Provision for earphones is made by tip jacks at the rear of the chassis, and a switch on the panel selects either earphones or speaker.

With separate sensitivity and volume controls a degree of flexibility is attained that more than justifies the extra control. The remaining tuning control on the panel, besides the tuning knob, is the balancing condenser. This becomes quite critical on the higher frequencies.  
*(Continued on page 104)*

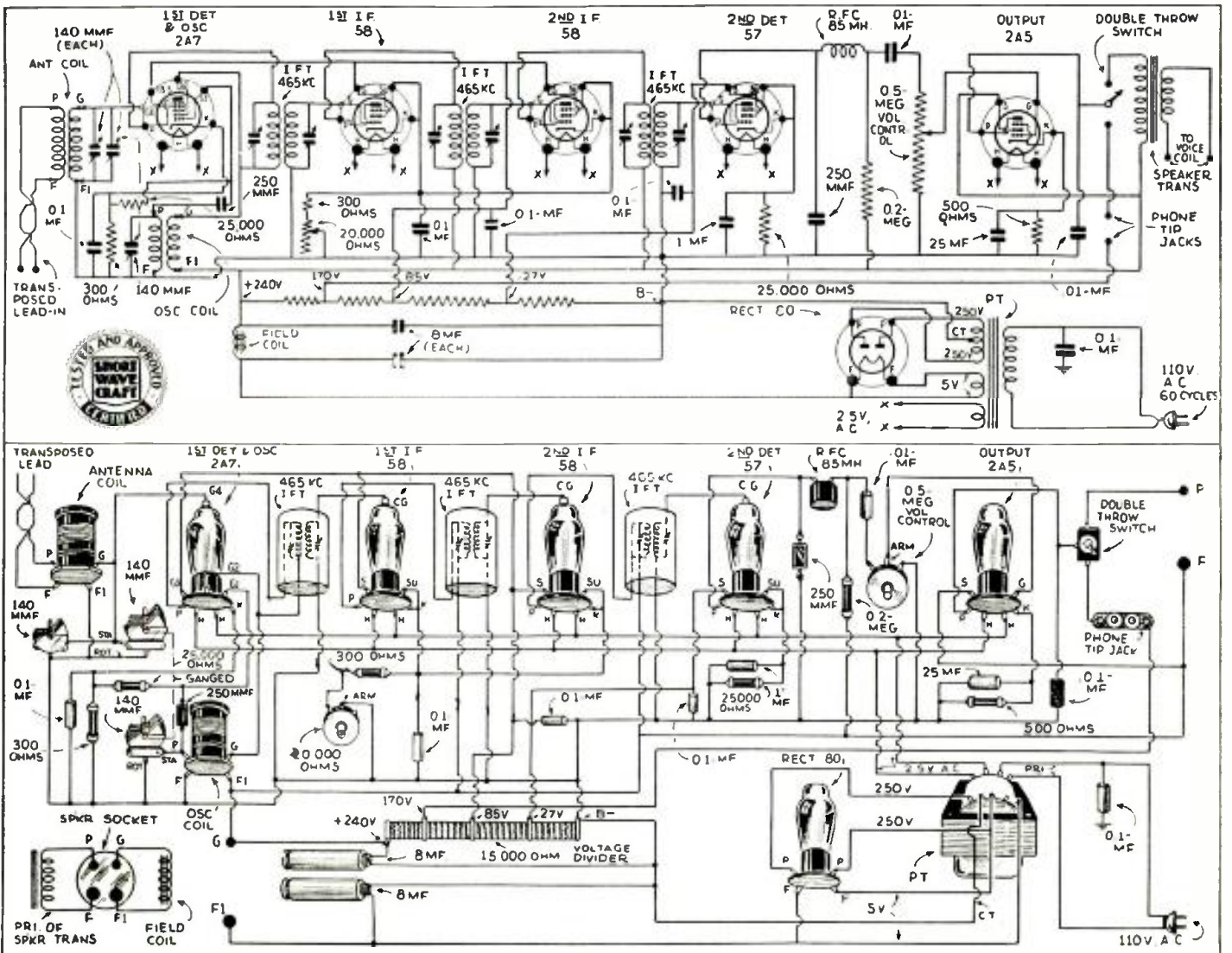

Schematic and picture diagrams which will permit even an inexperienced fan to build this excellent 6-tube super-het short-wave receiver. It uses plug-in coils.

# SHORT WAVES and

## Alfred King Has Dandy Listening Post



### Editor, SHORT WAVE CRAFT:

My radio activities go back to 1920 and I have never tired or lost interest in the hobby. I have also added to it writing to SWL pen-pals and now I correspond with about forty of them, here in the States and abroad. I have one very nice pen-pal in Japan and his name is Shokichi Yoshimura.

The rig is made up of two sets, one a Postal and the other a combination Sparton S-W. Converter used with a Philco B.C. set. I have had swell results with both. I use an RCA sky hook which is a double-doublet affair and have also a Lynch Cage Doublet. My other two ants. are 40-ft. single wires running east and west and north and south. I have them all connected to jacks which in turn are mounted on a panel shown between the two sets. I can use either antenna for any set.

I also have an amplifier with a 15-watt output for recording purposes which I plan to use with my moving pictures which, by the way, is another hobby of mine. I have a loudspeaker on each of the two floors above and one here in the shack which you can see on the rack to the right of the desk. I can use either or all three speakers at once with just a flip of a few switches and in that way can play recordings for my mother on the first floor or to my sister on the top landing. Hi! I can also send up the choice bits of SW DX to them in the same way with a double-button mike. The turntable is a double-speed electric one and is very good.

The walls of my shack are lined with 135 SWL and 150 QSL cards. I have also a swell collection of snapshots of my pen-pals here in the shack. I guess you know by the picture of my shack that it is in the cellar, and it is very dry and warm here in the winter and also dry and cool in the summer.

I sure would advise your many readers to go into this writing pastime and I know they will find it a very nice hobby along with listening in. I have made many friends this way and would hate to lose even one of them. My best pen-pal is a "YL" in Texas and I know when my other pen-pals see this they sure will give me the merry razz. Hi! Hi! I had some of these pen-pals at the shack last summer and we sure had one swell time chinning about the short waves and then we went to see "Radio City."

In closing I wish to say that I hope your

Alfred King maintains a very efficient short-wave listening station; among the S.W. receivers he possesses, are a Postal S.W. converter used in conjunction with a broadcast set.

readers get as much kick out of reading SHORT WAVE CRAFT as I do. Most of my pen-pals get it and so we have that in common to talk about. When writing to my friends I use the Ham short cuts in radio, so if I slipped here in writing this one, I hope you will overlook it, as it sure gets you. Hi! Hi! A n o t h e r S.W.C. Reader.

ALFRED G. KING,  
7417 Eighty-Seventh Ave.,  
Woodhaven, N.Y.

*(Thanks for sending in the photo of your short-wave "shack," Alfred, and we believe that many of our short-wave friends will derive a great deal of inspiration from your letter, as you have certainly been a very active short-wave enthusiast.—Editor.)*

### MIDWEST SET IN A NEAT SET-UP

Editor, SHORT WAVE CRAFT:

My receiver is 1935 Midwest 16-tube, all-wave, in the lower part of an angle iron rack. On the upper shelf is a Postal booster. A clock and coil rack is in the front; Masonite board was used for front and top. The top is on hinges which permits winding clock and changing antenna connections on Lynch receiver coupler. The back and sides are of screen wire. The bottom is celotex on which are two live rubber pads on which the receiver rests.

Ground wire, antenna and electric lead wires come up through the floor to the back of cabinet. The antenna lead is Lynch Giant Killer cable. The electric feed wire is BX cable and the ground wire is No. 12 lead-shielded cable. The table is on rollers which permit easy access to rear of cabinet, as several feet of wire is coiled in the back to permit table and cabinet to be moved out from wall several feet. The speaker is a Wright-DeCoster made especially for this set, and is enclosed in balsa

Here is a very efficient arrangement of a Midwest All-Wave receiver, and also a Postal booster or pre-amplifier; a clock is also included.

wood cabinet, 10 inches by 24 inches by 14 inches deep. The Balsa is 2 inches thick as well as the front baffle which is 2-inch celotex. The legs of the speaker rest on live rubber pads, cut from kneeling pads which can be bought from any 5-and-10 store. This same pad is used for receiver in cabinet. The entire layout is painted dull black and the trimmings are silver-bright aluminum. The aluminum was thoroughly cleaned and polished and water-white shellac applied to preserve it. Under the table are radio magazine and scrap-books in which I have pasted my acknowledgment cards from stations all over the world. The bottom shelf is used for tools.

The pictures were taken at night with a regular kodak and I used Eastman flash bulbs. The three label holders on front of cabinet show range of the coils for booster and frequencies of the important S.W. stations.

S. W. W. AMISS,  
c/o Standard Fruit and Steamship Co.,  
Union Bldg.,  
New Orleans, La.

*(Congratulations on the excellent way in which you have arranged your Midwest All-Wave receiver together with your Postal Booster, Mr. Amiss. You have the right idea in arranging your loudspeaker in a good-size cabinet with a substantial baffle as shown in your photo. The balsa wood should make an excellent baffle as it should not reflect or transmit sound waves; a very ingenious and neat-looking arrangement on the whole and one that you may well be proud of.—Editor.)*

### VICTOR 2-TUBE SUPER-HET SUITS HIM BEST

Editor, SHORT WAVE CRAFT:

I am a steady reader of your magazine and believe it the finest on the market today. I built several of your sets and liked them all fine, but I believe the best yet was the Victor 2-Tube Superheterodyne. This is my present receiver and if you think it isn't good listen to this. (This is the first super I ever built.)

I have this set hooked to a 15-ft. spring aerial about 10 feet high and a water-pipe ground. I have heard amateurs in 48 states and 11 in Canada. I have heard every district but the seventh.

Here are some of my best catches: CGA, VE9GW, VE9CL, CJRO, VE9OR, VYW, GCB, GCW, GSA, GSB, GSC, G6RX, G3A5, and G7LO.

I heard a station in Berlin, Germany, working WEM and WEN but he gave no





# LONG RAVES . . . OUR READERS' FORUM

call. Also: DJC, COC, FTM, EAQ, XIF, L2RO, IRS, IRA, CT3, RQ, H11A, NMS, NFB, LSI, T14NRH, HJ3ABF, HJ1ABB, YV3BC, PSK, HJ4ABE, YV4RC.

I have received all the important American S.W. stations and police calls from coast to coast (some 100 police stations). Some time ago I added a 37 audio, and boy! do I roll them in now with a wallop!

Well, I guess you have heard enough from me for a while—I would like to try for one of your "trophy cups."

I am waiting now for my SHORT-WAVE LEAGUE membership certificate.

HAROLD MARTIN,  
446 East Maple Ave.,  
Miamisburg, Ohio.

*(We are very glad indeed, Harold, to learn that you have had such excellent success with the 2-Tube Superheterodyne. It is quite surprising what very fine results can be obtained on a 2-tube super once it is properly adjusted and tuned. You have undoubtedly received your Short-Wave League membership certificate and we presume that you have had it framed and have already hung it on the wall of your shack.—Editor.)*

## FINE RESULTS WITH "2-TUBE CHAMP"!

Editor, SHORT WAVE CRAFT:

I am writing in regard to a 2-tube set called the "2-Tube Champ" described in the January 1934 issue. It does everything you claim it will do. It is a wonderful set and I am now listening to Germany while writing this letter. I am making a list below that I have heard; HJ4ABE, VK2ME, GSD, VK3ME, HJ4ABB, W1XAZ, W8XK, VE9GW, W9XAA, W1XAL, GSC, GSB, HJ1ABB, W2XE, HKD, W2XAF, VE9AP, W3XL, W3XAU, W9XF, EAQ, W3XALB, W3XAU, DJC, VE9CL, HKC, W3XAL.

This is a wonderful set. I have it hooked on a 7-tube set for audio amplifier.

JOHN W. POTTS,  
913 Seward Ave.,  
Akron, Ohio.

*(Well, the 2-Tube Champ seems to have made a great many friends, John, and we were very happy to learn from your letter that it does everything that we said it would do. We have received a great number of complimentary letters concerning the 2-Tube Champ and one excellent point in its favor is that it need cost but a very small amount to construct.—Editor.)*

## DOERLE A.C. 5 A PIPPIN!

Editor, SHORT WAVE CRAFT:

Just a word about the Doerle A.C. 5. In two weeks I logged among others the following stations: TIEP, Costa Rica; LSY, Buenos Aires; PRADO, Ecuador; HJ4ABE, Columbia; EAQ, Spain; TIF, Buenos Aires; CJRX, Canada; YV2RC, Venezuela; COC, Cuba; W9XF, Chicago; W8XAL, Cincinnati; WCRCT, Philadelphia; W8XK, Pittsburgh. All these stations came in crystal clear with volume enough to shake the table on which the set stands! Also all were received on the loudspeaker! This set is worth its weight in gold, even during these depression days. All I used was a homemade cage aerial with 178 ft. of stranded copper in it. I have a very poor location on account of numerous high-tension wires running parallel with my antenna. 73 to you all

FRANCIS KMEC,  
213 Linden St.,  
Allentown, Pa.

*(It seems, Francis, that the Doerle line of sets, particularly the A.C. 5 model will go down to posterity with a long line of honors behind them. It has really been surprising as to the very fine results which have been obtained in recent laboratory tests on the Doerle A.C. 5 and stations in practically every country have been heard on the loudspeaker with this set, paralleling*

## We Gave Him His Start in Short Waves

Prize-Winning Station Photo Awarded One Year's Subscription to SHORT WAVE CRAFT



A live-wire Ham station is that operated by Clifton Smith, Jr., which operates under Uncle Sam's amateur transmitting station license, W4CTM.

Editor, SHORT WAVE CRAFT:

In answer to your request for station pictures I enclose a photo of my little "rig." The transmitter is a 45TNT and has worked all U.S. districts and several Canadian on 12 watts input.

The station usually operates on 80 meter CW and always welcomes a call from OMS and YL's alike.

I have been reading SHORT WAVE CRAFT for over two years and still think it swell. SHORT WAVE CRAFT was my first introduction to short-wave radio and I shall always feel obligated to it.

*the loudspeaker performance you mention in your letter. The results you have obtained are really very outstanding and exceptional in view of your very poor location, with high-tension wires running parallel with your antenna.—Editor.)*

## 2-TUBE DX-ER ROLLS 'EM IN!

Editor, SHORT WAVE CRAFT:

I have not seen anything in your magazine about the results of the "2-Tube, Short-Wave DX-ER," the diagram of which was published in the July SHORT WAVE CRAFT.

This being my first set I think I had very good results with it. Some of the stations I have heard are: W8XK, Pittsburgh, Pa.; VE9GW, Bowmanville, Canada; W2XAF, Schenectady, N.Y.; W3XAL, Bound Brook, N.J.; W1XAZ, Springfield, Mass.; W9XF, Chicago, Ill.; W8XL, Cincinnati, Ohio; DJD, Berlin, Germany.

I have heard Hams from almost every district in U.S.A. also K4SA, in Porto Rico, and VE3HC in Canada.

I hear New York talking to Buenos Aires;

A.R.R.L. and Short Wave League membership certificates may be seen on the wall. Luck to SHORT WAVE CRAFT and Short Wave League and VY best 73.

CLIFTON SMITH, JR., W4CTM,  
409 East Lane St.,  
Shelbyville, Tenn.

*(It is gratifying to know that SHORT WAVE CRAFT magazine served to introduce you to the thrills of short-wave radio. Congratulations, Clifton, on having worked all U.S. districts and we shall be pleased to hear from you again.—Editor.)*

Buenos Aires comes in very clearly.

I think this is not so bad for 201-A's. I would like to see more stories in SHORT WAVE CRAFT. Also more 1- and 2-tube S.W. sets. SHORT WAVE CRAFT is a fine magazine. Keep it up!

73 to you and SHORT WAVE CRAFT,

PAUL DEITRICK,  
516 Hance Ave., N.W.,  
New Philadelphia, Ohio

*(Fine work, Paul, and we are glad to know that you have had such excellent reception results with the 2-tube short-wave DX-er. We will endeavor to follow the suggestions given in your letter regarding plenty of articles on 1- and 2-tube sets and in regard to stories, we will keep this in mind also. We would suggest that you read a copy of the current number of our sister publication, the Official Short Wave Listener, which contains S-W fiction.—Editor.)*

## HATS OFF TO THE "MEGADYNE"!

Editor, SHORT WAVE CRAFT:

I take this opportunity to congratulate Mr. Gernsback on his Short-Wave Megadyne described in your book "Ten Most Popular Short-Wave Receivers." I built this exactly as described, but for the coils, which are old Silver-Marshall forms with the tickler wound in slot. I completed this set about eight days ago and have heard England, France, Mexico City, and a station in Neuavo Laredo, Mexico. I also had a station in Rio de Janeiro, S.A., but it was

*(Continued on page 122)*

## One Year's Subscription to SHORT WAVE CRAFT

FREE

### for the "Best" Station Photo

Closing date for each contest—60 days preceding date of issue: June 1 for August issue, etc. The editors will act as judges and their opinions will be final. In the event of a tie a subscription will be given to each contestant so tying.



# De Luxe 5-Meter Trans-

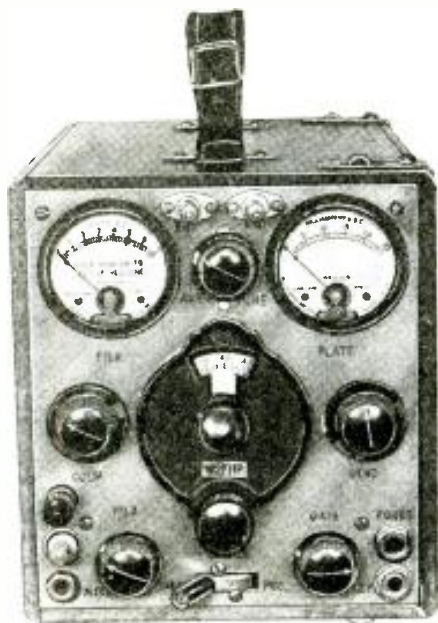

Front panel view of the De Luxe 5-meter Transmitter and Receiver which the author has designed for portable use.

● THIS portable set is not a transceiver, but is a true, separate receiver and transmitter for five meters and can also be used for duplex work. To conserve space and battery current, the audio system is common to both the detector and oscillator. No feedback trouble has been encountered, however, and duplex can be worked up to within a few divisions of the transmitter signal.

Separate antennas are best, but any length of wire will suffice for the receiver, while the transmitting antenna is usually of the single wire feed type.

Since an antenna-coupling condenser is provided for both transmitting and receiving, compensation for various antenna lengths and conditions can be made directly on the front panel, which is helpful in portable work where no two antenna installations are alike.

### The Cabinet—How Made

The box for the set is made entirely of  $\frac{1}{4}$ " tempered *presswood*. The pieces are fastened together with  $\frac{3}{8}$ " brass screws, holes for which must be drilled in the material or it will split. The screws are used to hold the pieces together until the glue used on all the joints dries, and are left in place afterward for added strength. The glue may be Ambroid or Duco Cement and it should be smeared on liberally and allowed to dry overnight in a warm place. After the joints are firm, the corners may be rounded off and the finish applied. Two or three coats of clear lacquer, sanded after each coat and waxed after the last give a very fine finish.

The side which opens is held on the bottom with a piece of a piano hinge, while the top has a brass angle strip which engages on a strip on the under side of the cover. This transfers the weight of the set evenly to both sides and the bottom.

The panel and chassis are of aluminum, the panel being  $6\frac{1}{4}$ " $\times$ 7" $\times$ 1/6". The chassis, when bent to shape measures  $6\frac{1}{4}$ " $\times$ 5" $\times$ 1  $\frac{3}{4}$ " high.

### Mounting and Wiring the Parts

All the parts may be mounted before wiring is started, as they are not very crowded.

The 4-prong plug and jack in the original set are made of phone tips and jacks and make a very neat job, but

there is plenty of room to use an ordinary small-size 4-prong socket and plug.

The wiring of the oscillating circuits of both receiver and transmitter must be as compact as possible and all parts that can be are mounted directly on the tube socket prongs.

The "mike" transformer must have also a primary for the detector tube, while the output transformer has the plate winding for the 33 and another for phones or speaker.

A jack is provided for a key which operates the buzzer when used for code (C.W.) operation. This is very handy for portable work and is quite frequently used. All jacks are of the midget type to conserve space. Right here it may be well to mention that a sensitive single-button mike must be used, since there is no speech amplifier.

The vernier dial on the receiver is a great help in easy tuning, but for transmitting it is not needed. It would be advisable to use some sort of dial or scale on the transmitter control so that settings could be more easily duplicated.

Quite a bit of experimentation was done on various types of antenna coupling, and a separate antenna coil was used at one time. This naturally allows a wider variety of antennas to be used, but the single wire feed is simplest and seems to be quite efficient, so the coupling coil was removed. It was attached to the insulating strip on the terminal of the plate current meter.

### What "Change-Over" Switch Does

The change-over switch is really only a filament switch, as there are no circuit changes to be made such as those in a transceiver when shifting from send to receive. The switch also cuts the mike current when in the receive

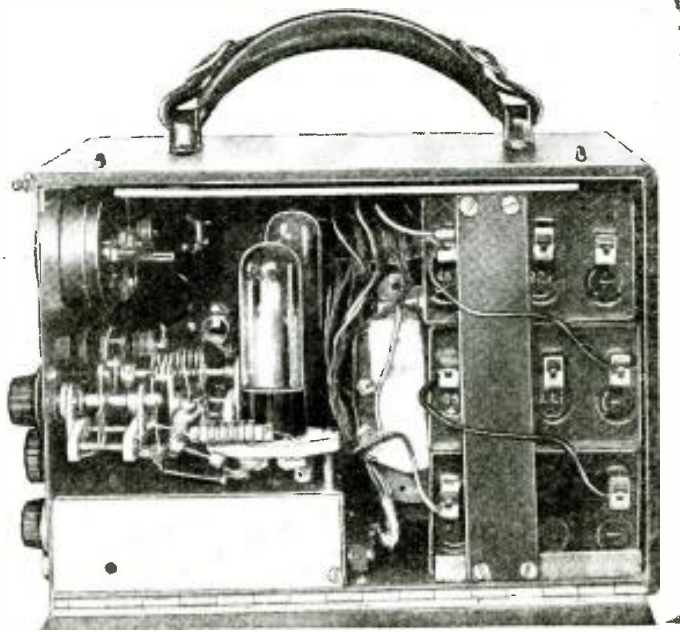
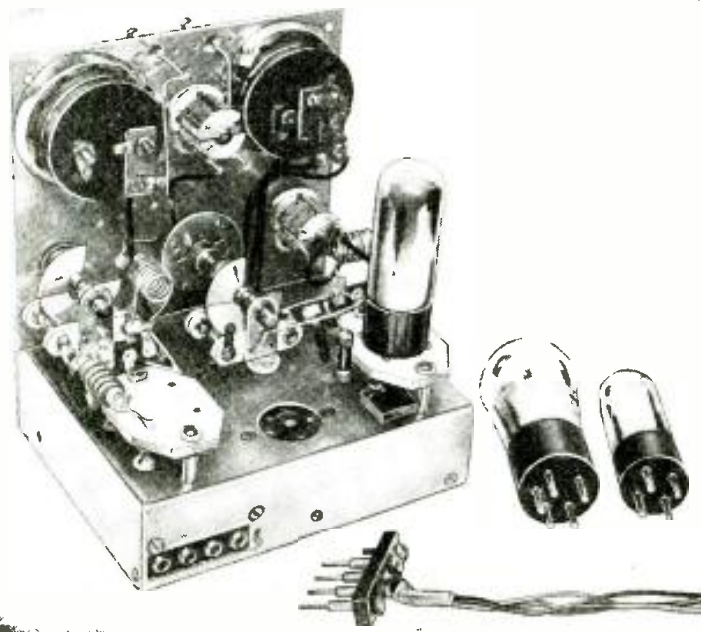

Photos above show rear view as well as interior appearance of the 5-meter combination transmitting and receiving set, designed, successfully built, and tested by the author. It was also demonstrated very successfully before the editors.



# mitter-Receiver

By Howard  
G. McEntee  
W2FHP



The author of this article constructed and has thoroughly tested this extremely compact 5-meter Transmitter and Receiver. It has been used for phone over distances as great as twenty miles. The whole apparatus is battery-operated and is fitted with a "quick-change" switch for Talking and Receiving.



Here is the midget transmitter and receiver for 5-meter work with the author at the "mike."

position, and turns off the transmitter oscillator.

In the transmit position, the detector tube is cut out, the audio tube being lighted in all positions. Several contacts on the switch are used to cut a small resistance in series with one lead of the filament battery. The resistance figures out at .4 ohms for the sending position, and .9 ohms for receiving. This is just a refinement to compensate for the varying total current when the different tubes are cut in and out of the circuit and makes it unnecessary to continually shift the rheostat. It may be set once and left that way.

When the circuit is completely wired up and checked, the batteries may be hooked on and the set tried out. The B battery is three 45 volt units, while two No. 6 dry cells light the filaments. The C battery is made by soldering nine small-size flashlight cells in series. This will give 13.5 volts bias for the 33.

The filament battery, of course, is the mike battery also.

The transmitter should work with the tap about three turns from the plate end of the coil. It should be shifted to get the best position, then soldered in place. If an R.K. 24 tube is available it should give better results than the 31 as it is really designed for high-frequency use. Also, a 30 may be used in place of the 31 with good results. With no antenna on the transmitter and 135 volts B battery, the plate current should be between 5 and 10 mils with the 31, this current increasing to about 20 mils with load, and it should not be run much over this.

The receiver should also be tried with no antenna and the ground tap set so that smooth oscillation is had all over the band. Then clip on the antenna lead and adjust the series condenser for best results. In crowd-

ed areas it is advisable to use as  
(Continued on page 114)

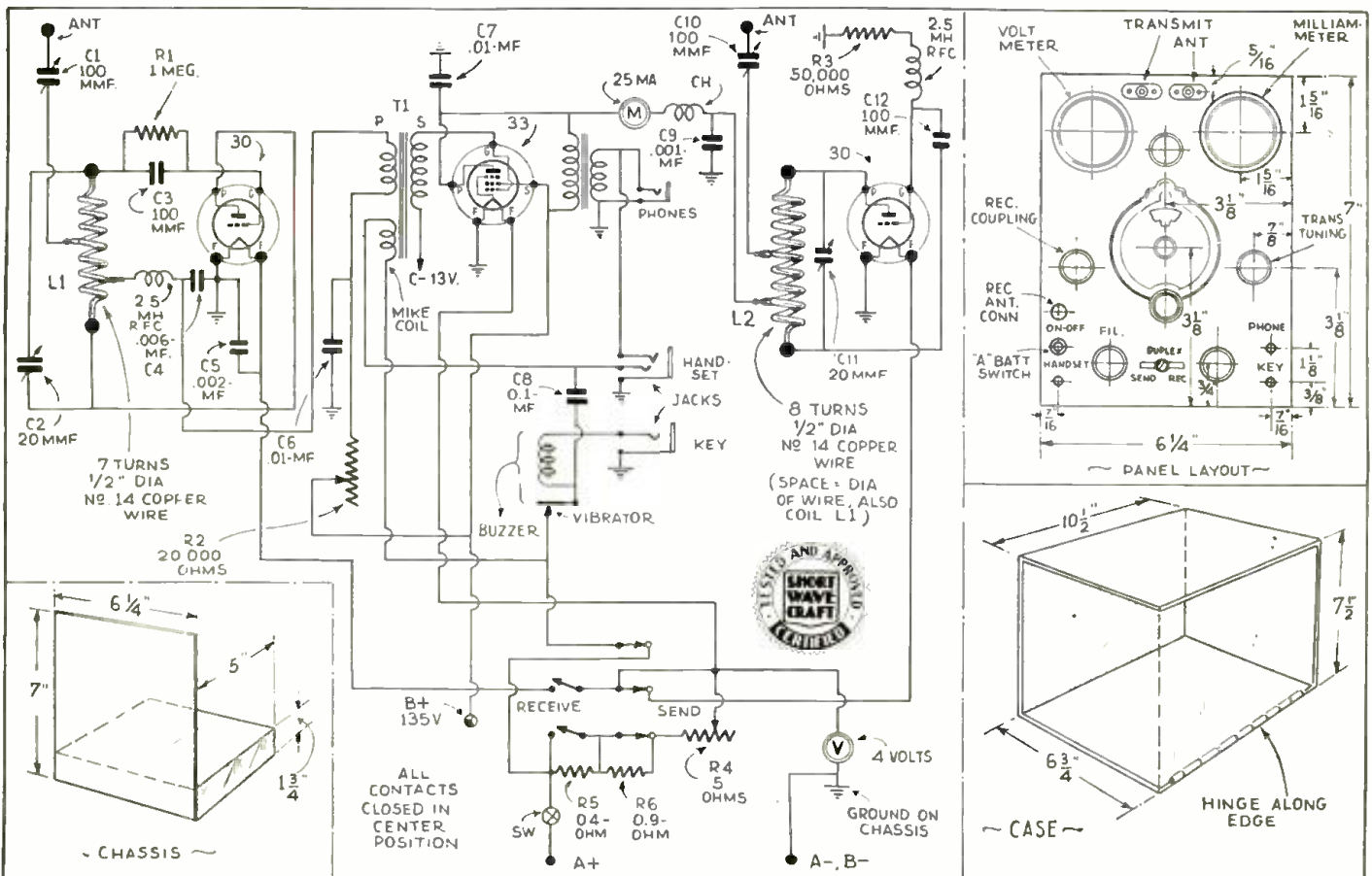

The simple wiring diagram for a 5-meter transmitter-receiver is given above and the cost of the parts is really very nominal, considering the efficiency and usefulness of this very well-designed apparatus. Dimensions for the panel and cabinet layouts are also given above.

# SIMPLEST HAM Transmitter Uses 802 Tube

By George W. Shuart, W2AMN



Front view of Mr. Shuart's latest simplified transmitter using the new 802 tube.

● WHENEVER there is a difficult problem to solve in radio the tube engineers are usually called upon to build a new tube which will solve that problem. Amateurs have for a long time needed a tube which would serve as a low-power oscillator and as a buffer or frequency doubler. A tube was needed that would make the average Ham transmitter simple and foolproof. Some Ham transmitters that were using power frequency multipliers were truly dangerous and very tricky and difficult to adjust. Not so today with the new RCA 802 screen-grid pentode, which will overcome all past ills if properly used.

There are dozens of uses for this new tube and they will immediately suggest themselves to the thoughtful amateur; space will not permit us to describe all of them, but it is safe to say that they will be used mostly as crystal-controlled oscillators, buffers and doublers.

The little transmitter unit shown in the photograph is really the most simple Ham transmitter that could be built. It really is a 1-tube crystal controlled MOPA and will serve as an excellent low-power transmitter or as an exciter unit to take the place of the oscillator stage in an already existing transmitter, with a marked increase in efficiency. There are a few important things to remember when using this new tube and we will give the readers the benefit of our experiments with it.

The 802 will replace the now popular 59 crystal controlled oscillator with an increase in output and flexibility. The shielding in the 802 is so complete that the plate circuit can be tuned to the crystal frequency when using the familiar electron-coupled circuit. There are seven prongs on the base of the 802, the reason being that the shielding has its own separate pin instead of being connected internally. This allows free operation of the cathode in the so-called "electron-coupled" circuit. The plate connection is brought out at the top of the bulb to reduce coupling between it and the other elements.

When using this tube in the oscillator circuit shown in the diagram it is absolutely necessary that the suppressor

This transmitter, while very simple and easy to build, has an output of 10 watts on C.W. or about 2 watts when used for phone. It is a complete crystal-controlled MOPA. This new 802 tube offers tremendous possibilities in simplifying amateur transmitters.

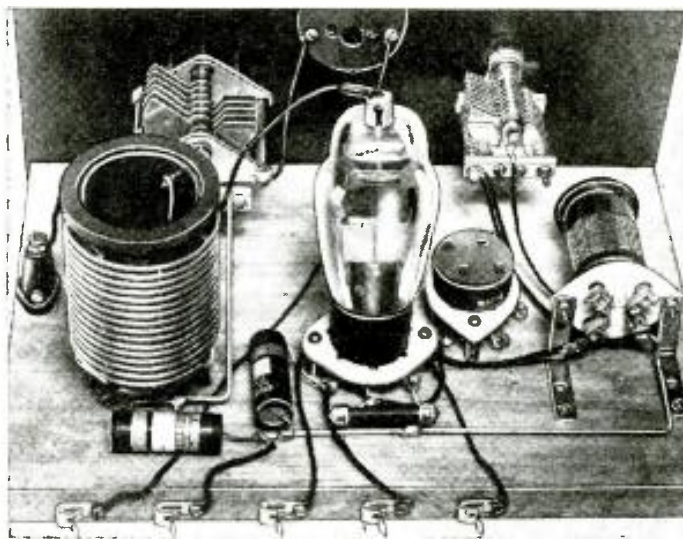

The 802 tube and its associated equipment as used in this Ham transmitter makes a very neat assembly.

grid be connected to the shield and the B minus. Do not connect the suppressor to the cathode if you are going to operate the plate circuit at the crystal frequency, because it will introduce coupling between the two circuits and the plate circuit will fall into oscillation and the whole thing will be useless. The liberal use of effective by-pass condensers is also necessary to maintain stable operation. The screen-grid should be by-passed to the B minus as near to the tube terminal as possible and the B minus or ground lead should be placed so that all these by-pass condenser leads are as short as possible. Probably a better method would be to use a metal (copper would be fine) base and make this the B minus or ground to which all leads should be thoroughly bolted or soldered.

The tube does not need a shield if the two coils are kept far enough apart. And with the cathode coil lying at right angles to the plate coil there is not the slightest trace of feedback from plate to grid. Plug-in coils are used in both cathode and plate circuits; the form for the plate coil is 2 1/4 inches in diameter and wound according to the data given in the coil table. The cathode coil is wound on a 1 1/4 inch dia. form with ordinary double cotton-covered magnet wire. The maximum and recommended voltages for the 802 tube are 500 for the plate and 250 for the screen-grid. The screen-grid voltage can be obtained either by a voltage dropping resistor or a voltage divider; the dropping resistor method would seem to be the best, as the two voltages, screen and plate, would then always have the same ratio. The tube is not a bit critical and a tap on a voltage divider can be used to supply the screen-grid voltage,

(Continued on page 105)

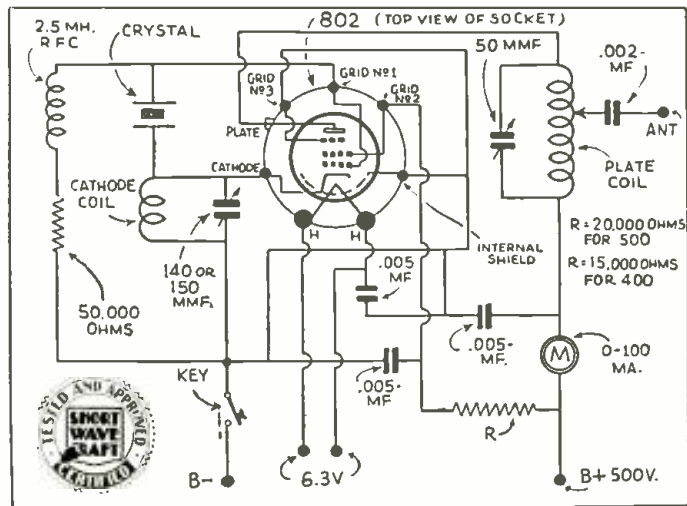

It is hard to conceive of a simpler transmitter than the one shown in diagram form above.



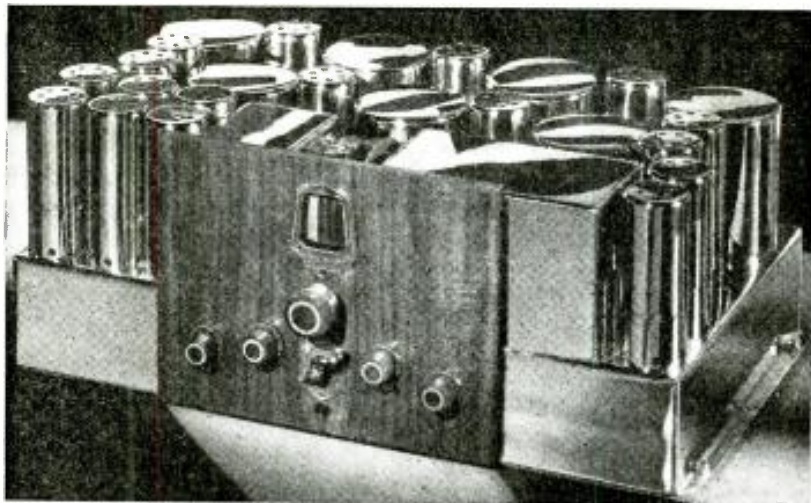

Beautiful chassis of the new Scott Imperial All-Wave 22-tube receiver.

# A New 22-Tube All-Wave Receiver

By E. H. Scott\*

A Custom-Built All-Wave Receiver  
That Will Create New Standards of  
Performance in World-Wide Reception  
and High-Fidelity Reproduction

● I WANT the reader to do a little "supposing" with me. Suppose you were a man of unlimited wealth, and were so much interested in radio that you could afford to equip a radio laboratory of your own with every modern piece of measuring apparatus used in research work. Then suppose you staffed that laboratory with the most competent engineers it was possible to secure, men who had been designing *all-wave* radio receivers for years. Then suppose you gave this staff instructions to go ahead and build for you the very finest receiver it was possible to build, and to incorporate in it every worth-while development in *all-wave* radio receiver design, plus any new features they discovered in their own research work. If you were to do that, then the probability is the receiver that would ultimately come into your possession would be one very similar to the new SCOTT IMPERIAL ALL-WAVE.

Some idea of the power in this new receiver will be gained from the fact that 22 tubes are used. Every one has a definite function to perform, and not one can be eliminated without decreasing the efficiency or performance of the receiver. Incorporated in its design are a large number of very advanced features, many of them recent developments of our own research laboratory.

If we are to secure the finest possible reception from distant stations on either the broadcast or short-wave bands, it is necessary that a receiver possess a very high degree of *usable* sensitivity.

Maximum antenna gain is secured by the use of separate antenna primary coupling coils for every waveband, each of which is designed to cover efficiently the range of frequencies over which it operates.

A separate tuned R.F. stage is used on each of the four wavebands, using a triple-grid, supercontrol, high-gain amplifier type 6D6 tube, giving maximum sensitivity, with a minimum of noise and image frequency interference.

#### Extreme Sensitivity Secured with Four I.F. Stages

Probably the most important section of any superheterodyne receiver is the I.F. amplifier. In the cheaper class of radio receiver, one I.F. stage is used;

the medium-priced receiver generally uses two, and some of the higher-priced receivers use a maximum of three stages. Where only one or two stages of I.F. amplification are used, the tubes have to be pushed to the limit to secure sufficient *sensitivity*. In this receiver four stages are used in the I.F. amplifier, and extreme efficiency is secured in each stage through the use of a remarkable newly developed multiple I.F. coil tuned by special low-loss condensers, 100 per cent shielding and filtration, and the scientific apportionment of *gain per stage*.

To eliminate overloading in the detector, one of the more common causes of distortion in the ordinary radio receiver, it is necessary to have more I.F. driving power than is supplied normally by the regular I.F. amplifier. In this receiver this is secured by a separate I.F. driver stage, and assures sufficient power at all times for the most efficient operation of both the detector and A.V.C. systems.

#### Selectivity Continuously Variable

The degree of *selectivity* possessed by a receiver determines its ability to tune through powerful local stations and bring in very weak distant signals. In this new set we have incorporated a remarkable new continuously variable *selectivity-fidelity* control, which en-

ables the user to obtain, at all times, not only the desired degree of selectivity required, but also the maximum fidelity of reproduction possible from stations, with a minimum of noise and interference. In the most selective position, adjacent channel discrimination of approximately 5000 to 1 is obtained, while in the maximum fidelity position, audio reproduction up to the limit of the human ear, or the highest frequency being broadcast by the station is obtained. This system enables you to reach out and bring in weak distant stations, which ordinarily would be blanketed by interference from powerful near-by stations on adjacent channels.

On the other hand, when listening to local stations, a high degree of selectivity is not necessary or desirable, and under these circumstances, the receiver can be adjusted to reproduce every tone, from the lowest fundamental to the highest harmonic which the highest fidelity station on the air is capable of broadcasting.

To bring in stations from great distances, a very high degree of *usable* sensitivity is (Continued on page 107)

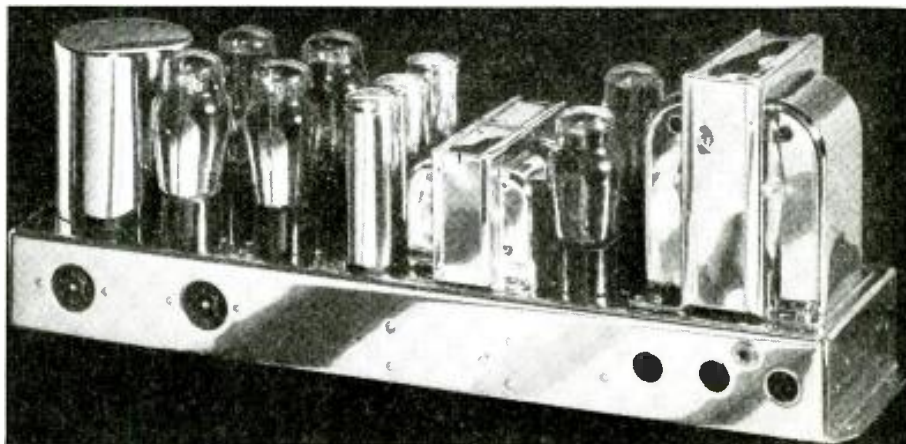

Powerful Amplifier of the new Scott Imperial All-Wave receiver.

\*President, E. H. Scott, Radio Laboratories, Inc.



# WHAT'S NEW In Short-Wave Apparatus

The short-wave apparatus here shown has been carefully selected for description by the editors after a rigid investigation of its merits

## The BROWNING 35- A 7-Tube A.C. Super- het in KIT FORM

The name BROWNING once more comes to the fore. This time he presents to radio fans a modern 7-tube "all-wave" receiver which has preselection, AVC, band-spread, tone control, beat oscillator, and a cleverly designed "band-switching" arrangement.

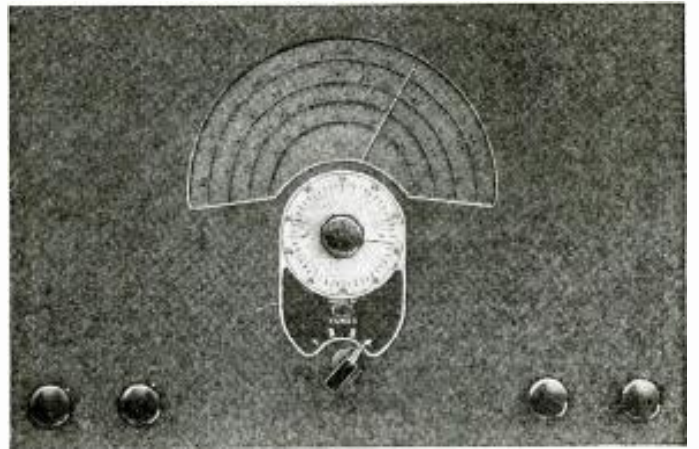

Front view of the new "Browning 35" receiver. Note its full-vision tuning dial and its very neat appearance.

● GLENN H. BROWNING, who won fame as co-author of the famous Browning and Drake receiver which was popular a few years ago, has recently designed an excellent all-wave superheterodyne receiver.

This set is not an assembled proposition; all the parts are

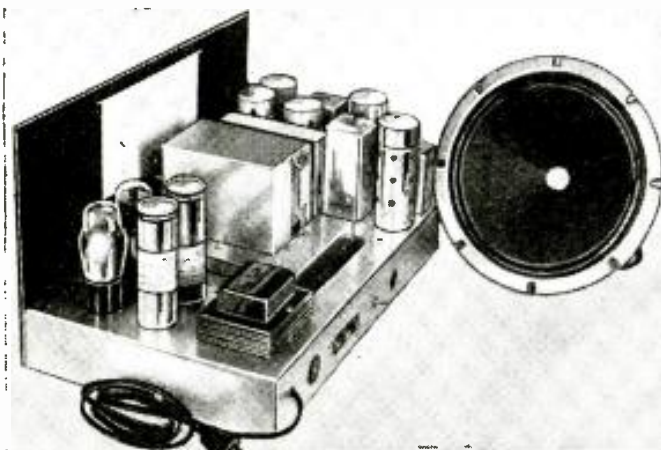

Rear view showing the layout of Mr. Browning's latest creation. No. 280.

available in a complete kit form and can be assembled and wired in a few hours' time by even the most inexperienced fan; very simple and complete instructions, of course, make this possible.

The "Browning 35," as it is called, is a 7-tube receiver entirely A.C. operated. The tube line-up is as follows: A 58 is used as a high-gain tuned RF amplifier, this is inductively coupled to a 2A7 pentagrid converter; the intermediate frequency amplifier is a 58 and a 2A6 is used as a diode detector, audio amplifier and automatic volume control tube. The output tube is a 2A5 and will operate a large dynamic speaker to full volume.

In order to receive "CW" signals and to aid in locating short-wave stations, a *beat oscillator* is used—this is a 56. A 280 is used for the rectifier in the heavy-duty power supply.

Together with its automatic volume control, tone control, beat oscillator, and provisions for a doublet antenna, this set presents something the short-wave fans have been seriously in need of. It will also give excellent service as an amateur band receiver. Band

switching is accomplished by the ingenious design of a special selector unit which includes all of the coils and the necessary switches, together with over a dozen padding condensers.

The inexperienced short-wave amateur can put this set together and sure of obtaining results because the band selector is *pre-aligned*. The only necessary adjustments are in the I.F. transformers, and even these are *preset* at the factory so that results will surely be obtained, and it is only necessary to set the tuning adjustments on the transformers to maximum volume. The photographs clearly show the efficient layout and ingenious design of the Browning 35.

The receiver has a measured sensitivity of less than one microvolt over all four bands. Indeed, in the broadcast band the sensitivity is never poorer than 0.2 microvolts. This is not only exceedingly good sensitivity, but surprisingly uniform sensitivity. A large, 4-scale tuning dial marked in megacycles makes tuning accurate and easy. The pointer is driven through a microvernier knob that provides effective band-spread. The vernier is divided into 100 divisions for logging. We are told that a special model of the receiver has been developed for amateur use. This model omits the broadcast band and tunes only to the 160, 80, 40 and 20 meter amateur bands with 150 dial degrees of band-spread and with enough overshoot to include most of the foreign broadcasting.

Bottom view of the "Browning 35." The "coil-switching" arrangement, together with the necessary padding condensers, can be clearly seen in the center of the set.

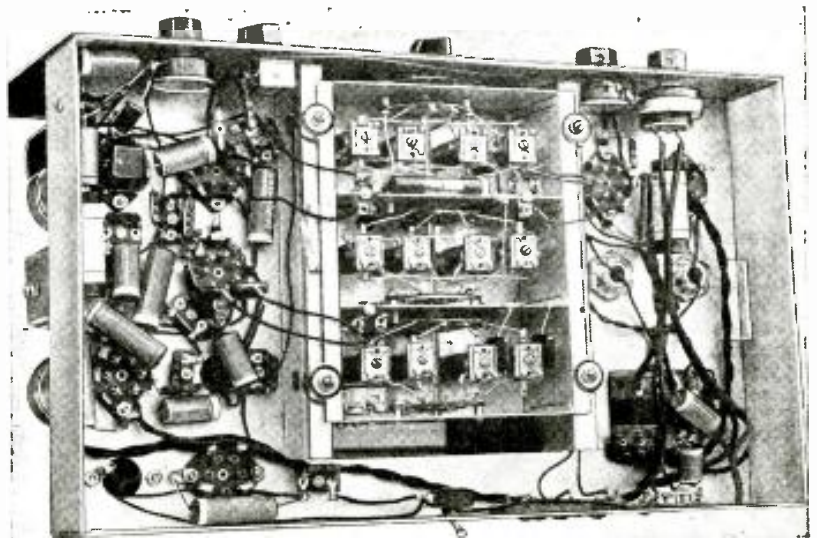



# New Devices of Interest to S-W Experimenters



## NEW VELOCITY MIKE

● **ALTHOUGH** 6 db. higher in output than formerly obtained in velocity microphones, the new 7-point microphones by Amperite are more compact. This was in part made possible by the use of the new nickel aluminum chrome magnets. The most powerful and expensive magnet available today—twice as powerful as 36 percent chrome steel—they found their first

American application in the 7-point microphone. Operating without background noise and a flat response over the entire audible range, the new velocities can be used for either speech or music. Acoustic feedback and hum pickup is eliminated entirely in public address or radio station installations. The flexibility of the microphone has been increased by the addition of a swivel bracket. It is thoroughly shielded and has an unusually rugged, mechanical construction in appearance. No. 231.

## NEW SOCKET AND CONDENSER

● **SEVERAL** very interesting new products have recently made their appearance on the market and they are being sponsored by the Alden Products Company. One is a very efficient and uniquely designed variable condenser of the midget variety, intended primarily for high frequency or short-wave use. The insulation of this condenser is Victron "AA." This condenser has a silver pressure contact on the rotor; no grease is used and no oxide skin forms in the bearing. The shaft is self-centering and self-tightening, and due to its cone-shaped bearing cannot become loose or produce noise. A single bearing is used and this aids in reducing losses to the lowest possible value.

This condenser is shown in one of the drawings. Although it cannot be seen, the shaft is hollow and will accommodate a 1/8 inch gang-rod. Any number of these condensers can thus be ganged together. These new variable condensers are available in three sizes, viz: 140 mmf., 50 mmf., and 15 mmf. The smallest (15 mmf.) size is ideally suited to ultra high-frequency work. Another interesting Alden product is a low-loss ultra-high frequency socket for the new Acorn 955 tube. This instrument has a Victron insulation in the plate and grid-mounting posts and is provided with a guard post located between the plate and grid terminals. This is necessary because, due to the symmetry of the terminals mountings, the tube could otherwise be inserted in the wrong direction. R.F. chokes of the 2 1/2 millihenry size and also special 5-meter R.F. chokes are available. wound on Victron insulation. These chokes are designed so that they can be

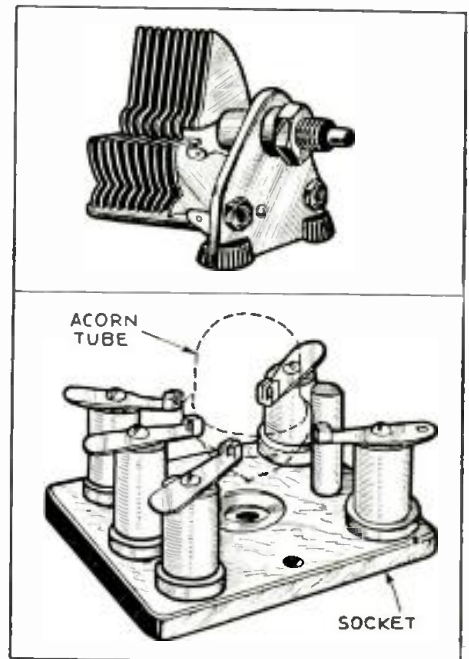

Above—New high-frequency condenser. Below—Latest Na-Ald idea—Victron socket for the Acorn 955 tube. No. 282.

mounted with screws to the base or chassis. Liquid Victron is available to use with a very low loss material to cement coil windings and construct self-supporting coils.

# New Multiple Antenna for All-Wave Sets

● **FOR** the past two years an attempt has been made to provide a suitable antenna system for use in radio stores and in small apartment houses, as well as homes in which more than one all-wave radio receiver is desired.

Multiple antenna systems for the broadcast band are now more or less common but they are unsuitable for use in connection with all-wave receivers.

The system very thoroughly outlined in the accompanying illustrations has been developed by Arthur H. Lynch, Inc., and has been put through the acid test of service in some of the largest radio stores in

the New York area. In many cases, where five or six different antennas were employed and where such facilities would not meet the requirements of noise-free reception on the short-wave bands, it has been found possible to do all the necessary demonstrating with one or two of the new aeriels.

A more rigid test of the efficacy of this system can hardly be imagined than is found in the various radio retail stores which are located in sections of the city where subway, elevated, streetcar and automobile traffic is found at its height. Here these new aeriels are rendering suitable

demonstration service every day.

In one week the installation of antennas of this nature resulted in the consummation of the sale of three radio installations valued at \$2400.00 each, which had been unsatisfactory with all other types of aeriels.

One very important feature in connection with this system is the fact that regardless of the number of receivers employed, it is but necessary to use one antenna transformer and one receiver transformer.

Coupling connections: With some receivers having a primary input circuit which is not grounded, the regular HI-FI receiver coupler, provided with all Lynch HI-FI kits, may sometimes be used in the manner shown in Fig. 1 with very gratifying results.

The connections for using the Lynch HI-FI Vario-coupler and their Ham-bands receiver coupler with receivers of conventional design, having antenna and ground binding posts, are shown in Fig. 2 and the method for using either of these couplers in conjunction with receivers having floating primaries, is shown in Fig. 3.

It will be noted that in every instance, the ground portion of the receiver coupler is connected to the ground posts on the receiver and that the use of a ground connection between the GND post on the receiver and a water pipe or similar ground, is determined by the performance of the receiver itself.

Receivers with "floating" primaries are distinguished by the fact that they have two "ANT" binding posts.

This instrument is particularly desirable in locations where radio fans wish to operate more than one receiver on the same antenna, principally because in a good many locations there is only sufficient space, if indeed that, to erect a high-class antenna. Rather than sacrifice efficiency with two badly crowded antennas, it would be more advisable to install a single good antenna and use such a device as this for operating more than one receiver.

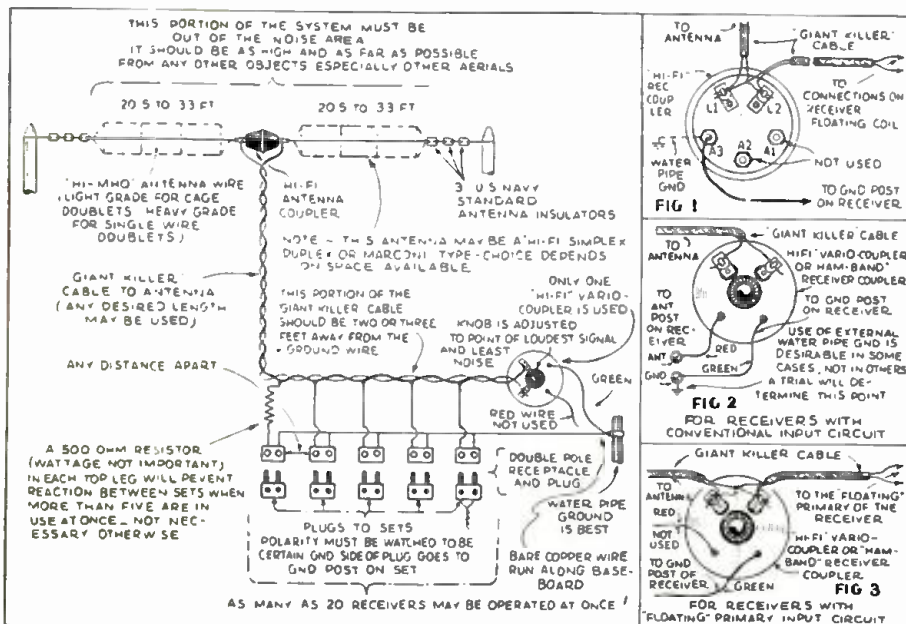

With this latest Lynch antenna design, a great number of all-wave sets can be simultaneously operated from a single aerial. No. 283.

Names and addresses of manufacturers of sets described on this and following pages furnished upon receipt of 3-cent stamp; mention No. of article.

# 17-In-1 "MULTI-KIT" SET

By W. Green\*

Once in a blue moon some radio genius has a really new idea—here is the very latest. By adding a few small parts to a foundation kit, any one of 17 different type receivers can be built up, including battery, A.C., and A.C.-D.C. models.

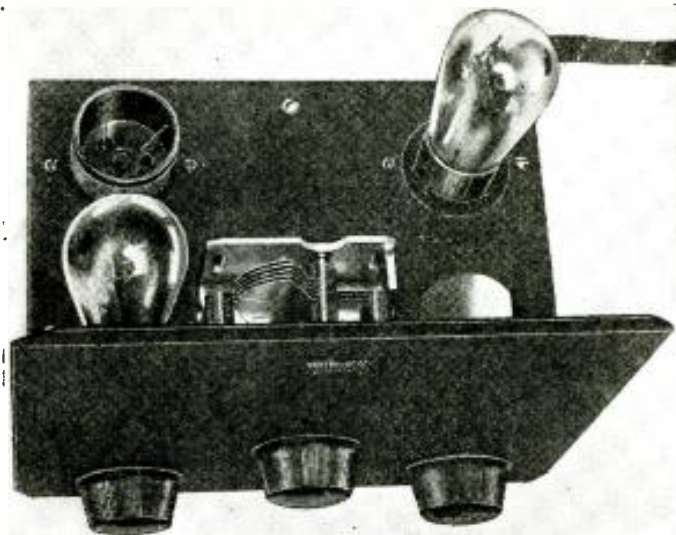

Above—extremely neat and workmanlike appearance of the 2-tube battery model receiver, built up from a "multi-kit" foundation unit.

● HERE is a new idea in radio set construction—an idea which is sure to appeal to every short-wave experimenter and listener. How would you like to make a set which is so simple in construction that anyone, even though they don't know the first thing about radio, can make it, and what's more make it work well enough to bring in those elusive *foreign* shortwave broadcasters? And then when you finish with the set and want to try something better—one which will give louder signals or more distance—you find that all the parts of the original set, including

have been devised around the original chassis and fundamental parts mentioned above, does not mean that this is the greatest number of circuits that you can use—these parts can be adapted to a great number of circuits—in fact almost any small set can be built with the parts.

### What the "Multi-Kit" Consists Of

To explain in somewhat greater detail just what makes up the "multi-kit," as the chassis and fundamental parts mentioned above have been called, the pictures on this page should be ex-

amined. This multi-kit contains the drilled, crystalline-finished metal chassis and panel, a variable condenser, dial, antenna compensating condenser, regeneration control, four coils, coil socket, grid resistor, three by-pass condensers, speaker jack, two knobs and all the necessary screws, wire, etc., needed.

With these parts, plus a few inexpensive additions, you can construct the set shown in Fig. 1 and further illustrated in the photo of the complete model on this page.

This is a battery-operated short-wave set, consisting of a regenerative detector and a stage of audio frequency amplification, using two type 30 economical dry cell tubes.

Or if you prefer, the A.C. receiver shown in Fig. 2 can be made, using two type 56 tubes—and a somewhat different set of additional parts. The multi-kit is used in its entirety, of course. This set is also a regenerative detector and audio amplifier, but instead of using batteries it gets its current from a step-down filament transformer and a "B" eliminator. It will be noticed that the set contains a voltage divider, so that the simplest kind of a "B" unit will suffice.

(Continued on page 112)



the chassis, can be used for the new receiver.

### 17 Sets from 1 Basic Unit

In fact, you can choose from 17 different circuits, some of which are *world famous*, and ranging from the simplest 1-tube battery-operated model to an A.C.-D.C. set using two or three of the composite or "twin tubes" and supplying the results of a 3- or 4-tube receiver. Each of these 17 sets uses the same parts which you employed in the original, simple 1-tube set—with a few inexpensive additions, of course.

Think of the amount of fun you can have trying each of the 17 different sets and deciding which one is the best all-round model for your needs and location. In fact, the 17 circuits which

Photo above shows all of the parts included in a "Multi-Kit" foundation set, plus the few extra parts required for building up the complete 2-tube receiver shown in the picture at the head of this page. No. 284.

The illustration at right shows some of the possibilities of the "Multi-Kit". Extra parts available for building up to 17 different types of receivers, only 5 being indicated in this drawing.

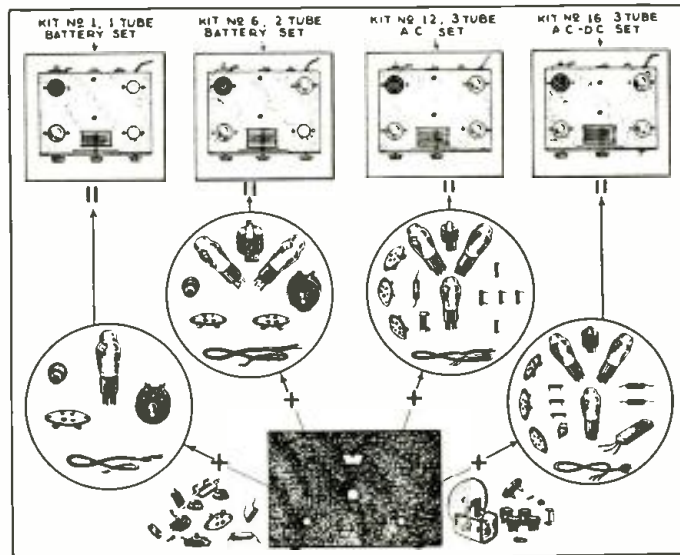

\*Chief Design Engineer, Harrison Radio Co.

Names and addresses of manufacturers of sets described on this and following pages furnished upon receipt of 3-cent stamp; mention No. of article.



# New Acorn-Pentode 954 Tube Is Here!



The extremely small size of the new "Acorn"-pentode 954 tube may be judged by comparison with the golf ball at the right of the photo. No. 285.

● THE New Type 954 Acorn-Pentode Tube is a heater-cathode type of pentode designed primarily for radio amateurs and experimenters working with wavelengths as short as 0.7 meter. As an R.F. amplifier at a wavelength of one meter, the 954 is capable of gains of three or more in circuits of conventional design. Higher gains are of course attainable at longer wavelengths. The pentode 954 is a companion tube to the triode 955 and employs a similar unconventional tube structure having small size, close electrode spacing, and short terminal connections. The suppressor is brought out to a separate terminal. In addition to its primary use as a pentode, the 954 with suitable arrangement of terminal connections has application in experimental circuits as a tetrode or triode.

### Installation

The terminals of the 954 require a special method of mounting by means of clips supplied with each tube. The two small clips are for the control grid and the plate terminal at the bottom and top of the bulb, respectively. The five large clips may be fastened to a supporting insulator. For minimum losses, it is desirable to clip circuit parts directly to the control-grid terminal and to the plate terminal. Since the circumferential tube terminals are located symmetrically, a stop of insulating material should be placed between the screen clip and the suppressor clip so that the cathode terminal will prevent insertion of the heater terminals in the screen and suppressor clips. This stop is identified as the Terminal Mounting Template (Fig. 1) as Alignment Plug. Do not attempt to solder connections to the terminals. The heat of the soldering operation is almost certain to crack the bulb seal.

The heater is designed to operate on either A.C. or D.C. When A.C. is used, the winding which supplies the heater circuit should operate the heater at its recommended value for full-load operating conditions at average line voltage. Then D.C. is used on the heater, the heater terminals should be connected directly across a 6-volt battery. Under any condition of operation, the heater voltage should not deviate more than plus or minus 10 percent from the normal value of 6.3 volts. Series operation of the 954 is not recommended.

The cathode of the 954, operated from a transformer, should prefer- (Continued on page 115)

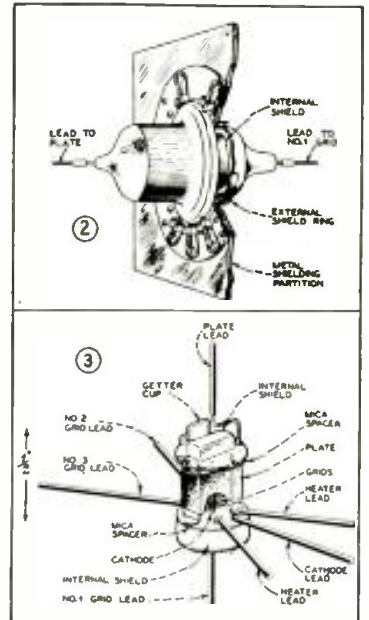

Figs. 2 and 3 above show mounting of new 954 pentode in metal shield and the internal construction of the tube's elements.

## The V-Doublet— A Practical S-W Antenna

By H. A. Crossland\*

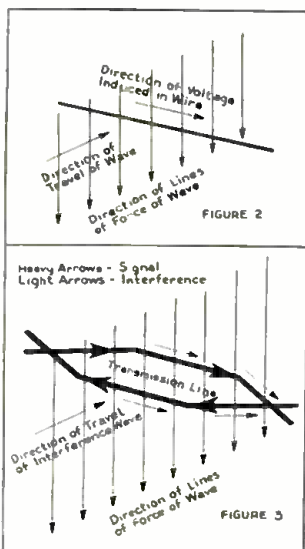

Figs. 2 and 3 above show single wire and "twisted pair" cut by a radio wave.

transoceanic and transcontinental antenna systems show that the doublet antenna with transmission line fills most requirements for efficient short-wave reception. The ordinary doublet antenna

● CONSTRUCTION of an antenna that will attract standard domestic broadcast radio waves is comparatively simple. Except in noisy locations, a single wire 50 to 75 feet long with an insulated lead-in and a good ground connection forms a satisfactory antenna. In noisy locations, a shielded lead-in with matching transformers and a longer antenna will perform the service.

Short waves, however, are more temperamental in their behavior. Somewhere in the range between 13 and 49 meters (42 to 161 feet) the length of the antenna is likely to be one wavelength long. The antenna will invite waves of such length, while waves of some other length may pass on. Although static is less troublesome at short waves, man-made interference is often severe. To exclude such interference, a shielded lead-in cannot be used because the short-wave signal won't travel any great distance through a shielded lead-in without becoming greatly weakened.

Results of many experiments and calculations in developing

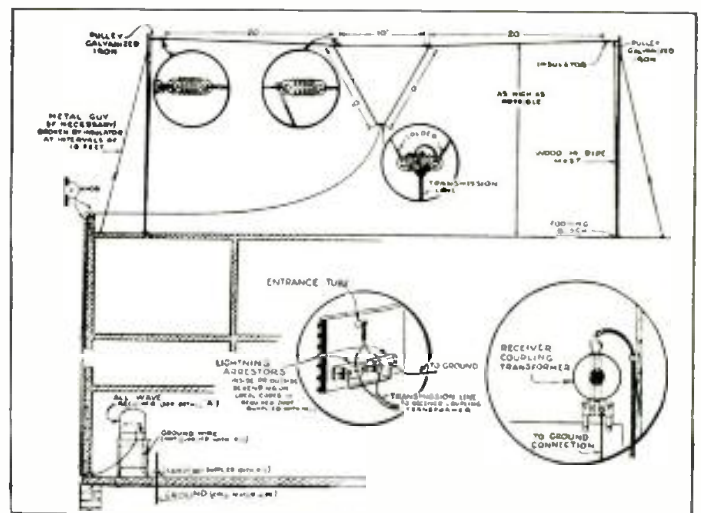

Typical installation of the new "V" Doublet antenna. No. 286.

consists of a straight wire divided at the center by an insulator, from which point a 2-conductor, transposed or twisted transmission line runs to the receiver. Properly designed, this type of doublet gives ideal efficiency at a frequency determined by its length, but not for a continuous range of frequencies covered by the short-wave bands.

The newly designed General Electric "V-doublet" Antenna System is illustrated in Fig. 1. The "V-doublet" differs from the elementary doublet which tends to favor certain frequencies and reject others. The "V-doublet" is coupled to the transmission line by the converging "V." This makes the doublet respond uniformly to a wider range of short-wave signals, and the "V" matches the doublet more perfectly to the transmission line so that the signal transfer is smooth. The explanation is simple. At the top where the spacing is wide, the characteristic impedance is high and comparable to that of the doublet, at the bottom where the wires are close together, it is low to match the low impedance of the transmission line.

One of the most valuable features of the "V-doublet" system is its ability to exclude interference (Continued on page 101)

\*Supervisor, Radio Field Service General Electric Co., Bridgeport, Conn.

Names and addresses of manufacturers of sets described on this and following pages furnished upon receipt of a 3-cent stamp; mention No. of article

# How to Eliminate . . . RADIO INTERFERENCE

By Wilhelm E. Schrage

● BEFORE starting to eliminate radio interference, amateurs and Service Men should keep in mind that not all the crackles and other noises radiated by loudspeakers are really caused through radio interference emanating from electrical apparatus in the neighborhood. Experience has often shown for example that aerials not in first-class condition contribute more crackling noises than one would expect, and an incandescent lamp not connected in the proper way with its socket may cause more disturbance than a large electric motor.

Strange as it may seem apparatus with heavy current flow are not usually responsible for interference, but rather the small electrical devices, consuming only a few watts. In this class belong all the devices used in private houses to "make kitchen work easy," and daily life more enjoyable for the housewife.

### Dress Shoes or Pullman Slippers?

It may seem ridiculous, but it frequently happens that the owner of an

The author describes in the accompanying article how to by-pass electric bells, motors, and other apparatus which frequently cause interference or noise to be heard in the loudspeaker of your radio set.

expensive radio set does not use a well-constructed aerial, but often only a piece of old wire fixed directly upon the walls, or even the steel frame of a mattress is used as an antenna. If one were to appear at a party in full evening dress but with Pullman slippers there would be reason for considerable gossip, but using some makeshift arrangement instead of a well-constructed aerial is often considered a novel bit of technique.

Since enjoyable radio reception can be obtained if the ratio between the interference strength and the radio signal strength is 1 to 50, only a well-designed aerial will deliver the necessary power to render strong interference no more noticeable than the scratch of a phonograph needle when playing a new record.

### The Interference Cloud Around the House

However, an excellent aerial may sometimes cause quite a lot of interference if the antenna is led through a so-called "interference cloud," very often covering the house and its surroundings. The best method to avoid this evil is to use a shielded aerial lead-in as shown in Fig. 1, or a so-called "doublet" antenna, with *transposition lead-in*, as shown in Fig. 2.

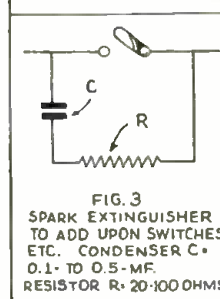
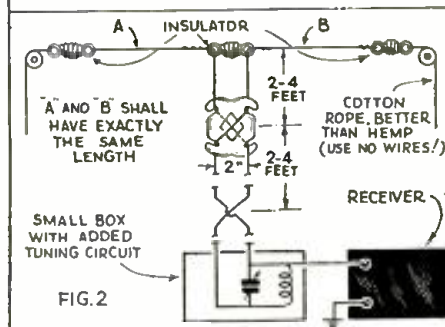
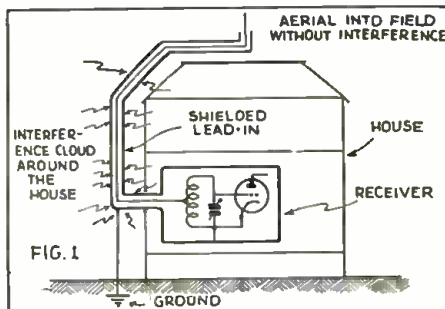

FIG. 3 SPARK EXTINGUISHER TO ADD UPON SWITCHES ETC. CONDENSER C • 0.1- TO 0.5-MF. RESISTOR R: 20-100 OHMS.

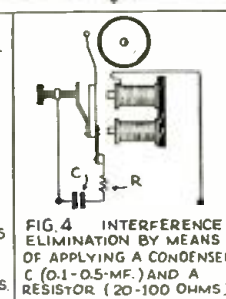

FIG. 4 INTERFERENCE ELIMINATION BY MEANS OF APPLYING A CONDENSER C (0.1-0.5-MF.) AND A RESISTOR (20-100 OHMS)

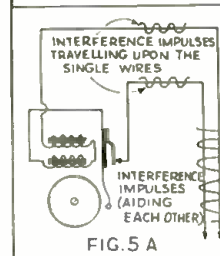

FIG. 5 A

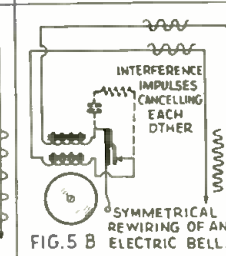

FIG. 5 B

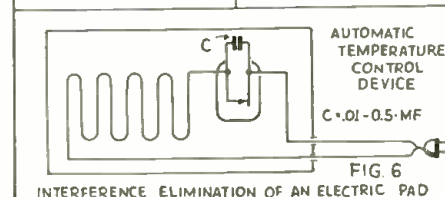

FIG. 6 INTERFERENCE ELIMINATION OF AN ELECTRIC PAD

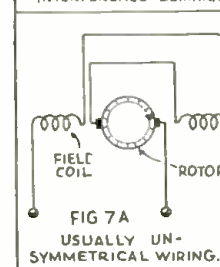

FIG. 7 A USUALLY UN-SYMMETRICAL WIRING.

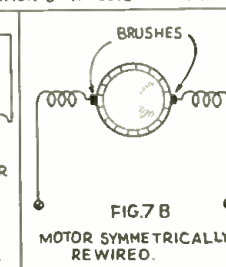

FIG. 7 B MOTOR SYMMETRICALLY REWIRED.

The diagrams Figs. 1 to 7-b above show various electrical apparatus and means of by-passing with condensers, etc., so as to eliminate interference from such sources.

Note in Fig. 5B, the connections for eliminating noise caused by the ordinary door bell, a frequent offender against short-wave receivers.

### How Transposed Lead-in Helps

Telephone engineers for 30 years have used transposed lines to decrease background noise of telephone lines caused by static. This type of lead-in has been applied with great success for radio aerials in the past few years. The transposed feed line is the secret of successful interference elimination picked up in the vicinity of the house.

This feed line works in the following way: The induced interference field is out of phase with the field caused by interference in the succeeding part of the feed line, a condition which results in cancellation of the induced interference voltage in any of the following feeder sections.

### Use Ground Wires of First-Class Condition

Another reason for so-called "interference" occurring is the ground line—the step-child of most broadcast receiving setups. If radio listeners knew how much trouble can be created by a "bad ground," and how much the reception can be improved through the use of a *good ground*, more attention would be paid to this simple wire which connects the receiver with the ground. This wire should be thoroughly inspected at least twice a year, because corrosion and oxidation may produce more noise than a thunderstorm. To avoid corrosion and oxidation, enameled solid copper wire at least No. 8 or No. 10 gauge should be used for the *ground line*. The wire should be connected by firmly clamping it to a "ground clamp" to the cold water pipe. It is advisable if possible to connect this ground wire on the *street side* of the water meter.

### A Covered Ground Post Important

Before connecting the ground clamp to the pipe the contact point should be cleaned with emery cloth or sandpaper until a shining surface is obtained. After connecting the wire and clamp to the pipe the whole thing should be painted with several coats of lacquer to keep out moisture and air. Radio listeners will often be surprised how many of the disturbing "interference" noises will disappear if ground and antenna are put in proper condition.

### Switches and Lamps

If antenna and ground are in first-class condition it is then worth while to begin with the elimination of the various sources of real radio interference. At first all incandescent lamps should be inspected insofar as proper connection with their socket is concerned. A small lamp oscillating through traffic vibrations may sometimes be the single source of interference in the entire house. Another simple device often responsible for crackling noises in your loudspeaker are switches. A so-called "spark extinguisher" consisting of a condenser "C" (0.1-0.5 mf.) and a resistor "R" (20-100 ohms) connected to the switch as shown in Fig. 3 will eliminate all of the click-clack noise at once.

(Continued on page 126)



# Short Wave Stations of the World

## Complete List of Broadcast, Police and Television Stations

We present herewith a revised list of the short-wave broadcasting, experimental and commercial radiophone stations of the world. This is arranged by frequency, but the wavelength figures are also given for the benefit of readers who are more accustomed to working with "meters."

All the stations in this list use telephone transmission of one kind or another

and can therefore be identified by the average listener.

Herewith is also presented a very fine list of police as well as television stations. Note: Stations marked with a star ★ are the most active and easily heard stations and transmit at fairly regular times.

Please write to us about any new stations or other important data that you

learn through announcements over the air or correspondence with the stations themselves. A post card will be sufficient. We will safely return to you any verifications that you send in to us. Communications of this kind are a big help.

Stations are classified as follows: C—Commercial phone. B—Broadcast service. X—Experimental transmissions.

## Around-the-Clock Listening Guide

Although short wave reception is notorious for its irregularity and seeming inconsistency (wherein lies its greatest appeal to the sporting listener), it is a good idea to follow a general schedule as far as wavelength in relation to the time of the day is concerned. The observ-

ance of a few simple rules will save the short wave fan a lot of otherwise wasted time.

From daybreak till 6 p. m. and particularly during bright daylight, listen between 13 and 19 meters (21540 to 15800 kc.).

To the east of the listener, from about 2 p. m.-12 m., the 25-35 meter will be found very

productive. To the west of the listener this same band is best from about 7 p.m. until shortly after daybreak. (After dark, results above 35 meters are usually much better than during daylight.) These general rules hold for any location.

## Short-Wave Broadcasting, Experimental and Commercial Radiophone Stations

<b>21540 kc. W8XK</b> -B- 13.93 meters WESTINGHOUSE ELECTRIC PITTSBURGH, PA. 6 a.m.-2 p.m.; relays KDKA	<b>19380 kc. WOP</b> -C- 15.46 meters OCEAN GATE, N. J. Calls Peru, daytime	<b>18115 kc. LSY3</b> -C- 16.56 meters MONTE GRANDE, ARGENTINA Tests irregularly	<b>16270 kc. WLK</b> -C- 18.44 meters LAWRENCEVILLE, N. J. Phones Arg., Braz., Peru, daytime	<b>15330kc.★W2XAD</b> -B- 19.56 meters GENERAL ELECTRIC CO. SCHENECTADY, N. Y. Relays WGY daily, 2-3 p.m.
<b>21530 kc. GSJ</b> -B- 13.93 meters DAVENTRY, ENGLAND B.B.C., BROADCASTING HOUSE, LONDON, ENGLAND See "When to Listen In" column	<b>19355 kc. FTM</b> -C- 15.50 meters ST. ASSISE, FRANCE Calls Argentine, mornings	<b>18040 kc. GAB</b> -C- 16.63 meters RUGBY, ENGLAND Calls Canada, morn. and early aftn.	<b>16270 kc. WOG</b> -C- 18.44 meters OCEAN GATE, N. J. Calls England, morning and early afternoon	<b>15280 kc. DJQ</b> -B- 19.63 meters BROADCASTING HOUSE BERLIN, GERMANY 12:30-2 a. m.
<b>21470 kc. GSH</b> -B- 13.97 meters DAVENTRY, ENGLAND B.B.C., BROADCASTING HOUSE, LONDON, ENGLAND See "When to Listen In" column	<b>19220 kc. WKF</b> -C- 15.60 meters LAWRENCEVILLE, N. J. Calls England, daytime	<b>17810 kc. PCV</b> -C- 16.84 meters KOOTWIJK, HOLLAND Calls Java, 6-9 a. m.	<b>16233 kc. FZR3</b> -C- 18.48 meters SAIGON, INDO-CHINA Calls Paris and Pacific Isles	<b>15270 kc.★W2XE</b> -B- 19.65 meters ATLANTIC BROADCASTING CORP. 485 Madison Av., N.Y.C. Relays WABC daily, 10 a.m.-12 n.
<b>21420 kc. WKK</b> -C- 14.01 meters A. T. & T. CO. LAWRENCEVILLE, N. J. Calls Argentina, Brazil and Paru, daytime	<b>19160 kc. GAP</b> -C- 15.66 meters RUGBY, ENGLAND Calls Australia, early a. m.	<b>17790 kc.★GSG</b> -B- 16.86 meters BRITISH BROAD. CORP. DAVENTRY, ENGLAND See "When to Listen In" Column	<b>15880 kc. FTK</b> -C- 18.90 meters ST. ASSISE, FRANCE Phones Saigon, morning	<b>15260 kc. GSI</b> -B- 19.66 meters DAVENTRY, ENGLAND B.B.C., BROADCASTING HOUSE, LONDON, ENGLAND See "When to Listen In" column
<b>21060 kc. WKA</b> -C- 14.25 meters LAWRENCEVILLE, N. J. Calls England noon	<b>18970 kc. GAQ</b> -C- 15.81 meters RUGBY, ENGLAND Calls S. Africa, mornings	<b>17780 kc★W3XAL</b> -B- 16.87 meters NATIONAL BROAD. CO. BOUND BROOK, N. J. Relays WJZ, Daily exc. Sun. 8-9 a.m., Tues., Thurs., Sat. 2-3 p.m.	<b>15810 kc. LSL</b> -C- 18.98 meters HURLINGHAM, ARGENTINA Calls Brazil and Europe, daytime	<b>15250 kc. W1XAL</b> -B- 19.67 meters BOSTON, MASS. Irregular, in morning
<b>21020 kc. LSN6</b> -C- 14.27 meters HURLINGHAM, ARG. Calls N. Y. C. 8 a. m.-5 p. m.	<b>18830 kc. PLE</b> -C- 15.93 meters BANDONG, JAVA Calls Holland, early a. m.	<b>17775 kc.★PHI</b> -B- 16.88 meters N. V. PHILIPS' RADIO HUIZEN, HOLLAND Daily exc. Tues. and Wed. 8:30- 10:30 or 10:45 a.m., Sat. till 11:30, Sun. till 11:15 a.m.	<b>15760 kc. JYT</b> -X- 19.04 meters KEMIKWA-CHO, CHIBA- KEN, JAPAN Irregular in late afternoon and early morning	<b>15243 kc. FYA</b> -B- 19.68 meters "RADIO COLONIAL" PARIS, FRANCE Service de la Radiodiffusion 103 Rue de Grenelle, Paris 6-10 a.m.
<b>20700 kc. LSY</b> -C- 14.49 meters MONTE GRANDE ARGENTINA Tests irregularly	<b>18620 kc. GAU</b> -C- 16.11 meters RUGBY, ENGLAND Calls N. Y., daytime	<b>17760 kc. DJE</b> -B- 16.89 meters BROADCASTING HOUSE BERLIN, GERMANY Irregular 8-11:30 a.m.	<b>15660 kc. JVE</b> -C- 19.18 meters NAZAKI, JAPAN Phones Java 3-5 a.m.	<b>15220 kc.★PCJ</b> -X- 19.71 meters N.V. PHILIPS' RADIO EINDHOVEN, HOLLAND Broadcasts relaying PHI
<b>20380 kc. GAA</b> -C- 14.72 meters RUGBY, ENGLAND Calls Argentina, Brazil, mornings	<b>18345 kc. FZS</b> -C- 16.35 meters SAIGON, INDO-CHINA Phones Paris, early morning	<b>17620 kc. IAC</b> -C- 16.89 meters PIZA, ITALY Calls ships, 6:30-7:30 a. m.	<b>15620 kc. JVF</b> -C- 19.2 meters NAZAKI, JAPAN Phones U.S., 5 a.m. & 8 p.m.	<b>15210 kc.★W8XK</b> -B- 19.72 meters WESTINGHOUSE ELECTRIC & MFG. CO. PITTSBURGH, PA. 6 a.m.-4:15 p.m. Relays KDKA
<b>19900 kc. LSG</b> -C- 15.08 meters MONTE GRANDE, ARGENTINA Tests irregularly, daytime	<b>18340 kc. WLA</b> -C- 16.36 meters LAWRENCEVILLE, N. J. Calls England, daytime	<b>17310 kc. W3XL</b> -X- 17.33 meters NATIONAL BROAD. CO. BOUND BROOK, N. J. Tests irregularly	<b>15415 kc. KWO</b> -C- 19.46 meters DIXON, CAL. Phones Hawaii 2-7 p.m.	<b>15200 kc. DJB</b> -B- 19.73 meters BROADCASTING HOUSE BERLIN, GERMANY 12:30-2, 3:45-7:15 a.m.
<b>19820 kc. WKN</b> -C- 15.14 meters LAWRENCEVILLE, N. J. Calls England, daytime	<b>18310 kc. GAS</b> -C- 16.38 meters RUGBY, ENGLAND Calls N. Y., daytime	<b>17120 kc. WOO</b> -C- 17.52 meters A. T. & T. CO., OCEAN GATE, N. J. Calls ships	<b>15370 kc.★HAS3</b> -B- 19.52 meters BUDAPEST, HUNGARY Broadcasts Sundays, 9-10 a.m.	<b>15140 kc.★GSF</b> -B- 19.82 meters BRITISH BROAD. CORP. DAVENTRY, ENGLAND See "When to Listen In" Column
<b>19650 kc. LSN5</b> -C- 15.27 meters HURLINGHAM, ARGENTINA Calls Europe, daytime	<b>18250 kc. FTO</b> -C- 16.43 meters ST. ASSISE, FRANCE Calls S. America, daytime	<b>17080 kc. GBC</b> -C- 17.56 meters RUGBY, ENGLAND Calls Ships	<b>15355 kc. KWU</b> -C- 19.53 meters DIXON, CAL. Phones Pacific Isles and Japan	<b>15120 kc.★HVJ</b> -B- 19.83 meters VATICAN CITY ROME, ITALY 10:30 to 10:45 a.m., except Sunday
<b>19600 kc. LSF</b> -C- 15.31 meters MONTE GRANDE, ARGENTINA Tests irregularly, daytime	<b>18200 kc. GAW</b> -C- 16.46 meters RUGBY, ENGLAND Calls N. Y., daytime			
	<b>18135 kc. PMC</b> -C- 16.54 meters BANDONG, JAVA Phones Holland, early a. m.			

(All Schedules Eastern Standard Time)

<p><b>15090 kc. RKI</b> -C- 19.88 meters MOSCOW, U.S.S.R. Phones Tashkent near 7 a.m. and relays RNE on Sundays irregularly</p>	<p><b>12825 kc. CNR</b> -B, C- 23.39 meters DIRECTOR GENERAL Telegraph and Telephone Stations, Rabat, Morocco Broadcasts, Sunday, 7:30-9 a.m.</p>	<p><b>11750 kc. ★GSD</b> -B- 25.53 meters BRITISH BROAD. CORP. DAVENTRY, ENGLAND See "When to Listen In" Column</p>	<p><b>10055 kc. ZFB</b> -C- 29.84 meters HAMILTON, BERMUDA Phones N. Y. C. daytime</p>	<p><b>9580 kc. ★VK3LR</b> -B- 31.32 meters Research Section. Postmaster Gen'l's. Dept., 61 Little Collins St., MELBOURNE, AUSTRALIA 3:15-7:30 a.m. except Sun.</p>
<p><b>15055 kc. WNC</b> -C- 19.92 meters HIALEAH, FLORIDA Calls Central America, daytime</p>	<p><b>12800 kc. IAC</b> -C- 23.45 meters PIZA, ITALY Calls Italian ships, mornings</p>	<p><b>11720 kc. ★CJRX</b> -B- 25.6 meters WINNIPEG, CANADA Daily, 8 p. m.-12 m.</p>	<p><b>9950 kc. GCU</b> -C- 30.15 meters RUGBY, ENGLAND Calls N.Y.C. evening</p>	<p><b>9570 kc. ★W1XK</b> -B- 31.35 meters WESTINGHOUSE ELECTRIC &amp; MFG. CO. SPRINGFIELD, MASS. Relays WBZ, 6 a.m.-12 m.</p>
<p><b>14980 kc. KAY</b> -C- 20.03 meters MANILA, P. I. Phones Pacific Isles</p>	<p><b>12780 kc. GBC</b> -C- 23.47 meters RUGBY, ENGLAND Calls ships</p>	<p><b>11705 kc. ★FYA</b> -B- 25.63 meters "RADIO COLONIAL" PARIS, FRANCE 6-9 p.m. 10 p.m.-12 m.</p>	<p><b>9890 kc. LSN</b> -C- 30.33 meters HURLINGHAM, ARGENTINA Calls New York, evenings</p>	<p><b>9565 kc. VUB</b> -B- 31.38 meters BOMBAY, INDIA 11 a. m.-12:30 p. m., Wed., Sat. Sun. 7:30-8:30 a. m.</p>
<p><b>14950 kc. HJB</b> -C- 20.07 meters BOGOTA, COL. Calls WNC, daytime</p>	<p><b>12396 kc. CT1GO</b> -B- 24.2 meters PAREDE, PORTUGAL Sun. 10-11:30 a.m., Tue., Thur., Fri. 1:00-2:15 p.m.</p>	<p><b>11680 kc. KIO</b> -X- 25.88 meters KAHUKU, HAWAII Tests in the evening</p>	<p><b>9870 kc. WON</b> -C- 30.4 meters LAWRENCEVILLE, N. J. Phones England, evening</p>	<p><b>9560 kc. DJA</b> -B- 31.38 meters BROADCASTING HOUSE, BERLIN 8-11:30 a.m., 5:05-9:15 p.m.</p>
<p><b>14590 kc. WMN</b> -C- 20.56 meters LAWRENCEVILLE, N. J. Phones England morning and afternoon</p>	<p><b>12290 kc. GBU</b> -C- 24.41 meters RUGBY, ENGLAND Calls N.Y.C., afternoon</p>	<p><b>10770 kc. GBP</b> -C- 27.85 meters RUGBY, ENGLAND Calls Sydney, Austral. early a. m.</p>	<p><b>9860 kc. ★EAQ</b> -B- 30.43 meters P. O. Box 951 MADRID, SPAIN Daily except Saturday, 5:15-7:30 p.m.; Saturday, 12 n.-2 p.m.,</p>	<p><b>9540 kc. ★DJN</b> -B- 31.45 meters BROADCASTING HOUSE BERLIN, GERMANY 3:45-7:15 a.m., 8-11:30 a.m., 5:05-10:30 p.m.</p>
<p><b>14535 kc. HBJ</b> -B- 20.64 meters RADIO NATIONS, GENEVA, SWITZERLAND Broadcasts irregularly</p>	<p><b>12150 kc. GBS</b> -C- 24.69 meters RUGBY, ENGLAND Calls N.Y.C., afternoon</p>	<p><b>10740 kc. ★JVM</b> -C- 27.93 meters NAZAKI, JAPAN Phones California evenings</p>	<p><b>9840 kc. JYS</b> -X- 30.49 meters KEMIKAWA-CHO, CHIBA- KEN, JAPAN Irregular, 4-7 a. m.</p>	<p><b>9540 kc. LKJ1</b> -B- 31.45 meters JELBY, NORWAY Relays Oslo 5-8 a. m.</p>
<p><b>14500 kc. LSM2</b> -C- 20.69 meters HURLINGHAM, ARGENTINA Calls U. S., evening</p>	<p><b>12000 kc. RNE</b> -B- 25 meters MOSCOW, U. S. S. R. Sun. 6-9, 10-11 a.m., 3-6 p.m. Wed. 5-6 a.m.</p>	<p><b>10675 kc. WNB</b> -C- 28.1 meters LAWRENCEVILLE, N. J. Calls Bermuda, daytime</p>	<p><b>9800 kc. LSE</b> -C- 30.61 meters MONTE GRANDE, ARGENTINA Tests irregularly</p>	<p><b>9530 kc. ★W2XAF</b> -B- 31.48 meters GENERAL ELECTRIC CO. SCHENECTADY, N. Y. Relays WGY 5:25-11 p.m.</p>
<p><b>14485 kc. TIR</b> -C- 20.71 meters CARTAGO, COSTA RICA Phones Cen. Amer. &amp; U.S.A. Daytime</p>	<p><b>11991 kc. FZS2</b> -C- 25.02 meters SAIGON, INDO-CHINA Phones Paris, morning</p>	<p><b>10660 kc. ★JVN</b> -C- 28.14 meters NAZAKI, JAPAN Broadcasts irregularly 2-7:45 a.m.</p>	<p><b>9790 kc. GCW</b> -C- 30.64 meters RUGBY, ENGLAND Calls N.Y.C., evening</p>	<p><b>9510 kc. GSB</b> -B- 31.55 meters BRITISH BROAD. CORP. DAVENTRY, ENGLAND See "When to Listen In" Column</p>
<p><b>14485 kc. HPF</b> -C- 20.71 meters PANAMA CITY, PAN. Phones WNC daytime</p>	<p><b>11950 kc. KKQ</b> -X- 25.10 meters BOLINAS, CALIF. Tests, irregularly, evenings</p>	<p><b>10550 kc. WOK</b> -C- 28.44 meters LAWRENCEVILLE, N. J. Phones Arg., Braz., Peru, nights</p>	<p><b>9760 kc. VLJ-VLZ2</b> -C- 30.74 meters AMALGAMATED WIRELESS OF AUSTRALIA SYDNEY, AUSTRALIA Phones Java and N. Zealand early a.m.</p>	<p><b>9510 kc. ★VK3ME</b> -B- 31.55 meters AMALGAMATED WIRELESS, Ltd. G. P. O. Box 1272L, MELBOURNE, AUSTRALIA Wed., Thurs., Fri., Sat. 5:00-7:00 a. m.</p>
<p><b>14485 kc. YNA</b> -C- 20.71 meters MANAGUA, NICARAGUA Phones WNC daytime</p>	<p><b>11940 kc. FTA</b> -C- 25.13 meters STE. ASSISE, FRANCE Phones CNR morning, Hurlingham, Arge., nights</p>	<p><b>10520 kc. VLK</b> -C- 28.51 meters SYDNEY, AUSTRALIA Calls Rugby, early a.m.</p>	<p><b>9750 kc. WOF</b> -C- 30.77 meters LAWRENCEVILLE, N. J. Phones England, evening</p>	<p><b>9500 kc. ★PRF5</b> -B- 31.58 meters RIO DE JANEIRO, BRAZIL except Sun. 5:30-6:15 p. m.</p>
<p><b>14470 kc. WMF</b> -C- 20.73 meters LAWRENCEVILLE, N. J. Phones England morning and afternoon</p>	<p><b>11875 kc. ★FYA</b> -B- 25.25 meters "RADIO COLONIAL" PARIS, FRANCE 10:15 a.m.-1:15 p.m., 2-5 p.m.</p>	<p><b>10430 kc. YBG</b> -C- 28.76 meters MEDAN, SUMATRA 5:30-6:30 a. m., 7:30-8:30 p. m.</p>	<p><b>9710 kc. GCA</b> -C- 30.89 meters RUGBY, ENGLAND Calls Arge. &amp; Brazil, evenings</p>	<p><b>9428 kc. ★COH</b> -B- 31.8 meters 2 B ST., VEDADO, HAVANA, CUBA 10 a.m.-12 n., 4-6:30, 8-10 p.m. also 11 a.m.-12 N. Thurs.</p>
<p><b>14440 kc. GBW</b> -C- 20.78 meters RUGBY, ENGLAND Calls U.S.A., afternoon</p>	<p><b>11870 kc. ★W8XK</b> -B- 25.26 meters WESTINGHOUSE ELECTRIC &amp; MFG. CO. PITTSBURGH, PA. 4:20-10 p.m. Fri. till 12 m Relays KDKA</p>	<p><b>10420 kc. XGW</b> -C- 28.79 meters SHANGHAI, CHINA Calls Manila and England, 6-9 a. m. and California late evening</p>	<p><b>9635 kc. ★I2RO</b> -B- 31.13 meters E. I. A. R., ROME, ITALY Daily 2:30-5 or 6 p.m. M., W., F. 6-7:30, 7:45-9:15 p.m.</p>	<p><b>9415 kc. PLV</b> -C- 31.87 meters BANDONG, JAVA Phones Holland, 7:40-9:40 a. m.</p>
<p><b>13990 kc. GBA</b> -C- 21.44 meters RUGBY, ENGLAND Calls Buenos Aires, late afternoon</p>	<p><b>11860 kc. GSE</b> -B- 25.29 meters BRITISH BROAD. CORP. DAVENTRY, ENGLAND See "When to Listen In" Column</p>	<p><b>10410 kc. PDK</b> -C- 28.80 meters KOOTWIJK, HOLLAND Calls Java 7:30-9:40 a. m.</p>	<p><b>9600 kc. ★CT1AA</b> -B- 31.25 meters LISBON, PORTUGAL Tues., Thurs., Sat. 3:30-6 p.m.</p>	<p><b>9330 kc. CJA2</b> -C- 32.15 meters DRUMMONDVILLE, CANADA Phones England irregularly</p>
<p><b>13610 kc. JYK</b> -C- 22.04 meters KEMIKAWA-CHO, CHIBA- KEN, JAPAN Phones California till 11 p. m.</p>	<p><b>11855 kc. DJP</b> -X- 25.31 meters BROADCASTING HOUSE BERLIN, GERMANY Tests irregularly</p>	<p><b>10410 kc. KES</b> -X- 28.80 meters BOLINAS, CALIF. Tests evenings</p>	<p><b>9595 kc. ★HBL</b> -B- 31.27 meters LEAGUE OF NATIONS GENEVA, SWITZERLAND Saturdays, 5:30-6:15 p. m.</p>	<p><b>9280 kc. GCB</b> -C- 32.33 meters RUGBY, ENGLAND Calls Can. &amp; Egypt, evenings</p>
<p><b>13585 kc. GBB</b> -C- 22.08 meters RUGBY, ENGLAND Calls Egypt &amp; Canada, afternoons</p>	<p><b>11830 kc. ★W2XE</b> -B- 25.36 meters ATLANTIC BROADCASTING CORP. 485 MADISON AVE., N. Y. C. 2-4 p.m. Relays WABC</p>	<p><b>10350 kc. ★LSX</b> -C- 28.98 meters MONTE GRANDE, ARGENTINA Tests irregularly 8 p.m.-12 mid- night.</p>	<p><b>9590 kc. ★VK2ME</b> -B- 31.28 meters AMALGAMATED WIRELESS, LTD., 47 YORK ST. SYDNEY, AUSTRALIA Sundays 1-3, 5-9 a.m., 10:30 a.m.-12:30 p.m.</p>	<p><b>9170 kc. WNA</b> -C- 32.72 meters LAWRENCEVILLE, N. J. Phones England, evening</p>
<p><b>13415 kc. GCJ</b> -C- 22.36 meters RUGBY, ENGLAND Calls Japan &amp; China early morning</p>	<p><b>11811 kc. I2RO</b> -B- 25.4 meters E. I. A. R., Via Montello 5 ROME, ITALY</p>	<p><b>10330 kc. ORK</b> -C- 29.04 meters RUYSSSELEDE, BELGIUM Broadcasts 1:30-3 p.m.</p>	<p><b>9590 kc. HP5J</b> -B- 31.28 meters J Street PANAMA CITY, PANAMA 7:30-11 p.m.</p>	<p><b>9125 kc. ★HAT4</b> -B- 32.88 meters "RADIOLABOR," GYAI-UT 22 BUDAPEST, HUNGARY Sunday 6-7 p.m.</p>
<p><b>13390 kc. WMA</b> -C- 22.40 meters LAWRENCEVILLE, N. J. Phones England morning and afternoon</p>	<p><b>11795 kc. DJO</b> -X- 25.43 meters BROADCASTING HOUSE BERLIN, GERMANY Tests irregularly</p>	<p><b>10300 kc. LSL2</b> -C- 29.13 meters HURLINGHAM, ARGENTINA Calls Europe, evenings</p>	<p><b>9590 kc. W3XAU</b> -B- 31.28 meters NEWTOWN SQUARE, PA. Relays WCAU 11 a.m.-6:50 p.m.</p>	<p><b>9020 kc. GCS</b> -C- 33.26 meters RUGBY, ENGLAND Calls N.Y.C., evenings</p>
<p><b>13075 kc. VP1A</b> -X- 22.94 meters SUVA, FIJI ISLANDS Daily exc. Sat. and Sun. 12:30-1:30 a.m.</p>	<p><b>11790 kc. W1XAL</b> -B- 25.45 meters BOSTON, MASS. Irregularly in the afternoon</p>	<p><b>10290 kc. DIQ</b> -X- 29.16 meters KONIGSWUSTERHAUSEN, GERMANY Broadcasts irregularly</p>	<p><b>9580 kc. ★GSC</b> -B- 31.32 meters BRITISH BROAD. CORP. DAVENTRY, ENGLAND See "When to Listen In" Column</p>	<p><b>9010 kc. KEJ</b> -C- 33.3 meters BOLINAS, CAL. Relays NBC &amp; CBS Programs in evening irregularly</p>
<p><b>12840 kc. WOO</b> -C- 23.36 meters OCEAN GATE, N. J. Calls ships</p>	<p><b>11770 kc. ★DJD</b> -B- 25.49 meters BROADCASTING HOUSE, BERLIN, GERMANY 12-4:30, 5:05-10:30 p.m.</p>	<p><b>10260 kc. PMN</b> -C- 29.24 meters BANDONG, JAVA Calls Australia 5 a.m.</p>	<p><b>9580 kc. PSH</b> -C- 29.35 meters RIO DE JANEIRO, BRAZIL</p>	<p><b>8775 kc. PNI</b> -C- 34.19 meters MAKASSER, CELEBES, D. E. I. Phones Java around 4 a. m.</p>

(All Schedules Eastern Standard Time)



<p><b>8760 kc. GCQ</b> -C- 34.25 meters RUGBY, ENGLAND Calls S. Africa, afternoon</p>	<p><b>6800 kc. HIH</b> -B- 44.12 meters SAN PEDRO de MACORIS DOMINICAN REP. 12:10-1:40 p.m., 6:40-7:40 p.m., Sun. 3-4 a.m., 12:10-1:40 p.m., 2:20-4:40 p.m.</p>	<p><b>6198 kc. CT1GO</b> -B- 48.4 meters Portuguese Radio Club. PAREDE, PORTUGAL Sun. 11:30 a.m.-1 p.m. Daily exc. Tues. 7:20-8:30 p.m.</p>	<p><b>6110 kc. VUC</b> -B- 49.1 meters CALCUTTA, INDIA Daily except Sat., 3-5:30 a. m., 9:30 a. m.-noon; Sat., 11:45 a. m.-3 p. m.</p>	<p><b>6042 kc. HJ1ABG</b> -B- 49.65 meters BARRANQUILLA, COLO. 12 n.-1 p.m., 6-10 p.m. Sun. 1-6 p.m.</p>
<p><b>8730 kc. GCI</b> -C- 34.36 meters RUGBY, ENGLAND Calls India, 8 a. m.</p>	<p><b>6755 kc. WOA</b> -C- 44.41 meters LAWRENCEVILLE, N. J. Phones England, evening</p>	<p><b>6185 kc. HI1A</b> -B- 48.5 meters P. D. BOX 423, SANTIAGO, DOMINICAN REP. 11:40 a. m.-1:40 p. m. 7:40-9:40 p. m.</p>	<p><b>6105 kc. HJ4ABL</b> -B- 49.14 meters MANISALES, COL. Daily 6-7:30 p.m., Sat. 11 p.m.- 12 m.</p>	<p><b>6040 kc. W1XAL</b> -B- 49.67 meters BOSTON, MASS. Tues., Thurs. 7:30-9 p.m. Sun. 5-7 p.m.</p>
<p><b>8680 kc. GBC</b> -C- 34.56 meters RUGBY, ENGLAND Calls ships</p>	<p><b>6750 kc. JVT</b> -X- 44.44 meters NAZAKI, JAPAN KOKUSAI-DENWA KAISHA, LTD., TOKIO Broadcasts 2-7:45 a.m.</p>	<p><b>6175 kc. HJ2ABA</b> -B- 48.58 meters TUNJA, COLOMBIA 1-2; 7:30-9:30 p.m.</p>	<p><b>6100 kc. W3XAL</b> -B- 49.18 meters NATIONAL BROADCASTING CO. BOUND BROOK, N. J. Relays WJZ Monday, Wednesday, Saturday, 4-5 p.m. Sat. also 11 p.m.-12 m.</p>	<p><b>6030 kc. HP5B</b> -B- 49.75 meters P. O. BOX 910 PANAMA CITY, PAN. 12 N.-1 p.m., 8-10:30 p.m.</p>
<p><b>8560 kc. WOO</b> -C- 35.05 meters OCEAN GATE, N. J. Calls ships irregular</p>	<p><b>6666 kc. HC2RL</b> -B- 45.00 meters P. D. BOX 759, GUAYAQUIL, ECUADOR, S. A. Sunday, 5:45-7:45 p. m. Tues., 9:15-11:15 p. m.</p>	<p><b>6170 kc. HJ3ABF</b> -B- 48.62 meters BOGOTA, COLOMBIA 6-11 p.m.</p>	<p><b>6100 kc. W9XF</b> -B- 49.18 meters DOWNERS GROVE, ILL. Relays WENR, Chicago Daily except Mon, Wed. &amp; Sat., 2:30 p. m.-2 a. m. Mon., Wed. 2:30-4, 6 p.m.-2 a.m. Sat. 2:30-4, 6 p.m.-12 m.</p>	<p><b>6030 kc. VE9CA</b> -B- 49.75 meters CALGARY, ALBERTA, CAN. 9 a.m.-3 p.m., 7 p.m.-12 m.</p>
<p><b>8380 kc. IAC</b> -C- 35.8 meters PIZA, ITALY</p>	<p><b>6660 kc. TIEP</b> -B- 45.05 meters LA-VOZ DEL TROPICO SAN JOSE, COSTA RICA APARTADO 257, Daily 7-10 p.m.</p>	<p><b>6160 kc. YV3RC</b> -B- 48.7 meters CARACAS, VENEZUELA Generally 4:00-10:00 p. m.</p>	<p><b>6090 kc. VE9GW</b> -B- 49.26 meters BOWMANVILLE, ONTARIO, CANADA</p>	<p><b>6020 kc. CQN</b> -B- 49.83 meters MACAO, CHINA Mon. and Fri. 3-5 a.m.</p>
<p><b>8036 kc. CNR</b> -B- 37.33 meters RABAT, MOROCCO Sunday, 2:30-5 p. m.</p>	<p><b>6650 kc. IAC</b> -C- 45.1 meters PIZA, ITALY Calls ships, evenings</p>	<p><b>6155 kc. CO9GC</b> -B- 48.74 meters GRAU &amp; CAMENOS LABS., BOX 137, SANTIAGO, CUBA 9-10 a.m., 11:30 a.m.-1:30 p.m., 3-4:30 p.m. and irregularly 7-11 p.m.</p>	<p><b>6090 kc. VE9BJ</b> -B- 49.28 meters SAINT JOHN, N. B., CAN. 7-8:30 p. m.</p>	<p><b>6020 kc. DJC</b> -B- 49.83 meters BROADCASTING HOUSE, BERLIN 12 n.-4:30 p.m., 9:30-10:30 p. m.</p>
<p><b>7880 kc. JYR</b> -B- 38.07 meters KEMIKAWA-CHO, CHIBA- KEN, JAPAN 4-7:40 a. m.</p>	<p><b>6620 kc. PRADO</b> -B- 45.30 meters RIOBAMBA, ECUADOR Thurs. 9-11:45 p.m.</p>	<p><b>6150 kc. CSL</b> -B- 48.78 meters LISBON, PORTUGAL 7-8:30 a.m., 2-7 p.m.</p>	<p><b>6080 kc. VE9BJ</b> -B- 49.28 meters SAINT JOHN, N. B., CAN. 7-8:30 p. m.</p>	<p><b>6012 kc. ZHI</b> -B- 49.9 meters RADIO SERVICE CO., 20 ORCHARD RD., SINGAPORE, MALAYA Mon., Wed., Thurs., 5:40-8:10 a. m.; Sat., 12:10-1:10 a. m., 10:40 p. m.-1:10 a. m. (Sunday)</p>
<p><b>7860 kc. HC2JSB</b> -B- 38.17 meters GUAYAQUIL, ECUADOR 8:15-11:15 p.m.</p>	<p><b>6611 kc. RW72</b> -B- 45.38 meters MOSCOW, U. S. S. R. 1-6 p. m.</p>	<p><b>6150 kc. CJRO</b> -B- 48.78 meters WINNIPEG, MAN., CANADA 6 p. m.-12 m. Sun. 3-10:30 p. m.</p>	<p><b>6080 kc. CP5</b> -B- 49.34 meters LAPAZ, BOLIVIA 7-10:30 p. m.</p>	<p><b>6010 kc. COC</b> -B- 49.92 meters P.O. BOX 98 HAVANA, CUBA Daily 9:30-11 a.m., 4-7 p.m. Sat. also at 11:30 p.m.</p>
<p><b>7799 kc. HBP</b> -B- 38.47 meters LEAGUE OF NATIONS, GENEVA, SWITZERLAND 5:30-6:15 p. m., Saturday</p>	<p><b>6610 kc. HI4D</b> -B- 45.39 meters SANTO DOMINGO, DOMINI- CAN REPUBLIC Except Sun. 11:55 a.m.-1:40 p.m.; 4:40-7:40 p.m.</p>	<p><b>6140 kc. W8XK</b> -B- 48.86 meters WESTINGHOUSE ELECTRIC &amp; MFG. CO. PITTSBURGH, PA. Relays KDKA 4:30 p.m.-12 m.</p>	<p><b>6079 kc. DJM</b> -X- 49.35 meters BROADCASTING HOUSE BERLIN, GERMANY Tests irregularly</p>	<p><b>6000 kc. RW59</b> -B- 50 meters MOSCOW, U. S. S. R. Daily 3-6 p.m.</p>
<p><b>7715 kc. KEE</b> -C- 38.89 meters BOLINAS, CAL. Relays NBC &amp; CBS Programs in evening irregularly</p>	<p><b>6528 kc. HIL</b> -B- 45.95 meters SANTO DOMINGO, D.R. Sat., 8-10 p.m.</p>	<p><b>6130 kc. ZGE</b> -B- 48.92 meters KUALA LUMPUR, FED. MALAY STATES Sun., Tue., and Fri., 6:40-8:40 a. m.</p>	<p><b>6072 kc. ZHJ</b> -B- 49.41 meters PENANG, MALAYA Mon., Wed., Sat. 8-10 Also heard Fri. till 3:30 a.m.</p>	<p><b>5990 kc. XEBT</b> -B- 50.08 meters MEXICO CITY, MEX. P. O. Box 79-44 7 p. m.-1 a. m.</p>
<p><b>7510 kc. JVP</b> -C- 39.95 meters NAZAKI, JAPAN Heard irregularly</p>	<p><b>6520 kc. YV6RV</b> -B- 46.01 meters VALENCIA, VENEZUELA 5-7, 9-11 p.m., irregular</p>	<p><b>6128 kc. LKJ1</b> -B- 48.94 meters JELOV, NORWAY Relays Oslo. 10 a.m.-6 p.m.</p>	<p><b>6072 kc. OER2</b> -B- 49.41 meters VIENNA, AUSTRIA 9 a. m.-5 p. m. daily</p>	<p><b>5980 kc. XECW</b> -B- 50.17 meters SANTO DOMINGO, DOMINI- CAN REP. Tues. and Fri. at 8:10 p.m. Sun. at 7:40 a.m., irreg. Tues. and Thurs.</p>
<p><b>7400 kc. HJ3ABD</b> -B- 40.54 meters P. O. Box 509 BOGOTA, COLOMBIA Daily 12-2 p. m.; 7-11 p. m. Sunday, 5-9 p. m.</p>	<p><b>6490 kc. HJ5ABD</b> -B- 46.22 meters MANIZALES, COL. 12-1:30 p. m., 7-10 p. m.</p>	<p><b>6122 kc. JB</b> -B- 49 meters JOHANNESBURG, SOUTH AFRICA Daily except Sat. and Sun., 11:45 p. m.-12:30 a. m., 4-7 a. m., 9 a. m.-3:30 p. m., Sat., only, 4-7 a. m., 9 a. m.- 11:45 p. m. Sun., only, 11:45 p. m.-12:30 a. m., 8-10:30 a. m. and 12:30- 3 p. m.</p>	<p><b>6070 kc. VE9CS</b> -B- 49.42 meters VANCOUVER, B. C., CANADA Sun. 1:45-9 p. m., 10:30 p. m.- 1 a. m.; Tues. 6-7:30 p. m., 11:30 p. m.-1:30 a. m. Daily 6-7:30 p. m.</p>	<p><b>5970 kc. HJ3ABH</b> -B- 50.25 meters BOGOTA, COLO. APARTADO 565 7-11 p.m.</p>
<p><b>7380 kc. XECR</b> -B- 40.65 meters FOREIGN OFFICE, MEXICO CITY, MEX. Sun. 6-7 p.m.</p>	<p><b>6447 kc. HJ1ABB</b> -B- 46.53 meters BARRANQUILLA, COL., S. A. P. O. BOX 715, 11:30 a. m.-1 p. m.; 5-10 p. m.</p>	<p><b>6120 kc. YDA</b> -B- 49.02 meters N.I.R.O.M. BANDDENG, JAVA 10:40 p.m.-1:40 a.m., 5-9:40 a.m.</p>	<p><b>6060 kc. OXY</b> -B- 49.50 meters SKAMLEBOEK, DENMARK 1-6:30 p. m.; also 11 a. m.-12 n. Sunday</p>	<p><b>5968 kc. HVJ</b> -B- 50.27 meters VATICAN CITY (ROME) 2-2:15 p. m., daily, Sun., 5-5:30 a. m.</p>
<p><b>7310 kc. HJ1ABD</b> -B- 41.04 meters CARTAGENA, COLO. Irregularly, evenings</p>	<p><b>6425 kc. W3XL</b> -X- 46.70 meters NATIONAL BROADCASTING CO. BOUND BROOK, N. J. Tests irregularly</p>	<p><b>6120 kc. W2XE</b> -B- 49.02 meters ATLANTIC BROADCASTING CORP. 485 MADISON AVE., N. Y. C. Relays WABC, 5-10 p.m.</p>	<p><b>6060 kc. W8XAL</b> -B- 49.50 meters CROSLY RADID CORP. CINCINNATI, OHIO 6:30 a.m.-7 p.m.; 10 p.m.-1 a.m. Relays WLW</p>	<p><b>5950 kc. HJ1ABJ</b> -B- 50.42 meters SANTA MARTA, COLO. 11 a.m.-1 p.m., 7-9 p.m.</p>
<p><b>7140 kc. HJ4ABB</b> -B- 42.02 meters MANIZALES, COL., G. A. P. O. Box 175 Mon. to Fri. 12:15-1 p. m.; Tues. &amp; Fri. 7:30-10 p. m.; Sun. 2:30-5 p. m.</p>	<p><b>6425 kc. VE9AS</b> -X- 46.7 meters FREDERICTON, N.B., CANADA Operates irregularly</p>	<p><b>6115 kc. HJ1ABE</b> -B- 49.05 meters CARTAGENA, COL. P. O. Box 31 Daily 11:15 a. m.-1 p. m.; Sun. 9-11 a.m.; Mon. 10 p.m.-12 m. Wed. 8-11 p.m.</p>	<p><b>6060 kc. VQ7LO</b> -B- 49.50 meters NAIROBI, KENYA, AFRICA Mon., Wed., Fri., 5:45-6:15 a. m., 11 a. m.-2 p. m., Tues., 3-4 a. m., 11 a. m.-2 p. m., Thurs., 8-9 a. m., 11 a. m.- 2 p. m., Sat., 11 a. m.-3 p. m., Sun., 10:50 a. m.-2 p. m.</p>	<p><b>5950 kc. HJ4ABE</b> -B- 50.42 meters MEDELLIN, COLO. Mon. 7-11 p.m., Tues., Thurs., Sat. 6:30-8 p.m., Wed. and Fri. 7:30-11 p.m.</p>
<p><b>7092 kc. HKE</b> -B- 42.3 meters BOGOTA, COL., S. A. Tue. and Sat. 8-9 p. m.; Mon. &amp; Thurs. 6:30-7 p. m.</p>	<p><b>6375 kc. YV4RC</b> -B- 47.06 meters CARACAS VENEZUELA 4:30-10:30 p.m.</p>	<p><b>6112 kc. YV2RC</b> -B- 49.08 meters CARACAS, VENEZUELA Sun. 9:30 a.m.-10:30 p.m., Daily except Sun. 10:30 a.m.-1:30 p.m.; 4-10 p.m.</p>	<p><b>6045 kc. HJ3ABI</b> -B- 49.63 meters BDGOTA, COLO. Irregular in evening</p>	<p><b>5940 kc. TGX</b> -B- 50.5 meters SR. M. NOVALES, GUATEMALA CITY, GUAT. Daily except Sun., 8-10 a.m., 1-2:30 p.m., 8 p.m.-12m.</p>
<p><b>7030 kc. HRP1</b> -B- 42.67 meters SAN PEDRO SULA, HONDURAS Reported on this and other waves irregularly in evening</p>	<p><b>6250 kc. HJ4ABC</b> -B- 48 meters PERIERA, COL. 9:30-11:30 a.m., 7-8 or 9 p.m.</p>	<p><b>6110 kc. GSL</b> -B- 48.10 meters British Broadcasting Corp. Davenport, England See "When To Listen In"</p>	<p><b>5890 kc. HJ2ABC</b> -B- 50.97 meters CUCUTA, COL.</p>	<p><b>5890 kc. HJ2ABC</b> -B- 50.97 meters CUCUTA, COL.</p>

# Television Stations

**2000-2100 kc.**

W2XDR—Long Island City, N.Y.  
 W8XAN—Jackson, Mich.  
 W9XK—Iowa City, Ia.  
 W9XAK—Manhattan, Kans.  
 W9XAO—Chicago, Ill.  
 W6XAH—Bakersfield, Calif.

**2750-2850 kc.**

W3XAK—Portable  
 W9XAP—Chicago, Ill.

W2XBS—Bellmore, N.Y.  
 W9XAL—Kansas City, Mo.  
 W9XG—W. Lafayette, Ind.  
 W2XAB—New York, N.Y.

**42000-56000, 60000-86000 kc.**

W2XAX—New York, N.Y.  
 W6XAO—Los Angeles, Calif.  
 W9XD—Milwaukee, Wis.  
 W2XBT—Portable  
 W2XF—New York, N.Y.

W3XE—Philadelphia, Pa.  
 W3XAD—Camden, N.J.  
 W10XX—Portable & Mobile (Vicinity of Camden)  
 W2XDR—Long Island City, N.Y.  
 W8XAN—Jackson, Mich.  
 W9XAT—Portable  
 W2XD—New York, N.Y.  
 W2XAG—Portable  
 W1XG—Boston, Mass.  
 W9XK—Iowa City, Ia.

# Police Radio Alarm Stations

CGZ Vancouver, B.C. 2452 kc.  
 CJW St. Johns, N.B. 2416 kc.  
 CJZ Verdeen, Que. 2452 kc.  
 KGHA Portable-Mobile 2490 kc.  
 KGHB }  
 KGHC } In State of Wash. 2490 kc.  
 KGHD }  
 KGHE }  
 KGHF }  
 KGHG } Las Vegas, Nev. 2474 kc.  
 KGHH } Palo Alto, Cal. 1674 kc.  
 KGHI } Reno, Nev. 2474 kc.  
 KGHJ } Hutchinson, Kans. 2450 kc.  
 KGHK } Des Moines, Iowa 1682 kc.  
 KGHL } Lakton, Okla. 2466 kc.  
 KGHM } Chinook Pass, W. 2490 kc.  
 KGHN } (Mobile) in Wash. 2490 kc.  
 KGHO } Spokane, Wash. 2414 kc.  
 KGHP } Brownsville, Tex. 2382 kc.  
 KGHQ } Austin, Tex. 2482 kc.  
 KGHR } Corpus Christi, Tex. 2382 kc.  
 KGHS } Centralia, Wash. 2414 kc.  
 KGHT } Santa Ana, Cal. 2490 kc.  
 KGHU } Whittier, Cal. 1712 kc.  
 KGHV } Little Rock, Ark. 2406 kc.  
 KGHW } Pasadena, Cal. 1712 kc.  
 KGHX } Albuquerque, N.M. 2414 kc.  
 KGHY } Cedar Rapids, Iowa 2466 kc.  
 KGHZ } Seattle, Wash. 2414 kc.  
 KGJX } Minneapolis, Minn. 2430 kc.  
 KGKX } St. Louis, Mo. 1706 kc.  
 KGLX } San Francisco, Cal. 2474 kc.  
 KGOX } Kansas City, Mo. 2422 kc.  
 KGPX } Santa Fe, N. Mex. 2414 kc.  
 KGPY } Vallejo, Cal. 2422 kc.  
 KGPZ } Oklahoma City, Okla. 2450 kc.  
 KGQX } Omaha, Neb. 2466 kc.  
 KGRX } Beaumont, Tex. 1712 kc.  
 KGRY } Sioux City, Iowa 2466 kc.  
 KGRZ } Los Angeles Cal. 1712 kc.  
 KGSA } San Jose, Cal. 2466 kc.  
 KGTA } Davenport, Iowa 2466 kc.  
 KGUB } Tulsa, Okla. 2450 kc.  
 KGUC } Portland, Ore. 2442 kc.  
 KGUD } Honolulu, T.H. 1712 kc.  
 KGUE } Minneapolis, Minn. 2430 kc.  
 KGUF } Bakersfield, Cal. 2414 kc.  
 KGUG } Salt Lake City, Utah 2406 kc.  
 KGUH } Denver, Colo. 2442 kc.  
 KGUI } Baton Rouge, La. 1574 kc.  
 KGUJ } Wichita, Kans. 2450 kc.  
 KGUK } Fresno, Calif. 2414 kc.  
 KGUL } Houston, Tex. 1712 kc.  
 KGUM } Topeka, Kans. 2422 kc.  
 KGUN } San Diego, Cal. 2490 kc.  
 KGUO } San Antonio, Tex. 2482 kc.  
 KGUP } Chanute, Kans. 2450 kc.  
 KGUQ } Des Moines, Iowa 2466 kc.  
 KGUR } Klamath Falls, Ore. 2382 kc.  
 KGUS } Wichita Falls, Tex. 2458 kc.  
 KGUT } Phoenix, Ariz. 2430 kc.  
 KGUV } Shreveport, La. 1712 kc.  
 KGUW } El Paso, Tex. 2414 kc.  
 KGUX } Tacoma, Wash. 2414 kc.  
 KGUY } Santa Barbara, Cal. 2414 kc.  
 KGUZ } Coffeyville, Kans. 2450 kc.  
 KGVA } Waco, Tex. 1712 kc.  
 KGVB } Salem, Ore. 2442 kc.  
 KGVC } McAlester, Okla. 2458 kc.  
 KGVD } Santa Cruz, Cal. 1674 kc.  
 KGVE } Lincoln, Neb. 2490 kc.  
 KGVF } Aberdeen, Wash. 2414 kc.  
 KGVG } Lubbock, Tex. 2458 kc.  
 KGVH } Albuquerque, N.Mex. 2414 kc.  
 KGVI } San Bernardino, Cal. 1712 kc.  
 KGVJ } Jefferson City, Mo. 1674 kc.  
 KGVK } Clovis, N. Mex. 2414 kc.

KNFB Idaho Falls, Idaho 2414 kc.  
 KNFC SS Gov. Stevens, (Wash.) 2490 kc.  
 KNFD SS Gov. J. Rogers, (Wash.) 2490 kc.  
 KNFE Duluth, Minn. 2382 kc.  
 KNFF Leavenworth, Kans. 2422 kc.  
 KNFG Olympia, Wash. 2490 kc.  
 KNFH Garden City, Kans. 2474 kc.  
 KNFI Mt. Vernon, Wash. 2414 kc.  
 KNFJ Pomona, Cal. 1712 kc.  
 KNFK Bellingham, Wash. 2490 kc.  
 KNFL Shuksan, Wash. 2490 kc.  
 KNFM Compton, Cal. 2490 kc.  
 KNFN Waterloo, Ia. 1682 kc.  
 KNFO Storm Lake, Ia. 1682 kc.  
 KNFP Everett, Wash. 2414 kc.  
 KNFQ Skykomish, Wash. 2490 kc.  
 KNFG Cleburne, Tex. 2490 kc.  
 KNGF Sacramento, Cal. 2422 kc.  
 KNGG Phoenix, Ariz. 1698 kc.  
 KNGH Dodge City, Kans. 2474 kc.  
 KNGJ El Centro, Cal. 2490 kc.  
 KNGK Duncan, Okla. 2450 kc.  
 KNGL Galveston, Tex. 1712 kc.  
 KSNE Duluth, Minn. 2382 kc.  
 KSW Berkeley, Cal. 1658 kc.  
 KVP Dallas, Tex. 1712 kc.  
 VYR Montreal, Can. 1712 kc.  
 VYW Winnipeg, Man. 2452 kc.  
 WCK Belle Island, Mich. 2414 kc.  
 WEY Boston, Mass. 1630 kc.  
 WKDT Detroit, Mich. 1630 kc.  
 WKDU Cincinnati, Ohio 1706 kc.  
 WMDZ Indianapolis, Ind. 2442 kc.  
 WMFP Niagara Falls, N. Y. 2422 kc.  
 WMJ Buffalo, N.Y. 2422 kc.  
 WMO Highland Park, Mich. 2414 kc.  
 WMP Framingham, Mass. 1666 kc.  
 WPDA Tulare, Cal. 2414 kc.  
 WPDB Chicago, Ill. 1712 kc.  
 WPDC Chicago, Ill. 1712 kc.  
 WPDD Chicago, Ill. 1712 kc.  
 WPDE Louisville, Ky. 2442 kc.  
 WPDF Flint, Mich. 2466 kc.  
 WPDG Youngstown, Ohio 2458 kc.  
 WPDH Richmond, Ind. 2442 kc.  
 WPGI Columbus, Ohio 2430 kc.  
 WPGJ Milwaukee, Wis. 2450 kc.  
 WPGK Lansing, Mich. 2442 kc.  
 WPGM Dayton, Ohio 2430 kc.  
 WPGN Auburn, N.Y. 2382 kc.  
 WPDO Akron, Ohio 2458 kc.  
 WPDQ Philadelphia, Pa. 2474 kc.  
 WPDV Rochester, N.Y. 2422 kc.  
 WPDW St. Paul, Minn. 2430 kc.  
 WPEA Kokomo, Ind. 2490 kc.  
 WPEB Pittsburgh, Pa. 1712 kc.  
 WPEC Charlotte, N.C. 2458 kc.  
 WPEF Washington, D.C. 2422 kc.  
 WPEG Detroit, Mich. 2414 kc.  
 WPEH Atlanta, Ga. 2414 kc.  
 WPEI Fort Wayne Ind. 2490 kc.  
 WPEJ Syracuse, N.Y. 2382 kc.  
 WPEK Grand Rapids, Mich. 2442 kc.  
 WPEL Memphis, Tenn. 2466 kc.  
 WPEM Arlington, Mass. 1712 kc.  
 WPEO New York, N.Y. 2450 kc.  
 WPEP New York, N.Y. 2450 kc.  
 WPEQ New York, N.Y. 2450 kc.  
 WPER Somerville, Mass. 1712 kc.  
 WPEU E. Providence, R.I. 1712 kc.  
 WPEV New Orleans, La. 2430 kc.  
 WPEW W. Bridgewater, Mass. 1666 kc.  
 WPEX Woonsocket, R.I. 2466 kc.  
 WPEY Kenosha, Wis. 2450 kc.

WPES Saginaw, Mich. 2442 kc.  
 WPET Lexington, Ky. 1706 kc.  
 WPEV Portable (in Mass.) 1666 kc.  
 WPEW Northampton, Mass. 1666 kc.  
 WPFA Newton, Mass. 1712 kc.  
 WPFM Muskegon, Mich. 2442 kc.  
 WPFN Reading, Pa. 2442 kc.  
 WPGJ Jacksonville, Fla. 2442 kc.  
 WPGK Baltimore, Md. 2414 kc.  
 WPGM Columbia, Ga. 2414 kc.  
 WPGN Hammond, Ind. 1712 kc.  
 WPGO Hackensack, N.J. 2430 kc.  
 WPGP Gary, Ind. 2474 kc.  
 WPGQ Birmingham, Ala. 2382 kc.  
 WPGR Fairhaven, Mass. 1712 kc.  
 WPGS Knoxville, Tenn. 2474 kc.  
 WPGT Clarksburg, W. Va. 2490 kc.  
 WPGU Swathmore, Pa. 2474 kc.  
 WPGV Johnson City, Tenn. 2470 kc.  
 WPGW Asheville, N.C. 2474 kc.  
 WPGX Lakeland, Fla. 2442 kc.  
 WPGY Portland, Me. 2422 kc.  
 WPGZ Pawtucket, R.I. 2466 kc.  
 WPHB Bridgeport, Conn. 2466 kc.  
 WPHC Palm Beach, Fla. 2442 kc.  
 WPHD Yonkers, N. Y. 2442 kc.  
 WPHF Miami, Fla. 2442 kc.  
 WPHG Bay City, Mich. 2466 kc.  
 WPHI Port Huron, Mich. 2466 kc.  
 WPHJ S. Schenectady, N.Y. 1658 kc.  
 WPHK Rockford, Ill. 2458 kc.  
 WPHL Providence, R.I. 1712 kc.  
 WPHM Findlay, Ohio 1596 kc.  
 WPHN Albany, N.Y. 2414 kc.  
 WPHO Portsmouth, Ohio 2430 kc.  
 WPHP Utica, N.Y. 2414 kc.  
 WPHQ Cranston, R.I. 2466 kc.  
 WPHR Binghamton, N.Y. 2442 kc.  
 WPHS South Bend, Ind. 2490 kc.  
 WPHU Huntington, N.Y. 2490 kc.  
 WPHV Muncie, Ind. 2442 kc.  
 WPHW Columbus, Ohio 1596 kc.  
 WPHX Mineola, N.Y. 2490 kc.  
 WPHY New Castle, Pa. 2482 kc.  
 WPIA Cohasset, Mass. 1712 kc.  
 WPIB Boston, Mass. 1712 kc.  
 WPIC Mobile, Ala. 2382 kc.  
 WPID Worcester, Mass. 2466 kc.  
 WPIE Johnson City, Tenn. 2474 kc.  
 WPIF Fitchburg, Mass. 2466 kc.  
 WPIG Nashua, N. H. 2422 kc.  
 WPIH Massillon, O. 1682 kc.  
 WPII Steubenville, O. 2458 kc.  
 WPIP Marion Co., Ind. 1634 kc.  
 WPIQ Richmond, Va. 2450 kc.  
 WPIR Medford, Mass. 1712 kc.  
 WPIU Charleston, W. Va. 2490 kc.  
 WPIV Fairmont, W. Va. 2490 kc.  
 WPIW Wilmington, O. 1596 kc.  
 WPIX Portable in Ohio 1682 kc.  
 WPIY Orlando, Fla. 2442 kc.  
 WPIZ Tampa, Fla. 2466 kc.  
 WPIA Zanesville, Ohio 2430 kc.  
 WPIB Jackson, Mich. 2466 kc.  
 WPIC Parkersburg, W. Va. 2490 kc.  
 WPID Culver, Ind. 1634 kc.  
 WPIE Cambridge, Ohio 1682 kc.  
 WPIF Bristol, Va. 2450 kc.  
 WPIG Elizabethton, Tenn. 2474 kc.  
 WPIH HARRISBURG, Pa. 1674 kc.  
 WPII CLEVELAND, Ohio 2458 kc.  
 WPIJ Toledo, Ohio 2474 kc.  
 WPIK GrossePt.Village, Mich. 2414 kc.  
 WPIP E. Lansing, Mich. 1666 kc.



**\$5.00 Prize**

**New Transposition Ring**

This is what I use for transposition

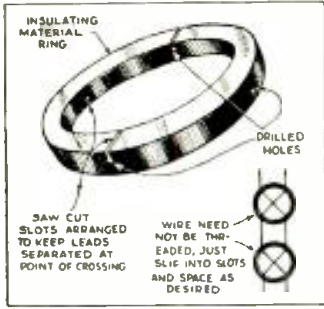

blocks. They are rings cut from any kind of insulating material that will stand the weather. A whole set can be made in a short time with a hand saw and mitre box.

Just saw them off a tube, then cut them square across on each side. If preferable, you can bore a hole in the bottom of the cut to be sure the wire won't slip out. They have:

1. The very minimum of material so they should be low loss.
2. All slides push to the center when there is a strain on them so they won't buckle.
3. Costs practically nothing.
4. The wire doesn't have to be threaded through holes—can be put on anywhere.—Alex D. Snider.

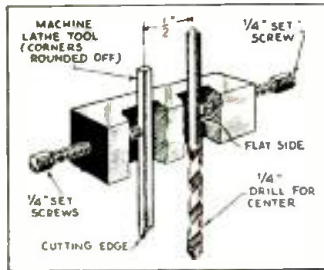

**Fly-Cutter**

Here is a fly-cutter constructed from easily obtained parts. It consists of a piece of  $\frac{1}{2}$ " stock  $1\frac{1}{2}$ " long and drilled as shown in diagram. One  $\frac{1}{4}$ " machine lathe tool, two  $\frac{1}{4}$ " set screws and a  $\frac{1}{4}$ " drill make up the rest of the parts necessary. The drill is ground flat on one side to receive the set screw to prevent slipping. A you see it has no adjustment and is used to cut  $1\frac{1}{2}$ " holes for tube sockets. It is very efficient and rids us of the annoying slippage of adjustment in factory-made cutters.—Arnold Forman.



**Varnish Can as Shield**

Here is how to save money in building a monitor or other short-wave apparatus requiring a shield pot. An old varnish can is just the thing for the job, being of the right size and shape. One may encounter difficulties in cleaning it; however, this can be done with turpentine or other paint-removing solutions. The first step is to cut off the handle and the spout; then proceed to cut a hole in the narrow side large enough to admit the batteries. Be sure to provide for a smooth edge around this hole so that you will not cut yourself on the rough or sharp edges. The opening should be fitted with a lead as shown in the drawing. After the can has been made over as desired, it can be given a coat of black enamel, or some other artistic decoration can be applied.—Calvin Sloan.

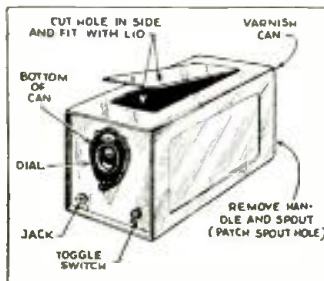

**\$5.00 FOR BEST SHORT-WAVE KINK**

The Editor will award a five dollar prize each month for the best short-wave kink submitted by our readers. All other kinks accepted and published will be awarded eight months' subscription to SHORT WAVE CRAFT. Look over these "kinks" and they will give you some idea of what the editors are looking for. Send a typewritten or ink description, with sketch, of your favorite short-wave kink to the "Kink" Editor, SHORT WAVE CRAFT.

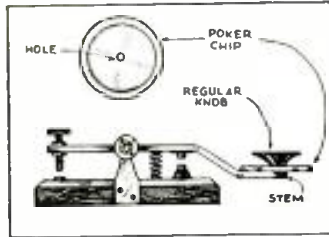

**Improving Key Handle**

By simply drilling a hole in the center of a poker chip, and placing it between the button and stem of your key, you have a semi-Navy type knob which is very easy to handle. The added poker chip flange gives more pressure and leverage during both the upward and downward stroke. (This system has been used in conjunction with the 500-watt transmitter at W6XBY since '33).—N. R. Radom, Opr.



**Code Practice Kink**

Many of the readers of SHORT WAVE CRAFT who desire to practice code without the cost of building an entirely separate audio oscillator can accomplish this very easily by building the unit described in the drawings. It consists of an audio transformer on which has been mounted a tube

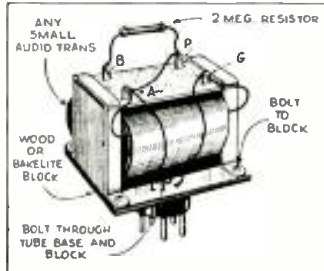

base. The number of prods conforms with the number of prods on your plug-in coils, and the entire instrument plugs into the coil socket, the same as your short-wave coils. A diagram is also shown and indicates where the key may be inserted.—John W. Dietrich.

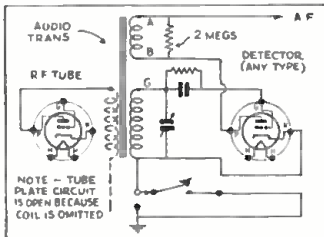

**Cement Mixture**

In making coil forms by cementing tube base together, I could not find a suitable cement and the coil forms soon fell apart. After much experiment I found a mixture which answered the purpose very well. It is made by mixing together two parts of ether and one part of alcohol, both of which can be obtained at any near-by drug store. To the mixture of alcohol and ether, celluloid chips are added and allowed to stand in a corked bottle overnight. In the morning if the solution is still watery, add more chips and let stand again. When a thick fluid is formed it will be

ready for us. Making coil forms is not fit only use for it can be used for holding the wire in place on spaced coils, fastening tubes that have become loosened from their bases and thousands of other uses.—Theodore Zukauskas.

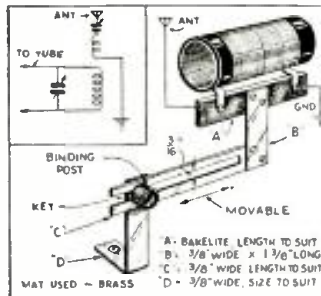
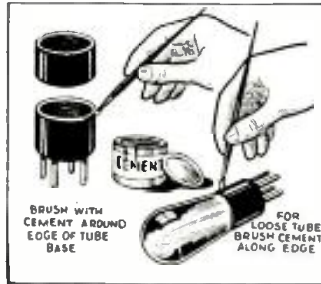

**Variable Antenna Coupler**

Many fans would like to use an antenna coupling coil instead of the usual capacitive coupling used in most receivers. The diagram clearly shows how a mounting bracket can be constructed which will allow varying the coupling for different short-wave bands. It is also advisable to use the condenser in series with the coil and the antenna in order to make use of what tuning may be possible.—Daniel Borneman.



**Substitute for Key Contacts**

The contacts for keys or relays can be replaced when worn by substituting the used contacts from almost any type of automobile distributor. The discarded points can usually be obtained from your local garage. After cleaning and a little filing, when soldered to the key or relay, they become a serviceable contact about 3/16 inch in diameter. The contact No. 1 is found only on Ford Model A and AA and serves well as the adjustable contact for a telegraph relay. Many of the readers of SHORT WAVE CRAFT who have burned out the contacts of their keys or relays will find this kink very useful and the new contacts will stand up for a very long time, because of the hardness of them and if sufficient filter is used to suppress the spark.—H. W. Crouter.

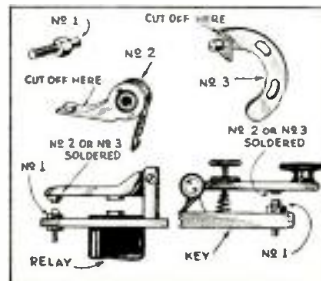

**Handle for Plug-In Coils**

There is a simple way to use attachment plugs as handles for plug-in coils. Saw off the projecting prongs and then cut a small disc from a piece of  $\frac{1}{8}$ " hard rubber or bakelite as shown in the diagram. After

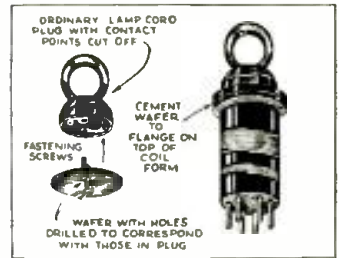

this has been fastened to the attachment plug, cement the whole thing to the top of the plug-in coil with household cement or some other such material.—George Mostacello.



**Low Current Relay**

Here is my radio kink. It is a simple relay that can be made in about one hour. Most of the parts can be found in your junk box. It can be used for many things; it will make a motor go by means of a beam of light. Of course, you have to have other parts, amplifier, etc. It will do what any other sensitive relay can do.—Paul R. Schmidt.

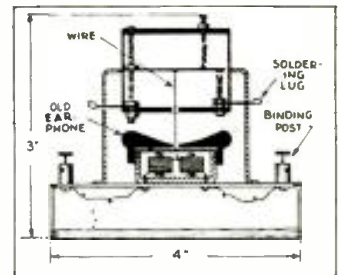

**Handy Bench Light**

Many experimenters have difficulty in obtaining sufficient light for their workbench without using a very powerful bulb. This can be overcome by stretching a piece of No. 14 wire across the length of the workbench and attaching an old fixture ring as shown in the drawing; the entire lamp can then be slid from one end of the bench to the other and will enable you to have a

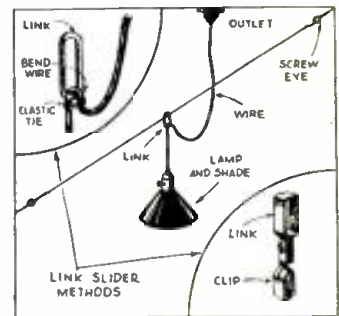

light where you want it. The drawing clearly shows how a separate clamp can be made if one desires to go to the extra

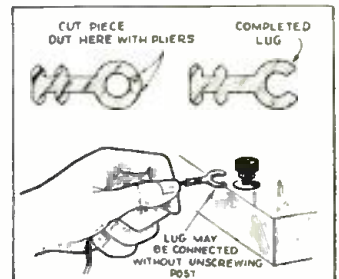

trouble. Another useful kink that I have used quite often is also shown among the drawings. When you have a closed connecting lug and you wish to overcome the necessity of removing the binding post nut each time, it is only necessary to cut out a section of the lug with a pair of diagonal pliers or tin snips.—Russell Hulver.

# Short Wave

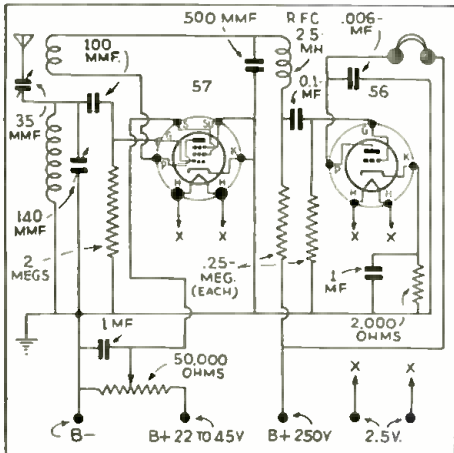

Circuit diagram of the 2-tube Electrified Doerle receiver.

### 2 TUBE DOERLE

Jack Guttman, Passaic, N.J.

(Q) Will you please be good enough to print a diagram of the 2 tube electrified receiver? This is the one using a 57 screen-

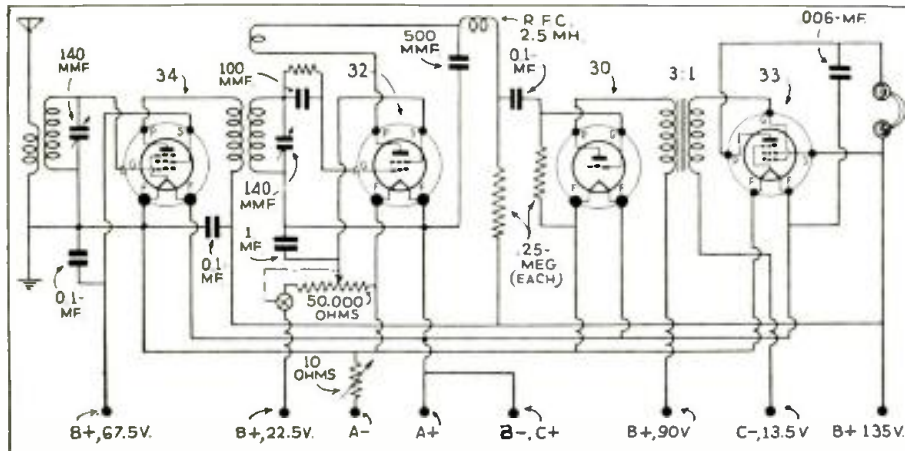

4-tube battery operated receiver having a stage of tuned R.F. ahead of the regenerative detector. This should give excellent results on all short-wave stations.

grid detector, resistance coupled to a 56 audio amplifier.

(A) We take pleasure in printing the 2 tube Doerle diagram, inasmuch as this has been one of our most popular receivers. Regeneration is controlled by use of a 50,000 ohm potentiometer and if one desires to employ throttle control of regeneration, condenser "C" instead of being a .0005 mf. condenser should be a .00014 mf. variable.

### PHONES OR SPEAKER?

Albert Kline, Apollo, Pa.

(Q) I have noticed in the various letters published in your magazine that the short-wave listeners are hearing a good many more stations than I have been able to hear. And I would like to know whether they are using earphones or a speaker in order to obtain such excellent results.

(A) Well, if a short-wave receiver is designed for speaker operation, stations will be heard just as well with a loud-speaker as they will with earphones. However, if you are using a 2- or 3-tube receiver by all means it will be necessary to use earphones to pick up those weaker stations. We cannot say whether our readers are using earphones or speakers but we believe the above will be sufficient to answer your question.

### 4 TUBE BATTERY SET

L. E. Clarkson, San Juan, Calif.

(Q) Will you please publish a diagram of a 4 tube, 2 volt battery set using a 34 tuned RF stage, a 32 regenerative detector, a 30 first audio, a 33 pentode, output tube. This set is to be used with standard plug-in coils and 140 mmf. tuning condensers in both stages, either ganged or operated separately, whichever is best.

(A) We are printing the 4 tube diagram you requested. This should make a very fine battery operated receiver and it should be capable of pulling in all the short-wave stations. Regeneration is controlled by varying the screen grid voltage. Make sure that the 50,000 ohm regeneration control potentiometer has a switch on the back of it, which should be connected in series with the 22½ volt lead in order that the potentiometer will not be a constant drain on the first section of the "B" batteries while the set is not in use. This switch should be turned off together with the filaments when the set is not in use. If you wish to gang the two tuning condensers it will be necessary to connect a 35 mmf. condenser across the RF. tuning condenser in order that compensation can be made for varying lengths of antennas, etc., and to keep the two stages in alignment.

### EDITED BY GEORGE

● Because the amount of work involved in the drawing of diagrams and the compilation of data, we are forced to charge 25c each for letters that are answered directly through the mail. This fee includes only hand-drawn schematic drawings. We cannot furnish "picture-layouts" or "full-sized" working drawings. Letters not accompanied by 25c will be answered in turn on this page. The 25c remit-

the receiver so you can see that it is a very difficult proposition, this overcoming ignition interference.

(Q) I have two 1 mf. condensers connected in series across the A.C. power line with the center connection grounded. This cuts out only a small amount of noise originated in the low power line. Would the addition of two large radio frequency chokes in series with each side of the power line materially assist in reducing the noise?

(A) It is quite possible that the R.F. choke you mentioned will work satisfactorily. We suggest, when you connect the two in series, you use one large choke and one small one in each leg of the power line.

### DOUBLET ANTENNA

C. Jones, Richmond, Va.

(Q) I expect to erect a doublet antenna and am unable to have the two sections of the doublet antenna in opposite directions and will be forced to erect it with a less than a 180 degree angle. Will this do any harm and can I expect just as good results?

(A) Generally speaking, if the one side of the doublet does not fold back too far you will not notice any difference in reception. However, if it were to approach a V shape, it would become quite directional and you may have trouble from these effects.

### SIMPLE "B" SUPPLY

N. Resnick, Philadelphia, Penna.

I built your "Pocket Receiver" described in the December issue of SHORT WAVE CRAFT and obtained very good results with it. I would like to have you print a suitable inexpensive "B" supply, one that does not use a power transformer. It should deliver from 45 to 90 volts in order to run the pocket set.

(A) We are printing diagram for a power supply which will deliver anything up to 110 volts. In using a power supply of this type, make sure that you do not attach the ground to the "B" negative side, otherwise the house fuses will be blown.

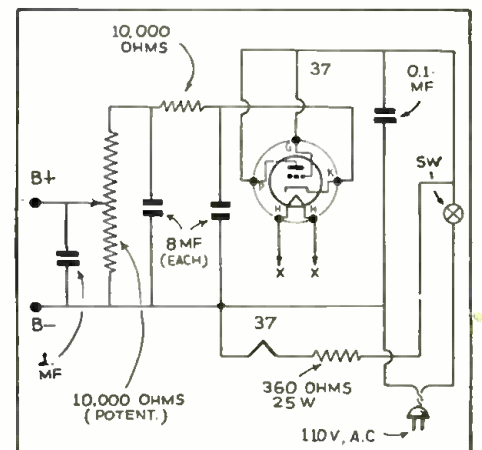

Simplest power supply which can be used to take the place of a B battery on short-wave receivers.

### 100 WATT PHONE TRANSMITTER

G. K. Burtner, Jr., Goldthwaite, Tex.

(Q) I would like to build a 160-meter amateur transmitter having 100 watts input using inexpensive parts. Can this transmitter be built for around \$30?

(A) We doubt very much that it is possible to build a good 160-meter phone transmitter such as you outlined for the small sum of \$30.00. We do suggest, however, that you read the series of articles that are being published on a low-power Raek and Pabel transmitter for the Ham. The first of this series was published in the March issue, the second in the April issue, and the final one in the May issue.

### DOUBLET ANTENNA

Dr. L. L. Hill, Jr., Montgomery, Ala.

(Q) Regarding the question of J. Rand about doublet antennas in the February Question Box, if most of the disturbance comes from passing automobiles, how far must the doublet be from the highway to be reasonably efficient?

(A) Offhand, we would say that the antenna would have to be 300 or 400 feet away from the highway in order to notice any improvement. However we have noticed that it is possible to hear some automobiles from 800 to 1000 feet away from



# QUESTION BOX

## W. SHUART, W2AMN

tance may be made in the form of stamps or coin.

Special problems involving considerable research will be quoted upon request. We cannot offer opinions as to the relative merits of commercial instruments.

Correspondents are requested to write or print their names and addresses clearly. Hundreds of letters remain unanswered because of incomplete or illegible addresses.

### AUDIO AMPLIFIER

Raymond Bourgett, Central Falls, R.I.

(Q) Will you please print a diagram of an all-electric audio amplifier which can be used in conjunction with any short-wave receiver in order to produce full loud-speaker volume. I would like to have this amplifier completely self-contained with just the input connections to be attached to the short-wave set.

(A) We are pleased to print the audio amplifier diagram you requested and complete details are given in the drawing. A volume control is incorporated in the grid circuit of the 56 first audio stage in order that you will have complete control of audio volume, independent of the short-wave

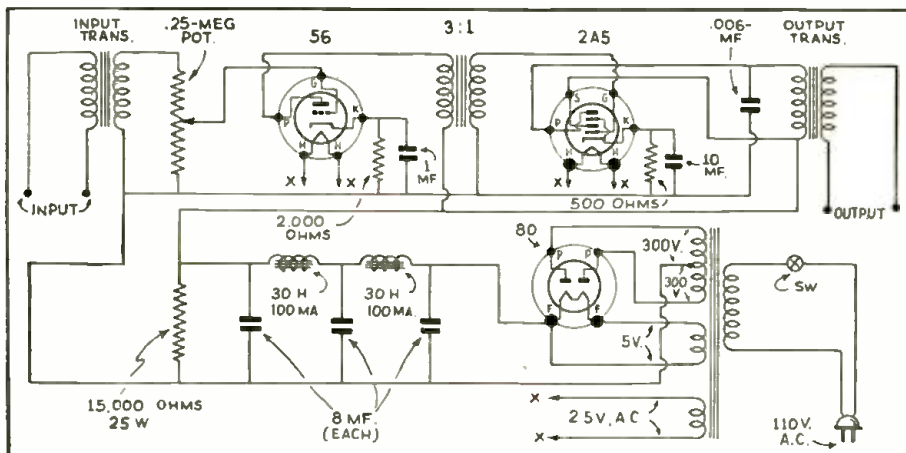

Complete AC operated high gain audio amplifier which can be used in conjunction with any short-wave receiver.

set. A 2A5 is used as the output stage and will give full speaker volume. If you wish to use a dynamic speaker, the field should be connected in place of one of the 30 henry filter chokes.

### 2-TUBE BAND-SPREAD SET

Rolland Johnson, Minneapolis, Minn.

(Q) I built the 2-tube band-spread set described in the February, 1933, issue on page 592. I have rebuilt it twice and checked all parts to make sure that they are all right and have also experimented with the various types of coils. I am using a good power supply with this receiver and still have not been able to get it to work. Could you offer any suggestions?

(A) The 2-tube band-spread you mention was built by a good many of our readers and none of them have had difficulty in getting it to work. If you have used a metal sub-base and panel or a box, similar to the one described in the article, it is possible that you may have a resistor or condenser shorted by coming in contact with the metal. Also it is quite possible that you may have your coil connections wrong. We have found that most of the trouble, with receivers not working properly, has been in incorrectly wired coils. We suggest that you check over the above-mentioned items and we are sure that you will get it to work.

### 2 TUBER

Harry Foss, Waterbury, Conn.

(Q) Please print a diagram in your Question Box of a 2 tube receiver which can be used as a portable. I would like to have this set use a type 34 screen grid detector and a 30 in the audio stage:

(A) This simple 2 tube battery set will make a very nice portable rig, especially for earphone operation and it will be very economical so far as battery consumption is concerned.

(Q) Would a 45 volt together with a 22½ volt battery be sufficient for the plate voltage?

(A) 67½ volts is not sufficient when using the screen-grid detector tube. They will work however with 90 volts of "B" battery supply, but best all-around results are obtained with the full 135 volts applied to the plate. This should cause no concern as extremely small 45 volt batteries are now being manufactured by the major battery companies.

One very important point to remember in a receiver of this type is the antenna condenser. We have shown a 35 mmf. condenser here and we trust that you will use one that has a very low minimum capacity because otherwise the condenser capacity

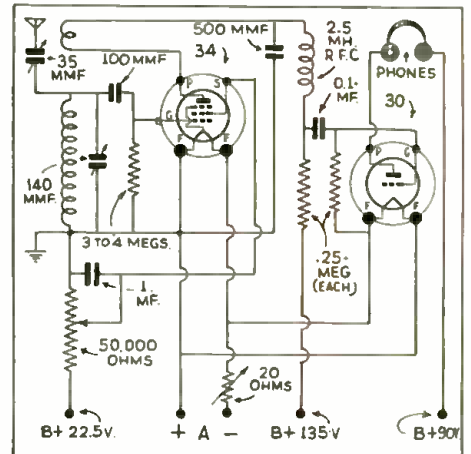

2-tube battery set intended for earphone operation.

with the "3 tubes = 6 super-het" described in the February issue of SHORT WAVE CRAFT. A resistance coupled 42 amplifier will be used in conjunction with this set.

(A) The power supply diagram presented herewith will run any short-wave receiver. When ordering the transformer for this power supply, make sure that you specify that you wish a 6.3 volt filament winding, otherwise you won't be able to run the 3 tube super-het from it.

While on the subject of this set, it might be well to mention that there were several mistakes in the Parts List for this receiver as published in the February issue.

The original Parts List called for twelve .1 mf. fixed condensers; actually only eleven are required; two lines further down on the Parts List, the original specifications called for one .5 mf. fixed condenser; the corrected version should be two of these condensers. There was also a mistake in the number of .001 mf. fixed condensers; the original specification called for one; there should be two. The original specification for the .0001 mf. fixed condensers called for three of them; corrected version should be only two of these.

In addition, on the circuit diagram for the receiver, the condenser which is shunted across the cathode biasing resistor for the 6B7 tube is listed as a .5 mf. condenser; actually it should be a 5 mf. electrolytic condenser.

The midget trimmer variable condenser is listed on the diagram as having a capacity of 35 mmf.

This is correct, although the 50 mmf. condenser specified in parts list will serve also. Either should give excellent service.

### POWER SUPPLY FOR "3=6 SUPER"

R. Cleaver, Lawrence, N.Y.

(Q) I would like to have you print a diagram of a power supply which can be used

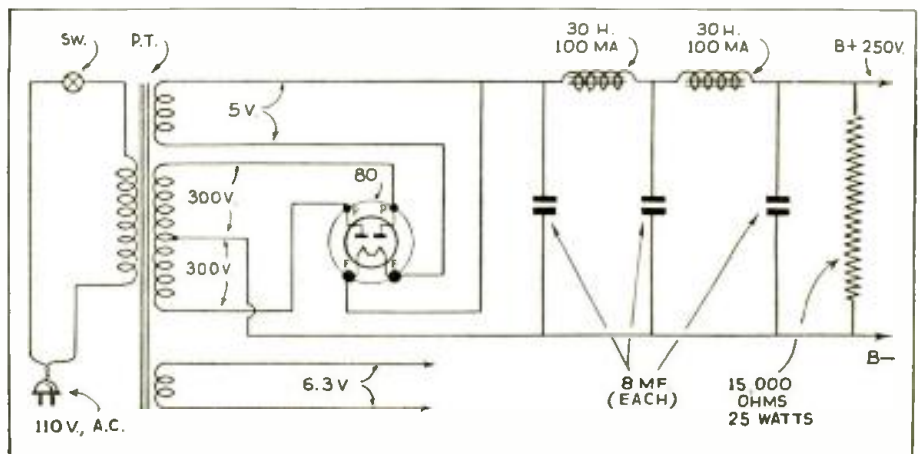

Power supply for the "3 tubes-6" super-het described in the February issue of Short Wave Craft.

**GET THIS FREE**  
**Radio Comparison CHECK LIST**  
*Tells you how to learn the TRUTH about today's Radios*



"World-wide reception!" "Beautiful tone!" Claims! Claims! Claims! The receiver at a "bargain basement" price boasts as loudly as the custom-built instrument. Yet there *must* be a difference—somewhere! We have devised a plan that shows you how to get the cold, hard facts about values. Whether or not you are in the market for a radio now, get this revealing Check List that shows you how to get the "low down!"

**We honestly believe we build "The World's Finest Receiver" —but we cordially invite you to CHECK UP ON US...**

The SCOTT Imperial Hi-Fidelity All Wave is the greatest distance-getting radio ever built . . . It has full range high fidelity—25 to 16,000 cycles . . . it has ample reserve power—35 watts strictly class "A" . . . It combines the greatest known sensitivity and selectivity with the finest tonal reproduction ever known in radio . . . It is custom-built to the most exacting standards known in radio. But those are mere statements—some of them so startling that you may doubt them. That's your privilege—but we ask you to CHECK THESE STATEMENTS—and the claims of other manufacturers. We will gladly rest our case on your impartial findings. Furthermore—when and if you decide to buy a SCOTT Imperial Hi-Fidelity All-Wave, you can have it for 30-day FREE TRIAL in your own home anywhere in the U. S. A., in side-by-side competition with any other radio. If it isn't better in every way, your test won't cost you a single penny. But first, learn to your own satisfaction which radio is REALLY best!

**SEND NOW FOR YOUR FREE Radio Comparison CHECK LIST**

E. H. SCOTT RADIO LABORATORIES, Inc.  
 4470 Ravenswood Ave., Dept. 28K5, Chicago, Illinois

Send me at once a copy of your Radio Comparison CHECK LIST, and complete details about the NEW SCOTT Imperial Hi-Fidelity All-Wave.

Name \_\_\_\_\_  
 Address \_\_\_\_\_  
 City \_\_\_\_\_ State \_\_\_\_\_

# Transmitting Antennas

By Lawrence Reilly

• THOSE who are planning to build amateur transmitters described in SHORT WAVE CRAFT are going to find that the antenna is the most important factor in determining the success of your station. Luckily, the "Ham" is not limited to a single type of antenna, but he may use one of several different types, usually hitting the one best adapted to his own particular location. It is my purpose to deal with as many different types of amateur transmitting antennas as possible.

First, let us consider a little of the theory of antennas. Early experiments with antennas for transmitting work, proved that radiating wires had definite characteristics and exhibited certain tendencies when different lengths were used. When a length of wire was connected to a high frequency generator or transmitter, the measurement of current and voltage distribution in its length were found to appear as in Fig. 1, when the length approached one-fourth the wavelength of the signal.

As the length of the wire was increased to one-fourth wavelength long, it was found that the voltage now assumed a sine wave shape and decreased at the generator end, while it increased at the outer end. The current and voltage were now two sine wave forms and were 90° out of phase, as in Fig. 2 above.

### Resonance in the Antenna

At this point where the current and voltage measured a full quarter-wave each, the antenna radiated much more efficiently; at this point that antenna was said to be *resonant*. It was found, by further trial that this type of grounded antenna would *resonate* and, of course, *radiate*, at 3/4 of a wavelength long and again at 5/4 wavelength long, and at any odd number of quarter wavelengths. These were the original Marconi, or *grounded* antennas. It was found that at resonance, an antenna appears to look like pure resistance, to the generator. If it was too short to resonate, it appeared as a condenser does, so by adding an inductance or coil in series, it could be made to come up to resonance by an effect known as *loading*. If it was too long to resonate, it appeared as an inductance, and by adding capacity or condensers in series, it could be made to tune to resonance. This ability to tune the antenna to any wavelength desired by adding coils and condensers, is very useful at long wavelengths, and is useful to the amateur who wants to work on 160 meters, but cannot put up a wire long enough to resonate without *loading*. An important fact to bring out here is that an antenna which is not tuned to resonance is useless, so the closer to resonance you cut all your antennas, the better luck you'll have. This is even more important in Hertzian antennas which cannot usually be tuned except by cutting them to the proper length.

### The Hertz Antenna

This brings us to the other type of antenna just mentioned, the Hertz. There are two general types of antenna, the Marconi and the Hertz. Others named the Doublet, the Zepp, the (Continued on page 124)

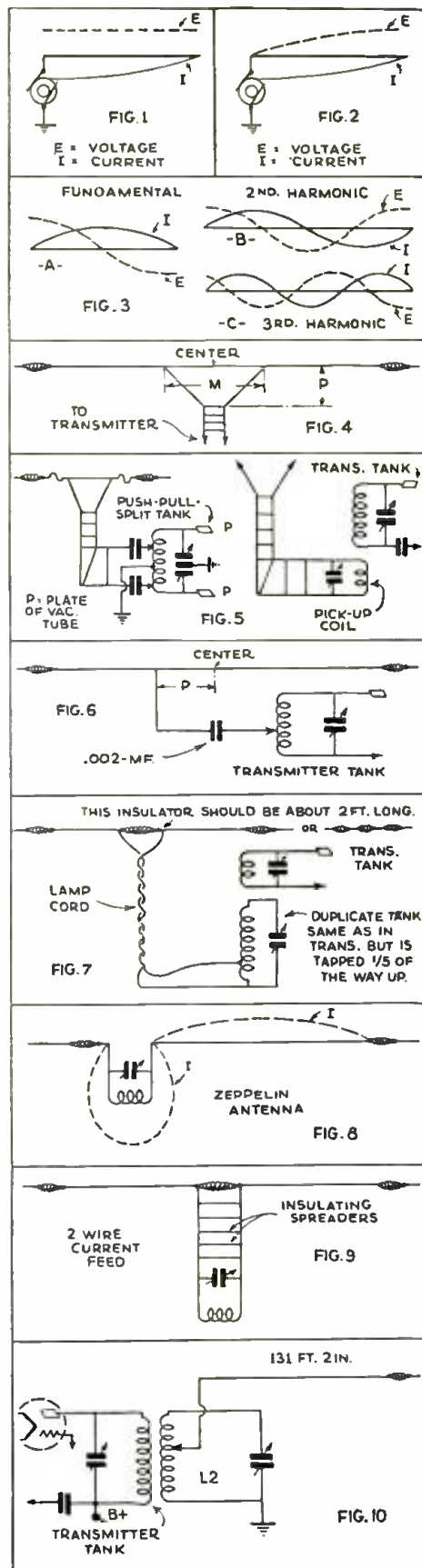

Figs. 1 and 2 show current and voltage distribution along aerial; 3, relations of harmonics; 4, matched - impedance transmission line; 5, coupling methods; 6, single-wire feeder; 7, "lamp cord" feeder; 8, current distribution; 9, 2-wire current feed; 10, "End-fed" Hertz.

Please mention SHORT WAVE CRAFT when writing advertisers



# The V-Doublet, a Practical S-W Antenna

(Continued from page 91)

from outside sources when the doublet is erected out of the field of interference. Figure 2 illustrates how the signal voltage in induced when the radio wave sweeps across a conductor. In the same way, interference radiation induces interference voltage in any conductor within its influence. The balanced transmission line of the "V-doublet" prevents such interference from reaching the receiver, as shown in Fig. 3.

This shows how voltage is induced in the transmission line. Since the direction in each conductor is the same, these voltages are said to be "in-phase." The signal currents conducted from the doublet, having opposite directions in each wire, are said to be "out-of-phase."

Figure 4 shows the "V-doublet" antenna with the transmission line terminated in a coil. This illustrates how a transposed lead-in can conduct a signal from the doublet to the receiver through interference.

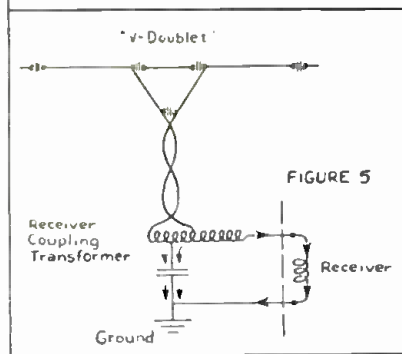
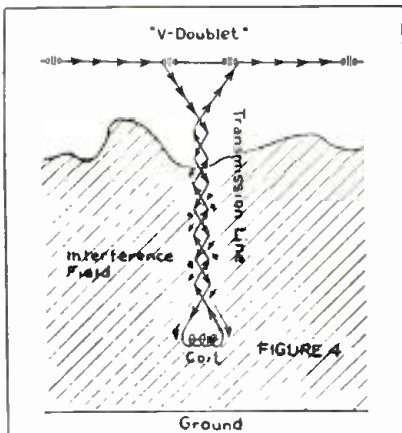

Fig. 4 above shows how currents induced by interference field cancel out, and Fig. 5 shows how interference currents may pass to ground through a condenser.

Arrows drawn on the line represent the signal, while arrows drawn alongside represent induced interference. The interference current does not flow through the coil and the receiver is not affected. The signal current, however, flows through the coil. If it is properly coupled to the receiver it will reproduce the signal in the loudspeaker.

The receiver-coupling transformer is illustrated in Fig. 1, and the circuit in Fig. 5. The transformer is a special balanced-primary auto-transformer which matches the transmission line to the antenna coil of the receiver and permits "in-phase" interference to flow to ground through a condenser without affecting the receiver. The size of this condenser makes it ineffective at broadcast frequencies. This permits the system to operate as a conventional "T" antenna system on broadcast signals and as a "V-doublet" on short waves. Below 55 meters the antenna is a "V-doublet"; above 55 meters it is a conventional "T-type" or standard broadcast antenna.

The design of the "V-doublet" antenna

# 17 SETS IN ONE

Here's a sensational NEW Idea in Short Wave Sets! With the Harrison "MULTI-KIT" as a foundation you can now build 17 different all wave receivers (more later)! A set for every purse and purpose—You can even start as a simple one tube affair and build up—Use dual-purpose tubes—Battery to all-electric—You can use the very latest tubes as they come out—Your set will always be up-to-date! Plan for the future! The MULTI-KIT costs you no more!

Our design laboratory gave you the phenomenally successful "Original 12,500 Mile Receiver" and the sensational "RP Star" of 1929. Now, in the Multi-Kit receivers our engineers have modernized these World famous sets. They have skillfully improved and incorporated every worthwhile feature available! THE RESULT—Every Multi-Kit receiver is positively a WORLD BEATER—Guaranteed to outperform by far any set in its class! FOREIGN RECEPTION! Loud Speaker Volume! Easy Tuning! Quiet Operation! Even if you have no desire to build your own receiver any MULTI-KIT set, wired and tested in our service department, is a wise investment! You will have chosen the best, insured against obsolescence at no premium, and you will have obtained the highest value per dollar!



## WITH THE MULTI-KIT FOUNDATION!!

\$3.45

<b>BUILD-UP UNIT NO. 1</b> Uses type 30 Tube, Battery operated. <b>\$.45</b>	<b>BUILD-UP UNIT NO. 3</b> Uses type 27 or 56 Tube, AC operated. <b>\$.45</b>	<b>BUILD-UP UNIT NO. 10</b> Uses two 27 or 56 Tubes, AC operated. <b>\$.95</b>	<b>BUILD-UP UNIT NO. 11</b> Uses 56 and 2A5 Power Pentode, AC operated. <b>\$1.15</b>	<b>BUILD-UP UNIT NO. 12</b> Uses two 27 or 56 and a 2A5 Pentode, AC operated. <b>\$1.65</b>	<b>BUILD-UP UNIT NO. 4</b> New "2 in 1" 12A7 Tube, All-Electric AC-DC <b>\$1.90</b>	
<b>BUILD-UP UNIT NO. 6</b> Uses two type 30 Tubes, Battery operated. <b>\$.90</b>	<b>The Harrison "MULTI-KIT"</b> Foundation brings you these highest quality parts: 1. Universal chassis and panel. Fabricated of heavy gauge steel with all holes drilled. Durably finished in attractive Crystalline. 2. Low loss ball bearing variable condenser. 3. Large, velvet smooth vernier dial. 4. Antenna compensating and sensitivity condenser. 5. Noiseless regeneration control. 6. Set of four accurately wound, high efficiency plug-in coils. Range 10 to 200 meters. 7. Coil socket. 8. Grid resistor. 9. Three bypass condensers. 10. Speaker Jack. 11. Two knobs all hardware wire etc. 12. Large, clear instructions showing each step in detail. Add to this Foundation any of the Build-up Units and you have every part needed to construct that complete set. Clear, simple instructions with schematic and pictorial diagrams and numerical E-Z Wire system makes wiring child's play! Later you may wish change to any other model at special low cost! Battery Models operate on 2 dry cells and 1 or 2 B Batts in A Model obtain power from any power pack or your regular receiver. All Electric AC-DC Models have a built in power supply. No batteries! Just plug into any house line! <b>ALL FOR \$3.45</b>				<b>BUILD-UP UNIT NO. 13</b> New 4 in 2 Circuit "Twin" 6F7 and "Twin" 12A7, All-Electric AC-DC. <b>\$2.45</b>	
<b>BUILD-UP UNIT NO. 7</b> Uses 30 and 33 Tubes, AC operated. <b>\$.90</b>	<b>BUILD-UP UNIT NO. 8</b> Uses two 30 and a 33 Power Pentode, Battery operated. <b>\$1.45</b>	<b>BUILD-UP UNIT NO. 9</b> New 3 in 2 Circuit, Uses "Twin" 19 and 33, Power Pentode. <b>\$1.80</b>	<b>BUILD-UP UNIT NO. 5</b> Uses 76 and 12Z3 All Electric AC-DC. <b>\$1.85</b>	<b>BUILD-UP UNIT NO. 16</b> Uses two 76 and a 12Z3, All-Electric AC-DC. <b>\$2.35</b>	<b>BUILD-UP UNIT NO. 17</b> New 4 in 3 Circuit, 6F7-7, 12Z3, All-Electric AC-DC. <b>\$2.40</b>	<b>BUILD-UP UNIT NO. 14</b> New 3 in 2 Circuit, Uses 75 and 12A7 Tubes, All Electric AC-DC. <b>\$2.30</b>
<b>BUILD-UP UNIT NO. 2</b> Uses new "2 in 1" Type 19 Tube, Battery operated. <b>\$1.10</b>	<b>BUILD-UP UNIT NO. 15</b> Uses 75 and 12A7 Tubes, All Electric AC-DC. <b>\$2.40</b>	<b>ANY KIT WIRED AND TESTED \$1.25</b>				

### — MULTI-KIT ACCESSORIES —

Neat Crystalline finished metal cabinet with hinged lid for the Multi-Kit receiver. Protects tubes, coils, and wiring from damage and dust. **\$1.00**  
 Set of two Broadcast Band coils. Tune from 200 to 625 meters. Enables you to hear all the regular broadcast stations and the long wave press and short transmission merely by plugging in these coils. Make any Multi-Kit a real ALL WAVE receiver! Set of two coils. **\$1.25**

**SYLVANIA TUBES**  
 The finest tube for Short Wave reception! Fully guaranteed for SIX MONTHS.  
 19 .\$.57 33 .\$.39 76 .\$.39 6F7 .\$.85  
 27 .\$.39 56 .\$.39 2A5 .\$.56 12Z3 .\$.59  
 All Power Jacks for AC Models. Delivers 250 volts and 2 1/2 amp. Also excellent for amplifier or transmitter. Complete Kit, **\$3.95**. Cannonball Headphones—**\$1.30**. Special Magnetic Loudspeaker—**\$1.35**. Sensitive Lightweight Headphones 2000 Ohm—**\$1.05**; 4000 Ohm—**\$1.45**.

### YOUR PRESENT RECEIVER

+ This Power Amplifier = Loudspeaker Reception  
 Add this new power amplifier to your present receiver! All-electric AC-DC Power Pentode—can be attached to any electric or battery operated set. Uses new "twin" 12A7 power pentode—rectifier tube!  
 No wiring—Just plug into phone jack and Presto! LOUD SPEAKER VOLUME!  
 Price wired, ready to plug in—Model PA-1... **\$2.95**  
 Loudspeaker \$2 for above  
 Neat crystal finished metal cabinet 6 1/2" x 7 1/2" x 3" will accommodate a 5" or 6" speaker... **\$1.00**  
**COMPLETE AMPLIFIER** with tube, speaker and cabinet, ready to operate... **\$5.99**

**HARRISON RADIO CO.** Dept. C-6 New York City  
 142 Liberty Street  
 ★★ THE HOME OF FOUR STAR SERVICE ★★

## SPACE SAVERS

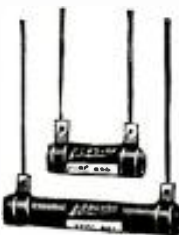

Pyrom Jr. Resistors . . .  
 Wire-wound Vitro-encased . . . 5, 10, 15, 20 watts . . . yet no larger than carbon jobs. For tight places . . . wire-wound security . . . for only a few pennies more.

**FREE DATA** New 1935 catalog on request. Sample copy Research Worker, too. And remember **AEROVOX**—more quality for less money.

**AEROVOX CORPORATION**  
 72 Washington St., Brooklyn, N. Y.

## FASTEST WAY TO LEARN CODE

Easy, Fascinating; Learn by Ear to Be a Good Op!

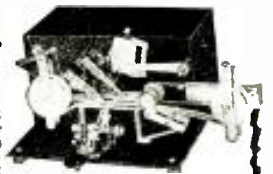

The New MASTER TELEPLEX Code Teaching Machine is exactly what hundreds are looking for. Has taught code to more operators in past 10 years than all other methods combined. No experience needed. Ideal for beginners—steps up with you for all ops. Only instrument ever produced which records your sending in visible dots and dashes on copper tapes—Then sends back your own key work. You actually HEAR the dots and dashes, any speed you want. You learn code the way you'll be using it—by SOUND! Complete Code Course included, no extra charge. Used by U. S. Army, Navy, R.C.A., A. T. & T. Co., and others. Low cost, easy terms. Money-Back Guarantee. Send now for booklet S-30, no obligation. Postcard will do.

**FREE BOOK**  
**TELEPLEX COMPANY**  
 76 CORTLAND ST. NEW YORK, N. Y.



## SUPERTONE'S 100% BANDSPREAD RECEIVER

Our Engineering Dept. has now perfected our short wave receiver to provide 100% band-spreading on all bands from 15-200 meters. This has been accomplished with the new dual ratio airplane dial with its 125-1 ratio band-spread pointer

You may now use this receiver for your daily communication work and log your stations accurately for repeat tuning. For the short wave fan these new features will aid in separation of the foreign and domestic stations on all congested bands.

Phone jacks with speaker cutout switch are mounted on front panel for easy accessibility. Complete shielding of all stages to eliminate R.F. and audio feedback. A highly sensitive regenerative circuit using a tuned R.F. stage with a newly perfected system for equalizing both stages, makes this an ideal short wave receiver for both ham and short wave fan.

Tubes employed are the newly developed 6.3 volt types: 6D6, 6F7, 76, 42 and 80. Set is mounted on a black wrinkled heavy steel chassis. Chassis wired and tested with coils

Cabinet for above	\$ 1.75
Five Sylvania set tested tubes	3.50
6" short wave dynamic speaker	2.00
Short wave hum free power supply	4.95
Complete kit of parts for set and power supply	14.75



MODEL S 1000

**\$11<sup>75</sup>**

### SUPERTONE PRODUCTS CORP.

35 Hooper Street, Dept. S-6 35, Brooklyn, N. Y.

# FREE Just Released!

## IMPORTANT BUYING GUIDE

For Radio Servicemen, Dealers, Experimenters and Short-Wave Fans. Supplement Catalog No. 29, 1935, Spring-Summer Edition

Lowest Prices—This Book Will Save You Money  
32 Pages — Two Colors — Profusely Illustrated

Packed between the covers of this new book is a huge array of modern radio equipment and other electrical and scientific merchandise—perhaps the very material for which you have been looking—and at prices which cannot possibly be any lower. A truly important buying guide for radio servicemen, experimenters, dealers, short-wave fans, biological and optical students, and other men following scientific professions.

Contains all-wave radio receivers, automobile sets, low-priced microscopes, field glasses, complete public address systems, Official Doerle and other short-wave receivers, crystal radios, radio replacement parts and accessories, latest testing instruments, etc., etc. NAME THE ITEM AND IT'S IN THE BOOK.

You can increase the value of your dollar by buying at the low prices contained in this buying guide. This amazing book will show you how to save money by buying economically. Why not start saving now? Don't delay. Write today for your free copy. You are not obligated in any way.

**WRITE TODAY—send postcard or letter.  
Buying guide sent by return mail. IT'S  
ABSOLUTELY FREE.**

### RADIO TRADING CO.

101A Hudson St. New York, N. Y.

See pages 125, 126 and 128 for our other "Ads"



# YOU DON'T

## READ AND THEN DISCARD SHORT WAVE CRAFT

Readers keep their copies for years as a steady reference and thousands of letters attest to this.

It is now possible to save your copies and for this purpose we designed a splendid binder for you which holds twelve copies. It is made of heavy substantial material and is covered with black grain leatherette. The name of the magazine is stamped in gold on the cover.

An ingenious mechanical arrangement is provided which makes it possible to hold the copies flat when reading from the binder.

SHORT WAVE CRAFT Binder as described, \$1<sup>25</sup> prepaid in the United States.

Canada and foreign countries 25c extra. We accept money order, check, stamps or cash.

### SHORT WAVE CRAFT

99-101 HUDSON STREET NEW YORK, N. Y.



lends itself readily to various methods of suspension and is simple to install. Only two points of support are required. All necessary parts are supplied with the kit, including antenna wire, insulators, transmission line and receiver-coupling transformer with connecting links and adapter. Ordinarily the antenna will be erected on the roof of a building or suspended between the roof and a near-by tree or pole. If inconvenient to erect masts, the doublet can be suspended between two chimneys, or from the eaves of a building. Where sufficient ground space is not available to provide the normal span of 51 feet, the doublet may be shortened, with a slight sacrifice of efficiency in the region of the 49-meter band only. The directional effect of the doublet is advantageous where a source of interference is unavoidably near. Least interference is intercepted by the doublet when the horizontal wires point toward the source of interference.

If desired, the transmission line can be extended as far as 500 feet from the receiver. This permits wide latitude in choosing a noise-free location for the doublet. At least 100 feet of line should be used to maintain correct electrical matching. Excess line can be coiled at the end nearest the receiver. Transmission line is supplied in rolls of 100 feet, and after the initial 100 feet, the line may be spliced or cut as desired. As the line has a definite known impedance, only the genuine transmission line should be used. Each conductor of this line is covered with a special high-grade white-rubber insulation, and a covering of waterproof braid is woven over the twisted pair.

The receiver-coupling transformer is housed in an attractive embossed aluminum case. Terminals are spaced to fit the antenna terminal board of General Electric receivers and some other makes, and the connecting links make rigid mounting easy. A good ground connection to the receiver chassis should be provided. For receivers having no antenna terminal board, an adapter is supplied to fasten the transformer conveniently to the receiver cabinet, as shown in Fig. 6.

The G-E "V-doublet" antenna, No. KV-100, will enhance the performance of practically any all-wave receiver, as well as G-E All-wave receivers. By using an antenna changeover switch with a receiver-coupling transformer at each receiver, convincing all-wave demonstrations are now possible in a dealer's store. Additional transformers and lengths of transmission line are available as spare parts. The antenna is completely assembled at the factory, guaranteeing perfect installation. All connections to lead-in and insulators are made and soldered at the factory. The antenna is ready to suspend between masts when the kit is unpacked.

Flexible and convenient to install, this new "V-doublet" antenna offers a wide appeal to set owners, radio dealers and Service Men.

## \$5.00 FOR BEST "YL" PHOTO

● THERE are many fine amateur short-wave transmitting stations operated by "YL" (young lady) operators; married women add one more initial and are known to the short-wave fraternity as "XYL's."

The editors are offering a \$5.00 prize for the best photo of the licensed lady amateur operator and her station and the opinion of the judges will be final. The deadline for photo entries for the next issue will be May 20.

In the event of a tie, equal prizes will be given to both. Send entries to "YL" Photo Editor, W2AMN, % Short Wave Craft, 99-101 Hudson St., N. Y. City.

Please mention SHORT WAVE CRAFT when writing advertisers



## Short Waves at the Hauptmann Trial

(Continued from page 70)

As explained in an article appearing in *Time* magazine, the Associated Press explained how a garbled radio message had been responsible for the wrong news flash, which undoubtedly got into many newspaper headlines all over the country, aside from the Press Radio Bureau, but few people believed it: some editors charged that the A.P. reporter had guessed at the verdict and made a bad job of it or else that he had been tricked by the word of a bribed court attaché.

The editor of this magazine endeavored to find out more details concerning the matter of the short-wave transmitters carried by the *Daily News* and also the Associated Press reporters at the Hauptmann trial, but aside from the fact that they did not deny that such ultramodern means of conveying intelligence were used, practically no information could be obtained. The *Daily News* admitted however, that undoubtedly miniature short-wave transmitters of this type would play many important rôles in gathering news at future court trials and other important hearings.

All of the foregoing is distinctly *not* news by any means to our forty odd thousand licensed Hams, and the editors do not need to point out that it is strange indeed that such use of small S.W. portable transmitters has not been made before—and, as a matter of fact, they undoubtedly have been used by many but no one happened to find out about it.

One of the accompanying pictures shows a brief-case short-wave receiving set which was designed and built by Clifford E. Denton and the editors three years ago! It was fully described and illustrated with diagrams in the June 1932 number of *SHORT WAVE CRAFT*. By making a slight change in the connections, this receiving set can be instantly converted into a transmitter for code signals and undoubtedly that is just about what the small battery-operated transmitters used at the Hauptmann trial consisted of. For the short distance over which the signals had to be transmitted, possibly no more than 100 feet, no aerial would be needed for the transmitter and this would also be true for the receiver.

The range of such a transmitter would probably be a half mile or more with only a small aerial; so far as the reception range is concerned, signals were picked up over a distance of 2,500 miles with this brief-case receiving set and a pair of fairly sensitive headphones.

## Magni-Dial Simplifies S-W Tuning

(Continued from page 76)

of it, and then perform the usual tuning operation by means of the vernier knob on the set.

Still another angle is that on sets having considerable band-spread, or those in which the stations are spread out on the dial pretty well, especially in some of the newer sets having switches to tune in the different bands, then you can easily arrange several dials made out of heavy cardboard or else drawing paper or bristol board, cemented or shellacked to a thin metal or cardboard backing, so that it will take but an instant to change dials for the different bands. By cutting a hole in the dial so that it will come just over the opening in the old escutcheon plate then when the set is turned on, the light may be seen through the hole which may be covered with a piece of red or green celluloid cemented to the back of the dial. In this way you have a pilot light, also very desirable.

(H. E. McCann, the author of this article, is manager of the El Varadero de Manla, Cañacao, Cavite, P.I., and the editors are pleased indeed to present this

**YOU'RE the TOP**

**Lafayette RADIO**  
The Largest Radio Mail Order House in the World  
Sound Amplifiers  
Trusted PARTS  
COMPLETE Wiring and Schematic Diagrams  
No. 57  
1935  
and it's FREE

**Wholesale Radio Service Co.**  
100 Sixth Avenue - New York, N.Y.

*The Whole Radio World is Singing the praise of this Sensational 100% RADIO CATALOG*

Certainly it's the **TOP CATALOG** of the Radio Industry—because there are more items listed (over 50,000), more specialized departments; more pages of special **BAR-GAINS**; more special summer items; more nationally known lines; the greatest line of S.W. and All-Wave Receivers (24 pages of them).

### AUTO RADIOS and ACCESSORIES

Featuring Lafayette receivers to meet every requirement. Prices from \$19.95 up. New **SUPPRESSORLESS** Type receivers. **DASHBOARD** Types and the New **SELF ALIGNING** Types which are so easily serviced. Also a complete selection of Auto Aerials—including those designed for the all metal turret-topped cars, noise suppressors, etc. This big section is a complete Auto Radio Catalog in itself!

Public Address is featured . . . 30 pages of Everything in Amplifiers from 3½ to 100 watts, complete systems suggested and illustrated for each amplifier. Permanent, portable and mobile systems for 6V. battery or 110V. operation; **PLUS** thousands of parts and accessories. The most comprehensive P.A. selection in America today!

### SHORT WAVE HEAD-QUARTERS

No matter what you seek in S.W. or All-Wave Receivers . . . we have it. A big 24 page section is devoted to receivers from 5-12 tubes; all latest circuits, beautiful cabinets; phono-radio combinations, etc.

### THE NEW BROWNING "35"

Seven tube, all wave Receiver with the **TOBE Tuner** is featured here too! We can supply complete kit of parts or the **Tobe Tuner** as a separate unit. See our ad on pg. 119.

Wholesale Radio Service Co.,  
100 Sixth Ave., Dept. SW-65,  
New York, N.Y.

( ) Send me your now **FREE** Catalog No. 57.  
( ) Send me details and price of the **Tobe** tuner. ( ) **Browning 35.**

Name \_\_\_\_\_  
Address \_\_\_\_\_  
City \_\_\_\_\_ State \_\_\_\_\_

**WHOLESALE RADIO SERVICE CO.**  
Main Office and Warehouse  
100 SIXTH AVENUE - NEW YORK, N.Y.  
BRANCH OFFICES: ATLANTA, GA. - LOS ANGELES, CALIF. - MEMPHIS, TENN. - NEW ORLEANS, LA.

## Health Ray Carbon Lamp

**PAYS FOR ITSELF IN A FEW TREATMENTS.**



Everyone in the family needs the health giving Violet Rays.

This is a large **CHROMIUM** plated lamp using standard carbons emitting rays of ultra violet and infra red. If Sun Tan is desired, order accordingly. Saves doctor's bills. Cures colds, rheumatism, and other ailments.  
Size 11 1/2" high, 10" wide, 5 1/2" deep. Weight 8 1/2 pounds.  
Interesting literature sent free.  
List price with Screen and Goggles—\$10.00.  
**YOUR COST—F.O.B., N.Y., \$3.38.**

**WONDERFUL VALUE!**  
Gold Shield Products Co., 17 West 60th St., N. Y. City

## THORNE'S RADIO COIL WINDER

DESIGNED FOR THE AMATEUR AND RADIO REPAIR SHOP

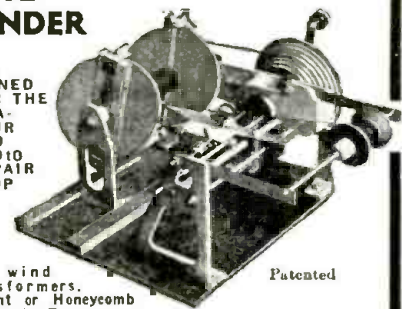

Will wind Transformers, Straight or Honeycomb coils and Ear phone armatures. Revolution recorder. 14 Speed changes.  
Write for illustrated Circular and Price.  
**SUNSHINE NOVELTY CO.**  
226 S. W. 2nd Ave., Miami, Florida.

Please mention *SHORT WAVE CRAFT* when writing advertisers



# Click! Instant QSY

(Frequency change)

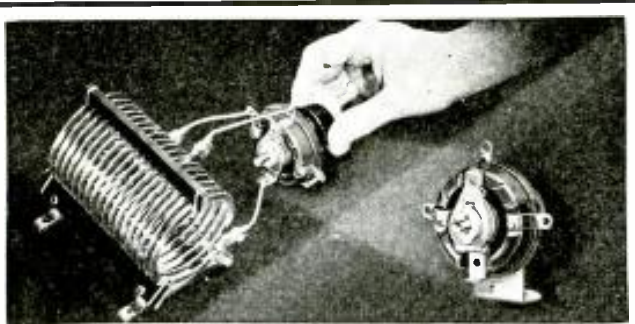

## with the OHMITE BAND-SWITCH\*

Are you anchored to one band because it's a big job to change coils and re-tune? Do you lose valuable operating time in drawn-out re-adjustments every time you QSY from one band to another? Bulletin 104 tells how you can instantly shift your transmitter from band to band the 1935 way... with the new OHMITE BAND-SWITCHES. Write for your copy today.

- **LOW LOSSES.** Low resistance, self aligning contact shoe. All-porcelain insulation. Low inter-contact capacity.
- **HIGH CURRENT CARRYING ABILITY.** Ampie contact surfaces and correct design insure efficient operation up to 1 K.W.
- **UNIVERSAL IN APPLICATION.** Adaptable to single-ended or push-pull tank circuits, impedance matching networks and antenna circuits. Two or more switches may easily be ganged for "single-control" band switching.

\*Patents pending

**OHMITE MANUFACTURING COMPANY**  
639 N. Albany Ave., Chicago, Ill., U.S.A.

idea as it will undoubtedly prove a boon indeed to the thousands of short-wave listeners. Of course one may use a magnifying glass to aid in reading the fine divisions on some of the dials fitted on many short-wave receivers, but what we can see with the unaided eye and without the medium of a lens is after all the most pleasant and comfortable tuning. Mr. McCann suggests a 10-inch radius or 20-inch diameter dial, but we imagine in some cases that a dial even larger than this may be used. Possibly some genius will even carry out the idea on a much larger scale and instead of using a long mechanical indicator may work out a simple light-beam arrangement, whereby a sharply focused pencil of light will sweep over a large dial. And this gives us another idea which may appeal to some of our set-builders—they may elect to arrange a small light on the end of the indicator needle so that it moves along behind a transparent dial, a sharp line being focused on the scale of the dial by means of a diaphragm of suitable shape)—Editor.

## A Good 6-Tube Super-Het Receiver

(Continued from page 81)

quencies and should always be adjusted carefully.

The coils used were bought on the open market and were not altered in any way except for one single coil. The oscillator coil of the 100-200 meter set requires approximately from 10 to 12 turns to be removed from the grid winding. This is necessary because this particular set of coils tuned into the broadcast band as high as 1200 kc. This is caused by the difference in the incoming signal and that which the local oscillator produces. In the higher frequencies this difference is not noticeable and the trimming condenser on the panel takes care of it. Bud coils were used in this particular case although any standard make of coil will do just as well. Only one thing is necessary and that is that the coils match the tuning condensers that are used. Coils are very reasonable and very easily obtained and it is not worth while winding them by hand.

After the receiver is completed and ready for trial the intermediate transformers must be lined up. If a test oscillator is available by all means use it as a more accurate adjustment can be made. However, this is a luxury with most experimenters, and the following method produces very good results.

A weak signal is tuned in (the weaker the better) and the plate condenser of the first intermediate of transformer is adjusted for maximum response. Next the grid condenser of the same transformer, and then proceed to the next two transformers in a similar manner. During this adjustment it is necessary that the trimming condenser on the panel be adjusted for maximum response. The receiver is now lined up and does not require any further adjustment. A bakelite or insulated screwdriver can be used to advantage in lining up as it tends to eliminate any hand-capacity effects that might be present. For the first adjustment it is best to choose a signal around 75 to 100 meters and then gradually work down to the lower wavelengths as the lower we go the more critical the tuning becomes.

### Plug-in Coil Data

Meters Wave-length	Grid coil turns	Tickler turns	Distance between 2 coils
200-80	52 T. No. 28 En. Wound 32 T. per inch.	19 T. No. 20 En. (Close wound (C.W.)	1 1/2"
80-40	23 T. No. 28 En. Wound 16 T. per inch.	11 T. No. 30 En. C. W.	1 1/4"
40-20	11 T. No. 28 En. 3-32" between turns	9 T. No. 30 En. C. W.	1 1/8"
20-10	5 T. No. 24 En. 3-16" between turns	7 T. No. 30 En. C. W.	1 1/8"
Coilform—2 3/4" long by 1 1/4" dia. 1-pin base.			



## The Breakers ATLANTIC CITY, NEW JERSEY On the Boardwalk

SITUATED DIRECTLY ON THE OCEANFRONT AND CONVENIENT TO ALL PIERS AND AMUSEMENTS



**\$6 WITH MEALS** Daily **WITHOUT MEALS \$3**  
PRIVATE BATH Per Person PRIVATE BATH

Hot and Cold Sea Water in all Baths

EXCELLENT FOOD

GARAGE ATTACHED

## IMPROVED POSTAL '35



Now over 50 important features including the New Postal improved Drawer Type Coils, Built-in Short Wave Booster, Continuous Band Spread, Audio Beat Oscillator, A.V.C., Manual Control, and many other important short wave features.

Write Immediately for Details and Special Price on the New and Improved Postal '35

**POSTAL RADIO**  
135 B LIBERTY ST. NEW YORK, N.Y.

## It's NOW 10c

EVERYDAY SCIENCE AND MECHANICS is the finest scientific—technical—mechanical—constructional magazine in the field. Up-to-the-minute with news flashes of scientific events. Dozens of constructional articles and many popular experiments. Ideas from which you can make things to sell. A HOST OF INTERESTING SUBJECTS COVERED:—Woodworking—Photography—Machine Patents and Inventions—Book Review—Metal-working—Chemistry—Engineering—Microscopy—Electrical Experiments—Household Helps—Astronomy—Prize Contests—and other subjects.



Edited by HUGO GERNSBACH

Get your copy today!  
On all newsstands

**10c** the copy

Over 150 Illustrations

Everyday Science and Mechanics  
99-C Hudson St., New York, N.Y.

Please mention SHORT WAVE CRAFT when writing advertisers



## Simplest Ham Transmitter Uses 802 Tube

(Continued from page 86)

in any case the same power supply should be used in order to prevent possible damage should the plate voltage fail. The plate voltage should not be removed unless the screen voltage is also disconnected, another good reason for the series resistor method of obtaining the screen voltage. For normal operation on either the fundamental or a harmonic of the crystal, the grid-leak found to give the best results was 20,000 ohms.

By glancing at the coil table we see that the cathode coil for an 80-meter crystal does not tune to 80 meters, but somewhere between 40 and 80, the adjustment of this cathode circuit is quite fussy; that is, it is neither adjusted for maximum plate current or minimum plate current, but for a maximum change in plate current as the plate circuit passes through resonance with either the fundamental or a harmonic. In other words adjust the cathode condenser until you get the greatest dip in plate current as the plate condenser is turned through resonance.

During tests it was possible to hit the fourth harmonic in the plate circuit with a noticeable dip. But for amateur use, the second is the only one which can be used, unless we have need for frequency tripling—and here the 802 is very good, as the third harmonic is nearly as strong as the second. The plate current will go as high as 40 mills (M.A.) and dip to 10 on the crystal frequency, 15 on the second harmonic and 25 on the third harmonic of the crystal frequency; these are with 500 volts on the plate, different voltages will, of course, give different readings. A word about the output—we worked stations on the 80-meter band over a distance of 600 miles and received fine reports with this 1-tube transmitter.

### Coil Data

#### Plate Coil

Band	Turns	Length of Winding
80 meter	30	3 inches
40 meter	16	3 inches
20 meter	10	3 inches

Wound on 2 1/4-inch dia. 4-prong form with No. 14 tinned, soft-drawn copper wire.

#### Cathode Coil

80-meter Xtal—20 turns No. 22 D.C.C. wire  
40-meter Xtal—10 turns No. 22 D.C.C. wire  
Wound on 1 1/4-inch dia. 4-prong form.

### Parts List for Transmitter

- 1—50 mmf. double-spaced variable condenser. National.
- 3—.005 mf. high-frequency by-pass condensers. Sprague.
- 1—50,000 ohm, 5-watt resistor. Electrad.
- 1—voltage-dropping resistor 20,000 ohms, 25 watt, Aerovox.
- 2—4-prong isolantite sockets. National.
- 1—7-prong large isolantite socket. National.
- 3—large plug-in coil forms (Bud).
- 2—small plug-in coil forms (Bud).
- 1—80-meter crystal and holder.
- 1—5-prong socket for crystal.
- 1—2.5 mh. R.F.C. (Radio frequency choke). Hammarlund.
- 1—.002 mf. high-frequency condenser. Sprague.
- 1—small 0-100 ma. Milliammeter. Triplett.
- 1—Bakelite panel 7x12 inches, I.C.A.
- 1—baseboard 7x12 inches.
- 2—dials. Na-Ald.
- 1—802 tube. R.C.A. Radiotron.

Awards in \$500.00 Prize Contest for "Best Titles" sent in by our readers for the March Cover Illustration will be published in July issue.

A  
**PORTRAIT**  
of  
**PRECISION**  
is this craftsman and his  
handiwork the **SUPER**  
**SKY-RIDER**



THE design of the Super SKYRIDER was born of scientific engineering.

Today's necessity for extreme sensitivity and single-channel selectivity in short wave practice demanded a precision instrument. To reproduce in any quantity such a model receiver necessitates a very high degree of precision at every step. Even tiny tolerances may not be permitted, else performance would be compromised to an intolerable basis in such an instrument which, like a fine watch, must function with unflinching accuracy and dependability.

Here the Hallicrafters unbending laboratory policy of "craftsmanship a creed—accuracy a law" found its true level. You will like the clean, thoroughbred appearance of the Super SKYRIDER. And, you will know that behind this performance lies a skillful precision in craftsmanship and high purpose. You will see the vigorous, abundant chassis size, the fine, finished excellence of the parts employed, a neatness and faultlessness of assembly that bespeaks of skill, understanding and experience. Seasoned, veteran Amateurs and short wave specialists have laid sure, deft hands on every part of its structure. Unhurried engineering experts have trimmed and balanced and tested each circuit to bring in your own operation of it, that unexcelled power, that unflinching accuracy of calibration, that sureness of selectivity, that sweetness of mechanical functioning that has placed the Super SKYRIDER in a preeminent position in the short wave radio field. This determined purpose to high standards of craftsmanship produce each receiver eager and able to provide that last ounce of performance the critical short wave operator of today has a right to expect.

Let us tell you this fascinating story in its entirety—the coupon will bring you FREE the new book of the Super SKYRIDER—a revelation of what can be done in this field—a Portrait of Precision, if you please. Mail the coupon now.

## the hallicrafters

### A Few Super SKY-RIDER Features:

- Four Short Wave Bands
- Smooth Electrical Bandsread
- High Gain R.F. Pre-selector
- Built-in Frequency Meter & Monitor
- Air-tuned I.F.'s; Isolantite Mounted
- Beat Frequency Oscillator
- Built-in Jensen Speaker and Power Supply
- Crystal Filter Circuit
- Transmit-Receive Switch, etc.

The Hallicrafters, Inc.  
3001-N Southport Ave.  
Chicago, U.S.A.

Send me your interesting new 16-page booklet fully describing the Super SKY-RIDER. Also send the name of my nearest dealer.



Name .....

Address .....

## STOPPANI COMPASS

A Precision Instrument made in Belgium. Purchased by the U. S. Government at more than \$30.00 each. Ideal for Radio Experimenters Laboratory, also may be used as a Galvanometer for detecting electric currents in radio circuits. Ruby, jeweled, solid bronze, 4 inches square, fitted in a hardwood case.



Our price prepaid \$4.50 each  
Gold Shield Products Co., 17 West 60th St., N. Y. City

Just Off the Press!

**RADIO'S GREATEST VALUES**

132 Pages. Filled with latest Design Portable, Mobile and Rack & Panel, Public Address Amplifiers, Short-Wave and All-Wave Receivers and Converters, Inter-Office Call Systems, Test Equipment, Replacement Parts, Kits, Tubes, and Accessories—all at Unbeatable Rock Bottom Prices! Send For Your Copy To-Day!  
**COAST TO COAST RADIO CORP.**  
539 SIXTH AVE., Dept. S., NEW YORK, N. Y.

**NEW 1935 Radio Bargain Catalog**

free

## RADIO ENGINEERING,

broadcasting, aviation and police radio, servicing, marine radio telegraphy and telephony, Morse telegraphy and railway accounting taught thoroughly. Engineering course of nine months' duration equivalent to three years of college radio work. All expenses low. Catalog free. School established 1874.  
Dodge's Institute, Turner St., Valparaiso, Ind.

Please mention SHORT WAVE CRAFT when writing advertisers

# SHORT WAVE LEAGUE



## HONORARY MEMBERS

Dr. Lee de Forest  
 John L. Reinartz  
 D. E. Replogle  
 Hollis Baird  
 E. T. Somerset  
 Baron Manfred von Ardenne  
 Hugo Gernsback  
*Executive Secretary*

## 5-Meter "No-Code Test" Argument Still Hot

### Benefits of No-Code 5-meter Exam.

Editor, SHORT WAVE CRAFT:

● I HAVE just finished reading Mr. Lomaster's arguments in favor of a no-code 5-meter license in your August issue; I agree absolutely with every statement he makes! I think that amateur work is the hardest part of radio to get started in, and that the issuance of licenses is entirely too restricted. In receiving, for example, it has been possible for me to start out by building a 50-cent crystal set and gradually work up over a period of two and a half years to the complex single-signal superhet. Every advance I made was based on practical experience, and I have learned much more than I would have had I got all my knowledge from a book, without ever having built or operated a receiver. In addition, my work has been much more interesting and enjoyable. But now, when I wish to get an amateur license, I find that an entirely different state of affairs obtains, that I must spend several tiresome hours a day practicing code and "boning" for a license, two tasks that are more a test of *perseverance* than of *ability*! Moreover, to really learn the code correctly, I must rent a machine, at \$16 for 3 months, or else go to a school, which is also expensive.

Now I am only 16, and have not had a great deal of experience, but I can see no earthly reason why the Government should not grant a restricted beginners' license, with a code requirement of about three words a minute, greater emphasis being placed on quality of sending than speed; with a simpler technical exam, dealing with less advanced transmitting apparatus; and with a maximum power output of one watt, or less, depending upon location and the wishes of nearby amateurs. Only the 5-meter band would be open to such licensees, except in such cases where the beginner could

get a signed statement from all amateurs within a two-mile radius permitting "censored" operation in regular bands. If, after a year, the licensee were not able to pass the regular exam., the license could be revoked. I believe that amateurs operating full-fledged stations for the first time would be infinitely more capable after a year's practical experience with  *flea-power* sets, than they are now, when their only experience comes out of the "Handbook." Of course, there would be objections on the grounds of *interference*, but surely the interference could be no worse than that now caused by regenerative receivers, which must number in the hundred thousands. Moreover, any amateur who is troubled by such interference would have the power to immediately stop it, except on the 5-meter band, where as Mr. Lomaster so truly points out, there is room enough for 40,000,000 stations.

The advantages of the plan are these: The code requirements are so simple that absolutely anyone could master them easily in two or three weeks; the knowledge and experience necessary for the regular license could be obtained under much more interesting and instructive conditions; the size, and hence influence of the amateur fraternity would be greatly magnified; and amateur interest would tend toward efficiency rather than high power. As for SHORT WAVE CRAFT, I think it is a great magazine, even though I sometimes do get disgusted with the picture wiring diagrams and the endless repetition of beginners' circuits; but of course I realize that a magazine must try to satisfy *everyone* and that is no easy job (I know)!!

Wishing you success,

WALTER N. BROWN, JR.  
 15 Pembroke Street.  
 Garrett Park, Md.

### Another Slap at the Code Test for the 5-meter Boys!

Editor, SHORT WAVE CRAFT:

● I HAVE been reading your magazine for the past three years and think it is the *best short-wave* magazine there is in print.

While reading your magazine one cannot escape reading the many letters for and



## Short Wave League

At a Directors Meeting held in New York City, New York, in the United States of America, the Short Wave League has elected

**John F. Müller**

a member of this League

In Witness whereof, this certificate has been officially signed and presented to the above.

*H. Winfield Secor*  
 Club Secretary

This is the handsome certificate that is presented FREE to all members of the SHORT WAVE LEAGUE. The full size is 7¼" x 9½".

See page 67 how to obtain certificate.

against the no-code exam. below 5 meters. I for one vote for the no-code exam. below 5 meters.

Some of these so-called amateurs have been writing to your magazine and telling us that we are too "lazy" to learn the code; this is not so! Some people cannot learn the code as easy as some of these narrow-minded, so-called "amateurs" think they can. And when I mean "narrow-minded" I mean it. Why some of these so-called "amateurs" even send their "rigs" for repairing to some other REAL AMATEUR who does not "HOWL" at every move somebody makes to advance the art of Radio. If you ask me what the trouble is, I think it is just plain JEALOUSY. They are afraid some of us are going to get a "ticket" with a little bit less work than they did! What else would it be besides JEALOUSY? Just how many of these so-called "amateurs" who take time to write and tell us how lazy we are, are right now working the 56 Meg. (5-meter) band? I would say very few. Just to prove it, build up a good 5-meter band receiver and see how

(Continued on page 121)

## Get Your Button

The illustration here-with shows the beautiful design of the "Official" Short Wave League button, which is available to everyone who becomes a member of the Short Wave League.

The requirements for joining the League are explained in a booklet, copies of which will be mailed upon request. The button measures ¾ inch in diameter and is inlaid in enamel—3 colors—red, white, and blue.



Please note that you can order your button AT ONCE—SHORT WAVE LEAGUE supplies it at cost, the price, including the mailing, being 35 cents. A solid gold button is furnished for \$2.00 prepaid. Address all communications to SHORT WAVE LEAGUE, 99-101 Hudson St., New York.



## A New 22-Tube All-Wave Receiver

(Continued from page 87)

required. This has been obtained in this new receiver by taking special precautions in the form of very careful shielding; thorough filtration of the I.F., oscillator, and audio stages, to prevent feedback between one element of the system and another. If any feedback or regeneration is present, it invariably results in noisy reception, especially on weak distant signals. These effects have been so minimized in this new set that you are able to use, to the greatest degree, the full sensitivity of the receiver.

The very advanced design and the high degree of efficiency in the antenna coupler, the antenna tuner, the R.F. stage and four I.F. stages, combined with an especially efficient A.V.C. system, makes it the ideal receiver for those who are particularly interested in reception from very weak, distant, foreign stations.

### Full Range "High Fidelity"

Although this receiver is undoubtedly the most powerful superheterodyne that has ever been offered to the general public, tone has not been sacrificed, for it has twice the frequency range of even the finest of the so-called "high fidelity" receivers available today, with a practically flat response covering the whole audible frequency range from 25 to 16,000 cycles. But it requires an actual listening test to realize the tremendous difference in reproduction that is secured by including the frequencies above 6000 cycles. It is only when a direct comparison can be made with an ordinary receiver and this new instrument, that one realizes that there are many instruments in the orchestra whose higher tones are never heard on the ordinary radio receiver.

Visualize yourself in a dimly lighted room in which you can barely distinguish the various objects, then imagine turning a control which gradually brings up the illumination in the room until everything is clear and distinct. Your reaction will be very much the same when you listen to an ordinary radio receiver, then to the new all-wave receiver. First, you hear music which you would consider perfectly pleasing and satisfactory. *until you switch over to this new set*, and then, and then only, do you realize what you have been missing, and it is certain you will never again be satisfied with an ordinary receiver which reproduces only about one half the musical tones of the various instruments being broadcast.

### Power Output Undistorted up to 50 Watts

To secure perfectly natural reception from all classes of programs, it is necessary that the amplifier be capable of handling the highest "peak" or loudest notes in the transmission without overloading or distortion. One of the many remarkable features of the power amplifier of this new set is the 35 watts of absolutely undistorted output with strict class "A" operation, and from 35 to 50 watts, class "A" prime.

The first automobiles produced had comparatively small engines, but as cars came into more general use, it was found that to secure smooth and comfortable performance at all speeds and under all conditions, it was necessary to have more reserve power. Automobile manufacturers today provide cars which have eight to ten times the power of those of a few years ago, so that an automobile owner may have satisfactory performance at all times. The day of a radio receiver with a limited undistorted output is past, and the new receiver is the first of a new era, for it meets all receiving conditions smoothly and efficiently, and is as far ahead of ordinary radio receivers, as the modern automobile of today is ahead of the first model "T" Ford.

Another remarkable feature of this new

## Electrical Efficiency

## plus BRUTE STRENGTH

**B**OTH frame and plates are "oversize," assuring greater rigidity and steadiness of signal. Features usually associated with only the highest-power transmitting condensers.

Heavy aluminum ends, four sturdy duralumin posts and Isolantite insulating cross-bars. Wide-spaced plates have

rounded edges for greatly increased voltages. Smooth bearings; self-cleaning contacts.

With a stator of the split-stator model (illustrated) connected to each side of the coil, the rotor is at ground potential. This permits mounting on a metal panel without insulation and reduces hand capacity.

Single and split-stator models; 18 capacity ratings. List prices, \$5.00 to \$18.00. Write Dept. SW-6 for New Catalog.

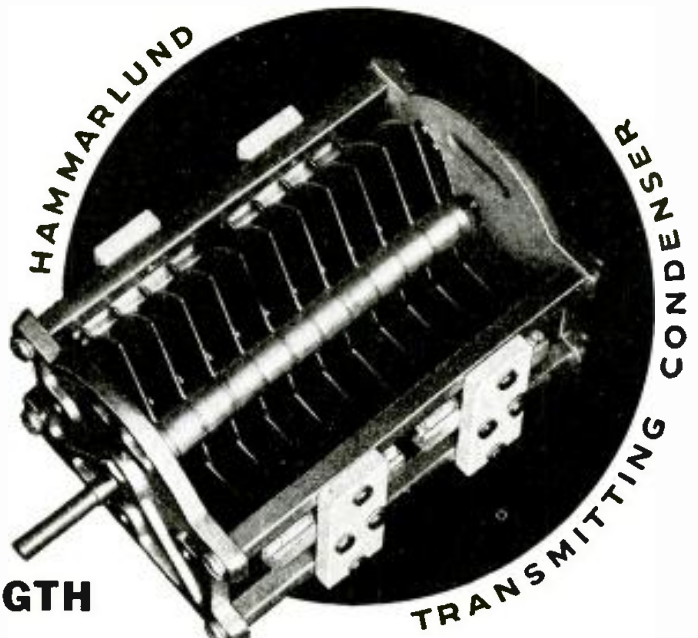

**Hammarlund Manufacturing Co.**   
424-438 W. 33rd St., New York

### The DX2 All-Wave Receiver



A good battery operated receiver that is GUARANTEED FOR FOREIGN RECEPTION. Good volume & economical in operation. See article page 601 Feb. issue SWC. Uses 30-33 tubes as reg. detector & power pentode amplifier. Works on 2 dry cells & 1-45V B battery & 1 C batt. Blank shirvel metal chassis & panel. Coils for 12-205 meters & instructions included.

**CANNONBALL HEADPHONES. \$1.35**  
Stamp for Literature  
**CENTRALION ENGINEERING CO.**  
Dept. SW6, 136 Liberty St., New York, N. Y.

Kit assembled & ready to wire.	<b>4.35</b>
Wired & tested.	
extra	<b>1.25</b>
Arcatun tubes	<b>1.55</b>
B C coils (2)	<b>1.00</b>
Metal cabinet	<b>1.00</b>
Special Complete set, ready to use, less phones, batteries, and cabinet	<b>\$7.75.</b>

## LEARN CODE

**BE A REAL** radio-telegraph operator. Make money with radio. Get your Amateur or COMMERCIAL TICKET. "Most of the holders of the EXTRA FIRST CLASS commercial licenses are Candler trained."



Stop reading letter by letter—make code a language. CANDLER will teach you the method that he has used in training all the Champion operators. (Australians: write W. Johnston (VK2YZ), 1 Searle Street, Ryde, Sydney Australia.)

## FREE



"BOOK OF FACTS for RADIO OPERATORS and Beginners." Contains story of the Champions and other valuable information you should have. No obligation.



## CANDLER

6243 SOUTH KEDZIE AVE., Dept. S-6, Chicago.

## WHEN CHOOSING A RADIO SCHOOL

RCA Institutes, with its reputation established by 26 years service, is an institution recognized as an important factor in the radio industry.

Whether elementary radio principles or advanced subjects, sound applications or practical radio engineering, RCA Institutes is prepared to give you the instruction you need.

**RESIDENT SCHOOLS NEW YORK AND CHICAGO** with modern standard equipment

**EXTENSION COURSES FOR HOME STUDY** under convenient "no obligations" plan

Illustrated Catalog on Request.

**R. C. A. INSTITUTES, Inc.** Dept. SW-35  
75 Varick St., New York—1154 Merchandise Mart, Chicago

**WHEN BETTER AERIALS ARE MADE LYNCH WILL MAKE THEM ... AND OTHERS WILL TRY TO COPY THEM**

Write for Free Bulletin on LYNCH PATENTED and GUARANTEED Noise-Reducing Antennas for Home, Auto Use.

**ARTHUR H. LYNCH, INC., 227 Fulton St., N. Y. PIONEER OF NOISE-REDUCING AERIALS**

Please mention SHORT WAVE CRAFT when writing advertisers

# An Announcement by HUGO GERNSBACK

I have created an entirely new magazine for the short wave listener, such as has not existed before. This new magazine is totally different in get-up and contents from any other short wave magazine, and nothing like it has ever been published before.

To begin with, the new magazine comes with a *four-color cover*, and it is beautifully printed throughout. It contains a great variety of material, all of which is essential today to the short wave listener.

IT IS NOT A TECHNICAL MAGAZINE. It is designed for the short wave-listener only. The second, the April-May issue, which is now on all newsstands, contains the material you find listed below.

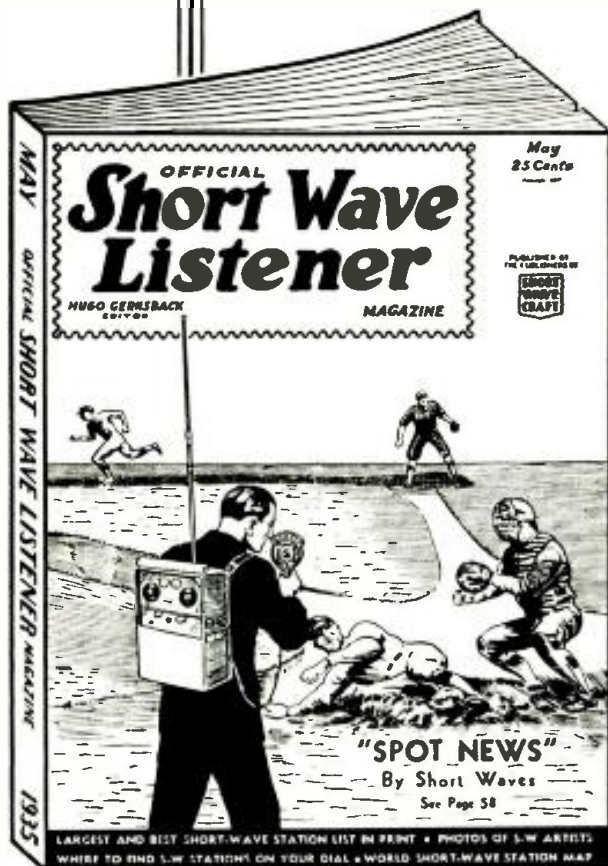

ASK YOUR  
NEWS DEALER  
FOR A COPY  
OF THIS NEW  
SHORT-WAVE  
MAGAZINE

25c the Copy  
Well  
Illustrated

## Contents of the May Issue:

Photos and stories about the leading short-wave artists of the world.  
Famous short-wave broadcasting stations—photos and descriptions.  
Hunting for DX short-wave stations on the dial of YOUR Receiver—and where to look for them.  
Grand List of Short Wave Stations of the World—with call letters and frequencies, including POLICE and TELEVISION stations.  
"Star" Short Wave Station List—"crack" stations with their frequencies and call letters.  
Short Wave Fiction Story.  
Latest "Program" News of the short-wave stations—both "foreign" and "domestic."  
Identifying short-wave stations by their "Musical Signals."  
Silver Cup Trophy Contest for the best "Listening Post" photo.  
Fitting Up an Ideal S.W. "Listening Den."  
A Lady Short-Wave "Fan" speaks.  
Thrills on the Short Waves.  
Old Short-Wave Aerials I Have Used, by George W. Stuart.  
Mechanical Aids to Short-Wave Tuning.  
More data on Short-Wave Antenna construction.  
"The Listener Asks"—Short Wave Question Box.

## I ASK YOU A FAVOR

You have been an enthusiastic reader of SHORT WAVE CRAFT and your letters to me have always shown that I give you your money's worth. Now I ask you as a special favor to me that you get from your nearest newsstand a copy of The Official Short Wave Listener Magazine. Take it home and look over it carefully.

If, after you have bought your first copy and have studied its contents and have read the new magazine, you are not fully satisfied with it in any way or form, I authorize you herewith to return the copy of the magazine to me and I will promptly refund you your quarter, as long as you state in your letter the reason why you do not like the magazine or if you do not think it is worth the money I ask for it. You to be the sole judge. This is my special promise to you.

*Hugo Gernsback*

OFFICIAL SHORT WAVE LISTENER MAGAZINE  
99 Hudson Street, New York, N.Y.

Please mention SHORT WAVE CRAFT when writing advertisers

amplifier is that although it has such a very large undistorted output, it is under perfect control at all times, and any degree of volume can be secured, from the faintest whisper to full volume. There is no detectable hum even under the quietest listening conditions, and this in spite of the fact that its frequency range is considerably greater than even the most gifted human ear.

## Improved Beat-Frequency Oscillator Locates Short-Wave Stations Quickly

Tuning, especially on the short waves, has been made particularly easy by a very accurate calibration of the dial. However, to make it easier still, we have also incorporated an improved beat-frequency oscillator, which uses a special compensating circuit which gives a clear, audible signal on all stations, both strong and weak, making it just as simple and easy to tune in short-wave stations, as it is to tune in stations on the regular broadcast band.

## Double A.V.C. System Holds Stations Steady

There is nothing more annoying than to tune in a distant station and have your reception spoiled by the constant fading in and out of the signal. This has been largely eliminated by means of a highly developed double A.V.C. system, which keeps the signal practically constant at any desired volume level, irrespective of variations in signal strength.

The reception of very weak or distant stations, particularly on the short-wave bands, is also often marred by a peculiar twisting or distorting effect due to the plate voltage on the oscillator varying. This defect has been overcome in this receiver by incorporating a self-stabilized oscillator with a voltage regulator which makes the plate voltage on the oscillator independent of either line voltage or signal strength. No matter what variation there may be in the line voltage, even though it drop as low as 90 volts or rise to as high as 130, and no matter what variation there is in the signal strength, this special voltage regulator keeps the plate voltage on the oscillator constant at all times to within three fourths of a volt, so eliminating another of the factors which up to this time has caused distortion and poor results on weak, distant stations.

## New "Noise Suppression" System Used

Reception in many locations is spoiled by various forms of electrical interference which brings in a considerable amount of noise, especially when tuning from one station to another. The new noise suppression system incorporated in this new set is especially valuable in locations where local electrical interference is bad. It is continuously variable and enables the operator to adjust the maximum sensitivity of the receiver to whatever noise level is prevalent at the time. This control, however, differs from all other sensitivity controls in that it does not impair the action of the A.V.C. in any way, nor does it affect the tone quality or cause distortion on any station, either local or distant.

The operation of this system will be readily understood when it is likened to the action of a speed governor on an automobile truck. The governor may be set so that it allows the truck to travel at a certain maximum speed, however, the governor does not affect in any way, the operation of the machine at any speed under the maximum for which the governor is set. In like manner, the new between-station noise suppressor enables you to adjust the receiver to the point where all noise caused by local electrical interference, etc., is eliminated, and all stations which are tuned in will be heard without interference or noise. This development means that the receiver can always be operated at the maximum sensitive position in your particular location, to give the most satisfactory reception.

From this, you will see that the magazine has been designed as a companion magazine to SHORT WAVE CRAFT.

If you are now a reader of SHORT WAVE CRAFT magazine, you will not wish to be without THE OFFICIAL SHORT WAVE LISTENER MAGAZINE. The new magazine will help you tremendously in your short wave reception at all times, and will give you priceless and invaluable information, such as you cannot get anywhere else. Nothing like it appears in print anywhere today. THE OFFICIAL SHORT WAVE LISTENER MAGAZINE, in other words, is a necessity.

P. S.—If you cannot get the magazine at your newsstand due to sell-out, send 25c in cash, stamps, or money order, and we will send the magazine to you direct, prepaid.



## S.W. Scout News

(Continued from page 77)

got a transmitter, HKE, 7,092 kc., was heard sending out an excellent program on Mar. 23. HJ1ABD, 7,310 kc., located in Cartagena, Colombia, was also heard. They asked for reports.

SUV, 10,014 kc., located in Cairo, Egypt, was heard transmitting a program for CBS, on Sunday, Mar. 10. The signal was very weak, almost inaudible at times, but we cannot be too particular when waves travel from that particular clime.

FZR, located in Saigon, Indo-China, was heard testing with FTK, Paris. The frequency of FZR was 16,200 kc.

Each week many letters are received from fans asking how they might identify certain Spanish-speaking stations. From experience, I find that the only way to properly recognize these stations is not by the station slogan or wavelength, but by the call letters. For the convenience of these listeners I print the Spanish alphabet:

A is pronounced as ah; B, bay; C, say; D, day; E, ay; F, effray; G, hay; H, ah-cheh; I, ee; J, hota; K, kah; L, el-lay; M, em-may; N, en-nay; O, oh; P, pay; Q, koo; R, air-ray; S, es-say; T, tay; U, oo; V, vay; W, doh-bleh-vay; X, eekis; Y, eegriega; Z, theta; Numerals: One, oono; Two, dos; Three, trehs; Four, quatro; Five, thing-ko; Six, sase; Seven, see-ate; Eight, ocho; Nine, noo-ay-ve; Ten, diez.

### Report from Edward G. Schmeichel, Illinois

● RECEPTION as a whole has been very, very good during the past month. All bands have played a fine part in aiding the "logging" of many new stations. It is very interesting to note the improvement on the 19- and 25-meter bands. Stations are picking up right along; for instance on 19 meters, PCJ — HAS3 — FYA — HVJ — DJB (occasionally heard) are reaching this post regularly QSA4-5 and R8-9. This also goes for 25 meters.

The 31-meter band is the one that is about the best and most consistent of all the bands. On this band VK3ME — VK2ME — VK3LR — VUB are received consistently. I also mention VUB, because this station has been heard four times in the past month with a bang.

A tip for the fan who wants to try for them—get up some Sunday morning about 7 a.m., E.S.T. Tune for VK2ME; if they are well received then tune slightly above them, and you will hear a loud signal. Many fans will be deceived into believing that this is W1XX, but note the carrier. The carrier of W1XX has a slight hum, while VUB has a clean-cut note. Their signal is on sometimes 30 to 40 minutes before they start broadcasting. On Mar. 15, I had them coming in with a bang, but as soon as W1XX came on the air it blocked the program from VUB. With the aid of my trusty *Postal Booster*, I was able to listen to the program till "sign-off." Many programs would have utterly been ruined for me had it not been for the booster. With the aid of the R.F. gain control on the booster I am able to cut through a station with razor-edge sharpness. Many programs have been logged that otherwise would never have come through, had it not been for this. This will answer many requests sent to me concerning the selectivity of this booster. So I hope many fans will try for this "rare" station. A veri from them is worth sticking your chest out for.

HJ4ABE—Medellin, Colombia, 50.42 meters or 5.95 megacycles, is reaching this post day after day. They are very loud and announce in English occasionally. Try for them.

PRF5 and HP5B both send veries showing three views of their stations. XECW—50.25 meters or 5.98 mc. Mexico City is coming through quite well. They send one

## Adds THOUSANDS of Miles to Your Receiving Range

It's a Treat to Listen In on This One!



### SARGENT REGENERATIVE PRE-SELECTOR

More than doubles the number of foreign stations you can hear! Greatly increases selectivity! REGENERATION is the answer. The most sensitive type of input for a radio set that engineers have been able to devise in 35 years of continuous radio development.

No guess-work about it, you can HEAR IT yourself. There is a cut-over switch on the Pre-selector so you can instantly compare signal, noise level and interference with and without the Pre-selector. Once you make the comparison, you are sold. Once you try it you will never operate a set without it. Band switch changes coils. Individual coils with separate antenna couplings for each band. Special tap switch shorts out unused coils. Works with any super, matches appearance of Sargent 8-34. **\$14.75** Net Price, including tube.

### Now You Can Build Your Own!

**8-34 COIL KIT, STANDARD MODEL**  
Same parts as used in 8-34 Receiver. Individual oscillator and detector coils for each band, short-circuiting type tap switch, paddler, full circuit blueprint, instructions and coil shield included. A TRIED AND PROVEN coil unit that YOU KNOW will give satisfaction. I.F. Transformers, not included. **\$7.50** Tunes 15-550 meters. Net Price.

**8-34 COIL KIT, MARINE MODEL**  
As above, with Marine waveband coils, padders and extra coil shield. Tunes 15-1500 meters. **\$12.00** Net Price.

**Regenerative Pre-selector Coil Kit**  
Same parts as used in our own Pre-selector. Tunes 15-550 meters, individual coils each band, special short-circuiting type tap switch, blueprint, instructions cut-over switch included. Net Price. **\$3.90**



\$54.50 Complete

### SARGENT 8-34 RECEIVER

Everything you want in a real Short Wave Receiver. Hundreds sold to enthusiastic amateurs and fans. Is our best testimonial. Tunes 15-550 meters, band spread, beat oscillator, self-contained power supply. Price includes tubes and dynamic speaker unit. Nothing else to buy. 5-Day Money Back Trial. Order Yours Today.

**MARINE MODEL 8-34 NET, \$62.50**  
As above, with another waveband added. Continuous tuning. 15 to 1500 meters. An ideal shipboard receiver. D.C. prices on request.

**AMATEUR SPECIAL KIT NET \$15.75**  
Our most popular kit! One stage tuned r.f., regenerative detector. 2.5 audio. Illuminated dials, band spread, plug-in coils included covering 15-200 meters. Excellent short wave broadcast and C.W. receiver. Complete kit includes chassis, crackle finished panel, all parts to build the set. Write for full data.

**ROUND-THE-WORLD-3**  
Not sold in kit form. Completely built-up ready to operate. Has power pack, tubes and coils to cover 15 to 200 meters. Uses regenerative 37 detector, 75 audio, 80 re-tifier. Price complete, less headphones, Net \$11.00. Ideal beginner's short wave set.

**E. M. SARGENT CO. 212-S NINTH ST. OAKLAND, CALIF.**

## CABINET SR. & for ALL-STAR JR.



With hinge cover finished to match the ALL-STAR set.

Our Low Price **\$3.95**

We do not supply panel, dial or knobs. receiver. Send drawing or give complete dimensions for estimate.

Dealers and Jobbers: Write for special price  
**KORROL MFG. CO., Inc.** Dept. S-6  
232 GREENWICH ST. NEW YORK CITY

### RADIO'S LIVEST MAGAZINE

Edited by HUGO GERNSBACH



RADIO-CRAFT is devoted not only to the radio experimenter and technician, but also to the beginner in radio. Picture diagrams simplify construction of sets. Kinks show simple ways out of difficult problems. The latest radio equipment is illustrated and described.

8 Months for **\$1.00**

RADIO-CRAFT is fully illustrated with photographs, diagrams and sketches. Each issue contains over 150 illustrations. 15c for Sample Copy.

## RADIO-CRAFT

99C Hudson Street New York, N. Y.



Why pay someone else to assemble YOUR radio? Save your money—get this powerful, inexpensive, ALL-WAVE receiver kit for only \$1.95. Assemble it yourself and tune in on the world's best programs. Modern instrument panel beautifully finished in bronze and red; easy reading dial; operates on two inexpensive batteries. You'll want your friends to have one, too. Full instructions furnished. WE GUARANTEE RESULTS! Send \$1.00 deposit or post paid if you send full amount. Tubes 85c—Double Headphones \$1.00—Write for our NEW catalogue.

**SECURITY MFG. CO. 5540 WEBB AVENUE DETROIT, MICH. Dept. 8-L**

### IN STOCK—IMMEDIATE DELIVERY

## Entire SARGENT Line

SARGENT 8-34 (15 to 550) Complete	\$54.50
MARINE MODEL 8-34 (15 to 1500) Complete	62.50
PATTERSON PR-12 (8 to 550) Complete	83.70
With crystal, complete	89.70
IME-9D (15 to 550)	112.50
Complete with tubes, speaker, speaker cabinet, etc.	127.50
SUPER-SKYRIDER (13 to 240) Complete	59.95
Including broadcast band (13 to 550) complete	69.95
Also available with crystal and/or 10 meter band	
RCA-ACR 136 (15 to 550) Complete	69.50
MEMORIO-SILVER 50 (13 to 200) Complete	74.70
PRE-SELECTORS	
SARGENT, complete	14.75
PATTERSON, complete	17.84
PEAK, less tubes	19.80

**SHIPPED PREPAID** if full purchase price accompanies your order (IME-9D and RCA-ACR-136 excepted)

## MARINE RADIO COMPANY

163-18 Jamaica Ave., Dept. 885, Jamaica, N. Y.  
Formerly L. I. MARINE & ELECTRIC CO.  
Same ownership—same management—New Name Only  
TELEPHONES:  
JAMAICA 6-2925  
NIGHT (long distance) LAurelton 8-0400  
Cable Address "ELECTMARINE NEWYORK"

## ACQUIRE THE CODE with SPEED—at low cost

To learn Radio Code, there is no better way than to practice regularly with INSTRUCTOGRAPH Automatic Code Teacher. No waiting for code schedules—no interference to annoy you. And it sends perfect Code—at the speed you want, fast or slow. To use INSTRUCTOGRAPH, no experience is necessary. Book of Instructions explains each step. Just as an Instructor would do. You practice when and where you please. You will be surprised when you hear how little it costs to buy or rent Instructograph. Tapes and Book of Instructions. Extra tapes are also sold separately. DON'T DELAY. If you want to learn the Code—if you want to qualify for Government examinations—if you want to increase your speed to that of a real "Ham"—write TODAY for full details.

INSTRUCTOGRAPH COMPANY, Dept. S W-6  
912 Lakeside Place Chicago, Ill.  
Representatives for Canada  
Radio College of Canada, Ltd., 863 Bay St., Toronto

### Demonstrating the Power of a Penny!

Just write your name and address on a postcard and receive—  
**1c 4 VALUABLE CIRCUITS FREE**  
1. Leonard Victor E. C. Four  
2. Martin EAGLE "6" all-wave  
3. EAGLE "7" all-wave super.  
4. Quadradyne 2-tube A.C.-D.C.  
**EAGLE RADIO, 84 Cortlandt St., N. Y. City**



# NEW! Just Out!

**H**ERE are two brand new books which you have been looking for for a long time. They contain everything that you have been asking for for many months. These new books will give you the latest information of everything you wish to know in two respective fields. Be sure to order them today. You will not regret it.

They make excellent companions to our other handbooks, which you may have.

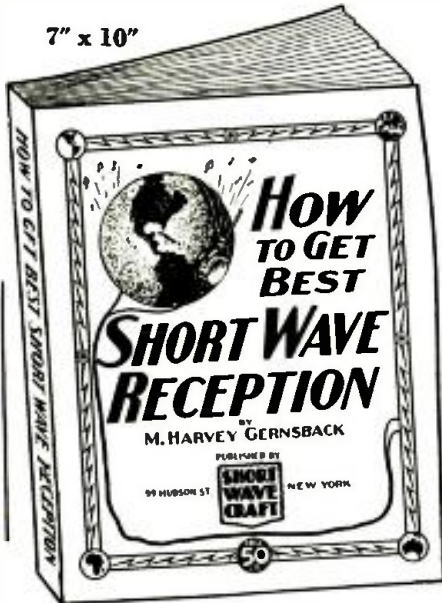

TWO BRAND NEW BOOKS WHICH EVERY ALERT SHORT-WAVE FAN SHOULD HAVE IN HIS LIBRARY

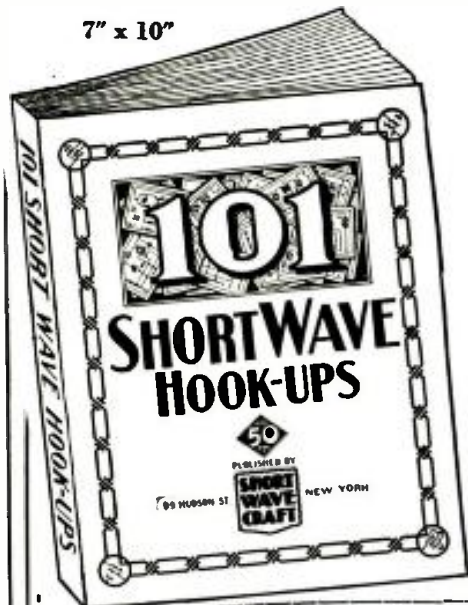

SHORT WAVE CRAFT, 99 Hudson Street, New York City.

Gentlemen: I enclose \$\_\_\_\_\_ for which you are to send to me, postpaid, at once, the books checked below:

- "How to Get Best Short Wave Reception"
- "101 Short Wave Hookups"

Name .....

Address .....

City and State.....  
(Send check or money order. If you send cash or uncanceled U. S. Postage Stamps, register it.)

SW-6-35

## "How to Get Best Short Wave Reception"

By M. HARVEY GERNSBACK

Here is a book that gives you everything you have ever wanted to know about short-wave reception.

The author, a professional radio listener and radio fan for many years, gives you his long experience in radio reception and all that goes with it.

Why is one radio listener enabled to pull in stations from all over the globe, even small 100 watters, 10,000 miles away, and why is it that the next fellow, with a much better and more expensive equipment, can only pull in the powerful stations that any child can get without much ado?

The reason is intimate knowledge of short waves and how they behave. Here are the chapters of this new book:

1. What are Short Waves and what can the listener hear on a short-wave receiver or converter?
2. How to tune and when to listen in on the short waves.
3. How to identify short-wave stations.
4. Seasonal changes in short-wave reception.
5. Types of receivers for short-wave reception.
6. Aerial systems for short-wave receivers.
7. How to get verifications from short-wave stations.
8. Short-wave hints.

The book is profusely illustrated with the best kind of illustrations that it was possible to obtain.

Please note that this is not a re-hash of anything that has appeared before. Everything in the entire book has been written to order, and there is no duplication of anything here that has appeared in print before.

The book will make excellent reading matter, whether you are a rank beginner or whether you have been at it for a long time. There are many tricks in short-wave reception that even some of the "old-timers" do not know. That is the reason for this book. Be sure to get it.

Place your order at once!  
72 pages, over 40 illustrations.  
Price .....

**50c**

## 101 SHORT WAVE HOOKUPS

Compiled by the Editors of SHORT WAVE CRAFT

Here is a worthwhile book that every short-wave listener, every short-wave fan, and every short-wave amateur has wanted for a long time. It gives you the 101 best short-wave hook-ups which have appeared heretofore. It is a veritable encyclopedia of the best in short-waves when it comes to hook-ups.

And do not run away with the idea that we just give you a few plain hook-ups. Each and every hook-up and diagram illustrated is also accompanied by a thorough explanation of what this particular hook-up accomplishes, what parts are required, coil-winding information, values of resistors, etc., in fact, everything you want to know in order to build the set or to look up the data required.

To be sure, all of the important sets which have appeared in print during the past five years are in this valuable book. Sets such as the Doerle, Dinsmore, the "19" Twinplex, Oscillodyne, Duo-ADHDyne, Denton "Stand-by," Megadyne Triplex 2, "Globe-Trotter," 2-Tube Superhet, Miniodyne, "Loop" Receiver, "Doerle" 2-tube Battery, "Doerle" 3-tube Battery, "Doerle" 2-tube A.C., "Doerle" 3-tube A.C., Doerle "Signal Gripper," "Unitrol" Band-Spread 2-tube Receiver, 1/2 Meter Portable Transmitter and Receiver, Duo R.F. 4-tube Receiver, The Sargent 9-33 Tapped Coil Receiver, Globe-Girdler 7, The 2-Tube "Champ"—2 Tubes Educ. 3, Han-Band "2-tube Pee-Wee," Wyeth All-Wave 6, "Rex" Portable Super-het Receiver, The "53" 1-tube Twinplex, Shuart Band-Spread S.W. Converter, The "Ace" Band-Spread 3, Denton Economy 3, 2-Tube "Regenerative-Oscillodyne" will be found here, with full descriptions. In many cases, where it was necessary, we have also included a picture hook-up for those who do not wish to follow the regular symbolic hook-up, but wish to have a regular wiring diagram.

Also note, that in many cases, we have not just reproduced old hook-ups or diagrams. In many cases they have been brought up-to-date, to give you the latest information available in such sets.

This is a very handy volume, especially for those "fans" who wish to study the best sets in the short-wave art, from one tube up to ten tubes, instead of leafing through a dozen magazines and going through back numbers.

The present volume brings you everything in a clarified manner, leaving nothing to your imagination. The book is thorough, and up to date, and will be a welcome addition to your Radio library.

72 pages, over 100 illustrations.  
Price .....

**50c**

of the finest oil-painted veries you ever saw. So if you log them send for a veri.

JVP, Nazaki, Japan, has been heard several times this month calling Manila. They are on wavelength of 39.95 meters. They speak English while calling Manila.

FZS, Saigon, Indo-China, has been heard at least ten times this month. They are on 25.02 meters and are directly above RNE. They call Paris in the mornings. They start out by saying, "Hello Parea! Hello Parea! This is FZS Saigon calling you."

VLK and VK2ME on 28.85 meters are heard every morning about 6 a.m., E.S.T. They call stations in England and America. Try for them.

## Bernard Kinzel, New York City, Reports

● ALTHOUGH quite busy with moving, I managed to get a few results, as a real fan and dyed-in-the-wool DX-er, when I reached the new home. The first thing, of course, was to get up the antennas and put the receiver to work. Outside of the flock of the European locals a number of newcomers could be logged, following the list of what has been heard and when; all time is given in E.S.T.

On the 49-meter band I found the most activity, with WIXAL getting active again and quite effectively spoiling reception from at least half a dozen foreigners, among them DJC, GSA, HJ1ABG, HJ3ABI, PRA8 and a few smaller South Americans, that bunch around the 6,010 to 6,050 kc., making a mess out of the band. Some very strong harmonics from amateurs around the 6,030 to 6,040 kc., in conjunction with the constant carriers of several commercial code stations, with HRB of Tegucigalpa, Guatemala, C.A., calling CQ "till the cows come home," make the band go up in a bunch of peanut whistles. Now I will start on the lower frequencies and report my way up.

HC2ET, 65.22 meters 4,600 kc., Guayaquil, Ecuador, every Wednesday and Saturday from 9:00 to 11:00 p.m., using 10 chimes as a signal.

HAT, 55.5 meters, 5,400 kc., Budapest, Hungary, every Sunday, from 8:00 to 9:00 p.m., beginning with a kind of church-bell ring.

CT1AA, 51.07 meters 5,870 kc., Lisbon, Portugal, testing irregularly from 4:30 to 7:00 p.m., using the same CooCoo call as on 31 m.

YNLF, 50.3 meters 5,960 kc., Managua, Nicaragua, irregular, 6 p.m. to 1 a.m.

XECW, 50.17 meters 5,980 kc., Mexico City, Mexico, 10:30 to 12 p.m.

PRA8, 49.6 meters 6,040 kc., Pernambuco, Brazil, 2:30 to 8:30 p.m., heard best at about 7 p.m., address: Radio Club of Pernambuco, Brazil, S.A.

HJ4ABL, 49.14 meters 6,105 kc., Manizales, Colombia, daily 6 to 7:30 p.m.

CSL, 48.78 meters 6,150 kc., Lisbon, Portugal, irregular from 1:30 to 7 p.m. A rather new station, announcing in several languages as: *Radio Emissora Nacional de Lisboa*, but cannot be heard after W8XK comes on the air as they are nearly on the same wave. I am waiting for a veri. Best time to hear them is between 3 and 4:30 p.m. on Sundays.

CO9GC, 48.7 meters, 6,150 kc., Santiago de Cuba, 3 to 5:30 p.m., but can be heard until 3 a.m. calling amateurs and testing. Address: Grau and Cameneros Laboratories, Box 137, Santiago de Cuba.

CT1GO, 48.4 meters, 6,198 kc., Parede, Portugal, Radio Club Portuguese. Two verifications of this station recently received state the station's history as follows: Transmitter 350 watt crystal-controlled on 48.40 meters and 24.20 meters (12,396 kc.) DX all continents, located 16 miles west of Lisbon, facing the Atlantic Ocean, Europe's most westerly transmitter. Schedule: 24.2 meters, every Tuesday, Thursday, and Friday 1 to 2:15 p.m., Sundays, 10 to 11:30 a.m. On 48.4 meters: Daily except Saturday and Monday 7:20 to 8:30 p.m.

Please mention SHORT WAVE CRAFT when writing advertisers



YV6RV, 46.01 meters, 6,520 kc., (new wave) Valencia, Venezuela, daily except Sunday from 5 to 7 and 9 to 11 p.m.

HJ4ABA, Medellin, Colombia, testing on 42 m., 25.65 meters and 21.5 m., irregular on either of these waves in late afternoon.

I2RO, Rome, Italy, changed to 31.13 meters. A very strong first harmonic is encountered on 25.64 meters from YV5RMO and mistaken for this station's regular signal, also many, too many, amateur's harmonics; will they ever take the hint and check their output before they radiate harmonics fairly strong enough to wipe out GSE's and FYA's signals completely? We have to thank the amateurs for quite a lot, they did their part to make it possible for us to listen to short waves, but should a few of them become a public nuisance just by piling up their uncontrolled harmonics in a couple of the most popular short-wave broadcast bands? I have quite a list of them and when the A.R.R.L. warns that these complaints are justified, they are rightly so and I will turn my list over to the A.R.R.L., so they may give their fellow members a friendly warning, for it is always the same fellows that I pick up and also several of my friends.

CNR, 23.39 meters 12,825 kc., was heard one Sunday morning for about 40 minutes, but fading badly, they should be on from 7:30 to 9 a.m., but can be heard as early as 5 a.m. phoning St. Assise.

VP1A, 22.94 meters 13,075 kc., Radio Suva, Fiji Islands, was heard again two days in succession, making it four times in all, they are on every morning from 12:30 to 1:30 a.m. and going on code at about 1:40 a.m.

PCJ, 19.71 meters 15,220 kc., Eindhoven, Holland, can be heard regularly every Sunday from 8:30 to 11:30 a.m. and on several mornings during the week irregularly. They have a brand new transmitter on this wave and are pounding in with tremendous volume.

HJV, 19.83 meters 15,120 kc., Radio Vaticano, Vatican City, Italy, are heard on a new schedule, daily from 10:30 to 10:45 a.m.

HAS3, 19.52 meters 15,370 kc., Budapest, Hungary, every Sunday from 8-9 a.m. The call letters of this station are HAS3 as so often stated, having received my verifications for reception of both stations HAS3 and HAT at their first day on the air; they are also, according to their own statement, only on Sundays on schedule. But their program on 5,400 kc. is usually ruined by a harmonic from WFAB, New York, who broadcasts on 1,300 kc. Maybe it is this harmonic that has been mistaken for HAT's signal on days when they were not on the air at all. (HAT on 5,400 kc. has been replaced by HAT4, 9,125 kc., 6-7 p.m. Sundays, editor.)

Now may I thank all those fans who so kindly wrote to me, sending congratulations, and I certainly appreciated every card or letter that I received. As the last reply to all those queries is in the mail now, those of you that did not get my card as yet, by the time this is printed, you will all have it. Those of you that came to see me personally, also many thanks and remember, that at this post everybody is welcome, at any time, but do not forget the new address: Bernard Kinzel, 362 East 156th Street, New York City (Bronx).

**Reports from Oliver Amlie, Philadelphia, Pa.**

● ONCE again the Amlie DX-er scores, from October, 1934, to March, 1935, the famous black magic receiver scores 85 morning reception reports on VK2ME, 3ME and 3LR, holding all three stations each month. I hope to double this record from April to September, 1935, which completes this post's one year test for Mr. W. T. Conder, General Manager, Broadcasting Commission of Sydney, Australia. Due to the poor reports they have received from both American and European listeners, Mr. Conder wrote this post in September, 1934, asking for my service for March alone. This post held all three Australian stations for 26 receptions, or 31 hours, hold-

★ **FIVE-IN-THREE** ★ **FULTONE V** ★ **6F7-76-12A7** ★

**RELIABLE AND CONSISTENT FOREIGN SPEAKER RECEPTION!!**

**ORDER YOUR FULTONE V NOW!!**

**Enjoy the thrill of real radio reception**

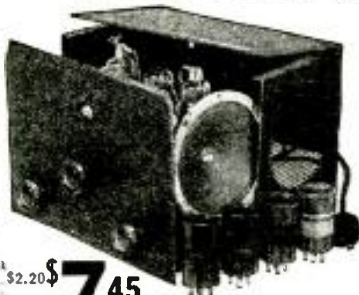

\$7.45 brings you the complete kit of parts to build this remarkable receiver. Price includes crystal finished metal chassis with all holes drilled, four coils tuning 15 to 200 meters, every part down to the last nut and screw and large—easy to follow—instructions

**\$12.75** SPECIAL COMBINATION OFFER Complete kit, tubes, speaker, cabinet and broadcast coils. (Wired and Tested add—\$1.25)

Set of Matched Sylvania Tubes \$2.20  
Metal Cabinet, as illustrated 1.25  
Stereal Loudspeaker 1.45  
Two Broadcast Band Coils 1.75

**\$7.45** Complete KIT

**FULTONE V-BATTERY MODEL**

**COMPACT, ECONOMICAL, PORTABLE**

Here's the same World renowned Fultone V in an economically operated battery model! Now, no matter where you go, be it in the wilds of the forest or the quiet of the farm, you can bring the pleasure, entertainment, and news of THE ENTIRE WORLD to you! You can THRILL to the same LOUDSPEAKER FOREIGN RECEPTION as do thousands of other FULTONE V owners!

Using the same tubes, the same chassis, and the same famous circuit as the All Electric FULTONE V (except that a 38 power pentode replaces the 12A7 combination pentode and rectifier), the battery model may be easily converted at any time into the regular All Electric Model.

Works on a 6 Volt storage battery (or from six 1½ volt dry cells) and three 45 volt B Batteries. ECONOMICAL—A set of batteries will give four to nine months service! FULL POWER OUTPUT! STURDY! Welded steel chassis and cabinet, durably finished. PORTABLE!—Weights only 8 lbs., complete with cabinet and speaker! Only 10"x7"x6". COMPLETE KIT OF ALL PARTS **\$6.95**

SEND FOR YOUR FREE COPY CATALOG-C73

SPECIAL COMBINATION OFFER Complete Kit, tubes, speaker, cabinet and broadcast coils. (Wired and Tested add \$1.25.) **\$12.20**

32 VOLT BATTERY MODEL Add \$1.20

TURN AT ONCE TO PAGE 101 FOR THE NEWEST IDEA IN RADIO!!

**HARRISON RADIO CO.** Dept. C-8 New York City  
142 Liberty Street  
★ ★ THE HOME OF FOUR STAR SERVICE ★ ★

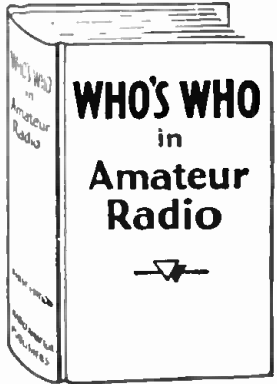

**HAMS NEED THIS BOOK!**  
**50c**  
144 Pages  
6 3/4 x 9 1/2" in size

An Excellent Radio Book

which every short-wave "ham" will want to have on his shelf or desk. Plenty of photos of the prominent "hams" with many descriptions of their careers and activities are given. The "ham" pedigrees are listed in numerical order by station calls, beginning with W1 and ending with W9. The book is printed on a fine stock of paper. Sent postpaid to readers of SHORT WAVE CRAFT for only fifty cents. Send stamps or coin.

RADIO PUBLICATIONS

97 Hudson St. New York, N. Y.

**Absolutely NEW**

- RACO Multi (7) BAND 1-Tube AC-DC Receiver. 12-2000 Meters
- The only All-Wave Receiver of such a LOW PRICE. Guaranteed by the RACO trademark. Uses the new multi-purpose 12A7 tube. A custom-built job. Foreign reception guaranteed.
- Dimension 5" x 6 1/2" x 9"
- Kit with 4 coils 12-300 meters \$3.95
- Cabinet \$1.00
- No. 5 coil (200-550) meters \$3
- No. 6 coil (550-1150) meters \$3
- No. 7 coil (1100-2100) meters \$6

136 LIBERTY STREET Dept. SW-207, New York, N. Y.

**PATENTS — TRADE MARKS**  
All inventions submitted held confidential and given personal attention by members of the firm.  
Form "Evidence of Conception" and instructions  
"How to Establish Your Rights"—Free  
LANCASTER, ALLWINE & ROMMEL, PATENT LAW OFFICES  
475 Bowen Bldg. Washington, D. C.

**WORLD WIDE ALL WAVE RADIO**

The Ace

A real powerful long and SHORT WAVE Radio Receiver that actually gets local and foreign broadcast stations, police, airplane, etc., transmissions direct! Thousands now in use. Owners report reception of Foreign Stations with amazing volume. Works on two inexpensive batteries.

Not a toy! RESULTS GUARANTEED!

Ace construction kits have all necessary parts mounted on attractive metal chassis and panel, all ready for wiring. Clear picture diagrams. Wire it yourself. It's easy. Only 3 connections and the set is ready to operate. Wave-length range 15 to 600 meters. Complete Kits.

- ONE TUBE KIT, \$1.95
- TWO TUBE, \$2.85

ALL ELECTRIC 105-125 Volt AC-DC two-tube house current set. No batteries needed! Complete Kit.....\$3.65  
Kits wired, 75c extra. Tubes, 75c ea. Double phones \$1.25  
ORDER NOW! Send \$1. balance C.O.D., or if full remittance with order, we pay postage.

ACE RADIO LABORATORIES  
1619 Broadway Dept. C-6 New York City

Help to tune in hard-to-get Foreign programs. Specify and insist on

**CANNONBALL HEADSETS**

Our phones are built with heavy bar magnets which greatly increase their efficiency.

The "popular" set with the "hams."

Write for illustrated circular S-6  
C. F. CANNON COMPANY  
SPRINGWATER, N. Y.

**ANNOUNCING OUR BIG 16th ANNIVERSARY RADIO CATALOG!**

2,967 AMAZING RADIO BARGAINS. For Amateurs, Experimenters, S.W. Listeners, P.A. Engineers and Servicemen.

Send For Your FREE Copy Today!  
**AMERICAN SALES COMPANY**  
Wholesale Radio Distributors  
S-44 West 18th Street, N.Y.C.

Please mention SHORT WAVE CRAFT when writing advertisers

# WRIGHT-DeCOSTER

## Universal Model 2000 Speaker and Cabinet

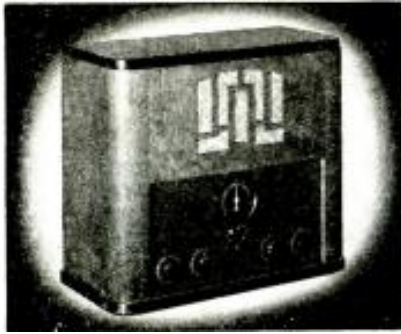

A beautiful, low priced modern cabinet equipped with a Wright-DeCoster Speaker and made to accommodate the many different radio kite and circuits now being built.

Model 2200 B for Browning 35 Set  
Model 2000 A.S. for all Star Sets

Same as Universal Model, only equipped with special speakers and correct panel openings to perfectly match the above sets.  
**Model 390 V. C.  
5" Speaker Chassis \$3.90**

Prices for large models furnished on request. Enjoy the finest tone by using the finest speaker. There is no substitute for quality.

Write for descriptive catalog, discounts and name of nearest distributor. You will always find the Wright-DeCoster distributors anxious to cooperate.



MODEL 390 V. C.

**WRIGHT-DeCOSTER, Inc.**  
2257 University Ave., St. Paul, Minn.  
Export Dept.—M. Simons & Son Co.  
Cable Address: SIMONTRICE, New York.

**Short Wave League Letter-heads**  
Designed for Members



*This is the official letterhead*

It is invaluable when it becomes necessary to deal with the radio industry, mail order houses, radio manufacturers. It can be used in many ways and gives you a professional standing. No member of the LEAGUE can afford to be without this letterhead.

This can only be used by members of the LEAGUE. No one else can purchase it.

See page 67 of this issue for order blank. Take advantage of this opportunity to handle your LEAGUE correspondence in a business-like manner.

**SHORT WAVE LEAGUE**  
99-101 Hudson St., New York, N. Y.

ing 3ME-3LR same morning, shifting from one station to the other for one full hour. Each morning this is repeated. All reports are sent to Mr. Conder for checking-up.

"Arabia. Hello, America—this is Arabia calling, hope our signals are getting through"—then a lot of Arabian talking and singing. No station call as yet; their signals were very poor; tried two Tuesday evenings from 7-9 p.m. but failed to receive their call. Will keep on till I do. On 31.28 meters each Tuesday evening.

Unless listeners come to the aid of VUB, Bombay, India, this station will close down, as they claim no reports are being received on their station. I have volunteered my service to both VUB and VUC for six months, starting April and ending September. VUC will also close down if no reports are received. Will you help? If so, write me, and I will send schedule when received from them.

VK3ME now on the air Wednesday, Thursday, Friday and Saturday from 5-7 a.m., announcement was made over 3ME Mar. 8; have heard four days a week already. 3LR Mondays till Saturdays; 2ME

Sundays, Mondays and Tuesdays, testing with W2XAF, New York, 7-8 a.m. often.

GSL, 4901 meters, testing Mar. 12-14-17 from 10-11 p.m.; no schedule as yet.

New station on 25 meters Tuesday evenings, 7-9 p.m. from Australia, have not as yet got a call on it; also two others, new to me. Two on 32.30 meters and 26 meters

VPD (VP1A) is not a new station, have seen verification dated Aug. 5, 1929, so they must be pretty old. VPD operates VK2ME, beam stations, ship-to-shore stations. Population Fiji 1929, 170,000. Address Amalgamated Wireless (Asia) Ltd., The Wireless Service of Fiji, Suva Fiji Islands. Owner of VPD veri refuse publicity, but can secure for SHORT WAVE CRAFT magazine publicity of card if readers so wish? Address your Editor.

Any reader of SHORT WAVE CRAFT writing to *Super-Wasp*, The R. S. Sampson Printing Co., 971-973 Hay Street, Perth, Western Australia, will receive a FREE copy of *West Australia Wireless News*; it has 67 pages—free for the asking.

Oliver Amlie,  
56th City Line Ave.,  
Overbrook, Philadelphia, Pa.

## 17-In-1 "Multi-Kit" Set

(Continued from page 90)

And to give a third example of the interesting sets that can be made up from the multi-kit, the one shown in Fig. 3 is presented. This is an A.C.-D.C. model—entirely self-powered and operating directly from any electric light socket. This set uses two type 76 tubes and a 1223 rectifier.

An examination of the values on the circuits of these three sets shows that the fundamental ones, in the multi-kit, are all the same and that the sets differ only because of the additional parts. This illustrates how it is possible to change from one circuit to another so easily.

the circuit wherever a wire terminates. These numbers are an invaluable aid in wiring any one of the 17 sets, as simple instructions can be obtained telling just how and where to connect the various wires. Each of the 17 circuits has the same numeral at each essential point, so that the changes from one circuit to another can be explained simply. The instructions merely tell that wire from figure 23 to figure 46 is removed and that a wire is added from 27 to 3, etc. Picture diagrams are included in these instructions and the numbers are given here also, so that a person with absolutely no knowledge of radio has no difficulty in making any of the sets or changing from one to another.

Complete instructions, including not only the easy wiring details described

### Assembly is Extremely Simple

A study of the "multi-kit" diagram discloses that numerals have been added to

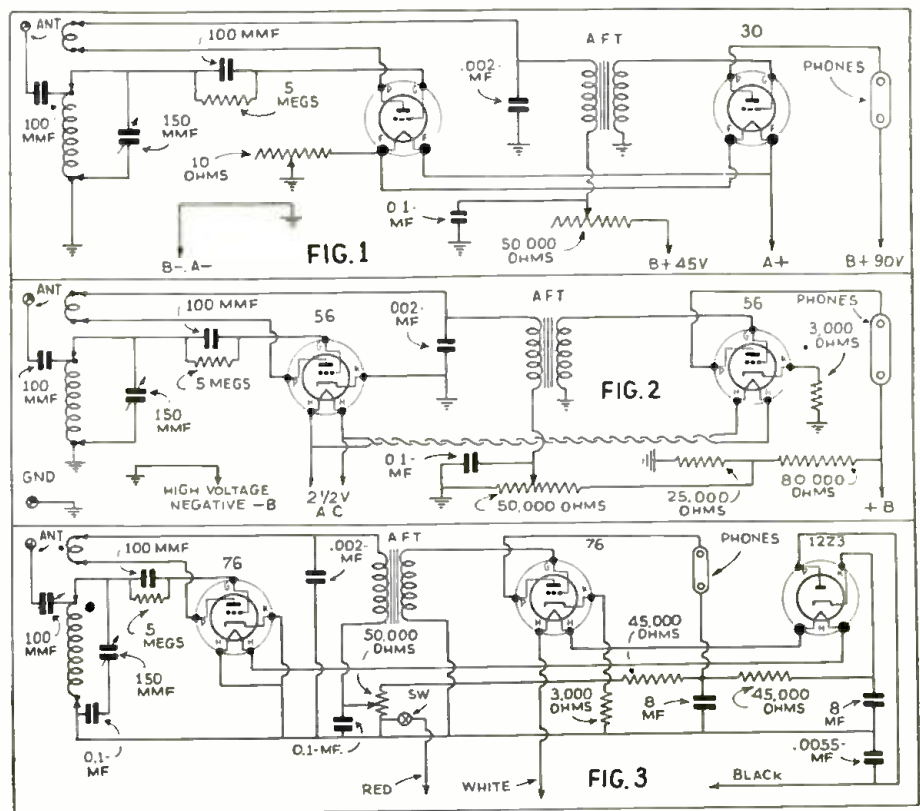

3 Circuits for S-W Receivers which can be built up with the "multi-kit."

Please mention SHORT WAVE CRAFT when writing advertisers



briefly above but also such fundamental facts as soldering hints, instructions for mounting parts, type of phones or speaker to employ, coil frequency ranges, instructions for adding band-spreading (for crowded amateur and broadcast short-wave bands) and hints on how to erect a good aerial and get the best all-round results can be obtained for any of the 17 sets.

**The 17 Sets—What They Are**

To give an idea just how versatile the 17-in-1 multi-kit set is, a brief description of each circuit, and the type of tubes employed, is listed below, in three classifications—battery—A.C.—and universal A.C.-D.C. operation.

**Battery Models**

1—One type 30 or 01A tube—recommended for the beginner is short waves.

2—One type 19—this new 2-in-1 tube equals a detector and stage of audio.

6—Two type 30 or 01A tubes—this is the set shown in Fig. 1.

7—One 30 and one 33—this is similar to No. 6, but uses a power pentode for more volume.

8—Two 30s and one 33—a detector and two audio stages—full loudspeaker volume.

9—One 19 and one 33—similar to set No. 2, but with a power pentode to give full loudspeaker volume.

**A.C. Models**

3—One 56. 27. 37 or 76 tube—a simple 1-tube short-wave set which requires only 45 volts of "B" potential.

10—Two 56 or 27 tubes—supplies a detector and one audio stage with transformer coupling.

11—One 56 and one 2A5 tube—similar to No. 10 but using a power pentode for greater volume and better quality.

12—Two 56s and one 2A5—a very powerful set having a detector and two audio stages one of which is a power pentode.

**Universal A.C.-D.C. Sets**

4—One 12A7 tube—this set supplies its own power due to the rectifier section of the 12A7 tube. It has one pentode detector and rectifier.

5—One 76 and one 12Z3—a triode detector for stability and a rectifier for plate supply.

13—One 6F7 and one 12A7—a new 4-in-2 circuit. Each tube acts as two separate tubes which makes a very powerful set.

14—One 78 and one 12A7—supplying a power pentode and a pentode detector—this set is very sensitive.

15—One 76 and one 12A7—which supplies 3-tube performance—a regenerative detector transformer coupled to a power pentode and a rectifier.

16—Two 76s and one 12Z3—this set supplies a triode detector, a triode amplifier and a separate rectifier.

17—One 6F7, one 76 and one 12Z3. This is a new 4-in-3 circuit supplying a detector, a triode A.F. stage, a pentode output tube and a rectifier for "B" supply. This set is both powerful and stable in operation.

This brief description and outline of the 17 circuits which have been devised up to this time for the multi-kit and accessories will serve to show you just what possibilities there are for the short-wave radio fan and constructor. If you are interested in making or listening to short-wave receivers, whether you know anything about radio set construction or not, you can have innumerable hours of fun making and trying these sets. And the cost of the multi-kit and the additional parts needed for changing from one circuit to another is so small that it will certainly not stand in the way of any ardent radio fan.

And just in case you prefer to obtain any of the 17 sets already assembled, ready to operate, they can be bought for a slightly higher price, though by obtaining them in this way you lose all the fun of making them and also the pride of doing something yourself which is really worthwhile.

A neat cabinet, in black crackle finish which fits any of the sets, is available. This cabinet is made in such a way that the aerial compensator, and the aerial, ground and speaker terminals are left exposed at the back. The top of this neat cabinet is also hinged so that tubes and coils can be easily changed.

There is plenty of room inside of the cabinet for the coils not in use. These sets, either in battery- or power-operated models make ideal portable units because of their small size and light weight.



"I am writing to ALLIED because I know you have always been able to serve me better." That's the way thousands of letters begin that are addressed to us yearly. Last year, we answered 64,340 inquiries—completely and promptly, in a helpful, personal way. There were letters on technical radio problems and requests for replacement parts recommendations, letters asking for kit quotations for radio building, letters requesting advice and prices on public address installations—inquiries from thousands of Amateurs, Servicemen, Dealers and Experimenters. We, at ALLIED, welcome your letters always, and invite your correspondence on all types of radio problems.



The new ALLIED Spring and Summer Catalog is now off the press. If you haven't received your copy, write for it at once. This new book offers you the recent sensational tube price reductions and again makes available R.C.A. Radiotron tubes for outright purchase. The Spring and Summer ALLIED Catalog is devoted 100% to Radio. It features everything for the Serviceman, Set-Builder, Sound Specialist and Experimenter. Lists thousands of exact duplicate standard replacement parts; up-to-the-minute test equipment; dozens of new set-building kits; new All-Wave Receivers—electric, battery, 32 Volt, and Auto Radios—the latest Sound Systems, everything for Short Wave Transmitting and Receiving. Write for this new Catalog now.

**ALL-STAR**  
★  
**Build These Kits**

Order your complete kits for building the famous All-Star Receivers and the All-Wave Browning 35, from ALLIED. Our prices are lower. Write for FREE wiring diagrams and parts lists. We are Radio Builders' Headquarters and can supply complete matched kits for building any radio circuit, at the lowest prices. See our new catalog for scores of other famous kits, including Short Wave receivers, Transceivers, All-Wave radios, Battery sets, Auto radios, etc. Be sure to write for the new Spring and Summer ALLIED Catalog now.

**NEW "NOISE FILTER"**

● A NEW YORK radio house announces a new type of noise filter which really is versatile. This instrument is designed to reduce noise coming from a power line into the radio set and successfully accomplishes this. One thing about it which is quite novel; it can be reversed. In other words, if you are using your vacuum cleaner on some Sunday morning and do not wish to interfere with your neighbors' radios, you plug your vacuum into the noise filter and the noise filter in turn is connected to the 110 volt power line. This prevents any noise being transmitted from your vacuum cleaner into the power line and we dare say it would make any neighborhood more peaceful to live in.

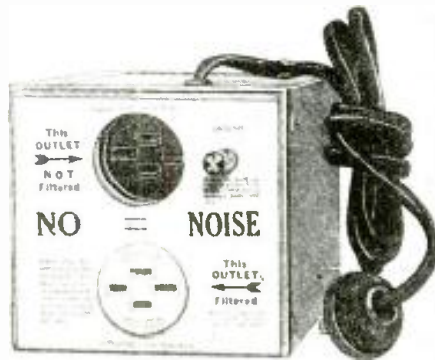

New Blan "line filter" for use with short or all-wave receivers. No. 278.

**\$20.00 PRIZE MONTHLY FOR BEST SET USING 1 OR MORE TUBES**

● THE Editors are looking for some "brand-new" Receiving Circuits USING BUT ONE TUBE. The tube must be a standard one and any type tube can be used. The new multi-element tubes provide Short-Wave "Fans" with almost limitless opportunities. Send along your set—or a circuit diagram and 200 word description for opinion as to acceptability.

The Editors offer a \$20.00 monthly prize for the best short-wave receiver submitted. If your set does not receive the monthly prize the Editors will pay space rates for any articles accepted and published.

You had better write the "S-W Contest Editor," giving him a short description of the set and diagram, BEFORE SHIPPING THE ACTUAL SET, as it will save time and expense all around. A \$20.00 prize will be paid each month for an article describing the best short-wave receiver, converter, or adapter. Set should not have more than five tubes and 1-tube sets featuring one of the new "twin-element" tubes are in great demand. Let's see "YOUR" idea of an Ultra-Modern 1-Tube Set!

Sets must be sent PREPAID and should be CAREFULLY PACKED in a WOODEN box!

The closing date for each contest is sixty days preceding date of issue (June 1 for the August issue, etc.). In the event of a "tie" an equal prize will be paid to each contestant so tying.

The judges will be the Editors of SHORT WAVE CRAFT, and George Shuart and Clifford E. Denton, who will also serve on the examining board. Their findings will be final.

Address your entries to:  
Editor,  
SHORT WAVE CRAFT,  
98 Park Place,  
New York City.

Please mention SHORT WAVE CRAFT when writing



**New 7-POINT MIKE**  
**ACHIEVES**  
**GREATER VOLUME**  
**and PERFECT**  
**REPRODUCTION**  
**WITHOUT FEEDBACK**

The ideal microphone brought within your reach . . . and guaranteed to be the finest value in mikes, regardless of price, or your money back! For the first time in America the new Super-flux Nickel Aluminum Magnets are used . . . magnets more powerful than even 36% Cobalt. You get 8 times more volume without feedback than you can get with diaphragm type mike.

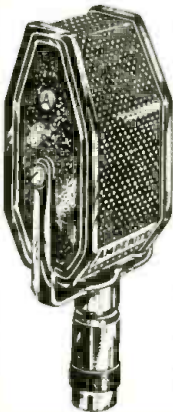

Completely free from distortion, peaks, or hum pickup. Rugged. Fitted with swivel bracket. Two Models: RB-S, especially designed for speech; output, -68 db. RB-M, recommended for speech and music; output, -64 db.

**A. C. PREAMPLIFIER**

Thoroughly shielded and guaranteed humless. 30-14,000 cycles (1 db.). Hum level, -100 db.

Write for Illustrated Bulletin S-4.

**AMPERITE Corporation**  
 351 BROADWAY NEW YORK

**AMPERITE 7-POINT**  
*velocity* **MICROPHONE**

**CQ, CQ-R9**  
**SIGNAL!**

with the **PROFESSIONAL DX5AC** Communications Receiver

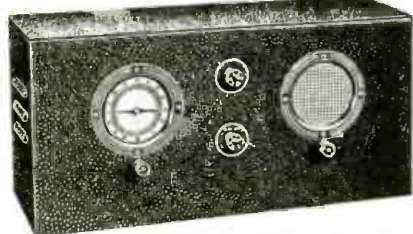

- ★ CONTINUOUS BAND-SPREAD ON ALL BANDS!
- ★ Excellent for CW!
- ★ Earphone outlet!
- ★ 12,500 mile range!
- ★ Low-loss ribbed coils!
- ★ Built-in coil rack!
- ★ High ratio Aero-plane dial!
- ★ Dynamic speaker!
- ★ Standard AC!
- ★ Remarkable performance!
- ★ Uses 79 DUAL, 6D6, 38 and 80 tubes.

\$675

**DeLuxe 5-Meter Transmitter-Receiver**

(Continued from page 85)

Right—bottom view of the 5 meter Transmitter-Receiver built by Mr. McEntee. Note the very compact arrangement of the apparatus; while it is not necessary to use a cam switch of the type shown, this will be found very useful, as it controls several circuits with one simple throw of the switch handle.

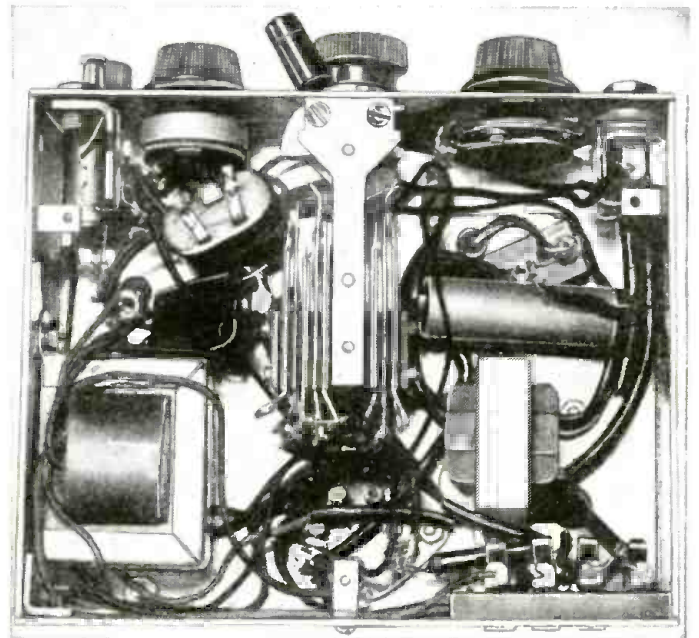

loose coupling as possible so that lower plate voltage may be used and in this way the radiation from the detector minimized. Of course, on a weak signal the coupling may be increased by using more capacity on the antenna condenser. By operating the set this way you can give the local hams a break by causing a lot less Q. R. M.

**Antenna**

As previously mentioned, almost any piece of wire will do for receiving. The best seems to be an 8-foot length with the lead-in taken from the top, the antenna wire being vertical. For transmitting, an 8-foot wire or rod with the tap about 12 to 14 inches either side of center, the vertical position also being best for this.

If desirable, the transmitting antenna can be used for receiving by using a short wire with a clip on one end to snap on the transmitter antenna post, and removing it when transmitting.

Care should be used to pick good tubes, the detector especially being rather fussy. The 30 and 31 in the set shown are of the old type with straight-side bulb, but the internal characteristics are the same as those of the new dome-top bulbs.

The hand-set (French type) is very convenient to use with a set of this type and they can be obtained at reasonable prices now. The mikes are usually all high sensitivity types of the standard 200 ohms resistance. Be sure to get an output transformer to match the type of receiver or headphones to be used, as any mismatch here, if serious, will result in decreased volume and poor quality.

The mike and key jacks are arranged in a sort of parallel circuit, so it is best to remove either one when the other is in use in order to get the maximum audio signal to the 33 grid.

This set has been worked duplex for

twenty miles but no great DX has been attempted or attained, since it is used more as a "stand-by" set and for odd "tricks" rather than consistent work.

It may be used with voltages up to 180 or so with increased output, but the C battery should then be increased to keep the 33 plate current at a reasonable value.

**List of Parts**

- C1, C10—100 mmf. variable air condenser, Hammarlund.
- C2, C11—20 mmf. variable air condenser, Hammarlund.
- C3, C12—.0001 mf. mica midget condenser, Aerovox.
- C4—.006 mf. mica midget condenser, Aerovox.
- C5—.002 mf. mica midget condenser, Aerovox.
- C6, C7—.01 mf. paper tubular, Aerovox.
- C8—.1 mf. paper tubular, Aerovox.
- C9—.001 mf. mica midget, Aerovox.
- R1—1 meg. 1/4 watt resistor I.R.C.
- R2—20,000 variable resistor, Electrad (choose nearest value).
- R3—50,000 1/4 watt resistor I.R.C.
- R4—5-ohm wire-wound variable rheostat.
- R5, R6—Made of wire from 4 to 6 ohm wire-wound resistor.
- T1—Transceiver type input transformer (Thordarson).
- T2—Output transformers, 33 to 5,000 ohms (Thordarson).
- CH—2.5 millihenry chokes Hammarlund (National).
- 2—Isolantite 4-prong sockets, Hammarlund (National).
- 1—5-prong wafer socket, Na-Ald.
- 1—5-volt meter (Triplet).
- 1—25 M.A. meter (Triplet).
- 1—Flexible coupling Hammarlund.
- 1—Buzzer, high-pitched.
- 1—Anti-capacity switch.
- 1—Small vernier dial, National.
- 1—On-off switch, ICA.

**"Go-Get-'em 2" for the Beginner**

(Continued from page 75)

We Want GOOD ARTICLES on 1-, 2- and 3-tube sets. Send us sketch or diagram of your set for approval. If it seems new, the Editors will at once advise you so you can send set in and write article. Let's hear from you!!

- 1—5-prong wafer socket, Na-Ald.
- 1—Ant. Gnd. binding post strip, Na-Ald.
- 1—Large National dial.
- 1—19 RCA Radiotron.
- 1—33 RCA Radiotron.
- 1—50,000-ohm potentiometer, Electrad.
- 1—Chassis and panel, Blan (Korrol).

Meters Wave-length	Grid coil turns	Tickler turns	Distance between 2 coils
200-80	52 T. No. 28 En. Wound	19 T. No. 30 En. Close wound (CW)	1/4"
80-40	32 T. per inch 23 T. No. 28 En. Wound	11 T. No. 30 En. C. W.	3/8"
40-20	16 T. per inch 11 T. No. 28 En. 3-32" between turns C. W.	9 T. No. 30 En. C. W.	1/2"
20-10	5 T. No. 28 En. 3-16" between turns C. W.	7 T. No. 30 En. C. W.	1/4"

Coilform—2 1/4" long by 1 1/4" dia. 4-pin base.

ention SHORT WAVE CRAFT when writing advertisers



# New Acorn-Pentode 954 Tube Is Here!

(Continued from page 91)

ably be connected directly to the electrical mid-point of the heater circuit. In the case of D.C. operation from a 6-volt storage battery, the cathode circuit is tied in either directly or through bias resistors to the negative battery terminals. In circuits where the cathode is not directly connected to the heater, the potential difference between heater and cathode should be kept as low as possible. If the use of a large resistor is necessary between heater and cathode in some circuit designs, it is essential that this resistor be by-passed by a suitable filter network or objectional hum may develop.

The screen voltage may be obtained from a fixed tap on the B-battery, or from a potentiometer across the B-supply, or from the B-supply through a series resistor when the tube is self-biased by means of a cathode resistor. This last method, however, is not recommended if the B-supply exceeds 250 volts.

Shielding of each R.F. amplifier stage employing the 954 is required in order to prevent interstage coupling. A convenient method of shield construction is illustrated in Fig. 2. The control-grid end of the tube is inserted through a hole in a metal plate so that the metal edge of the hole is in close proximity to the internal shield in the control-grid end of the tube. It may be desirable, depending upon circuit requirements, to provide a small collar on the baffle hole in order to increase the shielding effect.

R.F. grounding by means of condensers placed close to the tube terminals is required if the full capabilities of the 954 for ultra-high-frequency uses are to be obtained. Conventional by-passing methods and grounding are not adequate. One convenient method is to use ribbon lead-ins to the clips and to insulate the ribbon lead-ins and the terminal clips from the grounding plate by mica spacers to form by-pass condensers right at the tube terminals. It is important in the cases of the plate and control-grid circuits that separate R.F. grounding returns be made to a common point in order to avoid R.F. interaction through common return circuits. It may also be advisable in some applications to supplement the action of the by-pass condensers by R.F. chokes placed close to the condensers in the return or supply lead for the control-grid, the screen, the suppressor, the plate, and the heater.

### Application

As an amplifier, the 954 is applicable to

the audio or the radio-frequency stages of short-wave receivers, especially those operating at wavelengths as short as 0.7 meter.

For A.F. amplifier circuits, typical operating conditions are as follows: Plate-supply voltage, 250 volts; screen voltage, 50 volts; control-grid voltage, -2.1 volts; suppressor, connected to cathode at socket; plate-load resistor, 250,000 ohms; and plate current, 0.5 milliampere. The control-grid resistor may be made as high as 1.0 megohm. Under these conditions, an undistorted voltage output of 40 to 50 volts RMS may be obtained. The voltage amplification is approximately 100.

As a grid-bias detector, the 954 may be operated under the conditions given in detector data. The control-grid bias may be supplied from the voltage drop in a resistor between cathode and ground. The value of this self-biasing resistor is not critical, 20,000 to 50,000 ohms being suitable.

For miscellaneous applications around the laboratory, the 954 offers important features. For instance, its small size permits the design of vacuum-tube voltmeters such that the tube itself can be placed at the point of measurement.

### RCA-954 Tentative Characteristics Pentode Connection

HEATER VOLTAGE (A.C. or D.C.)	6.3	Volts
HEATER CURRENT	0.15	Amperes
CAPACITANCES:		
Control-Grid to Plate (with shield baffle)	0.007 max.	mmf.
Input	3	mmf.
Output	3	mmf.
OVERALL LENGTH	1-11/16" ± 3/16"	
OVERALL DIAMETER	1-3/32" ± 1/16"	
BULB	J-4	Special
TERMINAL MOUNTING—CLASS A		
D.C. PLATE VOLTAGE	250 max.	Volts
D.C. SUPPRESSOR (Grid No. 3) VOLTAGE	100 max.	Volts
D.C. SCREEN (Grid No. 2) VOLTAGE	100 max.	Volts
TYPICAL OPERATION AND CHARACTERISTICS:		
Heater Voltage	6.3	Volts
D.C. Plate Voltage	90	Volts
D.C. Screen Voltage	90	Volts
D.C. Control-Grid Voltage	-3	Volts
Suppressor	Connected to cathode at socket	
Amplification Factor	1100	Greater than 2000
Plate Resistance	1.0	Megohms
Mutual Conductance	1100	Microohms
Plate Current	1.2	Milliamperes
Screen Current	0.5	Milliamperes

### DETECTOR

D.C. PLATE VOLTAGE	250 max.	Volts
D.C. SUPPRESSOR (Grid No. 3) VOLTAGE	100 max.	Volts
D.C. SCREEN (Grid No. 2) VOLTAGE	100 max.	Volts

TYPICAL OPERATION AS BIASED DETECTOR:

Heater Voltage	6.3	Volts
Plate-Supply Voltage	250	Volts
D.C. Screen Voltage	100	Volts
D.C. Control-Grid Voltage	-6 approx.	Volts

Suppressor—Connected to cathode at socket  
Plate Load—250,000 ohms or equivalent impedance

For resistance load, voltage at the plate will be less than the plate-supply voltage by an amount equal to the voltage drop in the load resistor caused by the plate current.  
Plate Current—Adjusted to 0.1 ma. with no input signal.

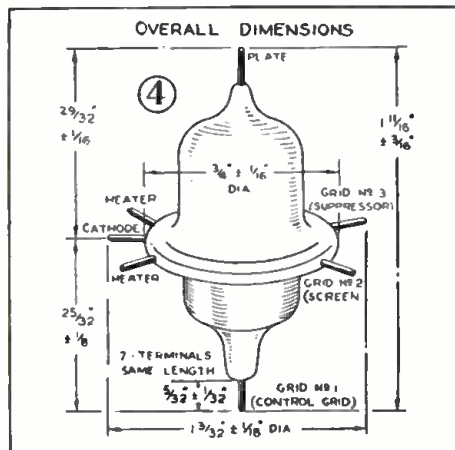
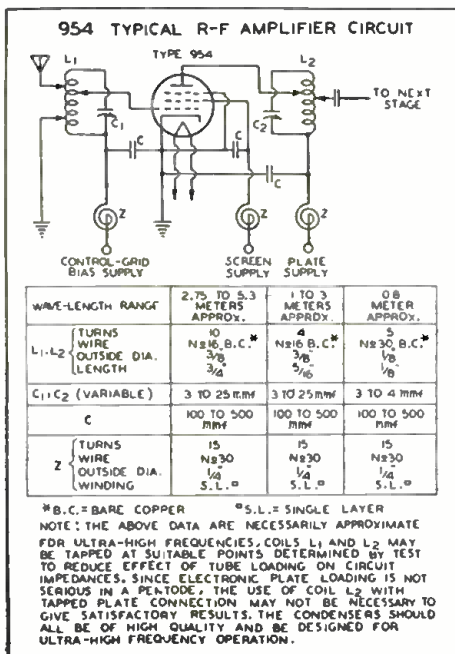

Dimensions of new 954 Acorn-Pentode.

# NATIONAL XR-20 COIL FORMS

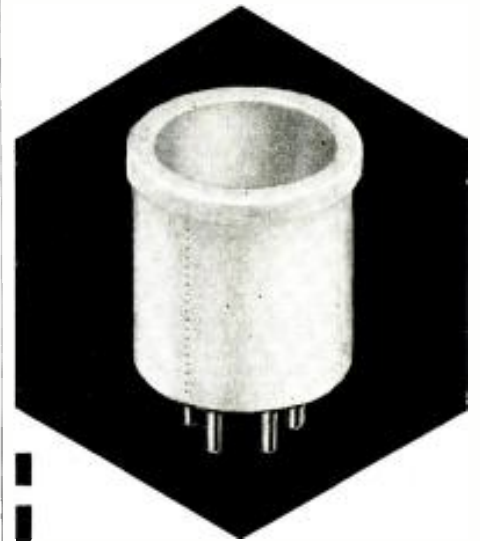

For short-wave receiver construction and experimental work when a small coil form at a low cost will fill the requirements. The XR-20 Coil Forms are made of Steatite, well known Low Loss National Dielectric. They are drilled for leads and left unglazed to provide a tooth for coil dope. Diameter 1 1/2". Made with 4, 5 or 6 prongs and fit Standard Coil-Sockets. List Price, XR-20, \$.35.

NATIONAL R-39 COIL FORMS. Machinable and drillable because made of R-39, outstanding exclusive National Dielectric. Length 2 1/4". Diameter 1 1/2". In 4, 5 or 6 prong types. List Price, XR-4, XR-5, or XR-6, \$.75 each.

List prices subject to 40% discount when purchased through an authorized NATIONAL Distributor.

USE COUPON BELOW

COUPON

National Company, Inc.  
Malden, Massachusetts

Gentlemen:  
Please send me your new catalogue No. 240. I enclose 6c to cover mailing costs.

Name .....

Address .....

.....

SWC-6-35

Please mention SHORT WAVE CRAFT when writing advertisers

# Be a RADIO EXPERT EARN BIG MONEY

**LEARN BY DOING IN 10 WEEKS**

The great and ever-expanding field of Radio — Broadcasting, Television, Talking Pictures, Aviation Radio, Radio Servicing — offers steady employment and a real future for young men who have the ambition to succeed. The famous Coyne "Learn-by-Doing" Method of training offers you the chance of a lifetime to quickly get into this fascinating, big-pay field. 10 weeks training in the Great Coyne Shops in Chicago will qualify you. Coyne Graduate EMPLOYMENT SERVICE will help to PLACE YOU IN THE JOB YOU ARE TRAINED FOR. Start any time.

## I'LL FINANCE YOUR TRAINING

If you are short of ready cash don't let that hold you back. You can get your training first—then I'll give you over a year to pay me back.

You can get your training first—then I'll give you over a year to pay me back. Training Period is over. Many earn while learning. Complete course in **ELECTRIC REFRIGERATION AND AIR CONDITIONING** included at NO EXTRA COST to those who enroll now. Write today for my Big FREE Illustrated Catalog and full details of my amazing "Pay After Graduation" offer—No obligation.



*H. C. Lewis*

**COYNE RADIO & ELECTRICAL SCHOOL**  
500 S. Paulina St., Dept. A5-2K, Chicago, Ill.

MIR. H. C. LEWIS, President, Coyne Schools, 500 S. Paulina St., Dept. A5-2K, Chicago, Ill. Send me the BIG FREE Illustrated Book explaining your Radio Course, special offer and Loan Plan.

Name \_\_\_\_\_  
Address \_\_\_\_\_  
City \_\_\_\_\_ State \_\_\_\_\_

## RESISTOR SPECIALISTS

Featuring:

- QUIET VOLUME CONTROLS, built on an entirely NEW principle.
- VITREOUS RESISTORS
- TRUVOLT RESISTORS
- POWER RHEOSTATS

Write Dept. SW-6 for Catalog

175 Varick St., New York, N.Y.

# ELECTRAD

## GET THE THRILLING LITTLE CHUM

Single-tube ALL-WAVE AC-DC BATTERY Weighs only 2 1/4 lbs. Size 14x13 1/2 inches

The only tiny set on the market, that works either on house current, or on batteries. An ideal portable and "after late hours" all-wave set. Excellent for DX. The complete line kit, containing all parts for the set and power supply, metal cabinet, 3 coils from 40 to 500 meters and instructions to suit the beginners.

**\$4.99**

Wiring, extra \$1.25 Electric or battery tube Earphone \$1.50 each Head-clamp \$1.00

SEND 10c in stamps for complete DATA, DIAGRAM, ILLUSTRATION, etc.

**EXPERIMENTAL RADIO LABS.**  
164 WASHINGTON STREET NEW YORK N. Y.

UNCONDITIONAL GUARANTEE ON ALL OUR RADIO SUPPLIES

# UNCLE DAVE'S

19 1/2 HOUR RADIO SHACK SERVICE 136 BROADWAY ALBANY, N. Y., U.S.A.

Send 5c for our new Ham Catalog—just off the press!

PEERLESS "40-DX" Transmitter . . . crystal controlled for phone or CW operation . . . standard rack mounted . . . 35 or 40 watt C.W. . . 10 watts phone. Transmitter complete with "ALL" accessories, everything but key and antenna, for combination phone CW, our net . . . \$63.50

PEERLESS "4-PRM" Receiver . . . communications type receiver . . . 4 tubes . . . Bandspread 15 to 200 meters, complete kit, less tubes . . . \$18.50

Kit of matched tubes, net . . . 2.00

Wired & tested, additional . . . 1.20

Handsome cabinet, net . . . 2.00

PEERLESS 3-tube Loudspeaker receiver . . . Foreign stations on the loudspeaker . . . Pentode R.F. . . regenerative detector . . . Hi-faln pentode audio . . . coils to cover 15 to 200 meters, either AC or DC kit, less tubes . . . \$7.95

Matched Tubes for AC . . . \$1.43 For DC . . . 2.00

Custom wiring and testing, additional . . . 1.50

# The Ionosphere—Where Short Waves Are Reflected

(Continued from page 73)

the total elapsed time, much as the distance to a mountain could be calculated by timing the return of a sound echo. With radio waves, however, an uncertainty enters because the reflection does not occur sharply at a plane. The wave penetrates the ionized region for some distance and in this region its velocity is reduced.

Because of this, two heights are referred to—the virtual height and the actual height. Virtual height is that calculated on the assumption that the radio wave travels with the velocity of light to the reflecting plane where it is sharply reflected and returns at the same velocity. Actual height is that of the highest point the wave reaches. The situation is suggested diagrammatically in Figure 1. When the virtual height is independent of frequency for a considerable range of frequencies, the virtual height is probably not greatly different from the actual height. When virtual height changes with frequency, it may be several times the actual height. Only the virtual height can be measured directly, but from plots of virtual height against frequency together with certain reasonable assumptions, it is possible to estimate ionic density of the different reflecting regions and to make approximate estimates of the actual heights.

For measuring virtual heights a radio transmitter and receiver are mounted side by side so as to be controlled by a single operator. The arrangement is shown in the photograph at the head of this article. Transmitting and receiving antennas are located above the small building housing the testing apparatus, as shown in Figure 2. Short pulses are sent out from the transmitter at the rate of sixty per second, which travel up to the reflecting layer and back to the ground. The receiver picks up both the direct and the reflected signal, and the time displacement of the two is a measure of the virtual height of the reflecting layer.

The output of the receiver is connected to one pair of deflecting plates of a cathode ray tube, while the other pair of deflecting plates is connected to the sixty-cycle source that controls the rate of emis-

sion of the transmitted pulses. When no signals are being sent out, the pattern on the cathode ray tube is a horizontal straight line caused by the electron stream sweeping back and forth across the tube sixty times a second. When pulses are being transmitted, the motion of the electron stream across the tube will be deflected vertically twice or more each trip—once for the direct pulse picked up and once or more for the reflected pulses. The appearance of such a pattern is shown in Figure 3. The time of sending the pulse relative to the sixty-cycle current can be adjusted, and is usually chosen to bring the first or direct received pulse near the left edge of the tube and at the zero of the small scale fastened on the front of the tube. The position of the second or reflected pulse can then be read directly from this scale. Since the receiving antenna is immediately adjacent to the transmitter, the direct signals are much stronger than the reflected ones. If the gain of the receiver is increased until the reflected signal produces a satisfactory deflection, however, the overloading effect limits the amplitude of the direct pulse to a satisfactory value.

An extremely useful method of studying the structure of the ionosphere is to measure the virtual height as a function

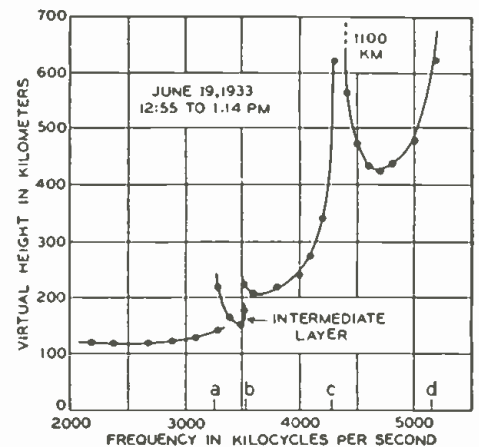

of frequency. To secure such data, the frequency is changed so rapidly that the condition of ionization remains essentially constant during the experiment. A plot of one such set of measurements is shown in Fig. 4 above. The significant feature of the relationship shown is that the virtual height remains essentially constant for a range of frequencies and then suddenly increases. Beyond these critical frequencies the virtual height rapidly decreases, but always to a value higher than that found below the critical frequency. The critical frequency is that at which the

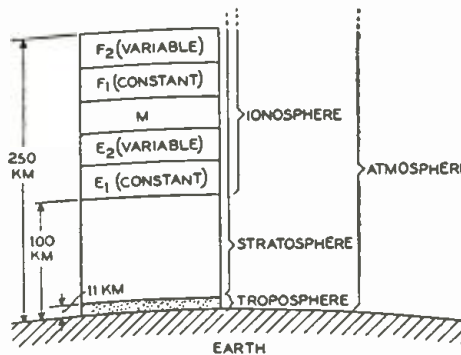
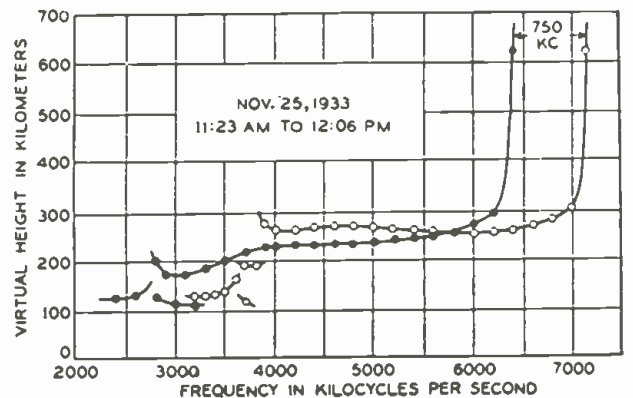

Fig. 4—A plot of virtual height against frequency showing at least three critical frequencies.

Fig. 5—Positions of various ionized regions in the upper atmosphere.

Fig. 6—Virtual height and frequency plot for two components of reflected wave.



Please mention SHORT WAVE CRAFT when writing advertisers



lower reflecting layer is completely penetrated, and the virtual height beyond the critical frequency is that of the next higher layer. The large virtual height obtained at the critical frequency is not due to a greater penetration but to a decrease in velocity of travel through the penetrated layer at the critical frequency. From such sets of measurements it becomes evident that there is more than one reflecting layer in the ionosphere.

At one time it was thought that there were two general ionized regions, an upper and a lower, designated the F and the E respectively. As a result of studies made by the Laboratories, however, it is now known that the ionosphere is composed of at least five, and possibly more, reflecting regions. Their heights are not constant and may even shift relative to each other, but a typical indication of their arrangement is shown in Figure 5. The various regions differ not only in their heights but in the manner in which their ionization varies.

In regions E<sub>1</sub> and F<sub>1</sub>, the ionization throughout the day varies uniformly with time in a manner that would be expected if the ionizing agent were the sun. The same cycle of ionic density repeats itself day after day, attaining a maximum shortly after noon. Tests made during the solar eclipse a few years ago indicate strongly that ultra-violet light from the sun is the ionizing agency. In the other regions, the ionization varies in an erratic manner from day to day and even from hour to hour. During winter the ionic density in the F<sub>2</sub> region may change as much as fifty per cent in from 15 to 30 minutes. The maximum for this region usually occurs about noon in winter and about sunset in summer. The ionization of the M region sometimes varies in a constant manner, as does that of the E<sub>1</sub>

and F<sub>1</sub> regions, and sometimes varies erratically from hour to hour.

Because of this variation in ionic density, it is not always possible to find all the regions at the same time. If, for example, the ionic density of the E<sub>2</sub> region should be greater than that of any higher regions, signals that completely penetrated the E<sub>2</sub> layer would not be returned to the earth, giving no indication of the existence of higher levels. In general a signal that completely penetrates one layer will be reflected only by a layer of higher density.

Besides this complexity of reflecting regions, there is an additional complication caused by the effect of the earth's magnetic field. In such a field the signal is split into two components, each of which in general is reflected at a different virtual height and has a different critical frequency. This is indicated in Figure 6, where one component is indicated by black dots and the other by circles.

The effects described so far are detected when the transmitter and receiver are side by side, and the signal is transmitted up and back vertically. When the receiver is at a considerable distance from the transmitter, however, the reflection phenomena are further complicated by there being a number of paths which use different parts of the ionosphere for reflection as shown in Figure 7. When it is remembered that the reflection along all of these paths encounters the diversity of reflecting regions and the splitting effect of the magnetic field already described, it becomes apparent that the transmission of short waves must be a very complicated process. Fundamental studies of the elements of this type of propagation should contribute materially to the improvements in long-distance radio transmission which the next few years should bring forth.—*Bell Laboratories Record.*

# YOUR TROPHY-CUP

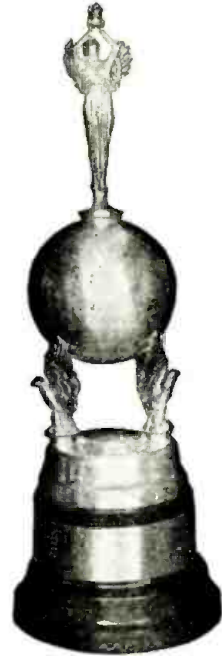

## WIN IT AND A YEAR'S SUPPLY OF BB'S

BB's (Burgess Batteries) will help you win your SWST (Short Wave Scout Trophy). They will give your set the increased power, the hair-line selectivity, the keen sensitivity it needs to bring in a record number of stations. Get a new supply of BB's today—and pick a prominent spot for your SWST. ● If the set you use to win the SWST is powered by BB's, we will give you all the BB's your set can use in a whole year—FREE! Mail notification of your prize award to BURGESS BATTERY CO., Freeport, Ill.



BURGESS Power House



BURGESS "B" and "C" Batteries

# BURGESS BATTERIES AND FLASHLIGHTS

## Short Wave Stations of the World

(Continued from page 95)

**5853 kc. WOB**  
-C- 51.26 meters  
LAWRENCEVILLE, N. J.  
Calls Bermuda, nights

**5850 kc. ★YV5RMO**  
-B- 51.28 meters  
MARACAIBO, VENEZUELA  
5:15-9 p. m.

**5825 kc. TIGPH**  
-B- 51.5 meters  
SAN JOSE, COSTA RICA  
6:15-11 p. m.

**5790 kc. JVU**  
-C- 51.81 meters  
NAZAKI, JAPAN  
Broadcasts 2-7:45 a. m.

**5780 kc. HI1J**  
-B- 51.9 meters  
SAN PEDRO DE MACORIS,  
DOM. REP.  
7-9:30 p. m.

**5780 kc. OAX4D**  
-B- 51.9 meters  
P. O. Box 853  
LIMA, PERU  
Mon., Wed. & Sat. 9-11:30 p. m.

**5714 kc. HCK**  
-B- 52.5 meters  
QUITO, ECUADOR, S. A.

**5660 kc. HJ5ABC**  
-B- 53 meters  
CALI, COLOMBIA  
11 a. m.-12 N.  
Tues. and Thurs. 8-10 p. m.  
Sun. 12 N.-1 p. m.

**5077 kc. WCN**  
-C- 59.08 meters  
LAWRENCEVILLE, N. J.  
Phonics England irregularly

**5025 kc. ZFA**  
-C- 59.7 meters  
HAMILTON, BERMUDA  
Calls U.S.A., nights

**4975 kc. GBC**  
-C- 60.30 meters  
RUGBY, ENGLAND  
Calls Ships, late at night

**4820 kc. GDW**  
-C- 62.24 meters  
RUGBY, ENGLAND  
Calls N.Y.C., late at night

**4752 kc. WOO**  
-C- 63.1 meters  
OCEAN GATE, N. J.  
Calls ships irregularly

**4600 kc. HC2ET**  
-B- 65.22 meters  
Apartado 249  
GUAYAQUIL, ECUADOR  
Reported Wed., Sat. 9-11:30 p. m.

**4320 kc. GDB**  
-C- 69.44 meters  
RUGBY, ENGLAND  
Tests. 8-11 p. m.

**4273 kc. RW15**  
-B- 70.20 meters  
Khabarovsk, SIBERIA.  
U. S. S. R.  
Daily, 3-9 a. m.

**4272 kc. WOO**  
-C- 70.22 meters  
OCEAN GATE, N. J.  
Calls ships irregularly

**4107 kc. HCJB**  
-B- 73 meters  
QUITO, ECUADOR  
7:14-10:15 p. m., except Monday

**4098 kc. WND**  
-C- 73.21 meters  
HIALEAH, FLORIDA  
Calls Bahama Isles

**4002 kc. CT2AJ**  
-B- 74.95 meters  
PONTA DELGADA,  
SAO MIGUEL, AZORES  
Wed. and Sat. 5-7 p. m.

**3543 kc. CR7AA**  
-B- 84.67 meters  
P. O. BOX 594  
LOURENCO MARQUES, MO-  
ZAMBIQUE, E. AFRICA  
1:30-3:30 p. m., Mon., Thurs.,  
and Sat.

**3490 kc. PK1WK**  
-B- 85.96 meters  
BANDOENG, JAVA  
Daily except Fri., 4:30-5:30  
a. m.

All Schedules Eastern Standard Time

Articles on good 1 to 5 tube sets wanted! The Editors are looking for good set construction articles on:  
A—One and Two Tube Receivers.  
B—Sets using new "dual-purpose" tubes.  
C—S-W Converters of efficient type and proven worth.  
D—Transmitters, low-power, efficient types, and allied "Ham" station apparatus including Monitors, etc.  
Send diagrams of set first and photo for editor's opinion, before shipping set.

Please mention SHORT WAVE CRAFT when writing advertisers

# DATAPRINTS

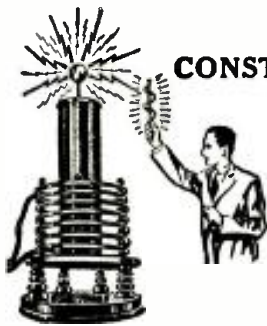

Just the  
**CONSTRUCTION**  
Information  
You Need  
To Build  
Electrical  
Apparatus

**TESLA OR OUDIN COILS**  
Dataprint containing data for constructing this 3 ft. spark Oudin-Tesla coil. Requires 1 K.W. 20,000 volt transformer as "exciter". See list below. Includes condenser data. . . **\$ .75**

- 8 inch spark, data for building, including condenser data; requires 1/2 K. W. 15,000 volt transformer; see list below. . . . . 0.50
- Violet type, high frequency coil data; 110 volt A.C. or D.C. type; 1" spark; used for "violet ray" treatments and "Experiments" . . . 0.50
- How to operate Oudin coil from a vacuum tube oscillator . . . . . 0.50
- 3 inch spark Tesla coil; operates on Ford ignition coil . . . . . 0.50
- 3 inch spark Oudin coil; 110 volt A.C. "Kick" coil . . . . . 0.50
- 20 Tricks with Tesla and Oudin Coils. . . . . 0.50

- TRANSFORMER DATA**
- 1 k.w. 20,000-volt transformer data, 110-volt, 60-cycle primary. Suitable for operating 3 ft. Oudin coil . . . . . 0.50
  - 1/2 K.W. 15,000-volt transformer data, 110-volt, 60-cycle primary. Suitable for operating 3-inch Oudin coil . . . . . 0.50
  - Electric Welding Trans. (2 K.W. 110 Vt. Prim. 18 Vt. Sec. Other Sec. Vt. data given.) . . . . . 0.50
  - Induction Coils—1 to 12 inch spark data. . . . . 0.50
  - ARTIFICIAL FEVER Apparatus. . . . . 0.75**
- (Low, Medium & High Power Data Given)



**SLIDE RULE**  
**MIDGET**  
Metal 4" Dia.  
Price \$1.50.  
Case 50c extra

This rule solves any problem in multiplication, division, addition, subtraction, and proportion; it also gives roots and powers of numbers, sines, cosines, tangents and cotangents of all angles; also logs of numbers. Adds and subtracts fractions. Approved by colleges.

10" Dia. 27" Scale "Special" Rule. \$2.75.  
Multiplies and Divides, but has no "Trig" Scales.

**TELEGRAPHONE** — Records Voice or "Code" signals on steel wire by magnetism. Code can be recorded "fast" and translated "slow." Construction data (special) . . . . . **\$0.50**

**MAGNET COIL DATA**

- Powerful battery electro-magnet; lifts 40 lbs. . . . . \$0.50
- 110 Volt D.C. magnet to lift 25 lbs. . . . . 0.50
- 110 Volt D.C., 300 lb. Lift electromagnet. . . . . 0.50
- 110 Volt D.C. solenoid; lifts 2 lb. through 1 in. . . . . 0.50
- 110 Volt D.C. solenoid, lifts 6 lb. through 1 in. . . . . 0.50
- 12 Volt D.C. solenoid, lifts 2 lb. through 1 in. . . . . 0.50
- A. C. Solenoid, powerful, 110-volt, 60-cycle. . . . . 0.50
- MOTOR**—1/16 H.P., 110 volt A.C., 60 cycle (suitable for driving 12" fan, etc.)—Data. . . . . 0.50
- 60 or 1,200 cycle Synchronous motor. . . . . 0.50

**MISCELLANEOUS DATAPRINTS**

- Treasure Locator . . . . . \$0.50
- Electric Refrigerator data. . . . . 0.50
- 20 motor circuits—hook-ups. . . . . 0.35
- 20 practical telephone hook-ups . . . . . 0.35
- 100 mechanical movements for inventors. . . . . 0.50
- Polarized Relay—1" Intra Sensitive . . . . . 0.50
- Electro-medical coil (shocking coil) . . . . . 0.50
- Water-Whisks—How to Build and Light your house . . . . . 0.50
- 20 Electric Bell circuits. . . . . 0.50
- Public Address System . . . . . 0.50
- Electric chime ringer; fits any clock. . . . . 0.50

20 "Electrical Tricks" for LODGES and PARTIES . . . . . \$0.50

How to Fry Eggs on Cakes of Ice Electrically. . . . . \$0.50  
"Rewinding" Small Motor Armatures. . . . . 0.50  
**"ENGINEERING SERVICE BY MAIL"**  
Send Sketch of Your Problem for Estimate.  
(20% off on orders for \$3.00 or more. No C.O.D.)

**The DATAPRINT COMPANY**  
Look Box 322 RAMSEY, N. J.

## When To Listen In

By M. Harvey Gernsback

### Australia

● VK3ME at Melbourne, 9510 kc. now operates from 5:30-7 a.m. on Wed., Thurs., Fri. and Sat. VK2ME at Sydney on 9590 kc. operates Sundays from 1-3, 5-9 a.m. and 10:30 a.m.-12:30 p.m.

### Berlin

The German stations have made some changes in their schedule. The program on DJC which formerly began at 5:30 p.m. now starts at 5:05 p.m. The program which began at 5:15 p.m. on DJA and DJN now starts at 5:05 p.m. also. DJE, 16.89 meters is used almost daily from 8-11:30 a.m. with a directional aerial for South America sending the same program as DJA and DJN do at that time. After May 1st, the evening program will be broadcast on DJD, 11770 kc. from 5:05-10:30 p.m. and on DJC, 6020 kc. from 9:30-10:30 p.m.

### Daventry

On April 14 daylight saving time went into effect in England. The following changes in schedule were made: Trans. 1, 12:15-2:15 a.m. (11:30 p.m.-1:30 a.m. after May 11) on GSD and GSB. Trans. 2, 6-8:45 a.m. (6:30-8:45 on Sun.) on GSG and GSF GSH or GSJ may replace GSF late in May. Trans. 3, 9 a.m.-12 n. on GSF and either GSG or GSE. Trans. 4, 12:15-3:45 p.m. on GSD and GSB GSF or GSI, may replace one of these. 4-5:45 p.m. (Sun. 4-4:55 p.m.) on GSB and either GSC or GSD. Trans. 5, 6-8 p.m. on GSD and GSC. Trans. 6, (experimental) 10-11 p.m. on Sun., Tues., Thurs. and Sat. on GSC and either GSL or GSD.

### France

Radio Coloniale (FYA) at Paris operated from 6-10 a.m. on 19.68 met., 10:15 a.m.-1:15 p.m. and 2-5 p.m. on 25.25 meters and from 6-9 and 10 p.m.-12 m. on 25.63 meters during April. They announced that a further change would be made the first of May and that they would shortly increase their transmitters' power, leading us to the conclusion that their new plant at Villejust, mentioned in this column several months ago, will be placed in service around May 1st. Several new waves have been assigned to this station. (6145 kc., 9585 kc., 11845 kc., 15295 kc., 17765 kc., and 21490 kc.) These are in addition to the old waves. As to what schedules and wave-lengths will be used when and if Villejust gets going we have no information.

### Madrid

EAQ at Madrid on 9860 kc., now seems to operate till 7:30 p.m. every night. The full schedule is daily 5:15-7:30 p.m. On Sat. from 1-3 p.m. in addition to the regular schedule.

### Budapest

The Budapest stations have changed frequencies and schedules, according to a letter just received direct from the station. HAS3 (it is HA\$3 and not HAS as some people claim) on 15370 kc., operates on Sundays from 9-10 a.m. HAT4 on 9125 kc. (32.88 met.) operates on Sun. from 6-7 p.m. Announcements are made in English. HAT on 5400 kc. is no longer used for broadcasting. The station requests reports and will answer letters. Address: Chief Engineer, Radiolabor, Gyali-ut, 22, Budapest, Hungary.

### Mexico

There are 2 new Mexican broadcasters. One is XECW, a 10 watter operating on about 5975 kc. (50.25 meters). It is reported from 4-4:30 p.m. and from 10:30 p.m.-12 m. Also irregularly from 4:30-10:30 p.m. The address is Carlos Codero, Calle del Bajio, No. 120, Mexico City, Mex.

The big news from Mexico is the inaugural of the new 20 kw. government broadcasting station which operates on 7390 kc. (40.6 meters). This station broadcasts each Sunday from 6-7 p.m. The station is under the direction of the Mexican Foreign Office. The transmitter is at Chapultepec. The station uses the studios of XEBT in Mexico City. Thanks to Manuel Ortiz Gomez of Mexico City for this information.

### Holland

PHI at Huizen, Holland is now back on its summer wavelength of 16.88 meters. During April PCJ on 19.71 meters relayed all of PHI's programs. PCJ is now reported to be testing on Tuesdays from 3 to 6 a.m. and on Wednesdays from 7 a.m. until 5 p.m. on 19.71 meters.

### Italy

The 30 meter transmitter of I2RO made two changes in wavelength in March to escape interference. First it moved from 9780 kc. to about 9600 kc. (Same as CT1AA.) After remaining there a week it decided that it was worse off than before so it made one more jump to 9635 kc. (31.13 meters) and settled down there. Incidentally, it seems to have cleared itself of all interference by this last move. The American Hour from Rome is still radiated on Mon., Wed., and Fri. from 6-7:30 p.m. By the time that this is printed it is probable that the American Hour will be broadcast on either 9635 kc. or on 2RO's old frequency of 11811 kc. (25.4 meters). The daily broadcasts from 2:30-5 p.m. (approximately) will probably be shifted to 11811 kc., too. A program for South America is broadcast on Mon., Wed. and Fri. from 7:45-9:15 p.m. on 9635 kc.

### Schenectady

From April 28th on the schedule of the Schenectady transmitters follow. W2XAD, 15330 kc. daily, 2-3 p.m. This station is also frequently heard on Sat. from about 11:30 a.m. till 12:30 p.m., sending NBC programs to London. W2XAF operates daily from 5:30-11 p.m. on 9530 kc.

### Springfield

W1XAZ at Springfield, Mass., is now known as W1XK. This station operates on 9570 kc. After April 28th, it will operate daily from 6 a.m. until 12 midnight.

### Costa Rica

A TIPG on 6550 kc. is reported on at 10:15 p.m., giving its address as P. O. box 225, (City unknown) in Costa Rica. Any information on this one? YV5RMO

The second harmonic of YV5RMO (5850 kc.) which is equal to 11700 kc., is heard very strongly in the evenings and is mistaken for a new station. It heterodynes FYA (11705 kc.).

This month about 25 stations have been added to the Short Wave Station list and about 60 added to the Police Radio Alarm List

**YOU Can Easily  
WIN  
A S-W SCOUT TROPHY!**

**Have You Read the Simple Rules on  
page 120?**

**In Next Issue More "Ham"  
Articles—Don't Miss 'Em!!**



# BROWNING 35

With the **TOBE** Tuner

Sweeping the Country!  
Buy YOUR Kit of Parts From  
Headquarters

for  
SHORT  
WAVE

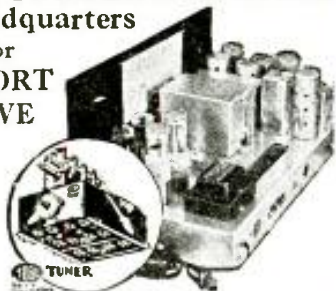

**NOISE WON'T BOTHER YOU** in your Short Wave Listening Post if you own a BROWNING 35! This newest of All-Wave Receivers with the TOBE TUNER, assures you of the finest foreign and American station reception that you have ever heard.

**SERVICE MEN!** Let us tell you how to make real money by assembling the Browning 35 and selling it as a modern, custom built job to replace out-moded sets in customers' expensive cabinets!

**AMATEURS!** If you appreciate the importance of high signal to noise ratio—build this remarkable receiver and ACTUALLY GET IT!

**FREE**—Big illustrated TABLOID giving the complete story of the BROWNING "35"; shows circuit diagrams, sensitivity curves, parts list, constructional details—and our LOWEST WHOLESALE PRICES! Address Dept. SWX-65.

**WHOLESALE RADIO SERVICE Co.**  
100 SIXTH AVENUE - NEW YORK, N.Y.

MADE BY GAT I. Goldberg Co. ATLANTA, GA. 488 W. 10th Street N.W. DETROIT, MICH. 540 Central Bldg.

## Short Wave League Members

IDENTIFY THEMSELVES WITH THE ORGANIZATION



In order that fellow members of the LEAGUE may be able to recognize each other when they meet, we have designed this button, which is sold only to members and which will give you a professional appearance.

If you are a member of the LEAGUE, you cannot afford to be without this insignia of your membership. It is sold only to those belonging to the LEAGUE and when you see it on another, you can be certain that he is a member.

See page 67

- Lapel Button, made in bronze, gold filled, not plated, prepaid..... 35c
- Lapel Button, like one described above, but in solid gold, prepaid.....\$2.00

Full details mailed FREE on

# Browning 35



Send For Free Catalog

**Radio Electric Service Co.**

N.E. Cor. 7th & Arch Sts., Phila., Pa.  
3145 N. Broad St., Phila., Pa.  
811 Federal St., Camden, N. J.

## Book Review

**APPLIED ACOUSTICS**, by Harry F. Olson, and Frank Massa. Published by P. Blakiston's Son & Co., Inc. Has stiff cover, measures 8½" by 6" by 1" thick. There are 430 pages. Price \$4.50.

This is one of the most complete books in its field that we have had the pleasure of reviewing. It has 15 chapters covering every conceivable phase of acoustics, from fundamental equations and definitions right through to miscellaneous acoustical applications. It gives definite information on measurements of noise, architectural acoustics, microphones, loud speakers, the calibration of microphones, and dynamic systems, electrical, mechanical and acoustic elements and systems of elements. Hundreds of interesting diagrams and graphs are given, together with various types of circuits and constructional data on microphones and speakers.

**PRACTICAL MATHEMATICS FOR HOME STUDY** by Palmer. Published by McGraw Hill Book Company. Bound in flexible leather cover. Measures 5" by 8" by 1½" thick. Contains 606 pages. Price \$4.00.

This book gives about the most comprehensive practical explanation imaginable of the art of mathematics, starting with elementary arithmetic. It is intended for the practical man and will undoubtedly aid him in his work considerably if he is not already thoroughly acquainted with mathematics. There are 11 chapters and it goes through logarithms and trigonometry. The author has written the book in such simple language that the most inexperienced reader will have no difficulty in thoroughly understanding it and gaining a really practical knowledge of mathematics. Various tables and illustrations accompany the text in order to make clear and fix in the reader's mind the thought that the author tries to convey.

**RADIO ENGINEERING HANDBOOK**, by Keith Henney. Published by McGraw Hill Book Company, New York City, N.Y. Measures 5" by 7" by 1½". Price \$5.00.

This book is intended for the more serious-minded radio man who wishes to have a handbook which thoroughly explains the various functions of radio circuits and components. It is a technical book, profusely illustrated with formulas, diagrams, charts, graphs, etc., and covers the entire field of radio. It has 23 sections covering mathematical and electrical tables, electric and magnetic circuits, resistance and inductance, capacities, measuring instruments, vacuum tubes, oscillating circuits, R.F. amplifiers, various types of receiving and transmitting systems, antennas, aircraft radio, facsimile transmission, photo-cells, and sound motion pictures.

### New Treatise on Super-Hets

● FOR those who are seriously interested in the superheterodyne and who wish to gain a thorough knowledge of the workings in this most efficient type of radio receiver, the Radio Research Laboratories are publishing a book entitled, "The Superheterodyne Receiver." This book is written by Dr. R. H. von Liedtke, M.S., E.E., D.Sc. University of Heidelberg.

It covers the design/construction, and aligning of superheterodyne and component circuits. It is profusely illustrated with drawings of oscillators and detectors, and design of an I.F. transformer and their selectivity curves.

It treats automatic volume control very thoroughly, giving circuits for several different methods of obtaining this very desirable feature. The difficult parts of superheterodyne design and construction are clearly explained in simple terms and also in elaborate mathematical expressions. One of the many charts provides for the rapid determination of the wavelength, frequency, and "L.C." values for radio frequency circuits. This book is ideally suited for classroom and laboratory use.

List price of this book is \$3.75.

A new All-Wave Receiver with the remarkable TOBE TUNER that assures you round-the-world reception with the clarity and strength of locals! Especially designed for S.W. Listening Post Observers who appreciate the importance of actually getting high signal to noise ratio.

## SERVICEMEN!

Servicemen; get our remarkable money making plan telling how to build, sell and install the Browning All-Wave Receiver, utilizing customers' present cabinets! They SAVE MONEY... and you make a big Profit too! List Price—\$66.50. (TOBE TUNER, as separate unit—\$31.00.) Get full circuit diagrams, lists of parts, and special discounts all sent ABSOLUTELY FREE. Write your favorite jobber. If he can't supply you, write direct to Tobe Deutschmann Corp., Dept. F-13, Canton, Mass. (Export Dept: 105 Hudson St., New York).

# BROWNING 35

With the **TOBE** Tuner

**NEW! AND WE HAVE IT.**  
**THE TALK OF THE**  
**SHORT WAVE WORLD**

**BUILD IT YOURSELF**

# Browning 35

WITH **TOBE** TUNER

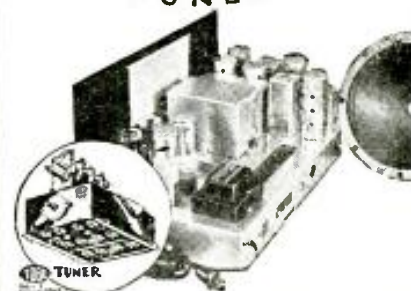

A brand new set incorporating a startling array of new principles. It includes the TOBE TUNER, the heart of the Browning 35. This tuner is a pre-adjusted unit including all R.F. tuning circuits. The TOBE TUNER comes to be set into the chassis with an aligned ready to be set into the chassis with only seven simple connections.

**M & H Sporting Goods Co.**

512 Market St., Phila.

### VEST POCKET SOLDERING IRON

Smallest good iron now on the market. Will do the work of irons twice its size. Only 10 inches long, ½ inch in diameter. By using the highest grade elements, it heats up in half the time of ordinary irons. Guaranteed to give satisfaction or money back. We issue no catalog on this item. Enclose \$1.20 and iron will be sent postpaid in U.S. 10c extra in Canada. Gold Shield Products Co., 17 West 60th St., N. Y. City



# Most Amazing TYPEWRITER BARGAIN

**10 DAY  
FREE TRIAL  
OFFER** EVER  
**OFFERED**



**NEW  
REMINGTON  
PORTABLE only**

**10¢  
A DAY**

FIRST TIME! Remington's new purchase plan lets you buy a genuine Remington Portable No. 5 direct from factory for 10¢ a day. Not used or rebuilt. Not incomplete. A beautiful brand new regulation Remington Portable. Standard 4-row keyboard, standard carriage, margin release on keyboard, back spacer, automatic ribbon reverse; every essential feature found in standard typewriters.

With your machine we send you free a 18-page course in typewriting. Teaches touch system quickly, easily. Soon you dash off letters quicker than with pen and ink. Yours is a handsome, sturdy carrying case free.

**FREE**  
Typewriting  
Course



**FREE**  
Carrying  
Case



**BIG PRICE REDUCTION**

The amazing low price and easy terms make this the greatest typewriter value ever offered. But everything points to higher prices. Present big price reduction cannot be guaranteed long. So we say, "Act Fast!"

**You Don't Risk One Cent**  
Try this typewriter in your home or office on our 10-day FREE TRIAL OFFER. Then, if you do not agree that it is the finest portable at any price, return it at our expense. You don't even risk shipping charges. Don't wait. Mail coupon now. It's the best chance you've ever had to own so complete a machine for so little money. So act NOW!

**CLIP COUPON NOW**

Remington Rand Inc., Dept. 214-6  
205 E. 42nd Street, New York City.

Please tell me how I can buy a new Remington Portable typewriter for only 10¢ a day. Also enclose your new catalog.

Name \_\_\_\_\_  
Address \_\_\_\_\_  
City \_\_\_\_\_ State \_\_\_\_\_

**SPECIAL SALE!  
SHORT-WAVE RECEIVER**

Complete Kit of Parts with instructions and one coil

**\$1.95**

Wired and tested extra . . . 50¢  
RCA licensed tube . . . 40¢  
Extra 3 Coils 50¢

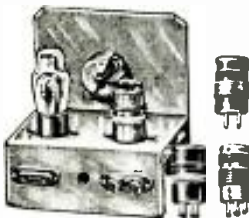

Accompanying hints and detailed instructions inform the builder the entire procedure as to how the receiver is to be assembled, and wired. Uses the low current consuming 230 tube; 1-45 volt and 2 No. 6 dry cells for operation. The receiver will cover the 15 to 200 meter bands with the four coils.

**FREE** Catalog of many other Radio Bargains. Prices guaranteed LOWEST. Wait for our book before you purchase a receiver.

**TRY-MO RADIO CO., INC.**  
85-S Cortland St., N.Y.C. 179-S Greenwich St., N.Y.C.

**SPECIAL FOR THIS MONTH**  
Send \$1.00 (\$1.25 Canada and Foreign) and we will send you SHORT WAVE CRAFT for Eight months. **DO IT NOW!**

**SHORT WAVE CRAFT**  
99-101 Hudson Street New York

## Short Wave Scouts

(Continued from page 72)

- W3XAL 17780 Kc. Daily, 10 a.m.—4 p.m.; Bound Brook, N.J.
- W3XAL 6100 Kc. Mon., Wed., Sat., 5:30 p.m.—1 a.m.; Bound Brook, N.J.
- W9XAA 6080 Kc. Tues., Thurs., Sat., 4—12 p.m.; Sun., 11:30 a.m.—9 p.m.; Chicago, Ill.
- W9XF 6100 Kc. Tues., Thurs., Fri., Sun., 2:30 p.m.—2 a.m.; Chicago, Ill.
- W3XAU 9590 Kc. 12—8 p.m., daily; Newtown Square, Pa.
- W3XAU 6060 Kc. 8—11 p.m., daily; Newtown Square, Pa.
- W8XAL 6060 Kc. Daily, 6:30 a.m.—8 p.m., 11 p.m.—2 a.m.; Cincinnati, Ohio.

up to one of sixteen tubes, or upwards, if they so desire.

9.—When sending in entries, note the following few simple instructions: Type your list, or write in ink, *pencilled matter is not allowed*. Send verification cards, letters and the list all in one package, either by mail or by express prepaid; *do not split up the package*. Verification cards and letters will be returned, at the end of the contest, to their owners; the expense to be borne by SHORT WAVE CRAFT magazine.

10.—In order to have uniformity of the entries, when writing or typing your list, observe the following routine: USE A SINGLE LINE FOR EACH STATION; type or write the entries IN THE FOLLOWING ORDER: Station call letters; frequency station transmits at; schedule of transmission, if known (all time should be reduced to Eastern Standard which is five hours behind Greenwich Meridian Time); name of station, city, country; identification signal if any. Sign your name at the bottom of the list and furthermore state the type of set used by you to receive these stations.

11.—Don't list amateur transmitters or code stations in this contest.

12.—This contest will close every month for the next twelve months on the first day of the month, by which time all entries must have been received in New York. Entries received after this date will be held over for the next month's contest.

13.—The next contest will close in New York, June 1.

14.—The judges of the contest will be the editors of SHORT WAVE CRAFT, and their findings will be final.

15.—Trophy awards will be made every month at which time the trophy will be sent to the winner. Names of the contesting SCOUTS not winning a trophy will be listed in Honorable Mention each month.

16.—From this contest are excluded all employes and their families of SHORT WAVE CRAFT magazine.

17.—Address all entries to SHORT WAVE SCOUT AWARD, 99-101 Hudson St., New York City.

**FREE BATTERIES TO TROPHY WINNER!**

The manufacturers of the well-known Burgess batteries have offered to furnish FREE one year's supply of batteries—all the batteries that the "trophy" winning set will need for a year—and providing it happens to be a Burgess Battery-powered set. A very fine offer indeed, and the editors are glad to pass on the good word to all of their embryo trophy contestants.

**A New Discovery in Crystallography**

By William Threm

I HAVE been cutting, grinding and experimenting with crystals for the past four years and discovered that a quartz crystal can be cut and ground and made to oscillate on its 1st, 2nd, 3rd and 4th harmonics of its fundamental frequency.

I have in my possession several of these crystals. One of them oscillating on 1820 kc, 3640 kc, 7280 kc and 14480 kc. Others ground to different frequencies repeating themselves likewise.

These cuts were discovered accidentally about a year ago and up to the present time I have not been able to produce this type quartz crystal at will. If this cut can be perfected it will be very useful for the high frequency bands because of its sturdiness.

These crystals were tested by Mr. G. F. Lampkins, in the G. F. Lampkins Laboratories in Cincinnati, and found to check with the tests of the writer.

I have also in my possession another type plate which oscillates on two distinct and separable frequencies in the same band.

**Trophy Contest Entry Rules**

NOTE that we have amended our rules and you will find that the rules now read:

In order to protect everyone, the rules have been amended that a sworn statement before a Notary Public which only costs a few cents to get, must be sent in at the same time.

For the complete article of the Purpose of the SHORT WAVE SCOUTS, we refer to page 393 of the November, 1933, issue.

Here are the rules amended:

You wish to know how you can win this valuable trophy, and here are the simple rules. Be sure to read them carefully. Do not jump at conclusions.

1.—A monthly trophy will be awarded to one SHORT WAVE SCOUT only.

2.—The purpose of this contest is to advance the art of radio by "logging" as many short-wave commercial phone stations, in a period not exceeding 30 days, as possible by any one contestant.

3.—The trophy will be awarded to that SHORT WAVE SCOUT who has logged the greatest number of short-wave stations during one month.

4.—In the event of a tie between two or more contestants each logging the same number of stations, the judges will award a similar trophy to each contestant so tying.

5.—Verifications are necessary; these must be sent in with each entry. All cards or verification letters must be sent in at the same time with a statement by the SHORT WAVE SCOUTS, giving the list of stations in typed or written form, with the station calls, wave-lengths, and other able information. (See below.) The verification letters and cards will be returned to the SHORT WAVE SCOUT at the end of each monthly contest. (See Jan., 1933, editorial how to obtain verifications.)

Note! All Stations Sent In Must Now Be Verified!

6.—The winner each month will be the person sending in the greatest number of verifications. Unverified stations should not be sent in, as they will not count in the selection of the winner. At least 50 percent of the verifications sent in by each listener must be for stations located outside of the country in which he resides! In other words, if the contestant lives in the United States at least 50 per cent of his "veris" must be from stations outside of the United States. Letters or cards which do not specifically verify reception, such as those sent by the Daventry stations and, also by commercial telephone stations, will not be accepted as verifications. Only letters or cards which "specifically" verify reception of a "given station," on a given wave length and on a given day, will be accepted! In other words it is useless to send in cards from commercial telephone stations or the Daventry stations, which state that specific verifications will not be given. Therefore do not put such stations on your list for entry in the trophy contest!

7.—This is an international contest in which any reader, no matter where located, can join. It is allowable for SHORT WAVE SCOUTS to list stations in their own countries, if they desire to do so.

8.—SHORT WAVE SCOUTS are allowed the use of any receiving set, from a one-tuber

Please mention SHORT WAVE CRAFT when writing advertisers



# Short Wave League

(Continued from page 106)

many QSO's you can get. If they are not working the band what difference should it make with them. But just the same it seems to make a difference and I think they should give us a reason.

If the 5-meter band was populated by licensed "hams" it would be different, but since it is not, I would advise the JEALOUS, so-called "amateurs" to quit the hollering and either populate or help us experimenters get it, so the commercial companies cannot get it. I am open for correspondence on this matter.

WYMAN M. WARREN,  
249 North Market St.,  
Wichita, Kansas.

## YOW!! Who Said "Code-less" Exam!

Editor, SHORT WAVE CRAFT:

I am a member of the SHORT WAVE LEAGUE and I have enjoyed every issue of SHORT WAVE CRAFT for over two years. I am an ordinary, every day, amateur radio fan and am not looking for arguments, but after reading the silly, nonsensical and hypocritical letter written by Mitchell Barrett in your March issue, my blood started to boil! The only way in which I could cool off a bit was to write an article for the SHORT WAVE LEAGUE page to tell this gentleman what one "ham" thinks of his foolish ideas. Here goes!

Mr. Barrett states, that in addition to being selfish, all the present hams are "air hogs." For this gentleman's information, permit me to state that amateurs operate only on frequencies assigned to their use by the Federal Radio Commission. There is a severe penalty for those caught operating outside the legal amateur bands. As for being selfish, if his statement were true, I would never have been able to go on the air. Hams gave me every bit of advice and help possible to aid me in starting, which any real ham will do today for any new beginner. If the word selfish must be used, I wonder what we are to think of this gentleman who wants 40,000 hams to discontinue using code, so he can "blat" into a mike with a lot of useless chatter.

He states also, that the hams disturb him with their old dots and dashes, which he refers to as a lot of silly quacking. Allow me to tell this bird that during the East Indian hurricane a few years ago, during the earthquake at Japan, and during the recent earthquake at Long Beach, California, the amateurs with their dots and dashes, which this squirt chooses to call silly quacking, saved hundreds of lives and brought relief quickly to thousands. They did not use a phone rig for that service either! During the hurricane in Florida a few years ago, after all other means of communication had failed, one ham, whose station was wrecked, rigged up a make-shift code transmitter which he installed in a body of an old truck. There he stuck to the key for three days and nights directing relief work. Yet, Mr. Barrett who is too darn lazy to learn the code for the reason he doesn't want to learn anything that he may never get a chance to use, says all amateurs are selfish. Tsk! Tsk!

He even goes further to state that half the amateurs are "terrible" operators who send so irregularly that even the best operators can't read what is being sent. I wonder from whom he picked all that "phony information," for he admits that he does not know the code and, furthermore, doesn't intend to learn it. I have been messing around with radio for about fourteen years. For the past three years, I have been operating my own station and, as yet, I have not contacted a ham that I was unable to read because of poor sending. The walls of my shack are covered with QSL cards which shows that I have been QSO with quite a few hams. Mr. Barrett states that if phone rigs were used exclusively, all this silly quacking would be done away with and we would hear real English on the air. I wonder if he calls: "OW'S MY 'OBULATION" real English? HII! HII!

Lackaday! I guess this is wasted effort as that bird wouldn't understand anyway!

If we are to judge the fellows who favor the codeless license below five meters by this young squirt, I suggest we cut out this discussion and use space in SHORT WAVE CRAFT for something useful. What do you think?

I think someone should give Mr. Barrett a nickel. Maybe he would go out, buy himself an all-day sucker, and leave radio to those who really know what they are talking about.

I think Mr. Putich, of Natal, B. C., Canada, and Mr. Baldwin of Oakville, California, have explained the reason for having a code test better than I could. I take my hat off to both gentlemen. Concerning this young squirt in New York, I think he needs a good boiling in transformer oil!

I would appreciate any replies to this letter and all communications will be answered.

ARNOLD T. FRAUNE, W9DJX,  
1125 W. Eighth St., Davenport, Ia.

## Charlie Miller Thinks "Code" Should Stay

Editor, SHORT WAVE CRAFT:

I have been reading, in the recent issues of SHORT WAVE CRAFT, the arguments for and against the "Code-Less License" and am herewith giving my views on the subject.

Personally, I don't think anyone should be allowed on the air, below 6 meters or elsewhere, unless he is a capable CW operator and has an FCC "ticket" for same.

The chances are, if the code test were abolished, there would be a great many persons go on the air without knowing A from B as far as technical details are concerned. They would get a friend to fix up a (phone) transmitter for them and go on the air for the fun of it. Then, woe to the short waves, they would be all over the amateur band, instead of staying below 6 meters.

At present I am studying on radio and soon hope to have a "ham" license. My experience with code has been unique, to say the least. I think it is easy to learn if a person just uses his brain for a while. I went to a friend's house one night knowing only six letters in code and came home with the ability to receive five words a minute. After a few days' practice, I was able to receive seven or eight and had no trouble at all in sending about fifteen.

So, I say again that I favor the exam, on code and sincerely hope it is not abolished, below 6 meters or anywhere else.

CHARLES MILLER,  
309 View Place,  
Covington, Ky.

## He Predicts "Terrific" Jam with "No-Code" Exam.

Editor, SHORT WAVE CRAFT:

I HAVE made a survey of the letters in the SHORT WAVE CRAFT, November issue, and wish to voice my opinion as regards the "codeless examination" for 56 megacycles (frequency) and above.

One fact remains that cannot be disputed and that is, if there were a "codeless-exam." for 1 to 5 meters, about 100,000 fellows would try to transmit in this band, and it must be said with all sincerity that the interference would be terrific! The 46,000 amateurs have "jammed" the other five bands (10 meters excepted) and with the general increase in numbers, there must be some room for expansion.

We have a club in Bordentown, which was formed to aid the embryo "ham," and I am proud to say that in the six meetings we have held, we have "brought up" about ten fellows in the code and every one has remarked that the code is one of the easiest parts to learn in radio.

I believe that if the fellows would devote a little time to the code instead of making such a fuss about a practical impossibility, there would be less squawks about the present exam.

OSCAR E. GRAY, JR., President,  
Bordentown Amateur Radio Assn.,  
239 Spring St., Bordentown, N.J.

Please mention SHORT WAVE CRAFT when writing a

# The All-Electric All-Wave Receiver

Greatest Value On The Market



6F7  
76  
12Z3  
tubes

New 4 in 3 circuit

A completely electrical all-wave receiver capable of world-wide reception. See article page 538 Jan. Issue of SWC. OWNERS REPORT RECEPTION OF AS HIGH AS 35 FOREIGN COUNTRIES. Uses 6F7 (2 tubes in 1 bulb), 76 & 12Z3 tubes as screen-grid regenerative detector, 2 stage audio amplifier, re-tuner & built-in power supply. Due to the dual purpose tube, the 6F7 this circuit gives 4 tube performance from 3 tubes.

**KIT \$5.95**

Simply plug into house lighting circuit & operate. Sensitive, hum-free & good volume. Works speaker on many stations. Covers 10-600 meters. Heavy black shirled finish metal chassis & panel. BEAUTIFUL APPEARANCE. Coils for 10-200 meters & in fractions included.

FOREIGN RECEPTION GUARANTEED. SPECIAL: Complete, ready to use, less phones \$11.15

## THE DC ALL-WAVE RECEIVER



19-33 tubes

New 3 in 2 Circuit

An extremely powerful battery operated set. Designed for loudspeaker operation. Tremendous headphone volume.

**KIT \$5.75**

Wired & tested extra \$1.35. Matched Arcatuna tubes 2.25. Broadcast coils (2) 1.00. Beautiful black finish metal cabinet 1.10.

See article page 282 Sept. issue SWC. Uses 19 (2 tubes in 1 bulb) & 33 tubes in special circuit producing 3 tube results. Special filament (fruit for low filament current drain. Requires 3 dry cells, 1 C battery & 1 or 2 B batteries. OWNERS REPORT FOREIGN STATIONS ON SPEAKER. Beautiful black shirled chassis & panel. Coils for 10-200 meters included. FOREIGN RECEPTION GUARANTEED.

SPECIAL: Complete, less batteries & phones \$10.60

## EILEN HG-35 ALL-WAVE RECEIVER



A CUSTOM-BUILT, high quality receiver designed so as to give regular broadcast receiver volume on FOREIGN SW stations. Uses five "high-gain" tubes, 58-57-56-2A5-84 types in special circuit producing REAL RESULTS. Covers 10-600 meters. Band spread tuning. Built-in dynamic speaker. Phone jack. Illuminated airplane dial. Built-in power supply. Operates on AC house lighting circuit current.

**RECEIVER, ready to wire \$14.75**  
Wired & tested, \$2.00. Matched Arcatuna tubes \$3.10. Beautiful Cab. 2.50. Broadcast coils (2) 1.45.  
SPECIAL: Complete, ready to use. \$22.50

Cannonball phones \$1.25. Magnetic speaker \$1.30

AMATEURS: Send 5 cents in stamps for illustrated catalogue of SW TRANSMITTERS (crystal controlled and self-excited), transmitters, monitors, and accessories. Ask for bulletin TX-1.

\$1.00 deposit on COD orders. Prompt shipment. Stamp for receiver catalogue.

**EILEN RADIO LABORATORIES**  
Dept. SC6, 136 Liberty St., New York, N. Y.

## HAVE YOU A HEADACHE

trying to find out where you can obtain certain

# AT LAST

## To fill your insistent demand

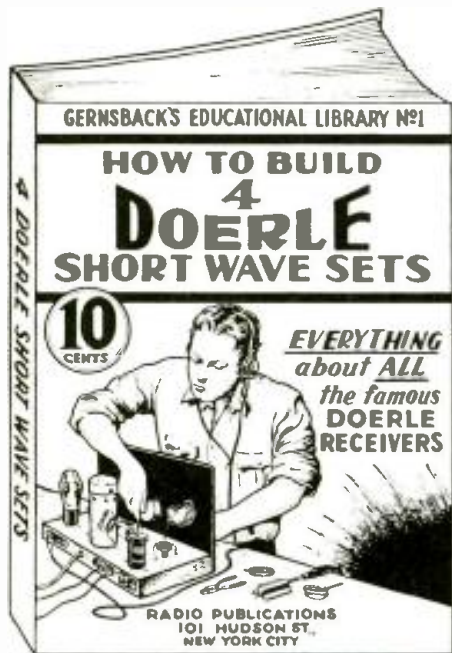

LITERALLY thousands of readers have built the now famous DOERLE Short Wave Radio Receivers. So insistent has been the demand for these receivers that all available literature, including back numbers of SHORT WAVE CRAFT, have long been exhausted.

For the thousands of readers who wish to build any, or all of the many approved DOERLE Short Wave sets, this book has been specially created.

### HOW TO MAKE FOUR DOERLE SHORT WAVE SETS

Contains EVERYTHING that has ever been printed on these famous receivers. Four of the most popular sets are described herein. These are the famous sets that appeared in the following issues of SHORT WAVE CRAFT: "A 2-Tube Receiver that Reaches the 12,500 Mile Mark," by Walter C. Doerle (Dec., 1931-Jan., 1932). "A 3-Tube 'Signal Gripper,'" by Walter C. Doerle (November 1932). "Doerle 2-Tube Adapted to A. C. Operation," (July 1933). "The Doerle 3-Tube 'Signal-Gripper' Electrified," (August 1933) and "The Doerle Goes 'Hand-Spread!'" (May, 1934).

Due to a special arrangement with SHORT WAVE CRAFT, we now present a complete as well as compact 32-page book with stiff covers, printed on an extra heavy grade of paper, with numerous illustrations. Nothing has been left out. Not only are all the DOERLE sets in this book, but an excellent power pack if you wish to electrify any of the DOERLE sets, is also described. A wealth of detail is presented in this book despite its ridiculously low price—and, believe it or not, it contains over 15,000 words of legible new type. Everything has been brought up to date; it isn't merely a reprint of what was printed originally, but any improvements on the original sets that were made by readers and various laboratories have been incorporated in this most up-to-date book.

And at the extraordinary price of 10c you cannot possibly go wrong. Despite its low cost, our usual guarantee goes with this book as well. IF YOU DO NOT THINK THAT THIS BOOK IS WORTH THE MONEY ASKED FOR IT, RETURN IT WITHIN TWENTY-FOUR HOURS AND YOUR MONEY WILL BE INSTANTLY REFUNDED.

There has never been such a wealth of data published in a low-priced radio book of this type in the history of the radio publishing business.

Take advantage of the special offer we are making and use the coupon below.

**RADIO PUBLICATIONS**  
101 Hudson Street  
New York, N. Y.



# Short Waves and Long Raves

(Continued from page 83)

very faint and it faded badly. The short-wave stations in Canada and the United States come in fairly well; W8XK on 19 meters comes in with the loudspeaker and can be heard all over a three-room house. This is the first radio set I have ever built and my opinion is that it is the best for the beginner to start on. At the present time, while I am writing this letter, the long-wave coil is plugged in and CFQC, Saskatoon is coming in with great volume and very good tone. Well, I could praise this set all day; at any rate I am very well pleased and it has done what you claimed.

LOUIS DARROW,  
White Bear,  
Saskatoon, Canada.

(The Megadyne short-wave receiver using but one tube and a fixed crystal detector, has made a great many friends and we are pleased to note that you have had such excellent success with it, Louis. The great secret of success with the Megadyne receiver lies in the selection of a really sensitive crystal detector.—Editor.)

(Shades of Heinrich Hertz, what next! We have received some very glowing letters from readers who have built Mr. Worcester's "Oscillodyne," but it seems, H. C. V., that you have gone them all one better. At any rate you have given the boys something to think about; our hunch is that the signals that you heard without the coil in the set, must have been pretty strong and the signals were able to affect the grid of the tube, without the benefit of any tuning coil.—Editor.)

### "CLIP COIL" SET BRINGS IN GERMANY!

Editor, SHORT WAVE CRAFT:

It is quite some time since I gave up constructing radio sets, but I buy your magazine to keep up with the times.

Recently I decided to try the "Clip Coil"—I got out the old "junk" box and got busy. I had no 3 1/2" coil form so I heated an old hard rubber panel and easily cut three strips with a knife for the circumference. These I bent around a jar while warm and made three perfect circles. I fastened six strips, 4" long, to these circles and had my "forms". My other parts looked as though they came out of the "ark", relics of the days when a new circuit came out every week, I guess I built them all. My variable condenser should have had a counter-clock-wise dial, but it didn't. Likewise, I used just a knob for the regeneration control. I could not buy any batteries so I used two 1 1/2 volt cells over three years old and an old eliminator with variable voltage taps. For tubes I used two bootleg 30's, also old and never any too good. Being in a hurry I did not give much thought to the best circuit, however, it worked from the start and the Pittsburgh, Schenectady, and other short-wave stations including Canada came rolling in! Finally I "bumped" into Germany, which came in as strong as the locals! If it works that well with my collection of odds and ends it must be good. I'd like to see it developed further.

E. J. FRENDEVALL,  
Maywood, N. J.

(Hats off to you, E. J. F., for your very fine reception report with the "Clip-Coil Two." One of the interesting technical points about this receiver is that the antenna is really close-coupled to the grid circuit, through the medium of a single coil constituting an auto-transformer, which transfers a maximum of energy to the grid circuit of the detector. Loose coupling in the antenna circuit is frequently a very desirable and useful feature and by having the primary or antenna coil mounted on a pivot or loop in respect to the grid coil, improved selectivity can be obtained, when two stations come in very close together on the dial; also by changing the coupling between the antenna and grid coils "dead-spots" can be eliminated. However, the "dead-spot" trouble can also be remedied by adjusting the small series antenna condenser usually employed. Experience has shown in many cases that, providing sufficient selectivity is afforded by the usual tuned grid circuit, then—other things being equal, the auto-transformer circuit, where the same winding is used as the "grid" and "antenna" coil, will provide the maximum range and number of stations picked up. At least that is the experience of a great many practical experimenters.—Editor)

### "POWERTONE" ROLLS 'EM IN!

Editor, SHORT WAVE CRAFT:

I haven't seen any log rolled up by the "Powertone 3-tube A.C. and D.C." short-wave receiver. I'm sending in my list of stations heard on the "Powertone." I have

### SET WORKS WITHOUT COIL!

Editor, SHORT WAVE CRAFT:

Some time since I decided to try out the one tube Oscillodyne, described by Mr. Worcester in the April issue, and built it on a cigar box using the cover turned back for the panel (I find cigar boxes quicker and better than table mounting) winding the coil according to the specifications given, and using a "37" tube.

I consider this one of my few failures, and I have been playing with wireless and "radio" since 1902. The set did not operate to my satisfaction, with the antenna condenser in the circuit, it was weak on the head-phones, by eliminating the antenna condenser it came in a bit louder, and was not selective, (not to be wondered at, we have about sixty stations in a radius five miles in diameter).

Started experimenting with it and found it would work at ordinary head-phone strength if the 50,000 ohm resistance contact was on the first turn of wire. Then, the antenna was hooked onto the wire leading from the antenna condenser to grid, still faint, started moving the coil in the socket, trying for bad contact; no result. Took the coil out to look at contacts, and the music came in as good as before, and the local stations could be tuned in one after another, without any coil in the set.

My antenna is forty feet long with a thirty-five foot lead-in, and have picked up all the European stations on a regenerative short wave set, using movable aperiodic primary, secondary, and tinker, airwound three-inch coils, and using RCA, 201 tubes bought in 1923 (in use ever since). The antenna is only about eight feet above the roof at the peak, stretched between two houses, sixteen foot alley between, but with sloping roofs, and only one end is within ten feet of the roof.

Have been predicting for the last couple of years that, one of these days, we shall be able to go to the store and say, "Give me two tubes, one to cover the 20 to 40 meter band and one to cover the broadcast band," and that will be all there is to it; no coils, and few wires in the set, the tube will do it all. Try this "wind a three-circuit tuner coil directly on the tube, use the usual circuit, and if it doesn't play a loud speaker for you, I've discovered something." Of course the wire will have to be stuck to the glass, but I'll leave that to the ingenuity of whoever tries it.

H. C. VARNUM,  
House 8,  
464 Rue Bourgeat,  
Shanghai, China.

Please mention SHORT WAVE CRAFT when writing advertisers



been a reader of SHORT WAVE CRAFT since 1930.

My log is as follows:

- W3XL—Bound Brook, N. J.
- W8XK—Saxonburg, Pa.
- W4XB—Miami, Fla.
- YV1BC—Caracas, Venezuela.
- DJC—Zeesen, Germany.
- VK3ME—Melbourne, Australia.
- GSC—Daventry, England.
- W3XAU—Newton Square, Pa.
- W1XAZ—Springfield, Mass.
- DJA—Zeesen, Germany.
- W2XAF—Schenectady, N. Y.
- GSB—Daventry, England.
- GBC—Rugby, England.
- W3XE—Philadelphia, Pa.
- W2XV—New York.
- W8XA6—Jackson, Mich.
- DOA—Coblenz, Germany.
- W9XL—Chicago.
- W2XO—New York.
- VE9HX—Halifax, Nova Scotia.
- LSN—Buenos Aires, S.A.
- FYA—Pontoise, Paris.
- G5SW—Rugby, England.
- VK2ME—Sydney, Australia.
- EAQ—Madrid, Spain.
- OXY—Skamleboek, Denmark.
- VE9JR—Winnipeg, Canada.
- GSE—Daventry, England.
- I2RO—Rome, Italy.
- VE9DR—Drummondville, Quebec, Can.
- VE9GW—Bowmanville, Ontario, Canada.
- GSA—Daventry, England.
- W3XAL—Bound Brook, N. Y.
- W9XF—Downers Grove, Ill.
- W2XAD—New York.
- W8XAL—Cincinnati, Ohio.
- G6RX—Rugby, England.
- W1XAB—Boston, Mass.
- YV3BC—Caracas, Venezuela.
- DJD—Zeesen, Germany.
- GCW—Rugby, England.
- W9XAA—Chicago, Ill.
- VE9CA—Calgary, Alta., Canada.
- VE9CL—Winnipeg, Canada.
- WOO—Ocean Gate, N. Y.
- VE9CU—Calgary, Canada.
- W1XAL—Boston, Mass.
- KEE—Bolinas, Calif.
- VDB—Esquimalt, B.C.
- LSX—Buenos Aires, Argentina.
- CT1AA—Lisbon, Portugal.
- GCU—Rugby, England.
- W2XE—New York.
- VQ7LO—Nairobi, Kenya, Africa.

NORMAN LARSEN,  
44 Holland Ave.,  
Floral Park, L.I., N.Y.

(A very nice "log," Norman, and we are sure that the designer of the Powertone 3-tube set will be more than pleased at the excellent "log" of stations you have rolled up on it.—Editor)

**MALSBERGER SET OK!**

Editor, SHORT WAVE CRAFT:

I constructed the receiver described by Curtis E. Malsberger in March 1934 issue of SHORT WAVE CRAFT. Have received so many foreign stations on this set the thrill has completely worn off! This set is certainly F.B. Although it isn't quite as selective as it should be, I am going to build a preselector, which will undoubtedly clear up this shortcoming.

Would like to hear from anybody who has constructed this set.

I think your mag. is F.B. (Fine Business.)

FRANK W. SCHWER,  
2118 W. Eighth St.,  
Muncie, Ind.

(Glad to know that Mr. Malsberger's receiver has given such excellent results, Frank. We have had quite a number of letters praising Mr. Malsberger's set and as the designer of that set did a lot of research on it before presenting it to the readers of SHORT WAVE CRAFT, it should give somewhat "out of the ordinary" results. We believe that if you take particular care in redesigning the wiring of your set and the placement of your coils, chokes, etc., that you will find the set as selective as any other set.—Editor)

**FINE RESULTS WITH OUR SETS!**

Editor, SHORT WAVE CRAFT:

Too much praise cannot be given to technical data published in each copy of SHORT WAVE CRAFT. The schematic diagrams if followed out studiously give results which speak for themselves. I constructed a 3-tube A.C. set from plans given in the March issue, and plenty of foreign stations "rolled in" with volume to spare. When "opened up" the headphones just rattled!

I was so pleased that when the June issue came along I dismantled the set and built the Mahco set, illustrated on page 93. However, instead of coupling the detector and audio stages with the two .25 megohm resistors, I employed a 3:1 ratio audio transformer (secondary and primary tied together) in the plate circuit, and a .75 megohm resistor in the grid. I find a 3-megohm, 1-watt resistor serves best as a grid-leak. I like the electronic coupling too and the ease with which volume is controlled by the use of the 50,000-ohm potentiometer. Instead of using a 57 tube detector as specified, use a 58. Added to this circuit is a No. 57 tube in an untuned R.F. stage. This decided improvement was worth the time spent in working it out. I purchased a vitreous insulator, tapered 1/4 to 1 inch, such as is used in attaching coils for "ham" transmitters. I wound 70 turns of No. 36 enamel wire around this and it serves as an efficient aerial inductance. The number of turns does not seem to be critical.

However coils did not seem to be efficient on all frequencies desired. After experimenting as to different diameters and dielectrics, I found that cellophane wrapped over a form of the desired diameter, plus the use of No. 20 cotton covered wire (shel-lacked and varnished once and allowed to dry, after which the coil is removed) and an old tube-base, sawed off close to the prongs and the leads soldered in gives excellent results.

When you listed PRFS and JYM as unknown stations they were coming in R6 to R9 here. In fact I had sent for verifications before you published their frequencies.

The above set performs efficiently from 15 to 60 meters. The 49-meter band was noisy (October)—the South Americans being a little squawky most of the time. Today at noon FYA-GSE rolled in on R9. The best bets are FYA-DJ-GS stations on 19.25- and 31-meter bands, PHI on 16.88 meters, and EAQ until recently. CT1AA and ORK come in very well occasionally. PRF5 at Rio roars in on 31.5 meters. HJIABB at Barranquilla, S.A., speaks for itself. VK2ME and VK3ME have exceptionally strong carriers but do not seem to hold up—quite a bit of fading generally.

The "hams" on the 20-meter band I respect. Not the lousy "frequency jumping" bunch to be heard on the 80-meter band. The "20-meter boys" have perfect "rigs"; of the scores I have listened to, believe it or not, none have ever graded under R9 from Texas to Florida, to California to Long Island. This speaks well of this most efficient of all frequencies listened in to yet. The Federal Communications should have a lot of love for these operators. They know their resistances and inductances.

GEORGE A. FIELDHOUSE,  
5300 39th Ave., So.,  
Minneapolis, Minn.

(The "20-meter boys" will sure have to doff their hats real low to you, George, and as you say, it does speak well for them in that they are "right on the spot" when it comes to maintaining their frequency. Germany, Spain, and England have been rolling in swell style on the editors' receivers. We note what you have to say about the fine results you obtained with the coils wound on cellophane, but after all, the engineering laboratories' tests have shown that isolantite and other new forms of insulation now offered to the short-wave fraternity, do have the highest insulating and low-loss properties for short-waves.—Editor)

**FACTS**  
You should know about  
Condensers

**WE PROVE IT!**

FREE! You owe it to yourself to write today for a copy of this BOOKLET.

Just what does the Power Factor rating really mean in the condensers you buy?

... What is the truth and the whole truth about leakage claims—capacity and voltage ratings?

As serviceman or amateur, how can you be SURE you are getting the most filtering, the best performance for the least money?

These and many other bothersome condenser questions are clearly explained in our new free booklet illustrated above. It will show you that we not only claim Sprague Condensers are the best—but explain exactly how we PROVE it! Write for a copy.

**SPRAGUE PRODUCTS CO.**  
North Adams, Mass.

**SPRAGUE CONDENSERS**

MADE RIGHT **600 LINE** PRICED RIGHT

**Amazing New 7-TUBE, 5-WAVE BAND SUPERHETRODYNE**



WORLD-WIDE RECEPTION

HERE'S today's most sensational radio value—a 7-tube, 5-wave band Superheterodyne... at a saving of 30% to 50%—on 30 days FREE trial. Only 7-tube all-wave radio covering 9 to 2400 meters. Has 20 advanced 1935 features. Five full wave bands bring in realistic American and Foreign Short Wave programs... Canadian, police, amateur, airplane and ship.

ONLY **27.50** COMPLETE WITH DYNAMIC SPEAKER AND TUBES

**30 DAYS FREE TRIAL**

Write for FREE 36-page, 4-color catalog. Money Back Guarantee

**TERMS 75¢ A WEEK AS LOW AS**

**MIDWEST RADIO CORP.**  
DEPT. 333—CINCINNATI, OHIO, U. S. A.  
Established 1910 Cable Address Midco... All Codes



ALL EXPERTS USE  
**TRIMM**  
FEATHERWEIGHT HEADSETS  
There Must Be A Reason

WRITE FOR INFORMATION

**TRIMM**

**RADIO MANUFACTURING CO.**  
1528 Armitage Ave. Chicago, Ill.

# DO YOU WANT TO OBTAIN AC ELECTRICAL POWER

from a Windmill, from available Waterpower, from your Automobile, from your Motorcycle, from your Bicycle, Footpedals or Handcrank (for transportable Radio Transmitters, Street Floodlights, Advertising Signs); do you want to operate AC Radio sets from 32 V.D.C. farm light systems; operate two generators in series to get 200 V.A.C.; obtain two phase and three phase A.C., etc., etc.

## GET OUR WESTINGHOUSE



200-WATT  
110 V. A.C.  
**Power Generator**  
MANUFACTURED FOR U. S. SIGN. CORPS

### SPECIFICATIONS:

HOUSING—Aluminum (Diameter 6 1/4 in. Length—5 1/4 in.). SHAFT—2 3/16 in. (driving end). Diameter 9/16 in. (the end is threaded for a distance of 1/4 in.). BASE—Cast Iron (Length—7 1/2 in. Height 1 9/16 in. Width 4 1/2 in.). OUTPUT—200 Watt 110 volts AC (speed 4500 R.P.M.). STATORS—Two pairs (two North and two South) ROTOR—12 tooth inductor. Built-in commutator. Rotor turns in ballbearings.  
1/2 to 1/2 H.P. needed to run Generator.

**FREE** With each Generator we supply a set of diagram-blue prints and instructions showing twenty-five different uses, technical information, electrical hook-ups and installing explanations. We also include a set of four replacement carbon brushes.

### There Are Over 25 Applications Some of which are:

A.C. Dynamo lighting from eight to ten 20 Watt 110 Volt lamps. Short Wave transmitter supplying 110 volts AC for operating "Ham" transmitter. Operating 110 v. AC 60 Cycle Radio Receiver in D+ districts. Motor Generator. Public Address Systems. Electric Sirens on motor boats, yachts, etc. Camp Lighting. Short Wave artificial "fever" apparatus. Television. Pelton Waterwheel for lighting or other purposes. Airplane: for lighting strong search lights or electric signs. Laboratory Work. Generator, as described, including four replacement carbon brushes. Blue-print and instructions \$7.90  
Shipping weight 18 lbs.

(Replacement carbon brushes bought separate \$1.50 per set of four. Set of instructions bought separate \$1.00.)

## Electrical Portable SPRAYER OUTFIT

**\$27.50**  
COMPLETE

Formerly sold for \$68.50

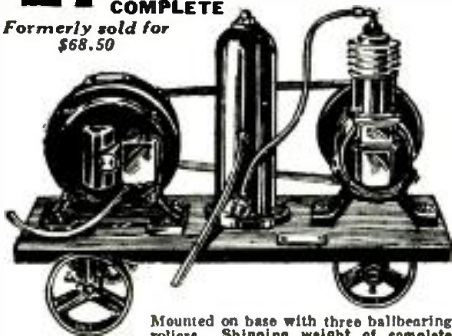

Mounted on base with three ballbearing rollers. Shipping weight of complete outfit, 55 lbs.

This is the ideal outfit for all-around spraying work wherever current is available. With it you can spray paint, varnish, dyes, enamel, lacquer, insecticides, etc., with speed. You can move it from one room to another. Simply insert plug into electric socket and this marvelous machine is ready.

Outfit equipped complete with Internal Mix Spray Gun, with quart aluminum cup, which enables you to obtain round or fan spray, 1/4-h.p. heavy duty motor, 110-volt, 60 cycles, A.C., and air filter Kellogg Air-Cooled Compressor, 1 1/2 x 1 1/2, 15 feet of hose, cord and plug.

Price of complete outfit with gun, \$27.50  
Price of outfit without motor, \$20.00  
Price of Internal Mix Spray Gun, \$7.50 alone  
Price of Filter Tank, \$4.25 alone  
(Complete with Gauge and 60 lbs. Safety Valve)  
Price of Compressor, \$7.50 alone

WELLWORTH TRADING COMPANY SW-6-35  
560 W. Washington Blvd., Chicago, Ill.  
Enclosed you will find my remittance of \$..... for which please send me

Name .....

Address .....

City..... State.....

# Transmitting Antennas

(Continued from page 100)

Matched impedance, etc., are merely variations of the Hertz. These different types of Hertzian antennas are the best adapted to amateur use and probably will always be for one reason. Namely: the Hertz is an ungrounded antenna and can be stretched up between two poles or houses, away from grounds and other objects which would be likely to absorb its energy, and it can then be fed "juice" by one of several means.

One of the first things to note about a Hertz antenna, is that it resonates at the even quarter waves, instead of the odd quarters as with the Marconi. The lowest frequency at which a Hertz can resonate, is found by the formula.

$$\text{Freq. in KC.s} = \frac{492,000}{\text{length in feet.}} \times K$$

Transposing the formula, we can find the length of antenna needed for any wavelength or frequency by: Length in

$$\text{ft.} = \frac{492,000}{\text{Freq. in KC.s.}} \times K$$

Where K, is a constant which depends on the range of frequencies as follows:

Frequencies	Constant, K
Down to 3000 KC.	K is .96
3000 to 28,000	K is .95
28,000 and up	K is .94

The voltage and current is found to distribute itself along the Hertz antenna as in Fig. 3. From this, it can be seen that a Hertz will work on its harmonics, i.e., on even multiples of frequency. Therefore, if you put up a Hertz for 3600 KC, it will resonate on 7200 KC and also on 14,400 KC. So, any "Ham" who wants to work the three major bands, 80, 40 and 20 meters, need have only one antenna.

### Feeders—How Used

Thus far, we have only considered the radiating antenna itself. We must now decide how we are to feed energy to it. There are several different ways of doing this. Many arrangements use true transmission lines, while other "Hams" prefer those antennas known as Zeppelin feeders. A transmission line may be any length, whereas a feeder is to be tuned, and must be cut to special lengths to produce the desired purpose.

There are other distinctions between the two which will appear later. It is difficult to say what antenna feed system is best. At any rate a true transmission line is to be preferred if it can be erected. An old law of physics tells us that a maximum of power will be transferred from a generator to a load if the impedance of the two are equal or matched. This applies to transmission lines and is an important factor in their design. For those who are mathematically minded the standard formula for this work can be used.

$$Z = 276 \times \log_{10} \frac{\text{wire spacing in inches}}{\text{radius of wires}}$$

This is for two wire transmission lines only. An impedance of 600 ohms is usually used in antenna work and a simpler formula has been evolved to make it easier to construct 600 ohm transmission lines. It is: Distance between wires = 75 x d, where d is the diameter of the wire to be used. Number 14 wire is a common size and is to be recommended. It is .064" in diam. Therefore for a 600 ohm line we will space our wires 4.8 or nearly 5". We now wish to find some way to tap this onto the Hertz antenna so that we will get no standing waves on the line, and we will have an exact impedance match. Our finished antenna will look like this. See Fig. 4. We find its length by our formula,

$$L = \frac{492,000}{\text{freq.}} \times K.$$

If the frequency is to be 3600 KC. the length figures to be 137' 2". Distance M is found

$$\text{by formula } M = \frac{492,000}{\text{freq.}} \times \text{Km. Km is}$$

another constant dependent upon frequency and is found thus:

Frequency	Km
1500-3000 KC.	.25
3000-28 M.C.	.24
28 M.C. Up	.23

Distance P is also required and is found by

$$P = \frac{492,000}{\text{freq.}} \times Kp \quad Kp \text{ is a fixed constant}$$

which does not vary. It is .30. By calculation we find distance M to be 32' 10" and distance P to be 41'. We now have a matched impedance antenna which will work on 80, 40 and 20 meters. It is coupled to the tank coil of the transmitter by one of the methods illustrated in Fig. 5.

For a simpler, and very effective type of transmission line refer to Fig. 6. This works very well and involves a rather unique theory that it has an image of itself at a distance beneath the earth's surface, similar to your own image reflected by a pool of water. The image wire (the "reflection" of this wire within the earth's surface) is considered to be a factor in keeping the actual wire from radiating and to make it function as a real transmission line. We need not concern ourselves with its theory of operation: like any true transmission line it can be of any convenient length. It works well and luckily or otherwise it obtains an impedance of 500 to 600 ohms with a single wire. It is pictured in Fig. 6.

The distance D is found by simply multiplying the length by .14. The length is found as before by the formula:

$$L = \frac{492,000}{f.} \times K$$

For our 137' 2" sky-wire the distance from the center D is 18' 5".

### Good Receiving Antenna

We may now consider an inexpensive method which is perhaps one of the best possible if one can erect it. This, by the way, is the very best antenna for "receiving" I have ever tried! Try it yourself!

It is the twisted pair transmission line. This is a current-fed arrangement and has a low impedance and low losses. First let us consider briefly its theory. It has been found that if a Hertz antenna is cut in two at its point of maximum current, the series impedance is somewhat on the order of 70 ohms. If the distance between the two parts is increased, the impedance goes up to perhaps 100 ohms. By the formula for two-wire transmission lines which is given above, it is found that the impedance to Radio Frequency of a twisted lampprod when properly terminated, is about 100 ohms. So we can attach our twisted pair to the center of our 3600 KC antenna and we have a fine transposed non-radiating transmission line with good impedance match. It will look like Fig. 7 and is coupled to the transmitter as shown. It's one fault is that it is useless for even harmonics. These three, the 2 wire matched-impedance, the single-wire transmission line, and the transposed current-fed transmission line, are true transmission lines, and must not be confused with Zepp and current fed arrangements which have standing waves on the feeder system. This can be readily proved by running a neon bulb along the feed wires. The bulb will glow brightly at points of maximum voltage and dimly or not at all at the current loops. On a transmission line, the bulb stays at the same brilliancy all along the wires. A diagram, showing what a Zepp actually is, appears below in Fig. 8. The well-known doublet, or current-fed, two-wire feeder type is pictured in Fig. 9.

These antennas are coupled directly to the transmitter tank by a coil; the feeders will be tuned with a parallel condenser if they are below a quarter-wave long, and will be tuned by a series condenser in each leg if they are over a quarter-wave length long. In reality a Zepp is a full-wave an-

Please mention SHORT WAVE CRAFT when writing advertisers



tenna with a part of it folded back on itself; the current-fed scheme is a 3/2-wave antenna with part of its length closely paralleled with another part to stop the sections which are close together from radiating to ground and nearby objects, thereby carrying as much of the energy as possible to the flat portion in the air.

**Using Hertz Antenna in Attic "Shack"**

In case your "shack" is in the attic and you want to use a Hertz antenna, you may not have room to put up an appropriate feeder system or a transmission line. You may bring a short portion of the actual antenna into your station and not lose a great deal of efficiency by using the arrangement shown in Fig. 10. Although a ground is used, this is NOT a Marconi system. The tank coil, L2, is similar to your transmitter tank and is grounded at one end. It is then tuned to resonance like a wave-meter. Then the antenna is clipped on to this tank at some point part way up from ground. Try different settings and see which one you get the best results with.

The reason that you must use the separate tank coil is because the Federal Radio Commission won't let you clip the antenna directly to the transmitter tank; it is bad dope to do it anyway. Therefore you just construct a duplicate tank circuit, inductively coupled to the transmitter tank and there you are!

There is no limit to the number of combinations which can be used, but fundamentally there are only two antennas. Feed them as best you can, design your transmission line with care. If you use feeder spreaders, boil them in paraffine wax. If you use twisted lamp cord do the same with that. Insulate well throughout and you have the key to efficiency in the operation of your ham "rig". The highest power can do little or nothing without an efficient radiator. Ten watts power in your transmitter with an antenna of nearly 100 per cent efficiency, is far better than a 50 watt outfit with an antenna of only 20 per cent efficiency. Remember that that twisted wire pair antenna is a beautiful short-wave receiving arrangement. Measure it for the frequency you wish to try most of your listening on. If you run into any difficulties send me a self-addressed stamped envelope in care of SHORT WAVE CRAFT and I'll see what can be done.

**NEW RADIO SWITCHES**



New improved type of radio switch, No. 279.

● A CHICAGO concern is introducing additions to its line of rotor switches in the form of compact, single and double-pole, two position units. The new switches fill requirements for tone control applications, phonograph switches, and wave-band switches for midget radios.

Retaining the desirable characteristics of the Oak Junior types, the new RG type, available with grounded common poles, measures only 1/2" deep from bushing shoulder by 1 1/2" long by 11/16" wide. The R type, of the same dimensions, has the common poles insulated from ground.

The single grounded pole S type is of the same construction and size as the RG type, except for its length which is only 1 1/16".

Three position units are now being developed. Standard bushings for both types are 3/8" by 1/4" thread length. Standard shafts are 1/4" diameter by length specified.

The superiority of these new switches will be readily recognized. As a result of undergoing the same rigid tests as the larger units in the well-known Oak line.

**"Beginners Special"**

4 tubes do the work of 5. Don't miss it—in the July number.

# CLASSIFIED

Advertisements are inserted at 5c per word to strictly amateurs, or 10c a word to manufacturers or dealers. Each word in a name and address is counted. Cash should accompany all orders. Copy for the July issue should reach us not later than May 5th

<p><b>CODE MACHINES</b></p> <p>OMNIGRAPH. HOME CODE Learner. Get ahead quickly. Thousands satisfied. Automatic; Everlasting dial; exchanged Free. Easy terms \$2.50 to \$25.00 Catalog. Agents, dealers and others get our special plan. Omnigraph Mfg. Co., 810 E. 39 Street, Brooklyn, N.Y.</p>	<p>HICKOK ALL WAVE OSCILLATOR \$38.00. Hickok Statklesier \$95.00. Case \$7.00. Multiplexes \$7.00. Hammarlund Pro \$60.00. Halabanow, Box 3, Roseville, Newark, N.J.</p>	<p>QSL CARDS, NEAT, ATTRACTIVE, reasonably priced, samples free. Miller, Printer, Ambler, Pa.</p>
<p><b>ELECTRICAL SUPPLIES</b></p> <p>INSULATION, WIRE, VARNISHES, SUPPLIES, etc. Send 3c stamp for bulletin. Auto Power, 414 S. Hoyle Ave., Chicago.</p>	<p><b>WANTED: FIRST ISSUE OF</b> Modern Electric. State Price and Condition. Box 6, Short Wave Craft, 90 Hudson Street, New York City.</p>	<p><b>SHORT WAVE COMPONENTS</b></p> <p>FOUR COILS, 13-200 Meters, Low Loss Forms 40c. Isolantite S.W. Chokes, High efficiency 10c. Prompt. Postpaid, Guaranteed. Gordon, 28 Clinton, Santa Cruz, Calif.</p>
<p><b>GENERATORS</b></p> <p>TWENTY PRACTICAL AND LOW cost changes converting Ford, Dodge, or Chevrolet generators into new generators and motors 100-500 watt capacity, direct or alternating current, with six to 400 volts for radio operation, power, light, or welding. Also instructions for rewinding armatures; 350 definitions of electrical terms, etc. All definitions in new, revised book with simplified instructions and illustrations. Endorsed by thousands—Only \$1.00 postpaid. Auto Power—414 S. Hoyle Ave., Chicago.</p>	<p><b>INSTRUCTION</b></p> <p>SHORT WAVE FANS, YOU'LL get more stations by using our World Time Chart. Gives the time for 111 countries, operating schedule for 45 stations. Send 15c coin to Linco &amp; Fitzpatrick, Box 366, Marion, Indiana.</p>	<p><b>SHORT WAVE RECEIVERS</b></p> <p>IN STOCK: SUPER-SKYRIDERS \$59.95 prepaid. Skyriders \$39.95 prepaid. Silver 5Cs \$71.70 prepaid. P1-12s, RME9Ds, Nationals, Hammarlunds. Trade-in your receiver. Code machines rented. Write, Henry Radio Shop, Butler, Mo.</p>
<p><b>"HAM" OFFERS &amp; WANTS</b></p> <p>\$100.00 RCA SUPERHET, BATTERY type, "built-in" horn, speaker, etc. Bargain \$37.00; Victoreen 8-tube battery superhet, Weston meter, \$8.00; MIB29 National Tuner with four 84G and detector tubes, \$15.00; 45 push-pull Thoradon Power-Pack, with 27 first A.F. (with Tubes), \$15.00; "High Fidelity" 6 ft. Victor orthodynamic (exponential) horn, speaker unit, tone arm; also "magnetic" pick-up, \$15.00; RCA 210 power-pack with Rectifier (originally \$70.00), \$8.00. Harry Ackerson, Box 322, Ramsey, N.J.</p>	<p><b>MISCELLANEOUS</b></p> <p>OHM'S LAW CALCULATOR—Lightning Slide Rule; solves all problems of Voltage, Current and Resistance, Power, Wire Sizes, etc. Range: 1 micro-amp. to 1000 amps.; 1 micro-ohm to 10,000 volts; 1 micro-ohm to 10 megohms; 1 micro-watt to 10 megawatts; wire sizes 0 to 36 B. &amp; S. gauge. Introductory price \$1.00 prepaid. The Datarulit Co., Box 322, Ramsey, N.J.</p>	<p><b>LONG SHORT WAVE KIT</b> Requires no tubes or batteries, clear reception, only \$1.00, blue print instructions, 10c. Radio Sales, P. O. Box 68, New Haven, Conn.</p>
	<p><b>STEER HORNS SIX FEET</b> spread for sale. Rare decoration for Station. Lee Bertillon, Mineola, Texas.</p>	<p><b>FOR SALE NEW AND USED</b> Short Wave Receiver. Sets of all types, Hammarlunds—Nationals—Lincolns—Pattersons, etc. Schwarz Radio Service, Dumont, N.J.</p>
	<p><b>QSL—CARDS—SWL</b></p> <p>SHORT WAVE LISTENERS cards that get Replies, QSLs, Samples (Stamps) WSESS, 1827 Cone, Toledo, Ohio.</p>	<p><b>TUBELESS CRYSTAL SET</b> Reports 2100 Miles. Blueprint, 17 Others 25c. Coln. Particular. Free. Modern Radiolabs, 151-A Liberty, San Francisco.</p>
		<p><b>TRANSCEIVERS</b></p> <p>TRANS-CEIVERS ONLY \$3.95—Guaranteed. Foreign Reception, local transmission. For detailed information write—Burks Radio Company, 1448 W. Decatur, Decatur, Illinois.</p>

## BARGAIN! 7-TUBE CHASSIS

With 11 Inch Dynamic Speaker

**Not a midget!—but a full-sized console chassis**  
200-550 Meters

Uses 4-58's, 2-2A5's in parallel and a type 80 full wave rectifier all arranged in a sensitive T.R.F. circuit. Has large, illuminated airplane dial, tone control, provisions for phonograph attachment and full 11" dynamic speaker. 5 tuned stages make for extreme sensitivity and exceptional selectivity. Only material of the highest quality is used in its construction. Undistorted output of better than 6 watts—enough power to operate four additional dynamic speakers. Resistance coupling is used throughout which means that radio programs are reproduced with exceptional fidelity of tone.

Limited quantity, hence, "first come, first served." Overall size 16x12x7 1/2". Ship. wt. 35 lbs. List price \$75.00

No. 643 7-tube TRF chassis including dynamic speaker, but less tubes.  
**YOUR PRICE** **\$16.50** Less Tubes  
Complete set of tubes \$3.60

**RADIO TRADING CO.**  
101A Hudson St. N.Y.C.

## 6 Copies of SHORT WAVE CRAFT 70c PREPAID

For a limited time only, and as long as they last, we will send you six back numbers of SHORT WAVE CRAFT assorted, your choice, for 70 cents.

The usual price for six copies would be \$1.50 and most publishers charge a higher price for back numbers over one year old.

We can supply all copies except the following: June-July, Aug.-Sept., Oct.-Nov., 1930; Dec.-Jan., 1931; Dec.-Jan., May, June, Sept., Nov., 1932; Jan., Feb., March, May, June, July, 1933.

If you do not specify copies we will use our own judgment in sending assorted numbers to fill your order. Note we cannot exchange the copies for ones that have been sent to you.

Practically every copy of SHORT WAVE CRAFT contains important information that you should have. Here is a chance to get those copies.

As we have only a small supply of back numbers on hand, this offer will be withdrawn as soon as they have been sold.

We accept U. S. stamps, U. S. coin, or money order. Rush your order today.

### SHORT WAVE CRAFT

99-101 Hudson Street New York, N. Y.

---

SHORT WAVE CRAFT 6-35  
99-101 Hudson Street, New York, N. Y.

Gentlemen: I enclose herewith 70c, for which you are to send me six back number copies of SHORT WAVE CRAFT as follows:

Name \_\_\_\_\_  
Address \_\_\_\_\_  
City \_\_\_\_\_ State \_\_\_\_\_

Please mention SHORT WAVE CRAFT when writing advertisers



# OFFICIAL DOERLE GLOBE-GIRDLING SHORT-WAVE SETS

## Economical 2-Volt Operation

These world-famous Official Doerle Battery Receivers undoubtedly offer you the best in short-wave equipment at low cost. They incorporate many high-priced features such as 2-gang tuning condensers (3 tube sets only), single-dial control, airplane dial, ribbed short-wave plug-in coils and the latest tubes.

The 3-tube receiver employs one—34; a 30 and a 19 (actually 2 tubes in one). Loud speaker operation is obtainable on most foreign stations with this receiver. Sold complete with 2 sets of 6-prong 3-winding plug-in coils. A special antenna loading circuit does away with the usual antenna trimming condenser which had to be adjusted each time the plug-in coils were changed. Furthermore, this new circuit does not in any way affect the tuning of the receiver; stations may be permanently logged on the airplane dial for future reference. Sold complete with metal cabinet. Ship wt. 12 lbs.

The 2-tube receivers use a type 30 and a type 19 output tube (actually 2 tubes in one). The use of this latter tube imparts to the set 3 tube performance. These 2-tube sets MAY BE HAD EITHER WITH BROADCAST COILS OR STANDARD 5-PRONG COILS. (Please be sure to specify which when ordering.) Sold complete with set of four 2-winding plug-in coils. Sold less cabinet. Ship. wt. 10 lbs.

No. 5009K Doerle 2-Tube 2-Volt Battery Receiver Kit with standard 5-prong coils, less tubes, batteries and cabinet. List price \$15.75. YOUR PRICE **\$7.75**



Rear view of 3-tube set

No. 5009KB. Above set with broadcast coils. List price—\$18.20. YOUR PRICE **\$9.20**

Set of Matched tubes \$1.00  
Black Crackle cabinet 57c.  
No. 5009K 3-tube 2-volt Doerle Receiver Kit complete with 8 coils and cabinet, less tubes. List price—\$23.75. YOUR PRICE **\$12.45**

Set of Matched tubes \$1.80  
WE WILL WIRE AND TEST ANY OF THESE KITS AT AN ADDITIONAL CHARGE OF \$1.50.



Two-Tube Set  
**\$7.75**  
KIT  
less tubes, batteries and cabinet including coils



Three-Tube Set  
**\$12.45**  
KIT  
less tubes and batteries including coils and cabinet

# FAMOUS "19"-TWINPLEX WORLD-WIDE SHORT-WAVE BATTERY RECEIVER

Brings in regularly European and other foreign stations

The Twinplex receiver incorporates a very sensitive circuit using a single tube which gives the effective performance of 2 individual tubes. The type 19 tube has a double set of elements, one section of which is used as regenerative detector, and the other as a stage of A.F. amplification. On loud signals, this small receiver will even work a loud speaker. Note the unique "unimount" arrangement of all the parts on the front panel. The entire circuit uses less than ten inches of hook-up wire. The set will receive regular broadcast stations too. Two coils are furnished with the set—one covering the 49 meter foreign broadcast band, and the other, the regular American broadcast band. A detailed set of instructions and diagrams shows you how to assemble this set even if you've never built a radio before. Only first class material is employed. Ship. wt. 5 lbs. Sold only in kit form.



**\$5.75**  
less tubes with coils and phone

No. 308 Famous "19" Twinplex Receiver Kit including single headphone and band, and 2-plug-in coils, less tube and batteries, YOUR PRICE **\$5.75**

No. 309 Accessories for the Twinplex Kit comprising one type 19 tube, 2—No. 6 dry cells, and 2—45 volt "B" batteries. Ship. wt. 20 lbs. YOUR PRICE **\$3.46**

Additional plug in coils to cover either the 20, 80 or 160 meter bands—45c each.

See pages 102, 125 and 128 for our other ads.

Radio Trading Co., 101-A Hudson St., New York City

## Know Thyself!

Well Illustrated



This new monthly magazine is also your own doctor. WHAT AILS YOU? POPULAR MEDICINE tells and advises you thoroughly. Written for you by doctors. Non-technical yet authoritative for all laymen. Many anatomical illustrations.

Special Offer!

8 Months \$1 for

Send 15c for sample copy POPULAR MEDICINE

97C Hudson St. New York, N. Y. On All Newsstands

# SEXOLOGY

THE MAGAZINE OF SEX SCIENCE  
SEXOLOGY, foremost educational sex magazine. Is written in simple language and can be read by every member of the family. It is instructive, enlightening—not a risqué book—contains no offensive matter.  
Contains 25 important articles on Sex Science, 68 pages, with attractive two-color cover. Here are a few of the more important articles:  
Lovers of Women's Clothing (Illustrated); Sex Problems of Widowhood; What Is Swollen Testicle? (Illustrated); Masturbation in Women; Sex Promiscuity in the South Seas (Illustrated); Signs of Pregnancy (Part I) (Illustrated); Sex Problems of Young Husband; Sex Life in Ancient Rome (Part II) (Illustrated); Difficulty in Urination (Part II) (Illustrated); Sex Education in the Movies (Part II); Questions and Answers

## SEXOLOGY

95 Hudson St. New York, N. Y.

Get a copy of SEXOLOGY on a ny newsstand, or, if your dealer cannot supply you, send 25c cash or stamps for current issue.

See Page 114 for special subscription offer on Short Wave Craft

## How to Eliminate Radio Interference

(Continued from page 92)

### Electric Bells

The same suppressor device can be successfully applied as shown in Fig. 4 to an electric bell, an apparatus which is often a strong producer of disturbing noises. While the condenser and the resistor used for switches in the normal power line should be of first-class quality, the condenser used for interference elimination on electric bells may be an old one. A few feet of resistance wire wound around a bobbin will do the trick for the resistor. A much better way to eliminate interference from electric bells is shown in Fig. 5. Directly upon the contact breaking piece, interference impulses are created by minute sparks. The interference impulses travel upon the wires and since they are in phase with each other, the power is added, as shown in Fig. 5-a. By rewiring the bell as shown in Fig. 5-b—in a so-called "symmetrical" manner—the impulses radiated from the breaker contact cancel each other. In some cases it might be advisable to add to the contact a spark extinguisher as indicated in Fig. 5-b, by the broken line.

### Electric Pads

Surprising as it may seem, electric pads are often a source of radio interference, especially the type containing a so-called automatic temperature contact. The pad must be opened and in parallel to the small glass tube containing the automatic contact, a small condenser of about 0.01-0.05 mf. should be connected. The condenser should be wrapped in cotton.

### Small Motors

Much trouble can be avoided by a symmetrical rewiring of small motors, which are often used in the home. Fig. 7-a shows

the usually unsymmetrical wiring of the field coils and the rotor. How the symmetrical rewiring has to be done is shown in Fig. 7-b. If this is not possible or makes too much trouble the circuit shown in Fig. 8 may be successfully applied. The condenser C 1, connected in parallel with the brushes of the rotor might be 0.02-0.1 mf., while the condenser C 2 to be connected with the frame of the motor might be about 0.005 mf. The circuit shown in Fig. 8 may of course be applied only for small transportable motors as used in the home, i.e., vacuum cleaners, hot-air blowers, sewing machines, fans, etc.

### Small Transportable Motors

Transportable motors of larger size are often used for professional purposes and may be made "interference-proof" by using the circuit shown in Fig. 9. The condensers C 1 and C 2 are of the same capacity (0.1-0.02 mf.) while the condenser C 3, to be connected with the frame of the motor, might be about 0.005 mf. To avoid trouble through a breakdown of a condenser, the fuses F 1 and F 2 may be inserted in the circuit.

### Stationary D.C. Motors

For stationary D.C. motors of larger size the circuit as shown in Fig. 10-a may be used. The condensers C 1 and C 2 are of about 0.5-4 mf. The fuses F 1 and F 2 according to the current drawn by the motor (between 0.5-6 amperes). In some cases the use of the condensers only will not be enough to eliminate interference entirely. Therefore the two chokes such as shown in Fig. 10-b, and 10-c, may be added. Each of these chokes (diameter 2 inches) have 150 turns. The wire used for these windings must be selected ac-

Please mention SHORT WAVE CRAFT when writing advertisers



● Index to Advertisers ●

<b>A</b>	
Ace Radio Laboratories.....	111
Aerovox Corporation.....	101
Allied Radio Corp.....	113
American Sales Co.....	111
Amperite Corporation.....	114
<b>B</b>	
Breakers Hotel.....	104
Burgess Battery Company.....	117
<b>C</b>	
Candler System Co.....	107
Cannon, C. F. Company.....	111
Centrallion Engineering Co.....	107
Classified Advertisements.....	125
Coast-to-Coast Radio Corp.....	105
Coyne Radio & Electrical School.....	116
<b>D</b>	
Dataprint Company.....	118
Deutschmann, Tobe, Corp.....	119
Dodge's Institute.....	105
<b>E</b>	
Earle Radio Co.....	109
Eilen Radio Laboratories.....	121
Electrad, Inc.....	116
Everyday Science & Mechanics.....	104
Experimental Radio Labs.....	116
<b>F</b>	
First National Television, Inc.....	127
<b>G</b>	
Gold Shield Products Co.....	103, 105, 119
<b>H</b>	
Hallierafter, Inc., The.....	105
Hammarlund Manufacturing Co.....	107
Harrison Radio Company.....	101, 111
<b>I</b>	
Instructograph Company.....	109
<b>K</b>	
Korrol Mfg. Co., Inc.....	109
<b>L</b>	
Lancaster, Allwine & Rommel.....	111
Leotone Radio Co.....	121
Lynch, Arthur H., Inc.....	107
<b>M</b>	
M. & H. Sporting Goods Co.....	119
Marine Electric Company.....	109
Midwest Radio Corp.....	123
<b>N</b>	
National Company, Inc.....	115
National Radio Institute.....	65
<b>O</b>	
Ohmite Manufacturing Company.....	104
<b>P</b>	
Popular Medicine.....	126
Postal Radio Corp.....	104
<b>R</b>	
Radio City Labs.....	127
Radio Construction Laboratories.....	111
Radio Craft.....	109
Radio Electric Service Co.....	119
Radio Publications.....	68, 122
Radio Trading Co.....	102, 125, 126, 128
RCA Institutes, Inc.....	107
Remington-Rand, Inc.....	120
<b>S</b>	
Sargent, E. M. Co.....	109
Scott, E. H., Radio Laboratories, Inc.....	100
Security Mfg. Co.....	109
Sexology Magazine.....	126
Short Wave League.....	67, 114, 119
Short Wave Listener Magazine.....	108
Sprague Products Co.....	123
Sunshine Novelty Company.....	103
Supertone Products Corp.....	102
<b>T</b>	
Teleplex Co.....	101
Thor Radio Co.....	127
Trimm Radio Mfg. Co.....	123
Try-Mo Radio Co., Inc.....	120
<b>U</b>	
Uncle Dave's Radio Shack.....	116
<b>W</b>	
Wellworth Trading Company.....	124
Wholesale Radio Service Co., Inc.....	103, 119
Who's Who in Amateur Radio.....	111
World Trotter Radio Labs.....	114
Wright-DeCoster, Inc.....	112

(While every precaution is taken to insure accuracy, we cannot guarantee against the possibility of an occasional change or omission in the preparation of this index.)

ording to the size of the motor with respect to its hp. or watts. The following table gives the necessary wire size in accordance to the hp. of the motor.

110 Volt Motors			
Hp.	Watts	Amperes	Wire No.
0.125	170	1.5	19
0.25	280	2.5	18
0.33	330	3.0	18
1.00	950	8.6	17
2.00	1900	17.5	13
3.00	2700	24.5	11

In diagram 10-b there is a condenser C 3. This condenser sometimes helps a great deal to eliminate interference. Its capacity is about 0.005 mf. However, it is advisable to ground the condensers C 1 and C 2 as shown in Fig. 10-a, if a good ground line is available. It is also advisable to ground the frame of the motor.

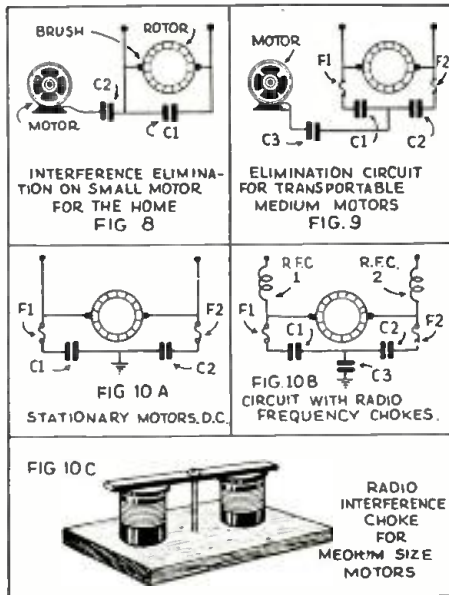

Figs. 8 to 10-c above show various methods of by-passing electric motors with condensers and chokes, in order to eliminate interference noises in the radio set from such sources.

**Spanish-English Class Broadcast**

● STUDENTS of the Spanish class of the Schenectady high school interchanged ideas with members of the English class of the Spanish high school in Barranquilla, South America, in a half-hour two-way short-wave radio program recently presented over General Electric's short-wave station W2XAF. W2XAF, operating on a wavelength of 31.48 meters, cooperated with station HJ1ABB in Barranquilla, operating on a wavelength of 46.50 meters, for this unique broadcast. Both stations carried both sides of the two-way conversations so that persons with all-wave receivers tuned to either station could hear the complete program. The program was informal. Students in this country explained to their South American friends the difficulties experienced in learning Spanish, while the Spanish students responded by telling about their problems in attempting to master English. Teachers of both classes were present at the studios and participated in the exchange of ideas.

**Brand New!**

Dual Channel Receiver—Tunes in 2 different stations simultaneously through a single set of tubes! In July Issue!

## EXPERIENCED MEN

### Get the Big Radio Jobs

**S. Q. NOEL**  
PRES. FIRST NATIONAL TELEVISION, INC.

"Every qualified man I train puts in actual hours at my 1,000 Watt Commercial Radio Station! When you have completed my training course, you are a tested radio and television expert—ready to step into the BIG PAY class! You have had actual experience behind you in genuine radio broadcasting work which gives you preference in any radio job. The hours you spend in my ultra-modern, "Hi-Fidelity" commercial station W9XBY and my licensed television experiment station W9XAL mean dollars to you. Never before have you been offered so great an opportunity! Tune in on "Hi-Fidelity" Station W9XBY—1530 kilocycles.

**Get your license while learning**

A government operator's license is a passport to a real job with a future! My students qualify for their licenses and get certified service records while learning. FREE employment service for life on graduation. No previous experience needed. Write today and let me point the way to the highest-pay radio jobs!"

**MAIL TODAY**

S. Q. Noel, Pres. First National Television, Inc. (Training Division)  
Dept. ITB-6, Power and Light Bldg., Kansas City, Mo.

Without obligation, send me postpaid FREE Illustrated Folder telling about new opportunities in radio and television. I am 17 years or older.

Name \_\_\_\_\_ Age \_\_\_\_\_  
Address \_\_\_\_\_

## SENSATIONAL ALL WAVE KIT

# RGH 5

### COMPLETE KIT

Including 8 S.W. Coils

The **RGH5** uses 2—58 2—2A5 and 1—80

in an A.C. self-powered regenerative circuit. Kits are shipped ready mounted on the handsome black crackle chassis with Gothic coil niches and airplane dial. Speaker \$2.50 extra

Mail Orders Filled—Send for Free Data

## THOR RADIO CORP.

167 Greenwich St., New York City

## FACTORY PRICES

Short Wave—All-Wave—Kits  
FREE 1935 CATALOG &  
**Free Colored Short-Wave Map**  
(Send 10c to cover Postage, etc.)  
Radio City Labs, Suite 1222  
30 Rockefeller Plaza New York, N. Y.



at last!  
**CONTINUOUS  
 BANDSPREAD**  
*on all bands*

THE OFFICIAL  
**DOERLE**  
**BANDSPREAD**

**5-TUBE DE-LUXE A. C.  
 SHORT-WAVE RECEIVER**

**NATION-WIDE  
 TESTIMONIALS  
 PRAISE THIS SET**

Gentlemen:  
 I received your "Official Doerle A. C. 5" today, after being adjusted by your engineers. I have had the receiver turned on less than 10 minutes and at the present time I am listening to the American Hour coming from IRA Rome, Italy. It is a wonderful relief to listen in without hearing a lot of noise. I would like to at this time thank you ever so much for making this adjustment. You cannot tell how much I appreciate this favor. You can certainly count on me as one of your boosters and I shall spread your name and products to all of my friends.  
**GEORGE LESLIE ALLEN,**  
 Morris Plains, N.J.

Dear Sir:  
 Just a letter of recommendation concerning the Doerle A. C. 5. What a set, oh boy, for brinking in the DX night after night. I receive about 14 stations a week, that are new programs, besides 50 I already received. Besides I logged 700 hams. Stations that aren't even listed in call books give me a thrill. I only use a 20 ft. antenna wrapped around a chimney.  
**FRANCIS KMEC,** Allentown, Pa.

Gentlemen:  
 This will acknowledge receipt of my Doerle short-wave receiver. This 1935 model is the smoothest and best operating set I have ever operated, both on amateur and foreign reception. I have heard practically all of the South American stations, Russia, Spain, and of course, France, Germany, Japan, and lots of others. This little receiver is just as you say it is—the best for the money and I have seen sets selling for lots more, which do not come within a mile of this Doerle.

If anybody wants to know if you people will treat them white, just let me know and I will tell absolutely yes.  
**S. L. SMITH,** Colorado, Texas.

Gentlemen:  
 I am very well satisfied with the set and here are some of DX stations which I have received on it:

On 20 meter coil: EAQ—Madrid, Spain; PRF5—Rio Grande, Brazil, S.A.; LSX—Monte Grande, Argentina, S.A.; DIQ—Germany (Koenig Wusterhausen); GSB—England (Daventry); COH—Havana, Cuba.

On 49 Meters: DJD—Berlin, Germany; H2-CRL—Guayaquil, So. America; 2RO—Rome, Italy; DKC and DKF—Germany; XE1T—Mexico City, Mexico.

Also many other South American Stations and Central American stations. Amateurs in more than 36 different states and including Canadian amateurs.

**AUGUSTE THEBERGE,** River Edge, N.J.

**FREE** JUST OFF THE PRESS!  
 IMPORTANT BUYING GUIDE FOR RADIO DEALERS, SERVICE MEN, EXPERIMENTERS AND SHORT-WAVE FANS  
 32 Pages, Two Colors, Profusely Illustrated  
 Up-to-the-minute catalog containing low prices which save you money. Contains radio sets, parts, public address equipment, short-wave receivers, etc. etc.  
 Name the item—it's in the catalog

Send post card or letter. Book sent by return mail. See pages 102, 125 and 126 for our other "ads."

Complete Price  
**\$27.55**  
 WITH TUBES  
 Nothing Else to Buy

- ▶ Doublet Antenna Input or
- ▶ Standard Antenna input
- ▶ 8-Low Loss Ribbed Plug-in Coils
- ▶ 15-200 Meters
- ▶ 12,500 Mile Range
- ▶ Airplane Dial
- ▶ Dynamic Speaker
- ▶ Headset Jack
- ▶ Beautiful Cabinet

**BEFORE** you buy any other Short-Wave Receiver, be sure to take advantage of our **FREE** five day trial offer explained below. Satisfy yourself, in your own home and at your leisure that this IS one of the greatest values in radio, and that it **DOES** have features which are found only in more expensive receivers.

**Will Outperform Many 10-Tube Expensive Sets**

A powerful 5-tube "big" complete with its self-contained hum-free power pack and dynamic speaker; all mounted on a single chassis and contained in a large handsomely finished black crackle cabinet with battered green speaker grill.

Two tuned stages—regenerative detector, 3AF stages with powerful 4I pentode output and perfectly matched dynamic speaker; all these features contribute to the enormous power and superlative performance of this Doerle short-wave receiver.

**CONTINUOUS BANDSPREAD ON ALL BANDS.** A special double-pointer, double-scale, airplane dial having a tuning ratio of 125 to 1 is employed.

Amateurs may now use this receiver for their daily communications work with the greatest of confidence. It is a real, reliable performer—A FULL-PLEGGED "HAM" RECEIVER.

All the fine features that you would expect to find in more expensive receivers are incorporated in this "ACE TOP-NOTCHER" of the entire Doerle line.

Either a short-wave doublet or standard antenna may be used. A new antenna-adjusting scheme permits perfect alignment of both tuned circuits without affecting the setting of the tuning dial. This means that all stations can be accurately located on the single tuning dial and always found in their allotted places. Provisions are made to use headphones if desired, with a switch to cut out the dynamic speaker.

**LOOK AT THIS DX-QSL LIST!**

During its initial test, in one sitting, this receiver pulled in on its loud speaker, at good room volume, the following enlilable log: WIXAL, WIXAZ, Boston; W3XAL, Boundbrook, N.J.; WRXAL, Cincinnati; W9XAA and W9XF, Chicago; GSC, GSD, GSE, GSF, Daventry, England; DJA, DJB, DJC, DJD, Zeesen, Germany; HBL, HBP, Geneva; VE9GW Ontario; V9DN Quebec; GE9DR Montreal; VE9HX Halifax; XETE Mexico City; YU1BC, YV3BC Caracas CP5 Bolivia; LSN Buenos Aires; COC Havana; EAQ Madrid; WQO and WEF, testing with the Byrd Expedition and a whole flock of amateurs in practically every radio district of the United States. After that, we could no longer keep our eyes open so we "signed off" to bed.

The testimonials printed on this page testify that, in actual use, our customers are attaining even greater success. Uses a simple regenerative circuit, so simple as to be entirely fool-proof. Tubes, 1—6D6, 1—6E7 (actually two tubes in one), 1—37, 1—4I power output tube and 1—80 full-wave rectifier. Two gang tuning condenser; single dial control; FULL-VISION ILLUMINATED BAND SPREAD AIRPLANE DIAL. Ship. wt. 35 lbs. No. 5000. "DOERLE AC-5" Short-Wave Receiver, Complete with Tubes, Speaker and 8 coils. 15 to 200 meters. Completely wired and tested. (NOT SOLD IN KIT FORM) YOUR PRICE **\$27.55**  
 Set of 2 Broadcast coils \$1.75 additional

**7 PAGES  
 of  
 Instructions  
 and  
 Diagrams  
 Included  
 with each  
 SET**

**USE THIS COUPON FOR ~  
 FREE 5-DAY TRIAL**

**RADIO TRADING CO., 101A HUDSON ST., NEW YORK**

Gentlemen: 6-35  
 I enclose ..... dollars ..... cents, for your new Doerle 5-Tube De-Luxe Short-Wave receiver on a five day free trial basis. I am to prove to my own satisfaction that it will give me world-wide reception and that your guarantee means exactly what it says. If, at the end of five days after receipt of radio, I am not perfectly satisfied, I will write you accordingly, whereupon you will send shipping instructions. Upon receipt of the radio, you will refund me the full purchase price. I agree to pay express charges one way, and you the other.

C.O.D. SHIPMENT. I enclose .....dollars.....cents deposit, balance of .....dollars..... cents C.O.D.

PRINT Name .....  
 Address .....  
 Town ..... State.....

**RADIO TRADING CO., 101A Hudson St., New York City**

Please mention SHORT WAVE CRAFT when writing advertisers



# The 4 ESSENTIAL SHORT WAVE BOOKS

'ROUND THE WORLD FANS USE THESE GREAT SHORT WAVE BOOKS

These great books contain everything on short waves that is really worth knowing—they are books which have been most enthusiastically welcomed by short-wave fans. The cost of the books is extremely low in comparison with the valuable material which they contain.

## Ten Most Popular Short Wave Receivers. How to Make and Work Them

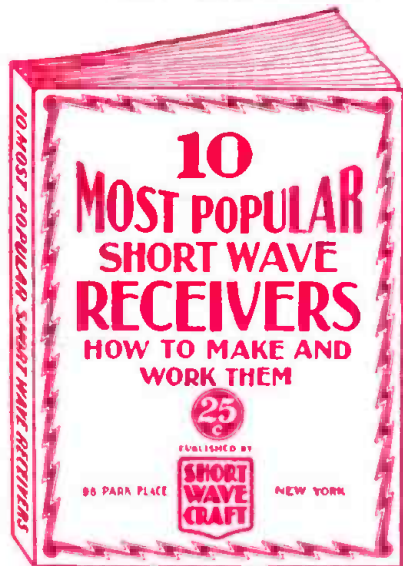

40 PAGES  
OVER 75 ILLUSTRATIONS  
IMPORTANT

THERE IS NO DUPLICATION BETWEEN THIS BOOK AND OUR OTHER VOLUME—"HOW TO BUILD AND OPERATE SHORT WAVE RECEIVERS"—ALL THE MATERIAL PUBLISHED IN THE NEW BOOK HAS NEVER APPEARED IN ANY BOOK BEFORE.

This new volume is a revelation to those who wish to build their own short wave receivers. The editors of SHORT WAVE CRAFT have selected ten outstanding short wave receivers and these are described in the new volume. Each receiver is fully illustrated with a complete layout, pictorial representation, photographs of the set complete, hookup and all worthwhile specifications. Everything from the simplest one tube set to a 5-tube T. R. F. receiver is presented. Complete lists of parts are given to make each set complete. You are shown how to operate the receiver to its maximum efficiency.

### CONTENTS

The Doerle 2-Tube Receiver That Reaches the 12,500 Mile Mark, by Walter C. Doerle.  
2-tube Pentode S-W Receiver having two stages of Tuned Radio Frequency, by Clifford E. Denton and H. W. Secor.  
My de Luxe S-W Receiver, by Edward G. Ingram.  
The Blinnweg 2-Tube 12,000 Miles DX Receiver, by A. Blinnweg, Jr.  
Build a Short Wave Receiver in Your "Brief-Case," by Hugo Gernsback and Clifford E. Denton.  
The Denton 2-Tube All-Wave Receiver, by Clifford E. Denton.  
The Denton "Stand-By," by Clifford E. Denton.  
The "Stand-By" Electrified.  
The Short-Wave MEGADYNE, by Hugo Gernsback.  
A COAT-POCKET Short Wave Receiver by Hugo Gernsback and Clifford E. Denton.  
Boy, Do They Roll In on this One Tube by C. E. Denton.  
The S-W PENTODE-4, by H. G. Cisin M. E.  
Louis Martin's Idea of A GOOD S-W RECEIVER, by Louis Martin.

25c

## How to Build and Operate Short Wave Receivers

is the best and most up-to-date book on the subject. It is edited and prepared by the editors of SHORT WAVE CRAFT, and contains a wealth of material on the building and operation, not only of typical short-wave receivers, but short-wave converters as well. Dozens of short-wave sets are found in this book, which contains hundreds of illustrations; actual photographs of sets built, hookups and diagrams galore.

The book comes with a heavy colored cover, and is printed throughout on first-class paper. No expense has been spared to make this the outstanding volume of its kind. The book measures 7½x10 inches.

This book is sold only at such a ridiculously low price because it is our aim to put this valuable work into the hands of every short-wave enthusiast.

We know that if you are at all interested in short waves you will not wish to do without this book. It is a most important and timely radio publication.

Over 150 Illustrations  
72 Pages 7x10 Inches

50c

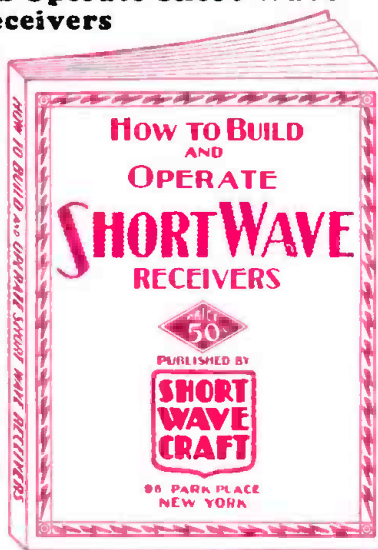

There is not a short-wave fan, experimenter or interested radio-minded reader who will not want these books. Right up-to-the-minute with new material on outstanding developments in the short wave field. The books are authoritative, completely illustrated and not too highly technical.

## The Short Wave Beginner's Book

Here is a book that will solve your short wave problems—leading you in easy stages from the simplest fundamentals to the present stage of the art as it is known today. It is the only low-priced reference book on short waves for the beginner.

The book is profusely illustrated with all sorts of photos, explanations and everything worth while knowing about short waves—the book is not "technical." It has no mathematics, no "high-faluting" language and no technical jargon. You are shown how to interpret a diagram and a few simple sets are also given to show you how to go about it in making them.

It abounds with many illustrations, photographs, simple charts, hookups, etc., all in simple language. It also gives you a tremendous amount of very important information which you usually do not find in other books, such as time conversion tables, all about aerials, noise elimination, how to get verification cards from foreign stations, all about radio tubes, data on coil winding and dozens of other subjects.

### Partial List of Contents

Getting Started in Short Waves—the fundamentals of electricity. Symbols the Short Hand of Radio—how to read schematic diagrams. Short Wave Coils—various types and hints in making them. Short Wave Aerials—the points that determine a good aerial from an inefficient one. The Transposed Lead-in for reducing Man Made Static.  
The Beginner's Short-Wave Receiver—a simple one tube set that anyone can build. The Beginner's Set Gets an Amplifier—how the volume may be increased by adding an amplifier.  
How to Tune the Short-Wave Set—telling the important points to get good results. Regeneration Control in Short Wave Receivers.  
Audio Amplifiers for S. W. Receivers. How to Couple the Speaker to the set. Learning the Code—for greater enjoyment with the S-W set.  
Wave length to Mileage Chart.  
Wire Chart—to assist in the construction of coils.  
Hints in the construction of S-W Receivers.

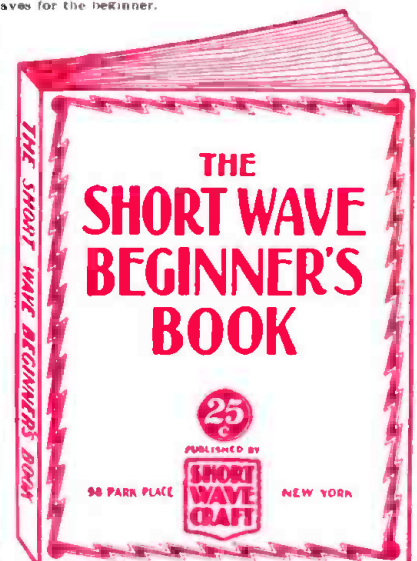

40 PAGES  
OVER 75 ILLUSTRATIONS

25c

## How to Become an Amateur Radio Operator

We chose Lieut. Myron F. Eddy to write this book because his long years of experience in the amateur field have made him pre-eminent in this line. For many years he was instructor of radio telegraphy at the I.R.E. Institute. He is a member of the I.R.E. (Institute of Radio Engineers), also the Veteran Wireless Operators Association.

If you intend to become a licensed code operator, if you wish to take up phone work eventually, if you wish to prepare yourself for this important subject—this is the book you must get.

### Partial List of Contents

Ways of learning the code. A system of sending and receiving with necessary drill words is supplied so that you may work with approved methods. Concise, authoritative definitions of radio terms, units and laws, brief descriptions of commonly used pieces of radio equipment. The chapter gives the working terminology of the radio operator. Graphic symbols are used to indicate the various parts of radio circuits. General radio theory particularly as it applies to the beginner. The electron theory is briefly given, then waves—their creation, propagation and reception. Fundamental laws of electric circuits, particularly those used in radio are explained neat and typical basic circuits are analyzed. Descriptions of modern receivers that are being used with success by amateurs. You are told how to build and operate these sets. Amateur transmitters. Diagrams with specifications are furnished so construction is made easy. Power equipment that may be used with transmitters and receivers, rectifiers, filters, batteries, etc. Regulations that apply to amateur operators. Appendix which contains the International "Q" signals, conversion tables for reference Purposes, etc.

Over 150 Illustrations  
72 Pages 7x10 Inches

50c

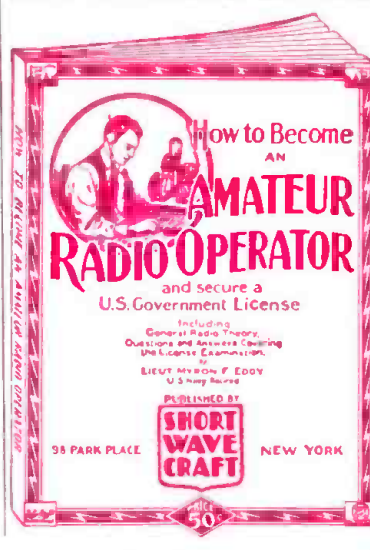

All the books shown on this page are published exclusively by

**SHORT WAVE CRAFT**

99-101 Hudson Street, New York, N. Y.

CLIP-MAIL

SHORT WAVE CRAFT

99-101 Hudson Street, New York, N. Y.

Gentlemen: I enclose herewith my remittance for the amount of \$..... for which you are to send me, postpaid, the books checked below.

- ( ) Ten Most Popular Short Wave Receivers, How to Make and Work Them... 25c each  
( ) The Short Wave Beginner's Book... 25c each

Name.....  
Address.....  
City..... State.....

(Send remittance in form of check or money order. If letter contains cash or unused U. S. Postage Stamp, register it.)

SW-6-35

These Books are Authentic For All Short Wave Work and LOW in Price

COUPON TODAY!

# WORLD GLOBES

## FOR SHORT WAVE ENTHUSIASTS

### NOW AT LOW PRICES

THESE remarkable globes, executed in fourteen colors, are absolutely indispensable for short wave fans. Notable among the numerous features of these world globes, is that a damp cloth quickly removes all dust and water does not harm the surface.

Short Wave fans are enabled to determine correct time in various centers of the world with the aid of these maps; distances from city to city can be accurately established.

There is a graduated "Meridian" scale of black enameled metal with the 9" and 12" globes. An additional feature is the movable hour scale found at the north pole—this facilitates determining the hour in any part of the world.

Only on a globe of this size is it possible to get an accurate picture of countries and their relative positions to each other. You will actually be amazed when you compare distances—from New York to Moscow; from Cape Town to Tokio; from Los Angeles to Rio de Janeiro, etc. A flat map is deceptive for measuring, but take a small string and stretch it across the globe, from city to city, and you have the correct distances.

Here are globes that add dignity to home, office, studio or laboratory—a globe that everyone would be proud to possess.

Each world globe contains a listing of over 7,500 cities in nations the world over—spellings conform to international geographic standards—all globes are of 1934 production. GET ONE OF THESE FINE WORLD GLOBES TODAY!



#### World Globe No. 147

12" Globe. New model—equipped with wooden floor stand finished in wainut. Height overall 35". Globe constructed with half meridian. New World Globe Handbook Included FREE. A marvelous buy. Never has a floor model Globe been sold at such a low price. Shipping weight 9 lbs.

**\$4.15**

F.O.B. Chicago.

No. 147



No. 99

#### World Globe No. 99

9" Globe, equipped with sturdy, black metal base and full meridian. Same ball as our No. 139 but reduced 1/4 in size and scale. Included with globe is newly printed World Globe Handbook FREE. Shipping weight 6 lbs.

PRICE

**\$2.05**

F.O.B. Chicago.

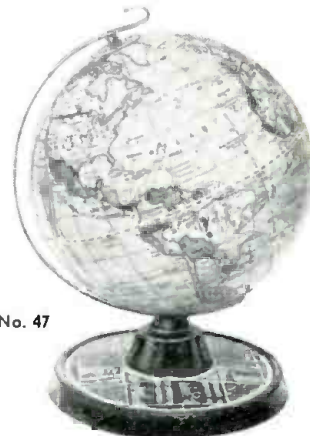

No. 47

#### World Globe No. 47

7" Globe, equipped with sturdy metal base and half meridian. Index to countries of the world by latitude and longitude shown on base. Shipping weight 2 lbs.

PRICE

**\$0.90**

F.O.B. Chicago.

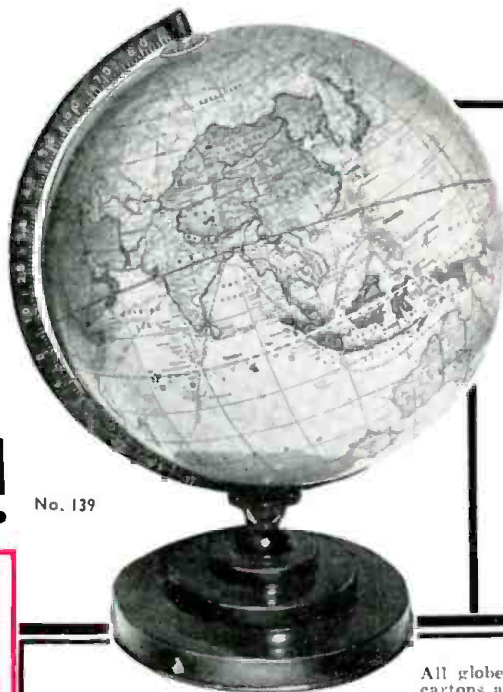

No. 139

## SPECIAL THIS MONTH

#### World Globe No. 139

12" Globe, equipped with sturdy, black metal base and half meridian. Contains over 7,500 names and cities. Spellings conform to authoritative world standards. Hundreds sold to many short wave fans during the last year. Copy of World Globe Handbook Included FREE. Shipping weight 8 lbs. PRICE

**\$2.95**

F.O.B. Chicago.

Gentlemen:

I received the World Globe and am certainly well pleased with its completeness, appearance and its usefulness.

Short wave listening has become a hobby with me, and this World Globe is a necessary accessory to any short wave listener or, for that matter, to any home.

P. C. ELLIS, Supt.  
Laboratory—19th and Campbell Streets, Kansas City, Mo.

## ORDER YOUR GLOBE TODAY!

#### SHORT WAVE CRAFT

SWC-6-35

59 Hudson Street, New York, N. Y.

Gentlemen: Enclosed you will find my remittance of \$..... for which please ship me the following World Globe.

- ( ) World Globe No. 99 @ \$2.05
- ( ) World Globe No. 147 @ \$4.15
- ( ) World Globe No. 47 @ \$0.90
- ( ) World Globe No. 139 @ \$2.95

Name .....

Address .....

City ..... State .....

Send remittance in check or money order—register letter if it contains cash, stamps or currency. GLOBES ARE SHIPPED FROM OUR WAREHOUSE IN CHICAGO—F. O. B. FROM THAT CITY.

sufficient postage for delivery by parcel post. Globes are shipped from our Chicago warehouse. Register letter if it contains cash, or currency or stamps. If preferred, specify that shipment be sent express collect. ALL ORDERS ARE FILLED PROMPTLY.

ALL GLOBES SHIPPED IMMEDIATELY

**SHORT WAVE CRAFT**

**99 HUDSON STREET,  
NEW YORK, N. Y.**