

HUGO GERNSBACK  
Editor

# SHORT WAVE CRAFT

April

WORLD'S  
LARGEST  
SHORT WAVE  
CIRCULATION

?  
**WHICH  
AERIAL  
IS BEST?**  
See Page 714

MRA  
CODE

25¢  
IN CANADA  
30¢

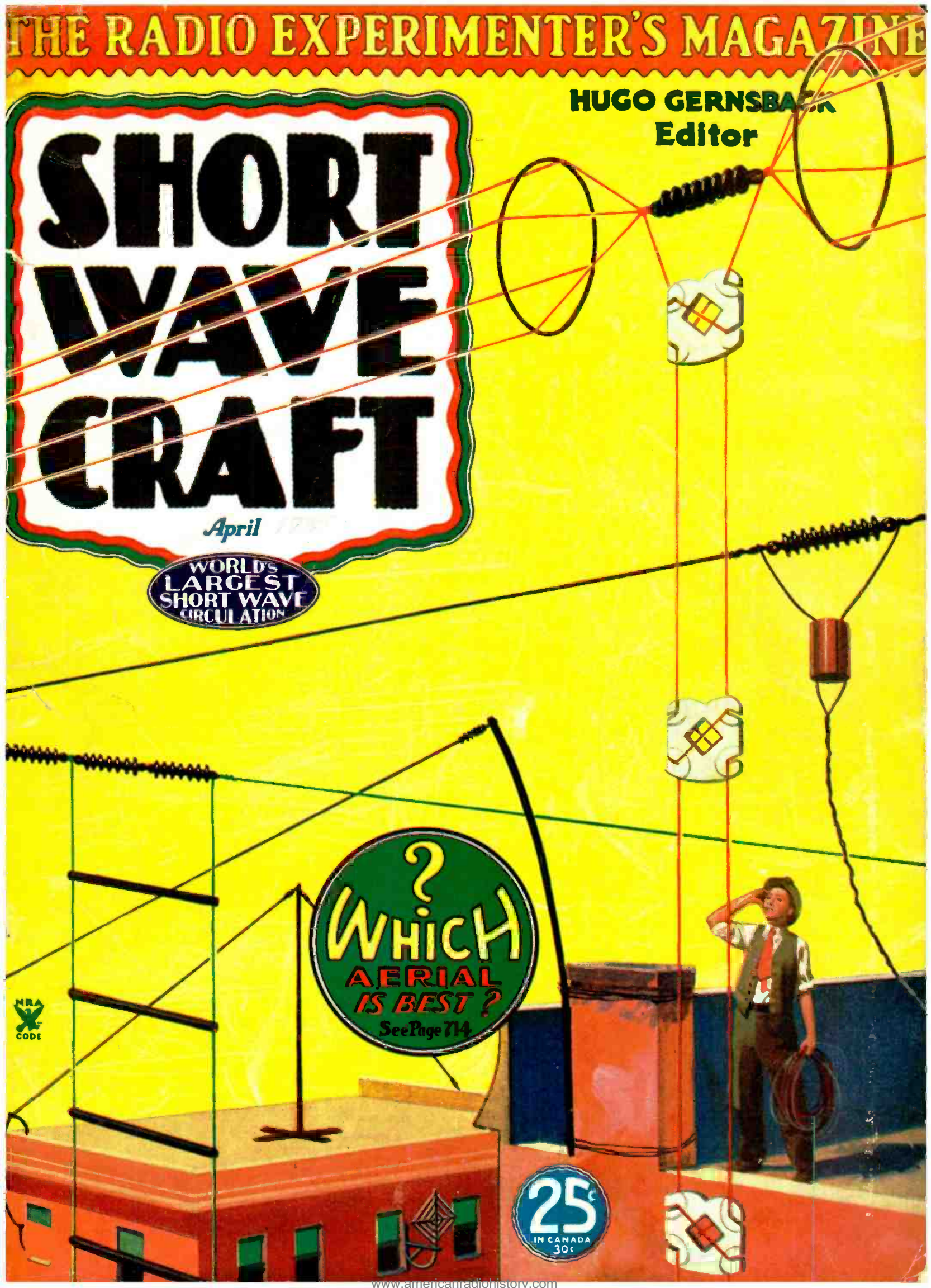



# WORLD GLOBES

## FOR SHORT WAVE ENTHUSIASTS

### NOW AT LOW PRICES



**World Globe No. 147**

12" Globe. New model—equipped with wooden floor stand finished in walnut. Height overall 35". Globe constructed with half meridian. New World Globe Handbook included FREE. A marvelous buy. Never has a floor model Globe been sold at such a low price. Shipping weight 9 lbs. **PRICE**

**\$4.15**

F.O.B. Chicago.

No. 147

Gentlemen:

I received the World Globe and am certainly well pleased with its completeness, appearance and its usefulness. Short wave listening has become a hobby with me, and this World Globe is a necessary accessory to any short wave listener or, for that matter, to any home.

P. C. ELLIS, Supt.  
Laboratory—19th and Campbell Streets, Kansas City, Mo.

## ORDER YOUR GLOBE TODAY!

SHORT WAVE CRAFT SWC-4-35

99 Hudson Street, New York, N. Y.

Gentlemen: Enclosed you will find my remittance of \$..... for which please ship me the following World Globe.

- ( ) World Globe No. 99 @ \$2.05
- ( ) World Globe No. 117 @ \$1.15
- ( ) World Globe No. 47 @ \$0.90
- ( ) World Globe No. 139 @ \$2.95

Name .....  
Address .....

City ..... State .....

Send remittance in check or money order—register letter if it contains cash, stamps or currency. **GLOBES ARE SHIPPED FROM OUR WAREHOUSE IN CHICAGO—E. O. B. FROM THAT CITY.**

THESE remarkable globes, executed in fourteen colors, are absolutely indispensable for short wave fans. Notable among the numerous features of these world globes, is that a damp cloth quickly removes all dust and water does not harm the surface.

Short Wave fans are enabled to determine correct time in various centers of the world with the aid of these maps; distances from city to city can be accurately established.

There is a graduated "Meridian" scale of black enameled metal with the 9" and 12" globes. An additional feature is the movable hour scale found at the north pole—this facilitates determining the hour in any part of the world.

Only on a globe of this size is it possible to get an accurate picture of countries and their relative positions to each other. You will actually be amazed when you compare distances—from New York to Moscow; from Cape Town to Tokio; from Los Angeles to Rio de Janeiro, etc. A flat map is deceptive for measuring, but take a small string and stretch it across the globe, from city to city, and you have the correct distances.

Here are globes that add dignity to home, office, studio or laboratory—a globe that everyone would be proud to possess.

Each world globe contains a listing of over 7,500 cities in nations the world over—spellings conform to international geographic standards—all globes are of 1934 production. **GET ONE OF THESE FINE WORLD GLOBES TODAY!**

**World Globe No. 99**

9" Globe, equipped with sturdy, black metal base and full meridian. Same ball as our No. 139 but reduced 1/4 in size and scale. Included with globe is newly printed World Globe Handbook FREE. Shipping weight 6 lbs.

**PRICE**  
**\$2.05**

F.O.B. Chicago.



No. 99

**World Globe No. 47**

7" Globe, equipped with sturdy metal base and half meridian. Index to countries of the world by latitude and longitude shown on base. Shipping weight 2 lbs.

**PRICE**  
**\$0.90**

F.O.B. Chicago.



No. 47



No. 139

## SPECIAL THIS MONTH

**World Globe No. 139**

12" Globe, equipped with sturdy, black metal base and half meridian. Contains over 7,500 names and cities. Spellings conform to authoritative world standards. Hundreds sold to many short wave fans during the last year. Copy of World Globe Handbook included FREE. Shipping weight 8 lbs. **PRICE**

**\$2.95**

F.O.B. Chicago.

All globes are carefully packed in original cartons assuring safe delivery. **ORDER BY NUMBER.** Send check or money order, plus sufficient postage for delivery by parcel post. Globes are shipped from our Chicago warehouse. Register letter if it contains cash, or currency or stamps. If preferred, specify that shipment be sent express collect. **ALL ORDERS ARE FILLED PROMPTLY.**

**ALL GLOBES SHIPPED IMMEDIATELY**

**SHORT WAVE CRAFT 99 HUDSON STREET, NEW YORK, N. Y.**



# I WILL TRAIN YOU AT HOME IN SPARE TIME FOR A GOOD RADIO JOB!



J. E. SMITH, Pres.  
National Radio Institute

**HERE'S  
PROOF**

### Good Position Station WSMK

"I have a good job, make a nice salary, and all my success is due to N.R.I. I am operator of Station WSMK. I highly recommend the N.R.I. Course. It enabled me to pass the Government examination for an operator's license." JOHN HAJDUK, Jr., 21 Gerard Avenue, Southern Hills, Dayton, Ohio.

### \$18 a Week in Spare Time

"Although I am doing only spare time Radio work, I have averaged \$18 a week. I recommend N.R.I. training. It is certainly a complete Course. In a short time it will take a man, give him a sound fundamental training in Radio theory, practice and design." STEPHEN J. DRAPCHATY, 407 Wunderlich Ave., Barberton, Ohio.

### Nets about \$50 a Week besides Sales

"I have been getting along fine. I average ten calls a week, which nets me about \$50, not counting profits on sales. I have serviced almost every make of set and have earned more than I ever expected. I owe my success to the N.R.I. and its wonderful Course." BERNARD COSTA, 150 Franklin St., Brooklyn, N.Y.

### FREE : Radio Servicing Tips

Let me PROVE that my Course is clear, easy to understand and fascinating to study. Send the coupon for a free lesson, "Trouble Shooting in D.C., A.C., and Battery Sets." This interesting lesson gives 132 ways to correct common Radio troubles. I am willing to send this book to prove that you too can master Radio—just as thousands of other fellows have done. Many of them, without even a grammar school education, and no Radio or technical experience, have become Radio experts and now earn two or three times their former pay. Mail the coupon now.



## FREE BOOK TELLS HOW MAIL COUPON

Act today for better pay. Act today to break away from a low pay, no-future job. Act to get away from having to skimp, scrape to pay your bills. Mail coupon for my free 64-page book. It tells you how I will train you at home in your spare time to be a Radio Expert; about my training that has doubled and tripled the pay of many.

### Many Radio Experts make \$40, \$60, \$75 a Week

Consider these facts—think of the good jobs they stand for. Over 17,000,000 Radio sets in use, over 600 broadcasting stations, over 40 large manufacturers of Radio sets, over 3,000 manufacturers of parts, over 100 Police Departments Radio equipped, airplanes and airports Radio equipped. Thousands of ships touching every seaport of the world are Radio equipped. Over 35,000 stores selling sets and parts, about 2,000,000 autos Radio equipped and about 20,000,000 unequipped. Loud speaker systems wherever people gather, indoors and outdoors. Commercial Radio stations dotting our coast lines. Radio a big industry—is growing bigger fast. A few hundred \$40, \$60, \$75 a week jobs, have grown to thousands.

### Get ready now for Jobs like these

A spare time or full time service shop; installing, maintaining, operating—broadcast, aviation, commercial, ship, television and police stations. A Radio retail business of your own. Installing, maintaining, servicing, loud speaker systems. A service or sales job with a store or jobber. I'll train you for good jobs in every branch of Radio.

### Many make \$5, \$10, \$15 a week extra in Spare Time While Learning

Every neighborhood can use a good part time serviceman. I'll start giving you special instruction material, plans, ideas, the day you enroll, for making money in spare time. Get my book—read how many of my students make \$200 to \$1,000 in their spare time while learning. Stanley Tulk, 2705 Hector Street, Montreal, Canada, writes—"I have been doing so much service work I haven't had time to study. In two months, I made about \$200 in spare time." Lloyd V. Sternberg, 217 Fourth Avenue, Willmar, Minn., tells me—"I earned enough in spare time to pay for my Course. In one month I earned \$125 in spare time." Yes, my training pays!

### Your money back if not satisfied

I'll make this agreement with you. If you are not entirely satisfied with my lesson and instruction service when you finish, I'll refund your tuition.

### Find out what Radio Offers

Mail the coupon. My book of information on Radio's spare time and full time opportunities is free to any ambitious fellow over 15. Read what Radio offers you. Read letters from graduates—what they are doing and making. There's no obligation. Mail coupon in an envelope or paste it on a postal card—NOW.

J. E. SMITH, President  
National Radio Institute, Dept. 5DB3  
Washington, D. C.



### SAVE MONEY—LEARN AT HOME Special Equipment Gives You Practical Experience

Hold your job. No need to leave home and spend a lot of money to be a Radio Expert. I'll train you quickly and inexpensively right at home in your spare time. You don't need a high school or college education. Many of my successful graduates didn't finish grade school. My practical 50-50 method of training—half with lessons, half with Radio equipment—gives you broad, practical experience—makes learning at home easy, fascinating, practical and rapid. There is opportunity for you in Radio. Old jobs are becoming more complicated—many need better trained men. New developments are making new jobs. Short wave, loud speaker systems, police Radio, auto Radio, aviation Radio, television—Radio's newest uses are covered by my training. Here's a field that's growing. It is where you find growth that you find opportunity.

I have doubled  
and tripled  
the salaries  
of many



## MAIL THIS NOW!

J. E. SMITH, PRESIDENT  
NATIONAL RADIO INSTITUTE, DEPARTMENT 5DB3  
WASHINGTON, D. C.

Dear Mr. Smith: Without obligation, send me the Service Manual and your free book about spare time and full time Radio opportunities, and how I can train for them at home in spare time. (Please print plainly.)

NAME ..... AGE.....  
ADDRESS .....  
CITY .....  
STATE ..... M

**The Tested Way to BETTER PAY**

Please mention SHORT WAVE CRAFT when writing advertisers

**IN THIS ISSUE: PROMINENT SHORT-WAVE AUTHORS**

**Hatschek • Frye • Shuart • Dobrovolny • Victor • Schrage**

**HUGO GERNSBACK**  
Editor



**H. WINFIELD SECOR**  
Managing Editor

**GEORGE W. SHUART,**  
W2AMN  
Associate Editor

**Contents for April, 1935**

Editorial—"Short Wave Aerials," by Hugo Gernsback	709
New Stunts with Short Waves, by Dr. P. Hatschek, Berlin	710
Amelia Earhart's S-W Radio Never Failed	711
Teaching by Short Waves	712
Why Your Son Should Learn Radio—A Talk with "Dad!" by John T. Frye, W9EGV	713
Which Short-Wave Aerial Is the Best? by George W. Shuart, W2AMN	714
A Good 3-Tube Super-het, by H. Dobrovolny	716
How To Bend Your Own Chassis	718
\$500.00 Prize Cover Contest Rules	719
World-Wide Short-Wave Review, edited by C. W. Palmer	720
SHORT WAVE SCOUT "NEWS"	722
14th Short Wave Scout Trophy Award	723
Short Waves and Long Raves—Our Readers' Forum	724
The Eagle "E-C" Four Receiver, by Leonard Victor, W2DHN	726
What's New in Short-Wave Apparatus	728
HIGH FIDELITY—How to Obtain It on your Old Loud Speaker, by Wilhelm Schrage	730
A Low-Power Rack & Panel Xmitter, by G. W. Shuart, W2AMN	731
\$5.00 for Best Short Wave "Kink"	732
SHORT-WAVE STATIONS OF THE WORLD, edited by M. Harvey Gernsback	733
WHEN TO LISTEN IN, by M. Harvey Gernsback	737
Short Wave QUESTION BOX	738
SHORT WAVE LEAGUE	740

**Features in the May Issue**

- Tiny Transceiver Talks Three Miles!, by Howard G. McEntee, W2FHP.
- A Good Television Hook-Up, by W. H. Singleton.
- Regenerative R.F. Booster, by George W. Shuart, W2AMN.
- A New All-Wave Converter—Don't Miss It!, by J. A. Worcester, Jr.
- Beginners A.C. 2—"Four Tube Results with but Two Tubes!"
- Transmitting Antennas—How to Design Them.



**Certified Circuits**

● **SHORT WAVE CRAFT** goes to a large expense in verifying new circuits. When you see this seal it is your guarantee that such sets have been tested in our laboratories, as well as privately, in different parts of

the country. Only "Constructional-Experimental" circuits are certified by us.

When you see our certified seal on any set described, you need not hesitate to spend money for parts, because you are assured in advance that the set and circuit are bona fide and that this magazine stands behind them.

**SHORT WAVE CRAFT** is the only magazine that certifies circuits and sets.

**OUR COVER**

● The word "aerial" is undoubtedly the "hottest" word in short-wave radio today, and especially does the choice of an aerial prove somewhat of a conundrum to the average short-wave "Fan." Realizing that there are many different choices of aerials, with "extra fancy" and just plain "garden variety" lead-ins, the article in this issue has been carefully prepared. Do not fail to read carefully this important article on page 714.

COPYRIGHT, 1935, BY H. GERNSBACK

Published by **POPULAR BOOK CORPORATION**

HUGO GERNSBACK, President - - - H. W. SECOR, Vice-President  
 EMIL GROSSMAN - - - - - Director of Advertising  
 Chicago Adv. Office - - - - - L. F. McCLURE, 919 No. Michigan Ave.  
 Publication Office - - - - - 404 N. Wesley Avenue, Mount Morris, Ill.  
 Editorial and General Offices - - - 99-101 Hudson St., New York, N. Y.  
 London Agent: HACHETTE & CIE., 16-17 King William St., Charing Cross, W.C.2  
 Paris Agent: HACHETTE & CIE., 111 Rue Reaumur  
 Australian Agents: MCGILL'S AGENCY, 179 Elizabeth St., Melbourne

**SHORT-WAVE CRAFT**—Monthly. Entered as second class matter May 7, 1930, at the post office at Mount Morris, Illinois, under the act of March 3, 1879. Trademarks and copyrights by permission of H. Gernsback, 99-101 Hudson St., N. Y. C. Text and illustrations of this magazine are copyrighted and must not be reproduced without permission. **SHORT WAVE CRAFT** is published on the 1st of every month. Twelve numbers per year. Subscription price is \$2.50 a year in the United States and possessions. Canada and foreign countries, \$3.00 a year. Single copies 25c. Address all contributions for publication to Editor, **SHORT WAVE CRAFT**, 99-101 Hudson St., New York, N. Y. Publishers are not responsible for lost manuscripts. Contributions cannot be returned unless authors remit full postage. **SHORT WAVE CRAFT** is for sale at all principal newsstands in the United States and Canada. European agents: Brentano's, London and Paris. Printed in U. S. A. Make all subscription checks payable to Popular Book Corporation.



# OPPORTUNITIES are many for the Radio Trained Man

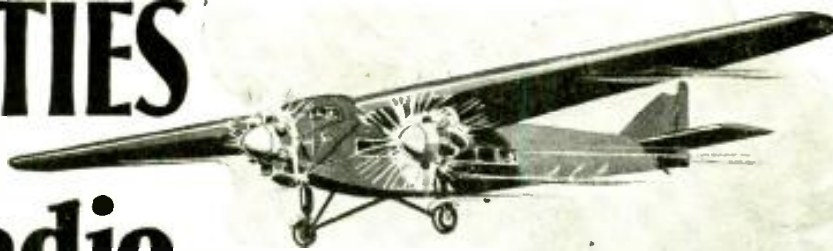

Don't be an untrained man. Let me show you how to get your start in Radio—the fastest growing, livest money-making game on earth.

## Jobs Leading to Salaries of \$35 a Week and Up

Prepare for jobs as Designer, Inspector and Tester—as Radio Salesman and in Service and Installation Work—or for work in a Broadcasting Station—as Wireless Operator on a Ship or Airplane, or in Talking Picture or Sound Work—HUNDREDS OF OPPORTUNITIES for a real future in Radio!

## Ten Weeks of Shop Training Pay Your Tuition After Graduation

We don't teach by book study. We train you on a great outlay of Radio, Television and Sound equipment—on scores of modern Radio Receivers, huge Broadcasting equipment, Television apparatus, Talking Picture and Sound Reproduction equipment, Code Practice equipment, etc. You don't need advanced education or previous experience. We give you—RIGHT HERE IN THE COYNE SHOPS—the actual practice and experience you'll need for your start in this great field. And because we cut out all useless theory and only give that which is necessary you get a practical training in 10 weeks.

# TELEVISION *and* TALKING PICTURES

And Television is already here! Soon there'll be a demand for THOUSANDS of TELEVISION EXPERTS! The man who learns Television now can have a great future in this great new field. Get in on the ground-floor of this amazing new Radio development! Come to COYNE and learn Television as it should be learned on Television equipment. Talking Picture and Public Address Systems offer opportunities to the Trained Radio Man. Here is a great new Radio field just beginning to grow! Prepare NOW for these wonderful opportunities! Learn Radio Sound Work at COYNE on actual Talking Picture and Sound Reproduction equipment.

## PAY FOR YOUR TRAINING After You Graduate

I am making an offer that no other school has dared to do. I mean exactly what I say. You can get a complete training by the world's oldest and largest Practical Radio School and I'll finance your Tuition. You won't have to start paying me back in small, monthly payments until 2 months after your required training period is over. I consider the fellow who is ambitious enough to want to get ahead by taking my Training, worthy of my help. MAIL THE COUPON BELOW, and you can prove to me that you are willing to spend just TEN WEEKS in the Coyne Training Shops Learning RADIO. Then, I'll tell you how I finance your Tuition—give you your complete Training and let you pay me back later.

I've got enough confidence in ambitious fellows and in my methods to give them the training they need and let them pay me back after they have completed their training.

### ELECTRIC REFRIGERATION AIR CONDITIONING

To assure your thorough preparation for a prosperous future, I include—at no extra cost—a course in Electric Refrigeration and Air Conditioning, taught you by personal instruction and actual work on latest-type equipment.

### ALL PRACTICAL WORK At COYNE in Chicago

ALL ACTUAL, PRACTICAL WORK. You build radio sets, install and service them. You actually operate great Broadcasting equipment. You construct Television Receiving Sets and actually transmit your own Television programs over our Television equip-

ment. You work on real Talking Picture machines and Sound equipment. You learn Wireless Operating on Actual Code Practice apparatus. We don't waste time on useless theory. We give you the practical training you'll need—in 10 short, pleasant weeks.

### MANY EARN WHILE LEARNING

You get Free Employment Service for Life. And don't let lack of money stop you—my plan makes it possible to get Coyne training with very little money. Many of our students make all or a good part of their living expenses while going to school and if you should need this help just write to me. Coyne is 36 years old. Coyne Training is tested—proved beyond all doubt. You can find out everything absolutely free. Just mail coupon for my big free book!

H. C. Lewis, Pres. RADIO DIVISION Founded 1899

## Coyne Electrical School

500 S. Paulina St., Dept. 45-2K, Chicago, Ill.

Mail Coupon Today for All the Facts

H. C. LEWIS, President

Radio Division, Coyne Electrical School

500 S. Paulina St., Dept. 45-2K, Chicago, Ill.

Dear Mr. Lewis:—Send me your Big Free Radio Book, and all details of your Special Offer, including Electric Refrigeration, Air Conditioning courses and your "Pay After Graduation" offer.

Name \_\_\_\_\_

Address \_\_\_\_\_

City \_\_\_\_\_ State \_\_\_\_\_



# The 6 Best Radio Books

We herewith present the six most important books in radio. These volumes have been selected after an exhaustive study of the foremost radio books published today. They represent the finest in radio books, and offer a variety of information on the subject.  
**WE PUBLISH NO CATALOG**, and ask you to please order from this page. Prompt shipments of all books will be made

to you directly from the publishers. We act only as a clearing house for a number of radio publishers, and **OUR PRICES ARE AS LOW OR LOWER THAN WILL BE FOUND ANYWHERE**. Remit by money order or certified check. Register all letters which contain cash.

**THESE BOOKS ARE ALSO OUR 6 BEST SELLERS.**



**The Radio Amateur's Handbook**  
 (New Revised Edition)  
 By **A. FREDERICK COLLINS**  
 Cloth covers, size 5 1/2 x 7 1/2", 394 pages,  
 116 illustrations.  
 This standard book on radio appeared among the first and has been continually reprinted and revised, not only to meet demand, but also to present constantly a work that is always up-to-date.  
 The book is almost entirely new in contents. Here are the important chapters: How to Begin Radio; Transmitting and Receiving; Telegraph and Electrical Tuning; Aerial, Simple Work; Mechanical and Electrical Receiver; Electricity; Simple Work; Mechanical and Electrical Receiver; A Simple Vacuum Tube Receiver; Short-Wave Receiver; The Amplification of the Hammarlund; Phonograph Amplifier; The Receiver in Radio Tubes; Operation of Vacuum Tubes; Developments in Radio Tubes; Use of Waveometers; Radio Transmitters; Construction and Use of Waveometers; Call and Its Use; Ultra-Short Waves; Appendix.  
 Your Price: **\$1.97**

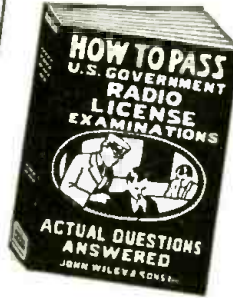

**How to Pass U. S. Government Radio License Examinations**  
 By **R. L. DUNCAN** and **C. E. DREW**  
 Flexible covers, size 9 1/2 x 7", 170 pages,  
 92 illustrations.  
 This is the most important book on the subject ever written. It gives every conceivable angle which will help you to pass a radio license examination successfully.  
 Here are the contents: Standard Regulations Governing the Issuance of Radio Operator Licenses; Commercial License; Radio License; Storage Batteries; Commercial Motors and Transmitters; Radio Receiving Apparatus; Apparatus; Radio Lanes and Regulations; Apparatus; taking an examination for the rank of an amateur; he thoroughly conversant with the theory that he contemplates in radio reception and transmission but also he must be distinguished with the practical considerations in connection with commercial apparatus which immediately only in his theory.  
 "How to Pass U. S. Government Radio License Examinations (Second Edition)" is the only publication which gives exactly this information in the most concise and practical form. It is a practical book on commercial radio practice.  
 Your Price: **\$1.89**

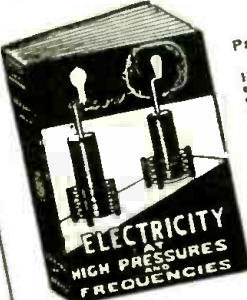

**Electricity at High Pressures and Frequencies**  
 and Frequencies  
 By **HENRY L. TRANSTROM**  
 Paper covers, size 5 1/2 x 7 1/2 inches, 141 illustrations, 266 pages.  
 High pressure and frequency phenomena in electric circuits constitute a field of activity quite foreign to most students and practitioners of radio and electricity. The amazing manner in which conductors become apparent insulators, and insulators become alternating conductors, constitute a section of high voltage and high frequency which is not only in the standard work on the subject, but also a field of study which is both instructive and remunerative.  
 In this standard work on the subject the author clearly distinguishes the line between high voltage and high frequency without recourse to mathematical derivations. A discussion of the fundamentals of high-voltage, high-frequency circuits, including Tesla and Oudin apparatus, is followed by descriptions of every type of generating equipment, including Tesla and Oudin apparatus, which the man who wishes to duplicate the results described by the author. Myriad types of apparatus are illustrated and described. This book is recommended to the earnest student of radio and electricity.  
 Your Price: **\$1.89**

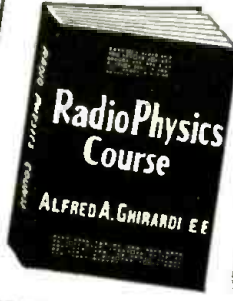

**Radio Physics Course**  
 (Second enlarged edition)  
 By **ALFRED A. GHIRARDI**  
 Cloth covers, size 7 1/2 x 9 1/2", 992 pages, 552 illustrations, numerous tables.  
 The finest and most popular book on radio and electricity. Each subject is clearly discussed, with the aid of dozens of excellent drawings.  
 Here are the chapters in this revised edition: Radio Broadcasting System; Sound, Speech and Music on Related Electrical Units and Circuits; Magnetism and Electro-Magnetic Currents; Inductance and Induction; Condensers and Capacitors; Radio Transmitters; Elementary Measuring Instruments; Radio Receiver; Elementary Study of the Vacuum Tube; Superheterodyne Receiver; Audio Amplifier; Loud Speakers; Automobile and Aircraft Receivers; Short-Wave Reception; Television; Amplifier; Servicing; Sound Motion Pictures; Appendix. Testing and Your Price: **\$3.89**



**Drake's Cyclopaedia of Radio and Electronics**  
 and Electronics  
 (Fifth Edition)  
 By **H. P. MANLY**  
 Cloth covers, size 6 1/2 x 9 inches, 1048 pages, 1178 illustrations, 130 tables, 105 graphs.  
 The new 1935 edition of that now very well-known volume, "Drake's Cyclopaedia of Radio and Electronics," is now available. Included in this latest edition are further sound valuable reference data on public address cells, also up-to-date pictures, television, and phonograph, and reception. Information on radio transmission and the great number of the new tubes and the new circuits are treated in the dark available form. Every technical detail is treated in the most complete manner. Every reference need be in the dark of topics covered by the reader no longer need be in the dark concerning any point.  
 The key note today is speed and accuracy, and "Drake's Cyclopaedia of Radio and Electronics" is the most comprehensive work available. In the finest book for the technician who wants to get accurate technical information in the shortest possible time.  
 Your Price: **\$4.88**

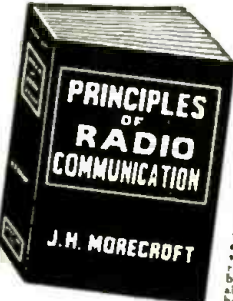

**Principles of Radio Communication**  
 By **J. H. MORECROFT**, Professor of Electrical Engineering, Columbia University  
 Cloth covers, size 9 1/2 x 6", 988 pages, profusely illustrated.  
 This book is the radio classic by the dean of radio. It covers the art of radio as no other book does.  
 The chapters are as follows: Fundamental Ideas and Laws; Resistance-Inductance-Capacitance-Shielding; Laws of Oscillation Circuits; General View of Radio Communication; Spark Telegraphy; Vacuum Tubes and Their Operation in Typical Circuits; Continuous-Wave Telegraphy; Radio Telegraphy; Antennae and Radiation Amplifiers.  
 Perhaps the most important single recommendation which we can make for this volume is the recommendation which is called in that it is the new 1935 edition. In other radio publications the most valuable single book in the entire field of radio has been brought right to the front. This book on the subject covering the broad field of radio theory both receiving and transmitting.  
 Your Price: **\$7.35**

## NEW LOW PRICED RADIO BOOKS

- Here are 13 new, up-to-date books on every conceivable radio subject, just published. Modern in every sense. All books uniform from 64 to 72 pages; 50 to 120 illustrations. All books are written by well-known radio authors. Order all your books by number.
- |  |  |  |
|--|--|--|
| No. 1 <b>RADIO SET ANALYZERS</b> , by L. Van Der Niel            | No. 6 <b>BRINGING ELECTRIC (RADIO) SETS UP-TO-DATE</b> , by Clifford E. Denton | No. 11 <b>POINT-TO-POINT RESISTANCE MEASUREMENTS</b> , by Clifford E. Denton.                    |
| No. 2 <b>MODERN RADIO VACUUM TUBES</b> , by Robert Hertzberg     | No. 7 <b>RADIO KINKS AND WRINKLES</b> (for experimenters), by C. W. Palmer     | No. 12 <b>PUBLIC ADDRESS INSTALLATION AND SERVICE</b> , by Jos. T. Bernsley.                     |
| No. 3 <b>THE SUPERHETERODYNE BOOK</b> , by Clyde J. Fitch        | No. 8 <b>RADIO QUESTIONS AND ANSWERS</b> , by R. D. Washburne                  | No. 13 <b>HOW TO BUILD AND OPERATE SHORT WAVE RECEIVERS</b> , by the Editors of SHORT WAVE CRAFT |
| No. 4 <b>MODERN RADIO HOOK-UPS</b> , by R. D. Washburne          | No. 9 <b>AUTOMOBILE RADIO AND SERVICING</b> , by Louis Martin                  | No. 14 <b>HOW TO BECOME AN AMATEUR RADIO OPERATOR</b> , by M. F. Eddy. <b>\$ .45</b>             |
| No. 5 <b>HOW TO BECOME A RADIO SERVICE MAN</b> , by Louis Martin | No. 10 <b>HOME RECORDING AND ALL ABOUT IT</b> , by George J. Saliba.           | Price Prepaid Each Book..... <b>\$ 6.00</b>  |
|  |  | Price Prepaid for all 14 Books..... <b>\$ 6.00</b>   |

**HOW TO ORDER**  
 We cannot ship C. O. D. Our prices are net, as shown. Some of the books sent prepaid (in U. S. only). Those that are not thus listed will be shipped by express collect if sufficient postage is not included by you.

**RADIO PUBLICATIONS**  
 97 Hudson St., New York City

**ORDER DIRECT FROM THIS PAGE**

Please mention SHORT WAVE CRAFT when writing advertisers



# Short Wave Aerials

An Editorial By HUGO GERNSBACK

● ONE of the things which puzzles most beginners in short waves and those who buy *all-wave* sets is no doubt the ever-recurring bugaboo of short-wave aerials. In broadcasting in the higher wavelengths, that is, from 200 to 545 meters, experience has taught that a 100-ft. aerial, no matter how you put it up, usually gives satisfactory results. In short waves, the situation at the present time is radically different because of the *interference*, due mainly to man-made static such as that caused by sparking of electric motors, automobile ignition, and other electrical appliances which abound all around us and which often make life miserable for the short-wave listener.

In general practice, it has been found that in order to get decent reception it is necessary to elevate the aerial *above* the source of the noise. Usually this is accomplished by means of a twisted pair of wires or a *transposition lead-in*, with transposition blocks, with two separate aerials running in two opposite directions on the roof of the house or building as far above all obstructions as feasible. This, however, is only an average solution. In many localities this scheme works out well, in others it does not.

In the first place, as has often been pointed out here, there is such a thing as *location* in short waves. Certain localities are better than others, and what holds good for one locality is not good for another. Experiment is the only thing that can tell you whether you are in a good location for short-wave reception or not. If you are in a good location, you will not have much trouble. If you are not, then you must take other means to overcome, not only the *noise-level*, but also poor reception conditions which may be purely local, and it is here where extra work must be performed in order to get good reception. The technical aspects of this problem have been pointed out in a special article on *aerials* which appears in this issue.

We know, however, as yet, mighty little about short waves in general and their behavior in different localities. Much research work remains to be done, and today it is possible only to speak in generalities. There is no such thing as hard and fast rules in ALL instances. For instance, people all over the country get exceptional results even if a regulation aerial is not used. Thus, for instance, those who have very sensitive multi-tube sets get excellent *foreign* reception, by using just 6 or 8 feet of wire which serves as an aerial, even when it is an *indoor* aerial. This, of course, if the building is not of steel, just an ordinary stone or wooden dwelling. Indeed, many short-wave listeners have obtained amazing distance records by using only *indoor* aerials and many have found by experience that the *shorter the aerial the less the man-made static noise-level!*

Then, again, we have that class of listeners who do not use a regulation aerial nor indeed any aerial at all. Some profess to have received excellent results without using any

aerial at all and use instead the *ground* only—and still good reception is realized! Others use *bedsprings* as aerials, still others get fine results by the use of a metallic window screen; some experimenters have tried various lead-ins using only a *twisted lamp cord* and instead of using the two conductors they use only one. Others use the one conductor and *ground* the other, either directly or by means of a variable condenser.

Still others seem to have gotten worth-while results by using a transposition aerial or twisted lead-in up to the roof and then using a capacity at both ends, such as a few square feet of chicken wire.

As you will note from this, there are today no hard and fast rules as to short-wave aerials, and the very system that brings marvelous results for one will be roundly condemned by the next one as totally unfit. This is in the nature of things as they are today; until we shall have more exact information on the behavior of short waves in free space, we will have to use whatever makeshift we can and get along on what we have.

There is, however, one point which most short-wave listeners overlook, and that is the importance of a *good* ground, as far as short-wave reception is concerned.

Too often, particularly when an A.C. or D.C. set is used, many people think that they can dispense with the ground entirely. Of course, you can get reception without any ground, using the lighting mains as a ground itself. This, however, has been found to be bad practice in practically all cases. A good cold water pipe supply line is still one of the best grounds if a good ground clamp is used, which makes perfect connection at all times. This is the rule when you live in an apartment house. A ground connection to the gas mains or steam radiators is to be condemned for all short-wave installations.

But if you live in a house and have access to the actual ground or earth, the chances are that your reception will be much enhanced, and that your interference also will be reduced if you use a good ground, such as by burying a 20-foot section of pipe about 4 to 6 feet in the moist earth.

It should be noted here that shielding of the lead-in is quite important, particularly when you live in a city or where there is much incidental man-made static on or near the premises. There should be a metallic grounded shield from the binding post of the set up to the first transposition block, or if you use a twisted pair of wires, then the shielding should extend from the binding post out through the window for several feet into the air.

This shield should, of course, be grounded for best results. Often such a grounded aerial shield will actually perform wonders in cutting down man-made static and other parasitic noises, and reception in most cases will improve.

---

**SHORT WAVE CRAFT IS PUBLISHED ON THE 1st OF EVERY MONTH**

This is the April, 1935, Issue—Vol. V, No. 12. The Next Issue Comes Out April 1

---

Editorial and Advertising Offices, 99-101 Hudson Street, New York City



# New STUNTS With Short Waves

By DR. P. HATSCHEK, Berlin

Among the newest accomplishments of short waves we have "crustless" cooking—the production of artificial fever for the treatment of various human ailments—the preservation of "fresh" vegetables and fruit—making toast by short waves, et cetera.

● FOR several years now we have heard unfounded prophecies that the evolution of the radio industry had about reached a definite development, or at least so near to the point of near-perfection that we would have to become resigned to a substantially diminished market, particularly in the case of radio receiving sets. Recent developments actually point in the opposite direction. The late German radio shows have shown such notable improvements and have brought so many new ideas into the radio industry, that there has been a tendency to exchange old sets for newer and more up-to-date equipment. This is particularly true now with the development of inexpensive *single-circuit* receivers with fixed selection and dynamic speakers, superheterodynes with only three tubes, marked acoustical improvements and last—but by no means least—the new *short-wave* receivers. Although a wide variety of possibil-

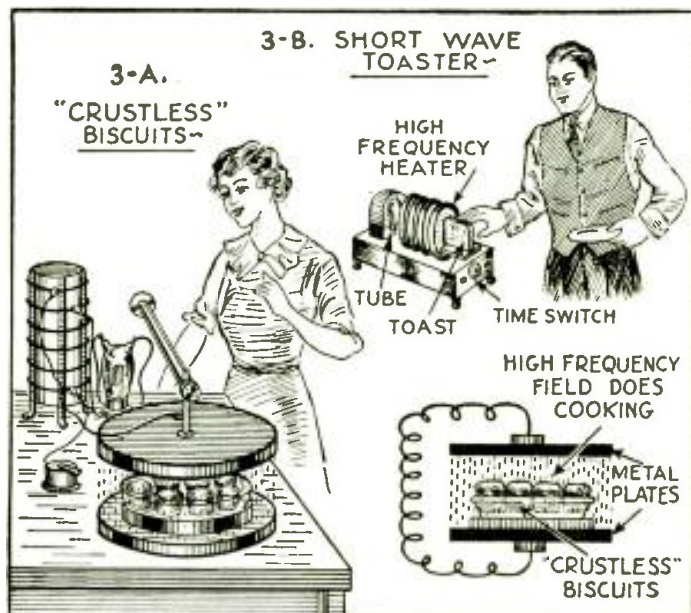

Tomorrow we shall be cooking our biscuits and making our toast by short waves as the picture shows. Biscuits for instance, when cooked in a short wave field are "crust-less."

ities have opened before the industry, it is perhaps not premature to ask whether the industry will not definitely concentrate upon the exploitation of only a few of these new developments. We are, at present, merely indicating the possibilities of these new fields, so that as soon as the apparatus has emerged from the laboratory stage, manufacturers will be able to place it in production forthwith.

### "Crust-less" Baking Tomorrow by Short Waves

One of the most interesting and promising new fields before the radio industry is that of short-wave generation for special purposes, particularly at the present time in the ultra-short-wave range of 3 to 15 meters. If waves of this range pass through a circuit containing a condenser of appreciable capacity and with a considerable distance between the plates, a variety of remarkable phenomena occur with regard to objects (condenser dielectrics) introduced between the plates. Prof. Esau has conducted an interesting experiment in which he placed a paraffin-water emulsion between the plates. The effect of the short waves boiled the water out of the emulsion although its temperature was only 50° to 80° Centigrade; in other words, 20° to 50° below the boiling point of water.

Therapeutic (medical) applications of this phenomenon are conceivable; for instance, replacing the emulsion by some infected portion of a human organism. Certain pathogenic constituents of the blood could thus be eliminated, while the body temperature would experience no dangerous increase. This is the principle upon which the modern "fever-machines" are based. It is already possible to apply this short-wave apparatus properly specific as to their bactericidal effect by regulating the wavelengths.

Bacteria are also responsible for the spoiling of "fresh" foods; since modern hygienic science disapproves of the sterilization of foods by boiling, etc., because of the destruction of important vitamins, it seems that the way is being opened to the utilization of *short waves* in this case also. The almost indefinite preservation of foods without the elimination of their vitamin content could thus be effected by simply exposing the foods to the correct type (frequency) of short-wave radiation. Somewhere in Holland a Robert Pape is working on this problem at present. In one of his laboratories there are a number of "fresh" vegetables, such as cauliflower, tomatoes and lettuce, on a table in open air, which have remained there since 1930 *without losing any of their freshness*; they have constantly been exposed to short-wave radiation.

As can readily be seen, the step from a laboratory apparatus to a "household implement" is not such a great one to take. Moreover, such an apparatus would be superior to our present refrigerators and certainly could hardly be more expensive to operate. Furthermore, there is the possibility of treating truly immense quantities of foods, quantities impossible to treat by present methods. Gigantic warehouses or water reservoirs could easily be kept in condition by using opposite walls as condenser plates. As yet these special generators are manufactured only for therapeutic purposes, especially those (Continued on page 747)

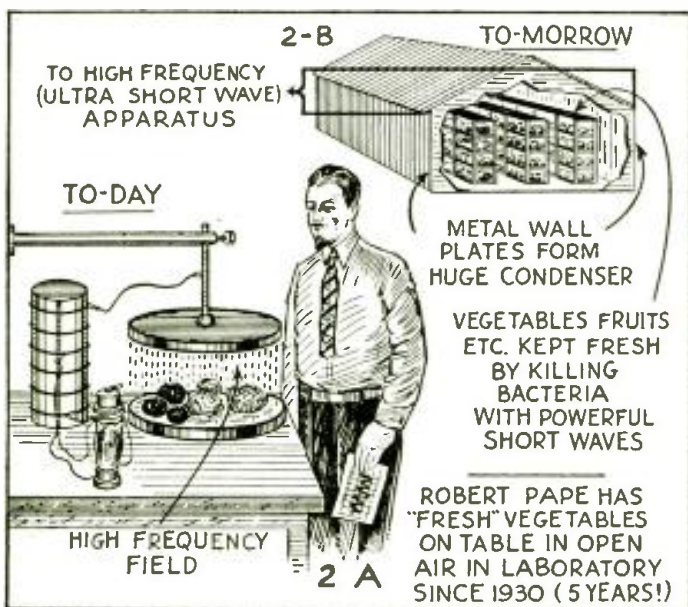

A European expert has in his laboratory specimens of "fresh" vegetables such as cauliflower, tomatoes, and lettuce, which he has kept on a table in "open air," since 1930, by the aid of short-wave treatments. Tomorrow undoubtedly we shall have short waves applied to large "preserving centers" in which many tons of vegetables and fruits will be treated daily to preserve them.



# Amelia Earhart's Short-Wave Radio Never Failed

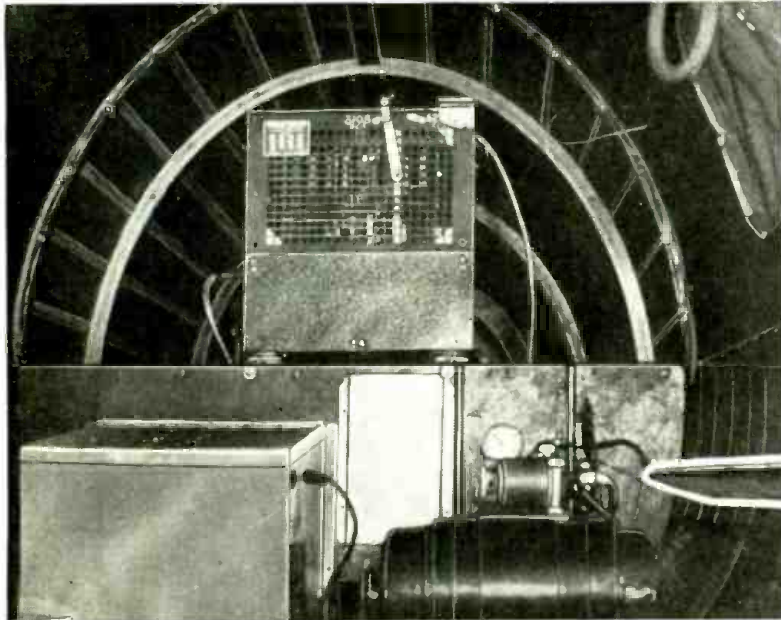

Above—The radio transmitting and receiving apparatus installed in Miss Earhart's plane. Right—Miss Earhart and Paul Mantz, technical director of her transpacific flight. Lower photo—The famous red Lockheed plane.

"W" indicates weight at the end of the trailing wire antenna which is lowered as required.

● SPECIAL and extremely efficient radio sending and receiving apparatus was installed in Miss Amelia Earhart's plane before it left Burbank, where, at the Union Air Terminal, exhaustive tests were made before the Lockheed was shipped to the Hawaiian Islands on the Matson Liner, Lur-

line. In addition to a receiving set for beam flying, the plane carried a special transport airplane transmitter manufactured by Western Electric. Night frequency was 3105 kc., day, 6210 (96.66 and 48.28 meters). Power generated from an automobile-type generator (Continued on page 754)

## Maps and Photos Sent by New Facsimile System

● A NEW radio facsimile system which reproduces entire messages, maps and pictures directly on ordinary paper at the rate of a full letter-sized sheet every 8 minutes, was

described by Charles J. Young, research engineer of the RCA Victor Company, to members of the Institute of Radio Engineers recently.

While Mr. Young emphasized that it is premature to attempt to evaluate all of the practical uses to which the new development might be put, he suggested that such a simplified system could be used to flash messages in their entirety, from city to city, exactly as written by the sender, to supplant the present method of sending such messages, letter by letter, in the comparatively laborious Morse code. He pointed out that the new facsimile system should prove useful in police and crime detection work. Fingerprints, identifying photographs and other useful information could be exchanged by police departments to aid in the apprehension of criminals. He also described a series of successful experiments conducted between the shore and ships at sea, in which complete weather maps were prepared by observers and sent to the vessels at frequent intervals to aid navigation.

The recorder system developed by Mr. Young in the RCA Victor laboratories dispenses with the cumbersome processing, or photo developing required by other facsimile systems, by utilizing ordinary carbon paper (Continued on page 744)



Photos, maps and complete telegraph messages can now be successfully transmitted and received at high speed, by means of the new facsimile recorder here shown.

## Clubs Hold Joint Meeting Over 10,000 Miles by S-W's

● SNOW driving against the antenna of the General Electric short-wave station W2XAF early one morning last week did create some static, but did not prevent the convening of the first joint meeting to be held between the Schenectady Amateur Radio Association and the Zero Beat Amateur Radio Club of Sydney, Australia. It was also the first time on record that two groups of Hams anywhere had talked back and forth with an (Continued on page 744)



# Teaching by SHORT • WAVES

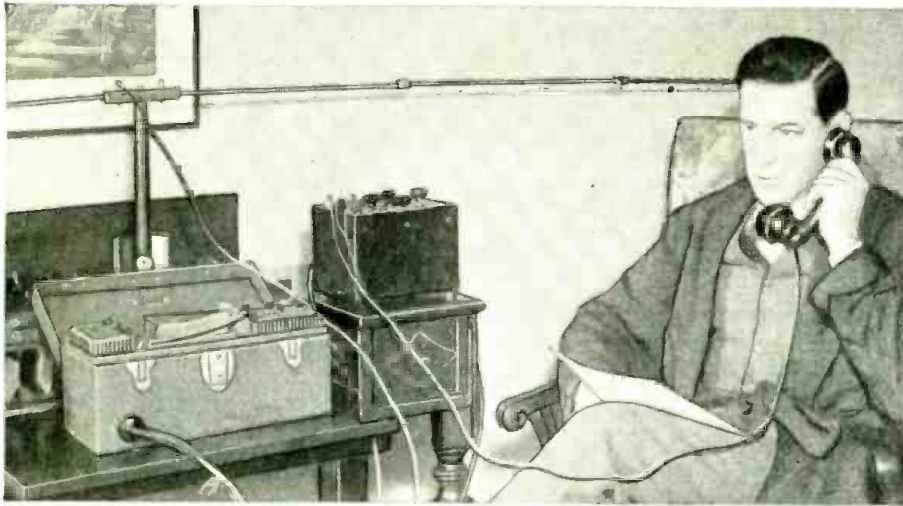

Short waves recently enabled Prof. C. C. Clark of New York University to conduct classes from his home. The class, located a quarter of a mile from the Professor's home, thanks to the two-way ultra-short wave National Transceivers, was also able to ask questions of the Professor, to which he at once responded.

Photos at right show what is probably the first class in history listening to a science lecture by Prof. Clark, whose voice is being received over ultra-short waves. Lawrence M. Cockaday, lecturer, has charge of the controls.

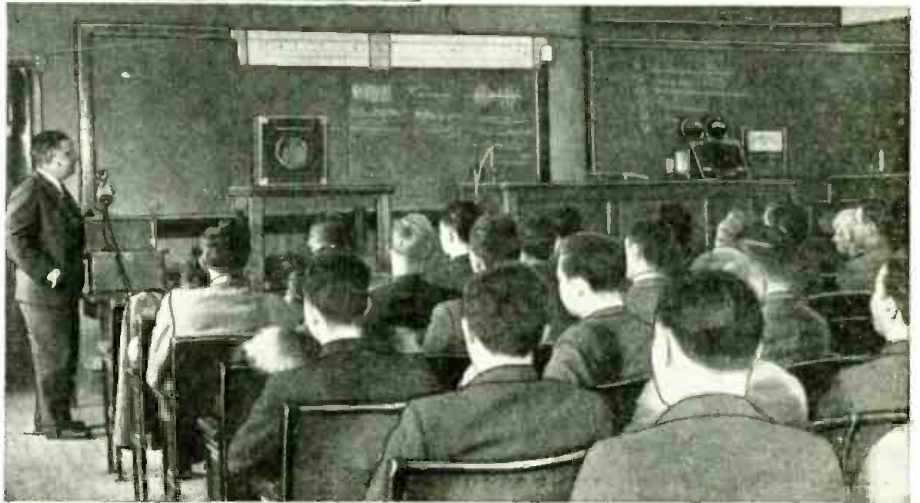

The editors have, several times in the past few years, written special articles accompanied by artists' drawings on the subject of teaching college courses by short waves. Here at last is concrete evidence that we shall shortly find short waves carrying college lectures into every home in the land.

• NEW YORK UNIVERSITY has started the ball rolling when it comes to getting our college education via *short waves*. Recently Prof. C. C. Clark of the University conducted a class in science from his home. In this very interesting and important experiment which was carried out on 5-meter waves, two National *transceivers* carried the speech waves between Prof. Clark and the class, located a quarter of a mile away from his residence. Dr. Clark is believed to be the first educator to have addressed his classes from his home by means of ultra-short waves. Dr. Clark is Chairman of the Science Department of New York University, School of Commerce, and he expressed himself as very well pleased with the results. The Professor's voice was

heard clearly and loudly by the whole class as it boomed forth from the loudspeaker at the head of the classroom. The students in turn had the thrilling experience of asking Prof. Clark questions and he in turn answered them over the short-wave transceiver set-up.

One of the angles brought out in this interesting and successful demonstration of the use of ultra-short waves in college teaching, is that the Professor can now address a very large number of students or several classrooms simultaneously, the transceivers, or possibly separate short-wave transmitters and receivers, requiring only a small rod a few feet long as an antenna, no ground connection being required for short range transmission. These midget sets, which were used in the New York University tests, were designed by James Millen of Malden, Mass. They are completely self-contained, operating from batteries contained within the carrying case and use ordinary French-type hand-mikes for sending and receiving the radiophone messages.

In these experiments the transceivers were connected to small telescopic doublet antennas, these doublets comprising two sets of telescopic metal tubes mounted in a central insulated sleeve or support. One of these antennas can be seen just to the rear of the transceiver in the photo showing Prof. Clark lecturing from his home. Arthur H. Lynch, well-known designer of interference-preventing antennas, gave the students a description of the apparatus employed for transmitting the lecture from Prof. Clark's home.

The scene at left will be a commonplace one tomorrow, without a doubt, when television will be as indispensable to our every day home life as the radio program receiver is today. Television advertising will be a "brand-new art" which our advertising experts will have to develop and perfect in the near future.

### Television Lectures in Our Homes Tomorrow!

In a recent letter to the editors, Mr. J. Wesley Weeks suggested a very good idea, which will undoubtedly find a practical application tomorrow when perfected television is given to us by our research laboratories. As the illustration

(Continued on page 741)

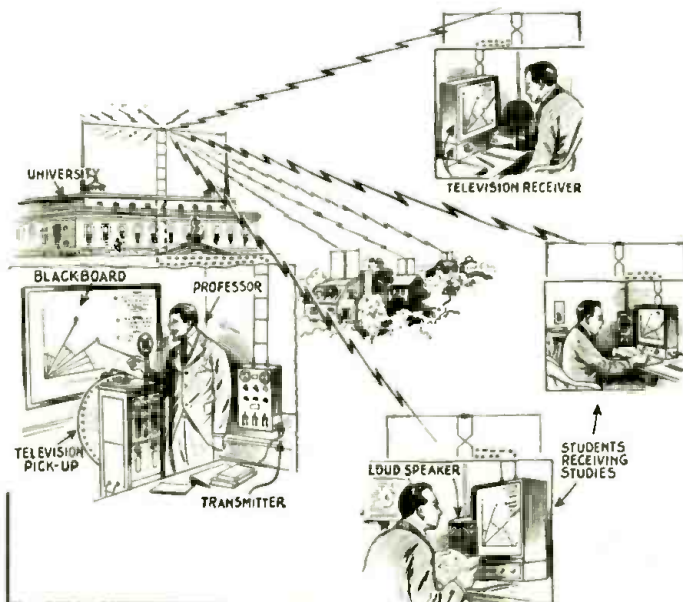





# Why Your SON Should Learn Radio—



## A Talk With "Dad"

By John T. Frye (W9EGV)

● HELLO there, DAD! I hope that you will not mind my calling you that; I am so used to hearing that boy of yours say "dad" that it seems to come rather natural. You see, I am the radio amateur with whom your kid has been spending most of his time lately. The boy tells me that you are none too enthusiastic about his new interest in radio; and, since I am chiefly responsible for his becoming interested in the game, I thought that I had better drop around and have a talk with you. If I cannot cause you to change your mind about Jack's new hobby, I shall have to try and undo the damage I have done. After all, he is your son; and it is your privilege to rear him as you see fit.

If you cling to your aversion for amateur radio, I do not think that you will have any trouble with Jack. He has a great deal of respect for your opinion. While he is all up in the air about becoming an amateur, if you say drop it, he will drop it. He reasons that if you do not want him to take up the hobby there must be something radically wrong with it.

By the way, just what are your reasons for not wanting him to go ahead with the game? Oh yes, I see. You are afraid that it will cost him too much money; that it will take his mind off his school studies; and that it will end up by his becoming a regular radio "nut." Well, those are good, hard business reasons such as I should expect from a business man like yourself. I shall attempt to answer them in the same businesslike manner.

### Author's First Transmitter Cost Less Than \$5.00

In the first place, let us take the matter of cost. You say that it will cost too much. Do you know that my first radio station, including both transmitter and receiver, was built for less than five dollars? Yet, with that little station, I consistently talked with other amateurs a thousand miles away! Surey, you do not consider five dollars an exhorbitant price to pay for a year's entertainment and instruction.

From another point of view, a thing costs too much only when the buyer pays more than it is worth. Let us take a glance at what this "amateur game" is going to do for your boy! Then we shall be in a better position to judge whether or not it will be worth the money he puts into it.

I always thought that that old "saw" about an idle mind being the Devil's workshop contained a good bit of common sense. Let me tell you a little incident that I saw the other evening.

The author discusses the many valuable things that the study of radio will do for young men.

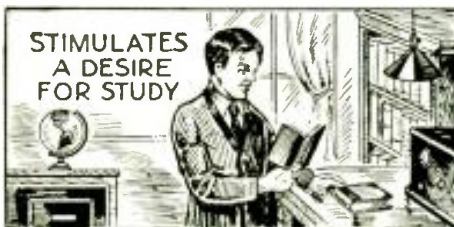

I dropped into the corner drug store for a soda, and while I was sitting there, two boys came in and stopped at the magazine rack. One of them made a grab for SHORT WAVE CRAFT and began to scan the pages avidly. The other loitered for some time without picking up any magazine; then, when he thought no one was watching him, he furtively snatched up one of those "rags" that specialize in pornographic pictures and smutty jokes. Which one of those boys would you rather have for a son? If amateur radio can give Jack something to keep his mind occupied, it will do him a service of incalculable value.

### "Ham" Radio Keeps Boy at Home!

Another thing that must be marked up to the credit of the amateur game is the fact that it keeps the boy at home, off the streets, and out of poolrooms. You might just as well face this fact: when your boy is home, he is under your influence; when he is away from home, you do not know whose influence he is under. There are too many boys who regard the ancestral roof-tree as merely a sort of refueling and rest station! I know several fathers who would consider almost any price a good investment if it would insure their son's presence around the house. Evenings are the best times for radio operation, and I am sure that you will discover Jack will spend the greater number of his evenings right here in the house if he becomes an amateur.

### Teaches Responsibility

Then, too, amateur radio is a great "teacher!" In the first place, it teaches responsibility. The amateur is licensed by the Federal government, and he is required to observe the rules and regulations of radio communication. He is made to realize that he is held strictly responsible for all the activities of his particular station. At the same time, the keeping of schedules and the handling of messages augment this feeling of responsibility. "Traffic handling" is a great instructor in punctuality, exactness, and dispatch.

One of the first things that Jack will learn is that he must use his head and his hands if he is going to do anything in the amateur game. Of the fifty thousand amateurs in the United States, no two of them are confronted with exactly the same problems. Radio, as does any modern science, demands the ability to reason clearly and logically. The building of a receiver, the ironing out of the "bugs" in a transmitter, and the erection of

(Continued on page 742)



# Which S-W AERIAL

● THERE is just one requirement for a good antenna, and that is "pickup." To get plenty of pickup we can put up an antenna several hundred feet long. But what we want is pickup at the precise frequency on which we are receiving. This is to obtain as much signal voltage for our detector as possible. We don't want an antenna that is reputed to have uniform pickup over a very wide range of frequencies. Because if we have such an antenna we are picking up noise over that whole range and feeding it to our receiver along with a very feeble amount of voltage which constitutes the station we are trying to receive. Thus it can be readily seen that there is every possibility of the noise exceeding the signal voltage. On the other hand, we may live in a neighborhood where there is a noise that peaks at a certain frequency, say 39 meters, and we are listening to the 49 or 31 meter broadcast stations. This will mean that our general coverage antenna is picking the noise up as well as the station while that particular station's frequency may be more or less free of noise!

### When Noise is Not Reduced

What to do about it? Someone will immediately suggest that we put up a "doublet." O.K.—but what good will that do, unless we take further precaution? Now no one has ever stated, at least we hope not, that a doublet reduced noise! The only conditions under which a doublet with transposed or twisted feeders does this is where the two flat-top sections of the antenna system are out of the field of the noise, the feeders or lead-ins not being sensitive

Short-wave antennas have always been the "buga-boo" of short-wave reception. The author in this article describes a method which provides a "tuned" antenna for practically all of the short-wave bands. There is no question that tuned antennas are the best of any type, providing the short-wave "Fan" wishes to go to the trouble of constructing and using the necessary extra equipment. A "tuned" antenna, besides boosting the strength of the incoming short-wave signal, tends to "reject" background noise.

to the noise, due to their extremely small field or pickup range. But a doublet of this kind will be of no use if the trouble we are having with noise is caused by an electric sign or some other instrument located several hundred feet or even a quarter of a mile away! We make no discrediting statements against some of the very fine antenna kits now being sold on the market. They are excellent for reducing noise that is originating somewhere near

the point where the lead-in is to be run. What we need is an antenna which is very sensitive to the particular frequency on which we are receiving and that discriminates against noise coming from adjacent wavelengths, the same as our receiver discriminates against other stations. We cannot at this time design such an antenna, but we can design one that will be sensitive at one particular frequency and provide enough signal voltage from the station to over-ride the noise level! This is nothing new, engineers in the short-wave transoceanic telephone service have been doing this for years! They have antennas that are resonant at the frequency of the station they wish to receive! We cannot put up several antennas and have them directional, so we must devise some sort of a tuning device which will permit us to "peak" our antennas, in other words tune them to the various wavelengths on which we wish to receive.

Some of our readers will undoubtedly be wondering why the loop aerial is not generally used for short-wave reception. The first reason is that a loop to be tuned through the short-wave bands would have to be too small to be of

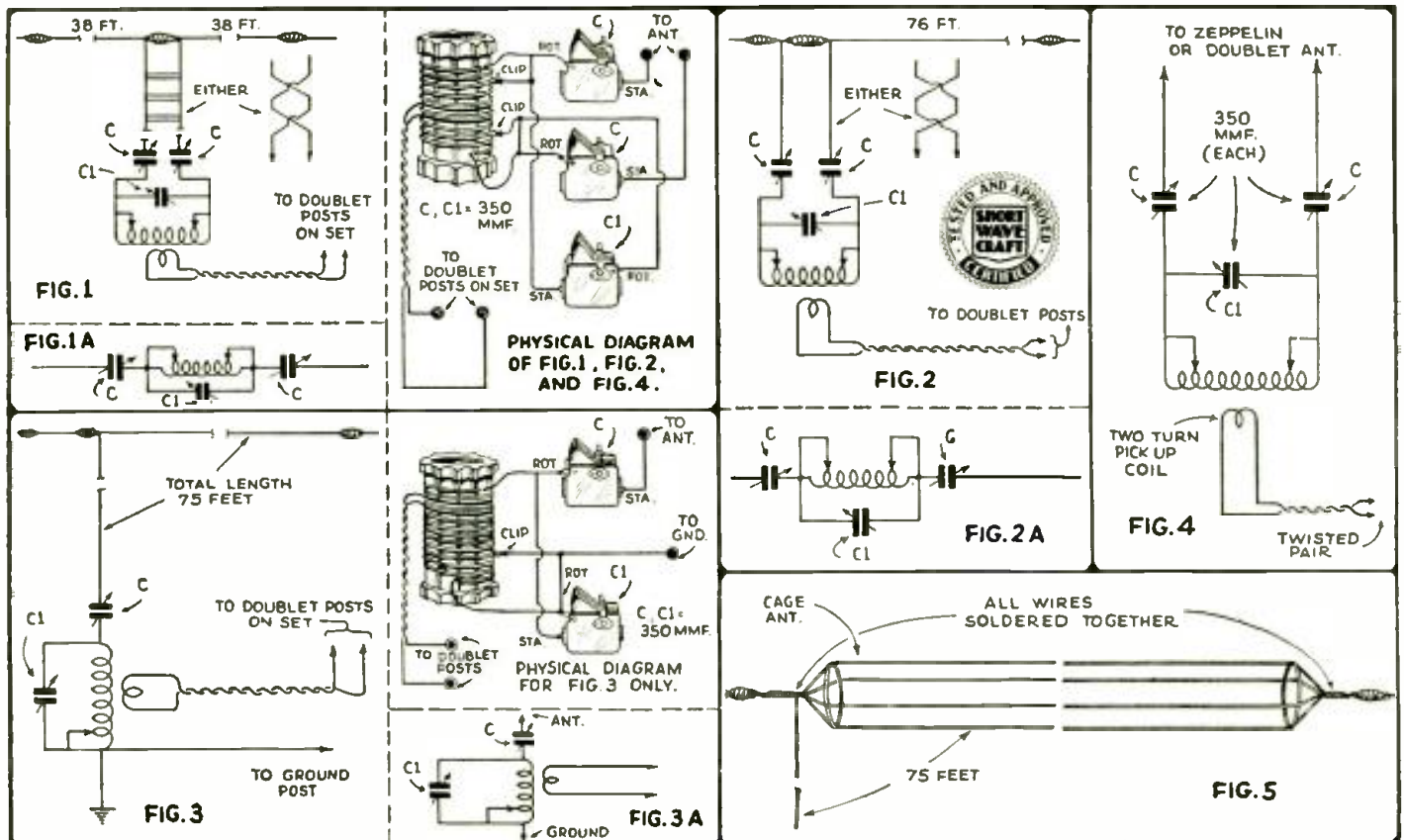

Here we present a complete set of drawings covering the various Short-Wave antenna systems described by Mr. Shuart.



# Is the Best?

By George W. Shuart, W2AMN

any practical value. However, it can be used just as a regular aerial if connected in the grid circuit of an R.F. amplifier. Such a diagram, together with an article explaining thoroughly the operation of such a loop, appeared in the August, 1933 issue of *SHORT WAVE CRAFT*. For those who are interested in experimenting along these lines, we suggest that they refer to the above-mentioned article.

## This "Impedance Matching" Business!

There is just one other point that should be made clear before we go any further and that is this "impedance matching" business. Considering "half-wave doublets" and their impedance, if you put up an antenna, that is of the doublet type, it will resonate at one particular frequency and at this frequency (meaning the lowest frequency at which it will resonate) it will be a half-wave doublet antenna and will have an impedance at the center of around 75 ohms. Now!—If you operate this antenna with a receiver tuned to some other frequency—then it will not be a half-wave doublet, in fact it is no longer a doublet. It's just a piece of wire cut at the center and not very effective except, as we said before, at the particular wavelength which is just twice the length of the antenna in meters. You can only expect this antenna to work well on *one wavelength, or an odd harmonic of that wavelength!* And on all other wavelengths you can look for a *loss* in signal strength.

This undoubtedly will bring to your mind cases where the doublet gives less volume on the stations than a plain antenna and ground. True, the noise level is *down*, but so is *the station!* This is because the ground and antenna combination is broader in response than the doublet, the doublet giving less volume because we are not operating it on its own "natural period." A doublet, being so much sharper than other types, is the worst one to use for general short-wave reception, *unless we make some arrangement for tuning it!*

## Doublet Should be Tuned!

We will probably hear plenty of "howls" as the result of the above statements, but nevertheless they are true and are *not* new ideas, as any good book on antennas will reveal. Why all this discussion? Because plenty of fans have put up these antennas *not to reduce noise*, but to get *better signals* and they have been disappointed.

In Figs. 1, 2, and 3 we find very practical methods of

---

Commercial "long distance" receiving stations tune their antennas to obtain maximum efficiency! The short-wave experimenter can now tune his antenna with the simple device described in this article.

---

tuning antennas in order to bring up the strength of the stations, so that they will at least be "in the running" with the *noise!* In Fig. 1 we have a *real* doublet, the resonant period of which can be adjusted by the three condensers and the coil. To make it clear we consider it as one single wire, as in Fig. 1a, its length can be shortened by reducing the capacity of condensers "C." To make it work as an antenna longer than it really is, we short condensers "C" and use condenser "C1" and the coil which is equipped with a clip to "short out" the unwanted turns. Now if we fold it as shown in Fig. 1, the fields of the lead-in section will cancel and reduce the danger of picking up noise. In Fig. 2 we have the same system but there is only one flat section and it is not split. The flat section, however, is the same length as the whole of the flat top of the doublet. This antenna is commonly called the "Zepp," because it was originally designed for use on Zeppelins. The feeders should be spaced with 1½ to 2-inch ceramic insulators; or

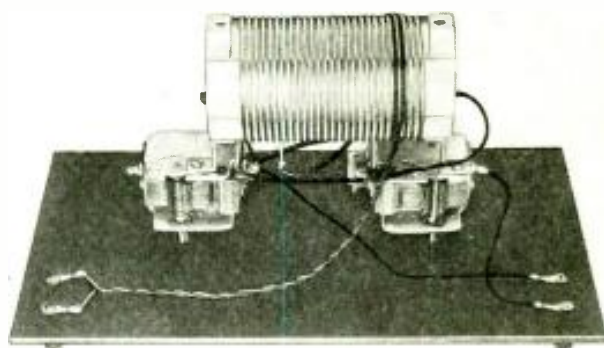
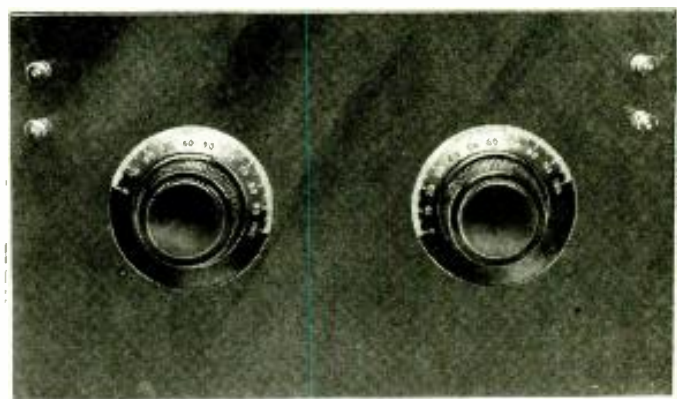

Front and rear views of the antenna tuning device described in this article.

they can be transposed with transposition blocks. The two condensers marked "C" should be varied simultaneously, but the ratio between the two should be varied slightly by either advancing or retarding one or the other in order to obtain the least background noise. These condensers, besides tuning the system, can be used as "phasing" adjustments to bring the currents in each feeder just opposite in order that the field will cancel and if they are run in the field of some electrical disturbance they will tend to reject the noise. The above holds true for both Figs. 1 and 2.

## How to Build "Tuner" for Doublet Antenna

Figure 3 shows just a single wire which is equipped with a coil and two condensers. Condenser "C" reduces the effective length of the wire, and "C2," together with the coil, lengthens it. This antenna is just as good as the other two if one is not going to run the wire near any electric wires, etc.

The coil used in the universal antenna tuner is wound on a National steatite threaded coil form and has 26 turns of No. 12 or 14 bare, tinned copper wire. It will be necessary to make a small clip to fit the wire for varying the number of turns. The receiver pickup coil has two turns of cotton-covered wire (No. 18 hookup wire will do) interwound with the bare wire. For antennas in Figs. 1 and 2 it should be placed exactly in the center of the large coil; for Fig. 3, it should be placed four or five turns from the antenna end of the coil. Only one "shorting" clip is needed for the antenna in Fig. 3, while two are needed for those of Figs. 1 and 2. Condensers "C" and "C1" have a capacity of .00035 mf. and are midget broadcast condensers.

Do not use twisted pair or similarly close-spaced wire for the feeders, because the high distributed capacity of this wire makes it difficult to tune.

Tuning this type of antenna coupler is quite simple after the initial adjustments for each wave band have been determined. The number of turns used in the coil for the antennas shown in Figs. 1 and 2 will depend upon the length of the feeders or lead-ins. The feeders of Fig. 1 should be between 55 and 65 feet long for best results. For the "Zepp" the feeders should be no less than 35 feet long and can be as long as 75 feet. This system is not as flexible

(Continued on page 755)



# A GOOD 3-

3-Tube sets are very popular and here is a super-Het, right up to the minute, in which 3 tubes do the work of 5. Regenerative I.F. is a feature and band-spread tuning is also provided. This set works on 110 volts, 60 cycles A.C. A dandy set for the short-wave "Fan."

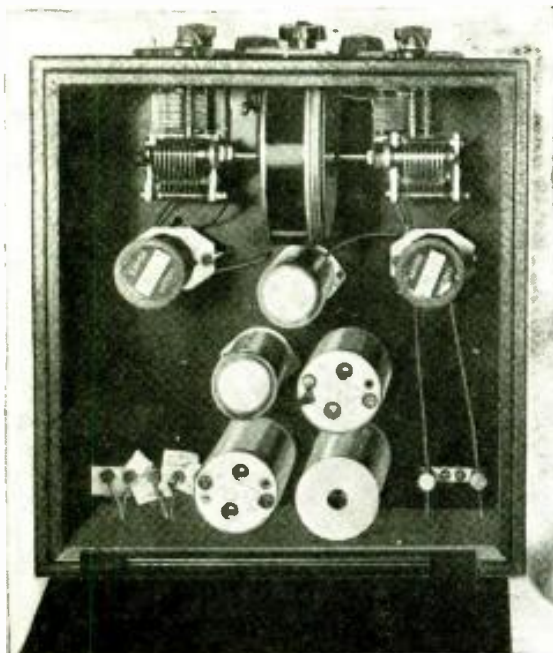

Photos above and at the right show the neat appearance of this very "smooth tuning" 3-tube superheterodyne receiver. Due to the use of "double-purpose" tubes, combined with a very ingenious circuit worked out by the author, 3 tubes actually perform the functions of 5 tubes! Band-spread and regeneration in the I.F. stages are special features. This set constitutes a first class "DX" headphone receiver and will appeal to every short-wave "Fan."



● NOT so long ago the performance of a 3-tube super-Het. did not justify its construction. Now, however, due to recent developments excellent results can be obtained.

By enumerating some of the more important features of the receiver shown in the photographs, I believe I can explain why a set of this type should be an attractive proposition for the "Fan" who likes to build his own sets. They are: Enough sensitivity to get down to the noise-level; extremely low background noise; hum-free A.C. or battery operation; adjustable selectivity; excellent tone control; continuous band-spread; continuous tuning range from 12 to 565 meters; economical operation, etc.

All of the parts necessary for constructing this receiver are of standard design and should be obtainable at all radio supply houses. The construction is so simple that it should present no difficulties to anybody who has a speaking acquaintance with superheterodynes. The cost, a very important consideration these days, is most reasonable when compared with that of receivers of equivalent grade and performance.

## Tubes and Circuit

Although the circuit may seem unusual in some respects it is by no means a *trick* circuit and contains nothing new. With 2.5-volt tubes a 2A7 is used as modulator and oscillator, a 58 as a regenerative I.F. amplifier and a 53 as a biased detector and A.F. amplifier. With 6.3-volt tubes a 6A7, 6D6 and 6A6 are used respectively. I prefer the 6.3-volt tubes because their heater current is less in comparison with the 53.

Since a good antenna is just as important as a good receiver the input

circuit is designed so that a *noise-reducing* antenna can be used.

A very effective "volume control" ahead of the I.F. stage is absolutely necessary. If placed in the cathode circuit of the —A7 its adjustment detunes the oscillator too much and on strong signals objectionable hum may develop, due to the excessive potential difference between cathode and heater. Grounding the cathode and connecting the volume control as shown in Fig. 1 eliminates this and, incidentally, the fixed bias increases the sensitivity of the first detector.

Grounding the cathode of the I.F. amplifier simplifies the circuit and reduces undesirable coupling. The I.F. circuit may seem strange to some; however, it is not new since the Ham has used it successfully for some time, not only for CW but also for phone reception. Using I.F. regeneration while scouting on the broadcast bands for eight months has convinced me of its usefulness, if the receiver as a whole is designed especially for this type of service.

The original model was equipped with a regenerative second detector and a regenerative I.F. stage. Those who have any doubts about R.F. regeneration could use the same arrangement to determine which type of regeneration they prefer.

A beat oscillator, although not needed for CW, is, of course, necessary for single-signal reception. Since the I.F. stage can be used as an excellent station finder, as will be explained later, it was omitted.

Consistent loud-speaker operation can be obtained by adding a power tube or by using a separate audio amplifier. However, if a sensitive headset is used, just as many stations can be "logged" without the power amplifier as with it.

In fact, I can do a little better with earphones.

The second I.F. amplifier was not omitted for economical reasons. Tests proved that this receiver will bring in every station that can be received with a set using two I.F. stages and, due to its variable selectivity and excellent tone control, more intelligible reception is often attained.

## Regeneration and T.R.F.

Controllable regeneration with two I.F. stages was a most difficult proposition and the only advantage obtained was that static and background noise could be amplified sufficiently at all times to overload the second detector.

The performance of every super-Het. which has only one tuned circuit between first detector and antenna can be improved by the addition of one or more T.R.F. amplifiers. The usual single R.F. stage does not always suppress *image* interference. However, more than one R.F. stage is too burdensome with plug-in coils—to say nothing about the cost and *tracking* difficulties. Numerous experiments made with a regenerative R.F. stage proved that it eliminated image interference and also increased the usable sensitivity so much that intelligible reception could be attained on some signals which otherwise were lost in the background noise. For best results the R.F. stage has to be housed in a separate box. By the way, a National type C-PSK cabinet fastened to the side of this set would provide a neat arrangement, and with the layout shown in the photographs single-dial tuning could easily be obtained. Since regeneration is needed only in extreme cases this control does not complicate the operation of the receiver, and for those who are willing to make a few



# Tube Super-Het

The band-spread feature of this set should make it applicable to the short-wave amateur, should he desire to add a "beat oscillator" which, of course, is really necessary for code reception.

By H. Dobrovlny

extra adjustments to "log" some of those elusive "foreign" stations it would prove an ideal arrangement.

Due to the grounded cathodes it is essential that the negative lead of the "B" supply and the negative terminals of the filter condensers be insulated from the power-pack chassis or ground. Of course "C" batteries could be used or the receiver could be operated above D.C. ground potential.

### Bleeder Currents

If a suitable voltmeter is not on hand R8 can be obtained with the sliders adjusted if the resistance between the contacts is specified. The set takes approximately 20 milliamperes and the bleeder current should be at least 10 milliamperes. For these values the resistance between first and second slider (3-volt tap) should be 100 ohms and between first and second slider (7.5-volt tap) 150 ohms. Since R11 is not included in the calculation it should not be used. The resistance between the second slider and "C" will depend on the total voltage available—500 ohms for 250 volts to 1500 ohms for 300 volts.

The bleeder current is obtained by connecting a 25,000-ohm resistor between "B plus" and "C plus."

### Constructional Details

The receiver is inclosed in a metal cabinet to shield it from dust, retain the full benefit of a noise-reducing antenna and to eliminate hand capacity. The National Type C-FB7 was selected not only for its neat appearance but also because it can be obtained for less than the cost of the aluminum necessary to make one—to say nothing about avoiding constructional difficulties. The cabinet is larger than necessary—but who has ever constructed a 3-tube set for DXing without any intentions of making additions later on. The cabinet can be taken apart by merely removing the screws which hold the bottom, back and sub-base in place.

When drilling the holes for the dials and also the four holes along the front edge of the base, used for mounting the two "tank" condensers, it should be remembered that the clearance on these parts is quite close. The location of (Continued on page 748)

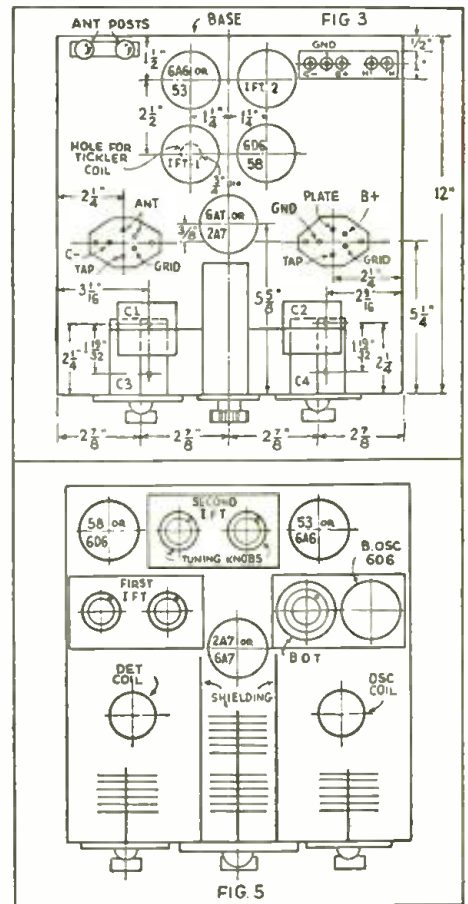
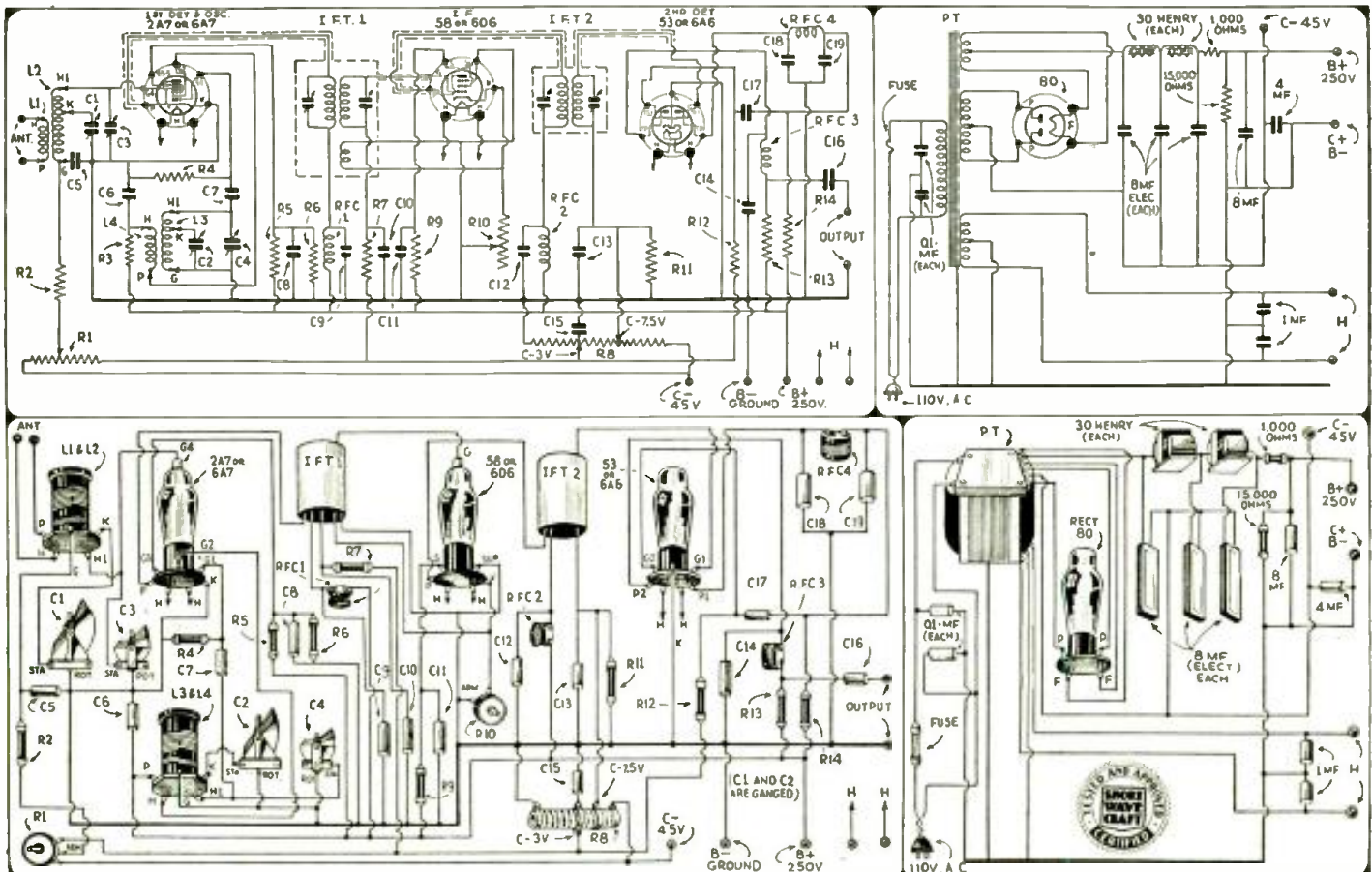

Fig. 3 above shows plan view of the sub-panel and Fig. 5, general layout looking down on top of the set.



Above—Complete wiring diagrams in both schematic and picture styles, which will enable even the beginner to construct this very excellent and smooth tuning 3-tube super-Het. receiver. It works on 110 volts 60 cycles A.C. and has its own plate supply.



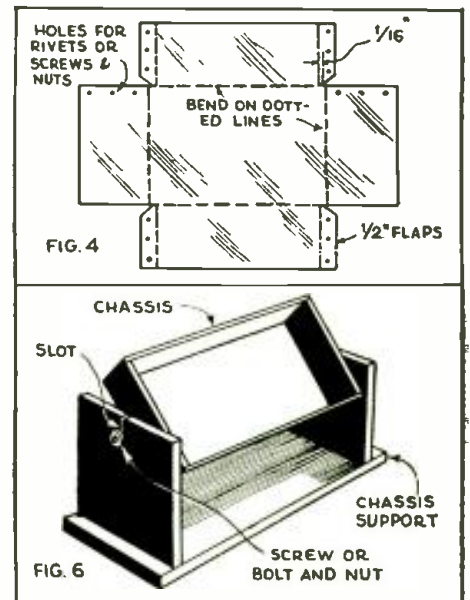
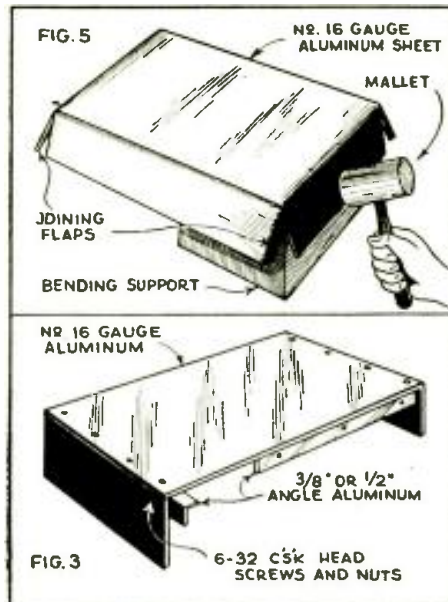
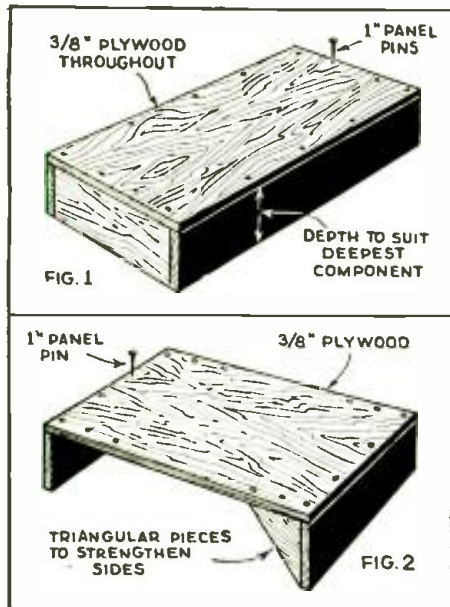

Fig. 1—Simplest wooden chassis. Fig. 2—More open type of wooden chassis. Fig. 3—Simple design of metal chassis, built up from flat pieces, without any bending. Angle aluminum or brass, tapped for 6 or 8-32 machine screws, serve to hold the sections together. Fig. 4—Shows how typical metal chassis is laid out before bending, which takes place along the dotted lines. Flaps are cut out with snips before bending. Fig. 5—The metal, aluminum or steel, is bent by hammering back and forth along the side to be folded. Don't try to bend it all at once, but a little at a time along the entire section. Fig. 6—Handy way of mounting chassis so it can be rotated while wiring. Screws permit clamping in any position.

# How to Bend Your Own Chassis

● TO EARN the coveted title of Advanced Constructor, you certainly must do something about set-chassis making. It all depends on how you go about the work. You can with advantage start off with a really simple wooden chassis, gaining confidence for more ambitious metal affairs as you construct various shapes and sizes.

Shall we take a look at Fig. 1, for a start? Here is the most straightforward complete chassis we can imagine. It is made up entirely of wood—preferably treated wood of the metallized variety. This is available in England, but not here, to our knowledge. Metal foil or screening could be put over the wood. Tin, zinc or brass could be used in an emergency.

So that the design in Fig. 1, built up of metallized wood, or metal-covered wood, is a really sound chassis. Its size depends, of course, on your own needs. The governing considerations will be the depth—determined by your deepest sub-chassis mounted component.

You can use 3/8 in. wood for this Fig. 1 chassis, tacking together the top, sides and ends with 1 inch panel pins

(brads). Be generous with these pins, and then you will have a stout chassis that will stand any amount of knocking about.

If you know that the sub-chassis wiring is going to be rather complicated, or if there are going to be a lot of components—some being therefore inaccessible—you might try the Fig. 2 chassis, which is a more skeletonized version.

Tack the top portion to two ends, strengthening up the structure with four triangular pieces of wood. Use the same wood as before, and the same pins. With a shallow chassis this method is very satisfactory.

So much for simple wood chassis, which are becoming more popular as amateurs realize the easy way they can be made up—and as it dawns on amateurs that a good metallized or metal covered, as explained, wood chassis can do all that a more ornate all metal job can do.

There are times, though, when a really nice metal chassis is wanted—and then, assuming you are inexperienced—the Fig. 3 construction is admirable.

All you need are three perfectly flat

pieces of No. 16 gauge aluminum, one for the top and two for the ends. These are then held together by angle brackets, which you can readily buy quite cheaply—especially in brass. But they are also available in aluminum if you look long enough.

Now we come to the more complicated sort of chassis—a real all-metal affair. You can see how it is dimensioned from Fig. 4.

About the bending. This is really quite an art—but an easily acquired one if you go the right way about it. The first need is a hardwood block to work upon. It should have true corners—to make sharp bends in the metal when it is hit.

Hit with a wooden or rawhide mallet, too. If an ordinary hammer is used it will badly mark the metal. You can see how this job is done from Fig. 5.

At Fig. 6 is just a little idea for chassis experiments. Make up a stand, with two slots in the ends, so that the chassis can be swiveled around—then you can examine components and get at tricky bits of wiring.—*Courtesy English "Amateur Wireless."*

## Experimental Short-Wave Surgery

● HERE is a circuit diagram and description of an oscillator which may be of interest to other readers of SHORT WAVE CRAFT. The circuit is an old one but the application is rather new to most experimenters. One application is to try "surgery." A piece of raw meat (beef steak is ideal) is placed on the metal plate shown in the diagram and the knife touched lightly to the meat. If the knife is moved along over the surface of the meat the result will be a dandy incision. The "knife" in my case was a service man's test lead with a phonograph needle tip. The meat may be cooked by placing a sheet of metal on each side and applying the r.f. voltage through the piece of meat. The oscillator may also be used to mys-

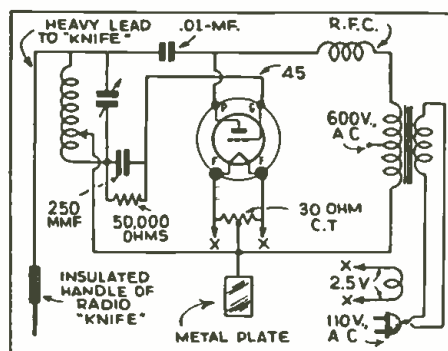

Hook-Up for Experimental Surgery

tify friends. I mounted the "works" under a card table and made a small table lamp by mounting a 32-candle-power auto headlight bulb on a spool and connecting it to three turns of heavy wire wound around the spool. This bulb lights brightly when it is placed on the table over the tank coil. A cigarette-lighter may be made by substituting a small coil of heater wire for the headlight bulb. RFC has 150 turns No. 30 wire on 1" dia. tube, wound in 3 sections. Tank coil is wound with 12 turns 1/4" tubing, 6 inches in dia.—Paul G. White.

For greater power use a 50-watt tube such as the 203A, with 1000 volts of D.C. on the plate, and 866 rectifier tube, the transformer being rated at 1000 volts either side of center tap.



# \$500.00 PRIZE CONTEST

## for the "Best Title" Describing March Cover

• THE cover illustration on our March cover showed a very irritating situation between "Hubby" and "Wifey" at about 3 a.m. in the morning with "Hubby" listening in to his favorite DX station by means of a pair of headphones. "Friend Wife" is sitting up in bed and shaking her finger at her spouse in a very angry fashion and aside from the fact that a small boudoir lamp is illuminated between the twin beds, the editors, after having the cover painted, were at a loss to quite figure out what should have caused "Wifey" to become all "steamed up." Instead of selecting a title for the cover, the editors are asking the readers of SHORT WAVE CRAFT to name this cover, and a total of 50 prizes will be awarded for the best titles suggested for the March cover. The rules governing this cover title contest are given herewith, as well as a partial list of the prizes, which will total 50 in all.

The first prize will be one of the new Pilot 11-tube Super-Dragon receivers. This is one of the very latest *all-wave* receivers, and one which we are sure every short-wave fan in the country will be wild to own. This set covers all waves between 13 and 555 meters.

### Rules Pertaining to This Contest

- 1.—A suitable title is wanted for the front cover of this month's issue.
- 2.—The title should be self-explanatory and should have in it some reference to radio, short waves, or both. It should be humorous, if possible.
- 3.—You may submit as many titles as you wish. There is no limit.
- 4.—Titles must be submitted on slips of paper size of a postal card, 3¼x5½ inches, or you can send your title on a 1-cent postal card if you prefer to do so. Only one title must go on one sheet of paper. Use only one side of the paper. If the paper or postal card is larger than that size the entry will be thrown out automatically.
- 5.—Write in ink or typewrite the title; no penciled matter considered.
- 6.—Name and address must be given on each title, no matter how many you send in.
- 7.—This contest is open to everyone whether you are a newsstand reader or subscriber.
- 8.—From the contest are excluded em-

ployees of SHORT WAVE CRAFT and their families.

9.—The contest closes on Apr. 30, at which time all entries must have been received.

10.—The editors of SHORT WAVE CRAFT will be the judges of this contest, and their findings will be final.

11.—No correspondence can be engaged in on this contest, nor letters answered, nor the entries returned.

12.—In the event of ties the prizes tied for will be awarded to the contestants so tying.

Address all entries to TITLE CONTEST EDITOR, SHORT WAVE CRAFT, 99 Hudson Street, New York City.

In the next issue the full list of prizes will be given.

The prizes will be sent from the radio manufacturers and radio firms to the winners at the end of the contest, and the results giving the winners' names will be published in our July issue.

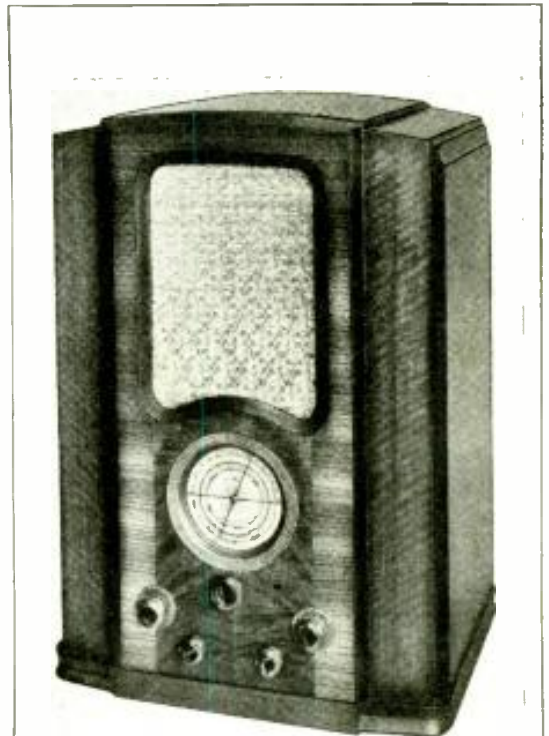

"First Prize"—This beautiful 11-tube Pilot All-Wave Set, Valued at \$99.50

• The "First Prize" Pilot 11-tube Super-Dragon All-wave set has class A.V. push-pull audio output stage with 12 watts output, feeding a 10-inch full dynamic speaker. It has a very stable separate oscillator tube; automatic volume control; automatic inter-station clarifier; "quick-shift" vernier or high-speed tuning dial; selective audio filter system (tone control); a separate switch control for the base accentuator; head-phone and phonograph "pick-up" jacks. Best of all, it has a tuned R.F. stage ahead of the mixer tube, which is used on all bands. It also has a universal input line transformer, which by changing a simple connection, enables the owner to operate the set on 50 to 60 cycles on any one of the following A.C. voltages—110, 125, 150, 220, or 240. The set uses three 6D6 tubes; two 76's; one 6A7; one 85 detector; two 42; one 5D3 rectifier, and one 6C6.

## Partial List of 50 Prizes

Alden Products Company, Brockton, Mass.

- 1—No. C-140, 140 mmf. Na-Ald Vietron "AA" Variable Condenser
- 1—No. C-15, 15 mmf. Na-Ald Vietron "AA" Variable Condenser
- 1—No. 702RV, 2½ mh. 150 m.a. Na-Ald Vietron R.F. Choke
- 1—No. 75V, 5 meter Na-Ald Vietron R.F. Choke
- 1—LV2, Na-Ald Vietron Coil Dope and No. 700, Na-Ald Coil Selector Unit.
- 1—No. 4955V Acorn Tube Socket of Vietron.

Anker Labs., New York, N.Y.

- 1—"Frigate" Twin Regeneration 6-Tube Receiver Kit
- 1—3-Tube A.C.-D.C. "Cruiser" Kit
- 1—Buccaneer S.W. Receiver Kit
- 1—Buccaneer Junior Receiver Kit

Blan, The Radio Man, New York, N.Y.

- 1—Pair Buddy Test Prods
- 1—6"x5½"x6" Shield Box
- 5—Individual prizes of aluminum panels each to the winner's specifications not exceeding 150 sq. inches each.

10—Individual prizes of ½ lb. packages of aluminum strips that make very handy bracket-shelf support handles, etc., in radio construction for homemade sets.

Burgess Battery Company, Freeport, Ill.

- 1—Burgess No. B76F Ribbon Battery

Eilen Radio Laboratories, New York.

- 1—All-Electric All-Wave set, wired, complete with B.C. Coils, Tubes, Cabinet and Phones.

Electrad, Inc., New York, N.Y.

- 1—Electrad Universal Service Kit containing six Standard Replacement Controls

Hammarlund Mfg. Co., New York.

- 1—Set short-wave plug-in coils and coil forms

Insuline Corporation of America, New York, N.Y.

- 1—No. 2651 Insulex Trans. Coil Form
- 1—No. 957 Insulex Trans. Socket
- 1—No. 965 Insulex 6-prong S.W. Coils

Arthur H. Lynch, Inc.

- 1—Hi-Fi, Marconi type, high fidelity receiver antenna kit

National Company, Malden, Mass.

- 1—Type CPO, Code Practice Audio Oscillator

Pilot Radio Corp., Long Island City, N.Y.

- 1—11-tube Pilot Super-Dragon All-Wave Receiver

World Trotter Radio Labs., New York City.

- 1—Prof. Band-Spread, Model DX-5 Receiver, in metal cabinet with dynamic speaker

Short Wave Craft, New York.

- 25—1 year subscriptions to SHORT WAVE CRAFT
- 12—Short-wave Manuals
- 25—50c Short-wave Books

Please mention SHORT WAVE CRAFT when writing advertisers



# WORLD-WIDE SHORT-

## Tune Your Short-Wave Aerial

● THE average short-wave fan takes for granted that when he rigs up an aerial for his short-wave receiver, whether it is an inverted L type or one of the more elaborate doublet types, that this aerial will give him everything desired on any wavelength that he might tune his set to.

An English amateur, in *Amateur Wireless*, recently, pointed out that you can often improve the signal strength of a signal picked up many times, by effectively lengthening or shortening the aerial to suit the particular wavelength in question. While it is not always possible to tune the aerial to that particular wavelength, you can usually find one of its harmonics or sub-harmonics which produces the same effect.

The aerial tuning is accomplished by the use of our old friend, the tuned circuit. You simply have to connect it in

● The Editors have endeavored to review the more important foreign magazines covering short-wave developments, for the benefit of the thousands of readers of this magazine who do not have the opportunity of seeing these magazines first-hand. The circuits shown are for the most part self-explanatory to the radio student, and wherever possible the constants or values of various condensers, coils, etc., are given. Please do not write to us asking for further data, picture-diagrams or lists of parts for these foreign circuits, as we do not have any further specific information other than that given. If the reader will remember that wherever a tuned circuit is shown, for instance, he may use any short-wave coil and the appropriate corresponding tuning condenser, data for which are given dozens of times in each issue of this magazine, he will have no difficulty in reconstructing these foreign circuits to try them out.

suit the parts at hand. The coils may be any well-made S.W. inductances, and the tuning condenser should have the value specified for the coils. It must be remembered that the frequency range will be shifted to a somewhat lower value for each coil because of the insertion of the regeneration coil in the tuned circuit. This may necessitate the removal of some turns from each coil to cover the desired frequencies.

## "Neutralized Inductance" Wave Change Scheme Improved

● SOME time ago on this page (February 1935 issue) we published an excerpt from an article on a new method of short-wave tuning, in which balanced inductances permitted a wide change of frequencies without either plug-in coils or wave-change switches.

By an unfortunate error, this was credited to an Austrian publication and the Editor wishes to make a correction at this time and credit the item correctly. The item appeared originally in *Amateur Wireless* magazine, an English publication.

The author has made a further development in the idea, as shown in the accompanying sketch, to permit a wider range of frequencies to be covered. By a simple switch to ground the point between the coils, the effective length of L1 is changed and the neutralizing inductance simply made larger or smaller, depending on the position of the switch arm. This lengthening and shortening of the neutralizing coil is easily compensated for by the variable condenser setting. A review of the original item will explain how this is done.

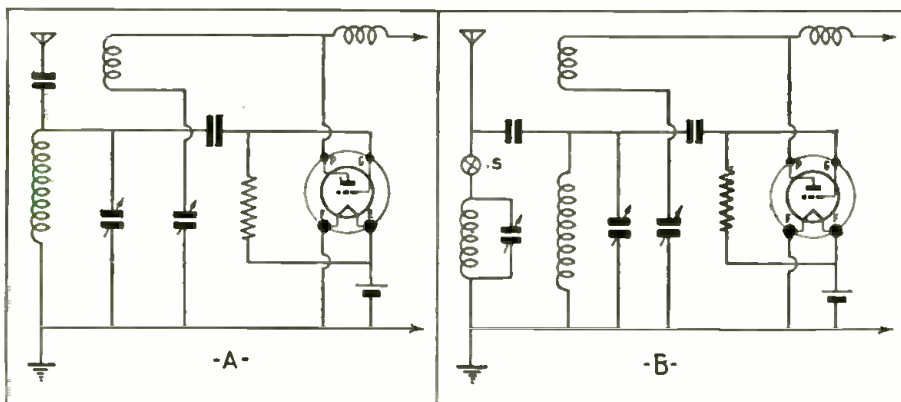

This circuit shows how you can improve the efficiency of short-wave reception by tuning the antenna.

the same manner as an absorptive wave-trap. Then, for a given setting of the tuning condenser, a point will be found for the condenser of the aerial tuning unit, at which the set either stops oscillating or the regeneration control must be advanced greatly to start oscillation. You may find that this will also necessitate a slight readjustment of the tuning control, but when you finally have the set retuned and the regeneration just below the point of oscillation, the signals will usually be greatly increased in strength.

This may sound like a complicated arrangement, but next time you find that you need "just a little more" to bring in that weak station, try this kink and see how easy it really is.

The coil is any good short-wave unit of the plug-in type, to cover the required wavebands and the condenser may be any size that you happen to have around, from .00025 to .0005 mf. maximum.

ordinary way from the plate circuit. This method supplies a smooth control of regeneration, and one that is unusually stable. This is the interesting point about the set (disregarding its geographic interest.)

It will also be noticed that the tuning condenser encompasses both coils, which are isolated by the use of fixed condensers to prevent a short-circuiting of the "A" and "B" current supplies. This means that the regeneration coil is actually part of the tuning circuit and supplies direct coupling—as far as the signal is concerned—between the tuning and feed-back circuits. This has the effect of reducing the loading of the tuned circuit and permits smooth regeneration on higher frequencies than most other methods.

The values of the parts are indicated on the circuit; they may be changed to

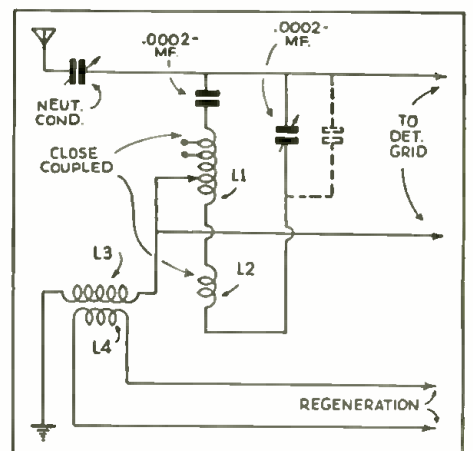

In this scheme for tuning in the various short-wave bands, balanced inductances permit a wide change of frequencies without using plug-in coils or switches.

## An Italian One-Tuber

● FROM time to time on this page, we have published typical circuits, each having some new kink or method that makes it interesting to short-wave fans in the U.S.—from various foreign countries.

This circuit is an Italian idea published in *La Radio Per Tutti* of how a 1-tube short-wave receiver should be made. Oddly enough, it is a combination battery and A.C. set for the filament of the single, indirectly-heated tube is actuated by a step-down transformer from the A.C. lines, while the plate supply is received from a "B" battery.

The regeneration is situated between the screen-grid of the tube and the cathode while the output is obtained in the

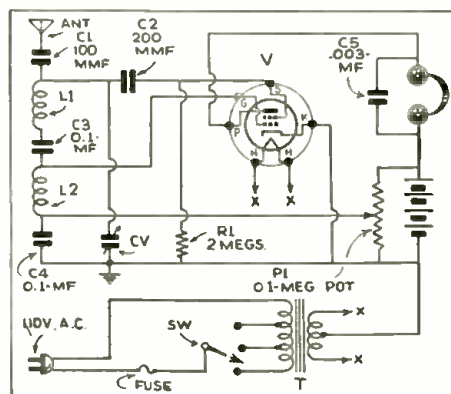

Hook-up of Italian 1-Tube Receiver

By winding the coils L1 and L2 on separate coils, the mutual inductance between them can be varied, thus producing a very effective control of the selectivity of the set. By loosening the coupling, the tuning of the receiver can be broadened to almost any extent—though of course the wave range will be decreased in proportion.

This circuit holds a wide field of research for the more experienced short-wave fans, and for the ordinary listener the greater efficiency permits new stations to be heard.

## A French Frequency Converter

● THE circuit diagram and photo here show a short-wave converter to be coupled to a broadcast receiver for tuning in short-wave stations. This unit was



# WAVE REVIEW ●● Edited by C. W. PALMER

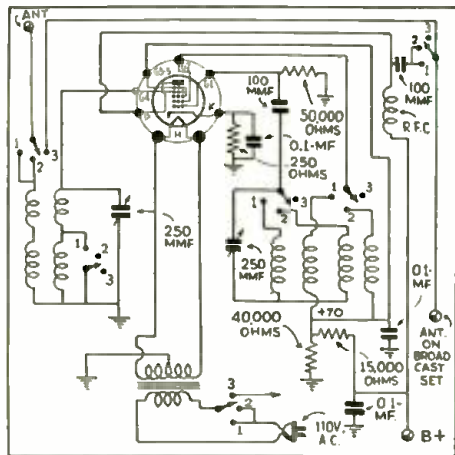

This diagram shows how to make a short-wave converter which can be coupled to a regular broadcast receiver, for the purpose of tuning in short-wave stations.

described in *La T.S.F. Pour Tous* a magazine published in Paris.

The unit employs a tube of the type known in the U.S. as a penta-grid converter tube (2A7 and 6A7) but known in Europe as the Octode.

Two sets of coils are needed, the aerial and grid coils, and the oscillator grid and plate coils. There are commercial units covering the wavebands required. The wave-change scheme consists of a 6-section switch having three positions. "The first and second are for the two short-wave bands covered while the third connects the aerial directly to the broadcast set and disconnects the primary of the filament transformer as well as disconnecting each of the coils of the converter unit.

The value of the resistors and condensers are indicated on the circuit, but these values must be adjusted to suit the coils and tube utilized.

The interest in this unit is the complete way in which the switch arrangement controls the various parts of the circuit.

## A Hi-Fidelity Amplifier

● HIGH fidelity has taken the entire radio industry by storm—and the conquest is not limited to the U.S. Interesting articles on the subject are found in many foreign radio magazines.

*Wireless Weekly*, an Australian magazine is one of the foremost of these hi-fidelity advocates and the amplifier diagram here is an example of the work they are doing along these lines.

This amplifier was designed by the staff of the magazine and after the engineer-

ing work was completed, independent radio laboratories checked the work and the results. Their findings are so encouraging that we do not hesitate to recommend the amplifier to anyone who wants a really fine amplifier for boosting the output of a short-wave receiver.

It is interesting also, since American tubes are utilized in the design, which permits short-wave experimenters in this country to duplicate the amplifier.

In design, the 55 tube is used as a phase-changer and amplifier to couple a single tube into a push-pull stage, without resorting to transformers, which might limit the response at the extremities of the audio range.

This amplifier has a flat response from 30 to 10,000 cycles (within 5 db.) and phase reversal is so perfect that with the values given, not only is the phase of the signal potentials 180 degrees apart, but the amplitude of the signals also match, within very close limits, which accounts for the fine frequency characteristic of the amplifier.

## Short-Wave Coil Switching

● MANY methods have been devised for changing from one coil to another in changing bands in short-wave receivers. One of these methods is to use a radial group of coils which are turned by a central shaft so that the coils not in use are actually disconnected from the entire circuit. However, this method has been rather difficult for the home-constructor as it required rather careful construction work.

In a copy of *Toute La Radio*, a French

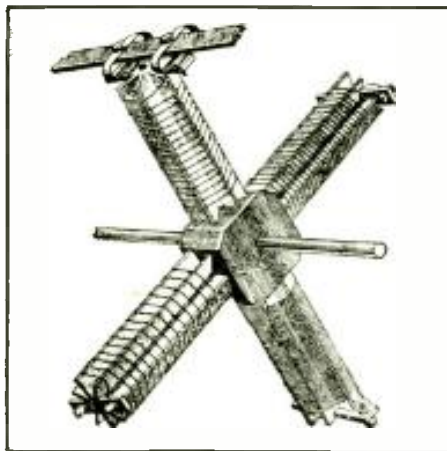

The switching of short-wave coils is always food for an argument among the experts—here is a simple arrangement of French extraction.

publication, the editor spotted a rather simple way of assembling such a coil assembly and making the necessary switch for it. The arrangement is shown in the accompanying sketch, which shows one set of four coils mounted on a block of wood and a metal or wooden shaft mounted in the center of the block. The coils may be made by taking insulating strips and securing them together radially with slots in the edges for the wire. But perhaps it would be easier to use commercial coils.

On the ends of the coils which may have any number of windings required by the circuit, are fastened strips of bakelite or other insulation, with contacts arranged as shown—one contact for each connection to be switched. On the panel or base-board, a strip having a similar number of contacts, but made this time of spring brass, is mounted. This strip is situated so that by turning the shaft, the coils are made to turn and make contact, one at a time with the contact strip.

The details of construction can easily be worked out by the individual constructor.

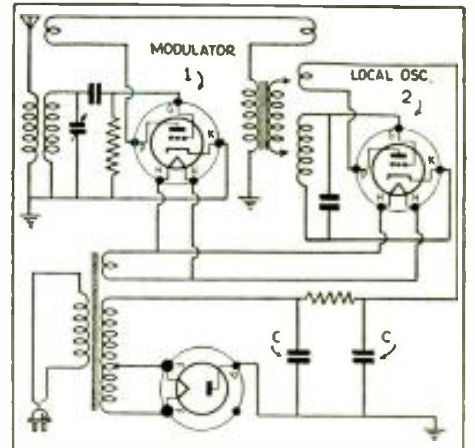

In this hook-up, tube 1 is the frequency changer and tube 2 is the local oscillator for a greatly simplified super-Het. with its own power supply.

## Receiving Conditions on 10 Meters

● ACCORDING to a recent Austrian patent the problem of using power lines as a source of current supply to receivers operating on the wavelengths of about 10 meters is quite difficult, on account of the elaborate filtering needed to prevent hum. Regenerative receivers operating around 7 meters, require, according to the account in a recent issue of *Funk-Technische* (Continued on page 741)

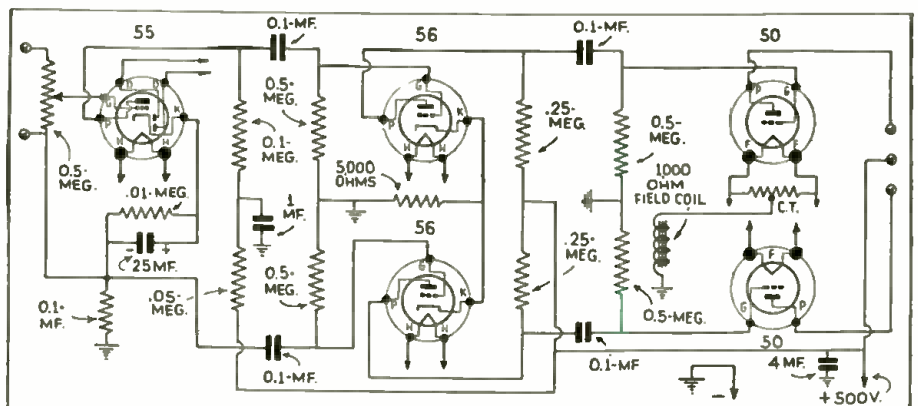

This diagram shows an interesting Australian high-fidelity amplifier circuit; it has a flat response from 30 to 10,000 cycles.



# Short Wave SCOUT NEWS

## Official Listening Post of Geo. D. Sallade, Sinking Spring, Pa.

● IN THIS column I recently reported hearing a Budapest transmitter on 5400 kc. This station was HAT and transmits each Sunday from 8:00-9:00 p.m. E.S.T. An official communication from this station reads as follows:

Dear Sir:

Thanks for your report on HAT, 55.56 meters, of 23 Dec, '34. This Xmitter is on the air each Sunday 8:00-9:00 p.m. (your time). Also HAS3 is working each Sunday 8:00-9:00 your time, on 19.518 meters. Both of them 5 kw.

Wishing good reception for the future, we remain,

Yours very truly,

Research Labs for Elect. Communications  
Budapest, Gyali St. 22.

In November, many listeners, including myself, reported an Italian station, IRS on 8000 kc. In order to remove any doubt concerning this station and the call letters, I present this verification:

Dear Sir:

In receipt of your letter of Nov. 16, 1934, we confirm as correct your report contained in the same.

Please note, however, that the call-letters of our transmitter are IRF and not IRS as you thought you heard; the wavelength is meters 37.15.

Yours truly,

Societa Italo Radio

New stations heard at this post are YV6RV, 6030 kc, in Valencia, Venezuela, and HJ4ABL, 6100 kc, located in Manizales, Colombia, S. A.

Verifications this month include HJ5ABD (Cali), TIX, HIX, DJN, VK2ME on 28.5 meters, and a pretty card, pink in color with large red letters from HP5B.

## Report From Oliver Amlie, Philadelphia, Pa.

### (10th S.W. Craft Trophy Winner)

● THE famous 3-tube Amlie, DXer, using the oldest radio tubes on the market, went back on the air Jan. 6, 1935, after a 7-day lay-up due to trouble with "B" Eliminator, (voltage trouble), but the receiver made up for lost time, taking a mighty sweep in the short-wave field for this month, with at least no less than 10 or 15 letters sent out for verifications, ending Jan. 27. Here are a few stations this post will receive verifications from:—KEE 43.70 meters sending programs to KGU, Honolulu, Mon., Tues., 11-12 mid. KEE is my old stand-by, had "veri" about a year ago, can't find it, will write for new one.

COK, 44.00 meters, Mon. 8:00 p.m. to 1:15 a.m., new station in Havana, Cuba. KWE, 19.60 meters, calling JVF on 19.02 meters 5-6 p.m. any eve.

KWU, 19.53 meters, sending test programs to JVM on 27.93 meters 5-6 p.m. any eve.

KDF 28.05 meters, testing with JVF 19.02 meters 6-7 p.m. irregular.

OAX41, 57.80 meters, Lima, Peru, sending programs out Wed-Sat. 9-11:30 p. m.

KNRA, 44.27 meters, heard Jan. 23, 1935. Time 11:25 p.m., 21 miles from Florida.

CMCI, 49½ meters, Havana, Cuba, Old stand-by; had "veri" April 23, 1932; back now on air; as yet, irregular from 8-11 p.m.

CTICT, 31.25 meters, Lisbon, Portugal, Thurs. 4-6 p.m.

XEBT 50 meters, daily 7 p.m. till 1 a.m.

C09CC, 48.78 meters, Havana, Cuba. Mon. 7-12 noon.

PRF5, 31.58 meters, daily 5:30-6:15 p.m. (All Time E. S. Time.)

The above are stations this post expects to receive verifications from for the month of January 1935. Heard both sides of California and Japan phones.

One personal letter, 1 verification, 2 pages of information of radio stations received from VK3LR from Mr. H. P. Brown, Director-General of Australia.

One letter from Mr. T. W. Conder, General Manager of Australia Radio Commission; equal qualification of verification on VK2ME-3LR-3ME; Mr. Conder receives reports from this post on all three stations each month for 12-months' test.

Oliver Amlie

56th City Line Ave.

Overbrook

Philadelphia, Penn.

## Listening Post Report From Herman Borchers, Greenfield, Mass.

● DURING January the short-wave reception was fair except the Australians; none of these stations came up to the expectations.

OAXHB—48 meters, Lima, Peru. Have heard this station several times on Wednesdays and Sundays at 8 p.m. Rep. R6.

HJ1ABB—46.51 meters, Barranquilla, Colombia, is on the air from 4:30 to 10:00 p.m. Received very good. R7.

## Latest "Hot" Tips for Short-Wave Listeners from our "OFFICIAL LISTENING POSTS"

HJ1ABE—49.5 meters, Cartagena, Colombia, strong signal. R8.

HJ3ABH—50.1 meters, Bogota, Colombia, very good R8.

XEBT—50.10 meters, Mexico, strong signal R7.

HP5B—49.9 meters, Panama City, have heard this station several times around 10:00 p.m. Announcements are in English, Spanish, R8.

DJB—19.73 meters, has discontinued sending their programs to United States in the morning.

DJC—49.83 meters, is still the best heard station; reception R9 plus. Have received a "veri" from 2RO Rome. Their station schedule is the following:

IRA—49.30 meters, Mon., Wed., and Fri., from 6 to 7:30 p.m.

2RO—30.67 meters, every day from 2:30 to 5 p.m. and Mon., Wed. and Fri. also from 7:45 to 9:15 p.m.

JB—Johannesburg, South Africa. This station is on 49.2 meters, 6097.56 kc. according to a letter received from this station and their schedule is as follows: 6:45 to 7:30 a.m.—10:30 a.m. to 2:00 p.m.—4:00 to 6:30 p.m. and 7 to 11 p.m., every day except Sunday.

Sunday schedule: 3:30 to 4:30 a.m. and 8 to 10:15 a. m. The address for JB is the following: Africa Broadcasting Co. Limited, Box 4559, Johannesburg, South Africa.

RNE—25 meters, received very weak R4-R6. EAQ—30.40 meters extra strong signal, R8.

VK3LR } All received very weak and  
VK2ME } plenty of static—R4 to R5.  
VK3ME }

—Herman Borchers

## John Sorensen Reports

● STATIONS heard and logged this month: GSA — GSB — GSD — GSE — GSF — GCW — GAS — FYA (19 meters), FYA (25 meters), — DJA — DJC — DJN — DFE — DIQ — DGU — HBL — HBP — ORK — IRM — IRA — EAQ — CT1AA — PHI — PCJ — RNE — LKJ1 — HAT (55 meters)—VK2ME — VK3ME — VK3LR — YDA — JVT — RW15 — COC — COH — H1A — HIX — T1EP — HCK — PRADO — PRF5 — YV2RC — YV3RC — YV4RC — HJ1ABB — HJ1ABD — HJ2ABC — YV5RMO — HJN — HC-2RL — XEBT — W8XAL — W9XAA — W2XE — W8XK — W1XAZ — W1XAL — W9XF — W3XAL — W3XL — W3XAU — WOO — WMA — WEZ — WEM — WO9 — CJRX — CJRO — VE9GW — VE9DN.

Verifications received: VK3RL — VK2ME — JVM — WO9 — IRM — IRA — DGU — HP5B.

Many unidentified South Americans have been heard and the 49 meter band seems to be best just now, 31 meters from 3 p.m. E.S.T. is also good. 25 and 19 meters generally have been weak except GSE — FYA — PHI — PCJ — these have come in here with strong signals. Some freak receptions have been noted, also "echoes" from GSE and DJN. The stations I have wanted have failed to come in, such as VUB — VUC — CQN — VATLO — ZHI — OER2 — CT3AQ; these I have tuned for, but so far they have not favored me by their signals.

Code transmitters on 49.3 to 49.5 meters here are very loud and give good reception from before dark to far into the evening. There are sometimes a dozen keying at one time. Amateurs take note, for I hear plenty of your call letters here at 49.4 meters.

Here is the "interval" signal you hear before HAT, Budapest, starts its broadcast.



—John Sorensen, 3301 Waterbury Ave., Bronx, N.Y.C.

## Edward Heiser Reports

● HEREWITH you will find short-wave log.

The whistle which is heard when listening to IRA on 49.20 meters is caused, I believe, by IRA operating too close to VE9GW's wave.

The new Panama station is also causing quite a whistle as they are right on WIXAL's wave and WIXAL is becoming more active again.

I have heard a station working in the 20 meter amateur band, broadcasting recordings, but they do not talk or give their call.

I sent in a report to England in regard to tests they were conducting, and received a fine picture of "Big Ben" and the London Studios. They also mentioned, that inasmuch as their programs are published before they are broadcast, they do not feel justified in sending verifications for the G.S. stations.

The 16, 19, 25, and 31 meter bands in general have been very poor.—Edward N. Heiser, Rt. 2, Box 124, Brecksville, Ohio.

(Continued on page 758)



# SHORT WAVE SCOUTS

## FOURTEENTH "TROPHY CUP" WINNER

Presented to  
SHORT WAVE SCOUT  
ANGELO CENTANINO  
FREEPORT, PA.

For his contribution toward the  
advancement of the art of Radio

by



Magazine

### 14th "TROPHY" WINNER

Angelo Centanino, Box 516,  
Freeport, Pa.

180 Stations; 90 Verified

● THIS month we take pleasure in awarding the fourteenth "Trophy" to Mr. Angelo Centanino of Freeport, Pa. Mr. Centanino's list consisted of a total of 180 stations, 90 of which were verified. The receiver used by the winner of the fourteenth "Trophy" was a Hammarlund "Comet"-Pro. Five separate antennas were used. One was a 41-foot doublet, another was a 75-foot cage antenna, a 23-foot doublet, a 30-foot doublet, and a 75-foot "L" type. Mr. Centanino states that the 75-foot doublet gave the best "all-around" results. He also had the advantage of understanding Italian, Spanish, French and English, and, of course, had very little trouble in identifying the signals of the different stations.

**IMPORTANT:** Do not fail to remember that all the entries must now be entered according to the new rules which are herewith reprinted for the benefit of those who intend submitting lists of stations. Read the new rules carefully!

Briefly they are: The Trophy will go to the person submitting the "greatest number of verifications!" No unverified stations are required! Also, at least 50 per cent of the verifications submitted must be for stations located OUTSIDE of the country in which the entrant resides. Only letters or cards specifically verifying reception of a given station will be considered.

#### MR. CENTANINO'S LIST OF VERIFIED STATIONS

Radio Coloniale—France, 19.68, 7-11 a.m., "Ici Radio Coloniale, Pareae."  
Radio Coloniale—France, 25.20, 11:15 a.m.-5 p.m., "Ici Radio Coloniale, Pareae."  
Radio Coloniale—France, 25.63, 5:15-11 p.m., "Ici Radio Coloniale, Pareae."  
HI1A—West Indies, 47.80, 7:40-9:40 p.m., "Aqui la voz del Yaque."  
HIH—West Indies, 44.00, 6:40-7:40 p.m., "Aqui la voz del Higuamo."  
YV4RC—Venezuela, 50.08, 4:30-10 p.m., "Estacion YV4RC in Caracas."  
HJ5-ABD—Colombia, 46.30, 7-10 p.m., three-note chime.  
VK3ME—Australia, 31.55, Sat., 5-7 a.m., clock chimes at opening.  
VK3LR—Australia, 31.31, 3-8 a.m., Sun.  
RK1—U.S.S.R., 19.94, Sun., 10-11 a.m., "Moscow calling."  
HC2RL—Ecuador, 45.00, Tues., 9:15-11:15 p.m., "Hello America."  
CT1AA—Portugal, 31.25, Fri., 3:30-6 p.m., three cuckoo calls.  
YV3RC—Venezuela, 48.78, 4:30-9:30 p.m., gongs and chimes.  
COC—Cuba, 50.00, 4-6 p.m., announce in English.  
HBL—Switzerland, 31.27, 5:30-6:30 p.m., "Radio Nations calling."  
HBP—Switzerland, 38.47, 5:30-6:30 p.m., "Radio Nations calling."  
PRADO—Ecuador, 45.31, 9-11 p.m., "Estacion el Prado en Riobamba, Ecuador."  
LSX—Argentina, 28.98, Wed., 8-11 p.m., relays KPZ.  
LSN—Argentina, 14.27, used in mornings of Eucharistic Congress Week, 8-10:30 a.m.  
LSN—Argentina, 20.65, used in mornings, 8-10:30 a.m.  
LSN—Argentina, 30.30, used evenings, 6-8 p.m.  
TIEP—Costa Rica, 44.71, 7-10 p.m., "La Voz del Tropico."



● ON this page is illustrated the handsome trophy, which was designed by one of New York's leading silversmiths. It is made of metal throughout, except the base, which is made of handsome black Bakelite. The metal itself is quadruple silver-plated, in the usual manner of all trophies today.

It is a most imposing piece of work, and stands from tip to base 22½". The diameter of the base is 7¾". The diameter of the globe is 5¼". The work throughout is first-class, and no money has been spared in its execution. It will enhance any home, and will be admired by everyone who sees it.

The trophy will be awarded every month, and the winner will be announced in the following issue of SHORT WAVE CRAFT. The winner's name will be hand engraved on the trophy.

The purpose of this contest is to advance the art of radio by "logging" as many short-wave commercial phone stations, in a period not exceeding thirty days, as possible by any one contestant. The trophy will be awarded to that SHORT WAVE SCOUT who has logged the greatest number of short-wave stations during any 30-day period.

#### HONORABLE MENTION AWARDS

Robert Woods, 14 W. Broadway,  
Sand Springs, Okla.  
110 stations; 55 verified.

CJRO—Canada, 48.85, 8 p.m.-midnight, "Stations CJRO and CJRX, Winnipeg, Manitoba."  
CJRX—Canada, 25.60, 8 p.m.-midnight, "Stations CJRO and CJRX, Winnipeg, Manitoba."  
GBU—England, 24.41, evenings, phones New York.  
GBS—England, 28.04, midnight to 8 a.m., phones New York.  
GBC—England, 32.22, late evenings, phones Canada.  
GCB—England, 32.33, afternoons, phones CGA.  
GBU—England, 16.11, mornings, phones New York.  
GAS—England, 16.38, 1-1:15 p.m., phones New York.  
GBS—England, 32.59, late evenings, phones New York.  
GBU—England, 13.45, mornings, phones New York.  
GBB—England, 22.08, daytime, phones Canada.  
GBC—England, 23.47, irregular, phones ships.  
GCW—England, 30.64, 6 p.m., phones New York.  
GBS—England, 16.38, mornings, phones New York.  
GBP—England, 28.04, midnight, 8 a.m., phones New York.  
GBC—England, 17.56, early afternoon, phones New York.  
GBS—England, 24.69, afternoons, phones New York.  
GDW—England, 62.24, evenings, phones New York.  
GCA—England, 30.90, 6 p.m., phones Argentina.  
GBB—England, 22.09, daytime, phones Canada.

PHI—Holland, 16.88, 7:30-10 a.m., except Tues., Wed., metronome.  
DJA—Germany, 31.38, 5-8 p.m., "Eight Piano Notes."  
DJB—Germany, 19.73, 8-11 a.m., "Eight Piano Notes."  
DJD—Germany, 25.51, noon-4 p.m., "Eight Piano Notes."  
DIQ—Germany, 29.15, special broadcast with DJD.  
DJM—Germany, 49.35, test with New York, 6 p.m.  
DJC—Germany, 49.83, 8-10:15 p.m., "Eight Piano Notes."  
DJE—Germany, 16.89, irregular, programs of DJB.  
DJO—Germany, 25.43, irregular, to Africa with DJD.  
DJN—Germany, 31.45, irregular.  
HJY—Colombia, 16.25, mornings of Eucharistic Congress.  
HJY—Colombia, 21.98, mornings of Eucharistic Congress.  
HJY—Colombia, 30.21, evenings of Eucharistic Congress.  
VE9GW—Canada, 49.22, see letter, "Baritone announcer."  
IRM—Italy, 30.52, irregular, phones South America.  
W2XAF—New York, 31.48, 7:30-11 p.m., relays WGY.  
W2XAD—New York, 19.56, 2:30-3:30 p.m., relays WGY.  
W9XF—Chicago, 49.18, see card, relays WENR.  
(Continued on page 757)

# SHORT WAVES and

## Karl Hurst Has Good Results With Our Sets!

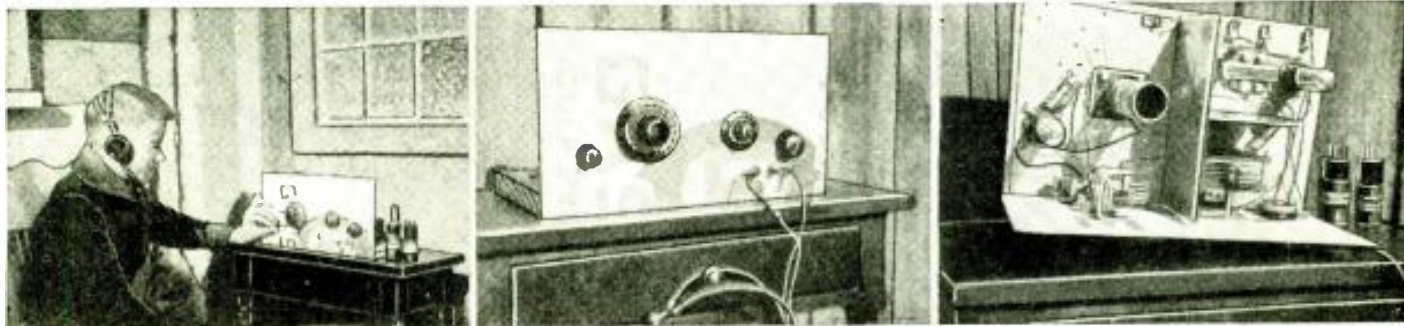

Mr. Hurst built the 2-tube short-wave receiver shown above from "odd parts" for a friend of his, whose likeness appears in the picture at the left. You will find Mr. Hurst's letter very interesting.

Editor, SHORT WAVE CRAFT:

I have been a short wave experimenter for about five years and a reader of SHORT WAVE CRAFT for about three years. Of course I consider it the best S.W. magazine on the market, or I would have stopped reading it long ago.

I have built quite a few of the sets you described and have had good luck with them. At present I am working on one similar to Mr. Dunsmore's "Consuelo Falcon" as described in the August 1933 issue. It will be my first A.C.-powered set.

I am always interested in the "S-W Kinks" section of the magazine, in which you print ideas contributed by other readers. Not only are these ideas valuable in themselves, but they often serve to give me ideas on solving some particular problem of my own.

I am enclosing photographs of a two-tube set I recently built for a young friend of mine. (He appears in one of the photos.) The circuit is the usual one, and the parts are mostly "junk" from old battery sets that we gathered together. It is in building a set from such a conglomeration of parts as we had, that ideas ob-

tained from the Short-Wave "Kinks" department come in handy.

You will notice that the shielding is of tin obtained from a coffee can, while the panel is of steel covered with enamel. It was cut from an old gasoline sign. Of course in time it will be given a coat of paint to improve the looks a little. The regeneration control condenser is at the right and is of very old make. So is the bayonet socket that supports the plug-in coils. The plug-in coils are "home-made," since we cannot wind on the tube base when it fits inside the socket. The antenna connection consists of an insulated wire twisted around the heavy bare wire fastened to one terminal of the bayonet socket. The set tunes from 23 to 205 meters, probably with vacant spaces instead of overlaps on the different coils, but it covers all the "important" bands.

The first day we tried it out, we tuned in GBS in the morning and GSC in the afternoon. Since then we have had EAQ, GSA, OJC, YVIBC, and numerous American 49-meter stations, as well as 80- and 160-meter amateur phone and police stations. The set is not troubled with "hand-

capacity" effects, but is rather noisy below 30 meters when the old regeneration condenser is turned. However, the set works better than I expected it would and the young chap is satisfied; I guess we will have to give SHORT WAVE CRAFT a vote of thanks for that! The "old magazine" sure is the answer to the "set-builders prayer"—as some one remarked in a letter to you recently—and he was right!

The cover picture on the January issue "is the berries"! I know several fellows, including myself, who would like a Christmas like that!

KARL F. HURST,  
Lyons Falls, N.Y.

(Fine business, Karl, and we are glad that you find in SHORT WAVE CRAFT the information regarding short-wave set construction that you are looking for. We believe you will find the information given in Mr. Dunsmore's article very satisfactory as we have received a goodly number of very favorable letters concerning the efficiency and smooth tuning obtained with that set.—Editor.)

## "POCKET SET" GOING GREAT GUNS!

Editor, SHORT WAVE CRAFT:

Recently I bought the December issue of SHORT WAVE CRAFT, and saw a diagram of a 1-Tube "Pocket Radio." Well, I set about to build it and had it finished within an hour. The first station I received was W3XAL, Bound Brook, N.J., coming in QSA5-R9! A friend of mine, who happened to be present at the time, asked me to build one for him if it could be made more compact than was shown in the "mag." This morning, I rebuilt the set in a box  $4\frac{1}{2} \times 5 \times 1\frac{3}{4}$ ". Everything including "A" power supply is contained in this box. I am using plug-in coils to cover 15-550 meters. (Who said there was no room for the socket for the plug-in coils?) I will recommend this set to anyone who wants to get the most radio for the least money.

I made contact with your "MAG" about two years ago. Thanks for some "fine dope," especially on the new "acorn" tubes. Nuff sed—so guess I'll sign.

JOHN KEEGAN,  
211 N. Blakley Street,  
Dunmore, Pa.

(Well, well, John, another letter on that "Pocket Radio Set"! We have had quite a "flock" of letters concerning Mr. Shuart's 1-tube "Pocket Radio Receiver" and the astonishing thing about this receiver is that those who have built it have, in many cases, been successful in operating a loud-speaker with this very small set, which ordinarily would only be expected to bring in signals on headphones.—Editor.)

## MR. WORCESTER'S HINTS A GREAT HELP!

Editor, SHORT WAVE CRAFT:

Wish to congratulate yourselves and Mr. Worcester, for the latter's idea—published in the January issue on "De-Henrying."

I have applied this scheme to two locally built regenerative sets, wrapping the grounded wire around the plate leads of the untuned R.F. 58 tubes, and the grid leads

### One Year's Subscription to Short Wave Craft FREE

for the "Best" Station Photo

Closing date for each contest—60 days preceding date of issue: April 1 for June issue, etc. The editors will act as judges and their opinions will be final. In the event of a tie a subscription will be given to each contestant so tying.

of the 57 detectors, the latter circuit being tuned, and the former inductively coupled to it.

The result has been an increase in sensitivity of at least 50 percent, and the owners of these sets are correspondingly happy.

D. M. DUNSMORE,  
Estate Consuelo,  
San Pedro Macoris, Dom. Rep.

(Thanks very much for your interesting letter, D.M.D., and we are indeed glad to learn that you had such good success with

Mr. Worcester's idea on "De-Henrying," published in the January issue. Those among our readers who have not read Mr. Worcester's article will find it very profitable to do so.—Editor.)

## 300 PERCENT "GAIN"—THANKS TO OUR ANTENNA DATA!

Editor, SHORT WAVE CRAFT:

Just a line to let you know what I think of the articles in your magazine. I think the magazine is OK. I haven't missed a copy in three years and have built many of your sets. At present I have a 2-tube D.C. Doerle receiver and have had fairly good success with it until I began thinking about a doublet antenna and looking through the back copies of SHORT WAVE CRAFT I came upon the article "Short Wave Antennas" in the 1934 October issue. After reading this over I picked out the one with a twisted lamp cord for a lead-in, but instead, I bought some water-proofed lead-in wire as the article suggested and is it a knock-out! It increased the volume 100 percent and the sensitivity at least 300 percent. This is especially true on the bands below 40 meters. I am deeply indebted to you for printing such a fine article and think it is worth the time of any short-wave fan to install such a system. These are a few of the stations I have received: W8XX (on three wave lengths), DJG, WEA, KWQ, W3XL (on three wave lengths), EAQ, COC, HC2RL, XENT, KES VE9GW, and 47 police stations; the many amateur stations heard

(Continued on page 761)



# LONG RAVES • • • OUR READERS' FORUM

## HOT-CHA FOR "2 TUBE DOERLE"!

Editor, SHORT WAVE CRAFT:

I wish to commend you on your splendid magazine. The articles are so clear, concise, and neatly written that anyone can read them!

I have built your "2-Tube Doerle D.C. Set" and have had "splendid" results! My results may not compare at all with those of other listeners in different cities, but here are a few stations I've received and I consider them a good start.

Among my United States stations are: W8XK, W3XAL, W1XAL, W9XAA, W9XF, W8XAE, W2XAF, W2XAD and others.

Foreign: VE9GW, VE9JR, GSE, and FYA.

Recently I made a 10-20 meter coil and have found it extremely valuable. On bright, sunny days, I can receive 19 and 16 meter stations extremely well, but on cloudy days or when the sun is temporarily hidden behind a cloud, the volume is decreased tremendously.

T. J. TRACY,  
1506 Hammond Avenue,  
Superior, Wisc.

*(Thanks a lot T.J.T., and we are pleased to note that you have found the 2-tube Doerle D.C. set to give such splendid results. One thing about the Doerle is that it has no "fancy frills" but, like a good race horse, it stands staunch and delivers the goods.—Editor.)*

## FINE RESULTS WITH "OSCILLO-DYNE" AND OTHER SETS.

Editor, SHORT WAVE CRAFT:

I thought I'd drop you a few lines to let you know that I have had great success with sets built from diagrams published in your wonderful magazine. Among the sets I have built are: The 3-tube "Doerle," "Triplex 2," "Oscillodyne," the 2-tube "DX-er," "Twinplex" and numerous others, mostly two and three tubers.

I never miss an issue of your "mag" and I think that it gives the most up-to-date information and ideas.

I always read your "Short Waves & Long Raves," but up to now I didn't have enough courage to write, but after reading other letters I decided to do so.

Editor, SHORT WAVE CRAFT:

Herewith is a picture of our Waupun High School Radio Club (Q.R.S. Club) of Waupun, Wis., also a list of the "foreign" stations heard by our members.

I do not believe that I've ever seen a picture of a High School Radio Club in your magazine, so I believe that this information may be of special interest to other clubs.

The sets shown in the picture are all made from "hook-ups" shown in SHORT WAVE CRAFT, copies of which are always available at our regular weekly meetings. The Q.S.L. cards shown include "verifications" from England, Germany, Bolivia, Venezuela, Canada and Australia. The three boys that are seated are the officers, with myself as advisor. This is the third year of our existence as an organized club and we expect to have four licensed operators by March 1.

We, as a club, sincerely hope that our picture and station list will be published.

We believe that our club name "Q.R.S. Club" is very appropriate for beginners in code and radio study. Hi!

We would be pleased to answer any questions regarding our activities as a club.

ERWIN PFEFFERKORN,  
Radio Club Advisor and  
H.S. Instructor of Physics,  
Waupun, Wisconsin.

*(Continued on page 761)*

## Dick Overholt's Calif. "Listening Post"

"Prize-Winning" Station Photo Awarded one year's subscription to SHORT WAVE CRAFT

Editor, SHORT WAVE CRAFT:

Here's a photo of "Yours Truly and his listening post out here in California. First I want to say that I've taken SHORT WAVE CRAFT since December 1931, and want to congratulate you on your "FB" Magazine and hope you keep up the good work.

Practically all of the equipment on the desk is "home-made" with the exception of the loudspeaker and radio cabinets. The radio is an all-wave set using 58-rf., 57-det., 56 and 2A5 in audios and 80 rectifier. The range of this set is 17-550 meters.

The "can" next to the receiver is a "monitor"; the following can is a "code practice" outfit. I also made the "coil racks" and wound all my own coils. Even the lamp was made from an old loudspeaker and a tube-base.

SHORT WAVE CRAFT has been helpful in more ways than one, when constructing sets; also my first S.W. set was the famous "Doerle"!

"I have received verification cards from EAQ, XETE and YV3BC and they sure are the "berries"!



Dick Overholt wins the prize this month for his station photo. Mr. Overholt is a clever constructor and he even built the coil racks shown in the picture.

Best of wishes for the continued success of SHORT WAVE CRAFT.

DICK C. OVERHOLT,  
710 Clayton St.,  
San Francisco, Calif.

*(Glad that you sent the picture in, Dick, and apparently you are very handy with tools, a fact which is not always true of short-wave "Fans." We hope to hear from you again when you have a photo of some new set that you have built and tested successfully, and our compliments to you on the loudspeaker receiver you have constructed.—Editor.)*

A few months ago I started a club, we call the "Modulators." We are trying to climb over that barrier to "amateurism"—called the code. At present I can read about 7 w.p.m. So when I get to the re-

quired number, I'll take the tests; then I'll probably send you a picture of my rig. Hi! Hi!

I will gladly exchange letters or two or  
*(Continued on page 761)*

## Q.R.S. Radio Club a "Live" Wire!

Special Prize Award of one year's subscription to SHORT WAVE CRAFT



We are glad to publish this very interesting picture of the QRS Radio Club of the Waupun High School of Waupun, Wis. All of the sets shown in the photos were built from articles published in SHORT WAVE CRAFT.





Here we have Mr. Victor operating the Eagle "E-C" Four.

# The EAGLE "E-C"

if any, how much, was the next topic under consideration. Final opinion agreed upon one stage of tuned radio-frequency amplification. Primarily, a stage of R.F., using a high-gain screen-grid type '58 tube will deliver enough swat to kick the grid of a detector stage around right merrily. Secondly, the R.F. stage serves to isolate the antenna from the detector, so that on a windy day when the antenna is bouncing in the breeze, the detector output will still be stable as a rock. Likewise, with an R.F. stage it is possible to get the full benefit of the doublet type of antenna, without worrying whether the detector will oscillate or not when well loaded (with inductance, not what you're thinking of). Two R.F. was definitely ruled out, because of the amount of shielding and extra equipment needed; one stage of R.F. will give more than satisfactory results.

## Electron Coupling Employed

Inductive coupling was agreed upon between R.F. and detector stage, to allow for highest possible gain, and the best possible "impedance match." The detector stage was next put on the witness stand for questioning. After a short check-up among those with previous experience, *electron coupling* was agreed upon. The electron-coupled circuit, originated by Lieutenant Dow, is the finest regenerator known to radio today. Extreme stability, which is usually a revelation to those who are accustomed to chasing a station up or down the dial, is only one of its admirable features. Another is the fact that it is by far the most sensitive regenera-

● Your writer has been teaching radio school in New York City during the past six months, and the receiver to be described in this article was the set finally chosen to suit the needs of the student body taking the short-wave course. The class was made up of everybody imaginable, from *rank beginners* to *licensed amateurs* and short-wave "bugs" of long standing. Hence an enormous amount of varied brain-cudgeling was gone into so as to evolve a good short-wave receiver that would fill all of the very exacting demands that follow:

1. The set had to be low in cost, since most of the students were not millionaires' sons.
2. Easy enough to build so that the beginners would not have too much trouble.
3. Extremely stable in operation, to hold the elusive low-power stations in the amateur bands.
4. Operative from phones or loud-speaker to suit both the S.W. listeners and the Hams.
5. By unanimous decision of the three girls in the class the set had to be neat and symmetrical, in other words, have "eye-appeal."
6. Coils to plug in from the front of the panel, eliminating one of the worst nuisances in the homemade S.W. set, that of reaching behind the panel to put coils in.
7. Must use noise-reducing doublet type aerial.
8. A.C. operated, to eliminate upkeep cost on batteries, and prevent complaints from "boss of house" about "mess."
9. Absolutely hum-free, even on phones.
10. Be easily adaptable to band-spread for the Hams.
11. Regeneration control must be *smooth* and practically *non-detuning*.
12. Under fair conditions, round-the-world signals, without undue loss of sleep or excess ear-strain.
13. No trick gadgets or circuits that would not be dependable and operative at all times.

## Regenerative Set Decided On

After these major stipulations and a host of minor ones had been decided on, the "dirty work" really began. The entire class assembled in solemn conclave

and the floor was thrown open to discussion to determine the type of set we would finally build. Supers were immediately ruled out, as being prohibitive in cost, as well as extremely difficult for beginners to construct and check up properly. All the honors were left to the *regenerative* circuit, and rightly so. For, given a fair chance, the old Armstrong, though with multitudinous variations, will still drag in that music from Moscow and speeches from Silesia, et al.

## 2.5 Volt Tube Used

Two and a half volt filament tubes were next decided on as standard, inasmuch as the tubes and supplementary equipment were readily available, at reasonable rates. R.F. or no R.F., and

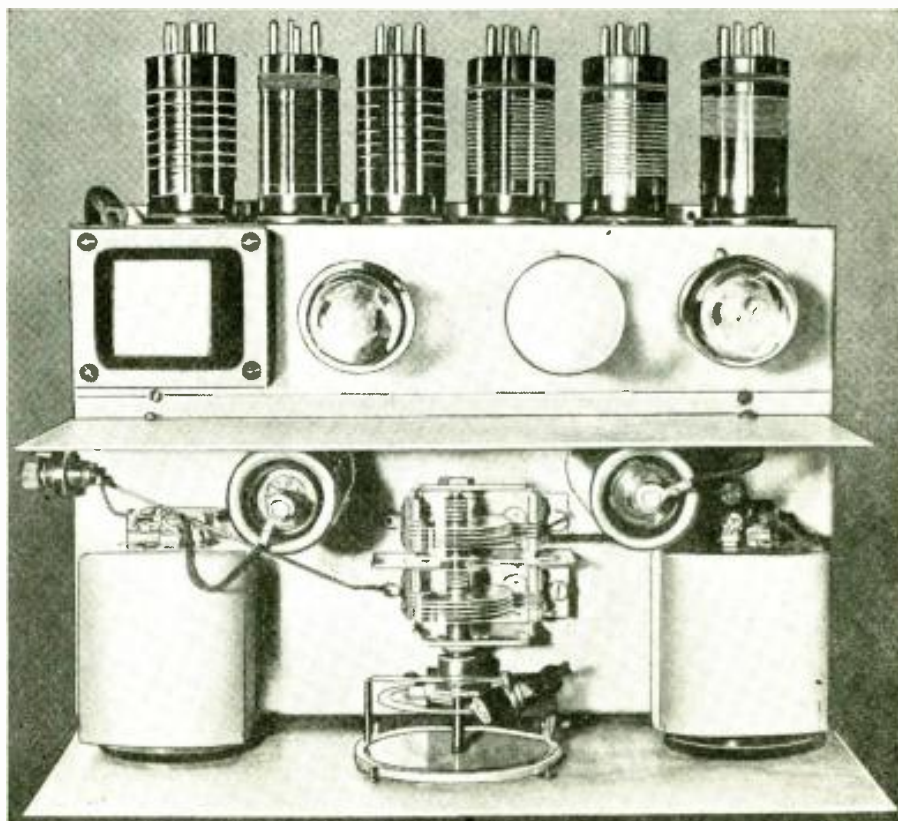

This view clearly shows the placement of the various parts used in Mr. Victor's receiver.



# FOUR Receiver



By Leonard J. Victor, W2DHN

tive circuit. Finally, the E.C. circuit is (practically) non detuning. In other words, it is not necessary to retune the set when shifting in and out of regeneration. Especially when hanging on to a whisper from the other side of the earth, this is a boon and blessing to a straining DXer.

### Audio Stage and Power Supply

There was a lot of argument on the question of audio but a final agreement

Mr. Victor here presents a very interesting set, designed and built during the teaching of a class of radio students, and we feel sure our readers will find it a very worth-while receiver. It consists of a 58 tuned R.F. stage, 57 electron-coupled regenerative detector, and a 2A5 power amplifier. This receiver has a built-in "power supply" which uses an 80 rectifier. A good many foreign stations were received with this set in one of the busiest sections of New York where reception is none too good.

### Parts List Eagle E-C Four

- 3—.0001 mf. mica condensers. Aerovox.
- 1—.05 mf. condenser. Aerovox.
- 3—.1 mf. condensers. Aerovox.
- 1—.5 mf. condenser. Aerovox.
- 1—Dual 8 mf. electrolytic condenser. Aerovox.
- 1—double gang .00014 mf. condenser. Hammarlund (Bud).
- 1—.000035 mf. variable condenser. Hammarlund (Bud).
- 1—300 ohm, 1 watt Resistor. Lynch (Ohmite, Aerovox).
- 2—50,000 ohm 1 watt Resistors.
- 1—25,000 ohm 1 watt Resistor.
- 1—100,000 ohm 1 watt Resistor.
- 1—500,000 ohm 1 watt Resistor.
- 1—1 megohm 1 watt Resistor.
- 1—5 megohm 1 watt Resistor.
- 1—20,000 ohm potentiometer. Eletrad.
- 1—50,000 ohm potentiometer. Eletrad.
- 3—6-prong sockets. Bud (Na-Ald).
- 1—4-prong socket. Bud (Na-Ald).
- 1 set three: winding coils: Eagle (Bud, Na-Ald).
- 1 set E.C. Electron coupling-coils. Eagle.
- 1—power transformer. Eagle.
- 2—2.5 m.h. R.F. chokes.
- Hardware, etc.
- 1—Chassis, Eagle Radio. (Blan; Korrol).

was finally reached on the type 2A5 pentode tube.

For those who wanted to be able to use earphones, a first stage of audio, using a '56 tube was added to the diagram. The earphone jack was placed on the back of the set, near the speaker plug. The diagram for this extra stage of audio is included in the article.

A conventional power supply was agreed on, with 16 microfarads of filter, and the speaker field used as a bias resistor and choke coil. The panel between power pack and set both above and below the chassis is a precautionary measure, to insure that no insidious 60 or 120

cycle "murmur" will be heard while proudly displaying the miracle to wondering neophytes.

Hence we had finally agreed on 58 R.F., 57 electron-coupled detector, optional '56 first audio, 2A5 audio, and a 280 rectifier. The next task was laying out the parts for shortest leads, always remembering the young ladies' appeal for symmetrical appearance. I will draw the curtain on our arduous labors and merely say we arrived at the result which is depicted in the accompanying photographs. The R.F. and Detector stages are laid out with all attention to

(Continued on page 751)

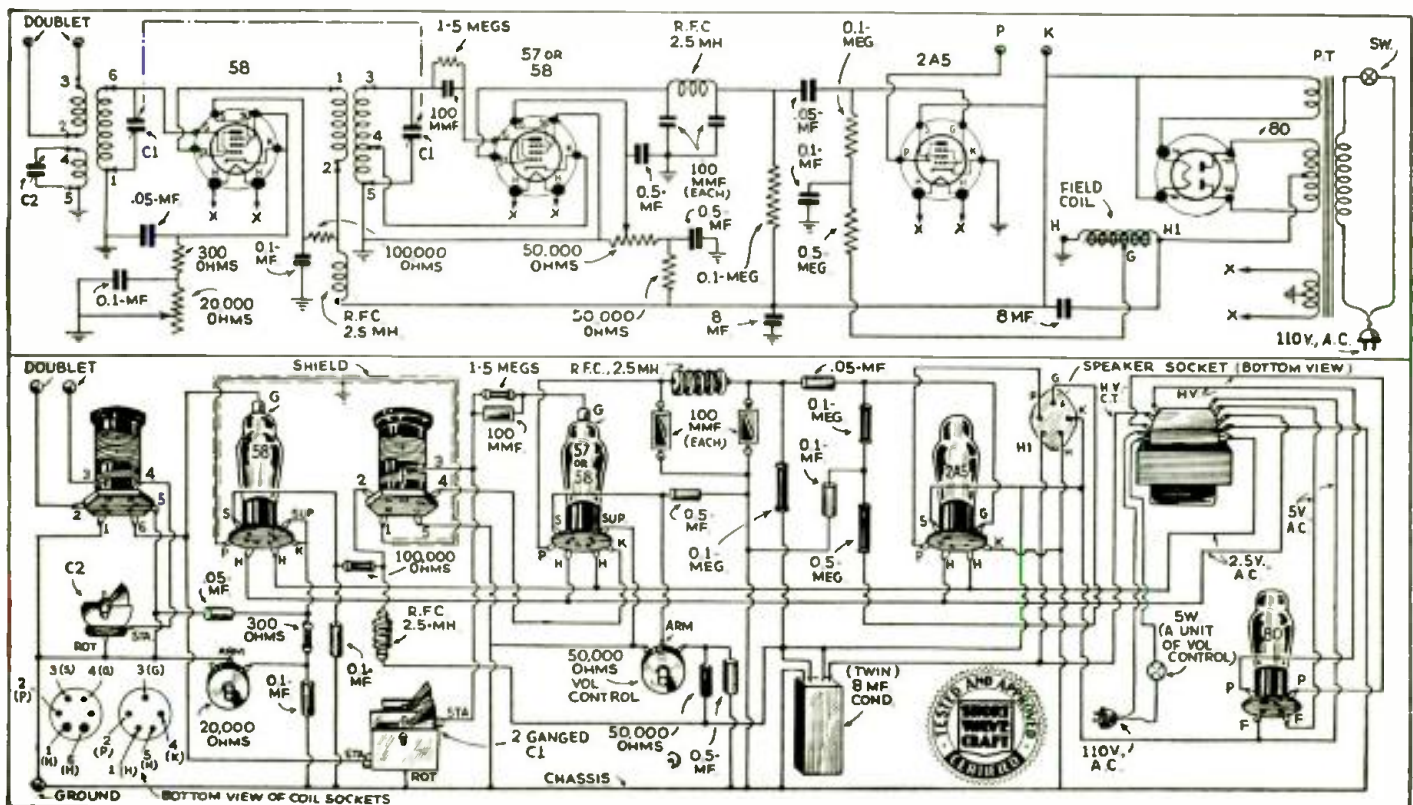

Physical and schematic diagrams for building the Eagle "E-C" Four receiver.

# WHAT'S NEW In Short-Wave Apparatus

The short-wave apparatus here shown has been carefully selected for description by the editors after a rigid investigation of its merits

## New 5- and 10-Meter Transceiver By Clifford E. Denton\*

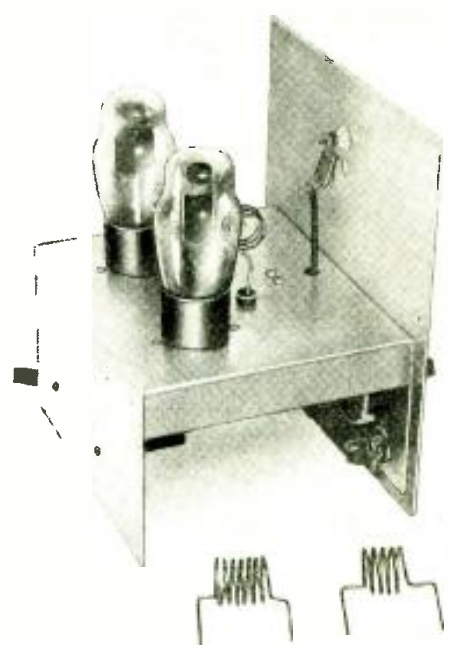
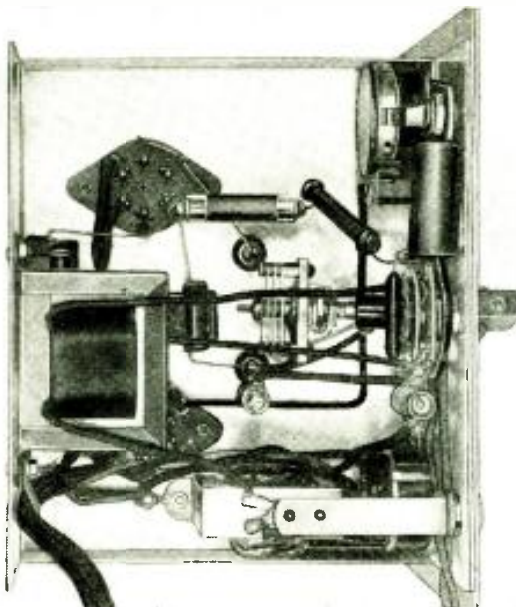

Above—bottom view of transceiver which is very compact and light to carry about.

Left—complete 5- and 10-meter Transceiver.

Above—rear view of transceiver chassis. Works on 6 volts D.C. or 110 A.C.. No. 267.

● NEVER in the history of radio has 5-meter reception and transmission received such world-wide attention. The extreme simplicity of equipment, the ease of operation, and the small amount of operating skill required has made ultra-short wave transmission the sport of the average "man in the street" rather than that of kings. Low initial cost and still lower upkeep account to a large extent for this general reaction.

Another possibility with 5-meter equipment is the practical combination of a receiver and transmitter in a single case with the necessary simple switches for quick change-over from transmission to reception.

And since many of the parts of the receiver can be used for the transmitter, the combination results in a cost proportionately lower than that of either one alone. Note the photograph of the new *Acratest Transceiver* (combination transmitter and receiver) with hand-set (sometimes called a French phone), having, in a single unit, the microphone and telephone receiver. Change-over from transmission to reception is accomplished with a single switch on the panel.

### The Schematic Circuit

The circuit, Fig. 1, as shown has several unique features. A single coil L is used for both transmission and reception. This

coil is of the plug-in type, and, by means of several coils provided with the instrument, the entire range from 26 to 62 megacycles can be covered. When the two ganged switches are thrown to the "receive" side, the antenna, to be described, connects through a coupling condenser C to the control grid of a type 42 tube. Plate voltage on this tube is secured through the choke RFC1 and resistor R1 which is connected to the B supply. Since R1 is in series with the high-voltage lead, regeneration may be obtained for maximum sensitivity.

This same type 42 tube rectifies the incoming signal, and the output is fed to the input to the second type 42 tube, which

(Continued on page 759)

## A Really New Idea in Transmitting Coils

● HERE is a brand new idea in a transmitting inductance and recently announced by Thordarson Electric and Manufacturing Company. This universal transmitting inductance is designed to replace a complete set of coils formerly used to cover the various amateur bands. It is a helically wound coil of copper tubing, 4½" in diameter, each turn of which is joined to the succeeding turn by means of a specially designed clip. Therefore, as many turns may be utilized as are necessary for a given frequency. We are printing a table showing the necessary capacity and number of turns for the various amateur bands.

Each inductance is composed of a number of four-turn units which are variable in one-turn steps. If one should desire to increase or decrease the inductance, a group of four turns can be added or taken off at any time. Each of the turns in the group are joined together by means of a

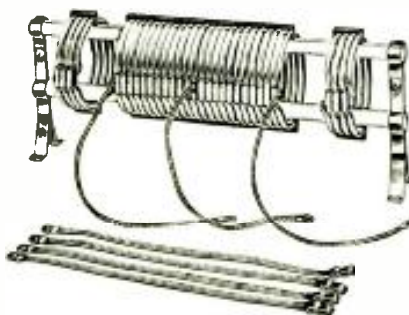

The newest style in short-wave transmitter inductance which has cleverly designed clips or clamps, permitting the operator to use any number of turns and also any number of coils. No. 268.

removable clip, in the same manner as the groups are joined together. The illustration clearly shows the general appearance and construction of this transmitting inductance.

This is a truly universal instrument.

Band	Tank Cir. Turns	Ant. Cir. Turns	K. C. Freq.	Mmfd. Cap.	K. C. Freq.	Tank Cap.	Mmfd. Rec. Cond. Value
80 Meter.	24	8	3500	86	4000	65	100
	20	8	2500	110	4000	80	125
	18	8	3500	140	4000	110	150
40 Meter.	12	8	7300	40	7000	45	50
	8	8	7300	57	7000	65	70
20 Meter.	4	8	14400	31	14000	33	35
160 Meter.	24	8	2000	260	1715	350	350

Names and addresses of manufacturers of sets described on this and following pages furnished upon receipt of stamped envelope; mention No. of article.



# Latest 30-Watt Transmitter

By Frank Lester, W2AMJ\*

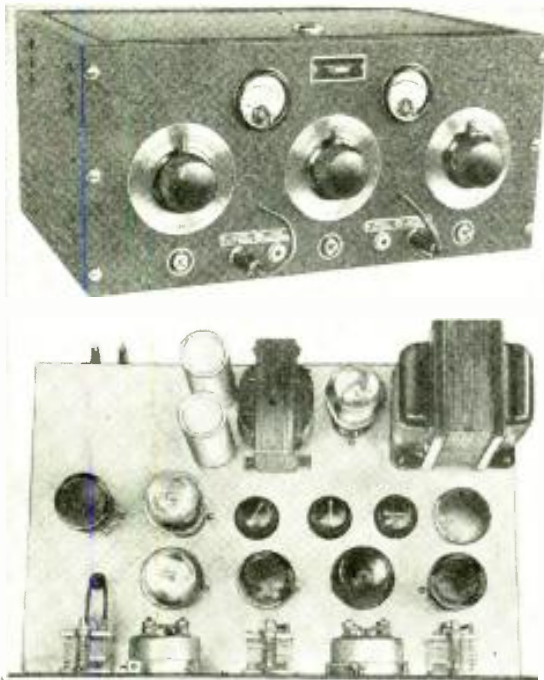

Above: We have front and top views of the handsome 30-watt transmitter which will appeal to many Hams, as it is inexpensive and of new and original design, which causes it to really "step out and go places!" No. 269.

● THE "Les-Tet" exciter using the 2B6 tube is rapidly gaining favor with amateurs everywhere as a simple, convenient and easily adjusted transmitting unit. It can be used by itself to form a low-powered rig with an output of about 5 to 7 watts, or it can be used as a driver for power stages using much larger tubes.

\*Engineer, Wholesale Radio Service Co., Inc.

Many Hams who cannot afford the Lafayette 100-watt outfit, but who want more "hop" than afforded by the 2B6 alone, have requested data on a medium-powered transmitter using inexpensive tubes. The 46's seem to be the favorites, probably for the reason that they cost only about 65 cents each retail and replacements can be made without straining the family bankroll.

Two 46's connected in parallel as a Class C final amplifier were found to afford a very conservative output of about 30 watts, 600 volts being applied to the plates. The final circuit that was selected for the present, self-contained Lafayette transmitter is shown in Fig. 1. Tube VI is the 2B6, which consists of one very small triode and one large triode in one envelope, with the cathode of the former connected inside the tube to the control grid of the latter. The crystal is connected across the grid-cathode section of the small triode, with the cathode-plate tank, consisting of L1 and C1, between the cathode and ground. The large triode acts as a direct-coupled amplifier, its plate circuit containing the tank L2-C2. Neutralizing voltage to overcome feed-back effects through the grid-plate capacity of the amplifier triode is supplied by the bottom section of L1, through the small neutralizing condenser C4.

The 46's are operated together as a straightforward, neutralized Class C stage, with the plate tank coil L3 tapped for neutralizing e.m.f.; C5 is the neutralizing condenser.

The variable bias resistor R1, in the cathode of the large triode section of the 2B6, acts as a very simple and effective excitation control for the 46's. A fixed resistor of 1000 ohms (R2) is provided so that there is always some bias on the 2B6 even with R1 turned down to zero.

For power supply, an 83 is used in a foolproof, standard hook-up, as shown. The bleeder resistor R5 has one tap, for the plate of the oscillator. The filter condensers are 1000-volt electrolytics.

Three separate single-pole snap switches, SW1, SW2, and SW3, are included in the circuit. The idea is to close SW1 first, giving all tube heaters a chance to warm up. SW3 is then snapped, (Continued on p. 763)

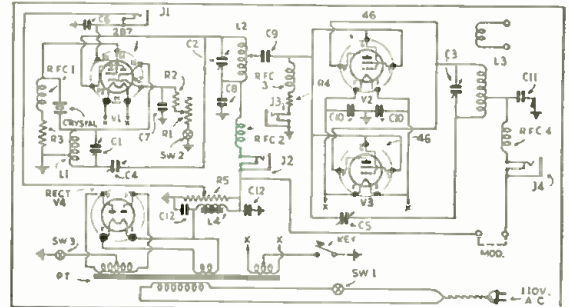

Hook-up of the new type P46 30-watt transmitter.

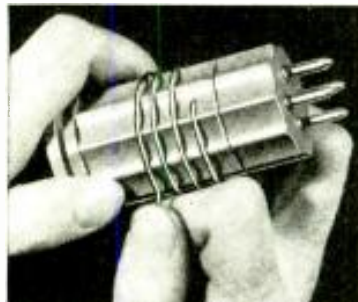

Above: Completing the winding of one of the short-wave coils. Note the characteristic grooved ribs. Right, above—A cutaway view of the coil form, showing the APC condenser mounted. Note that it doesn't touch the walls of the form, thus avoiding losses! No. 270.

● IN THE construction of any receiver, however simple or involved, the careful selection of parts which have been thoughtfully designed, developed, and produced, is as major a requirement, as the accuracy of the circuit itself. This message has been boomed and boomed, but its importance is such, that its repetition is an everlasting necessity. To this end, laboratory experts are continually at work, investigating new materials, in whole or in part. Every solution adds another rung to that ladder of anticipated perfection.

In short-wave radio, with its aeons and aeons of eccentric characteristics, particularly does this stringent factor exist. A member of this important family of parts is the "plug-in" coil. Any experimenter knows what a difference in results he can secure, as to volume, selectivity, and sensitivity, when various coils are used. A few weeks ago, the engineers of the Hammarlund laboratories, made an important announcement in this respect.

For years, Hammarlund engineers have been developing and producing accepted "plug-in" coils, but these have been just beyond the reach of the purse of the average set builder, and thus many experimenters were deprived of these effective units. Many tests were made to create a coil form which would solve this problem. As a result a new material was discovered—known as XP-53. Though it was found possible to produce this more within the means of the set-builder, it possessed, nevertheless the "low-loss" characteristics of the more expensive dielectrics.

To be assured of the efficiency of this new insulating material, it had to be formed, wound and

\*Hammarlund Mfg. Co., Inc.

# New Low-Loss Coil Forms

By Lewis Winner\*

actually used in actual practice, of course.

So that you will be enabled to duplicate the results of the engineers, not only are the coil data presented, but the reasons for the choice of these windings, as well as the reasons for the choice of other important factors.

The first step the engineers had to solve was the most practical frequency range for each coil. They had to determine not how much of the short-wave band could be covered with each coil, but the required range for each coil in relationship to the important short-wave stations. It is quite well known that the greatest short-wave tuning efficiency is obtained when the coil inductance is such, that relatively little tuning capacity is required to tune the coil to the desired frequency!

The problem therefore was to allocate the ranges so that as many as possible of the important frequency bands could be tuned in at relatively low capacity values. The bands aimed at primarily (Continued on page 765)

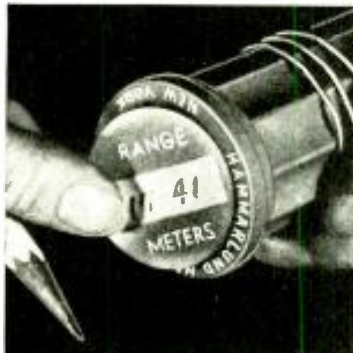

Above: Inserting the "range" disc, after the wavelengths have been properly written in. Right: the large openings in the pins, where the coil winding leads enter and are soldered.





# HIGH-FIDELITY

## HOW TO IMPROVE Old Loud-Speakers and Baffles

By  
WILHELM E. SCHRAGE

● THE last article on *high fidelity* receivers, which appeared in the February issue of this magazine, described in considerable detail how to improve the audio frequency circuits in short-wave receivers, so that they would produce higher quality music and speech from the loud-speaker. The reason why many receivers today do not yield very good quality sound reproduction from the loud-speaker is because of the fact that the loud-speaker itself is frequently at fault. Those who did not read my first article in the February issue, should certainly do so before deciding to make any changes in their loud-speaker system, after having read the present article.

Mr. Schrage, well-known expert on "high fidelity" acoustics, here explains how you can improve your "old" loud-speaker by "doctoring" the cone and also by using special baffle-boards.

*High fidelity* is not only a problem involving the sound reproducing mechanism, such as the loud-speaker, but it is also equally important that the audio frequency circuits as well as the detector and the radio frequency tuning circuits ahead of it, are all properly designed so as not to "cut" the side-bands. As we mentioned before, it is almost useless to start redesigning or reconstructing the loud-speaker or acoustic section of the radio receiver, if no attention whatever is to be given to the circuits and type of audio amplifier system employed. Generally speaking, the *resistance-coupled* audio amplifier stages give the highest fidelity reproduction, but today audio frequency transformers, having special iron-alloy cores are available, which pass frequencies up to twenty thousand cycles, which is far beyond anything that we require for our high fidelity results at present, the spectrum to be covered being from 50 to 7,500 cycles.

### Loud-Speakers Must Reproduce Wide-Band of Frequencies Too!

On the other hand, if the receiving circuits are capable of reproducing or passing through the set practically all of the frequencies that they receive from the transmitting station, then it is *equally important* that we see to it that our loud-speaker system is capable of translating the frequencies received into audio frequency sound. For instance, it has been found by checking the frequency response of quite a number of loud-speakers that they do not cover a frequency range greater than 100 to 3,000 cycles, and such speakers are therefore not suitable for rendering a real natural reproduction of a musical or other program. Thousands of people have been *falsely educated* by lis-

tening to numerous low-pitched loud-speakers (abnormally low-pitched) on receiving sets for a number of years now, so that many people do not realize that the voice or music they hear reproduced from their loud-speaker is *not* exactly like the original voice or music as rendered in the broadcast station studio!

Quite a number of the modern commercial higher quality receivers of the all-wave type are being fitted with two, and even *three* loud-speakers, each of a different pitch, so that by using low, medium, and high-pitched loud-speakers, operating simultaneously, the whole acoustic frequency scale, from 50 to 7,500 cycles, is faithfully reproduced. You may not think so but many a good-sounding dynamic loud-speaker has an abnormally *low* pitch, and such a speaker often lowers the tone of a singer half an octave or more. This is particularly noticeable on one make of receiver manufactured several years ago, which causes baritones to sound like basses, and sopranos like altos.

### What Is a High Quality Loud-Speaker?

Frequently we find that the frequency response curve of a dynamic loud-speaker resembles that shown in Fig. 1. This curve shows the reproduction range from approximately 50 to 7,500 cycles and such a loud-speaker should therefore fulfill our requirements of broad frequency response. Strange as it may seem, this loud-speaker as shown in Fig. 1, is a perfect example of an unsatisfactory type of speaker, its shortcomings not being apparent at first glance, owing to the small size of the curve here shown. Now glance at Fig. 2 where the weak points of this loud-speaker are shown graphically! Here the loud-speaker unveils its true face and, as we see, its response curve is a continuous chain of valleys and peaks. The useful sound reproduction range is much smaller than before, as becomes evident, and it is therefore not surprising if a loud-speaker having such a characteristic curve, when connected to even a good set, will yield very mediocre sound reproduction.

The reason for the radically different appearance of the curve in Fig. 2 and

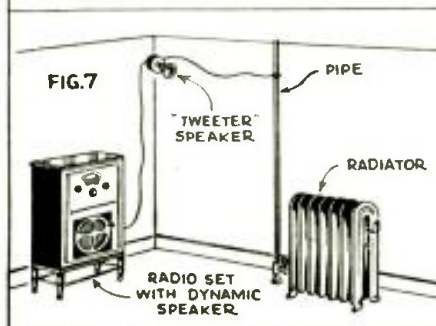
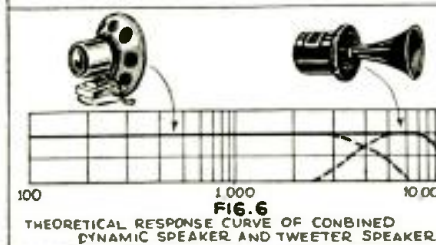
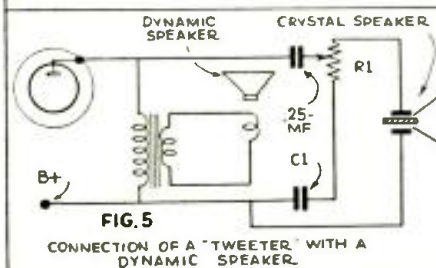
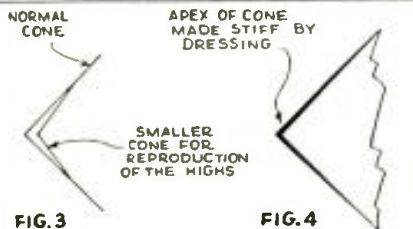
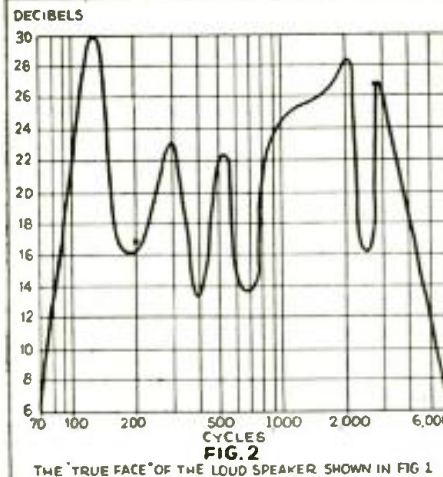
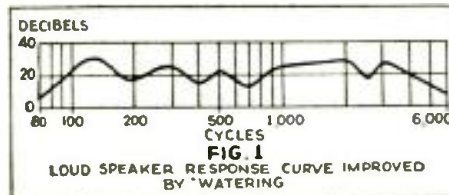

Fig. 1—Typical loud-speaker response curve. Fig. 2—"True pedigree" of speaker charted at Fig. 1. Figs. 3 and 4—"Modifying" the old cone. Fig. 5—Connection of "tweeter." Fig. 6—How response curves of "dynamic" and "tweeter" speakers overlap and spread the response. Fig. 7—Simple hook-up for "tweeter" speaker.

Fig. 1 is made apparent by noting the decibel (sound intensity unit) indication on the left side of the diagrams. Fig. 1 shows that the space between two indication lines is marked as a difference of 20 decibels, while the same space in Fig. 2 is indicated as only 2 decibels. This is, of course, an exaggeration.

(Continued on page 752)



# A Low-Power RACK & PANEL XMITTER



By George W. Shuart, W2AMN

This is the second of a series of articles describing a Low-Power Rack and Panel Transmitter for the Amateur. The unit described this month is the "Output Amplifier," which uses a pair of 46 tubes in parallel. In the next installment the complete transmitter, including the modulator for phone operation, will be described.

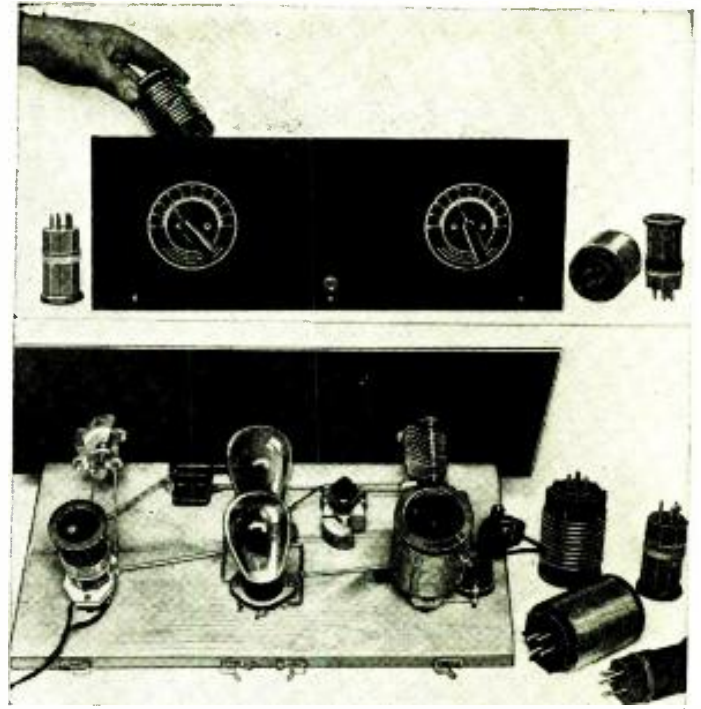

Front and back views of the power amplifier.

● THIS, the second of the series on low power transmitters, describes the final amplifier for the exciter described last month.

The exciter used a 2B6 double triode as an oscillator and buffer amplifier. This exciter has more than enough power output to excite a pair of 46's as the final or output stage. A pair of 46's in parallel will provide an output of 30 to 40 watts when operated with around 500 volts on the plates. The exciter and amplifier units are capable of working on any two of the amateur bands with only one crystal. That is, with the pair of 46's as a straight amplifier. It is not advisable to operate the two 46's as a doubler if they are to be used as the output amplifier. They can be used as a doubler, however, if another stage is used to feed the antenna. This added stage can be anything from a pair of 801's to a 75 watter, such as the 203A.

### Exciter "Link-Coupled"

Getting back to the point of this story, the exciter is

"link-coupled" to the grids of the 46 tubes. This is a very convenient and efficient method of coupling. Both the plate and grid circuits of the last stage are tuned to the frequency on which it operates. A small three-turn coil is wound next to the plate coil of the exciter and the grid coil of the amplifier; twisted pair is used to connect these two three-turn coils together. Plug-in coils are used in the amplifier as well as the oscillator in order to facilitate changing bands. The change from band to band can be made in approximately three minutes, after one has become familiar with the transmitter. The amplifier, like the exciter is mounted on a 7 by 19 inch bakelite panel of 3/16 inch thickness. The same size panels are used because the whole transmitter when finished, will be mounted in a wood rack. There are only two dials on the panel and room is left in the center for a meter should the builder desire to incorporate one instead of using the plug system for taking the various readings as is done in this rig. A 0-200 milliammeter is needed for this amplifier but it is mounted in the power supply panel so that readings can be taken in the modulator circuit. Both the modulator and the power supply (Continued on page 745)

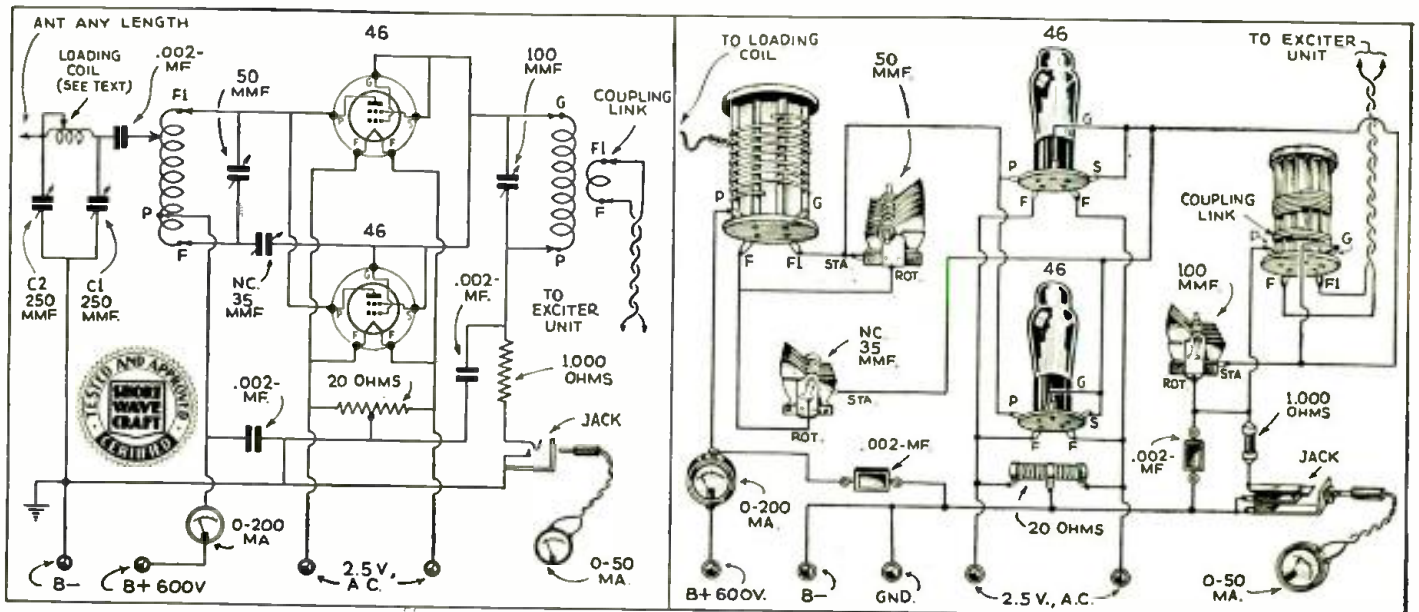

Physical and schematic diagrams of the amplifier, which uses two 46's in parallel.

**\$5.00 Prize Winner  
BAND SPREAD TRICK**

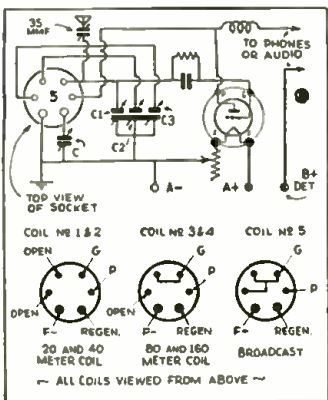

I am submitting a short-wave kink which I have found truly practical and very efficient. It is a band-spread kink which is fully automatic and which changes condensers when the different plug-in coils are inserted. This system is really very flexible and may be varied to suit the fancy of the builder. Connections of the secondaries and ticklers are shown for five different bands: C is regeneration condenser, .00025 mf.; C1, a condenser to spread 20- and 40-meter bands; C2 will spread the 80- and 160-meter band; C3 covers the broadcast band.—Wm. Porter.

**MAGNETIZING STUNT**



Many experimenters have had occasion to need a tool which has been magnetized in order to retrieve screws, nuts, or washers which have been dropped in the process of assembling radio apparatus. The drawing shows how a screwdriver or similar implement may be magnetized by bringing it in contact with the "pole-piece" of a dynamic speaker. Of course the speaker must be running in order that it will be magnetized. This stunt will only work of course on iron or steel tools and it will attract only like metal. Brass, copper, or aluminum will not be attracted to the magnetized screwdriver, of course.—Luther Burkhardt.

**HANDY LEAD-IN INSULATOR**

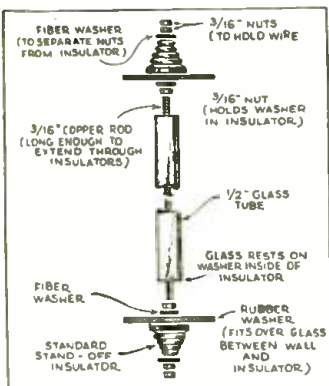

If a suitable lead-in insulator is not on hand, one can be constructed from a pair of regular stand-off insulators by the following method: Remove the fittings from two of these insulators and procure a length of 3/16-inch threaded brass or copper rod, 4 1/2-inch fiber washers, 6 nuts to fit the rod and a length of 1/2-inch glass tubing; also make two rubber washers 3 inches in diameter with a 3/4-inch center hole. These can be cut from an old inner tube. I am using a pair of these insulators for bringing in a transposed lead-in and I find them very satisfactory.—John Schlenker, Jr.

**\$5.00 FOR BEST  
SHORT WAVE KINK**

The Editor will award a five dollar prize each month for the best short-wave kink submitted by our readers. All other kinks accepted and published will be awarded eight months' subscription to **SHORT WAVE CRAFT**. Look over these "kinks" and they will give you some idea of what the editors are looking for. Send a typewritten or ink description, with sketch, of your favorite short-wave kink to the "kink" Editor, **SHORT WAVE CRAFT**.

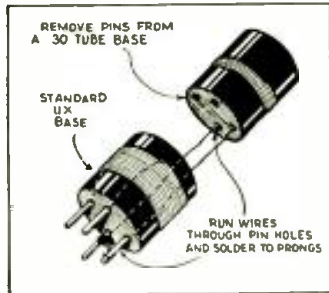

**HOMEMADE COIL FORM**

When making plug-in coils, especially the ones with larger windings, I found that the usual tube base was too short. In the drawing it can be seen that two tube bases are used; by removing the pins of one and cementing it in the top of the other, we have a very neat coil form. It is necessary, however, to wind the required number of turns on the lower coil form before the two forms are cemented together. Then wind the other form and run the two ends of the wire down through the holes which were left when the prongs were cut off. The drawing clearly shows how the entire unit is assembled.—Milton Saravett.

**INVERTED SOCKET**



There are many times when I have found that a socket could not be mounted in the way it was designed for, and have found that it was possible to turn it up-side-down and overcome the difficulty. A sub-panel socket or wafer socket can be turned up-side-down and mounted on top of the panel as shown in the drawing. Of course, all sockets, due to their peculiar contact construction, will not work this way. However, I have found that 90% of them will. I have also found that the base-mounting socket could be mounted underneath the sub-panel by replacing the screws which hold the contact and face them downward.—S. Javna.

**USES FOR OLD PHONE JACKS**

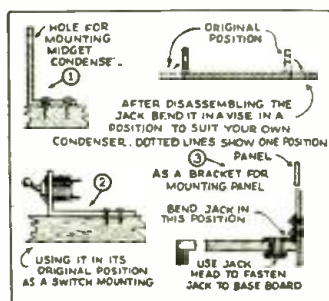

**HANDY CABLE LUGS**

Experimenters who have found difficulty in making a neat binding post connection, when using stranded hook-up wire, will find this odd wrinkle a cheap method of making positive contact. A number of eyelets (obtainable at any stationery store) and a pair of pliers comprise the necessary equipment. First, twist the strands of the end of the wire to be connected and loop this terminal about one of the eyelets; clamp the eyelet firmly to the pliers, and it will be found that the end of the wire is being gripped between the two sides of the eyelet. The latter can then be slipped on and off the binding post rapidly, and without danger of the wire being forced from under the head of the post, as often occurs when using stranded hook-up wire.—Walter Kells.

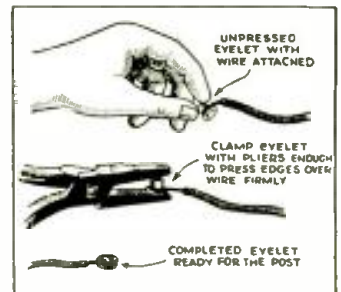

Undoubtedly nearly every experimenter who reads this magazine can find a large number of discarded old-fashioned phone jacks in the junk box. These should be saved by all means because they can be put to various uses such as shown in the accompanying drawing. In the drawing we have the base of the Jack forming an "L" bracket which can be used for mounting midjet condensers, volume controls, switches, and a number of other instruments.—James Slum.

**MENDING TUBE SOCKETS**

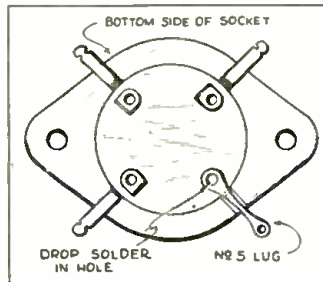

How many times have you broken the terminal on your last tube socket? This happened to me one time and as I could not obtain another socket immediately, I had to devise a method of repairing the damaged one. After much thought, a No. 5 soldering lug was finally brought to play. This was attached to the under side of the socket with a drop of solder and presto, the socket was as good as new! However, you will find that most of the metal parts on sockets are nickel-plated and it will be necessary for you to scrape the nickel-plated rivet until all nickel plating is removed and the brass or other metal shows through, otherwise the solder will not adhere to it. When you are in a "Jam" for a socket some time, try repairing your old one in this manner and see how nicely it works out.—Edward Kulakowski.

**WASH-BOILER RADIO CABINET**

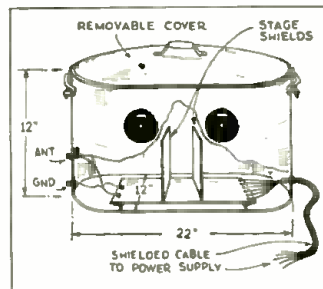

After completing a 4-tube short-wave receiving set I found, much to my disappointment that it was an excellent receiver of passing automobiles—ignition noise, of course! The next move was to completely shield the receiver but funds were low so the idea, presented in the drawing, came into being. The cabinet I used was made from an old wash boiler which, incidentally, is copper and provides very effective shielding. The removable cover offers ease in getting at the inside of the receiver for changing coils or tubes. A shielded power cable was also used in order to eliminate Dick-up. This in connection with the thorough shielding and the use of a good antenna, practically eliminated the interference.—C. E. Judson.

**IMPROVING SUPER WASP**

Brass wheels are put on the two shafts of hand-spreading condensers. This is simple enough but the detector band-spreading condenser's shaft will have to be removed and a 4-inch shaft inserted so that shaft may reach the new dial on the new panel. The brass wheels are now tied together by means of a piece of good fishing twine as shown in the sketch. If one prefers, the twine may be replaced by a metal strip similar to the one used in the Atwater Kent receiver. If twine is used a knot is made about the pin in each of the brass wheels.—Francis E. McGee, W3DM.

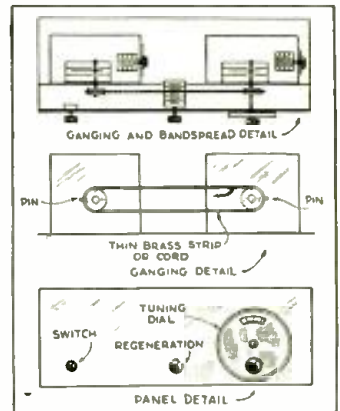

**USES FOR FAHNSTOCK CLIPS**

By cutting off and bending Fahnstock clips, as shown in the drawing, a very handy plug-in coil receptacle can be constructed. The drawing shows the method used in mounting these clips. The contacts for the coil are ordinary machine screws which are allowed to protrude and fit in the slot of the clip. The clip is to be formed so that when the coil is pushed down into them they will bear similarly against the nut which holds the screw to the coil form. Two windings are shown on the coil; however, this could be increased to three or four windings with a consequent increase in the number of clips.—Wm. H. Eaton.

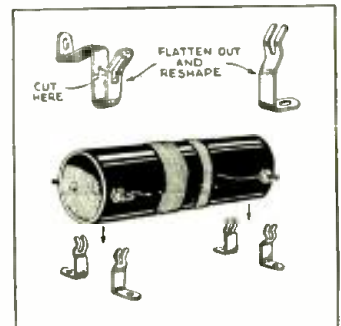



# Short Wave Stations of the World

## Complete List of Broadcast, Police and Television Stations

We present herewith a revised list of the short-wave broadcasting, experimental and commercial radiophone stations of the world. This is arranged by frequency, but the wavelength figures are also given for the benefit of readers who are more accustomed to working with "meters."

All the stations in this list use telephone transmission of one kind or another

and can therefore be identified by the average listener.

Herewith is also presented a very fine list of police as well as television stations. Note: Stations marked with a star ★ are the most active and easily heard stations and transmit at fairly regular times.

Please write to us about any new stations or other important data that you

learn through announcements over the air or correspondence with the stations themselves. A post card will be sufficient. We will safely return to you any verifications that you send in to us. Communications of this kind are a big help.

Stations are classified as follows: C—Commercial phone. B—Broadcast service. X—Experimental transmissions.

## Around-the-Clock Listening Guide

Although short wave reception is notorious for its irregularity and seeming inconsistency (wherein lies its greatest appeal to the sporting listener), it is a good idea to follow a general schedule as far as wavelength in relation to the time of the day is concerned. The observ-

ance of a few simple rules will save the short wave fan a lot of otherwise wasted time.

From daybreak till 4 p. m. and particularly during bright daylight, listen between 13 and 19 meters (21540 to 15800 kc.).

To the east of the listener, from about 3 a. m.-6 p. m., the 25-35 meter will be found very

productive. To the west of the listener this same band is best from about 7 p. m. until shortly after daybreak. (After dark, results above 35 meters are usually much better than during daylight.) These general rules hold for any location.

## Short-Wave Broadcasting, Experimental and Commercial Radiophone Stations

<b>21540 kc. W8XK</b> -B- 13.93 meters WESTINGHOUSE ELECTRIC PITTSBURGH, PA. 7 a. m.-2 p. m.; relays KDKA	<b>19220 kc. WKF</b> -C- 15.60 meters LAWRENCEVILLE, N. J. Calls England, daytime	<b>17810 kc. PCV</b> -C- 16.84 meters KOOTWIJK, HOLLAND Calls Java, 6-9 a. m.	<b>15880 kc. FTK</b> -C- 18.90 meters ST. ASSISE, FRANCE Phones Saigon, morning	<b>15270 kc. ★W2XE</b> -B- 19.65 meters ATLANTIC BROADCASTING CORP. 485 Madison Av., N.Y.C. Relays WABC daily, 11 a. m.-1 p. m.
<b>21420 kc. WKK</b> -C- 14.01 meters A. T. & T. CO. LAWRENCEVILLE, N. J. Calls Argentina, Brazil and Peru, daytime	<b>19160 kc. GAP</b> -C- 15.66 meters RUGBY, ENGLAND Calls Australia, early a. m.	<b>17790 kc. GSG</b> -B- 16.86 meters BRITISH BROAD. CORP. DAVENTRY, ENGLAND See "When to Listen In" Column	<b>15810 kc. LSL</b> -C- 18.98 meters HURLINGHAM, ARGENTINA Calls Brazil and Europe, daytime	<b>15250 kc. W1XAL</b> -B- 19.67 meters BOSTON, MASS. Irregular, in morning
<b>21060 kc. WKA</b> -C- 14.25 meters LAWRENCEVILLE, N. J. Calls England noon	<b>18970 kc. GAQ</b> -C- 15.81 meters RUGBY, ENGLAND Calls S. Africa, mornings	<b>17780 kc. ★W3XAL</b> -B- 16.87 meters NATIONAL BROAD. CO. BOUND BROOK, N. J. Relays WJZ, Daily exc. Sun. 9-10 a. m. Tues., Thurs., Sat. 3-4 p. m.	<b>15760 kc. JYT</b> -X- 19.04 meters KEMIKWA-CHD, CHIBA- KEN, JAPAN Irregular in late afternoon and early morning	<b>15243 kc. ★FYA</b> -B- 19.68 meters "RADIO COLONIAL" PARIS, FRANCE Service de la Radiodiffusion 103 Rue de Grenelle, Paris 7:00-11 a. m.
<b>21020 kc. LSN6</b> -C- 14.27 meters HURLINGHAM, ARG. Calls N. Y. C. 8 a. m.-5 p. m.	<b>18830 kc. PLE</b> -C- 15.93 meters BANDOENG, JAVA Calls Holland, early a. m.	<b>17760 kc. DJE</b> -B- 16.89 meters BROADCASTING HOUSE BERLIN, GERMANY Irregular 8 a. m.-2 p. m.	<b>15660 kc. JVE</b> -C- 19.16 meters NAZAKI, JAPAN Phones Java 3:5 a. m.	<b>15220 kc. ★PCJ</b> -X- 19.71 meters N.V. PHILIPS' RADIO EINDHOVEN, HOLLAND Broadcasts relaying PHI Sat. and Sun.
<b>20700 kc. LSY</b> -C- 14.49 meters MONTE GRANDE ARGENTINA Tests irregularly	<b>18620 kc. GAU</b> -C- 16.11 meters RUGBY, ENGLAND Calls N. Y., daytime	<b>17760 kc. IAC</b> -C- 16.89 meters PIZA, ITALY Calls ships, 6:30-7:30 a. m.	<b>15620 kc. JVF</b> -C- 19.2 meters NAZAKI, JAPAN Phones U.S., 5 a. m. & 8 p. m.	<b>15210 kc. ★W8XK</b> -B- 19.72 meters WESTINGHOUSE ELECTRIC & MFG. CO. PITTSBURGH, PA. 7 a. m.-4:15 p. m. Relays KDKA
<b>20380 kc. GAA</b> -C- 14.72 meters RUGBY, ENGLAND Calls Argentina, Brazil, mornings	<b>18345 kc. FZS</b> -C- 18.35 meters SAIGON, INDO-CHINA Phones Paris, early morning	<b>17310 kc. W3XL</b> -X- 17.33 meters NATIONAL BROAD. CO. BOUND BROOK, N. J. Tests irregularly	<b>15415 kc. KWO</b> -C- 19.46 meters DIXON, CAL. Phones Hawaii 2-7 p. m.	<b>15200 kc. DJB</b> -B- 19.73 meters BROADCASTING HOUSE BERLIN, GERMANY 12:30-2, 3:45-7:15 a. m.
<b>19900 kc. LSG</b> -C- 15.08 meters MONTE GRANDE, ARGENTINA Tests irregularly, daytime	<b>18340 kc. WLA</b> -C- 16.36 meters LAWRENCEVILLE, N. J. Calls England, daytime	<b>17120 kc. WOO</b> -C- 17.52 meters A. T. & T. CO., OCEAN GATE, N. J. Calls ships	<b>15370 kc. HAS3</b> -X- 19.52 meters BUDAPEST, HUNGARY Broadcasts Sundays, 8-9 a. m.	<b>15140 kc. ★GSF</b> -B- 19.82 meters BRITISH BROAD. CORP. DAVENTRY, ENGLAND See "When to Listen In" Column
<b>19820 kc. WKN</b> -C- 15.14 meters LAWRENCEVILLE, N. J. Calls England, daytime	<b>18310 kc. GAS</b> -C- 16.38 meters RUGBY, ENGLAND Calls N. Y., daytime	<b>17080 kc. GBC</b> -C- 17.56 meters RUGBY, ENGLAND Calls Ships	<b>15355 kc. KWU</b> -C- 19.53 meters DIXON, CAL. Phones Pacific Isles and Japan	<b>15120 kc. HVJ</b> -B- 19.83 meters VATICAN CITY ROME, ITALY 5:00 to 5:15 a. m., except Sun- day, Also Sat. 10-10:30 a. m.
<b>19650 kc. LSN5</b> -C- 15.2 meters HURLINGHAM, ARGENTINA Calls Europe, daytime	<b>18250 kc. FTO</b> -C- 16.43 meters ST. ASSISE, FRANCE Calls S. America, daytime	<b>16270 kc. WLK</b> -C- 18.44 meters LAWRENCEVILLE, N. J. Phones Arg., Braz., Peru, daytime	<b>15340 kc. DJR</b> -X- 19.56 meters BROADCASTING HOUSE BERLIN, GERMANY Testing irregularly	<b>15090 kc. RKI</b> -C- 19.88 meters MOSCOW, U.S.S.R. Phones Tashkent near 7 a. m. and relays RNE on Sundays irregularly
<b>19600 kc. LSF</b> -C- 15.31 meters MONTE GRANDE, ARGENTINA Tests irregularly, daytime	<b>18200 kc. GAW</b> -C- 16.48 meters RUGBY, ENGLAND Calls N. Y., daytime	<b>16270 kc. WOG</b> -C- 18.44 meters OCEAN GATE, N. J. Calls England, morning and early afternoon	<b>15330 kc. ★W2XAD</b> -B- 19.56 meters GENERAL ELECTRIC CO. SCHENECTADY, N. Y. Relays WGY daily, 2:30-3:30 p. m.	<b>15055 kc. WNC</b> -C- 19.92 meters HIALEAH, FLORIDA Calls Central America, daytime
<b>19380 kc. WOP</b> -C- 15.48 meters OCEAN GATE, N. J. Calls Peru, daytime	<b>18135 kc. PMC</b> -C- 16.54 meters BANDOENG, JAVA Phones Holland, early a. m.	<b>16233 kc. FZR3</b> -C- 18.48 meters SAIGON, INDO-CHINA Calls Paris and Pacific Isles	<b>15280 kc. DJQ</b> -B- 19.63 meters BROADCASTING HOUSE BERLIN, GERMANY 12:30-2 a. m.	
<b>19355 kc. FTM</b> -C- 15.50 meters ST. ASSISE, FRANCE Calls Argentine, mornings	<b>18115 kc. LSY3</b> -C- 16.56 meters MONTE GRANDE, ARGENTINA Tests irregularly			
<b>18040 kc. GAB</b> -C- 16.63 meters RUGBY, ENGLAND Calls Canada, morn. & early aftn.				

(All Schedules Eastern Standard Time)

**14980 kc. KAY**  
-C- 20.03 meters  
MANILA, P. I.  
Phones Pacific Isles

**14950 kc. HJB**  
-C- 20.07 meters  
BOGOTA, COL.  
Calls WNC, daytime

**14590 kc. WMN**  
-C- 20.56 meters  
LAWRENCEVILLE, N. J.  
Phones England  
morning and afternoon

**14535 kc. HBJ**  
-B- 20.64 meters  
RADIO NATIONS.  
GENEVA, SWITZERLAND  
Broadcasts irregularly

**14500 kc. LSM2**  
-C- 20.89 meters  
HURLINGHAM, ARGENTINA  
Calls U. S., evening

**14485 kc. TIR**  
-C- 20.71 meters  
CARTAGO, COSTA RICA  
Phones Cen. Amer. & U.S.A.  
Daytime

**14485 kc. HPF**  
-C- 20.71 meters  
PANAMA CITY, PAN.  
Phones WNC daytime

**14485 kc. TGF**  
-C- 20.71 meters  
GUATEMALA CITY, GUAT.  
Phones WNC daytime

**14485 kc. YNA**  
-C- 20.71 meters  
MANAGUA, NICARAGUA  
Phones WNC daytime

**14470 kc. WMF**  
-C- 20.73 meters  
LAWRENCEVILLE, N. J.  
Phones England  
morning and afternoon

**14440 kc. GBW**  
-C- 20.78 meters  
RUGBY, ENGLAND  
Calls U.S.A., afternoon

**13990 kc. GBA**  
-C- 21.44 meters  
RUGBY, ENGLAND  
Calls  
Buenos Aires, late afternoon

**13610 kc. JYK**  
-C- 22.04 meters  
KEMIKAWA-CHO, CHIBA-  
KEN, JAPAN  
Phones California till 11 p. m.

**13585 kc. GBB**  
-C- 22.08 meters  
RUGBY, ENGLAND  
Calls  
Egypt & Canada, afternoon

**13420 kc. TIEP**  
-B- 22.35 meters  
LA VOZ del TROPICO  
APARTADO 257  
SAN JOSE, COSTA RICA  
Sun, 1-4 p. m.

**13415 kc. GCJ**  
-C- 22.36 meters  
RUGBY, ENGLAND  
Calls Japan & China early  
morning

**13390 kc. WMA**  
-C- 22.40 meters  
LAWRENCEVILLE, N. J.  
Phones England  
morning and afternoon

**13075 kc. VPD**  
-X- 22.94 meters  
SUVA, FIJI ISLANDS  
Tests Mon. & Thurs. 12:30-1:30  
a. m.

**12840 kc. WOO**  
-C- 23.36 meters  
OCEAN GATE, N. J.  
Calls ships

**12825 kc. CNR**  
-B, C- 23.39 meters  
DIRECTOR GENERAL  
Telegraph and Telephone  
Stations, Rabat, Morocco  
Broadcasts, Sunday, 7:30-9 a. m.

**12800 kc. IAC**  
-C- 23.45 meters  
PIZA, ITALY  
Calls Italian ships, mornings

**12780 kc. GBC**  
-C- 23.47 meters  
RUGBY, ENGLAND  
Calls ships

**12396 kc. CT1GO**  
-B- 24.2 meters  
PAREDE, PORTUGAL  
Sun, 10-11:30 a. m., Tues.,  
Thurs., Fri. 1:00-2:15 p. m.

**12290 kc. GBU**  
-C- 24.41 meters  
RUGBY, ENGLAND  
Calls N.Y.C., afternoon

**12150 kc. GBS**  
-C- 24.69 meters  
RUGBY, ENGLAND  
Calls N.Y.C., afternoon

**12000 kc. RNE**  
-B- 25 meters  
MOSCOW, U. S. S. R.  
Sat. 10-11 p. m.  
Sun. 6-7 a. m., 10-11 a. m.

**11991 kc. FZS2**  
-C- 25.02 meters  
SAIGON, INDO-CHINA  
Phones Paris, morning

**11950 kc. KKQ**  
-X- 25.10 meters  
BOLINAS, CALIF.  
Tests, irregularly, evenings

**11940 kc. FTA**  
-C- 25.13 meters  
STE. ASSISE, FRANCE  
Phones CNR mornings,  
Hurlingham, Arge., nights

**11875 kc. FYA**  
-B- 25.25 meters  
"RADIO COLONIAL"  
PARIS, FRANCE  
11:15 a. m.-2:15 p. m., 3-6 p. m.

**11870 kc. W8XK**  
-B- 25.26 meters  
WESTINGHOUSE ELECTRIC  
& MFG. CO.  
PITTSBURGH, PA.  
4:20-11 p. m.  
Fri. till 1 a. m. (Sat.)  
Relays KDKA

**11860 kc. GSE**  
-B- 25.29 meters  
BRITISH BROAD. CORP.  
DAVENTRY, ENGLAND  
See  
"When to Listen In" Column

**11855 kc. DJP**  
-X- 25.31 meters  
BROADCASTING HOUSE  
BERLIN, GERMANY  
Tests irregularly

**11830 kc. W2XE**  
-B- 25.38 meters  
ATLANTIC BROADCASTING  
CORP.  
485 MADISON AVE., N. Y. C.  
3-5 p. m. Relays WABC

**11811 kc. I2RO**  
-B- 25.4 meters  
E. I. A. R.  
Via Montello 5  
ROME, ITALY

**11795 kc. DJO**  
-X- 25.43 meters  
BROADCASTING HOUSE  
BERLIN, GERMANY  
Tests irregularly

**11790 kc. W1XAL**  
-B- 25.45 meters  
BOSTON, MASS.  
Irregularly in the afternoon

**11770 kc. DJD**  
-B- 25.49 meters  
BROADCASTING HOUSE,  
BERLIN, GERMANY  
12-4:30 p. m.

**11750 kc. GSD**  
-B- 25.53 meters  
BRITISH BROAD. CORP.  
DAVENTRY, ENGLAND  
See  
"When to Listen In" Column

**11730 kc. PH1**  
-B- 25.57 meters  
HUIZEN, HOLLAND  
Daily ex. Tue. & Wed.  
8:30-10 a. m.; Sat. till 11:30:  
Sun. till 11 a. m.

**11720 kc. CJRX**  
-B- 25.6 meters  
WINNIPEG, CANADA  
Daily, 8 p. m.-12 m.  
Sunday, 3-10:30 p. m.

**11720 kc. FYA**  
-B- 25.6 meters  
"RADIO COLONIAL"  
PARIS, FRANCE  
7-10 p. m.  
11 p. m.-1 a. m.

**11680 kc. KIO**  
-X- 25.68 meters  
KAHUKU, HAWAII  
Tests in the evening

**10770 kc. GBP**  
-C- 27.85 meters  
RUGBY, ENGLAND  
Calls  
Sydney, Austral. early a. m.

**10740 kc. JVM**  
-C- 27.93 meters  
NAZAKI, JAPAN  
Phones California evenings

**10675 kc. WNB**  
-C- 28.1 meters  
LAWRENCEVILLE, N. J.  
Calls Bermuda, daytime

**10660 kc. JVN**  
-C- 28.14 meters  
NAZAKI, JAPAN  
Tests 2-7 a. m.

**10550 kc. WOK**  
-C- 28.44 meters  
LAWRENCEVILLE, N. J.  
Phones  
Arge., Braz., Peru, nights

**10520 kc. VLK**  
-C- 28.51 meters  
SYDNEY, AUSTRALIA  
Calls Rugby, early a. m.

**10430 kc. YBG**  
-C- 28.76 meters  
MEDAN, SUMATRA  
5:30-6:30 a. m., 7:30-8:30 p. m.

**10420 kc. XGW**  
-C- 28.79 meters  
SHANGHAI, CHINA  
Calls Manila and England, 6-9  
a. m. and California late evening

**10410 kc. PDK**  
-C- 28.80 meters  
KOOTWIJK, HOLLAND  
Calls Java 7:30-9:40 a. m.

**10410 kc. KES**  
-X- 28.80 meters  
BOLINAS, CALIF.  
Tests evenings

**10350 kc. LSX**  
-C- 28.98 meters  
MONTE GRANDE,  
ARGENTINA  
Tests irregularly 8 p. m.-12 mid-  
night.

**10330 kc. ORK**  
-C- 29.04 meters  
RUYSSSELEDE, BELGIUM  
Broadcasts 1:30-3 p. m.

**10300 kc. LSL2**  
-C- 29.13 meters  
HURLINGHAM, ARGENTINA  
Calls Europe, evenings

**10290 kc. DIQ**  
-X- 29.16 meters  
KONIGSWUSTERHAUSEN,  
GERMANY  
Broadcasts irregularly

**10260 kc. PMN**  
-C- 29.24 meters  
BANDONG, JAVA  
Calls Australia 5 a. m.

**10250 kv. LSK3**  
-C- 29.27 meters  
HURLINGHAM, ARGENTINA  
Calls Europe and U. S., after-  
noon and evening

**10220 kc. PSH**  
-C- 29.35 meters  
RIO DE JANEIRO, BRAZIL

**10055 kc. ZFB**  
-C- 29.84 meters  
HAMILTON, BERMUDA  
Phones N. Y. C. daytime

**9950 kc. GCU**  
-C- 30.15 meters  
RUGBY, ENGLAND  
Calls N.Y.C. evening

**9890 kc. LSN**  
-C- 30.33 meters  
HURLINGHAM, ARGENTINA  
Calls New York, evenings

**9870 kc. WON**  
-C- 30.4 meters  
LAWRENCEVILLE, N. J.  
Phones England, evening

**9860 kc. EAQ**  
-B- 30.43 meters  
P. O. Box 951  
MADRID, SPAIN  
Daily except Saturday, 5:15-7  
p. m.; Saturday, 1-3 p. m.,  
5:15-7:30 p. m.; Tues., Thurs.  
and Sun. 5:15-7:30 p. m.

**9840 kc. JYS**  
-X- 30.49 meters  
KEMIKAWA-CHO, CHIBA-  
KEN, JAPAN  
Irregular, 4-7 a. m.

**9800 kc. LSE**  
-C- 30.61 meters  
MONTE GRANDE,  
ARGENTINA  
Tests irregularly

**9790 kc. GCW**  
-C- 30.64 meters  
RUGBY, ENGLAND  
Calls N.Y.C., evening

**9780 kc. I2RO**  
-B- 30.67 meters  
E. I. A. R.  
ROME, ITALY  
Daily 2:30-5 or 6 p. m.  
Th., Sat., 7:45-9:15 p. m.

**9760 kc. VLJ-VLZ2**  
-C- 30.74 meters  
AMALGAMATED WIRELESS  
OF AUSTRALIA  
SYDNEY, AUSTRALIA  
Phones Java and N. Zealand  
early a. m.

**9750 kc. WOF**  
-C- 30.77 meters  
LAWRENCEVILLE, N. J.  
Phones England, evening

**9710 kc. GCA**  
-C- 30.89 meters  
RUGBY, ENGLAND  
Calls Arge. & Brazil, evenings

**9600 kc. CT1AA**  
-B- 31.25 meters  
LISBON, PORTUGAL  
Tues., Thurs., Sat. 4:30-  
7 p. m.

**9595 kc. HBL**  
-B- 31.27 meters  
LEAGUE OF NATIONS  
GENEVA, SWITZERLAND  
Saturdays, 5:30-8:15 p. m.

**9590 kc. VK2ME**  
-B- 31.28 meters  
AMALGAMATED WIRELESS,  
LTD., 47 YORK ST.  
SYDNEY, AUSTRALIA  
Sundays 1-3, 5-11 a. m.

**9590 kc. HP5J**  
-B- 31.28 meters  
J Street,  
PANAMA CITY, PANAMA  
Reported on daily 7:30-10 p. m.

**9590 kc. W3XAU**  
-B- 31.28 meters  
NEWTOWN SQUARE, PA.  
Relays WCAU  
12 noon-7:50 p. m.

**9580 kc. GSC**  
-B- 31.32 meters  
BRITISH BROAD CORP.  
DAVENTRY, ENGLAND  
See  
"When to Listen In" Column

**9580 kc. VK3LR**  
-B- 31.32 meters  
Research Section,  
Postmaster Gen'l's. Dept.,  
51 Little Collins St.  
MELBOURNE, AUSTRALIA  
3:15-7:30 a. m. except Sun.

**9570 kc. W1XAZ**  
-B- 31.35 meters  
WESTINGHOUSE ELECTRIC  
& MFG. CO.  
SPRINGFIELD, MASS.  
Relays WB2, 7 a. m.-1 a. m.

**9565 kc. VUB**  
-B- 31.36 meters  
BOMBAY, INDIA  
11 a. m.-12:30 p. m., Wed., Sat.  
and irregularly 7-9 a. m.

**9560 kc. DJA**  
-B- 31.38 meters  
BROADCASTING HOUSE,  
BERLIN  
8-11:30 a. m., 5:15-9:15 p. m.

**9540 kc. DJN**  
-B- 31.45 meters  
BROADCASTING HOUSE  
BERLIN, GERMANY  
3:45-7:15 a. m., 8-11:30 a. m.,  
5:15-10:45 p. m.

**9540 kc. LKJ1**  
-B- 31.45 meters  
JELOY, NORWAY  
Relays Oslo 5-8 a. m.

**9530 kc. W2XAF**  
-B- 31.48 meters  
GENERAL ELECTRIC CO.  
SCHENECTADY, N. Y.  
Relays WGY 6:25-11 p. m.  
Sundays, 6:25 p. m.-12:30 a. m.

**9510 kc. GSB**  
-B- 31.55 meters  
BRITISH BROAD. CORP.  
DAVENTRY, ENGLAND  
"When to Listen In" Column

**9510 kc. VK3ME**  
-B- 31.55 meters  
AMALGAMATED WIRELESS,  
Ltd.  
G. P. O. Box 1272L,  
MELBOURNE, AUSTRALIA  
Wed., 5-6:30 a. m.; Saturday,  
5:00-7:00 a. m.

**9500 kc. PRF5**  
-B- 31.58 meters  
RIO DE JANEIRO, BRAZIL  
Daily  
except Sun. 5:30-6:15 p. m.

**9428 kc. COH**  
-B- 31.8 meters  
2 B ST., VEDADD,  
HAVANA, CUBA  
10-11 a. m., 5-6, 8-9 p. m.  
also 11 a. m.-12 N. Thurs.

**9415 kc. PLV**  
-C- 31.87 meters  
BANDONG, JAVA  
Phones Holland, 7:40-9:40 a. m.

**9330 kc. CJA2**  
-C- 32.15 meters  
DRUMMONDVILLE, CANADA  
Phones England irregularly

**9280 kc. GCB**  
-C- 32.33 meters  
RUGBY, ENGLAND  
Calls Can. & Egypt, evenings

**9170 kc. WNA**  
-C- 32.72 meters  
LAWRENCEVILLE, N. J.  
Phones England, evening

**9020 kc. GCS**  
-C- 33.28 meters  
RUGBY, ENGLAND  
Calls N.Y.C., evenings

**8775 kc. PNI**  
-C- 34.19 meters  
MAKASSER, CELEBES,  
D. E. I.  
Phones Java around 4 a. m.

**8760 kc. GCQ**  
-C- 34.25 meters  
RUGBY, ENGLAND  
Calls S. Africa, afternoon

**8730 kc. GCI**  
-C- 34.36 meters  
RUGBY, ENGLAND  
Calls India, 8 a. m.



# THE WORLD'S FINEST ALL-WAVE RECEIVER



*Not because  
we say so....*

The reputation of this receiver has been won in the toughest kind of service to the most discriminating type of buyers. Scott capability . . . in distance-getting—in dependability—in gloriously rich, true tone . . . comes from finer methods of building—custom-construction in which every operation is held to the closest limitations known in radio manufacture.

## E. H. SCOTT RADIO LABORATORIES, INC.

4470 Ravenswood Avenue, Dept. 28F5, Chicago, Illinois

*Inquiries may be addressed direct to the laboratories, or the foreign office nearest you.*  
 AZORES, Rua da Misericordia, 2, 4, 6, Ponta Delgada; BRITISH WEST INDIES, 10—12 Port Royal St., Kingston, Jamaica; COLOMBIA, Apartado 741, Bogota; ENGLAND, Ethelburga House, 91—93 Bishopsgate, London; GREECE, 8 Rue Canaris, Athenes; MEXICO, Independencia 100, Mexico City, D. F.; Calle Diaz Miron 40, Ote. Tampico, Tamps., Mexico; NEW ZEALAND, 9—11 Pacific Bldg., Auckland; PERU, Casilla 1915, Lima; PUERTO RICO, 7 Jefferson St., San Turce; SPAIN, Alameda Recalde 46, Bilbao; Paz 14, Valencia; SOUTH AFRICA, Beckett's Bldg., President St., Johannesburg; STRAITS SETTLEMENT, 96 N. Bridge Rd., Singapore; VENEZUELA, Caracas.

**...but  
because we PROVE  
it in this sensational way!**

You must be satisfied that the SCOTT All-Wave XV is truly "The World's Finest All-Wave Receiver." To convince you, we make this offer: Get a SCOTT All-Wave XV from the laboratory where it is custom built. Install it in your home anywhere in U. S. A. and test it competitively against any other radio in the world during a 30-day trial period. If it does not bring in *more* stations, from *greater* distances, with *more volume* and *better tone*, on both the *short waves* and the *broadcast band*, it may be returned without question. Every part used in the construction of the SCOTT All-Wave XV (except tubes) is guaranteed for five years. The Console illustrated is the Waverley — one of a complete line of beautiful Scott Cabinets.

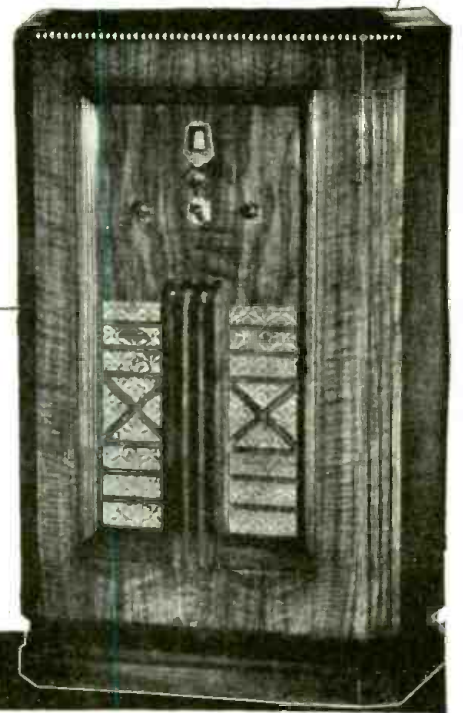

## SEND COUPON FOR DETAILS

*The*  
**SCOTT**  
ALL-WAVE XV

E. H. Scott Radio Laboratories, Inc. 4470 Ravenswood Ave., Dept. 28F5, Chicago, Ill.  
 Please send full particulars about the Scott All-Wave XV, including technical data, performance proofs, etc., and details of your 30-day trial offer anywhere in the U. S. A.

Name \_\_\_\_\_  
 Address \_\_\_\_\_  
 City \_\_\_\_\_ State \_\_\_\_\_

Please mention SHORT WAVE CRAFT when writing advertisers

8680 kc. GBC
-C- 34.56 meters
RUGBY, ENGLAND
Calls ships

8560 kc. WOO
-C- 35.05 meters
OCEAN GATE, N. J.
Calls ships irregular

8380 kc. IAC
-C- 35.8 meters
PIZA, ITALY

8185 kc. PSK
-C- 36.65 meters
RIO DE JANEIRO, BRAZIL
Irregularly

8036 kc. CNR
-B- 37.33 meters
RABAT, MOROCCO
Sunday, 2:30-5 p. m.

7901 kc. LSL
-C- 37.97 meters
HURLINGHAM, ARGENTINA
Calls Brazil, night

7880 kc. JYR
-B- 38.07 meters
KEMIKAWA-CHO, CHIBAKEN, JAPAN
4-7:40 a. m.

7799 kc. HBP
-B- 38.47 meters
LEAGUE OF NATIONS, GENEVA, SWITZERLAND
5:30-6:15 p. m., Saturday

7400 kc. HJ3ABD
-B- 40.54 meters
P. O. Box 509
BOGOTA, COLOMBIA
Daily 12-2 p. m.; 7-11 p. m.
Sunday, 5-9 p. m.

7220 kc. HKE
-B- 41.55 meters
BOGOTA, COL., S. A.
Tue. and Sat. 8-9 p. m.; Mon. & Thurs. 6:30-7 p. m.

7140 kc. HJ4ABB
-B- 42.02 meters
MANIZALES, COL. S. A.
P. O. Box 175
Mon. to Fri. 12:15-1 p. m.;
Tues. & Fri. 7:30-10 p. m.;
Sun. 2:30-5 p. m.

6905 kc. GDS
-C- 43.45 meters
RUGBY, ENGLAND
Calls N.Y.C. evening

6860 kc. KEL
-X- 43.70 meters
BOLINAS, CALIF.
Tests irregularly

6800 kc. HIH
-B- 44.12 meters
SAN PEDRO DE MACORIS
DOMINICAN REP.
4-7:30 p. m.

6755 kc. WOA
-C- 44.41 meters
LAWRENCEVILLE, N. J.
Phones England, evening

6750 kc. JVT
-X- 44.44 meters
NAZAKI, JAPAN
KOKUSAI-DENWA KAISHA, LTD., TOKIO
2-7:45 a. m.

6666 kc. HC2RL
-B- 45.00 meters
P. O. BOX 759, GUAYAQUIL,
ECUADOR, S. A.
Sunday, 5:45-7:45 p. m.
Tues., 9:15-11:15 p. m.

6660 kc. TIEP
-B- 45.05 meters
LA-VOZ DEL TROPICO
SAN JOSE, COSTA RICA
APARTADO 257, Daily 7-10
p. m.

6650 kc. IAC
-C- 45.1 meters
PIZA, ITALY
Calls ships, evenings

6620 kc. PRADO
-B- 45.30 meters
RIDBAMBA, ECUADOR
Thur. 9-11:30 p. m.

6611 kc. RW72
-B- 45.38 meters
MOSCOW, U. S. S. R.
1-6 p. m.

6500 kc. HI4D
-B- 46.15 meters
SANTO DOMINGO, DOMINI-
CAN REPUBLIC
Except Sun. 11:55 a.m.-1:40
p.m.; 4:40-7:40 p.m.

6490 kc. HJ5ABD
-B- 46.22 meters
MANIZALES, COL.
12-1:30 p. m., 7-10 p. m.

6447 kc. HJ1ABB
-B- 46.53 meters
BARRANQUILLA, COL., S. A.
P. O. BOX 715
11:30 a. m.-1 p. m.; 5-10 p. m.

6425 kc. W3XL
-X- 46.70 meters
NATIONAL BROADCASTING
CO.
BOUND BROOK, N. J.
Tests irregularly

6375 kc. YV4RC
-B- 47.06 meters
CARACAS, VENEZUELA
4:30-10:30 p. m.

6316 kc. HIZ
-B- 47.5 meters
SANTO DOMINGO
DOMINICAN REPUBLIC
Daily except Sat. and Sun.
4:40-5:40 p. m.; Sat. 9:40-
11:40 p. m.; Sun., 11:40 a.
m.-1:40 p. m.

6272 kc. HI1A
-B- 47.84 meters
P. O. BOX 423, SANTIAGO,
DOMINICAN REP.
11:40 a. m.-1:40 p. m.
7:40-9:40 p. m.

6250 kc. OAX4B
-B- 48 meters
Apartado 1242
LIMA, PERU
Wed. & Sun. 7-9 p. m.

6198 kc. CT1GO
-B- 48.4 meters
Portuguese Radio Club,
PAREDE, PORTUGAL
Sun. 11:30 a.m.-1 p.m.
Daily exc. Tues. 7:20-8:30 p.m.

6175 kc. HJ2ABA
-B- 48.58 meters
TUNJA, COLOMBIA
1-2: 7:30-9:30 p. m.

6160 kc. YV3RC
-B- 48.7 meters
CARACAS, VENEZUELA
Generally 4:00-10:00 p. m.

6150 kc. CJRO
-B- 48.78 meters
WINNIPEG, MAN., CANADA
8 p. m.-12 m.
Sun. 3-10:30 p. m.

6140 kc. W8XK
-B- 48.86 meters
WESTINGHOUSE ELECTRIC
& MFG. CO.
PITTSBURGH, PA.
Relays KDKA
4:30 p. m.-1 a. m.

6130 kc. ZGE
-B- 48.92 meters
KUALA LUMPUR,
FED. MALAY STATES
Sun., Tue. and Fri.
6:40-8:40 a. m.

6128 kc. LKJ1
-B- 48.94 meters
JELOV, NORWAY
Relays Oslo. 10 a.m.-6 p.m.

6122 kc. JB
-B- 49 meters
JOHANNESBURG,
SOUTH AFRICA
Daily except Sat. and Sun.,
11:45 p. m.-12:30 a. m., 4-7
a. m., 9 a. m.-3:30 p. m.
Sat., only 4-7 a. m., 9 a. m.-
4:45 p. m.
Sun., only 11:45 p. m.-12:30
a. m., 8-10:30 a. m. and 12:30-
3 p. m.

6120 kc. YDA
-B- 49.02 meters
N.I.R.O.M.
BANDONG, JAVA
10:40 p.m.-1:40 a.m.,
5-9:40 a. m.

6120 kc. W2XE
-B- 49.02 meters
ATLANTIC BROADCASTING
CORP.
485 MADISON AVE., N. Y. C.
Relays WABC, 8-11 p. m.

6115 kc. HJ1ABE
-B- 49.05 meters
CARTAGENA, COL.
P. O. Box 31
Daily 11:15 a. m.-1 p. m.; Sun.
9-11 a. m.; Mon. at 10 p. m.
Wed. 8-10 p. m.

6112 kc. YV2RC
-B- 49.08 meters
CARACAS, VENEZUELA
Sun. 1:30-10:30 p. m. Daily
except Sun. 11 a. m.-1:30 p. m.;
Mon., Thurs., Sat. 4:45-10 p.m.;
Tues., Wed., Fri. 4:45-9:30 p.m.

6110 kc. VE9HX
-B- 49.10 meters
HALIFAX, NOVA SCOTIA
9:30 a. m.-1 p. m.; 6-12 p. m.

6110 kc. VUC
-B- 49.1 meters
CALCUTTA, INDIA
Daily except Sat., 3-5:30 a. m.,
9:30 a. m.-noon;
Sat., 11:45 a. m.-3 p. m.

6100 kc. HJ1ABD
-B- 49.18 meters
CARTAGENA, COL.
11:30 a. m.-12:30 p. m.; 7-9
p. m.

6100 kc. W3XAL
-B- 49.18 meters
NATIONAL BROADCASTING
CO.
BOUND BROOK, N. J.
Relays WJZ
Monday, Wednesday, Saturday,
5-6 p.m. Sat. also 12 m.-1 a.m.
(Sun.)

6100 kc. W9XF
-B- 49.18 meters
DOWNERS GROVE, ILL.
Relays WENR, Chicago
Daily except Mon, Wed. & Sat.,
2:30 p. m.-2 a. m.
Mon., Wed. 2:30-5, 6 p.m.-2
a.m. Sat. 2:30-5, 6 p.m.-12 m.

6090 kc. VE9GW
-B- 49.26 meters
BOWMANVILLE, ONTARIO,
CANADA
Mon. Wed., 3 p. m.-12 m.
Thurs.-Sat., 7 a. m.-12 m.

6090 kc. VE9BJ
-B- 49.26 meters
SAINT JOHN, N. B., CAN.
7-8:30 p. m.

6085 kc. I2RO
-B- 49.3 meters
E.I.A.R.
Via Montello 5.
ROME, ITALY
Mon., Wed., Fri., 6-7:30
p. m.

6080 kc. CP5
-B- 49.34 meters
LAPAZ, BOLIVIA
7-10:30 p. m.

6080 kc. W9XAA
-B- 49.34 meters
CHICAGO FEDERATION OF
LABOR
CHICAGO, ILL.
Relays WCFL
Sunday 11:30 a. m.-9 p. m. and
Tues., Thurs., Sat., 4 p. m.-12 m.

6079 kc. DJM
-X- 49.35 meters
BROADCASTING HOUSE
BERLIN, GERMANY
Tests irregularly

6072 kc. OER2
-B- 49.41 meters
VIENNA, AUSTRIA
9 a. m.-5 p. m. daily

6070 kc. VE9CS
-B- 49.42 meters
VANCOUVER, B. C., CANADA
Sun. 1:45-9 p. m., 10:30 p. m.-
1 a. m.; Tues. 6-7:30 p. m.;
11:30 p. m.-1:30 a. m. Daily
6-7:30 p. m.

6060 kc. OXY
-B- 49.50 meters
SKAMLEBOEK, DENMARK
1-6:30 p. m.-at 11 a. m.-12 n.
Sunday

6060 kc. W8XAL
-B- 49.50 meters
GROSLY RADIO CORP.
CINCINNATI, OHIO
7:30 a. m.-8 p. m.; 11 p. m.-1
a. m.
Relays WLW

6060 kc. VQ7LO
-B- 49.50 meters
NAIROBI, KENYA, AFRICA
Mon., Wed., Fri., 5:45-6:15
a. m., 11 a. m.-2 p. m.
Tues., 3-4 a. m., 11 a. m.-2 p.
m., Thurs., 8-9 a. m., 11 a. m.-
2 p. m., Sat., 11 a. m.-3 p. m.,
Sun., 10:50 a. m.-2 p. m.

6060 kc. W3XAU
-B- 49.50 meters
NEWTOWN SQUARE, PA.
Relays WCAU, Philadelphia
8 p. m.-11 p. m.

6050 kc. GSA
-B- 49.59 meters
BRITISH BROADCAST. CORP.
DVENTRY, ENGLAND
See "When To Listen In" Col.

6040 kc. W1XAL
-B- 49.67 meters
BOSTON, MASS.
Tues., Thurs. 7:30-9 p.m.
Sun. 5-7 p.m.

6030 kc. HP5B
-B- 49.75 meters
P. O. BOX 910
PANAMA CITY, PAN.
12 N.-1 p.m., 8-10:30 p.m.

6030 kc. YV6RV
-B- 49.75 meters
VALENCIA, VENEZUELA
Heard every night 6-8 p.m.

6020 kc. DJC
-B- 49.83 meters
BROADCASTING HOUSE,
BERLIN
12 N.-4:30 p.m., 5:30-10:30
p. m.

6012 kc. ZHI
-B- 49.9 meters
RADIO SERVICE CO.,
20 ORCHARD RD.
SINGAPORE, MALAYA
Mon., Wed., Thurs., 5:40-8:10
a. m.; Sat., 12:10-1:10 a. m.,
10:40 p. m.-1:10 a. m. (Sunday)

6010 kc. COC
-B- 49.92 meters
P.O. BOX 98
HAVANA, CUBA
Daily 9:30-11 a.m., 4-7 p.m.
Sat. also at 11:30 p.m.

6005 kc. VE9DN
-B- 49.96 meters
MONTREAL, CAN.
Saturday 11:30 p.m.-12:30 a.m.

6000 kc. RW59
-B- 50 meters
MOSCOW, U. S. S. R.
Daily 3-6 p. m.

5980 kc. HIX
-B- 50.17 meters
SANTO DOMINGO, DOMINI-
CAN REP.
Tues. and Fri. at 8:10 p. m.

5970 kc. HJ2ABC
-B- 50.27 meters
CUCUTA, COL.
11 a. m.-12 n.; 6-9 p. m.

5968 kc. HVJ
-B- 50.27 meters
VATICAN CITY (ROME)
2-2:15 p. m., daily. Sun., 5-5:30
a. m.

5965 kc. XEBT
-B- 50.29 meters
MEXICO CITY, MEX.
P. O. Box 79.44
7 p. m.-1 a. m.

5940 kc. TGX
-B- 50.5 meters
SR. M. NOVALES,
GUATEMALA CITY, GUAT.
Daily except Sun., 8-10 a.m.,
1-2:30 p.m., 6 p.m.-12m.

5930 kc. HJ4ABE
-B- 50.6 meters
MEDELLIN, COLOMBIA
Mon., 7-11 p. m.; Tues., Thurs.,
Sat., 6:30-8:00 p. m.; Wed. and
Fri., 7:30-11:00 p. m.

5853 kc. WOB
-C- 51.26 meters
LAWRENCEVILLE, N. J.
Calls Bermuda, nights

5850 kc. YV5RMO
-B- 51.28 meters
MARACAIBO, VENEZUELA
5:15-9 p. m.

5790 kc. JYU
-X- 51.81 meters
NAZAKI, JAPAN
Broadcasts 2-7:45 a.m.

5780 kc. OAX4D
-B- 51.9 meters
P.O. Box 853
LIMA, PERU
Wed. and Sat. 9-11:30 p.m.

5714 kc. HCK
-B- 52.5 meters
QUITO, ECUADOR, S. A.

5660 kc. HJ5ABC
-B- 53 meters
CALI, COLOMBIA
11 a. m.-12 N.
Tues. and Thurs. 8-10 p. m.
Sun. 12 N.-1 p. m.

5400 kc. HAT
-X- 55.56 meters
Royal Hungarian Post, Gyallut
22.
BUDAPEST, HUNGARY
Broadcasts Sun. 8-9 p.m.

5077 kc. WCN
-C- 59.08 meters
LAWRENCEVILLE, N. J.
Phones England irregularly

5025 kc. ZFA
-C- 59.7 meters
HAMILTON, BERMUDA
Calls U.S.A., nights

4975 kc. GBC
-C- 60.30 meters
RUGBY, ENGLAND
Calls ships, late at night

4820 kc. GDW
-C- 82.24 meters
RUGBY, ENGLAND
Calls N.Y.C., late at night

4752 kc. WOO
-C- 63.1 meters
OCEAN GATE, N. J.
Calls ships irregularly

4600 kc. HC2ET
-B- 65.22 meters
Apartado 249
GUAYAQUIL, ECUADOR
Reported Wed., Sat. 9-11:30
p.m.

4320 kc. GDB
-C- 69.44 meters
RUGBY, ENGLAND
Tests, 8-11 p. m.

4273 kc. RW15
-B- 70.20 meters
KHABAROVSK, SIBERIA,
U. S. S. R.
Daily, 3-9 a. m.

4272 kc. WOO
-C- 70.22 meters
OCEAN GATE, N. J.
Calls ships irregularly

4107 kc. HCJB
-B- 73 meters
QUITO, ECUADOR
7:14-10:15 p. m., except Monday

4098 kc. WND
-C- 73.21 meters
HIALEAH, FLORIDA
Calls Bahama Isles

3600 kc. CT2AJ
-B- 83.5 meters
PONTA DELGADA,
SAO MIGUEL, AZORES
Wed. and Sat. 5-7 p. m.

3543 kc. CR7AA
-B- 84.67 meters
P. O. BOX 594
LOURENCO MARQUES, MO-
ZAMBIQUE, E. AFRICA
1:30-3:30 p.m., Mon., Thurs.,
and Sat.

3490 kc. PK1WK
-B- 85.96 meters
BANDONG, JAVA
Daily except Fri., 4:30-5:30
a. m.



# Television Stations

**2000-2100 kc.**

W2XDR—Long Island City, N.Y.  
 W8XAN—Jackson, Mich.  
 W9XK—Iowa City, Ia.  
 W9XAK—Manhattan, Kansas.  
 W9XAO—Chicago, Ill.  
 W6XAH—Bakersfield, Calif.

**2750-2850 kc.**

W3XAK—Portable  
 W9XAP—Chicago, Ill.

W2XBS—Bellmore, N.Y.  
 W6XS—Los Angeles, Calif.  
 W9XAL—Kansas City, Mo.  
 W9XG—W. Lafayette, Ind.  
 W2XAB—New York, N.Y.

**42000-56000, 60000-86000 kc.**

W2XAX—New York, N.Y.  
 W6XAO—Los Angeles, Calif.  
 W9XD—Milwaukee, Wis.  
 W2XBT—Portable  
 W2XF—New York, N.Y.

W3XE—Philadelphia, Pa.  
 W3XAD—Camden, N. J.  
 W10XX—Portable & Mobile (Vicinity of Camden)

W2XDR—Long Island City, N.Y.  
 W8XAN—Jackson, Mich.  
 W9XE—Chicago, Ill.  
 W9XAT—Portable  
 W2XD—New York, N.Y.  
 W2XAG—Portable  
 W1XG—Boston, Mass.

# Police Radio Alarm Stations

CGZ	Vancouver, B.C.	2452 kc.	KGZU	Lincoln, Neb.	2490 kc.	WPEM	Woonsocket, R.I.	2466 kc.
CJW	St. Johns, N.B.	2416 kc.	KGZW	Lubbock, Tex.	2458 kc.	WPEP	Arlington, Mass.	1712 kc.
CJZ	Verdean, Que.	2452 kc.	KGZY	Albuquerque, N.Mex.	2414 kc.	WPES	Saginaw, Mich.	2442 kc.
KGHG	Las Vegas, Nev.	2474 kc.	KGZZ	San Bernardino, Cal.	1712 kc.	WPET	Lexington, Ky.	1706 kc.
KGHK	Palo Alto, Cal.	1674 kc.	KMFE	Duluth, Minn.	2382 kc.	WPEW	Northampton, Mass.	1666 kc.
KGHM	Reno, Nev.	2474 kc.	KSW	Berkeley, Cal.	1658 kc.	WPFA	Newton, Mass.	1712 kc.
KGHO	Des Moines, Iowa	1682 kc.	KVP	Dallas, Tex.	1712 kc.	WPFC	Muskegon, Mich.	2442 kc.
KGHX	Santa Ana, Cal.	2430 kc.	VYR	Montreal, Can.	1712 kc.	WPFE	Reading, Pa.	2442 kc.
KGHY	Whittier, Cal.	1712 kc.	VYW	Winnipeg, Man.	2452 kc.	WPFJ	Jacksonville, Fla.	2442 kc.
KGHZ	Little Rock, Ark.	2406 kc.	WCK	Belle Island, Mich.	2414 kc.	WPFH	Baltimore, Md.	2414 kc.
KGJX	Pasadena, Cal.	1712 kc.	WEY	Boston, Mass.	1558 kc.	WPFJ	Columbus, Ga.	2414 kc.
KGJX	Albuquerque, N.M.	2414 kc.	WKDT	Detroit, Mich.	1558 kc.	WPFJ	Hammond, Ind.	1712 kc.
KGOZ	Cedar Rapids, Iowa	2466 kc.	WKDU	Cincinnati, Ohio	1706 kc.	WPFK	Hackensack, N.J.	2430 kc.
KGPA	Seattle, Wash.	2414 kc.	WMDZ	Indianapolis, Ind.	2442 kc.	WPFK	Gary, Ind.	2470 kc.
KGPC	St. Louis, Mo.	1706 kc.	WMFP	Niagara Falls, N. Y.	2422 kc.	WPFM	Birmingham, Ala.	2382 kc.
KGPD	San Francisco, Cal.	1674 kc.	WMI	Buffalo, N.Y.	2422 kc.	WPFN	Fairhaven, Mass.	1712 kc.
KGPE	Kansas City, Mo.	2422 kc.	WMO	Highland Park, Mich.	2414 kc.	WPFQ	Knoxville, Tenn.	2474 kc.
KGPG	Vallejo, Cal.	2422 kc.	WMP	Framingham, Mass.	1666 kc.	WPFQ	Clarksburg, W. Va.	2490 kc.
KGPH	Oklahoma City, Okla.	2450 kc.	WPDA	Tulare, Cal.	2414 kc.	WPFQ	Swathmore, Pa.	2474 kc.
KGPI	Omaha, Neb.	2466 kc.	WPDB	Chicago, Ill.	1712 kc.	WPFQ	Johnson City, Tenn.	2470 kc.
KGPI	Beaumont, Tex.	1712 kc.	WPDC	Chicago, Ill.	1712 kc.	WPFQ	Asheville, N.C.	2474 kc.
KGPK	Sioux City, Iowa	2466 kc.	WPDD	Chicago, Ill.	1712 kc.	WPFU	Portland, Me.	2422 kc.
KGPL	Los Angeles, Cal.	1712 kc.	WPDE	Louisville, Ky.	2442 kc.	WPFV	Pawtucket, R.I.	2466 kc.
KGPM	San Jose, Cal.	1674 kc.	WPDE	Flint, Mich.	2466 kc.	WPFV	Palm Beach, Fla.	2442 kc.
KGPN	Davenport, Iowa	2466 kc.	WPDF	Youngstown, Ohio	2458 kc.	WPFZ	Miami, Fla.	2442 kc.
KGPO	Tulsa, Okla.	2450 kc.	WPDG	Richmond, Ind.	2442 kc.	WPGA	Bay City, Mich.	2466 kc.
KGPP	Portland, Ore.	2442 kc.	WPDH	Columbus, Ohio	2430 kc.	WPGA	Port Huron, Mich.	2466 kc.
KGPP	Honolulu, T.H.	2450 kc.	WPDI	Milwaukee, Wis.	2450 kc.	WPGC	S. Schenectady, N.Y.	1658 kc.
KGPR	Minneapolis, Minn.	2430 kc.	WPKD	Lansing, Mich.	2442 kc.	WPGD	Rockford, Ill.	2458 kc.
KGPS	Bakersfield, Cal.	2414 kc.	WPDL	Dayton, Ohio	2430 kc.	WPGD	Providence, R.I.	1712 kc.
KGPS	Salt Lake City, Utah	2406 kc.	WPDN	Auburn, N.Y.	2382 kc.	WPGG	Findlay, Ohio	1596 kc.
KGPT	Denver, Colo.	2442 kc.	WPDO	Akron, Ohio	2458 kc.	WPGH	Albany, N.Y.	2414 kc.
KGPT	Baton Rouge, La.	1574 kc.	WPDP	Philadelphia, Pa.	2474 kc.	WPGI	Portsmouth, Ohio	2430 kc.
KGPT	Wichita, Kans.	2450 kc.	WPDR	Rochester, N.Y.	2382 kc.	WPGJ	Utica, N.Y.	2414 kc.
KGZA	Fresno, Calif.	2414 kc.	WPDS	St. Paul, Minn.	2430 kc.	WPGK	Cranston, R.I.	2466 kc.
KGZB	Houston, Tex.	1712 kc.	WPDT	Kokomo, Ind.	2490 kc.	WPGK	Binghamton, N.Y.	2442 kc.
KGZC	Topeka, Kans.	2422 kc.	WPDU	Pittsburgh, Pa.	1712 kc.	WPGN	South Bend, Ind.	2490 kc.
KGZD	San Diego, Cal.	2490 kc.	WPDV	Charlotte, N.C.	2458 kc.	WPGO	Huntington, N.Y.	2490 kc.
KGZE	San Antonio, Tex.	2482 kc.	WPDW	Washington, D.C.	2422 kc.	WPGQ	Columbus, Ohio	1596 kc.
KGZF	Chanute, Kans.	2450 kc.	WPDY	Detroit, Mich.	2414 kc.	WPGS	Mineola, N.Y.	2490 kc.
KGZG	Des Moines, Iowa	2466 kc.	WPDZ	Atlanta, Ga.	2414 kc.	WPGT	New Castle, Pa.	2470 kc.
KGZH	Klamath Falls, Ore.	2382 kc.	WPEA	Fort Wayne, Ind.	2490 kc.	WPGU	Boston, Mass.	1712 kc.
KGZI	Wichita Falls, Tex.	2458 kc.	WPEB	Syracuse, N.Y.	2382 kc.	WPGV	Mobile, Ala.	2382 kc.
KGZJ	Phoenix, Ariz.	2430 kc.	WPEC	Grand Rapids, Mich.	2442 kc.	WPGX	Worcester, Mass.	2466 kc.
KGZL	Shreveport, La.	1712 kc.	WPEE	Memphis, Tenn.	2466 kc.	WPHC	Massillon, O.	1596 kc.
KGZM	El Paso, Tex.	2414 kc.	WPEF	Arlington, Mass.	1712 kc.	WPHD	Steubenville, O.	2458 kc.
KGZN	Tacoma, Wash.	2414 kc.	WPEG	New York, N.Y.	2450 kc.	WPHF	Richmond, Va.	2450 kc.
KGZO	Santa Barbara, Cal.	2414 kc.	WPEH	New York, N.Y.	2450 kc.	WPHJ	Charleston, W. Va.	2490 kc.
KGZP	Coffeyville, Kans.	2450 kc.	WPEI	New York, N.Y.	2450 kc.	WPHK	Wilmington, O.	1596 kc.
KGZQ	Waco, Tex.	1712 kc.	WPEJ	Somerville, Mass.	1712 kc.	WRBQ	Cleveland, Ohio	2458 kc.
KGZR	Salem, Ore.	2442 kc.	WPEK	E. Providence, R.I.	1712 kc.	WRDQ	Toledo, Ohio	2474 kc.
KGZS	McAlester, Okla.	2458 kc.	WPEL	New Orleans, La.	2430 kc.	WRDR	GrossePt.Village, Mich.	2414 kc.
KGZT	Santa Cruz, Cal.	1674 kc.		W. Bridgewater, Mass.	1666 kc.	WRDS	E. Lansing, Mich.	1666 kc.

## When to Listen In

By M. Harvey Gernsback

### Davenport

Davenport has assigned itself another new wavelength and call which will eventually be employed in some of the transmissions from this famous station. The new wave is 49.10 meters or 6110 kc. The call letter for this wave is GSL. With the addition of this new wave the 2 Davenport transmitters have a choice of 11 different waves to operate on. In March the transmissions from Davenport will be as follows: Trans. 1, 2:15-4:15 a.m. till Mar. 17 (1:15-3:15 a.m. after Mar. 17) on GSD and GSB. \*\*\*\* Trans. 2, Sunday 7:30-9 a.m.; daily 6-9 a.m. on GSF and GSE. It is possible that GSG will be used in place of GSE. \*\*\*\*\* Trans. 3, 9:15-10:45 a.m. on GSE and either GSF or GSB; 10:45 a.m. -12 n. on

GSB and either GSE or GSA, 12n-12:45 p.m. on GSB and either GSD, GSE or GSA. \*\*\*Trans. 4, 1-4:30 p.m. on GSD and GSB; 4:30-5:45 p.m. on GSB and either GSA or GSD. Trans. 5, 6-8 p.m. on GSC and GSA.

### Panama

The Panama station HP5B definitely operates on 6030 kc. (49.75 meters) daily from 12n-1 p.m. and 8-10:30 p.m. The Address is "Estacion Radiodifusora Miramar" Apartado 910, Panama City, Panama. Ramon Benedetti of Panama City informs us that there is another s-w broadcaster operating in his city. The new one is HP5J on J Street, Panama City. It is supposed to operate on 31.28 meters (9590 kc.) daily from 7:30-10 p.m. We have had no reports

on this station as yet.

### Barbados

VP6YB is the call of a new station operated by Mr. Aubrey Archer in Barbados in the British West Indies. The station operates on about 7072 kc. (42.42 meters) in the middle of the 40 meter Ham band. It was active in February broadcasting descriptions of cricket games. The station has been heard from 5-6 p.m. Thanks to M. Macdonald of Trinidad, B.W.I., for this information.

### Fiji Islands

The lure of the South Sea Islands is now getting very strong. The Fiji Islands are on the air! VPD at Suva in the Fijis is (Continued on page 751)

# Short Wave

EDITED BY GEORGE

● Because the amount of work involved in the drawing of diagrams and the compilation of data, we are forced to charge 25c each for letters that are answered directly through the mail. This fee includes only hand-drawn schematic drawings. We cannot furnish "picture-layouts" or "full-sized" working drawings. Letters not accompanied by 25c will be answered in turn on this page. The 25c remit-

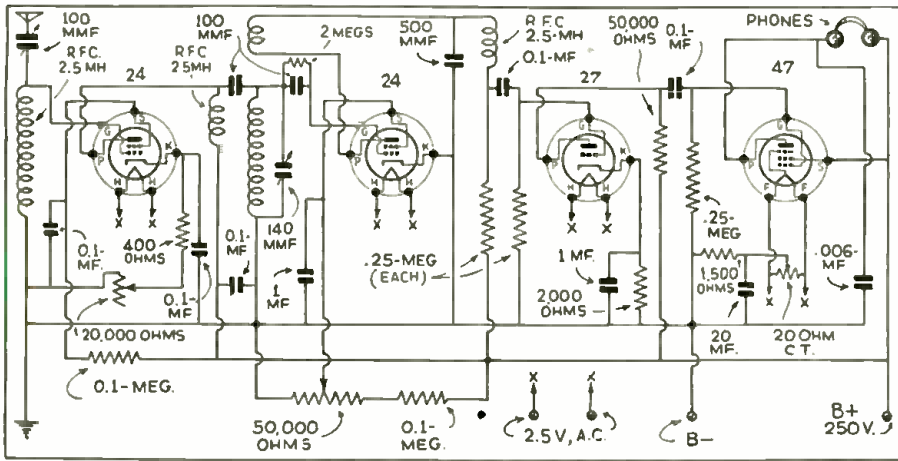

Diagram of 4-tube receiver using two 24's, one 27 and a 47.

### 4-TUBE RECEIVER

Francis X. Mercol, Newport, R.I.  
 (Q) Would you be kind enough to publish a diagram of an A.C. receiver using a 24 as an untuned R.F. stage, a 24 or 27 regenerative detector, and a 45 or 47 audio frequency amplifier in the A.F. amplifier? Use whichever tubes are the most suitable. Also could a small magnetic speaker be used instead of earphones without using an output transformer? I wish to use two winding coils in the detector circuit.  
 (A) We are very pleased to comply with your request for the above diagram and we are recommending that you use a 24 in the untuned R.F. stage and a 24 screen grid detector resistance coupled to a 27 first stage audio, which in turn is resistance coupled to 47 output tube. We are adding the 27 first stage of audio in order that full speaker volume may be obtained. The type 47 tube draws considerable plate current and it is advisable to use an output transformer for phones. However, a good magnetic speaker should work satisfactorily without the transformer.

### "HAM" MONITOR

John Quirk, Paterson, N. J.  
 (Q) Please answer in your Question Box the following questions: Is it permissible to connect an antenna directly to a tank coil of the "Flea Power" transmitter described in the March, 1933, issue?  
 (A) It is advisable to insert a .002 mf. condenser in series with the antenna in order to keep the D.C. plate voltage out of the antenna circuit.

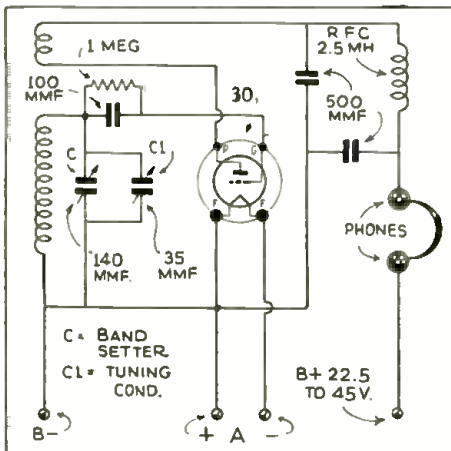

"Ham" hand monitor.

(Q) Please show a diagram of a simple monitor and wave meter for the "Ham" bands.  
 (A) We are very pleased to print your diagram which uses a type 30 detector tube. Condenser "C" is for setting the

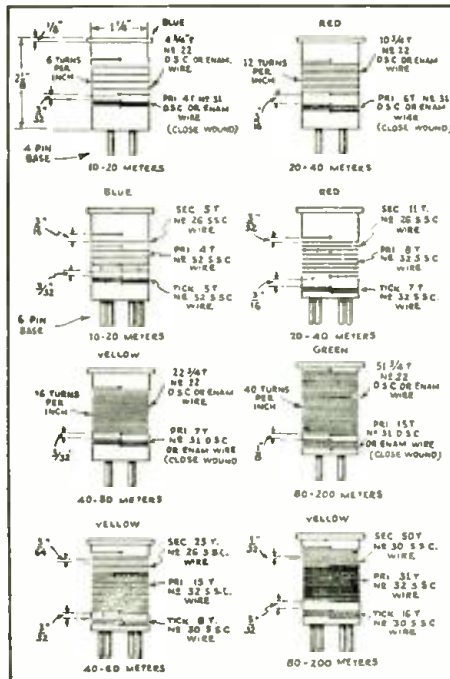

Coil data for 2 and 3 winding coils.

tune circuit so that "C1" will spread the band over a considerable portion of the dial. Needless to say, this entire monitor should be enclosed in a metal shield in order to reduce its sensitivity.

### COIL DATA

Thomas Payne, Philadelphia, Pa.  
 (Q) We are again printing complete data on both 4- and 6-prong, 2- and 3-winding coils, which can be used in any short-wave receiver. This information has been requested by hundreds of our readers since it was published in the July 1934 Question Box. In the 2-winding coils the spaced winding will be used as the grid coil of a detector and small winding at the bottom of the coil for the tickler, and in an R.F. stage this small winding should be

used as the antenna coupling coil. The 6-prong coils are used mostly in tuned R.F. receivers. When used as a detector coil, the large winding is for the grid circuit, the interwound winding (or primary) is used in the plate circuit of the R.F. tube, while the small winding is for the tickler. When used in the R.F. stage, the large winding (sec.) is the grid coil and the small winding (tick.), the antenna coupling coil. By connecting a 50 mmf. condenser across the interwound winding it can be used for padding or trimming the R.F. stage.

### 6-TUBE SUPER-HET.

R. S. Genkingea, New Castle, Pa.  
 (Q) I have built the 6-tube super-het. shown in the May, 1934, issue and have not experienced satisfactory results. Can you tell me what may be the cause?  
 (A) In the super-het. you mentioned a .002 mf. mica condenser should have been connected in series with the lead going to "G" of the oscillator coil. We believe if you insert this condenser you will obtain perfect results.

### AUDIO AMPLIFIER FOR A.C.-D.C. SETS

Roland C. Shaffer, Richmond, Ind.  
 (Q) Please print in your Question Box at the earliest convenience a diagram showing how a 43 pentode may be added to a 3-tube A.C.-D.C. set which uses type 37 tubes.  
 (A) We are showing a circuit diagram of a 43 pentode amplifier. In A.C.-D.C. sets the filaments or heaters of the tubes are usually connected in series with a suitable line voltage dropping resistor. When adding the 43, break the filament circuit and connect each side of the circuit where it is broken to points "X" and "X1" shown in the diagram. This will place the 43 in series with the other tubes. It is now necessary to change the value of the line dropping resistor. The 43 tube has a heater resistance of 83 ohms; the new value of the limiting resistor will now be 250 ohms if your line voltage is higher than 110 volts. If you have 110 volts or slightly less, use a 225 ohm resistor.

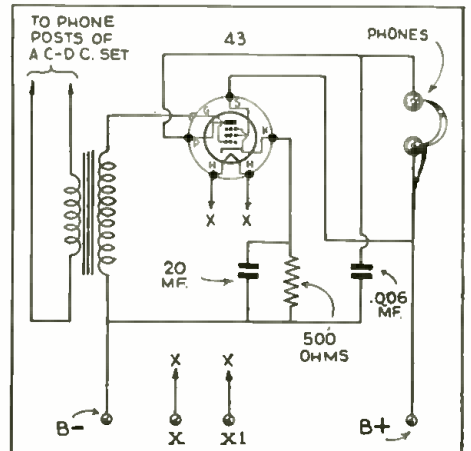

Audio amplifier for A.C.-D.C. set.



# QUESTION BOX

## W. SHUART, W2AMN

tance may be made in the form of stamps or coin.

Special problems involving considerable research will be quoted upon request. We cannot offer opinions as to the relative merits of commercial instruments.

Correspondents are requested to write or print their names and addresses clearly. Hundreds of letters remain unanswered because of incomplete or illegible addresses.

### S.W. CONVERTER

Jack Kenney, no address given.

(Q) I would be very pleased if you would publish a diagram of the short-wave converter using a type 77 as the detector, and type 76 as the high frequency oscillator. This should be coupled to the antenna post of a regular broadcast receiver.

(A) You will find on this page a diagram of a short-wave converter such as you requested and the coil data is given in another drawing. This converter will work very satisfactorily on any sensitive broadcast set. However, you will not obtain

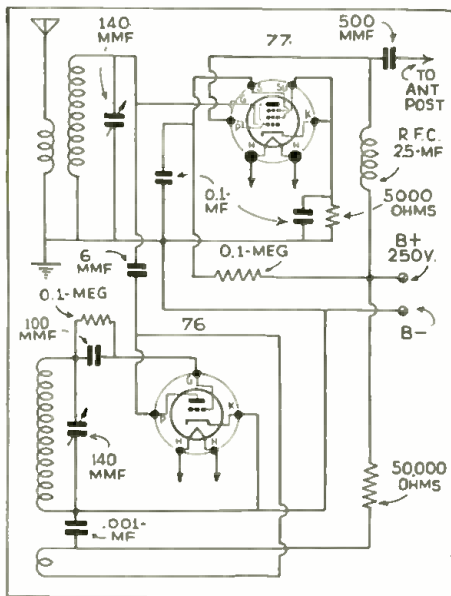

2-tube short-wave converter.

very satisfactory results on old type T.R.F. receivers using tubes such as the type 26 or 201A. The output of the converter is connected directly to the antenna post of the broadcast set.

### 3-TUBE SET USING 37'S

Oswald A. Hemminger, Shamokin, Pa.

(Q) I am a reader of SHORT WAVE CRAFT and would be very pleased if you would print a diagram of a short-wave receiver using 3-type 37 tubes consisting of a regenerative detector and two stages of transformer coupled audio amplification together with suitable coil data.

(A) The 3-tube diagram which you requested is shown in one of the drawings on this page. This receiver can be operated in conjunction with a storage battery and "B" batteries or from a conventional short-wave power pack having a 6.3 volt filament winding, in which case batteries are not needed. Coil data can be taken from the 4-prong coils shown in another drawing in this month's Question Box.

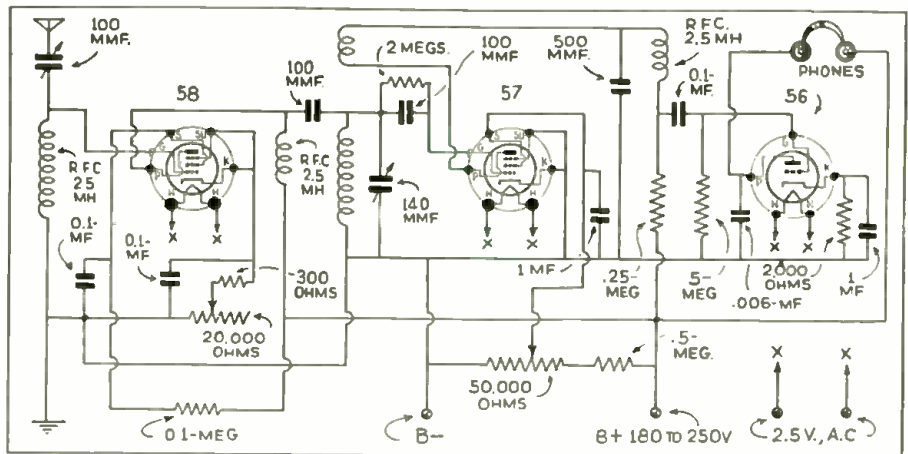

3-tube receiver with untuned R.F. stage.

### ADDING UNTUNED R.F. STAGE

Roy Hogan, Cedar Rapids, Iowa.

(Q) Would you be kind enough to print a diagram showing how a stage of untuned R.F. using a type 58 tube, can be added to a 57 regenerative detector with a 56 resistance coupled audio amplifier?

(A) We are very pleased to print your diagram, Roy, showing the method used to connect a 58 to the receiver you mention. The addition of an R.F. stage provides a very effective method of coupling the antenna and also allows the incorporation of the R.F. volume control. This is located in the cathode circuit of the 58. Make sure that the .0001 mf. mica condenser between the plate of the 58 and the grid circuit of the 57 is a good one. If this condenser were to become shorted it would short-circuit the high voltage supply and do damage to the power supply. Be sure to use a mica condenser not only for this reason but also that there will be no leakage and the D.C. voltage will not come in contact with the grid of the 57.

### 2-STAGE AUDIO AMPLIFIER

Donald Crutcher, Hamilton, Ohio

(Q) I would like to have you print a diagram of a 2-stage audio amplifier using a 56 in the first stage with a 2A5 in the last stage, also show how earphones may be connected to a 56 with a suitable jack arrangement which will turn off the 2A5.

(A) In this diagram which we are printing for you, a single closed circuit jack is used. When the phone plug is inserted the primary of the interstage audio

transformer is disconnected and no signal will be heard in the speaker. The input transformer, if you intend to use this amplifier in conjunction with a triode, can be a regular 3:1 unit, the same as that shown between the 56 and the 2A5.

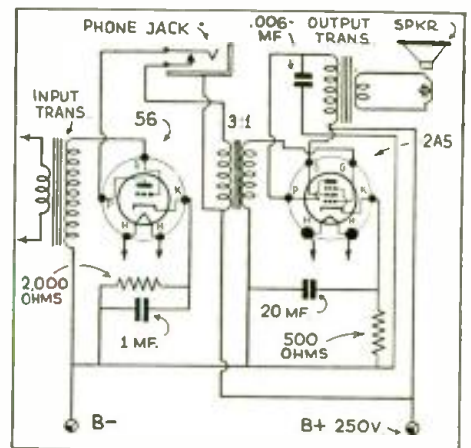

2-stage audio amplifier with headphone connection.

### TUNED ANTENNAS

John Adams, Phila., Pa.

(Q) Do tuned antennas really provide better reception on short waves?

(A) Tuned antennas, if properly used are very good. See article on antennas appearing in this issue.

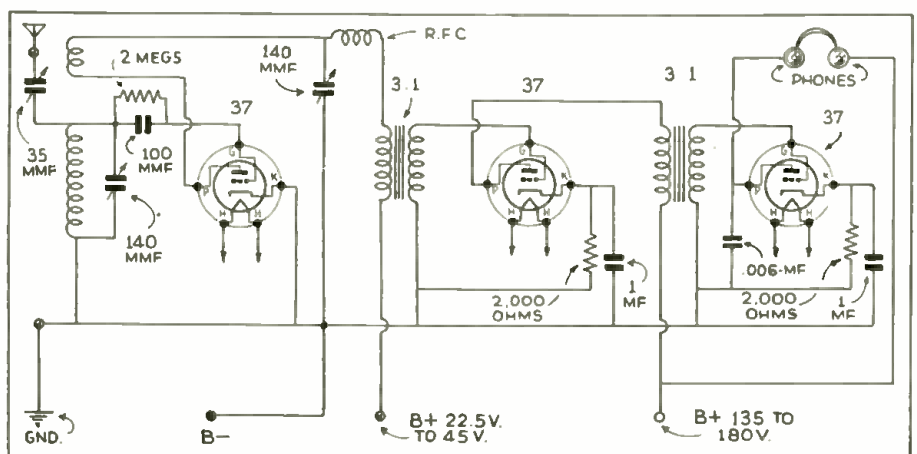

Regenerative receiver using type 37 tubes.

# SHORT WAVE LEAGUE



## HONORARY MEMBERS

Dr. Lee de Forest  
 John L. Reinartz  
 D. E. Replogle  
 Hollis Baird  
 E. T. Somerset  
 Baron Manfred von Ardenne  
 Hugo Gernsback  
*Executive Secretary*

## What Readers Think of "No Code" Test Below 6 Meters

### Suggests 3/4 Meter Band for "Code-less" Licenses.

*Editor, SHORT WAVE CRAFT:*

I would like to express my views of the "Code-less" five-meter license. In the first place I do not believe that a code-less five-meter license should be issued. Instead I think that the boys who want the "Code-less" ticket should set their goal at the 400,000-401,000 kc. band. Here is a band 1,000 kc. wide and one on which the principles of operation are practically the same as on five meters. If there is doubt as to whether successful operation can be had on 3/4 meters, I suggest that you read Charles Kostler's article on 3/4-meter operation published in the April issue of SHORT WAVE CRAFT. In this article Mr. Kostler stated that successful operation was had up to one mile with low-power equipment. As I understand it the boys who want code-less tickets, do not want them for "rag chewing" but for experimentation with modulation, etc.

If this be true, than why won't 3/4-meter band do? The equipment is simple and easy to build, and the range is even more restricted than on five meters. Therefore an indefinite number of experimenters could work on this band without interference. This band at present is not being used extensively by "Hams," therefore I do not think there will be any strong objection from them. On the other hand the "Hams" are beginning to use the five-meter band for "local" work because of the increasing number of stations on the other bands. It would not be fair for them to be bothered on this five-meter band, because they deserve little more privileges, as they have to learn the code. I also suggest that the means of identifying these experimental stations if they ever become a reality, be different from the ordinary "Ham" identification, that is they should not be issued a license and call like those the "Hams" use, but instead the license should be more of a permit to experiment, and furthermore these groups of experimenters should not be spoken of as "Hams," for after all there is a difference between the person who wants to go into transmitting for the purpose of learning the theory of radio and to experiment, and the "Ham" who gets his "ticket" namely to have a "rag chew" with a "brother Ham" in the next state or country.

I think that most of the "Hams" will back me up on this statement. These experimenters could be issued call numbers instead of letters, for instance W8A363, W8A364, etc. The reason for the letter "A" would be to distinguish the district number from the rest of the call. As the boys

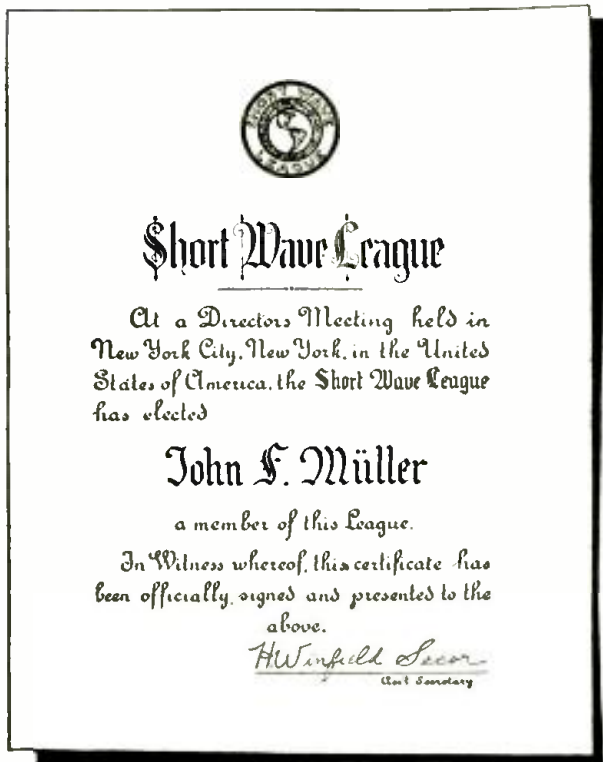

This is the handsome certificate that is presented FREE to all members of the SHORT WAVE LEAGUE. The full size is 7 1/4" x 9 1/2".

See page 762 how to obtain certificate.

### Get Your Button

The illustration here shows the beautiful design of the "Official" Short Wave League button, which is available to everyone who becomes a member of the Short Wave League.

The requirements for joining the League are explained in a booklet, copies of which will be mailed upon request. The button measures 3/4 inch in diameter and is inlaid in enamel—3 colors—red, white, and blue.

Please note that you can order your button AT ONCE—SHORT WAVE LEAGUE supplies it at cost, the price, including the mailing, being 35 cents. A solid gold button is furnished for \$2.00 prepaid. Address all communications to SHORT WAVE LEAGUE, 99-101 Hudson St., New York.



would naturally be using phone and not code, it would be as easy to speak numbers into a mike as it would letters. This system would save a lot of trouble by preventing these experimenters from going up on other bands and using their calls there.

Now that I have expressed by views are there any objections? What say we change our goal to 3/4 meters instead of five meters?

73,  
 W8LPZ,  
 Urbana, Ohio.

### A Howl and an Idea!

*Editor, SHORT WAVE CRAFT:*

I can't stand it any longer, I've got to get it off my chest before I blow a filter "or sumpin."

I'm tired of these dopes calling "Hams" names just because the government requires a code test for a license. It's not our fault and you "code-less Kiwis" could do a lot more good for yourselves by cultivating the friendship of "Ham" circles and getting us on your side rather than you do by calling us stuck-up, short-sighted, selfish buns, etc.

How many of you know why a code test is required? Bet you never stopped to think why! Well listen! The government "owns the air" and if you are going to use it you've got to show that you are doing the public a service! Now the main service that "Hams" render is emergency communication and until a few years ago CW was considered the backbone of emergency work, due to the speed with which a "code rig" can be built and gotten on the air under adverse

conditions. However, phone is coming into use more and more for relief work and is much better than CW—if handled right.

So, if you "5-meter hounds" will get your "think-tanks" working and gather some useful data to show the advantage of having a number of 5-meter stations feeding relief messages into a central high-powered "Ham" station during an emergency, you'll get somewhere.

True, some of the code-less stations would sooner or later get DX conscious and try "bootlegging" a call on 20 or 40 meters but that's pretty "unhealthy" in this part of the country. Ask the "lids" who signed W4ED, W4XYZ, and W2AZV; Hi!

There are 40,000 or more "Hams" in the United States now and some letters that have been printed in SHORT WAVE CRAFT would make 39,999 of them boiling mad—the one that didn't get mad is me. I don't give a darn for 5 meters anyway.

RICHARD CANFIELD,  
 W4BXL, Miami, Fla.,  
 W4BXM, Homestead, Fla.



## Teaching by Short Waves

(Continued from page 712)

tration shows we will undoubtedly have lectures of every conceivable kind presented to us right in our homes, when practical television arrives, possibly a year or two off. Mathematics, geometry, and dozens of other subjects will be "apple pie" so far as broadcasting them through the air by radio is concerned, when television is available for the purpose, compared to the present situation when it is quite impractical to attempt giving lectures on geometry or other subjects, which really require diagrams or pictures to make them clear to the uninitiated. Tomorrow our whole radio broadcast background, so far as the listener is concerned, will be changed when television becomes a common everyday convenience. Not only will various subjects be taught or lectured upon and brought into our homes, but the latest styles in men's and women's clothes, furniture, etc., will be flashed on our home television screen, and dozens of other advertised products, travel tours, etc., as well.

### Have You Seen Him?

● WE RECEIVED the following request from one of our readers—if you know of the whereabouts of this person, do not hesitate to get in touch with the editor:

"I appeal to you to help me locate my boy and have him come home. I thought that possibly you could do this by syndicating it to various short-wave stations located in and around the place in which he is last known to have been.

"He is Edmund Paul, about 20 years of age, fair complexioned, mastoid scar back of one ear, of stuttering speech when excited, walks occasionally with stooped head and shoulders, but looks in your eyes when spoken to. Well read, approximately 6 ft. tall, wears 8½ shoe. When last heard from was in Transient Camp at Tucson, Ariz., in Infirmary there for five days; was in this camp from Jan. 7 to 16. Money was forwarded for his return home; stated that he had left for destination unknown. His mother's health and happiness depends on his homecoming—please help!"

## World-Wide S-W Review

(Continued from page 721)

*Monatshefte*, a Berlin magazine, 24 mf. condensers for the filtering of the D.C. plate voltage—and even then the reception is not perfect.

Hum modulation at the line frequency, and particularly by its second harmonic, can often be observed and appears stronger as the amount of regeneration is increased.

It is well known that the superheterodyne method of reception is particularly favorable for waves below 10 meters. Completely unexpected, however, is the fact that the superheterodyne circuits simplify considerably the use of power supply from the A.C. lines.

In the arrangement shown in the accompanying circuit, tube 1 is the frequency changer or modulator and tube 2 is the local oscillator. The filtering system for the plate current of tube 2 requires only 2 condensers of 4 mf. each and a high resistance. In this particular circuit, tube 1 has no direct plate supply, being biased by the signal from the oscillator (an arrangement used by the late R. E. LaCault in his Ultradyne receivers—Ed.).

In other circuits using a direct current plate supply for the modulator, the filtering elements may have to be somewhat more elaborate, but the problem is still very much simplified.

# Variable I.F. COUPLING

provides SELECTIVITY or FIDELITY, as you choose

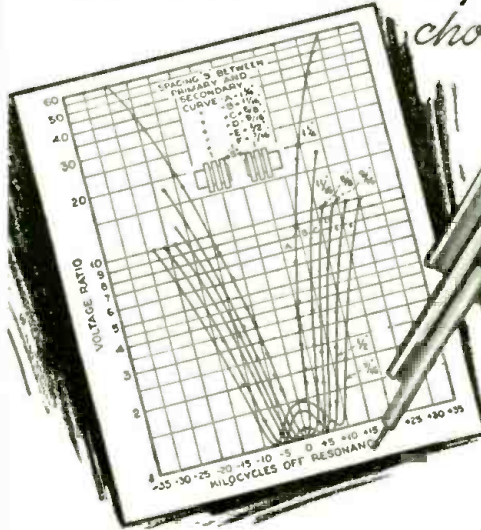

Shield cut away to show mechanism

**N**OW, the greatest single improvement in receiver flexibility in recent years.

CONTINUOUSLY VARIABLE SELECTIVITY, from a needle-sharp peak to the flat top required for fidelity—without affecting tuning.

The transformer, basically, is the time-tested Hammarlund I.F.T. design, with new triple-type, pie-wound Litz coils and air-dielectric condensers. Plus the startling feature of continuously variable coupling between the coils.

Adjustment of coupling in each transformer may be fixed at any point, or continuously varied by panel-control, either individually or ganged in groups, according to selectivity desired.

The diagram shows the variable selectivity characteristics of a single transformer only.

Designed primarily for use in the new COMET Super-"PRO" Receiver, soon to be announced, these transformers may easily be adapted to other superheterodynes.

Code No. VT-465 (465 kc.) List price, \$5.50 each, less 40% to experimenters.



Canadian Office:  
41 West Ave. North,  
Hamilton, Ontario



HAMMARLUND MANUFACTURING CO.,  
424-438 W. 33rd St., New York  
— Check here for details of new Variable-Coupling I.F. Transformer.  
— Check here for 1935 General Catalog.

Name.....  
Address.....

SW-4

Please mention SHORT WAVE CRAFT when writing advertisers



An Event of  
IMPORTANCE



SEE PAGE 745

**ALLIED RADIO**  
CORPORATION  
833 W. JACKSON BLDG., CHICAGO, ILL.

## WHEN CHOOSING A RADIO SCHOOL

RCA Institutes, with its reputation firmly established by 25 years service, is an institution recognized as an important factor in the radio industry.

Whether elementary radio principles or advanced subjects, sound applications, mathematics or practical radio engineering, RCA Institutes is prepared to give you the instruction you need.

### Resident Schools at New York and Chicago

Modern Apparatus and Laboratory Equipment—Conveniently Located—Day and Evening Classes—Tuition Rates \$3 to \$10 Weekly.

Extension courses for home study on convenient "no obligation" plan. Examination and technical advisory services. Free post-graduate practical training at resident school with modern equipment under instructing engineers.

Write for Catalog.

**RCA INSTITUTES, Inc.**

Dept. SW-35

75 Varick Street  
NEW YORK

1154 Merchandise Mart  
CHICAGO

Recognized Standard in Radio Instruction Since 1909.

## Why Your Son Should Learn Radio

(Continued from page 713)

a good antenna are literally "hotbeds" of problems in radio theory. These problems must be met and conquered by a combination of theoretical knowledge and *clean, sharp reasoning!*

Once the problems of *theory* are solved, the amateur is confronted by new problems of actual construction. He knows that his station will have to undergo the most exacting scrutiny at the hands of fellow amateurs, and he wishes to make it as *neat*, as *convenient*, and as *efficient* as it lies in his power to make it. In other words, his skill as a workman is "challenged"; and I could take you on a tour of amateur stations that would convince you how marvelously some amateurs meet this challenge!

### Short-Wave Radio Creates "Objective"!

In addition to teaching him to use his head and hands, amateur radio performs still another service for the amateur. It gives him a concrete "objective" for which to work, and it teaches him to expend the fruits of his labors wisely and carefully. I know a particular case of a boy who refused to work at any of the tasks that are usually depended upon for supplying a boy with "pocket money." Distributing newspapers, running errands, selling magazines, and all other suggestions left him unenthusiastic.

*Then he became interested in "radio"!* At once, his character underwent a marvelous change. He threw off his lethargy and became one of the most "industrious" boys in the town. He passed papers, sold magazines, ran errands, mowed lawns, and did a number of things to earn money that showed remarkable ingenuity and business acumen on his part. What was the reason for the change? Why the boy had a need for money. He looked upon his jobs in terms of transformers, tubes, and condensers. Money, to him, took on an entirely new meaning. For the first time, he understood that economic phrase "a medium of exchange."

The lesson that the lad learns from the expenditure of his money is almost as valuable as any of the other services of the hobby. He learns to spend his money in a manner which will give him the greatest return. It does not take an amateur long to realize that all catalogue bargains are *not* what they seem. He learns to compare prices and values, to select equipment with an eye to the future enlargement of his station, and to distinguish between actual quality and advertising propaganda. It is no unusual sight to see an amateur poring over half a score of catalogues in order to secure the best price on a particular piece of needed apparatus.

### Radio Answers Desire to Travel

Finally, we come to a service, that, although it does not possess the tangibility of the former listed services, has all of their importance. Do you know what it was that made the lad of a few decades ago run away to sea? It was the same urge which prompts the modern lad to "hitch-hike" across the country—an innate craving for adventure, for new experiences. *Amateur radio* furnishes a safe outlet for this desire; flinging messages across thousands of miles of spaces, chatting with fellow amateurs in the far corners of the earth, sending the spoken word into faraway homes, exploring the mysteries of the ultra-short waves, all of these things spell thrilling adventure to the youth of today. Why that is the factor that makes the hobby so fascinating to the boys from seven to seventy. They are given a chance to do things which they never did before; they are permitted to talk to people whom they will never see. Amateur radio has given them a key

to a "magic world" of modern science, and they revel in their esoteric delights.

To sum up what we have been talking about, we may expect amateur radio to do these things for Jack: It will keep him busy at home rather than loafing about on the streets. It will give him something to do with his head and his hands and will encourage him to use his faculties to the very limit of their power. It will teach him habits of punctuality, tenacity, and efficiency. It will instill in him a sense of responsibility and will make him resourceful and self-reliant. It will encourage him to work for his spending money and will give him experience in the wise spending of his funds. It will give to him that breath of adventure and romance that will satisfy his boyish craving for these qualities. Honestly, can you really believe that any price in terms of mere dollars and cents is too much to pay for an array of character-building services such as those listed above?

### Amateur Radio an Urge to Greater Scholastic Endeavors

Let us now take up your *second* objection: You say that you are afraid that the hobby will take the boy's mind off his school lessons. I am going to admit quite frankly that there is that possibility in the case of a boy who goes his own way, with absolutely no guidance from his parents. Happily, in Jack's particular case, this danger is not present. You know that a boy has an "immense amount of enthusiasm" and that he is likely to plunge into anything he does with his whole body and soul. There is where your steadying hand will be needed. Rightly controlled, Jack's interest in radio can be used as an impetus to scholastic endeavor rather than detriment.

Let me explain what I mean. Radio is a science, and it requires a knowledge of mathematics that goes quite a bit beyond the learning of multiplication. Jack will soon find himself up against formulae that will require a more than superficial acquaintance with the higher branches of mathematics. A knowledge of physics is nearly indispensable for the radio amateur. Light and sound are so closely related to electricity that a knowledge of the principles of all three should be in the mental quiver of the conscientious amateur. Chemistry, too, will prove to be a basic science for this new hobby. You have only to point out these facts to Jack and you will find him viewing these subjects with an entirely new interest. Encourage him to approach his hobby from a scientific angle. Make him desire to know the *why* as soon as he has learned the *how*. Let him learn the thrill of being able to forecast exactly how his apparatus will function even before he assembles the parts.

It is only natural that he will take a greater interest in the affairs of the world when he is in daily communication with amateurs in all parts of the globe. You will find him poring over maps in search of out-of-the-way countries, and he'll nonchalantly speak of outlandish little principalities that are halfway around the globe, as though they were in the next state. His horizon will be enlarged; geography will assume a reality that it never possessed before.

Finally, I may point out a fact that every parent knows and uses. A boy's "hobby" places in the hands of his father and mother a powerful tool with which to shape the lad's activities. The exercise of the hobby can be bestowed as a reward for commendable action, and the denial of this privilege can be used as a form of punishment. For instance, suppose that you tell Jack that he may "radio" as much as he pleases *after* he has finished his homework! Why not

Please mention SHORT WAVE CRAFT when writing advertisers



offer to buy him a new "bottle"—the Ham designation of a tube, sir—if he makes an average of B? You'll find that such methods will achieve marvelous results!

**No Danger of Son Becoming Radio "Nut"**

The third of your objections was expressed in the fear that Jack would become a radio "nut." I know what you mean. You think that perhaps he will become unbalanced and will be able to think only on radio. I have seen that type of individual, and I know what a bore he is. Monomania is just as much a form of insanity as any of the less common types. If I thought that there was any danger of Jack falling into that particular pitfall, I should be even more strongly opposed than you to his taking up amateur radio. However, I am not in the least worried about his becoming a "nut."

My faith is based on a knowledge of the boy and his habits. He likes outdoor sports; he is good in athletics; you and he go on hunting and fishing trips; he has a host of friends who are constantly demanding his company; and he enjoys the social gatherings of his crowds. In the face of all these varied interests, why do you fear his becoming unbalanced? Depend upon it: that healthy young body of his will demand exercise and activity that will not be satisfied by the pursuit of his hobby. In fact, the hobby will really balance up his life. At the present time, there is too strong an accent on the lazy, careless seeking for entertainment. Nothing the boy does builds toward a definite achievement by which he can measure his progress. This new hobby will inject a note of serious study and painstaking construction into his present butterfly existence. His completed station will be something that he can show to his friends with that pleasant glow of pride which arises from a knowledge of work well done.

**Dangers of Discouraging Boy's Scientific Interest**

Candidly, sir, I should dislike to take the responsibility of discouraging a boy's interest in any scientific line. Who knows what may come of his enthusiasm. Edison's interest in chemistry, Ford's interest in machinery, and Marconi's interest in radio were all, at one time, hobbies. Perhaps this boyish liking for radio may be a signpost of the lad's destiny. At least, it betokens a mental alertness, a healthy desire for knowledge on the part of Jack that I should welcome with the greatest happiness if I were his father. Give me a boy who asks questions, who experiments, and who takes a keen interest in his hobby. That boy has the foundation for a successful life. He is awake, and his brain "absorbs knowledge as a sponge does water"! I know some boys who go through life with a dull apathetic attitude that is entirely devoid of enthusiasm. Nothing stirs them; nothing arouses their interest. They have only scorn for others who become excited over a hobby. Would you prefer that Jack be one of those fellows?

**Resumé**

Well, Dad, I think that about winds up my little speech. I have tried to be perfectly honest in showing you what I believe to be the advantages of this amateur radio game, and what I have told you is based on my own observation and experience. I have showed you what the hobby has to offer the boy, and now I should like to add just one more point. Amateur radio is one hobby that can grow up with the youth. It offers the adult as much as it does the high school boy. From a simple knowledge of fundamental principles, the amateur can climb upward until he has mastered the intricacies of technical theory. From there, he can set forth intrepidly into the unexplored reaches of its various fields. Radio is new enough that it holds forth unparalleled opportunities for the radio experimenter.

**ALL RECORDS SMASHED!**  
**WITH FOREIGN SPEAKER RECEPTION ON EACH AND EVERY FULTONE V**

Read what a few of our customers write—

"It's the best I ever tried. In the first week I logged DJD Germany, EAQ Spain, RNE Russia and 15 other foreign stations. I got them all on the speaker."—"Police and amateurs all over the country and two South Americans on the first night. I only used an indoor aerial."—"Your Fultone V sure is Heaven's gift to the Short Wave fan. Hi! I wouldn't swap it for a ten tube set."—"No more headphones for me. The Fultone V set made me a speaker fan. It pulls in everything worth while real loud."

**ORDER YOUR FULTONE V NOW! PROMPT SERVICE!**

Enjoy the Thrill of Real Radio Reception

\$7.45 brings you the complete kit of parts to build this remarkable receiver. Price includes crystal finished metal chassis with all holes drilled, four coils tuning 15 to 200 meters, every part down to the last nut and screw and large—easy to follow—instructions.....

**\$12.75 SPECIAL COMBINATION OFFER**  
Complete kit, tubes, speaker, cabinet and broadcast coils.  
(Wired and Tested add—\$1.25)

Set of Matched Sylvania Tubes.....\$2.20  
Metal Cabinet, as illustrated..... 1.25  
Special Loudspeaker..... 1.45  
Two Broadcast Band Coils..... 1.25

**\$7.45**  
Complete KIT

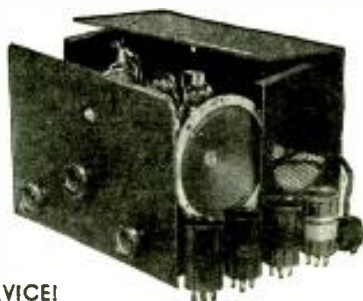

**THE HARRISON ORIGINAL 12,500 MILE TWO TUBE SETS**

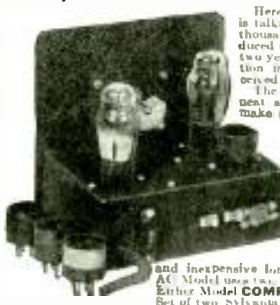

Here's the set that everyone is talking about! We have sold thousands since we first introduced this excellent receiver over two years ago. Every S.W. station in the world has been received with these sets! The remarkable performance, neat appearance, and low cost make this the outstanding value to a 2! No skimming. The finest parts throughout! Heavy chassis—audio transformer—four coils 15 to 200 meters—variable dial—modern, efficient design. The simplicity of construction and ease of operation make it the ideal Beginner's Set! Battery Model uses two type 30 tubes and inexpensive long life dry batteries. AC Model uses two 27 or 26 tubes. Either Model **COMPLETE KIT—\$4.45**  
Set of two Sylvania Tubes—\$1.10

**AC-DC ALL-ELECTRIC MODEL**

The world famous Harrison 12,500 mile set with a built-in hum free power pack supplying all necessary heater and plate voltages. Entirely self-contained! No batteries! Just plug into the 110 volt house line. Complete kit including drilled metal chassis, all parts, and clear picture diagrams. **\$5.95**



Set of three matched Sylvania tubes, \$1.50.

**ACCESSORIES**

Neat black crystal finished metal cabinet with hinged lid for the 12,500 Mile receiver. Protects tubes, coils, and wiring from damage and dust. **\$1.00**  
Set of two broadcast band coils for any of the sets described above. Tune from 200 to 625 meters. Enables you to hear all the regular broadcast stations and the long wave ship and press transmissions merely by plugging in these coils. Make your set a real All-Wave Receiver! **\$1.25**  
AC Power Pack for AC Model. Delivers 250 volts and 250 volts A.C., excellent for amplifier or transmitter. Complete Kit **\$3.45**  
Sensitiv Light Weight Headphones: 2000 ohm, \$1.05; 4000 ohm, \$1.45  
Complete Antenna Kit—includes antenna wire, lead-in wire, insulators, ground clamp, knobs, etc. **75c**

**FOR MORE VOLUME—**

Add this new power amplifier to your present receiver! All-electric AC-DC—Power Pentode—Can be attached to any electric or battery operated set.

No wiring—Just plug into phone jack and Presto! **LOUD SPEAKER VOLUME!** **\$2.95**  
Price wired, ready to plug in—Model PA-1—Sylvania 12A7 tube 95c extra

Loudspeaker for above.....\$1.45  
Neat crystal finished metal cabinet 6 1/2" x 7 1/2" with grille to accommodate any 5" or 6" speaker.....\$1.00  
**COMPLETE AMPLIFIER with tube, speaker \$5.99**  
and cabinet, ready to operate.....

**A Mighty Mite!!**

**The FULTONE "DUETTE" ALL-ELECTRIC TWO-IN-ONE 4 1/2" x 5 1/2" 2 1/4 pounds complete**



A powerful handful of radio that will surprise you with its volume and reception ability. Fultone's S.W. Broadcast stations are easily picked up with excellent headphone volume! Uses the new two-in-one type 12A7 Tube! High gain pentode detector and power rectifier. A real power-ful two tube receiver! **\$4.45**

Complete construction kit includes all necessary parts, drilled chassis and cabinet, 15 to 200 meter Sylvania 12A7 tube.....\$1.25  
200 to 625 meter broadcast band coils.....\$1.25

**SPECIAL COMBINATION OFFER**  
Complete Kit, tube, and B.C. coils **\$6.25**

**FULTONE "DUETTE" BATTERY MODEL**  
Uses the new type 19 tube—two separate tubes in one built Detector and one stage audio amplifier. Economical operation on two dry cells and one or two B batteries. **\$3.75**

Complete easy construction kit, as above.....  
**COMBINATION OFFER**  
Complete Kit, tube, and B.C. coils..... **\$5.50**

Any Kit on this page Assembled—Wired—and Tested..... **\$1.25**

**HARRISON RADIO CO. THE HOME OF FOUR STAR SERVICE**  
Dept. C-4 New York City 142 Liberty Street

**and now— THE IMPROVED MASTER TELEPLEX**

TELEPLEX again shows the way by its improved MASTER TELEPLEX code teaching machine with embossed copper tape plus Telespeed. No more fussing around with ink tapes; no more relays; no more complicated battery hook ups; no more fading of signals—all because Master Teleplex, "the choice of those who know," is now equipped with copper tapes on which the code signals are EMBOSSED.

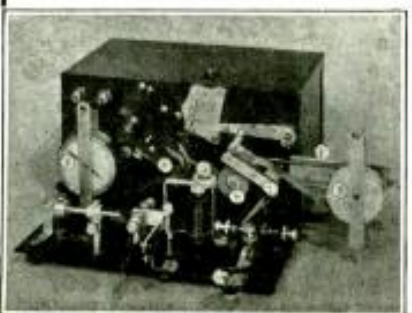

With Teleplex you get TELESPEED, unbelievably smooth automatic key. Teleplex has taught code to more operators in past 10 years than all other methods combined. No experience needed. Beginners, amateurs, experienced ops get ahead faster with Teleplex. Only instrument ever produced which records your sending in visible dots and dashes—then sends back your own key work. Used by U.S. Army, Navy, R.C.A., A.T. & T., and many others. We give you complete course, lend all equipment. Nothing to buy—give personal service on MONEY BACK GUARANTEE. Low cost, easy terms. Write today for folder 826. No obligation.

**TELEPLEX CO.**  
76 CORTLANDT ST. NEW YORK, N. Y.  
"Master Teleplex—The Choice of Those Who Know"



# ★ PEAK PRESELECTION and PREAMPLIFIER

**BRINGS IN FOREIGN STATIONS YOU NEVER HEARD BEFORE**

Here is what every foreign station listener has been waiting for! The PEAK increases the sensitivity and selectivity of your present short wave or all-wave receiver tremendously! You'll even get stations that you never heard before—and you'll practically eliminate back-ground noise. Image signals absolutely kept out. It's so easy to use; a moment and it's connected to any set. Every PEAK is sold with an unqualified guarantee to improve reception with any S.W. or all-wave receiver—far beyond any similar unit on the market. In other words it will make a "new" set of an old set at a fraction of the cost.

**HAMS!** PEAK P-11 is the talk of the country! Bring your weak unreadable signals up to R-9! Peak is complete less tubes, includes built-in coils covering 11-200 M. in 3 steps; 2 hi-gain stages for type 78 tubes; electron-coupled regeneration; self contained filament supply, silvered contact low capacity selector switch. You just can't afford to be without PEAK P-11.

Peak list at \$33.00  
— 40% discount to Hams and experimenters. Your cost less tubes \$19.80 at all Radio Supply Houses. Write for literature and name of our nearest dealer.



**EASTERN RADIO SPECIALTY CO.**  
Manufacturers of PEAK Products  
1845 Broadway Dept. S-45 New York, N. Y.

Ultra-short waves, television, power transmission, and pathological application are but a few of the many fields that beckon the experimenter.

Amateur radio might truly be said to be "all things to all men"! The amateur may expend as much money and as much time as he desires upon his hobby with the assurance that he will receive the greatest possible return in pleasure and instruction for his expenditure. The game has a dozen and one different branches from which the amateur may select his particular form of activity. Code transmission, phone transmission, television, "DX" hunting, five meter experimenting, traffic handling, and equipment design are a few of the branches of which I speak. Surely one of these will prove attractive to any person who is interested in the science of radio in any form.

There you are! My argument is complete! The decision is now in your hands. Will you permit that boy of yours to go ahead with his hobby?

## Maps and Photos Sent by New Facsimile System

(Continued from page 711)

to print directly on ordinary white paper. Continuously feeding rolls of both the carbon and the paper are led past a metal cylinder, on which a single spiral of wire projects slightly above the surface. The fluctuations in the intensity of the incoming signals press the paper and carbon together against this spiral to make marks corresponding to the light and shade of the original at the transmitter. Since the receiver and the transmitter are synchronized, an exact reproduction results. The facsimile recorder described by Mr. Young traverses a standard width letter-size page, measuring 8½ by 11 inches, at the rate of 1.2 inches per minute. Thus, a full-sized page filled with single-spaced typing is completed in 8 minutes, or at the rate of 100 words per minute.

## Clubs Hold Joint Meeting

(Continued from page 711)

ocean separating them. Scheduled for around 7:30, it was actually about 8 o'clock when President N. K. Eaton of the Schenectady club took the air with his "Good evening, members."

It was "good evening" because of the difference in time between Schenectady and Sydney. Eaton spoke for about 3 minutes, describing the organization of the local club and the routine of its meetings. He was followed by G. Moline of the Zero Beat Club in Australia. Others who spoke were Gerald Gaynor, Schenectady, on "Five-Meter Activity in the United States"; Alfred Korb, Schenectady, on a description of the W2XAF transmitter; Ray Hutchinson, of station VK2ZD, Sydney, "The Zero Beat Club Amateur Radio Station"; Norbert Sauter, Schenectady, "Amateur Radio Activities in the United States," and Harry Bourne of G2KB, Rugby, England, who spoke from Schenectady on "An English Amateur's Viewpoint of Amateur Radio in the United States." Ten-meter activity in Australia was also the topic discussed by a member of the club 10,000 miles away.

Arrangements for the joint meeting were made by E. S. Darlington of the General Electric Company. This end of the get-together took place in the studios of WGY and the participating stations which made the two-way conversation possible were W2XAF in Schenectady, operating on a frequency of 9530 kilocycles, and VK2ME of Amalgamated Wireless Australasia, Ltd., at Sydney, operating on a frequency of 9,590 kilocycles.

Negotiations are now under way for similar joint meetings between the Schenectady club and the amateur radio clubs of South America.

# YOU DON'T

## READ AND THEN DISCARD SHORT WAVE CRAFT

Readers keep their copies for years as a steady reference and thousands of letters attest to this. It is now possible to save your copies and for this purpose we designed a splendid binder for you which holds twelve copies. It is made of heavy substantial material and is covered with black grain leatherette. The name of the magazine is stamped in gold on the cover.

An ingenious mechanical arrangement is provided which makes it possible to hold the copies flat when reading from the binder.

SHORT WAVE CRAFT Binder as described, \$1.25 prepaid in the United States.

Canada and foreign countries 25c extra. We accept money order, check, stamps or cash.

**SHORT WAVE CRAFT**  
99-101 HUDSON STREET NEW YORK, N. Y.



## THE CENTRALLION 3 ALL-WAVE RECEIVER

A powerful electrified receiver GUARANTEED FOR FOREIGN RECEPTION. No expense was spared in improving the efficiency & beauty of this set. Uses 78 & 12A7 (2 tubes in 1 bulb) in 3 tube performance circuit as screen-grid regenerative detector, power pentode audio amplifier, & built-in power supply. No batteries. Operates from 110 volt house current. Operates speaker on local stations. Covers 12-600 meters. Heavy black shrivel metal chassis & panel. Coils for 12-205 meters, simple instructions included.

Kit, assembled & ready to wire. Wired & tested. extra..... \$1.35  
Arcornia tubes... 1.90  
Broadcast coils... 1.00  
Metal cabinet... 1.00

Special: Complete set ready to use, less phones \$10.90.

**5.95**

**The DX2 All-Wave Receiver**



A good battery operated receiver that is GUARANTEED FOR FOREIGN RECEPTION. Good volume & economical in operation. See article page 601 Feb. issue SWC. Uses 30-33 tubes as reg. detector & power pentode amplifier. Works on 2 dir. cells & 1-4.5V B battery, & 1 C batt. Black shrivel metal chassis & panel. Coils for 12-205 meters & instructions included.

Kit, assembled & ready to wire. Wired & tested. extra..... \$1.25  
Arcornia tubes... 1.35  
B C coils (2)... 1.00  
Metal cabinet... 1.00

Special: Complete set ready to use, less phones, batteries, and cabinet \$7.75

**4.35**

**CANNONBALL HEADPHONES, \$1.35**  
**CENTRALLION ENGINEERING CO.**  
Dept. SW4, 136 Liberty St., New York, N. Y.



## DIAMOND TUBES at REDUCED PRICES

Order Diamond tubes with confidence. Packed in sealed cartons. Guaranteed for six months. R.C.A. licensed. Ask for our special discounts on quantity orders. Distributors wanted in every big city. Free offer Dependable tube tester, etc. Write for particulars on how to get one.

Type	Price	Type	Price	Type	Price	Type	Price
01A	.25	31	.60	54	.45	606	.45
26	.28	36	.45	59	.55	401	1.00
27	.28	37	.40	75	.45	403	1.10
15	.28	38	.45	77	.60	485	.50
71A	.28	39	.50	78	.60	182	.50
80	.28	41	.45	79	.75	183	.50
21A	.45	42	.50	81	1.00	10	1.00
35	.45	43	.60	82	.40	50	1.00
51	.45	41	.50	83	.50	2A7	.65
17	.45	46	.50	81	.65	217	.75
12A	.35	48	1.75	85	.45	6A7	.65
30	.40	49	.60	89	.50	617	.75
31	.40	55	.45	X99	.45	25Z5	.65
32	.60	56	.35	V99	.45	2A5	.45
33	.60	57	.45	22	.75	218	1.20

No order accepted for less than \$5.00. All prices F.O.B. 20% deposit with orders. 10% Discount on orders of 25 Tubes.

**RADIO TUBE EXCHANGE OF AMERICA**  
177 Washington St. Dept. S., New York, N. Y.

## THORNE'S UNIVERSAL COIL WINDER

DESIGNED FOR THE AMATEUR AND RADIO REPAIR SHOP

Will wind Transformers, Straight or Honeycomb coils and Ear phone armatures. Revolution recorder. 14 Speed changes.

Write for Illustrated Circular and Price.

**SUNSHINE NOVELTY CO.**  
226 S. W. 2nd Ave., Miami, Florida.

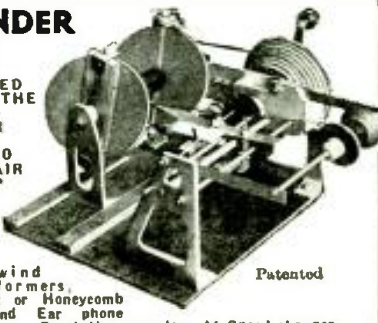



# Announcing the Spring & Summer Edition of RADIO'S LEADING CATALOG

A new ALLIED RADIO Catalog is on the press—not a meager supplement—but a full-size, meaty, complete book about Everything in Radio for Everyone in Radio. It's the kind of Value and Profit Guide for which ALLIED is famous. You need this new Catalog if you build, sell, service or operate radio equipment. Reserve your FREE copy immediately.

*What Will the new Allied Catalog Show in Sets?*

Everything: Short Wave, Dual Wave, All-Wave models—new Auto Radios—all types of electric, battery, and 32 Volt receivers. Prices are low, too.

*What About the Set Builder?*

He'll be in his element with more than a dozen great new kits to choose from. He'll find parts at lowest prices for building any radio circuit.

*Why Will The Amateur Want this New Book?*

Because it is complete in its listing of all the leading Amateur lines. It shows everything for Short Wave Transmitting and Receiving.

*Will There Be a Special Short Wave Section?*

Yes. With interests for everybody. There will be new receivers, transmitters, and parts for "DX" fans, Experimenters, Amateurs, and Set-Builders.

*What About the Serviceman?*

The new ALLIED Catalog will answer every Service need with the latest test equipment, and with thousands of parts priced for Servicemen's profits.

*Will There Be Anything New In Public Address?*

Yes, absolutely the most advanced Sound Equipment built today—portable, mobile and permanent—an amazing selection to fill every Public Address need.

## ALLIED RADIO CORPORATION

833 JACKSON BLVD., Dept. E1, CHICAGO, ILL.

Gentlemen: You may reserve my FREE copy of the new Spring and Summer ALLIED Catalog.

Name \_\_\_\_\_

Address \_\_\_\_\_

**RESERVE YOUR COPY NOW!**

# Low-Power Rack and Panel Xmitter

(Continued from page 731)

will be described in the third installment.

### 46 Tube Used in Amplifier

The 46 type tube is used in the amplifier because of three very important reasons and they are first, its low cost, for this is a low-power, low-cost outfit; they need no external bias, and they are very efficient as R.F. amplifiers. In this role they have their two grids connected together and returned to the B minus through a "limiting" resistor. The tubes are placed in the center of the baseboard with the grid tuning circuit on the right and the plate circuit on the left. However, if the builder did not follow the layout of the exciter unit previously described he should arrange this unit to suit the arrangement of the exciter. That is, the grid coil should be on the same side of the base that the plate coil is located on the exciter. This is to provide short leads when the amplifier is mounted above the exciter.

The grid coil is wound on Hammarlund XP-53 4-prong coil forms. Two prongs are used for the grid coil and two for the three-turn "link" coil. The plate coil is wound on the new 2 1/4-inch Bud transmitting plug-in coils and provides a very husky and efficient plate inductance. All the plate coils of the amplifier are wound with No. 14 tinned copper wire. Get the soft-drawn kind or you will have a difficult time with the winding operation. The two large prongs are used for the plate winding as the heavy wire will not fit through the small prongs. This coil is tapped in order that neutralizing can be effected. The tap is located approximately one third the total number of turns from the end of the winding which is not connected to the tube plates. The plate voltage is fed to the plate of the tubes through this tap. The tuning condenser is connected across the whole coil. The tuning condenser is of the

double-spaced *midget* variety and has a capacity of 50 mmf. The reason such a small or low capacity condenser is used is because we are using a very low "C" circuit in order to obtain high efficiency. When using such low capacity the coils have to be made accurately because we can do very little tuning to compensate for errors in the inductance. So follow the dope given in the coil table. The condenser used in the plate circuit is the one that was used in the plate circuit of the exciter unit last month. A 100 mmf. *midget* replaces the one used in the exciter.

### The Grid Coils

The grid coils are wound with No. 20 double cotton-covered wire and there is no spacing between the turns. The three-turn link winding is wound with No. 16 double cotton-covered wire. Heavy wire is used because of the high current that is present on this circuit. The link coil should be coupled to

the grid end of the grid winding and spaced from it about 3/16 of an inch. A similar three-turn coil is added to the plate coil of the exciter unit. Separate grid coils are used for each band in the amplifier although if a larger condenser (140 mmf.) were used a single coil could be made to cover two bands, although this would not be quite as efficient. The data for the grid coils is also given in the coil table.

By glancing at the circuit diagram it will be seen that only two by-pass condensers have been used, one in the grid circuit and one in the plate circuit. The whole

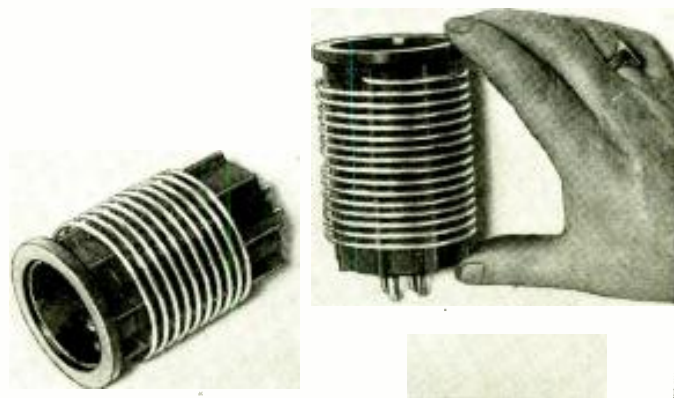

Close-up of Xmitter Coil

### Coil Data

Band	Turns	Plate Coil* Length winding	B plus tap	Grid Coils Band	Turns	Link Coil
80 meter	30	3 inches	10th turn	80	20	close wound
40 meter	16	3 inches	6th turn	40	10	close wound
20 meter	10	3 inches	3rd turn	20	6	close wound

\*Wound on 2 1/4-inch "ribbed" 4-prong plug-in coil forms with No. 11 soft-drawn tinned wire.  
†Wound on 1 1/2-inch "ribbed" 4-prong plug-in coil forms with No. 20 double cotton-covered wire.

Please mention SHORT WAVE CRAFT when writing advertisers



# 5-TUBE 1935 SUPERTONE BANDSPREAD RECEIVER

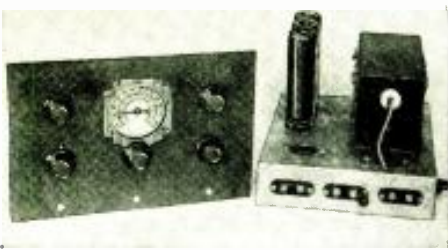

Our 1935 receiver is truly a new one. New circuit, revised to use a two gang condenser, band spread condensers on both radio frequency and detector stages to afford true bandspread. Regeneration control placed in screen lead to afford more positive and

smoother regeneration. New 6D6 in the radio frequency stage, 6F7 for detector and first audio, 37 second audio and 41 in the last audio, to give tremendous volume on all stations.

Laboratory tests have brought in GSA England, FYA France, EAQ Madrid, DJD Germany, EAQ Spain, VK2ME Australia. All South American stations, Mexico and Canada. Hams and police calls throughout the country with R8 and R9 volume.

Set is housed in a beautiful black wrinkled metal cabinet with vernier airplane dial and hinged top to facilitate removal of coils.

Power pack with brute force filter using 30 mfd. external voltage terminals and speaker field outlet gives a hum proof power supply which is so vital to every short wave set.

Chassis, wired and tested with coils.....		<b>\$10<sup>00</sup></b>
Power pack wired and tested.....	\$ 4.98	
5-Tube and 6" Dynamic speaker.....	6.00	
Complete kit of parts, tubes, speaker and power supply.....	18.75	
Cabinet for receiver.....	2.50	

## SUPERTONE PRODUCTS CORP.

35 Hooper Street, Dept. S-1 35, Brooklyn, N. Y.

amplifier has been built with the idea of keeping the cost down and still not impair its efficiency; R.F. chokes provided no benefit, neither did filament by-pass condensers, so they were left out.

To the left of the plate coil can be seen the antenna coupling condenser and the standoff insulator which supports it. This condenser is used to keep the D.C. plate voltage out of the antenna circuit. A small clip is necessary in order to vary the antenna tap on the plate coil. No antenna coupling coil is used because we are going to use an impedance matching network consisting of two condensers and a loading coil. This system, brought to the amateurs' attention by Arthur Collins, is used because of its simplicity and efficiency. This "network," as it is frequently called, will be described in detail in next month's issue.

### Tuning Up the "Rig"

After the amplifier has been wired and checked to make sure that no mistakes have been made we are ready to tune up the whole rig. Apply the connections from the exciter to the amplifier, and connect the filaments. Apply the plate voltages to the exciter and tune it as described last month (do not apply the plate voltage to the amplifier). Now tune the grid condenser of the amplifier until the plate current of the 2B6 rises to a peak value. Next rotate the plate condenser of the amplifier until R.F. can be detected in the plate circuit of the 46 amplifier. A suitable device for detecting R.F. is a single turn coil with a flashlight bulb in series. Now adjust the neutralizing condenser until, while swinging the plate condenser back and forth, no trace of R.F. can be detected in the plate circuit. The plate voltage can now be applied to the amplifier. Close the key and immediately adjust the plate condenser until the plate current reaches a minimum value; this will be around 15 to 20 milliamperes.

The antenna can be a plain piece of wire from 75 to 100 feet long; connect it to the input of the "network" and connect the "network" to the plate circuit about three turns from the plate end of the coil. Close the key again and adjust C1 till the plate current of the amplifier drops to its lowest value. Then adjust C2 until the plate current reaches 100 milliamperes. Always adjust C1 last, to bring the plate current of the 46's to a minimum value. Further details on the complete transmitter will be given in the next installment.

### Parts List for Rack and Panel Amplifier

- 1—50 mmf. double spaced midget condenser, Hammarlund, Bud.
  - 1—35 mmf. double spaced midget condenser (NC), Hammarlund, Bud.
  - 3—.002, 1000 volt condensers, Aerovox, Sprague.
  - 2—250 mmf. antenna tuning condensers, 1000 volt rate (C1, C2), National.
  - 3—4 prong plug-in coil forms, 1 1/2 inch outside diameter, Hammarlund.
  - 3—large Bud transmitting coil forms, 4 prong.
  - 6—4 prong, ceramic sockets, Bud, Hammarlund.
  - 2—5 prong ceramic sockets, Bud, Hammarlund.
  - 1—20 ohm resistor center tapped, Aerovox.
  - 1—1000 ohm resistor, 25-35 watts, Aerovox.
  - 1—National ceramic coil form for antenna network.
  - 1—7x19x3/16" bakelite panel, ICA.
  - 2—dials and pointers, four inches diam., ICA.
  - 1—closed circuit jack, ICA.
  - 5—Fahnestock clips.
  - 1—stand-off insulator, National.
- Sufficient amount 14 tinned copper wire to wind the three large plug-in coils.

# FREE!

Exclusively Short-Waves From Beginning to End  
52 PAGES 50 HOOK-UPS 500 ILLUSTRATIONS

## A Real Text Book On Short-Waves

ANOTHER GREAT EVENT! This special edition of our famous Treatise is exclusively short-wave from beginning to end. Packed between its two covers is a wealth of information covering the entire short-wave field. Every word in it is new.

This Short-Wave Treatise contains 52 solid pages of useful short-wave information, diagrams, illustrations, short-wave kinks and real live short-wave radio merchandise. It contains more valuable short-wave radio information—more real live "meat"—than many text books on the subject. Special attention has been given to the short-wave beginner. Numerous articles are devoted entirely to his interest. Yet, we have not forgotten all you old-timers. There is plenty of real "dope" for you too.

### PARTIAL LIST OF CONTENTS

Getting Started in Short-Waves—Helpful Short-Wave Kinks—Principles Of Short-Wave Converter Operation—Bandspreading Explained—How to Build the "19" Unimount Twinplex For Less Than \$5.00—How to Tune For Foreign Short-Wave Stations—How to "Bandspread" the 2-Tube Electrified Doerle Set—How to Build a 5 and 10 Meter Phone and C.W. Push-Pull Transmitter—How to Build a Medium Power Transmitter Using the New 203-A Tubes—All About the New Short-Wave Transmitting and Receiving Antennas—Notes On Short-Wave Operation (Effect of Time of Day and Season of Year on Short-Wave Reception).

Send 5c. coin or new U. S. Stamps, for postage. Treatise sent by return mail. PRINT NAME AND ADDRESS CLEARLY

WRITE TO-DAY

RADIO TRADING CO.

101A Hudson St.  
New York City



## BIG CAPACITY ... LITTLE MONEY

That's Aerovox Cartridge Condensers... selected dielectric and tinfoil section... triple-sealed moisture-proofing... mass produced for economy... 200, 400, 600 and 1000 v. Just compare quality... list prices... discounts!

FREE DATA: New 1935 Catalog is yours for the asking. Also sample copy of Research Worker. Look for yellow and black carton when buying condenser or resistor.



AEROVOX CORPORATION  
72 Washington St. Brooklyn, N. Y.

## EILEN DE LUXE ALL-WAVE RECEIVER



A high-quality, CUSTOM-BUILT, all-wave receiver suitable for use in any home. Designed so as to produce regular broadcast receiver volume on foreign short wave stations. Uses five "high gain" tubes, 5A-58-56, 2A5-80 types in a special circuit

which produces real results. Equipped with a built-in dynamic speaker & a jack which permits the use of headphones also. Operates from 110 Volt AC house current. Illuminated airplane type vernier dial & a beautiful black shrivel finished metal cabinet. Covers 12-600 meters. Coils for 12, 205 meters, built-in dynamic speaker, & instructions included. SATISFACTION GUARANTEED.

Receiver, assembled and ready to wire...	\$13.95
Wired and tested extra	\$2.00
Arcturus matched tubes	\$2.75
Broadband band coils 200-80 meters	\$1.00

EILEN RADIO LABORATORIES  
Dept. SC4, 136 LIBERTY ST., NEW YORK, N. Y.

## In Next Issue!

The Swellest Portable 5-meter Transceiver Imaginable! Full detail given!



## New Stunts With Short Waves

(Continued from page 710)

made by F. Reiner & Co., in Vienna and Dr. Paul Groag and Victor Tomberg, illustrated in Fig. 1. As is apparent from the diagram given, the idea of the hook-up lies in the three oscillating circuits, of which the middle one, No. 2, is not so much a circuit as it is a "bridge." The first circuit is the usual regenerating-oscillating circuit, and the happy idea of the variable bridge (2) will make it possible to have the therapeutic circuit at practically any distance from the primary. In the therapeutic circuit (3) either two condenser plates can be used as in 3A or one plate, with the ground functioning at the second as in 3B. The body, or portion of the body to be treated, would then be placed between the two plates or between the plate and the ground respectively. The latter arrangement changes the structure of the field, as indicated in the diagram, and it would be more efficient for treating superficial areas of infection, whereas arrangement 3A would seem to be indicated for the irradiation of the subsurface. It is to be expected that in the near future small therapeutic sets of this kind will replace the present rather cumbersome arrangements and displace our high-frequency apparatus of today.

### "Crustless" Baking Tomorrow by S-W's

Besides this field of utility in hygiene, there is also the possibility of using this principle in the arts of cooking and baking. Very even and penetrating heat will be achieved. As yet baking by any other means necessarily produces a crust; that is, the surface of the baked object is chemically different from the inside! With ultra short waves, on the other hand, it would be possible to achieve "crustless" baking! According to reports in the daily newspapers, a toaster for household use based on this principle has already been invented. It is by no means impossible that suitable arrangements of tubes and hook-ups will improve the efficiency of such cooking and baking utensils to the point where they will be far superior to our present electrical apparatus, based on the principle of ohmic resistance.

As can be seen from the foregoing, even the few possibilities in short-wave radio described in this article are not so far in the future as might be generally supposed. Indeed the laboratory work in some fields has progressed so far, that many types of apparatus have been manufactured as experimental specimens, and we may, in the not-far-distant future, expect the commercial appearance of a number of such devices. These speculations as to the enlargement of present radio technique and the opening up of new markets for the industry seem, therefore, not altogether out of place. —

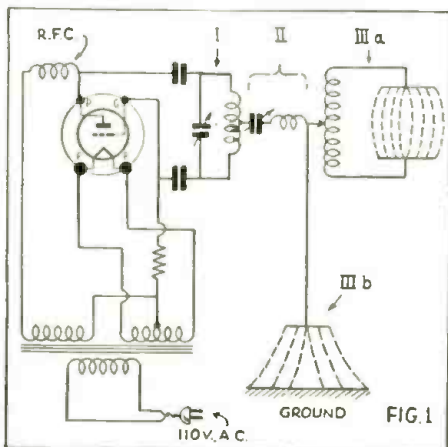

Circuit for producing short wave field for treatment of vegetables, etc.

# Here is RADIO'S GREATEST CATALOG for 1935

Another News Event! A brand new FREE 136-page catalog just off the press! It's a real surprise package for it lists the newest developments and quotes latest, lowest WHOLE-SALE prices. This Bargain Book 56C will save you money by bringing you right up to date. Thousands of timely bargains in merchandise most in demand during the Spring and Summer Months. Get your copy at once. You must have one if you want to keep up-to-date!

## SHORT WAVE HEADQUARTERS

Thousands of Hams, Amateurs and Experimenters from the Atlantic to the Pacific look to us for every latest development in Short Wave. They know that because we have the world's largest stock we can always render faster, more dependable service. Last, but not least they know that they can always save money because we list everything at

### LOWEST WHOLESALE PRICES!

# WHOLESALE RADIO SERVICE CO.

NEW YORK, N.Y. - 100 Sixth Avenue

ATLANTA, GA. 430 W. Peachtree St.

NEWARK, N.J. 219 Central Ave.

# 3 Short-Wave LEADERS



It's a sensation! It's sweeping the country! Seems as though everyone wants one! That's because it's a giant in performance despite its low cost. Even a novice can build it. Buy the complete kit of parts, less tubes and speaker for only \$26.19; or if you prefer send \$2.25 for the Foundation Kit which enables you to start building at once. You buy the balance of parts as needed.

## LES-TET 2B6 Oscillator Amplifier or Doubler

Beginners! You can now build your own four panel 30 watt phone and C.W. Transmitter on the "Installation plan." We carry the complete kit of essential parts for the Les-tet 2B6—a 1 tube M.O.P.A. low powered X'mitter to which other stages may be added later. (See March S.W. Craft, Pg. 676). Kit includes all tuning and fixed condensers, coils, resistors, bakelite panel, dial plates, Triplet meter, etc., \$19.50 etc. Price less tube and power supply..... \$19.50

## Lafayette "P46" 30 Watt TRANSMITTER

Here's a completely self contained job including power supply which will operate wherever 110 v. 50-60 cycle current is available. This unit will certainly be welcomed by those Hams who cannot afford a 100 watt job such as that described in S.W. Craft, March issue. The circuit employed is the popular Les-tet Oscillator Buffer or Doubler with a pair of 46's in parallel operated as a Class "C" Amplifier. Get all the facts about this job today. The price is LOW..... \$49.50

Wholesale Radio Service Company, 100 Sixth Ave., Dept. SW-45, New York, New York.

- I enclose \$..... Rush the following order.
- ( ) All-Star Jr. Kit @ \$26.19. ( ) Foundation Kit at \$2.25.
- ( ) Les-tet 2B6 Kit at \$19.50.
- ( ) Lafayette "P46" 30 watt Transmitter @ \$49.50.
- ( ) FREE NEW 136 PAGE CATALOG 56C.

Name.....  
Address.....  
City..... State.....

## NO. 245 CABINET

For 5 Meter Transceivers. Short Wave Sets. Pre-selector, Monitors, m a 11 Portable Transmitters, Frequency Meters, Test Equipment, and many other uses.

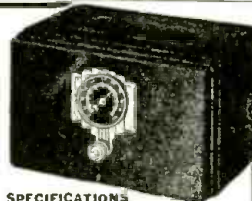

### SPECIFICATIONS OF CABINET

Length inside, 9 3/4 inches; Height inside, 6 5/16 inches; distance front to back, with deep back, 4 1/4 inches; gross weight with carton about 3 1/2 lbs.

Made of heavy stamped steel. Finished in durable black crystalline lacquer. Has removable metal bottom and is supplied with rubber feet.

List Price Cabinet only, packed in substantial carton, each..... \$3.75

Federal Tax of 5% to be added..... \$2.40

List Price No. 124 Dial, as illustrated..... \$2.40

State size of hub desired, and whether condenser closes on the left or right.

CROWE NAME PLATE & MANUFACTURING CO.  
1743 Grace Street, Chicago, Ill., U.S.A.  
Cable Address—Crowname—Chicago

## Entire SARGENT Line

IN STOCK IMMEDIATE DELIVERY  
SHIPPED PREPAID if Full Purchase Price Accompanies Your Order

L. I. MARINE & ELECTRIC CO.  
WHOLESALE DISTRIBUTORS  
163-18 Jamaica Ave., JAMAICA, N.Y.

## It's a Treat to Listen In on This One!



\$54.50 Complete

### SARGENT 8-34 RECEIVER

Everything you want in a real Short Wave Receiver. Hundreds sold to enthusiastic amateurs and fans is our best testimonial. Tunes 15-550 meters. Band spread, heat oscillator, self-contained power supply. Price includes tubes and dynamic speaker unit. Nothing else to buy. 5-Day Money Back Trial. Order Yours Today.

MARINE MODEL 8-34 NET, \$62.50  
As above, with another waveband added. Continuous tuning. 15 to 1500 meters. An ideal shipboard receiver. D.C. prices on request.

### Add Thousands of Miles to Your Range

Adds thousands of miles to your receiving range. A regenerative pre-selector unit, eliminates image, more DX, lower noise level, less money. Works with any super matches appearance of Sargent 8-34. Net \$14.75 price, complete with tube..... \$14.75

### AN UNBEATABLE COMBINATION

The DX Hound's dream come true, at a price he can afford to pay! Buy the Sargent Pre-Selector and 8-34 Receiver—there is nothing better at any price. Total cost, ready to operate, only..... \$69.25

E. M. SARGENT CO., OAKLAND, CALIF.

Please mention SHORT WAVE CRAFT when writing advertisers



# An Announcement by HUGO GERNSBACK

THE OFFICIAL SHORT WAVE LOG AND CALL MAGAZINE, of which three issues have been published, will hereafter come out every other month under the name of

## OFFICIAL SHORT WAVE LISTENER MAGAZINE

I have created an entirely new magazine for the short wave listener, such as has not existed before. This new magazine is totally different in get-up and contents from the former magazine, and nothing like it has ever been published before.

To begin with, the new magazine comes with a four-color cover, and it is beautifully printed throughout. It contains a great variety of material, all of which is essential today to the short wave listener.

IT IS NOT A TECHNICAL MAGAZINE. It is designed for the short wave listener only. The first, the February-March issue, which is now on all newsstands, contains the material you find listed below.



ASK YOUR  
NEWS DEALER  
FOR A COPY  
OF THIS NEW  
SHORT-WAVE  
MAGAZINE

25c the Copy  
Well  
Illustrated

### Contents of the March Issue:

Over 800 short-wave stations in various parts of the world await the touch of a finger on the tuning dial of your "short" or "all wave" receiver.

Photos and descriptions of short wave broadcasting stations in various parts of the world, with photos of short wave studio artists.

Where to find the important short-wave "DX" stations on the dial of your receiver.

Verification cards—what they are and how to get them.

Up-to-the-minute grand list of short-wave stations of the world with call letters and frequencies, including "Police," "Television" and short-wave stations.

Special list of the best or star short-wave stations, with their frequencies and call letters. Valuable hints to the "short-wave listener"—how to locate the "weak" distance stations, etc.

Different time zones in various parts of the world, together with a map showing the location of short-wave stations of the world.

How To Use Earphones on Standard Receivers.

Short-Wave Fiction Story—"Short Waves by Heart"—by Hugo Gernsback.

WINAL'S S-W Educational Programs.

Fading and Ship Distance Explained.

How to identify short-wave stations by their "musical note" signatures.

Question and Answer department for the Short-Wave Listener.

Notes on "foreign" as well as "domestic" short-wave programs, meaning of foreign language phrases spoken in stations, etc.

How to erect special types of short-wave antennas, etc., SILVER CUP TROPHY for best photo of readers' listening "Posts."

### I ASK YOU A FAVOR

You have been an enthusiastic reader of SHORT WAVE CRAFT and your letters to me have always shown that I give you your money's worth. Now, I ask you as a special favor to me, that on or after January 25th you get from your nearest newsstand a copy of The Official Short Wave Listener Magazine. Take it home and look over it carefully.

If, after you have bought your first copy and have studied its contents and have read herewith to return the copy of the magazine to me and I will promptly refund you your quarter, as long as you state in your letter the reason why you do not like the magazine or if you do not think it is worth the money I ask for it. You to be the sole judge. This is my special promise to you.

*Hugo Gernsback*

OFFICIAL SHORT WAVE LISTENER MAGAZINE  
99 Hudson Street, New York, N.Y.

Please mention SHORT WAVE CRAFT when writing advertisers

## A Good 3-Tube Super-Het

(Continued from page 717)

the other components is not so critical. The tank condensers are mounted about  $\frac{1}{4}$  inch above the base and lined up with their respective dials after the base is permanently fastened in place. The National "HS" dial is supplied with brackets which are used to mount the two band-spreading condensers. The arrangement of the components beneath the base is not particularly important, except that the "hot" leads should be short or else shielded and that the chassis should not be regarded as a satisfactory ground.

### I. F. Transformer Details

The first I. F. transformer requires minor alterations to adapt it to the regenerative circuit. To do this the grid clip should be unsoldered and the assembly removed from the can. The following changes are required to couple the tickler to the grid coil of the I. F. amplifier. The yellow lead is brought down so that it will pass through the bottom of the can and the blue lead is brought through the top. The coil connections should then be as follows: yellow, or inside lead of upper coil, to plate of -A7, black, outside lead to "B plus"; blue, inside lead of lower coil to grid of I. F. amplifier, red, outside lead, to C10 and R7; if the tickler coil is wound in the same direction as the other coils, inside lead to cathode of I. F. amplifier, outside lead to ground. The exact size of the tickler and its correct spacing from the secondary of the I. F. transformer will have to be determined experimentally after the receiver is finished. Fig. 4 shows a convenient arrangement for making these adjustments. However, don't forget to drill that  $\frac{3}{4}$  inch diameter hole in the sub-base; its location is indicated by dotted lines in Fig. 3.

For the 53 the grid lead of the second I. F. transformer will have to be brought down to pass through the bottom of the can.

By the way, the National 450 to 550 kc. unit seems to be the only commercially manufactured air-tuned I. F. transformer which can be adapted so readily. However, since it is a National product it is of the highest grade obtainable—so why worry?

Since mica-dielectric tuning just can't be used successfully in this receiver Fig. 5 is given to show the layout of a model using "homemade" I. F. transformers. The coils were borrowed from mica-dielectric transformers and the tuning condensers are Pilot Type "J 23" 100-mmf. midgets. The cans are made from 32-ounce copper sheeting. Two National Type "SE" 100-mmf. condensers are used for band setting and a National Type "2SE" 100 mmf. for band-spreading. Those who have a dual tuning condenser may prefer this arrangement. This model performs just as good as the one shown in the photographs.

The construction of some I. F. transformers almost prohibits the use of a tickler coil and in order to obtain controllable regeneration a makeshift arrangement will have to be used. It consists of a piece of hook-up wire about 4 inches long, run alongside the tube, inside the shield, with the upper end wrapped around the grid cap of the I. F. tube. R10 is connected as a volume control in series with a 300-ohm cathode resistor and a 1-mf. by-pass condenser is connected from cathode to ground. The grid return, of course, should be connected to ground. The length and position of the hook-up wire inside the tube is adjusted so that oscillation will take place only with the volume control full on. The chief advantage of this arrangement seems to be its easy application.

### Final Adjustments

The usual procedure is followed for lining up the I. F. circuit; however, the selectivity control should be set at minimum selectivity while the adjustments are

From this you will see that the magazine has been designed as a companion magazine to SHORT WAVE CRAFT.

If you are now a reader of SHORT WAVE CRAFT magazine, you will not wish to be without THE OFFICIAL SHORT WAVE LISTENER MAGAZINE. The new magazine will help you tremendously in your short wave reception at all times and will give you priceless and invaluable information, such as you cannot get anywhere else. Nothing like it appears in print anywhere today. THE OFFICIAL SHORT WAVE LISTENER MAGAZINE, in other words, is a necessity.

P. S.—If you cannot get the magazine at your newsstand due to sell-out, send 25c in cash, stamps, or money order, and we will send the magazine to you direct, prepaid.



made. The intermediate frequency should be around 465 kc.

After the I. F. transformers are tuned as accurately as possible, tune in a steady signal, preferably on the broadcast band if no test oscillator is on hand, advance the selectivity control until a whistle is

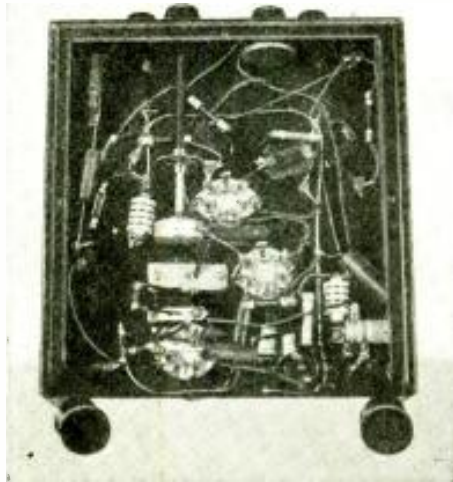

Bottom view of the 3-tube super-Het.

heard, indicating that the I. F. is oscillating. If oscillation fails the tickler coil connections will have to be reversed because an oversized tickler was intentionally specified in Fig. 4 and very likely it will be necessary to remove from 5 to 10 turns to obtain a smooth regeneration control. A method about as good as any to obtain the approximately correct amount of feedback is to remove turns until the I. F. circuit just fails to oscillate and then place a washer, about the thickness of a soldering lug, between the tickler coil and the mounting plate. Since the regeneration control and the volume control "interlock," to some extent, it is necessary to make the final adjustment so that oscillation can be obtained at all settings of the volume control.

It is good practice to realign the I. F. circuit after the final tickler coil adjustment has been made.

**Coils and Band-Spreading**

The band-spreading arrangement employed is only an extension of the tapped-coil method used in some of the best commercially manufactured short-wave receivers. Although about as simple as the more usual parallel-condenser method, it is more flexible and meets our requirements better. This system can be easily adjusted to give as much or as little band-spread as may be wanted on any band. It is a simple matter to determine the spread for the defined amateur bands; but what are the limits of the short-wave broadcast bands? With the coils specified each dial division will be equal to 10 kc. or less on most of the short-wave broadcast bands. However, the spread can be increased by moving the tap towards the ground terminal of the coil or the tuning range of the band-spread dial can be increased, of course, by moving the tap towards the grid end.

With only one tuned circuit between modulator grid and antenna, image interference is to be expected on the higher frequencies; of course, it will be no worse than with other super-Hets. that have no

T.R.F. stage. With the largest set of coils (No. 1 and 2) the oscillator is operated at a higher frequency. However, on the next set (No. 3) the lower frequency is used to prevent the image from falling right in the middle of the busy 40-meter amateur band when the receiver is operated on the 49-meter broadcast band. The two smallest sets (Nos. 4 and 5) are wound so that in order to be able to eliminate image interference, either the higher or the lower oscillator frequency may be used.

All coils are wound in the same direction and the windings are connected so that, if it were not for the difference in size, the detector coils could be used in the oscillator stage.

**How to Tune the Set**

The tuning is the same as that of any other "band-spreading" receiver. However, to illustrate the band-spread and to explain the manipulation of the selectivity control I will give a step-by-step procedure for tuning in stations on the 49-meter band.

With the third set of coils in their respective sockets and the power turned on, of course, advance the regeneration control until oscillation takes place and then back off just a little but not enough to

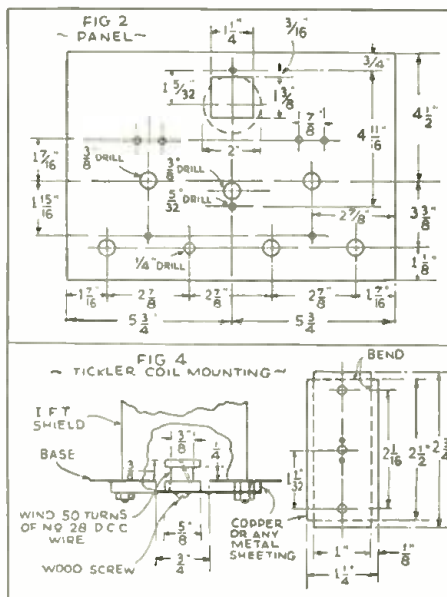

Fig. 2 above shows the drilling plan for the front panel of the set.

stop oscillation. Set the left hand dial (modulator) at 34 and the band-spread dial at 65, exactly. My key station on this band is W8XK. To receive the stations at the same point on the band-spread dial each time this band is explored, the right-hand dial (oscillator) is rotated slowly, from about 26 towards 28, until a strong whistle is heard—the weaker response on 6150 kc. is noted but not used. The OSC. dial is set for zero beat and the regeneration control retarded until satisfactory reception is obtained. The tuning is single-dial on this band; however, for HJ1ABB, 6447 kc., exact tracking is established by setting the modulator dial to not quite 36. The band-spread dial reading for HJ1ABB is 14; TGW, 6180 kc., about 62; VE9CL or YV3RC, 6150 kc., not quite 64; W8XK, 6140 kc., exactly 65; W9XF, 70; W8XAL, 75; XEBT. 6010 kc., 80.

**Coil Table**

Set No.	Frequency Range	Number of Turns				Tap	Wire Size (L1 L2 L3)			(L4)	
		L1	L2	L3	L4		Tap	Wire Size	Tap	Wire Size	
1	530 to 1400 kc.	25	115	*	49	*	28 en.	24	31 d.c.c.		
2	1400 to 3500 kc.	16	34	*	26	*	24 en.	13	34 d.c.c.		
3	3500 to 7000 kc.	9	16	9	19	10	22 d.c.c.	19	34 d.c.c.		
4	7 to 14 mc.	6	8	3	8	3	22 d.c.c.	6	31 d.c.c.		
5	12 to 24 mc.	3	4	1	4	1	22 d.c.c.	3	34 d.c.c.		

The actual range of each set of coils is greater than specified. \*Tap is connected to grid terminal. The taps are counted off from the lower or ground terminal. Coil turns are 1 1/2" dia., and all coils are close-wound. Space between L1 and L2 is about 1/4"; between L3 and L4 1/16" or less.



**A Dependable R.F. Choke  
Be Sure to Get the Genuine  
NATIONAL Type 100**

Don't sacrifice dependable day-in, day-out performance for a few pennies difference in R.F. Choke costs! Be sure you get the original and genuine NATIONAL Type 100 R.F. Choke. Designed for utmost convenience in installation, suitable for either grid-leak or pigtail mounting, small and compact, the patented Type 100 can be used close to tubes where longer leads would introduce operating difficulties. Its accurate and dependable rating adapts it to the majority of R.F. Choke Requirements in modern Short-Wave Receivers and Low Powered Transmitters. It is sturdy and reliable. Before you buy, look for the diamond NC trade-mark, proof of the advanced research and manufacturing facilities behind every NATIONAL RADIO PRODUCT.

Send coupon below for new Catalogue No. 240

**NATIONAL  
TYPE 100  
R.F. CHOKES**

 National Company, Inc.  
 Malden, Massachusetts  
 Gentlemen:  
 Please send me your new catalogue No. 240. I enclose 6c to cover mailing costs.  
 Name \_\_\_\_\_  
 Address \_\_\_\_\_

SWC-4-35

Please mention SHORT WAVE CRAFT when writing advertisers

# 2 new BOOKS on SHORT WAVES

HERE are two brand new books which you have been looking for for a long time. They contain everything that you have been asking for for many months. These new books will give you the latest information of everything you wish to know in two respective fields. Be sure to order them today. You will not regret it.

They make excellent companions to our other handbooks, which you may have.

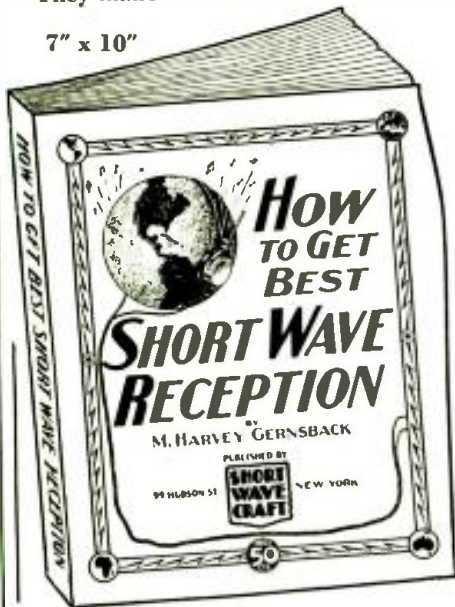

7" x 10"

TWO BRAND NEW BOOKS WHICH EVERY ALERT SHORT-WAVE FAN SHOULD HAVE IN HIS LIBRARY

7" x 10"

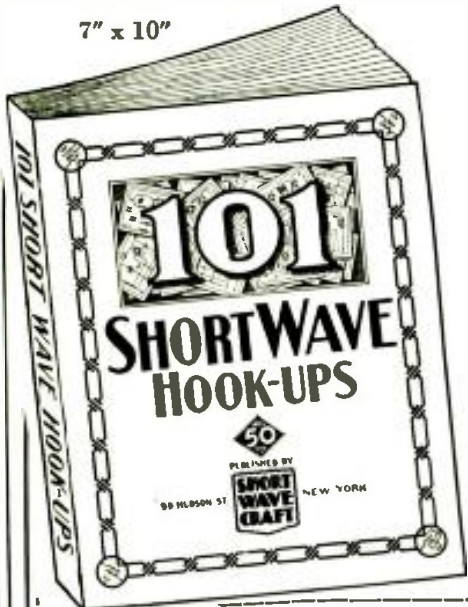

SHORT WAVE CRAFT, 99 Hudson Street, New York City.

Gentlemen: I enclose \$\_\_\_\_\_ for which you are to send to me, postpaid, immediately upon publication, the books checked below:  
 "How to Get Best Short Wave Reception"  
 "101 Short Wave Hookups"

Name .....

Address .....

City and State .....

(Send check or money order. If you send cash or uncancelled U. S. Postage Stamps, register it.)

SWC-4-35

## "How to Get Best Short Wave Reception"

By M. HARVEY GERNSBACK

Here is a book that gives you everything you have ever wanted to know about short-wave reception. The author, a professional radio listener and radio fan for many years, gives you his long experience in radio reception and all that goes with it. Why is one radio listener enabled to pull in stations from all over the globe, even small 100 watters, 10,000 miles away, and why is it that the next fellow, with a much better and more expensive equipment, can only pull in the powerful stations that any child can get without much ado? The reason is intimate knowledge of short waves and how they behave. Here are the chapters of this new book:

1. What are Short Waves and what can the listener hear on a short-wave receiver or converter?
2. How to tune and when to listen in on the short waves.
3. How to identify short-wave stations.
4. Seasonal changes in short-wave reception.
5. Types of receivers for short-wave reception.
6. Aerial systems for short-wave receivers.
7. How to get verifications from short-wave stations.
8. Short-wave hints.

The book is profusely illustrated with the best kind of illustrations that it was possible to obtain. Please note that this is not a re-hash of anything that has appeared before. Everything in the entire book has been written to order, and there is no duplication of anything here that has appeared in print before.

The book will make excellent reading matter, whether you are a rank beginner or whether you have been at it for a long time. There are many tricks in short-wave reception that even some of the "old-timers" do not know. That is the reason for this book. Be sure to get it. Place your order at once. 72 pages, over 40 illustrations.

50c

## 101 SHORT WAVE HOOKUPS

Compiled by the Editors of SHORT WAVE CRAFT

Here is a worthwhile book that every short-wave listener, every short-wave fan, and every short-wave amateur has wanted for a long time. It gives you the 101 best short-wave hook-ups which have appeared heretofore. It is a veritable encyclopedia of the best in short-waves when it comes to hook-ups. And do not run away with the idea that we just give you a few plain hook-ups. Each and every hook-up and diagram illustrated is also accompanied by a thorough explanation of what this particular hook-up accomplishes, what parts are required, coil-winding information, values of resistors, etc., in fact, everything you want to know in order to build the set or to look up the data required.

To be sure, all of the important sets which have appeared in print during the past five years are in this valuable book. Sets such as the Doerle, Dinsmore, the "19" Twinplex, Oscillodyne, Duo-Aplidyne, Denton "Stand-by" Megadyne Triplex 2, "Globe-Trotter," 2-Tube Superhet, Minidyne, "Loop" Receiver, "Doerle" 2-tube Battery, "Doerle" 3-tube Battery, "Doerle" 2-tube A.C., "Doerle" 3-tube A.C., Doerle "Signal Gripper," "Unicontrol" Band-Spread 2-tube Receiver, % Meter Portable Transmitter and Receiver, Duo R.F. 4-tube Receiver, The Sargent 9-33 Tapped Coil Receiver, Globe-Girdler 7, The 2-Tube "Champ," —2 Tubes Equal 3, Ham-Band and "Pie-Wee," Wyeth All-Wave 6, "Rex" Portable Super-het Receiver, The "53" 1-tube Twinplex, Stuart Band-Spread S.W. Converter, The "Ace" Band-Spread 3, Denton Economy 3, 2-Tube "Regenerative-Oscillodyne" will be found here, with full descriptions. In many cases, where it was necessary, we have also included a picture hook-up for those who do not wish to follow the regular symbolic hook-up, but wish to have a regular wiring diagram.

Also note, that in many cases, we have not just reproduced old hook-ups or diagrams. In many cases they have been brought up-to-date, to give you the latest information available in such sets.

This is a very handy volume, especially for those "fans" who wish to study the best sets in the short-wave art, from one tube up to ten tubes, instead of leafing through a dozen magazines and going through back numbers.

The present volume brings you everything in a clarified manner, leaving nothing to your imagination. The book is thorough, up to date, and will be a welcome addition to your radio library.

50c

72 pages, over 100 illustrations. Price .....

For good reproduction—high fidelity—no regeneration should be employed; however, in many instances the selectivity control makes an excellent tone control for eliminating interference which otherwise would prevent intelligible reception.

If the I. F. stage is permitted to oscillate while exploring the band for weak signals the receiver is less responsive to noise and the volume control can usually be turned full on. Even the weakest signal will produce a strong audible response if the receiver is operated in this condition and a right "on the nose" adjustment can be obtained by tuning for zero beat.

A "5 kc." selectivity can be obtained without making any critical regeneration control adjustments. Actual tests proved that VE9GW, on 6095 kc., could be received intelligibly without any interference from W9XF, on 6100 kc., and the most difficult adjustment was the setting of the band-spread dial, although the signal strength of VE9GW was only about R6, while that of W9XF was about R8 when the tests were made.

The maximum selectivity of this receiver can never be used for 'phone reception, but it is surprising how much one can use after becoming accustomed to it.

Since maximum regeneration is not required for 'phone reception the manipulation of the selectivity control is never critical, but increasing the selectivity increases the importance of accurate tuning. In other words *successful operation of this receiver depends mostly on how ACCURATELY the signals are TUNED IN.*

### List of Parts

- 1—National Type C-FB7 cabinet (plain)
- 1—National Type 118 drum dial
- 2—National Type B1-C 3 inch dial
- 2—National 450-550 kc. I.F. Transformer
- 1—National Statite socket S-7-pin (for 2A7 or 6A7)
- 1—National Statite socket M-7-pin (for 53 or 6A6)
- 1—National Statite socket 6-pin (for 58 or 6D6) (Hammarlund)
- 2—National Statite socket 5-pin (for coils) (Hammarlund)
- 3—Tube shields (53 requires a National Type TS)
- 10—1 1/2" dia. coil forms. 6-prong (ribbed type preferable for tapping)
- 1—6" x 1/2" dia. fibro shaft. 1-phone jack. Hook-up wire, screws, etc.
- 1—Flexible coupling
- C1—National Type SF-100 (Counter-Clockwise)
- C2—National Type SF-100 (Standard)
- C3 and C4—Hammarlund Type MC-140-M
- C5—.01 mf. Mica Aerovox
- C6—.01 mf. Mica Aerovox
- C7—.0001 mf. Mica Aerovox
- C8—.01 mf. Mica Aerovox
- C9—.01 mf. Mica Aerovox
- C10—.006 mf. Mica Aerovox
- C11—.1 mf. 400 volt paper
- C12—.01 mf. Mica
- C13—.25 mf. 300 volt paper
- C14—.0002 mf. Mica
- C15—.1 mf. 200 volt paper
- C16—.1 mf. 400 volt paper
- C17—.1 mf. 400 volt paper
- C18—.0004 mf. Mica
- C19—.0004 mf. Mica
- Condensers C11 to C19—Aerovox
- R.F. C1 to C4 may be any good choke, around 10 milli-henry or larger.
- All by-pass condensers may be of the non-inductive paper type.
- R1—50,000-ohm Potentiometer, Electro
- R2—250,000-ohm 1/2-watt Resistor, Lynch
- R3—40,000-ohm 1-watt Resistor, Lynch
- R4—100,000-ohm 1/2-watt Resistor, Lynch
- R5—40,000-ohm 2-watt Resistor, Lynch
- R6—60,000-ohm 1-watt Resistor, Lynch
- R7—250,000-ohm 1/2-watt Resistor, Lynch
- R8—2,500-ohm 25-watt (Electrad with 2 or 3 clips)
- R9—60,000-ohm 2-watt Resistor, Lynch
- R10—2,000-ohm Potentiometer (shield type)
- R11—500-ohm 1-watt Resistor, Lynch
- R12—250,000-ohm 1/2-watt Resistor, Lynch
- R13—250,000-ohm 1-watt Resistor, Lynch
- R14—100,000-ohm 1-watt Resistor, Lynch

### More Data on Woehr Transmitter

The writer has received about three dozen or more letters asking for additional information on the "Woehr Transmitter" appearing in the January SHORT WAVE CRAFT. Perhaps you might find space for the following information: Final tank plate coil 3" diameter, 40 turns No. 12 or No. 14 space-wound and CT. (center-tapped). Grid coils and all remaining plate coils are 2" diameter, No. 20 wire close-wound; plate coil of buffer is CT. It is possible to eliminate the "buffer" stage if an extra good crystal is used. Also if space permits, a paragraph explaining link coupling would be welcomed by many. Also it is still necessary to have an "Amateur license" to transmit.—W. A. Woehr, W9PTZ.

Please mention SHORT WAVE CRAFT when writing advertisers



# Eagle "E-C" Four Receiver

(Continued from page 727)

the shortest possible connections, and the audio and power equipment are completely isolated at the rear of the chassis.

### Use Good Parts—It Pays!

We agreed to build the sets with the best possible materials, inasmuch as you only get out what you put in! This age-old axiom is particularly applicable to short-wave radio, hence good mica condensers, R.M.A. coded resistors and parts from reputable manufacturers only were decided on for our Eagle of the sky-waves. . . . Remember to use a hot, clean iron,

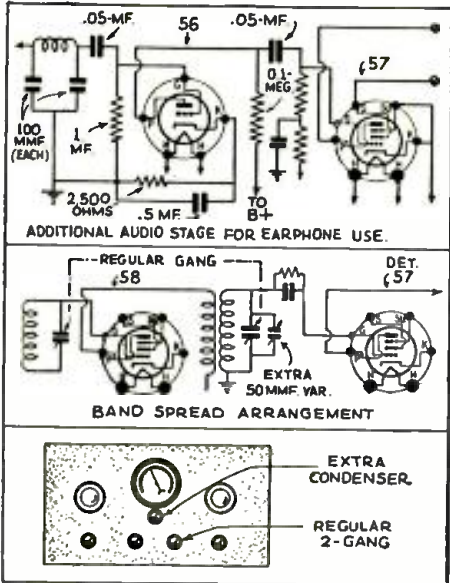

Band-spread and Earphone circuits; also position of "B-S" condenser on panel.

and a good grade of rosin core solder. Solid push-back wire is the best thing to use for hooking up the set. We will now denote a lapse of time until the set is built, praying that good parts are bought, and careful attention paid to soldering!

The '58 R.F. tube accommodatingly does marvelous things on the higher frequencies, and the 57 is absolutely no slouch as a detector. Electron coupling in the detector circuit will be practically a revelation to those who have never tried it before.

### Results—and How!

More specifically, here's what the set pulled in on a standard doublet on the roof of a 6-story building in lower mid-town New York City. One 160 meters produced Hams as far west as Dakota and as far south as Miami. Police stations were heard from every part of the United States including an awful shock when Seattle, Wash., came blasting in one morning at 2 a. m. with a call to all cars to watch out for a tall dark-complexioned man, in a torn gray coat, wanted for murder.

On the 80-meter coils, copious results were likewise obtained. Hams galore, aviation reports, and commercial code traffic. On the 40- and 20-meter Ham bands, all that could be desired was heard. VK's, ZL's, LU's, etc., were logged, all on loud-speaker. As for short-wave broadcast stations, the following is part of a list that I will be glad to swear to: VK2ME, Australia; CT1AA, Portugal; DJA, Germany; YV2RC, Caracas; GSD, England, and others on every continent but Asia. With a little better location than Manhattan Isle, I have a hunch that even that Asian won't be so hard to get.

There you are fellow short-wavers, a neat fairly cheap job that really brings 'em in. So, step up and try your luck, ladies and gentlemen, and let SHORT WAVE

CRAFT know what results you have. Happy DX and 73.

## When To Listen In

(Continued from page 737)

testing on 22.94 meters (13075 kc.) from 12:30-1:30 a.m., generally on Tuesday and Friday, although it has been heard on other mornings at this time.

### Valencia

YV6RV at Valencia, Venezuela, S.A., is the latest big noise in the 49 meter band. This newcomer operates on the same frequency as does HP5B in Panama (6030 kc.). It is generally on every evening from 5 or 6 till 8 p.m. and possibly at other hours.

### W3XAL

The schedule of W3XAL at Bound Brook, N.J., has been drastically curtailed. The station now operates on 17780 kc. from 9-10 a.m. daily except Sunday, and from 3-4 p.m. on Tuesday, Thursday, and Saturday. On 6100 kc. the schedule is Monday, Wednesday, and Saturday from 5-6 p.m.

### Pittsburgh

W8XK has made two slight changes in its schedule. On 15210 kc. it now operates daily from 7 a.m.-4:15 p.m., on Friday nights it operates on 11870 kc., from 10 p.m.-1 a.m. (Sat.) in addition to its regular schedule from 4:15-10 p.m.

### VE9GW

VE9GW at Bowmanville, Canada, many of our readers inform us, now operates on 6090 kc. or 49.26 meters instead of 6095 kc. as they did formerly. We stand corrected.

### Portugal

CT1GO, mentioned here last month operates as follows. On 12396 kc. Sunday 10:11:30 a.m.; Tuesday, Thursday, and Friday, 1-2:15 p.m. On 6198 kc. Sunday 11:30 a.m.-1 p.m. and daily except Tuesday from 7:20-8:30 p.m.

### Little America

KFZ, the Byrd Antarctic station at Little America, is no more. The explorers are now en route to New York via New Zealand.

### Sydney

In March and April VK2ME, Sydney, Australia, on 31.28 met. will operate on Sundays from 1-3, 5-9, and 9:30-11:30 a.m.

ALL SCHEDULES IN EASTERN STANDARD TIME.

## \$20.00 PRIZE MONTHLY FOR "BEST" 1-TUBE SET

Or other short-wave set article accepted and published. Send diagram first or set if you prefer.

Sets must be sent PREPAID and should be CAREFULLY PACKED in a WOODEN box!

The closing for each contest is sixty days preceding date of issue (Mar. 1 for the May issue, etc.). In the event of a "tie" an equal prize will be paid to each contestant so tying.

The judges will be the editors of SHORT WAVE CRAFT, and George Shuart and Clifford E. Denton, who will also serve on the examining board. Their findings will be final.

Address your entries to:

Editor,  
SHORT WAVE CRAFT,  
99-101 Hudson St.,  
New York City.

# Whether You Build a "Tin-Can" 4



# an Economy 3



# or Any Other Set

## WIRE

Burgess chrome-protected Batteries of the proper capacity to it and it will give you all the quiet, sensitive, powerful performance you have built into it.

All Burgess A, B and C Batteries are chrome-protected, the smaller types as well as the big POWER HOUSE—popular 400 Hour Dry "A" designed for use with 2-volt tubes. Because they are chrome-protected, Burgess Batteries are "full-powered" when you buy them—and they give maximum service, even if you use them 7 or 8 hours a day! Look for the Burgess Black and White Stripes whenever you buy batteries. BURGESS BATTERY COMPANY, Freeport, Illinois.

# BURGESS

BATTERIES AND FLASHLIGHTS

# BEFORE YOU BUILD INVESTIGATE KITS AND PARTS BEARING THIS SEAL OF QUALITY



## "MASCOT" 3 S.W. KIT



105-130 V. A.C.

A low priced all electric set that combines receiver and power pack in one unit. Utilizing dual purpose tubes giving 5-tube performance. Loud speaker operation. Gets foreign stations with ease. This is but one of the complete I.C.A. line of kits from 1 to 5 tubes listing from \$9.95 to \$39.75. They are the world's easiest to build. The Mascot "3" with complete hook-up and schematic diagram. List price..... **\$22.50**

## 5 METER TRAN-RECEIVER KITS

Choice of 3 models; 2 volt, 6 volt or A.C. model. Easy to build. Made completely of I.C.A. parts. Complete instructions, diagrams. List prices (respectively). **\$19.50. \$19.25. \$19.75**



**CRYSTAL HOLDER**  
Made of Insulux. Accommodates crystals to .250 thick x 1 1/4" square. Accurate and compact. List **\$1.75**



**WAFER SOCKETS**  
of Low-loss Insulux. For sub-panel or base board mounting. Fine for ultra high frequencies. List prices: 4 or 5 prong —40c; 6 prong, 45c; 7 prong large or small..... **50c**

DISCOUNT of 40% off the list prices shown when purchased through your jobber or mail order house. Your jobber sells I.C.A. products. Insist upon them for quality and reliability. If he cannot supply you, write us direct.

**INSULINE CORP. OF AMERICA**  
23-25 Park Place, Dept. SW-45 New York, N.Y.

# Learn CODE QUICKLY and EASILY at HOME

## CANDLER original SCIENTIFIC SOUND METHOD

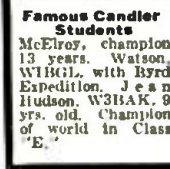

Enables you to qualify the **FASTEST WAY** for your Amateur or Commercial License. Teaches you **QUICKLY** to read **CODE** by **SOUND** just like you read newspaper print by **SIGHT**. To carry **WORDS** in your **MIND** and "Copy Behind."

THOUSANDS of BEST and FASTEST Amateurs and Commercial Operators have been trained by Original **CANDLER** Sound Method in past 24 years. It **MUST BE RIGHT**. Ask any Skilled Operator! Ask the **CHAMPIONS!**

**FREE—New 1935 BOOK OF FACTS** for Amateurs and Com'l Ops., just off the press. Send for it today. Explains everything. Whether you want to learn **CODE** or develop **Championship Speed**, it will be valuable to you.

**CANDLER SYSTEM Co.** Dept. S-4  
6243 S. Kedzie Ave., Chicago



## SPECIAL

FOR THIS MONTH

Send \$1.00 (\$1.25 Canada and foreign) and we will send you **SHORT WAVE CRAFT** for Eight months. **DO IT NOW.**

**SHORT WAVE CRAFT**  
99-101 Hudson Street New York

# High-Fidelity

(Continued from page 730)

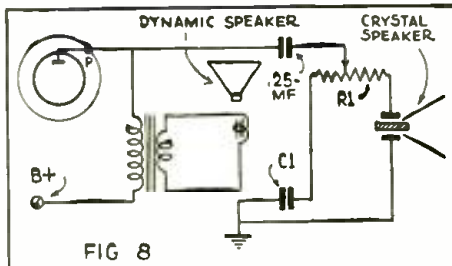

FIG 8

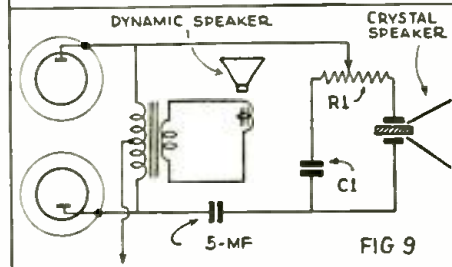

FIG 9

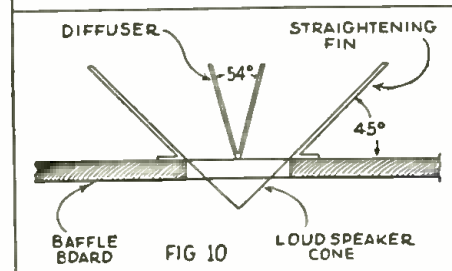

FIG 10

Fig. 8—Connection of "crystal speaker" with dynamic speaker. Fig. 9—Push-Pull output with dynamic and crystal speakers. Fig. 10—Use of "fins" and "diffuser" on speaker. Note angle of "diffuser" is 54 degrees.

audio frequency range by means of the methods shown in Figs. 3 and 4. The R. C.A. experts introduced into the center of the normal cone of a dynamic loud-speaker, a second but smaller cone, made from stiff cardboard. This method may easily be applied by experimenters successfully so as to improve the radiation of the higher audio frequencies.

The method used by the Hazeltine Laboratories is much simpler for the experimenter to apply. Here a cone such as that shown in Fig. 4 is used. The apex of the cone, close to the voice coil, is made of some stiff material, while the outer edge is constructed of lighter and more pliable cardboard. While the inner area radiates the high range the outer part of the cone, in connection with the inner part, radiates the lower range. This method can be applied to improve the response curve of your old loud-speaker with very little trouble. To the writer's best knowledge there are no cones of this type on the market and it is therefore necessary to build up such a modified cone yourself.

The simplest way to do this is by dressing the inner part of the old cone with glue in *very thin layers*. After one layer is dried, it is advisable to try the loud-speaker and if the effect is not sufficient, put another layer of glue upon the first one. The first layer shall cover, according to Fig. 4, about 1/5 of the entire cone length, the second layer but 1/6, and the third about 1/7, if a fourth one is necessary, it should cover about 1/4 of the whole length. So-called bookbinders' glue may be used for this purpose. Before actually starting the work it is important to make some experiments with small pieces of cardboard or heavy paper, because dressing it in very thin layers is not as simple as it might seem at first, and practice will be found necessary before the best routine is obtained.

Still another method for improving the sound of the speaker is to use very thin

gerated example of a response curve "improved by watering." It is generally quite satisfactory if the space indication between the two lines is marked at 10 decibels only, but a 20-decibel allotment in a loud-speaker response curve should provide a good reason to suspect some hocus-pocus somewhere, and response curves of this kind should have their "pedigree" thoroughly examined and substantiated, if the purchaser of such a speaker wishes to avoid later disappointments.

The great importance of having a short-wave or other receiver carefully checked up so that it is capable of passing a wide frequency spectrum, together with the proper selection of a loud-speaker, is now made apparent and *high fidelity* performances can only be obtained if both the set and the loud-speaker are properly matched and designed to cover the frequency band required. Furthermore, there should not be variations in the response curve of more than 10 decibels over the whole acoustic range.

### Improving Your Old Loud-Speaker

Well-designed and carefully matched loud-speakers are not cheap and experimenters and short-wave set builders are frequently the owners of a loud-speaker having a fairly satisfactory frequency-response curve, one covering for example 80 to 4,500 cycles. In such a case, it is not necessary to throw away the old loud-speaker and buy a new one, for it should be remembered also that there are on the market at present very few dynamic loud-speakers having a frequency-response range greater than 6,000 cycles, without showing a great many peaks and valleys.

A loud-speaker having a reproduction range up to 4,500 cycles can be radically improved by means of a relatively simple trick. According to electro-acoustic tests made by the R.C.A. and the Hazeltine Laboratories, the range of such a normal loud-speaker can be expanded to the higher

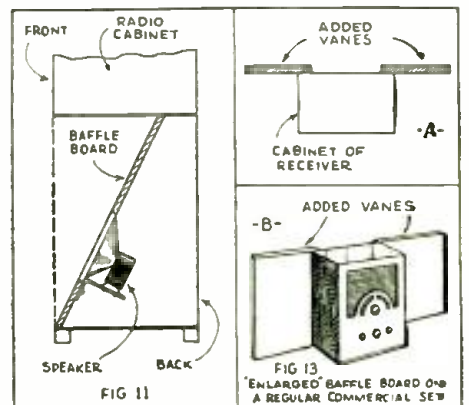

FIG 11

FIG 13 ENLARGED BAFFLE BOARD ON A REGULAR COMMERCIAL SET

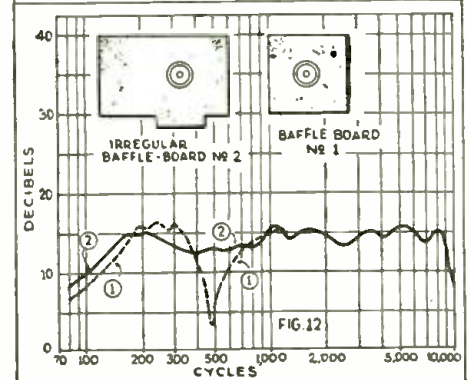

FIG 12

Fig. 11—Inclined baffle as an aid to "higher fidelity" sound reproduction. Fig. 12—Improved frequency response obtained by using "irregular shaped" baffle. Fig. 13—Improved acoustic response can often be obtained by enlarging baffle-board on many commercial sets.

Please mention **SHORT WAVE CRAFT** when writing advertisers



layers of paper, in place of the layers of glue, such as typewriter second sheets or India paper. The process of gluing the various paper layers upon the inner parts of the cone, and the sizes of the different paper layers, is about the same as that given for the glue dressing. The second method calls for an ingenious hand, because it is very difficult to stick or glue thin paper layers upon the cardboard without the appearance of small ripples in the paper.

**The Addition of "Tweeters"**

Another recommended method of expanding the frequency range of a given loud-speaker, without having recourse to expensive filter circuits and special transformers, to be described later, is that of adding a so-called *Crystal-Tweeter* to the old dynamic or other speaker. Fig. 5 shows how such a *tweeter* which reproduces the higher-pitched sounds, may be connected directly across the primary of the dynamic speaker transformer.

The sound reproduction range of the *tweeter* begins at the point where the response curve of the ordinary type speaker starts to fall off, and continues to 8,000 cycles. (See Fig. 6.) Since the efficiency of Crystal speakers is much greater than those of the dynamic type, it will often be found necessary to reduce the voltage supply of the crystal-tweeter by means of a potentiometer R1, in order that you may obtain the same acoustic output from the *tweeter* as that obtained from the dynamic speaker, through the use of a circuit like that shown at Fig. 5. The potentiometer R1 and the condensers C1 should have the following dimensions:

**Table I**

Type of the used tube	R1	C1
42	25,000 ohms	.015 mfd.
45	25,000 ohms	.05 mfd.
47	25,000 ohms	.015 mfd.
50	25,000 ohms	.05 mfd.
2A5	25,000 ohms	.015 mfd.

In case it is preferred to fix up the *crystal-speaker* a certain distance from the set, to obtain a kind of *binaural effect* as shown in Fig. 7, it is recommended you use the circuit shown in Fig. 8, because only one connection between set and speaker is then necessary. In order to reduce the capacity of the line, the other speaker connection may be obtained by grounding with the radiator pipe, etc. The *crystal-speaker* is really only a "singing" condenser, in which a rochelle salt crystal is used as the dielectric. Its capacity is about 0.002 mf. at 6,000 cycles only, but if the wire-to-earth capacity of the long lines frequently required is reasonably small, the reproduction range of the speaker may not be affected. In all other cases a cut-off in the upper frequency range may occur. The dimensions of R1 and C1 used in circuit Fig. 8 are the same as those given in Table I.

In case the *tweeter* is to be connected to a push-pull amplifier, the circuit shown in Fig. 9 should be used. When using this circuit the potentiometer R1 and the condenser C1 should have the following dimensions:

**Table II**

Type of the used tube	R1	C1
42	20,000 ohms	.03 mfd.
45	25,000 ohms	.1 mfd.
47	20,000 ohms	.03 mfd.
50	25,000 ohms	.1 mfd.
2A5	20,000 ohms	.03 mfd.

Another important factor often overlooked in trying to obtain faithful reproduction, is that sound waves are radiated in certain relation to their frequency. In other words—while the low frequencies have a propagation without definitive direction, the high ones have a radiation angle of limited degree only. What this physical phenomenon signifies can easily be checked up by listening to a concert in which the flute plays an important part. While the low audio frequencies can be heard in any direction from the loud-speaker, the high tones of the flute can only be recognized within an angle of about 20 degrees to the cone axis. That shows the high frequencies radiate only straight out from the

cone-center and that very little radiation is obtained in other directions.

To obtain a high quality performance a *diffuser* is needed, like that shown in Fig. 10, in order to spread the high frequencies around the room. These *diffusers* are made from stiff cardboard or iron sheets of simple angular shape. The length of the *diffuser* vanes should be in certain relation to the diameter of the cone, and to the highest frequency which one intends to radiate with high efficiency. For a frequency band up to 7,500 cycles, the required length of the *diffuser* vanes is 1.3 times the cone diameter. Parallel to the *diffuser* vanes, are arranged two vertical straightening fins to produce both lateral radiation and diffusion of the higher frequencies. It is sometimes useful to fix up a single horizontal iron or cardboard *wing* below the *diffuser* vanes, with a slight upward angle, in order to obtain sound deflection in a direction upward. Another method for upward radiation is that of using a slightly inclined *baffle-board* as shown in Fig. 11 and used by Philco in their "high-fidelity" receivers.

By use of such *diffuser* vanes, and a cone with a stiff apex, it is possible to reproduce the high audio frequencies with relatively good efficiency, without using a second loud-speaker.

The above described methods show only improvements concerning the *highs* of the audio frequency band; this alone is not sufficient to obtain real faithful reproduction. It is also necessary to improve the performance of the *low* audio frequencies, if the desired *natural* sound reproduction is to be obtained.

**Improving the "Low" Notes!**

The best manner in which to improve the radiation and thus the performance of the *low* frequencies, is by the *correct* use of the *baffle-board*. Before starting with improvements concerning the *baffle-board*, it is necessary to eliminate a widely believed "superstition" concerning *baffles*. The belief that *baffle-boards* act as "sounding boards" or as "resonance areas" is all wrong! The real purpose of the *baffle-board* is to act as a shield to prevent low sound waves, radiated from the back of the loud-speaker, *cancelling* similar waves radiated from the front of the loud-speaker.

In order to avoid this unwanted effect, it is necessary to give the *baffle-board* a size which has a certain relation to the wavelength of the lowest sound frequency that is to be reproduced. The relation between the lowest sound frequency which shall be reproduced and the necessary side length of the *baffle-board* to be used is given in the following Table No. 3 in centimeters. (1 centimeter = 0.39 inches.)

**Table III**

Lowest frequency to be radiated in cycles	Side length of the <i>baffle-board</i> in centimeters
500 cycles	75 centimeters
400 cycles	90 centimeters
300 cycles	100 centimeters
200 cycles	125 centimeters
100 cycles	175 centimeters
90 cycles	190 centimeters
80 cycles	205 centimeters
70 cycles	225 centimeters
60 cycles	250 centimeters
50 cycles	290 centimeters
40 cycles	400 centimeters

1 c.m. = .4 inch approx.

Table III shows that in order to obtain a natural reproduction in the *low* audio range, tremendous *baffle-boards* are necessary, especially for the range below 100 cycles! *Baffle-boards* of this size can be seldom applied in the home. Since *baffle-boards* offered the cheapest way in which to obtain a good reproduction of the *lows*, a great deal of work was done, to avoid the use of extremely large *baffle-boards*. Fig. 12 shows that the response curve of a loud-speaker can be much improved by using a *baffle-board* of *irregular* dimensions. A valley in the response curve resulting from the use of a *small* *baffle-board* in the frequency band of about 500 cycles (curve 1), is smoothed out by means of an *irregular* *baffle-board* No. 2 (curve 2). Fig. 13 shows how to improve the reproduction of the *lows* without employing tremendously large *baffle-boards*.

**The All-Electric All-Wave Receiver**



**Greatest Value On The Market**

6F7  
76  
12Z3  
tubes

New 4 in 3 circuit  
A completely electrified all-wave receiver capable of world-wide

reception. Circuit has been re-designed so as to be bigger and more powerful than ever. Uses 6F7 (2 tubes in 1 bulb), 76 & 12Z3 tubes as screen-grid regenerative detector, 2-stage audio amplifier, rectifier & built-in power supply. Due to the use of the dual purpose tube, the 6F7, this circuit produces 4 tube performance from 3 tubes. No batteries. Simply plug into 110 volts house lighting circuit & operate. Sensitive & gives great volume. Works speaker on many stations. Covers 10 600 meters. Mounted on heavy, black crackle finish metal chassis and panel. Coils for 10-200 meters. Instructions included. FOREIGN RECEPTION GUARANTEED.

**KIT ASSEMBLED and ready to wire**

**\$5.95**

- Wired & tested extra.....\$1.25
- Matched Arceturus tubes.....2.25
- Broadcast coils (2).....0.95
- Beautiful black finish metal cabinet hinged lid.....1.00

**THE DC ALL-WAVE RECEIVER**

19  
33  
tubes

New 3 in 3 circuit



An extremely powerful battery operated set. Designed for loudspeaker operation. Tremendous headphone (1 bulb) & 33 tubes in

**KIT ASSEMBLED and ready to wire**

**\$5.75**

- Wired & tested extra.....\$1.25
- Matched Arceturus tubes.....1.90
- Broadcast coils (2).....0.95
- Beautiful black finish metal cabinet hinged lid.....1.00

**THE EILEN 5**

6D6  
6F7  
12A7  
TUBES

A powerful & sensitive electric receiver operating entirely from 110 volt house lighting circuit. Uses new circuit for 6D6, 6F7 (2 tubes in 1 bulb), and 12A7 (2 tubes in 1 bulb) as remote "cut-off" regenerative detector.



RF amplifier, screen-grid triode audio amplifier, power pentode audio amplifier, rectifier & complete built-in power supply. Produces 5 tube results. Readily brings in those hard to get foreign stations. Operates speaker on many stations. Beautiful black crackle finish metal chassis & cabinet. Coils for 10-200 meters. Instructions included. Foreign reception guaranteed.

**KIT, assembled & ready to wire**

**\$7.35**

- Wired & tested extra.....\$1.25
- Matched Arceturus tubes.....2.45
- Beautiful black finish metal cabinet, hinged lid.....1.10
- Broadcast coils, (2)......95

**SPECIAL: Cannonball headphones \$1.45 Magnetic speaker \$1.45**

\$1.00 deposit on C.O.D. orders. Prompt shipment.  
**EILEN RADIO LABORATORIES**  
Dept. SC4, 136 Liberty St., New York, N. Y.

**RESISTOR SPECIALISTS**

Featuring:

- QUIET VOLUME CONTROLS, built on an entirely NEW principle.
- VITREOUS RESISTORS
- TRUVOLT RESISTORS
- POWER RHEOSTATS

Write Dept. SW-4 for 1935 Catalog

175 Varick St., New York, N.Y.

**ELECTRAD**



## ACRATONE 5-10 M. TRANSCEIVER!



**AMATEURS!**  
Be sure to Read Clifford E. Denton's Article!  
It gives you all the dope you've been looking for about the new and sensational Acratone 5 & 10 Meter Transceiver!

This is the first instrument that gives you real, honest-to-goodness transmission at a ridiculously low price! Actually the Acratone Transceiver is the most economical form of transmitter and receiver

yet devised. Unlike the 40 meter band which is jammed solid, the 5 and 10 meter band is comparatively open and you'll get plenty of thrills testing and experimenting in this band. The plug-in coils permit you to operate continuously from 5 to 10 meters.

Acratone 5 Meter Transceiver Standard 56 to 60 mc. Tubes: 2-42; Size: 15"x8"x6"; Shpg. Wt. 12 lbs. MODEL NO. 202 (code YECUD) Your cost less tubes.....**\$15.00**

Kit of Raytheon Tubes.....**\$1.27**  
Plug-in Coil Kit, 6 to 11 Meters, Model No. 225 (code: YEDBE) Your Cost...**\$1.00**

**FREE!** Send for your copy of the newest and most complete catalog in Radio! **JUST RELEASED!** Contains full description of the Acratone Transceiver and hundreds of bargains in Short Wave. Public Address, Parts, etc.—at the Lowest Wholesale Prices!

**Federated Purchaser, Inc.**

NEW YORK 25 Park Pl. Newark - Bronx - Jamaica - Phila. - Pittsburgh  
CHICAGO 1331 So. Mich. Ave.  
ATLANTA 546 Spring St. N. W.

## Amelia Earhart's Radio Never Failed

(Continued from page 711)

to the engine in the nose of the plane, feeds a nest of storage batteries. These batteries lie near the radio apparatus located just aft of the fuselage door in the stern of the ship. The batteries deliver current to a Dynamotor which carries the current to the high tension crystal-controlled transmitter set. Call numbers of the plane are KHABQ. Tests made early in January by Paul Mantz, flying the Earhart plane 12,000 feet over Honolulu, carried his voice over the intervening 2,228 nautical miles of the Pacific to stations in California and Arizona and a broadcast message sent out by KFI acknowledged the reception immediately afterwards. Mantz received the return message through the headset as clearly as though he were in Los Angeles. The message from the plane was spoken into a new type of close contact microphone, which eliminates cockpit noises.

### A Dandy 5-Tube All-Wave Set

● HERE is a modern 5-tube superheterodyne designed to receive short-wave and broadcast stations. It covers a range from 17,850 kilocycles to 535 kilocycles and operates directly from the 110 volt power lines. The tube line-up of this very interesting and handsome receiver is as follows: A 6F7 is used as the first detector and local oscillator, wherein the frequency of the incoming signal is changed to the intermediate frequency of the receiver. The I.F. amplifier consists of a 6D6 super-controlled pentode. The second detector, A.V.C., and first audio amplifier functions are all performed by a type 75 tube. A 42 pentode power amplifier is used in the last stage of audio with a 280 rectifier tube. This receiver has a special selector circuit which ensures maximum selectivity. The automatic volume control, together with tone control in this receiver, aid considerably in short-wave reception. The automatic volume control successfully combats the rapid fading of the majority of short-wave stations and the tone control can be adjusted to reduce background, hissing and crackling noises to a minimum. It might be interesting to mention that this receiver picked up London with very fine volume in the heart of New York City, on a very short antenna, which was located inside of a steel-frame building! Actual tests proved this set to be very sensitive and selective.



Highly efficient 5 tube set which has brought in London and other "foreigners" in a bad location in New York City. No. 271.

# HERE IT IS

SHORT WAVE SET BUILDERS MUST HAVE THIS BOOK

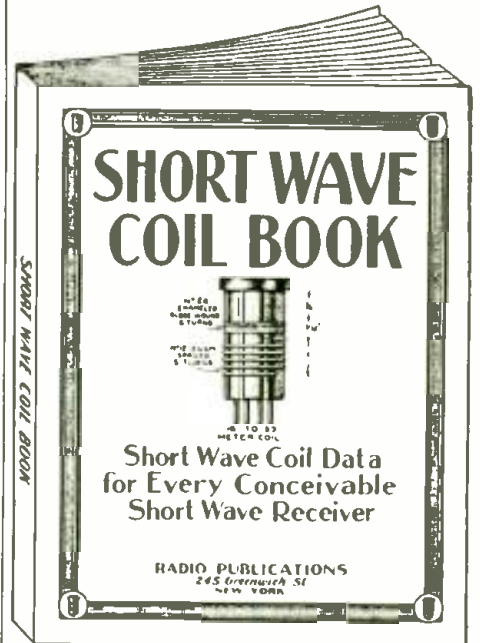

FOR the first time, it is now possible for the experimenter and short wave enthusiast to obtain the most exhaustive data on short wave coil winding information that has ever appeared in print.

As every experimenter who has ever tried to build a short wave set knows only too well by experience, the difference between a good and a poor receiver is usually found in the short wave coils. Very often you have to hunt through copies of magazines, books, etc., to find the information you require. The present data has been gotten up to obviate all these difficulties.

Between the two covers of this book you now find every possible bit of information on coil winding that has appeared in print during the past two years. Only the most modern "dope" has been published here.

No duplication. Illustrations galore, giving not only full instructions how to wind coils, but dimensions, sizes of wire, curves, how to plot them, by means of which any coil for any particular short wave set can be figured in advance, as to number of turns, size of wire, spacing, etc.

There has never been such data published in such easy accessible form as this.

Take advantage of the special offer we are making today, as due to increasing costs, there is no question that the price will increase soon.

**RADIO PUBLICATIONS**  
97 HUDSON STREET  
NEW YORK, N. Y.



Radio Publications,  
97 Hudson Street,  
New York, N. Y.

4-35

Please send immediately, your Short Wave Coil Book, for which I enclose 25c herewith (coin, U. S. stamps or money order acceptable). Book is to be sent prepaid to me.

Name.....  
Address.....  
City and State.....

Please mention SHORT WAVE CRAFT when writing advertisers

"We would have hesitated to demonstrate our New High-Fidelity Receiver without the



TRADE MARK REGISTERED  
(High-Fidelity)

## ANTENNA SYSTEMS"

We have used your No-Stat broadcast antenna system and your Hi-Fi All Wave Antenna System for demonstration on our broadcast and all wave receivers in many parts of the country with most gratifying results.

We were particularly pleased with the performance of your Hi-Fi system at a recent demonstration given by us at the Commodore Hotel—in the heart of New York City, where all kinds of electrical and automobile ignition interference are most severe—on which we had a 250 ft. lead-in, employing your Giant Killer Cable.

Without the use of this antenna, we would have hesitated to demonstrate our new High-Fidelity receiver.

—Leo McCann, Secretary & Manager,  
Sound Systems Division  
Stromberg-Carlson Telephone Mfg. Co.,  
Rochester, New York

"No Radio Can Be Better Than Its Aerial—  
No Aerial Is As Good As a LYNCH Aerial."

Full Information on Request

Arthur H. Lynch, Inc., 227 Fulton St., N. Y.  
PIONEER OF NOISE-REDUCING AERIALS

## RADIO COURSES



**Radio Servicing**  
Including short wave receivers.

**Radio Operating**  
Prepare for Gov't. license exam.

**Radio Amateur Code**

Resident Courses  
Write for Booklet

**New York YMCA Schools**  
6 West 64th Street New York City



FOREIGN BROADCASTS - POLICE CALLS - STANDARD BROADCASTS - AIRPLANES - CODE  
 SCOUT THE AIR WAVES WITH AN

## ALL-WAVE AIR SCOUT

NEW 1935 SPACE EXPLORER MODEL - 5 TUBES - DYNAMIC SPEAKER - 6 PLUG IN COILS 10 TO 2000 METERS - ALL ELECTRIC A.C. D.C. READY TO PLUG IN AND USE \$21.95

PROFESSIONAL 3 MODEL - ALL ELECTRIC A.C. D.C. 5 PLUG IN COILS 10 TO 550 METERS WITH TUBES READY TO USE \$49.00 SINGLE LAMPHORN \$24 EXTRA DOUBLE LAMPHORN \$120 EXTRA

STANDARD ALL ELECTRIC MODEL - COMPLETE WITH 2 COILS COVERING BAND FROM 10 TO 550 METERS - TWO TUBES - READY TO PLUG IN AND USE \$48.00 3 LAMPHORN COILS 10 TO 75 METERS \$1.50 - SINGLE LAMPHORN \$6.00

2 TUBE BATTERY-OPERATED FIND-ALL MODEL COMPLETE WITH ORNAMENTAL PANEL TUBES 2 COILS 10 TO 550 METERS - LAMPHORN READY TO USE (LESS MICROPHONE BATTERIES) \$47.95

1 TUBE BATTERY-OPERATED AIR SCOUT MODEL - COMPLETE WITH 2 COILS 10 TO 550 METERS - LAMPHORN & TUBE READY TO USE (LESS BATTERIES) \$45.95 SAME IN KIT FORM COLOR CODED \$5.00

BEGINNERS 1 TUBE ALL WAVE KIT NOT A TOY - COMPLETE WITH COIL \$41.95

COMPLETE LITERATURE AVAILABLE UPON RECEIPT OF 5¢ TO COVER HANDLING

**ALLIED ENGINEERING INSTITUTE**  
 Est. 1921  
 98 Park Place Dept. S-17 New York, N.Y.

## CABINET for ALL-STAR SR. & JR.

With hinge cover finished to match the ALL-STAR set.

Dur Low Price  
**\$3.95**

We do not supply panel, dial or knobs. We also make chassis and metal cabinets for any make receiver. Send drawing or give complete dimensions for estimate.

Dealers and Jobbers: Write for special price

**KORROL MFG. CO., Inc.** Dept. S-4  
 232 GREENWICH ST. NEW YORK CITY

## TRIMM

### FEATHERWEIGHT HEADSETS

Superior in performance  
 Small in size  
 Light in weight  
 Neat in appearance  
 High in quality

There is a difference between Trimm Featherweight phones and other headsets.

Your local dealer can supply you.

**TRIMM RADIO MFG. CO., SW-4**  
 1528 Armitage Ave. Chicago, Ill.



## HAVE YOU A HEADACHE

trying to find out where you can obtain certain parts that you need for your short wave radio or your station? Stop worrying!

This is the "House of a Million Parts", where you can obtain the most up-to-date or any obsolete part.

Send us a list of your needs and we will quote our lowest prices.

Interesting literature mailed free.

**LEOTONE RADIO CO.**  
 63 DEY STREET Dept. S-4-35 NEW YORK CITY

## SPECIAL FOR THIS MONTH

Send \$1.00 (\$1.25 Canada and foreign) and we will send you SHORT WAVE CRAFT for Eight months. **DO IT NOW.**

## SHORT WAVE CRAFT

99-101 Hudson Street New York

## Which S-W Aerial Is Best?

(Continued from page 715)

as that shown in Fig. 1. The system shown in Fig. 3 is by far the most flexible of the three. This system is used by the writer in amateur work and provides stronger signals on all bands and surprising as it may seem, the background noise is reduced about 90 per cent as compared with a simple untuned antenna and ground arrangement.

Set the "shorting" clips so that about one-third of the coil is not in use; set "C" to maximum capacity and vary "C1" and the turns in the coil until the signal is loudest, then try for a combination of both "C" and "C1" which will give a still stronger signal with less noise! The leads of the two-turn coil should be connected to the "doublet posts" on your receiver. If you have no provisions for this connection then connect them to the "antenna" and "ground" posts. The ground post of the receiver should always be grounded. If one doubts the practicability of tuned receiving antennas, one has only to ask the question—why transmitting antennas are tuned—and the answer is obvious! At a later date we will endeavor to describe simple direct-ive antennas for the "Fan" who is interested in picking up certain DX stations.

Figure 4 shows the schematic drawing of the coupler designed for use with either a doublet or a "Zepp" antenna. Note that there are two clips and these should be placed at equal distances from the center, the exact location depending upon the length of the feeders or the frequency on which it is being operated. Three condensers are used with this instrument while only two are used in the tuning unit for the Marconi antenna. The tuner for the Marconi antenna is shown in the photograph and a general idea of the construction and assembly can be obtained by referring to it.

### Cage Antennas

Many comments and suggestions have been offered regarding the use of cage antennas. However, we have yet to see actual proof of one of these antennas giving better results than a single wire. During tests absolutely no difference could be noted between the single wire antenna and the multi-wire affair such as the cage. However, we have no fault to find with this type of antenna and should the reader desire to construct his antenna either the doublet or Zeppelin type using the cage principle, he may do so but no increase in signal strength should be looked for. The construction of a cage antenna is shown in Fig. 5.

### Antenna Construction

A few words might also be said regarding the type of insulators, wire, and general construction of antennas.

One point which should be stressed is the use of good insulators and plenty of them! If small insulators are used about two or three inches long, it is advisable to use two or three of them connected in series with short pieces of wire. Isolantite (or other good ceramic insulators) or Pyrex insulators, of course, are the most efficient and are recommended in every case. Then too, the tie-wire, that is the wire supporting the antenna, if of any appreciable length, should be broken up every three or four feet with an insulator. If possible, of course, it is best to use a rope rather than a wire. All connections in the antenna should be well-soldered. Connections, whether soldered or not, should be avoided wherever possible. The down lead or feeders, whichever you prefer to term them, should be kept away from metal leader pipes, telephone wires, electric wires, or any other metal. Keep it well out in the clear and away from trees whose branches may come in contact with it. If your antenna is supported by a mast by all means try not to use metal. If possible the mast should be constructed of wood and any guy wires supporting it should be broken

## In Stock—Immediate Delivery The NEW PATTERSON PR-12



PR-12 (8-550)

- 56 Features . among them are:**
- Full range, 8 to 550 meters.
  - Patterson Selector-Band Dial; airplane type; shows only band in use; microphonic 2 speed tuning; 10 to 1 and 50 to 1 reduction; anti-barklash rubber drive.
  - Accurate logging bandspread; 15 inches on 75 meter band.
  - New 6 section tuning gang condenser gives an exceptionally low C tuned circuit, resulting in extremely high gain (approximately twice) on the short-wave bands, equalling or surpassing plug-in coils.
  - Newly designed coils, with new type of switch, lowering the amount of dielectric loss and skin effect in tuned circuit.
  - Pre-selection ahead of first detector results in higher signal to noise ratio, decreasing amount of image response to a minimum; increasing sensitivity, overall gain and selectivity.
  - Modulation and R meter.
  - Crystal filter, which can be cut in as a series or parallel filter; affords two degrees of selectivity, further raising signal to noise ratio and increasing selectivity.
  - Monitor switch, for use in checking quality of your own transmission percentage of modulation indicated visually and orally.
- NOTE: ● indicates NEW; ●● indicates NEW and EXCLUSIVE!

### NET DELIVERED PRICES

Complete (absolutely nothing else to Buy!)

PR-12 Crackle cabinet without crystal.....	\$82.00
PR-12 Crackle cabinet with crystal.....	87.90
PR-12 Console without crystal.....	99.65
PR-12 Console with crystal.....	105.55
(Chassis also available)	
PEAK Pre-Selector.....	\$19.80
PATTERSON Pre-Selector.....	\$17.64
<b>NEW "MARINE" 100 Watt Phone-C.W. XMITTER</b>	
Many exclusive features including Visual Distortion Indicator-Modulation Percentage Indicator. Send stamp for descriptive folder and details.	

**SHIPPED PREPAID** if full purchase price accompanies your order. Send for our bulletin "Amateur Transmitter" which lists and describes "Everything for the Ham"

**L. I. MARINE & ELECTRIC CO.**  
 W2GOT - W2GRQ  
 163-18 Jamaica Ave., Dept. S-45, Jamaica, N. Y.  
 CABLE ADDRESS "ELEC MARINE NEW YORK"

## "THE MISSING LINK"

A NECESSITY FOR EVERY RECEIVER

**The AMPLIVOX**  
 Double-purpose  
**PHONE RECEPTOR**

FOR RECEIVERS NOT EQUIPPED FOR EARPHONE RECEPTION

Automatically silences speaker when phone plug is inserted... Can be installed by anyone in ONE minute, without tools... Cannot damage or unbalance receiver in any way... AND THE EXTRA FEATURE, can be used, by means of extension cord, to operate a loudspeaker at a remote point.

List price \$6.75, your net cost \$3.95  
 Give make and model of receiver when ordering.

**AMPLIVOX ALL-WAVE LINE FILTER**, for all types of receivers. GUARANTEED to suppress line noises, connects between receiver and the electric outlet. Two outlets on filter itself provide for direct comparison between filtered and unfiltered current. List price \$6.75, your net cost \$3.95.

**NOISE REDUCING ALL WAVE ANTENNA SYSTEMS**, ready-to-hang-to-masts and kits. Lynch products used exclusively. WRITE FOR LITERATURE.

**AMPLIVOX LABORATORIES**  
 Chief Engineer—Sol Perlman, E.E., Consulting Engineer on Antenna Problems to Lynch Mfg. Co. 227 Fulton St., Dept. SW-7, New York, N. Y.

Please mention SHORT WAVE CRAFT when writing advertisers



**FOR REAL "DX" RECEPTION!**

**THE WORLD TROTTER SW4**



Sensational design! Uses one 76, one 6D6 and 12A7 dual tube!

- COMPLETE kit including all necessary parts, Continuous Band-Spread, AC-DC power pack, high ratio aeroplane dial, 4 precision spare wound coils covering from 12 to 200 Meters and fool-proof instructions..... **\$9.40**
- Neat metal cabinet, as illustrated—12x7x7..... \$1.75
- Special speaker to match..... 1.35
- Set of matched Arcatrus tubes..... 2.15
- Set of two Broadcast coils..... 1.10
- Set of coils for the 2000 Meter time signals and aeroplane beacons..... 2.45
- Laboratory charge for custom building & testing..... 1.65
- SPECIAL COMBINATION OFFER: complete kit, cabinet, tubes, speaker and the two Broadcast coils..... **\$14.30**

**The PROFESSIONAL BAND-SPREAD DX 5 AC**

Incorporates one 6D6, one 79 Dual tube, one 38 with 2.5 watts power output and one 80 rectifier.



COMPLETE kit includes: built-in dynamic speaker AC power supply, continuous band-spread, coils from 12 to 200 Meters and complete instructions

- Metal cabinet, size 21x10x8"..... \$2.50
- Matched Arcatrus tubes..... 3.10
- Set of two Broadcast coils..... 1.10
- If you prefer it custom built add..... 2.25

**\$14.95**

**WORLD TROTTER RADIO LABS.**  
168 Washington Street, Div. C7, New York, N.Y.

**RADIO CODE**

Learn at Home with

**Instructograph CODE TEACHER**



CODE STUDENTS everywhere are turning to Instructograph, because there is no better way to learn radio code. No experience necessary. Just "listen" and imitate. Instructograph sends perfect code. It is available any time regardless of schedule or interference. Book of Instruction explains each step just as an Instructor would do. Instructograph, Tapes and Book of Instruction for sale or rent.

Terms as low as \$3 per month. One additional month FREE if rented for two months. Rental applied on purchase price. Write for full details NOW! No obligation.

**FREE FOLDER**

**INSTRUCTOGRAPH COMPANY, Dept. S-W-16**  
912 Lakeside Place Chicago, Ill.  
Representatives for Canada, Radio College of Canada, Ltd., 863 Bay St., Toronto, Ont.

**UNIVERSAL**

Combination Recorder and Pick-Up



A scientific, sensitive instrument that insures clear, colorful recording and reproductions—Full amplitude ball bearing mounted—Extra heavy pole pieces, armature and voice coil—Thumb-screw permits featherweight pressure adjustment—Gloves worn and needles scratch minimized—Permits playing on wax and all soft material—Engineered to Universal standards of perfection.

**UNIVERSAL MICROPHONE CO., Ltd.**  
424 Warren Lane, Inglewood, Calif., U.S.A.

**RADIO ENGINEERING,**

broadcasting, aviation and police radio, servicing, marine radio telegraphy and telephony, Morse telegraphy and railway accounting taught thoroughly. Engineering course of nine months' duration equivalent to three years of college radio work. All expenses low. Catalog free. School established 1874.

**Dodge's Institute, Turner St., Valparaiso, Ind.**

every few feet with an insulator. If a metal mast is used to support the antenna don't run the end of the antenna too close to it! A good distance to keep is fifteen or twenty feet.

**The Ground**

When a ground is used and connected to a water pipe make sure that you attach it to the pipe where it enters the building if you are on the ground floor. Long ground wires are not very effective and considerable noise may be picked up by this wire even though it is grounded at one end. Therefore, in apartment houses it is permissible to ground the receiver to a steam or hot water radiator. Better results can be expected than if you were to run an extremely long and relatively fine wire from the set to the ground. Just merely driving a metal rod into the ground several feet does not necessarily constitute a good ground connection, unless the earth is quite moist and your ground rod is at least six or eight feet long. In many cases a much better ground is obtained by connecting to a water pipe.

**Parts List for Antenna Tuner**

- 2—35 mmf. midget variable condenser.
- 1—National grooved Ceramic coil form.
- Sufficient No. 12 or No. 14 tinned wire to wind the twenty-six turns.
- 1—Seven by ten inch bakelite panel.
- 4—Binding posts.
- 2—3-inch NaAld dials.

**New Regenerative Pre-Selector**



This Pre-Selector Will Boost Your Signals. No. 272.

• ONLY one tube is used. Research has shown that amplification at short waves is almost entirely of the REGENERATIVE type, and the limit of short-wave amplification can be reached in a properly designed circuit with one tube, the Sargent experts say.

The only way to increase distance range is to increase the sensitivity of the first tube in the receiver. If the signal is too weak to actuate the grid of the first tube the signal will be lost and all the amplification in the world, AFTER the first tube, will not bring it back. There is only one known method of increasing the first tube's sensitivity—REGENERATION.

This Pre-Selector will increase the distance range and number of foreign stations heard on any short-wave receiver not already having a regenerative input.

Tuning range 15 to 560 meters, 20,000 to 540 kc. Cut-over switch (lower center in photo) cuts pre-selector out of circuit when used with receivers that tune outside of pre-selector wavelength range. Power is drawn from receiver by an adapter that fits over base of receiver audio tube. This drain is very slight and any good receiver will stand it.

Coil switching system; individual coils for each band, short-circuited by tap switch when not in use.

**DATAPRINTS**

Just the CONSTRUCTION Information You Need To Build Electrical Apparatus

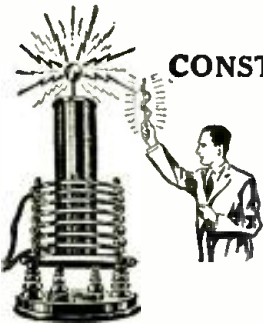

**TESLA OR OUDIN COILS**

Dataprint containing data for constructing this 3 ft. spark Oudin-Tesla coil. Requires 1 K.W. 20,000 volt transformer as "exciter"; see list below. Includes condenser data. . . **\$ .75**

- 3 inch spark, data for building, including condenser data; requires 1/4 K.W. 15,000 volt transformer; see list below..... 0.50
- Violeta type, high frequency coil data; 110 volt A.C. or D.C. type; 1" spark; used for "violet ray" treatments and "Experiments"..... 0.50
- How to operate Oudin coil from a vacuum tube oscillator..... 0.50
- 3 inch spark Tesla coil; operates on Ford ignition coil..... 0.50
- 3 inch spark Oudin coil; 110 volt A.C. "Kick-Cult"..... 0.50
- 20 Tricks with Tesla and Oudin Coils..... 0.50

**TRANSFORMER DATA**

- 1 k.w. 20,000-volt transformer data, 110-volt, 60-cycle primary. Suitable for operating 3 ft. Oudin coil..... 0.50
- 1/2 k.w. 15,000-volt transformer data, 110-volt, 60-cycle primary. Suitable for operating 3-inch Oudin coil..... 0.50
- Electric Welding Transformer (State secondary voltage)..... 0.50
- Induction Coils—1 to 12 inch spark data..... 0.50
- ARTIFICIAL FEVER Apparatus..... 0.75

(Low, Medium & High Power Data Given)

**SLIDE RULE MIDGET**

Metal 4" Dia. Price \$1.50. Case 50c extra



This rule solves any problem in multiplication, division, addition, subtraction, and proportion; it also gives roots and powers of numbers; sines, cosines, tangents and cotangents of all angles; also logs of numbers. Adds and subtracts fractions. Approved by colleges.

10" Dia. 27" Scale "Special" Rule, \$2.75. Multiplies and Divides, but has no "Trig" Scales.

**TELEGRAPHONE** — Records Voice or "Code" signals on steel wire by magnetism. Code can be recorded "fast" and translated "slow." Construction data (special)..... \$0.50

**MAGNET COIL DATA**

- Powerful battery electro-magnet; lifts 40 lbs..... \$0.50
- 110 Volt D.C. magnet to lift 25 lbs..... 0.50
- 110 Volt D.C., 300 lb., Lift electromagnet..... 0.50
- 110 Volt D.C. solenoid; lifts 2 lb. through 1 in. 0.50
- 110 Volt D.C. solenoid, lifts 6 lb. through 1 in. 0.50
- 12 Volt D.C. solenoid, lifts 2 lb. through 1 in. 0.50
- A. C. Solenoid, powerful, 110-volt, 60-cycle..... 0.50
- MOTOR—1/16 H.P., 110 volt A.C., 60 cycle (suitable for driving 12" fan, etc.)—Data..... 0.50
- 60 or 1,200 cycle Synchronous motor..... 0.50

**MISCELLANEOUS DATAPRINTS**

- Treasure Locator..... \$0.50
- 2 K. W. 110 vt. to 18 vt. transformer data..... 0.50
- 20 motor circuits—hook-ups..... 0.35
- 20 practical telephone hook-ups..... 0.35
- 100 mechanical movements for inventors..... 0.50
- Polarized Relay—Ultra Sensitive..... 0.50
- Electro-medical coil (shocking coil)..... 0.50
- Water-Wheels—How to Build and Light your house..... 0.50
- 20 Electric Bell circuits..... 0.50
- Public Address System..... 0.50
- Electric chime ringer; fits any clock..... 0.50

20 "Electrical Tricks" for LODGES and PARTIES..... \$0.50

How to Fry Eggs on Cake of Ice Electrically..... \$0.50

"Rowinding" Small Motor Armatures..... 0.50

**"ENGINEERING SERVICE BY MAIL"**

Send Sketch of Your Problem for Estimate. (20% off on orders for \$3.00 or more. No C.O.D.)

**The DATAPRINT COMPANY**  
Look Box 322 RAMSEY, N. J.

Please mention SHORT WAVE CRAFT when writing advertisers



**WORLD WIDE ALL-WAVE RADIO**



A real powerful long and SHORT WAVE Radio Receiver that actually gets local and foreign broadcasts, police, amateur, air-planes, etc., transmissions direct! Thousands now in use. Owners report reception of Foreign Stations with amazing volume. Works on two inexpensive batteries. Not a toy! **RESULTS GUARANTEED!**

**\$1.95**

See construction kits have all necessary parts mounted on attractive metal chassis and panel, all ready for wiring. Clear picture diagrams. Wire it yourself. It's easy. Range 15 to 600 meters. Complete Kits, with coil—

● **ONE TUBE KIT, \$1.95** ● **TWO TUBE, \$2.85**

**ALL ELECTRIC** 105-125 Volt AC-DC two-tube house current set. No batteries needed! Complete Kit, \$3.65. Kits wired, 75c extra. Tubes, 85c ea. Double Phones, \$1.25. **ORDER NOW.** Send \$1, balance C.O.D., or if full remittance with order, we pay postage. Free literature.

**FREE!!** Large color map of the World. Valuable Short Wave data, etc.! Send 10c for handling. **NDW!!**

**ACE RADIO LABORATORIES**  
1619 Broadway Dept. C-4 New York City

**RADIO'S LIVEST MAGAZINE**  
Edited by HUGO GERNSBACK



**RADIO-CRAFT** is devoted not only to the radio experimenter and technician, but also to the beginner in radio. Picture diagrams simplify construction of sets. Kinks show simple ways out of difficult problems. The latest radio equipment is illustrated and described.

**RADIO-CRAFT** is fully illustrated with photographs, diagrams and sketches. Each issue contains over 150 illustrations. 15c for Sample Copy.

**8 Months for \$1.00**

**RADIO-CRAFT**  
99C Hudson Street New York, N. Y.

**ONE CENT A DAY PAYS UP TO \$100.00 A MONTH**

The Sterling Casualty Insurance Co., 2562 Insurance Center Bldg., Chicago, Ill., is offering a NEW accident policy that covers every accident. Pays up to \$100 a month for 24 months for disability, and \$1,000 for death for 1c a day—only \$3.65 a year. A NEW policy issued by an OLD company that has already paid more than \$175,000.00 in cash benefits. Open to any one, ages 10 to 70, without doctor's examination. They will send you a policy for 10 days' FREE inspection. Send no money. Just mail them your age and beneficiary's name and relationship. This offer is limited. Write today.—Advertisement.

**FREE CIRCUIT DIAGRAM AND PARTS LIST**

**BUILD YOUR OWN ALL-STAR JR ALL-WAVE Superheterodyne RECEIVER**

Send For Free Catalog

**Radio Electric Service Co.**  
N.E. Cor. 7th & Arch Sts. Phila., Pa.  
85-S Cortlandt St., N.Y.C.  
811 Federal St., Camden, N. J.

★★ **FREE Parts Lists—Schematic** ★★

**BUILD YOUR OWN ALL-STAR JR ALL-WAVE Superheterodyne**

**TRY-MO RADIO CO., INC.**  
85-S Cortlandt St., N.Y.C.  
179-S Greenwich St., N.Y.C.

NOTE! Write for full particulars about FREE membership to the Try-Mo Radio-Saving Club.

**Short Wave Scouts**

(Continued from page 723)

- W3XAU—Philadelphia, 49.5, 7-10 p.m., relays WCAU.
- W3XAU—Philadelphia, 31.28, noon-7 p.m., relays WCAU.
- W8XK—Pittsburgh, 13.93, 7 a.m. to 2 p.m., relays KDKA.
- W8XK—Pittsburgh, 19.72, 10 a.m. to 4:15 p.m., relays KDKA.
- W8XK—Pittsburgh, 25.27, 4:30-10 p.m., relays KDKA.
- W8XK—Pittsburgh, 48.86, 4:30 p.m. to 1 a.m., relays KDKA.
- W3XAL—New Jersey, 16.87, 10 a.m. to 4 p.m., relays WJZ.
- W3XAL—New Jersey, 49.18, M., W., S., 4-11 p.m., relays WJZ.
- W2XE—New York, 49.02, 6-10 p.m., relays WABC.
- W2XE—New York, 25.86, 2-4 p.m., relays WABC.
- W2XE—New York, 19.64, 10 a.m. to noon, relays WABC.
- W3XAL—Cincinnati, 49.05, 6:30 a.m. to 7 p.m., relays WLW.
- WMA—New York, 22.40, daytime, phones England.
- WOA—New York, 44.41, nights, phones England.
- WMN—New York, 20.56, daytime, phones England.
- WOK—New York, 28.44, 6 p.m., phones LSN.
- KNRA, at sea—44.00, no schedule.
- KNRA, at sea—31.51, no schedule.
- KNRA, at sea—33.94, no schedule.
- WEA—Rocky Point, N.Y., 28.28, 10-11 a.m. Sun., tests with Moscow.
- WQV—Rocky Point, N.Y., 20.27, 10-11 a.m. Sun., tests with Moscow.
- WCG—Rocky Point, N.Y., 28.91, irregular, tests with Germany.
- KEJ—Bolinas, Cal., 33.29, irregular, sends programs to Hawaii.
- WQO—Rocky Point, N.Y., 44.67, irregular, tests with KNRA.
- WEL—Rocky Point, N.Y., 33.52, tests with LSX for Byrd broadcasts.
- W2XBJ—Rocky Point, N.Y., 33.52, tests with LSX for Byrd broadcasts.
- WET—Rocky Point, N.Y., 31.67, tests with LSX.
- KEE—Bolinas, Cal., 38.85, irregular, sends programs to Hawaii.
- KWU—Dixon, Cal., 19.54, 2-7 p.m., phones Hawaii.

**Trophy Contest Entry Rules**

● THE rules for entries in the SHORT WAVE SCOUT Trophy Contest have been amended as follows:

**Note! All Stations Sent in Must Now Be Verified!**

The winner each month will be the person sending in the greatest number of verifications. Unverified stations should not be sent in, as they will not count in the selection of the winner. At least 50 per cent of the verifications sent in by each listener must be for stations located outside of the country in which he resides! In other words, if the contestant lives in the United States, at least 50 per cent of his "veris" must be for stations outside of the United States. Letters or cards which do not specifically verify reception, such as those sent by the Daventry stations, and also by commercial telephone stations, will not be accepted as verifications. Only letters or cards which "specifically" verify reception of a "given station," a given wave-length and a given day, will be accepted! In other words it is useless to send in cards from commercial telephone stations or the Daventry stations, which cards or letters state that specific verifications will not be given. Therefore do not put such stations on your list for entry in the trophy contest!

The trophy will be awarded to the SHORT WAVE SCOUT who has logged the greatest number of short-wave stations during any 30 day period; this period need not be for the immediate month preceding the closing date. The complete list of rules appeared in the March issue of this magazine.

In the event of a tie between two or more contestants, each logging the same number of stations the judges will award a similar trophy to each contestant so tying. Each list of stations heard and submitted in the contest must be sworn to before a Notary Public and testify to the fact that the list of stations heard were "logged" over a given 30 day period, that reception was verified and that the contestant personally listened to the station announcements as given in the list.

Only commercial "phone" stations should be entered in your list, no "amateur" transmitters or "commercial exclusive" stations. This contest will close every month on the first day of the month, by which time all entries must be in the editors' hands in New York City. Entries received after this date will be held over for the next month's contest. The next contest will close in New York City, April 1.

The judges of the contest will be the editors of SHORT WAVE CRAFT, and their findings will be final. Trophy awards will be made every month, at which time the trophy will be sent to the winner. Names of the contesting SCOUTS not winning a trophy will be listed in Honorable Mention each month. From this contest are excluded all employees and their families of SHORT WAVE CRAFT magazine. Address all entries to SHORT WAVE SCOUT AWARD, 99-101 Hudson Street, New York City.

**DON'T MISS IT!**

How to Build a "Regenerative R.F. Booster" by George W. Shuart, W2AMN.

In Next Issue!!

**BUILD YOUR OWN ALL-STAR JR ALL-WAVE Superheterodyne**

**THESE ELEVEN ALL-STAR RADIO MANUFACTURERS MAKE THE OFFICIAL PARTS SPECIFIED FOR JUNIOR**

Meissner Mfg. Co.  
Radio Frequency Coils and Chokes.  
Cornell-Dubilier Corp.  
Paper, Electrolytic, and Mica Condensers.  
Hammarlund Mfg. Co.  
Variable Air Tuning Condensers.  
Thordarson Electric Mfg. Co.  
Power Transformer, Filter Choke, and Foundation Unit.  
Oxford Radio Corp.  
Loud Speaker.  
Crowe Name Plate & Mfg. Co.  
Dial and Name Plates.  
Ohmic Manufacturing Co.  
Resistors and Voltage Dividers.  
Electrad, Incorporated  
Potentiometer with Switch Volume Control.  
Oak Manufacturing Co.  
Wafer Sockets.  
Belden Manufacturing Co.  
All-Wave Aerial and Wiring Kit.  
Eric Can Co.  
Tube Shields.

FREE—Official Tablett, telling all you want to know about the ALL-STAR JUNIOR. Send to Headquarters for your copy. Buy your parts from your favorite distributor for HEADQUARTERS DOES NOT SELL PARTS.



**ALL-STAR JR HEADQUARTERS**  
360 N. Michigan Ave., Chicago

**TOUR THE WORLD!**

**BUILD YOUR OWN ALL-STAR JR ALL-WAVE Superheterodyne**

Short Wave Receiver Kit

**COMPLETE PARTS in stock**

Write for Free Diagram and parts list  
Send for our Big 1935 Catalog

**M & H Sporting Goods Co.**  
512 Market St., Phila., Pa.

**UNCONDITIONAL GUARANTEE ON ALL OUR RADIO SUPPLIES**

**UNCLE DAVE'S**

REPAIR SERVICE RADIO SHACK  
336 BROADWAY ALBANY, N. Y., U.S.A.

Cable Address: "Uncledave."  
Write for new Ham Catalog—Just off the press!

Peerless "40-DX" Transmitter, 35 watts output CW—10 watts phone, a beautiful job at an extremely low price. Write for details.

Breadboard power pack kits for small transmitters. 325 volts 100 ma; 2½ volt 6 a. complete with tube, net \$4.95

550 volts 150 ma; 2½ volts at 8 amps, an FTI job for that 30 watt CW phone, complete with tube \$9.85

Peerless "4-PRM" communications type bandspread professional amateur receiver. WRITE FOR INFORMATION!

**WANTED—USED TELEPLEXES**  
Transmitters to meet your needs and pocket-book!

A Professional type short-wave set using Standard Parts.

**BUILD YOUR OWN ALL-STAR JR ALL-WAVE Superheterodyne**

**FREE CIRCUIT DIAGRAM AND PARTS LIST**

will be mailed upon request. Write for Catalog.

**BURSTEIN-APPLEBE COMPANY**  
1012-14 McEE ST., DEPT. S, KANSAS CITY, MO.  
Specialists in Supplies for the Amateur and Serviceman

Please mention SHORT WAVE CRAFT when writing advertisers



# Most Amazing TYPEWRITER BARGAIN

**10 DAY  
FREE TRIAL  
OFFER** **EVER  
OFFERED**



**NEW  
REMINGTON  
PORTABLE only**

**10¢  
A DAY**

FIRST TIME! Remington's new purchase plan lets you buy a genuine Remington Portable No. 5 direct from factory for 10¢ a day. Not used or rebuilt. Not incomplete. A beautiful brand new regulation Remington Portable. Standard 4-row keyboard, standard width carriage, margin release on keyboard, back spacer, automatic ribbon reverse, every essential feature found in standard typewriters.

With your machine we send you free a 19-page course in typewriting. Teaches touch system quickly, easily. Soon you dash off letters quicker than with pen and ink. You also get a handsome, sturdy carrying case free.

**FREE** Typewriting Course  
**FREE** Carrying Case

**BIG PRICE REDUCTION**  
The amazing low price and easy terms make this the greatest typewriter value ever offered. But everything points to higher prices. Present big price reduction cannot be guaranteed long. So we say, "Act Fast!"

**You Don't Risk One Cent**  
Try this typewriter in your home or office on our 10-day FREE TRIAL OFFER. Then, if you do not agree that it is the finest portable at any price, return it at our expense. You don't even risk shipping charges. Don't wait. Mail coupon now. It's the best chance you've ever had to own so complete a machine for so little money. So act NOW!

**CLIP COUPON NOW**

Remington Rand Inc., Dept. 214-4  
Buffalo, N.Y.

Please tell me how I can buy a new Remington Portable typewriter for only 10¢ a day. Also enclose your new catalog.

Name \_\_\_\_\_  
Address \_\_\_\_\_  
City \_\_\_\_\_ State \_\_\_\_\_

## Health Ray Carbon Lamp



**PAYS FOR  
ITSELF IN A  
FEW TREAT-  
MENTS.**

Everyone in the family needs the health giving Violet Rays.

This is a large CHROMIUM plated lamp using standard carbons emitting rays of ultra violet and infra red. If Sun Tan is desired, order accordingly.

Saves doctor's bills. Cures colds, rheumatism, and other ailments.

Size: 11 1/4" high, 10" wide, 5 1/2" deep. Weight 8 1/2 pounds. Interesting literature sent free.

List price with Screen and Goggles—\$10.00.  
YOUR COST—F.O.B., N.Y., \$3.38.

**WONDERFUL VALUE!**

Gold Shield Products Co., 98 Park Place, N.Y. City

## S-W Scout News

(Continued from page 722)

### Official Short Wave Listening Post Report From Edward G. Schmeichel

● STATIONS on the 19 meter band have been reaching this post with excellent signal strength. DJB, FYA, HVJ, GSF, all have been coming in at an R7-R8 signal.

The 25 meter band is improving quite well. Station GSE reaches this post daily. FYA has been also fairly good up to about 6 p.m.

ORK—Brussels, Belgium, is still coming in. They are on the air daily from 2:45-3:15 p.m. E.S.T. on 29.04 meters.

EAQ—Madrid, Spain has been the outstanding station on the 30 meter band. They are reaching this post nightly.

PRF5, COH, CT1AA, VK2ME, VK3ME, VK3LR are all reaching this post with excellent volume and quality.

The new schedule of CT1AA—Lisbon, Portugal, is Tues.-Thurs.-Sat. from 3 to 7 p.m. E.S.T. They are on 31.25 meters.

The 49 meter band is very steady and there are still stations all over South America which have not been identified. They seem to spring up unexpectedly. Outstanding signals on this band have been HJ1ABB, YV4RC, YV3RC, HJ5ABD, DJC, GSA, COC, YV5RMO, etc.

Station HIX—Santo Domingo, is coming in fine on their new wavelength of 50.17 meters. They are on the air Tuesdays and Fridays from 8:10-10:10 p.m. E.S.T.

A new station is HJ5B. This station is located in Panama City. They broadcast on Wednesday and Saturday evenings from 7 until 11 p.m. E.S.T. They are found between DJC and XEBT on the dials of your set. Their address is HP5B, Box 910, Panama City, Panama, C.Z.

YDA—Bandoeng, Java, can be heard at this post almost any morning between 5 and 8 a.m. E.S.T. They are 49.02 meters. This is the exact wavelength used by W2XE. They announce in English quite frequently. Try for them!

RV15—Khabarovsk, Siberia, U.S.S.R., on 70.65, has been reaching this post with an R6-8 signal, but their quality is not very good and their announcements are more or less muffled.

A new one for everybody is station VPD-SUVA, Fiji Islands. This is a very rare station and anyone who receives a "veri" from this station is a pretty good DX-er. They are on the air Saturday mornings 8-10 a.m., and also on Tuesday and Friday from 12:30 until 1:30 a.m. on 22.75 meters.

CNR—Rabat, Morocco, Africa, has been heard only once this month. They broadcast on 37.33 meters on Sundays from 3-5 p.m. E.S.T.

### "Listening In at Heinie Johnson's SWC Post In Big Spring, Texas"

● FOR variety of program you'll find it mighty hard to beat the N1ROM signal on 49 meters. This signal will be heard best between 8 and 9 o'clock C.S.T. every morning.

It sounds odd to hear "Sears Roebuck" program over YV3RC in Caracas, doesn't it?

OAX4D furnished us with our best reception from Peru. They are heard on Wednesdays and Saturdays in the evening very regularly on 51 meters.

JVT brings us our best Japanese programs. Any night you are awake at 3:30 a.m. C.S.T. you will hear them well on 44 meters.

Our old favorite EAQ is now bursting out in fine style again; not so much interference as was true a while back and by far the best from Spain.

"Big Ben" is best heard right now over GSA and GSE—GSF not being heard at all at this post lately.

We are using Mr. Worcester's DX-er as described in the January issue, for some fine catches with aid of headphones. This set is a little "honey."

## DO YOU WANT TO OBTAIN ELECTRICAL POWER

from a Windmill, from available Waterpower, from your Automobile, from your Motorcycle, from your Bicycle, Footpedals or Handcrank (for transportable Radio Transmitters, Strong Floodlights, Advertising Signs); do you want to operate AC Radio sets from 32 V.DC farm light systems; operate two generators in series to get 200 V.AC; obtain two phase and three phase AC.. etc.. etc.

GET OUR

## WESTINGHOUSE

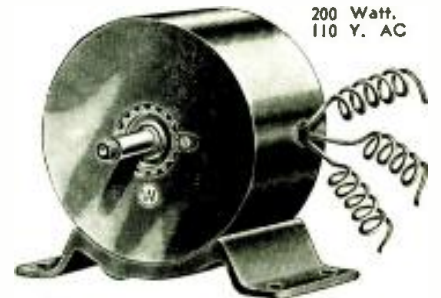

### Power Generator

MANUFACTURED FOR U. S. SIGN. CORPS  
SPECIFICATIONS

- WEIGHT—14 1/2 lbs.
- HOUSING—Aluminum (Diameter—6 1/4 in. Length—5 1/4 in.)
- SHAFT—2 3/16 in. (driving end) (diameter 9/16 in.—the end is threaded for a distance of 3/4 in.)
- BASE—Cast Iron. (Length—7 1/4 in. Height—1 9/16 in. Width—4 3/4 in.)
- OUTPUT—200 Watt 110 volts AC (speed 4500 R.P.M.)
- STATORS—Two pairs (two North and two South) ROTOR—12 tooth inductor. Built in commutator. Rotor turns in ballbearings.

(GENERATORS HAVE NEVER BEEN USED)

**FREE** With each Westinghouse Generator we supply free of charge a set of diagram-blue prints and instructions showing twenty-five different uses, giving technical information, electrical Hookups and installing explanations. We also include free of charge a set of four replacement carbon brushes.

### THERE ARE OVER 25 APPLICATIONS

SOME OF WHICH ARE:

- A.C. DYNAMO lighting from eight to ten 20 Watt 110 Volts lamps
- SHORT WAVE TRANSMITTER supplying 110 Volts AC for operating "Ham" transmitter.
- OPERATING 110 V. AC 60 CYCLE RADIO RECEIVER in DC districts.
- MOTOR GENERATOR.
- PUBLIC ADDRESS SYSTEMS.
- ELECTRIC SIRENS on motor boats, yachts, etc.
- CAMP LIGHTING.
- SHORT WAVE artificial "fever" apparatus.
- TELEVISION.
- PELTON WATERWHEEL for lighting or other purposes.
- AIRPLANE: for lighting strong search lights or electric signs.
- LABORATORY WORK.

Generator as described above including four replacement carbon brushes and folder containing instructions and uses **\$7.90**

Shipping weight 18 lbs. (Replacement carbon brushes bought separate \$1.50 per set of four. Set of instructions bought separate \$1.00.)

Remit by check or money order. Shipped Express Collect if sufficient money is not enclosed for parcel post. Money refunded if not satisfied.

**WELLWORTH TRADING COMPANY**  
560 W. Washington Blvd. CHICAGO, ILL.

**WELLWORTH TRADING COMPANY** SW-4-35  
560 W. Washington Blvd., Chicago, Ill.

Enclosed you will find my remittance of \$..... for which please send me

( ) Power Generator, \$7.90 each.

Name \_\_\_\_\_  
Address \_\_\_\_\_  
City \_\_\_\_\_ State \_\_\_\_\_

Please mention SHORT WAVE CRAFT when writing advertisers



## LEONARD VICTOR'S FAMOUS EAGLE EC FOUR

A Supersensitive A.C. All-Wave Receiver. Extremely efficient. Easy to build. Simple to operate.

Complete Kit—**\$14.95**

including 8 short-wave coils with Ready-Grip handles.

The kit includes a fully constructed foundation chassis and panel with built-in shielded coil compartments. Your choice in either Black Cracked or Cadmium Plated finish.

**EAGLE RADIO CO.,**  
84 Cortland St., Dept. S-4, N.Y.C.  
Write for our "Pay As You Build Plan."

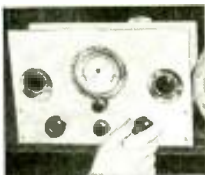

## SUPERHETERODYNE DATA

The only publication that describes the design, construction, and aligning of the superheterodyne. Every circuit is described in detail with drawings, formulas, and text in language you can understand.

Written by Dr. R. H. von Liedtke, M.E., E.E., University of Heidelberg, who has spent 16 years in the development of superheterodyne receivers and who ranks as the foremost authority on superheterodyne design.

**\$2.00** Send with order  
Foreign \$2.50

**RADIO RESEARCH LABORATORIES**  
Fort Wayne, Indiana, U. S. A.  
Manufacturers of Lone Eagle Radio Receivers  
Write for free Bulletins

## NA-ALD 5-METER PARTS



C15—15 mfd. 5 meter Condenser. List price.....\$2.30  
L6—1/2 turn Silvered 5 meter coil. List price..... 1.00  
75V—New 5 meter R.F. Choke coil. List price..... .70  
4955V—New 955 Atom Tube Socket. List price..... 1.50

Send us your dealer's name and address and get free your copy of this new 16-page catalog showing the line of Na-Ald quality products.  
**ALDEN PRODUCTS CO.**  
Dept. SW4, 715 Center St.  
BROCKTON, MASS.

## SEXOLOGY

THE MAGAZINE OF SEX SCIENCE

SEXOLOGY, foremost educational sex magazine. Is written in simple language and can be read by every member of the family. It is instructive, enlightening—not a risqué book—contains no offensive matter.

Contains 25 important articles on Sex Science, 68 pages, with attractive two-color cover. Here are a few of the more important articles:

Impotence Caused by Stricture (Illustrated); Sex Anxieties of Young Men (Illustrated); Sex Gods of Olden Times (Illustrated); Those "Frigid Women" (Illustrated); Childbirth in Primitive Races (Illustrated); Sex Life in Ancient Greece (Illustrated); Sex Causes of Divorce (Illustrated); Sex Life Under Polygamy (Illustrated); Sexless Sexual Acts (Illustrated); Little Husbands and Big Wives (Illustrated); Sale of Contraceptives: Questions and Answers; and Book Review.

**SEXOLOGY**  
95 Hudson St. New York, N. Y.

Get a copy of **SEXOLOGY** on any newsstand, or, if your dealer cannot supply you, send 25c cash or stamps for current issue.

## FLERON AERIAL EQUIPMENT

The Complete Line from One Source  
SEND FOR FREE CATALOG

M. M. Fleron & Son, Inc. DEPT 4  
TRUSTON, N. Y.

## New 5-and 10-Meter Transceiver

(Continued from page 728)

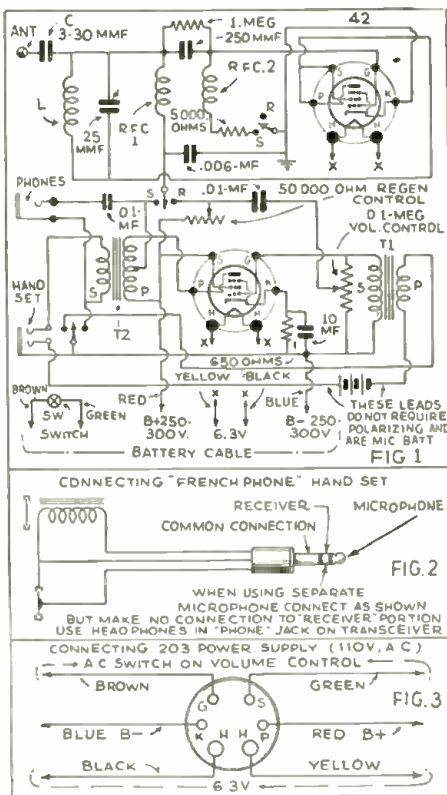

Hook-up of Transceiver

further amplifies the signal and applies it to the output transformer T2. The jack marked "phones" connects through a .1 mf. condenser between the center tap of the primary and —B—. Thus, the signal is heard. Tuning is accomplished by tuning the condenser across L.

When the switch is thrown to the "transmit" side, designated by S, the grid return of the first 42 is made through RFC2 and the 5000-ohm resistor to ground. RFC1 then connects to the center tap of T2 to obtain the output of the second 42.

### The Microphone Circuit

Figure 2 shows the connections of a typical hand-set. The microphone connects between the tip of the plug and the sleeve through the battery C, used for exciting the carbon microphone. Now the telephone receiver which is built into the hand-set connects between the sleeve and the third connection on the plug, between the tip and the sleeve, as shown. This means that when the hand-set is plugged into the "hand-set" jack of Fig. 1, the single button microphone connects, through the polarizing battery, to the primary P of microphone transformer T1. The secondary S of this transformer connects to the input of the second 42 for speech amplification, and the output appears across the primary P of transformer T2. The center tap of this transformer connects to the first 42 circuit, which is now the oscillator, and this audio signal modulates the oscillator through the choke RFC1. Note that no R.F. can "sneak in" the audio system because of the presence of this choke.

If a hand-set is not available, then an ordinary single-button microphone may be used without any circuit changes.

### The Power Supply

The power supply is so flexible that this Transceiver may be said to be universal, indeed. When operated from an automobile, a special 6-volt power supply is available which supplies all the necessary power with the exception of the small microphone polarizing battery C. When operation from 110 volts 60 cycles is desired,



**KNOWN**  
by the  
**COMPANY THEY KEEP**

In case you haven't already noticed it, we want to call your attention to an important fact you can readily verify: Sprague Condensers are featured by more of the better parts jobbers than any other make of condensers.

Jobbers of this type know quality—and feature it accordingly. Even though they may carry other makes of condensers, chances are ten to one they'll recommend Sprague's to the man who wants the best. Ask your jobber and see! SPRAGUE PRODUCTS CO., North Adams, Mass.

## SPRAGUE CONDENSERS

MADE RIGHT **SPRAGUE 600 LINE** PRICED RIGHT

## HOW TO BUILD, TEST AND REPAIR RADIO SETS



## Radio Construction Library

Including Television, Short-Wave Receivers and Auto Radios. 3 Volumes, 6x9—1177 pages, 561 illustrations.

This practical Library includes: PRACTICAL RADIO—The fundamental principles of radio, presented in an understandable manner. Illustrated with working diagrams. PRACTICAL RADIO CONSTRUCTION AND REPAIR—Methods of locating trouble and reception faults and making workmanlike repairs. Discusses modern Short-Wave Receivers and installations of automobile radios fully. RADIO RECEIVING TUBES—Principles underlying the operation of all vacuum tubes and their use in reception, remote control and precision measurements.

Helps you to understand modern type receiving sets—full of construction data and practical kinks for the experimenter.

**10 Days' Free Examination**  
Easy Terms

## Free Examination Coupon

McGraw-Hill Book Company, Inc.  
330 West 42nd Street, New York

Send me the new RADIO CONSTRUCTION LIBRARY, three volumes, for 10 days' free examination. If satisfactory I will send \$1.50 in ten days, and \$2.00 a month until \$7.50 has been paid. If not wanted I will return the books postpaid.

Name .....  
Home Address.....  
City and State.....  
Position.....  
Name of Company..... SWC-4-35

Please mention SHORT WAVE CRAFT when writing advertisers



# SWEEPING CLOSE-OUT SALE

= CLEARING ALL SHELVES =



PRICES LESS THAN  
**40¢**  
ON THE DOLLAR

## OF NEW STANDARD OVER-STOCKED RADIO AND SHORT-WAVE PARTS

Tremendous bargains, every one of them! All these items represent standard radio merchandise which we have discontinued cataloging. There is only a definite quantity of each item on sale. When they are gone no more can be had.

Act fast to take advantage of this amazing sale! We reserve the right to refund your money in the event any item you've ordered has become depleted. You can find most items listed in our various catalogs under identical catalog numbers. Immediate shipment can be made on all this merchandise. All goods guaranteed perfect.

### Short-Wave, B'Cast Receivers, Amplifiers

No. 3000 Wright DeCoster 7-Tube 2-volt Farm Sets. Requires 6-30's and 1-31 for operation. Less tubes and batteries. Your price.....\$8.00

No. 35 Baird Universal Short-Wave & Television Receiver, complete with coils. Requires 3-24's, 2-27's, 1-45 and a B1L rectifier for operation. Your price, less tubes.....\$14.95

No. 1614 Air-King 3-Tube Superhet S.W. Converter. Requires 3-27's for operation. Works with all receivers. Your price, less tubes.....\$3.50

No. 1617 A.C. Short-Wave Converter, with built-in filament transformer. Requires 3-27 tubes for operation. Works with all sets. Your price, less tubes.....\$4.00

No. 224-5-Tube DeLuxe Short Wave Receivers. Air-plane dial, plug-in coils, less tubes. Requires 2-58's, 1-56, 1-59, 1-80 for operation. Handsome black crackled finish cabinet. Your price, less tubes \$17.50

No. 7353 3-Tube 2-Volt Battery Short Wave Receivers. Complete with metal crystalline cabinet, including coils. Requires 2-30's and 1-31 for operation. Less tubes and batteries. Your price.....\$7.70

No. 46 20-Watt Class "B" Amplifier Kits. 110 volts, 60 cycles, A.C. Requires 1-57, 3-16's and 82 rectifier for operation. Input to grid of 57; output 4000 ohms. Instructions included. Less tubes. Your price \$20.00

### Tubes at "Give-Away" Prices

All these tubes are new, unused and boxed. WD12-38c; 201A-20c; 12A-20c; 20-44c; 24-18c; 35-33c; 10-40c; 11A-20c; 47-55c; 50-75c; 51-55c; 55-66c; 81-55c; 91 Triple Twin-50c; 93 Triple Twin-50c; ZRF (equivalent to 201A, excellent oscillator)-12c.

### Tremendous Bargains in Microphones

(All Standard 100 ohm per button units.) No. F Faraday 2-Button Carbon Mikes. Chromium Plated. YOUR PRICE.....\$3.60

No. 8 Lifetime 2-Button Carbon Mikes, Chromium Plated. YOUR PRICE.....\$3.75

No. 22M Shure Bros. Professional 2-Button Carbon Mikes. YOUR PRICE.....\$11.00

No. 11M Shure Bros. Professional 2-Button Hand Mikes. YOUR PRICE.....\$7.25

No. 99B Shure Bros. Radio Modulator Public Address Converter. Converts any radio into Public Address System. YOUR PRICE.....\$18.25

No. 1655 Single Button Lapel Microphone. Easily concealed. YOUR PRICE.....\$1.30

No. 1654 Complete Microphone Input Stages including Single Button Midset Mike, less battery. YOUR PRICE.....\$4.80

No. 401 Professional Connectophones. Consists of single button mike in cabinet with call button and single headphone. For intercommunication work. YOUR PRICE.....\$4.80

No. 1562 Complete Microphone Impedance-matching input stages for single button microphones. YOUR PRICE.....\$2.65

No. 2352 Microphone Mounting Rings. YOUR PRICE.....\$1.30

No. 88A Lifetime Microphone Table Stands. YOUR PRICE.....\$1.50

No. 7270 U.S. Signal Corps Interphone Box for intercommunication work. YOUR PRICE.....\$8.00

### All Types of Condensers

#### Electrolytics in Metal Cans

1 mf. rated at 30v volts-25c; triple 8 mf. section units 500 volts-\$1.05; double 8 mf. section units 500 volts-80c; single 8 mf. units, 500 volts-48c.

#### Electrolytics in Cardboard Boxes

Triple 8 mf. section units 500 volts-85c; single 8 mf. units 500 volts-35c; single 6 mf. units 500 volts-32c; single 4 mf. units 500 volts-30c; single 2 mf. units 500 volts-25c; single 25 mf. units at 50 volts-31c.

### Duplicate Replacement Condenser Blocks

The following condenser block units are all available at the amazing price of only \$1.30 each. They are exact duplicates for the following receivers: Fada 35; Stewart Warner 959; Philco 87; Kolster K13; Brandes B15; All American Lyric 90; Brunswick 11; Arbrophone 35; Zenith E9; Fada KA60; Apex 42; Majestic 901B; Majestic B; Kolster K24; Freed Elsenman NR80; RCA60; Steinle 70A; Atwater Kent 37. Your Price \$1.30 each.

### Replacement Power Transformers

for the following receivers. Fada RA; Kolster 5517; Edison B1-Plate; Apex 8A; Kolster C6; General Electric 100SLV; Majestic 7BP6-Plate; RCA 41; Fada 42. YOUR PRICE-ANY TRANSFORMER-\$1.75 EACH.

### Audio Transformers and Filter Chokes

All type audio transformers.....40c each  
30-Henry Filter Chokes rated at 30 and 60 mls.....50c each

Double 30-Henry Filter Chokes rated at 40 mls per section.....65c each

TERMS: Order directly from this "ad" and save money. 100% satisfaction guaranteed. All prices net, no further discounts allowed. No orders less than \$3.00. For C.O.D. orders send 20% remittance; balance C.O.D. Priority of shipment given to cash orders. ACT NOW. FREE CATALOG sent 5c (coin or new U.S. stamps) for postage. Book by return mail.

## RADIO TRADING CO., 101-A HUDSON ST., NEW YORK CITY

### Short Wave League Members

IDENTIFY THEMSELVES WITH THE ORGANIZATION



In order that fellow members of the LEAGUE may be able to recognize each other when they meet, we have designed this button, which is sold only to members and which will give you a professional appearance.

If you are a member of the LEAGUE, you cannot afford to be without this insignia of your membership. It is sold only to those belonging to the LEAGUE and when you see it on another, you can be certain that he is a member.

See page 762

Lapel Button, made in bronze, gold filled, not plated, prepaid..... 35c  
Lapel Button, like one described above, but in solid gold, prepaid.....\$2.00

## SPECIAL

FOR THIS MONTH

Send \$1.00 (\$1.25 Canada and foreign) and we will send you SHORT WAVE CRAFT for eight months. DO IT NOW!

**SHORT WAVE CRAFT**  
99-101 Hudson Street New York

**RUN YOUR A.C. RADIO by DIRECT CURRENT**

Operates AC Radios, amplifiers, transmitters, etc. from 6-32 or 110 DC. Sent on trial.

**KATO ENGINEERING CO.**  
Mankato, Minn. U. S. A.

AC generators \$16.00. Light plants \$99.00.

another special power supply is available. The connections of this special power supply to the transceiver appear in Fig. 3. When neither a storage battery nor power supply is available, then dry cells and "B" batteries may be used with excellent results.

The power output depends upon the plate voltage used. It is recommended that not less than 180 and not more than 300 volts be used on the plates of the tubes. With rated voltage, the power output will be approximately 10 watts.

### The Antenna System

It is necessary to use some form of adjustable-length antenna on ultra short waves. For this transceiver, the use of a telescopic vertical antenna is suggested which is connected to the Isolantite antenna connector located on the front panel. For operation on 56 megacycles, the antenna length should be 4 feet, 4 inches; for operation on 60 megacycles, the length should be 4 feet, 1 inch. The proper antenna length is easily adjustable.

Obviously, "two-way" duplex communication is not possible with a transceiver, unless a separate receiver is used. This means that for transmission, the switch is thrown to "S" and the regeneration and volume controls are disconnected from the circuit. The full power output of the device is then obtained.

### New High Voltage, High Frequency Condensers

The Sprague Products Company is marketing a fixed capacity, by-pass condenser which should appeal to the short-wave set constructors, as well as the transmitting amateurs. This condenser is designed especially for use in high frequency circuits. It is non-inductively wound, and oil impregnated. They are available in D.C. working voltages as high as 1500 volts and in capacities up to .1 mf. They are mounted in small containers with a tinned pigtail on each end for connecting and supporting.

### A CORRECTION

● ON page 602 in our February issue, we inadvertently described the New Lynch Resistors as belonging to the molded or carbon stick composition type. The manufacturer has called our attention to this error and we hasten to set our readers right on this point. The new Lynch Resistors are based upon an entirely new principle being of an extruded (not molded) composition of two conductive materials. Unlike the usual composition type, the new resistance material is absolutely homogeneous, having been extruded to form one compact, uniform, current-carrying substance, capable of carrying much heavier load without change in value.

These condensers can be used in circuits, where R.F. is either conducted or by-passed. For by-passing they can be used in the plate, grid, and filament circuits of the transmitters and receivers and in R.F. circuits such as an antenna series condenser, a plate blocking condenser, grid blocking condensers, and numerous other purposes which will immediately suggest themselves to the critical short-wave experimenter.



Please mention SHORT WAVE CRAFT when writing advertisers



**6** Copies of **SHORT WAVE CRAFT** **70c**  
PREPAID

For a limited time only, and as long as they last, we will send you six back numbers of SHORT WAVE CRAFT assorted, your choice, for 70 cents.

The usual price for six copies would be \$1.50 and most publishers charge a higher price for back numbers over one year old.

We can supply all copies except the following: June-July, Aug.-Sept., 1930; Dec.-Jan., Feb.-Mar., April, May, June, July, Oct., Nov., 1932; Feb., Mar., June, July, 1933.

If you do not specify copies we will use our own judgment in sending assorted numbers to fill your order. Note we cannot exchange the copies for ones that have been sent to you.

Practically every copy of SHORT WAVE CRAFT contains important information that you should have. Here is a chance to get those copies.

As we have only a small supply of back numbers on hand, this offer will be withdrawn as soon as they have been sold.

We accept U. S. stamps, U. S. coin, or money order. Rush your order today.

**SHORT WAVE CRAFT**  
99-101 Hudson Street New York, N. Y.

SHORT WAVE CRAFT 4-35  
99-101 Hudson Street, New York, N. Y.

Gentlemen: I enclose herewith 70c. for which you are to send me six back number copies of SHORT

WAVE CRAFT as follows:

Name .....

Address .....

City .....

**Know Thyself!**



This new monthly magazine is all your own doctor. WHAT AILS YOU? POPULAR MEDICINE tells and advises you thoroughly. Written for you by doctors. Non-technical yet authoritative for all laymen. Many anatomical illustrations.

Special Offer!

**8 Months \$1**

Send 15c for sample copy POPULAR MEDICINE

97c Hudson St. New York, N. Y. On All Newsstands

Just Off the Press!

**RADIO'S GREATEST VALUES**

132 Pages. Filled with Latest Design Portable, Mobile and Bank & Panel, Public Address Amplifiers, Short-Wave and All-Wave Receivers and Converters, Inter-Office Call Systems, Test Equipment, Replacement Parts, Kits, Tubes, and Accessories—all at Unbeatable Rock Bottom Prices! Send For Your Copy To-Day!

**COAST TO COAST RADIO CORP.**  
559 SIXTH AVE., Dept. S., NEW YORK, N. Y.

**NEW 1935 Radio Bargain Catalog**  
*Free*

**PATENTS — TRADE MARKS**  
All inventions submitted held confidential and given personal attention by members of the firm.  
Form "Evidence of Conception" and instructions  
"How to Establish Your Rights"—Free  
**LANCASTER, ALLWINE & ROMMEL**  
PATENT LAW OFFICES  
475 Bowen Bldg. Washington, D. C.

**Q. R. S. Club**  
(Continued from page 725)  
(Thanks a lot, Erwin, for the very fine picture of the members of the Q.R.S. Radio Club and we hope that other readers of SHORT WAVE CRAFT will take note of this excellent club picture and send us some photos of other clubs. We were particularly interested because of the fact that all of the sets shown in the photo were built from articles and diagrams published in past issues of SHORT WAVE CRAFT. A fine looking club of short-wave experimenters and if we know anything at all about reading character, we think that we can see some future radio stars among those in the photo.—Editor.)

The following is a list of the foreign stations and countries received by members of the Q.R.S. Club of Waupun High School:

- Sweden—SJO.
- Germany—DJA, DJB, DJC, DJD, DJE, DFT, DIN.
- England—GSA, GSB, GSC, GSD, GSE, GSF, GLY.
- France—FYA, FTY, FSI, FSL.
- Spain—EAQ, EAM.
- Australia—VK2ME, VK3ME, VK3LR.
- Italy—I2RO, HVJ.
- Russia—RW39, RTR.
- Switzerland—HBL, HBJ, HBP.
- Czechoslovakia—OKH, OKP.
- Belgium—ORX, ORP.
- Hungary—HAS, HAT.
- Holland—PCT, PGA, PCR.
- Portugal—CUY.
- Norway—LCL.
- Turkey—TDC, TDA.
- Japan—JAP.
- China—XMB.
- Syria—FXB.
- Philippine Is.—KUP, KTK.
- Dutch West Indies—PJQ.
- Java—PLN, PLV.
- Hawaiian Is.—KQI.
- Mexico—XEBT, XDC, XPA, XDB.
- Seth Parker Boat—KNRA.
- Byrd Expedition—KPF.
- Cuba—COC, CMA, CMB, CMK, CMS, CMB2.
- Canada—VE9GW, VE3II, VE2FO, CJRO, CJRX, CRCK, VE9DN.
- South America—Phone: PSK, PRADO, YV3RC, HJ4AB, HJ4ABE, HJ4ABE, HC2RL, PRAS, YV1BC, YV4RC, YV5RMO, C-W.: LS1, LSK, LSX, LQC, LQB, LQE2, HJP, HPD, YVR, YVQ, PSY, PVQ, PSH, PSM, C15, ZPZ.

**300 Per Cent Gain**  
(Continued from page 724)

are too numerous to mention. I have added a '33 amplifier, also described in your magazine and have had very good success with it. Well I guess I've chewed the "rag" long enough. Again thanking you for your helpful articles I'll say 73.

CHARLES BRADBURN, JR.  
Cedarburg, Wis.

(Hot-Cha, Charles, and we could hardly believe our eyes when we noted that you had obtained a sensitivity or signal pick-up gain of 300% by following the simple suggestion given in our short-wave antenna article in the October issue. We would strongly suggest that our readers who have not already studied that article take time out to look it up.—Editor.)

**Fine Results With Oscillodyne**  
(Continued from page 725)

three tube set diagrams with anyone.  
Ed. KOZIKOWSKI,  
3546 E. 112 St.,  
Cleveland, Ohio.

(Congratulations, Ed, on the success you have had in building the numerous receivers such as the Doerle and the Oscillodyne, etc., described in past numbers of SHORT WAVE CRAFT. We wish your new short-wave club—The "Modulators"—success. We shall be pleased to hear further news concerning their activities. Don't forget to send us a photo of the club members when you get a good clear one and also keep us in mind for a good picture of your short-wave station. We prefer a 5 by 7 inch photo but a 4 by 5 inch one will do, but it must be "clear"!—Editor.)

**Short Wave Speaker**  
Model S.W. 4830  
(formerly No. S.W. 429)

You will not have to switch over to head phones in order to bring in weak signals when using an S.W. 4830.

Those noticeable background noises will be reduced to a minimum and there will be no annoying hum.

The A.C. switch on the front panel enables the operator to turn off the field current when quiet night reception is desired.

Copies of interesting reports written by well-known short wave operators will gladly be furnished.

There is a Wright-DeCoster Dynamic Type Speaker of the correct size with a universal transformer for replacement in any type or size of radio.

Write for complete catalog, dealers' discounts and name of our nearest Distributor.

You will find the Wright-DeCoster Distributor anxious to cooperate with you in every way possible.

**WRIGHT-DeCOSTER, Inc.**  
2257 University Ave. St. Paul, Minn.  
Export Dept.: M. SIMON and SON CO.,  
25 Warren St., New York  
Cable Address: SIMONTRICE, New York

**THE GREAT 35 POSTAL ALL-WAVE**



**EXCLUSIVE POSTAL DESIGN**  
The NEW POSTAL '35 now employs every feature necessary to receive the most distant short wave stations. Exclusive triple shielded drawer coils—T.R.F. Preselector on all bands—Continuous hand spread Audio beat oscillator—Electron coupled oscillator—A. V. C.—Manual Control—Precision Tuning meter. Custom built and many other important features.

Sold with a 10 day trial money back guarantee. WRITE FOR INTERESTING DESCRIPTIVE LITERATURE AND SPECIAL PRICES.

**NEW 1935 POSTAL BOOSTER**  
Was used by Mr. Edward Schmelchel, the winner of the 12th Short Wave Craft DX Trophy.  
The Postal Booster is custom built Completely self-powered, employs two genuine stages of R.F. and is guaranteed to improve short wave reception 100% or your money back.  
WRITE IMMEDIATELY FOR DESCRIPTIVE LITERATURE AND SPECIAL PRICES.

**POSTAL RADIO**  
135 B LIBERTY ST. NEW YORK, N. Y.

**Free Colored Short-Wave Map**  
(Send 10c to cover Postage, etc.)  
**RADIO—Short-Wave—KITS**  
FACTORY PRICES FREE CATALOG H  
**RADIO CITY LABS.**  
Suite 1222-30 Rockefeller Plaza, New York, N. Y.





**Short Wave League Letter-heads**

Designed for Members



*This is the official letterhead*

It is invaluable when it becomes necessary to deal with the radio industry, mail order houses, radio manufacturers. It can be used in many ways and gives you a professional standing. No member of the LEAGUE can afford to be without this letterhead.

This can only be used by members of the LEAGUE. No one else can purchase it.

See page 762 of this issue for order blank. Take advantage of this opportunity to handle your LEAGUE correspondence in a business-like manner.

**SHORT WAVE LEAGUE**  
99-101 Hudson St., New York, N. Y.

**Latest 30 Watt Transmitter**

(Continued from page 729)

closing the B return circuits to all tubes. During reception periods SW3 is left open so that the 2B6 is inactive and does not swamp the receiver when the latter is tuned near the operating frequency.

The other switch, SW2, is a convenience in neutralizing the 2B6. Since plate voltage must be supplied to the oscillator section but not to the larger triode during this operation, it isn't feasible to open the common B minus return. SW2, however, opens the amplifier (or rather buffer, in this case) plate circuit by ungrounding the cathode, and neutralizing can then be done easily.

Neutralizing the parallel 46's, V2 and V3, is easy enough; simply leave the key up.

The proper procedure is as follows: put all tubes in their sockets. Close SW1, then SW3, with SW2 open. Let us assume the outfit is to work straight through on the crystal frequency. Plug a 0-25 ma. milliammeter into J1 and tune C1 for minimum plate current with C4 and C2 at zero. The oscillator will be more stable with C1 set a little lower (in capacity) than exact resonance. The receiver must be kept going, with the antenna disconnected, so that the output can be heard and checked at all times.

With SW2 still open, rotate the buffer condenser C2 over its entire range and closely watch the plate current reading of the oscillator section of the 2B6. As the I2-C2 circuit approaches resonance with the crystal frequency, the plate current as measured at J1 will increase, and in some cases the crystal stage will stop oscillating altogether. Now simply adjust the neutralizing condenser C4 gradually until the oscillator plate current remains steady no matter where C2 is adjusted. The buffer stage is now neutralized.

Close SW2, plug a 0-200 ma. meter into J2 and tune C2 for minimum plate current. The steady signal in the receiver should take a big jump in strength. You can see if the buffer is amplifying by opening SW2, observing the signal from the oscillator alone, and then closing SW2 and noting the difference.

We now have r.f. feeding the 46's through the coupling condenser C9. With a neon tube touched to the stator of C3, adjust C5 until all r.f. disappears from L3-C3. Plug the 0-200 ma. meter into J4, press the key and adjust C3 for minimum plate current.

The tank coil L3 is provided with a link coil, for coupling to an antenna or to feeder lines.

The 2B6 can, of course, be used for frequency doubling. In this case we don't have to worry about neutralizing the buffer section. For instance, with an 80-meter crystal, L1-C1 is tuned to the crystal frequency, but L2-C2 and L3-C3 to the second harmonic, in the 40-meter band. Other combinations may be tried readily. Different amateurs have different ideas in this regard and the flexibility of the circuit permits all kinds of experimenting.

In the diagram, there are two posts marked "MOD." For C.W. these are shorted, but for phone they are connected to the secondary of the modulating transformer of a companion unit. This will be described in another article.

The complete transmitter using the circuit of Fig. 1 is shown in the accompanying photographs. The construction is strong and rigid, and the placement of the parts closely follows their circuit positions. The front panel measures 19 by 8 3/4 inches, the chassis 17 by 11 by 2 1/2 inches. The black enamelled case is 19 by 12 by 9 inches.

The power pack occupies the back of the chassis. In a straight line across the center, reading from right to left, are the crystal, the neutralizing condensers, the bias control, one 46 and the amplifier tank coil.

(Continued on page 765)

**EXPERIENCED MEN**  
*Get the Big Radio Jobs*

**S. Q. NOEL**  
PRES. FIRST NATIONAL TELEVISION, INC.

"Every qualified man I train puts in actual hours at my 1,000 Watt Commercial Radio Station! When you have completed my training course, you are a tested radio and television expert—ready to step into the BIG PAY class! You have had actual experience behind you in genuine radio broadcasting work which gives you preference in any radio job. The hours you spend in my ultra-modern, "Hi-Fidelity" commercial station W9XBY and my licensed television experiment station W9XAL mean dollars to you. Never before have you been offered so great an opportunity! Tune in on "Hi-Fidelity" Station W9XBY—1530 kilocycles.

*Get your license while learning*

A government operator's license is a passport to a real job with a future! My students qualify for their licenses and get certified service records while learning. FREE employment service for life on graduation. No previous experience needed. Write today and let me point the way to the highest-pay radio jobs!



S. Q. Noel, Pres. First National Television, Inc.  
(Training Division)  
Dept. 15B-4, Power and Light Bldg., Kansas City, Mo.

Without obligation, send me postpaid FREE Illustrated Folder telling about new opportunities in radio and television. I am 17 years or older.

Name \_\_\_\_\_ Age \_\_\_\_\_

Address \_\_\_\_\_

**BEAM — 1935**

**AC-DC SUPER-HET PRIZE-WINNER**

5 Tube Universal AC-DC S.W. Superhet.....  
15-200 meters—coil switch—no plug-ins—phone jack—field supply—complete kit of parts, including black cracked chassis and front panel \$11.95

**\$11.95 Kit**

Wiring, extra \$3.10  
Best oscillator parts, add 1.79

**KIT OF ARCTURUS TUBES**

1-6F7 1-6D6 1-76  
1-43 1-2175 \$3.75 Net  
Cabinet (Has provision for built in speaker)  
extra \$2.65  
Dynamic Speaker to match 3.24

Write For Complete Information

**ANKER LABS**  
Sole Distributors

80 Cortlandt St., Dept. S-4, New York City

To get that **ELUSIVE** station

use **CANNONBALL HEADSETS**

*Sturdy construction. Excellent performance.*



The "popular" set with the "hams."

Write for illustrated circular S-4.

**C. F. CANNON COMPANY**  
SPRINGWATER, NEW YORK

**It's NOW**

EVERYDAY SCIENCE AND MECHANICS is the finest scientific—technical—mechanical—constructional magazine in the field. Up-to-the-minute with news flashes of scientific events. Dozens of constructional articles and many popular experiments. Ideas from which you can make things to sell. A HOST OF INTERESTING SUBJECTS COVERED:—Woodworking—Photography—Magic—Patents and Inventions—Book Reviews—Metal-working—Chemistry—Engineering—Microscopy—Electrical Experiments—Household Hints—Astronomy—Prize Contests—and other subjects.

**10¢**



Edited by **HUGO GERNSBACH**

Get your copy today!  
On all newsstands

**10c**  
the copy

Over 150 Illustrations

Send for **FREE** data of

**RGH**

**ALL-WAVE KITS**

**\$4.95 UP**

COMPLETE KITS AT MAIL ORDERS FILLED



167 GREENWICH ST., New York City

# Announcing More Winners



## Every Type of Desk Stand to Suit the Individual Need



No. 817. A modernistic desk stand beautifully finished in black crackel enamel. Octagon shaped ring is 5 3/4 inches in diameter. Over-all height 9 inches. Complete with eight springs.

No. 817-Price \$2.50



No. 818. A beautiful compact desk stand for the amateur and low priced sound system. 6-inch diameter ring will accommodate full size microphone. Black crackel finish. Height of stand 10 inches. Complete with eight springs.

No. 818-Price \$3.00



No. 819. A super value desk stand which is similar in construction to No. 818 but overall height is increased to 13 inches. Finished in black crackel enamel. Heavy cast base. Complete with springs.

No. 819-Price \$3.50



### Bud Senior Microphone Ring

Can be suspended either by microphone cord or braided cord. Full size 6-inch microphone ring—supplied complete with eight springs and suspension ring.

No. 800—Chromium Plated Finish. PRICE \$2.50

No. 801—Black Crackel Finish Price \$2.00

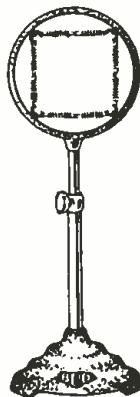

No. 802. BUD BANQUET MICROPHONE STAND—For use on tables, desks, pulpits, and also preferred by some studio announcers. Adjustable from 18 inches to 28 inches. Base 6 inches in diameter. Ring 6 inches in diameter, furnished with eight microphone springs. Base is well weighted down, so that stand cannot tip. Tubing finished in highly polished chromium plating. Base and Ring finished in black crackel.

No. 802—Banquet Stand.....Price \$8.50

No. 803 BUD ADJUSTABLE DESK STAND—Ideal for a speaker seated at a desk. Range of adjustment 12 to 18 inches.

Base is made of heavy casting and finished in beautiful black crackel. Tubing is brass with a chromium plated finish. Ring is standard 6 inches and also finished in black crackel.

No. 803—Desk Stand.....Price \$6.50



### Bud Junior Microphone Ring

Beautiful octagon shaped ring. Something different. Furnished complete with suspension ring and 8 springs. Size 5 3/4 inches.

No. 820—Black Crackel

Price \$1.50



### Bud Junior Microphone Floor Stand

Designed for the customer who wants a good floor stand but does not want to spend a lot of money. This stand represents more value for the money than any other stand that is on the market. All tubing is brass, chromium plated. Supplied with either 5" octagon ring or 6" heavy duty round ring. Good size cast base. Springs included with stand. Three sections. Adjustable from 32 to 72 inches. Ring and base finished in kinkle black enamel.

No. 822

With 5" Ring

Price \$10.00

No. 840

With 6" Ring

Price \$10.50

### Bud Collapsible Floor Stand



Light, compact, adjustable and collapsible floor stand that can easily be carried from place to place. Triple tube assembly made of brass, chromium plated. Extension range 36 to 78 inches. Furnished with 6" microphone Ring to take full size microphone. Springs included with stand.

No. 821

Price \$12.50

### Bud Crystal Microphone Floor Stand

This stand is similar to our No. 822 with a swivel tilt joint so that crystal microphone can be tilted to any angle desired.

No. 834

Price \$11.50

### Bud Superior Built Dual Midget Condensers



A small, compact two gang midget condenser which is built with the precision of a watch. As rigid and sturdy as a stone wall and engineered to give the greatest efficiency possible on high frequency receivers. Can be panel or base mounted. Midline tuning, brass plates, soldered assemblies, brass bearings, aluminum end plates and Isolantite insulated. Shield plate between stator sections. Shaft extends beyond rear bearing for ganging of units. Length of base 3 3/4", width 1 3/4".

No. 911 Capacity per section—100 mmfd. Price \$3.00

No. 912 Capacity per section—140 mmfd. Price \$3.50

### Bud Lo-Loss Transmitting Socket

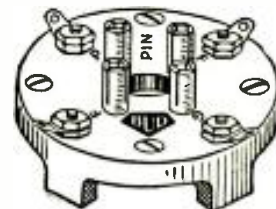

For Flush Mounting for 50 Watt Tubes

Most efficient transmitting socket on the market. Positive contacts. Base of socket is made of Iso-tex. All metal parts are heavy brass and nickel plated. For Low Loss Transmitting socket this is what you want.

No. 226.....Price \$1.50

Listed above are but a few of the items in the complete BUD line. Write for our Catalog! All list prices shown in this advertisement are subject to 40% discount when purchase is made from an authorized BUD jobber. If your jobber cannot supply BUD parts, send your order direct to us together with your jobber's name and we will make shipment direct.

**BUD RADIO INC.** 1937 E. 55th STREET CLEVELAND, OHIO



## Latest 30 Watt Transmitter

(Continued from page 763)

Just behind the panel are the oscillator and buffer coils, the 2B6 and the other 46. The wiring is directly point-to-point, the r.f. leads being less than 4 inches long at the most.

The front panel is neatly balanced. Oscillator, buffer and amplifier condensers are represented by large knobs and dial plates. At the right is a 0-25 ma. meter for oscillator plate and amplifier grid current readings; at the left a 0-200 ma. meter for the buffer and amplifier plates. The meters are connected to plugs that fit either J1 or J3 and J2 or J4, respectively. The three snap switches are on the same line with the jacks.

This transmitter is much simpler than many receivers, and although its description sounds involved, it can be tuned up completely and put on the air in about 10 minutes! It produces clean, steady signals of which any Ham will be proud. Laboratory measurements of the output, using a 100-ohm non-inductive dummy antenna, show an output of slightly more than 45 watts with 60 watts input to the 46's, on all bands except 20 meters. On 20 meters the output drops to approximately 37 watts with the same input.

### Parts List

- C1—100 mmf.
- C2—100 mmf.
- C3—100 mmf.
- C4—50 mmf.
- C5—35 mmf.
- C6, C7, C8—.002 mf.
- C9—.00005 mf.
- C10, C11—.002 mf.
- C12—4 mf. each.
- R1—5000 ohms.
- R2—1000 ohms.
- R3—100,000 ohms.
- R4—1500 ohms.
- R5—20,000 ohms.
- L1, L2, L3—plug-in coils
- L4—15 henry choke.

## New Low-Loss Coil Forms

(Continued from page 729)

marily, were the 19, 25, 31 and 49 meter broadcast bands and the 20, 40, 80 and 160 meter amateur bands. Provision also had to be made for ample overlap between ranges of the coils. The following were chosen, using a 140 mmf. Hammarlund mid-gut condenser: 17 to 41; 33 to 75; 66 to 150; 135 to 270, and 250 to 560.

Having determined the ranges for the coils, there were left the many other factors for study, such as the best form factor, the best wire sizes and "spacing," the best positions for the coils on the forms, and the spacing between the windings. Since most of these vary with the frequency, each individual coil represented a separate problem. The groove-ribbed shaped form was decided upon, since this provided the only medium of reducing the contact area between the winding and the form, to a minimum.

The ratio of the diameter of the form to the length of wire, for a given type of winding, has an important bearing on the radio frequency resistance of a coil. This problem has been carefully studied and solved so that both coil form and winding provide the correct factor.

Dielectric losses increase very rapidly with frequency and for this reason, an absolute minimum must be used. For minimum losses successive turns must be properly spaced to secure uniform current distribution. With the proper gauge wire, spaced correctly, maximum efficiency was obtained. The distributed capacitance was also reduced, in this way.

After the coils were wound in accordance with the design, they were checked under actual operating conditions, with the coil plugged into a typical band-spread (parallel condenser) receiver, and the antenna connected. The ranges were found to be conservative, because the test receiver was

(Continued on page 767)

# CLASSIFIED

Advertisements are inserted at 5c per word to strictly amateurs, or 10c a word to manufacturers or dealers. Each word in a name and address is counted. Cash should accompany all orders. Copy for the May issue should reach us not later than March 5th

<b>ELECTRICAL SUPPLIES</b> INSULATION, WIRE, VARNISHES, SUPPLIES, etc. Send 3c stamp for bulletin. Auto Power, 411 S. Hoyne Ave., Chicago.	<b>FOR SALE—5 TUBE DOERLE</b> A. C. \$17.00 Cash. Roy Osbelt, 137 Ross Park, Syracuse, N.Y.	<b>THE BEST RADIO CRYSTAL</b> ever made. Guaranteed to be sensitive all over. Sent in United States for Ten Cents. A. P. Thompson, 701 N. Marshall Ave., Dallas, Texas.
<b>GENERATORS</b> TWENTY PRACTICAL AND LOW cost changes converting Ford, Dodge, or Chevrolet generators into new generators and motors 100-500 watt capacity, direct or alternating current, with six to 100 volts for radio operation, power, light, or welding. Also instructions for rewinding armatures; 350 definitions of electrical terms, etc. All in new, revised book with simplified instructions and illustrations. Endorsed by thousands—Only \$1.00 postpaid. Auto Power—411 S. Hoyne Ave., Chicago.	<b>INSTRUCTION</b> ARMY-NAVY GIVES FREE RADIO operators' training for service on ships, aircraft. Salary expenses paid. Information pamphlet, how to study, 20c. Continental, Box 341F, Indianapolis, Ind.	<b>4 PLUG-IN COILS, TALL FORMS</b> 15-200 meters .50, 2 broadcast coils .40, List free. Short Wave Accessories, 121 Derby St., Valley Stream, New York.
<b>SLIGHTLY USED ALTERNATING</b> and Direct Current Motors and Generators at half price. Motor & Generator Supply Co., 4516 Clifton Ave., Chicago, Ill.	<b>MISCELLANEOUS</b> OHM'S LAW CALCULATOR—Lightning Slide Rule; solves all problems of Voltage, Current and Resistance, Power, Wire Sizes, etc. Range: 1 micro-amp. to 1000 amps.; 1 micro-volt to 10,000 volts; 1 micro-ohm to 10 megohms; 1 micro-watt to 10 megawatts; wire sizes 0 to 36 B. & S. Gauge. Introductory price \$1.00 postpaid. The Blueprint Co., Box 322, Ramsey, N.J.	<b>PLUG-IN COILS, WOUND ON</b> tube bases .30 per set. Regular forms .50 6 prong .75. Noel, 809 Alder, Scranton, Pa.
<b>"HAM" OFFERS &amp; WANTS</b> \$100.00 RCA SUPERHET, BATTERY type, "built-in" loop, speaker, etc. Bargain \$35.00; Victoreen 8-tube battery superhet, Weston meter, \$9.00; M129 National Tuner with 49 S.G. and detector tubes, \$15.00; 45 push-pull Thorlarsen Power-Pack, with 27 first A.F. (with Tubes), \$15.00; "Jitch Fidelity" 6 ft. Victor Orthophonic (exponential) Horn, speaker unit, tone arm; also "magnet" pick-up, \$15.00; RCA 210 power-pack with Rectifier (originally \$70.00), \$40.00. Harry Ackerson, Box 322, Ramsey, N.J.	<b>ELECTRIC SOLDERING IRON</b> works off battery or live wire of car. Solder, instantly, \$1.50 postpaid U.S.—M. F. Camp, Marshall, Mich.	<b>SHORT WAVE RECEIVERS</b> IN STOCK: SUPER-SKYRIDERS \$59.95 prepaid. Skyriders \$39.95 prepaid. Silver 5c's \$71.70 prepaid. PR-12s, RM590s, Nationals, Hammarlunds. Trade-in your receiver. Code machines rented. Write: Henry Radio Shop, Butler, Mo.
<b>SNAP-FULTONE V. ADVERTISED</b> January issue, coils include broadcast, factory assembled, perfect, \$15 value \$10., including used ear phones, No. 408—Y.M.C.A.—Denver, Colo.	<b>HAM FILM DEVELOPING—TWO</b> prints each negative—25c. Homer, 116 Marshall, W. Lafayette, Indiana.	<b>FOR SALE: NEW AND USED</b> Shortwave Receivers, Sets of all types, Hammarlund—Nationals—Scotts—Paterson, etc. Edward Schwarz, Dumont, N.J.
<b>ACSW3, 4 PAIR BAND-SPREAD,</b> 2 genov. coils, \$29; XC Xmtr, 47, 46, 210's pp. 650 ea 175 pwr ea fil sup, \$25. Both, \$40. H. Button, Aberdeen, S.D.	<b>HAM FILM DEVELOPING—TWO</b> prints each negative—25c. Homer, 116 Marshall, W. Lafayette, Indiana.	<b>NEW LONG DISTANCE CRYSTAL</b> Receiver, Blueprint, 17 Others 25c each. Parleulars Free. Modern Radiolabs, 151-A Liberty, San Francisco.
<b>VARIABLE CONDENSERS—00035</b> MfL. Pyrex Insulated, Low Loss, Good Condition 3c each, 1 for \$1.00. W81WV, 208 N. Main, Bluffton, Ohio.	<b>SMALLEST, QUICKEST ELECTRIC IRON</b> 8 in. long, \$1.50 postpaid U.S.—M. F. Camp, Marshall, Mich.	<b>USED SHORT WAVE SETS COMPLETE.</b> Coils, Tubes, Tested, Gets European, Only \$2.50. Radio Sales, P. O. Box 68, New Haven, Conn.
<b>QSL—CARDS—SWL</b> QSL'S 75c A 100 2 COLOR. WBDGH, 1816 N. 5 Ave., Minneapolis, Minn.	<b>QSL CARDS, NEAT, ATTRACTIVE,</b> reasonably priced, samples free. Miller, Printer, Ambler, Pa.	<b>BAND SPREAD RECEIVERS AC</b> DC, 120 points on dial, Data and Diagram 25 cents. Allen, Box 483, Fairview, Oklahoma.
<b>SHORT WAVE COMPONENTS</b> GUARANTEED BAKELITE PLUG-IN Coils, 15-200 meters. Silver plated Secondaries, Individually colored. Set of Four—Four prong \$1.75, 6 prong \$1.00.—Huckley, 3461 Jasper, Philadelphia, Pa.	<b>QSL CARDS, NEAT, ATTRACTIVE,</b> reasonably priced, samples free. Miller, Printer, Ambler, Pa.	<b>TRANSCEIVERS</b> TRANS-CEIVERS—ONLY \$3.95—Guaranteed, New one-tube set. Foreign reputation, local transmission. See illustration page 841, March S.W.C.; or write—The Turks Radio Company, 1448 W. Decatur St., Decatur, Illinois.

# FREE

1935 EDITION

## 108 Page RADIO and SHORT WAVE TREATISE

Over 100 Hook-Ups  
More Than 1,500 Illustrations



**A Veritable Text Book**

**NOT JUST ANOTHER CATALOG**

This completely revised and enlarged 1935 edition contains 108 solid pages of useful radio information, diagrams, illustrations, radio kinks and real live radio merchandise. It contains more valuable radio information—more real live "meat"—than many textbooks on the subject. As usual considerable space has been devoted to the beginner in radio.

**PARTIAL LIST OF CONTENTS**

Chapter Two of "Fundamental Principles of Radio for the Beginner"—The New Tubes, Their Uses, and Their Fundamental Circuits—How to Make Money with Public Address Systems. How to Install and Maintain Them—How to Revamp Six-Volt Battery Sets to Use Two-Volt Tubes. Prize Winning Kinks and Short Cuts in Radio—How to Build the "R T" Beginner's Transmitter—How to Build the Famous Twinplex Short Wave Receiver—How to Construct an Amateur Radio Transmitter—A Most Modern and Complete Tube Chart Including Socket Connections for all Tubes—Numerous Free Offers, etc., etc.

**WRITE TODAY**  
Send 5c. coin or new U. S. Stamps for postage.  
Treatise sent by return mail.  
PRINT NAME AND ADDRESS CLEARLY.

**RADIO TRADING CO.**  
101A Hudson Street, New York City

### WORLD FAMOUS INTERNATIONAL DX

NEW 1936 MODEL OUT  
3-Tube AC-DC  
ALL-WAVE RECEIVER  
With 4 Tube Performance

# 6.75

only



Complete Kit containing all parts for the set and power supply, including speaker, 4 coils to cover bands from 14 to 220 meters and detailed diagram  
Custom built, extra \$1.75  
Broadcast coil..... 75  
3 matched tubes 2.25  
Metal Cabinet..... 1.95



**BABY-RADIO**  
One-Tube AC-DC from 40 to 500 meters  
Kit contains all parts for the set and power supply, with cabinet, 3 coils to cover bands from 40 to 500 meters and picture diagram  
4.95  
Wiring, extra.....\$1.25  
Double Purpose tube 1.00  
Headphone 1.50  
FREE: Circular 130.

**EXPERIMENTAL RADIO LABS.**  
168 WASHINGTON STREET NEW YORK N. Y.

New Yorkers can hear them at 177 Greenwich St., Blau, The Radio Man, Inc.

## Vest Pocket SOLDERING IRON



Smallest good iron now on the market. Will do the work of irons twice its size. Only 10 inches long, 1/4 inch in diameter. By using the highest grade elements, it heats up in half the time of ordinary irons. Guaranteed to give satisfaction or money back. We issue no catalog on this item. Enclose \$1.20 and iron will be sent post-paid in U.S. 10c extra in Canada.  
Gold Shield Products Co., 98 Park Plaza, N.Y. City

Please mention SHORT WAVE CRAFT when writing advertisers



# The 4 ESSENTIAL SHORT WAVE BOOKS

'ROUND THE WORLD FANS USE THESE GREAT SHORT WAVE BOOKS

These great books contain everything on short waves that is really worth knowing—they are books which have been most enthusiastically welcomed by short-wave fans. The cost of the books is extremely low in comparison with the valuable material which they contain.

There is not a short-wave fan, experimenter or interested radio-minded reader who will not want these books. Right up-to-the-minute with new material on outstanding developments in the short wave field. The books are authoritative, completely illustrated and not too highly technical.

## Ten Most Popular Short Wave Receivers. How to Make and Work Them

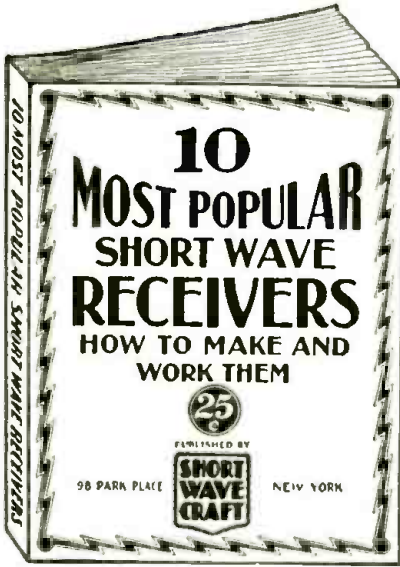

This new volume is a revelation to those who wish to build their own short wave receivers. The editors of **SHORT WAVE CRAFT** have selected ten outstanding short wave receivers and these are described in the new volume. Each receiver is fully illustrated with a complete layout, pictorial representation, photographs of the set complete, hookup and all worthwhile specifications. Everything from the simplest one tube set to a 5-tube T. R. F. receiver is presented. Complete lists of parts are given to make each set complete. You are shown how to operate the receiver to its maximum efficiency.

### CONTENTS

- The Doerle 2-Tube Receiver That Reaches the 12,500 Mc Mark, by Walter C. Doerle.
- 2-11-E Pentode S-W Receiver having two stages of Tuned Radio Frequency, by Clifford E. Denton and H. W. Seor.
- My de Luxe S-W Receiver, by Edward G. Ingram.
- The Binnewer 2-Tube 12,000 Mils DX Receiver, by A. Binnewer, Jr.
- Build a Short Wave Receiver in your "Brief-Case," by Hugo Gersback and Clifford E. Denton.
- The Denton 2-Tube All-Wave Receiver, by Clifford E. Denton.
- The Denton "Stand-By," by Clifford E. Denton.
- The "Stand-By" Electrified.
- The Short-Wave MEGADYNE, by Hugo Gersback.
- A COAT-POCKET Short Wave Receiver by Hugo Gersback and Clifford E. Denton.
- Boy, Do They Roll In on this One Tube by C. E. Denton.
- The S-W PENTODE-4, by H. G. Cisin M. E.
- Louis Martin's Idea of A GOOD S-W RECEIVER, by Louis Martin.

25c

40 PAGES  
OVER 75 ILLUSTRATIONS  
IMPORTANT

THERE IS NO DUPLICATION BETWEEN THIS BOOK AND OUR OTHER VOLUME—"HOW TO BUILD AND OPERATE SHORT WAVE RECEIVERS." ALL THE MATERIAL PUBLISHED IN THE NEW BOOK HAS NEVER APPEARED IN ANY BOOK BEFORE.

## How to Build and Operate Short Wave Receivers

Is the best and most up-to-date book on the subject. It is edited and prepared by the editors of **SHORT WAVE CRAFT**, and contains a wealth of material on the building and operation, not only of typical short-wave receivers, but short-wave converters as well. Dozens of short-wave sets are found in this book, which contains hundreds of illustrations; actual photographs of sets built, hookups and diagrams galore.

The book comes with a heavy colored cover, and is printed throughout on first-class paper. No expense has been spared to make this the outstanding volume of its kind. The book measures 7 1/2 x 10 inches.

This book is sold only at such a ridiculously low price because it is our aim to put this valuable work into the hands of every short-wave enthusiast.

We know that if you are at all interested in short waves you will not wish to do without this book. It is a most important and timely radio publication.

Over 150 Illustrations  
72 Pages 7x10 Inches

50c

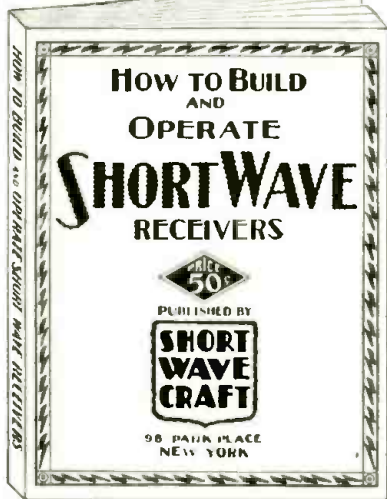

## How to Become an Amateur Radio Operator

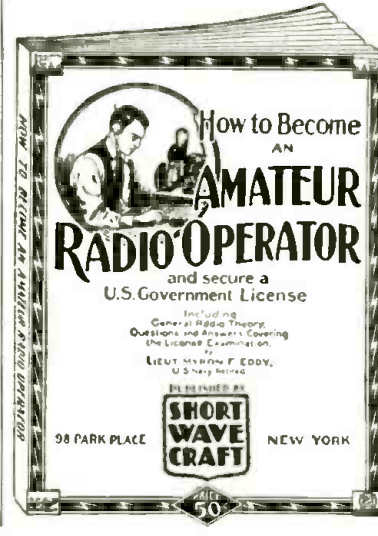

We chose Lieut. Myron F. Eddy to write this book because his long years of experience in the amateur field have made him pre-eminent in this line. For many years he was instructor of radio telegraphy at the I.R.C.A. Institute. He is a member of the I.R.E. (Institute of Radio Engineers), also the Veterans Wireless Operators Association.

If you intend to become a licensed code operator, if you wish to take up phone work eventually, if you wish to prepare yourself for this important subject—this is the book you must get.

### Partial List of Contents

Ways of learning the code. A system of sending and receiving with necessary drill words is supplied so that you may work with approved methods. Concise, authoritative definitions of radio terms, units and laws, brief descriptions of commonly used pieces of radio equipment. This chapter gives the working terminology of the radio operator. Graphic symbols are used to indicate the various parts of radio circuits. General radio theory particularly as it applies to the beginner. The electron theory is briefly given, then waves—their creation, propagation and reception. Fundamental laws of electric circuits, particularly those used in radio are explained, and typical basic circuits are analyzed. Descriptions of modern receivers that are being used with success by amateurs. You are told how to build and operate these sets. Amateur transmitters. Diagrams with specifications are furnished so construction is made easy. Power equipment that may be used with transmitters and receivers, rectifiers, filters, batteries, etc. Regulations that apply to amateur operators. Appendix which contains the International "Q" signals, conversion tables for reference purposes, etc.

Over 150 Illustrations  
72 Pages 7x10 Inches

50c

All the books shown on this page are published exclusively by

**SHORT WAVE CRAFT**

99-101 Hudson Street, New York, N. Y.

CLIP-MAIL

SHORT WAVE CRAFT

99-101 Hudson Street, New York, N. Y.

Gentlemen: I enclose herewith my remittance for the amount of \$..... for which you are to send me, postpaid, the books checked below.

- Ten Most Popular Short Wave Receivers, How to Make and Work Them... 25c each
- The Short Wave Beginner's Book... 25c each
- How to Build and Operate Short Wave Receivers... 50c each
- How to Become an Amateur Radio Operator... 50c each

Name.....  
Address.....  
City..... State.....

(Send remittance in form of check or money order. If letter contains cash or unused U. S. Postage Stamp, register it.)

SW-4-35

These Books are Authentic For All Short Wave Work and LOW in Price

COUPON TODAY!

Please mention SHORT WAVE CRAFT when writing advertisers



**● Index to Advertisers ●**

<b>A</b>	
Ace Radio Laboratories.....	757
Aerovox Corporation.....	746
Allden Products Co.....	759
Allied Engineering Institute.....	755
Allied Radio Corporation.....	742, 745
All-Star Headquarters.....	757
Amperite Corp.....	767
Amplivox Laboratories.....	755
Anker Labs.....	763
<b>B</b>	
Bud Radio Inc.....	764
Burgess Battery Company.....	751
Burstein-Applebee, Inc.....	757
<b>C</b>	
Candler System Co.....	752
Cannon, C. F., Company.....	763
Centralion Engineering Co.....	744
Classified Advertisements.....	765
Coast-to-Coast Radio Corp.....	761
Coyne Electrical School.....	707
Crowe Name Plate & Manufacturing Co.....	747
<b>D</b>	
Dataprint Company.....	756
Dodge's Institute.....	756
<b>E</b>	
Eagle Radio Co.....	759
Eastern Radio Specialty Co.....	744
Eilen Radio Laboratories.....	746, 753
Electrad, Inc.....	753
Everyday Science & Mechanics.....	763
Experimental Radio Labs.....	765
<b>F</b>	
Federated Purchaser, Inc.....	754
First National Television, Inc.....	763
Fleron, M. M., & Son, Inc.....	759
<b>G</b>	
Goldentone Radio Company.....	760
Gold Shield Products Co.....	758, 765
<b>H</b>	
Hammarlund Manufacturing Co.....	741
Harrison Radio Company.....	743
<b>I</b>	
Instructograph Company.....	756
Insuline Corp. of America.....	752
International Correspondence Schools.....	767
<b>K</b>	
Korrol Mfg. Co., Inc.....	755
<b>L</b>	
Lancaster, Allwine & Rommel.....	761
Leotone Radio Co.....	755
L. I. Marine & Electric Co.....	747, 755
Lynch, Arthur H., Inc.....	754
<b>M</b>	
McGraw-Hill Book Company, Inc.....	759
M. & H. Sporting Goods Co.....	757
Midwest Radio Corp.....	Back Cover
<b>N</b>	
National Company, Inc.....	749
National Radio Institute.....	705
New York YMCA Schools.....	754
<b>P</b>	
Popular Medicine.....	761
Postal Radio Corp.....	761
<b>R</b>	
Radio City Labs.....	761
Radio Craft.....	757
Radio Electric Service Co.....	757
Radio Publications.....	708
Radio Research Laboratories.....	759
Radio Trading Co.....	746, 760, 765, 768
Radio Tube Exchange of America.....	744
RCA Institutes, Inc.....	742
Remington-Rand, Inc.....	758
Ross, A. H. & Company.....	767
<b>S</b>	
Sargent, E. M., Co.....	747
Scott, E. H., Radio Laboratories, Inc.....	735
Sexology Magazine.....	759
Short Wave Coil Book.....	754
Short Wave League.....	760, 762, 763
Short Wave Listener Magazine.....	748
Sprague Products Co.....	759
Sterling Casualty Insurance Co.....	757
Sunshine Novelty Company.....	744
Supertone Products Corp.....	746
<b>T</b>	
Teleplex Co.....	743
Thor Radio Co.....	763
Trimm Radio Mfg. Co.....	755
Try-Mo Radio Co., Inc.....	757
<b>U</b>	
Uncle Dave's Radio Shack.....	757
Universal Microphone Co., Ltd.....	756
<b>W</b>	
Wellworth Trading Company.....	758
Wholesale Radio Service Co., Inc.....	747
World Trotter Radio Labs.....	756
Wright-DeCoster, Inc.....	761

(While every precaution is taken to insure accuracy, we cannot guarantee against the possibility of an occasional change or omission in the preparation of this index.)

**New Low-Loss Coil Forms**

(Continued from page 765)

completely shielded, and the proximity of the shield walls would naturally tend to reduce the coil ranges at the high frequency ends. This is important because it means that the builder of a receiver can depend upon these coils covering the ranges given.

Here is another important point found. A recent study of various type coils available on the open market, showed them to have an average "Q" of approximately 100 at 15 megacycles. Inasmuch as "Q" represents the efficiency of a coil in a tuned circuit, the higher it is, the better it is! With the Hammarlund coils, wound, as just described, on the XP-53 material, it was found that the "Q" at 15 megacycles exceeded 150! This is believed to be the highest value of efficiency obtainable in plug-in coils of the conventional type.

Even the use of artificial coloring, so prevalent in coils, and the cause of constant losses, has been avoided, thus leaving the material a natural light tan! For convenience too, the coil forms are moulded with an inside threaded shoulder, which permits the mounting of the new Hammarlund type APC, air-padded condenser within the form, where they are required for special band-spread, or fixed tuning purposes. A generous rim is also provided at the top edge of the form; thus it is quite easy to grasp. A removable wavelength index card is also supplied. This fits into the top of coil form, and the range of the coil can be written thereon, as shown in one of the photos. These blank index cards are orange in color.

The prongs of the forms have been made especially long and sturdy, with large openings at the tips for correct and long-life soldered connections. The prongs are so gripped into the form that they cannot shift or sway, further guaranteeing constant contact.

The blank coil forms are available in 4- and 6-prong types. For the benefit of those who do not wish to do their own winding, they are available completely wound, exactly as described here, and also in 4- and 6-prong types.

Coil (Meters)	Range	Primary Turns	Tickler Turns	Secondary Turns	
				With Turns Per Inch	en. W 7 to inch
A	17-41	5.3	3.8	8.7—No. 16	17.7—No. 16
B	33-75	11.8	5.8	Enameled 12 to inch	Enameled 24 to inch
C	66-150	24.8	10.8	37.7—No. 24	81.7—No. 24
D	135-270	47.8	16.8	Enameled 44 to inch	157.7—
E*	250-560	87.8	33.8	157.7—	

\*Primaries are wound with No. 34 D.S.C. wire. Ticklers are wound with No. 32 D.S.C. wire. Four-prong coil identical to 6-prong, except that primary winding is omitted. Primary windings are "interwound" with secondary windings starting at ground end, and have the same number of turns per inch as the secondaries. All coils are wound clockwise, looking down on form.

\*The primary turns are 95 to inch, using No. 34 D.S.C. wire. The secondary turns are 88 to inch, using No. 30 enameled and the total length of winding is 1.8". Tickler is wound with No. 34 D.S.C. wire, with 95 turns to the inch. Length of winding is .35". All windings are close wound with primary wound directly over secondary, starting at ground end. Windings are clockwise.

**FREE! COIL DATA BOOK!**

A 100-page book containing numerous radio receiving set wiring diagrams, together with a lot of data on every imaginable type of radio coil, including intermediate frequency transformers, can be obtained for 25c if you are a short-wave set builder and experimenter. This book contains a chart giving the inductance, resistance, and physical dimensions of coils wound with a certain size of wire, and it contains descriptions of every conceivable type of tuning and I.F. coil, including a brand-new "multi-wave" coil unit assembly with switches. To obtain one of these valuable 100-page books with its elaborate coil descriptive data, send 25c in stamps, asking for bulletin No. 506; address your request to:

Service Department  
SHORT WAVE CRAFT  
99 Hudson Street  
New York City



**THE FINEST SHORT WAVE RADIO - Direct from Factory to You!**

Specifically designed for "discriminating" short wave users the NEW ROSS SPECIAL comes direct to you at a saving in price and improvement in quality that will amaze you. Covers 15 to 550 meters (20,000 to 550 kc.).—Has both AVC and manual control—band spread tuning—beat oscillator and many other features. Finest "tailor-made" precision workmanship. Sold under 5-day MONEY BACK GUARANTEE. Before buying "any" S.W. receiver, you owe it to yourself to investigate this one. "Write for folder."

**A. H. ROSS and COMPANY**  
Dept. C-4  
Keswick Ave. & Waverly Rd., Glenside, Pa.  
(Near Philadelphia)



**7-POINT MIKE = NO FEEDBACK with speakers full blast**

"I set it up in the booth, and with the gain wide open I was able to completely eliminate feedback by turning the microphone at right angles to the monitor speaker." Thus writes the engineer of a large theatre (name on request). He continues, "The mike has plenty of gain. The quality, sensitivity, and directional effect are better than any other mike I have ever tested or heard." Order from your wholesaler. Or write for Bulletin 73S.



**RADIO biggest opportunities still ahead**

ALMOST in a decade radio has become a giant industry. The opportunities created will be enjoyed by trained men. The International Correspondence Schools Radio Course, prepared by leading authorities and constantly revised, will make you a trained man! A fascinating book—free.

**INTERNATIONAL CORRESPONDENCE SCHOOLS**

Box 2881-B, Scranton, Penna.  
Send me—free—information on subject checked:  
 Radio  Radio Service Man  
 Radio Operator  Electrical Engineer

Name.....  
Address.....

Please mention SHORT WAVE CRAFT when writing advertisers



# OFFICIAL DOERLE SHORT-WAVE GLOBE GIRDLING RECEIVER



COMPLETE  
**\$25.95**  
*nothing else to buy*

GREATEST <sup>SHORT-WAVE</sup> RADIO VALUE  
**-5-TUBE DE-LUXE**  
A.C. Short-Wave RECEIVER

GUARANTEED RECEPTION  
OF FOREIGN SPEECH  
MUSIC AND CODE

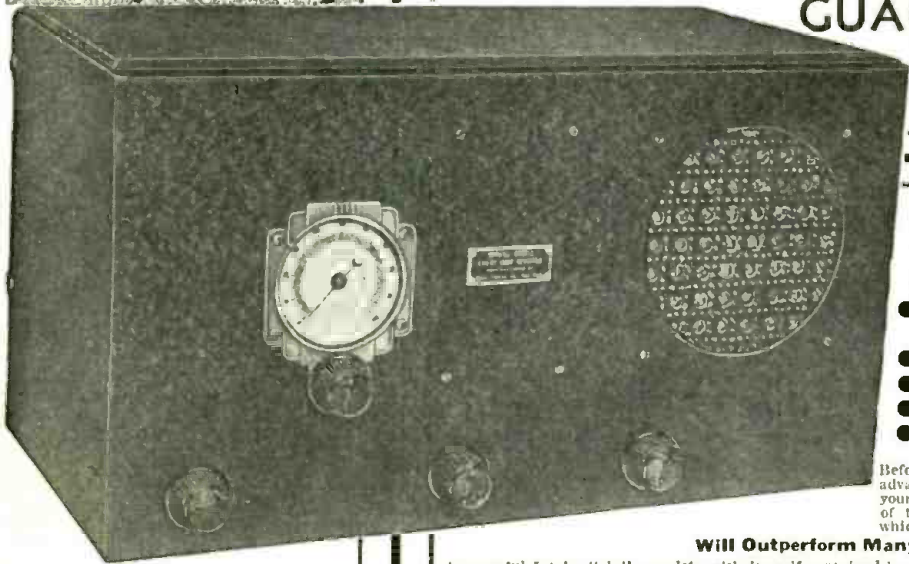

FEATURES FOUND ONLY IN  
MORE EXPENSIVE SETS

- Doublet Antenna Input or
- Standard Antenna input
- 8-Low Loss Ribbed Plug-in Coils
- 15-200 Meters
- 12,500 Mile Range
- Airplane Dial
- Dynamic Speaker
- Headset Jack
- Beautiful Cabinet

Before you buy any other Short-Wave Receiver, be sure to take advantage of our **FREE** five day trial offer explained below. Satisfy yourself, in your own home and at your leisure that this **IS** one of the greatest values in radio, and that it **DOES** have features which are found only in more expensive receivers.

**Will Outperform Many 10-Tube Expensive Sets**

A powerful 5-tube "rig" complete with its self-contained hum-free power pack and dynamic speaker; all mounted on a single chassis and contained in a large handsomely finished black crackle cabinet with patterned screen speaker grill. Two tuned stages—regenerative detector, 3AF stages with powerful 41 pentode output and perfectly matched dynamic speaker; all these features contribute to the enormous power and superlative performance of this Doerle short-wave receiver. All the fine features that you would expect to find in more expensive receivers are incorporated in this "ACE TOP-NOTCHER" of the entire Doerle line. Either a short-wave doublet or standard antenna may be used. A new antenna-adjusting scheme permits perfect alignment of both tuned circuits without affecting the setting of the tuning dial. This means that all stations can be accurately locked on the single tuning dial and always found in their allotted places. Provisions are made to use headphones if desired, with a switch to cut out the dynamic speaker.

**LOOK AT THIS DX-QSL LIST!**

During its initial test, in one sitting, this receiver pulled in on its loud speaker, at good room volume, the following enviable list: WIXAL, WIXAZ, Boston; W3XAL, Boundbrook, N.J.; W8XAL, Cincinnati; W9XAA and W9XF, Chicago; GSC, GSD, GSE, GSF, Daventry, England; OJA, DJB, DJC, DJD, Zeelen, Germany; HBL, HBP, Geneva; VE9GW Ontario; V9DN Quebec; GE9DR Montreal; VE9HX Halifax; XETE Mexico City; YU1BC, YV3BC Caracas; CP5 Bolivia; LSN Buenos Aires; COC Havana; EAQ Madrid; WQO and WEF, testing with the Byrd Expedition and a whole flock of amateurs in practically every radio district of the United States. After that, we could no longer keep our eyes open so we "signed off" to bed.

Uses a simple regenerative circuit—so simple as to be entirely fool-proof. Tubes: 1—6D6, 1—6F7 (actually two tubes in one), 1—37, 1—41 power output tube and 1—80 full-wave rectifier. Two gang tuning condenser; single dial control; FULL-VISION ILLUMINATED AIRPLANE DIAL. Ship. wt. 35 lbs.  
No. 5000. "DOERLE AC-5" Short Wave Receiver, Complete with Tubes, Speaker and 8 coils covering 15 to **\$25.95** 200 meters. Completely wired and tested. (NOT SOLD IN KIT FORM) YOUR PRICE  
No. 5002. "DOERLE DC 5" SHORT-WAVE RECEIVER WITH SELF-CONTAINED POWER SUPPLY AND DYNAMIC SPEAKER. Same circuit as the "Doerle AC 5." Uses 1—6D6; 1—6F7; 1—37; and 2—41's in parallel. Completely wired and tested. Ship. wt. 30 lbs. YOUR PRICE, Complete with Tubes and 8 coils covering 15 **\$23.95** to 200 meters.

Gentlemen:  
I am very well satisfied with the set and here are some of DX stations which I have received on it:  
On 20 meters coil: EAQ—Madrid, Spain; PFFS—Rio Grande, Brazil; S.A.; LSN—Monte Grande, Argentina; S.A.; DIQ—Germany (Kosack Waterhouse); GSB—England (Daventry); CO11—Havana, Cuba.  
On 49 Meters: DJD—Berlin, Germany; H2CRL—Guayniquil, B.C. America; 2RO—Rome, Italy; DKC and DKF—Germany; XEB1—Mexico City, Mexico.  
Also many other South American Stations and Central American stations. Amateurs in more than 30 different states and including Canadian amateurs.  
AUGUSTE THIERGE, River Edge, N.J.

**NATION-WIDE TESTIMONIALS PRAISE THIS SET**

Gentlemen:  
I received your "Official Doerle A. C. 5" today, after being adjusted by your engineers. I have had the receiver turned on less than 10 minutes and at the present time I am listening to the American Hour coming from IRA Rome, Italy. It is a wonderful relief to listen in without hearing a lot of noise. I would like to at this time thank you ever so much for making this adjustment. You cannot tell how much I appreciate this favor. You can certainly count on me as one of your boosters and I shall spread your name and products to all of my friends.  
GEORGE LESLIE ALLEN, Morris Plains, N. J.

Dear Sir:  
Just a letter of recommendation concerning the Doerle A. C. 5. What a set, oh boy, for bringing in the DX night after night. I receive about 10 stations a week, that are new programs, besides 50 I already received. Besides I logged 700 hours. Stations that aren't even listed in call books give me a thrill. I only use a 20 ft. antenna wrapped around a chimney.  
FRANCIS KMEC, Allentown, Pa.

Gentlemen:  
This will acknowledge receipt of my Doerle short-wave receiver. This 1935 model is the smoothest and best operating set I have ever operated, both on amateur and foreign reception. I have heard practically all of the South American stations, Russia, Spain, and of course, France, Germany, Japan, and lots of others. This little receiver is just as you say it is—the best for the money and I have seen sets selling for lots more, which do not come within a mile of this Doerle.  
If anybody wants to know if you people will treat them white, just let me know and I will tell absolutely yes.  
B. L. SMITH, Colorado, Texas.

USE THIS COUPON for ~  
**FREE 5 DAY TRIAL**

RADIO TRADING CO., 101A HUDSON ST., NEW YORK

Gentlemen:

I enclose ..... dollars ..... cents, for your new Doerle 5-Tube De-Luxe Short-Wave receiver on a five day free trial basis. I am to prove to my own satisfaction that it will give me world-wide reception and that your guarantee means exactly what it says. If, at the end of five days after receipt of radio, I am not perfectly satisfied, I will write you accordingly, whereupon, you will send shipping instructions. Upon receipt of the radio, you will refund me the full purchase price. I agree to pay express charges one way, and you the other.

C.O.D. SHIPMENT. I enclose .....dollars.....cents deposit, balance of .....dollars.....cents C.O.D.

PRINT Name .....  
Address .....  
Town ..... State .....

**FREE SHORT-WAVE TREATISE**

Large 52-page book of Short-Wave facts, data, diagrams, circuits and illustrations. Contains Short-Wave sets and equipment of all kinds and description. A gold-mine of information to Short-Wave enthusiasts. **DON'T DELAY. WRITE TODAY.**  
Send 5c (in coin or new U.S. stamps) for postage. Book sent by return mail. Print name and address clearly on request.  
See our other "ads" on pages 746 and 765 for additional information.

**RADIO TRADING CO., 101A Hudson St., New York City**

Please mention SHORT WAVE CRAFT when writing advertisers



Here's the new-Big

# 1935 OFFICIAL SHORT WAVE RADIO MANUAL

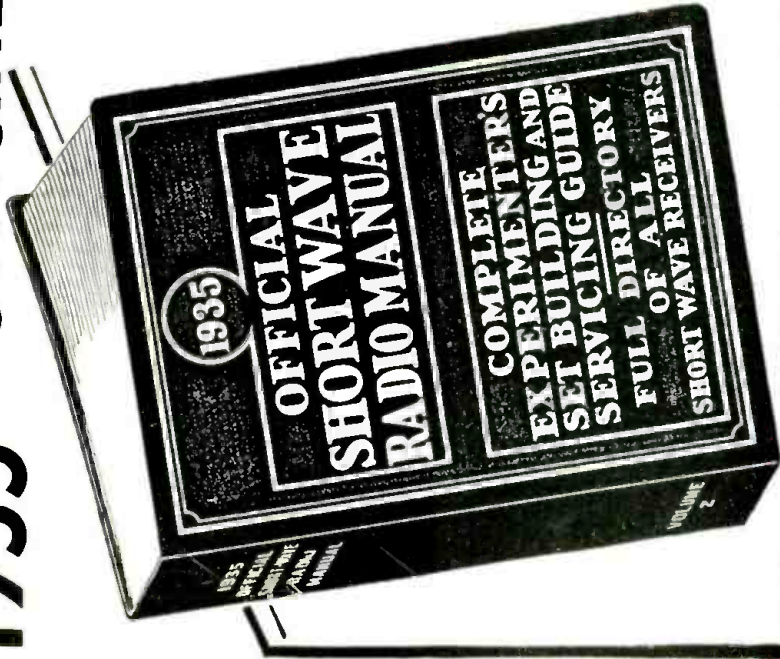

CLIP AND MAIL THIS MONEY SAVING COUPON TODAY

SHORT WAVE CRAFT  
59 Hudson Street,  
New York, N. Y.

Gentlemen: I enclose herewith my remittance of \$2.00 for which please send me one copy of the 1935 OFFICIAL SHORT WAVE RADIO MANUAL. All at the pre-publication price of \$2.00. I understand that the price of the book will be \$2.50 as soon as it is published. (Send remittance, check or money order. Register letter if it contains cash or currency.)

Name .....  
Address .....  
City ..... State .....

When we brought out our 1934 OFFICIAL SHORT WAVE RADIO MANUAL, of which many thousands of copies were bought by short wave enthusiasts, we promised you that a new volume would be published every year.

In keeping with this promise, we now take great pleasure in announcing the 1935 OFFICIAL SHORT WAVE RADIO MANUAL. There has been tremendous progress and a great boom in short waves in the past year, and the art has made such rapid progress that no single book, up to now, has been able to keep up with this progress. The 1935 OFFICIAL SHORT WAVE RADIO MANUAL fills this need, and it fills it completely. All the progress made in short waves, whether it is in set building, whether it is in radio servicing, whether it is in new models, whether it is in new short wave discoveries, all are faithfully reported and chronicled in this great 1935 volume.

Like its predecessor, it is a BIG book, in which you will find literally EVERYTHING in short waves—nothing has been left out. Not only is it a complete manual, but it is a great encyclopedia of short wave facts, information, hookups, photographs, tables, maps, etc., etc. The wealth of material is so great that it would take several pages to list all the valuable data that has been included in this volume.

Similar to last year's volume, the new book has been edited by Harro Gernsback, Editor of SHORT WAVE CRAFT and II W Secor, Managing Editor, and if you are and have been a reader of SHORT WAVE CRAFT, and particularly if you have seen the 1934 Manual, you will know just what you can expect from this, the greatest short wave manual ever put out by Mr. Gernsback. Here are the star features of the book:

## 29 ★ Features:

- ★ 1—Short-Wave Beginners' Section—Dozens of new simplified circuits for 1-2 and 3 tube receivers, including famous "Boerle" and "Oscillodyne", etc.
- ★ 2—Short-Wave Receivers—All types discussed with diagrams and pictures. The best types only with "Long Line" and "Short Line" circuit diagrams, etc. Full details for constructing them, etc. "Band-Spreading", the Dwerle, 5-tube T.R.F. Receivers, etc.
- ★ 3—Battery Short-Wave Receivers—1-2, & 3 tube sets—all the way up to special 5-tube super-heterodyne, designed especially for battery operation.
- ★ 4—"5-Meter" Department—All the latest "long" oscillators, improved "high sensitivity" receivers. How to arrange best aerial to get greatest distance, 5-meter transmitters, hook-ups, etc.
- ★ 5—Short-Wave "Artificial Fever" Apparatus—also newest thermionic and other allied applications of ultra short waves.
- ★ 6—Short-Wave Experimenter's Section—filled with Short-Wave Kinks, Short-cuts, etc., of interest to every experimenter.
- ★ 7—Ultra Short Waves—Newest circuits, apparatus, and results obtained in this field.
- ★ 8—Commercial "Short-Wave" and "All-Wave" Receivers—Full Servicing Data for "Set-Over" and "Servicemen."
- ★ 9—How to build "Power Supply" Units for Short-Wave Receivers.
- ★ 10—Latest Short-Wave Converters—With servicing data on Commercial Models.
- ★ 11—The Short-Wave Antenna—Including latest "Noise-Reduction" types, Transposed Leads in systems, shielded cable, Double-Doublers, etc.
- ★ 12—Short-Wave Superheterodynes—From 3 to 11 tubes—Latest descriptions and diagrams including commercial all-wave superhets.
- ★ 13—Phone Transmitters for Amateur Stations—How to build them.
- ★ 14—"Skip" Distance—Heaviside layer, etc.—explained, physics of Short Waves.
- ★ 15—Super-Regenerative Short-Wave Receivers—latest circuits, etc.
- ★ 16—Recording "Foreign" and "Domestic" Short-Wave programs. All systems in use.
- ★ 17—"High Fidelity"—How to obtain it in Short-Wave Receivers.
- ★ 18—The best Short-Wave Questions and answers of the year.
- ★ 19—The best Short-Wave "Kinks" of the year.
- ★ 20—Foreign Short-Wave Review—Novel circuits, apparatus, etc.
- ★ 21—Tubes for Short-Wave purposes—including tables of latest tubes for Short-Wave transmitters and Receivers.
- ★ 22—Short-Wave Transmitters—All about the new "Long Lines" Oscillators as well as other "simplified" high-efficiency transmitters, Rack and Panel Jobs, Crystal Control, etc.
- ★ 23—Multi-Purpose Tubes—How to use them on Short-Wave—Sets in which 2 tubes=4; 3 tubes=6; etc.
- ★ 24—"Audio Amplifiers" for Short-Wave Receivers, Circuits, etc.
- ★ 25—"Band-Spreading"—How to spread the stations over the dial for easier tuning.
- ★ 26—Plug-less "Mono-Coil" Receivers—How to build efficient switch-type coils to eliminate plus-in coils; "Clip-Coil" Receivers, etc.
- ★ 27—Boosters, Pre-amplifiers and Beat Oscillators—How they work, with constructional data, diagrams, etc.
- ★ 28—Portable Short-Wave Receivers and Transmitters—Transmitter Power supply from Ford Coils, etc.

### AND FOR SERVICE MEN

- ★ 29—Every short-wave diagram, every short-wave all-wave set, EVERYTHING, whether it is an amateur or commercial set, will be found in this special enlarged section. Hundreds of valuable diagrams, with tube layouts, resistor values, color codes of wiring cables, etc., and the purpose of each tube in each set clearly indicated on the diagram, wherever this information can possibly be obtained.

### SPECIAL PRE-PUBLICATION OFFER

As has been customary with us in the past, we give our readers the opportunity to order the book before it comes off press and save money. The price of the new 1935 OFFICIAL SHORT WAVE RADIO MANUAL will be \$2.50 as soon as it comes off the press. No reduction in price will be made later. To you, who order this book before publication, the price is \$2.00. As soon as the OFFICIAL SHORT WAVE RADIO MANUAL is published, the pre-publication price will be immediately withdrawn. It is, therefore, to your advantage to order your copy today.

OVER 240 BIG PAGES • OVER 1000 Illustrations  
Size 9 x 12 Inches — Flexible Looseleaf Leatherette Binder



SAVE UP TO 50% by BUYING YOUR RADIO *Direct from* MIDWEST LABORATORIES

Thrill to Guaranteed World-Wide HIGH FIDELITY Performance with This  
**Amazing New MIDWEST SUPER Deluxe 16-TUBE ALL-WAVE Radio!**  
 (ALL FIVE WAVE BANDS)

**Only Midwest Gives You These Exclusive Features**

HERE are a few reasons why Midwest is generally accepted as the world's most "Universal" set. They explain why it is so popular in Africa, Spain, and other countries where reception conditions vary widely—illustrate why so many police, army, navy and consular officials as well as listening posts prefer it—prove why many "hams," who own a number of sets, use the Midwest in preference to any other.

**Perfect Preconversion Amplification on All Bands**  
**Compact Centralized Band Switch**



Only the Midwest switch and coil arrangement makes it possible to use an efficient radio frequency amplifier stage in an ALL-WAVE receiver. If an attempt is made to get real amplification with other arrangements the usual result is howling and whistling due to oscillation. In the new Midwest 16-tube set, the inter-stage shielding, in the radio frequency amplifier is so complete that the utmost in gain and efficiency is obtained without regenerative efforts producing oscillation.

**Doublet Antenna Provision and Fully Loaded Plate Circuits**



Due to the very recent development in coil design, the coils in the plate circuits of the RF tubes are of a phenomenally large inductance. In order to fully load the plate of the RF tube. This loading results in the gaining of maximum voltage amplification. The primaries, in the antenna circuit, are brought out to insulated posts. They are especially designed to permit proper connection to the Doublet Antenna as well as to the more usual type—and have an inductance much greater than that used in the past. These very large coils are expensive to manufacture but give results not obtainable with old style coils.

**NEW STYLE CONSOLES**

The Midwest 36-page catalog pictures a complete line of beautiful, artistic deluxe consoles and chassis in four colors. Write for new FREE catalog . . . TODAY!

Midwest long-range radios are priced as low as... **\$27.50**

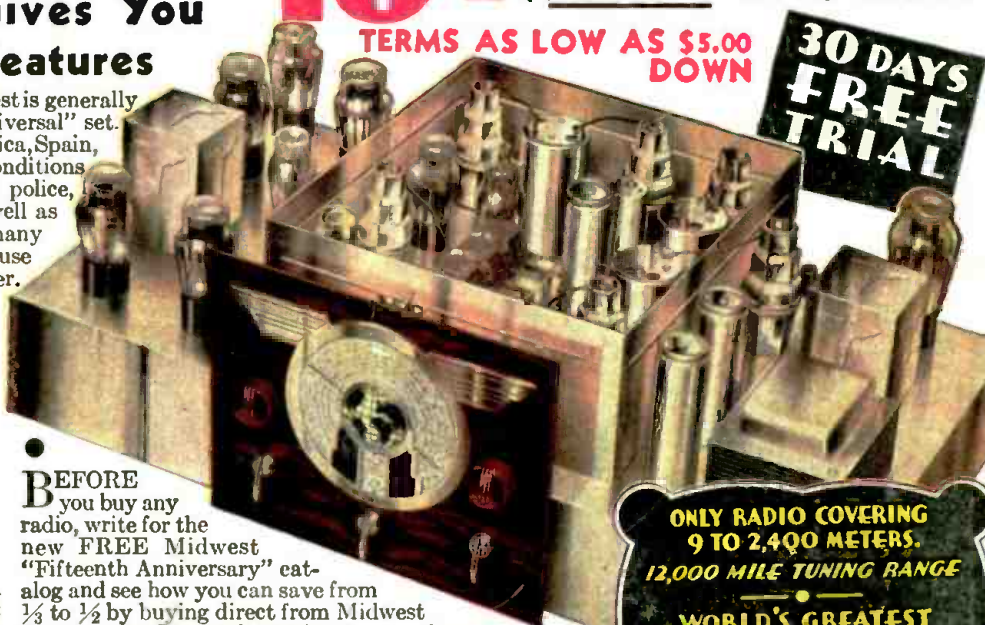

TERMS AS LOW AS \$5.00 DOWN

**30 DAYS FREE TRIAL**

**BEFORE** you buy any radio, write for the new FREE Midwest "Fifteenth Anniversary" catalog and see how you can save from 1/3 to 1/2 by buying direct from Midwest Laboratories. Learn why Midwest outperforms sets costing up to \$200 and more. Midwest gives you triple protection with: **One-Year Guarantee, Foreign Reception Guarantee, Money-Back Guarantee.**

**50 ADVANCED FEATURES**

Exclusive "Invisible Hands" features include: High Level Automatic Volume Control Action, Discriminating Automatic Tone Control, Multi-Function Dial, Micro-Tenuator, Fidel-A-Stat, etc. Only Midwest covers a tuning range of 9 to 2400 meters (33 Megacycles to 125 KC)—enabling you to easily and successfully tune in even low powered foreign stations up to 12,000 miles away—with crystal-clear, loud speaker, High Fidelity reception.

All 5 Wave bands enable you to enjoy today's finest High Fidelity American programs. In addition, you get Canadian, police, amateur, airplane broadcasts...commercial and ship signals...and delight in exciting world-wide broadcasts from England, France, Germany, Spain, Italy, Russia, Australia, etc. Send today for money-saving facts!

**Greater All-Wave Tuning Range**  
 9 to 2400 Meters (33 Megacycles to 125 KC)

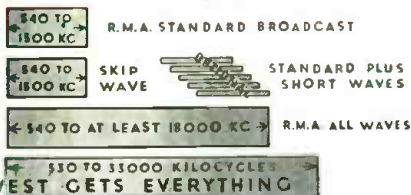

It is widely recognized that American-made radios are the best in the world—and that Midwest is the only American manufacturer who has sufficient acquaintance with world-wide reception problems to enable them to design a universally satisfactory all-wave radio. This experience has been gained through fifteen years of merchandising radios in almost every country of the world—from Australia to Greenland and from Japan to Portugal. Four years ago, Midwest developed and perfected an all-wave set. Each year, Midwest has consistently improved this set until, today, it represents the finest Higher Fidelity, super all-wave radio you can buy anywhere. It has a greater all-wave tuning range of 9 to 2400 meters (33 megacycles to 125 KC) and is guaranteed to bring in foreign reception up to 12,000 miles and more away. Its tuning range covers every useful portion of the radio spectrum.

**ONLY RADIO COVERING 9 TO 2,400 METERS.**  
**12,000 MILE TUNING RANGE**  
**WORLD'S GREATEST RADIO VALUE**  
**\$57.50 with New Deluxe Auditorium-Type SPEAKER**  
 (16 TUBES)

**EXPERIENCED RADIO MAN PRAISES MIDWEST**  
*Trenton, N. J.*—I am firmly convinced that I have received the most for my money in my 15 years' experience. My Midwest-16 brought in 12RO, Rome; EAQ, Madrid; FYA, France; GSA, GSB, Daventry; VK2ME, Sydney, etc. It has remarkable selectivity! With WCAU at 1170 KC and WOAI at 1190 KC, both 50,000-watt stations, transmitting at their peak, about 9 P.M., I have cut between these stations and received KOB, New Mexico, at 1180 K with loud speaker volume—and no interference. R. M. Scheid, Jr., 28 Boudinot Street.



**DEAL DIRECT WITH LABORATORIES**

Increasing costs are sure to result in high radio prices soon. Buy before the big advance . . . NOW . . . while you can take advantage of Midwest's sensational values. No middlemen's profits to pay! You save 30% to 50% when you buy this popular way . . . You get 30 days FREE trial . . . as little as \$5.00 down puts a Midwest radio in your home. Foreign Reception, One-Year and Money-Back GUARANTEES protect you! Write for FREE catalog now . . . TODAY!

**SAVE UP TO 50%**

**MAIL COUPON TODAY! FOR FREE MINIATURE DIAL.... FREE 30-DAY TRIAL OFFER... FREE CATALOG**

**MIDWEST RADIO CORP., Dept. 154-A, Cincinnati, Ohio.**  
 Without obligation on my part, send me your new FREE catalog, FREE Miniature Dial, and complete details of your liberal 30-day FREE trial offer. This is NOT an order.

User-Agents Make Easy Extra Money Check Here for Details

Name \_\_\_\_\_  
 Address \_\_\_\_\_  
 Town \_\_\_\_\_ State \_\_\_\_\_  
 Check here, if interested in Midwest World-Wide Battery Radio.  
 Check here, if interested in a Midwest Auto Radio.

**MIDWEST RADIO CORP.**  
 DEPT. 154-A — CINCINNATI, OHIO, U. S. A.  
 Established 1920 Cable Address Miraco. . . . All Codes