

THE RADIO EXPERIMENTER'S MAGAZINE

January

JAN
rt '34
ave
? 2604



SHORT WAVE ★ CRAFT

Edited by
HUGO GERNSBACK



*Dream
of a
Short Wave Fiend*

25¢
IN CANADA
30¢

Here It Is — Just What You've Wanted

A World-Wide, Short-Wave Radio Tours Map that Shows Location, Power and Frequency of All Stations at a Glance



COMPLETE TECHNICAL BULLETIN FOR THE TRANSMITTING AMATEUR

The DeForest Amateur Radio Division of the RCA Radiotron Company has prepared a comprehensive technical bulletin on amateur transmitting tubes. Full information is given on the application, installation and operation of popular amateur transmitting types. Of special interest to the transmitting amateur is the new RCA-800. Send for information on this and other transmitting types, enclosing 10c, to cover the cost of handling. Use coupon.



The New RCA-800

Here's a new short-wave map that is a real aid to the DX fan. All short-wave broadcasting stations operating on a regular schedule are included. And on these complete information is shown at a glance — location, power, frequency, operating time. Descriptions of the types of programs broadcast by each station are another feature.

No short-wave listener can afford to be without this new map. Send coupon below with 10c to cover handling.

Whether you listen, or transmit as well, you will find that the radio tubes manufactured and guaranteed by RCA are those best suited to your needs. Incorporating the latest engineering features, RCA tubes give you the best in radio tube performance.

RCA Radiotron Co., Inc.,
Camden, N. J.

Please send Short-Wave, World-Wide Radio Tours Map. I enclose 10c (stamps or coin) to cover handling charges.

Please send 464 booklet on amateur transmitting tubes. I enclose 10c (stamps or coin) to cover handling charges.

Name _____ Call _____

Address _____ City _____



Lunningham
Radiotron



SHORT WAVE CRAFT is published monthly, on the 5th of every month; subscription price is \$2.50 a year in the United States and possessions (in Canada and foreign countries \$3.00 a year to cover additional postage). Entered as second class matter May 7, 1930, at the Post Office at Mount Morris, Ill., under the act of March 3, 1879.

Learn at Home to Make More Money

**I'll train You Quickly for Radio's
GOOD Spare Time and Full Time Jobs**



J. E. SMITH, President
National Radio Institute

The man who has directed the Home-Study Training of more men for the Radio industry than any other man in America.



BROADCASTING STATIONS offer many fascinating, interesting, and good pay jobs to the trained Radio man.

Why slave your life away in a no-future job? Why skimp, why scrape, trying to pay your bills? I'll train you quickly for the live-wire field—the field with a future—RADIO. \$40, \$60, \$75 a week—that's what many Radio Experts make. \$5, \$10, \$15 a week extra money—that's what many of my students make in their spare time shortly after enrolling. My free book tells you about Radio's spare-time and full-time opportunities—about my tested training—about my students and graduates—what they are doing and making. Get this book. Be a Radio Expert. The Radio field is big enough to absorb many more properly trained men.

I'll train you for jobs like these

Spare-time and full-time Radio Servicing, Operating, Broadcast, Aircraft Radio, Commercial Land, Ship and Television stations, a Radio service business of your own. I'll train you for these and other good jobs in the manufacture, sale and service of Radio, Sound and Television apparatus. My FREE book tells you about the many money-making opportunities in Radio.

Save—learn at home in your spare time

You don't have to leave home and spend \$500 to \$1,000 to study Radio. I'll train you quickly and inexpensively right in your own home and in your spare time for a good Radio job. You don't need a high school or college education. Many of my successful graduates didn't even finish grade school. My amazingly practical 50-50 method of training—half with lessons, half with Radio equipment—gives you broad practical experience—makes learning at home easy, fascinating, practical and rapid.

(Continued on other side)

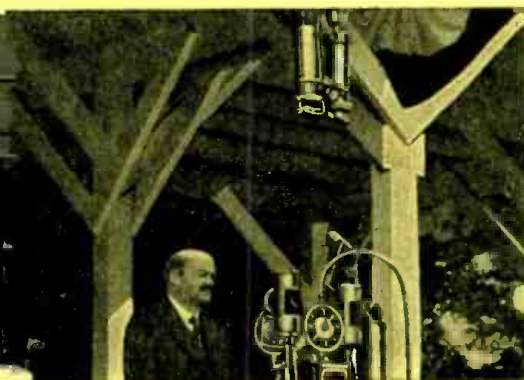

LOUD SPEAKER installation and service work is another growing, money-making field for trained Radio men.



TELEVISION, the coming field of great opportunities, is covered in my Course.

PLACE
ONE
CENT
STAMP
HERE

MR. J. E. SMITH, President

NATIONAL RADIO INSTITUTE

16th and U Streets, N. W.

Dept. 4AB3

WASHINGTON, D. C.

Many Radio Experts make \$40, \$60, \$75 a week

(Continued from other side)

Many make \$5, \$10, \$15 a week Extra in spare time almost at once

My book shows how my special training, instruction material, plans, ideas and my twenty years experience training men for Radio careers has helped many students make \$200 to \$1,000 a year quickly in their spare time. My Course is famous as "the one that pays for itself."

Your money back if not satisfied

I'm so sure you will be satisfied with my training that I agree in writing to refund every penny of your money if you are not entirely satisfied with my Lessons and Instruction Service when you finish.

Find out what Radio offers you

Act today. Mail the post card below. My 64-page book will be sent free to any ambitious fellow over 15 years of age. It tells about Radio's opportunities—explains the eighteen star features of my Course—shows letters of what others are doing and making. There is no obligation. Put a one cent stamp on the post card and mail it now.

**J. E. SMITH, President
NATIONAL RADIO INSTITUTE
WASHINGTON, D. C.**



*Find Out
What Radio
Offers You*
MAIL THIS NOW

Mr. J. E. SMITH, *President*
National Radio Institute, Dept. 4AB3
Washington, D. C.

Dear Mr. Smith: Without obligating me, send your book which points out the spare-time and full-time job opportunities in Radio and explains your amazingly practical 50-50 method of training men quickly and inexpensively at home in their spare time to be Radio Experts. *(Please print plainly.)*

Name..... Age.....

Address.....

City..... State.....



SET SERVICING has paid many N. R. I. men \$200 to \$1,000 a year for their spare time. Full-time men make as much as \$40, \$50, \$65 a week.

Some Other Jobs N.R.I. Trains Men For

- Broadcasting engineer
- Operator in broadcasting station
- Maintenance man in broadcasting station
- Superintendent in Radio factory
- Engineer in Radio factory
- Inspector in Radio factory
- Radio operator on ships
- Sales manager for Radio stores
- Service manager for Radio stores
- Buyer for Radio stores
- Government Radio electrician
- Government Radio supervisor
- Operator of government Radio beacon stations
- Aircraft Radio operator
- Aircraft Radio dispatcher
- Television engineer
- Television transmitter operator
- Television maintenance man
- Engineer in commercial Radio land stations
- Installation man on loud speaker systems
- Serviceman on loud speaker systems
- Automobile Radio installation and service man
- Police Radio transmitter operator
- Police Radio receiver serviceman

Here's Proof

\$50 to \$75 a week

 "The National Radio Institute put me in a position to make more money than I ever made in good times. I am in the Radio service business for myself, where it is possible for me to make from \$50 to \$75 a week. Service work has increased because people, who in normal times would buy a new Radio, now are contented to have the old one 'pepped up'."—BERNARD COSTA, 150 Franklin St., Brooklyn, N. Y.

"Made \$6,000 in 2 years"

 "Soon after the depression started, I found myself without a job, but I was well protected with N. R. I. training. I swung right to full-time Radio servicing and I have made over \$6,000 in a little over two years."—WM. SPARTY, Sparty Radio Service, 93 Broadway, Newark, N. J.

"\$500 a Year in Spare Time"

 "Although doing spare-time Radio work only, I have averaged about \$500 a year extra in addition to my regular income. Full-time Radio work would net me many times that amount."—EDW. H. FAWCETT, Slough Road, Ladner, B. C., Canada.

"Good Position, Good Pay"

 "I am Chief Operator at Radio Station WSMK. This is a good position, with good pay. I have advanced in Radio right along. I recommend N. R. I. to anyone who wants to be successful in Radio."—JOHN HAJDUK, JR., 3 Broxey Apts., Southern Hills, Dayton, Ohio.

Greatest Short Wave Book!

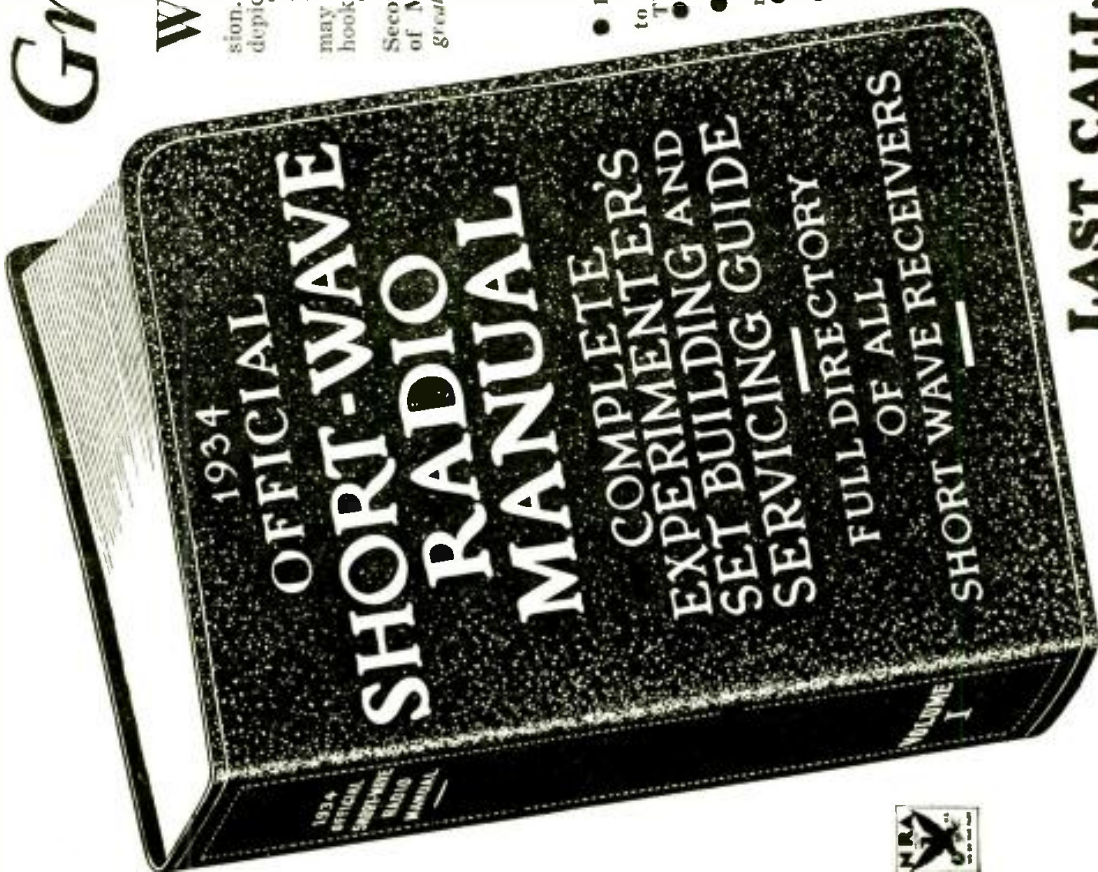

WE are pleased and proud to announce the greatest and most complete work on *SHORT WAVE* which has ever appeared in print. There has been a big boom in short waves during the past two years in spite of the depression. Tremendous progress has been made, yet up to now there has not been an adequate book depicting ALL the progress that has been made. THE OFFICIAL SHORT-WAVE RADIO MANUAL now fills this need completely. It is a big book in which you will find EVERYTHING in short waves, no matter what it may be. It is not only a complete manual, but it is a veritable encyclopedia of facts, information, hookups, illustrations. It is impossible to explain the entire volume in a few sentences. The book has been edited by Hugo Gernsback, Editor of *SHORT WAVE CRAFT*, and H. W. Secor, Managing Editor, and if you are a reader of *SHORT WAVE CRAFT* and have seen some of Mr. Gernsback's other publications, you know just about what you may expect from this, his greatest effort in the short-wave field.

Here are the contents of the book:

● 14 VALUABLE FEATURES ●

- 1. THE LARGEST SECTION, featuring the most important short-wave receivers and how to build them, EVER ASSEMBLED BETWEEN TWO COVERS.
- 2. Short wave amateur transmitters in all their phases.
- 3. A complete Ultra Short Wave section featuring construction of 1, 3, 5 and 10 meter receivers.
- 4. A complete Short Wave beginner's section.
- 5. A large section devoted exclusively to short wave coil winding and all about it.
- 6. The most complete section of commercial short wave receivers in print. Every important commercial Short Wave receiver (this includes all wave receivers) is represented WITH FULL SERVICING data. *Invaluable for Service Men.*
- 7. A large section devoted to A. C. short wave power packs and how to build them, from 1 to 7 tube receivers.
- 8. A big section for the Short Wave experimenter on short-wave kinks—hundreds of them.
- 9. A section on the important new art of short-wave therapy (treatment of diseases by short waves).
- 10. A section devoted exclusively to Short wave converters. This includes how to build them, as well as commercial models with FULL SERVICING DATA.
- 11. An important section on Short Wave antennae and noise eliminating procedures.
- 12. The most complete section of Short Wave Superheterodynes in print. This section includes both how to build as well as commercial models of receivers. The latter with full service data.
- 13. A section on amateur 'phone transmitters and how to build them.
- 14. A Short Wave Physics section on theoretical Short Wave data for the advanced experimenter, as well as student.

Clip—Mail This Coupon Today!

SHORT WAVE CRAFT,
96-98 Park Place,
New York, N. Y.

1-34

Gentlemen, I enclose herewith my remittance of \$2.00 for which please send me one copy of the 1934 OFFICIAL SHORT-WAVE RADIO MANUAL, at the pre-publication price of \$2.00. I understand that the price will be \$2.50 as soon as it is published (Some remittance or money order. Register letter if it contains cash or currency.)

Name

Address

CITY

State

Over 200 big pages
Over 1,000 illustrations
Size 9x12 inches
Flexible, loose-leaf binder

LAST CALL

SPECIAL PRE-PUBLICATION OFFER: You now have the opportunity to order this book before it comes off the press and save money. The price of the new OFFICIAL, SHORT-WAVE RADIO MANUAL, will be \$2.50 as soon as it comes off the press (late in October). No reduction in price will be made later. To you who order this book before publication the price is \$2.00. As soon as the OFFICIAL, SHORT-WAVE RADIO MANUAL is published the pre-publication price will be immediately withdrawn. It is to your advantage to order your copy today.

IMPORTANT!

Inasmuch as this is the first time that such a monumental work in short waves has been published, Mr. Hugo Gernsback has consented to personally autograph the first one thousand copies, all of which are numbered. If you wish an autographed copy of the Manual, place your order immediately.

IN THIS ISSUE: PROMINENT SHORT-WAVE AUTHORS

Mitchell • Granger • Hill • Shuart • Victor • Silver

HUGO GERNSBACK
Editor



H. WINFIELD SECOR
Managing Editor

Contents for January, 1934

Editorial—"Short Waves In Space," by Hugo Gernsback 517

When LITTLE AMERICA Speaks, by H. Winfield Secor 518

VK2ME—Short-Wave Voice of Australia 520

A Symmetrical Super-Regenerative Receiver, by H. Granger and H. H. Hill 524

5 and 10 Meter Transmitter, by George W. Shuart, W2AMN 526

Low-Power Modulator, by Leonard Victor, W2DHN 528

SHORT-WAVE SCOUTS—First "Trophy Cup" Award.. 529

SHORT WAVE LEAGUE 530

Short-Cuts for S-W Fans..... 531

"Smoothing Up" Your Receiver Controls, by Curtis E. Malsberger 532

\$5.00 Monthly For Best Short-Wave "Kink" 533

Short Waves and Long Raves—Our Readers' Forum 534

Power Transformer Data and Design Formulas, by O. K. Tipsel 536

RCA Victor's New 6-Tube "All-Wave" Set 537

4-Tube Supertone Has "Band-Spread" 538

350 Ft. Lead-In "Cable" Works Fine..... 538

2 New All Wave Receivers—The "DeWald" and the "Champion" 539

New "All-Wave" Atwater Kent..... 540

New NORDEN Superhet Tunes 15 to 550 Meters 541

The Masterpiece II—Official "All-Wave" Receiver of Byrd Expedition, by McMurdo Silver..... 542

SHORT WAVE STATIONS OF THE WORLD—Revised To Date, Edited by M. Harvey Gernsback 543

Short-Wave QUESTION BOX 546

"When To Listen In," by M. Harvey Gernsback..... 562

Short Waves Link Lt. Settle's Balloon to Ground..... 567

Short-Wave Reception in England, by "Megacycle"..... 575



WAVE CRAFT, this will be your guarantee that this set has been tested in our laboratories, as well as privately, in different parts of the country to make sure that the circuit and selected parts are right. Only "Constructional-Experimental" circuits are certified by us.

When you see our certificate seal on any set described you need not hesitate in spending money for parts, because you are assured in advance that the set and circuit are bona fide and that this magazine stands behind it.

SHORT WAVE CRAFT is the only magazine that thus certifies circuits and sets.

Certified Circuits

• SHORT WAVE CRAFT goes to a large expense in verifying new circuits published in this magazine. Whenever you see the seal shown here in connection with any of the sets published in this and future issues of SHORT

OUR COVER

• OUR cover illustration this month portrays a "Short-Wave Fan's Dream." As our artist has cleverly depicted, even the bed has become transformed into a short-wave receiver. Undoubtedly if the truth were known, many short-wave fans have experienced just such a dream under the spell of hearing the DX stations in Europe.

COPYRIGHT, 1933, BY H. GERNSBACK

Published by POPULAR BOOK CORPORATION

HUGO GERNSBACK, President - - H. W. SECOR, Vice-President
EMIL GROSSMAN - - - - - Director of Advertising
Chicago Adv. Office - - - L. F. McCLURE, 919 No. Michigan Ave
Publication Office - - - 404 N. Wesley Avenue, Mount Morris, Ill.
Editorial and General Offices - - 96-98 Park Place, New York, N. Y.
London Agent: HACHETTE & CIE., 16-17 King William St., Charing Cross, W.C.2

Paris Agent: HACHETTE & CIE., 111 Rue Reaumur
Australian Agents: MCGILL'S AGENCY, 179 Elizabeth St., Melbourne

FEATURES IN NEXT ISSUE

- The "Globe-Girdler" 7, by L. Victor, W2DHN, and E. Kahlert, W2BHZ. A dandy band-spread superhet for "fan" or "ham" use.
- Stability in Receivers—How To Attain It, by Curtis E. Malsberger.
- A Brand New 5-Meter Receiver, Using 3 of the New Tubes, by George W. Shuart, W2AMN.
- 3 Tubes-5!—Not a Reflex! In the new "Wonder" Receiver: Works loud speaker! By Harold Mitchell.
- A French Prize-Winning Transmitter.
- 250-Watt Crystal Controlled Transmitter.

SHORT-WAVE CRAFT—Monthly. Entered as second class matter May 7, 1930, at the post office at Mount Morris, Illinois, under the act of March 3, 1879. Trademarks and copyrights by permission of H. Gernsback, 96 Park Place, N. Y. C. Text and illustrations of this magazine are copyrighted and must not be reproduced without permission. SHORT WAVE CRAFT is published on the 5th of every month. Twelve numbers per year. Subscription price is \$2.50 a year in the United States and possessions. Canada and foreign countries, \$3.00 a year. Single copies 25c. Address all contributions for publication to Editor, SHORT WAVE CRAFT, 96-98 Park Place, New York, N. Y. Publishers are not responsible for lost manuscripts. Contributions cannot be returned unless authors remit full postage. SHORT WAVE CRAFT is for sale at all principal newsstands in the United States and Canada. European agents: Brentano's, London and Paris. Printed in U. S. A. Make all subscription checks payable to Popular Book Corporation.



DE LUXE SHORT WAVE RECEPTION

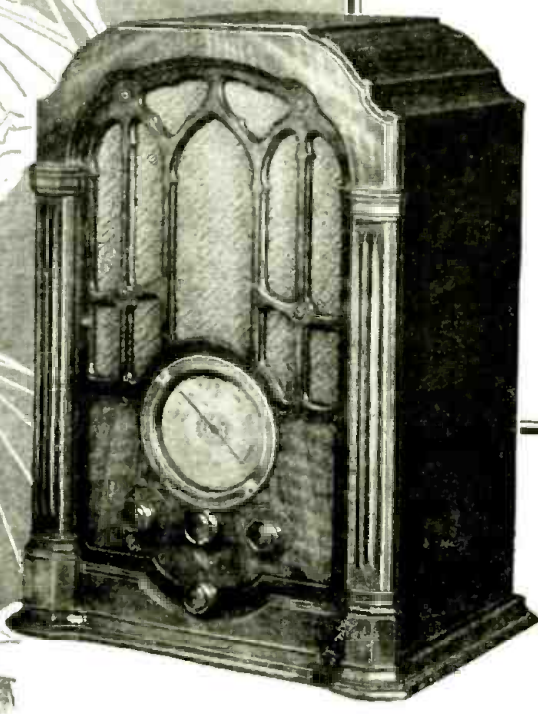

Here's the last word
...from RCA Victor
...for the short wave
fan...that gives you
four individual re-
ceivers in one

Model 140—Frequency range, four bands—16 to 555 meters, 18,740 KC. to 540 KC. Airplane dial, automatic volume control, tone control, 10" dynamic speaker. Price, with RCA Radiotrons, list, \$92.50.

THESE new instruments from RCA Victor... all-wave super-hets... put a kick into short wave reception that hasn't existed since the old DX and whistle chasing days. So perfect are they that our engineers call them "custom-made short wave sets."

They are designed to cover the more important sections of the short wave band, including the International Entertainment channels as well as some amateur, air-craft and commercial short wave bands, in addition to standard broadcasts.

Models 140 and 240 feature 8 Radiotrons (that do the work of ten) a 10-inch dynamic speaker; automatic volume control; micro rone control... and hairline tuning is made possible by the new full vision "airplane dial."

Four Receivers in One!

Now, the most important part about these receivers as all-wave

sets is the fact that RCA Victor engineers have kept away from the common idea of tapped coils for the various bands. For each tuning band a separate set of coils is used, three in a set, four sets. The net is that the receiver is in effect *four individual receivers in one*. Each set can be trimmed independently... adding much to easy adjustment and assuring maximum efficiency.

Furthermore, these sets have a low noise level ratio... and that's easier on the ears! All in all, now you can get technical superiority at a modest price. Hear either Model 140 or 240 at your nearest RCA Victor dealer's *today!* You'll want one!

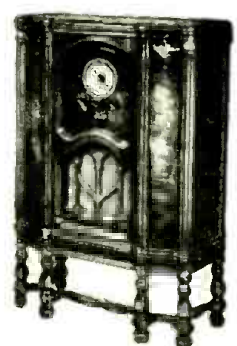

Model 240—Frequency range 16 to 555 meters, 18,740 KC. to 540 KC. frequency range divided into 4 bands. Automatic volume control, tone control, 10" dynamic speaker. Price, with RCA Radiotrons, list, \$128.75.

Prices subject to change without notice. Prices quoted are F. O. B., Camden, N. J.

RCA Victor Company, Inc.
CAMDEN, N. J. "Radio Headquarters"



Short Waves In Space

An Editorial By HUGO GERNSBACK

● IT seems to be pretty well proven that radio waves, up to a certain wavelength, are reflected from the Heaviside Layer. The action is here as though, instead of radio waves, we had to do with light waves, and the Heaviside Layer may be compared to a highly polished mirror surrounding the entire earth at a distance of about 80 miles. This is the best explanation of why the radio waves can be made to go half-way round the world, from transmitter to receiver. Radio waves from several thousand meters down to about five meters act in this manner; that is, the waves are seemingly reflected by the Heaviside Layer, which is composed of *ionized* gases, making a more or less conductive mirror which confines and guides the waves. But when we come to the shorter waves, from 5 meters downwards, a new phenomenon occurs, and the Heaviside Layer does not work any more as it did with the longer waves. As the wavelength is decreased, the Heaviside Layer seemingly becomes less and less effective. As we go downward in the wavelength range, we come to a point in the ultra-short-wave spectrum, from 2 meters downwards, where the Heaviside Layer has no further effect, and the waves are no longer refracted like the longer waves.

The waves now begin to act as if, instead of the highly-polished mirror, the former reflector has now become transparent, as if without its silver coating; and the very short waves instead of being reflected and refracted from point to point, pass right through the transparent mirror out into space. There are indeed some mirrors made with a very light silver coating, through which light will pass; so that you can see the light right through the mirror. This analogy holds true with the Heaviside Layer, when it comes to ultra short waves; and this is the reason why, when we work with ultra short waves, it is no longer possible for us to get a signal originating much beyond the horizon.

Thus, if you have a transmitter on the ground, and a receiver about 25 miles away, it is necessary that the two shall be able to "see each other." If the transmitter or the receiver is placed beyond the horizon, so that the curvature of the earth intervenes, no transmission is possible normally. There are some exceptions to this, as Marconi has pointed out, since he has found it possible to go as far as some 137 miles and still have reception. What the exact action is, in this case, we do not know today; but even Marconi admits that most of the energy goes right out into space and is lost. Only a small portion of the radio wave is received. It may be refracted in the air, just as sunlight is refracted in the atmosphere when it is possible to see the rays of the sun, although the sun has set below the true horizon.

Scientists, however, are pretty well agreed that, when it comes to ultra-short waves, most of their energy actually escapes into space, beyond the confines of the earth.

What happens to these ultra-short waves, as they travel through interplanetary space, never to return, no one, of course, knows at the present time. They are assumed to obey the same physical laws as light rays, which we see all

about us, coming from space. As the propagation of the ultra short waves is at the same rate of speed as that of light rays (*i.e.*, 187,000 miles a second) it will be seen that, if there is sufficient energy behind the waves, those directed towards the moon, for instance, will arrive on our satellite within $1\frac{1}{4}$ seconds. If directed toward our nearest planet, Venus, the ultra short waves would arrive in some $2\frac{1}{2}$ minutes—at the time of opposition, when the distance between the two planets is about 26 million miles. But this requires a sufficient amount of energy; because, if the energy behind them is too small, the distance reached by the waves will not be very great.

The ultra short waves may experience in open space other adventures of which we know absolutely nothing today. Scientists, for a number of years, have received so-called "echoes" from short-wave transmissions; the "signal" of the transmitted wave came back again sometimes after several seconds had elapsed since it was transmitted. This would call for another "ionized layer," far beyond the atmosphere of the earth, even beyond the orbit of the moon. That such an invisible sphere, millions of miles away from the earth, may exist is not impossible. It need not be, of course, an atmospheric layer; because at such distances from the earth we have almost a perfect vacuum. Yet there may be a "shell" of electro-magnetic force extending several million miles away from the center of the earth, of which we are, as yet, quite ignorant. Such a "shell" might be created from the combined effect of the earth's magnetism and the sun's magnetic field, and this terrestrial magnetic shell might have the necessary properties to reflect the ultra-short waves. This, at least, would account for the long-time echoes, which have actually been verified by a number of experimenters.

If this theory does not hold water, we are forced back upon the "dust-particle" theory. It is well known that the earth is continuously bombarded by microscopic meteorites, which actually fall by the million on the earth every day. Most of these meteorites are so small that they can only be called particles of dust; but this process goes on day after day, year after year. It is conceivable that, due to the action of the gravitational field between the sun and the earth, as well as the moon, there might exist such a dust shell, which would account for the echo action of the ultra-short waves. Of course, one guess is as good as another at the present time, and only long experiment by physicists will give the actual clue to the present riddle.

It seems that study of the action of short waves, in open space, will help us tremendously in our astronomical knowledge in years to come. Not only that but, from a practical standpoint, we are assured that, when rocket transportation comes, and when it becomes feasible to send rockets from the earth to the moon, and perhaps to other planets, it will be possible to effect radio communication by means of ultra-short waves, between the earth and the "space-flyers"—a thing that was not believed a few years ago, but which seems to be pretty well established today.

SHORT WAVE CRAFT IS PUBLISHED ON THE 5th OF EVERY MONTH

This is the January, 1934, Issue—Vol. IV, No. 9. The next Issue Comes out January 5th

Editorial and Advertising Offices - 96-98 Park Place, New York City

WHEN Little America SPEAKS

By H. WINFIELD SECOR

● OVER 10,000 miles of land and sea short waves will carry the voice of Little America. The first broadcast from Admiral Byrd's Antarctic Expedition was picked up from his vessel, the *Jacob Ruppert*, as it proceeded toward its destination down the west coast of South America. Regular weekly broadcast programs will be picked up from the Byrd Expedition while the ship is carrying his party of hardy adventurers to Little America, also from Little America itself after the radio, scientific, and food supplies have been landed on the ice and quarters established. The party expects to be able to support their antenna at Little America from the towers erected by the last expedition, but in the event that the severe Antarctic storms have blown them down, material for new towers is being carried by the new expedition.

The good ship *Jacob Ruppert* carries a remarkable assortment of radio transmitting and receiving equipment, most of it being of the short wave or high frequency type. The radio stores contain over 2000 pieces of transmitting and receiving equipment, weighing about three tons. Among other short-wave apparatus carried by the Byrd Expedition there are 10 transmitters, 14 receivers, 143 transmitting tubes, 440 receiver tubes, 115 quartz crystals, 23 microphones, 2 complete recording machines, and 55 measuring instruments.

Little America Will Talk to Us

Admiral Byrd's Second Antarctic expedition is carrying a complete 1000 watt transmitting set, which will enable programs to be broadcast from Little America to the Columbia Broadcasting System, and, through their central distributing plant, located in New York City, to fifty-nine key broadcast stations scattered across the United States. The Byrd broadcasts from Little America will also be sent via Columbia's short-wave station W2XE across the ocean to Europe, as well as Northward over Canada, and Westward across the Pacific. The broadcast from Little America can also be heard in various other countries, including Australia, where the signals from the 1000 watt transmitter may be picked up direct.

Weekly Programs from Byrd

So, every Saturday night at ten o'clock when Little America is put on the air thousands of listeners will hear the voices of Admiral Byrd and others in his expedition "way down south" in Little America, where the temperature may be anywhere from 50 to 80 degrees or more below zero. Admiral Byrd's

first expedition was well equipped with short-wave communication apparatus, but only official messages were sent by code from Little America and no broadcast programs emanated from the expedition itself. Elaborate plans have been worked out by the engineers of the Columbia Broadcasting System, with the help of experts of the Radio Corp. of America and T. S. McCaleb of Harvard University. A great deal

● SHORT WAVE listeners will hear the voices of Admiral Byrd and members of his expedition as they speak each week from *Little America*. This is, without a doubt, the most ambitious short-wave engineering feat ever attempted. The Columbia Broadcasting System, who have the honor of presenting the voice of *Little America* over 59 of their broadcast stations in this country, during the sojourn of the expedition in the Antarctic, are to be highly complimented. The airplanes and even the dog-sleds to be used by Admiral Byrd will all be fitted with short-wave transmitters and receivers.

of credit for the whole program, as finally worked out, is due to Edward King Cohan, technical director of the Columbia System.

How Little America Will Transmit Programs

The programs from Little America will not be picked up directly over the 10,000 mile gap to New York, but the 1000 watt transmitter and directive antenna at Admiral Byrd's quarters will carry the voice about 4000 miles to Buenos Aires, S. A., where a *relay station* has been arranged for. From this point another powerful short-wave transmitter will take up the work and instantly hurl the broadcast northward, where it will be picked up at the R. C. A. Communications receiving station at Riverhead, L. I. The program will then be transmitted over an 80 mile telephone circuit to New York City where the C. B. S.'s main studio and distribution center is located at 485 Madison Avenue. From here the program will be sent over the leased telephone wire circuit to fifty-nine broadcast stations of the ninety-odd in the Columbia System.

Broadcasts to Little America

Admiral Byrd's men will hear plenty of music, songs, and talks whenever the operators care to tune them in most probably, as those on the last expedition heard many broadcast stations, including those in Australia and other countries. If special programs are to be broadcast to Admiral Byrd's expedition at Little America, they will usually be staged in the Columbia studios in New York City, the program being transmitted by wire to the R. C. A. transmitting station at Rocky Point, Long Island. The powerful

short-wave *beam* stations located in Europe, particularly the German, French, English, and Spanish stations will undoubtedly be heard regularly in Little America. In the event that trouble is experienced in the reception of special programs intended for it, the programs can be relayed by short waves through other stations in the same way as the programs emanating from Little America are handled, via the relay station at Buenos Aires for example.

Radio Equipment on the Jacob Ruppert

The radio equipment installed in the operating room on board the *Jacob Ruppert* is almost parallel with that found on an important naval vessel. First, we have the highly important code or "CW" transmitting and receiving equipment, which handles the official business of the expedition via the Mackay radio system.

The special "broadcast" program emanating from the ship are transmitted by a special phone transmitting set using 1000 watts and employing large vacuum tubes, of course. One of the principal receivers installed on board the *Jacob Ruppert* is one of the famous National AGS communications type receivers. This type of receiver proves particularly valuable for operation on an expedition of this kind as it provides single dial tuning. A complete set of the special AGS coils, covering all conceivable wave bands, is included and mounted just above the receiver as the photo shows. Just above the receiver at the right of the panel, as shown in the picture, are four control knobs. These control the current in the four microphones installed in the ship's broadcasting studio, which is a small room about 6 x 8 feet and adjacent to the radio control room. So scarce is space for anything on board the ship that there are four bunks in the studio and four of the radio crew have their sleeping quarters here.

The ship's equipment includes receivers designed for reception on the broadcast, as well as the longer waves.

Trained Broadcast Men With Expedition

Those of our readers who have a bent for adventure will undoubtedly envy the two men the Columbia Broadcasting System sent with the expedition and who will stay with it during the two years' sojourn in the frigid wastes of the Antarctic. These two men are John N. Dyer, engineer, and Charles J. V. Murphy, who will act as production man and announcer.

It is really remarkable to see how completely the whole Byrd radio pro-

(Continued on page 551)

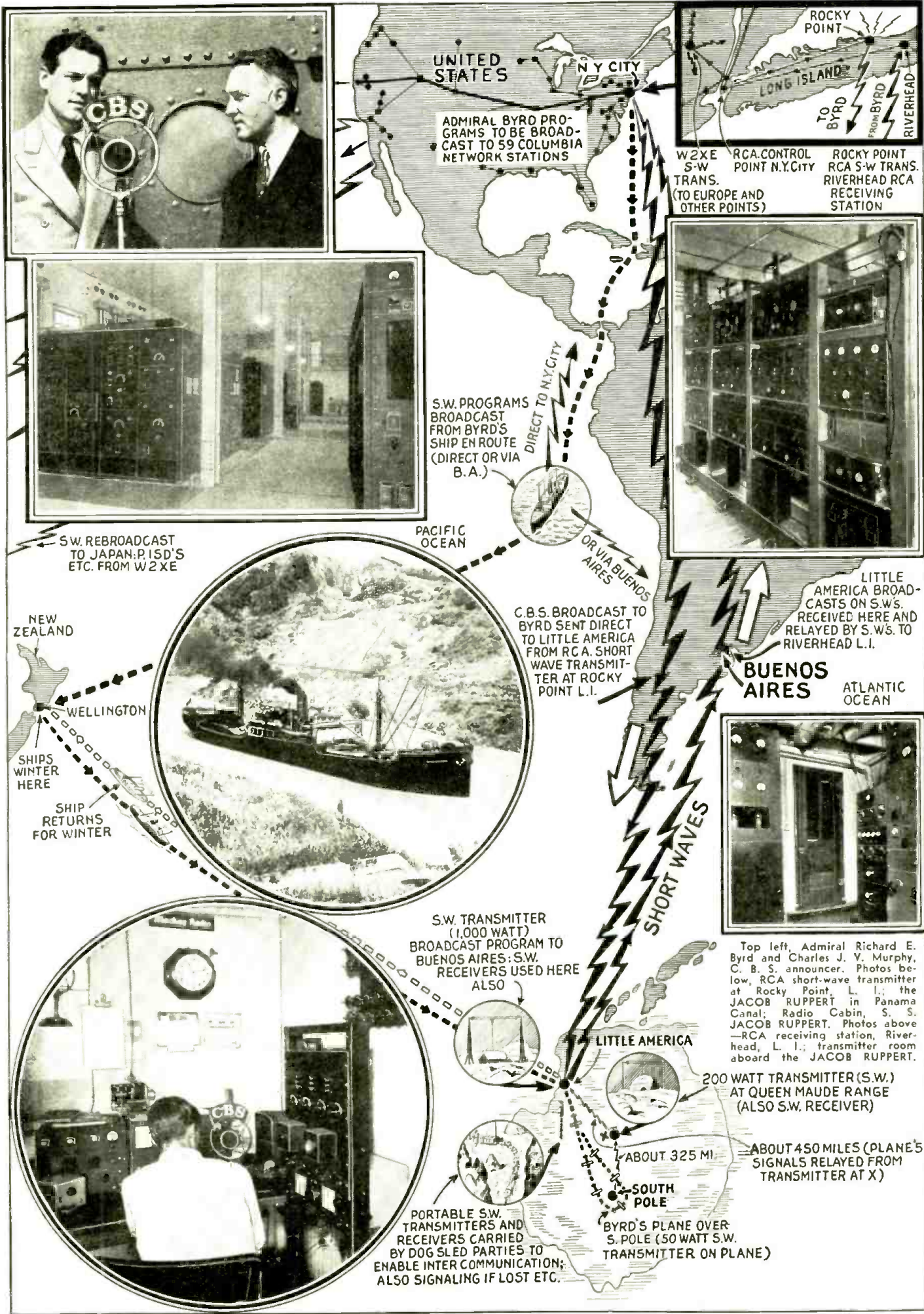

Top left, Admiral Richard E. Byrd and Charles J. V. Murphy, C. B. S. announcer. Photos below, RCA short-wave transmitter at Rocky Point, L. I.; the JACOB RUPPERT in Panama Canal; Radio Cabin, S. S. JACOB RUPPERT. Photos above —RCA receiving station, Riverhead, L. I.; transmitter room aboard the JACOB RUPPERT.

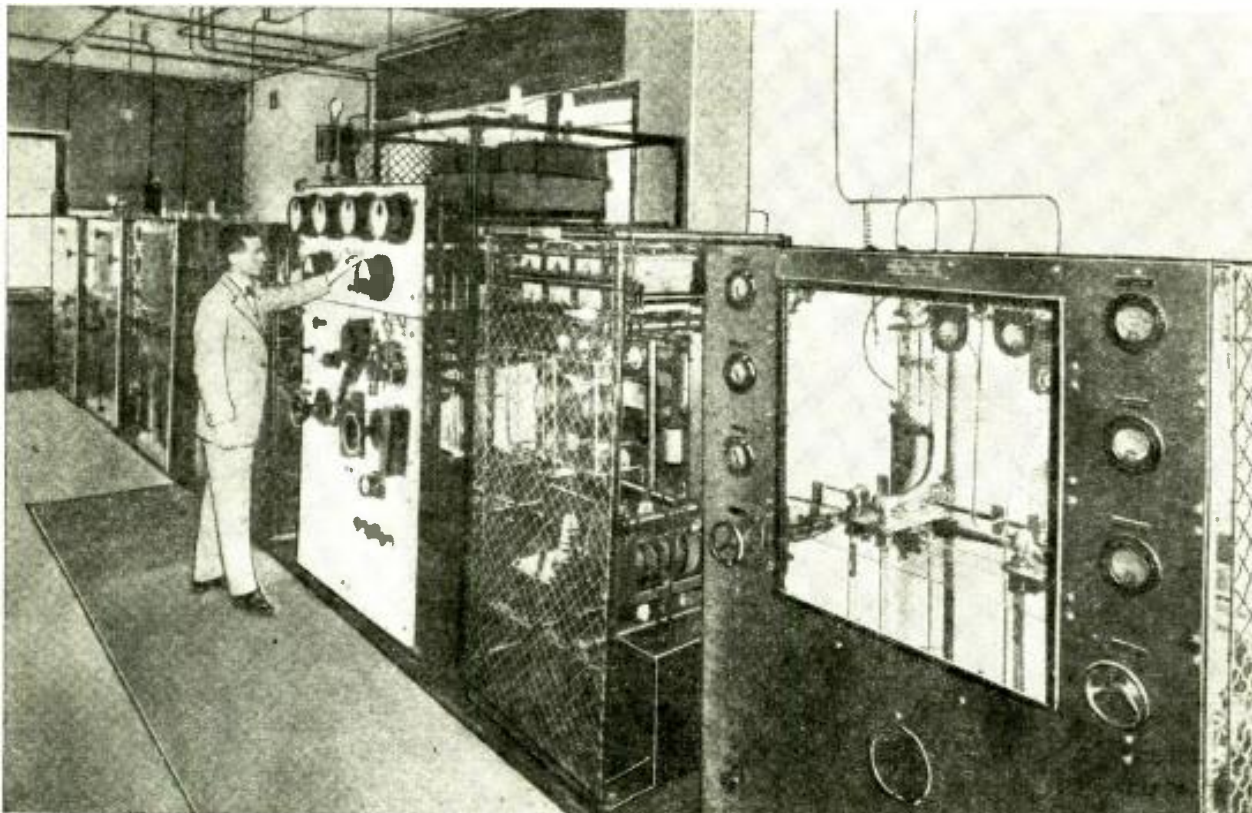

The 20 kw. short wave transmitter of station VK2ME, designed and manufactured in Australia by Amalgamated Wireless (A'sia) Ltd. and installed at A. W. S. Radio Centre, Pennant Hills, near Sydney, for use in the A. W. A. World-wide Broadcasting Service.

VK2ME—The Short-Wave VOICE OF AUSTRALIA

● THE short wave World-wide Broadcasting Service of Amalgamated Wireless is effected from Station VK2ME which is located at the A. W. A. Radio Centre at Pennant Hills, 14 miles from Sydney.

15 Transmitters at VK2ME

At Sydney Radio Centre, which comprises an area of 40 acres, more wireless transmitters are located under one roof than at any other place in the Southern Hemisphere. Here fifteen transmitters are situated, some of them working almost constantly.

The main mast is 400 feet in height and many aeriels are suspended from it to smaller masts, each aerial system provides a different service.

The studio of VK2ME is situated at the headquarters of Amalgamated Wireless in York Street in the city of Sydney, and it is from here that all programs are transmitted via land-lines to "Radio Centre," at Pennant Hills.

60 K.W. used for 1 Set

The largest transmitter installed at Sydney Radio Centre is the 20 k.w. combined telegraph-telephone transmitter. Actually over 60 k.w. is required to operate this transmitter. 22 large oil and air-cooled tubes are used and these are mounted in 7 separate units.

The transmitter of VK2ME was specially designed for Empire and World-

wide broadcasting and the station is known as "The Voice of Australia."

On July 5th, 1931, A. W. A. inaugurated the first regular "world-wide" broadcasting service arranged in an entirely new way, inasmuch as different sections of the world were served by a program at a time most suitable for reception and relay in the respective

VK2ME and 3ME are two outstanding short-wave stations in every short-wave fan's "log." Listeners in the eastern U. S. hear them regularly in the early morning hours. VK2ME is the official short-wave voice of Australia. These stations are the famous "mile-posts" by which listeners judge the DX range of their sets; as they are practically half-way round the globe they represent the prime tests for American receivers.

countries. To accomplish this the transmissions are divided into four periods; the first session covers the western portion of North and South America; the second embraces the southern and eastern portions of Australia, New Zealand, Papua, New Guinea, Fiji, New Caledonia, the New Hebrides and other islands; the third covers Western Australia, China, Japan, Philippine Islands, the Straits Settlements and most of India, and the fourth serves Great Britain, Western Europe, South Africa, Rhodesia and Egypt.

VK2ME is on the air every weekend and uses a wave-length of 31.28 metres which has been proved suitable for long distance work.

Time Schedule

It is well-known to radio engineers that at various times of the day radio stations are heard at particular places better than at other times. After about two years of experimenting, the company's engineers worked out the time of the day or night at which VK2ME is best received in various countries. In the light of this information programs are radiated at the following hours:

	Sydney Time	E. S. Time
1st Session Sunday	3-5 p.m.	12 m.-2 a.m.
2nd Session Sunday	7:30-9:30 p.m.	4:30-6:30 a.m.
3rd Session Sunday	9:30-11:30 p.m.	6:30-8:30 a.m.
4th Session Monday	1-30-3:30 a.m.	10:30 a.m.-12:30 p.m.

The program of VK2ME comprises both classical and popular musical

items, but jazz music is omitted. A few waltz compositions are broadcast and usefulness is added to the program by talks on many phases of Australian life. The Australian National Travel Association prepare many of these talks and there is an abundance of evidence that residents of many parts of the world have been favorably impressed with Australia as a place to be visited when opportunity affords.

VK2ME Heard in England Fine

Many "overseas" records have been effected through VK2ME, Sydney. To Australia fell the honor of transmitting the first Empire broadcast program on September 5th, 1927. The reception in Great Britain was remarkably successful, and the program was re-broadcast by the British Broadcasting Corporation to "crystal set" users and other listeners throughout Great Britain. It is estimated that over one million listeners heard the program!

This was followed on October 17th, 1927, by the second and what might be termed the first world-wide program through station VK2ME. This was the first occasion in Australia on which programs were transmitted on dual wavelengths—the normal wavelength of station 2FC, 422 metres for local reception, and that of the special experimental Station VK2ME, 28.5 metres, for overseas reception and re-broadcasting by the British Broadcasting Corporation.

The world-wide interest occasioned by the Eucharistic Congress in Sydney was increased by A. W. A. transmitting the proceedings to England and America through Station VK2ME, and the successful re-broadcasting in the latter country.

VK2ME Transmitted Program to Byrd

Another notable transmission was effected on January 10th, 1930, when the singing and talking portions of the Paramount "talkie" film, "The Love Parade," starring Maurice Chevalier, were transmitted from the Prince Edward Theatre, Sydney, to Admiral (then Commander) Byrd at the South Pole. The transmission was effected on the 20 k.w. overseas transmitter de-

signed and manufactured in Australia by A. W. A.

About half an hour after the transmission, Commander Byrd signalled back via San Francisco and A. W. A. Radio Centre, Pennant Hills:

"2ME Sydney. As Paramount's most southern representatives, at Antarctica, we are pleased to report your fine broadcast of the Paramount Sound Picture, 'The Love Parade,' enjoyed and greatly appreciated. This is the first sound reproduction received here. Admiral Byrd and inhabitants of the Antarctica join us in thanking you for your program and best wishes.—Joseph Rocker and Willard Van de Veer, Paramount's Cameramen in Byrd's Antarctic Expedition."

Station VK3ME, Melbourne.

VK3ME, the Melbourne short wave experimental station of Amalgamated Wireless (A'sia) Ltd., has been in operation with regular programs for two and a half years, and during that time its transmissions have been intercepted in all parts of the world.

The station operates on a frequency of 9510 k.c. (31.54 metres) and conducts a schedule made up principally of recorded music, each Wednesday from 8 p. m. to 9:30 p. m. Eastern Australian Standard time, and each Saturday from 8 p. m. to 10 p. m. E.A.S.T.

In spite of the fact that the aerial power of the station is less than 2 kilowatts, VK3ME puts down a considerable field strength not only in Australia, but in many overseas countries, particularly the United States of America.

Prior to the commencement of a regular scheme of transmission, the station was used extensively for long distance experimental work, and in collaboration with the General Electric Company of America much valuable data was secured. A notable example of two-way working in which VK3ME and W2XAF, Schenectady, N. Y., took part, was the occasion on which the Rotary Club of Melbourne and the Rotary Club of Schenectady conducted a joint meeting some eighteen months

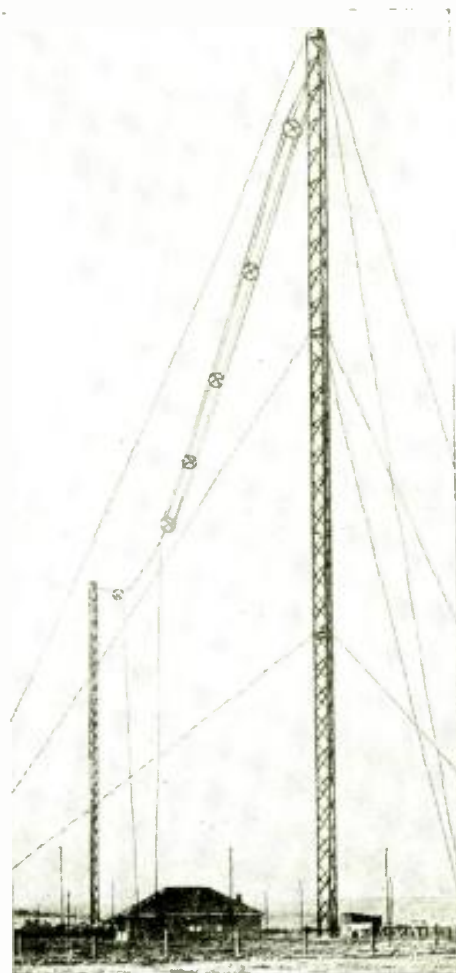

Masts of station VK3ME, Melbourne at A. W. A. Radio Centre, Braybrook, Victoria, Australia.

ago. Loudspeakers in the respective club-rooms rendered the distant proceedings audible, and the signal from each end was of such strength and clarity as to render the experiment a complete success.

Since the regular service was inaugurated, some thousand or so letters have been received from listeners outside

(Continued on page 548)

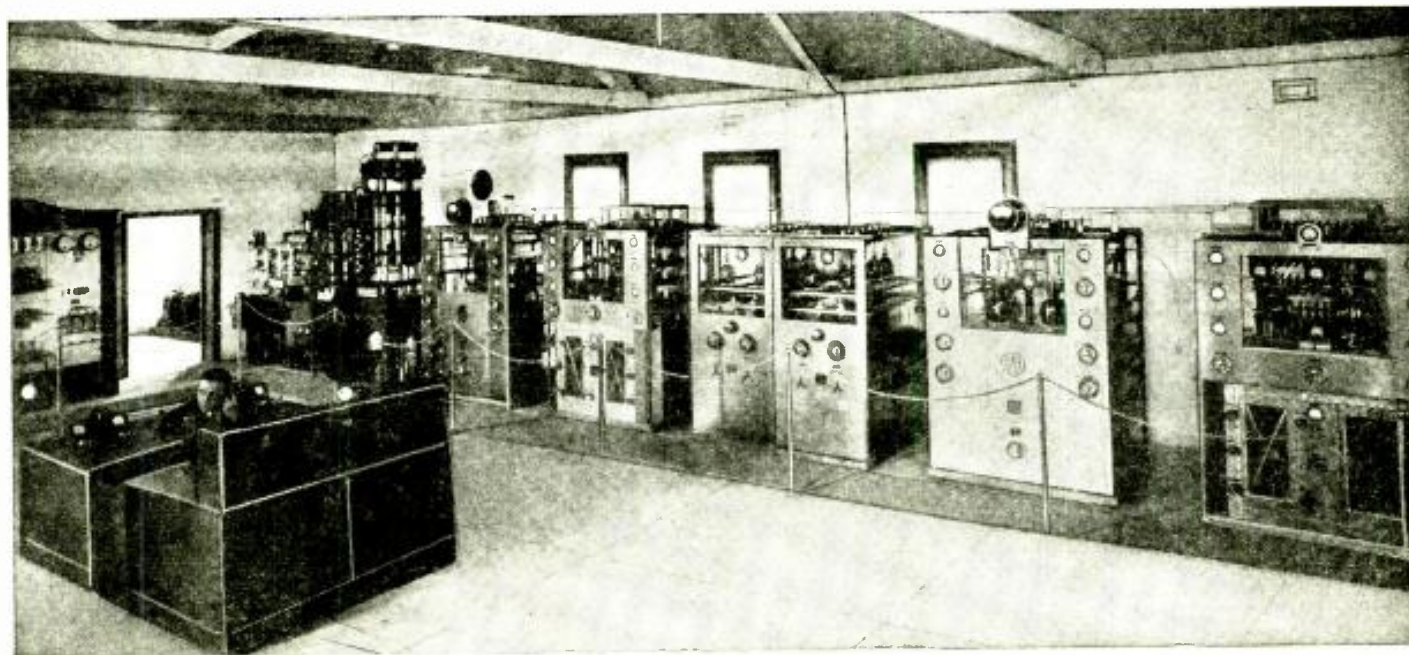

The transmitter of station VK3ME, Melbourne, situated at Radio Centre, Braybrook, Victoria. This Australian-designed and manufactured transmitter is used in the World-wide Broadcasting Services of VK3ME.

The 2-Tube "CHAMP" In Which 2 Tubes = 3

\$20.00 Prize Winner for October
By JACK WARING and
HAROLD MITCHELL



Left—here we see the 2-tube "Champ" in action! Thanks to the new two-element tubes, this set actually lives up to its name and gives the same results as though 3 tubes had been used.

The rotor plates of the main tuning condenser and the other side of the plug-in coil connects to ground. The screen-grid of the detector goes directly to the arm of the regeneration control at which point it is by-passed to ground with a half microfarad condenser. One side of the regeneration control which is a 100,000 ohm potentiometer, goes to ground and the other side goes to a 150,000 ohm resistor which in turn connects with the high voltage or "B" positive.

The cathode of the 6F7 tube is connected to ground through a five hundred ohm resistor which is by-passed with a tenth microfarad condenser. The grid of the triode portion of the "Six-F-Seven" tube goes to a one megohm resistor to ground and to a .01 mf. condenser. The other end of this condenser goes to the "B" positive terminal of the tickler winding of the coil socket through an R.F. choke.

The tickler coil end of the radio frequency choke is by-passed to ground



● INVARIABLY the Short Wave fan or Beginner prefers to "Break the ice," with a one tube or two tube short wave set, and it is because of this that the "2-Tube CHAMP" was designed.

In this compact little two tube short wave receiver we use only two tubes and yet we really get the results of three, and still better than that, many of the major foreign, and practically all of the local and domestic stations operate a speaker.

One of the many features of this set is that it uses one of the new tubes, the 6F7, in conjunction with a '37 type tube. The six volt tubes have been selected in preference to the conventional 2.5 volt tubes since all of us do not have 110 volt A.C. available. We may have to content ourselves with 110 volt D.C., or then again we may want to make it a portable affair. Therefore the power supply must be constructed to meet with your requirements or preference.

The 6F7 Tube

The new type 6F7 tube is a Pentode-Triode (really two tubes with a common filament), in one bulb. One of the many advantages in using this type tube is that you not only save the cost of additional parts, but valuable space as well. And you actually do get the result of two tubes.

Description of Set

The set is built up of mostly National parts. The pentode portion of the 6F7 operates as the detector, and the triode portion as the first audio amplifier. Beginning with the high frequency end of the set we connect a lead from the antenna or aerial post to the stator plates of the antenna trimming condenser. This condenser has a capacity of .000025 microfarad, and its function is to adjust, or permit adjustment of the antenna circuit. From the rotor

plates of this condenser, which incidentally is insulated from the chassis, we bring a lead to the grid side of the plug-in coil socket and to the stator plates of the main tuning condenser, which has a capacity of .00015 microfarad. From this point also we bring a lead to a .0001 mf. mica grid condenser which is shunted by a two megohm leak, or resistor. To the other side of this grid condenser and leak is connected the lead which goes to the control grid of the pentode portion of the 6F7 tube which is the terminal on the top of the tube.

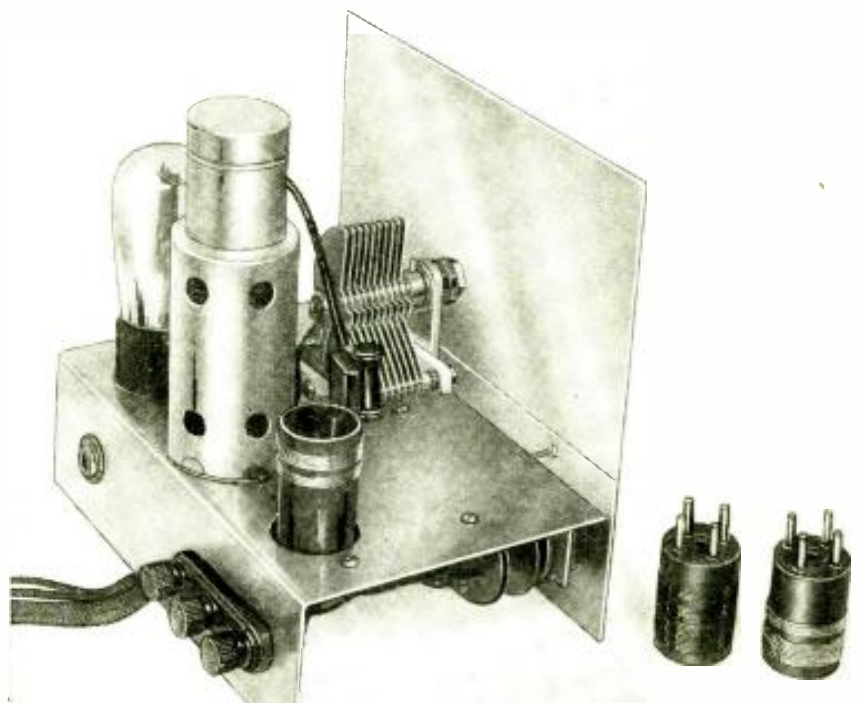

Rear view of the 2-Tube "Champ" which actually gives the same results as any ordinary 3-tube set; phones or loud speaker may be used.

through a .00025 mfd. condenser, and to the other end of the choke is connected a 250,000 ohm resistor the other side of which goes to "B" positive. The other side of the tickler winding, or the plate terminal of the coil we connect to the plate of the pentode section of the 6F7 tube.

The plate of the Triode portion is connected to a coupling condenser of .01 mf. and to "B" positive through a 250,000 ohm resistor. The other side of this coupling condenser goes to the grid of the '37 type tube socket and to a one megohm resistor to ground.

The cathode of the '37 type tube is now connected to a one thousand five hundred ohm bias resistor the other side of which is connected to ground.

To the plate of the '37 type tube we run a lead to one of the output terminals. The other output terminal goes to "B" positive.

"B" minus naturally goes to ground or chassis.

There is nothing very complicated about this set however, careful wiring is recommended for the success of this delightful little receiver, which is very easy to operate and it makes one of the dandiest little stand-by receivers you ever saw or heard, and is therefore ideally suited to the "Ham" that is particular.

There are no special adjustments to be made. After the wiring is completed, it should be carefully checked, and if correct, you are ready to tune in

Everyone is interested in obtaining the greatest output from a radio set using the least number of tubes. Here we have an ultra modern 2 - tube receiver which has actually brought in European stations on a loud speaker. This set uses two of the latest style tubes and it makes an ideal "low-cost" set for the beginner, while the few parts used render its construction very simple.

short wave stations, after having connected a suitable power supply.

The coils are wound on the National small type forms which are made of the new "low-loss" insulating material for high frequencies known as R-39.

The physical dimensions are: panel 7 x 6½, and the chassis 7 x 4 x 2. Both panel and chassis are made of aluminum.

Parts List

- 1 National Dial type B
- 1 National R.F. Choke 2.5 M.H.
- 1 National Tuning condenser type SE-100 (100 mmf.)
- 1 National .000025 mf. Variable condenser
- 1 .0001 mf. condenser
- 1 .00025 mf. condenser
- 2 .01 mf. condenser
- 1 .1 mf. condenser
- 1 .5 mf. condenser
- 1 2 megohm resistor Lynch
- 2 1 megohm resistor Lynch
- 1 150,000 ohm resistor Lynch
- 1 100,000 ohm resistor Lynch
- 1 250,000 ohm resistor Lynch
- 1 1,500 ohm resistor Lynch
- 1 '37 type socket
- 1 6F7 type socket
- 1 UX blank socket
- 1 500 ohm resistor Lynch
- 1 100,000 ohm potentiometer; Acra-test
- 1 chassis 7 x 4 x 2
- 1 panel 7 x 6½

Data for Winding Coils

Range in meters	Grid—size wire	Plate—size wire
14 to 22	6 turns 26 D.C.C.	6 turns 26 D.C.C.
20 to 40	12 turns 26 D.C.C.	8 turns 26 D.C.C.
40 to 80	25 turns 26 D.C.C.	12 turns 26 D.C.C.
80 to 200	45 turns 30 D.S.C.	15 turns 30 D.S.C.

Leave 3-16 inch space between grid and tickler coils. Dimensions of coil forms—1½ inch long by 1 inch in diameter; National 4-pin, special low-loss R-39 insulation forms.

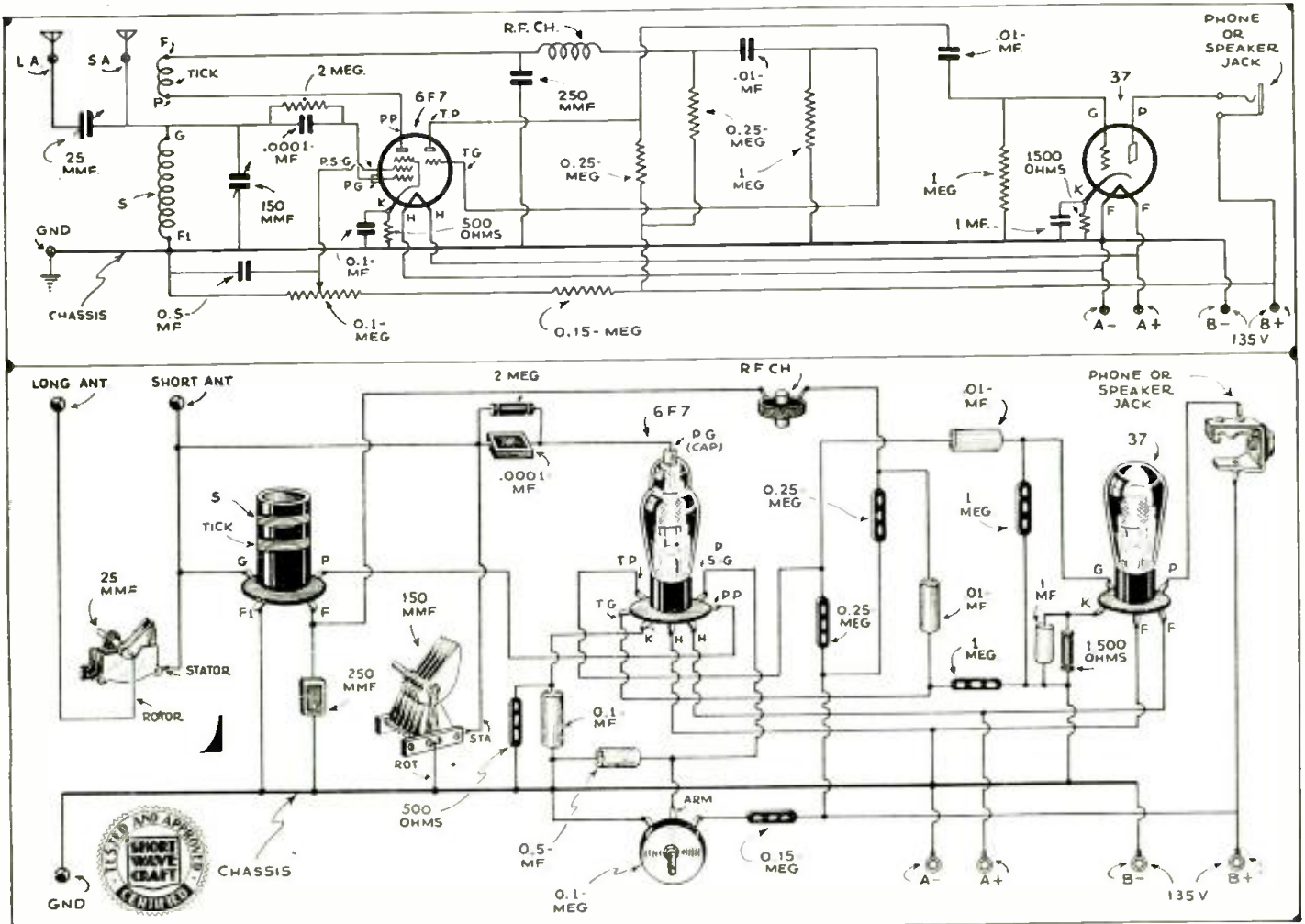

After all, most of us go into the short-wave game for the "fun" we get out of it. The 2-tube "Champ" is so simple to build and wire, with the aid of the picture diagram above, that it is really fun to build the set. And wait till you hear the distant stations roll in like a charm! Oh Boy!

A Symmetrical Input Super-Regenerative Receiver

By **H. GRANGER**
and **H. H. HILL**

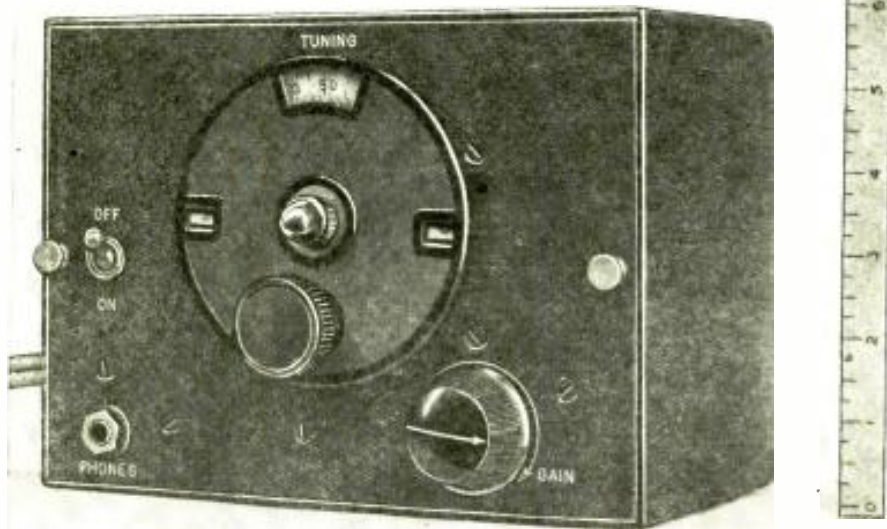

Front view of the "symmetrical input" super-regenerative receiver developed and here described by Messrs. Granger and Hill.

● THE super-regenerative receiver has some advantages, such as very high gain with few tubes, but in some cases, its inherent disadvantages, such as relatively high noise level, make the experimenter want something better. An effort is made herein to present a super-regenerative receiver that the average experimenter can build for use in the 56 megacycle band. A great many radio experimenters can not afford to build a super-heterodyne receiver for use on these high frequencies and at the present time, about the only thing remaining that is at all suitable for use at ultra high frequencies is the super-regenerative receiver. The new receiver described in this article has several novel features, is small, relatively cheap, and in it, all of the bad features of the ordinary super-regenerative receiver have been reduced and some have been entirely eliminated.

Consider the super-regenerative circuit shown in Fig. 1.

The point of maximum stable regeneration in a straight regenerative circuit is reached just below the point of zero input resistance. When the detector is in this condition, the incoming signal "triggers" the circuit into oscillation. Oscillations take place for a few cycles during each signal impulse and high amplitudes are obtained in the plate circuit. If the input circuit contains enough positive resistance to quench oscillations between successive signal impulses, the circuit is maintained at a high degree of sensitivity.

Theoretically, the super-regenerative detector is adjusted to the point of zero or slightly *negative* input resistance and, if the variation frequency is not applied to the detector, it will oscillate continuously and will not be in the most sensitive condition. This is due to the fact that oscillations are built up to considerable amplitude and, therefore, the incoming signal voltage is less effective in changing the plate current

than is the case when the detector is held just at the point of oscillation, so that it is "triggered" into oscillation by the incoming signal, allowed to oscillate for a few cycles and then stopped oscillating by injecting a positive input resistance into the circuit.

Conditions for Maximum Amplification

The conditions for maximum amplification in a super-regenerative circuit are such that the input circuit is at zero, or at a slightly negative resistance at the beginning of each signal impulse. Then after the signal has "triggered"

the circuit into oscillation, there is some means of introducing negative resistance so that high signal amplitudes are rapidly built up in the plate circuit. When this signal disturbance has passed through, say fifty or so cycles, and the maximum amplitude, as limited by tube and power is reached, there is introduced a positive resistance in the input circuit to quench the oscillations and restore the circuit to a high state of sensitivity.

As stated above the super-regenerative detector in Fig. 1, theoretically is adjusted to zero or slightly negative input resistance. A low frequency potential from the variation oscillator is applied to the detector grid. At the beginning of each positive half of the variation frequency cycle the detector begins to become extremely sensitive and thereby is in condition for "triggering" by the incoming signal. The incoming signal impulse "triggers" the detector into oscillation and the plate current amplitude rapidly builds up to the maximum value determined by the tube characteristics and the variation frequency. During the negative half of the variation frequency cycle the detector is blocked (which is equivalent to the introduction of positive input resistance) and the circuit is practically dead. Thus, the detector is kept in the region of zero input resistance where it is extremely sensitive.

This may be stated in another way by the aid of Fig. 2.

The variation frequency shifts the operating point from a high negative

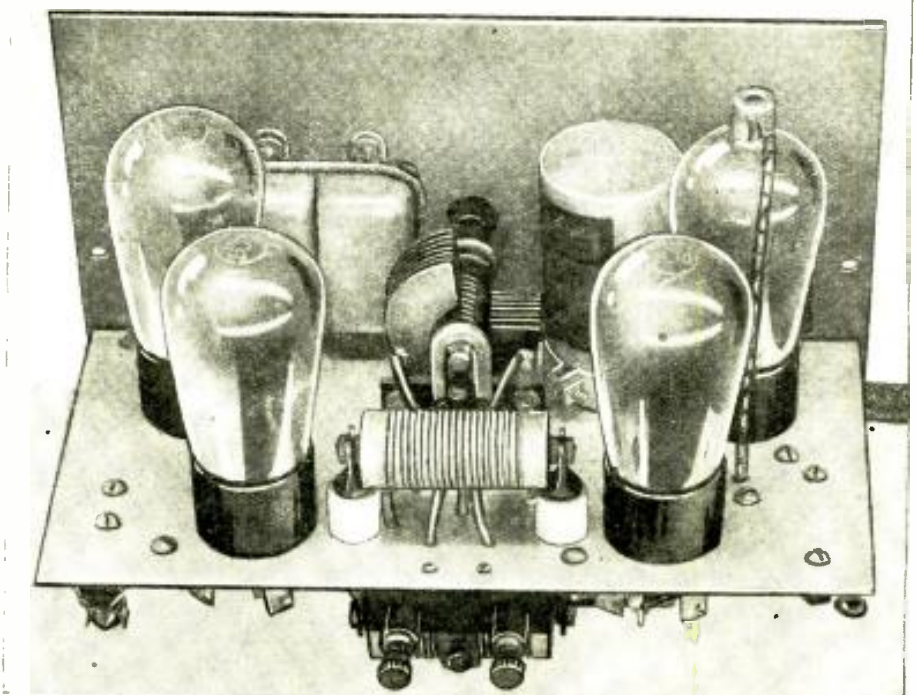

How the new "symmetrical input" super-regenerative set looks from the rear.

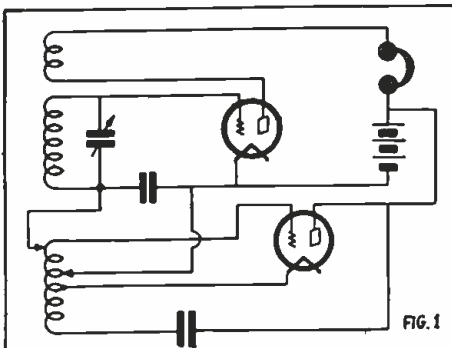

bias where the detector is blocked (Point C), to a point that gives high amplitude of plate current (Point B). The variation frequency is governed by the following factors:

- (a) The signal impulse in the detector plate circuit should be given time enough to increase to maximum, or near thereto, as limited by tube and power.
- (b) The frequency of the variation oscillator must be such that the periods of regeneration are sufficiently close together that the sound variations of the voice frequencies as encountered in telephony are faithfully amplified.
- (c) The frequency of interruption of regeneration must not be so low as to cause a disturbing hum or whistle.

From the above it can be seen that, for reasonable quality, the variation frequency must be relatively high. On the other hand, for code signals, the lower the variation frequency used, within limits, the greater is the amplification that will be obtained. This in-

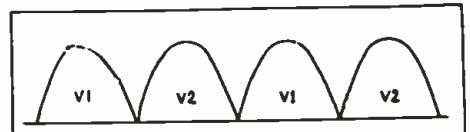

FIG. 6

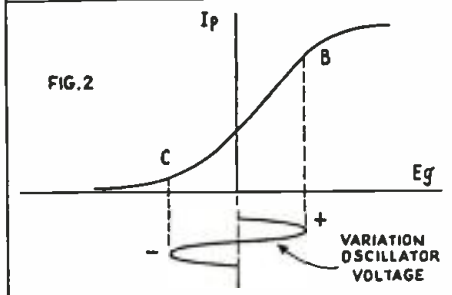

FIG. 2

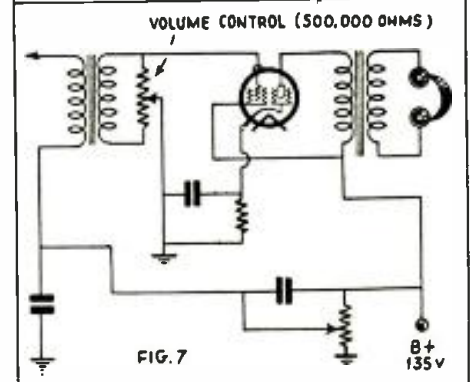

FIG. 7

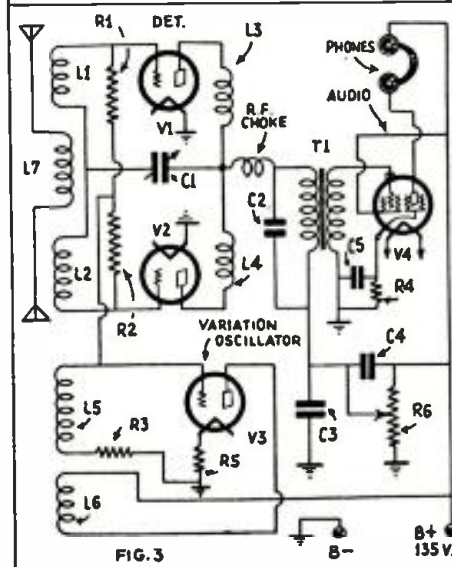

FIG. 3

The super-regenerative receiver has been given but scant attention by short-wave experts, and except on the very high frequencies there have been a number of undesirable features manifested in this type of receiver. The authors of the present article have performed a lot of research on the super-regenerative receiver and they give the benefits of their findings herewith, together with a description of the super-regenerator circuit which they recommend. Not only is the improved super-regenerative circuit, which the authors advocate, very sensitive but the "noise-level" has been tremendously reduced—a most important factor!

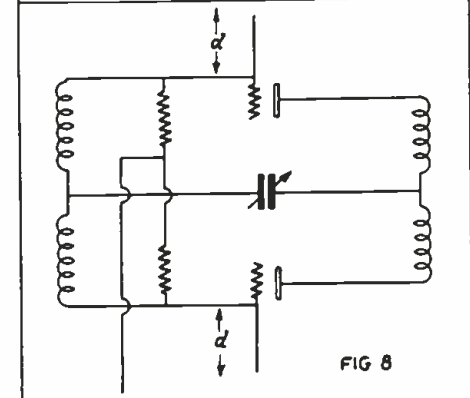

FIG. 8

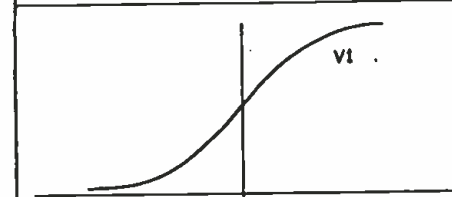

FIG. 4

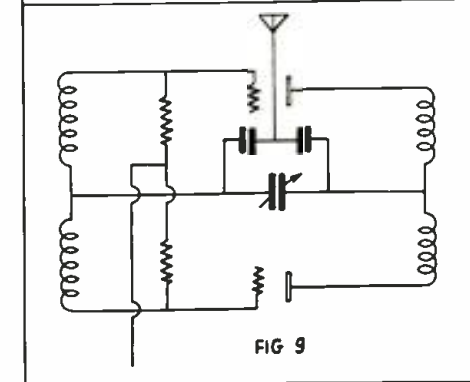

FIG. 9

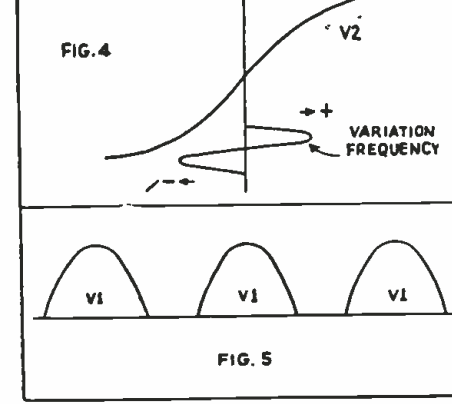

FIG. 5

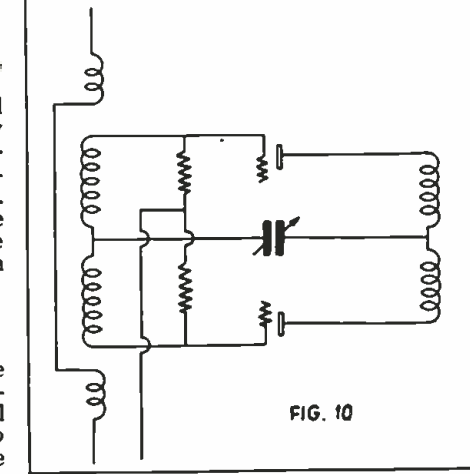

FIG. 10

Figs. 1 to 5 above show: a super-regenerative circuit; action of variation oscillator voltage; improved "symmetrical input" super-regenerator circuit, and, in Fig. 5, detector tube action in super-regenerator.

indicates that a compromise must be used for best results. A variation frequency of between 10 and 50 kilocycles is normally used for code work. If the variation frequency is much less than 50 kcs. for phone work, distortion results due to the fact that all components of the modulated signal are not amplified in proportion.

Efficiency Increases Rapidly With Signal Frequency

It may be said in general that the efficiency of the super-regenerative receiver increases rapidly with the signal frequency. Mr. A. K. Laing, in *Radio News*, January, 1926, states that the amplification obtained at 3,000 kilocycles was nine times as great as that obtained at 1,000 kilocycles. Others have stated that the amplification due to super-regeneration at 8,000 kilocycles was approximately 100 to 1 over
(Continued on page 569)

Fig. 6, double detector tube action; 7, volume control and output transformer hook-up; 8, preferred antenna coupling; 9, another type of coupling, and 10, the final coupling scheme.

5 and 10 Meter Transmitter

Using the 800 or 825 Tubes

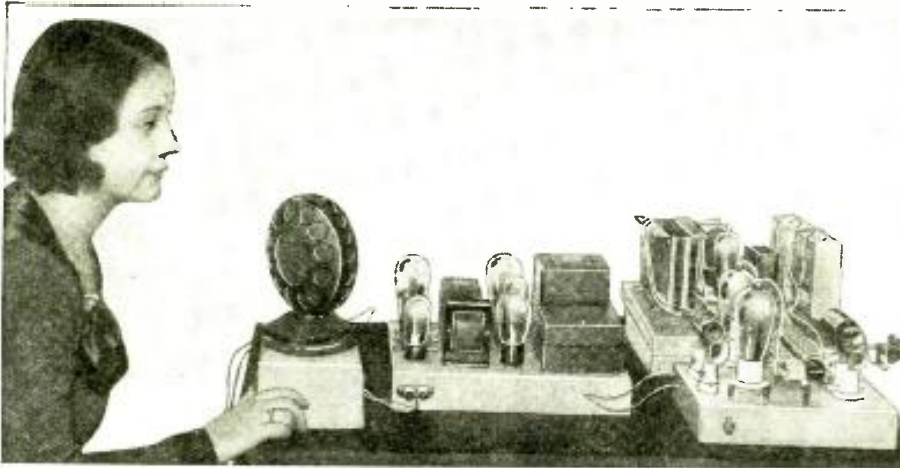

The 5 and 10 meter transmitter ready for action; the mike shown happens to comprise an old "commercial" shell, enclosing a moderate-priced amateur type microphone unit.

● **ACTIVITY** has greatly increased on the five meter amateur band within the last few months and if past performances are to be considered there should be a constant further increase of interest throughout the winter.

Here in the East (around New York City) each week brings new stations to the five meter band and seldom does a single night pass with no active stations to be heard, whereas a few months ago one could listen for weeks at a time without hearing even a lone station calling CQ.

New equipment has been made available to the amateur within the last six months that should find high favor on the five and ten meter bands. Most prominent of these new apparatus is the new ultra-high frequency tubes, which give very high radio-frequency output at 60 megacycles. It has been a more or less popular opinion that low power was sufficient for the five meter band. In cases of excellent locations this has, in general, proven true. But, we do not all have large enough pocket-books to choose our location and have to be content with what we are fortunate enough to have. And it is in these cases that the greater power made available with the new tubes comes in and saves the day.

Higher Power Does Count!

The writer has conducted tests on the five meter band with several types of transmitters of various power outputs and has found that higher power *does* actually give a greater communication range in all respects. We must bear in mind the fact that the present super-regenerative receiver used extensively on the ultra-high frequencies is a very insensitive piece of apparatus, especially to comparatively weak signals. A weak signal has a small chance of competing with the terrific hiss produced by the average super-regenerative receiver. Of course everyone knows that the ultra-high frequency receiver is doomed to take, should we say a gigantic step forward in design, but until then we will have to improve

our transmission and let the other fellow worry about reception.

It is the purpose of this article to bring forth a transmitter, which, while not of the highest possible power, shall combine greater stability and considerably higher power and efficiency than any of our former transmitters and still be comparatively simple and not too costly to construct.

New Tubes Spell "More Power"

This transmitter is constructed to facilitate the use of the new RCA Radiotron type 800 (or Sylvania 825) tubes, which have at this writing, just made their appearance on the market.

By
GEORGE W. SHUART,
W2AMN



Reports from many "Hams" during the past month indicate that interest in the 5 and 10 meter field is increasing by leaps and bounds. Several leading "Ham" station operators have complimented Mr. Shuart on the excellent quality and steadiness of the wave radiated by the 5 and 10 meter transmitter here described. Mr. Shuart has thoroughly tested this transmitter and has talked over distances exceeding 30 miles; the possible range is, of course, much greater than this.

While these tubes are rated to stand around a thousand volts on the plate no attempt was made to operate them at this value, 650 being the highest voltage applied. With a thousand volts on the plates of these tubes, it would be necessary to have a master-oscillator-amplifier arrangement to main-

(Continued on page 552)

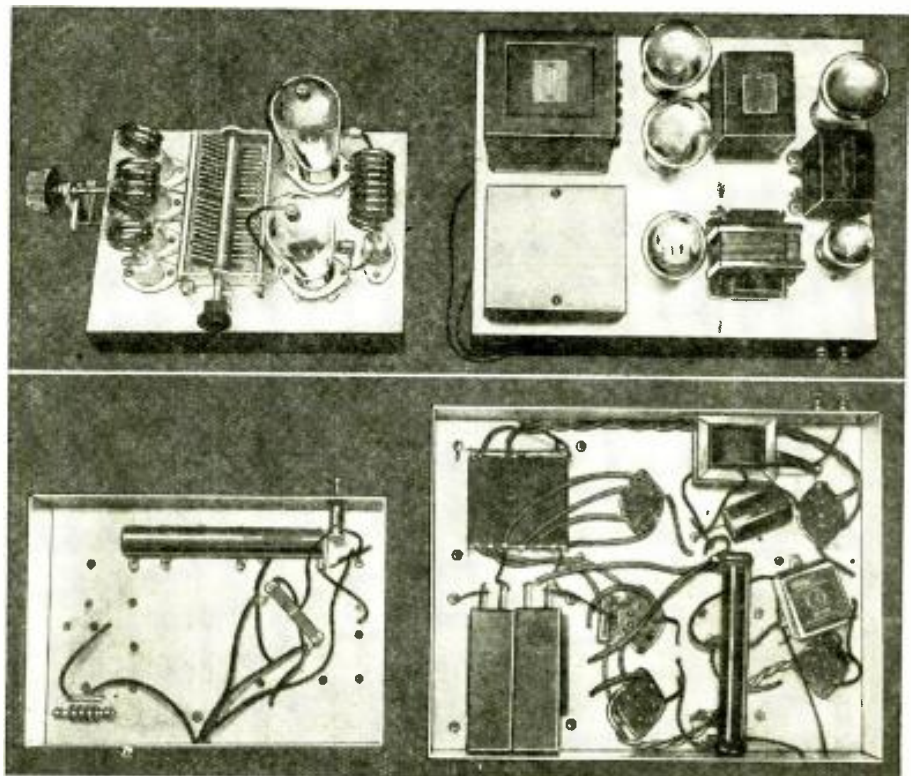

The two photos above show top and bottom views of the 5 and 10 meter push-pull oscillator and modulator, the latter having its own power supply "huilt in."

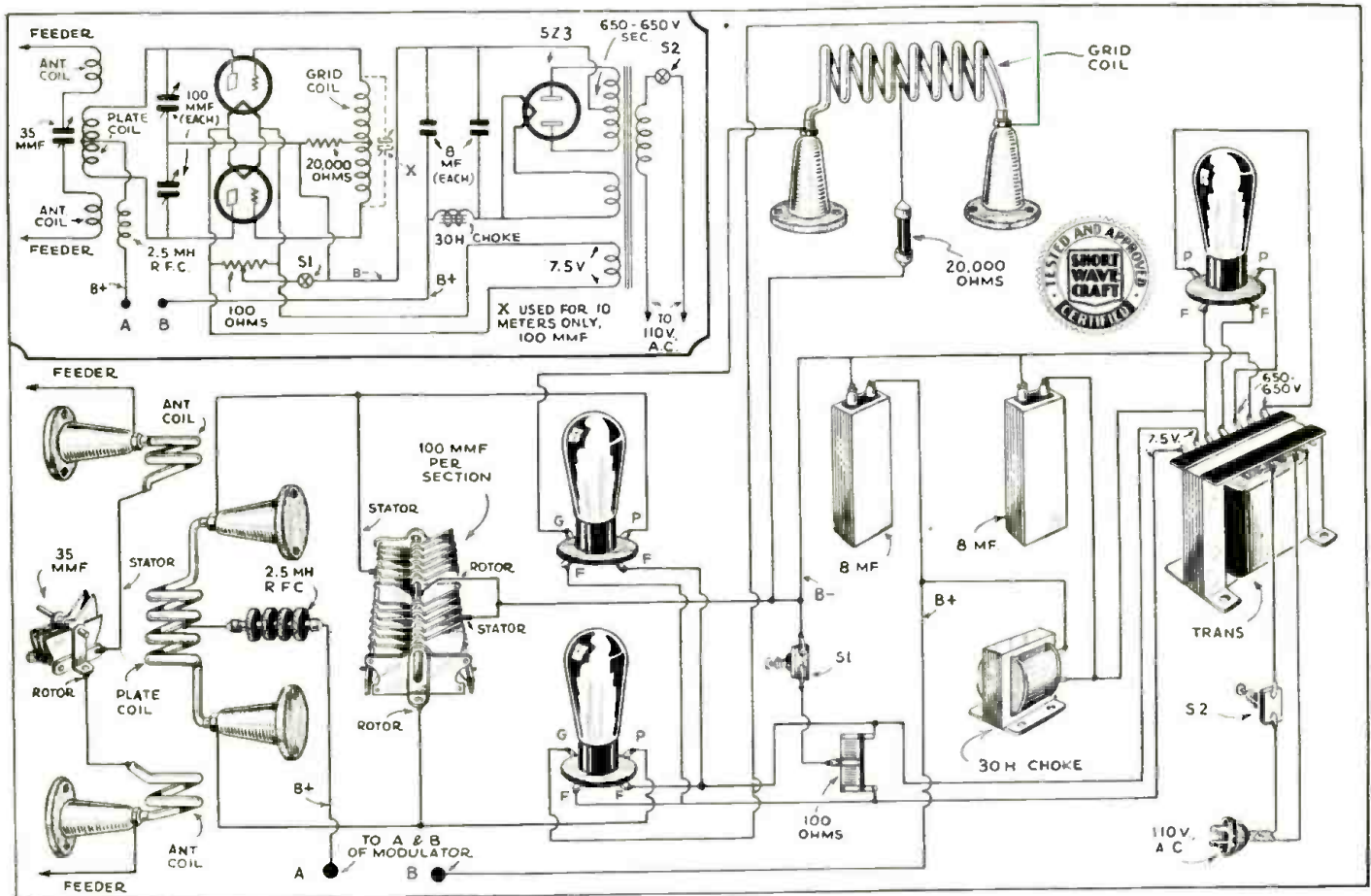

The schematic and picture diagrams above show how the various parts used in Mr. Shuart's 5 and 10 meter push-pull oscillator and power supply are connected together.

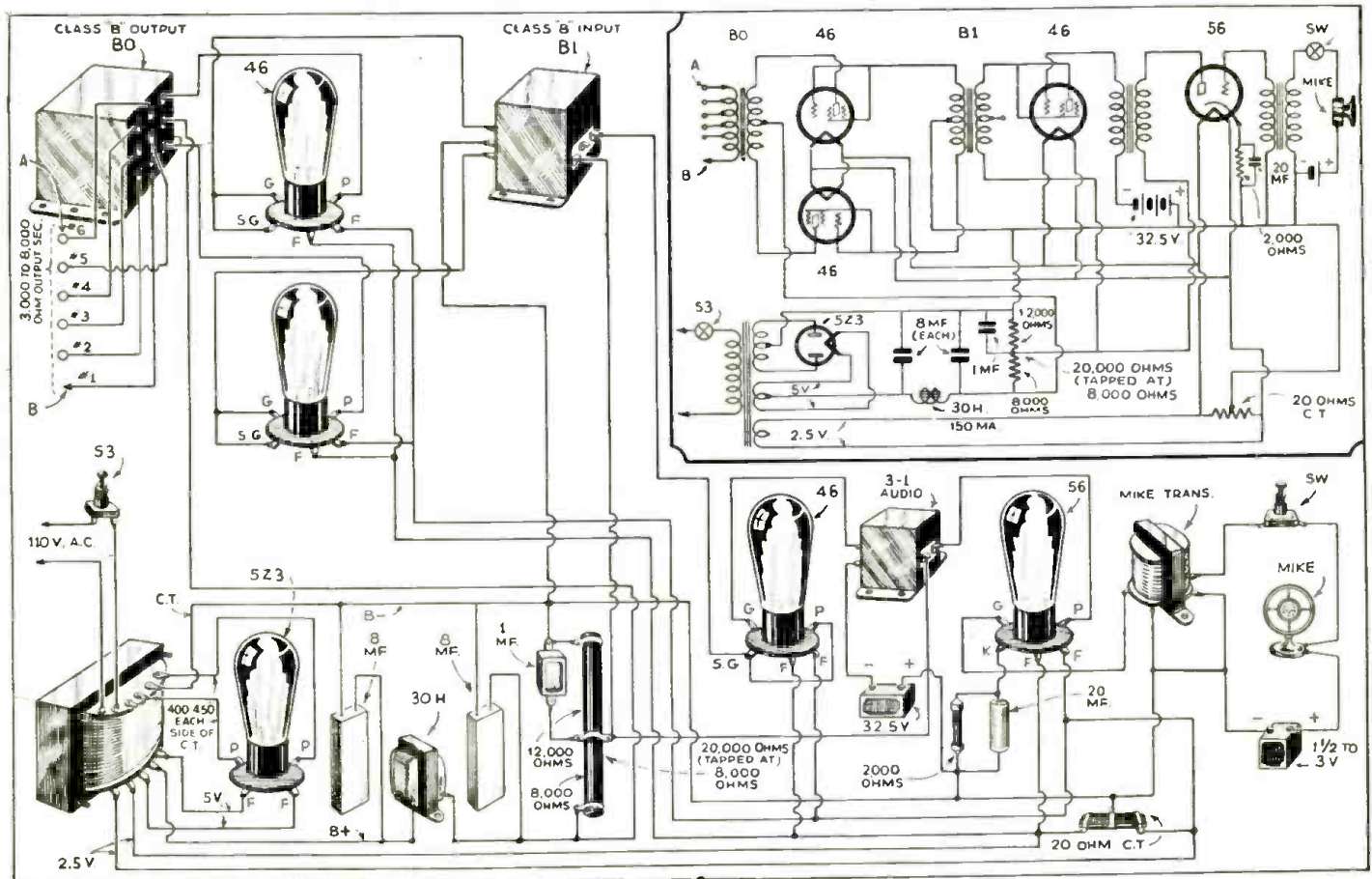

Here we have the schematic and physical wiring diagrams for the modulator unit used to excite the oscillator of the 5 and 10 meter push-pull transmitter.

Low-Power Modulator

By LEONARD VICTOR, W2DHN

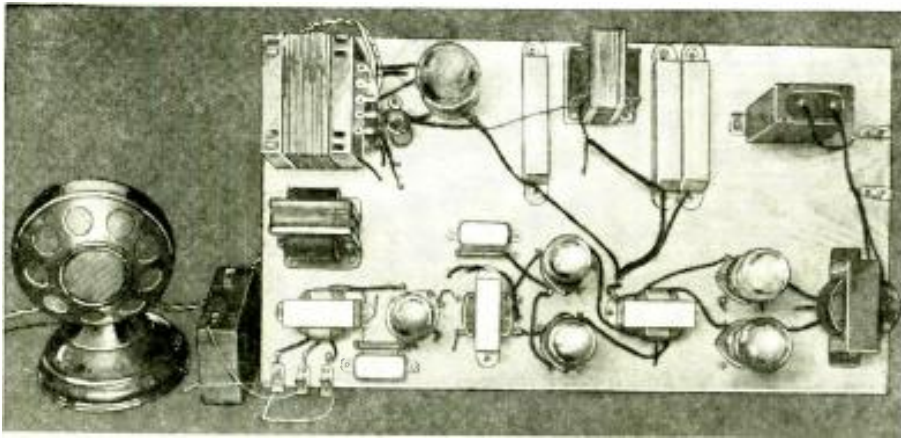

Top view of the low-power modulator, together with microphone and battery shown at the left of the photo.

Last month Mr. Victor described how to build an improved amateur CW transmitter, with crystal control, which would conform with the latest rules of the F.R.C. In the present article Mr. Victor tells how to build a low-priced yet efficient modulator for use with it.

● LAST month's transmitter story described an 80 or 160 meter code transmitter that is exceedingly adaptable to *phone* work. This transmitter uses *crystal control* which obviates the worry about frequency modulation and allows the modulation of the stage following the oscillator. Also, with this transmitter, it is possible to put out a good strong carrier with 100% modulation, using quite inexpensive apparatus. Any low-power rig must have excellent stability and very good quality. The transmitter described last month, coupled with the *modulator* unit described in this article, adequately meets all the requirements for good low-power operation.

The radio frequency amplifier, using a type '46 tube, is capable of taking 20 watts of power while being fully modulated. Hence, our problem was to secure some modulator (which in reality is only a speech power-amplifier), which would deliver 10 watts of undistorted audio, with good quality, and still not use any costly equipment.

Ordinary audio amplification, known as class "A," is very low in efficiency. To get our needed ten watts of audio, it would be necessary for us to use more than 100 watts input, which is much more than the entire radio frequency end of the transmitter uses.

Recently, however, a new system of audio, known as *Class A Prime*, has

come into common use. This system is a hybrid, somewhere between class A and class B in operation. Efficiency with Class A Prime is of the order of 35%, which is much better than the 8% to 10% efficiency obtainable with straight Class A.

One of the new tubes on the market, known as the 2A3, is admirably suited for "A Prime" operation. This tube is a triode, the big overgrown brother of the type '45. A pair of these tubes, operating in push-pull, will deliver between 10 and 12 watts of undistorted audio with only 250 to 300 volts on the plate. Second harmonic distortion with these tubes is very low.

At this point it might be advisable to again repeat the rules for matching the modulator to a radio frequency amplifier. (Continued on page 554)

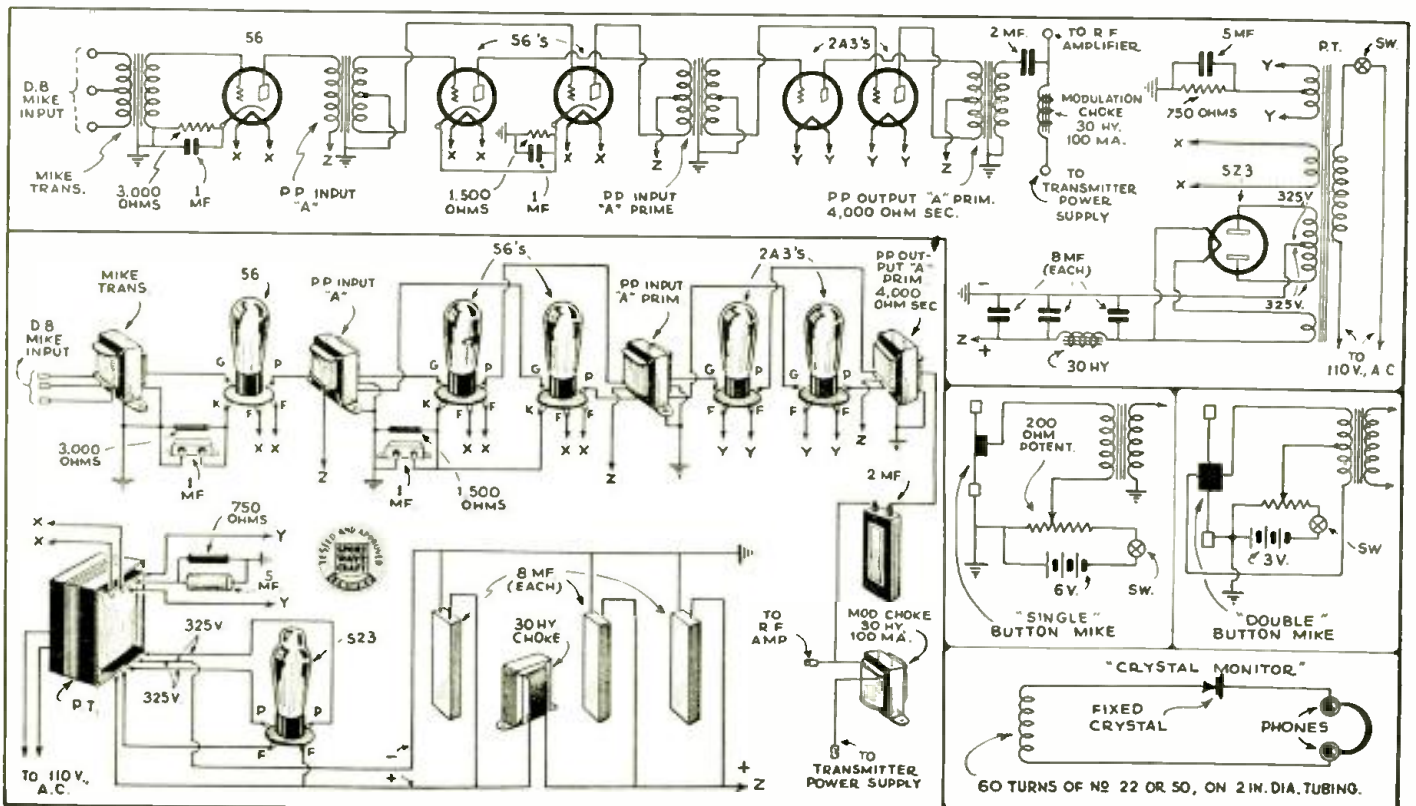

Wiring diagrams, both schematic and physical, for building the modulator here described by Mr. Victor are reproduced above; also, details for connecting single and double button mikes.

SHORT WAVE SCOUTS

FIRST "TROPHY CUP" WINNER

● THE first monthly contest for the silver "trophy cup" to be awarded to the SHORT WAVE SCOUT who submitted the log containing the greatest number of short-wave stations, properly verified, closed November first. Due to the short length of time between the first announcement of the SHORT WAVE SCOUT Trophy Cup Contest and the date of the first contest closing, November 1, only two entries were received. The first prize goes to Heinie Johnson, who wins the SHORT WAVE SCOUT silver trophy cup for the contest which closed November 1; the second entry, received from Warren Mallory, who is awarded Honorable Mention in the October contest.

Mr. Johnson used the well-known "National 45" receiver, with an added stage of tuned radio frequency which he built in ahead of the regular chassis line-up. Mr. Johnson, the winner of the trophy cup in the first or October contest, employed transposition lead-ins connected to specially tuned doublets and he also had at his disposal a directional underground antenna system.

We are pleased to present the "logs" of Messrs. Johnson and Mallory herewith and we hope to have a greater number of interesting short-wave "logs" to present to you next month, the second contest closing December 1.

Messrs. Johnson and Mallory have now pointed the way and have hung up a target for all of you short-wave "fans" and "hams" to start shooting at—let us see if you can beat them, and incidentally, win one of the handsome Silver Trophy cups which SHORT WAVE CRAFT is offering in accordance with the following rules.

On this page is illustrated the handsome trophy, which was designed by one of New York's leading silversmiths. It is made of metal throughout, except the base, which is made of handsome black Bakelite. The metal itself is quadruple silver-plated, in the usual manner of all trophies today.

It is a most imposing piece of work, and stands from tip to base 22½". The diameter of the base is 7¾". The diameter of the globe is 5¼". The



Presented to
SHORT WAVE SCOUT
Heinie Johnson
For his contributions toward the
advancement of the art of Radio
by
SHORT WAVE CRAFT
Magazine

The purpose of this contest is to advance the art of radio by "logging" as many short-wave commercial phone stations, in a period not exceeding thirty days, as possible by any one contestant. The trophy will be awarded to that SHORT WAVE SCOUT who has logged the greatest number of short-wave stations during the month for which the award is made.

This contest will close every month for the next twelve months on the first day of the month by which time all entries must have been received in New York. Entries received after this date will be held over for the next month's contest.

A monthly trophy will be awarded to the short-wave scout who has logged the greatest number of "short-wave" stations during the month for which the award is made. In the event of a tie between two or more contestants, each logging the same number of stations, the judges will award a similar trophy to each contestant so tying. Verifications must be sent with the list of stations heard (the verification cards will be returned) and each contestant is entitled to report a maximum of ten per cent of the

station calls listed, without verification cards. List of stations heard must be typed or written in ink; no pencil allowed. Send everything in one package prepaid. Use a single line for each station and state type of receiver used. Do not list "amateur" stations—only "commercial phone" stations; no CW or code stations! Address all entries to SHORT WAVE SCOUT AWARD, 98 Park Place, New York City.

work throughout is first-class, and no money has been spared in its execution. It will enhance any home, and will be admired by everyone who sees it.

The trophy will be awarded every month, and the winner will be announced in the following issue of SHORT WAVE CRAFT. The winner's name will be hand engraved on the trophy. The lettering on the wide lower silver band reads as follows:

ENTRY FOR FIRST SHORT WAVE SCOUT AWARD

Station	Frequency	Schedule
GSE, Daventry, Eng.	11965 KC	7 to 8:45, 9 to 11, heard best at 10.
GSE, Daventry, Eng.	15140 KC	7 to 8:45, 9 to 11, heard daily at 8.
GSD, Daventry, Eng.	11750 KC	11 to 1, 1:15 to 5:45, heard daily at 1.
GSE, Daventry, Eng.	9510 KC	11 to 1, 1:15 to 5:45, heard daily at 5.
GSG, Daventry, Eng.	17790 KC	7 to 8:45, only heard and reported once.
One verification only—see letter on above reception report.		
PHL, Holland	16:83 Meter	7:30 to 9:30, daily, heard irregular.
EAQ, Spain	30 Meter	5:30 to 7 Sat., 1 to 3, Loudest on air.
VEJR, Canada	25.6 Meter	Always on air at 7 p.m.
2RO, Italy	25.4 Meter	12 to 1:30, I hear that woman daily.
VEGW, Canada	6095 KC	See Carl Heard Evenings.
El Prado, Ecuador	45:31 Meter	9 to 11 Thurs., strong signal.
HVI, Italy	15120 KC	Mornings, confirmation not here yet.
FYA, France	19.68 Meter	Mornings, talks French until 10 daily.
W3XAU, Phila., USA.	60:60 KC	See card
W3XAU, Phila., USA.	31:28 Meter	See card.
W9XQ, Chicago, USA.	49 M. Band	See letter.
W9XF, Chicago, USA.	49 M. Band	See letter.
W3XAL, U. S. A.	49:18 Meter	Evenings.

W8XK, U. S. A.	25:26 Meter	Heard daily around p.m.
Q8XK, U. S. A.	13:93 Meter	Heard irregular in mornings.
W3XAL, U. S. A.	16:87 Meter	Daily, 10 to 4, see letter.
W8XAL, U. S. A.	49 M. Band	Mornings and evenings irregular.
W2XE, U. S. A.	25:36 Meter	3 to 5 p.m.
W2XE, U. S. A.	19:64 Meter	11 to 1.
W3XL, U. S. A.	46:70 Meter	Friday evenings, lately on air nightly.
DJB, Germany	19:73 Meter	Heard daily 9:30 to 10

Twenty-six Stations.

"Honorable Mention" Goes to Warren Mallory

The following are short-wave (verified) stations I received:

Call Letters	Freq. KC.	Schedule	E.S.T.	Location	Identification sign.
EAQ	9,860 KC.	Daily from 5:30-7:30 p. m.		Madrid, Spain.	announced EAQ in English
GSD	11,750 KC.	Irreg. from 2:00-4:00 a. m. and from 5:00 a. m. to 8:00 p. m.		London, England.	Chimes of Big Ben heard
DJD	11,760 KC.	Daily from 10 a. m.-4:50 p. m.		Berlin, Germany.	at intervals piano notes are played over and over again.
DJB	15,200 KC.	Daily from 8:00 a. m.-1:40 p. m.		Berlin, Germany.	signal same as DJD

(Continued on page 539)

First Trophy Cup Awarded To Heinie Johnson

Short Wave Scout Award, New York.

Gentlemen:

Inclosed find my list for first award contest. I have inclosed verifications on all but two which have not arrived to date. I picked two that are easy to hear here for my allowed 10% of unverified.

I have reports in now on VK2ME-3ME-XETE and 27 others which should arrive soon, sorry can't count them but let's stick to the rules. Announcer read my name over HC2RL. I get everything that is "on the air" as a rule, but could not find DENNE when they were scheduled recently.

I use a "National 45" S-W receiver with an added stage of T.R.F. built in ahead; fed by transposed lead-ins from special tuned doublets and directional underground antenna system.

Have sent Daventry consistent reports on 5 carriers.

HEINIE JOHNSON,
Big Springs, Texas.

SHORT WAVE LEAGUE



HONORARY MEMBERS

Dr. Lee de Forest
John L. Reinartz
D. E. Replogle
Hollis Baird
E. T. Somerset
Baron Manfred von Ardenne
Hugo Gernsback
Executive Secretary

Should the "Code Test" Be Abolished Below 6 Meters?

He Favors "No Code" Below 5 Meters

Editor, SHORT WAVE CRAFT:

For the last year I have read code arguments pertaining to no code under five meters. I just finished reading the November issue of *SHORT WAVE CRAFT*. I have noticed no other argument than this—"if others can learn the code why can't the rest?" Perhaps they could learn the code but what good is it if they are going to use phone? I don't see why if some beginner wants to use phone in his coming station, a license should not be provided for phone just as there is for code. I am not saying that some "punk" with no idea what radio is all about should be permitted to do this, but that an examination very much like the present one, except for the code test be given him. If this test is "stiff" enough no "punk" will get a license.

I noticed a letter some time ago where the writer said something about going and asking the "old men" of radio how important code was. Well, if we are to forever remain back in the "code days," phone will never come into perfection. Why not give the "little fellow" a chance? The perfection of phone below five meters means a great deal. Besides, if the heads of the League should have said, "No code on all amateur bands"—that would have been different. The five-meter bands are not being extensively used and they would not interfere with the present "hams." What is more, the sending range of these experimenters would be limited. As far as saying how marvelous some of the "hams" are, why all you hear on some bands is "ear-splitting" code. There is only one thing the matter with most present hams—THEY ARE SELFISH and do not want to see others get any privileges. If the hams would lend a little more cooperation maybe this "no code" business would get somewhere.

ROBERT MILLER,
646 North James St.,
Hazelton, Pa.

P. S. I am not afraid to sign my address like J. S. Waring, for fear of being "swamped" by protests!

Keep Code and Make "Exam" Stiffer

Editor, SHORT WAVE CRAFT:

I have been reading *Short Wave Craft* since the good old days when it cost "four bits," and I wish to say that I think that it has all the other magazines beat by the distance that you can send on twenty meters! But, I have one thing that I would like to get "off my chest."

I think that there should be a code law on any band. Any person who hasn't the ambition to learn the code would certainly not have the ambition to build a decent phone transmitter. The biggest share of those in favor with the "no code" exam are beginners, who think that the *tank* on a transmitter is where the water is kept to cool the tube. Hi.

In J. O. Roberts letter of the October number, he states that the "brass pounders" haven't the ambition to build a phone trans-

mitter; now I ask you, what would a "rank beginner," who hasn't even enough ambition to pass the simple code test do? There are enough "bum" stations operating, without having a whole lot more even ones cluttering up the air with a bunch of "broad" phone stations! I think that the examination should be made harder instead of easier. In this same letter Mr. Roberts states that "anyone can rig up an oscillator or an osc.-amp, and zig-zag out into space"; evidently he has never tried to build one, or his note would be a bit more D.C. for C.W.

call sometimes on 80 meters (3,600 kilocycles).

B. J. JONES,
265 Main St.,
Rockland, Me.

(Call letters not given.—Editor.)

"No Code" Would Increase Interference, He Says

Editor, SHORT WAVE CRAFT:

Although the movement discussed in your magazine for a codeless examination for amateur radiophone operation will probably die out anyway, I desire to add my voice in protest to it.

If one were merely sentimental an examination of this type could be opposed on the grounds that it would destroy all of the glorious traditions of amateur radio. And to those who sneer; every such thing must have traditions for creation of interest and enthusiasm.

Now to look at the matter practically. Amateur radiodom in the recent past was issued its 40,000th license, which is entirely too high a number for the narrow frequency bands which are now allotted to them. If the doors were thrown open to all comers the great increase in licenses would literally swamp the phone bands now in use, so that operation for anyone would become extremely difficult. There are some of the code-less "fans" (not HAMS you notice) who desire this feature for the 5-meter band only. They apparently cannot realize the "bedlam" that would result in the crowded metropolitan areas like New York and Chicago if there were not some restriction to cut down the number of stations.

Another point deals with the large numbers; that of legislation. The government has already been forced to cut down expenses to an absolute minimum and as large an increase of applicants as would result from a code-less examination would greatly increase the cost of license legislation of our already over-taxed Commission.

Most of those in favor of Code-less Examinations have never become familiar with radio frequency oscillators or amplifiers of the types used in transmitters. They should therefore become familiar with them in C. W. use where improper adjustment will not cause as much interference as in radiophone use.

Many of the fans in favor of a code-less phone examination insist that code is a dying method of communication. These fellows might look up the disaster which occurred when the U.S. Navy gave phone a tryout for communication purposes. We all know the Navy has the most reliable and extensive system of communication in the world today.

Just in case any of the fans think I am a confirmed C.W. man who knows nothing of phone; I have not only an amateur unlimited phone license, but a commercial Radio telephone First-Class license and Second Class Radiotelegraph license. Phone has been used here at my station in the past, although C.W. is used at present.

C. W. ARNOLD, (W4ZP)
2317 West End Ave.,
Nashville, Tennessee.

Get Your Button!

The illustration here shows the beautiful design of the "Official" Short Wave League button, which is available to everyone who becomes a member of the Short Wave League.

The requirements for joining the League are explained in a booklet, copies of which will be mailed upon request. The button measures 3/4 inch in diameter and is inlaid in enamel—3 colors—red, white, and blue.



Please note that you can order your button AT ONCE—SHORT WAVE LEAGUE supplies it at cost, the price, including the mailing, being 35 cents. A solid gold button is furnished for \$2.00 prepaid. Address all communications to SHORT WAVE LEAGUE, 96-98 Park Place, New York.

I have my license, and I don't see why anybody couldn't pass the same test, code included, as I did.

Well, now that I have that taken care of, I again wish to congratulate you on having such a "FB" magazine. More power to you.

MARVIN L. FARR,
775 Twenty-third Street,
Ogden, Utah.

Built Our Transmitter Successfully

Editor, SHORT WAVE CRAFT:

After reading the *SHORT WAVE LEAGUE* magazine for the past two years, I find that it is the craft for Hams to use. My dealer is a live wire and sees that I get my issue on time, as he knows I would be disappointed if it was a day late. So keep up *SHORT WAVE CRAFT*.

As a member of the LEAGUE just keep the *SHORT WAVE CRAFT* flag flying at all *SHORT WAVE CRAFT* readers' homes. I went to work on one of the transmitters that was described in *SHORT WAVE CRAFT* and built it; I successfully worked districts—W, 1, 2, 3, and 5, 6, 8 and 9 and VE 1, 2, and 3. This transmitter however so far worked 137 different Hams, from QSA5 to R4 to R9. I am getting started on Leonard Victor's rig and would like to hear from other members of the LEAGUE. Give me a

"Short-Cuts" for "Short-Wave" Fans

Antenna Reel

● HAVING recently built a portable two-tube Doerle receiver, with self-contained "A" and "B" batteries, in a wooden case and aluminum front panel, I desired a little better portable

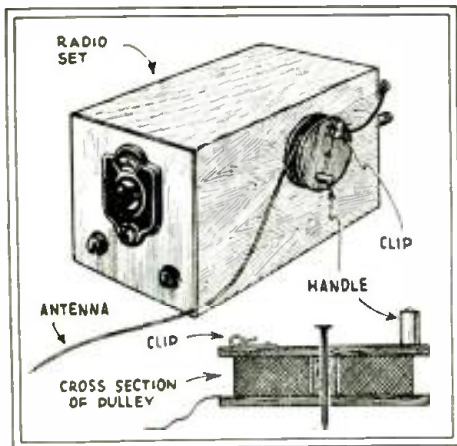

A nifty idea for an aerial to be used on a portable short-wave receiver. By means of the handle shown the aerial can be quickly reeled up.

aerial to use with it. I looked in my junk-box and discovered an old King battery set. This was of the flat type and the surprising thing about it was that it contained sixty feet of No. 20 D.C.C. copper wire.

By fastening this to the side of the case, by means of a screw and putting a screw and brass collar on the spool for a handle and a Fahnestock clip for the beginning of the winding, I can reel out anywhere from one foot to sixty feet. I have a simple connection to the set by means of the flexible cord, which I snap into the clip after reeling out the desired length of aerial.

This straight wire type aerial works better, even though it is the small size wire, than many so-called "trick loops," "cages," etc.—W. R. Scheetz.

Antenna to "Plate"—A Novelty

● HERE is a circuit with the antenna coupled to the set through a fixed .006 mf. Cond. to the plate of the detector tube. This set works excep-

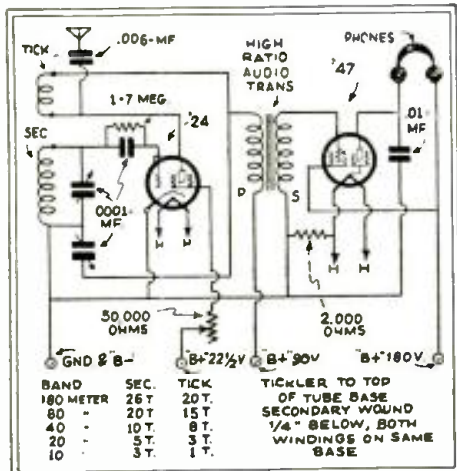

Mr. Perry had some interesting results with this unusual circuit, the antenna being connected to the grid instead of the grid circuit.

tionally well on any of the amateur bands as well as on the broadcast band and brings the stations in with a wall-plop that is sufficient for a speaker. It will oscillate with ease down as low as about five meters. It uses a 24 detector and a 47 pentode for the audio stage. Herewith is a sketch of the circuit which is self-explanatory, the coil data and all being furnished in the sketch.

So far as I know there is no circuit that works to any advantage or with any success at all with the antenna connected to the plate of a tube. However, this works well on any length antenna and does not seem to work unless the aerial is connected to the plate of the detector tube.—P. H. Perry, Jr., W5NH.

Low-Loss Coils

● I found a cardboard carton of two inches diameter and wound it first with thread. Then fitted over it a layer of waxed paper to prevent the dope sticking to the thread. Taking four strips of thin celluloid each about one-quarter of an inch wide and the length of the coil, I fastened these strips down long-wise over the wax paper with small elastic bands. The strips of celluloid are of course equally spaced apart. The coils are wound with No. 20 wire with the primaries space wound. After they are doped and dry the thread is pulled out from under the waxed paper and the coil slips easily from the form and they will be found to be quite rigid.

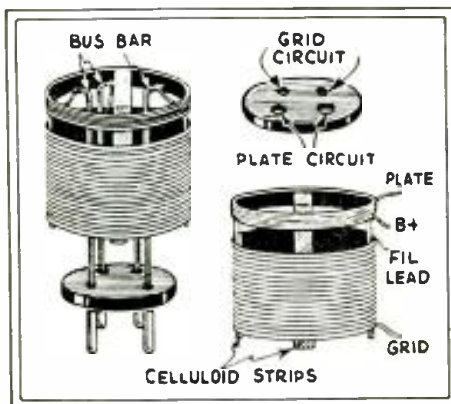

Ultra low-loss coil construction, the windings being supported on thin celluloid strips.

The tube-bases are sawed off flat, as in the sketch, and bus wire is soldered into each terminal. The coil is mounted in the center, suspended slightly above the base; the four leads are soldered to the bus bar; three of the bus bar leads are long enough to be level with the top of the coil when the ends of the leads are bent over. The grid lead of course is short and can be left straight up. The bus bar leads amply support the coil and at the same time supply a rigid handle to use when putting the coils in or out of the socket. This makes a coil about as nearly "low-loss" as I believe it is possible to make. It is practically free of the losses that are due to mounting on any kind of a form. I was amazed at the added efficiency of coils made in this manner and believe this bus bar stunt is entirely new. I adhered to the table of

windings given for coils of 2 inch diameter, but in some cases added slightly to the tickler winding. The windings are for use with a .0001 mf. tuning condenser.

Primary	Secondary	Tickler	Wavelength Range
5	3	3	16-24
7	6	5	23-39
7	13	5	37-80
9	36	5	76-180*

*Not space wound.

I would like to add that contrary to general practice, though I notice Mr. Reinartz did the same thing in his set with two detectors, I use an "A" Positive grid return in my detector circuit and have found it more sensitive than the usually shown "A" Negative grid return in S.W. Circuits. I also remove any wax paper that has adhered to the inside of the coil.—R. E. Johnson.

Improves "Globe Trotter"

● SOME time ago, I constructed the 2-Tube "Globe Trotter" by Robert Hertzberg and have gotten some very good results from it. I have heard amateurs from every district in the United States and most of the police and broadcasting stations; also Canada, Mexico, South America, and Hawaii. This location is not very good as far as "DX" is concerned, so I think I have done fairly well.

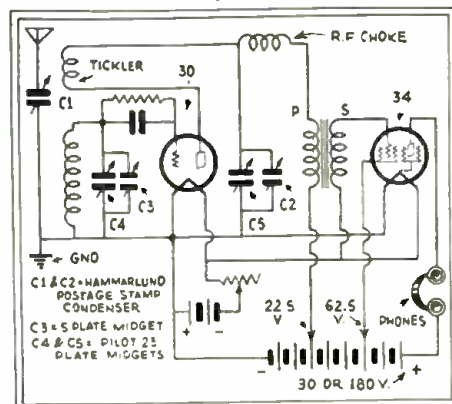

Improvements in the 2-tube "Globe Trotter" are shown above, the new circuit providing "band-spread" and also "greater volume."

However, I have made two improvements in the circuit that I have found of great value. First, I have spread out the various bands by using a five-plate (about 25 mmf.) midget condenser with the twenty-three plate midget across the secondary and have inserted a Hammarlund equalizing condenser (about 30 mmf.; same as in aerial circuit) across the regeneration condenser. The latter allows regeneration on the four coils any place on the dial. Also, I have increased the volume very noticeably by using a 34 tube as an amplifier. These changes may help those who have constructed this set, to get better results.—W. F. Frye.

● IF you are interested in listening in on the ultra short-wave bands from 5 to 10 meters, you will do best to minimize losses in the plug-in coils by using isolantite forms; also isolantite tube and coil sockets as well as properly insulated variable condensers. Most important, too, all lead wires must be kept very short, especially in the grid circuit. Ultra short-wave type R. F. chokes should also be employed.

“SMOOTHING UP” YOUR RECEIVER CONTROLS

Part II—Antenna Coupling Methods

● **COUPLING** the antenna to the grid of the first radio frequency tube has also caused quite some perplexity in the past, and in fig. 3, six methods are diagramed.

The circuit shown in fig. 3-A is not recommended due to the fact that the resistor cannot discriminate, even to the slightest degree, between the signal frequencies and any other type of unwanted noises, such as static, etc. A slight improvement is afforded by using a radio-frequency choke in the place of this resistor, as illustrated in Fig. 3-B. This choke may have a value of from 30 to 85 MH.

Figure 3-C is an elementary form of tuned input, and it is a very worthwhile improvement over the two previous systems. However it is a broadly tuned affair and not particularly advantageous in a modern short-wave receiver. The selectivity of this circuit can be improved somewhat if the antenna is connected to a tap on the coil L1, as is shown in Fig. 3-D. But there still remains a serious drawback in this method of coupling, due to too much of the antenna capacity and resistance being placed across the tuned circuit, thereby limiting the tuning range covered by a given coil and condenser.

**By
CURTIS E.
MALSBERGER**

In this second article, Mr. Malsberger describes some further improvements which will help to smooth up the operation of your short-wave receiver. Improved antenna coupling methods are discussed, together with circuits, and also improved methods of controlling volume.

Furthermore it is difficult to match the tuning ranges of the detector and input circuits, and “single-dial” control is almost impossible.

Inductive coupling (Fig. 3-E) provides a more suitable means of eliminating this disadvantage. Selectivity can be increased by employing looser coupling between the two coils L1 and L2, and “ganged” tuning is made considerably easier.

An interesting modification of the

system was developed for use in the new National FIG7 receiver, and it is illustrated in figure 3-F. Here the primary is interwound between the secondary or grid coil turns and rather tight coupling results. However it will be noted that the antenna is connected to the bottom end of the coil L1 and its capacity has been limited by placing a small condenser in series. Thus the coupling is made almost purely *inductive*, thereby greatly eliminating antenna tuning effects. This system was by far the most satisfactory tried by the writer.

The Control of Volume

In the past it was commonly believed the regeneration control was a satisfactory means of controlling the volume as well. However, in multi-tube receivers, which are becoming daily more popular, several forms of distortion results from this procedure. A powerful signal will oftentimes overload the grid of the detector tube, and if the regeneration control, particularly if of the *screen-grid potentiometer* type, is retarded, further distortion is introduced by the reduction of the applied detector voltages. Therefore a more suitable solution must be found for this problem. (Continued on page 556)

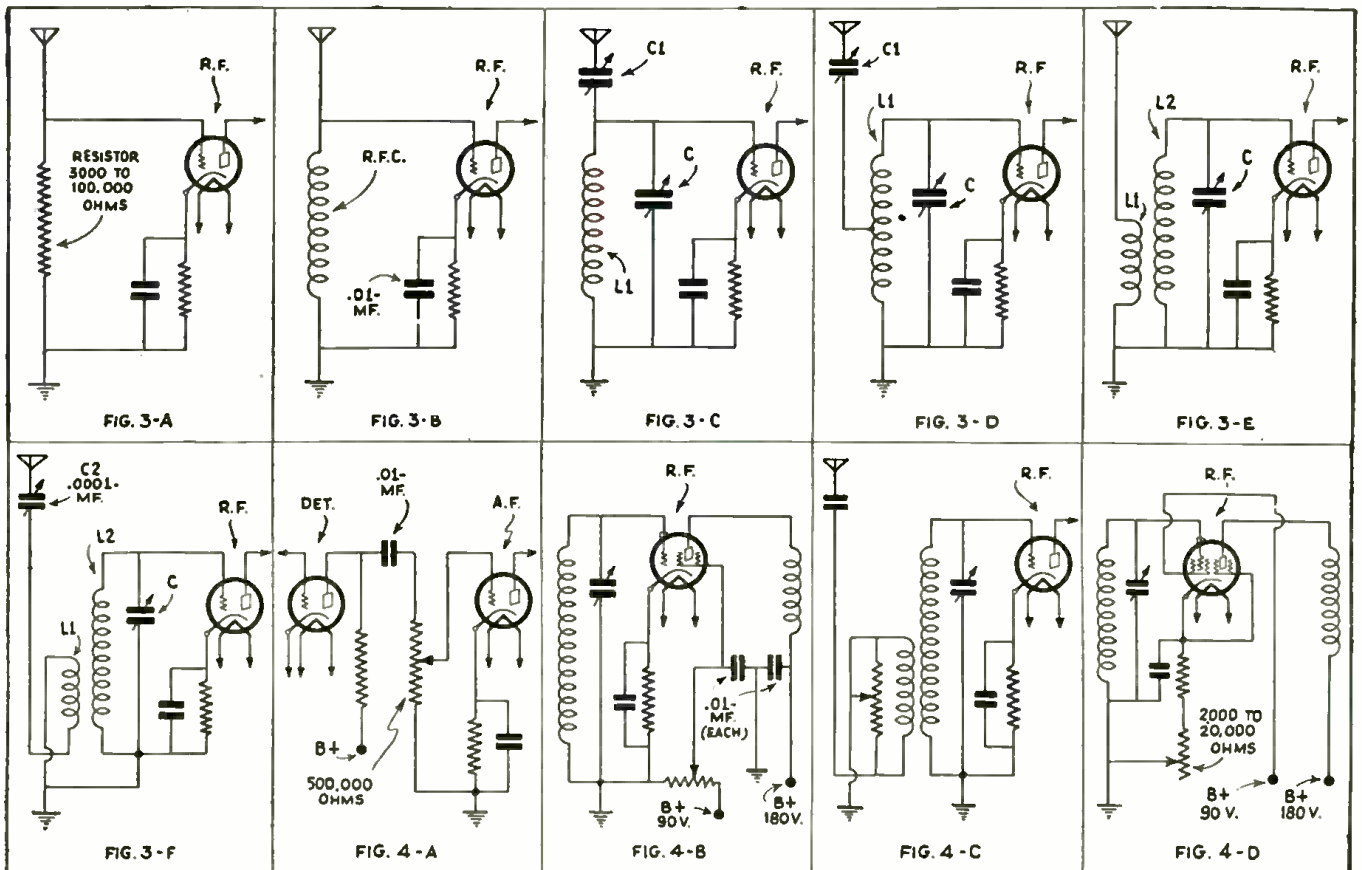

Herewith Mr. Malsberger shows a number of the different antenna coupling circuits which he tried out and which he discusses in the accompanying text; the lower group of circuits, 4A to 4D inclusive, illustrate various methods of controlling volume.

ANTENNA CONDENSER
\$5.00 PRIZE WINNER

An antenna condenser may be made from the plate of a type '22 tube and the plate of some other screen-grid tube such as the '21 or '35. When the plates are cut from the tubes, leave the wire supports as long as possible. Take a piece of bakelite 2 1/2 or 3 inches long and drill as indicated. A and B are the mounting holes. C is the hole for the screw which holds the '22 plate. D is for the '21 plate. The holes may be drilled to suit the maker. The other diagrams are self-explanatory. These plates must be handled carefully to prevent damage to them. I have used a condenser of this type for some time now, and it functions perfectly.—Albert Edwards.

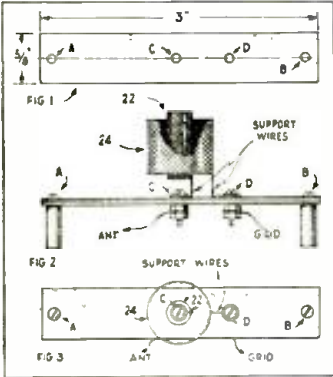

THREE KINKS IN ONE

In constructing an A.U. set I found that the filament wires, even though twisted, made quite a hum in the earphones or speaker. This was easily overcome by getting some old copper tubing and putting the twisted wires inside it. I then soldered a wire to the tubing and the ground. See sketch No. 1. Here's another—I was trying out a set and found that one of the

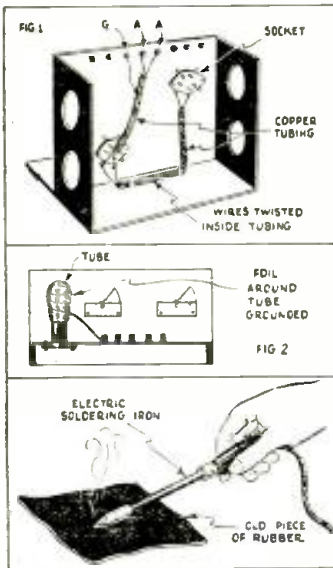

tubes needed shielding. Having no tube shields handy, I tried out this idea. I took the metal foil out of an old fixed condenser (any metal foil will do) and wrapped it around the tube, grounding one end of it. It made a very effective tube shield. See sketch No. 2. And still another one—I had to take the tinning off an iron used for soldering and, instead of filing it off, found that rubbing the iron on a piece of rubber did the job quickly. The iron must be hot, of course. See sketch No. 3.

DUAL RECEIVER

For reception of "both ends" of a radiophone conversation, when both stations are working within the range of the same coil and condenser combination,

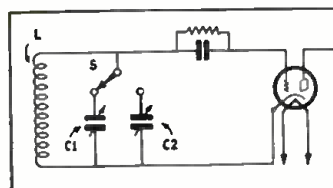

\$5.00 For Best Short Wave Kink

The Editor will award a five dollar prize each month for the best short-wave kink submitted by our readers. All other kinks accepted and published will be paid for at regular space rates. Look over these "kinks" and they will give you some idea of what the editors are looking for. Send a typewritten or ink description, with sketch, of your favorite short-wave kink to the "Kink" Editor, SHORT WAVE CRAFT.

here's the trick to use. Coil L is the regular grid winding of a plug-in coil. Condensers C1 and C2 are both .0001 mf. max. capacity. Switch S is a selector switch. In tuning for stations put switch S in place for using condenser C1. Tune C1 until a phone station is heard. Then throw switch S for condenser C2. With C2 find the "other end" of the conversation. After both stations have been found, all that need be done to hear "both ends" is to throw switch S back and forth between condensers C1 and C2, as each person speaks.—Robert Seitz.

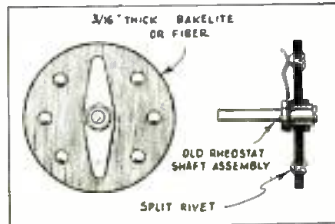

COIL FORM

The accompanying drawing shows a handy "form" in which to wind spaced short-wave coil windings, either of wire or tubing. This form is nothing more than the waste-threaded shaft taken from an old vlc. Sometimes a piece of closely threaded rod such as this, having about 1 to 6 threads per inch can be obtained around a machine shop, having previously performed as part of a lathe or other machine. If the threads are coarse enough, copper tube transmitting coils can be wound on it.—Carl Cook.

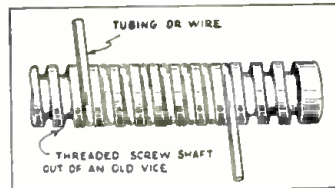

COIL SUPPORT

Being a "ham" I find it hard to keep plug-in coils handy, for they have a habit of rolling off the table on the floor. To overcome this three small brads, one-half inch long, were mounted on the bark of the receiver. A small hole drilled near the top of the form serves to hold the coil. These coils are not only ready for use, but are out of the way.—L. Murphy.

AERIAL TUNING CONDENSER

The small equalizer condensers used in capacitive antenna coupling can be adjusted from the front panel, by simply replacing the adjusting screw in the condenser with a screw of the same size, that has been inserted in one end of a 1/4" bakelite rod. The head of the screw must be removed and about 1/4" of the screw left protruding from the end of the rod. This makes possible the adjustment for maximum signal strength and eliminates the "hand capacity" experienced when using condensers with metallic rotor shafts.—Harold H. Shupert.

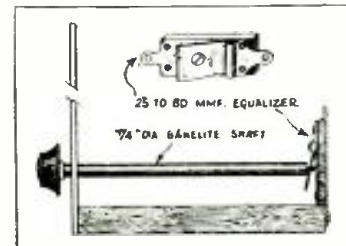

SELECTOR SWITCH

An improvised selector switch which may be used for changing short-wave coils, etc., and it was made from a few split copper rivets, together with a shaft and switch blade from old rheostats. The rivets were spaced equally around a red fibre disc about 3/16" thick. Many different arrangements of switching schemes have been illustrated diagrammatically in previous issues of this magazine, so there is no use in going into the various hook-ups which can be used as each experimenter will be able to work this out for himself.—Clarence Guthrie.

GRID-LEAK CONNECTION

There has always been a difference of opinion among amateurs as to the type of grid leak detection best suited for standard three element tubes. Some experi-

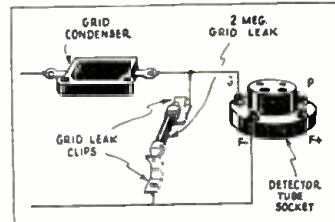

menters prefer the grid leak connected across the grid condenser and others believe that shunting it between grid and F- smooths out regeneration. With the layout illustrated in the drawing either method can be used, by just inserting the grid-leak in the proper pair of clips.—Dennis Delaney.

SHOCK-PROOF TEST CLIP

Almost everyone has been shocked ripping a connection onto a "hot" lead. A very simple shock proof lead may be made by slipping a nutting bottle nipple over the test clip. This will permit the clip to be used, but will give complete protection from high voltages.—M. W. Galsler.

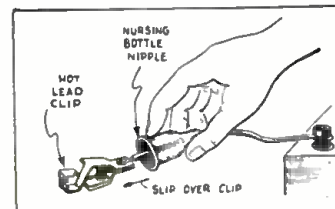

VOLUME CONTROL

When using an A.F. transformer as a choke I found that by shunting this impedance with an old Brailleyohn 100,000 ohm resistor, it made a very good volume control. You can also adjust it to cut the high note response. This control will not affect the regeneration control in the least.—Howard C. Rice.

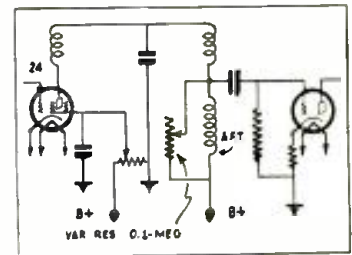

RHEOSTAT FOR R.F. CHOKE

I used a variable rheostat for the R.F. choke. The result was that when I changed my plug in coil, I could change the resistance for the best result. Any filament rheostat will work, but 5 ohms or less is best. I also used a 3-plate, double-spaced condenser, shunted across the 23 plate mid-grid feed-back. With the 3 plate condenser, I could get much louder reception, without making the set regenerate. With one more stage of audio frequency, it gives "loudspeaker" reception with good volume.—H. Kurz.

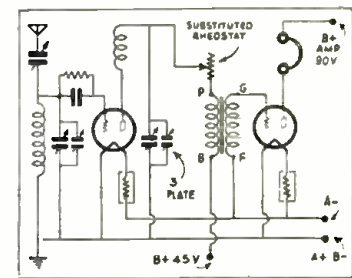

A "DEPRESSION" CONDENSER

A variable condenser of small capacity may be made from two tin cans. Select a strong can for the rotor. If the cover is available, solder it in place to support one end of the shaft; if not, cut the can longitudinally down the center line, and then fit in a piece to take the place of the cover. Both ends of the can should be cut so that the shaft can be placed on the center line. For the shaft, a piece of 1/4" round brass rod is suitable. The stator for this condenser is made from another can slightly larger than the one used for the rotor. The can is cut in half, and both ends are removed; it should then be tacked to a block of wood which serves as a base. The bearings for the rotor may be either wood or

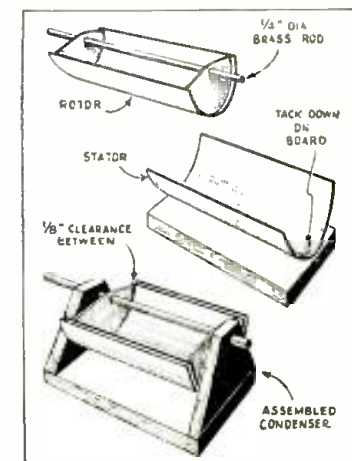

metal. The distance from the base to the center of the shaft should be about 1/4 inch greater than the radius of the rotor. After assembly, bend the stator plate so that there is about 1/8 inch clearance between the two plates. A brush bearing on the end of the shaft serves as a connection to the rotor; solder a wire to the stator.—A. E. Gesteland.

SHORT WAVES and

THIS STATION HAS ALL THE TRIMMINGS

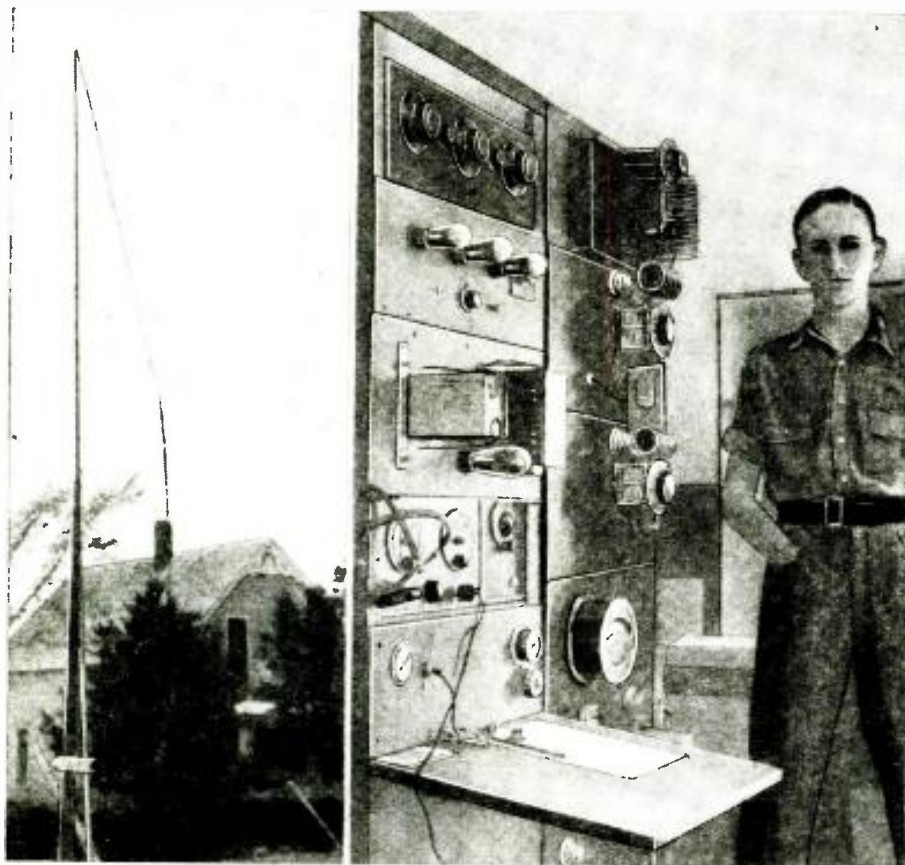

Photos above show the interesting antenna and station equipment of George Woznick at Loup City, Nebraska.

Editor, SHORT WAVE CRAFT:

Am enclosing a picture of my amateur station, W9JPN. I read your magazine and find it very interesting and helpful.

My transmitter uses a type 47 crystal oscillator, 46 doubler, and a 46 straight amplifier. Three separate power supply units are used, one for each stage, and all use the type 83 mercury vapor tubes. All of the transmitting equipment is mounted on the right-hand side rack. The left-hand rack contains the receiver, monitor, receiver power supply, batteries, battery charger, and an audio frequency oscillator with a two-stage amplifier, which is keyed with the transmitter so as to keep a check on all sending. The antenna is a 7 mc.

voltage-feed Hertz. All transmitting is done on the 40 meter band.

Bob Woznick
Loup City, Nebr.

(A mighty fine station, Bob, and if it works as good as it looks, which it undoubtedly does, you must derive a lot of pleasure contacting "fellow hams" both in this country and abroad. It really is amazing when one stops to consider the immense amount of technique involved in the installation and operation of a good "ham" station, and all that we can say is that you fellows who have built and tuned up a good transmitter such as the one you have, deserve all the credit in the world. More power to you.—Editor.)

2-TUBE "GLOBE TROTTER" ROLLS UP SOME "LOG"

Editor, SHORT WAVE CRAFT:

Last spring I wrote you regarding a "2-Tube Globe Trotter" which I had constructed. I had been unable to make it work properly because of the coils, which I had purchased ready-made.

Finally, after much experimenting, I managed to get the right number of turns on the coils and since then have been having much pleasure from the set. I now have a total of eleven coils wound. The coils that I purchased although specified for the "Globe Trotter" had to be entirely rewound, as only one of them would work the set, and that not on the band specified.

The number of turns on the grid coil was all wrong, and I also had to greatly increase the number of turns for the tickler coil.

I now have the set mounted in a cabinet made of cigar-box wood and have added

another stage of A.F. Also my set is peculiar, in that it has two antenna binding posts; one wired direct to the "postage stamp" antenna condenser in the conventional manner, the other to a small 5-plate condenser and then to the "postage stamp."

All coils below 80 meter phone, use the second binding post; I found the extra condenser was necessary to eliminate "dead-spots" and to make some coils work at all.

As for results, I can't kick.

And here, if you are interested, are my catches: 20 meters—GSF, Daventry, England; W8XK, Pittsburgh, Pa.; WNC, Deal, N. J.; KKZ, Bolinas, Calif. 25 meters—GBC, Rugby, England; GSD, Daventry, England; YVQ, Maracay, Venezuela; CGA, Drummondville, Canada. 31 meters—EAQ, Madrid, Spain; HBL, HRP, Geneva, Switzerland, 2 waves; W3XAU, Philadelphia,

Pa.; W1XAZ, Springfield; DJA, Königswusterhausen, Germany; W2XAF, Schenectady, N. Y.; GSB, Daventry, England; HJP, Bogota, Columbia; WNC, Hileah, Fla.; W3XR, testing with W10XAA. 49 meters—W3XL, Boundbrook, N. J.; W8XK, Pittsburgh, Pa.; VE9HX, Halifax; W2XE, Wayne, N. J.; VE9BJ, St. Johns, N. B., Canada; YV1BC, Caracas, Ven.; W3XAL, Boundbrook, N. J.; W9XF, Chicago, Ill.; VE9GW, Toronto, Ont., Canada; W9XAA, Chicago, Ill.; W8XAL, Cincinnati, Ohio; W3XAU, Philadelphia; GSA, Daventry; W1XAL, Boston; DJC, Zeesen, Germany, VE9DR, Drummondville, Que., Canada. 63 mete —WOO, Deal, N. J. 74 meters—NAA, Time Signals, Arlington, Va.

Most of the American stations are very consistent, while GSA, DJA, and EAQ and GSB are the most consistent "foreign" stations, EAQ being heard every evening. In fact, I can usually get the American stations without using any antenna or ground, and can often do the same with the above mentioned "foreign" stations.

Besides these I have "logged," so far, 53 police stations, including UYR, Montreal, and UYW, Winnipeg, and others as far as the Pacific Coast. Also dozens of airports and airplanes which are hard to identify, because they give no call letters.

I have also heard considerably ship-to-shore conversations, and other unidentified stations.

As for the Amateurs, I have had all American districts except the seventh, and many in Canada; this on 80 meters. I have also listened to many on 160 meters and a few on 20 meters. Literally hundreds of them, all told. I also have two coils which work the B. C. band from 1500 to 1170 kc. and from 1200 kc. to 790 kc.

Many of these stations I have had on the loud speaker, including Daventry and Germany, but I generally use the head phones.

So I thank you, SHORT WAVE CRAFT—the "Globe Trotter" works. This is my first attempt at set building and for a while I was pretty discouraged, but now I am tickled!

More power to you, and I'll be looking for the next issue of SHORT WAVE CRAFT at the newsstand.

ARTHUR M. CROUSE,
12 Grant St.,
Warren, Pa.

(This is a very fine "log," Arthur, and it is really remarkable in view of the fact that only two ordinary old style tubes were used. We have had many excellent reports on the "Globe Trotter"; one of the good points about this receiver is that it costs but very little to build and operate.—Editor.)

LIKES WALLACE SET WE DESCRIBED

Editor, SHORT WAVE CRAFT:

I sure have good news for you, I have completed the *Powertone Wallace S-W Receiver* which you described in your September issue. Inside of one-half hour I had twenty different stations from New York to Iowa! What do you think of that for tuning them in? My receiver sure is a wow!

Be sure to include more news on how to assemble short-wave receivers in your next issue.

STEPHEN J. STERBANUS,
P. O. B. 292,
Elkins, W. Va.

(Glad to hear you had such good results so quickly with the Wallace receiver described in our September issue. We hope you find plenty of material in this issue describing how to assemble short-wave receivers, per your last paragraph.—Editor.)

LONG RAVES . . . Our Readers Forum

GETS 2,730 STATIONS!

Editor, SHORT WAVE CRAFT:

After finishing my first copy of SHORT WAVE CRAFT I became immensely interested in short waves and decided to build a receiver. I selected a diagram and started construction. The circuit is the Reinartz which is well-known among the "old-timers." It uses an '01A as detector and another '01A as a transformer-coupled audio amplifier. The results obtained with this set have been extraordinary!

The broadcasters that I have received are the following: VK2ME, VK3ME (verified), ISOR, FYA, GSA, GSB, GSC, GSD, GSE, G5SW, DJA, DJB, DJC, DJD, I2RO, EAQ, EAR58, HBL, HBP, TI4NRH, HRB, YVLBC, PRADO, HJLABB, HJ2ABA, HJ3ABB, HJ4ABB, HJ4ABE, VE9GW, VE9DR, VE9JR, VE9HX, W1XAL, W1XAZ, W2XAF, W2XE, W3XAL, W3XAU, W3XL, W4XB, W6XN, W8XAL, W9XAA, W9XF.

Most of the listening is done on the 40 and 80 meter bands and I have also received some amateurs on the 20 and 160 meter bands. At the present time I have logged 2,165 amateurs in 24 countries, distributed as follows: United States, 2,021; Canada, 62; Cuba, 23; England, 13; Mexico, 11; Australia, 4; three each in France, Porto Rico, British West Indies; two each in Ireland, Spain, Germany, Belgium, Canal Zone, Costa Rica, Ecuador; one each in New Zealand, Alaska, Netherlands, Newfoundland, Colombia, Venezuela, Argentine, and Honduras. On 80 meter fone, XLG, XLQ and W6CNE have been heard.

Commercial code stations have been received from every continent. Total number is 210. I have received 24 police broadcasters as far west as St. Louis and St. Paul.

My total log of all stations received is 2,730! Can anyone beat this record with a pair of '01A's? I would like to hear from others who have tried this circuit.

COILS

	L1	L2	L3	L4
20 meters	4	2	2	
40 meters	8	4	4	
80 meters	8	8	4	4
160 meters	16	8	8	4
Broadcast band	32	16	16	8

The coils are wound on a three inch form with No. 24 D.C.C. wire. Six binding posts are placed directly behind the tuning condenser about one inch between each. These are for the coils. Where more than one lead goes to a binding post the leads may be twisted together to provide facility in changing coils. The specifications given for the coils may be found to be erratic, as when I first made the set the 20 meter coil worked from 28 to 49 meters. Upon experiment I made my own coils and the set worked down to 14 meters. This set is constructed with all broadcast parts. It may seem strange to tune short waves with a .00025 mf. condenser, but I have found no trouble at all in tuning at high frequencies. I believe

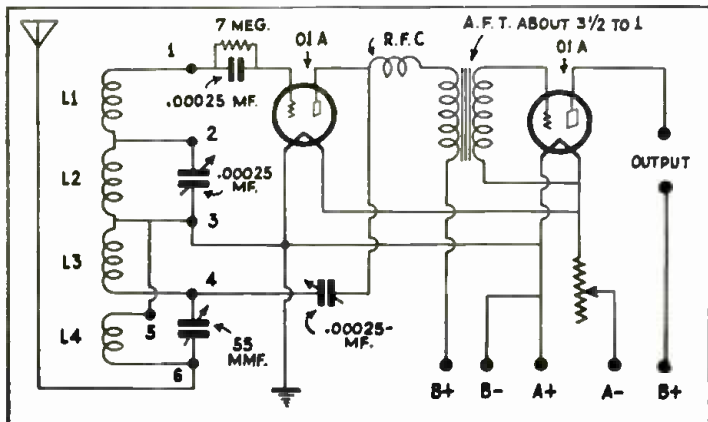

HERE'S A REAL "HAM" STATION

Editor, SHORT WAVE CRAFT:

I am a constant reader of SHORT WAVE CRAFT and must say that I look forward to the arrival of each copy. My only suggestion for improvement is a little more advanced transmitter designs. This I be-

lieve would interest the amateurs who have passed the preliminary stages and are interested in multi-stage transmitters. You asked for photos of stations so here's mine. Note the nicely arranged 110 volt leads from the wall sockets to the transmitter. Hi.

W5CFM and portable W5HU have been on the air several years. The first transmitter was a single TNT 210 with 300 volts plate. Later came push-pull 210s with 600 volts plate. These were followed by the present transmitter which consists of the following:

Type '47 crystal oscillator, types '46 buffer-doubler, and a pair of 510 push-pull in the Class "C" amplifier. The input to the final stage is 100 watts. In addition there is a Class "B" modulator (not shown in the picture) for 100% modulation. This is operated as phone in the 75 meter phone band.

In the picture from left to right you see, "home-built" electron-coupled frequency meter-monitor, "Bug" and key, a National FBX single-signal receiver, and the "mike." On the table to the right is the transmitter and power supply units; there is a mercury vapor type rectifier for each stage.

The operator, "yours truly," is primar-



ily interested in traffic work in the Army Amateur R. S. being a local net-control station in the eighth corps area. Occasionally I look for some DX but not often. Have worked all districts, VE's and an occasional ZL or VK.

Would like to express myself regarding the proposed "no code" requirement for 5 meters but have written too much now. Suffice it to say that I don't believe that any experimenter will be satisfied to remain on 5 meters, once he gets started. Then he will be forced to learn the code and after all "what's worth having is worth working for." 73.

J. N. ROYALL, JR.,
W5CFM-W5HU,
Corsicana, Texas.

(We doff our hats to you, J. N. R.—you surely have a very fine transmitting and receiving station. It is indeed interesting to note how you have developed the transmitter progressively, adding the latest type tubes and "crystal control" when these became available. Every ham aspiring to the highest honors should be proud to follow in your footsteps and become associated, when his experience and station equipment warrant it, with the Army Amateur net.—Editor)

that if this circuit were adapted to be used with the new "high-gain" tubes it would break all records.

CHARLES J. SAYKO,
330 Grier Avenue,
Elizabeth, N. J.

(Magnificent business, Charles, and the editors' heads are still swimming from looking at that total, which certainly caused us to rub our eyes in astonishment. 2,730 stations is some log—no mistake! Looks as if we are going to have some keen competition for the Short Wave Scout's "trophy cup" the first winner of which is an-

nounced in this issue. Better look over those rules again, for you should be able to walk away with one of these cups like nobody's business.—Editor)

HE HEARS ALL THE "BIG BOYS"!

Editor, SHORT WAVE CRAFT:

Herewith is a list of stations which I have received on an "old-timer," commonly known as the Junk-Box receiver. Most of these I have heard on the loud speaker, including some of the English amateurs.

So far I have been more than satisfied with this "battery-operated" set. I built the set in 1928 and got the hook-up from SHORT WAVE CRAFT.

I have been a faithful reader of SHORT WAVE CRAFT for the past years and I think it the most understandable radio magazine I have ever read.

List of Short Wave Broadcasting Stations

Novel receiving circuit used by Charles Sayko who has heard all the famous world-wide short-wave broadcasters, including VK2ME and 3ME, all on 2-01'As.

- G2NM Caterham, England
- PCJ Kootwijk Holland
- VK2ME Sydney, Australia
- VK3ME Melbourne, Australia
- LSH Buenos Aires, Argentine
- LSJ Buenos Aires, Argentine
- LSX Buenos Aires, Argentine
- I2RO Rome, Italy
- HVJ Rome, Italy

(Continued on page 549)

Power Transformer Data

● WITH the ever increasing multiplicity of radio tubes and apparatus, charts are becoming a necessary, integral part of radio work. To Service Men, experimenters and others, a radio power transformer chart fulfills a distinct need. It saves hours of computation by giving the information directly in many cases, or by easy comparison in special cases. To illustrate how the results, which are for the maximum number of tubes indicated in the transformer chart, were obtained, a power transformer of 85 watt rating will be designed as follows:

FUNDAMENTAL DATA

The electrical requirements of transformer design are fully met when use is made of the equation,

$$\phi = \frac{\sqrt{2} \times E \times 100,000,000}{2 \pi F N} \quad (1)$$

where

- φ = Total flux (magnetic force) in the core
- E = Line voltage
- F = Frequency
- N = Primary turns

Inspection of equation (1) shows that if the line voltage, E, is increased, the number of primary turns, N, must be increased the same percentage to keep the same flux. If the transformer is to be used with 220 volts on the primary, the number of turns, N, must be double that for 110 volts, for the same flux. The secondary turns, how-

and Method of Design By O. K. TIPSEL

This is probably the first time so much valuable information has been assembled and presented in one article. The coil data, size of wire, number of turns, size of iron core, etc., are given for power transformers of 40, 50, 70, 85, and 100 watts. Cut this data out and paste it in your "data-book."

ever, remain the same in both cases. For 25 cycle frequency, equation (1) shows that either the primary turns or the core area must be increased in the ratio of 60 to 25 above that required for 60 cycle frequency. In other words, a 25 cycle transformer will be satisfactory with twice the core area and 25% more turns on all the windings, compared with a 60 cycle transformer.

With 115 volts and 60 cycle frequency, equation (1) becomes

$$\phi = \frac{43,145,000}{N} \text{ or } \phi N = 43,145,000. \quad (2)$$

Which indicates that no matter what number of primary turns, the resultant flux, φ, times the number of primary turns, N, is always equal to 43,145,000. This number, of course, varies with the voltage and the frequency.

The object in this computation is to arrive at a definite relationship between flux density per sq. cm., core area in sq. inches and primary turns, from which results may be tabulated for ready reference. The flux density is desired per sq. cm. because the manufacturers of standard laminations use this method of description. The core area is desired in sq. inches because it is more convenient to consider lamination dimensions in inches.

Let C = Core area in sq. cm.

And A = Core area in sq. inches.

Then, since there are 6.45 sq. cm. in one sq. inch,

$$C = 6.45 A$$

But the flux density is $\frac{\phi}{C} = \frac{\phi}{6.45 A} = B$

Whence $\phi = B \times 6.45 \times A$

Substituting this value of φ in equation (2) we have

$$B \times 6.45 \times A \times N = 43,145,000.$$

$$\text{or } A \times N = \frac{6,689,000}{B} \quad (3)$$

where A = Core area in sq. inches

N = Primary turns

B = Flux per sq. cm.

(Continued on page 563)

115 Volts		RADIO POWER TRANSFORMER CHART															60 Cycles						
Rating	40 Watt				50 Watt				70 Watt					85 Watt					100 Watt				
No. of Tubes	3 or 4				4 to 6				4 to 9					5 to 12					6 to 15				
Winding	Pri.	Sec.	F-1	F-2	Pri.	Sec.	F-1	F-2	Pri.	Sec.	F-1	F-2	F-3	Pri.	Sec.	F-1	F-2	F-3	Pri.	Sec.	F-1	F-2	F-3
Wire Size	26	34	20	18	25	33	20	16	23	32	21	19	16	22	31	20	19	15	21	30	20	19	14
No. of Turns	600	3600	28	14	515	3200	24	12	430	2700	20	10	10	346	2200	16	8	8	346	2200	16	8	8
Av. Turn Length	5"	6"	7"	7"	5 3/4"	6 3/4"	8"	8"	6 1/2"	7 1/2"	8 3/4"	8 3/4"	8 3/4"	7"	8 1/2"	9 1/2"	9 1/2"	9 1/2"	7 1/4"	8 3/4"	9 3/4"	9 3/4"	9 3/4"
Total Length	250'	1800'	16.4'	8.2'	246'	1800'	16'	8'	230'	1690'	14.4'	7.2'	7.2'	200'	1560'	12.6'	6.3'	6.3'	209'	1600'	13'	6 1/2'	6 1/2'
Resistance	10.	470.	.167	.05	8.	370.	.16	.032	4.5	277.	.18	.057	.028	3.2	200.	.127	.05	.02	2.6	165.	.13	.051	.016
Amperes	.40	.045 .060	2.	4.	.49	.055 .070	2.	6.	.66	.065 .090	2.	3 1/2	7.	.83	.080 .110	3.	3 1/2	9.	.94	.090 .120	3.	3 1/2	12.
No Load Volts	115.	345. 345.	5.37	2.69	115.	360. 360.	5.36	2.68	115.	360. 360.	5.36	2.68	2.68	115.	360. 360.	5.32	2.66	2.66	115.	360. 360.	5.32	2.66	2.66
R I Drop		11/11	.33	.20		10/10	.32	.19		9/9	.36	.20	.20		8/8	.38	.17	.18		7/7	.39	.18	.19
Loaded Volts	115.	331. 334.	5.04	2.49	115.	350. 350.	5.04	2.49	115.	351. 351.	5.00	2.48	2.48	115.	352. 352.	4.94	2.49	2.48	115.	353. 353.	4.98	2.48	2.47
I ² R Loss	1.6	.94 .67	.67	.80	1.9	1.11 .64	.64	1.15	1.96	1.17 .72	.72	.70	1.37	2.2	1.28 1.14	.61	1.62		2.3	1.33 1.17	1.17	.62	2.3
Core Size	1 1/2" x 1 1/2"				1 1/8" x 1 1/2"				1 1/8" x 1 1/2"					1 1/2" x 1 1/2"					1 1/2" x 1 1/2"				
A X N	760				805				810					780					780				
Flux Density	9600				9100				9100					9400					9400				
Coil Length	1 1/2"				1 1/2"				2 1/2"					2 1/2"					2 1/2"				
Coil Space	5/8" x 1 1/4"				5/8" x 1 1/8"				1 1/8" x 2 1/4"					3/4" x 2 1/4"					3/4" x 2 1/4"				
Watts Output	40.				49.				67.					84.					96.				
Total I ² R Loss	4.01				4.80				5.92					6.85					7.72				
Iron Loss	2.0				2.6				3.4					4.5					4.5				
Watts Input	46.01				56.40				76.32					95.35					108.22				
Transfr Size	2 1/4" x 3 3/8" x 3 3/8"				2 1/2" x 3 1/8" x 3 3/4"				2 3/4" x 3 1/8" x 4 1/8"					3" x 3 3/4" x 4 1/2"					3 1/4" x 3 3/4" x 4 1/2"				
Transfr Weight	3 1/2 lbs.				4 1/4 lbs.				5.0 lbs.					6.0 lbs.					6 1/2 lbs.				

WHAT'S NEW

The short-wave apparatus here shown has been carefully selected for description by the editors after a rigid investigation of its merits.

In Short-Wave Apparatus

RCA Victor Has New 6-Tube All-Wave Set



Photo above shows latest RCA-Victor short-wave and broadcast band receiver, utilizing 6 tubes.

55.5 meters. Between the limits of the short-wave band available in this receiver at the throw of a switch are included four of the internationally assigned short-wave broadcast bands, located at 49, 31, 25, and 19 meters, respectively. Thus, in addition to providing fine entertainment from the American broadcasting stations in the usual band, this receiver permits direct reception of interesting programs from the principal short-wave broadcast transmitters located in all parts of the world. The short-wave facilities afforded by this instrument represent the very newest engineering developments. The short-wave feature is built in as an integral part of

for both short and broadcast band ranges.

As the diagram shows, each of the two wave bands made available in this set have independent tuned couplers or inductances and when the two-way switch S-1, 2, 3, 4, 5, and 6 knob is turned, either the short wave or broadcast coils are connected into circuit. It will be noted that the new 2A7 tube is used for the oscillator and first detector, while the very latest circuit improvements incorporating automatic volume control with the second detector are provided, by utilizing a 2B7 tube. The loud speaker is energized by one of the newest power audio frequency tubes, the 2A5. The manufacturers recommend the use of an outdoor antenna from 25 to 75 feet long, including lead in and ground wire, and where this is not possible an inside antenna may be used. These sets are designed for operation on 110 volts, 60 cycle A.C. and sets for 220 volt A.C. circuits are available. This receiver has its power switch and tone control combined in one knob.

● ONE of the very newest and highly interesting short-wave and broadcast receivers is the new 6-tube, two-band, RCA Victor model here illustrated. This receiver is available in different style cabinets and by operating a switch it reproduces through its loud speaker either stations on the regular broadcast band, between 200 and 550 meters, or else a fine selection of foreign short-wave stations in the popular bands extending from 19 to

the radio chassis, not simply an adapter connected to an old-style broadcast receiver. Both tuning ranges are quickly interchangeable by means of a push-pull switch on the front of the cabinet. Other features to be found on this receiver are the vernier dual-ratio selector drive, permitting either rapid or fine adjustments independently, and secondly—there is the clock-type full-vision illuminated dial, which is calibrated directly in terms of frequency

A brand new form of tuning time-chart has been developed for use with this receiver in which the program "time on the air" is plotted graphically; also Eastern Standard Time, as well as G.M.T. are given at the top of the chart to facilitate tuning in European stations. This set will win many friends, as a flip of the switch immediately takes one from the American Broadcast Band to the European and South American circuit. (No. 136)

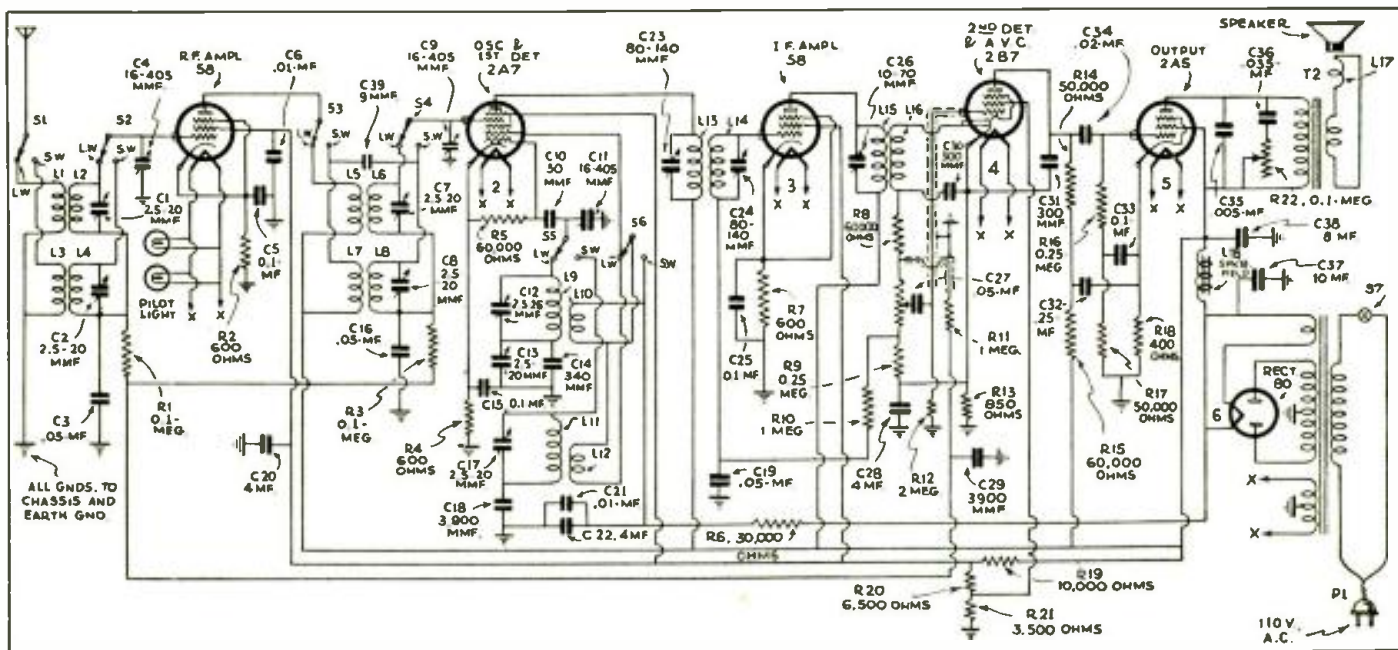

Diagram for the new RCA-Victor 2-band model, "short-wave" and "broadcast" 6-tube receiver.

(Names and addresses of manufacturers furnished upon receipt of stamped envelope; mention No. of article.)



The DeWald midget broadcast and short-wave receiver tuning from 550 down to 60 meters. (No. 134)

● ONE of the best sounding midget radio receivers we have heard in some time is the model 801 DeWald, which covers the broadcast and short-wave band down to 60 meters. Another model tunes clear down to 15 meters and includes the broadcast band from 200 to 550 meters. This receiver is encased in a handsome walnut cabinet; the chassis is an 8-tube superheterodyne.

Among other features found in this very smooth working receiver we find 100 per cent automatic volume control, full-range tone control, visual neon tube tuning, electron coupled circuit, a pre-selector antenna circuit, high sensitivity and diode detection.

The model 801 uses a well selected set of high gain tubes and by careful

NEW MIDGET RECEIVER Has 60 to 550 Meter Range

design of the various coupling circuits used to link the stages, a very high amplification is obtained, together with a very well balanced circuit, so that a surprisingly fine quality of reproduction is obtained. A dynamic speaker of the latest type and of the proper impedance to work with the particular tube used in this set provides an extra fine quality of sound reproduction. Liberal sized condensers and chokes

are used so that a minimum of noise results. Moreover the set occupies only a small space and will find favor for many requirements, including small apartments, cabins, study dens, etc. The size of the cabinet housing the model 801, and also its close relative, the model 811—which tunes down to 15 meters, is 16 3/4" high by 14 1/2" wide, by 8 3/4" deep.

(Continued on page 566)

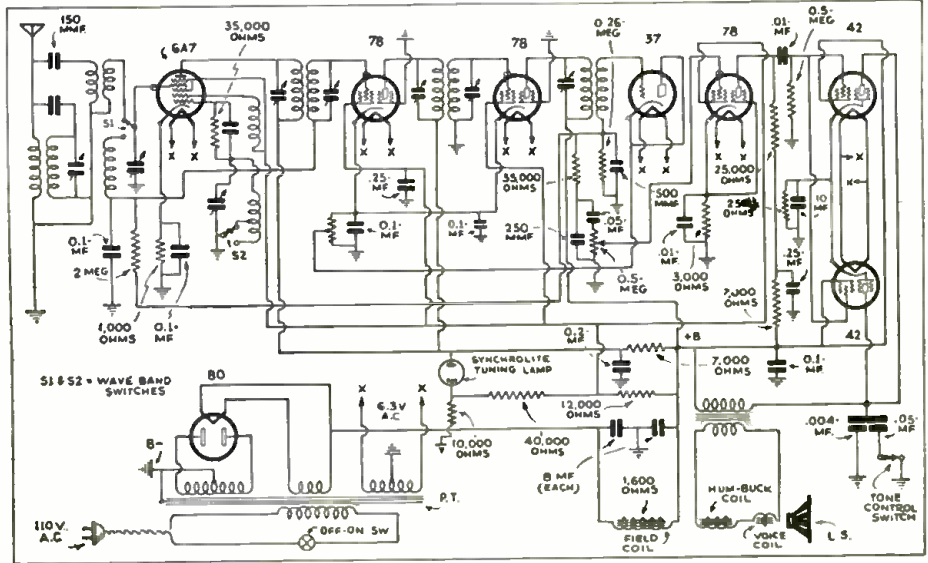

Wiring diagram of model 801 "BC" and "SW" receiver—an 8-tube superhet.

The LAFAYETTE S-W "Champion"

● THE Lafayette Short-Wave "Champion" is an all-pentode receiver using four of the newer type 2-volt tubes in an extremely sensitive tuned r.f. circuit. Naturally, a regenerative detector is used.

The r.f. tube is a 2-volt 34 type pentode possessing the same desirable variable mu features as the a. c. tubes of the 58 type. The detector tube is also a 34 tube. Regeneration is controlled by varying the screen-grid voltage. This method gives a very smooth even control. Resistance coupling is

*Wholesale Radio Service Company

By HUBERT SHORTT and FRANK LESTER*

employed between the detector and the first audio stage and also between the first audio and the output stage. A 32 type pentode serves as the first audio tube, while the output tube is a 33 pentode. This has a power output of 700 milliwatts.

The two-gang variable condenser C1, C2 tunes simultaneously the secondary of the antenna coupler L1 and the secondary of the r.f. coil L2. An additional midget variable condenser

C16, shunted across the primary of L1, provides for extra fine adjustments.

In accord with modern practice, the Champion is wired for use with "doublet" noise eliminating antennas such as the Lynch. Using an ordinary antenna system, the antenna is connected to binding post 3 and ground may be connected to post 2 or 1. If the doublet system is used, the two lead-in wires are connected to posts 2 and 3, thus making use of the isolated primary provided for this purpose.

It will be noted that the circuit is

(Continued on page 557)



The new Lafayette short-wave "Champion" receiver; it is of the two volt battery type.

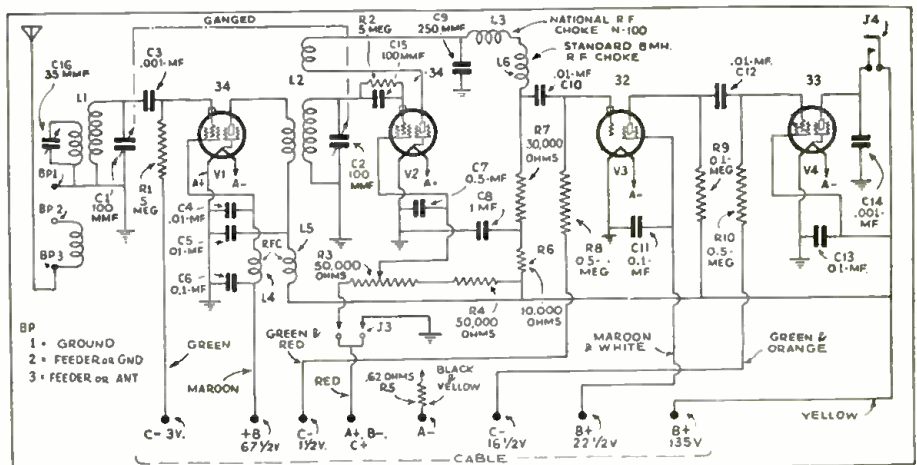

Diagram of connections used in "Champion" 4-pentode battery receiver. (No. 135)

(Names and addresses of manufacturers furnished upon receipt of stamped envelope; mention No. of article.)

New ALL-WAVE Atwater Kent

● THE all wave receiver is becoming almost a household word today and the average purchaser of a radio set is now beginning to look for the *short-wave* feature. One of the best engineered, as well as handsome appearing all wave receivers that has so far made its appearance on the American market, is the new model 711 Atwater Kent, shown in the illustration and accompanying diagram. This receiver provides family entertainment from any one of the leading European or other DX short-wave stations, as well as all of the American broadcast stations on the 200 to 550 meter band. After all, the average purchaser of an all-wave receiver of this general type will ask himself the question, sooner or later, as to which receiver he should eventually buy—and why.

With regard to the A-K all wave receiver here illustrated, it may be said that a tremendous amount of careful technical research has been carried on in developing this receiver through many different forms, before the engineers were satisfied to release this receiver to the public. A lot of probationary work was carried on in connection with a short-wave converter of the same make with which many thousands of people became familiar, and the converter in question was one of the best that the editors ever tried out. With the experience gained with the short-wave converter, plus a lot of hard laboratory work and thousands of tests, the model 711 finally saw the

Mounted in a very handsome cabinet, this 11-tube combination "broadcast" and "short-wave" superheterodyne receiver makes its bow to the short-wave minded American public. The Model 711 All-Wave receiver possesses automatic volume control, 4-point tone control, silent and shadow tuning, and with its auditorium type loud speaker it easily reproduces the trans-Atlantic short-wave stations with great volume.

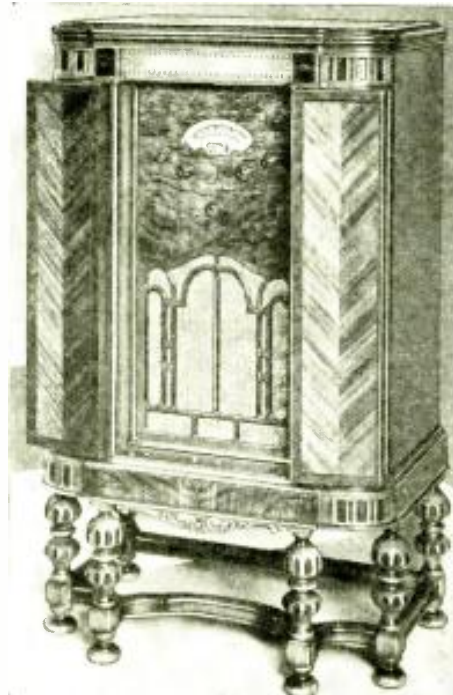

Note the handsome appearance of this newest Atwater Kent "Broadcast" and "Short-Wave" Superheterodyne Receiver. It has 11 tubes and a large auditorium type loud speaker. It provides all-wave tuning from 540 to 23,000 kc.

light of day, so far as the public is concerned.

As the diagram herewith shows, each wave-band covered has its own set of compensated tuning inductances or coils, and the coil unit for any given band is tuned by means of the master condensers, A2, A3, thanks to the gang-switch ABC and D controlled by a single knob, which connects into circuit any coil unit for a given band at the turn of a knob.

High sensitivity and improved selectivity are afforded by the 58 R.F. stage, connected ahead of the 58 first detector. A separate 58 oscillator is employed and after the first detector we find two "high gain" I. F. stages. The signal is now fed into the second detector—first A.F. 55 tube. Then, the signal passes on through a push-pull second A.F. stage employing two 56's and the output of this stage is transformer-coupled into the third A.F. stage, in which a pair of 2A3's are used in a push-pull arrangement. The powerfully amplified signal, whether short-wave or broadcast, passes from the plate circuits of the third A.F. stage through a carefully designed output transformer into the thoroughly adequate auditorium-type loud-speaker.

The power supply of the model 711 All-Wave receiver is very ably taken care of by the utilization of the newest rectifier tube, the type 5Z3. Plentifully large condensers are used in the power-supply filter so as to insure the minimum of noise or hum.

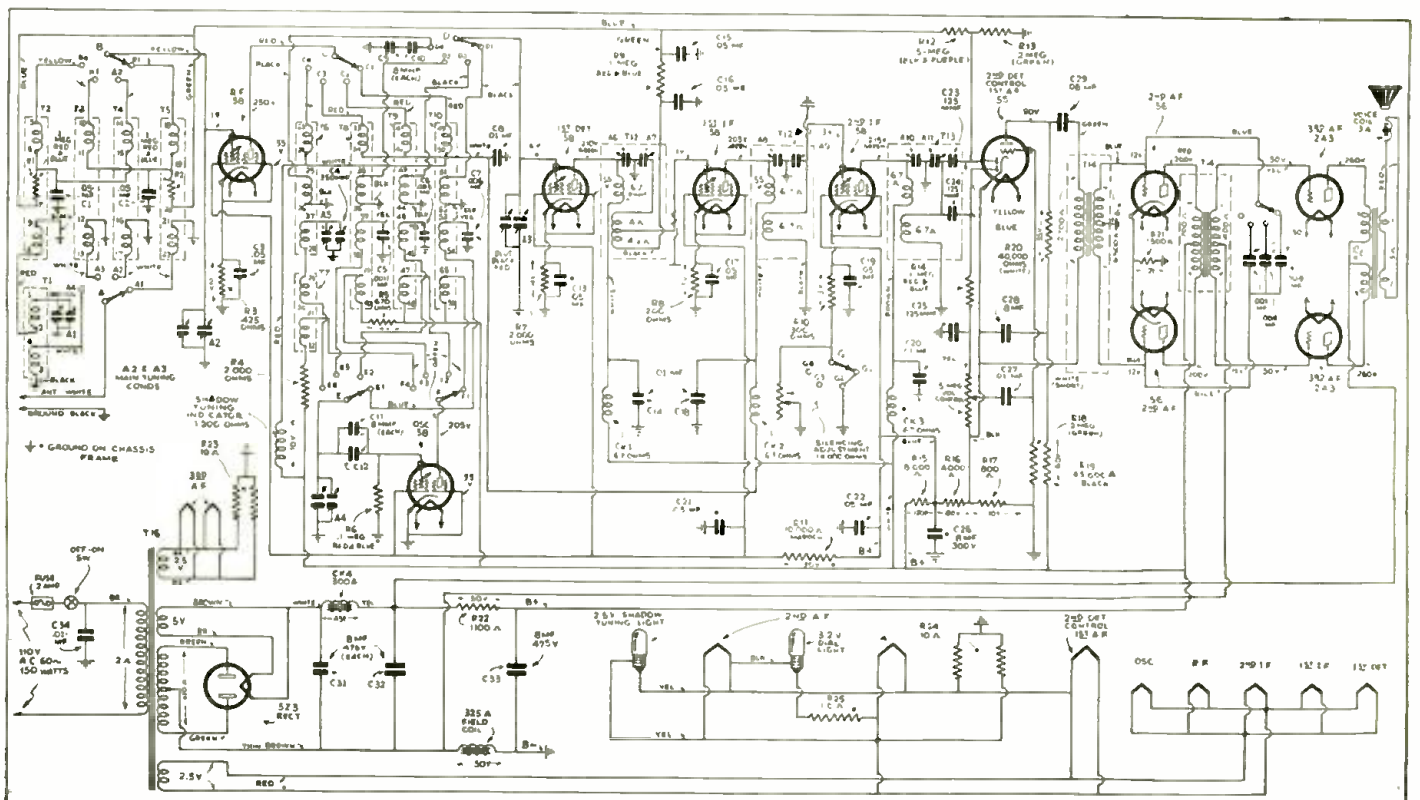

The Model 711 A-K All-Wave Receiver is shown diagrammatically above. The various coils to cover the different wave-bands are switched into circuit as required by simply turning a knob.

New Norden Superhet Tunes 15 to 550 Meters

A new multi-wave, 9-tube, superheterodyne having a wave length range of 15 to 550 meters, built on a very compact chassis; it has built-in power supply. Band-spread is provided to increase ease in tuning in DX stations. Specially wound plug-in coils insure highest efficiency. Has tuning meters and A.V.C.; also CW beat oscillator for code reception.



Alexander Norden, Jr., who sponsors the new 9-tube de Luxe multi-wave superheterodyne, here described.



Interesting control panel of the new Norden all-wave superhet; note the tuning meters.

● THERE have been a great many remarkable advances and improvements in the design of short-wave equipment but the new Norden Navy Model 34 incorporates some of the highest developments yet attained in radio engineering. The design makes it possible for nine tubes to accomplish the results of fifteen with even greater efficiency than was possible with previous designs. Definitely the day of the cumbersome receiver of many tubes is past. All good engineering tends to-

ward simplification which is the primary essential in proper design and this is exemplified in the new receiver here illustrated.

Primarily a receiver must have the necessary sensitivity and selectivity to receive the desired station and to do so with the exclusion of all other interfering signals. It is well known that the superheterodyne method of reception has long been the standard used by the U. S. Army and Navy and commercial communication companies, where the requirements are reception over extremely long distances without interference from nearby stations. The engineers who designed this receiver first introduced the superheterodyne for popular use in 1924 and have since continuously advocated this principle of design; consequently the new receiver represents the composite experiences of a decade of research and engineering development in this type of receiver.

High Sensitivity and Selectivity

The new receiver has a sensitivity of less than 1/4 micro-volt per meter

throughout the entire frequency range, which permits the reception of the very weakest signals. The sensitivity of any receiver is limited by the proportion of background noise in relation to signal strength. Great care has been exercised in the design of this set to insure the highest possible ratio of signal-to-noise, so that satisfactory reception is possible even under adverse conditions. Actually this ratio is about 4:1 which is higher than any other receiver now available, the designers of this set state, and signals that are inaudible to other receivers are easily picked up with the Navy Model 34 with satisfactory quality and volume.

The question of selectivity has always been one of the serious problems in the design of receiving sets. If a receiver has been designed for this purpose exclusively, the quality or reproduction suffers proportionately. It is absolutely necessary that many other factors be taken into consideration

(Continued on page 548)

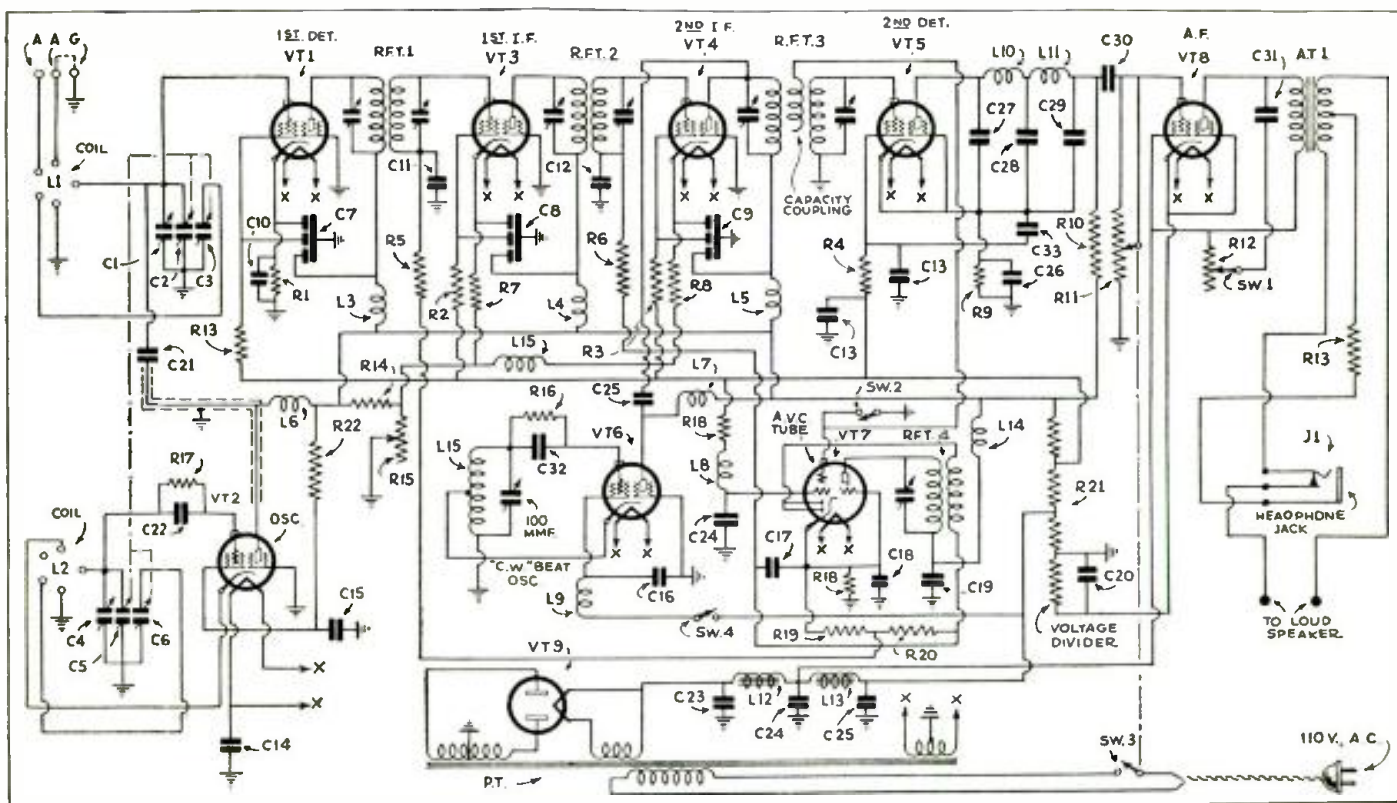

Wiring diagram of the new Navy model 34 multi-wave superhet receiver. This set represents one of the highest class receivers thus far offered to short-wave "fans" and "hams."

The Masterpiece II

Official All-Wave Receiver

Of the Byrd Antarctic Expedition

By McMURDO SILVER

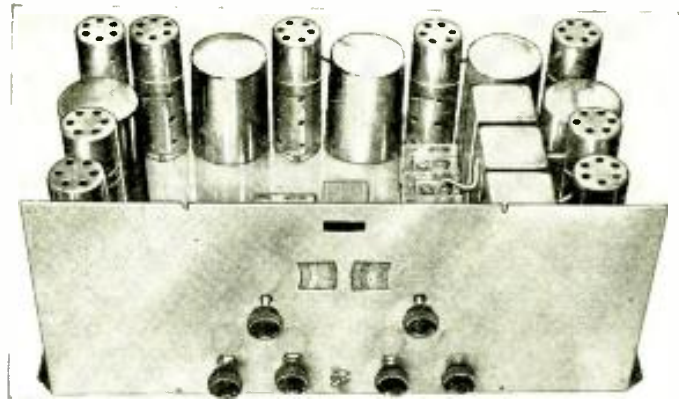

The Masterpiece II, designed by McMurdo Silver, which covers all waves from 13 to 570 meters; It has "band-spread" tuning.

● IN AUGUST of this year the MASTERPIECE fifteen tube all wave receiver had been in service for nine months, and the excellence of the reports on its performance received from sets in all parts of the world indicated no need for improvement. But at this time came the request of Admiral Byrd for a number of these sets for use under the rigorous conditions of his second Antarctic Expedition. Certain suggestions were made by a famous eastern university acting as his radio advisor, as to details which it was felt would insure somewhat more satisfactory results under the unusually severe usage of the Expedition's two year stay in the Antarctic.

At the same time came the request from another great eastern university engaged in short-wave transmission phenomena research for exactly the same features requested for Admiral Byrd.

So the MASTERPIECE II was born—the original MASTERPIECE with the added features desired by these two

Here's McMurdo Silver's latest—the Masterpiece II, "All-Wave" Receiver. It has a wavelength range of 13 to 570 meters and possesses tremendous amplification, thanks to the 12 high-gain tubes employed. A special switch changes the coil connections for the various wave bands.

great engineering schools and at the same time taking maximum advantage of certain simplifications made possible by new tubes introduced in recent months.

Better Performance Through Simplification

One year after the introduction of

the MASTERPIECE it has, therefore, been felt that by analyzing a cross-section of comments and suggestions certain mechanical changes could beneficially be made. Certain simpler electrical means of attaining the same ends having been developed during 1933, these might also advantageously be incorporated at this same time.

As stated above, these changes are not essential design changes, for they alter the results obtained hardly at all. They are simplifications of an electrical and mechanical nature, calculated to render the results previously obtained easier to obtain, both for the novice and the experienced engineer alike.

To those familiar with the MASTERPIECE two changes are outstanding upon looking at the set. The first is the polished chromium shielding cabinet over the entire chassis. This contributes additional shielding over and above that had by the individual circuit elements, helping to eliminate extraneous noise, and also keeping dust

(Continued on page 560)

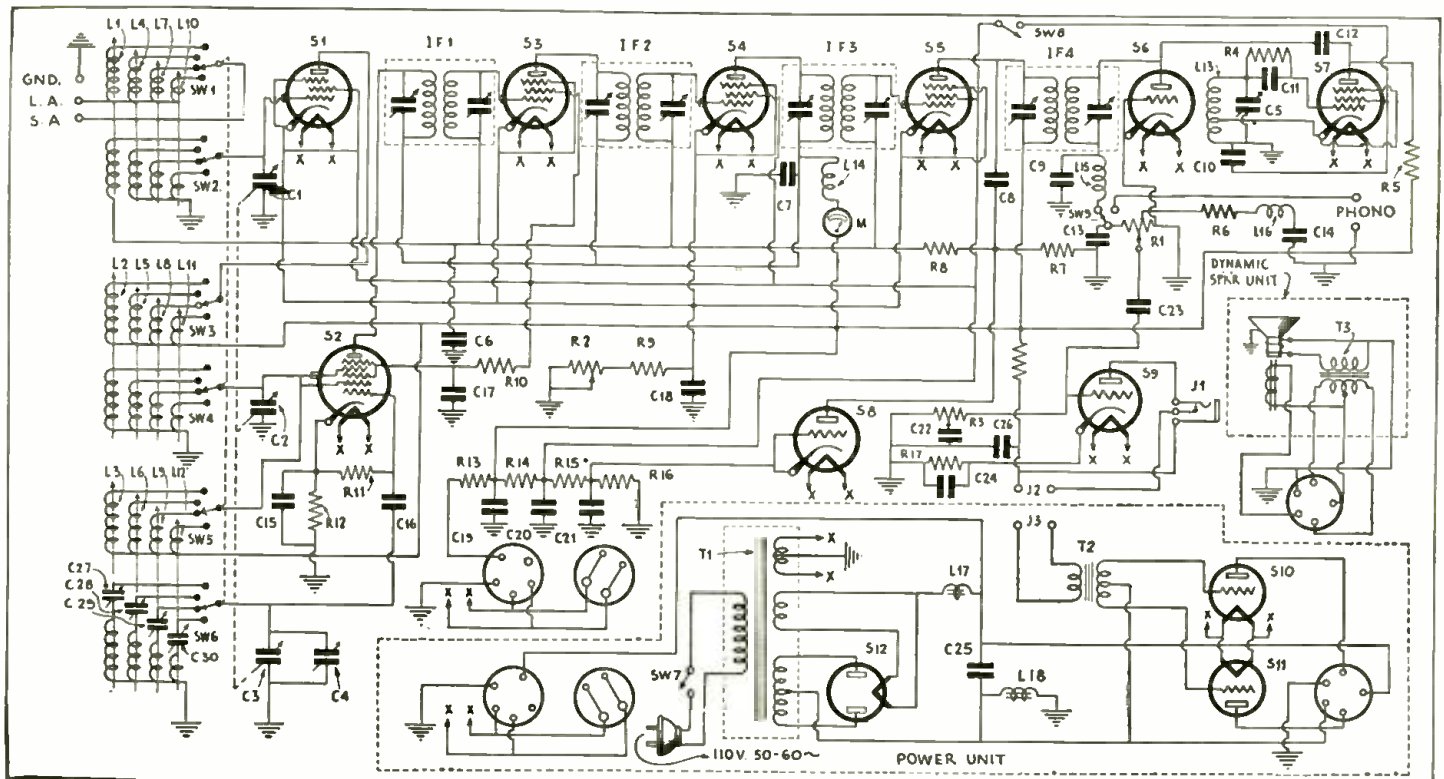

Here we have the schematic circuit diagram for the new McMurdo Silver "Masterpiece II" All-Wave Superheterodyne Receiver.

SHORT WAVE STATIONS OF THE WORLD

SECTION TWO

The lists that appear here with comprise Section Two of the SHORT WAVE CRAFT index of the world's short wave stations, which has proved very popular with S. W. fans everywhere. As compared with Section Two published in the November, 1933, number, it represents many additions and corrections.

Section One of this list, which appeared in the December, 1933, number, contained a "grand" list of short wave relay broadcasting, experimental and commercial radiophone stations. It will appear in the February, 1934, number, with further additions and last minute corrections.

Please write to us about any new stations, changes in schedules or other important data that you learn through announcements over the air or correspondence with the stations themselves. A post card will be sufficient. We will safely return to you any verifications that you send in to us. Communications of this kind are a big help.

AIRPORT RADIO STATIONS

The airport stations do not follow any fixed schedules, and are likely to be heard any time of the day or night. The airplane transmitters are usually heard on the same wavelengths. The little "boxes" are for your dial settings.

Group One

94.86 m.-3160 kc. 53.83 m.-5570 kc.
94.56 m.-3170 kc. 53.74 m.-5580 kc.
93.29 m.-3215 kc. 53.64 m.-5590 kc.
52.98 m.-5660 kc.

Bakersfield, Calif. **KQK**
Bellefonte, Pa. **WNAM**
Boise, Idaho **KRA**
Brooksville, Pa. **WNAL**
Burbank, Calif. **KEU**
Cheyenne, Wyo. **KOE**
Chicago, Ill. **WUCG**
Cleveland, Ohio **WNAK**
Dallas, Tex. **KNAT**
Des Moines, Iowa **KQM**
Elko, Nevada **KKO**
Fort Worth, Tex. **KGUC**
Fresno, Calif. **KGT**
Iowa City, Iowa **KQQ**
Kansas City, Mo. **KNAS**
Lincoln, Neb. **KRF**
Medford, Ore. **KGE**
Moline, Ill. **WNAU**
Newark, N. J. **WNAO**
North Platte, Nebr. **KMR**
Oakland, Calif. **KFO**
Okla. City, Okla. **KNAV**
Omaha, Nebr. **KMP**
Orlando Twsp., Ill. **WNAT**
Pasco, Wash. **KRD**
Ponca City, Okla. **KGUZ**
Portland, Ore. **KVO**
Redding, Calif. **KUT**
Rock Springs, Wyo. **KQC**
Sacramento, Calif. **KFM**
Salt Lake City, Utah **KQD**
San Diego, Calif. **KGQZ**
Seattle, Wash. **KZJ**
Spokane, Wash. **KGTZ**
Tulsa, Okla. **KNAU**
Wichita, Kans. **KGTE**

Group Two

103.23 m.-2905 kc. 60.15 m.-4990 kc.
97.63 m.-3070 kc. 54.45 m.-5510 kc.
97.15 m.-3090 kc. 52.88 m.-5680 kc.

60.39 m.-4970 kc. 52.7 m.-5690 kc.
52.45 m.-5720 kc.

Alameda, Calif. **KGSB**
Albuquerque, N. M. **KSX**
Burbank, Calif. **KSI**
Butte, Mont. **KGTY**
Camden, N. J. **WAE**
Columbus, Ohio **WHG**
Cresson, Pa. **WAEG**
Harrisburg, Pa. **WAED**
Indianapolis, Ind. **WHM**
Kansas City, Mo. **KST**
Kingman, Ariz. **KGTL**
Las Vegas, Nev. **KGTN**
Newark, N. J. **WAEF**
Pittsburgh, Pa. **WAE**
Pocatello, Idaho **KGTX**
Robertson, Mo. **KGTR**
Springfield, Mo. **KGTO**
Tulsa, Okla. **KSY**
Wichita, Kans. **KGTD**
Winslow, Ariz. **KGTA**

Group Three

103.23 m.-2905 kc. 60.15 m.-4990 kc.
97.63 m.-3070 kc. 54.45 m.-5510 kc.
97.15 m.-3090 kc. 53.83 m.-5570 kc.
94.86 m.-3160 kc. 53.74 m.-5580 kc.
94.56 m.-3170 kc. 53.64 m.-5590 kc.
94.26 m.-3180 kc. 52.98 m.-5660 kc.
93.29 m.-3215 kc. 52.88 m.-5670 kc.
60.39 m.-4970 kc. 52.7 m.-5690 kc.

Denver, Colo. **KGSP**
Las Vegas, Nev. **KGTJ**
Pueblo, Colo. **KGSR**
Salt Lake City, Utah **KGTH**

Group Four

93.09 m.-3220 kc. 86.52 m.-3470 kc.
92.8 m.-3230 kc. 86.08 m.-3490 kc.
92.52 m.-3240 kc. 61.00 m.-4920 kc.
92.09 m.-3250 kc. 53.55 m.-5600 kc.
87.02 m.-3450 kc. 53.45 m.-5610 kc.
86.77 m.-3460 kc. 53.26 m.-5630 kc.

Abilene, Tex. **KGUL**
Beaumont, Tex. **KGTV**

Birmingham, Ala. **WSDE**
Boston, Mass. **WSDD**
Mobile, Ala. **WAEK**
Newark, N. J. **WSDC**
Tuscon, Ariz. **KGUO**

Group Five

129.63 m.-2315 kc. 86.08 m.-3490 kc.
127.33 m.-2355 kc. 63.29 m.-4740 kc.
93.09 m.-3220 kc. 61.00 m.-4920 kc.
92.8 m.-3230 kc. 53.55 m.-5600 kc.
92.52 m.-3240 kc. 53.45 m.-5610 kc.
92.09 m.-3260 kc. 53.26 m.-5630 kc.
87.02 m.-3450 kc. 45.87 m.-6540 kc.
86.77 m.-3460 kc. 45.8 m.-6550 kc.
86.52 m.-3470 kc. 37.43 m.-8015 kc.

Atlanta, Ga. **WQPD**
Big Spring, Tex. **KGUG**
Brownsville, Tex. **KGUE**
Burbank, Calif. **KGUR**
Cincinnati, Ohio **WSID**
Dallas, Tex. **KGUF**
Douglas, Ariz. **KGUN**
El Paso, Tex. **KGUA**
Frijole, Tex. **KGUM**
Indio, Calif. **KGUQ**
Jackson, Miss. **KSDB**
Little Rock, Ark. **KQUU**
Memphis, Tenn. **WSDK**
Nashville, Tenn. **WSDT**
New Orleans, La. **WQDQ**
Omaha, Nebr. **KGTS**
Phoenix, Ariz. **KGUP**
Robertson, Mo. **KGUT**
San Antonio, Tex. **KGUD**
Shreveport, La. **KGUK**
Springfield, Ill. **WAEJ**
Waco, Tex. **KGUH**

Group Six

112.44 m.-2670 kc. 98.83 m.-3040 kc.
112.27 m.-2675 kc. 55.79 m.-5380 kc.
105.11 m.-2850 kc.

Chicago, Ill. **WSDS**

Duluth, Minn. **WSDL**
 Fargo, N. D. **KNWB**
 Madison, Wis. **WSDR**
 Milwaukee, Wis. **WAEH**
 Pembia, N. D. **KNWC**
 St. Paul, Minn. **KNWA**

Group Seven

111.19 m.-2680 kc. 51.5 m.-5820 kc.
102.1 m.-2935 kc.

Detroit, Mich. **WAEI**

Group Eight

129.63 m.-2310 kc. 45.87 m.-6540 kc.
127.33 m.-2355 kc. 45.8 m.-6550 kc.
86.52 m.-3470 kc. 45.73 m.-6560 kc.
63.29 m.-4740 kc. 37.45 m.-8010 kc.

Blythe, Calif. **KGUS**
Houston, Tex. **KGUB**

Group Nine

126.1 m.-2380 kc. 63.22 m.-4740 kc.
101.83 m.-2950 kc. 53.07 m.-5650 kc.
100.46 m.-2990 kc. 45.52 m.-6590 kc.
72.11 m.-4160 kc. 45.45 m.-6600 kc.

Baltimore, Md. **WEEB**
Charleston, S. Car. **WEEC**
Greensboro, N. Car. **WEEG**
Jacksonville, Fla. **WEEJ**
Linden, N. J. **WEEN**
McRae, Ga. **WEEH**
Miami, Fla. **WEEM**
Orlando, Fla. **WEEO**
Richmond, Va. **WEER**
Spartanburg, S. Car. **WEEF**

Group Ten

113.29 m.-2650 kc. 45.59 m.-6580 kc.
104.53 m.-2870 kc. 37.43 m.-8010 kc.
97.32 m.-3080 kc. 36.5 m.-8220 kc.
55.5 m.-5400 kc. 24.33 m.-12,330 kc.
53.64 m.-5700 kc. 18.47 m.-16,240 kc.
45.66 m.-6570 kc. 18.24 m.-16,450 kc.

Brownsville, Tex. **KGJW**
Miami, Fla. **WKDL**
San Juan, P. R. **WMDV**

AIRPORT RADIO STATIONS—Alphabetically by Call Letters

The number in parenthesis following the location indicates the frequency group in which the station operates.

KGTY Butte, Mont. (2)	KGTZ Spokane, Wash. (1)	KNAU Tulsa, Okla. (1)	WEER Richmond, Va. (9)
KEU Burbank, Calif. (1)	KGUA El Paso, Tex. (5)	KNAV Okla. City, Okla. (1)	WHG Columbus, Ohio (2)
KFM Sacramento, Calif. (1)	KGUB Houston, Tex. (8)	KNWA St. Paul, Minn. (6)	WHM Indianapolis, Ind. (2)
KFO Oakland, Calif. (1)	KGUD San Antonio, Tex. (5)	KNWB Fargo, N. D. (6)	WKDL Miami, Fla. (10)
KGE Medford, Ore. (1)	KGUE Brownsville, Tex. (5)	KNWC Pembina, N. D. (6)	WMDV San Juan, P. R. (10)
KGGUC Ft. Worth, Tex. (1)	KGUF Dallas, Tex. (5)	KOE Cheyenne, Wyo. (1)	WNAO Newark, N. J. (1)
KGJW Brownsville, Tex. (10)	KGUG Big Spring, Tex. (5)	WAEC Pittsburgh, Pa. (2)	WNAK Cleveland, Ohio (1)
KGOZ San Diego, Calif.	KGUH Waco, Tex. (5)	WAED Harrisburg, Pa. (2)	WNAL Brookville, Pa. (1)
KGSB Alameda, Calif. (2)	KGUK Shreveport, La. (5)	WAE Camden, N. J. (2)	WNAM Bellefont, Pa. (1)
KGSP Denver, Colo. (3)	KGUL Abilene, Tex. (4)	WAEF Newark, N. J. (2)	WNAT Orlando Twashp., Ill. (1)
KGSR Pueblo, Colo. (3)	KGUM Frijole, Tex. (5)	WAEG Cresson, Pa. (2)	
KGT Fresno, Calif. (1)	KGUN Douglas, Ariz. (5)	WAEH Milwaukee, Wis. (6)	WNAU Moline, Ill. (1)
KGTA Winslow, Ariz. (2)	KGUO Tucson, Ariz. (4)	WAEI Detroit, Mich. (7)	WQDQ New Orleans, La. (5)
KGTD Wichita, Kans. (2)	KGUP Phoenix, Ariz. (5)	WAEJ Springfield, Ill. (5)	WQPD Atlanta, Ga. (5)
KGTE Wichita, Kans. (1)	KGUQ Indio, Calif. (5)	WAEK Mobile, Ala. (4)	WSDC Newark, N. J. (4)
KGTH Salt Lake City, U. (3)	KGUR Burbank, Calif. (5)	WEEB Baltimore, Md. (9)	WSDD Boston, Mass. (4)
KG TJ Las Vegas, Nev. (3)	KGUS Blythe, Calif. (8)	WEEC Charleston, S. C. (9)	WSDE Birmingham, Ala. (4)
KGTL Kingman, Ariz. (2)	KGUT Robertson, Mo. (5)	WEEF Spartanburg, S. C. (9)	WSDK Memphis, Tenn. (5)
KG TN Las Vegas, Nev. (2)	KGUZ Ponca City, Okla. (1)	WEEG Greensboro, N. C. (9)	WSDL Duluth, Minn. (6)
KG TQ Springfield, Mo. (2)	KKO Elko, Neva. (1)	WEEH McRae, Ga. (9)	WSDS Chicago, Ill. (6)
KG TR Robertson, Mo. (2)	KMP Omaha, Neb. (1)	WEEJ Jacksonville, Fla. (9)	WSDT Nashville, Tenn. (5)
KG TS Omaha, Neb. (5)	KMR No. Platte, Nebr. (1)	WEEM Miami, Fla. (9)	WSID Cincinnati, Ohio (5)
KG TV Beaumont, Tex. (4)	KNAS Kansas City, Mo. (1)	WEEN Linden, N. J. (9)	WUCG Chicago, Ill. (1)
KG TX Pocatella, Idaho (2)	KNAT Dallas, Tex. (1)	WEEO Orlando, Fla. (9)	

TELEVISION STATIONS

Television transmission at the present time is highly experimental in nature, and for this reason it is difficult to give operating hours, scanning speeds, lines per second, etc., with any degree of accuracy.

According to frequency and wavelength	2100-2200 kc. 136.4-142.9 m.	W2XAB—Atlantic Broadcasting Corp. New York, N. Y. 500 watts (not in use)	W2XF—National Broadcasting Co. New York, N. Y. 5000 watts
1600-1700 kc. 176.5-187.5 m. Dial:	W3XAK —National Broadcasting Co. 5000 watts. Portable	43,000-46,000 kc. 6.52-6.98 m. 48,500-50,300 kc. 6.00-6.20 m. 60,000-80,000 kc. 3.75-5.00 m. Dial:	W6XAO —Don Lee Broadcasting System Los Angeles, Calif. 150 watts
W2XR —Radio Pictures, Inc. Long Island City, N. Y. 1000 watts. 60 lines	W2XBS —National Broadcasting Co. New York, N. Y. 5000 watts	W9XD —The Journal Co. Milwaukee, Wis. 500 watts	W3XE —Philadelphia Storage Battery Co. Philadelphia, Pa. 1500 watts
W8XAN —Sparks-Withington Co. 100 watts Jackson, Mich.	W6XS —Don Lee Broadcasting Corp. Los Angeles, Calif. 1000 watts	W9XE —U. S. Radio & Tele. Corp. Marion, Ind. 1000 watts	W2XAK —Atlantic Broadcasting Corp., New York, N. Y. 50 watts
2000-2100 kc. 142.9-150 m. Dial:	W9XAP —National Broadcasting Co. Chicago, Ill. 2,500 watts	W3XAD —RCA-Victor Co., Camden, N. J. 2000 watts	W10XX —RCA-Victor Co., Portable and Mobile. 50 watts
W9XAO —Western Television Corp. Chicago, Ill. 500 watts. 45 lines	W9XAK —Kansas State College, Manhattan, Kans. 125 watts	W2XBT —National Broadcasting Co. Portable 750 watts	W8XAN —Sparks-Withington Co., Jackson, Mich. 100 watts
W6XAH —Pioneer Mercantile Co. Bakersfield, Cal. 1000 watts. 60 lines	2200-2300 kc. 130.4-136.4 m. Dial:	W2XR —Radio Pictures, Inc. Long Island City, N. Y. 1000 watts	
W9XK —Iowa State University Iowa City, Iowa 100 watts. 60 lines	W9XAL —First National Television Corp. Kansas City, Mo. 500 watts		
	2750-2850 kc. 105.3-109.1 m. Dial:		
	W9XG —Purdue University W. Lafayette, Ind. 1500 watts. 60 lines		

POLICE RADIO ALARM STATIONS

By Frequency and Wavelength

2506 kc.-120 m.	Dial: <input type="text"/>
KGZE San Antonio, Tex.	
2470 kc.-121.5 m.	Dial: <input type="text"/>
KGOZ Cedar Rapids, Ia.	
KGPN Davenport, Ia.	
KGZG Des Moines, Ia.	
WPDZ Fort Wayne, Ind.	
WPDT Kokomo, Ind.	
WPEC Memphis, Tenn.	
KGPI Omaha, Neb.	
WPPD Philadelphia, Pa.	
KGPM San Jose, Cal.	
KGPM Salt Lake City, U.	
KGPK Sioux City, Ia.	
WRDQ Toledo, Ohio	
WPFL Gary, Ind.	
WPFQ Swathmore, Pa.	
WPFQ Knoxville, Tenn.	
WPFM Johnson City, Tenn.	
WPEM Woonsocket, R. I.	
WPFV Pawtucket, R. I.	
2458 kc.-122.0 m.	Dial: <input type="text"/>
WPDO Akron, Ohio	
WPDN Auburn, N. Y.	
WPDV Charlotte, N. C.	
WRDH Cleveland, Ohio	
WPDH Rochester, N. Y.	
WPEA Syracuse, N. Y.	
..... Asheville, N. C.	
WPDG Youngstown, O.	
2450 kc.-122.4 m.	Dial: <input type="text"/>
WPKD Milwaukee, Wis.	

WPEE New York, N. Y.	
WPEF New York, N. Y.	
WPEG New York, N. Y.	
KGPH Okla. City, Okla.	
KGPO Tulsa, Okla.	
KGPP Wichita, Kans.	
KGZF Chanute, Kans.	
KGZP Coffeyville, Kans.	
KGPPQ Honolulu, T. H.	
2442 kc.-122.8 m.	Dial: <input type="text"/>
KGPPX Denver, Col.	
WPDF Flint, Mich.	
WPEB Grd. Rapids, Mich.	
WMDZ Indianapolis, Ind.	
WPDH Lansing, Mich.	
WPDE Louisville, Ky.	
KGPP Portland, Ore.	
WPDH Richmond, Ind.	
KGZH Klamath Falls, Ore.	
WPFM Muskegon, Mich.	
WPEE Reading, Pa.	
KGZR Salem, Ore.	
WPEE Saginaw, Mich.	
2430 kc.-123.4 m.	Dial: <input type="text"/>
WPEK New Orleans, La.	
KGPP Minneapolis, Minn.	
WPDH Columbus, Ohio	
KGPP Portland, Ore.	
WPDH Dayton, Ohio	
KGZD San Diego, Cal.	
WPDF Highland Park, Ill.	
WPFM Toms River, N. J.	
WPFK Hackensack, N. J.	
KGZJ Phoenix, Ariz.	
2422 kc.-123.8 m.	Dial: <input type="text"/>

KSW Berkeley, Cal.	
WMJ Buffalo, N. Y.	
KGPE Kansas City, Mo.	
KGZC Topeka, Kan.	
KGPG Vallejo, Cal.	
WPDW Washington, D. C.	
WPFJ Jacksonville, Fla.	
2414 kc.-124.2 m.	Dial: <input type="text"/>
WPDY Atlanta, Ga.	
KGPS Bakersfield, Cal.	
WCK Belle Island, Mich.	
WPDH Detroit, Mich.	
KGZA Fresno, Cal.	
WRDR Grosse Pt. Vil. Mich.	
WMO Highland Pk., Mich.	
KGPA Seattle, Wash.	
WPDH Tulare, Cal.	
KGZM El Paso, Tex.	
WPFH Baltimore, Md.	
KGZN Tacoma, Wash.	
WPFM Columbus, Ga.	
WPFM Birmingham, Ala.	
WPFM Clarksburg, W. Va.	
..... Santa Barbara, Cal.	
..... Mount Pleasant, N. Y.	
KGPD San Francisco, Cal.	
1712 kc.-175.15 m.	Dial: <input type="text"/>
WPEE Arlington, Mass.	
KGPP Beaumont, Tex.	
WPDH Chicago, Ill.	
WPDH Chicago, Ill.	
WPDH Chicago, Ill.	
WPDH Chicago, Ill.	
WKDU Cincinnati, Ohio	
KVP Dallas, Tex.	
KGPL Los Angeles, Cal.	
KGJX Pasadena, Cal.	

WPDU Pittsburgh, Pa.	
KGPC St. Louis, Mo.	
KGZI Wichita Falls, Tex.	
WFFA Newton, Mass.	
KGZL Shreveport, La.	
WPEH Somerville, Mass.	
WPEP Arlington, Mass.	
KGZB Houston, Tex.	
WPFJ Hammond, Ind.	
WPFN Fairhaven, Mass.	
KGZQ Waco, Tex.	
WPET Lexington, Mass.	
WPEI E. Providence, R. I.	
..... Portland, Me.	
UYR Montreal, Can.	
1574 kc.-189.5 m.	Dial: <input type="text"/>
WRDS E. Lansing, Mich.	
WMP Fram'gham, Mass.	
WPEW North'pton, Mass.	
KGPI Shreveport, La.	
WPEL Middleboro, Mass.	
WPEV Portable, Mass.	
1558 kc.-192.5 m.	Dial: <input type="text"/>
WEY Boston, Mass.	
WKDT Detroit, Mich.	
1534 kc.-196.1 m.	Dial: <input type="text"/>
KGHO Des Moines, Ia.	
190 kc.-1570 m.	Dial: <input type="text"/>
WBR Butler, Pa.	
WJL Greensburg, Pa.	
WBA Harrisburg, Pa.	
WMB W. Reading, Pa.	
WDX Wyoming, Pa.	

Alphabetically By Call Letters

KGHO Des Moines, Iowa	1534 kc.	KGZR Salem, Ore.	2442 kc.	WPDZ Fort Wayne, Ind.	2470 kc.
KGJX Pasadena, Cal.	1712 kc.	KSW Berkeley, Cal.	1712 kc.	WPEA Syracuse, N. Y.	2458 kc.
KGOZ Cedar Rapids, Iowa	2470 kc.	KVP Dallas, Tex.	1712 kc.	WPEB Grand Rapids, Mich.	2442 kc.
KGPA Seattle, Wash.	2414 kc.	UYR Montreal, Can.	1712 kc.	WPEC Memphis, Tenn.	2470 kc.
KGPP Minneapolis, Minn.	2430 kc.	WBA Harrisburg, Pa.	257 kc.	WPED Arlington, Mass.	1712 kc.
KGPC St. Louis, Mo.	1712 kc.	WBR Butler, Pa.	257 kc.	WPEE New York, N. Y.	2450 kc.
KGPD San Francisco, Cal.	2414 kc.	WCK Belle Island, Mich.	2414 kc.	WPEF New York, N. Y.	2450 kc.
KGPE Kansas City, Mo.	2422 kc.	WDX Wyoming, Pa.	257 kc.	WPEG New York, N. Y.	2450 kc.
KGPG Vallejo, Cal.	2422 kc.	WEY Boston, Mass.	1558 kc.	WPEH Somerville, Mass.	1712 kc.
KGPH Oklahoma City, Okla.	2450 kc.	WJL Greensburg, Pa.	257 kc.	WPEI E. Providence, R. I.	1712 kc.
KGPI Omaha, Neb.	2470 kc.	WKDT Detroit, Mich.	1558 kc.	WPEK New Orleans, La.	2430 kc.
KGPP Beaumont, Tex.	1712 kc.	WKDU Cincinnati, Ohio	1712 kc.	WPEL Middleboro, Mass.	1574 kc.
KGPK Sioux City, Iowa	2470 kc.	WMB W. Reading, Pa.	257 kc.	WPEM Woonsocket, R. I.	2470 kc.
KGPL Los Angeles, Cal.	1712 kc.	WMDZ Indianapolis, Ind.	2442 kc.	WPEP Arlington, Mass.	1712 kc.
KGPM San Jose, Cal.	2470 kc.	WMJ Buffalo, N. Y.	2422 kc.	WPEE Saginaw, Mich.	2442 kc.
KGPN Davenport, Iowa	2470 kc.	WMO Highland Park, Mich.	2414 kc.	WPET Lexington, Mass.	1712 kc.
KGPO Tulsa, Okla.	2450 kc.	WMP Framingham, Mass.	1574 kc.	WPEV Portable, Mass.	1574 kc.
KGPP Portland, Ore.	2442 kc.	WPDH Tulare, Cal.	2414 kc.	WFFA Newton, Mass.	1712 kc.
KGPPQ Honolulu, T. H.	2450 kc.	WPDH Chicago, Ill.	1712 kc.	WPFM Muskegon, Mich.	2442 kc.
KGPS Bakersfield, Cal.	2414 kc.	WPDH Chicago, Ill.	1712 kc.	WPDF Highland Park, Ill.	2430 kc.
KGPM Salt Lake City, Utah	2470 kc.	WPDE Chicago, Ill.	1712 kc.	WPFH Reading, Pa.	2442 kc.
KGPPX Denver, Colo.	2442 kc.	WPDE Louisville, Ky.	2442 kc.	WPFM Toms River, N. J.	2430 kc.
KGPI Baton Rouge, La.	1574 kc.	WPDF Flint, Mich.	2442 kc.	WPFJ Jacksonville, Fla.	2442 kc.
KGPP Wichita, Kans.	2450 kc.	WPDG Youngstown, Ohio	2458 kc.	WPFH Baltimore, Md.	2414 kc.
KGZA Fresno, Calif.	2414 kc.	WPDH Richmond, Ind.	2442 kc.	WPFM Columbus, Ga.	2414 kc.
KGZB Houston, Tex.	1712 kc.	WPDH Columbus, Ohio	2430 kc.	WPFJ Hammond, Ind.	1712 kc.
KGZC Topeka, Kan.	2422 kc.	WPKD Milwaukee, Wis.	2450 kc.	WPFK Hackensack, N. J.	2430 kc.
KGZD San Diego, Cal.	2430 kc.	WPDH Lansing, Mich.	2442 kc.	WPFL Gary, Ind.	2470 kc.
KGZE San Antonio, Tex.	2506 kc.	WPDH Dayton, Ohio	2430 kc.	WPFM Birmingham, Ala.	2414 kc.
KGZF Chanute, Kans.	2450 kc.	WPDN Auburn, N. Y.	2458 kc.	WPFN Fairhaven, Mass.	1712 kc.
KGZG Des Moines, Iowa	2470 kc.	WPDO Akron, Ohio	2458 kc.	WPFQ Knoxville, Tenn.	2470 kc.
KGZH Klamath Falls, Ore.	2442 kc.	WPPD Philadelphia, Pa.	2470 kc.	WPFM Clark'sburgh, W. Va.	2414 kc.
KGZI Wichita Falls, Tex.	1712 kc.	WPDH Rochester, N. Y.	2458 kc.	WPFQ Swathmore, Pa.	2470 kc.
KGZJ Phoenix, Ariz.	2430 kc.	WPDF St. Paul, Minn.	2430 kc.	WPFM Johnson City, Tenn.	2470 kc.
KGZL Shreveport, La.	1712 kc.	WPDH Kokomo, Ind.	2470 kc.	WPFV Pawtucket, R. I.	2470 kc.
KGZM El Paso, Tex.	2414 kc.	WPDH Kokomo, Ind.	2470 kc.	WRDH Cleveland, Ohio	2458 kc.
KGZN Tacoma, Wash.	2414 kc.	WPDH Pittsburgh, Pa.	1712 kc.	WRDR Grosse Pt. Village, Mich.	2414 kc.
KGZP Coffeyville, Kans.	2450 kc.	WPDH Charlotte, N. C.	2458 kc.	WRDQ Toledo, Ohio	2470 kc.
KGZQ Waco, Tex.	1712 kc.	WPDH Washington, D. C.	2422 kc.	WRDS E. Lansing, Mich.	1574 kc.
		WPDH Detroit, Mich.	2414 kc.		
		WPDY Atlanta, Ga.	2414 kc.		

SHORT WAVE QUESTION BOX

COST OF LICENSE

Eleutherios Vozeolas, Lowell, Mass.

(Q) I am a boy of 15 and I always like to have a transmitter. I have a hunch that SHORT WAVE CRAFT was the exact magazine I needed and boy, is it good to read. Before I go any further in building a transmitter I would like to know what the cost of obtaining an amateur license is?

(A) There is no cost to obtaining operator's or station license of the amateur class in the United States. However there usually is a fee of twenty-five cents for each license to cover the cost of notarizing, which makes a total of 50c for operator's and station license.

DIAGRAM FOR 49 IN CLASS "A"

John L. Schlener, Jr., Elmhurst, Ill.

(Q) Will you please publish a circuit for an audio stage using a type 49 tube?

(A) The circuit you desire is given on this page. The 49 is intended for class "B" push-pull operation. However when the grid adjacent to the plate is tied to the plate, it will function as a class "A" amplifier. This is the diagram that is shown.

(Q) Which is better, a 37 or type 27 for detection?

(A) There is no difference in the working of the two tubes. They are identical in characteristics, except that the 37 is intended for six volt D.C. operation, while the type 27 is to be used with 2.5 volts A.C. on the heater.

SHIELDING

Jack Najork, Northport, N. Y.

(Q) My set has a metal panel which is connected to a very good ground. Nevertheless I am bothered with capacity effects very much. Will you please suggest a remedy for this?

(A) Metal panels do not always entirely eliminate *body capacity* effects, due to the fact that the ground connection can only be made to one part of the chassis, leaving another section of the chassis at a much higher potential difference, at very high radio frequencies. About the best way to overcome your problem is to move your variable condensers and other instruments, which are probably causing the trouble, further away from the grounded panel; or if you wish to go to the additional labor and expense, provide another shield directly behind your present panel with a space between the two of about 1/4 inch. This is known as *double shielding* and effectively eliminates all traces of *body capacity* effects.

SIMPLE 5 METER RECEIVER

John A. Burnham, Jr., Marblehead, Mass.

(Q) Will you please publish one of the simplest type of 5 meter receivers giving coil detail and various circuit constants?

(A) You will find shown on this page the diagram of a 5 meter receiver using type 30 tubes. No interruption frequency oscillator tube is used. The feed-back of the type 30 detector is increased until

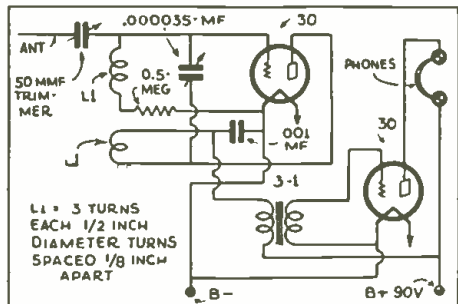

Simple two tube 5 meter receiver using type 30 tubes

Because of the amount of work involved in the drawing of diagrams and the compilation of data, we are forced to charge 25c each for letters that are answered directly through the mail. This fee includes only hand-drawn schematic drawings. We cannot furnish "picture-layouts" or "full-sized" working drawings. Letters not accompanied by 25c will be answered in turn on this page. The 25c remittance may be made in the form of stamps or coin.

Special problems involving considerable research will be quoted upon request. We cannot offer opinions as to the relative merits of commercial instruments.

Correspondents are requested to write or print their names and addresses clearly. Hundreds of letters remain unanswered because of incomplete or illegible addresses.

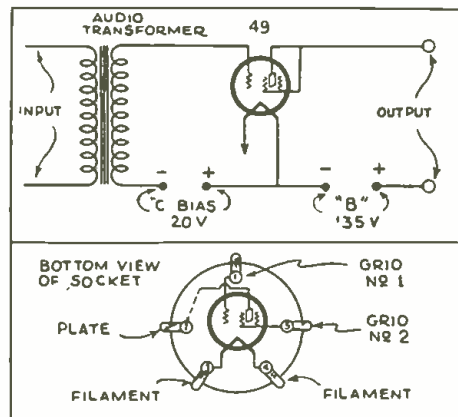

Diagram showing the connections of a '49 as a class "A" amplifier

"squedging" occurs. In this manner the type 30 tube can be made to provide its own interruption frequency oscillations.

NOISY RECEIVER

Milton Cecalek, Houston, Texas

(Q) I would like to know what could possibly cause terrific crashing in my short-wave set. My set uses one type 24 and 27. The noise is irregular and may even stop for a couple of weeks or so. I have already ruined one power pack trying to find the fault. Then I built another one and no improvement was noticed. I have tested everything from A to Z and secured a service man's help—but with no result. The noise is barely noticeable when the set is not regenerating, but when regenerating, increases to an unbearable degree. I am a senior E. E. student and I think, to my knowledge, I have done everything possible. You are my only salvation.

(A) The first thing we suggest is that you disconnect your antenna to determine whether or not the noise is actually in the receiver. It may be that you are picking up some electrical disturbance and no amount of rebuilding your receiver would overcome this in any way. However upon doing this if the noise still continues, you can rest assured that it is in the receiver itself. Many sizzling and crackling noises have been traced to *noisy* (cheap or cracked) resistors and faulty or leaking by-pass condensers. Many times the terminals on condensers and resistors are not securely made and at times through vibration become loosened and cause a terrific crashing noise in the receiver. We suggest that you carefully check this over by process of elimination and we feel sure that you will overcome your difficulty.

LOW POWER TRANSMITTER

H. G. Dunn, Grizzly Flats, Calif.

(Q) I have 110 volts D.C. local source of power. Is there any simple way of stepping this voltage up to a suitable value for a transmitter.

(A) There is no practical way of increasing your 110 volts D.C. unless you use some sort of converter to change your D.C. into A.C. which can then be stepped up through the use of a suitable power transformer.

(Q) Would heavy-duty "B" batteries be a feasible source for supplying 300 to 400 volts for transmitting?

(A) Heavy duty "B" batteries would serve very nicely but due to the fact that the average transmitter, running with 400 volts on the plate of the tube will draw around 50 mills (milliamperes), this would be a rather expensive arrangement.

(Q) What circuit and tube would you recommend for my initial set? I live in a rather isolated section, at least fifty miles from the nearest "Ham."

(A) As a starter we would suggest that you employ a single type 201A tube with from 135 to 250 volts on the plate, supplied by B batteries. The circuit we recommend would be the tuned-plate, tuned-grid type. Excellent results have been obtained from low-power transmitters of this type where care has been exercised in designing the antenna system. Remember that in low-power transmitters the antenna system has to be as near perfect as possible if any efficiency is to be obtained.

(Q) What issues of SHORT WAVE CRAFT will give the best dope on transmitters?

(A) Transmitters suitable for amateur use can be found in the September, October, November, and December issues of SHORT WAVE CRAFT.

TESTING POWER TRANSFORMERS

Edward Nohe, Baltimore, Md.

(Q) How can the primary and secondary of a power transformer be located and how can the voltages be found without a meter?

(A) It is very difficult to locate the different windings of a power transformer without some sort of measuring or indicating equipment. The primary of power transformers is usually wound next to the core and may have from two to five leads. The most convenient method of testing a power transformer is to use a 40 watt -110 volt lamp bulb in series with the 110 volt line and apply the voltage to what you think is the primary. Placing the bulb in series with the line will prevent any catastrophe in case you should apply the line voltage to the wrong winding. Some sort of a meter of course will be necessary to measure the voltages of the various winding after the primary has been located.

600 METER RECEIVER

Charles L. Culley, W5DOK, Boyce, La.

Will you please publish a circuit diagram of preferably one and not over two tubes for a receiver suitable for reception on the commercial frequencies around 600 meters? I would like something simple to be built from the average junk-box.

(A) The diagram shown here will perform very nicely for CW code, up to approximately 800 meters.

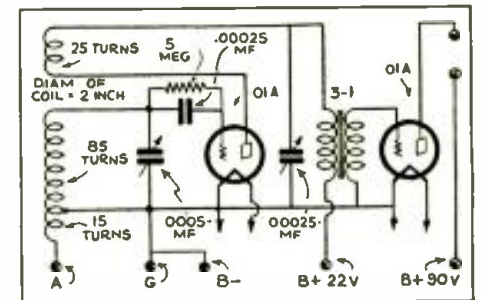

The circuit of a 600 meter "CW" receiver

Improved Filament-Control Circuit

● IN the usual filament-control jack circuit employed in d-c. short-wave sets, the jacks are wired so that the filaments of all of the tubes in the set are turned off when the headphones are not plugged in. When the headphone plug is put in the first jack, the detector tube is lighted; when the loud speaker plug is in the second jack, both the detector and amplifier tubes are lighted. However, two filament-control jacks are hardly necessary if a filament switch is employed. Instead, a single filament-control jack connected as shown in the diagram will make the set less complicated. This is an improvement over the usual filament-control jack circuit in that it is less expensive, easier to wire, and that when the headphones are plugged into the phone jack the filament of the last amplifier tube is turned off. When the phone plug is removed, all of the tubes are lighted and the loud speaker is in use. This arrangement is handy because it saves the operator the trouble of having a separate plug on the loud

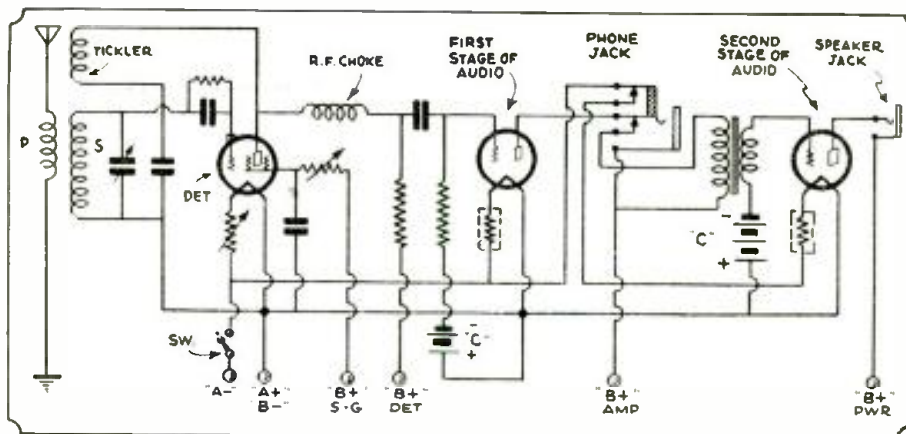

With this easily wired circuit, employing a single "filament-control" jack, the last audio tube is cut out of the circuit when headphones are used.

speaker. Headphones are not satisfactory for reception on more than one stage of audio amplification anyway, because the volume is usually too great. Binding posts or phone-tip jacks can be provided as connectors for the loud

speaker. The phone jack can be placed in the output of the detector tube, instead of in the first stage of audio amplification, if preferred; although the latter connection, which is given in the diagram, is better.—George Mark.

A "Lead Pencil" Receiver

● BOYS will be boys, so why not be a boy again and build this pencil radio set? Just an ordinary everyday lead pencil, about eight or ten feet of No. 30 enameled wire, a crystal, and head set, with a few binding posts thrown in for good measure will do the trick. Be sure to use a pencil that has an eraser attached in a tin housing. Remove the eraser and fasten your crystal to the tin housing, either on the end or on the side. Your tuning slide can be made out of a square piece of bus-bar wire. To use this set out of doors fasten a piece of copper wire two and

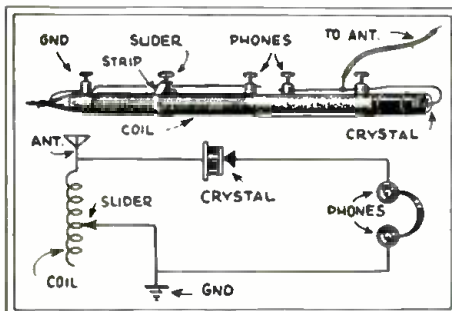

How to build a receiver on a "lead pencil."

½ feet long by ⅛ inch thick to the bottom of pencil, this will be convenient to ground the set and bring it up to the right height, so that you can tune in while sitting on a park bench; if the park bench is made of iron that will serve nicely as an antenna.—A. F. Kuenzel.

This crystal receiver can also be used in offices in cities where there are plenty of broadcasting stations. A good antenna in this instance is a small disc of metal placed under a regular desk phone base, connecting the antenna lead from the set to the disc.

Receiver Calibration As An Aid to "DX" Reception

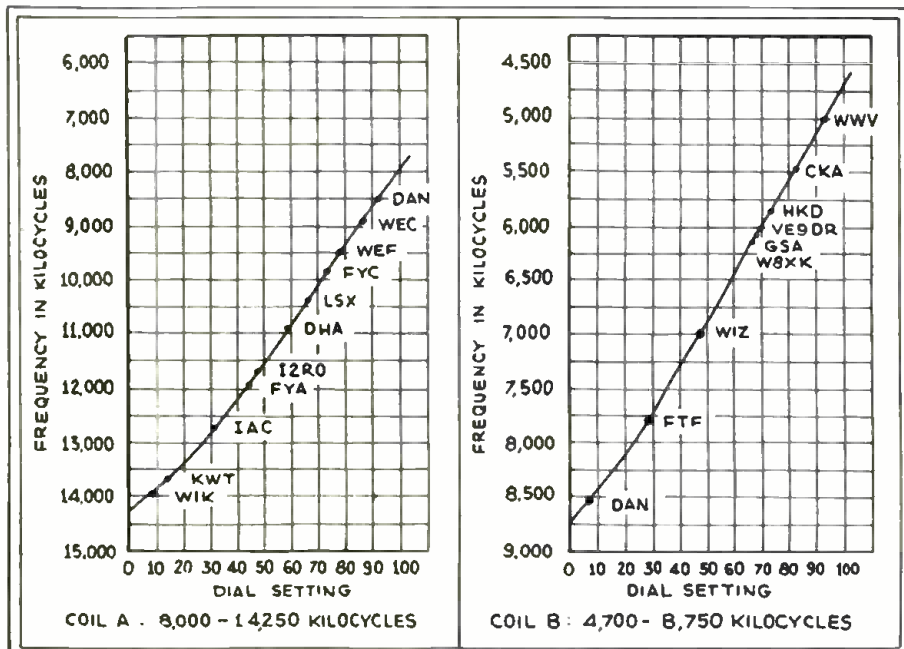

● ONE of the most interesting things about short-wave radio is the field it presents in the way of reception over very long distances. Many listeners have found that the only way to accomplish this with any degree of consistency is to go at it in a systematic way. Of course there is always a large element of chance in DX reception, but if the listener will spend a few hours in preparing a calibration system for his receiver, he will be amply repaid in the ease with which he can locate new stations. Many keep a log of their reception, with the dial settings corresponding to the stations heard. This is all well and good, and a very good way to simplify retuning a station, but it is not much help in locating those elusive ones not yet heard.

The method of calibration described herein is not at all new or original; in fact it is used by thousands of amateurs and short-wave listeners. But for the benefit of the beginner it may prove helpful. It was made for a simple regenerative set using two tubes in a straightforward circuit. No great degree of accuracy is claimed—on the contrary it is rather a rough approxi-

(Continued on page 570)

By means of the simple calibration charts here illustrated and described by Mr. Northrup, you will find it a cinch to locate any distant station.

New Norden Super-het

(Continued from page 541)



Around the Globe

WITH

"SYNCROLITE" TUNING

The "Visible Syncrolite Tuning" on the DeWald Little Giant puts the stations of the whole world "on the spot" at your command.



This new type high gain superheterodyne covers all waves between 15 and 550 meters with equal ease. You hear Paris as easily as a nearby station. You may also listen in on airplanes in midair, police emergency calls and other interesting short wave programs in addition to the full broadcast band. "Syncrolite Tuning" assures that you are always correctly tuned at the point of greatest signal response. A full toned dynamic speaker takes its output from the full powered variable mu duo audio circuit. Manual tone control, 100% automatic volume control, ultra sensibility, and pre-selector antenna circuit, 8 new type tubes—all add to give you superlative performance at low cost. Other Models —from \$19.95 up.

DEWALD RADIO

Pierce Airo, Inc., S.W.C.
512A 6th Avenue, N. Y.

Please send me full particulars on the entire DeWald line with the name of my nearest dealer.

Name

Address

City State

when designing a receiver in order to preserve true tone quality. In this receiver the cardinal principles of simplicity of design, coupled with the very highest quality of insulation and materials have been carefully observed; consequently this receiver is able to differentiate between signals of different frequencies to the highest advantage imaginable. Actually the selectivity is less than 10 kilocycles even at the upper end of the broadcast band with a field strength of approximately 10,000 to 1.

By employing variable condensers of different capacities on different frequency bands, the Model 34 achieves great ease of tuning, even at the highest frequencies (shortest wave lengths). Thus the usually congested short-wave broadcast bands no longer present a problem with this tuning system. The continuous hand-spread tuning arrangement provides ample separation of all stations, regardless of frequency and is so arranged, for example, that stations on the 25 meter band will occupy as much as three degrees on the band-spread tuning dial, thus illustrating the unusual ease of tuning of this instrument.

This set uses one 2B7 tube in a special circuit, which actually represents a stage of intermediate amplification as well as the control of the radio frequency amplification of the set. The control grid current for the automatic volume control tube is obtained through means of a separate winding in the last intermediate transformer, thereby eliminating drain on the detector grid. A switch cuts the "AVC" in or out of circuit, a desirable feature for CW reception.

High Quality Audio Amplifier

This set is capable of supplying approximately 4 watts into the loud speaker, which is more than sufficient for reproduction in the largest room. Excellent reproduction has been insured with complete low frequency compensation and equalized high frequencies by the use of proper reactance condensers and inductance in relation to the loud-speaker transformer. This results in true tone reproduction at all levels of volume.

The new Navy Model receiver chassis is exceedingly compact and it is possible to build this instrument into very small space. The dimensions of the chassis are 20" x 13" x 9" which is approximately half the size of previous designs. This chassis includes the complete receiver, together with its power supply.

Bill of Material for Modern Navy Model 34

- L-1 Antenna Inductance specially wound on threaded isolantite forms
- L-2 Oscillator Coil specially wound on threaded isolantite forms
- L-3, 4, 5, 6, 7, 8, 9, 14 8 M.H. Chokes
- L-10, 11 85 M.H. Chokes
- L-12, 13 Power Filter Chokes
- L-15 C.W. Oscillator Coil
- C-1 W.L. Tank Condenser .000138 mf. cap.
- C-2 W.L. Band-Spread Tuning Condensers .0000125 mf. cap.
- C-3 Auxiliary W.L. Band-Spread Tuning Condenser .000029 mf. cap.
- C-4 Oscillator Tank Condenser .000138 mf. cap.
- C-5 Oscillator Band-Spread Tuning Condenser .0000125 mf. cap.
- C-6 Auxiliary Oscillator Band-Spread Tuning Condenser .000029 mf. cap.
- C-7, 8, 9 Three-Section .1; .1; .1 mf. By-Pass Condenser Block
- C-10, 14, 15 .003 mf. By-Pass Condenser
- C-11, 12, 13, 16, 17, 19 .005 mf. By-Pass Condenser
- C-18 .1 mf. By-Pass Condenser
- C-20 8. mf. By-Pass Condenser
- C-21 .0000006 mf. Coupling Condenser
- C-22 .0001 mf. Condenser
- C-23, 24, 25, 8. mf. Filter Condensers
- C-26 1. mf. Audio By-Pass Condenser
- C-27, 28, 29 .00025 mf. Filter Condenser
- C-30 .02 mf. Blocking Condenser

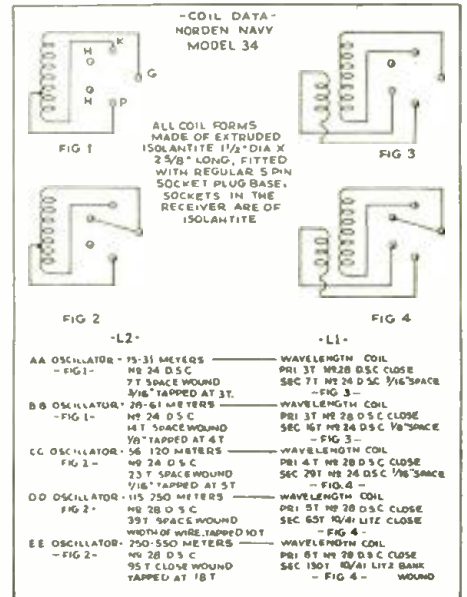

- C-31 .05 mf. Audio By-Pass Condenser
- C-32 .0001 mf. Grid Condenser
- C-33 .5 mf. Condenser
- R-1, 4, 9, 13 25,000 ohms Fixed
- R-2, 3, 18 15,000 ohms Fixed
- R-5 1. Megohm Fixed
- R-6 500,000 ohms Fixed
- R-7, 8 200 ohms Fixed
- R-10, 16 100,000 ohms Fixed
- R-11 250,000 ohms variable Potentiometer
- R-12 3,000 ohms Fixed
- R-14, 17, 22 50,000 ohms Fixed
- R-19, 20 125,000 ohms Fixed
- R-21 6,950 ohms Fixed
- J-1 Headphone Jack
- P.T.-1 Power Transformer
- A.T.-1 Audio Output Transformer
- R.F.T.-1, 2, 3 Intermediate Frequency Transformers 465 K.C.
- R.F.T.-4 A.V.C. Transformer
- S.W.-1 Audio Tone Switch
- S.W.-2 A.V.C. Switch
- S.W.-3 Power Switch
- S.W.-4 C.W. Oscillator Switch
- V.T.-1, 5 Type 57 Tube, RCA Radiotron
- V.T.-2, 3, 4, 6 Type 58 Tubes, RCA Radiotron
- V.T.-7 Type 2B7 Tube, RCA Radiotron
- V.T.-8 Type 2A5 Tube, RCA Radiotron
- V.T.-9 Type 80 Tube, RCA Radiotron

VK2ME—Short-Wave Voice of Australia

(Continued from page 521)

Australia, and many notable reception feats have been recorded; the chief of which was that of Mr. E. H. Scott of 4450 Ravenswood Avenue, Chicago, who, for twelve months, missed only three of our regular schedules.

VK3ME is located at the Amalgamated Wireless Victorian Transmitting Centre at Braybrook, about 6 miles west of Melbourne.

American Engineer Repairs Radio on Danish Ship

RECENTLY the Danish freighter Hoeg Trader, bringing a cargo of Russian pulp to the Port of Albany, had to cross the Atlantic without the comfort of her regular radio transmitting set, even though English and Norwegian experts had endeavored to repair it during the ship's calls in foreign ports. Thanks to the ingenuity of Ted Chadek, radio engineer of "Uncle Dave's Radio Shack," Albany, the trouble with the transmitter was finally located, a high voltage break-down to ground having been one of the ailments, besides a burned-out grid-bias resistor.

Short Waves and Long Waves

(Continued from page 535)

EAQ	Madrid, Spain
CN8MC	Rabat, Morocco
FYA	Paris, France
XDA	Mexico City, Mexico
HRB	Tequeigalpa, Honduras
NRH	Heredia, Costa Rica
VRY	Georgetown, British Guiana
HKC	Bogota, Colombia
HKM	Bogota, Colombia
HKA	Barrinquilla, Colombia
H(1DR	Quito, Ecuador
HBC	Berne, Switzerland
VE9BY	Windsor, Ontario, Canada
VE9CL	Winnipeg, Manitoba, Canada
VE9GW	Bowmanville, Manitoba, Canada
CJRX	Winnipeg, Manitoba, Canada
DJB	Konigswusterhausen, Germany
DJA	Konigswusterhausen, Germany
DHC	Nauen, Germany
HKD	Barrinquilla, Colombia
HKO	Medellion, Colombia
CMCI	Havana, Cuba
PRBA	Brazil, Rio De Janiero
YVQ	Maracay, Venezuela
PRAH	Bu-nos Aires, S. A.
HSP2J	Bangkok, Siam
TGA	Guatemala City, Panama

Foreign Calls 20 Meter Phone

G5BY	Croyden, England
G6AX	Rochdale, Lanc., England
G5QC	Wolverhampton, England
CM2JM	Havana, Cuba
PY2BQ	San Paulo, Brazil
TI3LA	Contombo, Costa Rica
OA1B	Negritos, Peru
X1B	Mexico City, Mexico

(NO NAME),
18 Woodlawn Street,
Springfield, Mass.

(Too bad you forgot to sign your name, but we are mighty glad to publish your letter, together with the very fine list of world-wide short-wave broadcast stations you have heard.—Editor)

Short Wave Scouts

(Continued from page 529)

12RO	11,810 KC.	Daily from 11:30 a. m.-12:15 p. m. and from 1:15-6:00 p. m., Rome, Italy. Lady announcer.
KDKA	11,870 KC.	Daily from 4:30-9 p. m., Pittsburgh, Pa.
VE9GW	6,095 KC.	Mon., Tues., Wed., Thurs., 3:00 p. m.-12 Mid., Fri., Sat., 8:00 a.m.-12 Mid. Sunday, 12 noon-9 p. m., Bowmanville, Ont., Can.
W2XAD	15,330 KC.	Mon., Wed., Fri., 3-4 p. m., and Sun. from 2-4 p. m., Schenectady, N.Y.
VE9JR	11,720 KC.	Irreg. from 9:30 a. m.-10 a. m., Winnipeg, Can.
FYA	11,775 KC.	Daily from 11:15 a. m.-1:15 p. m., Pontoise, France.
VK3ME	9,510 KC.	Wed. from 5-6:30 a. m. and Sat. from 5-7 a. m., Melbourne, Australia, announced station in English every four minutes.
XETE	9,600 KC.	Daily from 2:30-5 p. m. and 6:30 p. m.-12 midnight, Mexico City, Mexico; Chimes were played, at intervals a man announced XETE in English.
YV3BC	6,150 KC.	Daily from 10:30 a. m.-1:30 p.m., and 4:30-9:30 p.m. A new station on short waves, Caracas, Venezuela.
VK2ME	9,590 KC.	Sundays from 12:30-2:30 a. m., and 4:30-8:30 a. m., and 9:30 to 11:30 a. m., Sidney, Australia; Laughs of kookaburra bird.
GSE	11,865 KC.	Irreg. from 9-12 noon, London, England. Chimes of Big Ben.
XDC	9,340 KC.	Irreg. Heard testing from 3:00-5:00 p. m., Mexico City, Mexico.
GSB	9,510 KC.	Irreg. from 1-8 p. m., London, England. Chimes of Big Ben.
CGA	9,350 KC.	Irreg. heard from 6 p. m.-6 a. m., Drummondville, Canada.
GSF	15,140 KC.	Irreg. from 7 a. m.-3 p. m., London, England. Chimes of Big Ben.

18 Stations.
The set used was a home-made "Doerle" 2-tube short-wave set, using two RCA Radiotron 230 type tubes. I built this set from the description given in SHORT WAVE CRAFT.
Warren Mallory, 915 15th St.,
Boulder, Colo.

The ROYAL PR-5

NEW
-DIFFERENT-
-BETTER-



The **ALL-WAVE BAND-SPREAD RECEIVER**
You have been waiting for!

ROYAL LEADS AGAIN with a new, professional type of Short Wave Receiver especially designed for short wave listener and Amateur use. Its outstanding features are:

- "TRANS-X" (Pat. Pend.) COUPLING
- CONTINUOUS BAND SPREAD of all frequencies
- HIGHEST SIGNAL to NOISE RATIO
- TWIN MASTER CONTROL of Tank and Band-spread condensers
- LOUD SPEAKER RECEPTION OF FOREIGN STATIONS with amazing consistency and Volume
- HIGH GAIN Triple Winding Inductances
- ALL WAVE RECEPTION—8 to 2000 Meter Inductances available
- VELVET SMOOTH REGENERATION
- MOST ECONOMICAL
- LATEST TUBES—58 RF, 58 Detector, 56 AF Booster, and 2A5 heater Pentode
- PHONE JACK
- SOLIDLY CONSTRUCTED of the finest material obtainable
- MONEY BACK GUARANTEE

◆ **JUDGED BY PERFORMANCE IT IS THE GREATEST VALUE IN RADIO TODAY!**

ROYAL PR-5 \$18.00
SHORT WAVE RECEIVER List Price \$36.00

-ROYAL POWER PACK-

Separation of power supply from receiver chassis removes mechanical vibration of tubes and various tuned circuits eliminating hum and instability. The ROYAL Power Pack is an extra heavy supply especially designed for quiet and absolutely trouble-free operation of the ROYAL PR-5. Use same No. 95 tubes.
List Price \$15
Net \$9.00



-ROYAL PR-5 INDUCTANCES-

PR-52 13 to 26 meters PR-54 51 to 103 meters
PR-53 25 to 52 meters PR-55 100 to 205 meters
PER BAND—List Price \$3.00 NET \$1.80
Other Wave-length Ranges Available

◆ **SPECIAL!! \$31.50**
PR-5, POWER PACK, 13 to 205 METER INDUCTANCES, and TUBES

WHAT A SET!!

Short Wave Fans surely know a good thing when they see it! We've been actually swamped with orders for the sensational

12,500 Mile Two Tube Receivers

Chills are sending ten and twenty at a time—Many of our customers are selling them as fast as they can wire them (An excellent way to make your hobby pay, too!)—Schools are placing quantity orders—And Short Wave enthusiasts everywhere are buying them so fast that even we are amazed!

The reason? RESULTS and VALUE!!

Results that make the novice tinkle with delight and which thrill even the hard-boiled "old-timer"! Results that make the editors of leading magazines and newspapers write articles glowing with praise! Results that make competitive tests put to shame all other one and two tube "wonder" and "marvel" short wave receivers. Results that seem almost unbelievable, even to experienced short wave engineers!
But, you don't have to take our word for this! We have actual proof! Hundreds of unsolicited letters from delighted purchasers contain glowing reports of verified reception of English, French, African, Asian, South American, Australian, and many other stations under all kinds of conditions and in almost unbelievable locations! Of foreign stations received regularly, day after day, with loud speaker volume! Not one cent was paid for these testimonials, the writers only motives being sheer gratitude and pride in the possession of such a remarkable receiver.

that in unbiased, competitive tests put to shame all other one and two tube "wonder" and "marvel" short wave receivers. Results that seem almost unbelievable, even to experienced short wave engineers!

But, you don't have to take our word for this! We have actual proof! Hundreds of unsolicited letters from delighted purchasers contain glowing reports of verified reception of English, French, African, Asian, South American, Australian, and many other stations under all kinds of conditions and in almost unbelievable locations! Of foreign stations received regularly, day after day, with loud speaker volume! Not one cent was paid for these testimonials, the writers only motives being sheer gratitude and pride in the possession of such a remarkable receiver.

VALUE? Such as you have never seen before!

"How are you able to sell these neat, professional appearing receivers for only \$4.75?", we are constantly asked. We answer, "By making only a small margin of profit and letting the sensational VALUE and astounding RESULTS boost our sales into tremendous quantities!"
But wait! Don't let the low price fool you! It does not mean that we have sacrificed quality! On the contrary, these kits are composed of the fine-st material available—HAMBALUNO Condensers—Polymet—CRU—Allen-Bradley—etc. All HF insulation is of Genuine Bakelite. The four coils (15 to 200 meters) are wound on polished Bakelite forms. All losses are minimized! KK vernier dual makes tuning easy and sure. The heavy crystal finished metal chassis has all holes drilled and this, together with the clear plain instruction sheet and diagrams makes construction a simple matter, even for the most inexperienced! THE IDEAL BEGINNER'S SET!
Better order yours NOW, before we are forced to higher prices!

BATTERY MODEL
Uses two 230 tubes. Batteries required are two dry cells (or a 2-volt storage cell) and two 45 volt B Batteries. If you have a 6-volt storage battery you may use 201-A.
\$4.75
COMPLETE KIT

AC MODEL
Uses two of the new type 36 or 27 tubes. Power is obtained from the AC Power Pack listed below (or any GOOD pack), or it may be run on a 2 1/2 volt filament transformer and two 45 volt batteries.
\$4.95
COMPLETE KIT

-ACCESSORIES-

TUBES—230, 64c.	201A, 30c.	227, 35c.	56, 50c.
80 40c.			
Lightweight Headphones—2000 ohms			\$1.05
4000 ohms			\$1.90
2 1/2 volt Filament Transformers			.95
Special AC Power Pack for AC Model, Complete kit			4.85
Extra coils to cover 200 to 625 meters			1.25
Neat metal cabinet with hinged lid			1.00
Add \$1.50 if you wish the above kits assembled, wired, and laboratory tested.			

◆DUOVAC TRANSMITTING TUBES

At Bargain Prices!
Brand New and fully guaranteed to be perfect in every respect. Transmitter tested at high voltage and carefully packed!
845 242 (211) 203-A—\$9.75. 866—\$1.65.
860 100 Watt S. G. Amplifier—\$22.50.
205-D—\$2.95. 872 M. V. Rectifier—\$9.25.

◆ **ORDER NOW!! Deposit required.**
Send stamps for CATALOG

HARRISON RADIO CO. Dept. C-1 New York City
142 Liberty Street
★ ★ THE HOME OF FOUR STAR SERVICE ★ ★



FREE

1934 Official Short Wave Radio Manual
1934 Official Radio Service Manual



FREE WITH ARCO TUBE PURCHASES. You may select a 1934 OFFICIAL SHORT WAVE RADIO MANUAL which sells for \$2.50, with your order amounting to \$3.00. If you prefer you can get FREE, the 1934 OFFICIAL RADIO SERVICE MANUAL which sells for \$3.50 with orders amounting to \$4.00 or both manuals for orders of \$4.75.

THIS OFFER IS SUBJECT TO WITHDRAWAL WITHOUT NOTICE.

Complete Stock Ready for Immediate Shipment

Order from this page—Remit 20% with order, balance C. O. D. All prices are F. O. B. FACTORY, Newark. Shipments go forward express or Parcel Post. No order for less than \$3.00 accepted.

Type	Voltage	Description	Your Cost
UX-201A	-5.0	Detector Amplifier.....	\$.30
UX-226	-1.5	Amplifier (A-C Filament).....	.30
UY-227	-2.5	Detector Amplifier (A-C Heater).....	.30
UX-171	-5.0	Power Amplifier 1/2 amp.....	.30
UX-171A	-5.0	Power Amplifier 1/2 amp.....	.30
UX-240	-5.0	Voltage amplifier detector.....	.40
UX-120	-3.3	Power Amplifier.....	.40
UX-199	-3.3	Detector amplifier.....	.40
UY-199	-3.3	Detector amplifier short prong.....	.40
UX-199	-3.3	With a standard 201A base.....	.40
UX-112A	-5.0	Amplifier detector 1/2 amp.....	.40
UX-112	-5.0	Amplifier detector 1/2 amp.....	.40
UX-200A	-5.0	Detector.....	.40
UY-224	-2.5	Screen grid R-F amplifier (A-C Heater).....	.40
UX-245	-2.5	Power amplifier (A-C Filament).....	.40
UX-201B	-5.0	Detector amplifier 1/2 amp.....	.40
UY-246	-2.5	Detector amplifier Pentode (A-C Fil.).....	.60
UY-247	-2.5	Power amplifier pentode (A-C Fil.).....	.60
UY-257	-2.5	Power amplifier pentode (D-C Fil.).....	.85
WD-11	-1.1	Detector amplifier.....	.60
WD-12	-1.1	Detector amplifier.....	.60
UX-230	-2.0	Detector amplifier.....	.60
UX-231	-2.0	Power amplifier.....	.60
UX-232	-2.0	Screen grid radio frequency amplifier.....	.60
UY-233	-2.0	Power amplifier Pentode (A-C Heater).....	.60
UX-234	-2.0	Super-control R-F amplifier pentode.....	.85
UX-235	-2.5	Super-control R-F Amp. (A-C Heater).....	.60
UY-236	-6.3	Screen-Grid R-F Amp. (A-C Heater).....	.85
UY-237	-6.3	Detector amplifier (A-C Heater).....	.85
UY-238	-6.3	Power amplifier pentode (A-C Heater).....	.85
UY-239	-6.3	R-F amplifier pentode (A-C Heater).....	.85
UY-551	-2.5	Super-control R-F Amp. (A-C Heater).....	.60
2A3	-2.5	Power amplifier triode (A-C Heater).....	1.10
2A6	-2.5	Two Diodes and high Mu Triode.....	.85
2A7	-2.5	Pentagrid converter (A-C Heater).....	1.10
2B7	-2.5	Duodes-Diode Pentode (A-C Heater).....	1.10
6A7	-2.5	Pentagrid Converter (A-C Heater).....	1.10
6B7	-2.5	Duodes-Diode Pentode (A-C Heater).....	1.10
6C7	-2.5	R-F Pentode.....	1.10
6F7	-3	Remote Cut-Off Pentode.....	.85
2A5	-2.5	Power amplifier pentode (A-C Heater).....	.85
41	-2.5	Power amplifier pentode (A-C Heater).....	.60
42	-2.5	Power amplifier pentode (A-C Heater).....	.60
43	-2.5	Power amplifier pentode (A-C Heater).....	.60
44	-2.5	Power amplifier pentode (A-C Heater).....	.60
45	-2.5	R-F amplifier pentode (A-C Heater).....	.85
48	-2.5	Power amplifier Pentode (D-C Heater).....	1.10
49	-2.0	Dual Grid power amplifier.....	.85
52	-2.5	Twin class B output tube double triode.....	.85
53	-2.5	Duodes-Diode Triode (A-C Heater).....	.60
56	-2.5	Super-Triode amplifier (A-C Heater).....	.60
57	-2.5	Triple grid detector Amp. (A-C Heater).....	.60
58	-2.5	Triple grid R-F amplifier (A-C Heater).....	.60
59	-2.5	Triple grid power Amp. (A-C Heater).....	.60
75	-2.5	Duodes-Diode Triode (A-C Heater).....	.85
77	-2.5	Triple-grid detector amplifier (A-C Heater).....	.85
78	-2.5	Triple-grid R-F amp. (A-C Heater).....	.85
79	-2.5	Class B Twin amplifier (A-C Heater).....	.85
85	-2.5	Duodes-Diode Triode (A-C Heater).....	.60
89	-2.5	Triple grid power Amp. (A-C Heater).....	.60
89	-2.5	Power amplifier pentode (A-C Heater).....	.85
PZH	-2.5	Power amplifier oscillator (A-C Fil.).....	1.10
UX-210	-2.5	Screen grid radio frequency amplifier.....	1.10
UX-250	-7.5	Power amplifier (A-C Filament).....	1.10
UX-227A	-2.5	Detector amplifier (quick heater) (A-C Heater).....	.60
UX-224A	-2.5	Screen grid R-F amplifier (quick heater).....	.60
UX-182	-2.0	Sparton type power Amp. (A-C Fil.).....	.85
UX-183	-2.0	Sparton type power Amp. (A-C Fil.).....	.85
UX-484	-2.0	Sparton type detector Amp. (A-C Fil.).....	2.10
UX-686	-2.0	Sparton type power Amp. (A-C Fil.).....	.85
UX-686	-2.0	Sparton type amplifier.....	1.50
UX-401	-2.0	Kellogg type triode (A-C Heater).....	2.00
UX-403	-2.0	Kellogg type output triode (A-C Heater).....	2.00

RECTIFIER AND CHARGER BULBS

125 MB. rectifier tube B.H. (Raytheon type).....	1.25		
6-10 Amp. trickle charger Bulb (Tungar type).....	2.00		
2 Amp. charger Bulb (Tungar type).....	2.00		
6 amp. 5 Amp. charger Bulb (Tungar type).....	2.75		
18 Amp. charger Bulb (Tungar type).....	2.75		
UX-866	-2.5	Half Wave Rectifier (A-C Heater).....	.85
UX-866	-2.5	Half Wave Rectifier (A-C Heater).....	.85
1X-20M	-5.0	Full Wave Mercury Vapor Rectifier.....	1.10
UX-871	-2.5	Half Wave Mercury Vapor Rectifier.....	1.10
UX-280	-2.5	Half Wave Rectifier.....	.40
1223	-12.6	Half Wave Rectifier (Heater).....	.60
523	-5.0	Heavy-Duty Full-Wave Rectifier.....	.85
523	-2.5	Rectifier-double (Heater).....	.85
UX-281	-7.5	Half Wave Rectifier.....	1.10
UX-82	-2.5	Full Wave Mercury Vapor Rectifier.....	.85
UX-83	-5.0	Heavy duty full wave mercury vapor rectifier.....	.85
UX-216B	-7.5	Half Wave Rectifier.....	.40
UX-213	-5.0	Full Wave Rectifier.....	.40
UX-84	-5.0	Full Wave Rectifier (Heater).....	.85
UX-372	-7500	Volts Half Wave Mercury Vapor Rectifier.....	11.00

Specifications and quotations on PHOTOELECTRIC CELLS, TELEVISION TUBES, TRANSMITTER TUBES, CRATER TUBES, HIGH VACUUM TYPE CATHODE RAY TUBES suitable for television and standard oscillographic uses, SUBMITTED ON REQUEST.

ARCO TUBE COMPANY

40 Park Place Newark, N. J.

REGENT 4-Tube S-W Receiver

● ONE glance at the photograph will immediately reveal that a definite step has been taken to dress up our present day short-wave receivers. Broadcast receivers have received their beauty touches and there is no reason why shortwave sets should be slighted.

This is a 4-tube receiver employing a type 58 regenerative detector, a type 58 resistance coupled first stage audio and a type 2A5 resistance coupled power amplifier which drives a full-sized dynamic speaker on all of the various foreign short-wave stations. The power supply unit, consisting of a type 80 rectifier, standard power transformer, having a 5 volt and 2.5 volt windings, furnish the rectified A.C. which in turn is filtered by the field of the dynamic speaker and two 8 mf. electrolytic condensers. This filter serves to eliminate even the slightest trace of hum and very clear reception can be obtained.

Examining the circuit diagram further will show that a telephone jack is provided in the output of the 58 audio stage to provide earphone reception. Standard plug-in coils are used and cover a range of from 15 to 550 meters, five separate coils being used to accomplish this feat. The 58 resistance coupled audio stage is capable of delivering tremendous gain with very low tube and interstage noises and will drive a 2A5 to full output, which means that foreign broadcast stations can be tuned in with regular broadcast receiver volume. Looking at the front of the set the tuning control is located at the right and consists of an accurately calibrated dial located behind an artistic escutcheon plate. In the center is located a six inch dynamic speaker behind the fancy grilled opening in the cabinet. To the left is located the regeneration control condenser. Condenser control of regeneration is used for smooth action which makes tuning on the very high frequencies very simple. The cabinet is 14" long, 10" high and 10" deep, and is beautifully finished in cracked lacquer which gives a decidedly modernistic appearance.

It is necessary in a receiver of this type to shield a type 2A5 power amplifier tube in order to fully eliminate any trace of feed back. Most short-wave set constructors are familiar with the fact that if a 2A5 with its extremely high output with low signal voltage is left out in the open near other tubes or other parts of the set where possible feed back may exist a very definite high pitched audio feed back will occur or else there will be a thin ringing sound to the voice or music being reproduced. In all cases this tube should be effectively shielded. This set housed in its cabinet has practically the same appearance as the present day broadcast receivers and, incidentally, this provides a very efficient broadcast receiver, when one does not care to listen in to the short waves, by plugging in the broadcast band coil. This is also an excellent feature as many times the short-wave bands become extremely noisy or unusable for various other reasons and amusement can easily be furnished by the utilization of the regular broadcast band.

It is not necessary to go into minute circuit details as the diagram clearly shows all connections and all values of resistors and condensers. However, we must stress at this point in constructing any short-wave receiver that only the best of parts be used and so connected that the leads are as short as possible. This will eliminate any stray capacities and feed back between leads which may at times render the set inoperative at certain parts at a given short-wave band. The resistor values specified in the circuit diagram should be closely adhered to because they have been carefully worked out to give the best results commensurate with quiet operation. In wiring short-wave receivers it is necessary that all connections are thoroughly cleaned before an attempt is made at soldering. Don't try to solder a connection where the insulation on the wire interferes in the least with the operation. Use a hot and thoroughly tinned soldering iron with pure rosin core solder and wherever possible remove all surplus rosin as soon as

the solder has cooled enough to allow wiping.

PARTS LIST

- 1—Black cracked wood cabinet. Try-mo
- 1—Drilled and punched metal base. Try-mo
- 1—100 mmf. Ant. Series condenser. Hammarlund (National)
- 1—set of 4 plug-in coils wound (15-200 meters) Na-ald (Gen-Win; S.W. & Television Corp.)
- 1—.0001 fixed mica condenser
- 1—3 meg. grid-leak Lynch
- 2—variable .00014 mf. condensers. Hammarlund; (or National 150 mmf.; or Cardwell)
- 1—R. F. choke. 5 to 10 M. A. National or Hammarlund.
- 2—R.M.A. 7500 ohm resistors. Lynch.
- 2—R.M.A. 100,000 ohm resistors. Lynch
- 4—R.M.A. 250,000 ohm resistors. Lynch
- 1—R.M.A. 2 Meg. resistors. Lynch
- 2—.01 mf. condensers. Flechtheim
- 1—.1 mf. condenser (400 volts)
- 2—8 mf. Electrolytic condensers (500 volts). Flechtheim
- 1—Electrostatically-shielded power transformer. Try-mo
- 1—AC on-off switch. R. T. Co.
- 1—Special slow motion vernier dial. Try-mo
- 2—knobs
- 2—58 series tube shields. Hammarlund (National)
- 1—2A5 tube shield. Hammarlund (National)
- 1—Coil socket. Na-ald
- 2—58 sockets. Na-ald
- 1—2A5 socket. Na-ald
- 1—80 socket. Na-ald
- 1—6" tapped-field. 1800 ohm to match 2A5 output, dynamic speaker. Try-mo
- 1—roll hookup wire
- 1—kit of assorted hardware
- 1—A.C. cable (cord and plug)
- 2—58 tubes; RCA Radiotron (Arco)
- 1—2A5 tube; RCA Radiotron (Arco)
- 1—280 tube; RCA Radiotron (Arco)

Coil Data

Wave Band in meters	Grid turns	Grid wire size	Spacer between Ticker turns	Grid and Ticker wire size
15 to 22	5 No. 22, S.C.C.	7 No. 26, enam.	1/4 in.	
20 to 40	10 No. 22, S.C.C.	10 No. 26, enam.	7/32 in.	
40 to 95	21 No. 22, S.C.C.	15 No. 26, enam.	5/32 in.	
90 to 200	50 No. 26 enam.	25 No. 26 enam.	3/32 in.	
Broadcast				
coil		136 No. 32 enam.	59 No. 30 enam.	1/16 in.

Coil form—1 1/4 in. in diameter by 2 1/8 in. long.

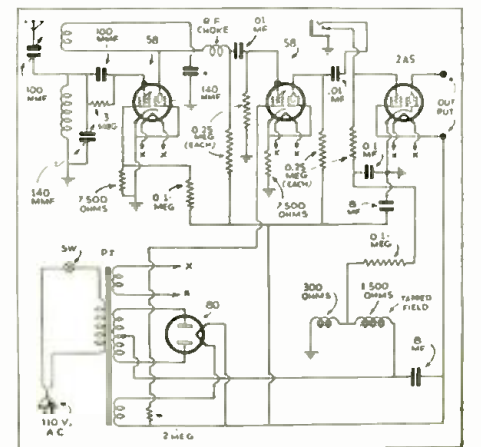
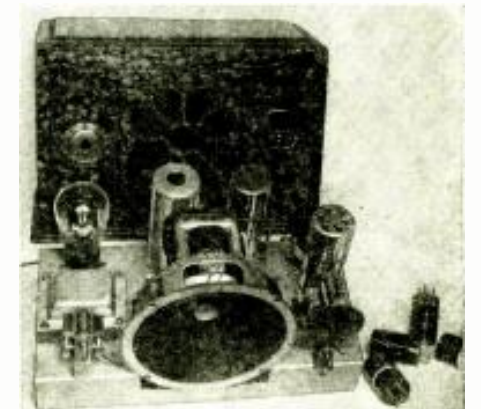

Diagram of connections for the Regent 4-Tube Receiver.



Note the handsome appearance of the Regent 4-tube SW receiver.

Little America Speaks

(Continued from page 518)

gram system has been worked out, the personnel, even including a trained announcer who will write the introductions and continuity for every program. Mr. Murphy will have the honor of introducing Admiral Byrd and other officers of the party. During the progress of the ship to Little America, microphones placed on deck will pick up the sound of the sea, and the barking of the Eskimo dogs housed on the ship's decks, 150 dogs being carried by the expedition.

The opening part of the program will emanate in the WABC studio; the 15 minute program from Little America will be placed in the center of the main program and it will close with a finale from the New York studio.

Accurate time is very essential, of course, for any scientific expedition, such as Admiral Byrd's and specially checked and cased chronometers will provide accurate time, which is also quite essential with regard to the broadcasting from Little America as there is seven hours difference in its time compared to New York. Aside from the regular weekly broadcasts from Little America, special broadcasts may be made and sent over the network from time to time whenever important news develops. Two circuits carrying code messages by short-wave will be in operation at practically all times between Little America and New York. Programs will be broadcast from time to time over the selected short-wave transmitting station W2XAF of the General Electric Company at Schenectady, New York.

Airplane Short-Wave Equipment

Admiral Byrd expects to fly again over the South Pole with a large Curtis-Condor plane and the Columbia engineers expect to be able to pick up this message from the plane while in flight and also over the South Pole and broadcast these over the network of American stations. The plane will carry a 50 watt transmitter, the power for operating it being supplied by the plane's regular generator, with a light-weight dynamo and gasoline-engine driven unit standing by. Other 7½ watt transmitters are carried by the expedition for use on the smaller planes, the power for operating them being supplied by storage batteries carried aboard the planes.

It is very interesting to note how the messages are to be relayed from the big Curtis-Condor plane in which Admiral Byrd expects to fly over the South Pole. As the power of transmitter is rather limited, a special short-wave relay station will be located at the Queen Maude Range. Here the message from the plane will be received and instantly re-transmitted by a 200 watt transmitter to the base station at Little America. The receiver will be connected to the 1000 watt short-wave transmitter at this point and the messages from the plane will hurtle on through space 4000 miles to Buenos Aires. Here as with the regular programs from Little America the messages from the planes will be picked up on a receiver connected to a short-wave transmitter and sent on their northward flight to Riverhead, Long Island. The message will then proceed as explained previously over a wire circuit to New York and thence over the network to various broadcast stations.

The short-wave receivers to be used on the planes are of the National SW-3 type, while the transmitters are of the W. E. Co., type. Dog-sled crews have a habit of getting lost, especially when a blizzard blows up out of nowhere as it frequently does in the Antarctic, and if this should happen the dog-sled party will be able to signal the base station as to their whereabouts for small 1 watt transmitters are to be carried by each dog-sled, as well as a receiver. Not only can each dog-sled party communicate with headquarters, but they can also talk to each other.

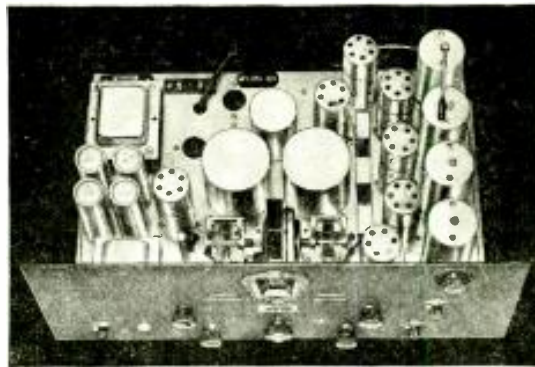

COMET "PRO"

The World-Wide Receiver with World-Wide Reputation

FROM the Arctic wastes to torrid Africa—from New York to humidity-drenched Singapore, the Hammarlund COMET "PRO" holds unquestioned leadership among professional short-wave receivers.

Now built in four models, for battery, D.C. and A.C. operation, in all voltages and all cycles, with or without Crystal Filter and Automatic Volume Control.

New CRYSTAL UNIT



and Automatic Volume Control May be Added to the Standard Model "PRO"

S-W CONDENSERS

Hammarlund Condensers hold first place for receiving and transmitting on standard or short waves. There is a Hammarlund variable model for every condenser requirement, all priced so moderately there is little excuse for using condensers of a lower grade.

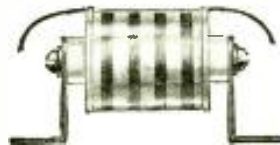

R-F CHOKES

The Hammarlund Radio Frequency Choke is designed particularly for short-wave and ultra short-wave receivers and transmitters, but its efficiency extends well over the regular broadcast band. Its compactness permits mounting in isolated positions well removed from stray r. f. fields, which together with its load characteristics, specially recommend it as a grid choke for multi-stage transmitters. Isolantite form. Moisture-proof windings.

COIL FORMS—SOCKETS

Sockets have Isolantite base and perfect spring contacts. Low losses and noiseless. 4, 5 and 6 prongs.

Isolantite Coil Forms for Ultra-short Waves. Low losses. No drilling. 4, 5 or 6 prongs for standard or Isolantite sockets.



Mail Coupon for Details

HAMMARLUND MANUFACTURING CO.
424 W. 33rd St., New York

—Check here for detailed description of the COMET "PRO"—Check here for information about adding Crystal Filter or Automatic Volume Control to the Standard "PRO"—Check here for General Catalog "34" of Radio Parts.

Name

Address

SW-1

Free to You

WE HAVE prepared a special list in which we have compiled all articles which have appeared in former issues of SHORT WAVE CRAFT. This list fully informs you as to all the important articles which have appeared in SHORT WAVE CRAFT since the beginning.

The greater portion of the back numbers are still available. If you are interested in getting this list, send at once three cent stamp for postage and it will be sent to you immediately.

SHORT WAVE CRAFT, 96 Park Place, New York, N. Y.

Universal Short-Wave Oscillator

INCLUDING 30 TUBE \$ **7.50**

SHOWN 1/2 ACTUAL SIZE

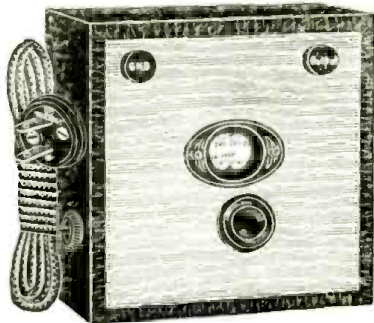

A NEW TEST oscillator, Model 30-S, has been produced by Herman Bernard, so that the requirements for linking up short-wave receivers and transmitters, and monitoring, may be fully and accurately met. The device works on 90-120 volts A.C. (any commercial frequency), 90-120 volts D.C. line and on 90 volts of B battery. No separate filament power supply is required. The oscillator is modulated with a strong, low note under all circumstances. It uses a 30 tube.

THE dial of the Bernard Model 30-S Test Oscillator is directly calibrated in kilocycles, so there is no awkward necessity of consulting a chart. The fundamental frequencies are 1,350 to 3,800 kc. The 150 kc. of the broadcast band are included so that by use of zero heat and harmonics very high accuracy for monitoring may be attained. The accuracy otherwise is 2%.

WHEREVER there is power to run a radio set (except crystal set) there is power to run this oscillator. It is wise to have an oscillator useful in any and all emergencies.

The oscillator is of the Hartley type, with excellent frequency stability. It yields unflinching zero heat on d. c. line or batteries, but may not zero heat on a. c. unless coupling to the tested circuit is very loose. The instruction booklet details the coupling treatment.

The fundamental frequencies on the dial, 1,350 to 1,400 kc. are 10 kc. apart, 1,400 to 1,800 kc. are 20 kc. apart and 1,800 to 3,800 are 50 kc. apart. Harmonics may be used to 76 mcg as explained in instruction booklet.

The overall size is only 5 x 5 x 3 inches.
Model 30-S, complete with 30 tube.....\$7.50
[Sent express collect; shipping weight, 6 lbs.]

Commercial Oscillator

THE Model 30 Test Oscillator is the same as the short-wave model, except for the higher inductance coil used. The fundamental range is 135 to 380 kc. and most commercial intermediate frequencies are thus read directly. Points for other intermediate frequencies are registered on the dial (400, 450, 456, 465 kc.). The broadcast band is also calibrated on the dial, with 10 kc. bars from 540 to 800 kc. and 20 kc. from 800 to 1500 kc. Model 30 Universal Test Oscillator, with 30 tube.....\$7.50

[Sent express collect, shipping weight, 6 lbs.]

"The Inductance Authority"

By Edward M. Shiepe, B. S., M. E. E. Coil winding for all radio frequencies without any computation whatever!

Coverage is from ultra frequencies to the borderline of audio frequencies. All one has to do is to read the charts. Accuracy to 1 per cent may be attained. There are thirty-eight charts, of which thirty-six cover the numbers of turns and inductive results for the various wire sizes used in commercial practice (Nos. 14 to 32), as well as the different types of covering (single silk, double silk, single cotton, double cotton and enamel) and diameters of 1/8, 3/16, 1/4, 5/16, 3/8, 1/2, 5/8, 3/4, 7/8, 1, 1 1/4, 1 1/2, 1 3/4, 2, 2 1/4, 2 1/2, 2 3/4 and 3 inches.

Sent postpaid with an 18x20" inductance-capacity-frequency supplementary chart on receipt of \$2.00.

HERMAN BERNARD

135 G. Liberty Street

New York, N. Y.

5 and 10 Meter Transmitter

(Continued from page 526)

tain frequency stability and it would be necessary to have a rather expensive modulator system.

With 650 volts on the plates of two of these tubes in a push-pull circuit, a very powerful and steady signal can be radiated, and can easily be modulated with a pair of 46's operated in class "B" push-pull. In the transmitter here described, every effort has been made to reduce losses, due to poor insulation, to an absolute minimum. Nothing but the highest grade parts with excellent insulation have been used. *Why use inferior insulation on a tube that has its grid and plate leads brought out on the glass envelope, for the sole purpose of improving their insulating qualities and to reduce the inter-element capacity.*

The Push-Pull Oscillator

The push-pull oscillator is mounted on a 7x10x2 inch aluminum chassis, in order that the filament and plate supply wiring could be isolated from the portions of the circuit carrying radio frequency currents. This isolation is really necessary if stable and efficient operation is to be obtained. Remember, we are working on 60 megacycles, not 3.5. And if there should be the slightest trace of R. F. in the filament circuit the chances of ruining the tubes are very great.

No filament by-pass condensers were used because without them, there was no trace of RF in the filament circuit. And the use of them provides a possible chance of the filament circuit being tuned to the frequency, or a harmonic of the frequency at which the transmitter is being operated. If no trouble of this sort is experienced without filament condensers *leave them out.* The switch shown in the filament center-tap lead is provided as a means of turning the oscillator on and off. If the switch were to be placed in the plate circuit, there would result a very heavy spark and in most cases it would continue to arc, due to the action caused by the modulation choke or the modulator output transformer secondary; at the center tap however there is only the slightest trace of a spark.

All inductances are provided with banana type plugs, in order that they can be changed easily. The stand-off insulators are equipped with jacks to accommodate these plugs. Be sure to use a good plug which makes a very tight contact, or losses will result at this point. A glance at the photographs and diagrams will give any further details and no more need be said of the oscillator at this point.

Oscillator Power Supply

The power supply for the oscillator should be capable of delivering around 650 to 675 volts at least one hundred milliamperes, although the highest plate current drawn by the oscillator was 90 mills. (M. A.) It should be well filtered in order that the quality of the voice will not be impaired by a "hum" on the carrier. A brute force filter was used because of its simplicity and effectiveness. Some might shudder when they see a 2 mf. condenser used directly across the mercury vapor tubes, but there is really no danger in this, because the tubes are operated well under their peak voltage rating. The type 866 can be used at this point in place of the 871's or 888's, whichever you wish to call them, that are shown in the diagram. A type 523 can also be used here with much less "hash" (noise caused by vaporization of the mercury) in the receiver, but this tube will be considerably overloaded and long life cannot be expected from them. However, they are not expensive and the reduction in noise might make their use worth while. The filter choke is of the common variety, rated at 30 henries and 150 mills. (M. A.) The power transformer has a high voltage secondary with 650 volts each side of

TWO SPLENDID HOLIDAY ITEMS

SOLAR RAY LAMP



Give your relatives or friends a real Christmas present or better still, be good to yourself and buy a Solar-Ray Health Lamp for your home. The Solar-Ray Carbon Lamp works for itself in a few treatments. Everyone in the family needs the health giving Ultra Violet Rays that you get from the sun during the summer and which you need in the winter more than at any other time of the year.

This is a LARGE LAMP, used by Physicians who charge \$5.00 for a treatment. Face of lamp 10 1/4". Width 10 1/4". Height 12 1/2". Depth 12 1/2". List price with Screen and Goggles. Complete \$17.50. Our price prepaid \$3.38.

A Precision Instrument made in Belgium. Purchased by the U. S. Government at more than \$30.00 each. Ideal for Radio Experimenters Laboratory, also may be used as a Galvanometer for detecting electric currents in radio circuits. Ruby jeweled, solid bronze, 4 inches square, fitted in a hardwood case.

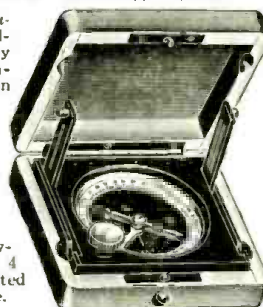

Large Professional Model. Full descriptive circular mailed upon request. Our price prepaid \$4.50 each. 112 S. Chambers St., New York City

GOLD SHIELD PRODUCTS CO.

center-tap, which with the filter system and rectifier tubes used, gives around 650 volts at 90 mills (M. A.) pure D.C. This transformer also has a 2.5 volt winding for the rectifier tubes and two 7.5 volt windings, which are hooked in parallel to supply filament voltage for the oscillator tubes. So much for the oscillator power supply.

The Modulator

A good modulator unit is just as important as the oscillator, because it is the modulator that is responsible for the voice being super-imposed upon the R.F. carrier wave.

The most economical modulator is the class "B" type, which has become very popular with the "Hams." The one shown here uses a 56 class "A" speech amplifier transformer, coupled to a 46 Class "A" driver, which in turn furnishes excitation for the two 46's in class "B" push-pull. The plate voltages for the tubes are as follows—250 for the 56, 250 for the 46 "A" and about 450 for the 46's in Class "B." With these voltages on the various amplifier tubes it is possible to completely modulate the R.F. oscillator with 650 volts at 90 milliamperes input. Here also good equipment is necessary if full output is to be obtained from the tubes, with anything like BC (broadcast) quality.

The output transformer used in this modulator has a secondary with taps varying from 3,000 to 8,000 ohms impedance and provides a very flexible unit, which can be coupled to almost any output load efficiently and thus permit a maximum transfer of audio voltage. The method of calculating the load impedance of the oscillator is—Plate voltage divided by plate current.

It is to be remembered that the microphone is responsible for the quality of voice fed into the modulator. Use nothing but the highest grade single-button, or preferably a good double-button mike for the best quality.

With the values shown in the diagrams the plate current of the oscillator should be 60 mills (M. A.) without the antenna coupled, and 90 mills with the antenna coupled loosely to the plate "tank." Do not exceed this value, or the tubes will lose their activeness; higher plate currents also make it difficult to obtain 100 per cent modulation. If everything is connected properly, an indicating device such as a Christmas tree bulb or an R.F. ammeter connected in the antenna will show a decided increase in brilliancy (or deflection) as the microphone is spoken into. Careful adjustment is absolutely necessary if maximum results and a good percentage of modulation are to be obtained. The writer has seen an adjustment in a five meter transmitter so slight as to cause the frequency to shift only 100 KC, bring the signal strength from R3 up to R8. Cooperation with another amateur is very necessary, for his reports checked against your adjustments is the only definite proof of the value of your efforts to obtain an optimum adjustment.

The radiophone described has been in operation about three months and the author has received an R8 to R9 report from most every station contacted. And the writer wouldn't part with it for—well, you build it and set your own price!

Parts List (Oscillator Circuit)

- 1—double-section Cardwell variable condenser 100 mmf. per section with mica-lex insulation (featherweight).
- 7—stand-off insulators with pin-jack receptacles (Johnson; Fleron).
- 1—35 mmf. midget tuning condenser, Hammarlund (National).
- 2—4-prong isolantite sockets, National (Hammarlund).
- 1—No. 100 National R.F. choke (2.5 mh.).
- 1—20,000 ohm grid-leak (10 watts or more).
- 1—100 ohm center-tap filament resistor.
- 1—single pole, single-throw snap switch.
- 1—set of coils—see coil table.
- 2—type 800 RCA Radiotron tubes (Sylvania 824).
- 1—aluminum chassis, 7"x10"x2" deep.

(Continued on page 569)

AMATEUR RADIO SUPPLY HOUSE.

UNCLE DAVE

73 TO ALL

356 BROADWAY ALBANY, N.Y., U.S.A.

WE BUY - SELL AND TRADE "HAM STUFF" SERVICE DAY & NIGHT - SHIP ANYWHERE



ONLY 40 LEFT—FIRST COME, FIRST SERVED!
CROCKER-WHEELER AIRCRAFT GENERATOR—made for the Signal Corps of United States Army; delivers 320 volts at no load, 275 volts at 60 mills, and 250 volts at 110 mills. This unit can be driven conveniently from almost any motor by the use of suitable groove pulley and small belt drive. Has threaded hex bolts on end of shaft. **OUR SPECIAL PRICE \$3.39**

METERS	
Weston Model 301 meters, all used, 0-5, 10, 25, 50, 100, 150, 200, 250, 300, 500 Milliammeters, each	\$4.05
High Voltage DC Voltmeters, slightly used Weston meters, calibration checked against accurate standards:	
0-300 volts	\$9.75
0-1000 volts	15.00
0-1500 volts	20.00
0-2000 volts	25.00
Weston all used AC voltmeters, 0-10, 50, 100, special each	\$ 4.25
Weston all used AC voltmeters, 0-150, 250, each	5.55
Weston all used AC voltmeters, 0-300, each	6.75
Weston all used AC voltmeters, 0-500-600	11.00

HERE'S A REAL JOB FOR THE BEGINNING PHONE HAM OR FOR AN AUXILIARY TRANSMITTER!
ARSCO PHONE TRANSMITTER using MOPA with 46 tube as oscillator, 46 as amplifier, 56 as speech amplifier, and 250 as modulator; complete with all tubes, power supply, Gavlit single button microphone which alone lists at \$10.00, with set of coils, all set and ready to go. **EXTRA SPECIAL \$36.50**

ARSCO PRECISION AMATEUR APPARATUS

ARSCO CALIBRATED MONITOR , an absolutely essential piece of apparatus in any ham station; 20-40-80 meter band coils with calibration curve. Bureau batteries; in a neat metal shell can 7 1/2" wide, 4" deep, 3" high, absolutely complete, all apparatus self-contained, nothing else to buy.	\$ 9.35
ARSCO WAVEMETER , invaluable for checking and neutralizing transmitters; 20-40-80 meter band coils, individually calibrated, neat wooden box, indicator lamp, binged lid, coils included, net	6.25
ARSCO 2-TUBE RECEIVER ; detector and one-stage with plug-in coils; sensitive and moderately selective; capable of excellent results and extremely simple; uses 2 type 30 tubes, 2 volt filament, may be operated entirely from dry batteries if desired; complete with plug-in coils for 20, 40, and 80 meters, in neat wooden cabinet.	7.95
Lean cabinet	7.50
ARSCO 1-TUBE RECEIVER ; best bet for the beginner; 1 tube with coils covering the wavelength range of from 15 to 200 meters; a nice job for the SWL or ham beginner, complete in compact metal cabinet	6.25

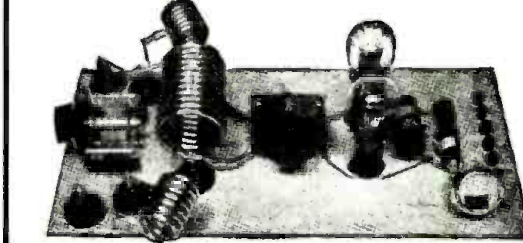

ARSCO JUNIOR TRANSMITTER, complete with tubes and pack—the single control transmitter described in the Handbook, 1-245 in TNT circuit; easy to tune; capable of high performance; plug-in coils, complete with tube, 40 meter coils, power supply and mercury vapor rectifier. **SPECIAL 10.95**

ARSCO SENIOR TRANSMITTER; complete with tubes and power pack; PE-245a high-C tank for frequency stability built exactly to ARRL spec. from 9th edition Handbook; capable of 10 watt output; TNT circuit; heavy copper tubing plate and antenna coils plate millimeter; complete with tubes and power supply including mercury vapor rectifier and coils for 40 meter band
 16.25 |

ARSCO CRYSTAL OVEN complete with crystal; Duralumin box 7"x6 1/2"x3 1/2"; Calorex lined; sensitive thermometer inside; within plus or minus 1/2° C. Heavy silver contacts—will not stick under heaviest load. Accuracy to your specified frequency plus or minus 1/2 cycle
 8.50 || 5.65 | |
ARSCO PRECISION CRYSTALS, made of best grade Brazilian quartz obtainable, ground to your specified frequency in 1715 or 3500 kc. band to a guaranteed accuracy of 0.1%; complete with milled bakelite adjustable dustproof crystal holder	2.75
Araco crystal complete with commercial type plug-in precision holder	3.60
7000 kc. crystals	7.50
Finished on bluing blanks, guaranteed each	1.50
Unfinished blanks guaranteed each	1.00
Precision grinding—your present crystal ground to any higher freq.	1.50
Precision type miniature plug-in holder, plates lapped Flat, each	1.25
Dustproof bakelite adjustable crystal holder, each	.74

ALL CRYSTAL WORK IS GUARANTEED!

RELAYS

DUNCO Midget Relay may be used wherever a compact sensitive relay is required—will interrupt currents up to 5 amperes and can be used in 110 or 230 volts; a beautiful keying relay.	\$3.10	5 V. D.C. special, \$3.25
24 V. D.C. special	3.20	
6 V. D.C. special	3.20	
DUNCO overvoltage relay, 4 volt Solenoid, same as above relay, each	\$5.75	
WESTERN ELECTRIC Polar and Non-Polar relays, 4V for steel core. Keying relays and many other uses where a sensitive, quick-acting relay is necessary, will operate on 5 M.A. 1200 ohm DC resistance, special	3.75	

CLOSING OUT—JUST A FEW LEFT! Brand new Heede Milliammeters, 0-10, 0-15, 0-25, 0-100, 0-150, 0-200, 0-250, 0-300, 0-500, 3 1/4" diameter, long scale, D'Arsonval jewelled movement, dead-beat, zero adjustment, Range mounting black enamel case, each
 \$2.95 |

TUBES

WE 212-D 250-watt, excellent modulators, NEARLY NEW	\$35.00	SPECIAL DUOVAC 211's, BRAND NEW, each, \$10.00
RCA 857's, used less than 100 hrs.	14.25	RCA 211's, used, each, 8.00
212-D, used but in excellent condition	25.00	BRAND NEW TAYLOR 845's, each, 10.00
212-A, used about 50 hours	25.00	NATIONAL R-81 Rectotubas, each, 3.45
NEW DEFOREST 302A's, 545's, each	17.50	NATIONAL R-3 Rectotubas, each, 5.90
RCA 800's, very old, used, each	16.50	NEW DEFOREST 481's and 450's, each, 1.69
DEFOREST 302A, all used, each	16.50	RCA 841's and 842's, BRAND NEW, each, 4.75
UNCONDITIONALLY GUARANTEED 25-watt tubes, made of Pyrex glass with thoriated filament, marks the other more like a silver than a 10. Plate voltage 350, base voltage 85-100, filament 7 1/2 volts, but bulky glass with terminals at the top, new and improved internal construction; each one tested at Uncle Dave's—a real addition to any transmitter, really an honest 25 watt!	\$4.75	
NEW TUBES DESIGNED ESPECIALLY FOR THE HAMS!		RAYTHEON RR-17, each, \$5.00
RAYTHEON RR-18, each	\$10.95	SYLVANIA 830's, each, 8.75
SYLVANIA 210's, each	4.75	
COMPLETE LINE OF RAYTHEON AND SYLVANIA TUBES—WRITE FOR NEW PRICE!		

HOT SPECIALS

WESTERN ELECTRIC Microphone filter, a well designed 2-button carbon mike filter; eliminates hiss, humming, packing and saves your microphones, list \$12.50, special	\$3.95
RODEL Mike canister—beautiful case which encloses the mike and protects it from possible damage; gold finish, special	.65
Relays, operate on 1 1/2 volts D.C.; PB for keying remote control	.59
4" black bakelite dials, extra large knob	.25
4" Remier dials, those will certainly load close to your transmitter; Silver finish with black porcelain and large bakelite knob	.95
General Radio audio transformers, fully mounted and shielded	.79
Variable condenser, .0003 heavy plates, 1000 volt spacing, PB for oscillator and buffer stages, also 10 PA, each	.89
Sprague transformer to supply filament and plate for 3 or 4 tube receivers	1.75
Silver-Morich POWER TRANSFORMER, built for 14 tube super, 110 V. CT, 750 V. CT, 5 V. 2A, and 2 1/2 V. 16 A. secondaries, completely shielded, lug terminals, electrostatic shield, SPECIAL	4.95
50 watt Extra Heavy duty guaranteed soldering iron, each	1.90
1CA Wound coils, for use with 800K condenser, tubes from 15 to 200 meters, four to a set, 4-prong, beautiful job, per set	1.10

UNCLE DAVE'S Re-designed and Improved Lofco-White amplifier, which uses one 224, one 245 and one 280. Has an output of about 4 watts. Uses International Rectifiers, Sprague Condensers, fully wired and assembled. **UNCONDITIONAL GUARANTEE**. Low tubes and speaker
 \$6.95 |

Output transformer to be based on the above, each
 .95 |

SONOCHORDIE S' dynamic speaker, 25,000 ohm field, specially designed for above amplifier
 3.95 |

COMPLETE STOCK OF NATIONAL SETS AND PARTS CARRIED IN STOCK FOR IMMEDIATE DELIVERY. HAMMARLUND COMET PROS ALSO IN STOCK WITH CRYSTAL FILTER AND AVC. WRITE IN FOR MOST COMPETITIVE PRICES IN THE COUNTRY.

SEND IN FOR OUR LATEST FREE HAM BULLETIN—JUST OFF THE PRESS! AND DON'T FORGET TO SEND FOR YOUR COPY OF THE RADIO AMATEUR CALLBOOK OR THE RADIO AMATEUR'S HANDBOOK—WE HAVE THEM HERE AT ONLY \$1.00 EACH, PREPAID TO YOU! CABLE ADDRESS "UNCLEDAVE" FOREIGN TRADE SOLICITED.

SEND FOR FREE HAM SHEET AND CATALOG

LONG DISTANCE PHONE 4-5746

UNCLE DAVE'S RADIO SHACK

356 BROADWAY ALBANY NEW YORK

"HAM" ADS

Advertisements in this section are inserted at 5c per word to strictly amateurs, or 10c a word (8 words to the line) to manufacturers or dealers for each insertion. Name, initial and address each count as a word. Cash should accompany "Ham" advertisements. Advertising for the February issue should reach us not later than December 9.

PILOT "SUPER WASP" (D. C.). LIKE NEW. Complete with R. C. A. tubes. For details write Edwin Huber, 1720 Ludlow Street, Philadelphia, Penna.

DE LUXE S. W. RECEIVER, PRICE ONE-half your valuation. Write No. 1711 Riverside Ave., Muncie, Ind.

ENJOY SHORT WAVE RECEPTION: MASTER Code. Simple method. 25c. Code Master. Box 326, Braddock, Penna.

SWAP: 35MM MOTION PICTURE CAMERA. Cost \$135.00. Want amplifier or S-W radio. Arthur Hart, E. College St., Oberlin, Ohio.

SHORT WAVE RECEIVERS WIRED AND tested, \$3 to \$10. Send in your parts. Used S-W parts on hand. Send requirements for prices. V. Narvydas Radio Service, 542 Lorimer St., Brooklyn, N. Y.

PLUG-IN COILS. INSIDE BAKELITE FORMS. Low-loss, any band. For most circuits. \$1.00 per set. M. Carney, 2041 So. Kennison Drive, Toledo, Ohio.

DIZZY CARTOON FOR QSL OR SHACK. Send \$2 with your rough idea for large original pen drawing. WIAFQ, Harwich, Mass.

QSL CARDS, NEAT, ATTRACTIVE, REASON-ably priced, samples free. MILLER, Printer, Ambler, Pa.

TUBELESS CRYSTAL SET, SOMETHING new. Separates all stations, operates speaker. 750 miles verified. Blueprint 6 others, 25c coin. Modern Radiolabs, 151-A Liberty, San Francisco.

RELAY RACKS 60 INCH \$7.50. WRITE! Commercial Radio, Sycamore, Illinois.

JOIN THE INTERNATIONAL AMATEUR and Short Wave Society. 560 stronk. "R" Monthly Bulletin. Foreign members 65c (coin). American members 50c (coin). Circuits published monthly in Bulletin. Write Secretary, Oliver Amlie, 56th City Line Ave., Overbrook, Philadelphia, Penna.

PLUG-IN COILS. SET OF FOUR WOUND ON Bakelite forms 50c. Noel, 809 Alder, Scranton, Penna.

WANTED CODE PRACTICE KIT. SWAP OR cash. Fred Turnell, Havana, Ill.

WE STILL HAVE THOSE 95c CRYSTALS. White Radio Laboratory, Sandpoint, Idaho.

BEST OFFER TAKES A COMPLETE TEN Watt Transmitter and A C receiver; DX guaranteed. W9DCN, Skelton Road, Gladstone, Michigan.

Let SLIDE RULES

Do Your Dividing and Multiplying!

Midget 5 in 1 Circular Type:



Metal 4" Dia.
Price \$1.50
Case 50c extra

1.23² = ? √50.41 = ?
1.24² = ?
Tan 8°5' = ?
Cot 79 1/2° = ?
4 3/4 × 1/4 = ?
Log 56.25 = ?
6% of 145.9 = ?
5.16 - 1/2 + 1.78 = ?

Solve easily all these and dozens of other mathematical problems without pencil and paper—by means of the Midget Slide Rule. This rule solves any problem in multiplication, division, addition, subtraction, and proportion. It also gives roots and powers of numbers. The "Tri" scale gives the sines, cosines, tangents and cotangents of all angles; also logs of numbers. Adds and subtracts fractions. Approved by colleges.

(Special 10" dia.; 27" Scale High Accuracy Slide Rule \$3.75)

Dataprint Co., Box 322, Ramsey, N. J.

Low-Power Modulator

(Continued from page 528)

1. Determine the audio output of the modulator (in this case 10 watts).

2. Determine the output impedance, or load resistance into which the modulator works best. (The load resistance for the secondary of the 2A3 output transformer is 4000 ohms.)

3. Find a value of voltage and current twice the audio output of the modulator that produces the correct value of load resistance. Ohm's law is used to determine the correct current and voltage values. The law is: "Current, in amperes equals voltage divided by resistance."—(I=E/R). Hence, if we substitute 4000 ohms, the proper load value for R, a few simple arithmetical calculations will indicate what value that equals 20 watts power input, approximately, also satisfies the requirements of proper load resistance. Power input in watts is determined by multiplying the plate voltage by the plate current in amperes. For example, 300 volts times .07 amperes, (70 milliamperes) equals 21 watts, which forms an approximate load resistance of 4000 ohms. In like manner, the proper values of power input to a radio frequency amplifier can be determined for virtually any values of voltage, current and impedance.

The modulator is actually a three-stage audio amplifier. The first stage uses a '56 tube, transformer coupled into two type '56 tubes in push-pull. These tubes are likewise transformer coupled into the two push-pull output tubes. The plates of the output tubes connect to a special 2A3 output transformer, the secondary of which works into a 4000 ohm load. An extremely heavy grid swing is necessary on the 2A3's, which is the reason for the use of two preceding audio stages.

The unit is built on a board 21" long by 12" wide. Two one inch under supports allow space under the board for wiring. On the front end of the board, from left to right, the layout is as follows:

Microphone transformer, first audio tube, push-pull input transformer, two second audio tubes, push-pull interstage transformer, output tubes, and special output transformer.

The layout on the back edge of the board, from left to right, is:

Power transformer, rectifier tube, 8 mf. filter condenser, filter choke, 16 mf. filter condenser, and 2 mf. output condenser.

In all audio work, only the best of equipment should be used, especially when another's ears are to hear the result. Ground all the audio transformer frames, and also the power transformer frame. This will help to eliminate hum, and the motor-boating that sometimes occurs with more than two stages of audio. The modulator is a relatively simple unit, and, provided good parts are used, and the diagrammatic and pictorial representations accompanying this article are carefully followed, no trouble will be experienced in getting the unit in operation.

Inasmuch as the microphone is the starting point of the transmitter, and can ruin the quality of the transmission, no matter how good the rest of the apparatus is, it might be well to interject a word as to its care and operation.

There are some very good single-button microphones on the market, and admirable results can be obtained with them, but extreme care should be taken in the choice of the instrument. The single-button microphone transformer should have an impedance of 200 ohms. Not more than six volts should be used on a single button, unless the manufacturer's instructions specify a higher voltage.

Recently, some very fine double-button mikes have been put on the market at prices almost as low as those charged for singles. If it can in any way be afforded, a double-button mike is an excellent thing to use, as it produces a great improvement in quality. The double-button mike transformer is necessarily center-tapped, and is usually of 200 ohms, impedance, per button. A double button microphone should

never be used on more than 3 volts, unless the manufacturer so specifies.

Never move or jar a microphone while it is connected to the battery, and always remember that it is an extremely delicate piece of equipment that should be handled with care. The best "approach" is to talk across the face of the microphone, as this minimizes breath hiss. If a double button mike is used, have "ma," or the "YLF," (young lady friend), sew a little cloth cover to put over it. This will keep out dust and dirt, as well as protect the diaphragm from corrosion by moisture condensed from the speaker's breath.

Tuning Hints

The R.F. end of the set is tuned up in the normal way, as described last month, with the exception of the fact that the modulation choke is in series with the positive lead. Load up the antenna to exactly 70 milliamperes, making sure that there is 300 volts on the plate of the amplifier. The oscillator is run at the full voltage of the power supply, somewhere between 350 and 400 volts. Now "fire up" the modulator and check in the monitor; the voice of the person speaking into the mike should be heard clearly and distinctly at zero beat in the monitor. A diagram is shown for a little crystal monitor to be used to check on the quality of the transmitter. A small flashlight bulb connected in series with the antenna lead, should flicker up much brighter than normal when a person speaks into the microphone. It may be necessary to use a 45 volt battery as grid bias for the 46 amplifier instead of the resistance. A circuit diagram shows how to connect and bypass it.

The milliammeter in the lead to the plate of the R. F. tube should never swing more than 4 or 5 mills (M.A.); a larger swing than this indicates distortion. Cut down on the battery current until there is only a slight swing, if any. Keep the transmitter and modulator as far from each other as possible to prevent R. F. pickup in the audio end.

A little careful tuning, testing, and checking in the monitor will do a lot to get a good signal that makes or breaks a fellow's reputation on the air.

As one old-timer said: "It's more the apparatus itself, that makes a good station."

Let's hope you are all the kind of op's, and build up the kind of stations that would make any "old timer" proud. 73's.

Parts List

- Microphone transformer, National. (Also R. T. Co.)
- 3—5-prong sockets, Eby.
- 3—4-prong sockets, Eby.
- Push-pull input transformer, National. (R. T. Co.)
- Push-pull interstage transformer, National. (R. T. Co.)
- 2A3 output transformer, National. (R. T. Co.)
- 2 mf. 1000 volt paper condenser, Flechtheim.
- 1—Power transformer, National. (R. T. Co.)
- 3—8 mf. 500 volt electrolytic condensers, Flechtheim.
- 2—30 henry 100 mill. chokes.
- 1—3000 ohm 1-watt resistor, Lynch (International).
- 1—1500 ohm 1-watt resistor, Lynch (International).
- 1—750 ohm 10 watt wire-wound resistor.
- 2—1mf. 200 volt paper condenser. Flechtheim.
- 1—50 volt 5 mf. electrolytic condenser.
- 1—Microphone; (Amplion; Lifetime; Miles; Mayo; Maylux).

Don't Miss Mr. Victor's Next Article in the "AMATEUR TRANSMITTER" Series!

5 and 10 Meter Gossip

By GEORGE W. SHUART, W2AMN

● THE reason this column did not appear in the December issue was because there were no stations to be heard on the 5 and 10 meter bands (at least in our vicinity), and it looked as though most of the amateurs had forgotten that these two valuable bands existed. The 10-meter band has remained as quiet as ever, with only one or two stations to be heard during the weekend, testing and calling CQ. However, on 5 meters, there has been a considerable increase in activity and a great number of stations can be heard any evening; also, quite a few new stations have appeared on the band, indicating that the general trend is back to 5 meters.

* * *

Among the popular stations that can be heard here in the East, around New York City, any evening, are:

- | | |
|-------|-------|
| W2AG | W2DZO |
| W2CUZ | W2EQT |
| W2DFU | W2GOW |
| W2ESP | W2DR |
| W2BMK | W2QF |
| W2GE | W2VH |
| W2AMF | W2CRT |

* * *

Most of the above listed stations produce a very strong signal at the writer's receiving station located in Hillsdale, New Jersey, and practically all of them have been worked from W2CBC (portable call of W2AMN). New receivers are making their appearance on 5 meters, which include the screen-grid detector tube and certainly do provide a much more sensitive job than those formerly using triodes.

* * *

The 57 which is a pentode screen-grid tube seems to function better than any other type tube previously used as a 5 meter detector, and is very sensitive to weak signals. The circuit employing the type 57 as an electron-coupled detector tube can be so adjusted to give an extremely low hiss level. It is highly recommended that those operating on 5 meters or contemplating building a 5 meter receiver incorporate this tube in their proposed receiver. When this tube is employed a much higher interruption frequency can be used without lowering the audio output of the set and also results in the decreased hiss level. This is accomplished, of course, by reducing the number of turns on the interruption frequency transformer, primary and secondary.

* * *

Superheterodynes have not yet received very much consideration on the 5 meter band, but we believe that in the near future this will be the predominating receiver and it will have approximately a 1500 kc. intermediate frequency amplifier.

A good line-up for the receiver mentioned previously and used at W2CBC is a type 57 detector, type 56 "I.F." oscillator and a type 2A5 audio amplifier, feeding a dynamic speaker. Due to the low hiss level and high sensitivity, excellent quality can be produced from even the weakest 5 meter station and this certainly is an improvement, as most 5 meter receivers do not give anything like the quality obtained by other types of receivers.

* * *

The writer would be very pleased to receive comment on any subject pertaining to 5 meter transmission and reception and worthwhile information will be presented in this column. Address your correspondence to "5 and 10 Meter Gossip Column" in care of SHORT WAVE CRAFT.

NOTICE!!

The Editors are looking for GOOD Set Construction articles! Let's see what you've got! Send articles or synopsis describing set to Editor for quick decision.

The ULTIMATE in Radio

WORLD-WIDE RECEPTION

- Berlin
- London
- Paris
- Rome
- Moscow
- Madrid
- Sydney
- Tokio
- Hawaii
- Buenos Aires

- ★
- ★
- ★
- ★

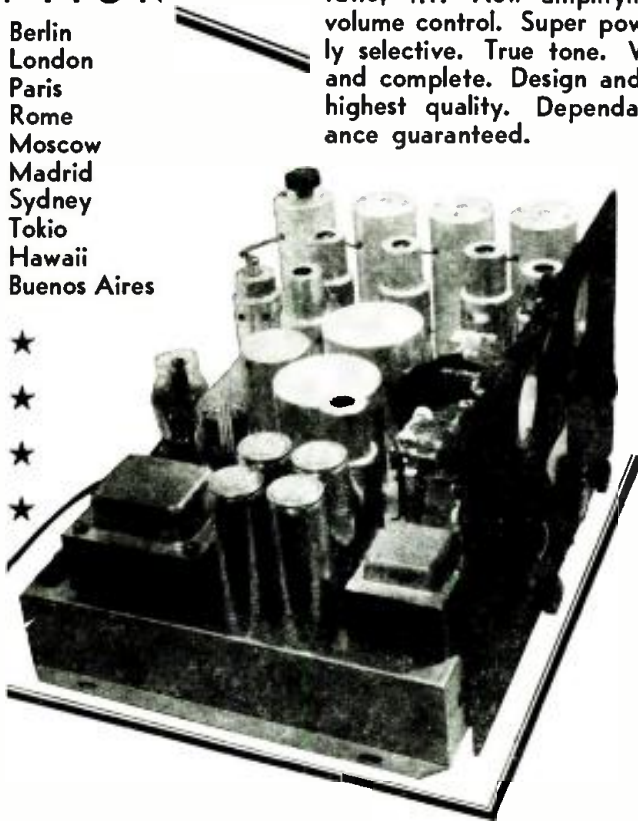

Range 15 to 550 meters. Highest amplification. Greatest signal to noise ratio, 4:1. New amplifying automatic volume control. Super power. Extremely selective. True tone. Very compact and complete. Design and construction highest quality. Dependable performance guaranteed.

Norden Navy Model 34

HIGHEST QUALITY RECEIVER IN THE WORLD

- Weston meters
- Isolantite coils
- Duplex shielding
- Band spread tuning
- C. W. Oscillator
- Tone modulator
- Corrosion proofed

Norden Radio Laboratories
315 Fourth Ave., New York

Norden Radio Laboratories
315 Fourth Ave., New York
Please send me complete details about the new NORDEN NAVY MODEL 34.

Name

Address

City..... State.....

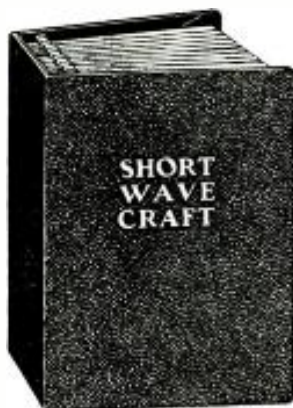

No! No!!

this is not the sort of magazine that you read and then discard.

Readers keep their copies for years as a steady reference and thousands of letters attest to this.

It is now possible to save your copies and for this purpose we designed a splendid binder for you which holds twelve copies. It is made of heavy substantial material and is covered with black grain leatherette. The name of the magazine is stamped in gold on the cover.

An ingenious mechanical arrangement is provided which makes it possible to hold the copies flat when reading from the binder.

SHORT WAVE CRAFT Binder as described, \$1.25 prepaid in the United States.....

Canada and foreign countries 25c extra. We accept money order, check, stamps or cash.

SHORT WAVE CRAFT
98 Park Place New York, N. Y.

Up to the Minute S.W. Receiver

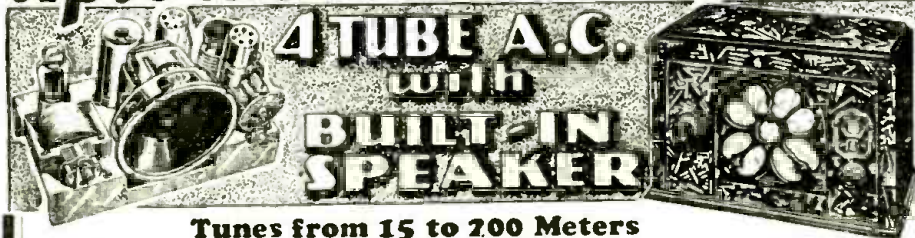

Tunes from 15 to 700 Meters

Absolutely the latest in short wave receivers. A complete 4 tube Short-Wave A.C. receiver with built-in dynamic speaker.

All short-wave bands are efficiently covered with the four octo form coils supplied with the receiver. Police band, amateur band, ship-to-shore signals, C.W. are all at your finger tips. True-toned, powerful reception is assured by the output of a 2A5 power tube. Perfect undistorted power is handled by a full sized dynamic speaker. Built-in power supply is carefully filtered to reduce noise to the lowest possible level.

All the parts, including the speaker are securely mounted on a strong, metal chassis. Will tune over the entire short-wave band from 15- to 200 meters. The entire receiver chassis is encased in a beautiful crackle-finished cabinet.

Complete kit of parts \$17.50 R. C. A. licensed tubes \$2.95 Wired and tested \$2.00 extra

One Tube Rocket

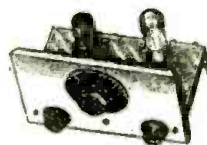

For the anxious "fan" who is endeavoring to enter the short-wave spectrum without overstraining his pocket book. Here is a little receiver that will bring in short wave stations from all parts of the country—Police band—amateur bands and C.W. Very

economical—uses one 230 low current tube. Requires two 1 1/2 volt dry cell and 1-45 volt B battery. Complete kit of parts, coils, blueprint. **\$3.95**
R. C. A. licensed tube. **70c**
Batteries 2-1 1/2 volts, 1-45 volt **\$1.50**
Wired and tested. **\$1.00 extra**

Universal A.C. - D.C. Short-Wave Receiver



Universal receivers are rapidly gaining popularity. Now the Universal principle has been successfully applied to short-wave receivers. The circuit features the new 25-Z-5 tube as rectifier for the power supply. A 43 tube is used in the power output. With a headset the receiver is capable of listening short-wave stations from all parts of the world. Worldwide loudspeaker reception under favorable conditions.

Complete kit of parts. **\$7.95**
R.C.A. Licensed Tubes **\$3.25**
Wired and Tested **\$2.00 extra**

Oxford A. C. Dynamic Speaker

11 1/2 inch Concert Model

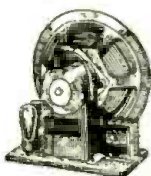

Three point suspension balanced cone type. May be used on any type of receiver. No internal connection necessary to operate. Simply connect phone tips to speaker connections on receiver or amplifier, and plug into any 110 volt A. C. line. Uses 250 for rectification. An 8" mid. electrolytic condenser is used to filter any possible line hum. Available for single or push-pull output.
Speaker complete with 2-50 tube. **\$5.95**
D.C. Model (2500 ohm Field) **\$3.95**

Beginners Twin Short-Wave Receiver

First introduced to the short-wave fan in the N. Y. Sun newspaper. No experience is necessary to build the "Twin". Very economical to operate. The two tubes used are the 30 type drawing but 40 M.A. filament drain, each. All nationally known parts.

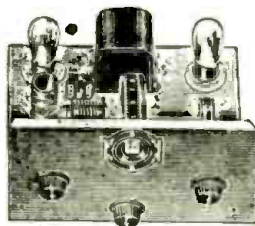

Complete kit of parts **\$7.95**
R. C. A. Licensed Tubes **\$1.35**
Complete set of Batteries **\$2.50** Wired and tested **\$2.00 extra**

BAIRD Two Tube Universal A.C.-D.C. Short-Wave Converter

A very simple short-wave converter for A.C. 110 volt current. A most compact job that is easily constructed in a short time. Tubes used—1-6-A-7 and 1-25Z5. Just connect to any regular broadcast receiver and electric outlet and you are ready to receive short wave signals. Tunes from 15 to 200 meters.

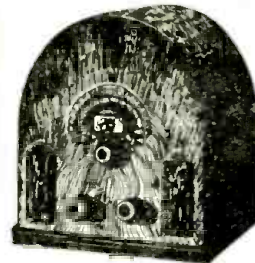

Complete kit of parts including cabinet **\$7.95**
R. C. A. Licensed tube **\$2.25**
Wired and Tested **\$1.00 extra**

Farrand Inductor Dynamic

The genuine Farrand Inductor for this low price. The 12" model has two magnets standing upright, with a bracket on the bottom to ease mounting. Dimensions 12" high, 6 1/2" deep. Price. **\$4.95**



The 9" model has two magnets parallel to each other with a bracket placed between them to facilitate mounting. Price. **\$3.95**
Please state type of power tube or tubes when ordering.

Byrd Expedition Gets Candler Trained Operators

IF there ever was a stiff competitive examination conducted for radio operators, where speed and accuracy in sending and receiving code signals were tremendously important, it was in the test conducted some time ago to select radio operators for the second Byrd Antarctic Expedition. The operators aboard the ship in the latest Byrd expedition now en route to Little America are Candler trained operators, which is certainly a fine badge of distinction conferred upon Mr. Candler and his system of training radio operators not only to send dots and dashes with lightning speed, but more important still, signals which are evenly spaced and which can be read with comfort and accuracy by other well-trained operators.

There is no "royal road" to learning the art of radio operating and this applies particularly to the code phase of the game; it takes time and patience to learn how to send the code dots and dashes fast and accurate, as to spacing and length of each dot and dash, but more important still is the calibre and system back of the school that teaches one. If the system is wrong or faulty, then no matter how fast the student may send, the chances are that he will use his own intuition in spacing the dots and dashes, and that means that every man will space them to suit himself, generally speaking.

Beginner's Code and Theory Class

● PROVIDED sufficient inquiries are received, Mr. L. Victor, operator of amateur station, W2DHN, and author of the "Beginner's Transmitter" series now running in SHORT WAVE CRAFT, has offered to conduct a class over the air to help beginners obtain their radio operator's license. Mr. Victor is at present constructing a half kilowatt 160 meter phone set and this rig should be able to reach from 200 to 300 miles outside of the New York area. Those interested should write a letter to Mr. Victor, in care of SHORT WAVE CRAFT, enclosing a stamped addressed postal. If there is sufficient interest manifested notification will be given in the pages of this magazine when and on what frequency these classes will be held. Suggestions are requested in regard to the time at which the class should be held. Those located outside the zone mentioned above should write to Mr. Victor and if sufficient interest is shown, other transmitting stations will be scheduled for code classes.

"Smoothing Up" Your Receiver Controls

(Continued from page 532)

Figure 4 illustrates four methods of controlling the volume. The first diagram Fig. 4-A, shows a 500,000 ohm potentiometer as replacing the more usual grid-leak in the first AF amplifier. This method provides a satisfactory control in small receivers, but no provision has been made to prevent the detector from overloading, and it is desirable to find a method whereby the signal strength can be reduced before it reaches the detector tube.

This has been accomplished successfully with the methods shown in Fig. 4-B and C, the preference being for the method in fig. 4-C. However, both of these systems do cause detuning to some extent and are therefore to be avoided if possible.

Figure 4-D shows a very successful method. Here detuning effects as well as overloading of the detector tube is avoided. A potentiometer of from 3,000 to 20,000 ohms will prove quite satisfactory in this position.

NOW READY!

HANDY SERVICEMEN'S MANUAL

128 Pages

Full of vital data—charts, formulas, servicing hints, curves, filtering systems, P. A. systems, Short-Wave Hookups, Tube Characteristics etc. \$1.00 manual for **25c**

SPECIALS!

- Power tone Sending Key **\$.69**
- Baldwin Type "C" Headphones **3.25**
- G. R. Type Standoff Insulators, Doz. **.50**
- Stromberg-Carlson Phono Pickup **5.95**
- R.C.A. 100 A-100, B-103 Replacement Speaker Chassis **2.75**
- R.C.A.-Victor Hand Mike **1.25**

TRY-MO RADIO COMPANY, INC.

Dept. S, 85 Cortlandt St., New York, N. Y.
Branch—179 Greenwich St., No. Cortlandt St.

The "Champion" S-W Receiver

(Continued from page 539)

carefully isolated at all necessary points by means of properly by-passed short-wave r.f. chokes. Both the screen-grid circuit and the plate circuit of the r.f. tube are isolated in this way. Radio frequency current is kept out of the audio portion of the circuit by means of the r.f. chokes L3 and L6. The r.f. chokes are bank wound for maximum efficiency.

The mechanical design and placement of parts in this receiver has been worked out with the idea of making all leads as short as possible. In other words, the Champion is custom-built throughout.

Each stage is shielded individually and the entire receiver is built into a metal cabinet. Both the r.f. tube and the detector are also individually shielded. As a result, this receiver possesses stability seldom found in a short-wave receiver.

New-Type Coils an Important Feature

Coils L1 and L2 are six-prong plug-in type coils. Coil L1 has the special isolated primary for use with special "noiseless" antennas. Coil L2 is wound with primary, secondary and tickler. The two coils furnished with the receiver cover the 20 meter band. Additional 35, 50 and 100 meter coils are available. The low-loss construction of these coils is especially noteworthy. They are solenoid wound on 1-1/2 inch diameter "grooved" isolantite forms. The wavelength range is plainly printed on the handle of each coil, thus affording quick wavelength changes.

A single-throw, double-pole jack switch J3 serves as the "on-off" switch for the B and C batteries and also connects the chassis to A plus, thus completing the filament circuits.

The loud speaker is connected to the output by means of the twin jacks, J1, J2. A special 8" permanent-magnet dynamic speaker is recommended for use with the Champion. This requires no external field excitation. A highly efficient magnetic speaker may be substituted if desired. A jack, J4, is provided at the rear for ear-phone reception.

The attractive crystalline finish steel cabinet does not show finger marks. The cabinet measures 12 1/2 inches wide by 6 inches deep by 8 3/4 inches high. The construction is such that all shielding is a part of the cabinet, since the entire job is spot-welded. A vernier dial of the drum type is provided.

The Lafayette Champion is especially designed for operation with a two-volt "air-cell" battery for supplying the filaments. A "B" supply of 135 volts is required. A long, color-coded, eight-wire battery cable is supplied with the receiver.

Set Is a "Champion" Distance Getter

This receiver is capable of bringing in real distance on a loud speaker and it does this consistently. Foreign stations, police calls, ships at sea, airplane messages, trans-Atlantic phones—the entire

array of short wave stations comes in as the dial is turned.

Hints on Operation

There are three controls on the Lafayette Champion. Facing the front of the chassis, the control on the left hand side is the *antenna trimmer*. This trimmer controls a special selector winding, which is interwound with the secondary and results in a highly efficient and selective radio frequency transformer. The control knob in the center is the *station selector* control. The knob on the right hand side is the *volume and regeneration* control. The "on-off" switch is in the center.

For a start, it is best to turn the regeneration control until the set "spills over" or a distinct hiss is heard. Adjust the antenna trimmer, by visual inspection, until the plates are approximately half way in. By rotating the station selector, a series of whistles and squeals should be heard as many stations, code, telephone, television, etc., are received. Adjust the trimmer for the loudest hiss.

Turn the dial knob slowly until a continual whistle is heard, (interrupted whistles indicate code stations). This is probably the carrier of a short-wave telephone station, and if modulated by speech or voice, these sounds will be heard above the squeal. Tune until the squeal is the loudest. The squeal can now be cleared by backing down the regeneration control until the receiver stops oscillating. A slight readjustment of the tuning dial may be necessary as the regeneration control is moved. Adjust the volume to suit by means of the regeneration control.

The trimmer adjustment is not critical, and need only be set for each set of coils, except for the reception of very weak signals, which necessitate careful adjustment, all around for best reception.

"Champion" Coil Data

The coils used on the "Champion" short wave receiver are identical. Coil data follows: **14 to 24 meters**

3 turns of No. 26 double silk wire in slot at the bottom. This is the primary.

6 turns of No. 24 enamel interwound with the secondary. This is the tickler.

6 turns of No. 14 enamel. This is the secondary.

23 to 41 meters

3 turns No. 26 double silk—primary.

10 turns No. 24 enamel—tickler.

12 turns No. 14 enamel—secondary.

38 to 70 meters

3 turns No. 26 double silk—primary.

13 turns No. 32 double silk—tickler.

20 turns No. 18 enamel—secondary.

65-115 meters

4 turns No. 25 double silk—primary.

22 turns No. 26 double cotton—tickler.

35 turns No. 20 enamel—secondary.

Coil Forms, 6-pin, threaded (or smooth) isolantite (or other insulating material. 1 1/2 in. dia. x 2 1/2 in. long).

NATIONAL SHORT WAVE PRODUCTS

Precision Type N Dial

The National Type N Dial has the mechanical smoothness and accuracy so essential for Short Wave use. It is of solid German Silver, engine divided and equipped with a Vernier reading to 1/10 division. The planetary reduction has a ratio of 5 to 1.



List Price, \$6.75



Short Wave Condensers

Fifty-two models! All embody the basic National features of insulated bearings, constant impedance pistails, Isolantite insulation and non-resonant aluminum plates.

National R39 Coil Forms

Made of the ultra low-loss material R-39, National Coil Forms insure stability, maintain calibration. Both sizes are designed for best form factor and lowest R.F. Resistance. The Standard Coil Form (4, 5 or 6 prong) is 1 1/2" in diameter, 2 3/4" long. List Price is \$7.75 each. The Midget Coil Form (4 prong only) is 1" in diameter, 1 1/2" long and lists for \$5.50.



Low-Loss Coil and Tube Sockets



A point which is often overlooked in ultra high-frequency receiver and transmitter design is the efficiency of coil and tube sockets. Suitable for either standard sub-panel or base-board mounting. Made in standard 1-, 5-, 6- and 7-prong styles as well as in special 6-prong for National coils. List Price, \$6.00.

National Short Wave Choke Type R-100

Isolantite mounting, continuous universal winding in four sections. For pistail connections or standard resistor mountings. For low powered transmitters and all types of high frequency receivers.

List Price, \$7.75



National Transmitting Choke, Type R-152

Isolantite insulation on metal base—10,000 v. insulation; continuous universal winding in 5 tapered sections. For both high and low powered transmitters and laboratory oscillators.

List Price, \$2.25

National Grid Grip

This remarkably convenient little Grid-Grip is easy to operate, never works loose, makes continuous electrical contact. Eliminates possibility of loosening cap on tube when removing lead. Two sizes, for broadcast tubes (List Price \$3.05) and for large tubes, such as the 872 (List Price \$4.10).



List prices include Federal Excise Tax and are subject to 40% discount when purchase is made through authorized NATIONAL CO. distributors

Send for the Free National Catalogue No. 220

Mail the coupon below for the National General Catalogue No. 220. Its sixteen pages describe a complete line of quality parts for the amateur and constructor.

NATIONAL COMPANY, INC.
61 Sherman Street
Malden, Massachusetts

Gentlemen: I enclose 6c in stamps to cover mailing costs of your General Catalogue No. 220. Please mail it at once to the address below.

Name

Address

SWC-1-34

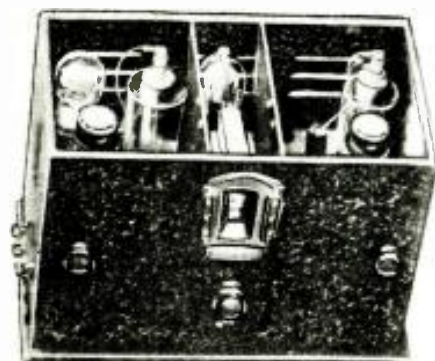

Another view of the Lafayette "Champion" short-wave receiver.



Improved plug-in coils of the 6-pin type, the wire being wound on grooved isolantite forms. The wavelength rating appears in a protected label set into the knob.

OCTOCOILS

Go With Byrd to the South Pole

Commander Byrd will depend on Octocoils to keep in touch with the world

You can depend on OCTOCOILS to give you BETTER results.
Beware of imitations—look for the word OCTOCOIL moulded on the form

The New Price is now \$2.50 per set of four

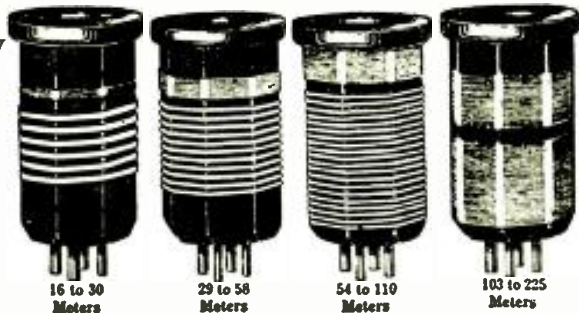

Wave-length Range 15 to 225 meters

A Standard for Short Wave Set Builders Since 1928

Now in use in more than SIXTY foreign countries.

OCTOCOILS are moulded in genuine bakelite in four distinctive colors, green, brown, blue and red, and are wound with Nos. 12, 14, 16 and 25 enamelled wire. They plug into the ordinary four prong socket. These coils will also cover the 10 to 80 meter amateur band when used with .00005 midset variable condenser. Ask the HAM, he knows. At your dealer or all Kresge \$1.00 stores—or sent postpaid anywhere on receipt of price. Free two and three tube S.W. diagrams included.

SHORTWAVE AND TELEVISION CORPORATION

Division of General Electronics Corporation, 70 Brookline Ave., Boston, Mass. Pioneer manufacturers of Television and short wave apparatus. Television and sound stations WIXAV, WIXAU, WIXG and Short Wave Station WIXAL—15000 watts

Europe or Asia — NO TRACE OF HUM IN SUPERTONE A-C SHORT WAVE SET WITH THE NEW BAND SPREAD FEATURE.

Plug-in coils are used, at conveniently accessible socket positions (near corners of the chassis top). Each tuned circuit is independently controlled. That insures sensitivity. Regeneration control is dual in character—usual feedback, condenser and a potentiometer besides. This brings in those elusive stations charmingly. At right is the separate power supply and its shield container.



Improved plug-in coils on the new ribbed form. Hammarlund Condensers used. Vernier Dial. Delivery on these sets can be made in 4 days.



Dual regeneration for C.W. reception as well as phone. Consistent daily reception of European stations assured.

A DREAM COME TRUE—BIG RESULTS ON SHORT WAVES AT VERY LITTLE COST!

Complete kit of parts for building both the receiver and the separate power supply, contains everything except tubes and set cabinet. The speaker is included. Five tubes (one 58, one 57, one 56, one 2A5, one 80) at \$3.75 extra.

The wired and tested model consists of the kit built up at our precision laboratory by expert engineers. The price, less tubes, but including speaker..... \$23.50

The receiver proper, less the power supply, less speaker, and less tubes. This outfit can be worked with a filament transformer and a B eliminator, and the price of the wired receiver \$12.00

SUPERTONE PRODUCTS CORP., 35 Hooper St., S. W., Brooklyn, N. Y.

SPECIAL To SHORT WAVE CRAFT READERS

For a limited time only, and as long as they last, we will send you six back numbers of SHORT WAVE CRAFT assorted, your choice, for 85c.

The usual price for six copies would be \$1.50 and most publishers charge a higher price for back numbers over one year old.

We can supply all copies except the following: June-July, Aug.-Sept., 1930; Dec.-Jan., Feb.-Mar., April, May, June, July, Oct., 1932.

If you do not specify copies we will use our own judgment in sending assorted numbers to fill your order. Note we cannot exchange the copies for ones that have been sent to you.

Short Wave Craft 1-34
96 Park Place,
New York, N. Y.

Gentlemen: I enclose herewith 85c for which you are to send me six back number copies of SHORT WAVE CRAFT as follows:

Name: _____
Address: _____
City: _____ State: _____

Practically every copy of SHORT WAVE CRAFT contains important information that you should have. Here is a chance to get those copies.

As we have only a small supply of back numbers on hand, this offer will be withdrawn as soon as they have been sold.

We accept U. S. stamps, U. S. coin or money order. Rush your order today.

SHORT WAVE CRAFT, 96 Park Place, New York, N. Y.

A Reliable "Station Finder"

By Sol Perlman, E.E.

Technical Advisor, N. Y. Chapter, International S.W. Club

● THE wavemeter is an instrument definitely associated with radio measurements. Its importance and usefulness has long been known by the Transmitting Amateur, but its application to receiving has not been so wide-spread. With the inception of the use of short wave transmission, the Oscillator-Wavemeter became of increasing importance to the listener. Its aid in locating the short wave stations and determining the wavelength of the unknown stations has made it an important accessory to the short wave DXer.

The author will describe in this article a simple and effective oscillator-wavemeter, how to construct it and how to calibrate it. An oscillator-wavemeter is a miniature radio transmitter and the signals that it emits can be tuned to the various wavelengths by adjustment of the dial. The oscillator-wavemeter to be described here is of the harmonic generator type; that is, in addition to generating a signal on the fundamental wave, it also generates a signal on a large number of harmonic wavelengths. "A harmonic" is an equal portion (which may be 1/2, 1/3, 1/4, 1/7, 1/10, 1/14, etc.) of a fundamental wavelength.

In order to positively identify the signal from the oscillator-wavemeter and render it useful to the owner of any type of receiver (regenerative, non-regenerative or superheterodyne) it incorporates an audio oscillator generating a note of a distinctive pitch to modulate the signal of the oscillator-wavemeter. The coil-condenser combination was chosen to tune in the broadcast band because it could readily be calibrated and the calibration checked at a future date for errors and variations due to change of tube, etc. The Federal Radio Commission's regulations demand that all broadcast stations maintain their frequency within 50 cycles for which they are licensed. Precision of frequency means only a variation of 50 in 550,000 cycles of 1 part in 11,000 (better than 0.01 % of one per cent). The oscillator-wavemeter being a measuring instrument, precision is its most important characteristic. An oscillator-wavemeter depends for its precision on three factors, the design, the construction and the care with which it is used. Simplicity in design lends itself to precision. The fewer components in its construction, the lower factors to vary its precision. The choice of the harmonic generator principle was made because it reduces the oscillator-wavemeter to the use of one coil.

In its construction, rigidity is an important consideration. A variable condenser that has good bearings, heavy plates and no end play should be chosen. The dial should be readily readable and if it is of the vernier type, it should not be prone to slippage. The coil should also be rigid in its mounting and the wiring should not be slip-shod. The oscillator-wavemeter serves the following purposes: it will, if accurately calibrated and used, locate the setting on a dial where a station of known wavelength should be heard and it will determine the wavelength of a station of unknown wavelength whose identity you want to find out. The station that you want to hear may be too weak to be readily heard as you twist the dial, but if you had an oscillator-wavemeter, you set it for a definite wavelength and tune for its signal. When the receiver is tuned for the signal of the oscillator-wavemeter, your receiver is more or less accurately set to receive that station. After switching off the oscillator-wavemeter, a slight readjustment of the receiver dial should bring in the station if it's on the air. To locate the wavelength of an unknown station you are hearing, you tune the wavemeter to zero beat with incoming signal and, referring to the calibration chart, you immediately find its wavelength.

Looking at the diagram of Fig. 1 you will see that the circuit indicates that the os-

cillator is of the simple "tickler" feed-back type and the audio oscillator is of the same type. The radio frequency oscillator is modulated by the audio oscillator in the plate supply circuit and is commonly called "Heising" modulation, after the name of its inventor. From the picture of the finished oscillator-wavemeter you can readily observe the simplicity of its construction. The fact that the entire units is mounted on the panel makes it compact and easy to wire. The leads are short; the unit can be readily checked for errors. The material for its construction is reasonable in price so that every short wave "fan" can readily afford to own one. The list of materials are as follows:

- 1—7"x10" Aluminum Panel
- 1—4" dial (Vernier), National (or other make)
- 1—toggle switch
- 2—National sockets
- 1—500 mmf. variable condenser (General Radio) National (Hammarlund)
- 1—Oscillator (revamped "broadcast" coil to suit condenser used to tune it)
- 2—25,000 ohm 1 watt resistors (Lynch)
- 1—.001 mf. mica condenser
- 1—.00025 mf. mica condenser
- 1—.1 mf. tubular condenser
- 1—8 ohm filament flat strip resistor
- 1—Cabinet to take 7"x10" panel
- 1—2 ft. length of 4 wire battery cable and 4 lugs

or some part of the wiring is wrong. As to the audio tone, the size of the audio tube's grid-leak and grid condenser may be varied for a more suitable tone.

To test the entire unit for signal, the unit is placed near a broadcast receiver and the receiver is switched on to receive a station (any frequency). A wire is connected from the B plus terminal of the B battery to the antenna post of the receiver in order to feed the signal from the "O-W" to the receiver. The "O-W" is switched on and the dial is turned until a whistle is heard in the receiver mixed with the distinctive low-pitched note and the radio program. If the whistle is not heard, check the wiring, the proper connection of the terminals of the tickler coil and the voltage for the operation of the tube at its socket. Now that it is made certain that the "O-W" works correctly, the next and most important procedure is to calibrate it.

Starting the dial of the broadcast receiver at the 1500 kc. end, a station is tuned in and brought to its peak setting. Then the dial of the "O-W" is tuned *s-l-o-w-l-y* until the distinctive low-pitched note is heard and then the whistle of the "O-W" heterodyning the signal. The dial of the "O-W" is turned *s-l-o-w-l-y* until

Wavelength	200	210	220	230	240	250	260	270	280	290	300	310	320	330	340	350	360	370	380	390	400	410	420	430	440	450	460	470	480	490	500	
Wavelength	100	110	120	130	140	150	160	170	180	190	200	210	220	230	240	250	260	270	280	290	300	310	320	330	340	350	360	370	380	390	400	
KC	3000	2727	2500	2315	2160	2033	1923	1827	1743	1670	1607	1553	1507	1467	1432	1401	1373	1348	1325	1304	1285	1268	1252	1238	1225	1213	1202	1192	1183	1175	1167	1160
Dial	100	110	120	130	140	150	160	170	180	190	200	210	220	230	240	250	260	270	280	290	300	310	320	330	340	350	360	370	380	390	400	

Fundamental wavelength and harmonic chart. Manufacturer of the Station locator supplies an elaborated chart, whereby a large number of the shorter wavelengths can be determined.

- 2—230 tubes; RCA Radiotron. Arco.
- 1—45 volt "B" battery
- 1—1½ volt dry cell
- 1—sheet of cross-section paper for calibration chart

Note that the coil is a revamped "broadcast" coil. That is, that the primary winding is removed, a sheet of this paper (foolscap) is wrapped over the tuned winding and a winding having about ¼ or ½ of the tuned winding is put on. The new winding must be wound in the same direction as the tuned winding.

When the unit is complete the following simple tests are made to determine if the oscillator-wavemeter will work. Hook up the batteries to the "O-W" and then put the tubes in their sockets. Snap the switch. Connect a pair of earphones between the B plus wire and the B plus of the B battery and listen for a tone. If the audio oscillator is working, a distinctive low-pitched tone will be heard. If it is not, reverse the primary connections to the audio transformer. If still no tone is heard then the audio transformer may be "open-circuited,"

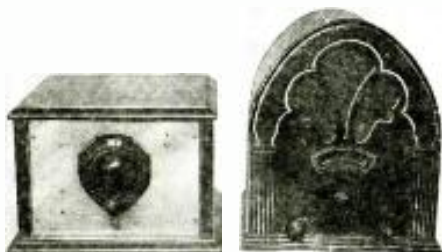

The "station locator" or oscillator unit is shown in the cabinet at the left; receiver at right.

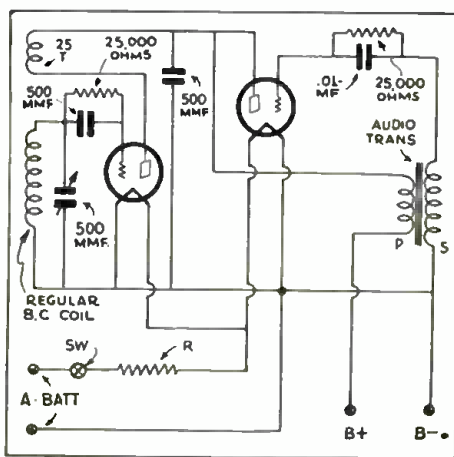

Diagram of connections for the "station finder" devised by Mr. Perlman.

the heterodyne whistle is brought to zero beat. The broadcast station wavelength and the dial setting of the oscillator-wavemeter are tabulated for a number of broadcast stations tuned in. This table should appear as shown below:

W.L.	KC	Dial	W.L.	KC	Dial
200	1500	10	297	1010	35
207	1450	12	319	940	40 1/3
214	1400	14	349	860	47 1/2
222	1350	16	370	810	53
231	1300	18	394	760	59 1/2
240	1250	20 1/2	422	710	67
254	1180	24	454	660	77
265	1130	27	492	610	89
295	1100	29	518	580	99

The information in the table of calibration points of the "O-W" dial is then plotted on the Calibration Chart. For example, 1300 kc. corresponds to No. 18 of the oscillator-wavemeter dial. 1300 kc. is 231 meters. Reading from right to left 231 meters is 16.5 divisions over. Reading up 18 divisions for the No. 18 of the dial a point is marked on the chart. In this manner a number of points are marked on the chart. Then the successive points are joined by a line. The successive short lines joined together form the calibration curve of this instrument. Note the table of wavelengths showing the fundamental wavelengths in the broadcast band of the successive harmonics shown up to and including the 15th. It is the information contained in the table of wavelengths which eliminates much of the mathematics necessary to determine the dial setting of the oscillator-wavemeter for any wavelength sought.

—building, testing and repairing all kinds of radio receivers!



THE three volumes of this Library cover the entire field of building, repairing and "trouble-shooting" on modern radio receivers. The Library is up-to-the-minute in every respect and is based on the very latest developments in the design and manufacture of equipment. The rapidly-growing interest in short-wave and television reception is thoroughly covered in a complete section which deals with the construction of this type of apparatus.

Radio Construction Library

INCLUDING SHORT-WAVE AND TELEVISION RECEIVERS AND AUTO RADIO

By JAMES A. MOYER and JOHN F. WOSTREL

Faculty, University Extension, Massachusetts Department of Education

Three Volumes—1087 Pages, 6x9 605 Illustrations

VOLUME I: presents the fundamental principles of radio so clearly and simply that anyone of average training will be able to read, understand and apply them. It gives actual working drawings and lists of materials for the construction of many typical sets.

VOLUME II: Newly revised edition, fully discusses all of the elementary principles of radio construction and repair. An explanation of the necessary steps for "trouble-shooting," repairing, servicing and constructing radio sets successfully. Practical data is also given on auto radio, midjet sets, radio-noise meters, automatic volume, tone and static control, etc. This volume includes complete instructions for the construction and operation of short-wave and television receivers.

VOLUME III: covers the essential principles underlying the operation of vacuum tubes in as non-technical a manner as is consistent with accuracy. It discusses the construction, action, reactivation, testing and use of vacuum tubes; and an interesting section is devoted to remote control of industrial processes, and precision measurements.

EXAMINE these books for 10 days FREE

This Library is not only a thorough home-study course, but a handy means of reference for the more experienced radio experimenter, repair man, and radio show-owner. To these men, as well as to those who desire to advance in the radio profession, this offer of a 10 days' Free Examination is made.

Simply clip, fill in, and mail this coupon

McGraw-Hill
FREE EXAMINATION COUPON

McGraw-Hill Book Company, Inc.,
330 W. 42nd St., New York.

Gentlemen:—Send me the new RADIO CONSTRUCTION LIBRARY, all charges prepaid, for 10 days' Free Examination. If satisfactory I will send \$1.50 in 10 days, and \$2.00 a month until \$7.50 has been paid. If not wanted I will return the books.

Name

Home Address

City and State

Position

Name of Company..... SWC-1-34

(WRITE PLAINLY AND FILL IN ALL LINES)

THE FINEST S. W. GLOBE



A Man's-Sized Globe for Short-Wave Fans

Here, at last, is the most marvelous globe bargain of the world. It's a big fellow, as you can see in comparison with the standard telephone set. The globe measures 12 inches in diameter, and the total height, with pedestal, is 16 inches. The globe is printed in some fourteen different colors, and is waterproof, so that it can be washed without trouble. The "Meridian" in which the globe moves is made of highly polished and nickel-plated metal, while the base is a beautiful dull black. A simple lock "A," makes it possible for you to change the angle of inclination, for easier inspection and measurement. Only the best of material is used in the making of this globe, and this is the first time that a large globe of this kind has been sold at such an extremely low price.

Only with a world globe of this kind is it possible to get a true picture of the relation of countries to each other, air line distances, etc. For instance, which is nearer to New York—Moscow, Russia, or Rio De Janeiro, Brazil? Capetown, South Africa, or Tokio, Japan? Honolulu, Hawaii, or Lima, Peru? You will be amazed when you actually come to measure the distances. This is best done by stretching a string over the globe. In such a way that it passes directly over the two cities or two points in question. Not only is a flat map deceptive but, when it comes to distance, it is all wrong. *The true measurements can be made only on a globe.* This globe is big enough to give you den or room a professional appearance; and those who own them would not part with theirs.

JUST THE THING FOR A X-MAS PRESENT.

The World Short-Wave Globe, as illustrated, 12-inch diameter, 16 inches high. Authentic, up-to-date (published late 1932); over 7,500 names and places—there have been 1362 official changes in the past ten years. Spelling conforms to rulings of U. S. Department of Commerce, and Royal Geographic Society, London, England. Names as they are spelled by

HOW TO ORDER

Send money order, certified check or check (be sure to register letter). Enclose sufficient money for latest post office rates, most ships express collect. Shipping weight 8 lbs.

their local broadcasters. Washable lacquer finish; movable-meridian style of mounting. Smart modern base design in black, polished nickel or plian. All globes are packed in a carton for safe shipment, and we guarantee delivery in perfect condition to you. List price, \$3.75 \$12.50. Your Special Price

SHORT WAVE CRAFT 98 Park Place New York City

DATAPRINTS!

Construction Data In Blueprint Form

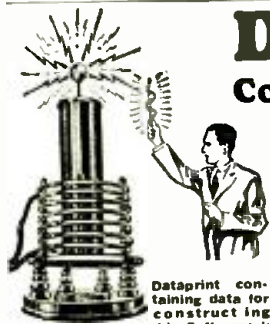

Dataprint containing data for constructing this 3 ft. spark Oudin-Tesla coil. Requires 1 K. W. "exciter". Price \$0.75
Exciter Transformer Data 0.50

TESLA OR OUDIN COILS		MAGNET COIL DATA	
36 inch spark data for building, including condenser data	\$0.75	Powerful battery electro-magnet; lifts 40 lbs	0.50
8 inch spark data for building, including coil, best data, requires 1/4 K. W. 15,000 volt transformer; see list below	0.75	110 Volt D.C. magnet to lift 25 lbs.	0.50
Vidua's type, high frequency coil data; 110 volt A.C. or D.C. type 1" spark, used for "ultra ray" treatments and "Experiments"	0.50	110 Volt D.C., 300 lb. Lift electro-magnet.	0.50
How to operate Oudin coil from a vacuum tube oscillator	0.50	110 Volt D.C. solenoid, lifts 2 lb. through 1 inch	0.50
3 inch spark Tesla coil; operates on Ford ignition coil	0.50	110 Volt D.C. solenoid, lifts 6 lb. through 1 inch	0.50
3 inch spark Oudin coil; 110 volt A.C. "Kick-Coil"	0.50	12 Volt D.C. solenoid, lifts 2 lb. through 1 inch	0.50
TRANSFORMER DATA		A.C. solenoid, powerful, 110-volt, 60-cycle	0.50
1 k.w. 20,000-volt transformer data, 110-volt, 60-cycle primary. Suitable for operating 3 ft. Oudin coil	0.50	MOTOR —1/16 H.P., 110 volt A.C. 60 cycle (suitable for driving 12" fan or light apparatus); constructional data	0.50
3/4 k.w. 15,000-volt transformer data, 110-volt, 60-cycle primary. Suitable for operating 8 inch Oudin coil	0.50	How to Thaw Pipes by Electricity (including 2 K. W. 110 vt. to 18 vt. transformer data)	0.50
Induction Coils—1 to 12 inch spark data	0.50	20 motor circuits—hook-up	0.35
20 "Electrical Tricks" for LODGES and PARTIES. How To Fry Eggs on Cake of Ice Electrically. "Rewinding." Small Motor Armatures.	0.50	20 practical telephone hook-ups	0.35
		Treasure Locator	0.50
		110 mechanical movements for inventors	0.50
		Polarized Relay—Ultra Sensitive	0.50
		Public Address System	\$0.50

(20% Discount on all orders for \$3.00 or more. No C.O.D.)

The DATAPRINT COMPANY
Lock Box 322 RAMSEY, N. J.

The Masterpiece II

(Continued from page 542)

and dirt out of the set. It further permits of the most advantageous physical location of the parts upon the chassis in terms of electrical efficiency, something, as can be seen from Figure 2, that makes for both mechanical and electrical symmetry.

Band-Spread Tuning Arrangement

The use of two dials instead of a single tuning dial is the second change referred to. The receiver is completely tuned by the right-hand dial and its single knob, as was the first MASTERPIECE. The second dial is simply a vernier, or band-spread tuning dial to permit the short wave bands such as the 6000, 9500 and 12,000 kc. short-wave broadcast bands being spread out over a whole full dial scale for easy tuning. It may likewise be used to spread the five amateur bands for easy tuning—or even small segments of the broadcast band. It is purely a vernier, not a second tuning control. It need not be used at all in operating the set, yet its use makes for much easier tuning of the short-wave bands.

Tuning of the short-wave bands in the first receiver was made easy by a 28:1 dial ratio. This was necessarily slow to tune with over any range, but even more important, did not permit of spreading the different short wave stations far enough apart on the dial scale itself to make for easy reading for the eye. With this new band-spread dial, the main tuning dial need only be set at, say 6.2 for the 6000 kc. or 50 meter short wave broadcast band, and all the stations in this band will be found spread out nicely on the vernier dial—actually making short-wave tuning easier than is broadcast band tuning on ordinary receivers.

Tuning is not rendered easy by any high ratio tuning dial, which will necessarily be mechanically stiff. By the use of 6:1 automatic take-up gear drives with opposed gears (an equivalent of the beautifully smooth helical gear control) the mechanical operation not only is smooth and entirely free of slippage, wear or backlash, but the control knobs turn with extreme ease and absence of effort. Tuning is thus made faster, easier, simpler, and easier to read. This simple mechanical change is invaluable, and in the hands of a novice can make all the difference between skipping over foreign short wave stations or having them actually easier to find than broadcast band stations.

Handiness of Control Increases Enjoyment

The control knobs are, looking at the polished chromium front panel, upper two, the main tuning knob and dial at the right and the vernier or band spread dial and knob at the left, with the visual tuning meter at the top center. The four lower knobs are left to right, audio volume level control, manual tone control, at the lower center the audio beat oscillator toggle switch, interstation noise suppressor or sensitivity control, and the four position wave-change switch.

In any sensitive receiver using a perfect automatic volume control system, sensitivity will rise to a maximum in the absence of a carrier signal, and local noise is bound to be heard between stations. In the daytime, this is particularly annoying when many channels are bound to be dead, and noise will be heard as the set is tuned between the stations normally heard in the daytime.

A New Kind of Sensitivity Control

A special squelch tube was used in the first MASTERPIECE connected to function as a valve refusing all signals and noise below a certain level when it was in use. By this means the set could be tuned from station to station with dead silence between stations when desired. This arrangement had two disadvantages. It required an extra tube, and its cut-off level had to be set at some arbitrary point—it could not easily be set to agree with

(Continued on page 561)

the different local noise conditions found in different locations. Also, it was found that many stations constituting good noise-free entertainment, would, in the course of their normal and continuous slight fading, fade across any arbitrarily established cut-off level, resulting in a periodic cut-off of reception, or if fading was rapid, in choppy, distorted reception when the squelch circuit was in use.

An r.f. (radio-frequency) sensitivity control has been substituted for the squelch circuit, which was a switch like valve and has been eliminated, therefore. This sensitivity control can be adjusted to suppress any prevailing condition or level of local noise, which is obviously advantageous, and eliminates entirely the possibility of choppy reception of stations fading slightly across the cut-off level of any automatic squelch or valve circuit. It permits of adjustment when desired, of the r.f.—i.f. (i.f.=intermediate frequency) gain to the exact degree desired, almost wholly independently of the actual loud speaker volume desired, and over all ordinary operating ranges, has no effect on the automatic volume control action, or on the operation of the audio volume level control.

The use of the better r.f.-i.f. sensitivity control eliminates the arbitrarily adjusted squelch tube, and together with three new and meritorious tubes recently introduced, permits of the elimination of a total of three tubes net, allowing somewhat better results to be obtained than with the original fifteen at first employed.

The Complete Circuit

Thus the revised tube circuit line-up is: '58 r.f. stage, 2A7 combined first detector and electron-coupled oscillator (the first combination tube so far introduced which gives actually better results than separate tubes performing the same functions), three '58 i.f. stages (the third stage used for selectivity, not for gain—its additional gain cannot be used), '56 first audio stage, 2A3 pushpull Class A fifteen watt power output stage and 5Z3 rectifier.

It can be seen that from the original tube complement the '56 oscillator and '57 first detector have been replaced by the even better 2A7 tube, which performs both functions with higher gain and the desirable frequency stability and uniform output of the electron-coupled oscillator. Thus one tube is eliminated, and the performance is improved a bit. The next tube eliminated is the squelch tube, referred to previously.

Two '80 rectifiers were originally used.

The new 5Z3 thermionic high vacuum rectifier, having the same power capacity as two '80s, allows one of the original two rectifiers to be dropped, thus effecting further simplification.

Actually, however, the improved and simplified receiver uses twelve tubes, the twelfth tube being a '58 in the added third dual tuned i.f. stage. The entire i.f. (intermediate-frequency) amplifier is air-tuned, making for permanency of setting in all climates, for the first time at no loss of selectivity. This tube is added only because it is the simple and obvious means of coupling the two extra tuned circuits added to the i.f. amplifier to set the selectivity up to absolute 9 kc.

A tuned or transposed antenna or lead-in system may be used when desired by virtue of separate antenna coupling coils for each of the four bands.

A tuned r.f. stage is used on both broadcast and short wave; the additional gain of this stage cuts down oscillator hiss and results in a very fine signal-to-noise ratio. It also eliminates the repeat spot or image interference so common in many improperly designed superhet receivers.

BOOK REVIEW

"Theory of Thermionic Vacuum Tubes," by E. Leon Chaffee, Ph.D. Published by McGraw Hill Book Company. 652 pages. Size 9 1/4"x6". Price \$6.00.

This extremely valuable book will find favor among all radio experimenters as it contains a wealth of definite information covering every conceivable characteristic of thermionic vacuum tubes. Some of the outstanding chapters are Molecules, Atoms and Electrons; Conduction of Electricity; Emission of Electrons; Practical Sources of Emission and some General Physical Aspects of Vacuum Tubes; Metal Filaments having an Absorbed Monatomic Film of an Electropositive Metal. Fundamental Considerations Pertaining to Triodes; Dynamic Measurements of Triode Coefficients; Effects of Gas in a Triode; Methods of Reducing Energy Interchange between Grid and Plate Circuits of a Triode (Neutralization); Theory of Operation of Non-linear Circuits with Large Electrical Variations, with special reference to detection with large signals. The book is profusely illustrated with curves, circuits, and formulas and there does not seem to be a single point not touched upon by the author of this book.

Here's a battery model Short Wave Receiver for the fan who lives where electricity is not available, yet which incorporates all the well known features of the A. C. operated S. W. Receiver.

In overall sensitivity this set is practically equal to A. C. models. This receiver operates on a 2 volt Aircell for filament current and 135 volts of "B" battery. All steel case in black crystalline finish.

- Model M-15 Receiver with set 20 meter coils, less tubes, batteries and speaker **\$23.50**
- Model M-18 as above, but with tubes..... **\$27.50**
- Special "8" Dynamic Speaker..... **\$ 8.50**
- Additional plug-in coils 35, 50, and 100 meters, per pair..... **\$ 2.50**

Look at These Bargains!
Variable Air Condenser



Precision built; suited for S. W. work. 26 Plates, max. cap. 500 mmf. No "Skidding." Clockwise rotation 180°..... **\$ 1.45**

Western Electric Headphones



One of the finest, very sensitive, adjustable, padded headband. Concealed terminals. 2000 ohms D. C. resistance..... **\$3.95**

Big New FREE Catalog

This Big, new Bargain Book of 160 pages is the greatest ever published. It has a big section devoted to Short Wave. Never before have we listed so many items. Now you can secure any conceivable part for Short Wave use at lowest wholesale prices from one source.

You'll find CONVERTERS, COILS, CONDENSERS, CRYSTALS, RECEIVERS, KITS, ANTENNA SYSTEMS and other Short Wave apparatus made by the Leaders—NATIONAL, HAMMARLUND, LAFAYETTE, LYNCH, etc.!

Wholesale Radio Service Co. Inc.
100 Sixth Ave., New York, N.Y.

Wholesale Radio Service Co.
100 Sixth Ave., New York, Dept. SW-14.
Gentlemen: Please send me your new Bargain Catalog No. 55.

Name.....
Address.....
City..... State.....

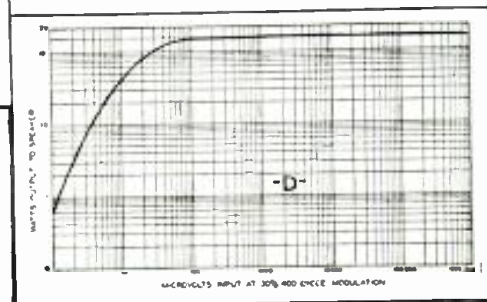
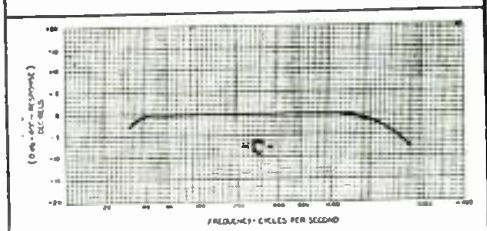
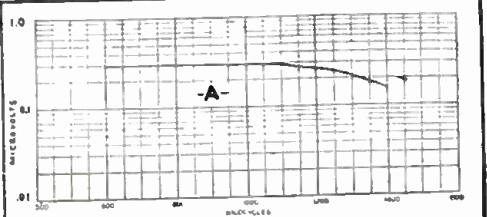
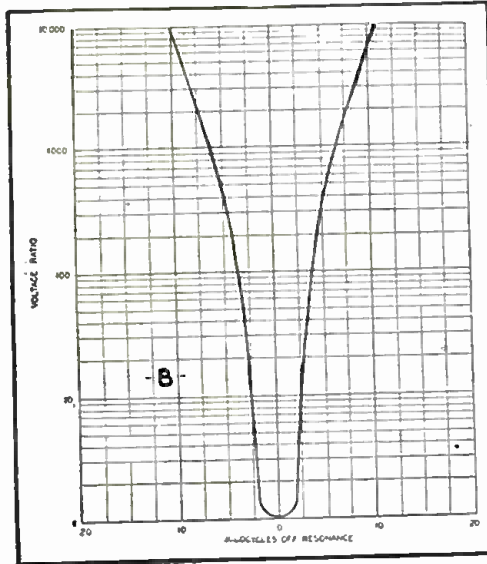

The graphic curves above show the following features for the Masterpiece II "all-wave" receiver: A—the curve of selectivity for the receiver; B—the selectivity curve; C—the fidelity curve, and D—the undistorted power output at different inputs.

BETTER SHORT WAVE RESULTS
with our custom-built short wave equipment.

RELIABLE STATION FINDER
(Oscillator-Wavemeter) indicates dial setting where station of desired wavelength will be heard, also determines wavelength of unknown stations. No more blind tuning.

know where to look and what you get.
No. 741. For all types of receivers. Wired, calibrated from 13.3 to 500 meters with chart and table of wavelengths to eliminate the use of mathematics. \$11.50
2 Genuine RCA tubes and batteries 3.30

BEAT NOTE OSCILLATOR
Eliminates searching and skimming of stations. LOCATES AND ANNOUNCES THE STATION BY EMITTING A WHISTLE as soon as you tune in station. Snap switch OFF, whistle disappears and there is your station. Electron coupled type, same as used in latest a.w. and all wave superhets.

No. 750. For superheterodyne receivers only, powered direct from receiver (uses 24A tube) \$8.95
Mention type of receiver when ordering.

IF YOUR RECEIVER HAS NO PHONE JACK
you miss many stations. DOUBLE PHONE JACK by installing Phone Receiver and listening on earphones at any time you please. Installs without touching receiver's wiring, inserting phone plug automatically silences speaker. 5 ft. cable provides for instant reach. No high voltage, absolutely safe. Complete as illustrated \$3.95
Give make and model of receiver when ordering.

WE SPECIALIZE IN LYNCH NOISE REDUCING ANTENNA SYSTEMS ready-to-go just attach to your mast. For estimate, give receiver dimensions of Antenna and sketch of location.
Lynch Short Wave Kit list \$6.00
Lynch Antenna Supplies, 40% off list prices.

AMPLIVOX LABORATORIES
Chief Engineer: S. Perlman, E. E., Technical Advisor, N. Y. Club, International S. W. Club, 647-A East 98 Street, Brooklyn, N. Y.

MAYO MICROPHONES

THE MAYO type "F" microphone formerly sold for \$25.00.—It is now sold for \$5.00 net to the trade.—It is a large, heavy, polished chromium plated, commercial type microphone two button, gold contacts, NEW SPECIAL HEAT TREATED DURALUMINUM DIAPHRAGM, on stretched cushion. Special process long life carbon. Frequency response 30 to 5000 cycles. Size 2 1/2" x 3 1/2", weight 1 1/4 lbs. Furnished either 100 or 200 ohms per unit.

At Your Distributor or Sent Postpaid on Receipt of Remittance

\$5.00 NET TO THE TRADE

Used by orchestras, Hams, public address companies, broadcasting and all places where a high grade microphone is needed. It is equal to any \$35.00 mike on the market, and is truly the best microphone value ever offered.

If you cannot obtain this microphone from your distributor send us your order. IF YOU ARE NOT THOROUGHLY SATISFIED RETURN WITHIN FIVE DAYS AND WE WILL REFUND PURCHASE PRICE.

MICROPHONE REPAIRS
Repairing microphones is part of our vast service. Our complete equipment and trained engineers insure accurate repairs to any make or type of microphone.

OUR REPAIR PRICES ARE LOW
FLOATING DIAPHRAGM FROM \$1.00 to \$2.50
STRETCHED DIAPHRAGM FROM \$2.50 to \$4.50
OTHER PRICES ON REQUEST
CARBON—Special Processed for repacking your own microphone, enough to repair five microphones—50c.
DISTRIBUTORS—Write for our proposition

MAYO MICROPHONES
19 Park Place New York, N. Y.

When to Listen In
By M. HARVEY GERNSBACK

● SINCE last month there have been three changes in the operations of the British Empire stations at Daventry, England. In transmission 1 the present schedule is: 3-5 a. m. daily on GSD, 11,750 kc. and also on either of these two: GSF, 15,140 kc. or GSC, 9,585 kc. In transmission 4 daily: 1:15-5:45 p.m. on GSC and either GSD or GSA, 6,050 kc. In transmission 5 daily: 6-8 p.m. on GSC and GSA.

The German S-W stations at Zeesen, Germany, are now transmitting on a new schedule, as follows daily: 8 a.m.-1:40 p.m. on DJB 15,200 kc., 10 a.m.-4:50 p.m. on DJD, 11,760 kc.; 2-6 or 7:30 p.m. (varies from day to day) on DJA, 9,560 kc., and from 5-9 p.m. on DJC, 6,020 kc. Daily at 10 a.m. a program resumé for the coming week is given in German and English on DJB and DJD.

More information on the Russian station mentioned last month as operating near 25 meters is available now. The call is RNE and it operates on 12,000 kc. or exactly 25 meters. I have heard no reports of reception in this country but from Europe come reports that it has been heard announcing in English that it was sending special programs for the benefit of listeners in the U. S. A. The schedule is unknown but it has been heard at 8:30 a.m. and at 12:30 p.m. (Eastern Standard Time).

On its last trip to the U.S.A. and the Century of Progress at Chicago the airship, *Graf Zeppelin*, was heard broadcasting special programs to the N.B.C. en route. It came over very clearly on several occasions when it was still over South America. The call letters used were DENNE. The transmissions were on 9,900 kc. Other listeners report hearing it around 6,000 kc. also.

HC2RL at Quayaquil, Ecuador, S.A., broadcasts on 6,670 kc. or 45 met. on Tuesday from 9:15-11:15 p.m. and Sundays 5:45-7:45 p.m. It is operated by Dr. Robert Levi, P. O. Box 795, Quayaquil, Ecuador, S.A. This information comes from James M. Coleman of New Orleans, La.

I have had several reports of a police radio station at Montreal, Canada. The call is UYR and it operates on 1,712 kc. Information comes from M. J. Cooper at Adrian, Mich., and others.

HIX on 5,950 kc. is on the air Tuesday and Friday at 8:10 p.m. and Sunday at 7:40 a.m. Address is: Secretaria D. E. de Hacienda, Trabajo y Comunicaciones, Estacion Radiofusora HIX, Santo Domingo, Rep. Dominicana, Central America.

IAC at Piza, Italy, a commercial phone station is heard calling Italian ships on 17,760 kc. from 6:30-7:30 a.m.; on 12,800 kc. later in the morning, on 8,380 kc. irregularly; and on 6,650 kc. in the evening.

VE9DR at Drummondville, Que., Can., relays CFCF of Montreal on 6,005 kc. daily from 8 a.m.-12 midnight, and on Sundays from 12:15-11:15 p.m.

Another new European station is LCL at Jeløy, Norway. It relays the Broadcast station at Oslo, Norway. It operates on 6,990 kc. or 42.92 meters. It seems to be on the air during the day anywhere from 8:30 a.m. till late afternoon.

Last month we printed the schedule of W3XAL at Bound Brook, N. J., operating on 17,780 kc. This schedule was received direct from the N.B.C. but does not seem to be correct. At present the station operates daily except Saturday from 10 a.m.-4 p.m.

JUST OUT

SHORT WAVE COIL BOOK

Short Wave Coil Data for Every Conceivable Short Wave Receiver

RADIO PUBLICATIONS
245 Greenwich St
NEW YORK

● FOR the first time, it is now possible for the experimenter and short wave enthusiast to obtain the most exhaustive data on short wave coil winding information that has ever appeared in print.

● As every experimenter who has ever tried to build a short wave set knows only too well by experience, the difference between a good and a poor receiver is usually found in the short wave coils. Very often you have to hunt through copies of magazines, books, etc., to find the information you require. The present data has been gotten up to obviate all these difficulties.

● Between the two covers of this book you now find every possible bit of information on coil winding that has appeared in print during the past two years. Only the most modern "dope" has been published here.

● No duplication. Illustrations galore, giving not only full instructions how to wind coils, but dimensions, sizes of wire, curves, how to plot them, by means of which any coil for any particular short wave set can be figured in advance, as to number of turns, size of wire, spacing, etc.

● There has never been such data published in such easy accessible form as this.

● Take advantage of the special offer we are making today, as due to increasing costs, there is no question that the price will increase soon.

● **RADIO PUBLICATIONS**
245 Greenwich Street
NEW YORK, N. Y.

Radio Publications, 245 Greenwich Street, New York, N. Y. I-32

Please send immediately, your Short Wave Coil Book, for which I enclose 25c herewith (coin, U. S. stamps or money order acceptable). Book is to be sent prepaid to me.

Name.....
Address.....
City and State.....

Power Transformer Data

(Continued from page 536)

Equation (3) establishes the relationship desired, and holds good for any 115 volt, 60 cycle transformer. Using values of B from 7,400 up to 10,000, the corresponding values of A x N may be calculated, using equation (3), and the results tabulated as shown in the Flux Table. B is the theoretical flux density. In actual practice this density is not possible, as bars and scale on the laminations use up approximately 10% of the area.

COIL DESIGN

115 Volts 60 Cycles

A flux density of 10,000 lines per sq. cm.* is often used for power transformers. For cooler operation, a density of 9400 will be used in our transformer. The theoretical density, B, then is 8550, since 8550 plus 10% is 9400, in round numbers. (The aforementioned values apply only when silicon steel is used for the core.) From the Flux Table and opposite B = 8600 we find A x N = 780. The product of the core area in sq. inches and the primary turns, then, must be 780.

To find the number of primary turns, a square core area using lamination in Fig. 2, will be tested. Since the center tongue width is 1 1/2", the core area is 1 1/2" x 1 1/2" = 2.25 sq. in.; and 780 divided by 2.25 = 346 primary turns.

Laboratory testing and experience has shown that when the I²R losses of the primary and the heavy ampere filament windings are about two watts each or less, and the losses of the secondary and the other filament windings, about one watt each or less, an 85 watt transformer with 9400 flux density will operate reasonably

*1 sq. inch contains 6.45 sq. cm. Hence 10,000 lines per sq. cm. = 64,500 lines per square inch.

cool. With 84 watts output, the input watts are 95.35 as shown in the chart, and the primary current .83 ampere. For 2 watts loss in the primary, then, at .83 ampere, the primary resistance must be close to 3 ohms. Having found the number of primary turns and resistance, it is now necessary to find the size of wire, and test the lamination coil space. With 1 1/2" x 1 1/2" sq. core, the average turn length of the primary winding is 7 inches, and 346 turns would require 200 ft. of wire. From the Wire Table we find that size 22 wire of 200 ft. length has 3.2 ohms resistance.

The next step is to see how much of the coil space is used up by 346 turns of No. 22 enamelled wire. The coil space is 3/4" x 2 1/4" = 1.69 sq. in. Allowing half the space for insulation, clearance and winding margins, the net wire space is .845 sq. in. From the Wire Table, 346 turns of No. 22 enamelled wire require .266 sq. inches, (346 divided by 1300). This is about one-third the total net wire space and leaves plenty of room for the secondary and filament windings. The primary, therefore, will be 346 turns of No. 22 enamelled wire.

The number of secondary turns is found by using the equation which expresses voltage relation between primaries and secondaries of transformers, namely,

$$\frac{N_1}{N_2} = \frac{E_1}{E_2} \text{ or } \frac{346}{N_2} = \frac{115}{720}$$

When N = 2166 turns
2200 turns will, therefore, be used in the secondary.

With an average turn length of 8 1/2 inches, 2200 turns would require 1560 feet of wire, and it should have a resistance of such value that the I²R loss is not much

(Continued on page 566)

FLUX TABLE, 60 V.

β at 110 V.	A x N	β at 115 V.
7400	864	7750
7600	842	7950
7800	820	8150
8000	800	8360
8200	780	8600
8400	762	8800
8600	744	9000
8800	727	9200
9000	711	9400
9200	696	9600
9400	681	9840
9600	667	10,000
9800	653	10,250
10,000	640	10,450

Actual Density = β + 10%
A = Core Area in Sq. inches.
N = Primary Turns.
β = Flux Density per sq. cm.

These tables will be found very useful by the student of transformer design, especially the table of turns per inch of enameled magnet wire.

ENAMELED WIRE TABLE

Size	Dia.	Ohms per 1,000 ft.	Turns per in.	Turns per sq. in.
14	.0670	2.527	15	225
15	.0600	3.186	16	266
16	.0535	4.018	18	324
17	.0175	5.066	21	440
18	.0420	6.388	24	580
19	.0370	8.055	27	730
20	.0340	10.158	29	840
21	.0305	12.809	32	1020
22	.0275	16.150	36	1300
23	.0250	20.367	40	1600
24	.0220	25.683	45	2025
25	.0200	32.383	50	2500
26	.0175	40.838	57	3250
27	.0155	51.495	64	4100
28	.0110	64.934	71	5010
29	.0123	81.883	81	6600
30	.0113	103.245	88	7750
31	.0102	130.176	98	9600
32	.0092	164.174	109	11900
33	.0082	207.000	122	14900
34	.0075	261.099	137	18800
35	.0068	329.225	147	21600

Diameter and Ohms from Gen. Elec. Table.

$$\text{Turns per in.} = \frac{1}{\text{dia.}}$$

—Tipesl.

NEW SENSATIONAL OFFER

Learn RADIO

PAY FOR TRAINING AFTER YOU GRADUATE



To a few honest fellows I am offering an opportunity to get a training and pay for it after they graduate in easy monthly payments. You get Free Employment Service for life. And if you need part-time work while at school to help pay expenses, we'll help you get it. Coyne is 33 years old. Coyne Training is tested—You can find out everything absolutely free. Just mail the Coupon for My Big Free Book.

Jobs Leading to Salaries of \$50 a Week and Up

Jobs as Designer, Inspector and Tester—as Radio Salesman and in Service and Installation—as Operator or Manager of a Broadcasting Station—as Wireless Operator on a Ship or Airplane, as a Talking Picture or Sound Expert—Hundreds of Opportunities for fascinating Big Pay Jobs!

10 Weeks' Shop Training AT COYNE IN CHICAGO

We don't teach you from books. We teach you by Actual Work on a great outlay of Radio, Broadcasting, Television, Talking Picture and Code equipment. And because we cut out useless theory, you get a practical training in 10 weeks.

TELEVISION Is Now Here!

And Television is already here! Soon there will be a demand for Television Experts! The man who gets in on the ground floor of Television can have dozens of opportunities in this new field! Learn Television at Coyne on the very latest Television equipment.

Talking Pictures A Big Field

Talking Pictures, and Public Address Systems offer golden opportunities to the Trained Radio Man. Learn at Coyne on actual Talking Picture and Sound Reproduction equipment.

Get the Facts

Don't spend your life slaving away in some dull, hopeless job! Don't be satisfied to Work for a mere \$20 or \$30 a week. Let me show you how to make Real Money in Radio—the fastest-growing, biggest money-making game on earth! Get my big Free book and all details of my pay after graduation offer. Mail the coupon today.

M. C. LEWIS, President
Radio Division, Coyne Electrical School
500 S. Paulina St., Dept. 14-2K, Chicago, Ill.

Dear Mr. Lewis:

Send me your big Free Book; details of your Free Employment Service; and tell me all about your special offer of allowing me to pay for training on easy monthly terms after graduation.

Name

Address

City..... State.....



The World at your Finger tips

WITH ANY ONE OF THESE

ELECTRIFIED DOERLE 2 and 3 Tube Receivers

Operates on either AC or Battery.
Also designed for 2-volt operation

Short-wave receivers have come and gone, but never have there been produced short-wave receivers which have taken the entire country by storm as have the famous Doerle Receivers.

And Now These Doerle Sets Have Been Completely Electrified

Mr. Doerle described his first receiver, the now famous 2 TUBE 12,500 MILE RECEIVER in the Dec-Jan. issue of Short Wave Craft, and his 3 TUBE SIGNAL GRIPPER in the Nov. 1932 issue.

If you are a reader of this magazine, you have undoubtedly been surprised at the great number of fan letters published in Short Wave Craft, praising these receivers to the skies—and for good reason! We have sold many hundreds of these sets, and they are still going strong.

They are low-priced, yet pull in short-wave stations from all over the world REGULARLY, in practically ANY LOCATION.

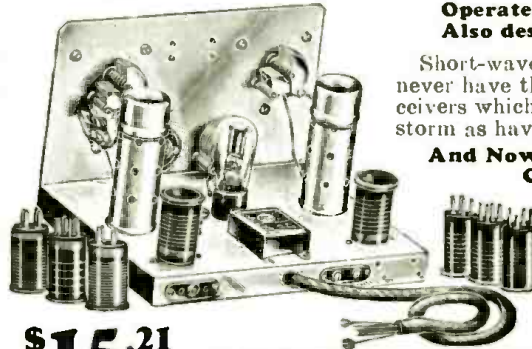

\$15.21

3-Tube Doerle Signal Gripper
Rear view of A.C. Model—2-volt model does not have tube shields.

These two receivers EMPLOY THE 2-VOLT, LOW-CURRENT CONSUMPTION TUBES, and are, therefore, most popular with people living in rural districts where electric service is scarce. For the thousands of fans however, who enjoy the benefits of electric service, we have developed the 2 and 3 Tube A. C. Doerle sets, employing the latest type triode-grid tubes, are naturally more selective and infinitely more sensitive than the original Doerle receivers. Furthermore, not only can they be used on alternating current, but with batteries as well. The 2-tube 12,500 Mile Electrified Doerle Receiver employs a type 57 triode-grid detector tube, which is resistance-coupled to the type 56 output tube. For operation on batteries the 57 is replaced with a 77-tube and the 56 with a 37. The set actually works in foul-weather on all local and many distant stations. The 3 Tube Electrified Doerle Signal Gripper employs a 58 triode-grid tube as a radio-frequency amplifier, followed by a type 57 detector, and finally, a 56 output tube. For battery operation the Type 78, 77 and 37 tubes are used. This receiver, in its sensitivity and DX ability, equals many expensive 5 and 6 tube short-wave sets.

Improved Circuit and Design

Despite the remarkable performance of the Doerle receivers, our technical staff felt that they could obtain better results by making slight modifications of the circuit. This is especially true of the 3 Tube Signal Gripper, both the new A. C. and 2-volt model. In the 2-volt model, the first type 30 R. F. tube was replaced by a type 34, which is a special-purpose screen-grid R. F. amplifier. In the A. C. model, a type 58 triode-grid, high-gain R. F. tube is employed. Furthermore, in this latter model the Antenna trimmer condenser has been eliminated through the use of inductive coupling. The detector plug-in coils are of the six-prong type, each having three separate windings. This means that the R. F. Stage is inductively coupled to the detector. With these various changes, we have not increased the price of these receivers. By special arrangements with the Publishers of Short Wave Craft, we have been given the exclusive right to manufacture and sell the Official Doerle Receivers, both the earlier 2-volt and the latest A. C. model—so that now, all short-wave enthusiasts who have ever wished to own any of these fine sets can buy them without the slightest doubt in their mind but what they will prefer 100%. This means that all the usual "hoax" have been ironed out by us in such a way that in practically every location, anywhere, they will "do their stuff".

Only First-Class Parts Are Used

It may be possible to buy the parts or complete sets at a lower price—we admit this at once—but without concern. For we have used only the best parts available in the construction of our sets. We have done away with all usual "hoax" which are incidental to the use of poor components. In these receivers, only the best tuning condensers, and that means Hammarlund are used! These sets could be produced for considerably less if we used cheaper condensers. We refrained from doing so, however, because we COULD NOT GUARANTEE RESULTS! And this goes for everything else in these sets. If you are skeptical of the results obtainable with these receivers, read the letters from our many short-wave fans and friends printed in the adjoining column.

Our Own Tests

Every one of these Doerle receivers, without exception, is tested in our laboratory under actual operating conditions. We refrain from giving you the astonishing list of stations which we ourselves have located during the course of our tests. We would much rather have you and our many other short-wave friends talk about the results. Each receiver is accompanied by schematic diagram and wiring blueprint as well as a pamphlet of detailed instructions.

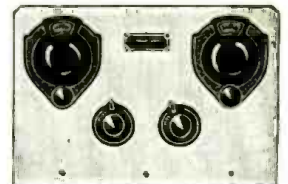

FRONT VIEW showing general appearance of Doerle receiver.

We Actually Guarantee Results on These Sets

These Are Fool-Proof Short Wave Sets—Sets Which Work At Your Command. No Longer Is It Necessary To Be Sceptical About Short Waves.

These fans tell you how our sets actually perform—

THE OSCILLODYNE HOW IT WORKS

I have constructed the OSCILLODYNE RECEIVER and boy! how it works! The first day without any trouble I received Spain, England, France, and other foreign countries. Amateurs! why I never knew there were that many north now. With the one tube Oscilodyne, I bring in more stations on one plug-in coil than with a set of coils on different short-wave sets. IF ANY ONE IS TRYING HIS LUCK ON SHORT-WAVE SETS, IT WILL BE WORTH WHILE TO CONSTRUCT THE ONE TUBE OSCILLODYNE.

PAUL KORNEKE, JR., N. S. Pittsburgh, Pa. A PEACH

The Oscilodyne receiver, believe me is a "peach." It set short-wave stations from Germany, France, Spain and Italy—not to mention the American stations, including amateurs all over the United States. I heartily recommend this set to any Short-Wave fan.

HENRY TOWNSEND, Ramsey, N. J.

THE DOERLE RECEIVERS SOME LIST

Have just completed your Doerle two-tube. I received the following on the loudspeaker: XDA, LQA, GMH, YEDH, YBGGW, KKK, WNAZ, WZAF, W3AL, W3AU, W8K, W8NL, W8F, W8AA, Bermuda, Honolulu, Budapest, Hungary, and "hams" in 38 states. MAURICE KRAAY, R. F. D. 1, Hammond, Ind.

THIS IS GOING SOME!

Today is my third day for working the Doerle set, and to date I have received over fifty stations. Some of the more distant ones I shall list. From my home in Maplewood, N. J., I received the following: WYR, Atlanta, Ga.; WOK, Ohio; WHUM, Ft. Wayne, Ind.; W8YS, Erie, Ill.; W8ERK, Girard, Ohio; and best of all, XDA, Mexico; IZA, Surinam, South America; THH, Cartago, Costa Rica; G2VM, Leicester, England. I have also received stations WDC and PJQ, which I have not found listed in the call book.

JACK PHOR, 9 Mosswood Terrace, Maplewood, N. J.

A DOERLE ENTHUSIAST

I have just completed my two-tube Doerle, and it surely is a great receiver! It works fine on all the wavelengths. Nobody could wish for any better job than this one. I can get W8K and W8NA to work on the loudspeaker at night, and the code stations come in with a volume behind them. Samuel E. Smith, Lock Box 241, Grayling, Mich.

FRANCE, SPAIN, ETC., ON LOUDSPEAKER I hooked up my two tube Doerle Kit and I received France, Rome, Spain, Germany and England on the loudspeaker as well as over 100 amateur phone stations.

I am very pleased with the receiver and would not part with it for anything. I have listened to many factory built short-wave receivers, but believe me, my DOERLE is the set for me.

ARTHUR W. SMITH, Springfield, Mass.

REGULAR FOREIGN RECEPTION

A few days ago, I purchased one of your TWO TUBE DOERLE WORLD WIDE SHORT WAVE RECEIVERS. I just want to tell you that this set does all you claim. In the short time I have had the set, I have brought in stations in England, Germany, France and South America. Daventry, England, and Nauen, Germany can be picked up daily with very strong volume. THE DOERLE IS A FINE SET.

ARTHUR C. GLUCK, Brooklyn, N. Y.

THRILLED BY DOERLE PERFORMANCE

I am very much pleased with the DOERLE N.W. radio I received; the local amateur stations come in loud and clear. The first foreign station I received was DJA, Gessen, Germany. I certainly received this station with a thrill. Yours for success. RANDOLPH GRAY, Quincy, Mass.

Special Doerle Designed Power Pack

Everyone knows that an A. C. short-wave set is no better than the power pack which supplies its power! A power supply for short-wave use must be constructed with extreme care. It must be absolutely free from hum or other disturbances caused by insufficient filtering, poor wiring, or faulty equipment. This unit has a two-section filter circuit, employing two-heavy duty 30 Henry chokes and a tremendous amount of capacity. This assures PURE D. C. with practically no ripple at all. The power pack supplies 250 volts at 50 ma for the plates of the tubes, 22½ volts for the screens, and 2½ volts at 5 amperes, for the filaments. These various voltages are obtained from convenient binding posts on the side of the pack. Furthermore, provisions are made for energizing the field of a dynamic speaker. Any speaker having a field resistance of from 1500 to 2500 ohms may be thus energized. All the component parts of this pack are built into a sturdy, metal base which is black, crackle finished. The power transformer and one of the chokes are the only units which are mounted on top of the chassis. The pack employs a type 280 full-wave rectifier which is inserted in a socket on top of the base. A convenient on-off switch is mounted on the side. The pack is sold complete with four feet of connecting cord, terminating in a special hidden soft rubber plug. Measures 7½" long x 4" wide x 4¼" high overall. Sold complete with 280 tube. Ship wt. 10 lbs. No. 2149 Short-Wave Power Pack, including 280 tube **\$7.26** YOUR PRICE.

This is a special Short-Wave Hum-Free A. C. Power Pack.

FREE CATALOG

116 page Radio and Short Wave Treatise. 100 hook-ups. 1,000 illustrations. Enclose 4c for postage. Treatise sent by return mail.

Radio Trading Company

MODERN SHORT WAVE RECEIVERS -

The OSCILLODYNE 1-Tube Wonder Set

If you have never operated a short-wave set, this is the one with which to start! If, on the other hand, you are already a hardboiled short-wave fan and are aware of the shortcomings of the average short-wave set, the *Oscilodyne* will instill you with new confidence. It is a set which will convince you that foreign stations CAN be tuned in whenever they are on the air. We have acquired the sole rights from the publishers of *Short Wave Craft* to manufacture exclusively the Official *Oscilodyne* 1 Tube Set, as described in the April, 1933 issue. Read what the editor of *Short Wave Craft* says in that issue:

A REALLY NEW CIRCUIT

We are pleased to present to our readers an entirely new development in radio circuits. Under the name of the "*Oscilodyne*," Mr. J. A. Worcester, Jr., has developed a fundamentally new circuit. This circuit which is of the regenerative variety, acts like a super-regenerative set although it does not belong in that class. Its sensitivity is tremendous. The editor, in his home on Riverside Drive, New York City, in a steel apartment building, was able to listen to amateurs in the midwest, using no aerial and no ground. With the ground alone, a number of Canadian stations were brought in, and with a short aerial of 40 feet many foreign stations were easily pulled in.

Here, then, is a set which brings in stations thousands of miles away; a set which frequently brings in Australia, loud enough to rattle your phones, and with power to spare; a set which, if you do not wish extreme distance, will bring in stations several thousand miles away without aerial or ground.

ABSOLUTELY FOOL-PROOF

This set, as we sell it, may be had either completely wired, or in kit form. There is absolutely nothing to go wrong with the *Oscilodyne*. Simple directions and blueprints show you how to build and operate the set for best results. It may be used either on A.C. or with batteries. If A.C. is employed, a type 227 tube is used in conjunction with a suitable A.C. power pack (such as the one listed on the opposite page.) 2½ volts will be required for the filament of the tube, and 90 volts for the plate. If batteries are employed, a 237 tube should be used in conjunction with either a storage battery or four No. 6 dry cells and two 45 volt B batteries.

Oscilodyne Wonder Set

The set is exactly as illustrated here, size of aluminum panel is 6" high by 4½" wide, base 5½" long by 4½" wide. List of materials used:

- No. 2146. Official One-Tube Wonder Set, completely wired and tested as per above specifications. YOUR PRICE **\$7.21**
- No. 2147. Official One-Tube Wonder Set, but not wired, with blueprint connections and instructions for operation, complete shipping weight 3 lbs. YOUR PRICE **\$6.36**
- No. 2148. COMPLETE ACCESSORIES, including the following: one 6 month guaranteed Neontron No. 237 tube; one set of standard matched headphones; four No. 6 Standard dry cells; two standard 45-volt "B" batteries, complete shipping weight 22 lbs. YOUR PRICE **\$5.51**



The Beginner's Ideal Set

The Twinplex One Tube "Double-Action" Receiver

Real Two Tube Performance

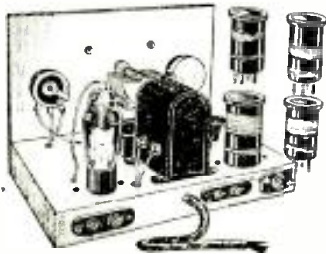

It may seem paradoxical when we say that this 1 tube receiver is a 2 tube set, but actually that is so. The type 53 tube employed is the latest to be placed on the market. It contains, in one glass envelope, TWO ENTIRELY INDEPENDENT RADIO TUBES which have only their cathodes in common. Hence this receiver is a REAL 2 tube set.

This "2 tube" Twinplex can now be constructed for the same money required to build a 1 tube receiver.

In operation this set is exactly the same as 2-tube regenerative receivers. The results obtained during a week of testing have been exceedingly good. Some of the foreign stations received during this period include EAQ, GBS, GSA, DJC, HKD and OXY. FOR A MAN WHO IS FIRST STARTING IN SHORT WAVES, THIS TWINPLEX RECEIVER IS THE "BEST BET."

The receiver is UNIVERSAL in operation, that is it may be operated either with batteries or an A.C. 110-volt power pack. A plate potential of 180 volts is required. The heaters require 2½ volts either A.C. or D.C.

Only high grade parts such as Hammarlund Condensers, etc., are used in the constructions of this set. All component parts are mounted on a cadmium-plated metal chassis, measuring 9 x 6½ x 5½ in. This set is available in two forms namely, completely wired ready to use, and in kit form. A complete set of instructions and blue-prints, are furnished with each set.

- No. 2115. Twinplex 1 Tube Short Wave Receiver, *Wired*, but less tubes and accessories. Ship. wt. 9 lbs. YOUR PRICE **\$9.50**
- No. 2116. Twinplex 1 Tube Short Wave Receiver in Kit Form including instructions. Ship. wt. 10 lbs. YOUR PRICE **\$8.50**

- No. 2117. ACCESSORIES ONLY—FOR A.C. OPERATION—including 1 special Mum-Frec A.C. Power pack, 1 250 Rectifier tube, 1-53 Tube and one set of matched headphones. YOUR PRICE **\$10.35**

- No. 2118. ACCESSORIES ONLY—FOR BATTERY OPERATION—including 1-53 Tube, 3-45 volt B Batteries, 4 No. 6 Dry Cells (arranged in series—parallel and 1 set of matched headphones. Ship. wt. 13 lbs. YOUR PRICE **\$6.25**

One Tube "Push-Pull" Ten Meter Transmitter



Paradoxical as it may sound, this ten meter transmitter EMPLOYS A SINGLE TUBE IN PUSH-PULL ARRANGEMENT. Herefore the word "push-pull" automatically implied the use of two tubes, yet here we are with a one tube push-pull transmitter.

It is the advent of the new type 53 tube, which makes this feat possible. The tube is actually "TWO" tubes, in one glass envelope.

This transmitter is not a high power job, for high power is not necessary in ultra short wave work. When properly coupled to a suitable antenna system such as a single-wire-fed Heitz or the familiar "Zeppelin" antenna, it will, under favorable conditions, circle the globe. The circuit is of the hard-tuned grid, tuned plate type and utilizes a pole-pitch of solid copper ribbon on the plate coil. All component parts are of the highest possible quality, since R.F. losses in ultra short wave work are fatal.

May be used for phone work, directly without the use of a microphone transformer, by hooking a single button mike in series with the grid return lead.

There are any number of uses to which a compact unit of this type may be placed. For instance it can be used as a master oscillator for multi-stage high frequency transmitters OR two such units may be connected together to produce a complete master oscillator—R.F. amplifier transmitter. Neutralizing condensers must be used when operated as an R.F. amplifier. Will work either with batteries or A.C. power pack. Requires 250 volts "B" supply and 2½ volts "A". A key circuit is in the cathode lead. The transmitter, on its neat bread-board measures 11" long x 9½" wide x 6" high overall. Furnished complete with a set of 10 meter coils. Shipping weight, 8 pounds.

No. 10-M Versatile 10 Meter Transmitter Less Tube. Your Price... **\$4.51**

2-Tube, 12,500 mile Doerle Receiver Rear view, both A.C. and Battery Model look alike.

Specifications of Doerle Sets

No. 2174. Electrified 2 Tube 12,500 Mile Doerle Receiver, completely wired and tested, less tubes. Measures 9" long x 6" high x 6 1/8" wide. Shipping wt., 6 lbs. YOUR PRICE **\$10.46**

No. 2175. Electrified 2 Tube 12,500 Mile Doerle Receiver in kit form, less tubes, but including blueprints and instructions. Ship. wt., 5 lbs. YOUR PRICE **\$10.26**

No. 2176. Complete set of tubes for above; either one—57 and one—56 for A.C. operation, or one—77 and one—37 for battery operation. YOUR PRICE **\$1.91**

No. 2177. Electrified 3 Tube Doerle Signal Gripper, completely wired and tested; less tubes. Measures 10½" long x 7" high x 5 1/8" wide. Ship. wt., 7 lbs. YOUR PRICE **\$15.21**

No. 2178. Electrified 3 Tube Doerle Signal Gripper in kit form, including blueprint and instructions; less tubes. Shipping wt., 7 lbs. YOUR PRICE **\$13.76**

No. 2179. Complete set of tubes; either one—58 one—57 and one—56 for A.C. operation or one—78 one—77— and one—37 for battery operation. YOUR PRICE **\$2.81**

BATTERY SETS

- No. 2140. TWO TUBE 12,500 MILE 2-VOLT DOERLE SHORT WAVE RECEIVER, completely wired and tested. Ship. wt. 5 lbs. YOUR PRICE **\$9.91**
- No. 2141. TWO TUBE 12,500 MILE 2-VOLT DOERLE SHORT WAVE RECEIVER KIT, with blueprint connections and instructions. Ship. wt. 5 lbs. YOUR PRICE **\$8.71**
- No. 2142. COMPLETE ACCESSORIES, including 2 No. 230 tubes; one set of standard headphones; 2 No. 6 dry cells, 2 standard 45-volt "B" batteries complete. Ship. wt. 22 lbs. YOUR PRICE **\$5.51**
- No. 2143. THREE TUBE 2-VOLT DOERLE SET, completely wired, ready to use. YOUR PRICE **\$12.86**
- No. 2144. THREE TUBE 2-VOLT DOERLE SET IN KIT FORM, with blueprint connections and instructions. Ship. wt. 7 lbs. YOUR PRICE **\$11.51**
- No. 2145. COMPLETE ACCESSORIES, including 2 No. 230 tubes; one type 34, one set of standard headphones; 2 No. 6 dry cells; 3 standard 45-volt "B" batteries; 1 B. B. L. 9 inch Magnetic Loud-speaker. Shipping weight, 32 lbs. YOUR PRICE **\$11.26**

Order From This Page Send money order or certified check. C. O. D. only, if 20% remittance accompanies all orders. Order NOW—TODAY.

100A Park Place, New York, N. Y.

YOUR CHOICE

of either one of books illustrated herewith—FREE OF CHARGE—with the purchase of any of the short-wave receivers listed on these pages.

Book No. 866 explains in a thorough manner the ways and means of obtaining an amateur transmitting license. Furthermore, all government rules regulating amateur transmissions are reviewed. Book 830 is a comprehensive compilation of the most prominent short-wave receiver circuits published during a period of two years. Build up your radio library with one of these books.

830

866

SHORT WAVE BOOKS FREE!

What Miles Socket Mike Will Do!

(PATENT PENDING)

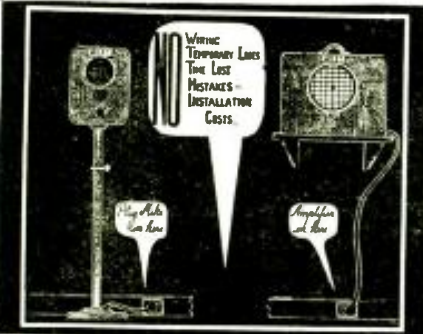

- 1) Miles SOCKET MIKE (Pat. Pend.) converts any Radio Receiver into an Ideal Socket Operated Public Address System requiring NO wiring. Desk type Socket Mike Model KF priced at \$47.50. Floor type \$25.00 extra.
- 2) Miles SOCKET MIKE (Pat. Pend.) couples to any standard Power Amplifier by means of MILES Special Intermediate Adaptor (Pat. Pend.) priced at \$12.50 thus doing away with all wiring between MIKE and AMPLIFIER.
- 3) MILES SOCKET MIKE works in conjunction with MILES SOCKET AMPLIFIER-speaker (Pat. Pend.) requiring NO wiring, priced at \$72.50.

Authorized MILES DEALERSHIP now available

MILES SOCKET MIKE CO.

244 West 23rd St. Dept. S, New York City, N. Y.

ARE YOU "STUCK"?

You Can Become a Fast, Capable RADIO OPERATOR at Home

The CANDLER SYSTEM MAKES IT EASY FOR YOU!

CANDLER Students Never Flunk. Advise us what license you seek and we will show how easily it is to be obtained.

Leading Instructors and Operators in U. S. Army, Navy and Aviation are CANDLER trained. Fastest and most skilled Amateurs and Commercial ops during past 22 years are CANDLER trained. One held championship 13 years. Jean Hudson, W3BAK, 9 years old, won championship Class "F" 2 months after enrolling for CANDLER CODE COURSE.

If you're wise, you'll get your SPEED where the champions get theirs. BYRD Antarctic Expedition Ships are manned by CANDLER trained operators who stood the rigid competitive examinations where SPEED and ACCURACY count.

3 GREAT COURSES—Junior Scientific Code Course for those with speeds under 10 wpm. Advanced Course for those with speeds over 10 wpm who want to do 40 to 50 wpm. "Mill" Course for fast copying.

Send for BOOK OF FACTS for Radio Ops., Amateurs and Beginners.



All questions answered promptly. No obligation.

CANDLER SYSTEM CO., Dept. 5-I
6343 S. Kedzie Ave., Chicago



World's Only Code Specialist

AUTOCRAT'S 1934 QUALITY RADIOS AT REASONABLE PRICES

Model 90SL New All-Wave Super 15-540 METERS. No coils to change. Far distant stations come in with tremendous volume and ease. Other 4-5-6 Tube Quality Radios. Write for Circular and Dealers Prices AUTOCRAT RADIO CO. 3855 N. Hamilton Ave. Chicago, Ill.

Power Transformer Data

(Continued from page 563)

over one watt. Since the load current is 110 Ma., the current on each side of the center tap is about 80 Ma. With one and a quarter watt loss, $1\frac{1}{4} = .08^2R$, or $R = 196$ ohms. From the Wire Table, No. 31 wire 1560 feet long has a resistance of 200 ohms which is close enough.

The secondary may be 2200 turns of No. 30, with a quarter of a watt less heat in that winding.

The filament windings are determined in the same way, with attention given to the operating volts and I²R loss. The number of turns for the five volt winding is 16, found as follows:

$$\frac{N}{346} = \frac{5.32}{115} \text{ allowing } .32 \text{ voltage drop.}$$

When $N = 16$. With an average turn length of $9\frac{1}{2}$ inches the wire length is 12.6 feet. For 1.14 watt loss at 3 amperes the resistance is .127 ohms, and the wire size is No. 20. When using the 5Z3 tube, the loaded voltage is slightly below normal (4.94); while with the 280 tube, the loaded voltage is 5.07.

The number of turns for the 2½ volt windings is 8 turns, since the five volt winding is 16 turns, and the no load voltage is 5.32 divided by 2 or 2.66 volts. The wire size should be such that the voltage drop in 6.3 feet length of wire will bring the loaded voltage near to normal. No. 19 wire for the 3½ ampere winding has a resistance of .05 ohms to give a loaded voltage of 2.49, and an I²R loss of .61 watts. For the 9 ampere winding, No. 15 wire of .02 ohms resistance gives a loaded voltage of 2.48, and an I²R loss of 1.62 watts.

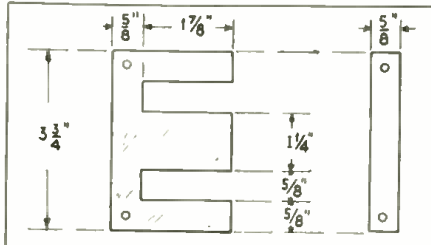

FIG. 1

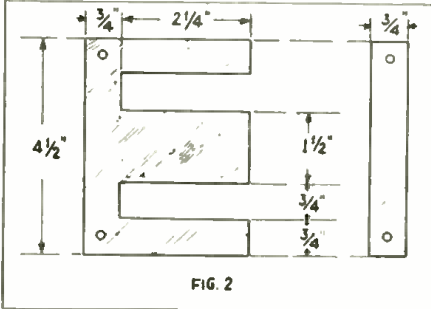

FIG. 2

New DeWald Set

(Continued from page 559)

Oscillator Coils

Tickler.....37 turns No. 38 enameled wire.
Grid.....approximately 74 turns, No. 32 enam. tapped at 37 turns wound on 1/8" tube with 1/64 space between the two windings all close wound.

Detector Coils

Short Wave
Antenna.....8 turns No. 32 single cotton covered.
Grid.....30 turns No. 32 enam.
Coils wound in same direction on a 7/8" form. Antenna coil is wound over the ground end of the grid coil, all coils close wound.

Detector Broadcast coil
Antenna coil.....1.52 mh. No. 38 enam.
Band pass.....245 mh. No. 40-7 strand litz.
Grid.....212 mh. No. 40-8 strand litz
Above coils are universal wound and mounted on a 1/2" dowel stick, spacing between grid and band pass coil is 1/2 inch.

FREE!

116 Page RADIO and SHORT WAVE TREATISE



Avail yourself now of the opportunity to receive the free 1933 Fall edition of our Radio and Short Wave Treatise, No. 25. 116 solid pages of useful information, radio items, diagrams & illustrations, etc. Considerably larger and more instructive than our treatise No. 25 and incidentally all our previous issues, you are familiar with the type of book we publish; but the new No. 25—What a book! The entire editorial section is new from beginning to end—not an old word remains. Considerable space has been devoted to articles for the radio beginner. This alone is worth its weight in gold. The Superheterodyne principle is thoroughly explained in this issue in clear, simple language. No. 25 is not just another catalog. It contains more valuable and up-to-date information than can be found in any radio text book on the subject.

Over 100 New Hook-Ups, Etc. 1000 Illustrations, No. 25 issue. If you had our treatise No. 25 and incidentally all our previous issues, you are familiar with the type of book we publish; but the new No. 25—What a book! The entire editorial section is new from beginning to end—not an old word remains. Considerable space has been devoted to articles for the radio beginner. This alone is worth its weight in gold. The Superheterodyne principle is thoroughly explained in this issue in clear, simple language. No. 25 is not just another catalog. It contains more valuable and up-to-date information than can be found in any radio text book on the subject.

PARTIAL LIST OF CONTENTS

Fundamental Principles of Radio—Ohm's Law—Discussion of New Tubes—Constructing a Triple Twin Amplifier—Constructing a Tiny A.C.-D.C. Portable Receiver—All About Superheterodynes—Eliminating Unwanted Station—Constructing a Two-tube Short Wave "Globetrotter" Receiver—Completely revised and up-to-date Radio Tube Chart—\$5.00 Prize Suggestions—Radio Kinks, Etc., Etc.

WRITE TODAY

Enclose 4 cents for postage. Treatise sent by return mail.

RADIO TRADING CO.
100A Park Place New York City

Did You Get "KEY KLIX"?



Thousands of amateur radio items, at the lowest prices, are contained in this FREE Big Book, together with many interesting articles by people well known in amateur radio circles.

AMERICAN SALES COMPANY
Wholesale Radio Distributors

SW-44 W. 18th St., N. Y., N. Y.
The Oldest Amateur Supply House, Est. 1919

"BARGAINS IN SHORT WAVE PARTS"

- TOBE 8 mfd. Dry Elec. Condensers in Moisture-proof Cardboard cases, 500 volts.....\$.49
- TOBE 8 mfd. Dry Elec. Condensers in Round Aluminum Cans, 500 volts.....\$.49
- 1/2 mfd. Tubular Paper-unceased Condensers, 300 volts.....\$.55
- VICTOR 30 Hy. Chokes, 150 M.A., 200 Ohms.....\$.49
- VICTOR Power Transformer for Model R1-32-46-78.....\$ 1.75
- ALDEN Type 7048WS 6 prong Short Wave Coils. Kit.....\$ 1.18
- ALDEN Type 7085WS 6 prong Short Wave Coils. Kit.....\$ 2.05
- 3/4 mfd. Tubular Elec. Tantalum Condensers, 200 volts.....\$ 1.19

Write for Bargain Sheet and free Bulletin. 20% deposit with all orders. Remit by M. O., include postage. Write for quotations on any radio part you are interested.

MAURICE SCHWARTZ & SON 710-712 Broadway Schenectady, N. Y.

PATENTS—TRADE MARKS

All inventions submitted held confidential and given personal attention by members of the firm. Form "Evidence of Conception" and instructions "How to Establish Your Rights"—Free LANCASTER, ALLWINE & ROMMEL PATENT LAW OFFICES 435 Bowen Bldg. Washington, D. C.



THE INSTRUCTOGRAPH

(Code Teachers) The Scientific, easy and quick way to learn the code. Send a post card today for literature. Machines, tapes and complete instructions for sale or rent. Terms as low as \$2.00 per month. Rental may be applied on purchase price if desired. Rent for a month. If the Instructograph meets every requirement, buy it. If not, send it back. INSTRUCTOGRAPH CO. 812 LAKESHORE PLACE, CHICAGO

Here Is a Way

to let all your correspondents know that you are members of THE SHORT WAVE LEAGUE



We have had designed for the use of LEAGUE members only, these seals or stickers. They can be placed on stationery, letter-heads, envelopes, postal cards, etc.

These seals or stickers are made in three colors. They measure 1 1/4 inches in diameter and are gummed on one side.

They are sold to members in 25 lots or multiples only. Per 25 prepaid 15c.

See Page 513

Short Waves Link Lieut. Settle To Ground

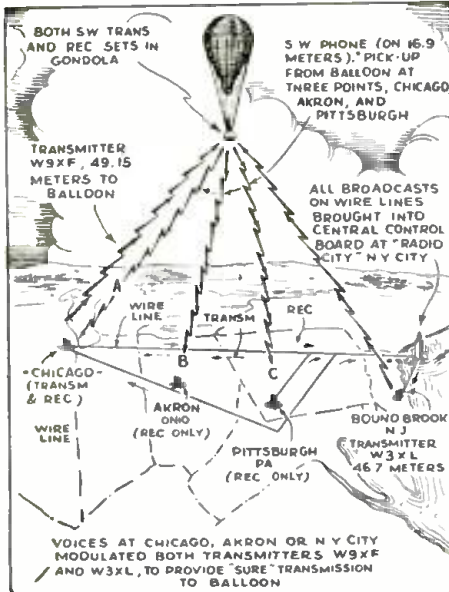

How Short Waves were used to link the stratosphere balloon to the ground.

● LIEUT. Commander T. G. W. Settle, U. S. N., and Major Chester L. Fordney of the U. S. Marine Corps, who recently attained the remarkable altitude of approximately 59,000 feet in a sealed metal gondola attached to a giant balloon, were kept in practically continuous radio contact with the earth, thanks to short-wave transmitters and receivers. The accompanying diagram shows how short-wave phone to and from the balloon was carried on under the auspices of the National Broadcasting Company. Two-way conversation was carried on and voices originating in Chicago, Akron, or New York City, were caused to simultaneously modulate two transmitters, one at Chicago and the other at Bound Brook, New Jersey. S-W phone messages from the balloon gondola were picked up at any one of three listening posts—Chicago, Akron, or Pittsburgh, and carried over wire (telephone) lines to N. B. C. Headquarters in Radio City, New York, from which point it was again sent over wire lines to the various broadcast stations constituting a special national hook-up.

Useful "AMATEUR BULLETIN" FREE!

● Every short-wave "ham" and "fan" will find extremely interesting and valuable the new AMATEUR BULLETIN, Number 935, a 12-page publication which we shall be glad to send you upon request. The articles and illustrations contained in this bulletin describe a brand new way of building a handsome appearing receiving and transmitting set at a nominal cost and with a minimum of labor. All of us are anxious to have our radio sets appear to the best advantage and the handsome designs of cabinets, panels, and dials portrayed in this hook are indeed an inspiration to every short-wave set constructor. We shall be glad to send you a copy of this bulletin No. 935, without charge upon request. Be sure to print your name and address clearly.

Service Department
SHORT WAVE CRAFT
98 Park Place
New York City

"All Is Not Gold That Glitters"

There are so many satisfactory users of LYNCH Noise Reducing Short Wave Antenna Systems that it is but natural for other manufacturers to attempt to copy our devices and "improve" them. Before we introduced the LYNCH Short Wave Antenna products we investigated the possibility of using glazed porcelain and decided it was unsatisfactory.



Don't be Fooled—Make this simple test



Leave a LYNCH Transposition Block and one of any competitive make in a bath of penetrating ink or wood dye for 48 hours; dry them off; break them up; and it will be easily seen which absorbs the dye. Nothing further need be said.

Lynch Short Wave Antenna System Complete Kit..... **\$6.00**
(with full instructions)

If your Jobber, Dealer or Serviceman cannot supply you, order direct from us.

Free Descriptive Folder Upon Request
LYNCH MANUFACTURING CO. Inc.
51 Vesey Street, New York, N.Y.
Makers of Famous Lynch Resistors

NEW ALDEN COILS

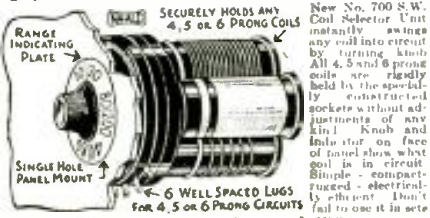

SECURELY HOLDS ANY 4, 5 OR 6 PRONG COILS
New No. 700 S.W. Coil Selector Unit instantly swings any coil into circuit by turning knob. All 4, 5 and 6 prong coils are rigidly held by the specially constructed sockets without adjustments of any kind. Knob and indicator on face of panel show what coil is in circuit. Simple, compact, rugged—electrically efficient. Don't fail to use it in sets you are building and new equipment you are designing.

NO. 700 COIL SELECTOR UNIT without coils. List Price \$3.50
Precision wound coils with the convenient gripping-ring for easy insertion and removal from socket.

The famous set of four precision wound N-W coils as specified for dozens of receivers described in "S-W Craft", 10 200 meters with 00014 mid condenser. Coils have UX bases. 704SWS List price \$2.00 set.

New! 706SWS Set of four six-prong coils with pre-sealed tickler windings. Secondary precision matched with 704SWS for perfect tracking 10-200 meters with 00014 mid. condenser. Uses standard six-coilnet tube socket. 706SWS List price \$3.50 set.

704BCS Set of two coils to cover 100 to 540 meters amateur police and broadcast bands with 00014 mid condenser. Precision and bank wound with silk insulation for maximum efficiency. Use the 704BCS to extend the tuning range of any S-W receiver using the 704SWS coils. Coils have UX bases. 704BCS List price \$1.50 set.

Genuine Makalot Coil Forms with color-coded easy-grip rings. 1 3/4 in. dia. x 2 in. winding space. Red, Yellow, Green or Blue.
704—4-pin coil form. List...25c
705—5-pin coil form. List...25c
706—6-pin coil form. List...30c

Here's the Data You Want!
Send two 3c stamps for new 16 page booklet showing illustrated tube socket connections for 203 different tubes, data and diagrams on how using any obsolete set and wire or tube checker and information on using the new tubes in place of old types. Includes catalog pages on all kinds of sockets, speaker plug connectors, wound and unwound coil form, coil winding data, S-W receiver references, etc.

ALDEN PRODUCTS CO.
Dept. SW1 715 Center St.
BROCKTON, MASS.

FREE 1934 CATALOG FORDSON

A 1¢ postcard brings it
RADIO SAVE 1/3 to 1/2

New, free catalog of latest 1934 models is the greatest display of VALUES—in performance, price—we ever offered! See for yourself the reasons for Fordson popularity around the world—why J. Trainor, N. M., writes: "You are doing for Radio what Henry Ford did for Auto industry—Not how cheap but how Good!" Big, free catalog shows you a set to answer every requirement, from 15 to 2400 meters; AC-DC; battery; long and short wave; all-wave supers; 6 and 32 volt; consoles, and all-electric auto radio. Fordson includes 4 to 7-tube sets for home, camp, car, farm and export—from 2000-mile midgets that get police calls to all-wave sets that span the world. Guaranteed. 30-DAY FREE TRIAL IN YOUR HOME. Prices \$8.95 up. Get your copy of this remarkable catalog. Send a postcard or coupon TODAY!

ANY SET ON 30-DAY FREE TRIAL



MAKE MONEY as our agent. No experience needed. Sales plan with REAL COMMISSIONS. 2-color literature, cards (with your name) all FREE. Agent's sample sets FREE. Write today!



FORDSON RADIO MFG. CO.
Dept. 1, 11703 Livernois Ave.,
Detroit, Mich.

Send me the New, FREE catalog and agent's plan.
Name
Address
City State

CUT PRICES ON RADIO BOOKS

● IT IS always the well-trained man who wins out over the horde of thousands of superficially trained and incompetent men. You are reading this magazine because you are interested in radio. Sooner or later, the time will come when you will wish to cash in on your knowledge. Your chance may come over night, and then the big and vital question will be, "How well equipped am I to fill the job?" You are in radio because you like it. You also realize that, at the present time, there are many branches of the radio art which you do not know as thoroughly as you should. Knowledge, these days, can be gotten cheaper than ever before. It isn't necessary

for you to go to college to become proficient in radio. Start today, to build a REAL radio library and become acquainted with all branches of this great and growing art. In this page are listed the world's best radio books. We have combed the market for the really important books in radio; so that, no matter what branch you are interested in, you can pick out the best books that are now printed. Start, now, to build a complete radio library. You do not have to get all the books at once, but make up your mind to get one book a month; so that, when your chance comes, you will be fully equipped to win out over the others not so well equipped.

IMPORTANT.—All prices have been drastically reduced—take advantage of it.

SHORT WAVE WIRELESS COMMUNICATION. by A. W. Lacher and C. H. Stoner. Cloth covers, size 6x9", 318 pages, 200 illustrations. 12 plates. **\$3.46** Price.

Short wave experimenters who have grown out of I-tube sets will revel in this book, which tells the "how come" of short-wave operation. A good portion of the volume is devoted to the amateur and commercial aspects of S. W. transmission.

RADIO FREQUENCY ELECTRICAL REQUIREMENTS. by Hugh A. Brown. Cloth covers, size 6x9". 386 pages, 235 illustrations. Price **\$3.90**

One of the few great books on this important subject. Everything from thermionic-tube coefficients to piezo-electric measurements.

PRACTICAL TELEVISION. by K. T. Larner. Cloth covers, size 5 1/2x8 1/2". 223 pages. Price **\$3.69**

This book explains television in full, including elementary principles, photo-electric cells, and all important types of television sets as well as basic principles of optics. I make, mirrors, lenses, etc.

MAGNETIC PHENOMENA. by Samuel Robinson Williams. Cloth covers, size 6x9", 230 pages, 150 illustrations, and numerous tables. Price **\$2.98**

All electric motors, coupling coils, magnetic and dynamic loud speakers, transformers, choke coils, etc., are dependent on magnetic phenomena. This fine book is complete on the subject.

CINEMATOGRAPHY. by James H. Cameron. Staff covers, size 7 1/4x5", 240 pages, 150 illustrations. Price **\$3.90**

Everything on the subject from "silent" and "talkie" 16 mm. film to its manufacture and to the final projection is in this marvelous volume.

AUDELS RADIOMAN'S GUIDE. by Frank D. Graham. Cloth covers (flexible), size 5 1/2x8 1/2". 220 pages, 300 illustrations. Price **\$.89**

A practical, concise book presenting the theoretical and practical information for the proper operation, maintenance and service as applied to modern radio practice.

THE RADIO AMATEUR'S HANDBOOK. (New Revised Edition), by A. Frederick Collins. Cloth covers, size 5 1/2x7 1/2". 394 pages, 116 illustrations. Price **\$1.97**

If you wish to become a radio amateur (radio ham) this book tells you how. Everything in receiving and transmitter sets and how to build them.

EXPERIMENTAL RADIO. by R. H. Ramsey, Prof. of Physics, Indiana University. Cloth covers, size 7 1/4x5 1/2". 256 pages, 188 illustrations. Price, **\$2.69** Postpaid

A marvelous book for the experimenter. Experiments galore in easy comprehensible language.

RADIO THEORY AND OPERATING. by M. T. Loomis. 5th revised Edition. Cloth-bound; size 5 1/2x8 1/2" thick; 1,000 pages; over 800 illus.; 450 review questions and answers. **\$4.38** Price

Written in textbook style, a tremendous amount of useful information has been crammed into this thin-paper, compact reference work. Radio transmission and reception have been covered "from soup to nuts." A truly great book.

S. GERNSBACK'S RADIO ENCYCLOPEDIA (Second Edition). Ryl Morocero Flexible Binder, 3-2 pages, 2201 radio definitions, 1213 illustrations, 34 tables. **\$3.19** Price

The most comprehensive encyclopedia of its kind in print. Remarkably up-to-date in every way, with marvellous illustrations.

DRAKE'S CYCLOPEDIA OF RADIO AND ELECTRONICS. by H. P. Manly. Cloth covers, size 6x9", 1670 pages, 1880 illustrations. New 1932 Edition. Price **\$4.88**

The largest work of its kind ever put between two covers. New and up-to-date; a standby for every radio man.

FUNDAMENTALS OF RADIO. by K. R. Ramsey, Professor of Physics, Indiana University. Cloth covers, size 9 1/2x6", 372 pages. Price prepaid **\$3.46**

The backbone of the radio art. This book gives you the foundation on radio from A to Z.

RADIO OPERATING QUESTIONS AND ANSWERS. (Revised Fifth Edition), by Wilson and Hornung. Cloth covers, size 3 1/2x8", 390 pages, 96 illustrations. Price **\$2.47**

Contains over 600 questions and answers covering all phases of licensed radio operation. Revised to contain much new material. Nothing better in print for the transmitting and receiving amateur.

OFFICIAL RADIO SERVICE MANUAL. Volume 1. by Hugo Gernsback and George B. Ghirardi. Flexible loose-leaf binder, size 9 1/2x12", over 2,000 illustrations, 650 pages. **COMPLETE WITH SIX SUPPLEMENTS. Price prepaid \$4.38**

The Service Man's Bible. Greatest book ever published on the subject. Contains all old circuits of every inmakable commercial radio set up to 1931.

THE RADIO MANUAL. by George E. Sterling and Robt S. Kruse, E.E. 2nd enlarged edition. Flexible fabrikoid covers. Size 5 1/2x8", 805 pages, 348 illustrations. Price **\$5.88**

A complete Radio Course for the operator, the technician, the amateur, the student and experimenter. Everything imaginable in the whole radio art is covered in this great book—the "radio Bible" of the amateur. DON'T MISS THIS.

RADIO CONSTRUCTION AND REPAIRING. by James A. Moyer and John E. Wostrel. Cloth covers, size 8x7", well illustrated, new revised fourth edition, containing 111 pages, still remaining at the same price. **\$2.50** Price

A handbook that every radio set tester and general student must have. The diagrams alone are worth the price of the book.

THEORY OF VACUUM TUBE CIRCUITS. by Leo James Peters. Cloth covers, size 6x9". 226 illustrations, 226 pages. Price **\$2.98**

It is one thing to "connect green lead No. 1 to pink lead No. 3," but it is another to know why the connections are made. Read this book and learn the design factors in tube circuits.

PRINCIPLES OF RADIO COMMUNICATION. by J. H. Morecroft, Prof. of Electrical Engineering, Columbia University. Cloth covers, size 9 1/2x6", 988 pages, profusely illustrated. Price **\$7.35**

THE radio classic, by the dean of radio. Covers entire radio art as does no other book.

RADIO ENGINEERING HANDBOOK. by Keith Henney. Flexible Leatherette, size 4 1/2x7", 581 pages, 182 illustrations. Price **\$4.88**

Each of the 23 sections has been written by a specialist! Includes valuable data on talkies and short waves.

RADIO SERVICE MAN'S HANDBOOK WITH ADDENDA DATA SHEETS. Flexible covers, size 9x12", 200 pages, 100 illustrations. Price **\$1.49** Price Prepaid.

The Service Man's standby. Contains the latest practical information on radio servicing.

HOW TO PASS U. S. GOVERNMENT RADIO LICENSE EXAMINATIONS. by R. L. Duncan and T. E. Drew. Flexible covers, size 9 1/2x7", 170 pages, 92 illustrations, appendix. Price **\$1.89**

The most important book on the subject ever published. Gives every conceivable angle which will help you to pass a radio license examination successfully.

RADIO MOVIES AND TELEVISION. by C. Francis Jenkins. Cloth covers, size 9 1/2x8". 144 pages, profusely illustrated. Price **\$.98**

A complete volume by the master of television, giving everything in detail for building your own television sets.

RADIO PHYSICS COURSE (2nd enlarged edition), by Alfred A. Ghirardi. Cloth covers, size 7 1/4x9 1/2". 992 pages, 510 illustrations, numerous tables. **\$3.89** Price.

The finest and most popular book on electricity and radio. Each subject is clearly discussed, with the aid of dozens of excellent drawings. Chapters on talkies, television, electronics and service work, etc. Biggest buy in radio books.

RADIO VISION. by C. Francis Jenkins. Cloth covers, size 9 1/2x8", 144 pages, profusely illustrated. Price prepaid **89c**

An excellent book. The Jenkins television system, as well as many other modern television systems fully described.

We herewith present the most complete collection of recent important radio books. We have, after an exhaustive study, selected these volumes because they represent the foremost radio books of their kind in print today. There is such a great variety that we are sure it will satisfy any taste as well as any requirement that the student of radio might have. We publish no catalog and our prices are as low as possible. Prompt shipments will be made to you direct from the publishers. We merely act as a clearing house for a number of radio publishers and OUR PRICES ARE AS LOW OR LOWER THAN WILL BE FOUND ANYWHERE. Remit by money order or certified check. Register all cash.

SHORT WAVES. by C. R. Leutz and H. B. Gable. Staff covers, size 6x9", 384 pages, 258 illustrations. Price, **\$2.98** Prepaid

The biggest and most complete book on short waves. Covers every imaginable phase, including S. W. Superheterodynes. The authors are famous S. W. authorities.

FIRST PRINCIPLES OF TELEVISION. by A. Dinsdale. Cloth covers, size 6x9". 212 pages, 130 illustrations, 38 plates. Price **\$3.46**

A real review of television in design, construction and operation. This amazingly comprehensive book contains many heretofore unpublished facts on this absorbing topic.

RADIO RECEIVING TUBES. by Moyer and Wostrel. Cloth covers, size 7 1/4x5 1/2". 298 pages, 141 illustrations. Price **\$2.47**

One of the finest books on vacuum tubes. Everything worthwhile on the subject treated in a masterful manner.

PHOTOCELLS AND THEIR APPLICATION. (Second Edition), by V. K. Zworykin and E. D. Wilson. Cloth covers, size 5 1/2x8", 312 pages, 180 illustrations. Price **\$2.88**

Does this book tell you why and how to use light-sensitive cell? The answer is that the first edition was a "sell out," and the second edition, brought right up to date, is even a better volume. Enough said.

ELECTRONICS. by H. C. Hudson. Cloth covers, size 6x9", 131 pages, 45 illustrations. Price **\$1.95**

"This book is written for the reader who may wish to know something about what is going on and who has not heretofore given the matter much attention," says the author. Read it and learn how dry rectifiers, vacuum tubes, batteries, television tubes, and other apparatus, work; get the "low down" on electrons and atoms.

RADIO SERVICING COURSE. by Ghirardi and Freed. Cloth covers, size 5 1/2x7 1/2". 192 pages, 24 illustrations; 14 test questions; 28 test-instrument circuits. Price **\$1.67**

A practical book for beginners and old-timers in radio service will find useful. Nine chapters discuss measuring instruments and tests, and trouble-shooting; the chapter, "Useful Information for Servicemen," closes the book.

RADIO ENGINEERING. by Frederick Emmons Terman. Cloth covers, size 6x9". 700 pages, 425 illustrations. Price **\$4.88**

Not a book for the beginner in radio, but a reference volume for the technician who wants modern information on the design and use of band-selectors, automatic volume control, diode detectors, and the thousand-and-one units and circuit arrangements which have been recently developed.

PRINCIPLES OF RADIO. by Keith Henney, M. A. Cloth covers, size 8 1/2x7", 478 pages, 141 illustrations. Price **\$3.46**

A marvellously written textbook with the latest radio principles, including screen grid and pentode amplifiers, etc.

NEW LOW PRICE RADIO BOOKS

Here are 12 new, up-to-date books on every conceivable radio subject, just published. Modern in every sense. ALL BOOKS UNIFORM from 64 to 72 pages; 50 to 120 illustrations. All books written by well-known radio authors. Order by Number.

- No. 1 **RADIO SET ANALYZERS.** by J. Van Der Ziel
- No. 2 **MODERN RADIO VACUUM TUBES.** by Robert Hertzberg
- No. 3 **THE SUPERHETERODYNE BOOK.** by Clyde Pritch
- No. 4 **MODERN RADIO HOOK-UPS.** by H. D. Washburne
- No. 5 **HOW TO BECOME A RADIO SERVICE MAN.** by Louis Martin
- No. 6 **BRINGING ELECTRIC (RADIO) SETS UP TO DATE.** by Clifford B. Denton
- No. 7 **RADIO KINKS & WRINKLES** (for Experimenters) by C. W. Palmer
- No. 8 **RADIO QUESTIONS & ANSWERS.** by H. D. Washburne
- No. 9 **AUTOMOBILE RADIO & SERVICING.** by Louis Martin
- No. 10 **HOME RECORDING AND ALL ABOUT IT.** by Geo. J. Sallha
- No. 12 **HOW TO BUILD AND OPERATE SHORT-WAVE RECEIVERS.** by the Editors of SHORT WAVE CRAFT
- No. 13 **HOW TO BECOME AN AMATEUR RADIO OPERATOR.** by M. F. Eddy.

PRICE PREPAID EACH BOOK **\$.45**
PRICE PREPAID FOR ALL 13 BOOKS **\$4.85**

HOW TO ORDER We cannot ship as shown. Some of the books sent prepaid (in U. S. only). Those that are not thus listed will be shipped by express collect if sufficient postage is not included by you.

FOUNDATIONS OF RADIO. by Randolph L. Duncan. Cloth covers, size 5 1/2x8", 246 pages, 145 illustrations. Numerous tables. Price **\$2.47**

This textbook gives you the fundamentals of electricity as applied to radio. It equips you for further study in the field of radio.

EXPERIMENTAL RADIO ENGINEERING. by John H. Morecroft. Cloth covers, size 6x9", 346 pages, 250 illustrations. Price **\$3.46**

A student's book; devoted to the principles of radio apparatus; intended to accompany a course in electricity. The best of its kind.

OFFICIAL RADIO SERVICE MANUAL. Volume II. by Hugo Gernsback, C. H. Denton and C. H. W. Nason, with 1932 Free Supplements, 1000 pages, 2000 illustrations. Flexible Loose-leaf Binder, size 9x12". Price prepaid **\$4.00**

The talk of the radio industry. This marvellous volume contains everything in radio, circuits and radio developments, for 1932. Not a line of duplication between 1931 and 1932 volumes. (Vol. 1 and Vol. 2.)



A Symmetrical Input Super-Regenerative Receiver

(Continued from page 525)

amplification with no super-regeneration. Still others state that the amplification obtained in a super-regenerative receiver is roughly proportional to the square of the difference between the signal frequency and the variation frequency, but that this does not hold true at the extremely high frequencies.

Briefly the advantages and disadvantages of the super-regenerative receiver may be summed up:

Advantages

- (1) Receiver may be built very compact.
- (2) Good amplification can be obtained ahead of the audio amplifier at frequencies too high for the present day radio frequency amplifier.
- (3) The super-regenerative receiver gives a broad, flat-topped response curve which is a real advantage for some kinds of work.

Disadvantages

- (1) All super-regenerative receivers are inclined to have a high noise level. This is the characteristic noise in a regenerative circuit but amplified, and increased due to rectification of the variation frequency.
- (2) There probably will be interference between adjacent super-regenerative receivers due to reradiation.

(3) A certain minimum signal voltage is required in order to "trigger" the detector. In other words, the super-regenerative receiver is inefficient for reception of weak signals.

A 4-Tube Improved Super-Regenerator

The diagram of Fig. 3 shows a receiver which has several unique features and is an improvement in super-regenerative receivers. The receiver consists of a symmetrical input back-to-back detector, a variation oscillator, and one stage of pentode audio.

- V1, V2, V3—237 type tubes. R. C. A. (Arco).
- V4—238 type tubes. R. C. A. (Arco).
- R1, R2—50,000 ohms, resistor. All Lynch.
- R3—500,000 ohms, resistor.
- R4—1,000 ohms, resistor.
- R5—2,500 ohms, resistor.
- R6—50,000 ohms, resistor.
- C1—100 mmf. Hammarlund Midget variable. (National).
- C2—.002 mf. condenser.
- C3—.5 mf. condenser. All Flechtheim.
- C4—.5 mf. condenser.
- C5—50 mf. condenser.

L1, L2, L3, L4 and L7 are wound on 3/4 inch victrol or other tubing with numbers of turns to suit the frequency desired. Care must be taken to make the input circuit symmetrical. With the number of turns on each coil as shown below the frequency range of the receiver was from 54 to 61 megacycles.

- L1—3 turns.
- L2—3 turns.
- L3—7 turns.
- L4—7 turns.
- L7—4 turns.

By changing the turns of various coils, frequencies from 40 to 185 megacycles have been covered with this receiver.

L5 and L6—Made by separating the winding of a No. 125, 250 mh, Samson choke into two separate coils with a ratio of 1 to 3. The coil L5 has roughly three times the numbers of turns as coil L6. The variation frequency is approximately 100 kcs.

The approximate number of turns for L5 is 1,200 and for L6, 500; in most cases it is necessary to tune each of these coils with a .001 or .002 mf. fixed condenser. More specifically the constructor may use

(Continued on page 571)

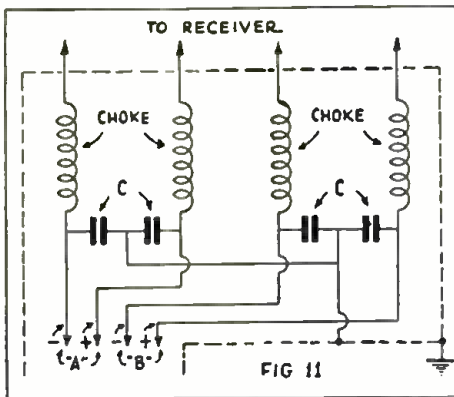

Showing use of chokes in "A" and "B" leads.

5 and 10 Meter Transmitter

(Continued from page 553)

Oscillator "Power Supply" Parts

- 1—power transformer, 650-0-650, 2.5, 7.5 volt filament. R. T. Co.
- 1—30 henry 150 mil. filter choke. National.
- 2—2mmf. 1000 volt filter condensers. Flechtheim.
- 2—4 prong sockets, National.
- 2—type 871, 888 or 866 mercury vapor rectifier tub-s. RCA Radiotron, (Arco).

Modulator Parts List

- 1—Microphone, Universal. (Single or double button.) Amplion; Lifetime; Miles; May.)
- 1—Microphone transformer, Universal. (Single or double button type.)
- 1—3:1 ratio audio transformer. National (or other make).
- 1—Class B input audio transformer, National.
- 1—Class B output audio transformer National. (With tapped secondary.)
- 1—Power transformer 450-0-450, 2.5, 2.5 windings, 5V. National.
- 2—8mmf. 500 volt electrolytic condensers, Flechtheim.
- 1—1mmf. 400 volt by-pass condenser, Flechtheim.
- 1—20 mmf. 25 V., electrolytic condenser, Flechtheim.

- 1—20,000 ohm resistor, tapped at 8,000 ohms.
- 1—2,000 ohm 2 watt resistor, Lynch.
- 1—20 ohm center-tapped filament resistor.
- 4—5 wafer sockets, Eby.
- 1—4-prong wafer socket, Eby.
- 1—aluminum chassis 13"x10"x2".
- Tubes for the modulator unit are:
- 3—type 46 RCA Radiotron.
- 1—type 56 RCA Radiotron.
- 1—type 5Z3 RCA Radiotron.

Coil Data

5 Meters

- Antenna—2 turns each (make two).
- Grid—8 turns, 1/8 inch space between turns.
- Plate—4 turns. 1/4 inch space between turns.

10 Meters

- Antenna—same as for 5 meters.
- Grid—same as for 5, but tuned with a 100 mmf. condenser.
- Plate—6 turns, 1/8 inch space between turns.
- *All coils are 1 inch inside diameter and wound with 1/8 inch diameter copper tubing.

QUALITY APPARATUS FOR Short Waves



These coils are considered the finest made. Each coil is precision wound on a different colored bakelite form for quick identification of wave lengths. Use 1 and highly recommended by all short wave experts. Range (19 to 225) meters, using .00014 or .00015 mfd. condenser. Recommended for the following sets: "The Globe Trotter," "The Overseas," "The Duster (2,500 Mile Two Tube Receiver and Double Three Tube Signal Gripper)," "The Magdiana."

- 4 Coil Enamel Wire Kit\$1.50
- 4 Coil Litz Wire Kit\$2.25
- Broadcast Coil, (200 to 550 meters) 55c

POLICE AND SHORT WAVE ADAPTER

Convert your broadcast set into a shortwave set tuning from 80 to 200 meters.

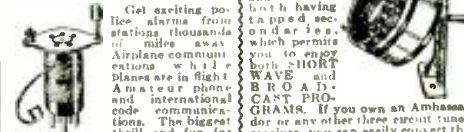

Get exciting police news from stations thousands of miles away. Airplane communications while planes are in flight. Amateur phone and international code communications. The biggest thrill and fun for a little money. Installed in a jiffy. Plug directly into the detector tube socket. Specify the detector tube in your set, or if uncertain as to detector tube, advise make and model number of set when ordering.

- No. 200—for '27, '37 \$1.39
- and '58 Det. tube
- No. 201—for '24, '35, and '36 Det. \$1.39
- tube

Send remittance in check or money order. Retailer later if it contains currency.

GENERAL WINDING COMPANY

254 W. 31st St. NEW YORK, N. Y.

Leotone WAVE A. C.

Described in Nov. issue Short Wave Craft 17 to 200 Meters!

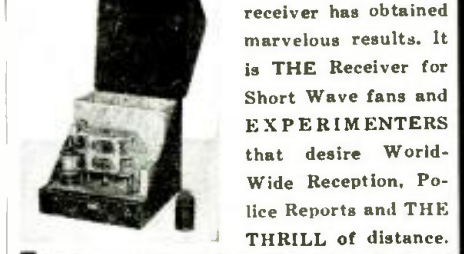

This newly designed receiver has obtained marvelous results. It is THE Receiver for Short Wave fans and EXPERIMENTERS that desire World-Wide Reception, Police Reports and THE THRILL of distance.

- The Leotone A. C. Receiver uses the following tubes: 58 R.F. 57 detector, 56 1st A.F., 47-2nd A.F., and 80 Rectifier. Complete Kit of Parts with 2 sets of coils (8 coils)\$16.45
- Above Kit with tubes 14.95
- Completely wired Kit (less tubes) 10.45
- Completely Wired Kit with tubes 11.95
- Foundation Kit, including 1 metal case, 1 chassis and 1 shielded compartment 2.45

SPECIAL-SHIELDED S.W. BATTERY SET

This Battery Set Featured in September S. W. Craft Perfect performance assured—the set with a "KICK" using following tubes: 1—'30, 1—'32, 1—'33, 1—'34 low current drain inexpensive Tubes. Complete Kit of parts with 2 sets of coils (8 coils) \$9.95. Kit (with tubes) \$11.95. Kit completely wired (less tubes) \$12.45— with tubes wired complete, \$14.45.

Practical Radio Engineering

An opportunity for RADIO MEN to enlarge their scope of training

Whether elementary radio principles or advanced subjects, sound applications or practical radio engineering, R. C. A. Institutes is prepared to give you the instruction you need.

Resident schools New York and Chicago with modern standard equipment

Extension Courses for Home Study under convenient "no obligation" plan. Illustrated Catalog on Request

R. C. A. INSTITUTES, Inc., Dept. SW-1 75 Varick St., New York—1154 Merchandise Mart, Chicago

American or European Plan—Complete Garage Facilities



The Breakers

ATLANTIC CITY, NEW JERSEY

On the Boardwalk

Extraordinary Reduction In Rates

AS LOW AS

Without Meals

\$2.50 Daily per Person



With Meals

\$5.00 Daily per Person

Hot and Cold Sea Water in all Baths

Receiver Calibration

(Continued from page 547)

mation—but the writer claims it to be very helpful and accurate enough for most purposes.

Take several sheets of standard cross-section paper having 10x10 squares to the half-inch—one sheet for each plug-in coil will be required. Along the short side (horizontal), number the dial settings for the tuning condenser so that each dial division will be allotted one tiny square. Along the long side (vertical) will be numbered the frequency in kilocycles to such a scale as will fit the size of the sheet well. If desired, wavelength in meters may be used for the vertical scale instead of frequency in kilocycles, but the latter is recommended for the simple reason that most call-books give a listing of stations by frequency rather than wavelength. If you should prefer, however, to use meters for units, keep in mind that wavelength is inversely proportional to frequency and your curves will slant in the opposite direction to those shown.

Now plug in one of the coils and tune in a station near the middle of the dial scale. When the station has been identified, look up the frequency in a call-book, and log the dial setting. Now locate stations near either end of the dial scale, and log their frequencies and dial settings. By now you can estimate what scale you wish to use on the cross-section paper for the frequency units, using that particular coil. Several more stations should be logged, as evenly spaced along the dial as possible. When you have eight or ten, plot the points on the sheet, and if you have collected your data carefully you will find you can draw a smooth curve through all the points. If one or two points seem *out of line*, recheck them, as you probably have made a mistake in logging them. The points at which the curve intersects the dial extremities, referred to the frequency scale, will show the range of the coil. The shape of the curve will depend largely on the characteristics of the tuning condenser. Some condensers will give a curve which is very nearly a straight line—others may produce a decidedly curved line. The above procedure may then be followed for each of the remaining coils. Sample curves for two different coils are shown in the sketch.

Now a few words as to the tuning methods used. Let it be said here that obviously the more care exercised in tuning in the "marker" stations, the more accurate will be the calibration. It is of vital importance that the calibration be made under exactly the same conditions that will exist when the calibration is used for reference later. Any change in the antenna system or in the coils will of course render the calibration worthless. An antenna that is too slack will sway in the wind and cause an appreciable variation of conditions. Be sure that the regeneration control is set very close to the critical point each time that a "marker" station is logged. If phone stations are used for calibration purposes a good plan is to identify the station with the detector just below oscillation, as usual, then advance the regeneration until the detector just oscillates, and retune the carrier wave to the point of resonance. If commercial or government CW stations are used for "markers," the detector should, of course, be just oscillating.

In some receivers a small three-plate midjet condenser is shunted across the main tuning condenser to act as a vernier control or band-spreader. If this is the case, it is well to set this vernier at a fixed point, say at the midpoint of its dial scale, and tune with the main condenser while calibrating. Then to refer to any frequency later, it is necessary merely to set the vernier as before, set the main tuning condenser to the dial reading taken from the calibration curve, and then do the final tuning with the vernier, which will only have to be varied slightly.—Nicholas C. Northrup.

SEXOLOGY

THE MAGAZINE OF SEX SCIENCE

SEXOLOGY, foremost educational sex magazine, is written in simple language and can be read by every member of the family. It is instructive, enlightening—not a risqué book—contains no Jargon Devoted to Science of Health Hygiene.

Contains 25 important articles on Sex Science, 68 pages, with attractive two-color cover. Here are a few of the more important articles:

The Male Reproductive Organs (Illustrated); The Cycle of Menstruation (Illustrated); Three Unusual Types of Pregnancy (Illustrated); Napoleon's Sexual Transformation; Bed-Wetting and Sex Weakness; Sex-Life During Pregnancy; Is Sexual Abstinence Harmful?—A Reply; Can We Control Sex of Offspring?; Masturbation—The Truth About It; Are Douches Necessary?; A Man Becomes a Woman.

Get a copy of SEXOLOGY on any new-stand, or, if your dealer cannot supply you, send 25c in stamps for a copy of the current issue.

SEXOLOGY 23 West Broadway New York, N. Y.

ONE CENT A DAY PAYS UP TO \$100 A MONTH

The Postal Life & Casualty Insurance Co., 103 Postal Life Building, Kansas City, Mo., is offering a new accident policy that pays up to \$100 a month for 24 months for disability and \$1,000.00 for deaths—costs 1c a day—\$3.65 a year. Covers all accidents including those of occupation. Men, women and children eligible. Send no money. Simply send name, address, age, beneficiary's name and relationship and they will send this policy on 10 days' FREE inspection. No examination is required. This offer is limited, so write the company today.

Announcing Amazing Typewriter Bargain

New Remington Portable only 10c a Day

10-DAY FREE TRIAL OFFER

Only 10c a day buys this latest model Remington Portable!

Not a used typewriter. Not a rebuilt machine. It's a brand new, regulation Remington typewriter. Simple to operate, yet does the finest work. Full set of keys with large and small letters.

Try this typewriter in your home or office on our 10-day FREE TRIAL OFFER. If at the end of 10 days you do not agree that this Remington is the finest portable at any price, you can return it at our expense. Don't delay. Don't put it off. Mail the coupon today. Or use postcard if you prefer.

Write for our new catalogue showing the most complete line of portable and desk models ever offered.

FREE TOUCH TYPEWRITING COURSE



MAIL COUPON

for full facts about this astounding offer

REMINGTON RAND INC., Dept. SW-1
BUFFALO, NEW YORK.

Please tell me how I can buy a new Remington Portable Typewriter for only 10c a day. Also enclose one of your new catalogues.

Name

Address

SURPLUS RADIO PRODUCTS

ORDER DIRECT FROM THIS ADVERTISEMENT—WE DO NOT ISSUE ANY CATALOG

WE HAVE ON HAND

251 Westinghouse Power Generators

The special generator illustrated is of the self-excited inductor type. The rotor serves two entirely distinct purposes: 1. It carries the inductor for the A.C. generator, which has stationary field and armature coils. 2. It carries the D.C. armature, which corresponds to the exciter in other machines.

Power Generator



Reg. Price Was \$75

There are two pairs of stator poles—two North and two South. Around these four poles are wound the four field coils which, when energized, induce poles of alternate polarity. Each of these poles is provided with four slots into which are fitted the A.C. windings. The rotor is a 12-tooth inductor that carries the D.C. armature coils which supply the D.C. exciter current required by the alternator; a built-in commutator takes off the generated D.C. Three leads extend through the casing to permit a 1½ V. flashlight-type battery to be switched into circuit for starting, and to control the A.C. output of the generator. Rotated at its normal speed of 4,500 r.p.m., the output is 200 W. at 115 to 125 V. (on open circuit), 900 cycles.

Manufactured by Westinghouse for the U. S. Signal Corps, the sturdy construction of this instrument recommends it to the technician. The rotor turns in ball bearings. Shaft length (driving end), 2 ins.; diameter, 9/16 in.; the end is threaded for a distance of 3/8 in. At the end opposite from the drive the shaft extends 3/8 in. Case dimensions, exclusive of the shaft, 4 1/2 x 6 1/4 in. in diameter. Guaranteed new and perfect. Worth \$75.00, but while they last, only \$4.95, plus shipping charges. Shipping weight 13 lbs. Send check or money order.

Sale of 285 King-Silvertone POWER PACKS



A replacement unit for the popular King and Silvertone sets. Consists of Power Transformer and Choke for Silvertone 1928 and 1929 Models, and for King Models H and J. Measure 6 1/2 x 5 1/2 x 2 3/4". Wt., 5 lbs. Supplies 4—226, 1—227, 2—71A and 1—280. Specifications: 1 1/2 V. at 1 1/2 amps.; 2 1/2 V. at 1 1/2 amps.; 5 V. at 1/2 amp.; 5 V. at 2 amps.; 600 V. C.T. at 60 mls.

PRICE \$1.73 Each as long as supply lasts

REMIT BY CHECK OR MONEY ORDER FOR FULL AMOUNT OF EACH ITEM—SHIPPED EXPRESS COLLECT, NO C. O. D. ORDER ACCEPTED—MONEY REFUNDED IF NOT SATISFIED.

Wellworth Trading Company 1-31
111 West Lake Street, Chicago, Ill.

Enclosed you will find my remittance of \$_____ for which please send me:

- () Power Generator, \$4.95 each
- () King-Silvertone Power Pack, \$1.73 each

Name _____

Address _____

City _____ State _____

A Symmetrical Input Receiver

(Continued from page 569)

a wooden form made from a piece of 1 1/4 inch diameter wood or bakelite rod. Two 1/4 inch wide by 1/2 inch deep grooves are cut in a piece of this rod, the grooves being 1/2 inch apart. In one groove wind 1,200 turns of No. 36 S. S. C. wire "scramble" wound (helter skelter fashion, i. e., not in even layers). In the second groove 500 turns of No. 36 S. S. C. wire are wound.

The choke consists of 45 turns of No. 40 D. S. C. copper wire on a slotted form with three slots. The overall length of the form is about 3/4 inch.

T1, the audio transformer may be any good transformer.

Reasonable care must be used in construction and wiring of the receiver. Some of the details are shown in the photographs.

Input Tubes Work "Back-to-Back"

The input works with the tubes "back-to-back." Tubes V1 and V2, forming the detector, oscillate very easily at these high frequencies.

On one half of the variation frequency cycle, Tube V1 say, is operating and tube V2 is practically dead insofar as the incoming signal is concerned. The tube capacities of tube V2; Cg, Cp, Cm; are in a parallel arrangement with C1. This parallel arrangement is in a series combination with the tube capacities of V1. On the other half of the variation cycle Tube V2 works and Tube V1 is practically dead insofar as the incoming signal is concerned. Conditions as regards the tube capacities and C1 are now reversed.

This method of series tuning makes it quite easy to tune at these high frequencies and still cover a reasonable range without having the circuit too critical.

In addition to tuning, C1 serves a most important purpose. At the lower end of the frequency range for any coil, more external coupling is required between plate and grid circuits. This requires more capacity. At the higher frequency end, less external coupling is required between plate and grid circuits, necessitating less capacity. From this it can be seen that the external coupling between plate and grid circuits, and tuning are both controlled by C1, and, fortunately, the coupling requirements are similar to the tuning requirements; that is, less capacity is required in each case at the high frequency end of the coil.

Noise Level Greatly Reduced

As shown in Fig. 3, the resistance of R3 is 500,000 ohms while R1 and R2 are each 50,000 ohms. Suppose on a signal of a certain amplitude an output of a certain value is obtained. Now, if one detector tube, say V2, is removed from the socket, the value of R3 must be reduced to about 100,000 ohms in order to get the previous value of output voltage. Also, the noise level is considerably increased. This means that with the symmetrical back-to-back detector, oscillations are easily obtained so that a lower variation frequency amplitude is needed for good operation. As a large part of the characteristic noise in a super-regenerative receiver is due to the variation frequency, a lower variation frequency amplitude will result in a lower noise level. In the present receiver this lower noise level is obtained and at the same time, the receiver is very sensitive.

On one test the receiver shown in Fig. 3 gave a signal of 55 volts with a noise level of 0.3 volts. An older type receiver with a single detector tube gave a signal of 50 volts with a noise level of 0.7 to 1.2 volts. The signal noise ratio with the symmetrical input receiver was 183.3 to 1.0 and with the single detector tube receiver was between 71.4 to 1 and 41.6 to 1.

(Continued on page 573)

The New 1934 Improved Prizewinner A.C.-D.C. S.W. Receiver

\$12.95 complete with four coils

Verified Worldwide Reception
Completely Self Powered Latest Type 77-43 and 25Z5 Tubes—15-200 meters

PROVISION FOR HEAD PHONES AND SPEAKER

Complete Kit of Improved Prize winner parts, identical with those used in built-up models, including hardware hook-up, wire cabinet, dial, 4 coils.

\$10.55

Assembled, wired, tested and enclosed in beautiful, crackle finish cabinet, binged cover ready to plug into your line \$12.95
Kit of RCA or Arcturus tubes to match \$3.75
Broadcast coil for covering from 200 to 500 meter. \$0.90
220 V. A. C. or D. C. Adaptor \$1.75

Send for full particulars

ALAN RADIO CORP.
538 Cortlandt St., New York City

MIND
OR
MATTER

WHICH CONTROLS YOU?

Science says that the chemical elements composing a man's body may be bought for sixty cents at a pharmacy shop. But the real part of you is the infinite, creative power within—it makes YOU a living, vital being.

By the proper use of this creative, sleeping force within you, you can DOMINATE YOUR LIFE and MASTER THE CONDITIONS WHICH SURROUND YOU. The Rosicrucians have shown thousands of thinking men and women how to use this infinite power. Learn to direct the inner processes of your mind.

This Free Book Explains

The Rosicrucians will send the SINCERE SEEKER a free copy of the new book, "The Wisdom of the Sages," which tells how you may become a student of these age-old truths. Address a letter (not a postcard of curiosity) to:

Friar M. J. F.

ROSIKRUCIAN BROTHERHOOD
AMORC
SAN JOSE, CALIFORNIA

Watch for the word AMORC. It's the Symbol of Rosicrucian Authenticity.

GET THE BIG RADIO CATALOG

THE RADIO SUPPLY WORLD IN 148 BIG PAGES

Just out for 1934. Make your request for it on your Dealer's, Service Man's, School's, Experimenter's or Amateur's letterhead. Order from America's Largest Radio House in America's Handiest Shipping Point.

BURSTEIN - APPLEBEE CO.
Dept. C-1 1012 (McGee St. Kansas City, Mo.

JUST OFF THE PRESS!

Free

1934 RADIO AND AMPLIFIER CATALOG

MAKE US YOUR HEADQUARTERS for PUBLIC ADDRESS AMPLIFIERS Deal DIRECT with Manufacturers and SAVE BIG MONEY.

COAST TO COAST RADIO CORP.
231-3 WEST 176th St. NEW YORK, N.Y.

The 4 ESSENTIAL SHORT WAVE BOOKS

'ROUND THE WORLD FANS USE THESE GREAT SHORT WAVE BOOKS

These great books contain everything on short waves that is really worth knowing—they are books which have been most enthusiastically welcomed by short-wave fans. The cost of the books is extremely low in comparison with the valuable material which they contain.

There is not a short-wave fan, experimenter or interested radio-minded reader who will not want these books. Right up-to-the-minute with new material on outstanding developments in the short wave field. The books are authoritative, completely illustrated and not too highly technical.

Ten Most Popular Short Wave Receivers. How to Make and Work Them

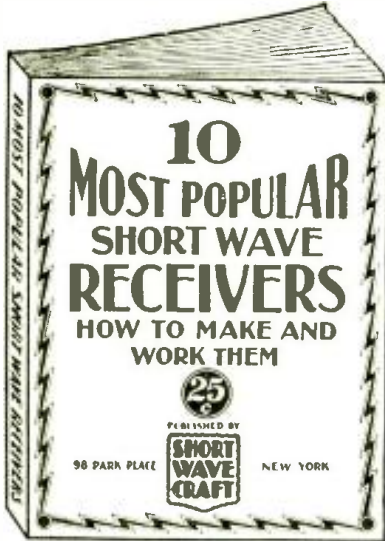

This new volume is a revelation to those who wish to build their own short wave receivers. The editors of SHORT WAVE CRAFT have selected ten outstanding short wave receivers and these are described in the new volume. Each receiver is fully illustrated with a complete layout, pictorial representation, photographs of the set complete, hookups and all worthwhile specifications. Everything from the simplest one tube set to a 5-tube T. R. F. receiver is presented. Complete lists of parts are given to make each set complete. You are shown how to operate the receiver to its maximum efficiency.

CONTENTS

The Doerle 2-Tube Receiver That Reaches the 12,500 Mile Mark, by Walter C. Doerle.
2-R.F. Pentode SW Receiver having two stages of Tuned Radio Frequency, by Clifford E. Denton and H. W. Secor.
My de Luxe S-W Receiver, by Edward G. Ingram.
The Binnewise 2 Tube 12,000 Mile DX Receiver, by A. Binnewise, Jr.
Build a Short Wave Receiver in your "Top Case," by Hugo Gernsback and Clifford E. Denton.
The Denton 2 Tube All-Wave Receiver, by Clifford E. Denton.
The Denton "Stand By" by Clifford E. Denton.
The "Stand-By" Licensed.
The Short Wave MEGADYNE, by Hugo Gernsback.
A GREAT POCKET Short Wave Receiver, by Hugo Gernsback and Clifford E. Denton.
Boy, Do They Roll In on this One Tube! by C. E. Denton.
The S-W PEN PAPER, by H. G. Cram M. E.
Louis Martin's Idea of A GOOD S-W RECEIVER, by Louis Martin.

40 PAGES
OVER 75 ILLUSTRATIONS
IMPORTANT

THERE IS NO DUPLICATION BETWEEN THIS BOOK AND OUR OTHER VOLUME—"HOW TO BUILD AND OPERATE SHORT WAVE RECEIVERS" ALL THE MATERIAL PUBLISHED IN THE NEW BOOK HAS NEVER APPEARED IN ANY BOOK BEFORE.

25c

How to Build and Operate Short Wave Receivers

is the best and most up-to-date book on the subject. It is edited and prepared by the editors of SHORT WAVE CRAFT, and contains a wealth of material on the building and operation, not only of typical short-wave receivers, but short-wave converters as well. Dozens of short-wave sets are found in this book, which contains hundreds of illustrations, actual photographs of sets built, hookups and diagrams as well.

The book comes with a heavy colored cover, and is printed throughout on first-class paper. No expense has been spared to make this the outstanding volume of its kind. The book measures 7½x10 inches.

This book is sold only at such a ridiculously low price because it is our aim to put this valuable work into the hands of every short-wave enthusiast.

We know that if you are at all interested in short waves you will not wish to do without this book. It is a most important and timely radio publication.

Over 150 Illustrations
72 Pages 7x10 Inches

50c

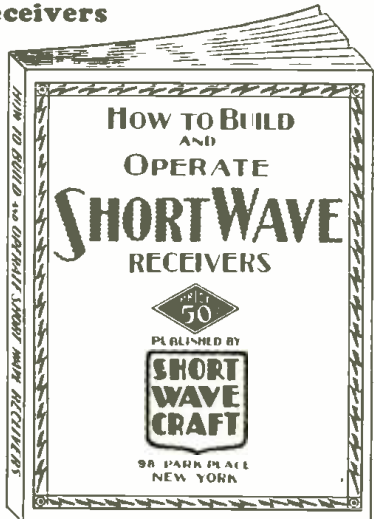

The Short Wave Beginner's Book

Here is a book that will solve your short wave problems—leading you in easy stages from the simplest fundamentals to the present state of the art as it is known today. It is the only low-priced reference book on short waves for the beginner.

The book is profusely illustrated with all sorts of photos, explanations and everything worthwhile knowing about short waves—the book is not "technical." It has no mathematics, no "high-faluting" language and no technical jargon. You are shown how to interpret a diagram and a few simple sets are also given to show you how to go about it in making them.

It abounds with many illustrations, photographs, simple charts, hookups, etc., all in simple language. It also gives you a tremendous amount of very important information which you usually do not find in other books, such as time conversion tables, all about aerials, noise elimination, how to get verification cards from foreign stations, all about radio tubes, data on coil winding and dozens of other subjects.

Partial List of Contents

Getting Started in Short Waves—the fundamentals of electronics—Send in the Short Hand of Radio—how to read schematic diagrams. Short Wave Codes—various types and when in making them. Short Wave Acids—the points that determine a good set of four or in the most one. The Transposed List of for reducing Man Made Static.
The Beginner's Short-Wave Receiver—a simple one tube set that anyone can build. The Beginner's Set Gets an Amplifier—how the volume may be increased by adding another.
How to Tune the Short Wave Set—telling the important points to get a good tuning. Regeneration Control in Short Wave Receivers.
Anti-Amplifier for S-W Receivers.
How to Couple the Speaker to the set.
Licensing the Cool—for greater enjoyment with the S-W set.
Ways to get to Kaly's Chart Wire Chart—to assist in the construction of coils.
Links to the other articles of S-W Receivers.

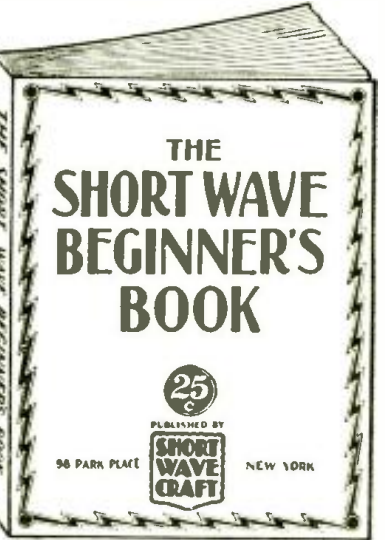

40 PAGES
OVER 75 ILLUSTRATIONS

25c

How to Become an Amateur Radio Operator

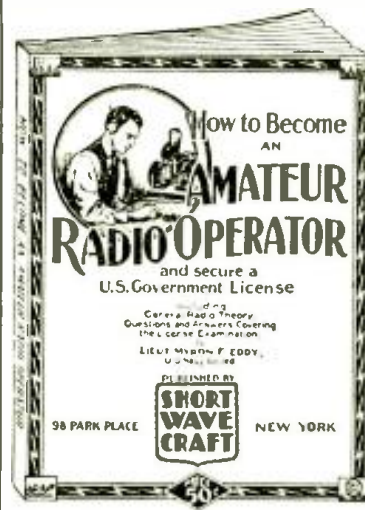

Who else but Milton F. Eddy to write the book? He has long years of experience in the amateur field, having held high positions in the I.R.T. for many years, he is a member of radio organizations of the R.C.A. Institute. He is a member of the I.R.T. Institute of Radio Engineers, the Veteran Wireless Operators' Association.

It is a treat to become a licensed radio operator, if you wish to take up those work eventually, it you wish to prepare yourself for the important subject—this is the book you must get.

Partial List of Contents

Waves of Learning the code. A system of sending and receiving with necessary drill words is supplied so that you may work with approved methods. Concise, authoritative definitions of radio terms, units and laws, and descriptions of commonly used pieces of radio equipment. The electrician's view of the working terminology of the radio operator. Complete manuals are used to indicate the various parts of radio circuits. General facts about particularly as it applies to the beginner. The electron theory is briefly given, then waves—their creation, propagation and reflection. Fundamental laws of electricity are particularly discussed in relation to radio and is a practical basis for the analysis. Descriptions of modern receivers that are in use with success in amateurs. You are told how to build and operate these sets. Amateur transmitters. Diagrams with specifications are furnished so construction is made easy. Power equipment that may be used with transmitters and receiver test sets, filters, batteries, etc. Regulations that apply to amateur operators. Appendix which contains the International "Q" signals, conversion tables for reference purposes, etc.

Over 150 Illustrations
72 Pages 7x10 Inches

50c

All the books shown on this page are published exclusively by

SHORT WAVE CRAFT

90-98 Park Place, New York, N. Y.

CLIP—MAIL

SHORT WAVE CRAFT
90-98 Park Place, New York, N. Y.

Gentlemen: I enclose herewith my remittance for the amount of \$..... for which you are to send me, postpaid, the books checked below.

- () Ten Most Popular Short Wave Receivers. How to Make and Work Them. 25c each
- () The Short Wave beginner's Book.....25c each
- () How to Build and Operate Short Wave Receivers.....50c each
- () How to Become an Amateur Radio Operator.....50c each

Name.....
Address.....
City..... State.....

(Send remittance in form of check or money order. If letter contains cash or unused U. S. Postage Stamps, register it.)

SW-1-31

These Books are Authentic For All Short Wave Work and LOW in Price

COUPON TODAY!

From the above data, the symmetrical input receiver appears to be at least three times as good as the other type considering the noise level. In each case the input was the same and the frequency was about 60 megacycles.

550 Gain by Super-Regeneration

On another test at about 60 megacycles, using a local oscillator, the signal was 0.1 volt with the variation oscillator out of the circuit. With the variation oscillator in the circuit the signal was 55 volts. This shows that there was a gain of 550 due to super-regeneration. Under similar conditions the gain due to super-regeneration in the older type receiver was about 62.5.

A brief analysis shows why the new symmetrical input receiver should give higher sensitivity than the older single tube detector receiver. Fig. 4 may be used to explain operation for the older single tube receiver as well as for that of the symmetrical input receiver.

Suppose only a single detector tube, V1, is used. On the positive half of the variation frequency cycle the tube is in a very sensitive condition as regards the incoming signal. During the negative half of the variation frequency cycle the tube is blocked and the receiver is practically dead. The responses may be pictured as in Fig. 5.

Now, suppose another tube is added to the detector circuit as shown in Fig. 3. During one half cycle, say the positive half as shown in Fig. 4, Tube V1, operates in a very sensitive condition; while tube V2 operates in a sensitive condition Tube V1 is blocked. In this case the response may be pictured as in Fig. 6.

This means that with the two tubes in operation, the time during which the receiver is sensitive is greatly increased over what it is when only one tube is used. This allows the use of a higher variation frequency with correspondingly better quality, while at the same time the receiver retains high sensitivity.

Advantages of "Symmetrical Input"

The advantages of the symmetrical input super-regenerative receiver over the older types of single input tube receivers may be summarized:

- (1) With the system of tuning shown in Fig. 3, a reasonable frequency range is covered with each coil.
- (2) The external coupling between plate and grid circuits is controlled by the tuning condenser. The required tuning capacity and the coupling capacity are similar, that is, at the low frequency end of any coil, more tuning capacity and more coupling capacity are necessary than is the case at the high frequency end of the same band.
- (3) With the input arrangement as shown in Fig. 3, a lower "trigger" (signal) amplitude is required for operation.

(4) The receiver is maintained in the sensitive condition over a much greater portion of the time. This makes it necessary to use a lower amplitude of variation frequency with a corresponding reduction in noise level.

(5) For the same reason as given in (4), above, a higher variation frequency can be used, while high sensitivity is still retained. This improves the quality.

(6) With the two tubes, a higher detector output results.

A later model of this receiver will incorporate a volume control and output transformer as shown in Fig. 7.

With this type of receiver at these frequencies considerable trouble has been experienced with antenna coupling. A close coupling must be used in order that sufficient signal voltage is impressed on the grids to "trigger" the detector on the weaker signal.

This coupling shown in Fig. 8 is satisfactory if the antenna lengths, "d" are proper.

This type of coupling, Fig. 9, was quite satisfactory in regard to efficiency of coupling but the type of antenna tends to affect the tuning.

The type of coupling shown in Fig. 10, is believed to be superior to that shown in Fig. 3, and is being used at present.

R. F. Filter Used in Battery Leads

In using this receiver it was found that considerable "pick-up" was due to the battery leads. It was desired to eliminate this so a radio frequency filter was incorporated and made a part of the battery leads entering the set. There are four entering leads and in each of these a radio-frequency choke was inserted, consisting of 20 turns of No. 18 enameled wire, wound on a threaded victrol (or other) form 1/2 inch in diameter. The thread pitch was 16 to the inch. In addition the chokes were each by-passed to ground with .005 mf. condenser. All four chokes and all four condensers were placed in a separate shielded compartment and the battery leads were shielded back to the batteries.

This filter helps to eliminate battery lead pick-up and constitutes a considerable improvement.

Fig. 11 is a diagram of the filter.

Ch—20 turns, No. 18, on 1/2 inch form.
C—.005 mfd.

To effectively eliminate all pickup from hatteries the leads must be choked and by-passed by means of a shielded filter, the leads themselves must be shielded, and the batteries must be placed in a shielded box.

It is believed that the "symmetrical input" receiver described above is an improvement in super-regenerative receivers and offers possibilities where a relatively cheap and small super-frequency receiver is required.



**NOW AVAILABLE
AN EASILY ASSEMBLED
ALL-WAVE
SUPER-HETERODYNE
COIL KIT**

By Miller

Scientific design, high grade workmanship and outstanding performance are assured with every MILLER ALL-WAVE INDUCTANCE KIT.

Blue print of circuit showing all values makes it a simple easy job to build a 7 tube ALL-WAVE Super-heterodyne receiver with outstanding performance as proved by present users.

Kit includes 5 inductances wound on bakelite forms, 3 intermediate transformers (465 KC), rectifier plate filter chokes, 3 padding condensers and 2 variable coupling condensers—securely packed for safe shipment anywhere.

LIST PRICE **\$15.00** POST PAID

Standard discounts to Dealers and Amateurs. A deposit of 20% required with order.

J. W. MILLER COMPANY
5917 So. Main St.
LOS ANGELES, CALIFORNIA

\$20.00 Prize Monthly For Best Set

● THE editors offer \$20.00 monthly prize for the best short-wave receiver submitted. If your set does not receive the monthly prize you still have a chance to win cash money, as the editors will be glad to pay space rates for any articles accepted and published in SHORT WAVE CRAFT.

You had better write the "S.W. Contest Editor," giving him a short description of the set and a diagram, BEFORE SHIPPING THE ACTUAL SET, as it will save time and expense all around. A \$20.00 prize will be paid each month for an article describing the best short-wave receiver, converter, or adapter. Sets should not have more than five tubes and those adapted to the wants of the average beginner are much in demand.

Sets must be sent PREPAID and should be CAREFULLY PACKED in a WOODEN box! The closing date for each contest is sixty days preceding date of issue (January 1 for the March issue, etc.)

The judges will be the editors of SHORT WAVE CRAFT, and George Shuart and Clifford E. Denton, who will also serve on the examining board. Their findings will be final.

Articles with complete coil, resistor and condenser values, together with diagram, must accompany each entry. All sets will be returned prepaid after publication.

REQUIREMENTS: Good workmanship always commands prize-winning attention on the part of the judges; neat wiring is practically imperative. Other important features the judges will note are: COMPACTNESS, NEW CIRCUIT FEATURES, and PORTABILITY. The sets may be A.C. or battery-operated. Straight Short-Wave Receivers, Short-Wave Converters, or Short-Wave Adapters. No manufactured sets will be considered; EVERY SET MUST BE BUILT BY THE ENTRANT. Tubes, batteries, etc., may be submitted with the set if desired, but this is not essential. NO THEORETICAL DESIGNS WILL BE CONSIDERED! The set must be actually built and in working order. Employees and their families of SHORT WAVE CRAFT are excluded. Address letters and packages to the SHORT WAVE CONTEST EDITOR, care of SHORT WAVE CRAFT Magazine, 96-98 Park Place, New York, N. Y.

It Wasn't



necessary to build special headphones for Admiral Byrd to use on his Antarctic Expedition. Every Trimm Featherweight headset is built to perform satisfactorily

whether the temperature is a hundred degrees below zero or in the heat and humidity of the Tropics.

Admiral Byrd chose TRIMM FEATHERWEIGHT phones because they could be depended upon in any emergency.

TRIMM RADIO MFG. CO., 1528 Armitage Ave., CHICAGO, U.S.A.
Earphone Specialists

It will be to your advantage to read special offer on page 513.

SENSATIONAL- BIG BROADCAST Magazine Prices SLASHED Save 25% to 50%

OVER 50 GREAT COMBINATION SUBSCRIPTION OFFERS RIGHT NOW

is the time of the year when millions of subscriptions to favorite magazines expire. RIGHT NOW is the time to renew your subscription when prices, for a limited time only, have been sensationally reduced. Ordering at this time will mean a saving of several dollars for you. In assembling these many combination subscription offers we have made it possible that our readers obtain standard, popular magazines at the lowest prices obtainable. Only by special arrangement with a group of famous publishers has this great combination of magazines been made available at the unusually low cost. NOW you should order—at money-saving prices. It is most appropriate at this time of the year to send your friend his favorite magazine. Read over the various combination offers, and see how we bring you double values for only half the price. Then order your magazines today. Prices are going up—this is your protection for one year. RIGHT NOW sit down and send us the list. If books are to be sent to individual people, mention specifically the name of the magazine and to whom and where it should be sent. Don't miss this wonderful opportunity. All prices quoted are for subscriptions in U. S. only. Canadian and Foreign subscriptions require additional postage.

OFFER NO. 1 Short Wave Craft \$2.50 Q S T Regular Price \$5.00 Our Price \$3.75	OFFER NO. 2 Short Wave Craft \$2.50 Radio-Craft Regular Price \$5.00 Our Price \$3.75	OFFER NO. 3 Short Wave Craft \$2.50 Radio News Regular Price \$5.00 Our Price \$3.75	OFFER NO. 4 Short Wave Craft \$2.50 Everyday Science and Mechanics Regular Price \$5.00 Our Price \$3.75	OFFER NO. 5 Short Wave Craft \$2.50 Popular Mechanics Regular Price \$5.00 Our Price \$3.85	OFFER NO. 6 Short Wave Craft \$2.50 Popular Science Regular Price \$4.00 Our Price \$3.35	OFFER NO. 7 Short Wave Craft \$2.50 Modern Mechanix Regular Price \$4.00 Our Price \$3.35	OFFER NO. 8 Short Wave Craft \$2.50 Christian Herald Regular Price \$4.50 Our Price \$3.50	OFFER NO. 9 Short Wave Craft \$2.50 Photoplay Regular Price \$5.00 Our Price \$3.85
---	---	--	--	---	---	---	--	---

OFFER NO. 10 Short Wave Craft \$4.50 Life or Judge (Only One) Regular Price \$4.00 Our Price \$3.25	OFFER NO. 11 Short Wave Craft \$2.50 Delineator Regular Price \$3.50 Our Price \$3.00	OFFER NO. 12 Short Wave Craft \$2.50 Pathfinder Regular Price \$3.50 Our Price \$3.00	OFFER NO. 13 Short Wave Craft \$2.50 American Boy Regular Price \$4.50 Our Price \$3.50	OFFER NO. 14 Short Wave Craft \$2.50 Motion Picture Regular Price \$4.00 Our Price \$3.25	OFFER NO. 15 Short Wave Craft \$2.50 College Humor Regular Price \$4.00 Our Price \$3.25	OFFER NO. 16 Short Wave Craft \$2.50 Screenland Regular Price \$4.00 Our Price \$3.25	OFFER NO. 17 Short Wave Craft \$2.50 Silver Screen Regular Price \$3.50 Our Price \$3.00	OFFER NO. 18 Short Wave Craft \$2.50 Golden Book Regular Price \$5.50 Our Price \$4.25
---	---	---	---	---	--	---	--	--

OFFER NO. 19 Short Wave Craft \$2.50 Review of Reviews Regular Price \$5.50 Our Price \$4.25	OFFER NO. 20 Short Wave Craft \$2.50 Nature Regular Price \$5.50 Our Price \$4.25	OFFER NO. 21 Short Wave Craft \$2.50 Scribner's Regular Price \$6.50 Our Price \$5.25	OFFER NO. 22 Short Wave Craft \$2.50 Physical Culture Regular Price \$5.00 Our Price \$3.25	OFFER NO. 23 Short Wave Craft \$2.50 Boys' Life Regular Price \$3.50 Our Price \$3.00	OFFER NO. 24 Short Wave Craft \$2.50 Pictorial Review Regular Price \$3.50 Our Price \$3.00	OFFER NO. 25 Short Wave Craft \$2.50 Wonder Stories Regular Price \$5.00 Our Price \$3.75
--	---	---	---	---	---	---



Your Choice of One or More of These Popular Magazines

Every Science and Mechanics	Boys' Life
Radio-Craft	Woman's Home Companion
Short Wave Craft	American Boy
Wonder Stories	Golden Book
Popular Mechanics	Screenland
Radio News	Silver Screen
Popular Science	Motion Picture
Modern Mechanix	Pathfinder
Christian Herald	College Humor
Photoplay	Pictorial Review
Life	McCall's
Judge	Physical Culture
Delineator	Scribner's
Review of Reviews	Q S T
Nature	

The BIG "4" Offer

Grouped below are many of the outstanding magazines which can be taken in combination with SHORT WAVE CRAFT. The individual groups represent a substantial saving over the regular newsstand rate of all the books. ORDER TODAY.

OFFER NO. 26 Short Wave Craft 1 year Modern Mechanix 1 year Wonder Stories 1 year Christian Herald 1 year ALL FOUR ONLY \$6.00	OFFER NO. 27 Short Wave Craft 1 year Popular Science 1 year Delineator 1 year Pathfinder 1 year ALL FOUR ONLY \$4.50	OFFER NO. 28 Short Wave Craft 1 year American Boy 1 year Motion Picture 1 year College Humor 1 year ALL FOUR ONLY \$5.00	OFFER NO. 29 Short Wave Craft 1 year Screenland 1 year Silver Screen 1 year Life or Judge (Only One) 1 year ALL FOUR ONLY \$4.75	OFFER NO. 30 Short Wave Craft 1 year Golden Book 1 year Review of Reviews 1 year Nature 1 year ALL FOUR ONLY \$7.00	OFFER NO. 31 Short Wave Craft 1 year Scribner's 1 year Nature 1 year Pathfinder 1 year ALL FOUR ONLY \$6.50	OFFER NO. 32 Short Wave Craft 1 year Physical Culture 1 year Life or Judge (Only One) 1 year Boys' Life 1 year ALL FOUR ONLY \$5.00	OFFER NO. 33 Short Wave Craft 1 year Modern Mechanix 1 year Pictorial Review 1 year Nature 1 year ALL FOUR ONLY \$5.60
---	---	---	---	--	--	--	---

The BIG "Popular" Offer

SHORT WAVE CRAFT for one Year and your choice of a subscription to any two of the publications listed below, each for one year, at the special combination rate of

ALL THREE FOR \$4.15

- MOTION PICTURE
- COLLEGE HUMOR
- SCREENLAND
- SILVER SCREEN
- PHYSICAL CULTURE
- BOYS' LIFE
- PATHFINDER
- MCCALL'S
- DELINEATOR
- PICTORIAL REVIEW
- WOMAN'S HOME COMPANION

Take Advantage of These Big Subscription Saving Offers—ORDER TODAY!

SHORT WAVE CRAFT
96-98 Park Place, New York, N. Y. SW134

Gentlemen: Enclosed you will find my remittance of \$..... for which please send me Combination Offer No., which consists of SHORT WAVE CRAFT and the following magazines:

Name Address

City State

(For Canadian or Foreign Subscription rates on any combination offer, write for cost of additional postage.)

Fill out this section of the coupon if magazine is to be sent to a friend. DO NOT DETACH FROM OTHER HALF OF COUPON. If several magazines are to be mailed to friends, make duplicate coupons of this section only, one for each magazine to be sent. Write on plain white stock.

Please send the to
(Name of magazine)

Name

Address

City State

Mention that it is sent by

(Print your name clearly)

English Short-Wave News

By "Megacycle"

● TO COMMENCE these notes it is thought that mention of the complete "fade-outs" on the 25 meter band for perhaps a week at a time is the most important phenomena. Reference to last month's report will show that during August—and indeed all summer—this particular channel has provided our main source of programmes if not "long-distance" listening. The sudden change is all the more remarkable for the fact that the usual telephony and teleggraphy stations on either side of the band were apparently unaffected. Those short-wave enthusiasts who have been listening for the past five years or so will find on reference to their "log books" that the 25 meter channel has only shown up to real advantage this year, and it is significant that this summer—in England at any rate—has been the best since 1921.

Long distance reception on the 16m. (meter) channel has been confined to W3XAL on the 16.87 m. To be precise this station was logged on September 4, 13, 28, and 29. On September 29, 3XAL was tuned in at 15.00 G. M. T. at full loud-speaker strength free of all "mush" and fading. According to schedule in England this station comes on the air at 17:30 G. M. T. but perhaps some American listeners will know of a change in schedule. PHI, the Dutch transmitter on this band is never heard in London, presumably because we are within the skip distance.

Turning our attention to that most variable of bands—the 19 m. channel—conditions have been as is usual in the spring and autumn, very variable. The Vatican City transmitter on 19.84 m. is received regularly on the 10:00-10:15 G. M. T. schedule but unfortunately this is the only station on this channel so consistent. The only long distance transmissions on this band are the U. S. A. group. W2XAD on certain evenings of his scheduled transmission is completely inaudible whilst two evenings later a complete programme may be enjoyed. Instances of this occurred on Sept. 8, at 20.00 G. M. T. when a talk on "road safety" was easily followed on the loud-speaker and again on September 29 when syncopated piano pieces at 20.30 G. M. T. were "local" in quality and volume!

For the past month Rome 25.4 m. has been delivering a perfectly strong carrier in England, but the modulation is about the worst that has ever been heard. Reports from all over England confirm this point and U. S. listeners cannot help but have experienced the same trouble. It appears as if Rome is inverting all audio frequencies like a commercial telephone station. Continuing with the 25 m. band Zeesen (Germany) has deteriorated from a usual R 9 strength to R 2-3 but was again received at R9 on September 29. On certain evenings during September Zeesen and in fact no local European 25m. transmitters were even audible—a very rare occurrence. W8XK, the Pittsburgh transmitter on this band, has been also very variable but on some evenings remarkable field strengths have been obtained. On September 6 a program was enjoyed from this station from the time of opening up to 02.00 G. M. T. when for obvious reasons listening had to be discontinued. Receptive conditions on that evening were remarkable as far as U. S. A. transmissions—code and telephony—were concerned, and it would be interesting for American listeners to consult their "logs" to see if the same abnormal conditions similarly affected the east to west route. On the night in question W2XE (49.02 m.) was picked up for the first time and held for quite an hour.

It is difficult to say what station has yielded the most consistent satisfactory signal because there has been so little to listen to that one is inclined to state that all transmissions have been poor. However EAQ (30 m.) must be awarded the palm—with CNR (23.29 m.) a good second—for really good signals at a time when no other station appeared above the R3 mark. Particular mention of EAQ appears on the

log on September 8 when the program value was almost "local" in intensity and quality. On September 9 at 19.30 G. M. T. similar conditions prevailed on this band and EAQ was once again the star—and only—transmission. It is a pity, now that winter conditions are rapidly approaching, that the 30 m. band is so comparatively empty. European listeners find very little other than EAQ, CT1AA, and W2XAF—who opens very late—to listen to. W3XAU on 31.28 m. is scheduled to operate from 13:00-04.00 G. M. T. daily but this station has not been heard for the past eight months. Confirmation that the station is still operative would be welcomed.

The 50 meter band, which is usually a certain channel for entertainment when all else fails, has towards the end of the period under review, deteriorated to such an extent that even Moscow 50 m. has fallen to R2 on certain occasions. OXY (49.4 m.) has disappeared entirely in a jumble of heterodynes and code transmissions towards the end of September.

Mention was made in these notes last month of the controversy raging among European S. W. listeners as to whether or not Moscow is broadcasting on 50 and 25 m. or only 50 m. The 25 meter transmission is never heard without the 50 m. program also being audible and according to the author's careful checks the programs are always identical. Several S. W. listeners have reported differing programs but this is not confirmed by the writer. It has been noted, however, that the 25 m. transmission is often much more powerful than the corresponding 50 m. transmission, but this does not detract from the validity of the first harmonic theory. Added to this, is the evidence supplied by Moscow during the opening announcement on Sunday, September 10th—heard both on 50 m. and harmonic 25 m.—at 15.00 G. M. T. when the 1841 m. and 50 m. transmissions only were mentioned. At any rate the problem is of real interest and American listeners may care to air their views in the matter. In closing this subject it is understood that a listener claims to have heard an announcement to the effect that the "mystery" transmission on 25 m. is actually RNF on 24.96 m. and is not therefore a harmonic!

Leaving the regular broadcast channels CNR (Rabat) on 23.39 m. on the Sunday transmission from 12.30 G. M. T. has provided musical programs of unsurpassed brilliance, free of all fading and interference. American listeners should certainly make a point of listening for this transmission as a welcome change from their home programs. The hour of transmission is certainly rather early—especially for Sunday listening—but the transmission does not cease till approximately 16.30 G. M. T. which should provide a good breakfast program. The same station broadcasts again on 37.33 meters at 20.00-21.00 G. M. T. on Sundays, but in England this transmission seldom approaches—either in quality or volume—the 23 meter transmission.

American listeners should make a point of listening on 42 meters where a new European relay station has commenced operations with the regular Oslo programs. Transmissions are experimental at the moment but appear to be consistently received at 19.00 G. M. T.

Telephony has been found productive of some long-distance reception but American listeners will be interested to hear that SUZ (21.7 m.) Cairo was received on September 29 at 15.00 G. M. T. at a strength seldom experienced on anything but medium wave broadcast. SUZ has not been heard previously in this location. PLF, Java, on approximately 17 meters is heard on Wednesdays at 20.00 G. M. T. giving a test concert of gramophone records and is received in England with wonderful volume and clarity!

If you want "more," send Editor a postcard marked "Want more Megacycle."

Begin with Crystal Control

RESULTS with crystal control are far more certain . . . and in the long run, cost much less. But remember, there's a difference in crystals.

Bliley Crystals, used by all the leading amateurs and engineers (and now by Admiral Byrd on his trip to the Antarctic) have been proven best.

BLILEY CRYSTALS AND HOLDERS					
Type	Mf. Band	Supplier	Frequency	Particulars	Price
BCX	17.3.5	±25Kc*	0.05%	Unmtd.	\$3.90
BCX	7.0	±50Kc*	0.08%	Unmtd.	3.90
H12	17.3.5.7	±25Kc*	0.03%	4.1L	4.95
H12	17.3.5.7	±5Kc	0.03%	4.1L	2.45
H12	17.3.5.7	±0.5Kc	0.03%	4.1L	9.85
H12	14.0	±50Kc	0.03%	N.A.	
H12	7.0	Special mount. for 7Mc BCX			1.50
H12	17.3.5	Standard mount. for BCX			1.50
NSF	465.500, or 525Kc S.S. Qtz filter. Mtd.				5.90

*Or your choice from distributor's stock.

Bliley Crystals are sold by all progressive distributors of amateur equipment, and manufactured under NRA.

BLILEY PIEZO-ELECTRIC CO.

227 Union Station Bldg.

Erie, Pa.

Be A Radio Operator



Learn at Home

It's Easy With The New Master Code Teaching Machine



Realize the advantage and success that comes with being a Radio Operator qualified to fill the highest-paid jobs. TELEPLEX teaches you quickly at home. No experience necessary. We furnish Complete Code Course and lend you the New Master Teleplex. Guide you step by step. Personal instruction. TELEPLEX has instructed more students in the code during the past ten years than all other systems combined. Used by U. S. Army and Navy, R. C. A., A. T. & T. Co. and principal schools. Get started NOW! Easy terms. Write today for folder SW-13 giving full details.

TELEPLEX COMPANY

76 Cortlandt Street, New York, N. Y.

It Satisfies Capt. Hall

A Short Wave Receiver that satisfies the critical CAPT. HALL. CAPT. HALL has to be good. The Captain now uses the POSTAL INTERNATIONAL 9 TUBE PROFESSIONAL SUPERHET. ERODYNE for his DX hunting. Received stations in every continent within 24 hours, on the POSTAL INTERNATIONAL.



New Short-Wave Sensation

For the Amateur or Short Wave Fan. Professional. Custom built. EMPLOY'S TUNED R. F. PRE-SELECTOR. New triple driver coils. Instantaneous band spread. C.W. beat oscillator. Electron coupled oscillator. Phono jack 3 watt output. Antenna trimmer. No images, harmonics or drifts. A new low price for professional receivers. Sold direct from our laboratory with money back guarantee. Short Wave fans and Amateurs, you owe it to yourself to send for our FREE Circular No. 6 describing and illustrating the POSTAL INTERNATIONAL and also our special price offer to SHORT WAVE CRAFT readers.

Postal Radio 135 Liberty St. New York, N. Y.

SUPER TESTING KIT!



Pencil Type Handles with interchangeable Tip End. Kit complete with 2 Plug-In-Prongs, 2 Alligator Clips, 2 Needle Point Phone Tips, and 2 Spade Leads, Long, Thin Pencil-Type handles for easy testing in tight places. Ideal for testing Long and Shortwave Sets, Coils, Condensers, Etc. Complete kit. Write for free catalog.

INTRODUCTORY PRICE NOW \$1.00 PREPAID
AMERICAN RADIO HARDWARE CO.
135 Grand Street New York, N. Y.

Be a Television Expert

LEARN Radio and Television Broadcast, Service, etc.
Leaders predict new system television requires thousands relief and broadcasting stations. Ultra-short waves permit 80,000 television stations in America alone. Here opportunity! Get it NOW and build up with new industry in new era. Thorough training qualifies for 1st Class Radiophone operator license. Real experience at Television Sta. W3XAL. Write for free folder, "Pictures on the Air."
E. O. Noel, Pres. First National Television, Inc. Dept. B-1, Power & Light Bldg. Kansas City, Mo.

YOUR DOLLAR BUYS MORE AT ALLIED

A FEW BARGAINS FROM OUR BOOK OF VALUES

"WORLD-WIDE" SPECIAL 7 TUBE RADIO
 15 to 2400 Meters
 4 separate wavebands
 Automatic volume control



SPECIAL PRICE
 Complete with Speaker and RCA Tubes
\$26⁴⁵

RCA Licensed

8 MFD. Electrolytic in metal can
38c



5 inch Magnetic Speaker
\$1²⁸



8000 ADDITIONAL BARGAINS IN THIS BIG BOOK OF VALUES

SPECIAL PRICES ON RCA and CUNNINGHAM TUBES

201A	227	245
26c	31c	33c



MAIL COUPON NOW
 ALLIED RADIO CORP., Dept. E.,
 833 W. Jackson Blvd., Chicago, Ill.

Please send me Free your NEW 1934 Catalog.

Name _____
 Address _____
 City _____ State _____
 Serviceman Dealer Engineer Experimenter

ALLIED COOPERATES

In spite of tremendous increases in the cost of labor and commodities, *thousands of items* in this book are being sold at *below the current market*. Hundreds of other items are being sold at prices that are still less than last year. *How was this achieved?* The answer is simple, *huge contracts, huge purchases*, made during the summer of 1933 when radio prices were at their *lowest in history*. Merchandise which was purchased at last year's low record prices is being passed on to our customers at tremendous savings. *Send for this Catalog now and save money.*

Here is the book that is making radio history. The *most complete lines* of quality radio sets, tubes, replacement parts, test equipment, and service men supplies, at the *lowest wholesale prices*.



SEND FOR THIS FREE CATALOG

LEADERSHIP

Thousands of radio dealers, service men, engineers and many broadcasting stations depend upon Allied for their radio needs. Allied consistently justifies this wide spread faith by offering a *complete* selection of high grade standard apparatus that can be counted on for *efficiency, long life and customer satisfaction*—at the lowest possible prices. Allied's huge stock enables you to get unusually *prompt and efficient* service. This is the simple secret of our great repeat business. If there ever was a time that you had to decide carefully where your money will buy its full money's worth, it is now. Allied will continue to protect you against unwarranted price increases to the fullest extent of its power. Allied's low net cash prices mean low, and will continue to mean low.

Allied Radio
 CORPORATION
 833 W. JACKSON BLVD. CHICAGO ILL.

ATWATER KENT RADIO

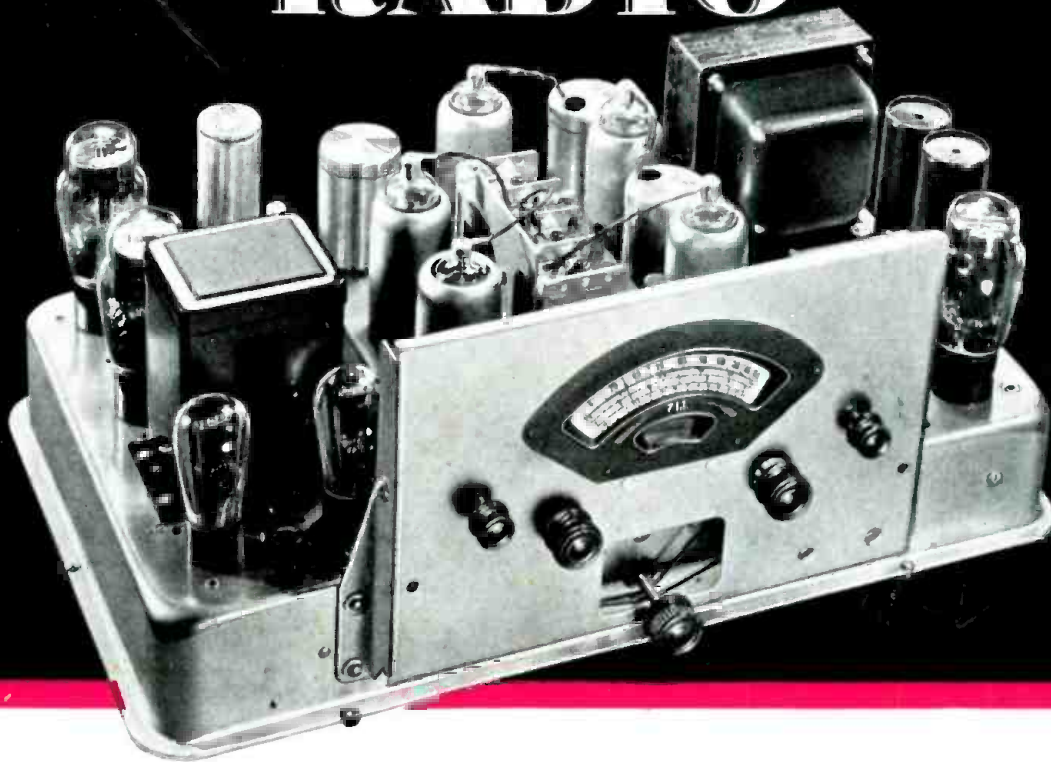

Announcing THE WORLD'S FINEST ALL-WAVE RADIO

FOR distant reception you need the finest precision workmanship to give TRUTHFUL reproduction of a broadcast. The slightest deviation—an eighth of a turn on a R. F. coil, or one loosely soldered wire—might not be noticed if you were tuned in on a local station, but it might easily ruin a broadcast from Germany.

The weakness of a signal from half way around the globe makes it imperative that "losses" in the set be held to a minimum, which is one of the chief reasons why

Atwater Kent Radios are so favored by short wavers.

The painstaking care with which every Atwater Kent Radio is built reaps its full reward when you tune in Siam or the Argentine and hear all the sparkle and color of their native music reproduced with lifelike realism.

Add to the dependable satisfaction of an Atwater Kent for regular programs, the exciting luxury of *truthful* short wave reception—and you have everything that radio has to offer.

ATWATER KENT MANUFACTURING CO.

A. Atwater Kent, Pres.

4700 Wissahickon Ave., Philadelphia, Pa.



- *At left* MODEL 711-J (11 tubes) tuning range from 540 to 23,000 kilocycles, 4-point switch for wave lengths, visual shadow tuning, auditorium type speaker, 15 watts undistorted output, 4-gang condenser, 10 tuned circuits. For truthful reproduction of broadcast through entire range of sound, it is the finest radio ever sold commercially! **\$135**
- *Above* MODEL 708 (8 tubes). Contains same set as model 808, entire, 8½-inch electro-dynamic speaker has full acoustical area. Cabinet is 15¼ inches wide. **\$6850**
- *At right* MODEL 808 (8 tubes) range from 540 to 20,000 kilocycles, 4-point switch for wave lengths, 11-inch speaker, 9 watts output, 4-gang condenser, 8 tuned circuits on broadcasting band, 9 on short wave band. All 8 tubes function at full power throughout the tuning range. **\$88**

All prices F.O.B. Philadelphia—subject to change without notice

I saved 1/2 by buying direct from the Midwest Laboratories

Yes, and it gives you WORLD-WIDE Reception!

Amazing New
SUPER Deluxe

16-TUBE
ALL-WAVE Radio
9 TO 2,000 METERS

30 DAYS FREE TRIAL



WRITE FOR NEW
FREE CATALOG

BEFORE you buy any radio, write for this big new FREE Midwest catalog... printed in four colors. It has helped thousands of satisfied customers save from 1/3 to 1/2 on their radios... by buying direct from the Midwest Laboratories. You, too, can make a positive saving of 30% to 50% by buying a Midwest 16-tube deluxe ALL-WAVE radio at sensationally low direct-from-laboratory prices. You'll be amazed and delighted with its super performance! Broadcasts from stations 10,000 miles and more away are brought in... "clear as locals". You get complete wave length coverage of 9 to 2,000 meters (33 megacycles to 150 KC). Now, you can enjoy the new DX-ing hobby... and secure verifications from world's most distant stations.

These bigger, better, more powerful, clearer-toned, super-selective radios have FIVE distinct wave bands: ultra-short, short, medium, broadcast and long... putting the whole world of radio at your finger tips. Now listen in on all U. S. programs... Canadian, police, amateur, commercial, airplane and ship broadcasts... and programs from the four corners of the earth. Thrill to the chimes of Big Ben from GSB, at Daventry, England—tune in on the "Marseillaise" from FYA, Pointoise, France—hear sparkling music from EAQ, Madrid, Spain—listen to the call of the Kookaburra bird from VK2ME, Sydney, Australia—etc. Never before so much radio for so little money! Write for FREE catalog.

WORLD'S GREATEST RADIO VALUE
\$49.50
with New
Deluxe Auditorium Type SPEAKER

... 40 NEW 1934 FEATURES ...

Try this Midwest radio... in your own home... for thirty days before you decide. See for yourself the 40 new 1934 features that insure amazing performance. Other features include: Automatic Select-O-Band, Amplified Automatic Volume Control, 16 New Type Tubes, Balanced Unit Superheterodyne Circuit, Velvety Action Tuning, Super-Power Class "A" Amplifier, 29 Tuned Circuits, New Duplex-Diode-High Mu Pentode Tubes, No-Image Heterodynes, Full Rubber Floated Chassis, Variable Tone Blender, Centralized Tuning, 7 KC Selectivity, New Thermionic Rectifier, Automatic Tone Compensation, Auditorium Type Speaker, etc. These features are usually found only in sets selling from \$100 to \$150.

AMAZING FOREIGN RECEPTION

AERON, OHIO—My Midwest 16 is a real getter for distance. Received 205 stations on regular wave band... including U. S., Canadian, Mexican, Cuban and Italian stations. Also many police, airport and "ham" stations from all over the country. Have logged England, France, Germany, Madrid, Rome, on 15-30 meter band. South American stations include Venezuela, Colombia, Brazil, Yucatan—L.H. MOELLER, 793 N. South St.

DEAL DIRECT WITH LABORATORIES
Increasing costs are sure to result in higher radio prices soon. Buy before the big advance... NOW, while you can take advantage of Midwest's amazingly low prices. No middlemen's profits to pay! You save from 30% to 50% when you buy direct from Midwest Laboratories... you get 30 days FREE trial—as little as \$5.00 down puts a Midwest radio in your home. Satisfaction guaranteed or your money back! FREE catalog shows sensationally radio values. Write TODAY!

SAVE UP TO 50%

TERMS AS LOW AS \$5.00 DOWN

NEW STYLE CONSOLES
Write quickly for your FREE copy of the new Midwest catalog. It pictures a complete line of beautiful, artistic deluxe consoles and chassis... in four colors! Sensational low prices save you 30% to 50%. Also shows performance curves that prove Midwest radios out-perform most of the \$150 sets. You can order your Midwest radio from this catalog with as much certainty of satisfaction as if you were to select it personally at our great radio laboratories. Write TODAY!

MAIL COUPON TODAY! FOR AMAZING 30-DAY FREE TRIAL OFFER AND NEW 1934 CATALOG

MIDWEST RADIO CORP., Dept. 381 Cincinnati, Ohio.

Without obligation on my part send me your new FREE 1934 catalog, and complete details of your liberal 30-day FREE trial offer. This is NOT an order.

AGENTS! Make Easy Extra Money Check Here for Details

Name.....
Address.....
City..... State.....

MIDWEST RADIO CORP.
DEPT. 381 — CINCINNATI, OHIO, U. S. A.
Established 1920 Cable Address Miraco ABC 5th Edition